



NSS **NORTHEAST**
SITE SOLUTIONS
Turnkey Wireless Development

Northeast Site Solutions
Victoria Masse
420 Main Street #2, Sturbridge, MA 01566
860-306-2326
victoria@northeastsitesolutions.com

August 9, 2021

Members of the Siting Council
Connecticut Siting Council
Ten Franklin Square
New Britain, CT 06051

RE: Exempt Modification Application
Station Drive-Line #1750 –Pole#1280, Greenwich CT 06807
Latitude: 41.02998600
Longitude: -73.597948400
T-Mobile Site#: CT11241A_L600

Dear Ms. Bachman:

T-Mobile currently maintains six (6) antennas at the 153-foot and 161-foot level of the existing 140-foot transmission pole at Station Drive-Line# 1750, Greenwich CT 06807. The electric transmission pole is owned by CL&P d/b/a Eversource, the property is owned by State of Connecticut Department of Transportation. T-Mobile now intends to replace three (3) existing antennas with three (3) new 600/700 MHz 5G antenna. The new antennas would be installed at the 161-foot level of the transmission pole.

T-Mobile Planned Modifications:

Remove: NONE

Remove and Replace:

(3) Andrew LNX-6512DS (Remove) - (3) RFS APXVAARR18- 600/700 MHz Antenna (Replace)

Install New:

(3) Smart Bias-T
(6) Coax
6' Pipe Mast

Existing to Remain:

(3) Andrew TMBXX-6516 1900/2100 MHz Antenna
(3) Smart Bias-T
(18) Coax



NSS **NORTHEAST**
SITE SOLUTIONS
Turnkey Wireless Development

Ground work:

Remove (3) existing radio units

Replace (3) new Radio 4449 B71+B85

This facility was approved by the CT Siting Council. Petition No.466 –on June 20, 2000 T-Mobile Northeast LLC and Eversource received permission to modify a transmission structure for telecommunication use (pole #1280). Total height approved is 164-feet. Please see attached.

Please accept this letter as notification pursuant to Regulations of Connecticut State Agencies § 16- SOj-73, for construction that constitutes an exempt modification pursuant to R.C.S.A. § 16-50j-72(b)(2). In accordance with R.C.S.A. § 16-SOj-73, a copy of this letter is being sent to Mayor Peter Tesei, Elected Official and Katie DeLuca, Director for the Town of Greenwich, as well as State of Connecticut Department of Transportation the property owner and CL&P d/b/a Eversource the tower owner.

The planned modifications to the facility fall squarely within those activities explicitly provided for in R.C.S.A. § 16-50j-72(b)(2).

1. The proposed modifications will not result in an increase in the height of the existing structure.
2. The proposed modifications will not require the extension of the site boundary.
3. The proposed modifications will not increase noise levels at the facility by six decibels or more, or to levels that exceed state and local criteria.
4. The operation of the replacement antennas will not increase radio frequency emissions at the facility to a level at or above the Federal Communications Commission safety standard.
5. The proposed modifications will not cause a change or alteration in the physical or environmental characteristics of the site.
6. The existing structure and its foundation can support the proposed loading.

For the foregoing reasons, T-Mobile respectfully submits that the proposed modifications to the above referenced telecommunications facility constitute an exempt modification under R.C.S.A. § 16-50j-72(b)(2).

Sincerely,

Victoria Masse
Mobile: 860-306-2326
Fax: 413-521-0558
Office: 420 Main Street, Unit 2, Sturbridge MA 01566
Email: victoria@northeastsitesolutions.com



NSS

NORTHEAST
SITE SOLUTIONS

Turnkey Wireless Development

Attachments

C: The Honorable Fred Camillo – First Selectman- Fred.Camillo@greenwichct.org

101 Field Point Road
Greenwich, CT 06830

Katie DeLuca- Director of Planning and Zoning / Zoning Enforcement Coordinator / Town Planner.

101 Field Point Road
Greenwich, CT 06830

Eversource Energy- as tower owner

107 Selden Street
Berlin, CT 06037

John A. Vital, Transportation Rail Officer II – as property owner

Connecticut Department of Transportation
Bureau of Public Transportation
Office of Rails-Property Management Unit
4 Brewery Street, 4th Floor
New Haven, Connecticut 06511

Exhibit A

Petition No. 466
Voicestream Wireless
Greenwich, Connecticut
Staff Report
June 20, 2000

On June 16, 2000, Connecticut Siting Council (Council) member Edward S. Wilensky, and Fred Cunliffe of Council staff met Voicestream Wireless (Voicestream) representatives J. Brendan Sharkey, Esq., Chetan Dharduk, and Haider Syed for inspection of a Connecticut Light & Power Company (CL&P) electric transmission line structure (no. 1280) located off Sound Shore Drive in Greenwich. Voicestream, with the agreement of CL&P, proposes to modify the transmission structure for telecommunications use and is petitioning the Council for a declaratory ruling that no Certificate of Environmental Compatibility and Public Need (Certificate) is required for the modification.

Voicestream proposes to attach a 7-inch diameter pipe extending the existing lattice structure height of 140 feet by 23 feet four inches for a total height of approximately 164 feet. A structural analysis concludes no additional reinforcement is necessary. Voicestream proposes to install two low profile antenna cluster mounts with centers of radiation at 161 feet and 152 feet 4 inches on the pipe and a 2-foot by 2-foot microwave antenna at the approximate 140-foot level of the structure. Voicestream proposes to place associated equipment cabinets on a concrete foundation within a 10.5-foot by 11.5-foot compound secured by a six-foot chain link fence. Since CL&P transmission line easement is limited to an aerial right-of-way, Voicestream will need to obtain a lease agreement with the Connecticut Department of Rail Transportation (ConnDOT) for underlying land use. Access to the CL&P structure would be from Sound Shore Drive over a ConnDOT easement. Utilities would be placed underground within this easement from an existing distribution pole located approximately 350 feet west of the proposed site.

Surrounding land uses include a CL&P substation and transmission lines, Town-owned water tank and abandoned power station, railroad right-of-way, and Interstate 95. Other existing transmission line structures in the area range in height from 95 feet to 140 feet AGL.

The Council approved Petition No. 399 on July 23, 1998 for Sprint to use structure no. 1281 just west of the proposed site and approved Petition No. 443 on February 2, 2000 for AT&T to use structure no. 1292 adjacent to the Cos Cob Substation. The zoning of the proposed site is Residential R-6. The nearest home is approximately 350 north across the railroad right-of-way of the site.

The worst case power density for the telecommunications operations at the site has been calculated to be less than 1.8% of the applicable standard for uncontrolled environments.

Voicestream contends that the proposed installation will not cause a substantial adverse environmental effect, and for this reason would not require a Certificate.

Exhibit B



1:1920
1"=160'



3/16/2021 3:23:15 PM

This map was produced from the Town of Greenwich GIS. The Town expressly disclaims any liability that may result from the use of this map. Basemap: 4/2/08. Parcels: 10/1/12. Copyright 2005 Town of Greenwich

ADMINISTRATIVE INFORMATION

OWNERSHIP

Tax ID 368/036

Printed 01/12/2021 Card No. 1 of 1

PARCEL NUMBER 02-4587/S
Parent Parcel Number
Property Address SOUND SHORE DRIVE 0000
Neighborhood 113020 INDIAN HARBOR [2]
Property Class 299 Exempt Commercial

CONNECTICUT STATE OF
FINANCE DEPT TOWN OF GREENWICH
101 FIELD POINT ROAD
GREENWICH, CT 06830
LOT NO C-1B SOUND SHORE D R S7Z

TRANSFER OF OWNERSHIP

Table with columns: Date, Description, Amount. Rows include 04/18/2007 and 07/31/1989.

EXEMPT

TAXING DISTRICT INFORMATION

Jurisdiction 57 Greenwich, CT
Area 001
Corporation 057
District 02
Section & Plat 236
Routing Number 7890S0007Z

VALUATION RECORD

Table with columns: Assessment Year, Reason for Change, VALUATION, Market, 70% Assessed. Rows for years 2015-2020.

Site Description

Topography:
Public Utilities: Sewer, Electric
Street or Road:

LAND DATA AND CALCULATIONS

Table with columns: Rating, Measured, Table, Prod. Factor, Depth Factor, Base Rate, Adjusted Rate, Extended Value, Influence Factor, Value. Includes Land Type and Zoning information.

CKMP: 6548, 6560
DBA: Metro-North Electric Substation

Supplemental Cards

TRUE TAX VALUE 973800

Permit Number FilingDate Est. Cost Field Visit
Type Est. SqFt

Supplemental Cards
TOTAL LAND VALUE

973800

PHYSICAL CHARACTERISTICS

IMPROVEMENT DATA

Item Description Units Cost Total Pct

- 01
- 02
- 03
- 04

(LCM: 150.00)

SPECIAL FEATURES

SUMMARY OF IMPROVEMENTS

Description	Value	ID	Use	Stry Hgt	Const Type	Grade	Year Const	Eff Year	Cond	Base Rate	Feat-ures	Adj Rate	Size or Area	Computed Value	Phys Depr	Obsol Depr	Market Adj	% Comp	Value
		01	UTLSHED	10.00	1	Avg	1900	1965	PR	44.50	N	66.75	16x 22	23500	53	0	100	100	11100
		02	UTLSHED	10.00	1	Fair	1900	1965	PR	44.50	N	30.26	18x 32	17430	53	0	100	100	8200
		03	UTLSHED	10.00	1	Avg+	1999	1999	AV	44.50	N	76.99	25x 80	153980	7	0	100	100	143200
		04	UTLSHED	10.00	1	Avg	1980	1985	AV	44.50	N	66.75	16x 20	21360	13	0	100	100	18600

Data Collector/Date

RV 02/22/2000

Appraiser/Date

TOG 10/01/2015

Neighborhood

Neigh 113020 AV

Supplemental Cards

TOTAL IMPROVEMENT VALUE

181100

Exhibit C

T-Mobile

GREENWICH/COS COB/1-95

SITE ID: CT11241A

STATION DRIVE

(LINE# 1750-POLE# 1280)

GREENWICH, CT 06830

T-MOBILE A&L TEMPLATE (PROVIDED BY RFDS)

67D94B_1DP+1QP+1OP

RAN TEMPLATE (PROVIDED BY RFDS)

67D94B OUTDOOR

GENERAL NOTES

1. ALL WORK SHALL BE IN ACCORDANCE WITH THE 2015 INTERNATIONAL BUILDING CODE AS MODIFIED BY THE 2018 CONNECTICUT SUPPLEMENT, INCLUDING THE TIA/EIA-222 REVISION "G" "STRUCTURAL STANDARDS FOR STEEL ANTENNA TOWERS AND SUPPORTING STRUCTURES," 2017 CONNECTICUT FIRE SAFETY CODE, NATIONAL ELECTRICAL CODE AND LOCAL CODES.
2. CONTRACTOR SHALL REVIEW ALL DRAWINGS AND SPECIFICATIONS IN THE CONTRACT DOCUMENT SET. CONTRACTOR SHALL COORDINATE ALL WORK SHOWN IN THE SET OF DRAWINGS. THE CONTRACTOR SHALL PROVIDE A COMPLETE SET OF DRAWINGS TO ALL SUBCONTRACTORS AND ALL RELATED PARTIES. THE SUBCONTRACTORS SHALL EXAMINE ALL THE DRAWINGS AND SPECIFICATIONS FOR THE INFORMATION THAT AFFECTS THEIR WORK.
3. CONTRACTOR SHALL PROVIDE A COMPLETE BUILD-OUT WITH ALL FINISHES, STRUCTURAL, MECHANICAL, AND ELECTRICAL COMPONENTS AND PROVIDE ALL ITEMS AS SHOWN OR INDICATED ON THE DRAWINGS OR IN THE WRITTEN SPECIFICATIONS.
4. CONTRACTOR SHALL FURNISH ALL MATERIAL, LABOR AND EQUIPMENT TO COMPLETE THE WORK AND FURNISH A COMPLETED JOB ALL IN ACCORDANCE WITH LOCAL AND STATE GOVERNING AUTHORITIES AND OTHER AUTHORITIES HAVING LAWFUL JURISDICTION OVER THE WORK.
5. CONTRACTOR SHALL SECURE AND PAY FOR ALL PERMITS AND ALL INSPECTIONS REQUIRED AND SHALL ALSO PAY FEES REQUIRED FOR THE GENERAL CONSTRUCTION, PLUMBING, ELECTRICAL, AND HVAC. PERMITS SHALL BE PAID FOR BY THE RESPECTIVE SUBCONTRACTORS.
6. CONTRACTOR SHALL MAINTAIN A CURRENT SET OF DRAWINGS AND SPECIFICATIONS ON SITE AT ALL TIMES AND INSURE DISTRIBUTION OF NEW DRAWINGS TO SUBCONTRACTORS AND OTHER RELEVANT PARTIES AS SOON AS THEY ARE MADE AVAILABLE. ALL OLD DRAWINGS SHALL BE MARKED VOID AND REMOVED FROM THE CONTRACT AREA. THE CONTRACTOR SHALL FURNISH AN "AS-BUILT" SET OF DRAWINGS TO OWNER UPON COMPLETION OF PROJECT.
7. LOCATION OF EQUIPMENT AND WORK SUPPLIED BY OTHERS THAT IS DIAGRAMMATICALLY INDICATED ON THE DRAWINGS, SHALL BE DETERMINED BY THE CONTRACTOR. THE CONTRACTOR SHALL DETERMINE LOCATIONS AND DIMENSIONS SUBJECT TO STRUCTURAL CONDITIONS AND WORK OF THE SUBCONTRACTORS.
8. THE CONTRACTOR IS SOLELY RESPONSIBLE TO DETERMINE CONSTRUCTION PROCEDURE AND SEQUENCE AND TO ENSURE THE SAFETY OF THE EXISTING STRUCTURES AND ITS COMPONENT PARTS DURING CONSTRUCTION. THIS INCLUDES THE ADDITION OF WHATEVER SHORING, BRACING, UNDERPINNINGS, ETC. THAT MAY BE NECESSARY.
9. DRAWINGS INDICATE THE MINIMUM STANDARDS, BUT IF ANY WORK SHOULD BE INDICATED TO BE SUBSTANDARD TO ANY ORDINANCES, LAWS, CODES, RULES, OR REGULATIONS BEARING ON THE WORK, THE CONTRACTOR SHALL INCLUDE IN HIS WORK AND SHALL EXECUTE THE WORK CORRECTLY IN ACCORDANCE WITH SUCH ORDINANCES, LAWS, CODES, RULES OR REGULATIONS WITH NO INCREASE IN COSTS.
10. ALL UTILITY WORK SHALL BE IN ACCORDANCE WITH LOCAL UTILITY COMPANY REQUIREMENTS AND SPECIFICATIONS.
11. ALL EQUIPMENT AND PRODUCTS PURCHASED ARE TO BE REVIEWED BY CONTRACTOR AND ALL APPLICABLE SUBCONTRACTORS FOR ANY CONDITION PER MANUFACTURER'S RECOMMENDATIONS. CONTRACTOR TO SUPPLY THESE ITEMS AT NO COST TO OWNER OR CONSTRUCTION MANAGER.
12. ANY AND ALL ERRORS, DISCREPANCIES, AND 'MISSED' ITEMS ARE TO BE BROUGHT TO THE ATTENTION OF THE T-MOBILE CONSTRUCTION MANAGER DURING THE BIDDING PROCESS BY THE CONTRACTOR. ALL THESE ITEMS ARE TO BE INCLUDED IN THE BID. NO 'EXTRA' WILL BE ALLOWED FOR MISSED ITEMS.
13. CONTRACTOR SHALL BE RESPONSIBLE FOR ALL ON-SITE SAFETY FROM THE TIME THE JOB IS AWARDED UNTIL ALL WORK IS COMPLETE AND ACCEPTED BY THE OWNER.
14. CONTRACTOR TO REVIEW ALL SHOP DRAWINGS AND SUBMIT COPY TO ENGINEER FOR APPROVAL. DRAWINGS MUST BEAR THE CHECKER'S INITIALS BEFORE SUBMITTING TO THE CONSTRUCTION MANAGER FOR REVIEW.
15. THE CONTRACTOR SHALL FIELD VERIFY ALL DIMENSIONS, ELEVATIONS, ANGLES AND EXISTING CONDITIONS AT THE SITE, PRIOR TO FABRICATION AND/OR INSTALLATION OF ANY WORK IN THE CONTRACT AREA.
16. COORDINATION, LAYOUT, FURNISHING AND INSTALLATION OF CONDUITS AND ALL APPURTENANCES REQUIRED FOR PROPER INSTALLATION OF ELECTRICAL AND TELECOMMUNICATION SERVICE SHALL BE THE SOLE RESPONSIBILITY OF THE CONTRACTOR.
17. ALL DAMAGE CAUSED TO ANY EXISTING STRUCTURE SHALL BE THE SOLE RESPONSIBILITY OF THE CONTRACTOR. THE CONTRACTOR WILL BE HELD LIABLE FOR ALL REPAIRS REQUIRED FOR EXISTING STRUCTURES IF DAMAGED DURING CONSTRUCTION ACTIVITIES.
18. THE CONTRACTOR SHALL CONTACT 'CALL BEFORE YOU DIG' AT LEAST 48 HOURS PRIOR TO ANY EXCAVATIONS AT 1-800-922-4455. ALL UTILITIES SHALL BE IDENTIFIED AND CLEARLY MARKED. CONTRACTOR SHALL MAINTAIN AND PROTECT MARKED UTILITIES THROUGHOUT PROJECT COMPLETION.
19. CONTRACTOR SHALL COMPLY WITH THE OWNER'S ENVIRONMENTAL ENGINEER ON ALL METHODS AND PROVISIONS FOR ALL EXCAVATION ACTIVITIES INCLUDING SOIL DISPOSAL. ALL BACKFILL MATERIALS TO BE PROVIDED BY THE CONTRACTOR.

SITE DIRECTIONS

FROM:	TO:
35 GRIFFIN ROAD SOUTH BLOOMFIELD, CT 06802	STATION DRIVE GREENWICH, CT 06830
<ol style="list-style-type: none"> 1. HEAD NORTH ON GRIFFIN ROAD S. TOWARD HARTMAN RD. 0.30 MI. 2. TAKE THE 2ND RIGHT ONTO DAY HILL RD. 0.14 MI. 3. TAKE THE 1ST RIGHT ONTO BLUE HILLS AVENUE EXT/CT-187 1.89 MI. 4. TURN LEFT ONTO CT-305/OLD WINDSOR RD. 2.32 MI. 5. STAY STRAIGHT TO GO ONTO BLOOMFIELD AVE/CT-305. 0.01 MI. 6. MERGE ONTO I-91 S TOWARD HARTFORD 44.03 MI. 7. KEEP RIGHT TOWARD NY CITY 0.21 MI. 8. MERGE ONTO 1-95 S VIA THE EXIT ON THE LEFT TOWARD NY CITY 43.94 MI. 9. TAKE THE INDIAN FIELD RD EXIT, EXIT 4 TOWARD COS COB 0.19 MI. 10. TURN RIGHT ONTO INDIAN FIELD RD 0.02 MI. 11. TURN RIGHT ONTO SOUND SHORE RD 0.21 MI. 12. TAKE 1ST LEFT ONTO SACHEM RD 0.04 MI. 13. TURN RIGHT ONTO STATION DRIVE 0.01 MI. 14. STATION DRIVE LINE# 1750-POLE# 1280 GREENWICH, CT 06830 	

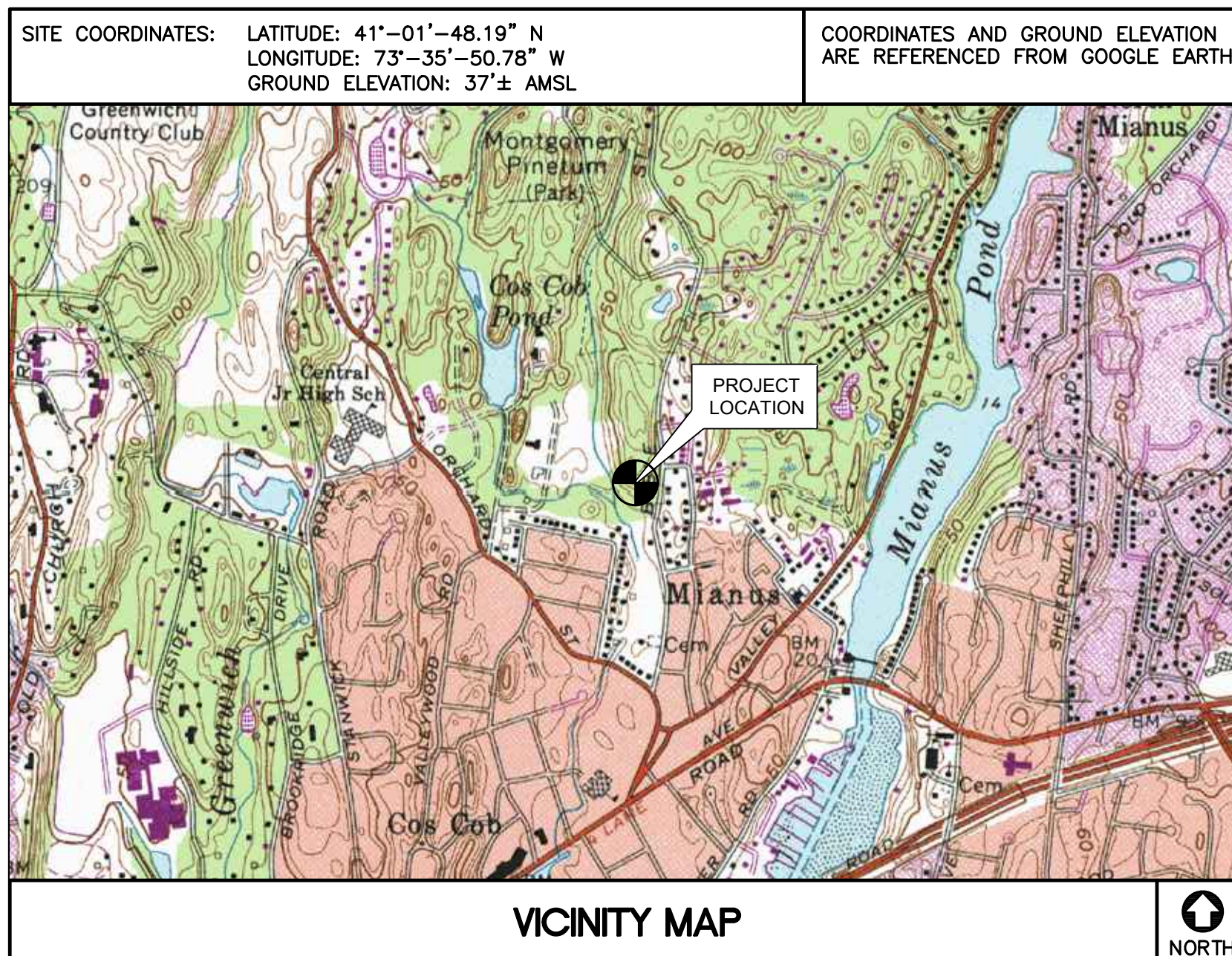

PROJECT SUMMARY

THE PROPOSED SCOPE OF WORK CONSISTS OF A MODIFICATION TO THE EXISTING UNMANNED TELECOMMUNICATIONS FACILITY INCLUDING THE FOLLOWING:

1. REMOVE (3) ANDREW - LNX-6513DS ANTENNAS
2. REMOVE (3) EXISTING T-MOBILE RADIOS
3. INSTALL (6) NEW COAX TO THE EXISTING (18) COAX CABLES
4. INSTALL (3) RFS - APXVAAR18_43-U-NA20
5. INSTALL (3) RADIO 4449 B71+B85 MOUNTED TO EXISTING H-FRAME AT CABINETS
6. INSTALL (3) ANDREW SMART BIAS T DEVICES AT ANTENNAS

PROJECT INFORMATION

SITE NAME:	GREENWICH/COS COB/1-95
SITE ID:	CT11241A
SITE ADDRESS:	STATION DRIVE GREENWICH, CT 06830
APPLICANT:	T-MOBILE NORTHEAST, LLC 35 GRIFFIN ROAD SOUTH BLOOMFIELD, CT 06802
CONTACT PERSON:	SHELDON FREINCLE (PROJECT MANAGER) NORTHEAST SITE SOLUTIONS (203) 776-8521
ENGINEER:	CENITEK ENGINEERING, INC. 63-2 NORTH BRANFORD RD. BRANFORD, CT 06405
PROJECT COORDINATES:	LATITUDE: 41°-01'-48.19" N LONGITUDE: 73°-35'-50.78" W GROUND ELEVATION: 37'± AMSL
	SITE COORDINATES AND GROUND ELEVATION REFERENCED FROM GOOGLE EARTH.

SHEET INDEX

SHT. NO.	DESCRIPTION	REV.
T-1	TITLE SHEET	1
N-1	GENERAL NOTES AND SPECIFICATIONS	1
C-1	SITE LOCATION PLAN	1
C-2	COMPOUND PLAN, EQUIPMENT PLAN, AND ELEVATION	1
C-3	ANTENNA PLANS AND ELEVATIONS	1
C-4	TYPICAL EQUIPMENT DETAILS	1
E-1	TYPICAL ELECTRICAL DETAILS	1
E-2	ELECTRICAL SPECIFICATIONS	1

PROFESSIONAL ENGINEER SEAL

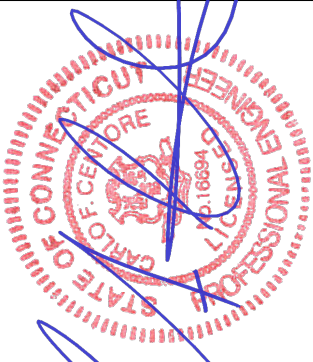

T-Mobile

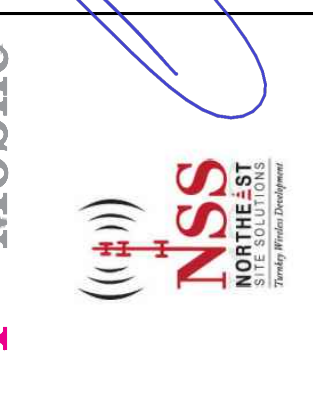

CENITEK engineering

Centered on Solutions
(203) 488-0980
(203) 488-8587 Fax
63-2 North Branford Road
Branford, CT 06405
www.CenitekEng.com

T-MOBILE NORTHEAST LLC
GREENWICH/COS COB/1-95
SITE ID: CT11241A
STATION DRIVE
GREENWICH, CT 06830

DATE: 06/18/21
SCALE: AS NOTED
JOB NO. 21051.06

TITLE SHEET

T-1

Sheet No. 1 of 8

REV.	DATE	BY	DESCRIPTION
0	07/26/21	ANC	CONSTRUCTION DRAWINGS - ISSUED FOR CONSTRUCTION
	09/10/21	ANC	CONSTRUCTION DRAWINGS - REVISED PER CLIENT COMMENTS

NOTES AND SPECIFICATIONS

DESIGN BASIS:

GOVERNING CODE: 2015 INTERNATIONAL BUILDING CODE (IBC) AS MODIFIED BY THE 2018 CONNECTICUT STATE BUILDING CODE.

1. DESIGN CRITERIA:
 - RISK CATEGORY II (BASED ON IBC TABLE 1604.5)
 - NOMINAL DESIGN SPEED (OTHER STRUCTURE): 93 MPH (V_{asd}) (EXPOSURE B/ IMPORTANCE FACTOR 1.0 BASED ON ASCE 7-10).

SITE NOTES

1. THE CONTRACTOR SHALL CALL UTILITIES PRIOR TO THE START OF CONSTRUCTION.
2. ACTIVE EXISTING UTILITIES, WHERE ENCOUNTERED IN THE WORK, SHALL BE PROTECTED AT ALL TIMES. THE ENGINEER SHALL BE NOTIFIED IMMEDIATELY, PRIOR TO PROCEEDING, SHOULD ANY UNCOVERED EXISTING UTILITY PRECLUDE COMPLETION OF THE WORK IN ACCORDANCE WITH THE CONTRACT DOCUMENTS.
3. THE AREAS OF THE COMPOUND DISTURBED BY THE WORK SHALL BE RETURNED TO THEIR ORIGINAL CONDITION.
4. CONTRACTOR SHALL MINIMIZE DISTURBANCE TO EXISTING SITE DURING CONSTRUCTION. EROSION CONTROL MEASURES, SHALL BE IN CONFORMANCE WITH THE LOCAL GUIDELINES FOR EROSION AND SEDIMENT CONTROL.
5. IF ANY FIELD CONDITIONS EXIST WHICH PRECLUDE COMPLIANCE WITH THE DRAWINGS, THE CONTRACTOR SHALL IMMEDIATELY NOTIFY THE ENGINEER AND SHALL PROCEED WITH AFFECTED WORK AFTER CONFLICT IS SATISFACTORILY RESOLVED.

GENERAL NOTES

1. ALL WORK SHALL BE IN ACCORDANCE WITH THE 2015 INTERNATIONAL BUILDING CODE AS MODIFIED BY THE 2018 CONNECTICUT SUPPLEMENT, INCLUDING THE TIA/EIA-222 REVISION "G" "STRUCTURAL STANDARDS FOR STEEL ANTENNA TOWERS AND SUPPORTING STRUCTURES." 2017 CONNECTICUT FIRE SAFETY CODE, NATIONAL ELECTRICAL CODE AND LOCAL CODES.
2. CONTRACTOR SHALL REVIEW ALL DRAWINGS AND SPECIFICATIONS IN THE CONTRACT DOCUMENT SET. CONTRACTOR SHALL COORDINATE ALL WORK SHOWN IN THE SET OF DRAWINGS. THE CONTRACTOR SHALL PROVIDE A COMPLETE SET OF DRAWINGS TO ALL SUBCONTRACTORS AND ALL RELATED PARTIES. THE SUBCONTRACTORS SHALL EXAMINE ALL THE DRAWINGS AND SPECIFICATIONS FOR THE INFORMATION THAT AFFECTS THEIR WORK.
3. CONTRACTOR SHALL PROVIDE A COMPLETE BUILD-OUT WITH ALL FINISHES, STRUCTURAL, MECHANICAL, AND ELECTRICAL COMPONENTS AND PROVIDE ALL ITEMS AS SHOWN OR INDICATED ON THE DRAWINGS OR IN THE WRITTEN SPECIFICATIONS.
4. CONTRACTOR SHALL FURNISH ALL MATERIAL, LABOR AND EQUIPMENT TO COMPLETE THE WORK AND FURNISH A COMPLETED JOB ALL IN ACCORDANCE WITH LOCAL AND STATE GOVERNING AUTHORITIES AND OTHER AUTHORITIES HAVING LAWFUL JURISDICTION OVER THE WORK.
5. CONTRACTOR SHALL SECURE AND PAY FOR ALL PERMITS AND ALL INSPECTIONS REQUIRED AND SHALL ALSO PAY FEES REQUIRED FOR THE GENERAL CONSTRUCTION, PLUMBING, ELECTRICAL AND HVAC. PERMITS SHALL BE PAID FOR BY THE RESPECTIVE SUBCONTRACTORS.
6. CONTRACTOR SHALL MAINTAIN A CURRENT SET OF DRAWINGS AND SPECIFICATIONS ON SITE AT ALL TIMES AND INSURE DISTRIBUTION OF NEW DRAWINGS TO SUBCONTRACTORS AND OTHER RELEVANT PARTIES AS SOON AS THEY ARE MADE AVAILABLE. ALL OLD DRAWINGS SHALL BE MARKED VOID AND REMOVED FROM THE CONTRACT AREA. THE CONTRACTOR SHALL FURNISH AN "AS-BUILT" SET OF DRAWINGS TO OWNER UPON COMPLETION OF PROJECT.
7. LOCATION OF EQUIPMENT AND WORK SUPPLIED BY OTHERS THAT IS DIAGRAMMATICALLY INDICATED ON THE DRAWINGS, SHALL BE DETERMINED BY THE CONTRACTOR. THE CONTRACTOR SHALL DETERMINE LOCATIONS AND DIMENSIONS SUBJECT TO STRUCTURAL CONDITIONS AND WORK OF THE SUBCONTRACTORS.
8. THE CONTRACTOR IS SOLELY RESPONSIBLE TO DETERMINE CONSTRUCTION PROCEDURE AND SEQUENCE, AND TO ENSURE THE SAFETY OF THE EXISTING STRUCTURES AND ITS COMPONENT PARTS DURING CONSTRUCTION. THIS INCLUDES THE ADDITION OF WHATEVER SHORING, BRACING, UNDERPINNING, ETC. THAT MAY BE NECESSARY.
9. DRAWINGS INDICATE THE MINIMUM STANDARDS, BUT IF ANY WORK SHOULD BE INDICATED TO BE SUBSTANDARD TO ANY ORDINANCES, LAWS, CODES, RULES, OR REGULATIONS BEARING ON THE WORK, THE CONTRACTOR SHALL INCLUDE IN HIS WORK AND SHALL EXECUTE THE WORK CORRECTLY IN ACCORDANCE WITH SUCH ORDINANCES, LAWS, CODES, RULES OR REGULATIONS WITH NO INCREASE IN COSTS.
10. ALL UTILITY WORK SHALL BE IN ACCORDANCE WITH LOCAL UTILITY COMPANY REQUIREMENTS AND SPECIFICATIONS.
11. ALL EQUIPMENT AND PRODUCTS PURCHASED ARE TO BE REVIEWED BY CONTRACTOR AND ALL APPLICABLE SUBCONTRACTORS FOR ANY CONDITION PER MFR.'S RECOMMENDATIONS. CONTRACTOR TO SUPPLY THESE ITEMS AT NO COST TO OWNER OR CONSTRUCTION MANAGER.
12. ANY AND ALL ERRORS, DISCREPANCIES, AND "MISSED" ITEMS, ARE TO BE BROUGHT TO THE ATTENTION OF THE SITE OWNER'S CONSTRUCTION MANAGER DURING THE BIDDING PROCESS BY THE CONTRACTOR. ALL THESE ITEMS ARE TO BE INCLUDED IN THE BID. NO 'EXTRA' WILL BE ALLOWED FOR MISSED ITEMS.
13. CONTRACTOR SHALL BE RESPONSIBLE FOR ALL ON-SITE SAFETY FROM THE TIME THE JOB IS AWARDED UNTIL ALL WORK IS COMPLETE AND ACCEPTED BY THE OWNER.
14. CONTRACTOR TO REVIEW ALL SHOP DRAWINGS AND SUBMIT COPY TO ENGINEER FOR APPROVAL. DRAWINGS MUST BEAR THE CHECKER'S INITIALS BEFORE SUBMITTING TO THE CONSTRUCTION MANAGER FOR REVIEW.
15. THE CONTRACTOR SHALL FIELD VERIFY ALL DIMENSIONS, ELEVATIONS, ANGLES, AND EXISTING CONDITIONS AT THE SITE, PRIOR TO FABRICATION AND/OR INSTALLATION OF ANY WORK IN THE CONTRACT AREA.
16. COORDINATION, LAYOUT, FURNISHING AND INSTALLATION OF CONDUIT AND ALL APPURTENANCES REQUIRED FOR PROPER INSTALLATION OF ELECTRICAL AND TELECOMMUNICATION SERVICE SHALL BE THE SOLE RESPONSIBILITY OF THE CONTRACTOR.
17. ALL DAMAGE CAUSED TO ANY EXISTING STRUCTURE SHALL BE THE SOLE RESPONSIBILITY OF THE CONTRACTOR. THE CONTRACTOR WILL BE HELD LIABLE FOR ALL REPAIRS REQUIRED FOR EXISTING STRUCTURES IF DAMAGED DURING CONSTRUCTION ACTIVITIES.
18. THE CONTRACTOR SHALL CONTACT 'CALL BEFORE YOU DIG' AT LEAST 48 HOURS PRIOR TO ANY EXCAVATIONS AT 1-800-922-4455. ALL UTILITIES SHALL BE IDENTIFIED AND CLEARLY MARKED. CONTRACTOR SHALL MAINTAIN AND PROTECT MARKED UTILITIES THROUGHOUT PROJECT COMPLETION.
18. CONTRACTOR SHALL COMPLY WITH OWNER'S ENVIRONMENTAL ENGINEER ON ALL METHODS AND PROVISIONS FOR ALL EXCAVATION ACTIVITIES INCLUDING SOIL DISPOSAL. ALL BACKFILL MATERIALS TO BE PROVIDED BY THE CONTRACTOR.
19. THE COUNTY/CITY/TOWN WILL MAKE PERIODIC FIELD OBSERVATION AND INSPECTIONS TO MONITOR THE INSTALLATION, MATERIALS, WORKMANSHIP AND EQUIPMENT INCORPORATED INTO THE PROJECT TO ENSURE COMPLIANCE WITH THE DESIGN PLANS, SPECIFICATIONS, CONTRACT DOCUMENTS AND APPROVED SHOP DRAWINGS.
20. THE COUNTY/CITY/TOWN MUST BE NOTIFIED (2) WORKING DAYS PRIOR TO CONCEALMENT/BURIAL OF ANY SYSTEM OR MATERIAL THAT WILL PREVENT THE DIRECT INSPECTION OF MATERIALS, METHODS OR WORKMANSHIP. EXAMPLES OF THESE PROCESSES ARE BACKFILLING A GROUND RING OR TOWER FOUNDATION, POURING TOWER FOUNDATIONS, BURYING GROUND RODS, PLATES OR GRIDS, ETC. THE CONTRACTOR MAY PROCEED WITH THE SCHEDULED PROCESS (2) WORKING DAYS AFTER PROVIDING NOTICE UNLESS NOTIFIED OTHERWISE BY THE COUNTY/CITY/TOWN.

REV.	DATE	DESCRPTION
0	08/10/21	TJR
	07/26/21	TJR

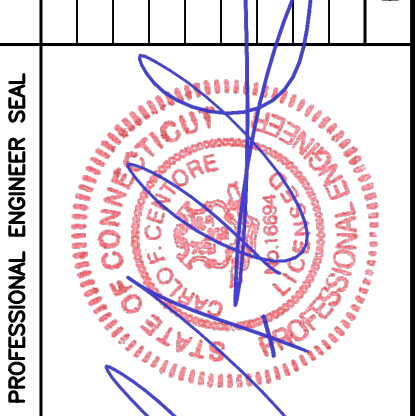

CEN-TEK engineering
Centered on Solutions
(203) 488-0360
(203) 488-8587 Fax
63-2 North Branford Road
Branford, CT 06405
www.CentekEng.com

T-MOBILE NORTHEAST LLC
GREENWICH/COS COB/1-95
SITE ID: CT11241A
STATION DRIVE
GREENWICH, CT 06830

DATE: 06/18/21
SCALE: AS NOTED
JOB NO. 21051.06

GENERAL NOTES AND SPECIFICATIONS

N-1

NOTE:
ALL COAX LENGTHS TO BE MEASURED
AND VERIFIED IN FIELD BEFORE ORDERING

ANTENNA SCHEDULE

SECTOR	EXISTING/PROPOSED	ANTENNA	SIZE (INCHES) (L x W x D)	ANTENNA ϕ HEIGHT	AZIMUTH	(E/P) RRU (QTY)	(E/P) TMA (QTY)	(QTY) PROPOSED COAX
A1	EXISTING	ANDREW (TMBXX-6516-A2M)	59.5 x 12 x 6.5	153'	20°		(E) GENERIC TWIN STYLE TMA (AT CABINET) (2), (P) ANDREW-SMART BIAS-T (AT ANTENNA) (1)	(2) 1-5/8" COAX CABLES
A2	PROPOSED	RFS (APXVAARR18_43-U-NA20)	72 x 24 x 8.5	161'	20°	(P) RADIO 4449 B71+B85 (AT CABINET) (1)	(E) ANDREW-SMART BIAS-T (AT ANTENNA) (1)	
B1	EXISTING	ANDREW (TMBXX-6516-A2M)	59.5 x 12 x 6.5	153'	140°		(E) GENERIC TWIN STYLE TMA (AT CABINET) (2), (P) ANDREW-SMART BIAS-T (AT ANTENNA) (1)	(2) 1-5/8" COAX CABLES
B2	PROPOSED	RFS (APXVAARR18_43-U-NA20)	72 x 24 x 8.5	161'	140°	(P) RADIO 4449 B71+B85 (AT CABINET) (1)	(E) ANDREW-SMART BIAS-T (AT ANTENNA) (1)	
C1	EXISTING	ANDREW (TMBXX-6516-A2M)	59.5 x 12 x 6.5	153'	240°		(E) GENERIC TWIN STYLE TMA (AT CABINET) (2), (P) ANDREW-SMART BIAS-T (AT ANTENNA) (1)	(2) 1-5/8" COAX CABLES
C2	PROPOSED	RFS (APXVAARR18_43-U-NA20)	72 x 24 x 8.5	161'	240°	(P) RADIO 4449 B71+B85 (AT CABINET) (1)	(E) ANDREW-SMART BIAS-T (AT ANTENNA) (1)	

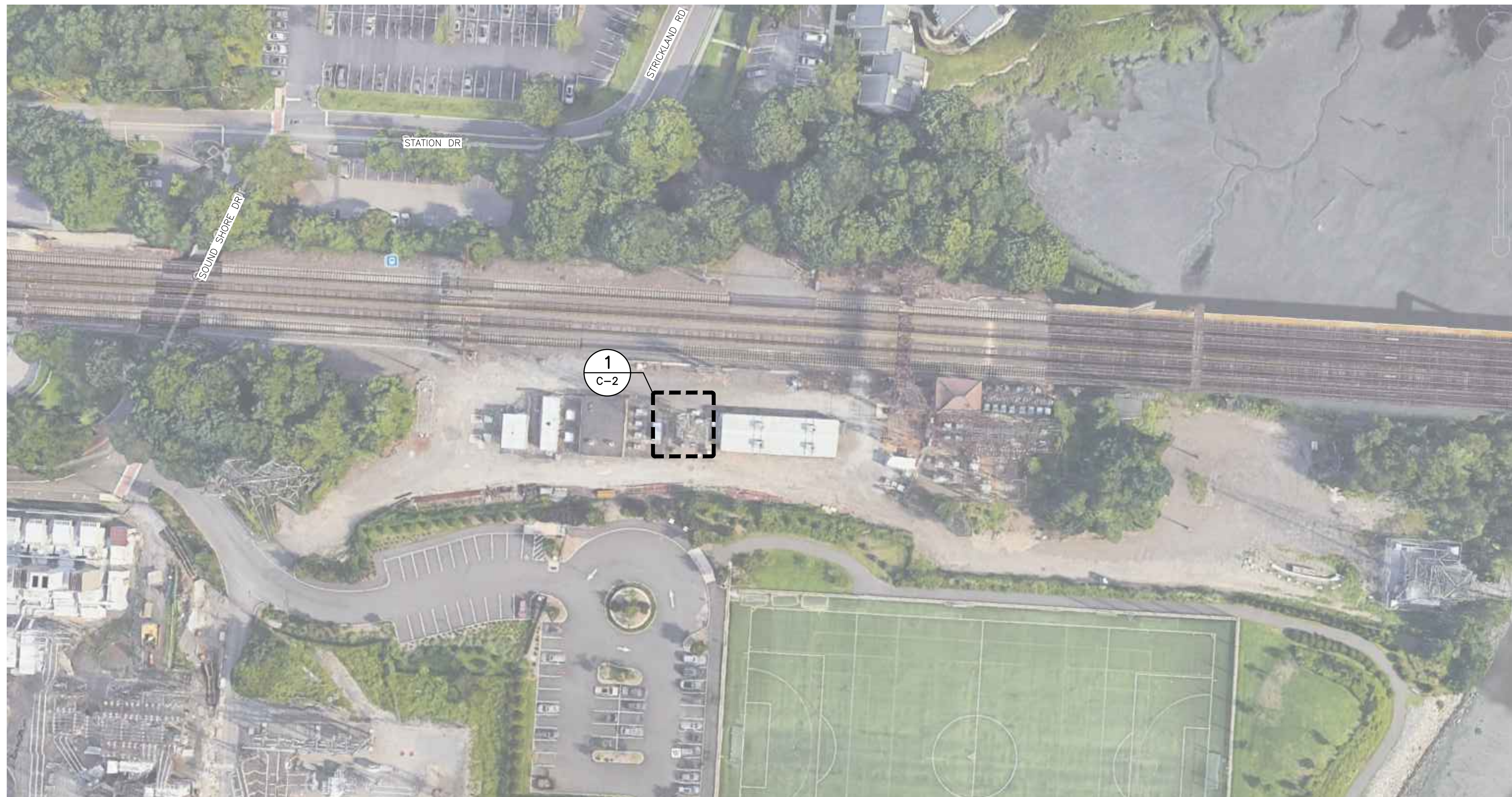

1 SITE LOCATION PLAN
SCALE: 1" = 50'

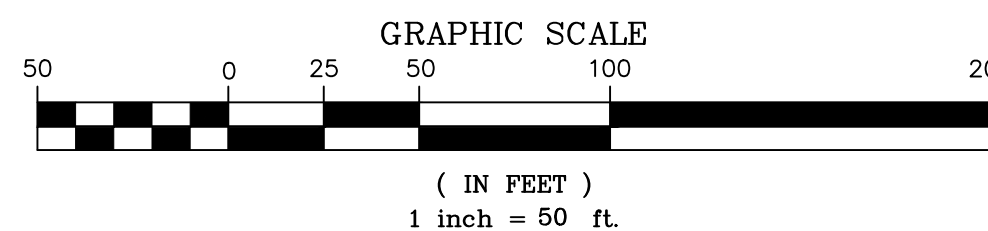

REV.	DATE	DESCRPTION
0	07/26/21	ANC
1	08/10/21	ANC

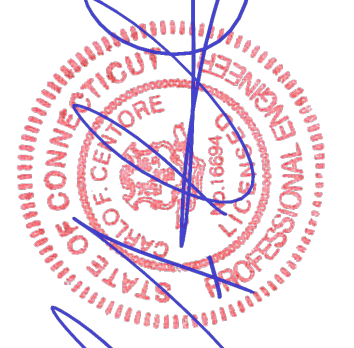

CENTEK engineering
Centered on Solutions
(203) 488-0580
(203) 488-8587 Fax
65-2 North Branford Road
Branford, CT 06405
www.CentekEng.com

T-MOBILE NORTHEAST LLC
GREENWICH/COS COB/1-95
SITE ID: CT11241A
STATION DRIVE
GREENWICH, CT 06830

DATE: 06/18/21
SCALE: AS NOTED
JOB NO. 21051.06

SITE LOCATION PLAN

C-1

STRUCTURAL COMPLIANCE

UTILITY STRUCTURE (EVERSOURCE STRUCTURE NO. 1280) AND ANTENNA MAST

A STRUCTURAL ANALYSIS OF THE UTILITY STRUCTURE AND ANTENNA MAST WAS PERFORMED FOR THE PROPOSED EQUIPMENT INSTALLATION AND THEY WERE FOUND TO BE STRUCTURALLY SUFFICIENT TO ACCOMMODATE THE PROPOSED LOADING.

REFER TO THE STRUCTURAL ANALYSIS REPORT PREPARED BY CENTEK ENGINEERING (PROJECT # 21051.06) DATED 08/09/21 FOR ADDITIONAL INFORMATION AND REQUIREMENTS.

NOTE: NO EQUIPMENT SHALL BE INSTALLED ON THE HOSTING STRUCTURE WITHOUT A PASSING STRUCTURAL ANALYSIS REPORT AND CONTRACTOR PRIOR CONFIRMATION THAT ANY AND ALL REQUISITE MODIFICATIONS HAVE BEEN COMPLETED.

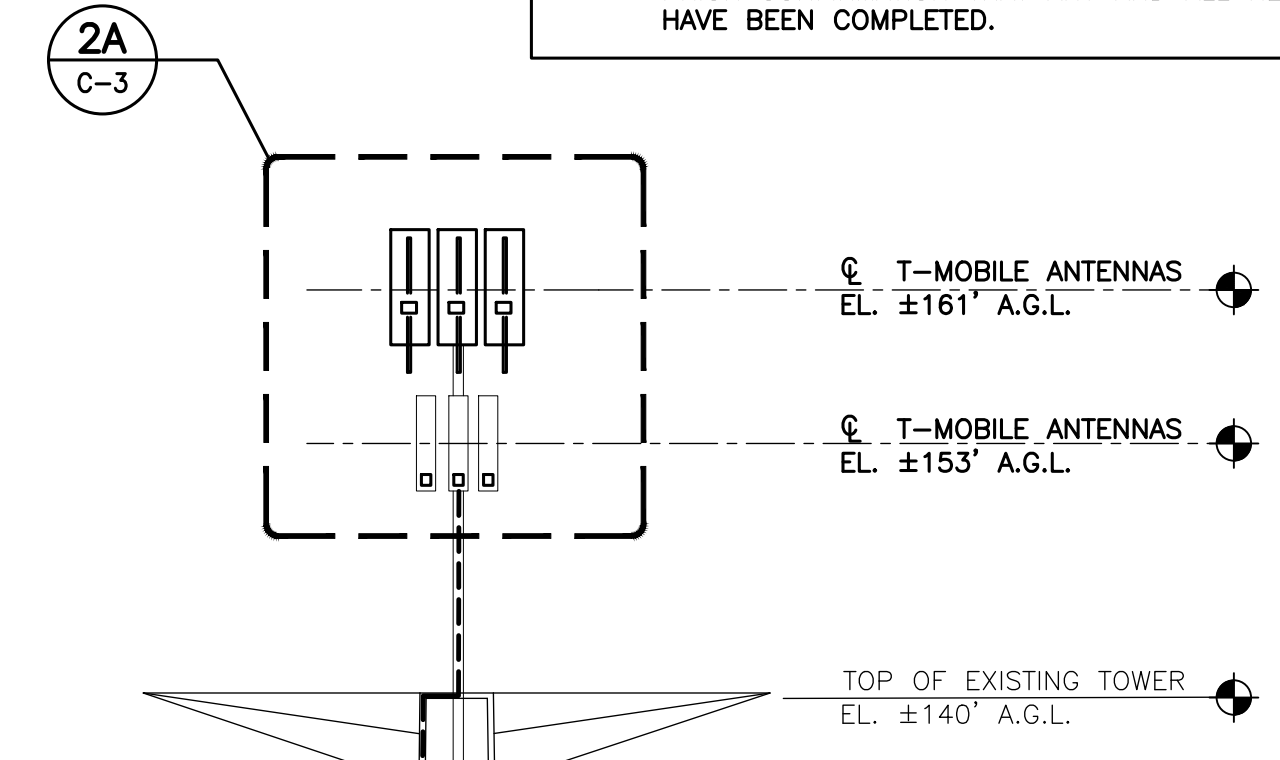

EXISTING T-MOBILE (18) COAXIAL LINES
• INSTALL (6) COAXIAL LINES

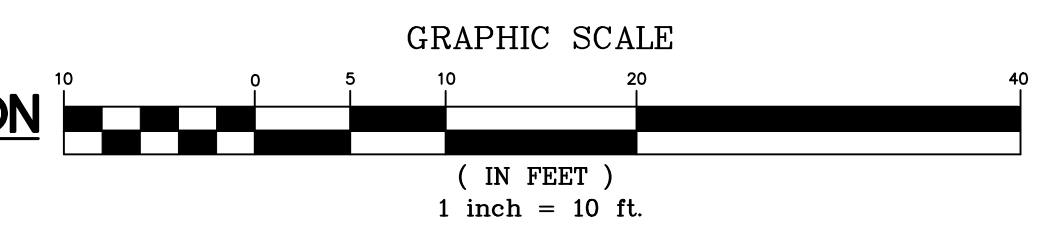
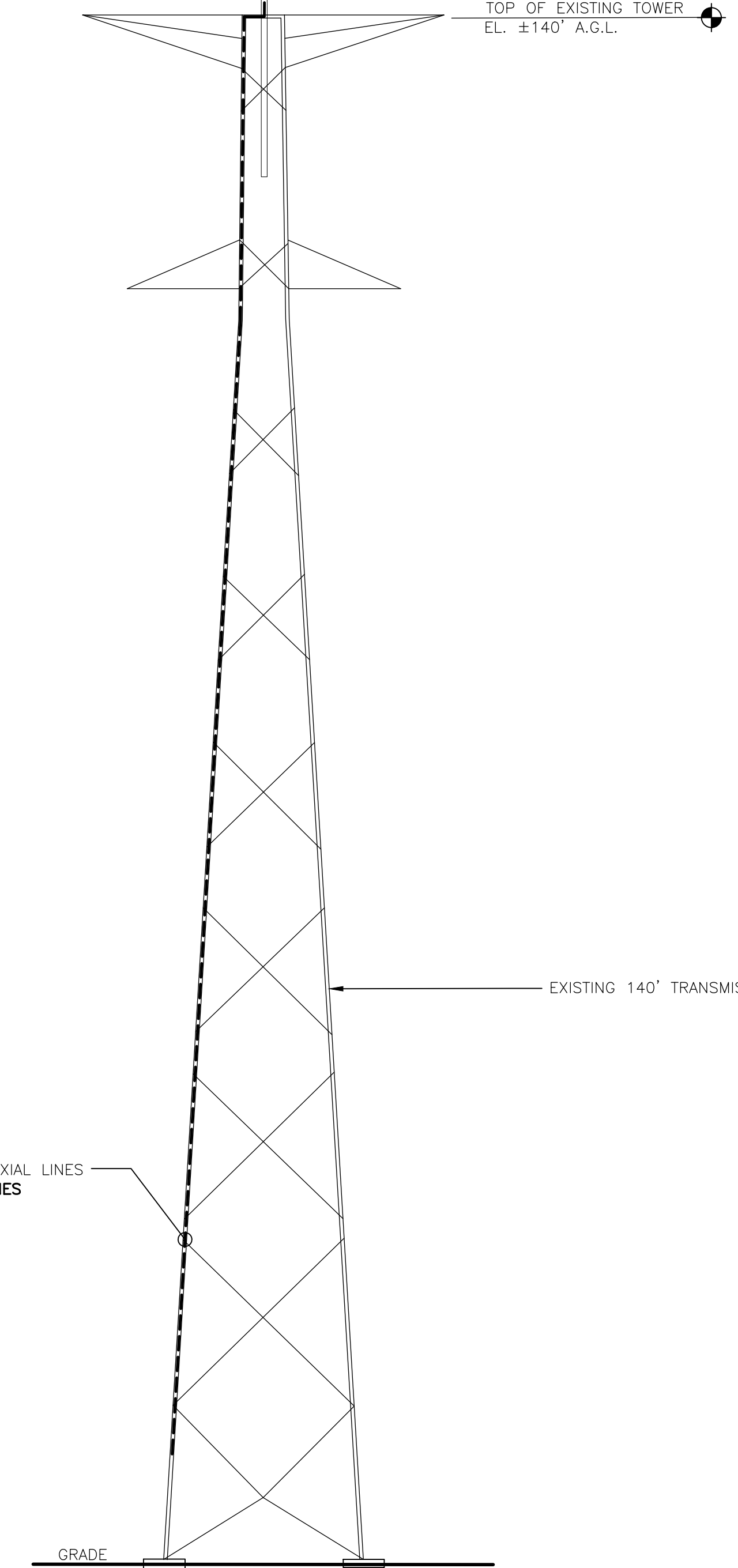

2 SOUTH TOWER ELEVATION
C-2 SCALE: 1" = 10'

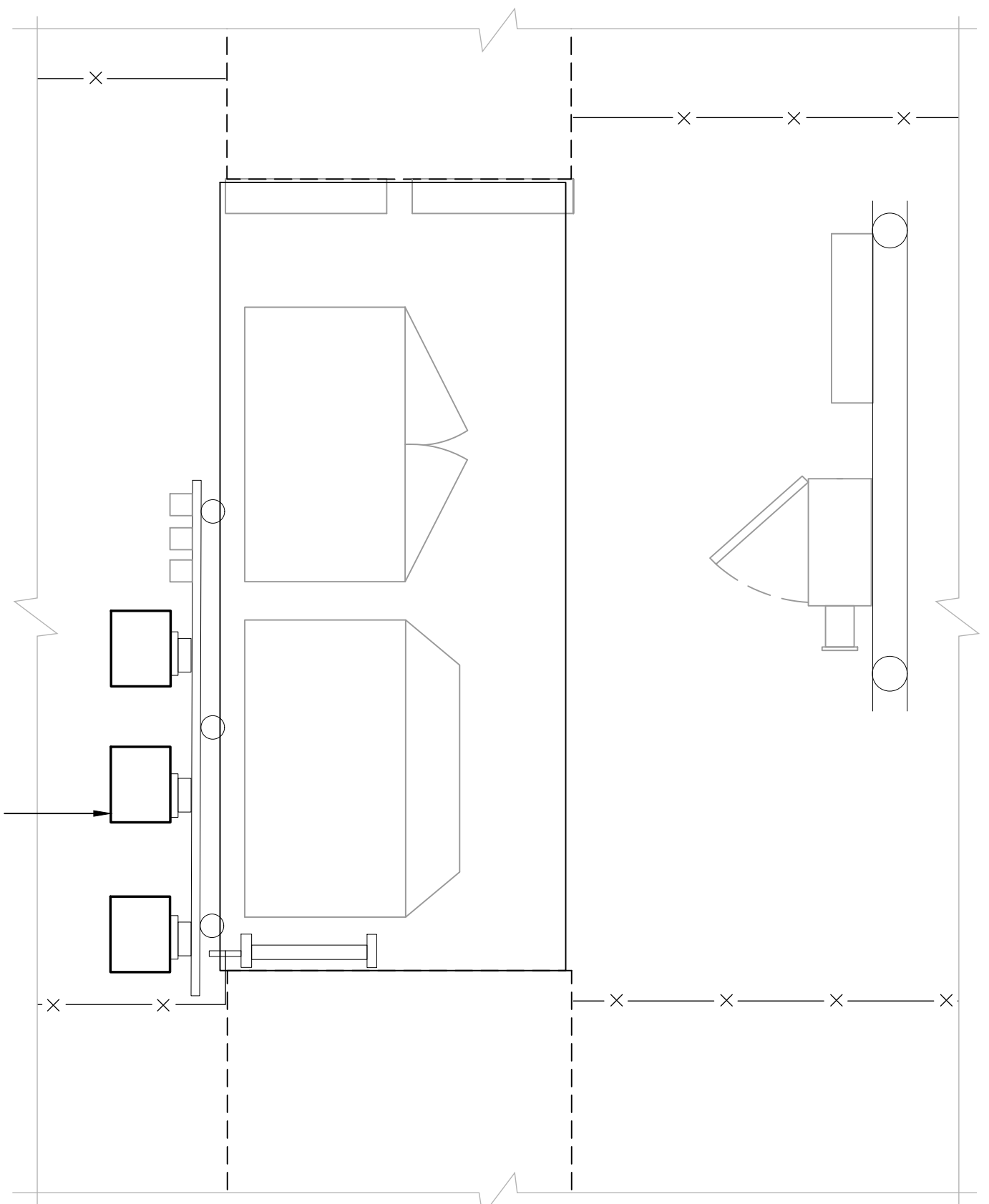

4 EQUIPMENT PLAN - PROPOSED
C-2 SCALE: 3/8" = 1' TRUE NORTH

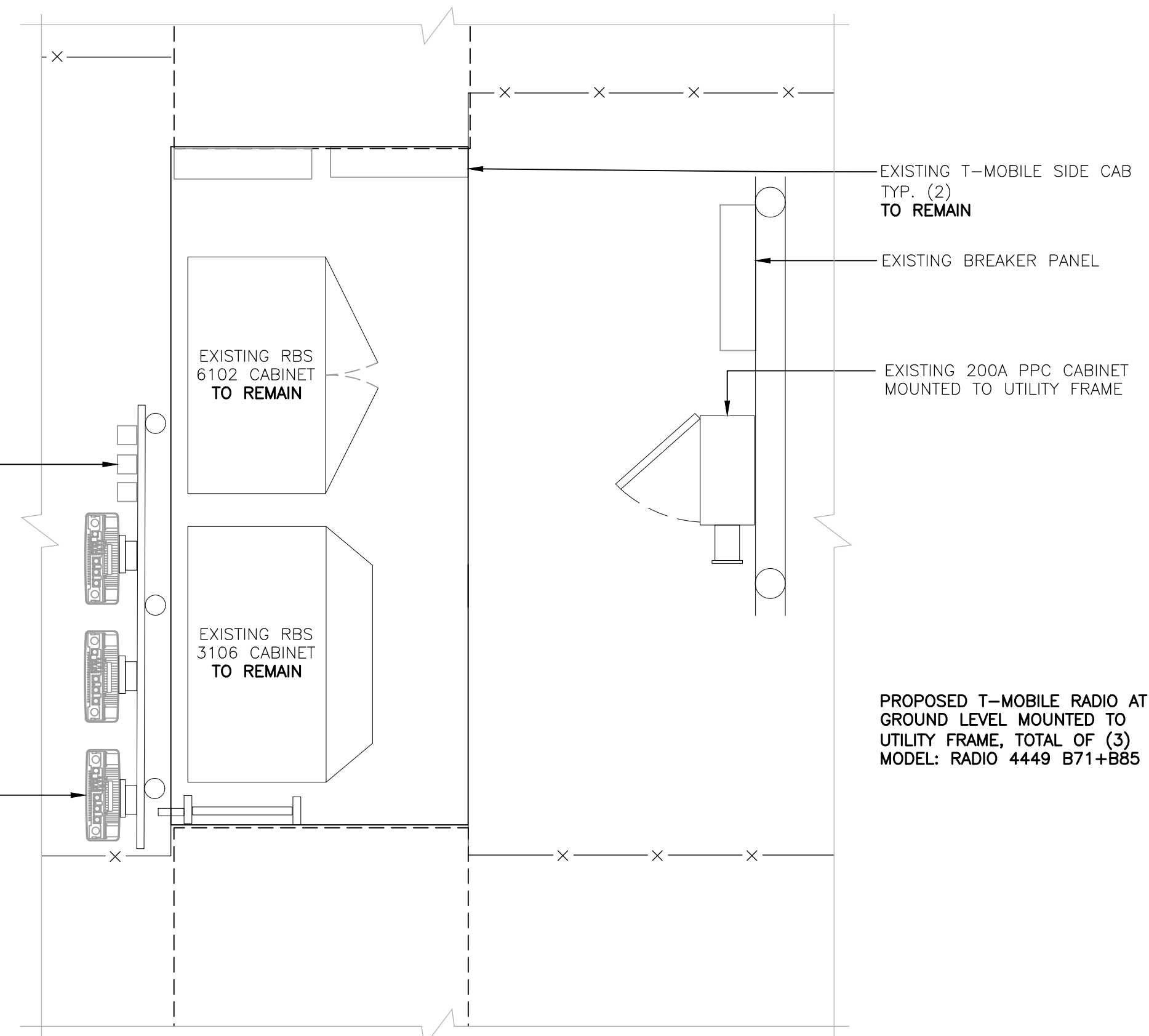

3 EQUIPMENT PLAN - EXISTING
C-2 SCALE: 1/2" = 1' TRUE NORTH

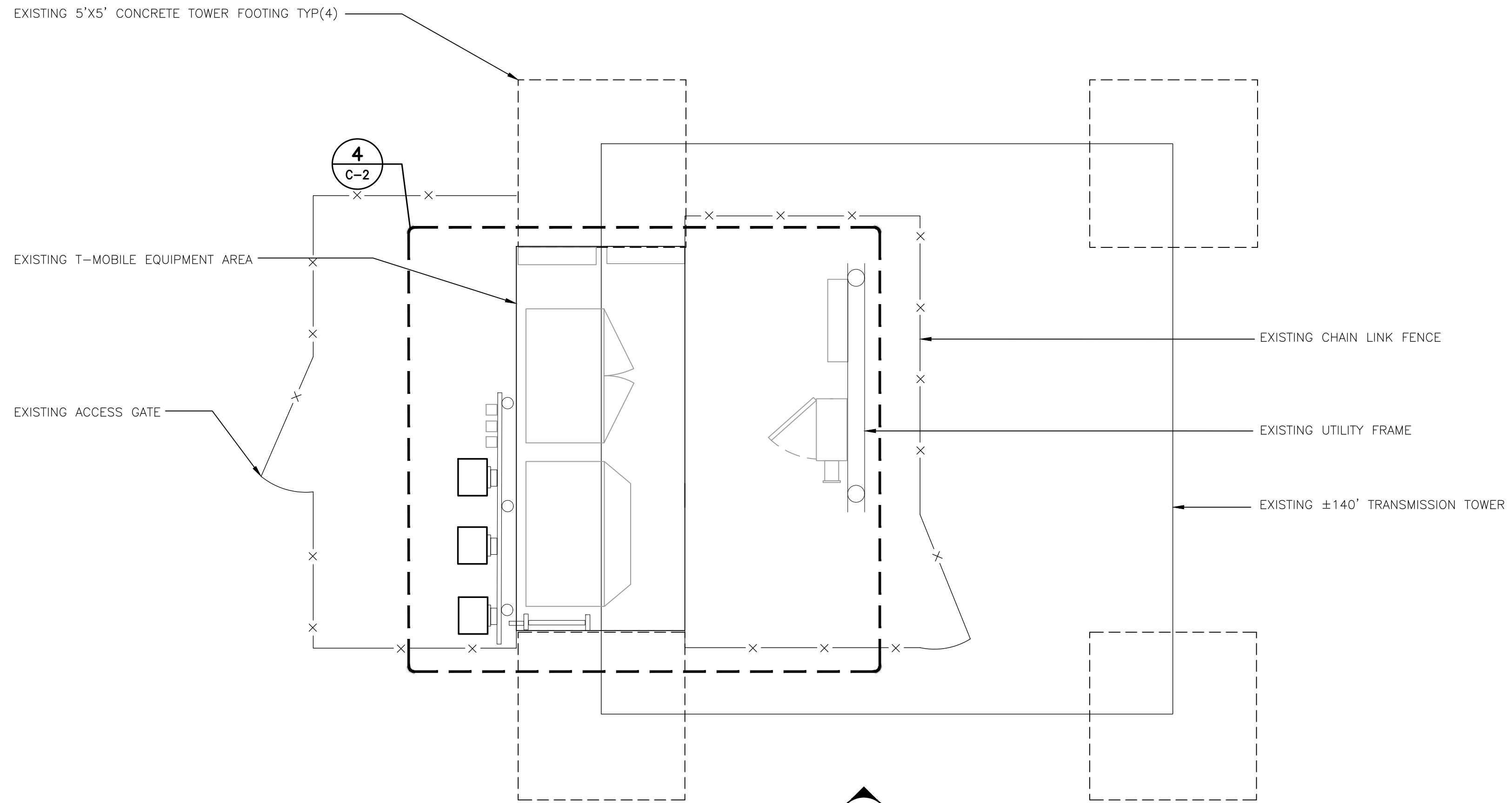

1 COMPOUND PLAN - PROPOSED
C-2 SCALE: 3/8" = 1' TRUE NORTH

T-MOBILE NORTHEAST LLC
GREENWICH/COS COB/I-95
SITE ID: CT11241A
STATION DRIVE
GREENWICH, CT 06830

DATE: 06/18/21
SCALE: AS NOTED
JOB NO. 21051.06

COMPOUND PLAN, EQUIPMENT PLANS, AND ELEVATION

C-2

Sheet No. 4 of 8

PROFESSIONAL ENGINEER SEAL
CENTEK engineering
Centered on Solutions
(203) 488-0380
(203) 488-8587 Fax
63-2 North Branford Road
Branford, CT 06405
www.CentekEng.com

PROFESSIONAL ENGINEER SEAL
STATE OF CONNECTICUT
CENTEK ENGINEERING
No. 11241A
06/18/21

REV.	DATE	BY	DESCRIPTION
0	07/26/21	ANC	CONSTRUCTION DRAWINGS - ISSUED FOR CONSTRUCTION
0	08/10/21	TJR	CONSTRUCTION DRAWINGS - REVISED PER CLIENT COMMENTS

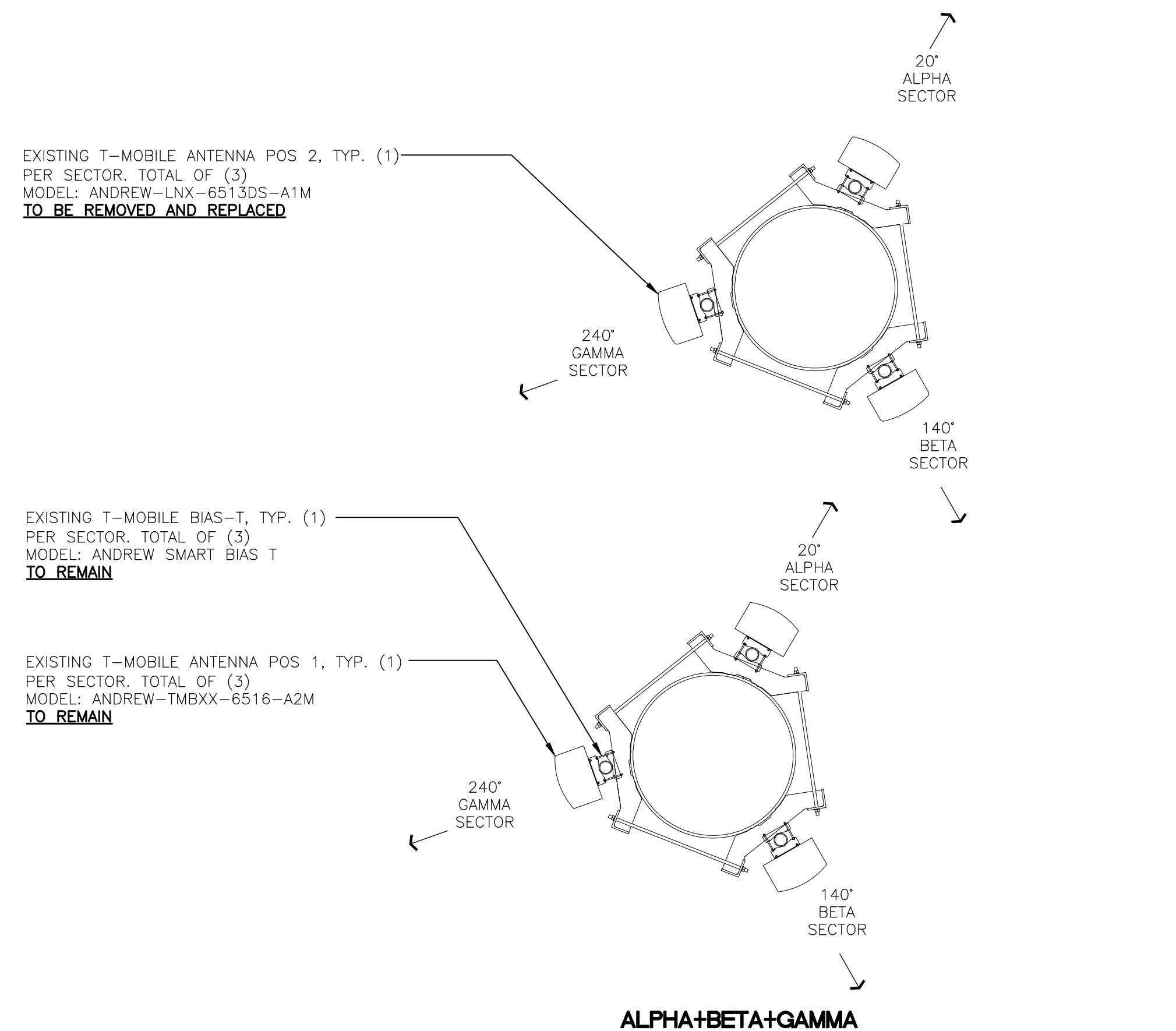

1 EXISTING ANTENNA MOUNTING CONFIGURATION
 C-3 SCALE: 1/2" = 1' TRUE NORTH

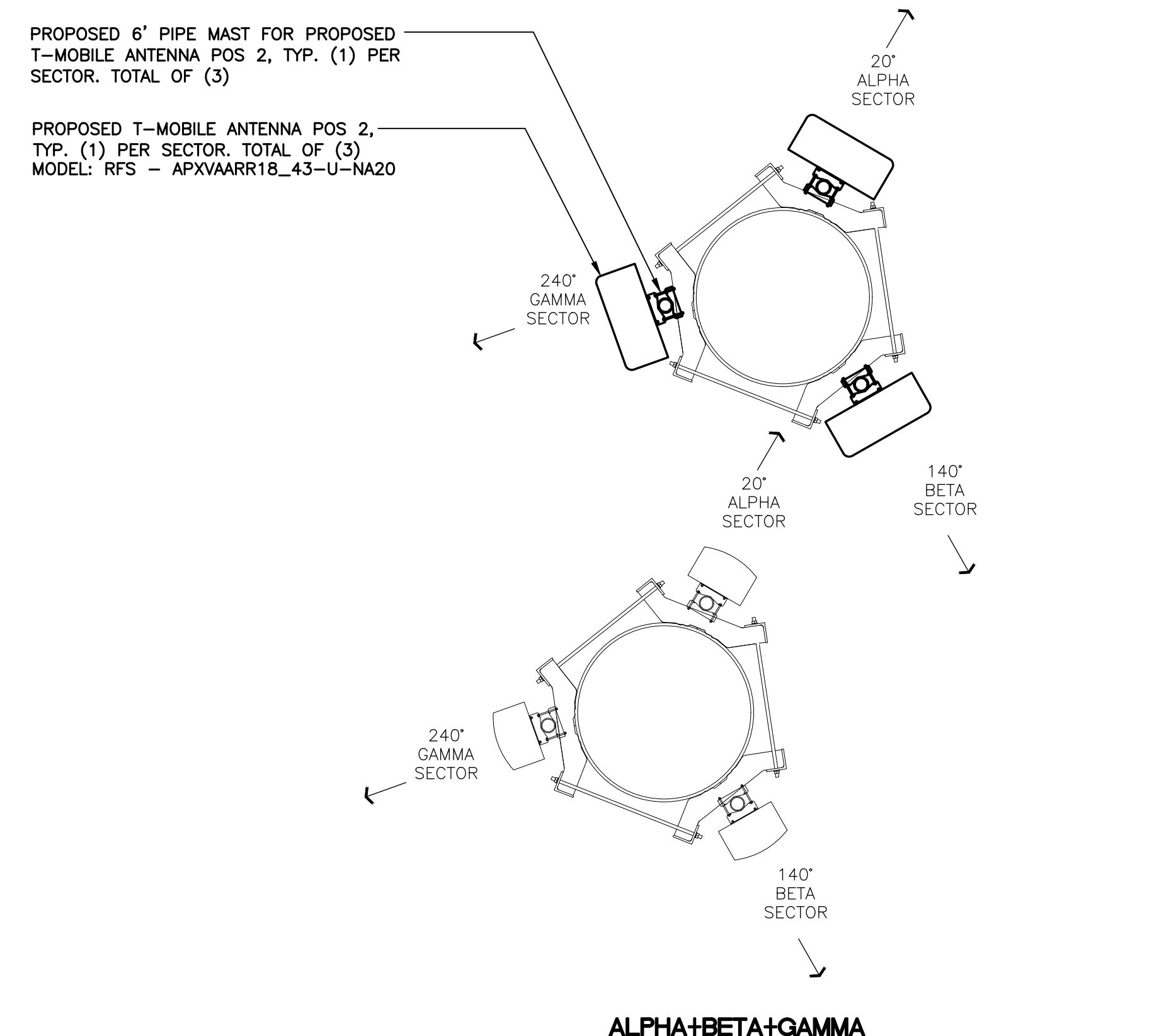

1A PROPOSED ANTENNA MOUNTING CONFIGURATION
 C-3 SCALE: 1/2" = 1' TRUE NORTH

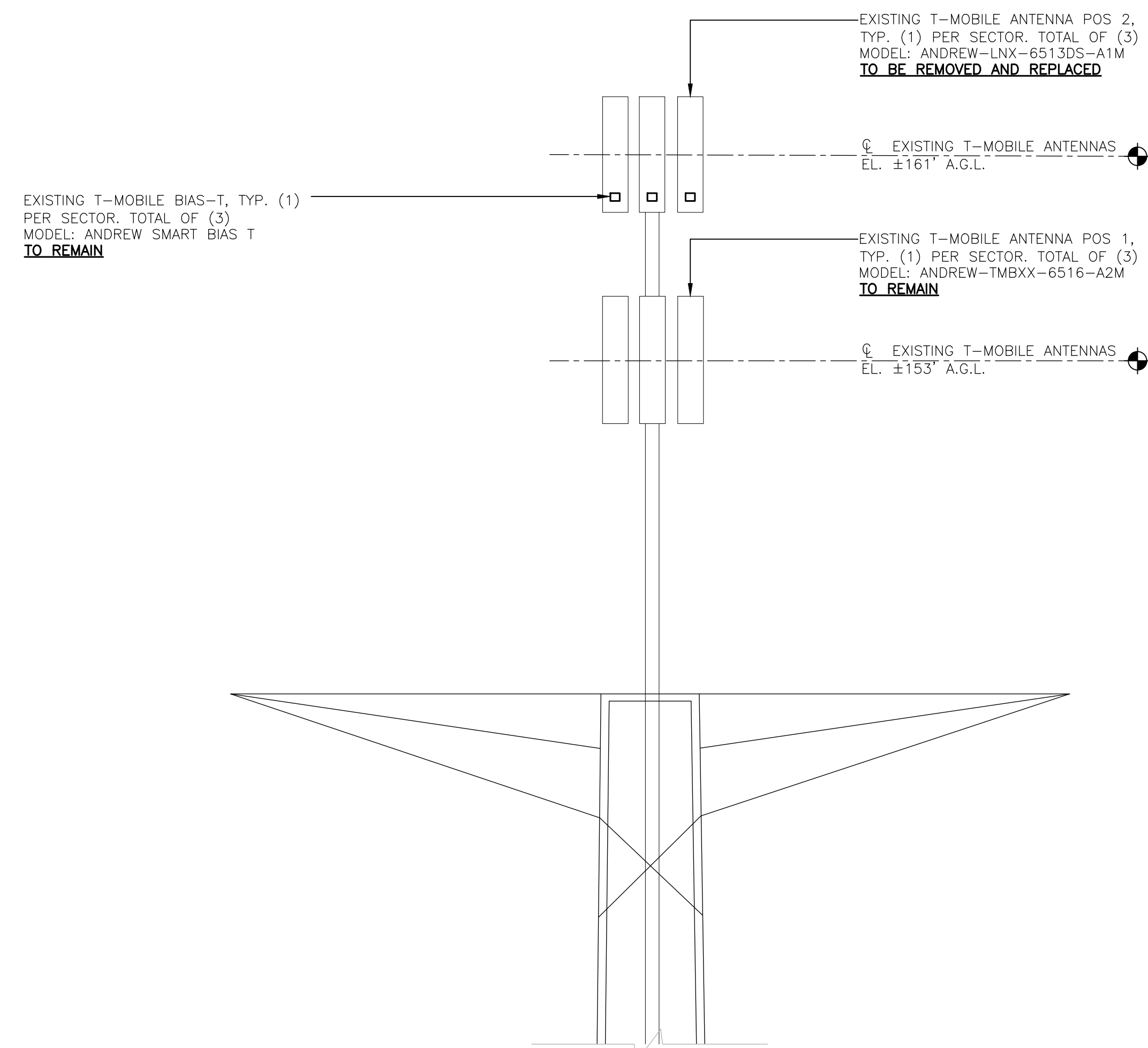

2 EXISTING ANTENNA ELEVATION
 C-3 SCALE: 1/4" = 1'

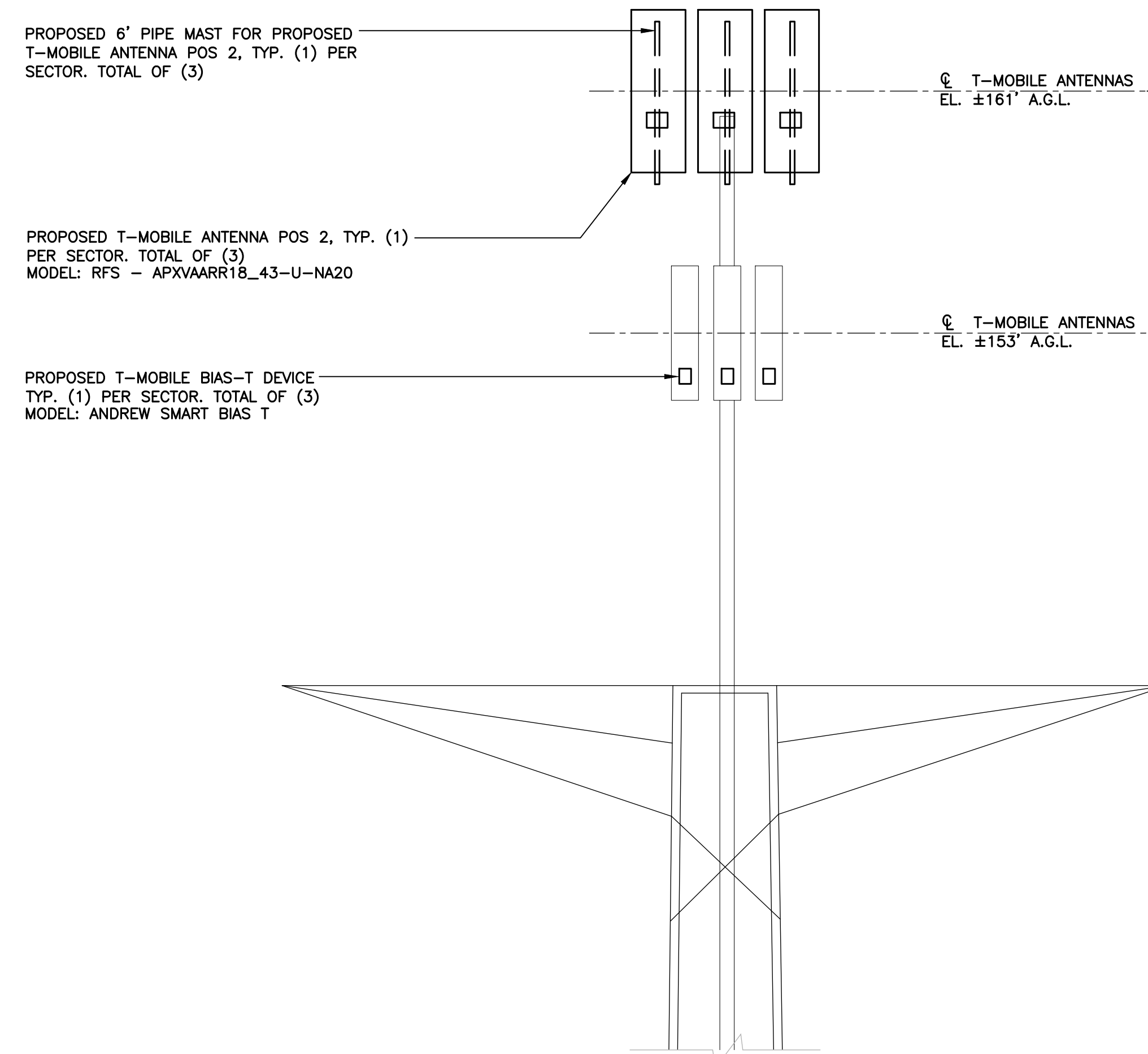

2A PROPOSED ANTENNA ELEVATION
 C-3 SCALE: 1/4" = 1'

PROFESSIONAL ENGINEER SEAL	CONSTRUCTION DRAWINGS - REVISED PER CLIENT COMMENTS
	CONSTRUCTION DRAWINGS - ISSUED FOR CONSTRUCTION
08/10/21	TJR
07/26/21	TJR
0	DATE
REV.	DESCRPTION
DATE	DRAWN BY/CHECK'D BY
T-MOBILE NORTHEAST LLC GREENWICH/COS COB/I-95 SITE ID: CT11241A STATION DRIVE GREENWICH, CT 06830	
DATE:	06/18/21
SCALE:	AS NOTED
JOB NO.	21051.06
ANTENNA PLANS AND ELEVATIONS	
Sheet No. 5	of 8

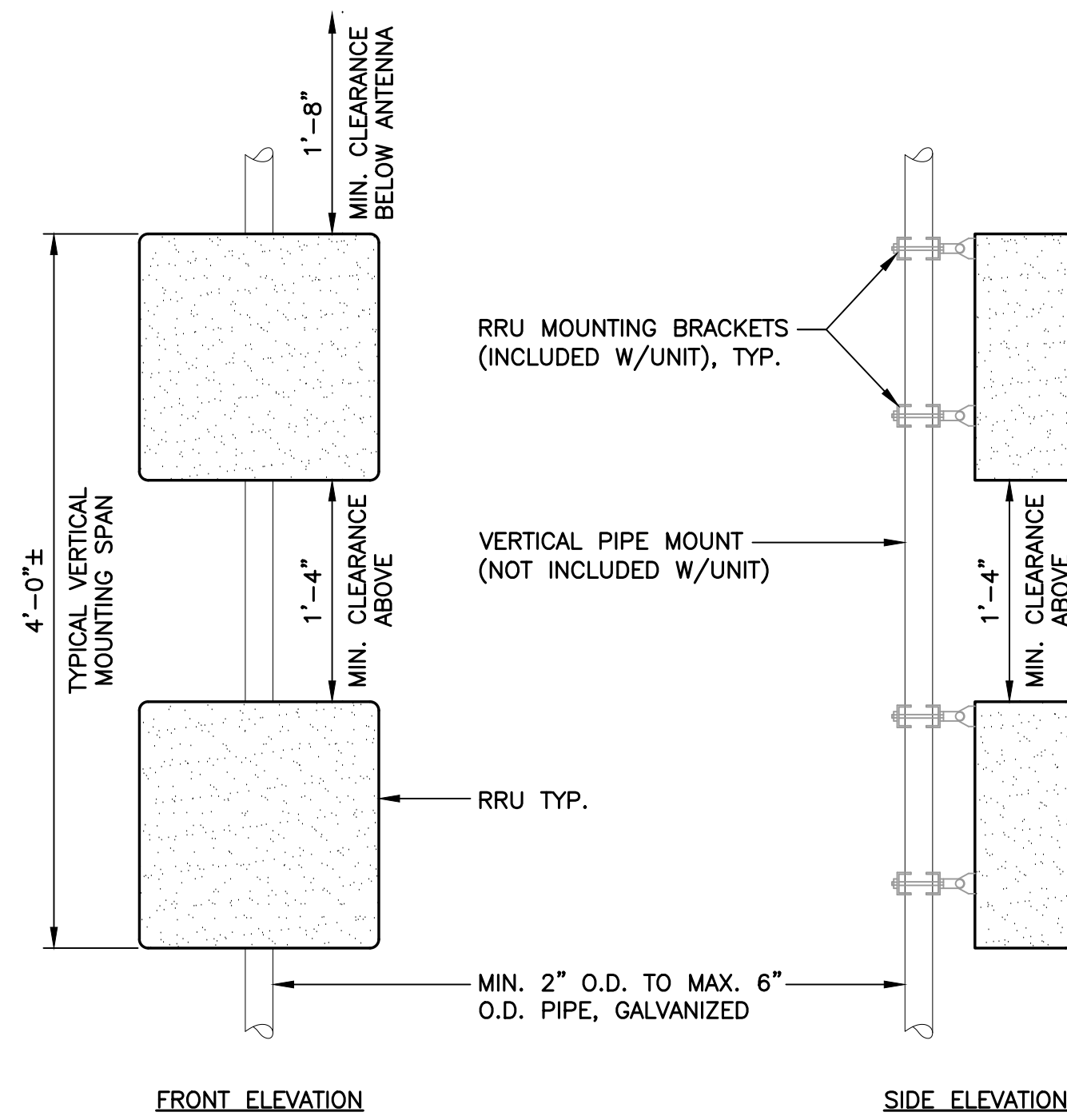

NOTES: (POLE MOUNTING)

- T-MOBILE SHALL SUPPLY RRU, AND RRU POLE-MOUNTING BRACKET. CONTRACTOR SHALL SUPPLY POLE/PIPE AND INSTALL ALL MOUNTING HARDWARE INCLUDING ERICSSON RRU POLE-MOUNTING BRACKET.
- NO PAINTING OF THE RRU OR SOLAR SHIELD IS ALLOWED.

1 TYPICAL RRU MOUNTING DETAILS
C-4 SCALE: NOT TO SCALE

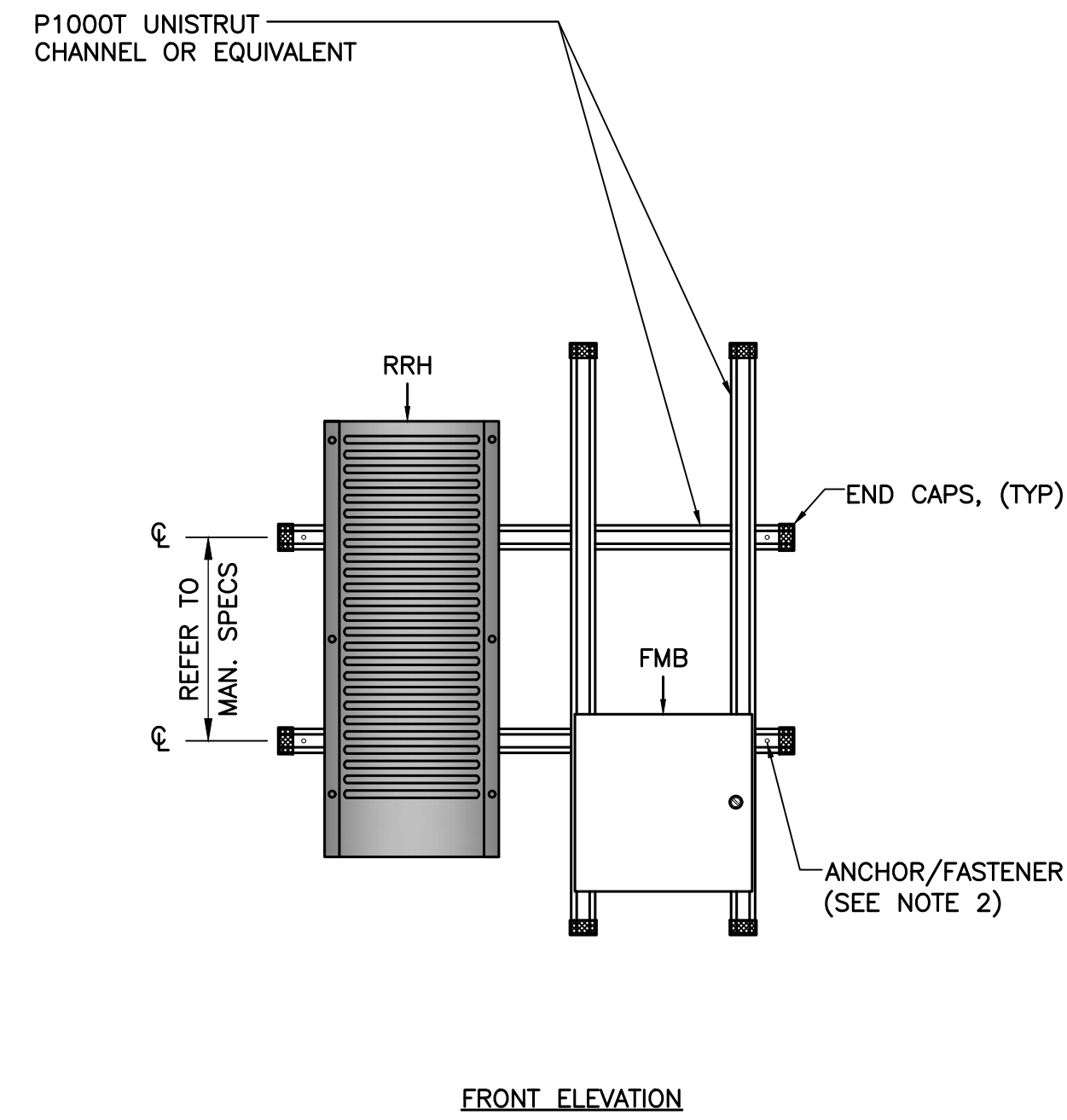

NOTES: (UNISTRUT MOUNTING)

- INSTALL A MINIMUM OF (2) ANCHORS PER UNISTRUT ($\pm 16^\circ$ o/c MIN).
- MOUNT RRU TO UNISTRUT WITH 3/8" UNISTRUT BOLTING HARDWARE AND SPRING NUTS. TYPICAL FOUR PER BRACKET.
- NO PAINTING OF THE RRU OR SOLAR SHIELD IS ALLOWED.



ANDREW SMART BIAS-T		
EQUIPMENT	DIMENSIONS	WEIGHT
MAKE: COMMSCOPE MODEL: ATSBT-TOP-FF-4G	5.63"L x 3.7"W x 2"D	±1.7 LBS.

NOTES:
1. CONTRACTOR TO COORDINATE FINAL EQUIPMENT MODEL SELECTION WITH T-MOBILE CONSTRUCTION MANAGER PRIOR TO ORDERING.

4 PROPOSED BIAS-T DETAIL
C-4 SCALE: NOT TO SCALE

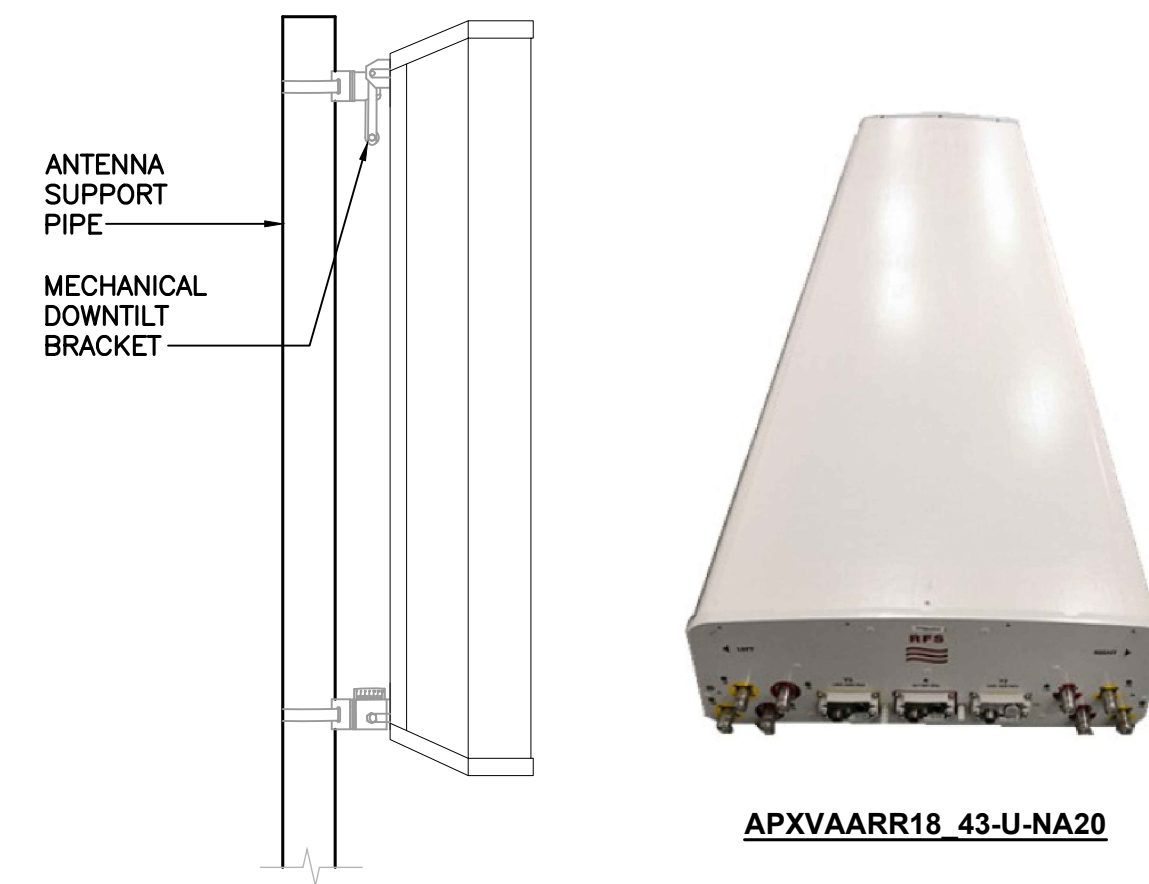

ALPHA/BETA/GAMMA ANTENNA		
EQUIPMENT	DIMENSIONS	WEIGHT
MAKE: RFS MODEL: APXVAARR18_43-U-NA20	72"L x 24"W x 8.5"D	±106 LBS.

NOTES:
1. CONTRACTOR TO COORDINATE FINAL EQUIPMENT MODEL SELECTION WITH T-MOBILE CONSTRUCTION MANAGER PRIOR TO ORDERING.

2 PROPOSED ANTENNA DETAIL
C-4 SCALE: NOT TO SCALE



RRU (REMOTE RADIO UNIT)			
EQUIPMENT	DIMENSIONS	WEIGHT	CLEARANCES
MAKE: ERICSSON MODEL: RADIO 4449 B71+B85	14.9"L x 13.2"W x 5.4"D	±74 LBS.	BEHIND ANT.: 8" MIN. BELOW ANT.: 20" MIN. BELOW RRU: 16" MIN.

NOTES:
1. CONTRACTOR TO COORDINATE FINAL EQUIPMENT MODEL SELECTION WITH T-MOBILE CONSTRUCTION MANAGER PRIOR TO ORDERING.

3 PROPOSED RRU DETAIL
C-4 SCALE: NOT TO SCALE

PROFESSIONAL ENGINEER SEAL

T-Mobile

CENTEX engineering
Centered on Solutions
(203) 488-0380
(203) 488-8587 Fax
63-2 North Branford Road
Branford, CT 06405
www.CentexEng.com

T-MOBILE NORTHEAST LLC
GREENWICH/COS COB/I-95
SITE ID: CT11241A
STATION DRIVE
GREENWICH, CT 06830

DATE: 06/18/21
SCALE: AS NOTED
JOB NO. 21051.06

TYPICAL EQUIPMENT DETAILS

C-4
Sheet No. 6 of 8

REV. DATE DRAWN BY/CHK'D BY DESCRIPTION
0 07/26/21 ANJ TJR CONSTRUCTION DRAWINGS - ISSUED FOR CONSTRUCTION
09/10/21 ANJ TJR CONSTRUCTION DRAWINGS - REVISED PER CLIENT COMMENTS

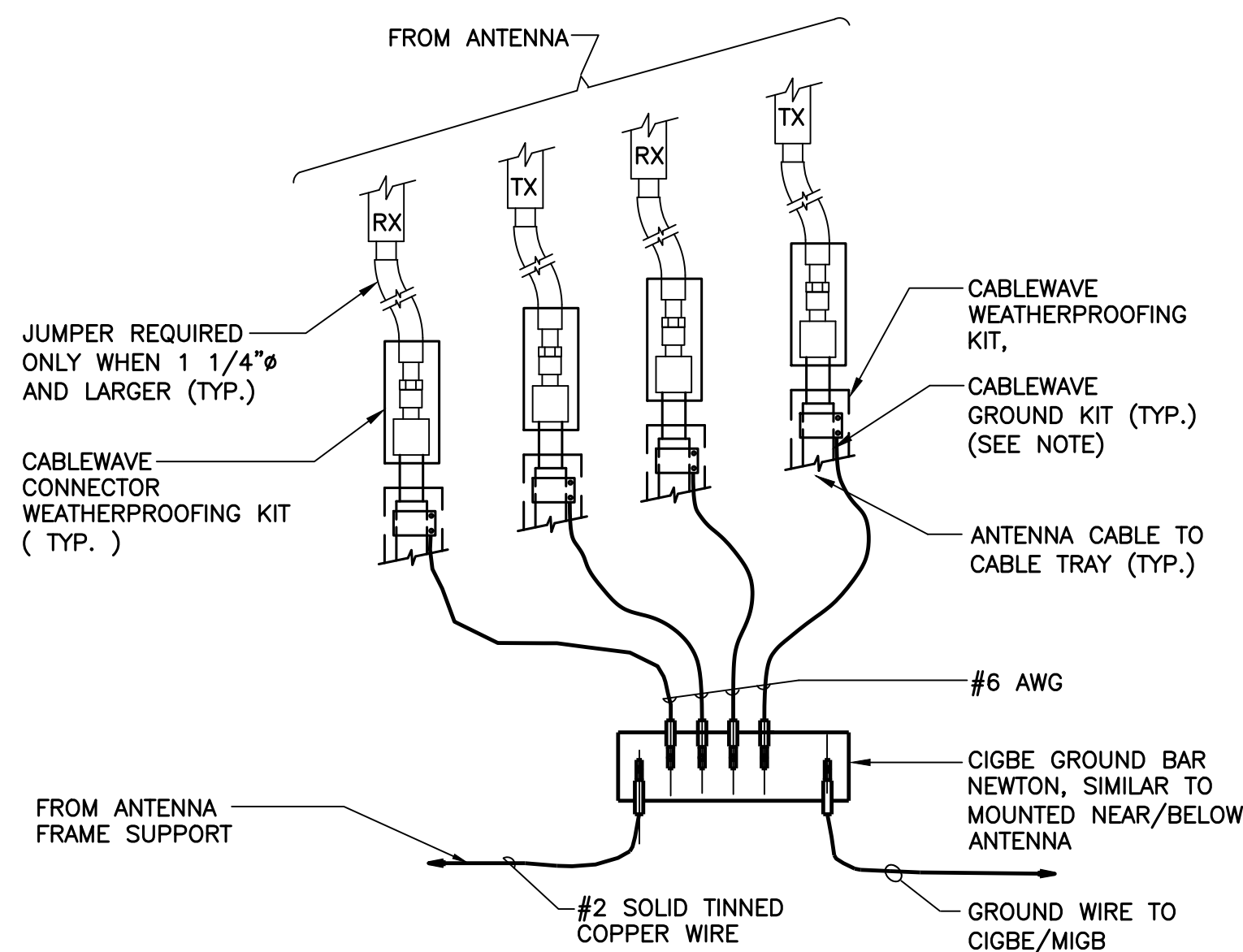

NOTES:

- DO NOT INSTALL CABLE GROUND KIT AT A BEND AND ALWAYS DIRECT GROUND WIRE DOWN TO CIGBE

1 CONNECTION OF GROUND WIRES TO GROUND BAR
E-1 SCALE: NOT TO SCALE

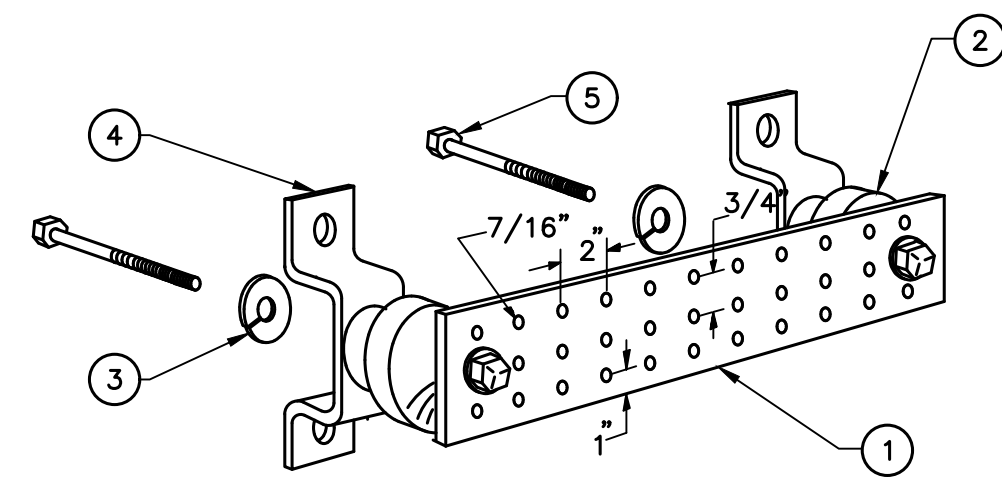

NOTES

- TINNED COPPER GROUND BAR, 1/4" x 4" x 20", NEWTON INSTRUMENT CO. HOLE CENTERS TO MATCH NEMA DOUBLE LUG CONFIGURATION.
- INSULATORS, NEWTON INSTRUMENT CAT. NO. 3061-4.
- 5/8" LOCK WASHERS, NEWTON INSTRUMENT CO. CAT. NO. 3015-8.
- WALL MOUNTING BRACKET, NEWTON INSTRUMENT CO. CAT NO. A-6056.
- 5/8-11 x 1" STAINLESS STEEL TRUSS SPANNER MACHINE SCREWS.

2 GROUND BAR DETAIL
E-1 SCALE: NOT TO SCALE

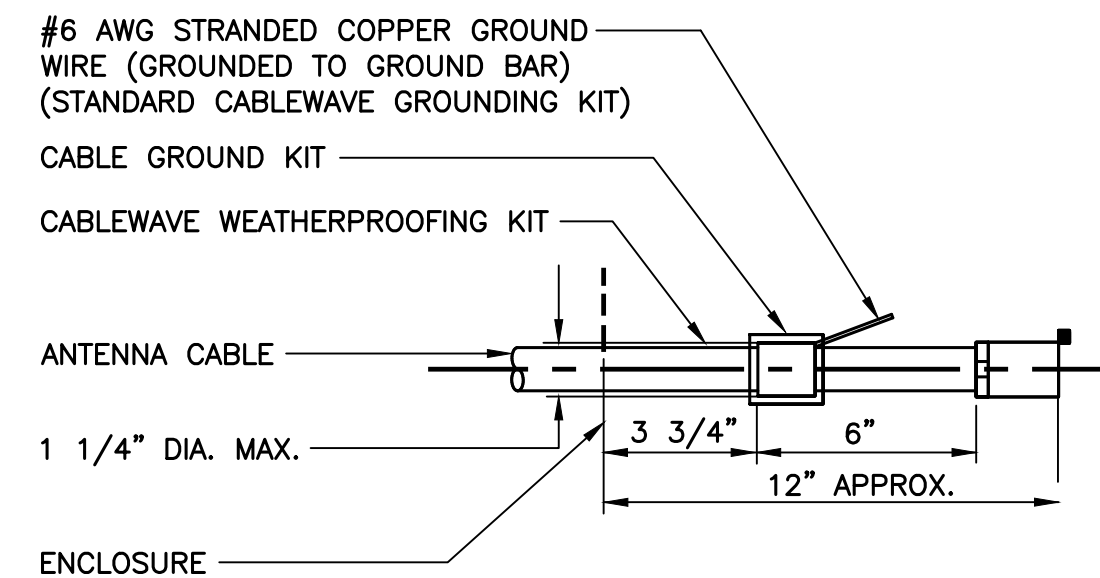

NOTES:

- DO NOT INSTALL CABLE GROUND KIT AT A BEND AND ALWAYS DIRECT GROUND WIRE DOWN TO GROUND BAR.

3 ANTENNA CABLE GROUNDING DETAIL
E-1 SCALE: NOT TO SCALE

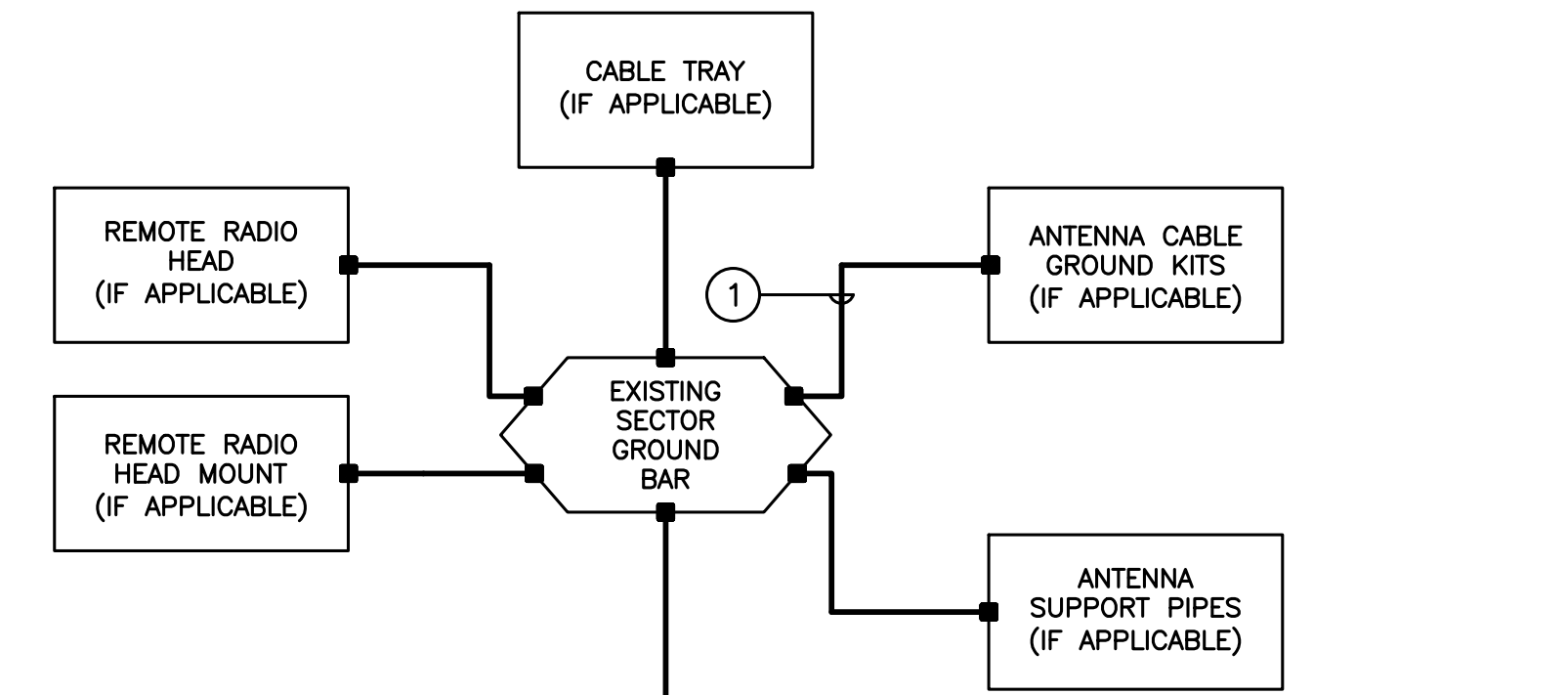

4 TYPICAL ANTENNA GROUNDING DETAIL
E-1 SCALE: NOT TO SCALE

EACH RRH CABINET SHALL BE GROUNDED IN THE FOLLOWING MANNER:
1. AT TOP OF THE CABINET
2. AT RIGHT SIDE OF THE CABINET.

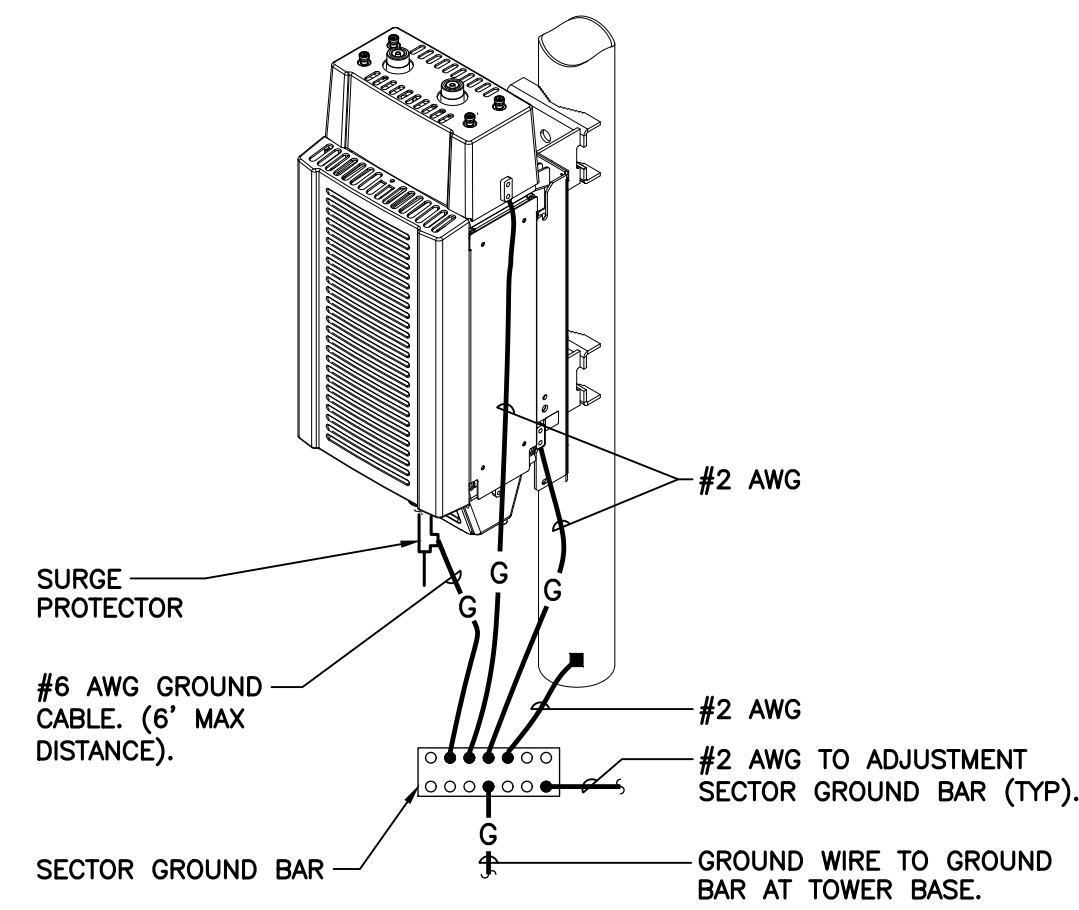

5 RRH POLE MOUNT GROUNDING
E-1 SCALE: NOT TO SCALE

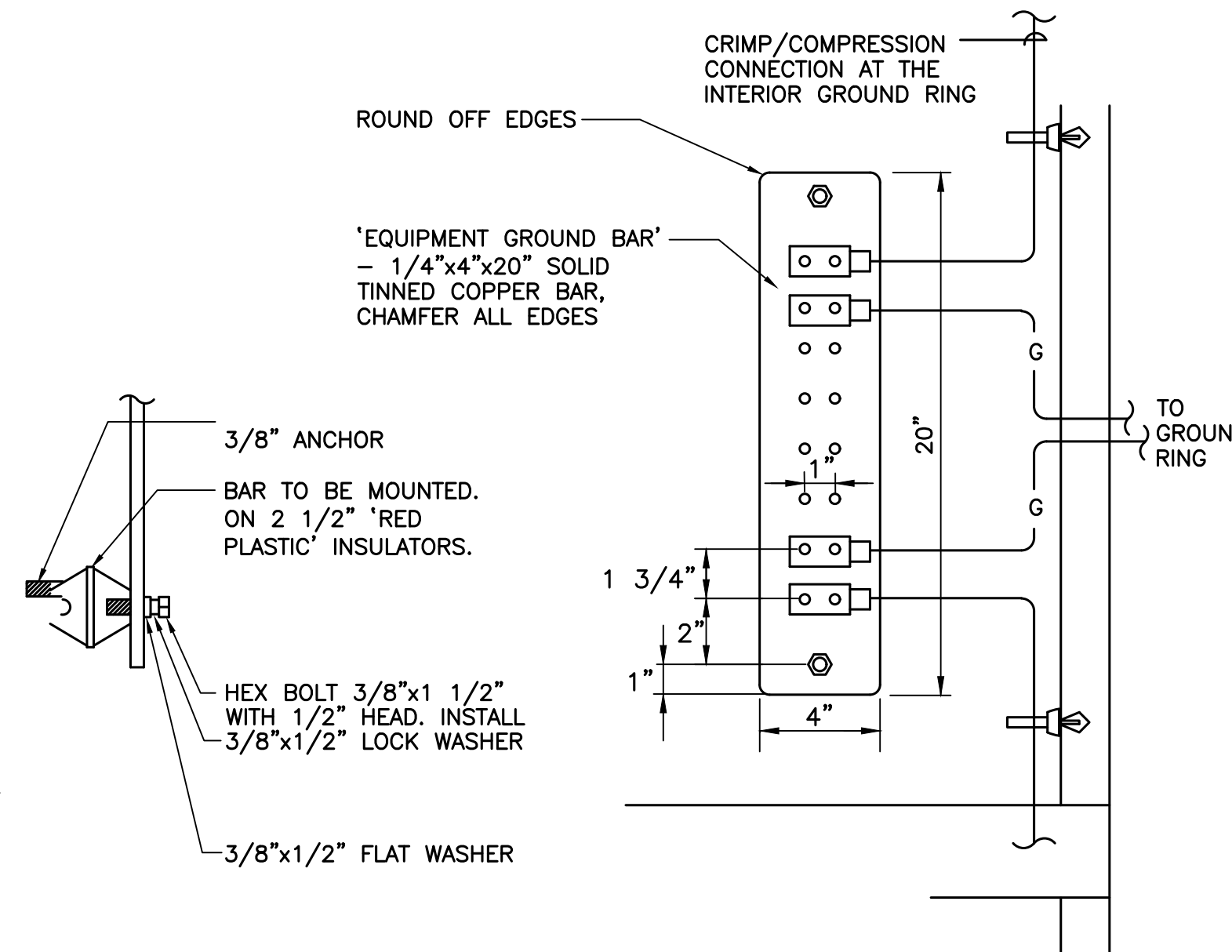

6 EQUIPMENT GROUND BAR DETAIL
E-1 SCALE: NOT TO SCALE

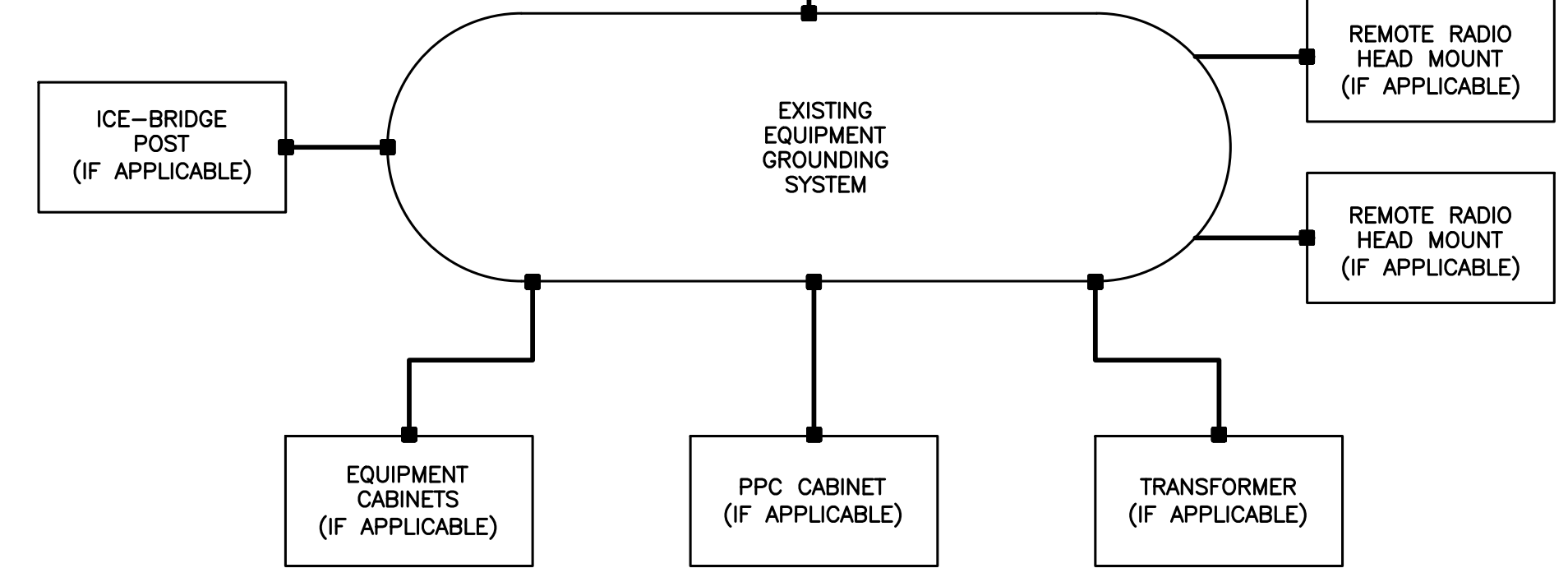

GROUNDING SCHEMATIC NOTES

- #6 AWG**
GENERAL NOTES:
1. ALL SURGE SUPPRESSION EQUIPMENT SHALL BE BONDED TO GROUND PER MANUFACTURER'S SPECIFICATIONS
2. UNLESS OTHERWISE NOTED OR REQUIRED BY CODE, GROUND CONDUCTORS SHOWN SHALL BE #2 AWG (SOLID TINNED BCW - EXTERIOR; STRANDED GREEN INSULATED - INTERIOR).
3. BOND CABLE TRAY SECTIONS TOGETHER WITH #6 AWG STRANDED GREEN INSULATED JUMPERS.
4. ALL SECTOR GROUND BARS SHALL BE BONDED TOGETHER WITH #2 AWG SOLID TINNED BCW.
5. BOND ALL EQUIPMENT CABINETS AND BATTERY CABINETS TO GROUND PER MANUFACTURER'S SPECIFICATIONS.
6. REFER TO ALL ELECTRICAL AND GROUNDING DETAILS.
7. COORDINATE ALL ROOF MOUNTED EQUIPMENT WITH OWNER.
8. ALL ROOF MOUNTED AMPLIFIERS AND ASSOCIATED EQUIPMENT SHALL BE BONDED TO THE SECTOR GROUND BAR PER MANUFACTURER'S SPECIFICATIONS.
9. ALL GROUNDING SHALL BE IN ACCORDANCE WITH NEC AND OWNER'S REQUIREMENTS.

7 ELECTRICAL SCHEMATIC DIAGRAM
E-1 SCALE: NOT TO SCALE

CONSTRUCTION DRAWINGS - REVISED PER CLIENT COMMENTS
CONSTRUCTION DRAWINGS - ISSUED FOR CONSTRUCTION

08/10/21
07/26/21
TJR
TJR
ANC
ANC
DATE
DATE
REV.
REV.
DRAWN BY/CHK'D BY
DESCRIPTION

PROFESSIONAL ENGINEER SEAL

T-Mobile

NSS
NORTHEAST
NORTHWEST
SOUTH

CENTER
engineering
Centered on Solutions

(203) 489-0380
(203) 488-8587 Fax
65-2 North Branford Road
Branford, CT 06405
www.CenterEng.com

T-MOBILE NORTHEAST LLC
GREENWICH/COS COB/1-95
SITE ID: CT11241A
STATION DRIVE
GREENWICH, CT 06830

DATE: 06/18/21
SCALE: AS NOTED
JOB NO. 21051.06

TYPICAL ELECTRICAL DETAILS

E-1

Sheet No. 7 of 8

Exhibit D

**Structural Analysis of
Antenna Mast and Tower**

T-Mobile Site Ref: CT11241A

*Eversource Structure No. 1280
140' Electric Transmission Lattice Tower*

*Station Drive
Greenwich, CT*

CEN TEK Project No. 21051.06

~~Date: June 29, 2021~~

Rev 1: August 9, 2021

Max Stress Ratio = 99.0%

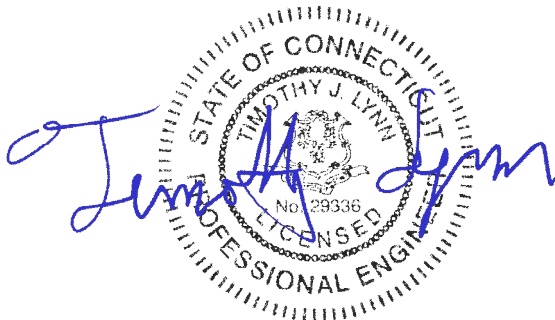

Prepared for:
T-Mobile USA
35 Griffin Road
Bloomfield, CT 06002

Table of Contents

SECTION 1 - REPORT

- INTRODUCTION
- PRIMARY ASSUMPTIONS USED IN THE ANALYSIS
- ANALYSIS
- DESIGN BASIS
- RESULTS
- CONCLUSION

SECTION 2 - CONDITIONS & SOFTWARE

- STANDARD ENGINEERING CONDITIONS
- GENERAL DESCRIPTION OF STRUCTURAL ANALYSIS PROGRAMS
 - RISA 3-D
 - PLS TOWER

SECTION 3 - DESIGN CRITERIA

- CRITERIA FOR DESIGN OF PCS FACILITIES ON OR EXTENDING ABOVE METAL ELECTRIC TRANSMISSION TOWERS
- EVERSOURCE DESIGN CRITERIA TABLE
- PCS SHAPE FACTOR CRITERIA
- WIRE LOADS SHEET

SECTION 4 - DRAWINGS

- MAST DRAWINGS

SECTION 5 - TIA-222-G LOAD CALCULATIONS FOR ANTENNA MAST ANALYSIS

- ANTENNA MAST WIND & ICE LOAD

SECTION 6 - ANTENNA MAST ANALYSIS PER TIA-222G

- RISA 3-D ANALYSIS REPORT
- ANTENNA MAST CONNECTION TO TOWER

**SECTION 7 - NECS/NU LOAD CALCULATIONS FOR UTILITY
STRUCTURE ANALYSIS**

- EQUIPMENT WIND LOAD CALCULATION

**SECTION 8 - ANTENNA MAST ANALYSIS PER NESC/NU FOR
OBTAINING PCS STRUCTURE REACTIONS APPLIED TO
UTILITY TOWER**

- RISA 3-D ANALYSIS REPORT

**SECTION 9 - PLS TOWER RESULTS FROM MAST REACTIONS
CALCULATED IN RISA WITH NESC/NU CRITERIA**

- COAX CABLE LOAD ON CL&P TOWER CALCULATION
- PLS REPORT
- ANCHOR BOLT ANALYSIS
- FOUNDATION ANALYSIS

SECTION 10 - REFERENCE MATERIAL

- RFDS DATA SHEET
- EQUIPMENT CUT SHEETS

Introduction

The purpose of this report is to analyze the existing antenna mast and 140' utility tower located at Station Drive in Greenwich, CT for the proposed antenna and equipment upgrade by T-Mobile.

The existing and proposed loads consist of the following:

- **T-MOBILE (Existing to Remain):**
Antennas: Three (3) Andrew TMBXX-6516 panel antennas flush mounted with a RAD center elevation of 153-ft above tower base and three (3) Andrew ATSBT-TOP-FM-4G Smart Bias Tees flush mounted with a RAD center elevation of 161-ft above tower base.
Coax Cables: Eighteen (18) 1-5/8" \varnothing coax cables running on a leg of the existing tower.
- **T-MOBILE (Existing to Remove):**
Antennas: Three (3) Andrew LNX-6512DS panel antennas flush mounted with a RAD center elevation of 161-ft above tower base.
- **T-MOBILE (Proposed):**
Antennas: Three (3) RFS APXVAARR18_43 panel antennas flush mounted with a RAD center elevation of 161-ft above tower base and three (3) Andrew ATSBT-TOP-FM-4G Smart Bias Tees flush mounted with a RAD center elevation of 153-ft above tower base.
Coax Cables: Six (6) 1-5/8" \varnothing coax cables running on a leg of the existing tower.

Primary assumptions used in the analysis

- ASCE Manual No. 10-97, "Design of Latticed Steel Transmission Structures", defines steel stresses for evaluation of the utility tower.
- All utility tower members are adequately protected to prevent corrosion of steel members.
- All proposed antenna mounts are modeled as listed above.
- All coaxial cable will be installed within the antenna mast unless specified otherwise.
- Antenna mast will be properly installed and maintained.
- No residual stresses exist due to incorrect tower erection.
- All bolts are appropriately tightened providing the necessary connection continuity.
- All welds conform to the requirements of AWS D1.1.
- Antenna mast and utility tower will be in plumb condition.
- Utility tower was properly installed and maintained and all members were properly designed, detailed, fabricated, and installed and have been properly maintained since erection.
- Any deviation from the analyzed loading will require a new analysis for verification of structural adequacy.

A n a l y s i s

Structural analysis of the existing antenna mast was independently completed using the current version of RISA-3D computer program licensed to CENTEK Engineering, Inc. The RISA-3D program contains a library of all AISC shapes and corresponding section properties are computed and applied directly within the program. The program's Steel Code Check option was also utilized.

The existing antenna mast consisting of a 10" Sch.80 x 29'-0" long pipe flange connected to a 6" Sch.80 x 14'-0" long pipe conforming to ASTM A53 Grade B ($F_y = 35\text{ksi}$) connected at two points to the existing tower was analyzed for its ability to resist loads prescribed by the TIA-222-G standard. Section 5 of this report details these gravity and lateral wind loads. Load cases and combinations used in RISA-3D for TIA/EIA loading are listed in report Section 6.

Structural analysis of the existing utility tower structure was completed using the current version of PLS-Tower computer program licensed to CENTEK Engineering, Inc. The NESC program contains a library of all AISC angle shapes and corresponding section properties are computed and applied directly within the program. The program's Steel Code Check option was also utilized.

The existing 140-ft tall lattice tower was analyzed for its ability to resist loads prescribed by the NESC standard. Maximum usage for the tower was calculated considering the additional forces from the antenna mast and associated appurtenances. Section 7 of this report details these gravity and lateral wind loads.

D e s i g n B a s i s

Our analysis was performed in accordance with TIA-222-G, ASCE Manual No. 10-97, "Design of Latticed Steel Transmission Structures", NESC C2-2012 and Northeast Utilities Design Criteria.

▪ UTILITY TOWER ANALYSIS

The purpose of this analysis is to determine the adequacy of the existing utility structure to support the proposed antenna loads. The loading and design requirements were analyzed in accordance with the NU Design Criteria Table, NESC C2-2012 ~ Construction Grade B, and ASCE Manual No. 10-97, "Design of Latticed Steel Transmission Structures".

Load cases considered:

Load Case 1: NESC Heavy

Wind Pressure.....	4.0 psf
Radial Ice Thickness.....	0.5"
Vertical Overload Capacity Factor.....	1.50
Wind Overload Capacity Factor.....	2.50
Wire Tension Overload Capacity Factor.....	1.65

Load Case 2: NESC Extreme

Wind Speed.....	110 mph ⁽¹⁾
Radial Ice Thickness.....	0"

Note 1: NESC C2-2012, Section 25, Rule 250C: Extreme Wind Loading, 1.25 x Gust Response Factor (wind speed: 3-second gust)

▪ **MAST ASSEMBLY ANALYSIS**

Mast, appurtenances and connections to the utility tower were analyzed and designed in accordance with the Design Criteria Table, TIA/EIA-222-G and AISC standards.

Load cases considered:

Load Case 1:

Wind Speed..... 93 mph ^(2018 CSBC Appendix-N)
 Radial Ice Thickness..... 0"

Load Case 2:

Wind Pressure..... 50 mph wind pressure
 Radial Ice Thickness..... 0.75"

Results

▪ **ANTENNA MAST**

The existing antenna mast was determined to be structurally **adequate**.

Component	Design Limit	Stress Ratio (percentage of capacity)	Result
10" Pipe	Bending	88.8%	PASS
6" Pipe	Bending	99.0%	PASS
Flange Connection	Shear	77.0%	PASS

▪ **UTILITY TOWER**

This analysis finds that the subject utility structure is adequate to support the proposed antenna mast and related appurtenances. The tower stresses meet the requirements set forth by the ASCE Manual No. 10-97, "Design of Latticed Steel Transmission Structures", for the applied NESC Heavy and Hi-Wind load cases. The detailed analysis results are provided in Section 8 of this report. The analysis results are summarized as follows:

A maximum usage of **89.89%** occurs in the utility structure under the **NESC Extreme** loading condition.

TOWER SECTION:

The utility structure was found to be within allowable limits.

Tower Member	Stress Ratio (% of capacity)	Result
Angle g89XY	89.89%	PASS

▪ **FOUNDATION AND ANCHORS**

The existing foundation consists of a 5-ft square x 12.5-ft long reinforced concrete pier with eight (8) rock anchor groups embedded 13-ft into rock. The base of the tower is connected to the foundation by four (4) 2.50" Ø A36 bolts per leg. Foundation information was obtained from NUSCO drawing no. 01037-60010.

BASE REACTIONS:

From PLS-Tower analysis of utility tower based on NESC/EVERSOURCE prescribed loads.

Load Case	Shear	Uplift	Compression
NESC Heavy Wind	17.89 kips	131.30 kips	174.95 kips
NESC Extreme Wind	26.91 kips	224.76 kips	248.33 kips

Note 1 – 10% increase to be applied to the above tower base reactions for foundation verification per OTRM 051

ANCHOR BOLTS:

The anchor bolts were found to be within allowable limits.

Component	Design Check	Stress Ratio (percentage of capacity)	Result
Anchor Bolts	Tension	65.7%	PASS

FOUNDATION:

The foundation was found to be within allowable limits.

Foundation	Design Check	Design Limit	Proposed Loading	Result
Reinf. Conc. Pier w/ Rock Anchors	Uplift	1.0 FS ⁽²⁾	2.06 FS ⁽²⁾	PASS
	OTM ⁽¹⁾	1.0 FS ⁽²⁾	2.50 FS ⁽²⁾	PASS
	Soil Bearing	50 ksf	30.6 ksf	PASS

Note 1: OTM denote overturning moment.

Note 2: FS denotes Factor of Safety.

Conclusion

This analysis shows that the subject utility tower **is adequate** to support the proposed T-Mobile equipment upgrade.

The analysis is based, in part on the information provided to this office by Eversource and T-Mobile. If the existing conditions are different than the information in this report, CENTEK engineering, Inc. must be contacted for resolution of any potential issues.

Please feel free to call with any questions or comments.

Respectfully Submitted by:



Timothy J. Lynn, PE
Structural Engineer

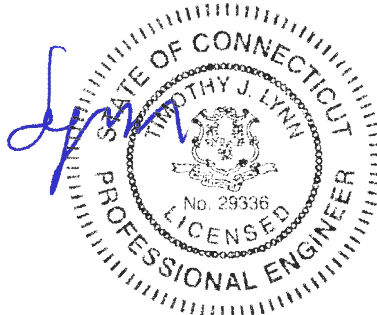

STANDARD CONDITIONS FOR FURNISHING OF
PROFESSIONAL ENGINEERING SERVICES ON
EXISTING STRUCTURES

All engineering services are performed on the basis that the information used is current and correct. This information may consist of, but is not necessarily limited to:

- Information supplied by the client regarding the structure itself, its foundations, the soil conditions, the antenna and feed line loading on the structure and its components, or other relevant information.
- Information from the field and/or drawings in the possession of CENTEK engineering, Inc. or generated by field inspections or measurements of the structure.
- It is the responsibility of the client to ensure that the information provided to CENTEK engineering, Inc. and used in the performance of our engineering services is correct and complete. In the absence of information to the contrary, we assume that all structures were constructed in accordance with the drawings and specifications and are in an un-corroded condition and have not deteriorated. It is therefore assumed that its capacity has not significantly changed from the “as new” condition.
- All services will be performed to the codes specified by the client, and we do not imply to meet any other codes or requirements unless explicitly agreed in writing. If wind and ice loads or other relevant parameters are to be different from the minimum values recommended by the codes, the client shall specify the exact requirement. In the absence of information to the contrary, all work will be performed in accordance with the latest revision of ANSI/ASCE10 & ANSI/EIA-222.
- All services are performed, results obtained, and recommendations made in accordance with generally accepted engineering principles and practices. CENTEK engineering, Inc. is not responsible for the conclusions, opinions and recommendations made by others based on the information we supply.

GENERAL DESCRIPTION OF STRUCTURAL ANALYSIS PROGRAM ~ RISA - 3 D

RISA-3D Structural Analysis Program is an integrated structural analysis and design software package for buildings, bridges, tower structures, etc.

Modeling Features

- Comprehensive CAD-like drawing/editing environment: draw, generate, modify and load elements as well as snap, move, rotate, copy, mirror, scale, split, merge, mesh, delete, apply, trim, extend, etc.
- Versatile drawing grids (orthogonal, radial, skewed, DXF underlay)
- Universal snaps and object snaps allow drawing without grids
- Powerful graphic select/unselect tools including box, line, polygon, invert, criteria, spreadsheet based, save/recall selections with locking
- True spreadsheet editing with cut, paste, fill, math, sort, find, etc.
- Dynamic synchronization between spreadsheets and graphics
- Open multiple spreadsheets simultaneously
- Constant in-stream error checking and data validation
- Unlimited undo/redo capability, automatic timed backup
- Generation templates for grids, disks, cylinders, cones, arcs, trusses, tanks, hydrostatic loads, geodesic domes, etc.
- Support for all units systems & conversions at any time
- Automatic interaction with RISASection custom shape libraries
- Steel Shapes: AISC, Historic, Australian, British, Canadian, Chilean, Chinese, European, Indian, Mexican
- Light Gage Shapes: AISI, SSMA, Dale/Incor, Dietrich, Marino\WARE
- Import DXF, RISA-2D, STAAD and CIS/2 files
- Export DXF, SDNF and CIS/2 files
- Robust two-way link with Revit Structure 2019
- Link with Tekla Structures 2018

Analysis Features

- Analysis of 1D members (beams, columns, braces, etc.) using Finite Element Method
- Analysis of 2D elements (plates, walls) using Finite Element Method
- Analysis of 3D elements (solids) using Finite Element Method
- Partial fixity member end releases using rotational spring constants
- Time History Analysis
- Accelerated true sparse solver for static analysis
- Flexible modeling of P-Delta effects
- Accelerated Sparse Lanczos dynamics solver, very fast and robust
- Multiple simultaneous dynamic and response spectra analysis using Gupta, CQC or SRSS with automatic calc of scaling factors
- Automatic inclusion of mass offset (5% or user defined) for dynamics when integrated with RISAFloor
- Ritz vector dynamic solver
- True physical member modeling (members are aware of interior joints)
- Plate/shell elements with plane stress only option
- 8 node solid elements
- High end mesh generation — draw a polygon with any number of sides to create a mesh of well formed quadrilateral (NO triangular) elements
- Automatic rigid diaphragm modeling with detachable joints

- Area loads with one-way or two-way distributions with optional “blow through” distribution for loading open structures
- Plate thermal loads
- Simultaneous moving loads, AASHTO/custom for bridges, cranes...
- Torsional warping calculations for stiffness, stress and design of hot rolled steel
- Member end releases, rigid end offsets, analysis offsets
- Enforced joint displacements
- One Way members, for tension only bracing, slipping, etc.
- One Way springs, for modeling soils and other effects
- Euler members: Compression up to buckling load, then disable
- Stress calculations on any arbitrary shape
- Inactivate members, plates, solids and diaphragms without deleting them
- Story drift calculations provide relative drift and ratio to height
- Automatic self-weight calculations for members, plates and solids

Graphics Features

- Unlimited simultaneous model view windows
- “True to scale” rendering with translucency, even when drawing
- High-speed redraw algorithm for instant refreshing
- Dynamically zoom, pan, rotate, scroll, snap views
- Font and color control
- Saved views to quickly restore frequent or desired views
- Rendered or wire-frame animations of deflected model and mode shapes
- Animation of moving loads with speed control
- Distance tool for measuring between points
- Force/moment summation about any arbitrary cut line
- High quality customizable graphics printing

Design Codes

- Steel Design Codes: AISC 360-16/10/05: ASD & LRFD, AISC 2nd & 3rd: LRFD, AISC 9th: ASD, CSA S16-14/09/05/01/CSA-S16.1-94, BS 5950-1: 2000, EN 1993-1-1:2014/2005, ENV 1993-1-1:1992, IS 800: 2007/1998, AS 4100-1998, NZS 3404: 1997
- Seismic design per AISC 341-10/05, including 358 prequalified connections
- Concrete Design Codes: ACI 318-14/11/08/05/02/99, CSA A23.3-14/04/94, NTC-DF 2004, BS 8110-1: 1997, BS EN 1992-1-1: 2004+A1: 2014/2004, EN 1992-1-1:1992, IS 456: 2000, AS 3600-2001, NZS 3101: 1995, SBC 304-2007
- Cold Formed Steel Design Codes: AISI S100-16/12/10/07: ASD & LRFD, AISI NAS-04/01: ASD & LRFD, AISI 1999: ASD & LRFD, CSA S136-16/12/10/07/04/01: LSD, CANACERO 16: ASD, CANACERO 12/10/07/04/01: ASD & LRFD
- Aluminum Design Codes: AA ADM1-15/10: ASD & LRFD, AA ADM1-05: ASD
- Wood Design Codes: AWC NDS-18/15/12: ASD, AF&PA NDS-08/05/01/97/91: ASD, CSA 086-14/09 Ultimate, Structural Composite Lumber, multi-ply, full sawn, Glulam, shear walls
- Masonry Design Codes: TMS 402-16: ASD & Strength, ACI 530-13/11/08/05/02: ASD & Strength, ACI 530-99: ASD, UBC 1997: ASD & Strength
- Stainless Steel Design Code: AISC 360-10: ASD & LRFD
- Wind loads are generated automatically (ASCE 7-16/10/05/02/98/95, NBC 15/10/05, NTC 2004, & IS 875: 1987) for building-type structures, including partial wind cases
- Seismic loads are generated automatically (ASCE 7-16/10/05/02, CBC 2001, IBC 2000, UBC 1997, NBC 15/10/05, NTC 2004, & IS 1893: 2002) for building-type structures, including accidental torsion

Design Features

- Designs/optimizes concrete, hot rolled & cold formed steel, masonry, wood and aluminum

- Program selected or user-defined rebar layouts for flexure and shear
- Concrete beam detailing (Rectangular, T and L).
- Concrete column interaction diagrams
- Concrete wall design including in-plane, out-of-plane & bearing loads
- Automatic spectra generation for ASCE 7, NBC, IS 1893, NTC
- Extensive user controlled generation of load combinations
- Intelligent unbraced length calculations for physical members
- Tapered wide flange design per AISC Design Guide 25
- Masonry wall design for in-plane and out-of-plane
- Wood Shapes: Complete NDS species/grade and Glulam database
- Complete wood wall design for bearing & shear walls: Segmented, Perforated & Force Transfer Around Openings design methods
- Strap and Hold Down design for Wood Shear Walls
- Seismic design of concrete walls using ACI 318-14 Chapter 18
- Concrete seismic coupling beams for multi-story walls with diaphragms

Results Features

- Graphic presentation of color-coded results and plotted designs
- Color contours on plates, solid stresses/forces with smoothing and animation
- Spreadsheet results with sorting and filtering of: deflections, forces, stresses, optimized sizes for strength or deflection, code designs, concrete reinforcing, material takeoffs, etc.
- Standard and user-defined reports
- Graphic member detail reports with force/stress/deflection diagrams and detailed design calculations and expanded diagrams

Integrated Building Design

RISA-3D, RISAFloor, RISAFoundation and RISACconnection are so tightly integrated that they operate as one program on the same building model. Optimize the gravity system in RISAFloor, the lateral system in RISA-3D, the connection design in RISACconnection and the foundation system in RISAFoundation, with a complete flow of information both ways.

General Features

- Compatible with Windows 7/8.1/10 (64-bit Windows)
- Program technical support provided by Professional Engineers

GENERAL DESCRIPTION OF STRUCTURAL ANALYSIS PROGRAM ~ PLS-TOWER

PLS-TOWER is a Microsoft Windows program for the analysis and design of steel latticed towers used in electric power lines or communication facilities. Both self-supporting and guyed towers can be modeled. The program performs design checks of structures under user specified loads. For electric power structures it can also calculate maximum allowable wind and weight spans and interaction diagrams between different ratios of allowable wind and weight spans.

Modeling Features:

- Powerful graphics module (stress usages shown in different colors)
- Graphical selection of joints and members allows graphical editing and checking
- Towers can be shown as lines, wire frames or can be rendered as 3-d polygon surfaces
- Can extract geometry and connectivity information from a DXF CAD drawing
- CAD design drawings, title blocks, drawing borders or photos can be tied to structure model
- XML based post processor interface
- Steel Detailing Neutral File (SDNF) export to link with detailing packages
- Can link directly to line design program PLS-CADD
- Automatic generation of structure files for PLS-CADD
- Databases of steel angles, rounds, bolts, guys, etc.
- Automatic generation of joints and members by symmetries and interpolations
- Automated mast generation (quickly builds model for towers that have regular repeating sections) via graphical copy/paste
- Steel angles and rounds modeled either as truss, beam or tension-only elements
- Guys are easily handled (can be modeled as exact cable elements)

Analysis Features:

- Automatic handling of tension-only members
- Automatic distribution of loads in 2-part suspension insulators (v-strings, horizontal vees, etc.)
- Automatic calculation of tower dead, ice, and wind loads as well as drag coefficients according to:
 - ASCE 74-1991, 2009
 - NESC 2002, 2007, 2012, 2017
 - IEC 60826:2003, 2017
 - IS 802 : 1995, 2015
 - ISEC-NCR-83
 - EN50341-1:2001 and 2012 (CENELEC)
 - EN50341-3-2:2001 (Belgium NNA)
 - EN50341-3-9:2001, EN50341-2-9:2015, 2017 (UK NNA)
 - EN50341-3-17:2001 (Portugal NNA)
 - EN50341-2-22:2016 (Poland NNA)
 - AS/NZS 7000:2010, 2016
 - ESAA C(b)1-2003 (Austalia)
 - TPNZ (New Zealand)
 - REE (Spain)
 - SP 16.13330.2011 (SNiP Russia)
- Automated microwave antenna loading as per EIA/TIA 222-F and ANSI/TIA 222-G
- Minimization of problems caused by unstable joints and mechanisms
- Automatic bandwidth minimization and ability to solve large problems

- Design checks according to (other standards can be added easily):
 - ASCE Standard 10-90
 - AS 3995 (Australian Standard 3995)
 - BS 8100 (British Standard 8100)
 - EN50341-1 (CENELEC, both empirical and analytical methods are available)
 - ECCS 1985
 - NGT-ECCS
 - PN-90/B-03200
 - EIA/TIA 222-F
 - ANSI/TIA 222-G
 - CSA S37-01
 - EDF/RTE Resal
 - IS 802 (India Standard 802)

Results Features:

- Design summaries printed for each group of members
 - Easy to interpret text, spreadsheet and graphics design summaries
 - Automatic determination of allowable wind and weight spans
 - Automatic determination of interaction diagrams between allowable wind and weight spans
 - Capability to batch run multiple tower configurations and consolidate the results
 - Automated optimum angle member size selection and bolt quantity determination
- Tool for interactive angle member sizing and bolt quantity determination.

*Criteria for Design of PCS Facilities On or
Extending Above Metal Electric Transmission
Towers & Analysis of Transmission Towers
Supporting PCS Masts* ⁽¹⁾

Introduction

This criteria is the result from an evaluation of the methods and loadings specified by the separate standards, which are used in designing telecommunications towers and electric transmission towers. That evaluation is detailed elsewhere, but in summary; the methods and loadings are significantly different. This criteria specifies the manner in which the appropriate standard is used to design PCS facilities including masts and brackets (hereafter referred to as “masts”), and to evaluate the electric transmission towers to support PCS masts. The intent is to achieve an equivalent level of safety and security under the extreme design conditions expected in Connecticut and Massachusetts.

ANSI Standard TIA-222-G covering the design of telecommunications structures specifies a limit state design approach. This approach applies the loads from extreme weather loading conditions, and designs the structure so that the design strength exceeds the required strength.

ANSI Standard C2-2012 (National Electrical Safety Code) covering the design of electric transmission metal structures is based upon an ultimate strength/yield stress design approach. This approach applies a multiplier (overload capacity factor) to the loads possible from extreme weather loading conditions, and designs the structure so that it does not exceed its ultimate strength (yield stress).

Each standard defines the details of how loads are to be calculated differently. Most of the NU effort in “unifying” both codes was to establish what level of strength each approach would provide, and then increasing the appropriate elements of each to achieve a similar level of security under extreme weather loadings.

Two extreme weather conditions are considered. The first is an extreme wind condition (hurricane) based upon a 50-year recurrence (2% annual probability). The second is a winter condition combining wind and ice loadings.

The following sections describe the design criteria for any PCS mast extending above the top of an electric transmission tower, and the analysis criteria for evaluating the loads on the transmission tower from such a mast from the lower portions of such a mast, and loads on the pre-existing electric lower portions of such a mast, and loads on the pre-existing electric transmission tower and the conductors it supports.

| Note 1: Prepared from documentation provide from Northeast Utilities.

PCS Mast

The PCS facility (mast, external cable/trays, including the initial and any planned future support platforms, antennas, etc. extending the full height above the top level of the electric transmission structure) shall be designed in accordance with the provisions of TIA 222-G:

ELECTRIC TRANSMISSION TOWER

The electric transmission tower shall be analyzed using yield stress theory in accordance with the attached table titled “NU Design Criteria”. This specifies uniform loadings (different from the TIA loadings) on the each of the following components of the installed facility:

- PCS mast for its total height above ground level, including the initial and planned future support platforms, antennas, etc. above the top of an electric transmission structure.
- Conductors are related devices and hardware.
- Electric transmission structure. The loads from the PCS facility and from the electric conductors shall be applied to the structure at conductor and PCS mast attachment points, where those load transfer to the tower.

The uniform loadings and factors specified for the above components in the table are based upon the National Electrical Safety Code 2007 Edition Extreme Wind (Rule 250C) and Combined Ice and Wind (Rule 250B-Heavy) Loadings. These provide equivalent loadings compared to TIA and its loads and factors with the exceptions noted above. (Note that the NESC does not require the projected wind surfaces of structures and equipment to be increased by the ice covering.)

In the event that the electric transmission tower is not sufficient to support the additional loadings of the PCS mast, reinforcement will be necessary to upgrade the strength of the overstressed members.

Overhead Transmission Standards

Attachment A
Eversource Design Criteria

		Attachment A ES Design Criteria	Basic Wind Speed	Pressure	Height Factor	Gust Factor	Load or Stress Factor	Force Coef. - Shape Factor
			V (MPH)	Q (PSF)	Kz	Gh		
Ice Condition	TIA/EIA	Antenna Mount	TIA	TIA (0.75Wi)	TIA	TIA	TIA, Section 3.1.1.1 disallowed for connection design	TIA
	NESCH Heavy	Tower/Pole Analysis with antennas extending above top of Tower/Pole (Yield Stress)	-----	4	1	1	2.5	1.6 Flat Surfaces 1.3 Round Surfaces
		Tower/Pole Analysis with antennas below top of Tower/Pole (on two faces)	-----	4	1	1	2.5	1.6 Flat Surfaces 1.3 Round Surfaces
	Conductors:		Conductor Loads Provided by ES					
High Wind Condition	TIA/EIA	Antenna Mount	85	TIA	TIA	TIA	TIA, Section 3.1.1.1 disallowed for connection design	TIA
	NESCH Extreme Wind	Tower/Pole Analysis with antennas extending above top of Tower/Pole	For wind speed use OTRM 060 Map 1, Rule 250C: Extreme Wind Loading Apply a 1.25 x Gust Response Factor to all telecommunication equipment projected above top of tower/pole and apply a 1.0 x Gust Response Factor to the tower/pole structure					1.6 Flat Surfaces 1.3 Round Surfaces
		Tower/Pole Analysis with antennas below top of Tower/Pole	For wind speed use OTRM 060 Map 1, Rule 250C: Extreme Wind Loading Height above ground is based on overall height to top of tower/pole					1.6 Flat Surfaces 1.3 Round Surfaces
	Conductors:		Conductor Loads Provided by ES					
NESCH Extreme Ice with Wind Condition*		Tower/Pole Analysis with antennas extending above top of Tower/Pole	For wind speed use OTRM 060 Map 1, Rule 250D: Extreme Ice with Wind Loading 4 PSF Wind Load 1.25 x Gust Response Factor Apply a 1.25 x Gust Response Factor to all telecommunication equipment projected above top of tower/pole and apply a 1.0 x Gust Response Factor to the tower/pole structure					1.6 Flat Surfaces 1.3 Round Surfaces
		Tower/Pole Analysis with antennas below top of Tower/Pole	For wind speed use OTRM 060 Map 1, Rule 250D: Extreme Ice with Wind Loading 4 PSF Wind Load Height above ground is based on overall height to top of tower/pole					1.6 Flat Surfaces 1.3 Round Surfaces
	Conductors:		Conductor Loads Provided by ES					

*Only for structures installed after 2007

Communication Antennas on Transmission Structures

Eversource Approved by: CPS (CT/WMA) JCC (NH/EMA)	Design	OTRM 059	Rev. 1 11/19/2018
		Page 8 of 10	

Overhead Transmission Standards

determined from NESC applied loading conditions (not TIA Loads) on the structure and mount as specified below, and shall include the wireless communication mast and antenna loads per NESC criteria)

The strength reduction factor obtained from the field investigation shall be applied to the members or connections that are showing signs of deterioration from their original condition. With the written approval of Eversource Transmission Line Engineering on a case by case the existing structures may be analyzed initially using the current NESC code, then it is permitted to use the original design code with the original conductor load should the existing tower fail the current NESC code.

The structure shall be analyzed using yield stress theory in accordance with Attachment A, "Eversource Design Criteria." This specifies uniform loadings (different from the TIA loadings) on each of the following components of the installed facility:

- a) Wireless communication mast for its total height above ground level, including the initial and any planned future equipment (Support Platforms, Antennas, TMA's etc.) above the top of an electric transmission structure.
- b) Conductors and related devices and hardware (wire loads will be provided by Eversource).
- c) Electric Transmission Structure

- i) The loads from the wireless communication equipment components based on NESC and Eversource Criteria in Attachment A, and from the electric conductors shall be applied to the structure at conductor and wireless communication mast attachment points, where those loads transfer to the tower. ii)
- ii) Shape Factor Multiplier:

NESC Structure Shape	Cd
Polyround (for polygonal steel poles)	1.3
Flat	1.6
Open Lattice	3.2
Pole with Coaxial Cable	See Below Table

- iii) When Coaxial Cables are mounted alongside the pole structure, the shape multiplier shall be:

Mount Type	Cable Cd	Pole Cd
Coaxial Cables on outside periphery (One layer)	1.45	1.45
Coaxial Cables mounted on stand offs	1.6	1.6

- d) The uniform loadings and factors specified for the above components in Attachment A, "Eversource Design Criteria" are based upon the National Electric Safety Code 2007 Edition Extreme Wind (Rule 250C) and Combined Ice and Wind (Rule 250B-Heavy) Loadings. These provide equivalent loadings compared to the TIA and its loads and factors with the exceptions noted above.

Communication Antennas on Transmission Structures			
Eversource Approved by: CPS (CT/WMA) JCC (NH/EMA)	Design	OTRM 059	Rev. 1 11/19/2018
		Page 3 of 10	

Project: 1740/1750 Lines, Structure 1280
Date: 7/23/19
Engineer: JS
Purpose: Recalculate wire loads for T-Mobile site.

Shield Wires:
1740: 336 "Linnet" ACSR, sagged in PLS-CADD
1750: AFL DNO-8363 OPGW, sagged in PLS-CADD

Conductors:
1272 "Bittern" ACSR, sagged in PLS-CADD

NESC 250B

1740 Line			1750 Line		
Linnet V	1154		1129 V OPGW		
T	2661		2793 T		
L	100		50 L		
Top Phase: V	2695		2759 V		
T	3509		3838 T		
L	-2239		-603 L		
Mid Phase: V	2653		2671 V		
T	3409		3543 T		
L	-2923		-2851 L		
Bot Phase: V	2769		2856 V		
T	3772		4238 T		
L	-286		1055 L		

Project: 1740/1750 Lines, Structure 1280
Date: 7/23/19
Engineer: JS
Purpose: Recalculate wire loads for T-Mobile site.

Shield Wires:
1740: 336 "Linnet" ACSR, sagged in PLS-CADD
1750: AFL DNO-8363 OPGW, sagged in PLS-CADD

Conductors:
1272 "Bittern" ACSR, sagged in PLS-CADD

NESC 250C

1740 Line			1750 Line		
Linnet V	518				536 V OPGW
T	2150				2172 T
L	100				50 L
Phase: V	1458				1502 V
T	3656				3791 T
L	-1890				-1232 L
Phase: V	1423				1450 V
T	3548				3599 T
L	-2193				-2203 L
t Phase: V	1482				1531 V
T	3631				3830 T
L	-988				-670 L

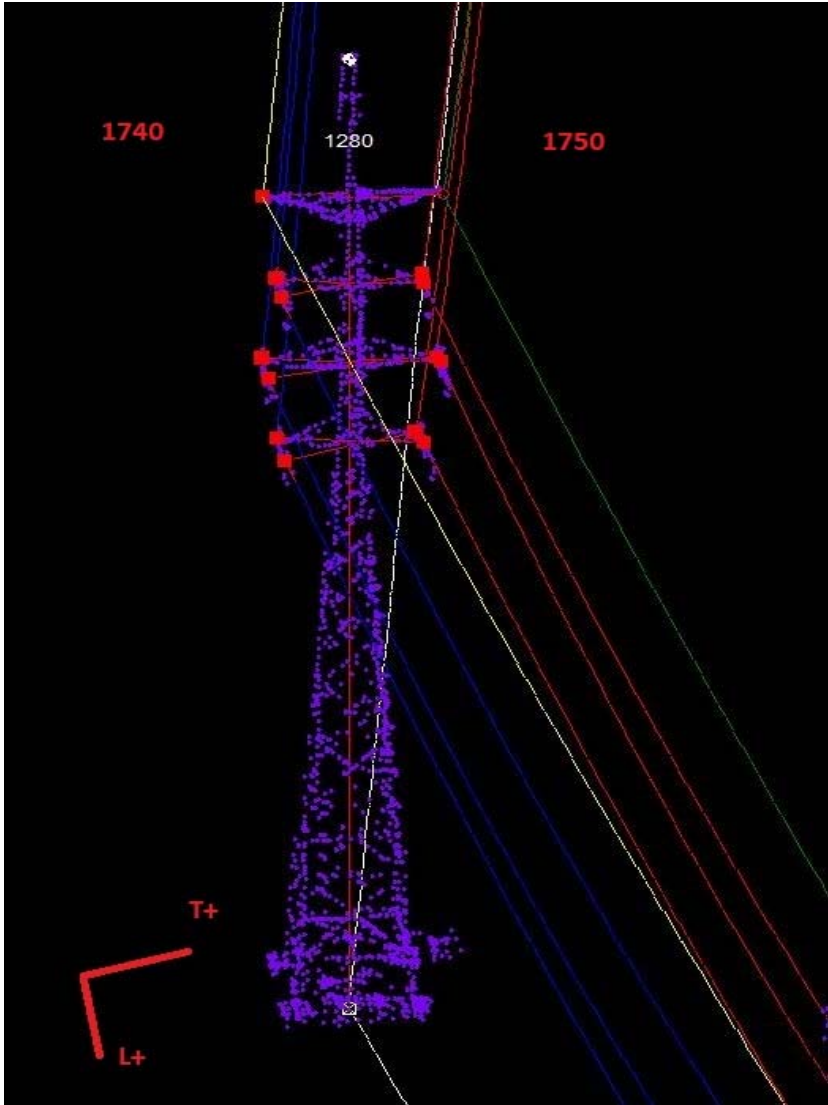

☉ T-MOBILE ANTENNAS
EL. ±161'-0" AGL

☉ T-MOBILE ANTENNAS
EL. ±153'-0" AGL

EXISTING 10" DIA.
SCH.80 PIPE MAST

EXISTING 140' TALL
STEEL TOWER
STRUCTURE NO. 1280

T-MOBILE EXISTING
EIGHTEEN (18) 1 5/8"
DIA. COAX CABLES

T-MOBILE PROPOSED
SIX (6) 1 5/8" DIA.
COAX CABLES

T-MOBILE (TO REMAIN): THREE (3) ANDREW
TMBXX-6516 PANEL ANTENNAS AND THREE
(3) ANDREW ATSBT-TOP-FM-4G SMART
BIAS TEE FLUSH MOUNTED.

T-MOBILE (EXISTING TO REMOVE): THREE
(3) ANDREW LNX-6512DS PANEL ANTENNAS
FLUSH MOUNTED.

T-MOBILE (PROPOSED): THREE (3) RFS
APXVAARR18_43 PANEL ANTENNAS AND
THREE (3) ANDREW ATSBT-TOP-FM-4G
SMART BIAS TEE FLUSH MOUNTED.

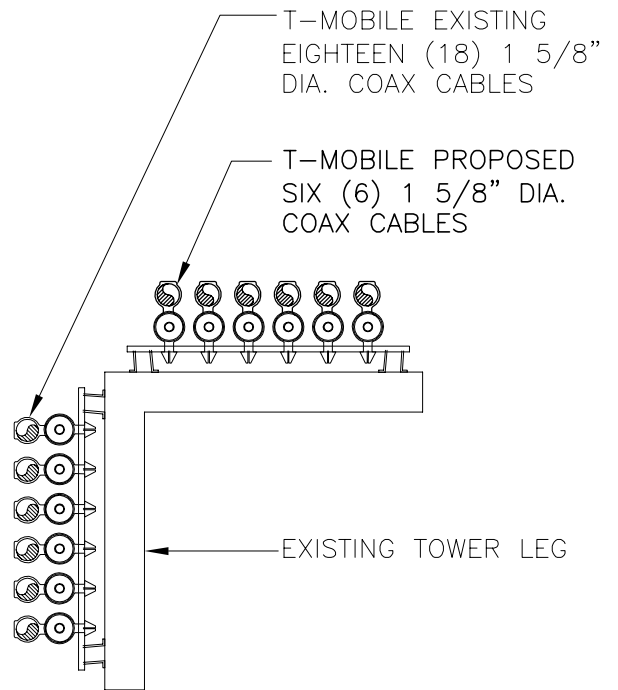

2 COAX MOUNTING PLAN
EL-1 NOT TO SCALE

1 TOWER & MAST ELEVATION
EL-1 SCALE: NOT TO SCALE

REVISIONS		
0	6/29/21	ISSUED FOR REVIEW

CEN TEK engineering
Centered on Solutions™
www.CentekEng.com
(203) 488-0580
(203) 488-8587 Fax
63-2 North Branford Road, Branford, CT 06405

CT11241A
EVERSOURCE 1280
STATION DRIVE
GREENWICH, CT 06830

PROJECT NO: 21051.06
DRAWN BY: TJL
CHECKED BY: CFC
SCALE: AS NOTED
DATE: 6/29/21

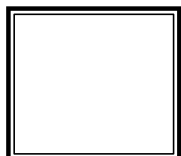

TOWER AND MAST
ELEVATION
EL-1
DWG. 1 OF 1

**Development of Design Heights, Exposure Coefficients,
 and Velocity Pressures Per TIA-222-G**

Wind Speeds

Basic Wind Speed	$V := 93$	mph	(User Input - 2018 CSBC Appendix N)
Basic Wind Speed with Ice	$V_i := 50$	mph	(User Input per Annex B of TIA-222-G)
Basic Wind Speed Service Loads	$V_{Ser} := 60$	mph	(User Input - TIA-222-G Section 2.8.3)

Input

Structure Type =	Structure_Type := Lattice		(User Input)
Structure Category =	SC := III		(User Input)
Exposure Category =	Exp := C		(User Input)
Structure Height =	h := 140	ft	(User Input)
Height to Center of Antennas =	$z_{T-Mo} := 161$	ft	(User Input)
Height to Center of Mast =	$z_{Mast1} := 140$	ft	(User Input)
Radial Ice Thickness =	$t_i := 0.75$	in	(User Input per Annex B of TIA-222-G)
Radial Ice Density =	$\rho_d := 56.00$	pcf	(User Input)
Topographic Factor =	$K_{Zt} := 1.0$		(User Input)
	$K_a := 1.0$		(User Input)
Gust Response Factor =	$G_H := 1.35$		(User Input)

Output

Wind Direction Probability Factor =	$K_d := \begin{cases} 0.95 & \text{if Structure_Type = Pole} \\ 0.85 & \text{if Structure_Type = Lattice} \end{cases} = 0.85$	(Per Table 2-2 of TIA-222-G)
Importance Factors =	$I_{Wind} := \begin{cases} 0.87 & \text{if SC = 1} \\ 1.00 & \text{if SC = 2} \\ 1.15 & \text{if SC = 3} \end{cases} = 1.15$	(Per Table 2-3 of TIA-222-G)
	$I_{Wind_w_Ice} := \begin{cases} 0 & \text{if SC = 1} \\ 1.00 & \text{if SC = 2} \\ 1.00 & \text{if SC = 3} \end{cases} = 1$	
	$I_{ice} := \begin{cases} 0 & \text{if SC = 1} \\ 1.00 & \text{if SC = 2} \\ 1.25 & \text{if SC = 3} \end{cases} = 1.25$	
Wind Direction Probability Factor (Service) =	$K_{dSer} := 0.85$	(Per Section 2.8.3 of TIA-222-G)
Importance Factor (Service) =	$I_{Ser} := 1$	(Per Section 2.8.3 of TIA-222-G)

$$K_{iz} := \left(\frac{z_{T-Mo}}{33} \right)^{0.1} = 1.172$$

Velocity Pressure Coefficient Antennas =

Velocity Pressure w/o Ice Antennas =

Velocity Pressure with Ice Antennas =

Velocity Pressure Service =

$$K_{izMast1} := \left(\frac{z_{Mast1}}{33} \right)^{0.1} = 1.155$$

Velocity Pressure Coefficient Mast =

Velocity Pressure w/o Ice Mast =

Velocity Pressure with Ice Mast =

Velocity Pressure Service =

$$t_{izT-Mo} := 2.0 \cdot t_{ice} \cdot K_{iz} \cdot K_{zt}^{0.35} = 2.197$$

$$K_{zT-Mo} := 2.01 \left(\frac{\left(\frac{z_{T-Mo}}{z_g} \right)^{\frac{2}{\alpha}}}{z_g} \right) = 1.399$$

$$q_{zT-Mo} := 0.00256 \cdot K_d \cdot K_{zT-Mo} \cdot V_{Wind}^2 \cdot I_{Wind} = 30.281$$

$$q_{z_{ice.T-Mo}} := 0.00256 \cdot K_d \cdot K_{zT-Mo} \cdot V_i^2 \cdot I_{Wind_w_Ice} = 7.611$$

$$q_{zT-Mo.Ser} := 0.00256 \cdot K_{dSer} \cdot K_{zT-Mo} \cdot V_{Ser}^2 \cdot I_{Ser} = 10.96$$

$$t_{izMast1} := 2.0 \cdot t_{ice} \cdot K_{izMast1} \cdot K_{zt}^{0.35} = 2.167$$

$$K_{zMast1} := 2.01 \left(\frac{\left(\frac{z_{Mast1}}{z_g} \right)^{\frac{2}{\alpha}}}{z_g} \right) = 1.359$$

$$q_{zMast1} := 0.00256 \cdot K_d \cdot K_{zMast1} \cdot V_{Wind}^2 \cdot I_{Wind} = 29.403$$

$$q_{z_{ice.Mast1}} := 0.00256 \cdot K_d \cdot K_{zMast1} \cdot V_i^2 \cdot I_{Wind_w_Ice} = 7.39$$

$$q_{zMast1.Ser} := 0.00256 \cdot K_{dSer} \cdot K_{zMast1} \cdot V_{Ser}^2 \cdot I_{Ser} = 10.642$$

Development of Wind & Ice Load on Mast

Mast Data:

	(Pipe 10" SCH. 80)	(User Input)
Mast Shape =	Round	(User Input)
Mast Diameter =	$D_{mast} := 10.75$ in	(User Input)
Mast Length =	$L_{mast} := 29$ ft	(User Input)
Mast Thickness =	$t_{mast} := 0.5$ in	(User Input)
Mast Aspect Ratio =	$Ar_{mast} := \frac{12L_{mast}}{D_{mast}} = 32.4$	
Mast Force Coefficient =	$Ca_{mast} = 1.2$	

Wind Load (without ice)

Mast Projected Surface Area = $A_{mast} := \frac{D_{mast}}{12} = 0.896$ s/ft

Total Mast Wind Force = $qZ_{Mast1} \cdot G_H \cdot Ca_{mast} \cdot A_{mast} = 43$ plf **BLC 5**

Wind Load (with ice)

Mast Projected Surface Area w/ Ice = $A_{ICE_{mast}} := \frac{(D_{mast} + 2 \cdot t_{izMast1})}{12} = 1.257$ s/ft

Total Mast Wind Force w/ Ice = $qZ_{ice.Mast1} \cdot G_H \cdot Ca_{mast} \cdot A_{ICE_{mast}} = 15$ plf **BLC 4**

Wind Load (Service)

Total Mast Wind Force Service Loads = $qZ_{Mast1.Ser} \cdot G_H \cdot Ca_{mast} \cdot A_{mast} = 15$ plf **BLC 6**

Gravity Loads (without ice)

Weight of the mast = Self Weight (Computed internally by Risa-3D) plf **BLC 1**

Gravity Loads (ice only)

Ice Area per Linear Foot = $Ai_{mast} := \frac{\pi}{4} [(D_{mast} + t_{izMast1} \cdot 2)^2 - D_{mast}^2] = 87.9$ sq in

Weight of Ice on Mast = $W_{ICE_{mast}} := Id \cdot \frac{Ai_{mast}}{144} = 34$ plf **BLC 3**

Development of Wind & Ice Load on Mast

Mast Data:

	(Pipe 6" SCH. 80)	(User Input)
Mast Shape =	Round	(User Input)
Mast Diameter =	$D_{mast} := 6.625$ in	(User Input)
Mast Length =	$L_{mast} := 14$ ft	(User Input)
Mast Thickness =	$t_{mast} := 0.432$ in	(User Input)
Mast Aspect Ratio =	$Ar_{mast} := \frac{12L_{mast}}{D_{mast}} = 25.4$	
Mast Force Coefficient =	$Ca_{mast} = 1.2$	

Wind Load (without ice)

Mast Projected Surface Area = $A_{mast} := \frac{D_{mast}}{12} = 0.552$ sf

Total Mast Wind Force = $qZ_{Mast1} \cdot G_H \cdot Ca_{mast} \cdot A_{mast} = 26$ plf **BLC 5**

Wind Load (with ice)

Mast Projected Surface Area w/ Ice = $A_{ICE_{mast}} := \frac{(D_{mast} + 2 \cdot t_{izMast1})}{12} = 0.913$ sf

Total Mast Wind Force w/ Ice = $qZ_{ice.Mast1} \cdot G_H \cdot Ca_{mast} \cdot A_{ICE_{mast}} = 11$ plf **BLC 4**

Wind Load (Service)

Total Mast Wind Force Service Loads = $qZ_{Mast1.Ser} \cdot G_H \cdot Ca_{mast} \cdot A_{mast} = 10$ plf **BLC 6**

Gravity Loads (without ice)

Weight of the mast = Self Weight (Computed internally by Risa-3D) plf **BLC 1**

Gravity Loads (ice only)

Ice Area per Linear Foot = $Ai_{mast} := \frac{\pi}{4} [(D_{mast} + t_{izMast1} \cdot 2)^2 - D_{mast}^2] = 59.8$ sq in

Weight of Ice on Mast = $W_{ICE_{mast}} := Id \cdot \frac{Ai_{mast}}{144} = 23$ plf **BLC 3**

Development of Wind & Ice Load on Antennas

Antenna Data:

Antenna Model =	RFSAPXVAARR18_43	
Antenna Shape =	Flat	(User Input)
Antenna Height =	$L_{ant} := 72$	in (User Input)
Antenna Width =	$W_{ant} := 24$	in (User Input)
Antenna Thickness =	$T_{ant} := 8.5$	in (User Input)
Antenna Weight =	$WT_{ant} := 132$	lbs (User Input)
Number of Antennas =	$N_{ant} := 3$	(User Input)
Antenna Aspect Ratio =	$Ar_{ant} := \frac{L_{ant}}{W_{ant}} = 3.0$	
Antenna Force Coefficient =	$Ca_{ant} = 1.22$	

Wind Load (without ice)

Surface Area for One Antenna =	$SA_{ant} := \frac{L_{ant} \cdot W_{ant}}{144} = 12$	sf
Antenna Projected Surface Area =	$A_{ant} := SA_{ant} \cdot N_{ant} = 36$	sf
Total Antenna Wind Force =	$F_{ant} := qz_{T-Mo} \cdot G_H \cdot Ca_{ant} \cdot K_a \cdot A_{ant} = 1799$	lbs BLC 5

Wind Load (with ice)

Surface Area for One Antenna w/ Ice =	$SA_{ICEant} := \frac{(L_{ant} + 2 \cdot t_{izT-Mo}) \cdot (W_{ant} + 2 \cdot t_{izT-Mo})}{144} = 15.1$	sf
Antenna Projected Surface Area w/ Ice =	$A_{ICEant} := SA_{ICEant} \cdot N_{ant} = 45.2$	sf
Total Antenna Wind Force w/ Ice =	$F_{ant} := qz_{ice.T-Mo} \cdot G_H \cdot Ca_{ant} \cdot K_a \cdot A_{ICEant} = 568$	lbs BLC 4

Wind Load (Service)

Total Antenna Wind Force Service Loads =	$F_{ant.Ser} := qz_{T-Mo.Ser} \cdot G_H \cdot Ca_{ant} \cdot K_a \cdot A_{ant} = 651$	lbs BLC 6
---	---	------------------

Gravity Load (without ice)

Weight of All Antennas =	$WT_{ant} \cdot N_{ant} = 396$	lbs BLC 2
---------------------------------	--------------------------------	------------------

Gravity Loads (ice only)

Volume of Each Antenna =	$V_{ant} := L_{ant} \cdot W_{ant} \cdot T_{ant} = 1 \times 10^4$	cu in
Volume of Ice on Each Antenna =	$V_{ice} := (L_{ant} + 2 \cdot t_{izT-Mo}) \cdot (W_{ant} + 2 \cdot t_{izT-Mo}) \cdot (T_{ant} + 2 \cdot t_{izT-Mo}) - V_{ant} = 1 \times 10^4$	
Weight of Ice on Each Antenna =	$W_{ICEant} := \frac{V_{ice}}{1728} \cdot \rho = 430$	lbs
Weight of Ice on All Antennas =	$W_{ICEant} \cdot N_{ant} = 1291$	lbs BLC 3

Development of Wind & Ice Load on Antennas

Antenna Data:

Antenna Model =	Andrew TMBXX-6516	
Antenna Shape =	Flat	(User Input)
Antenna Height =	$L_{ant} := 59$	in (User Input)
Antenna Width =	$W_{ant} := 11.9$	in (User Input)
Antenna Thickness =	$T_{ant} := 6.3$	in (User Input)
Antenna Weight =	$WT_{ant} := 35$	lbs (User Input)
Number of Antennas =	$N_{ant} := 3$	(User Input)
Antenna Aspect Ratio =	$Ar_{ant} := \frac{L_{ant}}{W_{ant}} = 5.0$	
Antenna Force Coefficient =	$Ca_{ant} = 1.31$	

Wind Load (without ice)

Surface Area for One Antenna =	$SA_{ant} := \frac{L_{ant} \cdot W_{ant}}{144} = 4.9$	sf
Antenna Projected Surface Area =	$A_{ant} := SA_{ant} \cdot N_{ant} = 14.6$	sf

Total Antenna Wind Force =

$F_{ant} := qz_{T-Mo} \cdot G_H \cdot Ca_{ant} \cdot K_a \cdot A_{ant} = 783$ lbs **BLC 5**

Wind Load (with ice)

Surface Area for One Antenna w/ Ice =	$SA_{ICEant} := \frac{(L_{ant} + 2 \cdot t_{izT-Mo}) \cdot (W_{ant} + 2 \cdot t_{izT-Mo})}{144} = 7.2$	sf
Antenna Projected Surface Area w/ Ice =	$A_{ICEant} := SA_{ICEant} \cdot N_{ant} = 21.5$	sf

Total Antenna Wind Force w/ Ice =

$F_{ant} := qz_{ice.T-Mo} \cdot G_H \cdot Ca_{ant} \cdot K_a \cdot A_{ICEant} = 289$ lbs **BLC 4**

Wind Load (Service)

Total Antenna Wind Force Service Loads =

$F_{ant.Ser} := qz_{T-Mo.Ser} \cdot G_H \cdot Ca_{ant} \cdot K_a \cdot A_{ant} = 283$ lbs **BLC 6**

Gravity Load (without ice)

Weight of All Antennas =

$WT_{ant} \cdot N_{ant} = 105$ lbs **BLC 2**

Gravity Loads (ice only)

Volume of Each Antenna = $V_{ant} := L_{ant} \cdot W_{ant} \cdot T_{ant} = 4423$ cu in

Volume of Ice on Each Antenna = $V_{ice} := (L_{ant} + 2 \cdot t_{izT-Mo}) \cdot (W_{ant} + 2 \cdot t_{izT-Mo}) \cdot (T_{ant} + 2 \cdot t_{izT-Mo}) - V_{ant} = 6623$

Weight of Ice on Each Antenna = $W_{ICEant} := \frac{V_{ice}}{1728} \cdot \rho_d = 215$ lbs

Weight of Ice on All Antennas =

$W_{ICEant} \cdot N_{ant} = 644$ lbs **BLC 3**

Development of Wind & Ice Load on Antennas

Antenna Data:

Antenna Model =	Commscope ATSBT-TOP-FM-4G Bias Tee
Antenna Shape =	Flat (User Input)
Antenna Height =	$L_{ant} := 5.63$ in (User Input)
Antenna Width =	$W_{ant} := 3.7$ in (User Input)
Antenna Thickness =	$T_{ant} := 2$ in (User Input)
Antenna Weight =	$WT_{ant} := 2$ lbs (User Input)
Number of Antennas =	$N_{ant} := 6$ (User Input)
Antenna Aspect Ratio =	$Ar_{ant} := \frac{L_{ant}}{W_{ant}} = 1.5$
Antenna Force Coefficient =	$Ca_{ant} = 1.2$

Wind Load (without ice)

Surface Area for One Antenna =	$SA_{ant} := \frac{L_{ant} \cdot W_{ant}}{144} = 0.1$	sf
Antenna Projected Surface Area =	$A_{ant} := SA_{ant} \cdot N_{ant} = 0.9$	sf

Total Antenna Wind Force =

$F_{ant} := qz_{T-Mo} \cdot G_H \cdot Ca_{ant} \cdot K_a \cdot A_{ant} = 43$ lbs **BLC 5**

Wind Load (with ice)

Surface Area for One Antenna w/ Ice =	$SA_{ICEant} := \frac{(L_{ant} + 2 \cdot t_{izT-Mo}) \cdot (W_{ant} + 2 \cdot t_{izT-Mo})}{144} = 0.6$	sf
Antenna Projected Surface Area w/ Ice =	$A_{ICEant} := SA_{ICEant} \cdot N_{ant} = 3.4$	sf

Total Antenna Wind Force w/ Ice =

$F_{ant} := qz_{ice.T-Mo} \cdot G_H \cdot Ca_{ant} \cdot K_a \cdot A_{ICEant} = 42$ lbs **BLC 4**

Wind Load (Service)

Total Antenna Wind Force Service Loads =

$F_{ant.Ser} := qz_{T-Mo.Ser} \cdot G_H \cdot Ca_{ant} \cdot K_a \cdot A_{ant} = 15$ lbs **BLC 6**

Gravity Load (without ice)

Weight of All Antennas =

$WT_{ant} \cdot N_{ant} = 12$ lbs **BLC 2**

Gravity Loads (ice only)

Volume of Each Antenna =	$V_{ant} := L_{ant} \cdot W_{ant} \cdot T_{ant} = 42$	cu in
Volume of Ice on Each Antenna =	$V_{ice} := (L_{ant} + 2 \cdot t_{izT-Mo}) \cdot (W_{ant} + 2 \cdot t_{izT-Mo}) \cdot (T_{ant} + 2 \cdot t_{izT-Mo}) - V_{ant} = 477$	

Weight of Ice on Each Antenna =	$W_{ICEant} := \frac{V_{ice}}{1728} \cdot Id = 15$	lbs
---------------------------------	--	-----

Weight of Ice on All Antennas =

$W_{ICEant} \cdot N_{ant} = 93$ lbs **BLC 3**

Development of Wind & Ice Load on Coax Cables

Coax Cable Data:

	(140-ft - 151-ft)	
Coax Type =	HELIAX 1-5/8"	
Shape =	Round	(User Input)
Coax Outside Diameter =	D _{coax} := 1.98 in	(User Input)
Coax Cable Length =	L _{coax} := 11 ft	(User Input)
Weight of Coax per foot =	Wt _{coax} := 1.04 plf	(User Input)
Total Number of Coax =	N _{coax} := 24	(User Input)
No. of Coax Projecting Outside Face of PCS Mast =	NP _{coax} := 5	(User Input)

Coax aspect ratio, $Ar_{coax} := \frac{(L_{coax} \cdot 12)}{D_{coax}} = 66.7$

Coax Cable Force Factor Coefficient = $Ca_{coax} = 1.2$

Wind Load (without ice)

Coax projected surface area = $A_{coax} := \frac{(NP_{coax} \cdot D_{coax})}{12} = 0.8$ sqft

Total Coax Wind Force = $F_{coax} := Ca_{coax} \cdot qz_{Mast1} \cdot G_H \cdot A_{coax} = 39$ plf **BLC 5**

Wind Load (with ice)

Coax projected surface area w/ Ice = $AICE_{coax} := \frac{(NP_{coax} \cdot D_{coax} + 2 \cdot t_{izMast1})}{12} = 1.2$ sqft

Total Coax Wind Force w/ Ice = $F_{i_{coax}} := Ca_{coax} \cdot qz_{ice.Mast1} \cdot G_H \cdot AICE_{coax} = 14$ plf **BLC 4**

Wind Load (Service)

Total Coax Wind Force Service Loads = $F_{coax} := Ca_{coax} \cdot qz_{Mast1.Ser} \cdot G_H \cdot A_{coax} = 14$ plf **BLC 6**

Gravity Loads (without ice)

Weight of all cables w/o ice $WT_{coax} := Wt_{coax} \cdot N_{coax} = 25$ plf **BLC 2**

Gravity Loads (ice only)

Ice Area per Linear Foot = $Ai_{coax} := \frac{\pi}{4} [(D_{coax} + 2 \cdot t_{izMast1})^2 - D_{coax}^2] = 28.2$ sq in

Ice Weight All Coax per foot = $WTi_{coax} := N_{coax} \cdot Id \cdot \frac{Ai_{coax}}{144} = 263$ plf **BLC 3**

Development of Wind & Ice Load on Coax Cables

Coax Cable Data:

	(151-ft - 159-ft)	
Coax Type =	HELIAX 1-5/8"	
Shape =	Round	(User Input)
Coax Outside Diameter =	$D_{\text{coax}} := 1.98$ in	(User Input)
Coax Cable Length =	$L_{\text{coax}} := 8$ ft	(User Input)
Weight of Coax per foot =	$W_{t_{\text{coax}}} := 1.04$ plf	(User Input)
Total Number of Coax =	$N_{\text{coax}} := 12$	(User Input)
No. of Coax Projecting Outside Face of PCS Mast =	$NP_{\text{coax}} := 3$	(User Input)

Coax aspect ratio, $Ar_{\text{coax}} := \frac{(L_{\text{coax}} \cdot 12)}{D_{\text{coax}}} = 48.5$

Coax Cable Force Factor Coefficient = $Ca_{\text{coax}} = 1.2$

Wind Load (without ice)

Coax projected surface area = $A_{\text{coax}} := \frac{(NP_{\text{coax}} \cdot D_{\text{coax}})}{12} = 0.5$ sq/ft

Total Coax Wind Force = $F_{\text{coax}} := Ca_{\text{coax}} \cdot q_{z_{\text{Mast1}}} \cdot G_H \cdot A_{\text{coax}} = 24$ plf **BLC 5**

Wind Load (with ice)

Coax projected surface area w/ Ice = $A_{\text{ICE}_{\text{coax}}} := \frac{(NP_{\text{coax}} \cdot D_{\text{coax}} + 2 \cdot t_{\text{izMast1}})}{12} = 0.9$ sq/ft

Total Coax Wind Force w/ Ice = $F_{\text{coax}} := Ca_{\text{coax}} \cdot q_{z_{\text{ice.Mast1}}} \cdot G_H \cdot A_{\text{ICE}_{\text{coax}}} = 10$ plf **BLC 4**

Wind Load (Service)

Total Coax Wind Force Service Loads = $F_{\text{coax}} := Ca_{\text{coax}} \cdot q_{z_{\text{Mast1.Ser}}} \cdot G_H \cdot A_{\text{coax}} = 9$ plf **BLC 6**

Gravity Loads (without ice)

Weight of all cables w/o ice $WT_{\text{coax}} := W_{t_{\text{coax}}} \cdot N_{\text{coax}} = 12$ plf **BLC 2**

Gravity Loads (ice only)

Ice Area per Linear Foot = $A_{\text{ice}} := \frac{\pi}{4} [(D_{\text{coax}} + 2 \cdot t_{\text{izMast1}})^2 - D_{\text{coax}}^2] = 28.2$ sq in

Ice Weight All Coax per foot = $WT_{\text{ice}} := N_{\text{coax}} \cdot Id \cdot \frac{A_{\text{ice}}}{144} = 132$ plf **BLC 3**

(Global) Model Settings

Display Sections for Member Calcs	5
Max Internal Sections for Member Calcs	97
Include Shear Deformation?	Yes
Increase Nailing Capacity for Wind?	Yes
Include Warping?	Yes
Trans Load Btwn Intersecting Wood Wall?	Yes
Area Load Mesh (in^2)	144
Merge Tolerance (in)	.12
P-Delta Analysis Tolerance	0.50%
Include P-Delta for Walls?	Yes
Automatically Iterate Stiffness for Walls?	No
Max Iterations for Wall Stiffness	3
Gravity Acceleration (ft/sec^2)	32.2
Wall Mesh Size (in)	12
Eigensolution Convergence Tol. (1.E-)	4
Vertical Axis	Y
Global Member Orientation Plane	XZ
Static Solver	Sparse Accelerated
Dynamic Solver	Accelerated Solver

Hot Rolled Steel Code	AISC 14th(360-10): LRFD
Adjust Stiffness?	Yes(Iterative)
RISAConnection Code	AISC 14th(360-10): ASD
Cold Formed Steel Code	AISI 1999: ASD
Wood Code	AF&PA NDS-91/97: ASD
Wood Temperature	< 100F
Concrete Code	ACI 318-02
Masonry Code	ACI 530-05: ASD
Aluminum Code	AA ADM1-05: ASD - Building
Stainless Steel Code	AISC 14th(360-10): ASD
Adjust Stiffness?	Yes(Iterative)

Number of Shear Regions	4
Region Spacing Increment (in)	4
Biaxial Column Method	PCA Load Contour
Parme Beta Factor (PCA)	.65
Concrete Stress Block	Rectangular
Use Cracked Sections?	Yes
Use Cracked Sections Slab?	Yes
Bad Framing Warnings?	No
Unused Force Warnings?	Yes
Min 1 Bar Diam. Spacing?	No
Concrete Rebar Set	REBAR_SET_ASTMA615
Min % Steel for Column	1
Max % Steel for Column	8

(Global) Model Settings, Continued

Seismic Code	UBC 1997
Seismic Base Elevation (ft)	Not Entered
Add Base Weight?	No
Ct X	.035
Ct Z	.035
T X (sec)	Not Entered
T Z (sec)	Not Entered
R X	8.5
R Z	8.5
Ca	.36
Cv	.54
Nv	1
Occupancy Category	4
Seismic Zone	3
Om Z	1
Om X	1
Rho Z	1
Rho X	1
Footing Overturning Safety Factor	1.5
Optimize for OTM/Sliding	No
Check Concrete Bearing	No
Footing Concrete Weight (k/ft^3)	0
Footing Concrete f'c (ksi)	3
Footing Concrete Ec (ksi)	4000
Lambda	1
Footing Steel fy (ksi)	60
Minimum Steel	0.0018
Maximum Steel	0.0075
Footing Top Bar	#3
Footing Top Bar Cover (in)	3.5
Footing Bottom Bar	#3
Footing Bottom Bar Cover (in)	3.5
Pedestal Bar	#3
Pedestal Bar Cover (in)	1.5
Pedestal Ties	#3

Hot Rolled Steel Properties

	Label	E [ksi]	G [ksi]	Nu	Therm (\...	Density[k/ft^3]	Yield[ksi]	Ry	Fu[ksi]	Rt
1	A36 Gr.36	29000	11154	.3	.65	.49	36	1.5	58	1.2
2	A572 Gr.50	29000	11154	.3	.65	.49	50	1.1	58	1.2
3	A992	29000	11154	.3	.65	.49	50	1.1	58	1.2
4	A500 Gr.42	29000	11154	.3	.65	.49	42	1.3	58	1.1
5	A500 Gr.46	29000	11154	.3	.65	.49	46	1.2	58	1.1
6	A53 Gr. B	29000	11154	.3	.65	.49	35	1.5	58	1.2

Hot Rolled Steel Section Sets

	Label	Shape	Type	Design List	Material	Design Ru...	A [in ²]	Iyy [in ⁴]	Izz [in ⁴]	J [in ⁴]
1	Mast1	PIPE 10.0X	Column	Pipe	A53 Gr. B	Typical	15.1	199	199	398
2	Mast2	PIPE 6.0X	Column	Pipe	A53 Gr. B	Typical	7.83	38.3	38.3	76.6

Hot Rolled Steel Design Parameters

	Label	Shape	Length[ft]	Lbyy[ft]	Lbzz[ft]	Lcomp top[...]	Lcomp bot[...]	L-torq[...]	Kyy	Kzz	Cb	Funci...
1	M1	Mast1	29			Lbyy						Lateral
2	M2	Mast2	14			Lbyy						Lateral

Member Primary Data

	Label	I Joint	J Joint	K Joint	Rotate(...)	Section/Shape	Type	Design List	Material	Design R...
1	M1	BOTC...	FLANGE			Mast1	Column	Pipe	A53 Gr. B	Typical
2	M2	FLANGE	TOPM...			Mast2	Column	Pipe	A53 Gr. B	Typical

Joint Coordinates and Temperatures

	Label	X [ft]	Y [ft]	Z [ft]	Temp [F]	Detach From Diap...
1	BOTCONNECTION	0	0	0	0	
2	TOPCONNECTION	0	15.25	0	0	
3	FLANGE	0	29	0	0	
4	TOPMAST	0	43	0	0	

Joint Boundary Conditions

	Joint Label	X [k/in]	Y [k/in]	Z [k/in]	X Rot.[k-ft/rad]	Y Rot.[k-ft/rad]	Z Rot.[k-ft/rad]
1	BOTCONNECTION	Reaction	Reaction	Reaction		Fixed	
2	TOPCONNECTION	Reaction		Reaction			

Member Point Loads (BLC 2 : Weight of Appurtenances)

	Member Label	Direction	Magnitude[k,k-ft]	Location[ft,%]
1	M2	Y	-.396	11.5
2	M2	Y	-.105	3.5
3	M2	Y	-.012	11.5

Member Point Loads (BLC 3 : Weight of Ice Only)

	Member Label	Direction	Magnitude[k,k-ft]	Location[ft,%]
1	M2	Y	-1.291	11.5
2	M2	Y	-.644	3.5
3	M2	Y	-.093	11.5

Member Point Loads (BLC 4 : TIA Wind with Ice)

	Member Label	Direction	Magnitude[k,k-ft]	Location[ft,%]
1	M2	X	.568	11.5
2	M2	X	.289	3.5
3	M2	X	.042	11.5

Member Point Loads (BLC 5 : TIA Wind)

	Member Label	Direction	Magnitude[k,k-ft]	Location[ft,%]
1	M2	X	1.799	11.5
2	M2	X	.783	3.5
3	M2	X	.043	11.5

Member Point Loads (BLC 6 : Service Wind)

	Member Label	Direction	Magnitude[k,k-ft]	Location[ft,%]
1	M2	X	.651	11.5
2	M2	X	.283	3.5
3	M2	X	.015	11.5

Member Distributed Loads (BLC 2 : Weight of Appurtenances)

	Member Label	Direction	Start Magnitude[k/ft,F,ksf]	End Magnitude[k/f...]	Start Location[ft,%]	End Location[ft,%]
1	M1	Y	-.025	-.025	19.5	29
2	M2	Y	-.025	-.025	0	1
3	M2	Y	-.012	-.012	1	8.5

Member Distributed Loads (BLC 3 : Weight of Ice Only)

	Member Label	Direction	Start Magnitude[k/ft,F,ksf]	End Magnitude[k/f...]	Start Location[ft,%]	End Location[ft,%]
1	M1	Y	-.034	-.034	0	0
2	M2	Y	-.023	-.023	0	0
3	M1	Y	-.263	-.263	19.5	29
4	M2	Y	-.263	-.263	0	1
5	M2	Y	-.132	-.132	1	8.5

Member Distributed Loads (BLC 4 : TIA Wind with Ice)

	Member Label	Direction	Start Magnitude[k/ft,F,ksf]	End Magnitude[k/f...]	Start Location[ft,%]	End Location[ft,%]
1	M1	X	.015	.015	0	0
2	M2	X	.011	.011	0	1
3	M2	X	.011	.011	6	8.5
4	M1	X	.014	.014	19.5	29
5	M2	X	.014	.014	0	1
6	M2	X	.01	.01	6	8.5

Member Distributed Loads (BLC 5 : TIA Wind)

	Member Label	Direction	Start Magnitude[k/ft,F,ksf]	End Magnitude[k/f...]	Start Location[ft,%]	End Location[ft,%]
1	M1	X	.043	.043	0	0
2	M2	X	.026	.026	0	1
3	M2	X	.026	.026	6	8.5
4	M1	X	.039	.039	19.5	29
5	M2	X	.039	.039	0	1
6	M2	X	.024	.024	6	8.5

Member Distributed Loads (BLC 6 : Service Wind)

	Member Label	Direction	Start Magnitude[k/ft,F,ksf]	End Magnitude[k/f...]	Start Location[ft,%]	End Location[ft,%]
1	M1	X	.015	.015	0	0
2	M2	X	.01	.01	0	1
3	M2	X	.01	.01	6	8.5
4	M1	X	.014	.014	19.5	29



Member Distributed Loads (BLC 6 : Service Wind) (Continued)

	Member Label	Direction	Start Magnitude[k/ft,F,ksf]	End Magnitude[k/f...]	Start Location[ft,%]	End Location[ft,%]
5	M2	X	.014	.014	0	1
6	M2	X	.009	.009	6	8.5

Basic Load Cases

	BLC Description	Category	X Gra...	Y Gra...	Z Gra...	Joint	Point	Distrib...	Area(... Surfa...
1	Self Weight	None		-1					
2	Weight of Appurtenances	None					3	3	
3	Weight of Ice Only	None					3	5	
4	TIA Wind with Ice	None					3	6	
5	TIA Wind	None					3	6	
6	Service Wind	None					3	6	

Load Combinations

	Description	Solve	P...	S...	B...	Fa...	BLC	Fact...	BLC	Fa...	BLC	Fa...	B...	Fa...	B...	Fa...	B...	Fa...	B...	Fa...
1	1.2D + 1.6W (X-dir...	Yes	Y		1	1.2	2	1.2	5	1.6										
2	0.9D + 1.6W (X-dir...	Yes	Y		1	.9	2	.9	5	1.6										
3	1.2D + 1.0Di + 1.0...	Yes	Y		1	1.2	2	1.2	3	1	4	1								
4	1.0D + 1.0WService	Yes	Y		1	1	2	1	6	1										

Envelope Joint Reactions

	Joint		X [k]	LC	Y [k]	LC	Z [k]	LC	MX [k-ft]	LC	MY [k-ft]	LC	MZ [k-ft]	LC
1	BOTCONN...	max	7.022	1	10.362	3	0	4	0	4	NC	NC	0	4
2		min	1.578	3	2.456	2	0	1	0	1	NC	NC	0	1
3	TOPCONN...	max	-3.123	3	0	4	0	4	0	4	0	4	0	4
4		min	-14.114	1	0	1	0	1	0	1	0	1	0	1
5	Totals:	max	-1.544	3	10.362	3	0	4						
6		min	-7.092	1	2.456	2	0	1						

Envelope Joint Displacements

	Joint		X [in]	LC	Y [in]	LC	Z [in]	LC	X Rotation [rad]	LC	Y Rotatio...	LC	Z Rotation [rad]	LC
1	BOTCONN...	max	0	4	0	4	0	4	0	4	0	4	8.722e-03	1
2		min	0	1	0	1	0	1	0	1	0	1	1.958e-03	3
3	TOPCONN...	max	0	4	-0.001	2	0	4	0	4	0	4	-4.042e-03	3
4		min	0	1	-0.005	3	0	1	0	1	0	1	-1.801e-02	1
5	FLANGE	max	6.11	1	-0.002	2	0	4	0	4	0	4	-1.133e-02	3
6		min	1.37	3	-0.008	3	0	1	0	1	0	1	-5.057e-02	1
7	TOPMAST	max	18.862	1	-0.002	2	0	4	0	4	0	4	-1.902e-02	3
8		min	4.221	3	-0.011	3	0	1	0	1	0	1	-8.498e-02	1

Envelope AISC 14th(360-10): LRFD Steel Code Checks

	Member	Shape	Code Check	Lo...	LC	She...Lo...	Dir	...phi*...	phi*...	phi*...	phi*...	Cb	Eqn
1	M1	PIPE 10.0X	.888	15...	1	.05615...		1	297...	475.65	129.15	129.15	1.2...H1-...
2	M2	PIPE 6.0X	.990	0	1	.061 0		1	183...	246...	40.95	40.95	2.11H1-...



Joint Reactions

LC	Joint Label	X [k]	Y [k]	Z [k]	MX [k-ft]	MY [k-ft]	MZ [k-ft]
1	1 BOTCONNECTION	7.022	3.274	0	0	NC	0
2	1 TOPCONNECTION	-14.114	0	0	0	0	0
3	1 Totals:	-7.092	3.274	0			
4	1 COG (ft):	X: 0	Y: 23.641	Z: 0			



Company : CENTEK Engineering, INC.
Designer : TJL
Job Number : 19066.02 - T-Mobile CT11241A
Model Name : Structure #1280 Mast

June 28, 2021
4:24 PM
Checked By: CFC

Joint Reactions

	LC	Joint Label	X [k]	Y [k]	Z [k]	MX [k-ft]	MY [k-ft]	MZ [k-ft]
1	2	BOTCONNECTION	6.997	2.456	0	0	NC	0
2	2	TOPCONNECTION	-14.089	0	0	0	0	0
3	2	Totals:	-7.092	2.456	0			
4	2	COG (ft):	X: 0	Y: 23.641	Z: 0			



Company : CENTEK Engineering, INC.
Designer : TJJ
Job Number : 19066.02 - T-Mobile CT11241A
Model Name : Structure #1280 Mast

June 28, 2021
4:24 PM
Checked By: CFC

Joint Reactions

	LC	Joint Label	X [k]	Y [k]	Z [k]	MX [k-ft]	MY [k-ft]	MZ [k-ft]
1	3	BOTCONNECTION	1.578	10.362	0	0	NC	0
2	3	TOPCONNECTION	-3.123	0	0	0	0	0
3	3	Totals:	-1.544	10.362	0			
4	3	COG (ft):	X: 0	Y: 27.219	Z: 0			



Code Check (Env)	
Black	No Calc
Red	> 1.0
Magenta	.90-1.0
Green	.75-.90
Cyan	.50-.75
Blue	0-.50

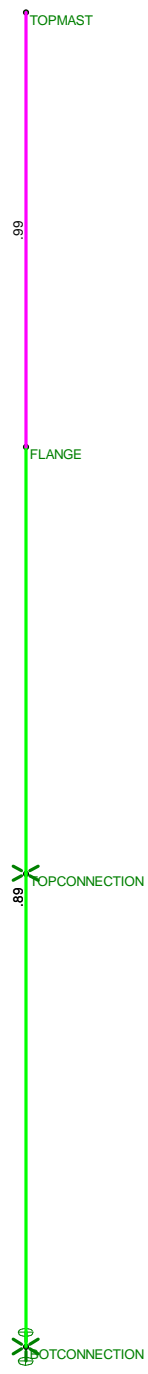

Member Code Checks Displayed (Enveloped)
Envelope Only Solution

CENTEK Engineering, INC.	Structure #1280 Mast Unity Check	June 28, 2021 at 4:22 PM
TJL		TIA.r3d
19066.02 - T-Mobile CT112...		

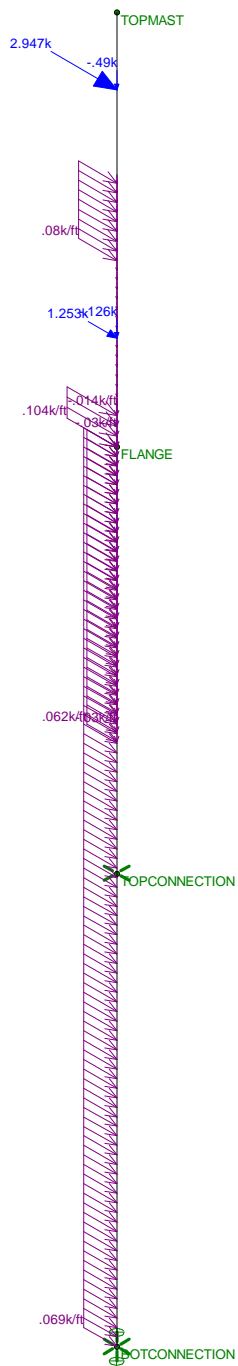

Loads: LC 1, 1.2D + 1.6W (X-direction)
Envelope Only Solution

CEN TEK Engineering, INC.

TJL

19066.02 - T-Mobile CT112...

Structure #1280 Mast

LC #1 Loads

June 28, 2021 at 4:21 PM

TIA.r3d



Code Check (LC 1)	
Black	No Calc
Red	> 1.0
Magenta	.90-1.0
Green	.75-.90
Cyan	.50-.75
Blue	0-.50

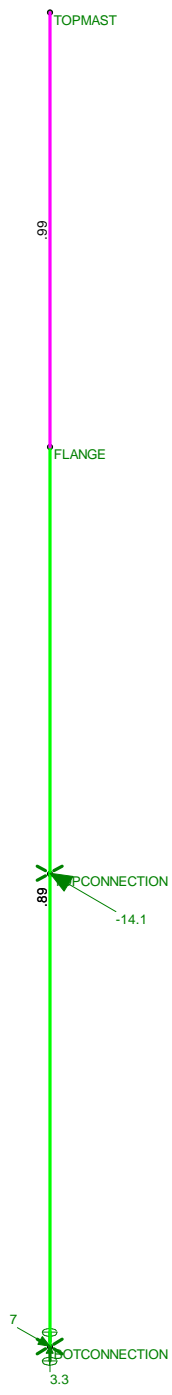

Member Code Checks Displayed
 Results for LC 1, 1.2D + 1.6W (X-direction)
 Reaction and Moment Units are k and k-ft

CENTEK Engineering, INC.	Structure #1280 Mast LC #1 Reactions	June 28, 2021 at 4:23 PM
TJL		TIA.r3d
19066.02 - T-Mobile CT112...		

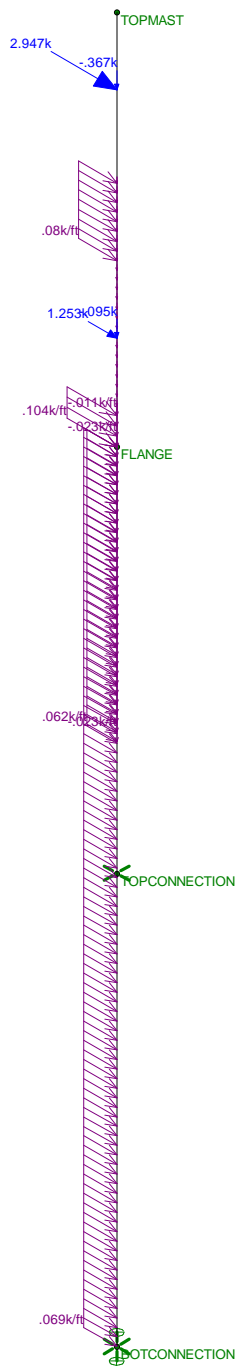

Loads: LC 2, 0.9D + 1.6W (X-direction)
Envelope Only Solution

CENTEK Engineering, INC.	Structure #1280 Mast LC #2 Loads	June 28, 2021 at 4:22 PM
TJL		TIA.r3d
19066.02 - T-Mobile CT112...		



Code Check (LC 2)	
Black	No Calc
Red	> 1.0
Magenta	.90-1.0
Green	.75-.90
Cyan	.50-.75
Blue	0-.50

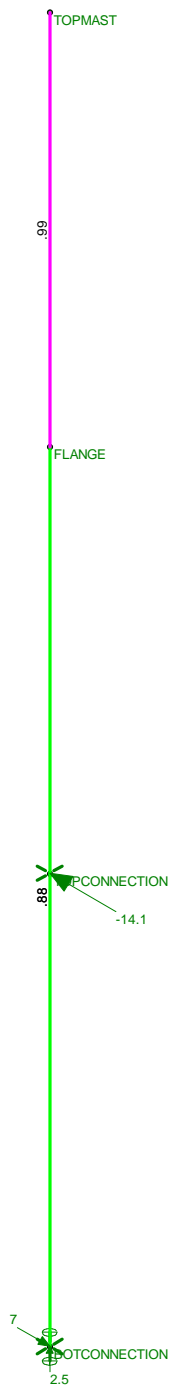

Member Code Checks Displayed
Results for LC 2, 0.9D + 1.6W (X-direction)
Reaction and Moment Units are k and k-ft

CENTEK Engineering, INC.	Structure #1280 Mast LC #2 Reactions	June 28, 2021 at 4:23 PM
TJL		TIA.r3d
19066.02 - T-Mobile CT112...		

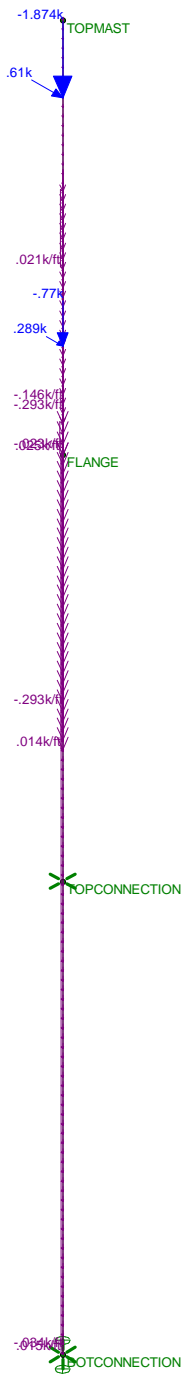

Loads: LC 3, 1.2D + 1.0Di + 1.0Wi (X-direction)
Envelope Only Solution

CENTEK Engineering, INC.

TJL

19066.02 - T-Mobile CT112...

Structure #1280 Mast

LC #3 Loads

June 28, 2021 at 4:22 PM

TIA.r3d



Code Check (LC 3)

No Calc
> 1.0
.90-1.0
.75-.90
.50-.75
0-.50

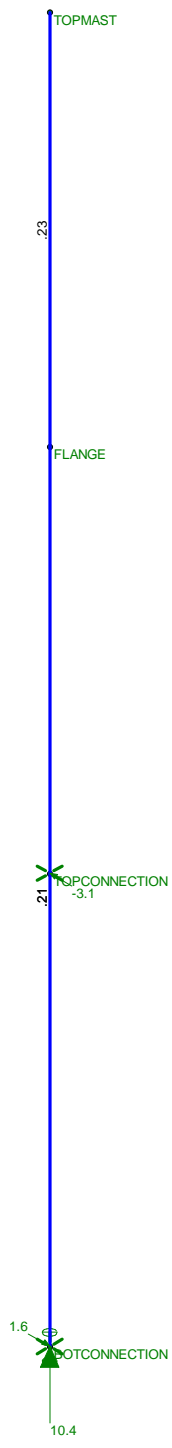

Member Code Checks Displayed
Results for LC 3, 1.2D + 1.0Di + 1.0Wi (X-direction)
Reaction and Moment Units are k and k-ft

CENTEK Engineering, INC.	Structure #1280 Mast LC #3 Reactions	June 28, 2021 at 4:24 PM
TJL		TIA.r3d
19066.02 - T-Mobile CT112...		

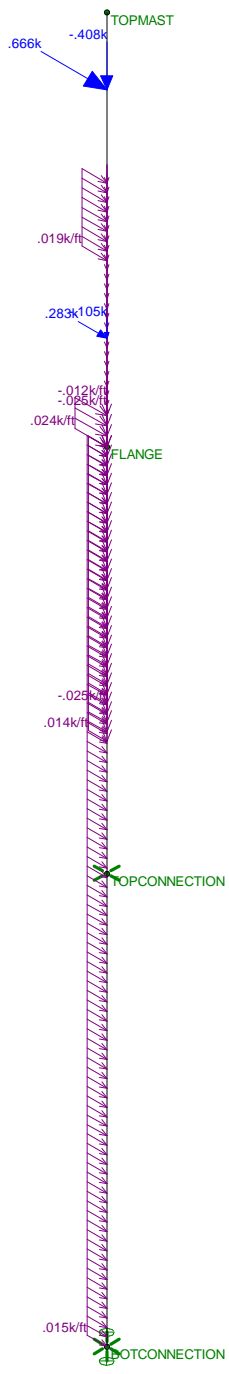

Loads: LC 4, 1.0D + 1.0WService
Envelope Only Solution

CENTEK Engineering, INC.	Structure #1280 Mast LC #4 Loads	June 28, 2021 at 4:22 PM
TJL		TIA.r3d
19066.02 - T-Mobile CT112...		

Column: **M2**

Shape: **PIPE_6.0X**

Material: **A53 Gr. B**

Length: **14 ft**

I Joint: **FLANGE**

J Joint: **TOPMAST**

LC 4: **1.0D + 1.0W** Service

Code Check: **0.226 (bending)**

Report Based On 97 Sections

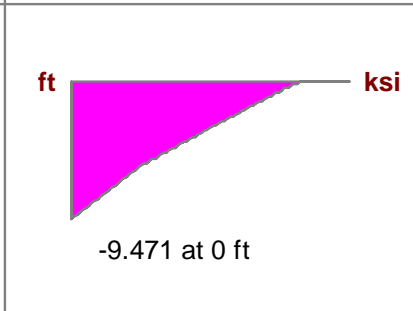
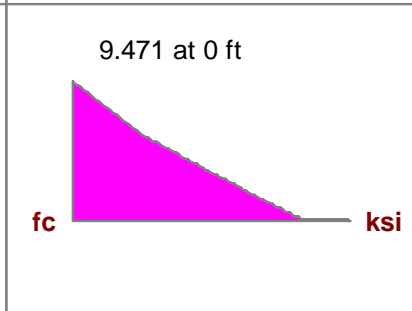
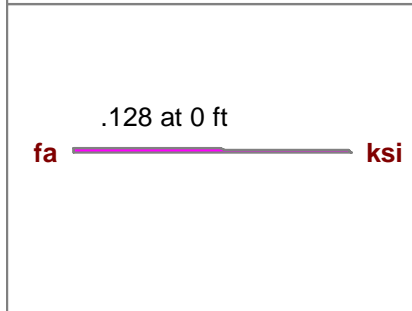
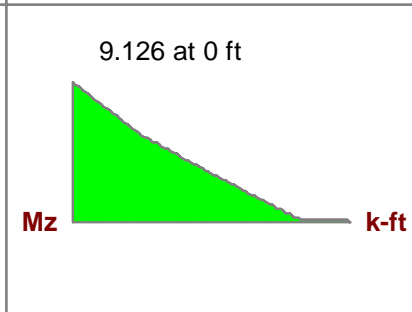
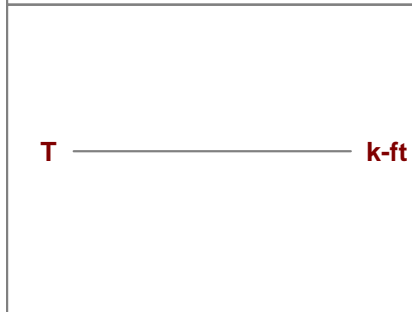
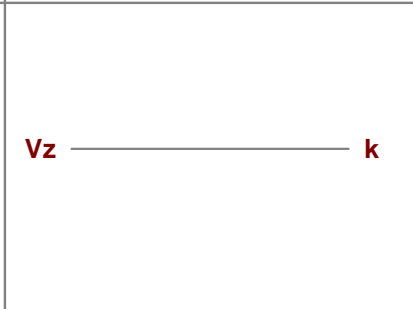
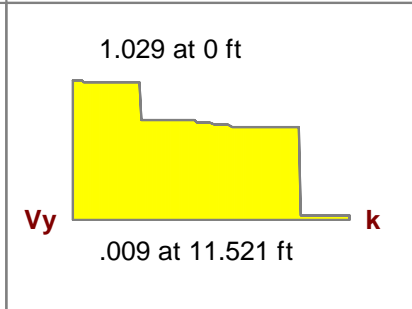
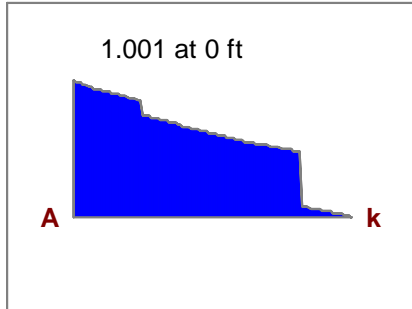
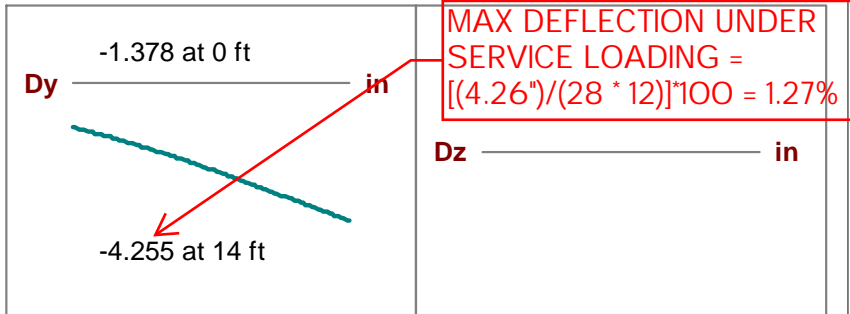

AISC 14th(360-10): LRFD Code Check

Direct Analysis Method

Max Bending Check **0.226**
 Location **0 ft**
 Equation **H1-1b**

Max Shear Check **0.014 (s)**
 Location **0 ft**
 Max Defl Ratio **L/58**

Bending

Compact

Compression

Non-Slender

Fy **35 ksi**
 phi*Pnc **183.575 k**
 phi*Pnt **246.645 k**
 phi*Mny **40.95 k-ft**
 phi*Mnz **40.95 k-ft**
 phi*Vny **73.994 k**
 phi*Vnz **73.994 k**
 phi*Tn **38.598 k-ft**
 Cb **2.112**

y-y z-z
 Lb **14 ft** **14 ft**
 KL/r **75.961** **75.961**
 L Comp Flange **14 ft**
 L-torque **14 ft**
 Tau_b **1**

Column: **M2**

Shape: **PIPE_6.0X**

Material: **A53 Gr. B**

Length: **14 ft**

I Joint: **FLANGE**

J Joint: **TOPMAST**

LC 1: **1.2D + 1.6W (X-direction)**

Code Check: **0.990 (bending)**

Report Based On 97 Sections

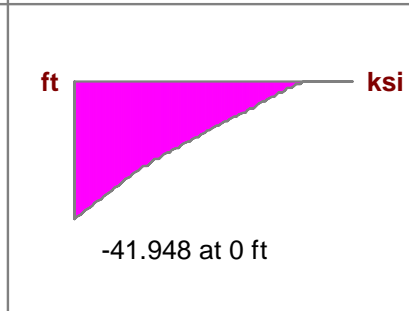
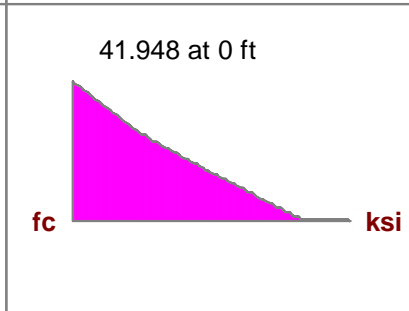
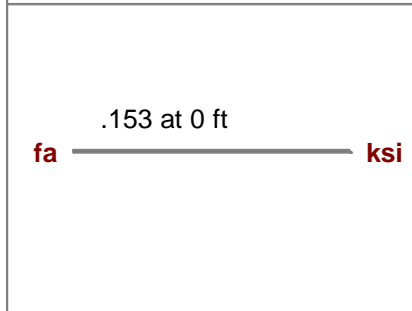
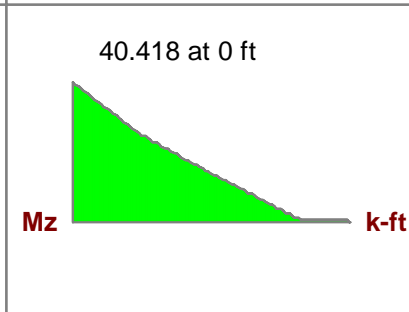
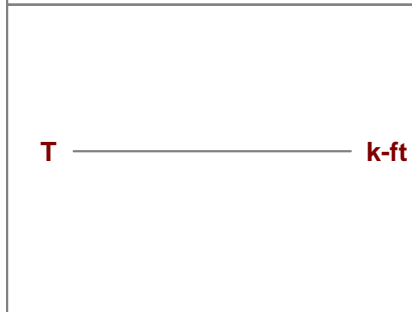
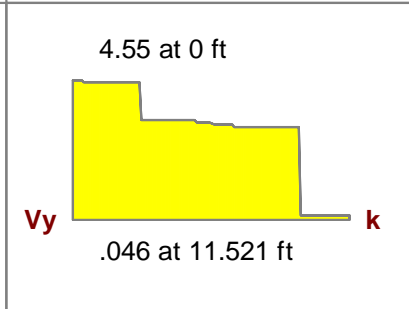
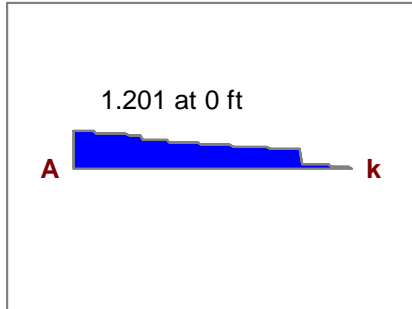
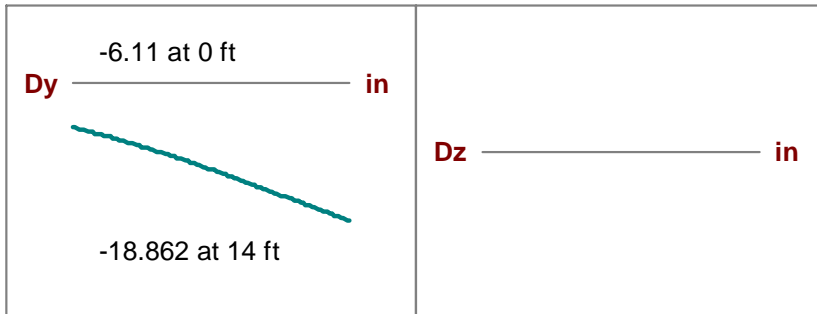

AISC 14th(360-10): LRFD Code Check

Direct Analysis Method

Max Bending Check **0.990**
Location **0 ft**
Equation **H1-1b**

Max Shear Check **0.061 (s)**
Location **0 ft**
Max Defl Ratio **L/13**

Bending

Compact

Compression

Non-Slender

Fy **35 ksi**
phi*Pnc **183.575 k**
phi*Pnt **246.645 k**
phi*Mny **40.95 k-ft**
phi*Mnz **40.95 k-ft**
phi*Vny **73.994 k**
phi*Vnz **73.994 k**
phi*Tn **38.598 k-ft**
Cb **2.11**

y-y z-z
Lb **14 ft** **14 ft**
KL/r **75.961** **75.961**
L Comp Flange **14 ft**
L-torque **14 ft**
Tau_b **1**

Mast Top Connection to CL&P Tower:

Design Basis:

Analysis of the existing mast connection to the CL&P tower is based on the original connection design by Paul J. Ford and company project no. A01-T067 drawings S-1 to S-3. The connection was assumed to be pinned horizontally but free vertically. The bolts are checked for tension as a result of the horizontal force.

Reactions:

Moment =	M := 0-kips	(Input From Risa-3D LC #1)
Vertical =	V := 0-kips	(Input From Risa-3D LC #1)
Horizontal =	H := 14.1-kips	(Input From Risa-3D LC #1)

Bolt Data:

Bolt Type =	ASTMA325	
Number of Bolts =	N := 8	(User Input)
Bolt Diameter =	D := 0.75-in	(User Input)
Bolt Design Strength Tension =	T _{design} := 29.8-kips	(User Input)
Threads per Inch =	n := 10	(User Input)

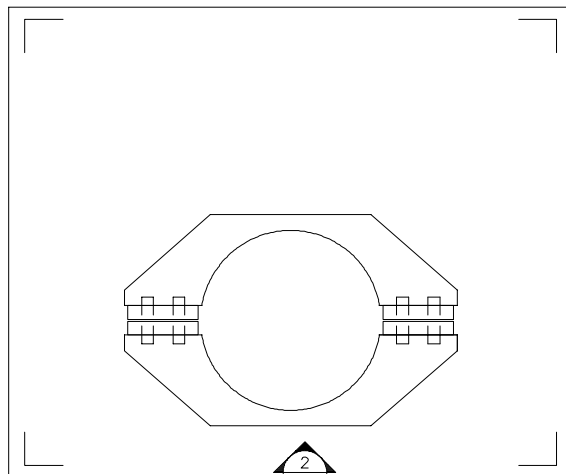

1 TOP CONNECTION PLAN
 TC-1 NOT TO SCALE

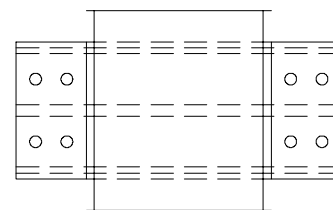

2 TOP CONNECTION ELEVATION
 TC-1 NOT TO SCALE

Bolt Analysis:

Calculated Bolt Properties:

GrossArea of Bolt = $A_g := \frac{\pi}{4} \cdot D^2 = 0.442 \cdot \text{in}^2$

NetArea of Bolt = $A_n := \frac{\pi}{4} \cdot \left(D - \frac{0.9743 \cdot \text{in}}{n} \right)^2 = 0.334 \cdot \text{in}^2$

Net Diameter = $D_n := \frac{2 \cdot \sqrt{A_n}}{\sqrt{\pi}} = 0.653 \cdot \text{in}$

Radius of Gyration of Bolt = $r := \frac{D_n}{4} = 0.163 \cdot \text{in}$

Section Modulus of Bolt = $S_x := \frac{\pi \cdot D_n^3}{32} = 0.027 \cdot \text{in}^3$

Check Bolt Tension Force:

Maximum Tensile Force = $T_{\text{Max}} := \frac{H}{N} = 1.8 \cdot \text{kips}$

Bolt Tension % of Capacity = $\frac{T_{\text{Max}}}{T_{\text{design}}} = 0.06$

Condition1 = $\text{Condition1} := \text{if} \left(\frac{T_{\text{Max}}}{T_{\text{design}}} \leq 1.00, \text{"OK"}, \text{"Overstressed"} \right)$

Condition1 = "OK"

Mast Bottom Connection to CL&P Tower:

Design Basis:

Analysis of the existing mast connection to the CL&P tower is based on the original connection design by Paul J. Ford and company project no. A01-T067 drawings S-1 to S-3. The connection was assumed to be pinned horizontally and vertically.

Input Data:

Tower Reactions:

Overturing Moment =	OM := 0-ft-kips	(Input From Risa-3D LC #1)
Horizontal Force =	H := 7.0-kips	(Input From Risa-3D LC #1)
Vertical Force =	V := 3.3-kips	(Input From Risa-3D LC #1)

Anchor Bolt Data:

Use ASTM A394

Number of Bolts =	N := 6	(User Input)
Diameter of Bolt Circle =	D _{bc} := 13.25-in	(User Input)
Bolt "Column" Distance =	l := 0-in	(User Input)
Bolt Design Strength Tension =	T _{design} := 24.7-kips	(User Input)
Bolt Design Strength Shear =	V _{design} := 13.6-kips	(User Input)
Bolt Modulus =	E := 29000-ksi	(User Input)
Diameter of Bolts =	D := .75-in	(User Input)
Threads per Inch =	n := 8	(User Input)

Base Plate Data:

Use ASTM A36

Plate Yield Strength =	F _{ybp} := 36-ksi	(User Input)
Plate Thickness =	t _{bp} := .375-in	(User Input)
Plate Diameter =	D _{bp} := 15.75-in	(User Input)
Outer Pole Diameter =	D _{pole} := 10.75-in	(User Input)

Geometric Layout Data:

Distance from Bolts to Centroid of Pole:

Radius of Bolt Circle =: $R_{bc} := \frac{D_{bc}}{2} = 6.625\text{-in}$

Distance to Bolts = $i := 1..N$

$$d_i := \begin{cases} \theta \leftarrow 2\pi \cdot \left(\frac{i}{N}\right) & d_1 = 5.74\text{-in} & d_4 = -5.74\text{-in} \\ d \leftarrow R_{bc} \cdot \sin(\theta) & d_2 = 5.74\text{-in} & d_5 = -5.74\text{-in} \\ & d_3 = 0.00\text{-in} & d_6 = -0.00\text{-in} \end{cases}$$

Critical Distances For Bending in Plate:

Outer Pole Radius = $R_{pole} := \frac{D_{pole}}{2} = 5.4\text{-in}$

Moment Arms of Bolts about Neutral Axis = $MA_i := \text{if}(d_i \geq R_{pole}, d_i - R_{pole}, 0\text{in})$

$MA_1 = 0.36\text{-in}$	$MA_4 = 0.00\text{-in}$
$MA_2 = 0.36\text{-in}$	$MA_5 = 0.00\text{-in}$
$MA_3 = 0.00\text{-in}$	$MA_6 = 0.00\text{-in}$

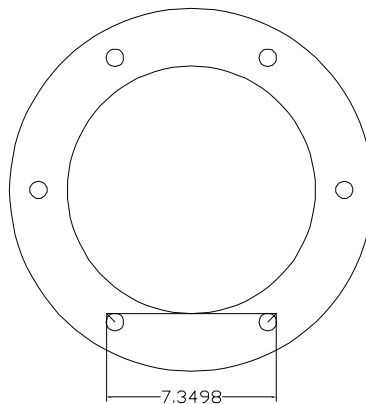

Bottom Connection

Effective Width = $W_{eff} := 7.35\text{-in}$

Bolt Analysis:

Calculated Bolt Properties:

Polar Moment of Inertia = $I_p := \sum_i (d_i)^2 = 131.67 \cdot \text{in}^2$

Gross Area of Bolt = $A_g := \frac{\pi}{4} \cdot D^2 = 0.442 \cdot \text{in}^2$

Net Area of Bolt = $A_n := \frac{\pi}{4} \cdot \left(D - \frac{0.9743 \cdot \text{in}}{n} \right)^2 = 0.31 \cdot \text{in}^2$

Net Diameter = $D_n := \frac{2 \cdot \sqrt{A_n}}{\sqrt{\pi}} = 0.628 \cdot \text{in}$

Radius of Gyration of Bolt = $r := \frac{D_n}{4} = 0.157 \cdot \text{in}$

Section Modulus of Bolt = $S_x := \frac{\pi \cdot D_n^3}{32} = 0.024 \cdot \text{in}^3$

Check Bolt Tension Force:

Maximum Tensile Force = $T_{\text{Max}} := \frac{V}{N} = 0.6 \cdot \text{kips}$

Maximum Shear Force = $V_{\text{Max}} := \frac{H}{N} = 1.2 \cdot \text{kips}$

Bolt % of Capacity = $\frac{T_{\text{Max}}}{T_{\text{design}}} + \frac{V_{\text{Max}}}{V_{\text{design}}} = 0.108$

Condition1 = $\text{Condition1} := \text{if} \left(\frac{T_{\text{Max}}}{T_{\text{design}}} + \frac{V_{\text{Max}}}{V_{\text{design}}} \leq 1.00, \text{"OK"}, \text{"Overstressed"} \right)$

Condition1 = "OK"

Plate Analysis:

Force from Bolts =

$$C_i := \frac{V}{N}$$

$C_1 = 0.6 \text{ kips}$

$C_4 = 0.6 \text{ kips}$

$C_2 = 0.6 \text{ kips}$

$C_5 = 0.6 \text{ kips}$

$C_3 = 0.6 \text{ kips}$

$C_6 = 0.6 \text{ kips}$

Maximum Bending Stress in Plate =

$$f_{bp} := \sum_i \frac{C_i \cdot M A_i \cdot 6}{(W_{eff} t_{bp}^2)} = 2.3 \text{ ksi}$$

Allowable Bending Stress in Plate =

$F_{bp} := 0.9 \cdot F_y_{bp} = 32.4 \text{ ksi}$

Plate Bending Stresse % of Capacity =

$\frac{f_{bp}}{F_{bp}} = 0.071$

Condition3 =

Condition2 := if $\left(\frac{f_{bp}}{F_{bp}} < 1.00, "Ok", "Overstressed" \right)$

Condition2 = "Ok"

Flange Bolt and Flange Plate Analysis:**Input Data:**Tower Reactions:

Overturing Moment =	OM := 40-ft-kips	(Input From Risa-3D LC #1)
Shear Force =	Shear := 4.5-kips	(Input From Risa-3D LC #1)
Axial Force =	Axial := 1.2-kips	(Input From Risa-3D LC #1)

Flange Bolt Data:

UseASTMA325

Number of Flange Bolts =	N := 10	(User Input)
Diameter of Bolt Circle =	D _{bc} := 13.5-in	(User Input)
Bolt "Column" Distance =	l := 0-in	(User Input)
Bolt Design Strength Tension =	T _{design} := 29.8-kips	(User Input)
Bolt Modulus =	E := 29000-ksi	(User Input)
Diameter of Flange Bolts =	D := .75-in	(User Input)
Threads per Inch =	n := 10	(User Input)

Flange Plate Data:

UseASTMA36

Plate Yield Strength =	F _{ybp} := 36-ksi	(User Input)
Base Plate Thickness =	t _{bp} := 0.75-in	(User Input)
Base Plate Diameter =	D _{bp} := 16-in	(User Input)
Outer Pole Diameter =	D _{pole} := 6.63-in	(User Input)

Geometric Layout Data:

Distance from Bolts to Centroid of Pole:

Radius of Bolt Circle =: $R_{bc} := \frac{D_{bc}}{2} = 6.75\text{-in}$

Distance to Bolts = $i := 1..N$

$$d_i := \begin{cases} \theta \leftarrow 2\pi \cdot \left(\frac{i}{N}\right) \\ d \leftarrow R_{bc} \cdot \sin(\theta) \end{cases}$$

$d_1 = 3.97\text{-in}$	$d_6 = -3.97\text{-in}$
$d_2 = 6.42\text{-in}$	$d_7 = -6.42\text{-in}$
$d_3 = 6.42\text{-in}$	$d_8 = -6.42\text{-in}$
$d_4 = 3.97\text{-in}$	$d_9 = -3.97\text{-in}$
$d_5 = 0.00\text{-in}$	$d_{10} = -0.00\text{-in}$

Critical Distances For Bending in Plate:

Outer Pole Radius = $R_{pole} := \frac{D_{pole}}{2} = 3.3\text{-in}$

Moment Arms of Bolts about Neutral Axis = $MA_i := \text{if}(d_i \geq R_{pole}, d_i - R_{pole}, 0\text{in})$

$MA_1 = 0.65\text{-in}$	$MA_6 = 0.00\text{-in}$
$MA_2 = 3.10\text{-in}$	$MA_7 = 0.00\text{-in}$
$MA_3 = 3.10\text{-in}$	$MA_8 = 0.00\text{-in}$
$MA_4 = 0.65\text{-in}$	$MA_9 = 0.00\text{-in}$
$MA_5 = 0.00\text{-in}$	$MA_{10} = 0.00\text{-in}$

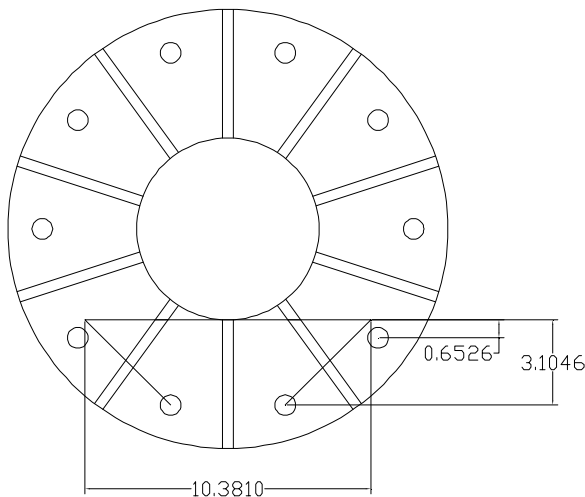

Effective Width = $W_{eff} := 10.38\text{-in}$

Flange Bolt Analysis :

Calculated Flange Bolt Properties:

Polar Moment of Inertia = $I_p := \sum_i (d_i)^2 = 227.81 \cdot \text{in}^2$

Gross Area of Bolt = $A_g := \frac{\pi}{4} \cdot D^2 = 0.442 \cdot \text{in}^2$

Net Area of Bolt = $A_n := \frac{\pi}{4} \cdot \left(D - \frac{0.9743 \cdot \text{in}}{n} \right)^2 = 0.334 \cdot \text{in}^2$

Net Diameter = $D_n := \frac{2 \cdot \sqrt{A_n}}{\sqrt{\pi}} = 0.653 \cdot \text{in}$

Radius of Gyration of Bolt = $r := \frac{D_n}{4} = 0.163 \cdot \text{in}$

Section Modulus of Bolt = $S_x := \frac{\pi \cdot D_n^3}{32} = 0.027 \cdot \text{in}^3$

Check Flange Bolt Tension Force:

Maximum Tensile Force = $T_{\text{Max}} := \text{OM} \cdot \frac{R_{bc}}{I_p} - \frac{\text{Axial}}{N} = 14.1 \cdot \text{kips}$

Bolt Tension % of Capacity = $\frac{T_{\text{Max}}}{T_{\text{design}}} = 0.473$

Condition1 = $\text{Condition1} := \text{if} \left(\frac{T_{\text{Max}}}{T_{\text{design}}} \leq 1.00, \text{"OK"}, \text{"Overstressed"} \right)$

Condition1 = "OK"

Flange Plate Analysis:

Force from Bolts = $C_i := \frac{OM \cdot d_i}{I_p} + \frac{|Axial|}{N}$

$C_1 = 8.5 \text{ kips}$	$C_6 = -8.2 \text{ kips}$
$C_2 = 13.6 \text{ kips}$	$C_7 = -13.4 \text{ kips}$
$C_3 = 13.6 \text{ kips}$	$C_8 = -13.4 \text{ kips}$
$C_4 = 8.5 \text{ kips}$	$C_9 = -8.2 \text{ kips}$
$C_5 = 0.1 \text{ kips}$	$C_{10} = 0.1 \text{ kips}$

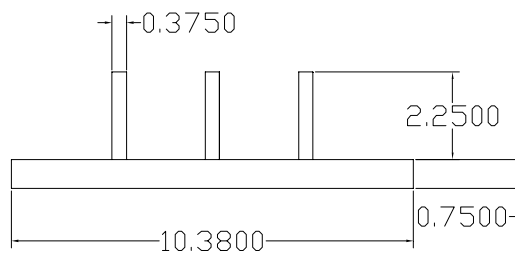

Section Modulus of Base Plate w/ Gusset Plates =

$S_{xplt} := 3.84 \text{ in}^3$

Maximum Bending Stress in Plate =

$f_{bp} := \sum_i \frac{C_i \cdot M A_i}{S_{xplt}} = 24.9 \text{ ksi}$

Design Bending Stress in Plate =

$F_{bp} := 0.9 \cdot F_{ybp} = 32.4 \text{ ksi}$

Plate Bending Stress % of Capacity =

$\frac{f_{bp}}{F_{bp}} = 0.77$

Condition3 =

Condition2 := if $\left(\frac{f_{bp}}{F_{bp}} < 1.00, \text{"Ok"}, \text{"Overstressed"} \right)$

Condition2 = "Ok"

Basic Components

Heavy Wind Pressure =	p := 4.00	psf	(User Input NESC 2012 Figure 250-1 & Table 250-1)
Basic Windspeed =	V := 110	mph	(User Input NESC 2012 Figure 250-2(e))
Radial Ice Thickness =	Ir := 0.50	in	(User Input)
Radial Ice Density =	Id := 56.0	pcf	(User Input)

Factors for Extreme Wind Calculation

Elevation of Top of Mast Above Grade =	TME := 163.5	ft	(User Input)
Multiplier Gust Response Factor =	m := 1.25		(User Input - Only for NESC Extreme wind case)
NESC Factor =	kv := 1.43		(User Input from NESC 2012 Table 250-3 equation)
Importance Factor =	I := 1.0		(User Input from NESC 2012 Section 250.C.2)

Velocity Pressure Coefficient = $K_z := 2.01 \cdot \left(\frac{TME}{900} \right)^{\frac{2}{9.5}} = 1.404$ (NESC 2012 Table 250-2)

Exposure Factor = $E_s := 0.346 \left[\frac{33}{(0.67 \cdot TME)} \right]^{\frac{1}{7}} = 0.291$ (NESC 2012 Table 250-3)

Response Term = $B_s := \frac{1}{\left(1 + 0.375 \cdot \frac{TME}{220} \right)} = 0.782$ (NESC 2012 Table 250-3)

Gust Response Factor = $G_{rf} := \frac{\left[1 + \left(2.7 \cdot E_s \cdot B_s \cdot \frac{1}{2} \right) \right]}{k_v^2} = 0.829$ (NESC 2012 Table 250-3)

Wind Pressure = $q_z := 0.00256 \cdot K_z \cdot V^2 \cdot G_{rf} \cdot I = 36.1$ psf (NESC 2012 Section 250.C.2)

Shape Factors

Shape Factor for Round Members =	$C_{dR} := 1.3$	(User Input)
Shape Factor for Flat Members =	$C_{dF} := 1.6$	(User Input)
Shape Factor for Coax Cables Attached to Outside of Pole =	$C_{d_{coax}} := 1.6$	(User Input)

Overload Factors

Overload Factors for Wind Loads:

NESC Heavy Loading =	2.5	(User Input)	Apply in Risa-3D Analysis
NESC Extreme Loading =	1.0	(User Input)	Apply in Risa-3D Analysis

Overload Factors for Vertical Loads:

NESC Heavy Loading =	1.5	(User Input)	Apply in Risa-3D Analysis
NESC Extreme Loading =	1.0	(User Input)	Apply in Risa-3D Analysis

Development of Wind & Ice Load on Mast

Mast Data:

(Pipe 10.0" SCH. 80)

Mast Shape =	Round	(User Input)
Mast Diameter =	$D_{mast} := 10.75$ in	(User Input)
Mast Length =	$L_{mast} := 29$ ft	(User Input)
Mast Thickness =	$t_{mast} := 0.5$ in	(User Input)

Wind Load (NESC Extreme)

Mast Projected Surface Area = $A_{mast} := \frac{D_{mast}}{12} = 0.896$

Total Mast Wind Force (Above NU Structure) = $qz \cdot C_d R \cdot A_{mast} \cdot m = 52$ plf **BLC 5**

Total Mast Wind Force (Below NU Structure) = $qz \cdot C_d R \cdot A_{mast} = 42$ plf **BLC 5**

Wind Load (NESE Heavy)

Mast Projected Surface Area w/ Ice = $A_{ICE_{mast}} := \frac{(D_{mast} + 2 \cdot I_r)}{12} = 0.979$

Total Mast Wind Force w/ Ice = $p \cdot C_d R \cdot A_{ICE_{mast}} = 5$ plf **BLC 4**

Gravity Loads (without ice)

Weight of the mast = Self Weight (Computed internally by Risa-3D) plf **BLC 1**

Gravity Loads (ice only)

Ice Area per Linear Foot = $A_{i_{mast}} := \frac{\pi}{4} [(D_{mast} + I_r \cdot 2)^2 - D_{mast}^2] = 17.7$ sq in

Weight of Ice on Mast = $W_{ICE_{mast}} := I_d \cdot \frac{A_{i_{mast}}}{144} = 7$ plf **BLC 3**

Development of Wind & Ice Load on Mast

Mast Data:

(Pipe 6.0" SCH. 80)

Mast Shape =	Round	(User Input)
Mast Diameter =	$D_{mast} := 6.625$ in	(User Input)
Mast Length =	$L_{mast} := 14$ ft	(User Input)
Mast Thickness =	$t_{mast} := 0.432$ in	(User Input)

Wind Load (NESC Extreme)

Mast Projected Surface Area = $A_{mast} := \frac{D_{mast}}{12} = 0.552$

Total Mast Wind Force (Above NU Structure) = $qz \cdot C_d R \cdot A_{mast}^m = 32$ plf **BLC 5**

Wind Load (NESE Heavy)

Mast Projected Surface Area w/ Ice = $A_{ICE_{mast}} := \frac{(D_{mast} + 2 \cdot I_r)}{12} = 0.635$

Total Mast Wind Force w/ Ice = $p \cdot C_d R \cdot A_{ICE_{mast}} = 3$ plf **BLC 4**

Gravity Loads (without ice)

Weight of the mast = Self Weight (Computed internally by Risa-3D) plf **BLC 1**

Gravity Loads (ice only)

Ice Area per Linear Foot = $A_{i_{mast}} := \frac{\pi}{4} [(D_{mast} + I_r \cdot 2)^2 - D_{mast}^2] = 11.2$ sq in

Weight of Ice on Mast = $W_{ICE_{mast}} := I_d \cdot \frac{A_{i_{mast}}}{144} = 4$ plf **BLC 3**

Development of Wind & Ice Load on Antennas

Antenna Data:

Antenna Model =	RFSAPXVAARR18_43	
Antenna Shape =	Flat	(User Input)
Antenna Height =	$L_{ant} := 72$	in (User Input)
Antenna Width =	$W_{ant} := 24$	in (User Input)
Antenna Thickness =	$T_{ant} := 8.5$	in (User Input)
Antenna Weight =	$WT_{ant} := 132$	lbs (User Input)
Number of Antennas =	$N_{ant} := 3$	(User Input)

Wind Load (NESC Extreme)

Assumes Maximum Possible Wind Pressure Applied to all Antennas Simultaneously

Surface Area for One Antenna =	$SA_{ant} := \frac{L_{ant} \cdot W_{ant}}{144} = 12$	sf
Antenna Projected Surface Area =	$A_{ant} := SA_{ant} \cdot N_{ant} = 36$	sf

Total Antenna Wind Force =

$F_{ant} := qz \cdot Cd_F \cdot A_{ant} \cdot m = 2596$ lbs **BLC 5**

Wind Load (NESC Heavy)

Assumes Maximum Possible Wind Pressure Applied to all Antennas Simultaneously

Surface Area for One Antenna w/ Ice =	$SA_{ICEant} := \frac{(L_{ant} + 1) \cdot (W_{ant} + 1)}{144} = 12.7$	sf
Antenna Projected Surface Area w/ Ice =	$A_{ICEant} := SA_{ICEant} \cdot N_{ant} = 38$	sf

Total Antenna Wind Force w/ Ice =

$F_{i_{ant}} := p \cdot Cd_F \cdot A_{ICEant} = 243$ lbs **BLC 4**

Gravity Load (without ice)

Weight of All Antennas =

$WT_{ant} \cdot N_{ant} = 396$ lbs **BLC 2**

Gravity Load (ice only)

Volume of Each Antenna =	$V_{ant} := L_{ant} \cdot W_{ant} \cdot T_{ant} = 1 \times 10^4$	cu in
Volume of Ice on Each Antenna =	$V_{ice} := (L_{ant} + 1) \cdot (W_{ant} + 1) \cdot (T_{ant} + 1) - V_{ant} = 2650$	cu in
Weight of Ice on Each Antenna =	$W_{ICEant} := \frac{V_{ice}}{1728} \cdot Id = 86$	lbs

Weight of Ice on All Antennas =

$W_{ICEant} \cdot N_{ant} = 258$ lbs **BLC 3**

Development of Wind & Ice Load on Antennas

Antenna Data:

Antenna Model =	Andrew TMBXX-6516
Antenna Shape =	Flat (User Input)
Antenna Height =	$L_{ant} := 59$ in (User Input)
Antenna Width =	$W_{ant} := 11.9$ in (User Input)
Antenna Thickness =	$T_{ant} := 6.3$ in (User Input)
Antenna Weight =	$WT_{ant} := 35$ lbs (User Input)
Number of Antennas =	$N_{ant} := 3$ (User Input)

Wind Load (NESC Extreme)

Assumes Maximum Possible Wind Pressure Applied to all Antennas Simultaneously

Surface Area for One Antenna =

$$SA_{ant} := \frac{L_{ant} \cdot W_{ant}}{144} = 4.9 \quad \text{sf}$$

Antenna Projected Surface Area =

$$A_{ant} := SA_{ant} \cdot N_{ant} = 14.6 \quad \text{sf}$$

Total Antenna Wind Force =

$$F_{ant} := qz \cdot Cd_F \cdot A_{ant} \cdot m = 1055 \quad \text{lbs} \quad \text{BLC 5}$$

Wind Load (NESC Heavy)

Assumes Maximum Possible Wind Pressure Applied to all Antennas Simultaneously

Surface Area for One Antenna w/ Ice =

$$SA_{ICEant} := \frac{(L_{ant} + 1) \cdot (W_{ant} + 1)}{144} = 5.4 \quad \text{sf}$$

Antenna Projected Surface Area w/ Ice =

$$A_{ICEant} := SA_{ICEant} \cdot N_{ant} = 16.1 \quad \text{sf}$$

Total Antenna Wind Force w/ Ice =

$$F_{ant} := p \cdot Cd_F \cdot A_{ICEant} = 103 \quad \text{lbs} \quad \text{BLC 4}$$

Gravity Load (without ice)

Weight of All Antennas =

$$WT_{ant} \cdot N_{ant} = 105 \quad \text{lbs} \quad \text{BLC 2}$$

Gravity Load (ice only)

Volume of Each Antenna =

$$V_{ant} := L_{ant} \cdot W_{ant} \cdot T_{ant} = 4423 \quad \text{cu in}$$

Volume of Ice on Each Antenna =

$$V_{ice} := (L_{ant} + 1) \cdot (W_{ant} + 1) \cdot (T_{ant} + 1) - V_{ant} = 1227 \quad \text{cu in}$$

Weight of Ice on Each Antenna =

$$W_{ICEant} := \frac{V_{ice}}{1728} \cdot Id = 40 \quad \text{lbs}$$

Weight of Ice on All Antennas =

$$W_{ICEant} \cdot N_{ant} = 119 \quad \text{lbs} \quad \text{BLC 3}$$

Development of Wind & Ice Load on Antennas

Antenna Data:

Antenna Model =	Andrew ATSBT-TOP-FM-4G
Antenna Shape =	Flat (User Input)
Antenna Height =	$L_{ant} := 5.63$ in (User Input)
Antenna Width =	$W_{ant} := 3.7$ in (User Input)
Antenna Thickness =	$T_{ant} := 2.0$ in (User Input)
Antenna Weight =	$WT_{ant} := 2$ lbs (User Input)
Number of Antennas =	$N_{ant} := 6$ (User Input)

Wind Load (NESC Extreme)

Assumes Maximum Possible Wind Pressure Applied to all Antennas Simultaneously

Surface Area for One Antenna =

$$SA_{ant} := \frac{L_{ant} \cdot W_{ant}}{144} = 0.1 \quad sf$$

Antenna Projected Surface Area =

$$A_{ant} := SA_{ant} \cdot N_{ant} = 0.9 \quad sf$$

Total Antenna Wind Force =

$$F_{ant} := qz \cdot C_d \cdot A_{ant} = 63 \quad lbs \quad \text{BLC 5}$$

Wind Load (NESC Heavy)

Assumes Maximum Possible Wind Pressure Applied to all Antennas Simultaneously

Surface Area for One Antenna w/ Ice =

$$SA_{ICEant} := \frac{(L_{ant} + 1) \cdot (W_{ant} + 1)}{144} = 0.2 \quad sf$$

Antenna Projected Surface Area w/ Ice =

$$A_{ICEant} := SA_{ICEant} \cdot N_{ant} = 1.3 \quad sf$$

Total Antenna Wind Force w/ Ice =

$$F_{i_{ant}} := p \cdot C_d \cdot A_{ICEant} = 8 \quad lbs \quad \text{BLC 4}$$

Gravity Load (without ice)

Weight of All Antennas =

$$WT_{ant} \cdot N_{ant} = 12 \quad lbs \quad \text{BLC 2}$$

Gravity Load (ice only)

Volume of Each Antenna =

$$V_{ant} := L_{ant} \cdot W_{ant} \cdot T_{ant} = 42 \quad cu \text{ in}$$

Volume of Ice on Each Antenna =

$$V_{ice} := (L_{ant} + 1) \cdot (W_{ant} + 1) \cdot (T_{ant} + 1) - V_{ant} = 52 \quad cu \text{ in}$$

Weight of Ice on Each Antenna =

$$W_{ICEant} := \frac{V_{ice}}{1728} \cdot \rho_d = 2 \quad lbs$$

Weight of Ice on All Antennas =

$$W_{ICEant} \cdot N_{ant} = 10 \quad lbs \quad \text{BLC 3}$$

Development of Wind & Ice Load on Coax Cables

Coax Cable Data:

	(140ft - 151ft)	
Coax Type =	HELIAX 1-5/8"	
Shape =	Round	(User Input)
Coax Outside Diameter =	$D_{coax} := 1.98$	in (User Input)
Coax Cable Length =	$L_{coax} := 11$	ft (User Input)
Weight of Coax per foot =	$Wt_{coax} := 1.04$	plf (User Input)
Total Number of Coax =	$N_{coax} := 24$	(User Input)
No. of Coax Projecting Outside Face of Mast =	$NP_{coax} := 5$	(User Input)

Wind Load (NESC Extreme)

Coax projected surface area = $A_{coax} := \frac{(NP_{coax} D_{coax})}{12} = 0.8$ ft

Total Coax Wind Force (Above NU Structure) =

$F_{coax} := qz \cdot Cd_{coax} \cdot A_{coax} \cdot m = 60$ plf **BLC 5**

Wind Load (NESC Heavy)

Coax projected surface area w/ Ice = $A_{ICE_{coax}} := \frac{(NP_{coax} D_{coax} + 2 \cdot 1r)}{12} = 0.9$ ft

Total Coax Wind Force w/ Ice =

$F_{i_{coax}} := p \cdot Cd_{coax} \cdot A_{ICE_{coax}} = 6$ plf **BLC 4**

Gravity Loads (without ice)

Weight of all cables w/o ice

$WT_{coax} := Wt_{coax} \cdot N_{coax} = 25$ plf **BLC 2**

Gravity Load (ice only)

Ice Area per Linear Foot =

$A_{i_{coax}} := \frac{\pi}{4} \left[(D_{coax} + 2 \cdot 1r)^2 - D_{coax}^2 \right] = 3.9$ sq in

Ice Weight All Coax per foot =

$WT_{i_{coax}} := N_{coax} \cdot Id \cdot \frac{A_{i_{coax}}}{144} = 36$ plf **BLC 3**

Development of Wind & Ice Load on Coax Cables

Coax Cable Data:

	(151ft - 159ft)	
Coax Type =	HELIAX 1-5/8"	
Shape =	Round	(User Input)
Coax Outside Diameter =	$D_{coax} := 1.98$ in	(User Input)
Coax Cable Length =	$L_{coax} := 8$ ft	(User Input)
Weight of Coax per foot =	$Wt_{coax} := 1.04$ plf	(User Input)
Total Number of Coax =	$N_{coax} := 12$	(User Input)
No. of Coax Projecting Outside Face of Mast =	$NP_{coax} := 3$	(User Input)

Wind Load (NESC Extreme)

Coax projected surface area = $A_{coax} := \frac{(NP_{coax} \cdot D_{coax})}{12} = 0.5$ ft

Total Coax Wind Force (Above NU Structure) =

$F_{coax} := qz \cdot Cd_{coax} \cdot A_{coax} \cdot m = 36$ plf **BLC 5**

Wind Load (NESC Heavy)

Coax projected surface area w/ Ice = $AICE_{coax} := \frac{(NP_{coax} \cdot D_{coax} + 2 \cdot Ir)}{12} = 0.6$ ft

Total Coax Wind Force w/ Ice =

$Fi_{coax} := p \cdot Cd_{coax} \cdot AICE_{coax} = 4$ plf **BLC 4**

Gravity Loads (without ice)

Weight of all cables w/o ice

$WT_{coax} := Wt_{coax} \cdot N_{coax} = 12$ plf **BLC 2**

Gravity Load (ice only)

Ice Area per Linear Foot =

$Ai_{coax} := \frac{\pi}{4} \left[(D_{coax} + 2 \cdot Ir)^2 - D_{coax}^2 \right] = 3.9$ sq in

Ice Weight All Coax per foot =

$WTi_{coax} := N_{coax} \cdot Id \cdot \frac{Ai_{coax}}{144} = 18$ plf **BLC 3**

(Global) Model Settings

Display Sections for Member Calcs	5
Max Internal Sections for Member Calcs	97
Include Shear Deformation?	Yes
Increase Nailing Capacity for Wind?	Yes
Include Warping?	Yes
Trans Load Btwn Intersecting Wood Wall?	Yes
Area Load Mesh (in^2)	144
Merge Tolerance (in)	.12
P-Delta Analysis Tolerance	0.50%
Include P-Delta for Walls?	Yes
Automatically Iterate Stiffness for Walls?	No
Max Iterations for Wall Stiffness	3
Gravity Acceleration (ft/sec^2)	32.2
Wall Mesh Size (in)	12
Eigensolution Convergence Tol. (1.E-)	4
Vertical Axis	Y
Global Member Orientation Plane	XZ
Static Solver	Sparse Accelerated
Dynamic Solver	Accelerated Solver

Hot Rolled Steel Code	AISC 14th(360-10): LRFD
Adjust Stiffness?	Yes(Iterative)
RISAConnection Code	AISC 14th(360-10): ASD
Cold Formed Steel Code	AISI 1999: ASD
Wood Code	AF&PA NDS-91/97: ASD
Wood Temperature	< 100F
Concrete Code	ACI 318-02
Masonry Code	ACI 530-05: ASD
Aluminum Code	AA ADM1-05: ASD - Building
Stainless Steel Code	AISC 14th(360-10): ASD
Adjust Stiffness?	Yes(Iterative)

Number of Shear Regions	4
Region Spacing Increment (in)	4
Biaxial Column Method	PCA Load Contour
Parme Beta Factor (PCA)	.65
Concrete Stress Block	Rectangular
Use Cracked Sections?	Yes
Use Cracked Sections Slab?	Yes
Bad Framing Warnings?	No
Unused Force Warnings?	Yes
Min 1 Bar Diam. Spacing?	No
Concrete Rebar Set	REBAR_SET_ASTMA615
Min % Steel for Column	1
Max % Steel for Column	8

(Global) Model Settings, Continued

Seismic Code	UBC 1997
Seismic Base Elevation (ft)	Not Entered
Add Base Weight?	No
Ct X	.035
Ct Z	.035
T X (sec)	Not Entered
T Z (sec)	Not Entered
R X	8.5
R Z	8.5
Ca	.36
Cv	.54
Nv	1
Occupancy Category	4
Seismic Zone	3
Om Z	1
Om X	1
Rho Z	1
Rho X	1
Footing Overturning Safety Factor	1.5
Optimize for OTM/Sliding	No
Check Concrete Bearing	No
Footing Concrete Weight (k/ft^3)	0
Footing Concrete f'c (ksi)	3
Footing Concrete Ec (ksi)	4000
Lambda	1
Footing Steel fy (ksi)	60
Minimum Steel	0.0018
Maximum Steel	0.0075
Footing Top Bar	#3
Footing Top Bar Cover (in)	3.5
Footing Bottom Bar	#3
Footing Bottom Bar Cover (in)	3.5
Pedestal Bar	#3
Pedestal Bar Cover (in)	1.5
Pedestal Ties	#3

Hot Rolled Steel Properties

	Label	E [ksi]	G [ksi]	Nu	Therm (\...	Density[k/ft^3]	Yield[ksi]	Ry	Fu[ksi]	Rt
1	A36 Gr.36	29000	11154	.3	.65	.49	36	1.5	58	1.2
2	A572 Gr.50	29000	11154	.3	.65	.49	50	1.1	58	1.2
3	A992	29000	11154	.3	.65	.49	50	1.1	58	1.2
4	A500 Gr.42	29000	11154	.3	.65	.49	42	1.3	58	1.1
5	A500 Gr.46	29000	11154	.3	.65	.49	46	1.2	58	1.1
6	A53 Gr. B	29000	11154	.3	.65	.49	35	1.5	58	1.2

Hot Rolled Steel Section Sets

	Label	Shape	Type	Design List	Material	Design Ru...	A [in ²]	Iyy [in ⁴]	Izz [in ⁴]	J [in ⁴]
1	Mast1	PIPE 10.0X	Column	Pipe	A53 Gr. B	Typical	15.1	199	199	398
2	Mast2	PIPE 6.0X	Column	Pipe	A53 Gr. B	Typical	7.83	38.3	38.3	76.6

Hot Rolled Steel Design Parameters

	Label	Shape	Length[ft]	Lbyy[ft]	Lbzz[ft]	Lcomp top[...]	Lcomp bot[...]	L-torq[...]	Kyy	Kzz	Cb	Funci...
1	M1	Mast1	29			Lbyy						Lateral
2	M2	Mast2	14			Lbyy						Lateral

Member Primary Data

	Label	I Joint	J Joint	K Joint	Rotate(...)	Section/Shape	Type	Design List	Material	Design R...
1	M1	BOTC...	FLANGE			Mast1	Column	Pipe	A53 Gr. B	Typical
2	M2	FLANGE	TOPM...			Mast2	Column	Pipe	A53 Gr. B	Typical

Joint Coordinates and Temperatures

	Label	X [ft]	Y [ft]	Z [ft]	Temp [F]	Detach From Diap...
1	BOTCONNECTION	0	0	0	0	
2	TOPCONNECTION	0	15.25	0	0	
3	FLANGE	0	29	0	0	
4	TOPMAST	0	43	0	0	

Joint Boundary Conditions

	Joint Label	X [k/in]	Y [k/in]	Z [k/in]	X Rot.[k-ft/rad]	Y Rot.[k-ft/rad]	Z Rot.[k-ft/rad]
1	BOTCONNECTION	Reaction	Reaction	Reaction		Fixed	
2	TOPCONNECTION	Reaction		Reaction			

Member Point Loads (BLC 2 : Weight of Appurtenances)

	Member Label	Direction	Magnitude[k,k-ft]	Location[ft,%]
1	M2	Y	-.396	11.5
2	M2	Y	-.105	3.5
3	M2	Y	-.012	11.5

Member Point Loads (BLC 3 : Weight of Ice Only)

	Member Label	Direction	Magnitude[k,k-ft]	Location[ft,%]
1	M2	Y	-.258	11.5
2	M2	Y	-.119	3.5
3	M2	Y	-.01	11.5

Member Point Loads (BLC 4 : NESG Heavy Wind)

	Member Label	Direction	Magnitude[k,k-ft]	Location[ft,%]
1	M2	X	.243	11.5
2	M2	X	.103	3.5
3	M2	X	.008	11.5

Member Point Loads (BLC 5 : NESC Extreme Wind)

	Member Label	Direction	Magnitude[k,k-ft]	Location[ft,%]
1	M2	X	2.596	11.5
2	M2	X	1.055	3.5
3	M2	X	.063	11.5

Member Distributed Loads (BLC 2 : Weight of Appurtenances)

	Member Label	Direction	Start Magnitude[k/ft,F,ksf]	End Magnitude[k/f...]	Start Location[ft,%]	End Location[ft,%]
1	M1	Y	-.025	-.025	19.5	29
2	M2	Y	-.025	-.025	0	1
3	M2	Y	-.012	-.012	1	8.5

Member Distributed Loads (BLC 3 : Weight of Ice Only)

	Member Label	Direction	Start Magnitude[k/ft,F,ksf]	End Magnitude[k/f...]	Start Location[ft,%]	End Location[ft,%]
1	M1	Y	-.007	-.007	0	0
2	M2	Y	-.004	-.004	0	0
3	M1	Y	-.036	-.036	19.5	29
4	M2	Y	-.036	-.036	0	1
5	M2	Y	-.018	-.018	1	8.5

Member Distributed Loads (BLC 4 : NESC Heavy Wind)

	Member Label	Direction	Start Magnitude[k/ft,F,ksf]	End Magnitude[k/f...]	Start Location[ft,%]	End Location[ft,%]
1	M1	X	.005	.005	0	0
2	M2	X	.003	.003	0	1
3	M2	X	.003	.003	6	8.5
4	M1	X	.006	.006	19.5	29
5	M2	X	.006	.006	0	1
6	M2	X	.004	.004	6	8.5

Member Distributed Loads (BLC 5 : NESC Extreme Wind)

	Member Label	Direction	Start Magnitude[k/ft,F,ksf]	End Magnitude[k/f...]	Start Location[ft,%]	End Location[ft,%]
1	M1	X	.042	.042	0	19.5
2	M1	X	.052	.052	19.5	29
3	M2	X	.032	.032	0	1
4	M2	X	.032	.032	6	8.5
5	M1	X	.06	.06	19.5	29
6	M2	X	.06	.06	0	1
7	M2	X	.036	.036	6	8.5

Basic Load Cases

	BLC Description	Category	X Gra...	Y Gra...	Z Gra...	Joint	Point	Distrib..	Area(... Surfa...
1	Self Weight	None		-1					
2	Weight of Appurtenances	None					3	3	
3	Weight of Ice Only	None					3	5	
4	NESC Heavy Wind	None					3	6	
5	NESC Extreme Wind	None					3	7	



Company : CENTEK Engineering, Inc.
 Designer : TJL
 Job Number : 19066.02 - T-Mobile CT11241A
 Model Name : Structure #1280 Mast

June 28, 2021
 4:30 PM
 Checked By: CFC

Load Combinations

	Description	Solve	P...	S...	B...	Fa...	BLC	Fact...	BLC	Fa...	BLC	Fa...	BLC	Fa...	B...	Fa...	B...	Fa...	B...	Fa...	B...	Fa...	
1	NESC Heavy Wind	Yes	Y		1	1.5	2	1.5	3	1.5	4	2.5											
2	NESC Extreme Wind	Yes	Y		1	1	2	1	5	1													

Envelope Joint Reactions

	Joint		X [k]	LC	Y [k]	LC	Z [k]	LC	MX [k-ft]	LC	MY [k-ft]	LC	MZ [k-ft]	LC
1	BOTCONNEC...	max	6.323	2	5.831	1	0	2	0	2	NC	NC	0	2
2		min	1.521	1	2.729	2	0	1	0	1	NC	NC	0	1
3	TOPCONNEC...	max	-2.977	1	0	2	0	2	0	2	0	2	0	2
4		min	-12.182	2	0	1	0	1	0	1	0	1	0	1
5	Totals:	max	-1.456	1	5.831	1	0	2						
6		min	-5.859	2	2.729	2	0	1						



Company : CENTEK Engineering, Inc.
Designer : TJL
Job Number : 19066.02 - T-Mobile CT11241A
Model Name : Structure #1280 Mast

June 28, 2021
4:31 PM
Checked By: CFC

Joint Reactions

	LC	Joint Label	X [k]	Y [k]	Z [k]	MX [k-ft]	MY [k-ft]	MZ [k-ft]
1	1	BOTCONNECTION	1.521	5.831	0	0	NC	0
2	1	TOPCONNECTION	-2.977	0	0	0	0	0
3	1	Totals:	-1.456	5.831	0			
4	1	COG (ft):	X: 0	Y: 25.234	Z: 0			



Company : CENTEK Engineering, Inc.
Designer : TJL
Job Number : 19066.02 - T-Mobile CT11241A
Model Name : Structure #1280 Mast

June 28, 2021
4:31 PM
Checked By: CFC

Joint Reactions

	LC	Joint Label	X [k]	Y [k]	Z [k]	MX [k-ft]	MY [k-ft]	MZ [k-ft]
1	2	BOTCONNECTION	6.323	2.729	0	0	NC	0
2	2	TOPCONNECTION	-12.182	0	0	0	0	0
3	2	Totals:	-5.859	2.729	0			
4	2	COG (ft):	X: 0	Y: 23.641	Z: 0			

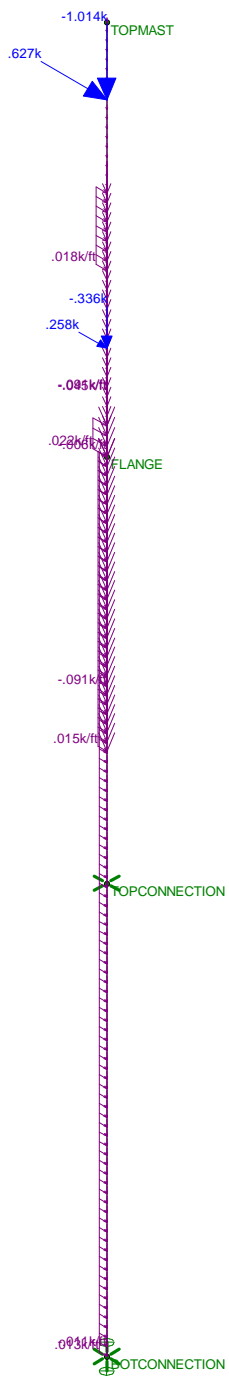

Loads: LC 1, NESC Heavy Wind
Envelope Only Solution

CENTEK Engineering, Inc.	Structure #1280 Mast LC #1 Loads	June 28, 2021 at 4:30 PM
TJL		NESC.r3d
19066.02 - T-Mobile CT112...		



TOPMAST

FLANGE

TOPCONNECTION
-3

1.5
TOPCONNECTION
5.8

Results for LC 1, NESC Heavy Wind
Reaction and Moment Units are k and k-ft

CENTEK Engineering, Inc.	Structure #1280 Mast LC #1 Reactions	June 28, 2021 at 4:31 PM
TJL		NESC.r3d
19066.02 - T-Mobile CT112...		

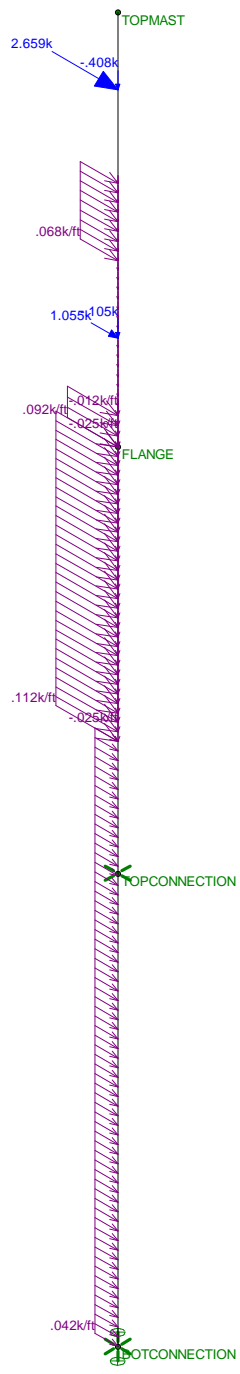

Loads: LC 2, NESC Extreme Wind
Envelope Only Solution

CENTEK Engineering, Inc.	Structure #1280 Mast LC #2 Loads	June 28, 2021 at 4:30 PM
TJL		NESC.r3d
19066.02 - T-Mobile CT112...		



TOPMAST

FLANGE

TOPCONNECTION
-12.2

6.3
BOTCONNECTION
2.7

Results for LC 2, NESC Extreme Wind
Reaction and Moment Units are k and k-ft

CENTEK Engineering, Inc.	Structure #1280 Mast LC #2 Reactions	June 28, 2021 at 4:31 PM
TJL		NESC.r3d
19066.02 - T-Mobile CT112...		

Coax Cable on CL&P Tower

Distance Between Coax Cable Attach Points =

Coaxial Cable Span =	CoaxSpan :=	$\left(\begin{array}{c} 6.25 \\ 11.5 \\ 10.5 \\ 10.5 \\ 10.625 \\ 10.375 \\ 11 \\ 12.5 \\ 11.625 \\ 11 \\ 12.5 \\ 14.125 \end{array} \right) \text{ .ft}$	(User Input)
----------------------	-------------	--	--------------

Diameter of Coax Cable = Weight of Coax Cable = Number of Coax Cables = Number of Projected Coax Cables = Extreme Wind Pressure = Heavy Wind Pressure = Radial Ice Thickness = Radial Ice Density = Shape Factor = Overload Factor for NESC Heavy Wind Load = Overload Factor for NESC Extreme Wind Load = Overload Factor for NESC Heavy Vertical Load = Overload Factor for NESC Extreme Vertical Load = Wind Area with Ice = Wind Area without Ice = Ice Area per Liner Ft = Weight of Ice on All Coax Cables =	$D_{\text{coax}} := 1.98\text{-in}$ $W_{\text{coax}} := 1.04\text{-plf}$ $N_{\text{coax}} := 24$ $NP_{\text{coax}} := 6$ $qz := 36.1\text{-psf}$ $p := 4\text{-psf}$ $Ir := 0.5\text{-in}$ $Id := 56\text{-pcf}$ $Cd_{\text{coax}} := 1.6$ $OF_{\text{HW}} := 2.5$ $OF_{\text{EW}} := 1.0$ $OF_{\text{HV}} := 1.5$ $OF_{\text{EV}} := 1.0$ $A_{\text{ice}} := (NP_{\text{coax}} \cdot D_{\text{coax}} + 2 \cdot Ir) = 12.88\text{-in}$ $A := (NP_{\text{coax}} \cdot D_{\text{coax}}) = 11.88\text{-in}$ $A_{i\text{coax}} := \frac{\pi}{4} \cdot \left[(D_{\text{coax}} + 2 \cdot Ir)^2 - D_{\text{coax}}^2 \right] = 0.027\text{ft}^2$ $W_{\text{ice}} := A_{i\text{coax}} \cdot Id \cdot N_{\text{coax}} = 36.359\text{-plf}$	(User Input) (User Input) (User Input) (User Input) (User Input) (User Input) (User Input) (User Input) (User Input) (User Input) (User Input) (User Input) (User Input) (User Input) (User Input) (User Input)
--	---	--

Heavy Vertical Load =

$$\text{HeavyVert} := \overrightarrow{\left[(N_{\text{coax}} \cdot W_{\text{coax}} + W_{\text{ice}}) \cdot \text{CoaxSpan} \cdot \text{OFHV} \right]}$$

Heavy Transverse Load =

$$\text{HeavyTrans} := \overrightarrow{\left(p \cdot A_{\text{ice}} \cdot C_{d_{\text{coax}}} \cdot \text{CoaxSpan} \cdot \text{OFHW} \right)}$$

	0		0
0	575	0	107
1	1058	1	197
2	966	2	180
3	966	3	180
4	977	4	182
HeavyVert = 5	954 lb	HeavyTrans = 5	178 lb
6	1012	6	189
7	1150	7	215
8	1069	8	200
9	1012	9	189
10	1150	10	215
11	1299	11	243

Extreme Vertical Load =

$$\text{ExtremeVert} := \overrightarrow{\left[(N_{\text{coax}} \cdot W_{\text{coax}}) \cdot \text{CoaxSpan} \cdot \text{OFEV} \right]}$$

Extreme Transverse Load =

$$\text{ExtremeTrans} := \overrightarrow{\left[(qz \cdot A \cdot C_{d_{\text{coax}}}) \cdot \text{CoaxSpan} \cdot \text{OFEW} \right]}$$

	0		0
0	156	0	357
1	287	1	658
2	262	2	600
3	262	3	600
4	265	4	608
ExtremeVert = 5	259 lb	ExtremeTrans = 5	593 lb
6	275	6	629
7	312	7	715
8	290	8	665
9	275	9	629
10	312	10	715
11	353	11	808

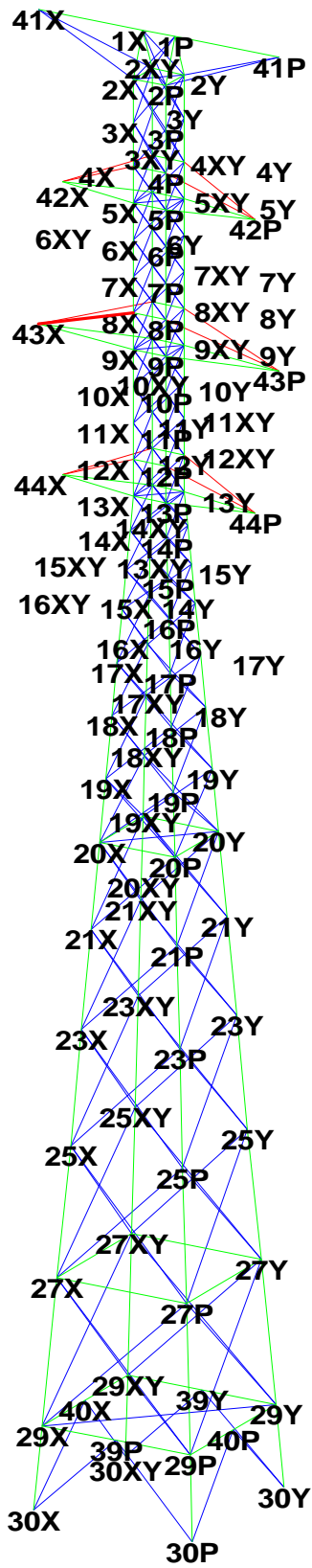

Project Name :
 Project Notes:
 Project File : J:\Jobs\2105100.WI\06_CT11241A\05_Structural\Backup Documentation\Calcs\PLS Tower\cl&p tower # 1280.tow
 Date run : 4:39:24 PM Monday, June 28, 2021
 by : Tower Version 12.50
 Licensed to : Centek Engineering Inc

Successfully performed nonlinear analysis

KL/R value of 226.21 exceeds maximum of 200.00 for member "g106P" ??
 KL/R value of 226.21 exceeds maximum of 200.00 for member "g106X" ??
 The model has 2 warnings. ??

Member check option: ASCE 10
 Connection rupture check: ASCE 10
 Crossing diagonal check: ASCE 10 [Alternate Unsupported RLOUT = 1]
 Included angle check: None
 Climbing load check: None
 Redundant members checked with: Actual Force

Loads from file: j:\jobs\2105100.wi\06_ct11241a\05_structural\backup documentation\calcs\pls tower\cl&p tower # 1280.lca

*** Analysis Results:

Maximum element usage is 89.89% for Angle "g89XY" in load case "NESC Extreme"
 Maximum insulator usage is 10.81% for Clamp "C5" in load case "NESC Heavy"

Summary of Joint Support Reactions For All Load Cases:

Load Case	Joint Label	Long. Force (kips)	Tran. Force (kips)	Vert. Force (kips)	Shear Force (kips)	Tran. Moment (ft-k)	Long. Moment (ft-k)	Bending Moment (ft-k)	Vert. Moment (ft-k)	Found. Usage %
NESC Heavy	30P	-7.82	-10.34	-124.50	12.96	0.10	-0.03	0.11	-0.09	0.00
NESC Heavy	30X	8.47	-10.70	131.30	13.65	0.18	-0.10	0.20	-0.02	0.00
NESC Heavy	30XY	-5.67	-5.88	78.27	8.17	-0.45	-0.54	0.71	-0.12	0.00
NESC Heavy	30Y	12.71	-12.59	-174.95	17.89	-0.35	0.45	0.57	-0.14	0.00
NESC Extreme	30P	-12.47	-17.62	-189.73	21.59	0.77	-0.24	0.81	0.41	0.00
NESC Extreme	30X	14.90	-19.75	224.76	24.75	0.82	0.12	0.83	0.53	0.00
NESC Extreme	30XY	-11.14	-14.09	161.90	17.96	0.14	-0.69	0.70	-0.58	0.00
NESC Extreme	30Y	17.73	-20.25	-248.33	26.91	0.24	0.54	0.59	-0.54	0.00

Summary of Joint Support Reactions For All Load Cases in Direction of Leg:

Load Case	Support Joint	Origin Joint	Leg Member	Force In Leg (kips)	Residual Perpendicular (kips)	Residual Shear Horizontal (kips)	Residual Shear Horizontal (kips)	Residual Shear Horizontal (kips)	Total Force (kips)	Total Tran. Force (kips)	Total Vert. Force (kips)
NESC Heavy	30P	29P	g89X	125.161	2.022	2.024	-0.588	1.937	-7.82	-10.34	-124.50
NESC Heavy	30X	29X	g89P	-131.996	1.872	1.874	0.388	1.834	8.47	-10.70	131.30
NESC Heavy	30XY	29XY	g89Y	-78.689	0.713	0.716	0.391	0.600	-5.67	-5.88	78.27
NESC Heavy	30Y	29Y	g89XY	175.856	1.190	1.196	-0.904	0.783	12.71	-12.59	-174.95
NESC Extreme	30P	29P	g89X	190.889	4.815	4.825	-0.337	4.813	-12.47	-17.62	-189.73
NESC Extreme	30X	29X	g89P	-226.074	4.582	4.591	0.267	4.583	14.90	-19.75	224.76
NESC Extreme	30XY	29XY	g89Y	-162.865	3.161	3.169	0.207	3.162	-11.14	-14.09	161.90
NESC Extreme	30Y	29Y	g89XY	249.755	3.604	3.617	-0.965	3.486	17.73	-20.25	-248.33

Overtopping Moment Summary For All Load Cases:

Load Case	Transverse Moment (ft-k)	Longitudinal Moment (ft-k)	Resultant Moment (ft-k)
NESC Heavy	4189.247	-851.623	4274.933
NESC Extreme	6787.422	-999.612	6860.636

Sections Information:

Section Label	Top Z (ft)	Bottom Z (ft)	Joint Count	Member Count	Tran. Face Top Width (ft)	Tran. Face Bot Width (ft)	Tran. Face Gross Area (ft^2)	Long. Face Top Width (ft)	Long. Face Bot Width (ft)	Long. Face Gross Area (ft^2)
2	140.000	96.000	58	201	0.00	3.34	139.996	25.00	20.00	288.336
1	96.000	0.000	60	176	3.34	16.46	949.193	3.34	16.46	949.193

*** Overall summary for all load cases - Usage = Maximum Stress / Allowable Stress
Printed capacities do not include the strength factor entered for each load case.
The Group Summary reports on the member and load case that resulted in maximum usage
which may not necessarily be the same as that which produces maximum force.

Group Summary (Compression Portion):

Group KL/R Length Label Comp. No.	Group Angle Curve No. Desc. Type Of Bolts	Angle Size	Steel Strength (ksi)	Max Usage %	Max Usage Cont-rol	Max Use In Member Comp.	Comp. Control	Comp. Force (kips)	Comp. Control Load Case	L/R Capacity (kips)	Comp. Connect. Shear Capacity (kips)	Comp. Connect. Bearing Capacity (kips)	RLX	RLY	RLZ	L/R
Diag1 115.87	Diagonal 1 2	SAU 2X1.5X0.1875	36.0	19.27	Comp	19.27	g1P	-2.485	NESC Hea	12.897	27.200	24.469	0.500	0.750	0.500	114.50
Diag2 91.02	Diagonal 2 2	SAE 2X2X0.1875	36.0	57.18	Tens	39.43	g5XY	-7.453	NESC Ext	18.901	27.200	24.469	0.750	0.500	0.500	81.36
Diag3 116.38	Diagonal 3 2	SAU 3X2.5X0.25	36.0	13.11	Comp	13.11	g37X	-3.548	NESC Ext	27.075	40.800	48.937	0.765	0.531	0.531	115.17
Diag4 66.77	Diagonal 4 2	SAE 3X3X0.25	36.0	32.80	Tens	23.88	g9X	-10.646	NESC Ext	44.572	54.400	65.250	0.750	0.500	0.500	49.03
Diag5 65.73	Diagonal 5 2	SAU 3.5X3X0.25	36.0	29.15	Tens	18.61	g15XY	-9.033	NESC Ext	48.531	54.400	65.250	0.500	0.750	0.500	47.64
Diag6 166.24	Diagonal 6 6	SAE 3.5X3.5X0.25	36.0	24.70	Cross	24.70	g46Y	-4.324	NESC Ext	17.502	27.200	32.625	1.000	0.537	0.537	195.19
Diag7 163.12	Diagonal 7 6	SAU 4X3.5X0.25	36.0	52.56	Cross	52.56	g48Y	-10.233	NESC Ext	19.469	27.200	32.625	1.000	0.533	0.533	190.12
Diag8 160.76	Diagonal 8 5	SAE 4X4X0.25	36.0	31.94	Comp	31.94	g49X	-6.862	NESC Ext	21.486	27.200	32.625	1.000	1.000	1.000	173.44
Diag9 0.00	Diagonal 9 0	SAU 5X3X0.3125	36.0	0.00		0.00		0.000		0.000	0.000	0.000	0.000	0.000	0.000	0.00
Diag10 61.70	Diagonal 10 2	SAU 5X3.5X0.3125	36.0	21.29	Tens	16.61	g19X	-13.438	NESC Ext	80.889	81.600	122.344	0.500	0.750	0.500	42.27
Diag11 62.02	Diagonal 11 2	SAU 5X3.5X0.375	36.0	18.92	Tens	15.60	g23XY	-12.732	NESC Ext	96.521	81.600	146.812	0.500	0.750	0.500	42.69

Horz1	Horizontal	1	SAU	2X1.5X0.1875	36.0	48.49	Tens	0.00	g57Y	0.000	11.446	13.600	12.234	1.000	1.000	1.000	124.47
124.47	3.340	4	1														
Horz2	Horizontal	2	SAE	2X2X0.1875	36.0	56.81	Comp	56.81	g60X	-3.109NESC Ext	5.474	27.200	24.469	1.000	1.000	1.000	238.17
192.68	7.820	6	2														
Horz3	Horizontal	3	SAU	2.5X2X0.1875	36.0	0.00		0.00		0.000	0.000	0.000	0.000	0.000	0.000	0.000	0.00
0.00	0.000	0	0														
Horz4	Horizontal	4	SAE	2.5X2.5X0.1875	36.0	0.00		0.00		0.000	0.000	0.000	0.000	0.000	0.000	0.000	0.00
0.00	0.000	0	0														
Horz5	Horizontal	5	SAU	3X2X0.25	36.0	7.82	Tens	5.55	g51P	-1.509NESC Hea	27.684	27.200	32.625	1.000	1.000	1.000	92.14
106.07	3.340	3	2														
Horz6	Horizontal	6	SAU	3X2.5X0.25	36.0	19.87	Tens	15.93	g56X	-4.334NESC Ext	32.931	27.200	32.625	1.000	1.000	1.000	75.91
97.95	3.340	3	2														
Horz7	Horizontal	7	SAU	3.5X3X0.25	36.0	0.00		0.00		0.000	0.000	0.000	0.000	0.000	0.000	0.000	0.00
0.00	0.000	0	0														
Horz8	Horizontal	8	SAE	3.5X3.5X0.25	36.0	71.46	Comp	71.46	g62X	-9.642NESC Ext	13.494	27.200	32.625	1.000	1.000	1.000	232.74
189.33	13.460	6	2														
Horz9	Horizontal	9	SAE	3X3X0.1875	36.0	0.00		0.00		0.000	0.000	0.000	0.000	0.000	0.000	0.000	0.00
0.00	0.000	0	0														
Horz10	Horizontal	10	SAU	4X3.5X0.3125	36.0	26.00	Tens	22.02	g64XY	-5.988NESC Ext	41.251	27.200	40.781	1.000	1.000	1.000	126.41
124.93	7.690	5	2														
Leg 1		Leg 1	SAE	4X4X0.25	50.0	56.04	Tens	43.37	g68X	-32.689NESC Ext	75.378	81.600	109.687	1.000	1.000	1.000	52.83
52.83	3.500	1	6														
Leg 2		Leg 2	SAE	6X6X0.5	50.0	45.61	Comp	45.61	g72XY	-86.841NESC Ext	271.593	190.400	511.874	1.000	1.000	1.000	35.59
35.59	3.500	1	14														
Leg 3		Leg 3	SAE	8X8X0.75	50.0	75.96	Comp	75.96	g76XY	-165.281NESC Ext	554.347	217.600	877.499	1.000	1.000	1.000	26.58
26.58	3.500	1	16														
Leg 4		Leg 4	SAE	8X8X0.875	50.0	89.89	Comp	89.89	g89XY	-244.489NESC Ext	552.500	272.000	1279.686	1.000	1.000	1.000	61.42
61.42	8.036	1	20														
Horz11	Horizontal	11	SAU	5X3X0.25	36.0	11.95	Comp	11.95	g92Y	-5.376NESC Hea	44.997	54.400	65.250	1.000	1.000	1.000	60.45
90.23	3.340	3	4														
Horz12	Horizontal	12	SAU	5X3X0.3125	36.0	12.90	Comp	12.90	g98Y	-8.259NESC Hea	64.028	68.000	101.953	1.000	1.000	1.000	60.91
90.46	3.340	3	5														
Horz13	Horizontal	13	SAU	5X3.5X0.375	36.0	19.46	Comp	19.46	g97Y	-13.236NESC Hea	73.070	68.000	122.344	1.000	0.500	0.500	86.28
103.14	10.958	3	5														
Arm		Arm	SAE	2X2X0.1875	36.0	25.79	Tens	0.00	g96Y	0.000	3.474	27.200	24.469	1.000	1.000	1.000	279.85
241.85	9.188	5	2														
top		top	DAL	4X3.5X0.375	36.0	22.88	Tens	2.33	g100P	-0.634NESC Ext	116.434	27.200	97.875	1.000	1.000	1.000	103.97
111.98	10.830	3	2														
Arm2		Arm2	SAE	2.5X2.5X0.1875	36.0	36.71	Tens	0.00	g99Y	0.000	4.441	27.200	24.469	1.000	1.000	1.000	278.87
241.10	11.503	5	2														
Inner1		Inner 1	SAU	2X1.5X0.25	36.0	2.72	Cross	2.72	g102P	-0.366NESC Hea	13.467	13.600	16.312	0.500	1.000	0.500	131.21
131.21	4.723	4	1														
Inner2		Inner 2	SAU	2X1.5X0.1875	36.0	12.93	Comp	12.93	g106P	-0.449NESC Ext	3.468	13.600	12.234	0.500	0.750	0.500	226.21
226.21	11.059	4	1														
Inner3		Inner 3	SAE	2X2X0.1875	36.0	2.54	Cross	2.54	g105P	-0.420NESC Hea	16.541	27.200	24.469	1.000	0.500	0.500	91.87
105.93	4.723	3	2														
Inner4		Inner 4	SAE	3X3X0.1875	36.0	1.94	Comp	1.94	g107P	-0.159NESC Ext	8.167	27.200	24.469	0.750	0.500	0.500	218.97
195.45	21.751	5	2														
Diag12	Diagonal	5	SAU	3.5X3X0.25	36.0	6.79	Comp	6.79	g90X	-2.265NESC Hea	33.365	40.800	48.937	0.500	0.500	0.500	111.49
113.61	11.725	2	3														

Group Summary (Tension Portion):

Group Hole Label Diameter	Group Desc.	Angle Type	Angle Size	Steel Strength	Max Usage Cont-rol	Max Tension Use	Tension Control In	Tension Control Member	Tension Force	Net Section	Tension Connect.	Tension Connect.	Tension Connect.	Tension Connect.	Length Tens.	No. Of Bolts	No. Of Holes
---------------------------	-------------	------------	------------	----------------	--------------------	-----------------	--------------------	------------------------	---------------	-------------	------------------	------------------	------------------	------------------	--------------	--------------	--------------

(in)				(ksi)	%	Tens. %		(kips)	Case	(kips)	Capacity (kips)	Capacity (kips)	Capacity (kips)	Tens. (ft)				
0.875	Diag1	Diagonal 1	SAU	2X1.5X0.1875	36.0	19.27	Comp	17.77	g1X	2.264NESC	Hea	14.772	27.200	24.469	12.741	5.598	2	1.000
0.875	Diag2	Diagonal 2	SAE	2X2X0.1875	36.0	57.18	Tens	57.18	g5Y	7.751NESC	Ext	17.688	27.200	24.469	13.556	5.343	2	1.000
0.875	Diag3	Diagonal 3	SAU	3X2.5X0.25	36.0	13.11	Comp	11.55	g37P	3.616NESC	Ext	31.306	40.800	48.937	34.228	9.543	3	1.000
0.875	Diag4	Diagonal 4	SAE	3X3X0.25	36.0	32.80	Tens	32.80	g9P	10.653NESC	Ext	32.481	54.400	65.250	42.170	4.838	4	2.000
0.875	Diag5	Diagonal 5	SAU	3.5X3X0.25	36.0	29.15	Tens	29.15	g15P	10.602NESC	Ext	36.369	54.400	65.250	43.828	4.838	4	2.000
0.875	Diag6	Diagonal 6	SAE	3.5X3.5X0.25	36.0	24.70	Cross	21.66	g43P	5.891NESC	Ext	47.668	27.200	32.625	27.943	15.522	2	1.000
0.875	Diag7	Diagonal 7	SAU	4X3.5X0.25	36.0	52.56	Cross	31.65	g48XY	8.610NESC	Ext	47.506	27.200	32.625	27.943	20.121	2	1.000
0.875	Diag8	Diagonal 8	SAE	4X4X0.25	36.0	31.94	Comp	23.02	g49P	6.259NESC	Ext	55.768	27.200	32.625	27.187	11.490	2	1.000
0	Diag9	Diagonal 9	SAU	5X3X0.3125	36.0	0.00		0.00		0.000		0.000	0.000	0.000	0.000	0.000	0	0.000
0.875	Diag10	Diagonal 10	SAU	5X3.5X0.3125	36.0	21.29	Tens	21.29	g21P	13.888NESC	Ext	65.225	81.600	122.344	67.985	4.838	6	2.000
0.875	Diag11	Diagonal 11	SAU	5X3.5X0.375	36.0	18.92	Tens	18.92	g23P	14.527NESC	Ext	77.557	81.600	146.812	76.781	4.838	6	2.000
0.875	Horz1	Horizontal 1	SAU	2X1.5X0.1875	36.0	48.49	Tens	48.49	g55P	3.607NESC	Hea	14.772	13.600	12.234	7.439	3.340	1	1.000
0.875	Horz2	Horizontal 2	SAE	2X2X0.1875	36.0	56.81	Comp	18.21	g60P	3.221NESC	Ext	17.688	27.200	24.469	18.658	7.820	2	1.000
0	Horz3	Horizontal 3	SAU	2.5X2X0.1875	36.0	0.00		0.00		0.000		0.000	0.000	0.000	0.000	0.000	0	0.000
0	Horz4	Horizontal 4	SAE	2.5X2.5X0.1875	36.0	0.00		0.00		0.000		0.000	0.000	0.000	0.000	0.000	0	0.000
0.875	Horz5	Horizontal 5	SAU	3X2X0.25	36.0	7.82	Tens	7.82	g52P	2.127NESC	Hea	31.468	27.200	32.625	27.187	3.340	2	1.000
0.875	Horz6	Horizontal 6	SAU	3X2.5X0.25	36.0	19.87	Tens	19.87	g56P	5.403NESC	Ext	35.356	27.200	32.625	27.187	3.340	2	1.000
0	Horz7	Horizontal 7	SAU	3.5X3X0.25	36.0	0.00		0.00		0.000		0.000	0.000	0.000	0.000	0.000	0	0.000
0.875	Horz8	Horizontal 8	SAE	3.5X3.5X0.25	36.0	71.46	Comp	39.43	g62P	10.720NESC	Ext	47.668	27.200	32.625	27.187	13.460	2	1.000
0	Horz9	Horizontal 9	SAE	3X3X0.1875	36.0	0.00		0.00		0.000		0.000	0.000	0.000	0.000	0.000	0	0.000
0.875	Horz 10	Horizontal 10	SAU	4X3.5X0.3125	36.0	26.00	Tens	26.00	g64Y	7.072NESC	Ext	58.978	27.200	40.781	33.984	7.690	2	1.000
0.875	Leg 1	Leg 1	SAE	4X4X0.25	50.0	56.04	Tens	56.04	g68Y	29.840NESC	Ext	53.250	81.600	109.687	81.851	3.500	6	4.000
0.875	Leg 2	Leg 2	SAE	6X6X0.5	50.0	45.61	Comp	41.87	g72P	79.722NESC	Ext	200.000	190.400	511.874	201.890	3.500	14	4.000
0.875	Leg 3	Leg 3	SAE	8X8X0.75	50.0	75.96	Comp	71.66	g76P	155.923NESC	Ext	375.124	217.600	877.499	287.882	3.500	16	6.000
0.875	Leg 4	Leg 4	SAE	8X8X0.875	50.0	89.89	Comp	81.67	g89P	222.134NESC	Ext	508.374	272.000	1279.686	341.386	8.036	20	4.000
0.875	Horz 11	Horizontal 11	SAU	5X3X0.25	36.0	11.95	Comp	3.18	g92P	1.315NESC	Ext	41.593	54.400	65.250	41.391	3.340	4	3.000
0.875	Horz 12	Horizontal 12	SAU	5X3X0.3125	36.0	12.90	Comp	4.16	g98P	2.129NESC	Hea	51.182	68.000	101.953	62.613	3.340	5	3.000

Horz 13	Horizontal 13	SAU	5X3.5X0.375	36.0	19.46	Comp	8.16	g97X	5.464	NESC Ext	66.926	68.000	122.344	75.136	10.958	5	3.000	
0.875	Arm	Arm	SAE	2X2X0.1875	36.0	25.79	Tens	25.79	g93X	4.337	NESC Hea	17.688	27.200	24.469	16.819	9.188	2	1.000
0.875	top	top	DAL	4X3.5X0.375	36.0	22.88	Tens	22.88	g100X	6.225	NESC Hea	139.603	27.200	97.875	90.625	10.830	2	2.000
0.875	Arm2	Arm2	SAE	2.5X2.5X0.1875	36.0	36.71	Tens	36.71	g99P	7.104	NESC Hea	23.909	27.200	24.469	19.350	11.503	2	1.000
0.875	Inner1	Inner 1	SAU	2X1.5X0.25	36.0	2.72	Cross	0.00	g102X	0.000		19.156	13.600	16.312	9.919	4.723	1	1.000
0.875	Inner2	Inner 2	SAU	2X1.5X0.1875	36.0	12.93	Comp	8.94	g106X	0.665	NESC Ext	14.772	13.600	12.234	7.439	11.059	1	1.000
0.875	Inner3	Inner 3	SAE	2X2X0.1875	36.0	2.54	Cross	0.38	g105X	0.067	NESC Hea	17.688	27.200	24.469	18.658	4.723	2	1.000
0.875	Inner4	Inner 4	SAE	3X3X0.1875	36.0	1.94	Comp	1.80	g107X	0.342	NESC Ext	30.000	27.200	24.469	18.998	21.751	2	1.000
0.875	Diag12	Diagonal 5	SAU	3.5X3X0.25	36.0	6.79	Comp	0.00	g90Y	0.000		39.406	40.800	48.937	31.639	11.725	3	1.000
0.875																		

*** Maximum Stress Summary for Each Load Case

Summary of Maximum Usages by Load Case:

Load Case	Maximum Usage %	Element Label	Element Type
NESC Heavy	63.74	g89XY	Angle
NESC Extreme	89.89	g89XY	Angle

Summary of Insulator Usages:

Insulator Label	Insulator Type	Maximum Usage %	Load Case	Weight (lbs)
C1	Clamp	6.26	NESC Heavy	0.0
C2	Clamp	6.05	NESC Heavy	0.0
C3	Clamp	9.76	NESC Heavy	0.0
C4	Clamp	10.13	NESC Heavy	0.0
C5	Clamp	10.81	NESC Heavy	0.0
C6	Clamp	10.70	NESC Heavy	0.0
C7	Clamp	10.65	NESC Heavy	0.0
C8	Clamp	9.61	NESC Heavy	0.0
C9	Clamp	6.40	NESC Extreme	0.0
C10	Clamp	6.40	NESC Extreme	0.0
C11	Clamp	6.40	NESC Extreme	0.0
C12	Clamp	6.40	NESC Extreme	0.0
C13	Clamp	3.35	NESC Heavy	0.0
C14	Clamp	3.35	NESC Heavy	0.0
C15	Clamp	3.35	NESC Heavy	0.0
C16	Clamp	3.35	NESC Heavy	0.0
C17	Clamp	1.71	NESC Heavy	0.0
C18	Clamp	2.36	NESC Heavy	0.0
C19	Clamp	2.34	NESC Heavy	0.0
C20	Clamp	2.67	NESC Heavy	0.0

C21	Clamp	2.95	NESC Heavy	0.0
C22	Clamp	2.79	NESC Heavy	0.0
C23	Clamp	3.11	NESC Heavy	0.0
C24	Clamp	3.78	NESC Heavy	0.0
C25	Clamp	4.17	NESC Heavy	0.0
C26	Clamp	4.36	NESC Heavy	0.0
C27	Clamp	5.22	NESC Heavy	0.0
C28	Clamp	4.94	NESC Heavy	0.0

*** Weight of structure (lbs):
Weight of Angles*Section DLF: 35451.7
Total: 35451.7

*** End of Report

```
*****
*
* TOWER - Analysis and Design - Copyright Power Line Systems, Inc. 1986-2011 *
*
*****
```

```
Project Name :
Project Notes:
Project File : J:\Jobs\2105100.WI\06_CT11241A\05_Structural\Backup Documentation\Calcs\PLS Tower\cl&p tower # 1280.tow
Date run      : 4:39:23 PM Monday, June 28, 2021
by           : Tower Version 12.50
Licensed to   : Centek Engineering Inc
```

Successfully performed nonlinear analysis

```
KL/R value of 226.21 exceeds maximum of 200.00 for member "g106P" ??
KL/R value of 226.21 exceeds maximum of 200.00 for member "g106X" ??
The model has 2 warnings. ??
```

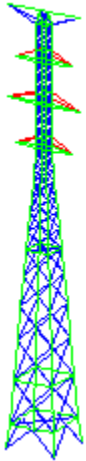

```
Nonlinear convergence parameters: Use Standard Parameters
Tension only member maximum compression load as a percent of compression capacity: 100%
Member check option: ASCE 10
Connection rupture check: ASCE 10
Crossing diagonal check: ASCE 10 [Alternate Unsupported RLOUT = 1]
Included angle check: None
Climbing load check: None
Redundant members checked with: Actual Force
```

Joints Geometry:

Joint Label	Symmetry Code	X Coord. (ft)	Y Coord. (ft)	Z Coord. (ft)	X Disp. Rest.	Y Disp. Rest.	Z Disp. Rest.	X Rot. Rest.	Y Rot. Rest.	Z Rot. Rest.
1P	X-Symmetry	0	1.67	140	Free	Free	Free	Free	Free	Free
2P	XY-Symmetry	1.67	1.67	135.8	Free	Free	Free	Free	Free	Free
3P	XY-Symmetry	1.67	1.67	131.7	Free	Free	Free	Free	Free	Free

4P	XY-Symmetry	1.67	1.67	127.5	Free	Free	Free	Free	Free	Free
5P	XY-Symmetry	1.67	1.67	124	Free	Free	Free	Free	Free	Free
6P	XY-Symmetry	1.67	1.67	120.5	Free	Free	Free	Free	Free	Free
7P	XY-Symmetry	1.67	1.67	117	Free	Free	Free	Free	Free	Free
8P	XY-Symmetry	1.67	1.67	113.5	Free	Free	Free	Free	Free	Free
9P	XY-Symmetry	1.67	1.67	110	Free	Free	Free	Free	Free	Free
10P	XY-Symmetry	1.67	1.67	106.5	Free	Free	Free	Free	Free	Free
11P	XY-Symmetry	1.67	1.67	103	Free	Free	Free	Free	Free	Free
12P	XY-Symmetry	1.67	1.67	99.5	Free	Free	Free	Free	Free	Free
13P	XY-Symmetry	1.67	1.67	96	Free	Free	Free	Free	Free	Free
14P	XY-Symmetry	1.89	1.89	92.75	Free	Free	Free	Free	Free	Free
15P	XY-Symmetry	2.15	2.15	89	Free	Free	Free	Free	Free	Free
16P	XY-Symmetry	2.4	2.4	85.25	Free	Free	Free	Free	Free	Free
17P	XY-Symmetry	2.75	2.75	80.25	Free	Free	Free	Free	Free	Free
18P	XY-Symmetry	3.09	3.09	75.25	Free	Free	Free	Free	Free	Free
19P	XY-Symmetry	3.5	3.5	69.25	Free	Free	Free	Free	Free	Free
20P	XY-Symmetry	3.91	3.91	63.25	Free	Free	Free	Free	Free	Free
21P	XY-Symmetry	4.47	4.47	55	Free	Free	Free	Free	Free	Free
23P	XY-Symmetry	5.12	5.12	45.5	Free	Free	Free	Free	Free	Free
25P	XY-Symmetry	5.81	5.81	34.5	Free	Free	Free	Free	Free	Free
27P	XY-Symmetry	6.73	6.73	22	Free	Free	Free	Free	Free	Free
29P	XY-Symmetry	7.69	7.69	8	Free	Free	Free	Free	Free	Free
30P	XY-Symmetry	8.23	8.23	0	Fixed	Fixed	Fixed	Fixed	Fixed	Fixed
39P	Y-Symmetry	7.69	0	8	Free	Free	Free	Free	Free	Free
40P	X-Symmetry	0	7.69	8	Free	Free	Free	Free	Free	Free
41P	X-Symmetry	0	12.5	140	Free	Free	Free	Free	Free	Free
42P	X-Symmetry	0	10	124	Free	Free	Free	Free	Free	Free
43P	X-Symmetry	0	12.5	110	Free	Free	Free	Free	Free	Free
44P	X-Symmetry	0	10	96	Free	Free	Free	Free	Free	Free
1X	X-Gen	0	-1.67	140	Free	Free	Free	Free	Free	Free
2X	X-GenXY	1.67	-1.67	135.8	Free	Free	Free	Free	Free	Free
2XY	XY-GenXY	-1.67	-1.67	135.8	Free	Free	Free	Free	Free	Free
2Y	Y-GenXY	-1.67	1.67	135.8	Free	Free	Free	Free	Free	Free
3X	X-GenXY	1.67	-1.67	131.7	Free	Free	Free	Free	Free	Free
3XY	XY-GenXY	-1.67	-1.67	131.7	Free	Free	Free	Free	Free	Free
3Y	Y-GenXY	-1.67	1.67	131.7	Free	Free	Free	Free	Free	Free
4X	X-GenXY	1.67	-1.67	127.5	Free	Free	Free	Free	Free	Free
4XY	XY-GenXY	-1.67	-1.67	127.5	Free	Free	Free	Free	Free	Free
4Y	Y-GenXY	-1.67	1.67	127.5	Free	Free	Free	Free	Free	Free
5X	X-GenXY	1.67	-1.67	124	Free	Free	Free	Free	Free	Free
5XY	XY-GenXY	-1.67	-1.67	124	Free	Free	Free	Free	Free	Free
5Y	Y-GenXY	-1.67	1.67	124	Free	Free	Free	Free	Free	Free
6X	X-GenXY	1.67	-1.67	120.5	Free	Free	Free	Free	Free	Free
6XY	XY-GenXY	-1.67	-1.67	120.5	Free	Free	Free	Free	Free	Free
6Y	Y-GenXY	-1.67	1.67	120.5	Free	Free	Free	Free	Free	Free
7X	X-GenXY	1.67	-1.67	117	Free	Free	Free	Free	Free	Free
7XY	XY-GenXY	-1.67	-1.67	117	Free	Free	Free	Free	Free	Free
7Y	Y-GenXY	-1.67	1.67	117	Free	Free	Free	Free	Free	Free
8X	X-GenXY	1.67	-1.67	113.5	Free	Free	Free	Free	Free	Free
8XY	XY-GenXY	-1.67	-1.67	113.5	Free	Free	Free	Free	Free	Free
8Y	Y-GenXY	-1.67	1.67	113.5	Free	Free	Free	Free	Free	Free
9X	X-GenXY	1.67	-1.67	110	Free	Free	Free	Free	Free	Free
9XY	XY-GenXY	-1.67	-1.67	110	Free	Free	Free	Free	Free	Free
9Y	Y-GenXY	-1.67	1.67	110	Free	Free	Free	Free	Free	Free
10X	X-GenXY	1.67	-1.67	106.5	Free	Free	Free	Free	Free	Free
10XY	XY-GenXY	-1.67	-1.67	106.5	Free	Free	Free	Free	Free	Free
10Y	Y-GenXY	-1.67	1.67	106.5	Free	Free	Free	Free	Free	Free
11X	X-GenXY	1.67	-1.67	103	Free	Free	Free	Free	Free	Free
11XY	XY-GenXY	-1.67	-1.67	103	Free	Free	Free	Free	Free	Free

11Y	Y-GenXY	-1.67	1.67	103	Free	Free	Free	Free	Free	Free
12X	X-GenXY	1.67	-1.67	99.5	Free	Free	Free	Free	Free	Free
12XY	XY-GenXY	-1.67	-1.67	99.5	Free	Free	Free	Free	Free	Free
12Y	Y-GenXY	-1.67	1.67	99.5	Free	Free	Free	Free	Free	Free
13X	X-GenXY	1.67	-1.67	96	Free	Free	Free	Free	Free	Free
13XY	XY-GenXY	-1.67	-1.67	96	Free	Free	Free	Free	Free	Free
13Y	Y-GenXY	-1.67	1.67	96	Free	Free	Free	Free	Free	Free
14X	X-GenXY	1.89	-1.89	92.75	Free	Free	Free	Free	Free	Free
14XY	XY-GenXY	-1.89	-1.89	92.75	Free	Free	Free	Free	Free	Free
14Y	Y-GenXY	-1.89	1.89	92.75	Free	Free	Free	Free	Free	Free
15X	X-GenXY	2.15	-2.15	89	Free	Free	Free	Free	Free	Free
15XY	XY-GenXY	-2.15	-2.15	89	Free	Free	Free	Free	Free	Free
15Y	Y-GenXY	-2.15	2.15	89	Free	Free	Free	Free	Free	Free
16X	X-GenXY	2.4	-2.4	85.25	Free	Free	Free	Free	Free	Free
16XY	XY-GenXY	-2.4	-2.4	85.25	Free	Free	Free	Free	Free	Free
16Y	Y-GenXY	-2.4	2.4	85.25	Free	Free	Free	Free	Free	Free
17X	X-GenXY	2.75	-2.75	80.25	Free	Free	Free	Free	Free	Free
17XY	XY-GenXY	-2.75	-2.75	80.25	Free	Free	Free	Free	Free	Free
17Y	Y-GenXY	-2.75	2.75	80.25	Free	Free	Free	Free	Free	Free
18X	X-GenXY	3.09	-3.09	75.25	Free	Free	Free	Free	Free	Free
18XY	XY-GenXY	-3.09	-3.09	75.25	Free	Free	Free	Free	Free	Free
18Y	Y-GenXY	-3.09	3.09	75.25	Free	Free	Free	Free	Free	Free
19X	X-GenXY	3.5	-3.5	69.25	Free	Free	Free	Free	Free	Free
19XY	XY-GenXY	-3.5	-3.5	69.25	Free	Free	Free	Free	Free	Free
19Y	Y-GenXY	-3.5	3.5	69.25	Free	Free	Free	Free	Free	Free
20X	X-GenXY	3.91	-3.91	63.25	Free	Free	Free	Free	Free	Free
20XY	XY-GenXY	-3.91	-3.91	63.25	Free	Free	Free	Free	Free	Free
20Y	Y-GenXY	-3.91	3.91	63.25	Free	Free	Free	Free	Free	Free
21X	X-GenXY	4.47	-4.47	55	Free	Free	Free	Free	Free	Free
21XY	XY-GenXY	-4.47	-4.47	55	Free	Free	Free	Free	Free	Free
21Y	Y-GenXY	-4.47	4.47	55	Free	Free	Free	Free	Free	Free
23X	X-GenXY	5.12	-5.12	45.5	Free	Free	Free	Free	Free	Free
23XY	XY-GenXY	-5.12	-5.12	45.5	Free	Free	Free	Free	Free	Free
23Y	Y-GenXY	-5.12	5.12	45.5	Free	Free	Free	Free	Free	Free
25X	X-GenXY	5.81	-5.81	34.5	Free	Free	Free	Free	Free	Free
25XY	XY-GenXY	-5.81	-5.81	34.5	Free	Free	Free	Free	Free	Free
25Y	Y-GenXY	-5.81	5.81	34.5	Free	Free	Free	Free	Free	Free
27X	X-GenXY	6.73	-6.73	22	Free	Free	Free	Free	Free	Free
27XY	XY-GenXY	-6.73	-6.73	22	Free	Free	Free	Free	Free	Free
27Y	Y-GenXY	-6.73	6.73	22	Free	Free	Free	Free	Free	Free
29X	X-GenXY	7.69	-7.69	8	Free	Free	Free	Free	Free	Free
29XY	XY-GenXY	-7.69	-7.69	8	Free	Free	Free	Free	Free	Free
29Y	Y-GenXY	-7.69	7.69	8	Free	Free	Free	Free	Free	Free
30X	X-GenXY	8.23	-8.23	0	Fixed	Fixed	Fixed	Fixed	Fixed	Fixed
30XY	XY-GenXY	-8.23	-8.23	0	Fixed	Fixed	Fixed	Fixed	Fixed	Fixed
30Y	Y-GenXY	-8.23	8.23	0	Fixed	Fixed	Fixed	Fixed	Fixed	Fixed
39Y	Y-Gen	-7.69	0	8	Free	Free	Free	Free	Free	Free
40X	X-Gen	0	-7.69	8	Free	Free	Free	Free	Free	Free
41X	X-Gen	0	-12.5	140	Free	Free	Free	Free	Free	Free
42X	X-Gen	0	-10	124	Free	Free	Free	Free	Free	Free
43X	X-Gen	0	-12.5	110	Free	Free	Free	Free	Free	Free
44X	X-Gen	0	-10	96	Free	Free	Free	Free	Free	Free

The model contains 114 primary and 0 secondary joints for a total of 114 joints.

Steel Material Properties:

Steel Material	Modulus of Stress	Yield Ultimate Stress	Member Stress All.	Member Stress All.	Member Stress All.	Member Rupture	Member Rupture	Member Bearing	Member Bearing
----------------	-------------------	-----------------------	--------------------	--------------------	--------------------	----------------	----------------	----------------	----------------

Label	Elasticity (ksi)	Fy (ksi)	Fu (ksi)	Hyp. 1 (ksi)	Hyp. 2 (ksi)	Hyp. 1 (ksi)	Hyp. 2 (ksi)	Hyp. 1 (ksi)	Hyp. 2 (ksi)
A 36	2.9e+004	36	58	0	0	0	0	0	0
A572-50	2.9e+004	50	65	0	0	0	0	0	0

Bolt Properties:

Bolt Label	Bolt Diameter (in)	Hole Diameter (in)	Ultimate Shear Capacity (kips)	Default End Distance (in)	Default Bolt Spacing (in)	Shear Hyp. 1 Capacity (kips)	Shear Hyp. 2 Capacity (kips)
3/4 A394	0.75	0.875	13.6	1.35	1.8	0	0

Number Bolts Used By Type:

Bolt Type	Number Bolts
3/4 A394	1358

Angle Properties:

Angle Type	Angle Size (in)	Long Leg (in)	Short Leg (in)	Thick. (in)	Unit Weight (lbs/ft)	Gross Area (in^2)	w/t Ratio	Radius of Gyration Rx (in)	Radius of Gyration Ry (in)	Radius of Gyration Rz (in)	Number of Angles	Wind Width (in)	Short Edge Dist. (in)	Long Edge Dist. (in)	Optimize Cost Factor	Section Modulus (in^3)
SAE	8X8X0.875	8	8	0.875	45	13.23	7.43	2.45	2.45	1.57	1	8	4	0	1.0000	0
SAE	8X8X0.75	8	8	0.75	38.9	11.44	8.83	2.47	2.47	1.58	1	8	4	0	1.0000	0
SAE	6X6X0.5	6	6	0.5	19.6	5.75	10	1.86	1.86	1.18	1	6	3	0	1.0000	0
SAE	4X4X0.25	4	4	0.25	6.6	1.94	13.5	1.25	1.25	0.795	1	4	2	0	1.0000	0
SAE	3.5X3.5X0.25	3.5	3.5	0.25	5.8	1.69	11.5	1.09	1.09	0.694	1	3.5	1.75	0	1.0000	0
SAE	3X3X0.25	3	3	0.25	4.9	1.44	9.75	0.93	0.93	0.592	1	3	1.5	0	1.0000	0
SAE	3X3X0.1875	3	3	0.1875	3.71	1.09	13.33	0.939	0.939	0.596	1	3	1.5	0	1.0000	0
SAE	2.5X2.5X0.1875	2.5	2.5	0.1875	3.07	0.902	10.67	0.778	0.778	0.495	1	2.5	1.25	0	1.0000	0
SAE	2X2X0.1875	2	2	0.1875	2.44	0.71	8	0.617	0.617	0.394	1	2	1	0	1.0000	0
SAU	5X3.5X0.375	5	3.5	0.375	10.4	3.05	11	1.6	1.02	0.762	1	5	1.75	0	1.0000	0
SAU	5X3.5X0.3125	5	3.5	0.3125	8.7	2.56	13.4	1.61	1.03	0.766	1	5	1.75	0	1.0000	0
SAU	5X3X0.3125	5	3	0.3125	8.2	2.4	13.4	1.61	0.853	0.658	1	5	1.5	0	1.0000	0
SAU	5X3X0.25	5	3	0.25	6.6	1.94	17	1.62	0.861	0.663	1	5	1.5	0	1.0000	0
SAU	4X3.5X0.3125	4	3.5	0.3125	7.7	2.25	10.4	1.26	1.07	0.73	1	4	1.75	0	1.0000	0
SAU	4X3.5X0.25	4	3.5	0.25	6.2	1.81	13.25	1.27	1.07	0.734	1	4	1.75	0	1.0000	0
SAU	3.5X3X0.25	3.5	3	0.25	5.4	1.56	11.25	1.11	0.914	0.631	1	3.5	1.5	0	1.0000	0
SAU	3X2.5X0.25	3	2.5	0.25	4.5	1.31	9.5	0.945	0.753	0.528	1	3	1.25	0	1.0000	0
SAU	3X2X0.25	3	2	0.25	4.1	1.19	9.75	0.957	0.574	0.435	1	3	1	0	1.0000	0
SAU	2.5X2X0.1875	2.5	2	0.1875	2.75	0.81	10.67	0.793	0.6	0.427	1	2.5	1	0	1.0000	0
SAU	2X1.5X0.25	2	1.5	0.25	2.77	0.81	6	0.623	0.432	0.32	1	2	0.75	0	1.0000	0
SAU	2X1.5X0.1875	2	1.5	0.1875	2.12	0.62	8.33	0.632	0.44	0.322	1	2	0.75	0	1.0000	0
DAL	4X3.5X0.375	4	3.5	0.375	18.2	5.34	8.5	1.25	1.56	1.25	2	4	1.75	0	1.0000	0

Angle Groups:

Group Label	Group Description	Angle Type	Angle Size	Material Type	Element Type	Group Type	Optimize Group	Allow. Angle	Add. Width
									For Optimize (in)

Diag1	Diagonal 1	SAU	2X1.5X0.1875	A 36	Truss Crossing Diagonal	None	0.000
Diag2	Diagonal 2	SAE	2X2X0.1875	A 36	Truss Crossing Diagonal	None	0.000
Diag3	Diagonal 3	SAU	3X2.5X0.25	A 36	Truss Crossing Diagonal	None	0.000
Diag4	Diagonal 4	SAE	3X3X0.25	A 36	Truss Crossing Diagonal	None	0.000
Diag5	Diagonal 5	SAU	3.5X3X0.25	A 36	Truss Crossing Diagonal	None	0.000
Diag6	Diagonal 6	SAE	3.5X3.5X0.25	A 36	Truss Crossing Diagonal	None	0.000
Diag7	Diagonal 7	SAU	4X3.5X0.25	A 36	Truss Crossing Diagonal	None	0.000
Diag8	Diagonal 8	SAE	4X4X0.25	A 36	Truss Other	None	0.000
Diag9	Diagonal 9	SAU	5X3X0.3125	A 36	Truss Crossing Diagonal	None	0.000
Diag10	Diagonal 10	SAU	5X3.5X0.3125	A 36	Truss Crossing Diagonal	None	0.000
Diag11	Diagonal 11	SAU	5X3.5X0.375	A 36	Truss Crossing Diagonal	None	0.000
Horz1	Horizontal 1	SAU	2X1.5X0.1875	A 36	Beam Other	None	0.000
Horz2	Horizontal 2	SAE	2X2X0.1875	A 36	Beam Other	None	0.000
Horz3	Horizontal 3	SAU	2.5X2X0.1875	A 36	Beam Other	None	0.000
Horz4	Horizontal 4	SAE	2.5X2.5X0.1875	A 36	Beam Other	None	0.000
Horz5	Horizontal 5	SAU	3X2X0.25	A 36	Beam Other	None	0.000
Horz6	Horizontal 6	SAU	3X2.5X0.25	A 36	Truss Other	None	0.000
Horz7	Horizontal 7	SAU	3.5X3X0.25	A 36	Beam Other	None	0.000
Horz8	Horizontal 8	SAE	3.5X3.5X0.25	A 36	Beam Other	None	0.000
Horz9	Horizontal 9	SAE	3X3X0.1875	A 36	Beam Other	None	0.000
Horz 10	Horizontal 10	SAU	4X3.5X0.3125	A 36	Beam Other	None	0.000
Leg 1	Leg 1	SAE	4X4X0.25	A572-50	Beam Leg	None	0.000
Leg 2	Leg 2	SAE	6X6X0.5	A572-50	Beam Leg	None	0.000
Leg 3	Leg 3	SAE	8X8X0.75	A572-50	Beam Leg	None	0.000
Leg 4	Leg 4	SAE	8X8X0.875	A572-50	Beam Leg	None	0.000
Horz 11	Horizontal 11	SAU	5X3X0.25	A 36	Beam Other	None	0.000
Horz 12	Horizontal 12	SAU	5X3X0.3125	A 36	Beam Other	None	0.000
Horz 13	Horizontal 13	SAU	5X3.5X0.375	A 36	Beam Other	None	0.000
Arm	Arm	SAE	2X2X0.1875	A 36	T-Only Other	None	0.000
top	top	DAL	4X3.5X0.375	A 36	Beam Other	None	0.000
Arm2	Arm2	SAE	2.5X2.5X0.1875	A 36	T-Only Other	None	0.000
Inner1	Inner 1	SAU	2X1.5X0.25	A 36	Truss Crossing Diagonal	None	0.000
Inner2	Inner 2	SAU	2X1.5X0.1875	A 36	Truss Crossing Diagonal	None	0.000
Inner3	Inner 3	SAE	2X2X0.1875	A 36	Truss Crossing Diagonal	None	0.000
Inner4	Inner 4	SAE	3X3X0.1875	A 36	Truss Crossing Diagonal	None	0.000
Diag12	Diagonal 5	SAU	3.5X3X0.25	A 36	Truss Other	None	0.000

Aggregate Angle Information:

Note: Estimate of surface area reported for painting purposes, not wind loading.

Angle Type	Angle Size	Material Type	Total Length (ft)	Total Surface Area (ft^2)	Total Weight (lbs)
SAU	2X1.5X0.1875	A 36	83.44	48.67	176.90
SAE	2X2X0.1875	A 36	238.36	158.91	581.60
SAE	3X3X0.25	A 36	343.23	343.23	1681.83
SAU	3.5X3X0.25	A 36	298.42	323.29	1611.47
SAU	5X3.5X0.3125	A 36	198.86	281.72	1730.08
SAU	5X3.5X0.375	A 36	150.50	213.21	1565.22
SAU	3X2.5X0.25	A 36	96.39	88.35	433.74
SAE	3.5X3.5X0.25	A 36	319.86	373.17	1855.17
SAU	4X3.5X0.25	A 36	160.97	201.21	998.01
SAE	4X4X0.25	A 36	91.92	122.56	606.68
SAU	3X2X0.25	A 36	13.36	11.13	54.78
SAU	4X3.5X0.3125	A 36	61.52	76.90	473.70
SAE	4X4X0.25	A572-50	65.29	87.05	430.90

SAE	6X6X0.5	A572-50	56.00	112.00	1097.60
SAE	8X8X0.75	A572-50	56.00	149.33	2178.40
SAE	8X8X0.875	A572-50	385.79	1028.78	17360.63
SAU	5X3X0.25	A 36	13.36	17.81	88.18
SAU	5X3X0.3125	A 36	6.68	8.91	54.78
SAE	2.5X2.5X0.1875	A 36	46.01	38.34	141.26
DAL	4X3.5X0.375	A 36	25.00	31.25	455.00
SAU	2X1.5X0.25	A 36	9.45	5.51	26.17
SAE	3X3X0.1875	A 36	43.50	43.50	161.39

Sections:

The adjustment factors below only apply to dead load and wind areas that are calculated for members in the model. They do not apply to equipment or to manually input dead load and drag areas.

Section Label	Joint Defining Section Bottom	Dead Load Adjust. Factor	Transverse Drag x Area For Face	Longitudinal Drag x Area For Face	Transverse Area Factor (CD From Code)	Longitudinal Area Factor (CD From Code)	Af Factor For EIA Only	Flat For Face	Ar For Face	Round For Face	Transverse Drag x Area Factor For All	Longitudinal Drag x Area Factor For All	SAPS Drag x Area Factor	Angle Drag x Area Factor	SAPS Round Drag x Area Factor	Force Solid Face
2	13P	1.050	3.300	3.300	1.000	1.000	0.000	0.000	1.000	1.000	1.000	1.000	1.000	1.000	1.000	None
1	30P	1.050	3.300	3.300	1.000	1.000	0.000	0.000	1.000	1.000	1.000	1.000	1.000	1.000	1.000	None

Angle Member Connectivity:

Member Shear Path	Group Label	Section Label	Symmetry Code	Origin Joint	End Joint	Ecc. Code	Rest. Code	Ratio RLX	Ratio RLY	Ratio RLZ	Bolt Type	# Bolts	# Holes	Shear Planes	Connect Leg	Short Edge	Long Edge	End Dist.	Bolt Spacing
Length (in)	Length (in)	Path Coef.																	
0	g1P	Diag1	X-Symmetry	1X	2P	2	5	0.5	0.75	0.5	3/4 A394	2	1	1	Long only	0.875	0	1	1.8125
0	g1X	Diag1	X-Gen	1P	2X	2	5	0.5	0.75	0.5	3/4 A394	2	1	1	Long only	0.875	0	1	1.8125
0	g2P	Diag1	X-Symmetry	2XY	1P	2	5	0.5	0.75	0.5	3/4 A394	2	1	1	Long only	0.875	0	1	1.8125
0	g2X	Diag1	X-Gen	2Y	1X	2	5	0.5	0.75	0.5	3/4 A394	2	1	1	Long only	0.875	0	1	1.8125
0	g3P	Diag2	XY-Symmetry	2X	3P	2	5	0.75	0.5	0.5	3/4 A394	2	1	1	Short only	0.875	0	1.125	1.875
0	g3X	Diag2	X-GenXY	2P	3X	2	5	0.75	0.5	0.5	3/4 A394	2	1	1	Short only	0.875	0	1.125	1.875
0	g3XY	Diag2	XY-GenXY	2Y	3XY	2	5	0.75	0.5	0.5	3/4 A394	2	1	1	Short only	0.875	0	1.125	1.875
0	g3Y	Diag2	Y-GenXY	2XY	3Y	2	5	0.75	0.5	0.5	3/4 A394	2	1	1	Short only	0.875	0	1.125	1.875
0	g4P	Diag2	XY-Symmetry	3P	2Y	2	5	0.75	0.5	0.5	3/4 A394	2	1	1	Short only	0.875	0	1.125	1.875
0	g4X	Diag2	X-GenXY	3X	2XY	2	5	0.75	0.5	0.5	3/4 A394	2	1	1	Short only	0.875	0	1.125	1.875
0	g4XY	Diag2	XY-GenXY	3XY	2X	2	5	0.75	0.5	0.5	3/4 A394	2	1	1	Short only	0.875	0	1.125	1.875
0	g4Y	Diag2	Y-GenXY	3Y	2P	2	5	0.75	0.5	0.5	3/4 A394	2	1	1	Short only	0.875	0	1.125	1.875
0	g5P	Diag2	XY-Symmetry	4X	3P	2	5	0.75	0.5	0.5	3/4 A394	2	1	1	Short only	0.875	0	1.125	1.8125

0	0	0																		
0	g5X	Diag2	X-GenXY	4P	3X	2	5	0.75	0.5	0.5	3/4	A394	2	1	1	Short only	0.875	0	1.125	1.8125
0	0	0																		
0	g5XY	Diag2	XY-GenXY	4Y	3XY	2	5	0.75	0.5	0.5	3/4	A394	2	1	1	Short only	0.875	0	1.125	1.8125
0	0	0																		
0	g5Y	Diag2	Y-GenXY	4XY	3Y	2	5	0.75	0.5	0.5	3/4	A394	2	1	1	Short only	0.875	0	1.125	1.8125
0	0	0																		
0	g6P	Diag2	XY-Symmetry	4P	3Y	2	5	0.75	0.5	0.5	3/4	A394	2	1	1	Short only	0.875	0	1.125	1.8125
0	0	0																		
0	g6X	Diag2	X-GenXY	4X	3XY	2	5	0.75	0.5	0.5	3/4	A394	2	1	1	Short only	0.875	0	1.125	1.8125
0	0	0																		
0	g6XY	Diag2	XY-GenXY	4XY	3X	2	5	0.75	0.5	0.5	3/4	A394	2	1	1	Short only	0.875	0	1.125	1.8125
0	0	0																		
0	g6Y	Diag2	Y-GenXY	4Y	3P	2	5	0.75	0.5	0.5	3/4	A394	2	1	1	Short only	0.875	0	1.125	1.8125
0	0	0																		
0	g7P	Diag2	XY-Symmetry	5X	4P	2	5	0.75	0.5	0.5	3/4	A394	2	1	1	Short only	0.875	0	1.15625	1.8125
0	0	0																		
0	g7X	Diag2	X-GenXY	5P	4X	2	5	0.75	0.5	0.5	3/4	A394	2	1	1	Short only	0.875	0	1.15625	1.8125
0	0	0																		
0	g7XY	Diag2	XY-GenXY	5Y	4XY	2	5	0.75	0.5	0.5	3/4	A394	2	1	1	Short only	0.875	0	1.15625	1.8125
0	0	0																		
0	g7Y	Diag2	Y-GenXY	5XY	4Y	2	5	0.75	0.5	0.5	3/4	A394	2	1	1	Short only	0.875	0	1.15625	1.8125
0	0	0																		
0	g8P	Diag2	XY-Symmetry	5P	4Y	2	5	0.75	0.5	0.5	3/4	A394	2	1	1	Short only	0.875	0	1.15625	1.8125
0	0	0																		
0	g8X	Diag2	X-GenXY	5X	4XY	2	5	0.75	0.5	0.5	3/4	A394	2	1	1	Short only	0.875	0	1.15625	1.8125
0	0	0																		
0	g8XY	Diag2	XY-GenXY	5XY	4X	2	5	0.75	0.5	0.5	3/4	A394	2	1	1	Short only	0.875	0	1.15625	1.8125
0	0	0																		
0	g8Y	Diag2	Y-GenXY	5Y	4P	2	5	0.75	0.5	0.5	3/4	A394	2	1	1	Short only	0.875	0	1.15625	1.8125
0	0	0																		
0	g9P	Diag4	XY-Symmetry	6X	5P	2	5	0.75	0.5	0.5	3/4	A394	4	2	1	Short only	0.875	1.75	1.125	3.5
3.4063	1.3928	0																		
0	g9X	Diag4	X-GenXY	6P	5X	2	5	0.75	0.5	0.5	3/4	A394	4	2	1	Short only	0.875	1.75	1.125	3.5
3.4063	1.3928	0																		
0	g9XY	Diag4	XY-GenXY	6Y	5XY	2	5	0.75	0.5	0.5	3/4	A394	4	2	1	Short only	0.875	1.75	1.125	3.5
3.4063	1.3928	0																		
0	g9Y	Diag4	Y-GenXY	6XY	5Y	2	5	0.75	0.5	0.5	3/4	A394	4	2	1	Short only	0.875	1.75	1.125	3.5
3.4063	1.3928	0																		
0	g10P	Diag4	XY-Symmetry	6P	5Y	2	5	0.75	0.5	0.5	3/4	A394	4	2	1	Short only	0.875	1.75	1.125	3.5
3.4063	1.3928	0																		
0	g10X	Diag4	X-GenXY	6X	5XY	2	5	0.75	0.5	0.5	3/4	A394	4	2	1	Short only	0.875	1.75	1.125	3.5
3.4063	1.3928	0																		
0	g10XY	Diag4	XY-GenXY	6XY	5X	2	5	0.75	0.5	0.5	3/4	A394	4	2	1	Short only	0.875	1.75	1.125	3.5
3.4063	1.3928	0																		
0	g10Y	Diag4	Y-GenXY	6Y	5P	2	5	0.75	0.5	0.5	3/4	A394	4	2	1	Short only	0.875	1.75	1.125	3.5
3.4063	1.3928	0																		
0	g11P	Diag4	XY-Symmetry	7X	6P	2	5	0.75	0.5	0.5	3/4	A394	4	2	1	Short only	0.875	1.75	1.15625	3.25
3.2188	1.67	0																		
0	g11X	Diag4	X-GenXY	7P	6X	2	5	0.75	0.5	0.5	3/4	A394	4	2	1	Short only	0.875	1.75	1.15625	3.25
3.2188	1.67	0																		
0	g11XY	Diag4	XY-GenXY	7Y	6XY	2	5	0.75	0.5	0.5	3/4	A394	4	2	1	Short only	0.875	1.75	1.15625	3.25
3.2188	1.67	0																		
0	g11Y	Diag4	Y-GenXY	7XY	6Y	2	5	0.75	0.5	0.5	3/4	A394	4	2	1	Short only	0.875	1.75	1.15625	3.25
3.2188	1.67	0																		
0	g12P	Diag4	XY-Symmetry	7P	6Y	2	5	0.75	0.5	0.5	3/4	A394	4	2	1	Short only	0.875	1.75	1.15625	3.25
3.2188	1.67	0																		
0	g12X	Diag4	X-GenXY	7X	6XY	2	5	0.75	0.5	0.5	3/4	A394	4	2	1	Short only	0.875	1.75	1.15625	3.25
3.2188	1.67	0																		

g12XY	Diag4		XY-GenXY	7XY	6X	2	5	0.75	0.5	0.5	3/4	A394	4	2	1 Short only	0.875	1.75	1.15625	3.25
3.2188	1.67	0																	
g12Y	Diag4		Y-GenXY	7Y	6P	2	5	0.75	0.5	0.5	3/4	A394	4	2	1 Short only	0.875	1.75	1.15625	3.25
3.2188	1.67	0																	
g13P	Diag4		XY-Symmetry	8X	7P	2	5	0.75	0.5	0.5	3/4	A394	4	2	1 Short only	0.875	1.75	1.15625	3.25
3.2188	1.67	0																	
g13X	Diag4		X-GenXY	8P	7X	2	5	0.75	0.5	0.5	3/4	A394	4	2	1 Short only	0.875	1.75	1.15625	3.25
3.2188	1.67	0																	
g13XY	Diag4		XY-GenXY	8Y	7XY	2	5	0.75	0.5	0.5	3/4	A394	4	2	1 Short only	0.875	1.75	1.15625	3.25
3.2188	1.67	0																	
g13Y	Diag4		Y-GenXY	8XY	7Y	2	5	0.75	0.5	0.5	3/4	A394	4	2	1 Short only	0.875	1.75	1.15625	3.25
3.2188	1.67	0																	
g14P	Diag4		XY-Symmetry	8P	7Y	2	5	0.75	0.5	0.5	3/4	A394	4	2	1 Short only	0.875	1.75	1.15625	3.25
3.2188	1.67	0																	
g14X	Diag4		X-GenXY	8X	7XY	2	5	0.75	0.5	0.5	3/4	A394	4	2	1 Short only	0.875	1.75	1.15625	3.25
3.2188	1.67	0																	
g14XY	Diag4		XY-GenXY	8XY	7X	2	5	0.75	0.5	0.5	3/4	A394	4	2	1 Short only	0.875	1.75	1.15625	3.25
3.2188	1.67	0																	
g14Y	Diag4		Y-GenXY	8Y	7P	2	5	0.75	0.5	0.5	3/4	A394	4	2	1 Short only	0.875	1.75	1.15625	3.25
3.2188	1.67	0																	
g15P	Diag5		XY-Symmetry	9X	8P	2	5	0.5	0.75	0.5	3/4	A394	4	2	1 Long only	1.375	2.25	1.15625	3
2.9688	2	0																	
g15X	Diag5		X-GenXY	9P	8X	2	5	0.5	0.75	0.5	3/4	A394	4	2	1 Long only	1.375	2.25	1.15625	3
2.9688	2	0																	
g15XY	Diag5		XY-GenXY	9Y	8XY	2	5	0.5	0.75	0.5	3/4	A394	4	2	1 Long only	1.375	2.25	1.15625	3
2.9688	2	0																	
g15Y	Diag5		Y-GenXY	9XY	8Y	2	5	0.5	0.75	0.5	3/4	A394	4	2	1 Long only	1.375	2.25	1.15625	3
2.9688	2	0																	
g16P	Diag5		XY-Symmetry	9P	8Y	2	5	0.5	0.75	0.5	3/4	A394	4	2	1 Long only	1.375	2.25	1.15625	3
2.9688	2	0																	
g16X	Diag5		X-GenXY	9X	8XY	2	5	0.5	0.75	0.5	3/4	A394	4	2	1 Long only	1.375	2.25	1.15625	3
2.9688	2	0																	
g16XY	Diag5		XY-GenXY	9XY	8X	2	5	0.5	0.75	0.5	3/4	A394	4	2	1 Long only	1.375	2.25	1.15625	3
2.9688	2	0																	
g16Y	Diag5		Y-GenXY	9Y	8P	2	5	0.5	0.75	0.5	3/4	A394	4	2	1 Long only	1.375	2.25	1.15625	3
2.9688	2	0																	
g17P	Diag10		XY-Symmetry	10X	9P	2	5	0.5	0.75	0.5	3/4	A394	6	2	1 Long only	1.25	3.25	1.15625	4.5
3.5938	2.995	0																	
g17X	Diag10		X-GenXY	10P	9X	2	5	0.5	0.75	0.5	3/4	A394	6	2	1 Long only	1.25	3.25	1.15625	4.5
3.5938	2.995	0																	
g17XY	Diag10		XY-GenXY	10Y	9XY	2	5	0.5	0.75	0.5	3/4	A394	6	2	1 Long only	1.25	3.25	1.15625	4.5
3.5938	2.995	0																	
g17Y	Diag10		Y-GenXY	10XY	9Y	2	5	0.5	0.75	0.5	3/4	A394	6	2	1 Long only	1.25	3.25	1.15625	4.5
3.5938	2.995	0																	
g18P	Diag10		XY-Symmetry	10P	9Y	2	5	0.5	0.75	0.5	3/4	A394	6	2	1 Long only	1.25	3.25	1.15625	4.5
3.5938	2.995	0																	
g18X	Diag10		X-GenXY	10X	9XY	2	5	0.5	0.75	0.5	3/4	A394	6	2	1 Long only	1.25	3.25	1.15625	4.5
3.5938	2.995	0																	
g18XY	Diag10		XY-GenXY	10XY	9X	2	5	0.5	0.75	0.5	3/4	A394	6	2	1 Long only	1.25	3.25	1.15625	4.5
3.5938	2.995	0																	
g18Y	Diag10		Y-GenXY	10Y	9P	2	5	0.5	0.75	0.5	3/4	A394	6	2	1 Long only	1.25	3.25	1.15625	4.5
3.5938	2.995	0																	
g19P	Diag10		XY-Symmetry	11X	10P	2	5	0.5	0.75	0.5	3/4	A394	6	2	1 Long only	1.25	3.25	1.125	4.125
3.4688	2.69	0																	
g19X	Diag10		X-GenXY	11P	10X	2	5	0.5	0.75	0.5	3/4	A394	6	2	1 Long only	1.25	3.25	1.125	4.125
3.4688	2.69	0																	
g19XY	Diag10		XY-GenXY	11Y	10XY	2	5	0.5	0.75	0.5	3/4	A394	6	2	1 Long only	1.25	3.25	1.125	4.125
3.4688	2.69	0																	
g19Y	Diag10		Y-GenXY	11XY	10Y	2	5	0.5	0.75	0.5	3/4	A394	6	2	1 Long only	1.25	3.25	1.125	4.125

3.4688	2.69	0																		
	g20P	Diag10	XY-Symmetry	11P	10Y	2	5	0.5	0.75	0.5	3/4	A394	6	2	1	Long only	1.25	3.25	1.125	4.125
3.4688	2.69	0																		
	g20X	Diag10	X-GenXY	11X	10XY	2	5	0.5	0.75	0.5	3/4	A394	6	2	1	Long only	1.25	3.25	1.125	4.125
3.4688	2.69	0																		
	g20XY	Diag10	XY-GenXY	11XY	10X	2	5	0.5	0.75	0.5	3/4	A394	6	2	1	Long only	1.25	3.25	1.125	4.125
3.4688	2.69	0																		
	g20Y	Diag10	Y-GenXY	11Y	10P	2	5	0.5	0.75	0.5	3/4	A394	6	2	1	Long only	1.25	3.25	1.125	4.125
3.4688	2.69	0																		
	g21P	Diag10	XY-Symmetry	12X	11P	2	5	0.5	0.75	0.5	3/4	A394	6	2	1	Long only	1.25	3.25	1.125	4.125
3.4688	2.69	0																		
	g21X	Diag10	X-GenXY	12P	11X	2	5	0.5	0.75	0.5	3/4	A394	6	2	1	Long only	1.25	3.25	1.125	4.125
3.4688	2.69	0																		
	g21XY	Diag10	XY-GenXY	12Y	11XY	2	5	0.5	0.75	0.5	3/4	A394	6	2	1	Long only	1.25	3.25	1.125	4.125
3.4688	2.69	0																		
	g21Y	Diag10	Y-GenXY	12XY	11Y	2	5	0.5	0.75	0.5	3/4	A394	6	2	1	Long only	1.25	3.25	1.125	4.125
3.4688	2.69	0																		
	g22P	Diag10	XY-Symmetry	12P	11Y	2	5	0.5	0.75	0.5	3/4	A394	6	2	1	Long only	1.25	3.25	1.125	4.125
3.4688	2.69	0																		
	g22X	Diag10	X-GenXY	12X	11XY	2	5	0.5	0.75	0.5	3/4	A394	6	2	1	Long only	1.25	3.25	1.125	4.125
3.4688	2.69	0																		
	g22XY	Diag10	XY-GenXY	12XY	11X	2	5	0.5	0.75	0.5	3/4	A394	6	2	1	Long only	1.25	3.25	1.125	4.125
3.4688	2.69	0																		
	g22Y	Diag10	Y-GenXY	12Y	11P	2	5	0.5	0.75	0.5	3/4	A394	6	2	1	Long only	1.25	3.25	1.125	4.125
3.4688	2.69	0																		
	g23P	Diag11	XY-Symmetry	13X	12P	2	5	0.5	0.75	0.5	3/4	A394	6	2	1	Long only	1.25	3.25	1.15625	3.625
3.2188	2.576	0																		
	g23X	Diag11	X-GenXY	13P	12X	2	5	0.5	0.75	0.5	3/4	A394	6	2	1	Long only	1.25	3.25	1.15625	3.625
3.2188	2.576	0																		
	g23XY	Diag11	XY-GenXY	13Y	12XY	2	5	0.5	0.75	0.5	3/4	A394	6	2	1	Long only	1.25	3.25	1.15625	3.625
3.2188	2.576	0																		
	g23Y	Diag11	Y-GenXY	13XY	12Y	2	5	0.5	0.75	0.5	3/4	A394	6	2	1	Long only	1.25	3.25	1.15625	3.625
3.2188	2.576	0																		
	g24P	Diag11	XY-Symmetry	13P	12Y	2	5	0.5	0.75	0.5	3/4	A394	6	2	1	Long only	1.25	3.25	1.15625	3.625
3.2188	2.576	0																		
	g24X	Diag11	X-GenXY	13X	12XY	2	5	0.5	0.75	0.5	3/4	A394	6	2	1	Long only	1.25	3.25	1.15625	3.625
3.2188	2.576	0																		
	g24XY	Diag11	XY-GenXY	13XY	12X	2	5	0.5	0.75	0.5	3/4	A394	6	2	1	Long only	1.25	3.25	1.15625	3.625
3.2188	2.576	0																		
	g24Y	Diag11	Y-GenXY	13Y	12P	2	5	0.5	0.75	0.5	3/4	A394	6	2	1	Long only	1.25	3.25	1.15625	3.625
3.2188	2.576	0																		
	g25P	Diag10	XY-Symmetry	14X	13P	2	5	0.555	0.778	0.555	3/4	A394	6	2	1	Long only	1.25	3.25	1.15625	2.75
3.5313	2.608	0																		
	g25X	Diag10	X-GenXY	14P	13X	2	5	0.555	0.778	0.555	3/4	A394	6	2	1	Long only	1.25	3.25	1.15625	2.75
3.5313	2.608	0																		
	g25XY	Diag10	XY-GenXY	14Y	13XY	2	5	0.555	0.778	0.555	3/4	A394	6	2	1	Long only	1.25	3.25	1.15625	2.75
3.5313	2.608	0																		
	g25Y	Diag10	Y-GenXY	14XY	13Y	2	5	0.555	0.778	0.555	3/4	A394	6	2	1	Long only	1.25	3.25	1.15625	2.75
3.5313	2.608	0																		
	g26P	Diag10	XY-Symmetry	14P	13Y	2	5	0.555	0.778	0.555	3/4	A394	6	2	1	Long only	1.25	3.25	1.15625	2.75
3.5313	2.608	0																		
	g26X	Diag10	X-GenXY	14X	13XY	2	5	0.555	0.778	0.555	3/4	A394	6	2	1	Long only	1.25	3.25	1.15625	2.75
3.5313	2.608	0																		
	g26XY	Diag10	XY-GenXY	14XY	13X	2	5	0.555	0.778	0.555	3/4	A394	6	2	1	Long only	1.25	3.25	1.15625	2.75
3.5313	2.608	0																		
	g26Y	Diag10	Y-GenXY	14Y	13P	2	5	0.555	0.778	0.555	3/4	A394	6	2	1	Long only	1.25	3.25	1.15625	2.75
3.5313	2.608	0																		
	g27P	Diag10	XY-Symmetry	15X	14P	2	5	0.539	0.77	0.539	3/4	A394	5	2	1	Long only	1.25	3.25	1.15625	3
3.5313	2.8438	0																		

g27X	Diag10		X-GenXY	15P	14X	2	5	0.539	0.77	0.539	3/4	A394	5	2	1	Long only	1.25	3.25	1.15625	3
3.5313	2.8438	0																		
g27XY	Diag10		XY-GenXY	15Y	14XY	2	5	0.539	0.77	0.539	3/4	A394	5	2	1	Long only	1.25	3.25	1.15625	3
3.5313	2.8438	0																		
g27Y	Diag10		Y-GenXY	15XY	14Y	2	5	0.539	0.77	0.539	3/4	A394	5	2	1	Long only	1.25	3.25	1.15625	3
3.5313	2.8438	0																		
g28P	Diag10		XY-Symmetry	15P	14Y	2	5	0.539	0.77	0.539	3/4	A394	5	2	1	Long only	1.25	3.25	1.15625	3
3.5313	2.8438	0																		
g28X	Diag10		X-GenXY	15X	14XY	2	5	0.539	0.77	0.539	3/4	A394	5	2	1	Long only	1.25	3.25	1.15625	3
3.5313	2.8438	0																		
g28XY	Diag10		XY-GenXY	15XY	14X	2	5	0.539	0.77	0.539	3/4	A394	5	2	1	Long only	1.25	3.25	1.15625	3
3.5313	2.8438	0																		
g28Y	Diag10		Y-GenXY	15Y	14P	2	5	0.539	0.77	0.539	3/4	A394	5	2	1	Long only	1.25	3.25	1.15625	3
3.5313	2.8438	0																		
g29P	Diag5		XY-Symmetry	16X	15P	2	5	0.768	0.537	0.537	3/4	A394	4	2	1	Short only	0.875	1.75	1.15625	2.5
3.2188	1.908	0																		
g29X	Diag5		X-GenXY	16P	15X	2	5	0.768	0.537	0.537	3/4	A394	4	2	1	Short only	0.875	1.75	1.15625	2.5
3.2188	1.908	0																		
g29XY	Diag5		XY-GenXY	16Y	15XY	2	5	0.768	0.537	0.537	3/4	A394	4	2	1	Short only	0.875	1.75	1.15625	2.5
3.2188	1.908	0																		
g29Y	Diag5		Y-GenXY	16XY	15Y	2	5	0.768	0.537	0.537	3/4	A394	4	2	1	Short only	0.875	1.75	1.15625	2.5
3.2188	1.908	0																		
g30P	Diag5		XY-Symmetry	16P	15Y	2	5	0.768	0.537	0.537	3/4	A394	4	2	1	Short only	0.875	1.75	1.15625	2.5
3.2188	1.908	0																		
g30X	Diag5		X-GenXY	16X	15XY	2	5	0.768	0.537	0.537	3/4	A394	4	2	1	Short only	0.875	1.75	1.15625	2.5
3.2188	1.908	0																		
g30XY	Diag5		XY-GenXY	16XY	15X	2	5	0.768	0.537	0.537	3/4	A394	4	2	1	Short only	0.875	1.75	1.15625	2.5
3.2188	1.908	0																		
g30Y	Diag5		Y-GenXY	16Y	15P	2	5	0.768	0.537	0.537	3/4	A394	4	2	1	Short only	0.875	1.75	1.15625	2.5
3.2188	1.908	0																		
g31P	Diag5		XY-Symmetry	17X	16P	2	5	0.771	0.541	0.541	3/4	A394	4	2	1	Short only	0.875	1.75	1.15625	3.5
3.4688	1.67	0																		
g31X	Diag5		X-GenXY	17P	16X	2	5	0.771	0.541	0.541	3/4	A394	4	2	1	Short only	0.875	1.75	1.15625	3.5
3.4688	1.67	0																		
g31XY	Diag5		XY-GenXY	17Y	16XY	2	5	0.771	0.541	0.541	3/4	A394	4	2	1	Short only	0.875	1.75	1.15625	3.5
3.4688	1.67	0																		
g31Y	Diag5		Y-GenXY	17XY	16Y	2	5	0.771	0.541	0.541	3/4	A394	4	2	1	Short only	0.875	1.75	1.15625	3.5
3.4688	1.67	0																		
g32P	Diag5		XY-Symmetry	17P	16Y	2	5	0.771	0.541	0.541	3/4	A394	4	2	1	Short only	0.875	1.75	1.15625	3.5
3.4688	1.67	0																		
g32X	Diag5		X-GenXY	17X	16XY	2	5	0.771	0.541	0.541	3/4	A394	4	2	1	Short only	0.875	1.75	1.15625	3.5
3.4688	1.67	0																		
g32XY	Diag5		XY-GenXY	17XY	16X	2	5	0.771	0.541	0.541	3/4	A394	4	2	1	Short only	0.875	1.75	1.15625	3.5
3.4688	1.67	0																		
g32Y	Diag5		Y-GenXY	17Y	16P	2	5	0.771	0.541	0.541	3/4	A394	4	2	1	Short only	0.875	1.75	1.15625	3.5
3.4688	1.67	0																		
g33P	Diag4		XY-Symmetry	18X	17P	2	5	0.766	0.531	0.531	3/4	A394	3	1	1	Short only	1.5	0	1.125	2.125
0	0	0																		
g33X	Diag4		X-GenXY	18P	17X	2	5	0.766	0.531	0.531	3/4	A394	3	1	1	Short only	1.5	0	1.125	2.125
0	0	0																		
g33XY	Diag4		XY-GenXY	18Y	17XY	2	5	0.766	0.531	0.531	3/4	A394	3	1	1	Short only	1.5	0	1.125	2.125
0	0	0																		
g33Y	Diag4		Y-GenXY	18XY	17Y	2	5	0.766	0.531	0.531	3/4	A394	3	1	1	Short only	1.5	0	1.125	2.125
0	0	0																		
g34P	Diag4		XY-Symmetry	18P	17Y	2	5	0.766	0.531	0.531	3/4	A394	3	1	1	Short only	1.5	0	1.125	2.125
0	0	0																		
g34X	Diag4		X-GenXY	18X	17XY	2	5	0.766	0.531	0.531	3/4	A394	3	1	1	Short only	1.5	0	1.125	2.125
0	0	0																		
g34XY	Diag4		XY-GenXY	18XY	17X	2	5	0.766	0.531	0.531	3/4	A394	3	1	1	Short only	1.5	0	1.125	2.125

0	0	0																		
0	g34Y	Diag4	Y-GenXY	18Y	17P	2	5	0.766	0.531	0.531	3/4	A394	3	1	1	Short only	1.5	0	1.125	2.125
0	0	0																		
0	g35P	Diag4	XY-Symmetry	19X	18P	2	5	0.767	0.534	0.534	3/4	A394	3	1	1	Short only	1.5	0	1.125	2.1875
0	0	0																		
0	g35X	Diag4	X-GenXY	19P	18X	2	5	0.767	0.534	0.534	3/4	A394	3	1	1	Short only	1.5	0	1.125	2.1875
0	0	0																		
0	g35XY	Diag4	XY-GenXY	19Y	18XY	2	5	0.767	0.534	0.534	3/4	A394	3	1	1	Short only	1.5	0	1.125	2.1875
0	0	0																		
0	g35Y	Diag4	Y-GenXY	19XY	18Y	2	5	0.767	0.534	0.534	3/4	A394	3	1	1	Short only	1.5	0	1.125	2.1875
0	0	0																		
0	g36P	Diag4	XY-Symmetry	19P	18Y	2	5	0.767	0.534	0.534	3/4	A394	3	1	1	Short only	1.5	0	1.125	2.1875
0	0	0																		
0	g36X	Diag4	X-GenXY	19X	18XY	2	5	0.767	0.534	0.534	3/4	A394	3	1	1	Short only	1.5	0	1.125	2.1875
0	0	0																		
0	g36XY	Diag4	XY-GenXY	19XY	18X	2	5	0.767	0.534	0.534	3/4	A394	3	1	1	Short only	1.5	0	1.125	2.1875
0	0	0																		
0	g36Y	Diag4	Y-GenXY	19Y	18P	2	5	0.767	0.534	0.534	3/4	A394	3	1	1	Short only	1.5	0	1.125	2.1875
0	0	0																		
0	g37P	Diag3	XY-Symmetry	20X	19P	2	5	0.765	0.531	0.531	3/4	A394	3	1	1	Short only	1.25	0	1.15625	2.0625
0	0	0																		
0	g37X	Diag3	X-GenXY	20P	19X	2	5	0.765	0.531	0.531	3/4	A394	3	1	1	Short only	1.25	0	1.15625	2.0625
0	0	0																		
0	g37XY	Diag3	XY-GenXY	20Y	19XY	2	5	0.765	0.531	0.531	3/4	A394	3	1	1	Short only	1.25	0	1.15625	2.0625
0	0	0																		
0	g37Y	Diag3	Y-GenXY	20XY	19Y	2	5	0.765	0.531	0.531	3/4	A394	3	1	1	Short only	1.25	0	1.15625	2.0625
0	0	0																		
0	g38P	Diag3	XY-Symmetry	20P	19Y	2	5	0.765	0.531	0.531	3/4	A394	3	1	1	Short only	1.25	0	1.15625	2.0625
0	0	0																		
0	g38X	Diag3	X-GenXY	20X	19XY	2	5	0.765	0.531	0.531	3/4	A394	3	1	1	Short only	1.25	0	1.15625	2.0625
0	0	0																		
0	g38XY	Diag3	XY-GenXY	20XY	19X	2	5	0.765	0.531	0.531	3/4	A394	3	1	1	Short only	1.25	0	1.15625	2.0625
0	0	0																		
0	g38Y	Diag3	Y-GenXY	20Y	19P	2	5	0.765	0.531	0.531	3/4	A394	3	1	1	Short only	1.25	0	1.15625	2.0625
0	0	0																		
0	g39P	Diag4	XY-Symmetry	21X	20P	2	5	0.768	0.535	0.535	3/4	A394	3	1	1	Short only	1.5	0	1.15625	2
0	0	0																		
0	g39X	Diag4	X-GenXY	21P	20X	2	5	0.768	0.535	0.535	3/4	A394	3	1	1	Short only	1.5	0	1.15625	2
0	0	0																		
0	g39XY	Diag4	XY-GenXY	21Y	20XY	2	5	0.768	0.535	0.535	3/4	A394	3	1	1	Short only	1.5	0	1.15625	2
0	0	0																		
0	g39Y	Diag4	Y-GenXY	21XY	20Y	2	5	0.768	0.535	0.535	3/4	A394	3	1	1	Short only	1.5	0	1.15625	2
0	0	0																		
0	g40P	Diag4	XY-Symmetry	21P	20Y	2	5	0.768	0.535	0.535	3/4	A394	3	1	1	Short only	1.5	0	1.15625	2
0	0	0																		
0	g40X	Diag4	X-GenXY	21X	20XY	2	5	0.768	0.535	0.535	3/4	A394	3	1	1	Short only	1.5	0	1.15625	2
0	0	0																		
0	g40XY	Diag4	XY-GenXY	21XY	20X	2	5	0.768	0.535	0.535	3/4	A394	3	1	1	Short only	1.5	0	1.15625	2
0	0	0																		
0	g40Y	Diag4	Y-GenXY	21Y	20P	2	5	0.768	0.535	0.535	3/4	A394	3	1	1	Short only	1.5	0	1.15625	2
0	0	0																		
0	g41P	Diag5	XY-Symmetry	23X	21P	2	5	0.768	0.536	0.536	3/4	A394	2	1	1	Short only	1.5	0	1.15625	4.0625
0	0	0																		
0	g41X	Diag5	X-GenXY	23P	21X	2	5	0.768	0.536	0.536	3/4	A394	2	1	1	Short only	1.5	0	1.15625	4.0625
0	0	0																		
0	g41XY	Diag5	XY-GenXY	23Y	21XY	2	5	0.768	0.536	0.536	3/4	A394	2	1	1	Short only	1.5	0	1.15625	4.0625
0	0	0																		
0	g41Y	Diag5	Y-GenXY	23XY	21Y	2	5	0.768	0.536	0.536	3/4	A394	2	1	1	Short only	1.5	0	1.15625	4.0625
0	0	0																		

0	g42P	Diag5	XY-Symmetry	23P	21Y	2	5	0.768	0.536	0.536	3/4	A394	2	1	1 Short only	1.5	0	1.15625	4.0625
0	g42X	Diag5	X-GenXY	23X	21XY	2	5	0.768	0.536	0.536	3/4	A394	2	1	1 Short only	1.5	0	1.15625	4.0625
0	g42XY	Diag5	XY-GenXY	23XY	21X	2	5	0.768	0.536	0.536	3/4	A394	2	1	1 Short only	1.5	0	1.15625	4.0625
0	g42Y	Diag5	Y-GenXY	23Y	21P	2	5	0.768	0.536	0.536	3/4	A394	2	1	1 Short only	1.5	0	1.15625	4.0625
0	g43P	Diag6	XY-Symmetry	25X	23P	2	5	0.768	0.537	0.537	3/4	A394	2	1	1 Short only	1.75	0	1.15625	4.0625
0	g43X	Diag6	X-GenXY	25P	23X	2	5	0.768	0.537	0.537	3/4	A394	2	1	1 Short only	1.75	0	1.15625	4.0625
0	g43XY	Diag6	XY-GenXY	25Y	23XY	2	5	0.768	0.537	0.537	3/4	A394	2	1	1 Short only	1.75	0	1.15625	4.0625
0	g43Y	Diag6	Y-GenXY	25XY	23Y	2	5	0.768	0.537	0.537	3/4	A394	2	1	1 Short only	1.75	0	1.15625	4.0625
0	g44P	Diag6	XY-Symmetry	25P	23Y	2	5	0.768	0.537	0.537	3/4	A394	2	1	1 Short only	1.75	0	1.15625	4.0625
0	g44X	Diag6	X-GenXY	25X	23XY	2	5	0.768	0.537	0.537	3/4	A394	2	1	1 Short only	1.75	0	1.15625	4.0625
0	g44XY	Diag6	XY-GenXY	25XY	23X	2	5	0.768	0.537	0.537	3/4	A394	2	1	1 Short only	1.75	0	1.15625	4.0625
0	g44Y	Diag6	Y-GenXY	25Y	23P	2	5	0.768	0.537	0.537	3/4	A394	2	1	1 Short only	1.75	0	1.15625	4.0625
0	g45P	Diag6	XY-Symmetry	27X	25P	2	5	0.766	0.537	0.537	3/4	A394	2	1	1 Short only	1.75	0	1.125	3.9375
0	g45X	Diag6	X-GenXY	27P	25X	2	5	0.766	0.537	0.537	3/4	A394	2	1	1 Short only	1.75	0	1.125	3.9375
0	g45XY	Diag6	XY-GenXY	27Y	25XY	2	5	0.766	0.537	0.537	3/4	A394	2	1	1 Short only	1.75	0	1.125	3.9375
0	g45Y	Diag6	Y-GenXY	27XY	25Y	2	5	0.766	0.537	0.537	3/4	A394	2	1	1 Short only	1.75	0	1.125	3.9375
0	g46P	Diag6	XY-Symmetry	27P	25Y	2	5	0.766	0.537	0.537	3/4	A394	2	1	1 Short only	1.75	0	1.125	3.9375
0	g46X	Diag6	X-GenXY	27X	25XY	2	5	0.766	0.537	0.537	3/4	A394	2	1	1 Short only	1.75	0	1.125	3.9375
0	g46XY	Diag6	XY-GenXY	27XY	25X	2	5	0.766	0.537	0.537	3/4	A394	2	1	1 Short only	1.75	0	1.125	3.9375
0	g46Y	Diag6	Y-GenXY	27Y	25P	2	5	0.766	0.537	0.537	3/4	A394	2	1	1 Short only	1.75	0	1.125	3.9375
0	g47P	Diag7	XY-Symmetry	29X	27P	2	5	0.767	0.533	0.533	3/4	A394	2	1	1 Short only	1.75	0	1.15625	3.875
0	g47X	Diag7	X-GenXY	29P	27X	2	5	0.767	0.533	0.533	3/4	A394	2	1	1 Short only	1.75	0	1.15625	3.875
0	g47XY	Diag7	XY-GenXY	29Y	27XY	2	5	0.767	0.533	0.533	3/4	A394	2	1	1 Short only	1.75	0	1.15625	3.875
0	g47Y	Diag7	Y-GenXY	29XY	27Y	2	5	0.767	0.533	0.533	3/4	A394	2	1	1 Short only	1.75	0	1.15625	3.875
0	g48P	Diag7	XY-Symmetry	29P	27Y	2	5	0.767	0.533	0.533	3/4	A394	2	1	1 Short only	1.75	0	1.15625	3.875
0	g48X	Diag7	X-GenXY	29X	27XY	2	5	0.767	0.533	0.533	3/4	A394	2	1	1 Short only	1.75	0	1.15625	3.875
0	g48XY	Diag7	XY-GenXY	29XY	27X	2	5	0.767	0.533	0.533	3/4	A394	2	1	1 Short only	1.75	0	1.15625	3.875
0	g48Y	Diag7	Y-GenXY	29Y	27P	2	5	0.767	0.533	0.533	3/4	A394	2	1	1 Short only	1.75	0	1.15625	3.875
0	g49P	Diag8	XY-Symmetry	30X	39P	2	5	1	1	1	3/4	A394	2	1	1 Short only	2.5	0	1.125	2
0	g49X	Diag8	X-GenXY	30P	39P	2	5	1	1	1	3/4	A394	2	1	1 Short only	2.5	0	1.125	2

0	0	0																	
0	g49XY	Diag8	XY-GenXY	30Y	39Y	2	5	1	1	1 3/4	A394	2	1	1	Short only	2.5	0	1.125	2
0	0	0																	
0	g49Y	Diag8	Y-GenXY	30XY	39Y	2	5	1	1	1 3/4	A394	2	1	1	Short only	2.5	0	1.125	2
0	0	0																	
0	g50P	Diag8	XY-Symmetry	30P	40P	2	5	1	1	1 3/4	A394	2	1	1	Short only	2.5	0	1.125	2
0	0	0																	
0	g50X	Diag8	X-GenXY	30X	40X	2	5	1	1	1 3/4	A394	2	1	1	Short only	2.5	0	1.125	2
0	0	0																	
0	g50XY	Diag8	XY-GenXY	30XY	40X	2	5	1	1	1 3/4	A394	2	1	1	Short only	2.5	0	1.125	2
0	0	0																	
0	g50Y	Diag8	Y-GenXY	30Y	40P	2	5	1	1	1 3/4	A394	2	1	1	Short only	2.5	0	1.125	2
0	0	0																	
0	g51P	Horz5	Y-Symmetry	2X	2P	3	6	1	1	1 3/4	A394	2	1	1	Long only	1.5	0	1.125	2.25
0	0	0																	
0	g51Y	Horz5	Y-Gen	2XY	2Y	3	6	1	1	1 3/4	A394	2	1	1	Long only	1.5	0	1.125	2.25
0	0	0																	
0	g52P	Horz5	X-Symmetry	2P	2Y	3	6	1	1	1 3/4	A394	2	1	1	Long only	1.5	0	1.125	2.25
0	0	0																	
0	g52X	Horz5	X-Gen	2X	2XY	3	6	1	1	1 3/4	A394	2	1	1	Long only	1.5	0	1.125	2.25
0	0	0																	
0	g53P	Horz1	Y-Symmetry	4X	4P	3	4	1	1	1 3/4	A394	1	1	1	Long only	0.875	0	1.125	0
0	0	0																	
0	g53Y	Horz1	Y-Gen	4XY	4Y	3	4	1	1	1 3/4	A394	1	1	1	Long only	0.875	0	1.125	0
0	0	0																	
0	g54P	Horz6	X-Symmetry	5P	5Y	3	6	1	1	1 3/4	A394	2	1	1	Long only	1.5	0	1.125	2.75
0	0	0																	
0	g54X	Horz6	X-Gen	5X	5XY	3	6	1	1	1 3/4	A394	2	1	1	Long only	1.5	0	1.125	2.75
0	0	0																	
0	g55P	Horz1	Y-Symmetry	8X	8P	3	4	1	1	1 3/4	A394	1	1	1	Long only	0.875	0	1.125	0
0	0	0																	
0	g55Y	Horz1	Y-Gen	8XY	8Y	3	4	1	1	1 3/4	A394	1	1	1	Long only	0.875	0	1.125	0
0	0	0																	
0	g56P	Horz6	X-Symmetry	9P	9Y	3	6	1	1	1 3/4	A394	2	1	1	Long only	1.5	0	1.125	2.75
0	0	0																	
0	g56X	Horz6	X-Gen	9X	9XY	3	6	1	1	1 3/4	A394	2	1	1	Long only	1.5	0	1.125	2.75
0	0	0																	
0	g57P	Horz1	Y-Symmetry	12X	12P	3	4	1	1	1 3/4	A394	1	1	1	Long only	0.875	0	1.125	0
0	0	0																	
0	g57Y	Horz1	Y-Gen	12XY	12Y	3	4	1	1	1 3/4	A394	1	1	1	Long only	0.875	0	1.125	0
0	0	0																	
0	g58P	Horz6	X-Symmetry	13P	13Y	3	6	1	1	1 3/4	A394	2	1	1	Long only	1.5	0	1.125	2.75
0	0	0																	
0	g58X	Horz6	X-Gen	13X	13XY	3	6	1	1	1 3/4	A394	2	1	1	Long only	1.5	0	1.125	2.75
0	0	0																	
0	g59P	Horz2	Y-Symmetry	20X	20P	3	6	1	1	1 3/4	A394	2	1	1	Short only	0.875	0	1.125	3
0	0	0																	
0	g59Y	Horz2	Y-Gen	20XY	20Y	3	6	1	1	1 3/4	A394	2	1	1	Short only	0.875	0	1.125	3
0	0	0																	
0	g60P	Horz2	X-Symmetry	20P	20Y	3	6	1	1	1 3/4	A394	2	1	1	Short only	0.875	0	1.125	3
0	0	0																	
0	g60X	Horz2	X-Gen	20X	20XY	3	6	1	1	1 3/4	A394	2	1	1	Short only	0.875	0	1.125	3
0	0	0																	
0	g61P	Horz8	Y-Symmetry	27X	27P	3	6	1	1	1 3/4	A394	2	1	1	Short only	1.75	0	1.125	3
0	0	0																	
0	g61Y	Horz8	Y-Gen	27XY	27Y	3	6	1	1	1 3/4	A394	2	1	1	Short only	1.75	0	1.125	3
0	0	0																	
0	g62P	Horz8	X-Symmetry	27P	27Y	3	6	1	1	1 3/4	A394	2	1	1	Short only	1.75	0	1.125	3
0	0	0																	

0	g62X	Horz 8		X-Gen	27X	27XY	3	6	1	1	1 3/4	A394	2	1	1 Short only	1.75	0	1.125	3	
0	0	0																		
0	g63P	Horz 10		XY-Symmetry	29X	39P	3	5	1	1	1 3/4	A394	2	1	1 Short only	1.75	0	1.125	3	
0	0	0																		
0	g63X	Horz 10		X-GenXY	29P	39P	3	5	1	1	1 3/4	A394	2	1	1 Short only	1.75	0	1.125	3	
0	0	0																		
0	g63XY	Horz 10		XY-GenXY	29Y	39Y	3	5	1	1	1 3/4	A394	2	1	1 Short only	1.75	0	1.125	3	
0	0	0																		
0	g63Y	Horz 10		Y-GenXY	29XY	39Y	3	5	1	1	1 3/4	A394	2	1	1 Short only	1.75	0	1.125	3	
0	0	0																		
0	g64P	Horz 10		XY-Symmetry	29P	40P	3	5	1	1	1 3/4	A394	2	1	1 Short only	1.75	0	1.125	3	
0	0	0																		
0	g64X	Horz 10		X-GenXY	29X	40X	3	5	1	1	1 3/4	A394	2	1	1 Short only	1.75	0	1.125	3	
0	0	0																		
0	g64XY	Horz 10		XY-GenXY	29XY	40X	3	5	1	1	1 3/4	A394	2	1	1 Short only	1.75	0	1.125	3	
0	0	0																		
0	g64Y	Horz 10		Y-GenXY	29Y	40P	3	5	1	1	1 3/4	A394	2	1	1 Short only	1.75	0	1.125	3	
0	0	0																		
0	g65P	Leg 1		XY-Symmetry	1X	2X	1	4	1	1	1 3/4	A394	0	4	0	0	0	0	0	
0	0	0																		
0	g65X	Leg 1		X-GenXY	1P	2P	1	4	1	1	1 3/4	A394	0	4	0	0	0	0	0	
0	0	0																		
0	g65XY	Leg 1		XY-GenXY	1P	2Y	1	4	1	1	1 3/4	A394	0	4	0	0	0	0	0	
0	0	0																		
0	g65Y	Leg 1		Y-GenXY	1X	2XY	1	4	1	1	1 3/4	A394	0	4	0	0	0	0	0	
0	0	0																		
0	g66P	Leg 1		XY-Symmetry	2X	3X	1	4	1	1	1 3/4	A394	0	4	0	0	0	0	0	
0	0	0																		
0	g66X	Leg 1		X-GenXY	2P	3P	1	4	1	1	1 3/4	A394	0	4	0	0	0	0	0	
0	0	0																		
0	g66XY	Leg 1		XY-GenXY	2Y	3Y	1	4	1	1	1 3/4	A394	0	4	0	0	0	0	0	
0	0	0																		
0	g66Y	Leg 1		Y-GenXY	2XY	3XY	1	4	1	1	1 3/4	A394	0	4	0	0	0	0	0	
0	0	0																		
0	g67P	Leg 1		XY-Symmetry	3X	4X	1	4	1	1	1 3/4	A394	0	4	0	0	0	0	0	
0	0	0																		
0	g67X	Leg 1		X-GenXY	3P	4P	1	4	1	1	1 3/4	A394	0	4	0	0	0	0	0	
0	0	0																		
0	g67XY	Leg 1		XY-GenXY	3Y	4Y	1	4	1	1	1 3/4	A394	0	4	0	0	0	0	0	
0	0	0																		
0	g67Y	Leg 1		Y-GenXY	3XY	4XY	1	4	1	1	1 3/4	A394	0	4	0	0	0	0	0	
0	0	0																		
6.0313	g68P	Leg 1	0	XY-Symmetry	4X	5X	1	4	1	1	1 3/4	A394	6	4	1	Both	1	2.25	1.25	6
1.8438	0																			
6.0313	g68X	Leg 1	0	X-GenXY	4P	5P	1	4	1	1	1 3/4	A394	6	4	1	Both	1	2.25	1.25	6
1.8438	0																			
6.0313	g68XY	Leg 1	0	XY-GenXY	4Y	5Y	1	4	1	1	1 3/4	A394	6	4	1	Both	1	2.25	1.25	6
1.8438	0																			
6.0313	g68Y	Leg 1	0	Y-GenXY	4XY	5XY	1	4	1	1	1 3/4	A394	6	4	1	Both	1	2.25	1.25	6
1.8438	0																			
0	g69P	Leg 2		XY-Symmetry	5X	6X	1	4	1	1	1 3/4	A394	0	4	0	0	0	0	0	
0	0	0																		
0	g69X	Leg 2		X-GenXY	5P	6P	1	4	1	1	1 3/4	A394	0	4	0	0	0	0	0	
0	0	0																		
0	g69XY	Leg 2		XY-GenXY	5Y	6Y	1	4	1	1	1 3/4	A394	0	4	0	0	0	0	0	
0	0	0																		
0	g69Y	Leg 2		Y-GenXY	5XY	6XY	1	4	1	1	1 3/4	A394	0	4	0	0	0	0	0	
0	0	0																		
0	g70P	Leg 2		XY-Symmetry	6X	7X	1	4	1	1	1 3/4	A394	0	4	0	0	0	0	0	

0	0	0																			
0	g70X	Leg 2		X-GenXY	6P	7P	1	4	1	1	1 3/4	A394	0	4	0		0	0	0	0	
0	0	0																			
0	g70XY	Leg 2		XY-GenXY	6Y	7Y	1	4	1	1	1 3/4	A394	0	4	0		0	0	0	0	
0	0	0																			
0	g70Y	Leg 2		Y-GenXY	6XY	7XY	1	4	1	1	1 3/4	A394	0	4	0		0	0	0	0	
0	0	0																			
0	g71P	Leg 2		XY-Symmetry	7X	8X	1	4	1	1	1 3/4	A394	0	4	0		0	0	0	0	
0	0	0																			
0	g71X	Leg 2		X-GenXY	7P	8P	1	4	1	1	1 3/4	A394	0	4	0		0	0	0	0	
0	0	0																			
0	g71XY	Leg 2		XY-GenXY	7Y	8Y	1	4	1	1	1 3/4	A394	0	4	0		0	0	0	0	
0	0	0																			
0	g71Y	Leg 2		Y-GenXY	7XY	8XY	1	4	1	1	1 3/4	A394	0	4	0		0	0	0	0	
0	0	0																			
5.9063	g72P	Leg 2	0	XY-Symmetry	8X	9X	1	4	1	1	1 3/4	A394	14	4	1		Both	1.125	3.875	1.25	0
5.9063	3.4688	0																			
5.9063	g72X	Leg 2	0	X-GenXY	8P	9P	1	4	1	1	1 3/4	A394	14	4	1		Both	1.125	3.875	1.25	0
5.9063	3.4688	0																			
5.9063	g72XY	Leg 2	0	XY-GenXY	8Y	9Y	1	4	1	1	1 3/4	A394	14	4	1		Both	1.125	3.875	1.25	0
5.9063	3.4688	0																			
5.9063	g72Y	Leg 2	0	Y-GenXY	8XY	9XY	1	4	1	1	1 3/4	A394	14	4	1		Both	1.125	3.875	1.25	0
5.9063	3.4688	0																			
0	g73P	Leg 3		XY-Symmetry	9X	10X	1	4	1	1	1 3/4	A394	0	6	0		0	0	0	0	
0	0	0																			
0	g73X	Leg 3		X-GenXY	9P	10P	1	4	1	1	1 3/4	A394	0	6	0		0	0	0	0	
0	0	0																			
0	g73XY	Leg 3		XY-GenXY	9Y	10Y	1	4	1	1	1 3/4	A394	0	6	0		0	0	0	0	
0	0	0																			
0	g73Y	Leg 3		Y-GenXY	9XY	10XY	1	4	1	1	1 3/4	A394	0	6	0		0	0	0	0	
0	0	0																			
0	g74P	Leg 3		XY-Symmetry	10X	11X	1	4	1	1	1 3/4	A394	0	6	0		0	0	0	0	
0	0	0																			
0	g74X	Leg 3		X-GenXY	10P	11P	1	4	1	1	1 3/4	A394	0	6	0		0	0	0	0	
0	0	0																			
0	g74XY	Leg 3		XY-GenXY	10Y	11Y	1	4	1	1	1 3/4	A394	0	6	0		0	0	0	0	
0	0	0																			
0	g74Y	Leg 3		Y-GenXY	10XY	11XY	1	4	1	1	1 3/4	A394	0	6	0		0	0	0	0	
0	0	0																			
0	g75P	Leg 3		XY-Symmetry	11X	12X	1	4	1	1	1 3/4	A394	0	6	0		0	0	0	0	
0	0	0																			
0	g75X	Leg 3		X-GenXY	11P	12P	1	4	1	1	1 3/4	A394	0	6	0		0	0	0	0	
0	0	0																			
0	g75XY	Leg 3		XY-GenXY	11Y	12Y	1	4	1	1	1 3/4	A394	0	6	0		0	0	0	0	
0	0	0																			
0	g75Y	Leg 3		Y-GenXY	11XY	12XY	1	4	1	1	1 3/4	A394	0	6	0		0	0	0	0	
0	0	0																			
4.5938	g76P	Leg 3	0	XY-Symmetry	12X	13X	1	4	1	1	1 3/4	A394	16	6	1		Both	1.5	4.5	1.25	3.5
4.5938	4.0938	0																			
4.5938	g76X	Leg 3	0	X-GenXY	12P	13P	1	4	1	1	1 3/4	A394	16	6	1		Both	1.5	4.5	1.25	3.5
4.5938	4.0938	0																			
4.5938	g76XY	Leg 3	0	XY-GenXY	12Y	13Y	1	4	1	1	1 3/4	A394	16	6	1		Both	1.5	4.5	1.25	3.5
4.5938	4.0938	0																			
4.5938	g76Y	Leg 3	0	Y-GenXY	12XY	13XY	1	4	1	1	1 3/4	A394	16	6	1		Both	1.5	4.5	1.25	3.5
4.5938	4.0938	0																			
0	g77P	Leg 4		XY-Symmetry	13X	14X	1	4	1	1	1 3/4	A394	0	6	0		0	0	0	0	
0	0	0																			
0	g77X	Leg 4		X-GenXY	13P	14P	1	4	1	1	1 3/4	A394	0	6	0		0	0	0	0	
0	0	0																			

g77XY	Leg 4	XY-GenXY	13Y	14Y	1	4	1	1	1 3/4	A394	0	6	0	0	0	0	0	
0	0																	
g77Y	Leg 4	Y-GenXY	13XY	14XY	1	4	1	1	1 3/4	A394	0	6	0	0	0	0	0	
0	0																	
g78P	Leg 4	XY-Symmetry	14X	15X	1	4	1	1	1 3/4	A394	0	6	0	0	0	0	0	
0	0																	
g78X	Leg 4	X-GenXY	14P	15P	1	4	1	1	1 3/4	A394	0	6	0	0	0	0	0	
0	0																	
g78XY	Leg 4	XY-GenXY	14Y	15Y	1	4	1	1	1 3/4	A394	0	6	0	0	0	0	0	
0	0																	
g78Y	Leg 4	Y-GenXY	14XY	15XY	1	4	1	1	1 3/4	A394	0	6	0	0	0	0	0	
0	0																	
g79P	Leg 4	XY-Symmetry	15X	16X	1	4	1	1	1 3/4	A394	0	4	0	0	0	0	0	
0	0																	
g79X	Leg 4	X-GenXY	15P	16P	1	4	1	1	1 3/4	A394	0	4	0	0	0	0	0	
0	0																	
g79XY	Leg 4	XY-GenXY	15Y	16Y	1	4	1	1	1 3/4	A394	0	4	0	0	0	0	0	
0	0																	
g79Y	Leg 4	Y-GenXY	15XY	16XY	1	4	1	1	1 3/4	A394	0	4	0	0	0	0	0	
0	0																	
g80P	Leg 4	XY-Symmetry	16X	17X	1	4	1	1	1 3/4	A394	0	4	0	0	0	0	0	
0	0																	
g80X	Leg 4	X-GenXY	16P	17P	1	4	1	1	1 3/4	A394	0	4	0	0	0	0	0	
0	0																	
g80XY	Leg 4	XY-GenXY	16Y	17Y	1	4	1	1	1 3/4	A394	0	4	0	0	0	0	0	
0	0																	
g80Y	Leg 4	Y-GenXY	16XY	17XY	1	4	1	1	1 3/4	A394	0	4	0	0	0	0	0	
0	0																	
g81P	Leg 4	XY-Symmetry	17X	18X	1	4	1	1	1 3/4	A394	0	6	0	0	0	0	0	
0	0																	
g81X	Leg 4	X-GenXY	17P	18P	1	4	1	1	1 3/4	A394	0	6	0	0	0	0	0	
0	0																	
g81XY	Leg 4	XY-GenXY	17Y	18Y	1	4	1	1	1 3/4	A394	0	6	0	0	0	0	0	
0	0																	
g81Y	Leg 4	Y-GenXY	17XY	18XY	1	4	1	1	1 3/4	A394	0	6	0	0	0	0	0	
0	0																	
g82P	Leg 4	XY-Symmetry	18X	19X	1	4	1	1	1 3/4	A394	0	6	0	0	0	0	0	
0	0																	
g82X	Leg 4	X-GenXY	18P	19P	1	4	1	1	1 3/4	A394	0	6	0	0	0	0	0	
0	0																	
g82XY	Leg 4	XY-GenXY	18Y	19Y	1	4	1	1	1 3/4	A394	0	6	0	0	0	0	0	
0	0																	
g82Y	Leg 4	Y-GenXY	18XY	19XY	1	4	1	1	1 3/4	A394	0	6	0	0	0	0	0	
0	0																	
g83P	Leg 4	XY-Symmetry	19X	20X	1	4	1	1	1 3/4	A394	18	6	1	Both	1.5	4.5	1.25	2
5.5938	4.0938	0																
g83X	Leg 4	X-GenXY	19P	20P	1	4	1	1	1 3/4	A394	18	6	1	Both	1.5	4.5	1.25	2
5.5938	4.0938	0																
g83XY	Leg 4	XY-GenXY	19Y	20Y	1	4	1	1	1 3/4	A394	18	6	1	Both	1.5	4.5	1.25	2
5.5938	4.0938	0																
g83Y	Leg 4	Y-GenXY	19XY	20XY	1	4	1	1	1 3/4	A394	18	6	1	Both	1.5	4.5	1.25	2
5.5938	4.0938	0																
g84P	Leg 4	XY-Symmetry	20X	21X	1	4	1	1	1 3/4	A394	0	6	0	0	0	0	0	
0	0																	
g84X	Leg 4	X-GenXY	20P	21P	1	4	1	1	1 3/4	A394	0	6	0	0	0	0	0	
0	0																	
g84XY	Leg 4	XY-GenXY	20Y	21Y	1	4	1	1	1 3/4	A394	0	6	0	0	0	0	0	
0	0																	
g84Y	Leg 4	Y-GenXY	20XY	21XY	1	4	1	1	1 3/4	A394	0	6	0	0	0	0	0	

0	0	0																		
0	g85P	Leg 4	XY-Symmetry	21X	23X	1	4	0.5	0.5	0.5	3/4	A394	0	4	0		0	0	0	
0	0	0																		
0	g85X	Leg 4	X-GenXY	21P	23P	1	4	0.5	0.5	0.5	3/4	A394	0	4	0		0	0	0	
0	0	0																		
0	g85XY	Leg 4	XY-GenXY	21Y	23Y	1	4	0.5	0.5	0.5	3/4	A394	0	4	0		0	0	0	
0	0	0																		
0	g85Y	Leg 4	Y-GenXY	21XY	23XY	1	4	0.5	0.5	0.5	3/4	A394	0	4	0		0	0	0	
0	0	0																		
5.5938	g86P	Leg 4	XY-Symmetry	23X	25X	1	4	0.5	0.5	0.5	3/4	A394	20	4	1	Both	1.5	4.5	1.25	2
3.44	0	0																		
5.5938	g86X	Leg 4	X-GenXY	23P	25P	1	4	0.5	0.5	0.5	3/4	A394	20	4	1	Both	1.5	4.5	1.25	2
3.44	0	0																		
5.5938	g86XY	Leg 4	XY-GenXY	23Y	25Y	1	4	0.5	0.5	0.5	3/4	A394	20	4	1	Both	1.5	4.5	1.25	2
3.44	0	0																		
5.5938	g86Y	Leg 4	Y-GenXY	23XY	25XY	1	4	0.5	0.5	0.5	3/4	A394	20	4	1	Both	1.5	4.5	1.25	2
3.44	0	0																		
0	g87P	Leg 4	XY-Symmetry	25X	27X	1	4	0.5	0.5	0.5	3/4	A394	0	4	0		0	0	0	
0	0	0																		
0	g87X	Leg 4	X-GenXY	25P	27P	1	4	0.5	0.5	0.5	3/4	A394	0	4	0		0	0	0	
0	0	0																		
0	g87XY	Leg 4	XY-GenXY	25Y	27Y	1	4	0.5	0.5	0.5	3/4	A394	0	4	0		0	0	0	
0	0	0																		
0	g87Y	Leg 4	Y-GenXY	25XY	27XY	1	4	0.5	0.5	0.5	3/4	A394	0	4	0		0	0	0	
0	0	0																		
5.5938	g88P	Leg 4	XY-Symmetry	27X	29X	1	4	0.5	0.5	0.5	3/4	A394	20	4	1	Both	1.5	4.5	1.25	2
3.44	0	0																		
5.5938	g88X	Leg 4	X-GenXY	27P	29P	1	4	0.5	0.5	0.5	3/4	A394	20	4	1	Both	1.5	4.5	1.25	2
3.44	0	0																		
5.5938	g88XY	Leg 4	XY-GenXY	27Y	29Y	1	4	0.5	0.5	0.5	3/4	A394	20	4	1	Both	1.5	4.5	1.25	2
3.44	0	0																		
5.5938	g88Y	Leg 4	Y-GenXY	27XY	29XY	1	4	0.5	0.5	0.5	3/4	A394	20	4	1	Both	1.5	4.5	1.25	2
3.44	0	0																		
5.5938	g89P	Leg 4	XY-Symmetry	29X	30X	1	4	1	1	1	3/4	A394	20	4	1	Both	1.5	4.5	1.25	2
3.44	0	0																		
5.5938	g89X	Leg 4	X-GenXY	29P	30P	1	4	1	1	1	3/4	A394	20	4	1	Both	1.5	4.5	1.25	2
3.44	0	0																		
5.5938	g89XY	Leg 4	XY-GenXY	29Y	30Y	1	4	1	1	1	3/4	A394	20	4	1	Both	1.5	4.5	1.25	2
3.44	0	0																		
5.5938	g89Y	Leg 4	Y-GenXY	29XY	30XY	1	4	1	1	1	3/4	A394	20	4	1	Both	1.5	4.5	1.25	2
3.44	0	0																		
0	g90P	Diag12	XY-Symmetry	41X	2X	2	5	0.5	0.5	0.5	3/4	A394	3	1	1	Short only	1.5	0	1.125	0
0	0	0																		
0	g90X	Diag12	X-GenXY	41P	2P	2	5	0.5	0.5	0.5	3/4	A394	3	1	1	Short only	1.5	0	1.125	0
0	0	0																		
0	g90XY	Diag12	XY-GenXY	41P	2Y	2	5	0.5	0.5	0.5	3/4	A394	3	1	1	Short only	1.5	0	1.125	0
0	0	0																		
0	g90Y	Diag12	Y-GenXY	41X	2XY	2	5	0.5	0.5	0.5	3/4	A394	3	1	1	Short only	1.5	0	1.125	0
0	0	0																		
2.6563	g91P	Horz 13	XY-Symmetry	42X	5X	3	5	1	1	1	3/4	A394	4	2	1	Long only	1.25	3.25	1.3125	2.75
2.0313	0	0																		
2.6563	g91X	Horz 13	X-GenXY	42P	5P	3	5	1	1	1	3/4	A394	4	2	1	Long only	1.25	3.25	1.3125	2.75
2.0313	0	0																		
2.6563	g91XY	Horz 13	XY-GenXY	42P	5Y	3	5	1	1	1	3/4	A394	4	2	1	Long only	1.25	3.25	1.3125	2.75
2.0313	0	0																		
2.6563	g91Y	Horz 13	Y-GenXY	42X	5XY	3	5	1	1	1	3/4	A394	4	2	1	Long only	1.25	3.25	1.3125	2.75
2.0313	0	0																		
2.6563	g92P	Horz 11	Y-Symmetry	5X	5P	3	6	1	1	1	3/4	A394	4	3	1	Long only	1.25	3.25	1.125	2.75
2.0313	0	0																		

g92Y	Horz	11	0	Y-Gen	5XY	5Y	3	6	1	1	1 3/4	A394	4	3	1	Long only	1.25	3.25	1.125	2.75
2.6563	2.0313																			
g93P	Arm	0	0	XY-Symmetry	42X	4X	3	5	1	1	1 3/4	A394	2	1	1	Short only	0.875	0	1.1875	2.25
g93X	Arm	0	0	X-GenXY	42P	4P	3	5	1	1	1 3/4	A394	2	1	1	Short only	0.875	0	1.1875	2.25
g93XY	Arm	0	0	XY-GenXY	42P	4Y	3	5	1	1	1 3/4	A394	2	1	1	Short only	0.875	0	1.1875	2.25
g93Y	Arm	0	0	Y-GenXY	42X	4XY	3	5	1	1	1 3/4	A394	2	1	1	Short only	0.875	0	1.1875	2.25
g94P	Horz	13	0	XY-Symmetry	44X	13X	3	5	1	1	1 3/4	A394	4	2	1	Long only	1.25	3.25	1.3125	3
3.5313	2.0313																			
g94X	Horz	13	0	X-GenXY	44P	13P	3	5	1	1	1 3/4	A394	4	2	1	Long only	1.25	3.25	1.3125	3
3.5313	2.0313																			
g94XY	Horz	13	0	XY-GenXY	44P	13Y	3	5	1	1	1 3/4	A394	4	2	1	Long only	1.25	3.25	1.3125	3
3.5313	2.0313																			
g94Y	Horz	13	0	Y-GenXY	44X	13XY	3	5	1	1	1 3/4	A394	4	2	1	Long only	1.25	3.25	1.3125	3
3.5313	2.0313																			
g95P	Horz	11	0	Y-Symmetry	13X	13P	3	6	1	1	1 3/4	A394	4	3	1	Long only	1.25	3.25	1.75	3
3.5313	2.0313																			
g95Y	Horz	11	0	Y-Gen	13XY	13Y	3	6	1	1	1 3/4	A394	4	3	1	Long only	1.25	3.25	1.75	3
3.5313	2.0313																			
g96P	Arm	0	0	XY-Symmetry	44X	12X	3	5	1	1	1 3/4	A394	2	1	1	Short only	0.875	0	1.1875	2.25
g96X	Arm	0	0	X-GenXY	44P	12P	3	5	1	1	1 3/4	A394	2	1	1	Short only	0.875	0	1.1875	2.25
g96XY	Arm	0	0	XY-GenXY	44P	12Y	3	5	1	1	1 3/4	A394	2	1	1	Short only	0.875	0	1.1875	2.25
g96Y	Arm	0	0	Y-GenXY	44X	12XY	3	5	1	1	1 3/4	A394	2	1	1	Short only	0.875	0	1.1875	2.25
g97P	Horz	13	0	XY-Symmetry	43X	9X	3	5	1	0.5	0.5 3/4	A394	5	3	1	Long only	1.25	3.25	1.3125	3
3.6563	2.0313																			
g97X	Horz	13	0	X-GenXY	43P	9P	3	5	1	0.5	0.5 3/4	A394	5	3	1	Long only	1.25	3.25	1.3125	3
3.6563	2.0313																			
g97XY	Horz	13	0	XY-GenXY	43P	9Y	3	5	1	0.5	0.5 3/4	A394	5	3	1	Long only	1.25	3.25	1.3125	3
3.6563	2.0313																			
g97Y	Horz	13	0	Y-GenXY	43X	9XY	3	5	1	0.5	0.5 3/4	A394	5	3	1	Long only	1.25	3.25	1.3125	3
3.6563	2.0313																			
g98P	Horz	12	0	Y-Symmetry	9X	9P	3	6	1	1	1 3/4	A394	5	3	1	Long only	1.25	3.25	1.875	3
3.6563	2.0313																			
g98Y	Horz	12	0	Y-Gen	9XY	9Y	3	6	1	1	1 3/4	A394	5	3	1	Long only	1.25	3.25	1.875	3
3.6563	2.0313																			
g99P	Arm2	0	0	XY-Symmetry	43X	8X	3	5	1	1	1 3/4	A394	2	1	1	Short only	1.25	0	1.1875	2.25
g99X	Arm2	0	0	X-GenXY	43P	8P	3	5	1	1	1 3/4	A394	2	1	1	Short only	1.25	0	1.1875	2.25
g99XY	Arm2	0	0	XY-GenXY	43P	8Y	3	5	1	1	1 3/4	A394	2	1	1	Short only	1.25	0	1.1875	2.25
g99Y	Arm2	0	0	Y-GenXY	43X	8XY	3	5	1	1	1 3/4	A394	2	1	1	Short only	1.25	0	1.1875	2.25
g100P	top	0	0	X-Symmetry	41X	1X	3	4	1	1	1 3/4	A394	2	2	1	Short only	2	0	1.25	2.25
g100X	top	0	0	X-Gen	41P	1P	3	4	1	1	1 3/4	A394	2	2	1	Short only	2	0	1.25	2.25
g101P	top	0	0	None	1X	1P	3	4	1	1	1 3/4	A394	2	2	1	Short only	2	0	1.25	2.25
g102P	Inner1	0	0	X-Symmetry	2X	2Y	2	4	0.5	0.75	0.5 3/4	A394	1	1	1	Long only	0.875	0	1.125	0
g102X	Inner1			X-Gen	2P	2XY	2	4	0.5	0.75	0.5 3/4	A394	1	1	1	Long only	0.875	0	1.125	0

0	0	0																		
	g103P	Inner2	X-Symmetry	5X	5Y	2	5	0.5	0.75	0.5	3/4	A394	2	1	1	Long only	0.875	0	1.125	2.75
0	0	0																		
	g103X	Inner2	X-Gen	5P	5XY	2	5	0.5	0.75	0.5	3/4	A394	2	1	1	Long only	0.875	0	1.125	2.75
0	0	0																		
	g104P	Inner2	X-Symmetry	13X	13Y	2	5	0.5	0.75	0.5	3/4	A394	2	1	1	Long only	0.875	0	1.125	2.75
0	0	0																		
	g104X	Inner2	X-Gen	13P	13XY	2	5	0.5	0.75	0.5	3/4	A394	2	1	1	Long only	0.875	0	1.125	2.75
0	0	0																		
	g105P	Inner3	X-Symmetry	9X	9Y	2	5	0.75	0.5	0.5	3/4	A394	2	1	1	Short only	0.875	0	1.125	2.75
0	0	0																		
	g105X	Inner3	X-Gen	9P	9XY	2	5	0.75	0.5	0.5	3/4	A394	2	1	1	Short only	0.875	0	1.125	2.75
0	0	0																		
	g106P	Inner2	X-Symmetry	20X	20Y	2	4	0.5	0.75	0.5	3/4	A394	1	1	1	Long only	0.875	0	1.125	0
0	0	0																		
	g106X	Inner2	X-Gen	20P	20XY	2	4	0.5	0.75	0.5	3/4	A394	1	1	1	Long only	0.875	0	1.125	0
0	0	0																		
	g107P	Inner4	X-Symmetry	29X	29Y	2	5	0.75	0.5	0.5	3/4	A394	2	1	1	Short only	1.5	0	1.125	2
0	0	0																		
	g107X	Inner4	X-Gen	29P	29XY	2	5	0.75	0.5	0.5	3/4	A394	2	1	1	Short only	1.5	0	1.125	2
0	0	0																		

Member Capacities and Overrides:

Member Override Label	Group Override Label	Design Override Comp. Tension Capacity Control	Comp. Override Control Face	Design Tension Capacity Member	Tension Control Criterion	L/r	Length (ft)	L/r Comp. Capacity (kips)	Connection Shear Capacity (kips)	Connection Bearing Capacity (kips)	Net Section or Errors Warnings Tension Capacity (kips)	Rupture Tension Capacity (kips)	RTE Dist. Tension Capacity (kips)	Edge Dist. Tension Capacity (kips)	Override Comp. Capacity (kips)	Override Comp. Capacity Unsup. (kips)		
0.000	g1P	Diag1	Automatic	12.897	L/r	12.741	Rupture	114	5.60	12.897	27.200	24.469	14.772	12.741	0.000	0.000	0.000	0.000
0.000	g1X	Diag1	Automatic	12.897	L/r	12.741	Rupture	114	5.60	12.897	27.200	24.469	14.772	12.741	0.000	0.000	0.000	0.000
0.000	g2P	Diag1	Automatic	12.897	L/r	12.741	Rupture	114	5.60	12.897	27.200	24.469	14.772	12.741	0.000	0.000	0.000	0.000
0.000	g2X	Diag1	Automatic	12.897	L/r	12.741	Rupture	114	5.60	12.897	27.200	24.469	14.772	12.741	0.000	0.000	0.000	0.000
0.000	g3P	Diag2	Automatic	18.914	L/r	13.964	Rupture	81	5.33	18.914	27.200	24.469	17.688	13.964	0.000	0.000	0.000	0.000
0.000	g3X	Diag2	Automatic	18.914	L/r	13.964	Rupture	81	5.33	18.914	27.200	24.469	17.688	13.964	0.000	0.000	0.000	0.000
0.000	g3XY	Diag2	Automatic	18.914	L/r	13.964	Rupture	81	5.33	18.914	27.200	24.469	17.688	13.964	0.000	0.000	0.000	0.000
0.000	g3Y	Diag2	Automatic	18.914	L/r	13.964	Rupture	81	5.33	18.914	27.200	24.469	17.688	13.964	0.000	0.000	0.000	0.000
0.000	g4P	Diag2	Automatic	18.914	L/r	13.964	Rupture	81	5.33	18.914	27.200	24.469	17.688	13.964	0.000	0.000	0.000	0.000
0.000	g4X	Diag2	Automatic	18.914	L/r	13.964	Rupture	81	5.33	18.914	27.200	24.469	17.688	13.964	0.000	0.000	0.000	0.000
0.000	g4XY	Diag2	Automatic	18.914	L/r	13.964	Rupture	81	5.33	18.914	27.200	24.469	17.688	13.964	0.000	0.000	0.000	0.000
0.000	g4Y	Diag2	Automatic	18.914	L/r	13.964	Rupture	81	5.33	18.914	27.200	24.469	17.688	13.964	0.000	0.000	0.000	0.000

g27P	Diag10	68.000	Shear	65.225	Net Sect	50	5.52	78.878	68.000	101.953	65.225	70.394	0.000	0.000	0.000	0.000
0.000		Automatic														
g27X	Diag10	68.000	Shear	65.225	Net Sect	50	5.52	78.878	68.000	101.953	65.225	70.394	0.000	0.000	0.000	0.000
0.000		Automatic														
g27XY	Diag10	68.000	Shear	65.225	Net Sect	50	5.52	78.878	68.000	101.953	65.225	70.394	0.000	0.000	0.000	0.000
0.000		Automatic														
g27Y	Diag10	68.000	Shear	65.225	Net Sect	50	5.52	78.878	68.000	101.953	65.225	70.394	0.000	0.000	0.000	0.000
0.000		Automatic														
g28P	Diag10	68.000	Shear	65.225	Net Sect	50	5.52	78.878	68.000	101.953	65.225	70.394	0.000	0.000	0.000	0.000
0.000		Automatic														
g28X	Diag10	68.000	Shear	65.225	Net Sect	50	5.52	78.878	68.000	101.953	65.225	70.394	0.000	0.000	0.000	0.000
0.000		Automatic														
g28XY	Diag10	68.000	Shear	65.225	Net Sect	50	5.52	78.878	68.000	101.953	65.225	70.394	0.000	0.000	0.000	0.000
0.000		Automatic														
g28Y	Diag10	68.000	Shear	65.225	Net Sect	50	5.52	78.878	68.000	101.953	65.225	70.394	0.000	0.000	0.000	0.000
0.000		Automatic														
g29P	Diag5	46.173	L/r	32.319	Net Sect	60	5.90	46.173	54.400	65.250	32.319	45.175	0.000	0.000	0.000	0.000
0.000		Automatic														
g29X	Diag5	46.173	L/r	32.319	Net Sect	60	5.90	46.173	54.400	65.250	32.319	45.175	0.000	0.000	0.000	0.000
0.000		Automatic														
g29XY	Diag5	46.173	L/r	32.319	Net Sect	60	5.90	46.173	54.400	65.250	32.319	45.175	0.000	0.000	0.000	0.000
0.000		Automatic														
g29Y	Diag5	46.173	L/r	32.319	Net Sect	60	5.90	46.173	54.400	65.250	32.319	45.175	0.000	0.000	0.000	0.000
0.000		Automatic														
g30P	Diag5	46.173	L/r	32.319	Net Sect	60	5.90	46.173	54.400	65.250	32.319	45.175	0.000	0.000	0.000	0.000
0.000		Automatic														
g30X	Diag5	46.173	L/r	32.319	Net Sect	60	5.90	46.173	54.400	65.250	32.319	45.175	0.000	0.000	0.000	0.000
0.000		Automatic														
g30XY	Diag5	46.173	L/r	32.319	Net Sect	60	5.90	46.173	54.400	65.250	32.319	45.175	0.000	0.000	0.000	0.000
0.000		Automatic														
g30Y	Diag5	46.173	L/r	32.319	Net Sect	60	5.90	46.173	54.400	65.250	32.319	45.175	0.000	0.000	0.000	0.000
0.000		Automatic														
g31P	Diag5	43.265	L/r	32.319	Net Sect	74	7.19	43.265	54.400	65.250	32.319	45.208	0.000	0.000	0.000	0.000
0.000		Automatic														
g31X	Diag5	43.265	L/r	32.319	Net Sect	74	7.19	43.265	54.400	65.250	32.319	45.208	0.000	0.000	0.000	0.000
0.000		Automatic														
g31XY	Diag5	43.265	L/r	32.319	Net Sect	74	7.19	43.265	54.400	65.250	32.319	45.208	0.000	0.000	0.000	0.000
0.000		Automatic														
g31Y	Diag5	43.265	L/r	32.319	Net Sect	74	7.19	43.265	54.400	65.250	32.319	45.208	0.000	0.000	0.000	0.000
0.000		Automatic														
g32P	Diag5	43.265	L/r	32.319	Net Sect	74	7.19	43.265	54.400	65.250	32.319	45.208	0.000	0.000	0.000	0.000
0.000		Automatic														
g32X	Diag5	43.265	L/r	32.319	Net Sect	74	7.19	43.265	54.400	65.250	32.319	45.208	0.000	0.000	0.000	0.000
0.000		Automatic														
g32XY	Diag5	43.265	L/r	32.319	Net Sect	74	7.19	43.265	54.400	65.250	32.319	45.208	0.000	0.000	0.000	0.000
0.000		Automatic														
g32Y	Diag5	43.265	L/r	32.319	Net Sect	74	7.19	43.265	54.400	65.250	32.319	45.208	0.000	0.000	0.000	0.000
0.000		Automatic														
g33P	Diag4	38.006	L/r	37.294	Rupture	83	7.70	38.006	40.800	48.937	39.568	37.294	0.000	0.000	0.000	0.000
0.000		Automatic														
g33X	Diag4	38.006	L/r	37.294	Rupture	83	7.70	38.006	40.800	48.937	39.568	37.294	0.000	0.000	0.000	0.000
0.000		Automatic														
g33XY	Diag4	38.006	L/r	37.294	Rupture	83	7.70	38.006	40.800	48.937	39.568	37.294	0.000	0.000	0.000	0.000
0.000		Automatic														
g33Y	Diag4	38.006	L/r	37.294	Rupture	83	7.70	38.006	40.800	48.937	39.568	37.294	0.000	0.000	0.000	0.000
0.000		Automatic														
g34P	Diag4	38.006	L/r	37.294	Rupture	83	7.70	38.006	40.800	48.937	39.568	37.294	0.000	0.000	0.000	0.000
0.000		Automatic														
g34X	Diag4	38.006	L/r	37.294	Rupture	83	7.70	38.006	40.800	48.937	39.568	37.294	0.000	0.000	0.000	0.000

0.000		Automatic														
g34XY	Diag4	38.006	L/r	37.294	Rupture	83	7.70	38.006	40.800	48.937	39.568	37.294	0.000	0.000	0.000	0.000
0.000		Automatic														
g34Y	Diag4	38.006	L/r	37.294	Rupture	83	7.70	38.006	40.800	48.937	39.568	37.294	0.000	0.000	0.000	0.000
0.000		Automatic														
g35P	Diag4	34.738	L/r	38.381	Rupture	97	8.92	34.738	40.800	48.937	39.568	38.381	0.000	0.000	0.000	0.000
0.000		Automatic														
g35X	Diag4	34.738	L/r	38.381	Rupture	97	8.92	34.738	40.800	48.937	39.568	38.381	0.000	0.000	0.000	0.000
0.000		Automatic														
g35XY	Diag4	34.738	L/r	38.381	Rupture	97	8.92	34.738	40.800	48.937	39.568	38.381	0.000	0.000	0.000	0.000
0.000		Automatic														
g35Y	Diag4	34.738	L/r	38.381	Rupture	97	8.92	34.738	40.800	48.937	39.568	38.381	0.000	0.000	0.000	0.000
0.000		Automatic														
g36P	Diag4	34.738	L/r	38.381	Rupture	97	8.92	34.738	40.800	48.937	39.568	38.381	0.000	0.000	0.000	0.000
0.000		Automatic														
g36X	Diag4	34.738	L/r	38.381	Rupture	97	8.92	34.738	40.800	48.937	39.568	38.381	0.000	0.000	0.000	0.000
0.000		Automatic														
g36XY	Diag4	34.738	L/r	38.381	Rupture	97	8.92	34.738	40.800	48.937	39.568	38.381	0.000	0.000	0.000	0.000
0.000		Automatic														
g36Y	Diag4	34.738	L/r	38.381	Rupture	97	8.92	34.738	40.800	48.937	39.568	38.381	0.000	0.000	0.000	0.000
0.000		Automatic														
g37P	Diag3	27.075	L/r	31.306	Net Sect	115	9.54	27.075	40.800	48.937	31.306	34.228	0.000	0.000	0.000	0.000
0.000		Automatic														
g37X	Diag3	27.075	L/r	31.306	Net Sect	115	9.54	27.075	40.800	48.937	31.306	34.228	0.000	0.000	0.000	0.000
0.000		Automatic														
g37XY	Diag3	27.075	L/r	31.306	Net Sect	115	9.54	27.075	40.800	48.937	31.306	34.228	0.000	0.000	0.000	0.000
0.000		Automatic														
g37Y	Diag3	27.075	L/r	31.306	Net Sect	115	9.54	27.075	40.800	48.937	31.306	34.228	0.000	0.000	0.000	0.000
0.000		Automatic														
g38P	Diag3	27.075	L/r	31.306	Net Sect	115	9.54	27.075	40.800	48.937	31.306	34.228	0.000	0.000	0.000	0.000
0.000		Automatic														
g38X	Diag3	27.075	L/r	31.306	Net Sect	115	9.54	27.075	40.800	48.937	31.306	34.228	0.000	0.000	0.000	0.000
0.000		Automatic														
g38XY	Diag3	27.075	L/r	31.306	Net Sect	115	9.54	27.075	40.800	48.937	31.306	34.228	0.000	0.000	0.000	0.000
0.000		Automatic														
g38Y	Diag3	27.075	L/r	31.306	Net Sect	115	9.54	27.075	40.800	48.937	31.306	34.228	0.000	0.000	0.000	0.000
0.000		Automatic														
g39P	Diag4	26.008	L/r	35.391	Rupture	128	11.77	26.008	40.800	48.937	39.568	35.391	0.000	0.000	0.000	0.000
0.000		Automatic														
g39X	Diag4	26.008	L/r	35.391	Rupture	128	11.77	26.008	40.800	48.937	39.568	35.391	0.000	0.000	0.000	0.000
0.000		Automatic														
g39XY	Diag4	26.008	L/r	35.391	Rupture	128	11.77	26.008	40.800	48.937	39.568	35.391	0.000	0.000	0.000	0.000
0.000		Automatic														
g39Y	Diag4	26.008	L/r	35.391	Rupture	128	11.77	26.008	40.800	48.937	39.568	35.391	0.000	0.000	0.000	0.000
0.000		Automatic														
g40P	Diag4	26.008	L/r	35.391	Rupture	128	11.77	26.008	40.800	48.937	39.568	35.391	0.000	0.000	0.000	0.000
0.000		Automatic														
g40X	Diag4	26.008	L/r	35.391	Rupture	128	11.77	26.008	40.800	48.937	39.568	35.391	0.000	0.000	0.000	0.000
0.000		Automatic														
g40XY	Diag4	26.008	L/r	35.391	Rupture	128	11.77	26.008	40.800	48.937	39.568	35.391	0.000	0.000	0.000	0.000
0.000		Automatic														
g40Y	Diag4	26.008	L/r	35.391	Rupture	128	11.77	26.008	40.800	48.937	39.568	35.391	0.000	0.000	0.000	0.000
0.000		Automatic														
g41P	Diag5	25.026	L/r	27.200	Shear	138	13.51	25.026	27.200	32.625	39.406	27.943	0.000	0.000	0.000	0.000
0.000		Automatic														
g41X	Diag5	25.026	L/r	27.200	Shear	138	13.51	25.026	27.200	32.625	39.406	27.943	0.000	0.000	0.000	0.000
0.000		Automatic														
g41XY	Diag5	25.026	L/r	27.200	Shear	138	13.51	25.026	27.200	32.625	39.406	27.943	0.000	0.000	0.000	0.000
0.000		Automatic														

g41Y	Diag5	25.026	L/r	27.200	Shear	138	13.51	25.026	27.200	32.625	39.406	27.943	0.000	0.000	0.000	0.000
0.000		Automatic														
g42P	Diag5	25.026	L/r	27.200	Shear	138	13.51	25.026	27.200	32.625	39.406	27.943	0.000	0.000	0.000	0.000
0.000		Automatic														
g42X	Diag5	25.026	L/r	27.200	Shear	138	13.51	25.026	27.200	32.625	39.406	27.943	0.000	0.000	0.000	0.000
0.000		Automatic														
g42XY	Diag5	25.026	L/r	27.200	Shear	138	13.51	25.026	27.200	32.625	39.406	27.943	0.000	0.000	0.000	0.000
0.000		Automatic														
g42Y	Diag5	25.026	L/r	27.200	Shear	138	13.51	25.026	27.200	32.625	39.406	27.943	0.000	0.000	0.000	0.000
0.000		Automatic														
g43P	Diag6	25.243	L/r	27.200	Shear	144	15.52	25.243	27.200	32.625	47.668	27.943	0.000	0.000	0.000	0.000
0.000		Automatic														
g43X	Diag6	25.243	L/r	27.200	Shear	144	15.52	25.243	27.200	32.625	47.668	27.943	0.000	0.000	0.000	0.000
0.000		Automatic														
g43XY	Diag6	25.243	L/r	27.200	Shear	144	15.52	25.243	27.200	32.625	47.668	27.943	0.000	0.000	0.000	0.000
0.000		Automatic														
g43Y	Diag6	25.243	L/r	27.200	Shear	144	15.52	25.243	27.200	32.625	47.668	27.943	0.000	0.000	0.000	0.000
0.000		Automatic														
g44P	Diag6	25.243	L/r	27.200	Shear	144	15.52	25.243	27.200	32.625	47.668	27.943	0.000	0.000	0.000	0.000
0.000		Automatic														
g44X	Diag6	25.243	L/r	27.200	Shear	144	15.52	25.243	27.200	32.625	47.668	27.943	0.000	0.000	0.000	0.000
0.000		Automatic														
g44XY	Diag6	25.243	L/r	27.200	Shear	144	15.52	25.243	27.200	32.625	47.668	27.943	0.000	0.000	0.000	0.000
0.000		Automatic														
g44Y	Diag6	25.243	L/r	27.200	Shear	144	15.52	25.243	27.200	32.625	47.668	27.943	0.000	0.000	0.000	0.000
0.000		Automatic														
g45P	Diag6	20.384	L/r	27.187	Rupture	165	17.73	20.384	27.200	32.625	47.668	27.187	0.000	0.000	0.000	0.000
0.000		Automatic														
g45X	Diag6	20.384	L/r	27.187	Rupture	165	17.73	20.384	27.200	32.625	47.668	27.187	0.000	0.000	0.000	0.000
0.000		Automatic														
g45XY	Diag6	20.384	L/r	27.187	Rupture	165	17.73	20.384	27.200	32.625	47.668	27.187	0.000	0.000	0.000	0.000
0.000		Automatic														
g45Y	Diag6	20.384	L/r	27.187	Rupture	165	17.73	20.384	27.200	32.625	47.668	27.187	0.000	0.000	0.000	0.000
0.000		Automatic														
g46P	Diag6	20.384	L/r	27.187	Rupture	165	17.73	20.384	27.200	32.625	47.668	27.187	0.000	0.000	0.000	0.000
0.000		Automatic														
g46X	Diag6	20.384	L/r	27.187	Rupture	165	17.73	20.384	27.200	32.625	47.668	27.187	0.000	0.000	0.000	0.000
0.000		Automatic														
g46XY	Diag6	20.384	L/r	27.187	Rupture	165	17.73	20.384	27.200	32.625	47.668	27.187	0.000	0.000	0.000	0.000
0.000		Automatic														
g46Y	Diag6	20.384	L/r	27.187	Rupture	165	17.73	20.384	27.200	32.625	47.668	27.187	0.000	0.000	0.000	0.000
0.000		Automatic														
g47P	Diag7	19.690	L/r	27.200	Shear	175	20.12	19.690	27.200	32.625	47.506	27.943	0.000	0.000	0.000	0.000
0.000		Automatic														
g47X	Diag7	19.690	L/r	27.200	Shear	175	20.12	19.690	27.200	32.625	47.506	27.943	0.000	0.000	0.000	0.000
0.000		Automatic														
g47XY	Diag7	19.690	L/r	27.200	Shear	175	20.12	19.690	27.200	32.625	47.506	27.943	0.000	0.000	0.000	0.000
0.000		Automatic														
g47Y	Diag7	19.690	L/r	27.200	Shear	175	20.12	19.690	27.200	32.625	47.506	27.943	0.000	0.000	0.000	0.000
0.000		Automatic														
g48P	Diag7	19.690	L/r	27.200	Shear	175	20.12	19.690	27.200	32.625	47.506	27.943	0.000	0.000	0.000	0.000
0.000		Automatic														
g48X	Diag7	19.690	L/r	27.200	Shear	175	20.12	19.690	27.200	32.625	47.506	27.943	0.000	0.000	0.000	0.000
0.000		Automatic														
g48XY	Diag7	19.690	L/r	27.200	Shear	175	20.12	19.690	27.200	32.625	47.506	27.943	0.000	0.000	0.000	0.000
0.000		Automatic														
g48Y	Diag7	19.690	L/r	27.200	Shear	175	20.12	19.690	27.200	32.625	47.506	27.943	0.000	0.000	0.000	0.000
0.000		Automatic														
g49P	Diag8	21.486	L/r	27.187	Rupture	173	11.49	21.486	27.200	32.625	55.768	27.187	0.000	0.000	0.000	0.000

0.000		Automatic														
g49X	Diag8	21.486	L/r	27.187	Rupture	173	11.49	21.486	27.200	32.625	55.768	27.187	0.000	0.000	0.000	0.000
0.000		Automatic														
g49XY	Diag8	21.486	L/r	27.187	Rupture	173	11.49	21.486	27.200	32.625	55.768	27.187	0.000	0.000	0.000	0.000
0.000		Automatic														
g49Y	Diag8	21.486	L/r	27.187	Rupture	173	11.49	21.486	27.200	32.625	55.768	27.187	0.000	0.000	0.000	0.000
0.000		Automatic														
g50P	Diag8	21.486	L/r	27.187	Rupture	173	11.49	21.486	27.200	32.625	55.768	27.187	0.000	0.000	0.000	0.000
0.000		Automatic														
g50X	Diag8	21.486	L/r	27.187	Rupture	173	11.49	21.486	27.200	32.625	55.768	27.187	0.000	0.000	0.000	0.000
0.000		Automatic														
g50XY	Diag8	21.486	L/r	27.187	Rupture	173	11.49	21.486	27.200	32.625	55.768	27.187	0.000	0.000	0.000	0.000
0.000		Automatic														
g50Y	Diag8	21.486	L/r	27.187	Rupture	173	11.49	21.486	27.200	32.625	55.768	27.187	0.000	0.000	0.000	0.000
0.000		Automatic														
g51P	Horz5	27.200	Shear	27.187	Rupture	92	3.34	27.684	27.200	32.625	31.468	27.187	0.000	0.000	0.000	0.000
0.000		Automatic														
g51Y	Horz5	27.200	Shear	27.187	Rupture	92	3.34	27.684	27.200	32.625	31.468	27.187	0.000	0.000	0.000	0.000
0.000		Automatic														
g52P	Horz5	27.200	Shear	27.187	Rupture	92	3.34	27.684	27.200	32.625	31.468	27.187	0.000	0.000	0.000	0.000
0.000		Automatic														
g52X	Horz5	27.200	Shear	27.187	Rupture	92	3.34	27.684	27.200	32.625	31.468	27.187	0.000	0.000	0.000	0.000
0.000		Automatic														
g53P	Horz1	11.446	L/r	7.439	Rupture	124	3.34	11.446	13.600	12.234	14.772	7.439	0.000	0.000	0.000	0.000
0.000		Automatic														
g53Y	Horz1	11.446	L/r	7.439	Rupture	124	3.34	11.446	13.600	12.234	14.772	7.439	0.000	0.000	0.000	0.000
0.000		Automatic														
g54P	Horz6	27.200	Shear	27.187	Rupture	76	3.34	32.931	27.200	32.625	35.356	27.187	0.000	0.000	0.000	0.000
0.000		Automatic														
g54X	Horz6	27.200	Shear	27.187	Rupture	76	3.34	32.931	27.200	32.625	35.356	27.187	0.000	0.000	0.000	0.000
0.000		Automatic														
g55P	Horz1	11.446	L/r	7.439	Rupture	124	3.34	11.446	13.600	12.234	14.772	7.439	0.000	0.000	0.000	0.000
0.000		Automatic														
g55Y	Horz1	11.446	L/r	7.439	Rupture	124	3.34	11.446	13.600	12.234	14.772	7.439	0.000	0.000	0.000	0.000
0.000		Automatic														
g56P	Horz6	27.200	Shear	27.187	Rupture	76	3.34	32.931	27.200	32.625	35.356	27.187	0.000	0.000	0.000	0.000
0.000		Automatic														
g56X	Horz6	27.200	Shear	27.187	Rupture	76	3.34	32.931	27.200	32.625	35.356	27.187	0.000	0.000	0.000	0.000
0.000		Automatic														
g57P	Horz1	11.446	L/r	7.439	Rupture	124	3.34	11.446	13.600	12.234	14.772	7.439	0.000	0.000	0.000	0.000
0.000		Automatic														
g57Y	Horz1	11.446	L/r	7.439	Rupture	124	3.34	11.446	13.600	12.234	14.772	7.439	0.000	0.000	0.000	0.000
0.000		Automatic														
g58P	Horz6	27.200	Shear	27.187	Rupture	76	3.34	32.931	27.200	32.625	35.356	27.187	0.000	0.000	0.000	0.000
0.000		Automatic														
g58X	Horz6	27.200	Shear	27.187	Rupture	76	3.34	32.931	27.200	32.625	35.356	27.187	0.000	0.000	0.000	0.000
0.000		Automatic														
g59P	Horz2	5.474	L/r	17.688	Net Sect	238	7.82	5.474	27.200	24.469	17.688	18.658	0.000	0.000	0.000	0.000
0.000		Automatic														
g59Y	Horz2	5.474	L/r	17.688	Net Sect	238	7.82	5.474	27.200	24.469	17.688	18.658	0.000	0.000	0.000	0.000
0.000		Automatic														
g60P	Horz2	5.474	L/r	17.688	Net Sect	238	7.82	5.474	27.200	24.469	17.688	18.658	0.000	0.000	0.000	0.000
0.000		Automatic														
g60X	Horz2	5.474	L/r	17.688	Net Sect	238	7.82	5.474	27.200	24.469	17.688	18.658	0.000	0.000	0.000	0.000
0.000		Automatic														
g61P	Horz8	13.494	L/r	27.187	Rupture	233	13.46	13.494	27.200	32.625	47.668	27.187	0.000	0.000	0.000	0.000
0.000		Automatic														
g61Y	Horz8	13.494	L/r	27.187	Rupture	233	13.46	13.494	27.200	32.625	47.668	27.187	0.000	0.000	0.000	0.000
0.000		Automatic														

g62P	Horz8	13.494	L/r	27.187	Rupture	233	13.46	13.494	27.200	32.625	47.668	27.187	0.000	0.000	0.000	0.000
0.000		Automatic														
g62X	Horz8	13.494	L/r	27.187	Rupture	233	13.46	13.494	27.200	32.625	47.668	27.187	0.000	0.000	0.000	0.000
0.000		Automatic														
g63P	Horz 10	27.200	Shear	27.200	Shear	126	7.69	41.251	27.200	40.781	58.978	33.984	0.000	0.000	0.000	0.000
0.000		Automatic														
g63X	Horz 10	27.200	Shear	27.200	Shear	126	7.69	41.251	27.200	40.781	58.978	33.984	0.000	0.000	0.000	0.000
0.000		Automatic														
g63XY	Horz 10	27.200	Shear	27.200	Shear	126	7.69	41.251	27.200	40.781	58.978	33.984	0.000	0.000	0.000	0.000
0.000		Automatic														
g63Y	Horz 10	27.200	Shear	27.200	Shear	126	7.69	41.251	27.200	40.781	58.978	33.984	0.000	0.000	0.000	0.000
0.000		Automatic														
g64P	Horz 10	27.200	Shear	27.200	Shear	126	7.69	41.251	27.200	40.781	58.978	33.984	0.000	0.000	0.000	0.000
0.000		Automatic														
g64X	Horz 10	27.200	Shear	27.200	Shear	126	7.69	41.251	27.200	40.781	58.978	33.984	0.000	0.000	0.000	0.000
0.000		Automatic														
g64XY	Horz 10	27.200	Shear	27.200	Shear	126	7.69	41.251	27.200	40.781	58.978	33.984	0.000	0.000	0.000	0.000
0.000		Automatic														
g64Y	Horz 10	27.200	Shear	27.200	Shear	126	7.69	41.251	27.200	40.781	58.978	33.984	0.000	0.000	0.000	0.000
0.000		Automatic														
g65P	Leg 1	69.597	L/r	53.250	Net Sect	68	4.49	69.597	0.000	0.000	53.250	0.000	0.000	0.000	0.000	0.000
0.000		Automatic														
g65X	Leg 1	69.597	L/r	53.250	Net Sect	68	4.49	69.597	0.000	0.000	53.250	0.000	0.000	0.000	0.000	0.000
0.000		Automatic														
g65XY	Leg 1	69.597	L/r	53.250	Net Sect	68	4.49	69.597	0.000	0.000	53.250	0.000	0.000	0.000	0.000	0.000
0.000		Automatic														
g65Y	Leg 1	69.597	L/r	53.250	Net Sect	68	4.49	69.597	0.000	0.000	53.250	0.000	0.000	0.000	0.000	0.000
0.000		Automatic														
g66P	Leg 1	71.691	L/r	53.250	Net Sect	63	4.16	71.691	0.000	0.000	53.250	0.000	0.000	0.000	0.000	0.000
0.000		Automatic														
g66X	Leg 1	71.691	L/r	53.250	Net Sect	63	4.16	71.691	0.000	0.000	53.250	0.000	0.000	0.000	0.000	0.000
0.000		Automatic														
g66XY	Leg 1	71.691	L/r	53.250	Net Sect	63	4.16	71.691	0.000	0.000	53.250	0.000	0.000	0.000	0.000	0.000
0.000		Automatic														
g66Y	Leg 1	71.691	L/r	53.250	Net Sect	63	4.16	71.691	0.000	0.000	53.250	0.000	0.000	0.000	0.000	0.000
0.000		Automatic														
g67P	Leg 1	71.630	L/r	53.250	Net Sect	63	4.17	71.630	0.000	0.000	53.250	0.000	0.000	0.000	0.000	0.000
0.000		Automatic														
g67X	Leg 1	71.630	L/r	53.250	Net Sect	63	4.17	71.630	0.000	0.000	53.250	0.000	0.000	0.000	0.000	0.000
0.000		Automatic														
g67XY	Leg 1	71.630	L/r	53.250	Net Sect	63	4.17	71.630	0.000	0.000	53.250	0.000	0.000	0.000	0.000	0.000
0.000		Automatic														
g67Y	Leg 1	71.630	L/r	53.250	Net Sect	63	4.17	71.630	0.000	0.000	53.250	0.000	0.000	0.000	0.000	0.000
0.000		Automatic														
g68P	Leg 1	75.378	L/r	53.250	Net Sect	53	3.50	75.378	81.600	109.687	53.250	81.851	0.000	0.000	0.000	0.000
0.000		Automatic														
g68X	Leg 1	75.378	L/r	53.250	Net Sect	53	3.50	75.378	81.600	109.687	53.250	81.851	0.000	0.000	0.000	0.000
0.000		Automatic														
g68XY	Leg 1	75.378	L/r	53.250	Net Sect	53	3.50	75.378	81.600	109.687	53.250	81.851	0.000	0.000	0.000	0.000
0.000		Automatic														
g68Y	Leg 1	75.378	L/r	53.250	Net Sect	53	3.50	75.378	81.600	109.687	53.250	81.851	0.000	0.000	0.000	0.000
0.000		Automatic														
g69P	Leg 2	271.593	L/r	200.000	Net Sect	36	3.50	271.593	0.000	0.000	200.000	0.000	0.000	0.000	0.000	0.000
0.000		Automatic														
g69X	Leg 2	271.593	L/r	200.000	Net Sect	36	3.50	271.593	0.000	0.000	200.000	0.000	0.000	0.000	0.000	0.000
0.000		Automatic														
g69XY	Leg 2	271.593	L/r	200.000	Net Sect	36	3.50	271.593	0.000	0.000	200.000	0.000	0.000	0.000	0.000	0.000
0.000		Automatic														
g69Y	Leg 2	271.593	L/r	200.000	Net Sect	36	3.50	271.593	0.000	0.000	200.000	0.000	0.000	0.000	0.000	0.000

g77X	Leg 4	643.509	L/r	431.812	Net Sect	25	3.26	643.509	0.000	0.000	431.812	0.000	0.000	0.000	0.000	0.000
0.000		Automatic														
g77XY	Leg 4	643.509	L/r	431.812	Net Sect	25	3.26	643.509	0.000	0.000	431.812	0.000	0.000	0.000	0.000	0.000
0.000		Automatic														
g77Y	Leg 4	643.509	L/r	431.812	Net Sect	25	3.26	643.509	0.000	0.000	431.812	0.000	0.000	0.000	0.000	0.000
0.000		Automatic														
g78P	Leg 4	637.537	L/r	431.812	Net Sect	29	3.77	637.537	0.000	0.000	431.812	0.000	0.000	0.000	0.000	0.000
0.000		Automatic														
g78X	Leg 4	637.537	L/r	431.812	Net Sect	29	3.77	637.537	0.000	0.000	431.812	0.000	0.000	0.000	0.000	0.000
0.000		Automatic														
g78XY	Leg 4	637.537	L/r	431.812	Net Sect	29	3.77	637.537	0.000	0.000	431.812	0.000	0.000	0.000	0.000	0.000
0.000		Automatic														
g78Y	Leg 4	637.537	L/r	431.812	Net Sect	29	3.77	637.537	0.000	0.000	431.812	0.000	0.000	0.000	0.000	0.000
0.000		Automatic														
g79P	Leg 4	637.554	L/r	508.374	Net Sect	29	3.77	637.554	0.000	0.000	508.374	0.000	0.000	0.000	0.000	0.000
0.000		Automatic														
g79X	Leg 4	637.554	L/r	508.374	Net Sect	29	3.77	637.554	0.000	0.000	508.374	0.000	0.000	0.000	0.000	0.000
0.000		Automatic														
g79XY	Leg 4	637.554	L/r	508.374	Net Sect	29	3.77	637.554	0.000	0.000	508.374	0.000	0.000	0.000	0.000	0.000
0.000		Automatic														
g79Y	Leg 4	637.554	L/r	508.374	Net Sect	29	3.77	637.554	0.000	0.000	508.374	0.000	0.000	0.000	0.000	0.000
0.000		Automatic														
g80P	Leg 4	618.892	L/r	508.374	Net Sect	38	5.02	618.892	0.000	0.000	508.374	0.000	0.000	0.000	0.000	0.000
0.000		Automatic														
g80X	Leg 4	618.892	L/r	508.374	Net Sect	38	5.02	618.892	0.000	0.000	508.374	0.000	0.000	0.000	0.000	0.000
0.000		Automatic														
g80XY	Leg 4	618.892	L/r	508.374	Net Sect	38	5.02	618.892	0.000	0.000	508.374	0.000	0.000	0.000	0.000	0.000
0.000		Automatic														
g80Y	Leg 4	618.892	L/r	508.374	Net Sect	38	5.02	618.892	0.000	0.000	508.374	0.000	0.000	0.000	0.000	0.000
0.000		Automatic														
g81P	Leg 4	618.915	L/r	431.812	Net Sect	38	5.02	618.915	0.000	0.000	431.812	0.000	0.000	0.000	0.000	0.000
0.000		Automatic														
g81X	Leg 4	618.915	L/r	431.812	Net Sect	38	5.02	618.915	0.000	0.000	431.812	0.000	0.000	0.000	0.000	0.000
0.000		Automatic														
g81XY	Leg 4	618.915	L/r	431.812	Net Sect	38	5.02	618.915	0.000	0.000	431.812	0.000	0.000	0.000	0.000	0.000
0.000		Automatic														
g81Y	Leg 4	618.915	L/r	431.812	Net Sect	38	5.02	618.915	0.000	0.000	431.812	0.000	0.000	0.000	0.000	0.000
0.000		Automatic														
g82P	Leg 4	600.173	L/r	431.812	Net Sect	46	6.03	600.173	0.000	0.000	431.812	0.000	0.000	0.000	0.000	0.000
0.000		Automatic														
g82X	Leg 4	600.173	L/r	431.812	Net Sect	46	6.03	600.173	0.000	0.000	431.812	0.000	0.000	0.000	0.000	0.000
0.000		Automatic														
g82XY	Leg 4	600.173	L/r	431.812	Net Sect	46	6.03	600.173	0.000	0.000	431.812	0.000	0.000	0.000	0.000	0.000
0.000		Automatic														
g82Y	Leg 4	600.173	L/r	431.812	Net Sect	46	6.03	600.173	0.000	0.000	431.812	0.000	0.000	0.000	0.000	0.000
0.000		Automatic														
g83P	Leg 4	244.800	Shear	244.800	Shear	46	6.03	600.173	244.800	1151.717	431.812	369.988	0.000	0.000	0.000	0.000
0.000		Automatic														
g83X	Leg 4	244.800	Shear	244.800	Shear	46	6.03	600.173	244.800	1151.717	431.812	369.988	0.000	0.000	0.000	0.000
0.000		Automatic														
g83XY	Leg 4	244.800	Shear	244.800	Shear	46	6.03	600.173	244.800	1151.717	431.812	369.988	0.000	0.000	0.000	0.000
0.000		Automatic														
g83Y	Leg 4	244.800	Shear	244.800	Shear	46	6.03	600.173	244.800	1151.717	431.812	369.988	0.000	0.000	0.000	0.000
0.000		Automatic														
g84P	Leg 4	545.569	L/r	431.812	Net Sect	63	8.29	545.569	0.000	0.000	431.812	0.000	0.000	0.000	0.000	0.000
0.000		Automatic														
g84X	Leg 4	545.569	L/r	431.812	Net Sect	63	8.29	545.569	0.000	0.000	431.812	0.000	0.000	0.000	0.000	0.000
0.000		Automatic														
g84XY	Leg 4	545.569	L/r	431.812	Net Sect	63	8.29	545.569	0.000	0.000	431.812	0.000	0.000	0.000	0.000	0.000

0.000		Automatic														
g84Y	Leg 4	545.569	L/r	431.812	Net Sect	63	8.29	545.569	0.000	0.000	431.812	0.000	0.000	0.000	0.000	0.000
0.000		Automatic														
g85P	Leg 4	623.063	L/r	508.374	Net Sect	36	9.54	623.063	0.000	0.000	508.374	0.000	0.000	0.000	0.000	0.000
0.000		Automatic														
g85X	Leg 4	623.063	L/r	508.374	Net Sect	36	9.54	623.063	0.000	0.000	508.374	0.000	0.000	0.000	0.000	0.000
0.000		Automatic														
g85XY	Leg 4	623.063	L/r	508.374	Net Sect	36	9.54	623.063	0.000	0.000	508.374	0.000	0.000	0.000	0.000	0.000
0.000		Automatic														
g85Y	Leg 4	623.063	L/r	508.374	Net Sect	36	9.54	623.063	0.000	0.000	508.374	0.000	0.000	0.000	0.000	0.000
0.000		Automatic														
g86P	Leg 4	272.000	Shear	272.000	Shear	42	11.04	610.043	272.000	1279.686	508.374	341.386	0.000	0.000	0.000	0.000
0.000		Automatic														
g86X	Leg 4	272.000	Shear	272.000	Shear	42	11.04	610.043	272.000	1279.686	508.374	341.386	0.000	0.000	0.000	0.000
0.000		Automatic														
g86XY	Leg 4	272.000	Shear	272.000	Shear	42	11.04	610.043	272.000	1279.686	508.374	341.386	0.000	0.000	0.000	0.000
0.000		Automatic														
g86Y	Leg 4	272.000	Shear	272.000	Shear	42	11.04	610.043	272.000	1279.686	508.374	341.386	0.000	0.000	0.000	0.000
0.000		Automatic														
g87P	Leg 4	594.858	L/r	508.374	Net Sect	48	12.57	594.858	0.000	0.000	508.374	0.000	0.000	0.000	0.000	0.000
0.000		Automatic														
g87X	Leg 4	594.858	L/r	508.374	Net Sect	48	12.57	594.858	0.000	0.000	508.374	0.000	0.000	0.000	0.000	0.000
0.000		Automatic														
g87XY	Leg 4	594.858	L/r	508.374	Net Sect	48	12.57	594.858	0.000	0.000	508.374	0.000	0.000	0.000	0.000	0.000
0.000		Automatic														
g87Y	Leg 4	594.858	L/r	508.374	Net Sect	48	12.57	594.858	0.000	0.000	508.374	0.000	0.000	0.000	0.000	0.000
0.000		Automatic														
g88P	Leg 4	272.000	Shear	272.000	Shear	54	14.07	578.022	272.000	1279.686	508.374	341.386	0.000	0.000	0.000	0.000
0.000		Automatic														
g88X	Leg 4	272.000	Shear	272.000	Shear	54	14.07	578.022	272.000	1279.686	508.374	341.386	0.000	0.000	0.000	0.000
0.000		Automatic														
g88XY	Leg 4	272.000	Shear	272.000	Shear	54	14.07	578.022	272.000	1279.686	508.374	341.386	0.000	0.000	0.000	0.000
0.000		Automatic														
g88Y	Leg 4	272.000	Shear	272.000	Shear	54	14.07	578.022	272.000	1279.686	508.374	341.386	0.000	0.000	0.000	0.000
0.000		Automatic														
g89P	Leg 4	272.000	Shear	272.000	Shear	61	8.04	552.500	272.000	1279.686	508.374	341.386	0.000	0.000	0.000	0.000
0.000		Automatic														
g89X	Leg 4	272.000	Shear	272.000	Shear	61	8.04	552.500	272.000	1279.686	508.374	341.386	0.000	0.000	0.000	0.000
0.000		Automatic														
g89XY	Leg 4	272.000	Shear	272.000	Shear	61	8.04	552.500	272.000	1279.686	508.374	341.386	0.000	0.000	0.000	0.000
0.000		Automatic														
g89Y	Leg 4	272.000	Shear	272.000	Shear	61	8.04	552.500	272.000	1279.686	508.374	341.386	0.000	0.000	0.000	0.000
0.000		Automatic														
g90P	Diag12	33.365	L/r	31.639	Rupture	111	11.72	33.365	40.800	48.937	39.406	31.639	0.000	0.000	0.000	0.000
0.000		Automatic														
g90X	Diag12	33.365	L/r	31.639	Rupture	111	11.72	33.365	40.800	48.937	39.406	31.639	0.000	0.000	0.000	0.000
0.000		Automatic														
g90XY	Diag12	33.365	L/r	31.639	Rupture	111	11.72	33.365	40.800	48.937	39.406	31.639	0.000	0.000	0.000	0.000
0.000		Automatic														
g90Y	Diag12	33.365	L/r	31.639	Rupture	111	11.72	33.365	40.800	48.937	39.406	31.639	0.000	0.000	0.000	0.000
0.000		Automatic														
g91P	Horz 13	51.221	L/r	54.400	Shear	134	8.50	51.221	54.400	97.875	77.557	62.086	0.000	0.000	0.000	0.000
0.000		Automatic														
g91X	Horz 13	51.221	L/r	54.400	Shear	134	8.50	51.221	54.400	97.875	77.557	62.086	0.000	0.000	0.000	0.000
0.000		Automatic														
g91XY	Horz 13	51.221	L/r	54.400	Shear	134	8.50	51.221	54.400	97.875	77.557	62.086	0.000	0.000	0.000	0.000
0.000		Automatic														
g91Y	Horz 13	51.221	L/r	54.400	Shear	134	8.50	51.221	54.400	97.875	77.557	62.086	0.000	0.000	0.000	0.000
0.000		Automatic														

g92P	Horz	11	44.997	L/r	41.391	Rupture	60	3.34	44.997	54.400	65.250	41.593	41.391	0.000	0.000	0.000	0.000
0.000			Automatic														
g92Y	Horz	11	44.997	L/r	41.391	Rupture	60	3.34	44.997	54.400	65.250	41.593	41.391	0.000	0.000	0.000	0.000
0.000			Automatic														
g93P	Arm		3.474	L/r	16.819	Rupture	280	9.19	3.474	27.200	24.469	17.688	16.819	0.000	0.000	0.000	0.000
0.000			Automatic														
g93X	Arm		3.474	L/r	16.819	Rupture	280	9.19	3.474	27.200	24.469	17.688	16.819	0.000	0.000	0.000	0.000
0.000			Automatic														
g93XY	Arm		3.474	L/r	16.819	Rupture	280	9.19	3.474	27.200	24.469	17.688	16.819	0.000	0.000	0.000	0.000
0.000			Automatic														
g93Y	Arm		3.474	L/r	16.819	Rupture	280	9.19	3.474	27.200	24.469	17.688	16.819	0.000	0.000	0.000	0.000
0.000			Automatic														
g94P	Horz	13	51.221	L/r	54.400	Shear	134	8.50	51.221	54.400	97.875	77.557	73.505	0.000	0.000	0.000	0.000
0.000			Automatic														
g94X	Horz	13	51.221	L/r	54.400	Shear	134	8.50	51.221	54.400	97.875	77.557	73.505	0.000	0.000	0.000	0.000
0.000			Automatic														
g94XY	Horz	13	51.221	L/r	54.400	Shear	134	8.50	51.221	54.400	97.875	77.557	73.505	0.000	0.000	0.000	0.000
0.000			Automatic														
g94Y	Horz	13	51.221	L/r	54.400	Shear	134	8.50	51.221	54.400	97.875	77.557	73.505	0.000	0.000	0.000	0.000
0.000			Automatic														
g95P	Horz	11	44.997	L/r	41.593	Net Sect	60	3.34	44.997	54.400	65.250	41.593	49.003	0.000	0.000	0.000	0.000
0.000			Automatic														
g95Y	Horz	11	44.997	L/r	41.593	Net Sect	60	3.34	44.997	54.400	65.250	41.593	49.003	0.000	0.000	0.000	0.000
0.000			Automatic														
g96P	Arm		3.474	L/r	16.819	Rupture	280	9.19	3.474	27.200	24.469	17.688	16.819	0.000	0.000	0.000	0.000
0.000			Automatic														
g96X	Arm		3.474	L/r	16.819	Rupture	280	9.19	3.474	27.200	24.469	17.688	16.819	0.000	0.000	0.000	0.000
0.000			Automatic														
g96XY	Arm		3.474	L/r	16.819	Rupture	280	9.19	3.474	27.200	24.469	17.688	16.819	0.000	0.000	0.000	0.000
0.000			Automatic														
g96Y	Arm		3.474	L/r	16.819	Rupture	280	9.19	3.474	27.200	24.469	17.688	16.819	0.000	0.000	0.000	0.000
0.000			Automatic														
g97P	Horz	13	68.000	Shear	66.926	Net Sect	86	10.96	73.070	68.000	122.344	66.926	75.136	0.000	0.000	0.000	0.000
0.000			Automatic														
g97X	Horz	13	68.000	Shear	66.926	Net Sect	86	10.96	73.070	68.000	122.344	66.926	75.136	0.000	0.000	0.000	0.000
0.000			Automatic														
g97XY	Horz	13	68.000	Shear	66.926	Net Sect	86	10.96	73.070	68.000	122.344	66.926	75.136	0.000	0.000	0.000	0.000
0.000			Automatic														
g97Y	Horz	13	68.000	Shear	66.926	Net Sect	86	10.96	73.070	68.000	122.344	66.926	75.136	0.000	0.000	0.000	0.000
0.000			Automatic														
g98P	Horz	12	64.028	L/r	51.182	Net Sect	61	3.34	64.028	68.000	101.953	51.182	62.613	0.000	0.000	0.000	0.000
0.000			Automatic														
g98Y	Horz	12	64.028	L/r	51.182	Net Sect	61	3.34	64.028	68.000	101.953	51.182	62.613	0.000	0.000	0.000	0.000
0.000			Automatic														
g99P	Arm2		4.441	L/r	19.350	Rupture	279	11.50	4.441	27.200	24.469	23.909	19.350	0.000	0.000	0.000	0.000
0.000			Automatic														
g99X	Arm2		4.441	L/r	19.350	Rupture	279	11.50	4.441	27.200	24.469	23.909	19.350	0.000	0.000	0.000	0.000
0.000			Automatic														
g99XY	Arm2		4.441	L/r	19.350	Rupture	279	11.50	4.441	27.200	24.469	23.909	19.350	0.000	0.000	0.000	0.000
0.000			Automatic														
g99Y	Arm2		4.441	L/r	19.350	Rupture	279	11.50	4.441	27.200	24.469	23.909	19.350	0.000	0.000	0.000	0.000
0.000			Automatic														
g100P	top		27.200	Shear	27.200	Shear	104	10.83	116.434	27.200	97.875	139.603	90.625	0.000	0.000	0.000	0.000
0.000			Automatic														
g100X	top		27.200	Shear	27.200	Shear	104	10.83	116.434	27.200	97.875	139.603	90.625	0.000	0.000	0.000	0.000
0.000			Automatic														
g101P	top		27.200	Shear	27.200	Shear	32	3.34	157.295	27.200	97.875	139.603	90.625	0.000	0.000	0.000	0.000
0.000			Automatic														
g102P	Inner1		13.600	Shear	9.919	Rupture	98	4.72	19.280	13.600	16.312	19.156	9.919	0.000	0.000	0.000	0.000

0.000		Automatic														
g102X	Inner1	13.600	Shear	9.919	Rupture	98	4.72	19.280	13.600	16.312	19.156	9.919	0.000	0.000	0.000	0.000
0.000		Automatic														
g103P	Inner2	14.952	L/r	14.772	Net Sect	97	4.72	14.952	27.200	24.469	14.772	18.658	0.000	0.000	0.000	0.000
0.000		Automatic														
g103X	Inner2	14.952	L/r	14.772	Net Sect	97	4.72	14.952	27.200	24.469	14.772	18.658	0.000	0.000	0.000	0.000
0.000		Automatic														
g104P	Inner2	14.952	L/r	14.772	Net Sect	97	4.72	14.952	27.200	24.469	14.772	18.658	0.000	0.000	0.000	0.000
0.000		Automatic														
g104X	Inner2	14.952	L/r	14.772	Net Sect	97	4.72	14.952	27.200	24.469	14.772	18.658	0.000	0.000	0.000	0.000
0.000		Automatic														
g105P	Inner3	19.896	L/r	17.688	Net Sect	72	4.72	19.896	27.200	24.469	17.688	18.658	0.000	0.000	0.000	0.000
0.000		Automatic														
g105X	Inner3	19.896	L/r	17.688	Net Sect	72	4.72	19.896	27.200	24.469	17.688	18.658	0.000	0.000	0.000	0.000
0.000		Automatic														
g106P	Inner2	3.468	L/r	7.439	Rupture	226	11.06	3.468	13.600	12.234	14.772	7.439	0.000	0.000	0.000	0.000
0.000		Automatic	KL/R	value	of 226.21	exceeds	maximum	of 200.00	for	member	"g106P"	??				
g106X	Inner2	3.468	L/r	7.439	Rupture	226	11.06	3.468	13.600	12.234	14.772	7.439	0.000	0.000	0.000	0.000
0.000		Automatic	KL/R	value	of 226.21	exceeds	maximum	of 200.00	for	member	"g106X"	??				
g107P	Inner4	8.167	L/r	18.998	Rupture	219	21.75	8.167	27.200	24.469	30.000	18.998	0.000	0.000	0.000	0.000
0.000		Automatic														
g107X	Inner4	8.167	L/r	18.998	Rupture	219	21.75	8.167	27.200	24.469	30.000	18.998	0.000	0.000	0.000	0.000
0.000		Automatic														

The model contains 377 angle members.

Sum of Unfactored Dead Load and Drag Areas From Equipment, Input and Calculated:

Joint Label	Dead Load (kips)	X-Drag Area (ft^2)	Y-Drag Area (ft^2)
1P	0.17	4.642	2.246
2P	0.0994	5.013	3.958
3P	0.0535	2.972	2.972
4P	0.0649	3.797	3.089
5P	0.149	5.905	4.239
6P	0.116	3.834	3.834
7P	0.116	3.834	3.834
8P	0.14	5.472	4.412
9P	0.255	8.225	6.038
10P	0.22	5.807	5.807
11P	0.22	5.807	5.807
12P	0.243	6.839	6.131
13P	0.302	8.382	6.716
14P	0.248	5.953	5.953
15P	0.249	5.845	5.845
16P	0.268	6.109	6.109
17P	0.303	6.706	6.706
18P	0.33	7.128	7.128
19P	0.358	7.819	7.819
20P	0.454	10.511	10.511
21P	0.532	11.791	11.791
23P	0.626	14.074	14.074
25P	0.724	16.131	16.131
27P	0.905	20.917	20.917
29P	0.722	16.243	16.243
30P	0.257	5.922	5.922
39P	0.135	6.389	2.673

40P	0.135	2.673	6.389
41P	0.162	5.190	1.310
42P	0.111	4.977	1.342
43P	0.149	6.884	1.504
44P	0.111	4.977	1.342
1X	0.17	4.642	2.246
2X	0.0994	5.013	3.958
2XY	0.0994	5.013	3.958
2Y	0.0994	5.013	3.958
3X	0.0535	2.972	2.972
3XY	0.0535	2.972	2.972
3Y	0.0535	2.972	2.972
4X	0.0649	3.797	3.089
4XY	0.0649	3.797	3.089
4Y	0.0649	3.797	3.089
5X	0.149	5.905	4.239
5XY	0.149	5.905	4.239
5Y	0.149	5.905	4.239
6X	0.116	3.834	3.834
6XY	0.116	3.834	3.834
6Y	0.116	3.834	3.834
7X	0.116	3.834	3.834
7XY	0.116	3.834	3.834
7Y	0.116	3.834	3.834
8X	0.14	5.472	4.412
8XY	0.14	5.472	4.412
8Y	0.14	5.472	4.412
9X	0.255	8.225	6.038
9XY	0.255	8.225	6.038
9Y	0.255	8.225	6.038
10X	0.22	5.807	5.807
10XY	0.22	5.807	5.807
10Y	0.22	5.807	5.807
11X	0.22	5.807	5.807
11XY	0.22	5.807	5.807
11Y	0.22	5.807	5.807
12X	0.243	6.839	6.131
12XY	0.243	6.839	6.131
12Y	0.243	6.839	6.131
13X	0.302	8.382	6.716
13XY	0.302	8.382	6.716
13Y	0.302	8.382	6.716
14X	0.248	5.953	5.953
14XY	0.248	5.953	5.953
14Y	0.248	5.953	5.953
15X	0.249	5.845	5.845
15XY	0.249	5.845	5.845
15Y	0.249	5.845	5.845
16X	0.268	6.109	6.109
16XY	0.268	6.109	6.109
16Y	0.268	6.109	6.109
17X	0.303	6.706	6.706
17XY	0.303	6.706	6.706
17Y	0.303	6.706	6.706
18X	0.33	7.128	7.128
18XY	0.33	7.128	7.128
18Y	0.33	7.128	7.128
19X	0.358	7.819	7.819
19XY	0.358	7.819	7.819

19Y	0.358	7.819	7.819
20X	0.454	10.511	10.511
20XY	0.454	10.511	10.511
20Y	0.454	10.511	10.511
21X	0.532	11.791	11.791
21XY	0.532	11.791	11.791
21Y	0.532	11.791	11.791
23X	0.626	14.074	14.074
23XY	0.626	14.074	14.074
23Y	0.626	14.074	14.074
25X	0.724	16.131	16.131
25XY	0.724	16.131	16.131
25Y	0.724	16.131	16.131
27X	0.905	20.917	20.917
27XY	0.905	20.917	20.917
27Y	0.905	20.917	20.917
29X	0.722	16.243	16.243
29XY	0.722	16.243	16.243
29Y	0.722	16.243	16.243
30X	0.257	5.922	5.922
30XY	0.257	5.922	5.922
30Y	0.257	5.922	5.922
39Y	0.135	6.389	2.673
40X	0.135	2.673	6.389
41X	0.162	5.190	1.310
42X	0.111	4.977	1.342
43X	0.149	6.884	1.504
44X	0.111	4.977	1.342
Total	33.8	875.620	801.574

Unadjusted Dead Load and Drag Areas by Section:

Section Label	Unfactored Dead Load (kips)	X-Drag Area All (ft ²)	Y-Drag Area All (ft ²)	X-Drag Area Face (ft ²)	Y-Drag Area Face (ft ²)
2	8.859	305.821	231.775	131.949	83.762
1	24.904	569.800	569.800	222.138	222.138
Total	33.763	875.620	801.574	354.087	305.900

Angle Member Weights and Surface Areas by Section:

Section Label	Unfactored Weight (kips)	Factored Weight (kips)	Unfactored Surface Area (ft ²)	Factored Surface Area (ft ²)
2	8.859	9.302	1240.084	1302.088
1	24.904	26.150	2524.763	2651.001
Total	33.763	35.452	3764.846	3953.089

Section Joint Information:

Section Label	Joint Label	Joint Elevation (ft)
2	1X	140.000
2	2P	135.830
2	1P	140.000

2	2X	135.830
2	2XY	135.830
2	2Y	135.830
2	3P	131.670
2	3X	131.670
2	3XY	131.670
2	3Y	131.670
2	4X	127.500
2	4P	127.500
2	4Y	127.500
2	4XY	127.500
2	5X	124.000
2	5P	124.000
2	5Y	124.000
2	5XY	124.000
2	6X	120.500
2	6P	120.500
2	6Y	120.500
2	6XY	120.500
2	7X	117.000
2	7P	117.000
2	7Y	117.000
2	7XY	117.000
2	8X	113.500
2	8P	113.500
2	8Y	113.500
2	8XY	113.500
2	9X	110.000
2	9P	110.000
2	9Y	110.000
2	9XY	110.000
2	10X	106.500
2	10P	106.500
2	10Y	106.500
2	10XY	106.500
2	11X	103.000
2	11P	103.000
2	11Y	103.000
2	11XY	103.000
2	12X	99.500
2	12P	99.500
2	12Y	99.500
2	12XY	99.500
2	13X	96.000
2	13P	96.000
2	13Y	96.000
2	13XY	96.000
2	41X	140.000
2	41P	140.000
2	42X	124.000
2	42P	124.000
2	44X	96.000
2	44P	96.000
2	43X	110.000
2	43P	110.000
1	14X	92.750
1	13P	96.000
1	14P	92.750
1	13X	96.000

1	14Y	92.750
1	13XY	96.000
1	14XY	92.750
1	13Y	96.000
1	15X	89.000
1	15P	89.000
1	15Y	89.000
1	15XY	89.000
1	16X	85.250
1	16P	85.250
1	16Y	85.250
1	16XY	85.250
1	17X	80.250
1	17P	80.250
1	17Y	80.250
1	17XY	80.250
1	18X	75.250
1	18P	75.250
1	18Y	75.250
1	18XY	75.250
1	19X	69.250
1	19P	69.250
1	19Y	69.250
1	19XY	69.250
1	20X	63.250
1	20P	63.250
1	20Y	63.250
1	20XY	63.250
1	21X	55.000
1	21P	55.000
1	21Y	55.000
1	21XY	55.000
1	23X	45.500
1	23P	45.500
1	23Y	45.500
1	23XY	45.500
1	25X	34.500
1	25P	34.500
1	25Y	34.500
1	25XY	34.500
1	27X	22.000
1	27P	22.000
1	27Y	22.000
1	27XY	22.000
1	29X	8.000
1	29P	8.000
1	29Y	8.000
1	29XY	8.000
1	30X	0.000
1	39P	8.000
1	30P	0.000
1	30Y	0.000
1	39Y	8.000
1	30XY	0.000
1	40P	8.000
1	40X	8.000

Sections Information:

Section Label	Top Z (ft)	Bottom Z (ft)	Joint Count	Member Count	Tran. Face Top Width (ft)	Tran. Face Bot Width (ft)	Tran. Face Gross Area (ft^2)	Long. Face Top Width (ft)	Long. Face Bot Width (ft)	Long. Face Gross Area (ft^2)
2	140.000	96.000	58	201	0.00	3.34	139.996	25.00	20.00	288.336
1	96.000	0.000	60	176	3.34	16.46	949.193	3.34	16.46	949.193

*** Insulator Data

Clamp Properties:

Label	Stock Number	Holding Capacity (lbs)
C-EX1		5e+004

Clamp Insulator Connectivity:

Clamp Label	Structure And Tip Attach	Property Set	Min. Required Vertical Load (uplift) (lbs)
C1	41X	C-EX1	No Limit
C2	41P	C-EX1	No Limit
C3	42X	C-EX1	No Limit
C4	42P	C-EX1	No Limit
C5	43X	C-EX1	No Limit
C6	43P	C-EX1	No Limit
C7	44X	C-EX1	No Limit
C8	44P	C-EX1	No Limit
C9	2P	C-EX1	No Limit
C10	2X	C-EX1	No Limit
C11	2XY	C-EX1	No Limit
C12	2Y	C-EX1	No Limit
C13	6P	C-EX1	No Limit
C14	6X	C-EX1	No Limit
C15	6XY	C-EX1	No Limit
C16	6Y	C-EX1	No Limit
C17	1P	C-EX1	No Limit
C18	4P	C-EX1	No Limit
C19	7P	C-EX1	No Limit
C20	10P	C-EX1	No Limit
C21	13P	C-EX1	No Limit
C22	16P	C-EX1	No Limit
C23	18P	C-EX1	No Limit
C24	20P	C-EX1	No Limit
C25	23P	C-EX1	No Limit
C26	25P	C-EX1	No Limit
C27	27P	C-EX1	No Limit
C28	29P	C-EX1	No Limit

*** Loads Data

Loads from file: j:\jobs\2105100.wi\06_ct11241a\05_structural\backup documentation\calcs\pls tower\cl&p tower # 1280.lca

Insulator dead and wind loads are already included in the point loads printed below.

Loading Method Parameters:

Structure Height Summary (used for calculating wind/ice adjust with height):

Z of ground for wind height adjust 0.00 (ft) and structure Z coordinate that will be put on the centerline ground profile in PLS-CADD.
 Ground elevation shift 0.00 (ft)
 Z of ground with shift 0.00 (ft)
 Z of structure top (highest joint) 140.00 (ft)
 Structure height 140.00 (ft)
 Structure height above ground 140.00 (ft)
 Tower Shape Rectangular

Load distributed evenly among joints in section for section based load cases

Vector Load Cases:

Load Case Description	Dead Load Factor	Wind Area Factor	SF for Steel Tubular and Towers	SF for Poles Arms and Cables	SF for Insuls.	SF For Found.	Point Loads	Wind/Ice Model	Trans. Wind Pressure (psf)	Longit. Wind Pressure (psf)	Ice Thick. (in)	Ice Density (lbs/ft^3)	Temperature (deg F)	Joint Displ.
NESC Heavy	1.5000	2.5000	1.00000	1.0000	1.0000	1.0000	28 loads	Wind on All	4	0	0.000	0.000	60.0	
NESC Extreme	1.0000	1.0000	1.00000	1.0000	1.0000	1.0000	28 loads	NESC 2012	31	0	0.000	0.000	60.0	

Point Loads for Load Case "NESC Heavy":

Joint Label	Vertical Load (lbs)	Transverse Load (lbs)	Longitudinal Load (lbs)	Load Comment
41P	1154	2661	100	Shield Wire
41X	1129	2793	50	Shield Wire
42P	2695	3509	-2239	Conductor Wire
42X	2759	3838	-603	Conductor Wire
43P	2653	3409	-2923	Conductor Wire
43X	2671	3543	-2851	Conductor Wire
44P	2769	3772	-286	Conductor Wire
44X	2856	4238	1055	Conductor Wire
2P	0	744.5	0	Top Connection
2X	0	744.5	0	Top Connection
2XY	0	744.5	0	Top Connection
2Y	0	744.5	0	Top Connection
6P	1458	-380	0	Bottom Connection
6X	1458	-380	0	Bottom Connection
6XY	1458	-380	0	Bottom Connection
6Y	1458	-380	0	Bottom Connection
1P	575	107	0	Coax Cable
4P	1058	197	0	Coax Cable
7P	966	180	0	Coax Cable
10P	966	180	0	Coax Cable

13P	977	182	0	Coax Cable
16P	954	178	0	Coax Cable
18P	1012	189	0	Coax Cable
20P	1150	215	0	Coax Cable
23P	1069	200	0	Coax Cable
25P	1012	189	0	Coax Cable
27P	1150	215	0	Coax Cable
29P	1299	243	0	Coax Cable

Section Load Case Information (Standard) for "NESC Heavy":

Section Label	Z of Top	Z of Bottom	Ave. Elev.	Res. Adj.	Tran Adj.	Tran Drag Coef	Tran Wind Load	Long Adj. Wind Pres.	Long Drag Coef	Long Wind Load	Ice Weight	Total Weight
	(ft)	(ft)	(ft)	(psf)	(psf)		(lbs)	(psf)		(lbs)	(lbs)	(lbs)
2	140.00	96.00	118.00	10.00	10.00	1.000	2317.7	0.00	1.000	0.0	0	13953
1	96.00	0.00	48.00	10.00	10.00	1.000	5698.0	0.00	1.000	0.0	0	39224

Point Loads for Load Case "NESC Extreme":

Joint Label	Vertical Load (lbs)	Transverse Load (lbs)	Longitudinal Load (lbs)	Load Comment
41P	518	2150	100	Shield Wire
41X	536	2172	50	Shield Wire
42P	1458	3656	-1890	Conductor Wire
42X	1502	3791	-1232	Conductor Wire
43P	1423	3548	-2193	Conductor Wire
43X	1450	3599	-2203	Conductor Wire
44P	1482	3631	-988	Conductor Wire
44X	1531	3830	-670	Conductor Wire
2P	0	3046	0	Top Connection
2X	0	3046	0	Top Connection
2XY	0	3046	0	Top Connection
2Y	0	3046	0	Top Connection
6P	682	-1581	0	Bottom Connection
6X	682	-1581	0	Bottom Connection
6XY	682	-1581	0	Bottom Connection
6Y	682	-1581	0	Bottom Connection
1P	156	357	0	Coax Cable
4P	287	658	0	Coax Cable
7P	262	600	0	Coax Cable
10P	262	600	0	Coax Cable
13P	265	608	0	Coax Cable
16P	259	593	0	Coax Cable
18P	275	629	0	Coax Cable
20P	312	715	0	Coax Cable
23P	290	665	0	Coax Cable
25P	275	629	0	Coax Cable
27P	312	715	0	Coax Cable
29P	353	808	0	Coax Cable

Section Load Case Information (Code) for "NESC Extreme":

Section Label	Z of	Z of	Ave. Elev.	Res. Adj.	Tran Adj.	Tran Angle	Tran Gross	Tran Soli-	Tran Angle	Tran Wind	Long Adj.	Long Angle	Long Gross	Long Soli-	Long Angle	Long Wind	Ice Weight	Total Weight
---------------	------	------	------------	-----------	-----------	------------	------------	------------	------------	-----------	-----------	------------	------------	------------	------------	-----------	------------	--------------

	Top	Bottom	Above	Wind	Wind	Face	Area	dity	Drag	Load	Wind	Face	Area	dity	Drag	Load			
	(ft)	(ft)	Ground	Pres.	Pres.	Area	(ft^2)	Ratio	Coef	(lbs)	Pres.	Area	(ft^2)	Ratio	Coef	(lbs)	(lbs)	(lbs)	
2	140.00	96.00	118.00	32.59	32.59	83.76	140.00	0.598	3.200	8734.5	0.00	131.95	288.34	0.458	3.200	0.0	0	9302	
1	96.00	0.00	48.00	32.59	32.59	222.14	949.19	0.234	3.200	23163.9	0.00	222.14	949.19	0.234	3.200	0.0	0	26150	

*** Analysis Results:

Maximum element usage is 89.89% for Angle "g89XY" in load case "NESC Extreme"
 Maximum insulator usage is 10.81% for Clamp "C5" in load case "NESC Heavy"

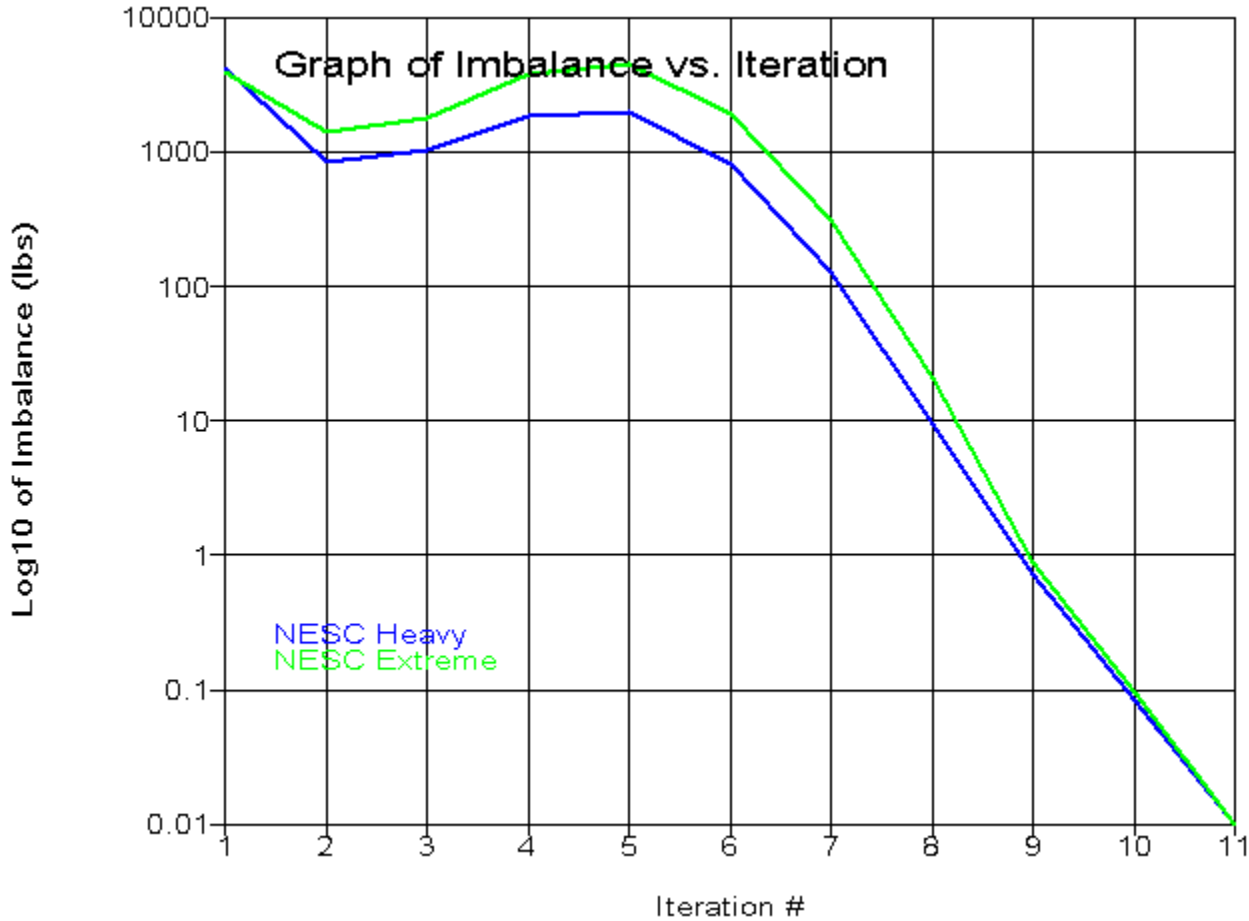

Angle Forces For All Load Cases:

Positive for tension - negative for compression

Group Label	Angle Label	Max. Usage For All LC %	Max. Tens. For All LC (kips)	Max. Comp. For All LC (kips)	LC 1 (kips)	LC 2 (kips)
Diag1	g1P	19.27	0.000	-2.485	-2.485	-2.247
Diag1	g1X	17.77	2.264	0.000	2.264	2.138
Diag1	g2P	17.29	2.203	0.000	2.203	2.113
Diag1	g2X	18.27	0.000	-2.357	-2.357	-2.158

Diag2	g3P	38.31	0.000	-7.245	-3.714	-7.245
Diag2	g3X	48.43	6.763	0.000	2.919	6.763
Diag2	g3XY	51.08	7.133	0.000	3.358	7.133
Diag2	g3Y	39.10	0.000	-7.395	-3.967	-7.395
Diag2	g4P	2.56	0.000	-0.398	-0.122	-0.398
Diag2	g4X	2.93	0.410	0.000	0.339	0.410
Diag2	g4XY	3.66	0.511	0.000	0.511	0.501
Diag2	g4Y	1.50	0.000	-0.233	-0.048	-0.233
Diag2	g5P	56.06	7.599	0.000	3.819	7.599
Diag2	g5X	37.46	0.000	-7.080	-2.951	-7.080
Diag2	g5XY	39.43	0.000	-7.453	-3.393	-7.453
Diag2	g5Y	57.18	7.751	0.000	4.081	7.751
Diag2	g6P	2.73	0.370	0.000	0.078	0.370
Diag2	g6X	4.84	0.000	-0.749	-0.673	-0.749
Diag2	g6XY	4.21	0.000	-0.653	-0.497	-0.653
Diag2	g6Y	3.97	0.538	0.000	0.160	0.538
Diag2	g7P	53.59	7.374	0.000	3.617	7.374
Diag2	g7X	34.16	0.000	-6.736	-3.066	-6.736
Diag2	g7XY	35.23	0.000	-6.946	-3.112	-6.946
Diag2	g7Y	47.43	6.527	0.000	2.901	6.527
Diag2	g8P	7.02	0.000	-1.147	-1.004	-1.147
Diag2	g8X	5.38	0.740	-0.100	-0.100	0.740
Diag2	g8XY	3.55	0.489	-0.149	-0.149	0.489
Diag2	g8Y	8.60	0.000	-1.406	-1.406	-1.397
Diag4	g9P	32.80	10.653	0.000	7.443	10.653
Diag4	g9X	23.88	0.000	-10.646	-7.710	-10.646
Diag4	g9XY	22.05	0.000	-9.827	-4.957	-9.827
Diag4	g9Y	26.82	8.710	0.000	3.551	8.710
Diag4	g10P	6.20	2.013	0.000	2.013	0.675
Diag4	g10X	4.81	1.562	0.000	0.105	1.562
Diag4	g10XY	4.36	1.416	0.000	1.416	0.937
Diag4	g10Y	7.05	0.000	-3.144	-3.144	-2.929
Diag4	g11P	27.00	8.770	0.000	6.960	8.770
Diag4	g11X	20.82	0.000	-9.279	-7.830	-9.279
Diag4	g11XY	16.60	0.000	-7.397	-3.801	-7.397
Diag4	g11Y	23.68	7.693	0.000	3.984	7.693
Diag4	g12P	8.64	2.806	0.000	2.806	2.104
Diag4	g12X	1.71	0.084	-0.760	-0.760	0.084
Diag4	g12XY	1.87	0.607	-0.536	0.607	-0.536
Diag4	g12Y	5.47	0.000	-2.439	-2.439	-1.547
Diag4	g13P	31.99	10.391	0.000	8.697	10.391
Diag4	g13X	19.31	0.000	-8.605	-6.266	-8.605
Diag4	g13XY	16.90	0.000	-7.534	-3.441	-7.534
Diag4	g13Y	23.96	7.783	0.000	4.434	7.783
Diag4	g14P	9.37	3.044	0.000	3.044	2.748
Diag4	g14X	3.89	0.000	-1.489	-1.489	-0.804
Diag4	g14XY	3.83	0.000	-1.466	-0.184	-1.466
Diag4	g14Y	4.97	0.000	-2.214	-2.214	-0.917
Diag5	g15P	29.15	10.602	0.000	8.792	10.602
Diag5	g15X	15.83	0.000	-7.682	-4.980	-7.682
Diag5	g15XY	18.61	0.000	-9.033	-5.557	-9.033
Diag5	g15Y	18.17	6.607	0.000	3.052	6.607
Diag5	g16P	2.60	0.624	-1.074	0.624	-1.074
Diag5	g16X	9.06	3.294	0.000	1.049	3.294
Diag5	g16XY	5.12	1.862	0.000	1.260	1.862
Diag5	g16Y	12.88	0.000	-5.317	-5.317	-5.287
Diag10	g17P	19.22	12.534	0.000	9.848	12.534
Diag10	g17X	14.31	0.000	-11.575	-9.657	-11.575
Diag10	g17XY	14.90	0.000	-12.049	-8.560	-12.049

Diag10	g17Y	13.90	9.063	0.000	4.275	9.063
Diag10	g18P	5.21	3.399	0.000	3.399	1.017
Diag10	g18X	6.52	4.253	0.000	2.759	4.253
Diag10	g18XY	1.29	0.843	0.000	0.546	0.843
Diag10	g18Y	8.53	0.000	-6.280	-6.280	-5.924
Diag10	g19P	19.41	12.660	0.000	9.785	12.660
Diag10	g19X	16.61	0.000	-13.438	-10.790	-13.438
Diag10	g19XY	13.27	0.000	-10.738	-6.284	-10.738
Diag10	g19Y	17.67	11.528	0.000	7.207	11.528
Diag10	g20P	8.09	5.280	0.000	5.280	4.086
Diag10	g20X	1.90	1.238	0.000	0.906	1.238
Diag10	g20XY	2.84	0.000	-2.294	-1.466	-2.294
Diag10	g20Y	5.56	0.000	-4.498	-4.498	-2.927
Diag10	g21P	21.29	13.888	0.000	11.467	13.888
Diag10	g21X	15.58	0.000	-12.601	-9.123	-12.601
Diag10	g21XY	13.54	0.000	-10.949	-5.851	-10.949
Diag10	g21Y	17.92	11.687	0.000	7.777	11.687
Diag10	g22P	9.21	6.008	0.000	6.008	5.511
Diag10	g22X	0.61	0.000	-0.427	-0.385	-0.427
Diag10	g22XY	5.80	0.000	-4.028	-2.839	-4.028
Diag10	g22Y	4.50	0.000	-3.643	-3.643	-1.434
Diag11	g23P	18.92	14.527	0.000	11.289	14.527
Diag11	g23X	13.31	0.000	-10.864	-8.846	-10.864
Diag11	g23XY	15.60	0.000	-12.732	-7.677	-12.732
Diag11	g23Y	11.47	8.805	0.000	4.876	8.805
Diag11	g24P	4.61	0.000	-3.766	-0.386	-3.766
Diag11	g24X	11.02	8.460	0.000	4.853	8.460
Diag11	g24XY	6.27	4.811	0.000	2.922	4.811
Diag11	g24Y	13.41	0.000	-10.945	-10.129	-10.945
Diag10	g25P	6.21	4.048	0.000	4.048	3.004
Diag10	g25X	6.71	0.000	-5.403	-5.403	-2.625
Diag10	g25XY	3.45	0.000	-2.399	-1.085	-2.399
Diag10	g25Y	3.07	0.000	-2.135	-2.135	-0.659
Diag10	g26P	3.40	0.368	-2.360	0.368	-2.360
Diag10	g26X	7.09	4.623	0.000	0.985	4.623
Diag10	g26XY	8.08	5.268	0.000	5.268	4.952
Diag10	g26Y	10.58	0.000	-7.353	-6.804	-7.353
Diag10	g27P	6.18	4.034	0.000	4.034	1.864
Diag10	g27X	5.79	0.000	-3.940	-3.940	-2.277
Diag10	g27XY	2.00	1.304	-0.072	1.304	-0.072
Diag10	g27Y	1.67	0.233	-1.138	-1.138	0.233
Diag10	g28P	5.33	3.476	0.000	3.476	2.623
Diag10	g28X	3.76	0.000	-2.558	-2.558	-0.703
Diag10	g28XY	2.99	1.952	-0.104	1.952	-0.104
Diag10	g28Y	4.50	0.000	-3.057	-3.057	-1.870
Diag5	g29P	10.51	3.396	0.000	3.396	2.480
Diag5	g29X	7.61	0.000	-3.514	-3.514	-2.552
Diag5	g29XY	2.62	0.848	-0.831	0.848	-0.831
Diag5	g29Y	3.24	1.047	-0.454	-0.454	1.047
Diag5	g30P	10.37	3.350	0.000	3.350	2.861
Diag5	g30X	5.08	0.000	-2.344	-2.344	-1.201
Diag5	g30XY	3.22	1.042	-0.889	1.042	-0.889
Diag5	g30Y	4.08	0.000	-1.884	-1.884	-0.748
Diag5	g31P	10.04	3.245	0.000	3.245	2.895
Diag5	g31X	7.40	0.000	-3.200	-3.200	-2.687
Diag5	g31XY	2.91	0.550	-1.261	0.550	-1.261
Diag5	g31Y	3.01	0.484	-1.303	-1.303	0.484
Diag5	g32P	4.56	1.474	0.000	1.474	0.221
Diag5	g32X	3.43	1.108	-0.920	-0.920	1.108

Diag5 g32XY	7.85	2.537	0.000	2.537	1.517
Diag5 g32Y	8.26	0.000	-3.576	-3.576	-3.159
Diag4 g33P	8.12	3.028	0.000	2.846	3.028
Diag4 g33X	8.44	0.000	-3.207	-3.042	-3.207
Diag4 g33XY	3.52	0.694	-1.338	0.694	-1.338
Diag4 g33Y	4.06	1.514	-0.390	-0.390	1.514
Diag4 g34P	7.54	2.813	0.000	2.813	2.418
Diag4 g34X	5.26	0.000	-1.999	-1.999	-1.078
Diag4 g34XY	2.67	0.771	-0.860	0.771	-0.860
Diag4 g34Y	3.79	0.000	-1.439	-1.439	-0.424
Diag4 g35P	9.71	3.726	0.000	2.834	3.726
Diag4 g35X	10.57	0.000	-3.670	-2.877	-3.670
Diag4 g35XY	5.48	0.328	-1.902	0.328	-1.902
Diag4 g35Y	4.16	1.597	-0.546	-0.546	1.597
Diag4 g36P	4.56	1.748	0.000	1.748	1.012
Diag4 g36X	3.20	0.164	-1.112	-1.112	0.164
Diag4 g36XY	3.61	1.387	0.000	1.387	0.303
Diag4 g36Y	6.25	0.000	-2.170	-2.170	-1.537
Diag3 g37P	11.55	3.616	0.000	2.469	3.616
Diag3 g37X	13.11	0.000	-3.548	-2.499	-3.548
Diag3 g37XY	8.01	0.050	-2.170	0.050	-2.170
Diag3 g37Y	5.27	1.651	-0.546	-0.546	1.651
Diag3 g38P	3.31	1.036	0.000	1.036	0.236
Diag3 g38X	2.45	0.619	-0.663	-0.663	0.619
Diag3 g38XY	4.59	1.437	0.000	1.437	0.751
Diag3 g38Y	8.32	0.000	-2.253	-2.253	-1.909
Diag4 g39P	11.69	4.137	0.000	2.556	4.137
Diag4 g39X	15.15	0.000	-3.940	-2.489	-3.940
Diag4 g39XY	13.38	0.000	-3.479	-0.652	-3.479
Diag4 g39Y	6.36	2.251	-0.569	-0.569	2.251
Diag4 g40P	4.37	0.073	-0.925	0.073	-0.925
Diag4 g40X	4.72	1.669	0.000	0.094	1.669
Diag4 g40XY	7.45	2.636	0.000	2.434	2.636
Diag4 g40Y	18.61	0.000	-3.935	-3.555	-3.935
Diag5 g41P	14.03	3.816	0.000	2.185	3.816
Diag5 g41X	16.71	0.000	-4.181	-2.461	-4.181
Diag5 g41XY	11.15	0.081	-2.791	0.081	-2.791
Diag5 g41Y	11.30	3.073	0.000	0.334	3.073
Diag5 g42P	9.72	2.643	0.000	2.484	2.643
Diag5 g42X	7.45	0.000	-1.797	-1.797	-1.656
Diag5 g42XY	3.32	0.260	-0.800	0.260	-0.800
Diag5 g42Y	2.63	0.046	-0.657	-0.657	0.046
Diag6 g43P	21.66	5.891	0.000	3.097	5.891
Diag6 g43X	22.55	0.000	-5.692	-3.238	-5.692
Diag6 g43XY	17.45	0.000	-4.404	-1.080	-4.404
Diag6 g43Y	15.78	4.293	0.000	1.101	4.293
Diag6 g44P	6.97	1.896	0.000	1.896	1.876
Diag6 g44X	4.22	0.000	-1.066	-1.066	-0.697
Diag6 g44XY	1.92	0.369	-0.406	0.369	-0.406
Diag6 g44Y	5.11	0.000	-1.290	-1.290	-0.772
Diag6 g45P	13.49	3.668	0.000	1.449	3.668
Diag6 g45X	14.85	0.000	-3.028	-1.333	-3.028
Diag6 g45XY	12.23	0.000	-2.493	-0.366	-2.493
Diag6 g45Y	8.07	0.736	-1.412	-1.412	0.736
Diag6 g46P	16.60	0.000	-2.906	-1.501	-2.906
Diag6 g46X	10.21	2.776	0.000	0.861	2.776
Diag6 g46XY	13.76	3.740	0.000	2.756	3.740
Diag6 g46Y	24.70	0.000	-4.324	-3.591	-4.324
Diag7 g47P	21.68	5.896	0.000	2.497	5.896

Diag7	g47X	20.93	0.000	-4.122	-2.047	-4.122
Diag7	g47XY	24.75	0.000	-4.873	-2.570	-4.873
Diag7	g47Y	8.43	1.062	-1.642	-1.642	1.062
Diag7	g48P	44.75	0.000	-8.712	-5.438	-8.712
Diag7	g48X	30.00	8.161	0.000	3.974	8.161
Diag7	g48XY	31.65	8.610	0.000	5.308	8.610
Diag7	g48Y	52.56	0.000	-10.233	-7.610	-10.233
Diag8	g49P	23.02	6.259	0.000	2.750	6.259
Diag8	g49X	31.94	0.000	-6.862	-3.050	-6.862
Diag8	g49XY	23.30	0.000	-5.005	-1.425	-5.005
Diag8	g49Y	15.96	4.339	0.000	1.072	4.339
Diag8	g50P	3.25	0.884	0.000	0.884	0.548
Diag8	g50X	2.58	0.000	-0.553	-0.553	-0.418
Diag8	g50XY	1.35	0.366	0.000	0.366	0.043
Diag8	g50Y	6.75	0.000	-1.450	-1.353	-1.450
Horz5	g51P	5.55	0.000	-1.509	-1.509	-0.803
Horz5	g51Y	4.01	0.000	-1.091	-1.091	-0.410
Horz5	g52P	7.82	2.127	0.000	2.127	1.786
Horz5	g52X	4.76	0.000	-1.294	-1.127	-1.294
Horz1	g53P	46.34	3.448	0.000	3.448	2.326
Horz1	g53Y	33.69	2.507	0.000	2.507	1.169
Horz6	g54P	7.75	2.108	0.000	1.825	2.108
Horz6	g54X	3.64	0.392	-0.990	0.392	-0.990
Horz1	g55P	48.49	3.607	0.000	3.607	1.921
Horz1	g55Y	30.32	2.256	0.000	2.256	1.157
Horz6	g56P	19.87	5.403	0.000	3.908	5.403
Horz6	g56X	15.93	0.000	-4.334	-1.868	-4.334
Horz1	g57P	12.89	0.959	0.000	0.959	0.279
Horz1	g57Y	34.60	2.574	0.000	2.574	1.587
Horz6	g58P	7.52	2.044	0.000	1.680	2.044
Horz6	g58X	5.47	0.000	-1.487	-0.435	-1.487
Horz2	g59P	4.26	0.000	-0.233	-0.233	-0.194
Horz2	g59Y	3.52	0.622	0.000	0.622	0.580
Horz2	g60P	18.21	3.221	0.000	2.212	3.221
Horz2	g60X	56.81	0.000	-3.109	-1.911	-3.109
Horz8	g61P	6.44	0.000	-0.868	-0.359	-0.868
Horz8	g61Y	8.33	2.265	0.000	2.265	2.036
Horz8	g62P	39.43	10.720	0.000	7.303	10.720
Horz8	g62X	71.46	0.000	-9.642	-5.428	-9.642
Horz 10	g63P	18.40	0.000	-5.006	-2.424	-5.006
Horz 10	g63X	14.73	4.006	0.000	1.704	4.006
Horz 10	g63XY	15.33	4.171	0.000	2.031	4.171
Horz 10	g63Y	7.85	0.270	-2.136	0.270	-2.136
Horz 10	g64P	20.74	5.641	0.000	3.391	5.641
Horz 10	g64X	20.80	0.000	-5.658	-3.048	-5.658
Horz 10	g64XY	22.02	0.000	-5.988	-3.706	-5.988
Horz 10	g64Y	26.00	7.072	0.000	4.993	7.072
Leg 1	g65P	3.66	1.948	0.000	1.948	1.796
Leg 1	g65X	3.43	0.000	-2.389	-2.389	-1.979
Leg 1	g65XY	3.29	0.000	-2.290	-2.290	-1.912
Leg 1	g65Y	3.38	1.799	0.000	1.799	1.686
Leg 1	g66P	15.25	8.119	0.000	5.162	8.119
Leg 1	g66X	12.86	0.000	-9.220	-7.320	-9.220
Leg 1	g66XY	12.55	0.000	-8.996	-7.154	-8.996
Leg 1	g66Y	15.62	8.320	0.000	5.453	8.320
Leg 1	g67P	36.78	19.587	0.000	10.308	19.587
Leg 1	g67X	30.28	0.000	-21.691	-13.502	-21.691
Leg 1	g67XY	29.94	0.000	-21.443	-13.616	-21.443
Leg 1	g67Y	38.53	20.515	0.000	11.559	20.515

Leg 1	g68P	53.05	28.247	0.000	13.406	28.247
Leg 1	g68X	43.37	0.000	-32.689	-20.172	-32.689
Leg 1	g68XY	41.59	0.000	-31.352	-18.663	-31.352
Leg 1	g68Y	56.04	29.840	0.000	15.333	29.840
Leg 2	g69P	20.73	41.456	0.000	20.524	41.456
Leg 2	g69X	16.45	0.000	-44.671	-26.809	-44.671
Leg 2	g69XY	16.50	0.000	-44.809	-26.444	-44.809
Leg 2	g69Y	20.57	41.148	0.000	20.767	41.148
Leg 2	g70P	28.26	56.522	0.000	29.564	56.522
Leg 2	g70X	21.35	0.000	-57.981	-35.848	-57.981
Leg 2	g70XY	22.83	0.000	-61.994	-38.861	-61.994
Leg 2	g70Y	26.27	52.548	0.000	26.016	52.548
Leg 2	g71P	35.03	70.052	0.000	38.530	70.052
Leg 2	g71X	25.94	0.000	-70.442	-45.323	-70.442
Leg 2	g71XY	28.07	0.000	-76.243	-48.968	-76.243
Leg 2	g71Y	31.80	63.596	0.000	32.721	63.596
Leg 2	g72P	41.87	79.722	0.000	44.063	79.722
Leg 2	g72X	41.94	0.000	-79.853	-52.306	-79.853
Leg 2	g72XY	45.61	0.000	-86.841	-56.812	-86.841
Leg 2	g72Y	37.78	71.936	0.000	38.175	71.936
Leg 3	g73P	26.05	97.717	0.000	57.628	97.717
Leg 3	g73X	16.51	0.000	-91.511	-58.766	-91.511
Leg 3	g73XY	18.94	0.000	-104.979	-70.847	-104.979
Leg 3	g73Y	22.35	83.824	0.000	45.247	83.824
Leg 3	g74P	32.28	121.079	0.000	75.266	121.079
Leg 3	g74X	19.23	0.000	-106.611	-68.434	-106.611
Leg 3	g74XY	23.35	0.000	-129.439	-90.963	-129.439
Leg 3	g74Y	26.04	97.700	0.000	52.276	97.700
Leg 3	g75P	38.12	143.001	0.000	91.306	143.001
Leg 3	g75X	22.11	0.000	-122.554	-78.433	-122.554
Leg 3	g75XY	27.41	0.000	-151.928	-109.082	-151.928
Leg 3	g75Y	29.98	112.444	0.000	60.592	112.444
Leg 3	g76P	71.66	155.923	0.000	101.784	155.923
Leg 3	g76X	60.37	0.000	-131.362	-83.285	-131.362
Leg 3	g76XY	75.96	0.000	-165.281	-121.015	-165.281
Leg 3	g76Y	55.28	120.283	0.000	64.309	120.283
Leg 4	g77P	39.63	171.142	0.000	113.632	171.142
Leg 4	g77X	21.84	0.000	-140.556	-90.068	-140.556
Leg 4	g77XY	28.24	0.000	-181.754	-133.747	-181.754
Leg 4	g77Y	29.78	128.603	0.000	69.830	128.603
Leg 4	g78P	41.17	177.756	0.000	118.140	177.756
Leg 4	g78X	22.68	0.000	-144.617	-94.723	-144.617
Leg 4	g78XY	29.97	0.000	-191.063	-141.319	-191.063
Leg 4	g78Y	30.52	131.794	0.000	72.504	131.794
Leg 4	g79P	35.45	180.203	0.000	120.270	180.203
Leg 4	g79X	22.87	0.000	-145.833	-96.339	-145.833
Leg 4	g79XY	30.62	0.000	-195.213	-144.679	-195.213
Leg 4	g79Y	26.10	132.668	0.000	73.585	132.668
Leg 4	g80P	35.69	181.434	0.000	121.004	181.434
Leg 4	g80X	23.62	0.000	-146.204	-97.627	-146.204
Leg 4	g80XY	31.87	0.000	-197.212	-145.925	-197.212
Leg 4	g80Y	26.06	132.471	0.000	73.813	132.471
Leg 4	g81P	43.18	186.441	0.000	123.623	186.441
Leg 4	g81X	24.25	0.000	-150.057	-100.234	-150.057
Leg 4	g81XY	32.85	0.000	-203.311	-150.105	-203.311
Leg 4	g81Y	31.26	135.002	0.000	75.044	135.002
Leg 4	g82P	43.88	189.498	0.000	124.631	189.498
Leg 4	g82X	25.45	0.000	-152.746	-102.353	-152.746
Leg 4	g82XY	34.43	0.000	-206.628	-151.897	-206.628

Leg 4	g82Y	31.53	136.136	0.000	75.287	136.136
Leg 4	g83P	79.05	193.513	0.000	125.931	193.513
Leg 4	g83X	63.77	0.000	-156.111	-103.861	-156.111
Leg 4	g83XY	86.05	0.000	-210.658	-154.076	-210.658
Leg 4	g83Y	56.37	137.996	0.000	75.693	137.996
Leg 4	g84P	45.52	196.576	0.000	126.342	196.576
Leg 4	g84X	29.15	0.000	-159.050	-105.917	-159.050
Leg 4	g84XY	39.33	0.000	-214.549	-155.785	-214.549
Leg 4	g84Y	32.49	140.298	0.000	75.909	140.298
Leg 4	g85P	40.08	203.780	0.000	128.942	203.780
Leg 4	g85X	26.59	0.000	-165.684	-109.571	-165.684
Leg 4	g85XY	36.00	0.000	-224.303	-161.622	-224.303
Leg 4	g85Y	28.81	146.465	0.000	77.605	146.465
Leg 4	g86P	76.85	209.028	0.000	130.159	209.028
Leg 4	g86X	62.88	0.000	-171.021	-112.821	-171.021
Leg 4	g86XY	84.89	0.000	-230.907	-165.030	-230.907
Leg 4	g86Y	55.57	151.138	0.000	78.500	151.138
Leg 4	g87P	41.72	212.077	0.000	129.634	212.077
Leg 4	g87X	29.29	0.000	-174.255	-114.596	-174.255
Leg 4	g87XY	39.31	0.000	-233.856	-166.053	-233.856
Leg 4	g87Y	30.19	153.481	0.000	78.162	153.481
Leg 4	g88P	78.27	212.898	0.000	127.462	212.898
Leg 4	g88X	64.73	0.000	-176.070	-115.541	-176.070
Leg 4	g88XY	85.89	0.000	-233.632	-165.231	-233.632
Leg 4	g88Y	56.54	153.795	0.000	76.643	153.795
Leg 4	g89P	81.67	222.134	0.000	130.759	222.134
Leg 4	g89X	68.28	0.000	-185.728	-123.142	-185.728
Leg 4	g89XY	89.89	0.000	-244.489	-173.382	-244.489
Leg 4	g89Y	58.83	160.012	0.000	78.018	160.012
Diag12	g90P	6.25	0.000	-2.086	-2.086	-1.097
Diag12	g90X	6.79	0.000	-2.265	-2.265	-1.219
Diag12	g90XY	4.67	0.000	-1.560	-1.560	-0.530
Diag12	g90Y	5.13	0.000	-1.710	-1.710	-0.745
Horz 13	g91P	8.38	0.000	-4.295	-4.295	-1.502
Horz 13	g91X	8.05	4.382	0.000	3.433	4.382
Horz 13	g91XY	12.31	0.000	-6.307	-6.307	-3.820
Horz 13	g91Y	12.87	0.000	-6.591	-6.591	-6.566
Horz 11	g92P	3.18	1.315	-0.185	-0.185	1.315
Horz 11	g92Y	11.95	0.000	-5.376	-5.376	-4.348
Arm	g93P	24.87	4.182	0.000	4.182	2.825
Arm	g93X	25.79	4.337	0.000	4.337	2.530
Arm	g93XY	16.06	2.701	0.000	2.701	1.098
Arm	g93Y	19.65	3.305	0.000	3.305	1.517
Horz 13	g94P	16.28	0.000	-8.340	-8.340	-2.867
Horz 13	g94X	4.15	2.260	-0.625	-0.625	2.260
Horz 13	g94XY	4.35	0.000	-2.229	-2.229	-1.938
Horz 13	g94Y	10.34	0.000	-5.299	-3.216	-5.299
Horz 11	g95P	7.06	0.000	-3.177	-3.177	-0.536
Horz 11	g95Y	4.01	0.000	-1.803	-1.223	-1.803
Arm	g96P	22.60	3.802	0.000	3.802	2.744
Arm	g96X	21.13	3.553	0.000	3.553	2.353
Arm	g96XY	22.20	3.734	0.000	3.734	1.493
Arm	g96Y	23.69	3.984	0.000	3.984	1.673
Horz 13	g97P	1.68	1.127	0.000	0.742	1.127
Horz 13	g97X	8.16	5.464	0.000	5.336	5.464
Horz 13	g97XY	15.37	0.000	-10.451	-10.451	-6.187
Horz 13	g97Y	19.46	0.000	-13.236	-13.236	-9.855
Horz 12	g98P	4.16	2.129	0.000	2.129	2.078
Horz 12	g98Y	12.90	0.000	-8.259	-8.259	-5.444

Arm2 g99P	36.71	7.104	0.000	7.104	4.376
Arm2 g99X	32.14	6.220	0.000	6.220	3.739
Arm2 g99XY	14.60	2.825	0.000	2.825	0.979
Arm2 g99Y	11.38	2.201	0.000	2.201	0.776
top g100P	2.51	0.683	-0.634	0.683	-0.634
top g100X	22.88	6.225	0.000	6.225	3.929
top g101P	13.34	3.627	0.000	3.627	1.877
Inner1 g102P	2.72	0.000	-0.366	-0.366	-0.162
Inner1 g102X	1.32	0.000	-0.178	-0.178	-0.084
Inner2 g103P	8.22	0.000	-1.230	-1.230	-0.648
Inner2 g103X	5.86	0.866	0.000	0.866	0.428
Inner2 g104P	8.48	0.000	-1.269	-1.269	-0.721
Inner2 g104X	5.82	0.860	0.000	0.860	0.479
Inner3 g105P	2.54	0.000	-0.420	-0.420	-0.269
Inner3 g105X	0.38	0.067	0.000	0.067	0.061
Inner2 g106P	12.93	0.000	-0.449	-0.061	-0.449
Inner2 g106X	8.94	0.665	0.000	0.362	0.665
Inner4 g107P	1.94	0.164	-0.159	0.164	-0.159
Inner4 g107X	1.80	0.342	0.000	0.221	0.342

Equilibrium Joint Positions and Rotations for Load Case "NESC Heavy":

Joint Label	X-Displ (ft)	Y-Displ (ft)	Z-Displ (ft)	X-Rot (deg)	Y-Rot (deg)	Z-Rot (deg)	X-Pos (ft)	Y-Pos (ft)	Z-Pos (ft)
1P	-0.1425	0.7168	-0.02885	-0.7146	-0.1054	0.1463	-0.1425	2.387	140
2P	-0.1346	0.6686	-0.02518	-0.7134	-0.1082	0.1382	1.535	2.339	135.8
3P	-0.1264	0.6172	-0.02431	-0.6977	-0.1144	0.1378	1.544	2.287	131.6
4P	-0.1183	0.5675	-0.02301	-0.6717	-0.0965	0.1371	1.552	2.237	127.5
5P	-0.1123	0.5273	-0.02152	-0.6349	-0.1176	0.1433	1.558	2.197	124
6P	-0.1049	0.4889	-0.02074	-0.6224	-0.1162	0.1350	1.565	2.159	120.5
7P	-0.09774	0.4516	-0.01978	-0.5930	-0.1165	0.1266	1.572	2.122	117
8P	-0.09051	0.4165	-0.01864	-0.5648	-0.1076	0.1182	1.579	2.087	113.5
9P	-0.08408	0.3829	-0.01738	-0.5274	-0.1118	0.1107	1.586	2.053	110
10P	-0.07703	0.3513	-0.01661	-0.5069	-0.1118	0.1059	1.593	2.021	106.5
11P	-0.07032	0.3211	-0.01575	-0.4783	-0.1084	0.1012	1.6	1.991	103
12P	-0.06387	0.2929	-0.0148	-0.4493	-0.0927	0.0963	1.606	1.963	99.49
13P	-0.05858	0.2665	-0.01382	-0.4116	-0.0917	0.0918	1.611	1.936	95.99
14P	-0.05341	0.2445	-0.01411	-0.3765	-0.0927	0.0892	1.837	2.135	92.74
15P	-0.04838	0.2211	-0.01437	-0.3506	-0.0783	0.0860	2.102	2.371	88.99
16P	-0.04363	0.1993	-0.01449	-0.3256	-0.0780	0.0819	2.356	2.599	85.24
17P	-0.03758	0.1728	-0.01457	-0.2928	-0.0698	0.0769	2.712	2.923	80.24
18P	-0.03236	0.1488	-0.01446	-0.2647	-0.0640	0.0715	3.058	3.239	75.24
19P	-0.02653	0.1232	-0.01414	-0.2332	-0.0522	0.0650	3.473	3.623	69.24
20P	-0.02215	0.1006	-0.0137	-0.2054	-0.0496	0.0578	3.888	4.011	63.24
21P	-0.01489	0.07391	-0.01268	-0.1698	-0.0496	0.0491	4.455	4.544	54.99
23P	-0.009221	0.04925	-0.0112	-0.1345	-0.0329	0.0396	5.111	5.169	45.49
25P	-0.004107	0.02712	-0.008989	-0.0958	-0.0221	0.0280	5.806	5.837	34.49
27P	-0.001698	0.01096	-0.006216	-0.0578	-0.0108	0.0137	6.728	6.741	21.99
29P	8.021e-005	0.001027	-0.002516	-0.0172	-0.0026	0.0021	7.69	7.691	7.997
30P	0	0	0	0.0000	0.0000	0.0000	8.23	8.23	0
39P	-0.0005368	0.000827	-8.022e-005	-0.0202	-0.0025	-0.0023	7.689	0.000827	8
40P	-0.0003189	0.002459	9.669e-005	-0.0147	-0.0030	0.0001	-0.0003189	7.692	8
41P	-0.1693	0.7164	-0.1676	-0.7436	-0.1055	0.1416	-0.1693	13.22	139.8
42P	-0.1368	0.522	-0.1257	-0.7248	-0.1087	0.1810	-0.1368	10.52	123.9
43P	-0.1123	0.3785	-0.1326	-0.6280	-0.1062	0.1674	-0.1123	12.88	109.9
44P	-0.07208	0.2634	-0.08447	-0.4982	-0.0870	0.0942	-0.07208	10.26	95.92
1X	-0.134	0.717	0.01236	-0.7086	-0.1048	0.1480	-0.134	-0.953	140
2X	-0.1263	0.669	0.01557	-0.7121	-0.1032	0.1368	1.544	-1.001	135.8
2XY	-0.1262	0.6604	0.009463	-0.7132	-0.1064	0.1529	-1.796	-1.01	135.8
2Y	-0.1348	0.6601	-0.03136	-0.7145	-0.1045	0.1526	-1.805	2.33	135.8
3X	-0.1188	0.6174	0.01551	-0.7069	-0.0917	0.1316	1.551	-1.053	131.7
3XY	-0.1183	0.6086	0.00939	-0.7100	-0.1156	0.1494	-1.788	-1.061	131.7
3Y	-0.1274	0.6084	-0.0305	-0.7019	-0.0970	0.1530	-1.797	2.278	131.6
4X	-0.1117	0.5671	0.01506	-0.6688	-0.1173	0.1269	1.558	-1.103	127.5
4XY	-0.1097	0.5582	0.008847	-0.6669	-0.0957	0.1457	-1.78	-1.112	127.5
4Y	-0.1198	0.5584	-0.02918	-0.6741	-0.1149	0.1537	-1.79	2.228	127.5
5X	-0.104	0.5275	0.01445	-0.6284	-0.1030	0.1280	1.566	-1.143	124
5XY	-0.104	0.5188	0.008119	-0.6248	-0.1099	0.1345	-1.774	-1.151	124
5Y	-0.1124	0.5183	-0.02778	-0.6265	-0.1074	0.1466	-1.782	2.188	124
6X	-0.09775	0.489	0.01424	-0.6211	-0.1037	0.1182	1.572	-1.181	120.5
6XY	-0.09705	0.4808	0.007897	-0.6126	-0.1076	0.1266	-1.767	-1.189	120.5
6Y	-0.1057	0.4808	-0.02702	-0.6080	-0.1116	0.1383	-1.776	2.151	120.5
7X	-0.0911	0.4519	0.01382	-0.5994	-0.1006	0.1084	1.579	-1.218	117
7XY	-0.09053	0.4443	0.007547	-0.5872	-0.1089	0.1187	-1.761	-1.226	117

7Y	-0.09861	0.4442	-0.02601	-0.5839	-0.1093	0.1301	-1.769	2.114	117
8X	-0.08498	0.416	0.0132	-0.5677	-0.1069	0.0987	1.585	-1.254	113.5
8XY	-0.08368	0.4092	0.007042	-0.5537	-0.0998	0.1108	-1.754	-1.261	113.5
8Y	-0.09183	0.4095	-0.0248	-0.5615	-0.1163	0.1219	-1.762	2.079	113.5
9X	-0.07797	0.3829	0.01244	-0.5195	-0.1036	0.0894	1.592	-1.287	110
9XY	-0.07778	0.3767	0.006397	-0.5214	-0.1052	0.1017	-1.748	-1.293	110
9Y	-0.08441	0.3761	-0.02344	-0.5174	-0.1092	0.1125	-1.754	2.046	110
10X	-0.07179	0.3515	0.01198	-0.5055	-0.1002	0.0854	1.598	-1.319	106.5
10XY	-0.07112	0.3451	0.006069	-0.5043	-0.1057	0.0988	-1.741	-1.325	106.5
10Y	-0.07784	0.3452	-0.02255	-0.4981	-0.1058	0.1068	-1.748	2.015	106.5
11X	-0.06562	0.3214	0.01132	-0.4817	-0.0951	0.0814	1.604	-1.349	103
11XY	-0.06481	0.3153	0.00565	-0.4758	-0.1025	0.0958	-1.735	-1.355	103
11Y	-0.07133	0.3154	-0.02146	-0.4741	-0.1014	0.1010	-1.741	1.985	103
12X	-0.05987	0.2928	0.01048	-0.4486	-0.0990	0.0775	1.61	-1.377	99.51
12XY	-0.05868	0.2871	0.00513	-0.4430	-0.0883	0.0928	-1.729	-1.383	99.51
12Y	-0.06514	0.2874	-0.02019	-0.4466	-0.1049	0.0953	-1.735	1.957	99.48
13X	-0.05377	0.2667	0.009508	-0.4063	-0.0842	0.0736	1.616	-1.403	96.01
13XY	-0.05372	0.2613	0.004549	-0.4018	-0.0832	0.0896	-1.724	-1.409	96
13Y	-0.05871	0.2612	-0.01881	-0.4043	-0.0902	0.0893	-1.729	1.931	95.98
14X	-0.04937	0.2447	0.0104	-0.3772	-0.0681	0.0706	1.841	-1.645	92.76
14XY	-0.04846	0.239	0.00519	-0.3718	-0.0825	0.0853	-1.938	-1.651	92.76
14Y	-0.05449	0.2392	-0.01936	-0.3645	-0.0762	0.0848	-1.944	2.129	92.73
15X	-0.04424	0.2213	0.01129	-0.3486	-0.0700	0.0683	2.106	-1.929	89.01
15XY	-0.04332	0.2154	0.005832	-0.3389	-0.0674	0.0795	-2.193	-1.935	89.01
15Y	-0.04949	0.2157	-0.01987	-0.3401	-0.0801	0.0799	-2.199	2.366	88.98
16X	-0.0396	0.1995	0.01194	-0.3236	-0.0596	0.0648	2.36	-2.201	85.26
16XY	-0.03871	0.1937	0.006311	-0.3127	-0.0643	0.0749	-2.439	-2.206	85.26
16Y	-0.04471	0.1939	-0.02015	-0.3109	-0.0714	0.0754	-2.445	2.594	85.23
17X	-0.03422	0.173	0.01265	-0.2914	-0.0535	0.0606	2.716	-2.577	80.26
17XY	-0.03293	0.1674	0.006852	-0.2802	-0.0570	0.0689	-2.783	-2.583	80.26
17Y	-0.03917	0.1677	-0.02038	-0.2786	-0.0648	0.0695	-2.789	2.918	80.23
18X	-0.02921	0.149	0.01305	-0.2632	-0.0475	0.0562	3.061	-2.941	75.26
18XY	-0.02795	0.1437	0.007192	-0.2524	-0.0514	0.0632	-3.118	-2.946	75.26
18Y	-0.03391	0.1441	-0.02031	-0.2505	-0.0578	0.0639	-3.124	3.234	75.23
19X	-0.02406	0.1234	0.01324	-0.2324	-0.0443	0.0509	3.476	-3.377	69.26
19XY	-0.0225	0.1184	0.007415	-0.2199	-0.0416	0.0562	-3.522	-3.382	69.26
19Y	-0.02853	0.119	-0.01994	-0.2209	-0.0554	0.0571	-3.529	3.619	69.23
20X	-0.01904	0.1007	0.01319	-0.2042	-0.0358	0.0451	3.891	-3.809	63.26
20XY	-0.01831	0.09646	0.007476	-0.1940	-0.0383	0.0502	-3.928	-3.814	63.26
20Y	-0.02299	0.09665	-0.01937	-0.1930	-0.0460	0.0509	-3.933	4.007	63.23
21X	-0.01476	0.07428	0.01258	-0.1677	-0.0226	0.0381	4.455	-4.396	55.01
21XY	-0.01203	0.07004	0.007241	-0.1624	-0.0367	0.0433	-4.482	-4.4	55.01
21Y	-0.01844	0.07104	-0.01799	-0.1563	-0.0301	0.0438	-4.488	4.541	54.98
23X	-0.01007	0.04952	0.01141	-0.1341	-0.0225	0.0304	5.11	-5.07	45.51
23XY	-0.007016	0.04579	0.00665	-0.1268	-0.0244	0.0347	-5.127	-5.074	45.51
23Y	-0.01318	0.04699	-0.01593	-0.1258	-0.0299	0.0353	-5.133	5.167	45.48
25X	-0.005994	0.02745	0.009307	-0.0953	-0.0166	0.0211	5.804	-5.783	34.51
25XY	-0.002647	0.02434	0.005475	-0.0883	-0.0151	0.0254	-5.813	-5.786	34.51
25Y	-0.008529	0.02563	-0.01277	-0.0887	-0.0230	0.0258	-5.819	5.836	34.49
27X	-0.002126	0.01107	0.006539	-0.0580	-0.0114	0.0099	6.728	-6.719	22.01
27XY	-0.0006347	0.009198	0.003876	-0.0519	-0.0069	0.0160	-6.731	-6.721	22
27Y	-0.003704	0.009813	-0.008812	-0.0535	-0.0166	0.0158	-6.734	6.74	21.99
29X	-0.0002291	0.001113	0.002661	-0.0176	-0.0024	0.0005	7.69	-7.689	8.003
29XY	0.0005689	0.0003243	0.001581	-0.0107	0.0025	0.0076	-7.689	-7.69	8.002
29Y	-0.0009063	0.0005944	-0.003547	-0.0122	-0.0084	0.0073	-7.691	7.691	7.996
30X	0	0	0	0.0000	0.0000	0.0000	8.23	-8.23	0
30XY	0	0	0	0.0000	0.0000	0.0000	-8.23	-8.23	0
30Y	0	0	0	0.0000	0.0000	0.0000	-8.23	8.23	0
39Y	0.0004196	0.0003559	-8.01e-005	-0.0229	-0.0029	0.0045	-7.69	0.0003559	8

40X	0.0001311	0.003723	-0.0002796	-0.0142	-0.0061	0.0024	0.0001311	-7.686	8
41X	-0.1061	0.7179	0.1466	-0.7107	-0.1048	0.1496	-0.1061	-11.78	140.1
42X	-0.08325	0.5242	0.1	-0.6015	-0.1088	0.1507	-0.08325	-9.476	124.1
43X	-0.06349	0.381	0.1024	-0.4779	-0.1041	0.0688	-0.06349	-12.12	110.1
44X	-0.03915	0.2648	0.06338	-0.3794	-0.0858	0.1101	-0.03915	-9.735	96.06

Joint Support Reactions for Load Case "NESC Heavy":

Joint Label	X Force (kips)	X Usage %	Y Force (kips)	Y Usage %	H-Shear Usage %	Z Force (kips)	Z Comp. Usage %	Uplift Usage %	Result. Force (kips)	Result. Usage %	X Moment (ft-k)	X-M. Usage %	Y Moment (ft-k)	Y-M. Usage %	H-Bend-M Usage %	Z Moment (ft-k)	Z-M. Usage %	Max. Usage %
30P	-7.82	0.0	-10.34	0.0	0.0	-124.50	0.0	0.0	125.18	0.0	0.10	0.0	-0.0	0.0	0.0	-0.09	0.0	0.0
30X	8.47	0.0	-10.70	0.0	0.0	131.30	0.0	0.0	132.01	0.0	0.18	0.0	-0.1	0.0	0.0	-0.02	0.0	0.0
30XY	-5.67	0.0	-5.88	0.0	0.0	78.27	0.0	0.0	78.69	0.0	-0.45	0.0	-0.5	0.0	0.0	-0.12	0.0	0.0
30Y	12.71	0.0	-12.59	0.0	0.0	-174.95	0.0	0.0	175.86	0.0	-0.35	0.0	0.4	0.0	0.0	-0.14	0.0	0.0

Joint Displacements, Loads and Member Forces on Joints for Load Case "NESC Heavy":

Joint Label	X External Load (kips)	Y External Load (kips)	Z External Load (kips)	X Member Force (kips)	Y Member Force (kips)	Z Member Force (kips)	X Disp. (ft)	Y Disp. (ft)	Z Disp. (ft)
1P	0.0000	0.1295	-0.8435	0.0000	-0.1295	0.8435	-0.1425	0.7168	-0.0288
2P	0.0000	0.7841	-0.1565	0.0000	-0.7841	0.1565	-0.1346	0.6686	-0.0252
3P	0.0000	0.0297	-0.0843	-0.0000	-0.0297	0.0843	-0.1264	0.6172	-0.0243
4P	0.0000	0.2279	-1.1602	0.0000	-0.2279	1.1602	-0.1183	0.5675	-0.0230
5P	0.0000	0.0424	-0.2348	-0.0000	-0.0424	0.2348	-0.1123	0.5273	-0.0215
6P	0.0000	-0.3417	-1.6407	0.0000	0.3417	1.6407	-0.1049	0.4889	-0.0207
7P	0.0000	0.2183	-1.1487	-0.0000	-0.2183	1.1487	-0.0977	0.4516	-0.0198
8P	0.0000	0.0441	-0.2199	0.0000	-0.0441	0.2199	-0.0905	0.4165	-0.0186
9P	0.0000	0.0604	-0.4009	-0.0000	-0.0604	0.4009	-0.0841	0.3829	-0.0174
10P	0.0000	0.2381	-1.3130	0.0000	-0.2381	1.3130	-0.0770	0.3513	-0.0166
11P	0.0000	0.0581	-0.3470	-0.0000	-0.0581	0.3470	-0.0703	0.3211	-0.0157
12P	0.0000	0.0613	-0.3832	0.0000	-0.0613	0.3832	-0.0639	0.2929	-0.0148
13P	0.0000	0.2492	-1.4519	-0.0000	-0.2492	1.4519	-0.0586	0.2665	-0.0138
14P	0.0000	0.0595	-0.3910	0.0000	-0.0595	0.3910	-0.0534	0.2445	-0.0141
15P	0.0000	0.0585	-0.3928	0.0000	-0.0585	0.3928	-0.0484	0.2211	-0.0144
16P	0.0000	0.2391	-1.3768	0.0000	-0.2391	1.3768	-0.0436	0.1993	-0.0145
17P	0.0000	0.0671	-0.4766	0.0000	-0.0671	0.4766	-0.0376	0.1728	-0.0146
18P	0.0000	0.2603	-1.5319	0.0000	-0.2603	1.5319	-0.0324	0.1488	-0.0145
19P	0.0000	0.0782	-0.5637	0.0000	-0.0782	0.5637	-0.0265	0.1232	-0.0141
20P	0.0000	0.3201	-1.8643	0.0000	-0.3201	1.8643	-0.0222	0.1006	-0.0137
21P	0.0000	0.1179	-0.8377	0.0000	-0.1179	0.8377	-0.0149	0.0739	-0.0127
23P	0.0000	0.3407	-2.0553	0.0000	-0.3407	2.0553	-0.0092	0.0492	-0.0112
25P	0.0000	0.3503	-2.1525	0.0000	-0.3503	2.1525	-0.0041	0.0271	-0.0090
27P	0.0000	0.4242	-2.5752	0.0000	-0.4242	2.5752	-0.0017	0.0110	-0.0062
29P	0.0000	0.4054	-2.4355	0.0000	-0.4054	2.4355	0.0001	0.0010	-0.0025
30P	0.0000	0.0592	-0.4042	7.8162	0.0000	-124.1005	0.0000	0.0000	0.0000
39P	0.0000	0.0267	-0.2127	-0.0000	-0.0267	0.2127	-0.0005	0.0008	-0.0001
40P	0.0000	0.0639	-0.2127	0.0000	-0.0639	0.2127	-0.0003	0.0025	0.0001
41P	0.1000	2.6741	-1.4089	-0.1000	-2.6741	1.4089	-0.1693	0.7164	-0.1676
42P	-2.2390	3.5224	-2.8695	2.2390	-3.5224	2.8695	-0.1368	0.5220	-0.1257
43P	-2.9230	3.4240	-2.8881	2.9230	-3.4240	2.8881	-0.1123	0.3785	-0.1326
44P	-0.2860	3.7854	-2.9435	0.2860	-3.7854	2.9435	-0.0721	0.2634	-0.0845
1X	0.0000	0.0225	-0.2685	-0.0000	-0.0225	0.2685	-0.1340	0.7170	0.0124
2X	0.0000	0.7841	-0.1565	0.0000	-0.7841	0.1565	-0.1263	0.6690	0.0156
2XY	0.0000	0.7841	-0.1565	-0.0000	-0.7841	0.1565	-0.1262	0.6604	0.0095

2Y	0.0000	0.7841	-0.1565	-0.0000	-0.7841	0.1565	-0.1348	0.6601	-0.0314
3X	0.0000	0.0297	-0.0843	-0.0000	-0.0297	0.0843	-0.1188	0.6174	0.0155
3XY	0.0000	0.0297	-0.0843	-0.0000	-0.0297	0.0843	-0.1183	0.6086	0.0094
3Y	0.0000	0.0297	-0.0843	-0.0000	-0.0297	0.0843	-0.1274	0.6084	-0.0305
4X	0.0000	0.0309	-0.1022	-0.0000	-0.0309	0.1022	-0.1117	0.5671	0.0151
4XY	0.0000	0.0309	-0.1022	-0.0000	-0.0309	0.1022	-0.1097	0.5582	0.0088
4Y	0.0000	0.0309	-0.1022	-0.0000	-0.0309	0.1022	-0.1198	0.5584	-0.0292
5X	0.0000	0.0424	-0.2348	-0.0000	-0.0424	0.2348	-0.1040	0.5275	0.0145
5XY	0.0000	0.0424	-0.2348	-0.0000	-0.0424	0.2348	-0.1040	0.5188	0.0081
5Y	0.0000	0.0424	-0.2348	-0.0000	-0.0424	0.2348	-0.1124	0.5183	-0.0278
6X	0.0000	-0.3417	-1.6407	0.0000	0.3417	1.6407	-0.0978	0.4890	0.0142
6XY	0.0000	-0.3417	-1.6407	0.0000	0.3417	1.6407	-0.0971	0.4808	0.0079
6Y	0.0000	-0.3417	-1.6407	-0.0000	0.3417	1.6407	-0.1057	0.4808	-0.0270
7X	0.0000	0.0383	-0.1827	0.0000	-0.0383	0.1827	-0.0911	0.4519	0.0138
7XY	0.0000	0.0383	-0.1827	-0.0000	-0.0383	0.1827	-0.0905	0.4443	0.0075
7Y	0.0000	0.0383	-0.1827	0.0000	-0.0383	0.1827	-0.0986	0.4442	-0.0260
8X	0.0000	0.0441	-0.2199	0.0000	-0.0441	0.2199	-0.0850	0.4160	0.0132
8XY	0.0000	0.0441	-0.2199	0.0000	-0.0441	0.2199	-0.0837	0.4092	0.0070
8Y	0.0000	0.0441	-0.2199	-0.0000	-0.0441	0.2199	-0.0918	0.4095	-0.0248
9X	0.0000	0.0604	-0.4009	-0.0000	-0.0604	0.4009	-0.0780	0.3829	0.0124
9XY	0.0000	0.0604	-0.4009	-0.0000	-0.0604	0.4009	-0.0778	0.3767	0.0064
9Y	0.0000	0.0604	-0.4009	-0.0000	-0.0604	0.4009	-0.0844	0.3761	-0.0234
10X	0.0000	0.0581	-0.3470	0.0000	-0.0581	0.3470	-0.0718	0.3515	0.0120
10XY	0.0000	0.0581	-0.3470	0.0000	-0.0581	0.3470	-0.0711	0.3451	0.0061
10Y	0.0000	0.0581	-0.3470	0.0000	-0.0581	0.3470	-0.0778	0.3452	-0.0226
11X	0.0000	0.0581	-0.3470	0.0000	-0.0581	0.3470	-0.0656	0.3214	0.0113
11XY	0.0000	0.0581	-0.3470	-0.0000	-0.0581	0.3470	-0.0648	0.3153	0.0056
11Y	0.0000	0.0581	-0.3470	0.0000	-0.0581	0.3470	-0.0713	0.3154	-0.0215
12X	0.0000	0.0613	-0.3832	-0.0000	-0.0613	0.3832	-0.0599	0.2928	0.0105
12XY	0.0000	0.0613	-0.3832	0.0000	-0.0613	0.3832	-0.0587	0.2871	0.0051
12Y	0.0000	0.0613	-0.3832	0.0000	-0.0613	0.3832	-0.0651	0.2874	-0.0202
13X	0.0000	0.0672	-0.4749	-0.0000	-0.0672	0.4749	-0.0538	0.2667	0.0095
13XY	0.0000	0.0672	-0.4749	0.0000	-0.0672	0.4749	-0.0537	0.2613	0.0045
13Y	0.0000	0.0672	-0.4749	0.0000	-0.0672	0.4749	-0.0587	0.2612	-0.0188
14X	0.0000	0.0595	-0.3910	0.0000	-0.0595	0.3910	-0.0494	0.2447	0.0104
14XY	0.0000	0.0595	-0.3910	0.0000	-0.0595	0.3910	-0.0485	0.2390	0.0052
14Y	0.0000	0.0595	-0.3910	0.0000	-0.0595	0.3910	-0.0545	0.2392	-0.0194
15X	0.0000	0.0585	-0.3928	0.0000	-0.0585	0.3928	-0.0442	0.2213	0.0113
15XY	0.0000	0.0585	-0.3928	0.0000	-0.0585	0.3928	-0.0433	0.2154	0.0058
15Y	0.0000	0.0585	-0.3928	-0.0000	-0.0585	0.3928	-0.0495	0.2157	-0.0199
16X	0.0000	0.0611	-0.4228	0.0000	-0.0611	0.4228	-0.0396	0.1995	0.0119
16XY	0.0000	0.0611	-0.4228	0.0000	-0.0611	0.4228	-0.0387	0.1937	0.0063
16Y	0.0000	0.0611	-0.4228	0.0000	-0.0611	0.4228	-0.0447	0.1939	-0.0201
17X	0.0000	0.0671	-0.4766	0.0000	-0.0671	0.4766	-0.0342	0.1730	0.0126
17XY	0.0000	0.0671	-0.4766	0.0000	-0.0671	0.4766	-0.0329	0.1674	0.0069
17Y	0.0000	0.0671	-0.4766	0.0000	-0.0671	0.4766	-0.0392	0.1677	-0.0204
18X	0.0000	0.0713	-0.5199	0.0000	-0.0713	0.5199	-0.0292	0.1490	0.0131
18XY	0.0000	0.0713	-0.5199	0.0000	-0.0713	0.5199	-0.0279	0.1437	0.0072
18Y	0.0000	0.0713	-0.5199	0.0000	-0.0713	0.5199	-0.0339	0.1441	-0.0203
19X	0.0000	0.0782	-0.5637	0.0000	-0.0782	0.5637	-0.0241	0.1234	0.0132
19XY	0.0000	0.0782	-0.5637	0.0000	-0.0782	0.5637	-0.0225	0.1184	0.0074
19Y	0.0000	0.0782	-0.5637	0.0000	-0.0782	0.5637	-0.0285	0.1190	-0.0199
20X	0.0000	0.1051	-0.7143	0.0000	-0.1051	0.7143	-0.0190	0.1007	0.0132
20XY	0.0000	0.1051	-0.7143	0.0000	-0.1051	0.7143	-0.0183	0.0965	0.0075
20Y	0.0000	0.1051	-0.7143	0.0000	-0.1051	0.7143	-0.0230	0.0967	-0.0194
21X	0.0000	0.1179	-0.8377	0.0000	-0.1179	0.8377	-0.0148	0.0743	0.0126
21XY	0.0000	0.1179	-0.8377	0.0000	-0.1179	0.8377	-0.0120	0.0700	0.0072
21Y	0.0000	0.1179	-0.8377	0.0000	-0.1179	0.8377	-0.0184	0.0710	-0.0180
23X	0.0000	0.1407	-0.9863	0.0000	-0.1407	0.9863	-0.0101	0.0495	0.0114

23XY	0.0000	0.1407	-0.9863	0.0000	-0.1407	0.9863	-0.0070	0.0458	0.0066
23Y	0.0000	0.1407	-0.9863	0.0000	-0.1407	0.9863	-0.0132	0.0470	-0.0159
25X	0.0000	0.1613	-1.1405	0.0000	-0.1613	1.1405	-0.0060	0.0275	0.0093
25XY	0.0000	0.1613	-1.1405	0.0000	-0.1613	1.1405	-0.0026	0.0243	0.0055
25Y	0.0000	0.1613	-1.1405	0.0000	-0.1613	1.1405	-0.0085	0.0256	-0.0128
27X	0.0000	0.2092	-1.4252	0.0000	-0.2092	1.4252	-0.0021	0.0111	0.0065
27XY	0.0000	0.2092	-1.4252	0.0000	-0.2092	1.4252	-0.0006	0.0092	0.0039
27Y	0.0000	0.2092	-1.4252	0.0000	-0.2092	1.4252	-0.0037	0.0098	-0.0088
29X	0.0000	0.1624	-1.1365	0.0000	-0.1624	1.1365	-0.0002	0.0011	0.0027
29XY	0.0000	0.1624	-1.1365	0.0000	-0.1624	1.1365	0.0006	0.0003	0.0016
29Y	0.0000	0.1624	-1.1365	0.0000	-0.1624	1.1365	-0.0009	0.0006	-0.0035
30X	0.0000	0.0592	-0.4042	-8.4748	10.6374	131.7061	0.0000	0.0000	0.0000
30XY	0.0000	0.0592	-0.4042	5.6744	5.8234	78.6713	0.0000	0.0000	0.0000
30Y	0.0000	0.0592	-0.4042	-12.7127	12.5324	-174.5435	0.0000	0.0000	0.0000
39Y	0.0000	0.0267	-0.2127	-0.0000	-0.0267	0.2127	0.0004	0.0004	-0.0001
40X	0.0000	0.0639	-0.2127	-0.0000	-0.0639	0.2127	0.0001	0.0037	-0.0003
41X	0.0500	2.8061	-1.3839	-0.0500	-2.8061	1.3839	-0.1061	0.7179	0.1466
42X	-0.6030	3.8514	-2.9335	0.6030	-3.8514	2.9335	-0.0832	0.5242	0.1000
43X	-2.8510	3.5580	-2.9061	2.8510	-3.5580	2.9061	-0.0635	0.3810	0.1024
44X	1.0550	4.2514	-3.0305	-1.0550	-4.2514	3.0305	-0.0391	0.2648	0.0634

Crossing Diagonal Check for Load Case "NESC Heavy" (RLOUT controls):

Comp. Member Label	Tens. Member Label	Connect Leg for Comp. Member	Force In Comp. Member (kips)	Force In Tens. Member (kips)	-----Original-----							-----Alternate-----						
					-----Supported-----							-----Unsupported-----						
					L/R	RLX	RLY	RLZ	L/R	KL/R	Curve	No.	L/R	RLOUT	L/R	KL/R	Curve	No.
g4P	g4Y	Short	only	-0.12	-0.05	18.91	0.750	0.500	0.500	81.24	90.93	2	15.50	1.000	103.76	111.88	3	
g4Y	g4P	Short	only	-0.05	-0.12	18.91	0.750	0.500	0.500	81.24	90.93	2	15.50	1.000	103.76	111.88	3	
g6X	g6XY	Short	only	-0.67	-0.50	18.90	0.750	0.500	0.500	81.36	91.02	2	15.49	1.000	103.91	111.95	3	
g6XY	g6X	Short	only	-0.50	-0.67	18.90	0.750	0.500	0.500	81.36	91.02	2	15.49	1.000	103.91	111.95	3	
g8P	g8Y	Short	only	-1.00	-1.41	19.72	0.750	0.500	0.500	73.67	85.26	2	16.35	1.000	94.09	107.05	3	
g8X	g8XY	Short	only	-0.10	-0.15	19.72	0.750	0.500	0.500	73.67	85.26	2	16.35	1.000	94.09	107.05	3	
g8XY	g8X	Short	only	-0.15	-0.10	19.72	0.750	0.500	0.500	73.67	85.26	2	16.35	1.000	94.09	107.05	3	
g8Y	g8P	Short	only	-1.41	-1.00	19.72	0.750	0.500	0.500	73.67	85.26	2	16.35	1.000	94.09	107.05	3	
g14X	g14XY	Short	only	-1.49	-0.18	44.57	0.750	0.500	0.500	49.03	66.77	2	38.28	1.000	62.42	91.21	3	
g14XY	g14X	Short	only	-0.18	-1.49	44.57	0.750	0.500	0.500	49.03	66.77	2	38.28	1.000	62.42	91.21	3	
g16Y	g16P	Long	only	-5.32	0.62	48.53	0.500	0.750	0.500	47.64	65.73	2	41.29	1.000	63.52	91.76	3	
g22X	g22XY	Long	only	-0.39	-2.84	80.89	0.500	0.750	0.500	42.27	61.70	2	69.47	1.000	56.36	88.18	3	
g22XY	g22X	Long	only	-2.84	-0.39	80.89	0.500	0.750	0.500	42.27	61.70	2	69.47	1.000	56.36	88.18	3	
g24P	g24Y	Long	only	-0.39	-10.13	96.52	0.500	0.750	0.500	42.69	62.02	2	82.78	1.000	56.92	88.46	3	
g24Y	g24P	Long	only	-10.13	-0.39	96.52	0.500	0.750	0.500	42.69	62.02	2	82.78	1.000	56.92	88.46	3	
g25XY	g25Y	Long	only	-1.08	-2.13	80.49	0.555	0.778	0.555	43.74	62.80	2	69.50	1.000	56.22	88.11	3	
g25Y	g25XY	Long	only	-2.13	-1.08	80.49	0.555	0.778	0.555	43.74	62.80	2	69.50	1.000	56.22	88.11	3	
g26Y	g26P	Long	only	-6.80	0.37	80.49	0.555	0.778	0.555	43.74	62.80	2	69.50	1.000	56.22	88.11	3	
g37Y	g37XY	Short	only	-0.55	0.05	27.08	0.765	0.531	0.531	115.17	116.38	2	25.55	1.000	121.19	120.73	6	
g39XY	g39Y	Short	only	-0.65	-0.57	26.01	0.768	0.535	0.535	127.67	125.89	5	21.14	1.000	151.91	139.62	6	
g39Y	g39XY	Short	only	-0.57	-0.65	26.01	0.768	0.535	0.535	127.67	125.89	5	21.14	1.000	151.91	139.62	6	
g40Y	g40P	Short	only	-3.55	0.07	26.01	0.768	0.535	0.535	127.67	125.89	5	21.14	1.000	151.91	139.62	6	
g42X	g42XY	Short	only	-1.80	0.26	25.03	0.768	0.536	0.536	137.76	133.57	5	24.12	1.000	146.10	136.05	6	
g45XY	g45Y	Short	only	-0.37	-1.41	20.38	0.766	0.537	0.537	164.63	154.05	5	17.50	1.000	195.19	166.24	6	
g45Y	g45XY	Short	only	-1.41	-0.37	20.38	0.766	0.537	0.537	164.63	154.05	5	17.50	1.000	195.19	166.24	6	
g46P	g46Y	Short	only	-1.50	-3.59	20.38	0.766	0.537	0.537	164.63	154.05	5	17.50	1.000	195.19	166.24	6	
g46Y	g46P	Short	only	-3.59	-1.50	20.38	0.766	0.537	0.537	164.63	154.05	5	17.50	1.000	195.19	166.24	6	
g47XY	g47Y	Short	only	-2.57	-1.64	19.69	0.767	0.533	0.533	175.33	162.20	5	19.47	1.000	190.12	163.12	6	
g47Y	g47XY	Short	only	-1.64	-2.57	19.69	0.767	0.533	0.533	175.33	162.20	5	19.47	1.000	190.12	163.12	6	
g48P	g48Y	Short	only	-5.44	-7.61	19.69	0.767	0.533	0.533	175.33	162.20	5	19.47	1.000	190.12	163.12	6	

g48Y	g48P	Short only	-7.61	-5.44	19.69	0.767	0.533	0.533	175.33	162.20	5	19.47	1.000	190.12	163.12	6
g102P	g102X	Long only	-0.37	-0.18	19.28	0.500	0.750	0.500	98.41	103.80	2	13.47	1.000	131.21	131.21	4
g102X	g102P	Long only	-0.18	-0.37	19.28	0.500	0.750	0.500	98.41	103.80	2	13.47	1.000	131.21	131.21	4
g105P	g105X	Short only	-0.42	0.07	19.90	0.750	0.500	0.500	71.93	83.95	2	16.54	1.000	91.87	105.93	3

Summary of Clamp Capacities and Usages for Load Case "NESC Heavy":

Clamp Label	Force (kips)	Input Holding Capacity (kips)	Factored Holding Capacity (kips)	Usage %
C1	3.129	50.00	50.00	6.26
C2	3.024	50.00	50.00	6.05
C3	4.879	50.00	50.00	9.76
C4	5.065	50.00	50.00	10.13
C5	5.407	50.00	50.00	10.81
C6	5.349	50.00	50.00	10.70
C7	5.326	50.00	50.00	10.65
C8	4.804	50.00	50.00	9.61
C9	0.800	50.00	50.00	1.60
C10	0.800	50.00	50.00	1.60
C11	0.800	50.00	50.00	1.60
C12	0.800	50.00	50.00	1.60
C13	1.676	50.00	50.00	3.35
C14	1.676	50.00	50.00	3.35
C15	1.676	50.00	50.00	3.35
C16	1.676	50.00	50.00	3.35
C17	0.853	50.00	50.00	1.71
C18	1.182	50.00	50.00	2.36
C19	1.169	50.00	50.00	2.34
C20	1.334	50.00	50.00	2.67
C21	1.473	50.00	50.00	2.95
C22	1.397	50.00	50.00	2.79
C23	1.554	50.00	50.00	3.11
C24	1.892	50.00	50.00	3.78
C25	2.083	50.00	50.00	4.17
C26	2.181	50.00	50.00	4.36
C27	2.610	50.00	50.00	5.22
C28	2.469	50.00	50.00	4.94

Equilibrium Joint Positions and Rotations for Load Case "NESC Extreme":

Joint Label	X-Displ (ft)	Y-Displ (ft)	Z-Displ (ft)	X-Rot (deg)	Y-Rot (deg)	Z-Rot (deg)	X-Pos (ft)	Y-Pos (ft)	Z-Pos (ft)
1P	-0.1537	1.123	-0.04284	-1.1201	-0.1141	0.0734	-0.1537	2.793	140
2P	-0.1451	1.043	-0.03848	-1.1295	-0.1139	0.0679	1.525	2.713	135.8
3P	-0.1362	0.9605	-0.03697	-1.1260	-0.1323	0.0653	1.534	2.63	131.6
4P	-0.1268	0.8806	-0.03459	-1.0724	-0.0999	0.0617	1.543	2.551	127.5
5P	-0.1211	0.8169	-0.03197	-0.9951	-0.1283	0.0729	1.549	2.487	124
6P	-0.113	0.7569	-0.03051	-0.9657	-0.1241	0.0684	1.557	2.427	120.5
7P	-0.1056	0.6993	-0.02881	-0.9180	-0.1248	0.0639	1.564	2.369	117
8P	-0.09783	0.6448	-0.0269	-0.8711	-0.1108	0.0593	1.572	2.315	113.5
9P	-0.09148	0.5934	-0.02484	-0.8053	-0.1168	0.0564	1.579	2.263	110
10P	-0.08404	0.545	-0.02353	-0.7748	-0.1176	0.0539	1.586	2.215	106.5
11P	-0.07705	0.499	-0.02209	-0.7318	-0.1144	0.0514	1.593	2.169	103
12P	-0.07026	0.4558	-0.02053	-0.6837	-0.0946	0.0487	1.6	2.126	99.48
13P	-0.06497	0.4157	-0.01891	-0.6232	-0.0967	0.0467	1.605	2.086	95.98
14P	-0.05911	0.3821	-0.01941	-0.5706	-0.1018	0.0460	1.831	2.272	92.73
15P	-0.05354	0.3463	-0.0199	-0.5279	-0.0828	0.0453	2.096	2.496	88.98
16P	-0.0483	0.3131	-0.02018	-0.4909	-0.0838	0.0430	2.352	2.713	85.23
17P	-0.04154	0.2725	-0.02045	-0.4433	-0.0750	0.0404	2.708	3.023	80.23
18P	-0.03575	0.2358	-0.02044	-0.4027	-0.0690	0.0371	3.054	3.326	75.23
19P	-0.02923	0.1961	-0.02017	-0.3571	-0.0547	0.0335	3.471	3.696	69.23
20P	-0.02453	0.161	-0.01967	-0.3162	-0.0536	0.0287	3.885	4.071	63.23
21P	-0.01594	0.1191	-0.01837	-0.2635	-0.0568	0.0224	4.454	4.589	54.98
23P	-0.009433	0.08032	-0.01636	-0.2097	-0.0361	0.0160	5.111	5.2	45.48
25P	-0.003552	0.04499	-0.01321	-0.1520	-0.0230	0.0076	5.806	5.855	34.49
27P	-0.001322	0.01883	-0.009205	-0.0919	-0.0094	-0.0034	6.729	6.749	21.99
29P	0.0003679	0.002342	-0.003725	-0.0322	0.0002	-0.0160	7.69	7.692	7.996
30P	0	0	0	0.0000	0.0000	0.0000	8.23	8.23	0
39P	-0.001025	0.001871	-0.0001579	-0.0296	-0.0033	0.0034	7.689	0.001871	8
40P	-0.0002848	0.01521	0.0008799	-0.0292	-0.0042	0.0014	-0.0002848	7.705	8.001
41P	-0.1666	1.121	-0.2573	-1.1417	-0.1142	0.0691	-0.1666	13.62	139.7
42P	-0.1345	0.8131	-0.1903	-1.0998	-0.1176	0.1008	-0.1345	10.81	123.8
43P	-0.1078	0.5902	-0.192	-0.8991	-0.1123	0.0988	-0.1078	13.09	109.8
44P	-0.07314	0.4137	-0.1204	-0.7076	-0.0941	0.0595	-0.07314	10.41	95.88
1X	-0.1494	1.124	0.02215	-1.1173	-0.1136	0.0750	-0.1494	-0.5465	140
2X	-0.1411	1.044	0.02611	-1.1284	-0.1104	0.0669	1.529	-0.6263	135.9
2XY	-0.141	1.039	0.01948	-1.1289	-0.1172	0.0775	-1.811	-0.6307	135.8
2Y	-0.1453	1.039	-0.04516	-1.1296	-0.1159	0.0780	-1.815	2.709	135.8
3X	-0.1332	0.9611	0.02634	-1.1316	-0.0921	0.0599	1.537	-0.7089	131.7
3XY	-0.1322	0.9566	0.01969	-1.1335	-0.1340	0.0791	-1.802	-0.7134	131.7
3Y	-0.1375	0.956	-0.04366	-1.1293	-0.0967	0.0836	-1.807	2.626	131.6
4X	-0.1259	0.8807	0.02567	-1.0724	-0.1334	0.0540	1.544	-0.7893	127.5
4XY	-0.1226	0.8762	0.01896	-1.0697	-0.0967	0.0799	-1.793	-0.7938	127.5
4Y	-0.13	0.8758	-0.0413	-1.0748	-0.1303	0.0905	-1.8	2.546	127.5
5X	-0.1171	0.8173	0.02449	-0.9892	-0.1103	0.0605	1.553	-0.8527	124
5XY	-0.117	0.813	0.01768	-0.9900	-0.1240	0.0671	-1.787	-0.857	124
5Y	-0.1213	0.8122	-0.03876	-0.9895	-0.1115	0.0823	-1.791	2.482	124
6X	-0.1104	0.7573	0.02414	-0.9646	-0.1131	0.0553	1.56	-0.9127	120.5
6XY	-0.1091	0.753	0.01734	-0.9624	-0.1206	0.0643	-1.779	-0.917	120.5
6Y	-0.1144	0.7527	-0.0373	-0.9585	-0.1170	0.0787	-1.784	2.423	120.5
7X	-0.1031	0.6998	0.02344	-0.9221	-0.1096	0.0500	1.567	-0.9702	117
7XY	-0.102	0.6958	0.01671	-0.9156	-0.1216	0.0616	-1.772	-0.9742	117

7Y	-0.1069	0.6955	-0.03552	-0.9145	-0.1136	0.0751	-1.777	2.365	117
8X	-0.09651	0.6448	0.02241	-0.8730	-0.1203	0.0449	1.573	-1.025	113.5
8XY	-0.09435	0.6412	0.01581	-0.8645	-0.1074	0.0587	-1.764	-1.029	113.5
8Y	-0.1	0.6411	-0.03349	-0.8701	-0.1242	0.0716	-1.77	2.311	113.5
9X	-0.08862	0.5936	0.02112	-0.8003	-0.1113	0.0409	1.581	-1.076	110
9XY	-0.08823	0.5903	0.01467	-0.8028	-0.1137	0.0543	-1.758	-1.08	110
9Y	-0.09195	0.5897	-0.03129	-0.7992	-0.1134	0.0664	-1.762	2.26	110
10X	-0.08212	0.5454	0.02042	-0.7725	-0.1062	0.0390	1.588	-1.125	106.5
10XY	-0.08096	0.542	0.01413	-0.7735	-0.1149	0.0532	-1.751	-1.128	106.5
10Y	-0.08527	0.5419	-0.02984	-0.7689	-0.1085	0.0633	-1.755	2.212	106.5
11X	-0.07555	0.4994	0.01945	-0.7333	-0.1011	0.0371	1.594	-1.171	103
11XY	-0.07416	0.4961	0.01341	-0.7302	-0.1116	0.0521	-1.744	-1.174	103
11Y	-0.07853	0.496	-0.02817	-0.7294	-0.1038	0.0603	-1.749	2.166	103
12X	-0.06941	0.456	0.01822	-0.6858	-0.1097	0.0354	1.601	-1.214	99.52
12XY	-0.06753	0.4529	0.01249	-0.6807	-0.0924	0.0508	-1.738	-1.217	99.51
12Y	-0.07219	0.4529	-0.0263	-0.6848	-0.1125	0.0573	-1.742	2.123	99.47
13X	-0.06254	0.416	0.01681	-0.6188	-0.0929	0.0338	1.607	-1.254	96.02
13XY	-0.06241	0.4131	0.01145	-0.6192	-0.0925	0.0493	-1.732	-1.257	96.01
13Y	-0.06514	0.4128	-0.02432	-0.6191	-0.0962	0.0539	-1.735	2.083	95.98
14X	-0.05797	0.3825	0.0181	-0.5680	-0.0739	0.0326	1.832	-1.508	92.77
14XY	-0.05651	0.3792	0.01244	-0.5702	-0.0971	0.0469	-1.947	-1.511	92.76
14Y	-0.06067	0.3793	-0.02516	-0.5635	-0.0787	0.0509	-1.951	2.269	92.72
15X	-0.05236	0.3467	0.01939	-0.5278	-0.0810	0.0323	2.098	-1.803	89.02
15XY	-0.05088	0.3432	0.01342	-0.5245	-0.0779	0.0430	-2.201	-1.807	89.01
15Y	-0.05512	0.3433	-0.02598	-0.5254	-0.0868	0.0477	-2.205	2.493	88.97
16X	-0.04713	0.3134	0.02033	-0.4885	-0.0695	0.0304	2.353	-2.087	85.27
16XY	-0.0457	0.3098	0.01414	-0.4862	-0.0775	0.0411	-2.446	-2.09	85.26
16Y	-0.04984	0.3099	-0.02648	-0.4842	-0.0755	0.0453	-2.45	2.71	85.22
17X	-0.04108	0.273	0.02137	-0.4421	-0.0633	0.0281	2.709	-2.477	80.27
17XY	-0.03902	0.2692	0.01494	-0.4383	-0.0695	0.0382	-2.789	-2.481	80.26
17Y	-0.04378	0.2694	-0.02698	-0.4365	-0.0688	0.0423	-2.794	3.019	80.22
18X	-0.03531	0.2361	0.02195	-0.4011	-0.0567	0.0255	3.055	-2.854	75.27
18XY	-0.03327	0.2324	0.01542	-0.3971	-0.0636	0.0359	-3.123	-2.858	75.27
18Y	-0.03796	0.2327	-0.02706	-0.3952	-0.0612	0.0396	-3.128	3.323	75.22
19X	-0.02938	0.1966	0.0222	-0.3567	-0.0553	0.0225	3.471	-3.303	69.27
19XY	-0.02683	0.1929	0.01566	-0.3499	-0.0509	0.0329	-3.527	-3.307	69.27
19Y	-0.03206	0.1933	-0.02676	-0.3505	-0.0601	0.0363	-3.532	3.693	69.22
20X	-0.02325	0.1612	0.02209	-0.3151	-0.0439	0.0185	3.887	-3.749	63.27
20XY	-0.02207	0.1581	0.01564	-0.3108	-0.0480	0.0311	-3.932	-3.752	63.27
20Y	-0.02575	0.1582	-0.02616	-0.3098	-0.0492	0.0339	-3.936	4.068	63.22
21X	-0.01874	0.1199	0.02103	-0.2600	-0.0250	0.0130	4.451	-4.35	55.02
21XY	-0.0142	0.1162	0.01501	-0.2610	-0.0484	0.0296	-4.484	-4.354	55.02
21Y	-0.02103	0.117	-0.02452	-0.2554	-0.0301	0.0313	-4.491	4.587	54.98
23X	-0.01334	0.08077	0.01907	-0.2100	-0.0277	0.0076	5.107	-5.039	45.52
23XY	-0.008121	0.0772	0.01368	-0.2067	-0.0310	0.0267	-5.128	-5.043	45.51
23Y	-0.01517	0.07826	-0.02188	-0.2058	-0.0323	0.0279	-5.135	5.198	45.48
25X	-0.008556	0.04567	0.01559	-0.1506	-0.0221	0.0007	5.801	-5.764	34.52
25XY	-0.002762	0.04235	0.01122	-0.1464	-0.0187	0.0242	-5.813	-5.768	34.51
25Y	-0.01004	0.04345	-0.01766	-0.1469	-0.0257	0.0244	-5.82	5.853	34.48
27X	-0.00332	0.01908	0.01097	-0.0928	-0.0168	-0.0082	6.727	-6.711	22.01
27XY	-0.0006714	0.01695	0.007909	-0.0871	-0.0079	0.0230	-6.731	-6.713	22.01
27Y	-0.004265	0.0175	-0.01227	-0.0885	-0.0194	0.0216	-6.734	6.747	21.99
29X	-0.0006217	0.002462	0.004466	-0.0326	-0.0068	-0.0199	7.689	-7.688	8.004
29XY	0.0007933	0.001585	0.003206	-0.0251	0.0043	0.0244	-7.689	-7.688	8.003
29Y	-0.001104	0.001822	-0.004947	-0.0265	-0.0105	0.0219	-7.691	7.692	7.995
30X	0	0	0	0.0000	0.0000	0.0000	8.23	-8.23	0
30XY	0	0	0	0.0000	0.0000	0.0000	-8.23	-8.23	0
30Y	0	0	0	0.0000	0.0000	0.0000	-8.23	8.23	0
39Y	0.0008737	0.001332	-0.0001568	-0.0326	-0.0031	-0.0009	-7.689	0.001332	8

40X	6.576e-005	0.0193	-0.001381	-0.0291	-0.0064	0.0038	6.576e-005	-7.671	7.999
41X	-0.1355	1.126	0.2345	-1.1261	-0.1136	0.0768	-0.1355	-11.37	140.2
42X	-0.1078	0.8168	0.1693	-1.0331	-0.1169	0.0669	-0.1078	-9.183	124.2
43X	-0.08266	0.5936	0.1716	-0.8185	-0.1117	0.0251	-0.08266	-11.91	110.2
44X	-0.05618	0.4155	0.1065	-0.6431	-0.0924	0.0459	-0.05618	-9.585	96.11

Joint Support Reactions for Load Case "NESC Extreme":

Joint Label	X Force (kips)	X Usage %	Y Force (kips)	Y Usage %	H-Shear Usage %	Z Force (kips)	Z Usage %	Uplift Usage %	Result. Force (kips)	Result. Usage %	X Moment (ft-k)	X-M. Usage %	Y Moment (ft-k)	Y-M. Usage %	H-Bend-M Usage %	Z Moment (ft-k)	Z-M. Usage %	Max. Usage %
30P	-12.47	0.0	-17.62	0.0	0.0	-189.73	0.0	0.0	190.95	0.0	0.77	0.0	-0.2	0.0	0.0	0.41	0.0	0.0
30X	14.90	0.0	-19.75	0.0	0.0	224.76	0.0	0.0	226.12	0.0	0.82	0.0	0.1	0.0	0.0	0.53	0.0	0.0
30XY	-11.14	0.0	-14.09	0.0	0.0	161.90	0.0	0.0	162.90	0.0	0.14	0.0	-0.7	0.0	0.0	-0.58	0.0	0.0
30Y	17.73	0.0	-20.25	0.0	0.0	-248.33	0.0	0.0	249.78	0.0	0.24	0.0	0.5	0.0	0.0	-0.54	0.0	0.0

Joint Displacements, Loads and Member Forces on Joints for Load Case "NESC Extreme":

Joint Label	X External Load (kips)	Y External Load (kips)	Z External Load (kips)	X Member Force (kips)	Y Member Force (kips)	Z Member Force (kips)	X Disp. (ft)	Y Disp. (ft)	Z Disp. (ft)
1P	0.0000	0.5076	-0.3164	0.0000	-0.5076	0.3164	-0.1537	1.1229	-0.0428
2P	0.0000	3.1966	-0.1604	0.0000	-3.1966	0.1604	-0.1451	1.0430	-0.0385
3P	0.0000	0.1506	-0.1604	-0.0000	-0.1506	0.1604	-0.1362	0.9605	-0.0370
4P	0.0000	0.8086	-0.4474	0.0000	-0.8086	0.4474	-0.1268	0.8806	-0.0346
5P	0.0000	0.1506	-0.1604	-0.0000	-0.1506	0.1604	-0.1211	0.8169	-0.0320
6P	0.0000	-1.4304	-0.8424	0.0000	1.4304	0.8424	-0.1130	0.7569	-0.0305
7P	0.0000	0.7506	-0.4224	-0.0000	-0.7506	0.4224	-0.1056	0.6993	-0.0288
8P	0.0000	0.1506	-0.1604	0.0000	-0.1506	0.1604	-0.0978	0.6448	-0.0269
9P	0.0000	0.1506	-0.1604	-0.0000	-0.1506	0.1604	-0.0915	0.5934	-0.0248
10P	0.0000	0.7506	-0.4224	-0.0000	-0.7506	0.4224	-0.0840	0.5450	-0.0235
11P	0.0000	0.1506	-0.1604	-0.0000	-0.1506	0.1604	-0.0771	0.4990	-0.0221
12P	0.0000	0.1506	-0.1604	0.0000	-0.1506	0.1604	-0.0703	0.4558	-0.0205
13P	0.0000	1.1447	-0.8612	-0.0000	-1.1447	0.8612	-0.0650	0.4157	-0.0189
14P	0.0000	0.3861	-0.4358	-0.0000	-0.3861	0.4358	-0.0591	0.3821	-0.0194
15P	0.0000	0.3861	-0.4358	0.0000	-0.3861	0.4358	-0.0535	0.3463	-0.0199
16P	0.0000	0.9791	-0.6948	0.0000	-0.9791	0.6948	-0.0483	0.3131	-0.0202
17P	0.0000	0.3861	-0.4358	0.0000	-0.3861	0.4358	-0.0415	0.2725	-0.0205
18P	0.0000	1.0151	-0.7108	0.0000	-1.0151	0.7108	-0.0357	0.2358	-0.0204
19P	0.0000	0.3861	-0.4358	0.0000	-0.3861	0.4358	-0.0292	0.1961	-0.0202
20P	0.0000	1.1011	-0.7478	0.0000	-1.1011	0.7478	-0.0245	0.1610	-0.0197
21P	0.0000	0.3861	-0.4358	0.0000	-0.3861	0.4358	-0.0159	0.1191	-0.0184
23P	0.0000	1.0511	-0.7258	0.0000	-1.0511	0.7258	-0.0094	0.0803	-0.0164
25P	0.0000	1.0151	-0.7108	0.0000	-1.0151	0.7108	-0.0036	0.0450	-0.0132
27P	0.0000	1.1011	-0.7478	0.0000	-1.1011	0.7478	-0.0013	0.0188	-0.0092
29P	0.0000	1.1941	-0.7888	-0.0000	-1.1941	0.7888	0.0004	0.0023	-0.0037
30P	0.0000	0.3861	-0.4358	12.4695	17.2334	-189.2900	0.0000	0.0000	0.0000
39P	0.0000	0.3861	-0.4358	0.0000	-0.3861	0.4358	-0.0010	0.0019	-0.0002
40P	0.0000	0.3861	-0.4358	0.0000	-0.3861	0.4358	-0.0003	0.0152	0.0009
41P	0.1000	2.3006	-0.6784	-0.1000	-2.3006	0.6784	-0.1666	1.1211	-0.2573
42P	-1.8900	3.8066	-1.6184	1.8900	-3.8066	1.6184	-0.1345	0.8131	-0.1903
43P	-2.1930	3.6986	-1.5834	2.1930	-3.6986	1.5834	-0.1078	0.5902	-0.1920
44P	-0.9880	3.7816	-1.6424	0.9880	-3.7816	1.6424	-0.0731	0.4137	-0.1204
1X	0.0000	0.1506	-0.1604	-0.0000	-0.1506	0.1604	-0.1494	1.1235	0.0222
2X	0.0000	3.1966	-0.1604	0.0000	-3.1966	0.1604	-0.1411	1.0437	0.0261
2XY	0.0000	3.1966	-0.1604	-0.0000	-3.1966	0.1604	-0.1410	1.0393	0.0195

2Y	0.0000	3.1966	-0.1604	-0.0000	-3.1966	0.1604	-0.1453	1.0387	-0.0452
3X	0.0000	0.1506	-0.1604	0.0000	-0.1506	0.1604	-0.1332	0.9611	0.0263
3XY	0.0000	0.1506	-0.1604	-0.0000	-0.1506	0.1604	-0.1322	0.9566	0.0197
3Y	0.0000	0.1506	-0.1604	0.0000	-0.1506	0.1604	-0.1375	0.9560	-0.0437
4X	0.0000	0.1506	-0.1604	-0.0000	-0.1506	0.1604	-0.1259	0.8807	0.0257
4XY	0.0000	0.1506	-0.1604	-0.0000	-0.1506	0.1604	-0.1226	0.8762	0.0190
4Y	0.0000	0.1506	-0.1604	-0.0000	-0.1506	0.1604	-0.1300	0.8758	-0.0413
5X	0.0000	0.1506	-0.1604	-0.0000	-0.1506	0.1604	-0.1171	0.8173	0.0245
5XY	0.0000	0.1506	-0.1604	-0.0000	-0.1506	0.1604	-0.1170	0.8130	0.0177
5Y	0.0000	0.1506	-0.1604	-0.0000	-0.1506	0.1604	-0.1213	0.8122	-0.0388
6X	0.0000	-1.4304	-0.8424	-0.0000	1.4304	0.8424	-0.1104	0.7573	0.0241
6XY	0.0000	-1.4304	-0.8424	0.0000	1.4304	0.8424	-0.1091	0.7530	0.0173
6Y	0.0000	-1.4304	-0.8424	-0.0000	1.4304	0.8424	-0.1144	0.7527	-0.0373
7X	0.0000	0.1506	-0.1604	0.0000	-0.1506	0.1604	-0.1031	0.6998	0.0234
7XY	0.0000	0.1506	-0.1604	-0.0000	-0.1506	0.1604	-0.1020	0.6958	0.0167
7Y	0.0000	0.1506	-0.1604	0.0000	-0.1506	0.1604	-0.1069	0.6955	-0.0355
8X	0.0000	0.1506	-0.1604	-0.0000	-0.1506	0.1604	-0.0965	0.6448	0.0224
8XY	0.0000	0.1506	-0.1604	0.0000	-0.1506	0.1604	-0.0943	0.6412	0.0158
8Y	0.0000	0.1506	-0.1604	-0.0000	-0.1506	0.1604	-0.1000	0.6411	-0.0335
9X	0.0000	0.1506	-0.1604	-0.0000	-0.1506	0.1604	-0.0886	0.5936	0.0211
9XY	0.0000	0.1506	-0.1604	-0.0000	-0.1506	0.1604	-0.0882	0.5903	0.0147
9Y	0.0000	0.1506	-0.1604	-0.0000	-0.1506	0.1604	-0.0919	0.5897	-0.0313
10X	0.0000	0.1506	-0.1604	0.0000	-0.1506	0.1604	-0.0821	0.5454	0.0204
10XY	0.0000	0.1506	-0.1604	-0.0000	-0.1506	0.1604	-0.0810	0.5420	0.0141
10Y	0.0000	0.1506	-0.1604	0.0000	-0.1506	0.1604	-0.0853	0.5419	-0.0298
11X	0.0000	0.1506	-0.1604	0.0000	-0.1506	0.1604	-0.0755	0.4994	0.0195
11XY	0.0000	0.1506	-0.1604	-0.0000	-0.1506	0.1604	-0.0742	0.4961	0.0134
11Y	0.0000	0.1506	-0.1604	0.0000	-0.1506	0.1604	-0.0785	0.4960	-0.0282
12X	0.0000	0.1506	-0.1604	-0.0000	-0.1506	0.1604	-0.0694	0.4560	0.0182
12XY	0.0000	0.1506	-0.1604	0.0000	-0.1506	0.1604	-0.0675	0.4529	0.0125
12Y	0.0000	0.1506	-0.1604	-0.0000	-0.1506	0.1604	-0.0722	0.4529	-0.0263
13X	0.0000	0.5367	-0.5962	-0.0000	-0.5367	0.5962	-0.0625	0.4160	0.0168
13XY	0.0000	0.5367	-0.5962	0.0000	-0.5367	0.5962	-0.0624	0.4131	0.0115
13Y	0.0000	0.5367	-0.5962	0.0000	-0.5367	0.5962	-0.0651	0.4128	-0.0243
14X	0.0000	0.3861	-0.4358	0.0000	-0.3861	0.4358	-0.0580	0.3825	0.0181
14XY	0.0000	0.3861	-0.4358	-0.0000	-0.3861	0.4358	-0.0565	0.3792	0.0124
14Y	0.0000	0.3861	-0.4358	0.0000	-0.3861	0.4358	-0.0607	0.3793	-0.0252
15X	0.0000	0.3861	-0.4358	-0.0000	-0.3861	0.4358	-0.0524	0.3467	0.0194
15XY	0.0000	0.3861	-0.4358	0.0000	-0.3861	0.4358	-0.0509	0.3432	0.0134
15Y	0.0000	0.3861	-0.4358	-0.0000	-0.3861	0.4358	-0.0551	0.3433	-0.0260
16X	0.0000	0.3861	-0.4358	0.0000	-0.3861	0.4358	-0.0471	0.3134	0.0203
16XY	0.0000	0.3861	-0.4358	-0.0000	-0.3861	0.4358	-0.0457	0.3098	0.0141
16Y	0.0000	0.3861	-0.4358	0.0000	-0.3861	0.4358	-0.0498	0.3099	-0.0265
17X	0.0000	0.3861	-0.4358	0.0000	-0.3861	0.4358	-0.0411	0.2730	0.0214
17XY	0.0000	0.3861	-0.4358	-0.0000	-0.3861	0.4358	-0.0390	0.2692	0.0149
17Y	0.0000	0.3861	-0.4358	-0.0000	-0.3861	0.4358	-0.0438	0.2694	-0.0270
18X	0.0000	0.3861	-0.4358	0.0000	-0.3861	0.4358	-0.0353	0.2361	0.0220
18XY	0.0000	0.3861	-0.4358	-0.0000	-0.3861	0.4358	-0.0333	0.2324	0.0154
18Y	0.0000	0.3861	-0.4358	0.0000	-0.3861	0.4358	-0.0380	0.2327	-0.0271
19X	0.0000	0.3861	-0.4358	0.0000	-0.3861	0.4358	-0.0294	0.1966	0.0222
19XY	0.0000	0.3861	-0.4358	-0.0000	-0.3861	0.4358	-0.0268	0.1929	0.0157
19Y	0.0000	0.3861	-0.4358	-0.0000	-0.3861	0.4358	-0.0321	0.1933	-0.0268
20X	0.0000	0.3861	-0.4358	0.0000	-0.3861	0.4358	-0.0233	0.1612	0.0221
20XY	0.0000	0.3861	-0.4358	-0.0000	-0.3861	0.4358	-0.0221	0.1581	0.0156
20Y	0.0000	0.3861	-0.4358	-0.0000	-0.3861	0.4358	-0.0258	0.1582	-0.0262
21X	0.0000	0.3861	-0.4358	0.0000	-0.3861	0.4358	-0.0187	0.1199	0.0210
21XY	0.0000	0.3861	-0.4358	-0.0000	-0.3861	0.4358	-0.0142	0.1162	0.0150
21Y	0.0000	0.3861	-0.4358	0.0000	-0.3861	0.4358	-0.0210	0.1170	-0.0245
23X	0.0000	0.3861	-0.4358	0.0000	-0.3861	0.4358	-0.0133	0.0808	0.0191

23XY	0.0000	0.3861	-0.4358	-0.0000	-0.3861	0.4358	-0.0081	0.0772	0.0137
23Y	0.0000	0.3861	-0.4358	-0.0000	-0.3861	0.4358	-0.0152	0.0783	-0.0219
25X	0.0000	0.3861	-0.4358	0.0000	-0.3861	0.4358	-0.0086	0.0457	0.0156
25XY	0.0000	0.3861	-0.4358	0.0000	-0.3861	0.4358	-0.0028	0.0423	0.0112
25Y	0.0000	0.3861	-0.4358	0.0000	-0.3861	0.4358	-0.0100	0.0434	-0.0177
27X	0.0000	0.3861	-0.4358	0.0000	-0.3861	0.4358	-0.0033	0.0191	0.0110
27XY	0.0000	0.3861	-0.4358	-0.0000	-0.3861	0.4358	-0.0007	0.0170	0.0079
27Y	0.0000	0.3861	-0.4358	-0.0000	-0.3861	0.4358	-0.0043	0.0175	-0.0123
29X	0.0000	0.3861	-0.4358	-0.0000	-0.3861	0.4358	-0.0006	0.0025	0.0045
29XY	0.0000	0.3861	-0.4358	0.0000	-0.3861	0.4358	0.0008	0.0016	0.0032
29Y	0.0000	0.3861	-0.4358	0.0000	-0.3861	0.4358	-0.0011	0.0018	-0.0049
30X	0.0000	0.3861	-0.4358	-14.9046	19.3683	225.1976	0.0000	0.0000	0.0000
30XY	0.0000	0.3861	-0.4358	11.1358	13.7046	162.3388	0.0000	0.0000	0.0000
30Y	0.0000	0.3861	-0.4358	-17.7266	19.8618	-247.8908	0.0000	0.0000	0.0000
39Y	0.0000	0.3861	-0.4358	-0.0000	-0.3861	0.4358	0.0009	0.0013	-0.0002
40X	0.0000	0.3861	-0.4358	-0.0000	-0.3861	0.4358	0.0001	0.0193	-0.0014
41X	0.0500	2.3226	-0.6964	-0.0500	-2.3226	0.6964	-0.1355	1.1257	0.2345
42X	-1.2320	3.9416	-1.6624	1.2320	-3.9416	1.6624	-0.1078	0.8168	0.1693
43X	-2.2030	3.7496	-1.6104	2.2030	-3.7496	1.6104	-0.0827	0.5936	0.1716
44X	-0.6700	3.9806	-1.6914	0.6700	-3.9806	1.6914	-0.0562	0.4155	0.1065

Crossing Diagonal Check for Load Case "NESC Extreme" (RLOUT controls):

Comp. Member Label	Tens. Member Label	Connect Leg for Comp. Member	Force In Comp. Member (kips)	Force In Tens. Member (kips)	-----Original-----							-----Alternate-----						
					-----Supported-----							-----Unsupported-----						
					L/R	RLX	RLY	RLZ	L/R	KL/R	Curve	No.	L/R	RLOUT	L/R	KL/R	Curve	No.
g4P	g4Y	Short	only	-0.40	-0.23	18.91	0.750	0.500	0.500	81.24	90.93	2	15.50	1.000	103.76	111.88		3
g4Y	g4P	Short	only	-0.23	-0.40	18.91	0.750	0.500	0.500	81.24	90.93	2	15.50	1.000	103.76	111.88		3
g6X	g6XY	Short	only	-0.75	-0.65	18.90	0.750	0.500	0.500	81.36	91.02	2	15.49	1.000	103.91	111.95		3
g6XY	g6X	Short	only	-0.65	-0.75	18.90	0.750	0.500	0.500	81.36	91.02	2	15.49	1.000	103.91	111.95		3
g8P	g8Y	Short	only	-1.15	-1.40	19.72	0.750	0.500	0.500	73.67	85.26	2	16.35	1.000	94.09	107.05		3
g8Y	g8P	Short	only	-1.40	-1.15	19.72	0.750	0.500	0.500	73.67	85.26	2	16.35	1.000	94.09	107.05		3
g12XY	g12X	Short	only	-0.54	0.08	44.57	0.750	0.500	0.500	49.03	66.77	2	38.28	1.000	62.42	91.21		3
g14X	g14XY	Short	only	-0.80	-1.47	44.57	0.750	0.500	0.500	49.03	66.77	2	38.28	1.000	62.42	91.21		3
g14XY	g14X	Short	only	-1.47	-0.80	44.57	0.750	0.500	0.500	49.03	66.77	2	38.28	1.000	62.42	91.21		3
g16P	g16Y	Long	only	-1.07	-5.29	48.53	0.500	0.750	0.500	47.64	65.73	2	41.29	1.000	63.52	91.76		3
g16Y	g16P	Long	only	-5.29	-1.07	48.53	0.500	0.750	0.500	47.64	65.73	2	41.29	1.000	63.52	91.76		3
g18Y	g18P	Long	only	-5.92	1.02	80.89	0.500	0.750	0.500	42.27	61.70	2	69.47	1.000	56.36	88.18		3
g22X	g22XY	Long	only	-0.43	-4.03	80.89	0.500	0.750	0.500	42.27	61.70	2	69.47	1.000	56.36	88.18		3
g22XY	g22X	Long	only	-4.03	-0.43	80.89	0.500	0.750	0.500	42.27	61.70	2	69.47	1.000	56.36	88.18		3
g24P	g24Y	Long	only	-3.77	-10.95	96.52	0.500	0.750	0.500	42.69	62.02	2	82.78	1.000	56.92	88.46		3
g24Y	g24P	Long	only	-10.95	-3.77	96.52	0.500	0.750	0.500	42.69	62.02	2	82.78	1.000	56.92	88.46		3
g25XY	g25Y	Long	only	-2.40	-0.66	80.49	0.555	0.778	0.555	43.74	62.80	2	69.50	1.000	56.22	88.11		3
g25Y	g25XY	Long	only	-0.66	-2.40	80.49	0.555	0.778	0.555	43.74	62.80	2	69.50	1.000	56.22	88.11		3
g26P	g26Y	Long	only	-2.36	-7.35	80.49	0.555	0.778	0.555	43.74	62.80	2	69.50	1.000	56.22	88.11		3
g26Y	g26P	Long	only	-7.35	-2.36	80.49	0.555	0.778	0.555	43.74	62.80	2	69.50	1.000	56.22	88.11		3
g28X	g28XY	Long	only	-0.70	-0.10	78.88	0.539	0.770	0.539	49.50	67.13	2	67.41	1.000	64.29	92.15		3
g28XY	g28X	Long	only	-0.10	-0.70	78.88	0.539	0.770	0.539	49.50	67.13	2	67.41	1.000	64.29	92.15		3
g30X	g30XY	Short	only	-1.20	-0.89	46.17	0.768	0.537	0.537	60.27	75.20	2	41.25	1.000	63.80	91.90		3
g30XY	g30X	Short	only	-0.89	-1.20	46.17	0.768	0.537	0.537	60.27	75.20	2	41.25	1.000	63.80	91.90		3
g32Y	g32P	Short	only	-3.16	0.22	43.26	0.771	0.541	0.541	73.94	85.45	2	38.91	1.000	77.69	98.85		3
g34X	g34XY	Short	only	-1.08	-0.86	38.01	0.766	0.531	0.531	82.83	92.12	2	32.24	1.000	99.30	109.65		3
g34XY	g34X	Short	only	-0.86	-1.08	38.01	0.766	0.531	0.531	82.83	92.12	2	32.24	1.000	99.30	109.65		3
g38Y	g38P	Short	only	-1.91	0.24	27.08	0.765	0.531	0.531	115.17	116.38	2	25.55	1.000	121.19	120.73		6
g40P	g40Y	Short	only	-0.92	-3.94	26.01	0.768	0.535	0.535	127.67	125.89	5	21.14	1.000	151.91	139.62		6
g40Y	g40P	Short	only	-3.94	-0.92	26.01	0.768	0.535	0.535	127.67	125.89	5	21.14	1.000	151.91	139.62		6

g42X	g42XY	Short only	-1.66	-0.80	25.03	0.768	0.536	0.536	137.76	133.57	5	24.12	1.000	146.10	136.05	6
g42XY	g42X	Short only	-0.80	-1.66	25.03	0.768	0.536	0.536	137.76	133.57	5	24.12	1.000	146.10	136.05	6
g44X	g44XY	Short only	-0.70	-0.41	25.24	0.768	0.537	0.537	144.13	138.43	5	21.13	1.000	170.89	151.30	6
g44XY	g44X	Short only	-0.41	-0.70	25.24	0.768	0.537	0.537	144.13	138.43	5	21.13	1.000	170.89	151.30	6
g46P	g46Y	Short only	-2.91	-4.32	20.38	0.766	0.537	0.537	164.63	154.05	5	17.50	1.000	195.19	166.24	6
g46Y	g46P	Short only	-4.32	-2.91	20.38	0.766	0.537	0.537	164.63	154.05	5	17.50	1.000	195.19	166.24	6
g48P	g48Y	Short only	-8.71	-10.23	19.69	0.767	0.533	0.533	175.33	162.20	5	19.47	1.000	190.12	163.12	6
g48Y	g48P	Short only	-10.23	-8.71	19.69	0.767	0.533	0.533	175.33	162.20	5	19.47	1.000	190.12	163.12	6
g102P	g102X	Long only	-0.16	-0.08	19.28	0.500	0.750	0.500	98.41	103.80	2	13.47	1.000	131.21	131.21	4
g102X	g102P	Long only	-0.08	-0.16	19.28	0.500	0.750	0.500	98.41	103.80	2	13.47	1.000	131.21	131.21	4

Summary of Clamp Capacities and Usages for Load Case "NESC Extreme":

Clamp Label	Force (kips)	Input Holding Capacity (kips)	Factored Holding Capacity (kips)	Usage %
C1	2.425	50.00	50.00	4.85
C2	2.401	50.00	50.00	4.80
C3	4.452	50.00	50.00	8.90
C4	4.548	50.00	50.00	9.10
C5	4.637	50.00	50.00	9.27
C6	4.582	50.00	50.00	9.16
C7	4.377	50.00	50.00	8.75
C8	4.240	50.00	50.00	8.48
C9	3.201	50.00	50.00	6.40
C10	3.201	50.00	50.00	6.40
C11	3.201	50.00	50.00	6.40
C12	3.201	50.00	50.00	6.40
C13	1.660	50.00	50.00	3.32
C14	1.660	50.00	50.00	3.32
C15	1.660	50.00	50.00	3.32
C16	1.660	50.00	50.00	3.32
C17	0.598	50.00	50.00	1.20
C18	0.924	50.00	50.00	1.85
C19	0.861	50.00	50.00	1.72
C20	0.861	50.00	50.00	1.72
C21	1.432	50.00	50.00	2.86
C22	1.201	50.00	50.00	2.40
C23	1.239	50.00	50.00	2.48
C24	1.331	50.00	50.00	2.66
C25	1.277	50.00	50.00	2.55
C26	1.239	50.00	50.00	2.48
C27	1.331	50.00	50.00	2.66
C28	1.431	50.00	50.00	2.86

*** Overall summary for all load cases - Usage = Maximum Stress / Allowable Stress
 Printed capacities do not include the strength factor entered for each load case.
 The Group Summary reports on the member and load case that resulted in maximum usage
 which may not necessarily be the same as that which produces maximum force.

Group Summary (Compression Portion):

Group KL/R Label Comp.	Group Length No.	Angle Curve Desc.	Angle No. Type	Steel Strength	Max Usage Usage	Max Cont-	Comp. Use	Comp. Control	Comp. Force	Comp. Control	L/R Capacity	Comp. Connect.	Comp. Connect.	RLX	RLY	RLZ	L/R	
Member	Bolts			(ksi)	%	rol	In	Member	Case	Load	(kips)	Shear Capacity	Bearing Capacity					
Comp.							Comp.				(kips)	(kips)	(kips)					
(ft)																		
Diag1	Diagonal	1	SAU	2X1.5X0.1875	36.0	19.27	Comp	19.27	g1P	-2.485NESC	Hea	12.897	27.200	24.469	0.500	0.750	0.500	114.50
115.87	5.598	2	2															
Diag2	Diagonal	2	SAE	2X2X0.1875	36.0	57.18	Tens	39.43	g5XY	-7.453NESC	Ext	18.901	27.200	24.469	0.750	0.500	0.500	81.36
91.02	5.343	2	2															
Diag3	Diagonal	3	SAU	3X2.5X0.25	36.0	13.11	Comp	13.11	g37X	-3.548NESC	Ext	27.075	40.800	48.937	0.765	0.531	0.531	115.17
116.38	9.543	2	3															
Diag4	Diagonal	4	SAE	3X3X0.25	36.0	32.80	Tens	23.88	g9X	-10.646NESC	Ext	44.572	54.400	65.250	0.750	0.500	0.500	49.03
66.77	4.838	2	4															
Diag5	Diagonal	5	SAU	3.5X3X0.25	36.0	29.15	Tens	18.61	g15XY	-9.033NESC	Ext	48.531	54.400	65.250	0.500	0.750	0.500	47.64
65.73	4.838	2	4															
Diag6	Diagonal	6	SAE	3.5X3.5X0.25	36.0	24.70	Cross	24.70	g46Y	-4.324NESC	Ext	17.502	27.200	32.625	1.000	0.537	0.537	195.19
166.24	17.730	6	2															
Diag7	Diagonal	7	SAU	4X3.5X0.25	36.0	52.56	Cross	52.56	g48Y	-10.233NESC	Ext	19.469	27.200	32.625	1.000	0.533	0.533	190.12
163.12	20.121	6	2															
Diag8	Diagonal	8	SAE	4X4X0.25	36.0	31.94	Comp	31.94	g49X	-6.862NESC	Ext	21.486	27.200	32.625	1.000	1.000	1.000	173.44
160.76	11.490	5	2															
Diag9	Diagonal	9	SAU	5X3X0.3125	36.0	0.00		0.00		0.000		0.000	0.000	0.000	0.000	0.000	0.000	0.00
0.00	0.000	0	0															
Diag10	Diagonal	10	SAU	5X3.5X0.3125	36.0	21.29	Tens	16.61	g19X	-13.438NESC	Ext	80.889	81.600	122.344	0.500	0.750	0.500	42.27
61.70	4.838	2	6															
Diag11	Diagonal	11	SAU	5X3.5X0.375	36.0	18.92	Tens	15.60	g23XY	-12.732NESC	Ext	96.521	81.600	146.812	0.500	0.750	0.500	42.69
62.02	4.838	2	6															
Horz1	Horizontal	1	SAU	2X1.5X0.1875	36.0	48.49	Tens	0.00	g57Y	0.000		11.446	13.600	12.234	1.000	1.000	1.000	124.47
124.47	3.340	4	1															
Horz2	Horizontal	2	SAE	2X2X0.1875	36.0	56.81	Comp	56.81	g60X	-3.109NESC	Ext	5.474	27.200	24.469	1.000	1.000	1.000	238.17
192.68	7.820	6	2															
Horz3	Horizontal	3	SAU	2.5X2X0.1875	36.0	0.00		0.00		0.000		0.000	0.000	0.000	0.000	0.000	0.000	0.00
0.00	0.000	0	0															
Horz4	Horizontal	4	SAE	2.5X2.5X0.1875	36.0	0.00		0.00		0.000		0.000	0.000	0.000	0.000	0.000	0.000	0.00
0.00	0.000	0	0															
Horz5	Horizontal	5	SAU	3X2X0.25	36.0	7.82	Tens	5.55	g51P	-1.509NESC	Hea	27.684	27.200	32.625	1.000	1.000	1.000	92.14
106.07	3.340	3	2															
Horz6	Horizontal	6	SAU	3X2.5X0.25	36.0	19.87	Tens	15.93	g56X	-4.334NESC	Ext	32.931	27.200	32.625	1.000	1.000	1.000	75.91
97.95	3.340	3	2															
Horz7	Horizontal	7	SAU	3.5X3X0.25	36.0	0.00		0.00		0.000		0.000	0.000	0.000	0.000	0.000	0.000	0.00
0.00	0.000	0	0															
Horz8	Horizontal	8	SAE	3.5X3.5X0.25	36.0	71.46	Comp	71.46	g62X	-9.642NESC	Ext	13.494	27.200	32.625	1.000	1.000	1.000	232.74

189.33	13.460	6	2																
Horz9	Horizontal	9	SAE	3X3X0.1875	36.0	0.00	0.00		0.000		0.000	0.000	0.000	0.000	0.000	0.000	0.000	0.000	0.00
0.00	0.000	0	0																
Horz 10	Horizontal	10	SAU	4X3.5X0.3125	36.0	26.00	Tens	22.02	g64XY	-5.988	NESC Ext	41.251	27.200	40.781	1.000	1.000	1.000	1.000	126.41
124.93	7.690	5	2																
Leg 1	Leg 1	SAE	4X4X0.25	50.0	56.04	Tens	43.37	g68X	-32.689	NESC Ext	75.378	81.600	109.687	1.000	1.000	1.000	1.000	52.83	
52.83	3.500	1	6																
Leg 2	Leg 2	SAE	6X6X0.5	50.0	45.61	Comp	45.61	g72XY	-86.841	NESC Ext	271.593	190.400	511.874	1.000	1.000	1.000	1.000	35.59	
35.59	3.500	1	14																
Leg 3	Leg 3	SAE	8X8X0.75	50.0	75.96	Comp	75.96	g76XY	-165.281	NESC Ext	554.347	217.600	877.499	1.000	1.000	1.000	1.000	26.58	
26.58	3.500	1	16																
Leg 4	Leg 4	SAE	8X8X0.875	50.0	89.89	Comp	89.89	g89XY	-244.489	NESC Ext	552.500	272.000	1279.686	1.000	1.000	1.000	1.000	61.42	
61.42	8.036	1	20																
Horz 11	Horizontal	11	SAU	5X3X0.25	36.0	11.95	Comp	11.95	g92Y	-5.376	NESC Hea	44.997	54.400	65.250	1.000	1.000	1.000	1.000	60.45
90.23	3.340	3	4																
Horz 12	Horizontal	12	SAU	5X3X0.3125	36.0	12.90	Comp	12.90	g98Y	-8.259	NESC Hea	64.028	68.000	101.953	1.000	1.000	1.000	1.000	60.91
90.46	3.340	3	5																
Horz 13	Horizontal	13	SAU	5X3.5X0.375	36.0	19.46	Comp	19.46	g97Y	-13.236	NESC Hea	73.070	68.000	122.344	1.000	0.500	0.500	0.500	86.28
103.14	10.958	3	5																
Arm	Arm	SAE	2X2X0.1875	36.0	25.79	Tens	0.00	g96Y	0.000		3.474	27.200	24.469	1.000	1.000	1.000	1.000	279.85	
241.85	9.188	5	2																
top	top	DAL	4X3.5X0.375	36.0	22.88	Tens	2.33	g100P	-0.634	NESC Ext	116.434	27.200	97.875	1.000	1.000	1.000	1.000	103.97	
111.98	10.830	3	2																
Arm2	Arm2	SAE	2.5X2.5X0.1875	36.0	36.71	Tens	0.00	g99Y	0.000		4.441	27.200	24.469	1.000	1.000	1.000	1.000	278.87	
241.10	11.503	5	2																
Inner1	Inner 1	SAU	2X1.5X0.25	36.0	2.72	Cross	2.72	g102P	-0.366	NESC Hea	13.467	13.600	16.312	0.500	1.000	0.500	0.500	131.21	
131.21	4.723	4	1																
Inner2	Inner 2	SAU	2X1.5X0.1875	36.0	12.93	Comp	12.93	g106P	-0.449	NESC Ext	3.468	13.600	12.234	0.500	0.750	0.500	0.500	226.21	
226.21	11.059	4	1																
Inner3	Inner 3	SAE	2X2X0.1875	36.0	2.54	Cross	2.54	g105P	-0.420	NESC Hea	16.541	27.200	24.469	1.000	0.500	0.500	0.500	91.87	
105.93	4.723	3	2																
Inner4	Inner 4	SAE	3X3X0.1875	36.0	1.94	Comp	1.94	g107P	-0.159	NESC Ext	8.167	27.200	24.469	0.750	0.500	0.500	0.500	218.97	
195.45	21.751	5	2																
Diag12	Diagonal	5	SAU	3.5X3X0.25	36.0	6.79	Comp	6.79	g90X	-2.265	NESC Hea	33.365	40.800	48.937	0.500	0.500	0.500	0.500	111.49
113.61	11.725	2	3																

Group Summary (Tension Portion):

Group Hole Label Diameter	Group Desc.	Angle Type	Angle Size	Steel Strength (ksi)	Max Usage %	Max Usage Cont-	Max Tension Use	Tension Control	Tension Force	Tension Control	Net Section	Tension Connect.	Tension Connect.	Tension Connect.	Tension Connect.	Length Tens. (ft)	No. Of Bolts Tens.	No. Of Holes
Diag1 0.875	Diagonal	1 SAU	2X1.5X0.1875	36.0	19.27	Comp	17.77	g1X	2.264	NESC Hea	14.772	27.200	24.469	12.741	5.598	2	1.000	
Diag2 0.875	Diagonal	2 SAE	2X2X0.1875	36.0	57.18	Tens	57.18	g5Y	7.751	NESC Ext	17.688	27.200	24.469	13.556	5.343	2	1.000	
Diag3 0.875	Diagonal	3 SAU	3X2.5X0.25	36.0	13.11	Comp	11.55	g37P	3.616	NESC Ext	31.306	40.800	48.937	34.228	9.543	3	1.000	
Diag4 0.875	Diagonal	4 SAE	3X3X0.25	36.0	32.80	Tens	32.80	g9P	10.653	NESC Ext	32.481	54.400	65.250	42.170	4.838	4	2.000	
Diag5 0.875	Diagonal	5 SAU	3.5X3X0.25	36.0	29.15	Tens	29.15	g15P	10.602	NESC Ext	36.369	54.400	65.250	43.828	4.838	4	2.000	

0.875	Diag6	Diagonal 6	SAE	3.5X3.5X0.25	36.0	24.70	Cross	21.66	g43P	5.891NESC	Ext	47.668	27.200	32.625	27.943	15.522	2	1.000
0.875	Diag7	Diagonal 7	SAU	4X3.5X0.25	36.0	52.56	Cross	31.65	g48XY	8.610NESC	Ext	47.506	27.200	32.625	27.943	20.121	2	1.000
0.875	Diag8	Diagonal 8	SAE	4X4X0.25	36.0	31.94	Comp	23.02	g49P	6.259NESC	Ext	55.768	27.200	32.625	27.187	11.490	2	1.000
0	Diag9	Diagonal 9	SAU	5X3X0.3125	36.0	0.00		0.00		0.000		0.000	0.000	0.000	0.000	0.000	0	0.000
0.875	Diag10	Diagonal 10	SAU	5X3.5X0.3125	36.0	21.29	Tens	21.29	g21P	13.888NESC	Ext	65.225	81.600	122.344	67.985	4.838	6	2.000
0.875	Diag11	Diagonal 11	SAU	5X3.5X0.375	36.0	18.92	Tens	18.92	g23P	14.527NESC	Ext	77.557	81.600	146.812	76.781	4.838	6	2.000
0.875	Horz1	Horizontal 1	SAU	2X1.5X0.1875	36.0	48.49	Tens	48.49	g55P	3.607NESC	Hea	14.772	13.600	12.234	7.439	3.340	1	1.000
0.875	Horz2	Horizontal 2	SAE	2X2X0.1875	36.0	56.81	Comp	18.21	g60P	3.221NESC	Ext	17.688	27.200	24.469	18.658	7.820	2	1.000
0	Horz3	Horizontal 3	SAU	2.5X2X0.1875	36.0	0.00		0.00		0.000		0.000	0.000	0.000	0.000	0.000	0	0.000
0	Horz4	Horizontal 4	SAE	2.5X2.5X0.1875	36.0	0.00		0.00		0.000		0.000	0.000	0.000	0.000	0.000	0	0.000
0.875	Horz5	Horizontal 5	SAU	3X2X0.25	36.0	7.82	Tens	7.82	g52P	2.127NESC	Hea	31.468	27.200	32.625	27.187	3.340	2	1.000
0.875	Horz6	Horizontal 6	SAU	3X2.5X0.25	36.0	19.87	Tens	19.87	g56P	5.403NESC	Ext	35.356	27.200	32.625	27.187	3.340	2	1.000
0	Horz7	Horizontal 7	SAU	3.5X3X0.25	36.0	0.00		0.00		0.000		0.000	0.000	0.000	0.000	0.000	0	0.000
0.875	Horz8	Horizontal 8	SAE	3.5X3.5X0.25	36.0	71.46	Comp	39.43	g62P	10.720NESC	Ext	47.668	27.200	32.625	27.187	13.460	2	1.000
0	Horz9	Horizontal 9	SAE	3X3X0.1875	36.0	0.00		0.00		0.000		0.000	0.000	0.000	0.000	0.000	0	0.000
0.875	Horz 10	Horizontal 10	SAU	4X3.5X0.3125	36.0	26.00	Tens	26.00	g64Y	7.072NESC	Ext	58.978	27.200	40.781	33.984	7.690	2	1.000
0.875	Leg 1	Leg 1	SAE	4X4X0.25	50.0	56.04	Tens	56.04	g68Y	29.840NESC	Ext	53.250	81.600	109.687	81.851	3.500	6	4.000
0.875	Leg 2	Leg 2	SAE	6X6X0.5	50.0	45.61	Comp	41.87	g72P	79.722NESC	Ext	200.000	190.400	511.874	201.890	3.500	14	4.000
0.875	Leg 3	Leg 3	SAE	8X8X0.75	50.0	75.96	Comp	71.66	g76P	155.923NESC	Ext	375.124	217.600	877.499	287.882	3.500	16	6.000
0.875	Leg 4	Leg 4	SAE	8X8X0.875	50.0	89.89	Comp	81.67	g89P	222.134NESC	Ext	508.374	272.000	1279.686	341.386	8.036	20	4.000
0.875	Horz 11	Horizontal 11	SAU	5X3X0.25	36.0	11.95	Comp	3.18	g92P	1.315NESC	Ext	41.593	54.400	65.250	41.391	3.340	4	3.000
0.875	Horz 12	Horizontal 12	SAU	5X3X0.3125	36.0	12.90	Comp	4.16	g98P	2.129NESC	Hea	51.182	68.000	101.953	62.613	3.340	5	3.000
0.875	Horz 13	Horizontal 13	SAU	5X3.5X0.375	36.0	19.46	Comp	8.16	g97X	5.464NESC	Ext	66.926	68.000	122.344	75.136	10.958	5	3.000
0.875	Arm	Arm	SAE	2X2X0.1875	36.0	25.79	Tens	25.79	g93X	4.337NESC	Hea	17.688	27.200	24.469	16.819	9.188	2	1.000
0.875	top	top	DAL	4X3.5X0.375	36.0	22.88	Tens	22.88	g100X	6.225NESC	Hea	139.603	27.200	97.875	90.625	10.830	2	2.000
0.875	Arm2	Arm2	SAE	2.5X2.5X0.1875	36.0	36.71	Tens	36.71	g99P	7.104NESC	Hea	23.909	27.200	24.469	19.350	11.503	2	1.000
0.875	Inner1	Inner 1	SAU	2X1.5X0.25	36.0	2.72	Cross	0.00	g102X	0.000		19.156	13.600	16.312	9.919	4.723	1	1.000
0.875	Inner2	Inner 2	SAU	2X1.5X0.1875	36.0	12.93	Comp	8.94	g106X	0.665NESC	Ext	14.772	13.600	12.234	7.439	11.059	1	1.000
0.875	Inner3	Inner 3	SAE	2X2X0.1875	36.0	2.54	Cross	0.38	g105X	0.067NESC	Hea	17.688	27.200	24.469	18.658	4.723	2	1.000
0.875	Inner4	Inner 4	SAE	3X3X0.1875	36.0	1.94	Comp	1.80	g107X	0.342NESC	Ext	30.000	27.200	24.469	18.998	21.751	2	1.000

NESC Heavy	C1	Clamp	41X	0.050	2.806	1.384	3.129
NESC Heavy	C2	Clamp	41P	0.100	2.674	1.409	3.024
NESC Heavy	C3	Clamp	42X	-0.603	3.851	2.933	4.879
NESC Heavy	C4	Clamp	42P	-2.239	3.522	2.869	5.065
NESC Heavy	C5	Clamp	43X	-2.851	3.558	2.906	5.407
NESC Heavy	C6	Clamp	43P	-2.923	3.424	2.888	5.349
NESC Heavy	C7	Clamp	44X	1.055	4.251	3.030	5.326
NESC Heavy	C8	Clamp	44P	-0.286	3.785	2.943	4.804
NESC Heavy	C9	Clamp	2P	0.000	0.784	0.157	0.800
NESC Heavy	C10	Clamp	2X	0.000	0.784	0.157	0.800
NESC Heavy	C11	Clamp	2XY	0.000	0.784	0.157	0.800
NESC Heavy	C12	Clamp	2Y	0.000	0.784	0.157	0.800
NESC Heavy	C13	Clamp	6P	0.000	-0.342	1.641	1.676
NESC Heavy	C14	Clamp	6X	0.000	-0.342	1.641	1.676
NESC Heavy	C15	Clamp	6XY	0.000	-0.342	1.641	1.676
NESC Heavy	C16	Clamp	6Y	0.000	-0.342	1.641	1.676
NESC Heavy	C17	Clamp	1P	0.000	0.129	0.843	0.853
NESC Heavy	C18	Clamp	4P	0.000	0.228	1.160	1.182
NESC Heavy	C19	Clamp	7P	0.000	0.218	1.149	1.169
NESC Heavy	C20	Clamp	10P	0.000	0.238	1.313	1.334
NESC Heavy	C21	Clamp	13P	0.000	0.249	1.452	1.473
NESC Heavy	C22	Clamp	16P	0.000	0.239	1.377	1.397
NESC Heavy	C23	Clamp	18P	0.000	0.260	1.532	1.554
NESC Heavy	C24	Clamp	20P	0.000	0.320	1.864	1.892
NESC Heavy	C25	Clamp	23P	0.000	0.341	2.055	2.083
NESC Heavy	C26	Clamp	25P	0.000	0.350	2.152	2.181
NESC Heavy	C27	Clamp	27P	0.000	0.424	2.575	2.610
NESC Heavy	C28	Clamp	29P	0.000	0.405	2.436	2.469
NESC Extreme	C1	Clamp	41X	0.050	2.323	0.696	2.425
NESC Extreme	C2	Clamp	41P	0.100	2.301	0.678	2.401
NESC Extreme	C3	Clamp	42X	-1.232	3.942	1.662	4.452
NESC Extreme	C4	Clamp	42P	-1.890	3.807	1.618	4.548
NESC Extreme	C5	Clamp	43X	-2.203	3.750	1.610	4.637
NESC Extreme	C6	Clamp	43P	-2.193	3.699	1.583	4.582
NESC Extreme	C7	Clamp	44X	-0.670	3.981	1.691	4.377
NESC Extreme	C8	Clamp	44P	-0.988	3.782	1.642	4.240
NESC Extreme	C9	Clamp	2P	0.000	3.197	0.160	3.201
NESC Extreme	C10	Clamp	2X	0.000	3.197	0.160	3.201
NESC Extreme	C11	Clamp	2XY	0.000	3.197	0.160	3.201
NESC Extreme	C12	Clamp	2Y	0.000	3.197	0.160	3.201
NESC Extreme	C13	Clamp	6P	0.000	-1.430	0.842	1.660
NESC Extreme	C14	Clamp	6X	0.000	-1.430	0.842	1.660
NESC Extreme	C15	Clamp	6XY	0.000	-1.430	0.842	1.660
NESC Extreme	C16	Clamp	6Y	0.000	-1.430	0.842	1.660
NESC Extreme	C17	Clamp	1P	0.000	0.508	0.316	0.598
NESC Extreme	C18	Clamp	4P	0.000	0.809	0.447	0.924
NESC Extreme	C19	Clamp	7P	0.000	0.751	0.422	0.861
NESC Extreme	C20	Clamp	10P	0.000	0.751	0.422	0.861
NESC Extreme	C21	Clamp	13P	0.000	1.145	0.861	1.432
NESC Extreme	C22	Clamp	16P	0.000	0.979	0.695	1.201
NESC Extreme	C23	Clamp	18P	0.000	1.015	0.711	1.239
NESC Extreme	C24	Clamp	20P	0.000	1.101	0.748	1.331
NESC Extreme	C25	Clamp	23P	0.000	1.051	0.726	1.277
NESC Extreme	C26	Clamp	25P	0.000	1.015	0.711	1.239
NESC Extreme	C27	Clamp	27P	0.000	1.101	0.748	1.331
NESC Extreme	C28	Clamp	29P	0.000	1.194	0.789	1.431

Overturning Moments For User Input Concentrated Loads:

Moments are static equivalents based on central axis of 0,0 (i.e. a single pole).

Load Case	Total Tran. Load (kips)	Total Long. Load (kips)	Total Vert. Load (kips)	Transverse Overturning Moment (ft-k)	Longitudinal Overturning Moment (ft-k)	Torsional Moment (ft-k)
NESC Heavy	31.496	-7.697	36.706	3637.857	-847.104	38.569
NESC Extreme	39.814	-9.026	15.936	4478.602	-996.471	37.375

*** Weight of structure (lbs):
Weight of Angles*Section DLF: 35451.7
Total: 35451.7

*** End of Report

Tower Anchor Bolt Analysis

Max Leg Reactions:

Uplift = Uplift := 224.8-kips (User Input)

Shear = Shear := 26.9-kips (User Input)

Compression = Compression := 248.3-kips (User Input)

Moment = Moment := 0.83-kip-ft (User Input)

Anchor Bolt Data:

Use AST MA36 (Assumed Conservative Value - Actual Grade Unknown)

Number of Anchor Bolts = N := 4 (User Input)

Bolt Ultimate Strength = $F_u := 58\text{ksi}$ (User Input)

Bolt Yield Strength = $F_y := 36\text{ksi}$ (User Input)

Diameter of Bolts = D := 2.5in (User Input)

Threads per Inch = n := 4 (User Input)

Coefficient of Friction = $\mu := 0.55$ (User Input)

Anchor Spacing (Orthogonal) = sp := 12.5-in (User Input)

Anchor Spacing (Diagonal) = $sp_d := 17.625\text{-in}$ (User Input)

Anchor Bolt Area:

Gross Area of Bolt = $A_g := \frac{\pi}{4} \cdot D^2 = 4.909\text{-in}^2$

Net Area of Bolt = $A_n := \frac{\pi}{4} \cdot \left(D - \frac{0.9743\text{-in}}{n} \right)^2 = 3.999\text{-in}^2$ (AISC 13th Ed. pg. 7-83)

Check Tensile Force:

Maximum Tensile Force (GrossArea) =

$$F_{\text{gross.area}} := 1.0 \cdot (0.33 \cdot A_g \cdot F_u) = 94 \cdot \text{kips}$$

Maximum Tensile Force (NetArea) =

$$F_{\text{net.area}} := 1.0 \cdot (0.60 \cdot A_n \cdot F_y) = 86.4 \cdot \text{kips}$$

Allowable Tension =

$$\text{AllowableTension} := \begin{cases} F_{\text{gross.area}} & \text{if } F_{\text{gross.area}} < F_{\text{net.area}} \\ F_{\text{net.area}} & \text{if } F_{\text{net.area}} < F_{\text{gross.area}} \end{cases}$$

$$\text{AllowableTension} = 86.4 \cdot \text{kips}$$

Applied Tension =

$$\text{MaxTension} := \frac{\text{Uplift}}{N} + \max\left(\frac{\text{Moment}}{sp \cdot \frac{n}{2}}, \frac{\text{Moment}}{sp_d}\right) = 56.77 \cdot \text{kips}$$

$$\frac{\text{MaxTension}}{F_{\text{net.area}}} = 65.7\%$$

$$\text{Condition1} := \text{if}\left(\frac{\text{MaxTension}}{F_{\text{net.area}}} \leq 1.00, \text{"OK"}, \text{"Overstressed"}\right)$$

Condition1 = "OK"

Check Anchor Bolt Area:

Based on the ASCE 10-97 Design of Latticed Steel Transmission Structures

Required Area =

$$A_{s1} := \frac{\text{Uplift}}{F_y} + \frac{\text{Shear}}{\mu \cdot 0.85 \cdot F_y} = 7.8 \cdot \text{in}^2$$

$$A_{s2} := \left[\frac{\text{Shear} - (0.3 \cdot \text{Compression})}{\mu \cdot 0.85 \cdot F_y} \right] = -2.828 \cdot \text{in}^2$$

Provided Area =

$$A_{\text{sprovided}} := A_n \cdot N = 16 \cdot \text{in}^2$$

$$\text{Condition2} := \text{if}\left(\frac{A_{s1}}{A_{\text{sprovided}}} \leq 1.00, \text{"OK"}, \text{"Overstressed"}\right)$$

Condition2 = "OK"

$$\text{Condition3} := \text{if}\left(\frac{A_{s2}}{A_{\text{sprovided}}} \leq 1.00, \text{"OK"}, \text{"Overstressed"}\right)$$

Condition3 = "OK"

Foundation:

Input Data:

Tower Data

Shear (Compression Leg) =	Shear _{comp} := 26.9·1.1·kips = 29.6·kips	(User Input from PLS Tower)
Shear (Uplift Leg) =	Shear _{up} := 24.8·1.1·kips = 27.3·kips	(User Input from PLS Tower)
Compression =	Comp := 248.3·1.1·kips = 273.1·kips	(User Input from PLS Tower)
Uplift =	Uplift := 224.8·1.1·kips = 247.3·kips	(User Input from PLS Tower)
Tower Height =	H _t := 140-ft	(User Input)

Footing Data:

Depth to Bottom of Footing =	D _f := 12-ft	(User Input)
Length of Pier =	L _p := 12.5-ft	(User Input)
Extension of Pier Above Grade =	L _{pag} := 0.5-ft	(User Input)
Width of Pier =	W _p := 5-ft	(User Input)
Depth of Soil =	D _{soil} := 12-ft	(User Input)
Depth of Rock =	D _{rock} := 13-ft	(User Input)

Material Properties:

Concrete Compressive Strength =	f _c := 3500·psi	(User Input)
Steel Reinforcement Yield Strength =	f _y := 60000·psi	(User Input)
Anchor Bolt Yield Strength =	f _{ya} := 75000·psi	(User Input)
Internal Friction Angle of Soil =	Φ _s := 30·deg	(User Input)
Allowable Soil Bearing Capacity =	q _s := 4000·psf	(User Input)
Allowable Rock Bearing Capacity =	q _{rock} := 50000·psf	(User Input)
Unit Weight of Soil =	γ _{soil} := 100·pcf	(User Input)
Unit Weight of Concrete =	γ _{conc} := 150·pcf	(User Input)
Unit Weight of Rock =	γ _{rock} := 160·pcf	(User Input)
Foundation Bouyancy =	Bouyancy := 0	(User Input) (Yes=1 / No=0)
Depth to Neglect =	n := 1.0·ft	(User Input)
Cohesion of Clay Type Soil =	c := 0·ksf	(User Input) (Use 0 for Sandy Soil)
Seismic Zone Factor =	Z := 2	(User Input) (UBC-1997 Fig 23-2)
Coefficient of Friction Between Concrete =	μ := 0.45	(User Input)

RockAnchor Properties:

ASTMA615 Grade 60

Bolt Ultimate Strength =	$F_U := 90\text{-ksi}$	(User Input)	
Bolt Yield Strength =	$F_y := 60\text{-ksi}$	(User Input)	
Anchor Diameter =	$d_{ra1} := 1.00\text{-in}$	(User Input)	(1 #8 and 2 #11 per Rock Group)
Anchor Diameter =	$d_{ra2} := 1.41\text{-in}$	(User Input)	
Hole Diameter =	$d_{Hole} := 4\text{-in}$	(User Input)	
Grout Strength =	$\tau := 120\text{-psi}$	(User Input)	
Distance to RockAnchor Group 1 =	$D_{a1} := 24\text{-in}$	(User Input)	
Number of RockAnchors in Group 1 =	$N_{a1} := 6$	(User Input)	
Total Number of Rock Bolts =	$N_{atot} := 8$	(User Input)	

Check Uplift:

Adjusted Concrete Unit Weight = $\gamma_c := \text{if}(\text{Bouyancy} = 1, \gamma_{\text{conc}} - 62.4\text{pcf}, \gamma_{\text{conc}}) = 150\text{-pcf}$

Adjusted Soil Unit Weight = $\gamma_s := \text{if}(\text{Bouyancy} = 1, \gamma_{\text{soil}} - 62.4\text{pcf}, \gamma_{\text{soil}}) = 100\text{-pcf}$

Weight of Concrete = $WT_c := (W_p^2 \cdot L_p) \cdot \gamma_c = 46.875\text{-kip}$

Base Area 1 of Resisting Pyramid = $B_1 := (D_{a1} \cdot 2)^2 = 16\text{ft}^2$

Base Area 2 of Resisting Pyramid = $B_2 := [\tan(\Phi_s) \cdot (D_{\text{rock}} \cdot 0.5) \cdot 2 + D_{a1} \cdot 2]^2 = 132.4\text{ft}^2$

Base Area 3 of Resisting Pyramid = $B_3 := [\tan(\Phi_s) \cdot (D_{\text{rock}} \cdot 0.5 + D_{\text{soil}}) \cdot 2 + D_{a1} \cdot 2]^2 = 643.2\text{ft}^2$

Weight of Soil = $WT_{\text{soil}} := \left[\frac{D_{\text{soil}}}{3} \cdot (B_2 + B_3 + \sqrt{B_2 \cdot B_3}) - W_p^2 \cdot L_p \right] \cdot \gamma_s = 395.714\text{-kip}$

Weight of Rock = $WT_{\text{rock}} := \left[\frac{D_{\text{rock}} \cdot 0.5}{3} \cdot (B_1 + B_2 + \sqrt{B_1 \cdot B_2}) \right] \cdot \gamma_{\text{rock}} = 67.392\text{-kip}$

Total Resistance = $WT_{\text{tot}} := WT_c + WT_{\text{rock}} + WT_{\text{soil}} = 510\text{-kips}$

Factor of Safety Actual = $FS := \frac{WT_{\text{tot}}}{\text{Uplift}} = 2.06$

Factor of Safety Required = $FS_{\text{req}} := 1.0$

Uplift_Check := $\text{if}(FS \geq FS_{\text{req}}, \text{"Okay"}, \text{"No Good"})$

Uplift_Check = "Okay"

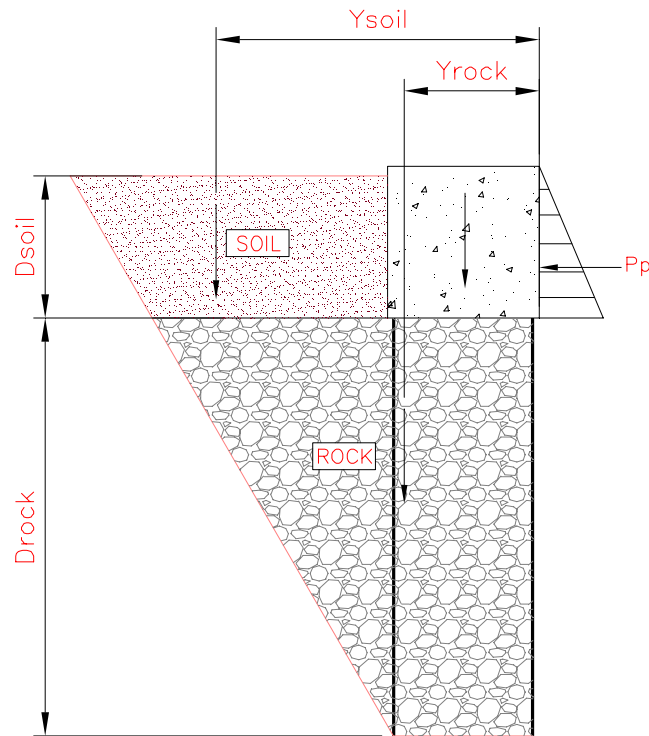

Area 1 =	$A1 := \frac{1}{2} \cdot \tan(\Phi_s) \cdot D_{soil}^2 = 41.569 \text{ft}^2$	sf
Area 2 =	$A2 := \tan(\Phi_s) \cdot D_{rock} \cdot D_{soil} = 90.067 \text{ft}^2$	sf
Distance to Centroid 1 =	$Y1 := \tan(\Phi_s) \cdot D_{rock} + \frac{1}{3} \cdot \tan(\Phi_s) \cdot D_{soil} = 9.815 \text{ft}$	ft
Distance to Centroid 2 =	$Y2 := \frac{1}{2} \cdot \tan(\Phi_s) \cdot D_{rock} = 3.753 \text{ft}$	ft
Distance from Toe to Centroid of Soil =	$Y_{soil} := \frac{(A1 \cdot Y1 + A2 \cdot Y2)}{(A1 + A2)} + W_p = 10.67 \text{ft}$	ft
Area 3 =	$A3 := \frac{1}{2} \cdot \tan(\Phi_s) \cdot D_{rock}^2 = 48.786 \text{ft}^2$	sf
Area 4 =	$A4 := W_p \cdot D_{rock} = 65 \text{ft}^2$	sf
Distance to Centroid 3 =	$Y3 := W_p + \frac{1}{3} \cdot \tan(\Phi_s) \cdot D_{rock} = 7.502 \text{ft}$	ft
Distance to Centroid 4 =	$Y4 := \frac{W_p}{2} = 2.5 \text{ft}$	ft
Distance from Toe to Centroid of Rock =	$Y_{rock} := \frac{(A3 \cdot Y3 + A4 \cdot Y4)}{(A3 + A4)} = 4.64 \text{ft}$	ft

Check Overturning:

Coefficient of Lateral Soil Pressure = $K_p := \frac{1 + \sin(\Phi_s)}{1 - \sin(\Phi_s)} = 3$

Passive Pressure = $P_{top} := 0 = 0 \text{ ksf}$

$P_{bot} := K_p \cdot \gamma_s \cdot D_f + c \cdot 2 \cdot \sqrt{K_p} = 3.6 \text{ ksf}$

$P_{ave} := \frac{P_{top} + P_{bot}}{2} = 1.8 \text{ ksf}$

$A_p := W_p \cdot (L_p - L_{pag}) = 60 \text{ ft}^2$

Ultimate Shear = $S_u := P_{ave} \cdot A_p = 108 \text{ kip}$

Weight of Concrete Pad = $WT_c := (W_p^2 \cdot L_p) \cdot \gamma_c = 46.875 \text{ kip}$

Weight of Soil Wedge at Back Face Corners = $WT_{s2} := 2 \cdot \left[(D_{soil})^3 \cdot \frac{\tan(\Phi_s)}{3} \right] \cdot \gamma_s = 66.511 \text{ kips}$

Total Weight of Soil = $WT_{Stot} := (A1 + A2) \cdot W_p \cdot \gamma_s + WT_{s2} = 132.3 \text{ kips}$

Total Weight of Rock = $WT_{Rtot} := (A3 + A4) \cdot W_p \cdot \gamma_{rock} = 91 \text{ kips}$

Resisting Moment = $M_r := (WT_c) \cdot \frac{W_p}{2} + S_u \cdot \frac{L_p}{3} + WT_{Stot} \cdot Y_{soil} + WT_{Rtot} \cdot Y_{rock} = 2402 \text{ kip-ft}$

Overturning Moment = $M_{ot} := \text{Uplift} \cdot \frac{W_p}{2} + \text{Shear}_{up} \cdot L_p = 959 \text{ kip-ft}$

Factor of Safety Actual = $FS := \frac{M_r}{M_{ot}} = 2.5$

Factor of Safety Required = $FS_{req} := 1.0$

$\text{OverTurning_Moment_Check} := \text{if}(FS \geq FS_{req}, \text{"Okay"}, \text{"No Good"})$

OverTurning_Moment_Check = "Okay"

Check Bearing Pressure:

Area of the Pier = $A_{mat} := W_p^2 = 25 \text{ ft}^2$

Section Modulus of Pier = $S := \frac{W_p^3}{6} = 20.83 \cdot \text{ft}^3$

Maximum Bearing Pressure = $P_{max} := \frac{WT_c + \text{Comp}}{A_{mat}} + \frac{\text{Shear}_{comp} \cdot L_p}{S} = 30.554 \cdot \text{ksf}$

Max_Pressure_Check := if($P_{max} < q_{rock}$, "Okay", "No Good")

Max_Pressure_Check = "Okay"

Check Rock Anchors:

RockAnchor Check

Polar Moment of Inertia = $I_p := (D_{a1}^2 \cdot N_{a1}) = 3456 \cdot \text{in}^2$

Maximum Tension Force = $T_{Max} := \frac{\text{Uplift}}{N_{atot}} + \frac{\text{Shear}_{up} \cdot L_p \cdot D_{a1}}{I_p} - \frac{WT_c}{N_{atot}} = 53.5 \cdot \text{kips}$

GrossArea of BoltGroup = $A_g := \frac{\pi}{4} \cdot (d_{ra1}^2 + 2 \cdot d_{ra2}^2) = 3.908 \cdot \text{in}^2$

Design Tension = $T_d := 0.9 A_g \cdot F_y = 211 \cdot \text{kips}$

$\frac{T_{Max}}{T_d} = 25.3\%$

Condition1 := if($T_{Max} < T_d$, "OK", "NG")

Condition1 = "OK"

Check Bond Strength:

Bond Strength = $\text{Bond_Strength} := d_{Hole} \cdot \pi \cdot (D_{rock} \cdot 0.5) \cdot \tau = 118 \cdot \text{kips}$

$\frac{T_{Max}}{\text{Bond_Strength}} = 45.5\%$

Condition2 := if($T_{Max} < \text{Bond_Strength}$, "OK", "NG")

Condition2 = "OK"

RAN Template: 67D94B Outdoor	A&L Template: 67D94B_1DP+1QP+1OP
--	--

Section 1 - Site Information

Site ID: CT11241A	Site Name: GREENWICH/COS COB/I-95	Latitude: 41.02998600
Status: Draft	Site Class: Utility Lattice Tower	Longitude: -73.59748400
Version: 5	Site Type: Structure Non Building	Address: Station drive - Line # 1750 - Pole# 1280
Project Type: L600	Plan Year:	City, State: Greenwich, CT
Approved: Not Approved	Market: CONNECTICUT CT	Region: NORTHEAST
Approved By: Not Approved	Vendor: Ericsson	
Last Modified: 5/7/2021 10:59:31 AM	Landlord: CL&P	
Last Modified By: Farhan.Badar@T-Mobile.com		

RAN Template: 67D94B Outdoor		AL Template: 67D94B_1DP+1QP+1OP		
Sector Count: 3	Antenna Count: 6	Coax Line Count: 24	TMA Count: 0	RRU Count: 3

Section 2 - Existing Template Images

704Bu.png

704Bu Cabinet View

RUS01 B4 for LTE and U21
RUS01 B2 for GSM and U19
RRUS11 B12 for L700

From
RRUS11 B12

To GPS Splitter/
Receivers

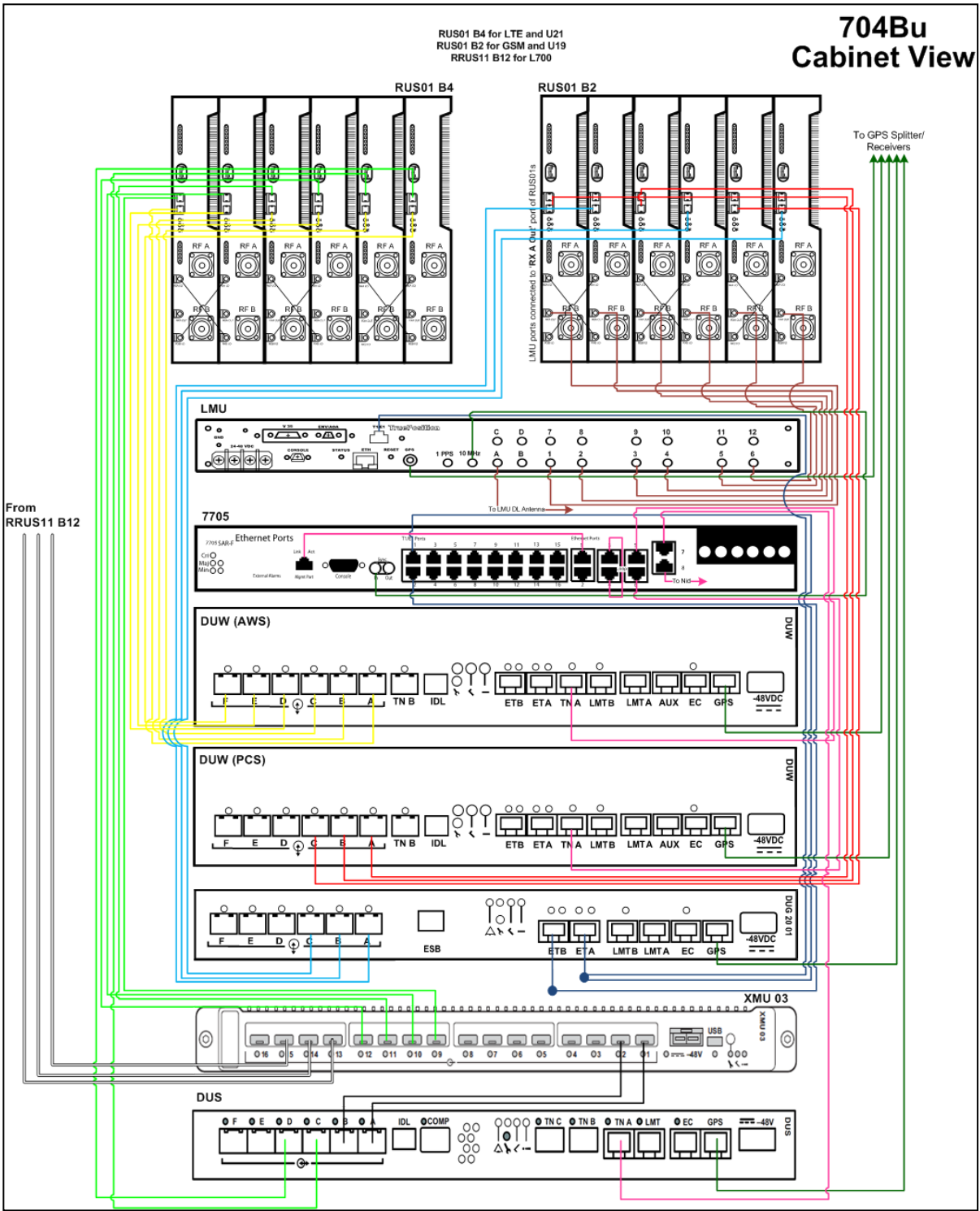

Notes:

Section 3 - Proposed Template Images

67D04B_2QP+10P.JPG

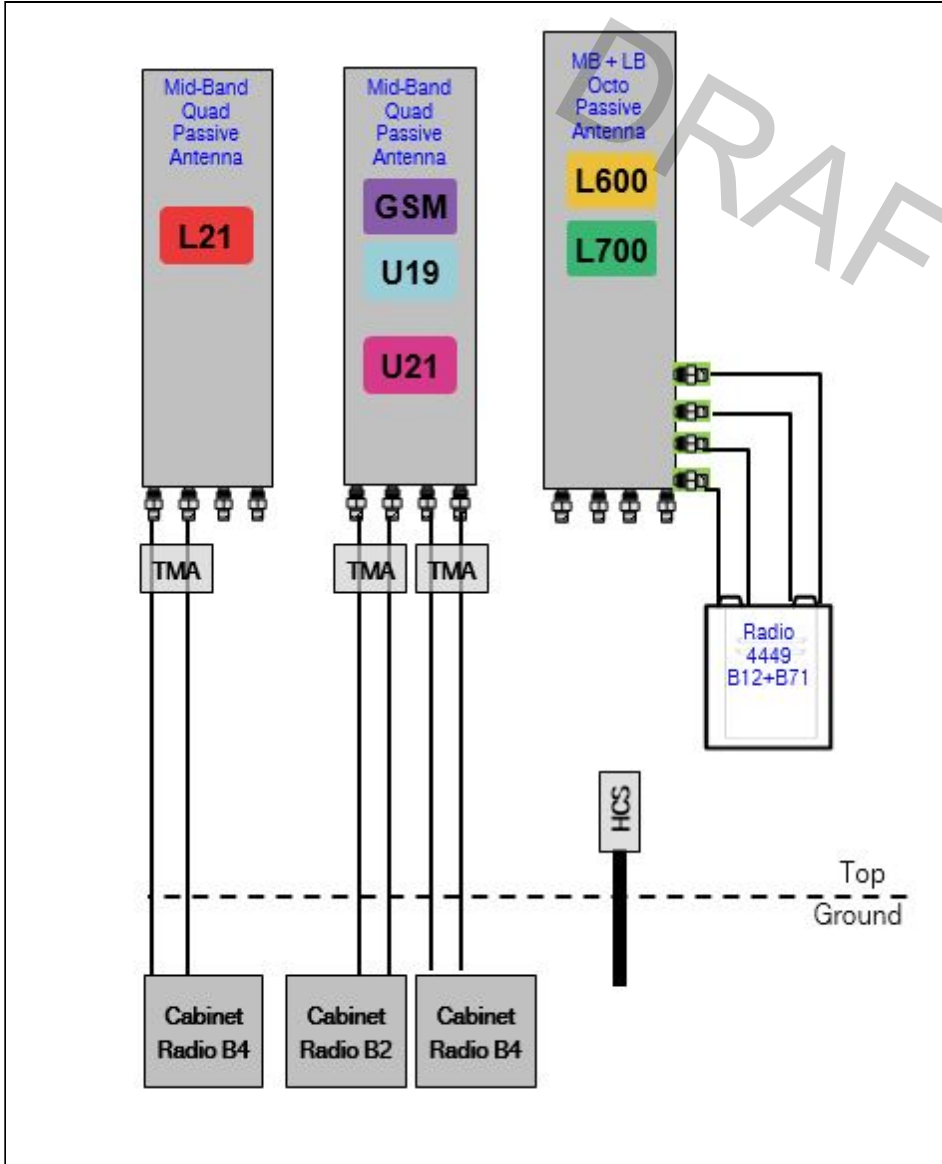

Notes:

Section 4 - Siteplan Images

----- This section is intentionally blank. -----

DRAFT

RAN Template: 67D94B Outdoor	A&L Template: 67D94B_1DP+1QP+1OP
--	--

Section 5 - RAN Equipment

Existing RAN Equipment

Template: 704Bu Outdoor

Enclosure	1		2	
Enclosure Type	RBS 6102		Ground Mount (Ericsson)	
Baseband	DUW30 U1900 (DECOMMISSIONED)	DUW30 U2100	DUG20 G1900	BB 5216 L1900 L2100 L700
Multiplexer	XMU L1900 L2100 L700			
Radio	RUS01 B2 (x 3) L1900 G1900	RUS01 B2 (x 3) L1900 U1900 (DECOMMISSIONED)	RUS01 B4 (x 3) U2100 RUS01 B4 (x 3) L2100	RRUS11 B12 (x 3) L700

Proposed RAN Equipment

Template: 67D94B Outdoor

Enclosure	1			
Enclosure Type	RBS 6102			
Baseband	DUW30 U2100	DUG20 G1900	BB 5216 L2100 L1900	BB 6648 N600 L700 L600
Multiplexer	XMU L2100 L1900			
Radio	RUS01 B2 (x 3) G1900 L1900	RUS01 B4 (x 6) U2100 L2100	RUS01 B2 (x 3) L1900	

RAN Scope of Work:

Existing: (18) Coaxial Lines
Add (6) Coaxial Lines

RAN Template: 67D94B Outdoor	A&L Template: 67D94B_1DP+1QP+1OP
--	--

Section 6 - A&L Equipment

Existing Template: 1HP_704Bu
Proposed Template: 67D94B_1DP+1QP+1OP

Sector 1 (Existing) view from behind

Coverage Type	A - Outdoor Macro		
Antenna	1	2	
Antenna Model	Andrew - TMBXX-6516-A2M (Quad)	Andrew - LNX-6513DS-A1M (Dual)	
Azimuth	20	20	
M. Tilt	0	0	
Height	153	161	
Ports	P1	P2	P3
Active Tech.	L1900 G1900	U2100 L2100	L700
Dark Tech.			
Restricted Tech.			
Decomm. Tech.	U1900		
E. Tilt	2	2	2
Cables	1-5/8" Coax - 170 ft. (x8)	1-5/8" Coax - 170 ft. (x8)	1-5/8" Coax - 170 ft. (x8)
TMA's	Generic Twin Style 1A - PCS (AtCabinet)	Generic Twin Style 1B - AWS (AtCabinet)	
Diplexers / Combiners			
Radio			
Sector Equipment			Andrew Smart Bias T (Ericsson) (At Antenna)

Unconnected Equipment:

Scope of Work:

Leave the Andrews TMZXX antenna and install a new L700 antenna. Intall GMA's on ground and Bias T- up top for RETS

RAN Template: 67D94B Outdoor	A&L Template: 67D94B_1DP+1QP+1OP
--	--

Sector 1 (Proposed) view from behind						
Coverage Type	A - Outdoor Macro					
Antenna	1			2		
Antenna Model	Andrew - TMBXX-6516-A2M (Quad)			RFS - APXVAARR18_43-U-NA20 (Octo)		
Azimuth	20			20		
M. Tilt	0			0		
Height	153			161		
Ports	P1	P2	P3	P4	P5	P6
Active Tech.	G1900 L1900	U2100 L2100	N600 L700 L600	N600 L700 L600		
Dark Tech.						
Restricted Tech.						
Decomm. Tech.	U1900					
E. Tilt	2	2	2	2		
Cables	1-5/8" Coax - 170 ft. (x2)	1-5/8" Coax - 170 ft. (x2)	1-5/8" Coax - 170 ft. (x2)	1-5/8" Coax - 170 ft. (x2)		
TMA's	Generic Twin Style 1A - PCS (AtCabinet)	Generic Twin Style 1B - AWS (AtCabinet)				
Diplexers / Combiners						
Radio			Radio 4449 B71+B85 (At Cabinet)	SHARED Radio 4449 B71+B85 (At Cabinet)		
Sector Equipment		Andrew Smart Bias T (Ericsson) (At Antenna)				Andrew Smart Bias T (Ericsson) (At Antenna)
Unconnected Equipment:						
Scope of Work:						
<p>*** Existing TMAs are Ground Mounted *** Replace LB Dual in Position 2 with (1) LB/MB Octo. *** VAARR18 *** Replace RRUS11 B12 with (1) Radio 4449 B71+B12 for L600 and L700 at Ground Level. Daisy Chain Bias-Ts for RETs.</p>						
*A dashed border indicates shared equipment. Any connected equipment is denoted with the SHARED keyword.						

RAN Template: 67D94B Outdoor	A&L Template: 67D94B_1DP+1QP+1OP
--	--

Sector 2 (Existing) view from behind			
Coverage Type	A - Outdoor Macro		
Antenna	1		2
Antenna Model	Andrew - TMBXX-6516-A2M (Quad)		Andrew - LNX-6513DS-A1M (Dual)
Azimuth	140		140
M. Tilt	0		0
Height	153		161
Ports	P1	P2	P3
Active Tech.	L1900 G1900	U2100 L2100	L700
Dark Tech.			
Restricted Tech.			
Decomm. Tech.	U1900		
E. Tilt	2		2
Cables	1-5/8" Coax - 170 ft. (x8)		1-5/8" Coax - 170 ft. (x8)
TMA's	Generic Twin Style 1A - PCS (AtCabinet)	Generic Twin Style 1B - AWS (AtCabinet)	
Diplexers / Combiners			
Radio			
Sector Equipment			Andrew Smart Bias T (Ericsson) (At Antenna)
Unconnected Equipment:			
Scope of Work:			
Leave the Andrews TMZXX antenna and install a new L700 antenna. Intall GMA's on ground and Bias T- up top for RETS			

RAN Template: 67D94B Outdoor	A&L Template: 67D94B_1DP+1QP+1OP
--	--

Sector 2 (Proposed) view from behind						
Coverage Type	A - Outdoor Macro					
Antenna	1			2		
Antenna Model	Andrew - TMBXX-6516-A2M (Quad)			RFS - APXVAARR18_43-U-NA20 (Octo)		
Azimuth	140			140		
M. Tilt	0			0		
Height	153			161		
Ports	P1	P2	P3	P4	P5	P6
Active Tech.	G1900 L1900	U2100 L2100	N600 L700 L600	N600 L700 L600		
Dark Tech.						
Restricted Tech.						
Decomm. Tech.	U1900					
E. Tilt	2	2	2	2		
Cables	1-5/8" Coax - 170 ft. (x2)	1-5/8" Coax - 170 ft. (x2)	1-5/8" Coax - 170 ft. (x2)	1-5/8" Coax - 170 ft. (x2)		
TMA	Generic Twin Style 1A - PCS (AtCabinet)	Generic Twin Style 1B - AWS (AtCabinet)				
Diplexers / Combiners						
Radio			Radio 4449 B71+B85 (At Cabinet)	SHARED Radio 4449 B71+B85 (At Cabinet)		
Sector Equipment		Andrew Smart Bias T (Ericsson) (At Antenna)				Andrew Smart Bias T (Ericsson) (At Antenna)
Unconnected Equipment:						
Scope of Work:						
<p>*** Existing TMAs are Ground Mounted *** Replace LB Dual in Position 2 with (1) LB/MB Octo. *** VAARR18 *** Replace RRUS11 B12 with (1) Radio 4449 B71+B12 for L600 and L700 at Ground Level. Daisy Chain Bias-Ts.</p>						
*A dashed border indicates shared equipment. Any connected equipment is denoted with the SHARED keyword.						

RAN Template: 67D94B Outdoor	A&L Template: 67D94B_1DP+1QP+1OP
--	--

Sector 3 (Existing) view from behind			
Coverage Type	A - Outdoor Macro		
Antenna	1		2
Antenna Model	Andrew - TMBXX-6516-A2M (Quad)		Andrew - LNX-6513DS-A1M (Dual)
Azimuth	240		240
M. Tilt	0		0
Height	153		161
Ports	P1	P2	P3
Active Tech.	L1900 G1900	U2100 L2100	L700
Dark Tech.			
Restricted Tech.			
Decomm. Tech.	U1900		
E. Tilt	2		2
Cables	1-5/8" Coax - 170 ft. (x8)		1-5/8" Coax - 170 ft. (x8)
TMA's	Generic Twin Style 1A - PCS (AtCabinet)	Generic Twin Style 1B - AWS (AtCabinet)	
Diplexers / Combiners			
Radio			
Sector Equipment			Andrew Smart Bias T (Ericsson) (At Antenna)
Unconnected Equipment:			
Scope of Work:			
Leave the Andrews TMZXX antenna and install a new L700 antenna. Intall GMA's on ground and Bias T- up top for RETS			

RAN Template: 67D94B Outdoor	A&L Template: 67D94B_1DP+1QP+1OP
--	--

Sector 3 (Proposed) view from behind

Coverage Type	A - Outdoor Macro					
Antenna	1			2		
Antenna Model	Andrew - TMBXX-6516-A2M (Quad)			RFS - APXVAARR18_43-U-NA20 (Octo)		
Azimuth	240			240		
M. Tilt	0			0		
Height	153			161		
Ports	P1	P2	P3	P4	P5	P6
Active Tech.	G1900 L1900	U2100 L2100	N600 L700 L600	N600 L700 L600		
Dark Tech.						
Restricted Tech.						
Decomm. Tech.	U1900					
E. Tilt	2	2	2	2		
Cables	1-5/8" Coax - 170 ft. (x2)	1-5/8" Coax - 170 ft. (x2)	1-5/8" Coax - 170 ft. (x2)	1-5/8" Coax - 170 ft. (x2)		
TMAs	Generic Twin Style 1A - PCS (AtCabinet)	Generic Twin Style 1B - AWS (AtCabinet)				
Diplexers / Combiners						
Radio			Radio 4449 B71+B85 (At Cabinet)	SHARED Radio 4449 B71+B85 (At Cabinet)		
Sector Equipment		Andrew Smart Bias T (Ericsson) (At Antenna)				Andrew Smart Bias T (Ericsson) (At Antenna)

Unconnected Equipment:

Scope of Work:

*** Existing TMAs are Ground Mounted ***
 Replace LB Dual in Position 2 with (1) LB/MB Octo.
 Replace RRUS11 B12 with (1) Radio 4449 B71+B12 for L600 and L700 at Ground Level.
 Daisy Chain Bias-Ts.

*A dashed border indicates shared equipment. Any connected equipment is denoted with the SHARED keyword.

RAN Template: 67D94B Outdoor	A&L Template: 67D94B_1DP+1QP+1OP
--	--

Section 7 - Power Systems Equipment

Existing Power Systems Equipment

----- This section is intentionally blank. -----

Proposed Power Systems Equipment



Dual Slant Polarized Quad Band (8 Port) Antenna, 617-746/617-746/1695-2200/1695-2200MHz, 65deg, 14.9/14.5/18.6/18.6 dBi, 1.8m (6ft), VET, RET, 0-14°/0-14°/2-12°/2-12°

FEATURES / BENEFITS

This antenna provides a 8 Port multi-band flexible platform for advanced use for flexible use in deployment scenarios for encompassing 600MHz, 700MHz, AWS & PCS applications.



- ➔ 24 Inch Width For Easier Zoning
- ➔ Field Replaceable (Integrated) AISG RET platform for reduced environmental exposure and long lasting quality
- ➔ Superior elevation pattern performance across the entire electrical down tilt range
- ➔ Includes three AISG RET motors - Includes 0.5m AISG jumper for optional daisy chain of two high band RET motors for one single AISG point of high band tilt control.
- ➔ Low band arrays driven by a single RET motor

Technical Features

LOW BAND LEFT ARRAY (617-746 MHZ) [R1]

Frequency Band	MHz	617-698	698-746
Gain Over All Tilts	dBi	14.1 +/- .3	14.5 +/- .4
Horizontal Beamwidth @3dB	Deg	66.1+/-4.3	63.1+/-2.3
Vertical Beamwidth @3dB	Deg	14.2+/-0.8	13.0+/-0.5
Electrical Downtilt Range	Deg	0-14	
Upper Side Lobe Suppression 0 to +20	dB	20.5	21.4
Front-to-Back, at +/-30°, Copolar	dB	22.4	21.8
Cross Polar Discrimination (XPD) @ Boresight	dB	21.4	20.1
Cross Polar Discrimination (XPD) @ +/-60	dB	5.2	3.5
3rd Order PIM 2 x 43dBm	dBc	-153	
VSWR	-	1.5:1	
Cross Polar Isolation	dB	25	
Maximum Effective Power per Port	Watt	250	

LOW BAND RIGHT ARRAY (617-746 MHZ) [R2]

Frequency Band	MHz	617-698	698-746
Gain Over All Tilts	dBi	13.8 +/- .3	14.1 +/- .4
Horizontal Beamwidth @3dB	Deg	66.5+/-4.9	63.3+/-2.2
Vertical Beamwidth @3dB	Deg	14.2+/-0.8	12.9+/-0.6
Electrical Downtilt Range	Deg	0-14	
Upper Side Lobe Suppression 0 to +20	dB	20.3	21.3
Front-to-Back, at +/-30°, Copolar	dB	22.4	21.4
Cross Polar Discrimination (XPD) @ Boresight	dB	20.2	19.7
Cross Polar Discrimination (XPD) @ +/-60	dB	4.5	1.7
3rd Order PIM 2 x 43dBm	dBc	-153	
VSWR	-	1.5:1	
Cross Polar Isolation	dB	25	
Maximum Effective Power per Port	Watt	250	



Dual Slant Polarized Quad Band (8 Port) Antenna, 617-746/617-746/1695-2200/1695-2200MHz, 65deg, 14.9/14.5/18.6/18.6 dBi, 1.8m (6ft), VET, RET, 0-14°/0-14°/2-12°/2-12°

ELECTRICAL SPECIFICATIONS

Impedance	Ohm	50.0
Polarization	Deg	±45°

MECHANICAL SPECIFICATIONS

Dimensions - H x W x D	mm (in)	1829 x 609 x 215 (72 x 24 x 8.5)
Weight (Antenna Only)	kg (lb)	48 (106)
Weight (Mounting Hardware only)	kg (lb)	11.5 (25.3)
Packing size- HxWxD	mm (in)	1980 x 735 x 375 (77.9 x 28.9 x 14.8)
Shipping Weight	kg (lb)	70 (154)
Connector type		8 x 4.3-10 female at bottom + 6 AISG connectors (3 male, 3 female)
Adjustment mechanism		Integrated RET solution AISG compliant (Field Replaceable) + Manual Override + External Tilt Indicator
Mounting Hardware Material		Galvanized steel
Radome Material / Color		Fiber Glass / Light Grey RAL7035

TESTING AND ENVIRONMENTAL

Temperature Range	°C (°F)	-40 to 60 (-40 to 140)
Lightning protection		IEC 61000-4-5
Survival/Rated Wind Velocity	km/h	240 (150)
Wind Load @Rated Wind Front	N	1072.0
Wind Load @Rated Wind Side	N	326.0
Wind Load @Rated Wind Rear	N	1160.0
Environmental		ETSI 300-019-2-4 Class 4.1E

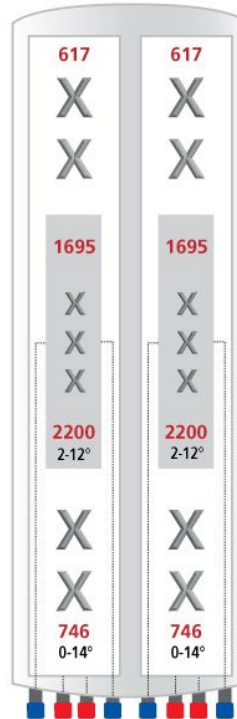
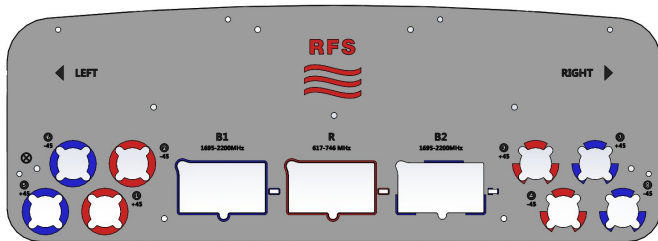



ATSBT-TOP-FM-4G

Teletilt® Top Smart Bias Tee

- Injects AISG power and control signals onto a coaxial cable line
- Reduces cable and site lease costs by eliminating the need for AISG home run cables
- AISG 1.1 and 2.0 compliant
- Operates at 10-30 Vdc
- Weatherproof AISG connectors
- Intuitive schematics simplify and ensure proper installation
- Enhanced lightning protection plus grounding stud for additional surge protection
- 7-16 DIN female connector (BTS)
- 7-16 DIN male connector (ANT)

General Specifications

Smart Bias Tee Type	10–30 V Top
Brand	Teletilt®
Operating Frequency Band	694 – 2690 MHz

Electrical Specifications

EU Certification	CE
Protocol	AISG 1.1 AISG 2.0
Antenna Interface Signal	dc Blocked RF
BTS Interface Signal	AISG data dc RF
Interface Protocol Signal	Data dc
Voltage Range	10–30 Vdc
VSWR Return Loss	1.17:1 22 dB, typical
Power Consumption, maximum	0.6 W
RF Power, maximum	250 W @ 1850 MHz 500 W @ 850 MHz
Impedance	50 ohm
Insertion Loss, typical	0.1 dB
3rd Order IMD	-158.0 dBc (relative to carrier)
3rd Order IMD Test Method	Two +43 dBm carriers
Electromagnetic Compatibility (EMC)	CFR 47 Part 15, Subpart B, Class B EN 55022, Class B ICES-003 Issue 4 CAN/CSA-CEI/IEC CISPR 22:02

Mechanical Specifications

Antenna Interface	7-16 DIN Male
BTS Interface	7-16 DIN Female
AISG Input Connector	8-pin DIN Female
Color	Silver
Grounding Lug Thread Size	M8
Material Type	Aluminum
Lightning Surge Capability	5 times @ -3 kA 5 times @ 3 kA

ATSBT-TOP-FM-4G

POWERED BY



Lightning Surge Capability Test Method IEC 61000-4-5, Level X

Lightning Surge Capability Waveform 1.2/50 voltage and 8/20 current combination waveform

Environmental Specifications

Ingress Protection Test Method IEC 60529:2001, IP66

Operating Temperature -40 °C to +70 °C (-40 °F to +158 °F)

Interface Port Drawing



Dimensions

Width	94.0 mm 3.7 in
Depth	50.0 mm 2.0 in
Height	143.00 mm 5.63 in
Net Weight	0.8 kg 1.8 lb

Regulatory Compliance/Certifications

Agency
RoHS 2011/65/EU

Classification
Compliant by Exemption



TMBXX-6516-R2M

±45° Dual Band Quad Antenna

Decibel®
Base Station Antennas

- Patented cross dipole and feed system
- Rugged, reliable design with excellent PIM suppression
- Includes factory installed AISG RET actuator
- Fully compatible with Andrew Teletilt® remote control antenna system

ELECTRICAL

Frequency Range (MHz):	1710–2155				
Characteristic Impedance (Ohms):	50				
Azimuth BW (Deg):	64.5 ± 8				
Elevation BW (Deg):	7.2 ± 1.2				
Gain (dBi) :	17.5 ± 8				
Polarization:	±45°				
Front-to-Back Ratio (dB)	2°	4°	6°	8°	10°
Copol, 180° ± 30°:	>24	>24	>24	>24	>24
Total Power, 180° ± 30°:	>24	>23	>22	>23	>23
Upper Sidelobe (dB)	2°	4°	6°	8°	10°
Main Beam to +20°:	>18	>17	>15	>14	>11
VSWR / Return Loss (dB):	1.35:1 / 16.5				
Port-to-Port Isolation (dB):	>30				
Electrical Tilt Range (Deg):	2–10				
Electrical Downtilt Accuracy (Deg):	± 0.9				
Cross-pol (dBc)	2°	4°	6°	8°	10°
3 dB Beamwidth:	>13	>13	>12	>12	>12
Intermodulation Products (dBc)					
3rd Order, 2 x 20 Watts:	155				
Max. Input Power (Watts):	250				
Lightning Protection:	DC Ground				

PERFORMANCE TRACKING

Gain Variation (dB) (between UL and DL frequency pair):	1.3
Electrical Tilt Accuracy (Deg) (between UL and DL frequency pair within 0.5°):	<0.55
Azimuth HPBW (Deg) (between UL and DL frequency pair):	11.5

MECHANICAL

Net Weight (kg / lbs):	15.7 / 34.6
Dimensions—LxWxD: (with actuator)	1499 x 302 x 160 mm 59 x 11.9 x 6.3 inch
Max. Wind Area (m ² / ft ²):	0.27 / 2.9
Max. Wind Load (N / lbf):	729.4 / 164
Max. Wind Speed (km/h / mph):	241 / 150
Hardware Material:	Hot Dip Galvanized
Connector Type:	7-16 DIN, Female (4)
Color:	Off White
Standard Mounting Hardware:	TM600899A-2

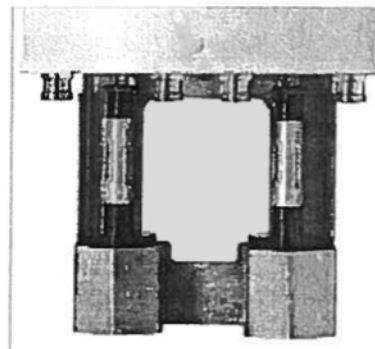
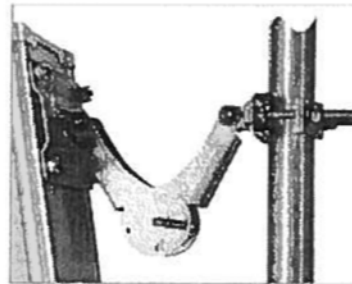

Andrew Corporation
2601 Telecom Parkway
Richardson, Texas U.S.A. 755082-3521
Tel: 214.631.0310

Fax: 214.688.0089
Toll Free Tel: 1.800.676.5342
Fax: 1.800.229.4706
www.andrew.com

11/27/2006
Page 1 of 3
dbtech@andrew.com

Exhibit E



Non-Ionizing Radiation Report

Compiled For: Northeast Site Solutions on behalf of T-Mobile

Site Name: CT11241A

Site ID: CT11241A

Station Drive - Line #1759 - Pole # 1280, Greenwich, CT 06830

Latitude: 41.029986; Longitude: -73.597484

Structure Type: Utility Lattice Tower

Report Date: July 7, 2021

Report Written By: Tim Harris

Status: T-Mobile will be compliant with FCC rules on RF Exposure.

Table of Contents

1. Executive Summary:	3
2. Site Summary:	4
3. Site Compliance	4
4. Site Compliance Recommendations	5
5. Antenna Inventory Table	6
6. RF Guidelines.....	7
7. T-Mobile Exposure Analysis By Band and Technology.....	8
8. Appendix A: FCC Guidelines.....	11
FCC Policies.....	11
Occupational / Controlled	11
General Population / Uncontrolled	11
9. Preparer Certification	14

1. Executive Summary:

Northeast Site Solutions on behalf of T-Mobile has contracted Infinigy Solutions, LLC to determine whether the site CT11241A located at Station Drive - Line #1759 - Pole # 1280 in Greenwich, CT Will Be Compliant with all Federal Communications Commission (FCC) rules and regulations for radio frequency (RF) exposure as indicated in **47CFR§1.1310**.

The report incorporates a theoretical RF field analysis in accordance with the FCC Rules and Regulations for all individuals classified as “Occupational or Controlled” and “General Public or Uncontrolled” (see Appendix A and B).

This document and the conclusions herein are based on information provided by Northeast Site Solutions on behalf of T-Mobile.

As a result of the analysis, **T-Mobile Will Be Compliant with FCC rules.**

T-Mobile, All Bands Cumulative Exposure %		
Uncontrolled / General Population	Exposure values at the site (mW/cm ²)	0.0102
	% Exposure	1.37 %
Controlled / Occupational	Exposure values at the site (mW/cm ²)	0.0102
	% Exposure	0.28 %

2. Site Summary:

Site Information	
Site Name: CT11241A	
Site Address: Station Drive - Line #1759 - Pole # 1280, Greenwich, CT 06830	
Site Type: Utility Lattice Tower	
Compliance Status	Will Be Compliant
Mitigation Required	No
Signage Required	Yes
Barriers Required	No
Access Locked	No
Area Controlled or Uncontrolled	Uncontrolled

3. Site Compliance

This report also incorporates overview of the site information:

- Antenna Inventory Table
- Calculation Tables showing exposure for each carrier transmit frequency
- Total exposure for all carriers existing and proposed at ground level considering the centerline of all antennas and horizontal distance from the tower.
- Maximum Effective Radiated Power Assumed as Worst Case for Calculations used in this study
- Calculations based on flat ground around base of the structure

4. Site Compliance Recommendations

Infinigy recommends the following upon the installation of antennas at the site:

Base of tower

Install an RF caution sign. Note: The recommendation for alerting signage is moot if there is an RF caution, or greater already installed.

5. Antenna Inventory Table

Ant ID	Sector	Operator	Antenna manufacturer	Antenna Model	Operating Frequency/Technology	Rad Ctr (Ft)	Az (Deg)	Total ERP Power (Watts)
1a	Alpha	T-Mobile	Commscope	TMBXX-6516-A2M	1900 MHz GSM	153	20	3052
1b	Alpha	T-Mobile	Commscope	TMBXX-6516-A2M	1900 MHz LTE	153	20	3052
1c	Alpha	T-Mobile	Commscope	TMBXX-6516-A2M	2100 MHz UMTS	153	20	2154
1d	Alpha	T-Mobile	Commscope	TMBXX-6516-A2M	2100 MHz LTE	153	20	2154
2a	Alpha	T-Mobile	RFS	APXVAARR18_N43-U-NA20	700 MHz LTE	161	20	2256
2b	Alpha	T-Mobile	RFS	APXVAARR18_N43-U-NA20	600 MHz LTE	161	20	1128
2c	Alpha	T-Mobile	RFS	APXVAARR18_N43-U-NA20	600 MHz 5G	161	20	1128
3a	Beta	T-Mobile	Commscope	TMBXX-6516-A2M	1900 MHz GSM	153	140	3052
3b	Beta	T-Mobile	Commscope	TMBXX-6516-A2M	1900 MHz LTE	153	140	3052
3c	Beta	T-Mobile	Commscope	TMBXX-6516-A2M	2100 MHz UMTS	153	140	2154
3d	Beta	T-Mobile	Commscope	TMBXX-6516-A2M	2100 MHz LTE	153	140	2154
4a	Beta	T-Mobile	RFS	APXVAARR18_N43-U-NA20	700 MHz LTE	161	140	2256
4b	Beta	T-Mobile	RFS	APXVAARR18_N43-U-NA20	600 MHz LTE	161	140	1128
4c	Beta	T-Mobile	RFS	APXVAARR18_N43-U-NA20	600 MHz 5G	161	140	1128
5a	Gamma	T-Mobile	Commscope	TMBXX-6516-A2M	1900 MHz GSM	153	240	3052
5b	Gamma	T-Mobile	Commscope	TMBXX-6516-A2M	1900 MHz LTE	153	240	3052
5c	Gamma	T-Mobile	Commscope	TMBXX-6516-A2M	2100 MHz UMTS	153	240	2154
5d	Gamma	T-Mobile	Commscope	TMBXX-6516-A2M	2100 MHz LTE	153	240	2154
6a	Gamma	T-Mobile	RFS	APXVAARR18_N43-U-NA20	700 MHz LTE	161	240	2256
6b	Gamma	T-Mobile	RFS	APXVAARR18_N43-U-NA20	600 MHz LTE	161	240	1128
6c	Gamma	T-Mobile	RFS	APXVAARR18_N43-U-NA20	600 MHz 5G	161	240	1128

6. RF Guidelines

To ensure safety of company workers, the following points need to be taken into consideration and implemented at wireless sites in accordance with the Carriers policies:

- a) **Worksite:** Any employee at the site should avoid working directly in front of the antenna or in areas predicted to exceed general population exposure limits by 100%. Workers should insist that the transmitters be switched off during the work period.
- b) **RF Safety Training and Awareness:** All employees working in areas exceeding the general population limits should have a basic awareness of RF safety measures. Videos, classroom lectures and online courses are all appropriate training methods on these topics.
- c) **Site Access:** Restricting access to transmitting antenna locations is one of the most important elements of RF safety. This can be done with:
 - Locked doors/gates/ladder access
 - Alarmed doors
 - Restrictive barriers
- d) **Three-foot Buffer:** There is an inverse relationship between the strength of the field and the distance from the antenna. The RF field diminishes with distance from the antenna. Workers should maintain a three-foot distance from the antennas.
- e) **Antennas:** Workers should always assume that the antenna is transmitting and should never stop right in front of the antenna. If someone must pass by an antenna, he/she should move quickly, thus reducing RF exposure.

7. T-Mobile Exposure Analysis By Band and Technology

T-Mobile 600 MHz LTE		
Uncontrolled / General Population	FCC's exposure limits (mW/cm ²)	0.4
	Exposure values at the site (mW/cm ²)	0.0007
	% Exposure	0.18%
Controlled / Occupational	FCC's Exposure limits(mW/cm ²)	2.0
	Exposure values at the site (mW/cm ²)	0.0007
	% Exposure	0.04%

T-Mobile 600 MHz 5G		
Uncontrolled / General Population	FCC's exposure limits (mW/cm ²)	0.4
	Exposure values at the site (mW/cm ²)	0.0007
	% Exposure	0.18%
Controlled / Occupational	FCC's Exposure limits(mW/cm ²)	2.0
	Exposure values at the site (mW/cm ²)	0.0007
	% Exposure	0.04%

T-Mobile 700 MHz LTE		
Uncontrolled / General Population	FCC's exposure limits (mW/cm ²)	0.5
	Exposure values at the site (mW/cm ²)	0.0014
	% Exposure	0.29%
Controlled / Occupational	FCC's Exposure limits(mW/cm ²)	2.3
	Exposure values at the site (mW/cm ²)	0.0014
	% Exposure	0.06%

T-Mobile 1900 MHz GSM		
Uncontrolled / General Population	FCC's exposure limits (mW/cm ²)	1.0
	Exposure values at the site (mW/cm ²)	0.0021
	% Exposure	0.21%
Controlled / Occupational	FCC's Exposure limits(mW/cm ²)	5.0
	Exposure values at the site (mW/cm ²)	0.0021
	% Exposure	0.04%

T-Mobile 1900 MHz LTE		
Uncontrolled / General Population	FCC's exposure limits (mW/cm ²)	1.0
	Exposure values at the site (mW/cm ²)	0.0021
	% Exposure	0.21%
Controlled / Occupational	FCC's Exposure limits(mW/cm ²)	5.0
	Exposure values at the site (mW/cm ²)	0.0021
	% Exposure	0.04%

T-Mobile 2100 MHz LTE		
Uncontrolled / General Population	FCC's exposure limits (mW/cm ²)	1.0
	Exposure values at the site (mW/cm ²)	0.0015
	% Exposure	0.15%
Controlled / Occupational	FCC's Exposure limits(mW/cm ²)	5.0
	Exposure values at the site (mW/cm ²)	0.0015
	% Exposure	0.03%

T-Mobile 2100 MHz UMTS		
Uncontrolled / General Population	FCC's exposure limits (mW/cm ²)	1.0
	Exposure values at the site (mW/cm ²)	0.0015
	% Exposure	0.15%
Controlled / Occupational	FCC's Exposure limits(mW/cm ²)	5.0
	Exposure values at the site (mW/cm ²)	0.0015
	% Exposure	0.03%

8. Appendix A: FCC Guidelines

FCC Policies

The Federal Communications Commission (FCC) in 1996 implemented regulations and policies for analysis of RF propagation to evaluate RF emissions. All the analysis and results of this report are compared with FCC's (Federal Communications Commission) rules to determine whether a site is compliant for Occupational/Controlled or General Public/Uncontrolled exposure. All the analysis of RF propagation is done in terms of a percentage. The limits primarily indicate the power density and are generally expressed in terms of milliwatts per centimeter square, mW/cm².

FCC guidelines incorporate two separate tiers of exposure limits that are dependent on the scenario/ situation in which that exposure takes place or the status of the individuals who are subjected to that exposure. The decision as to which tier is applied to a scenario is based on the following definitions:

Occupational / Controlled

These limits apply in situations when someone is exposed to RF energy through his/her occupation, is fully aware of the harmful effects of the RF exposure and has an ability to exercise control over this exposure. Occupational / controlled exposure limits also apply when exposure is of a transient nature as a result of incidental passage through a location where exposure levels may be above general population/uncontrolled limits (see below), as long as the exposed person has been made fully aware of the potential for exposure and can exercise control over his or her exposure by leaving the area or by some other appropriate means. limits for Occupational/Controlled exposure can be found on Table 1(A).

General Population / Uncontrolled

These limits apply to situations in which the general public may be exposed or in which persons who are exposed because of their employment may not be made fully aware of the potential for exposure or cannot exercise control over their exposure to RF. Therefore, members of the general public would always be considered under this category, for example, in the case of a telecommunications tower that exposes people in a nearby residential area. Exposure limits for General Population/Uncontrolled can be found on Table 1(B).

Table 1. LIMITS FOR MAXIMUM PERMISSIBLE EXPOSURE (MPE)

(A) Limits for Occupational/Controlled Exposure

Frequency Range (MHz)	Electric Field Strength (E) (V/m)	Magnetic Field Strength (H) (A/m)	Power Density (S) (mW/cm ²)	Averaging Time E ² , H ² or S (minutes)
0.3-3.0	614	1.63	(100)*	6
3.0-30	1842/f	4.89/f	(900/f ²)*	6
30-300	61.4	0.163	1.0	6
300-1500	--	--	f/300	6
1500-100,000	--	--	5	6

(B) Limits for General Population/Uncontrolled Exposure

Frequency Range (MHz)	Electric Field Strength (E) (V/m)	Magnetic Field Strength (H) (A/m)	Power Density (S) (mW/cm ²)	Averaging Time E ² , H ² or S (minutes)
0.3-1.34	614	1.63	(100)*	30
1.34-30	824/f	2.19/f	(180/f ²)*	30
30-300	27.5	0.073	0.2	30
300-1500	--	--	f/1500	30
1500-100,000	--	--	1.0	30

f = frequency in MHz

*Plane-wave equivalent power density

Figure 1. FCC Limits for Maximum Permissible Exposure (MPE)
Plane-wave Equivalent Power Density

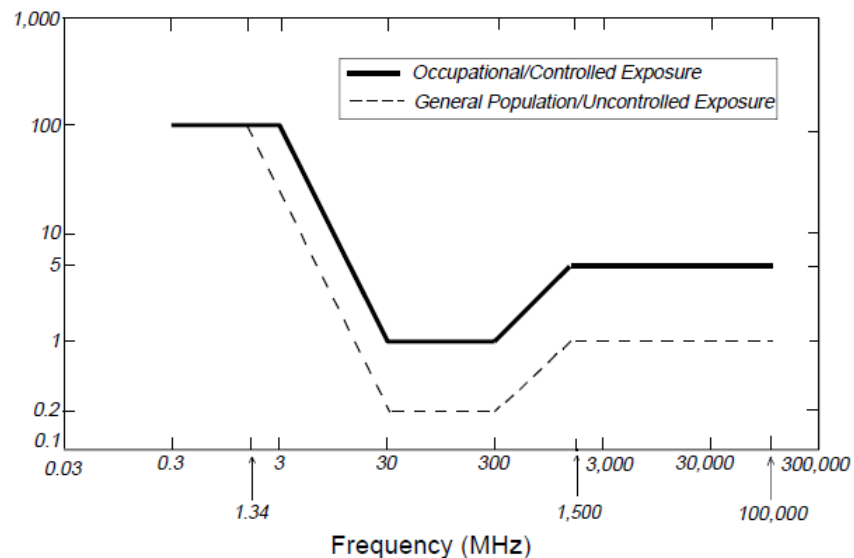

OSHA Statement:

The objective of the OSHA Act is to ensure the safety and health of the working men and women by enforcing certain standards. The act also assists and encourages the states in their efforts to ensure safe and healthy working conditions through means of research, information, education and training in the field of occupational safety and health and for other purposes.

According to OSHA Act section 5, important duties to be considered are:

(a) Each employer

- 1) Shall furnish to each of his employees' employment and a place of employment which are free from recognized hazards that are causing or are likely to cause death or serious harm to his employees
- 2) Shall comply with occupational safety and health standards promulgated under this act.

(b) Each employee shall comply with occupational safety and health standards and all rules, regulations, and orders issued pursuant to this Act which are applicable to his own actions and conduct.

9. Preparer Certification

I, Tim Harris, preparer of this report, certify that I am fully trained and aware of the rules and regulations of both the Federal Communications Commission and the Occupational Safety and Health Administration regarding Human Exposure to Radio Frequency Radiation. In addition, I have been trained in RF safety practices, rules, and regulations.

I certify that the information contained in this report is true and correct to the best of my knowledge.

Timothy A. Harris

7/7/2021

Signature

Date

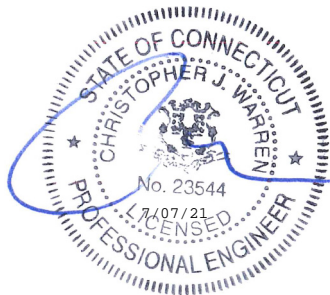

Exhibit F



56 Prospect Street,
Hartford, CT 06103

P.O. Box 270
Hartford, CT 06141-0270
(860) 665-5000

August 11, 2021

Mr. Sheldon Freinle
Northeast Site Solutions
420 Main St,
Sturbridge, MA 01566

RE: T-Mobile Antenna Site CT11241A, Station Dr, Greenwich CT, Eversource Structure 1280

Dear Mr. Freinle:

Based on our reviews of the site drawings, the structural analysis and foundation review provided by Centek Engineering, along with a third party review performed by Paul J. Ford and Company, we accept the proposed modification.

Please work with Christopher Gelinis of Eversource Real Estate to process the site lease amendment. Please do not hesitate to contact us with questions or concerns. Christopher can be contacted at 860-665-2008, and I can be contacted at (203) 623-0409.

Sincerely,

Richard Badon

Richard Badon
Transmission Line Engineering

Ref: 2021-0809 - CT11241A Structural Analysis Rev1 (21051.06)
2021-0810_21051.06 CT11241A - Rev1 CDs (S&S)

Exhibit G



**UNITED STATES
POSTAL SERVICE®**

Click-N-Ship®

P

usps.com 9405 5036 9930 0470 0847 90 0155 0000 0010 6051
US POSTAGE
 MD Flat Rate Box

U.S. POSTAGE PAID
click-n-ship®

08/13/2021 Mailed from 01566

PRIORITY MAIL 2-DAY™

Expected Delivery Date: 08/16/21
 Ref#: 241-L600
0004

DEBORAH CHASE
 NORTHEAST SITE SOLUTIONS
 420 MAIN ST
 STE 1
 STURBRIDGE MA 01566-1359

C006

SHIP TO: LISA A MATTHEWS
 CT SITING COUNCIL
 10 FRANKLIN SQ
 NEW BRITAIN CT 06051-2655

USPS TRACKING #

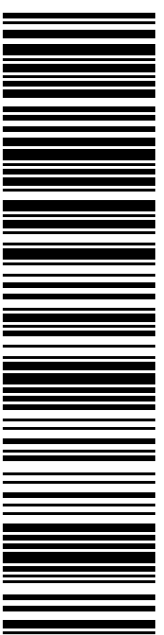

9405 5036 9930 0470 0847 90

Electronic Rate Approved #038555749



Cut on dotted line.

Instructions

1. Each Click-N-Ship® label is unique. Labels are to be used as printed and used only once. DO NOT PHOTO COPY OR ALTER LABEL.
2. Place your label so it does not wrap around the edge of the package.
3. Adhere your label to the package. A self-adhesive label is recommended. If tape or glue is used, DO NOT TAPE OVER BARCODE. Be sure all edges are secure.
4. To mail your package with PC Postage®, you may schedule a Package Pickup online, hand to your letter carrier, take to a Post Office™, or drop in a USPS collection box.
5. Mail your package on the "Ship Date" you selected when creating this label.

Click-N-Ship® Label Record

USPS TRACKING # :
9405 5036 9930 0470 0847 90

Trans. #: 540485993	Priority Mail® Postage: \$15.50
Print Date: 08/10/2021	Total: \$15.50
Ship Date: 08/13/2021	
Expected Delivery Date: 08/16/2021	

From: DEBORAH CHASE Ref#: 241-L600
 NORTHEAST SITE SOLUTIONS
 420 MAIN ST
 STE 1
 STURBRIDGE MA 01566-1359

To: LISA A MATTHEWS
 CT SITING COUNCIL
 10 FRANKLIN SQ
 NEW BRITAIN CT 06051-2655

* Retail Pricing Priority Mail rates apply. There is no fee for USPS Tracking® service on Priority Mail service with use of this electronic rate shipping label. Refunds for unused postage paid labels can be requested online 30 days from the print date.



Thank you for shipping with the United States Postal Service!
 Check the status of your shipment on the USPS Tracking® page at usps.com



UNITED STATES POSTAL SERVICE®

Click-N-Ship®

P

usps.com 9405 5036 9930 0473 5069 54 0082 5000 0020 6830
US POSTAGE
 Legal Flat Rate Env

U.S. POSTAGE PAID
Click-N-Ship®

08/16/2021 Mailed from 01566

PRIORITY MAIL 2-DAY™

Expected Delivery Date: 08/19/21
 Ref#: 241-L600
0006

C027

SHIP TO: KATIE DELUCA
 PLANNING & ZONING-ZEO-TOWN PLANNER
 101 FIELD POINT RD
 GREENWICH CT 06830-6463

USPS TRACKING #

9405 5036 9930 0473 5069 54

Electronic Rate Approved #038555749



Cut on dotted line.

Instructions

1. Each Click-N-Ship® label is unique. Labels are to be used as printed and used only once. DO NOT PHOTO COPY OR ALTER LABEL.
2. Place your label so it does not wrap around the edge of the package.
3. Adhere your label to the package. A self-adhesive label is recommended. If tape or glue is used, DO NOT TAPE OVER BARCODE. Be sure all edges are secure.
4. To mail your package with PC Postage®, you may schedule a Package Pickup online, hand to your letter carrier, take to a Post Office™, or drop in a USPS collection box.
5. Mail your package on the "Ship Date" you selected when creating this label.

Click-N-Ship® Label Record

USPS TRACKING # :
9405 5036 9930 0473 5069 54

Trans. #: 540767724	Priority Mail® Postage: \$8.25
Print Date: 08/13/2021	Total: \$8.25
Ship Date: 08/16/2021	
Expected Delivery Date: 08/19/2021	

From: DEBORAH CHASE Ref#: 241-L600
 NORTHEAST SITE SOLUTIONS
 420 MAIN ST
 STE 1
 STURBRIDGE MA 01566-1359

To: KATIE DELUCA
 PLANNING & ZONING-ZEO-TOWN PLANNER
 101 FIELD POINT RD
 GREENWICH CT 06830-6463

* Retail Pricing Priority Mail rates apply. There is no fee for USPS Tracking® service on Priority Mail service with use of this electronic rate shipping label. Refunds for unused postage paid labels can be requested online 30 days from the print date.



Thank you for shipping with the United States Postal Service!
 Check the status of your shipment on the USPS Tracking® page at usps.com



FISKDALE
 458 MAIN ST
 FISKDALE, MA 01518-9998
 (800)275-8777

10/14/2021 12:27 PM

Product	Qty	Unit Price	Price
Prepaid Mail	1		\$0.00
New Haven, CT 06511			
Weight: 2 lb 5.50 oz			
Acceptance Date:			
Thu 10/14/2021			
Tracking #:			
9405 5036 9930 0032 3620 45			
Prepaid Mail	1		\$0.00
New Haven, CT 06511			
Weight: 2 lb 3.50 oz			
Acceptance Date:			
Thu 10/14/2021			
Tracking #:			
9405 5036 9930 0032 3620 69			
Grand Total:			\$0.00

 USPS is experiencing unprecedented volume increases and limited employee availability due to the impacts of COVID-19. We appreciate your patience.

Preview your Mail
 Track your Packages
 Sign up for FREE @
<https://informedelivery.usps.com>

Earn rewards on your business account purchases of Priority Mail labels with the USPS Loyalty program by using Click and Ship. Visit www.usps.com/smallbizloyalty for more info.

United States Postal Service
 NOW HIRING NATIONWIDE
 Career Path Positions with Benefits
 Apply online at
www.usps.com/careers

All sales final on stamps and postage.
 Refunds for guaranteed services only.
 Thank you for your business.

Tell us about your experience.
 Go to: <https://postalexperience.com/Pos>
 or scan this code with your mobile device,



or call 1-800-410-7420.

UFN: 242703-0518
 Receipt #: 840-50180227-2-2448255-1
 Clerk: 3

Tracking Number: 9405503699300032362045

Remove X

Status

 **Delivered, In/At Mailbox**

October 18, 2021 at 10:36 am
NEW HAVEN, CT 06511

Your item was delivered in or at the mailbox at 10:36 am on October 18, 2021 in NEW HAVEN, CT 06511.

USPS Tracking Plus™ Available 

Get Updates 

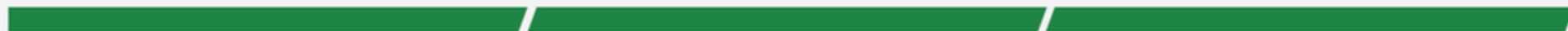

Delivered

Text & Email Updates



Tracking History



USPS Tracking Plus™



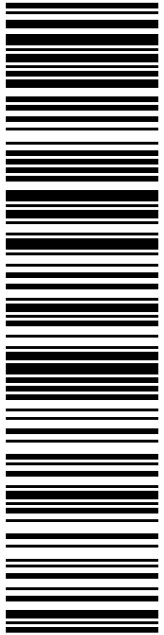

USPS TRACKING #

9405 5036 9930 0473 5069 61

Electronic Rate Approved #038555749

SHIP

TO: FRED CAMILLO
 FIRST SELECTMAN-GREENWICH
 101 FIELD POINT RD
 GREENWICH CT 06830-6463

P

US POSTAGE
 Legal Flat Rate Env

U.S. POSTAGE PAID
 Click-N-Ship®

Mailed from 01566

PRIORITY MAIL 2-DAY™

Expected Delivery Date: 08/19/21
 Ref#: 241-L600
0006

C027

UNITED STATES POSTAL SERVICE®

Click-N-Ship®

usps.com

9405 5036 9930 0473 5069 61 0082 5000 0020 6630

US POSTAGE
 Legal Flat Rate Env

08/16/2021



Cut on dotted line.

Instructions

1. Each Click-N-Ship® label is unique. Labels are to be used as printed and used only once. **DO NOT PHOTO COPY OR ALTER LABEL.**
2. Place your label so it does not wrap around the edge of the package.
3. Adhere your label to the package. A self-adhesive label is recommended. If tape or glue is used, **DO NOT TAPE OVER BARCODE.** Be sure all edges are secure.
4. To mail your package with PC Postage®, you may schedule a Package Pickup online, hand to your letter carrier, take to a Post Office™, or drop in a USPS collection box.
5. Mail your package on the "Ship Date" you selected when creating this label.

Click-N-Ship® Label Record

USPS TRACKING # :
9405 5036 9930 0473 5069 61

Trans. #: 540767724	Priority Mail® Postage: \$8.25
Print Date: 08/13/2021	Total: \$8.25
Ship Date: 08/16/2021	
Expected Delivery Date: 08/19/2021	

From: DEBORAH CHASE Ref#: 241-L600
 NORTHEAST SITE SOLUTIONS
 420 MAIN ST
 STE 1
 STURBRIDGE MA 01566-1359

To: FRED CAMILLO
 FIRST SELECTMAN-GREENWICH
 101 FIELD POINT RD
 GREENWICH CT 06830-6463

* Retail Pricing Priority Mail rates apply. There is no fee for USPS Tracking® service on Priority Mail service with use of this electronic rate shipping label. Refunds for unused postage paid labels can be requested online 30 days from the print date.



Thank you for shipping with the United States Postal Service!
 Check the status of your shipment on the USPS Tracking® page at usps.com



**UNITED STATES
POSTAL SERVICE®**

Click-N-Ship®

P

usps.com 9405 5036 9930 0473 5069 78 0082 5000 0010 6037
US POSTAGE
 Legal Flat Rate Env

U.S. POSTAGE PAID
Click-N-Ship®

08/16/2021 Mailed from 01566

PRIORITY MAIL 2-DAY™

Expected Delivery Date: 08/19/21
 Ref#: 241-L600
0006

DEBORAH CHASE
 NORTHEAST SITE SOLUTIONS
 420 MAIN ST
 STE 1
 STURBRIDGE MA 01566-1359

C015

SHIP TO: CHRIS GELINAS
 EVERSOURCE
 107 SELDEN ST
 BERLIN CT 06037-1616

USPS TRACKING #



9405 5036 9930 0473 5069 78

Electronic Rate Approved #038555749



Cut on dotted line.

Instructions

1. Each Click-N-Ship® label is unique. Labels are to be used as printed and used only once. DO NOT PHOTO COPY OR ALTER LABEL.
2. Place your label so it does not wrap around the edge of the package.
3. Adhere your label to the package. A self-adhesive label is recommended. If tape or glue is used, DO NOT TAPE OVER BARCODE. Be sure all edges are secure.
4. To mail your package with PC Postage®, you may schedule a Package Pickup online, hand to your letter carrier, take to a Post Office™, or drop in a USPS collection box.
5. Mail your package on the "Ship Date" you selected when creating this label.

Click-N-Ship® Label Record

USPS TRACKING # :
9405 5036 9930 0473 5069 78

Trans. #: 540767724	Priority Mail® Postage: \$8.25
Print Date: 08/13/2021	Total: \$8.25
Ship Date: 08/16/2021	
Expected Delivery Date: 08/19/2021	

From: DEBORAH CHASE Ref#: 241-L600
 NORTHEAST SITE SOLUTIONS
 420 MAIN ST
 STE 1
 STURBRIDGE MA 01566-1359

To: CHRIS GELINAS
 EVERSOURCE
 107 SELDEN ST
 BERLIN CT 06037-1616

* Retail Pricing Priority Mail rates apply. There is no fee for USPS Tracking® service on Priority Mail service with use of this electronic rate shipping label. Refunds for unused postage paid labels can be requested online 30 days from the print date.



Thank you for shipping with the United States Postal Service!
 Check the status of your shipment on the USPS Tracking® page at usps.com



UNITED STATES POSTAL SERVICE®

Click-N-Ship®

P

10/14/2021

Mailed from 01566

usps.com 9405 5036 9930 0032 3620 45 0162 5000 0010 6511

US POSTAGE \$16.25

MD Flat Rate Box

U.S. POSTAGE PAID

click-n-ship®

PRIORITY MAIL 2-DAY™

Expected Delivery Date: 10/18/21

Ref#: 241-L600

0004

SHIP TO: JOHN A VITALE
CT DEPT OF TRANSPORTATION
4 BREWERY ST
NEW HAVEN CT 06511-5957

USPS TRACKING #

9405 5036 9930 0032 3620 45

Electronic Rate Approved #038555749



Cut on dotted line.

Instructions

1. Each Click-N-Ship® label is unique. Labels are to be used as printed and used only once. DO NOT PHOTO COPY OR ALTER LABEL.
2. Place your label so it does not wrap around the edge of the package.
3. Adhere your label to the package. A self-adhesive label is recommended. If tape or glue is used, DO NOT TAPE OVER BARCODE. Be sure all edges are secure.
4. To mail your package with PC Postage®, you may schedule a Package Pickup online, hand to your letter carrier, take to a Post Office™, or drop in a USPS collection box.
5. Mail your package on the "Ship Date" you selected when creating this label.

Click-N-Ship® Label Record

USPS TRACKING # :

9405 5036 9930 0032 3620 45

<p>Trans. #: 545933823</p> <p>Print Date: 10/14/2021</p> <p>Ship Date: 10/14/2021</p> <p>Expected Delivery Date: 10/18/2021</p>	<p>Priority Mail® Postage: \$16.25</p> <p>Total: \$16.25</p>
---	--

From: DEBORAH CHASE
NORTHEAST SITE SOLUTIONS
420 MAIN ST
STE 1
STURBRIDGE MA 01566-1359

Ref#: 241-L600

To: JOHN A VITALE
CT DEPT OF TRANSPORTATION
4 BREWERY ST
NEW HAVEN CT 06511-5957

* Retail Pricing Priority Mail rates apply. There is no fee for USPS Tracking® service on Priority Mail service with use of this electronic rate shipping label. Refunds for unused postage paid labels can be requested online 30 days from the print date.



Thank you for shipping with the United States Postal Service!
Check the status of your shipment on the USPS Tracking® page at usps.com