

November 17, 2016

VIA EMAIL AND OVERNIGHT DELIVERY

Ms. Melanie A. Bachman
Acting Executive Director
Connecticut Siting Council
Ten Franklin Square
New Britain, CT 06051

RE: T-Mobile Northeast LLC – CT11099G
Notice of Exempt Modification
395 Round Hill Road, Greenwich, CT
LAT: 41-51-59.89N
LNG: -72-40-29.19W

Dear Ms. Bachman:

T-Mobile Northeast LLC ("T-Mobile") currently maintains three (3) antennas at the 110' level on the existing 115' tall flagpole located at 395 Round Hill Road, Greenwich, CT. The structure is owned by Cellco Partnership d/b/a Verizon Wireless ("Cellco"), their use of the structure was approved by the Council on February 6, 2007 (Docket No. 309).

Please accept this letter as notification pursuant to Regulations of Connecticut State Agencies 16-50j-73, for construction that constitutes an exempt modification pursuant to R.C.S.A.16-50j-72(b)(2). In accordance with R.C.S.A. 16-50j-73, a copy of this letter is being sent to, Mayor Peter J. Tesei, Town of Greenwich, and the property owner, Round Hill Community Church.

The planned modifications to the facility fall squarely within those activities explicitly provided for in RC.S.A. 16-50j-72(b)(s).

1. The proposed modifications will not result in an increase in the height of the existing structure. T-Mobile proposes to swap three (3) existing antennas with (3) L700 antennas at a centerline height of 110', as well as add (3) TMAs.
2. The proposed modifications will not require the extension of the site boundary. There will be no effect on the site compound or T-Mobile's leased area.
3. The proposed modifications will not increase noise levels at the facility by six decibels or more, or to levels that exceed state and local criteria. The incremental effect of the proposed changes will be

negligible.

4. The operation of the replacement antennas will not increase radio frequency emissions at the facility to a level at or above the Federal Communications Commission safety standard. As indicated in the attached power density calculations, T-Mobile's operations at the site will result in a power density of 2.58%; the combined site operations will result in a total power density of 12.38%.
5. The proposed modifications will not cause a change or alteration in the physical or environmental characteristics of the site. T-Mobile will swap antennas on the existing mounts.
6. The existing structure and its foundation can support the proposed loading. As indicated in the attached structural analysis the subject tower is adequate to support the proposed T-Mobile equipment upgrade.

For the foregoing reasons, T-Mobile respectfully submits that the proposed modifications to the above-referenced telecommunications facility constitute an exempt modification under R.C.S.A. J 6-50j-72(b)(2) .

Please feel free to call me with any questions or concerns regarding this matter. Thank you for your consideration.

Respectfully submitted,



By: _____
Jamie Ford, Agent for T-Mobile
jford@verticaldevelopmentllc.com
774-248-5373

Attachments

cc: Mayor Peter J. Tesei, Town of Greenwich
Church Administrator Lynda C. Kinney, Round Hill Community Church
Aleksy Tyurin, Cellco Partnership

T-Mobile WIRELESS COMMUNICATIONS FACILITY

ROUND HILL CHURCH
SITE ID: CT11099G
395 ROUND HILL ROAD
GREENWICH, CT 06831

T-MOBILE RF CONFIGURATION:
1HP_704Bu

GENERAL NOTES

1. ALL WORK SHALL BE IN ACCORDANCE WITH THE 2012 INTERNATIONAL BUILDING CODE AS MODIFIED BY THE 2016 CONNECTICUT SUPPLEMENT, INCLUDING THE TIA/EIA-222 REVISION "G" STRUCTURAL STANDARDS FOR STEEL ANTENNA TOWERS AND SUPPORTING STRUCTURES." 2016 CONNECTICUT FIRE SAFETY CODE, NATIONAL ELECTRICAL CODE AND LOCAL CODES.
2. CONTRACTOR SHALL REVIEW ALL DRAWINGS AND SPECIFICATIONS IN THE CONTRACT DOCUMENT SET. CONTRACTOR SHALL COORDINATE ALL WORK SHOWN IN THE SET OF DRAWINGS. THE CONTRACTOR SHALL PROVIDE A COMPLETE SET OF DRAWINGS TO ALL SUBCONTRACTORS AND ALL RELATED PARTIES. THE SUBCONTRACTORS SHALL EXAMINE ALL THE DRAWINGS AND SPECIFICATIONS FOR THE INFORMATION THAT AFFECTS THEIR WORK.
3. CONTRACTOR SHALL PROVIDE A COMPLETE BUILD-OUT WITH ALL FINISHES, STRUCTURAL, MECHANICAL, AND ELECTRICAL COMPONENTS AND PROVIDE ALL ITEMS AS SHOWN OR INDICATED ON THE DRAWINGS OR IN THE WRITTEN SPECIFICATIONS.
4. CONTRACTOR SHALL FURNISH ALL MATERIAL, LABOR AND EQUIPMENT TO COMPLETE THE WORK AND FURNISH A COMPLETED JOB ALL IN ACCORDANCE WITH LOCAL AND STATE GOVERNING AUTHORITIES AND OTHER AUTHORITIES HAVING LAWFUL JURISDICTION OVER THE WORK.
5. CONTRACTOR SHALL SECURE AND PAY FOR ALL PERMITS AND ALL INSPECTIONS REQUIRED AND SHALL ALSO PAY FEES REQUIRED FOR THE GENERAL CONSTRUCTION, PLUMBING, ELECTRICAL AND HVAC. PERMITS SHALL BE PAID FOR BY THE RESPECTIVE SUBCONTRACTORS.
6. CONTRACTOR SHALL MAINTAIN A CURRENT SET OF DRAWINGS AND SPECIFICATIONS ON SITE AT ALL TIMES AND INSURE DISTRIBUTION OF NEW DRAWINGS TO SUBCONTRACTORS AND OTHER RELEVANT PARTIES AS SOON AS THEY ARE MADE AVAILABLE. ALL OLD DRAWINGS SHALL BE MARKED VOID AND REMOVED FROM THE CONTRACT AREA. THE CONTRACTOR SHALL FURNISH AN 'AS-BUILT' SET OF DRAWINGS TO OWNER UPON COMPLETION OF PROJECT.
7. LOCATION OF EQUIPMENT, AND WORK SUPPLIED BY OTHERS THAT IS DIAGRAMMATICALLY INDICATED ON THE DRAWINGS SHALL BE DETERMINED BY THE CONTRACTOR. THE CONTRACTOR SHALL DETERMINE LOCATIONS AND DIMENSIONS SUBJECT TO STRUCTURAL CONDITIONS AND WORK OF THE SUBCONTRACTORS.
8. THE CONTRACTOR IS SOLELY RESPONSIBLE TO DETERMINE CONSTRUCTION PROCEDURE AND SEQUENCE, AND TO ENSURE THE SAFETY OF THE EXISTING STRUCTURES AND ITS COMPONENT PARTS DURING CONSTRUCTION. THIS INCLUDES THE ADDITION OF WHATEVER SHORING, BRACING, UNDERPINNING, ETC. THAT MAY BE NECESSARY.
9. DRAWINGS INDICATE THE MINIMUM STANDARDS, BUT IF ANY WORK SHOULD BE INDICATED TO BE SUBSTANDARD TO ANY ORDINANCES, LAWS, CODES, RULES, OR REGULATIONS BEARING ON THE WORK, THE CONTRACTOR SHALL INCLUDE IN HIS WORK AND SHALL EXECUTE THE WORK CORRECTLY IN ACCORDANCE WITH SUCH ORDINANCES, LAWS, CODES, RULES OR REGULATIONS WITH NO INCREASE IN COSTS.
10. ALL UTILITY WORK SHALL BE IN ACCORDANCE WITH LOCAL UTILITY COMPANY REQUIREMENTS AND SPECIFICATIONS.
11. ALL EQUIPMENT AND PRODUCTS PURCHASED ARE TO BE REVIEWED BY CONTRACTOR AND ALL APPLICABLE SUBCONTRACTORS FOR ANY CONDITION PER MFR.'S RECOMMENDATIONS. CONTRACTOR TO SUPPLY THESE ITEMS AT NO COST TO OWNER OR CONSTRUCTION MANAGER.
12. ANY AND ALL ERRORS, DISCREPANCIES, AND 'MISSED' ITEMS ARE TO BE BROUGHT TO THE ATTENTION OF THE T-MOBILE CONSTRUCTION MANAGER DURING THE BIDDING PROCESS BY THE CONTRACTOR. ALL THESE ITEMS ARE TO BE INCLUDED IN THE BID. NO 'EXTRA' WILL BE ALLOWED FOR MISSED ITEMS.
13. CONTRACTOR SHALL BE RESPONSIBLE FOR ALL ON-SITE SAFETY FROM THE TIME THE JOB IS AWARDED UNTIL ALL WORK IS COMPLETE AND ACCEPTED BY THE OWNER.
14. CONTRACTOR TO REVIEW ALL SHOP DRAWINGS AND SUBMIT COPY TO ENGINEER FOR APPROVAL. DRAWINGS MUST BEAR THE CHECKER'S INITIALS BEFORE SUBMITTING TO THE CONSTRUCTION MANAGER FOR REVIEW.
15. THE CONTRACTOR SHALL FIELD VERIFY ALL DIMENSIONS, ELEVATIONS, ANGLES, AND EXISTING CONDITIONS AT THE SITE, PRIOR TO FABRICATION AND/OR INSTALLATION OF ANY WORK IN THE CONTRACT AREA.
16. COORDINATION, LAYOUT, FURNISHING AND INSTALLATION OF CONDUIT AND ALL APPURTENANCES REQUIRED FOR PROPER INSTALLATION OF ELECTRICAL AND TELECOMMUNICATION SERVICE SHALL BE THE SOLE RESPONSIBILITY OF THE CONTRACTOR.
17. ALL DAMAGE CAUSED TO ANY EXISTING STRUCTURE SHALL BE THE SOLE RESPONSIBILITY OF THE CONTRACTOR. THE CONTRACTOR WILL BE HELD LIABLE FOR ALL REPAIRS REQUIRED FOR EXISTING STRUCTURES IF DAMAGED DURING CONSTRUCTION ACTIVITIES.
18. THE CONTRACTOR SHALL CONTACT "CALL BEFORE YOU DIG" AT LEAST 48 HOURS PRIOR TO ANY EXCAVATIONS AT 1-800-922-4455. ALL UTILITIES SHALL BE IDENTIFIED AND CLEARLY MARKED. CONTRACTOR SHALL MAINTAIN AND PROTECT MARKED UTILITIES THROUGHOUT PROJECT COMPLETION.
19. CONTRACTOR SHALL COMPLY WITH OWNERS ENVIRONMENTAL ENGINEER ON ALL METHODS AND PROVISIONS FOR ALL EXCAVATION ACTIVITIES INCLUDING SOIL DISPOSAL. ALL BACKFILL MATERIALS TO BE PROVIDED BY THE CONTRACTOR.

SITE DIRECTIONS

FROM: 35 GRIFFIN ROAD SOUTH BLOOMFIELD, CT 06002 **TO:** 395 ROUND HILL ROAD GREENWICH, CT 06831

1. HEAD NORTH ON GRIFFIN RD S TOWARD HARTMAN RD 0.2 MI.
2. TAKE SECOND RIGHT ONTO DAY HILL RD 0.2 MI.
3. TAKE FIRST RIGHT ONTO BLUE HILLS AVE 1.9 MI.
4. TURN LEFT ONTO CT-305 2.4 MI.
5. STAY STRAIGHT TO GO ONTO BLOOMFIELD AVE 0.1 MI.
6. MERGE ONTO I-91 S 24.7 MI.
7. MERGE ONTO CT-15 S VIA EXIT 17 61.3 MI.
8. TAKE THE ROUND HILL RD EXIT, EXIT 28 0.1 MI.
9. TURN RIGHT ONTO ROUND HILL RD. DESTINATION IS ON THE RIGHT 0.8 MI.

VICINITY MAP

SCALE: 1" = 1000'

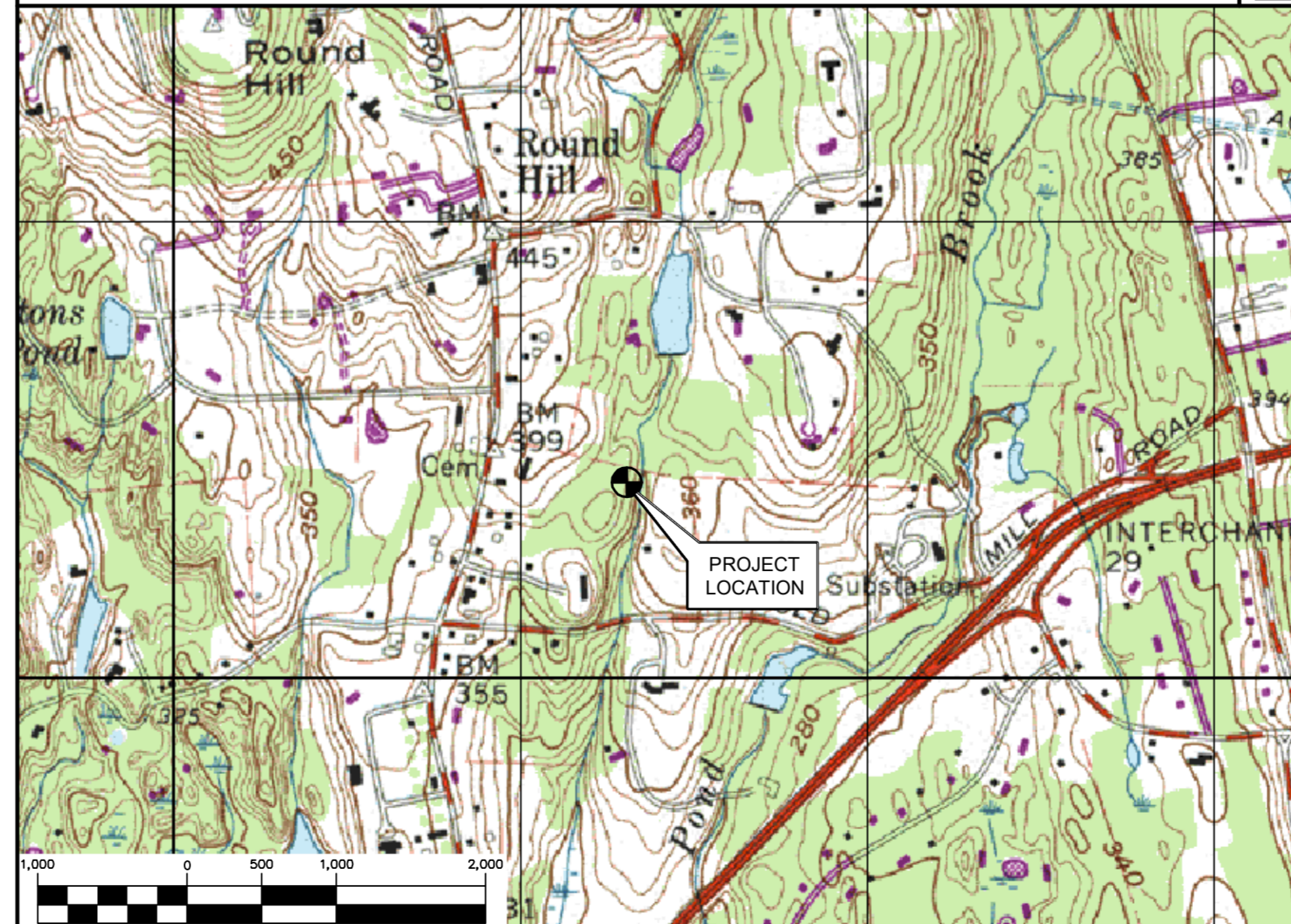

PROJECT SUMMARY

- THE GENERAL SCOPE OF WORK CONSISTS OF THE FOLLOWING:
1. A TOTAL OF THREE (3) REPLACEMENT DIRECTIONAL PANEL ANTENNAS ARE TO BE MOUNTED AT A CENTERLINE ELEVATION OF ±110' A.G.L. ON A 115' RF TRANSPARENT FLAG POLE.
 2. POWER & TELCO UTILITIES WILL BE ROUTED UNDERGROUND FROM THEIR RESPECTIVE DEMARCS LOCATED ADJACENT TO THE EXISTING RF TRANSPARENT FLAG POLE.

PROJECT INFORMATION

SITE NAME: ROUND HILL CHURCH
SITE ID: CT11099G
SITE ADDRESS: 395 ROUND HILL ROAD GREENWICH, CT 06831
APPLICANT: T-MOBILE NORTHEAST, LLC
 35 GRIFFIN ROAD SOUTH BLOOMFIELD, CT 06002
CONTACT PERSON: JAIME FORD (PROJECT MANAGER)
 VERTICAL DEVELOPMENT, LLC (774) 248-5373
ENGINEER: CENTEK ENGINEERING, INC.
 63-2 NORTH BRANFORD RD. BRANFORD, CT 06405
PROJECT COORDINATES: LATITUDE: 41°-05'-42.33" N
 LONGITUDE: 73°-39'-50.81" W
 GROUND ELEVATION: 379'± AMSL
 SITE COORDINATES AND ELEVATION REFERENCED FROM THE CSC DATABASE.

SHEET INDEX

SHT. NO.	DESCRIPTION	REV.
T-1	TITLE SHEET	1
N-1	DESIGN BASIS AND SITE NOTES	1
C-1	SITE LOCATION PLAN	1
C-2	COMPOUND PLAN, ELEVATION AND ANTENNA MOUNTING CONFIG.	1
C-3	ANTENNA DETAILS	1

REV.	DATE	BY	CHK'D BY	DESCRIPTION
0	11/07/16	JTD	HMR	CONSTRUCTION DRAWINGS
0	10/26/16	JTD	HMR	CONSTRUCTION DRAWINGS

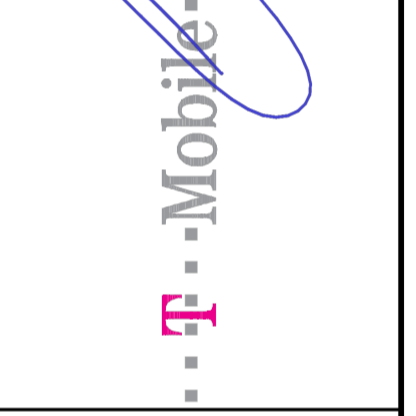

CENTEK engineering
 Centek on Solutions
 (203) 498-0380
 (203) 498-3387 Fax
 632 North Branford Road
 Branford, CT 06405
 www.CentekEng.com

T-MOBILE NORTHEAST LLC
 WIRELESS COMMUNICATIONS FACILITY
ROUND HILL CHURCH
SITE ID: CT11099G
395 ROUND HILL ROAD
GREENWICH, CT 06831

DATE: 10/11/16
 SCALE: AS NOTED
 JOB NO. 16159.01

TITLE SHEET

T-1
 Sheet No. 1 of 5

DESIGN BASIS

1. GOVERNING CODE: 2012 INTERNATIONAL BUILDING CODE AS MODIFIED BY THE 2016 CT STATE SUPPLEMENT.
2. TIA/EIA-222 REVISION "G", ASCE MANUAL NO. 72 - "DESIGN OF STEEL TRANSMISSION POLE STRUCTURES SECOND EDITION".
3. DESIGN CRITERIA:

WIND LOAD: (TOWER & FOUNDATION)
 NOMINAL DESIGN WIND SPEED (V) = 93 MPH (2016 CSBC: APPENDIX 'N')

GENERAL NOTES

1. IF ANY FIELD CONDITIONS EXIST WHICH PRECLUDE COMPLIANCE WITH THE DRAWINGS, THE CONTRACTOR SHALL IMMEDIATELY NOTIFY THE ENGINEER AND SHALL PROCEED WITH AFFECTED WORK AFTER CONFLICT IS SATISFACTORILY RESOLVED.
2. DIMENSIONS AND DETAILS SHALL BE CHECKED AGAINST THE PRE MANUFACTURED EQUIPMENT BUILDING SHOP DRAWINGS.
3. THE CONTRACTOR SHALL VERIFY AND COORDINATE THE SIZE AND LOCATION OF ALL OPENINGS, SLEEVES AND ANCHOR BOLTS AS REQUIRED BY ALL TRADES.
4. REFER TO DRAWING T1 FOR ADDITIONAL NOTES AND REQUIREMENTS.

SITE NOTES

1. THE CONTRACTOR SHALL CALL UTILITIES PRIOR TO THE START OF CONSTRUCTION.
2. ACTIVE EXISTING UTILITIES, WHERE ENCOUNTERED IN THE WORK, SHALL BE PROTECTED AT ALL TIMES. THE ENGINEER SHALL BE NOTIFIED IMMEDIATELY, PRIOR TO PROCEEDING, SHOULD ANY UNCOVERED EXISTING UTILITY PRECLUDE COMPLETION OF THE WORK IN ACCORDANCE WITH THE CONTRACT DOCUMENTS.
3. ALL RUBBISH, STUMPS, DEBRIS, STICKS, STONES AND OTHER REFUSE SHALL BE REMOVED OFF SITE AND BE LEGALLY DISPOSED, AT NO ADDITIONAL COST.
4. THE SITE SHALL BE GRADED TO CAUSE SURFACE WATER TO FLOW AWAY FROM THE EQUIPMENT AND TOWER AREAS.
5. NO FILL OR EMBANKMENT MATERIAL SHALL BE PLACED ON FROZEN GROUND. FROZEN MATERIALS, SNOW OR ICE SHALL NOT BE PLACED IN ANY FILL OR EMBANKMENT.
6. THE SUBGRADE SHALL BE COMPACTED AND BROUGHT TO A SMOOTH UNIFORM GRADE PRIOR TO FINISHED SURFACE APPLICATION.
7. THE AREAS OF THE COMPOUND DISTURBED BY THE WORK SHALL BE RETURNED TO THEIR ORIGINAL CONDITION.
8. CONTRACTOR SHALL MINIMIZE DISTURBANCE TO EXISTING SITE DURING CONSTRUCTION. EROSION CONTROL MEASURES, SHALL BE IN CONFORMANCE WITH THE LOCAL GUIDELINES FOR EROSION AND SEDIMENT CONTROL.
9. IF ANY FIELD CONDITIONS EXIST WHICH PRECLUDE COMPLIANCE WITH THE DRAWINGS, THE CONTRACTOR SHALL IMMEDIATELY NOTIFY THE ENGINEER AND SHALL PROCEED WITH AFFECTED WORK AFTER CONFLICT IS SATISFACTORILY RESOLVED.
10. DIMENSIONS AND DETAILS SHALL BE CHECKED AGAINST THE PRE MANUFACTURED EQUIPMENT BUILDING SHOP DRAWINGS.

ELECTRIC NOTES

1. ALL NEW ANTENNAS SHALL BE BONDED TO EXISTING GROUNDING SYSTEM PER MANUFACTURERS AND NEC SPECIFICATIONS. COORDINATE WITH CONSTRUCTION MANAGER FOR REQUIREMENTS.
2. PROVIDE NEW POWER FEED TO NEW EQUIPMENT CABINET FROM EXISTING PANEL PER MANUFACTURERS SPECIFICATIONS. COORDINATE EXISTING CAPACITY PRIOR TO INSTALLATION.
3. BOND NEW EQUIPMENT CABINET TO EXISTING INTERIOR GROUNDING SYSTEM PER MANUFACTURERS SPECIFICATIONS.

REV.	DATE	BY	CHK'D BY	DESCRIPTION
0	11/07/16	JTD	HMR	CONSTRUCTION DRAWINGS
	10/26/16	JTD	HMR	CONSTRUCTION DRAWINGS

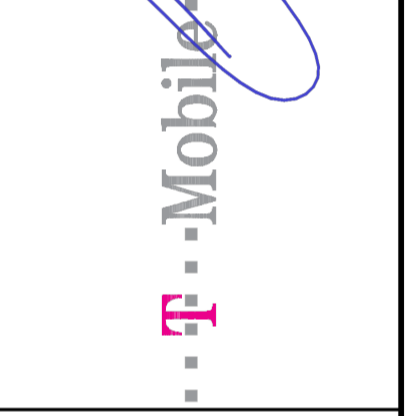
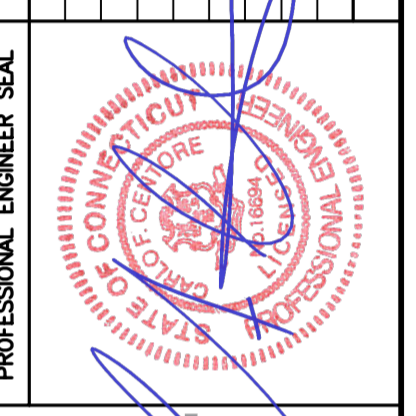

CEN TEK engineering
 Centered on Solutions
 (203) 498-0390
 (203) 498-3397 Fax
 652 North Branford Road
 Branford, CT 06405
 www.CenTekEng.com

T-MOBILE NORTHEAST LLC
 WIRELESS COMMUNICATIONS FACILITY
ROUND HILL CHURCH
SITE ID: CT11099G
 395 ROUND HILL ROAD
 GREENWICH, CT 06831

DATE: 10/11/16
 SCALE: AS NOTED
 JOB NO. 16159.01

DESIGN BASIS
 AND SITE NOTES

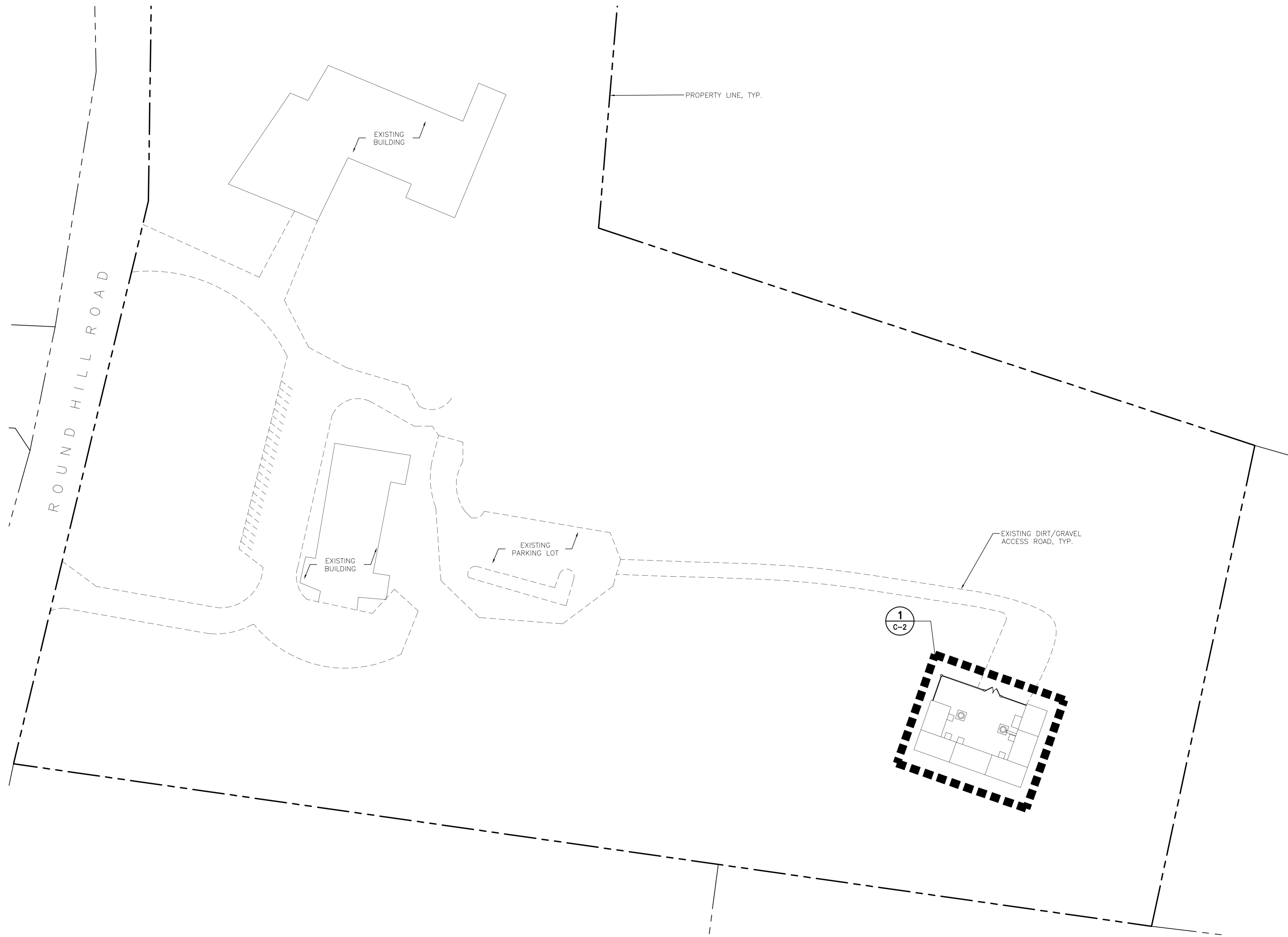

1 SITE LOCATION PLAN
C-1 SCALE: 1" = 40'

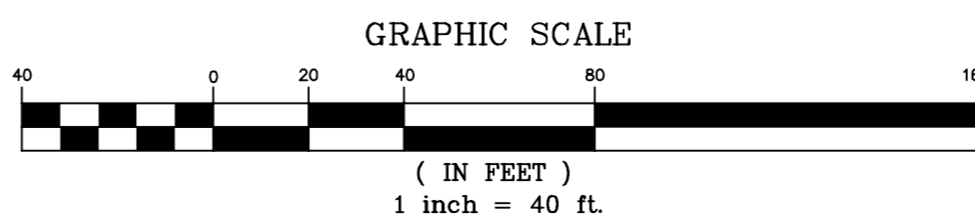

DATE: 10/11/16
SCALE: AS NOTED
JOB NO. 16159.01

SITE LOCATION PLAN

C-1
Sheet No. 3 of 5

T-MOBILE NORTHEAST LLC
WIRELESS COMMUNICATIONS FACILITY
ROUND HILL CHURCH
SITE ID: CT11099G
395 ROUND HILL ROAD
GREENWICH, CT 06831

CEN TEK engineering
Centered on Solutions
(203) 488-0390
(203) 488-3397 Fax
632 North Branford Road
Branford, CT 06405
www.CenTekEng.com

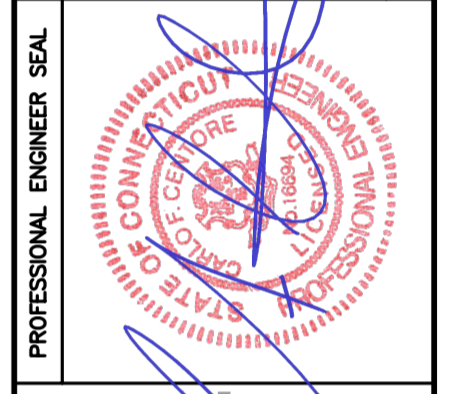
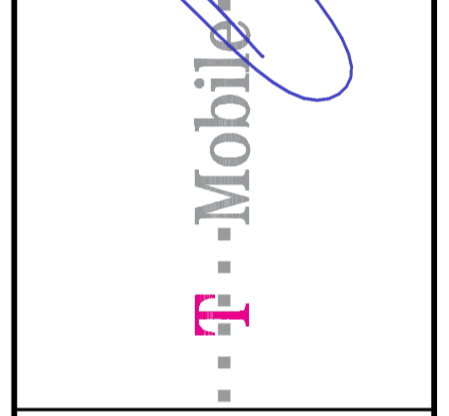

REV.	DATE	BY	CHK'D BY	DESCRIPTION
0	11/07/16	JTD	HMR	CONSTRUCTION DRAWINGS
1	10/26/16	JTD	HMR	CONSTRUCTION DRAWINGS - ISSUED FOR CLIENT REVIEW

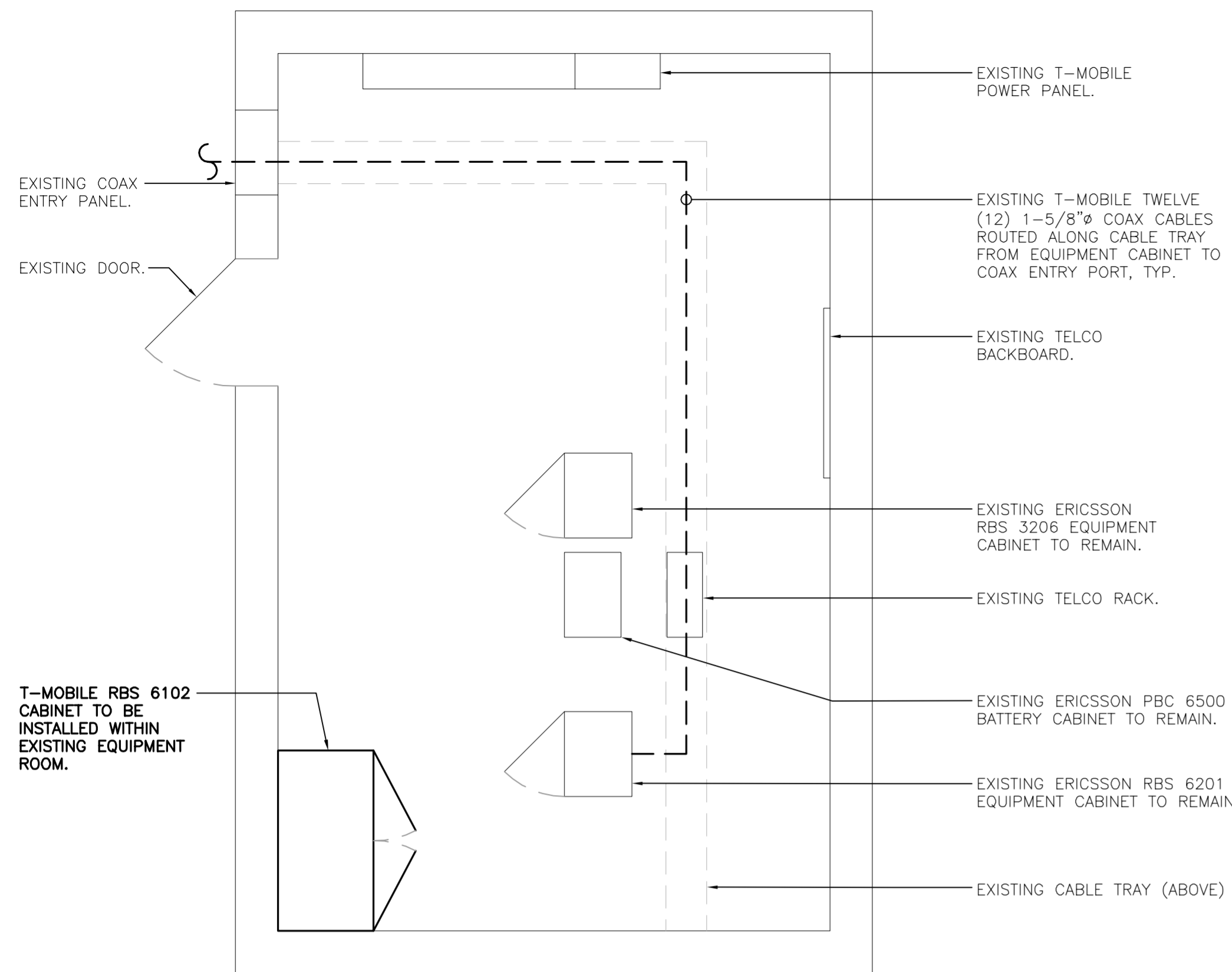

3 EQUIPMENT PLAN
SCALE: 3/8" = 1'
TRUE NORTH

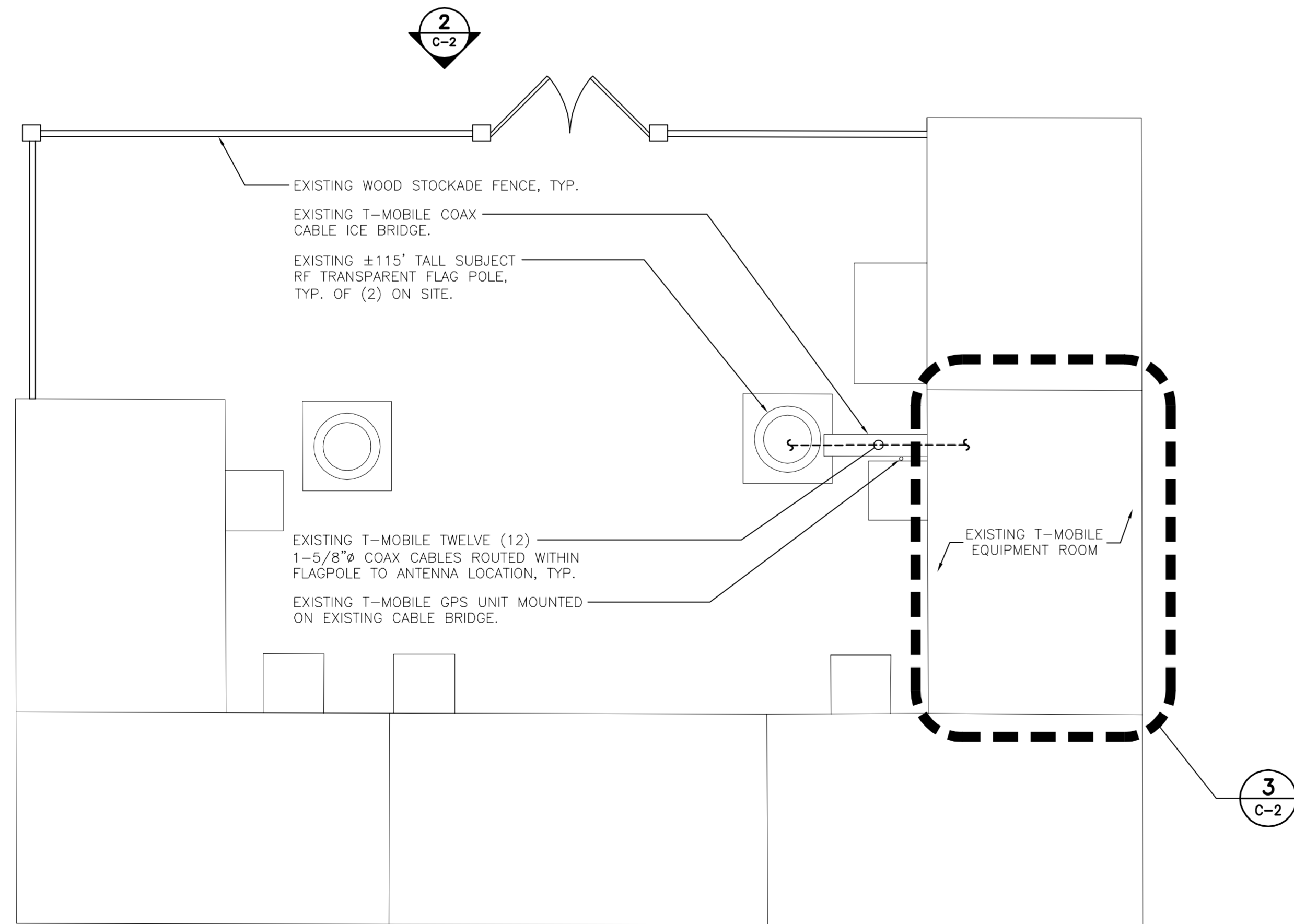

1 COMPOUND PLAN
SCALE: 1/8" = 1'
TRUE NORTH

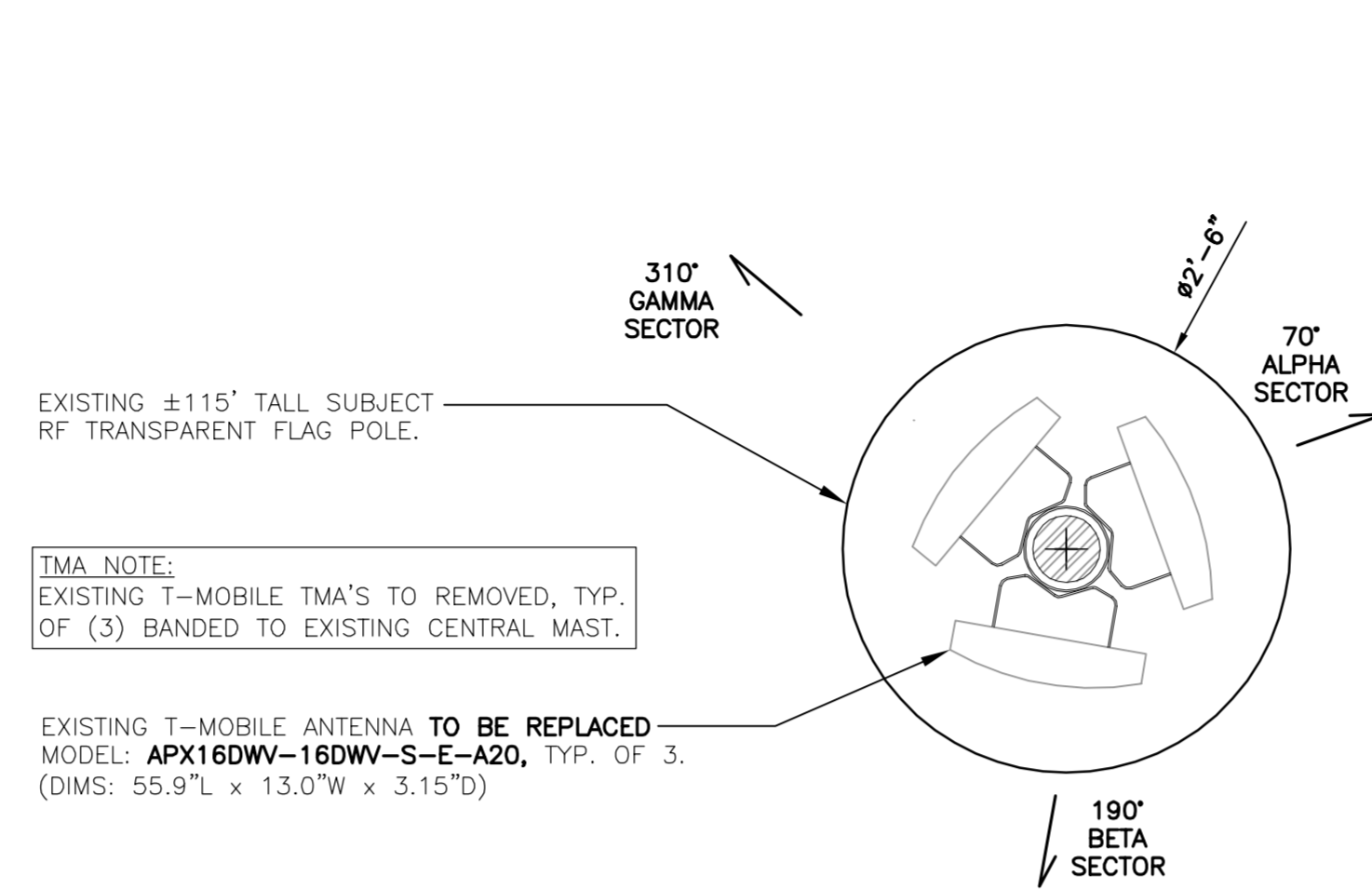
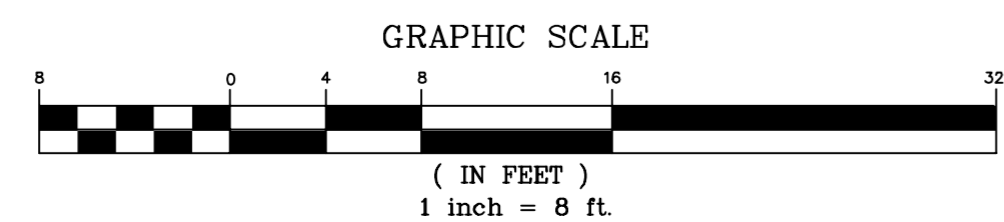

4 EXISTING ANTENNA MOUNTING CONFIGURATION
SCALE: 1" = 1'
TRUE NORTH

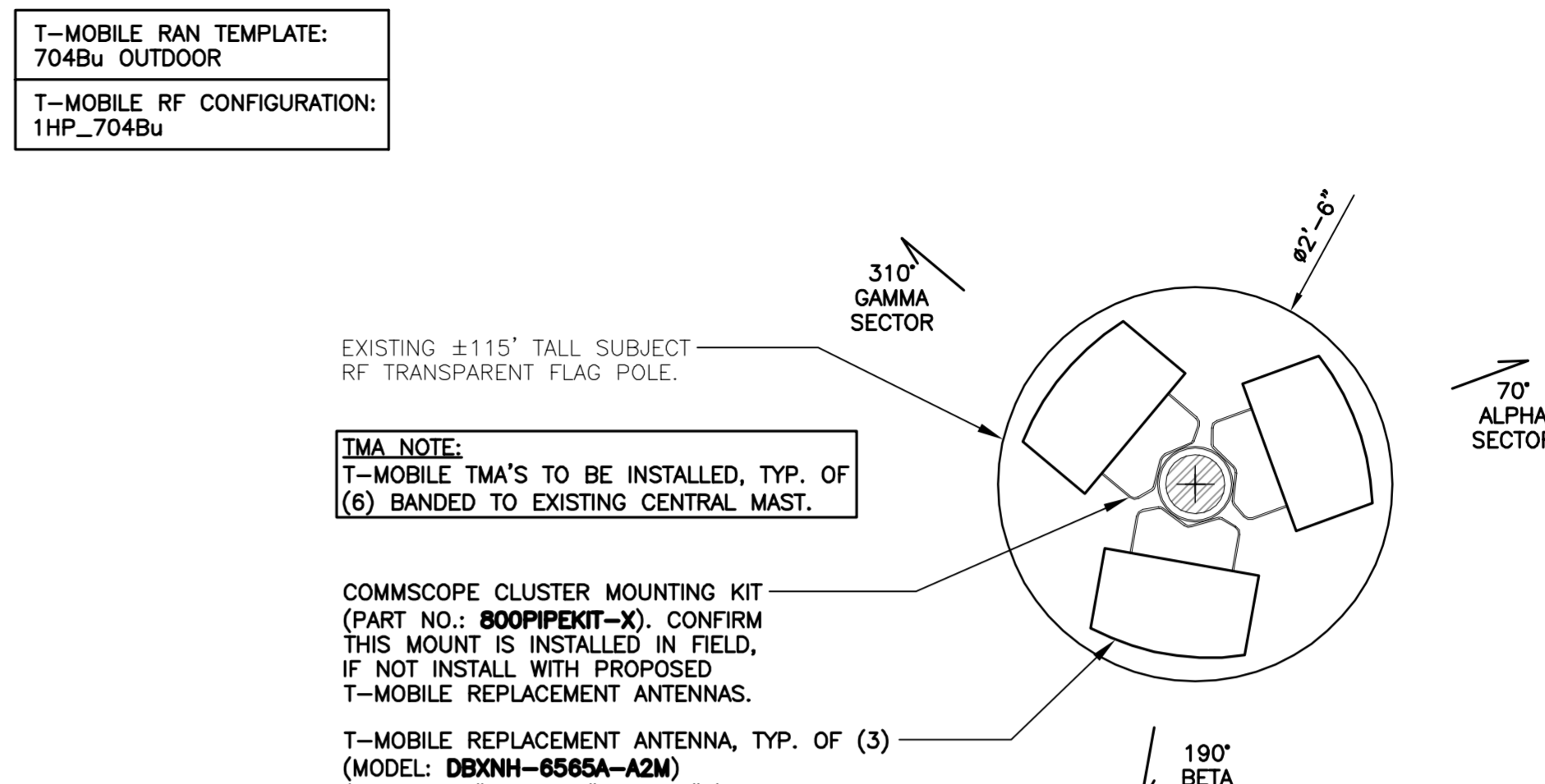

5 PROPOSED ANTENNA MOUNTING CONFIGURATION
SCALE: 1" = 1'
TRUE NORTH

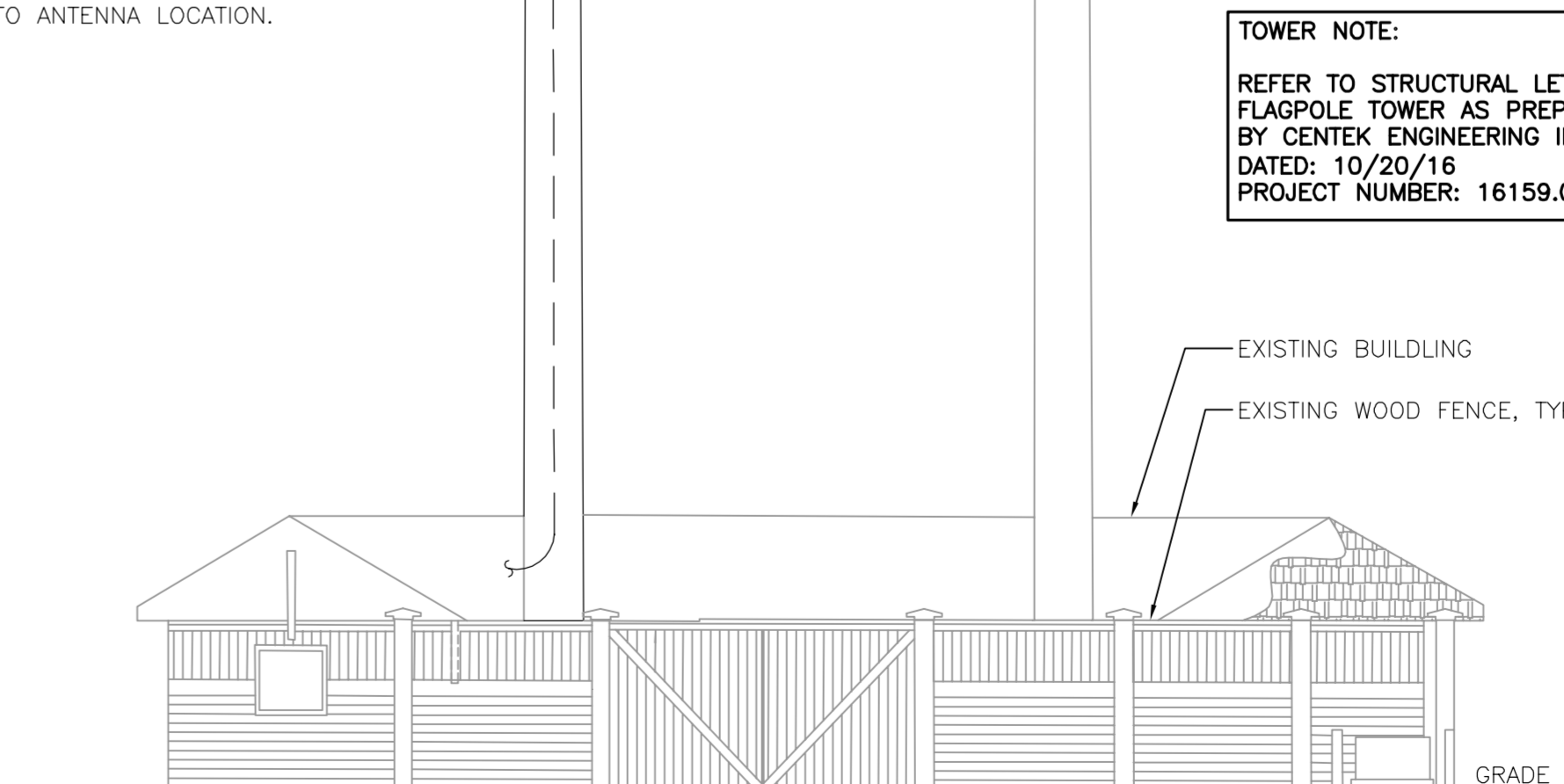
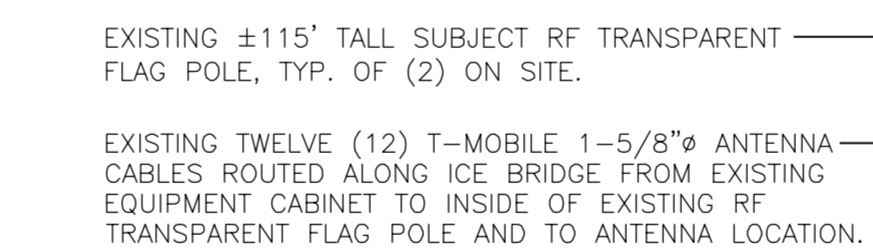
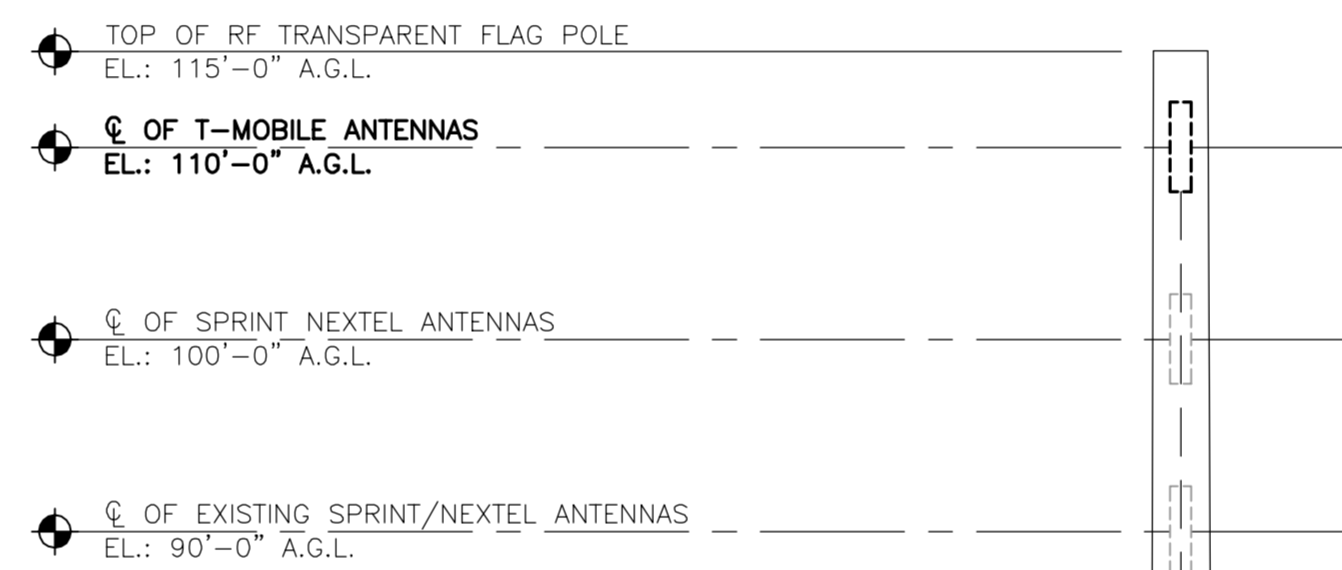

2 TOWER ELEVATION
SCALE: 1" = 10'
GRAPHIC SCALE
(IN FEET)
1 inch = 10 ft.

TOWER NOTE:
REFER TO STRUCTURAL LETTER OF FLAGPOLE TOWER AS PREPARED BY CENTEK ENGINEERING INC., DATED: 10/20/16 PROJECT NUMBER: 16159.01

CONSTRUCTION DRAWINGS	HMR	DATE	11/07/16	BY	JTD	CHK'D BY	HMR	ISSUED FOR CLIENT REVIEW
CONSTRUCTION DRAWINGS	HMR	DATE	10/26/16	BY	JTD	CHK'D BY	HMR	ISSUED FOR CLIENT REVIEW
CONSTRUCTION DRAWINGS	HMR	DATE	0	BY	JTD	CHK'D BY	HMR	ISSUED FOR CLIENT REVIEW

PROFESSIONAL ENGINEER SEAL

Centek engineering
Centered on Solutions™
(203) 498-0380
(203) 498-3387 Fax
632 North Branford Road
Branford, CT 06405
www.CentekEng.com

T-MOBILE NORTHEAST LLC
WIRELESS COMMUNICATIONS FACILITY
ROUND HILL CHURCH
SITE ID: CT1099G
395 ROUND HILL ROAD
GREENWICH, CT 06831

DATE: 10/11/16
SCALE: AS NOTED
JOB NO. 16159.01

COMPOUND PLAN,
ELEVATION AND
ANTENNA
MOUNTING CONFIG.

C-2

Sheet No. 4 of 5

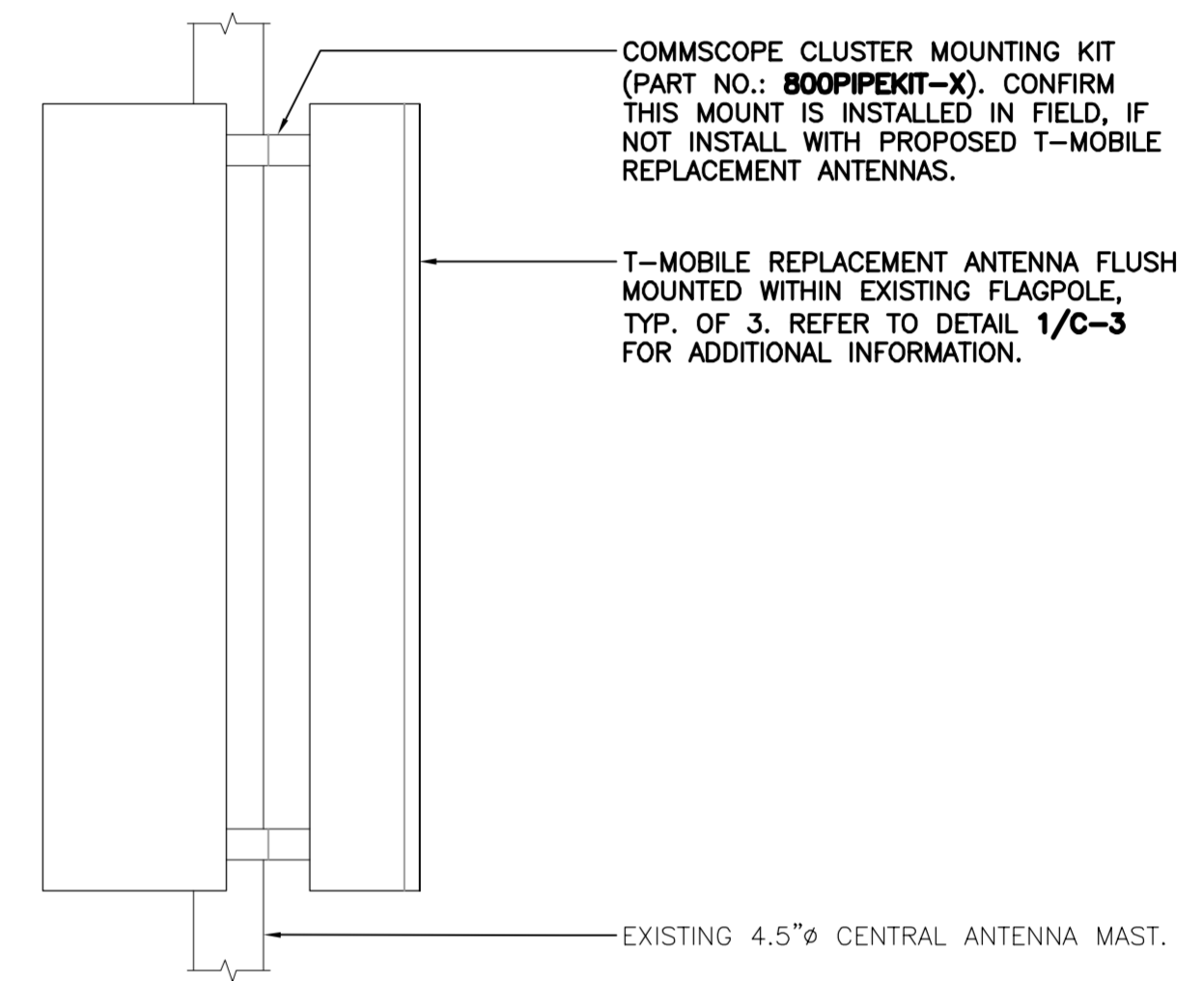

2 PROPOSED ANTENNA MOUNTING DETAIL
 C-3 SCALE: 1/2" = 1'-0"

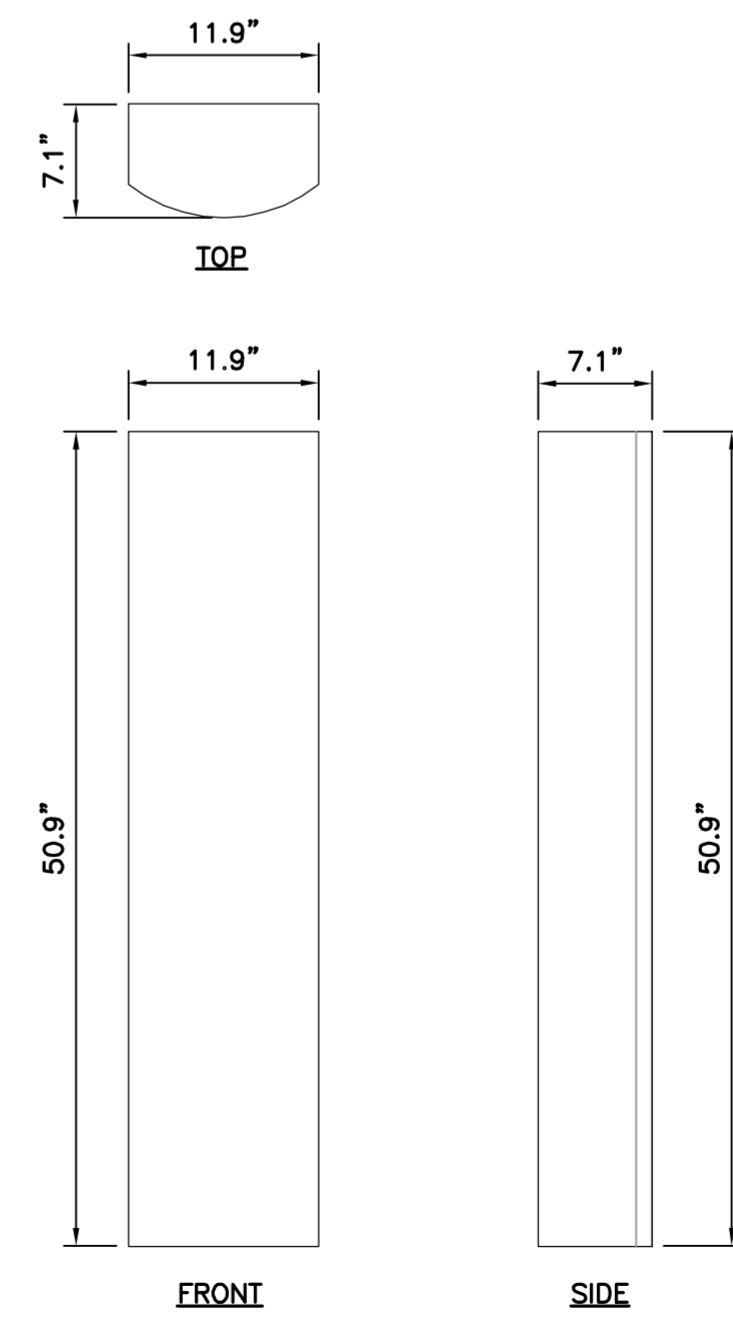

1 PROPOSED ANTENNA DETAIL
 C-3 SCALE: 1" = 1'-0"

WEIGHT: 34.2 LB
 COMMSCOPE DBXNH-6565A-A2M ANTENNA

REV.	DATE	BY	CHK'D BY	DESCRIPTION
0	11/07/16	JTD	HMR	CONSTRUCTION DRAWINGS
1	10/26/16	JTD	HMR	CONSTRUCTION DRAWINGS - ISSUED FOR CLIENT REVIEW

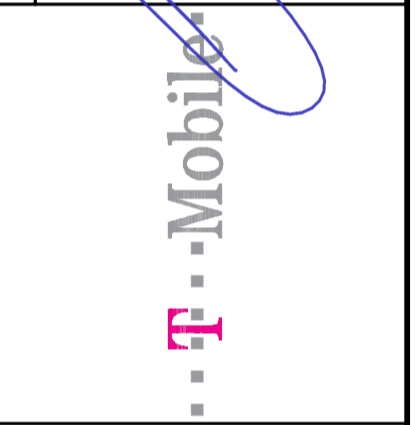
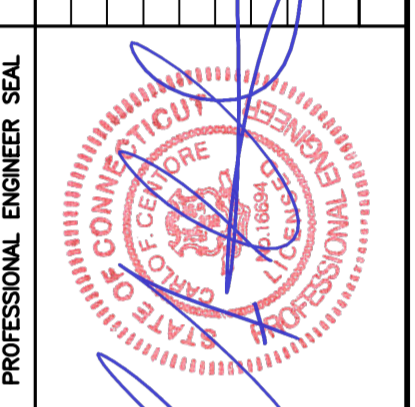

CEN TEK engineering
 Centered on Solutions™
 (203) 488-0390
 (203) 488-3397 Fax
 632 North Branford Road
 Branford, CT 06405
 www.CenTekEng.com

T-MOBILE NORTHEAST LLC
 WIRELESS COMMUNICATIONS FACILITY
ROUND HILL CHURCH
SITE ID: CT11099G
 395 ROUND HILL ROAD
 GREENWICH, CT 06831

DATE: 10/11/16
 SCALE: AS NOTED
 JOB NO. 16159.01

ANTENNA DETAILS

October 20, 2016

Ms. Jamie Ford
Vertical Development
20 Commercial Street
Branford, CT 06405

*Re: Structural Evaluation Letter ~ Antenna Upgrade
T-Mobile Site Ref ~ CT11099G
395 Round Hill Road
Greenwich, CT 06831*

Centek Project No. 16159.01

Dear Ms. Ford,

Centek Engineering, Inc. has reviewed the proposed T-Mobile antenna upgrade at the above referenced site. The purpose of the review is to determine the structural adequacy of the existing 115-ft +/- tall host flagpole to support the proposed modified antenna configuration. The existing installation consists of one (1) array of three (3) antennas mounted within the existing flagpole. The review considered the effects of wind load, dead load, ice load and seismic forces in accordance with the 2012 International Building Code as amended by the 2016 CT State Building Code and TIA-222-G "Structural Standard for Antenna Supporting Structures and Antennas".

The existing and proposed T-Mobile loads considered in this analysis consist of the following:

- **T-Mobile (Existing to Remain):**
Coax: Twelve (12) 1-5/8-in dia. coaxial cables routed within the existing flagpole.
- **T-Mobile (Existing to Remove):**
Antennas: Three (3) RFS APX16DWV-16DWVS panel antennas and three (3) TMA's mounted within the existing flagpole with a RAD center elevation of 110-ft +/- AGL.
- **T-Mobile (Proposed):**
Antennas: Three (3) Andrew DBXNH-6565A panel antennas and six (6) TMA's mounted within the existing flagpole with a RAD center elevation of 110-ft +/- AGL.

The proposed antenna installation meets the requirements of 2012 International Building Code as amended by the 2016 CT State Building Code and TIA-222-G considering the nominal design wind speed of 93 mph as required in Appendix N of the CSBC. Our findings are based on the assumption that the hosting structure, all structural members and appurtenances were properly designed, detailed, fabricated, installed and have been properly maintained since erection.

In conclusion, the proposed T-Mobile antenna upgrade will not negatively impact the structural integrity of the existing host flagpole. If there are any questions regarding this matter, please feel free to call.

Respectfully Submitted by:

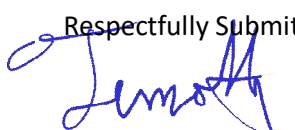
Timothy J. Lynn, PE
Structural Engineer

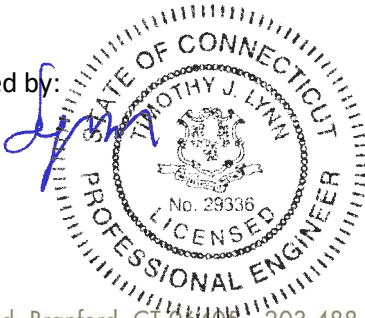

RADIO FREQUENCY EMISSIONS ANALYSIS REPORT
EVALUATION OF HUMAN EXPOSURE POTENTIAL
TO NON-IONIZING EMISSIONS

T-Mobile Existing Facility

Site ID: CT11099G

Round Hill Church
395 Round Hill Road
Greenwich, CT 06831

November 15, 2016

EBI Project Number: 6216005290

Site Compliance Summary	
Compliance Status:	COMPLIANT
Site total MPE% of FCC general public allowable limit:	12.38 %

November 15, 2016

T-Mobile USA
Attn: Jason Overbey, RF Manager
35 Griffin Road South
Bloomfield, CT 06002

Emissions Analysis for Site: **CT11099G – Round Hill Church**

EBI Consulting was directed to analyze the proposed T-Mobile facility located at **395 Round Hill Road, Greenwich, CT**, for the purpose of determining whether the emissions from the Proposed T-Mobile Antenna Installation located on this property are within specified federal limits.

All information used in this report was analyzed as a percentage of current Maximum Permissible Exposure (% MPE) as listed in the FCC OET Bulletin 65 Edition 97-01 and ANSI/IEEE Std C95.1. The FCC regulates Maximum Permissible Exposure in units of microwatts per square centimeter ($\mu\text{W}/\text{cm}^2$). The number of $\mu\text{W}/\text{cm}^2$ calculated at each sample point is called the power density. The exposure limit for power density varies depending upon the frequencies being utilized. Wireless Carriers and Paging Services use different frequency bands each with different exposure limits, therefore it is necessary to report results and limits in terms of percent MPE rather than power density.

All results were compared to the FCC (Federal Communications Commission) radio frequency exposure rules, 47 CFR 1.1307(b)(1) – (b)(3), to determine compliance with the Maximum Permissible Exposure (MPE) limits for General Population/Uncontrolled environments as defined below.

General population/uncontrolled exposure limits apply to situations in which the general public may be exposed or in which persons who are exposed as a consequence of their employment may not be made fully aware of the potential for exposure or cannot exercise control over their exposure. Therefore, members of the general public would always be considered under this category when exposure is not employment related, for example, in the case of a telecommunications tower that exposes persons in a nearby residential area.

Public exposure to radio frequencies is regulated and enforced in units of microwatts per square centimeter ($\mu\text{W}/\text{cm}^2$). The general population exposure limit for the 700 MHz Band is approximately 467 $\mu\text{W}/\text{cm}^2$, and the general population exposure limit for the 1900 MHz (PCS) and 2100 MHz (AWS) bands is 1000 $\mu\text{W}/\text{cm}^2$. Because each carrier will be using different frequency bands, and each frequency band has different exposure limits, it is necessary to report percent of MPE rather than power density.

Occupational/controlled exposure limits apply to situations in which persons are exposed as a consequence of their employment and in which those persons who are exposed have been made fully aware of the potential for exposure and can exercise control over their exposure. Occupational/controlled exposure limits also apply where exposure is of a transient nature as a result of incidental passage through a location where exposure levels may be above general population/uncontrolled limits (see below), as long as the exposed person has been made fully aware of the potential for exposure and can exercise control over his or her exposure by leaving the area or by some other appropriate means.

Additional details can be found in FCC OET 65.

CALCULATIONS

Calculations were done for the proposed T-Mobile Wireless antenna facility located at **395 Round Hill Road, Greenwich, CT**, using the equipment information listed below. All calculations were performed per the specifications under FCC OET 65. Since T-Mobile is proposing highly focused directional panel antennas, which project most of the emitted energy out toward the horizon, all calculations were performed assuming a lobe representing the maximum gain of the antenna per the antenna manufactures supplied specifications, minus 10 dB, was focused at the base of the tower. For this report the sample point is the top of a 6-foot person standing at the base of the tower.

For all calculations, all equipment was calculated using the following assumptions:

- 1) 2 GSM channels (PCS Band - 1900 MHz) were considered for each sector of the proposed installation. These Channels have a transmit power of 30 Watts per Channel.
- 2) 2 UMTS channels (PCS Band - 1900 MHz) were considered for each sector of the proposed installation. These Channels have a transmit power of 30 Watts per Channel.
- 3) 2 UMTS channels (AWS Band – 2100 MHz) were considered for each sector of the proposed installation. These Channels have a transmit power of 30 Watts per Channel.
- 4) 2 LTE channels (AWS Band – 2100 MHz) were considered for each sector of the proposed installation. These Channels have a transmit power of 60 Watts per Channel
- 5) 1 LTE channel (700 MHz Band) was considered for each sector of the proposed installation. This channel has a transmit power of 30 Watts.

- 6) Since all radios are ground mounted there are additional cabling losses accounted for. For each ground mounted RF path the following losses were calculated. 0.95 dB of additional cable loss for all ground mounted 700 MHz Channels, 1.75 dB of additional cable loss for all ground mounted 1900 MHz channels and 1.80 dB of additional cable loss for all ground mounted 2100 MHz channels. This is based on manufacturers Specifications for 175 feet of 1-5/8" coax cable on each path.
- 7) All radios at the proposed installation were considered to be running at full power and were uncombined in their RF transmissions paths per carrier prescribed configuration. Per FCC OET Bulletin No. 65 - Edition 97-01 recommendations to achieve the maximum anticipated value at each sample point, all power levels emitting from the proposed antenna installation are increased by a factor of 2.56 to account for possible in-phase reflections from the surrounding environment. This is rarely the case, and if so, is never continuous.
- 8) For the following calculations the sample point was the top of a 6-foot person standing at the base of the tower. The maximum gain of the antenna per the antenna manufactures supplied specifications minus 10 dB was used in this direction. This value is a very conservative estimate as gain reductions for these particular antennas are typically much higher in this direction.
- 9) The antennas used in this modeling are the **Commscope DBXNH-6565A-A2M** for all 700 MHz, 1900 MHz (PCS) and 2100 MHz (AWS) channels. This is based on feedback from the carrier with regards to anticipated antenna selection. The **Commscope DBXNH-6565A-A2M** has a maximum gain of **15.5 dBd** at its main lobe at 1900 MHz and 2100 MHz and a maximum gain of **11.3 dBd** at its main lobe at 700 MHz. The maximum gain of the antenna per the antenna manufactures supplied specifications, minus 10 dB, was used for all calculations. This value is a very conservative estimate as gain reductions for these particular antennas are typically much higher in this direction.
- 10) The antenna mounting height centerline of the proposed antennas is **110 feet** above ground level (AGL).
- 11) Emissions values for additional carriers were taken from the Connecticut Siting Council active database. Values in this database are provided by the individual carriers themselves. Emissions values from an adjacent tower located immediately next to the subject tower were added to the composite emissions values for the property.
- 12) All calculations were done with respect to uncontrolled / general public threshold limits.

T-Mobile Site Inventory and Power Data

Sector:	A	Sector:	B	Sector:	C
Antenna #:	1	Antenna #:	1	Antenna #:	1
Make / Model:	Commscope DBXNH-6565A-A2M	Make / Model:	Commscope DBXNH-6565A-A2M	Make / Model:	Commscope DBXNH-6565A-A2M
Gain:	11.3 dBd / 15.5 dBd	Gain:	11.3 dBd / 15.5 dBd	Gain:	11.3 dBd / 15.5 dBd
Height (AGL):	110	Height (AGL):	110	Height (AGL):	110
Frequency Bands	700 MHz / 1900 MHz (PCS) / 2100 MHz (AWS)	Frequency Bands	700 MHz / 1900 MHz (PCS) / 2100 MHz (AWS)	Frequency Bands	700 MHz / 1900 MHz (PCS) / 2100 MHz (AWS)
Channel Count	9	Channel Count	9	Channel Count	9
Total TX Power(W):	330	Total TX Power(W):	330	Total TX Power(W):	330
ERP (W):	7,390.44	ERP (W):	7,390.44	ERP (W):	7,390.44
Antenna A1 MPE%	2.58	Antenna B1 MPE%	2.58	Antenna C1 MPE%	2.58

Site Composite MPE%	
Carrier	MPE%
T-Mobile (Per Sector Max)	2.58 %
Sprint	2.62 %
Verizon Wireless (Adjacent Tower)	3.76 %
AT&T (Adjacent Tower)	3.42 %
Site Total MPE %:	12.38 %

T-Mobile Sector A Total:	2.58 %
T-Mobile Sector B Total:	2.58 %
T-Mobile Sector C Total:	2.58 %
Site Total:	12.38 %

T-Mobile _per sector	# Channels	Watts ERP (Per Channel)	Height (feet)	Total Power Density ($\mu\text{W}/\text{cm}^2$)	Frequency (MHz)	Allowable MPE ($\mu\text{W}/\text{cm}^2$)	Calculated % MPE
T-Mobile AWS - 2100 MHz LTE	2	1,406.54	110	9.35	AWS - 2100 MHz	1000	0.94%
T-Mobile AWS - 2100 MHz UMTS	2	703.27	110	4.68	AWS - 2100 MHz	1000	0.47%
T-Mobile PCS - 1950 MHz UMTS	2	711.41	110	4.73	PCS - 1950 MHz	1000	0.47%
T-Mobile PCS - 1950 MHz GSM	2	711.41	110	4.73	PCS - 1950 MHz	1000	0.47%
T-Mobile 700 MHz LTE	1	325.18	110	1.08	700 MHz	467	0.23%
						Total:	2.58%

Summary

All calculations performed for this analysis yielded results that were **within** the allowable limits for general public exposure to RF Emissions.

The anticipated maximum composite contributions from the T-Mobile facility as well as the site composite emissions value with regards to compliance with FCC's allowable limits for general public exposure to RF Emissions are shown here:

T-Mobile Sector	Power Density Value (%)
Sector A:	2.58 %
Sector B:	2.58 %
Sector C:	2.58 %
T-Mobile Per Sector Maximum:	2.58 %
Site Total:	12.38 %
Site Compliance Status:	COMPLIANT

The anticipated composite MPE value for this site assuming all carriers present is **12.38%** of the allowable FCC established general public limit sampled at the ground level. This is based upon values listed in the Connecticut Siting Council database for existing carrier emissions.

FCC guidelines state that if a site is found to be out of compliance (over allowable thresholds), that carriers over a 5% contribution to the composite value will require measures to bring the site into compliance. For this facility, the composite values calculated were well within the allowable 100% threshold standard per the federal government.