

Notice of Exempt Modification

5 Perryridge Road, Greenwich, CT

Sprint Nextel Corporation ("Sprint") submits this Notice of Exempt Modification to the Connecticut Siting Council ("Council") pursuant to Sections 16-50j-73 and 16-50j-72(b) of the Regulations of Connecticut State Agencies ("Regulations") in connection with Sprint's planned modification of antennas and associated equipment on an existing 164' Monopole tower located @ 5 Perryridge Road Greenwich, CT. More particularly, Sprint plans to upgrade this site by adding 4G LTE technology to its facilities. The proposed modifications will not increase the tower height, extend the boundaries of the tower site, cause a significant adverse change or alteration in the physical or environmental characteristics of the site, increase noise levels at the tower site boundary by six (6) decibels, add radio frequency sending or receiving capability which increases the total radio frequency electromagnetic radiation power density measured at the tower site boundary to or above the standard adopted by the Federal Communications Commission pursuant to Section 704 of the Telecommunications Act of 1996, as amended, and the State Department of Energy and Environmental Protection, pursuant to Section 22a-162 of the Connecticut General Statutes, or impair the structural integrity of the facility, as determined in a certification provided by a professional engineer licensed in Connecticut.

To better meet the growing voice and data demands of its wireless customers, Sprint is upgrading their network nationwide to include 4G technology, which will provide faster service and better overall performance. Pursuant to the 4G upgrade at this site, Sprint will add antennas, install RRUs (Remote Radio Units) and install related equipment to its equipment area within the fenced tower compound.

The 164' Monopole located @ 5Perryridge Road Greenwich, CT (lat. 41°.03419 N, long. 73°.63082 W, is owned by Greenwich Hospital. It is located on a 7.3274 acre parcel. Sprint currently has three (3) antennas, one (1) antenna on each on three (3) sectors) with a centerline of 155' 6" installed on the tower. Sprint's base station equipment is located inside a building adjacent to the base of the tower. A site plan depicting this is attached.

Sprint plans to add three (3) RFS APXVTM-14-C-I20 panel antennas, one (1) per sector, all with a centerline of 155' 6". Connected to each new RFS antenna will be one (1) ALU TD RRH 8x20 RRH which will be located behind the antenna. The height of the tower will not be increased. Sprint also plans to install a new 2500 MHz 9929 Growth Cabinet which is to be installed within the existing equipment building. The compound's boundaries will not be extended. The proposed modifications will not cause a significant adverse change or alteration in the physical or environmental characteristics of the site, since it is already a telecommunications installation and the modifications will be compatible with this. Other than brief, construction-related noise, these modifications will not increase noise levels at the tower site boundary by six (6) decibels.

The proposed modifications will not add radio frequency sending or receiving capability which increases the total radio frequency electromagnetic radiation power density measured at the tower site boundary to or above the standard adopted by the Federal Communications Commission pursuant to Section 704 of the Telecommunications Act of 1996, as amended, and the State Department of Energy and Environmental Protection, pursuant to Section 22a-162 of the Connecticut General Statutes. A radio frequency emissions analysis prepared by EBI Consulting indicates that the proposed final configuration (including other carriers on the tower) will emit 90.29% of the allowable FCC established general public limit sampled at the ground level (see the 3rd page of Emissions Analysis Report - Evaluation of Human Exposure Potential to Non-Ionizing Emissions, August 23, 2014). Emission values for the Sprint antennas have been calculated from the sample point, which is the top of a six foot person standing at the base of the tower. Emissions values for additional carriers were based upon values listed in Connecticut Siting Council active database (see page 5 of Radio Frequency Emissions Analysis Report - Evaluation of Human Exposure Potential to Non-Ionizing Emissions, August 23, 2014). The information used in the report was analyzed as a percentage of current Maximum Permissible Exposure (% MPE) as listed in the FCC OET Bulletin 65 Edition 97-01 and ANSI/IEEE Std C95.1 (see the second page of Radio Frequency Emissions Analysis Report - Evaluation of Human Exposure Potential to Non-Ionizing Emissions, August 23, 2014).

The proposed modifications will not impair the structural integrity of the facility. Sprint commissioned Infinigy Engineering to perform a structural analysis of the tower to verify that it can support the proposed loading. The structure and foundation were found to be of "Sufficient Capacity" with the proposed modifications (see the first page of Post-Mod Tower Analysis Report, June 12, 2014). The tower is rated at 47.2% of its capacity with the proposed modifications (see the first page of Post-Mod Tower Analysis Report, June 12, 2014).

In conclusion, Sprint's proposed modifications do not constitute a modification subject to the Council's review because Sprint will not change the height of the tower, will not extend the boundaries of the compound, will not cause a significant adverse change or alteration in the physical or environmental characteristics of the site, will not increase the noise levels at the site, will not increase the total radio frequency electromagnetic radiation power density at the site to levels above applicable standards, and will not impair the structural integrity of the facility. Therefore, Sprint respectfully requests that the Council acknowledge that this Notice of Exempt Modification meets the Council's exemption criteria.

RADIO FREQUENCY FCC REGULATORY COMPLIANCE
MAXIMUM PERMISSIBLE EXPOSURE (MPE) ASSESSMENT

Sprint Existing Facility

Site ID: CT43XC855

Greenwich Hospital

5 Perryridge Road
Greenwich, CT 06830

August 23, 2014

EBI Project Number: 62144365

August 23, 2014

Sprint
Attn: RF Engineering Manager
1 International Boulevard, Suite 800
Mahwah, NJ 07495

Re: Radio Frequency Maximum Permissible Exposure (MPE) Assessment for Site:
CT43XC855 - Greenwich Hospital

Site Total: 90.29% - MPE% in full compliance

EBI Consulting was directed to analyze the proposed upgrades to the existing Sprint facility located at **5 Perryridge Road, Greenwich, CT**, for the purpose of determining whether the radio frequency (RF) exposure levels from the proposed Sprint equipment upgrades on this property are within specified federal limits.

All information used in this report was analyzed as a percentage of current Maximum Permissible Exposure (% MPE) as listed in the FCC OET Bulletin 65 Edition 97-01 and ANSI/IEEE Std C95.1. The FCC regulates Maximum Permissible Exposure in units of microwatts per square centimeter ($\mu\text{W}/\text{cm}^2$). The number of $\mu\text{W}/\text{cm}^2$ calculated at each sample point is called the power density. The exposure limit for power density varies depending upon the frequencies being utilized. Wireless Carriers and Paging Services use different frequency bands each with different exposure limits, therefore it is necessary to report results and limits in terms of percent MPE rather than power density.

All results were compared to the FCC (Federal Communications Commission) radio frequency exposure rules, 47 CFR 1.1307(b)(1) – (b)(3), to determine compliance with the Maximum Permissible Exposure (MPE) limits for General Population/Uncontrolled environments as defined below.

General population/uncontrolled exposure limits apply to situations in which the general public may be exposed or in which persons who are exposed as a consequence of their employment may not be made fully aware of the potential for exposure or cannot exercise control over their exposure. Therefore, members of the general public would always be considered under this category when exposure is not employment related, for example, in the case of a telecommunications tower that exposes persons in a nearby residential area.

Public exposure to radio frequencies is regulated and enforced in units of microwatts per square centimeter ($\mu\text{W}/\text{cm}^2$). The general population exposure limit for the cellular band (850 MHz Band) is approximately $567 \mu\text{W}/\text{cm}^2$, and the general population exposure limit for the 1900 MHz and 2500 MHz bands is $1000 \mu\text{W}/\text{cm}^2$. Because each carrier will be using different frequency bands, and each frequency band has different exposure limits, it is necessary to report percent of MPE rather than power density.

Occupational/controlled exposure limits apply to situations in which persons are exposed as a consequence of their employment and in which those persons who are exposed have been made fully aware of the potential for exposure and can exercise control over their exposure. Occupational/controlled exposure limits also apply where exposure is of a transient nature as a result of incidental passage through a location where exposure levels may be above general population/uncontrolled limits (see below), as long as the exposed person has been made fully aware of the potential for exposure and can exercise control over his or her exposure by leaving the area or by some other appropriate means.

Additional details can be found in FCC OET 65.

CALCULATIONS

Calculations were done for the proposed upgrades to the existing Sprint Wireless antenna facility located at **5 Perryridge Road, Greenwich, CT**, using the equipment information listed below. All calculations were performed per the specifications under FCC OET 65. All calculations were performed assuming a lobe representing the maximum gain of the antenna per the antenna manufactures supplied specifications, minus 10 dB, was focused at the base of the tower. For this report the sample point is the top of a 6 foot person standing at the base of the tower.

For all calculations, all emissions were calculated using the following assumptions:

- 1) 3 channels in the 1900 MHz Band were considered for each sector of the proposed installation.
- 2) 1 channel in the 800 MHz Band was considered for each sector of the proposed installation
- 3) 2 channels in the 2500 MHz Band were considered for each sector of the proposed installation.
- 4) All radios at the proposed installation were considered to be running at full power and were uncombined in their RF transmissions paths per carrier prescribed configuration. Per FCC OET Bulletin No. 65 - Edition 97-01 recommendations to achieve the maximum anticipated value at each sample point, all power levels emitting from the proposed antenna installation are increased by a factor of 2.56 to account for possible in-phase reflections from the surrounding environment. This is rarely the case, and if so, is never continuous.

- 5) For the following calculations the sample point was the top of a six foot person standing at the base of the tower. The maximum gain of the antenna per the antenna manufactures supplied specifications minus 10 dB was used in this direction. This value is a very conservative estimate as gain reductions for these particular antennas are typically much higher in this direction.
- 6) The antennas used in this modeling are the RFS APXVSPP18-C-A20, POWERWAVE P40-16-XLPP-RR-A and the RFS APXVTM14-C-I20. This is based on feedback from the carrier with regards to anticipated antenna selection. The RFS APXVSPP18-C-A20 has a 15.9 dBd gain value at its main lobe at 1900 MHz and 13.4 dBd at its main lobe for 850 MHz. The POWERWAVE P40-16-XLPP-RR-A has a 15.9 dBd gain value at its main lobe at 1900 MHz and 13.4 dBd at its main lobe for 850 MHz. The RFS APXVTM14-C-I20 has a 15.9 dBd gain value at its main lobe at 2500 MHz. The maximum gain of the antenna per the antenna manufactures supplied specifications, minus 10 dB, was used for all calculations. This value is a very conservative estimate as gain reductions for these particular antennas are typically much higher in this direction.
- 7) The antenna mounting height centerline for the proposed antennas is **155 feet** above ground level (AGL).
- 8) Emissions values for additional carriers were taken from the Connecticut Siting Council active database. Values in this database are provided by the individual carriers themselves.

All calculation were done with respect to uncontrolled / general public threshold limits

Site ID	CT43XC855 - Greenwich Hospital
Site Address	5 Perryridge Road, Greenwich, CT, 06830
Site Type	Monopole

Sector 1

Antenna Number	Antenna Make	Antenna Model	Radio Type	Frequency Band	Technology	Power Out Per Channel (Watts)	Number of Channels	Composite Power	Antenna Gain (10 db reduction)	Antenna Height (ft)	analysis height	Cable Size	Cable Loss (dB)	Additional Loss (dB)	ERP	Power Density Percentage
1a	RFS	APXVSP18-C-A20	RRH	1900 MHz	CDMA / LTE	20	3	60	5.9	155	149	1/2 "	0.5	0	208.04	0.34%
1a	RFS	APXVSP18-C-A20	RRH	850 MHz	CDMA / LTE	20	1	20	3.4	155	149	1/2 "	0.5	0	39.00	0.11%
1B	RFS	APXVTMM14-C-120	RRH	2500 MHz	CDMA / LTE	20	2	40	5.9	155	149	1/2 "	0.5	0	138.69	0.40%
Sector total Power Density Value:																0.84%

Sector 2

Antenna Number	Antenna Make	Antenna Model	Radio Type	Frequency Band	Technology	Power Out Per Channel (Watts)	Number of Channels	Composite Power	Antenna Gain (10 db reduction)	Antenna Height (ft)	analysis height	Cable Size	Cable Loss (dB)	Additional Loss (dB)	ERP	Power Density Percentage
2a	RFS	APXVSP18-C-A20	RRH	1900 MHz	CDMA / LTE	20	3	60	5.9	155	149	1/2 "	0.5	0	208.04	0.34%
2a	RFS	APXVSP18-C-A20	RRH	850 MHz	CDMA / LTE	20	1	20	3.4	155	149	1/2 "	0.5	0	39.00	0.11%
2B	RFS	APXVTMM14-C-120	RRH	2500 MHz	CDMA / LTE	20	2	40	5.9	155	149	1/2 "	0.5	0	138.69	0.40%
Sector total Power Density Value:																0.84%

Sector 3

Antenna Number	Antenna Make	Antenna Model	Radio Type	Frequency Band	Technology	Power Out Per Channel (Watts)	Number of Channels	Composite Power	Antenna Gain (10 db reduction)	Antenna Height (ft)	analysis height	Cable Size	Cable Loss (dB)	Additional Loss (dB)	ERP	Power Density Percentage
3a	Powerwave	P40-16-XLPP-RR-A	RRH	1900 MHz	CDMA / LTE	20	3	60	5.9	155	149	1/2 "	0.5	0	208.04	0.34%
3a	Powerwave	P40-16-XLPP-RR-A	RRH	850 MHz	CDMA / LTE	20	1	20	3.4	155	149	1/2 "	0.5	0	39.00	0.11%
3B	RFS	APXVTMM14-C-120	RRH	2500 MHz	CDMA / LTE	20	2	40	5.9	155	149	1/2 "	0.5	0	138.69	0.40%
Sector total Power Density Value:																0.84%

Site Composite MPE %	
Carrier	MPE %
Sprint	2.53%
Verizon Wireless	34.38%
AT&T	26.02%
MW to Bruce	6.85%
MW to PD	0.17%
MW to Putnam	6.85%
Trunked system	2.04%
Mutual Aid	1.13%
CMED	0.77%
FirePaging	1.15%
SP Hotline	1.49%
Clearwire	0.78%
T-Mobile	0.17%
Nextel	5.96%
Total Site MPE %	90.29%

Summary

All calculations performed for this analysis yielded results that were well within the allowable limits for general public Maximum Permissible Exposure (MPE) to radio frequency energy.

The anticipated Maximum Composite contributions from the Sprint facility are **2.53% (0.84% from sector 1, 0.84% from sector 2 and 0.84% from sector 3)** of the allowable FCC established general public limit considering all three sectors simultaneously sampled at the ground level.

The anticipated composite MPE value for this site assuming all carriers present is **90.29%** of the allowable FCC established general public limit sampled at 6 feet above ground level. This total composite site value is based upon MPE values listed in the Connecticut Siting Council database for existing carrier emissions.

FCC guidelines state that if a site is found to be out of compliance (over allowable thresholds), that carriers over a 5% contribution to the composite value will require measures to bring the site into compliance. For this facility, the composite values calculated were well within the allowable 100% threshold standard per the federal government.



Scott Heffernan
RF Engineering Director

EBI Consulting
21 B Street
Burlington, MA 01803

Tower Analysis Report

June 12, 2014

Site Name	Greenwich Hospital - CT43XC855
Infinigy Job Number	333-000
Client	Sprint
Proposed Carrier	Sprint
Site Location	5 Perryridge Dr., Greenwich, CT 06830 Fairfield County 41° 2' 2.04" N NAD83 73° 37' 50.8794" W NAD83
Structure Type	164' Monopole
Structural Usage Ratio	47.2%
Overall Result	Pass

Upon reviewing the results of this analysis, it is our opinion that the structure meets the specified TIA code requirements. The tower and foundations are therefore deemed adequate to support the existing and proposed loading as listed in this report.



Maxwell R. Becker, E.I.T.
Structural Engineer I

Contents

Introduction.....	3
Supporting Documentation.....	3
Analysis Code Requirements.....	3
Conclusion.....	3
Existing and Reserved Loading.....	4
Proposed Loading.....	4
Structure Usages.....	4
Foundation Reactions.....	5
Deflection, Twist, and Sway.....	5
Assumptions and Limitations.....	5
Calculations.....	Appended

Introduction

Infinigy Engineering has been requested to perform a structural analysis on the existing 164' Monopole. All supporting documents have been obtained from the client and are assumed to be accurate and applicable to this site. The tower was analyzed using tnxTower version 6.1.3.1 tower analysis software.

Supporting Documentation

Construction Drawings	Infinigy Engineering, Job # 333-000, dated October 01, 2013
Previous Analysis	Salient Associates Site # CT43XC855, dated January 18, 2013

Analysis Code Requirements

Wind Speed	100 mph (3-Second Gust)
Wind Speed w/ ice	50 mph (3-Second Gust) w/ 3/4" ice
TIA Revision	ANSI/TIA-222-G
Adopted IBC	2003 IBC w/ 2005 CT Supplement & 2009 CT Amendment
Structure Class	2
Exposure Category	B
Topographic Category	1
Calculated Crest Height	0 ft

Conclusion

Upon reviewing the results of this analysis, it is our opinion that the structure meets the specified TIA code requirements. The tower and foundations are therefore deemed adequate to support the existing and proposed loading as listed in this report.

If you have any questions, require additional information, or actual conditions differ from those as detailed in this report please contact me via the information below:

Maxwell R. Becker, E.I.T.
 Structural Engineer I | Infinigy
 1033 Watervliet Shaker Road, Albany, NY 12205
 (O) (518) 690-0790 | (M) (518) 221-4665
mbecker@infinigy.com | www.infinigy.com

Existing and Reserved Loading

Mount Height (ft)	Qty.	Appurtenance	Mount Type	Coax& Lines	Carrier
165.0	1	Camera	Platform	(6) 1-5/8"	Town of Greenwich
	1	GPS			
	3	RFS BMR12			
	1	Celwave PD1142-1			
	1	Celwave PD620-3			
	1	Celwave ALR8-0			
160.0	2	4 ft. STD Dish	Pipes	(3) 1-5/8"	
	1	Andrew VP2-180A	Pipe		
155.0	1	GPS	Platform	(1) 2-1/4" (2) 1/2"	Clearwire
	3	Commscope LLPX310R			
	2	Dragonwave 24" Dish			
	2	RFS APXVSP18-C			
152.0	1	Powerwave P4-16-XLPP-RR-A		(1) 1/2"	Sprint
	3	Alcatel-Lucent 800 MHz RRH		(3) 1-1/4"	
145.0	3	Alcatel-Lucent 1900 MHz RRH		Hybriflex	
	6	RFS APX16PV-16PVL-C	Platform	(12) 1-5/8"	T-Mobile
6	Ericsson KRY 112 71				
135.0	6	Powerwave 7770.00	Platform	(12) 1-5/8"	AT&T
	4	Powerwave LGP 21401 TMA			
	2	Powerwave LGP 17201 TMA			
125.0	6	Decibel DB844G45ZAXY	Platform	(18) 1-5/8"	Verizon Wireless
	3	LNX-6514DS-T0M			
115.0	12	Decibel DB846G90A-XY	Platform	(12) 1-5/8"	Nextel

Proposed Loading

Mount Height (ft)	Qty.	Appurtenance	Mount Type	Coax& Lines	Carrier
155.5	3	RFS APXVTM14-C-120	Platform	(3) 1-1/4" Fiber	Sprint
	3	Alcatel Lucent TD-RRH8X20			

Structure Usages

Pole (T5)	35.5	Pass
Base Plate	47.2	Pass
RATING =	47.2	Pass

Foundation Reactions

Reaction Data	Design Reactions	Analysis Reactions	Result
Moment (kip)	--	4760.9	--
Shear (kip)	--	41.5	--
Axial (kip)	--	136.3	--

The existing foundation was not evaluated because no information was made available at the time of this analysis.

Deflection, Twist, and Sway

Antenna Elevation (ft)	Deflection (in)	Twist (°)	Sway (°)
155.5	5.71	0.00	0.29

*Per ANSI/TIA-222-G Section 2.8.2 maximum serviceability structural deflection limit is 3% of structure height.

*Per ANSI/TIA-222-G Section 2.8.2 maximum serviceability structural twist and sway limit is 4 degrees.

*Per ANSI/TIA-222-G Section 2.8.3 deflection, Twist, and sway values were calculated using a basic 3-second gust wind speed of 60 mph.

*It is the responsibility of the client to ensure their proposed and/or existing equipment will meet ANSI/TIA-222-G Annex D or other appropriate microwave signal degradation limits based on the provided values above.

Assumptions and Limitations

All engineering services are completed assuming all information provided to Infinigy Engineering is current and correct. If actual conditions differ from those described in this report we should be notified immediately to complete a revised evaluation.

It is the responsibility of the client to ensure that the information provided to Infinigy Engineering is correct and complete. In the absence of information to the contrary, we assume that all structures were constructed in accordance with the design drawings and specifications that have been supplied.

All calculations are completed in accordance with generally accepted engineering principles and practices. Infinigy Engineering is not responsible the conclusions, opinions, and recommendations made by others based on the information we supply.

This report is an evaluation of the tower structure only and does not reflect adequacy of any existing antenna mounts, mount connections, or coax mounting attachments. These elements are assumed to be adequate for the purposes of this analysis and are assumed to have been installed per their manufacturer requirements.

DESIGNED APPURTENANCE LOADING

TYPE	ELEVATION	TYPE	ELEVATION
Angle Low Profile Platform (Town of Greenwich)	165	1900 MHz RRH (Sprint)	152
BMR12-A (Town of Greenwich)	165	1900 MHz RRH (Sprint)	152
BMR12-A (Town of Greenwich)	165	1900 MHz RRH (Sprint)	152
BMR12-A (Town of Greenwich)	165	800 MHz RRH (Sprint)	152
BMR12-A (Town of Greenwich)	165	800 MHz RRH (Sprint)	152
GPS (Town of Greenwich)	165	(2) KRY11271/2 (T-Mobile)	145
ALR8 (Town of Greenwich)	165	Angle Low Profile Platform (T-Mobile)	145
PD1142-1 (Town of Greenwich)	165	(2) APX16PV-16PVL (T-Mobile)	145
PD620 (Town of Greenwich)	165	(2) APX16PV-16PVL (T-Mobile)	145
Camera (Town of Greenwich)	165	(2) APX16PV-16PVL (T-Mobile)	145
Dish Pipe Mount (Town of Greenwich)	160	(2) KRY11271/2 (T-Mobile)	145
Dish Pipe Mount (Town of Greenwich)	160	(2) KRY11271/2 (T-Mobile)	145
Dish Pipe Mount (Town of Greenwich)	160	(2) LGP21401 (ATI)	135
4' Std. Dish (Town of Greenwich)	160	(2) LGP17201 (ATI)	135
4' Std. Dish (Town of Greenwich)	160	(2) 7700.00 (ATI)	135
VP2-180A (Town of Greenwich)	160	(2) 7700.00 (ATI)	135
APXVTM14-C-120 (Sprint)	155.5	(2) 7700.00 (ATI)	135
APXVTM14-C-120 (Sprint)	155.5	(2) LGP21401 (ATI)	135
APXVTM14-C-120 (Sprint)	155.5	Angle Low Profile Platform (ATI)	135
TD-RRH8X20 (Sprint)	155.5	DB844G45ZAXY (Verizon Wireless)	125
TD-RRH8X20 (Sprint)	155.5	DB844G45ZAXY (Verizon Wireless)	125
TD-RRH8X20 (Sprint)	155.5	LNX-6514DS-VTM (Verizon Wireless)	125
DB980F90E-M (Sprint)	155	LNX-6514DS-VTM (Verizon Wireless)	125
DB980F90E-M (Sprint)	155	LNX-6514DS-VTM (Verizon Wireless)	125
DB950F65T2E-M (Sprint)	155	Angle Low Profile Platform (Verizon Wireless)	125
LLPX310R (Sprint)	155	DB844G45ZAXY (Verizon Wireless)	125
LLPX310R (Sprint)	155	DB844G45ZAXY (Verizon Wireless)	125
LLPX310R (Sprint)	155	DB844G45ZAXY (Verizon Wireless)	125
P40-16-XLPP-RR-A (Sprint)	155	DB844G45ZAXY (Verizon Wireless)	125
Angle Low Profile Platform (Sprint)	155	DB844G45ZAXY (Verizon Wireless)	125
APXVSP18-C-A20 (Sprint)	155	(4) DB846G90A-XY (Nextel)	115
APXVSP18-C-A20 (Sprint)	155	(4) DB846G90A-XY (Nextel)	115
A-ANT-23G-24 (Sprint)	155	(4) DB846G90A-XY (Nextel)	115
A-ANT-23G-24 (Sprint)	155	Angle Low Profile Platform (Nextel)	115
800 MHz RRH (Sprint)	152		

MATERIAL STRENGTH

GRADE	Fy	Fu	GRADE	Fy	Fu
A572-65	65 ksi	80 ksi			

TOWER DESIGN NOTES

1. Tower is located in Fairfield County, Connecticut.
2. Tower designed for Exposure B to the TIA-222-G Standard.
3. Tower designed for a 100 mph basic wind in accordance with the TIA-222-G Standard.
4. Tower is also designed for a 50 mph basic wind with 0.75 in ice. Ice is considered to increase in thickness with height.
5. Deflections are based upon a 60 mph wind.
6. Tower Structure Class II.
7. Topographic Category 1 with Crest Height of 0.00 ft
8. TOWER RATING: 80%

ALL REACTIONS
ARE FACTORED

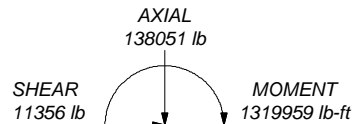

TORQUE 5458 lb-ft
50 mph WIND - 0.7500 in ICE

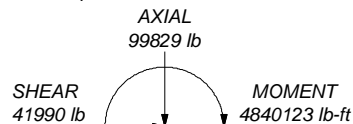

TORQUE 21038 lb-ft
REACTIONS - 100 mph WIND

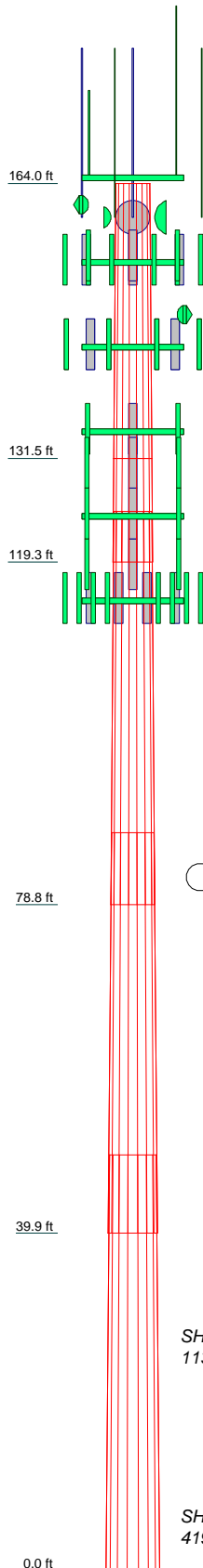

Section	Length (ft)	Number of Sides	Thickness (in)	Socket Length (ft)	Top Dia (in)	Bot Dia (in)	Grade	Weight (lb)
1	32.50	18	0.3125	47.0000	53.4200	56.1500	A572-65	5473.4
2	12.21	18	0.3750	6.00	53.4200	56.1500	A572-65	2690.7
3	46.50	18	0.4375	8.42	54.0585	62.9700	A572-65	12760.7
4	47.33	18	0.5625	9.25	60.4813	69.6600	A572-65	18548.8
5	49.13	18	0.5625	66.7412	76.0000		A572-65	21134.6
								60608.2

Infinigy Engineering		
2255 Sewell Mill Road, Suite 130 Marietta, GA 30062 Phone: (678) 444-4463 FAX: (678)444-4472		
Job: 333-000	Project: Greenwich Hospital	Client: Sprint
Code: TIA-222-G	Date: 06/09/14	Drawn by: MBecker
Path: <small>N:\Sprint2-Sprint Direct\Southern CT\CT43XC855\Structural\Structural Documents\CT43XC855.dwg</small>	App'd:	Scale: NTS
		Dwg No. E-1

tnxTower Infinigy Engineering 2255 Sewell Mill Road, Suite 130 Marietta, GA 30062 Phone: (678) 444-4463 FAX: (678)444-4472	Job	333-000	Page	1 of 13
	Project	Greenwich Hospital	Date	14:11:52 06/09/14
	Client	Sprint	Designed by	MBecker

Tower Input Data

There is a pole section.

This tower is designed using the TIA-222-G standard.

The following design criteria apply:

Tower is located in Fairfield County, Connecticut.

Basic wind speed of 100 mph.

Structure Class II.

Exposure Category B.

Topographic Category 1.

Crest Height 0.00 ft.

Nominal ice thickness of 0.7500 in.

Ice thickness is considered to increase with height.

Ice density of 56 pcf.

A wind speed of 50 mph is used in combination with ice.

Temperature drop of 50 °F.

Deflections calculated using a wind speed of 60 mph.

A non-linear (P-delta) analysis was used.

Pressures are calculated at each section.

Stress ratio used in pole design is 1.

Local bending stresses due to climbing loads, feed line supports, and appurtenance mounts are not considered.

Options

Consider Moments - Legs	Distribute Leg Loads As Uniform	Treat Feedline Bundles As Cylinder
Consider Moments - Horizontals	Assume Legs Pinned	Use ASCE 10 X-Brace Ly Rules
Consider Moments - Diagonals	√ Assume Rigid Index Plate	Calculate Redundant Bracing Forces
Use Moment Magnification	√ Use Clear Spans For Wind Area	Ignore Redundant Members in FEA
√ Use Code Stress Ratios	√ Use Clear Spans For KL/r	SR Leg Bolts Resist Compression
√ Use Code Safety Factors - Guys	√ Retension Guys To Initial Tension	√ All Leg Panels Have Same Allowable
Escalate Ice	Bypass Mast Stability Checks	Offset Girt At Foundation
Always Use Max Kz	√ Use Azimuth Dish Coefficients	√ Consider Feedline Torque
Use Special Wind Profile	√ Project Wind Area of Appurt.	√ Include Angle Block Shear Check
√ Include Bolts In Member Capacity	√ Autocalc Torque Arm Areas	Poles
Leg Bolts Are At Top Of Section	SR Members Have Cut Ends	Include Shear-Torsion Interaction
√ Secondary Horizontal Braces Leg	Sort Capacity Reports By Component	Always Use Sub-Critical Flow
Use Diamond Inner Bracing (4 Sided)	√ Triangulate Diamond Inner Bracing	Use Top Mounted Sockets
Add IBC .6D+W Combination	Use TIA-222-G Tension Splice Capacity	
	Exemption	

Tapered Pole Section Geometry

Section	Elevation	Section Length	Splice Length	Number of Sides	Top Diameter	Bottom Diameter	Wall Thickness	Bend Radius	Pole Grade
	ft	ft	ft		in	in	in	in	
L1	164.00-131.50	32.50	0.00	18	47.0000	53.4200	0.3125	1.2500	A572-65 (65 ksi)
L2	131.50-119.29	12.21	6.00	18	53.4200	56.1500	0.3750	1.5000	A572-65 (65 ksi)

tnxTower Infinigy Engineering 2255 Sewell Mill Road, Suite 130 Marietta, GA 30062 Phone: (678) 444-4463 FAX: (678)444-4472	Job 333-000	Page 2 of 13
	Project Greenwich Hospital	Date 14:11:52 06/09/14
	Client Sprint	Designed by MBecker

Section	Elevation ft	Section Length ft	Splice Length ft	Number of Sides	Top Diameter in	Bottom Diameter in	Wall Thickness in	Bend Radius in	Pole Grade
L3	119.29-78.79	46.50	8.42	18	54.0585	62.9700	0.4375	1.7500	A572-65 (65 ksi)
L4	78.79-39.88	47.33	9.25	18	60.4813	69.6600	0.5625	2.2500	A572-65 (65 ksi)
L5	39.88-0.00	49.13		18	66.7412	76.0000	0.5625	2.2500	A572-65 (65 ksi)

Tapered Pole Properties

Section	Tip Dia. in	Area in ²	I in ⁴	r in	C in	I/C in ³	J in ⁴	It/Q in ²	w in	w/t
L1	47.7251	46.3082	12752.5270	16.5741	23.8760	534.1149	25521.8341	23.1585	7.7220	24.71
	54.2441	52.6760	18769.9004	18.8532	27.1374	691.6627	37564.4987	26.3430	8.8519	28.326
L2	54.2441	63.1368	22444.4518	18.8310	27.1374	827.0684	44918.4365	31.5744	8.7419	23.312
	57.0162	66.3862	26091.2194	19.8001	28.5242	914.7047	52216.7704	33.1994	9.2224	24.593
L3	56.0600	74.4594	27047.4664	19.0354	27.4617	984.9157	54130.5226	37.2368	8.7443	19.987
	63.9414	86.8342	42898.2727	22.1990	31.9888	1341.0421	85852.9920	43.4253	10.3127	23.572
L4	63.0724	106.9776	48524.0640	21.2712	30.7245	1579.3269	97111.9772	53.4990	9.6547	17.164
	70.7346	123.3649	74413.8720	24.5296	35.3873	2102.8424	148925.6597	61.6942	11.2702	20.036
L5	69.5409	118.1537	65376.3628	23.4934	33.9045	1928.2499	130838.7495	59.0881	10.7564	19.123
	77.1724	134.6842	96834.1984	26.7803	38.6080	2508.1382	193795.8137	67.3549	12.3860	22.02

Tower Elevation ft	Gusset Area (per face) ft ²	Gusset Thickness in	Gusset Grade	Adjust. Factor A _f	Adjust. Factor A _r	Weight Mult.	Double Angle Stitch Bolt Spacing Diagonals in	Double Angle Stitch Bolt Spacing Horizontals in
L1 164.00-131.50				1	1	1		
L2 131.50-119.29				1	1	1		
L3 119.29-78.79				1	1	1		
L4 78.79-39.88				1	1	1		
L5 39.88-0.00				1	1	1		

Monopole Base Plate Data

Base Plate Data	
Base plate is square	
Base plate is grouted	
Anchor bolt grade	A615-75
Anchor bolt size	2.2500 in
Number of bolts	30
Embedment length	48.0000 in
f _c	3 ksi
Grout space	2.0000 in
Base plate grade	A36
Base plate thickness	3.0000 in

tnxTower Infinigy Engineering 2255 Sewell Mill Road, Suite 130 Marietta, GA 30062 Phone: (678) 444-4463 FAX: (678)444-4472	Job	333-000	Page	4 of 13
	Project	Greenwich Hospital	Date	14:11:52 06/09/14
	Client	Sprint	Designed by	MBecker

Description	Face or Leg	Allow Shield	Component Type	Placement ft	Total Number	C _{AA}		Weight plf
						In Face	Out Face	
1 1/4	C	No	Inside Pole	155.50 - 4.50	3	No Ice	0.00	0.66
						1/2" Ice	0.00	0.66
						1" Ice	0.00	0.66
1-1/4" Hybrid	C	No	Inside Pole	155.50 - 4.50	3	No Ice	0.00	0.83
						1/2" Ice	0.00	0.83
						1" Ice	0.00	0.83

Feed Line/Linear Appurtenances Section Areas

Tower Section	Tower Elevation ft	Face	A _R ft ²	A _F ft ²	C _{AA} In Face ft ²	C _{AA} Out Face ft ²	Weight lb
L1	164.00-131.50	A	0.000	0.000	0.000	0.000	227.93
		B	0.000	0.000	0.000	0.000	244.92
		C	0.000	0.000	0.000	0.000	341.50
L2	131.50-119.29	A	0.000	0.000	0.000	0.000	182.47
		B	0.000	0.000	0.000	0.000	219.87
		C	0.000	0.000	0.000	0.000	283.26
L3	119.29-78.79	A	0.000	0.000	0.000	0.000	915.71
		B	0.000	0.000	0.000	0.000	884.52
		C	0.000	0.000	0.000	0.000	1378.98
L4	78.79-39.88	A	0.000	0.000	0.000	0.000	879.76
		B	0.000	0.000	0.000	0.000	849.79
		C	0.000	0.000	0.000	0.000	1388.27
L5	39.88-0.00	A	0.000	0.000	0.000	0.000	781.22
		B	0.000	0.000	0.000	0.000	694.70
		C	0.000	0.000	0.000	0.000	1218.64

Feed Line/Linear Appurtenances Section Areas - With Ice

Tower Section	Tower Elevation ft	Face or Leg	Ice Thickness in	A _R ft ²	A _F ft ²	C _{AA} In Face ft ²	C _{AA} Out Face ft ²	Weight lb
L1	164.00-131.50	A	1.742	0.000	0.000	0.000	0.000	227.93
		B		0.000	0.000	0.000	0.000	244.92
		C		0.000	0.000	0.000	0.000	341.50
L2	131.50-119.29	A	1.714	0.000	0.000	0.000	0.000	182.47
		B		0.000	0.000	0.000	0.000	219.87
		C		0.000	0.000	0.000	0.000	283.26
L3	119.29-78.79	A	1.674	0.000	0.000	0.000	0.000	915.71
		B		0.000	0.000	0.000	0.000	884.52
		C		0.000	0.000	0.000	0.000	1378.98
L4	78.79-39.88	A	1.591	0.000	0.000	0.000	0.000	879.76
		B		0.000	0.000	0.000	0.000	849.79
		C		0.000	0.000	0.000	0.000	1388.27
L5	39.88-0.00	A	1.424	0.000	0.000	0.000	0.000	781.22
		B		0.000	0.000	0.000	0.000	694.70
		C		0.000	0.000	0.000	0.000	1218.64

Feed Line Center of Pressure

tnxTower Infinigy Engineering 2255 Sewell Mill Road, Suite 130 Marietta, GA 30062 Phone: (678) 444-4463 FAX: (678)444-4472	Job 333-000	Page 5 of 13
	Project Greenwich Hospital	Date 14:11:52 06/09/14
	Client Sprint	Designed by MBecker

Section	Elevation	CP _x	CP _z	CP _x	CP _z
	ft	in	in	Ice in	Ice in
L1	164.00-131.50	0.0000	0.0000	0.0000	0.0000
L2	131.50-119.29	0.0000	0.0000	0.0000	0.0000
L3	119.29-78.79	0.0000	0.0000	0.0000	0.0000
L4	78.79-39.88	0.0000	0.0000	0.0000	0.0000
L5	39.88-0.00	0.0000	0.0000	0.0000	0.0000

Shielding Factor Ka

Tower Section	Feed Line Record No.	Description	Feed Line Segment Elev.	K _a No Ice	K _a Ice
---------------	----------------------	-------------	-------------------------	-----------------------	--------------------

Discrete Tower Loads

Description	Face or Leg	Offset Type	Offsets: Horz Lateral Vert	Azimuth Adjustment °	Placement ft	C _A A _A Front ft ²	C _A A _A Side ft ²	Weight lb	
Angle Low Profile Platform (Town of Greenwich)	C	From Leg	0.00	0.0000	165.00	No Ice	26.10	26.10	1500.00
			0.00			1/2" Ice	31.60	31.60	1700.00
			0.00			1" Ice	37.10	37.10	1900.00
BMR12-A (Town of Greenwich)	A	From Leg	4.00	0.0000	165.00	No Ice	13.25	13.25	92.00
			-6.00			1/2" Ice	15.31	15.31	180.53
			5.00			1" Ice	17.39	17.39	282.10
BMR12-A (Town of Greenwich)	B	From Leg	4.00	0.0000	165.00	No Ice	13.25	13.25	92.00
			-6.00			1/2" Ice	15.31	15.31	180.53
			5.00			1" Ice	17.39	17.39	282.10
BMR12-A (Town of Greenwich)	C	From Leg	4.00	0.0000	165.00	No Ice	13.25	13.25	92.00
			-6.00			1/2" Ice	15.31	15.31	180.53
			5.00			1" Ice	17.39	17.39	282.10
GPS (Town of Greenwich)	B	From Leg	4.00	0.0000	165.00	No Ice	0.50	0.50	10.00
			-6.00			1/2" Ice	0.63	0.63	15.96
			3.00			1" Ice	0.78	0.78	23.49
ALR8 (Town of Greenwich)	C	From Leg	4.00	0.0000	165.00	No Ice	8.10	8.10	70.00
			0.00			1/2" Ice	9.29	9.29	80.00
			5.00			1" Ice	10.48	10.48	90.00
PD1142-1 (Town of Greenwich)	A	From Leg	4.00	0.0000	165.00	No Ice	1.86	1.86	10.00
			0.00			1/2" Ice	3.76	3.76	27.21
			5.00			1" Ice	5.67	5.67	56.16
PD620 (Town of Greenwich)	B	From Leg	4.00	0.0000	165.00	No Ice	4.27	4.27	53.00
			0.00			1/2" Ice	7.68	7.68	95.00
			10.00			1" Ice	11.09	11.09	137.00
Camera (Town of Greenwich)	C	From Leg	4.00	0.0000	165.00	No Ice	1.40	2.80	15.00
			0.00			1/2" Ice	1.56	3.04	39.92
			0.00			1" Ice	1.73	3.28	68.15

Dish Pipe Mount (Town of Greenwich)	A	From Leg	1.00	0.0000	160.00	No Ice	2.09	2.09	54.66
			0.00			1/2" Ice	2.46	2.46	80.59
			0.00			1" Ice	2.85	2.85	110.49
Dish Pipe Mount (Town of Greenwich)	B	From Leg	1.00	0.0000	160.00	No Ice	2.09	2.09	54.66
			0.00			1/2" Ice	2.46	2.46	80.59
			0.00			1" Ice	2.85	2.85	110.49

tnxTower Infinigy Engineering 2255 Sewell Mill Road, Suite 130 Marietta, GA 30062 Phone: (678) 444-4463 FAX: (678)444-4472	Job	333-000	Page	6 of 13
	Project	Greenwich Hospital	Date	14:11:52 06/09/14
	Client	Sprint	Designed by	MBecker

Description	Face or Leg	Offset Type	Offsets:		Azimuth Adjustment °	Placement ft	C _{AA} Front ft ²	C _{AA} Side ft ²	Weight lb
			Horz ft	Lateral ft					
Dish Pipe Mount (Town of Greenwich)	C	From Leg	1.00 0.00 0.00		0.0000	160.00	No Ice 2.09 1/2" Ice 2.46 1" Ice 2.85	2.09 2.46 2.85	54.66 80.59 110.49

Angle Low Profile Platform (Sprint)	C	From Leg	0.00 0.00 0.00		0.0000	155.00	No Ice 26.10 1/2" Ice 31.60 1" Ice 37.10	26.10 31.60 37.10	1500.00 1700.00 1900.00
APXVSP18-C-A20 (Sprint)	C	From Leg	4.00 -5.50 0.00		0.0000	155.00	No Ice 8.26 1/2" Ice 8.81 1" Ice 9.36	5.28 5.74 6.20	57.00 106.52 162.12
APXVSP18-C-A20 (Sprint)	A	From Leg	4.00 -5.50 0.00		0.0000	155.00	No Ice 8.26 1/2" Ice 8.81 1" Ice 9.36	5.28 5.74 6.20	57.00 106.52 162.12
P40-16-XLPP-RR-A (Sprint)	B	From Leg	4.00 -5.50 0.00		0.0000	155.00	No Ice 10.50 1/2" Ice 10.98 1" Ice 11.48	3.52 3.87 4.22	64.00 117.23 175.87
1900 MHz RRH (Sprint)	A	From Leg	0.00 -1.00 0.00		0.0000	152.00	No Ice 2.73 1/2" Ice 2.96 1" Ice 3.20	1.45 1.64 1.84	44.09 62.32 83.43
1900 MHz RRH (Sprint)	B	From Leg	0.00 -1.00 0.00		0.0000	152.00	No Ice 2.73 1/2" Ice 2.96 1" Ice 3.20	1.45 1.64 1.84	44.09 62.32 83.43
1900 MHz RRH (Sprint)	C	From Leg	0.00 -1.00 0.00		0.0000	152.00	No Ice 2.73 1/2" Ice 2.96 1" Ice 3.20	1.45 1.64 1.84	44.09 62.32 83.43
800 MHz RRH (Sprint)	A	From Leg	0.00 1.00 0.00		0.0000	152.00	No Ice 2.25 1/2" Ice 2.46 1" Ice 2.68	2.40 2.61 2.83	64.00 86.12 111.30
800 MHz RRH (Sprint)	B	From Leg	0.00 1.00 0.00		0.0000	152.00	No Ice 2.25 1/2" Ice 2.46 1" Ice 2.68	2.40 2.61 2.83	64.00 86.12 111.30
800 MHz RRH (Sprint)	C	From Leg	0.00 1.00 0.00		0.0000	152.00	No Ice 2.25 1/2" Ice 2.46 1" Ice 2.68	2.40 2.61 2.83	64.00 86.12 111.30
DB980F90E-M (Sprint)	C	From Leg	4.00 5.50 0.00		0.0000	155.00	No Ice 3.90 1/2" Ice 4.28 1" Ice 4.66	2.29 2.65 3.02	8.50 29.47 55.13
DB980F90E-M (Sprint)	B	From Leg	4.00 5.50 0.00		0.0000	155.00	No Ice 3.90 1/2" Ice 4.28 1" Ice 4.66	2.29 2.65 3.02	8.50 29.47 55.13
DB950F65T2E-M (Sprint)	A	From Leg	4.00 5.50 0.00		0.0000	155.00	No Ice 6.13 1/2" Ice 6.59 1" Ice 7.06	4.24 4.62 5.01	15.00 53.95 98.13
LLPX310R (Sprint)	A	From Leg	4.00 0.00 0.00		0.0000	155.00	No Ice 4.86 1/2" Ice 5.22 1" Ice 5.58	1.96 2.23 2.51	27.60 53.65 83.70
LLPX310R (Sprint)	B	From Leg	4.00 0.00 0.00		0.0000	155.00	No Ice 4.86 1/2" Ice 5.22 1" Ice 5.58	1.96 2.23 2.51	27.60 53.65 83.70
LLPX310R (Sprint)	C	From Leg	4.00 0.00 0.00		0.0000	155.00	No Ice 4.86 1/2" Ice 5.22 1" Ice 5.58	1.96 2.23 2.51	27.60 53.65 83.70

(2) APX16PV-16PVL (T-Mobile)	A	From Leg	4.00 0.00 0.00		0.0000	145.00	No Ice 6.80 1/2" Ice 7.27 1" Ice 7.75	3.31 3.94 4.58	46.95 93.66 147.19
(2) APX16PV-16PVL	B	From Leg	4.00		0.0000	145.00	No Ice 6.80	3.31	46.95

tnxTower Infinigy Engineering 2255 Sewell Mill Road, Suite 130 Marietta, GA 30062 Phone: (678) 444-4463 FAX: (678)444-4472	Job	333-000	Page	7 of 13
	Project	Greenwich Hospital	Date	14:11:52 06/09/14
	Client	Sprint	Designed by	MBecker

Description	Face or Leg	Offset Type	Offsets:		Azimuth Adjustment	Placement	C _{AA} Front	C _{AA} Side	Weight
			Horz Lateral	Vert					
(T-Mobile)			0.00			1/2" Ice	7.27	3.94	93.66
			0.00			1" Ice	7.75	4.58	147.19
(2) APX16PV-16PVL (T-Mobile)	C	From Leg	4.00	0.0000	145.00	No Ice	6.80	3.31	46.95
			0.00			1/2" Ice	7.27	3.94	93.66
			0.00			1" Ice	7.75	4.58	147.19
(2) KRY11271/2 (T-Mobile)	A	From Leg	4.00	0.0000	145.00	No Ice	0.68	0.45	13.20
			0.00			1/2" Ice	0.80	0.56	18.38
			0.00			1" Ice	0.93	0.68	25.16
(2) KRY11271/2 (T-Mobile)	B	From Leg	4.00	0.0000	145.00	No Ice	0.68	0.45	13.20
			0.00			1/2" Ice	0.80	0.56	18.38
			0.00			1" Ice	0.93	0.68	25.16
(2) KRY11271/2 (T-Mobile)	C	From Leg	4.00	0.0000	145.00	No Ice	0.68	0.45	13.20
			0.00			1/2" Ice	0.80	0.56	18.38
			0.00			1" Ice	0.93	0.68	25.16
Angle Low Profile Platform (T-Mobile)	C	From Leg	0.00	0.0000	145.00	No Ice	26.10	26.10	1500.00
			0.00			1/2" Ice	31.60	31.60	1700.00
			0.00			1" Ice	37.10	37.10	1900.00

(2) 7700.00 (AT&T)	A	From Leg	4.00	0.0000	135.00	No Ice	1.58	0.82	22.00
			0.00			1/2" Ice	1.79	1.00	31.66
			0.00			1" Ice	2.02	1.19	43.84
(2) 7700.00 (AT&T)	B	From Leg	4.00	0.0000	135.00	No Ice	1.58	0.82	22.00
			0.00			1/2" Ice	1.79	1.00	31.66
			0.00			1" Ice	2.02	1.19	43.84
(2) 7700.00 (AT&T)	C	From Leg	4.00	0.0000	135.00	No Ice	1.58	0.82	22.00
			0.00			1/2" Ice	1.79	1.00	31.66
			0.00			1" Ice	2.02	1.19	43.84
(2) LGP21401 (AT&T)	A	From Leg	4.00	0.0000	135.00	No Ice	0.95	0.37	17.50
			0.00			1/2" Ice	1.09	0.48	23.31
			0.00			1" Ice	1.24	0.60	30.86
(2) LGP21401 (AT&T)	C	From Leg	4.00	0.0000	135.00	No Ice	0.95	0.37	17.50
			0.00			1/2" Ice	1.09	0.48	23.31
			0.00			1" Ice	1.24	0.60	30.86
(2) LGP17201 (AT&T)	B	From Leg	4.00	0.0000	135.00	No Ice	1.95	0.50	31.00
			0.00			1/2" Ice	2.13	0.62	41.95
			0.00			1" Ice	2.33	0.75	55.17
Angle Low Profile Platform (AT&T)	C	From Leg	4.00	0.0000	135.00	No Ice	26.10	26.10	1500.00
			0.00			1/2" Ice	31.60	31.60	1700.00
			0.00			1" Ice	37.10	37.10	1900.00

DB844G45ZAXY (Verizon Wireless)	A	From Leg	4.00	0.0000	125.00	No Ice	7.00	3.97	21.00
			0.00			1/2" Ice	7.41	4.34	64.04
			6.00			1" Ice	7.83	4.72	111.90
DB844G45ZAXY (Verizon Wireless)	B	From Leg	4.00	0.0000	125.00	No Ice	7.00	3.97	21.00
			0.00			1/2" Ice	7.41	4.34	64.04
			6.00			1" Ice	7.83	4.72	111.90
DB844G45ZAXY (Verizon Wireless)	C	From Leg	4.00	0.0000	125.00	No Ice	7.00	3.97	21.00
			0.00			1/2" Ice	7.41	4.34	64.04
			6.00			1" Ice	7.83	4.72	111.90
DB844G45ZAXY (Verizon Wireless)	A	From Leg	4.00	0.0000	125.00	No Ice	7.00	3.97	21.00
			0.00			1/2" Ice	7.41	4.34	64.04
			-6.00			1" Ice	7.83	4.72	111.90
DB844G45ZAXY (Verizon Wireless)	B	From Leg	4.00	0.0000	125.00	No Ice	7.00	3.97	21.00
			0.00			1/2" Ice	7.41	4.34	64.04
			-6.00			1" Ice	7.83	4.72	111.90
DB844G45ZAXY (Verizon Wireless)	C	From Leg	4.00	0.0000	125.00	No Ice	7.00	3.97	21.00
			0.00			1/2" Ice	7.41	4.34	64.04

tnxTower Infinigy Engineering 2255 Sewell Mill Road, Suite 130 Marietta, GA 30062 Phone: (678) 444-4463 FAX: (678)444-4472	Job	333-000	Page	8 of 13
	Project	Greenwich Hospital	Date	14:11:52 06/09/14
	Client	Sprint	Designed by	MBecker

Description	Face or Leg	Offset Type	Offsets:		Azimuth Adjustment	Placement	C _{AA} Front	C _{AA} Side	Weight	
			Horz Lateral	Vert						°
LNX-6514DS-VTM (Verizon Wireless)	A	From Leg	-6.00		0.0000	125.00	1" Ice	7.83	4.72	111.90
			4.00				No Ice	8.41	5.88	38.30
			0.00				1/2" Ice	8.96	6.34	91.03
			0.00				1" Ice	9.52	6.81	149.94
LNX-6514DS-VTM (Verizon Wireless)	B	From Leg	4.00		0.0000	125.00	No Ice	8.41	5.88	38.30
			0.00				1/2" Ice	8.96	6.34	91.03
			0.00				1" Ice	9.52	6.81	149.94
			0.00				No Ice	8.41	5.88	38.30
LNX-6514DS-VTM (Verizon Wireless)	C	From Leg	4.00		0.0000	125.00	1/2" Ice	8.96	6.34	91.03
			0.00				1" Ice	9.52	6.81	149.94
			0.00				No Ice	8.41	5.88	38.30
			0.00				1/2" Ice	8.96	6.34	91.03
Angle Low Profile Platform (Verizon Wireless)	C	From Leg	0.00		0.0000	125.00	No Ice	26.10	26.10	1500.00
			0.00				1/2" Ice	31.60	31.60	1700.00
			0.00				1" Ice	37.10	37.10	1900.00

Angle Low Profile Platform (Nextel)	C	From Leg	0.00		0.0000	115.00	No Ice	26.10	26.10	1500.00
			0.00				1/2" Ice	31.60	31.60	1700.00
			0.00				1" Ice	37.10	37.10	1900.00
(4) DB846G90A-XY (Nextel)	A	From Leg	4.00		0.0000	115.00	No Ice	4.99	5.87	15.40
			0.00				1/2" Ice	5.44	6.32	53.75
			0.00				1" Ice	5.90	6.79	97.91
(4) DB846G90A-XY (Nextel)	B	From Leg	4.00		0.0000	115.00	No Ice	4.99	5.87	15.40
			0.00				1/2" Ice	5.44	6.32	53.75
			0.00				1" Ice	5.90	6.79	97.91
(4) DB846G90A-XY (Nextel)	C	From Leg	4.00		0.0000	115.00	No Ice	4.99	5.87	15.40
			0.00				1/2" Ice	5.44	6.32	53.75
			0.00				1" Ice	5.90	6.79	97.91

APXVTM14-C-120 (Sprint)	A	From Leg	4.00		0.0000	155.50	No Ice	6.53	3.38	52.90
			0.00				1/2" Ice	6.96	3.72	90.49
			0.00				1" Ice	7.40	4.07	132.96
APXVTM14-C-120 (Sprint)	B	From Leg	4.00		0.0000	155.50	No Ice	6.53	3.38	52.90
			0.00				1/2" Ice	6.96	3.72	90.49
			0.00				1" Ice	7.40	4.07	132.96
APXVTM14-C-120 (Sprint)	C	From Leg	4.00		0.0000	155.50	No Ice	6.53	3.38	52.90
			0.00				1/2" Ice	6.96	3.72	90.49
			0.00				1" Ice	7.40	4.07	132.96
TD-RRH8X20 (Sprint)	A	From Leg	4.00		0.0000	155.50	No Ice	4.32	1.41	66.14
			0.00				1/2" Ice	4.60	1.61	90.08
			0.00				1" Ice	4.89	1.83	117.36
TD-RRH8X20 (Sprint)	B	From Leg	4.00		0.0000	155.50	No Ice	4.32	1.41	66.14
			0.00				1/2" Ice	4.60	1.61	90.08
			0.00				1" Ice	4.89	1.83	117.36
TD-RRH8X20 (Sprint)	C	From Leg	4.00		0.0000	155.50	No Ice	4.32	1.41	66.14
			0.00				1/2" Ice	4.60	1.61	90.08
			0.00				1" Ice	4.89	1.83	117.36

Dishes

<p style="text-align: center;">tnxTower</p> <p style="text-align: center;">Infinigy Engineering 2255 Sewell Mill Road, Suite 130 Marietta, GA 30062 Phone: (678) 444-4463 FAX: (678)444-4472</p>	Job	333-000	Page	9 of 13
	Project	Greenwich Hospital	Date	14:11:52 06/09/14
	Client	Sprint	Designed by	MBecker

Description	Face or Leg	Dish Type	Offset Type	Offsets: Horz Lateral Vert ft	Azimuth Adjustment °	3 dB Beam Width °	Elevation ft	Outside Diameter ft	Aperture Area ft ²	Weight lb	
4' Std. Dish (Town of Greenwich)	A	Paraboloid w/o Radome	From Leg	1.00	0.0000		160.00	4.00	No Ice	12.57	190.00
				0.00					1/2" Ice	13.10	260.00
				0.00					1" Ice	13.62	320.00
4' Std. Dish (Town of Greenwich)	B	Paraboloid w/o Radome	From Leg	1.00	0.0000		160.00	4.00	No Ice	12.57	190.00
				0.00					1/2" Ice	13.10	260.00
				0.00					1" Ice	13.62	320.00
VP2-180A (Town of Greenwich)	C	Paraboloid w/o Radome	From Leg	1.00	0.0000		160.00	2.50	No Ice	4.91	64.00
				0.00					1/2" Ice	5.24	90.90
				0.00					1" Ice	5.57	117.80

A-ANT-23G-24 (Sprint)	B	Paraboloid w/Radome	From Leg	4.00	0.0000		155.00	2.17	No Ice	3.72	12.30
				0.00					1/2" Ice	4.01	32.88
				-6.50					1" Ice	4.30	53.47
A-ANT-23G-24 (Sprint)	C	Paraboloid w/Radome	From Leg	4.00	0.0000		155.00	2.17	No Ice	3.72	12.30
				0.00					1/2" Ice	4.01	32.88
				6.50					1" Ice	4.30	53.47

Load Combinations

Comb. No.	Description
1	Dead Only
2	1.2 Dead+1.6 Wind 0 deg - No Ice
3	0.9 Dead+1.6 Wind 0 deg - No Ice
4	1.2 Dead+1.6 Wind 30 deg - No Ice
5	0.9 Dead+1.6 Wind 30 deg - No Ice
6	1.2 Dead+1.6 Wind 60 deg - No Ice
7	0.9 Dead+1.6 Wind 60 deg - No Ice
8	1.2 Dead+1.6 Wind 90 deg - No Ice
9	0.9 Dead+1.6 Wind 90 deg - No Ice
10	1.2 Dead+1.6 Wind 120 deg - No Ice
11	0.9 Dead+1.6 Wind 120 deg - No Ice
12	1.2 Dead+1.6 Wind 150 deg - No Ice
13	0.9 Dead+1.6 Wind 150 deg - No Ice
14	1.2 Dead+1.6 Wind 180 deg - No Ice
15	0.9 Dead+1.6 Wind 180 deg - No Ice
16	1.2 Dead+1.6 Wind 210 deg - No Ice
17	0.9 Dead+1.6 Wind 210 deg - No Ice
18	1.2 Dead+1.6 Wind 240 deg - No Ice
19	0.9 Dead+1.6 Wind 240 deg - No Ice
20	1.2 Dead+1.6 Wind 270 deg - No Ice
21	0.9 Dead+1.6 Wind 270 deg - No Ice
22	1.2 Dead+1.6 Wind 300 deg - No Ice
23	0.9 Dead+1.6 Wind 300 deg - No Ice
24	1.2 Dead+1.6 Wind 330 deg - No Ice
25	0.9 Dead+1.6 Wind 330 deg - No Ice
26	1.2 Dead+1.0 Ice+1.0 Temp
27	1.2 Dead+1.0 Wind 0 deg+1.0 Ice+1.0 Temp
28	1.2 Dead+1.0 Wind 30 deg+1.0 Ice+1.0 Temp
29	1.2 Dead+1.0 Wind 60 deg+1.0 Ice+1.0 Temp
30	1.2 Dead+1.0 Wind 90 deg+1.0 Ice+1.0 Temp
31	1.2 Dead+1.0 Wind 120 deg+1.0 Ice+1.0 Temp
32	1.2 Dead+1.0 Wind 150 deg+1.0 Ice+1.0 Temp
33	1.2 Dead+1.0 Wind 180 deg+1.0 Ice+1.0 Temp
34	1.2 Dead+1.0 Wind 210 deg+1.0 Ice+1.0 Temp
35	1.2 Dead+1.0 Wind 240 deg+1.0 Ice+1.0 Temp

tnxTower Infinigy Engineering 2255 Sewell Mill Road, Suite 130 Marietta, GA 30062 Phone: (678) 444-4463 FAX: (678)444-4472	Job	333-000	Page	10 of 13
	Project	Greenwich Hospital	Date	14:11:52 06/09/14
	Client	Sprint	Designed by	MBecker

<i>Comb. No.</i>	<i>Description</i>
36	1.2 Dead+1.0 Wind 270 deg+1.0 Ice+1.0 Temp
37	1.2 Dead+1.0 Wind 300 deg+1.0 Ice+1.0 Temp
38	1.2 Dead+1.0 Wind 330 deg+1.0 Ice+1.0 Temp
39	Dead+Wind 0 deg - Service
40	Dead+Wind 30 deg - Service
41	Dead+Wind 60 deg - Service
42	Dead+Wind 90 deg - Service
43	Dead+Wind 120 deg - Service
44	Dead+Wind 150 deg - Service
45	Dead+Wind 180 deg - Service
46	Dead+Wind 210 deg - Service
47	Dead+Wind 240 deg - Service
48	Dead+Wind 270 deg - Service
49	Dead+Wind 300 deg - Service
50	Dead+Wind 330 deg - Service

Maximum Tower Deflections - Service Wind

<i>Section No.</i>	<i>Elevation</i>	<i>Horz. Deflection</i>	<i>Gov. Load Comb.</i>	<i>Tilt</i>	<i>Twist</i>
	<i>ft</i>	<i>in</i>		<i>°</i>	<i>°</i>
L1	164 - 131.5	6.363	47	0.3033	0.0047
L2	131.5 - 119.29	4.350	47	0.2809	0.0037
L3	125.29 - 78.79	3.989	47	0.2726	0.0033
L4	87.21 - 39.88	2.049	47	0.2033	0.0018
L5	49.13 - 0	0.705	47	0.1245	0.0009

Critical Deflections and Radius of Curvature - Service Wind

<i>Elevation</i>	<i>Appurtenance</i>	<i>Gov. Load Comb.</i>	<i>Deflection</i>	<i>Tilt</i>	<i>Twist</i>	<i>Radius of Curvature</i>
<i>ft</i>			<i>in</i>	<i>°</i>	<i>°</i>	<i>ft</i>
165.00	Angle Low Profile Platform	47	6.363	0.3033	0.0047	272990
161.50	A-ANT-23G-24	47	6.205	0.3022	0.0046	272990
160.00	4' Std. Dish	47	6.109	0.3016	0.0046	272990
155.50	APXVTM14-C-120	47	5.824	0.2995	0.0045	160583
155.00	Angle Low Profile Platform	47	5.793	0.2993	0.0045	151661
152.00	1900 MHz RRH	47	5.604	0.2977	0.0044	113746
148.50	A-ANT-23G-24	47	5.384	0.2957	0.0043	88061
145.00	(2) APX16PV-16PVL	47	5.167	0.2935	0.0042	71839
135.00	(2) 7700.00	47	4.557	0.2848	0.0038	47101
125.00	DB844G45ZAXY	47	3.973	0.2721	0.0033	41110
115.00	Angle Low Profile Platform	47	3.418	0.2562	0.0029	38002

Maximum Tower Deflections - Design Wind

<i>Section No.</i>	<i>Elevation</i>	<i>Horz. Deflection</i>	<i>Gov. Load Comb.</i>	<i>Tilt</i>	<i>Twist</i>
	<i>ft</i>	<i>in</i>		<i>°</i>	<i>°</i>
L1	164 - 131.5	30.496	18	1.4316	0.0233
L2	131.5 - 119.29	20.965	18	1.3357	0.0181

tnxTower Infinigy Engineering 2255 Sewell Mill Road, Suite 130 Marietta, GA 30062 Phone: (678) 444-4463 FAX: (678)444-4472	Job 333-000	Page 11 of 13
	Project Greenwich Hospital	Date 14:11:52 06/09/14
	Client Sprint	Designed by MBecker

Section No.	Elevation ft	Horz. Deflection in	Gov. Load Comb.	Tilt °	Twist °
L3	125.29 - 78.79	19.251	18	1.2994	0.0166
L4	87.21 - 39.88	9.950	22	0.9820	0.0087
L5	49.13 - 0	3.438	22	0.6058	0.0042

Critical Deflections and Radius of Curvature - Design Wind

Elevation ft	Appurtenance	Gov. Load Comb.	Deflection in	Tilt °	Twist °	Radius of Curvature ft
165.00	Angle Low Profile Platform	18	30.496	1.4316	0.0233	63256
161.50	A-ANT-23G-24	18	29.746	1.4270	0.0230	63256
160.00	4' Std. Dish	18	29.297	1.4243	0.0228	63256
155.50	APXVTM14-C-120	18	27.950	1.4155	0.0222	37209
155.00	Angle Low Profile Platform	18	27.801	1.4145	0.0222	35142
152.00	1900 MHz RRH	18	26.908	1.4080	0.0218	26356
148.50	A-ANT-23G-24	18	25.870	1.3995	0.0213	20405
145.00	(2) APX16PV-16PVL	18	24.840	1.3898	0.0207	16646
135.00	(2) 7700.00	18	21.952	1.3528	0.0189	10912
125.00	DB844G45ZAXY	18	19.172	1.2976	0.0165	9308
115.00	Angle Low Profile Platform	18	16.522	1.2265	0.0142	8443

Base Plate Design Data

Plate Thickness in	Number of Anchor Bolts	Anchor Bolt Size in	Actual Allowable Ratio Bolt Tension lb	Actual Allowable Ratio Bolt Compression lb	Actual Allowable Ratio Plate Stress ksi	Actual Allowable Ratio Stiffener Stress ksi	Controlling Condition	Ratio
3.0000	30	2.2500	86580.37	92882.78	25.935		Plate	0.80
			223654.40	371266.30	32.400			
			0.39	0.25	0.80			

Compression Checks

Pole Design Data

Section No.	Elevation ft	Size	L ft	L _u ft	Kl/r	A in ²	P _u lb	φP _n lb	Ratio P _u / φP _n
L1	164 - 131.5 (1)	TP53.42x47x0.3125	32.50	164.00	104.4	52.6760	-17514.80	1092120.00	0.016
L2	131.5 - 119.29 (2)	TP56.15x53.42x0.375	12.21	164.00	101.8	64.7894	-19548.00	1411180.00	0.014
L3	119.29 - 78.79 (3)	TP62.97x54.0585x0.4375	46.50	164.00	91.0	84.5934	-40955.70	2300840.00	0.018
L4	78.79 - 39.88	TP69.66x60.4813x0.5625	47.33	164.00	82.4	120.162	-65357.30	3896170.00	0.017

tnxTower Infinigy Engineering 2255 Sewell Mill Road, Suite 130 Marietta, GA 30062 Phone: (678) 444-4463 FAX: (678)444-4472	Job 333-000	Page 12 of 13
	Project Greenwich Hospital	Date 14:11:52 06/09/14
	Client Sprint	Designed by MBecker

Section No.	Elevation ft	Size	L ft	L _u ft	Kl/r	A in ²	P _u lb	φP _n lb	Ratio $\frac{P_u}{\phi P_n}$
L5	39.88 - 0 (5)	TP76x66.7412x0.5625	49.13	164.00	73.5	134.684 0	-99818.40	5041620.00	0.020

Pole Bending Design Data

Section No.	Elevation ft	Size	M _{ux} lb-ft	φM _{ux} lb-ft	Ratio $\frac{M_{ux}}{\phi M_{ux}}$	M _{uy} lb-ft	φM _{uy} lb-ft	Ratio $\frac{M_{uy}}{\phi M_{uy}}$
L1	164 - 131.5 (1)	TP53.42x47x0.3125	420606.67	3531850.00	0.119	0.00	3531850.00	0.000
L2	131.5 - 119.29 (2)	TP56.15x53.42x0.375	538480.00	4783283.33	0.113	0.00	4783283.33	0.000
L3	119.29 - 78.79 (3)	TP62.97x54.0585x0.4375	1606866.67	7104258.00	0.226	0.00	7104258.00	0.000
L4	78.79 - 39.88 (4)	TP69.66x60.4813x0.5625	2904400.00	11742749.33	0.247	0.00	11742749.33	0.000
L5	39.88 - 0 (5)	TP76x66.7412x0.5625	4840125.00	14202666.67	0.341	0.00	14202666.67	0.000

Pole Shear Design Data

Section No.	Elevation ft	Size	Actual V _u lb	φV _n lb	Ratio $\frac{V_u}{\phi V_n}$	Actual T _u lb-ft	φT _n lb-ft	Ratio $\frac{T_u}{\phi T_n}$
L1	164 - 131.5 (1)	TP53.42x47x0.3125	18550.60	1613880.00	0.011	391.61	7072341.33	0.000
L2	131.5 - 119.29 (2)	TP56.15x53.42x0.375	19420.50	2134620.00	0.009	391.61	9578250.00	0.000
L3	119.29 - 78.79 (3)	TP62.97x54.0585x0.4375	31456.70	2833690.00	0.011	391.57	14225916.00	0.000
L4	78.79 - 39.88 (4)	TP69.66x60.4813x0.5625	36529.30	4244460.00	0.009	391.49	23514165.33	0.000
L5	39.88 - 0 (5)	TP76x66.7412x0.5625	41952.30	4576000.00	0.009	18087.58	28440082.67	0.001

Pole Interaction Design Data

Section No.	Elevation ft	Ratio $\frac{P_u}{\phi P_n}$	Ratio $\frac{M_{ux}}{\phi M_{ux}}$	Ratio $\frac{M_{uy}}{\phi M_{uy}}$	Ratio $\frac{V_u}{\phi V_n}$	Ratio $\frac{T_u}{\phi T_n}$	Comb. Stress Ratio	Allow. Stress Ratio	Criteria
L1	164 - 131.5 (1)	0.016	0.119	0.000	0.011	0.000	0.135	1.000	4.8.2 ✓
L2	131.5 - 119.29 (2)	0.014	0.113	0.000	0.009	0.000	0.127	1.000	4.8.2 ✓
L3	119.29 - 78.79 (3)	0.018	0.226	0.000	0.011	0.000	0.244	1.000	4.8.2 ✓
L4	78.79 - 39.88 (4)	0.017	0.247	0.000	0.009	0.000	0.264	1.000	4.8.2 ✓

tnxTower Infinigy Engineering 2255 Sewell Mill Road, Suite 130 Marietta, GA 30062 Phone: (678) 444-4463 FAX: (678)444-4472	Job	333-000	Page	13 of 13
	Project	Greenwich Hospital	Date	14:11:52 06/09/14
	Client	Sprint	Designed by	MBecker

Section No.	Elevation ft	Ratio P_u	Ratio M_{ux}	Ratio M_{uy}	Ratio V_u	Ratio T_u	Comb. Stress Ratio	Allow. Stress Ratio	Criteria
L5	39.88 - 0 (5)	0.020	0.341	0.000	0.009	0.001	0.361 ✓	1.000	4.8.2 ✓

Section Capacity Table

Section No.	Elevation ft	Component Type	Size	Critical Element	P lb	ϕP_{allow} lb	% Capacity	Pass Fail	
L1	164 - 131.5	Pole	TP53.42x47x0.3125	1	-17514.80	1092120.00	13.5	Pass	
L2	131.5 - 119.29	Pole	TP56.15x53.42x0.375	2	-19548.00	1411180.00	12.7	Pass	
L3	119.29 - 78.79	Pole	TP62.97x54.0585x0.4375	3	-40955.70	2300840.00	24.4	Pass	
L4	78.79 - 39.88	Pole	TP69.66x60.4813x0.5625	4	-65357.30	3896170.00	26.4	Pass	
L5	39.88 - 0	Pole	TP76x66.7412x0.5625	5	-99818.40	5041620.00	36.1	Pass	
							Summary		
							Pole (L5)	36.1	Pass
							Base Plate	80.0	Pass
							RATING =	80.0	Pass

Date:	6/9/2014
Customer:	Sprint 2.5
Engineer:	MAXB
Job #:	333-000
Baseplate/Flange:	Base Plate
Plate Shape:	Circle

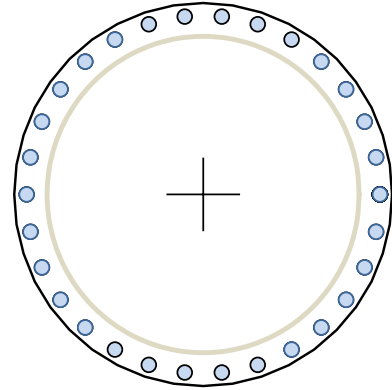

Loading Data		
--------------	--	--

TIA Code Revision:	Rev-G	
Axial:	138.1	kips
Moment:	4840.1	k-ft

Plate Data		
------------	--	--

Pole Base Diameter:	76	in
Pole Base Shape:	18 Sided	
Pole thickness:	0.5625	in
Base Weld Size:	0.25	in
Plate Diameter:	92	in
Plate Thickness:	3	in
Plate Steel Grade:	A36	ksi

Bolt Data		
-----------	--	--

Bolt Diameter:	2.25	in
Bolt Hole Diameter:	2.625	in
Bolt Quantity:	30	
Bolt Grade:	A615 Gr. 75	psi
Bolt Circle:	86	in
Bolt Spacing:		in

Stiffener Data		
----------------	--	--

Stiffener Quantity:		
Stiffener Height:		in
Stiffener Width:		in
Stiffener Thickness:		in
Stiffener Steel Grade:		
Vertical Weld Size:		in
Horizontal Weld Size:		in
Stiffener Notch width:		in

Plate Ratio:	58.12
Bolt Ratio:	36.40
Vertical Weld Ratio:	-
Horizontal Weld Ratio:	-
Stiffener Ratio:	-



PROJECT: 2.5 EQUIPMENT DEPLOYMENT
 SITE NAME: GREENWICH HOSPITAL
 SITE CASCADE: CT43XC855
 SITE ADDRESS: 9 PERRYRIDGE RD.
 GREENWICH, CT 06830
 SITE TYPE: MONOPOLE TOWER
 MARKET: SOUTHERN CONNECTICUT

PLANS PREPARED FOR:

6580 Sprint Parkway
Overland Park, Kansas 66251

PLANS PREPARED BY:

1033 Watervliet Shaker Rd
Albany, NY 12205
Office # (518) 690-0790
Fax # (518) 690-0793
JOB NUMBER 333-000

ENGINEERING LICENSE:

SITE INFORMATION

TOWER OWNER:
GREENWICH HOSPITAL
5 PERRYRIDGE DR
GREENWICH, CT 06830

LATITUDE (NAD83):
41° 2' 2.04" N
41.0339°

LONGITUDE (NAD83):
73° 37' 50.8794" W
-73.6308°

COUNTY:
LITCHFIELD

ZONING JURISDICTION:
GREENWICH

ZONING DISTRICT:
TBD

POWER COMPANY:
CONNECTICUT LIGHT AND POWER
(800) 286-2000

AAV PROVIDER:
AT&T
(800) 246-2020

SPRINT CM:
GARY WOOD
PHONE: (860) 940-9168
gary.wood@sprint.com

AREA MAP



LOCATION MAP



PROJECT DESCRIPTION

SPRINT PROPOSES TO MODIFY AN EXISTING UNMANNED TELECOMMUNICATIONS FACILITY.

- INSTALL 2.5 EQUIPMENT IN EXISTING N.V. MMBS CABINET
- INSTALL (3) PANEL ANTENNAS
- INSTALL (3) RRU'S TO TOWER
- INSTALL (27) JUMPER CABLES
- INSTALL (1) FIBER CABLE
- INSTALL (4) BATTERIES IN EXISTING BBU CABINET

THESE PLANS HAVE BEEN DEVELOPED FOR THE MODIFICATION OF AN EXISTING UNMANNED TELECOMMUNICATIONS FACILITY OWNED OR LEASED BY SPRINT IN ACCORDANCE WITH THE SCOPE OF WORK PROVIDED BY SPRINT. INFINIGY HAS INCORPORATED THIS SCOPE OF WORK IN THE PLANS. THESE PLANS ARE NOT FOR CONSTRUCTION UNLESS ACCOMPANIED BY A PASSING STRUCTURAL STABILITY ANALYSIS PREPARED BY A LICENSED STRUCTURAL ENGINEER. STRUCTURAL ANALYSIS MUST INCLUDE BOTH TOWER AND MOUNT.

APPLICABLE CODES

- ALL WORK SHALL BE PERFORMED AND MATERIALS INSTALL IN ACCORDANCE WITH THE CURRENT EDITIONS OF THE FOLLOWING CODES AS ADOPTED BY THE LOCAL GOVERNING AUTHORITIES. NOTHING IN THESE PLANS IS TO BE CONSTRUED TO PERMIT WORK NOT CONFORMING TO THESE CODES.
1. INTERNATIONAL BUILDING CODE (2012 IBC)
 2. TIA-EIA-222-G OR LATEST EDITION
 3. NFPA 780 - LIGHTNING PROTECTION CODE
 4. 2011 NATIONAL ELECTRIC CODE OR LATEST EDITION
 5. ANY OTHER NATIONAL OR LOCAL APPLICABLE CODES, MOST RECENT EDITIONS
 6. CT BUILDING CODE
 7. LOCAL BUILDING CODE
 8. CITY/COUNTY ORDINANCES

DRAWING INDEX

SHEET NO.	SHEET TITLE	REV.
T-1	TITLE SHEET & PROJECT DATA	A
SP-1	SPRINT SPECIFICATIONS	A
SP-2	SPRINT SPECIFICATIONS	A
SP-3	SPRINT SPECIFICATIONS	A
A-1	SITE PLAN	A
A-2	TOWER ELEVATION & CABLE PLAN	A
A-3	ANTENNA LAYOUT & MOUNTING DETAILS	A
A-4	COLOR CODING & NOTES	A
A-5	EQUIPMENT & MOUNTING DETAILS	A
A-6	CIVIL DETAILS	A
A-7	PLUMBING DIAGRAM	A
E-1	ELECTRICAL & GROUNDING PLAN	A
E-2	ELECTRICAL & GROUNDING DETAILS	A

ENGINEERING LICENSE:

DRAWING NOTICE:

THESE DOCUMENTS ARE CONFIDENTIAL AND ARE THE SOLE PROPERTY OF SPRINT AND MAY NOT BE REPRODUCED, DISSEMINATED OR REDISTRIBUTED WITHOUT THE EXPRESS WRITTEN CONSENT OF SPRINT.

REVISIONS:

DESCRIPTION	DATE	BY	REV
ISSUED FOR REVIEW	05/13/14	JDV	A

SITE NAME:

GREENWICH HOSPITAL

SITE CASCADE:

CT43XC855

SITE ADDRESS:

**9 PERRYRIDGE RD
GREENWICH, CT 06830.**

SHEET DESCRIPTION:

TITLE SHEET & PROJECT DATA

SHEET NUMBER:

T-1



THESE OUTLINE SPECIFICATIONS IN CONJUNCTION WITH THE SPRINT STANDARD CONSTRUCTION SPECIFICATIONS, INCLUDING CONTRACT DOCUMENTS AND THE CONSTRUCTION DRAWINGS DESCRIBE THE WORK TO BE PERFORMED BY THE CONTRACTOR.

SECTION 01 100 – SCOPE OF WORK

PART 1 – GENERAL

- 1.1 THE WORK: THESE STANDARD CONSTRUCTION SPECIFICATIONS IN CONJUNCTION WITH THE SPRINT CONSTRUCTION STANDARDS FOR WIRELESS SITES, CONTRACT DOCUMENTS AND THE CONSTRUCTION DRAWINGS DESCRIBE THE WORK TO BE PERFORMED BY THE CONTRACTOR.
- 1.2 RELATED DOCUMENTS:
 - A. THE REQUIREMENTS OF THIS SECTION APPLY TO ALL SECTIONS IN THIS SPECIFICATION.
 - B. SPRINT "STANDARD CONSTRUCTION DETAILS FOR WIRELESS SITES" ARE INCLUDED IN AND MADE A PART OF THESE SPECIFICATIONS HEREWITH.
- 1.3 PRECEDENCE: SHOULD CONFLICTS OCCUR BETWEEN THE STANDARD CONSTRUCTION SPECIFICATIONS FOR WIRELESS SITES INCLUDING THE STANDARD CONSTRUCTION DETAILS FOR WIRELESS SITES AND THE CONSTRUCTION DRAWINGS, INFORMATION ON THE CONSTRUCTION DRAWINGS SHALL TAKE PRECEDENCE. NOTIFY SPRINT CONSTRUCTION MANAGER IF THIS OCCURS.
- 1.4 NATIONALLY RECOGNIZED CODES AND STANDARDS:
 - A. THE WORK SHALL COMPLY WITH APPLICABLE NATIONAL AND LOCAL CODES AND STANDARDS, LATEST EDITION, AND PORTIONS THEREOF, INCLUDED BUT NOT LIMITED TO THE FOLLOWING:
 - 1. GR-63-CORE NEBS REQUIREMENTS: PHYSICAL PROTECTION
 - 5. GR-78-CORE GENERIC REQUIREMENTS FOR THE PHYSICAL DESIGN AND MANUFACTURE OF TELECOMMUNICATIONS EQUIPMENT.
 - 3. GR-1089 CORE, ELECTROMAGNETIC COMPATIBILITY AND ELECTRICAL SAFETY –GENERIC CRITERIA FOR NETWORK TELECOMMUNICATIONS EQUIPMENT.
 - 4. NATIONAL FIRE PROTECTION ASSOCIATION CODES AND STANDARDS (NFPA) INCLUDING NFPA 70 (NATIONAL ELECTRICAL CODE – 'NEC') AND NFPA 101 (LIFE SAFETY CODE).
 - 5. AMERICAN SOCIETY FOR TESTING OF MATERIALS (ASTM)
 - 6. INSTITUTE OF ELECTRONIC AND ELECTRICAL ENGINEERS (IEEE)
 - 7. AMERICAN CONCRETE INSTITUTE (ACI)
 - 8. AMERICAN WIRE PRODUCERS ASSOCIATION (AWPA)
 - 9. CONCRETE REINFORCING STEEL INSTITUTE (CRSI)
 - 10. AMERICAN ASSOCIATION OF STATE HIGHWAY AND TRANSPORTATION OFFICIALS (ASHTO)
 - 11. PORTLAND CEMENT ASSOCIATION (PCA)
 - 12. NATIONAL CONCRETE MASONRY ASSOCIATION (NCMA)
 - 13. BRICK INDUSTRY ASSOCIATION (BIA)
 - 14. AMERICAN WELDING SOCIETY (AWS)
 - 15. NATIONAL ROOFING CONTRACTORS ASSOCIATION (NRCA)
 - 16. SHEET METAL AND AIR CONDITIONING CONTRACTORS' NATIONAL ASSOCIATION (SMACNA)
 - 17. DOOR AND HARDWARE INSTITUTE (DHI)
 - 18. OCCUPATIONAL SAFETY AND HEALTH ACT (OSHA)
 - 19. APPLICABLE BUILDING CODES INCLUDING UNIFORM BUILDING CODE, SOUTHERN BUILDING CODE, BOCA, AND THE INTERNATIONAL BUILDING CODE.
- 1.5 DEFINITIONS:
 - A. WORK: THE SUM OF TASKS AND RESPONSIBILITIES IDENTIFIED IN THE CONTRACT DOCUMENTS.
 - B. COMPANY: SPRINT CORPORATION
 - C. ENGINEER: SYNONYMOUS WITH ARCHITECT & ENGINEER AND "A&E". THE DESIGN PROFESSIONAL HAVING PROFESSIONAL RESPONSIBILITY FOR DESIGN OF THE PROJECT.
 - D. CONTRACTOR: CONSTRUCTION CONTRACTOR; CONSTRUCTION VENDOR; INDIVIDUAL OR ENTITY WHO AFTER EXECUTION OF A CONTRACT IS BOUND TO ACCOMPLISH THE WORK.
 - E. THIRD PARTY VENDOR OR AGENCY: A VENDOR OR AGENCY ENGAGED SEPARATELY BY THE COMPANY, A&E, OR CONTRACTOR TO PROVIDE MATERIALS OR TO ACCOMPLISH SPECIFIC TASKS RELATED TO BUT NOT INCLUDED IN THE WORK.
 - F. OFCI: OWNER FURNISHED, CONTRACTOR INSTALLED EQUIPMENT.
 - G. CONSTRUCTION MANAGER – ALL PROJECTS RELATED COMMUNICATION TO FLOW THROUGH SPRINT REPRESENTATIVE IN CHARGE OF PROJECT...

- 1.6 SITE FAMILIARITY: CONTRACTOR SHALL BE RESPONSIBLE FOR FAMILIARIZING HIMSELF WITH ALL CONTRACT DOCUMENTS, FIELD CONDITIONS AND DIMENSIONS PRIOR TO PROCEEDING WITH CONSTRUCTION. ANY DISCREPANCIES SHALL BE BROUGHT TO THE ATTENTION OF THE SPRINT CONSTRUCTION MANAGER PRIOR TO THE COMMENCEMENT OF WORK. NO COMPENSATION WILL BE AWARDED BASED ON CLAIM OF LACK OF KNOWLEDGE OR FIELD CONDITIONS.
- 1.7 POINT OF CONTACT: COMMUNICATION BETWEEN SPRINT AND THE CONTRACTOR SHALL FLOW THROUGH THE SINGLE SPRINT CONSTRUCTION MANAGER APPOINTED TO MANAGE THE PROJECT FOR SPRINT.
- 1.8 ON-SITE SUPERVISION: THE CONTRACTOR SHALL SUPERVISE AND DIRECT THE WORK AND SHALL BE RESPONSIBLE FOR CONSTRUCTION MEANS, METHODS, TECHNIQUES, SEQUENCES, AND PROCEDURES IN ACCORDANCE WITH THE CONTRACT DOCUMENTS. THE CONTRACTOR SHALL EMPLOY A COMPETENT SUPERINTENDENT WHO SHALL BE IN ATTENDANCE AT THE SITE AT ALL TIMES DURING PERFORMANCE OF THE WORK.
- 1.9 DRAWINGS, SPECIFICATIONS AND DETAILS REQUIRED AT JOBSITE: THE CONSTRUCTION CONTRACTOR SHALL MAINTAIN A FULL SET OF THE CONSTRUCTION DRAWINGS, STANDARD CONSTRUCTION DETAILS FOR WIRELESS SITES AND THE STANDARD CONSTRUCTION SPECIFICATIONS FOR WIRELESS SITES AT THE JOBSITE FROM MOBILIZATION THROUGH CONSTRUCTION COMPLETION.
 - A. THE JOBSITE DRAWINGS, SPECIFICATIONS AND DETAILS SHALL BE CLEARLY MARKED DAILY IN RED PENCIL WITH ANY CHANGES IN CONSTRUCTION OVER WHAT IS DEPICTED IN THE DOCUMENTS. AT CONSTRUCTION COMPLETION, THIS JOBSITE MARKUP SET SHALL BE DELIVERED TO THE COMPANY OR COMPANY'S DESIGNATED REPRESENTATIVE TO BE FORWARDED TO THE COMPANY'S A&E VENDOR FOR PRODUCTION OF "AS-BUILT" DRAWINGS.
 - B. DETAILS ARE INTENDED TO SHOW DESIGN INTENT. MODIFICATIONS MAY BE REQUIRED TO SUIT JOB DIMENSIONS OR CONDITIONS, AND SUCH MODIFICATIONS SHALL BE INCLUDED AS PART OF THE WORK. CONTRACTOR SHALL NOTIFY SPRINT CONSTRUCTION MANAGER OF ANY VARIATIONS PRIOR TO PROCEEDING WITH THE WORK.
 - C. DIMENSIONS SHOWN ARE TO FINISH SURFACES UNLESS NOTED OTHERWISE. SPACING BETWEEN EQUIPMENT IS THE REQUIRED CLEARANCE. SHOULD THERE BE ANY QUESTIONS REGARDING THE CONTRACT DOCUMENTS, EXISTING CONDITIONS AND/OR DESIGN INTENT, THE CONTRACTOR SHALL BE RESPONSIBLE FOR OBTAINING A CLARIFICATION FROM THE SPRINT CONSTRUCTION MANAGER PRIOR TO PROCEEDING WITH THE WORK.
- 1.10 USE OF JOB SITE: THE CONTRACTOR SHALL CONFINE ALL CONSTRUCTION AND RELATED OPERATIONS INCLUDING STAGING AND STORAGE OF MATERIALS AND EQUIPMENT, PARKING, TEMPORARY FACILITIES, AND WASTE STORAGE TO THE LEASE PARCEL UNLESS OTHERWISE PERMITTED BY THE CONTRACT DOCUMENTS.
- 1.11 UTILITIES SERVICES: WHERE NECESSARY TO CUT EXISTING PIPES, ELECTRICAL WIRES, CONDUITS, CABLES, ETC., OF UTILITY SERVICES, OR OF FIRE PROTECTION OR COMMUNICATIONS SYSTEMS, THEY SHALL BE CUT AND CAPPED AT SUITABLE PLACES OR WHERE SHOWN. ALL SUCH ACTIONS SHALL BE COORDINATED WITH THE UTILITY COMPANY INVOLVED:
- 1.12 PERMITS / FEES: WHEN REQUIRED THAT A PERMIT OR CONNECTION FEE BE PAID TO A PUBLIC UTILITY PROVIDER FOR NEW SERVICE TO THE CONSTRUCTION PROJECT, PAYMENT OF SUCH FEE SHALL BE THE RESPONSIBILITY OF THE CONTRACTOR.
- 1.13 CONTRACTOR SHALL TAKE ALL MEASURES AND PROVIDE ALL MATERIAL NECESSARY FOR PROTECTING EXISTING EQUIPMENT AND PROPERTY.
- 1.14 METHODS OF PROCEDURE (MOPS) FOR CONSTRUCTION: CONTRACTOR SHALL PERFORM WORK AS DESCRIBED IN THE FOLLOWING INSTALLATION AND COMMISSIONING MOPS.

NOTE: IN SHORT-FORM SPECIFICATIONS ON THE DRAWINGS, A/E TO INSERT LIST OF APPLICABLE MOPS INCLUDING EN-2012-001, EN-2013-002, EL-0568, AND TS-0193
- 1.15 USE OF ELECTRONIC PROJECT MANAGEMENT SYSTEMS:

PART 2 – PRODUCTS (NOT USED)

PART 3 – EXECUTION

- 3.1 TEMPORARY UTILITIES AND FACILITIES: THE CONTRACTOR SHALL BE RESPONSIBLE FOR ALL TEMPORARY UTILITIES AND FACILITIES NECESSARY EXCEPT AS OTHERWISE INDICATED IN THE CONSTRUCTION DOCUMENTS. TEMPORARY UTILITIES AND FACILITIES INCLUDE POTABLE WATER, HEAT, HVAC, ELECTRICITY, SANITARY FACILITIES, WASTE DISPOSAL FACILITIES, AND TELEPHONE/COMMUNICATION SERVICES. PROVIDE TEMPORARY UTILITIES AND FACILITIES IN ACCORDANCE WITH OSHA AND THE AUTHORITY HAVING JURISDICTION. CONTRACTOR MAY UTILIZE THE COMPANY ELECTRICAL SERVICE IN THE COMPLETION OF THE WORK WHEN IT BECOMES AVAILABLE. USE OF THE LESSORS OR SITE OWNER'S UTILITIES OR FACILITIES IS EXPRESSLY FORBIDDEN EXCEPT AS OTHERWISE ALLOWED IN THE CONTRACT DOCUMENTS.
- 3.2 ACCESS TO WORK: THE CONTRACTOR SHALL PROVIDE ACCESS TO THE JOB SITE FOR AUTHORIZED COMPANY PERSONNEL AND AUTHORIZED REPRESENTATIVES OF THE ARCHITECT/ENGINEER DURING ALL PHASES OF THE WORK.
- 3.3 TESTING: REQUIREMENTS FOR TESTING BY THIS CONTRACTOR SHALL BE AS INDICATED HEREWITH. ON THE CONSTRUCTION DRAWINGS, AND IN THE INDIVIDUAL SECTIONS OF THESE SPECIFICATIONS. SHOULD COMPANY CHOOSE TO ENGAGE ANY THIRD-PARTY TO CONDUCT ADDITIONAL TESTING, THE CONTRACTOR SHALL COOPERATE WITH AND PROVIDE A WORK AREA FOR COMPANY'S TEST AGENCY.
- 3.4 DIMENSIONS: VERIFY DIMENSIONS INDICATED ON DRAWINGS WITH FIELD DIMENSIONS BEFORE FABRICATION OR ORDERING OF MATERIALS. DO NOT SCALE DRAWINGS.

3.5 EXISTING CONDITIONS: NOTIFY THE SPRINT CONSTRUCTION MANAGER OF EXISTING CONDITIONS DIFFERING FROM THOSE INDICATED ON THE DRAWINGS. DO NOT REMOVE OR ALTER STRUCTURAL COMPONENTS WITHOUT PRIOR WRITTEN APPROVAL FROM THE ARCHITECT AND ENGINEER.

SECTION 01 200 – COMPANY FURNISHED MATERIAL AND EQUIPMENT

PART 1 – GENERAL

- 1.1 THE WORK: THESE STANDARD CONSTRUCTION SPECIFICATIONS IN CONJUNCTION WITH THE OTHER CONTRACT DOCUMENTS AND THE CONSTRUCTION DRAWINGS DESCRIBE THE WORK TO BE PERFORMED BY THE CONTRACTOR.
- 1.2 RELATED DOCUMENTS:
 - A. THE REQUIREMENTS OF THIS SECTION APPLY TO ALL SECTIONS IN THIS SPECIFICATION.
 - B. SPRINT "STANDARD CONSTRUCTION DETAILS FOR WIRELESS SITES" ARE INCLUDED IN AND MADE A PART OF THESE SPECIFICATIONS HEREWITH.

PART 2 – PRODUCTS (NOT USED)

PART 3 – EXECUTION

- 3.1 RECEIPT OF MATERIAL AND EQUIPMENT:
 - A. A COMPANY FURNISHED MATERIAL AND EQUIPMENT IS IDENTIFIED ON THE RF DATA SHEET IN THE CONSTRUCTION DOCUMENTS.
 - B. THE CONTRACTOR IS RESPONSIBLE FOR SPRINT PROVIDED MATERIAL AND EQUIPMENT AND UPON RECEIPT SHALL:
 - 1. ACCEPT DELIVERIES AS SHIPPED AND TAKE RECEIPT.
 - 2. VERIFY COMPLETENESS AND CONDITION OF ALL DELIVERIES.
 - 3. TAKE RESPONSIBILITY FOR EQUIPMENT AND PROVIDE INSURANCE PROTECTION AS REQUIRED IN AGREEMENT.
 - 4. RECORD ANY DEFECTS OR DAMAGES AND WITHIN TWENTY-FOUR HOURS AFTER RECEIPT, REPORT TO SPRINT OR ITS DESIGNATED PROJECT REPRESENTATIVE OF SUCH.
 - 5. PROVIDE SECURE AND NECESSARY WEATHER PROTECTED WAREHOUSING.
 - 6. COORDINATE SAFE AND SECURE TRANSPORTATION OF MATERIAL AND EQUIPMENT, DELIVERING AND OFF-LOADING FROM CONTRACTOR'S WAREHOUSE TO SITE.
- 3.2 DELIVERABLES:
 - A. COMPLETE SHIPPING AND RECEIPT DOCUMENTATION IN ACCORDANCE WITH COMPANY PRACTICE.
 - B. IF APPLICABLE, COMPLETE LOST/STOLEN/DAMAGED DOCUMENTATION REPORT AS NECESSARY IN ACCORDANCE WITH COMPANY PRACTICE, AND AS DIRECTED BY COMPANY.
 - C. UPLOAD DOCUMENTATION INTO SPRINT SITE MANAGEMENT SYSTEM (SMS) AND/OR PROVIDE HARD COPY DOCUMENTATION AS REQUESTED.

SECTION 01 300 – CELL SITE CONSTRUCTION CO.

PART 1 – GENERAL

- 1.1 THE WORK: THESE STANDARD CONSTRUCTION SPECIFICATIONS IN CONJUNCTION WITH THE OTHER CONTRACT DOCUMENTS AND THE CONSTRUCTION DRAWINGS DESCRIBE THE WORK TO BE PERFORMED BY THE CONTRACTOR.
- 1.2 RELATED DOCUMENTS:
 - A. THE REQUIREMENTS OF THIS SECTION APPLY TO ALL SECTIONS IN THIS SPECIFICATION.
 - B. SPRINT "STANDARD CONSTRUCTION DETAILS FOR WIRELESS SITES" ARE INCLUDED IN AND MADE A PART OF THESE SPECIFICATIONS HEREWITH.
- 1.3 NOTICE TO PROCEED
 - A. NO WORK SHALL COMMENCE PRIOR TO COMPANY'S WRITTEN NOTICE TO PROCEED AND THE ISSUANCE OF THE WORK ORDER.
 - B. UPON RECEIVING NOTICE TO PROCEED, CONTRACTOR SHALL FULLY PERFORM ALL WORK NECESSARY TO PROVIDE SPRINT WITH AN OPERATIONAL WIRELESS FACILITY.

PART 2 – PRODUCTS (NOT USED)

PART 3 – EXECUTION

- 3.1 FUNCTIONAL REQUIREMENTS:
 - A. THE ACTIVITIES DESCRIBED IN THIS PARAGRAPH REPRESENT MINIMUM ACTIONS AND PROCESSES REQUIRED TO SUCCESSFULLY COMPLETE THE WORK. THE ACTIVITIES DESCRIBED ARE NOT EXHAUSTIVE, AND CONTRACTOR SHALL TAKE ANY AND ALL ACTIONS AS NECESSARY TO SUCCESSFULLY COMPLETE THE CONSTRUCTION OF A FULLY FUNCTIONING WIRELESS FACILITY AT THE SITE IN ACCORDANCE WITH COMPANY PROCESSES.
 - B. SUBMIT SPECIFIC DOCUMENTATION AS INDICATED HEREIN, AND OBTAIN REQUIRED APPROVALS WHILE THE WORK IS BEING PERFORMED.
 - C. MANAGE AND CONDUCT ALL FIELD CONSTRUCTION SERVICE RELATED ACTIVITIES
 - D. PROVIDE CONSTRUCTION ACTIVITIES TO THE EXTENT REQUIRED BY THE CONTRACT DOCUMENTS, INCLUDING BUT NOT LIMITED TO THE FOLLOWING:

PLANS PREPARED FOR:



6580 Sprint Parkway
Overland Park, Kansas 66251

PLANS PREPARED BY:



1033 Watervliet Shaker Rd
Albany, NY 12205
Office # (518) 690-0790
Fax # (518) 690-0793
JOB NUMBER 333-000



ENGINEERING LICENSE:

DRAWING NOTICE:

THESE DOCUMENTS ARE CONFIDENTIAL AND ARE THE SOLE PROPERTY OF SPRINT AND MAY NOT BE REPRODUCED, DISSEMINATED OR REDISTRIBUTED WITHOUT THE EXPRESS WRITTEN CONSENT OF SPRINT.

REVISIONS:

DESCRIPTION	DATE	BY	REV
ISSUED FOR REVIEW	05/13/14	JDV	A

SITE NAME:

GREENWICH HOSPITAL

SITE CASCADE:

CT43XC855

SITE ADDRESS:

**9 PERRYRIDGE RD
GREENWICH, CT 06830.**

SHEET DESCRIPTION:

SPRINT SPECIFICATIONS

SHEET NUMBER:

SP-1

CONTINUE FROM SP-1

1. PERFORM ANY REQUIRED SITE ENVIRONMENTAL MITIGATION.
2. PREPARE GROUND SITES; PROVIDE DE-GRUBBING; AND ROUGH AND FINAL GRADING, AND COMPOUND SURFACE TREATMENTS.
3. MANAGE AND CONDUCT ALL ACTIVITIES FOR INSTALLATION OF UTILITIES INCLUDING ELECTRICAL AND TELCO BACKHAUL.
4. INSTALL UNDERGROUND FACILITIES INCLUDING UNDERGROUND POWER AND COMMUNICATIONS CONDUITS, AND UNDERGROUND GROUNDING SYSTEM.
5. INSTALL ABOVE GROUND GROUNDING SYSTEMS.
6. PROVIDE NEW HVAC INSTALLATIONS AND MODIFICATIONS.
7. INSTALL "H-FRAMES", CABINETS AND SHELTERS AS INDICATED.
8. INSTALL ROADS, ACCESS WAYS, CURBS AND DRAINS AS INDICATED.
9. ACCOMPLISH REQUIRED MODIFICATION OF EXISTING FACILITIES.
10. PROVIDE ANTENNA SUPPORT STRUCTURE FOUNDATIONS.
11. PROVIDE SLABS AND EQUIPMENT PLATFORMS.
12. INSTALL COMPOUND FENCING, SIGHT SHIELDING, LANDSCAPING AND ACCESS BARRIERS.
13. PERFORM INSPECTION AND MATERIAL TESTING AS REQUIRED HEREINAFTER.
14. CONDUCT SITE RESISTANCE TO EARTH TESTING AS REQUIRED HEREINAFTER
15. INSTALL FIXED GENERATOR SETS AND OTHER STANDBY POWER SOLUTIONS.
16. INSTALL TOWERS, ANTENNA SUPPORT STRUCTURES AND PLATFORMS ON EXISTING TOWERS AS REQUIRED.
17. INSTALL CELL SITE RADIOS, MICROWAVE, GPS, COAXIAL MAINLINE, ANTENNAS, CROSS BAND COUPLERS, TOWER TOP AMPLIFIERS, LOW NOISE AMPLIFIERS AND RELATED EQUIPMENT.
18. PERFORM, DOCUMENT, AND CLOSE OUT ANY CONSTRUCTION CONTROL DOCUMENTS THAT MAY BE REQUIRED BY GOVERNMENT AGENCIES AND LANDLORDS.
19. PERFORM ANTENNA AND COAX SWEEP TESTING AND MAKE ANY AND ALL NECESSARY CORRECTIONS.
20. REMAIN ON SITE MOBILIZED THROUGHOUT HAND-OFF AND INTEGRATION TO ASSIST AS NEEDED UNTIL SITE IS DEEMED SUBSTANTIALLY COMPLETE AND PLACED "ON AIR."

3.2 GENERAL REQUIREMENTS FOR CIVIL CONSTRUCTION:

- A. CONTRACTOR SHALL KEEP THE SITE FREE FROM ACCUMULATING WASTE MATERIAL, DEBRIS, AND TRASH. AT THE COMPLETION OF THE WORK, CONTRACTOR SHALL REMOVE FROM THE SITE ALL REMAINING RUBBISH, IMPLEMENTS, TEMPORARY FACILITIES, AND SURPLUS MATERIALS.
- B. EQUIPMENT ROOMS SHALL AT ALL TIMES BE MAINTAINED "BROOM CLEAN" AND CLEAR OF DEBRIS.
- C. CONTRACTOR SHALL TAKE ALL REASONABLE PRECAUTIONS TO DISCOVER AND LOCATE ANY HAZARDOUS CONDITION.
 1. IN THE EVENT CONTRACTOR ENCOUNTERS ANY HAZARDOUS CONDITION WHICH HAS NOT BEEN ABATED OR OTHERWISE MITIGATED, CONTRACTOR AND ALL OTHER PERSONS SHALL IMMEDIATELY STOP WORK IN THE AFFECTED AREA AND NOTIFY COMPANY IN WRITING. THE WORK IN THE AFFECTED AREA SHALL NOT BE RESUMED EXCEPT BY WRITTEN NOTIFICATION BY COMPANY.
 2. CONTRACTOR AGREES TO USE CARE WHILE ON THE SITE AND SHALL NOT TAKE ANY ACTION THAT WILL OR MAY RESULT IN OR CAUSE THE HAZARDOUS CONDITION TO BE FURTHER RELEASED IN THE ENVIRONMENT, OR TO FURTHER EXPOSE INDIVIDUALS TO THE HAZARD.

D. CONTRACTOR'S ACTIVITIES SHALL BE RESTRICTED TO THE PROJECT LIMITS. SHOULD AREAS OUTSIDE THE PROJECT LIMITS BE AFFECTED BY CONTRACTOR'S ACTIVITIES, CONTRACTOR SHALL IMMEDIATELY RETURN THEM TO ORIGINAL CONDITION

E. CONDUCT TESTING AS REQUIRED HEREIN.

3.3 DELIVERABLES:

- A. CONTRACTOR SHALL REVIEW, APPROVE, AND SUBMIT TO SPRINT SHOP DRAWINGS, PRODUCT DATA, SAMPLES, AND SIMILAR SUBMITTALS AS REQUIRED HEREINAFTER
- B. PROVIDE DOCUMENTATION INCLUDING, BUT NOT LIMITED TO, THE FOLLOWING. DOCUMENTATION SHALL BE FORWARDED IN ORIGINAL FORMAT AND/OR UPLOADED INTO SMS.
 1. ALL CORRESPONDENCE AND PRELIMINARY CONSTRUCTION REPORTS.
 2. PROJECT PROGRESS REPORTS.
 3. CIVIL CONSTRUCTION START DATE (POPULATE FIELD IN SMS AND/OR FORWARD NOTIFICATION).
 4. ELECTRICAL SERVICE COMPLETION DATE (POPULATE FIELD IN SMS AND/OR FORWARD NOTIFICATION).

5. LINES AND ANTENNA INSTALL DATE (POPULATE FIELD IN SMS AND/OR FORWARD NOTIFICATION).
6. POWER INSTALL DATE (POPULATE FIELD IN SMS AND/OR FORWARD NOTIFICATION).
7. TELCO READY DATE (POPULATE FIELD IN SMS AND/OR FORWARD NOTIFICATION).
8. PPC (OR SHELTER) INSTALL DATE (POPULATE FIELD IN SMS AND/OR FORWARD NOTIFICATION).
9. TOWER CONSTRUCTION START DATE (POPULATE FIELD IN SMS AND/OR FORWARD NOTIFICATION).
10. TOWER CONSTRUCTION COMPLETE DATE (POPULATE FIELD IN SMS AND/OR FORWARD NOTIFICATION).
11. BTS AND RADIO EQUIPMENT DELIVERED AT SITE DATE (POPULATE FIELD IN SMS AND/OR FORWARD NOTIFICATION).
12. NETWORK OPERATIONS HANDOFF CHECKLIST (HOC WALK) COMPLETE (UPLOAD FORM IN SMS)
13. CIVIL CONSTRUCTION COMPLETE DATE (POPULATE FIELD IN SMS AND/OR FORWARD NOTIFICATION).
14. SITE CONSTRUCTION PROGRESS PHOTOS UNLOADED INTO SMS.

SECTION 01 400 - SUBMITTALS & TESTS

PART 1 - GENERAL

1.1 THE WORK: THESE STANDARD CONSTRUCTION SPECIFICATIONS IN CONJUNCTION WITH THE OTHER CONTRACT DOCUMENTS AND THE CONSTRUCTION DRAWINGS DESCRIBE THE WORK TO BE PERFORMED BY THE CONTRACTOR.

1.2 RELATED DOCUMENTS:

- A. THE REQUIREMENTS OF THIS SECTION APPLY TO ALL SECTIONS IN THIS SPECIFICATION.
- B. SPRINT "STANDARD CONSTRUCTION DETAILS FOR WIRELESS SITES" ARE INCLUDED IN AND MADE A PART OF THESE SPECIFICATIONS HERewith.

1.3 SUBMITTALS:

- A. THE WORK IN ALL ASPECTS SHALL COMPLY WITH THE CONSTRUCTION DRAWINGS AND THESE SPECIFICATIONS.
- B. SUBMIT THE FOLLOWING TO COMPANY REPRESENTATIVE FOR APPROVAL.
 1. CONCRETE MIX-DESIGNS FOR TOWER FOUNDATIONS, ANCHORS PIERS, AND CONCRETE PAVING.
 2. CONCRETE BREAK TESTS AS SPECIFIED HEREIN.
 3. SPECIAL FINISHES FOR INTERIOR SPACES, IF ANY.
 4. ALL EQUIPMENT AND MATERIALS SO IDENTIFIED ON THE CONSTRUCTION DRAWINGS.
 5. CHEMICAL GROUNDING DESIGN
- D. ALTERNATES: AT THE COMPANY'S REQUEST, ANY ALTERNATIVES TO THE MATERIALS OR METHODS SPECIFIED SHALL BE SUBMITTED TO SPRINT'S CONSTRUCTION MANAGER FOR APPROVAL PRIOR TO BEING SHIPPED TO SITE. SPRINT WILL REVIEW AND APPROVE ONLY THOSE REQUESTS MADE IN WRITING. NO VERBAL APPROVALS WILL BE CONSIDERED. SUBMITTAL FOR APPROVAL SHALL INCLUDE A STATEMENT OF COST REDUCTION PROPOSED FOR USE OF ALTERNATE PRODUCT.

1.4 TESTS AND INSPECTIONS:

- A. THE CONTRACTOR SHALL BE RESPONSIBLE FOR ALL CONSTRUCTION TESTS, INSPECTIONS AND PROJECT DOCUMENTATION.
- B. CONTRACTOR SHALL ACCOMPLISH TESTING INCLUDING BUT NOT LIMITED TO THE FOLLOWING:
 1. COAX SWEEPS AND FIBER TESTS PER TS-0200 REV 4 ANTENNA LINE ACCEPTANCE STANDARDS.
 2. AGL, AZIMUTH AND DOWNTILT USING ELECTRONIC COMMERCIAL MADE-FOR-THE-PURPOSE ANTENNA ALIGNMENT TOOL.
 3. CONTRACTOR SHALL BE RESPONSIBLE FOR ANY AND ALL CORRECTIONS TO ANY WORK IDENTIFIED AS UNACCEPTABLE IN SITE INSPECTION ACTIVITIES AND/OR AS A RESULT OF TESTING.
- C. REQUIRED CLOSEOUT DOCUMENTATION INCLUDES, BUT IS NOT LIMITED TO THE FOLLOWING:
 1. AZIMUTH, DOWNTILT, AGL - UPLOAD REPORT FROM ANTENNA ALIGNMENT TOOL TO SITERRA TASK 465. INSTALLED AZIMUTH, DOWNTILT, AND AGL MUST CONFORM TO THE RF DATA SHEETS. SWEEP AND FIBER TESTS
 2. SCANABLE BARCODE PHOTOGRAPHS OF TOWER TOP AND INACCESSIBLE SERIALIZED EQUIPMENT
 3. ALL AVAILABLE JURISDICTIONAL INFORMATION
 4. PDF SCAN OF REDLINES PRODUCED IN FIELD

5. ELECTRONIC AS-BUILT DRAWINGS IN AUTOCAD AND PDF FORMATS. ANY FIELD CHANGE MUST BE REFLECTED BY MODIFYING THE PLANS, ELEVATIONS, AND DETAILS IN THE DRAWING SETS. GENERAL NOTES INDICATING MODIFICATIONS WILL NOT BE ACCEPTED. CHANGES SHALL BE HIGHLIGHTED AS "CLOUDS" IDENTIFIED AS THE "AS-BUILT" CONDITION.
6. LIEN WAIVERS
7. FINAL PAYMENT APPLICATION
8. REQUIRED FINAL CONSTRUCTION PHOTOS
9. CONSTRUCTION AND COMMISSIONING CHECKLIST COMPLETE WITH NO DEFICIENT ITEMS
10. ALL POST NTP TASKS INCLUDING DOCUMENT UPLOADS COMPLETED IN SITERRA (SPRINTS DOCUMENT REPOSITORY OF RECORD).

1.5 COMMISSIONING: PERFORM ALL COMMISSIONING AS REQUIRED BY APPLICABLE MOPs

1.6 INTEGRATION: PERFORM ALL INTEGRATION ACTIVITIES AS REQUIRED BY APPLICABLE MOPs

PART 2 - PRODUCTS (NOT USED)

PART 3 - EXECUTION

3.1 REQUIREMENTS FOR TESTING:

A. THIRD PARTY TESTING AGENCY:

1. WHEN THE USE OF A THIRD PARTY INDEPENDENT TESTING AGENCY IS REQUIRED, THE AGENCY THAT IS SELECTED MUST PERFORM SUCH WORK ON A REGULAR BASIS IN THE STATE WHERE THE PROJECT IS LOCATED AND HAVE A THOROUGH UNDERSTANDING OF LOCAL AVAILABLE MATERIALS, INCLUDING THE SOIL, ROCK, AND GROUNDWATER CONDITIONS.
2. THE THIRD PARTY TESTING AGENCY IS TO BE FAMILIAR WITH THE APPLICABLE REQUIREMENTS FOR THE TESTS TO BE DONE, EQUIPMENT TO BE USED, AND ASSOCIATED HEALTH AND SAFETY ISSUES.
3. EXPERIENCE IN SOILS, CONCRETE, MASONRY, AGGREGATE, AND ASPHALT TESTING USING ASTM, AASHTO, AND OTHER METHODS IS NEEDED.
4. EXPERIENCE IN SOILS, CONCRETE, MASONRY, AGGREGATE, AND ASPHALT TESTING USING ASTM, AASHTO, AND OTHER METHODS IS NEEDED.

3.2 REQUIRED TESTS:

- A. CONTRACTOR SHALL ACCOMPLISH TESTING INCLUDING BUT NOT LIMITED TO THE FOLLOWING:
 1. CONCRETE CYLINDER BREAK TESTS FOR THE TOWER AND ANCHOR FOUNDATIONS AS SPECIFIED IN SECTION: PORTLAND CEMENT CONCRETE PAVING.
 2. ASPHALT ROADWAY COMPACTED THICKNESS, SURFACE SMOOTHNESS, AND COMPACTED DENSITY TESTING AS SPECIFIED IN SECTION: HOT MIX ASPHALT PAVING.
 3. FIELD QUALITY CONTROL TESTING AS SPECIFIED IN SECTION: PORTLAND CEMENT CONCRETE PAVING.
 4. TESTING REQUIRED UNDER SECTION: AGGREGATE BASE FOR ACCESS ROADS, PADS AND ANCHOR LOCATIONS
 5. STRUCTURAL BACKFILL COMPACTION TESTS FOR THE TOWER FOUNDATION.
 6. SITE RESISTANCE TO EARTH TESTING PER EXHIBIT: CELL SITE GROUNDING SYSTEM DESIGN.
 7. ANTENNA AND COAX SWEEP TESTS PER EXHIBIT: ANTENNA TRANSMISSION LINE ACCEPTANCE STANDARDS.
 8. GROUNDING AT ANTENNA MASTS FOR GPS AND ANTENNAS
 9. ALL OTHER TESTS REQUIRED BY COMPANY OR JURISDICTION.

3.3 REQUIRED INSPECTIONS

- A. SCHEDULE INSPECTIONS WITH COMPANY REPRESENTATIVE.
- B. CONDUCT INSPECTIONS INCLUDING BUT NOT LIMITED TO THE FOLLOWING:
 1. GROUNDING SYSTEM INSTALLATION PRIOR TO EARTH CONCEALMENT DOCUMENTED WITH DIGITAL PHOTOGRAPHS BY CONTRACTOR, APPROVED BY A&E OR SPRINT REPRESENTATIVE.
 2. FORMING FOR CONCRETE AND REBAR PLACEMENT PRIOR TO POUR DOCUMENTED WITH DIGITAL PHOTOGRAPHS BY CONTRACTOR, APPROVED BY A&E OR SPRINT REPRESENTATIVE.
 3. COMPACTION OF BACKFILL MATERIALS; AGGREGATE BASE FOR ROADS, PADS, AND ANCHORS; ASPHALT PAVING; AND SHAFT BACKFILL FOR CONCRETE AND WOOD POLES, BY INDEPENDENT THIRD PARTY AGENCY.
 4. PRE- AND POST-CONSTRUCTION ROOFTOP AND STRUCTURAL INSPECTIONS ON EXISTING FACILITIES.
 5. TOWER ERECTION SECTION STACKING AND PLATFORM ATTACHMENT DOCUMENTED BY DIGITAL PHOTOGRAPHS BY THIRD PARTY AGENCY.
 6. ANTENNA AZIMUTH , DOWN TILT AND PER SUNLIGHT TOOL SUNSIGHT INSTRUMENTS - ANTENNALIGN ALIGNMENT TOOL (AAT)

PLANS PREPARED FOR:



PLANS PREPARED BY:



ENGINEERING LICENSE:

DRAWING NOTICE:

THESE DOCUMENTS ARE CONFIDENTIAL AND ARE THE SOLE PROPERTY OF SPRINT AND MAY NOT BE REPRODUCED, DISSEMINATED OR REDISTRIBUTED WITHOUT THE EXPRESS WRITTEN CONSENT OF SPRINT.

REVISIONS:

DESCRIPTION	DATE	BY	REV
ISSUED FOR REVIEW	05/13/14	JDV	A

SITE NAME:

GREENWICH HOSPITAL

SITE CASCADE:

CT43XC855

SITE ADDRESS:

**9 PERRYRIDGE RD
GREENWICH, CT 06830.**

SHEET DESCRIPTION:

SPRINT SPECIFICATIONS

SHEET NUMBER:

SP-2

CONTINUE FROM SP-2

- 7. VERIFICATION DOCUMENTED WITH THE ANTENNA CHECKLIST REPORT, BY A&E, SITE DEVELOPMENT REP, OR RF REP.
- 8. FINAL INSPECTION CHECKLIST AND HANDOFF WALK (HOC.). SIGNED FORM SHOWING ACCEPTANCE BY FIELD OPS IS TO BE UPLOADED INTO SMS.
- 9. COAX SWEEP AND FIBER TESTING DOCUMENTS SUBMITTED VIA SMS FOR RF APPROVAL.
- 10. SCAN-ABLE BARCODE PHOTOGRAPHS OF TOWER TOP AND INACCESSIBLE SERIALIZED EQUIPMENT
- 11. ALL AVAILABLE JURISDICTIONAL INFORMATION
- 12. PDF SCAN OF REDLINES PRODUCED IN FIELD
- C. THE CONTRACTOR SHALL BE RESPONSIBLE FOR ANY AND ALL CORRECTIONS TO ANY WORK IDENTIFIED AS UNACCEPTABLE IN SITE INSPECTION ACTIVITIES AND/OR AS A RESULT OF TESTING.
- D. CONSTRUCTION INSPECTIONS AND CORRECTIVE MEASURES SHALL BE DOCUMENTED BY THE CONTRACTOR WITH WRITTEN REPORTS AND PHOTOGRAPHS. PHOTOGRAPHS MUST BE DIGITAL AND OF SUFFICIENT QUALITY TO CLEARLY SHOW THE SITE CONSTRUCTION. PHOTOGRAPHS MUST CLEARLY IDENTIFY THE PHOTOGRAPHED ITEM AND BE LABELED WITH THE SITE CASCADE NUMBER, SITE NAME, DESCRIPTION, AND DATE.
- 3.4 DELIVERABLES: TEST AND INSPECTION REPORTS AND CLOSEOUT DOCUMENTATION SHALL BE UPLOADED TO THE SMS AND/OR FORWARDED TO SPRINT FOR INCLUSION INTO THE PERMANENT SITE FILES.
 - A. THE FOLLOWING TEST AND INSPECTION REPORTS SHALL BE PROVIDED AS APPLICABLE.
 - 1. CONCRETE MIX AND CYLINDER BREAK REPORTS.
 - 2. STRUCTURAL BACKFILL COMPACTION REPORTS.
 - 3. SITE RESISTANCE TO EARTH TEST.
 - 4. ANTENNA AZIMUTH AND DOWN TILT VERIFICATION
 - 5. TOWER ERECTION INSPECTIONS AND MEASUREMENTS DOCUMENTING TOWER INSTALLED PER SUPPLIER'S REQUIREMENTS AND THE APPLICABLE SECTIONS HEREIN.
 - 6. COAX CABLE SWEEP TESTS PER COMPANY'S "ANTENNA LINE ACCEPTANCE STANDARDS".
 - B. REQUIRED CLOSEOUT DOCUMENTATION INCLUDES THE FOLLOWING;
 - 1. TEST WELLS AND TRENCHES: PHOTOGRAPHS OF ALL TEST WELLS; PHOTOGRAPHS SHOWING ALL OPEN EXCAVATIONS AND TRENCHING PRIOR TO BACKFILLING SHOWING A TAPE MEASURE VISIBLE IN THE EXCAVATIONS INDICATING DEPTH.
 - 2. CONDUITS, CONDUCTORS AND GROUNDING: PHOTOGRAPHS SHOWING TYPICAL INSTALLATION OF CONDUCTORS AND CONNECTORS; PHOTOGRAPHS SHOWING TYPICAL BEND RADIUS OF INSTALLED GROUND WIRES AND GROUND ROD SPACING;
 - 3. CONCRETE FORMS AND REINFORCING: CONCRETE FORMING AT TOWER AND EQUIPMENT/SHELTER PAD/FOUNDATIONS - PHOTOGRAPHS SHOWING ALL REINFORCING STEEL, UTILITY AND CONDUIT STUB OUTS; PHOTOGRAPHS SHOWING CONCRETE POUR OF SHELTER SLAB/FOUNDATION, TOWER FOUNDATION AND GUY ANCHORS WITH VIBRATOR IN USE; PHOTOGRAPHS SHOWING EACH ANCHOR ON GUYED TOWERS, BEFORE CONCRETE POUR.
 - 4. TOWER, ANTENNAS AND MAINLINE: INSPECTION AND PHOTOGRAPHS OF SECTION STACKING; INSPECTION AND PHOTOGRAPHS OF PLATFORM COMPONENT ATTACHMENT POINTS; PHOTOGRAPHS OF TOWER TOP GROUNDING; PHOTOS OF TOWER COAX LINE COLOR CODING AT THE TOP AND AT GROUND LEVEL; INSPECTION AND PHOTOGRAPHS OF OPERATIONAL OF TOWER LIGHTING, AND PLACEMENT OF FAA REGISTRATION SIGN; PHOTOGRAPHS SHOWING ADDITIONAL GROUNDING POINTS FOR TOWERS GREATER THAN 200 FEET.; PHOTOS OF ANTENNA GROUND BAR, EQUIPMENT GROUND BAR, AND MASTER GROUND BAR; PHOTOS OF GPS ANTENNA(S); PHOTOS OF EACH SECTOR OF ANTENNAS; ONE PHOTOGRAPH LOOKING AT THE SECTOR AND ONE FROM BEHIND SHOWING THE PROJECTED COVERAGE AREA; PHOTOS OF COAX WEATHERPROOFING - TOP AND BOTTOM; PHOTOS OF COAX GROUNDING--TOP AND BOTTOM; PHOTOS OF ANTENNA AND MAST GROUNDING; PHOTOS OF COAX CABLE ENTRY INTO SHELTER; PHOTOS OF PLATFORM MECHANICAL CONNECTIONS TO TOWER/MONOPOLE.
 - 5. ROOF TOPS: PRE-CONSTRUCTION AND POST-CONSTRUCTION VISUAL INSPECTION AND PHOTOGRAPHS OF THE ROOF AND INTERIOR TO DETERMINE AND DOCUMENT CONDITIONS; ROOF TOP CONSTRUCTION INSPECTIONS AS REQUIRED BY THE JURISDICTION; PHOTOGRAPHS OF CABLE TRAY AND/OR ICE BRIDGE; PHOTOGRAPHS OF DOGHOUSE/CABLE EXIT FROM ROOF;
 - 6. SITE LAYOUT - PHOTOGRAPHS OF THE OVERALL COMPOUND, INCLUDING EQUIPMENT PLATFORM FROM ALL FOUR CORNERS.
 - 7. FINISHED UTILITIES: CLOSE-UP PHOTOGRAPHS OF THE PPC BREAKER PANEL; CLOSE-UP PHOTOGRAPH OF THE INSIDE OF THE TELCO PANEL AND NIU; CLOSE-UP PHOTOGRAPH OF THE POWER METER AND DISCONNECT; PHOTOS OF POWER AND TELCO ENTRANCE TO COMPANY ENCLOSURE; PHOTOGRAPHS AT METER BOX AND/OR FACILITY DISTRIBUTION PANEL.
 - 8. REQUIRED MATERIALS CERTIFICATIONS: CONCRETE MIX DESIGNS; MILL CERTIFICATION FOR ALL REINFORCING AND STRUCTURAL STEEL; AND ASPHALT PAVING MIX DESIGN.
 - 9. ANY AND ALL SUBMITTALS BY THE JURISDICTION OR COMPANY.

SECTION 01 400 - SUBMITTALS & TESTS

PART 1 - GENERAL

- 1.1 THE WORK: THESE STANDARD CONSTRUCTION SPECIFICATIONS IN CONJUNCTION WITH THE OTHER CONTRACT DOCUMENTS AND THE CONSTRUCTION DRAWINGS DESCRIBE THE WORK TO BE PERFORMED BY THE CONTRACTOR.
- 1.2 RELATED DOCUMENTS:
 - A. THE REQUIREMENTS OF THIS SECTION APPLY TO ALL SECTIONS IN THIS SPECIFICATION.
 - B. SPRINT "STANDARD CONSTRUCTION DETAILS FOR WIRELESS SITES" ARE INCLUDED IN AND MADE A PART OF THESE SPECIFICATIONS HEREWITH.

PART 2 - PRODUCTS (NOT USED)

PART 3 - EXECUTION

- 3.1 WEEKLY REPORTS:
 - A. CONTRACTOR SHALL PROVIDE SPRINT WITH WEEKLY REPORTS SHOWING PROJECT STATUS. THIS STATUS REPORT FORMAT WILL BE PROVIDED TO THE CONTRACTOR BY SPRINT. THE REPORT WILL CONTAIN SITE ID NUMBER, THE MILESTONES FOR EACH SITE, INCLUDING THE BASELINE DATE, ESTIMATED COMPLETION DATE AND ACTUAL COMPLETION DATE.
 - B. REPORT INFORMATION WILL BE TRANSMITTED TO SPRINT VIA ELECTRONIC MEANS AS REQUIRED. THIS INFORMATION WILL PROVIDE A BASIS FOR PROGRESS MONITORING AND PAYMENT.
- 3.2 PROJECT CONFERENCE CALLS:
 - A. SPRINT MAY HOLD WEEKLY PROJECT CONFERENCE CALLS. CONTRACTOR WILL BE REQUIRED TO COMMUNICATE SITE STATUS, MILESTONE COMPLETIONS AND UPCOMING MILESTONE PROJECTIONS, AND ANSWER ANY OTHER SITE STATUS QUESTIONS AS NECESSARY.
- 3.3 PROJECT TRACKING IN SMS:
 - A. CONTRACTOR SHALL PROVIDE SCHEDULE UPDATES AND PROJECTIONS IN THE SMS SYSTEM ON A WEEKLY BASIS.
- 3.4 ADDITIONAL REPORTING:
 - A. ADDITIONAL OR ALTERNATE REPORTING REQUIREMENTS MAY BE ADDED TO THE REPORT AS DETERMINED TO BE REASONABLY NECESSARY BY COMPANY.
- 3.5 PROJECT PHOTOGRAPHS:
 - A. FILE DIGITAL PHOTOGRAPHS OF COMPLETED SITE IN JPEG FORMAT IN THE SMS PHOTO LIBRARY FOR THE RESPECTIVE SITE. PHOTOGRAPHS SHALL BE CLEARLY LABELED WITH SITE NUMBER, NAME AND DESCRIPTION, AND SHALL INCLUDE AT A MINIMUM THE FOLLOWING AS APPLICABLE:
 - 1. SHELTER AND TOWER OVERVIEW.
 - 2. TOWER FOUNDATION(S) - FORMS AND STEEL BEFORE POUR (EACH ANCHOR ON GUYED TOWERS).
 - 3. TOWER FOUNDATION(S) POUR WITH VIBRATOR IN USE (EACH ANCHOR ON GUYED TOWERS).
 - 4. TOWER STEEL AS BEING INSTALLED INTO HOLE (SHOW ANCHOR STEEL ON GUYED TOWERS).
 - 5. PHOTOS OF TOWER SECTION STACKING.
 - 6. CONCRETE TESTING / SAMPLES.
 - 7. PLACING OF ANCHOR BOLTS IN TOWER FOUNDATION.
 - 8. BUILDING/WATER TANK FROM ROAD FOR TENANT IMPROVEMENTS OR COMMENTS.
 - 9. SHELTER FOUNDATION--FORMS AND STEEL BEFORE POURING.
 - 10. SHELTER FOUNDATION POUR WITH VIBRATOR IN USE.
 - 11. COAX CABLE ENTRY INTO SHELTER.
 - 12. PLATFORM MECHANICAL CONNECTIONS TO TOWER/MONOPOLE.
 - 13. ROOFTOP PRE AND POST CONSTRUCTION PHOTOS TO INCLUDE PENETRATIONS AND INTERIOR CEILING.
 - 14. PHOTOS OF TOWER TOP COAX LINE COLOR CODING AND COLOR CODING AT GROUND LEVEL.
 - 15. PHOTOS OF ALL APPROPRIATE COMPANY OR REGULATORY SIGNAGE.
 - 16. PHOTOS OF EQUIPMENT BOLT DOWN INSIDE SHELTER.
 - 17. POWER AND TELCO ENTRANCE TO COMPANY ENCLOSURE AND POWER AND TELCO SUPPLY LOCATIONS INCLUDING METER/DISCONNECT.
 - 18. ELECTRICAL TRENCH(S) WITH ELECTRICAL / CONDUIT BEFORE BACKFILL.
 - 19. ELECTRICAL TRENCH(S) WITH FOIL-BACKED TAPE BEFORE FURTHER BACKFILL.
 - 20. TELCO TRENCH WITH TELEPHONE / CONDUIT BEFORE BACKFILL.
 - 21. TELCO TRENCH WITH FOIL-BACKED TAPE BEFORE FURTHER BACKFILL.
 - 22. SHELTER GROUND-RING TRENCH WITH GROUND-WIRE BEFORE BACKFILL (SHOW ALL CAD WELDS AND BEND RADII).
 - 23. TOWER GROUND-RING TRENCH WITH GROUND-WIRE BEFORE BACKFILL (SHOW ALL CAD WELDS AND BEND RADII).

- 24. FENCE GROUND-RING TRENCH WITH GROUND-WIRE BEFORE BACKFILL (SHOW ALL CAD WELDS AND BEND RADII).
- 25. ALL BTS GROUND CONNECTIONS.
- 26. ALL GROUND TEST WELLS.
- 27. ANTENNA GROUND BAR AND EQUIPMENT GROUND BAR.
- 28. ADDITIONAL GROUNDING POINTS ON TOWERS ABOVE 200'.
- 29. HVAC UNITS INCLUDING CONDENSERS ON SPLIT SYSTEMS.
- 30. GPS ANTENNAS.
- 31. CABLE TRAY AND/OR WAVEGUIDE BRIDGE.
- 32. DOGHOUSE/CABLE EXIT FROM ROOF.
- 33. EACH SECTOR OF ANTENNAS; ONE PHOTOGRAPH LOOKING AT THE SECTOR AND ONE FROM BEHIND SHOWING THE PROJECTED COVERAGE AREA.
- 34. MASTER BUS BAR.
- 35. TELCO BOARD AND NIU.
- 36. ELECTRICAL DISTRIBUTION WALL.
- 37. CABLE ENTRY WITH SURGE SUPPRESSION.
- 38. ENTRANCE TO EQUIPMENT ROOM.
- 39. COAX WEATHERPROOFING--TOP AND BOTTOM OF TOWER.
- 40. COAX GROUNDING -TOP AND BOTTOM OF TOWER.
- 41. ANTENNA AND MAST GROUNDING.
- 42. LANDSCAPING - WHERE APPLICABLE.

3.6 FINAL PROJECT ACCEPTANCE: COMPLETE ALL REQUIRED REPORTING TASKS PER CONTRACT, CONTRACT DOCUMENTS OR THE SPRINT INTEGRATED CONSTRUCTION STANDARDS FOR WIRELESS SITES AND UPLOAD INTO SITERRA.

PLANS PREPARED FOR:



6580 Sprint Parkway
Overland Park, Kansas 66251

PLANS PREPARED BY:



1033 Watervliet Shaker Rd
Albany, NY 12205
Office # (518) 690-0790
Fax # (518) 690-0793
JOB NUMBER 333-000

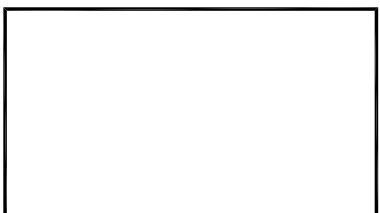

ENGINEERING LICENSE:

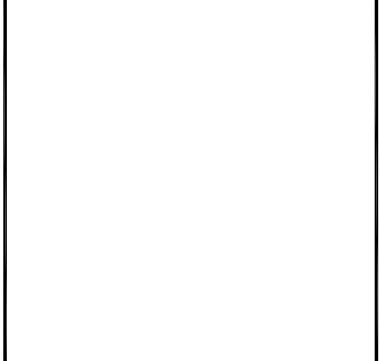

DRAWING NOTICE:

THESE DOCUMENTS ARE CONFIDENTIAL AND ARE THE SOLE PROPERTY OF SPRINT AND MAY NOT BE REPRODUCED, DISSEMINATED OR REDISTRIBUTED WITHOUT THE EXPRESS WRITTEN CONSENT OF SPRINT.

REVISIONS:

DESCRIPTION	DATE	BY	REV
ISSUED FOR REVIEW	05/13/14	JDV	A

SITE NAME:

GREENWICH HOSPITAL

SITE CASCADE:

CT43XC855

SITE ADDRESS:

**9 PERRYRIDGE RD
GREENWICH, CT 06830.**

SHEET DESCRIPTION:

SPRINT SPECIFICATIONS

SHEET NUMBER:

SP-3

INFORMATION CONTAINED WITHIN DRAWINGS ARE BASED ON PROVIDED INFORMATION AND ARE NOT THE RESULT OF A FIELD SURVEY.

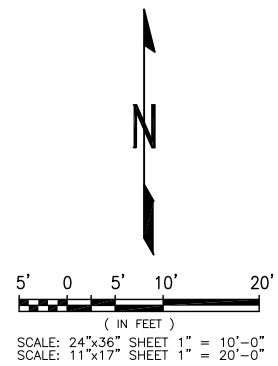
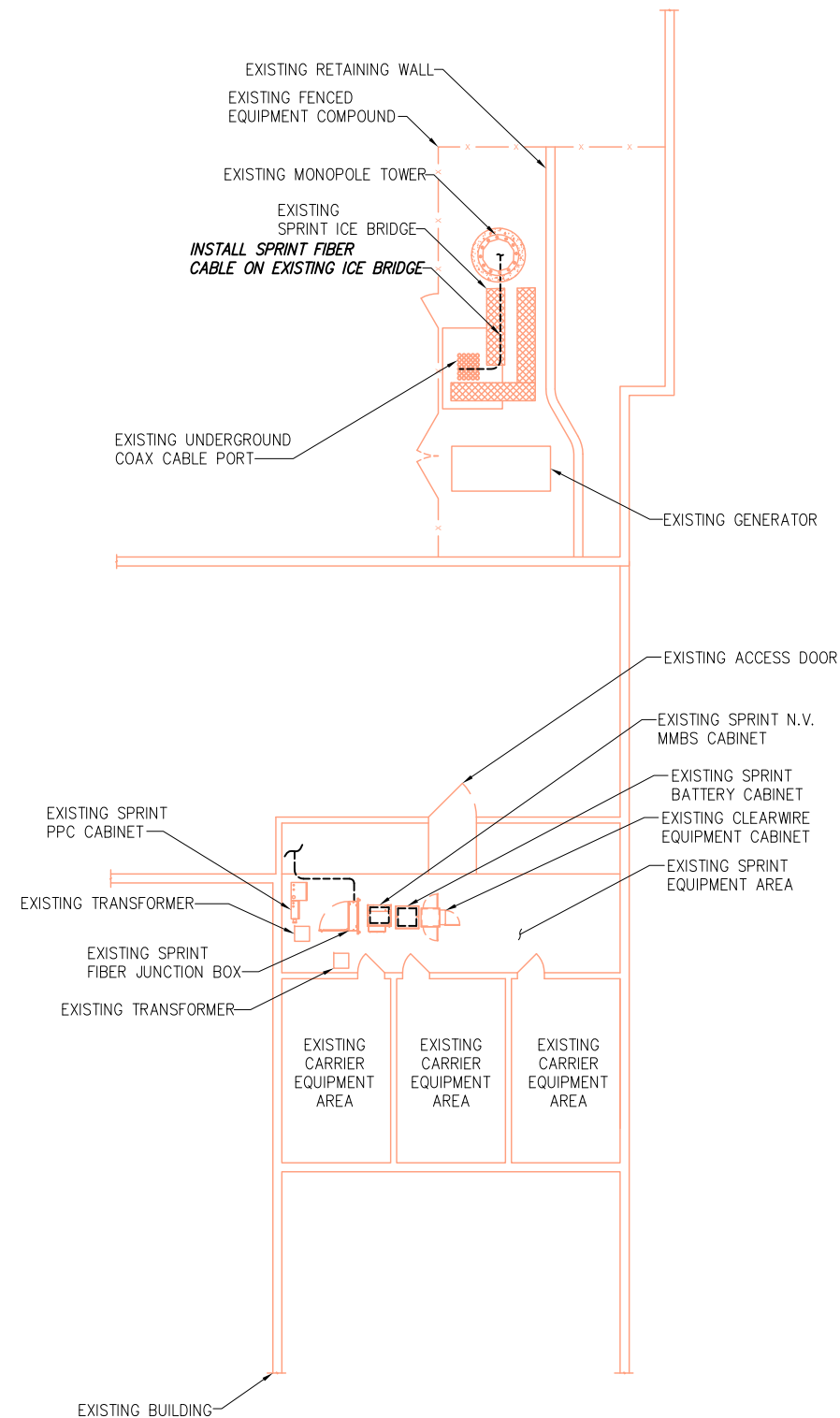

OVERALL SITE PLAN

SCALE: AS NOTED 1

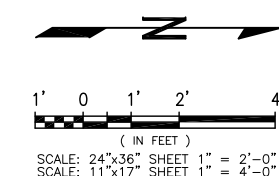
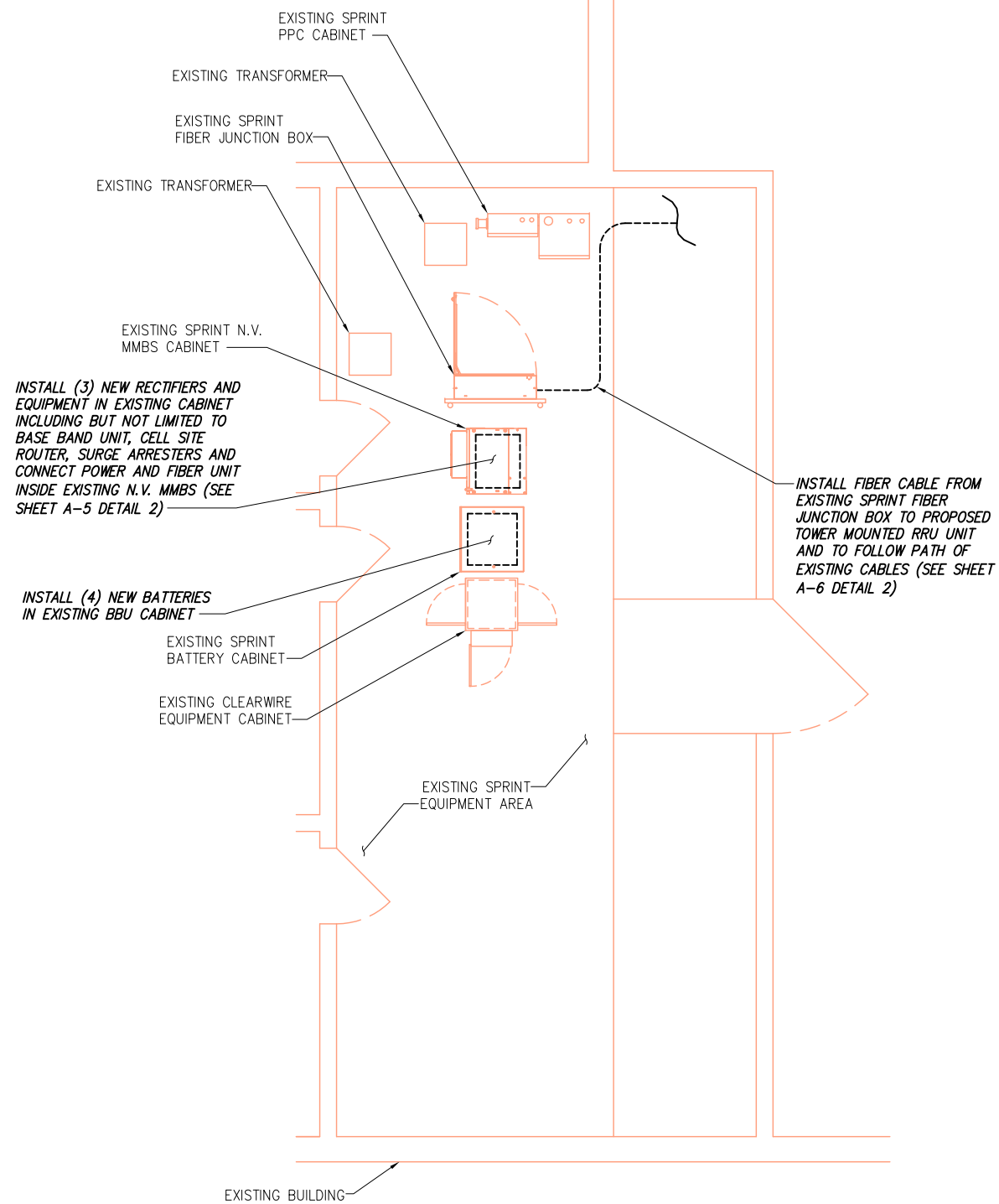

SPRINT EQUIPMENT PLAN

SCALE: AS NOTED 2

PLANS PREPARED FOR:



PLANS PREPARED BY:



ENGINEERING LICENSE:

DRAWING NOTICE:

THESE DOCUMENTS ARE CONFIDENTIAL AND ARE THE SOLE PROPERTY OF SPRINT AND MAY NOT BE REPRODUCED, DISSEMINATED OR REDISTRIBUTED WITHOUT THE EXPRESS WRITTEN CONSENT OF SPRINT.

REVISIONS:

DESCRIPTION	DATE	BY	REV
ISSUED FOR REVIEW	05/13/14	JDV	A

SITE NAME:

GREENWICH HOSPITAL

SITE CASCADE:

CT43XC855

SITE ADDRESS:

9 PERRYRIDGE RD
GREENWICH, CT 06830.

SHEET DESCRIPTION:

SITE PLAN

SHEET NUMBER:

A-1

NOTE:
 INFINIGY ENGINEERING HAS NOT EVALUATED THE
 EXISTING STRUCTURE FOR THIS SITE, AND
 ASSUMES NO RESPONSIBILITY FOR ITS STRUCTURAL
 INTEGRITY. REFER TO STRUCTURAL ANALYSIS BY
 OTHERS PRIOR TO ANY CONSTRUCTION.

NOTE:
 SEE DETAIL 2 ON A-3
 FOR ANTENNA LAYOUT

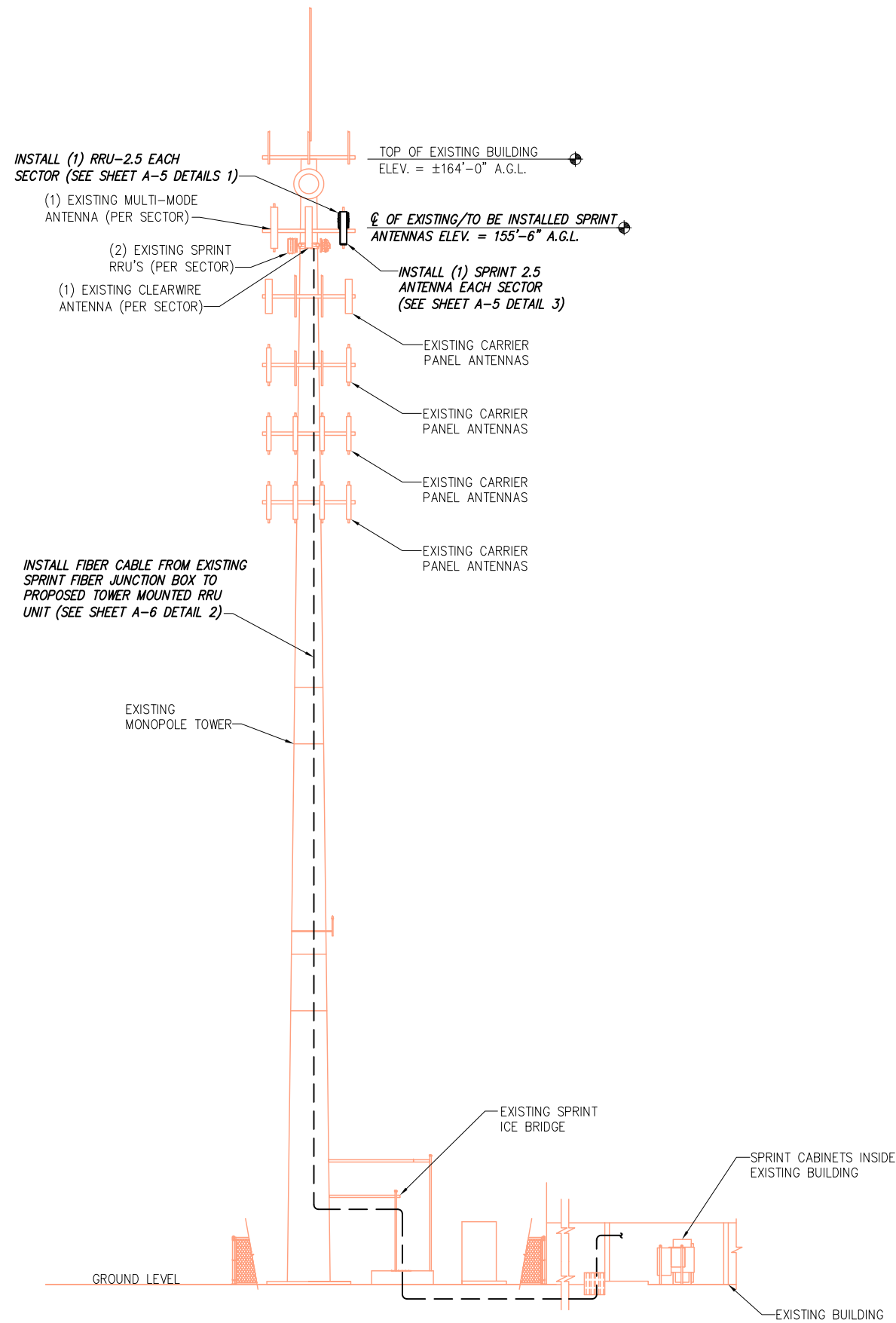

PLANS PREPARED FOR:

Sprint

6580 Sprint Parkway
 Overland Park, Kansas 66251

PLANS PREPARED BY:

INFINIGY Design. Build. Deliver.

1033 Watervliet Shaker Rd
 Albany, NY 12205
 Office # (518) 690-0790
 Fax # (518) 690-0793

JOB NUMBER 333-000

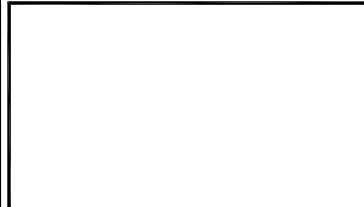

ENGINEERING LICENSE:

DRAWING NOTICE:

THESE DOCUMENTS ARE CONFIDENTIAL AND ARE THE SOLE PROPERTY OF SPRINT AND MAY NOT BE REPRODUCED, DISSEMINATED OR REDISTRIBUTED WITHOUT THE EXPRESS WRITTEN CONSENT OF SPRINT.

REVISIONS:

DESCRIPTION	DATE	BY	REV
ISSUED FOR REVIEW	05/13/14	JDV	A

SITE NAME:

GREENWICH HOSPITAL

SITE CASCADE:

CT43XC855

SITE ADDRESS:

**9 PERRYRIDGE RD
 GREENWICH, CT 06830.**

SHEET DESCRIPTION:

**TOWER ELEVATION
 & CABLE PLAN**

SHEET NUMBER:

A-2

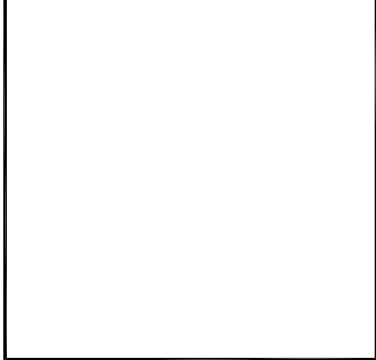

THESE DOCUMENTS ARE CONFIDENTIAL AND ARE THE SOLE PROPERTY OF SPRINT AND MAY NOT BE REPRODUCED, DISSEMINATED OR REDISTRIBUTED WITHOUT THE EXPRESS WRITTEN CONSENT OF SPRINT.

REVISIONS:			
DESCRIPTION	DATE	BY	REV
ISSUED FOR REVIEW	05/13/14	JDV	A

GREENWICH HOSPITAL

CT43XC855

**9 PERRYRIDGE RD
GREENWICH, CT 06830.**

ANTENNA LAYOUT & MOUNTING DETAILS

A-3

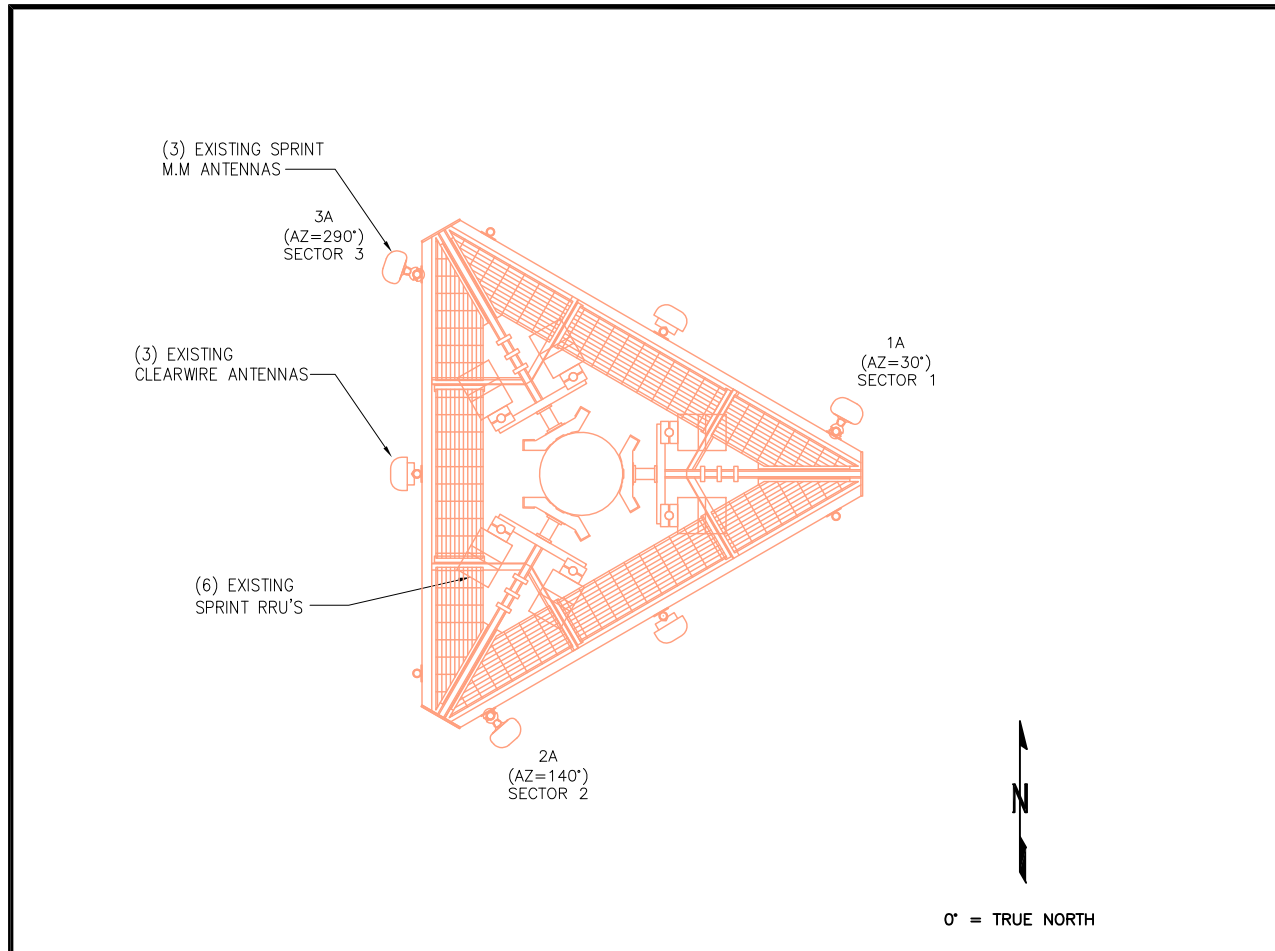

EXISTING ANTENNA & RRU LAYOUT

NO SCALE

1

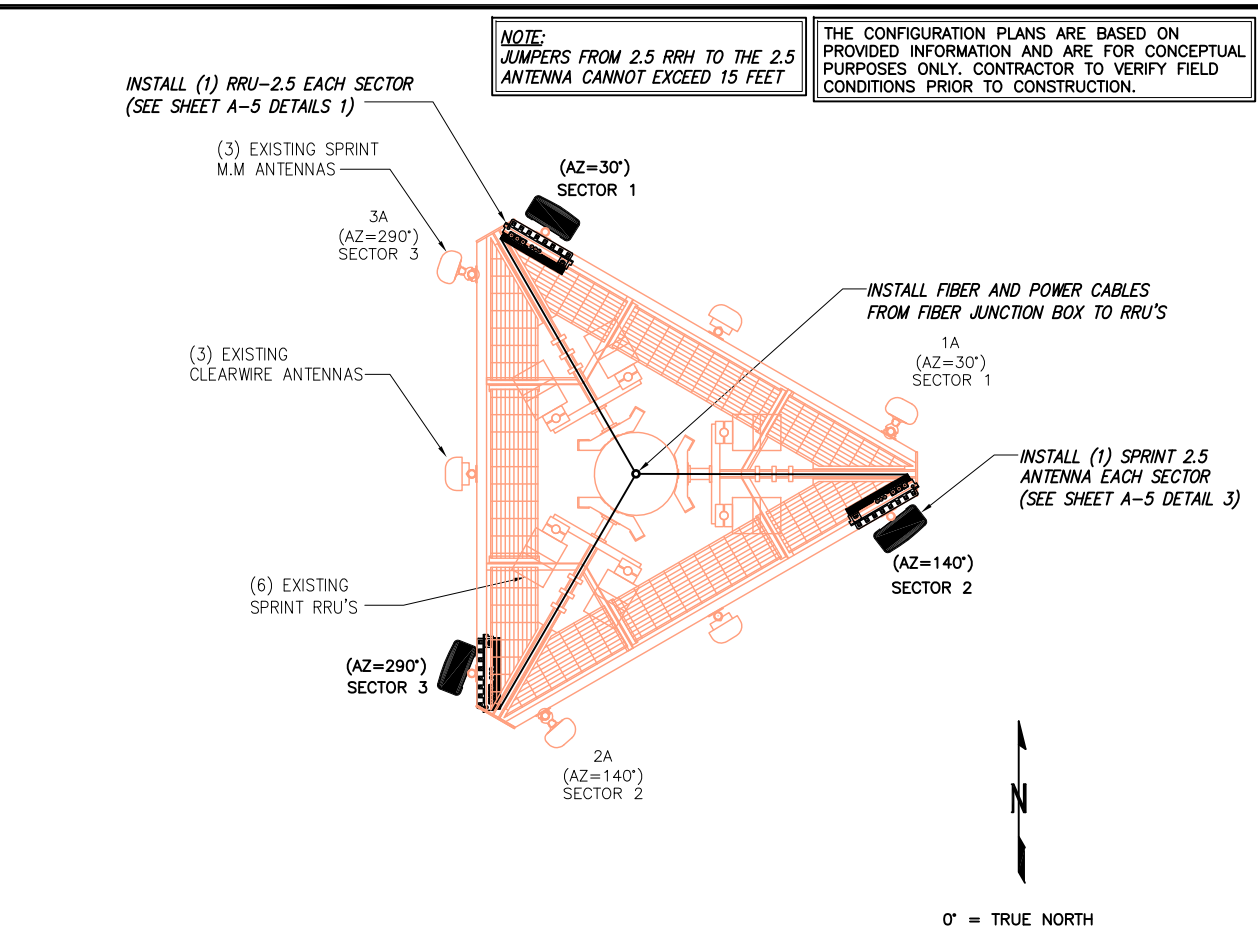

FINAL ANTENNA LAYOUT

NO SCALE

2

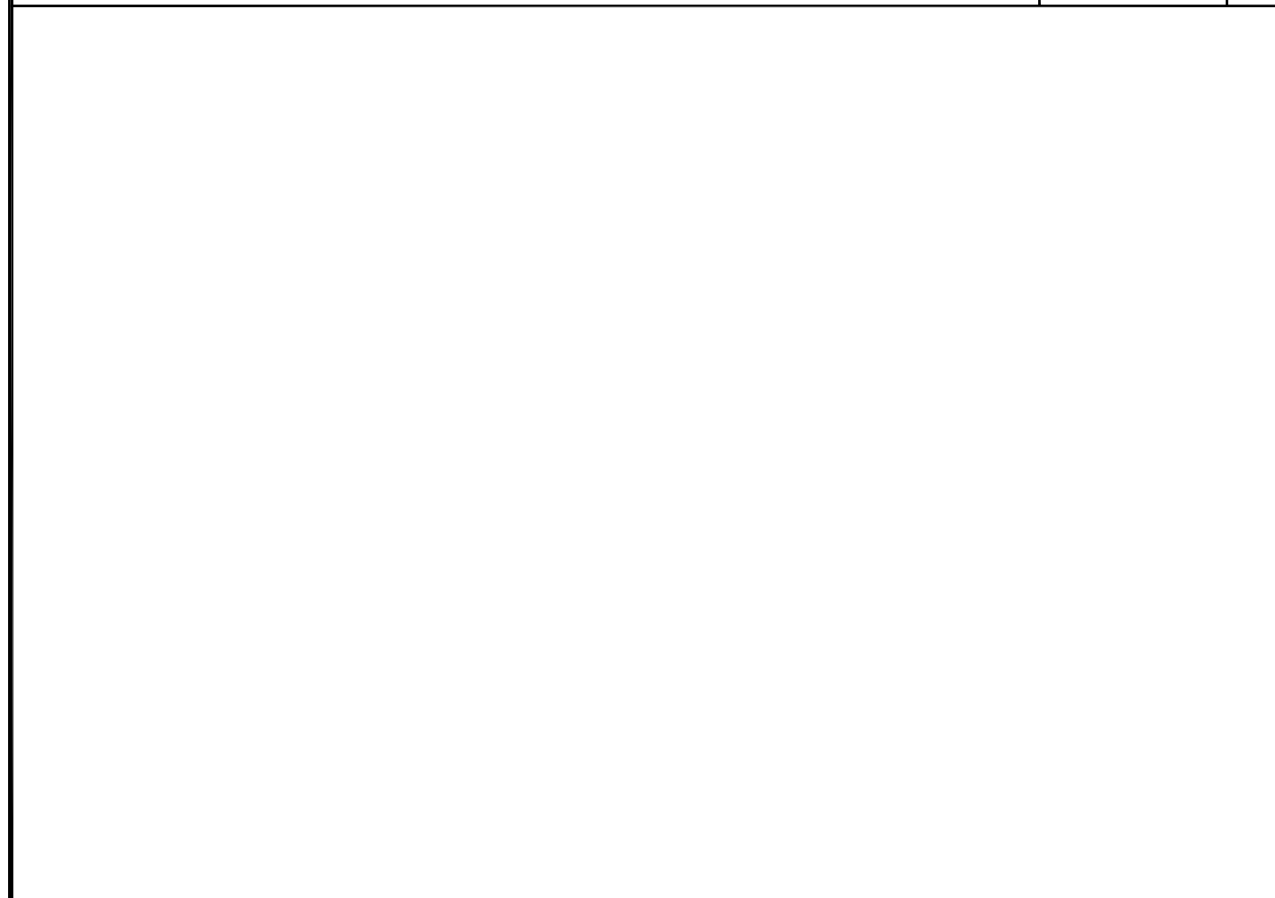

DETAIL NOT USED

NO SCALE

3

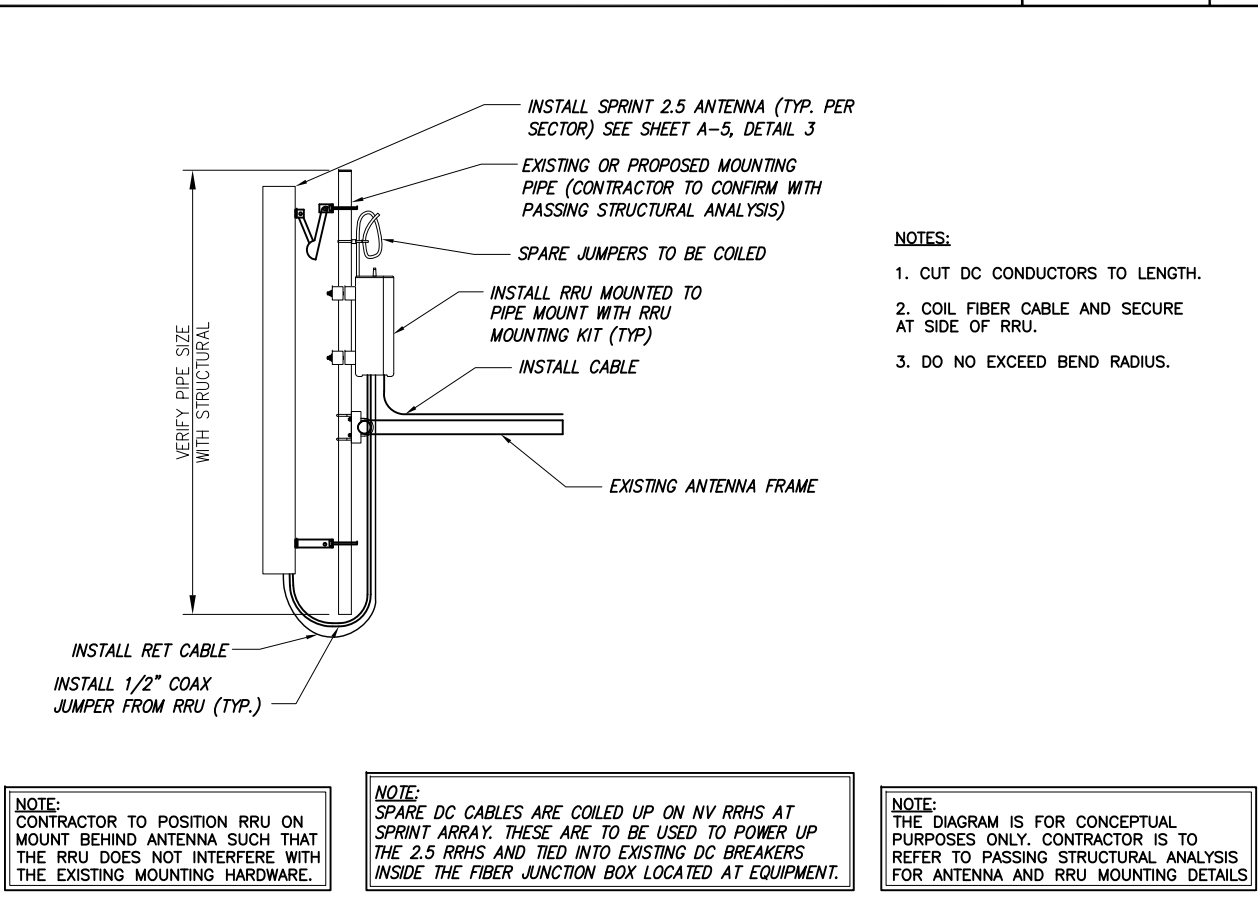

TYPICAL ANTENNA & RRU MOUNTING DETAILS

NO SCALE

4

NOTE:
CONTRACTOR TO POSITION RRU ON MOUNT BEHIND ANTENNA SUCH THAT THE RRU DOES NOT INTERFERE WITH THE EXISTING MOUNTING HARDWARE.

NOTE:
SPARE DC CABLES ARE COILED UP ON NV RRHS AT SPRINT ARRAY. THESE ARE TO BE USED TO POWER UP THE 2.5 RRHS AND TIED INTO EXISTING DC BREAKERS INSIDE THE FIBER JUNCTION BOX LOCATED AT EQUIPMENT.

NOTE:
THE DIAGRAM IS FOR CONCEPTUAL PURPOSES ONLY. CONTRACTOR IS TO REFER TO PASSING STRUCTURAL ANALYSIS FOR ANTENNA AND RRU MOUNTING DETAILS

NOTES:

- CUT DC CONDUCTORS TO LENGTH.
- COIL FIBER CABLE AND SECURE AT SIDE OF RRU.
- DO NOT EXCEED BEND RADIUS.

NV CABLES				
BAND	INDICATOR		PORT	COLOR
800-1	YEL	GRN	NV-1	GRN
1900-1	YEL	RED	NV-2	BLU
1900-2	YEL	BRN	NV-3	BRN
1900-3	YEL	BLU	NV-4	WHT
1900-4	YEL	SLT	NV-5	RED
800-2	YEL	ORG	NV-6	SLT
SPARE	YEL	WHT	NV-7	PPL
2500	YEL	PPL	NV-8	ORG

HYBRID	
HYBRID	COLOR
1	GRN
2	BLU
3	BRN
4	WHT
5	RED
6	SLT
7	PPL
8	ORG

2.5 Band		
2500 Radio 1	COLOR	
YEL	WHT	GRN
YEL	WHT	BLU
YEL	WHT	BRN
YEL	WHT	WHT
YEL	WHT	RED
YEL	WHT	SLT
YEL	WHT	PPL
YEL	WHT	ORG

Figure 1: Antenna Orientation

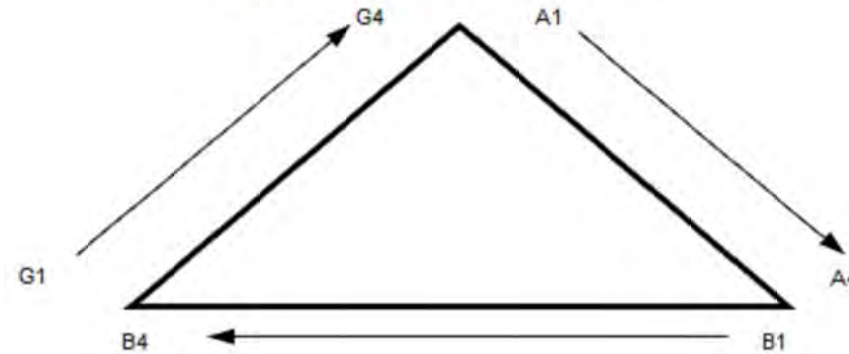

NOTES:

- ALL CABLES SHALL BE MARKED WITH 2" WIDE, UV STABILIZED, UL APPROVED TAPE.
- THE FIRST RING SHALL BE CLOSEST TO THE END OF THE CABLE AND SPACED APPROXIMATELY 2" FROM THE END CONNECTOR, WEATHERPROOFING, OR BREAK-OUT CYLINDER. THERE SHALL BE A 1" SPACE BETWEEN EACH RING FOR THE CABLE IDENTIFIER, AND NO SPACES BETWEEN THE FREQUENCY BANDS.
- A 2" GAP SHALL SEPARATE THE CABLE COLOR CODE FROM THE FREQUENCY COLOR CODE. THE 2" COLOR RINGS FOR THE FREQUENCY CODE SHALL BE PLACED NEXT TO EACH OTHER WITH NO SPACES.
- THE 2" COLORED TAPE(S) SHALL EACH BE WRAPPED A MINIMUM OF 3 TIMES AROUND THE INDIVIDUAL CABLES, AND THE TAPE SHALL BE KEPT IN THE SAME LOCATION AS MUCH AS POSSIBLE.
- SITES WITH MORE THAN FOUR (4) SECTORS WILL REQUIRE ADDITIONAL RINGS FOR EACH SECTOR, FOLLOWING THE PATTERN. HIGH CAPACITY SITES WILL USE THE NEXT COLOR IN THE SEQUENCE FOR ADDITIONAL CABLES IN EACH SECTOR.
- HYBRID FIBER CABLE SHALL BE SECTOR IDENTIFIED INSIDE THE CABINET ON FREQUENCY BUNDLES, ON THE SEALTITE, ON THE MAIN LINE UPON EXIT OF SEALTITE, AND BEFORE AND AFTER THE BREAKOUT UNIT (MEDUSA), AS WELL AS BEFORE AND AFTER ANY ENTRANCE OR EXIT.
- HFC "MAIN TRUNK" WILL NOT BE MARKED WITH THE FREQUENCY CODES, AS IT CONTAINS ALL FREQUENCIES.
- INDIVIDUAL POWER PAIRS AND FIBER BUNDLES SHALL BE LABELED WITH BOTH THE CABLE AND FREQUENCY.

Sector	Cable	First Ring	Second Ring	Third Ring
1 Alpha	1	Green	No Tape	No Tape
1	2	Blue	No Tape	No Tape
1	3	Brown	No Tape	No Tape
1	4	White	No Tape	No Tape
1	5	Red	No Tape	No Tape
1	6	Grey	No Tape	No Tape
1	7	Purple	No Tape	No Tape
1	8	Orange	No Tape	No Tape
2 Beta	1	Green	Green	No Tape
2	2	Blue	Blue	No Tape
2	3	Brown	Brown	No Tape
2	4	White	White	No Tape
2	5	Red	Red	No Tape
2	6	Grey	Grey	No Tape
2	7	Purple	Purple	No Tape
2	8	Orange	Orange	No Tape
3 Gamma	1	Green	Green	Green
3	2	Blue	Blue	Blue
3	3	Brown	Brown	Brown
3	4	White	White	White
3	5	Red	Red	Red
3	6	Grey	Grey	Grey
3	7	Purple	Purple	Purple
3	8	Orange	Orange	Orange

NV FREQUENCY	INDICATOR	ID
800-1	YEL	GRN
1900-1	YEL	RED
1900-2	YEL	BRN
1900-3	YEL	BLU
1900-4	YEL	SLT
800-1	YEL	ORG
RESERVED	YEL	WHT
RESERVED	YEL	PPL

2.5 FREQUENCY	INDICATOR		ID
2500 -1	YEL	WHT	GRN
2500 -2	YEL	WHT	RED
2500 -3	YEL	WHT	BRN
2500 -4	YEL	WHT	BLU
2500 -5	YEL	WHT	SLT
2500 -6	YEL	WHT	ORG
2500 -7	YEL	WHT	WHT
2500 -8	YEL	WHT	PPL

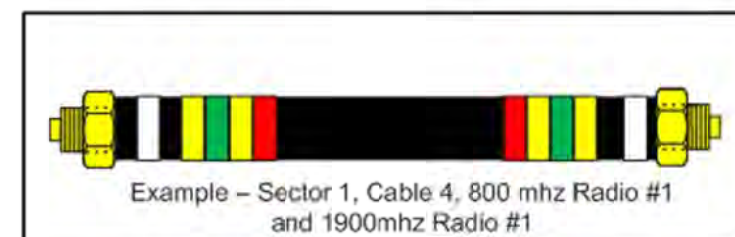
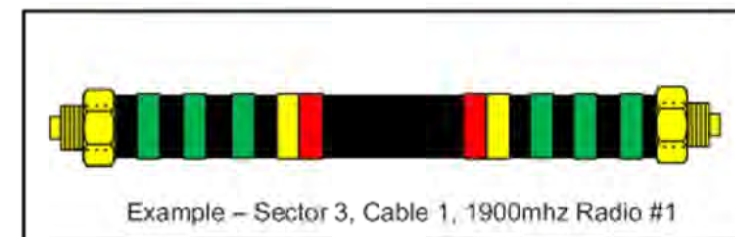
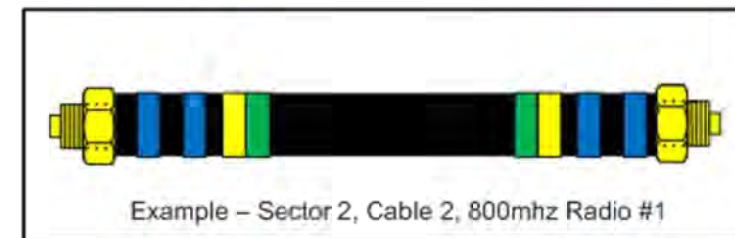

PLANS PREPARED FOR:

6580 Sprint Parkway
Overland Park, Kansas 66251

PLANS PREPARED BY:

1033 Watervliet Shaker Rd
Albany, NY 12205
Office # (518) 690-0790
Fax # (518) 690-0793
JOB NUMBER 333-000

ENGINEERING LICENSE:

DRAWING NOTICE:

THESE DOCUMENTS ARE CONFIDENTIAL AND ARE THE SOLE PROPERTY OF SPRINT AND MAY NOT BE REPRODUCED, DISSEMINATED OR REDISTRIBUTED WITHOUT THE EXPRESS WRITTEN CONSENT OF SPRINT.

REVISIONS:	DESCRIPTION	DATE	BY	REV
ISSUED FOR REVIEW		05/13/14	JDV	A

SITE NAME:
GREENWICH HOSPITAL

SITE CASCADE:
CT43XC855

SITE ADDRESS:
**9 PERRYRIDGE RD
GREENWICH, CT 06830.**

SHEET DESCRIPTION:
COLOR CODING AND NOTES

SHEET NUMBER:
A-4

RRU: ALCATEL LUCENT TD-RRH8X20
 COLOR: LIGHT GREY
 WEIGHT: 70 LBS.

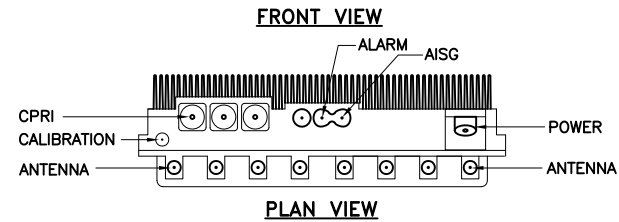
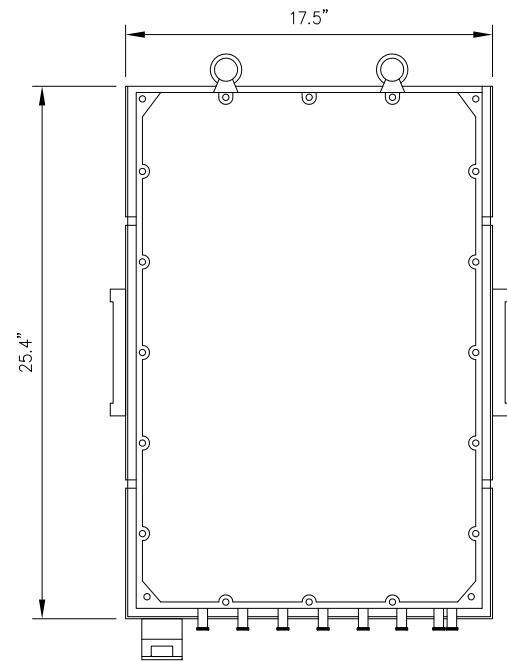
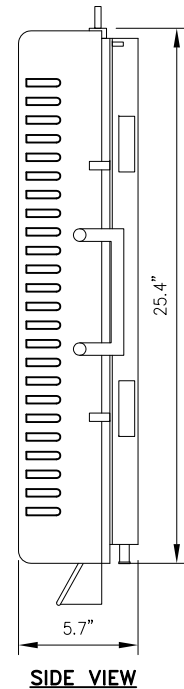

NOTES
 COMPLY WITH MANUFACTURERS INSTRUCTIONS TO ENSURE THAT ALL RRU'S RECEIVE ELECTRICAL POWER WITHIN 24 HOURS OF BEING REMOVED FROM THE MANUFACTURER'S PACKAGING. DO NOT OPEN RRU PACKAGES IN THE RAIN.

2.5 RRU'S

NO SCALE

1

- DS3 SURGE PROTECTOR
- POWER INJECTOR 5-8
- POWER INJECTOR 1-4
- 7210 SAS-M 2
- 7210 SAS-M 1
- 7205 SAR-8
- LTE-BBU 2.5GHz
- LTE-BBU FDD
- CDMA MT-BBU GROWTH
- CDMA MT-BBU PRIMARY
- PDP1
- PDP2
- 15MHz SPLITTER
- ETHERNET HUB SEC-B
- PRIMARY PROTECTION T1
- SEC-B #1, #1 & #3
- RECTIFIER SHELF PRIMARY
- RECTIFIER SHELF 2.5GHz

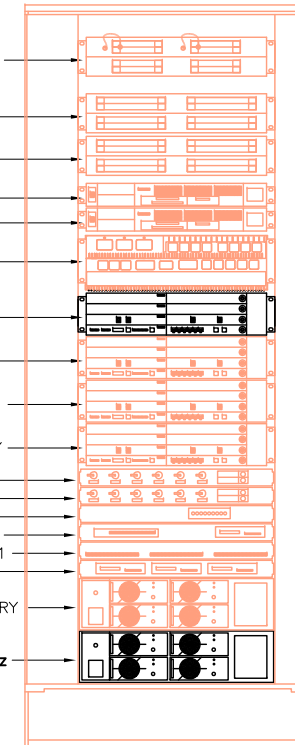

FRONT VIEW

2.5 EQUIPMENT IN EXISTING N.V. MMBS

NO SCALE

2

ANTENNA RFS APXVTM14-C-I20

- RADOME MATERIAL: ASA
- RADOME COLOR: LIGHT GREY
- DIMENSIONS, HxWxD.in(mim): 56.3"x12.6"x6.3" (1430x320x160mm)
- WEIGHT: 52.9 lbs
- CONNECTORS: (8) 4.1/9.5 DIN FEMALE
(1) NF - CALIBRATION CONNECTOR

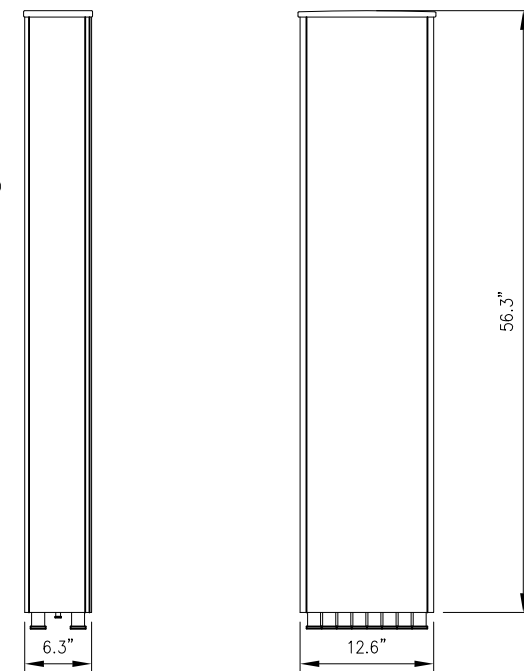
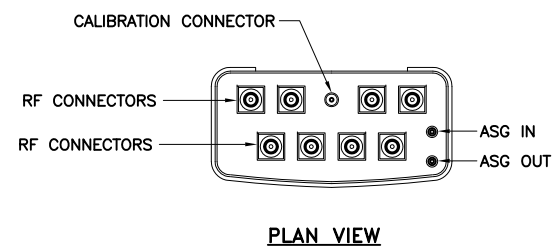

SIDE VIEW

FRONT VIEW

2.5 ANTENNA

NO SCALE

3

PLANS PREPARED FOR:



PLANS PREPARED BY:



ENGINEERING LICENSE:

DRAWING NOTICE:

THESE DOCUMENTS ARE CONFIDENTIAL AND ARE THE SOLE PROPERTY OF SPRINT AND MAY NOT BE REPRODUCED, DISSEMINATED OR REDISTRIBUTED WITHOUT THE EXPRESS WRITTEN CONSENT OF SPRINT.

REVISIONS:

DESCRIPTION	DATE	BY	REV
ISSUED FOR REVIEW	05/13/14	JDV	A

SITE NAME:

GREENWICH HOSPITAL

SITE CASCADE:

CT43XC855

SITE ADDRESS:

9 PERRYRIDGE RD
 GREENWICH, CT 06830.

SHEET DESCRIPTION:

EQUIPMENT & MOUNTING DETAILS

SHEET NUMBER:

A-5

DETAIL NOT USED

NO SCALE

4

RFS HYBRIFLEX RISER CABLE SCHEDULE

Fiber Only (Existing DC Power)	Hybrid cable MN: HB058-M12-050F 12x multi-mode fiber pairs, Top: Outdoor protected connectors, Bottom: LC Connectors, 5/8 cable, 50 ft	50 ft
	MN: HB058-M12-075F	75 ft
	MN: HB058-M12-100F	100 ft
	MN: HB058-M12-125F	125 ft
	MN: HB058-M12-150F	150 ft
	MN: HB058-M12-175F	175 ft
MN: HB058-M12-200F	200 ft	
8 AWG Power	Hybrid cable MN: HB114-08U3M12-050F 3x 8 AWG power pairs, 12x multi-mode fiber pairs, Outdoor rated connectors & LC Connectors, 1 1/4 cable, 50 ft	50 ft
	MN: HB114-08U3M12-075F	75 ft
	MN: HB114-08U3M12-100F	100 ft
	MN: HB114-08U3M12-125F	125 ft
	MN: HB114-08U3M12-150F	150 ft
	MN: HB114-08U3M12-175F	175 ft
MN: HB114-08U3M12-200F	200 ft	
6 AWG Power	Hybrid cable MN: HB114-13U3M12-225F 3x 6 AWG power pair, 12x multi-mode fiber pairs, Outdoor rated connectors & LC Connectors, 1 1/4 cable, 225 ft	225 ft
	MN: HB114-13U3M12-250F	250 ft
	MN: HB114-13U3M12-275F	275 ft
4 AWG Power	Hybrid cable MN: HB114-21U3M12-325F 3x 4 AWG power pair, 12x multi-mode fiber pairs, Outdoor rated connectors & LC Connectors, 1 1/4 cable, 325 ft	325 ft
	MN: HB114-21U3M12-350F	350 ft
	MN: HB114-21U3M12-375F	375 ft

RFS HYBRIFLEX JUMPER CABLE SCHEDULE

Fiber Only	Hybrid Jumper cable MN: HBF012-M3-5F1 5 ft, 3x multi-mode fiber pairs, Outdoor & LC connectors, 1/2 cable	5 ft
	MN: HBF012-M3-10F1	10 ft
	MN: HBF012-M3-15F1	15 ft
	MN: HBF012-M3-20F1	20 ft
	MN: HBF012-M3-25F1	25 ft
	MN: HBF012-M3-30F1	30 ft
8 AWG Power	Hybrid Jumper cable MN: HBF058-08U1M3-5F1 5 ft, 1x 8 AWG power pair, 3x multi-mode fiber pairs, Outdoor & LC Connectors, 5/8 cable	5 ft
	MN: HBF058-08U1M3-10F1	10 ft
	MN: HBF058-08U1M3-15F1	15 ft
	MN: HBF058-08U1M3-20F1	20 ft
	MN: HBF058-08U1M3-25F1	25 ft
	MN: HBF058-08U1M3-30F1	30 ft
6 AWG Power	Hybrid Jumper cable MN: HBF058-13U1M3-5F1 5 ft, 1x 6 AWG power pair, 3x multi-mode fiber pairs, Outdoor & LC Connectors, 5/8 cable	5 ft
	MN: HBF058-13U1M3-10F1	10 ft
	MN: HBF058-13U1M3-15F1	15 ft
	MN: HBF058-13U1M3-20F1	20 ft
	MN: HBF058-13U1M3-25F1	25 ft
	MN: HBF058-13U1M3-30F1	30 ft
4 AWG Power	Hybrid Jumper cable MN: HBF078-21U1M3-5F1 5 ft, 1x 4 AWG power pair, 3x multi-mode fiber pairs, Outdoor & LC Connectors, 7/8 cable	5 ft
	MN: HBF078-21U1M3-10F1	10 ft
	MN: HBF078-21U1M3-15F1	15 ft
	MN: HBF078-21U1M3-20F1	20 ft
	MN: HBF078-21U1M3-25F1	25 ft
	MN: HBF078-21U1M3-30F1	30 ft

NOTE:
SPRINT CM TO CONFIRM HYBRID OR FIBER RISER CABLE AND HYBRID OR FIBER JUMPER CABLE MODEL NUMBERS IF HYBRID CABLES ARE REQUIRED BEFORE PREPARING BOM.

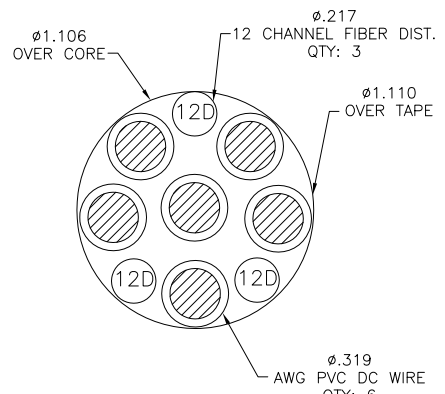

4 AWG

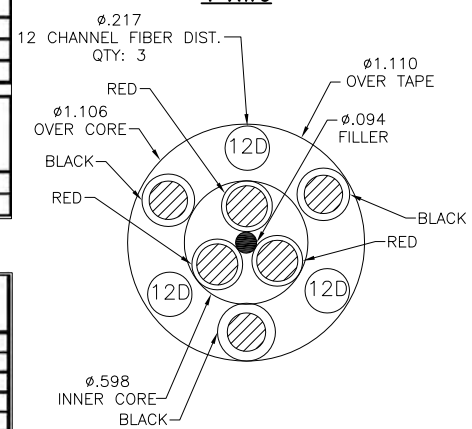

8 & 6 AWG

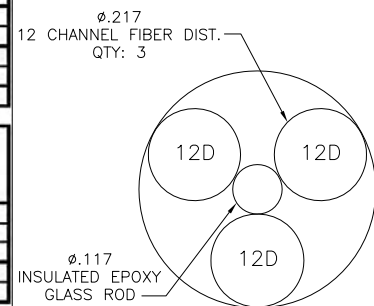

FIBER ONLY

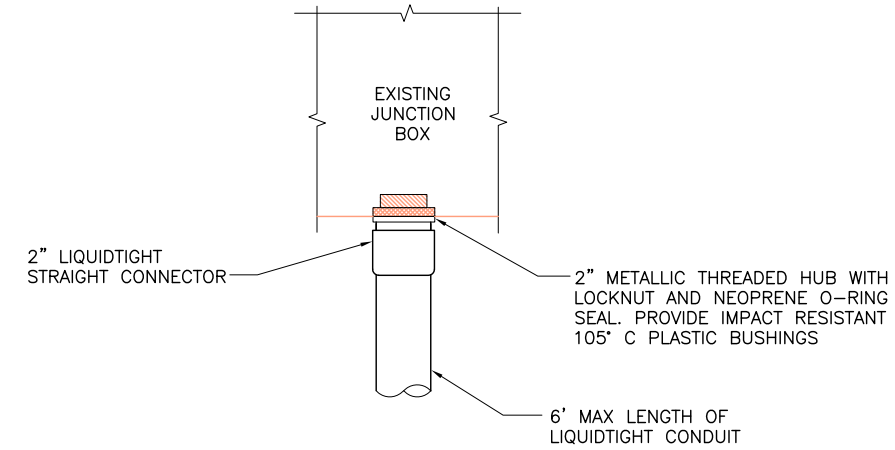

FIBER JUNCTION BOX PENETRATION

NO SCALE

2

2.5 CABLE CROSS SECTION DATA

NO SCALE

1

DETAIL NOT USED

NO SCALE

3

PLANS PREPARED FOR:



PLANS PREPARED BY:



1033 Watervliet Shaker Rd
Albany, NY 12205
Office # (518) 690-0790
Fax # (518) 690-0793

JOB NUMBER 333-000

ENGINEERING LICENSE:

DRAWING NOTICE:

THESE DOCUMENTS ARE CONFIDENTIAL AND ARE THE SOLE PROPERTY OF SPRINT AND MAY NOT BE REPRODUCED, DISSEMINATED OR REDISTRIBUTED WITHOUT THE EXPRESS WRITTEN CONSENT OF SPRINT.

REVISIONS:

DESCRIPTION	DATE	BY	REV
ISSUED FOR REVIEW	05/13/14	JDV	A

SITE NAME:

GREENWICH HOSPITAL

SITE CASCADE:

CT43XC855

SITE ADDRESS:

**9 PERRYRIDGE RD
GREENWICH, CT 06830.**

SHEET DESCRIPTION:

CIVIL DETAILS

SHEET NUMBER:

A-6

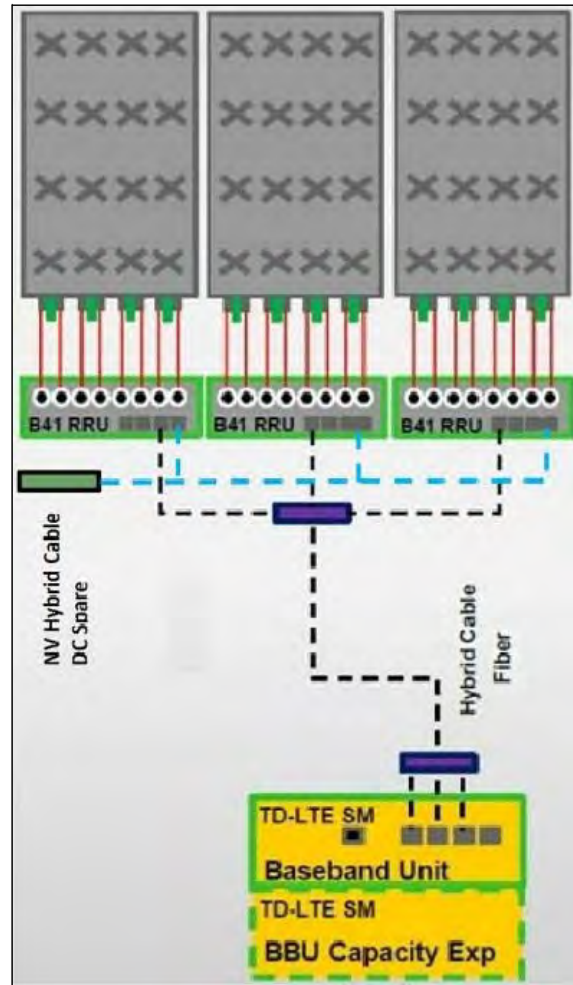

ALU 2.5 ALU SCENARIO 1

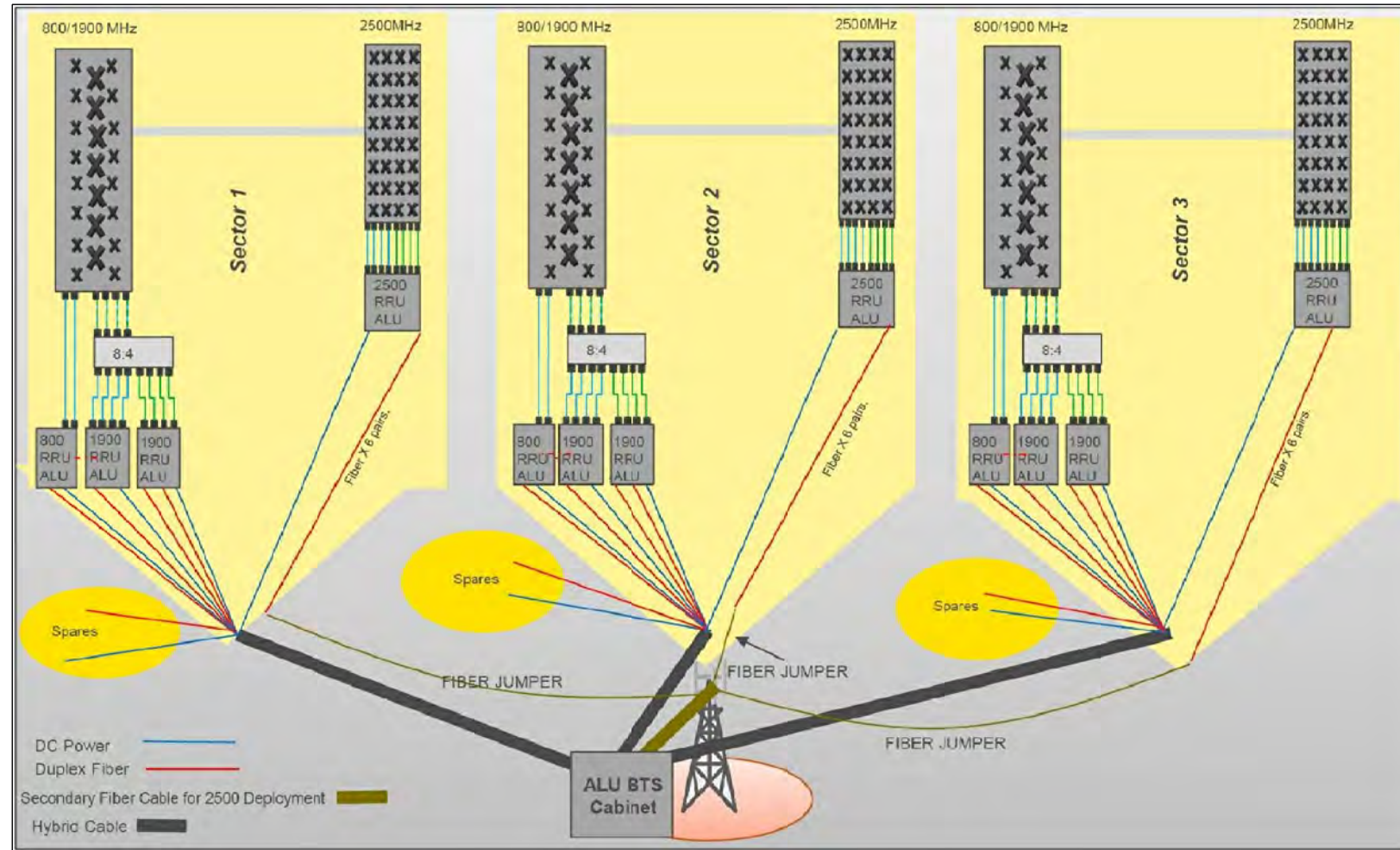

RAN WIRING DIAGRAM

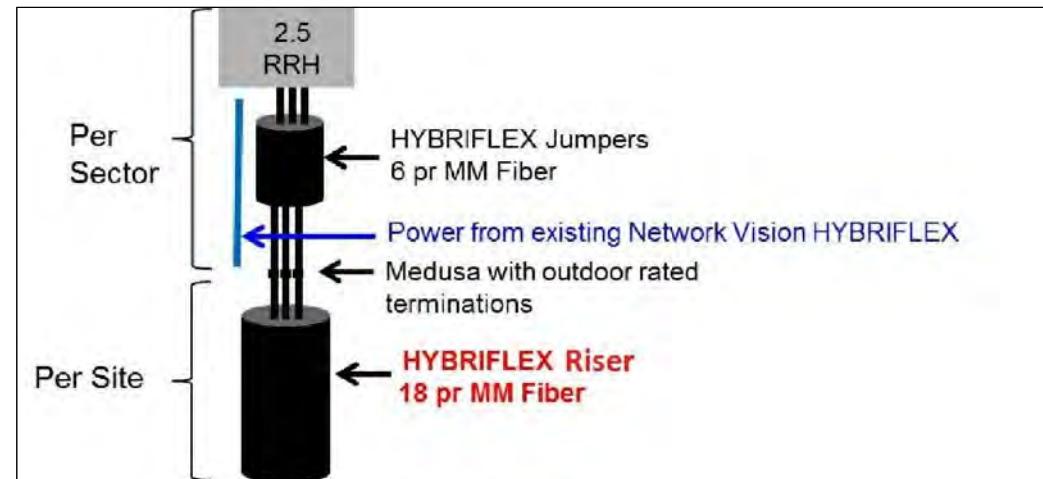

RF 2.5 ALU SCENARIO 1

PLUMBING DIAGRAM

PLANS PREPARED FOR:



PLANS PREPARED BY:



1033 Watervliet Shaker Rd
Albany, NY 12205
Office # (518) 690-0790
Fax # (518) 690-0793

JOB NUMBER 333-000

ENGINEERING LICENSE:

DRAWING NOTICE:

THESE DOCUMENTS ARE CONFIDENTIAL AND ARE THE SOLE PROPERTY OF SPRINT AND MAY NOT BE REPRODUCED, DISSEMINATED OR REDISTRIBUTED WITHOUT THE EXPRESS WRITTEN CONSENT OF SPRINT.

REVISIONS:

DESCRIPTION	DATE	BY	REV
ISSUED FOR REVIEW	05/13/14	JDV	A

SITE NAME:

GREENWICH HOSPITAL

SITE CASCADE:

CT43XC855

SITE ADDRESS:

9 PERRYRIDGE RD
GREENWICH, CT 06830.

SHEET DESCRIPTION:

PLUMBING DIAGRAM

SHEET NUMBER:

A-7

PLANS PREPARED FOR:



PLANS PREPARED BY:



ENGINEERING LICENSE:

DRAWING NOTICE:

THESE DOCUMENTS ARE CONFIDENTIAL AND ARE THE SOLE PROPERTY OF SPRINT AND MAY NOT BE REPRODUCED, DISSEMINATED OR REDISTRIBUTED WITHOUT THE EXPRESS WRITTEN CONSENT OF SPRINT.

REVISIONS:

DESCRIPTION	DATE	BY	REV
ISSUED FOR REVIEW	05/13/14	JDV	A

SITE NAME:

GREENWICH HOSPITAL

SITE CASCADE:

CT43XC855

SITE ADDRESS:

**9 PERRYRIDGE RD
GREENWICH, CT 06830.**

SHEET DESCRIPTION:

ELECTRICAL & GROUNDING PLAN

SHEET NUMBER:

E-1

PLAN NOT USED

NO SCALE 1

- LEGEND:**
- G — EXISTING GROUND RING
 - CADWELD CONNECTION (EXOTHERMIC WELD)
 - ▲ MECHANICAL CONNECTION
 - ⊗ GROUND ROD
 - CABLE GROUND KIT

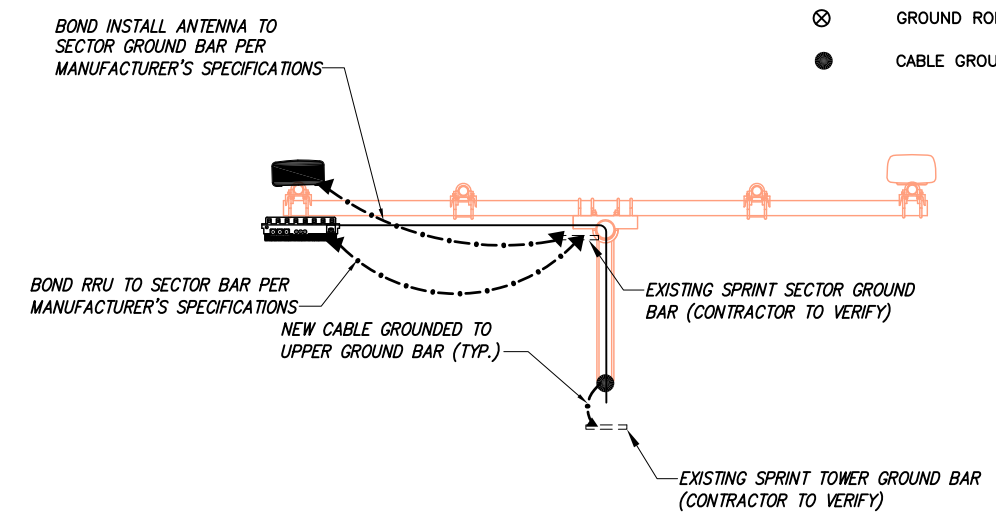

TYPICAL ANTENNA GROUNDING PLAN

NO SCALE 2

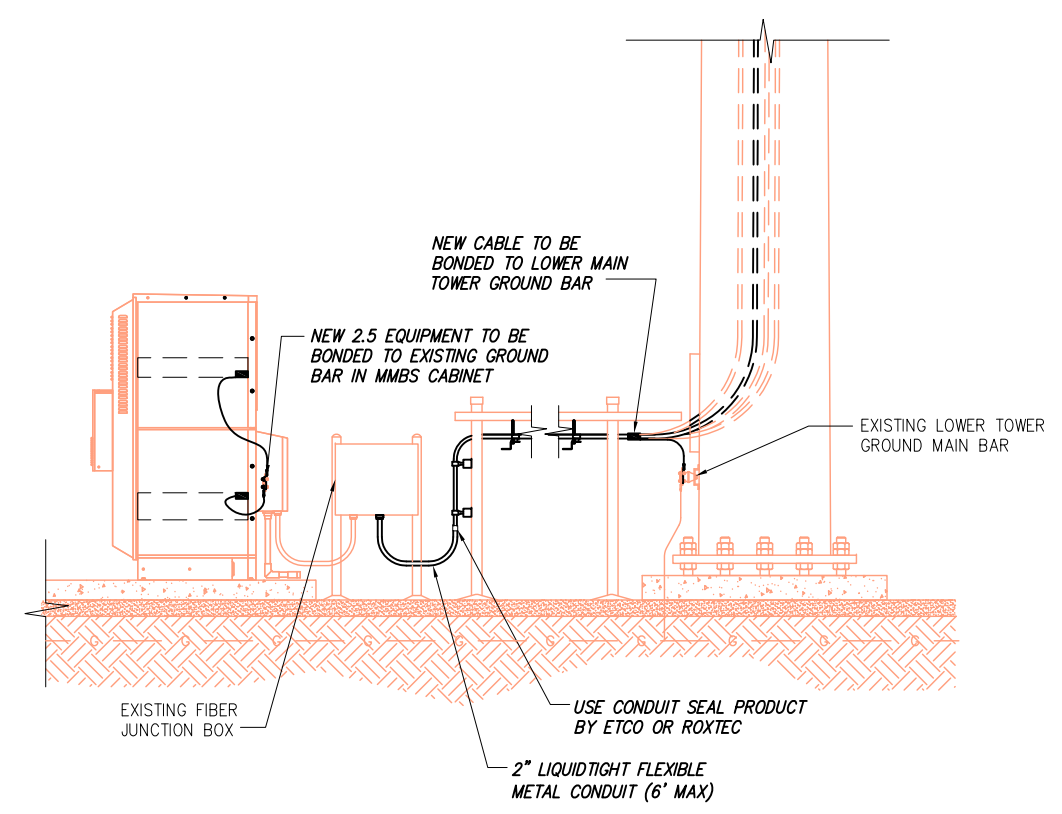

TYPICAL EQUIPMENT GROUNDING PLAN (ELEVATION)

NO SCALE 3

THESE DOCUMENTS ARE CONFIDENTIAL AND ARE THE SOLE PROPERTY OF SPRINT AND MAY NOT BE REPRODUCED, DISSEMINATED OR REDISTRIBUTED WITHOUT THE EXPRESS WRITTEN CONSENT OF SPRINT.

DESCRIPTION	DATE	BY	REV
ISSUED FOR REVIEW	05/13/14	JDV	A

GREENWICH HOSPITAL

CT43XC855

**9 PERRYRIDGE RD
 GREENWICH, CT 06830.**

ELECTRICAL & GROUNDING DETAILS

E-2

NOTES
 CG SHALL REFERENCE ALL SPECS FOR "CONNECTING THE POWER SUPPLY" OF THE NEW INSTALLATION DOCUMENTS, FOR ALL CONNECTION SPECIFICATIONS.

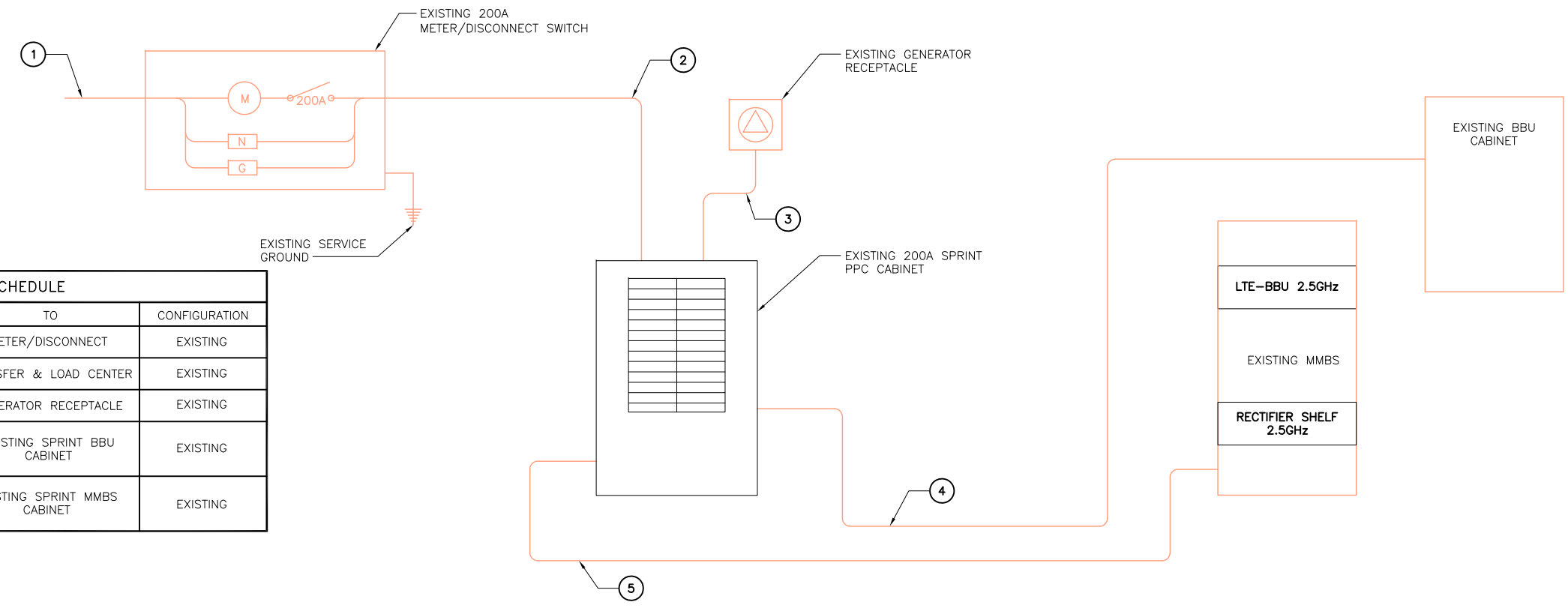

CIRCUIT SCHEDULE			
NO	FROM	TO	CONFIGURATION
①	UTILITY SOURCE	METER/DISCONNECT	EXISTING
②	METER/DISCONNECT	TRANSFER & LOAD CENTER	EXISTING
③	TRANSFER & LOAD CENTER	GENERATOR RECEPTACLE	EXISTING
④	TRANSFER & LOAD CENTER	EXISTING SPRINT BBU CABINET	EXISTING
⑤	TRANSFER & LOAD CENTER	EXISTING SPRINT MMBS CABINET	EXISTING

ELECTRICAL ONE-LINE DIAGRAM

NO SCALE 1

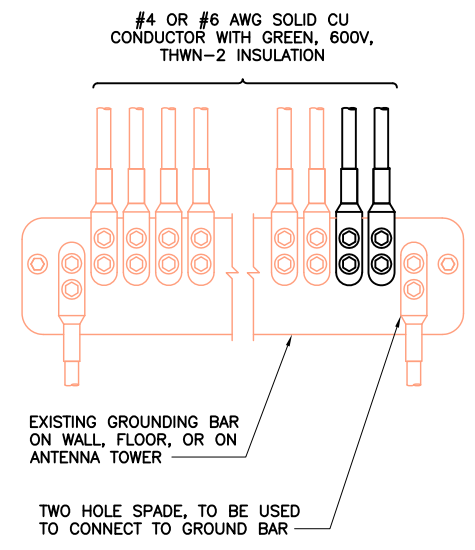

NOTES
 1. APPLY NO-OX TO LUG AND BAR CONTACT SURFACE. DO NOT COAT INLINE LUG.
 2. IF STOLEN GROUND BARS ARE ENCOUNTERED, CONTACT SPRINT CM FOR REPLACEMENT THREADED ROD KIT.

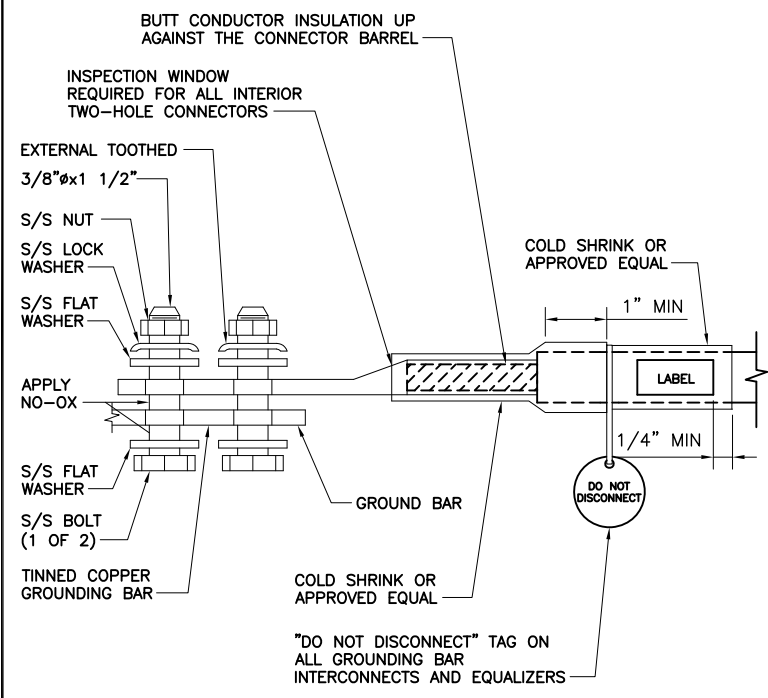

"DO NOT DISCONNECT" TAG ON ALL GROUNDING BAR INTERCONNECTS AND EQUALIZERS

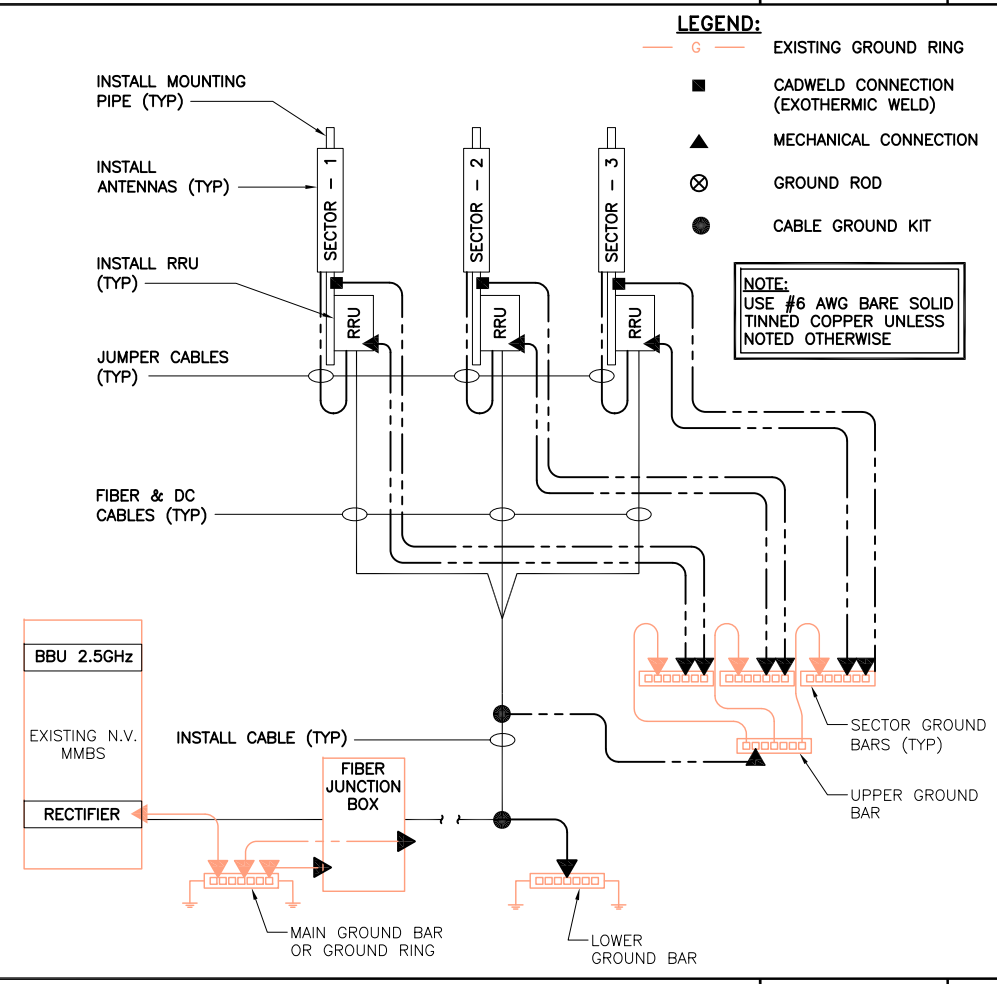

LEGEND:
 - G - EXISTING GROUND RING
 ■ CADWELD CONNECTION (EXOTHERMIC WELD)
 ▲ MECHANICAL CONNECTION
 ⊗ GROUND ROD
 ● CABLE GROUND KIT

NOTE:
 USE #6 AWG BARE SOLID TINNED COPPER UNLESS NOTED OTHERWISE

INSTALLATION OF GROUNDING CONDUCTOR TO GROUNDING BAR

NO SCALE 2

TWO HOLE LUG

NO SCALE 3

GROUNDING RISER DIAGRAM

NO SCALE 4