



10 INDUSTRIAL AVE,  
SUITE 3  
MAHWAH NJ 07430

PHONE: 201.684.0055  
FAX: 201.684.0066

January 13, 2021

Members of the Siting Council  
Connecticut Siting Council  
Ten Franklin Square  
New Britain, CT 06051

RE: Notice of Exempt Modification  
1111 E. Putnam Avenue, Greenwich, CT 06878  
Latitude: 41.04120700  
Longitude: -73.58346000  
T-Mobile Site#: CT11005D – Anchor

Dear Ms. Bachman:

T-Mobile currently maintains nine (9) antennas at the 43-foot level of the existing 32-foot rooftop at 1111 E. Putnam Avenue, Greenwich, CT. The building is owned by Fountainhead Properties LLC. T-Mobile now intends to remove the existing antennas and replace with nine (9) new 600/700/1900/2100/2500 MHz antennas. The new antennas will be installed at the same 43-foot level of the tower.

**Planned Modifications:**

**Tower:**

Remove

(12) 1-5/8" Coax

Remove and Replace:

(3) LNX-6515DS-A1M antennas for (3) RFS APXVARR24\_43-U-NA20 600/700/1900/2100 MHz antennas

(3) AIR 21 antennas for (3) AIR 6449 B41 2500 MHz antennas

(3) AIR 21 antennas for (3) AIR 32 1900/2100 MHz antennas

(3) Ericsson RRUS11B12 for (3) Ericsson Radio 4449 RRU

Install New:

(3) Ericsson 4415 B25

(3) Commscope SDX1926Q-43 Diplexers

(3) 1-5/8" Hybrid Cables

Existing to Remain

(3) TMA

(6) 1-5/8" Coax

(3) 1-5/8" Hybrid Cables

**Ground:**

Install New:

- (1) 6160 Cabinet
- (1) B160 Battery Cabinet
- (1) BBU

This telecommunications facility was originally approved by the Siting Council in Docket No. 120. T-Mobile has been most recently approved for exempt modification at the site on September 22, 2015 in EM-T-Mobile-057-150831.

Please accept this letter as notification pursuant to Regulations of Connecticut State Agencies § 16-50j-73, for construction that constitutes an exempt modification pursuant to R.C.S.A. § 16-50j-72(b)(2). In accordance with R.C.S.A. § 16-50j-73, a copy of this letter is being sent to First Selectman -Fred Camilo, Elected Official, and Katie DeLuca, Director of Planning & Zoning for the Town of Greenwich, as well as the owner.

The planned modifications to the facility fall squarely within those activities explicitly provided for in R.C.S.A. § 16-50j-72(b)(2).

1. The proposed modifications will not result in an increase in the height of the existing structure.
2. The proposed modifications will not require the extension of the site boundary.
3. The proposed modifications will not increase noise levels at the facility by six decibels or more, or to levels that exceed state and local criteria.
4. The operation of the replacement antennas will not increase radio frequency emissions at the facility to a level at or above the Federal Communications Commission safety standard.
5. The proposed modifications will not cause a change or alteration in the physical or environmental characteristics of the site.
6. The existing structure and its foundation can support the proposed loading.

For the foregoing reasons, T-Mobile respectfully submits that the proposed modifications to the above referenced telecommunications facility constitute an exempt modification under R.C.S.A. § 16-50j-72(b)(2).

Sincerely,

**Kyle Richers**

Transcend Wireless

Cell: 908-447-4716

Email: [krichers@transcendwireless.com](mailto:krichers@transcendwireless.com)

**Attachments**

cc: Fred Camilo– First Selectman – Town of Greenwich  
Katie DeLuca– Director of Planning & Zoning – Town of Greenwich  
Fountainhead Properties LLC – Owner

# View/Print Label

1. **Ensure there are no other shipping or tracking labels attached to your package.** Select the Print button on the print dialogue box that appears. Note: If your browser does not support this function, select Print from the File menu to print the label.

2. **Fold the printed label at the solid line below.** Place the label in a UPS Shipping Pouch. If you do not have a pouch, affix the folded label using clear plastic shipping tape over the entire label.

### 3. GETTING YOUR SHIPMENT TO UPS

#### Customers with a scheduled Pickup

- o Your driver will pickup your shipment(s) as usual.

#### Customers without a scheduled Pickup



- o Schedule a Pickup on ups.com to have a UPS driver pickup all of your packages.
- o Take your package to any location of The UPS Store®, UPS Access Point(TM) location, UPS Drop Box, UPS Customer Center, Staples® or Authorized Shipping Outlet near you. To find the location nearest you, please visit the 'Locations' Quick link at ups.com.

UPS Access Point™  
 MICHAELS STORE # 7773  
 75 INTERSTATE SHOP CTR  
 RAMSEY NJ 07446-1130

UPS Access Point™  
 THE UPS STORE  
 115 FRANKLIN TPKE  
 MAHWAH NJ 07430-1325

UPS Access Point™  
 THE UPS STORE  
 120 E MAIN ST  
 RAMSEY NJ 07446-1925

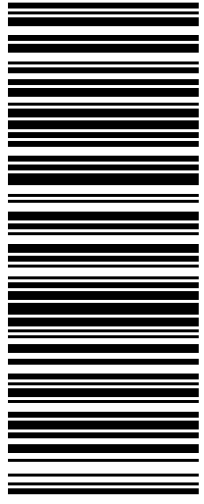
FOLD HERE

<p>NEIL GUERRIERO          3473040176          TRANSCEND WIRELESS          10 INDUSTRIAL AVE          MAHWAH NJ 07430</p> <p><b>SHIP TO:</b>          FOUNTAINHEAD PROPERTIES LLC          116 MASON STREET  <b>GREENWICH CT 06830</b></p>	<p><b>1 LBS</b></p> <p><b>1 OF 1</b></p>	<p><b>CT 069 9-01</b></p> 	<p><b>UPS GROUND</b></p> <p>TRACKING #: 1Z V25 742 42 9331 5316</p> 	<p>BILLING: P/P          SIGNATURE REQUIRED          UPS CARBON NEUTRAL SHIPMENT</p> <p>Reference #1: CT11005D CSC Owner</p> <p>XOL 20.12.11 NV45-42.0A 01/2021*</p> 
--	--	---	--	--

# View/Print Label

1. **Ensure there are no other shipping or tracking labels attached to your package.** Select the Print button on the print dialogue box that appears. Note: If your browser does not support this function, select Print from the File menu to print the label.

2. **Fold the printed label at the solid line below.** Place the label in a UPS Shipping Pouch. If you do not have a pouch, affix the folded label using clear plastic shipping tape over the entire label.

### 3. GETTING YOUR SHIPMENT TO UPS

#### Customers with a scheduled Pickup

- o Your driver will pickup your shipment(s) as usual.

#### Customers without a scheduled Pickup



- o Schedule a Pickup on ups.com to have a UPS driver pickup all of your packages.
- o Take your package to any location of The UPS Store®, UPS Access Point(TM) location, UPS Drop Box, UPS Customer Center, Staples® or Authorized Shipping Outlet near you. To find the location nearest you, please visit the 'Locations' Quick link at ups.com.

UPS Access Point™  
 MICHAELS STORE # 7773  
 75 INTERSTATE SHOP CTR  
 RAMSEY NJ 07446-1130

UPS Access Point™  
 THE UPS STORE  
 115 FRANKLIN TPKE  
 MAHWAH NJ 07430-1325

UPS Access Point™  
 THE UPS STORE  
 120 E MAIN ST  
 RAMSEY NJ 07446-1925

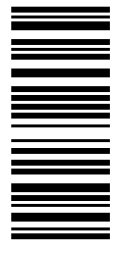
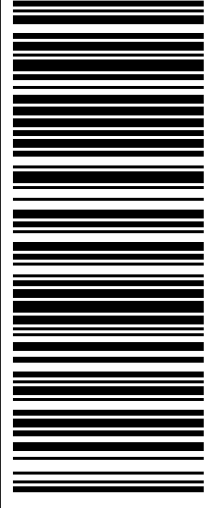
FOLD HERE

<p>NEIL GUERRIERO        3473040176        TRANSCEND WIRELESS        10 INDUSTRIAL AVE        MAHWAH NJ 07430</p> <p><b>SHIP TO:</b>        KATIE DELUCA        TOWN OF GREENWICH        SECOND FLOOR        101 FIELD POINT ROAD        GREENWICH CT 06830</p>	<p>1 LBS</p> <p>1 OF 1</p> <p><b>CT 069 9-01</b></p> 	<p><b>UPS GROUND</b></p> <p>TRACKING #: 1Z V25 742 42 9444 5326</p>		<p>BILLING: P/P        SIGNATURE REQUIRED</p> <p>Reference #1: CT11005D CSC ZO</p> <p>XOL 20.12.11 NV45-42.0A 01/2021*</p> 
---	--	---	--	--

# View/Print Label

1. **Ensure there are no other shipping or tracking labels attached to your package.** Select the Print button on the print dialogue box that appears. Note: If your browser does not support this function, select Print from the File menu to print the label.

2. **Fold the printed label at the solid line below.** Place the label in a UPS Shipping Pouch. If you do not have a pouch, affix the folded label using clear plastic shipping tape over the entire label.

### 3. GETTING YOUR SHIPMENT TO UPS

#### Customers with a scheduled Pickup

- o Your driver will pickup your shipment(s) as usual.

#### Customers without a scheduled Pickup



- o Schedule a Pickup on ups.com to have a UPS driver pickup all of your packages.
- o Take your package to any location of The UPS Store®, UPS Access Point(TM) location, UPS Drop Box, UPS Customer Center, Staples® or Authorized Shipping Outlet near you. To find the location nearest you, please visit the 'Locations' Quick link at ups.com.

UPS Access Point™  
 MICHAELS STORE # 7773  
 75 INTERSTATE SHOP CTR  
 RAMSEY NJ 07446-1130

UPS Access Point™  
 THE UPS STORE  
 115 FRANKLIN TPKE  
 MAHWAH NJ 07430-1325

UPS Access Point™  
 THE UPS STORE  
 120 E MAIN ST  
 RAMSEY NJ 07446-1925

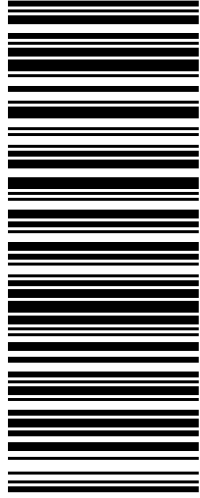
FOLD HERE

<p>NEIL GUERRIERO          3473040176          TRANSCEND WIRELESS          10 INDUSTRIAL AVE          MAHWAH NJ 07430</p> <p><b>SHIP TO:</b>          FRED CAMILO          TOWN OF GREENWICH          FIRST FLOOR          101 FIELD POINT ROAD  <b>GREENWICH CT 06830</b></p>	<p><b>1 LBS</b></p> <p><b>1 OF 1</b></p>	<p><b>CT 069 9-01</b></p> 	<p><b>UPS GROUND</b></p> <p>TRACKING #: 1Z V25 742 42 9257 9338</p> 	<p><b>BILLING: P/P</b>  <b>SIGNATURE REQUIRED</b></p> <p>Reference #1: CT11005D CSC EO</p> <p><small>XOL 20.12.11 NV45-42.0A 01/2021*</small></p> 
--	--	---	--	---



**IMPROVEMENT DATA**

**PHYSICAL CHARACTERISTICS**

**ROOFING**

Built-up

**WALLS**

Frame 1 2 U  
Brick Yes Yes  
Metal Guard

**FRAMING**

F Prf B 0 3730 2 6240 U 6240

**FINISH**

UF SF FO FD  
1 0 0 0 3730  
2 0 0 0 6240  
U 0 0 0 6240  
Total 0 0 0 16210

**HEATING AND AIR CONDITIONING**

Heat B 0 3730 2 6240 U 6240  
Sprink 0 3730 2 6240

02

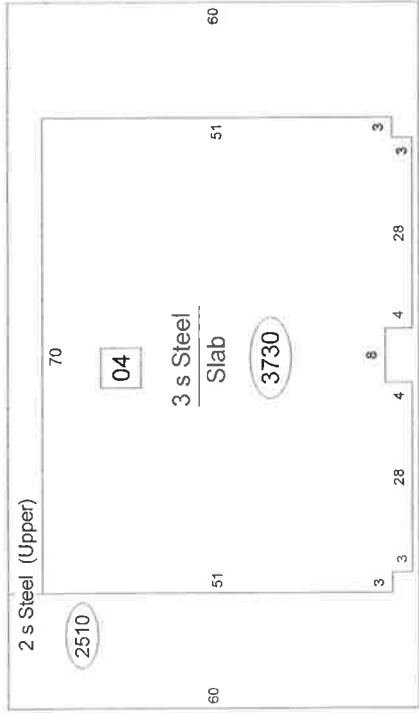

104

01

03



**SPECIAL FEATURES**

Description Value

**SUMMARY OF IMPROVEMENTS**

ID	Use	Stry Hgt	Const Year	Grade	Base Rate	Feat-ures	Adj Rate	Size Area	Computed Value	Phys Obsol	Market %	Depr Adj	Comp Value		
C	GENOFF	0.00	AVG-	1969	1985	AV	0.00	N	0.00	6240	0	0	150	100	3699600
01	PAVING	0.00	85	Good	1969	1985	AV	4.60	N	10.35	16000	13	0	100	144100
02	RTWCONC	10.00	6D	Good	1969	1985	AV	26.00	N	58.50	10x 56	13	0	100	2900
03	RTWCONC	5.00	6D	Good	1969	1985	AV	26.00	N	58.50	5x 90	13	0	100	4600
04	ELEVCOM	3.00	2H	AVG+	1969	1985	AV	169000	N	304200	1E 0	13	0	100	264700

(LCM: 150.00)

Data Collector/Date

JLT 12/08/1999

Appraiser/Date

TOG 10/01/2015

Neighborhood

Neigh 2300 AV

Supplemental Cards

TOTAL IMPROVEMENT VALUE

4115900

4145E

DOCKET NO. 120 - An application of Metro Mobile CTS of Fairfield County, Inc., for a Certificate of Environmental Compatibility and Public Need for the construction, operation, and maintenance of cellular telephone antennas and associated equipment located in the Town of Greenwich, Connecticut.

CONNECTICUT

SITING

COUNCIL

FEBRUARY 26, 1990

DECISION AND ORDER

Pursuant to the foregoing Findings of Fact and Opinion, the Connecticut Siting Council finds that the effects associated with the construction, operation, and maintenance of a cellular telecommunications facility at the proposed site in Greenwich, Connecticut, including effects on the natural environment; ecological balance; public health and safety; scenic, historic, and recreational values; forests and parks; air and water purity; and fish and wildlife are not significant either alone or cumulatively with other effects, are not in conflict with the policies of the State concerning such effects, and are not sufficient reason to deny the proposed Greenwich (East) site in this application, and therefore directs that a Certificate of Environmental Compatibility and Public Need, as provided by Section 16-50k of the Connecticut General Statutes (CGS), be issued to Metro Mobile CTS of Fairfield County, Inc., for the construction, operation, and maintenance of a cellular telephone facility at the proposed site on 1111 East Putnam Avenue, Greenwich, Connecticut.

The Facility shall be constructed, operated, and maintained substantially as specified in the Council's record on this matter, and subject to the following conditions:

1. The facility shall be constructed in accordance with applicable sections of the State of Connecticut Basic Building Code.
2. The Certificate holder shall notify the Council if and when any equipment other than that listed in this application is added to this facility.
3. The Certificate Holder shall prepare a Development and Management Plan (D&M Plan) for this site which shall include detailed plans for the attachment of the antenna structures to the roof top facade showing mounting brackets, modifications to the facade and building structure, cable pathway from antennas to the equipment room, and the location of emergency power generation. The Certificate Holder shall consult with the building's owner in the preparation of the D&M Plan.



4. The antenna bases shall be mounted no higher than 49 feet above ground level, or 144 feet above mean sea level.
5. The Certificate Holder shall provide a final report to the Council upon completion of construction, including the final construction costs and date of commercial operation.
6. If this facility does not initially provide, or permanently ceases to provide, cellular service following the completion of construction, this Decision and Order shall be void, and the antennas and all associated equipment in this application shall be dismantled and removed or reapplication for any new use shall be made to the Council and a Certificate granted before any such new use is made.
7. The Certificate Holder shall comply with any future radio frequency (RF) standard promulgated by State or federal regulatory agencies. Upon the establishment of any new governmental RF standards, the facility granted in this Decision and Order shall be brought into compliance with such standards.
8. The Certificate Holder or its successor shall provide the Council with a report of recalculated power density if and when additional channels over the proposed 90 channels, higher wattage over the proposed 100 watts per channel, or if other circumstances in operation cause change in power density above the levels originally calculated in the application.
9. Unless otherwise approved by the Council, this Decision and Order shall be void if all construction authorized herein is not completed within three years of the issuance of this Decision and Order, or within three years of the completion of any appeal taken to this Decision and Order.

Pursuant to Section 16-50p, we hereby direct that a copy of the Findings of Fact, Opinion, and Decision and Order be served on each person listed below. A notice of issuance shall be published in the The Advocate and Greenwich Time. By this Decision and Order, the Council disposes of the legal rights, duties, and privileges of each party named or admitted to the proceeding in accordance with Section 16-50j-17 of the Regulations of State Agencies.

The parties or intervenors to this proceeding are:

(Applicant)	(Its Representatives)
Metro Mobile CTS of Fairfield County, Inc. 50 Rockland Road South Norwalk, CT 06854 Attn: Phillip Mayberry Vice President and General Manager	Robinson & Cole One Commercial Plaza Hartford, CT 0613-3597 Attn: Earl W. Phillips, Esq.

(Party)

Patrick J. Pellegrino  
Mary G. Pellegrino  
268 Milbank Avenue  
Greenwich, CT 06830

(Intervenor)

SNET Cellular, Inc.  
227 Church Street  
New Haven, CT 06506

Peter H. Tyrrell, Esq.  
Senior Attorney  
SNET Cellular, Inc.  
227 Church Street  
New Haven, CT 06506

TEF/cp

CERTIFICATION

The undersigned members of the Connecticut Siting Council hereby certify that they have heard this case in Docket No. 120 or read the record thereof, and that we voted as follows:

Dated at New Britain, Connecticut the 26 day of February, 1990.

<u>Council Members</u>	<u>Vote Cast</u>
<u><i>Gloria Dibble Pond</i></u> Gloria Dibble Pond Chairperson	Yes
<u><i>Robert A. Pulito</i></u> Commissioner Peter Boucher Designee: Robert A. Pulito	Yes
<u><i>Brian Emerick</i></u> Commissioner Leslie Carothers Designee: Brian Emerick	Yes
<u><i>Harry E. Covey</i></u> Harry E. Covey	Yes
<u><i>Mortimer A. Gelston</i></u> Mortimer A. Gelston	Yes
<u><i>Daniel P. Lynch, Jr.</i></u> Daniel P. Lynch, Jr.	Yes
<u><i>Paulann H. Sheets</i></u> Paulann H. Sheets	Abstain
<u><i>William H. Smith</i></u> William H. Smith	Yes
<u><i>Colin C. Tait</i></u> Colin C. Tait	Yes

# T-Mobile

## WIRELESS COMMUNICATIONS FACILITY

### GREENWICH/ROUTE 1

#### SITE ID: CT11005D

#### 1111 E. PUTNAM AVENUE

#### GREENWICH, CT 06878

**T-MOBILE RF CONFIGURATION**

**67D5997DB\_2xAIR+1OP**

- #### GENERAL NOTES
1. ALL WORK SHALL BE IN ACCORDANCE WITH THE 2015 INTERNATIONAL BUILDING CODE AS MODIFIED BY THE 2018 CONNECTICUT SUPPLEMENT, INCLUDING THE IA/EIA-222 REVISION "G" "STRUCTURAL STANDARDS FOR STEEL ANTENNA TOWERS AND SUPPORTING STRUCTURES," 2017 CONNECTICUT FIRE SAFETY CODE, NATIONAL ELECTRICAL CODE AND LOCAL CODES.
  2. CONTRACTOR SHALL REVIEW ALL DRAWINGS AND SPECIFICATIONS IN THE CONTRACT DOCUMENT SET. CONTRACTOR SHALL COORDINATE ALL WORK SHOWN IN THE SET OF DRAWINGS. THE CONTRACTOR SHALL PROVIDE A COMPLETE SET OF DRAWINGS TO ALL SUBCONTRACTORS AND ALL RELATED PARTIES. THE SUBCONTRACTORS SHALL EXAMINE ALL THE DRAWINGS AND SPECIFICATIONS FOR THE INFORMATION THAT AFFECTS THEIR WORK.
  3. CONTRACTOR SHALL PROVIDE A COMPLETE BUILD-OUT WITH ALL FINISHES, STRUCTURAL, MECHANICAL, AND ELECTRICAL COMPONENTS AND PROVIDE ALL ITEMS AS SHOWN OR INDICATED ON THE DRAWINGS OR IN THE WRITTEN SPECIFICATIONS.
  4. CONTRACTOR SHALL FURNISH ALL MATERIAL, LABOR AND EQUIPMENT TO COMPLETE THE WORK AND FURNISH A COMPLETED JOB ALL IN ACCORDANCE WITH LOCAL AND STATE GOVERNING AUTHORITIES AND OTHER AUTHORITIES HAVING LAWFUL JURISDICTION OVER THE WORK.
  5. CONTRACTOR SHALL SECURE AND PAY FOR ALL PERMITS AND ALL INSPECTIONS REQUIRED AND SHALL ALSO PAY FEES REQUIRED FOR THE GENERAL CONSTRUCTION, PLUMBING, ELECTRICAL, AND HVAC. PERMITS SHALL BE PAID FOR BY THE RESPECTIVE SUBCONTRACTORS.
  6. CONTRACTOR SHALL MAINTAIN A CURRENT SET OF DRAWINGS AND SPECIFICATIONS ON SITE AT ALL TIMES AND INSURE DISTRIBUTION AND SPECIFICATIONS ON SITE AT ALL TIMES AND INSURE DISTRIBUTION OF NEW DRAWINGS TO SUBCONTRACTORS AND OTHER RELEVANT PARTIES AS SOON AS THEY ARE MADE AVAILABLE. ALL OLD DRAWINGS SHALL BE MARKED VOID AND REMOVED FROM THE CONTRACT AREA. THE CONTRACTOR SHALL FURNISH AN "AS-BUILT" SET OF DRAWINGS TO OWNER UPON COMPLETION OF PROJECT.
  7. LOCATION OF EQUIPMENT, AND WORK SUPPLIED BY OTHERS THAT IS DIAGRAMMATICALLY INDICATED ON THE DRAWINGS SHALL BE DETERMINED BY THE CONTRACTOR. THE CONTRACTOR SHALL DETERMINE LOCATIONS AND DIMENSIONS SUBJECT TO STRUCTURAL CONDITIONS AND WORK OF THE SUBCONTRACTORS.
  8. THE CONTRACTOR IS SOLELY RESPONSIBLE TO DETERMINE CONSTRUCTION PROCEDURE AND SEQUENCE AND TO ENSURE THE SAFETY OF THE EXISTING STRUCTURES AND ITS COMPONENT PARTS DURING CONSTRUCTION. THIS INCLUDES THE ADDITION OF WHATEVER SHORING, BRACING, UNDERPINNING, ETC. THAT MAY BE NECESSARY.
  9. DRAWINGS INDICATE THE MINIMUM STANDARDS, BUT IF ANY WORK SHOULD BE INDICATED TO BE SUBSTANDARD TO ANY ORDINANCES, LAWS, CODES, RULES, OR REGULATIONS BEARING ON THE WORK, THE CONTRACTOR SHALL INCLUDE IN HIS WORK AND SHALL EXECUTE THE WORK CORRECTLY IN ACCORDANCE WITH SUCH ORDINANCES, LAWS, CODES, RULES OR REGULATIONS WITH NO INCREASE IN COSTS.
  10. ALL UTILITY WORK SHALL BE IN ACCORDANCE WITH LOCAL UTILITY COMPANY REQUIREMENTS AND SPECIFICATIONS.
  11. ALL EQUIPMENT AND PRODUCTS PURCHASED ARE TO BE REVIEWED BY CONTRACTOR AND ALL APPLICABLE SUBCONTRACTORS FOR ANY CONDITION PER MANUFACTURER'S RECOMMENDATIONS. CONTRACTOR TO SUPPLY THESE ITEMS AT NO COST TO OWNER OR CONSTRUCTION MANAGER.
  12. ANY AND ALL ERRORS, DISCREPANCIES, AND 'MISSED' ITEMS ARE TO BE BROUGHT TO THE ATTENTION OF THE T-MOBILE CONSTRUCTION MANAGER DURING THE BIDDING PROCESS BY THE CONTRACTOR. ALL THESE ITEMS ARE TO BE INCLUDED IN THE BID. NO 'EXTRA' WILL BE ALLOWED FOR MISSED ITEMS.
  13. CONTRACTOR SHALL BE RESPONSIBLE FOR ALL ON-SITE SAFETY FROM THE TIME THE JOB IS AWARDED UNTIL ALL WORK IS COMPLETE AND ACCEPTED BY THE OWNER.
  14. CONTRACTOR TO REVIEW ALL SHOP DRAWINGS AND SUBMIT COPY TO ENGINEER FOR APPROVAL. DRAWINGS MUST BEAR THE CHECKER'S INITIALS BEFORE SUBMITTING TO THE CONSTRUCTION MANAGER FOR REVIEW.
  15. THE CONTRACTOR SHALL FIELD VERIFY ALL DIMENSIONS, ELEVATIONS, ANGLES AND EXISTING CONDITIONS AT THE SITE, PRIOR TO FABRICATION AND/OR INSTALLATION OF ANY WORK IN THE CONTRACT AREA.
  16. COORDINATION, LAYOUT, FURNISHING AND INSTALLATION OF CONDUITS AND ALL APPURTENANCES REQUIRED FOR PROPER INSTALLATION OF ELECTRICAL AND TELECOMMUNICATION SERVICE SHALL BE THE SOLE RESPONSIBILITY OF THE CONTRACTOR.
  17. ALL DAMAGE CAUSED TO ANY EXISTING STRUCTURE SHALL BE THE SOLE RESPONSIBILITY OF THE CONTRACTOR. THE CONTRACTOR WILL BE HELD LIABLE FOR ALL REPAIRS REQUIRED FOR EXISTING STRUCTURES IF DAMAGED DURING CONSTRUCTION ACTIVITIES.
  18. THE CONTRACTOR SHALL CONTACT 'CALL BEFORE YOU DIG' AT LEAST 48 HOURS PRIOR TO ANY EXCAVATIONS AT 1-800-922-4455. ALL UTILITIES SHALL BE IDENTIFIED AND CLEARLY MARKED. CONTRACTOR SHALL MAINTAIN AND PROTECT MARKED UTILITIES THROUGHOUT PROJECT COMPLETION.
  19. CONTRACTOR SHALL COMPLY WITH THE OWNER'S ENVIRONMENTAL ENGINEER ON ALL METHODS AND PROVISIONS FOR ALL EXCAVATION ACTIVITIES INCLUDING SOIL DISPOSAL. ALL BACKFILL MATERIALS TO BE PROVIDED BY THE CONTRACTOR.

#### SITE DIRECTIONS

<b>FROM:</b> 35 GRIFFIN ROAD SOUTH BLOOMFIELD, CT 06002	<b>TO:</b> 1111 E. PUTNAM AVENUE GREENWICH, CT 06878
--	---

1. HEAD NORTH ON GRIFFIN ROAD S. TOWARD HARTMAN RD. 0.21 MI.
2. TAKE THE 2ND RIGHT ONTO DAY HILL RD. 0.14 MI.
3. TAKE THE 1ST RIGHT ONTO BLUE HILLS AVENUE EXT/CT-187 1.89 MI.
4. TURN LEFT ONTO CT-305/OLD WINDSOR RD. 2.32 MI.
5. STAY STRAIGHT TO GO ONTO BLOOMFIELD AVE/CT-305. 0.01 MI.
6. MERGE ONTO I-91 S TOWARD HARTFORD 44.19 MI.
7. KEEP RIGHT TOWARD NY CITY 0.08 MI.
8. MERGE ONTO I-95 S VIA THE EXIT ON THE LEFT TOWARD NY CITY 42.17 MI.
9. TAKE THE US-1 EXIT, EXIT 5, TOWARD RIVERSIDE/OLD GREENWICH 0.13 MI.
10. KEEP LEFT TO TAKE THE RAMP TOWARD BUSH HOLLEY HOUSE MUSEUM 0.04 MI.
11. TURN SLIGHT LEFT ONTO E. PUTNAM AVE/US-1 S 0.30 MI.

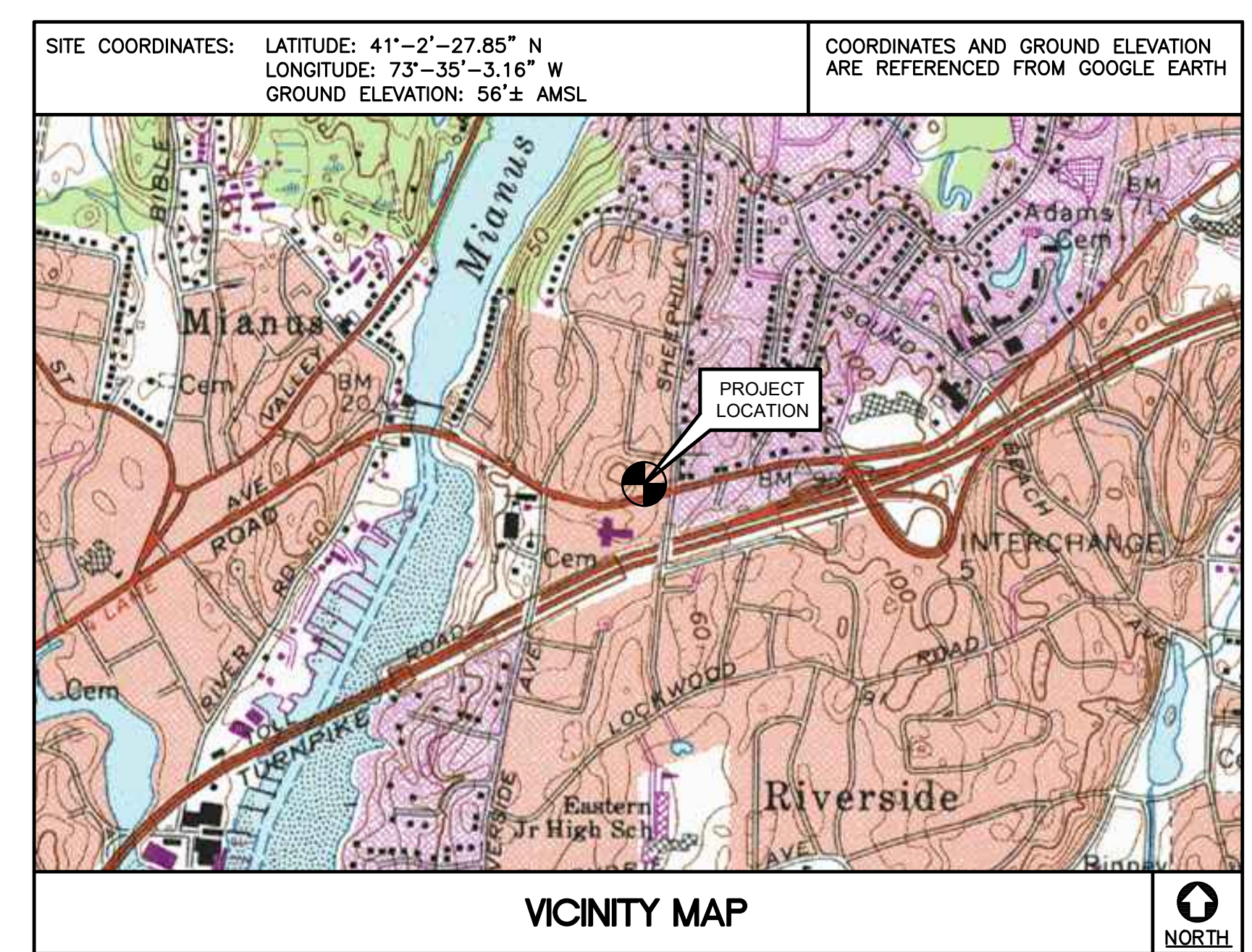

- #### PROJECT SUMMARY
- THE PROPOSED SCOPE OF WORK CONSISTS OF A MODIFICATION TO THE EXISTING UNMANNED TELECOMMUNICATIONS FACILITY INCLUDING THE FOLLOWING:
1. REMOVE NORTEL CABINETS.
  2. INSTALL BBU.
  3. INSTALL (1) BATTERY CABINET B160.
  4. INSTALL (1) ENCLOSURE 6160.
  5. ADD (1) iXRe ROUTER, (1) BB6630 FOR L2500, (1) BB6648 FOR N2500, (1) PSU4813 VOLTAGE BOOSTER TO NEW ENCLOSURE 6160.
  6. REMOVE (12) COAXIAL LINES FOR NEW TOTAL OF (6) COAXIAL LINES.
  7. INSTALL (3) 6X12 HCS CONNECTED TO NEW ENCLOSURE 6160.
  8. REPLACE (1) AIR21 ANTENNA WITH (1) AIR6449 B41 ANTENNA PER SECTOR, TOTAL OF (3).
  9. REPLACE (1) AIR21 ANTENNA WITH (1) AIR32 ANTENNA PER SECTOR, TOTAL OF (3).
  10. REPLACE LNX-6515DA-A1M ANTENNA WITH (1) APXVAARR24 ANTENNA PER SECTOR, TOTAL OF (3).
  11. INSTALL (1) 8:4 SDX1926Q-43 DIPLEXER WITH APXVAARR24 ANTENNA PER SECTOR, TOTAL OF (3).
  12. INSTALL (1) RADIO 4415 B25 WITH APXVAARR24 ANTENNA PER SECTOR, TOTAL OF (3).
  13. REPLACE EXISTING RRUS11 B12 WITH (1) RADIO 4449 B71+B85 PER SECTOR, TOTAL OF (3).
  14. MOVE GSM TO AIR32 ANTENNA PER SECTOR, TOTAL OF (3).
  15. MOVE EXISTING (2) COAX LINES, AWS TMA, & U21 TO APXVAARR24 ANTENNA PER SECTOR, TOTAL OF (3).
- #### PROJECT SUMMARY (STRUCTURAL)
- FOR REQUIRED STRUCTURAL MODIFICATIONS, SEE SHEET(S) S-1 FOR ADDITIONAL DETAILS. STEEL NEEDED FOR PLATFORM REINFORCEMENT.

#### PROJECT INFORMATION

<b>SITE NAME:</b>	GREENWICH/ROUTE 1
<b>SITE ID:</b>	CT11005D
<b>SITE ADDRESS:</b>	1111 E. PUTNAM AVENUE, GREENWICH, CT 06878
<b>APPLICANT:</b>	T-MOBILE NORTHEAST, LLC 35 GRIFFIN ROAD SOUTH BLOOMFIELD, CT 06002
<b>CONTACT PERSON:</b>	DAN REID (PROJECT MANAGER) TRANSCEND WIRELESS, LLC (203) 592-8291
<b>ENGINEER OF RECORD:</b>	CEN TEK ENGINEERING, INC. 63-2 NORTH BRANFORD RD. BRANFORD, CT 06405
<b>PROJECT COORDINATES:</b>	LATITUDE: 41°-2'-27.85" N LONGITUDE: 73°-35'-3.16" W GROUND ELEVATION: 56± AMSL

SITE COORDINATES AND GROUND ELEVATION REFERENCED FROM GOOGLE EARTH.

#### SHEET INDEX

SHT. NO.	DESCRIPTION	REV.
T-1	TITLE SHEET	1
N-1	GENERAL NOTES AND SPECIFICATIONS	1
C-1	SITE LOCATION PLAN	1
C-2	COMPOUND PLAN, EQUIPMENT PLAN, AND ELEVATION	1
C-3	ANTENNA PLANS	1
C-4	ANETNNA ELEVATIONS	1
C-5	TYPICAL EQUIPMENT DETAILS	1
C-6	TYPICAL EQUIPMENT DETAILS	1
S-1	EQUIPMENT PLATFORM AND DETAILS	1
E-1	TYPICAL ELECTRICAL DETAILS	1

T-MOBILE NORTHEAST LLC	WIRELESS COMMUNICATIONS FACILITY	GREENWICH/ROUTE 1	SITE ID: CT11005D	1111 E. PUTNAM AVENUE	GREENWICH, CT 06878	DATE: 10/14/20	SCALE: AS NOTED	JOB NO. 20143.12	TITLE SHEET
T-1									
Sheet No. 1 of 10									

**NOTES AND SPECIFICATIONS**

**DESIGN BASIS:**

GOVERNING CODE: 2015 INTERNATIONAL BUILDING CODE (IBC) AS MODIFIED BY THE 2018 CONNECTICUT STATE BUILDING CODE.

1. DESIGN CRITERIA:

- RISK CATEGORY III-IV (BASED ON IBC TABLE 1604.5)
- ULTIMATE DESIGN SPEED (OTHER STRUCTURE): 120 MPH (V<sub>sed</sub>) (EXPOSURE C/ IMPORTANCE FACTOR 1.0 BASED ON ASCE 7-10).

**SITE NOTES**

1. THE CONTRACTOR SHALL CALL UTILITIES PRIOR TO THE START OF CONSTRUCTION.
2. ACTIVE EXISTING UTILITIES, WHERE ENCOUNTERED IN THE WORK, SHALL BE PROTECTED AT ALL TIMES. THE ENGINEER SHALL BE NOTIFIED IMMEDIATELY, PRIOR TO PROCEEDING, SHOULD ANY UNCOVERED EXISTING UTILITY PRECLUDE COMPLETION OF THE WORK IN ACCORDANCE WITH THE CONTRACT DOCUMENTS.
3. THE AREAS OF THE COMPOUND DISTURBED BY THE WORK SHALL BE RETURNED TO THEIR ORIGINAL CONDITION.
4. CONTRACTOR SHALL MINIMIZE DISTURBANCE TO EXISTING SITE DURING CONSTRUCTION. EROSION CONTROL MEASURES, SHALL BE IN CONFORMANCE WITH THE LOCAL GUIDELINES FOR EROSION AND SEDIMENT CONTROL.
5. IF ANY FIELD CONDITIONS EXIST WHICH PRECLUDE COMPLIANCE WITH THE DRAWINGS, THE CONTRACTOR SHALL IMMEDIATELY NOTIFY THE ENGINEER AND SHALL PROCEED WITH AFFECTED WORK AFTER CONFLICT IS SATISFACTORILY RESOLVED.

**GENERAL NOTES**

1. ALL WORK SHALL BE IN ACCORDANCE WITH THE 2015 INTERNATIONAL BUILDING CODE AS MODIFIED BY THE 2018 CONNECTICUT SUPPLEMENT, INCLUDING THE TIA/EIA-222 REVISION "G" "STRUCTURAL STANDARDS FOR STEEL ANTENNA TOWERS AND SUPPORTING STRUCTURES." 2017 CONNECTICUT FIRE SAFETY CODE, NATIONAL ELECTRICAL CODE AND LOCAL CODES.
2. CONTRACTOR SHALL REVIEW ALL DRAWINGS AND SPECIFICATIONS IN THE CONTRACT DOCUMENT SET. CONTRACTOR SHALL COORDINATE ALL WORK SHOWN IN THE SET OF DRAWINGS. THE CONTRACTOR SHALL PROVIDE A COMPLETE SET OF DRAWINGS TO ALL SUBCONTRACTORS AND ALL RELATED PARTIES. THE SUBCONTRACTORS SHALL EXAMINE ALL THE DRAWINGS AND SPECIFICATIONS FOR THE INFORMATION THAT AFFECTS THEIR WORK.
3. CONTRACTOR SHALL PROVIDE A COMPLETE BUILD-OUT WITH ALL FINISHES, STRUCTURAL, MECHANICAL, AND ELECTRICAL COMPONENTS AND PROVIDE ALL ITEMS AS SHOWN OR INDICATED ON THE DRAWINGS OR IN THE WRITTEN SPECIFICATIONS.
4. CONTRACTOR SHALL FURNISH ALL MATERIAL, LABOR AND EQUIPMENT TO COMPLETE THE WORK AND FURNISH A COMPLETED JOB ALL IN ACCORDANCE WITH LOCAL AND STATE GOVERNING AUTHORITIES AND OTHER AUTHORITIES HAVING LAWFUL JURISDICTION OVER THE WORK.
5. CONTRACTOR SHALL SECURE AND PAY FOR ALL PERMITS AND ALL INSPECTIONS REQUIRED AND SHALL ALSO PAY FEES REQUIRED FOR THE GENERAL CONSTRUCTION, PLUMBING, ELECTRICAL AND HVAC. PERMITS SHALL BE PAID FOR BY THE RESPECTIVE SUBCONTRACTORS.
6. CONTRACTOR SHALL MAINTAIN A CURRENT SET OF DRAWINGS AND SPECIFICATIONS ON SITE AT ALL TIMES AND INSURE DISTRIBUTION OF NEW DRAWINGS TO SUBCONTRACTORS AND OTHER RELEVANT PARTIES AS SOON AS THEY ARE MADE AVAILABLE. ALL OLD DRAWINGS SHALL BE MARKED VOID AND REMOVED FROM THE CONTRACT AREA. THE CONTRACTOR SHALL FURNISH AN "AS-BUILT" SET OF DRAWINGS TO OWNER UPON COMPLETION OF PROJECT.
7. LOCATION OF EQUIPMENT AND WORK SUPPLIED BY OTHERS THAT IS DIAGRAMMATICALLY INDICATED ON THE DRAWINGS, SHALL BE DETERMINED BY THE CONTRACTOR. THE CONTRACTOR SHALL DETERMINE LOCATIONS AND DIMENSIONS SUBJECT TO STRUCTURAL CONDITIONS AND WORK OF THE SUBCONTRACTORS.
8. THE CONTRACTOR IS SOLELY RESPONSIBLE TO DETERMINE CONSTRUCTION PROCEDURE AND SEQUENCE, AND TO ENSURE THE SAFETY OF THE EXISTING STRUCTURES AND IT'S COMPONENT PARTS DURING CONSTRUCTION. THIS INCLUDES THE ADDITION OF WHATEVER SHORING, BRACING, UNDERPINNING, ETC. THAT MAY BE NECESSARY.
9. DRAWINGS INDICATE THE MINIMUM STANDARDS, BUT IF ANY WORK SHOULD BE INDICATED TO BE SUBSTANDARD TO ANY ORDINANCES, LAWS, CODES, RULES, OR REGULATIONS BEARING ON THE WORK, THE CONTRACTOR SHALL INCLUDE IN HIS WORK AND SHALL EXECUTE THE WORK CORRECTLY IN ACCORDANCE WITH SUCH ORDINANCES, LAWS, CODES, RULES OR REGULATIONS WITH NO INCREASE IN COSTS.
10. ALL UTILITY WORK SHALL BE IN ACCORDANCE WITH LOCAL UTILITY COMPANY REQUIREMENTS AND SPECIFICATIONS.
11. ALL EQUIPMENT AND PRODUCTS PURCHASED ARE TO BE REVIEWED BY CONTRACTOR AND ALL APPLICABLE SUBCONTRACTORS FOR ANY CONDITION PER MFR.'S RECOMMENDATIONS. CONTRACTOR TO SUPPLY THESE ITEMS AT NO COST TO OWNER OR CONSTRUCTION MANAGER.
12. ANY AND ALL ERRORS, DISCREPANCIES, AND "MISSED" ITEMS, ARE TO BE BROUGHT TO THE ATTENTION OF THE SITE OWNER'S CONSTRUCTION MANAGER DURING THE BIDDING PROCESS BY THE CONTRACTOR. ALL THESE ITEMS ARE TO BE INCLUDED IN THE BID. NO 'EXTRA' WILL BE ALLOWED FOR MISSED ITEMS.
13. CONTRACTOR SHALL BE RESPONSIBLE FOR ALL ON-SITE SAFETY FROM THE TIME THE JOB IS AWARDED UNTIL ALL WORK IS COMPLETE AND ACCEPTED BY THE OWNER.
14. CONTRACTOR TO REVIEW ALL SHOP DRAWINGS AND SUBMIT COPY TO ENGINEER FOR APPROVAL. DRAWINGS MUST BEAR THE CHECKER'S INITIALS BEFORE SUBMITTING TO THE CONSTRUCTION MANAGER FOR REVIEW.
15. THE CONTRACTOR SHALL FIELD VERIFY ALL DIMENSIONS, ELEVATIONS, ANGLES, AND EXISTING CONDITIONS AT THE SITE, PRIOR TO FABRICATION AND/OR INSTALLATION OF ANY WORK IN THE CONTRACT AREA.
16. COORDINATION, LAYOUT, FURNISHING AND INSTALLATION OF CONDUIT AND ALL APPURTENANCES REQUIRED FOR PROPER INSTALLATION OF ELECTRICAL AND TELECOMMUNICATION SERVICE SHALL BE THE SOLE RESPONSIBILITY OF THE CONTRACTOR.
17. ALL DAMAGE CAUSED TO ANY EXISTING STRUCTURE SHALL BE THE SOLE RESPONSIBILITY OF THE CONTRACTOR. THE CONTRACTOR WILL BE HELD LIABLE FOR ALL REPAIRS REQUIRED FOR EXISTING STRUCTURES IF DAMAGED DURING CONSTRUCTION ACTIVITIES.
18. THE CONTRACTOR SHALL CONTACT 'CALL BEFORE YOU DIG' AT LEAST 48 HOURS PRIOR TO ANY EXCAVATIONS AT 1-800-922-4455. ALL UTILITIES SHALL BE IDENTIFIED AND CLEARLY MARKED. CONTRACTOR SHALL MAINTAIN AND PROTECT MARKED UTILITIES THROUGHOUT PROJECT COMPLETION.
18. CONTRACTOR SHALL COMPLY WITH OWNER'S ENVIRONMENTAL ENGINEER ON ALL METHODS AND PROVISIONS FOR ALL EXCAVATION ACTIVITIES INCLUDING SOIL DISPOSAL. ALL BACKFILL MATERIALS TO BE PROVIDED BY THE CONTRACTOR.
19. THE COUNTY/CITY/TOWN WILL MAKE PERIODIC FIELD OBSERVATION AND INSPECTIONS TO MONITOR THE INSTALLATION, MATERIALS, WORKMANSHIP AND EQUIPMENT INCORPORATED INTO THE PROJECT TO ENSURE COMPLIANCE WITH THE DESIGN PLANS, SPECIFICATIONS, CONTRACT DOCUMENTS AND APPROVED SHOP DRAWINGS.
20. THE COUNTY/CITY/TOWN MUST BE NOTIFIED (2) WORKING DAYS PRIOR TO CONCEALMENT/BURIAL OF ANY SYSTEM OR MATERIAL THAT WILL PREVENT THE DIRECT INSPECTION OF MATERIALS, METHODS OR WORKMANSHIP. EXAMPLES OF THESE PROCESSES ARE BACKFILLING A GROUND RING OR TOWER FOUNDATION, POURING TOWER FOUNDATIONS, BURYING GROUND RODS, PLATES OR GRIDS, ETC. THE CONTRACTOR MAY PROCEED WITH THE SCHEDULED PROCESS (2) WORKING DAYS AFTER PROVIDING NOTICE UNLESS NOTIFIED OTHERWISE BY THE COUNTY/CITY/TOWN.

REV.	DATE	DRAWN BY	CHECK'D BY	DESCRIPTION
0	12/16/20 11/16/20	JLW JLW	TJR TJR	CONSTRUCTION DRAWINGS - ADDED ANTENNA PAINTING NOTE CONSTRUCTION DRAWINGS - ISSUED FOR CONSTRUCTION

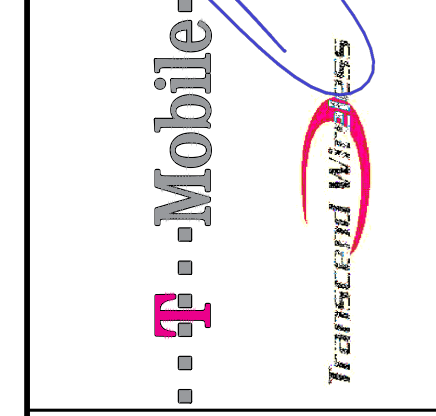
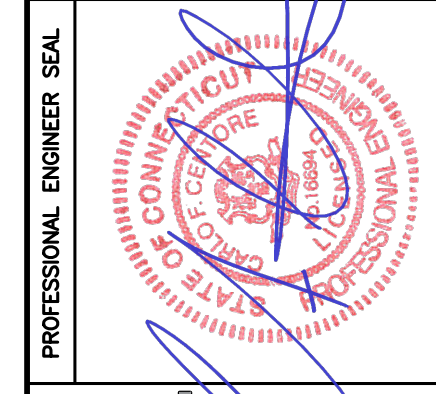

**CENTEX**  
engineering  
Centered on Solutions  
(203) 488-0380  
(203) 488-8387 Fax  
63-2 North Branford Road  
Branford, CT 06405  
www.CentexEng.com

**T-MOBILE NORTHEAST LLC**  
WIRELESS COMMUNICATIONS FACILITY  
**GREENWICH/ROUTE 1**  
**SITE ID: CT11005D**  
1111 E. PUTNAM AVENUE  
GREENWICH, CT 06878

DATE: 10/14/20  
SCALE: AS NOTED  
JOB NO. 20143.12

GENERAL NOTES  
AND  
SPECIFICATIONS



NOTE:  
ALL COAX LENGTHS TO BE MEASURED  
AND VERIFIED IN FIELD BEFORE ORDERING

### ANTENNA SCHEDULE

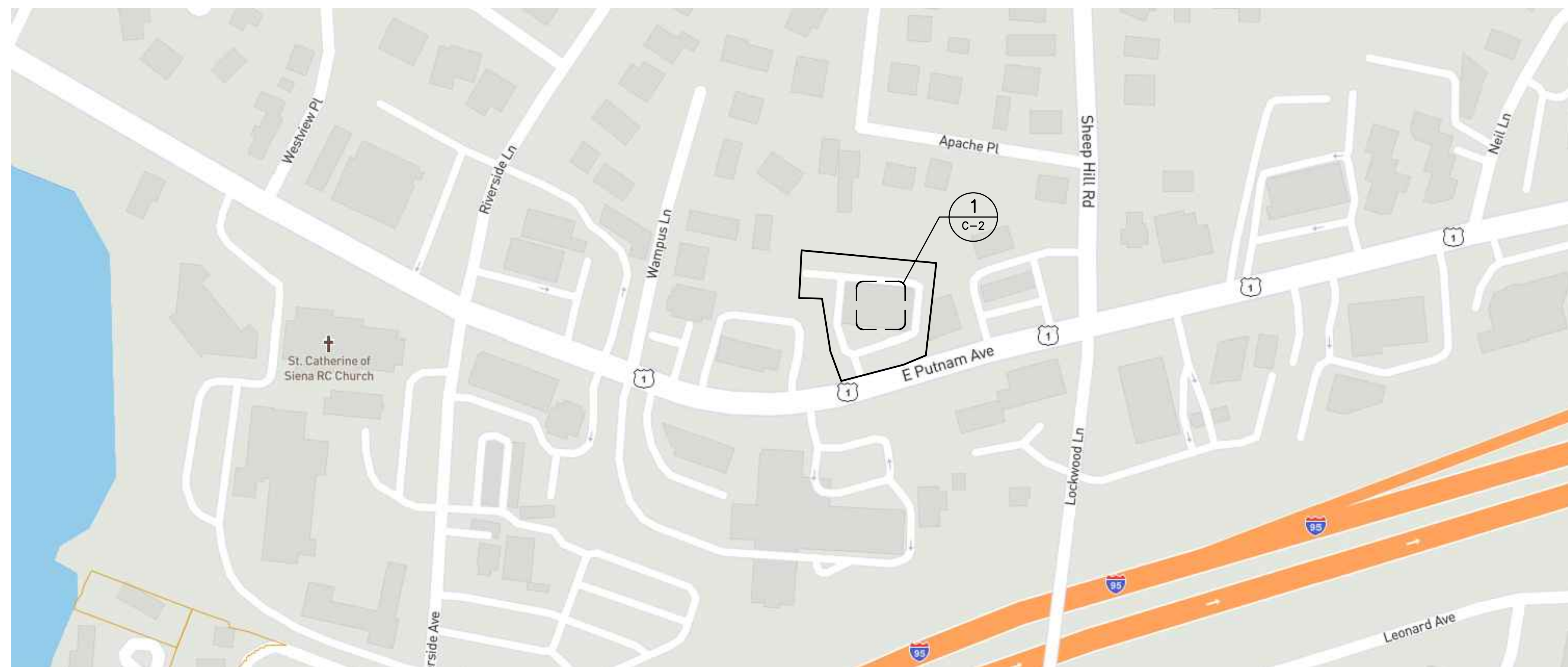
SECTOR	EXISTING/PROPOSED	ANTENNA	SIZE (INCHES) (L x W x D)	ANTENNA Ø HEIGHT	AZIMUTH	(E/P) RRU (QTY)	(E/P) TMA & DIPLEXER (QTY)	(QTY) PROPOSED COAX (LENGTH)
A1	PROPOSED	ERICSSON (AIR32 KRD901146-1_B66A_B2A)	56.6 x 12.9 x 8.7	43'	0°			(1) 6x12 HYBRID CABLE (±180')
A2	PROPOSED	RFS (APXVAARR24_43-U-N-NA20)	95.9 x 24 x 8.7	43'	0°	(P) RADIO 4449 B71+B85 (1), (P) RADIO 4415 B25 (1)	(E) GENERIC TWIN STYLE 1B (1), (P) COMMSCOPE-SDX1926Q-43 (1)	
A3	PROPOSED	ERICSSON (AIR6449 B41)	33.1 x 20.6 x 8.6	43'	0°			
B1	PROPOSED	ERICSSON (AIR32 KRD901146-1_B66A_B2A)	56.6 x 12.9 x 8.7	43'	120°			(1) 6x12 HYBRID CABLE (±180')
B2	PROPOSED	ERICSSON (AIR6449 B41)	33.1 x 20.6 x 8.6	43'	120°			
B3	PROPOSED	RFS (APXVAARR24_43-U-N-NA20)	95.9 x 24 x 8.7	43'	120°	(P) RADIO 4449 B71+B85 (1), (P) RADIO 4415 B25 (1)	(E) GENERIC TWIN STYLE 1B (1), (P) COMMSCOPE-SDX1926Q-43 (1)	
C1	PROPOSED	ERICSSON (AIR32 KRD901146-1_B66A_B2A)	56.6 x 12.9 x 8.7	43'	240°			(1) 6x12 HYBRID CABLE (±180')
C2	PROPOSED	ERICSSON (AIR6449 B41)	33.1 x 20.6 x 8.6	43'	240°			
C3	PROPOSED	RFS (APXVAARR24_43-U-N-NA20)	95.9 x 24 x 8.7	43'	240°	(P) RADIO 4449 B71+B85 (1), (P) RADIO 4415 B25 (1)	(E) GENERIC TWIN STYLE 1B (1), (P) COMMSCOPE-SDX1926Q-43 (1)	

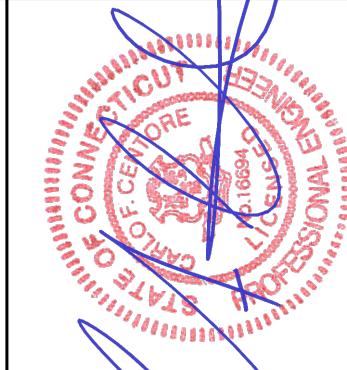
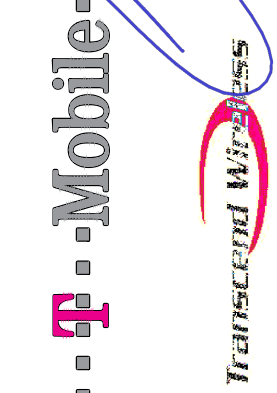

**1** SITE LOCATION PLAN  
C-1 SCALE: NOT TO SCALE TRUE NORTH

 PROFESSIONAL ENGINEER SEAL	 T-Mobile	 CENTEK engineering Centered on Solutions (203) 488-0580 (203) 488-8587 Fax 63-2 North Branford Road Branford, CT 06405 www.CentekEng.com	<b>T-MOBILE NORTHEAST LLC</b> WIRELESS COMMUNICATIONS FACILITY <b>GREENWICH/ROUTE 1</b> <b>SITE ID: CT11005D</b> 1111 E. PUTNAM AVENUE GREENWICH, CT 06878					DATE: 10/14/20 SCALE: AS NOTED JOB NO. 20143.12	SITE LOCATION PLAN
<div style="font-size: 2em; font-weight: bold; display: inline-block;">C-1</div>							SHEET NO. 3 OF 10		

**STRUCTURAL COMPLIANCE**

**ANTENNA MOUNTS & EQUIPMENT PLATFORM**

A STRUCTURAL ANALYSIS OF THE ANTENNA MOUNTS AND EQUIPMENT PLATFORM WAS PERFORMED FOR THE PROPOSED EQUIPMENT INSTALLATION AND THEY WERE FOUND TO BE STRUCTURALLY DEFICIENT AND WARRANTING MODIFICATION PRIOR TO INSTALLATION OF THE PROPOSED EQUIPMENT. FOR REQUIRED STRUCTURAL MODIFICATIONS, SEE SHEET(S) S-1 FOR DETAILS.

REFER TO THE STRUCTURAL ANALYSIS REPORT PREPARED BY CENTEK ENGINEERING (PROJECT # 20143.12) DATED 10/29/20 FOR ADDITIONAL INFORMATION AND REQUIREMENTS.

**NOTE:** NO EQUIPMENT SHALL BE INSTALLED ON THE HOSTING STRUCTURE WITHOUT A PASSING STRUCTURAL ANALYSIS REPORT AND CONTRACTOR PRIOR CONFIRMATION THAT ANY AND ALL REQUISITE MODIFICATIONS HAVE BEEN COMPLETED.

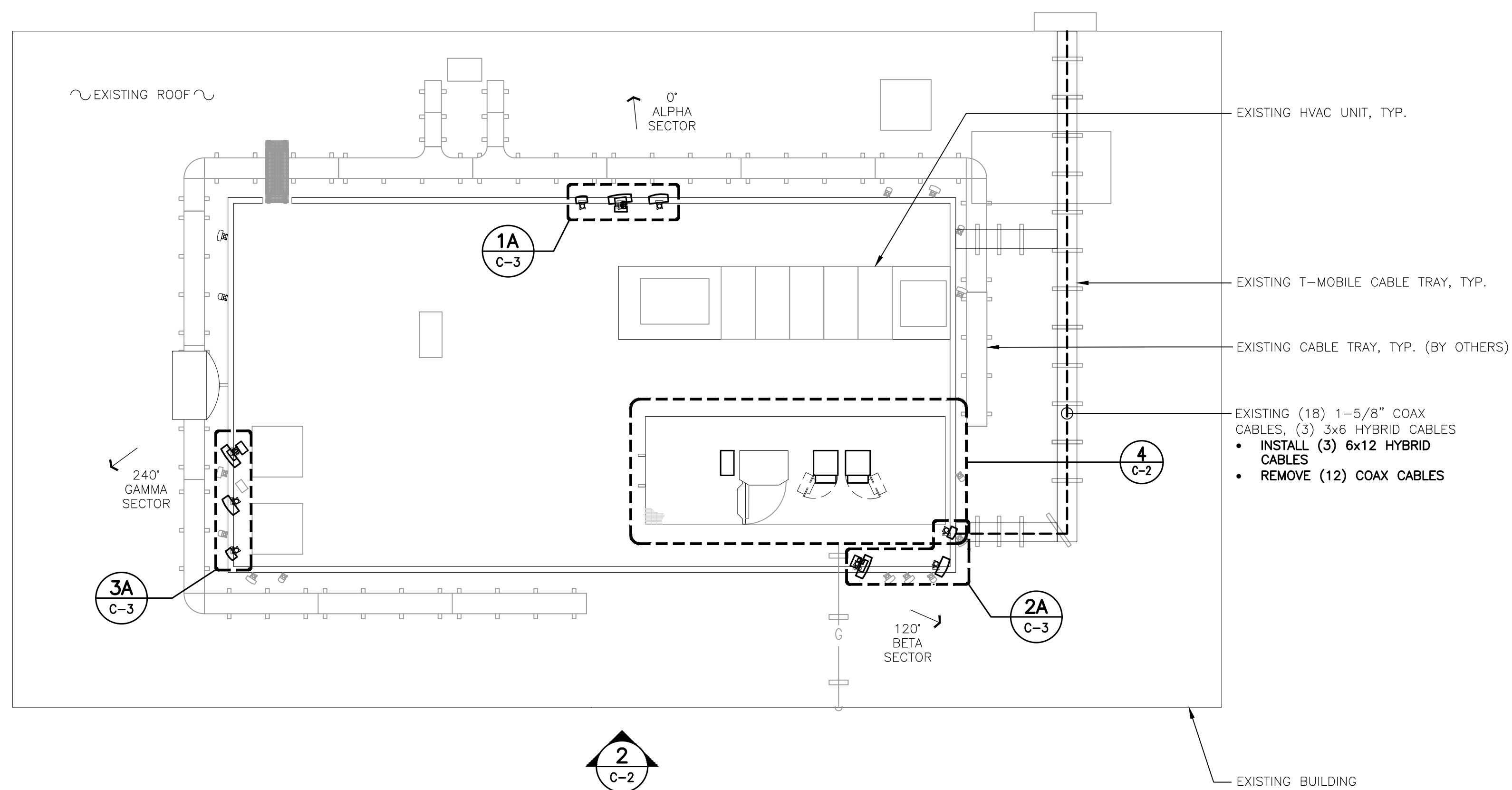

**1 COMPOUND PLAN - PROPOSED**  
C-2 SCALE: 1" = 8'

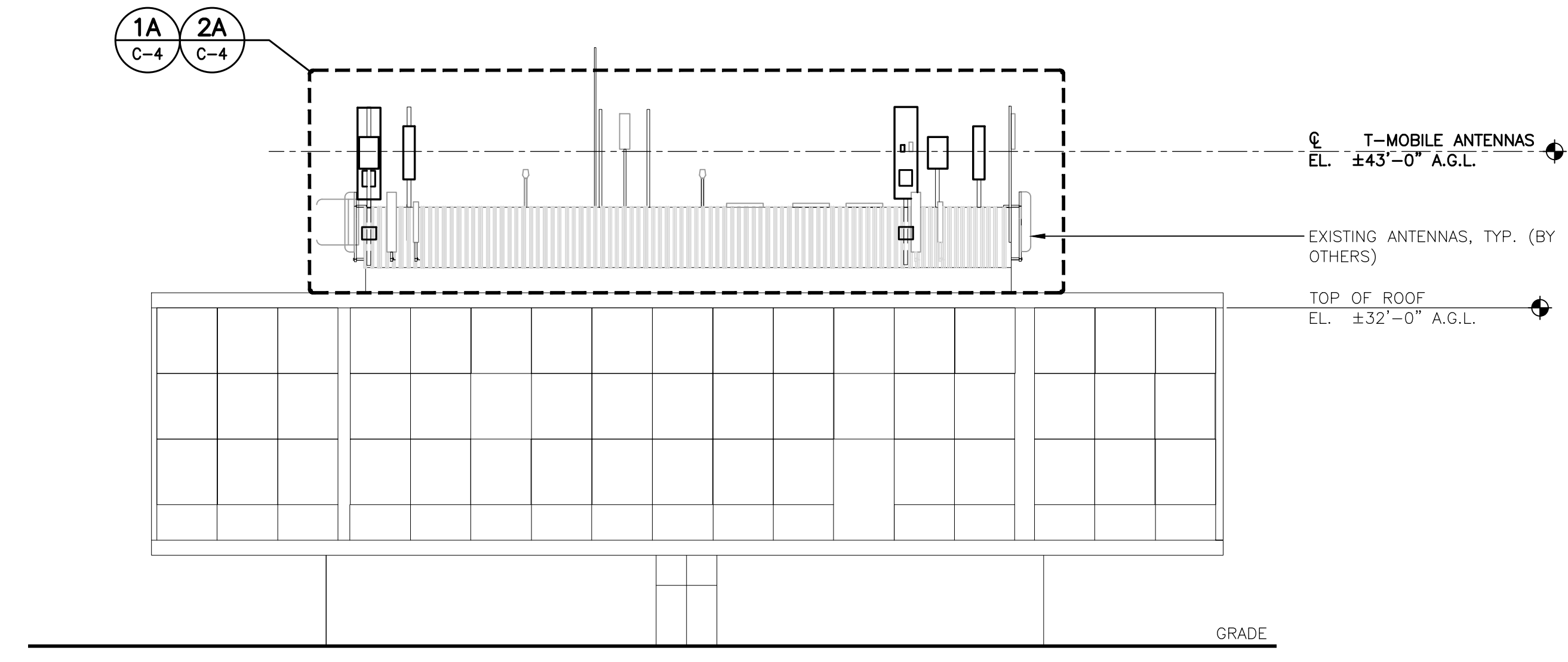
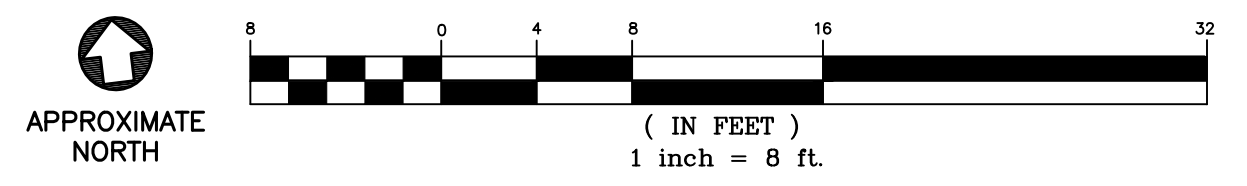

**2 SOUTH BUILDING ELEVATION - PROPOSED**  
C-2 SCALE: 1" = 10'

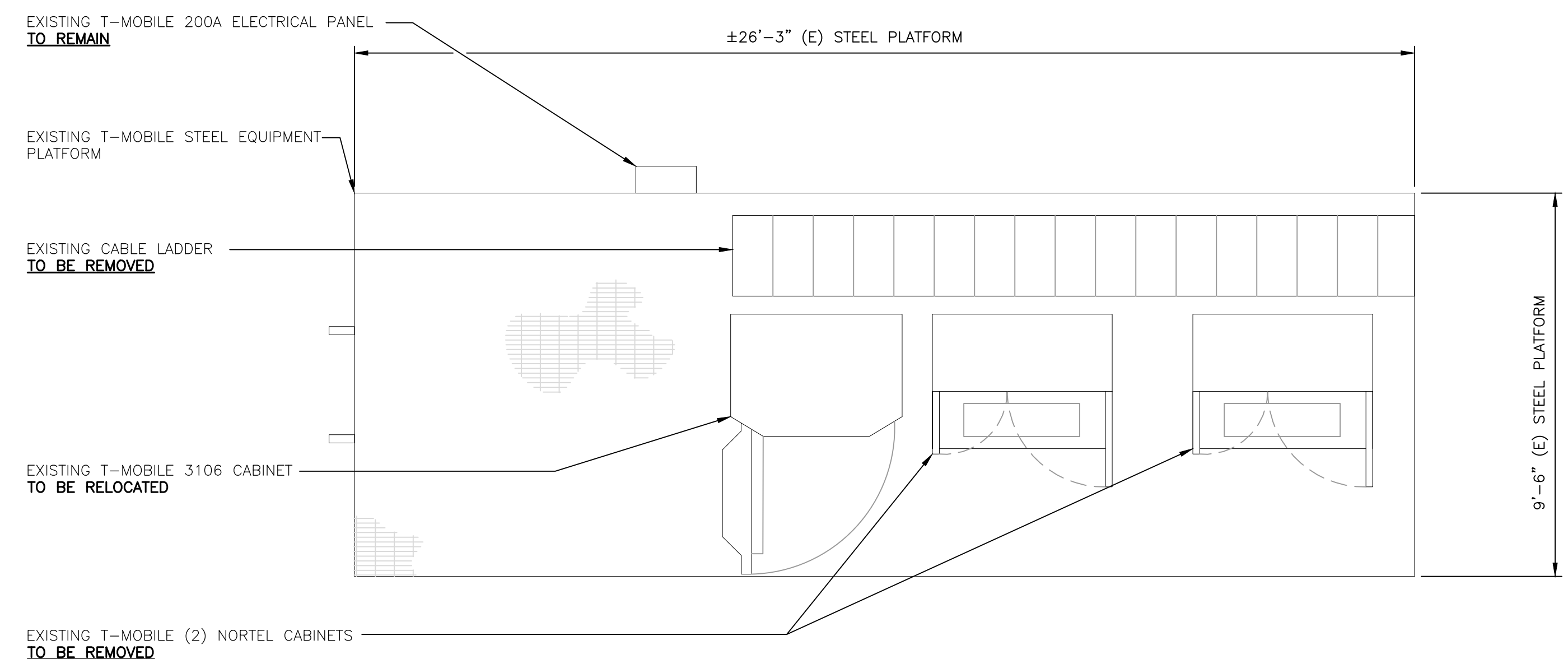
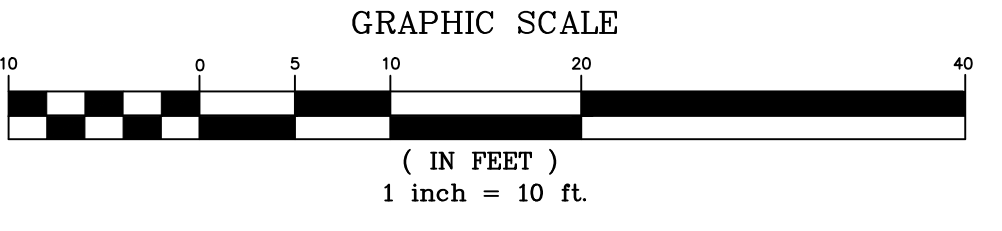

**3 EXISTING EQUIPMENT PLAN**  
C-2 SCALE: 3/8" = 1'  
APPROXIMATE NORTH

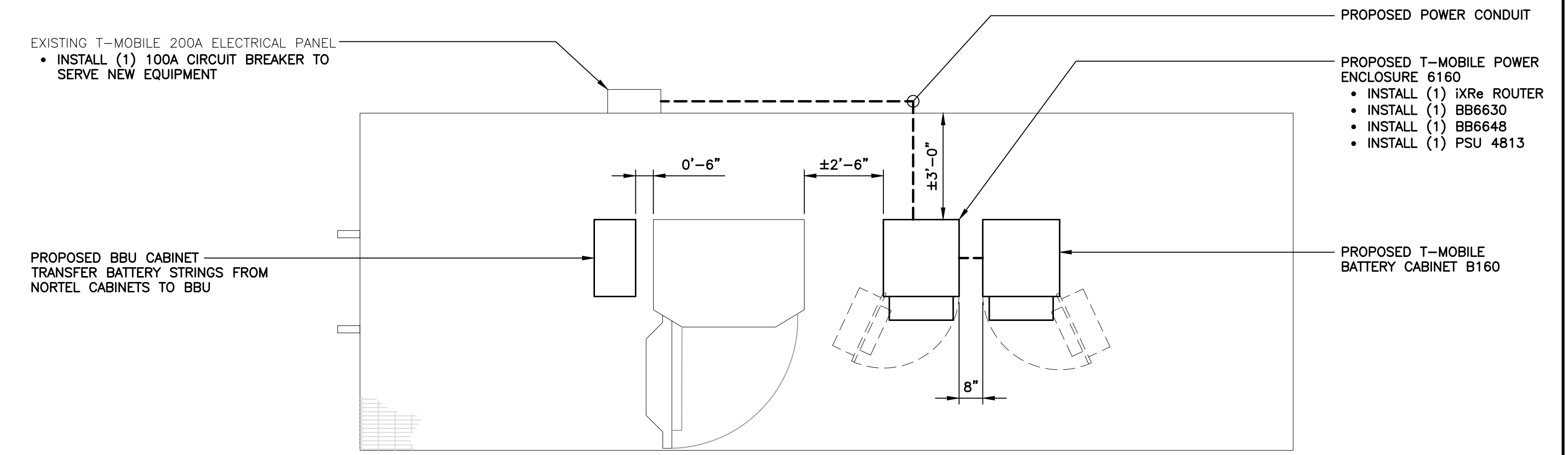

**4 PROPOSED EQUIPMENT PLAN**  
C-2 SCALE: 3/8" = 1'  
APPROXIMATE NORTH

PROFESSIONAL ENGINEER SEAL

**T-MOBILE**

Trinity Solutions

**CENTEK engineering**  
Centered on Solutions

(203) 488-0380  
(203) 488-8387 Fax  
63-2 North Branford Road  
Branford, CT 06405  
www.CentekEng.com

**T-MOBILE NORTHEAST LLC**  
WIRELESS COMMUNICATIONS FACILITY  
**GREENWICH/ROUTE 1**  
**SITE ID: CT11005D**  
111 E. PUTNAM AVENUE  
GREENWICH, CT 06878

DATE: 10/14/20  
SCALE: AS NOTED  
JOB NO. 20143.12

CONSTRUCTION DRAWINGS - ADDED ANTENNA PAINTING NOTE  
CONSTRUCTION DRAWINGS - ISSUED FOR CONSTRUCTION

12/16/20 TJR  
0 11/16/20 JLV  
REV. DATE DRAWN BY/CHK'D BY DESCRIPTION

**C-2**

Sheet No. 4 of 10

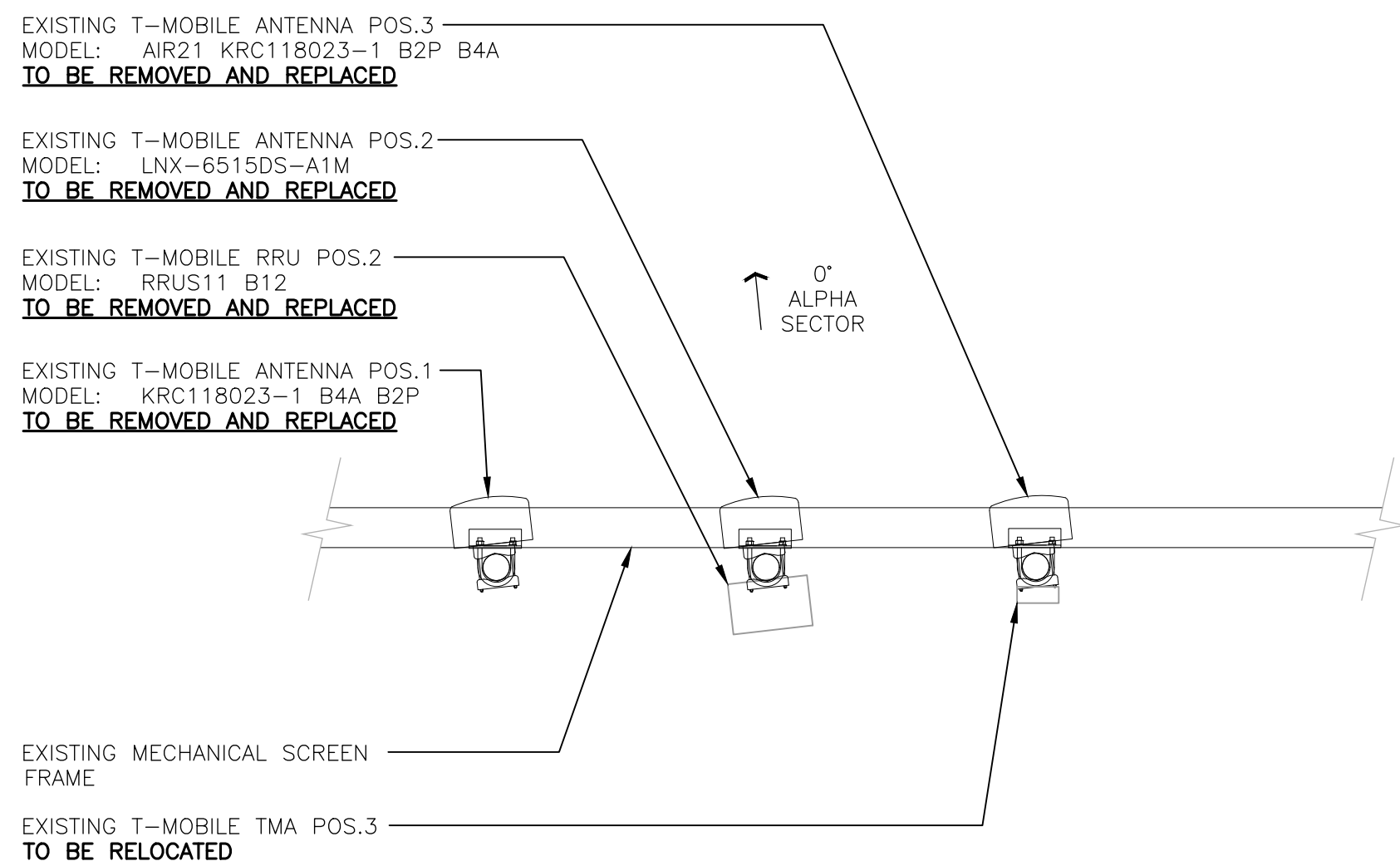

**1** EXISTING ANTENNA MOUNTING CONFIGURATION (ALPHA SECTOR) APPROXIMATE NORTH  
 C-3 SCALE: 1/2" = 1'

NOTE: ANTENNAS TO BE PAINTED BROWN TO MATCH EXISTING SCREENING.

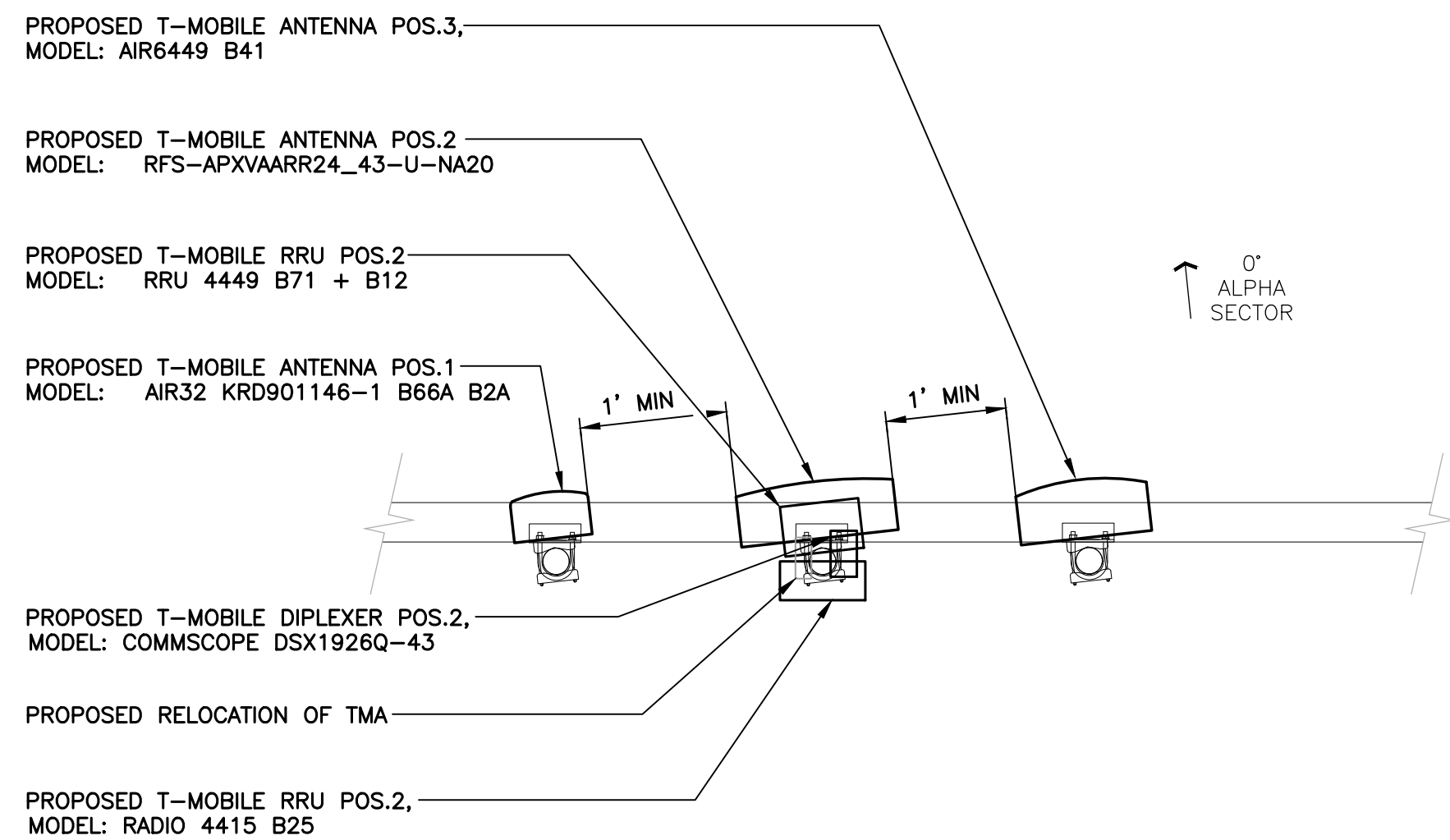

**1A** PROPOSED ANTENNA MOUNTING CONFIGURATION (ALPHA SECTOR) 43' ELEVATION APPROXIMATE NORTH  
 C-3 SCALE: 1/2" = 1'

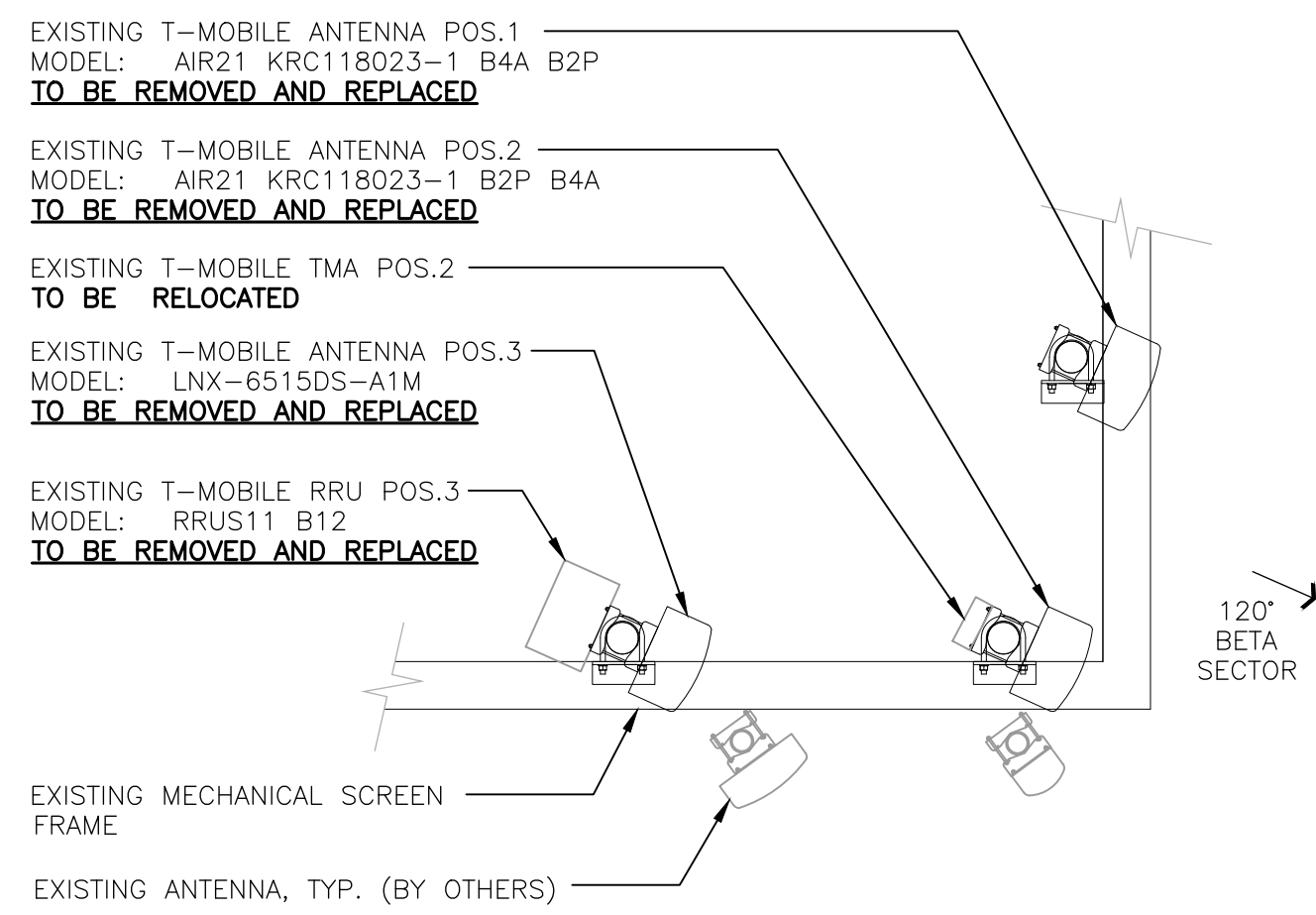

**2** EXISTING ANTENNA MOUNTING CONFIGURATION (BETA SECTOR) APPROXIMATE NORTH  
 C-3 SCALE: 1/2" = 1'

NOTE: ANTENNAS TO BE PAINTED BROWN TO MATCH EXISTING SCREENING.

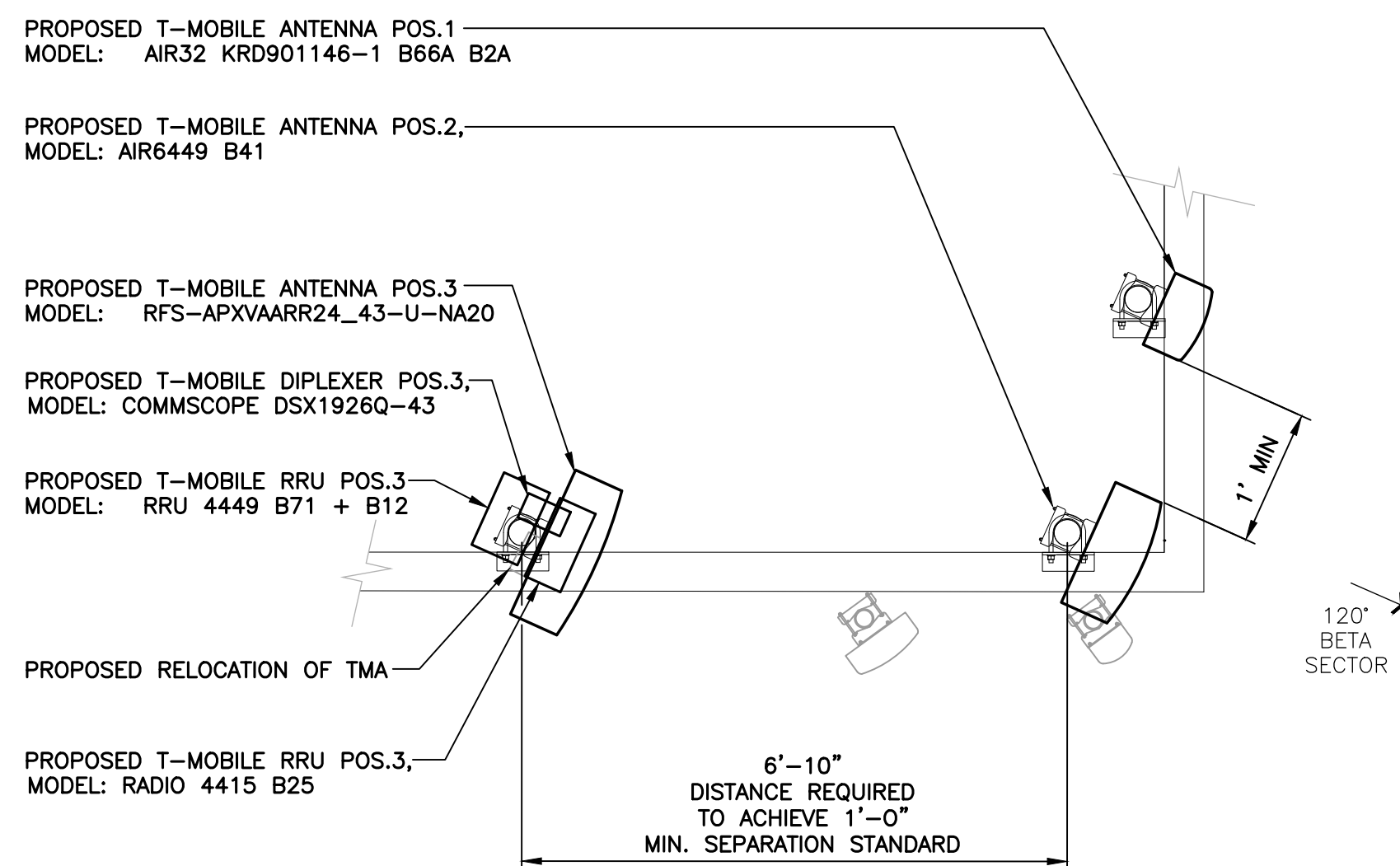

**2A** PROPOSED ANTENNA MOUNTING CONFIGURATION (BETA SECTOR) 43' ELEVATION APPROXIMATE NORTH  
 C-3 SCALE: 1/2" = 1'

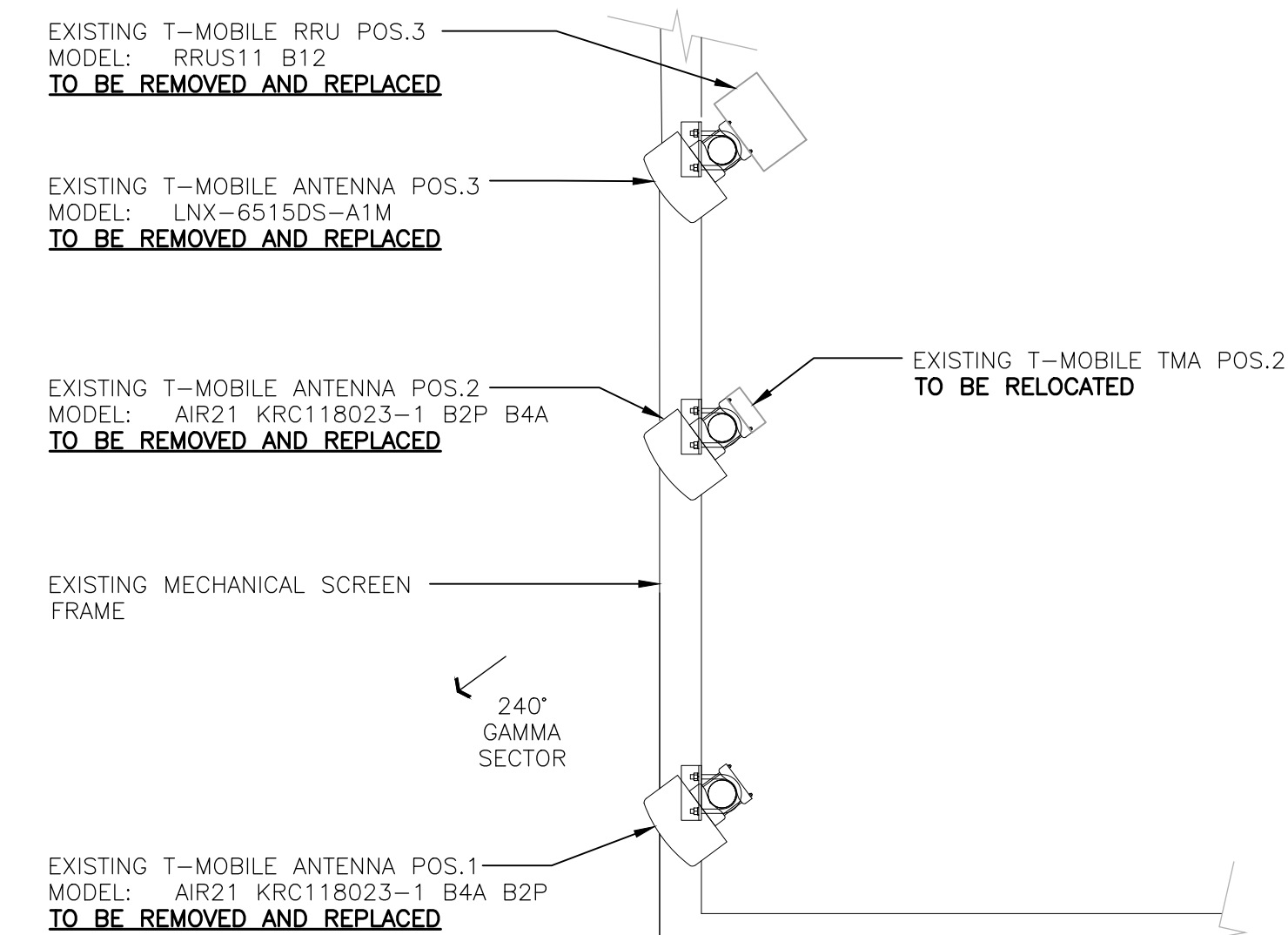

**3** EXISTING ANTENNA MOUNTING CONFIGURATION (GAMMA SECTOR) APPROXIMATE NORTH  
 C-3 SCALE: 1/2" = 1'

NOTE: ANTENNAS TO BE PAINTED BROWN TO MATCH EXISTING SCREENING.

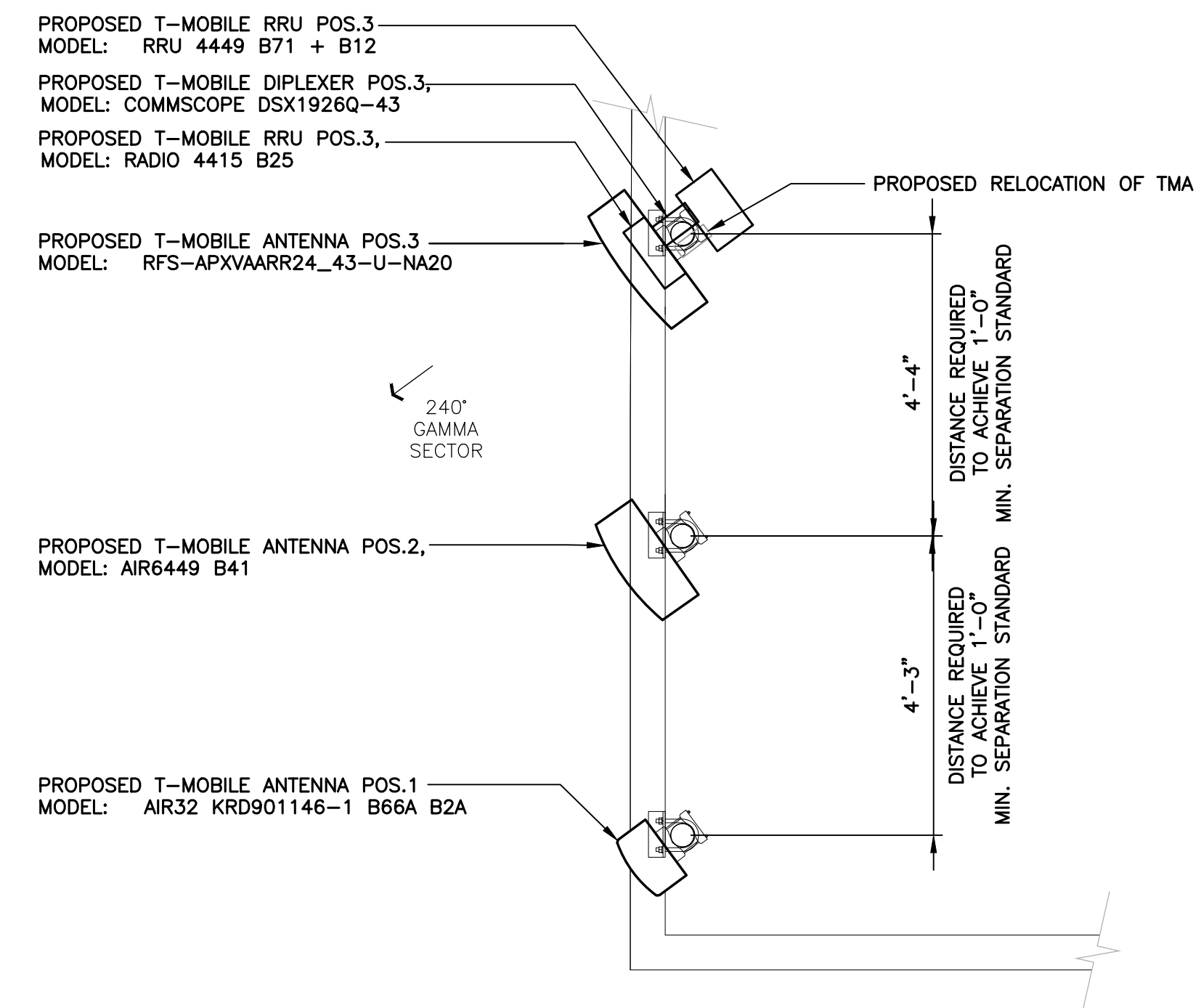

**3A** PROPOSED ANTENNA MOUNTING CONFIGURATION (GAMMA SECTOR) 43' ELEVATION APPROXIMATE NORTH  
 C-3 SCALE: 1/2" = 1'

REV.	DATE	BY	DESCRIPTION
0	11/16/20	JLW	CONSTRUCTION DRAWINGS - ISSUED FOR CONSTRUCTION
1	12/16/20	JLW	CONSTRUCTION DRAWINGS - ADDED ANTENNA PAINTING NOTE

PROFESSIONAL ENGINEER SEAL

**T-Mobile**

TRAFFIC ENGINEER 14123-0005

**CENTEX** engineering  
 Centered on Solutions

(203) 489-0380  
 (203) 488-8587 Fax  
 63-2 North Branford Road  
 Branford, CT 06405  
 www.CentexEng.com

**T-MOBILE NORTHEAST LLC**  
 WIRELESS COMMUNICATIONS FACILITY  
**GREENWICH/ROUTE 1**  
**SITE ID: CT1005D**  
 111 E. PUTNAM AVENUE  
 GREENWICH, CT 06878

DATE:	10/14/20
SCALE:	AS NOTED
JOB NO.:	20143.12

ANTENNA PLANS





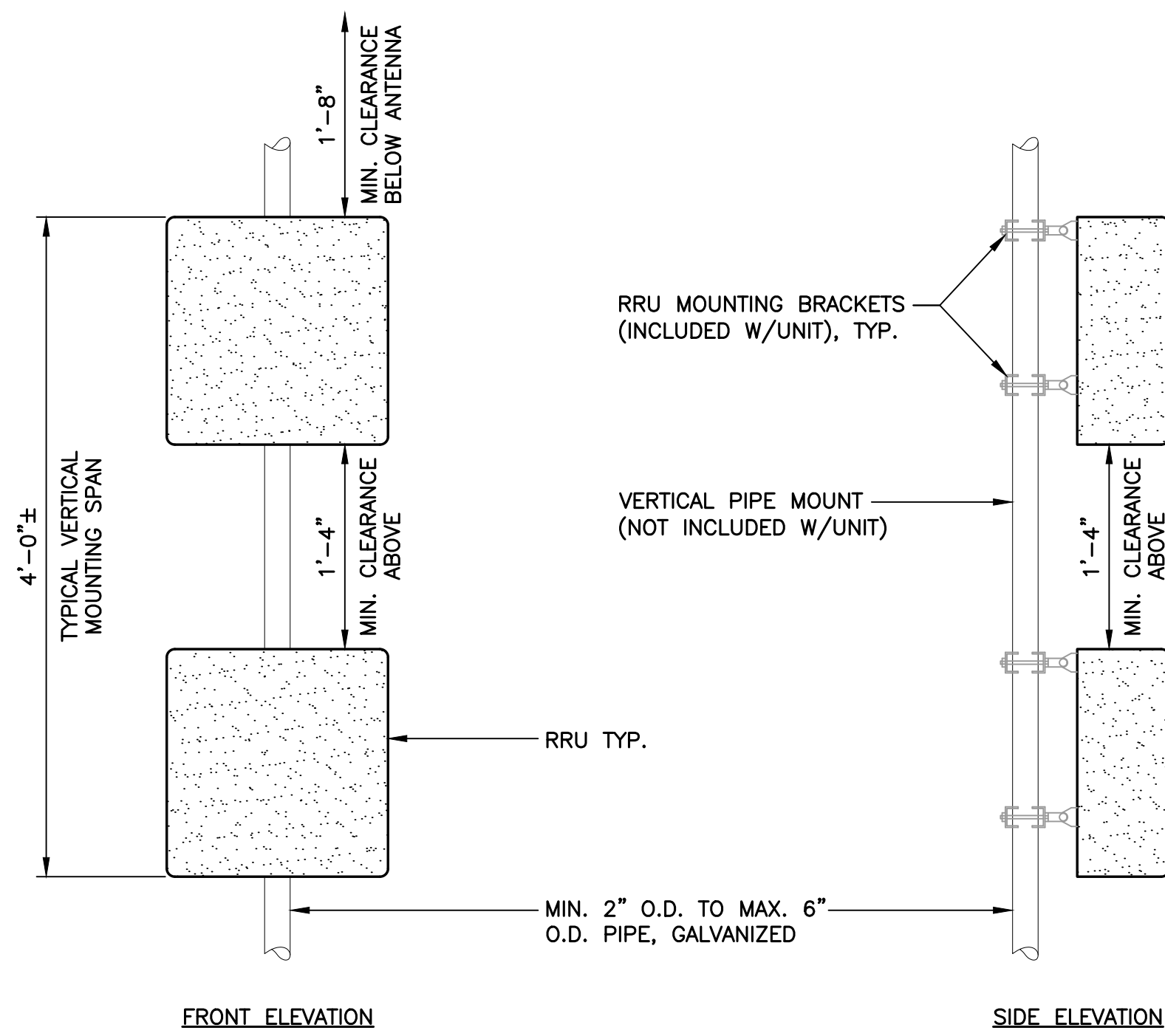

**NOTES:**

- T-MOBILE SHALL SUPPLY RRU, AND RRU POLE-MOUNTING BRACKET. CONTRACTOR SHALL SUPPLY POLE/PIPE AND INSTALL ALL MOUNTING HARDWARE INCLUDING ERICSSON RRU POLE-MOUNTING BRACKET. CONTRACTOR SHALL INSTALLS RRU AND MAKES CABLE TERMINATIONS.
- NO PAINTING OF THE RRU OR SOLAR SHIELD IS ALLOWED.

**1 TYPICAL RRU MOUNTING DETAIL**  
C-5 SCALE: NOT TO SCALE

NOTE:  
ANTENNAS TO BE PAINTED BROWN TO  
MATCH EXISTING SCREENING.



ALPHA/BETA/GAMMA ANTENNA		
EQUIPMENT	DIMENSIONS	WEIGHT
MAKE: ERICSSON MODEL: AIR6449 B41	33.1"L x 20.6"W x 8.6"D	±104 LBS.
MAKE: RFS MODEL: APXVAALL24_43-U-NA20	95.9"L x 24.0"W x 8.5"D	±150 LBS.
MAKE: ERICSSON MODEL: AIR32 KRD901146-1 B66A B2A	56.6"L x 12.9"W x 8.7"D	±132 LBS.

**NOTES:**  
1. CONTRACTOR TO COORDINATE FINAL EQUIPMENT MODEL SELECTION WITH T-MOBILE CONSTRUCTION MANAGER PRIOR TO ORDERING.

**2 PROPOSED ANTENNA DETAIL**  
C-5 SCALE: NOT TO SCALE



RRU (REMOTE RADIO UNIT)			
EQUIPMENT	DIMENSIONS	WEIGHT	CLEARANCES
MAKE: ERICSSON MODEL: RADIO 4415 B25	16.5"L x 13.4"W x 5.9"D	±46 LBS.	BEHIND ANT.: 8" MIN. BELOW ANT.: 20" MIN. BELOW RRU: 16" MIN.
MAKE: ERICSSON MODEL: RADIO 4449 B71+B85	14.9"L x 13.2"W x 5.4"D	±74 LBS.	BEHIND ANT.: 8" MIN. BELOW ANT.: 20" MIN. BELOW RRU: 16" MIN.

**NOTES:**  
1. CONTRACTOR TO COORDINATE FINAL EQUIPMENT MODEL SELECTION WITH T-MOBILE CONSTRUCTION MANAGER PRIOR TO ORDERING.

**3 PROPOSED RRU DETAIL**  
C-5 SCALE: NOT TO SCALE



EQUIPMENT CABINET		
EQUIPMENT	DIMENSIONS	WEIGHT
MAKE: ERICSSON MODEL: ENCLOSURE 6160 CABINET	62.0"H x 26.0"W x 26.0"D	±1200 LBS

**4 ENCLOSURE 6160 CABINET DETAIL**  
C-5 SCALE: NOT TO SCALE



EQUIPMENT CABINET		
EQUIPMENT	DIMENSIONS	WEIGHT
MAKE: ERICSSON MODEL: BATTERY B160 CABINET	62.0"H x 26.0"W x 26.0"D	±1883 LBS

**5 BATTERY B160 CABINET DETAIL**  
C-5 SCALE: NOT TO SCALE

Specifications	
Maximum Battery Size	190Ah
Maximum Number of Batteries	4
Internal Circuit Breaker Rating (Optional)	200 Amperes Max.
Input Circuit Breaker Rating	200 Amperes Max.
Input Connections	1/4" inch 2 hole 5/8 inch Spacing
Expansion	Modular / Stringable
Temp Control	Direct Contact Heater Mat Convection Cooled
Local Safety Ground Connection	1/4" inch 2 hole 5/8 inch Spacing
Enclosure Rating	Outdoor
Access Restriction	Front Hatch 5/32 Allen
Dimensions	Body
Height	32.240"
Width	14.040"
Depth	26.305"
Unit Weight / Shipping Weight	60 lbs / 65 lbs
Paint	Almond Powder Coat
Construction	Aluminum



**6 BATTERY CABINET DETAIL**  
C-5 SCALE: NOT TO SCALE

REV.	DATE	BY	CHK'D	DESCRIPTION
0	12/16/20	JLW	TJR	CONSTRUCTION DRAWINGS - ADDED ANTENNA PAINTING NOTE
1	11/16/20	JLW	TJR	CONSTRUCTION DRAWINGS - ISSUED FOR CONSTRUCTION

PROFESSIONAL ENGINEER SEAL

T-Mobile  
T-Mobile Solutions

**CENTEX** engineering  
Centered on Solutions

(203) 488-0380  
(203) 488-8587 Fax  
63-2 North Branford Road  
Branford, CT 06405  
www.CentexEng.com

**T-MOBILE NORTHEAST LLC**  
WIRELESS COMMUNICATIONS FACILITY  
**GREENWICH/ROUTE 1**  
**SITE ID: CT11005D**  
111 E. PUTNAM AVENUE  
GREENWICH, CT 06878

DATE:	10/14/20
SCALE:	AS NOTED
JOB NO.	20143.12

TYPICAL  
EQUIPMENT  
DETAILS

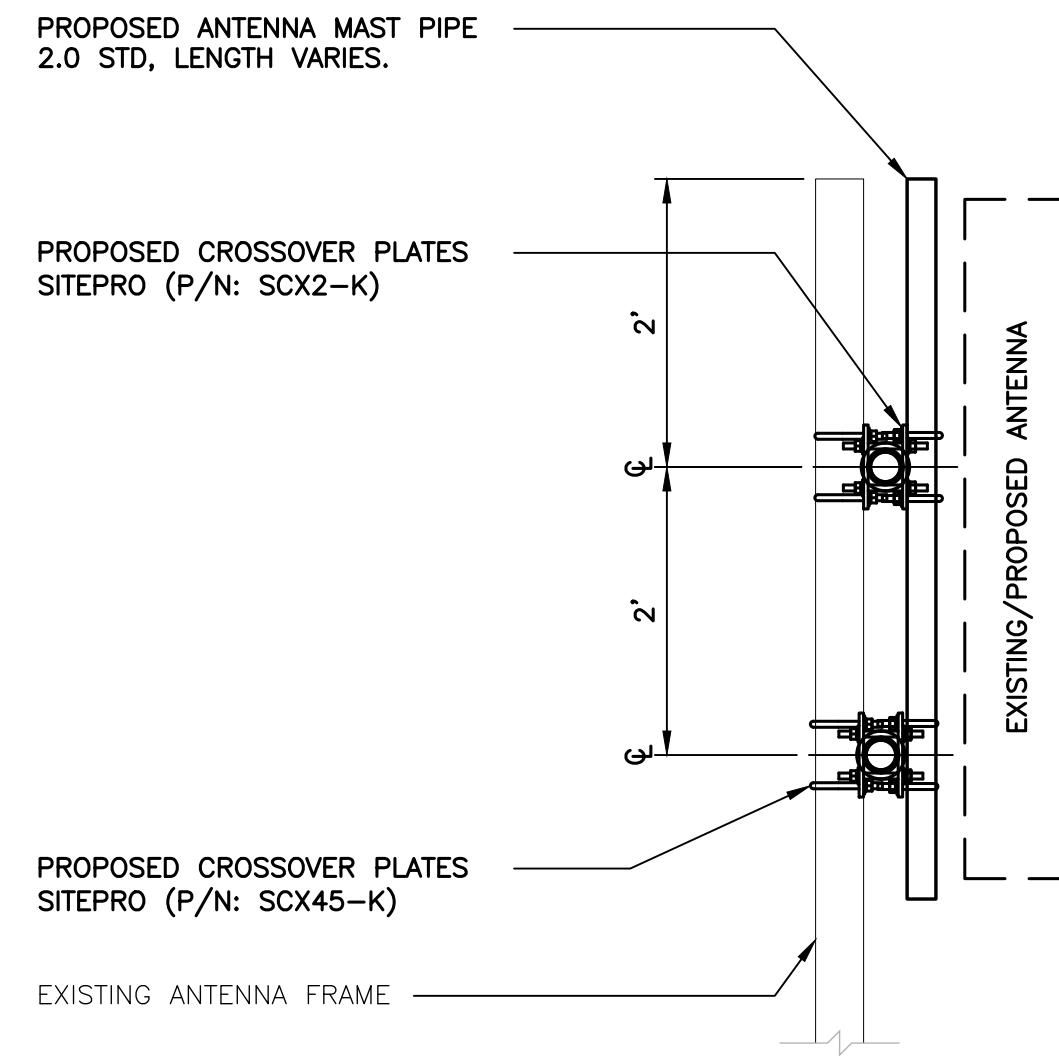

**1** TYPICAL ANTENNA MAST CONNECTION DETAIL  
C-6 SCALE: 3/4" = 1'-0"



DIPLEXER		
EQUIPMENT	DIMENSIONS	WEIGHT
MAKE: COMMSCOPE MODEL: SDX1926Q-43(E14F05P86)	4.2"L x 7.0"W x 3.0"D	-
NOTES: 1. CONTRACTOR TO COORDINATE FINAL EQUIPMENT MODEL SELECTION WITH T-MOBILE CONSTRUCTION MANAGER PRIOR TO ORDERING.		

**2** PROPOSED DIPLEXER DETAIL  
C-6 SCALE: NOT TO SCALE

REV.	DATE	BY	CHK'D	DESCRIPTION
0	11/16/20	JLW	TJR	CONSTRUCTION DRAWINGS - ISSUED FOR CONSTRUCTION
	12/16/20	JLW	TJR	CONSTRUCTION DRAWINGS - ADDED ANTENNA PAINTING NOTE

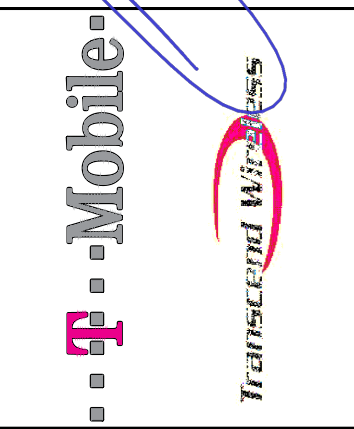
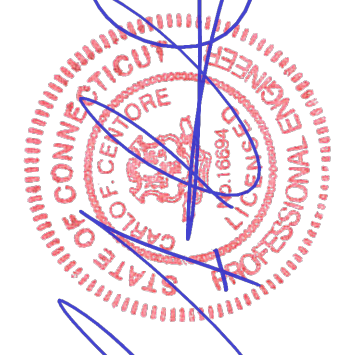

**CENTEK** engineering  
Centered on Solutions™  
(203) 488-0580  
(203) 488-8587 Fax  
63-2 North Branford Road  
Branford, CT 06405  
www.CentekEng.com

**T-MOBILE NORTHEAST LLC**  
WIRELESS COMMUNICATIONS FACILITY  
**GREENWICH/ROUTE 1**  
**SITE ID: CT11005D**  
1111 E. PUTNAM AVENUE  
GREENWICH, CT 06878

DATE: 10/14/20  
SCALE: AS NOTED  
JOB NO. 20143.12

TYPICAL  
EQUIPMENT  
DETAILS

**C-6**

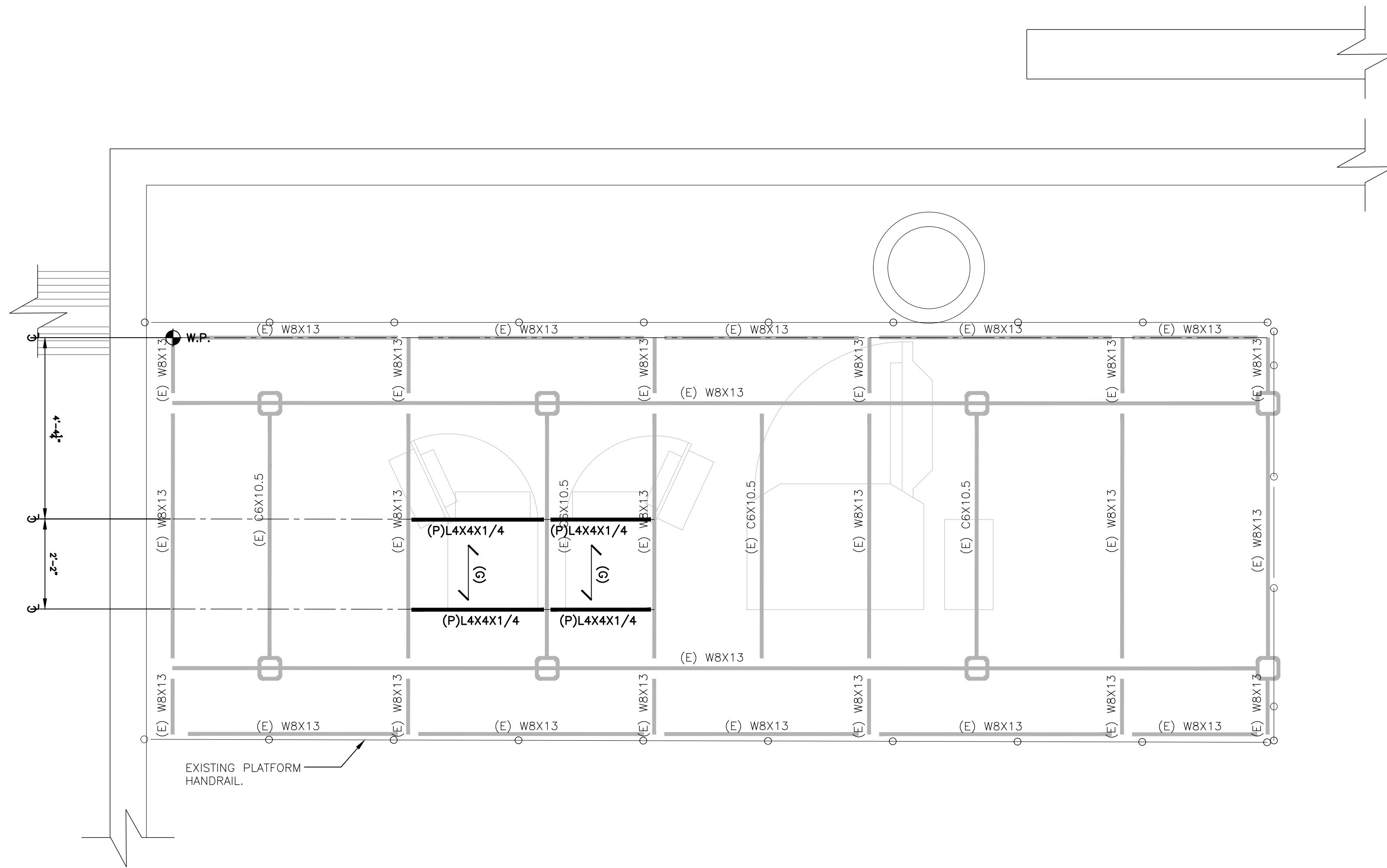

**1**  
S-1 **EQUIPMENT PLATFORM FRAMING PLAN**  
SCALE: 1/2" = 1'-0"

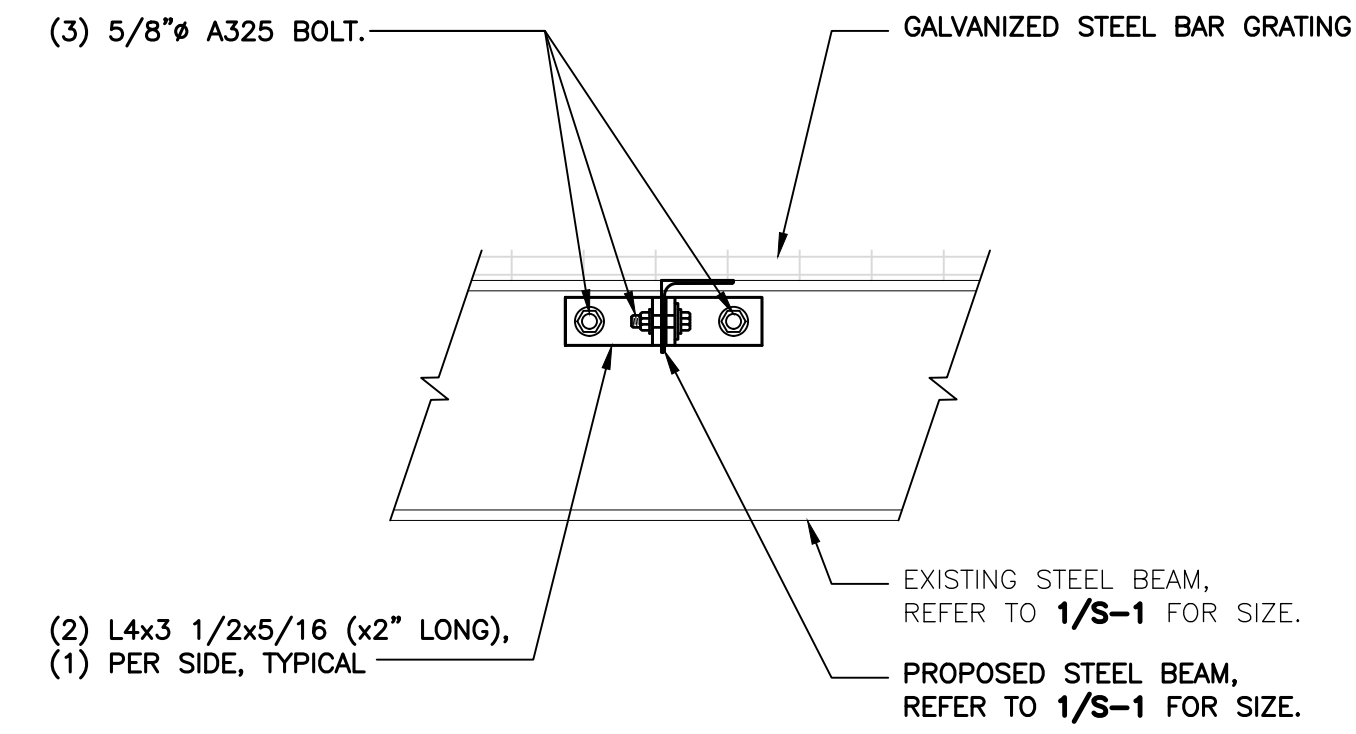

**2**  
S-1 **TYPICAL ANGLE CONNECTION DETAIL**  
SCALE: 1 1/2" = 1'-0"

**LEGEND**

INDICATES SPAN DIRECTION OF GALVANIZED BAR GRATING - Mc. NICHOLS GW-100A, 1 1/4" x 1/8" BAR GRATING WITH STANDARD SADDLE CLIP FASTENERS. REFER TO FRAMING PLAN FOR DECK SPAN DIRECTION.

W.P. DENOTES WORKING POINT.

**PLAN NOTES**

1. VERIFY ALL DIMENSIONS, ELEVATIONS, EXISTING FRAMING MEMBER SIZES AND GENERAL CONDITIONS PRIOR TO COMMENCEMENT OF WORK. NOTIFY ENGINEER OF RECORD OF ANY DISCREPANCIES BETWEEN THESE DRAWINGS AND EXISTING CONDITIONS.
2. DIMENSIONS APPLY TO THE CENTER OF MEMBERS UNLESS NOTED OTHERWISE.
3. REFER TO CIVIL DRAWINGS FOR EQUIPMENT LAYOUT AND CONFIGURATIONS.

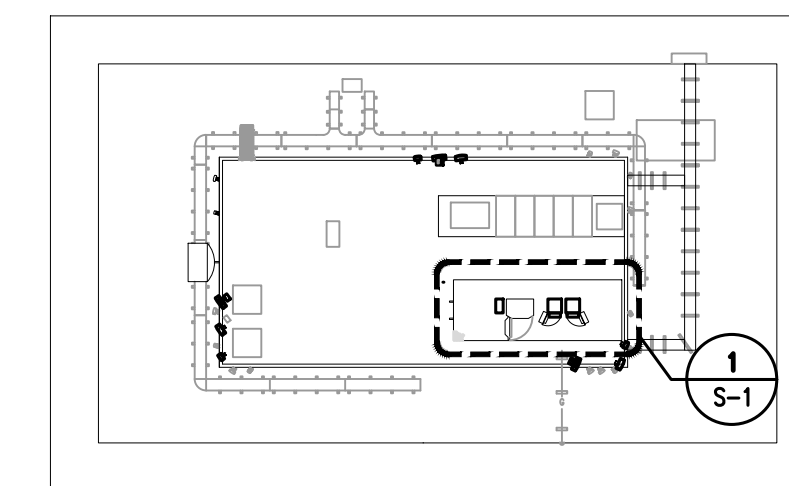

**SITE KEY PLAN**  
SCALE: 1" = 30'

<b>T-MOBILE NORTHEAST LLC</b> WIRELESS COMMUNICATIONS FACILITY <b>GREENWICH/ROUTE 1</b> <b>SITE ID: CT11005D</b> 1111 E. PUTNAM AVENUE GREENWICH, CT 06878	DATE: 10/14/20 SCALE: AS NOTED JOB NO. 20143.12
	EQUIPMENT PLATFORM PLAN AND DETAILS
<b>S-1</b> Sheet No. 9 of 10	PROFESSIONAL ENGINEER SEAL    (203) 488-0580 (203) 488-8587 Fax 65-2 North Branford Road Branford, CT 06405 www.CentekEng.com
CONSTRUCTION DRAWINGS - ADDED ANTENNA PAINTING NOTE CONSTRUCTION DRAWINGS - ISSUED FOR CONSTRUCTION	DATE 12/16/20 DRAWN BY TJR CHECKED BY TJR DESCRIPTION

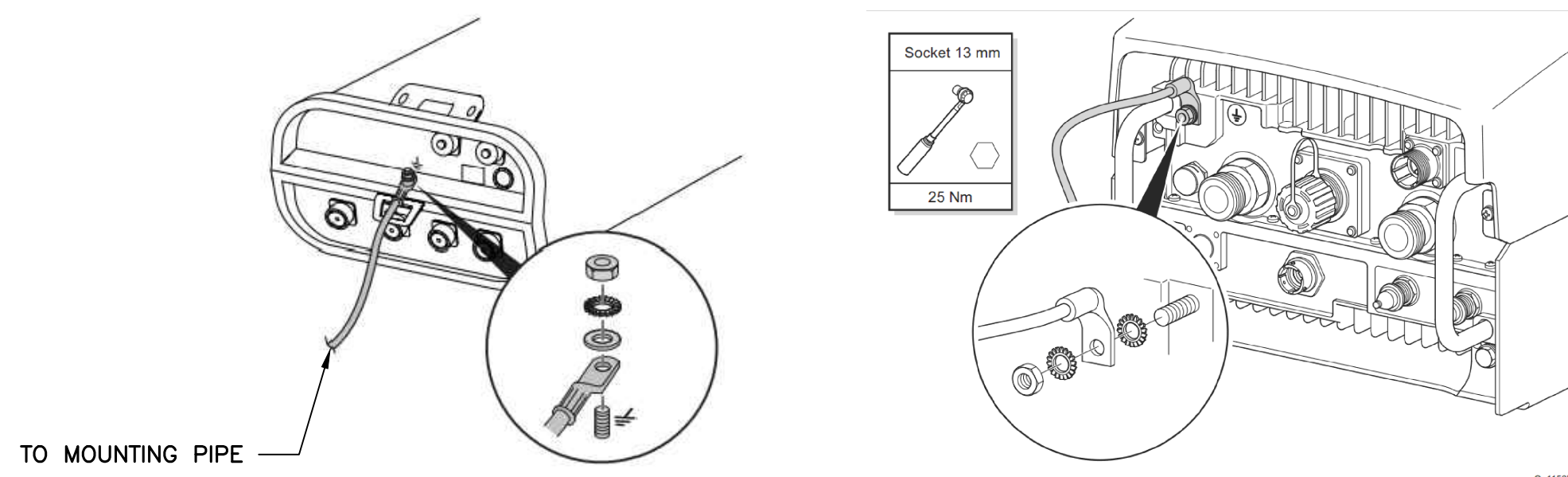

**1 TYPICAL ANTENNA/RRU GROUNDING DETAILS**  
E-1 SCALE: NOT TO SCALE

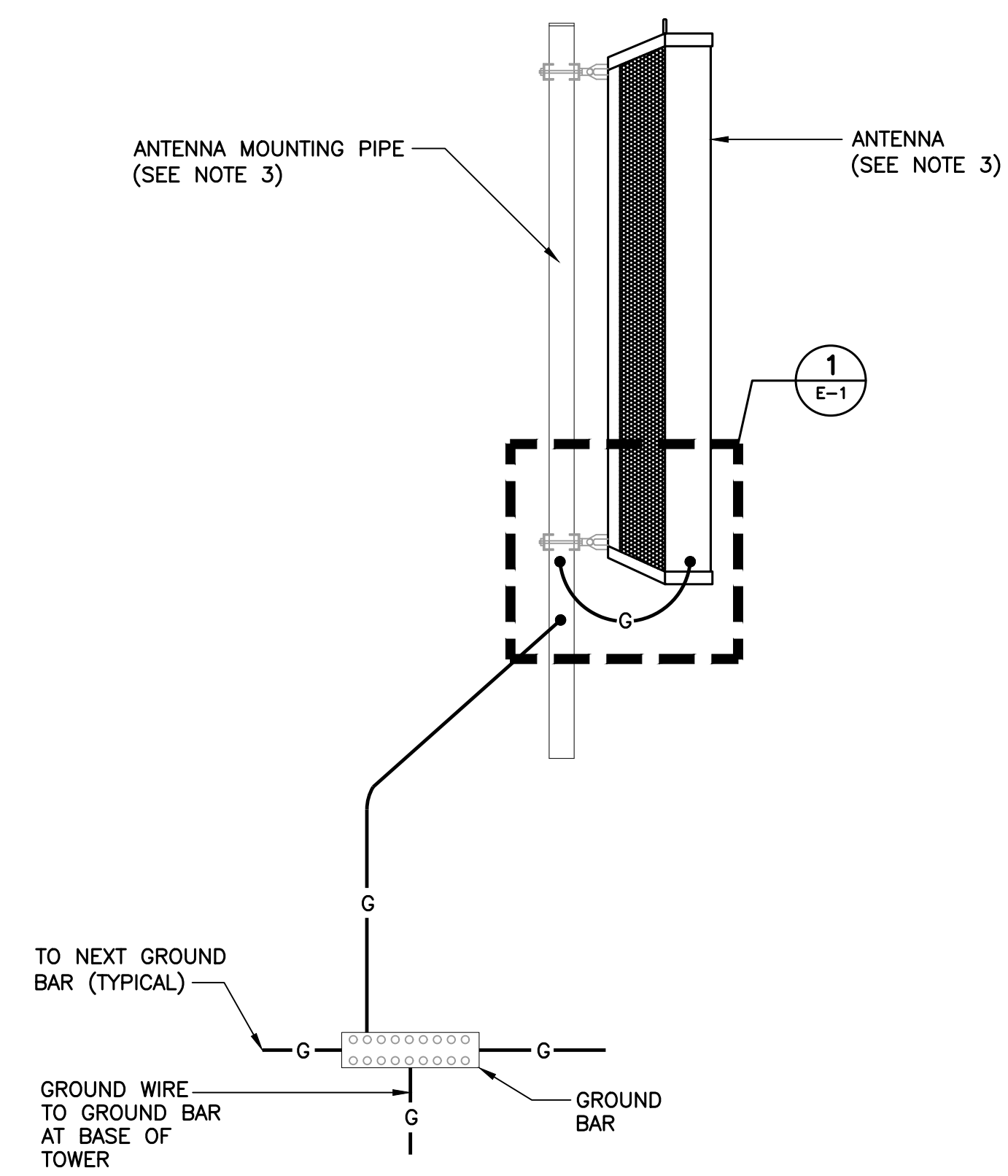

- NOTES:**
1. BOND COAXIAL CABLE GROUND KITS TO EACH OWNER'S GROUND BAR ALONG ENTIRE COAX RUN FROM ANTENNA TO SHELTER.
  2. BOND ALL EQUIPMENT TO GROUND PER NEC AND MANUFACTURERS SPECIFICATIONS.
  3. DETAIL IS TYPICAL FOR ALL ANTENNA SECTORS, INCLUDING GPS ANTENNA.

**2 TYPICAL ANTENNA GROUNDING DETAIL**  
E-1 SCALE: NOT TO SCALE

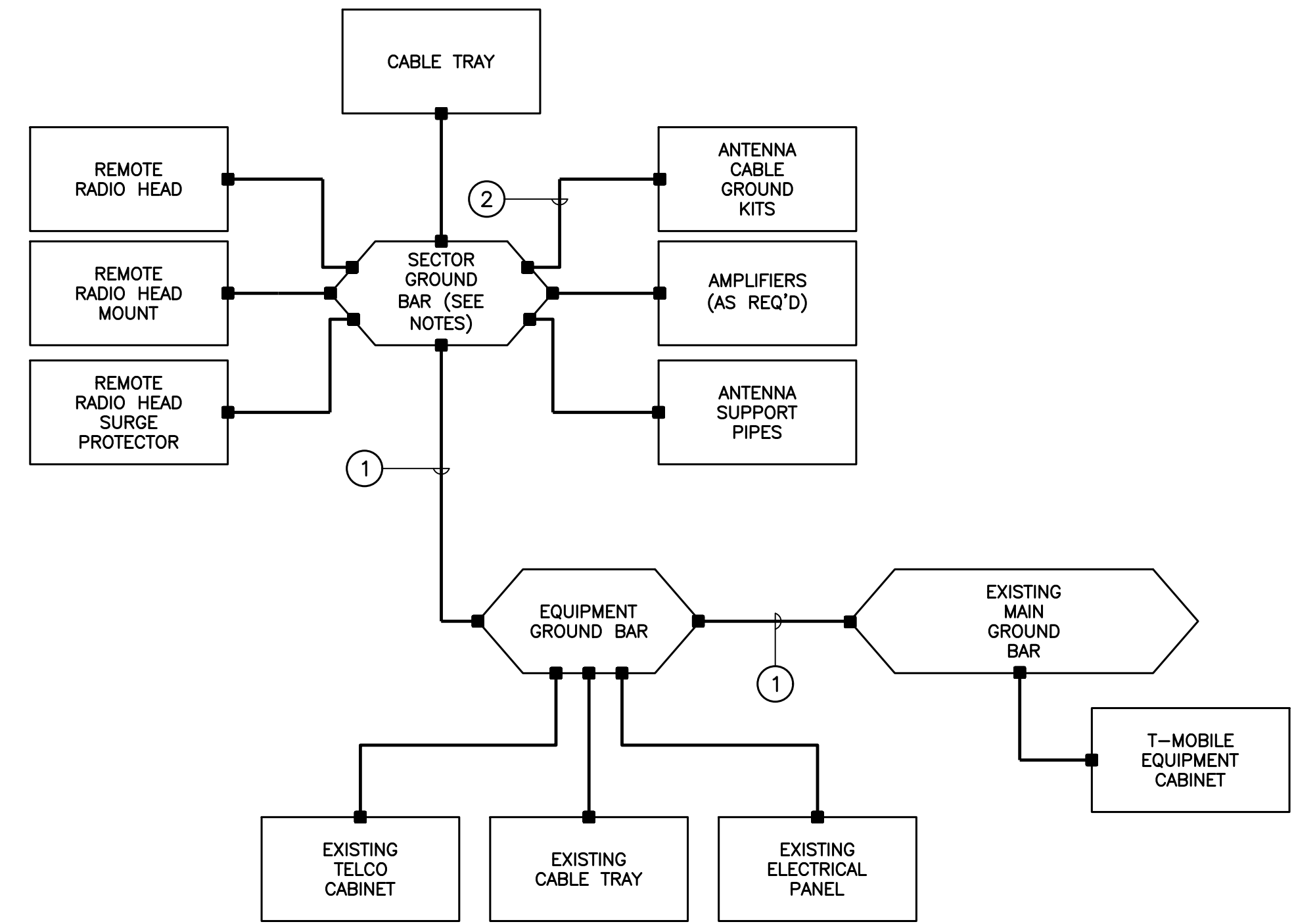

**GROUNDING SCHEMATIC NOTES**

- 1 #2 AWG
  - 2 #6 AWG
- GENERAL NOTES:**
1. ALL SURGE SUPPRESSION EQUIPMENT SHALL BE BONDED TO GROUND PER MANUFACTURER'S SPECIFICATIONS
  2. UNLESS OTHERWISE NOTED OR REQUIRED BY CODE, GROUND CONDUCTORS SHOWN SHALL BE #2 AWG (SOLID TINNED BCW - EXTERIOR; STRANDED GREEN INSULATED - INTERIOR).
  3. ALL SECTOR GROUND BARS SHALL BE BONDED TOGETHER WITH #2 AWG SOLID TINNED BCW.
  4. BOND ALL EQUIPMENT CABINETS AND BATTERY CABINETS TO GROUND PER MANUFACTURER'S SPECIFICATIONS.
  5. COORDINATE ALL ROOF MOUNTED EQUIPMENT WITH OWNER.
  6. ALL ROOF MOUNTED AMPLIFIERS AND ASSOCIATED EQUIPMENT SHALL BE BONDED TO THE SECTOR GROUND BAR PER MANUFACTURER'S SPECIFICATIONS.
  7. ALL GROUNDING SHALL BE IN ACCORDANCE WITH NEC AND OWNER'S REQUIREMENTS.

**4 TYPICAL GROUNDING SCHEMATIC DETAIL**  
E-1 SCALE: NOT TO SCALE

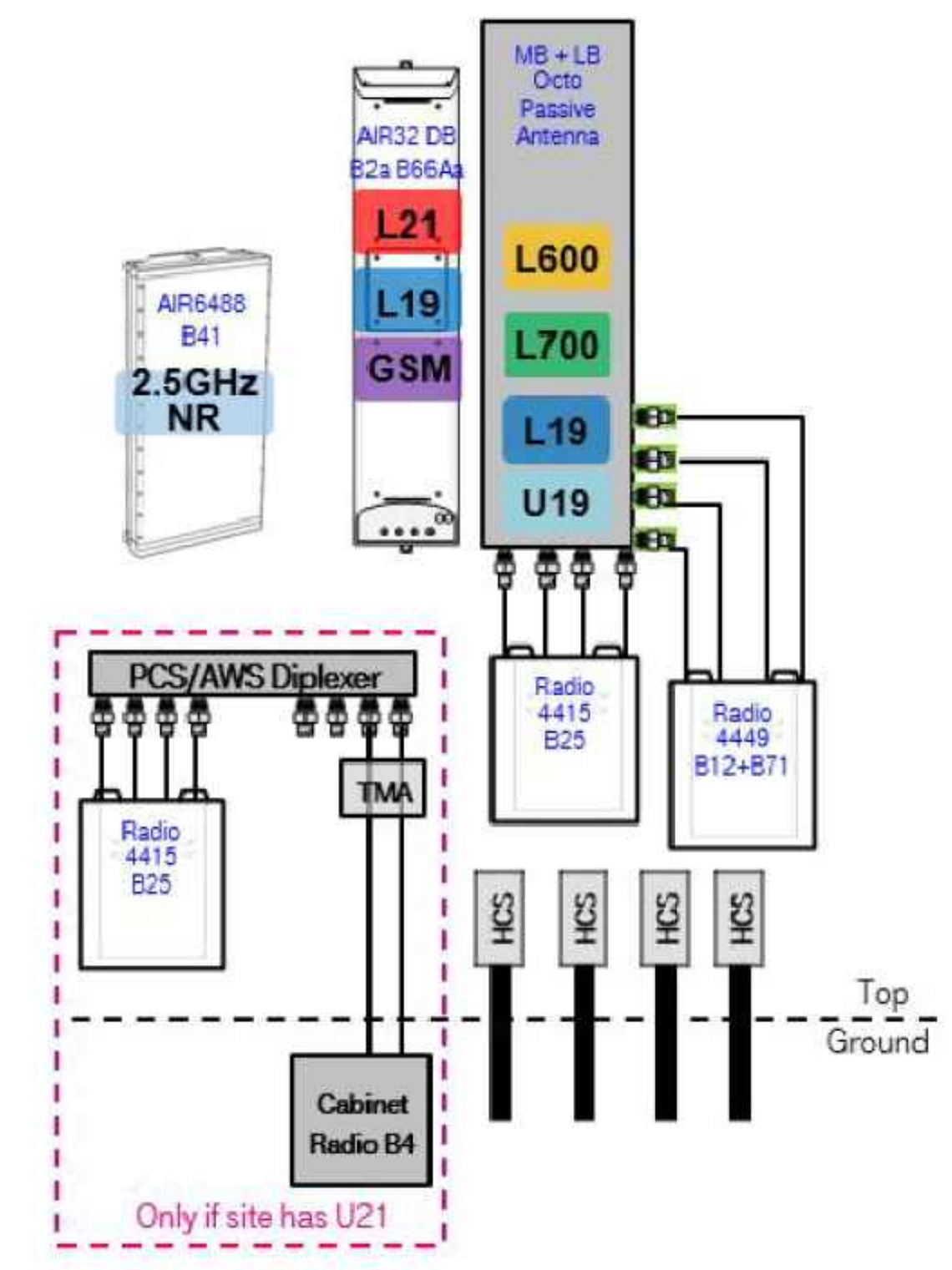

**3 PROPOSED PLUMBING DIAGRAM**  
E-1 SCALE: NOT TO SCALE

**RISER DIAGRAM NOTES**

- 1 EXISTING 200A, ELECTRICAL PANEL TO REMAIN.
- 2 NEW 100A/2P CIRCUIT BREAKER TO SERVE NEW EQUIPMENT CABINET.
- 3 EXISTING CABINETS AND ASSOCIATED CONDUITS AND CONDUCTORS TO BE REMOVED.
- 4 (3) #1 AWG, (1) #8 AWG GROUND, 1-1/2" CONDUIT.
- 5 EXISTING CONDUITS AND CONDUCTORS TO REMAIN.
- 6 NEW T-MOBILE EQUIPMENT CABINET
- 7 NEW T-MOBILE BATTERY CABINET
- 8 DC CONDUIT AND CONDUCTORS FOR BATTERY CABINET CONNECTION PER MANUFACTURERS SPECIFICATIONS.
- 9 EXISTING CABINET TO REMAIN.
- 10 NEW BBU CABINET

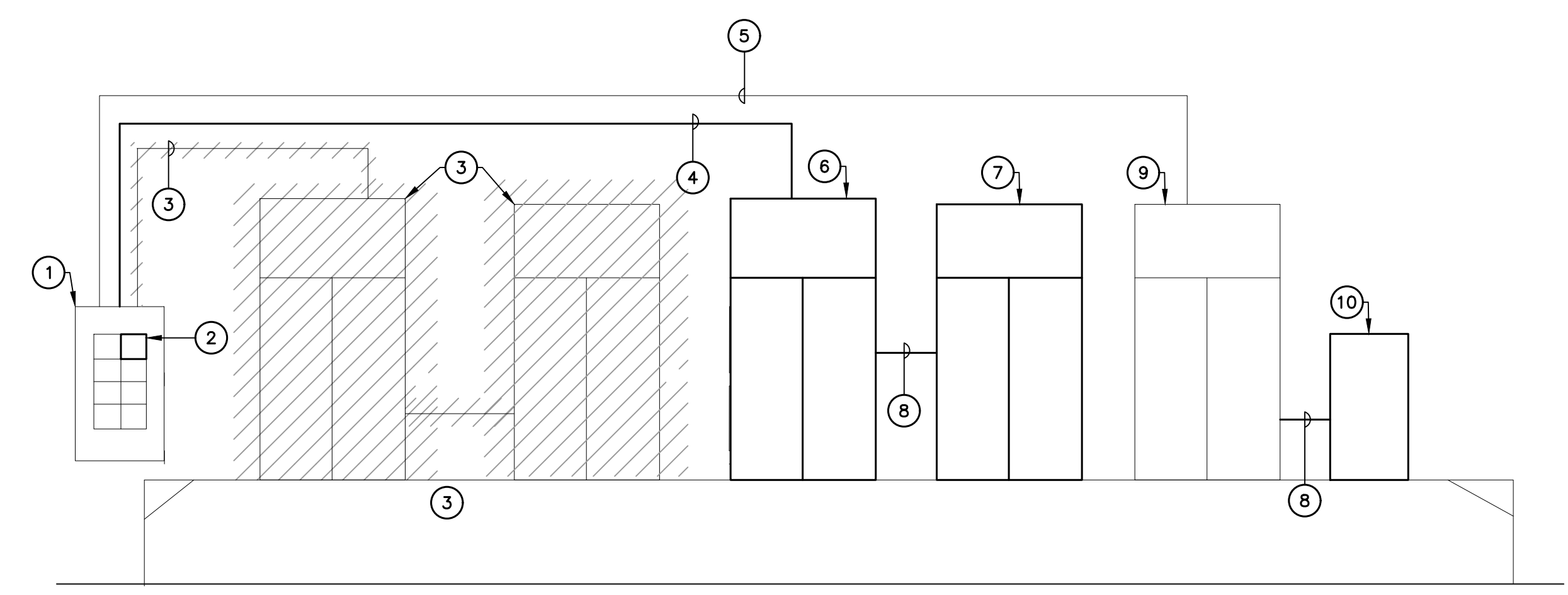

**5 ELECTRICAL POWER RISER DIAGRAM**  
E-1 SCALE: NOT TO SCALE

PROFESSIONAL ENGINEER SEAL	CONSTRUCTION DRAWINGS - ADDED ANTENNA PAINTING NOTE
	CONSTRUCTION DRAWINGS - ISSUED FOR CONSTRUCTION
T. J. R.	T. J. R.
12/16/20	JLW
0	11/16/20
REV.	DATE
	DRAWN BY/CHECK'D BY
	DESCRIPTION
 T-Mobile T-Mobile Solutions (203) 488-0380 (203) 488-8587 Fax 63-2 North Branford Road Branford, CT 06405 www.CenterEng.com	
<b>T-MOBILE NORTHEAST LLC</b> WIRELESS COMMUNICATIONS FACILITY <b>GREENWICH/ROUTE 1</b> <b>SITE ID: CT1005D</b> 1111 E. PUTNAM AVENUE GREENWICH, CT 06878	
DATE:	10/14/20
SCALE:	AS NOTED
JOB NO.	20143.12
TYPICAL ELECTRICAL DETAILS	
<b>E-1</b>	
Sheet No. 10	of 10

# *Structural Analysis Report*

*Antenna Frames & Equipment Platform*

*Proposed T-Mobile  
Equipment Upgrade-Anchor*

*Site Ref: CT11005D*

*1111 East Putnam Avenue  
Greenwich, CT*

*CEN TEK Project No. 20143.12*

~~*Date: October 26, 2020*~~  
*Rev. 1: October 29, 2020*

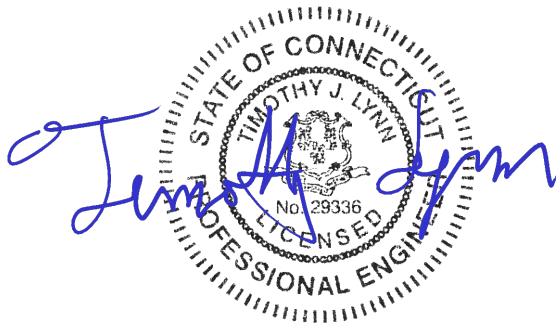

**Prepared for:**  
T-Mobile USA  
35 Griffin Road  
Bloomfield, CT 06002

# **Table of Contents**

## **SECTION 1 - REPORT**

- INTRODUCTION
- PRIMARY ASSUMPTIONS USED IN THE ANALYSIS
- ANTENNA AND EQUIPMENT INSTALLATION SUMMARY
- ANALYSIS
- DESIGN LOADING
- RESULTS
- CONCLUSION

## **SECTION 2 – CONDITIONS & SOFTWARE**

- STANDARD ENGINEERING CONDITIONS
- GENERAL DESCRIPTION OF STRUCTURAL ANALYSIS PROGRAM

## **SECTION 3 – CALCULATIONS**

- WIND LOAD CALCULATION
- RISA3D OUTPUT REPORT-ANTENNA MOUNT
- RISA3D OUTPUT REPORT- EQUIPMENT PLATFORM

## **SECTION 4 – REFERENCE MATERIAL**

- RF DATA SHEET

## *Introduction*

The purpose of this structural analysis report (SAR) is to summarize the results, of the impacted structural components, by the modified equipment upgrade proposed by T-Mobile on the existing host rooftop located in Greenwich, CT.

The T-Mobile antennas are mounted on antenna masts attached to existing screen wall. The T-Mobile equipment cabinets are mounted on a steel dunnage platform on the roof of the building.

The antenna mounts structure geometry and member size information were obtained from previous CDs/structural report and a site visit performed by Centek personnel on October 2, 2020.

The existing roof framing consists of steel beams and bearing walls. The existing equipment platform bears directly over the host building bearing walls at (4) locations and steel beams at (4) locations.

## *Primary Assumptions Used in the Analysis*

- The host structure's theoretical capacity not including any assessment of the condition of the host structure.
- The existing elevated steel platform carries the horizontal and vertical loads due to the weight of equipment, and wind and transfers into host structure.
- Proposed reinforcement and support steel will be properly installed and maintained.
- Structure is in plumb condition.
- Loading for equipment and enclosure as listed in this report.
- All bolts are appropriately tightened providing the necessary connection continuity.
- All welds are fabricated with ER-70S-6 electrodes.
- All members are assumed to be as observed during roof framing mapping.
- All members are "hot dipped" galvanized in accordance with ASTM A123 and ASTM A153 Standards.
- All member protective coatings are in good condition.



## Antenna and Equipment Summary

Location	Appurtenance / Equipment		Elevation (AGL)	Mount Type
Alpha Sector	<del>(1) Andrew-LNX-6515DS Antenna</del> <del>(2) Ericsson AIR21 Antenna</del> <b>(1) Ericsson AIR32 Antenna</b> <b>(1) RFS-APXVAARR24_43 Antenna</b> <b>(1) Ericsson AIR6449 Antenna</b> <del>(1) Ericsson RRUS14</del> <b>(1) Ericsson 4449 RRU</b> <b>(1) Ericsson 4415 RRU</b> (1) TMA <b>(1) Commscope SDX1926Q-43 Diplexer</b>		43-ft	Antenna Masts Attached to Screen Wall
Beta Sector	<del>(1) Andrew-LNX-6515DS Antenna</del> <del>(2) Ericsson AIR21 Antenna</del> <b>(1) Ericsson AIR32 Antenna</b> <b>(1) RFS-APXVAARR24_43 Antenna</b> <b>(1) Ericsson AIR6449 Antenna</b> <del>(1) Ericsson RRUS14</del> <b>(1) Ericsson 4449 RRU</b> <b>(1) Ericsson 4415 RRU</b> (1) TMA <b>(1) Commscope SDX1926Q-43 Diplexer</b>		43-ft	Antenna Masts Attached to Screen Wall
Gamma Sector	<del>(1) Andrew-LNX-6515DS Antenna</del> <del>(2) Ericsson AIR21 Antenna</del> <b>(1) Ericsson AIR32 Antenna</b> <b>(1) RFS-APXVAARR24_43 Antenna</b> <b>(1) Ericsson AIR6449 Antenna</b> <del>(1) Ericsson RRUS14</del> <b>(1) Ericsson 4449 RRU</b> <b>(1) Ericsson 4415 RRU</b> (1) TMA <b>(1) Commscope SDX1926Q-43 Diplexer</b>		43-ft	Antenna Masts Attached to Screen Wall
Equipment Platform	(1) Ericsson 3106	2600 lbs.	-	Steel dunnage platform on building roof
	<b>(1) BBU</b>	589 lbs.	-	
	<b>(1) Ericsson B160</b>	1883 lbs.	-	
	<b>(1) Ericsson 6160</b>	1200 lbs.	-	

**Equipment** – Indicates equipment to be installed.

~~Equipment~~ – Indicates equipment to be removed.

## Analysis

The antenna frames and equipment platform were analyzed using a comprehensive computer program titled Risa3D. The program analyzes the equipment platform and antenna mounts considering the worst case code prescribed loading condition. The structures were considered to be loaded by concentric forces, and the model assumes that the members are subjected to bending, axial, and shear forces.

## Design Loading

Loading was determined per the requirements of the 2015 International Building Code amended by the 2018 CSBC and ASCE 7-10 “Minimum Design Loads for Buildings and Other Structures”.

Wind Speed:	$V_{ult} = 120$ mph	Appendix N of the 2018 CT State Building Code
Risk Category:	II	2015 IBC; Table 1604.05
Exposure Category:	Surface Roughness B	ASCE 7-10; Section 26.7.2
Ground Snow Load	30 psf	Appendix N of the 2018 CT State Building Code
Dead Load	Equipment and framing self-weight	Identified within SAR design calculations
Live Load	20 psf	ASCE 7-10; Table 4-1 “Roofs – All Other Construction”

## Reference Standards

### 2015 International Building Code:

1. ACI 318-14, *Building Code Requirements for Structural Concrete*.
2. ACI 530-13, *Building Code Requirements for Masonry Structures*.
3. AISC 360-10, *Specification for Structural Steel Buildings*
4. AWS D1.1 – 00, *Structural Welding Code – Steel*.
5. AF&PA-12, *Span Tables for Joists and Rafters*.
6. ANSI/AWC NDS-2015, *National Design Specifications (NDS) for Wood Construction – with 2012 Supplement*.

## Results

Member stresses and design reactions were calculated utilizing the structural analysis software RISA 3D.

The following table provides a summary of structural components impacted by the proposed upgrade along with associated member percent capacity and PASS/FAIL result:

Location	Component	Capacity (%)	Result
Antenna Mounts	Pipe 3.0 STD. Antenna Mast	56%	<b>PASS</b>
Equipment Platform	W8X13 Platform Member	45.6%	<b>PASS</b>
	C6X10.5 Platform Member	14.6%	<b>PASS</b>
	L4X4X1/4 Platform Member	19.2%	<b>PASS</b>
	HSS4X4X1/4 Platform Post	18.5%	<b>PASS</b>

## Conclusion

This analysis shows that the subject antenna mounts **have sufficient capacity** to support the proposed modified antenna configuration.

The analysis is based, in part, on the information provided to this office by T-Mobile. If the existing conditions are different than the information in this report, Centek Engineering, Inc. must be contacted for resolution of any potential issues.

Please feel free to call with any questions or comments.

Respectfully Submitted by:

Prepared by:

  
Timothy J. Lynn, PE  
Structural Engineer

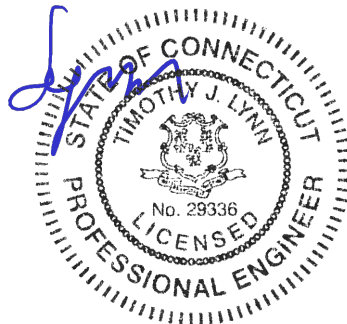

  
Fernando J. Palacios  
Engineer

*Standard Conditions for Furnishing of  
Professional Engineering Services on  
Existing Structures*

All engineering services are performed on the basis that the information used is current and correct. This information may consist of, but is not necessarily limited to:

- Information supplied by the client regarding the structure itself, its foundations, the soil conditions, the antenna and feed line loading on the structure and its components, or other relevant information.
- Information from the field and/or drawings in the possession of Centek Engineering, Inc. or generated by field inspections or measurements of the structure.
- It is the responsibility of the client to ensure that the information provided to Centek Engineering, Inc. and used in the performance of our engineering services is correct and complete. In the absence of information to the contrary, we assume that all structures were constructed in accordance with the drawings and specifications and are in an un-corroded condition and have not deteriorated. It is therefore assumed that its capacity has not significantly changed from the “as new” condition.
- All services will be performed to the codes specified by the client, and we do not imply to meet any other codes or requirements unless explicitly agreed in writing. If wind and ice loads or other relevant parameters are to be different from the minimum values recommended by the codes, the client shall specify the exact requirement. In the absence of information to the contrary, all work will be performed in accordance with the latest revision of ANSI/ASCE10 & ANSI/EIA-222
- All services performed, results obtained, and recommendations made are in accordance with generally accepted engineering principles and practices. Centek Engineering, Inc. is not responsible for the conclusions, opinions and recommendations made by others based on the information we supply.

**CEN TEK** Engineering, Inc.  
Structural Analysis – Antenna Frames & Equipment Platform  
T-Mobile Equipment Upgrade – CT11005D-Anchor  
Greenwich, CT  
Rev.1 ~ October 29, 2020

## Antenna Sectors



**Design Wind Load on Other Structures:**

(Based on IBC 2015, CSBC 2018 and ASCE 7-10)

Wind Speed =	V := 120	mph	(User Input)	(CSBC Appendix-N)
Risk Category =	BC := II		(User Input)	(IBC Table 1604.5)
Exposure Category =	Exp := C		(User Input)	
Height Above Grade =	Z := 43	ft	(User Input)	
Structure Type =	Structuretype := Square_Chimney			
Structure Height =	Height := 8	ft	(User Input)	
Horizontal Dimension of Structure =	Width := 2	ft	(User Input)	

Terrain Exposure Constants:

Nominal Height of the Atmospheric Boundary Layer =  $z_g := \begin{cases} \text{if Exp} = B & 900 \\ \text{if Exp} = C & 1200 \\ \text{if Exp} = D & 900 \\ & 700 \end{cases}$  (Table 26.9-1)

3-Sec Gust Speed Power Law Exponent =  $\alpha := \begin{cases} \text{if Exp} = B & 7 \\ \text{if Exp} = C & 9.5 \\ \text{if Exp} = D & 11.5 \end{cases}$  (Table 26.9-1)

Integral Length Scale Factor =  $l := \begin{cases} \text{if Exp} = B & 320 \\ \text{if Exp} = C & 500 \\ \text{if Exp} = D & 650 \end{cases}$  (Table 26.9-1)

Integral Length Scale Power Law Exponent =  $E := \begin{cases} \text{if Exp} = B & \frac{1}{3} \\ \text{if Exp} = C & \frac{1}{5} \\ \text{if Exp} = D & \frac{1}{8} \end{cases}$  (Table 26.9-1)

Turbulence Intensity Factor =  $c := \begin{cases} \text{if Exp} = B & 0.3 \\ \text{if Exp} = C & 0.2 \\ \text{if Exp} = D & 0.15 \end{cases}$  (Table 26.9-1)

Exposure Constant =	$Z_{min} := \begin{cases} \text{if Exp} = B \\ 30 \\ \text{if Exp} = C \\ 15 \\ \text{if Exp} = D \\ 7 \end{cases} = 15$	(Table 26.9-1)
Exposure Coefficient =	$K_z := \begin{cases} \text{if } 15 \leq Z \leq z_g \\ 2.01 \cdot \left(\frac{Z}{z_g}\right)^{\left(\frac{2}{\alpha}\right)} \\ \text{if } Z < 15 \\ 2.01 \cdot \left(\frac{15}{z_g}\right)^{\left(\frac{2}{\alpha}\right)} \end{cases} = 1.06$	(Table 29.3-1)
Topographic Factor =	$K_{zt} := 1$	(Eq. 26.8-2)
Wind Directionality Factor =	$K_d = 0.9$	(Table 26.6-1)
Velocity Pressure =	$q_z := 0.00256 \cdot K_z \cdot K_{zt} \cdot K_d \cdot V^2 = 35.15$	(Eq. 29.3-1)
Peak Factor for Background Response =	$g_O = 3.4$	(Sec 26.9.4)
Peak Factor for Wind Response =	$g_v = 3.4$	(Sec 26.9.4)
Equivalent Height of Structure =	$z := \begin{cases} \text{if } Z_{min} > 0.6 \cdot \text{Height} \\ Z_{min} \\ \text{else} \\ 0.6 \cdot \text{Height} \end{cases} = 15$	(Sec 26.9.4)
Intensity of Turbulence =	$I_z := c \cdot \left(\frac{33}{Z}\right)^{\left(\frac{1}{6}\right)} = 0.228$	(Eq. 26.9-7)
Integral Length Scale of Turbulence =	$L_z := 1 \cdot \left(\frac{Z}{33}\right)^E = 427.057$	(Eq. 26.9-9)
Background Response Factor =	$Q := \sqrt{\frac{1}{1 + 0.63 \cdot \left(\frac{\text{Width} + \text{Height}}{L_z}\right)^{0.63}}} = 0.972$	(Eq. 26.9-8)
Gust Response Factor =	$G := 0.925 \cdot \left(\frac{(1 + 1.7 \cdot g_O \cdot I_z \cdot Q)}{1 + 1.7 \cdot g_v \cdot I_z}\right) = 0.91$	(Eq. 26.9-6)
Force Coefficient =	$GC_f := 1.9$	(Section 29.5-1)
<b>Wind Force =</b>	<b><math>F := q_z \cdot G \cdot C_f = 43</math></b>	<b>psf</b>

**Development of Wind on Antennas**

**Antenna Data:**

Antenna Model =	Ericsson AIR6449 B41	
Antenna Shape =	Flat	(User Input)
Antenna Height =	$L_{ant} := 33.1$	in (User Input)
Antenna Width =	$W_{ant} := 20.6$	in (User Input)
Antenna Thickness =	$T_{ant} := 8.6$	in (User Input)
Antenna Weight =	$WT_{ant} := 104$	lbs (User Input)
Number of Antennas =	$N_{ant} := 1$	(User Input)

**Wind Load (Front)**

Surface Area for One Antenna =	$SA_{ant} := \frac{L_{ant} \cdot W_{ant}}{144} = 4.7$	sf
Antenna Projected Surface Area =	$A_{ant} := SA_{ant} \cdot N_{ant} = 4.7$	sf
<b>Total Antenna Wind Force =</b>	<b><math>F_{ant} := F \cdot A_{ant} = 205</math></b>	<b>lbs</b>

**Wind Load (Side)**

Surface Area for One Antenna =	$SA_{ant} := \frac{L_{ant} \cdot T_{ant}}{144} = 2$	sf
Antenna Projected Surface Area =	$A_{ant} := SA_{ant} \cdot N_{ant} = 2$	sf
<b>Total Antenna Wind Force =</b>	<b><math>F_{ant} := F \cdot A_{ant} = 85</math></b>	<b>lbs</b>

**Gravity Load (without ice)**

<b>Weight of All Antennas =</b>	<b><math>WT_{ant} \cdot N_{ant} = 104</math></b>	<b>lbs</b>
---------------------------------	--	------------



**Development of Wind on Antennas**

**Antenna Data:**

Antenna Model =	Ericsson AIR32 B66	
Antenna Shape =	Flat	(User Input)
Antenna Height =	$L_{ant} := 56.6$	in (User Input)
Antenna Width =	$W_{ant} := 12.9$	in (User Input)
Antenna Thickness =	$T_{ant} := 8.7$	in (User Input)
Antenna Weight =	$WT_{ant} := 133$	lbs (User Input)
Number of Antennas =	$N_{ant} := 1$	(User Input)

**Wind Load (Front)**

Surface Area for One Antenna =	$SA_{ant} := \frac{L_{ant} \cdot W_{ant}}{144} = 5.1$	sf
Antenna Projected Surface Area =	$A_{ant} := SA_{ant} \cdot N_{ant} = 5.1$	sf
<b>Total Antenna Wind Force =</b>	<b><math>F_{ant} := F \cdot A_{ant} = 219</math></b>	<b>lbs</b>

**Wind Load (Side)**

Surface Area for One Antenna =	$SA_{ant} := \frac{L_{ant} \cdot T_{ant}}{144} = 3.4$	sf
Antenna Projected Surface Area =	$A_{ant} := SA_{ant} \cdot N_{ant} = 3.4$	sf
<b>Total Antenna Wind Force =</b>	<b><math>F_{ant} := F \cdot A_{ant} = 148</math></b>	<b>lbs</b>

**Gravity Load (without ice)**

<b>Weight of All Antennas =</b>	<b><math>WT_{ant} \cdot N_{ant} = 133</math></b>	<b>lbs</b>
---------------------------------	--	------------

**Development of Wind on Antennas**

**Antenna Data:**

Antenna Model =	RFS APXVAARR24-43	
Antenna Shape =	Flat	(User Input)
Antenna Height =	$L_{ant} := 95.5$	in (User Input)
Antenna Width =	$W_{ant} := 24$	in (User Input)
Antenna Thickness =	$T_{ant} := 8.7$	in (User Input)
Antenna Weight =	$WT_{ant} := 153$	lbs (User Input)
Number of Antennas =	$N_{ant} := 1$	(User Input)

**Wind Load (Front)**

Surface Area for One Antenna =	$SA_{ant} := \frac{L_{ant} \cdot W_{ant}}{144} = 15.9$	sf
Antenna Projected Surface Area =	$A_{ant} := SA_{ant} \cdot N_{ant} = 15.9$	sf
<b>Total Antenna Wind Force =</b>	<b><math>F_{ant} := F \cdot A_{ant} = 687</math></b>	<b>lbs</b>

**Wind Load (Side)**

Surface Area for One Antenna =	$SA_{ant} := \frac{L_{ant} \cdot T_{ant}}{144} = 5.8$	sf
Antenna Projected Surface Area =	$A_{ant} := SA_{ant} \cdot N_{ant} = 5.8$	sf
<b>Total Antenna Wind Force =</b>	<b><math>F_{ant} := F \cdot A_{ant} = 249</math></b>	<b>lbs</b>

**Gravity Load (without ice)**

<b>Weight of All Antennas =</b>	<b><math>WT_{ant} \cdot N_{ant} = 153</math></b>	<b>lbs</b>
---------------------------------	--	------------

**Development of Wind & Ice Load on RRHs**

**RRH Data:**

RRH Model =	Ericsson 4449 B71B12	
RRH Shape =	Flat	(User Input)
RRH Height =	$L_{RRH} := 14.9$	in (User Input)
RRH Width =	$W_{RRH} := 13.2$	in (User Input)
RRH Thickness =	$T_{RRH} := 10.4$	in (User Input)
RRH Weight =	$WT_{RRH} := 74$	lbs (User Input)
Number of RRHs =	$N_{RRH} := 1$	(User Input)

**Wind Load (Front)**

Surface Area for One RRH =	$SA_{RRH} := \frac{L_{RRH} \cdot W_{RRH}}{144} = 1.4$	sf
RRH Projected Surface Area =	$A_{RRH} := SA_{RRH} \cdot N_{RRH} = 1.4$	sf
<b>Total RRH Wind Force =</b>	<b><math>F_{RRH} := F \cdot A_{RRH} = 59</math></b>	<b>lbs</b>

**Wind Load (Side)**

Surface Area for One RRH =	$SA_{RRH} := \frac{L_{RRH} \cdot T_{RRH}}{144} = 1.1$	sf
RRH Projected Surface Area =	$A_{RRH} := SA_{RRH} \cdot N_{RRH} = 1.1$	sf
<b>Total RRH Wind Force =</b>	<b><math>F_{RRH} := F \cdot A_{RRH} = 46</math></b>	<b>lbs</b>

**Gravity Load (without ice)**

<b>Weight of All RRHs =</b>	<b><math>WT_{RRH} \cdot N_{RRH} = 74</math></b>	<b>lbs</b>
-----------------------------	---	------------

**Development of Wind & Ice Load on RRHs**

**RRH Data:**

RRH Model =	Ericsson 4415 B25	
RRH Shape =	Flat	(User Input)
RRH Height =	$L_{RRH} := 16.5$	in (User Input)
RRH Width =	$W_{RRH} := 13.4$	in (User Input)
RRH Thickness =	$T_{RRH} := 5.9$	in (User Input)
RRH Weight =	$WT_{RRH} := 46$	lbs (User Input)
Number of RRHs =	$N_{RRH} := 1$	(User Input)

**Wind Load (Front)**

Surface Area for One RRH =	$SA_{RRH} := \frac{L_{RRH} \cdot W_{RRH}}{144} = 1.5$	sf
RRH Projected Surface Area =	$A_{RRH} := SA_{RRH} \cdot N_{RRH} = 1.5$	sf
<b>Total RRH Wind Force =</b>	<b><math>F_{RRH} := F \cdot A_{RRH} = 66</math></b>	<b>lbs</b>

**Wind Load (Side)**

Surface Area for One RRH =	$SA_{RRH} := \frac{L_{RRH} \cdot T_{RRH}}{144} = 0.7$	sf
RRH Projected Surface Area =	$A_{RRH} := SA_{RRH} \cdot N_{RRH} = 0.7$	sf
<b>Total RRH Wind Force =</b>	<b><math>F_{RRH} := F \cdot A_{RRH} = 29</math></b>	<b>lbs</b>

**Gravity Load (without ice)**

<b>Weight of All RRHs =</b>	<b><math>WT_{RRH} \cdot N_{RRH} = 46</math></b>	<b>lbs</b>
-----------------------------	---	------------

**Development of Wind on Equipment**

**Equipment Data:**

Equipment Model =	PTS 8003S Battery Cabinet		
Equipment Shape =	Flat		(User Input)
Equipment Height =	$L_{Eq} := 32.2$	in	(User Input)
Equipment Width =	$W_{Eq} := 14.1$	in	(User Input)
Equipment Thickness =	$T_{Eq} := 26.3$	in	(User Input)
Equipment Weight =	$WT_{Eq} := 589$	lbs	(User Input)
Number of Equipments =	$N_{Eq} := 1$		(User Input)

**Gravity Load (without ice)**

Equipment Bearing Points=  $n_{bp} := 2$

**Weight of All Equipments =**

$\frac{WT_{Eq}}{n_{bp}} = 295$	<b>lbs</b>
--------------------------------	------------

**Development of Wind on Equipment**

**Equipment Data:**

Equipment Model =	Ericsson B160 Battery Cabinet	
Equipment Shape =	Flat	(User Input)
Equipment Height =	$L_{Eq} := 63$	in (User Input)
Equipment Width =	$W_{Eq} := 26$	in (User Input)
Equipment Thickness =	$T_{Eq} := 26$	in (User Input)
Equipment Weight =	$WT_{Eq} := 1883$	lbs (User Input)
Equipment Bearing Points =	$N_{Bp} := 4$	(User Input)
Number of Equipment =	$N_{Eq} := 1$	(User Input)

**Gravity Load (without ice)**

**Weight of All Equipments =**  $\frac{WT_{Eq}}{N_{Bp}} = 471$  **lbs**

**Development of Wind on Equipment**

**Equipment Data:**

Equipment Model =	Ericsson 6160 Cabinet	
Equipment Shape =	Flat	(User Input)
Equipment Height =	$L_{Eq} := 63$	in (User Input)
Equipment Width =	$W_{Eq} := 26$	in (User Input)
Equipment Thickness =	$T_{Eq} := 26$	in (User Input)
Equipment Weight =	$WT_{Eq} := 1200$	lbs (User Input)
Equipment Bearing Points =	$N_{Bp} := 4$	(User Input)
Number of Equipment =	$N_{Eq} := 1$	(User Input)

**Gravity Load (without ice)**

**Weight of All Equipments =**  $\frac{WT_{Eq}}{N_{Bp}} = 300$  lbs

**Development of Wind on Equipment**

**Equipment Data:**

Equipment Model =	RBS 2106/3106		
Equipment Shape =	Flat		(User Input)
Equipment Height =	$L_{Eq} := 63.625$	in	(User Input)
Equipment Width =	$W_{Eq} := 51.187$	in	(User Input)
Equipment Thickness =	$T_{Eq} := 36.375$	in	(User Input)
Equipment Weight =	$WT_{Eq} := 2593$	lbs	(User Input)
Number of Equipments =	$N_{ant} := 1$		(User Input)

**Gravity Load (without ice)**

Equipment Bearing Points=  $n_{bp} := 4$

**Weight of All Equipments =**  $\frac{WT_{Eq}}{n_{bp}} = 648.25$  **lbs**





N3

PIPE 3.0



Envelope Only Solution

Centek Engineering

LAA

20143.12

CT11005D - Antenna Mount  
Member Framing

Oct 26, 2020 at 1:59 PM

Antenna Mount.r3d



Code Check (Env)	
Black	No Calc
Red	> 1.0
Magenta	.90-1.0
Green	.75-.90
Cyan	.50-.75
Blue	0-.50



Member Code Checks Displayed (Enveloped)  
Envelope Only Solution

Centek Engineering	CT11005D - Antenna Mount Unity Check	
LAA		Oct 26, 2020 at 2:00 PM
20143.12		Antenna Mount.r3d

**(Global) Model Settings**

Display Sections for Member Calcs	5
Max Internal Sections for Member Calcs	97
Include Shear Deformation?	Yes
Increase Nailing Capacity for Wind?	Yes
Include Warping?	Yes
Trans Load Btwn Intersecting Wood Wall?	Yes
Area Load Mesh (in^2)	144
Merge Tolerance (in)	.12
P-Delta Analysis Tolerance	0.50%
Include P-Delta for Walls?	Yes
Automatically Iterate Stiffness for Walls?	Yes
Max Iterations for Wall Stiffness	3
Gravity Acceleration (ft/sec^2)	32.2
Wall Mesh Size (in)	12
Eigensolution Convergence Tol. (1.E-)	4
Vertical Axis	Y
Global Member Orientation Plane	XZ
Static Solver	Sparse Accelerated
Dynamic Solver	Accelerated Solver

Hot Rolled Steel Code	AISC 14th(360-10): ASD
Adjust Stiffness?	Yes(Iterative)
RISAConnection Code	AISC 14th(360-10): ASD
Cold Formed Steel Code	AISI S100-10: ASD
Wood Code	AWC NDS-12: ASD
Wood Temperature	< 100F
Concrete Code	ACI 318-11
Masonry Code	ACI 530-11: ASD
Aluminum Code	AA ADM1-10: ASD - Building
Stainless Steel Code	AISC 14th(360-10): ASD
Adjust Stiffness?	Yes(Iterative)

Number of Shear Regions	4
Region Spacing Increment (in)	4
Biaxial Column Method	Exact Integration
Parme Beta Factor (PCA)	.65
Concrete Stress Block	Rectangular
Use Cracked Sections?	Yes
Use Cracked Sections Slab?	Yes
Bad Framing Warnings?	No
Unused Force Warnings?	Yes
Min 1 Bar Diam. Spacing?	No
Concrete Rebar Set	REBAR_SET_ASTMA615
Min % Steel for Column	1
Max % Steel for Column	8

**(Global) Model Settings, Continued**

Seismic Code	ASCE 7-10
Seismic Base Elevation (ft)	Not Entered
Add Base Weight?	Yes
Ct X	.02
Ct Z	.02
T X (sec)	Not Entered
T Z (sec)	Not Entered
R X	3
R Z	3
Ct Exp. X	.75
Ct Exp. Z	.75
SD1	1
SDS	1
S1	1
TL (sec)	5
Risk Cat	I or II
Drift Cat	Other
Om Z	1
Om X	1
Cd Z	4
Cd X	4
Rho Z	1
Rho X	1
Footing Overturning Safety Factor	1
Optimize for OTM/Sliding	No
Check Concrete Bearing	No
Footing Concrete Weight (k/ft^3)	150.001
Footing Concrete f'c (ksi)	4
Footing Concrete Ec (ksi)	3644
Lambda	1
Footing Steel fy (ksi)	60
Minimum Steel	0.0018
Maximum Steel	0.0075
Footing Top Bar	#3
Footing Top Bar Cover (in)	2
Footing Bottom Bar	#3
Footing Bottom Bar Cover (in)	3.5
Pedestal Bar	#3
Pedestal Bar Cover (in)	1.5
Pedestal Ties	#3

**Hot Rolled Steel Properties**

	Label	E [ksi]	G [ksi]	Nu	Therm (\... Density[k/ft^3]	Yield[ksi]	Ry	Fu[ksi]	Rt	
1	A36 Gr.36	29000	11154	.3	.65	.49	36	1.5	58	1.2
2	A572 Gr.50	29000	11154	.3	.65	.49	50	1.1	58	1.2
3	A992	29000	11154	.3	.65	.49	50	1.1	58	1.2
4	A500 Gr.42	29000	11154	.3	.65	.49	42	1.3	58	1.1
5	A500 Gr.46	29000	11154	.3	.65	.49	46	1.2	58	1.1
6	A53 Grade B	29000	11154	.3	.65	.49	35	1.5	58	1.2

### Hot Rolled Steel Section Sets

	Label	Shape	Type	Design List	Material	Design Rul...A [in2]	lyy [in4]	lzz [in4]	J [in4]	
1	Pipe Mast	PIPE_3.0	Beam	Pipe	A53 Grade B	Typical	2.07	2.85	2.85	5.69

### Hot Rolled Steel Design Parameters

	Label	Shape	Length[ft]	Lbyy[ft]	Lbzz[ft]	Lcomp top[...Lcomp bot[...L-torq...	Kyy	Kzz	Cb	Functi...
1	M1	Pipe Mast	16			Lbyy				Lateral

### Member Primary Data

	Label	I Joint	J Joint	K Joint	Rotate(d...	Section/Shape	Type	Design List	Material	Design Rul...
1	M1	N3	N1			Pipe Mast	Beam	Pipe	A53 Gra...	Typical

### Joint Coordinates and Temperatures

	Label	X [ft]	Y [ft]	Z [ft]	Temp [F]	Detach From Dia...
1	N1	0	0	0	0	
2	N2	0	7	0	0	
3	N3	0	16	0	0	

### Joint Boundary Conditions

	Joint Label	X [k/in]	Y [k/in]	Z [k/in]	X Rot.[k-ft/rad]	Y Rot.[k-ft/rad]	Z Rot.[k-ft/rad]
1	N1	Reaction	Reaction	Reaction		Reaction	
2	N2	Reaction	Reaction	Reaction		Reaction	

### Member Point Loads (BLC 2 : Weight of Equipment)

	Member Label	Direction	Magnitude[k,k-ft]	Location[ft,%]
1	M1	Y	-.077	1
2	M1	Y	-.077	7
3	M1	Y	-.074	12
4	M1	Y	-.046	15

### Member Point Loads (BLC 3 : Wind X-Direction)

	Member Label	Direction	Magnitude[k,k-ft]	Location[ft,%]
1	M1	X	.125	1
2	M1	X	.125	7

### Member Point Loads (BLC 4 : Wind Z-Direction)

	Member Label	Direction	Magnitude[k,k-ft]	Location[ft,%]
1	M1	Z	.344	1
2	M1	Z	.344	7

### Member Distributed Loads

Member Label	Direction	Start Magnitude[k/ft,...	End Magnitude[k/ft,F...	Start Location[ft,%]	End Location[ft,%]
No Data to Print ...					

### Basic Load Cases

BLC Description	Category	X Gra...	Y Gra...	Z Gra...	Joint	Point	Distrib..	Area(...	Surfa...
1 Self Weight	DL		-1						
2 Weight of Equipment	DL					4			
3 Wind X-Direction	WLX					2			
4 Wind Z-Direction	WLZ					2			

### Load Combinations

Description	Solve	P...	S...	B...	Fa...	BLC	Fact...	BLC	Fa...	BLC	Fa...	B...	Fa...	B...	Fa...	B...	Fa...	B...	Fa...
1 IBC 16-8	Yes	Y		DL	1														
2 IBC 16-9	Yes	Y		DL	1	LL	1	LLS	1										
3 IBC 16-10 (a)	Yes	Y		DL	1	RLL	1												
4 IBC 16-10 (b)	Yes	Y		DL	1	SL	1	SLN	1										
5 IBC 16-10 (c)	Yes	Y		DL	1	RL	1												
6 IBC 16-11 (a)	Yes	Y		DL	1	LL	.75	LLS	.75	RLL	.75								
7 IBC 16-11 (b)	Yes	Y		DL	1	LL	.75	LLS	.75	SL	.75	SLN	.75						
8 IBC 16-11 (c)	Yes	Y		DL	1	LL	.75	LLS	.75	RL	.75								
9 IBC 16-12 (a) (a)	Yes	Y		DL	1	WLX	.6												
10 IBC 16-12 (a) (b)	Yes	Y		DL	1	WLZ	.6												
11 IBC 16-12 (a) (c)	Yes	Y		DL	1	WLX	-.6												
12 IBC 16-12 (a) (d)	Yes	Y		DL	1	WLZ	-.6												
13 IBC 16-13 (a) (a)	Yes	Y		DL	1	WLX	.45	LL	.75	LLS	.75	RLL	.75						
14 IBC 16-13 (a) (b)	Yes	Y		DL	1	WLZ	.45	LL	.75	LLS	.75	RLL	.75						
15 IBC 16-13 (a) (c)	Yes	Y		DL	1	WLX	-.45	LL	.75	LLS	.75	RLL	.75						
16 IBC 16-13 (a) (d)	Yes	Y		DL	1	WLZ	-.45	LL	.75	LLS	.75	RLL	.75						
17 IBC 16-13 (b) (a)	Yes	Y		DL	1	WLX	.45	LL	.75	LLS	.75	SL	.75	S...	.75				
18 IBC 16-13 (b) (b)	Yes	Y		DL	1	WLZ	.45	LL	.75	LLS	.75	SL	.75	S...	.75				
19 IBC 16-13 (b) (c)	Yes	Y		DL	1	WLX	-.45	LL	.75	LLS	.75	SL	.75	S...	.75				
20 IBC 16-13 (b) (d)	Yes	Y		DL	1	WLZ	-.45	LL	.75	LLS	.75	SL	.75	S...	.75				
21 IBC 16-13 (c) (a)	Yes	Y		DL	1	WLX	.45	LL	.75	LLS	.75	RL	.75						
22 IBC 16-13 (c) (b)	Yes	Y		DL	1	WLZ	.45	LL	.75	LLS	.75	RL	.75						
23 IBC 16-13 (c) (c)	Yes	Y		DL	1	WLX	-.45	LL	.75	LLS	.75	RL	.75						
24 IBC 16-13 (c) (d)	Yes	Y		DL	1	WLZ	-.45	LL	.75	LLS	.75	RL	.75						
25 IBC 16-15 (a)	Yes	Y		DL	.6	WLX	.6												
26 IBC 16-15 (b)	Yes	Y		DL	.6	WLZ	.6												
27 IBC 16-15 (c)	Yes	Y		DL	.6	WLX	-.6												
28 IBC 16-15 (d)	Yes	Y		DL	.6	WLZ	-.6												

### Envelope Joint Reactions

Joint		X [k]	LC	Y [k]	LC	Z [k]	LC	MX [k-ft]	LC	MY [k-ft]	LC	MZ [k-ft]	LC	
1	N1	max	.109	9	.096	24	.3	10	0	28	0	28	0	28
2		min	-.109	11	.057	25	-.3	12	0	1	0	1	0	1
3	N2	max	.259	11	.291	24	.713	12	0	28	0	28	0	28
4		min	-.259	9	.175	25	-.713	10	0	1	0	1	0	1



**Envelope Joint Reactions (Continued)**

	Joint		X [k]	LC	Y [k]	LC	Z [k]	LC	MX [k-ft]	LC	MY [k-ft]	LC	MZ [k-ft]	LC
5	Totals:	max	.15	27	.387	24	.413	28						
6		min	-.15	9	.232	25	-.413	10						

**Envelope Joint Displacements**

	Joint		X [in]	LC	Y [in]	LC	Z [in]	LC	X Rotation [rad]	LC	Y Rotatio...	LC	Z Rotatio...	LC
1	N1	max	0	28	0	28	0	28	5.307e-03	12	0	28	1.928e-03	9
2		min	0	1	0	1	0	1	-5.307e-03	10	0	1	-1.928e-03	11
3	N2	max	0	28	0	28	0	28	1.069e-02	10	0	28	3.883e-03	11
4		min	0	1	0	1	0	1	-1.069e-02	12	0	1	-3.883e-03	9
5	N3	max	.859	9	0	28	2.363	10	2.631e-02	10	0	28	9.559e-03	11
6		min	-.859	11	0	1	-2.363	12	-2.631e-02	12	0	1	-9.559e-03	9

**Envelope AISC 14th(360-10): ASD Steel Code Checks**

Member	Shape	Code Check	Lo...	LC	She...Lo.....	Pnc/...	Pnt/o...	Mnyy...	Mnzz...	Cb	Eqn			
1	M1	PIPE_3.0	.558	9	12	.032	7....	...	11.62	43.383	3.825	3.825	1	H1-...

**CEN TEK** Engineering, Inc.  
Structural Analysis – Antenna Frames & Equipment Platform  
T-Mobile Equipment Upgrade – CT11005D-Anchor  
Greenwich, CT  
Rev.1 ~ October 29, 2020

## Equipment Platform





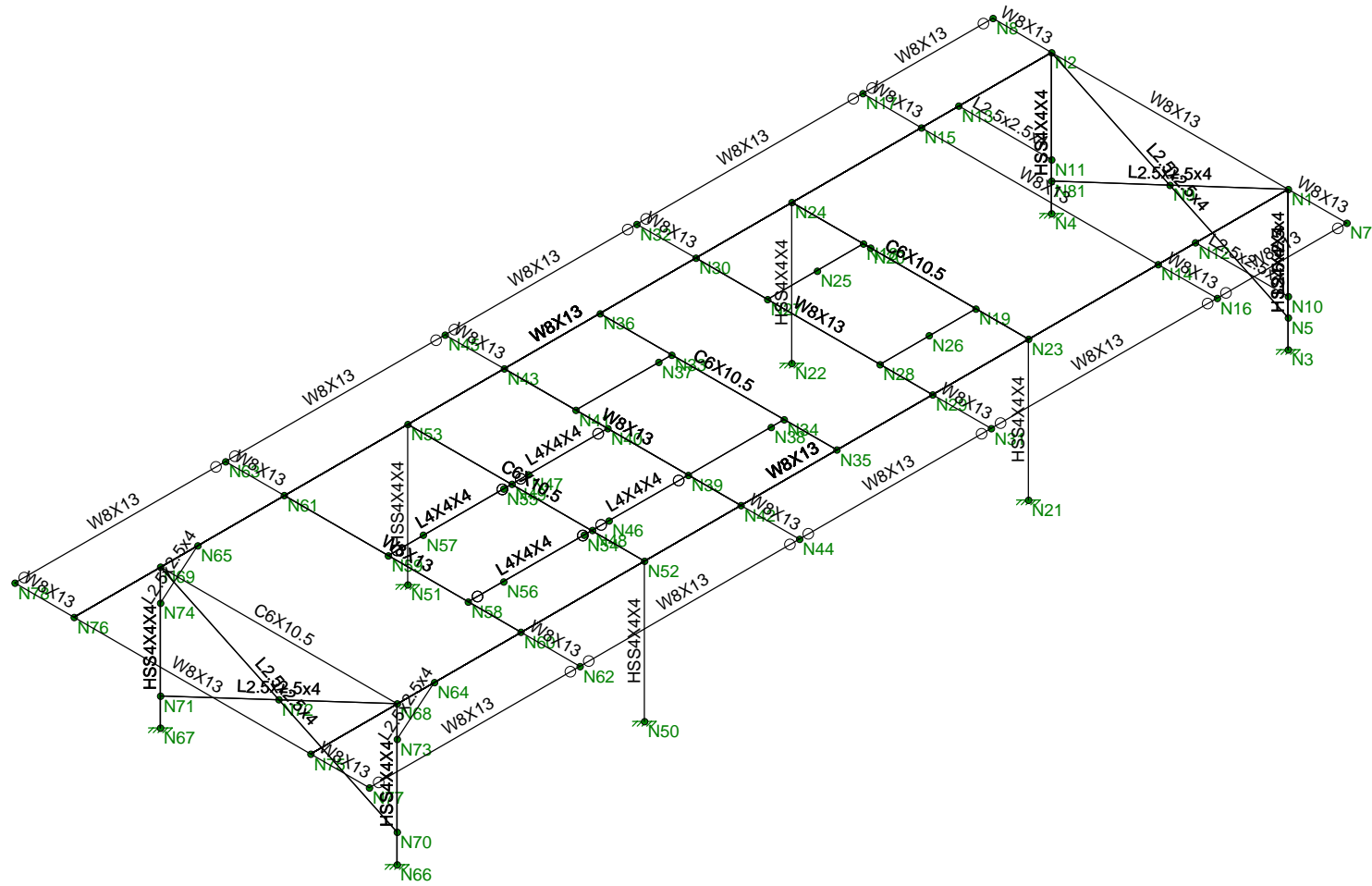
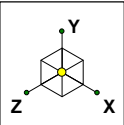

Envelope Only Solution

Centek Engineering
FJP
20143.12

CT11005D - Eq. Platform - Rev.1
Member Framing

Oct 29, 2020 at 4:19 PM
CT11005D_Eq.Platform_Rev.1.r3d

**(Global) Model Settings**

Display Sections for Member Calcs	5
Max Internal Sections for Member Calcs	97
Include Shear Deformation?	Yes
Increase Nailing Capacity for Wind?	Yes
Include Warping?	Yes
Trans Load Btwn Intersecting Wood Wall?	Yes
Area Load Mesh (in^2)	144
Merge Tolerance (in)	.12
P-Delta Analysis Tolerance	0.50%
Include P-Delta for Walls?	Yes
Automatically Iterate Stiffness for Walls?	Yes
Max Iterations for Wall Stiffness	3
Gravity Acceleration (ft/sec^2)	32.2
Wall Mesh Size (in)	24
Eigensolution Convergence Tol. (1.E-)	4
Vertical Axis	Y
Global Member Orientation Plane	XZ
Static Solver	Sparse Accelerated
Dynamic Solver	Accelerated Solver

Hot Rolled Steel Code	AISC 14th(360-10): ASD
Adjust Stiffness?	Yes(Iterative)
RISAConnection Code	AISC 14th(360-10): ASD
Cold Formed Steel Code	AISI S100-12: ASD
Wood Code	AWC NDS-15: ASD
Wood Temperature	< 100F
Concrete Code	ACI 318-14
Masonry Code	ACI 530-13: ASD
Aluminum Code	AA ADM1-15: ASD - Building
Stainless Steel Code	AISC 14th(360-10): ASD
Adjust Stiffness?	Yes(Iterative)

Number of Shear Regions	4
Region Spacing Increment (in)	4
Biaxial Column Method	Exact Integration
Parme Beta Factor (PCA)	.65
Concrete Stress Block	Rectangular
Use Cracked Sections?	Yes
Use Cracked Sections Slab?	Yes
Bad Framing Warnings?	No
Unused Force Warnings?	Yes
Min 1 Bar Diam. Spacing?	No
Concrete Rebar Set	REBAR_SET_ASTMA615
Min % Steel for Column	1
Max % Steel for Column	8

**(Global) Model Settings, Continued**

Seismic Code	ASCE 7-10
Seismic Base Elevation (ft)	Not Entered
Add Base Weight?	Yes
Ct X	.02
Ct Z	.02
T X (sec)	Not Entered
T Z (sec)	Not Entered
R X	3
R Z	3
Ct Exp. X	.75
Ct Exp. Z	.75
SD1	1
SDS	1
S1	1
TL (sec)	5
Risk Cat	I or II
Drift Cat	Other
Om Z	1
Om X	1
Cd Z	4
Cd X	4
Rho Z	1
Rho X	1
Footing Overturning Safety Factor	1
Optimize for OTM/Sliding	No
Check Concrete Bearing	No
Footing Concrete Weight (k/ft^3)	.145
Footing Concrete f'c (ksi)	4
Footing Concrete Ec (ksi)	3644
Lambda	1
Footing Steel fy (ksi)	60
Minimum Steel	0.0018
Maximum Steel	0.0075
Footing Top Bar	#6
Footing Top Bar Cover (in)	1.5
Footing Bottom Bar	#6
Footing Bottom Bar Cover (in)	3
Pedestal Bar	#6
Pedestal Bar Cover (in)	1.5
Pedestal Ties	#4

**Hot Rolled Steel Properties**

	Label	E [ksi]	G [ksi]	Nu	Therm (\... Density[k/ft^3]	Yield[ksi]	Ry	Fu[ksi]	Rt	
1	A992	29000	11154	.3	.65	.49	50	1.1	65	1.1
2	A36 Gr.36	29000	11154	.3	.65	.49	36	1.5	58	1.2
3	A572 Gr.50	29000	11154	.3	.65	.49	50	1.1	65	1.1
4	A500 Gr.B RND	29000	11154	.3	.65	.527	42	1.4	58	1.3
5	A500 Gr.B Rect	29000	11154	.3	.65	.527	46	1.4	58	1.3
6	A53 Gr.B	29000	11154	.3	.65	.49	35	1.6	60	1.2
7	A1085	29000	11154	.3	.65	.49	50	1.4	65	1.3

### Hot Rolled Steel Section Sets

	Label	Shape	Type	Design List	Material	Design Rul...A [in2]	Iyy [in4]	Izz [in4]	J [in4]	
1	(E) W8X13 A	W8X13	Beam	Wide Flange	A36 Gr.36	Typical	3.84	2.73	39.6	.087
2	(E)C6X10.5 B	C6X10.5	Beam	Channel	A36 Gr.36	Typical	3.07	.86	15.1	.128
3	(E)L2.5x2.5x1/4	L2.5x2.5x4	VBrace	Single Angle	A36 Gr.36	Typical	1.19	.692	.692	.026
4	(E)HSS4X4X1/4	HSS4X4X4	Column	HSS Pipe	A500 Gr.B ...	Typical	3.37	7.8	7.8	12.8
5	(P) L4X4X1/4	L4X4X4	Beam	Single Angle	A36 Gr.36	Typical	1.93	3	3	.044

### Hot Rolled Steel Design Parameters

	Label	Shape	Length[ft]	Lbyy[ft]	Lbzz[ft]	Lcomp top[...Lcomp bot[...L-torq...	Kyy	Kzz	Cb	Functi...
1	M1	(E)HSS4X4X1/4	3.75							Lateral
2	M2	(E)HSS4X4X1/4	3.75							Lateral
3	M3	(E)HSS4X4X1/4	3.75							Lateral
4	M4	(E)HSS4X4X1/4	3.75							Lateral
5	M5	(E)HSS4X4X1/4	3.75							Lateral
6	M6	(E)HSS4X4X1/4	3.75							Lateral
7	M7	(E)HSS4X4X1/4	3.75							Lateral
8	M8	(E)HSS4X4X1/4	3.75							Lateral
9	M9	(E) W8X13 A	26.333	Segment		Lbyy				Lateral
10	M10	(E) W8X13 A	26.333	Segment		Lbyy				Lateral
11	M11	(E)C6X10.5 B	6.375			Lbyy				Lateral
12	M12	(E)C6X10.5 B	6.375			Lbyy				Lateral
13	M13	(E)C6X10.5 B	6.375			Lbyy				Lateral
14	M14	(E) W8X13 A	6.375			Lbyy				Lateral
15	M15	(E) W8X13 A	1.583			Lbyy				Lateral
16	M16	(E) W8X13 A	1.583			Lbyy				Lateral
17	M17	(E) W8X13 A	1.583			Lbyy				Lateral
18	M18	(E) W8X13 A	1.583			Lbyy				Lateral
19	M19	(E) W8X13 A	1.583			Lbyy				Lateral
20	M20	(E) W8X13 A	1.583			Lbyy				Lateral
21	M21	(E) W8X13 A	1.583			Lbyy				Lateral
22	M22	(E) W8X13 A	1.583			Lbyy				Lateral
23	M23	(E) W8X13 A	6.375			Lbyy				Lateral
24	M24	(E) W8X13 A	1.583			Lbyy				Lateral
25	M25	(E) W8X13 A	1.583			Lbyy				Lateral
26	M26	(E) W8X13 A	6.375			Lbyy				Lateral
27	M27	(E)C6X10.5 B	6.375			Lbyy				Lateral
28	M28	(E) W8X13 A	6.375			Lbyy				Lateral
29	M29	(E) W8X13 A	6.375			Lbyy				Lateral
30	M30	(E) W8X13 A	1.583			Lbyy				Lateral
31	M31	(E) W8X13 A	1.583			Lbyy				Lateral
32	M32	(E) W8X13 A	6.375			Lbyy				Lateral
33	M33	(E)L2.5x2.5x1/4	7.046			Lbyy				Lateral
34	M34	(E)L2.5x2.5x1/4	3			Lbyy				Lateral
35	M35	(E)L2.5x2.5x1/4	7.046			Lbyy				Lateral
36	M36	(E)L2.5x2.5x1/4	7.046			Lbyy				Lateral
37	M37	(E) W8X13 A	3.5			Lbyy				Lateral
38	M38	(E) W8X13 A	6.083			Lbyy				Lateral
39	M39	(E) W8X13 A	5.167	.833		Lbyy				Lateral
40	M40	(E) W8X13 A	5.917	.833		Lbyy				Lateral
41	M41	(E) W8X13 A	5.667			Lbyy				Lateral

### Hot Rolled Steel Design Parameters (Continued)

Label	Shape	Length[ft]	Lbyy[ft]	Lbzz[ft]	Lcomp top[...Lcomp bot[...L-torq...	Kyy	Kzz	Cb	Functi...
42	M42	(E) W8X13 A	3.5		Lbyy				Lateral
43	M43	(E) W8X13 A	6.083		Lbyy				Lateral
44	M44	(E) W8X13 A	5.167		Lbyy				Lateral
45	M45	(E) W8X13 A	5.917		Lbyy				Lateral
46	M46	(E) W8X13 A	5.667		Lbyy				Lateral
47	M47	(E)L2.5x2.5x1/4	3.536		Lbyy				Lateral
48	M48	(E)L2.5x2.5x1/4	3.536		Lbyy				Lateral
49	M49	(E)L2.5x2.5x1/4	1.302		Lbyy				Lateral
50	M50	(E)L2.5x2.5x1/4	1.302		Lbyy				Lateral
51	M51	(P) L4X4X1/4	2.583		Lbyy				Lateral
52	M52	(P) L4X4X1/4	3.333		Lbyy				Lateral
53	M53	(P) L4X4X1/4	2.583		Lbyy				Lateral
54	M54	(P) L4X4X1/4	3.333		Lbyy				Lateral
55	M59	(E)L2.5x2.5x1/4	7.046		Lbyy				Lateral

### Member Primary Data

Label	I Joint	J Joint	K Joint	Rotate(d...	Section/Shape	Type	Design List	Material	Design Ru...
1	M1	N4	N2		(E)HSS4X4X1/4	Column	HSS Pipe	A500 Gr...	Typical
2	M2	N3	N1		(E)HSS4X4X1/4	Column	HSS Pipe	A500 Gr...	Typical
3	M3	N22	N24		(E)HSS4X4X1/4	Column	HSS Pipe	A500 Gr...	Typical
4	M4	N21	N23		(E)HSS4X4X1/4	Column	HSS Pipe	A500 Gr...	Typical
5	M5	N51	N53		(E)HSS4X4X1/4	Column	HSS Pipe	A500 Gr...	Typical
6	M6	N50	N52		(E)HSS4X4X1/4	Column	HSS Pipe	A500 Gr...	Typical
7	M7	N67	N69		(E)HSS4X4X1/4	Column	HSS Pipe	A500 Gr...	Typical
8	M8	N66	N68		(E)HSS4X4X1/4	Column	HSS Pipe	A500 Gr...	Typical
9	M9	N76	N2		(E) W8X13 A	Beam	Wide Flange	A36 Gr.36	Typical
10	M10	N75	N1		(E) W8X13 A	Beam	Wide Flange	A36 Gr.36	Typical
11	M11	N69	N68		(E)C6X10.5 B	Beam	Channel	A36 Gr.36	Typical
12	M12	N53	N52		(E)C6X10.5 B	Beam	Channel	A36 Gr.36	Typical
13	M13	N24	N23		(E)C6X10.5 B	Beam	Channel	A36 Gr.36	Typical
14	M14	N2	N1		(E) W8X13 A	Beam	Wide Flange	A36 Gr.36	Typical
15	M15	N62	N60		(E) W8X13 A	Beam	Wide Flange	A36 Gr.36	Typical
16	M16	N61	N63		(E) W8X13 A	Beam	Wide Flange	A36 Gr.36	Typical
17	M17	N44	N42		(E) W8X13 A	Beam	Wide Flange	A36 Gr.36	Typical
18	M18	N43	N45		(E) W8X13 A	Beam	Wide Flange	A36 Gr.36	Typical
19	M19	N30	N32		(E) W8X13 A	Beam	Wide Flange	A36 Gr.36	Typical
20	M20	N31	N29		(E) W8X13 A	Beam	Wide Flange	A36 Gr.36	Typical
21	M21	N16	N14		(E) W8X13 A	Beam	Wide Flange	A36 Gr.36	Typical
22	M22	N15	N17		(E) W8X13 A	Beam	Wide Flange	A36 Gr.36	Typical
23	M23	N15	N14		(E) W8X13 A	Beam	Wide Flange	A36 Gr.36	Typical
24	M24	N7	N1		(E) W8X13 A	Beam	Wide Flange	A36 Gr.36	Typical
25	M25	N2	N8		(E) W8X13 A	Beam	Wide Flange	A36 Gr.36	Typical
26	M26	N30	N29		(E) W8X13 A	Beam	Wide Flange	A36 Gr.36	Typical
27	M27	N36	N35		(E)C6X10.5 B	Beam	Channel	A36 Gr.36	Typical
28	M28	N43	N42		(E) W8X13 A	Beam	Wide Flange	A36 Gr.36	Typical
29	M29	N61	N60		(E) W8X13 A	Beam	Wide Flange	A36 Gr.36	Typical
30	M30	N78	N76		(E) W8X13 A	Beam	Wide Flange	A36 Gr.36	Typical
31	M31	N75	N77		(E) W8X13 A	Beam	Wide Flange	A36 Gr.36	Typical
32	M32	N76	N75		(E) W8X13 A	Beam	Wide Flange	A36 Gr.36	Typical
33	M33	N2	N5		(E)L2.5x2.5x1/4	VBrace	Single Angle	A36 Gr.36	Typical

**Member Primary Data (Continued)**

	Label	I Joint	J Joint	K Joint	Rotate(d...	Section/Shape	Type	Design List	Material	Design Rul...
34	M34	N5	N1			(E)L2.5x2.5x1/4	VBrace	Single Angle	A36 Gr.36	Typical
35	M35	N69	N70			(E)L2.5x2.5x1/4	VBrace	Single Angle	A36 Gr.36	Typical
36	M36	N68	N71			(E)L2.5x2.5x1/4	VBrace	Single Angle	A36 Gr.36	Typical
37	M37	N7	N16			(E) W8X13_A	Beam	Wide Flange	A36 Gr.36	Typical
38	M38	N16	N31			(E) W8X13_A	Beam	Wide Flange	A36 Gr.36	Typical
39	M39	N31	N44			(E) W8X13_A	Beam	Wide Flange	A36 Gr.36	Typical
40	M40	N44	N62			(E) W8X13_A	Beam	Wide Flange	A36 Gr.36	Typical
41	M41	N62	N77			(E) W8X13_A	Beam	Wide Flange	A36 Gr.36	Typical
42	M42	N8	N17			(E) W8X13_A	Beam	Wide Flange	A36 Gr.36	Typical
43	M43	N17	N32			(E) W8X13_A	Beam	Wide Flange	A36 Gr.36	Typical
44	M44	N32	N45			(E) W8X13_A	Beam	Wide Flange	A36 Gr.36	Typical
45	M45	N45	N63			(E) W8X13_A	Beam	Wide Flange	A36 Gr.36	Typical
46	M46	N63	N78			(E) W8X13_A	Beam	Wide Flange	A36 Gr.36	Typical
47	M47	N11	N13		90	(E)L2.5x2.5x1/4	VBrace	Single Angle	A36 Gr.36	Typical
48	M48	N10	N12		180	(E)L2.5x2.5x1/4	VBrace	Single Angle	A36 Gr.36	Typical
49	M49	N65	N74			(E)L2.5x2.5x1/4	VBrace	Single Angle	A36 Gr.36	Typical
50	M50	N64	N73		270	(E)L2.5x2.5x1/4	VBrace	Single Angle	A36 Gr.36	Typical
51	M51	N40	N49		90	(P) L4X4X1/4	Beam	Single Angle	A36 Gr.36	Typical
52	M52	N49	N59		90	(P) L4X4X1/4	Beam	Single Angle	A36 Gr.36	Typical
53	M53	N39	N48		90	(P) L4X4X1/4	Beam	Single Angle	A36 Gr.36	Typical
54	M54	N48	N58		90	(P) L4X4X1/4	Beam	Single Angle	A36 Gr.36	Typical
55	M55	N18	N27			RIGID	None	None	RIGID	Typical
56	M56	N19	N28			RIGID	None	None	RIGID	Typical
57	M57	N34	N39			RIGID	None	None	RIGID	Typical
58	M58	N33	N41			RIGID	None	None	RIGID	Typical
59	M59	N1	N81			(E)L2.5x2.5x1/4	VBrace	Single Angle	A36 Gr.36	Typical

**Joint Coordinates and Temperatures**

	Label	X [ft]	Y [ft]	Z [ft]	Temp [F]	Detach From Dia...
1	N1	6.375	3.75	0	0	
2	N2	0.	3.75	0	0	
3	N3	6.375	0	0	0	
4	N4	0.	0	0	0	
5	N5	6.375	.75	0	0	
6	N7	7.958333	3.75	0	0	
7	N8	-1.583333	3.75	0	0	
8	N9	3.1875	2.25	0	0	
9	N10	6.375	1.25	0	0	
10	N11	0.	1.25	0	0	
11	N12	6.375	3.75	2.5	0	
12	N13	0.	3.75	2.5	0	
13	N14	6.375	3.75	3.5	0	
14	N15	0	3.75	3.5	0	
15	N16	7.958333	3.75	3.5	0	
16	N17	-1.583333	3.75	3.5	0	
17	N18	1.933333	3.75	7	0	
18	N19	4.958333	3.75	7	0	
19	N20	2.125	3.75	7	0	
20	N21	6.375	0	7	0	
21	N22	0.	0	7	0	



**Joint Coordinates and Temperatures (Continued)**

	Label	X [ft]	Y [ft]	Z [ft]	Temp [F]	Detach From Dia...
22	N23	6.375	3.75	7	0	
23	N24	0.	3.75	7	0	
24	N25	1.933333	3.75	8.25	0	
25	N26	4.958333	3.75	8.25	0	
26	N27	1.933333	3.75	9.583333	0	
27	N28	4.958333	3.75	9.583333	0	
28	N29	6.375	3.75	9.583333	0	
29	N30	0.	3.75	9.583333	0	
30	N31	7.958333	3.75	9.583333	0	
31	N32	-1.583333	3.75	9.583333	0	
32	N33	1.933333	3.75	12.166667	0	
33	N34	4.958333	3.75	12.166667	0	
34	N35	6.375	3.75	12.166667	0	
35	N36	0.	3.75	12.166667	0	
36	N37	1.933333	3.75	12.516667	0	
37	N38	4.958333	3.75	12.516667	0	
38	N39	4.958333	3.75	14.75	0	
39	N40	2.791667	3.75	14.75	0	
40	N41	1.933333	3.75	14.75	0	
41	N42	6.375	3.75	14.75	0	
42	N43	0.	3.75	14.75	0	
43	N44	7.958333	3.75	14.75	0	
44	N45	-1.583333	3.75	14.75	0	
45	N46	4.958333	3.75	16.883333	0	
46	N47	2.791667	3.75	16.883333	0	
47	N48	4.958333	3.75	17.333333	0	
48	N49	2.791667	3.75	17.333333	0	
49	N50	6.375	0	17.333333	0	
50	N51	0.	0	17.333333	0	
51	N52	6.375	3.75	17.333333	0	
52	N53	0.	3.75	17.333333	0	
53	N54	4.958333	3.75	17.55	0	
54	N55	2.791667	3.75	17.55	0	
55	N56	4.958333	3.75	19.716667	0	
56	N57	2.791667	3.75	19.716667	0	
57	N58	4.958333	3.75	20.666667	0	
58	N59	2.791667	3.75	20.666667	0	
59	N60	6.375	3.75	20.666667	0	
60	N61	0.	3.75	20.666667	0	
61	N62	7.958333	3.75	20.666667	0	
62	N63	-1.583333	3.75	20.666667	0	
63	N64	6.375	3.75	23	0	
64	N65	0.	3.75	23	0	
65	N66	6.375	0	24	0	
66	N67	0.	0	24	0	
67	N68	6.375	3.75	24	0	
68	N69	0.	3.75	24	0	
69	N70	6.375	.75	24	0	
70	N71	0.	.75	24	0	
71	N72	3.1875	2.25	24	0	
72	N73	6.375	2.916667	24	0	
73	N74	0.	2.916667	24	0	

**Joint Coordinates and Temperatures (Continued)**

	Label	X [ft]	Y [ft]	Z [ft]	Temp [F]	Detach From Dia...
74	N75	6.375	3.75	26.333333	0	
75	N76	0.	3.75	26.333333	0	
76	N77	7.958333	3.75	26.333333	0	
77	N78	-1.583333	3.75	26.333333	0	
78	N81	0.	.75	0	0	

**Joint Boundary Conditions**

	Joint Label	X [k/in]	Y [k/in]	Z [k/in]	X Rot.[k-ft/rad]	Y Rot.[k-ft/rad]	Z Rot.[k-ft/rad]
1	N1						
2	N2						
3	N3	Reaction	Reaction	Reaction	Reaction	Reaction	Reaction
4	N4	Reaction	Reaction	Reaction	Reaction	Reaction	Reaction
5	N21	Reaction	Reaction	Reaction	Reaction	Reaction	Reaction
6	N22	Reaction	Reaction	Reaction	Reaction	Reaction	Reaction
7	N50	Reaction	Reaction	Reaction	Reaction	Reaction	Reaction
8	N51	Reaction	Reaction	Reaction	Reaction	Reaction	Reaction
9	N66	Reaction	Reaction	Reaction	Reaction	Reaction	Reaction
10	N67	Reaction	Reaction	Reaction	Reaction	Reaction	Reaction
11	N23						
12	N24						
13	N52						
14	N53						
15	N68						
16	N69						
17	N35						
18	N36						
19	N5						
20	N70						
21	N71						
22	N44						
23	N62						
24	N45						
25	N63						
26	N10						
27	N11						
28	N12						
29	N13						
30	N73						
31	N74						
32	N64						
33	N65						
34	N48						
35	N49						
36	N18						
37	N33						
38	N19						
39	N34						
40	N25						
41	N26						
42	N37						



**Joint Boundary Conditions (Continued)**

	Joint Label	X [k/in]	Y [k/in]	Z [k/in]	X Rot.[k-ft/rad]	Y Rot.[k-ft/rad]	Z Rot.[k-ft/rad]
43	N38						
44	N41						
45	N56						
46	N57						
47	N54						
48	N55						
49	N81						

**Member Point Loads (BLC 5 : Weight of Equipment)**

	Member Label	Direction	Magnitude[k,k-ft]	Location[ft,%]
1	M13	Y	-.295	2.833
2	M13	Y	-.295	4.967
3	M55	Y	-.648	1.267
4	M56	Y	-.648	1.267
5	M57	Y	-.648	.35
6	M58	Y	-.648	.35
7	M51	Y	-.3	0
8	M53	Y	-.3	0
9	M51	Y	-.3	2.133
10	M53	Y	-.3	2.133
11	M52	Y	-.471	.217
12	M54	Y	-.471	.217
13	M52	Y	-.471	2.383
14	M54	Y	-.471	2.383

**Member Distributed Loads (BLC 2 : Grating & Railing (9psf))**

	Member Label	Direction	Start Magnitude[k/ft,...	End Magnitude[k/ft,F...	Start Location[ft,%]	End Location[ft,%]
1	M14	Y	-.015	-.015	0	0
2	M24	Y	-.015	-.015	0	0
3	M25	Y	-.015	-.015	0	0
4	M37	Y	-.015	-.015	0	0
5	M38	Y	-.015	-.015	0	0
6	M39	Y	-.015	-.015	0	0
7	M40	Y	-.015	-.015	0	0
8	M41	Y	-.015	-.015	0	0
9	M42	Y	-.015	-.015	0	0
10	M43	Y	-.015	-.015	0	0
11	M44	Y	-.015	-.015	0	0
12	M45	Y	-.015	-.015	0	0
13	M46	Y	-.015	-.015	0	0

**Member Distributed Loads (BLC 6 : BLC 2 Transient Area Loads)**

	Member Label	Direction	Start Magnitude[k/ft,...	End Magnitude[k/ft,F...	Start Location[ft,%]	End Location[ft,%]
1	M11	Y	-.02	-.021	0	1.275
2	M11	Y	-.021	-.033	1.275	2.55
3	M11	Y	-.033	-.033	2.55	3.825
4	M11	Y	-.033	-.021	3.825	5.1
5	M11	Y	-.021	-.02	5.1	6.375



**Member Distributed Loads (BLC 6 : BLC 2 Transient Area Loads) (Continued)**

	Member Label	Direction	Start Magnitude[k/ft,...	End Magnitude[k/ft,F...	Start Location[ft,%]	End Location[ft,%]
6	M15	Y	-.023	-.023	8.327e-16	1.583
7	M16	Y	-.053	-.053	0	1.583
8	M29	Y	-.027	-.029	0	1.275
9	M29	Y	-.029	-.034	1.275	2.55
10	M29	Y	-.034	-.032	2.55	3.825
11	M29	Y	-.032	-.027	3.825	5.1
12	M29	Y	-.027	-.03	5.1	6.375
13	M30	Y	-.028	-.028	0	1.583
14	M31	Y	-.028	-.028	1.499e-15	1.583
15	M32	Y	-.01	-.011	0	2.125
16	M32	Y	-.011	-.011	2.125	4.25
17	M32	Y	-.011	-.01	4.25	6.375
18	M12	Y	-.021	-.031	0	1.275
19	M12	Y	-.031	-.029	1.275	2.55
20	M12	Y	-.029	-.021	2.55	3.825
21	M12	Y	-.021	-.025	3.825	5.1
22	M12	Y	-.025	-.034	5.1	6.375
23	M15	Y	-.028	-.028	.0007906	1.583
24	M17	Y	-.025	-.025	0	1.583
25	M18	Y	-.023	-.023	3.886e-16	1.583
26	M28	Y	-.008	-.009	0	1.594
27	M28	Y	-.009	-.014	1.594	3.187
28	M28	Y	-.014	-.015	3.187	4.781
29	M28	Y	-.015	-.007	4.781	6.375
30	M17	Y	-.043	-.017	0	.528
31	M17	Y	-.017	-.016	.528	1.056
32	M17	Y	-.016	-.04	1.056	1.583
33	M18	Y	-.023	-.023	0	1.583
34	M19	Y	-.047	-.047	0	1.583
35	M20	Y	-.023	-.022	0	.792
36	M20	Y	-.022	-.021	.792	1.583
37	M26	Y	-.005	-.026	0	1.275
38	M26	Y	-.026	-.028	1.275	2.55
39	M26	Y	-.028	-.024	2.55	3.825
40	M26	Y	-.024	-.026	3.825	5.1
41	M26	Y	-.026	-.022	5.1	6.375
42	M27	Y	-.011	-.026	0	1.275
43	M27	Y	-.026	-.025	1.275	2.55
44	M27	Y	-.025	-.021	2.55	3.825
45	M27	Y	-.021	-.025	3.825	5.1
46	M27	Y	-.025	-.024	5.1	6.375
47	M28	Y	-.01	-.014	0	1.275
48	M28	Y	-.014	-.012	1.275	2.55
49	M28	Y	-.012	-.009	2.55	3.825
50	M28	Y	-.009	-.012	3.825	5.1
51	M28	Y	-.012	-.014	5.1	6.375
52	M13	Y	-.017	-.032	0	1.275
53	M13	Y	-.032	-.03	1.275	2.55
54	M13	Y	-.03	-.023	2.55	3.825
55	M13	Y	-.023	-.027	3.825	5.1
56	M13	Y	-.027	-.026	5.1	6.375
57	M20	Y	-.025	-.025	0	1.583

**Member Distributed Loads (BLC 6 : BLC 2 Transient Area Loads) (Continued)**

	Member Label	Direction	Start Magnitude[k/ft,...	End Magnitude[k/ft,F...	Start Location[ft, %]	End Location[ft, %]
58	M21	Y	-0.029	-0.029	0	1.583
59	M22	Y	-0.047	-0.047	0	1.583
60	M23	Y	-0.022	-0.029	0	1.275
61	M23	Y	-0.029	-0.041	1.275	2.55
62	M23	Y	-0.041	-0.039	2.55	3.825
63	M23	Y	-0.039	-0.029	3.825	5.1
64	M23	Y	-0.029	-0.027	5.1	6.375
65	M14	Y	-0.012	-0.013	0	1.275
66	M14	Y	-0.013	-0.02	1.275	2.55
67	M14	Y	-0.02	-0.02	2.55	3.825
68	M14	Y	-0.02	-0.013	3.825	5.1
69	M14	Y	-0.013	-0.012	5.1	6.375
70	M21	Y	-0.016	-0.016	1.499e-15	1.583
71	M24	Y	-0.016	-0.016	7.216e-16	1.583
72	M25	Y	-0.016	-0.016	3.12e-14	1.583

**Member Distributed Loads (BLC 7 : BLC 3 Transient Area Loads)**

	Member Label	Direction	Start Magnitude[k/ft,...	End Magnitude[k/ft,F...	Start Location[ft, %]	End Location[ft, %]
1	M14	Y	-0.035	-0.035	0	6.375
2	M23	Y	-0.035	-0.035	1.56e-13	6.375
3	M10	Y	-0.016	-0.016	22.833	26.333
4	M37	Y	-0.016	-0.016	1.665e-16	3.5
5	M9	Y	-0.016	-0.016	22.833	26.333
6	M42	Y	-0.016	-0.016	5.757e-14	3.5
7	M13	Y	-0.035	-0.035	0	6.375
8	M23	Y	-0.035	-0.035	7.239e-14	6.375
9	M10	Y	-0.016	-0.016	16.75	22.833
10	M38	Y	-0.016	-0.016	1.943e-15	6.083
11	M9	Y	-0.016	-0.016	16.75	22.833
12	M43	Y	-0.016	-0.016	1.721e-14	6.083
13	M9	Y	-0.019	-0.019	16.75	19.333
14	M55	Y	-0.019	-0.019	0	2.583
15	M13	Y	-0.025	-0.025	1.933	4.958
16	M10	Y	-0.014	-0.014	16.75	19.333
17	M56	Y	-0.014	-0.014	5.551e-16	2.583
18	M9	Y	-0.016	-0.016	11.583	16.75
19	M44	Y	-0.016	-0.016	1.721e-15	5.167
20	M10	Y	-0.016	-0.016	11.583	16.75
21	M39	Y	-0.016	-0.016	2.498e-15	5.167
22	M10	Y	-0.028	-0.028	14.167	16.75
23	M9	Y	-0.039	-0.039	14.167	16.75
24	M9	Y	-0.019	-0.019	11.583	14.167
25	M58	Y	-0.019	-0.019	1.11e-16	2.583
26	M10	Y	-0.014	-0.014	11.583	14.167
27	M57	Y	-0.014	-0.014	0	2.583
28	M27	Y	-0.022	-0.022	1.933	4.958
29	M28	Y	-0.022	-0.022	1.933	4.958
30	M9	Y	-0.016	-0.016	5.667	11.583
31	M45	Y	-0.016	-0.016	1.61e-15	5.917
32	M9	Y	-0.029	-0.025	5.267	7.9
33	M9	Y	-0.025	-0.019	7.9	10.533

**Member Distributed Loads (BLC 7 : BLC 3 Transient Area Loads) (Continued)**

	Member Label	Direction	Start Magnitude[k/ft,...	End Magnitude[k/ft,F...	Start Location[ft,%]	End Location[ft,%]
34	M9	Y	-.019	-.01	10.533	13.167
35	M51	Y	-.028	-.028	0	2.583
36	M52	Y	-.028	-.028	2.22e-16	3.333
37	M12	Y	0	-.006	1.912	2.677
38	M12	Y	-.006	-.013	2.677	3.442
39	M12	Y	-.013	-.013	3.442	4.207
40	M12	Y	-.013	-.006	4.207	4.972
41	M12	Y	-.006	0	4.972	5.737
42	M29	Y	-.019	-.019	2.792	4.958
43	M10	Y	-.013	-.013	5.267	7.242
44	M10	Y	-.013	-.014	7.242	9.217
45	M10	Y	-.014	-.01	9.217	11.192
46	M10	Y	-.01	-.0005791	11.192	13.167
47	M53	Y	-.014	-.014	3.719e-15	2.583
48	M54	Y	-.014	-.014	0	3.333
49	M10	Y	-.016	-.016	5.667	11.583
50	M40	Y	-.016	-.016	4.663e-15	5.917
51	M9	Y	-.016	-.016	2.776e-16	5.667
52	M46	Y	-.016	-.016	0	5.667
53	M10	Y	-.016	-.016	4.996e-16	5.667
54	M41	Y	-.016	-.016	0	5.667
55	M11	Y	-.033	-.033	0	6.375
56	M29	Y	-.033	-.033	1.443e-15	6.375
57	M11	Y	-.023	-.023	3.331e-16	6.375
58	M32	Y	-.023	-.023	3.331e-16	6.375

**Member Distributed Loads (BLC 8 : BLC 4 Transient Area Loads)**

	Member Label	Direction	Start Magnitude[k/ft,...	End Magnitude[k/ft,F...	Start Location[ft,%]	End Location[ft,%]
1	M11	Y	-.066	-.07	0	1.275
2	M11	Y	-.07	-.11	1.275	2.55
3	M11	Y	-.11	-.11	2.55	3.825
4	M11	Y	-.11	-.07	3.825	5.1
5	M11	Y	-.07	-.066	5.1	6.375
6	M15	Y	-.075	-.075	8.327e-16	1.583
7	M16	Y	-.175	-.175	0	1.583
8	M29	Y	-.091	-.095	0	1.275
9	M29	Y	-.095	-.113	1.275	2.55
10	M29	Y	-.113	-.106	2.55	3.825
11	M29	Y	-.106	-.089	3.825	5.1
12	M29	Y	-.089	-.101	5.1	6.375
13	M30	Y	-.095	-.095	0	1.583
14	M31	Y	-.095	-.095	1.499e-15	1.583
15	M32	Y	-.033	-.036	0	2.125
16	M32	Y	-.036	-.036	2.125	4.25
17	M32	Y	-.036	-.033	4.25	6.375
18	M12	Y	-.07	-.103	0	1.275
19	M12	Y	-.103	-.098	1.275	2.55
20	M12	Y	-.098	-.071	2.55	3.825
21	M12	Y	-.071	-.083	3.825	5.1
22	M12	Y	-.083	-.115	5.1	6.375
23	M15	Y	-.094	-.094	.0007906	1.583

**Member Distributed Loads (BLC 8 : BLC 4 Transient Area Loads) (Continued)**

	Member Label	Direction	Start Magnitude[k/ft,...	End Magnitude[k/ft,F...	Start Location[ft, %]	End Location[ft, %]
24	M17	Y	-.084	-.084	0	1.583
25	M18	Y	-.078	-.078	3.886e-16	1.583
26	M28	Y	-.025	-.031	0	1.594
27	M28	Y	-.031	-.048	1.594	3.187
28	M28	Y	-.048	-.049	3.187	4.781
29	M28	Y	-.049	-.024	4.781	6.375
30	M17	Y	-.142	-.056	0	.528
31	M17	Y	-.056	-.053	.528	1.056
32	M17	Y	-.053	-.132	1.056	1.583
33	M18	Y	-.077	-.077	0	1.583
34	M19	Y	-.156	-.156	0	1.583
35	M20	Y	-.077	-.073	0	.792
36	M20	Y	-.073	-.069	.792	1.583
37	M26	Y	-.017	-.085	0	1.275
38	M26	Y	-.085	-.092	1.275	2.55
39	M26	Y	-.092	-.079	2.55	3.825
40	M26	Y	-.079	-.087	3.825	5.1
41	M26	Y	-.087	-.073	5.1	6.375
42	M27	Y	-.038	-.087	0	1.275
43	M27	Y	-.087	-.083	1.275	2.55
44	M27	Y	-.083	-.069	2.55	3.825
45	M27	Y	-.069	-.082	3.825	5.1
46	M27	Y	-.082	-.079	5.1	6.375
47	M28	Y	-.033	-.046	0	1.275
48	M28	Y	-.046	-.04	1.275	2.55
49	M28	Y	-.04	-.031	2.55	3.825
50	M28	Y	-.031	-.039	3.825	5.1
51	M28	Y	-.039	-.048	5.1	6.375
52	M13	Y	-.056	-.107	0	1.275
53	M13	Y	-.107	-.099	1.275	2.55
54	M13	Y	-.099	-.078	2.55	3.825
55	M13	Y	-.078	-.09	3.825	5.1
56	M13	Y	-.09	-.088	5.1	6.375
57	M20	Y	-.085	-.085	0	1.583
58	M21	Y	-.098	-.098	0	1.583
59	M22	Y	-.156	-.156	0	1.583
60	M23	Y	-.072	-.097	0	1.275
61	M23	Y	-.097	-.135	1.275	2.55
62	M23	Y	-.135	-.129	2.55	3.825
63	M23	Y	-.129	-.095	3.825	5.1
64	M23	Y	-.095	-.091	5.1	6.375
65	M14	Y	-.041	-.043	0	1.275
66	M14	Y	-.043	-.067	1.275	2.55
67	M14	Y	-.067	-.067	2.55	3.825
68	M14	Y	-.067	-.043	3.825	5.1
69	M14	Y	-.043	-.041	5.1	6.375
70	M21	Y	-.053	-.053	1.499e-15	1.583
71	M24	Y	-.052	-.052	7.216e-16	1.583
72	M25	Y	-.053	-.053	3.12e-14	1.583

### Basic Load Cases

	BLC Description	Category	X Gra...	Y Gra...	Z Gra...	Joint	Point	Distrib...	Area(...	Surfa...
1	Self Weight	DL		-1						
2	Grating & Railing (9psf)	DL						13	5	
3	Live Load (20 psf)	LL							26	
4	Snow Load (30 psf)	SL							5	
5	Weight of Equipment	DL					14			
6	BLC 2 Transient Area Loads	None						72		
7	BLC 3 Transient Area Loads	None						58		
8	BLC 4 Transient Area Loads	None						72		

### Load Combinations

	Description	Solve	P...	S...	B...	Fa...	BLC	Fact...	BLC Fa...	BLC Fa...	BLC Fa...	B...	Fa...	B...	Fa...	B...	Fa...	B...	Fa...
1	IBC 16-8	Yes	Y		DL	1													
2	IBC 16-9	Yes	Y		DL	1	LL	1	LLS	1									
3	IBC 16-10 (b)	Yes	Y		DL	1	SL	1	SLN	1									
4	IBC 16-11 (b)	Yes	Y		DL	1	LL	.75	LLS	.75	SL	.75	SLN	.75					
5	IBC 16-12 (a) (a)	Yes	Y		DL	1	WLX	.6											
6	IBC 16-12 (a) (b)	Yes	Y		DL	1	WLZ	.6											
7	IBC 16-12 (a) (c)	Yes	Y		DL	1	WLX	-.6											
8	IBC 16-12 (a) (d)	Yes	Y		DL	1	WLZ	-.6											
9	IBC 16-13 (a) (a)	Yes	Y		DL	1	WLX	.45	LL	.75	LLS	.75							
10	IBC 16-13 (a) (b)	Yes	Y		DL	1	WLZ	.45	LL	.75	LLS	.75							
11	IBC 16-13 (a) (c)	Yes	Y		DL	1	WLX	-.45	LL	.75	LLS	.75							
12	IBC 16-13 (a) (d)	Yes	Y		DL	1	WLZ	-.45	LL	.75	LLS	.75							
13	IBC 16-13 (b) (a)	Yes	Y		DL	1	WLX	.45	LL	.75	LLS	.75	SL	.75	S...	.75			
14	IBC 16-13 (b) (b)	Yes	Y		DL	1	WLZ	.45	LL	.75	LLS	.75	SL	.75	S...	.75			
15	IBC 16-13 (b) (c)	Yes	Y		DL	1	WLX	-.45	LL	.75	LLS	.75	SL	.75	S...	.75			
16	IBC 16-13 (b) (d)	Yes	Y		DL	1	WLZ	-.45	LL	.75	LLS	.75	SL	.75	S...	.75			
17	IBC 16-15 (a)	Yes	Y		DL	.6	WLX	.6											
18	IBC 16-15 (b)	Yes	Y		DL	.6	WLZ	.6											
19	IBC 16-15 (c)	Yes	Y		DL	.6	WLX	-.6											
20	IBC 16-15 (d)	Yes	Y		DL	.6	WLZ	-.6											

### Envelope Joint Reactions

	Joint		X [k]	LC	Y [k]	LC	Z [k]	LC	MX [k-ft]	LC	MY [k-ft]	LC	MZ [k-ft]	LC
1	N3	max	-.015	20	.886	16	.041	16	0	16	0	20	.042	16
2		min	-.054	4	.206	17	-.051	1	-.037	1	-.001	4	.008	17
3	N4	max	.055	16	.899	16	.06	16	.015	16	0	8	-.009	20
4		min	.016	17	.213	17	-.037	1	-.029	1	-.001	4	-.043	4
5	N21	max	-.097	20	4.132	16	.225	3	.253	3	0	2	.267	16
6		min	-.225	4	1.532	17	.111	17	.136	17	0	17	.113	17
7	N22	max	.232	16	3.728	16	.202	16	.221	3	0	8	-.124	20
8		min	.1	17	1.304	17	.099	17	.12	17	0	17	-.283	4
9	N50	max	-.188	20	4.596	16	-.1	20	-.119	20	0	16	.451	16
10		min	-.387	4	1.891	17	-.287	4	-.368	4	0	1	.217	17
11	N51	max	.375	16	3.959	16	-.092	20	-.11	20	0	16	-.225	20
12		min	.18	17	1.495	17	-.271	4	-.349	4	0	1	-.467	4
13	N66	max	-.032	20	1.693	16	.024	8	.033	8	-.003	20	.15	16
14		min	-.145	4	.431	17	.009	2	-.006	4	-.011	4	.028	17

### Envelope Joint Reactions (Continued)

	Joint		X [k]	LC	Y [k]	LC	Z [k]	LC	MX [k-ft]	LC	MY [k-ft]	LC	MZ [k-ft]	LC
15	N67	max	.149	16	1.661	16	.036	8	.046	8	-.002	20	-.03	20
16		min	.035	17	.407	17	.022	17	.007	4	-.006	4	-.152	4
17	Totals:	max	0	20	21.555	16	0	16						
18		min	0	1	7.479	17	0	1						

### Envelope Joint Displacements

	Joint		X [in]	LC	Y [in]	LC	Z [in]	LC	X Rotation [rad]	LC	Y Rotatio...	LC	Z Rotatio...	LC
1	N1	max	0	20	0	20	.002	16	6.98e-05	16	5.482e-06	16	5.201e-06	16
2		min	0	4	0	4	0	1	-1.612e-05	1	6.606e-07	17	4.73e-06	17
3	N2	max	0	20	0	20	.002	16	7.577e-05	16	-1.27e-06	20	-4.16e-06	20
4		min	0	3	0	4	0	1	-9.437e-06	1	-2.539e-06	2	-5.031e-05	4
5	N3	max	0	20	0	20	0	20	0	20	0	20	0	20
6		min	0	1	0	1	0	1	0	1	0	1	0	1
7	N4	max	0	20	0	20	0	20	0	20	0	20	0	20
8		min	0	1	0	1	0	1	0	1	0	1	0	1
9	N5	max	0	16	0	20	0	8	1.183e-05	3	8.497e-07	16	-1.16e-06	20
10		min	0	17	0	4	0	4	6.49e-06	17	1.899e-07	17	-1.334e-05	4
11	N7	max	0	20	0	16	.001	16	6.98e-05	16	1.245e-05	16	2.964e-05	16
12		min	0	4	0	1	0	1	-1.612e-05	1	2.916e-06	17	-6.351e-06	1
13	N8	max	0	20	0	16	.002	16	7.577e-05	16	-1.845e-06	20	7.304e-06	8
14		min	0	3	0	1	0	1	-9.437e-06	1	-1.118e-05	4	-2.794e-05	4
15	N9	max	0	20	0	20	0	16	5.389e-05	16	1.335e-05	16	8.208e-07	16
16		min	0	3	0	4	0	17	-6.177e-06	1	2.322e-06	17	1.163e-07	17
17	N10	max	0	16	0	20	0	8	2.445e-05	16	6.836e-07	3	-8.194e-07	20
18		min	0	17	0	4	0	4	3.438e-06	17	3.106e-07	17	-1.361e-05	4
19	N11	max	0	20	0	20	0	8	2.29e-05	16	1.283e-06	16	1.444e-05	16
20		min	0	4	0	4	0	4	3.807e-06	17	-6.836e-07	1	1.418e-06	17
21	N12	max	0	16	0	8	.002	16	-6.001e-06	16	-3.503e-06	20	7.779e-05	16
22		min	0	1	-.002	4	0	1	-3.683e-05	1	-5.851e-06	1	3.498e-06	17
23	N13	max	0	16	0	8	.002	16	-2.02e-06	16	-1.463e-06	16	-3.175e-06	20
24		min	0	1	-.002	4	0	1	-3.204e-05	1	-4.291e-06	1	-7.884e-05	4
25	N14	max	0	16	.001	8	.002	16	-2.861e-05	20	1.09e-06	16	6.076e-05	16
26		min	0	1	-.002	4	0	1	-7.688e-05	4	-1.926e-06	1	-5.783e-05	1
27	N15	max	0	16	0	8	.002	16	-2.756e-05	20	-1.617e-06	20	6.56e-05	8
28		min	0	1	-.002	4	0	1	-7.589e-05	4	-3.354e-06	4	-5.155e-05	4
29	N16	max	0	16	0	20	.001	16	-2.861e-05	20	1.46e-05	16	5.535e-06	16
30		min	0	1	-.001	4	0	1	-7.688e-05	4	3.92e-06	17	-9.016e-05	1
31	N17	max	0	16	0	20	.002	16	-2.756e-05	20	-1.797e-06	20	9.81e-05	8
32		min	0	1	-.002	4	0	1	-7.589e-05	4	-1.09e-05	4	4.329e-06	4
33	N18	max	0	16	-.006	20	.002	16	7.709e-04	16	-1.984e-06	20	-1.253e-04	20
34		min	0	1	-.014	4	0	1	3.006e-04	17	-4.445e-06	4	-2.839e-04	3
35	N19	max	0	20	-.005	20	.002	16	8.428e-04	16	-1.915e-07	3	3.073e-04	3
36		min	0	1	-.011	4	0	1	3.302e-04	17	-1.325e-06	2	1.328e-04	17
37	N20	max	0	16	-.006	20	.002	16	7.755e-04	16	-6.411e-07	20	-1.083e-04	20
38		min	0	1	-.015	4	0	1	3.025e-04	17	-2.109e-06	2	-2.442e-04	3
39	N21	max	0	20	0	20	0	20	0	20	0	20	0	20
40		min	0	1	0	1	0	1	0	1	0	1	0	1
41	N22	max	0	20	0	20	0	20	0	20	0	20	0	20
42		min	0	1	0	1	0	1	0	1	0	1	0	1
43	N23	max	0	20	0	20	.002	16	5.106e-04	16	-1.71e-06	20	4.617e-04	16

**Envelope Joint Displacements (Continued)**

Joint	X [in]	LC	Y [in]	LC	Z [in]	LC	X Rotation [rad]	LC	Y Rotatio...	LC	Z Rotatio...	LC		
44		min	0	1	-.002	4	0	1	2.155e-04	17	-3.436e-06	2	2.047e-04	17
45	N24	max	0	16	0	20	.002	16	4.764e-04	16	-1.689e-06	20	-1.886e-04	20
46		min	0	1	-.002	4	0	1	1.951e-04	17	-2.822e-06	1	-4.52e-04	4
47	N25	max	0	20	-.01	20	.002	16	7.709e-04	16	-1.984e-06	20	-1.253e-04	20
48		min	0	1	-.026	4	0	1	3.006e-04	17	-4.445e-06	4	-2.839e-04	3
49	N26	max	0	20	-.01	20	.002	16	8.428e-04	16	-1.915e-07	3	3.073e-04	3
50		min	0	1	-.024	4	0	1	3.302e-04	17	-1.325e-06	2	1.328e-04	17
51	N27	max	0	20	-.015	20	.002	16	7.709e-04	16	-1.984e-06	20	-1.253e-04	20
52		min	0	1	-.038	4	0	1	3.006e-04	17	-4.445e-06	4	-2.839e-04	3
53	N28	max	0	20	-.015	20	.002	16	8.428e-04	16	-1.915e-07	3	3.073e-04	3
54		min	0	1	-.037	4	0	1	3.302e-04	17	-1.325e-06	2	1.328e-04	17
55	N29	max	0	20	-.013	20	.002	16	8.953e-04	16	1.182e-06	3	2.838e-04	3
56		min	0	1	-.032	4	0	1	3.539e-04	17	-1.764e-07	2	1.259e-04	17
57	N30	max	0	20	-.011	20	.002	16	8.252e-04	16	-2.663e-06	20	-1.451e-04	20
58		min	0	1	-.03	4	0	1	3.138e-04	17	-6.484e-06	4	-3.24e-04	3
59	N31	max	0	20	-.011	20	.001	16	8.953e-04	16	7.036e-06	16	2.299e-04	3
60		min	0	1	-.028	4	0	1	3.539e-04	17	2.659e-06	17	1.035e-04	17
61	N32	max	0	20	-.009	20	.002	16	8.252e-04	16	-1.533e-07	20	-1.227e-04	20
62		min	0	1	-.026	4	0	1	3.138e-04	17	-1.065e-06	4	-2.706e-04	3
63	N33	max	0	20	-.026	20	.001	16	-2.903e-04	20	-1.381e-06	20	-1.818e-04	20
64		min	0	1	-.063	4	0	1	-7.095e-04	4	-3.582e-06	4	-3.909e-04	3
65	N34	max	0	20	-.025	20	.001	16	-2.632e-04	20	-1.442e-06	20	4.02e-04	16
66		min	0	1	-.061	4	0	1	-6.478e-04	4	-3.744e-06	4	1.836e-04	17
67	N35	max	0	20	-.019	20	.001	16	2.008e-05	16	-4.036e-06	20	7.964e-04	3
68		min	0	1	-.049	4	0	1	9.517e-06	17	-9.598e-06	4	3.648e-04	17
69	N36	max	0	20	-.017	20	.002	16	5.793e-06	2	-3.184e-06	20	-4.392e-04	20
70		min	0	1	-.045	4	0	1	1.507e-06	17	-6.608e-06	2	-9.603e-04	3
71	N37	max	0	20	-.024	20	.001	16	-2.903e-04	20	-1.381e-06	20	-1.818e-04	20
72		min	0	1	-.06	4	0	1	-7.095e-04	4	-3.582e-06	4	-3.909e-04	3
73	N38	max	0	20	-.024	20	.001	16	-2.632e-04	20	-1.442e-06	20	4.02e-04	16
74		min	0	1	-.058	4	0	1	-6.478e-04	4	-3.744e-06	4	1.836e-04	17
75	N39	max	0	20	-.017	20	.001	16	-2.632e-04	20	-1.442e-06	20	4.02e-04	16
76		min	0	2	-.041	4	0	1	-6.478e-04	4	-3.744e-06	4	1.836e-04	17
77	N40	max	0	20	-.018	20	.001	16	-2.826e-04	20	4.722e-06	3	-8.287e-05	20
78		min	0	2	-.044	4	0	1	-6.92e-04	4	2.453e-06	17	-1.756e-04	3
79	N41	max	0	20	-.017	20	.001	16	-2.903e-04	20	-1.381e-06	20	-1.818e-04	20
80		min	0	2	-.041	4	0	1	-7.095e-04	4	-3.582e-06	4	-3.909e-04	3
81	N42	max	0	20	-.013	20	.001	16	-3.537e-04	20	-1.946e-06	20	4.099e-04	3
82		min	0	2	-.033	4	0	1	-8.954e-04	4	-5.552e-06	4	1.969e-04	17
83	N43	max	0	20	-.011	20	.001	16	-3.131e-04	20	2.741e-06	3	-2.108e-04	20
84		min	0	2	-.03	4	0	1	-8.242e-04	4	1.023e-06	17	-4.422e-04	3
85	N44	max	0	20	-.01	20	.001	16	-3.537e-04	20	-5.702e-07	20	3.544e-04	3
86		min	0	2	-.027	4	0	1	-8.954e-04	4	-3.384e-06	4	1.744e-04	17
87	N45	max	0	20	-.008	20	.002	16	-3.131e-04	20	8.019e-06	16	-1.887e-04	20
88		min	0	2	-.023	4	0	1	-8.242e-04	4	2.087e-06	17	-3.893e-04	3
89	N46	max	-.001	20	-.012	20	.001	16	-3.688e-04	20	1.392e-04	2	7.613e-04	16
90		min	-.002	2	-.025	4	0	1	-9.241e-04	4	7.44e-05	17	3.666e-04	17
91	N47	max	-.001	20	-.015	20	.001	16	-2.816e-04	20	1.594e-04	2	-1.331e-04	20
92		min	-.002	2	-.033	4	0	1	-7.684e-04	4	7.65e-05	17	-2.627e-04	4
93	N48	max	0	20	-.009	20	.001	16	-2.029e-04	20	5.207e-06	3	8.371e-04	16
94		min	-.001	2	-.02	4	0	1	-5.024e-04	4	2.19e-06	17	4.052e-04	17
95	N49	max	0	20	-.014	20	.001	16	-1.962e-04	20	1.339e-06	8	-1.437e-04	20



**Envelope Joint Displacements (Continued)**

	Joint		X [in]	LC	Y [in]	LC	Z [in]	LC	X Rotation [rad]	LC	Y Rotatio...	LC	Z Rotatio...	LC
96		min	-.001	2	-.028	4	0	1	-4.9e-04	4	2.22e-07	2	-2.827e-04	4
97	N50	max	0	20	0	20	0	20	0	20	0	20	0	20
98		min	0	1	0	1	0	1	0	1	0	1	0	1
99	N51	max	0	20	0	20	0	20	0	20	0	20	0	20
100		min	0	1	0	1	0	1	0	1	0	1	0	1
101	N52	max	0	20	-.001	20	.001	16	-2.073e-04	20	6.935e-07	8	8.197e-04	16
102		min	-.001	2	-.003	4	0	1	-5.106e-04	4	-1.295e-06	4	4.015e-04	17
103	N53	max	0	20	0	20	.001	16	-1.875e-04	20	1.602e-06	8	-3.337e-04	20
104		min	0	2	-.002	4	0	1	-4.739e-04	4	-1.311e-06	4	-7.052e-04	4
105	N54	max	-.002	20	-.011	20	.001	16	8.406e-04	2	-3.814e-04	20	7.974e-04	16
106		min	-.003	2	-.022	4	0	1	4.672e-04	17	-6.786e-04	2	3.845e-04	17
107	N55	max	-.002	20	-.015	20	.001	16	7.644e-04	2	-3.831e-04	20	-1.367e-04	20
108		min	-.003	2	-.03	4	0	1	3.855e-04	17	-7.225e-04	2	-2.695e-04	4
109	N56	max	-.005	20	-.012	20	.001	16	-5.698e-04	20	4.364e-04	2	3.998e-04	16
110		min	-.008	2	-.023	4	0	1	-1.021e-03	4	2.465e-04	17	1.781e-04	17
111	N57	max	-.005	20	-.014	20	.001	16	-6.515e-04	20	4.589e-04	2	-6.666e-05	20
112		min	-.009	2	-.028	4	0	1	-1.212e-03	4	2.449e-04	17	-1.378e-04	4
113	N58	max	0	20	-.002	20	.001	16	3.385e-05	3	2.997e-06	3	2.255e-04	16
114		min	0	4	-.006	4	0	1	1.709e-05	17	9.533e-07	17	8.765e-05	17
115	N59	max	0	20	-.003	20	.001	16	3.22e-05	3	8.762e-07	8	-3.594e-05	20
116		min	0	4	-.009	4	0	1	1.638e-05	17	-8.936e-07	2	-8.004e-05	4
117	N60	max	0	20	0	20	.001	16	3.492e-05	3	6.448e-06	8	2.322e-04	16
118		min	0	4	-.001	4	0	1	1.756e-05	17	3.862e-06	17	9.724e-05	17
119	N61	max	0	20	0	8	.001	16	3.007e-05	3	7.918e-06	16	-9.213e-05	20
120		min	0	4	0	4	0	1	1.545e-05	17	4.192e-06	17	-2.171e-04	4
121	N62	max	0	20	.002	3	.001	16	3.492e-05	3	-4.716e-06	20	1.744e-04	3
122		min	0	4	.001	17	0	1	1.756e-05	17	-1.387e-05	4	7.411e-05	17
123	N63	max	0	20	.002	3	.002	16	3.007e-05	3	1.115e-05	16	-6.889e-05	20
124		min	0	4	.001	17	0	1	1.545e-05	17	1.825e-06	17	-1.59e-04	3
125	N64	max	0	20	0	3	.001	16	2.502e-05	3	1.973e-05	16	2.026e-04	16
126		min	0	4	0	2	0	1	1.657e-06	17	9.539e-06	17	3.509e-05	17
127	N65	max	0	20	0	3	.001	16	4.038e-05	3	2.571e-05	16	-3.675e-05	20
128		min	0	4	0	2	0	1	1.42e-05	17	1.085e-05	17	-2.007e-04	4
129	N66	max	0	20	0	20	0	20	0	20	0	20	0	20
130		min	0	1	0	1	0	1	0	1	0	1	0	1
131	N67	max	0	20	0	20	0	20	0	20	0	20	0	20
132		min	0	1	0	1	0	1	0	1	0	1	0	1
133	N68	max	0	20	0	20	.001	16	1.449e-04	16	2.698e-05	16	2.365e-04	16
134		min	0	4	0	4	0	1	3.196e-05	17	8.148e-06	17	3.728e-05	17
135	N69	max	0	16	0	20	.001	16	1.634e-04	16	1.799e-05	16	-3.778e-05	20
136		min	0	17	0	4	0	1	4.493e-05	17	5.726e-06	17	-2.376e-04	4
137	N70	max	0	16	0	20	0	16	6.298e-06	16	8.127e-06	16	-9.291e-06	20
138		min	0	17	0	4	0	1	-1.456e-05	1	2.079e-06	17	-5.716e-05	4
139	N71	max	0	20	0	20	0	16	9.84e-07	16	4.539e-06	16	5.771e-05	16
140		min	0	4	0	4	0	1	-1.943e-05	1	1.384e-06	17	9.737e-06	17
141	N72	max	0	20	0	20	0	16	2.236e-05	16	4.827e-05	16	-2.591e-07	20
142		min	0	1	-.001	4	0	1	-1.452e-05	1	7.259e-06	17	-4.752e-07	3
143	N73	max	.001	16	0	20	0	16	5.075e-05	16	2.634e-05	16	7.126e-05	16
144		min	0	17	0	4	0	1	1.734e-06	17	7.591e-06	17	1.181e-05	17
145	N74	max	0	20	0	20	0	16	6.096e-05	16	9.977e-06	16	-1.183e-05	20
146		min	-.001	4	0	4	0	1	9.312e-06	17	3.605e-06	17	-7.139e-05	4
147	N75	max	0	16	-.002	20	.001	16	3.691e-04	16	1.816e-06	3	-2.454e-05	20

**Envelope Joint Displacements (Continued)**

Joint	X [in]	LC	Y [in]	LC	Z [in]	LC	X Rotation [rad]	LC	Y Rotatio...	LC	Z Rotatio...	LC		
148	min	0	17	-.01	4	0	1	9.099e-05	17	7.172e-07	17	-4.179e-05	3	
149	N76	max	0	16	-.003	20	.001	16	3.875e-04	16	6.595e-06	16	5.615e-05	8
150	min	0	17	-.01	4	0	1	1.039e-04	17	2.169e-06	17	3.369e-05	17	
151	N77	max	0	16	-.003	20	.001	16	3.691e-04	16	-2.112e-06	20	-3.647e-05	20
152	min	0	17	-.011	4	0	1	9.099e-05	17	-8.75e-06	4	-7.215e-05	4	
153	N78	max	0	16	-.004	20	.002	16	3.875e-04	16	8.564e-06	16	8.523e-05	16
154	min	0	17	-.012	4	0	1	1.039e-04	17	1.719e-06	17	4.561e-05	17	
155	N81	max	0	20	0	20	0	8	9.27e-06	8	7.7e-07	16	1.361e-05	16
156	min	0	4	0	4	0	4	4.781e-06	4	-2.49e-07	1	1.7e-06	17	

**Envelope AISC 14th(360-10): ASD Steel Code Checks**

Member	Shape	Code Check	Lo...	LC	She...	Lo.....	Pnc/...	Pnt/o...	Mnyy...	Mnzz...	Cb	Eqn		
1	M10	W8X13	.456	9....	16	.080	9....	y ...	49.72	82.778	3.862	7.581	1.6...	H1-...
2	M9	W8X13	.420	9....	16	.073	9....	y ...	49.72	82.778	3.862	7.516	1.6...	H1-...
3	M54	L4X4X4	.326	2....	8	.050	0	z 2	33.461	41.605	2.088	4.468	1.8...	H2-1
4	M52	L4X4X4	.326	2....	3	.050	0	z 2	33.461	41.605	2.088	4.468	1.8...	H2-1
5	M6	HSS4X4X4	.185	3.75	16	.015	0	y ...	87.521	92.826	10.765	10.765	2.1...	H1-...
6	M5	HSS4X4X4	.172	3.75	16	.015	0	y ...	87.521	92.826	10.765	10.765	2.1...	H1-...
7	M12	C6X10.5	.146	2....	16	.059	6....	y 3	22.088	66.18	1.616	11.102	1.3...	H1-...
8	M4	HSS4X4X4	.131	3.75	16	.009	0	y ...	87.521	92.826	10.765	10.765	2.1...	H1-...
9	M27	C6X10.5	.127	1....	3	.048	4.98	y ...	22.088	66.18	1.616	11.102	1.5...	H1-...
10	M3	HSS4X4X4	.125	3.75	16	.009	0	y ...	87.521	92.826	10.765	10.765	2.1...	H1-...
11	M13	C6X10.5	.102	4.98	16	.053	5....	y ...	22.088	66.18	1.616	11.102	1.7...	H1-...
12	M28	W8X13	.087	2....	3	.035	6....	y ...	53.668	82.778	3.862	20.479	1.2...	H1-...
13	M51	L4X4X4	.064	2....	2	.023	2....	z 2	35.177	41.605	2.088	4.468	1.29	H2-1
14	M26	W8X13	.063	3....	3	.027	0	y 3	53.668	82.778	3.862	20.479	1.1...	H1-...
15	M7	HSS4X4X4	.060	3.75	16	.011	2.93	z ...	87.521	92.826	10.765	10.765	2.1...	H1-...
16	M53	L4X4X4	.060	2....	2	.024	2....	z 2	35.177	41.605	2.088	4.468	1.3...	H2-1
17	M8	HSS4X4X4	.060	3.75	16	.011	2.93	z ...	87.521	92.826	10.765	10.765	2.1...	H1-...
18	M29	W8X13	.052	2....	16	.036	6....	y ...	53.668	82.778	3.862	20.479	1.2...	H1-...
19	M11	C6X10.5	.044	3....	16	.019	6....	y ...	22.088	66.18	1.616	11.102	1.2...	H1-...
20	M15	W8X13	.032	1....	16	.020	1....	y ...	80.595	82.778	3.862	20.479	1.8...	H1-...
21	M16	W8X13	.030	0	16	.021	0	y 3	80.595	82.778	3.862	20.479	1.8...	H1-...
22	M20	W8X13	.029	1....	16	.019	1....	y ...	80.595	82.778	3.862	20.479	1.8...	H1-...
23	M19	W8X13	.029	0	16	.019	0	y ...	80.595	82.778	3.862	20.479	1.87	H1-...
24	M17	W8X13	.029	1....	16	.020	1....	y ...	80.595	82.778	3.862	20.479	1.8...	H1-...
25	M18	W8X13	.029	0	16	.019	0	y ...	80.595	82.778	3.862	20.479	1.87	H1-...
26	M21	W8X13	.027	1....	16	.018	1....	y 3	80.595	82.778	3.862	20.479	1.8...	H1-...
27	M22	W8X13	.027	0	16	.018	0	y 3	80.595	82.778	3.862	20.479	1.8...	H1-...
28	M23	W8X13	.026	0	16	.022	6....	y ...	53.668	82.778	3.862	20.479	1.5...	H1-...
29	M36	L2.5x2.5x4	.025	0	16	.002	3....	y ...	5.813	25.653	.741	1.629	2.2...	H2-1
30	M35	L2.5x2.5x4	.024	0	16	.003	3....	y ...	5.813	25.653	.741	1.596	1.9...	H2-1
31	M50	L2.5x2.5x4	.023	0	16	.003	0	z ...	24.273	25.653	.741	1.688	2.03	H2-1
32	M49	L2.5x2.5x4	.022	0	16	.003	0	y ...	24.273	25.653	.741	1.688	2.1	H2-1
33	M47	L2.5x2.5x4	.020	0	16	.001	0	z ...	17.061	25.653	.741	1.688	2.7...	H2-1
34	M48	L2.5x2.5x4	.017	0	16	.001	0	y ...	17.061	25.653	.741	1.688	2.7...	H2-1
35	M31	W8X13	.017	0	16	.011	0	y 3	80.595	82.778	3.862	20.479	1.9...	H1-...
36	M34	L2.5x2.5x4	.017	.5	16	.001	0	z 8	19.125	25.653	.741	1.688	2.2...	H2-1
37	M32	W8X13	.016	0	16	.008	6....	y ...	53.668	82.778	3.862	20.479	3.15	H1-...
38	M30	W8X13	.016	1....	16	.011	1....	y 3	80.595	82.778	3.862	20.479	1.9...	H1-...



**Envelope AISC 14th(360-10): ASD Steel Code Checks (Continued)**

Member	Shape	Code Check	Lo...	LC	She...	Lo.....	Pnc/...	Pnt/o...	Mnyy...	Mnzz...	Cb	Eqn		
39	M14	W8X13	.015	3....	16	.013	6....	y...	53.668	82.778	3.862	20.479	1.3...	H1-...
40	M59	L2.5x2.5x4	.015	7....	16	.001	3....	y...	5.813	25.653	.741	1.474	1.3...	H2-1
41	M33	L2.5x2.5x4	.015	7....	16	.001	3....	y...	5.813	25.653	.741	1.549	1.6...	H2-1
42	M25	W8X13	.012	0	16	.008	0	y...	80.595	82.778	3.862	20.479	1.9...	H1-...
43	M24	W8X13	.012	1....	16	.008	1....	y...	80.595	82.778	3.862	20.479	1.9...	H1-...
44	M1	HSS4X4X4	.011	1.25	16	.003	1.25	z...	87.521	92.826	10.765	10.765	2.2...	H1-...
45	M2	HSS4X4X4	.010	0	16	.002	0	y...	87.521	92.826	10.765	10.765	2.1...	H1-...
46	M38	W8X13	.010	3....	2	.006	6....	y 2	55.788	82.778	3.862	20.404	1.1...	H1-...
47	M43	W8X13	.010	3....	2	.006	6....	y 2	55.788	82.778	3.862	20.404	1.1...	H1-...
48	M40	W8X13	.009	2....	2	.005	0	y 2	80.675	82.778	3.862	20.479	1	H1-...
49	M45	W8X13	.009	2....	2	.005	0	y 2	56.991	82.778	3.862	20.479	1.1...	H1-...
50	M41	W8X13	.009	2....	2	.005	0	y 2	58.778	82.778	3.862	20.479	1.1...	H1-...
51	M46	W8X13	.009	2....	2	.005	0	y 2	58.778	82.778	3.862	20.479	1.1...	H1-...
52	M39	W8X13	.007	2....	2	.005	5....	y 2	81.17	82.778	3.862	20.479	1	H1-...
53	M44	W8X13	.007	2....	2	.005	5....	y 2	62.273	82.778	3.862	20.479	1.1...	H1-...
54	M37	W8X13	.003	1.75	2	.003	3.5	y 2	72.642	82.778	3.862	20.479	1.1...	H1-...
55	M42	W8X13	.003	1.75	2	.003	3.5	y 2	72.642	82.778	3.862	20.479	1.1...	H1-...

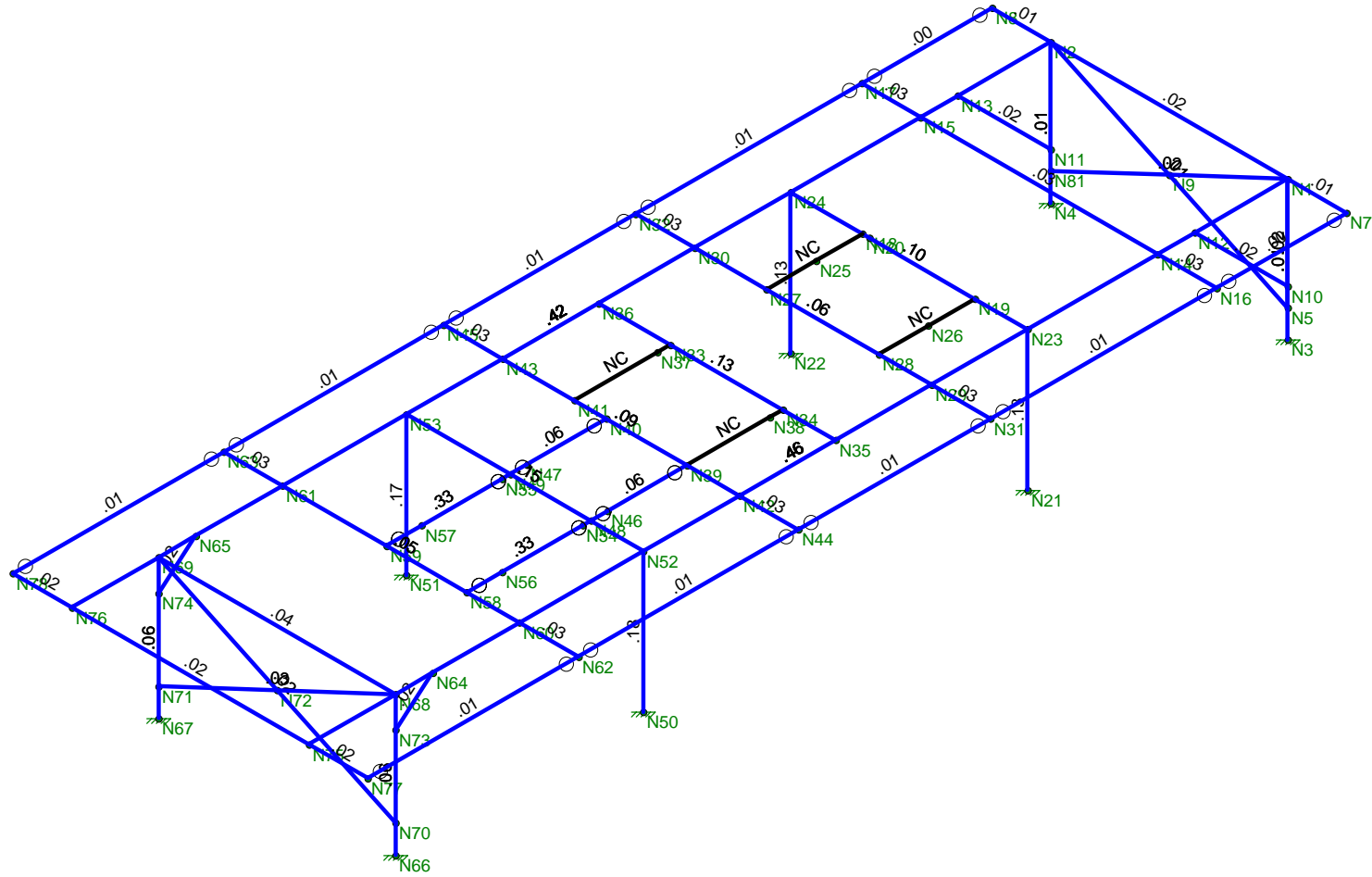
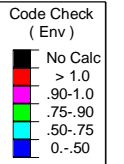
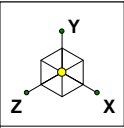

Member Code Checks Displayed (Enveloped)  
Envelope Only Solution

Centek Engineering
FJP
20143.12

CT11005D - Eq. PPlatform - Rev.1
Unity Check

Oct 29, 2020 at 4:19 PM
CT11005D_Eq.Platform_Rev.1.r3d

RADIO FREQUENCY EMISSIONS ANALYSIS REPORT  
EVALUATION OF HUMAN EXPOSURE POTENTIAL  
TO NON-IONIZING EMISSIONS

T-Mobile Existing Facility

Site ID: CT11005D

Greenwich/Route 1  
1111 E. Putnam Avenue  
Greenwich, Connecticut 06878

**January 12, 2021**

**EBI Project Number: 6221000090**

Site Compliance Summary	
Compliance Status:	<b>COMPLIANT</b>
Site total MPE% of FCC general population allowable limit:	<b>93.73%</b>

January 12, 2021

T-Mobile

Attn: Jason Overbey, RF Manager  
35 Griffin Road South  
Bloomfield, Connecticut 06002

Emissions Analysis for Site: CT11005D - Greenwich/Route 1

EBI Consulting was directed to analyze the proposed T-Mobile facility located at **1111 E. Putnam Avenue in Greenwich, Connecticut** for the purpose of determining whether the emissions from the Proposed T-Mobile Antenna Installation located on this property are within specified federal limits.

All information used in this report was analyzed as a percentage of current Maximum Permissible Exposure (% MPE) as listed in the FCC OET Bulletin 65 Edition 97-01 and ANSI/IEEE Std C95.1. The FCC regulates Maximum Permissible Exposure in units of microwatts per square centimeter ( $\mu\text{W}/\text{cm}^2$ ). The number of  $\mu\text{W}/\text{cm}^2$  calculated at each sample point is called the power density. The exposure limit for power density varies depending upon the frequencies being utilized. Wireless Carriers and Paging Services use different frequency bands each with different exposure limits; therefore, it is necessary to report results and limits in terms of percent MPE rather than power density.

All results were compared to the FCC (Federal Communications Commission) radio frequency exposure rules, 47 CFR 1.1307(b)(1) – (b)(3), to determine compliance with the Maximum Permissible Exposure (MPE) limits for General Population/Uncontrolled environments as defined below.

General population/uncontrolled exposure limits apply to situations in which the general population may be exposed or in which persons who are exposed as a consequence of their employment may not be made fully aware of the potential for exposure or cannot exercise control over their exposure. Therefore, members of the general population would always be considered under this category when exposure is not employment related, for example, in the case of a telecommunications tower that exposes persons in a nearby residential area.

Public exposure to radio frequencies is regulated and enforced in units of microwatts per square centimeter ( $\mu\text{W}/\text{cm}^2$ ). The general population exposure limits for the 600 MHz and 700 MHz frequency bands are approximately  $400 \mu\text{W}/\text{cm}^2$  and  $467 \mu\text{W}/\text{cm}^2$ , respectively. The general population exposure limit for the 1900 MHz (PCS), 2100 MHz (AWS) and 11 GHz frequency bands is  $1000 \mu\text{W}/\text{cm}^2$ . Because each carrier will be using different frequency bands, and each frequency band has different exposure limits, it is necessary to report percent of MPE rather than power density.

Occupational/controlled exposure limits apply to situations in which persons are exposed as a consequence of their employment and in which those persons who are exposed have been made fully aware of the potential for exposure and can exercise control over their exposure. Occupational/controlled exposure limits also apply where exposure is of a transient nature as a result of incidental passage through a location where exposure levels may be above general population/uncontrolled limits (see below), as long as the exposed person has been made fully aware of the potential for exposure and can exercise control over his or her exposure by leaving the area or by some other appropriate means.

Additional details can be found in FCC OET 65.

## **CALCULATIONS**

Calculations were done for the proposed T-Mobile Wireless antenna facility located at 1111 E. Putnam Avenue in Greenwich, Connecticut using the equipment information listed below. All calculations were performed per the specifications under FCC OET 65. Since T-Mobile is proposing highly focused directional panel antennas, which project most of the emitted energy out toward the horizon, all calculations were performed assuming a lobe representing the maximum gain of the antenna per the antenna manufacturer's supplied specifications, minus 10 dB for directional panel antennas and 20 dB for highly focused parabolic microwave dishes, was focused at the base of the tower. A conservative roof attenuation factor of 10 dB, in which a radiofrequency signal is reduced by a factor of 10 due to intervening roof building materials<sup>[1]</sup>, was also used. It is assumed, for purposes of this analysis, that the roof building material is comprised of a poured concrete and steel underlayment with a rubber fabric roof membrane. For this report, the sample point is the top of a 6-foot person standing at the base of the tower.

For all calculations, all equipment was calculated using the following assumptions:

- 1) 2 LTE channels (600 MHz Band) were considered for each sector of the proposed installation. These Channels have a transmit power of 30 Watts per Channel.
- 2) 1 NR channel (600 MHz Band) was considered for each sector of the proposed installation. This Channel has a transmit power of 80 Watts.
- 3) 2 LTE channels (700 MHz Band) were considered for each sector of the proposed installation. These Channels have a transmit power of 30 Watts per Channel.
- 4) 4 GSM channels (PCS Band - 1900 MHz) were considered for each sector of the proposed installation. These Channels have a transmit power of 30 Watts per Channel.

---

<sup>[1]</sup> Based upon wireless signal roof attenuation factors for similar materials cited in Jackman, Swartz, Burton, Head, "CWDP Certified Wireless Design Professional Official Study Guide," Wiley Publishers, 2011, Table 6-3.

- 5) 4 LTE channels (PCS Band - 1900 MHz) were considered for each sector of the proposed installation. These Channels have a transmit power of 60 Watts per Channel.
- 6) 2 UMTS channels (AWS Band - 2100 MHz) were considered for each sector of the proposed installation. These Channels have a transmit power of 30 Watts per Channel.
- 7) 2 LTE channels (AWS Band – 2100 MHz) were considered for each sector of the proposed installation. These Channels have a transmit power of 60 Watts per Channel.
- 8) 1 LTE channel (BRS Band - 2500 MHz) was considered for each sector of the proposed installation. This Channel has a transmit power of 120 Watts.
- 9) 1 NR channel (BRS Band - 2500 MHz) was considered for each sector of the proposed installation. This Channel has a transmit power of 120 Watts.
- 10) All radios at the proposed installation were considered to be running at full power and were uncombined in their RF transmissions paths per carrier prescribed configuration. Per FCC OET Bulletin No. 65 - Edition 97-01 recommendations to achieve the maximum anticipated value at each sample point, all power levels emitting from the proposed antenna installation are increased by a factor of 2.56 to account for possible in-phase reflections from the surrounding environment. This is rarely the case, and if so, is never continuous.
- 11) For the following calculations, the sample point was the top of a 6-foot person standing at the base of the tower. The maximum gain of the antenna per the antenna manufacturer's supplied specifications, minus 10 dB for directional panel antennas and 20 dB for highly focused parabolic microwave dishes, was used in this direction. This value is a very conservative estimate as gain reductions for these particular antennas are typically much higher in this direction.
- 12) A conservative roof attenuation factor of 10 dB, in which a radiofrequency signal is reduced by a factor of 10 due to intervening roof building materials, was also used. It is assumed, for purposes of this analysis, that the roof building material is comprised of a poured concrete and steel underlayment with a rubber fabric roof membrane.
- 13) The antennas used in this modeling are the Ericsson AIR 32 for the 1900 MHz / 1900 MHz / 2100 MHz channel(s), the RFS APXVAARR24\_43-U-NA20 for the 600 MHz / 600 MHz / 700 MHz / 1900 MHz / 2100 MHz channel(s), the Ericsson AIR 6449 for the 2500 MHz / 2500 MHz channel(s) in Sector A, the Ericsson AIR 32 for the 1900 MHz / 1900 MHz / 2100 MHz channel(s), the RFS APXVAARR24\_43-U-NA20 for the 600 MHz / 600 MHz / 700 MHz / 1900 MHz / 2100 MHz channel(s), the Ericsson AIR 6449 for the 2500 MHz / 2500 MHz channel(s) in Sector B, the Ericsson AIR 32 for the 1900 MHz / 1900 MHz / 2100 MHz channel(s), the



RFS APXVAARR24\_43-U-NA20 for the 600 MHz / 600 MHz / 700 MHz / 1900 MHz / 2100 MHz channel(s), the Ericsson AIR 6449 for the 2500 MHz / 2500 MHz channel(s) in Sector C. This is based on feedback from the carrier with regard to anticipated antenna selection. All Antenna gain values and associated transmit power levels are shown in the Site Inventory and Power Data table below. The maximum gain of the antenna per the antenna manufacturer's supplied specifications, minus 10 dB for directional panel antennas and 20 dB for highly focused parabolic microwave dishes, was used for all calculations. This value is a very conservative estimate as gain reductions for these particular antennas are typically much higher in this direction.

- 14) The antenna mounting height centerline of the proposed antennas is 43 feet above ground level (AGL).
- 15) Emissions values for additional carriers were taken from the Connecticut Siting Council active database. Values in this database are provided by the individual carriers themselves.
- 16) All calculations were done with respect to uncontrolled / general population threshold limits.

## T-Mobile Site Inventory and Power Data

Sector:	A	Sector:	B	Sector:	C
Antenna #:	1	Antenna #:	1	Antenna #:	1
Make / Model:	Ericsson AIR 32	Make / Model:	Ericsson AIR 32	Make / Model:	Ericsson AIR 32
Frequency Bands:	1900 MHz / 1900 MHz / 2100 MHz	Frequency Bands:	1900 MHz / 1900 MHz / 2100 MHz	Frequency Bands:	1900 MHz / 1900 MHz / 2100 MHz
Gain:	15.35 dBd / 15.35 dBd / 15.85 dBd	Gain:	15.35 dBd / 15.35 dBd / 15.85 dBd	Gain:	15.35 dBd / 15.35 dBd / 15.85 dBd
Height (AGL):	43 feet	Height (AGL):	43 feet	Height (AGL):	43 feet
Channel Count:	8	Channel Count:	8	Channel Count:	8
Total TX Power (W):	360 Watts	Total TX Power (W):	360 Watts	Total TX Power (W):	360 Watts
ERP (W):	2,149.30	ERP (W):	2,149.30	ERP (W):	2,149.30
Antenna A1 MPE %:	4.18%	Antenna B1 MPE %:	4.18%	Antenna C1 MPE %:	4.18%
Antenna #:	2	Antenna #:	2	Antenna #:	2
Make / Model:	RFS APXVAARR24_43-U-NA20	Make / Model:	RFS APXVAARR24_43-U-NA20	Make / Model:	RFS APXVAARR24_43-U-NA20
Frequency Bands:	600 MHz / 600 MHz / 700 MHz / 1900 MHz / 2100 MHz	Frequency Bands:	600 MHz / 600 MHz / 700 MHz / 1900 MHz / 2100 MHz	Frequency Bands:	600 MHz / 600 MHz / 700 MHz / 1900 MHz / 2100 MHz
Gain:	12.95 dBd / 12.95 dBd / 13.35 dBd / 15.65 dBd / 16.35 dBd	Gain:	12.95 dBd / 12.95 dBd / 13.35 dBd / 15.65 dBd / 16.35 dBd	Gain:	12.95 dBd / 12.95 dBd / 13.35 dBd / 15.65 dBd / 16.35 dBd
Height (AGL):	43 feet	Height (AGL):	43 feet	Height (AGL):	43 feet
Channel Count:	9	Channel Count:	9	Channel Count:	9
Total TX Power (W):	380 Watts	Total TX Power (W):	380 Watts	Total TX Power (W):	380 Watts
ERP (W):	2,022.18	ERP (W):	2,022.18	ERP (W):	2,022.18
Antenna A2 MPE %:	6.36%	Antenna B2 MPE %:	6.36%	Antenna C2 MPE %:	6.36%
Antenna #:	3	Antenna #:	3	Antenna #:	3
Make / Model:	Ericsson AIR 6449	Make / Model:	Ericsson AIR 6449	Make / Model:	Ericsson AIR 6449
Frequency Bands:	2500 MHz / 2500 MHz	Frequency Bands:	2500 MHz / 2500 MHz	Frequency Bands:	2500 MHz / 2500 MHz
Gain:	22.05 dBd / 22.05 dBd	Gain:	22.05 dBd / 22.05 dBd	Gain:	22.05 dBd / 22.05 dBd
Height (AGL):	43 feet	Height (AGL):	43 feet	Height (AGL):	43 feet
Channel Count:	2	Channel Count:	2	Channel Count:	2
Total TX Power (W):	240 Watts	Total TX Power (W):	240 Watts	Total TX Power (W):	240 Watts
ERP (W):	3,038.86	ERP (W):	3,038.86	ERP (W):	3,038.86
Antenna A3 MPE %:	5.91%	Antenna B3 MPE %:	5.91%	Antenna C3 MPE %:	5.91%

Site Composite MPE %	
Carrier	MPE %
T-Mobile (Max at Sector A):	16.45%
Verizon	47.66%
Greenwich PD	2.09%
Sprint	27.53%
<b>Site Total MPE % :</b>	<b>93.73%</b>

T-Mobile MPE % Per Sector	
T-Mobile Sector A Total:	16.45%
T-Mobile Sector B Total:	16.45%
T-Mobile Sector C Total:	16.45%
<b>Site Total MPE % :</b>	<b>93.73%</b>

T-Mobile Maximum MPE Power Values (Sector A)							
T-Mobile Frequency Band / Technology (Sector A)	# Channels	Watts ERP (Per Channel)	Height (feet)	Total Power Density ( $\mu\text{W}/\text{cm}^2$ )	Frequency (MHz)	Allowable MPE ( $\mu\text{W}/\text{cm}^2$ )	Calculated % MPE
T-Mobile 1900 MHz GSM	4	1028.30	43.0	79.98	1900 MHz GSM	1000	8.00%
T-Mobile 1900 MHz LTE	2	2056.61	43.0	79.98	1900 MHz LTE	1000	8.00%
T-Mobile 2100 MHz LTE	2	2307.55	43.0	89.73	2100 MHz LTE	1000	8.97%
T-Mobile 600 MHz LTE	2	591.73	43.0	23.01	600 MHz LTE	400	5.75%
T-Mobile 600 MHz NR	1	1577.94	43.0	30.68	600 MHz NR	400	7.67%
T-Mobile 700 MHz LTE	2	648.82	43.0	25.23	700 MHz LTE	467	5.40%
T-Mobile 1900 MHz LTE	2	2203.69	43.0	85.70	1900 MHz LTE	1000	8.57%
T-Mobile 2100 MHz UMTS	2	1294.56	43.0	50.34	2100 MHz UMTS	1000	5.03%
T-Mobile 2500 MHz LTE	1	19238.94	43.0	374.08	2500 MHz LTE	1000	37.41%
T-Mobile 2500 MHz NR	1	19238.94	43.0	374.08	2500 MHz NR	1000	37.41%
						<b>Total:</b>	<b>16.45%</b>

• NOTE: Totals may vary by approximately 0.01% due to summation of remainders in calculations.

## Summary

All calculations performed for this analysis yielded results that were **within** the allowable limits for general population exposure to RF Emissions.

The anticipated maximum composite contributions from the T-Mobile facility as well as the site composite emissions value with regards to compliance with FCC's allowable limits for general population exposure to RF Emissions are shown here:

T-Mobile Sector	Power Density Value (%)
Sector A:	16.45%
Sector B:	16.45%
Sector C:	16.45%
T-Mobile Maximum MPE % (Sector A):	16.45%
Site Total:	93.73%
Site Compliance Status:	<b>COMPLIANT</b>

The anticipated composite MPE value for this site assuming all carriers present is **93.73%** of the allowable FCC established general population limit sampled at the ground level. This is based upon values listed in the Connecticut Siting Council database for existing carrier emissions.

FCC guidelines state that if a site is found to be out of compliance (over allowable thresholds), that carriers over a 5% contribution to the composite value will require measures to bring the site into compliance. For this facility, the composite values calculated were within the allowable 100% threshold standard per the federal government.