



445 Hamilton Avenue, 14th Floor
White Plains, New York 10601
T 914 761 1300
F 914 761 5372
cuddyfeder.com

Lucia Chiocchio
lchiocchio@cuddyfeder.com

April 30, 2019

VIA EMAIL & OVERNIGHT DELIVERY

Members of the Connecticut Siting Council
Connecticut Siting Council
10 Franklin Square
New Britain, Connecticut 06051

Re: Tower Sharing Request by New Cingular Wireless PCS, LLC
Facility as Approved in Siting Council Docket 478
Premises: 63 Woodland Street, Glastonbury, Connecticut

Dear Members of the Siting Council:

Pursuant to Connecticut General Statutes (C.G.S.) § 16-50aa, New Cingular Wireless PCS, LLC (“AT&T”) hereby requests an order from the Connecticut Siting Council (the “Council”) to approve the proposed shared use of a communications tower and associated compound at the parcel identified as 63 Woodland Street in the Town of Glastonbury (the “Woodland Street Facility”). The Certificate Holder and tower owner is Eco-Site, Inc. (“Eco-Site”). AT&T and Eco-Site have agreed to share the use of the Woodland Street Facility as detailed below. Additionally, annexed here as **Attachment 4** is the Letter of Authorization between the Applicant and the Certificate Holder authorizing the Applicant to prepare and file an application for the Applicant’s use of the existing tower.

The Woodland Street Facility

The Woodland Street Facility consists of an approximately one hundred and fifty-foot (150’) monopole (the “Tower”) and associated equipment for wireless communications use by Verizon and others. The tower and compound are located on an approximately 177.1-acre parcel owned by Paul Cavanna.

AT&T’s Wireless Facility

As depicted on the enclosed plans annexed hereto as **Attachment 1** prepared by Fullerton Engineering Design last updated March 26, 2019, including a site plan, compound and



April 30, 2019

Page 2

equipment layout and tower elevation, AT&T proposes shared use of the Facility to provide FCC licensed services. AT&T will install 9 antennas, 15 remote radiohead units, and 3 raycap units on a v-boom antenna mount at approximately the 135-foot level of the Tower. As also depicted on the drawings, within the existing compound AT&T will install a 6'-8"x6'-8" walk in equipment cabinet and a 20kw backup diesel generator, both on a new 13'-10"x6'-8" steel platform.

Connecticut General Statutes § 16-50aa provides that, upon written request for shared use approval, an order approving such use shall be issued "if the Council finds that the proposed shared use of the facility is technically, legally, environmentally and economically feasible and meets public safety concerns." (C.G.S. § 16-50aa(c)(1)). Further, upon approval of such shared use, it is exclusive, and no local zoning or land use approvals are required. (C.G.S. § 16-50x). Shared use of the Woodland Street Facility satisfies the approval criteria set forth in C.G.S. § 16-50aa as follows:

- A. Technical Feasibility: As evidenced in the structural report prepared by Morrison Hershfield and dated February 22, 2019 annexed hereto as **Attachment 2**, AT&T confirmed that the tower is designed to support the addition of AT&T's antennas and tower mounted equipment in addition to the existing loading. The proposed shared use of this tower is therefore technically feasible.
- B. Legal Feasibility: Pursuant to C.G.S. § 16-50aa, the Council is authorized to issue an order approving shared use of the existing Woodland Street Facility. (C.G.S. § 16-50aa(c)(1)). Under the authority vested in the Council by C.G.S. § 16-50aa, an order by the Council approving the shared use of a tower would permit the Applicant to obtain a building permit for the proposed installation. Notably, the tower is subject to the approval granted in Docket 478. In addition, Condition 5 of the Decision and Order in Docket 478 mandates that the tower be available for shared use where feasible and such is the case with this proposal.
- C. Environmental Feasibility: The proposed shared use would have a minimal environmental effect, for the following reasons:
 1. The proposed installation would have a *de minimis* visual impact and would not cause any significant change or alteration in the physical or environmental characteristics of the approved facility.
 2. The installation by AT&T will not increase the height of the approved Tower nor extend the site boundaries;



April 30, 2019

Page 3

3. The proposed installation will not increase the noise levels at the site boundaries by six decibels or more;
 4. Operation of AT&T's antennas at this site will not exceed the total radio frequency electromagnetic radiation power density level adopted by the FCC and Connecticut Department of Health. AT&T's proposed antenna installation along with other carriers is calculated to be within 12.34% of FCC Standard for General Public/Uncontrolled Maximum Permissible Exposure (MPE). Please see the assessment of RF power density dated March 27, 2019, prepared by Keith Vellante, Director of RF Services, C Squared Systems, LLC, annexed hereto as **Attachment 3**; and
 5. The proposed shared use of the Woodland Street Facility would not require any water or sanitary facilities or discharges into any waterbodies. The only air emissions would be from weekly testing of the emergency back-up generator and its use during a power outage. Further, the installation will not generate any traffic other than for periodic maintenance visits.
- D. Economic Feasibility: The Applicant and the Certificate Holder entered into a mutual agreement to share use of the Woodland Street Facility on terms agreeable to both parties. The proposed tower sharing is therefore economically feasible.
- E. Public Safety: As stated above and evidenced in attachments hereto the tower is structurally capable of supporting AT&T's installation and emissions are well within the maximum permitted by the FCC and the Connecticut Department of Health. Further, the addition of AT&T's wireless telecommunications service in the Glastonbury area through shared use of the Woodland Street Facility is expected to enhance the safety and welfare of local residents and travelers through the area resulting in an improvement to public safety in this area of the State.

Conclusion

As explained above, the proposed shared use of the Woodland Street Facility satisfies the criteria set forth in C.G.S. §16-50aa and advances the General Assembly's and the Siting Council's goal of preventing the proliferation of towers in the State of Connecticut. AT&T therefore requests the Siting Council issue an order approving the proposed shared use of the Woodland Street Facility.



April 30, 2019
Page 4

Respectfully submitted,

A handwritten signature in blue ink, reading 'Lucia Chiochio', is written in a cursive style.

Lucia Chiochio
On behalf of AT&T

Attachments

cc: Richard Johnson, Town Manager, Glastonbury
Eco-Site, Inc.
Paul Cavanna
AT&T
C Squared Systems, LLC
Daniel Patrick, Esq.
Julie Durkin

Attachment 1

AT&T APPROVALS		
PRINT NAME	SIGNATURE	DATE
SA MANAGER		
SMARTLINK CM		
SMARTLINK SA PM		
SMARTLINK SA SPEC.		
SMARTLINK COMPLIANCE MGR.		
AT&T RF PM		
AT&T PM		
APPROVED FOR CONSTRUCTION		
NETWORK DEVELOPMENT		
SA		
RF		
CONSTRUCTION		
PROPERTY OWNER		



SITE NAME: WOODLAND STREET FACILITY
 SEARCH RING NUMBER: CT2421S
 USID: 245301
 FA NUMBER: 14644530
 SITE ADDRESS: 63 WOODLAND STREET
 SOUTH GLASTONBURY, CT 06073
 SITE TYPE: MONOPOLE



PROJECT INFORMATION	
SITE NAME:	WOODLAND STREET FACILITY
USID:	245301
SITE ADDRESS:	63 WOODLAND STREET SOUTH GLASTONBURY, CT 06073
SITE TYPE:	MONOPOLE
COUNTY:	HARTFORD
JURISDICTION:	TOWN OF GLASTONBURY
APN:	-
ZONING CLASSIFICATION:	RURAL RESIDENTIAL
FA#:	14644530
APPLICANT:	AT&T WIRELESS 7150 STANDARD DRIVE HANOVER, MD 21076
SITE COORDINATES:	
LATITUDE:	41.6607920°
LONGITUDE:	-72.5740970°
GROUND ELEV. (A.M.S.L.):	319'
PROPERTY OWNER:	PAUL CAVANNA 80 WOODLAND STREET GLASTONBURY, CT 06073

SCOPE OF WORK
THE SCOPE OF WORK CONSISTS OF:
<ul style="list-style-type: none"> (3) ANTENNA SECTOR FRAMES (9) NEW ANTENNAS (15) NEW RRH UNITS (3) NEW RAYCAP UNITS (2) NEW FIBER CABLES & (6) NEW DC POWER CABLES NEW 6'-8"x6'-8" WIC SHELTER NEW 20KW AC GENERATOR W/ FUEL TANK (2) NEW DC12 ON NEW UNISTRUT
<ul style="list-style-type: none"> CONTRACTOR SHALL FURNISH ALL MATERIAL WITH THE EXCEPTION OF AT&T SUPPLIED MATERIAL. ALL MATERIAL SHALL BE INSTALLED BY THE CONTRACTOR, UNLESS STATED OTHERWISE.

APPLICABLE BUILDING CODES AND STANDARDS
ALL WORK AND MATERIALS SHALL BE PERFORMED AND INSTALLED IN ACCORDANCE WITH THE CURRENT EDITIONS OF THE FOLLOWING CODES AS ADOPTED BY THE LOCAL GOVERNING AUTHORITIES.
BUILDING CODE: 2015 INTERNATIONAL BUILDING CODE 2018 CONNECTICUT STATE BUILDING CODE
ELECTRICAL CODE: 2017 NATIONAL ELECTRICAL CODE
FACILITY IS UNMANNED AND NOT FOR HUMAN HABITATION. ADA ACCESS REQUIREMENTS ARE NOT REQUIRED. THIS FACILITY DOES NOT REQUIRE POTABLE WATER AND WILL NOT PRODUCE ANY SEWAGE

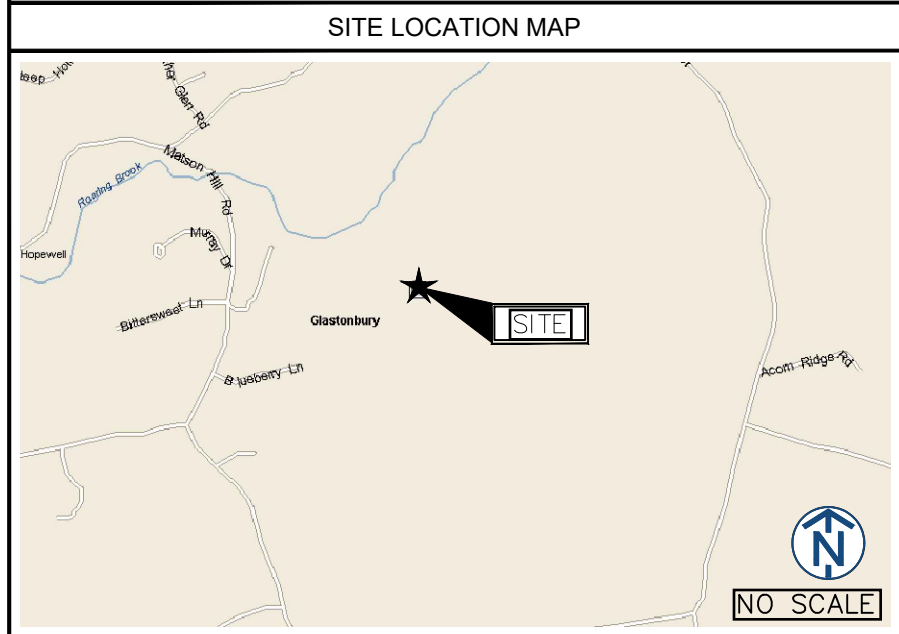

DRAWING INDEX	
T-1	TITLE SHEET
T-2	GENERAL NOTES
C-1	SITE PLAN
C-2	ENLARGED SITE PLAN
C-2A	EQUIPMENT LAYOUT
C-3	ELEVATION AND ANTENNA PLAN
C-4	SITE DETAILS
C-4A	SITE DETAILS
C-5	WIC SHELTER ELEVATIONS
C-6	GENERATOR
C-6A	CONCRETE FOUNDATION DETAILS
C-7	ANTENNA INFORMATION CHART
C-8	PLUMBING DIAGRAM
E-1	UTILITY PLAN
E-2	ELECTRICAL NOTES AND DETAILS
G-1	GROUNDING PLAN & NOTES
G-2	RISER DIAGRAM AND DETAILS
G-3	GROUNDING NOTES AND DETAILS

REV	DATE	DESCRIPTION	BY
A	02/19/19	90% REVIEW	EB
B	03/19/19	REV. 90% REVIEW	EB
1	03/26/19	FOR PERMIT	KC
2	04/11/19	FOR CONSTRUCTION	KC
3	04/26/19	FOR CONSTRUCTION	EB

I HEREBY CERTIFY THAT THESE DRAWINGS WERE PREPARED BY ME OR UNDER MY DIRECT SUPERVISION AND CONTROL, AND TO THE BEST OF MY KNOWLEDGE AND BELIEF COMPLY WITH THE REQUIREMENTS OF ALL APPLICABLE CODES.



SITE NUMBER	CT2421S
SITE NAME	WOODLAND STREET FACILITY
FA NUMBER:	14644530
USID:	245301
SITE ADDRESS	63 WOODLAND STREET SOUTH GLASTONBURY, CT 06073

PROJECT CONSULTANTS			
	NAME	COMPANY	PHONE
A/E	MILEN DIMITROV	FULLERTON	(847) 908-8439
REAL ESTATE	DAVID WALSH	SMARTLINK	(860) 933-5191
RF	RADU ALECSANDRU	AT&T	(860) 258-6395
PM	KRISTEN SMITH	SMARTLINK	(603) 261-6416
REGULATORY	PATRICK BAKER	SMARTLINK	(410) 263-5465
CM	ROBERT PICARD	SMARTLINK	(603) 209-5505

DIRECTIONS

SCAN QR CODE FOR LINK TO SITE LOCATION MAP

DRAWING SCALES ARE FOR 11"x17" SHEETS

SHEET NAME	TITLE SHEET
SHEET NUMBER	T-1

GENERAL:

1. THE CONTRACTOR SHALL BE RESPONSIBLE FOR FOLLOWING ALL LAWS, REGULATIONS, AND RULES SET FORTH BY FEDERAL, STATE, AND LOCAL AUTHORITIES WITH JURISDICTION OVER THE PROJECT. THIS RESPONSIBILITY IS IN EFFECT REGARDLESS OF WHETHER THE LAW, ORDINANCE, REGULATION OR RULE IS MENTIONED IN THESE SPECIFICATIONS.
2. ALL WORK SHALL BE COMPLETED AS INDICATED ON THE DRAWINGS, PROJECT SPECIFICATIONS, AND THE CONSTRUCTION CONTRACT DOCUMENTS.
3. THE CONTRACTOR SHALL HAVE AND MAINTAIN A VALID CONTRACTOR'S LICENSE FOR THE LOCATION IN WHICH THE WORK IS TO BE PERFORMED. FOR JURISDICTIONS THAT LICENSE INDIVIDUAL TRADES, THE TRADESMAN OR SUBCONTRACTOR PERFORMING THOSE TRADES SHALL BE LICENSED.
4. FOLLOW ALL APPLICABLE RULES AND REGULATIONS OF THE OCCUPATIONAL SAFETY AND HEALTH ADMINISTRATION (OSHA) AND STATE LAW AS DEFINED IN THE FEDERAL OCCUPATIONAL SAFETY AND HEALTH ACT.
5. PRIOR TO THE SUBMISSION OF THE BID, THE CONTRACTOR SHALL VISIT THE JOB SITE, VERIFY ALL DIMENSIONS AND BECOME FAMILIAR WITH THE FIELD CONDITIONS. ANY DISCREPANCIES SHALL BE BROUGHT TO THE ATTENTION OF THE PROJECT MANAGER.
6. DRAWING PLANS SHALL NOT BE SCALED.
7. THE CONTRACTOR SHALL NOT PROCEED WITH ANY WORK NOT CLEARLY IDENTIFIED ON THE DRAWINGS WITHOUT THE PRIOR WRITTEN APPROVAL OF THE PROJECT MANAGER.
8. THE CONTRACTOR SHALL INSTALL ALL EQUIPMENT AND MATERIALS IN ACCORDANCE WITH MANUFACTURER RECOMMENDATIONS UNLESS SPECIFICALLY OTHERWISE NOTED.
9. ALL MEANS AND METHODS OF CONSTRUCTION DEALING WITH TOWER CONSTRUCTION AND SAFETY, STEEL ERECTION, EXCAVATIONS, TRENCHING, SCAFFOLDING, FORMWORK, ELECTRICAL, AND WORK IN CONFINED SPACES ARE THE SOLE RESPONSIBILITY OF THE CONTRACTOR.
10. WHEN THE CONTRACTOR ACTIVITIES IMPEDE OR OBSTRUCT TRAFFIC FLOW, CONTRACTOR SHALL PROVIDE TRAFFIC CONTROL DEVICES, SIGNS, AND FLAGMEN IN ACCORDANCE WITH APPLICABLE FEDERAL, STATE, DOT AND LOCAL REQUIREMENTS.
11. THE CONTRACTOR SHALL COORDINATE SITE ACCESS AND SECURITY WITH THE PROPERTY OWNER AND THE PROJECT MANAGER PRIOR TO CONSTRUCTION.
12. THE CONTRACTOR SHALL BE RESPONSIBLE FOR COORDINATION WITH UTILITIES.
13. THE CONTRACTOR SHALL CALL THE LOCAL PUBLIC UTILITY LOCATING PROVIDER (811) A MINIMUM OF THREE BUSINESS DAYS PRIOR TO EXCAVATING IN THE PUBLIC RIGHT OF WAY.
14. THE CONTRACTOR SHALL BE RESPONSIBLE FOR LOCATING PRIVATE UTILITIES.
15. THE CONTRACTOR SHALL PROVIDE ANY TEMPORARY UTILITIES OR FACILITIES IT DEEMS NECESSARY TO COMPLETE THE WORK. THIS INCLUDES, BUT IS NOT LIMITED TO WATER, SEWER, POWER, TELEPHONE, HEAT, LIGHTING OR SECURITY.
16. WHEN EXCAVATING IN THE AREA OF EXISTING UTILITIES, THE CONTRACTOR SHALL USE REASONABLE CARE IN PROTECTING SUCH UTILITIES. CONTRACTOR SHALL NOTIFY THE PROJECT MANAGER IMMEDIATELY OF ANY CONFLICTS BETWEEN EXISTING UTILITIES AND PROPOSED CONSTRUCTION.
17. DAMAGE TO PUBLIC OR PRIVATE UTILITIES SHALL BE REPORTED TO THE PROJECT MANAGER AND THE OWNER OF THE UTILITY IMMEDIATELY. ANY DAMAGE RESULTING FROM CONTRACTORS NEGLIGENCE OR FAILURE TO ACT WITH DUE REGARD SHALL BE REPAIRED AT CONTRACTORS EXPENSE.
18. UNLESS OTHERWISE NOTED ON THE PLANS, CONTRACTOR SHALL ASSUME ALL SURFACE FEATURES SUCH AS BUT NOT LIMITED TO BUILDINGS, PAVEMENTS, LANDSCAPING FEATURES, PLANTS, ETC. ARE TO BE SAVED AND PROTECTED FROM DAMAGE. CONTRACTOR SHALL MAKE NECESSARY PROVISIONS TO PROTECT EXISTING SITE CONDITIONS AND UPON COMPLETION OF WORK REPAIR BACK TO ORIGINAL CONDITIONS ANY DAMAGE THAT OCCURRED DURING CONSTRUCTION.
19. KEEP THE CONSTRUCTION SITE CLEAN, HAZARD FREE, AND DISPOSE OF ALL DIRT, DEBRIS, RUBBISH AND REMOVE EQUIPMENT NOT SPECIFIED AS REMAINING ON THE PROPERTY. LEAVE PREMISES IN CLEAN CONDITION AND SHALL BE SUBJECT TO APPROVAL BY THE PROPERTY OWNER AND THE PROJECT MANAGER.
20. THE CONTRACTOR SHALL PROVIDE ON-SITE TRASH RECEPTACLES FOR COLLECTION OF NON-TOXIC DEBRIS. ALL TRASH SHALL BE COLLECTED ON A DAILY BASIS.
21. ALL TOXIC AND ENVIRONMENTALLY HAZARDOUS SUBSTANCES SHALL BE USED AND DISPOSED OF IN ACCORDANCE WITH MANUFACTURER SPECIFICATIONS. UNDER NO CIRCUMSTANCES SHALL RINSING OR DUMPING OF THESE SUBSTANCES OCCUR ON-SITE.
22. UNLESS NOTED OTHERWISE, CONTRACTOR SHALL BE RESPONSIBLE FOR OBTAINING AND PAYING FOR ALL PERMITS NECESSARY FOR CONSTRUCTION.
23. THE PROJECT MANAGER MAY RETAIN THE SERVICES OF A TESTING LABORATORY TO PERFORM QUALITY ASSURANCE TESTING ON VARIOUS PORTIONS OF THE CONTRACTORS WORK. WHEN REQUESTED, THE CONTRACTOR SHALL INFORM THE TESTING LABORATORY AND ASSIST THEM IN COMPLETING TESTS.
24. THE CONTRACTOR SHALL MAINTAIN AND SUPPLY THE PROJECT MANAGER WITH AS-BUILT PLANS UPON COMPLETION OF THE PROJECT.

ELECTRIC:

1. THE CONTRACTOR SHALL PERFORM WORK IN ACCORDANCE WITH ALL GOVERNING STATE, COUNTY AND LOCAL CODES AND OSHA REQUIREMENTS.
2. THE ENTIRE ELECTRICAL INSTALLATION SHALL BE GROUNDED AS REQUIRED BY ALL APPLICABLE CODES.
3. THE CONTRACTOR SHALL PROVIDE ALL LABOR, MATERIALS, INSURANCE, EQUIPMENT, INSTALLATION, CONSTRUCTION TOOLS AND TRANSPORTATION FOR A COMPLETE AND PROPERLY OPERATIVE SYSTEM ENERGIZED THROUGHOUT AND AS INDICATED ON DRAWINGS.
4. THE CONTRACTOR SHALL OBTAIN ALL PERMITS, PAY PERMIT AND INSPECTION FEES, AND BE RESPONSIBLE FOR SCHEDULING INSPECTIONS WITH THE AUTHORITY HAVING JURISDICTION.
5. MATERIALS SHALL BE MANUFACTURED IN ACCORDANCE WITH APPLICABLE STANDARDS ESTABLISHED BY ANSI, IEEE, NEMA AND NFPA.
6. ALL MATERIALS SHALL BE U.L. LISTED.
7. ALL MATERIALS AND EQUIPMENT SHALL BE NEW AND IN PERFECT CONDITION WHEN INSTALLED AND SHALL BE OF THE BEST GRADE AND OF THE SAME MANUFACTURER THROUGHOUT FOR EACH CLASS OR GROUP OF EQUIPMENT.
8. MATERIALS SHALL MEET WITH APPROVAL OF THE AUTHORITY HAVING JURISDICTION.
9. THE CONTRACTOR SHALL PERFORM ALL VERIFICATION OBSERVATIONS TEST, AND EXAMINATION WORK PRIOR TO THE ORDERING OF THE ELECTRICAL EQUIPMENT AND STARTING CONSTRUCTION. CONTRACTOR SHALL ISSUE A WRITTEN NOTICE OF ALL FINDINGS TO THE PROJECT MANAGER LISTING ALL MALFUNCTIONS, FAULTY EQUIPMENT AND DISCREPANCIES.
10. THE CONTRACTOR SHALL COORDINATE WITH UTILITY COMPANY FOR CONNECTION OF THE TEMPORARY AND PERMANENT POWER TO THE SITE. THE TEMPORARY POWER AND ALL HOOKUP COSTS TO BE PAID BY CONTRACTOR.
11. UPON COMPLETION OF WORK, CONDUCT CONTINUITY, SHORT CIRCUIT, AND FALL OF POTENTIAL GROUND TESTS FOR APPROVAL. SUBMIT TEST REPORTS TO THE PROJECT MANAGER.
12. ALL BROCHURES, OPERATING MANUALS, CATALOGS, SHOP DRAWINGS, ETC. SHALL BE TURNED OVER TO THE PROJECT MANAGER AT JOB COMPLETION.
13. POST-INSTALLATION, ANY WORK, MATERIAL OR EQUIPMENT FOUND TO BE FAULTY SHALL BE CORRECTED AT ONCE, UPON WRITTEN NOTIFICATION, AT THE EXPENSE OF THE CONTRACTOR.
14. PROVIDE THE PROJECT MANAGER WITH ONE SET OF COMPLETE ELECTRICAL "AS-INSTALLED" DRAWINGS AT THE COMPLETION OF THE JOB, SHOWING ACTUAL DIMENSIONS, ROUTINGS AND CIRCUITS.
15. ALL ELECTRICAL EQUIPMENT SHALL BE LABELED WITH PERMANENT ENGRAVED PLASTIC LABELS NOTING USE FUNCTION.
16. EACH CONDUCTOR OF EVERY SYSTEM SHALL BE PERMANENTLY TAGGED IN EACH PANEL BOARD, PULL BOX, J-BOX, SWITCH BOX, ETC.
17. ALL CONDUIT INSTALLED SHALL BE SURFACE MOUNTED OR DIRECT BURIAL UNLESS OTHERWISE NOTED.
18. ALL CONDUIT SHALL HAVE A PULL WIRE OR ROPE.
19. ALL CONDUCTORS SHALL BE COPPER.
20. ALL CIRCUIT BREAKERS, FUSES AND ELECTRICAL EQUIPMENT SHALL HAVE AN INTERRUPTING SHORT CIRCUIT CURRENT TO WHICH THEY MAY BE SUBJECTED, AND A MINIMUM OF 10,000 A.I.C.
21. PATCH, REPAIR AND PAINT ANY AREA THAT HAS BEEN DAMAGED IN THE COURSE OF THE ELECTRICAL WORK.
22. PENETRATIONS IN FIRE RATED WALLS SHALL BE FIRE STOPPED TO MATCH ORIGINAL RATING.
23. BX OR ROMEX CABLE IS NOT PERMITTED.
24. ALL ELECTRICAL/FIBER ENCLOSURES, JUNCTION BOXES, CONDUIT KNOCKOUTS, RACEWAYS, ETC. SHALL BE RODENT-PROOF.
25. CLEAN PREMISES OF ALL DEBRIS RESULTING FROM WORK AND LEAVE WORK IN A COMPLETE AND UNDAMAGED CONDITION.



7150 STANDARD DRIVE
HANOVER, MD 21076



1362 MELLON ROAD, SUITE 140
HANOVER, MD 21076



1100 E. WOODFIELD ROAD, SUITE 500
SCHAUMBURG, ILLINOIS 60173
TEL: 847-908-8400
COA# PEC.0001444
www.FullertonEngineering.com

REV	DATE	DESCRIPTION	BY
A	02/19/19	90% REVIEW	EB
B	03/19/19	REV. 90% REVIEW	EB
1	03/26/19	FOR PERMIT	KC
2	04/11/19	FOR CONSTRUCTION	KC
3	04/26/19	FOR CONSTRUCTION	EB

I HEREBY CERTIFY THAT THESE DRAWINGS WERE PREPARED BY ME OR UNDER MY DIRECT SUPERVISION AND CONTROL, AND TO THE BEST OF MY KNOWLEDGE AND BELIEF COMPLY WITH THE REQUIREMENTS OF ALL APPLICABLE CODES.



SITE NUMBER
CT2421S

SITE NAME
WOODLAND STREET FACILITY

FA NUMBER:
14644530

USID:
245301

SITE ADDRESS
**63 WOODLAND STREET
SOUTH GLASTONBURY, CT 06073**

SHEET NAME
GENERAL NOTES

SHEET NUMBER
T-2

GENERAL ABBREVIATIONS	
AFF	ABOVE FINISHED FLOOR
AGL	ABOVE GRADE LEVEL
AMSL	ABOVE MEAN SEA LEVEL
APPROX	APPROXIMATE
ATS	AUTOMATIC TRANSFER SWITCH
AWG	AMERICAN WIRE GAUGE
BLDG	BUILDING
CL	CENTERLINE
CLR	CLEAR
COL	COLUMN
CONC	CONCRETE
CND	CONDUIT
DIA	DIAMETER
DWG	DRAWING
FT	FOOT(FEET)
EGB	EQUIPMENT GROUND BAR
ELEC	ELECTRICAL
EMT	ELECTRICAL METALLIC TUBING
ELEV	ELEVATION
EQUIP	EQUIPMENT
(E)	EXISTING
EXT	EXTERIOR
FND	FOUNDATION
F	FIBER
GA	GAUGE
GALV	GALVANIZED
GPS	GLOBAL POSITIONING SYSTEM
GND	GROUND
LP	LIQUID PROPANE
MAX	MAXIMUM
MFR	MANUFACTURER
MGB	MASTER GROUND BAR
MIN	MINIMUM
MTS	MANUAL TRANSFER SWITCH
N.T.S.	NOT TO SCALE
O.C.	ON CENTER
OE/OT	OVERHEAD ELECTRIC/TELCO
PPC	POWER PROTECTION CABINET
PL	PROPERTY LINE
RGS	RIGID GALVANIZED STEEL
IN	INCH(ES)
INT	INTERIOR
LB(S), #	POUND(S)
SF	SQUARE FOOT
STL	STEEL
TYP	TYPICAL
UE/UT	UNDERGROUND ELECTRIC/TELCO
UNO	UNLESS NOTED OTHERWISE
VIF	VERIFY IN FIELD
W/	WITH
XFMR	TRANSFORMER

TELECOM ABBREVIATIONS	
FIF	FACILITY INTERFACE FRAME
GSM	GLOBAL SYSTEM FOR MOBILE COMMUNICATION
LTE	LONG TERM EVOLUTION
MW	MICROWAVE
MCPA	MULTI-CARRIER POWER AMPLIFIER
RBS	RADIO BASED STATION
RET	REMOTE ELECTRIC TILT
TMA	TOWER MOUNTED AMPLIFIER
UMTS	UNIVERSAL MOBILE TELECOMMUNICATION SYSTEM

SYMBOLS	
	REVISION
	WORK POINT
	UTILITY POLE
	BRICK
	COMPRESSED STONE
	CONCRETE
	EARTH
	GRAVEL
	CENTERLINE
	PROPERTY LINE
	LEASE LINE
	EASEMENT LINE
	FENCE
	CHAINLINK
	WOOD
	WROUGHT IRON
	ELECTRIC OVERHEAD
	UNDERGROUND
	FIBER OVERHEAD
	UNDERGROUND
	TELEPHONE OVERHEAD
	UNDERGROUND
	DCPOWER

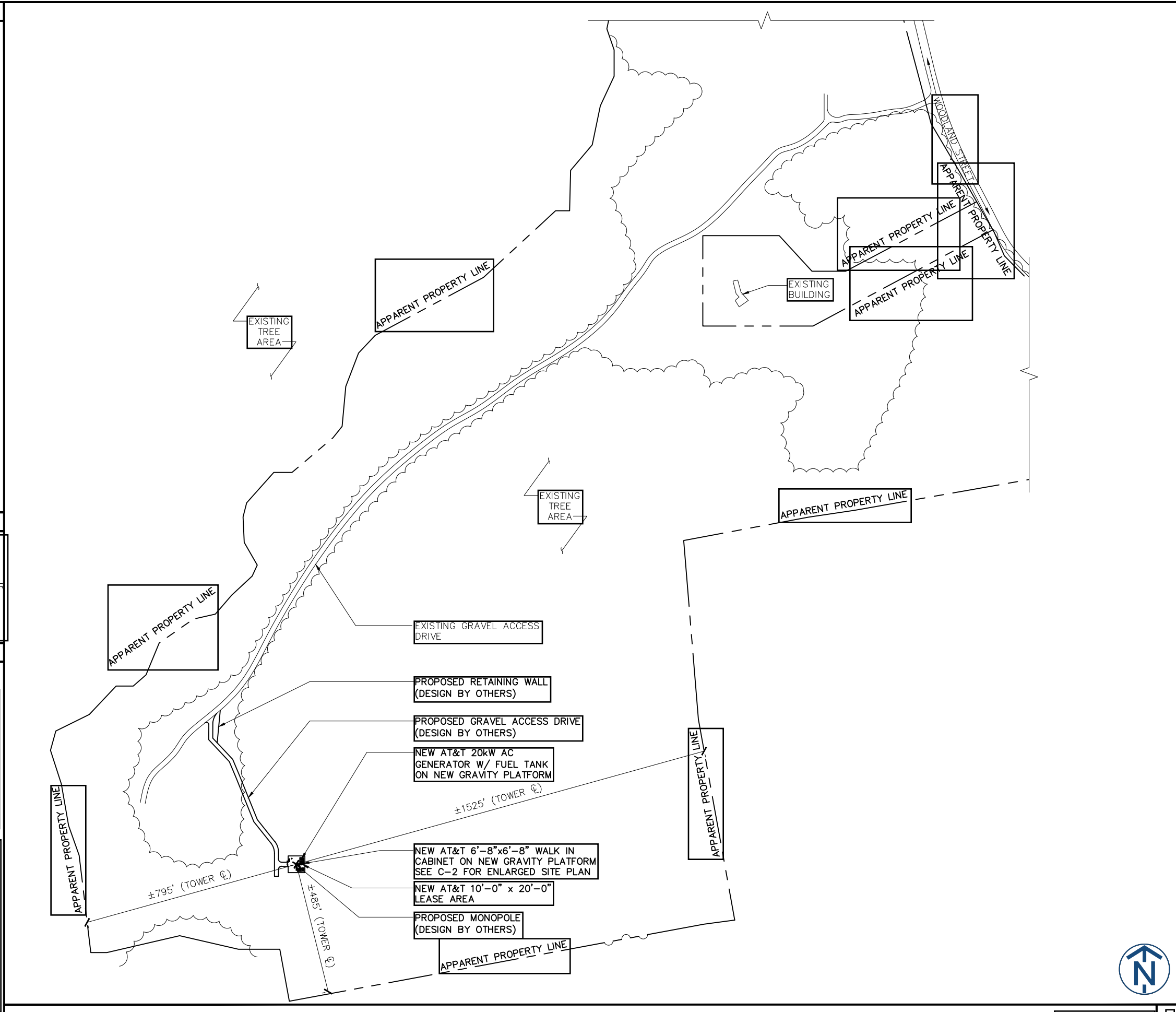

SITE PLAN

SCALE: 1" = 20'-0"

7150 STANDARD DRIVE
HANOVER, MD 21076

1362 MELLON ROAD, SUITE 140
HANOVER, MD 21076

FULLERTON
ENGINEERING-DESIGN

1100 E. WOODFIELD ROAD, SUITE 500
SCHAUMBURG, ILLINOIS 60173
TEL: 847-908-8400
COA# PEC.0001444
www.FullertonEngineering.com

REV	DATE	DESCRIPTION	BY
A	02/19/19	90% REVIEW	EB
B	03/19/19	REV. 90% REVIEW	EB
1	03/26/19	FOR PERMIT	KC
2	04/11/19	FOR CONSTRUCTION	KC
3	04/26/19	FOR CONSTRUCTION	EB

I HEREBY CERTIFY THAT THESE DRAWINGS WERE PREPARED BY ME OR UNDER MY DIRECT SUPERVISION AND CONTROL, AND TO THE BEST OF MY KNOWLEDGE AND BELIEF COMPLY WITH THE REQUIREMENTS OF ALL APPLICABLE CODES.



SITE NUMBER
CT2421S

SITE NAME
WOODLAND STREET FACILITY

FA NUMBER:
14644530

USID:
245301

SITE ADDRESS
**63 WOODLAND STREET
SOUTH GLASTONBURY, CT 06073**

SHEET NAME
SITE PLAN

SHEET NUMBER
C-1



7150 STANDARD DRIVE
HANOVER, MD 21076



1362 MELLON ROAD, SUITE 140
HANOVER, MD 21076



1100 E. WOODFIELD ROAD, SUITE 500
SCHAUMBURG, ILLINOIS 60173
TEL: 847-908-8400
COA# PEC.0001444
www.FullertonEngineering.com

REV	DATE	DESCRIPTION	BY
A	02/19/19	90% REVIEW	EB
B	03/19/19	REV. 90% REVIEW	EB
1	03/26/19	FOR PERMIT	KC
2	04/11/19	FOR CONSTRUCTION	KC
3	04/26/19	FOR CONSTRUCTION	EB

I HEREBY CERTIFY THAT THESE DRAWINGS WERE PREPARED BY ME OR UNDER MY DIRECT SUPERVISION AND CONTROL, AND TO THE BEST OF MY KNOWLEDGE AND BELIEF COMPLY WITH THE REQUIREMENTS OF ALL APPLICABLE CODES.



SITE NUMBER
CT2421S

SITE NAME
WOODLAND STREET FACILITY

FA NUMBER:
14644530

USID:
245301

SITE ADDRESS
**63 WOODLAND STREET
SOUTH GLASTONBURY, CT 06073**

SHEET NAME
ENLARGED SITE PLAN

SHEET NUMBER
C-2

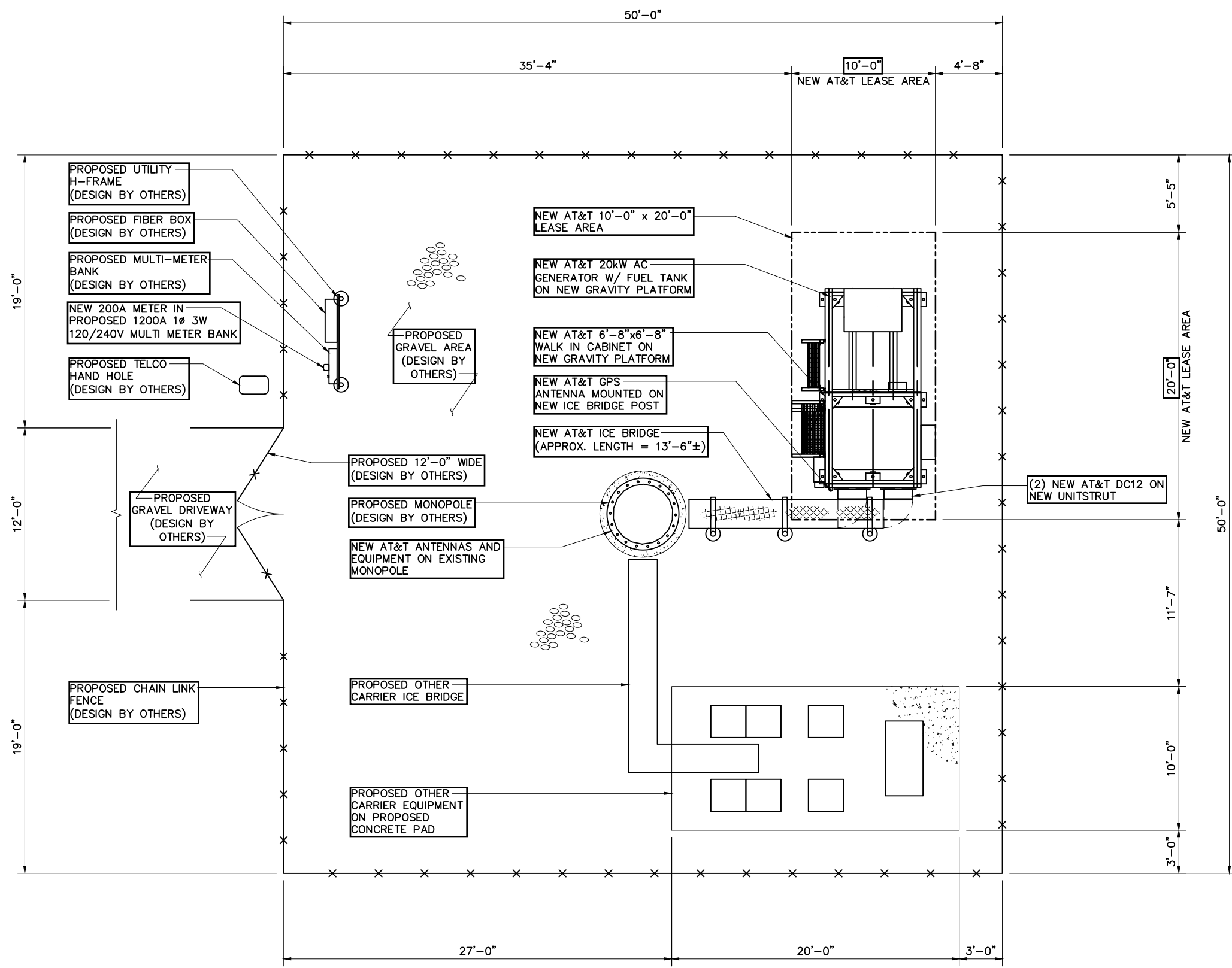

SCALE: 1/8" = 1'-0"

ENLARGED SITE PLAN



7150 STANDARD DRIVE
HANOVER, MD 21076



1362 MELLON ROAD, SUITE 140
HANOVER, MD 21076



1100 E. WOODFIELD ROAD, SUITE 500
SCHAUMBURG, ILLINOIS 60173
TEL: 847-908-8400
COA# PEC.0001444
www.FullertonEngineering.com

REV	DATE	DESCRIPTION	BY
A	02/19/19	90% REVIEW	EB
B	03/19/19	REV. 90% REVIEW	EB
1	03/26/19	FOR PERMIT	KC
2	04/11/19	FOR CONSTRUCTION	KC
3	04/26/19	FOR CONSTRUCTION	EB

I HEREBY CERTIFY THAT THESE DRAWINGS WERE PREPARED BY ME OR UNDER MY DIRECT SUPERVISION AND CONTROL, AND TO THE BEST OF MY KNOWLEDGE AND BELIEF COMPLY WITH THE REQUIREMENTS OF ALL APPLICABLE CODES.



SITE NUMBER
CT2421S

SITE NAME
WOODLAND STREET FACILITY

FA NUMBER:
14644530

USID:
245301

SITE ADDRESS
**63 WOODLAND STREET
SOUTH GLASTONBURY, CT 06073**

SHEET NAME
EQUIPMENT LAYOUT

SHEET NUMBER
C-2A

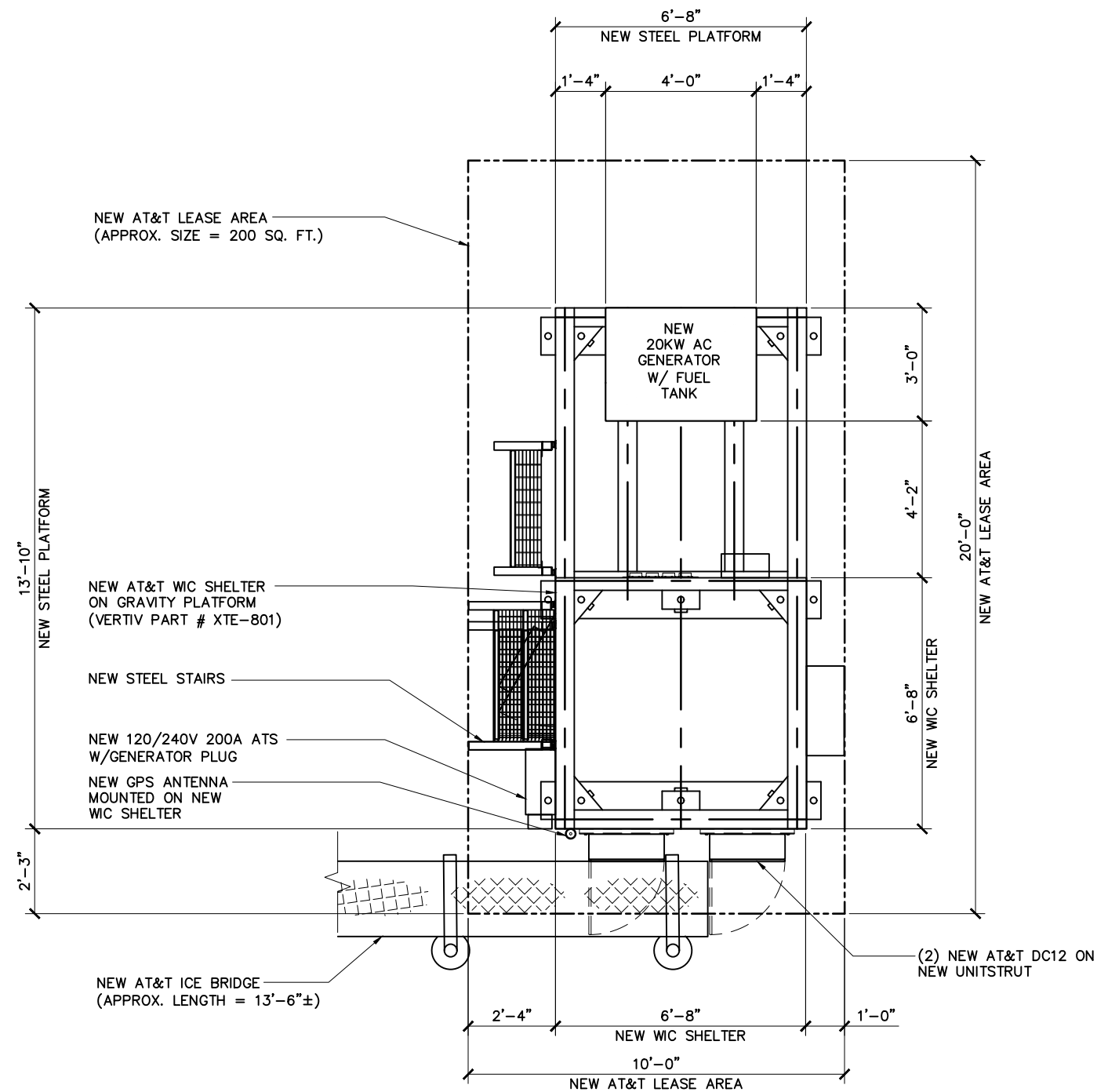

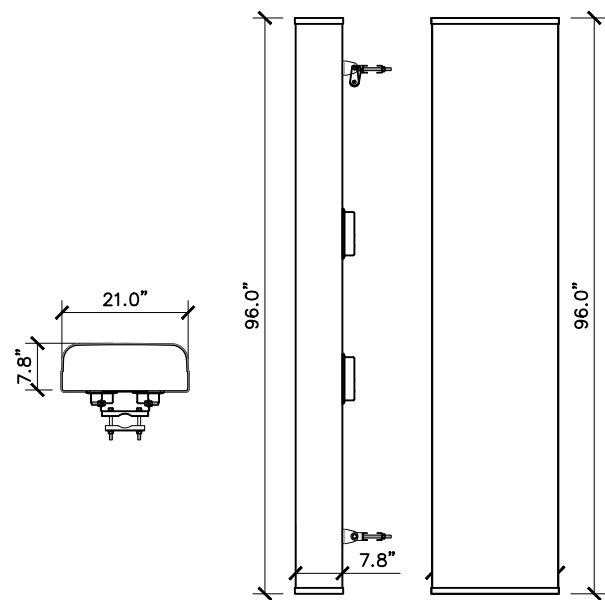

PLAN VIEW SIDE VIEW FRONT VIEW

CCI – TPA65R-BU8D
MULTI-BAND TWELVE ANTENNA

FREQUENCY RANGE 4 LOW x 698-896 MHz
8 HIGH 1695-2400 MHz
ANTENNA 82.5 Lbs
(3) RETS 15 Lbs
BRACKET 16.1 Lbs
TOTAL WEIGHT 113.6 Lbs

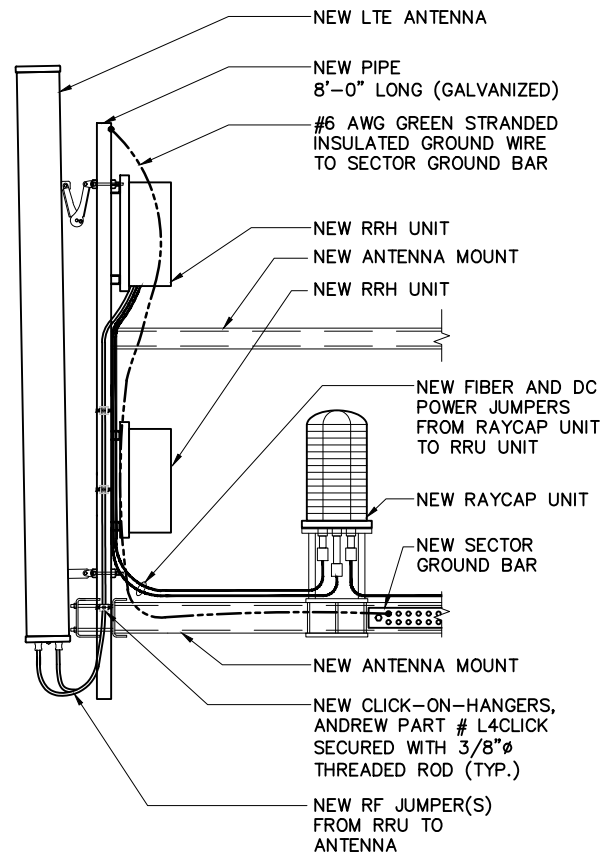

ANTENNA SCHEMATIC

SCALE: N.T.S. 2

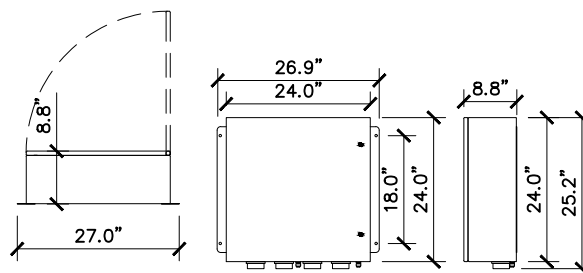

PLAN VIEW FRONT VIEW SIDE VIEW

RAYCAP – DC12-48-60-0-25E

DC SURGE PROTECTION SOLUTION
SURGE PROTECT 60 kA
MAXIMUM IMPULSE CURRENT 5 kA
ENCLOSURE TYPE (OUTDOOR) NEMA 4
WEIGHT 56.3 LBS

RAYCAP DC12-48-60-0-25E SPECS

SCALE: N.T.S. 3

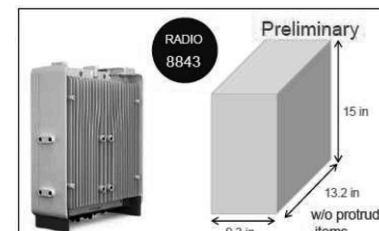

Size and Weight				
Radio 8843 B06A, B2	Height	Width	Depth	Weight
w/ protruding items	15 in	13.2 in	9.3 in	70 lbs

ERICSSON – RADIO 8843
SINGLE BAND B66A AND B2

RRU SPEC

SCALE: N.T.S. 4

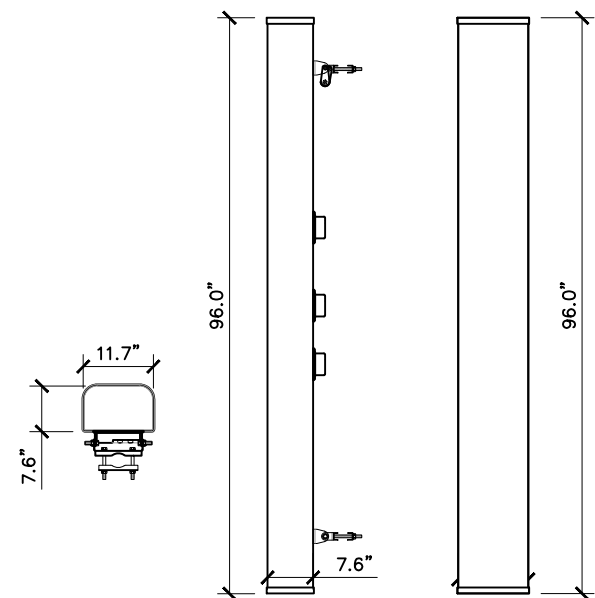

PLAN VIEW SIDE VIEW FRONT VIEW

CCI – HPA65R-BU8A
HEXPORT MULTI-BAND ANTENNA

FREQUENCY RANGE 2 x LOW BAND 698-896 MHz
4 x HIGH BAND 1695-2400 MHz
ANTENNA 54.0 Lbs
(3) RETS 5.0 Lbs
BRACKET 16.6 Lbs
TOTAL WEIGHT 75.6 Lbs

ANTENNA SPECS

SCALE: N.T.S. 5



ERICSSON – RRU 4478 B14

FREQUENCY RANGE TX 758-768 MHz
RX 788-798 MHz
TOTAL WEIGHT 59.9 Lbs

RRU SPEC

SCALE: N.T.S. 6

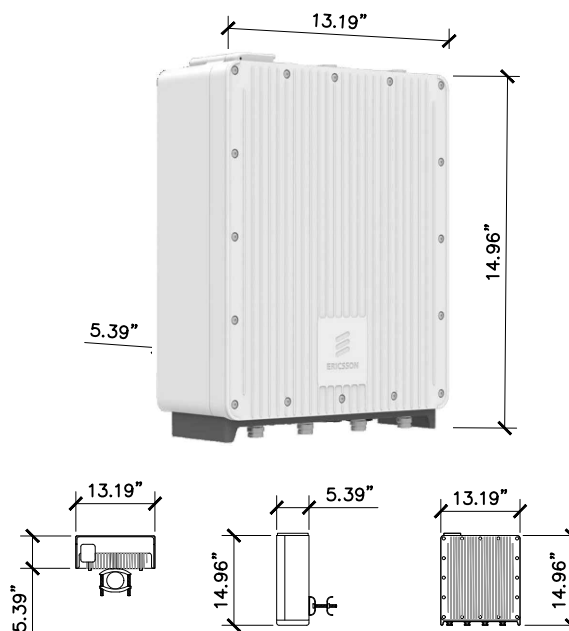

PLAN VIEW SIDE VIEW FRONT VIEW

ERICSSON – RRU 4415 B30

TOTAL WEIGHT 46.0 Lbs

RRU SPEC

SCALE: N.T.S. 7

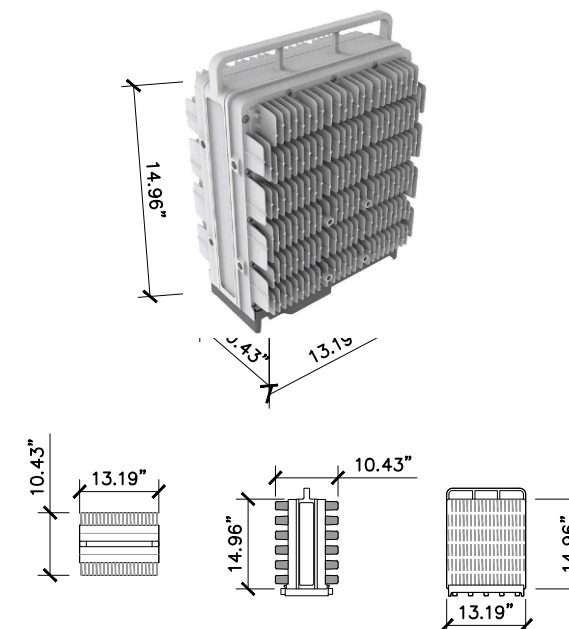

PLAN VIEW SIDE VIEW FRONT VIEW

ERICSSON
RADIO 4449 DUAL B5 & B12
AISG TMA & RET SUPPORT
4TX/4RX PER BAND (B5 & B12)

WEIGHT ~73 Lbs

RRU SPEC

SCALE: N.T.S. 8



7150 STANDARD DRIVE
HANOVER, MD 21076



1362 MELLON ROAD, SUITE 140
HANOVER, MD 21076



1100 E. WOODFIELD ROAD, SUITE 500
SCHAUMBURG, ILLINOIS 60173
TEL: 847-908-8400
COA# PEC.0001444
www.FullertonEngineering.com

REV	DATE	DESCRIPTION	BY
A	02/19/19	90% REVIEW	EB
B	03/19/19	REV. 90% REVIEW	EB
1	03/26/19	FOR PERMIT	KC
2	04/11/19	FOR CONSTRUCTION	KC
3	04/26/19	FOR CONSTRUCTION	EB

I HEREBY CERTIFY THAT THESE DRAWINGS WERE PREPARED BY ME OR UNDER MY DIRECT SUPERVISION AND CONTROL, AND TO THE BEST OF MY KNOWLEDGE AND BELIEF COMPLY WITH THE REQUIREMENTS OF ALL APPLICABLE CODES.



SITE NUMBER
CT2421S

SITE NAME
WOODLAND STREET FACILITY

FA NUMBER:
14644530

USID:
245301

SITE ADDRESS
63 WOODLAND STREET
SOUTH GLASTONBURY, CT 06073

SHEET NAME
SITE DETAILS

SHEET NUMBER

C-4

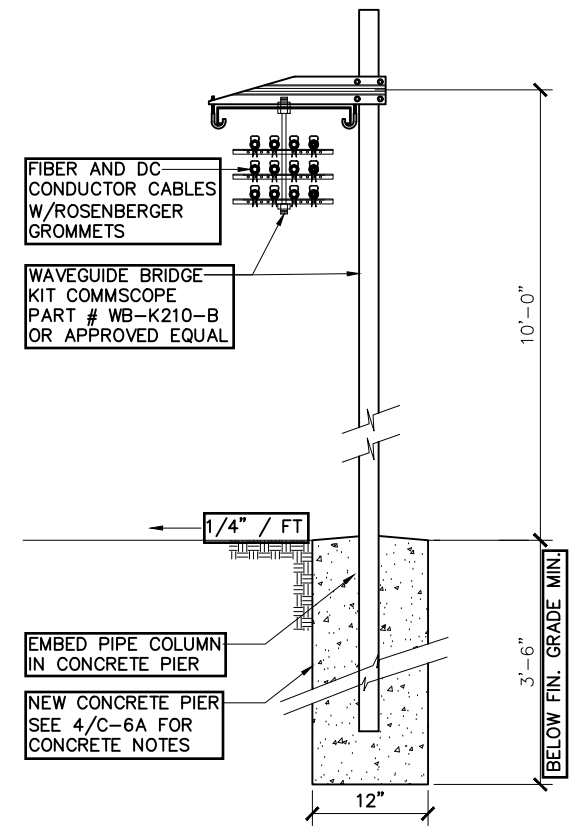
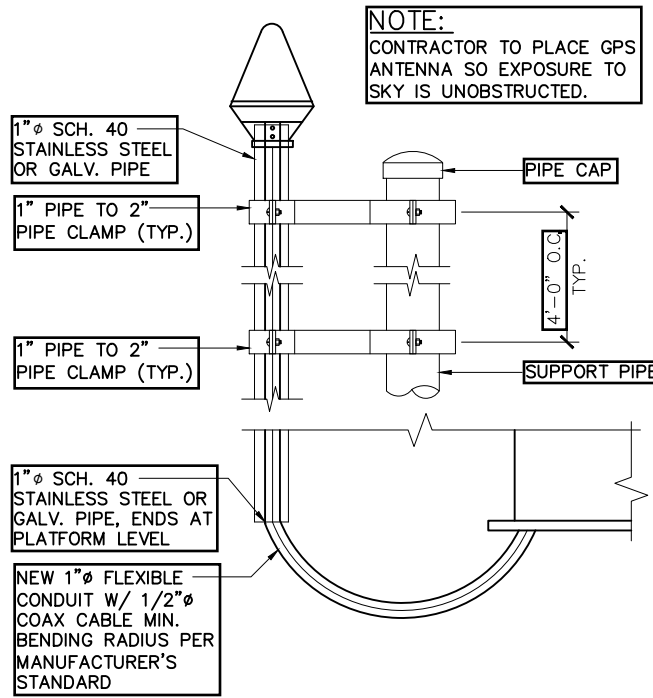
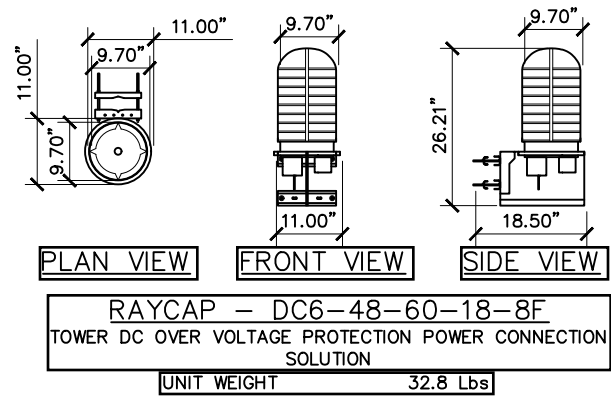

at&t
7150 STANDARD DRIVE
HANOVER, MD 21076

smartlink
1362 MELLON ROAD, SUITE 140
HANOVER, MD 21076

FULLERTON
ENGINEERING-DESIGN
1100 E. WOODFIELD ROAD, SUITE 500
SCHAUMBURG, ILLINOIS 60173
TEL: 847-908-8400
COA# PEC.0001444
www.FullertonEngineering.com

REV	DATE	DESCRIPTION	BY
A	02/19/19	90% REVIEW	EB
B	03/19/19	REV. 90% REVIEW	EB
1	03/26/19	FOR PERMIT	KC
2	04/11/19	FOR CONSTRUCTION	KC
3	04/26/19	FOR CONSTRUCTION	EB

I HEREBY CERTIFY THAT THESE DRAWINGS WERE PREPARED BY ME OR UNDER MY DIRECT SUPERVISION AND CONTROL, AND TO THE BEST OF MY KNOWLEDGE AND BELIEF COMPLY WITH THE REQUIREMENTS OF ALL APPLICABLE CODES.

NOT USED SCALE: N.T.S. 1

RAYCAP DC6-48-60-18-8F SPECS SCALE: N.T.S. 2

GPS ANTENNA SCALE: N.T.S. 3

ICE BRIDGE DETAIL SCALE: N.T.S. 4

NOMINAL OPERATING VOLTAGE:	48 VDC
NOMINAL DISCHARGE CURRENT:	20 kA 8/20ms
MAXIMUM DISCHARGE CURRENT:	60 kA 8/20ms
MAXIMUM CONTINUOUS OPERATING VOLTAGE:	75 VDC
VOLTAGE PROTECTION RATING:	400 V
WIND LOADING:	150 MPH SUSTAINED (105.7 lbs) 195 MPH GUST (213.6 lbs)

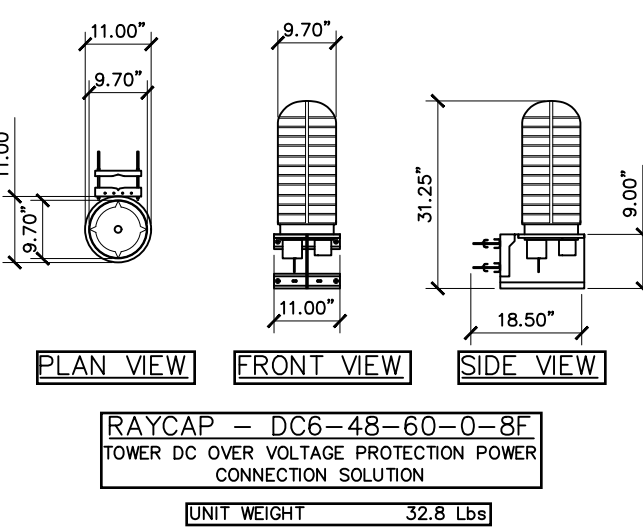
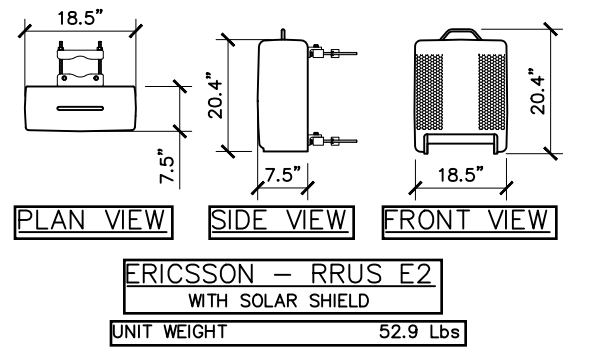

CONTRACTOR TO USE "THREAD LUBRICANT" ON MOUNTING BOLTS DURING INSTALLATION ON EXISTING STRUCTURAL MEMBER

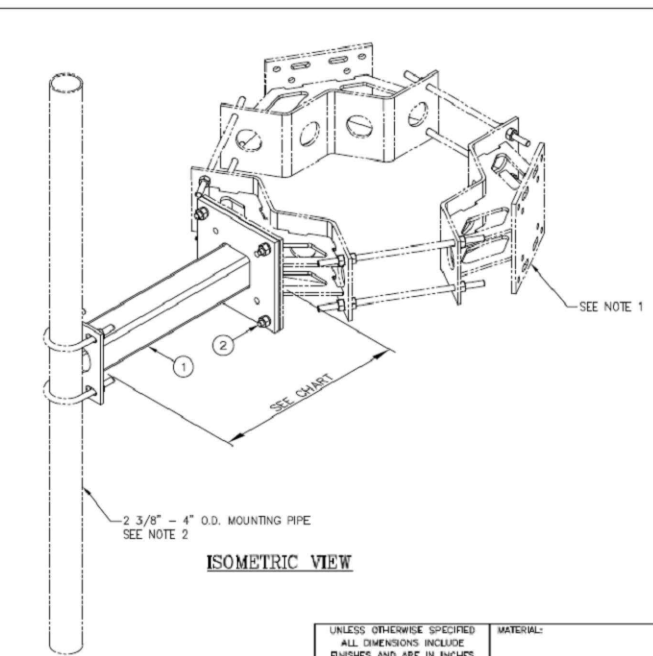

LIST OF MATERIAL					
ITEM	KIT NO.	DWG. NO.	QTY.	DESCRIPTION	WEIGHT
	C10114001	CW00484	1	1'-0" STANDOFF ARM WELDMENT	38.0#
	C10114002	CW00018	1	2'-0" STANDOFF ARM WELDMENT	50.6#
	C10114003	CW00525	1	3'-0" STANDOFF ARM WELDMENT	63.3#
	C10114004	CW00019	1	4'-0" STANDOFF ARM WELDMENT	76.0#
	C10114005	CW00526	1	5'-0" STANDOFF ARM WELDMENT	88.7#
	C10114006	CW00220	1	6'-0" STANDOFF ARM WELDMENT	101.4#
	C10114007	CW01019	1	0'-8" STANDOFF ARM WELDMENT	33.7#

TYPICAL HARDWARE				
ITEM	PART NO.	QTY.	DESCRIPTION	WEIGHT
2	C40026025	4	BOLT ASSEMBLY, 5/8" x 2 1/2 A325	2.0#

NOTES:
1. TRI-COLLAR MOUNTS ARE SHOWN TYPICAL AND MUST BE PURCHASED SEPARATELY.
2. 2 3/8" TO 4" O.D. MOUNTING PIPE & U-BOLTS MUST BE PURCHASED SEPARATELY.
3. QUANTITIES SHOWN ARE FOR ONE (1) STANDOFF ARM.

UNLESS OTHERWISE SPECIFIED ALL DIMENSIONS INCLUDE FINISHES AND ARE IN INCHES
TOLERANCES: FRACTIONS $\pm 1/16"$
ANGLES $\pm 1/2$ DEG.
DECIMALS $\pm .010"$

MATERIAL: TOLERANCES DO NOT APPLY TO RAW MATERIAL

Sabre Industries
Towers and Poles

CONFIDENTIAL
This document and the information contained herein is the confidential trade secret property of Sabre Communications Corporation ("Sabre") and must not be reproduced, copied or used, in whole or in part, for any purpose without the prior written consent of Sabre.
© 2014 Sabre Communications Corporation. All rights reserved.

DATE	8/26/00	SIZE	B	DRAWING NO.	C10114	REV	6
DRAWN BY	KLE	SCALE	None	PAGE	1	OF	1
CHECKED BY	BCT						

STATE OF CONNECTICUT
HENRY M. BELLAGAMBA
25358
LICENSED PROFESSIONAL ENGINEER

SITE NUMBER: CT2421S

SITE NAME: WOODLAND STREET FACILITY

FA NUMBER: 14644530

USID: 245301

SITE ADDRESS: 63 WOODLAND STREET SOUTH GLASTONBURY, CT 06073

SHEET NAME: SITE DETAILS

SHEET NUMBER: C-4A

RRUS SPEC SCALE: N.T.S. 5

RAYCAP DC6-48-60-0-8F SPECS SCALE: N.T.S. 6

STAND-OFF ARM SPECS SCALE: N.T.S. 7

SCALE: N.T.S. 7

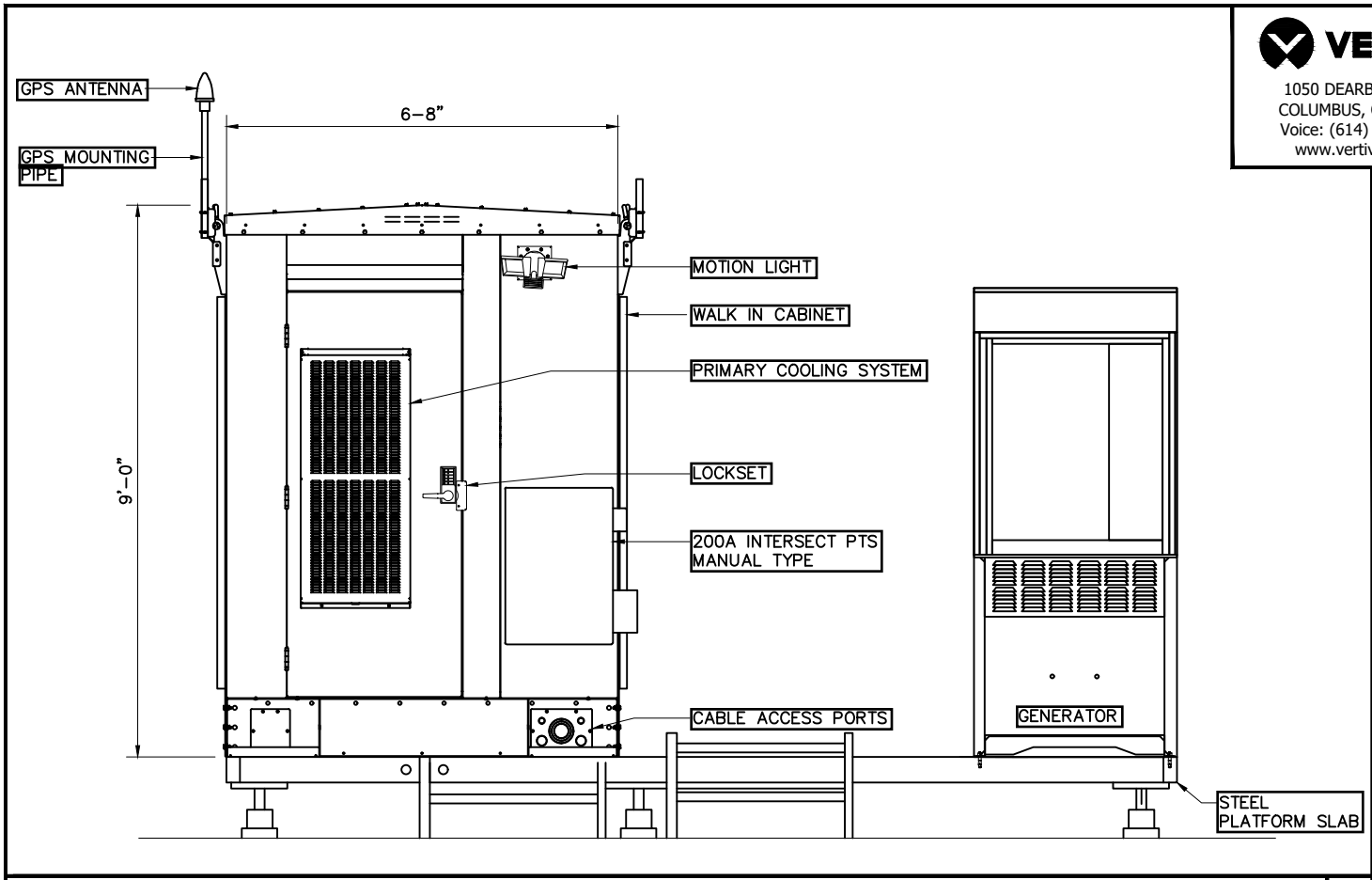

VERTIV
 1050 DEARBORN DR.
 COLUMBUS, OH 43085
 Voice: (614) 888-0246
 www.vertivco.com

SEE MANUFACTURER'S DRAWING FOR FULL EQUIPMENT SHELTER SPECIFICATION AND DETAILS. THIS SHEET PROVIDED FOR REFERENCE ONLY.

at&t
 7150 STANDARD DRIVE
 HANOVER, MD 21076

smartlink
 1362 MELLON ROAD, SUITE 140
 HANOVER, MD 21076

FULLERTON
 ENGINEERING-DESIGN
 1100 E. WOODFIELD ROAD, SUITE 500
 SCHAUMBURG, ILLINOIS 60173
 TEL: 847-908-8400
 COA# PEC.0001444
 www.FullertonEngineering.com

REV	DATE	DESCRIPTION	BY
A	02/19/19	90% REVIEW	EB
B	03/19/19	REV. 90% REVIEW	EB
1	03/26/19	FOR PERMIT	KC
2	04/11/19	FOR CONSTRUCTION	KC
3	04/26/19	FOR CONSTRUCTION	EB

I HEREBY CERTIFY THAT THESE DRAWINGS WERE PREPARED BY ME OR UNDER MY DIRECT SUPERVISION AND CONTROL, AND TO THE BEST OF MY KNOWLEDGE AND BELIEF COMPLY WITH THE REQUIREMENTS OF ALL APPLICABLE CODES.

ELEVATION A SCALE: 3/8" = 1'-0" 1

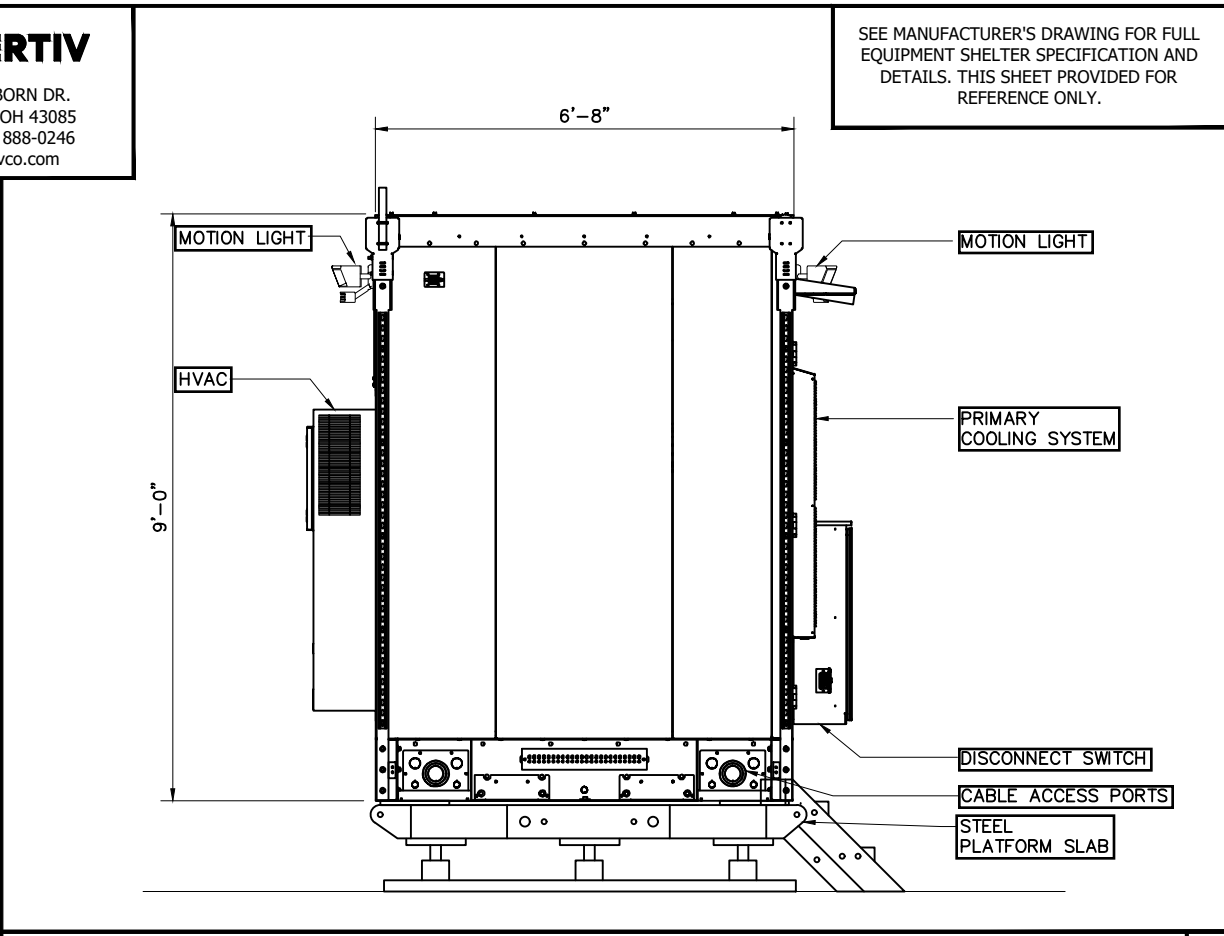

ELEVATION B SCALE: 3/8" = 1'-0" 2

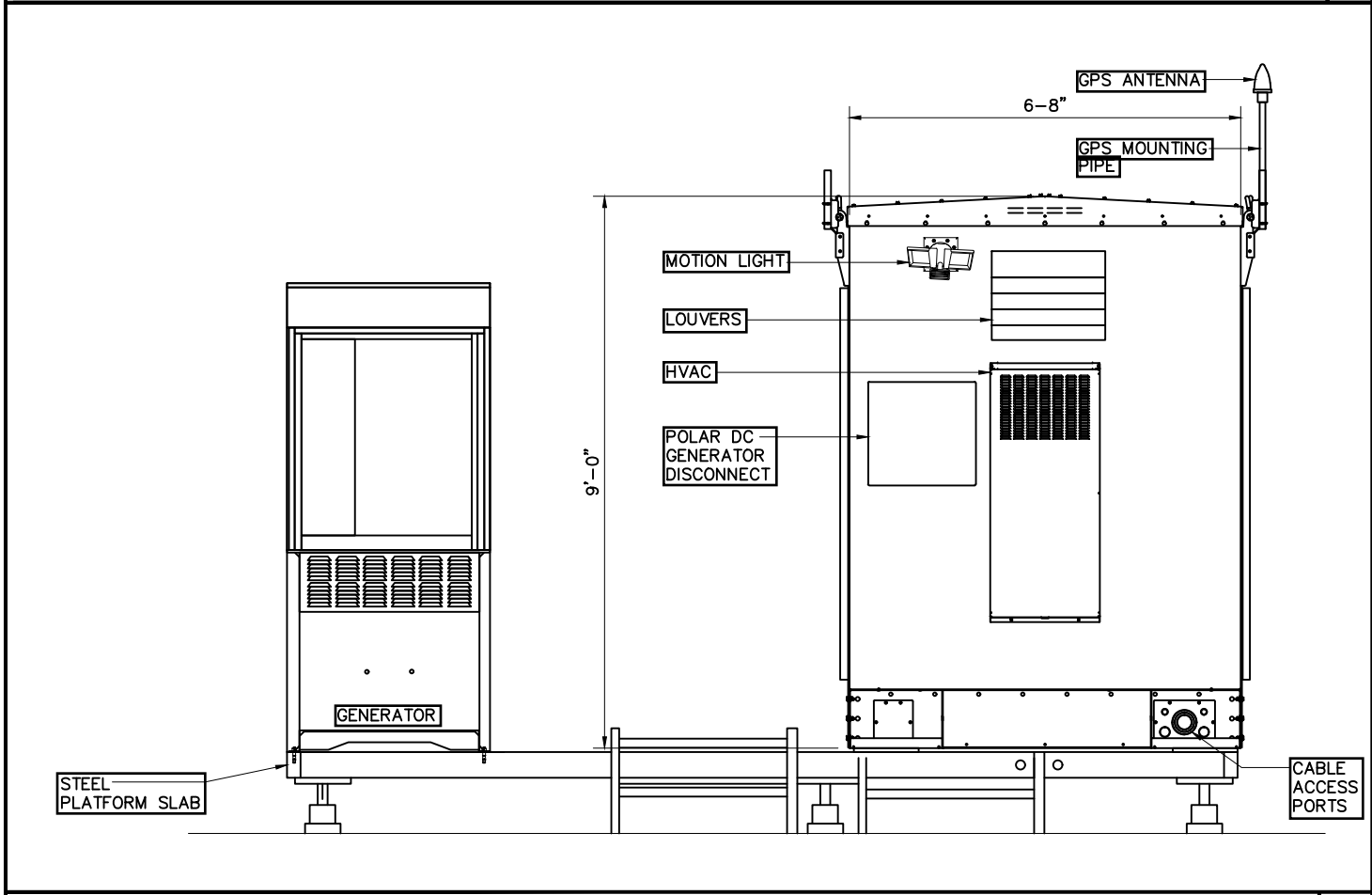

ELEVATION C SCALE: 3/8" = 1'-0" 3

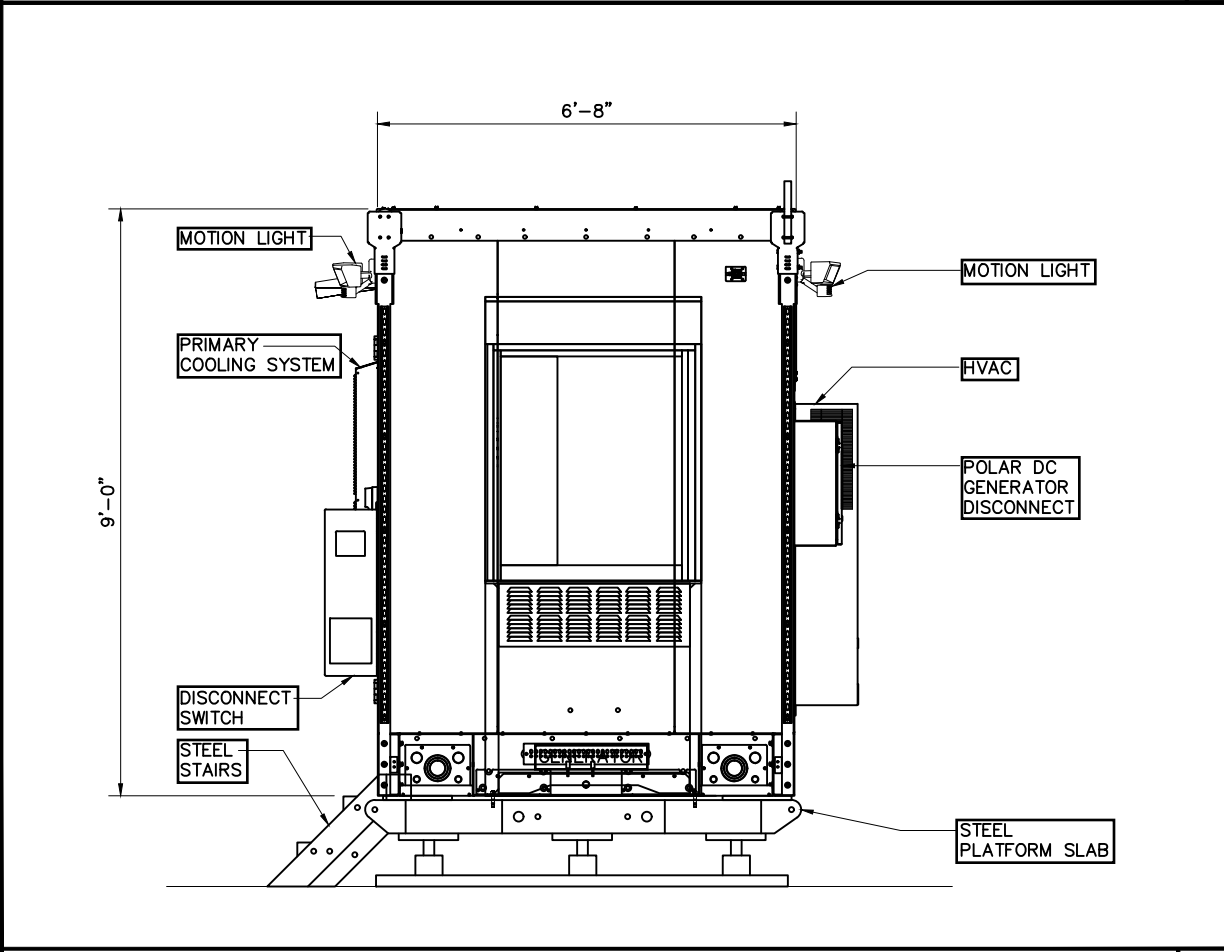

ELEVATION D SCALE: 3/8" = 1'-0" 4



SITE NUMBER: CT2421S
 SITE NAME: WOODLAND STREET FACILITY
 FA NUMBER: 14644530
 USID: 245301
 SITE ADDRESS: 63 WOODLAND STREET, SOUTH GLASTONBURY, CT 06073
 SHEET NAME: WIC SHELTER ELEVATION
 SHEET NUMBER: C-5

APPLICATION AND ENGINEERING DATA

ENGINE SPECIFICATIONS

General

Make	Mitsubishi
EPA Emissions Compliance	Interim Tier 4
Cylinder #	4
Type	In-Line
Displacement - L (Cu In)	2.5 (158)
Bore - mm (in)	88 (3.5)
Stroke - mm (in)	103 (4.1)
Compression Ratio	22:1
Intake Air Method	Naturally Aspirated

Engine Governing

Governor	Electronic Isochronous
Frequency Regulation (Steady State)	± 0.25%

Lubrication System

Oil Pump Type	Trochoid Gear Pump
Oil Filter Type	Filtering Paper, Full Flow
Crankcase Capacity - L (qts)	6.5 (6.9)

ALTERNATOR SPECIFICATIONS

Standard Model	Mecc Alte ECP 28-2L/4
Poles	4
Field Type	Revolving
Insulation Class - Rotor	H
Insulation Class - Stator	H
Total Harmonic Distortion	<.5%
Telephone Interference Factor (TIF)	<.45
Standard Excitation	Brushless

Cooling System

Cooling System Type	Forced Circulation
Water Pump Type	Centrifugal Pump
Fan Type	Pusher
Fan Speed (rpm)	2100
Fan Diameter - mm (in)	431.8 (17)
Coolant Heater Wattage	1000
Coolant Heater Voltage	120

Fuel System

Fuel Type	Ultra Low Sulfur Diesel #2
Fuel Specifications	ASTM
Fuel Filtering (microns)	6
Fuel Inject Pump Make	Bosch
Injector Type	Engine Driven Gear
Engine Type	Diesel
Fuel Supply Line - mm (in.)	6.6 (0.26)

Engine Electrical System

System Voltage	12 VDC
Battery Charger Alternator	12V-50A
Battery Size	650 CCA
Battery Group	35
Battery Voltage	12 VDC
Ground Polarity	Negative

Bearings

Bearings	Dual Sealed
Coupling	Belt, Pulley
Load Capacity - Standby	100%
Prototype Short Circuit Test	Yes
Voltage Regulator Type	Digital
Number of Sensed Phases	All
Regulation Accuracy (Steady State)	± 0.5%

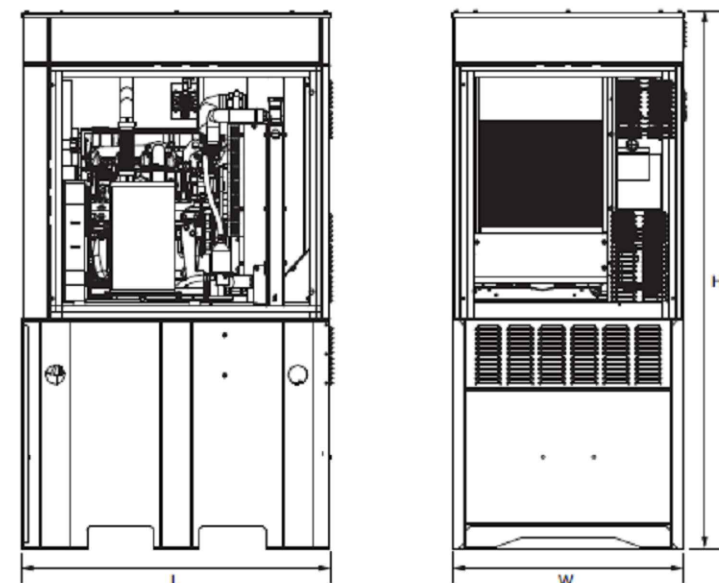

Level 2 Sound Attenuation Enclosure

Run Time Hours	48
Usable Capacity Gal (L)	92 (348.2)
L x W x H in (mm)	48 x 36 x 90 (1219.2 x 914.4 x 2286)
Weight lbs (kg)	2400 (1089)
Sound Level	71 dBA

OPERATING DATA

POWER RATINGS

Single-Phase 120/240 VAC @1.0pf	20 kW	Amps: 83
Circuit Breaker Size	100A	

FUEL CONSUMPTION RATES*

Diesel - gph (lph)	
Percent Load	Standby
25%	0.74 (2.80)
50%	0.99 (3.75)
75%	1.41 (5.30)
100%	1.90 (7.19)

* Fuel supply installation must accommodate fuel consumption rates at 100% load.

COOLING

Coolant Flow per Minute	gpm (lpm)	Standby
Coolant System Capacity	gal (L)	11.9 (45)
Heat Rejection to Coolant	BTU/hr	3.5 (13.2)
Inlet Air	cfm (m³/min)	236.200
Max. Operating Ambient Temperature (Before Derate)	°F (°C)	77° (25°)
Maximum Radiator Backpressure	in H₂O	0.50

COMBUSTION AIR REQUIREMENTS

Flow at Rated Power cfm (m³/min)	Standby
	88 (2.49)

ENGINE

Rated Engine Speed	rpm	Standby
Horsepower at Rated kW**	hp	1800
Piston Speed	ft/min	33.5
BMEP	psi	1220.47
		96.5

EXHAUST

Exhaust Flow (Rated Output)	cfm (m³/min)	Standby
Max. Backpressure (Post Silencer)	inHg (kPa)	193 (328)
Exhaust Temp (Rated Output - Post Silencer)	°F (°C)	1.36 (4.67)
		928 (497.7)

GENERAC
SDC20 2.5L 20 KW - AC
MODEL # G007098-0



7150 STANDARD DRIVE
HANOVER, MD 21076



1362 MELLON ROAD, SUITE 140
HANOVER, MD 21076



1100 E. WOODFIELD ROAD, SUITE 500
SCHAUMBURG, ILLINOIS 60173
TEL: 847-908-8400
COA# PEC.0001444
www.FullertonEngineering.com

REV	DATE	DESCRIPTION	BY
A	02/19/19	90% REVIEW	EB
B	03/19/19	REV. 90% REVIEW	EB
1	03/26/19	FOR PERMIT	KC
2	04/11/19	FOR CONSTRUCTION	KC
3	04/26/19	FOR CONSTRUCTION	EB

I HEREBY CERTIFY THAT THESE DRAWINGS WERE PREPARED BY ME OR UNDER MY DIRECT SUPERVISION AND CONTROL, AND TO THE BEST OF MY KNOWLEDGE AND BELIEF COMPLY WITH THE REQUIREMENTS OF ALL APPLICABLE CODES.



SITE NUMBER
CT2421S

SITE NAME
WOODLAND STREET FACILITY

FA NUMBER:
14644530

USID:
245301

SITE ADDRESS
**63 WOODLAND STREET
SOUTH GLASTONBURY, CT 06073**

SHEET NAME
GENERATOR

SHEET NUMBER
C-6

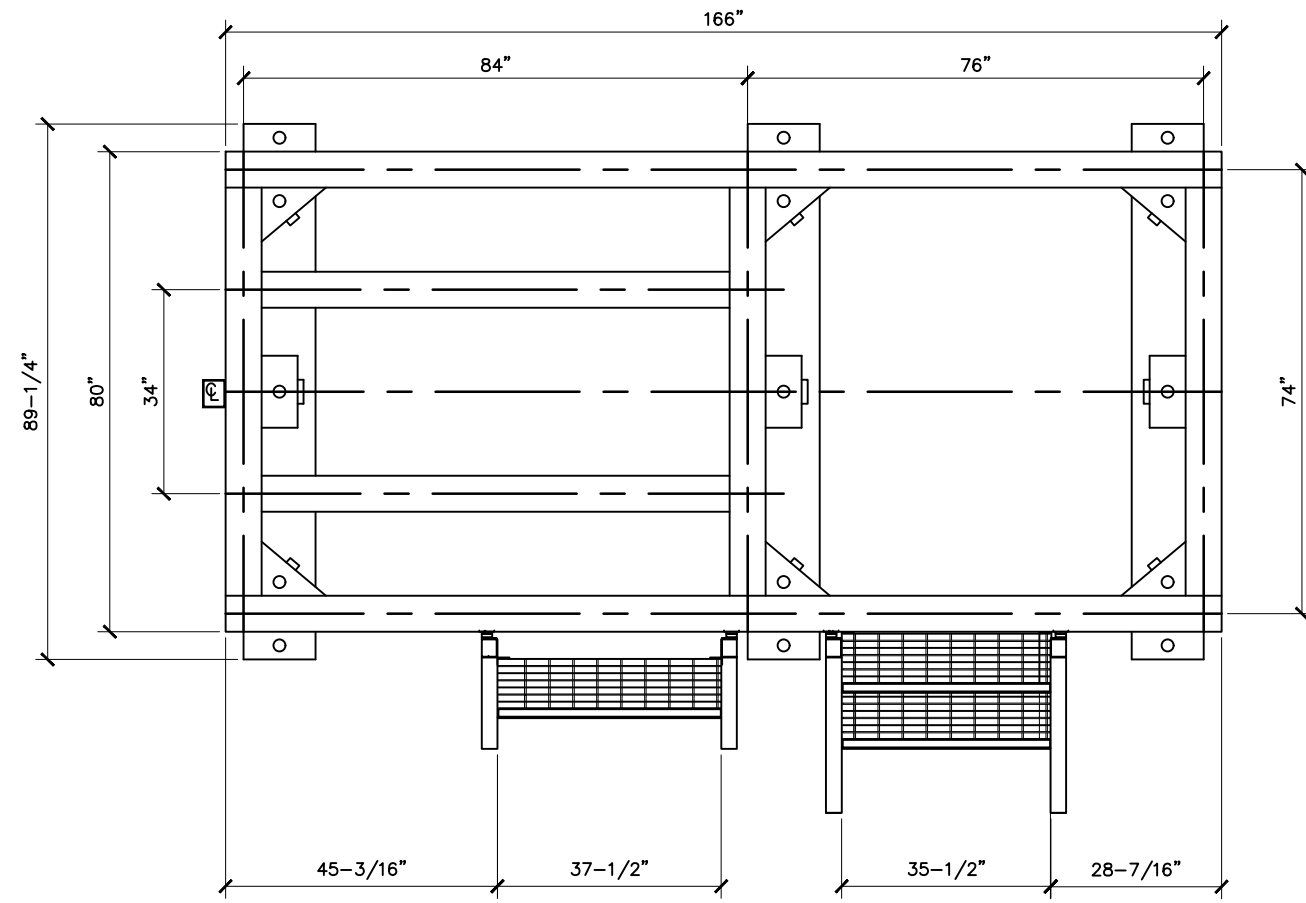
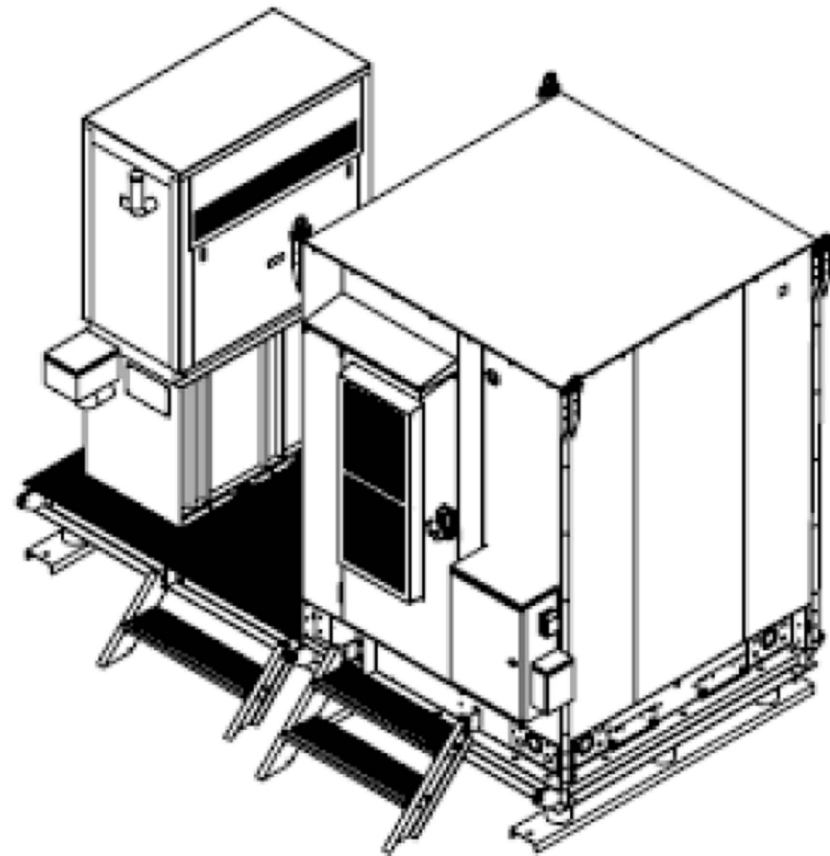

TOP VIEW

MAINTAIN MAXIMUM
18" FROM GRADE TO
BOTTOM OF WIC TO
ACCOMMODATE STAIRS

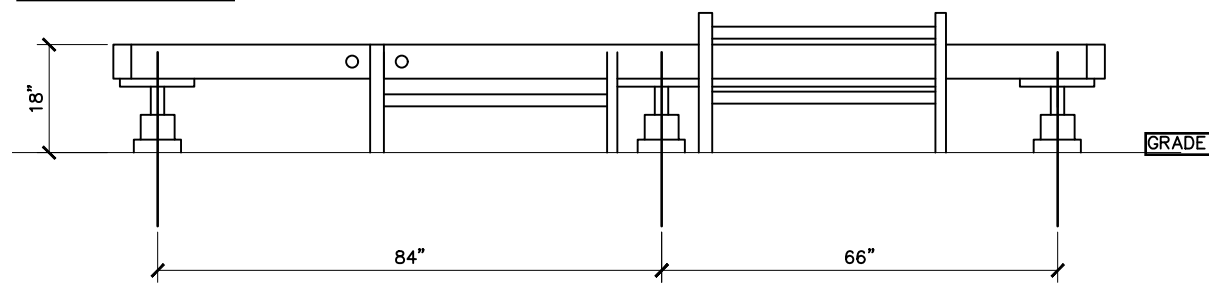

FRONT VIEW

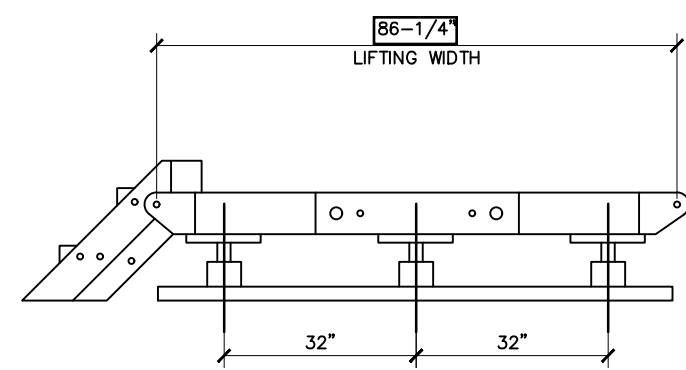

SIDE VIEW



7150 STANDARD DRIVE
HANOVER, MD 21076



1362 MELLON ROAD, SUITE 140
HANOVER, MD 21076



1100 E. WOODFIELD ROAD, SUITE 500
SCHAUMBURG, ILLINOIS 60173
TEL: 847-908-8400
COA# PEC.0001444
www.FullertonEngineering.com

REV	DATE	DESCRIPTION	BY
A	02/19/19	90% REVIEW	EB
B	03/19/19	REV. 90% REVIEW	EB
1	03/26/19	FOR PERMIT	KC
2	04/11/19	FOR CONSTRUCTION	KC
3	04/26/19	FOR CONSTRUCTION	EB

I HEREBY CERTIFY THAT THESE DRAWINGS WERE PREPARED BY ME OR UNDER MY DIRECT SUPERVISION AND CONTROL, AND TO THE BEST OF MY KNOWLEDGE AND BELIEF COMPLY WITH THE REQUIREMENTS OF ALL APPLICABLE CODES.



SITE NUMBER
CT2421S

SITE NAME
WOODLAND STREET FACILITY

FA NUMBER:
14644530

USID:
245301

SITE ADDRESS
**63 WOODLAND STREET
SOUTH GLASTONBURY, CT 06073**

SHEET NAME
**GRAVITY
PLATFORM DETAILS**

SHEET NUMBER
C-6A

RF DESIGN NOTE:
 THIS ANTENNA AND COAX CABLE SCHEDULE HAS BEEN CREATED USING THE FOLLOWING RFDS DATED: 02/26/19 V3
 ALL ANTENNA DESIGN, ZONING, STRUCTURAL ANALYSIS PERMITS AND COMPLIANCE SUBMISSIONS ARE COORDINATED WITH THE AFOREMENTIONED DOCUMENT



REV	DATE	DESCRIPTION	BY
A	02/19/19	90% REVIEW	EB
B	03/19/19	REV. 90% REVIEW	EB
1	03/26/19	FOR PERMIT	KC
2	04/11/19	FOR CONSTRUCTION	KC
3	04/26/19	FOR CONSTRUCTION	EB

I HEREBY CERTIFY THAT THESE DRAWINGS WERE PREPARED BY ME OR UNDER MY DIRECT SUPERVISION AND CONTROL, AND TO THE BEST OF MY KNOWLEDGE AND BELIEF COMPLY WITH THE REQUIREMENTS OF ALL APPLICABLE CODES.



SITE NUMBER: **CT2421S**

SITE NAME: **WOODLAND STREET FACILITY**

FA NUMBER: **14644530**

USID: **245301**

SITE ADDRESS: **63 WOODLAND STREET SOUTH GLASTONBURY, CT 06073**

SHEET NAME: **ANTENNA INFORMATION CHART**

SHEET NUMBER: **C-7**

SECTOR	ANTENNA NUMBER	ANTENNA STATUS & TYPE	ANTENNA MODEL NUMBER	ANTENNA VENDOR	ANTENNA SIZE (HxWxD)	ANTENNA WEIGHT (LBS.)	RRU MODEL NUMBER	ANTENNA PORTS	TECH.	AZIMUTH	MECHANICAL DOWN TILT	ELECTRICAL DOWN TILT	ANTENNA C FROM GROUND	ANTENNA TIP HEIGHT	CABLE FEEDER	
															TYPE	LENGTH
A	A-1	NEW LTE ANTENNA	TPA65R-BU8D	CCI	96"x21"x7.8"	83 LBS.	(1) NEW RRUS-4478 B14	1	700	120°	0°	2'/2"	135'-0"	139'-0"	(1) FIBER CABLE	190'-0"
							5	AWS	(2) DC POWER CABLES						190'-0"	
	A-2	NEW LTE ANTENNA	HPA65R-BU8A	CCI	96"x11.7"x7.6"	57.3 LBS.	(1) NEW RRUS-E2	5	AWS	120°	0°	2'	135'-0"	139'-0"	(2) DC POWER CABLES	190'-0"
							1	700	SEE ANTENNA A-3 FOR FIBER CABLE							
A-3	NEW LTE ANTENNA	TPA65R-BU8D	CCI	96"x21"x7.8"	83 LBS.	(1) NEW RRUS-4449 B5/B12	3	850	120°	0°	2'/2'/2"	135'-0"	139'-0"	(1) FIBER CABLE	190'-0"	
						9	PCS	(2) DC POWER CABLES						190'-0"		
A-4																
B	B-5	NEW LTE ANTENNA	TPA65R-BU8D	CCI	96"x21"x7.8"	83 LBS.	(1) NEW RRUS-4478 B14	1	700	240°	0°	2'/2"	135'-0"	139'-0"	SEE ANTENNA A-1 FOR CABLE TYPE AND LENGTH	
							5	AWS								
	B-6	NEW LTE ANTENNA	HPA65R-BU8A	CCI	96"x11.7"x7.6"	57.3 LBS.	(1) NEW RRUS-E2	5	AWS	240°	0°	2'	135'-0"	139'-0"	SEE ANTENNA A-2 FOR CABLE TYPE AND LENGTH	
							1	700								
B-7	NEW LTE ANTENNA	TPA65R-BU8D	CCI	96"x21"x7.8"	83 LBS.	(1) NEW RRUS-4449 B5/B12	3	850	240°	0°	2'/2'/2"	135'-0"	139'-0"	SEE ANTENNA A-3 FOR CABLE TYPE AND LENGTH		
						9	PCS									
B-8																
C	C-9	NEW LTE ANTENNA	TPA65R-BU8D	CCI	96"x21"x7.8"	83 LBS.	(1) NEW RRUS-4478 B14	1	700	340°	0°	2'/2"	135'-0"	139'-0"	SEE ANTENNA A-1 FOR CABLE TYPE AND LENGTH	
							5	AWS								
	C-10	NEW LTE ANTENNA	HPA65R-BU8A	CCI	96"x11.7"x7.6"	57.3 LBS.	(1) NEW RRUS-E2	5	AWS	340°	0°	2'	135'-0"	139'-0"	SEE ANTENNA A-2 FOR CABLE TYPE AND LENGTH	
							1	700								
C-11	NEW LTE ANTENNA	TPA65R-BU8D	CCI	96"x21"x7.8"	83 LBS.	(1) NEW RRUS-4449 B5/B12	3	850	340°	0°	2'/2'/2"	135'-0"	139'-0"	SEE ANTENNA A-3 FOR CABLE TYPE AND LENGTH		
						9	PCS									
C-12																
N/A	N/A															



7150 STANDARD DRIVE
 HANOVER, MD 21076



1362 MELLON ROAD, SUITE 140
 HANOVER, MD 21076



1100 E. WOODFIELD ROAD, SUITE 500
 SCHAUMBURG, ILLINOIS 60173
 TEL: 847-908-8400
 COA# PEC.0001444
 www.FullertonEngineering.com

REV	DATE	DESCRIPTION	BY
A	02/19/19	90% REVIEW	EB
B	03/19/19	REV. 90% REVIEW	EB
1	03/26/19	FOR PERMIT	KC
2	04/11/19	FOR CONSTRUCTION	KC
3	04/26/19	FOR CONSTRUCTION	EB

I HEREBY CERTIFY THAT THESE DRAWINGS WERE PREPARED BY ME OR UNDER MY DIRECT SUPERVISION AND CONTROL, AND TO THE BEST OF MY KNOWLEDGE AND BELIEF COMPLY WITH THE REQUIREMENTS OF ALL APPLICABLE CODES.



SITE NUMBER	CT2421S
SITE NAME	WOODLAND STREET FACILITY
FA NUMBER:	14644530
USID:	245301
SITE ADDRESS	63 WOODLAND STREET SOUTH GLASTONBURY, CT 06073
SHEET NAME	PLUMBING DIAGRAM
SHEET NUMBER	C-8

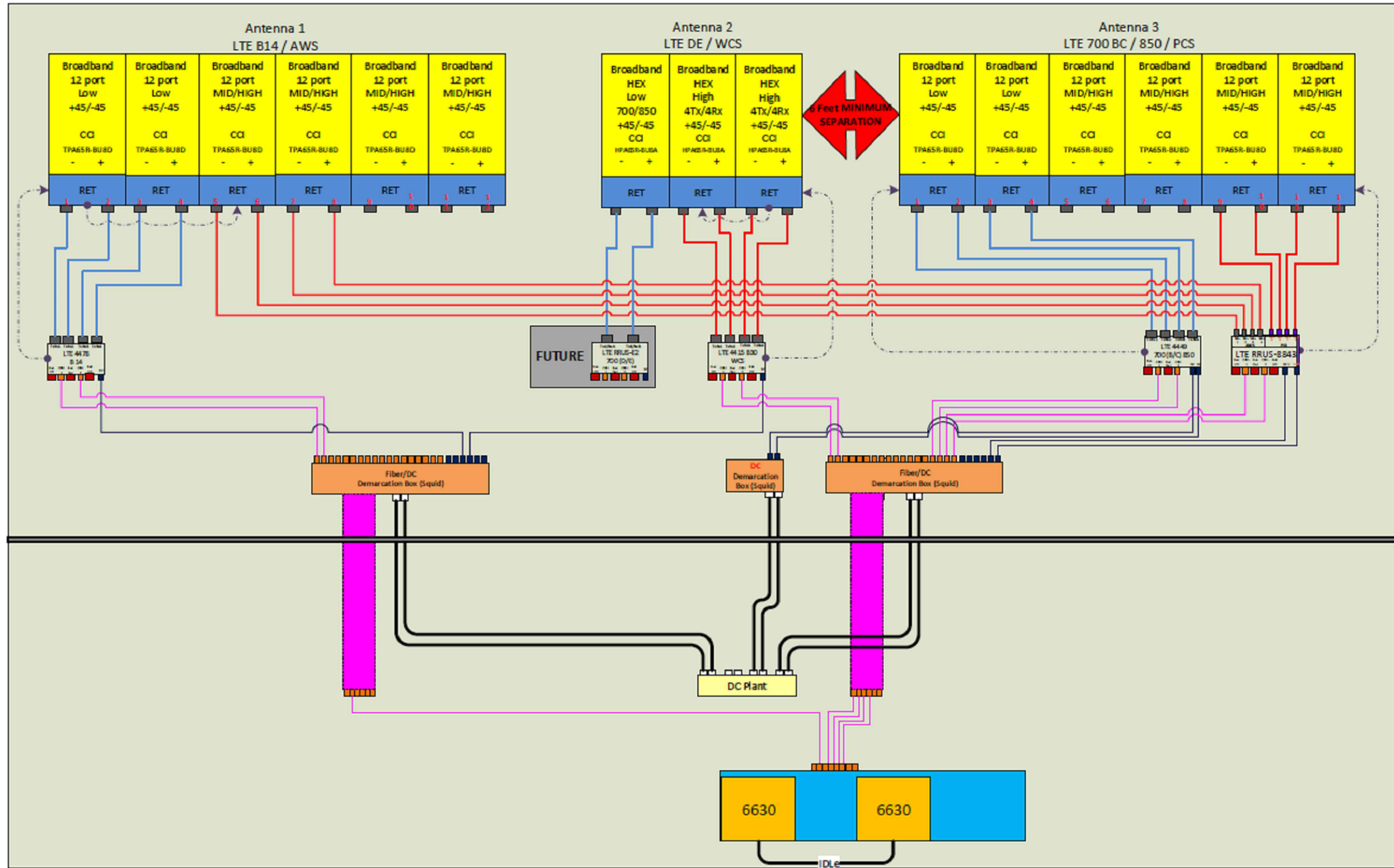

*BASED ON RFDS V2.0, DATED (02/19/19)

NOTES:
 1. CONTRACTOR TO CALL 811, 48 HRS PRIOR TO EXCAVATING FOR UNDERGROUND UTILITY LOCATIONS. LOCATION SURROUNDING EXCAVATED AREA MUST BE PRIVATELY LOCATED FOR NON-PUBLIC UTILITIES.



FULLERTON
 ENGINEERING-DESIGN
 1100 E. WOODFIELD ROAD, SUITE 500
 SCHAUMBURG, ILLINOIS 60173
 TEL: 847-908-8400
 COA# PEC.0001444
 www.FullertonEngineering.com

REV	DATE	DESCRIPTION	BY
A	02/19/19	90% REVIEW	EB
B	03/19/19	REV. 90% REVIEW	EB
1	03/26/19	FOR PERMIT	KC
2	04/11/19	FOR CONSTRUCTION	KC
3	04/26/19	FOR CONSTRUCTION	EB

I HEREBY CERTIFY THAT THESE DRAWINGS WERE PREPARED BY ME OR UNDER MY DIRECT SUPERVISION AND CONTROL, AND TO THE BEST OF MY KNOWLEDGE AND BELIEF COMPLY WITH THE REQUIREMENTS OF ALL APPLICABLE CODES.



SITE NUMBER
CT2421S

SITE NAME
WOODLAND STREET FACILITY

FA NUMBER:
14644530

USID:
245301

SITE ADDRESS
**63 WOODLAND STREET
 SOUTH GLASTONBURY, CT 06073**

SHEET NAME
UTILITY PLAN

SHEET NUMBER
E-1

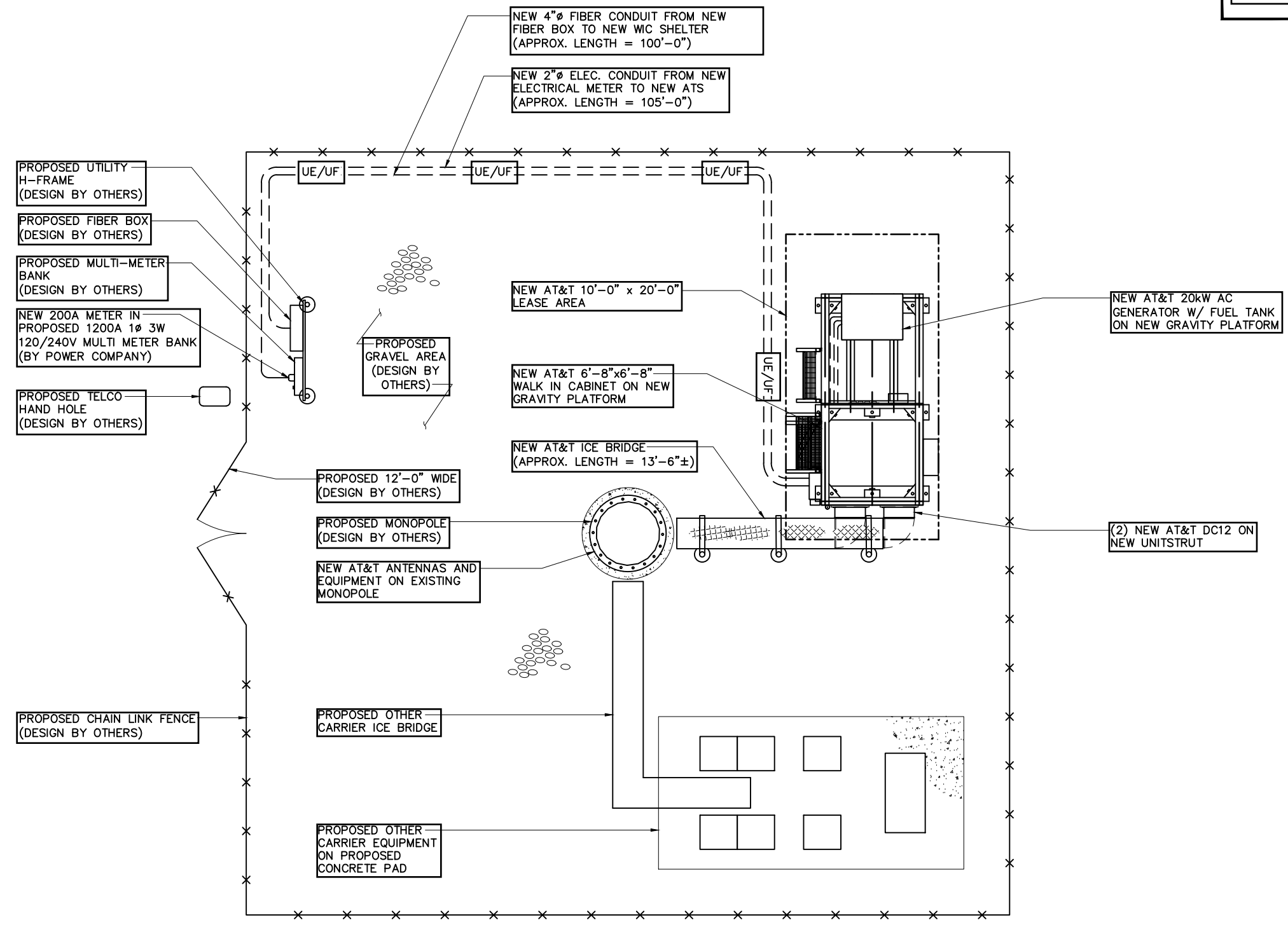

ELECTRICAL INSTALLATION NOTES:

- ALL ELECTRICAL WORK SHALL BE PERFORMED IN ACCORDANCE WITH THE PROJECT SPECIFICATIONS
- CONDUIT ROUTINGS ARE SCHEMATIC. SUBCONTRACTOR SHALL INSTALL CONDUITS SO THAT ACCESS TO EQUIPMENT IS NOT BLOCKED.
- WIRING, RACEWAY, AND SUPPORT METHODS AND MATERIAL SHALL COMPLY WITH THE REQUIREMENTS OF THE NEC.
- ALL CIRCUITS SHALL BE SEGREGATED AND MAINTAIN MINIMUM CABLE SEPARATION AS REQUIRED BY THE NEC
- CABLES SHALL NOT BE ROUTED THROUGH LADDER-STYLE CABLE TRAY RUNGS.
- EACH END OF EVERY POWER, POWER PHASE CONDUCTOR (I.E. HOTS), GROUNDING, AND T1 CONDUCTOR AND CABLE SHALL BE LABELED WITH COLOR-CODED INSULATION OR ELECTRICAL TAPE (3M BRAND, 1/2" PLASTIC ELECTRICAL TAPE WITH UV PROTECTION, OR EQUAL). THE IDENTIFICATION METHOD SHALL CONFORM WITH NEC & OSHA.
- ALL ELECTRICAL COMPONENTS SHALL BE CLEARLY LABELED WITH PLASTIC TAPE PER COLOR SCHEDULE. ALL EQUIPMENT SHALL BE LABELED WITH THEIR VOLTAGE RATING, PHASE CONFIGURATION, WIRE CONFIGURATION, POWER OR AMPACITY RATING, AND BRANCH CIRCUIT ID NUMBERS (I.E. PANELBOARD AND CIRCUIT ID'S). PER AT&T STANDARD.
- PANELBOARDS (ID NUMBERS) AND INTERNAL CIRCUIT BREAKERS (CIRCUIT ID NUMBERS) SHALL BE CLEARLY LABELED WITH PLASTIC LABELS. PER AT&T STANDARD.
- ALL TIE WRAPS SHALL BE CUT FLUSH WITH APPROVED CUTTING TOOL TO REMOVE SHARP EDGES.
- POWER, CONTROL, AND EQUIPMENT GROUND WIRING IN TUBING OR CONDUIT SHALL BE SINGLE CONDUCTOR (#14 AWG OR LARGER), 600 V, OIL RESISTANT THHN OR THWN-2, CLASS B STRANDED COPPER CABLE RATED FOR 90°C (WET AND DRY) OPERATION: LISTED OR LABELED FOR THE LOCATION AND RACEWAY SYSTEM USED, UNLESS OTHERWISE SPECIFIED.
- SUPPLEMENTAL EQUIPMENT GROUND WIRING LOCATED INDOORS SHALL BE SINGLE CONDUCTOR (#6 AWG OR LARGER), 600 V, OIL RESISTANT THHN OR THWN-2 GREEN INSULATION, CLASS B STRANDED COPPER CABLE RATED FOR 90°C (WET AND DRY) OPERATION: LISTED OR LABELED FOR THE LOCATION AND RACEWAY SYSTEM USED, UNLESS OTHERWISE SPECIFIED.
- POWER AND CONTROL WIRING, NOT IN TUBING OR CONDUIT, SHALL BE MULTI-CONDUCTOR, TYPE TC CABLE (#14 AWG OR LARGER), 600 V, OIL RESISTANT THHN OR THWN-2, CLASS B STRANDED COPPER CABLE RATED FOR 90°C (WET AND DRY) OPERATION: WITH OUTER JACKET: LISTED OR LABELED FOR THE LOCATION USED, UNLESS OTHERWISE SPECIFIED.
- ALL POWER AND GROUNDING CONNECTIONS SHALL BE CRIMP-STYLE, COMPRESSION WIRE LUGS AND WIRENUTS BY THOMAS AND BETTS (OR EQUAL). LUGS AND WIRENUTS SHALL BE RATED FOR OPERATION AT NO LESS THAT 75°C (90°C IF AVAILABLE).
- RACEWAY AND CABLE TRAY SHALL BE LISTED OR LABELED FOR ELECTRICAL USE IN ACCORDANCE WITH NEMA, UL, ANSI/IEEE, AND NEC.
- ELECTRICAL METALLIC TUBING (EMT) OR RIGID NONMETALLIC CONDUIT (I.E. RIGID PVC SCHEDULE 40, OR RIGID PVC SCHEDULE 80 FOR LOCATIONS SUBJECT TO PHYSICAL DAMAGE) SHALL BE USED FOR EXPOSED INDOOR LOCATIONS.
- ELECTRICAL METALLIC TUBING (EMT), ELECTRICAL NONMETALLIC TUBING (ENT), OR RIGID NONMETALLIC CONDUIT (RIGID PVC, SCHEDULE 40) SHALL BE USED FOR CONCEALED INDOOR LOCATIONS.
- GALVANIZED STEEL INTERMEDIATE METALLIC CONDUIT (IMC) SHALL BE USED FOR OUTDOOR LOCATIONS ABOVE GRADE.
- RIGID NONMETALLIC CONDUIT (I.E. RIGID PVC SCHEDULE 40 OR RIGID PVC SCHEDULE 80) SHALL BE USED UNDERGROUND: DIRECT BURIED, IN AREAS OF OCCASIONAL LIGHT VEHICLE TRAFFIC OR ENCASED IN REINFORCED CONCRETE IN AREA OF HEAVY VEHICLE TRAFFIC.
- LIQUID-TIGHT FLEXIBLE METALLIC CONDUIT (LIQUID-TITE FLEX) SHALL BE USED INDOORS AND OUTDOORS, WHERE VIBRATION OCCURS OR FLEXIBILITY IS NEEDED.
- CONDUIT AND TUBING FITTING SHALL BE THREADED OR COMPRESSION-TYPE AND APPROVED FOR THE LOCATION USED. SETSCREW FITTING ARE NOT ACCEPTABLE.
- CABINETS, BOXES, AND WIREWAYS SHALL BE LISTED OR LABELED FOR ELECTRICAL USE IN ACCORDANCE WITH NEMA, UL, ANSI/IEEE, AND NEC.
- WIREWAYS SHALL BE EPOXY-COATED (GRAY) AND INCLUDE A HINGED COVER, DESIGNED TO SWING OPEN DOWNWARD SHALL BE PANDUIT TYPE E (OR EQUAL) AND RATED NEMA 1 (OR BETTER).
- EQUIPMENT CABINETS, TERMINAL BOXES, JUNCTION BOXES, AND PULL BOXES SHALL BE GALVANIZED OR EPOXY-COATED SHEET STEEL, SHALL MEET OR EXCEED UL 50, AND RATED NEMA 1 (OR BETTER) INDOORS OR NEMA 3R (OR BETTER) OUTDOORS.
- METAL RECEPTACLE, SWITCH, AND DEVICE BOXES SHALL BE GALVANIZED, EPOXY-COATED, OR NON-CORRODING: SHALL MEET OR EXCEED UL 514A AND NEMA OS 1: AND RATED NEMA 1 (OR BETTER) INDOORS, OR WEATHER PROTECTED (WP OR BETTER) OUTDOORS.
- NONMETALLIC RECEPTACLE, SWITCH AND DEVICE BOXES SHALL MEET OR EXCEED NEMA OS 2: AND RATED NEMA 1 (OR BETTER) INDOORS, OR WEATHER PROTECTED (WP OR BETTER) OUTDOORS.
- THE SUBCONTRACTOR SHALL NOTIFY AND OBTAIN NECESSARY AUTHORIZATION FROM THE CONTRACTOR BEFORE COMMENCING WORK ON THE AC POWER DISTRIBUTION PANELS.
- THE SUBCONTRACTOR SHALL PROVIDE NECESSARY TAGGING ON THE BREAKERS, CABLES AND DISTRIBUTION PANELS IN ACCORDANCE WITH THE APPLICABLE CODES AND STANDARDS TO SAFE GUARD AGAINST LIFE AND PROPERTY.

ONE LINE DIAGRAM

SCALE: N.T.S. 1

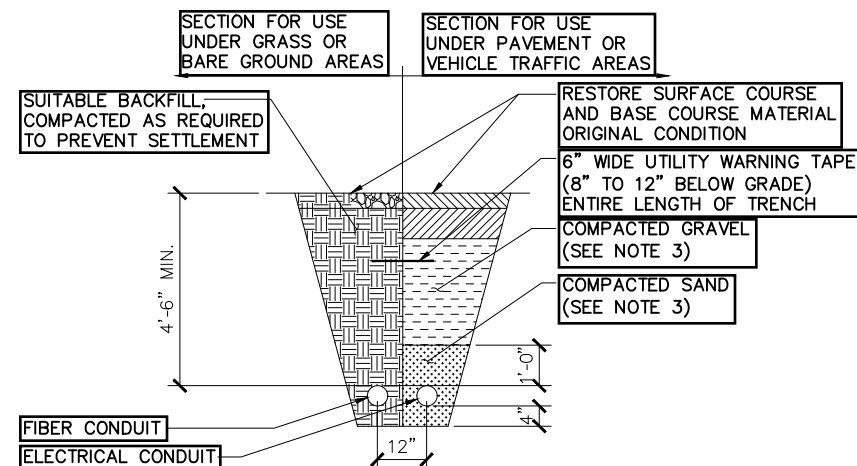

- NOTES:**
- CONTRACTOR TO VERIFY LOCAL UTILITY REQUIREMENTS FOR DEPTH, SIZE & SEPARATION OF CONDUITS PRIOR TO INSTALLATION. NOTIFY CONSTRUCTION MANAGER IMMEDIATELY OF ANY DISCREPANCIES.
 - CONTRACTOR TO CALL 811, 48 HRS PRIOR TO EXCAVATING FOR UNDERGROUND UTILITY LOCATIONS. LOCATION SURROUNDING EXCAVATED AREA MUST BE PRIVATELY LOCATED FOR NON-PUBLIC UTILITIES.
 - ALL SUITABLE FILL MATERIAL SHALL BE INSTALLED IN HORIZONTAL LAYERS NOT EXCEEDING A LOOSE DEPTH OF 9 INCHES AND SHALL BE COMPACTED TO NOT LESS THAN 95% OF THE MAXIMUM DRY DENSITY PER THE MODIFIED PROCTOR TEST, ASTM D1557.

UTILITY TRENCH DETAIL

SCALE: N.T.S. 3

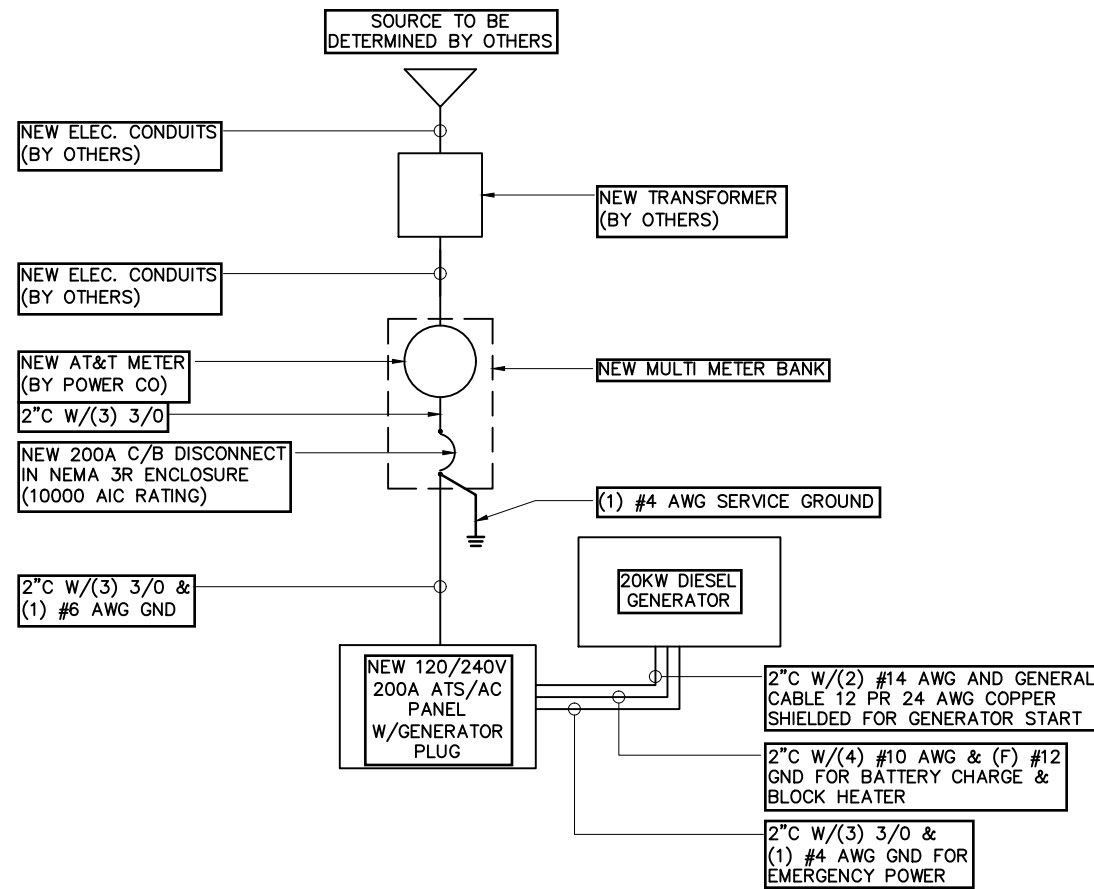

ONE LINE DIAGRAM

SCALE: N.T.S. 2

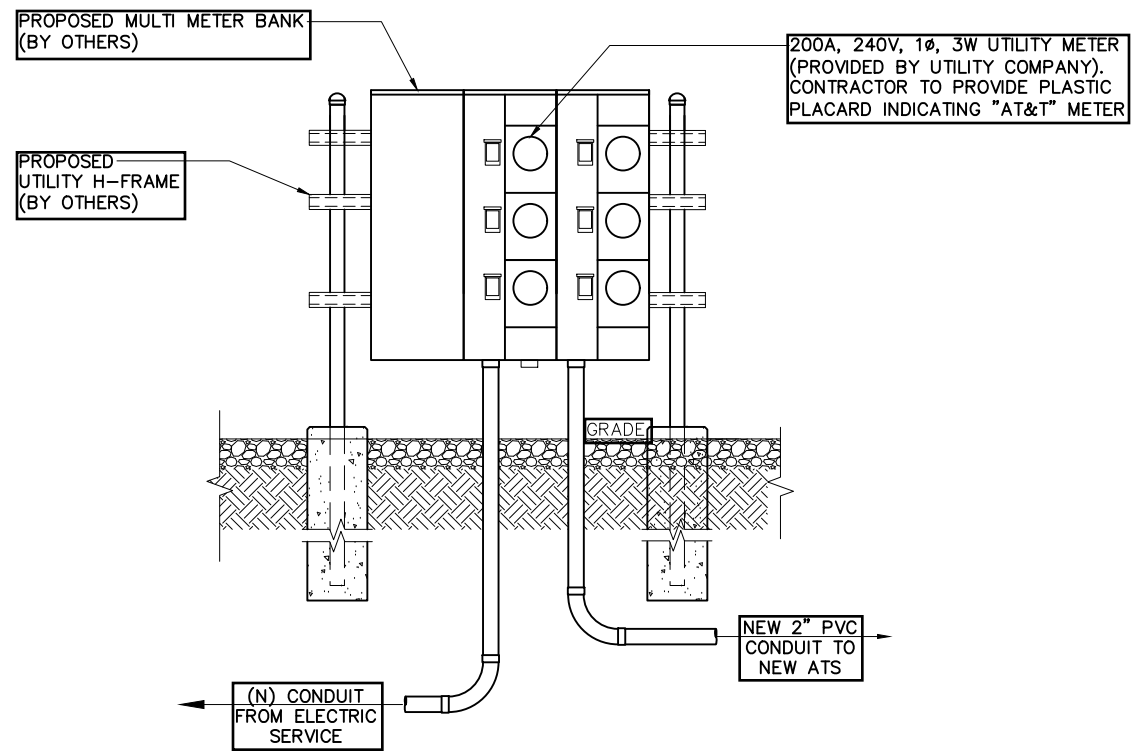

H-FRAME DETAIL

SCALE: N.T.S. 4



REV	DATE	DESCRIPTION	BY
A	02/19/19	90% REVIEW	EB
B	03/19/19	REV. 90% REVIEW	EB
1	03/26/19	FOR PERMIT	KC
2	04/11/19	FOR CONSTRUCTION	KC
3	04/26/19	FOR CONSTRUCTION	EB

I HEREBY CERTIFY THAT THESE DRAWINGS WERE PREPARED BY ME OR UNDER MY DIRECT SUPERVISION AND CONTROL, AND TO THE BEST OF MY KNOWLEDGE AND BELIEF COMPLY WITH THE REQUIREMENTS OF ALL APPLICABLE CODES.



SITE NUMBER: CT2421S

SITE NAME: WOODLAND STREET FACILITY

FA NUMBER: 14644530

USID: 245301

SITE ADDRESS: 63 WOODLAND STREET SOUTH GLASTONBURY, CT 06073

SHEET NAME: ELECTRICAL NOTES AND DETAILS

SHEET NUMBER: E-2

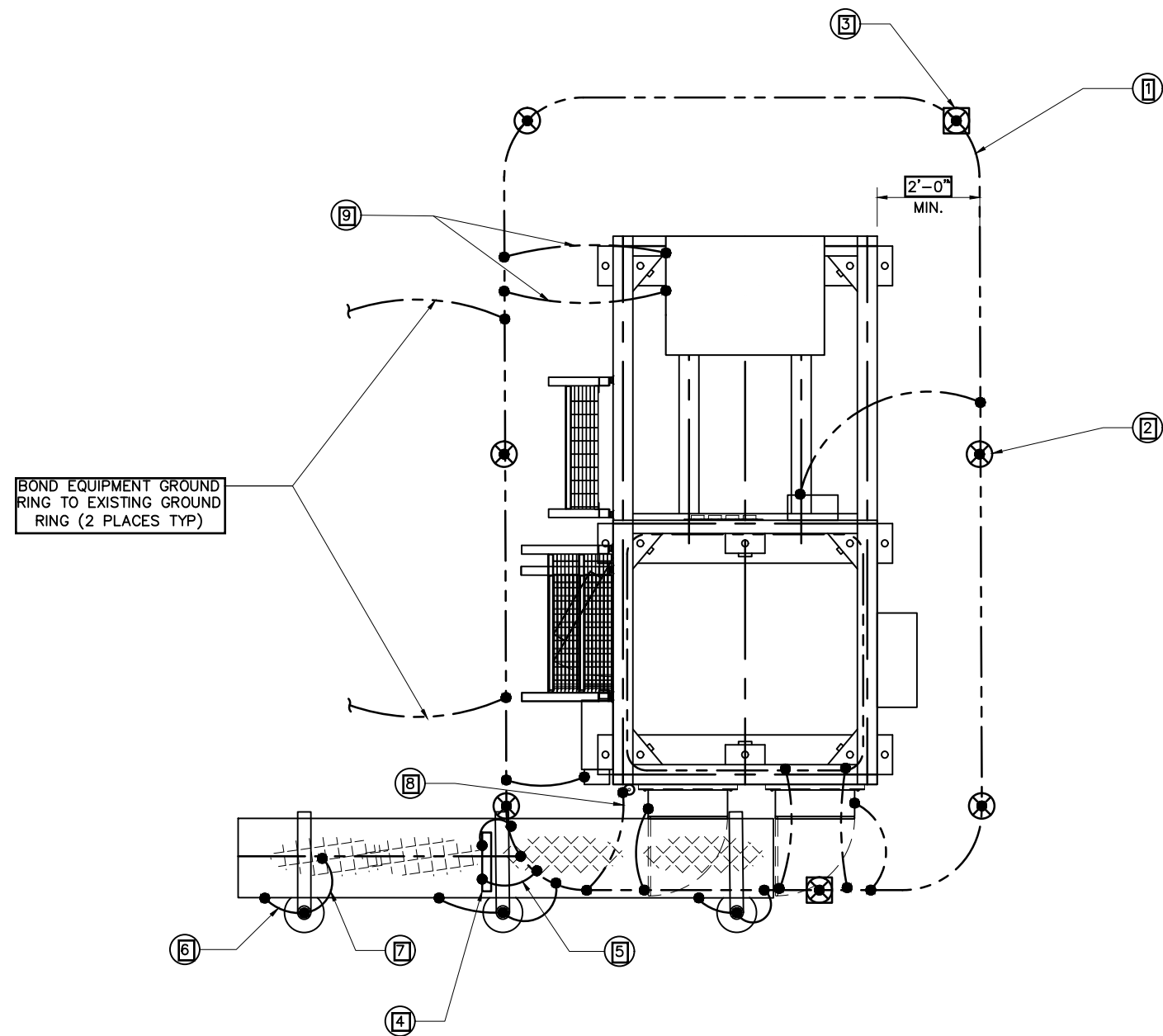

BOND EQUIPMENT GROUND RING TO EXISTING GROUND RING (2 PLACES TYP)

LEGEND

- GROUND BAR
- - - EXISTING GROUND RING
- - - NEW GROUND RING
- ⊗ 5/8" x 10'-0" GROUND ROD
- ⊗ GROUND SYSTEM TEST WELL
- ▲ MECHANICAL CONNECTION
- CADWELD OR APPROVED CONNECTION

- KEY NOTES**
1. GROUND RING, #2 SOLID, TINNED BARE COPPER WIRE. CONSTRUCT RING FROM ONE CONTINUOUS PIECE (NO EXCEPTIONS ALLOWED).
 2. 5/8" x 10'-0" COPPER CLAD STEEL GROUND ROD SPACED MIN. 10'-0", MAX 15'-0" APART
 3. GROUND SYSTEM TEST WELL.
 4. GROUND BAR ATTACHED TO ICE BRIDGE.
 5. #2 SOLID, TINNED BARE COPPER GROUND WIRE FROM GROUND BAR TO GROUND RING (2 REQ'D).
 6. #2 SOLID, TINNED BARE COPPER GROUND WIRE FROM ICE BRIDGE TO ICE BRIDGE POST.
 7. #2 SOLID, TINNED BARE COPPER GROUND WIRE IN 1/2" CARFLEX SLEEVE, BOND ICE BRIDGE POST W/ VS TYPE CADWELD. (1 PER POST REQ'D).
 8. #6 SOLID TINNED, BARE COPPER GROUND WIRE FROM GPS ANTENNA TO GROUND RING.
 9. #2 SOLID TINNED, BARE COPPER GROUND WIRE FROM GENERATOR TO GROUND RING.

7150 STANDARD DRIVE
HANOVER, MD 21076

1362 MELLON ROAD, SUITE 140
HANOVER, MD 21076

FULLERTON
ENGINEERING-DESIGN

1100 E. WOODFIELD ROAD, SUITE 500
SCHAUMBURG, ILLINOIS 60173
TEL: 847-908-8400
COA# PEC.0001444
www.FullertonEngineering.com

REV	DATE	DESCRIPTION	BY
A	02/19/19	90% REVIEW	EB
B	03/19/19	REV. 90% REVIEW	EB
1	03/26/19	FOR PERMIT	KC
2	04/11/19	FOR CONSTRUCTION	KC
3	04/26/19	FOR CONSTRUCTION	EB

I HEREBY CERTIFY THAT THESE DRAWINGS WERE PREPARED BY ME OR UNDER MY DIRECT SUPERVISION AND CONTROL, AND TO THE BEST OF MY KNOWLEDGE AND BELIEF COMPLY WITH THE REQUIREMENTS OF ALL APPLICABLE CODES.



SITE NUMBER: CT2421S

SITE NAME: WOODLAND STREET FACILITY

FA NUMBER: 14644530

USID: 245301

SITE ADDRESS: 63 WOODLAND STREET, SOUTH GLASTONBURY, CT 06073

SHEET NAME: GROUNDING PLAN & NOTES

SHEET NUMBER: G-1

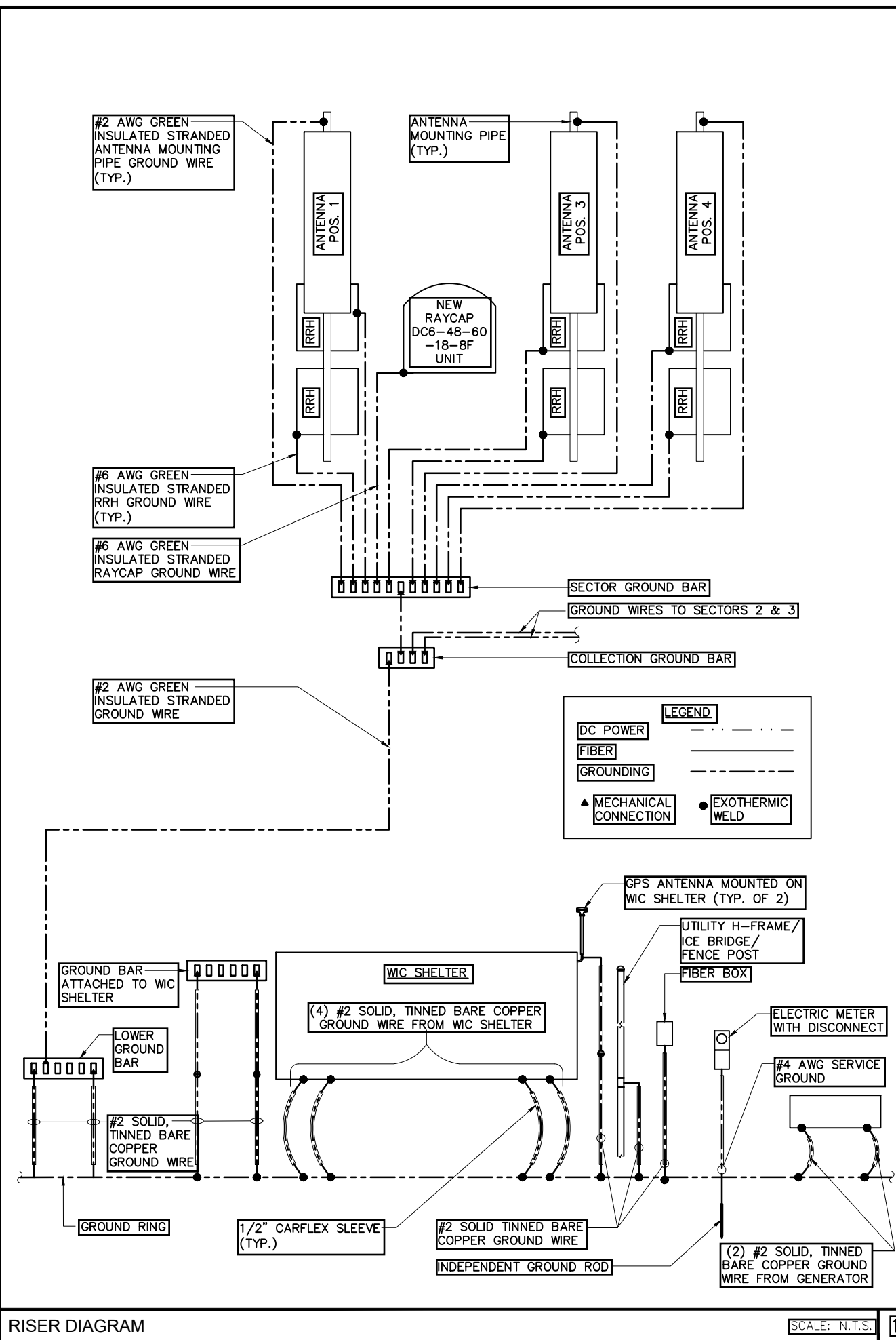

RISER DIAGRAM SCALE: N.T.S. 1

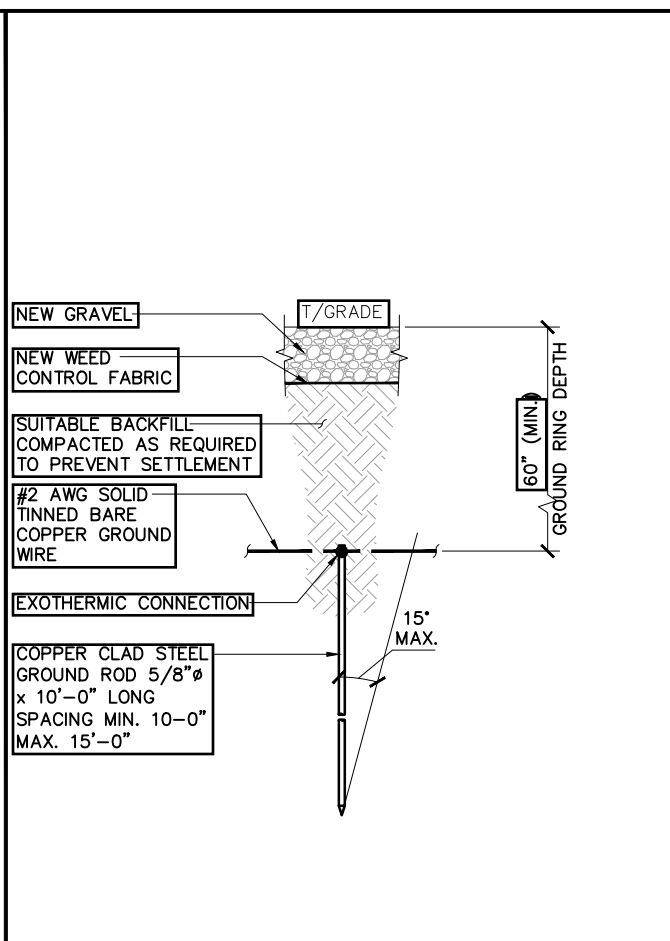

GROUND DETAIL SCALE: N.T.S. 2

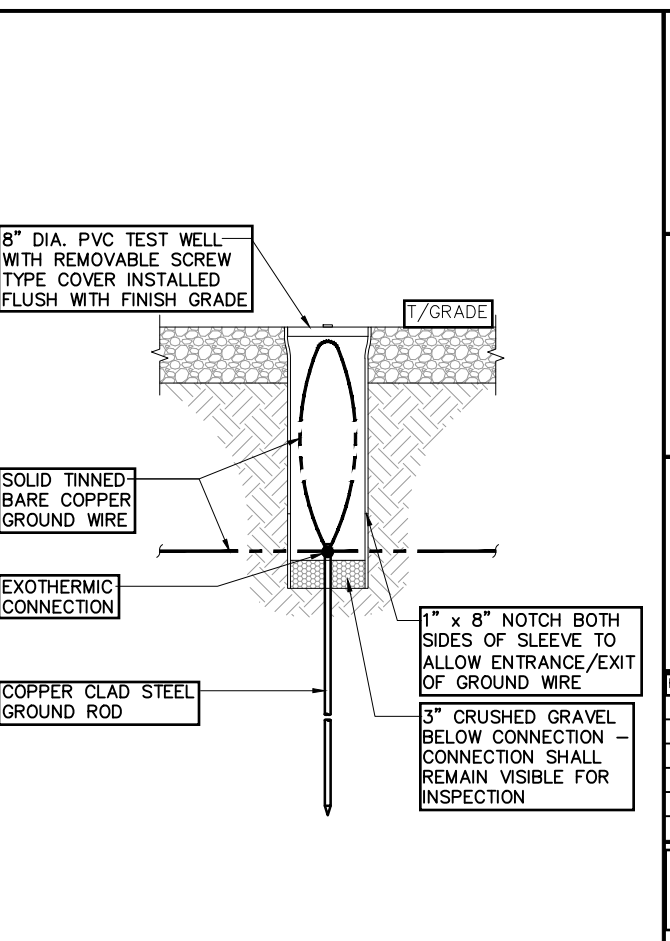

GROUND TEST WELL DETAIL SCALE: N.T.S. 3

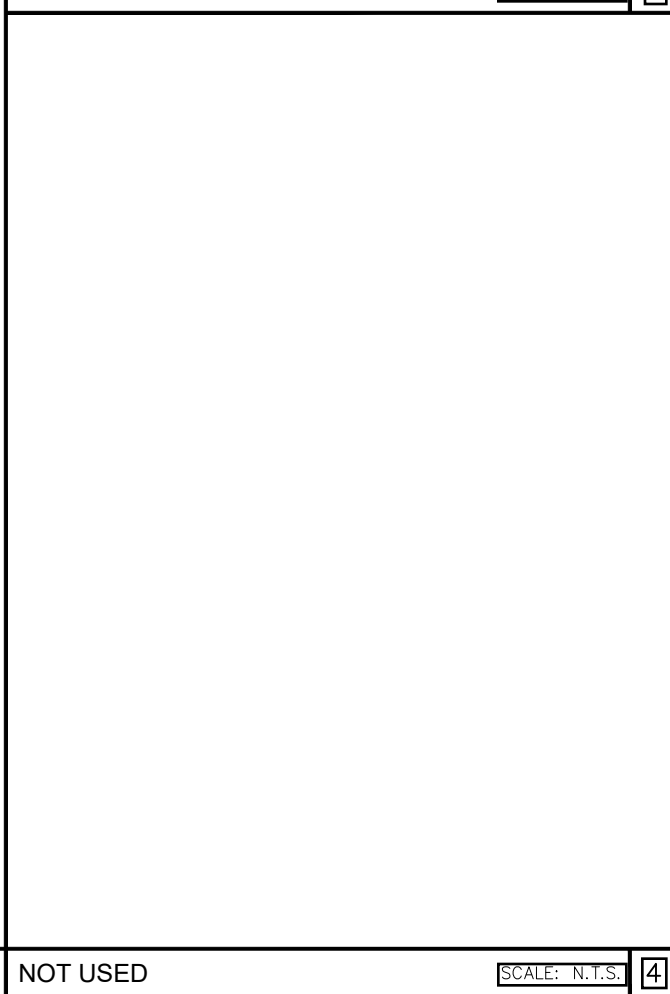

NOT USED SCALE: N.T.S. 4

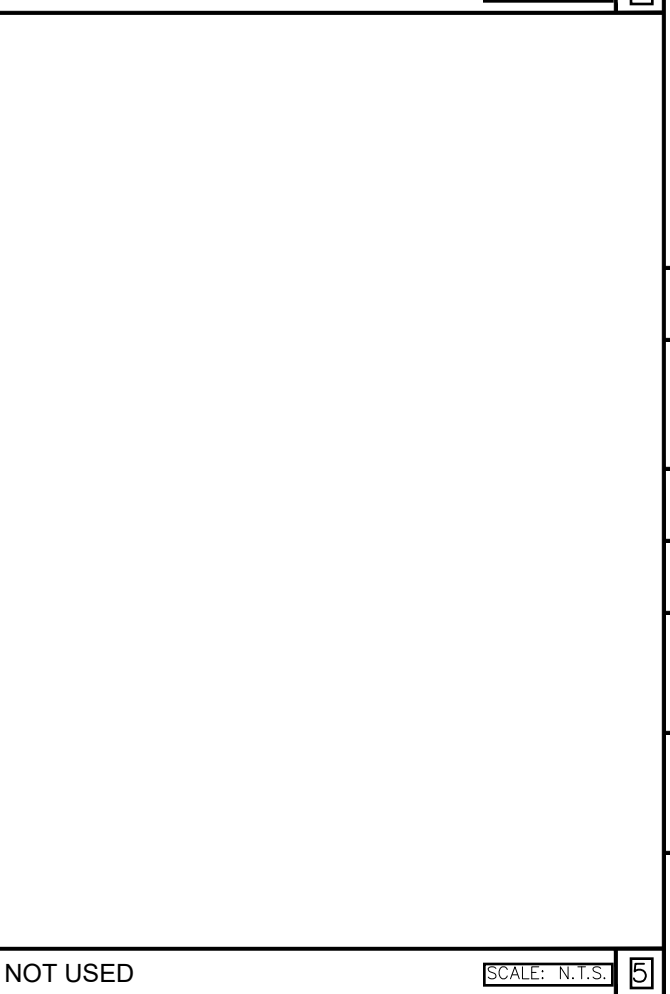

NOT USED SCALE: N.T.S. 5

at&t
7150 STANDARD DRIVE
HANOVER, MD 21076

smartlink
1362 MELLON ROAD, SUITE 140
HANOVER, MD 21076

FULLERTON
ENGINEERING-DESIGN
1100 E. WOODFIELD ROAD, SUITE 500
SCHAUMBURG, ILLINOIS 60173
TEL: 847-908-8400
COA# PEC.0001444
www.FullertonEngineering.com

REV	DATE	DESCRIPTION	BY
A	02/19/19	90% REVIEW	EB
B	03/19/19	REV. 90% REVIEW	EB
1	03/26/19	FOR PERMIT	KC
2	04/11/19	FOR CONSTRUCTION	KC
3	04/26/19	FOR CONSTRUCTION	EB

I HEREBY CERTIFY THAT THESE DRAWINGS WERE PREPARED BY ME OR UNDER MY DIRECT SUPERVISION AND CONTROL, AND TO THE BEST OF MY KNOWLEDGE AND BELIEF COMPLY WITH THE REQUIREMENTS OF ALL APPLICABLE CODES.



SITE NUMBER: CT2421S
SITE NAME: WOODLAND STREET FACILITY
FA NUMBER: 14644530
USID: 245301
SITE ADDRESS: 63 WOODLAND STREET, SOUTH GLASTONBURY, CT 06073
SHEET NAME: RISER DIAGRAM AND DETAILS
SHEET NUMBER:

G-2

GROUNDING NOTES:

- ALL GROUND ELECTRODE SYSTEMS (INCLUDING TELECOMMUNICATION, RADIO, LIGHTNING PROTECTION, AND AC POWER) SHALL BE BONDED TOGETHER BELOW GRADE BY TWO OR MORE COPPER BONDING CONDUCTORS IN ACCORDANCE WITH THE ELECTRICAL CODE
- THE SUBCONTRACTOR SHALL PERFORM IEEE FALL-OF-POTENTIAL RESISTANCE TO EARTH TESTING (PER IEEE 1100 AND 81) FOR GROUND ELECTRODE SYSTEMS. THE SUBCONTRACTOR SHALL FURNISH AND INSTALL SUPPLEMENTAL GROUND ELECTRODES AS NEEDED TO ACHIEVE A TEST RESULT OF 5 OHMS OR LESS.
- THE SUBCONTRACTOR IS RESPONSIBLE FOR PROPERLY SEQUENCING GROUNDING AND UNDERGROUND CONDUIT INSTALLATION AS TO PREVENT ANY LOSS OF CONTINUITY IN THE GROUNDING SYSTEM OR DAMAGE TO THE CONDUIT & PROVIDE TESTING RESULTS.
- METAL CONDUIT AND TRAY SHALL BE GROUNDED AND MADE ELECTRICALLY CONTINUOUS WITH LISTED CODING FITTINGS OR BY BONDING ACROSS THE DISCONTINUITY WITH #6 AWG COPPER WIRE UL APPROVED GROUNDING TYPE CONDUIT CLAMPS.
- METAL RACEWAY SHALL NOT BE USED AS THE NEC REQUIRED EQUIPMENT GROUND CONDUCTOR. STRANDED COPPER CONDUCTORS WITH GREEN INSULATION, SIZED IN ACCORDANCE WITH THE NEC, SHALL BE FURNISHED AND INSTALLED WITH THE POWER CIRCUITS TO BTS EQUIPMENT.
- EACH BTS CABINET FRAME SHALL BE DIRECTLY CONNECTED TO THE MASTER GROUND BAR WITH GREEN INSULATED SUPPLEMENTAL EQUIPMENT GROUND WIRES, #6 AWG STRANDED COPPER OR LARGER FOR INDOOR BTS; #2 AWG STRANDED COPPER FOR OUTDOOR BTS.
- CONNECTIONS TO THE GROUND BUS SHALL NOT BE DOUBLED UP OR STACKED. BACK TO BACK CONNECTIONS ON OPPOSITE SIDES OF THE GROUND BUS ARE PERMITTED.
- ALL EXTERIOR GROUND CONDUCTORS BETWEEN EQUIPMENT/GROUND BARS AND THE GROUND RING, SHALL BE #2 AWG SOLID TINNED COPPER UNLESS OTHERWISE INDICATED.
- ALUMINUM CONDUCTOR OR COPPER CLAD STEEL CONDUCTOR SHALL NOT BE USED FOR GROUNDING CONNECTIONS.
- USE OF 90° BENDS IN THE PROTECTION GROUNDING CONDUCTORS SHALL BE AVOIDED WHEN 45° BENDS CAN BE ADEQUATELY SUPPORTED.
- EXOTHERMIC WELDS SHALL BE USED FOR ALL GROUNDING CONNECTIONS BELOW GRADE.
- ALL GROUND CONNECTIONS ABOVE GRADE (INTERIOR & EXTERIOR) SHALL BE FORMED USING HIGH PRESS CRIMPS.
- COMPRESSION GROUND CONNECTIONS MAY BE REPLACED BY EXOTHERMIC WELD CONNECTIONS.
- ICE BRIDGE BONDING CONDUCTORS SHALL BE EXOTHERMICALLY BONDED OR BOLTED TO THE BRIDGE AND THE TOWER GROUND BAR.
- APPROVED ANTIOXIDANT COATINGS (I.E. CONDUCTIVE GEL OR PASTE) SHALL BE USED ON ALL COMPRESSION AND BOLTED GROUND CONNECTIONS.
- ALL EXTERIOR GROUND CONNECTIONS SHALL BE COATED WITH A CORROSION RESISTANT MATERIAL.
- MISCELLANEOUS ELECTRICAL AND NON-ELECTRICAL METAL BOXES, FRAMES AND SUPPORTS SHALL BE BONDED TO THE GROUND RING, IN ACCORDANCE WITH THE NEC.
- BOND ALL METALLIC OBJECTS WITHIN 6 FT. OF MAIN GROUND WIRES WITH 1-#2 AWG TIN-PLATED COPPER GROUND CONDUCTOR.
- GROUND CONDUCTORS USED IN THE FACILITY GROUND AND LIGHTNING PROTECTION SYSTEMS SHALL NOT BE ROUTED THROUGH METALLIC OBJECTS THAT FORM A RING AROUND THE CONDUCTOR, SUCH AS METALLIC CONDUITS, METAL SUPPORT CLIPS OR SLEEVES THROUGH WALLS OR FLOORS. WHEN IT IS REQUIRED TO BE HOUSED IN CONDUIT TO MEET CODE REQUIREMENTS OR LOCAL CONDITIONS, NONMETALLIC MATERIAL SUCH AS PVC PLASTIC CONDUIT SHALL BE USED. WHERE USE OF METAL CONDUIT IS UNAVOIDABLE (E.G. NON-METALLIC CONDUIT PROHIBITED BY LOCAL CODE) THE GROUND CONDUCTOR SHALL BE BONDED TO EACH END OF THE METAL CONDUIT.
- CONTRACTOR TO USE NO-OX COPPER SHIELD OR APPROVED EQUAL.

GROUNDING NOTES

SCALE: N.T.S.

1

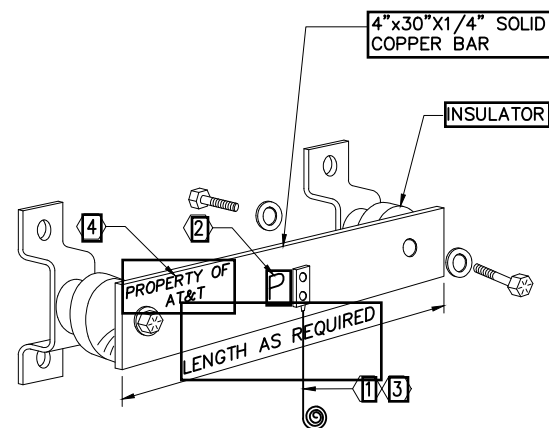
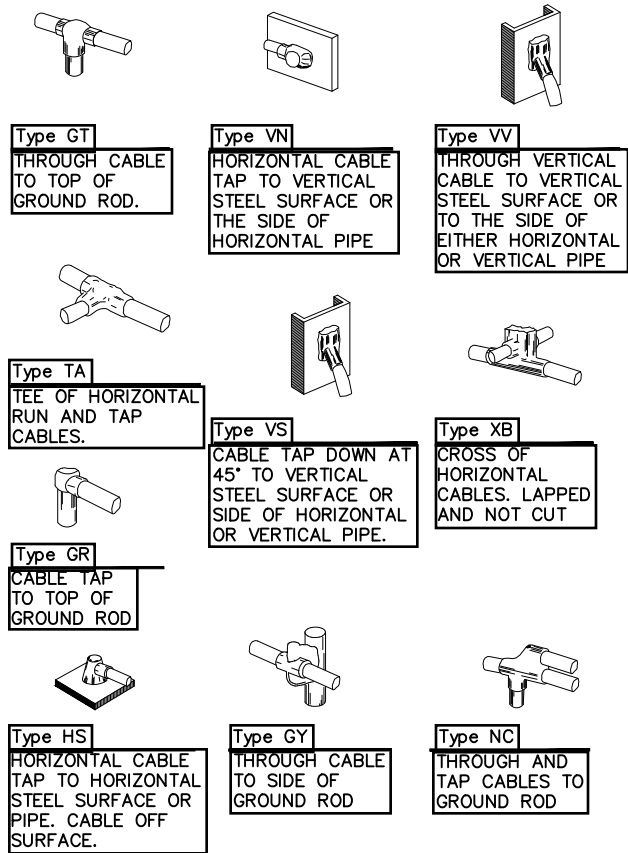

EXOTHERMIC WELD DETAILS

SCALE: N.T.S.

2

GROUND BAR DETAIL

SCALE: N.T.S.

3

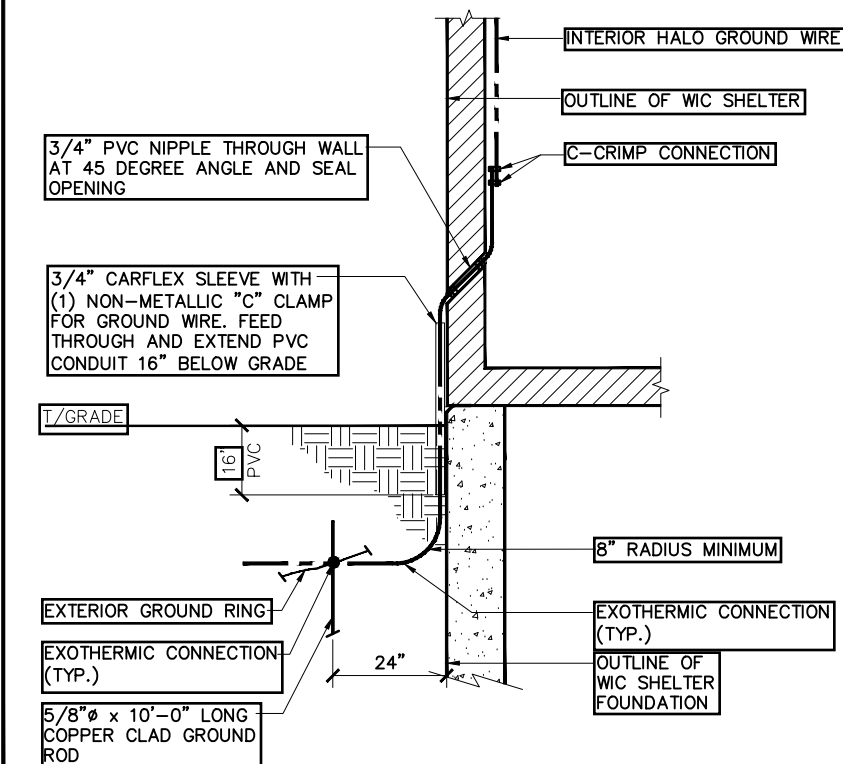

WIC SHELTER GROUNDING DETAIL

SCALE: N.T.S.

4

HVAC GROUNDING DETAIL

SCALE: N.T.S.

5

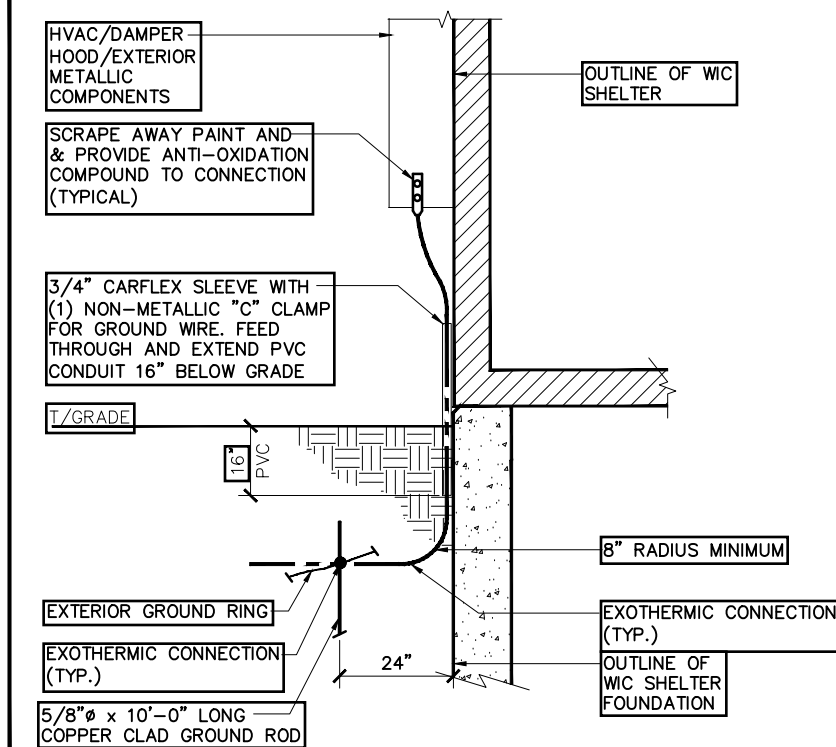

EACH GROUND CONDUCTOR TERMINATING ON ANY GROUND BAR SHALL HAVE AN IDENTIFICATION TAG ATTACHED AT EACH END THAT WILL IDENTIFY ITS ORIGIN AND DESTINATION.

- CONNECTION FOR:
- COAXIAL CABLE SHIELD
 - COAXIAL CABLE SURGE SUPPRESSORS
 - CABLE ENTRY PORTS (HATCH PLATES)
 - RECTIFIER FRAMES
 - 24V & 48V DC POWER RETURN BAR
 - GENERATOR FRAME WORK
 - TELECO GROUND BAR MASTER GROUND BAR

DETAIL NOTES:

- TWO-HOLE, LONG BARREL COMPRESSION LUG WITH AWG STRANDED COPPER CONDUCTOR AND GREEN THW INSULATION TO GROUND BAR. ROUTE CONDUCTOR AS APPLICABLE TO BURIED GROUND CONDUCTOR OR MASTER GROUND BAR AND CONNECT WITH TWO-HOLE LUG TO "P" SECTION.
- USE PERMANENT MARKER TO LABEL THE WHOLE BAR AS "P" WITH 1" HIGH LETTERS.
- FOR GROUND BAR LOCATED OUTDOORS, ON-GRADE ONLY, EXOTHERMICALLY WELD A 2 AWG BARE TINNED COPPER CONDUCTOR TO GROUND BAR AND EXOTHERMICALLY WELD TO BURIED GROUND CONDUCTOR.
- GROUND BARS SHALL BE TINNED COPPER AND SHALL BE ENGRAVED OR IMPRESSED "STOLEN-DO NOT RECYCLE" AND/OR "PROPERTY OF AT&T", ETCHED OR STAMPED WITH SITE FA LOCATION AND SECURED WITH ANTI-THEFT HARDWARE.
- CONTRACTOR TO PROVIDE GROUND BAR WITH ADEQUATE 2 HOLE CONNECTIONS BASED UPON TOTAL EQUIPMENT BEING CONNECTED.
- CONTRACTOR TO USE NO-OX COPPER SHIELD OR APPROVED EQUAL.

7150 STANDARD DRIVE
HANOVER, MD 21076

1362 MELLON ROAD, SUITE 140
HANOVER, MD 21076

FULLERTON
ENGINEERING-DESIGN

1100 E. WOODFIELD ROAD, SUITE 500
SCHAUMBURG, ILLINOIS 60173
TEL: 847-908-8400
COA# PEC.0001444
www.FullertonEngineering.com

REV	DATE	DESCRIPTION	BY
A	02/19/19	90% REVIEW	EB
B	03/19/19	REV. 90% REVIEW	EB
1	03/26/19	FOR PERMIT	KC
2	04/11/19	FOR CONSTRUCTION	KC
3	04/26/19	FOR CONSTRUCTION	EB

HEREBY CERTIFY THAT THESE DRAWINGS WERE PREPARED BY ME OR UNDER MY DIRECT SUPERVISION AND CONTROL, AND TO THE BEST OF MY KNOWLEDGE AND BELIEF COMPLY WITH THE REQUIREMENTS OF ALL APPLICABLE CODES.



SITE NUMBER
CT2421S

SITE NAME
WOODLAND STREET FACILITY

FA NUMBER:
14644530

USID:
245301

SITE ADDRESS
63 WOODLAND STREET
SOUTH GLASTONBURY, CT 06073

SHEET NAME
GROUNDING NOTES AND DETAILS

SHEET NUMBER

G-3

Attachment 2



Kimberly Anthony
Eco-Site
240 Leigh Farm Road, Suite 415
Durham, NC 27707
(919) 551-5041



MORRISON HERSHFIELD

Morrison Hershfield
1455 Lincoln Parkway, Suite 500
Atlanta, GA 30346
(770) 379-8500

Date: February 22, 2019

Subject: Rigorous Structural Analysis Report

Eco-Site Site Number: CT-0007
Eco-Site Site Name: HOPEWELL

Carrier: AT&T Mobility
Carrier Site Number: CT2421
Carrier Site Name: Glatsonbury_Woodland Ln

Site Address: 63 Woodland Street, Glastonbury, Hartford County, CT 06073
Site Coordinates: Latitude 41° 39' 38.85", Longitude 72° 34' 26.75"
Tower Description: 150 ft –Monopole

Morrison Hershfield Project Number: ECO-077 / 190025101

Dear Ms. Anthony,

Morrison Hershfield has carried out a structural analysis of the above referenced structure for the existing and proposed antenna and equipment noted. This rigorous analysis has been performed in accordance with the 2018 Connecticut Building Code (2015 IBC) based upon an ultimate 3-second gust wind speed of 125 mph converted to a nominal 3-second gust wind speed of 97 mph per Section 1609.3.1 as required for use in the TIA-222-G Standard per Exception #5 of Section 1609.1.1. Exposure Category C, Topographic Category 1 and Risk Category II were used in this analysis.

Our analysis demonstrates that the existing tower and foundation **ARE in conformance (tower at 75.2% and foundation at 74.2%)** with the requirements of the above noted standards under the effects of loading described.

We at *Morrison Hershfield* appreciate the opportunity of providing our continuing professional services to you and Eco-Site. If you have any questions or need further assistance on this or any other projects please give us a call.

Respectfully submitted by:
Morrison Hershfield



G. Lance Cooke, P.E. (CT License No. PEN.0028133)
Senior Engineer

Firm License No. 0918208

INTRODUCTION

This tower is a 150 ft monopole designed by Ehresmann Engineering, Inc., in December of 2018. The tower was originally designed for a wind speed of 103 mph and per TIA-222-G Standard.

This rigorous analysis has been performed in accordance with the requirements of the 2018 Connecticut Building Code (2015 IBC) based upon an ultimate 3-second gust wind speed of 125 mph converted to a nominal 3-second gust wind speed of 97 mph with no ice, 50 mph with 1.00 inch of radial ice thickness and 60 mph under service conditions per section 1609.3.1 as required for use in the TIA-222-G Standard per Exception # 5 of Section 1609.1.1. Exposure category C, Topographic Category 1 and Risk Category II were used in this analysis. The design spectral response accelerations of $S_{DS} = 0.144$ and $S_{D1} = 0.071$ for Site Soil Class C were considered in this analysis.

Seismic design factors have been considered in this analysis. The seismic spectral response acceleration at short periods ($S_s = 0.18$) was determined to be less than 1.00; therefore as per ASCE7-10 seismic effects have not been considered in this analysis.

The structural analysis was based on the following documentation:

Documentation

Document	Description	Source
Geotechnical Report	FDH Velocitel., Project No. 18PGJC1600, dated 04/10/2018	Client
Tower and Foundation Design	Ehresmann Engineering, Inc., Job No. 102800, dated 12/17/2018	Client
Proposed Loading	Client Collocation Application, Site ID: CT2421, dated 02/13/2019	Client

1.0 ANALYSIS LOADING

The existing and proposed antennas, transmission lines, and other equipment considered in this analysis were provided by the client and are noted in the attachments.

ANALYSIS PROCEDURE

tnxTower (Version 8.0.5.0), a commercially available analysis software package, was used to create a three-dimensional model of the tower and calculate member stresses for various loading cases. Selected output from the analysis is attached at the end of this report.

2.0 ASSUMPTIONS

The analysis provided by Morrison Hershfield is based on the theoretical capacity of the structure and is not a condition assessment of the tower. Morrison Hershfield has not performed an engineering inspection of the tower and the analysis was completed based on information supplied by the client. Morrison Hershfield has not made any independent determination of the accuracy of the information provided.

- 1) Tower and structures were built in accordance with the manufacturer's specifications and the applicable ANSI/TIA/EIA standard.
- 2) The tower and structures have been maintained in accordance with the manufacturer's specification.
- 3) The tower is assumed to be in good condition and capable of supporting its full design capacity.
- 4) The foundation was properly designed and constructed for the original design loads.
- 5) The configuration of antennas, transmission cables, mounts and other appurtenances are as specified in the attached Tower Analysis Summary Form.
- 6) All existing/proposed antennas and antenna mounts are assumed to be adequate for the existing/proposed loads. Analysis of these antennas and antenna mounts is considered to be outside of the scope of this analysis. Morrison Hershfield has not performed an analysis of the existing/proposed antennas or antenna mounts.
- 7) Proposed loading for AT&T Mobility has been taken from the Client Collocation Application, Site No. CT-0007, dated 02/13/2019, and is considered to be correct.



- 8) Reserved loading for AT&T Mobility has been taken as an aggregate wind load surface area of twenty eight thousand (28,000) square inches as requested by the client.
- 9) Reserved loading for T-Mobile has been taken as an aggregate wind load surface area of twenty five thousand (25,000) square inches and twenty-four (24) 1-5/8" lines as requested by the client.

If any assumptions are not valid or have been made in error, this analysis is invalid. Morrison Hershfield should be notified to determine the effect on the structural integrity of the tower.

3.0 SUMMARY OF RESULTS

The following tables summarize the location and utilized percentage of available capacity for each component of the tower. With consideration to the appropriate safety factors, 100% represents the full capacity of the component. Percentages below 100% indicate available capacity and conformance of the component. Percentages above 100% indicate an overstressed situation requiring structural modification to ensure conformance with the applicable codes and standards.

Based on our analysis results, the **tower and foundation ARE within capacity** to support the loads under the current loading scenario.

Tower Section Capacity

Section No.	Elevation ft	Component Type	Size	% Capacity	Pass Fail	
L1	150 - 100	Pole	TP39.6x26.4x0.3	53.3	Pass	
L2	100 - 65.5	Pole	TP48.3x37.7x0.4	46.9	Pass	
L3	65.5 - 32.25	Pole	TP56.3x45.7x0.4	46.9	Pass	
L4	32.25 - 0	Pole	TP64x53.4x0.4	54.4	Pass	
				Summary		
				Pole (L4)	54.4	Pass
				RATING =	54.4	Pass

Capacity of Additional Components

Component	% Capacity	Pass/Fail
Anchor Rods	65.7	Pass
Base Plate	75.2	Pass
Caisson Soil Interaction (Option #1)	22.9	Pass
Caisson Structural (Option #1)	50.2	Pass
Foundation Bearing (Option #2)	26.4	Pass
Foundation Overturning (Option #2)	74.2	Pass

Note: This analysis has been performed according to the controlling load case of reserved and proposed loading

4.0 RECOMMENDATIONS

1. All assumptions made in this analysis should be carefully reviewed. Morrison Hershfield should be contacted for any discrepancies so that a full assessment may be made to validate the results of this analysis.

ATTACHMENTS: Tower Loading, Tower Profile, Program Output, Coax Sketch, Additional Calculations, ASCE Design Parameters and Colocation Application.



Site Inventory Analysis Sheet

Analysis Results (% Maximum Usage)

	Reserved	Reserved + Proposed
Pole	47.7%	54.4%
Anchor Rods	57.6%	65.7%
Base Plate	66.0%	75.2%
Caisson Soil Interaction (Option #1)	19.8%	22.9%
Caisson Structural (Option #1)	43.4%	50.2%
Foundation Bearing (Option #2)	23.0%	26.4%
Foundation Overturning (Option #2)	65.3%	74.2%

Reserved Loading

Appurtenances						Mount			Feed Lines	
Mount Height (ft)	Antenna CL (ft)	Quantity	Appurtenance Description	Carrier	Azimuth	Quantity	Manufacturer	Type	Quantity	Size
136	136	-	28,000 sq. in.	AT&T Mobility	-	-	-	Same as Proposed	-	-

Proposed Loading

Appurtenances						Mount			Feed Lines	
Mount Height (ft)	Antenna CL (ft)	Quantity	Appurtenance Description	Carrier	Azimuth	Quantity	Manufacturer	Type	Quantity	Size
136	136	6	CCI TPA65R-BU8D Panel	AT&T Mobility	120/240/340	3	Sabre	C10857001C Sector Mount	6	5/8" DC
136	136	3	CCI HPA65R-BU8A Panel						2	3/8" Fiber
136	136	3	Ericsson 4478 B14 RRH							
136	136	3	Ericsson E2-700 RRH							
136	136	3	Ericsson 4415 B30 RRH							
136	136	3	Ericsson 4449 RRH							
136	136	3	Ericsson 8843 RRH							
136	136	3	DC Box							

Reserved Loading

Appurtenances						Mount			Feed Lines	
Mount Height (ft)	Antenna CL (ft)	Quantity	Appurtenance Description	Carrier	Azimuth	Quantity	Manufacturer	Type	Quantity	Size
146	146	-	25,000 sq. in.	T-Mobile	-	-	Unknown		24	1-5/8"

Section	1	2	3	4	
Length (ft)	50.0	40.0	40.0	40.0	
Number of Sides	18	18	18	18	
Thickness (in)	0.3	0.4	0.4	0.4	
Socket Length (ft)	5.5	6.8	7.8		
Top Dia (in)	26.4	37.7	45.7	53.4	
Bot Dia (in)	39.6	48.3	56.3	64.0	
Grade		A572-65			
Weight (K)	4.4	6.9	9.6	11.0	31.9

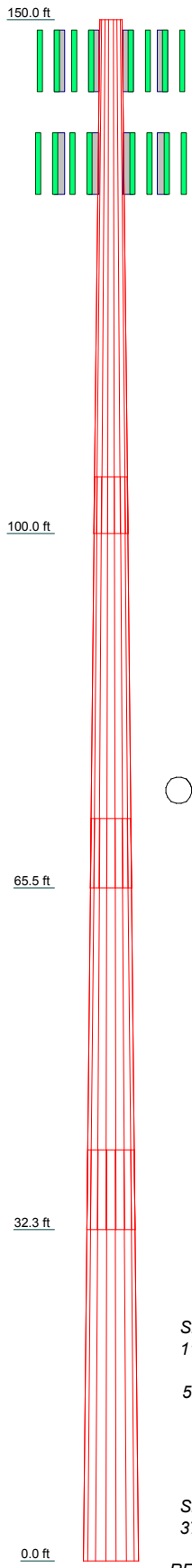

DESIGNED APPURTENANCE LOADING

TYPE	ELEVATION	TYPE	ELEVATION
(4) Generic Panel (2083 sq. in.) (R)	146	RRUS-E2 B29	136
(4) Generic Panel (2083 sq. in.) (R)	146	RRUS-E2 B29	136
(4) Generic Panel (2083 sq. in.) (R)	146	RRUS-E2 B29	136
(2) CCI HPA65R-BU8A	136	RRUS 4415	136
(2) CCI HPA65R-BU8A	136	RRUS 4415	136
(2) CCI HPA65R-BU8A	136	RRUS 4415	136
CCI TPA65R-BU8D	136	Ericsson 8843	136
CCI TPA65R-BU8D	136	Ericsson 8843	136
CCI TPA65R-BU8D	136	Ericsson 8843	136
B14 4478	136	DC Box	136
B14 4478	136	DC Box	136
B14 4478	136	DC Box	136
RADIO 4449 B12/B71	136	Sector Mount [SM 602-1]	136
RADIO 4449 B12/B71	136	Sector Mount [SM 602-1]	136
RADIO 4449 B12/B71	136	Sector Mount [SM 602-1]	136

MATERIAL STRENGTH

GRADE	Fy	Fu	GRADE	Fy	Fu
A572-65	65 ksi	80 ksi			

TOWER DESIGN NOTES

1. Tower is located in Hartford County, Connecticut.
2. Tower designed for Exposure C to the TIA-222-G Standard.
3. Tower designed for a 97 mph basic wind in accordance with the TIA-222-G Standard.
4. Tower is also designed for a 50 mph basic wind with 1.00 in ice. Ice is considered to increase in thickness with height.
5. Deflections are based upon a 60 mph wind.
6. Tower Structure Class II.
7. Topographic Category 1 with Crest Height of 0.0 ft
8. TOWER RATING: 54.4%

ALL REACTIONS ARE FACTORED

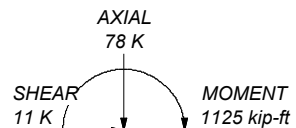

50 mph WIND - 1.0 in ICE

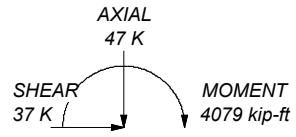

REACTIONS - 97 mph WIND

Morrison Hershfield		Job: ECO-077 / 190025101	
1455 Lincoln Parkway, Suite 500		Project: CT-0007/Hopewell	
Atlanta, GA		Client: Eco-Site	Drawn by: GWESH
Consulting Engineers		Code: TIA-222-G	Date: 02/21/19
Phone: (770) 379-8500		App'd: _____	
FAX: (770) 379-8501		Scale: NTS	
		Path: _____	

tnxTower Morrison Hershfield 1455 Lincoln Parkway, Suite 500 Atlanta, GA Phone: (770) 379-8500 FAX: (770) 379-8501	Job ECO-077 / 190025101	Page 1 of 5
	Project CT-0007/Hopewell	Date 17:24:59 02/20/19
	Client Eco-Site	Designed by GWESH

Tower Input Data

The tower is a monopole.

This tower is designed using the TIA-222-G standard.

The following design criteria apply:

Tower is located in Hartford County, Connecticut.

Basic wind speed of 97 mph.

Structure Class II.

Exposure Category C.

Topographic Category 1.

Crest Height 0.0 ft.

Nominal ice thickness of 1.0 in.

Ice thickness is considered to increase with height.

Ice density of 56 pcf.

A wind speed of 50 mph is used in combination with ice.

Temperature drop of 50 °F.

Deflections calculated using a wind speed of 60 mph.

A non-linear (P-delta) analysis was used.

Pressures are calculated at each section.

Stress ratio used in pole design is 1.

Local bending stresses due to climbing loads, feed line supports, and appurtenance mounts are not considered.

Options

<ul style="list-style-type: none"> Consider Moments - Legs Consider Moments - Horizontals Consider Moments - Diagonals Use Moment Magnification √ Use Code Stress Ratios √ Use Code Safety Factors - Guys Escalate Ice Always Use Max Kz Use Special Wind Profile Include Bolts In Member Capacity Leg Bolts Are At Top Of Section Secondary Horizontal Braces Leg Use Diamond Inner Bracing (4 Sided) SR Members Have Cut Ends SR Members Are Concentric 	<ul style="list-style-type: none"> Distribute Leg Loads As Uniform Assume Legs Pinned √ Assume Rigid Index Plate √ Use Clear Spans For Wind Area Use Clear Spans For KL/r Retension Guys To Initial Tension √ Bypass Mast Stability Checks √ Use Azimuth Dish Coefficients √ Project Wind Area of Appurt. Autocalc Torque Arm Areas Add IBC .6D+W Combination √ Sort Capacity Reports By Component Triangulate Diamond Inner Bracing Treat Feed Line Bundles As Cylinder Ignore KL/ry For 60 Deg. Angle Legs 	<ul style="list-style-type: none"> Use ASCE 10 X-Brace Ly Rules √ Calculate Redundant Bracing Forces Ignore Redundant Members in FEA SR Leg Bolts Resist Compression All Leg Panels Have Same Allowable Offset Girt At Foundation √ Consider Feed Line Torque Include Angle Block Shear Check Use TIA-222-G Bracing Resist. Exemption Use TIA-222-G Tension Splice Exemption
Poles		
<ul style="list-style-type: none"> Include Shear-Torsion Interaction Always Use Sub-Critical Flow Use Top Mounted Sockets Pole Without Linear Attachments Pole With Shroud Or No Appurtenances Outside and Inside Corner Radii Are Known 		

Tapered Pole Section Geometry

Section	Elevation ft	Section Length ft	Splice Length ft	Number of Sides	Top Diameter in	Bottom Diameter in	Wall Thickness in	Bend Radius in	Pole Grade
L1	150.0-100.0	50.0	5.5	18	26.4	39.6	0.3	1.0	A572-65 (65 ksi)
L2	100.0-65.5	40.0	6.8	18	37.7	48.3	0.4	1.5	A572-65 (65 ksi)
L3	65.5-32.3	40.0	7.8	18	45.7	56.3	0.4	1.8	A572-65 (65 ksi)
L4	32.3-0.0	40.0		18	53.4	64.0	0.4	1.8	A572-65

tnxTower Morrison Hershfield 1455 Lincoln Parkway, Suite 500 Atlanta, GA Phone: (770) 379-8500 FAX: (770) 379-8501	Job ECO-077 / 190025101	Page 2 of 5
	Project CT-0007/Hopewell	Date 17:24:59 02/20/19
	Client Eco-Site	Designed by GWESH

Section	Elevation	Section Length	Splice Length	Number of Sides	Top Diameter	Bottom Diameter	Wall Thickness	Bend Radius	Pole Grade
	ft	ft	ft		in	in	in	in	

(65 ksi)

Tapered Pole Properties

Section	Tip Dia.	Area	I	r	C	I/C	J	I/Q	w	w/t
	in	in ²	in ⁴	in	in	in ³	in ⁴	in ²	in	
L1	26.8	20.7	1792.4	9.3	13.4	133.7	3587.1	10.4	4.2	16.825
	40.2	31.3	6127.4	14.0	20.1	304.3	12262.8	15.6	6.5	26.147
L2	39.7	44.4	7809.6	13.2	19.1	407.9	15629.4	22.2	6.0	15.927
	49.0	57.0	16530.0	17.0	24.5	674.0	33081.7	28.5	7.8	20.899
L3	48.2	62.9	16311.9	16.1	23.2	702.0	32645.3	31.5	7.3	16.641
	57.1	77.6	30640.1	19.8	28.6	1070.7	61320.5	38.8	9.1	20.903
L4	56.2	73.6	26073.6	18.8	27.1	961.0	52181.4	36.8	8.6	19.725
	64.9	88.3	45055.3	22.6	32.5	1385.8	90169.9	44.1	10.5	23.987

Feed Line/Linear Appurtenances - Entered As Area

Description	Face or Leg	Allow Shield	Exclude From Torque Calculation	Component Type	Placement	Total Number		C _{AA}	Weight
					ft			ft ² /ft	plf

1-5/8" (ATT)	A	No	No	Inside Pole	136.0 - 2.0	2	No Ice 1/2" Ice 1" Ice	0.0 0.0 0.0	1.0 1.0 1.0
1-5/8" (ATT)	B	No	No	Inside Pole	136.0 - 2.0	2	No Ice 1/2" Ice 1" Ice	0.0 0.0 0.0	1.0 1.0 1.0
1-5/8" (ATT)	C	No	No	Inside Pole	136.0 - 2.0	2	No Ice 1/2" Ice 1" Ice	0.0 0.0 0.0	1.0 1.0 1.0
Fiber (3/8") (ATT)	A	No	No	Inside Pole	136.0 - 2.0	1	No Ice 1/2" Ice 1" Ice	0.0 0.0 0.0	0.1 0.1 0.1
Fiber (3/8") (ATT)	B	No	No	Inside Pole	136.0 - 2.0	1	No Ice 1/2" Ice 1" Ice	0.0 0.0 0.0	0.1 0.1 0.1

1-5/8" (TMO)	B	No	No	Inside Pole	146.0 - 2.0	24	No Ice 1/2" Ice 1" Ice	0.0 0.0 0.0	0.8 0.8 0.8

Feed Line/Linear Appurtenances Section Areas

Tower Section	Tower Elevation	Face	A _R	A _F	C _{AA} In Face	C _{AA} Out Face	Weight
	ft		ft ²	ft ²	ft ²	ft ²	K
L1	150.0-100.0	A	0.000	0.000	0.000	0.000	0.1
		B	0.000	0.000	0.000	0.000	1.0
		C	0.000	0.000	0.000	0.000	0.1
L2	100.0-65.5	A	0.000	0.000	0.000	0.000	0.1
		B	0.000	0.000	0.000	0.000	0.8
		C	0.000	0.000	0.000	0.000	0.1
L3	65.5-32.3	A	0.000	0.000	0.000	0.000	0.1
		B	0.000	0.000	0.000	0.000	0.7
		C	0.000	0.000	0.000	0.000	0.1
L4	32.3-0.0	A	0.000	0.000	0.000	0.000	0.1

tnxTower Morrison Hershfield 1455 Lincoln Parkway, Suite 500 Atlanta, GA Phone: (770) 379-8500 FAX: (770) 379-8501	Job	ECO-077 / 190025101	Page	3 of 5
	Project	CT-0007/Hopewell	Date	17:24:59 02/20/19
	Client	Eco-Site	Designed by	GWESH

Tower Section	Tower Elevation ft	Face	A_R ft ²	A_F ft ²	C_{AA} In Face ft ²	C_{AA} Out Face ft ²	Weight K
		B	0.000	0.000	0.000	0.000	0.7
		C	0.000	0.000	0.000	0.000	0.1

Feed Line/Linear Appurtenances Section Areas - With Ice

Tower Section	Tower Elevation ft	Face or Leg	Ice Thickness in	A_R ft ²	A_F ft ²	C_{AA} In Face ft ²	C_{AA} Out Face ft ²	Weight K
L1	150.0-100.0	A	2.282	0.000	0.000	0.000	0.000	0.1
		B		0.000	0.000	0.000	0.000	1.0
		C		0.000	0.000	0.000	0.000	0.1
L2	100.0-65.5	A	2.191	0.000	0.000	0.000	0.000	0.1
		B		0.000	0.000	0.000	0.000	0.8
		C		0.000	0.000	0.000	0.000	0.1
L3	65.5-32.3	A	2.079	0.000	0.000	0.000	0.000	0.1
		B		0.000	0.000	0.000	0.000	0.7
		C		0.000	0.000	0.000	0.000	0.1
L4	32.3-0.0	A	1.862	0.000	0.000	0.000	0.000	0.1
		B		0.000	0.000	0.000	0.000	0.7
		C		0.000	0.000	0.000	0.000	0.1

Discrete Tower Loads

Description	Face or Leg	Offset Type	Offsets: Horz Lateral Vert ft ft ft	Azimuth Adjustment °	Placement ft	C_{AA} Front ft ²	C_{AA} Side ft ²	Weight K	
Reserved									
(4) Generic Panel (2083 sq. in.) (R)	A	From Leg	4.0	0.00	146.0	No Ice	17.4	9.2	0.0
			0.0			1/2" Ice	18.2	10.0	0.0
			0.0			1" Ice	19.0	10.7	0.0
(4) Generic Panel (2083 sq. in.) (R)	C	From Leg	4.0	0.00	146.0	No Ice	17.4	9.2	0.0
			0.0			1/2" Ice	18.2	10.0	0.0
			0.0			1" Ice	19.0	10.7	0.0
(4) Generic Panel (2083 sq. in.) (R)	B	From Leg	4.0	0.00	146.0	No Ice	17.4	9.2	0.0
			0.0			1/2" Ice	18.2	10.0	0.0
			0.0			1" Ice	19.0	10.7	0.0

Proposed									
(2) CCI HPA65R-BU8A	A	From Leg	4.0	0.00	136.0	No Ice	18.1	8.2	0.1
			0.0			1/2" Ice	18.7	8.8	0.2
			0.0			1" Ice	19.4	9.4	0.3
(2) CCI HPA65R-BU8A	B	From Leg	4.0	0.00	136.0	No Ice	18.1	8.2	0.1
			0.0			1/2" Ice	18.7	8.8	0.2
			0.0			1" Ice	19.4	9.4	0.3
(2) CCI HPA65R-BU8A	C	From Leg	4.0	0.00	136.0	No Ice	18.1	8.2	0.1
			0.0			1/2" Ice	18.7	8.8	0.2
			0.0			1" Ice	19.4	9.4	0.3
CCI TPA65R-BU8D	A	From Leg	4.0	0.00	136.0	No Ice	18.1	8.2	0.1
			0.0			1/2" Ice	18.7	8.8	0.2
			0.0			1" Ice	19.4	9.4	0.3
CCI TPA65R-BU8D	B	From Leg	4.0	0.00	136.0	No Ice	18.1	8.2	0.1
			0.0			1/2" Ice	18.7	8.8	0.2
			0.0			1" Ice	19.4	9.4	0.3
CCI TPA65R-BU8D	C	From Leg	4.0	0.00	136.0	No Ice	18.1	8.2	0.1
			0.0			1/2" Ice	18.7	8.8	0.2
			0.0			1" Ice	19.4	9.4	0.3

tnxTower Morrison Hershfield 1455 Lincoln Parkway, Suite 500 Atlanta, GA Phone: (770) 379-8500 FAX: (770) 379-8501	Job	ECO-077 / 190025101	Page	5 of 5
	Project	CT-0007/Hopewell	Date	17:24:59 02/20/19
	Client	Eco-Site	Designed by	GWESH

Description	Face or Leg	Offset Type	Offsets: Horz Lateral Vert	Azimuth Adjustment	Placement	C _{AA} Front	C _{AA} Side	Weight	
			ft ft ft	°	ft	ft ²	ft ²	K	
						1/2" Ice	24.8	15.2	0.7
						1" Ice	30.7	19.7	0.9
Sector Mount [SM 602-1]	C	None		0.00	136.0	No Ice	18.8	10.6	0.5
						1/2" Ice	24.8	15.2	0.7
						1" Ice	30.7	19.7	0.9

Section Capacity Table

Section No.	Elevation ft	Component Type	Size	Critical Element	P K	ϕP_{allow} K	% Capacity	Pass Fail	
L1	150 - 100	Pole	TP39.6x26.4x0.3	1	-8.4	1946.6	53.3	Pass	
L2	100 - 65.5	Pole	TP48.3x37.7x0.4	2	-17.2	3843.7	46.9	Pass	
L3	65.5 - 32.25	Pole	TP56.3x45.7x0.4	3	-29.2	5234.5	46.9	Pass	
L4	32.25 - 0	Pole	TP64x53.4x0.4	4	-46.6	5814.0	54.4	Pass	
							Summary		
							Pole (L4)	54.4	Pass
							RATING =	54.4	Pass

Feed Line Plan 65'6"

Round

Flat

App In Face

App Out Face

Section @ 65'6"

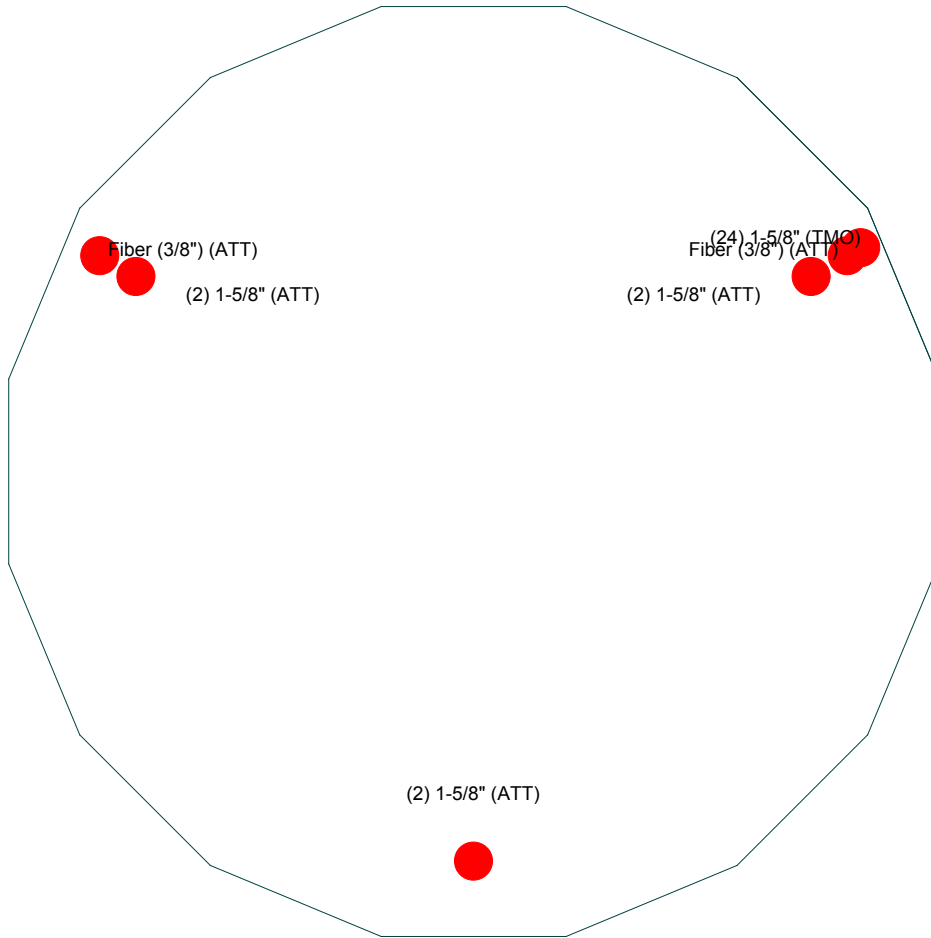

Morrison Hershfield
1455 Lincoln Parkway, Suite 500
Atlanta, GA
Consulting Engineers Phone: (770) 379-8500
FAX: (770) 379-8501

Job: ECO-077 / 190025101		
Project: CT-0007/Hopewell		
Client: Eco-Site	Drawn by: GWESH	App'd:
Code: TIA-222-G	Date: 02/20/19	Scale: NTS
Path:		Dwg No. E-7



MORRISON HERSHFIELD

Project: ECO-077 / 190025101 Client: Eco-Site
Site Name: Hopewell Site ID: CT-0007
Des. By: GW Ck. By: TH
Date: 2/21/2019 page: 1 OF 1

Base Plate & Anchor Rod Analysis Summary

Table with 5 main sections: Base Reactions, Anchor Rod Data, Base Plate Data, Stiffener Data, and Pole Data. Each section contains key parameters and their values in various units.



MORRISON HERSHFIELD

Project: ECO-077 / 190025101 Client: Eco-Site
Site Name: Hopewell Site ID: CT-0007
Des. By: GW Ck. By: TH
Date: 2/21/2019 page: 1 OF 1

Pad & Pier Analysis Summary

Base Reactions:		
TIA Revision :	G	
Factored DL Axial, Pdu:	39	kips
Factored WL Axial, Pwu:	8	kips
Factored WL Shear, Vu:	37	kips
Factored WL Moment, Mu:	4079	ft-kips

Pad and Pier Data:		
Base PL Dist. Above Pier:	0	in
Pier Dist. Above Grade:	6	in
Pad Bearing Depth, D:	4	ft
Pad Thickness, T:	3	ft
Pad Width/Length, L:	28	ft
Pier Cross Section Shape:	Round	
Enter Pier Diameter:	8	ft
Concrete Density:	150	pcf
Pier Cross Section Area:	50.27	ft ²
Pier Height:	1.5	ft
Soil (above pad) Height:	1	ft

Soil Parameters:		
Unit Weight, γ :	105	pcf
Ultimate Bearing Capacity, q_n :	20	ksf
Strength Reduct. factor, ϕ :	0.35	
Angle of Friction, Φ :	29	degrees
Undrained Shear Strength, C_u :	0	ksf
Allowable Bearing: $\phi * q_n$:	7	ksf
Passive Pres. Coeff., K_p :	2.88	

Bearing Results:		
Orthogonal Direction =	22.0%	Pass
Diagonal Direction =	26.4%	Pass

Overturning Stability Results:		
Moment Orthogonal =	74.2%	Pass
Moment Diagonal =	74.2%	Pass

* PIER FOUNDATIONS ANALYSIS AND DESIGN - (C) 1995, POWER LINE SYSTEMS, INC.*

*** ANALYSIS IDENTIFICATION : ECO-077 / 190025101
NOTES :

*** PIER PROPERTIES CONCRETE STRENGTH (ksi) = 4.50 STEEL STRENGTH (ksi) = 65.00
DIAMETER (ft) = 8.000 DISTANCE FROM TOP OF PIER TO GROUND LEVEL (ft) = 0.50

*** SOIL PROPERTIES	LAYER	TYPE	THICKNESS (ft)	DEPTH AT TOP OF LAYER (ft)	DENSITY (pcf)	CU (psf)	KP	PHI (degrees)
	1	S	2.00	0.00	105.0		2.882	29.00
	2	S	3.00	2.00	120.0		3.537	34.00
	3	S	5.00	5.00	130.0		4.204	38.00
	4	S	5.00	10.00	68.0		4.204	38.00
	5	C	15.00	15.00	98.0	15000.0		

*** DESIGN (FACTORED) LOADS AT TOP OF PIER MOMENT (ft-k) = 4079.0 VERTICAL (k) = 47.0 SHEAR (k) = 37.0
ADDITIONAL SAFETY FACTOR AGAINST SOIL FAILURE = 5.80

*** CALCULATED PIER LENGTH (ft) = 24.000

*** CHECK OF SOILS PROPERTIES AND ULTIMATE RESISTING FORCES ALONG PIER

TYPE	TOP OF LAYER BELOW TOP OF PIER (ft)	THICKNESS (ft)	DENSITY (pcf)	CU (psf)	KP	FORCE (k)	ARM (ft)
S	0.50	2.00	105.0		2.882	14.53	1.83
S	2.50	3.00	120.0		3.537	99.32	4.23
S	5.50	5.00	130.0		4.204	451.51	8.30
S	10.50	5.00	68.0		4.204	701.23	13.10
C	15.50	3.70	98.0	15000.0		3554.24	17.35
C	19.20	4.80	98.0	15000.0		-4605.74	21.60

*** SHEAR AND MOMENTS ALONG PIER

DISTANCE BELOW TOP OF PIER (ft)	WITH THE ADDITIONAL SAFETY FACTOR		WITHOUT ADDITIONAL SAFETY FACTOR	
	SHEAR (k)	MOMENT (ft-k)	SHEAR (k)	MOMENT (ft-k)
0.00	215.1	24436.2	37.1	4213.1
2.40	202.0	24944.1	34.8	4300.7
4.80	132.6	25357.7	22.9	4372.0
7.20	-15.5	25518.1	-2.7	4399.7
9.60	-244.8	25220.8	-42.2	4348.4
12.00	-542.6	24286.1	-93.6	4187.3
14.40	-882.5	22583.9	-152.2	3893.8
16.80	-2299.5	19342.8	-396.5	3335.0
19.20	-4603.5	11059.2	-793.7	1906.8
21.60	-2304.0	2764.8	-397.2	476.7
24.00	0.0	-0.0	0.0	-0.0

*** TOTAL REINFORCEMENT PCT = 0.44 REINFORCEMENT AREA (in^2) = 31.85
*** USABLE AXIAL CAP. (k) = 47.0 USABLE MOMENT CAP. (ft-k) = 6241.3

*** US Standard Re-Bars (Select one of the following):
160 BARS #4 (AREA = 0.20 in^2 DIA = 0.500 in) AT SPACING (in) = 1.69
103 BARS #5 (AREA = 0.31 in^2 DIA = 0.625 in) AT SPACING (in) = 2.62
73 BARS #6 (AREA = 0.44 in^2 DIA = 0.750 in) AT SPACING (in) = 3.70
54 BARS #7 (AREA = 0.60 in^2 DIA = 0.875 in) AT SPACING (in) = 5.00
41 BARS #8 (AREA = 0.79 in^2 DIA = 1.000 in) AT SPACING (in) = 6.59
32 BARS #9 (AREA = 1.00 in^2 DIA = 1.128 in) AT SPACING (in) = 8.44
26 BARS #10 (AREA = 1.27 in^2 DIA = 1.270 in) AT SPACING (in) = 10.39
21 BARS #11 (AREA = 1.56 in^2 DIA = 1.410 in) AT SPACING (in) = 12.87
15 BARS #14 (AREA = 2.25 in^2 DIA = 1.693 in) AT SPACING (in) = 18.01

*** PRESSURE UNDER CAISSON DUE TO DESIGN AXIAL LOAD (psf) = 935.0



MORRISON HERSHFIELD

Project:	ECO-077 / 190025101	Client	Eco-Site
Site Name:	Hopewell	Site ID:	CT-0007
Des. By:	GW	Ck. By:	TH
Date:	2/21/2019	page:	1 OF 1

Moment Capacity of Drilled Concrete Shaft Summary

Maximum Shaft Superimposed Forces:		
M:	4399.7	ft-kips
Axial, P:	47.0	kips
Code Rev	G	
Pier Properties:		
Pier Diameter:	8	ft
Clear Cover to Tie:	6.00	in
Horz. Tie Bar Size:	5	
Vertical Bar Size:	10	
Number of Bars:	38	
Material Properties:		
Concrete Comp. Strength, f'_c :	4500	psi
Reinforcement Yield Strength, F_y :	60	ksi
Reinforcing Modulus of Elasticity, E :	29000	ksi
Limiting Compressive Strain:	0.003	
Analysis ACI Code:	2008	
Seismic Design Category:	B	
Analysis Results:		
Drilled Shaft Flexure:	50.2%	Pass

ASCE 7 Hazards Report

Address:

63 Woodland St
South Glastonbury, Connecticut
06073

Standard:

ASCE/SEI 7-10

Risk Category: II

Soil Class:

C - Very Dense
Soil and Soft Rock

Elevation: 304.56 ft (NAVD 88)

Latitude: 41.667093

Longitude: -72.564706

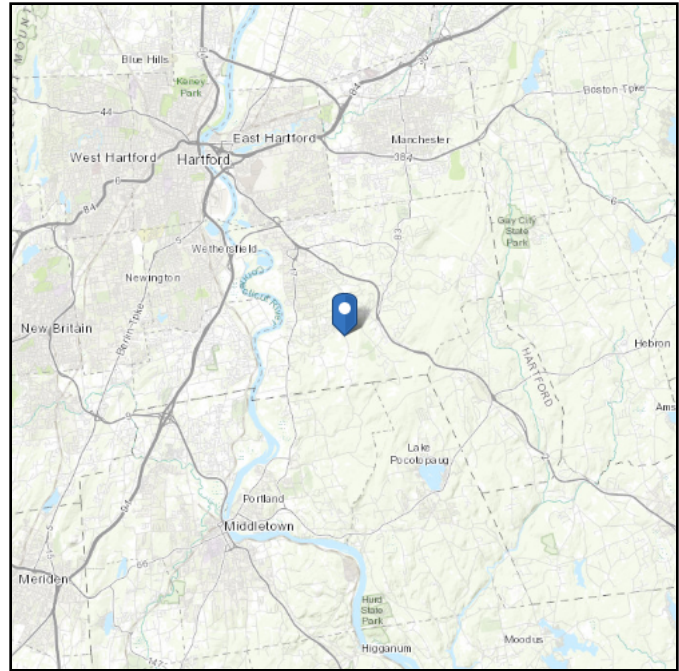
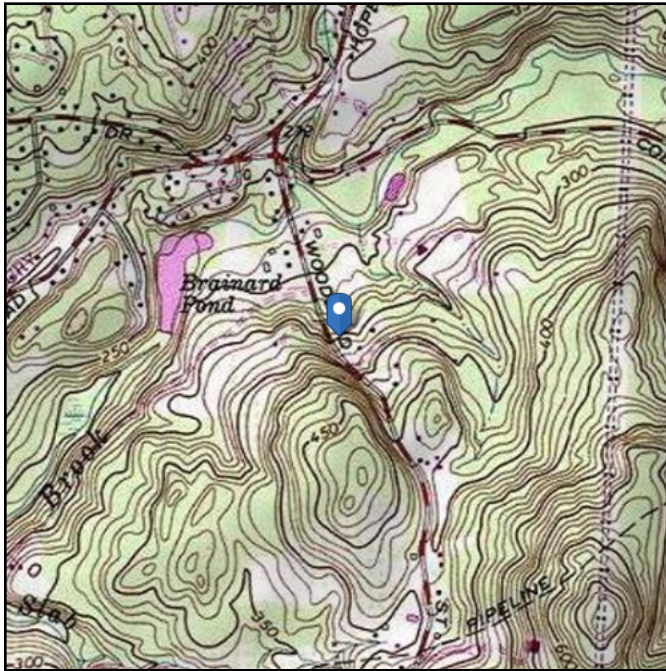

Wind

Results:

Wind Speed:	125 Vmph
10-year MRI	77 Vmph
25-year MRI	87 Vmph
50-year MRI	94 Vmph
100-year MRI	102 Vmph

Data Source:

ASCE/SEI 7-10, Fig. 26.5-1A and Figs. CC-1–CC-4, incorporating errata of March 12, 2014

Date Accessed:

Mon Feb 18 2019

Value provided is 3-second gust wind speeds at 33 ft above ground for Exposure C Category, based on linear interpolation between contours. Wind speeds are interpolated in accordance with the 7-10 Standard. Wind speeds correspond to approximately a 7% probability of exceedance in 50 years (annual exceedance probability = 0.00143, MRI = 700 years).

Site is in a hurricane-prone region as defined in ASCE/SEI 7-10 Section 26.2. Glazed openings need not be protected against wind-borne debris.

Mountainous terrain, gorges, ocean promontories, and special wind regions should be examined for unusual wind conditions.

Site Soil Class: C - Very Dense Soil and Soft Rock

Results:

S_s :	0.18	S_{DS} :	0.144
S_1 :	0.063	S_{D1} :	0.071
F_a :	1.2	T_L :	6
F_v :	1.7	PGA :	0.091
S_{MS} :	0.215	PGA _M :	0.109
S_{M1} :	0.107	F _{PGA} :	1.2
		I_e :	1

Seismic Design Category B

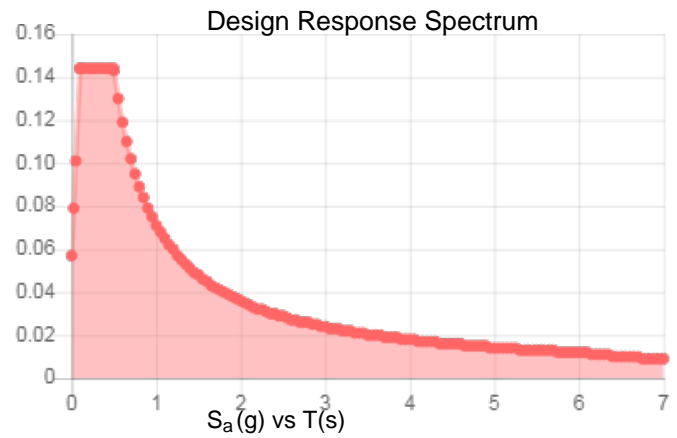
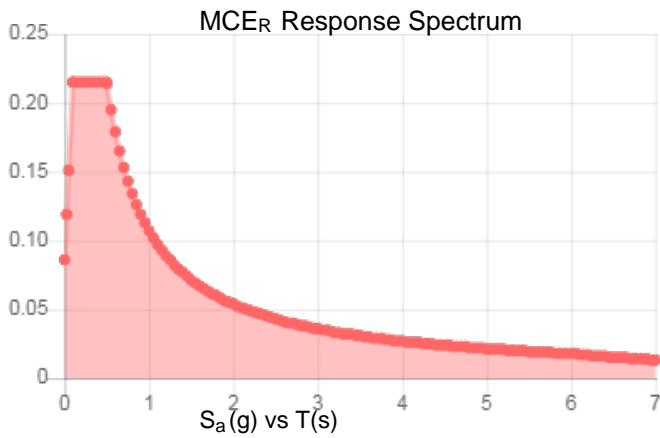

Data Accessed:

Mon Feb 18 2019

Date Source:

USGS Seismic Design Maps based on ASCE/SEI 7-10, incorporating Supplement 1 and errata of March 31, 2013, and ASCE/SEI 7-10 Table 1.5-2. Additional data for site-specific ground motion procedures in accordance with ASCE/SEI 7-10 Ch. 21 are available from USGS.

Ice

Results:

Ice Thickness: 1.00 in.
Concurrent Temperature: 5 F
Gust Speed: 50 mph

Data Source: Standard ASCE/SEI 7-10, Figs. 10-2 through 10-8

Date Accessed: Mon Feb 18 2019

Ice thicknesses on structures in exposed locations at elevations higher than the surrounding terrain and in valleys and gorges may exceed the mapped values.

Values provided are equivalent radial ice thicknesses due to freezing rain with concurrent 3-second gust speeds, for a 50-year mean recurrence interval, and temperatures concurrent with ice thicknesses due to freezing rain. Thicknesses for ice accretions caused by other sources shall be obtained from local meteorological studies. Ice thicknesses in exposed locations at elevations higher than the surrounding terrain and in valleys and gorges may exceed the mapped values.

The ASCE 7 Hazard Tool is provided for your convenience, for informational purposes only, and is provided “as is” and without warranties of any kind. The location data included herein has been obtained from information developed, produced, and maintained by third party providers; or has been extrapolated from maps incorporated in the ASCE 7 standard. While ASCE has made every effort to use data obtained from reliable sources or methodologies, ASCE does not make any representations or warranties as to the accuracy, completeness, reliability, currency, or quality of any data provided herein. Any third-party links provided by this Tool should not be construed as an endorsement, affiliation, relationship, or sponsorship of such third-party content by or from ASCE.

ASCE does not intend, nor should anyone interpret, the results provided by this Tool to replace the sound judgment of a competent professional, having knowledge and experience in the appropriate field(s) of practice, nor to substitute for the standard of care required of such professionals in interpreting and applying the contents of this Tool or the ASCE 7 standard.

In using this Tool, you expressly assume all risks associated with your use. Under no circumstances shall ASCE or its officers, directors, employees, members, affiliates, or agents be liable to you or any other person for any direct, indirect, special, incidental, or consequential damages arising from or related to your use of, or reliance on, the Tool or any information obtained therein. To the fullest extent permitted by law, you agree to release and hold harmless ASCE from any and all liability of any nature arising out of or resulting from any use of data provided by the ASCE 7 Hazard Tool.



Colocation Application

Check one: New <input checked="" type="checkbox"/> Addition to Existing <input type="checkbox"/> Modification <input type="checkbox"/> <i>(Double click to check)</i>	
PLEASE RETURN THIS APPLICATION TO:	
ECO-SITE, LLC 240 Leigh Farm Rd Suite 415 Durham, NC 27707	E-Mail: sales@eco-site.com Office: 919-636-6810
Eco-Site Site Number: <u>CT-0007</u>	Eco-Site Site Name: <u>Hopewell</u>
Date Received: <u>2/13/19</u>	Revision Dates: _____
Install Date: _____	

APPLICANT/CARRIER INFORMATION

Carrier Name: <u>AT&T Mobility</u>	Contact Name: <u>David Walsh</u>
Carrier Site Name: <u>Glastonbury_ Woodland Ln</u>	Contact Number: <u>860.933.5191</u>
Carrier Site Number: <u>CT2421</u>	Contact Fax: <u>N/A</u>
Carrier Legal Entity Name: <u>New Cingular Wireless PCS, LLC</u>	
State of Registration: <u>Delaware</u>	
Type of Entity (LP, LLC, Corp) d/b/a (if applicable): <u>Limited liability company</u>	Contact Address: <u>85 Rangeway Rd.</u>
Carrier Invoice Address: <u>575 Morosgo Drive NE, 13F</u> <u>Atlanta, GA 30324</u>	<u>Bldg. #3 #102</u> <u>North Billerica, MA 01862</u>
	Contact Email: <u>David.Walsh@smartlinkllc.com</u>
	Other: _____
Carrier Invoice Contact Name: <u>TBD</u>	
Title: <u>TBD</u>	
Phone No: <u>TBD</u>	

ADDITIONAL CARRIER INFORMATION

Leasing Contact Name/Number: <u>David Walsh 860.933.5191</u>
RF Contact Name/Number: <u>David Walsh 860.933.5191</u>
Construction Contact Name/Number: <u>Robert Picard 603.209.5505</u>
Emergency Contact Name/Number: <u>David Walsh 860.933.5191</u>

SITE INFORMATION

Latitude: <u>41</u> <u>39</u> <u>38.85</u> <u>N</u>	Existing Structure Type: <u>Monopole</u>
Longitude: <u>-72</u> <u>34</u> <u>26.75</u> <u>W</u>	Existing Structure Height: <u>150</u>
Site Address: <u>63 Woodland St, Glastonbury , CT, 06073</u>	

ANTENNAS & CABLES

Sector	1	2	3	4
Desired Rad Center (AGL)	136	136	136	-
Antenna Mount Mounting Height (CL - AGL)	136	136	136	-
Antenna Mounting Type	T-Frame <input type="checkbox"/> Sector <input checked="" type="checkbox"/> Platform <input type="checkbox"/> Low Profile <input type="checkbox"/> Other: _____			
Antenna Mounting Manufacturer	Saber Industries	Saber Industries	Saber Industries	-
Antenna Mounting Model No./Part No.	C10857001C (mount) C10899050 (tri-collar)	C10857001C (mount) C10899050 (tri-collar)	C10857001C (mount) C10899050 (tri-collar)	-
Antenna Quantity	3	3	3	-
Antenna Manufacturer	CCI	CCI	CCI	-
Antenna Model (attach spec sheet)	(2) TPA65R-BU8D, (1) HPA65R-BU8A	(2) TPA65R-BU8D, (1) HPA65R-BU8A	(2) TPA65R-BU8D, (1) HPA65R-BU8A	-
Antenna Dimensions (H"xW"xD")	96 X 21 X 7.8	96 X 21 X 7.8	96 X 21 X 7.8	-
Antenna Weight (per antenna)	(2) 83 lbs. (1) 57.5 lbs.	(2) 83 lbs. (1) 57.5 lbs.	(2) 83 lbs. (1) 57.5 lbs.	-
Antenna Orientation/Azimuth (degrees)	120	240	340	-
Antenna Mechanical Tilt (degrees)	0	0	0	-
DC Surge Protector Quantity	1	1	1	-
DC Surge Protector Dimensions	18.2 x 10.2 x 31.4	18.2 x 10.2 x 31.4	18.2 x 10.2 x 31.4	-
DC Surge Protector Weight	26.2	26.2	26.2	-
RRU Quantity	5	5	5	-
RRU Manufacturer & Model	Ericsson-4478 B14 / E2- 700 / 4415 B30 / 4449 / 8843	Ericsson-4478 B14 / E2- 700 / 4415 B30 / 4449 / 8843	Ericsson-4478 B14 / E2- 700 / 4415 B30 / 4449 / 8843	-

Colocation Application (Page 2)

RRU Dimensions (H"xW"xD")	18 x 13 x 8.2 / 20 x 18.5 x 7.4 / 16.5 x 13.4 x 6 / 15 x 13 x 10 / 15 x 13 x 11	18 x 13 x 8.2 / 20 x 18.5 x 7.4 / 16.5 x 13.4 x 6 / 15 x 13 x 10 / 15 x 13 x 11	18 x 13 x 8.2 / 20 x 18.5 x 7.4 / 16.5 x 13.4 x 6 / 15 x 13 x 10 / 15 x 13 x 11	-
RRU Weight	59 / 52 / 44 / 73 / 75	59 / 52 / 44 / 73 / 75	59 / 52 / 44 / 73 / 75	-
TMA/Diplexer Quantity	-	-	-	-
TMA/Diplexer Manufacturer & Model	-	-	-	-
TMA/Diplexer Dimensions (H"xW"xD")	-	-	-	-
TMA/Diplexer Weight	-	-	-	-
Other Equipment Quantity	-	-	-	-
Other Equipment Manufacturer & Model	-	-	-	-
Other Equipment Dimensions (H"xW"xD")	-	-	-	-
Other Equipment Weight	-	-	-	-
Quantity of Coax Cables	2 (DC)	2 (DC)	2 (DC)	-
Diameter of Coax Cables	5/8"	5/8"	5/8"	-
Quantity of Fiber/Hybrid Cables	1 (Fiber)	1 (Fiber)	-	-
Diameter of Fiber/Hybrid Cables	3/8"	3/8"	-	-
# Of Channels	12 / 6	12 / 6	12 / 6	-
ERP (watts)	16.4 dBi / 15.9 dBi	16.4 dBi / 15.9 dBi	16.4 dBi / 15.9 dBi	-
Transmit Frequency	Please see attached FX table	Please see attached FX table	Please see attached FX table	-
Receive Frequency	Please see attached FX table	Please see attached FX table	Please see attached FX table	-
Type of Service (i.e. LTE, CDMA, UMTS)	FirstNet (B14), AWS, LTE, WCS, 700, 850 and PCS	FirstNet (B14), AWS, LTE, WCS, 700, 850 and PCS	FirstNet (B14), AWS, LTE, WCS, 700, 850 and PCS	-

MICROWAVE

Sector	1	2	3	4
Microwave Desired Rad Center (AGL)	-	-	-	-
Microwave Mount Mounting Height (AGL)	-	-	-	-
Microwave Quantity	-	-	-	-
Microwave Manufacturer	-	-	-	-
Microwave Model (attach spec sheet)	-	-	-	-
Microwave Dimensions (diameter)	-	-	-	-
Microwave Weight (per dish)	-	-	-	-
Microwave Orientation/Azimuth (degrees)	-	-	-	-
Microwave Mechanical Tilt (degrees)	-	-	-	-
ODU Quantity	-	-	-	-
ODU Manufacturer & Model	-	-	-	-
ODU Dimensions (H"xW"xD")	-	-	-	-
ODU Weight	-	-	-	-
Quantity of Coax Cables	-	-	-	-
Diameter of Coax Cables	-	-	-	-
Quantity of Fiber/Hybrid Cables	-	-	-	-
Diameter of Fiber/Hybrid Cables	-	-	-	-
Transmit Frequency	-	-	-	-
Receive Frequency	-	-	-	-

GROUND SPACE REQUIREMENTS

Total Ground Area Dimensions (length x width in ft.)	10'x20'	Generator: <input checked="" type="checkbox"/> Diesel <input type="checkbox"/> Propane <input type="checkbox"/> Natural Gas <i>(Double click to check)</i> Pad Dimension (L X W X H in ft.): 4' x 6' Size (KW): 15 kW Sound Attenuation:	
Cabinet Dimensions L x W x D	6'4" x 6'4" Walk In	Cabinet Manufacturer	Vertiv
Shelter Dimensions L x W x D	-	Shelter Manufacturer	-

AC POWER REQUIREMENTS

Voltage:	240	Total Amperage:	200
----------	-----	-----------------	-----

BRIEF DESCRIPTION OF WORK TO BE PERFORMED/ADDITIONAL COMMENTS

Install the following at 136' centerline – (9) Panel Antenna, (15) RRU, (3) Demarc Boxes, (2) 3/8" fiber lines, (6) 5/8" DC lines.

Install on ground in 10'x20' area – (1) 15kW Diesel Generator on 4'x6' pad, (1) 6' x 6' walk in cabinet on a 8' x 8' pad.

Attachment 3



C Squared Systems, LLC
65 Dartmouth Drive
Auburn, NH 03032
603-644-2800
support@csquaredsystems.com

Calculated Radio Frequency Exposure



CT2421

63 Woodland Street, South Glastonbury, CT 06073

March 27, 2019

Table of Contents

1. Introduction.....	1
2. FCC Guidelines for Evaluating RF Radiation Exposure Limits.....	1
3. RF Exposure Calculation Methods	2
4. Calculation Results	3
5. Conclusion	4
6. Statement of Certification.....	4
Attachment A: References	5
Attachment B: FCC Limits for Maximum Permissible Exposure (MPE)	6
Attachment C: AT&T Antenna Data Sheets and Electrical Patterns.....	8

List of Tables

Table 1: Carrier Information.....	3
Table 2: FCC Limits for Maximum Permissible Exposure (MPE)	6

List of Figures

Figure 1: Graph of FCC Limits for Maximum Permissible Exposure (MPE).....	7
---	---

1. Introduction

The purpose of this report is to investigate compliance with applicable FCC regulations for the proposed installation of AT&T antenna arrays on the previously approved monopole tower that will be located at 63 Woodland Street in South Glastonbury, CT. The coordinates of the tower are 41° 40' 50.85" N, 72° 34' 26.75" W.

AT&T is proposing the following:

- 1) Install nine (9) multi-band antennas (three per sector) to support its commercial LTE network and the FirstNet National Public Safety Broadband Network ("NPSBN").

This report considers the planned antenna configuration for AT&T¹ to derive the resulting % Maximum Permissible Exposure of its proposed installation.

2. FCC Guidelines for Evaluating RF Radiation Exposure Limits

In 1985, the FCC established rules to regulate radio frequency (RF) exposure from FCC licensed antenna facilities. In 1996, the FCC updated these rules, which were further amended in August 1997 by OET Bulletin 65 Edition 97-01. These new rules include Maximum Permissible Exposure (MPE) limits for transmitters operating between 300 kHz and 100 GHz. The FCC MPE limits are based upon those recommended by the National Council on Radiation Protection and Measurements (NCRP), developed by the Institute of Electrical and Electronics Engineers, Inc., (IEEE) and adopted by the American National Standards Institute (ANSI).

The FCC general population/uncontrolled limits set the maximum exposure to which most people may be subjected. General population/uncontrolled exposures apply in situations in which the general public may be exposed, or in which persons that are exposed as a consequence of their employment may not be fully aware of the potential for exposure or cannot exercise control over their exposure.

Public exposure to radio frequencies is regulated and enforced in units of milliwatts per square centimeter (mW/cm²). The general population exposure limits for the various frequency ranges are defined in the attached "FCC Limits for Maximum Permissible Exposure (MPE)" in Attachment B of this report.

Higher exposure limits are permitted under the occupational/controlled exposure category, but only for persons who are exposed as a consequence of their employment and who have been made fully aware of the potential for exposure, and they must be able to exercise control over their exposure. General population/uncontrolled limits are five times more stringent than the levels that are acceptable for occupational, or radio frequency trained individuals. Attachment B contains excerpts from OET Bulletin 65 and defines the Maximum Exposure Limit.

Finally, it should be noted that the MPE limits adopted by the FCC for both general population/uncontrolled exposure and for occupational/controlled exposure incorporate a substantial margin of safety and have been established to be well below levels generally accepted as having the potential to cause adverse health effects.

¹ As referenced to AT&T's Radio Frequency Design Sheet updated 2/26/2019.

3. RF Exposure Calculation Methods

The power density calculation results were generated using the following formula as outlined in FCC bulletin OET 65, and Connecticut Siting Council recommendations:

$$\text{Power Density} = \left(\frac{1.6^2 \times 1.64 \times \text{ERP}}{4\pi \times R^2} \right) \times \text{Off Beam Loss}$$

Where:

ERP = Effective Radiated Power

R = Radial Distance = $\sqrt{(H^2 + V^2)}$

H = Horizontal Distance from antenna in meters

V = Vertical Distance from radiation center of antenna in meters

Ground reflection factor of 1.6

Off Beam Loss is determined by the selected antenna pattern

These calculations assume that the antennas are operating at 100 percent capacity and power, and that all antenna channels are transmitting simultaneously. Obstructions (trees, buildings, etc.) that would normally attenuate the signal are not taken into account. The calculations assume even terrain in the area of study and do not consider actual terrain elevations which could attenuate the signal. As a result, the predicted signal levels reported below are much higher than the actual signal levels will be from the final installations.

4. Calculation Results

Table 1 below outlines the power density information for the site. The proposed AT&T antennas are directional in nature; therefore, the majority of the RF power is focused out towards the horizon. As a result, there will be less RF power directed below the antennas relative to the horizon, and consequently lower power density levels around the base of the tower. Please refer to Attachment C for the vertical pattern of the proposed AT&T antennas. The calculated results in Table 1 include a nominal 10 dB off-beam pattern loss to account for the lower relative gain below the antennas.

Carrier	Antenna Height (Feet)	Operating Frequency (MHz)	Number of Trans.	ERP Per Transmitter (Watts)	Power Density (mw/cm ²)	Limit	% MPE
T-Mobile	146	2100	2	1964	0.0072097	1.0000	0.72%
T-Mobile	146	1900	2	1710	0.0062773	1.0000	0.63%
T-Mobile	146	700	1	209	0.0003836	0.4667	0.08%
T-Mobile	146	2100	2	1142	0.0041922	1.0000	0.42%
T-Mobile	146	2100	2	1141	0.0041885	1.0000	0.42%
AT&T	136	722	1	1730	0.0037	0.4813	0.77%
AT&T	136	739	1	3541	0.0075	0.4927	1.53%
AT&T	136	763	1	3541	0.0075	0.5087	1.48%
AT&T	136	885	1	4257	0.0091	0.5900	1.54%
AT&T	136	1900	1	6297	0.0134	1.0000	1.34%
AT&T	136	2100	1	9890	0.0211	1.0000	2.11%
AT&T	136	2300	1	6153	0.0131	1.0000	1.31%
						Total	12.34%

Table 1: Carrier Information^{2 3 4}

² The power density information for T-Mobile is based on the details provided within the Application for Docket No. 478 (Attachment 6 – Emissions Analysis Report) as posted on the CSC webpage. https://www.ct.gov/csc/lib/csc/pendingproceeds/docket_478/1_application/application_attachment_6.pdf.

³ Please note that % MPE values listed are rounded to two decimal points and the total % MPE listed is a summation of each unrounded contribution. Therefore, summing each rounded value may not identically match the total value reflected in the table.

⁴ Antenna height listed for AT&T is in reference to the Fullerton Engineering Design preliminary construction drawings dated 2/19/2019 and the Morrison Hershfield Structural Analysis Report dated 2/22/2019. The proposed 10' extension and associated antennas shown on the preliminary construction drawings are understood to be part of a separate petition and have not been included here.

5. Conclusion

The above analysis verifies that RF exposure at ground level from the proposed site will be below the maximum power density levels as outlined by the FCC in the OET Bulletin 65 Ed. 97-01. Using conservative calculation methods, the cumulative power density from the proposed transmit antennas at the extended facility is well below the limits for the general public. The highest expected percent of Maximum Permissible Exposure at ground level is **12.34% of the FCC General Population/Uncontrolled limit**.

As noted previously, the predicted signal levels are more conservative (higher) than the actual signal levels will be from the finished modifications.

6. Statement of Certification

I certify to the best of my knowledge that the statements in this report are true and accurate. The calculations follow guidelines set forth in ANSI/IEEE Std. C95.3, ANSI/IEEE Std. C95.1 and FCC OET Bulletin 65 Edition 97-01.

Keith Vellante

Report Prepared By: Keith Vellante
Director of RF Services
C Squared Systems, LLC

March 27, 2019
Date

Attachment A: References

OET Bulletin 65 - Edition 97-01 - August 1997 Federal Communications Commission Office of Engineering & Technology

IEEE C95.1-2005, IEEE Standard Safety Levels With Respect to Human Exposure to Radio Frequency Electromagnetic Fields, 3 kHz to 300 GHz IEEE-SA Standards Board

IEEE C95.3-2002 (R2008), IEEE Recommended Practice for Measurements and Computations of Radio Frequency Electromagnetic Fields With Respect to Human Exposure to Such Fields, 100 kHz-300 GHz IEEE-SA Standards Board

Attachment B: FCC Limits for Maximum Permissible Exposure (MPE)

(A) Limits for Occupational/Controlled Exposure⁵

Frequency Range (MHz)	Electric Field Strength (E) (V/m)	Magnetic Field Strength (E) (A/m)	Power Density (S) (mW/cm ²)	Averaging Time E ² , H ² or S (minutes)
0.3-3.0	614	1.63	(100)*	6
3.0-30	1842/f	4.89/f	(900/f ²)*	6
30-300	61.4	0.163	1.0	6
300-1500	-	-	f/300	6
1500-100,000	-	-	5	6

(B) Limits for General Population/Uncontrolled Exposure⁶

Frequency Range (MHz)	Electric Field Strength (E) (V/m)	Magnetic Field Strength (E) (A/m)	Power Density (S) (mW/cm ²)	Averaging Time E ² , H ² or S (minutes)
0.3-1.34	614	1.63	(100)*	30
1.34-30	824/f	2.19/f	(180/f ²)*	30
30-300	27.5	0.073	0.2	30
300-1500	-	-	f/1500	30
1500-100,000	-	-	1.0	30

f = frequency in MHz * Plane-wave equivalent power density

Table 2: FCC Limits for Maximum Permissible Exposure (MPE)

⁵ Occupational/controlled limits apply in situations in which persons are exposed as a consequence of their employment provided those persons are fully aware of the potential for exposure and can exercise control over their exposure. Limits for occupational/controlled exposure also apply in situations when an individual is transient through a location where occupational/controlled limits apply provided he or she is made aware of the potential for exposure

⁶ General population/uncontrolled exposures apply in situations in which the general public may be exposed, or in which persons that are exposed as a consequence of their employment may not be fully aware of the potential for exposure or cannot exercise control over their exposure

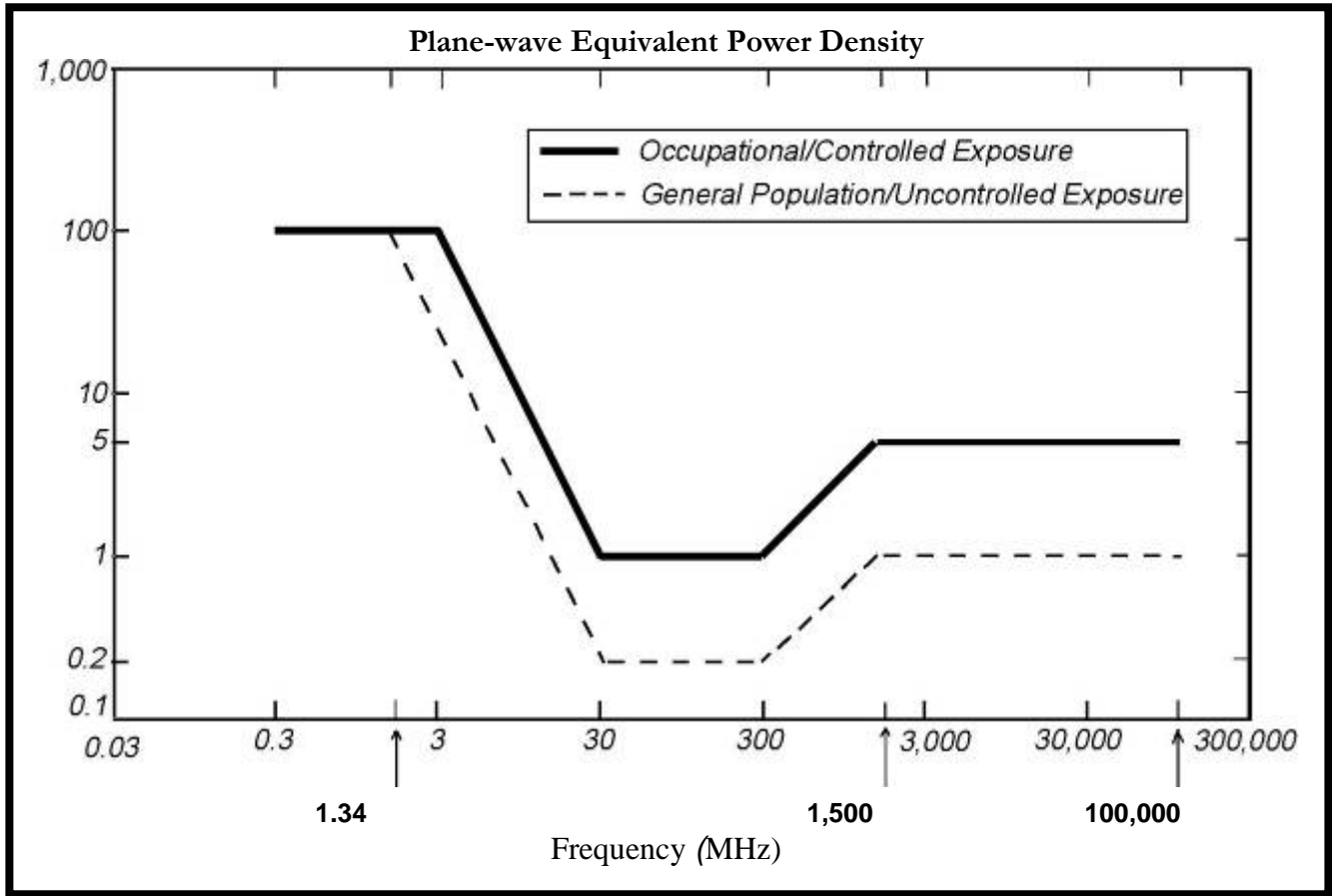
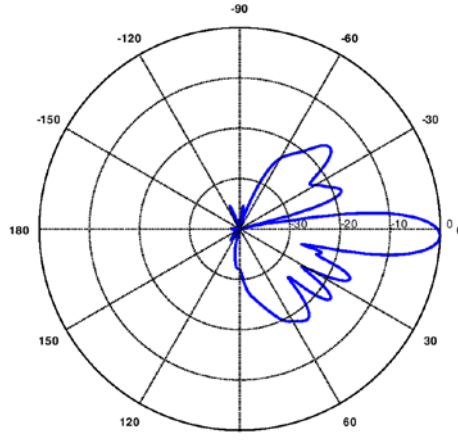
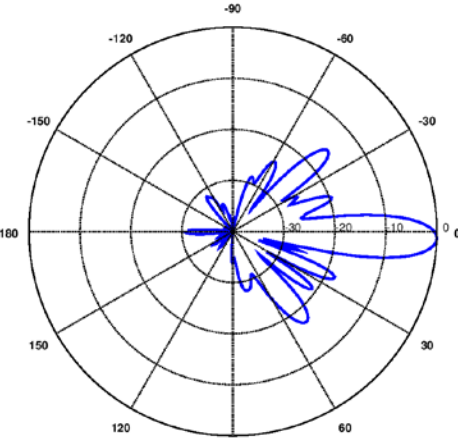
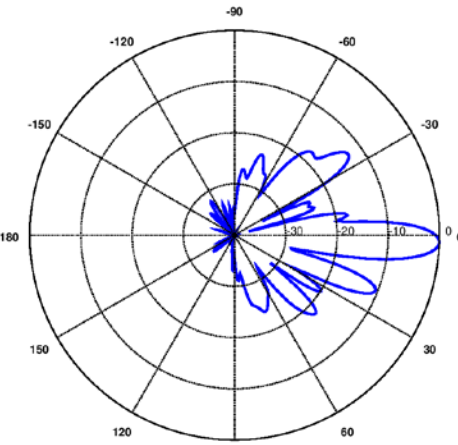

Figure 1: Graph of FCC Limits for Maximum Permissible Exposure (MPE)

Attachment C: AT&T Antenna Data Sheets and Electrical Patterns

<p>722 MHz</p> <p>Manufacturer: CCI Model #: HPA65R-BU8A Frequency Band: 698-806 MHz Gain: 15.5 dBi Vertical Beamwidth: 9.7° Horizontal Beamwidth: 67° Polarization: ±45° Dimensions (L x W x D): 96.0" x 11.7" x 7.6"</p>	
<p>739/763 MHz</p> <p>Manufacturer: CCI Model #: TPA65R-BU8D Frequency Band: 698-806 MHz Gain: 15.6 dBi Vertical Beamwidth: 9.5° Horizontal Beamwidth: 73° Polarization: ±45° Dimensions (L x W x D): 96.0" x 21.0" x 7.8"</p>	
<p>885 MHz</p> <p>Manufacturer: CCI Model #: TPA65R-BU8D Frequency Band: 824-896 MHz Gain: 16.4 dBi Vertical Beamwidth: 7.9° Horizontal Beamwidth: 64° Polarization: ±45° Dimensions (L x W x D): 96.0" x 21.0" x 7.8"</p>	

1900 MHz

Manufacturer: CCI
 Model #: TPA65R-BU8D
 Frequency Band: 1850-1990 MHz
 Gain: 18.1 dBi
 Vertical Beamwidth: 5.1°
 Horizontal Beamwidth: 66°
 Polarization: ±45°
 Dimensions (L x W x D): 96.0" x 21.0" x 7.8"

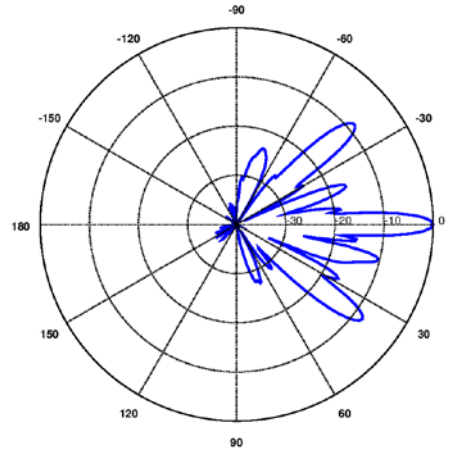

2100 MHz

Manufacturer: CCI
 Model #: TPA65R-BU8D
 Frequency Band: 1920-2180 MHz
 Gain: 18.3 dBi
 Vertical Beamwidth: 4.8°
 Horizontal Beamwidth: 66°
 Polarization: ±45°
 Dimensions (L x W x D): 96.0" x 21.0" x 7.8"

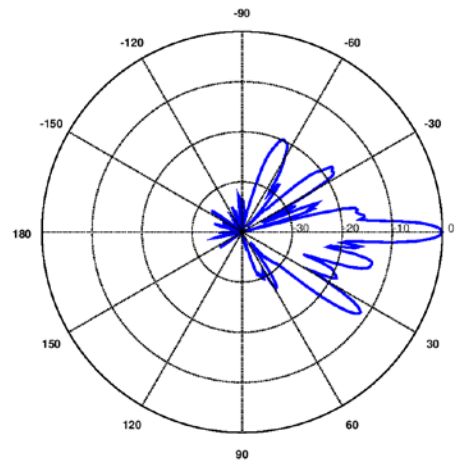

2300 MHz

Manufacturer: CCI
 Model #: HPA65R-BU8A
 Frequency Band: 2300-2400 MHz
 Gain: 18.0 dBi
 Vertical Beamwidth: 4.0°
 Horizontal Beamwidth: 60°
 Polarization: ±45°
 Dimensions (L x W x D): 96.0" x 11.7" x 7.6"

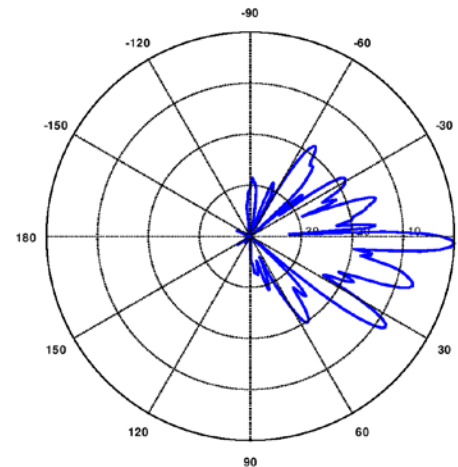

Attachment 4



Date: 3/18/19

Eco-Site
240 Leigh Farm Road, Suite 415
Durham, NC 27707

RE: **Letter of Authorization**
63 Woodland Street
South Glastonbury, CT 06073
AT&T Site Name: Glastonbury-Woodland St
AT&T Site No.: CT2421 / FA# 14644530

Eco-Site II, LLC (“Property Owner”) does hereby appoint **New Cingular Wireless PCS, LLC (AT&T)** (“Carrier”) and its authorized contractors/agents including but not limited to **Smartlink, LLC** to act as “Applicant/Agent” for the purpose of preparing and filing any application or document necessary to ensure Carrier’s ability to use the Property as a telecommunications facility. The Property Owner understands and agrees that this application may be denied, modified, or approved with conditions and that such conditions or modifications must be complied with prior to the issuance of building permits. It is understood by both Property Owner and Carrier that the authorization given herein does not constitute a commitment by the Property Owner to Carrier or otherwise convey right to the Property to Carrier, and that such conveyance shall only be accomplished by the execution of a further agreement by both parties.

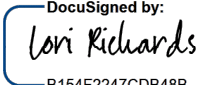
DocuSigned by:

B154F2247CDB48B...

By: _____
Lori Richards
Printed Name: _____
Colocation Sr Manager
Title: _____
3/21/2019
Date: _____

Smartlink, LLC
85 Rangeway Road, Building 3, Suite 102
Billerica, MA 01862