

October 19, 2015

Members of the Siting Council
Connecticut Siting Council
Ten Franklin Square
New Britain, CT 06051

RE: Notice of Exempt Modification
2577 Main Street
Glastonbury, CT 06033
N 41.71442
W -72.61314
T-Mobile Site #: CT11786D_L700

Members of the Siting Council:

On behalf of T-Mobile, SBA Communications is submitting an exempt modification application to the Connecticut Siting council for modification of existing equipment at a tower facility located at 2577 Main Street, Glastonbury, CT

The 2577 Main Street facility consists of a 130' Self Support Tower owned and operated by SBA 2012 TC Assets, LLC. In order to accommodate technological changes and enhance system performance in the State of Connecticut, T-Mobile plans to modify the equipment configurations at many of its existing cell sites. Please accept this letter and attachments as notification, pursuant to R.C.S.A. Section 16-50j-73, of construction which constitutes an exempt modification pursuant to R.C.S.A. Section 16-50j-72(b)(2). In compliance with R.C.S.A. Section 16-50j-73, a copy of this letter and attachments is being sent to the chief elected official of the municipality in which the affected cell site is located, Richard Johnson Town Manager of Glastonbury, as well as the property owner, St. Paul's Roman Catholic Church.

As part of T-Mobile's L700 project, T-Mobile desires to upgrade their equipment to meet the new standards of 4G technology. The new equipment will allow customers to download files and browse the internet at a high rate of speed while also allowing their phones to be compatible with the latest 4G technology.

Attached is a summary of the planned modifications, including power density calculations reflecting the change in T-Mobile's operations at the site along with the required fee of \$625.

The changes to the facility do not constitute modifications as defined in Connecticut General Statutes ("C.G.S.") Section 16-50i(d) because the general physical characteristics of the facility will not be significantly changed or altered. Rather, the planned changes to the facility fall squarely within those activities explicitly provided for in R.C.S.A. Section 16-50j-72(b)(2).

1. The overall height of the structure will be unaffected.
2. The proposed changes will not extend the site boundaries. There will be no effect on the site compound.
3. The proposed changes will not increase the noise level at the existing facility by six decibels or more.
4. The changes in radio frequency power density will not increase the calculated "worst case" power density for the combined operations at the site to a level at or above the applicable standard for uncontrolled environments as calculated for a mixed frequency site.

For the foregoing reasons, SBA Communications on behalf of T-Mobile, respectfully submits that he proposed changes at the referenced site constitute exempt modifications under R.C.S.A. Section 16-50j-72(b)(2).

Please feel free to call me at 508.251.0720 x 3804 with any questions you may have concerning this matter.

Thank you,



Kri Pelletier
SBA Communications Corporation
33 Boston Post Road West Suite 320
Marlborough, MA 01752
508-251-0720 x 3804 + T
508-251-1755 + F
203-446-7700 + C
kpelletier@sbsite.com



T-Mobile

Equipment Modification

2577 Main Street, Glastonbury, CT
Site number CT11786D_L700

Tower Owner: SBA 2012 TC Assets, LLC

Equipment Configuration: Self Support Tower

Current and/or approved:

- (3) Ericsson AIR 21 B2A/B4P
- (3) Ericsson AIR 21 B4A/B2P
- (3) Ericsson KRY 112 144/1 TMA
- (13) 1-5/8 feed lines

Final Configuration:

- (3) Ericsson AIR 21 B2A/B4P
- (3) Ericsson AIR 21 B4A/B2P
- (3) Ericsson KRY 112 144/1 TMA
- (3) Commscope LNX-6515DS-A1M
- (3) Ericsson S11B12
- (13) 1-5/8" feed lines

Structural Information:

The attached structural analysis demonstrates that the tower and foundation will have adequate structural capacity to accommodate the proposed modifications.

Power Density:

The anticipated Maximum Composite contributions from the T-Mobile facility are 5.31% of the allowable FCC established general public limit. The anticipated composite MPE value for this site assuming all carriers present is 33.46% of the allowable FCC established general public limit sampled at the ground level.

Site Composite MPE%	
Carrier	MPE%
T-Mobile (Per Sector Max)	5.31 %
MetroPCS	1.22 %
Sprint	0.03 %
Clearwire	0.12 %
Nextel	0.35 %
AT&T	2.96 %
Verizon Wireless	23.47 %
Site Total MPE %:	33.46 %



October 19, 2015

Mr. Richard Johnson
Town Manager
Town of Glastonbury
2155 Main Street
Glastonbury, CT 06033

RE: Telecommunications Facility @ 2577 Main Street, Glastonbury, CT

Dear Mr. Johnson,

In order to accommodate technological changes and enhance system performance in the State of Connecticut, T-Mobile will be changing its equipment configuration at certain cell sites.

As required by Regulations of Connecticut State Agencies (R.C.S.A.) Section 16-50j-73, the Connecticut Siting Council has been notified of the changes and will review T-Mobile's proposal. Please accept this letter as notification under Section 16-50j-73 of construction which constitutes an exempt modification pursuant to R.C.S.A. Section 16-50j-72(b)(2).

The accompanying letter to the Siting Council fully describes T-Mobile's proposal for the referenced cell site. However, if you have any questions or require any further information on our plans or the Siting Council's procedures, please call me at 508.251.0720 x 3804.

Thank you,

A handwritten signature in blue ink, appearing to read "Kri Pelletier", is written over a light blue horizontal line.

Kri Pelletier
SBA Communications Company
33 Boston Post Road West Suite 320
Marlborough, MA 01752
508-251-0720 x 3804 + T
508-251-1755 + F
203-446-7700 + C
kpelletier@sbsite.com



October 19, 2015

St. Paul's Roman Catholic Church
2577 Main Street
Glastonbury CT 06033

RE: Telecommunications Facility @ 2577 Main Street, Glastonbury, CT

To Whom It May Concern:

In order to accommodate technological changes and enhance system performance in the State of Connecticut, T-Mobile will be changing its equipment configuration at certain cell sites.

As required by Regulations of Connecticut State Agencies (R.C.S.A.) Section 16-50j-73, the Connecticut Siting Council has been notified of the changes and will review T-Mobile's proposal. Please accept this letter as notification under Section 16-50j-73 of construction which constitutes an exempt modification pursuant to R.C.S.A. Section 16-50j-72(b)(2).

The accompanying letter to the Siting Council fully describes T-Mobile's proposal for the referenced cell site. However, if you have any questions or require any further information on our plans or the Siting Council's procedures, please call me at 508.251.0720 x 3804.

Thank you,

A handwritten signature in blue ink, appearing to read "Kri Pelletier", is positioned above the typed name.

Kri Pelletier
SBA Communications Company
33 Boston Post Road West Suite 320
Marlborough, MA 01752
508-251-0720 x 3804 + T
508-251-1755 + F
203-446-7700 + C
kpelletier@sbsite.com

RADIO FREQUENCY EMISSIONS ANALYSIS REPORT
EVALUATION OF HUMAN EXPOSURE POTENTIAL
TO NON-IONIZING EMISSIONS

T-Mobile Existing Facility

Site ID: CT11786D

Nextel Glastonbury
2557 Main Street
Glastonbury, CT 06033

October 8, 2015

EBI Project Number: 6215005051

Site Compliance Summary	
Compliance Status:	COMPLIANT
Site total MPE% of FCC general public allowable limit:	33.46 %

October 8, 2015

T-Mobile USA
Attn: Jason Overbey, RF Manager
35 Griffin Road South
Bloomfield, CT 06002

Emissions Analysis for Site: **CT11786D – Nextel Glastonbury**

EBI Consulting was directed to analyze the proposed T-Mobile facility located at **2557 Main Street, Glastonbury, CT**, for the purpose of determining whether the emissions from the Proposed T-Mobile Antenna Installation located on this property are within specified federal limits.

All information used in this report was analyzed as a percentage of current Maximum Permissible Exposure (% MPE) as listed in the FCC OET Bulletin 65 Edition 97-01 and ANSI/IEEE Std C95.1. The FCC regulates Maximum Permissible Exposure in units of microwatts per square centimeter ($\mu\text{W}/\text{cm}^2$). The number of $\mu\text{W}/\text{cm}^2$ calculated at each sample point is called the power density. The exposure limit for power density varies depending upon the frequencies being utilized. Wireless Carriers and Paging Services use different frequency bands each with different exposure limits, therefore it is necessary to report results and limits in terms of percent MPE rather than power density.

All results were compared to the FCC (Federal Communications Commission) radio frequency exposure rules, 47 CFR 1.1307(b)(1) – (b)(3), to determine compliance with the Maximum Permissible Exposure (MPE) limits for General Population/Uncontrolled environments as defined below.

General population/uncontrolled exposure limits apply to situations in which the general public may be exposed or in which persons who are exposed as a consequence of their employment may not be made fully aware of the potential for exposure or cannot exercise control over their exposure. Therefore, members of the general public would always be considered under this category when exposure is not employment related, for example, in the case of a telecommunications tower that exposes persons in a nearby residential area.

Public exposure to radio frequencies is regulated and enforced in units of microwatts per square centimeter ($\mu\text{W}/\text{cm}^2$). The general population exposure limit for the 700 MHz Band is approximately 467 $\mu\text{W}/\text{cm}^2$, and the general population exposure limit for the PCS and AWS bands is 1000 $\mu\text{W}/\text{cm}^2$. Because each carrier will be using different frequency bands, and each frequency band has different exposure limits, it is necessary to report percent of MPE rather than power density.

Occupational/controlled exposure limits apply to situations in which persons are exposed as a consequence of their employment and in which those persons who are exposed have been made fully aware of the potential for exposure and can exercise control over their exposure. Occupational/controlled exposure limits also apply where exposure is of a transient nature as a result of incidental passage through a location where exposure levels may be above general population/uncontrolled limits (see below), as long as the exposed person has been made fully aware of the potential for exposure and can exercise control over his or her exposure by leaving the area or by some other appropriate means.

Additional details can be found in FCC OET 65.

CALCULATIONS

Calculations were done for the proposed T-Mobile Wireless antenna facility located at **2557 Main Street, Glastonbury, CT**, using the equipment information listed below. All calculations were performed per the specifications under FCC OET 65. Since T-Mobile is proposing highly focused directional panel antennas, which project most of the emitted energy out toward the horizon, all calculations were performed assuming a lobe representing the maximum gain of the antenna per the antenna manufactures supplied specifications, minus 10 dB, was focused at the base of the tower. For this report the sample point is the top of a 6 foot person standing at the base of the tower.

For all calculations, all equipment was calculated using the following assumptions:

- 1) 2 GSM / UMTS channels (PCS Band - 1900 MHz) were considered for each sector of the proposed installation. These Channels have a transmit power of 30 Watts per Channel
- 2) 2 UMTS channels (AWS Band – 2100 MHz) were considered for each sector of the proposed installation. These Channels have a transmit power of 30 Watts per Channel.
- 3) 2 LTE channels (AWS Band – 2100 MHz) were considered for each sector of the proposed installation. These Channels have a transmit power of 60 Watts per Channel.
- 4) 1 LTE channel (700 MHz Band) was considered for each sector of the proposed installation. This channel has a transmit power of 30 Watts.
- 5) All radios at the proposed installation were considered to be running at full power and were uncombined in their RF transmissions paths per carrier prescribed configuration. Per FCC OET Bulletin No. 65 - Edition 97-01 recommendations to achieve the maximum anticipated value at each sample point, all power levels emitting from the proposed antenna installation are increased by a factor of 2.56 to account for possible in-phase reflections from the surrounding environment. This is rarely the case, and if so, is never continuous.

- 6) For the following calculations the sample point was the top of a six foot person standing at the base of the tower. The maximum gain of the antenna per the antenna manufactures supplied specifications minus 10 dB was used in this direction. This value is a very conservative estimate as gain reductions for these particular antennas are typically much higher in this direction.
- 7) The antennas used in this modeling are the **Ericsson AIR21 (B4A/B2P & B2A/B4P)** for 1900 MHz (PCS) and 2100 MHz (AWS) channels and the **Commscope LNX-6515DS-VTM** for 700 MHz channels. This is based on feedback from the carrier with regards to anticipated antenna selection. The **Ericsson AIR21 (B4A/B2P & B2A/B4P)** have a maximum gain of **15.9 dBd** at their main lobe. The **Commscope LNX-6515DS-VTM** has a maximum gain of **14.6 dBd** at its main lobe. The maximum gain of the antenna per the antenna manufactures supplied specifications, minus 10 dB, was used for all calculations. This value is a very conservative estimate as gain reductions for these particular antennas are typically much higher in this direction.
- 8) The antenna mounting height centerline of the proposed antennas is **93 feet** above ground level (AGL).
- 9) Emissions values for additional carriers were taken from the Connecticut Siting Council active database. Values in this database are provided by the individual carriers themselves.

All calculations were done with respect to uncontrolled / general public threshold limits.

T-Mobile Site Inventory and Power Data

Sector:	A	Sector:	B	Sector:	C
Antenna #:	1	Antenna #:	1	Antenna #:	1
Make / Model:	Ericsson AIR21 B4A/B2P	Make / Model:	Ericsson AIR21 B4A/B2P	Make / Model:	Ericsson AIR21 B4A/B2P
Gain:	15.9 dBd	Gain:	15.9 dBd	Gain:	15.9 dBd
Height (AGL):	93	Height (AGL):	93	Height (AGL):	93
Frequency Bands	1900 MHz(PCS) / 2100 MHz (AWS)	Frequency Bands	1900 MHz(PCS) / 2100 MHz (AWS)	Frequency Bands	1900 MHz(PCS) / 2100 MHz (AWS)
Channel Count	2	Channel Count	2	# PCS Channels:	2
Total TX Power:	120	Total TX Power:	120	# AWS Channels:	120
ERP (W):	4,668.54	ERP (W):	4,668.54	ERP (W):	4,668.54
Antenna A1 MPE%	2.22	Antenna B1 MPE%	2.22	Antenna C1 MPE%	2.22
Antenna #:	2	Antenna #:	2	Antenna #:	2
Make / Model:	Ericsson AIR21 B4A/B2P	Make / Model:	Ericsson AIR21 B4A/B2P	Make / Model:	Ericsson AIR21 B4A/B2P
Gain:	15.9 dBd	Gain:	15.9 dBd	Gain:	15.9 dBd
Height (AGL):	93	Height (AGL):	93	Height (AGL):	93
Frequency Bands	1900 MHz(PCS) / 2100 MHz (AWS)	Frequency Bands	1900 MHz(PCS) / 2100 MHz (AWS)	Frequency Bands	1900 MHz(PCS) / 2100 MHz (AWS)
Channel Count	4	Channel Count	4	Channel Count	4
Total TX Power:	120	Total TX Power:	120	Total TX Power:	120
ERP (W):	4,668.54	ERP (W):	4,668.54	ERP (W):	4,668.54
Antenna A2 MPE%	2.22	Antenna B2 MPE%	2.22	Antenna C2 MPE%	2.22
Antenna #:	3	Antenna #:	3	Antenna #:	3
Make / Model:	Commscope LNX-6515DS-VTM	Make / Model:	Commscope LNX-6515DS-VTM	Make / Model:	Commscope LNX-6515DS-VTM
Gain:	14.6 dBd	Gain:	14.6 dBd	Gain:	14.6 dBd
Height (AGL):	93	Height (AGL):	93	Height (AGL):	93
Frequency Bands	700 MHz	Frequency Bands	700 MHz	Frequency Bands	700 MHz
Channel Count	1	Channel Count	1	Channel Count	1
Total TX Power:	30	Total TX Power:	30	Total TX Power:	30
ERP (W):	865.21	ERP (W):	865.21	ERP (W):	865.21
Antenna A3 MPE%	0.88	Antenna B3 MPE%	0.88	Antenna C3 MPE%	0.88

Site Composite MPE%	
Carrier	MPE%
T-Mobile (Per Sector Max)	5.31 %
MetroPCS	1.22 %
Sprint	0.03 %
Clearwire	0.12 %
Nextel	0.35 %
AT&T	2.96 %
Verizon Wireless	23.47 %
Site Total MPE %:	33.46 %

T-Mobile Sector 1 Total:	5.31 %
T-Mobile Sector 2 Total:	5.31 %
T-Mobile Sector 3 Total:	5.31 %
Site Total:	33.46 %

T-Mobile _per sector	# Channels	Watts ERP (Per Channel)	Height (feet)	Total Power Density ($\mu\text{W}/\text{cm}^2$)	Frequency (MHz)	Allowable MPE ($\mu\text{W}/\text{cm}^2$)	Calculated % MPE
T-Mobile 2100 MHz (AWS) LTE	2	2334.27	93	22.17	2100	1000	2.22 %
T-Mobile 700 MHz LTE	1	865.21	93	4.11	700	467	0.88 %
T-Mobile 1900 MHz (PCS) GSM/UMTS	2	1167.14	93	11.09	1900	1000	1.11 %
T-Mobile 2100 MHz (AWS) UMTS	2	1167.14	93	11.09	2100	1000	1.11 %
						Total:	5.31%

Summary

All calculations performed for this analysis yielded results that were **within** the allowable limits for general public exposure to RF Emissions.

The anticipated maximum composite contributions from the T-Mobile facility as well as the site composite emissions value with regards to compliance with FCC's allowable limits for general public exposure to RF Emissions are shown here:

T-Mobile Sector	Power Density Value (%)
Sector 1:	5.31 %
Sector 2:	5.31 %
Sector 3 :	5.31 %
T-Mobile Per Sector Maximum:	5.31 %
Site Total:	33.46 %
Site Compliance Status:	COMPLIANT

The anticipated composite MPE value for this site assuming all carriers present is **33.46%** of the allowable FCC established general public limit sampled at the ground level. This is based upon values listed in the Connecticut Siting Council database for existing carrier emissions.

FCC guidelines state that if a site is found to be out of compliance (over allowable thresholds), that carriers over a 5% contribution to the composite value will require measures to bring the site into compliance. For this facility, the composite values calculated were well within the allowable 100% threshold standard per the federal government.



Scott Heffernan
RF Engineering Director

EBI Consulting
21 B Street
Burlington, MA 01803

September 25, 2015

Mark Luther
SBA Communications Corporation
9900 Westpoint Drive, Suite 116
Indianapolis, IN 46256
(570) 561-3200



B+T Group
1717 S. Boulder, Suite 300
Tulsa, OK 74119
(918) 587-4630
btwo@btgrp.com

Subject: Structural Analysis Report

Carrier Designation: T-Mobile Co-Locate
Site Number: CT11786D
Site Name: CT11786D

SBA Communications Designation: **Site Number:** CT46126-A
Site Name: Glastonbury-main st
Application Number: 25231, v1

Engineering Firm Designation: **B+T Group Project Number:** 101341.001.01

Site Data: 2577 Main St, Glastonbury, CT 06033, Hartford County, CT
Latitude 41° 42' 51.8", Longitude -72° 36' 46.9"
130 Foot - Self Support Tower

Dear Mark Luther,

B+T Group is pleased to submit this "Structural Analysis Report" to determine the structural integrity of the above mentioned tower.

The purpose of the analysis is to determine acceptability of the tower stress level. Based on our analysis we have determined the tower stress level for the structure and foundation, under the following load case, to be:

Existing + Proposed Equipment

Note: See Table 1 and Table 2 for the proposed and existing loading, respectively.

Sufficient Capacity

Tower Rating: 96.4%
Foundation: 74.6%

The analysis has been performed in accordance with the TIA/EIA-222-F standard and IBC 2006 based upon a wind speed of 80 mph fastest mile.

All equipment proposed in this report shall be installed in accordance with the attached drawings for the determined available structural capacity to be effective.

We at B+T Group appreciate the opportunity of providing our continuing professional services to you and SBA Communications Corporation. If you have any questions or need further assistance on this or any other projects please give us a call.

Respectfully submitted by:
B+T Engineering, Inc.

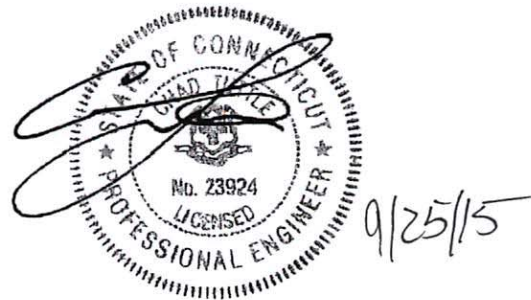

Zach Smith
Project Engineer

Chad E. Tuttle, P.E.
Engineer of Record
COA: PEC.0001564 Expires: 02/10/2016

TABLE OF CONTENTS

1) INTRODUCTION

2) ANALYSIS CRITERIA

Table 1 – Existing and Reserved Antenna and Cable Information

Table 2 - Proposed Antenna and Cable Information

Table 3 - Design Antenna and Cable Information

3) ANALYSIS PROCEDURE

Table 4 - Documents Provided

3.1) Analysis Method

3.2) Assumptions

4) ANALYSIS RESULTS

Table 5 - Section Capacity (Summary)

Table 6 – Tower Components vs. Capacity

4.1) Recommendations

5) APPENDIX A

tnxTower Output

6) APPENDIX B

Base Level Drawing

7) APPENDIX C

Additional Calculations

1) INTRODUCTION

This tower is a 130 ft Self Support tower designed by Fred A. Nudd Corporation in September of 1999. The tower was originally designed for a wind speed of 85 mph per TIA/EIA-222-F. This tower has been modified by FDH Engineering in June and September of 2013 and those modifications are incorporated in this analysis.

2) ANALYSIS CRITERIA

The structural analysis was performed for this tower in accordance with the requirements of TIA/EIA-222-F Structural Standards for Steel Antenna Towers and Antenna Supporting Structures using a fastest mile wind speed of 80 mph with no ice, 37.6 mph with 1 inch ice thickness and 50 mph under service loads.

Table 1 – Existing and Reserved Antenna and Cable Information

Mounting Level (ft)	Center Line Elevation (ft)	Number of Antennas	Manufacturer	Equipment Model	Number of Feed Lines	Feed Line Size (in)	Note
128.0	130.0	1	Andrew	VHLP2.5	6 4	5/16 1/2	Sprint Existing
	128.0	3	Unknown	24"x14"x9"			
		2	Argus Tech.	LLPX310R			
		1	Kathrein	840 10054			
		1	Motorola	TIMING 2000			
		3	--	T-Frames			
	126.0	1	Andrew	VHLP2.5			
	124.0	3	Unknown	MODEM			
1		Andrew	VHLP2.5				
118.5	120.0	3	Alcatel Lucent	TD-RRH8x20-25	4	1-1/4	Sprint Existing
		3	Rfs Celwave	APXVTM14-C-120			
	118.5	4	RFS	ACU-A20-N RETs			
		3	Ericsson	1900 MHz			
		3	Ericsson	800 MHz			
		1	Powerwave Tech.	P40-16-XLPP-RR-A			
		2	Rfs Celwave	APXVSPP18-C-A20			
		3	Samsung	800 MHz Filter			
3	--	T-Arms					
110.0	110.0	6	Allgon	7700.00	12 1	1-1/4 3/8	AT&T Existing
		1	Andrew	SBNH-1D6565C			
		6	Ericsson	RRUS-11 1900MHz			
		2	Kmw Comm.	AM-X-CD-16-65-00T-RET			
		6	Powerwave Tech.	LGP13519			
		6	Powerwave Tech.	LGP21401			
		1	Raycap	DC6-48-60-18-8F			
3	--	T-Frames					
93.0	93.0	3	Ericsson	AIR 21 B2A/B4P	13	1-5/8	T-Mobile Existing
		3	Ericsson	AIR 21 B4A/B2P			
		3	Ericsson	KRY 112 144/1 TMA			
		3	--	T-Frames			

Mounting Level (ft)	Center Line Elevation (ft)	Number of Antennas	Equipment Manufacturer	Equipment Model	Number of Feed Lines	Feed Line Size (in)	Note
80.0	80.0	3	Alcatel Lucent	RRH2X60-PCS	2	1-5/8	Verizon Existing
		3	Alcatel Lucent	RRH2x60-700			
		3	Alcatel Lucent	RRH2x60-AWS			
		6	Andrew	HBXX-6517DS-A2M			
		6	Andrew	LNx-6514DS-A1M			
		2	Rfs Celwave	DB-T1-6Z-8AB-0Z			
		3	--	T-Frames			
55.5	55.5	1	Unknown	GPS	1	1/2	Unknown Existing
		1	--	Side Arm Mount			
50.5	50.5	2	Unknown	GPS	2	1/2	Unknown Existing
		2	--	Side Arm Mount			

Table 2 – Proposed Antenna and Cable Information

Mounting Level (ft)	Center Line Elevation (ft)	Number of Antennas	Equipment Manufacturer	Equipment Model	Number of Feed Lines	Feed Line Size (in)	Note
93.0	93.0	3	Commscope	LNx-6515DS-A1M	--	--	T-Mobile Proposed
		3	Ericsson	S11B12			

Table 3 - Design Antenna and Cable Information

Mounting Level (ft)	Center Line Elevation (ft)	Number of Antennas	Equipment Manufacturer	Equipment Model	Number of Feed Lines	Feed Line Size (in)
130.0	130.0	3	Generic	12' Cellular Boom	12	1-1/4
		12	Generic	ALP 9212		
120.0	120.0	3	Generic	12' Cellular Boom	12	1-1/4
		12	Generic	ALP 9212		

3) ANALYSIS PROCEDURE

Table 4 - Documents Provided

Document	Remarks	Reference	Source
Tower Data	Manufacturer Drawing By Fred A. Nudd, Drawing No. 99-6893-1	Date: 07/12/1999	SBA
Tower Modification Data	Modification Drawings by FDH, Project No. 1338401400	Date: 06/17/2013	SBA
Post Modification Inspection	Inspection Report by FDH, Project No. 1304001700	Date: 11/01/2013	SBA
Tower Modification Data	Modification Drawings by FDH, Project No. 13SB5C1400	Date: 09/10/2013	SBA
Post Modification Inspection	Inspection Report by FDH, Project No. 1305911700	Date: 02/25/2014	SBA
Foundation Data	Foundation Drawings by Fred A. Nudd, Drawing No. 99-6893-1	Date: 07/12/1999	SBA
Soil Properties	Geotech Report by Tectonic Engineering, Project No. 1170.C057	Date: 08/26/1999	SBA
Existing Loading	Previous Analysis by FDH Velocitel, Project No. 15BRLU1400	Date: 06/10/2015	SBA
Proposed Loading	Application #: 25231, v1	Date: 09/16/2015	SBA

3.1) Analysis Method

tnxTower (version 6.1.4.1), a commercially available analysis software package, was used to create a three-dimensional model of the tower and calculate member stresses for various loading cases. Selected output from the analysis is included in Appendix A.

3.2) Assumptions

- 1) Tower and structures were built in accordance with the manufacturer's specifications.
- 2) The tower and structures have been maintained in accordance with the manufacturer's specification.
- 3) The configuration of antennas, transmission cables, mounts and other appurtenances are as specified in Tables 1 and 2 and the referenced drawings.
- 4) When applicable, transmission cables are considered as structural components for calculating wind loads as allowed by TIA/EIA-222-F.
- 5) Mount areas and weights are assumed based on photographs provided.

This analysis may be affected if any assumptions are not valid or have been made in error. B+T Group should be notified to determine the effect on the structural integrity of the tower.

4) ANALYSIS RESULTS

Table 5 - Section Capacity (Summary)

Section No.	Elevation (ft)	Component Type	Size	Critical Element	P (K)	SF*P_allow (K)	% Capacity	Pass / Fail
T1	130 - 120	Leg	1 1/2	2	-9.511	42.280	22.5	Pass
T2	120 - 117.143	Leg	2	44	-12.816	83.570	15.3	Pass
T3	117.143 - 114.286	Leg	2	56	-19.265	83.570	23.1	Pass
T4	114.286 - 111.43	Leg	2	65	-25.991	82.306	31.6	Pass
T5	111.43 - 108.573	Leg	2	74	-34.097	82.306	41.4	Pass
T6	108.573 - 105.716	Leg	2	83	-44.392	82.306	53.9	Pass
T7	105.716 - 102.859	Leg	2	92	-55.895	82.306	67.9	Pass
T8	102.859 - 100	Leg	2	101	-72.275	101.583	71.1	Pass
T9	100 - 96	Leg	P4.5 x 0.237	116	-75.228	122.309	61.5	Pass
T10	96 - 92	Leg	P4.5 x 0.237	125	-87.120	122.309	71.2	Pass
T11	92 - 88	Leg	P4.5 x 0.237	134	-95.919	130.687	73.4	Pass
T12	88 - 84	Leg	BT101341- P4.5 x 0.237 w/ HP5.625x0.375	146	-108.967	191.515	56.9	Pass
T13	84 - 80	Leg	BT101341- P4.5 x 0.237 w/ HP5.625x0.375	158	-120.834	191.536	63.1	Pass
T14	80 - 75	Leg	P6.625x0.280	170	-137.007	220.348	62.2	Pass
T15	75 - 70	Leg	P6.625x0.280	179	-155.648	220.348	70.6	Pass
T16	70 - 65	Leg	P6.625x0.280	187	-172.855	220.348	78.4	Pass
T17	65 - 60	Leg	P6.625x0.280	196	-188.375	220.348	85.5	Pass
T18	60 - 55	Leg	P6.625x0.280	205	-201.727	231.994	87.0	Pass
T19	55 - 50	Leg	BT101341- P6.625x0.280 w/ HP7.625x0.301(45'-55')	217	-218.056	295.949	73.7	Pass
T20	50 - 45	Leg	BT101341- P6.625x0.280 w/ HP7.625x0.301(45'-55')	226	-230.773	295.949	78.0	Pass
T21	45 - 40	Leg	BT101341- P6.625x0.280 w/ HP7.625x0.301	235	-242.772	306.666	79.2	Pass
T22	40 - 33.3333	Leg	P6.625x.432	247	-256.755	316.102	81.2	Pass
T23	33.3333 - 26.6667	Leg	P6.625x.432	256	-273.170	316.102	86.4	Pass
T24	26.6667 - 20	Leg	P6.625x.432	265	-287.252	316.102	90.9	Pass
T25	20 - 13.3333	Leg	P6.625x.432	274	-300.414	316.102	95.0	Pass
T26	13.3333 - 6.66666	Leg	P6.625x.432	283	-312.646	343.191	91.1	Pass
T27	6.66666 - 0	Leg	BT101341- P6.625 x .432 w/ HP7.625x0.301	295	-333.913	382.811	87.2	Pass
T1	130 - 120	Diagonal	1/2	13	-1.471	1.872	78.6	Pass
T2	120 - 117.143	Diagonal	3/4	52	-2.302	7.257	31.7	Pass
T3	117.143 - 114.286	Diagonal	3/4	61	-3.097	7.257	42.7	Pass
T4	114.286 - 111.43	Diagonal	3/4	70	-2.933	7.203	40.7	Pass
T5	111.43 - 108.573	Diagonal	3/4	79	-3.729	7.203	51.8	Pass
T6	108.573 - 105.716	Diagonal	3/4	88	-4.556	7.203	63.2	Pass

Section No.	Elevation (ft)	Component Type	Size	Critical Element	P (K)	SF*P_allow (K)	% Capacity	Pass / Fail
T7	105.716 - 102.859	Diagonal	3/4	97	-4.466	7.203	62.0	Pass
T8	102.859 - 100	Diagonal	3/4	109	-4.551	7.255	62.7	Pass
T9	100 - 96	Diagonal	L1 1/2x1 1/2x3/16	121	-3.602	9.776	36.8 83.4 (b)	Pass
T10	96 - 92	Diagonal	L2x2x1/4	130	-4.160	19.502	21.3 53.0 (b)	Pass
T11	92 - 88	Diagonal	2L1 1/2x1 1/2x3/16x3/8	139	-6.080	24.551	24.8 68.9 (b)	Pass
T12	88 - 84	Diagonal	2L1 1/2x1 1/2x3/16x3/8	151	-5.550	24.298	22.8 63.8 (b)	Pass
T13	84 - 80	Diagonal	2L1 1/2x1 1/2x3/16x3/8	163	-5.147	24.039	21.4 59.1 (b)	Pass
T14	80 - 75	Diagonal	L2x2x1/4	172	-6.455	17.786	36.3 82.2 (b)	Pass
T15	75 - 70	Diagonal	2L1 1/2x1 1/2x3/16x3/8	181	-6.968	21.048	33.1 77.6 (b)	Pass
T16	70 - 65	Diagonal	2L1 1/2x1 1/2x3/16x3/8	190	-6.298	20.758	30.3 68.8 (b)	Pass
T17	65 - 60	Diagonal	2L1 1/2x1 1/2x3/16x3/8	199	-6.196	20.462	30.3 68.2 (b)	Pass
T18	60 - 55	Diagonal	2L1 1/2x1 1/2x3/16x3/8	208	-6.671	21.395	31.2 73.5 (b)	Pass
T19	55 - 50	Diagonal	2L1 1/2x1 1/2x3/16x3/8	220	-5.494	19.847	27.7 60.5 (b)	Pass
T20	50 - 45	Diagonal	2L1 1/2x1 1/2x3/16x3/8	229	-5.813	19.528	29.8 64.2 (b)	Pass
T21	45 - 40	Diagonal	L2x2x1/4	238	-5.574	15.634	35.7 71.0 (b)	Pass
T22	40 - 33.3333	Diagonal	2L1 3/4x1 3/4x3/16x3/8	250	-6.100	22.194	27.5 55.5 (b)	Pass
T23	33.3333 - 26.6667	Diagonal	2L1 3/4x1 3/4x3/16x3/8	259	-6.122	21.782	28.1 55.7 (b)	Pass
T24	26.6667 - 20	Diagonal	2L1 3/4x1 3/4x3/16x3/8	268	-5.739	21.356	26.9 52.2 (b)	Pass
T25	20 - 13.3333	Diagonal	L2x2x3/16	277	-5.680	8.155	69.6 94.1 (b)	Pass
T26	13.3333 - 6.66666	Diagonal	L2x2x3/16	286	-5.013	7.355	68.2 83.9 (b)	Pass
T27	6.66666 - 0	Diagonal	2L2x2x3/16x3/8	298	-7.264	25.562	28.4 66.1 (b)	Pass
T1	130 - 120	Horizontal	L1 1/4x1 1/4x3/16	36	-0.257	6.068	4.2	Pass
T8	102.859 - 100	Secondary Horizontal	L2x2x1/8	112	-1.252	9.513	13.2	Pass
T11	92 - 88	Secondary Horizontal	4x3/8	144	-2.841	14.141	20.1 57.3 (b)	Pass
T12	88 - 84	Secondary Horizontal	4x3/8	156	-3.370	12.213	27.6 67.9 (b)	Pass
T13	84 - 80	Secondary Horizontal	4x3/8	168	-2.913	10.644	27.4 58.1 (b)	Pass
T18	60 - 55	Secondary Horizontal	L2x2x1/8	214	-3.495	10.851	32.2 96.4 (b)	Pass
T21	45 - 40	Secondary Horizontal	L3x3x5/16	244	-4.206	43.729	9.6 76.5 (b)	Pass
T26	13.3333 - 6.66666	Secondary Horizontal	L2x2x1/4	292	-5.417	16.403	33.0 63.1 (b)	Pass
T1	130 - 120	Top Girt	L1 1/4x1 1/4x3/16	6	-0.061	6.068	1.0	Pass
T2	120 - 117.143	Top Girt	L1 1/4x1 1/4x3/16	48	-0.032	6.152	0.5	Pass

Section No.	Elevation (ft)	Component Type	Size	Critical Element	P (K)	SF*P_allow (K)	% Capacity	Pass / Fail
T1	130 - 120	Bottom Girt	L1 1/4x1 1/4x3/16	9	-0.206	6.068	3.4	Pass
T8	102.859 - 100	Bottom Girt	L1 1/4x1 1/4x3/16	105	-0.829	6.152	13.5	Pass
							Summary	
							Leg (T25)	95.0 Pass
							Diagonal (T25)	94.1 Pass
							Horizontal (T1)	4.2 Pass
							Secondary Horizontal (T18)	96.4 Pass
							Top Girt (T1)	1.0 Pass
							Bottom Girt (T8)	13.5 Pass
							Bolt Checks	96.4 Pass
							RATING =	96.4 Pass

Table 6 - Tower Component Stresses vs. Capacity

Notes	Component	Elevation (ft)	% Capacity	Pass / Fail
--	Anchor Rods	Base	78.5	Pass
1	Base Foundation	Base	71.2	Pass

Structure Rating (max from all components) =	96.4%
---	--------------

Notes:

- 1) See additional documentation in "Appendix C – Additional Calculations" for calculations supporting the % capacity consumed.
- 2) Capacities up to 105% are considered acceptable based on analysis methods used.

4.1) Recommendations

The tower and its foundation have sufficient capacity to carry the existing and proposed loads. No modifications are required at this time.

APPENDIX A
TNXTOWER OUTPUT

Section	T1	T2	T3	T4	T5	T6	T7	T8	T9	T10	T11	T12	T13	T14	T15	T16	T17	T18	T19	T20	T21	T22	T23	T24	T25	T26	T27																	
Legs	SR 1 1/2											SR 2											SR 3/4											SR 1/2										
Leg Grade	A570-45											A570-45											A570-45											A570-45										
Diagonals	P4.5 x 0.237											P4.5 x 0.237											L2x2x1/4											L2x2x1/4										
Diagonal Grade	A36											A36											A36											A36										
Top Girts	L1 1/4x1 1/4x3/16											L1 1/4x1 1/4x3/16											L1 1/4x1 1/4x3/16											L1 1/4x1 1/4x3/16										
Bottom Girts	N.A.											N.A.											N.A.											N.A.										
Horizontal	N.A.											N.A.											N.A.											N.A.										
Sec. Horizontals	N.A.											N.A.											N.A.											N.A.										
Face Width (ft)	7.5											7.16667											6.83333											6.5										
# Panels @ (ft)	M											M											M											M										
Weight (K)	11.9											1.0											0.7											0.8										

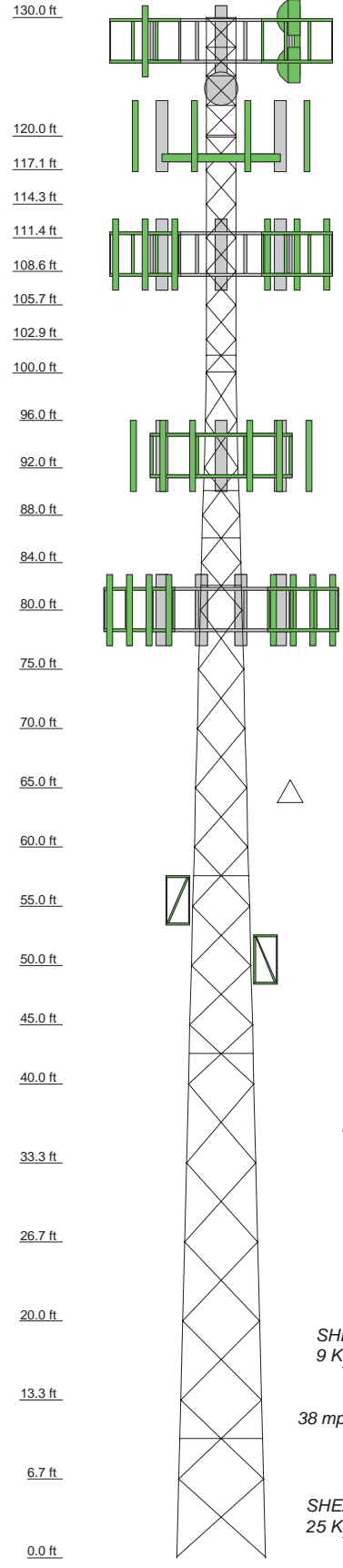

SYMBOL LIST

MARK	SIZE	MARK	SIZE
A	BT101341- P4.5 x 0.237 w/ HP5.625x0.375	H	2L2x2x3/16x3/8
B	BT101341- P6.625x0.280 w/ HP7.625x0.301(45'-55')	I	L1 1/4x1 1/4x3/16
C	BT101341- P6.625x0.280 w/ HP7.625x0.301	J	L2x2x1/8
D	BT101341- P6.625 x .432 w/ HP7.625x0.301	K	L3x3x5/16
E	L1 1/2x1 1/2x3/16	L	1 @ 2.77604
F	L2x2x1/4	M	1 @ 6.58333

MATERIAL STRENGTH

GRADE	Fy	Fu	GRADE	Fy	Fu
A570-45	45 ksi	60 ksi	A500M-54	54 ksi	70 ksi
A36	36 ksi	58 ksi			

- ### TOWER DESIGN NOTES
1. Tower is located in Hartford County, Connecticut.
 2. Tower designed for a 80 mph basic wind in accordance with the TIA/EIA-222-F Standard.
 3. Tower is also designed for a 38 mph basic wind with 1.00 in ice. Ice is considered to increase in thickness with height.
 4. Deflections are based upon a 50 mph wind.
 5. TOWER RATING: 96.4%

MAX. CORNER REACTIONS AT BASE:
 DOWN: 334 K
 SHEAR: 18 K

UPLIFT: -311 K
 SHEAR: 17 K

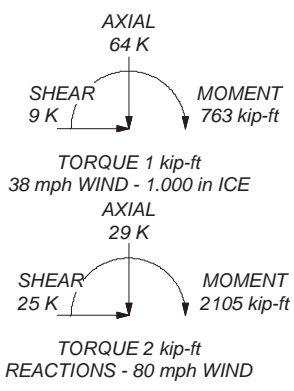

 B+T Group 1717 S Boulder Ave, Suite 300 Tulsa, OK 74119 Phone: (918) 587-4630 FAX: (918) 295-0265	Job: 101341.001.01 - Glastonbury-main st, CT (Site# CT46126-A)		
	Project:		
	Client: SBA Communications Corporation	Drawn by: zsmith	App'd:
	Code: TIA/EIA-222-F	Date: 09/25/15	Scale: NTS
	Path:	Dwg No: E-1	

S:\Projects\SBA\101341-CT46126-A_Glastonbury-main st\Engineering\Tower\101341-001-01_Glastonbury-main st-CT.dwg

Plot Plan
Total Area - 0.03 Acres

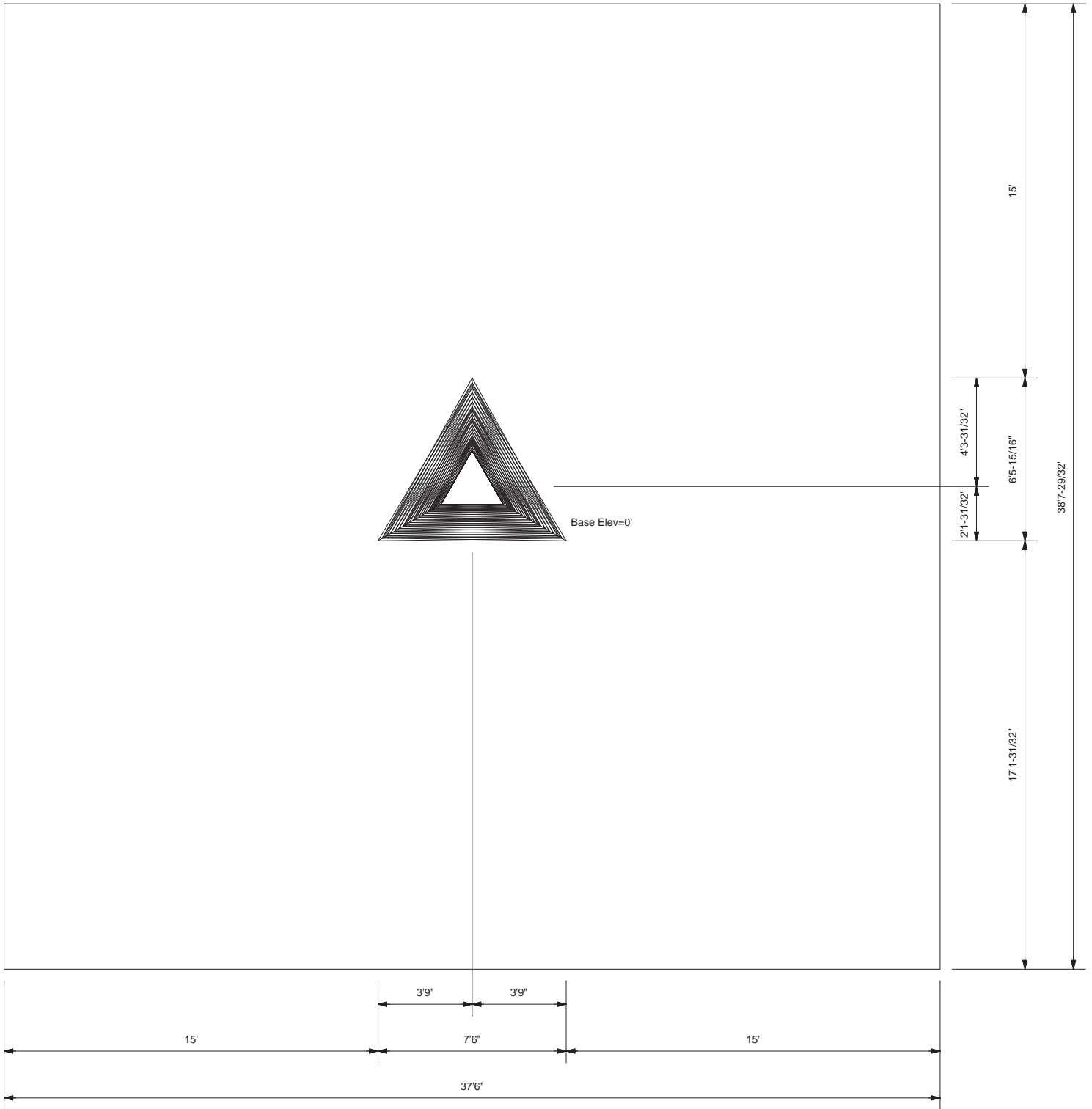



 <p>B+T Group 1717 S Boulder Ave, Suite 300 Tulsa, OK 74119 Phone: (918) 587-4630 FAX: (918) 295-0265</p>	Job: 101341.001.01 - Glastonbury-main st, CT (Site# CT46126-A)		
	Project:		
	Client: SBA Communications Corporation	Drawn by: zsmith	App'd:
	Code: TIA/EIA-222-F	Date: 09/25/15	Scale: NTS
	Path:	Dwg No: E-2	

S:\Projects\SBA\101341-CT46126-A-Glastonbury-main st\Engineering\Tower\101341-001-01-Glastonbury-main st-CT.plt

TIA/EIA-222-F - 80 mph/38 mph 1.000 in Ice

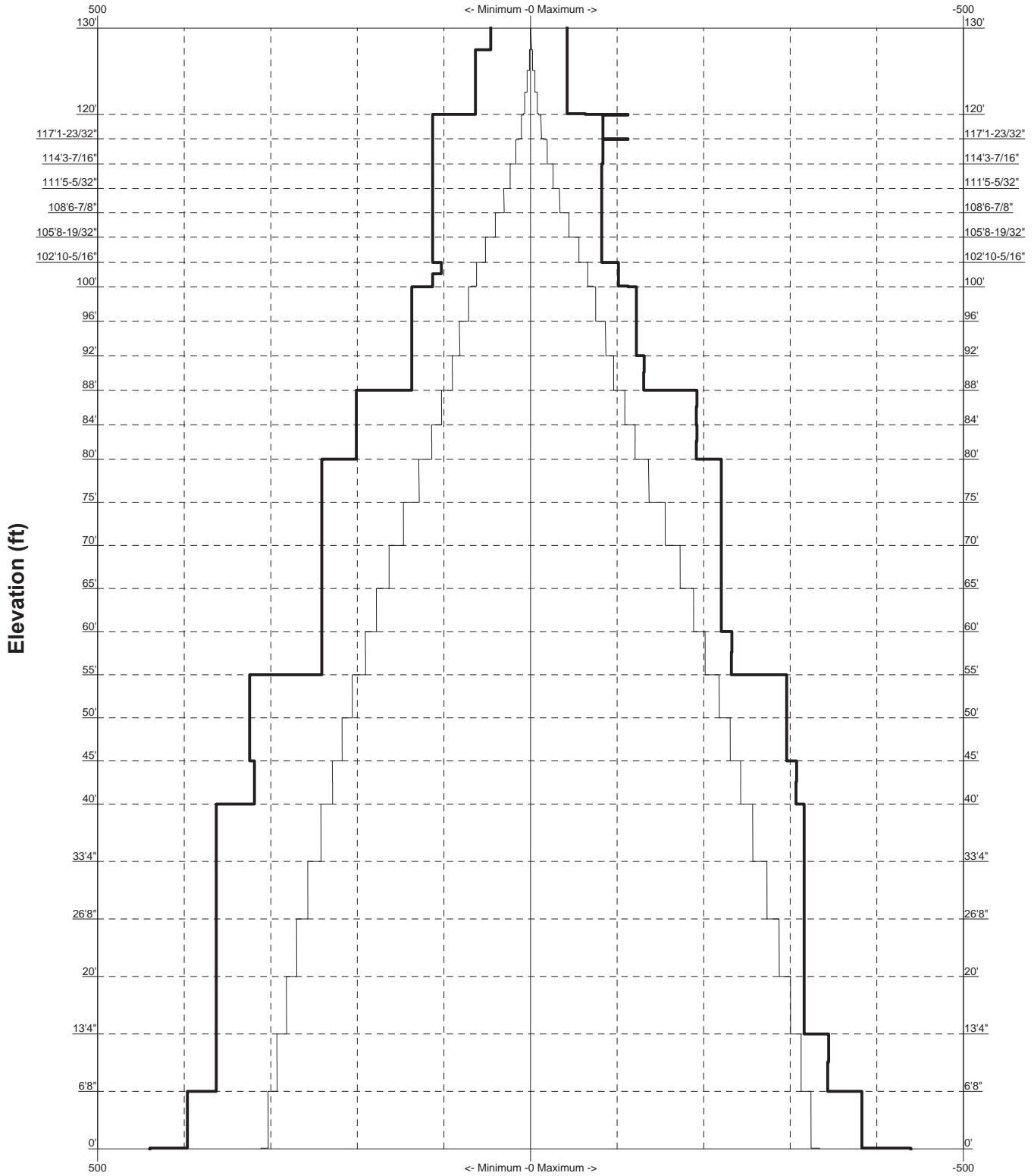
Leg Capacity ——— Leg Compression (K)



 <p>B+T Group 1717 S Boulder Ave, Suite 300 Tulsa, OK 74119 Phone: (918) 587-4630 FAX: (918) 295-0265</p>	Job: 101341.001.01 - Glastonbury-main st, CT (Site# CT46126-A)		
	Project:		
	Client: SBA Communications Corporation	Drawn by: zsmith	App'd:
	Code: TIA/EIA-222-F	Date: 09/25/15	Scale: NTS
	Path:	Dwg No: E-3	

S:\Projects\SBA\101341-CT46126-A_Glastonbury-main st\Engineering\Tower\101341_001_01_Glastonbury-main st-CT.dwg

Vx

Vz

Mx

Mz

Global Mast Shear (K)

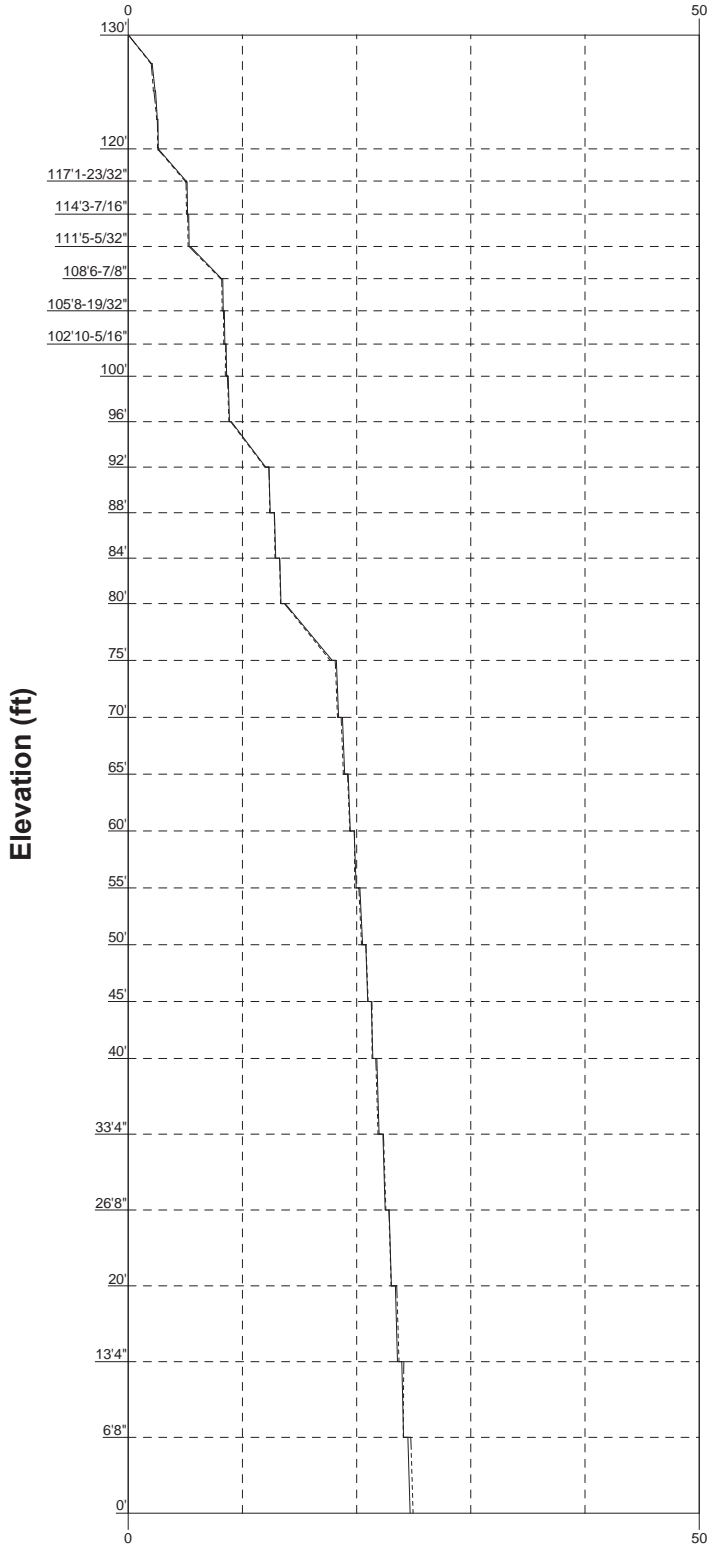

Global Mast Moment (kip-ft)

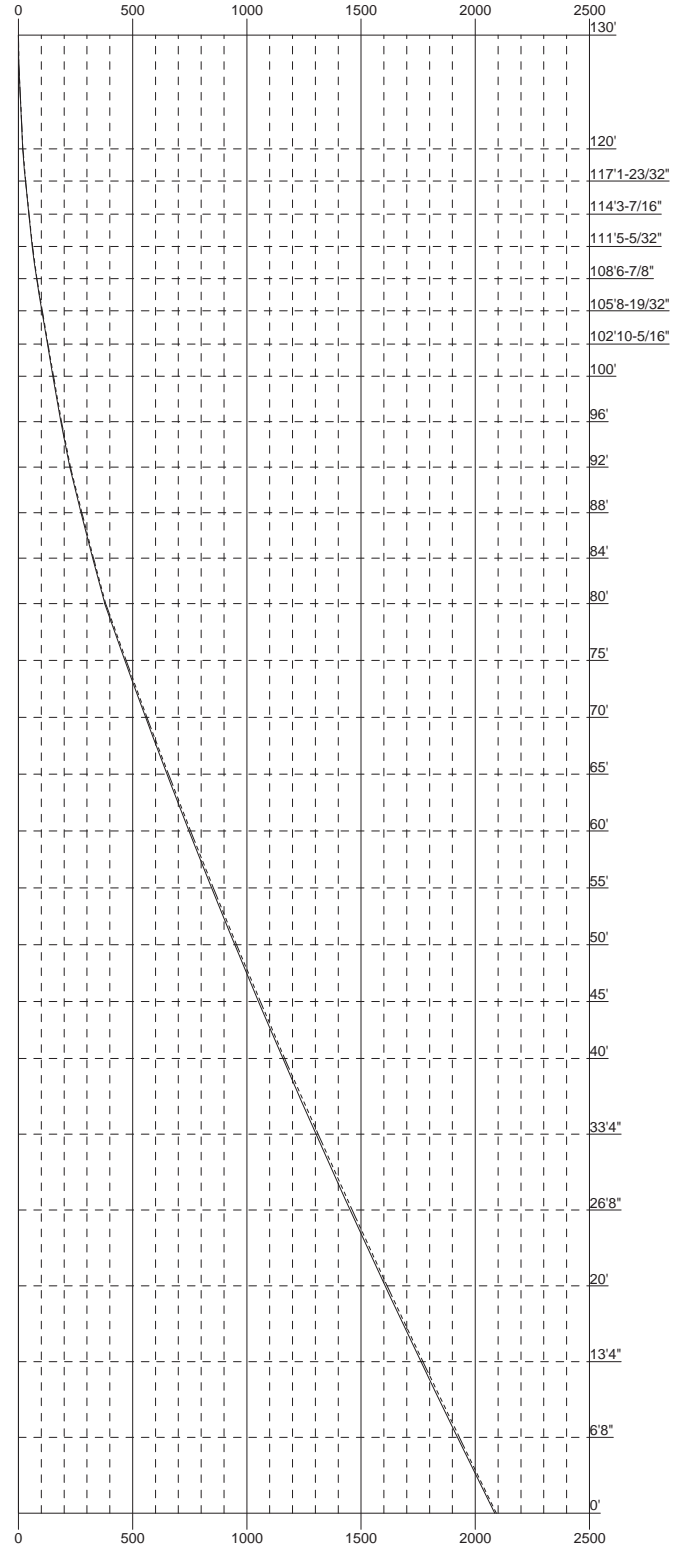

 <p>B+T Group 1717 S Boulder Ave, Suite 300 Tulsa, OK 74119 Phone: (918) 587-4630 FAX: (918) 295-0265</p>	<p>Job: 101341.001.01 - Glastonbury-main st, CT (Site# CT46126-A)</p>		
	<p>Project:</p>		
	<p>Client: SBA Communications Corporation</p>	<p>Drawn by: zsmith</p>	<p>App'd:</p>
	<p>Code: TIA/EIA-222-F</p>	<p>Date: 09/25/15</p>	<p>Scale: NTS</p>
	<p>Path:</p>	<p>Dwg No: E-4</p>	

S:\Projects\SBA\101341-CT46126-A_Glastonbury-main st\Engineering\Tower\101341-001-01_Glastonbury-main st-CT.dwg

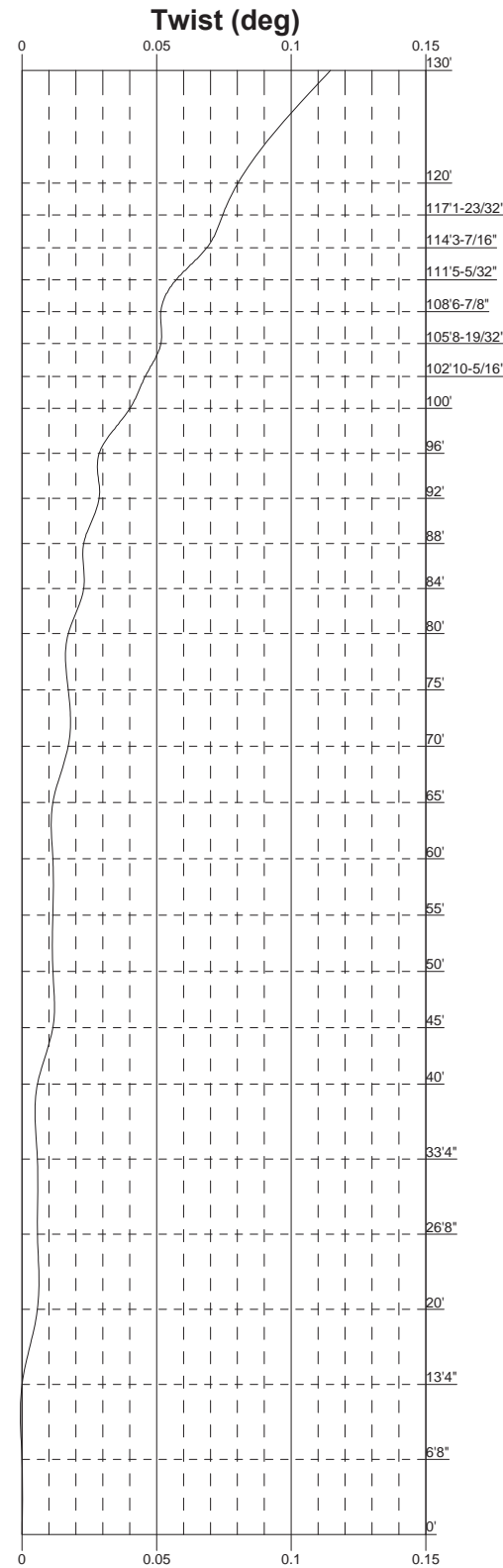
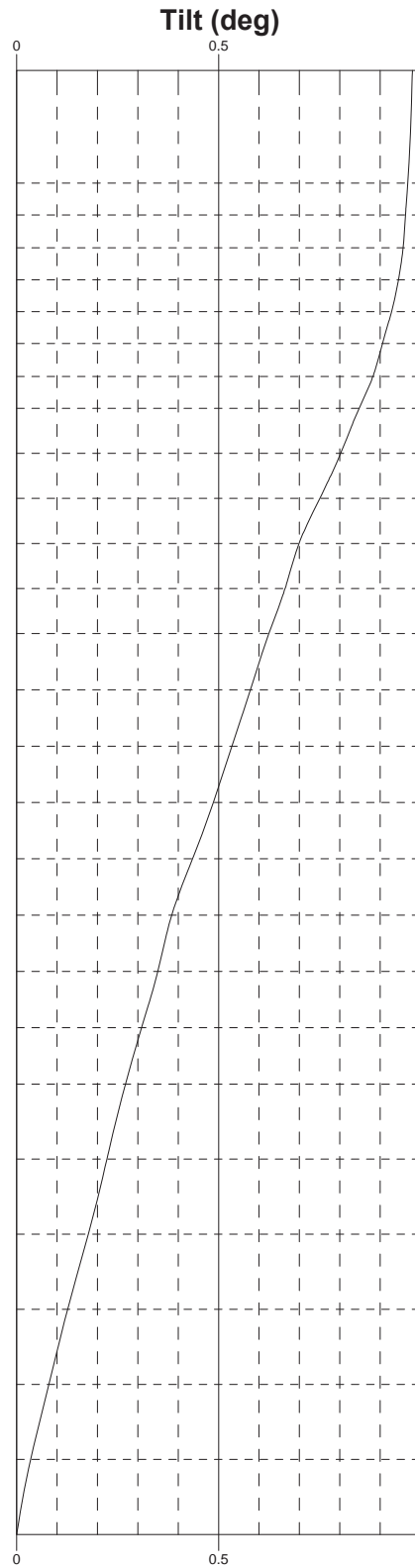
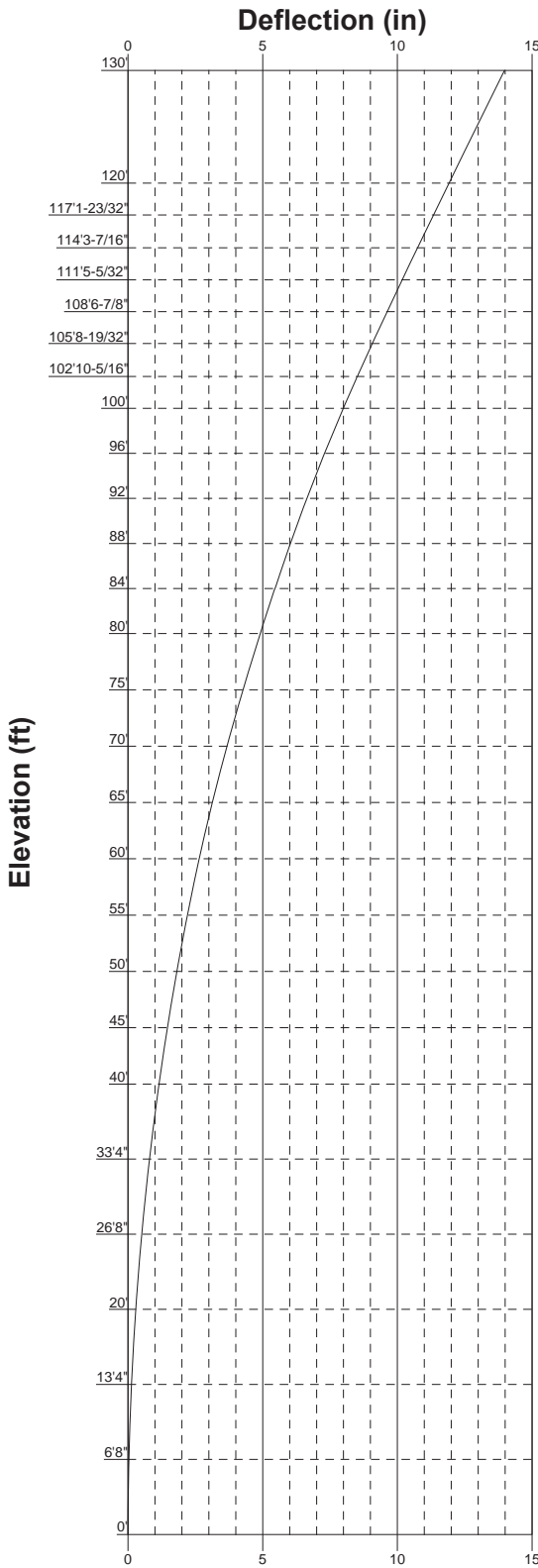

Elevation (ft)

 <p>B+T Group 1717 S Boulder Ave, Suite 300 Tulsa, OK 74119 Phone: (918) 587-4630 FAX: (918) 295-0265</p>	Job: 101341.001.01 - Glastonbury-main st, CT (Site# CT46126-A)		
	Project:		
	Client: SBA Communications Corporation	Drawn by: zsmith	App'd:
	Code: TIA/EIA-222-F	Date: 09/25/15	Scale: NTS
	Path:	Dwg No: E-5	

S:\Projects\SBA\101341-CT46126-A_Glastonbury-main st\Engineering\Tower\101341-001-01_Glastonbury-main st.ct.plt

Feed Line Distribution Chart

0' - 130'

Round
Flat
App In Face
App Out Face
Truss Leg

Elevation (ft)

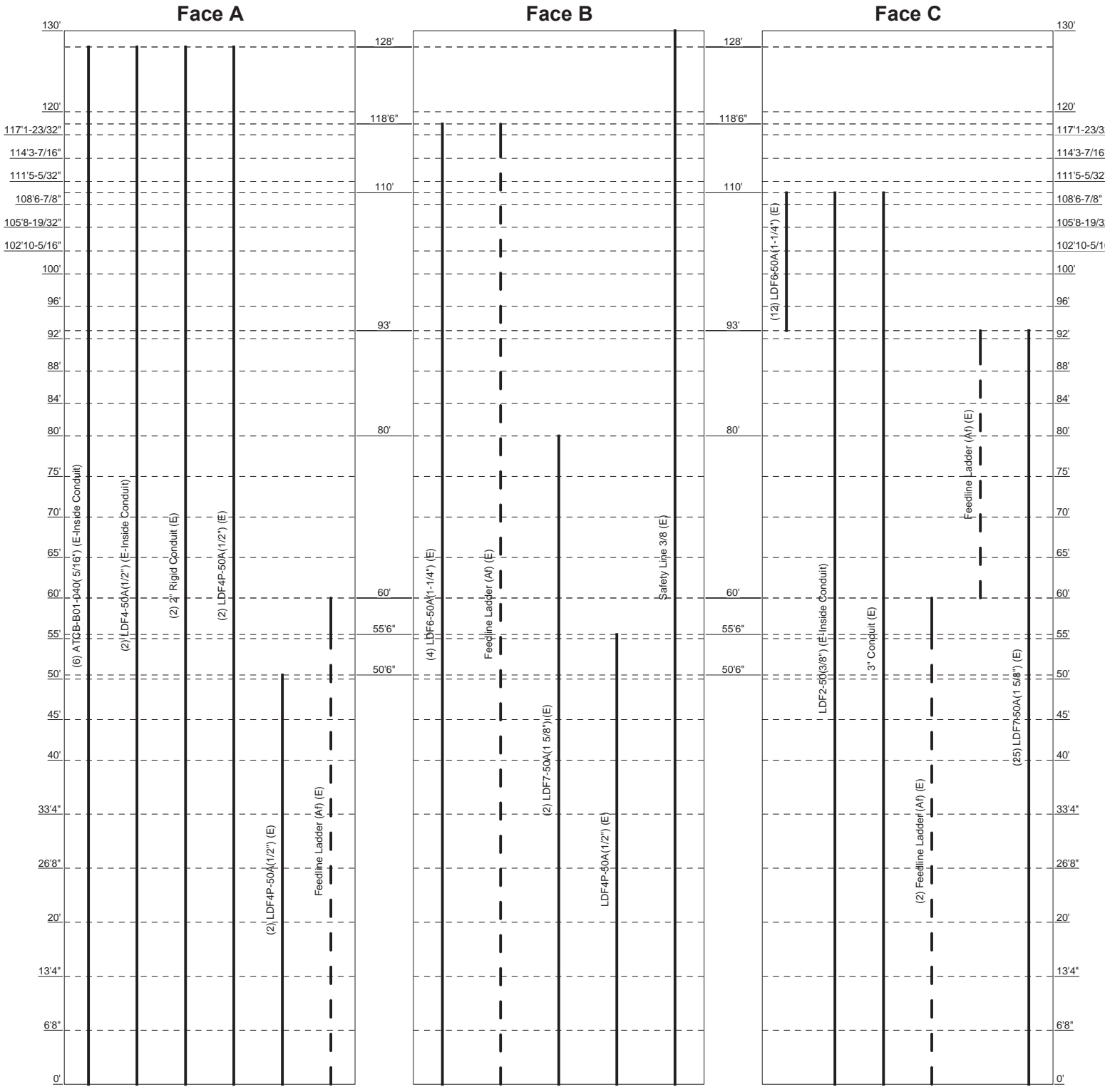

<p>B+T Group 1717 S Boulder Ave, Suite 300 Tulsa, OK 74119 Phone: (918) 587-4630 FAX: (918) 295-0265</p>	Job: 101341.001.01 - Glastonbury-main st, CT (Site# CT46126-A)		
	Project:		
	Client: SBA Communications Corporation	Drawn by: zsmith	App'd:
	Code: TIA/EIA-222-F	Date: 09/25/15	Scale: NTS
	Path:	Dwg No: E-7	

S:\Projects\SBA\101341-CT46126-A_Glastonbury-main st\Engineering\Tower\101341-001-01_Glastonbury-main st-CT.dwg

<p>tnxTower</p> <p>B+T Group 1717 S Boulder Ave, Suite 300 Tulsa, OK 74119 Phone: (918) 587-4630 FAX: (918) 295-0265</p>	Job 101341.001.01 - Glastonbury-main st, CT (Site# CT46126-A)	Page 1 of 48
	Project	Date 17:44:11 09/25/15
	Client SBA Communications Corporation	Designed by zsmith

Tower Input Data

The main tower is a 3x free standing tower with an overall height of 130' above the ground line.

The base of the tower is set at an elevation of 0' above the ground line.

The face width of the tower is 2'6" at the top and 7'6" at the base.

This tower is designed using the TIA/EIA-222-F standard.

The following design criteria apply:

Tower is located in Hartford County, Connecticut.

Basic wind speed of 80 mph.

Nominal ice thickness of 1.000 in.

Ice thickness is considered to increase with height.

Ice density of 56.000 pcf.

A wind speed of 38 mph is used in combination with ice.

Temperature drop of 50.000 °F.

Deflections calculated using a wind speed of 50 mph.

A non-linear (P-delta) analysis was used.

Pressures are calculated at each section.

Stress ratio used in tower member design is 1.333.

Local bending stresses due to climbing loads, feed line supports, and appurtenance mounts are not considered.

Options

<ul style="list-style-type: none"> Consider Moments - Legs Consider Moments - Horizontals Consider Moments - Diagonals Use Moment Magnification √ Use Code Stress Ratios √ Use Code Safety Factors - Guys √ Escalate Ice Always Use Max Kz Use Special Wind Profile √ Include Bolts In Member Capacity Leg Bolts Are At Top Of Section √ Secondary Horizontal Braces Leg Use Diamond Inner Bracing (4 Sided) Add IBC .6D+W Combination 	<ul style="list-style-type: none"> Distribute Leg Loads As Uniform Assume Legs Pinned √ Assume Rigid Index Plate √ Use Clear Spans For Wind Area √ Use Clear Spans For KL/r Retention Guys To Initial Tension √ Bypass Mast Stability Checks √ Use Azimuth Dish Coefficients √ Project Wind Area of Appurt. Autocalc Torque Arm Areas SR Members Have Cut Ends √ Sort Capacity Reports By Component Triangulate Diamond Inner Bracing Use TIA-222-G Tension Splice Capacity Exemption 	<ul style="list-style-type: none"> Treat Feedline Bundles As Cylinder Use ASCE 10 X-Brace Ly Rules √ Calculate Redundant Bracing Forces Ignore Redundant Members in FEA √ SR Leg Bolts Resist Compression All Leg Panels Have Same Allowable √ Offset Girt At Foundation √ Consider Feedline Torque √ Include Angle Block Shear Check <p style="text-align: center;">Poles</p> <ul style="list-style-type: none"> Include Shear-Torsion Interaction Always Use Sub-Critical Flow Use Top Mounted Sockets
--	--	--

Job 101341.001.01 - Glastonbury-main st, CT (Site# CT46126-A)	Page 2 of 48
Project	Date 17:44:11 09/25/15
Client SBA Communications Corporation	Designed by zsmith

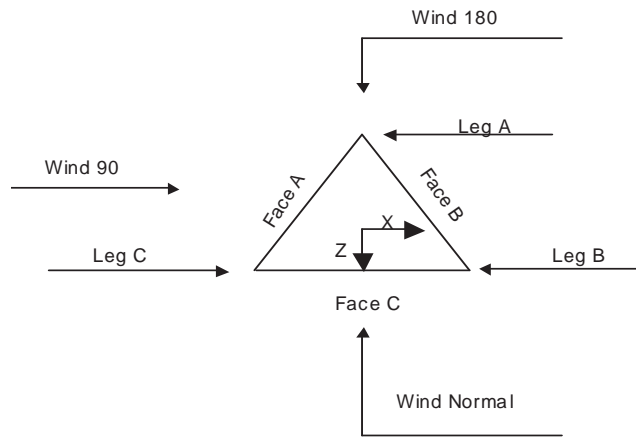

Triangular Tower

Tower Section Geometry

Tower Section	Tower Elevation	Assembly Database	Description	Section Width	Number of Sections	Section Length
	ft			ft		ft
T1	130'-120'			2'6"	1	10'
T2	120'-117'1-23/32"			2'6"	1	2'10-9/32"
T3	117'1-23/32"-114'3-7/16"			2'6"	1	2'10-9/32"
T4	114'3-7/16"-111'5-5/32"			2'6"	1	2'10-9/32"
T5	111'5-5/32"-108'6-7/8"			2'6"	1	2'10-9/32"
T6	108'6-7/8"-105'8-19/32"			2'6"	1	2'10-9/32"
T7	105'8-19/32"-102'10-5/16"			2'6"	1	2'10-9/32"
T8	102'10-5/16"-100'			2'6"	1	2'10-5/16"
T9	100'-96'			2'6"	1	4'
T10	96'-92'			2'8-13/32"	1	4'
T11	92'-88'			2'10-13/16"	1	4'
T12	88'-84'			3'1-3/16"	1	4'
T13	84'-80'			3'3-19/32"	1	4'
T14	80'-75'			3'6"	1	5'
T15	75'-70'			3'9"	1	5'
T16	70'-65'			4'	1	5'
T17	65'-60'			4'3"	1	5'
T18	60'-55'			4'6"	1	5'
T19	55'-50'			4'9"	1	5'
T20	50'-45'			5'	1	5'
T21	45'-40'			5'3"	1	5'

tnxTower B+T Group 1717 S Boulder Ave, Suite 300 Tulsa, OK 74119 Phone: (918) 587-4630 FAX: (918) 295-0265	Job 101341.001.01 - Glastonbury-main st, CT (Site# CT46126-A)	Page 3 of 48
	Project	Date 17:44:11 09/25/15
	Client SBA Communications Corporation	Designed by zsmith

Tower Section	Tower Elevation	Assembly Database	Description	Section Width	Number of Sections	Section Length
	ft			ft		ft
T22	40'-33'4"			5'6"	1	6'8"
T23	33'4"-26'8"			5'10"	1	6'8"
T24	26'8"-20'			6'2"	1	6'8"
T25	20'-13'4"			6'6"	1	6'8"
T26	13'4"-6'8"			6'10"	1	6'8"
T27	6'8"-0'			7'2"	1	6'8"

Tower Section Geometry (cont'd)

Tower Section	Tower Elevation	Diagonal Spacing	Bracing Type	Has K Brace End Panels	Has Horizontals	Top Girt Offset	Bottom Girt Offset
	ft	ft				in	in
T1	130'-120'	2'5-3/4"	X Brace	No	Yes	0.000	1.000
T2	120'-117'1-23/32"	2'9-9/32"	X Brace	No	Yes	1.000	0.000
T3	117'1-23/32"-114'3-7/16"	2'9-9/32"	X Brace	No	Yes	1.000	0.000
T4	114'3-7/16"-111'5-5/32"	2'10-9/32"	X Brace	No	Yes	0.000	0.000
T5	111'5-5/32"-108'6-7/8"	2'10-9/32"	X Brace	No	Yes	0.000	0.000
T6	108'6-7/8"-105'8-19/32"	2'10-9/32"	X Brace	No	Yes	0.000	0.000
T7	105'8-19/32"-102'10-5/16"	2'10-9/32"	X Brace	No	Yes	0.000	0.000
T8	102'10-5/16"-100'	2'9-5/16"	X Brace	No	Yes	0.000	1.000
T9	100'-96'	4'	X Brace	No	Yes	0.000	0.000
T10	96'-92'	4'	X Brace	No	Yes	0.000	0.000
T11	92'-88'	4'	X Brace	No	Yes	0.000	0.000
T12	88'-84'	4'	X Brace	No	Yes	0.000	0.000
T13	84'-80'	4'	X Brace	No	Yes	0.000	0.000
T14	80'-75'	5'	X Brace	No	Yes	0.000	0.000
T15	75'-70'	5'	X Brace	No	Yes	0.000	0.000
T16	70'-65'	5'	X Brace	No	Yes	0.000	0.000
T17	65'-60'	5'	X Brace	No	Yes	0.000	0.000
T18	60'-55'	5'	X Brace	No	Yes	0.000	0.000
T19	55'-50'	5'	X Brace	No	Yes	0.000	0.000
T20	50'-45'	5'	X Brace	No	Yes	0.000	0.000
T21	45'-40'	5'	X Brace	No	Yes	0.000	0.000
T22	40'-33'4"	6'8"	X Brace	No	Yes	0.000	0.000
T23	33'4"-26'8"	6'8"	X Brace	No	Yes	0.000	0.000
T24	26'8"-20'	6'8"	X Brace	No	Yes	0.000	0.000
T25	20'-13'4"	6'8"	X Brace	No	Yes	0.000	0.000
T26	13'4"-6'8"	6'8"	X Brace	No	Yes	0.000	0.000
T27	6'8"-0'	6'7"	X Brace	No	Yes	0.000	1.000

Tower Section Geometry (cont'd)

Tower Elevation	Leg Type	Leg Size	Leg Grade	Diagonal Type	Diagonal Size	Diagonal Grade
ft						
T1 130'-120'	Solid Round	1 1/2	A570-45	Solid Round	1/2	A36

tnxTower

B+T Group
1717 S Boulder Ave, Suite 300
Tulsa, OK 74119
Phone: (918) 587-4630
FAX: (918) 295-0265

Job
101341.001.01 - Glastonbury-main st, CT (Site# CT46126-A)

Page
4 of 48

Project
Date
17:44:11 09/25/15

Client
SBA Communications Corporation
Designed by
zsmith

Tower Elevation ft	Leg Type	Leg Size	Leg Grade	Diagonal Type	Diagonal Size	Diagonal Grade
T2 120'-117'-23/32"	Solid Round	2	(45 ksi) A570-45	Solid Round	3/4	(36 ksi) A36
T3 117'-23/32"-114' 3-7/16"	Solid Round	2	(45 ksi) A570-45	Solid Round	3/4	(36 ksi) A36
T4 114'-3-7/16"-111' -5/32"	Solid Round	2	(45 ksi) A570-45	Solid Round	3/4	(36 ksi) A36
T5 111'-5-5/32"-108' -7/8"	Solid Round	2	(45 ksi) A570-45	Solid Round	3/4	(36 ksi) A36
T6 108'-6-7/8"-105' 8-19/32"	Solid Round	2	(45 ksi) A570-45	Solid Round	3/4	(36 ksi) A36
T7 105'-8-19/32"-102' 10-5/16"	Solid Round	2	(45 ksi) A570-45	Solid Round	3/4	(36 ksi) A36
T8 102'-10-5/16"-100'	Solid Round	2	(45 ksi) A570-45	Solid Round	3/4	(36 ksi) A36
T9 100'-96'	Pipe	P4.5 x 0.237	A500M-54 (54 ksi)	Equal Angle	L1 1/2x1 1/2x3/16	(36 ksi) A36
T10 96'-92'	Pipe	P4.5 x 0.237	A500M-54 (54 ksi)	Equal Angle	L2x2x1/4	(36 ksi) A36
T11 92'-88'	Pipe	P4.5 x 0.237	A500M-54 (54 ksi)	Double Equal Angle	2L1 1/2x1 1/2x3/16x3/8	(36 ksi) A36
T12 88'-84'	Pipe	BT101341- P4.5 x 0.237 w/ HP5.625x0.375	A500M-54 (54 ksi)	Double Equal Angle	2L1 1/2x1 1/2x3/16x3/8	(36 ksi) A36
T13 84'-80'	Pipe	BT101341- P4.5 x 0.237 w/ HP5.625x0.375	A500M-54 (54 ksi)	Double Equal Angle	2L1 1/2x1 1/2x3/16x3/8	(36 ksi) A36
T14 80'-75'	Pipe	P6.625x0.280	A500M-54 (54 ksi)	Equal Angle	L2x2x1/4	(36 ksi) A36
T15 75'-70'	Pipe	P6.625x0.280	A500M-54 (54 ksi)	Double Equal Angle	2L1 1/2x1 1/2x3/16x3/8	(36 ksi) A36
T16 70'-65'	Pipe	P6.625x0.280	A500M-54 (54 ksi)	Double Equal Angle	2L1 1/2x1 1/2x3/16x3/8	(36 ksi) A36
T17 65'-60'	Pipe	P6.625x0.280	A500M-54 (54 ksi)	Double Equal Angle	2L1 1/2x1 1/2x3/16x3/8	(36 ksi) A36
T18 60'-55'	Pipe	P6.625x0.280	A500M-54 (54 ksi)	Double Equal Angle	2L1 1/2x1 1/2x3/16x3/8	(36 ksi) A36
T19 55'-50'	Pipe	BT101341- P6.625x0.280 w/ HP7.625x0.301(45'-55')	A500M-54 (54 ksi)	Double Equal Angle	2L1 1/2x1 1/2x3/16x3/8	(36 ksi) A36
T20 50'-45'	Pipe	BT101341- P6.625x0.280 w/ HP7.625x0.301(45'-55')	A500M-54 (54 ksi)	Double Equal Angle	2L1 1/2x1 1/2x3/16x3/8	(36 ksi) A36
T21 45'-40'	Pipe	BT101341- P6.625x0.280 w/ HP7.625x0.301	A500M-54 (54 ksi)	Equal Angle	L2x2x1/4	(36 ksi) A36
T22 40'-33'4"	Pipe	P6.625x.432	A500M-54 (54 ksi)	Double Equal Angle	2L1 3/4x1 3/4x3/16x3/8	(36 ksi) A36
T23 33'4"-26'8"	Pipe	P6.625x.432	A500M-54 (54 ksi)	Double Equal Angle	2L1 3/4x1 3/4x3/16x3/8	(36 ksi) A36
T24 26'8"-20'	Pipe	P6.625x.432	A500M-54 (54 ksi)	Double Equal Angle	2L1 3/4x1 3/4x3/16x3/8	(36 ksi) A36
T25 20'-13'4"	Pipe	P6.625x.432	A500M-54 (54 ksi)	Equal Angle	L2x2x3/16	(36 ksi) A36
T26 13'4"-6'8"	Pipe	P6.625x.432	A500M-54 (54 ksi)	Equal Angle	L2x2x3/16	(36 ksi) A36
T27 6'8"-0'	Pipe	BT101341- P6.625 x .432 w/ HP7.625x0.301	A500M-54 (54 ksi)	Double Equal Angle	2L2x2x3/16x3/8	(36 ksi) A36

tnxTower B+T Group 1717 S Boulder Ave, Suite 300 Tulsa, OK 74119 Phone: (918) 587-4630 FAX: (918) 295-0265	Job 101341.001.01 - Glastonbury-main st, CT (Site# CT46126-A)	Page 5 of 48
	Project	Date 17:44:11 09/25/15
	Client SBA Communications Corporation	Designed by zsmith

Tower Section Geometry (cont'd)

Tower Elevation ft	Top Girt Type	Top Girt Size	Top Girt Grade	Bottom Girt Type	Bottom Girt Size	Bottom Girt Grade
T1 130'-120'	Equal Angle	L1 1/4x1 1/4x3/16	A36 (36 ksi)	Equal Angle	L1 1/4x1 1/4x3/16	A36 (36 ksi)
T2 120'-117'-23/32"	Equal Angle	L1 1/4x1 1/4x3/16	A36 (36 ksi)	Equal Angle		A36 (36 ksi)
T8 102'10'-5/16"-100'	Solid Round		A36 (36 ksi)	Equal Angle	L1 1/4x1 1/4x3/16	A36 (36 ksi)

Tower Section Geometry (cont'd)

Tower Elevation ft	No. of Mid Girts	Mid Girt Type	Mid Girt Size	Mid Girt Grade	Horizontal Type	Horizontal Size	Horizontal Grade
T1 130'-120'	None	Flat Bar		A36 (36 ksi)	Equal Angle	L1 1/4x1 1/4x3/16	A36 (36 ksi)

Tower Section Geometry (cont'd)

Tower Elevation ft	Secondary Horizontal Type	Secondary Horizontal Size	Secondary Horizontal Grade	Inner Bracing Type	Inner Bracing Size	Inner Bracing Grade
T8 102'10'-5/16"-100'	Equal Angle	L2x2x1/8	A36 (36 ksi)	Solid Round		A572-50 (50 ksi)
T11 92'-88'	Flat Bar	4x3/8	A36 (36 ksi)	Solid Round		A572-50 (50 ksi)
T12 88'-84'	Flat Bar	4x3/8	A36 (36 ksi)	Solid Round		A572-50 (50 ksi)
T13 84'-80'	Flat Bar	4x3/8	A36 (36 ksi)	Solid Round		A572-50 (50 ksi)
T18 60'-55'	Equal Angle	L2x2x1/8	A36 (36 ksi)	Solid Round		A572-50 (50 ksi)
T21 45'-40'	Equal Angle	L3x3x5/16	A36 (36 ksi)	Solid Round		A572-50 (50 ksi)
T26 13'4"-6'8"	Equal Angle	L2x2x1/4	A36 (36 ksi)	Solid Round		A572-50 (50 ksi)

Tower Section Geometry (cont'd)

tnxTower

B+T Group
1717 S Boulder Ave, Suite 300
Tulsa, OK 74119
Phone: (918) 587-4630
FAX: (918) 295-0265

Job
101341.001.01 - Glastonbury-main st, CT (Site# CT46126-A)

Page
6 of 48

Project
Date
17:44:11 09/25/15

Client
SBA Communications Corporation
Designed by
zsmith

Tower Elevation	Gusset Area (per face)	Gusset Thickness	Gusset Grade	Adjust. Factor A_f	Adjust. Factor A_r	Weight Mult.	Double Angle Stitch Bolt Spacing Diagonals in	Double Angle Stitch Bolt Spacing Horizontals in
ft	ft ²	in						
T1 130'-120'	0.000	0.000	A36 (36 ksi)	1	1	1.05	Mid-Pt	Mid-Pt
T2 120'-117'-23/32"	0.000	0.000	A36 (36 ksi)	1	1	1.05	Mid-Pt	Mid-Pt
T3 117'-23/32"-14'3-7/16"	0.000	0.000	A36 (36 ksi)	1	1	1.05	Mid-Pt	Mid-Pt
T4 114'3-7/16"-11'5-5/32"	0.000	0.000	A36 (36 ksi)	1	1	1.05	Mid-Pt	Mid-Pt
T5 111'5-5/32"-10'8'-7/8"	0.000	0.000	A36 (36 ksi)	1	1	1.05	Mid-Pt	Mid-Pt
T6 108'6-7/8"-105'8-19/32"	0.000	0.000	A36 (36 ksi)	1	1	1.05	Mid-Pt	Mid-Pt
T7 105'8-19/32"-102'10-5/16"	0.000	0.000	A36 (36 ksi)	1	1	1.05	Mid-Pt	Mid-Pt
T8 102'10-5/16"-100'	0.000	0.000	A36 (36 ksi)	1.05	1	1.05	Mid-Pt	Mid-Pt
T9 100'-96'	0.000	0.000	A36 (36 ksi)	1.05	1	1.05	Mid-Pt	Mid-Pt
T10 96'-92'	0.000	0.000	A36 (36 ksi)	1.05	1	1.05	Mid-Pt	Mid-Pt
T11 92'-88'	0.000	0.000	A36 (36 ksi)	1.05	1	1.05	Mid-Pt	Mid-Pt
T12 88'-84'	0.000	0.000	A36 (36 ksi)	1.05	1	1.05	Mid-Pt	Mid-Pt
T13 84'-80'	0.000	0.000	A36 (36 ksi)	1.05	1	1.05	Mid-Pt	Mid-Pt
T14 80'-75'	0.000	0.000	A36 (36 ksi)	1.05	1	1.05	Mid-Pt	Mid-Pt
T15 75'-70'	0.000	0.000	A36 (36 ksi)	1.05	1	1.05	Mid-Pt	Mid-Pt
T16 70'-65'	0.000	0.000	A36 (36 ksi)	1.05	1	1.05	Mid-Pt	Mid-Pt
T17 65'-60'	0.000	0.000	A36 (36 ksi)	1.05	1	1.05	Mid-Pt	Mid-Pt
T18 60'-55'	0.000	0.000	A36 (36 ksi)	1.05	1	1.05	Mid-Pt	Mid-Pt
T19 55'-50'	0.000	0.000	A36 (36 ksi)	1.05	1	1.05	Mid-Pt	Mid-Pt
T20 50'-45'	0.000	0.000	A36 (36 ksi)	1.05	1	1.05	Mid-Pt	Mid-Pt
T21 45'-40'	0.000	0.000	A36 (36 ksi)	1.05	1	1.05	Mid-Pt	Mid-Pt
T22 40'-33'4"	0.000	0.000	A36 (36 ksi)	1.05	1	1.05	Mid-Pt	Mid-Pt
T23 33'4"-26'8"	0.000	0.000	A36 (36 ksi)	1.05	1	1.05	Mid-Pt	Mid-Pt
T24 26'8"-20'	0.000	0.000	A36 (36 ksi)	1.05	1	1.05	Mid-Pt	Mid-Pt
T25 20'-13'4"	0.000	0.000	A36 (36 ksi)	1.05	1	1.05	Mid-Pt	Mid-Pt
T26 13'4"-6'8"	0.000	0.000	A36 (36 ksi)	1.05	1	1.05	Mid-Pt	Mid-Pt

Tower Elevation	Gusset Area (per face)	Gusset Thickness	Gusset Grade	Adjust. Factor A_f	Adjust. Factor A_r	Weight Mult.	Double Angle Stitch Bolt Spacing Diagonals in	Double Angle Stitch Bolt Spacing Horizontals in
ft	ft ²	in						
T27 6'8"-0'	0.000	0.000	A36 (36 ksi)	1.05	1	1.05	Mid-Pt	Mid-Pt

Tower Section Geometry (cont'd)

Tower Elevation	Calc K Single Angles	Calc K Solid Rounds	Legs	K Factors ¹							
				X Brace Diags	K Brace Diags	Single Diags	Girts	Horiz.	Sec. Horiz.	Inner Brace	
											X
ft				Y	Y	Y	Y	Y	Y	Y	Y
T1 130'-120'	Yes	Yes	1	1	1	1	1	1	1	1	1
T2 120'-117'-23/32"	Yes	Yes	1	1	1	1	1	1	1	1	1
T3 117'-23/32"-114'-3-7/16"	Yes	Yes	1	1	1	1	1	1	1	1	1
T4 114'-3-7/16"-111'-5-5/32"	Yes	Yes	1	1	1	1	1	1	1	1	1
T5 111'-5-5/32"-108'-6-7/8"	Yes	Yes	1	1	1	1	1	1	1	1	1
T6 108'-6-7/8"-105'-8-19/32"	Yes	Yes	1	1	1	1	1	1	1	1	1
T7 105'-8-19/32"-102'-10-5/16"	Yes	Yes	1	1	1	1	1	1	1	1	1
T8 102'-10-5/16"-100'	Yes	No	1	1	1	1	1	1	1	1	1
T9 100'-96'	Yes	No	1	1	1	1	1	1	1	1	1
T10 96'-92'	Yes	No	1	1	1	1	1	1	1	1	1
T11 92'-88'	No	No	1	1	1	1	1	1	0.5	1	1
T12 88'-84'	No	No	1	1	1	1	1	1	0.5	1	1
T13 84'-80'	No	No	1	1	1	1	1	1	0.5	1	1
T14 80'-75'	Yes	No	1	1	1	1	1	1	1	1	1
T15 75'-70'	Yes	No	1	1	1	1	1	1	1	1	1
T16 70'-65'	Yes	No	1	1	1	1	1	1	1	1	1
T17 65'-60'	Yes	No	1	1	1	1	1	1	1	1	1
T18 60'-55'	No	No	1	1	1	1	1	1	0.5	1	1
T19 55'-50'	Yes	No	1	1	1	1	1	1	0.5	1	1

Tower Elevation ft	Leg		Diagonal		Top Girt		Bottom Girt		Mid Girt		Long Horizontal		Short Horizontal	
	Net Width Deduct in	U	Net Width Deduct in	U	Net Width Deduct in	U	Net Width Deduct in	U	Net Width Deduct in	U	Net Width Deduct in	U	Net Width Deduct in	U
T12 88'-84'	0.000	1	0.000	0.75	0.000	0.75	0.000	0.75	0.000	0.75	0.000	0.75	0.000	0.75
T13 84'-80'	0.000	1	0.000	0.75	0.000	0.75	0.000	0.75	0.000	0.75	0.000	0.75	0.000	0.75
T14 80'-75'	0.000	1	0.000	0.75	0.000	0.75	0.000	0.75	0.000	0.75	0.000	0.75	0.000	0.75
T15 75'-70'	0.000	1	0.000	0.75	0.000	0.75	0.000	0.75	0.000	0.75	0.000	0.75	0.000	0.75
T16 70'-65'	0.000	1	0.000	0.75	0.000	0.75	0.000	0.75	0.000	0.75	0.000	0.75	0.000	0.75
T17 65'-60'	0.000	1	0.000	0.75	0.000	0.75	0.000	0.75	0.000	0.75	0.000	0.75	0.000	0.75
T18 60'-55'	0.000	1	0.000	0.75	0.000	0.75	0.000	0.75	0.000	0.75	0.000	0.75	0.000	0.75
T19 55'-50'	0.000	1	0.000	0.75	0.000	0.75	0.000	0.75	0.000	0.75	0.000	0.75	0.000	0.75
T20 50'-45'	0.000	1	0.000	0.75	0.000	0.75	0.000	0.75	0.000	0.75	0.000	0.75	0.000	0.75
T21 45'-40'	0.000	1	0.000	0.75	0.000	0.75	0.000	0.75	0.000	0.75	0.000	0.75	0.000	0.75
T22 40'-33'4"	0.000	1	0.000	0.75	0.000	0.75	0.000	0.75	0.000	0.75	0.000	0.75	0.000	0.75
T23 33'4"-26'8"	0.000	1	0.000	0.75	0.000	0.75	0.000	0.75	0.000	0.75	0.000	0.75	0.000	0.75
T24 26'8"-20'	0.000	1	0.000	0.75	0.000	0.75	0.000	0.75	0.000	0.75	0.000	0.75	0.000	0.75
T25 20'-13'4"	0.000	1	0.000	0.75	0.000	0.75	0.000	0.75	0.000	0.75	0.000	0.75	0.000	0.75
T26 13'4"-6'8"	0.000	1	0.000	0.75	0.000	0.75	0.000	0.75	0.000	0.75	0.000	0.75	0.000	0.75
T27 6'8"-0'	0.000	1	0.000	0.75	0.000	0.75	0.000	0.75	0.000	0.75	0.000	0.75	0.000	0.75

Tower Section Geometry (cont'd)

Tower Elevation ft	Leg Connection Type	Leg		Diagonal		Top Girt		Bottom Girt		Mid Girt		Long Horizontal		Short Horizontal	
		Bolt Size in	No.	Bolt Size in	No.	Bolt Size in	No.	Bolt Size in	No.	Bolt Size in	No.	Bolt Size in	No.	Bolt Size in	No.
T1 130'-120'	Flange	1.000	1	0.500	0	0.625	0	0.625	0	0.625	0	0.625	0	0.500	0
		A325N		A325N		A325N		A325N		A325N		A325N		A325N	
T2 120'-117'1"-23/32"	Flange	0.750	0	0.500	0	0.625	0	0.000	0	0.625	0	0.625	0	0.500	0
		A325N		A325N		A325N		A325N		A325N		A325N		A325N	
T3 117'1"-23/32"-14'3"-7/16"	Flange	0.750	0	0.500	0	0.625	0	0.000	0	0.625	0	0.625	0	0.500	0
		A325N		A325N		A325N		A325N		A325N		A325N		A325N	
T4 114'3"-7/16"-11'5"-5/32"	Flange	0.750	0	0.500	0	0.625	0	0.000	0	0.625	0	0.625	0	0.500	0
		A325N		A325N		A325N		A325N		A325N		A325N		A325N	
T5 111'5"-5/32"-10'8"-7/8"	Flange	0.750	0	0.500	0	0.625	0	0.000	0	0.625	0	0.625	0	0.500	0
		A325N		A325N		A325N		A325N		A325N		A325N		A325N	
T6 108'6"-7/8"-105'8"-19/32"	Flange	0.750	0	0.500	0	0.625	0	0.000	0	0.625	0	0.625	0	0.500	0
		A325N		A325N		A325N		A325N		A325N		A325N		A325N	
T7 105'8"-19/32"-102'10"-5/16"	Flange	0.750	0	0.500	0	0.625	0	0.000	0	0.625	0	0.625	0	0.500	0
		A325N		A325N		A325N		A325N		A325N		A325N		A325N	
T8 102'10"-5/16"-100'	Flange	0.750	4	0.500	0	0.625	0	0.625	0	0.625	0	0.625	0	0.500	0
		A325N		A325N		A325N		A325N		A325N		A325N		A325N	
T9 100'-96'	Flange	1.000	0	0.500	1	0.625	0	0.000	0	0.625	0	0.625	0	0.500	0
		A325N		A325N		A325N		A325N		A325N		A325N		A325N	
T10 96'-92'	Flange	1.000	0	0.500	1	0.625	0	0.000	0	0.625	0	0.625	0	0.500	0
		A325N		A325X		A325N		A325N		A325N		A325N		A325N	

<p>tnxTower</p> <p>B+T Group 1717 S Boulder Ave, Suite 300 Tulsa, OK 74119 Phone: (918) 587-4630 FAX: (918) 295-0265</p>	<p>Job 101341.001.01 - Glastonbury-main st, CT (Site# CT46126-A)</p>	<p>Page 10 of 48</p>
	<p>Project</p>	<p>Date 17:44:11 09/25/15</p>
	<p>Client SBA Communications Corporation</p>	<p>Designed by zsmith</p>

Tower Elevation ft	Leg Connection Type	Leg		Diagonal		Top Girt		Bottom Girt		Mid Girt		Long Horizontal		Short Horizontal	
		Bolt Size in	No.	Bolt Size in	No.	Bolt Size in	No.	Bolt Size in	No.	Bolt Size in	No.	Bolt Size in	No.	Bolt Size in	No.
T11 92'-88'	Flange	1.000	0	0.500	1	0.625	0	0.000	0	0.625	0	0.625	0	0.500	1
		A325N		A325N		A325N		A325N		A325N		A325N		A325N	
T12 88'-84'	Flange	1.000	0	0.500	1	0.625	0	0.000	0	0.625	0	0.625	0	0.500	1
		A325N		A325N		A325N		A325N		A325N		A325N		A325N	
T13 84'-80'	Flange	1.000	8	0.500	1	0.625	0	0.625	0	0.625	0	0.625	0	0.500	1
		A325N		A325N		A325N		A325N		A325N		A325N		A325N	
T14 80'-75'	Flange	1.000	0	0.500	1	0.625	0	0.000	0	0.625	0	0.625	0	0.500	0
		A325N		A325X		A325N		A325N		A325N		A325N		A325N	
T15 75'-70'	Flange	1.000	0	0.500	1	0.625	0	0.000	0	0.625	0	0.625	0	0.500	0
		A325N		A325N		A325N		A325N		A325N		A325N		A325N	
T16 70'-65'	Flange	1.000	0	0.500	1	0.625	0	0.000	0	0.625	0	0.625	0	0.500	0
		A325N		A325N		A325N		A325N		A325N		A325N		A325N	
T17 65'-60'	Flange	1.000	8	0.500	1	0.625	0	0.625	0	0.625	0	0.625	0	0.500	0
		A325N		A325N		A325N		A325N		A325N		A325N		A325N	
T18 60'-55'	Flange	1.000	0	0.500	1	0.625	0	0.000	0	0.625	0	0.625	0	0.500	1
		A325N		A325N		A325N		A325N		A325N		A325N		A325N	
T19 55'-50'	Flange	1.000	0	0.500	1	0.625	0	0.000	0	0.625	0	0.625	0	0.500	0
		A325N		A325N		A325N		A325N		A325N		A325N		A325N	
T20 50'-45'	Flange	1.000	0	0.500	1	0.625	0	0.000	0	0.625	0	0.625	0	0.500	0
		A325N		A325N		A325N		A325N		A325N		A325N		A325N	
T21 45'-40'	Flange	1.000	8	0.500	1	0.625	0	0.625	0	0.625	0	0.625	0	0.500	1
		A325N		A325X		A325N		A325N		A325N		A325N		A325N	
T22 40'-33'4"	Flange	1.000	0	0.500	1	0.625	0	0.000	0	0.625	0	0.625	0	0.500	0
		A325N		A325N		A325N		A325N		A325N		A325N		A325N	
T23 33'4"-26'8"	Flange	1.000	0	0.500	1	0.625	0	0.000	0	0.625	0	0.625	0	0.500	0
		A325N		A325N		A325N		A325N		A325N		A325N		A325N	
T24 26'8"-20'	Flange	1.000	8	0.500	1	0.625	0	0.625	0	0.625	0	0.625	0	0.500	0
		A325N		A325N		A325N		A325N		A325N		A325N		A325N	
T25 20'-13'4"	Flange	1.500	0	0.500	1	0.625	0	0.000	0	0.625	0	0.625	0	0.500	0
		A36M-55		A325X		A325N		A325N		A325N		A325N		A325N	
T26 13'4"-6'8"	Flange	1.500	0	0.500	1	0.625	0	0.000	0	0.625	0	0.625	0	0.625	1
		A36M-55		A325X		A325N		A325N		A325N		A325N		A325N	
T27 6'8"-0'	Flange	1.500	6	0.500	1	0.625	0	0.625	0	0.625	0	0.625	0	0.500	0
		A36M-55		A325N		A325N		A325N		A325N		A325N		A325N	

Feed Line/Linear Appurtenances - Entered As Round Or Flat

Description	Face or Leg	Allow Shield	Component Type	Placement ft	Face Offset in	Lateral Offset (Frac FW)	#	# Per Row	Clear Spacing in	Width or Diameter in	Perimeter in	Weight klf
ATCB-B01-04 0(5/16") (E-Inside Conduit)	A	Yes	Ar (CfAe)	128' - 0'	0.000	0.2	6	6	0.315	0.000		0.000
LDF4-50A(1/ 2") (E-Inside Conduit)	A	Yes	Ar (CfAe)	128' - 0'	0.000	0.2	2	2	0.500 0.630	0.000		0.000
2" Rigid Conduit (E)	A	Yes	Ar (CfAe)	128' - 0'	0.000	0.2	2	2	2.000	2.000		0.003
LDF4P-50A(1/ 2") (E)	A	Yes	Ar (CfAe)	128' - 0'	0.000	0.1	2	2	0.630	0.630		0.000

<p>tnxTower</p> <p>B+T Group 1717 S Boulder Ave, Suite 300 Tulsa, OK 74119 Phone: (918) 587-4630 FAX: (918) 295-0265</p>	<p>Job 101341.001.01 - Glastonbury-main st, CT (Site# CT46126-A)</p>	<p>Page 11 of 48</p>
	<p>Project</p>	<p>Date 17:44:11 09/25/15</p>
	<p>Client SBA Communications Corporation</p>	<p>Designed by zsmith</p>

Description	Face or Leg	Allow Shield	Component Type	Placement ft	Face Offset in	Lateral Offset (Frac FW)	#	# Per Row	Clear Spacing in	Width or Diameter in	Perimeter in	Weight klf
LDF4P-50A(1/2") (E) Feedline Ladder (Af) (E) *R*	A	Yes	Ar (CfAe)	50'6" - 0'	0.000	0.02	2	2	0.630	0.630		0.000
LDF6-50A(1-1/4") (E) Feedline Ladder (Af) (E) *R*	B	Yes	Ar (CfAe)	118'6" - 0'	-1.000	0	4	4	0.850 0.750	1.550		0.001
LDF6-50A(1-1/4") (E) Feedline Ladder (Af) (E) *R*	B	Yes	Af (CfAe)	118'6" - 0'	-1.000	0	1	1	3.000	3.000	12.000	0.008
LDF6-50A(1-1/4") (E)	C	Yes	Ar (CfAe)	110' - 93'	0.000	0	12	6	0.850 0.750	1.550		0.001
LDF2-50(3/8") (E-Inside Conduit) 3" Conduit (E) Feedline Ladder (Af) (E) *R*	C	Yes	Ar (CfAe)	110' - 0'	0.000	-0.1	1	1	0.440	0.000		0.000
3" Conduit (E) Feedline Ladder (Af) (E) *R*	C	Yes	Ar (CfAe)	110' - 0'	0.000	-0.1	1	1	3.000	3.000		0.003
Feedline Ladder (Af) (E) *R*	C	Yes	Af (CfAe)	60' - 0'	-1.000	0	2	1	3.000 1.500	3.000	12.000	0.008
Feedline Ladder (Af) (E) *R*	C	Yes	Af (CfAe)	93' - 60'	-1.000	0	1	1	3.000 1.500	3.000	12.000	0.008
LDF7-50A(1 5/8") (E) *R*	C	Yes	Ar (CfAe)	93' - 0'	-3.000	0	25	9	0.850 0.750	1.980		0.001
LDF7-50A(1 5/8") (E) *R*	B	Yes	Ar (CfAe)	80' - 0'	-1.000	0.1	2	2	0.850 0.750	1.980		0.001
LDF4P-50A(1/2") (E) *R*	B	Yes	Ar (CfAe)	55'6" - 0'	-1.000	-0.08	1	1	0.630	0.630		0.000
Safety Line 3/8 (E) *R*	B	Yes	Ar (CfAe)	130' - 0'	0.000	-0.5	1	1	0.375	0.375		0.000

Feed Line/Linear Appurtenances - Entered As Area

Description	Face or Leg	Allow Shield	Component Type	Placement ft	Total Number	C _{AA} ft ² /ft	Weight klf
R							

Feed Line/Linear Appurtenances Section Areas

tnxTower

B+T Group
1717 S Boulder Ave, Suite 300
Tulsa, OK 74119
Phone: (918) 587-4630
FAX: (918) 295-0265

Job
101341.001.01 - Glastonbury-main st, CT (Site# CT46126-A)

Page
12 of 48

Project

Date
17:44:11 09/25/15

Client
SBA Communications Corporation

Designed by
zsmith

Tower Section	Tower Elevation ft	Face	A _R ft ²	A _F ft ²	C _{AA} In Face ft ²	C _{AA} Out Face ft ²	Weight K
T1	130'-120'	A	3.507	0.000	0.000	0.000	0.053
		B	0.313	0.000	0.000	0.000	0.002
		C	0.000	0.000	0.000	0.000	0.000
T2	120'-117'1-23/32"	A	1.252	0.000	0.000	0.000	0.019
		B	0.790	0.339	0.000	0.000	0.016
		C	0.000	0.000	0.000	0.000	0.000
T3	117'1-23/32"-114' 3-7/16"	A	1.252	0.000	0.000	0.000	0.019
		B	1.565	0.714	0.000	0.000	0.032
		C	0.000	0.000	0.000	0.000	0.000
T4	114'3-7/16"-111'5'- 5/32"	A	1.252	0.000	0.000	0.000	0.019
		B	1.565	0.714	0.000	0.000	0.032
		C	0.000	0.000	0.000	0.000	0.000
T5	111'5-5/32"-108'6'- 7/8"	A	1.252	0.000	0.000	0.000	0.019
		B	1.565	0.714	0.000	0.000	0.032
		C	1.463	0.000	0.000	0.000	0.015
T6	108'6-7/8"-105'8-1 9/32"	A	1.252	0.000	0.000	0.000	0.019
		B	1.565	0.714	0.000	0.000	0.032
		C	2.928	0.000	0.000	0.000	0.031
T7	105'8-19/32"-102' 10-5/16"	A	1.252	0.000	0.000	0.000	0.019
		B	1.565	0.714	0.000	0.000	0.032
		C	2.928	0.000	0.000	0.000	0.031
T8	102'10-5/16"-100'	A	1.253	0.000	0.000	0.000	0.019
		B	1.567	0.715	0.000	0.000	0.032
		C	2.931	0.000	0.000	0.000	0.031
T9	100'-96'	A	1.753	0.000	0.000	0.000	0.027
		B	2.192	1.000	0.000	0.000	0.045
		C	4.100	0.000	0.000	0.000	0.043
T10	96'-92'	A	1.753	0.000	0.000	0.000	0.027
		B	2.192	1.000	0.000	0.000	0.045
		C	4.810	0.250	0.000	0.000	0.064
T11	92'-88'	A	1.753	0.000	0.000	0.000	0.027
		B	2.192	1.000	0.000	0.000	0.045
		C	6.940	1.000	0.000	0.000	0.127
T12	88'-84'	A	1.753	0.000	0.000	0.000	0.027
		B	2.192	1.000	0.000	0.000	0.045
		C	6.940	1.000	0.000	0.000	0.127
T13	84'-80'	A	1.753	0.000	0.000	0.000	0.027
		B	2.192	1.000	0.000	0.000	0.045
		C	6.940	1.000	0.000	0.000	0.127
T14	80'-75'	A	2.192	0.000	0.000	0.000	0.033
		B	4.390	1.250	0.000	0.000	0.065
		C	8.675	1.250	0.000	0.000	0.159
T15	75'-70'	A	2.192	0.000	0.000	0.000	0.033
		B	4.390	1.250	0.000	0.000	0.065
		C	8.675	1.250	0.000	0.000	0.159
T16	70'-65'	A	2.192	0.000	0.000	0.000	0.033
		B	4.390	1.250	0.000	0.000	0.065
		C	8.675	1.250	0.000	0.000	0.159
T17	65'-60'	A	2.192	0.000	0.000	0.000	0.033
		B	4.390	1.250	0.000	0.000	0.065
		C	8.675	1.250	0.000	0.000	0.159
T18	60'-55'	A	2.192	1.250	0.000	0.000	0.075
		B	4.416	1.250	0.000	0.000	0.065
		C	8.675	1.250	0.000	0.000	0.201
T19	55'-50'	A	2.244	1.250	0.000	0.000	0.075
		B	4.652	1.250	0.000	0.000	0.065
		C	8.675	1.250	0.000	0.000	0.201
T20	50'-45'	A	2.717	1.250	0.000	0.000	0.077
		B	4.652	1.250	0.000	0.000	0.065
		C	8.675	1.250	0.000	0.000	0.201
T21	45'-40'	A	2.717	1.250	0.000	0.000	0.077

<p>tnxTower</p> <p>B+T Group 1717 S Boulder Ave, Suite 300 Tulsa, OK 74119 Phone: (918) 587-4630 FAX: (918) 295-0265</p>	<p>Job 101341.001.01 - Glastonbury-main st, CT (Site# CT46126-A)</p>	<p>Page 13 of 48</p>
	<p>Project</p>	<p>Date 17:44:11 09/25/15</p>
	<p>Client SBA Communications Corporation</p>	<p>Designed by zsmith</p>

Tower Section	Tower Elevation ft	Face	A _R ft ²	A _F ft ²	C _{AA} In Face ft ²	C _{AA} Out Face ft ²	Weight K
T22	40'-33'4"	B	4.652	1.250	0.000	0.000	0.065
		C	8.675	1.250	0.000	0.000	0.201
		A	3.622	1.667	0.000	0.000	0.102
T23	33'4"-26'8"	B	6.203	1.667	0.000	0.000	0.087
		C	11.567	1.667	0.000	0.000	0.268
		A	3.622	1.667	0.000	0.000	0.102
T24	26'8"-20'	B	6.203	1.667	0.000	0.000	0.087
		C	11.567	1.667	0.000	0.000	0.268
		A	3.622	1.667	0.000	0.000	0.102
T25	20'-13'4"	B	6.203	1.667	0.000	0.000	0.087
		C	11.567	1.667	0.000	0.000	0.268
		A	3.622	1.667	0.000	0.000	0.102
T26	13'4"-6'8"	B	6.203	1.667	0.000	0.000	0.087
		C	11.567	1.667	0.000	0.000	0.268
		A	3.622	1.667	0.000	0.000	0.102
T27	6'8"-0'	B	6.203	1.667	0.000	0.000	0.087
		C	11.567	1.667	0.000	0.000	0.268
		A	3.622	1.667	0.000	0.000	0.102

Feed Line/Linear Appurtenances Section Areas - With Ice

Tower Section	Tower Elevation ft	Face or Leg	Ice Thickness in	A _R ft ²	A _F ft ²	C _{AA} In Face ft ²	C _{AA} Out Face ft ²	Weight K
T1	130'-120'	A	1.173	8.011	4.890	0.000	0.000	0.207
		B		2.268	0.000	0.000	0.000	0.024
		C		0.000	0.000	0.000	0.000	0.000
T2	120'-117'1-23/32"	A	1.166	2.847	1.746	0.000	0.000	0.074
		B		1.083	1.329	0.000	0.000	0.049
		C		0.000	0.000	0.000	0.000	0.000
T3	117'1-23/32"-114' 3-7/16"	A	1.162	2.840	1.746	0.000	0.000	0.073
		B		1.565	2.797	0.000	0.000	0.095
		C		0.000	0.000	0.000	0.000	0.000
T4	114'3-7/16"-111'5- 5/32"	A	1.159	2.833	1.746	0.000	0.000	0.073
		B		1.562	2.796	0.000	0.000	0.095
		C		0.000	0.000	0.000	0.000	0.000
T5	111'5-5/32"-108'6- 7/8"	A	1.155	2.827	1.746	0.000	0.000	0.073
		B		1.559	2.795	0.000	0.000	0.095
		C		1.366	1.427	0.000	0.000	0.066
T6	108'6-7/8"-105'8-1 9/32"	A	1.152	2.820	1.746	0.000	0.000	0.073
		B		1.555	2.794	0.000	0.000	0.095
		C		2.728	2.857	0.000	0.000	0.132
T7	105'8-19/32"-102' 10-5/16"	A	1.148	2.813	1.746	0.000	0.000	0.073
		B		1.552	2.793	0.000	0.000	0.094
		C		2.723	2.857	0.000	0.000	0.132
T8	102'10-5/16"-100'	A	1.144	2.808	1.748	0.000	0.000	0.072
		B		1.549	2.794	0.000	0.000	0.094
		C		2.720	2.859	0.000	0.000	0.131
T9	100'-96'	A	1.140	3.915	2.445	0.000	0.000	0.101
		B		2.161	3.906	0.000	0.000	0.131
		C		3.796	4.000	0.000	0.000	0.183
T10	96'-92'	A	1.134	3.900	2.445	0.000	0.000	0.100
		B		2.153	3.904	0.000	0.000	0.131
		C		3.820	5.263	0.000	0.000	0.246
T11	92'-88'	A	1.128	3.885	2.445	0.000	0.000	0.100
		B		2.146	3.901	0.000	0.000	0.130

<p>tnxTower</p> <p>B+T Group 1717 S Boulder Ave, Suite 300 Tulsa, OK 74119 Phone: (918) 587-4630 FAX: (918) 295-0265</p>	<p>Job 101341.001.01 - Glastonbury-main st, CT (Site# CT46126-A)</p>	<p>Page 14 of 48</p>
	<p>Project</p>	<p>Date 17:44:11 09/25/15</p>
	<p>Client SBA Communications Corporation</p>	<p>Designed by zsmith</p>

Tower Section	Tower Elevation ft	Face or Leg	Ice Thickness in	A _R ft ²	A _F ft ²	C _{AA} In Face ft ²	C _{AA} Out Face ft ²	Weight K
T12	88'-84'	C	1.122	3.916	9.048	0.000	0.000	0.436
		A		3.868	2.445	0.000	0.000	0.100
		B		2.137	3.899	0.000	0.000	0.130
T13	84'-80'	C	1.115	3.904	9.045	0.000	0.000	0.435
		A		3.851	2.445	0.000	0.000	0.099
		B		2.129	3.896	0.000	0.000	0.129
T14	80'-75'	C	1.108	3.891	9.042	0.000	0.000	0.434
		A		4.789	3.056	0.000	0.000	0.123
		B		4.397	6.045	0.000	0.000	0.207
T15	75'-70'	C	1.099	4.845	11.299	0.000	0.000	0.541
		A		4.759	3.056	0.000	0.000	0.122
		B		4.375	6.040	0.000	0.000	0.206
T16	70'-65'	C	1.090	4.823	11.294	0.000	0.000	0.539
		A		4.728	3.056	0.000	0.000	0.121
		B		4.351	6.035	0.000	0.000	0.205
T17	65'-60'	C	1.080	4.799	11.289	0.000	0.000	0.537
		A		4.695	3.056	0.000	0.000	0.120
		B		4.326	6.029	0.000	0.000	0.203
T18	60'-55'	C	1.069	4.774	11.283	0.000	0.000	0.535
		A		4.659	4.900	0.000	0.000	0.195
		B		4.415	6.023	0.000	0.000	0.203
T19	55'-50'	C	1.057	4.747	11.277	0.000	0.000	0.608
		A		4.735	4.946	0.000	0.000	0.195
		B		5.414	6.017	0.000	0.000	0.212
T20	50'-45'	C	1.045	4.718	11.271	0.000	0.000	0.605
		A		5.711	5.412	0.000	0.000	0.210
		B		5.372	6.010	0.000	0.000	0.210
T21	45'-40'	C	1.031	4.687	11.264	0.000	0.000	0.602
		A		5.653	5.404	0.000	0.000	0.207
		B		5.326	6.002	0.000	0.000	0.207
T22	40'-33'4"	C	1.013	4.652	11.256	0.000	0.000	0.598
		A		7.437	7.192	0.000	0.000	0.273
		B		7.020	7.989	0.000	0.000	0.273
T23	33'4"-26'8"	C	1.000	6.142	14.995	0.000	0.000	0.791
		A		7.367	7.182	0.000	0.000	0.270
		B		6.964	7.980	0.000	0.000	0.270
T24	26'8"-20'	C	1.000	6.100	14.985	0.000	0.000	0.787
		A		7.367	7.182	0.000	0.000	0.270
		B		6.964	7.980	0.000	0.000	0.270
T25	20'-13'4"	C	1.000	6.100	14.985	0.000	0.000	0.787
		A		7.367	7.182	0.000	0.000	0.270
		B		6.964	7.980	0.000	0.000	0.270
T26	13'4"-6'8"	C	1.000	6.100	14.985	0.000	0.000	0.787
		A		7.367	7.182	0.000	0.000	0.270
		B		6.964	7.980	0.000	0.000	0.270
T27	6'8"-0'	C	1.000	6.100	14.985	0.000	0.000	0.787
		A		7.367	7.182	0.000	0.000	0.270
		B		6.964	7.980	0.000	0.000	0.270
		C		6.100	14.985	0.000	0.000	0.787

Feed Line Shielding

Section	Elevation ft	Face	A _R ft ²	A _R Ice ft ²	A _F ft ²	A _F Ice ft ²
T1	130'-120'	A	0.165	4.709	0.183	0.672
		B	0.015	0.828	0.016	0.118

tnxTower

B+T Group
1717 S Boulder Ave, Suite 300
Tulsa, OK 74119
Phone: (918) 587-4630
FAX: (918) 295-0265

Job
101341.001.01 - Glastonbury-main st, CT (Site# CT46126-A)

Page
15 of 48

Project

Date
17:44:11 09/25/15

Client
SBA Communications Corporation

Designed by
zsmith

Section	Elevation	Face	A_R	A_R	A_F	A_F
	ft		ft ²	Ice ft ²	ft ²	Ice ft ²
T2	120'-117'1-23/32"	C	0.000	0.000	0.000	0.000
		A	0.082	1.546	0.046	0.167
		B	0.074	0.841	0.041	0.091
T3	117'1-23/32"-114'3-7/16"	C	0.000	0.000	0.000	0.000
		A	0.082	1.229	0.000	0.000
		B	0.149	1.218	0.000	0.000
T4	114'3-7/16"-111'5-5/32"	C	0.000	0.000	0.000	0.000
		A	0.083	1.245	0.000	0.000
		B	0.151	1.234	0.000	0.000
T5	111'5-5/32"-108'6-7/8"	C	0.000	0.000	0.000	0.000
		A	0.083	1.240	0.000	0.000
		B	0.151	1.230	0.000	0.000
T6	108'6-7/8"-105'8-19/32"	C	0.097	0.757	0.000	0.000
		A	0.083	1.235	0.000	0.000
		B	0.151	1.226	0.000	0.000
T7	105'8-19/32"-102'10-5/16"	C	0.195	1.511	0.000	0.000
		A	0.083	1.230	0.000	0.000
		B	0.151	1.221	0.000	0.000
T8	102'10-5/16"-100'	C	0.195	1.506	0.000	0.000
		A	0.082	1.813	0.119	0.432
		B	0.149	1.801	0.216	0.429
T9	100'-96'	C	0.191	2.221	0.278	0.528
		A	0.000	1.108	0.201	0.729
		B	0.000	1.101	0.366	0.725
T10	96'-92'	C	0.000	1.358	0.470	0.894
		A	0.000	1.045	0.255	0.922
		B	0.000	1.039	0.464	0.917
T11	92'-88'	C	0.000	1.506	0.735	1.329
		A	0.000	1.289	0.329	1.187
		B	0.000	1.282	0.598	1.181
T12	88'-84'	C	0.000	2.691	1.489	2.478
		A	0.000	1.240	0.322	1.158
		B	0.000	1.234	0.585	1.153
T13	84'-80'	C	0.000	2.592	1.456	2.420
		A	0.000	1.196	0.315	1.132
		B	0.000	1.192	0.574	1.128
T14	80'-75'	C	0.000	2.504	1.428	2.370
		A	0.000	0.987	0.249	0.891
		B	0.000	1.352	0.640	1.221
T15	75'-70'	C	0.000	2.070	1.127	1.868
		A	0.000	0.935	0.179	0.638
		B	0.000	1.282	0.460	0.875
T16	70'-65'	C	0.000	1.964	0.810	1.340
		A	0.000	0.889	0.172	0.612
		B	0.000	1.220	0.443	0.840
T17	65'-60'	C	0.000	1.871	0.780	1.288
		A	0.000	0.847	0.166	0.588
		B	0.000	1.165	0.428	0.809
T18	60'-55'	C	0.000	1.788	0.754	1.242
		A	0.000	1.385	0.368	1.054
		B	0.000	1.509	0.606	1.148
T19	55'-50'	C	0.000	2.294	1.062	1.746
		A	0.000	1.007	0.250	0.714
		B	0.000	1.184	0.423	0.840
T20	50'-45'	C	0.000	1.644	0.711	1.166
		A	0.000	1.110	0.277	0.797
		B	0.000	1.136	0.412	0.815
T21	45'-40'	C	0.000	1.580	0.693	1.134
		A	0.000	1.454	0.559	1.600
		B	0.000	1.489	0.832	1.638
		C	0.000	2.076	1.400	2.284

Section	Elevation	Face	A_R	A_R	A_F	A_F
			ft^2	Ice ft^2	ft^2	Ice ft^2
T22	40'-33'4"	A	0.000	1.173	0.357	1.013
		B	0.000	1.203	0.532	1.039
		C	0.000	1.682	0.894	1.453
T23	33'4"-26'8"	A	0.000	1.115	0.346	0.976
		B	0.000	1.145	0.515	1.001
		C	0.000	1.604	0.865	1.403
T24	26'8"-20'	A	0.000	1.083	0.336	0.948
		B	0.000	1.112	0.500	0.973
		C	0.000	1.557	0.841	1.363
T25	20'-13'4"	A	0.000	1.055	0.374	1.055
		B	0.000	1.083	0.556	1.083
		C	0.000	1.517	0.936	1.517
T26	13'4"-6'8"	A	0.000	1.403	0.497	1.403
		B	0.000	1.440	0.740	1.440
		C	0.000	2.018	1.245	2.018
T27	6'8"-0'	A	0.000	1.003	0.355	1.003
		B	0.000	1.029	0.529	1.029
		C	0.000	1.442	0.889	1.442

Feed Line Center of Pressure

Section	Elevation	CP_x	CP_z	CP_x	CP_z
		in	in	Ice in	Ice in
T1	130'-120'	-0.978	-1.909	0.047	-0.335
T2	120'-117'1-23/32"	-0.126	-2.131	0.193	-0.540
T3	117'1-23/32"-114'3-7/16"	0.705	-2.568	0.405	-1.054
T4	114'3-7/16"-111'5-5/32"	0.703	-2.559	0.404	-1.038
T5	111'5-5/32"-108'6-7/8"	0.707	-0.546	0.462	-0.134
T6	108'6-7/8"-105'8-19/32"	0.711	0.931	0.509	0.608
T7	105'8-19/32"-102'10-5/16"	0.711	0.931	0.509	0.608
T8	102'10-5/16"-100'	0.569	0.745	0.444	0.658
T9	100'-96'	0.504	0.627	0.453	0.536
T10	96'-92'	0.505	0.792	0.474	0.682
T11	92'-88'	0.455	1.238	0.448	1.019
T12	88'-84'	0.495	1.320	0.476	1.074
T13	84'-80'	0.533	1.401	0.503	1.129
T14	80'-75'	0.984	1.358	0.612	1.124
T15	75'-70'	1.132	1.547	0.698	1.223
T16	70'-65'	1.220	1.653	0.753	1.300
T17	65'-60'	1.308	1.758	0.806	1.376
T18	60'-55'	0.996	1.224	0.559	1.002
T19	55'-50'	1.180	1.304	0.805	0.895
T20	50'-45'	1.074	1.246	0.785	0.886
T21	45'-40'	0.952	1.094	0.709	0.930
T22	40'-33'4"	1.209	1.376	0.891	0.974
T23	33'4"-26'8"	1.294	1.458	0.950	1.028
T24	26'8"-20'	1.378	1.539	1.009	1.077
T25	20'-13'4"	1.425	1.579	1.051	1.124
T26	13'4"-6'8"	1.397	1.537	1.012	1.151
T27	6'8"-0'	1.586	1.734	1.165	1.220

tnxTower B+T Group 1717 S Boulder Ave, Suite 300 Tulsa, OK 74119 Phone: (918) 587-4630 FAX: (918) 295-0265	Job 101341.001.01 - Glastonbury-main st, CT (Site# CT46126-A)	Page 17 of 48
	Project	Date 17:44:11 09/25/15
	Client SBA Communications Corporation	Designed by zsmith

Discrete Tower Loads

Description	Face or Leg	Offset Type	Offsets:		Azimuth Adjustment	Placement	C _{AA} Front	C _{AA} Side	Weight
			Horz	Vert					
			Lateral		°	ft	ft ²	ft ²	K
			ft	ft					
LLPX310R w/ Mount Pipe (E)	A	From Leg	4.000	0.000	128'	No Ice	5.065	2.985	0.045
						1/2" Ice	5.480	3.528	0.083
						1" Ice	5.905	4.087	0.126
						2" Ice	6.788	5.314	0.232
						4" Ice	8.705	8.133	0.544
LLPX310R w/ Mount Pipe (E)	B	From Leg	4.000	0.000	128'	No Ice	5.065	2.985	0.045
						1/2" Ice	5.480	3.528	0.083
						1" Ice	5.905	4.087	0.126
						2" Ice	6.788	5.314	0.232
						4" Ice	8.705	8.133	0.544
840 10054 w/ Mount Pipe (E)	C	From Leg	4.000	0.000	128'	No Ice	5.413	2.385	0.051
						1/2" Ice	5.833	2.917	0.088
						1" Ice	6.263	3.466	0.129
						2" Ice	7.156	4.614	0.230
						4" Ice	9.093	7.316	0.533
24"x14"x9" (E)	A	From Leg	4.000	0.000	128'	No Ice	3.442	2.639	0.064
						1/2" Ice	3.696	2.870	0.091
						1" Ice	3.959	3.111	0.122
						2" Ice	4.512	3.618	0.195
						4" Ice	5.720	4.735	0.391
24"x14"x9" (E)	B	From Leg	4.000	0.000	128'	No Ice	3.442	2.639	0.064
						1/2" Ice	3.696	2.870	0.091
						1" Ice	3.959	3.111	0.122
						2" Ice	4.512	3.618	0.195
						4" Ice	5.720	4.735	0.391
24"x14"x9" (E)	C	From Leg	4.000	0.000	128'	No Ice	3.442	2.639	0.064
						1/2" Ice	3.696	2.870	0.091
						1" Ice	3.959	3.111	0.122
						2" Ice	4.512	3.618	0.195
						4" Ice	5.720	4.735	0.391
TIMING 2000 (E)	C	From Leg	4.000	0.000	128'	No Ice	0.126	0.126	0.001
						1/2" Ice	0.177	0.177	0.002
						1" Ice	0.237	0.237	0.005
						2" Ice	0.383	0.383	0.014
						4" Ice	0.778	0.778	0.052
MODEM (E)	A	From Leg	4.000	0.000	128'	No Ice	0.130	0.107	0.002
						1/2" Ice	0.183	0.157	0.003
						1" Ice	0.244	0.215	0.005
						2" Ice	0.393	0.358	0.013
						4" Ice	0.795	0.747	0.047
MODEM (E)	B	From Leg	4.000	0.000	128'	No Ice	0.130	0.107	0.002
						1/2" Ice	0.183	0.157	0.003
						1" Ice	0.244	0.215	0.005
						2" Ice	0.393	0.358	0.013
						4" Ice	0.795	0.747	0.047
MODEM (E)	C	From Leg	4.000	0.000	128'	No Ice	0.130	0.107	0.002
						1/2" Ice	0.183	0.157	0.003
						1" Ice	0.244	0.215	0.005
						2" Ice	0.393	0.358	0.013
						4" Ice	0.795	0.747	0.047

<p>tnxTower</p> <p>B+T Group 1717 S Boulder Ave, Suite 300 Tulsa, OK 74119 Phone: (918) 587-4630 FAX: (918) 295-0265</p>	<p>Job 101341.001.01 - Glastonbury-main st, CT (Site# CT46126-A)</p>	<p>Page 18 of 48</p>
	<p>Project</p>	<p>Date 17:44:11 09/25/15</p>
	<p>Client SBA Communications Corporation</p>	<p>Designed by zsmith</p>

Description	Face or Leg	Offset Type	Offsets:		Azimuth Adjustment	Placement	C _{AA} Front	C _{AA} Side	Weight
			Horz	Vert					
			ft	ft	°	ft	ft ²	ft ²	K
Sector Mount [SM 803-3] (E)	C	None			0.000	128'	No Ice 40.400 1/2" Ice 51.200 1" Ice 62.000 2" Ice 83.600 4" Ice 126.800	40.400 51.200 62.000 83.600 126.800	0.985 1.226 1.467 1.948 2.912
R									
APXVTM14-C-120 w/ Mount Pipe (E)	A	From Leg	4.000 0' 1'6"		0.000	118'6"	No Ice 7.134 1/2" Ice 7.662 1" Ice 8.183 2" Ice 9.256 4" Ice 11.526	4.959 5.754 6.472 8.010 11.412	0.077 0.131 0.193 0.338 0.752
APXVTM14-C-120 w/ Mount Pipe (E)	B	From Leg	4.000 0' 1'6"		0.000	118'6"	No Ice 7.134 1/2" Ice 7.662 1" Ice 8.183 2" Ice 9.256 4" Ice 11.526	4.959 5.754 6.472 8.010 11.412	0.077 0.131 0.193 0.338 0.752
APXVTM14-C-120 w/ Mount Pipe (E)	C	From Leg	4.000 0' 1'6"		0.000	118'6"	No Ice 7.134 1/2" Ice 7.662 1" Ice 8.183 2" Ice 9.256 4" Ice 11.526	4.959 5.754 6.472 8.010 11.412	0.077 0.131 0.193 0.338 0.752
APXVSP18-C-A20 w/ Mount Pipe (E)	A	From Leg	4.000 0' 0'		0.000	118'6"	No Ice 8.498 1/2" Ice 9.149 1" Ice 9.767 2" Ice 11.031 4" Ice 13.679	6.946 8.127 9.021 10.844 14.851	0.083 0.151 0.227 0.406 0.909
APXVSP18-C-A20 w/ Mount Pipe (E)	B	From Leg	4.000 0' 0'		0.000	118'6"	No Ice 8.498 1/2" Ice 9.149 1" Ice 9.767 2" Ice 11.031 4" Ice 13.679	6.946 8.127 9.021 10.844 14.851	0.083 0.151 0.227 0.406 0.909
P40-16-XLPP-RR-A w/ Mount Pipe (E)	C	From Leg	4.000 0' 0'		0.000	118'6"	No Ice 9.373 1/2" Ice 9.912 1" Ice 10.450 2" Ice 11.556 4" Ice 13.892	4.825 5.571 6.265 7.803 11.107	0.073 0.136 0.205 0.368 0.816
TD-RRH8x20-25 (E)	A	From Leg	4.000 0' 1'6"		0.000	118'6"	No Ice 4.720 1/2" Ice 5.014 1" Ice 5.316 2" Ice 5.948 4" Ice 7.314	1.703 1.920 2.145 2.622 3.680	0.070 0.097 0.128 0.201 0.397
TD-RRH8x20-25 (E)	B	From Leg	4.000 0' 1'6"		0.000	118'6"	No Ice 4.720 1/2" Ice 5.014 1" Ice 5.316 2" Ice 5.948 4" Ice 7.314	1.703 1.920 2.145 2.622 3.680	0.070 0.097 0.128 0.201 0.397
TD-RRH8x20-25 (E)	C	From Leg	4.000 0' 1'6"		0.000	118'6"	No Ice 4.720 1/2" Ice 5.014 1" Ice 5.316 2" Ice 5.948 4" Ice 7.314	1.703 1.920 2.145 2.622 3.680	0.070 0.097 0.128 0.201 0.397
1900 MHz (E)	A	From Leg	4.000 0' 0'		0.000	118'6"	No Ice 2.781 1/2" Ice 3.012 1" Ice 3.252 2" Ice 3.757 4" Ice 4.872	1.497 1.690 1.890 2.318 3.277	0.044 0.063 0.084 0.137 0.285
1900 MHz	B	From Leg	4.000		0.000	118'6"	No Ice 2.781	1.497	0.044

tnxTower B+T Group 1717 S Boulder Ave, Suite 300 Tulsa, OK 74119 Phone: (918) 587-4630 FAX: (918) 295-0265	Job		101341.001.01 - Glastonbury-main st, CT (Site# CT46126-A)		Page		19 of 48	
	Project				Date		17:44:11 09/25/15	
	Client		SBA Communications Corporation		Designed by		zsmith	

Description	Face or Leg	Offset Type	Offsets:		Azimuth Adjustment	Placement	C _{AA} Front	C _{AA} Side	Weight
			Horz	Lateral					
(E)				0'		1/2" Ice	3.012	1.690	0.063
				0'		1" Ice	3.252	1.890	0.084
						2" Ice	3.757	2.318	0.137
						4" Ice	4.872	3.277	0.285
1900 MHz	C	From Leg	4.000	0.000	118'6"	No Ice	2.781	1.497	0.044
(E)				0'		1/2" Ice	3.012	1.690	0.063
				0'		1" Ice	3.252	1.890	0.084
						2" Ice	3.757	2.318	0.137
						4" Ice	4.872	3.277	0.285
800 MHz	A	From Leg	4.000	0.000	118'6"	No Ice	2.490	2.068	0.053
(E)				0'		1/2" Ice	2.706	2.271	0.074
				0'		1" Ice	2.931	2.481	0.098
						2" Ice	3.407	2.928	0.157
						4" Ice	4.462	3.927	0.318
800 MHz	B	From Leg	4.000	0.000	118'6"	No Ice	2.490	2.068	0.053
(E)				0'		1/2" Ice	2.706	2.271	0.074
				0'		1" Ice	2.931	2.481	0.098
						2" Ice	3.407	2.928	0.157
						4" Ice	4.462	3.927	0.318
800 MHz	C	From Leg	4.000	0.000	118'6"	No Ice	2.490	2.068	0.053
(E)				0'		1/2" Ice	2.706	2.271	0.074
				0'		1" Ice	2.931	2.481	0.098
						2" Ice	3.407	2.928	0.157
						4" Ice	4.462	3.927	0.318
(2) ACU-A20-N RETs	A	From Leg	4.000	0.000	118'6"	No Ice	0.078	0.136	0.001
(E)				0'		1/2" Ice	0.121	0.189	0.002
				0'		1" Ice	0.173	0.251	0.004
						2" Ice	0.302	0.400	0.012
						4" Ice	0.665	0.802	0.045
ACU-A20-N RETs	B	From Leg	4.000	0.000	118'6"	No Ice	0.078	0.136	0.001
(E)				0'		1/2" Ice	0.121	0.189	0.002
				0'		1" Ice	0.173	0.251	0.004
						2" Ice	0.302	0.400	0.012
						4" Ice	0.665	0.802	0.045
ACU-A20-N RETs	C	From Leg	4.000	0.000	118'6"	No Ice	0.078	0.136	0.001
(E)				0'		1/2" Ice	0.121	0.189	0.002
				0'		1" Ice	0.173	0.251	0.004
						2" Ice	0.302	0.400	0.012
						4" Ice	0.665	0.802	0.045
800 MHz Filter	A	From Leg	4.000	0.000	118'6"	No Ice	1.820	0.604	0.009
(E)				0'		1/2" Ice	2.008	0.747	0.019
				0'		1" Ice	2.205	0.899	0.032
						2" Ice	2.625	1.228	0.064
						4" Ice	3.568	1.991	0.165
800 MHz Filter	B	From Leg	4.000	0.000	118'6"	No Ice	1.820	0.604	0.009
(E)				0'		1/2" Ice	2.008	0.747	0.019
				0'		1" Ice	2.205	0.899	0.032
						2" Ice	2.625	1.228	0.064
						4" Ice	3.568	1.991	0.165
800 MHz Filter	C	From Leg	4.000	0.000	118'6"	No Ice	1.820	0.604	0.009
(E)				0'		1/2" Ice	2.008	0.747	0.019
				0'		1" Ice	2.205	0.899	0.032
						2" Ice	2.625	1.228	0.064
						4" Ice	3.568	1.991	0.165
6' x 2" Mount Pipe	A	From Leg	4.000	0.000	118'6"	No Ice	1.425	1.425	0.022
(E)				0'		1/2" Ice	1.925	1.925	0.033
				0'		1" Ice	2.294	2.294	0.048

tnxTower

B+T Group
1717 S Boulder Ave, Suite 300
Tulsa, OK 74119
Phone: (918) 587-4630
FAX: (918) 295-0265

Job
101341.001.01 - Glastonbury-main st, CT (Site# CT46126-A)

Page
20 of 48

Project
Date
17:44:11 09/25/15

Client
SBA Communications Corporation
Designed by
zsmith

Description	Face or Leg	Offset Type	Offsets:		Azimuth Adjustment	Placement	C _{AA} Front	C _{AA} Side	Weight	
			Horz	Lateral						°
			ft	ft						
6' x 2" Mount Pipe (E)	B	From Leg	4.000	0'	0.000	118'6"	2" Ice	3.060	3.060	0.090
							4" Ice	4.702	4.702	0.231
							No Ice	1.425	1.425	0.022
							1/2" Ice	1.925	1.925	0.033
							1" Ice	2.294	2.294	0.048
6' x 2" Mount Pipe (E)	C	From Leg	4.000	0'	0.000	118'6"	2" Ice	3.060	3.060	0.090
							4" Ice	4.702	4.702	0.231
							No Ice	1.425	1.425	0.022
							1/2" Ice	1.925	1.925	0.033
							1" Ice	2.294	2.294	0.048
T-Arm Mount [TA 601-3] (E)	C	None			0.000	118'6"	2" Ice	3.060	3.060	0.090
							4" Ice	4.702	4.702	0.231
							No Ice	10.900	10.900	0.726
							1/2" Ice	14.650	14.650	0.926
							1" Ice	18.400	18.400	1.125
R (2) 7700.00 w/ Mount Pipe (E)	A	From Leg	4.000	0'	0.000	110'	2" Ice	25.900	25.900	1.524
							4" Ice	40.900	40.900	2.322
							No Ice	6.119	4.254	0.055
							1/2" Ice	6.626	5.014	0.103
							1" Ice	7.128	5.711	0.157
(2) 7700.00 w/ Mount Pipe (E)	B	From Leg	4.000	0'	0.000	110'	2" Ice	8.164	7.155	0.287
							4" Ice	10.360	10.412	0.665
							No Ice	6.119	4.254	0.055
							1/2" Ice	6.626	5.014	0.103
							1" Ice	7.128	5.711	0.157
(2) 7700.00 w/ Mount Pipe (E)	C	From Leg	4.000	0'	0.000	110'	2" Ice	8.164	7.155	0.287
							4" Ice	10.360	10.412	0.665
							No Ice	6.119	4.254	0.055
							1/2" Ice	6.626	5.014	0.103
							1" Ice	7.128	5.711	0.157
AM-X-CD-16-65-00T-RET w/ Mount Pipe (E)	A	From Leg	4.000	0'	0.000	110'	2" Ice	8.164	7.155	0.287
							4" Ice	10.360	10.412	0.665
							No Ice	8.498	6.304	0.074
							1/2" Ice	9.149	7.479	0.139
							1" Ice	9.767	8.368	0.212
AM-X-CD-16-65-00T-RET w/ Mount Pipe (E)	B	From Leg	4.000	0'	0.000	110'	2" Ice	11.031	10.179	0.385
							4" Ice	13.679	14.024	0.874
							No Ice	8.498	6.304	0.074
							1/2" Ice	9.149	7.479	0.139
							1" Ice	9.767	8.368	0.212
SBNH-1D6565C w/ Mount Pipe (E)	C	From Leg	4.000	0'	0.000	110'	2" Ice	11.031	10.179	0.385
							4" Ice	13.679	14.024	0.874
							No Ice	11.683	9.842	0.099
							1/2" Ice	12.404	11.366	0.189
							1" Ice	13.135	12.914	0.288
(2) LGP13519 (E)	A	From Leg	4.000	0'	0.000	110'	2" Ice	14.601	15.267	0.522
							4" Ice	17.875	20.139	1.167
							No Ice	0.338	0.207	0.005
							1/2" Ice	0.422	0.280	0.008
							1" Ice	0.515	0.362	0.012
(2) LGP13519 (E)	B	From Leg	4.000	0'	0.000	110'	2" Ice	0.726	0.551	0.024
							4" Ice	1.252	1.034	0.071
							No Ice	0.338	0.207	0.005
							1/2" Ice	0.422	0.280	0.008
							1" Ice	0.515	0.362	0.012
2" Ice	0.726	0.551	0.024							

tnxTower B+T Group 1717 S Boulder Ave, Suite 300 Tulsa, OK 74119 Phone: (918) 587-4630 FAX: (918) 295-0265	Job		101341.001.01 - Glastonbury-main st, CT (Site# CT46126-A)		Page		21 of 48	
	Project				Date		17:44:11 09/25/15	
	Client		SBA Communications Corporation		Designed by		zsmith	

Description	Face or Leg	Offset Type	Offsets:			Azimuth Adjustment	Placement	C _{AA} Front	C _{AA} Side	Weight
			Horz	Lateral	Vert					
(2) LGP13519 (E)	C	From Leg	4.000	0.000	110'	4" Ice	1.252	1.034	0.071	
						No Ice	0.338	0.207	0.005	
						1/2" Ice	0.422	0.280	0.008	
						1" Ice	0.515	0.362	0.012	
						2" Ice	0.726	0.551	0.024	
(2) LGP21401 (E)	A	From Leg	4.000	0.000	110'	4" Ice	1.252	1.034	0.071	
						No Ice	1.288	0.233	0.014	
						1/2" Ice	1.445	0.313	0.021	
						1" Ice	1.611	0.403	0.030	
						2" Ice	1.969	0.608	0.055	
(2) LGP21401 (E)	B	From Leg	4.000	0.000	110'	4" Ice	2.788	1.121	0.135	
						No Ice	1.288	0.233	0.014	
						1/2" Ice	1.445	0.313	0.021	
						1" Ice	1.611	0.403	0.030	
						2" Ice	1.969	0.608	0.055	
(2) LGP21401 (E)	C	From Leg	4.000	0.000	110'	4" Ice	2.788	1.121	0.135	
						No Ice	1.288	0.233	0.014	
						1/2" Ice	1.445	0.313	0.021	
						1" Ice	1.611	0.403	0.030	
						2" Ice	1.969	0.608	0.055	
(2) RRUS-11 1900MHz (E)	A	From Face	0.500	0.000	110'	4" Ice	2.788	1.121	0.135	
						No Ice	2.942	1.190	0.044	
						1/2" Ice	3.172	1.351	0.063	
						1" Ice	3.410	1.521	0.086	
						2" Ice	3.913	1.887	0.140	
(2) RRUS-11 1900MHz (E)	B	From Face	0.500	0.000	110'	4" Ice	5.023	2.721	0.291	
						No Ice	2.942	1.190	0.044	
						1/2" Ice	3.172	1.351	0.063	
						1" Ice	3.410	1.521	0.086	
						2" Ice	3.913	1.887	0.140	
(2) RRUS-11 1900MHz (E)	C	From Face	0.500	0.000	110'	4" Ice	5.023	2.721	0.291	
						No Ice	2.942	1.190	0.044	
						1/2" Ice	3.172	1.351	0.063	
						1" Ice	3.410	1.521	0.086	
						2" Ice	3.913	1.887	0.140	
DC6-48-60-18-8F (E)	B	From Leg	0.500	0.000	110'	4" Ice	5.023	2.721	0.291	
						No Ice	1.467	1.467	0.019	
						1/2" Ice	1.667	1.667	0.037	
						1" Ice	1.878	1.878	0.057	
						2" Ice	2.333	2.333	0.105	
Sector Mount [SM 409-3] (E)	C	None	0.000	110'	4" Ice	3.378	3.378	0.239		
					No Ice	22.470	22.470	1.035		
					1/2" Ice	31.990	31.990	1.500		
					1" Ice	41.510	41.510	1.966		
					2" Ice	60.550	60.550	2.898		
R AIR 21 B2A/B4P (E)	A	From Leg	4.000	0.000	93'	4" Ice	98.630	98.630	4.761	
						No Ice	6.522	4.256	0.092	
						1/2" Ice	6.966	4.656	0.133	
						1" Ice	7.419	5.082	0.179	
						2" Ice	8.351	5.960	0.288	
AIR 21 B2A/B4P (E)	B	From Leg	4.000	0.000	93'	4" Ice	10.319	7.819	0.576	
						No Ice	6.522	4.256	0.092	
						1/2" Ice	6.966	4.656	0.133	
						1" Ice	7.419	5.082	0.179	
						2" Ice	8.351	5.960	0.288	
						4" Ice	10.319	7.819	0.576	

<p>tnxTower</p> <p>B+T Group 1717 S Boulder Ave, Suite 300 Tulsa, OK 74119 Phone: (918) 587-4630 FAX: (918) 295-0265</p>	Job		101341.001.01 - Glastonbury-main st, CT (Site# CT46126-A)		Page		22 of 48	
	Project				Date		17:44:11 09/25/15	
	Client		SBA Communications Corporation		Designed by		zsmith	

Description	Face or Leg	Offset Type	Offsets:		Azimuth Adjustment	Placement	C _{AA} Front	C _{AA} Side	Weight
			Horz	Lateral					
AIR 21 B2A/B4P (E)	C	From Leg	4.000	0.000	93'	No Ice	6.522	4.256	0.092
			0'	0'		1/2" Ice	6.966	4.656	0.133
			0'	0'		1" Ice	7.419	5.082	0.179
			0'	0'		2" Ice	8.351	5.960	0.288
			0'	0'		4" Ice	10.319	7.819	0.576
AIR 21 B4A/B2P (E)	A	From Leg	4.000	0.000	93'	No Ice	6.522	4.256	0.090
			0'	0'		1/2" Ice	6.966	4.656	0.132
			0'	0'		1" Ice	7.419	5.082	0.178
			0'	0'		2" Ice	8.351	5.960	0.287
			0'	0'		4" Ice	10.319	7.819	0.575
AIR 21 B4A/B2P (E)	B	From Leg	4.000	0.000	93'	No Ice	6.522	4.256	0.090
			0'	0'		1/2" Ice	6.966	4.656	0.132
			0'	0'		1" Ice	7.419	5.082	0.178
			0'	0'		2" Ice	8.351	5.960	0.287
			0'	0'		4" Ice	10.319	7.819	0.575
AIR 21 B4A/B2P (E)	C	From Leg	4.000	0.000	93'	No Ice	6.522	4.256	0.090
			0'	0'		1/2" Ice	6.966	4.656	0.132
			0'	0'		1" Ice	7.419	5.082	0.178
			0'	0'		2" Ice	8.351	5.960	0.287
			0'	0'		4" Ice	10.319	7.819	0.575
KRY 112 144/1 TMA (E)	A	From Leg	4.000	0.000	93'	No Ice	0.411	0.189	0.011
			0'	0'		1/2" Ice	0.500	0.256	0.014
			0'	0'		1" Ice	0.597	0.332	0.018
			0'	0'		2" Ice	0.818	0.510	0.031
			0'	0'		4" Ice	1.363	0.970	0.081
KRY 112 144/1 TMA (E)	B	From Leg	4.000	0.000	93'	No Ice	0.411	0.189	0.011
			0'	0'		1/2" Ice	0.500	0.256	0.014
			0'	0'		1" Ice	0.597	0.332	0.018
			0'	0'		2" Ice	0.818	0.510	0.031
			0'	0'		4" Ice	1.363	0.970	0.081
KRY 112 144/1 TMA (E)	C	From Leg	4.000	0.000	93'	No Ice	0.411	0.189	0.011
			0'	0'		1/2" Ice	0.500	0.256	0.014
			0'	0'		1" Ice	0.597	0.332	0.018
			0'	0'		2" Ice	0.818	0.510	0.031
			0'	0'		4" Ice	1.363	0.970	0.081
LNX-6515DS-A1M w/ Mount Pipe (P)	A	From Leg	4.000	0.000	93'	No Ice	11.683	9.842	0.083
			0'	0'		1/2" Ice	12.404	11.366	0.173
			0'	0'		1" Ice	13.135	12.914	0.273
			0'	0'		2" Ice	14.601	15.267	0.506
			0'	0'		4" Ice	17.875	20.139	1.151
LNX-6515DS-A1M w/ Mount Pipe (P)	B	From Leg	4.000	0.000	93'	No Ice	11.683	9.842	0.083
			0'	0'		1/2" Ice	12.404	11.366	0.173
			0'	0'		1" Ice	13.135	12.914	0.273
			0'	0'		2" Ice	14.601	15.267	0.506
			0'	0'		4" Ice	17.875	20.139	1.151
LNX-6515DS-A1M w/ Mount Pipe (P)	C	From Leg	4.000	0.000	93'	No Ice	11.683	9.842	0.083
			0'	0'		1/2" Ice	12.404	11.366	0.173
			0'	0'		1" Ice	13.135	12.914	0.273
			0'	0'		2" Ice	14.601	15.267	0.506
			0'	0'		4" Ice	17.875	20.139	1.151
S11B12 (P)	A	From Leg	4.000	0.000	93'	No Ice	3.306	1.361	0.051
			0'	0'		1/2" Ice	3.550	1.540	0.072
			0'	0'		1" Ice	3.802	1.728	0.096
			0'	0'		2" Ice	4.334	2.130	0.154
			0'	0'		4" Ice	5.501	3.038	0.314
S11B12 (P)	B	From Leg	4.000	0.000	93'	No Ice	3.306	1.361	0.051
			0'	0'		1/2" Ice	3.550	1.540	0.072

tnxTower B+T Group 1717 S Boulder Ave, Suite 300 Tulsa, OK 74119 Phone: (918) 587-4630 FAX: (918) 295-0265	Job 101341.001.01 - Glastonbury-main st, CT (Site# CT46126-A)	Page 25 of 48
	Project	Date 17:44:11 09/25/15
	Client SBA Communications Corporation	Designed by zsmith

Description	Face or Leg	Offset Type	Offsets:		Azimuth Adjustment	Placement	C _{AA}		Weight
			Horz	Lateral			Front	Side	
			ft	ft	°	ft	ft ²	ft ²	K
Side Arm Mount [SO 701-1] (E)	C	From Leg	1.500	0.000	55'6"	4" Ice	0.847	0.847	0.051
						No Ice	0.850	1.670	0.065
						1/2" Ice	1.140	2.340	0.079
						1" Ice	1.430	3.010	0.093
						2" Ice	2.010	4.350	0.121
R GPS (E)	A	From Leg	3.000	0.000	50'6"	4" Ice	3.170	7.030	0.177
						No Ice	0.151	0.151	0.000
						1/2" Ice	0.208	0.208	0.002
						1" Ice	0.273	0.273	0.005
						2" Ice	0.430	0.430	0.014
GPS (E)	B	From Leg	3.000	0.000	50'6"	4" Ice	0.847	0.847	0.051
						No Ice	0.151	0.151	0.000
						1/2" Ice	0.208	0.208	0.002
						1" Ice	0.273	0.273	0.005
						2" Ice	0.430	0.430	0.014
Side Arm Mount [SO 701-1] (E)	A	From Leg	1.500	0.000	50'6"	4" Ice	0.847	0.847	0.051
						No Ice	0.850	1.670	0.065
						1/2" Ice	1.140	2.340	0.079
						1" Ice	1.430	3.010	0.093
						2" Ice	2.010	4.350	0.121
Side Arm Mount [SO 701-1] (E)	B	From Leg	1.500	0.000	50'6"	4" Ice	3.170	7.030	0.177
						No Ice	0.850	1.670	0.065
						1/2" Ice	1.140	2.340	0.079
						1" Ice	1.430	3.010	0.093
						2" Ice	2.010	4.350	0.121
						4" Ice	3.170	7.030	0.177

R

Dishes

Description	Face or Leg	Dish Type	Offset Type	Offsets:		Azimuth Adjustment	3 dB Beam Width	Elevation	Outside Diameter	Aperture Area	Weight
				Horz	Lateral						
			ft	ft	°	°	ft	ft	ft ²	K	
VHLP2.5 (E)	A	Paraboloid w/Shroud (HP)	From Leg	4.000	0.000	128'	2.917	No Ice	6.681	0.048	
								1/2" Ice	7.069	0.077	
								1" Ice	7.456	0.106	
								2" Ice	8.230	0.164	
								4" Ice	9.779	0.280	
VHLP2.5 (E)	B	Paraboloid w/Shroud (HP)	From Leg	4.000	0.000	128'	2.917	No Ice	6.681	0.048	
								1/2" Ice	7.069	0.077	
								1" Ice	7.456	0.106	
								2" Ice	8.230	0.164	
								4" Ice	9.779	0.280	
VHLP2.5 (E)	B	Paraboloid w/Shroud (HP)	From Leg	4.000	0.000	128'	2.917	No Ice	6.681	0.048	
								1/2" Ice	7.069	0.077	
								1" Ice	7.456	0.106	
								2" Ice	8.230	0.164	
								4" Ice	9.779	0.280	

tnxTower B+T Group 1717 S Boulder Ave, Suite 300 Tulsa, OK 74119 Phone: (918) 587-4630 FAX: (918) 295-0265	Job 101341.001.01 - Glastonbury-main st, CT (Site# CT46126-A)	Page 26 of 48
	Project	Date 17:44:11 09/25/15
	Client SBA Communications Corporation	Designed by zsmith

Description	Face or Leg	Dish Type	Offset Type	Offsets: Horz Lateral Vert	Azimuth Adjustment °	3 dB Beam Width °	Elevation ft	Outside Diameter ft	Aperture Area ft ²	Weight K
R										

Load Combinations

Comb. No.	Description
1	Dead Only
2	Dead+Wind 0 deg - No Ice
3	Dead+Wind 30 deg - No Ice
4	Dead+Wind 60 deg - No Ice
5	Dead+Wind 90 deg - No Ice
6	Dead+Wind 120 deg - No Ice
7	Dead+Wind 150 deg - No Ice
8	Dead+Wind 180 deg - No Ice
9	Dead+Wind 210 deg - No Ice
10	Dead+Wind 240 deg - No Ice
11	Dead+Wind 270 deg - No Ice
12	Dead+Wind 300 deg - No Ice
13	Dead+Wind 330 deg - No Ice
14	Dead+Ice+Temp
15	Dead+Wind 0 deg+Ice+Temp
16	Dead+Wind 30 deg+Ice+Temp
17	Dead+Wind 60 deg+Ice+Temp
18	Dead+Wind 90 deg+Ice+Temp
19	Dead+Wind 120 deg+Ice+Temp
20	Dead+Wind 150 deg+Ice+Temp
21	Dead+Wind 180 deg+Ice+Temp
22	Dead+Wind 210 deg+Ice+Temp
23	Dead+Wind 240 deg+Ice+Temp
24	Dead+Wind 270 deg+Ice+Temp
25	Dead+Wind 300 deg+Ice+Temp
26	Dead+Wind 330 deg+Ice+Temp
27	Dead+Wind 0 deg - Service
28	Dead+Wind 30 deg - Service
29	Dead+Wind 60 deg - Service
30	Dead+Wind 90 deg - Service
31	Dead+Wind 120 deg - Service
32	Dead+Wind 150 deg - Service
33	Dead+Wind 180 deg - Service
34	Dead+Wind 210 deg - Service
35	Dead+Wind 240 deg - Service
36	Dead+Wind 270 deg - Service
37	Dead+Wind 300 deg - Service
38	Dead+Wind 330 deg - Service

Maximum Member Forces

Section No.	Elevation ft	Component Type	Condition	Gov. Load Comb.	Force K	Major Axis Moment kip-ft	Minor Axis Moment kip-ft
T1	130 - 120	Leg	Max Tension	12	8.346	0.039	0.018
			Max. Compression	6	-9.511	-0.122	-0.079
			Max. Mx	5	-0.357	0.159	-0.003

tnxTower B+T Group 1717 S Boulder Ave, Suite 300 Tulsa, OK 74119 Phone: (918) 587-4630 FAX: (918) 295-0265	Job 101341.001.01 - Glastonbury-main st, CT (Site# CT46126-A)	Page 27 of 48
	Project	Date 17:44:11 09/25/15
	Client SBA Communications Corporation	Designed by zsmith

Section No.	Elevation ft	Component Type	Condition	Gov. Load Comb.	Force K	Major Axis Moment kip-ft	Minor Axis Moment kip-ft	
T2	120 - 117.143	Diagonal	Max. My	8	-0.468	0.007	0.156	
			Max. Vy	10	-1.070	0.132	-0.060	
			Max. Vx	2	-1.190	0.021	0.143	
			Max Tension	13	1.430	0.000	0.000	
			Max. Compression	13	-1.471	0.000	0.000	
			Max. Mx	18	0.244	-0.001	0.000	
			Max. My	9	-0.962	-0.001	-0.001	
			Max. Vy	18	0.002	-0.001	-0.000	
			Max. Vx	9	-0.000	0.000	0.000	
			Max Tension	10	0.291	0.000	0.000	
			Max. Compression	12	-0.257	0.000	0.000	
			Max. Mx	14	0.056	-0.005	0.000	
		Horizontal	Max. My	9	0.011	0.000	0.000	
			Max. Vy	14	0.007	0.000	0.000	
			Max. Vx	9	-0.000	0.000	0.000	
			Max Tension	10	0.291	0.000	0.000	
			Max. Compression	12	-0.257	0.000	0.000	
			Max. Mx	14	0.056	-0.005	0.000	
			Top Girt	Max. My	9	0.004	0.000	0.000
				Max. Vy	14	0.007	0.000	0.000
				Max. Vx	9	-0.000	0.000	0.000
				Max Tension	6	0.055	0.000	0.000
				Max. Compression	12	-0.061	0.000	0.000
				Max. Mx	14	-0.002	-0.005	0.000
		Bottom Girt	Max. My	9	0.004	0.000	0.000	
			Max. Vy	14	0.007	0.000	0.000	
			Max. Vx	9	-0.000	0.000	0.000	
			Max Tension	12	0.234	0.000	0.000	
			Max. Compression	6	-0.206	0.000	0.000	
			Max. Mx	14	0.020	-0.005	0.000	
Leg	120 - 117.143	Leg	Max. My	9	-0.004	0.000	0.000	
			Max. Vy	14	0.007	0.000	0.000	
			Max. Vx	9	-0.000	0.000	0.000	
		Max Tension	12	10.543	0.203	0.141		
		Max. Compression	6	-12.816	-0.057	-0.035		
		Max. Mx	5	-0.170	0.426	-0.004		
		Max. My	8	-6.591	-0.022	0.422		
		Max. Vy	10	-1.069	0.221	-0.102		
		Max. Vx	2	-1.190	0.040	0.242		
		Diagonal	Max Tension	8	2.380	0.000	0.000	
			Max. Compression	2	-2.302	0.000	0.000	
			Max. Mx	6	0.280	-0.003	-0.000	
			Max. My	9	-1.066	-0.002	-0.001	
			Max. Vy	18	0.004	-0.002	-0.000	
			Max. Vx	9	-0.000	0.000	0.000	
		Top Girt	Max Tension	10	0.059	0.000	0.000	
			Max. Compression	12	-0.032	0.000	0.000	
			Max. Mx	14	0.023	-0.005	0.000	
Max. My	9		0.016	0.000	0.000			
Max. Vy	14		0.007	0.000	0.000			
Max. Vx	9		-0.000	0.000	0.000			
Leg	117.143 - 114.286	Leg	Max Tension	12	16.897	0.239	0.159	
			Max. Compression	6	-19.265	0.087	0.048	
			Max. Mx	5	13.970	-0.258	0.057	
		Max. My	8	16.269	-0.017	-0.285		
		Max. Vy	10	-2.305	0.250	-0.146		
		Max. Vx	2	-2.593	0.017	0.284		
		Diagonal	Max Tension	13	3.104	0.000	0.000	
			Max. Compression	13	-3.097	0.000	0.000	
			Max. Mx	10	-0.071	-0.004	-0.000	
			Max. My	8	-2.834	-0.001	-0.002	
			Max. Vy	18	-0.004	-0.002	0.000	
			Max. Vx	8	-0.001	0.000	0.000	
		Leg	Max Tension	12	23.647	-0.088	-0.048	
			Max. Compression	6	-25.990	-0.231	-0.113	
			Max. Mx	5	13.970	-0.258	0.057	

tnxTower B+T Group 1717 S Boulder Ave, Suite 300 Tulsa, OK 74119 Phone: (918) 587-4630 FAX: (918) 295-0265	Job 101341.001.01 - Glastonbury-main st, CT (Site# CT46126-A)	Page 28 of 48
	Project	Date 17:44:11 09/25/15
	Client SBA Communications Corporation	Designed by zsmith

Section No.	Elevation ft	Component Type	Condition	Gov. Load Comb.	Force K	Major Axis Moment kip-ft	Minor Axis Moment kip-ft
T5	111.43 - 108.573	Diagonal	Max. Mx	11	-22.163	0.248	-0.014
			Max. My	2	-25.528	-0.014	0.256
			Max. Vy	5	0.120	-0.246	0.012
			Max. Vx	2	-0.132	-0.014	0.256
			Max Tension	13	2.899	0.000	0.000
			Max. Compression	13	-2.933	0.000	0.000
			Max. Mx	11	1.535	-0.003	-0.000
		Leg	Max. My	9	-2.046	0.001	-0.001
			Max. Vy	19	0.004	-0.002	-0.000
			Max. Vx	9	0.001	0.001	-0.001
			Max Tension	12	31.017	0.229	0.112
			Max. Compression	6	-34.097	-0.198	-0.091
			Max. Mx	11	-28.604	-0.433	-0.014
			Max. My	8	-16.688	-0.029	0.461
T6	108.573 - 105.716	Diagonal	Max. Vy	11	0.479	0.248	-0.014
			Max. Vx	2	-0.508	0.022	0.261
			Max Tension	13	3.730	0.000	0.000
			Max. Compression	13	-3.729	0.000	0.000
			Max. Mx	11	2.325	-0.004	-0.000
			Max. My	8	-3.138	0.000	-0.001
			Max. Vy	20	0.004	-0.002	-0.000
		Leg	Max. Vx	8	-0.001	0.000	0.000
			Max Tension	12	40.723	0.204	0.094
			Max. Compression	6	-44.392	-0.037	-0.027
			Max. Mx	11	-3.361	0.240	-0.002
			Max. My	2	17.335	0.022	0.261
			Max. Vy	11	0.098	0.240	-0.002
			Max. Vx	2	0.103	0.022	0.261
T7	105.716 - 102.859	Diagonal	Max Tension	13	4.484	0.000	0.000
			Max. Compression	13	-4.556	0.000	0.000
			Max. Mx	11	2.419	-0.004	-0.000
			Max. My	8	-4.024	0.000	-0.001
			Max. Vy	20	0.004	-0.002	-0.000
			Max. Vx	8	-0.001	0.000	0.000
			Max Tension	12	52.084	0.027	0.021
		Leg	Max. Compression	6	-55.895	0.015	0.007
			Max. Mx	11	-3.700	0.207	-0.009
			Max. My	13	-3.108	0.097	0.184
			Max. Vy	11	-0.086	0.207	-0.009
			Max. Vx	13	-0.081	0.097	0.184
			Max Tension	13	4.408	0.000	0.000
			Max. Compression	13	-4.466	0.000	0.000
T8	102.859 - 100	Diagonal	Max. Mx	11	2.033	-0.005	-0.000
			Max. My	8	-4.139	0.001	-0.002
			Max. Vy	19	0.004	-0.003	-0.000
			Max. Vx	8	-0.001	0.000	0.000
			Max Tension	12	68.221	0.120	0.067
			Max. Compression	6	-72.275	-0.390	-0.233
			Max. Mx	4	66.746	-0.405	0.219
		Leg	Max. My	8	66.871	-0.021	-0.460
			Max. Vy	10	-3.482	0.398	-0.216
			Max. Vx	2	-3.941	0.019	0.450
			Max Tension	13	4.454	0.000	0.000
			Max. Compression	13	-4.551	0.000	0.000
			Max. Mx	11	-1.683	0.005	-0.001
			Max. My	9	-3.887	0.003	-0.003
Diagonal	Max. Vy	19	0.004	-0.003	0.000		
	Max. Vx	9	0.002	0.003	-0.003		

tnxTower B+T Group 1717 S Boulder Ave, Suite 300 Tulsa, OK 74119 Phone: (918) 587-4630 FAX: (918) 295-0265	Job 101341.001.01 - Glastonbury-main st, CT (Site# CT46126-A)	Page 29 of 48
	Project	Date 17:44:11 09/25/15
	Client SBA Communications Corporation	Designed by zsmith

Section No.	Elevation ft	Component Type	Condition	Gov. Load Comb.	Force K	Major Axis Moment kip-ft	Minor Axis Moment kip-ft
T9	100 - 96	Secondary Horizontal	Max Tension	6	1.252	0.000	0.000
			Max. Compression	6	-1.252	0.000	0.000
			Max. Mx	14	0.093	-0.006	0.000
			Max. My	9	1.062	0.000	0.000
			Max. Vy	14	-0.009	0.000	0.000
		Bottom Girt	Max. Vx	9	-0.000	0.000	0.000
			Max Tension	12	0.825	0.000	0.000
			Max. Compression	6	-0.829	0.000	0.000
			Max. Mx	14	0.048	-0.005	0.000
			Max. My	9	-0.013	0.000	0.000
		Leg	Max. Vy	14	0.007	0.000	0.000
			Max. Vx	9	-0.000	0.000	0.000
			Max Tension	12	71.565	-0.469	-0.009
			Max. Compression	6	-75.228	1.085	0.024
			Max. Mx	12	71.517	-1.095	-0.020
T10	96 - 92	Diagonal	Max. My	11	-3.999	0.003	-1.564
			Max. Vy	6	-0.176	1.085	0.024
			Max. Vx	11	0.362	0.003	-1.564
			Max Tension	8	3.475	0.038	0.007
			Max. Compression	2	-3.602	0.000	0.000
		Leg	Max. Mx	11	2.725	0.040	-0.004
			Max. My	13	-3.308	-0.028	-0.013
			Max. Vy	11	0.018	0.040	-0.004
			Max. Vx	13	0.006	0.000	0.000
			Max Tension	12	82.289	-1.095	-0.020
		Diagonal	Max. Compression	6	-87.120	0.435	0.011
			Max. Mx	12	82.289	-1.095	-0.020
			Max. My	11	-4.447	0.003	-1.564
			Max. Vy	4	0.630	-0.581	-0.021
			Max. Vx	7	0.730	-0.040	-1.500
T11	92 - 88	Diagonal	Max Tension	7	3.854	0.094	-0.007
			Max. Compression	13	-4.160	0.000	0.000
			Max. Mx	11	-2.233	-0.127	0.006
			Max. My	9	-3.349	-0.092	0.015
			Max. Vy	11	0.056	0.000	0.000
		Leg	Max. Vx	9	-0.007	-0.092	0.015
			Max Tension	12	90.381	-0.586	-0.005
			Max. Compression	6	-95.948	2.605	-0.006
			Max. Mx	6	-95.948	2.605	-0.006
			Max. My	11	-5.020	-0.154	-2.448
		Diagonal	Max. Vy	6	1.745	2.605	-0.006
			Max. Vx	13	-1.512	-0.150	2.445
			Max Tension	8	5.745	-0.067	0.006
			Max. Compression	2	-6.080	0.000	0.000
			Max. Mx	6	2.367	-0.071	0.009
T12	88 - 84	Secondary Horizontal	Max. My	9	-4.478	0.060	-0.019
			Max. Vy	6	0.032	-0.071	0.009
			Max. Vx	9	0.008	0.057	-0.019
			Max Tension	12	3.151	0.000	0.000
			Max. Compression	6	-2.841	0.000	0.000
		Leg	Max. Mx	14	0.296	0.012	0.000
			Max. My	22	0.628	0.000	-0.000
			Max. Vy	14	-0.016	0.000	0.000
			Max. Vx	22	0.000	0.000	0.000
			Max Tension	12	102.838	0.648	-0.011
		Leg	Max. Compression	6	-108.999	2.494	-0.008
			Max. Mx	6	-108.999	2.494	-0.008
			Max. My	11	-5.248	-0.154	-2.448
			Max. Vy	6	-1.801	2.494	-0.008

tnxTower B+T Group 1717 S Boulder Ave, Suite 300 Tulsa, OK 74119 Phone: (918) 587-4630 FAX: (918) 295-0265	Job 101341.001.01 - Glastonbury-main st, CT (Site# CT46126-A)	Page 30 of 48
	Project	Date 17:44:11 09/25/15
	Client SBA Communications Corporation	Designed by zsmith

Section No.	Elevation ft	Component Type	Condition	Gov. Load Comb.	Force K	Major Axis Moment kip-ft	Minor Axis Moment kip-ft	
T13	84 - 80	Diagonal	Max. Vx	13	1.668	-0.150	2.445	
			Max Tension	8	5.318	-0.049	0.002	
			Max. Compression	2	-5.550	0.000	0.000	
			Max. Mx	6	2.302	-0.050	0.004	
			Max. My	9	-4.121	0.042	-0.012	
			Max. Vy	6	0.023	-0.050	0.004	
			Max. Vx	9	0.005	0.040	-0.012	
			Max Tension	12	3.732	0.000	0.000	
			Secondary Horizontal	Max. Compression	6	-3.370	0.000	0.000
				Max. Mx	14	0.360	0.014	0.000
				Max. My	22	0.708	0.000	-0.000
				Max. Vy	14	-0.017	0.000	0.000
		Max. Vx		22	-0.000	0.000	0.000	
		Max Tension		12	114.256	0.463	-0.002	
		Leg	Max. Compression	6	-120.850	2.574	0.004	
			Max. Mx	6	-120.850	2.574	0.004	
			Max. My	13	-4.945	-0.103	2.206	
			Max. Vy	6	-1.696	2.574	0.004	
			Max. Vx	13	1.484	-0.103	2.206	
			Diagonal	Max Tension	8	4.925	-0.054	-0.013
				Max. Compression	2	-5.147	0.000	0.000
				Max. Mx	12	4.627	-0.054	-0.009
				Max. My	8	-2.742	0.023	-0.016
				Max. Vy	12	-0.023	-0.054	-0.009
Max. Vx	8			0.006	0.000	0.000		
Secondary Horizontal	Max Tension		12	3.195	0.000	0.000		
	Max. Compression	6	-2.913	0.000	0.000			
	Max. Mx	14	0.288	0.015	0.000			
	Max. My	22	0.782	0.000	-0.000			
	Max. Vy	14	-0.018	0.000	0.000			
	Max. Vx	22	-0.000	0.000	0.000			
T14	80 - 75	Leg	Max Tension	12	129.216	-0.305	-0.036	
			Max. Compression	6	-137.007	2.628	0.013	
			Max. Mx	12	128.471	-2.651	0.005	
			Max. My	11	-6.637	0.014	-3.066	
			Max. Vy	4	-0.914	-0.296	-0.022	
			Max. Vx	7	-1.159	-0.062	-1.789	
		Diagonal	Max Tension	11	6.078	0.067	0.005	
			Max. Compression	11	-6.455	0.000	0.000	
			Max. Mx	12	5.569	0.082	-0.004	
			Max. My	4	-5.280	-0.033	-0.011	
			Max. Vy	12	0.029	0.082	-0.004	
			Max. Vx	11	-0.004	0.000	0.000	
T15	75 - 70	Leg	Max Tension	12	146.773	-2.651	0.005	
			Max. Compression	6	-155.648	2.511	0.012	
			Max. Mx	12	146.773	-2.651	0.005	
			Max. My	11	-6.827	0.014	-3.066	
			Max. Vy	12	-0.065	-2.651	0.005	
			Max. Vx	9	0.264	0.000	3.051	
		Diagonal	Max Tension	11	6.467	-0.046	0.003	
			Max. Compression	11	-6.968	0.000	0.000	
			Max. Mx	6	5.736	-0.054	-0.002	
			Max. My	9	-6.575	0.041	-0.008	
			Max. Vy	6	0.021	-0.054	-0.002	
			Max. Vx	9	0.003	0.039	-0.008	
T16	70 - 65	Leg	Max Tension	12	163.404	-2.502	-0.001	
			Max. Compression	10	-172.855	2.631	0.037	
			Max. Mx	10	-172.855	2.631	0.037	
			Max. My	11	-7.067	0.021	-2.842	

<p>tnxTower</p> <p>B+T Group 1717 S Boulder Ave, Suite 300 Tulsa, OK 74119 Phone: (918) 587-4630 FAX: (918) 295-0265</p>	<p>Job 101341.001.01 - Glastonbury-main st, CT (Site# CT46126-A)</p>	<p>Page 31 of 48</p>
	<p>Project</p>	<p>Date 17:44:11 09/25/15</p>
	<p>Client SBA Communications Corporation</p>	<p>Designed by zsmith</p>

Section No.	Elevation ft	Component Type	Condition	Gov. Load Comb.	Force K	Major Axis Moment kip-ft	Minor Axis Moment kip-ft
T17	65 - 60	Diagonal	Max. Vy	4	0.055	-2.584	-0.029
			Max. Vx	9	-0.216	0.010	2.821
			Max Tension	11	5.733	-0.047	-0.005
			Max. Compression	11	-6.298	0.000	0.000
			Max. Mx	12	4.720	-0.055	0.003
			Max. My	4	-5.611	0.022	0.009
		Leg	Max. Vy	6	0.021	-0.053	-0.003
			Max. Vx	4	-0.003	0.000	0.000
			Max Tension	12	178.059	-2.607	-0.000
			Max. Compression	10	-188.375	1.395	0.040
			Max. Mx	10	-188.272	2.631	0.037
			Max. My	11	-7.294	-0.056	-3.629
			Max. Vy	10	0.277	2.631	0.037
			Max. Vx	9	-0.193	-0.064	3.602
T18	60 - 55	Diagonal	Max Tension	11	5.681	-0.047	0.006
			Max. Compression	11	-6.196	0.000	0.000
			Max. Mx	10	4.610	-0.057	-0.007
			Max. My	9	-5.810	0.041	-0.012
			Max. Vy	10	0.022	-0.057	-0.007
			Max. Vx	9	0.004	0.040	-0.012
		Leg	Max Tension	12	190.758	-1.663	0.003
			Max. Compression	10	-201.727	1.496	0.032
			Max. Mx	10	-201.651	5.262	-0.003
			Max. My	11	-7.184	-0.056	-3.629
			Max. Vy	10	-1.603	5.262	-0.003
			Max. Vx	13	1.562	-0.058	3.614
			Max Tension	4	6.123	0.000	0.000
			Max. Compression	10	-6.671	0.000	0.000
T19	55 - 50	Diagonal	Max. Mx	10	3.122	-0.055	-0.005
			Max. My	9	-5.643	0.040	-0.008
			Max. Vy	10	0.021	-0.055	-0.005
			Max. Vx	9	0.003	0.039	-0.008
			Max Tension	10	3.495	0.000	0.000
			Max. Compression	10	-3.495	0.000	0.000
		Leg	Max. Mx	14	0.290	-0.018	0.000
			Max. My	22	1.289	0.000	0.000
			Max. Vy	14	0.016	0.000	0.000
			Max. Vx	22	-0.000	0.000	0.000
			Max Tension	12	205.912	-1.729	0.000
			Max. Compression	10	-218.056	2.678	0.036
			Max. Mx	10	-218.056	2.678	0.036
			Max. My	11	-7.861	-0.015	-3.463
T20	50 - 45	Diagonal	Max. Vy	10	-0.284	2.678	0.036
			Max. Vx	9	-0.151	-0.023	3.440
			Max Tension	11	5.044	0.000	0.000
			Max. Compression	11	-5.494	0.000	0.000
			Max. Mx	12	4.027	-0.043	0.005
			Max. My	11	-5.484	0.029	-0.011
		Leg	Max. Vy	23	0.019	-0.025	0.001
			Max. Vx	11	0.003	0.000	0.000
			Max Tension	12	217.717	-2.629	0.005
			Max. Compression	10	-230.773	1.456	0.018
			Max. Mx	10	-230.627	2.678	0.036
			Max. My	11	-7.963	-0.015	-3.463
			Max. Vy	10	0.270	2.678	0.036
			Max. Vx	9	0.191	-0.023	3.440
Diagonal	Max Tension	11	5.355	0.000	0.000		
	Max. Compression	11	-5.813	0.000	0.000		
	Max. Mx	10	4.159	-0.045	-0.010		
	Max. My	9	-5.443	0.028	-0.017		

tnxTower B+T Group 1717 S Boulder Ave, Suite 300 Tulsa, OK 74119 Phone: (918) 587-4630 FAX: (918) 295-0265	Job 101341.001.01 - Glastonbury-main st, CT (Site# CT46126-A)	Page 32 of 48
	Project	Date 17:44:11 09/25/15
	Client SBA Communications Corporation	Designed by zsmith

Section No.	Elevation ft	Component Type	Condition	Gov. Load Comb.	Force K	Major Axis Moment kip-ft	Minor Axis Moment kip-ft
T21	45 - 40	Leg	Max. Vy	19	0.020	-0.029	-0.004
			Max. Vx	9	0.005	0.027	-0.017
			Max Tension	12	228.892	-1.651	0.000
			Max. Compression	10	-242.772	1.600	0.039
			Max. Mx	10	-242.756	5.967	-0.011
			Max. My	11	-8.243	-0.019	-3.452
		Diagonal	Max. Vy	10	-1.859	5.967	-0.011
			Max. Vx	11	1.771	-0.019	-3.452
			Max Tension	4	5.194	0.000	0.000
			Max. Compression	10	-5.574	0.000	0.000
			Max. Mx	12	4.932	0.062	-0.002
			Max. My	11	-5.186	-0.046	0.006
		Secondary Horizontal	Max. Vy	12	0.021	0.062	-0.002
			Max. Vx	11	-0.002	0.000	0.000
			Max Tension	10	4.206	0.000	0.000
			Max. Compression	10	-4.206	0.000	0.000
			Max. Mx	14	0.312	-0.046	0.000
			Max. My	22	1.539	0.000	0.001
			Max. Vy	14	0.034	0.000	0.000
T22	40 - 33.3333	Leg	Max. Vx	22	-0.000	0.000	0.000
			Max Tension	12	242.122	-1.794	0.007
			Max. Compression	10	-256.755	2.367	0.031
			Max. Mx	12	241.902	-2.389	0.005
			Max. My	11	-8.805	-0.047	-3.531
		Diagonal	Max. Vy	10	-0.146	2.367	0.031
			Max. Vx	4	0.052	1.140	-3.094
			Max Tension	4	5.406	0.000	0.000
			Max. Compression	11	-6.100	0.000	0.000
			Max. Mx	12	5.089	-0.068	0.013
T23	33.3333 - 26.6667	Leg	Max. My	11	-6.085	0.045	-0.025
			Max. Vy	19	0.024	-0.038	-0.004
			Max. Vx	11	0.006	0.000	0.000
			Max Tension	12	257.400	-2.389	0.005
			Max. Compression	10	-273.170	3.030	0.021
		Diagonal	Max. Mx	10	-273.170	3.030	0.021
			Max. My	11	-9.098	-0.047	-3.531
			Max. Vy	10	-0.130	3.030	0.021
			Max. Vx	9	0.321	-0.054	3.510
			Max Tension	5	5.353	0.000	0.000
T24	26.6667 - 20	Leg	Max. Compression	11	-6.122	0.000	0.000
			Max. Mx	10	4.725	-0.070	-0.009
			Max. My	9	-5.720	0.043	-0.014
			Max. Vy	19	0.026	-0.044	-0.004
			Max. Vx	9	0.003	0.042	-0.014
		Diagonal	Max Tension	12	270.240	-2.956	0.005
			Max. Compression	10	-287.252	2.033	0.001
			Max. Mx	10	-287.036	3.030	0.021
			Max. My	11	-9.680	-0.086	-3.224
			Max. Vy	10	0.180	3.030	0.021
T25	20 - 13.3333	Leg	Max. Vx	11	0.271	-0.086	-3.224
			Max Tension	11	4.947	0.000	□
			Max. Compression	11	-5.739	0.000	0.000
			Max. Mx	12	4.074	-0.065	0.005
			Max. My	4	-5.021	0.020	0.012
		Diagonal	Max. Vy	19	0.026	-0.042	-0.000
			Max. Vx	4	-0.003	0.000	0.000
			Max Tension	12	281.965	-2.097	-0.004
			Max. Compression	10	-300.414	1.300	0.018
			Max. Mx	12	281.965	-2.097	-0.004

tnxTower B+T Group 1717 S Boulder Ave, Suite 300 Tulsa, OK 74119 Phone: (918) 587-4630 FAX: (918) 295-0265	Job 101341.001.01 - Glastonbury-main st, CT (Site# CT46126-A)	Page 33 of 48
	Project	Date 17:44:11 09/25/15
	Client SBA Communications Corporation	Designed by zsmith

Section No.	Elevation ft	Component Type	Condition	Gov. Load Comb.	Force K	Major Axis Moment kip-ft	Minor Axis Moment kip-ft
T26	13.3333 - 6.66666	Diagonal	Max. My	11	-9.820	-0.086	-3.224
			Max. Vy	15	0.199	1.040	-0.005
			Max. Vx	11	-0.140	-0.086	-3.224
			Max Tension	11	5.117	0.000	0.000
			Max. Compression	11	-5.680	0.000	0.000
			Max. Mx	10	3.921	0.050	0.002
			Max. My	9	-5.278	-0.030	0.008
			Max. Vy	19	-0.019	0.031	0.002
			Max. Vx	9	-0.002	-0.030	0.008
			Max Tension	12	293.003	-1.441	0.005
		Leg	Max. Compression	10	-312.646	0.882	0.088
			Max. Mx	10	-312.535	7.013	0.005
			Max. My	9	-9.855	-0.206	6.946
			Max. Vy	10	1.811	7.013	0.005
			Max. Vx	9	-2.270	-0.206	6.946
			Max Tension	4	4.563	0.000	0.000
			Max. Compression	10	-5.013	0.000	0.000
			Max. Mx	12	4.288	0.045	-0.001
			Max. My	11	-4.959	-0.030	0.006
			Max. Vy	21	0.020	0.034	0.001
Secondary Horizontal	Max. Vx	11	-0.001	0.000	0.000		
	Max Tension	10	5.417	0.000	0.000		
	Max. Compression	10	-5.417	0.000	0.000		
	Max. Mx	14	0.347	-0.049	0.000		
	Max. My	22	1.962	0.000	0.001		
	Max. Vy	14	0.028	0.000	0.000		
	Max. Vx	22	-0.000	0.000	0.000		
	Max Tension	12	311.472	0.641	-0.004		
	Max. Compression	10	-333.913	0.000	0.000		
	Max. Mx	15	-134.025	1.527	-0.020		
T27	6.66666 - 0	Leg	Max. My	9	-10.010	-0.206	6.946
			Max. Vy	10	-8.778	0.000	0.000
			Max. Vx	9	1.081	-0.206	6.946
			Max Tension	4	6.509	0.000	0.000
			Max. Compression	10	-7.264	0.000	0.000
			Max. Mx	10	3.014	-0.085	-0.025
			Max. My	9	-5.895	0.043	-0.039
			Max. Vy	19	0.030	-0.041	-0.011
			Max. Vx	9	0.008	0.041	-0.039
			Diagonal	Max Tension	4	6.509	0.000

Maximum Reactions

Location	Condition	Gov. Load Comb.	Vertical K	Horizontal, X K	Horizontal, Z K
Leg C	Max. Vert	10	333.545	15.616	-8.872
	Max. H _x	10	333.545	15.616	-8.872
	Max. H _z	4	-310.165	-14.818	8.402
	Min. Vert	4	-310.165	-14.818	8.402
	Min. H _x	4	-310.165	-14.818	8.402
	Min. H _z	10	333.545	15.616	-8.872
Leg B	Max. Vert	6	332.466	-15.530	-8.881
	Max. H _x	12	-311.096	14.791	8.483
	Max. H _z	12	-311.096	14.791	8.483
	Min. Vert	12	-311.096	14.791	8.483

<p>tnxTower</p> <p>B+T Group 1717 S Boulder Ave, Suite 300 Tulsa, OK 74119 Phone: (918) 587-4630 FAX: (918) 295-0265</p>	<p>Job 101341.001.01 - Glastonbury-main st, CT (Site# CT46126-A)</p>	<p>Page 34 of 48</p>
	<p>Project</p>	<p>Date 17:44:11 09/25/15</p>
	<p>Client SBA Communications Corporation</p>	<p>Designed by zsmith</p>

Location	Condition	Gov. Load Comb.	Vertical K	Horizontal, X K	Horizontal, Z K
Leg A	Min. H _x	6	332.466	-15.530	-8.881
	Min. H _z	6	332.466	-15.530	-8.881
	Max. Vert	2	330.947	0.052	17.846
	Max. H _x	5	8.788	0.993	0.320
	Max. H _z	2	330.947	0.052	17.846
	Min. Vert	8	-309.674	-0.083	-16.978
	Min. H _x	11	10.884	-1.004	0.375
	Min. H _z	8	-309.674	-0.083	-16.978

Tower Mast Reaction Summary

Load Combination	Vertical K	Shear _x K	Shear _z K	Overtuning Moment, M _x kip-ft	Overtuning Moment, M _z kip-ft	Torque kip-ft
Dead Only	28.619	-0.000	0.000	2.453	-0.418	-0.000
Dead+Wind 0 deg - No Ice	28.619	-0.124	-24.972	-2087.601	19.385	1.029
Dead+Wind 30 deg - No Ice	28.619	12.434	-21.356	-1790.722	-1045.702	2.198
Dead+Wind 60 deg - No Ice	28.619	21.411	-12.276	-1027.530	-1804.545	1.913
Dead+Wind 90 deg - No Ice	28.619	24.767	-0.009	4.882	-2083.462	1.168
Dead+Wind 120 deg - No Ice	28.619	21.661	12.512	1053.749	-1813.562	0.798
Dead+Wind 150 deg - No Ice	28.619	12.379	21.343	1797.827	-1044.400	-0.058
Dead+Wind 180 deg - No Ice	28.619	0.036	24.584	2073.351	-8.818	-1.257
Dead+Wind 210 deg - No Ice	28.619	-12.377	21.441	1806.898	1036.922	-2.200
Dead+Wind 240 deg - No Ice	28.619	-21.817	12.459	1040.467	1829.326	-1.828
Dead+Wind 270 deg - No Ice	28.619	-24.859	-0.057	-8.730	2094.588	-1.164
Dead+Wind 300 deg - No Ice	28.619	-21.396	-12.308	-1038.191	1805.372	-0.656
Dead+Wind 330 deg - No Ice	28.619	-12.436	-21.364	-1795.492	1051.458	0.055
Dead+Ice+Temp	64.087	-0.000	-0.000	8.006	-1.224	-0.000
Dead+Wind 0 deg+Ice+Temp	64.087	-0.034	-8.967	-748.411	4.235	0.287
Dead+Wind 30 deg+Ice+Temp	64.087	4.385	-7.556	-636.302	-375.453	0.606
Dead+Wind 60 deg+Ice+Temp	64.087	7.512	-4.315	-360.742	-645.357	0.570
Dead+Wind 90 deg+Ice+Temp	64.087	8.751	0.001	9.137	-748.384	0.405
Dead+Wind 120 deg+Ice+Temp	64.087	7.773	4.493	388.348	-657.059	0.282
Dead+Wind 150 deg+Ice+Temp	64.087	4.377	7.557	653.516	-375.764	0.005
Dead+Wind 180 deg+Ice+Temp	64.087	0.012	8.645	749.359	-3.767	-0.332
Dead+Wind 210 deg+Ice+Temp	64.087	-4.371	7.578	655.478	370.946	-0.606
Dead+Wind 240 deg+Ice+Temp	64.087	-7.809	4.474	384.285	658.493	-0.569
Dead+Wind 270 deg+Ice+Temp	64.087	-8.774	-0.018	4.891	748.993	-0.404
Dead+Wind 300 deg+Ice+Temp	64.087	-7.511	-4.329	-364.126	643.686	-0.239
Dead+Wind 330 deg+Ice+Temp	64.087	-4.391	-7.562	-637.899	375.325	-0.006
Dead+Wind 0 deg - Service	28.619	-0.048	-9.755	-814.114	7.317	0.402
Dead+Wind 30 deg - Service	28.619	4.858	-8.342	-698.119	-408.787	0.838
Dead+Wind 60 deg - Service	28.619	8.364	-4.795	-399.932	-705.267	0.748
Dead+Wind 90 deg - Service	28.619	9.675	-0.004	3.435	-814.255	0.478
Dead+Wind 120 deg - Service	28.619	8.461	4.887	413.213	-708.824	0.311
Dead+Wind 150 deg - Service	28.619	4.835	8.338	703.904	-408.314	-0.044
Dead+Wind 180 deg - Service	28.619	0.014	9.604	811.541	-3.702	-0.492
Dead+Wind 210 deg - Service	28.619	-4.835	8.376	707.443	404.878	-0.839
Dead+Wind 240 deg - Service	28.619	-8.522	4.867	408.020	714.462	-0.715
Dead+Wind 270 deg - Service	28.619	-9.711	-0.023	-1.885	818.082	-0.476
Dead+Wind 300 deg - Service	28.619	-8.358	-4.808	-404.094	705.073	-0.258
Dead+Wind 330 deg - Service	28.619	-4.858	-8.345	-699.981	410.524	0.043

Solution Summary

tnxTower B+T Group 1717 S Boulder Ave, Suite 300 Tulsa, OK 74119 Phone: (918) 587-4630 FAX: (918) 295-0265	Job 101341.001.01 - Glastonbury-main st, CT (Site# CT46126-A)	Page 35 of 48
	Project	Date 17:44:11 09/25/15
	Client SBA Communications Corporation	Designed by zsmith

Load Comb.	Sum of Applied Forces			Sum of Reactions			% Error
	PX K	PY K	PZ K	PX K	PY K	PZ K	
1	0.000	-28.619	0.000	0.000	28.619	-0.000	0.000%
2	-0.124	-28.619	-24.972	0.124	28.619	24.972	0.000%
3	12.436	-28.619	-21.356	-12.434	28.619	21.356	0.005%
4	21.412	-28.619	-12.276	-21.411	28.619	12.276	0.003%
5	24.768	-28.619	-0.010	-24.767	28.619	0.009	0.005%
6	21.661	-28.619	12.512	-21.661	28.619	-12.512	0.000%
7	12.378	-28.619	21.345	-12.379	28.619	-21.343	0.005%
8	0.036	-28.619	24.585	-0.036	28.619	-24.584	0.003%
9	-12.377	-28.619	21.442	12.377	28.619	-21.441	0.005%
10	-21.817	-28.619	12.459	21.817	28.619	-12.459	0.000%
11	-24.860	-28.619	-0.058	24.859	28.619	0.057	0.005%
12	-21.397	-28.619	-12.309	21.396	28.619	12.308	0.003%
13	-12.438	-28.619	-21.364	12.436	28.619	21.364	0.005%
14	0.000	-64.087	0.000	0.000	64.087	0.000	0.000%
15	-0.034	-64.087	-8.967	0.034	64.087	8.967	0.000%
16	4.385	-64.087	-7.556	-4.385	64.087	7.556	0.001%
17	7.512	-64.087	-4.315	-7.512	64.087	4.315	0.001%
18	8.751	-64.087	0.001	-8.751	64.087	-0.001	0.001%
19	7.773	-64.087	4.493	-7.773	64.087	-4.493	0.000%
20	4.377	-64.087	7.557	-4.377	64.087	-7.557	0.001%
21	0.012	-64.087	8.645	-0.012	64.087	-8.645	0.001%
22	-4.371	-64.087	7.578	4.371	64.087	-7.578	0.001%
23	-7.809	-64.087	4.474	7.809	64.087	-4.474	0.000%
24	-8.774	-64.087	-0.018	8.774	64.087	0.018	0.001%
25	-7.512	-64.087	-4.330	7.511	64.087	4.329	0.001%
26	-4.392	-64.087	-7.562	4.391	64.087	7.562	0.001%
27	-0.048	-28.619	-9.755	0.048	28.619	9.755	0.000%
28	4.858	-28.619	-8.342	-4.858	28.619	8.342	0.000%
29	8.364	-28.619	-4.795	-8.364	28.619	4.795	0.000%
30	9.675	-28.619	-0.004	-9.675	28.619	0.004	0.000%
31	8.461	-28.619	4.887	-8.461	28.619	-4.887	0.000%
32	4.835	-28.619	8.338	-4.835	28.619	-8.338	0.000%
33	0.014	-28.619	9.604	-0.014	28.619	-9.604	0.000%
34	-4.835	-28.619	8.376	4.835	28.619	-8.376	0.000%
35	-8.522	-28.619	4.867	8.522	28.619	-4.867	0.000%
36	-9.711	-28.619	-0.023	9.711	28.619	0.023	0.000%
37	-8.358	-28.619	-4.808	8.358	28.619	4.808	0.000%
38	-4.859	-28.619	-8.345	4.858	28.619	8.345	0.000%

Non-Linear Convergence Results

Load Combination	Converged?	Number of Cycles	Displacement Tolerance	Force Tolerance
1	Yes	4	0.00000001	0.00000001
2	Yes	4	0.00000001	0.00000945
3	Yes	4	0.00000001	0.00003867
4	Yes	4	0.00000001	0.00002123
5	Yes	4	0.00000001	0.00003866
6	Yes	4	0.00000001	0.00001076
7	Yes	4	0.00000001	0.00003908
8	Yes	4	0.00000001	0.00001953
9	Yes	4	0.00000001	0.00003901
10	Yes	4	0.00000001	0.00001089
11	Yes	4	0.00000001	0.00003923
12	Yes	4	0.00000001	0.00002124

<p>tnxTower</p> <p>B+T Group 1717 S Boulder Ave, Suite 300 Tulsa, OK 74119 Phone: (918) 587-4630 FAX: (918) 295-0265</p>	<p>Job 101341.001.01 - Glastonbury-main st, CT (Site# CT46126-A)</p>	<p>Page 36 of 48</p>
	<p>Project</p>	<p>Date 17:44:11 09/25/15</p>
	<p>Client SBA Communications Corporation</p>	<p>Designed by zsmith</p>

13	Yes	4	0.00000001	0.00003930
14	Yes	4	0.00000001	0.00000001
15	Yes	4	0.00000001	0.00010987
16	Yes	4	0.00000001	0.00011498
17	Yes	4	0.00000001	0.00011806
18	Yes	4	0.00000001	0.00011336
19	Yes	4	0.00000001	0.00011140
20	Yes	4	0.00000001	0.00011492
21	Yes	4	0.00000001	0.00011672
22	Yes	4	0.00000001	0.00011486
23	Yes	4	0.00000001	0.00011119
24	Yes	4	0.00000001	0.00011347
25	Yes	4	0.00000001	0.00011820
26	Yes	4	0.00000001	0.00011507
27	Yes	4	0.00000001	0.00000972
28	Yes	4	0.00000001	0.00001107
29	Yes	4	0.00000001	0.00001138
30	Yes	4	0.00000001	0.00001087
31	Yes	4	0.00000001	0.00000986
32	Yes	4	0.00000001	0.00001104
33	Yes	4	0.00000001	0.00001124
34	Yes	4	0.00000001	0.00001107
35	Yes	4	0.00000001	0.00000984
36	Yes	4	0.00000001	0.00001091
37	Yes	4	0.00000001	0.00001141
38	Yes	4	0.00000001	0.00001107

Maximum Tower Deflections - Service Wind

Section No.	Elevation ft	Horz. Deflection in	Gov. Load Comb.	Tilt °	Twist °
T1	130 - 120	13.976	31	0.981	0.116
T2	120 - 117.143	11.915	36	0.969	0.079
T3	117.143 - 114.286	11.333	36	0.964	0.073
T4	114.286 - 111.43	10.752	36	0.955	0.066
T5	111.43 - 108.573	10.182	35	0.943	0.060
T6	108.573 - 105.716	9.617	35	0.927	0.054
T7	105.716 - 102.859	9.061	35	0.906	0.049
T8	102.859 - 100	8.519	35	0.880	0.044
T9	100 - 96	7.995	35	0.849	0.038
T10	96 - 92	7.294	35	0.802	0.030
T11	92 - 88	6.641	35	0.752	0.026
T12	88 - 84	6.029	35	0.700	0.024
T13	84 - 80	5.454	35	0.662	0.022
T14	80 - 75	4.910	35	0.623	0.019
T15	75 - 70	4.267	35	0.580	0.017
T16	70 - 65	3.675	35	0.534	0.015
T17	65 - 60	3.131	35	0.485	0.014
T18	60 - 55	2.642	35	0.436	0.012
T19	55 - 50	2.204	35	0.385	0.011
T20	50 - 45	1.812	35	0.347	0.010
T21	45 - 40	1.463	35	0.308	0.009
T22	40 - 33.3333	1.152	35	0.269	0.008
T23	33.3333 - 26.6667	0.797	35	0.222	0.006
T24	26.6667 - 20	0.512	35	0.175	0.005
T25	20 - 13.3333	0.289	35	0.129	0.004
T26	13.3333 - 6.66666	0.129	35	0.083	0.002
T27	6.66666 - 0	0.029	35	0.037	0.001

tnxTower B+T Group 1717 S Boulder Ave, Suite 300 Tulsa, OK 74119 Phone: (918) 587-4630 FAX: (918) 295-0265	Job 101341.001.01 - Glastonbury-main st, CT (Site# CT46126-A)	Page 37 of 48
	Project	Date 17:44:11 09/25/15
	Client SBA Communications Corporation	Designed by zsmith

Section No.	Elevation ft	Horz. Deflection in	Gov. Load Comb.	Tilt °	Twist °
-------------	-----------------	------------------------	-----------------	-----------	------------

Critical Deflections and Radius of Curvature - Service Wind

Elevation ft	Appurtenance	Gov. Load Comb.	Deflection in	Tilt °	Twist °	Radius of Curvature ft
130'	VHLP2.5	31	13.976	0.981	0.116	39571
128'	LLPX310R w/ Mount Pipe	31	13.561	0.979	0.107	39571
126'	VHLP2.5	31	13.148	0.977	0.099	39571
124'	VHLP2.5	31	12.735	0.975	0.092	33220
118'6"	APXVTM14-C-120 w/ Mount Pipe	36	11.609	0.967	0.076	38512
110'	(2) 7700.00 w/ Mount Pipe	35	9.898	0.935	0.057	13009
93'	AIR 21 B2A/B4P	35	6.800	0.765	0.027	4305
80'	(2) LNX-6514DS-A1M w/ Mount Pipe	35	4.910	0.623	0.019	7011
55'6"	GPS	35	2.246	0.390	0.011	6608
50'6"	GPS	35	1.849	0.350	0.010	6825

Maximum Tower Deflections - Design Wind

Section No.	Elevation ft	Horz. Deflection in	Gov. Load Comb.	Tilt °	Twist °
T1	130 - 120	35.787	11	2.509	0.297
T2	120 - 117.143	30.511	11	2.482	0.204
T3	117.143 - 114.286	29.021	11	2.468	0.187
T4	114.286 - 111.43	27.533	11	2.446	0.171
T5	111.43 - 108.573	26.067	11	2.415	0.155
T6	108.573 - 105.716	24.614	11	2.375	0.140
T7	105.716 - 102.859	23.185	11	2.322	0.126
T8	102.859 - 100	21.791	11	2.255	0.112
T9	100 - 96	20.447	11	2.175	0.098
T10	96 - 92	18.646	11	2.054	0.078
T11	92 - 88	16.971	11	1.925	0.068
T12	88 - 84	15.405	10	1.792	0.062
T13	84 - 80	13.937	10	1.696	0.056
T14	80 - 75	12.546	10	1.595	0.051
T15	75 - 70	10.905	10	1.483	0.045
T16	70 - 65	9.391	10	1.365	0.040
T17	65 - 60	8.003	10	1.241	0.036
T18	60 - 55	6.751	10	1.114	0.032
T19	55 - 50	5.634	10	0.985	0.029
T20	50 - 45	4.632	10	0.886	0.026
T21	45 - 40	3.740	10	0.788	0.023
T22	40 - 33.3333	2.944	10	0.687	0.020
T23	33.3333 - 26.6667	2.037	10	0.567	0.016
T24	26.6667 - 20	1.308	10	0.448	0.013
T25	20 - 13.3333	0.740	10	0.329	0.011
T26	13.3333 - 6.66666	0.330	10	0.212	0.006
T27	6.66666 - 0	0.075	10	0.095	0.002

tnxTower B+T Group 1717 S Boulder Ave, Suite 300 Tulsa, OK 74119 Phone: (918) 587-4630 FAX: (918) 295-0265	Job 101341.001.01 - Glastonbury-main st, CT (Site# CT46126-A)	Page 38 of 48
	Project	Date 17:44:11 09/25/15
	Client SBA Communications Corporation	Designed by zsmith

Critical Deflections and Radius of Curvature - Design Wind

Elevation	Appurtenance	Gov. Load Comb.	Deflection in	Tilt °	Twist °	Radius of Curvature ft
130'	VHLP2.5	11	35.787	2.509	0.297	16074
128'	LLPX310R w/ Mount Pipe	11	34.727	2.505	0.275	16074
126'	VHLP2.5	11	33.668	2.500	0.255	16074
124'	VHLP2.5	11	32.612	2.495	0.236	13495
118'6"	APXVTM14-C-120 w/ Mount Pipe	11	29.729	2.476	0.195	15707
110'	(2) 7700.00 w/ Mount Pipe	11	25.338	2.397	0.147	5101
93'	AIR 21 B2A/B4P	11	17.379	1.958	0.070	1678
80'	(2) LNX-6514DS-A1M w/ Mount Pipe	10	12.546	1.595	0.051	2739
55'6"	GPS	10	5.740	0.996	0.029	2583
50'6"	GPS	10	4.727	0.896	0.026	2660

Bolt Design Data

Section No.	Elevation ft	Component Type	Bolt Grade	Bolt Size in	Number Of Bolts	Maximum Load per Bolt K	Allowable Load K	Ratio Load/Allowable	Allowable Ratio	Criteria
T1	130	Leg	A325N	1.000	1	8.346	34.462	0.242	1.333	Bolt Tension
T8	102.859	Leg	A325N	0.750	4	17.055	19.326	0.882	1.333	Bolt Tension
T9	100	Diagonal	A325N	0.500	1	3.475	3.127	1.111	1.333	Member Block Shear
T10	96	Diagonal	A325X	0.500	1	4.160	5.890	0.706	1.333	Bolt Shear
T11	92	Diagonal	A325N	0.500	1	5.745	6.253	0.919	1.333	Member Block Shear
T12	88	Secondary Horizontal Diagonal	A325N	0.500	1	3.151	4.123	0.764	1.333	Bolt Shear
T13	84	Secondary Horizontal Leg	A325N	0.500	1	3.732	4.123	0.905	1.333	Member Block Shear
T13	84	Leg	A325N	1.000	8	14.265	34.557	0.413	1.333	Bolt Tension
T13	84	Diagonal	A325N	0.500	1	4.925	6.253	0.788	1.333	Member Block Shear
T13	84	Secondary Horizontal	A325N	0.500	1	3.195	4.123	0.775	1.333	Bolt Shear
T14	80	Diagonal	A325X	0.500	1	6.455	5.890	1.096	1.333	Bolt Shear
T15	75	Diagonal	A325N	0.500	1	6.467	6.253	1.034	1.333	Member Block Shear
T16	70	Diagonal	A325N	0.500	1	5.733	6.253	0.917	1.333	Member Block Shear
T17	65	Leg	A325N	1.000	8	22.257	34.557	0.644	1.333	Bolt Tension
T17	65	Diagonal	A325N	0.500	1	5.681	6.253	0.909	1.333	Member Block Shear
T18	60	Diagonal	A325N	0.500	1	6.123	6.253	0.979	1.333	Member Block Shear
T18	60	Secondary Horizontal	A325N	0.500	1	3.495	2.719	1.286	1.333	Member Bearing
T19	55	Diagonal	A325N	0.500	1	5.044	6.253	0.807	1.333	Member Block

tnxTower B+T Group 1717 S Boulder Ave, Suite 300 Tulsa, OK 74119 Phone: (918) 587-4630 FAX: (918) 295-0265	Job 101341.001.01 - Glastonbury-main st, CT (Site# CT46126-A)	Page 39 of 48
	Project	Date 17:44:11 09/25/15
	Client SBA Communications Corporation	Designed by zsmith

Section No.	Elevation ft	Component Type	Bolt Grade	Bolt Size in	Number Of Bolts	Maximum Load per Bolt K	Allowable Load K	Ratio Load Allowable	Allowable Ratio	Criteria
T20	50	Diagonal	A325N	0.500	1	5.355	6.253	0.856 ✓	1.333	Shear Member Block Shear
T21	45	Leg	A325N	1.000	8	28.586	34.556	0.827 ✓	1.333	Bolt Tension
		Diagonal	A325X	0.500	1	5.574	5.890	0.946 ✓	1.333	Bolt Shear
		Secondary Horizontal	A325N	0.500	1	4.206	4.123	1.020 ✓	1.333	Bolt Shear
T22	40	Diagonal	A325N	0.500	1	6.100	8.247	0.740 ✓	1.333	Bolt Shear
T23	33.3333	Diagonal	A325N	0.500	1	6.122	8.247	0.742 ✓	1.333	Bolt Shear
T24	26.6667	Leg	A325N	1.000	8	33.780	34.557	0.978 ✓	1.333	Bolt Tension
		Diagonal	A325N	0.500	1	5.739	8.247	0.696 ✓	1.333	Bolt Shear
T25	20	Diagonal	A325X	0.500	1	5.117	4.078	1.255 ✓	1.333	Member Bearing
T26	13.3333	Diagonal	A325X	0.500	1	4.563	4.078	1.119 ✓	1.333	Member Bearing
		Secondary Horizontal	A325N	0.625	1	5.417	6.443	0.841 ✓	1.333	Bolt Shear
T27	6.66666	Leg	A36M-55	1.500	6	51.912	49.568	1.047 ✓	1.333	Bolt Tension
		Diagonal	A325N	0.500	1	7.264	8.247	0.881 ✓	1.333	Bolt Shear

Compression Checks

Leg Design Data (Compression)

Section No.	Elevation ft	Size	L ft	L _a ft	Kl/r	F _a ksi	A in ²	Actual P K	Allow. P _a K	Ratio P/P _a
T1	130 - 120	1 1/2	10'	2'5-3/4"	79.3 K=1.00	17.949	1.767	-9.511	31.718	0.300 ✓
T2	120 - 117.143	2	2'10-9/32'	2'9-9/32"	66.6 K=1.00	19.956	3.142	-12.816	62.693	0.204 ✓
T3	117.143 - 114.286	2	2'10-9/32'	2'9-9/32"	66.6 K=1.00	19.956	3.142	-19.265	62.693	0.307 ✓
T4	114.286 - 111.43	2	2'10-9/32'	2'10-9/32"	68.6 K=1.00	19.654	3.142	-25.991	61.745	0.421 ✓
T5	111.43 - 108.573	2	2'10-9/32'	2'10-9/32"	68.6 K=1.00	19.654	3.142	-34.097	61.745	0.552 ✓
T6	108.573 - 105.716	2	2'10-9/32'	2'10-9/32"	68.6 K=1.00	19.654	3.142	-44.392	61.745	0.719 ✓
T7	105.716 - 102.859	2	2'10-9/32'	2'10-9/32"	68.6 K=1.00	19.654	3.142	-55.895	61.745	0.905 ✓
T8	102.859 - 100	2	2'10-5/16'	1'4-21/32"	33.3 K=1.00	24.257	3.142	-72.275	76.206	0.948 ✓
T9	100 - 96	P4.5 x 0.237	4'1/32"	4'1/32"	31.8 K=1.00	28.908	3.174	-75.228	91.755	0.820 ✓
T10	96 - 92	P4.5 x 0.237	4'1/32"	4'1/32"	31.8	28.908	3.174	-87.120	91.755	0.949 ✓

tnxTower B+T Group 1717 S Boulder Ave, Suite 300 Tulsa, OK 74119 Phone: (918) 587-4630 FAX: (918) 295-0265	Job 101341.001.01 - Glastonbury-main st, CT (Site# CT46126-A)	Page 40 of 48
	Project	Date 17:44:11 09/25/15
	Client SBA Communications Corporation	Designed by zsmith

Section No.	Elevation ft	Size	L ft	L _u ft	Kl/r	F _a ksi	A in ²	Actual P K	Allow. P _a K	Ratio P P _a
T11	92 - 88	P4.5 x 0.237	4'1/32"	2'13/16"	K=1.00 16.4	30.888	3.174	-95.919	98.040	0.978
T12	88 - 84	BT101341- P4.5 x 0.237 w/ HP5.625x0.375	4'1/32"	2'25/32"	K=1.00 16.8	30.841	4.658	-108.967	143.672	0.758
T13	84 - 80	BT101341- P4.5 x 0.237 w/ HP5.625x0.375	4'1/32"	2'23/32"	K=1.00 16.8	30.844	4.658	-120.834	143.688	0.841
T14	80 - 75	P6.625x0.280	5'1/32"	5'1/32"	K=1.00 26.7	29.617	5.581	-137.007	165.302	0.829
T15	75 - 70	P6.625x0.280	5'1/32"	5'1/32"	K=1.00 26.7	29.617	5.581	-155.648	165.302	0.942
T16	70 - 65	P6.625x0.280	5'1/32"	5'1/32"	K=1.00 26.7	29.617	5.581	-172.855	165.302	1.046
T17	65 - 60	P6.625x0.280	5'1/32"	5'1/32"	K=1.00 26.7	29.617	5.581	-188.375	165.302	1.140
T18	60 - 55	P6.625x0.280	5'1/32"	2'6-13/16"	K=1.00 13.7	31.182	5.581	-201.727	174.039	1.159
T19	55 - 50	BT101341- P6.625x0.280 w/ HP7.625x0.301(45'-55')	5'1/32"	5'1/32"	K=1.00 27.1	29.561	7.511	-218.056	222.017	0.982
T20	50 - 45	BT101341- P6.625x0.280 w/ HP7.625x0.301(45'-55')	5'1/32"	5'1/32"	K=1.00 27.1	29.561	7.511	-230.773	222.017	1.039
T21	45 - 40	BT101341- P6.625x0.280 w/ HP7.625x0.301	5'1/32"	2'6-23/32"	K=1.00 13.9	31.166	7.382	-242.772	230.057	1.055
T22	40 - 33.3333	P6.625x.432	6'8-1/32"	6'8-1/32"	K=1.00 36.5	28.214	8.405	-256.755	237.136	1.083
T23	33.3333 - 26.6667	P6.625x.432	6'8-1/32"	6'8-1/32"	K=1.00 36.5	28.214	8.405	-273.170	237.136	1.152
T24	26.6667 - 20	P6.625x.432	6'8-1/32"	6'8-1/32"	K=1.00 36.5	28.214	8.405	-287.252	237.136	1.211
T25	20 - 13.3333	P6.625x.432	6'8-1/32"	6'8-1/32"	K=1.00 36.5	28.214	8.405	-300.414	237.136	1.267
T26	13.3333 - 6.66666	P6.625x.432	6'8-1/32"	3'4-31/32"	K=1.00 18.7	30.632	8.405	-312.646	257.458	1.214
T27	6.66666 - 0	BT101341- P6.625 x .432 w/ HP7.625x0.301	6'8-1/32"	6'7-1/32"	K=1.00 36.5	28.201	10.183	-333.913	287.180	1.163

Diagonal Design Data (Compression)

Section No.	Elevation ft	Size	L ft	L _u ft	Kl/r	F _a ksi	A in ²	Actual P K	Allow. P _a K	Ratio P P _a
T1	130 - 120	1/2	3'6-1/4"	1'8-1/16"	144.5 K=0.90	7.152	0.196	-1.471	1.404	1.047
T2	120 - 117.143	3/4	3'8-13/16"	1'8-29/32"	105.1 K=0.94	12.322	0.442	-2.302	5.444	0.423
T3	117.143 - 114.286	3/4	3'8-13/16"	1'8-29/32"	105.1 K=0.94	12.322	0.442	-3.097	5.444	0.569
T4	114.286 - 111.43	3/4	3'9-9/16"	1'9-1/4"	105.8 K=0.93	12.231	0.442	-2.933	5.403	0.543
T5	111.43 -	3/4	3'9-9/16"	1'9-1/4"	105.8	12.231	0.442	-3.729	5.403	0.690

tnxTower

B+T Group
 1717 S Boulder Ave, Suite 300
 Tulsa, OK 74119
 Phone: (918) 587-4630
 FAX: (918) 295-0265

Job 101341.001.01 - Glastonbury-main st, CT (Site# CT46126-A)	Page 41 of 48
Project	Date 17:44:11 09/25/15
Client SBA Communications Corporation	Designed by zsmith

Section No.	Elevation ft	Size	L ft	L _a ft	Kl/r	F _a ksi	A in ²	Actual P K	Allow. P _a K	Ratio P P _a
	108.573				K=0.93					✓
T6	108.573 - 105.716	3/4	3'9-9/16"	1'9-1/4"	105.8 K=0.93	12.231	0.442	-4.556	5.403	0.843
T7	105.716 - 102.859	3/4	3'9-9/16"	1'9-1/4"	105.8 K=0.93	12.231	0.442	-4.466	5.403	0.827
T8	102.859 - 100	3/4	3'8-27/32"	1'8-29/32"	105.1 K=0.94	12.320	0.442	-4.551	5.443	0.836
T9	100 - 96	L1 1/2x1 1/2x3/16	4'9-1/4"	2'7/16"	92.5 K=1.11	13.907	0.527	-3.602	7.334	0.491
T10	96 - 92	L2x2x1/4	4'10-19/32"	2'15/16"	77.8 K=1.22	15.597	0.938	-4.160	14.630	0.284
T11	92 - 88	2L1 1/2x1 1/2x3/16x3/8	5'	2'3-1/4"	59.7 K=1.00	17.463	1.055	-6.080	18.418	0.330
T12	88 - 84	2L 'a' > 13.124 in - 139 2L1 1/2x1 1/2x3/16x3/8	5'1-15/32"	2'4-3/32"	61.5 K=1.00	17.283	1.055	-5.550	18.228	0.304
T13	84 - 80	2L 'a' > 13.535 in - 151 2L1 1/2x1 1/2x3/16x3/8	5'3"	2'4-31/32"	63.4 K=1.00	17.098	1.055	-5.147	18.034	0.285
T14	80 - 75	2L 'a' > 13.949 in - 163 L2x2x1/4	6'2-1/8"	2'7-3/16"	89.8 K=1.13	14.225	0.938	-6.455	13.343	0.484
T15	75 - 70	2L1 1/2x1 1/2x3/16x3/8	6'3-29/32"	2'8-17/32"	83.4 K=1.17	14.971	1.055	-6.968	15.790	0.441
T16	70 - 65	2L1 1/2x1 1/2x3/16x3/8	6'5-25/32"	2'9-5/8"	85.2 K=1.16	14.765	1.055	-6.298	15.573	0.404
T17	65 - 60	2L1 1/2x1 1/2x3/16x3/8	6'7-23/32"	2'10-23/32"	87.0 K=1.14	14.555	1.055	-6.196	15.351	0.404
T18	60 - 55	2L1 1/2x1 1/2x3/16x3/8	6'9-23/32"	3'1-3/32"	81.2 K=1.00	15.218	1.055	-6.671	16.050	0.416
T19	55 - 50	2L 'a' > 17.871 in - 208 2L1 1/2x1 1/2x3/16x3/8	6'11-13/16"	3'31/32"	90.7 K=1.12	14.117	1.055	-5.494	14.889	0.369
T20	50 - 45	2L1 1/2x1 1/2x3/16x3/8	7'1-29/32"	3'2-1/8"	92.6 K=1.11	13.890	1.055	-5.813	14.650	0.397
T21	45 - 40	L2x2x1/4	7'4-3/32"	3'4-9/16"	103.7 K=1.00	12.503	0.938	-5.574	11.728	0.475
T22	40 - 33.3333	2L1 3/4x1 3/4x3/16x3/8	8'9"	3'11-11/16"	96.6 K=1.09	13.404	1.242	-6.100	16.650	0.366
T23	33.3333 - 26.6667	2L1 3/4x1 3/4x3/16x3/8	8'11-5/8"	4'1-1/8"	98.6 K=1.08	13.154	1.242	-6.122	16.340	0.375
T24	26.6667 - 20	2L1 3/4x1 3/4x3/16x3/8	9'2-11/32"	4'2-9/16"	100.6 K=1.07	12.897	1.242	-5.739	16.021	0.358
T25	20 - 13.3333	L2x2x3/16	9'5-5/32"	4'4-1/16"	132.1 K=1.00	8.556	0.715	-5.680	6.118	0.928
T26	13.3333 - 6.66666	L2x2x3/16	9'8"	4'6-13/16"	139.1 K=1.00	7.717	0.715	-5.013	5.517	0.909
T27	6.66666 - 0	2L2x2x3/16x3/8	9'10-1/4"	4'6-3/4"	96.5 K=1.09	13.410	1.430	-7.264	19.176	0.379

tnxTower B+T Group 1717 S Boulder Ave, Suite 300 Tulsa, OK 74119 Phone: (918) 587-4630 FAX: (918) 295-0265	Job 101341.001.01 - Glastonbury-main st, CT (Site# CT46126-A)	Page 42 of 48
	Project	Date 17:44:11 09/25/15
	Client SBA Communications Corporation	Designed by zsmith

Horizontal Design Data (Compression)

Section No.	Elevation ft	Size	L ft	L _a ft	Kl/r	F _a ksi	A in ²	Actual P K	Allow. P _a K	Ratio P P _a
T1	130 - 120	L1 1/4x1 1/4x3/16	2'6"	2'4-1/2"	118.5 K=1.01	10.498	0.434	-0.257	4.552	0.056 ✓

Secondary Horizontal Design Data (Compression)

Section No.	Elevation ft	Size	L ft	L _a ft	Kl/r	F _a ksi	A in ²	Actual P K	Allow. P _a K	Ratio P P _a
T8	102.859 - 100	L2x2x1/8	2'6"	2'4"	82.4 K=1.84	14.733	0.484	-1.252	7.136	0.175 ✓
T11	92 - 88	4x3/8	2'11-31/32"	2'7-15/32"	145.3 K=0.50	7.072	1.500	-2.841	10.608	0.268 ✓
T12	88 - 84	4x3/8	3'2-11/32"	2'9-27/32"	156.4 K=0.50	6.108	1.500	-3.370	9.162	0.368 ✓
T13	84 - 80	4x3/8	3'4-3/4"	3'1/4"	167.5 K=0.50	5.324	1.500	-2.913	7.985	0.365 ✓
T18	60 - 55	L2x2x1/8	4'7-15/32"	4'27/32"	61.4 K=0.50	16.805	0.484	-3.495	8.140	0.429 ✓
T21	45 - 40	L3x3x5/16	5'4-15/32"	4'9-27/32"	49.1 K=0.50	18.430	1.780	-4.206	32.805	0.128 ✓
T26	13.3333 - 6.66666	L2x2x1/4	6'11-15/16"	6'5-5/16"	98.9 K=0.50	13.118	0.938	-5.417	12.305	0.440 ✓

Top Girt Design Data (Compression)

Section No.	Elevation ft	Size	L ft	L _a ft	Kl/r	F _a ksi	A in ²	Actual P K	Allow. P _a K	Ratio P P _a
T1	130 - 120	L1 1/4x1 1/4x3/16	2'6"	2'4-1/2"	118.5 K=1.01	10.498	0.434	-0.061	4.552	0.013 ✓
T2	120 - 117.143	L1 1/4x1 1/4x3/16	2'6"	2'4"	117.5 K=1.02	10.643	0.434	-0.032	4.615	0.007 ✓

Bottom Girt Design Data (Compression)

Section No.	Elevation ft	Size	L ft	L _a ft	Kl/r	F _a ksi	A in ²	Actual P K	Allow. P _a K	Ratio P P _a
T1	130 - 120	L1 1/4x1 1/4x3/16	2'6"	2'4-1/2"	118.5 K=1.01	10.498	0.434	-0.206	4.552	0.045 ✓
T8	102.859 - 100	L1 1/4x1 1/4x3/16	2'6"	2'4"	117.5 K=1.02	10.643	0.434	-0.829	4.615	0.180 ✓

tnxTower B+T Group 1717 S Boulder Ave, Suite 300 Tulsa, OK 74119 Phone: (918) 587-4630 FAX: (918) 295-0265	Job 101341.001.01 - Glastonbury-main st, CT (Site# CT46126-A)	Page 43 of 48
	Project	Date 17:44:11 09/25/15
	Client SBA Communications Corporation	Designed by zsmith

Section No.	Elevation ft	Size	L ft	L _a ft	Kl/r	F _a ksi	A in ²	Actual P K	Allow. P _a K	Ratio P P _a
-------------	-----------------	------	---------	----------------------	------	-----------------------	----------------------	---------------	----------------------------	---------------------------

Tension Checks

Leg Design Data (Tension)

Section No.	Elevation ft	Size	L ft	L _a ft	Kl/r	F _a ksi	A in ²	Actual P K	Allow. P _a K	Ratio P P _a
T1	130 - 120	1 1/2	10'	1"	2.7	27.000	1.767	8.346	47.713	0.175
T2	120 - 117.143	2	2'10-9/32'	2'9-9/32"	66.6	27.000	3.142	10.543	84.823	0.124
T3	117.143 - 114.286	2	2'10-9/32'	2'9-9/32"	66.6	27.000	3.142	16.897	84.823	0.199
T4	114.286 - 111.43	2	2'10-9/32'	2'10-9/32'	68.6	27.000	3.142	23.647	84.823	0.279
T5	111.43 - 108.573	2	2'10-9/32'	2'10-9/32'	68.6	27.000	3.142	31.017	84.823	0.366
T6	108.573 - 105.716	2	2'10-9/32'	2'10-9/32'	68.6	27.000	3.142	40.723	84.823	0.480
T7	105.716 - 102.859	2	2'10-9/32'	2'10-9/32'	68.6	27.000	3.142	52.084	84.823	0.614
T8	102.859 - 100	2	2'10-5/16'	1"	2.0	27.000	3.142	68.221	84.823	0.804
T9	100 - 96	P4.5 x 0.237	4'1/32"	4'1/32"	31.8	32.400	3.174	71.565	102.839	0.696
T10	96 - 92	P4.5 x 0.237	4'1/32"	4'1/32"	31.8	32.400	3.174	82.289	102.839	0.800
T11	92 - 88	P4.5 x 0.237	4'1/32"	1'11-7/32'	15.4	32.400	3.174	90.381	102.839	0.879
T12	88 - 84	BT101341- P4.5 x 0.237 w/ HP5.625x0.375	4'1/32"	1'11-1/4"	15.8	32.400	4.658	102.838	150.934	0.681
T13	84 - 80	BT101341- P4.5 x 0.237 w/ HP5.625x0.375	4'1/32"	1'11-5/16'	15.9	32.400	4.658	114.256	150.934	0.757
T14	80 - 75	P6.625x0.280	5'1/32"	5'1/32"	26.7	32.400	5.581	129.216	180.836	0.715
T15	75 - 70	P6.625x0.280	5'1/32"	5'1/32"	26.7	32.400	5.581	146.773	180.836	0.812
T16	70 - 65	P6.625x0.280	5'1/32"	5'1/32"	26.7	32.400	5.581	163.404	180.836	0.904
T17	65 - 60	P6.625x0.280	5'1/32"	5'1/32"	26.7	32.400	5.581	178.059	180.836	0.985
T18	60 - 55	P6.625x0.280	5'1/32"	2'5-3/16"	13.0	32.400	5.581	190.758	180.836	1.055
T19	55 - 50	BT101341- P6.625x0.280 w/ HP7.625x0.301(45'-55')	5'1/32"	5'1/32"	27.1	32.400	7.511	205.912	243.342	0.846
T20	50 - 45	BT101341- P6.625x0.280 w/ HP7.625x0.301(45'-55')	5'1/32"	5'1/32"	27.1	32.400	7.511	217.717	243.342	0.895

Section No.	Elevation ft	Size	L ft	L _a ft	Kl/r	F _a ksi	A in ²	Actual P K	Allow. P _a K	Ratio P/P _a
T21	45 - 40	BT101341- P6.625x0.280 w/ HP7.625x0.301	5'1/32"	2'5-5/16"	13.2	32.400	7.382	228.892	239.163	0.957
T22	40 - 33.3333	P6.625x.432	6'8-1/32"	6'8-1/32"	36.5	32.400	8.405	242.122	272.320	0.889
T23	33.3333 - 26.6667	P6.625x.432	6'8-1/32"	6'8-1/32"	36.5	32.400	8.405	257.400	272.320	0.945
T24	26.6667 - 20	P6.625x.432	6'8-1/32"	6'8-1/32"	36.5	32.400	8.405	270.240	272.320	0.992
T25	20 - 13.3333	P6.625x.432	6'8-1/32"	6'8-1/32"	36.5	32.400	8.405	281.965	272.320	1.035
T26	13.3333 - 6.66666	P6.625x.432	6'8-1/32"	3'3-1/16"	17.8	32.400	8.405	293.003	272.320	1.076
T27	6.66666 - 0	BT101341- P6.625 x .432 w/ HP7.625x0.301	6'8-1/32"	1"	0.5	32.400	10.183	311.472	329.942	0.944

Diagonal Design Data (Tension)

Section No.	Elevation ft	Size	L ft	L _a ft	Kl/r	F _a ksi	A in ²	Actual P K	Allow. P _a K	Ratio P/P _a
T1	130 - 120	1/2	3'6-1/4"	1'8-1/16"	160.6	21.600	0.196	1.430	4.241	0.337
T2	120 - 117.143	3/4	3'8-13/16"	1'8-29/32"	111.5	21.600	0.442	2.380	9.543	0.249
T3	117.143 - 114.286	3/4	3'8-13/16"	1'8-29/32"	111.5	21.600	0.442	3.104	9.543	0.325
T4	114.286 - 111.43	3/4	3'9-9/16"	1'9-1/4"	113.4	21.600	0.442	2.899	9.543	0.304
T5	111.43 - 108.573	3/4	3'9-9/16"	1'9-1/4"	113.4	21.600	0.442	3.730	9.543	0.391
T6	108.573 - 105.716	3/4	3'9-9/16"	1'9-1/4"	113.4	21.600	0.442	4.484	9.543	0.470
T7	105.716 - 102.859	3/4	3'9-9/16"	1'9-1/4"	113.4	21.600	0.442	4.408	9.543	0.462
T8	102.859 - 100	3/4	3'8-27/32"	1'8-29/32"	111.6	21.600	0.442	4.454	9.543	0.467
T9	100 - 96	L1 1/2x1 1/2x3/16	4'9-1/4"	2'7/16"	56.3	29.000	0.308	3.475	8.921	0.390
T10	96 - 92	L2x2x1/4	4'10-19/32"	2'15/16"	43.4	29.000	0.586	3.854	17.003	0.227
T11	92 - 88	2L1 1/2x1 1/2x3/16x3/8	5'	2'3-1/4"	59.7	29.000	0.615	5.745	17.842	0.322
T12	88 - 84	2L 'a' > 13.124 in - 139 2L1 1/2x1 1/2x3/16x3/8	5'1-15/32"	2'4-3/32"	61.5	29.000	0.615	5.318	17.842	0.298
T13	84 - 80	2L 'a' > 13.535 in - 151 2L1 1/2x1 1/2x3/16x3/8	5'3"	2'4-31/32"	63.4	29.000	0.615	4.925	17.842	0.276
T14	80 - 75	2L 'a' > 13.949 in - 163 L2x2x1/4	6'2-1/8"	2'7-3/16"	53.7	29.000	0.586	6.078	17.003	0.357

<p>tnxTower</p> <p>B+T Group 1717 S Boulder Ave, Suite 300 Tulsa, OK 74119 Phone: (918) 587-4630 FAX: (918) 295-0265</p>	<p>Job 101341.001.01 - Glastonbury-main st, CT (Site# CT46126-A)</p>	<p>Page 45 of 48</p>
	<p>Project</p>	<p>Date 17:44:11 09/25/15</p>
	<p>Client SBA Communications Corporation</p>	<p>Designed by zsmith</p>

Section No.	Elevation ft	Size	L ft	L _a ft	Kl/r	F _a ksi	A in ²	Actual P K	Allow. P _a K	Ratio P P _a
T15	75 - 70	2L1 1/2x1 1/2x3/16x3/8	6'3-29/32'	2'8-17/32'	74.0	29.000	0.615	6.467	17.842	0.362
T16	70 - 65	2L1 1/2x1 1/2x3/16x3/8	6'5-25/32'	2'9-5/8"	76.4	29.000	0.615	5.733	17.842	0.321
T17	65 - 60	2L1 1/2x1 1/2x3/16x3/8	6'7-23/32'	2'10-23/32"	78.8	29.000	0.615	5.681	17.842	0.318
T18	60 - 55	2L1 1/2x1 1/2x3/16x3/8	6'9-23/32'	3'1-3/32"	81.2	29.000	0.615	6.123	17.842	0.343
T19	55 - 50	2L 'a' > 17.871 in - 208 2L1 1/2x1 1/2x3/16x3/8	6'11-13/16"	3'31/32"	83.7	29.000	0.615	5.044	17.842	0.283
T20	50 - 45	2L1 1/2x1 1/2x3/16x3/8	7'1-29/32'	3'2-1/8"	86.2	29.000	0.615	5.355	17.842	0.300
T21	45 - 40	L2x2x1/4	7'4-3/32"	3'4-9/16"	66.6	29.000	0.586	5.194	17.003	0.305
T22	40 - 33.3333	2L1 3/4x1 3/4x3/16x3/8	8'9"	3'11-11/16"	91.1	29.000	0.756	5.406	21.920	0.247
T23	33.3333 - 26.6667	2L1 3/4x1 3/4x3/16x3/8	8'11-5/8"	4'1-1/8"	93.8	29.000	0.756	5.353	21.920	0.244
T24	26.6667 - 20	2L1 3/4x1 3/4x3/16x3/8	9'2-11/32'	4'2-9/16"	96.5	29.000	0.756	4.947	21.920	0.226
T25	20 - 13.3333	L2x2x3/16	9'5-5/32"	4'4-1/16"	86.4	29.000	0.448	5.117	13.002	0.394
T26	13.3333 - 6.66666	L2x2x3/16	9'8"	4'6-13/16"	88.8	29.000	0.448	4.563	13.002	0.351
T27	6.66666 - 0	2L2x2x3/16x3/8	9'10-1/4"	4'6-3/4"	90.8	29.000	0.897	6.509	26.005	0.250

Horizontal Design Data (Tension)

Section No.	Elevation ft	Size	L ft	L _a ft	Kl/r	F _a ksi	A in ²	Actual P K	Allow. P _a K	Ratio P P _a
T1	130 - 120	L1 1/4x1 1/4x3/16	2'6"	2'4-1/2"	75.7	21.600	0.434	0.291	9.366	0.031

Secondary Horizontal Design Data (Tension)

Section No.	Elevation ft	Size	L ft	L _a ft	Kl/r	F _a ksi	A in ²	Actual P K	Allow. P _a K	Ratio P P _a
T8	102.859 - 100	L2x2x1/8	2'6"	2'4"	44.7	21.600	0.484	1.252	10.463	0.120
T11	92 - 88	4x3/8	2'11-31/32"	2'7-15/32"	290.6	29.000	0.949	3.151	27.527	0.114
T12	88 - 84	4x3/8	3'2-11/32"	2'9-27/32"	312.7	29.000	0.949	3.732	27.527	0.136

tnxTower B+T Group 1717 S Boulder Ave, Suite 300 Tulsa, OK 74119 Phone: (918) 587-4630 FAX: (918) 295-0265	Job 101341.001.01 - Glastonbury-main st, CT (Site# CT46126-A)	Page 46 of 48
	Project	Date 17:44:11 09/25/15
	Client SBA Communications Corporation	Designed by zsmith

Section No.	Elevation ft	Size	L ft	L _a ft	Kl/r	F _a ksi	A in ²	Actual P K	Allow. P _a K	Ratio P P _a
T13	84 - 80	4x3/8	3'4-3/4"	3'1/4"	335.0	29.000	0.949	3.195	27.527	0.116
T18	60 - 55	L2x2x1/8	4'7-15/32"	4'27/32"	78.0	29.000	0.305	3.495	8.836	0.396
T21	45 - 40	L3x3x5/16	5'4-15/32"	4'9-27/32"	62.7	29.000	1.189	4.206	34.467	0.122
T26	13.3333 - 6.66666	L2x2x1/4	6'11-15/16"	6'5-5/16"	127.0	29.000	0.563	5.417	16.323	0.332

Top Girt Design Data (Tension)

Section No.	Elevation ft	Size	L ft	L _a ft	Kl/r	F _a ksi	A in ²	Actual P K	Allow. P _a K	Ratio P P _a
T1	130 - 120	L1 1/4x1 1/4x3/16	2'6"	2'4-1/2"	75.7	21.600	0.434	0.055	9.366	0.006
T2	120 - 117.143	L1 1/4x1 1/4x3/16	2'6"	2'4"	74.4	21.600	0.434	0.059	9.366	0.006

Bottom Girt Design Data (Tension)

Section No.	Elevation ft	Size	L ft	L _a ft	Kl/r	F _a ksi	A in ²	Actual P K	Allow. P _a K	Ratio P P _a
T1	130 - 120	L1 1/4x1 1/4x3/16	2'6"	2'4-1/2"	75.7	21.600	0.434	0.234	9.366	0.025
T8	102.859 - 100	L1 1/4x1 1/4x3/16	2'6"	2'4"	74.4	21.600	0.434	0.825	9.366	0.088

Section Capacity Table

Section No.	Elevation ft	Component Type	Size	Critical Element	P K	SF*P _{allow} K	% Capacity	Pass Fail
T1	130 - 120	Leg	1 1/2	2	-9.511	42.280	22.5	Pass
T2	120 - 117.143	Leg	2	44	-12.816	83.570	15.3	Pass
T3	117.143 - 114.286	Leg	2	56	-19.265	83.570	23.1	Pass
T4	114.286 - 111.43	Leg	2	65	-25.991	82.306	31.6	Pass
T5	111.43 - 108.573	Leg	2	74	-34.097	82.306	41.4	Pass
T6	108.573 - 105.716	Leg	2	83	-44.392	82.306	53.9	Pass
T7	105.716 - 102.859	Leg	2	92	-55.895	82.306	67.9	Pass
T8	102.859 - 100	Leg	2	101	-72.275	101.583	71.1	Pass

tnxTower

B+T Group
1717 S Boulder Ave, Suite 300
Tulsa, OK 74119
Phone: (918) 587-4630
FAX: (918) 295-0265

Job 101341.001.01 - Glastonbury-main st, CT (Site# CT46126-A)	Page 47 of 48
Project	Date 17:44:11 09/25/15
Client SBA Communications Corporation	Designed by zsmith

Section No.	Elevation ft	Component Type	Size	Critical Element	P K	SF*P _{allow} K	% Capacity	Pass Fail
T9	100 - 96	Leg	P4.5 x 0.237	116	-75.228	122.309	61.5	Pass
T10	96 - 92	Leg	P4.5 x 0.237	125	-87.120	122.309	71.2	Pass
T11	92 - 88	Leg	P4.5 x 0.237	134	-95.919	130.687	73.4	Pass
T12	88 - 84	Leg	BT101341- P4.5 x 0.237 w/ HP5.625x0.375	146	-108.967	191.515	56.9	Pass
T13	84 - 80	Leg	BT101341- P4.5 x 0.237 w/ HP5.625x0.375	158	-120.834	191.536	63.1	Pass
T14	80 - 75	Leg	P6.625x0.280	170	-137.007	220.348	62.2	Pass
T15	75 - 70	Leg	P6.625x0.280	179	-155.648	220.348	70.6	Pass
T16	70 - 65	Leg	P6.625x0.280	187	-172.855	220.348	78.4	Pass
T17	65 - 60	Leg	P6.625x0.280	196	-188.375	220.348	85.5	Pass
T18	60 - 55	Leg	P6.625x0.280	205	-201.727	231.994	87.0	Pass
T19	55 - 50	Leg	BT101341- P6.625x0.280 w/ HP7.625x0.301(45'-55')	217	-218.056	295.949	73.7	Pass
T20	50 - 45	Leg	BT101341- P6.625x0.280 w/ HP7.625x0.301(45'-55')	226	-230.773	295.949	78.0	Pass
T21	45 - 40	Leg	BT101341- P6.625x0.280 w/ HP7.625x0.301	235	-242.772	306.666	79.2	Pass
T22	40 - 33.3333	Leg	P6.625x.432	247	-256.755	316.102	81.2	Pass
T23	33.3333 - 26.6667	Leg	P6.625x.432	256	-273.170	316.102	86.4	Pass
T24	26.6667 - 20	Leg	P6.625x.432	265	-287.252	316.102	90.9	Pass
T25	20 - 13.3333	Leg	P6.625x.432	274	-300.414	316.102	95.0	Pass
T26	13.3333 - 6.66666	Leg	P6.625x.432	283	-312.646	343.191	91.1	Pass
T27	6.66666 - 0	Leg	BT101341- P6.625 x .432 w/ HP7.625x0.301	295	-333.913	382.811	87.2	Pass
T1	130 - 120	Diagonal	1/2	13	-1.471	1.872	78.6	Pass
T2	120 - 117.143	Diagonal	3/4	52	-2.302	7.257	31.7	Pass
T3	117.143 - 114.286	Diagonal	3/4	61	-3.097	7.257	42.7	Pass
T4	114.286 - 111.43	Diagonal	3/4	70	-2.933	7.203	40.7	Pass
T5	111.43 - 108.573	Diagonal	3/4	79	-3.729	7.203	51.8	Pass
T6	108.573 - 105.716	Diagonal	3/4	88	-4.556	7.203	63.2	Pass
T7	105.716 - 102.859	Diagonal	3/4	97	-4.466	7.203	62.0	Pass
T8	102.859 - 100	Diagonal	3/4	109	-4.551	7.255	62.7	Pass
T9	100 - 96	Diagonal	L1 1/2x1 1/2x3/16	121	-3.602	9.776	36.8	Pass
T10	96 - 92	Diagonal	L2x2x1/4	130	-4.160	19.502	83.4 (b) 21.3	Pass
T11	92 - 88	Diagonal	2L1 1/2x1 1/2x3/16x3/8	139	-6.080	24.551	53.0 (b) 24.8	Pass
T12	88 - 84	Diagonal	2L1 1/2x1 1/2x3/16x3/8	151	-5.550	24.298	68.9 (b) 22.8	Pass
T13	84 - 80	Diagonal	2L1 1/2x1 1/2x3/16x3/8	163	-5.147	24.039	63.8 (b) 21.4	Pass
T14	80 - 75	Diagonal	L2x2x1/4	172	-6.455	17.786	59.1 (b) 36.3	Pass
T15	75 - 70	Diagonal	2L1 1/2x1 1/2x3/16x3/8	181	-6.968	21.048	82.2 (b) 33.1	Pass
T16	70 - 65	Diagonal	2L1 1/2x1 1/2x3/16x3/8	190	-6.298	20.758	77.6 (b) 30.3	Pass
T17	65 - 60	Diagonal	2L1 1/2x1 1/2x3/16x3/8	199	-6.196	20.462	68.8 (b) 30.3	Pass
T18	60 - 55	Diagonal	2L1 1/2x1 1/2x3/16x3/8	208	-6.671	21.395	68.2 (b) 31.2	Pass
T19	55 - 50	Diagonal	2L1 1/2x1 1/2x3/16x3/8	220	-5.494	19.847	73.5 (b) 27.7	Pass
T20	50 - 45	Diagonal	2L1 1/2x1 1/2x3/16x3/8	229	-5.813	19.528	60.5 (b) 29.8	Pass

tnxTower B+T Group 1717 S Boulder Ave, Suite 300 Tulsa, OK 74119 Phone: (918) 587-4630 FAX: (918) 295-0265	Job 101341.001.01 - Glastonbury-main st, CT (Site# CT46126-A)	Page 48 of 48
	Project	Date 17:44:11 09/25/15
	Client SBA Communications Corporation	Designed by zsmith

Section No.	Elevation ft	Component Type	Size	Critical Element	P K	SF*P _{allow} K	% Capacity	Pass Fail	
T21	45 - 40	Diagonal	L2x2x1/4	238	-5.574	15.634	64.2 (b) 35.7	Pass	
T22	40 - 33.3333	Diagonal	2L1 3/4x1 3/4x3/16x3/8	250	-6.100	22.194	71.0 (b) 27.5	Pass	
T23	33.3333 - 26.6667	Diagonal	2L1 3/4x1 3/4x3/16x3/8	259	-6.122	21.782	55.5 (b) 28.1	Pass	
T24	26.6667 - 20	Diagonal	2L1 3/4x1 3/4x3/16x3/8	268	-5.739	21.356	55.7 (b) 26.9	Pass	
T25	20 - 13.3333	Diagonal	L2x2x3/16	277	-5.680	8.155	52.2 (b) 69.6	Pass	
T26	13.3333 - 6.66666	Diagonal	L2x2x3/16	286	-5.013	7.355	94.1 (b) 68.2	Pass	
T27	6.66666 - 0	Diagonal	2L2x2x3/16x3/8	298	-7.264	25.562	83.9 (b) 28.4	Pass	
T1	130 - 120	Horizontal	L1 1/4x1 1/4x3/16	36	-0.257	6.068	66.1 (b) 4.2	Pass	
T8	102.859 - 100	Secondary Horizontal	L2x2x1/8	112	-1.252	9.513	13.2	Pass	
T11	92 - 88	Secondary Horizontal	4x3/8	144	-2.841	14.141	20.1	Pass	
T12	88 - 84	Secondary Horizontal	4x3/8	156	-3.370	12.213	57.3 (b) 27.6	Pass	
T13	84 - 80	Secondary Horizontal	4x3/8	168	-2.913	10.644	67.9 (b) 27.4	Pass	
T18	60 - 55	Secondary Horizontal	L2x2x1/8	214	-3.495	10.851	58.1 (b) 32.2	Pass	
T21	45 - 40	Secondary Horizontal	L3x3x5/16	244	-4.206	43.729	96.4 (b) 9.6	Pass	
T26	13.3333 - 6.66666	Secondary Horizontal	L2x2x1/4	292	-5.417	16.403	76.5 (b) 33.0	Pass	
T1	130 - 120	Top Girt	L1 1/4x1 1/4x3/16	6	-0.061	6.068	63.1 (b) 1.0	Pass	
T2	120 - 117.143	Top Girt	L1 1/4x1 1/4x3/16	48	-0.032	6.152	0.5	Pass	
T1	130 - 120	Bottom Girt	L1 1/4x1 1/4x3/16	9	-0.206	6.068	3.4	Pass	
T8	102.859 - 100	Bottom Girt	L1 1/4x1 1/4x3/16	105	-0.829	6.152	13.5	Pass	
							Summary		
							Leg (T25)	95.0	Pass
							Diagonal (T25)	94.1	Pass
							Horizontal (T1)	4.2	Pass
							Secondary Horizontal (T18)	96.4	Pass
							Top Girt (T1)	1.0	Pass
							Bottom Girt (T8)	13.5	Pass
							Bolt Checks	96.4	Pass
							RATING =	96.4	Pass

APPENDIX B
BASE LEVEL DRAWING

Feed Line Plan

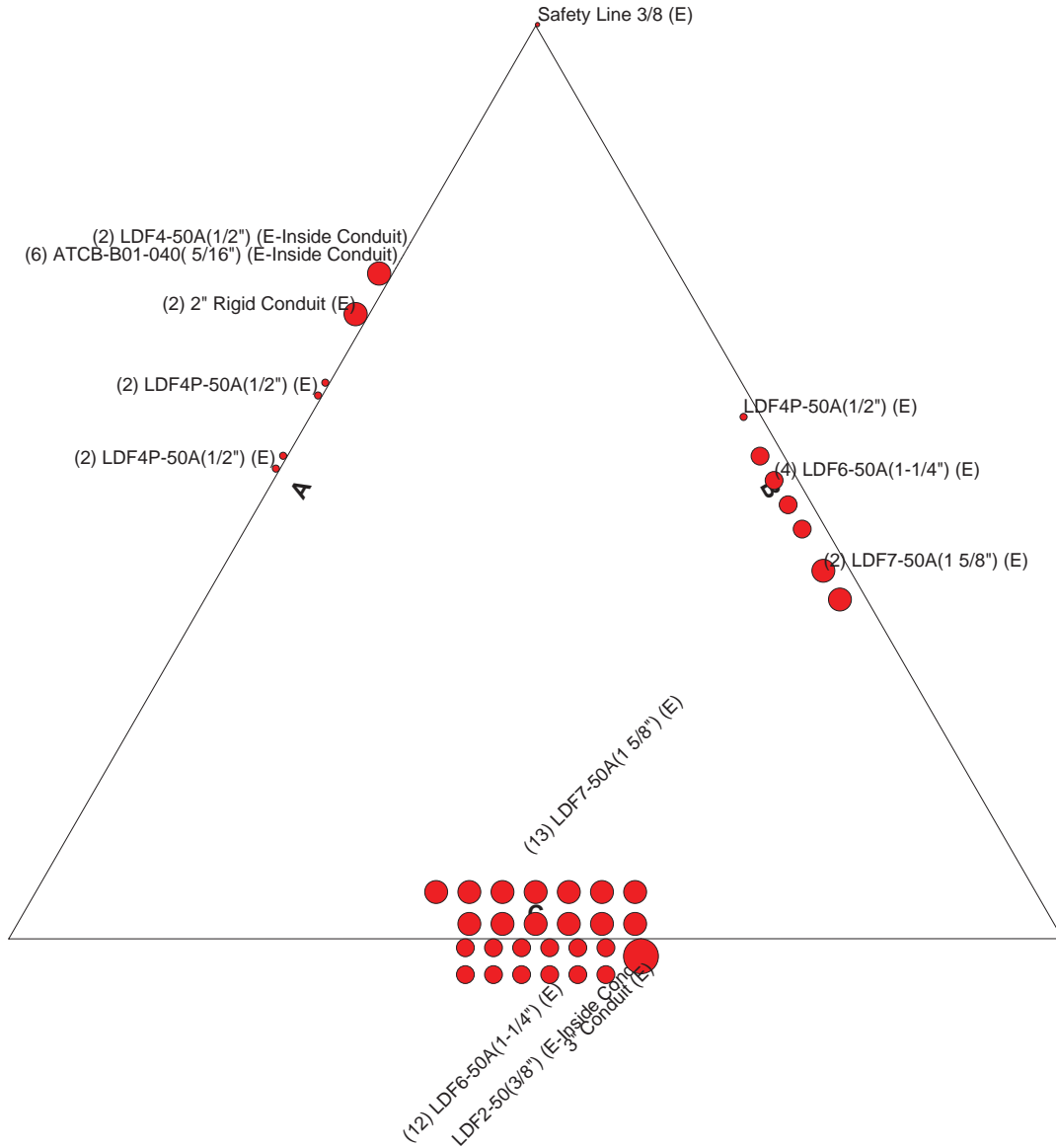

 B+T GRP	B+T Group	Job: 101341.001.01 - Glastonbury-main st, CT (Site# CT46126-A)		
	1717 S Boulder Ave, Suite 300		Project:	Drawn by: zsmith
	Tulsa, OK 74119		Client: SBA Communications Corporation	App'd:
	Phone: (918) 587-4630		Code: TIA/EIA-222-F	Date: 09/25/15
	FAX: (918) 295-0265		Path:	Scale: NTS
			Dwg No: E-7	

S:\Projects\SBA\101341-CT46126-A-Glastonbury-main st\Engineering\Tower\101341-001-01-Glastonbury-main st-CT.bst

APPENDIX C
ADDITIONAL CALCULATIONS

PROJECT	101341.001.01 - Glastonbury-main st, CT ss		
SUBJECT	Pad Footing Analysis		
DATE	09/25/15	PAGE	1 OF 9



101341_001_01_SS Unit Base Unified (1 5)_Square_Rev F-G.xls

B&T Proj. No.: 0

Combined Footing Foundation Analysis

Design Loads:

Compression per leg (P_c)	=	<u>334.0</u>	(k)
Tension per leg (P_T)	=	<u>311.0</u>	(k)
Overturing Moment (M_o)	=	<u>2,105.0</u>	(k)
Total Tower Horizontal Load	=	<u>25.0</u>	(k-ft)
Tower + Appurtenances	=	<u>29.0</u>	(k)

Safety Factors

Uplift S.F. (Conc. Wt.)	=	<u>1.25</u>
Uplift S.F. (Soil Wt.)	=	<u>2.00</u>
Overturing S.F.	=	<u>1.50</u>
Bearinging S.F.	=	<u>2.00</u>

Rev. Type: **F**

Tower Information

Tower base width	=	<u>7.50</u>	ft
------------------	---	-------------	----

Pad & Pier Dimensions / Properties:

Tower Shape (triangle or square)	=	<u>T</u>	
Pier Shape (round or square)	=	<u>R</u>	
Pier Diameter (H_p)	=	<u>3.00</u>	(ft)
Pier height above grade (D_A)	=	<u>0.50</u>	(ft)
Footing Width (W_F)	=	<u>26.00</u>	(ft)
Footing Thickness (H_F)	=	<u>3.00</u>	(ft)
Depth to BOC (D)	=	<u>4.00</u>	(ft)
Concrete Strength (F'_c)	=	<u>3.00</u>	(ksi)
Rebar Strength (F_y)	=	<u>60.00</u>	(ksi)
Ultimate Load Factor	=	<u>1.30</u>	
Min. Cover over Rebar	=	<u>3.00</u>	(in)
Qty of footing Rebar (1 layer)	=	<u>17</u>	
Size of footing Rebar	=	<u># 8</u>	(bar)
Qty of Vertical Rebar per Pier	=	<u>11</u>	
Size of Pier Vertical Rebar	=	<u># 8</u>	(bar)
Qty of Rebar Ties per Pier	=	<u>4</u>	
Size of Pier Rebar Ties	=	<u># 4</u>	(bar)

Plan View for Triangle or Square Tower

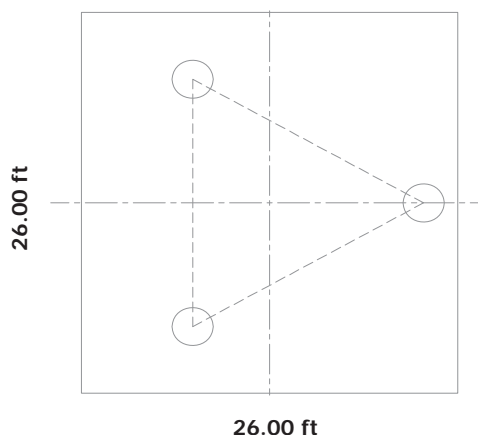

Total Overview

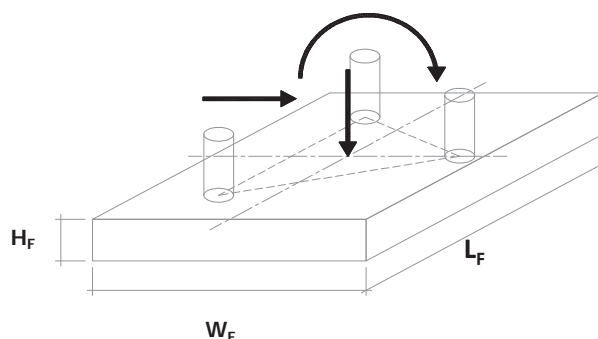

Soil Data:

Soil bearing	=	<u>3000</u>	(psf)
Soil bearing (ultimate)	=	<u>6000</u>	(psf)
Soil Cone for Uplift (θ)	=	<u>0</u>	(degrees)
Cohesion (C)	=	<u>0.00</u>	(ft)
Top Soil to Neglect (N)	=	<u>3.33</u>	(ft)
Base Sliding (μ)	=	<u>0.35</u>	(ksf)
Dry Soil Density (γ_{DRY})	=	<u>95</u>	(pcf)

Summary of Results

Overturing	71.18%
Soil Bearing	35.93%
Base Sliding	29.38%
One way Shear	13.88%
Punching Shear	39.56%
Pad Moment Capacity	64.04%
Pier Moment Capacity	27.56%

ANTENNA MOUNT STRUCTURAL ASSESSMENT REQUIREMENT:
 ENGINEER OF RECORD HAS MADE A VISUAL ASSESSMENT ONLY AND DETERMINED THAT THE EXISTING ANTENNA MOUNT SHALL BE REPLACED OR MODIFIED TO ACCOMMODATE ANY ADDITIONAL EQUIPMENT LOADS. STRUCTURAL DESIGNS AND DETAILS AS SHOWN HEREIN FOR STRUCTURAL MODIFICATIONS OF THE EXISTING ANTENNA MOUNT ARE PRELIMINARY ONLY AND FINAL CONSTRUCTION DETAILS ARE SUBJECT TO CHANGE PENDING THE COMPLETION OF AN ANTENNA MOUNT STRUCTURAL ASSESSMENT.

STRUCTURAL NOTES:
 PRIOR TO COMMENCING CONSTRUCTION, GC SHALL REFER TO TOWER STRUCTURAL ANALYSIS PROVIDED BY SBA TO DETERMINE IF THERE ARE ANY SUPPLEMENTAL OR SPECIAL INSTALLATION REQUIREMENTS FOR TOWER TOP EQUIPMENT AND FOR CABLE BUNDLING, SHIELDING, MOUNTING, OR RELOCATION ARRANGEMENTS

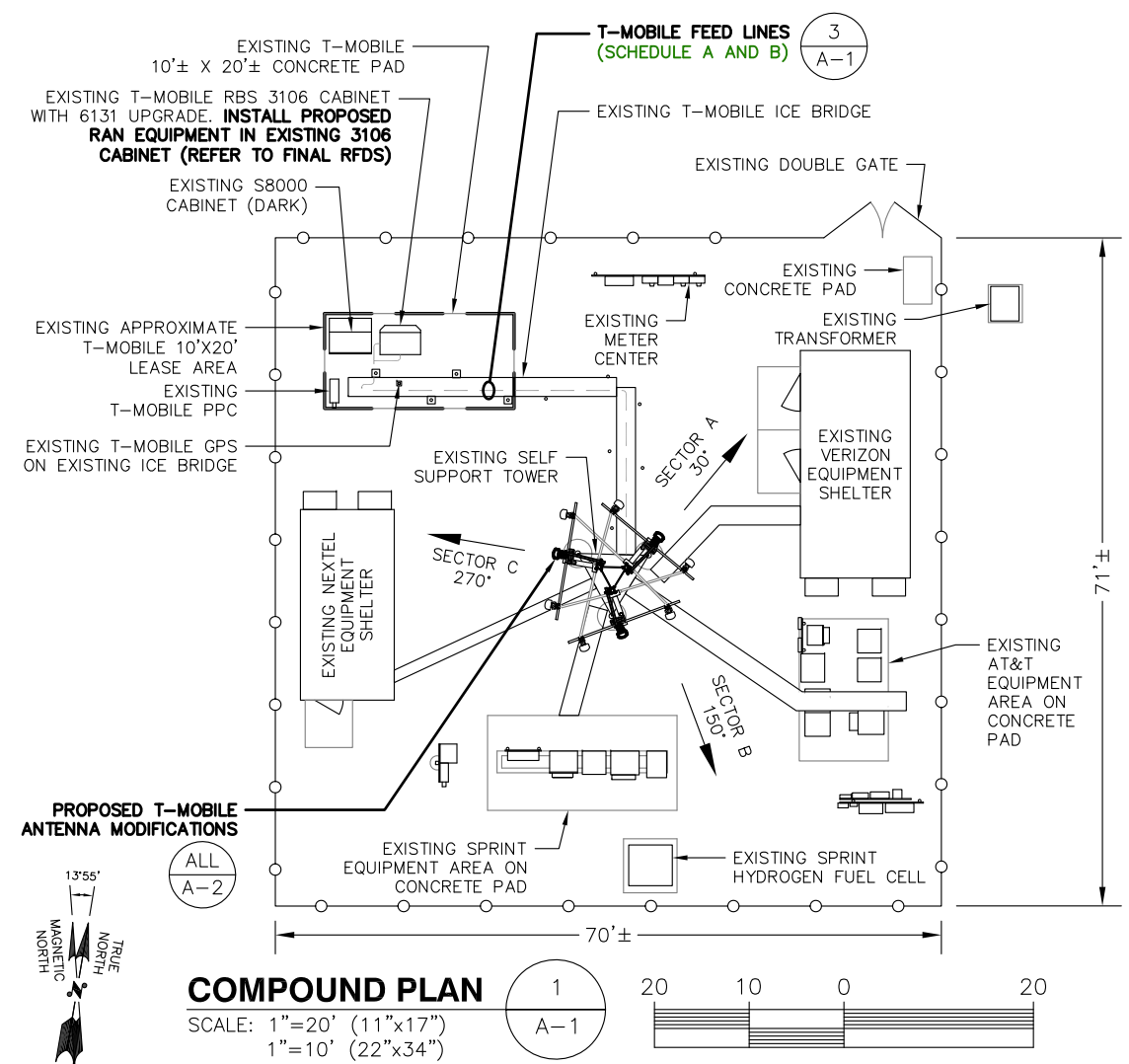

FEEDLINE SCHEDULE	FEEDLINE DESCRIPTION	LOCATION
A	EXISTING: TO REMAIN (12) 1-5/8" COAX AND (1) HYBRID TRUNK TO 93' RAD	UP SELF SUPPORT TOWER
B	PROPOSED: USE EXISTING SPARE FIBER TO 93' RAD	UP SELF SUPPORT TOWER

EXISTING T-MOBILE RBS 3106 CABINET WITH 6131 UPGRADE. **INSTALL PROPOSED RAN EQUIPMENT IN EXISTING 3106 CABINET (REFER TO FINAL RFDS)**
 T-MOBILE FEED LINES
 EXISTING T-MOBILE ICE BRIDGE
 EXISTING S8000 CABINET (DARK)
 EXISTING T-MOBILE GPS ON EXISTING ICE BRIDGE
 EXISTING T-MOBILE PPC



EQUIPMENT PHOTO DETAIL
 SCALE: N.T.S.

EXISTING (6) (12) 1-5/8" COAX AND (1) HYBRID TRUNK ACROSS EXISTING ICE BRIDGE & UP SELF SUPPORT TOWER, **ALL TO REMAIN (REFER TO SBA-PROVIDED STRUCTURAL ANALYSIS FOR SPECIAL FEEDLINE INSTALLATION REQUIREMENTS, STACKING, BUNDLING, SHIELDING, MOUNTING AND RELOCATION OF EXISTING OR PROPOSED FEEDLINES)**

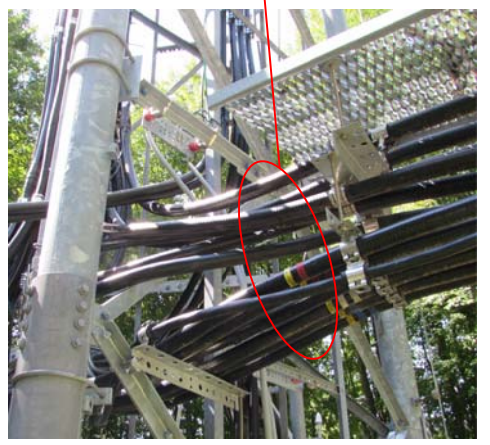

FEEDLINE PHOTO DETAIL AT TOWER BASE
 SCALE: N.T.S.

☉ OF PROPOSED T-MOBILE ANTENNAS
 ELEV.= 93'± AGL (SBA DATABASE)



PARTIAL ELEVATION PHOTO DETAIL
 SCALE: N.T.S.

T-Mobile
 T-MOBILE NORTHEAST LLC
 35 GRIFFIN ROAD SOUTH
 BLOOMFIELD, CT 06002
 OFFICE: (860) 648-1116

SBA
 SBA COMMUNICATIONS CORP.
 33 BOSTON POST ROAD WEST, SUITE 320
 MARLBOROUGH, MA 01752 TEL: (508) 251-0720

ProTerra
 DESIGN GROUP, LLC
 4 Bay Road, Building A
 Suite 200
 Hadley, MA 01035 Ph: (413)320-4918

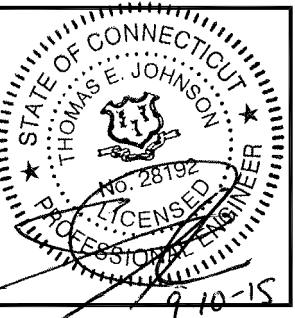

CHECKED BY: JMM/TEJ
 APPROVED BY: JMM/TEJ

SUBMITTALS

REV.	DATE	DESCRIPTION	BY
0	09/10/15	ISSUED FOR CONSTRUCTION	JEB

SITE NUMBER:
 CT11786D
 SITE NAME:
 NEXTEL GLASTONBURY
 SITE ADDRESS:
 2557 MAIN STREET
 GLASTONBURY, CT 06033
 HARTFORD COUNTY

SHEET TITLE
 COMPOUND & ELEVATION PLAN

SHEET NUMBER
 A-1



T-MOBILE NORTHEAST LLC
 35 GRIFFIN ROAD SOUTH
 BLOOMFIELD, CT 06002
 OFFICE: (860) 648-1116



SBA COMMUNICATIONS CORP.
 33 BOSTON POST ROAD WEST, SUITE 320
 MARLBOROUGH, MA 01752 TEL: (508) 251-0720



4 Bay Road, Building A
 Suite 200
 Hadley, MA 01035 Ph: (413) 320-4918

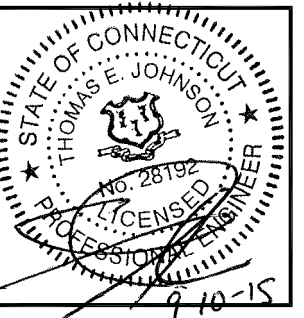

CHECKED BY: JMM/TEJ

APPROVED BY: JMM/TEJ

SUBMITTALS

REV.	DATE	DESCRIPTION	BY
0	09/10/15	ISSUED FOR CONSTRUCTION	JEB

SITE NUMBER:
CT11786D
 SITE NAME:
NEXTEL GLASTONBURY
 SITE ADDRESS:
 2557 MAIN STREET
 GLASTONBURY, CT 06033
 HARTFORD COUNTY

SHEET TITLE
EXISTING & PROPOSED ANTENNA PLAN

SHEET NUMBER
A-2

ANTENNA MOUNT STRUCTURAL ASSESSMENT REQUIREMENT:

ENGINEER OF RECORD HAS MADE A VISUAL ASSESSMENT ONLY AND DETERMINED THAT THE EXISTING ANTENNA MOUNT SHALL BE REPLACED OR MODIFIED TO ACCOMMODATE ANY ADDITIONAL EQUIPMENT LOADS. STRUCTURAL DESIGNS AND DETAILS AS SHOWN HEREIN FOR STRUCTURAL MODIFICATIONS OF THE EXISTING ANTENNA MOUNT ARE PRELIMINARY ONLY AND FINAL CONSTRUCTION DETAILS ARE SUBJECT TO CHANGE PENDING THE COMPLETION OF AN ANTENNA MOUNT STRUCTURAL ASSESSMENT.

STRUCTURAL NOTES:

PRIOR TO COMMENCING CONSTRUCTION, GC SHALL REFER TO TOWER STRUCTURAL ANALYSIS PROVIDED BY SBA TO DETERMINE IF THERE ARE ANY SUPPLEMENTAL OR SPECIAL INSTALLATION REQUIREMENTS FOR TOWER TOP EQUIPMENT AND FOR CABLE BUNDLING, SHIELDING, MOUNTING, OR RELOCATION ARRANGEMENTS

SPECIAL WORK NOTE:

VERTICALLY CENTER THE PIPE MAST AND THE PROPOSED ANTENNAS BETWEEN THE EXISTING MOUNTING RAILS

NOTE:
 REFER TO THE FINAL RF DATA SHEET FOR FINAL ANTENNA SETTINGS.

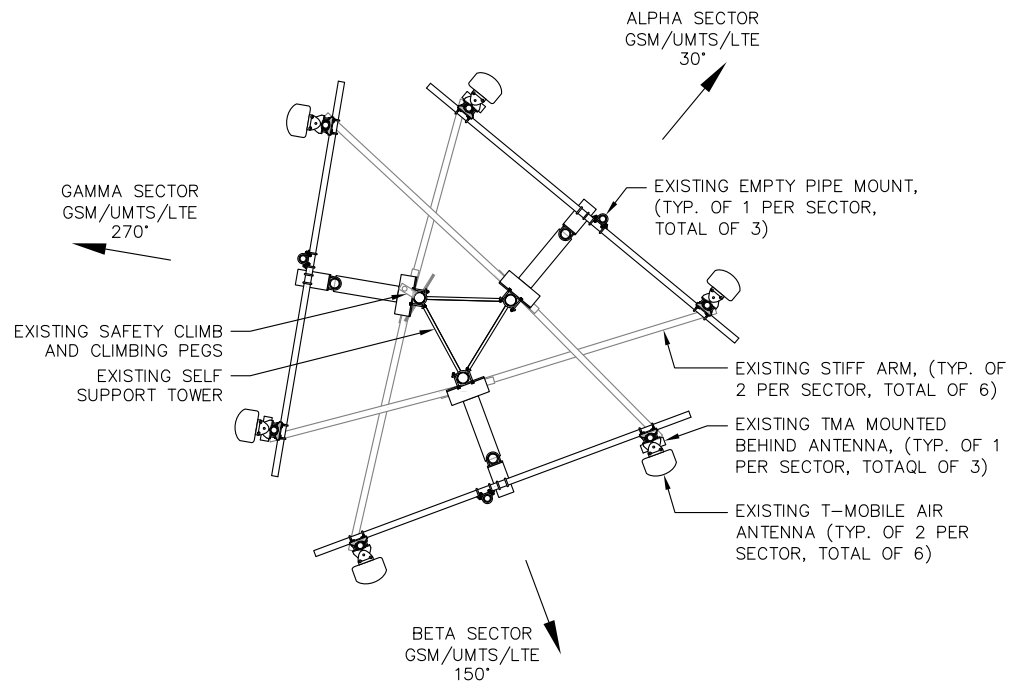

EXISTING ANTENNA PLAN

SCALE: N.T.S.

1
A-2

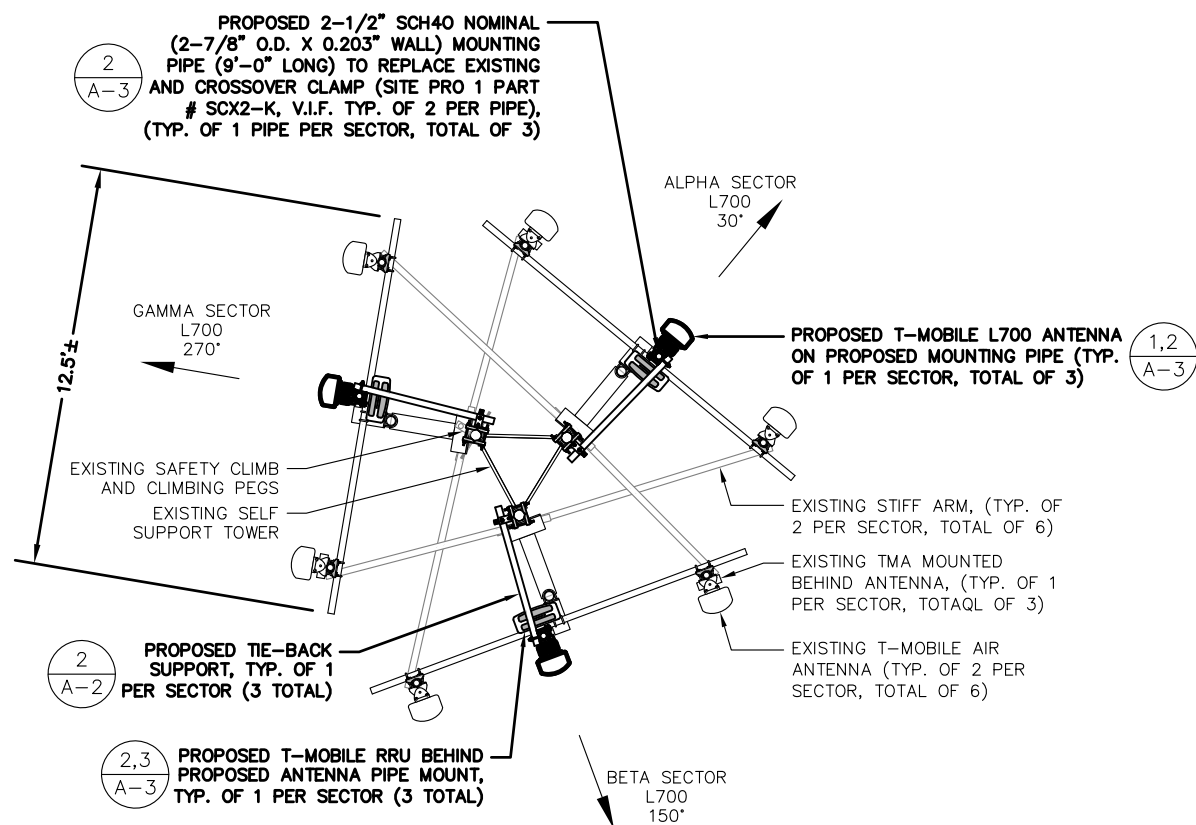

PROPOSED ANTENNA PLAN

SCALE: N.T.S.

2
A-2

NOTE:
 ALL PIPE TO BE SCH40 GALVANIZED ASTM A53 GRADE B (35 KSI)

PROPOSED 2-1/2" SCH40 NOMINAL (2-7/8" O.D. X 0.203" WALL) MOUNTING PIPE (9'-0" LONG) TO REPLACE EXISTING AND CROSSOVER CLAMP (SITE PRO 1 PART # SCX2-K, V.I.F. TYP. OF 2 PER PIPE), (TYP. OF 1 PIPE PER SECTOR, TOTAL OF 3) 2/A-3

PROPOSED T-MOBILE L700 ANTENNA ON PROPOSED MOUNTING PIPE (TYP. OF 1 PER SECTOR, TOTAL OF 3) 1,2/A-3

EXISTING T-MOBILE AIR ANTENNA (TYP. OF 2 PER SECTOR, TOTAL OF 6)

PROPOSED TIE-BACK SUPPORT, TYP. OF 1 PER SECTOR (3 TOTAL) 2/A-3

PROPOSED T-MOBILE RRU BEHIND PROPOSED ANTENNA PIPE MOUNT, TYP. OF 1 PER SECTOR (3 TOTAL) 2,3/A-3

⊙ OF PROPOSED T-MOBILE ANTENNAS
 ELEV.= 93'± AGL (SBA DATABASE)

2/A-2 1,2/A-3

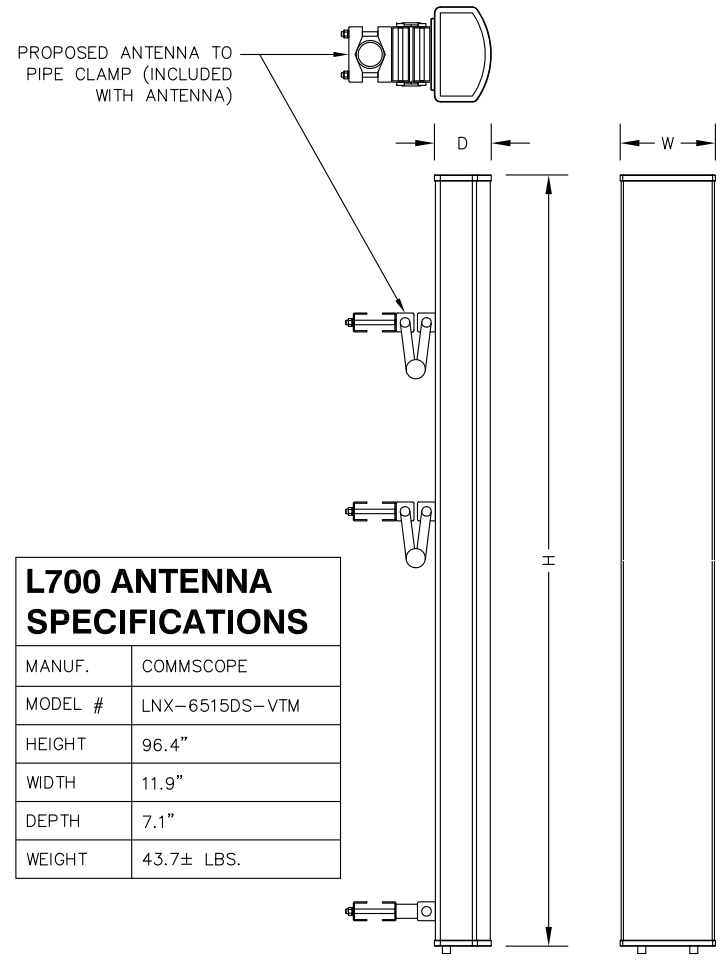

IMAGE SOURCE: PROTERRA 08/29/15
 NOTE: ONE SECTOR SHOWN FOR CLARITY

ANTENNA PHOTO DETAIL

SCALE: N.T.S.

3
A-2



L700 ANTENNA SPECIFICATIONS	
MANUF.	COMMSCOPE
MODEL #	LNx-6515DS-VTM
HEIGHT	96.4"
WIDTH	11.9"
DEPTH	7.1"
WEIGHT	43.7± LBS.

L700 ANTENNA DETAIL
SCALE: N.T.S.

1
A-3

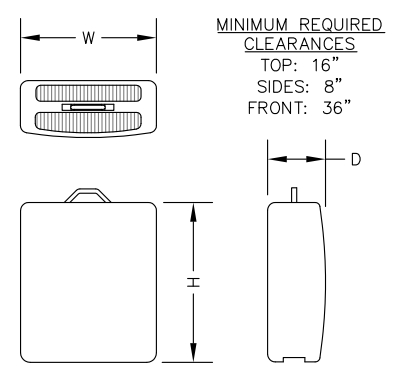

RRU SPECIFICATIONS	
MANUF.	ERICSSON
MODEL #	RRUS11 B12
HEIGHT	20"
WIDTH	17"
DEPTH	7"
WEIGHT	50.7 LBS.

REMOTE RADIO UNIT (RRU)
SCALE: N.T.S.

3
A-3

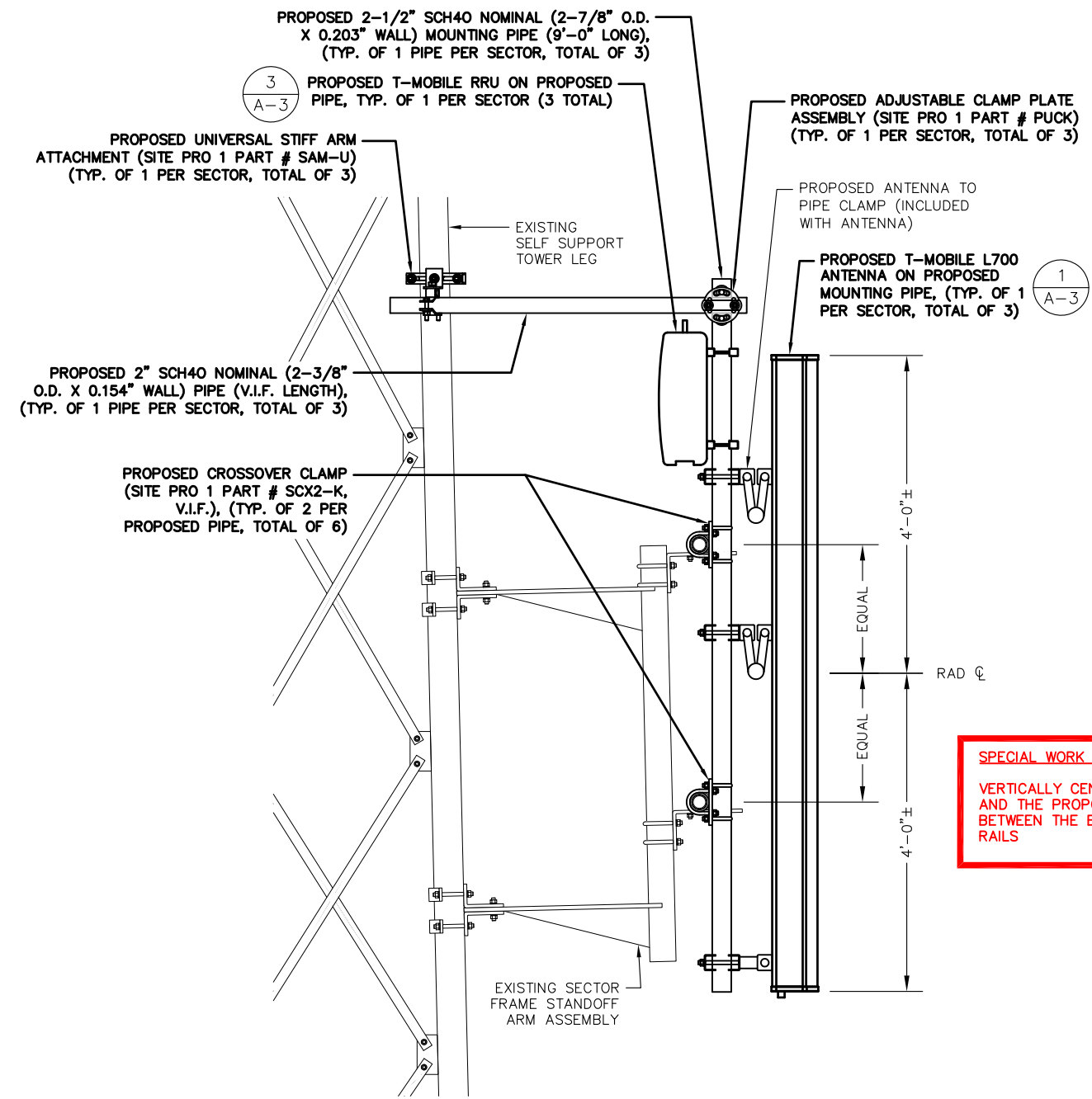

SPECIAL WORK NOTE:
VERTICALLY CENTER THE PIPE MAST AND THE PROPOSED ANTENNAS BETWEEN THE EXISTING MOUNTING RAILS

PROPOSED L700 ANTENNA MOUNTING DETAIL
SCALE: N.T.S.

2
A-3

ANTENNA MOUNT STRUCTURAL ASSESSMENT REQUIREMENT:
ENGINEER OF RECORD HAS MADE A VISUAL ASSESSMENT ONLY AND DETERMINED THAT THE EXISTING ANTENNA MOUNT SHALL BE REPLACED OR MODIFIED TO ACCOMMODATE ANY ADDITIONAL EQUIPMENT LOADS. STRUCTURAL DESIGNS AND DETAILS AS SHOWN HEREIN FOR STRUCTURAL MODIFICATIONS OF THE EXISTING ANTENNA MOUNT ARE PRELIMINARY ONLY AND FINAL CONSTRUCTION DETAILS ARE SUBJECT TO CHANGE PENDING THE COMPLETION OF AN ANTENNA MOUNT STRUCTURAL ASSESSMENT.

T-Mobile
T-MOBILE NORTHEAST LLC
35 GRIFFIN ROAD SOUTH
BLOOMFIELD, CT 06002
OFFICE: (860) 648-1116

SBA
SBA COMMUNICATIONS CORP.
33 BOSTON POST ROAD WEST, SUITE 320
MARLBOROUGH, MA 01752 TEL: (508) 251-0720

ProTerra
DESIGN GROUP, LLC
4 Bay Road, Building A
Suite 200
Hadley, MA 01035 Ph: (413)320-4918

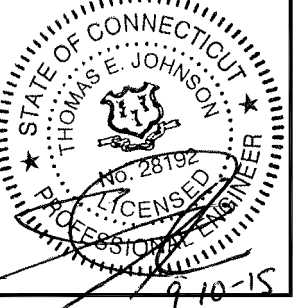

CHECKED BY: JMM/TEJ

APPROVED BY: JMM/TEJ

SUBMITTALS			
REV.	DATE	DESCRIPTION	BY
0	09/10/15	ISSUED FOR CONSTRUCTION	JEB

SITE NUMBER:
CT11786D
SITE NAME:
NEXTEL GLASTONBURY
SITE ADDRESS:
2557 MAIN STREET
GLASTONBURY, CT 06033
HARTFORD COUNTY

SHEET TITLE
DETAILS

SHEET NUMBER
A-3