

STATE OF CONNECTICUT
CONNECTICUT SITING COUNCIL

Ten Franklin Square, New Britain, CT 06051

Phone: (860) 827-2935 Fax: (860) 827-2950

E-Mail: siting.council@ct.gov

www.ct.gov/csc

February 24, 2014

Neil J. Alexander, Esq.
Cuddy & Feder LLP
445 Hamilton Avenue, 14th Floor
White Plains, NY 10601

RE: **EM-CING-052-131023** - New Cingular Wireless PCS, LLC notice of intent to install a temporary cellular telecommunications facility located at 500 South Road, Farmington, Connecticut.

Dear Attorney Alexander:

This letter serves as a correction to the original decision letter dated January 27, 2014 for the above-referenced temporary cellular telecommunications facility located at 500 South Road, Farmington. Unfortunately, in the original decision letter, a statement regarding the temporary facility located in Monroe was inadvertently included. We apologize for any inconvenience this may have caused.

At a public meeting held on January 23, 2014, the Connecticut Siting Council (Council) considered and voted to grant your request dated January 10, 2014, for an extension of time for this temporary facility. Pursuant to Regulations of Connecticut State Agencies Section 16-50j-72 (d)(4), the Council may grant an extension past 30-days where good cause is shown and with the permission of the property owner and the municipality.

This decision is under the exclusive jurisdiction of the Council. Any additional change to this temporary facility will require explicit notice to this agency pursuant to Regulations of Connecticut State Agencies Section 16-50j-73. Such notice shall include all relevant information regarding the proposed change with cumulative worst-case modeling of radio frequency exposure at the closest point of uncontrolled access to the tower base, consistent with Federal Communications Commission, Office of Engineering and Technology, Bulletin 65.

Thank you for your attention and cooperation.

Very truly yours,

A handwritten signature in black ink that reads "Robert Stein" with a stylized initial "RS" to the right.

Robert Stein
Chairman

RS/CDM/cm

c: The Honorable Nancy Nickerson, Chairman, Town of Farmington
Kathleen Eagen, Town Manager, Town of Farmington
Elizabeth Dolphin, Assistant Planner, Town of Farmington

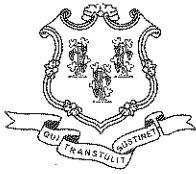

STATE OF CONNECTICUT

CONNECTICUT SITING COUNCIL

Ten Franklin Square, New Britain, CT 06051

Phone: (860) 827-2935 Fax: (860) 827-2950

E-Mail: siting.council@ct.gov

www.ct.gov/csc

January 27, 2014

Neil J. Alexander, Esq.
Cuddy & Feder LLP
445 Hamilton Avenue, 14th Floor
White Plains, NY 10601

RE: **EM-CING-052-131023** - New Cingular Wireless PCS, LLC notice of intent to install a temporary cellular telecommunications facility located at 500 South Road, Farmington, Connecticut.

Dear Attorney Alexander:

At a public meeting held on January 23, 2014, the Connecticut Siting Council (Council) considered and voted to grant your request dated January 10, 2014, for an extension of time for this temporary facility. Pursuant to Regulations of Connecticut State Agencies Sections 16-50j-3 and 16-50j-72 (d)(4), the Council may grant an extension past 30-days where good cause is shown and with the permission of the property owner and the municipality. Due to the tragic event that occurred in Newtown, the students from the Sandy Hook Elementary School are being temporarily schooled in Monroe where temporary cellular coverage is necessary until a more permanent telecommunications facility is proposed. The Council hereby extends the installation of the existing temporary facility to June 30, 2014.

This decision is under the exclusive jurisdiction of the Council. Any additional change to this temporary facility will require explicit notice to this agency pursuant to Regulations of Connecticut State Agencies Section 16-50j-73. Such notice shall include all relevant information regarding the proposed change with cumulative worst-case modeling of radio frequency exposure at the closest point of uncontrolled access to the tower base, consistent with Federal Communications Commission, Office of Engineering and Technology, Bulletin 65.

Thank you for your attention and cooperation.

Very truly yours,

Robert Stein
Chairman

RS/CDM/cm

c: The Honorable Jeffery Hogan, Chairman, Town of Farmington
Elizabeth Dolphin, Assistant Planner, Town of Farmington

ORIGINAL

RECEIVED
JAN 13 2014

**CONNECTICUT
SITING COUNCIL**

January 10, 2014

VIA ELECTRONIC MAIL

Melanie Bachman
Executive Director
Connecticut Siting Council
10 Franklin Square
New Britain, CT 06051

Re: **EM-CING-052-131023** – New Cingular Wireless PCS, LLC notice of intent to install a temporary cellular telephone facility located at 500 South Road, Farmington, Connecticut

Dear Executive Director Bachman:

On November 8, 2013, the Council acknowledged use of a temporary cellular telephone facility ("COW") in the above-referenced regulatory filing filed on behalf of New Cingular Wireless PCS, LLC ("AT&T"). AT&T, in its filing, noticed the Council that it intended to remove the COW after the first of the year. We have, nevertheless, been advised by AT&T of their desire to keep the COW in place and operational for a further, albeit temporary period of time.

In the original Notice of Exempt Modification, AT&T had highlighted its Fall 2013 land use approvals from the Town of Farmington and the Town of West Hartford for a permanent wireless facility atop the Westfarms Mall. The COW was intended to provide service from the Westfarms Mall at grade while this permanent wireless facility underwent construction on the rooftop, particularly during the busy holiday shopping season.

Regrettably, the leasing and construction process for the permanent wireless facility has taken longer than anticipated. Yet, the property owner of the Westfarms Mall has authorized AT&T to continue the use of the temporary installation at this retail center until such time as the permanent installation is complete.

By way of this letter, we are seeking to extend the authorization and acknowledgment in **EM-CING-052-131023** six months through June of 2014. There are no changes to the COW proposed as part of this request. As such, we respectfully request on AT&T's behalf such additional time to maintain the COW and your acknowledgment to do so on the Council's behalf.

Very truly yours,

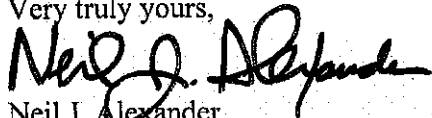

Neil J. Alexander

cc: Christopher B. Fisher, Esq.



STATE OF CONNECTICUT
CONNECTICUT SITING COUNCIL

Ten Franklin Square, New Britain, CT 06051

Phone: (860) 827-2935 Fax: (860) 827-2950

E-Mail: siting.council@ct.gov

www.ct.gov/csc

November 8, 2013

Neil J. Alexander, Esq.
Cuddy & Feder, LLP
45 Hamilton Avenue, 14th Floor
White Plains, NY 10601

RE: **EM-CING-052-131023**- - New Cingular Wireless PCS, LLC notice of intent to install a temporary cellular telephone facility located at 500 South Road, Farmington, Connecticut.

Dear Attorney Alexander:

The Connecticut Siting Council (Council) hereby acknowledges your notice to modify this existing telecommunications facility, pursuant to Section 16-50j-73 of the Regulations of Connecticut State Agencies with the following conditions:

- Any deviation from the proposed modification as specified in this notice and supporting materials with the Council shall render this acknowledgement invalid;
- Any material changes to this modification as proposed shall require the filing of a new notice with the Council;
- Within 45 days after completion of construction, the Council shall be notified in writing that construction has been completed;
- The validity of this action shall expire one year from the date of this letter; and
- The applicant may file a request for an extension of time beyond the one year deadline provided that such request is submitted to the Council not less than 60 days prior to the expiration.

The proposed modifications including the placement of all necessary equipment and shelters within the tower compound are to be implemented as specified here and in your notice dated October 23, 2013. The modifications are in compliance with the exception criteria in Section 16-50j-72 (b) of the Regulations of Connecticut State Agencies as changes to an existing facility site that would not increase tower height, extend the boundaries of the tower site, increase noise levels at the tower site boundary by six decibels, and increase the total radio frequencies electromagnetic radiation power density measured at the tower site boundary to or above the standard adopted by the State Department of Environmental Protection pursuant to General Statutes § 22a-162. This facility has also been carefully modeled to ensure that radio frequency emissions are conservatively below State and federal standards applicable to the frequencies now used on this tower.

This decision is under the exclusive jurisdiction of the Council. Please be advised that the validity of this action shall expire one year from the date of this letter. Any additional change to this facility will require explicit notice to this agency pursuant to Regulations of Connecticut State Agencies Section 16-50j-73. Such notice shall include all relevant information regarding the proposed change with cumulative worst-case modeling of radio frequency exposure at the closest point of uncontrolled access to the tower base, consistent with Federal Communications Commission, Office of Engineering and Technology, Bulletin 65. Thank you for your attention and cooperation.

Very truly yours,



Melanie A. Bachman
Acting Executive Director

MAB/CDM/cm

- c: The Honorable Jeffrey Hogan, Chairman, Town of Farmington
- Kathleen Eagen (via e-mail service), Town Manager, Town of Farmington
- Jeffrey Ollendorf (via e-mail service), Town Planner, Town of Farmington

**NOTICE OF EXEMPT MODIFICATION
TO PLACE A CELL ON WHEELS AT
WESTFARMS MALL, 500 SOUTH ROAD, FARMINGTON, CONNECTICUT**

Pursuant to the Public Utility Environmental Standards Act, Connecticut General Statutes § 16-50g et. seq. (“PUESA”), and Sections 16-50j-72(d) and 16-50j-73 of the Regulations of Connecticut State Agencies adopted pursuant to the PUESA, New Cingular Wireless PCS, LLC (“AT&T”) hereby notifies the Connecticut Siting Council of its intent for the temporary use of telecommunications equipment by placing a Cell On Wheels (COW) on the grounds of the Westfarms Mall located at 500 South Road, Farmington, Connecticut.

AT&T’s Recent Local Land Use Approvals for a Permanent Rooftop Wireless Facility

AT&T has obtained land use approvals from both the Town of Farmington and the Town of West Hartford to co-locate (with Verizon Wireless and T-Mobile) and camouflage a wireless facility atop the Westfarms Mall, which is a 1.3 million square foot regional shopping center owned by West Farms Associates and operated by Taubman Centers. The Westfarms Mall has a street address of 500 South Road in the Town of Farmington and a street address of 1500/1502 New Britain Avenue in the Town of West Hartford, Connecticut. The fully approved rooftop wireless facility will be predominantly installed in the Town of Farmington with a portion in the Town of West Hartford. The wireless facility was designed to look similar to the Verizon Wireless installation with the antennas mounted to the upper penthouse rooftop screen wall behind boxes designed to mimic the screen wall and with the equipment shelter affixed to a steel dunnage on the main roof level. AT&T also will mount a 50kW natural gas fueled emergency power generator on an existing HVAC unit dunnage frame on the main roof.

On September 16, 2013, the Farmington Plan and Zoning Commission unanimously approved AT&T’s “application for special permit and site plan approval to co-locate (with Verizon and T-Mobile) and screen a wireless facility on the rooftop of West Farms Mall, 500 South Road, BR zone....” A copy of the September 24, 2013 Farmington Approval is attached as Attachment 1.

On September 10, 2013, the West Hartford Town Council authorized the Town Planner to approve AT&T’s “request for an administrative amendment to Special Development District #12 located at 1500/1502 New Britain Avenue (Westfarms Mall) to co-locate and architecturally screen a wireless antenna facility atop Westfarms Mall”. A copy of that September 11, 2013 Approval letter is attached as Attachment 2.

AT&T’s Temporary Use of Telecommunications Equipment (i.e., Proposed COW)

Notwithstanding these recent local land use approvals, AT&T’s permanent rooftop wireless facility will not be in service until early 2014. To provide coverage to Westfarms Mall and the surrounding area, AT&T intends to deploy a COW until the permanent rooftop wireless facility is operational. Existing AT&T coverage is inadequate in the area. The Thanksgiving to New Year’s time frame is the highest-volume shopping period during the entire year as well as very high-volume traffic days for holiday travelers and shoppers. There are also frequent inclement weather events often in the form of snow, ice, and sleet. For these reasons, it is essential to maintain E911 service and normal AT&T telecommunications service. As such, AT&T seeks to set up a COW to provide telecommunications service and enhance public safety during the period of time the permanent facility is in construction.

AT&T has located a site on the Westfarms Mall loop road at coordinates 41.724522, -72.7653833. See attached location maps attached as Attachment 3. This location is within an easement granted by the Westfarms Mall to AT&T for landline equipment cabinets and buried telephone lines. On October 17, 2013, Westfarms Mall Manager Kevin Keenan gave email consent to placing the COW at that location. Written consent is pending. The COW will arrive at the site on or about November 22, 2013 for set-up in advance of the holiday, and it is planned for removal on January 6, 2014.

AT&T's temporary use of telecommunications equipment will consist of radio equipment on the COW, which is approximately 40 feet in length and 8 feet in width. A photograph of a typical AT&T COW is attached as Attachment 4. A mast will be extended upward from the COW to a height of approximately 60 feet above ground level to support the AT&T antennas. The antenna centerline will be 60 feet above grade level with a tip height of 61 feet. Electric power and telephone service will be obtained from sources within the AT&T easement area.

Power Density Calculations

AT&T's temporary use of telecommunications equipment will not result in a total radio frequency electromagnetic radiation power density, measured at ground level in this location, at or above State or Federal standards. AT&T will transmit and received in the 800, 1900 and 700 Bands. The "worst case" power density calculation demonstrates that AT&T's temporary transmissions from the COW will result in a power density corresponding to approximately 37.7% of the ANSI/IEEE standard for uncontrolled environments. A table for that worst case power density calculation along with specification sheets for the Kathrein antennas is attached as Attachment 5. Therefore, total worst-case density levels from AT&T's temporary use of telecommunications equipment at this location would be within the applicable standard limits.

The Siting Council's Prior Review of a COW at this Exact Same Location

On November 10, 2011 in EM-CING-052-111102, the Council acknowledged AT&T's notice of intent to install a temporary cellular telecommunications facility located at West Farms Mall, Farmington, Connecticut in compliance with the exception criteria in Section 16-50j-72(d) of the Regulations of Connecticut State Agencies for temporary cellular service for events of statewide significance. A copy of that November 10, 2011 Approval is attached as Attachment 6. The prior COW was 65 feet tall, 40 feet in length and 8 feet wide. It was installed in the exact same location currently proposed by AT&T and the electric power and telephone service was obtained in that instance as is currently proposed by AT&T.

AT&T's Proposal Constitutes An Exempt Modification

AT&T's proposed COW constitutes an exempt modification for the temporary use of telecommunications equipment for events of statewide significance as defined in Connecticut General Statutes Section 16-50j-72(d) and previously interpreted by the Siting Council pursuant to its regulations. There will be no routine increase in noise levels at the property boundary as a result of AT&T's COW. AT&T's temporary facility has been carefully modeled to ensure that radio frequency emissions are conservatively below State and federal standards applicable to the frequencies to be used on this COW.

For all the foregoing reasons, AT&T's COW at the site constitutes an exempt modification and meets the Council's regulatory criteria for acknowledgement.

Conclusion

We respectfully request that the Connecticut Siting Council acknowledge that AT&T's proposed COW for the West Farms Mall is in compliance with the exception criteria in Section 16-50j-72(d) of the Regulations of Connecticut State Agencies for the temporary use of telecommunications equipment for events of statewide significance.

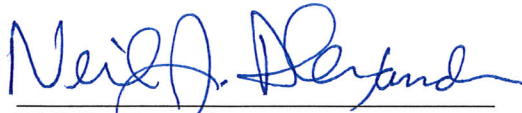

Neil J. Alexander
Counsel for AT&T
Cuddy & Feder, LLP
445 Hamilton Avenue, 14th Floor
White Plains, NY 10601
(914) 761-1300

cc: Hon. Jeffrey J. Hogan, Chair of Farmington Town Council
Kathleen A. Eagen, Farmington Town Manager
Scott Slifka, Mayor of West Hartford
Ron Van Winkle, West Hartford Town Manager
Michele Briggs, AT&T
David Osuch, SAI
Christopher B. Fisher, Esq.

ATTACHMENT 1



September 24, 2013

Neil J. Alexander, Esq.
Cuddy & Feder LLP
445 Hamilton Avenue, 14th Floor
White Plains, NY 10601

CERTIFIED MAIL

Re: AT&T Wireless PCS, LLC – 500 South Road, Farmington, CT

Dear Attorney Alexander,

At a meeting of the Town Plan and Zoning Commission held on September 16, 2013, it was unanimously voted to approve the application for special permit and site plan approval to co-locate (with Verizon and T-Mobile) and screen a wireless facility on the rooftop of West Farms Mall, 500 South Road, BR zone as presented with the condition that routine testing of the generator be conducted between the hours of 8:30 a.m. and 4:30 p.m.

Section 8-3d of the Connecticut General Statute requires that this special permit be recorded on the land records. The certificate for such recording will be available on Wednesday, September 25, 2013. Please be advised, however, that there is a 15-day appeal period following the publication of the legal ad. The appeal period will expire on October 11, 2013. You may come into our office any time on or after September 25th to pick up your certificate and record it in the Town Clerk's office.

Please contact the Planning Department at (860) 675-2325 if you have any questions. Thank you.

Very truly yours,

Don Doeg, Secretary
Town Plan and Zoning Commission

DD/sjm



ATTACHMENT 2

DEPARTMENT OF
COMMUNITY SERVICES

September 11, 2013

Neil J. Alexander, Esq.
Cuddy & Feder, LLP
445 Hamilton Avenue, 14th Floor
White Plains, NY 10601

**SUBJECT: 1500/1502 New Britain Avenue – Westfarms Mall
SDD #12-R2-13**

Dear Attorney Alexander:

On September 10, 2013, the Town Council authorized me to approve your request for an administrative amendment to Special Development District #12 located at 1500/1502 New Britain Avenue (Westfarms Mall) to co-locate and architecturally screen a wireless antenna facility atop Westfarms Mall.

Approval is given pursuant to your narrative dated August 20, 2013 and plans dated June 25, 2013.

In order to finalize your SDD Amendment you must now prepare mylars reflecting the approved changes which will then be filed with the office of the Town Clerk and the Planning Division. Please contact me to discuss the details of the information which should be included on the mylars. *Note that these mylars must meet State statutory requirements for filing on the Land Records.*

You are required to submit two (2) mylars and three (3) paper copies of each sheet (18" x 24" or 24" x 36") you intend to file. A check payable to the Town of West Hartford in the amount of \$10 per sheet for one (1) plan set shall also be submitted. *The attached letter of approval from the Town Council should be stripped into the final plan set.* This approval is valid for ninety (90) days. Under Town Zoning Ordinances if you fail to file your plans within this time limit the approval becomes null and void.

Upon receipt and filing of the mylars you will be authorized to obtain building permits for the proposed work on your property.

If I can be of further assistance please contact me at 860.561.7556.

Best regards,

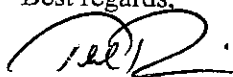

Todd Dumais
Town Planner

Cc: Mark McGovern, Director of Community Services
Joseph O'Brien, Corporation Counsel
Essie Labrot, Town Clerk
Brian Pudlik, Zoning Enforcement Officer
SDD Subject File

U: sd/TPZ/SDD/NewBritainAve_Westfarms_SDD#12-R2-13_Sept1113



TOWN OF WEST HARTFORD

TOWN OF WEST HARTFORD
50 SOUTH MAIN STREET
WEST HARTFORD, CONNECTICUT 06107-2485
(860) 561-7555 FAX: (860) 561-7504
<http://www.westhartford.org>

An Equal Opportunity/Affirmative Action Employer

ATTACHMENT 3

WFM COW

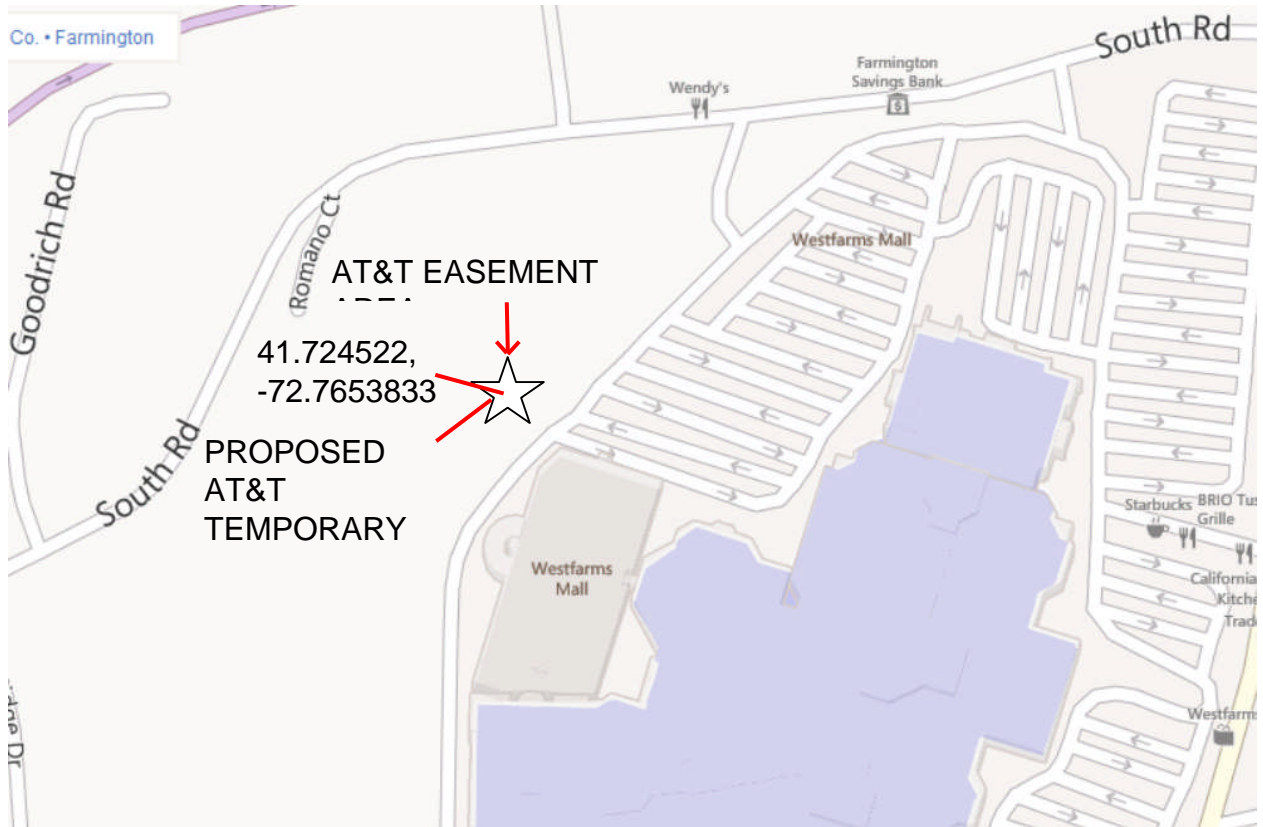

West Farms Mall-proposed location for temporary COW (pic3)

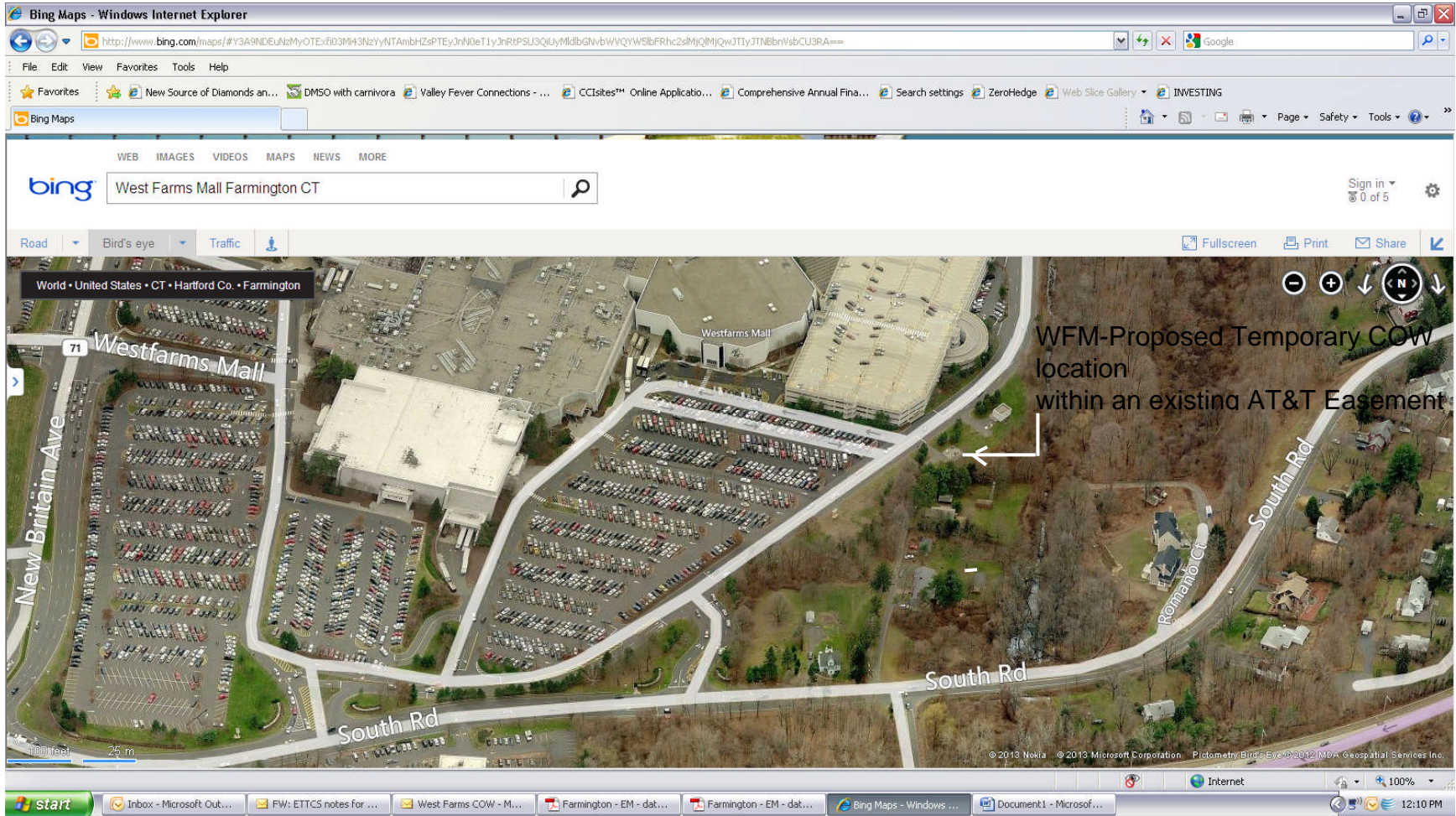



ATTACHMENT 4





KOHLSCHUTTER
GENERATOR

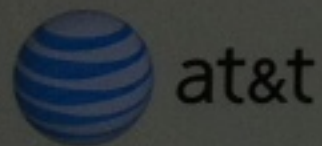

Bunker Hill
att.com

ATTACHMENT 5

**65° Dualband Directional Antenna
with Integrated Combiner**

Kathrein's multi-band antennas are ready for 4G applications, covering all existing wireless bands for AMPS, PCS and 3G/UMTS as well as all spectrum under consideration for future systems. These cross-polarized antennas offer diversity operation in the same space as a conventional 800 MHz antenna, and are mountable on our compact sector brackets.

- Wide band operation.
- Exceptional intermodulation characteristics.
- High strength pultruded fiberglass radome.
- Integrated combiner reduces RF feedline requirements from 4 to 2.

General specifications:

Frequency range	698–894 MHz 1710–2170 MHz
Impedance	50 ohms
VSWR	<1.5:1
Intermodulation (2x20w)	IM3: <-150 dBc
Polarization	+45° and -45°
Connector	2 x 7-16 DIN female
Isolation intrasystem	>30 dB
Weight	15.9 lb (7.2 kg) 20.3 lb (9.2 kg) clamps included
Dimensions	23.3 x 10.6 x 6.2 inches (593 x 270 x 157 mm)
Wind load Front/Side/Rear	at 93 mph (150kph) 37 lbf / 21 lbf / 56 lbf (163 N) / (92 N) / (245 N)
Wind survival rating*	120 mph (200 kph)
Shipping dimensions	29 x 11.9 x 7.6 inches (736 x 302 x 192 mm)
Shipping weight	23.6 lb (10.7 kg)
Mounting	Fixed mounts for 2 to 4.6 inch (50 to 115 mm). OD masts are included and tilt options are available.

See reverse for order information.

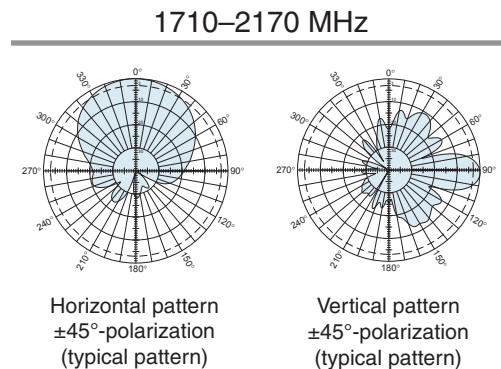
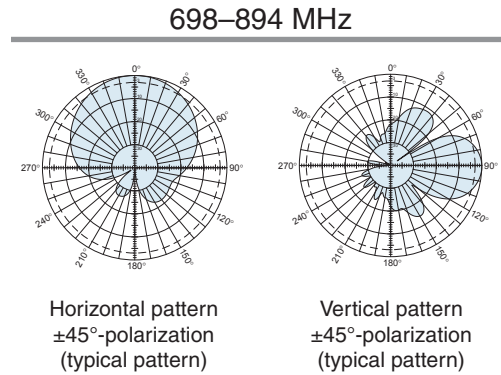

Specifications:	698–806 MHz	824–894 MHz	1710–1755 MHz	1850–1990 MHz	2110–2170 MHz
Gain*	10.8 dBi	11.4 dBi	12.6 dBi	13.2 dBi	12.2 dBi
Front-to-back ratio	>27 dB (co-polar)	>30 dB (co-polar)	>27 dB (co-polar)	>27 dB (co-polar)	>27 dB (co-polar)
Maximum input power	250 watts (at 50°C)	250 watts (at 50°C)	200 watts (at 50°C)	200 watts (at 50°C)	200 watts (at 50°C)
+45° and -45° polarization horizontal beamwidth	72° (half-power)	69° (half-power)	65° (half-power)	65° (half-power)	75° (half-power)
+45° and -45° polarization vertical beamwidth	36° (half-power)	32° (half-power)	23° (half-power)	19° (half-power)	18° (half-power)
Cross polar ratio (typical)					
Main direction 0°	30 dB	30 dB	22 dB	25 dB	22 dB
Sector ±60°	>10 dB	>10 dB	>10 dB	>10 dB	>10 dB
Integrated combiner	*The insertion loss is included in the given antenna gain values				

* Mechanical design is based on environmental conditions as stipulated in TIA-222-G-2 (December 2009) and/or ETS 300 019-1-4 which include the static mechanical load imposed on an antenna by wind at maximum velocity. See the Engineering Section of the catalog for further details.



11203-C

**65° Dualband Directional Antenna
with Integrated Combiner**

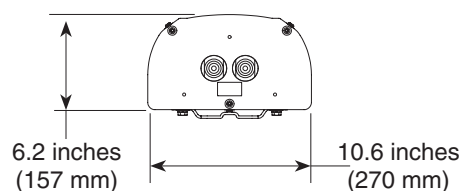
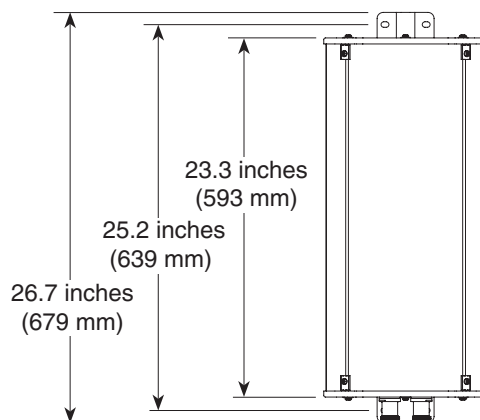
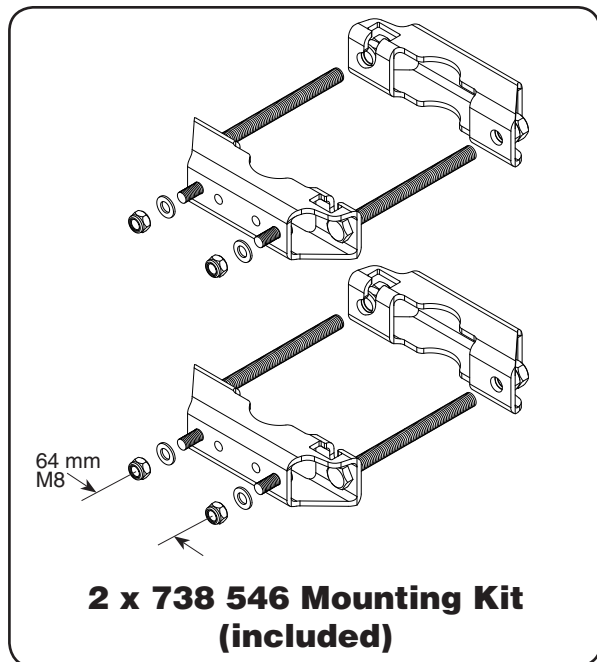

Profile PA3

Mounting Options:

Model	Description
2 x 738 546 (included)	Mounting Kit for 2 to 4.6 inch (50 to 115 mm) OD mast.
850 10013	Tilt Kit for use with the 2 x 738 546 mounting kit 0–34 degrees downtilt angle.

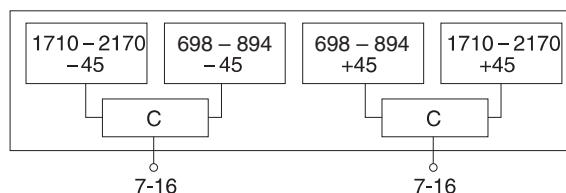

Order Information:

Model	Description
840 10520	Antenna with 7-16 DIN connectors

All specifications are subject to change without notice. The latest specifications are available at www.kathrein-scala.com.

ATTACHMENT 6

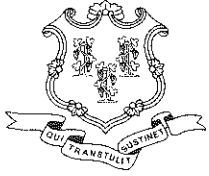

STATE OF CONNECTICUT

CONNECTICUT SITING COUNCIL

Ten Franklin Square, New Britain, CT 06051

Phone: (860) 827-2935 Fax: (860) 827-2950

E-Mail: siting.council@ct.gov

www.ct.gov/csc

November 10, 2011

Steven L. Levine
Real Estate Consultant
New Cingular Wireless PCS, LLC
500 Enterprise Drive
Rocky Hill, CT 06067-3900

RE: **EM-CING-052-111102** - New Cingular Wireless PCS, LLC notice of intent to install a temporary cellular telecommunications facility located at West Farms Mall, Farmington, Connecticut.

Dear Mr. Levine:

The Connecticut Siting Council (Council) hereby acknowledges your notice to construct a temporary telecommunications facility, pursuant to Section 16-50j-73 of the Regulations of Connecticut State Agencies.

The proposed facility is to be developed as specified here and in your notice dated November 2, 2011. The facility is in compliance with the exception criteria in Section 16-50j-72 (d) of the Regulations of Connecticut State Agencies for temporary cellular service for events of statewide significance. This temporary facility has also been carefully modeled to ensure that radio frequency emissions are conservatively below State and federal standards applicable to the frequencies to be used on this tower.

This decision is under the exclusive jurisdiction of the Council. Any additional change to this temporary facility will require explicit notice to this agency pursuant to Regulations of Connecticut State Agencies Section 16-50j-73. Such notice shall include all relevant information regarding the proposed change with cumulative worst-case modeling of radio frequency exposure at the closest point of uncontrolled access to the tower base, consistent with Federal Communications Commission, Office of Engineering and Technology, Bulletin 65. Any deviation from this format may result in the Council implementing enforcement proceedings pursuant to General Statutes § 16-50u including, without limitation, imposition of expenses resulting from such failure and of civil penalties in an amount not less than one thousand dollars per day for each day of construction or operation in material violation.

Thank you for your attention and cooperation.

Very truly yours,

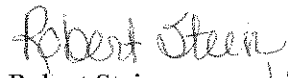
Robert Stein
Chairman

RS/CDM/laf

c: The Honorable Mike Clark, Chairman, Town of Farmington
Jeffrey Ollendorf (via e-mail service), Town Planner, Town of Farmington