



**NORTHEAST**  
SITE SOLUTIONS

*Turnkey Wireless Development*

Northeast Site Solutions  
Denise Sabo  
4 Angela's Way, Burlington CT 06013  
860-209-4690  
denise@northeastsitesolutions.com

July 15, 2019

Members of the Siting Council  
Connecticut Siting Council  
Ten Franklin Square  
New Britain, CT 06051

RE: Notice of Exempt Modification  
40 Maple Ridge Drive, Farmington CT 06032  
Latitude: 41.71809167  
Longitude: -72.7677778  
T-Mobile Site#: CT11135J\_L700 4x2

Dear Ms. Bachman:

T-Mobile currently maintains three (3) antenna at the 82-ft level and three (3) antenna at the 73-ft level of the existing 84-foot self-utility pole located (#8011) at 40 Maple Ridge Drive, Farmington CT. The 84-foot utility pole and property are owned by Conn Light and Power d/b/a Eversource. T-Mobile now intends to replace three (3) of the existing antenna with three (3) new 600/700 MHz antenna. The new antennas would be installed at the 73-foot level of the tower.

Planned Modifications:

Remove:  
NONE

Remove and Replace:

(3) LNX6515DS (Remove) – (3) APXVAARR24-43-U-NA20 Antenna 611/700 MHz (73-ft RAD) (Replace)

Install New:  
NONE

Existing to Remain:

(18) 7/8" Coax  
(3) APX16DWV-16DWV Antenna 1900/2100 MHz (82-ft RAD)

Ground:

(3) Diplexers on exiting H-Frame  
(3) RRH (Remove) – (3) RRU 4449 B71 +B12 (Replace) on Exiting H-Frame

This facility was approved by the CT Siting Council Petition No. 423. Please see attached.

This facility was approved by the Town of Farmington PZC. The tower was built in the 1980's the original zoning approval file is not available – See attached letter from the Town Planner.

Please accept this letter as notification pursuant to Regulations of Connecticut State Agencies § 16-50j-73, for construction that constitutes an exempt modification pursuant to R.C.S.A. § 16-50j-72(b)(2). In accordance with R.C.S.A. § 16-50j-73, a copy of this letter is being sent to Kathleen Eagen, Town Manager, as Elected Official for the Town of Farmington and William Warner, Town Planner as well as the property owner and the tower owner.

The planned modifications to the facility fall squarely within those activities explicitly provided for in R.C.S.A. § 16-50j-72(b)(2).

1. The proposed modifications will not result in an increase in the height of the existing structure.
2. The proposed modifications will not require the extension of the site boundary.
3. The proposed modifications will not increase noise levels at the facility by six decibels or more, or to levels that exceed state and local criteria.
4. The operation of the replacement antennas will not increase radio frequency emissions at the facility to a level at or above the Federal Communications Commission safety standard.
5. The proposed modifications will not cause a change or alteration in the physical or environmental characteristics of the site.
6. The existing structure and its foundation can support the proposed loading.

For the foregoing reasons, T-Mobile respectfully submits that the proposed modifications to the above referenced telecommunications facility constitute an exempt modification under R.C.S.A. § 16-50j-72(b)(2).

Sincerely,

Denise Sabo  
Mobile: 860-209-4690  
Fax: 413-521-0558  
Office: 4 Angela's Way, Burlington CT 06013  
Email: denise@northeastsitesolutions.com

Attachments

cc:

Farmington Town Hall  
Kathleen A. Eagen – Town Manager - as elected official  
1 Monteith Drive  
Farmington CT 06032

Farmington Town Hall  
1 Monteith Drive  
Farmington CT 06032  
ATTN: Planning and Zoning Dept.  
William Warner- Town Planner

Eversource - Tower and property owner  
Northeast Utilities  
107 Selden Street  
Berlin CT 06037  
Attn: Chris Gelinis

# Exhibit A

Petition No. 423  
Omnipoint Communications Inc.  
Staff Report  
August 16, 1999

On July 9, 1999, Connecticut Siting Council (Council) member Pamela B. Katz and Council staff Joel M. Rinebold and Paul M. Aresta met Omnipoint Communications Inc (Omnipoint) representatives J. Brendan Sharkey, Chetan Dhaduk, and Joe Rollins for a site inspection of a proposed modification to a Connecticut Light and Power (CL&P) high-voltage electric transmission line support structure located approximately 90 feet east of Maple Ridge Road in Farmington, Connecticut. Omnipoint is petitioning the Council for a declaratory ruling that no Certificate of Environmental Compatibility and Public Need (Certificate) is required for the proposed modification to a CL&P high-voltage electric transmission line support structure.

Omnipoint proposes to replace a 65-foot H-frame transmission line structure with a new laminated wood structure. CL&P has requested the replacement of the H-frame structure in anticipation of its having to make similar replacements to handle increased weight loads in the future. Omnipoint proposes to construct one of the poles of the new H-frame structure 15 feet taller than is existing for a total height of 80 feet above ground level (AGL). Omnipoint proposes to install two approximately five-foot by four-inch PCS antennas in a cluster configuration onto the proposed laminated wood pole with a centerline at 77.5 feet AGL. In addition, Omnipoint would install an equipment cabinet at the base of the proposed new structure enclosed by a 6-foot high chain link fence, 10-foot by 15-foot in area. Access to the proposed equipment would be from Maple Ridge Road along an 8-foot wide footpath within the existing easement.

The proposed equipment and utility routing would be located within the existing CL&P transmission line easement. The proposed site is zoned Industrial CR Zone. Land uses surrounding the area include residential homes to the north and south, commercial retail to the east and northeast, and a limited access highway to the west. The closest residences are located approximately 250 feet north and south of the proposed structure. The surrounding properties currently have an obscured view of the transmission line support structure due to dense overgrowth and mature trees. Omnipoint has agreed to maintain the existing mature vegetation within the easement. The associated equipment compound would be obscured from the view of adjacent properties.

Omnipoint contends that although one pole of the H-frame transmission line support structure would be 15 feet taller than the existing pole, the new structure would remain in scale with the existing structure and the surrounding landscape and would not materially affect the view from surrounding properties. Omnipoint further contends there would be no damage to existing scenic, historical or recreational values; the proposed PCS equipment would not meet or exceed the ANSI Standard for worst case radio-frequency power density levels at the base of the proposed structure; and therefore, the proposed modification would not result in a substantial adverse environmental effect.

# Exhibit B

The Assessor's office is responsible for the maintenance of records on the ownership of properties. Assessments are computed at 70% of the estimated market value of real property at the time of the last revaluation which was 2017.



Information on the Property Records for the Municipality of Farmington was last updated on 4/10/2019.

### Parcel Information

Location:	45 MAPLE RIDGE DR	Property Use:	Vacant Land	Primary Use:	Commercial Vacant Land
Unique ID:	11950045	Map Block Lot:	0109 37A	Acres:	2.00
490 Acres:	0.00	Zone:	R20	Volume / Page:	0288/0347
Developers Map / Lot:		Census:	4601-00		

### Value Information

	Appraised Value	Assessed Value
Land	275,000	192,500
Buildings	0	0
Detached Outbuildings	2,400	1,680
Total	277,400	194,180

## Owner's Information

### Owner's Data

CONN LIGHT & POWER CO  
POST OFFICE BOX 270  
HARTFORD, CT 06141

## Detached Outbuildings

Type:	Year Built:	Length:	Width:	Area:
Pump House Utility	1960	0.00	0.00	240

## Owner History - Sales

Owner Name	Volume	Page	Sale Date	Deed Type	Valid Sale	Sale Price
CONN LIGHT & POWER CO	0288	0347			No	\$0

## Building Permits

Permit Number	Permit Type	Date Opened	Date Closed	Permit Status	Reason
35598		04/19/2016		Closed	Antenna



# 27

# Town of Farmington, Connecticut - Assessment Parcel Map

UNIQUE ID: 11950045

Address: 45 MAPLE RIDGE DR

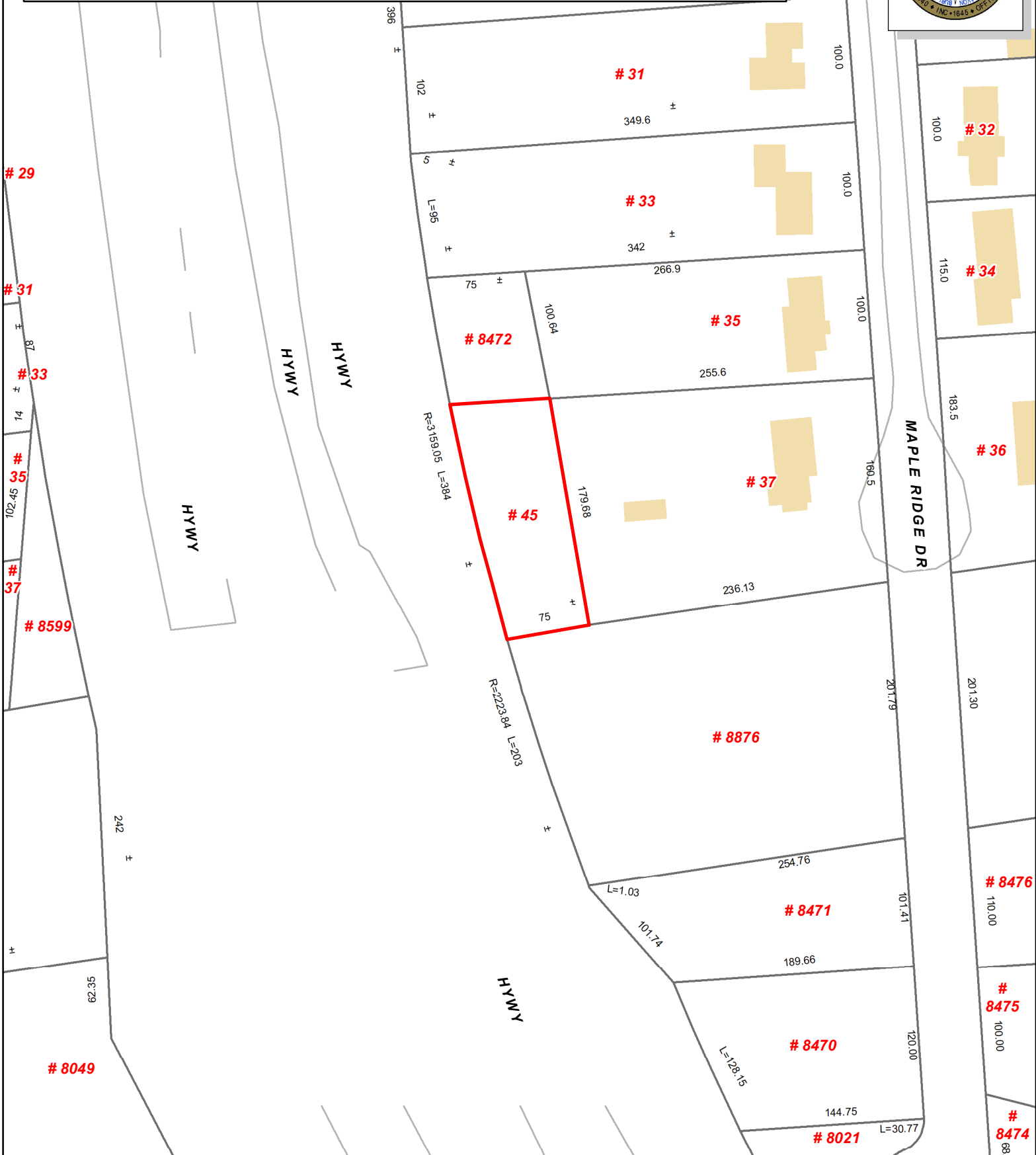
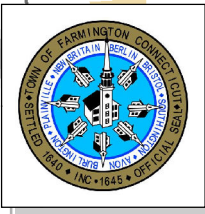

Approximate Scale: 1 inch = 100 feet

Disclaimer: This map is for informational purposes only. All information is subject to verification by any user. The Town of Farmington and its mapping contractors assume no legal responsibility for the information contained herein.

Map Produced Aug 2018

# Exhibit C



# WIRELESS COMMUNICATIONS FACILITY

## WEST HARTFORD/I-84X42/M

### SITE ID: CT11135J

## EVERSOURCE STRUCTURE 8011

### 40 MAPLE RIDGE DR

### FARMINGTON, CT 06032

#### GENERAL NOTES

- ALL WORK SHALL BE IN ACCORDANCE WITH THE 2015 INTERNATIONAL BUILDING CODE AS MODIFIED BY THE 2018 CONNECTICUT SUPPLEMENT, INCLUDING THE TIA/EIA-222 REVISION "G" "STRUCTURAL STANDARDS FOR STEEL ANTENNA TOWERS AND SUPPORTING STRUCTURES," 2018 CONNECTICUT FIRE SAFETY CODE, NATIONAL ELECTRICAL CODE AND LOCAL CODES.
- CONTRACTOR SHALL REVIEW ALL DRAWINGS AND SPECIFICATIONS IN THE CONTRACT DOCUMENT SET. CONTRACTOR SHALL COORDINATE ALL WORK SHOWN IN THE SET OF DRAWINGS. THE CONTRACTOR SHALL PROVIDE A COMPLETE SET OF DRAWINGS TO ALL SUBCONTRACTORS AND ALL RELATED PARTIES. THE SUBCONTRACTORS SHALL EXAMINE ALL THE DRAWINGS AND SPECIFICATIONS FOR THE INFORMATION THAT AFFECTS THEIR WORK.
- CONTRACTOR SHALL PROVIDE A COMPLETE BUILD-OUT WITH ALL FINISHES, STRUCTURAL, MECHANICAL, AND ELECTRICAL COMPONENTS AND PROVIDE ALL ITEMS AS SHOWN OR INDICATED ON THE DRAWINGS OR IN THE WRITTEN SPECIFICATIONS.
- CONTRACTOR SHALL FURNISH ALL MATERIAL, LABOR AND EQUIPMENT TO COMPLETE THE WORK AND FURNISH A COMPLETED JOB ALL IN ACCORDANCE WITH LOCAL AND STATE GOVERNING AUTHORITIES AND OTHER AUTHORITIES HAVING LAWFUL JURISDICTION OVER THE WORK.
- CONTRACTOR SHALL SECURE AND PAY FOR ALL PERMITS AND ALL INSPECTIONS REQUIRED AND SHALL ALSO PAY FEES REQUIRED FOR THE GENERAL CONSTRUCTION, PLUMBING, ELECTRICAL AND HVAC. PERMITS SHALL BE PAID FOR BY THE RESPECTIVE SUBCONTRACTORS.
- CONTRACTOR SHALL MAINTAIN A CURRENT SET OF DRAWINGS AND SPECIFICATIONS ON SITE AT ALL TIMES AND INSURE DISTRIBUTION OF NEW DRAWINGS TO SUBCONTRACTORS AND OTHER RELEVANT PARTIES AS SOON AS THEY ARE MADE AVAILABLE. ALL OLD DRAWINGS SHALL BE MARKED VOID AND REMOVED FROM THE CONTRACT AREA. THE CONTRACTOR SHALL FURNISH AN "AS-BUILT" SET OF DRAWINGS TO OWNER UPON COMPLETION OF PROJECT.
- LOCATION OF EQUIPMENT, AND WORK SUPPLIED BY OTHERS THAT IS DIAGRAMMATICALLY INDICATED ON THE DRAWINGS SHALL BE DETERMINED BY THE CONTRACTOR. THE CONTRACTOR SHALL DETERMINE LOCATIONS AND DIMENSIONS SUBJECT TO STRUCTURAL CONDITIONS AND WORK OF THE SUBCONTRACTORS.
- THE CONTRACTOR IS SOLELY RESPONSIBLE TO DETERMINE CONSTRUCTION PROCEDURE AND SEQUENCE, AND TO ENSURE THE SAFETY OF THE EXISTING STRUCTURES AND ITS COMPONENT PARTS DURING CONSTRUCTION. THIS INCLUDES THE ADDITION OF WHATEVER SHORING, BRACING, UNDERPINNING, ETC. THAT MAY BE NECESSARY.
- DRAWINGS INDICATE THE MINIMUM STANDARDS, BUT IF ANY WORK SHOULD BE INDICATED TO BE SUBSTANDARD TO ANY ORDINANCES, LAWS, CODES, RULES, OR REGULATIONS BEARING ON THE WORK, THE CONTRACTOR SHALL INCLUDE IN HIS WORK AND SHALL EXECUTE THE WORK CORRECTLY IN ACCORDANCE WITH SUCH ORDINANCES, LAWS, CODES, RULES OR REGULATIONS WITH NO INCREASE IN COSTS.
- ALL UTILITY WORK SHALL BE IN ACCORDANCE WITH LOCAL UTILITY COMPANY REQUIREMENTS AND SPECIFICATIONS.
- ALL EQUIPMENT AND PRODUCTS PURCHASED ARE TO BE REVIEWED BY CONTRACTOR AND ALL APPLICABLE SUBCONTRACTORS FOR ANY CONDITION PER MFR.'S RECOMMENDATIONS. CONTRACTOR TO SUPPLY THESE ITEMS AT NO COST TO OWNER OR CONSTRUCTION MANAGER.
- ANY AND ALL ERRORS, DISCREPANCIES, AND "MISSED" ITEMS ARE TO BE BROUGHT TO THE ATTENTION OF THE T-MOBILE CONSTRUCTION MANAGER DURING THE BIDDING PROCESS BY THE CONTRACTOR. ALL THESE ITEMS ARE TO BE INCLUDED IN THE BID. NO "EXTRA" WILL BE ALLOWED FOR MISSED ITEMS.
- CONTRACTOR SHALL BE RESPONSIBLE FOR ALL ON-SITE SAFETY FROM THE TIME THE JOB IS AWARDED UNTIL ALL WORK IS COMPLETE AND ACCEPTED BY THE OWNER.
- CONTRACTOR TO REVIEW ALL SHOP DRAWINGS AND SUBMIT COPY TO ENGINEER FOR APPROVAL. DRAWINGS MUST BEAR THE CHECKER'S INITIALS BEFORE SUBMITTING TO THE CONSTRUCTION MANAGER FOR REVIEW.
- THE CONTRACTOR SHALL FIELD VERIFY ALL DIMENSIONS, ELEVATIONS, ANGLES, AND EXISTING CONDITIONS AT THE SITE, PRIOR TO FABRICATION AND/OR INSTALLATION OF ANY WORK IN THE CONTRACT AREA.
- COORDINATION, LAYOUT, FURNISHING AND INSTALLATION OF CONDUIT AND ALL APPURTENANCES REQUIRED FOR PROPER INSTALLATION OF ELECTRICAL AND TELECOMMUNICATION SERVICE SHALL BE THE SOLE RESPONSIBILITY OF THE CONTRACTOR.
- ALL DAMAGE CAUSED TO ANY EXISTING STRUCTURE SHALL BE THE SOLE RESPONSIBILITY OF THE CONTRACTOR. THE CONTRACTOR WILL BE HELD LIABLE FOR ALL REPAIRS REQUIRED FOR EXISTING STRUCTURES IF DAMAGED DURING CONSTRUCTION ACTIVITIES.
- THE CONTRACTOR SHALL CONTACT "CALL BEFORE YOU DIG" AT LEAST 2 DAYS PRIOR TO ANY EXCAVATIONS AT 1-800-922-4455. ALL UTILITIES SHALL BE IDENTIFIED AND CLEARLY MARKED. CONTRACTOR SHALL MAINTAIN AND PROTECT MARKED UTILITIES THROUGHOUT PROJECT COMPLETION.
- CONTRACTOR SHALL COMPLY WITH OWNERS ENVIRONMENTAL ENGINEER ON ALL METHODS AND PROVISIONS FOR ALL EXCAVATION ACTIVITIES INCLUDING SOIL DISPOSAL. ALL BACKFILL MATERIALS TO BE PROVIDED BY THE CONTRACTOR.

#### SITE DIRECTIONS

<b>FROM:</b> 35 GRIFFIN ROAD SOUTH BLOOMFIELD, CT 06002	<b>TO:</b> 40 MAPLE RIDGE DR FARMINGTON, CT 06032
1. HEAD NORTHWEST ON W NEWBERRY RD TOWARD GRIFFIN RD S.	0.90 MI.
2. TURN RIGHT ONTO WOODLAND AVE.	2.50 MI.
3. TURN RIGHT ONTO WINTONBURY AVE.	0.20 MI.
4. TURN LEFT ONTO CT-189 S.	1.00 MI.
5. TURN RIGHT ONTO CT-218 W.	1.30 MI.
6. TURN RIGHT ONTO STILL RD.	0.90 MI.
7. TURN LEFT ONTO MOUNTAIN RD.	3.80 MI.
8. TURN RIGHT ONTO BUENA VISTA RD.	0.01 MI.
9. TURN RIGHT ONTO MOUNTAIN RD.	0.40 MI.
10. TURN RIGHT ONTO TUNXIS RD.	0.50 MI.
11. TURN LEFT ONTO WOODRUFF DR.	1.10 MI.
12. TURN LEFT ONTO MAPLE RIDGE DR.	0.10 MI.

#### VICINITY MAP

SCALE: 1" = 1000'

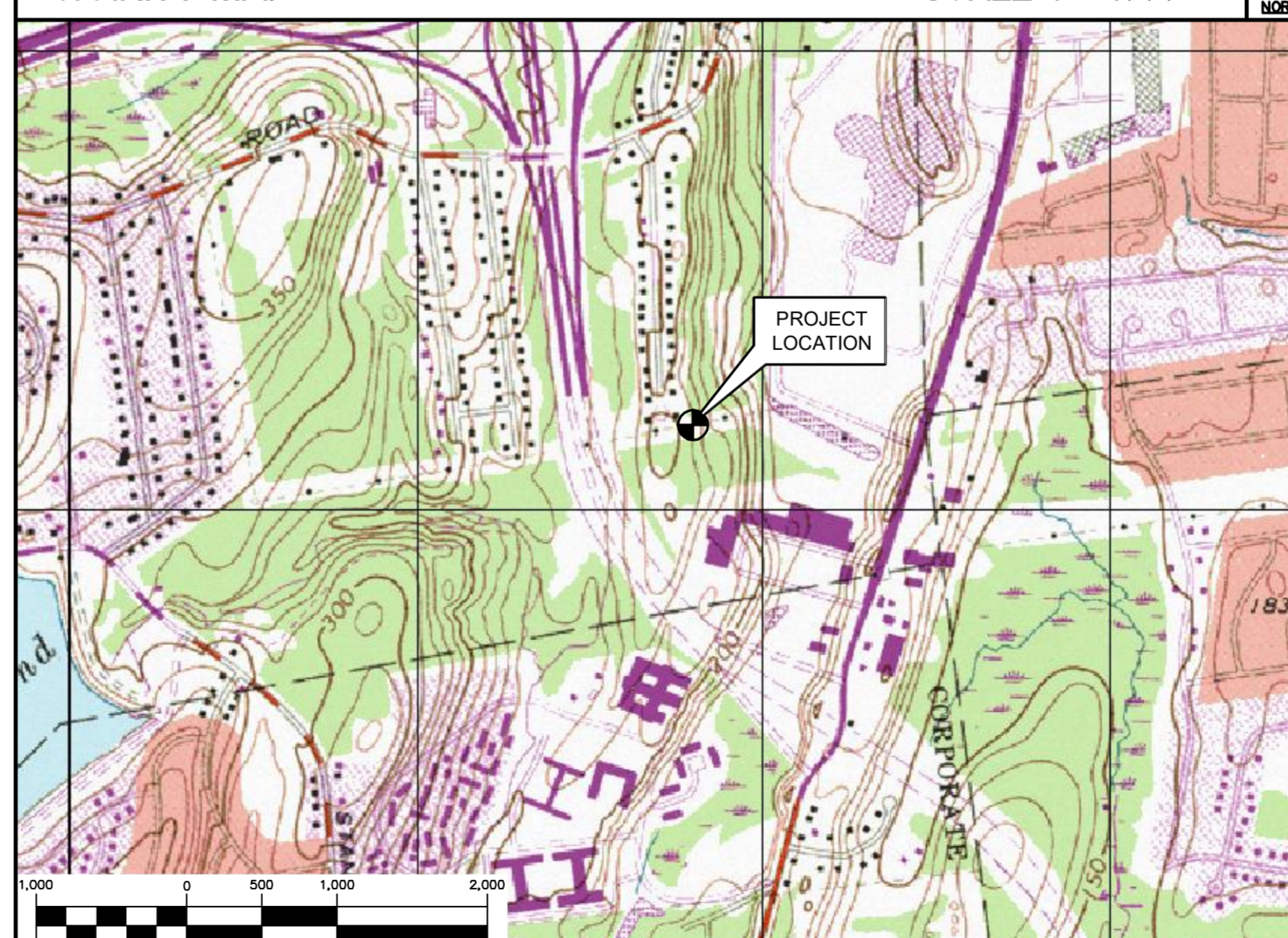

#### T-MOBILE RF CONFIGURATION

67D94B\_1DP+10P

#### PROJECT SUMMARY

- THE PROPOSED SCOPE OF WORK CONSISTS OF A MODIFICATION TO THE EXISTING UNMANNED TELECOMMUNICATIONS FACILITY INCLUDING THE FOLLOWING:
  - REMOVE AND REPLACE (3) PANEL ANTENNAS ON TOWER.
  - REMOVE AND REPLACE (3) REMOTE RADIO UNITS ON EXISTING RACK AT GRADE.
  - INSTALL (3) DIPLEXERS ON EXISTING RACK AT GRADE.

#### PROJECT INFORMATION

SITE NAME:	WEST HARTFORD/I-84X42/M
SITE ID:	CT11135J
SITE ADDRESS:	40 MAPLE RIDGE DR FARMINGTON, CT 06032
APPLICANT:	T-MOBILE NORTHEAST, LLC 35 GRIFFIN ROAD SOUTH BLOOMFIELD, CT 06002
CONTACT PERSON:	SHELDON FREINCLE (PROJECT MANAGER) NORTHEAST SITE SOLUTIONS (201) 776-8521
ENGINEER:	CENITEK ENGINEERING, INC. 63-2 NORTH BRANFORD RD. BRANFORD, CT 06405
PROJECT COORDINATES:	LATITUDE: 41°-43'-05.13" N LONGITUDE: 72°-46'-04.56" W GROUND ELEVATION: 254'± AMSL  SITE COORDINATES AND GROUND ELEVATION REFERENCED FROM GOOGLE EARTH.

#### SHEET INDEX

SHT. NO.	DESCRIPTION	REV.
T-1	TITLE SHEET	0
N-1	DESIGN BASIS AND SITE NOTES	0
C-1	SITE LOCATION PLAN	0
C-2	COMPOUND PLAN, ELEVATION AND ANTENNA MOUNTING CONFIG.	0
C-3	TYPICAL DETAILS	0

ISSUED FOR CONSTRUCTION	CAG	TUL	DATE	4/8/19	REV.	0
DESCRIPTION	DRAWN BY	CHK'D BY				
T-MOBILE NORTHEAST LLC WIRELESS COMMUNICATIONS FACILITY <b>WEST HARTFORD/I-84X42/M</b> SITE ID: CT11135J 40 MAPLE RIDGE DR FARMINGTON, CT 06032						
DATE: 3/11/19 SCALE: AS NOTED JOB NO. 18098.04						
TITLE SHEET						
<b>T-1</b>						
Sheet No. 1 of 5						





**1 SITE LOCATION PLAN**  
 C-1 SCALE: 1" = 50'

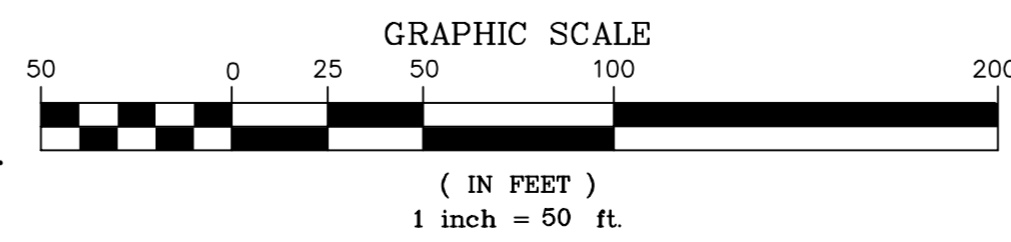

REV.	DATE	BY	CHK'D BY	DESCRIPTION
0	4/8/19	TUL	CAG	ISSUED FOR CONSTRUCTION

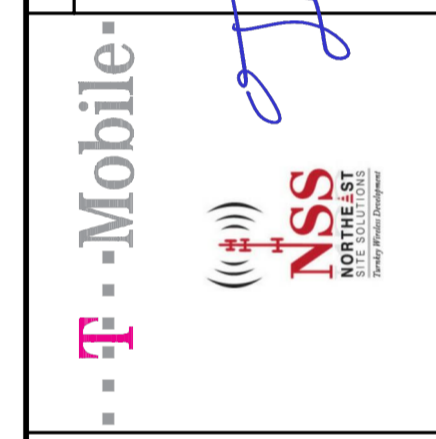
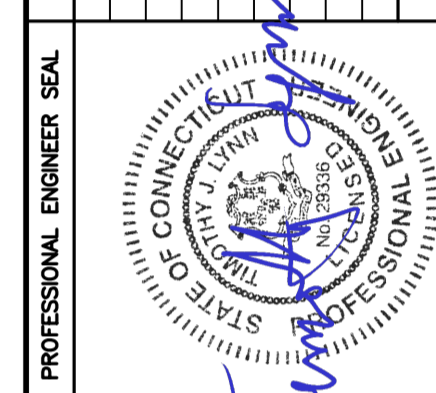

**CENTEK engineering**  
 Centered on Solutions  
 (203) 488-0380  
 (203) 488-8387 Fax  
 63-2 North Branford Road  
 Branford, CT 06405  
 www.CentekEng.com

**T-MOBILE NORTHEAST LLC**  
 WIRELESS COMMUNICATIONS FACILITY  
**WEST HARTFORD/I-84X42/M**  
**SITE ID: CT1135J**  
 40 MAPLE RIDGE DR  
 FARMINGTON, CT 06032

DATE: 3/11/19  
 SCALE: AS NOTED  
 JOB NO. 18098.04

**SITE LOCATION PLAN**

**C-1**  
 Sheet No. 3 of 5

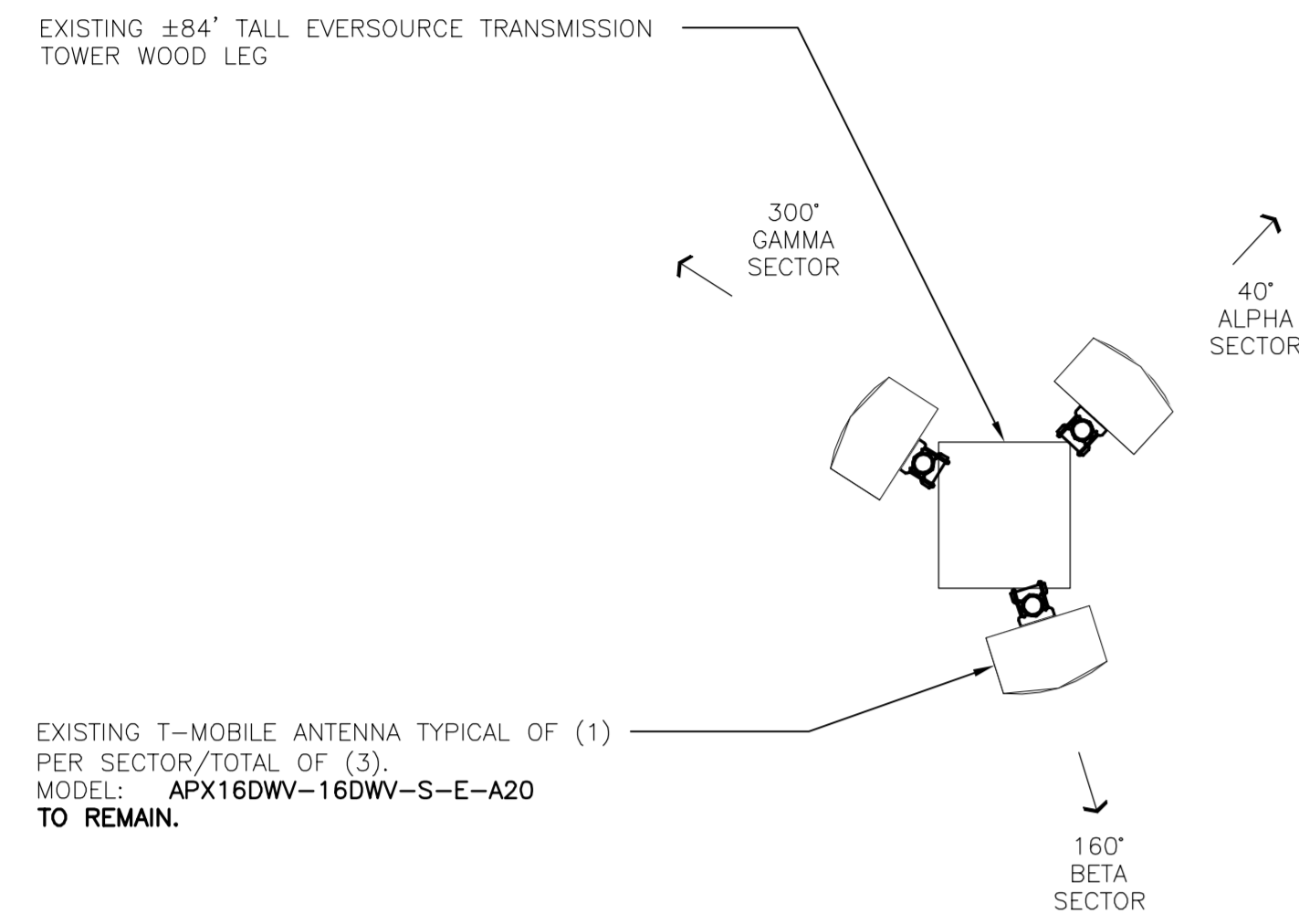

**3 PROPOSED ANTENNA MOUNTING CONFIGURATION**  
C-2 SCALE: 1/2" = 1' (82'-0" AGL) APPROX. NORTH

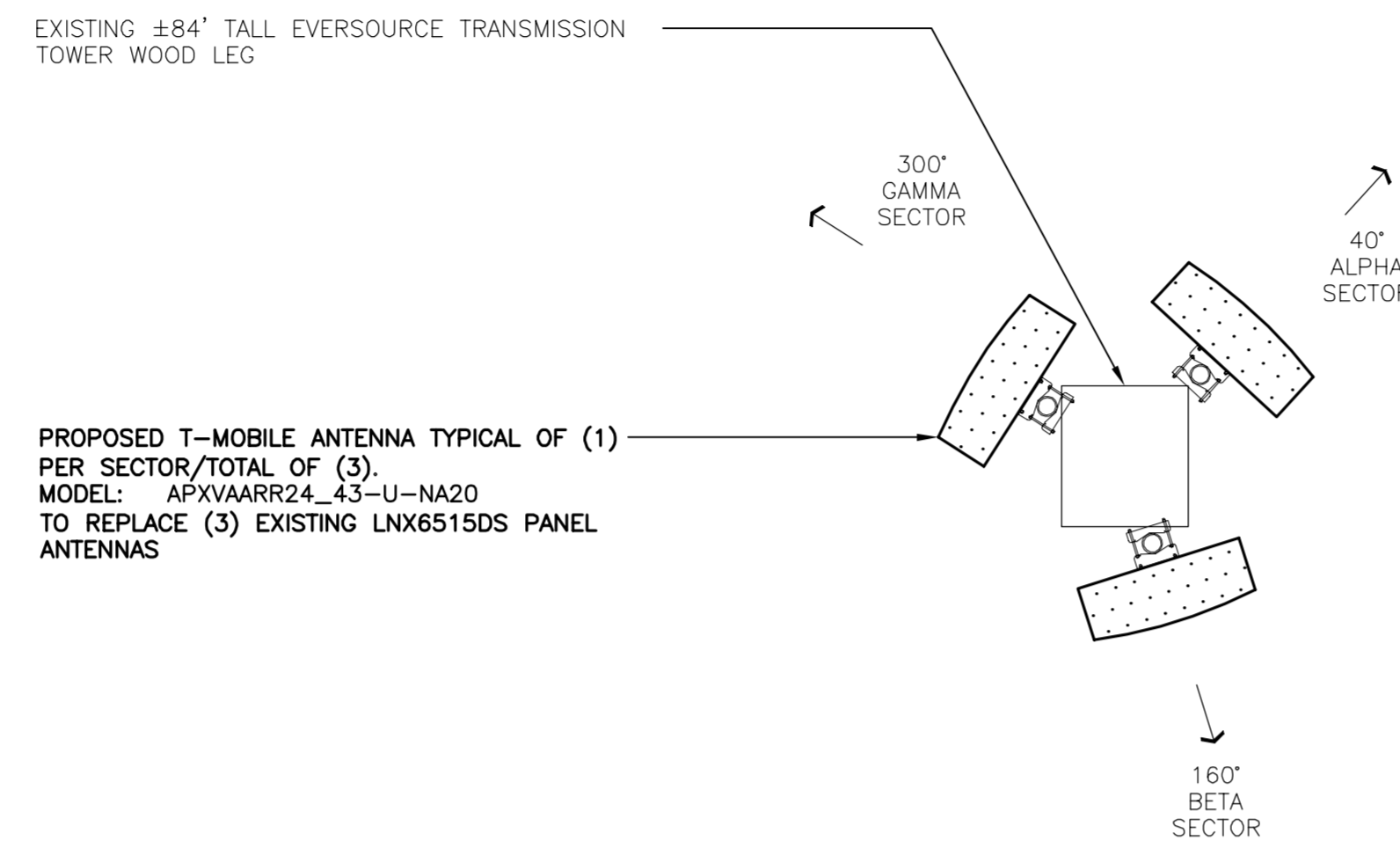

**4 PROPOSED ANTENNA MOUNTING CONFIGURATION**  
C-2 SCALE: 1/2" = 1' (73'-0" AGL) APPROX. NORTH

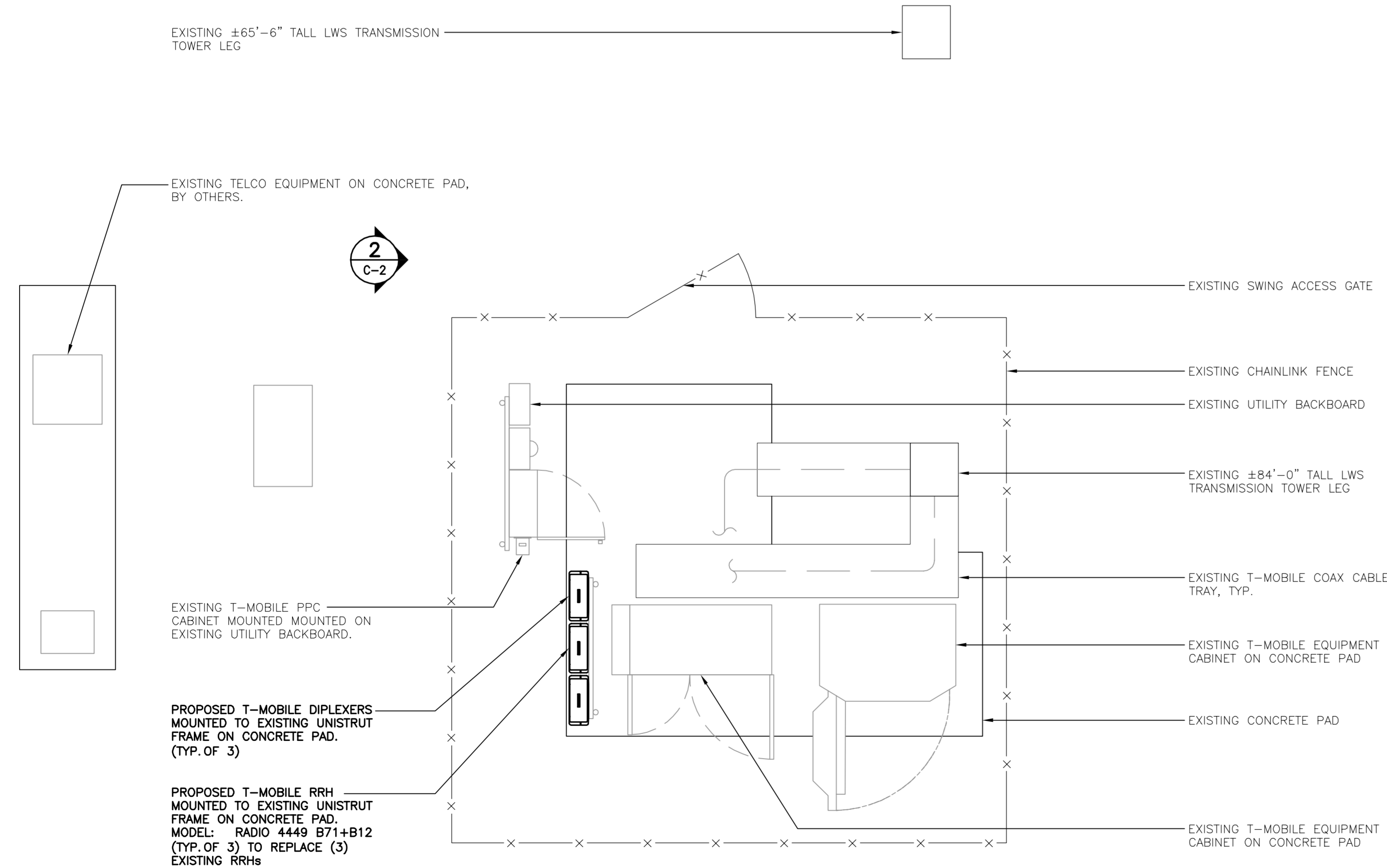

**1 COMPOUND PLAN**  
C-2 SCALE: 3/8" = 1' APPROX. NORTH

GRAPHIC SCALE (IN FEET) 1 inch = 4 ft.

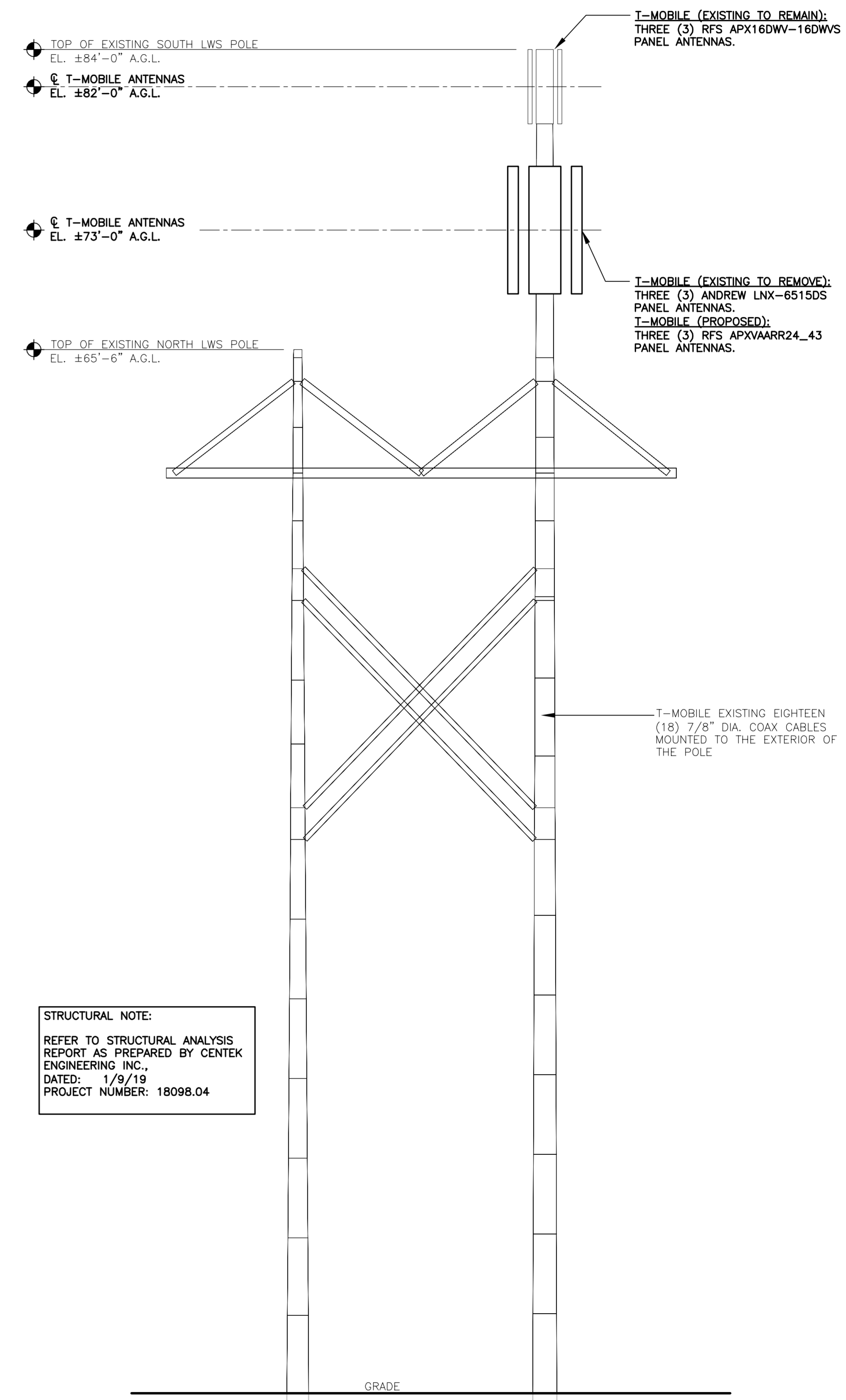

STRUCTURAL NOTE:  
REFER TO STRUCTURAL ANALYSIS REPORT AS PREPARED BY CENTEK ENGINEERING INC., DATED: 1/9/19 PROJECT NUMBER: 18098.04

**2 TOWER ELEVATION**  
C-2 SCALE: 1" = 5' APPROX. NORTH

GRAPHIC SCALE (IN FEET) 1 inch = 5 ft.

ISSUED FOR CONSTRUCTION	CAG	DATE	REV.
		4/8/19	0
DRAWN BY: CHK'D BY:			
T-MOBILE NORTHEAST LLC WIRELESS COMMUNICATIONS FACILITY WEST HARTFORD/I-84X42/M SITE ID: CT1135J 40 MAPLE RIDGE DR FARMINGTON, CT 06032			
DATE:	3/11/19		
SCALE:	AS NOTED		
JOB NO.	18098.04		
COMPOUND PLAN, ELEVATION AND ANTENNA MOUNTING CONFIG.			
<b>C-2</b>			
Sheet No. 4 of 5			

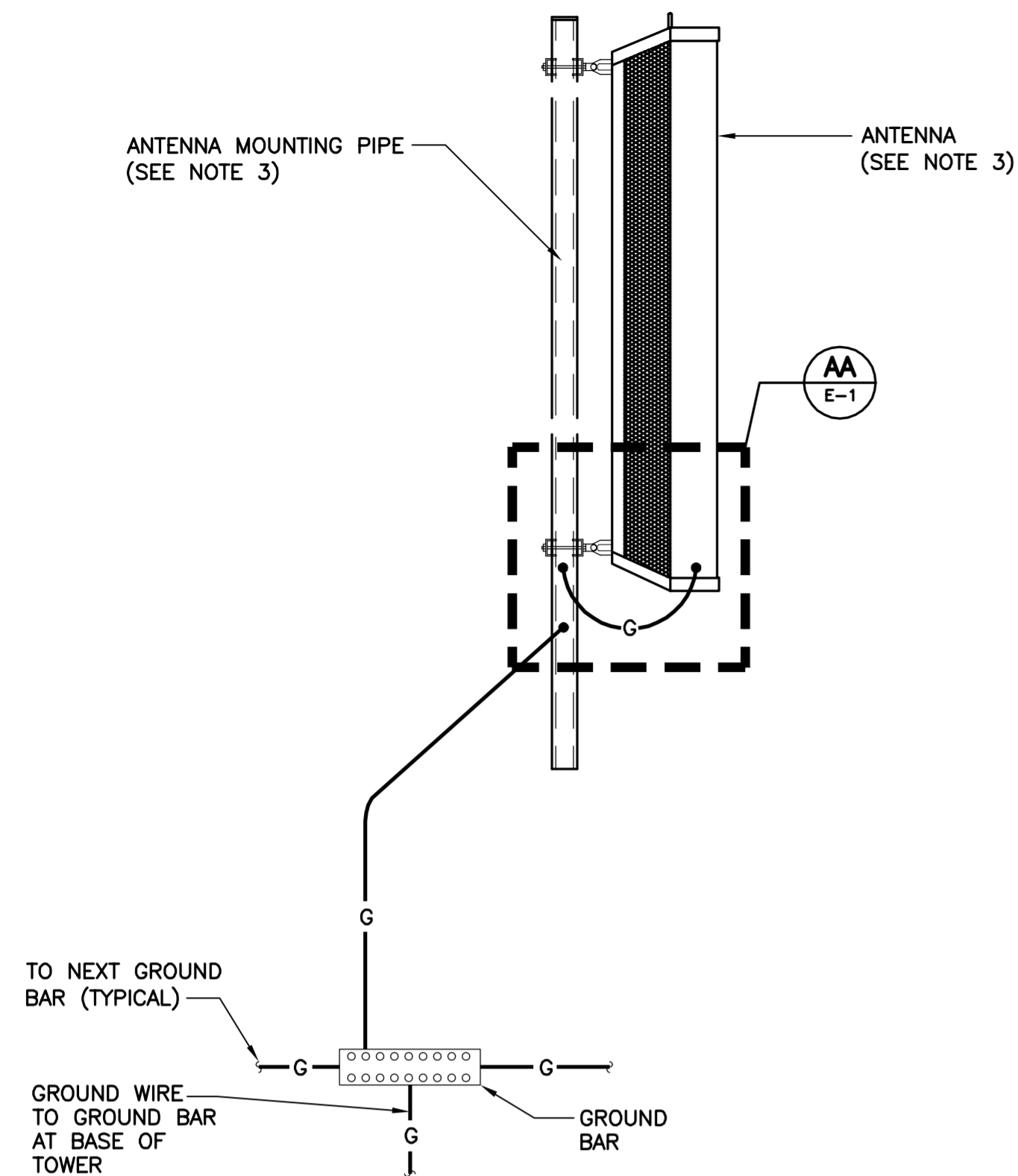

NOTES:

1. BOND COAXIAL CABLE GROUND KITS TO EACH OWNER'S GROUND BAR ALONG ENTIRE COAX RUN FROM ANTENNA TO SHELTER.
2. BOND ALL EQUIPMENT TO GROUND PER NEC AND MANUFACTURERS SPECIFICATIONS.
3. DETAIL IS TYPICAL FOR ALL ANTENNA SECTORS, INCLUDING GPS ANTENNA.

**1** TYPICAL ANTENNA GROUNDING DETAIL  
C-3 SCALE: NONE

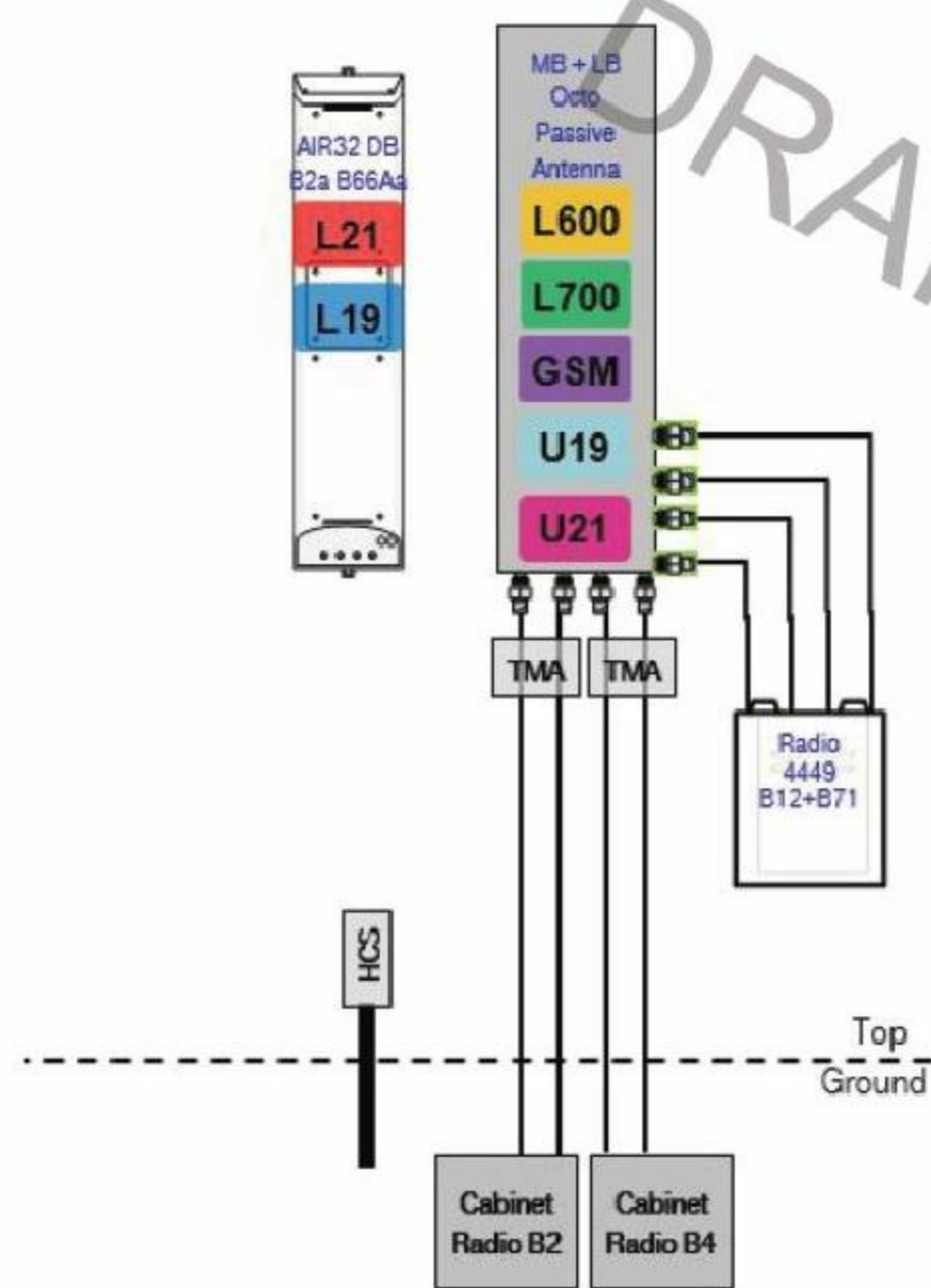

**2** PROPOSED PLUMBING DIAGRAM  
C-3 SCALE: NONE

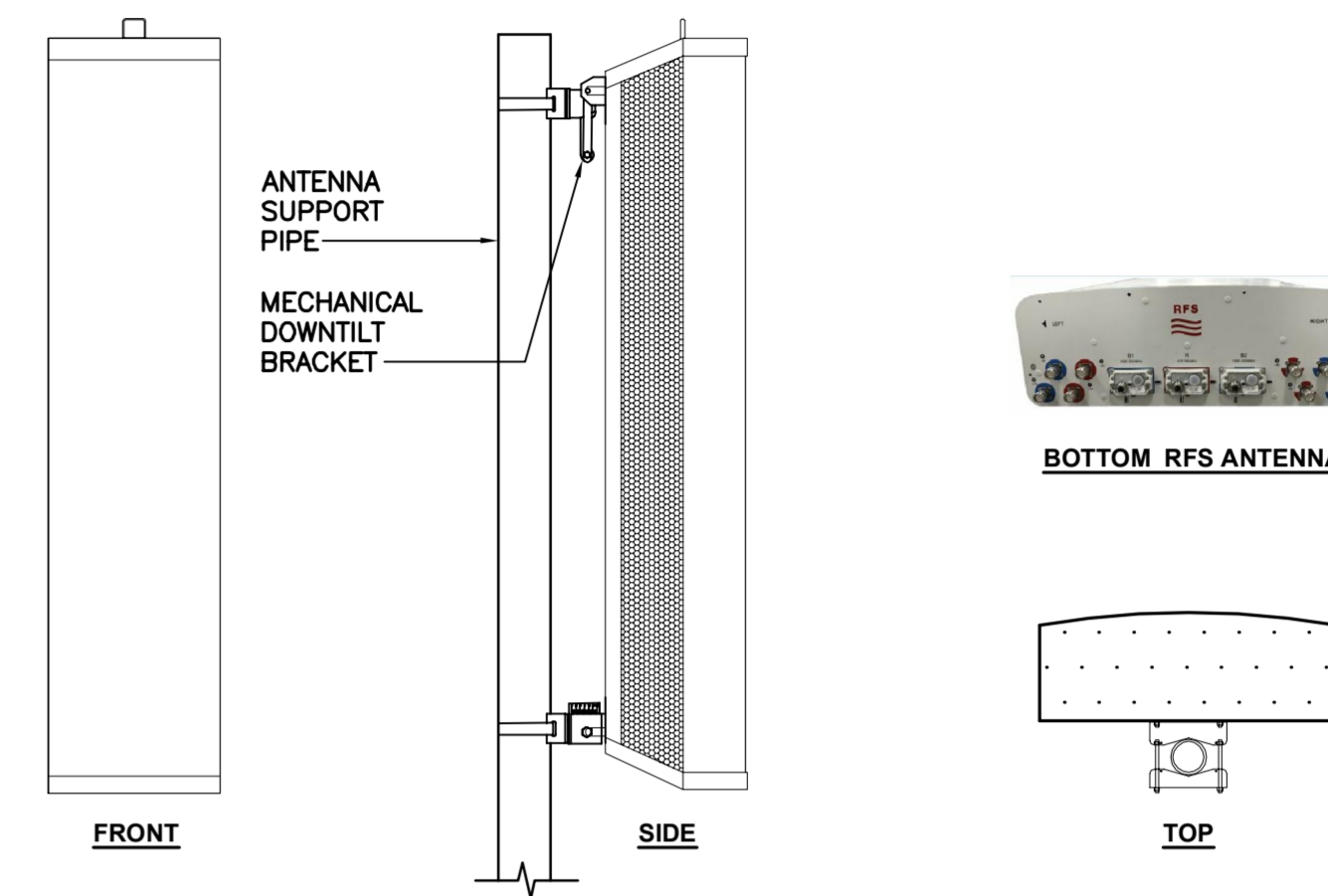

ALPHA/BETA/GAMMA ANTENNA		
EQUIPMENT	DIMENSIONS	WEIGHT
MAKE: RFS MODEL: APXVAARR24_43-U-NA20	95.9"L x 24.0"W x 8.7"D	153 LBS.

**3** PROPOSED ANTENNA DETAIL  
C-3 SCALE: NONE

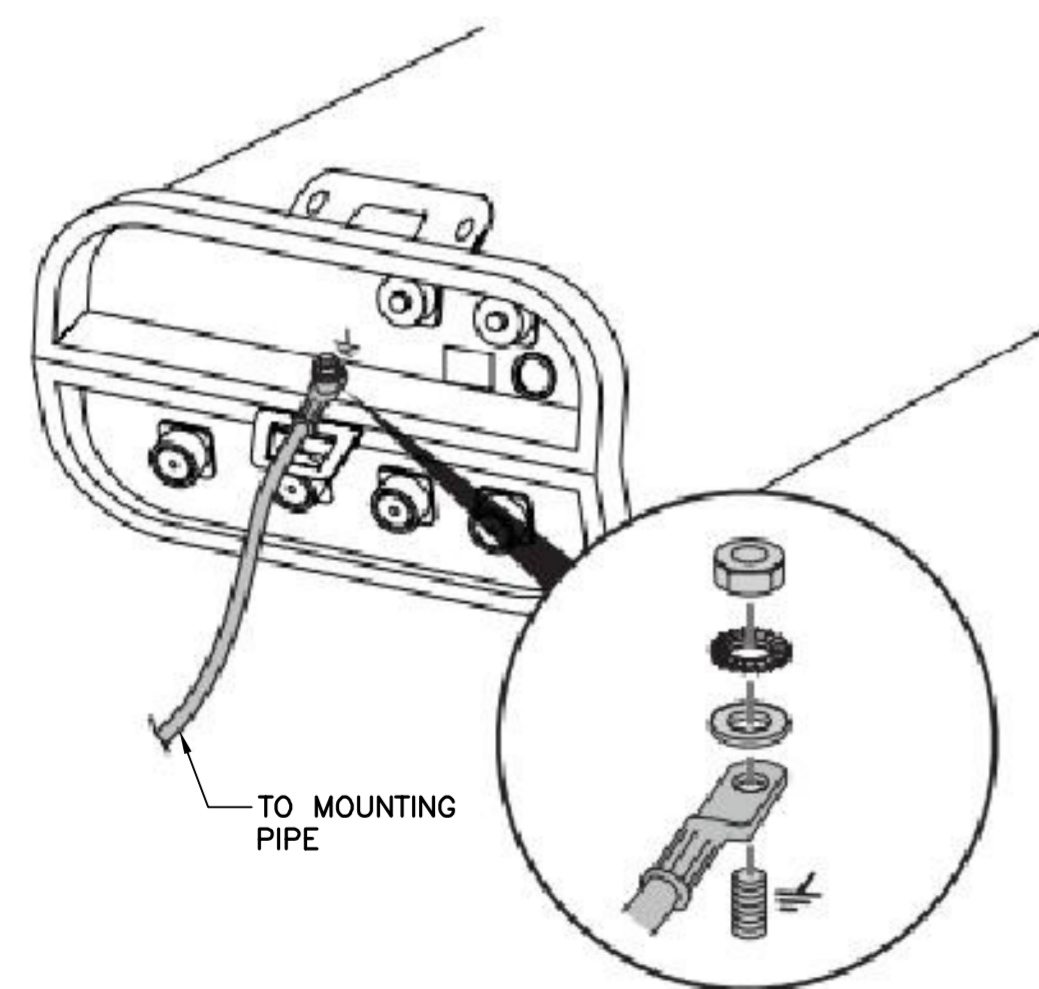

**AA** TYPICAL ANTENNA GROUNDING DETAIL  
C-3 SCALE: NONE

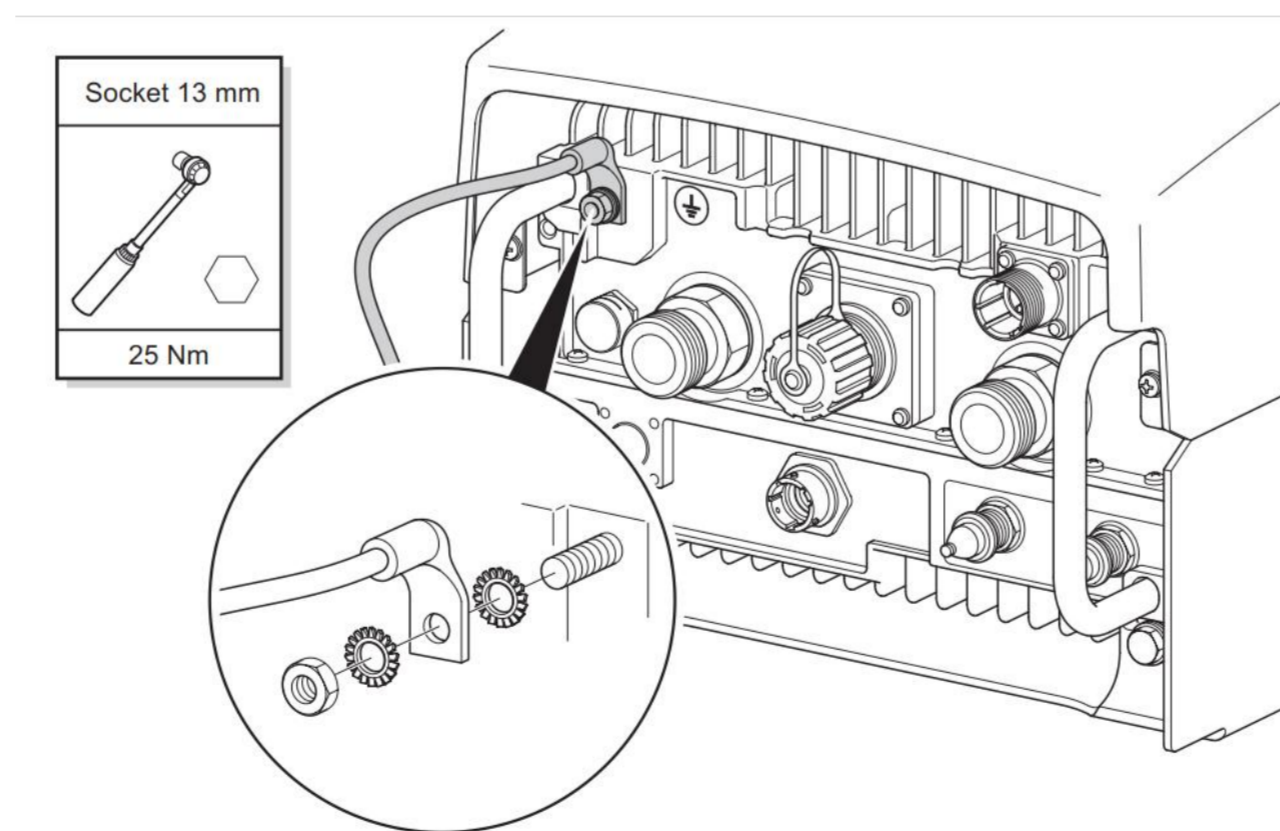

**4** TYPICAL RRU GROUNDING DETAIL  
C-3 NOT TO SCALE



ISOMETRIC VIEW

RRU (REMOTE RADIO UNIT)			
EQUIPMENT	DIMENSIONS	WEIGHT	CLEARANCES
MAKE: ERICSSON MODEL: RADIO 4449 B71B12	14.9"L x 13.2"W x 10.4"D	74 LBS.	ABOVE: 16" MIN. BELOW: 12" MIN. FRONT: 36" MIN.

NOTES:  
1. CONTRACTOR TO COORDINATE FINAL EQUIPMENT MODEL SELECTION WITH T-MOBILE CONSTRUCTION MANAGER PRIOR TO ORDERING.

**5** PROPOSED RRU DETAIL  
C-3 SCALE: NONE

ISSUED FOR CONSTRUCTION  
DRAWN BY CHK'D BY  
DATE 4/8/19 TUL  
REV. 0

PROFESSIONAL ENGINEER SEAL  
STATE OF CONNECTICUT  
TIMOTHY J. WILSON  
Professional Engineer No. 10000  
Professional Seal No. 10000

T-Mobile  
NSS  
NORTH EAST

CENTEK engineering  
Centered on Solutions™  
(203) 488-0380  
(203) 488-8387 Fax  
63-2 North Branford Road  
Branford, CT 06405  
www.CentekEng.com

**T-MOBILE NORTHEAST LLC**  
WIRELESS COMMUNICATIONS FACILITY  
**WEST HARTFORD/I-84X42/M**  
**SITE ID: CT1135J**  
40 MAPLE RIDGE DR  
FARMINGTON, CT 06032

DATE: 3/11/19  
SCALE: AS NOTED  
JOB NO. 18098.04

TYPICAL  
DETAILS

**C-3**

Sheet No. 5 of 5

# Exhibit D



**Structural Analysis of**  
**Utility Tower**

*T-Mobile Site Ref: CT11135J*

*Eversource Structure No. 8011  
84' (AGL) Electric Transmission LWS Pole*

*40 Maple Ridge Drive  
Farmington, CT*

*CEN TEK Project No. 18098.04*

~~*Date: October 2, 2018*~~  
*Rev 2: January 9, 2019*

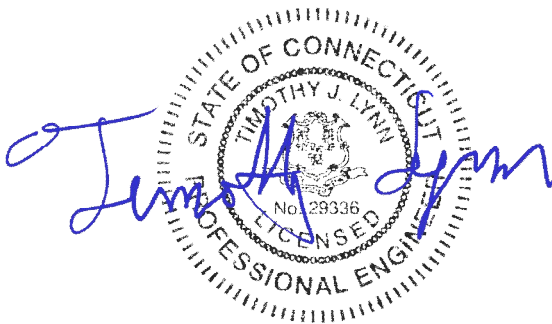

**Prepared for:**  
**T-Mobile USA**  
**35 Griffin Road**  
**Bloomfield, CT 06002**

# **Table of Contents**

## **SECTION 1 - REPORT**

- INTRODUCTION
- PRIMARY ASSUMPTIONS USED IN THE ANALYSIS
- ANALYSIS
- DESIGN BASIS
- RESULTS
- CONCLUSION

## **SECTION 2 - CONDITIONS & SOFTWARE**

- STANDARD ENGINEERING CONDITIONS
- GENERAL DESCRIPTION OF STRUCTURAL ANALYSIS PROGRAMS
  - RISA 3-D
  - PLS TOWER

## **SECTION 3 - DESIGN CRITERIA**

- CRITERIA FOR DESIGN OF PCS FACILITIES ON OR EXTENDING ABOVE METAL ELECTRIC TRANSMISSION TOWERS
- NU DESIGN CRITERIA TABLE
- WIRE LOADS SHEET

## **SECTION 4 - DRAWINGS**

- EL-1 TOWER ELEVATION

## **SECTION 5 - NECS/NU LOAD CALCULATIONS**

- EQUIPMENT LOAD CALCULATION
- COAX CABLE LOAD CALCULATION – ON TOWER

## **SECTION 6 - PLS TOWER RESULTS**

- PLS REPORT

## **SECTION 7 - REFERENCE MATERIAL**

- RF SHEET
- EQUIPMENT CUT SHEETS

## Introduction

The purpose of this report is to analyze the existing 98' utility pole (embedded 14'-0" into the ground) located at 40 Maple Ridge Drive in Farmington, CT for the proposed antenna and equipment upgrade by T-Mobile.

The existing/proposed loads consist of the following:

- **T-MOBILE (Existing to Remain):**  
Antennas: Three (3) RFS APX16DWV-16DWVS panel antennas flush mounted to the existing tower with a RAD center elevation of 82-ft above grade level.  
Coax Cables: Eighteen (18) 7/8"  $\varnothing$  coax cables running on the exterior of the pole.
- **T-MOBILE (Existing to Remove):**  
Antennas: Three (3) Andrew LNX-6515DS panel antennas flush mounted to the existing tower with a RAD center elevation of 73-ft above grade level.
- **T-MOBILE (Proposed):**  
Antennas: **Three (3) RFS APXVAARR24\_43 panel antennas flush mounted to the existing tower with a RAD center elevation of 73-ft above grade level.**

## Primary assumptions used in the analysis

- All antenna mounts are modeled as listed above.
- All coaxial cable will be installed as indicated in Section 4 of this report.
- No residual stresses exist due to incorrect tower erection.
- Utility tower was properly installed and maintained and all members were properly designed, detailed, fabricated, and installed and have been properly maintained since erection.
- Any deviation from the analyzed loading will require a new analysis for verification of structural adequacy.

## Analysis

Structural analysis of the utility pole was completed using the current version of PLS-Pole computer program licensed to CEN TEK Engineering. Loading was developed per the requirements of the NESC standard and Northeast Utilities Design Criteria. These loads are developed in Section 5 of this report.

Design Basis

Our analysis was performed in accordance with NESC C2-2012 and Northeast Utilities Design Criteria.

▪ UTILITY TOWER ANALYSIS

The purpose of this analysis is to determine the adequacy of the existing utility structure to support the proposed antenna loads. The loading and design requirements were analyzed in accordance with the NU Design Criteria Table, NESC C2-2012 ~ Construction Grade B.

Load cases considered:

Load Case 1: NESC Heavy

Wind Pressure.....	4.0 psf
Radial Ice Thickness.....	0.5"
Vertical Overload Capacity Factor.....	1.50
Wind Overload Capacity Factor.....	2.50
Wire Tension Overload Capacity Factor.....	1.65

Load Case 2: NESC Extreme

Wind Speed.....	110 mph <sup>(1)</sup>
Radial Ice Thickness.....	0"

Results

▪ UTILITY POLE

This analysis finds that the subject utility pole is adequate to support the proposed antenna configuration. A maximum usage of **98.54%** occurs in the utility pole under the **NESC Extreme** loading condition.

POLE SECTION:

The utility pole was found to be within allowable limits.

Tower Section	Elevation	Stress Ratio (% of capacity)	Result
Cross Arm	57'-9" AGL	98.54%	<b>PASS</b>

▪ FOUNDATION

The pole is directly embedded in the ground.

Tower Section	Required Embedment (1)	Actual Embedment	Result
North Pole	9.5-ft	9.5-ft	<b>PASS</b>
South Pole	11.8-ft	14.0-ft	<b>PASS</b>

1. Required embedment per OTRM 051 section 9.0 and OTRM 163 – 10% of overall length plus 2-ft.

Tower Section	Uplift	Result
North Pole	79.1%	<b>PASS</b>
South Pole	43.7%	<b>PASS</b>

## C o n c l u s i o n

This analysis shows that the subject utility tower **is adequate** to support the proposed equipment installation.

The analysis is based, in part, on the information provided to this office by Eversource and Sprint. If the existing conditions are different than the information in this report, Centek Engineering, Inc. must be contacted for resolution of any potential issues.

Please feel free to call with any questions or comments.

Respectfully Submitted by:



Timothy J. Lynn, PE  
Structural Engineer

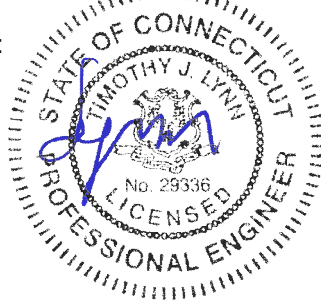

STANDARD CONDITIONS FOR FURNISHING OF  
PROFESSIONAL ENGINEERING SERVICES ON  
EXISTING STRUCTURES

All engineering services are performed on the basis that the information used is current and correct. This information may consist of, but is not necessarily limited to:

- Information supplied by the client regarding the structure itself, its foundations, the soil conditions, the antenna and feed line loading on the structure and its components, or other relevant information.
- Information from the field and/or drawings in the possession of CEN TEK engineering, Inc. or generated by field inspections or measurements of the structure.
- It is the responsibility of the client to ensure that the information provided to CEN TEK engineering, Inc. and used in the performance of our engineering services is correct and complete. In the absence of information to the contrary, we assume that all structures were constructed in accordance with the drawings and specifications and are in an un-corroded condition and have not deteriorated. It is therefore assumed that its capacity has not significantly changed from the “as new” condition.
- All services will be performed to the codes specified by the client, and we do not imply to meet any other codes or requirements unless explicitly agreed in writing. If wind and ice loads or other relevant parameters are to be different from the minimum values recommended by the codes, the client shall specify the exact requirement. In the absence of information to the contrary, all work will be performed in accordance with the latest revision of ANSI/ASCE10 & ANSI/EIA-222.
- All services are performed, results obtained, and recommendations made in accordance with generally accepted engineering principles and practices. CEN TEK engineering, Inc. is not responsible for the conclusions, opinions and recommendations made by others based on the information we supply.

Criteria for Design of PCS Facilities On or  
Extending Above Metal Electric Transmission  
Towers & Analysis of Transmission Towers  
Supporting PCS Masts <sup>(1)</sup>

Introduction

This criteria is the result from an evaluation of the methods and loadings specified by the separate standards, which are used in designing telecommunications towers and electric transmission towers. That evaluation is detailed elsewhere, but in summary; the methods and loadings are significantly different. This criteria specifies the manner in which the appropriate standard is used to design PCS facilities including masts and brackets (hereafter referred to as “masts”), and to evaluate the electric transmission towers to support PCS masts. The intent is to achieve an equivalent level of safety and security under the extreme design conditions expected in Connecticut and Massachusetts.

ANSI Standard TIA/EIA-222 covering the design of telecommunications structures specifies a working strength/allowable stress design approach. This approach applies the loads from extreme weather loading conditions, and designs the structure so that it does not exceed some defined percentage of failure strength (allowable stress).

ANSI Standard C2-2007 (National Electrical Safety Code) covering the design of electric transmission metal structures is based upon an ultimate strength/yield stress design approach. This approach applies a multiplier (overload capacity factor) to the loads possible from extreme weather loading conditions, and designs the structure so that it does not exceed its ultimate strength (yield stress).

Each standard defines the details of how loads are to be calculated differently. Most of the NU effort in “unifying” both codes was to establish what level of strength each approach would provide, and then increasing the appropriate elements of each to achieve a similar level of security under extreme weather loadings.

Two extreme weather conditions are considered. The first is an extreme wind condition (hurricane) based upon a 50-year recurrence (2% annual probability). The second is a winter condition combining wind and ice loadings.

The following sections describe the design criteria for any PCS mast extending above the top of an electric transmission tower, and the analysis criteria for evaluating the loads on the transmission tower from such a mast from the lower portions of such a mast, and loads on the pre-existing electric lower portions of such a mast, and loads on the pre-existing electric transmission tower and the conductors it supports.

| Note 1: Prepared from documentation provide from Northeast Utilities.

## PCS Mast

The PCS facility (mast, external cable/trays, including the initial and any planned future support platforms, antennas, etc. extending the full height above the top level of the electric transmission structure) shall be designed in accordance with the provisions of TIA/EIA Standard 222 with two exceptions:

1. An 85 mph extreme wind speed shall be used for locations in all counties throughout the NU system.
2. The stress increase of TIA Section 3.1.1.1 is disallowed. The combined wind and ice condition shall consider ½" radial ice in combination with the wind load (0.75  $W_i$ ) as specified in TIA section 2.3.16.

## ELECTRIC TRANSMISSION TOWER

The electric transmission tower shall be analyzed using yield stress theory in accordance with the attached table titled "NU Design Criteria". This specifies uniform loadings (different from the TIA loadings) on the each of the following components of the installed facility:

- PCS mast for its total height above ground level, including the initial and planned future support platforms, antennas, etc. above the top of an electric transmission structure.
- Conductors are related devices and hardware.
- Electric transmission structure. The loads from the PCS facility and from the electric conductors shall be applied to the structure at conductor and PCS mast attachment points, where those load transfer to the tower.

The uniform loadings and factors specified for the above components in the table are based upon the National Electrical Safety Code 2007 Edition Extreme Wind (Rule 250C) and Combined Ice and Wind (Rule 250B-Heavy) Loadings. These provide equivalent loadings compared to TIA and its loads and factors with the exceptions noted above. (Note that the NESC does not require the projected wind surfaces of structures and equipment to be increased by the ice covering.)

In the event that the electric transmission tower is not sufficient to support the additional loadings of the PCS mast, reinforcement will be necessary to upgrade the strength of the overstressed members.



# Eversource Overhead Transmission Standards

## Attachment A Eversource Design Criteria

Attachment A NU Design Criteria		Basic Wind Speed	Pressure	Height factor	Gust Factor	Load or Stress Factor	Force Coef. - Shape Factor	
		V (MPH)	Q (PSF)	Kz	Gh			
Ice Condition	TIA/EIA	Antenna Mount	TIA	TIA (0.75Wi)	TIA	TIA	TIA, Section 3.1.1.1 disallowed for connection design	TIA
	NESC Heavy	Tower/Pole Analysis with antennas extending above top of Tower/Pole (Yield Stress)	—	4	1	1	2.50	1.6 Flat Surfaces 1.3 Round Surfaces
		Tower/Pole Analysis with antennas below top of Tower/Pole (on two faces)	—	4	1	1	2.50	1.6 Flat Surfaces 1.3 Round Surfaces
Conductors:		Conductor Loads Provided by NU						
High Wind Condition	TIA/EIA	Antenna Mount	85	TIA	TIA	TIA	TIA, Section 3.1.1.1 disallowed for connection design	TIA
	NESC Extreme Wind	Tower/Pole Analysis with antennas extending above top of Tower/Pole	For wind speed use OTRM 060 Map 1, Rule 250C: Extreme Wind Loading Apply a 1.25 X Gust Response Factor to all telecommunication equipment projected above top of tower/pole and apply a 1.0 x Gust Response Factor to the tower/pole structure					1.6 Flat Surfaces 1.3 Round Surfaces
		Tower/Pole Analysis with antennas below top of Tower/Pole	For wind speed use OTRM 060 Map 1, Rule 250C: Extreme Wind Loading Height above ground is based on overall height to top of tower/pole					1.6 Flat Surfaces 1.3 Round Surfaces
Conductors:		Conductor Loads Provided by NU						
NESC Extreme Ice with Wind Condition *		Tower/Pole Analysis with antennas extending above top of Tower/Pole	For wind speed use OTRM 060 Map 1, Rule 250D: Extreme Ice with Wind Loading 4 PSF Wind Load 1.25 X Gust Response Factor Apply a 1.25 X Gust Response Factor to all telecommunication equipment projected above top of tower/pole and apply a 1.0 x Gust Response Factor to the tower/pole structure					1.6 Flat Surfaces 1.3 Round Surfaces
		Tower/Pole Analysis with antennas below top of Tower/Pole	For wind speed use OTRM 060 Map 1, Rule 250D: Extreme Ice with Wind Loading 4 PSF Wind Load Height above ground is based on overall height to top of tower/pole					1.6 Flat Surfaces 1.3 Round Surfaces
	Conductors:		Conductor Loads Provided by NU					
* Only for structures installed after 2007								

### Communication Antennas on Transmission Structures

# Eversource Overhead Transmission Standards

---

mount as specified below, and shall include the wireless communication mast and antenna loads per NESC criteria)

The strength reduction factor obtained from the field investigation shall be applied to the members or connections that are showing signs of deterioration from their original condition

With the written approval of Eversource Transmission Line Engineering on a case by case the existing structures may be analyzed initially using the current NESC code, then it is permitted to use the original design code with the original conductor load should the existing tower fail the current NESC code.

The structure shall be analyzed using yield stress theory in accordance with Attachment A, "Eversource Design Criteria." This specifies uniform loadings (different from the TIA loadings) on each of the following components of the installed facility:

- a) Wireless communication mast for its total height above ground level, including the initial and any planned future equipment (Support Platforms, Antennas, TMA's etc.) above the top of an electric transmission structure.
- b) Conductors and related devices and hardware (wire loads will be provided by Eversource).
- c) Electric Transmission Structure
  - i) The loads from the wireless communication equipment components based on NESC and Eversource Criteria in Attachment A, and from the electric conductors shall be applied to the structure at conductor and wireless communication mast attachment points, where those loads transfer to the tower.
  - ii) Shape Factor Multiplier:

NESC Structure Shape	Cd
Polyround (for polygonal steel poles)	1.3
Flat	1.6
Open Lattice	3.2
Pole with Coaxial Cable	1.6

- iii) When Coaxial Cables are mounted alongside the pole structure, the shape multiplier shall be:

Mount Type	Cable Cd	Pole Cd
Coaxial Cables on outside periphery (One layer)	1.45	1.45
Coaxial Cables mounted on stand offs	1.6	1.6

- d) The uniform loadings and factors specified for the above components in Attachment A, "Eversource Design Criteria" are based upon the National Electric Safety Code 2007 Edition Extreme Wind (Rule 250C) and Combined Ice and Wind (Rule 250B-Heavy) Loadings. These provide equivalent loadings compared to the TIA and its loads and factors with the exceptions noted above.

**Note:** The NESC does not require ice load be included in the supporting structure. (Ice on conductors and shield wire only, and Eversource will provide these loads).

- e) Mast reaction loads shall be evaluated for local effects on the transmission structure members at the attachment points.

**Project: 1783 Line, Structure 8011**

**Date: 8/28/18**

**Engineer: JS**

**Purpose: Recalculate wire loads for T-Mobile site.**

**Shield Wires:**

**(1) 0.457" OPGW, sagged in PLS-CADD. Attached on north side**

**(1) 7#8 Alumoweld, sagged in PLS-CADD. Attached on south side**

**Conductors:**

**336 ACSR, sagged in PLS-CADD**

**NESC 250B**

	Vertical	Transverse	Longitudinal
Alumoweld	1581	-610	-50
OPGW	1611	-443	-25
Conductor	2338	-707	-25

**NESC 250C**

	Vertical	Transverse	Longitudinal
Alumoweld	785	-415	-54
OPGW	835	-398	-50
Conductor	1260	-807	-75

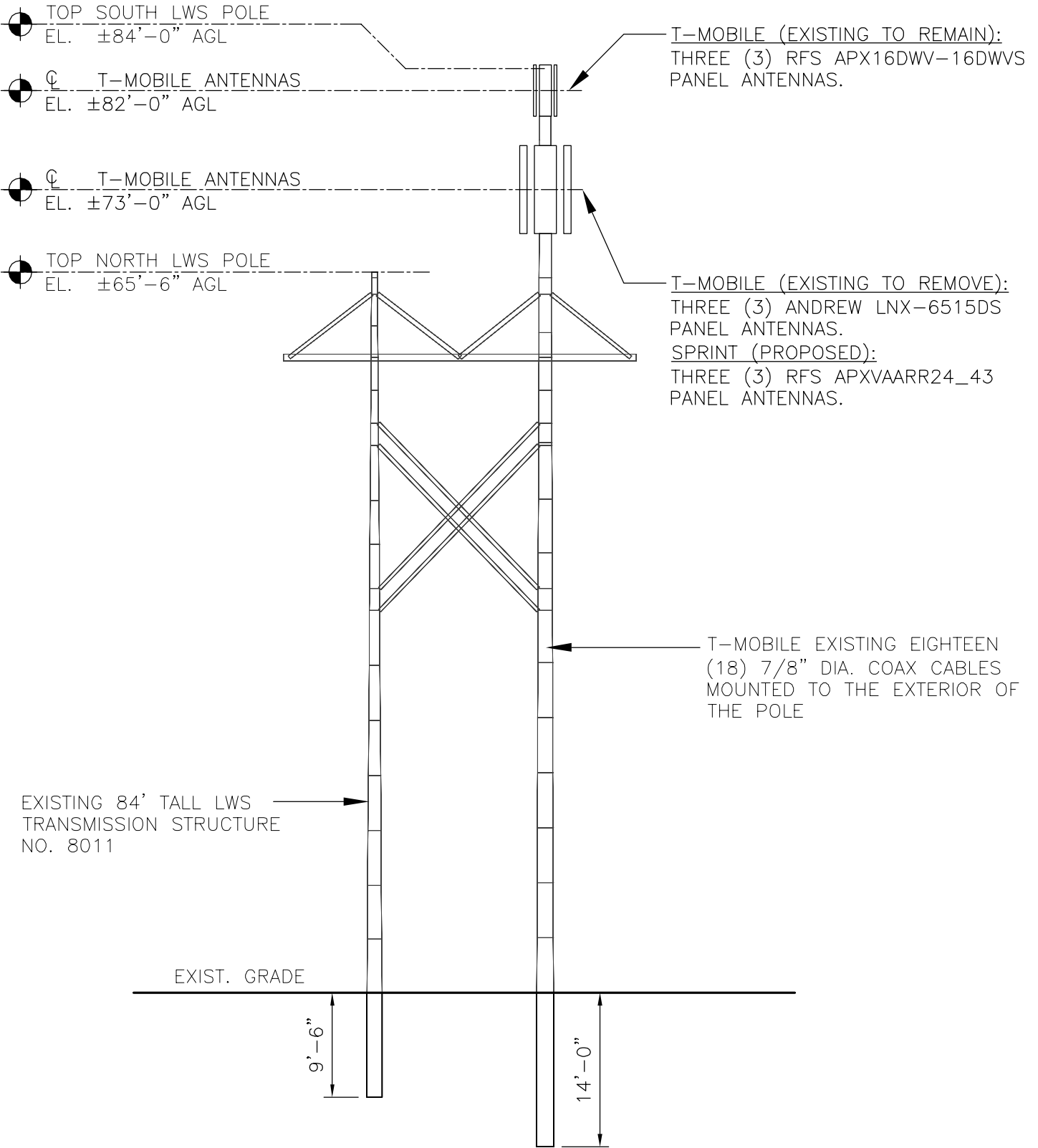

1  
EL-1

# TOWER ELEVATION

SCALE: NOT TO SCALE

REVISIONS		
00	10/2/18	ISSUED FOR REVIEW
01	11/6/18	CONSTRUCTION

**CEN TEK** engineering  
Centered on Solutions™  
www.CentekEng.com  
(203) 488-0580  
(203) 488-8587 Fax  
63-2 North Branford Road, Branford, CT 06405

CT11135J  
EVERSOURCE 8011  
40 MAPLE RIDGE DRIVE  
FARMINGTON, CT 06032

PROJECT NO:	18098.04
DRAWN BY:	TJL
CHECKED BY:	CFC
SCALE:	AS NOTED
DATE:	10/2/18



TOWER ELEVATION  
**EL-1**  
DWG. 1 OF 1

**Basic Components**

Heavy Wind Pressure =	p := 4.00	psf	(User Input NESC 2007 Figure 250-1 & Table 250-1)
Basic Windspeed =	V := 110	mph	(User Input NESC 2007 Figure 250-2(e) )
Radial Ice Thickness =	Ir := 0.50	in	(User Input)
Radial Ice Density =	Id := 56.0	pcf	(User Input)

**Factors for Extreme Wind Calculation**

Elevation of Top of Mast Above Grade =	TME := 84	ft	(User Input)
Multiplier Gust Response Factor =	m := 1.25		(User Input - Only for NESC Extreme wind case)
NESC Factor =	kv := 1.43		(User Input from NESC 2007 Table 250-3 equation)
Importance Factor =	I := 1.0		(User Input from NESC 2007 Section 250.C.2)

Velocity Pressure Coefficient = 
$$Kz := 2.01 \cdot \left( \frac{TME}{900} \right)^{\frac{2}{9.5}} = 1.22$$
 (NESC 2007 Table 250-2)

Exposure Factor = 
$$Es := 0.346 \left[ \frac{33}{(0.67 \cdot TME)} \right]^{\frac{1}{7}} = 0.321$$
 (NESC 2007 Table 250-3)

Response Term = 
$$Bs := \frac{1}{\left( 1 + 0.375 \cdot \frac{TME}{220} \right)} = 0.875$$
 (NESC 2007 Table 250-3)

Gust Response Factor = 
$$Grf := \frac{\left[ 1 + \left( 2.7 \cdot Es \cdot Bs \cdot \frac{1}{2} \right) \right]}{kv^2} = 0.885$$
 (NESC 2007 Table 250-3)

Wind Pressure = 
$$qz := 0.00256 \cdot Kz \cdot V^2 \cdot Grf \cdot I = 33.4$$
 psf (NESC 2007 Section 250.C.2)

**Shape Factors**

Shape Factor for Round Members =	Cd <sub>R</sub> := 1.3	(User Input)
Shape Factor for Flat Members =	Cd <sub>F</sub> := 1.6	(User Input)
Shape Factor for Coax Cables Attached to Outside of Pole =	Cd <sub>coax</sub> := 1.6	(User Input)

**Overload Factors**

NU Design Criteria Table

**Overload Factors for Wind Loads:**

NESC Heavy Loading =	2.5	(User Input)	Apply in Risa-3D Analysis
NESC Extreme Loading =	1.0	(User Input)	Apply in Risa-3D Analysis

**Overload Factors for Vertical Loads:**

NESC Heavy Loading =	1.5	(User Input)	Apply in Risa-3D Analysis
NESC Extreme Loading =	1.0	(User Input)	Apply in Risa-3D Analysis

**Development of Wind & Ice Load on Antennas**

**Antenna Data:**

Antenna Model =	RFSAPX16DWV-16DWVS-E-A20	
Antenna Shape =	Flat	(User Input)
Antenna Height =	$L_{ant} := 55.9$	in (User Input)
Antenna Width =	$W_{ant} := 13$	in (User Input)
Antenna Thickness =	$T_{ant} := 3.15$	in (User Input)
Antenna Weight =	$WT_{ant} := 41$	lbs (User Input)
Number of Antennas =	$N_{ant} := 3$	(User Input)

**Gravity Load (without ice)**

Weight of All Antennas =  $Wt_{ant1} := WT_{ant} \cdot N_{ant} = 123$  lbs

**Gravity Load (ice only)**

Volume of Each Antenna =  $V_{ant} := L_{ant} \cdot W_{ant} \cdot T_{ant} = 2289$  cu in

Volume of Ice on Each Antenna =  $V_{ice} := (L_{ant} + 2 \cdot Ir)(W_{ant} + 2 \cdot Ir)(T_{ant} + 2 \cdot Ir) - V_{ant} = 1017$  cu in

Weight of Ice on Each Antenna =  $W_{ICEant} := \frac{V_{ice}}{1728} \cdot Id = 33$  lbs

Weight of Ice on All Antennas =  $Wt_{ice.ant1} := W_{ICEant} \cdot N_{ant} = 99$  lbs

**Wind Load (NESC Heavy)**

Surface Area for One Antenna w/ Ice =  $SA_{ICEant} := \frac{(L_{ant} + 2 \cdot Ir) \cdot (W_{ant} + 2 \cdot Ir)}{144} = 5.5$  sf

Total Antenna Wind Force w/ Ice =  $Fi_{ant1} := p \cdot Cd_F \cdot (SA_{ICEant} \cdot N_{ant}) = 106$  lbs

**Wind Load (NESC Extreme)**

Surface Area for One Antenna =  $SA_{ant} := \frac{L_{ant} \cdot W_{ant}}{144} = 5$  sf

Total Antenna Wind Force =  $F_{ant1} := qz \cdot Cd_F \cdot (SA_{ant} \cdot N_{ant}) = 810$  lbs

**Development of Wind & Ice Load on Antenna Mounts**

**Mount Data:**

Mount Type =	Pipe Mount	
Mount Shape =	Round	(User Input)
Pipe Mount Length =	$L_{mnt} := 72$	in (User Input)
Pipe Mount Linear Weight =	$W_{mnt} := 3.66$	plf (User Input)
Pipe Mount Outside Diameter =	$D_{mnt} := 2.375$	in (User Input)
Number of Mounting Pipes =	$N_{mnt} := 3$	(User Input)

**Wind Load (NESC Extreme)**

Mount Projected Surface Area =  $A_{mnt} := \frac{D_{mnt} \cdot L_{mnt}}{144} \cdot N_{mnt} = 3.563$  sf

Total Mount Wind Force =  $F_{mnt1} := qz \cdot C_dR \cdot A_{mnt} = 155$  lbs

**Wind Load (NESC Heavy)**

Mount Projected Surface Area w/ Ice =  $A_{ICEmnt} := \frac{(L_{mnt} + 1) \cdot (D_{mnt} + 1)}{144} \cdot N_{mnt} = 5.133$  sf

Total Mount Wind Force =  $F_{mnt1} := p \cdot C_dR \cdot A_{ICEmnt} = 27$  lbs

**Gravity Loads (without ice)**

Weight Each Pipe Mount =  $WT_{mnt} := W_{mnt} \cdot \frac{L_{mnt}}{12} = 22$  lbs

Weight of All Mounts =  $Wt_{mnt1} := WT_{mnt} \cdot N_{mnt} = 66$  lbs

**Gravity Load (ice only)**

Volume of Each Pipe =  $V_{mnt} := \frac{\pi}{4} \cdot D_{mnt}^2 \cdot L_{mnt} = 319$  cu in

Volume of Ice on Each Pipe =  $V_{ice} := \left[ \frac{\pi}{4} \cdot (D_{mnt} + 1)^2 \cdot (L_{mnt} + 1) \right] - V_{mnt} = 334$  cu in

Weight of Ice each mount (incl. hardware) =  $W_{ICEmnt} := \frac{V_{ice}}{1728} \cdot \rho_{ice} = 11$  lbs

Weight of Ice on All Mounts =  $Wt_{ice.mnt1} := (W_{ICEmnt} \cdot N_{mnt} + 5) = 37$  lbs

**Development of Wind & Ice Load on Antennas**

**Antenna Data:**

Antenna Model =	RFSAPXVAARR24_43	
Antenna Shape =	Flat	(User Input)
Antenna Height =	$L_{ant} := 95.9$	in (User Input)
Antenna Width =	$W_{ant} := 24$	in (User Input)
Antenna Thickness =	$T_{ant} := 8.7$	in (User Input)
Antenna Weight =	$WT_{ant} := 154$	lbs (User Input)
Number of Antennas =	$N_{ant} := 3$	(User Input)

**Gravity Load (without ice)**

Weight of All Antennas =  $Wt_{ant2} := WT_{ant} \cdot N_{ant} = 462$  lbs

**Gravity Load (ice only)**

Volume of Each Antenna =  $V_{ant} := L_{ant} \cdot W_{ant} \cdot T_{ant} = 2 \times 10^4$  cu in

Volume of Ice on Each Antenna =  $V_{ice} := (L_{ant} + 2 \cdot Ir)(W_{ant} + 2 \cdot Ir)(T_{ant} + 2 \cdot Ir) - V_{ant} = 3474$  cu in

Weight of Ice on Each Antenna =  $W_{ICEant} := \frac{V_{ice}}{1728} \cdot Id = 113$  lbs

Weight of Ice on All Antennas =  $Wt_{ice.ant2} := W_{ICEant} \cdot N_{ant} = 338$  lbs

**Wind Load (NESC Heavy)**

Surface Area for One Antenna w/ Ice =  $SA_{ICEant} := \frac{(L_{ant} + 2 \cdot Ir) \cdot (W_{ant} + 2 \cdot Ir)}{144} = 16.8$  sf

Total Antenna Wind Force w/ Ice =  $Fi_{ant2} := p \cdot Cd_F \cdot (SA_{ICEant} \cdot N_{ant}) = 323$  lbs

**Wind Load (NESC Extreme)**

Surface Area for One Antenna =  $SA_{ant} := \frac{L_{ant} \cdot W_{ant}}{144} = 16$  sf

Total Antenna Wind Force =  $F_{ant2} := qz \cdot Cd_F \cdot (SA_{ant} \cdot N_{ant}) = 2566$  lbs



**Development of Wind & Ice Load on Antenna Mounts**

**Mount Data:**

Mount Type =	Pipe Mount	
Mount Shape =	Round	(User Input)
Pipe Mount Length =	$L_{mnt} := 84$	in (User Input)
Pipe Mount Linear Weight =	$W_{mnt} := 3.66$	plf (User Input)
Pipe Mount Outside Diameter =	$D_{mnt} := 2.375$	in (User Input)
Number of Mounting Pipes =	$N_{mnt} := 3$	(User Input)

**Wind Load (NESC Extreme)**

Mount Projected Surface Area =  $A_{mnt} := \frac{D_{mnt} \cdot L_{mnt}}{144} \cdot N_{mnt} = 4.156$  sf

Total Mount Wind Force =  $F_{mnt2} := qz \cdot C_dR \cdot A_{mnt} = 181$  lbs

**Wind Load (NESC Heavy)**

Mount Projected Surface Area w/ Ice =  $A_{ICEmnt} := \frac{(L_{mnt} + 1) \cdot (D_{mnt} + 1)}{144} \cdot N_{mnt} = 5.977$  sf

Total Mount Wind Force =  $F_{mnt2} := p \cdot C_dR \cdot A_{ICEmnt} = 31$  lbs

**Gravity Loads (without ice)**

Weight Each Pipe Mount =  $W_{Tmnt} := W_{mnt} \cdot \frac{L_{mnt}}{12} = 26$  lbs

Weight of All Mounts =  $W_{t\_mnt2} := W_{Tmnt} \cdot N_{mnt} = 77$  lbs

**Gravity Load (ice only)**

Volume of Each Pipe =  $V_{mnt} := \frac{\pi}{4} \cdot D_{mnt}^2 \cdot L_{mnt} = 372$  cu in

Volume of Ice on Each Pipe =  $V_{ice} := \left[ \frac{\pi}{4} \cdot \left[ (D_{mnt} + 1)^2 \right] \cdot (L_{mnt} + 1) \right] - V_{mnt} = 388$  cu in

Weight of Ice each mount (incl. hardware) =  $W_{ICEmnt} := \frac{V_{ice}}{1728} \cdot \rho_d = 13$  lbs

Weight of Ice on All Mounts =  $W_{t\_ice.mnt2} := (W_{ICEmnt} \cdot N_{mnt} + 5) = 43$  lbs

T-Mobile @ 82-ftAGL

NESC Heavy Wind Vertical =  $(W_{t_{ant1}} + W_{t_{ice.ant1}} + W_{t_{mnt1}} + W_{t_{ice.mnt1}}) \cdot 1.5 = 488$

NESC Heavy Wind Transverse =  $(F_{i_{ant1}} + F_{i_{mnt1}}) \cdot 2.5 = 332$

NESC Extreme Wind Vertical =  $(W_{t_{ant1}} + W_{t_{mnt1}}) = 189$

NESC Extreme Wind Transverse =  $(F_{ant1} + F_{mnt1}) = 965$

T-Mobile @ 73-ftAGL

NESC Heavy Wind Vertical =  $(W_{t_{ant2}} + W_{t_{ice.ant2}} + W_{t_{mnt2}} + W_{t_{ice.mnt2}}) \cdot 1.5 = 1379$

NESC Heavy Wind Transverse =  $(F_{i_{ant2}} + F_{i_{mnt2}}) \cdot 2.5 = 885$

NESC Extreme Wind Vertical =  $(W_{t_{ant2}} + W_{t_{mnt2}}) = 539$

NESC Extreme Wind Transverse =  $(F_{ant2} + F_{mnt2}) = 2746$

**Coax Cable on Tower**

Heavy Wind Pressure =	$p := 4$ psf	(User Input)
Radial Ice Thickness =	$I_r := 0.5$ in	(User Input)
Radial Ice Density =	$I_d := 56$ pcf	(User Input)
Basic Windspeed =	$V := 110$ mph	(User Input NESC 2007 Figure 250-2(e) )
Height to Top of Coax Above Grade =	$TC := 84$ ft	(User Input)
NESC Factor =	$k_v := 1.43$	(User Input from NESC 2007 Table 250-3 equation)
Importance Factor =	$I := 1.0$	(User Input from NESC 2007 Section 250.C.2)
Velocity Pressure Coefficient =	$K_z := 2.01 \cdot \left( \frac{0.67TC}{900} \right)^{\frac{2}{9.5}} = 1.121$	(NESC 2007 Table 250-2)
Exposure Factor =	$E_s := 0.346 \left[ \frac{33}{(0.67 \cdot TC)} \right]^{\frac{1}{7}} = 0.321$	(NESC 2007 Table 250-3)
Response Term =	$B_s := \frac{1}{\left( 1 + 0.375 \cdot \frac{TC}{220} \right)} = 0.875$	(NESC 2007 Table 250-3)
Gust Response Factor =	$G_{rf} := \frac{\left[ 1 + \left( 2.7 \cdot E_s \cdot B_s \cdot \frac{1}{2} \right) \right]}{k_v^2} = 0.885$	(NESC 2007 Table 250-3)
Wind Pressure =	$q_z := 0.00256 \cdot K_z \cdot V^2 \cdot G_{rf} \cdot I = 30.7$ psf	(NESC 2007 Section 250.C.2)

**Coax Cable on Tower**

Distance Between Coax Cable Attach Points =

Coax Cable Span =

$$\text{CoaxSpan} := \begin{pmatrix} 10 \\ 10 \\ 10 \\ 10 \\ 10 \\ 10 \\ 10 \end{pmatrix} \cdot \text{ft} \quad (User Input)$$

Diameter of Coax Cable =

$$D_{\text{coax}} := 1.11 \cdot \text{in} \quad (User Input)$$

Weight of Coax Cable =

$$W_{\text{coax}} := 0.54 \cdot \text{plf} \quad (User Input)$$

Number of Coax Cables =

$$N_{\text{coax}} := 18 \quad (User Input)$$

Number of Projected Coax Cables Transverse =

$$NP_{\text{Tcoax}} := 2 \quad (User Input)$$

Number of Projected Coax Cables Long =

$$NP_{\text{Lcoax}} := 4 \quad (User Input)$$

Shape Factor =

$$Cd_{\text{coax}} := 1.6 \quad (User Input)$$

Overload Factor for NESC Heavy Wind Load =

$$OF_{\text{HW}} := 2.5 \quad (User Input)$$

Overload Factor for NESC Extreme Wind Load =

$$OF_{\text{EW}} := 1.0 \quad (User Input)$$

Overload Factor for NESC Heavy Vertical Load =

$$OF_{\text{HV}} := 1.5 \quad (User Input)$$

Overload Factor for NESC Extreme Vertical Load =

$$OF_{\text{EV}} := 1.0 \quad (User Input)$$

Wind Area with Ice Transverse =

$$A_{\text{Tice}} := (NP_{\text{Tcoax}} \cdot D_{\text{coax}} + 2 \cdot \text{lr}) = 3.22 \cdot \text{in}$$

Wind Area with Ice Long =

$$A_{\text{Lice}} := (NP_{\text{Lcoax}} \cdot D_{\text{coax}} + 2 \cdot \text{lr}) = 5.44 \cdot \text{in}$$

Wind Area without Ice Transverse =

$$A_{\text{T}} := (NP_{\text{Tcoax}} \cdot D_{\text{coax}}) = 2.22 \cdot \text{in}$$

Wind Area without Ice Long =

$$A_{\text{L}} := (NP_{\text{Lcoax}} \cdot D_{\text{coax}}) = 4.44 \cdot \text{in}$$

Ice Area per Liner Ft =

$$A_{\text{icoax}} := \frac{\pi}{4} \cdot [(D_{\text{coax}} + 2 \cdot \text{lr})^2 - D_{\text{coax}}^2] = 0.018 \text{ft}^2$$

Weight of Ice on All Coax Cables =

$$W_{\text{ice}} := A_{\text{icoax}} \cdot \text{ld} \cdot N_{\text{coax}} = 17.703 \cdot \text{plf}$$

Heavy Vertical Load =

$$\text{HeavyVert} := \overrightarrow{\left[ (N_{\text{coax}} \cdot W_{\text{coax}} + W_{\text{ice}}) \cdot \text{CoaxSpan} \cdot \text{OF}_{\text{HV}} \right]}$$

Heavy Transverse Load =

$$\text{HeavyTrans} := \overrightarrow{\left( p \cdot A_{\text{Tice}} \cdot C_{d_{\text{coax}}} \cdot \text{CoaxSpan} \cdot \text{OF}_{\text{HW}} \right)}$$

Heavy Transverse Load =

$$\text{HeavyLong} := \overrightarrow{\left( p \cdot A_{\text{Lice}} \cdot C_{d_{\text{coax}}} \cdot \text{CoaxSpan} \cdot \text{OF}_{\text{HW}} \right)}$$

$$\text{HeavyVert} = \begin{pmatrix} 411 \\ 411 \\ 411 \\ 411 \\ 411 \\ 411 \end{pmatrix} \text{ lb}$$

$$\text{HeavyTrans} = \begin{pmatrix} 43 \\ 43 \\ 43 \\ 43 \\ 43 \\ 43 \end{pmatrix} \text{ lb}$$

$$\text{HeavyLong} = \begin{pmatrix} 73 \\ 73 \\ 73 \\ 73 \\ 73 \\ 73 \end{pmatrix} \text{ lb}$$

Extreme Vertical Load =

$$\text{ExtremeVert} := \overrightarrow{\left[ (N_{\text{coax}} \cdot W_{\text{coax}}) \cdot \text{CoaxSpan} \cdot \text{OF}_{\text{EV}} \right]}$$

Extreme Transverse Load =

$$\text{ExtremeTrans} := \overrightarrow{\left[ (qz \cdot \text{psf} \cdot A_{\text{T}} \cdot C_{d_{\text{coax}}}) \cdot \text{CoaxSpan} \cdot \text{OF}_{\text{EW}} \right]}$$

Extreme Long Load =

$$\text{ExtremeLong} := \overrightarrow{\left[ (qz \cdot \text{psf} \cdot A_{\text{L}} \cdot C_{d_{\text{coax}}}) \cdot \text{CoaxSpan} \cdot \text{OF}_{\text{EW}} \right]}$$

$$\text{ExtremeVert} = \begin{pmatrix} 97 \\ 97 \\ 97 \\ 97 \\ 97 \\ 97 \end{pmatrix} \text{ lb}$$

$$\text{ExtremeTrans} = \begin{pmatrix} 91 \\ 91 \\ 91 \\ 91 \\ 91 \\ 91 \end{pmatrix} \text{ lb}$$

$$\text{ExtremeLong} = \begin{pmatrix} 182 \\ 182 \\ 182 \\ 182 \\ 182 \\ 182 \end{pmatrix} \text{ lb}$$

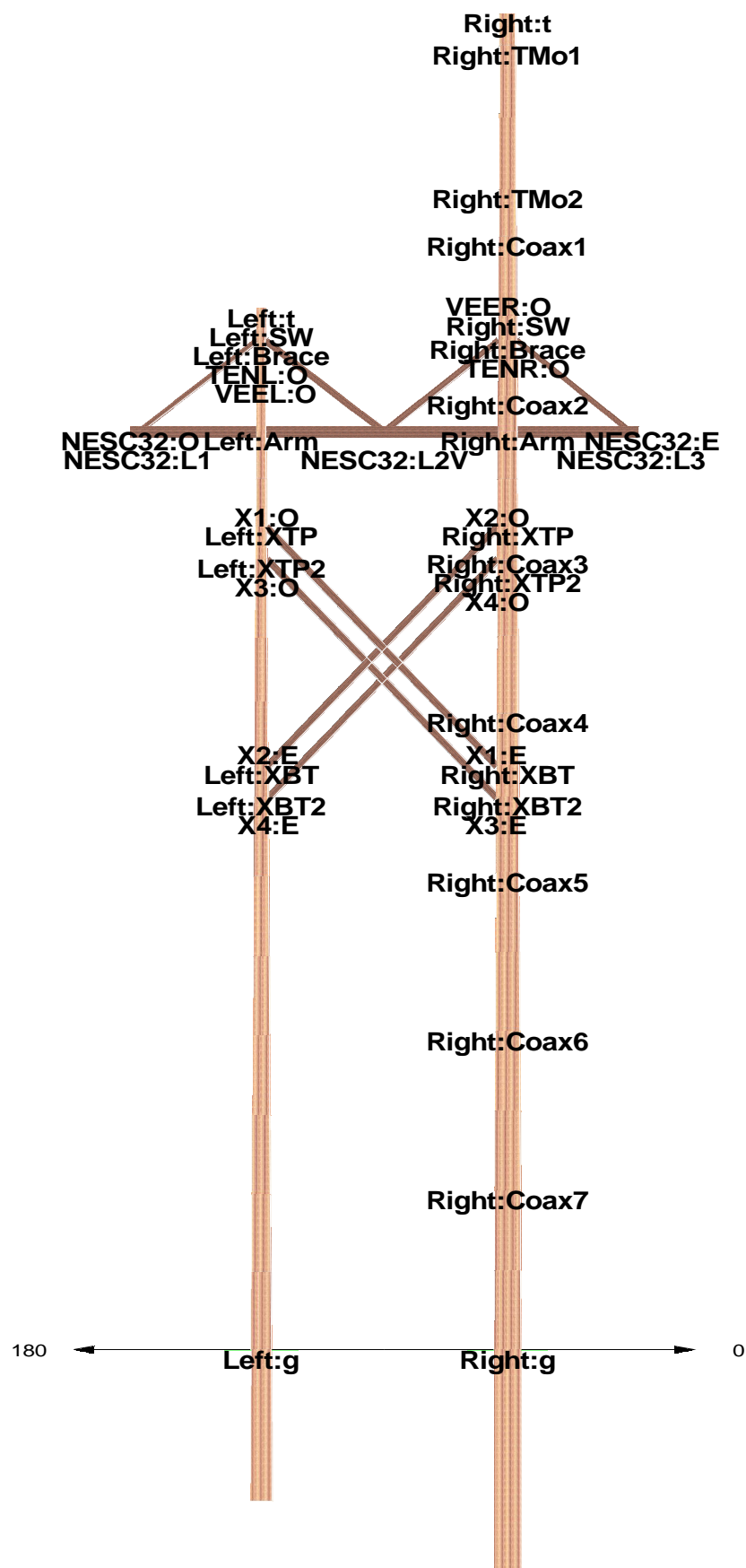

Project Name : 18098.04 - CT11135J  
 Project Notes: Structure 8011 - Farmington  
 Project File : J:\Jobs\1809800.WI\04\_CT11135J\04\_Structural\Calcs\Rev (1)\PLS Pole\Structure 8011.pol  
 Date run : 9:21:47 AM Tuesday, November 06, 2018  
 by : PLS-POLE Version 14.21  
 Licensed to : Centek Engineering Inc

Successfully performed nonlinear analysis

The model has 0 warnings.

Loads from file: j:\jobs\1809800.wi\04\_ct11135j\04\_structural\calcs\rev (1)\pls pole\8011.lca

\*\*\* Analysis Results:

Maximum element usage is 98.54% for X-Arm "NESC32" in load case "Ext. Wind L"  
 Maximum insulator usage is 30.74% for Clamp "C7" in load case "Ext. Wind T"

Summary of Joint Support Reactions For All Load Cases:

Load Case	Joint Label	Long. Force (kips)	Tran. Force (kips)	Vert. Force (kips)	Shear Force (kips)	Tran. Moment (ft-k)	Long. Moment (ft-k)	Bending Moment (ft-k)	Vert. Moment (ft-k)	Found. Usage %
NESC Heavy T	Left:g	0.03	-2.10	7.10	2.10	40.75	1.38	40.77	0.34	0.00
NESC Heavy T	Right:g	0.08	-5.82	-39.31	5.82	132.62	7.91	132.86	0.44	0.00
NESC Heavy L	Left:g	-0.78	0.03	-9.35	0.78	-0.69	-14.34	14.36	-3.42	0.00
NESC Heavy L	Right:g	-1.32	-0.08	-22.86	1.32	0.38	-24.87	24.88	-7.72	0.00
Ext. Wind T	Left:g	0.15	-4.98	28.84	4.98	87.33	4.02	87.42	0.96	0.00
Ext. Wind T	Right:g	0.14	-12.55	-47.15	12.55	279.72	16.64	280.21	1.24	0.00
Ext. Wind L	Left:g	-2.47	-0.03	-5.25	2.47	-0.16	-45.76	45.76	-10.31	0.00
Ext. Wind L	Right:g	-4.44	-0.10	-13.07	4.44	0.37	-95.14	95.14	-23.17	0.00

Summary of Tip Deflections For All Load Cases:

Note: positive tip load results in positive deflection

Load Case	Joint Label	Long. Defl. (in)	Tran. Defl. (in)	Vert. Defl. (in)	Resultant Defl. (in)	Long. Rot. (deg)	Tran. Rot. (deg)	Twist (deg)
NESC Heavy T	Left:t	-1.27	2.88	-0.01	3.15	-0.15	0.46	-0.09
NESC Heavy T	Right:t	-1.38	5.52	-0.05	5.69	-0.11	-0.46	-0.01
NESC Heavy L	Left:t	3.72	-0.17	-0.03	3.72	0.12	0.15	0.94
NESC Heavy L	Right:t	-0.18	0.54	-0.02	0.57	-0.16	-0.10	0.25
Ext. Wind T	Left:t	-2.86	5.97	-0.02	6.62	-0.33	0.92	-0.23
Ext. Wind T	Right:t	-2.95	11.75	-0.12	12.11	-0.23	-1.08	-0.04
Ext. Wind L	Left:t	13.31	0.04	-0.14	13.31	0.60	0.13	2.85
Ext. Wind L	Right:t	2.41	0.17	-0.02	2.42	-0.25	-0.04	0.76

\*\*\* Overall summary for all load cases - Usage = Maximum Stress / Allowable Stress

Summary of Laminated Wood Pole Usages:

Laminated Wood Pole Label	Maximum Usage %	Load Case	Segment Number	Weight (lbs)
Left	90.08	Ext. Wind T	4	2842.5
Right	51.74	Ext. Wind T	23	9671.7

Summary of X-Arm Usages:

X-Arm Label	Maximum Usage %	Load Case	Segment	Weight Number	Weight (lbs)
NESC32	98.54	Ext. Wind L		7	393.0

Summary of Brace Usages:

Brace Label	Maximum Usage %	Load Case	Weight (lbs)
TENL	21.16	NESC Heavy T	47.0
TENR	20.30	NESC Heavy T	47.0
VEEL	47.21	Ext. Wind T	58.0
VEER	76.27	Ext. Wind T	58.0
X1	59.25	Ext. Wind T	142.0
X2	31.77	Ext. Wind T	142.0
X3	78.75	Ext. Wind T	142.0
X4	36.41	Ext. Wind T	142.0

\*\*\* Maximum Stress Summary for Each Load Case

Summary of Maximum Usages by Load Case:

Load Case	Maximum Usage %	Element Label	Element Type
NESC Heavy T	54.71	Left Laminated Wood	
NESC Heavy L	37.71	NESC32 X-Arm	
Ext. Wind T	90.08	Left Laminated Wood	
Ext. Wind L	98.54	NESC32 X-Arm	

Summary of Laminated Wood Pole Usages by Load Case:

Load Case	Maximum Usage %	Laminated Wood Pole Label	Segment Number
NESC Heavy T	54.71	Left	4
NESC Heavy L	13.69	Left	18
Ext. Wind T	90.08	Left	4
Ext. Wind L	34.21	Left	18

Summary of X-Arm Usages by Load Case:

Load Case	Maximum Usage %	X-Arm Label	Segment Number
NESC Heavy T	19.91	NESC32	5
NESC Heavy L	37.71	NESC32	7
Ext. Wind T	37.83	NESC32	5
Ext. Wind L	98.54	NESC32	7

Summary of Brace Usages by Load Case:



	Load Case	Maximum Usage %	Brace Label
NESC Heavy T	47.40	VEER	
NESC Heavy L	25.79	VEEL	
Ext. Wind T	78.75	X3	
Ext. Wind L	12.51	VEEL	

Summary of Insulator Usages:

Insulator Label	Insulator Type	Maximum Usage %	Load Case	Weight (lbs)
C1	Clamp	16.75	NESC Heavy T	0.0
C2	Clamp	17.25	NESC Heavy T	0.0
C3	Clamp	24.43	NESC Heavy T	0.0
C4	Clamp	24.43	NESC Heavy T	0.0
C5	Clamp	24.43	NESC Heavy T	0.0
C6	Clamp	12.23	Ext. Wind T	0.0
C7	Clamp	30.74	Ext. Wind T	0.0
C8	Clamp	4.34	NESC Heavy T	0.0
C9	Clamp	4.26	NESC Heavy T	0.0
C10	Clamp	4.16	NESC Heavy T	0.0
C11	Clamp	4.35	NESC Heavy T	0.0
C12	Clamp	4.66	Ext. Wind T	0.0
C13	Clamp	4.75	Ext. Wind T	0.0
C14	Clamp	4.75	Ext. Wind T	0.0

\*\*\* Weight of structure (lbs):  
 Weight of Braces: 778.0  
 Weight of X-Arms: 393.0  
 Weight of Laminated Wood Poles: 12514.2  
 Total: 13685.2

\*\*\* End of Report

```

*****
*
*                PLS-POLE
*                POLE AND FRAME ANALYSIS AND DESIGN
*                Copyright Power Line Systems, Inc. 1999-2016
*
*****

```

```

Project Name : 18098.04 - CT11135J
Project Notes: Structure 8011 - Farmington
Project File : J:\Jobs\1809800.WI\04_CT11135J\04_Structural\Calcs\Rev (1)\PLS Pole\Structure 8011.pol
Date run    : 9:21:44 AM Tuesday, November 06, 2018
by         : PLS-POLE Version 14.21
Licensed to : Centek Engineering Inc

```

Successfully performed nonlinear analysis

The model has 0 warnings.



Modeling options:

```

Offset Arms from Pole/Mast: Yes
Offset Braces from Pole/Mast: Yes
Offset Guys from Pole/Mast: Yes
Offset Posts from Pole/Mast: Yes
Offset Strains from Pole/Mast: Yes
Use Alternate Convergence Process: No

```

Laminated Wood Pole Properties:

Laminated Pole Long. MOR	Stock Property Number Label	Pole Length (ft)	Default Embedded Length (ft)	Taper Stop From Butt (ft)	Trans. Tip Dim. (in)	Long. Tip Dim. (in)	Trans. Base Dim. (in)	Long. Base Dim. (in)	Default Drag	Modulus of Elasticity (ksi)	Density (lbs/ft^3)	Trans. MOR (ksi)
(ksi)		(ft)	(ft)	(ft)	(in)	(in)	(in)	(in)	Coef.	Elasticity	(ksi)	(ksi)

----														
8	PEL-1-75		SYP (LWS)	75.00	9.5	0.00	6.25	10.25	16.9	10.25	1.60	2222	46	7.6
8	AP840G140T15P		SYP (LWS)	98.00	14	14.00	12	18.25	20.63	18.25	1.60	2222	46	7.6

Laminated Wood Pole Connectivity:

Pole Label	Tip Joint	Base Joint	X of Base (ft)	Y of Base (ft)	Z of Base (ft)	Inclin. About X (deg)	Inclin. About Y (deg)	Property Set	Attach. Labels	Base Connect	Embed % Override	Embed C. Override (ft)
Left			0	-7.75	0	0	0	PEL-1-75	7 labels	Fixed	0.00	0
Right			0	7.75	0	0	0	AP840G140T15P	16 labels	Fixed	0.00	0

Relative Attachment Labels for Laminated Wood Pole "Left":

Joint Label	Distance From Origin/Top Joint (ft)	Global Z of Attach (ft)
Left:SW	0.50	0.00
Left:Brace	2.00	0.00
Left:Arm	7.75	0.00
Left:XTP	13.75	0.00
Left:XBT	28.75	0.00
Left:XTP2	15.75	0.00
Left:XBT2	30.75	0.00

Relative Attachment Labels for Laminated Wood Pole "Right":

Joint Label	Distance From Origin/Top Joint (ft)	Global Z of Attach (ft)
Right:TMo1	2.00	0.00
Right:TMo2	11.00	0.00
Right:SW	19.00	0.00
Right:Brace	20.50	0.00
Right:Arm	26.25	0.00
Right:XTP	32.25	0.00
Right:XBT	47.25	0.00
Right:Coax1	0.00	70.00
Right:Coax2	0.00	60.00
Right:Coax3	0.00	50.00
Right:Coax4	0.00	40.00
Right:Coax5	0.00	30.00
Right:Coax6	0.00	20.00
Right:Coax7	0.00	10.00
Right:XTP2	34.25	0.00
Right:XBT2	49.25	0.00

Detailed Laminated Wood Properties:

Element Label	Pole Feature	Dist. Above Ground	Dist. From Tip	Trans. Dim.	Long. Dim.	Area	Trans. Section Modulus	Long. Section Modulus	Trans. Inertia	Long. Inertia	Trans. MOR	Long. MOR	Trans. Moment Capacity	Long. Moment Capacity
---------------	--------------	--------------------	----------------	-------------	------------	------	------------------------	-----------------------	----------------	---------------	------------	-----------	------------------------	-----------------------

		(ft)	(ft)	(in)	(in)	(in^2)	(in^3)	(in^3)	(in^4)	(in^4)	(ksi)	(ksi)	(ft-k)	(ft-k)
Left	Left:t	65.50	0.00	6.25	10.25	64.06	66.73	109.44	208.54	560.88	7.600	8.000	42.263	72.960
Left	Left:SW	65.00	0.50	6.32	10.25	64.79	68.26	110.68	215.72	567.25	7.600	8.000	43.229	73.789
Left	Left:Brace	63.50	2.00	6.53	10.25	66.97	72.93	114.41	238.28	586.37	7.600	8.000	46.192	76.275
Left		60.62	4.88	6.94	10.25	71.16	82.33	121.56	285.79	623.00	7.600	8.000	52.144	81.041
Left	Left:Arm	57.75	7.75	7.35	10.25	75.34	92.30	128.71	339.23	659.64	7.600	8.000	58.457	85.807
Left		54.75	10.75	7.78	10.25	79.71	103.31	136.17	401.69	697.87	7.600	8.000	65.429	90.780
Left	Left:XTP	51.75	13.75	8.20	10.25	84.08	114.94	143.63	471.39	736.10	7.600	8.000	72.794	95.753
Left	Left:XTP2	49.75	15.75	8.49	10.25	86.99	123.04	148.60	522.07	761.59	7.600	8.000	77.922	99.068
Left		44.75	20.75	9.20	10.25	94.26	144.48	161.03	664.37	825.30	7.600	8.000	91.506	107.356
Left		40.75	24.75	9.76	10.25	100.09	162.88	170.98	795.23	876.27	7.600	8.000	103.158	113.987
Left	Left:XBT	36.75	28.75	10.33	10.25	105.91	182.38	180.93	942.23	927.25	7.600	8.000	115.509	120.617
Left	Left:XBT2	34.75	30.75	10.62	10.25	108.82	192.55	185.90	1022.08	952.73	7.600	8.000	121.946	123.933
Left		29.75	35.75	11.33	10.25	116.10	219.16	198.33	1241.17	1016.45	7.600	8.000	138.802	132.221
Left		24.75	40.75	12.04	10.25	123.37	247.50	210.76	1489.51	1080.17	7.600	8.000	156.749	140.509
Left		19.75	45.75	12.75	10.25	130.65	277.56	223.20	1768.95	1143.88	7.600	8.000	175.787	148.797
Left		14.75	50.75	13.46	10.25	137.93	309.34	235.63	2081.32	1207.60	7.600	8.000	195.915	157.086
Left		9.75	55.75	14.17	10.25	145.21	342.84	248.06	2428.46	1271.31	7.600	8.000	217.135	165.374
Left		4.87	60.63	14.86	10.25	152.30	377.17	260.18	2802.14	1333.44	7.600	8.000	238.874	173.455
Left	Left:g	0.00	65.50	15.55	10.25	159.40	413.13	272.30	3212.31	1395.56	7.600	8.000	261.650	181.536
Right	Right:t	84.00	0.00	12.00	18.25	219.00	438.00	666.13	2628.00	6078.39	7.600	8.000	277.400	444.083
Right	Right:TMO1	82.00	2.00	12.21	18.25	222.75	453.12	677.52	2765.24	6182.41	7.600	8.000	286.975	451.682
Right		77.50	6.50	12.67	18.25	231.18	488.08	703.17	3091.33	6416.46	7.600	8.000	309.114	468.781
Right	Right:TMO2	73.00	11.00	13.13	18.25	239.61	524.33	728.82	3442.09	6650.50	7.600	8.000	332.076	485.881
Right	Right:Coax1	70.00	14.00	13.44	18.25	245.23	549.22	745.92	3690.09	6806.53	7.600	8.000	347.841	497.280
Right	Right:SW	65.00	19.00	13.95	18.25	254.60	591.99	774.42	4129.41	7066.58	7.600	8.000	374.927	516.279
Right	Right:Brace	63.50	20.50	14.10	18.25	257.41	605.14	782.97	4267.69	7144.60	7.600	8.000	383.252	521.979
Right	Right:Coax2	60.00	24.00	14.46	18.25	263.97	636.36	802.92	4602.28	7326.63	7.600	8.000	403.030	535.278
Right	Right:Arm	57.75	26.25	14.70	18.25	268.19	656.85	815.74	4826.34	7443.65	7.600	8.000	416.007	543.828
Right		54.75	29.25	15.00	18.25	273.81	684.68	832.84	5136.25	7599.68	7.600	8.000	433.630	555.227
Right	Right:XTP	51.75	32.25	15.31	18.25	279.43	713.08	849.94	5459.15	7755.71	7.600	8.000	451.619	566.627
Right	Right:Coax3	50.00	34.00	15.49	18.25	282.71	729.92	859.92	5653.61	7846.73	7.600	8.000	462.281	573.276
Right	Right:XTP2	49.75	34.25	15.52	18.25	283.18	732.34	861.34	5681.76	7859.73	7.600	8.000	463.814	574.226
Right		44.88	39.13	16.02	18.25	292.32	780.35	889.13	6249.56	8113.28	7.599	8.000	494.168	592.750
Right	Right:Coax4	40.00	44.00	16.52	18.25	301.45	829.89	916.91	6853.98	8366.83	7.576	8.000	523.923	611.274
Right	Right:XBT	36.75	47.25	16.85	18.25	307.54	863.76	935.44	7277.83	8535.86	7.561	8.000	544.216	623.624
Right	Right:XBT2	34.75	49.25	17.06	18.25	311.29	884.94	946.84	7547.16	8639.89	7.552	8.000	556.886	631.223
Right	Right:Coax5	30.00	54.00	17.54	18.25	320.19	936.27	973.91	8213.25	8886.93	7.530	8.000	587.530	649.273
Right		25.00	59.00	18.06	18.25	329.56	991.87	1002.41	8955.57	9146.98	7.509	8.000	620.625	668.272
Right	Right:Coax6	20.00	64.00	18.57	18.25	338.93	1049.06	1030.91	9741.31	9407.03	7.488	8.000	654.578	687.271
Right		15.00	69.00	19.08	18.25	348.30	1107.87	1059.41	10571.73	9667.08	7.467	8.000	689.386	706.270
Right	Right:Coax7	10.00	74.00	19.60	18.25	357.67	1168.27	1087.91	11448.04	9927.13	7.447	8.000	725.048	725.269
Right		5.00	79.00	20.11	18.25	367.04	1230.28	1116.40	12371.49	10187.18	7.428	8.000	761.560	744.268
Right	Right:g	0.00	84.00	20.63	18.25	376.41	1293.90	1144.90	13343.31	10447.23	7.409	8.000	798.921	763.267

Brace Properties:

Brace	Stock	Cross Length	Depth	Width	Weight	Unit Wt.	Modulus	Drag	Strength	Use	Tension	Compres.	Net Design	X-Moment	Z-Moment	
Unbraced	Unbraced	Property	Number	Section		(If Length		of Coef.	Check Steel	Capacity	Capacity		Area Normal	Of	Of	
Length	Length	Label	Area		Unknown)	Elasticity		Type	S.F.				Stress	Inertia	Inertia	
Ratio-X	Ratio-Z		(in^2)	(ft)	(in)	(in)	(lbs)	(lbs/ft)	(ksi)		(lbs)	(lbs)	(in^2)	(ksi)	(in^4)	(in^4)

ten2043	2043-75.7	14.76	9.5	4.375	3.375	47	0	1600	1.6	Nominal	No	30000	15370	0	0	0	0
x2094	2094-15-6	21.56	20.5	5.75	3.75	142	0	1600	1.6	Nominal	No	25000	26375	0	0	0	0
vee2037	2037AEK103.7	18.1	9.3	5.375	3.375	58	0	1600	1.6	Nominal	No	20000	18883	0	0	0	0

**Brace Connectivity:**

Brace Label	Origin Label	End Label	Brace Property	Element Type	Set
TENL	Left:Brace	NESC32:L1	ten2043	Standard	
TENR	Right:Brace	NESC32:L3	ten2043	Standard	Brace "TENR" with property "ten2043" uses nominal strength based on a length of 9.50 (ft), but the actual geometric length is 9.18 (ft) ??
VEEL	Left:Brace	NESC32:L2V	vee2037	Standard	
VEER	Right:Brace	NESC32:L2V	vee2037	Standard	
X1	Left:XTP	Right:XBT	x2094	Standard	
X2	Right:XTP	Left:XBT	x2094	Standard	
X3	Left:XTP2	Right:XBT2	x2094	Standard	
X4	Right:XTP2	Left:XBT2	x2094	Standard	

**X-Arm Properties:**

Cross X	Arm Z	Stock Z	Cross Section Label	Cross Section Area	X Inertia	Z Inertia	Weight (lbs)	Depth (in)	Width (in)	Length (ft)	Modulus of Elasticity (ksi)	Drag Coef.	Geometry	Strength Check Type	Use Steel S.F.	Vertical Capacity (lbs)	Trans. Capacity (lbs)	Long. Capacity (lbs)	Design Normal Stress (psi)
3)	(in^3)			(in^2)	(in^4)	(in^4)	(lbs)	(in)	(in)	(ft)	(ksi)			Calculated		(lbs)	(lbs)	(lbs)	(psi)
nesc32				38.4	84.1	180.2	393	7.5	5.125	32	2100	1.6	5 points	Calculated	No	0	0	0	8000
32.83	48.04																		

**Intermediate Joints and Bolt Holes for Cross Arm Property "nesc32":**

Joint Label	Offset (ft)	Horz. Hole Diameter (in)	Vert. Hole Diameter (in)
L1	0.5	0	0
PL	8.25	0	0
L2V	16	0	0
PR	23.75	0	0
L3	31.5	0	0

**X-Arm Connectivity:**

X-Arm Label	X-Arm Property Set	Azimuth (deg)	Slope (deg)	Attach. Labels	Connects
NESC32	nesc32	0	0		7 connections

X-Arm Connections for "NESC32":

Attach Offset Label	Connect At	Connection Code Type
(ft)		
-----		
NESC32:O 0.000		Pinned X
NESC32:L1 0.500		Pinned X
NESC32:PL 8.250	Left:Arm	Pinned X
NESC32:L2V 16.000		Pinned X
NESC32:PR 23.750	Right:Arm	Pinned X
NESC32:L3 31.500		Pinned X
NESC32:E 32.000		Pinned X

\*\*\* Insulator Data

Clamp Properties:

Label	Stock Number	Holding Capacity (lbs)
-----		
Clamp 1		1e+004

Clamp Insulator Connectivity:

Clamp Label	Structure And Tip Attach	Property Set	Min. Required Vertical Load (uplift) (lbs)
-----			
C1	Left:SW	Clamp 1	No Limit
C2	Right:SW	Clamp 1	No Limit
C3	NESC32:L1	Clamp 1	No Limit
C4	NESC32:L2V	Clamp 1	No Limit
C5	NESC32:L3	Clamp 1	No Limit
C6	Right:TMo1	Clamp 1	No Limit
C7	Right:TMo2	Clamp 1	No Limit
C8	Right:Coax1	Clamp 1	No Limit
C9	Right:Coax2	Clamp 1	No Limit
C10	Right:Coax3	Clamp 1	No Limit
C11	Right:Coax4	Clamp 1	No Limit
C12	Right:Coax5	Clamp 1	No Limit
C13	Right:Coax6	Clamp 1	No Limit
C14	Right:Coax7	Clamp 1	No Limit

Material List

Stock Number	Item Description	Quantity	Unit of Measure
-----			
2043-75.7	Brace property: ten2043	2.00	Each
2037AEK103.7	Brace property: vee2037	2.00	Each
2094-15-6	Brace property: x2094	4.00	Each



\*\*\* Loads Data

Loads from file: j:\jobs\1809800.wi\04\_ct11135j\04\_structural\calcs\rev (1)\pls pole\8011.lca

Insulator dead and wind loads are already included in the point loads printed below.

Loading Method Parameters:

Structure Height Summary (used for calculating wind/ice adjust with height):

Z of ground for wind height adjust 0.00 (ft) and structure Z coordinate that will be put on the centerline ground profile in PLS-CADD.  
 Ground elevation shift 0.00 (ft)  
 Z of ground with shift 0.00 (ft)  
 Z of structure top (highest joint) 84.00 (ft)  
 Structure height 84.00 (ft)  
 Structure height above ground 84.00 (ft)

Vector Load Cases:

Load Case	Dead	Wind	SF for Pole	SF for Wood	SF for Conc.	SF for Conc.	SF for Guys	SF for Non Braces	SF for Insuls.	SF For Found.	Point Loads	Wind/Ice Model	Trans. Wind	Longit. Wind		
Ice Description Thick.	Temperature Load	Area	Steel Tubular	Poles Arms	Conc. Deflection	Conc. Deflection	Ult. First	Zero Tens.	Cables and Tubular	Arms			(psf)	(psf)		
Check	Limit	Factor	Factor	and Towers	% or (ft)	Crack	Tens.	Cables	Arms				(psf)	(psf)		
(in)	(lbs/ft^3)	(deg F)														
NESC Heavy T	1.5000	2.5000	1.00000	0.6500	0.0000	0.0000	0.0000	1.0000	0.6500	0.6500	1.0000	1.0000	14 loads	Wind on All	4	0
0.000	0.000	0.0	No Limit		0											
NESC Heavy L	1.5000	2.5000	1.00000	0.6500	0.0000	0.0000	0.0000	1.0000	0.6500	0.6500	1.0000	1.0000	14 loads	Wind on All	0	4
0.000	0.000	0.0	No Limit		0											
Ext. Wind T	1.0000	1.0000	1.00000	0.7500	0.0000	0.0000	0.0000	1.0000	0.7500	0.7500	1.0000	1.0000	14 loads	NESC 2012	31	0
0.000	0.000	0.0	No Limit		0											
Ext. Wind L	1.0000	1.0000	1.00000	0.7500	0.0000	0.0000	0.0000	1.0000	0.7500	0.7500	1.0000	1.0000	14 loads	NESC 2012	0	31
0.000	0.000	0.0	No Limit		0											

Point Loads for Load Case "NESC Heavy T":

Joint Label	Vertical Load (lbs)	Transverse Load (lbs)	Longitudinal Load (lbs)	Load Comment
Left:SW	1611	443	-25	Shield Wire
Right:SW	1581	610	-50	Shield Wire
NESC32:L1	2338	707	-25	Conductor
NESC32:L2V	2338	707	-25	Conductor
NESC32:L3	2338	707	-25	Conductor
Right:TMO1	488	332	0	T-Mobile
Right:TMO2	1379	885	0	T-Mobile
Right:Coax1	411	43	0	Coax
Right:Coax2	411	43	0	Coax
Right:Coax3	411	43	0	Coax
Right:Coax4	411	43	0	Coax
Right:Coax5	411	43	0	Coax



Right:Coax6 411 43 0 Coax  
 Right:Coax7 411 43 0 Coax

Detailed Pole Loading Data for Load Case "NESC Heavy T":

Notes: Does not include loads from equipment, arms, guys, braces, etc. or user input loads.  
 Wind load is calculated for the undeformed shape of a pole.

Pole Label	Top Joint	Bottom Joint	Section Top Z (ft)	Section Bottom Z (ft)	Section Average Elevation (ft)	Outer Diameter (in)	Reynolds Number	Drag Coef.	Adjusted Wind Pressure (psf)	Adjusted Ice Thickness (in)	Pole Vert. Load (lbs)	Pole Wind Load (lbs)	Pole Ice Vertical Load (lbs)	Pole Ice Wind Load (lbs)	Tran. Wind Load (lbs)	Long. Wind Load (lbs)
Left	Left:t	Left:SW	65.50	65.00	65.25	6.286	2.98e+005	1.600	10.00	0.00	15.44	6.83	0.00	0.00	6.83	0.04
Left	Left:SW	Left:Brace	65.00	63.50	64.25	6.428	3.04e+005	1.600	10.00	0.00	47.35	20.50	0.00	0.00	20.50	0.13
Left	Left:Brace		63.50	60.62	62.06	6.738	3.19e+005	1.600	10.00	0.00	95.15	39.29	0.00	0.00	39.29	0.27
Left		Left:Arm	60.62	57.75	59.19	7.146	3.38e+005	1.600	10.00	0.00	100.91	39.29	0.00	0.00	39.29	0.29
Left	Left:Arm		57.75	54.75	56.25	7.564	3.58e+005	1.600	10.00	0.00	111.44	41.00	0.00	0.00	41.00	0.32
Left		Left:XTP	54.75	51.75	53.25	7.989	3.78e+005	1.600	10.00	0.00	117.72	41.00	0.00	0.00	41.00	0.33
Left	Left:XTP	Left:XTP2	51.75	49.75	50.75	8.345	3.95e+005	1.600	10.00	0.00	81.97	27.33	0.00	0.00	27.33	0.23
Left	Left:XTP2		49.75	44.75	47.25	8.841	4.19e+005	1.600	10.00	0.00	217.12	68.34	0.00	0.00	68.33	0.62
Left			44.75	40.75	42.75	9.480	4.49e+005	1.600	10.00	0.00	186.25	54.67	0.00	0.00	54.67	0.53
Left		Left:XBT	40.75	36.75	38.75	10.049	4.76e+005	1.600	10.00	0.00	197.41	54.67	0.00	0.00	54.67	0.56
Left	Left:XBT	Left:XBT2	36.75	34.75	35.75	10.250	4.85e+005	1.600	10.00	0.00	102.89	27.33	0.00	0.00	27.33	0.29
Left	Left:XBT2		34.75	29.75	32.25	10.250	4.85e+005	1.600	10.00	0.00	269.43	68.34	0.00	0.00	68.33	0.76
Left			29.75	24.75	27.25	10.250	4.85e+005	1.600	10.00	0.00	286.87	68.34	0.00	0.00	68.33	0.81
Left			24.75	19.75	22.25	10.250	4.85e+005	1.600	10.00	0.00	304.30	68.34	0.00	0.00	68.33	0.86
Left			19.75	14.75	17.25	10.250	4.85e+005	1.600	10.00	0.00	321.74	68.34	0.00	0.00	68.33	0.91
Left			14.75	9.75	12.25	10.250	4.85e+005	1.600	10.00	0.00	339.17	68.34	0.00	0.00	68.33	0.96
Left			9.75	4.87	7.31	10.250	4.85e+005	1.600	10.00	0.00	347.48	66.63	0.00	0.00	66.62	0.99
Left		Left:g	4.87	0.00	2.44	10.250	4.85e+005	1.600	10.00	0.00	364.06	66.63	0.00	0.00	66.62	1.03
Right	Right:t	Right:TMO1	84.00	82.00	83.00	12.103	5.73e+005	1.600	10.00	0.00	211.67	48.67	0.00	0.00	48.67	0.34
Right	Right:TMO1		82.00	77.50	79.75	12.436	5.89e+005	1.600	10.00	0.00	489.39	109.50	0.00	0.00	109.50	0.78
Right		Right:TMO2	77.50	73.00	75.25	12.898	6.11e+005	1.600	10.00	0.00	507.57	109.50	0.00	0.00	109.50	0.81
Right	Right:TMO2	Right:Coax1	73.00	70.00	71.50	13.283	6.29e+005	1.600	10.00	0.00	348.48	73.00	0.00	0.00	73.00	0.55
Right	Right:Coax1	Right:SW	70.00	65.00	67.50	13.694	6.48e+005	1.600	10.00	0.00	598.76	121.67	0.00	0.00	121.67	0.95
Right	Right:SW	Right:Brace	65.00	63.50	64.25	14.028	6.64e+005	1.600	10.00	0.00	184.01	36.50	0.00	0.00	36.50	0.29
Right	Right:Brace	Right:Coax2	63.50	60.00	61.75	14.285	6.76e+005	1.600	10.00	0.00	437.21	85.17	0.00	0.00	85.17	0.70
Right	Right:Coax2	Right:Arm	60.00	57.75	58.88	14.580	6.9e+005	1.600	10.00	0.00	286.87	54.75	0.00	0.00	54.75	0.46
Right	Right:Arm		57.75	54.75	56.25	14.849	7.03e+005	1.600	10.00	0.00	389.56	73.00	0.00	0.00	73.00	0.62
Right		Right:XTP	54.75	51.75	53.25	15.157	7.18e+005	1.600	10.00	0.00	397.64	73.00	0.00	0.00	73.00	0.63
Right	Right:XTP	Right:Coax3	51.75	50.00	50.88	15.401	7.29e+005	1.600	10.00	0.00	235.69	42.58	0.00	0.00	42.58	0.38
Right	Right:Coax3	Right:XTP2	50.00	49.75	49.88	15.504	7.34e+005	1.600	10.00	0.00	33.89	6.08	0.00	0.00	6.08	0.05
Right	Right:XTP2		49.75	44.88	47.31	15.767	7.46e+005	1.600	10.00	0.00	672.16	118.63	0.00	0.00	118.62	1.07
Right		Right:Coax4	44.88	40.00	42.44	16.268	7.7e+005	1.600	10.00	0.00	693.50	118.63	0.00	0.00	118.62	1.10
Right	Right:Coax4	Right:XBT	40.00	36.75	38.38	16.685	7.9e+005	1.600	10.00	0.00	474.19	79.09	0.00	0.00	79.08	0.76
Right	Right:XBT	Right:XBT2	36.75	34.75	35.75	16.954	8.03e+005	1.600	10.00	0.00	296.52	48.67	0.00	0.00	48.67	0.47
Right	Right:XBT2	Right:Coax5	34.75	30.00	32.38	17.301	8.19e+005	1.600	10.00	0.00	718.64	115.59	0.00	0.00	115.58	1.14
Right	Right:Coax5		30.00	25.00	27.50	17.801	8.43e+005	1.600	10.00	0.00	778.35	121.67	0.00	0.00	121.67	1.24
Right		Right:Coax6	25.00	20.00	22.50	18.250	8.64e+005	1.600	10.00	0.00	800.79	121.67	0.00	0.00	121.67	1.28
Right	Right:Coax6		20.00	15.00	17.50	18.250	8.64e+005	1.600	10.00	0.00	823.24	121.67	0.00	0.00	121.67	1.31
Right		Right:Coax7	15.00	10.00	12.50	18.250	8.64e+005	1.600	10.00	0.00	845.69	121.67	0.00	0.00	121.67	1.35
Right	Right:Coax7		10.00	5.00	7.50	18.250	8.64e+005	1.600	10.00	0.00	868.14	121.67	0.00	0.00	121.67	1.38
Right		Right:g	5.00	0.00	2.50	18.250	8.64e+005	1.600	10.00	0.00	890.58	121.67	0.00	0.00	121.67	1.42

Point Loads for Load Case "NESC Heavy L":

Joint Label	Vertical Load	Transverse Load	Longitudinal Load	Load Comment
-------------	---------------	-----------------	-------------------	--------------

	(lbs)	(lbs)	(lbs)	
Left:SW	1611	0	-25	Shield Wire
Right:SW	1581	0	-50	Shield Wire
NESC32:L1	2338	0	-25	Conductor
NESC32:L2V	2338	0	-25	Conductor
NESC32:L3	2338	0	-25	Conductor
Right:TMo1	488	0	-332	T-Mobile
Right:TMo2	1379	0	-885	T-Mobile
Right:Coax1	411	0	-73	Coax
Right:Coax2	411	0	-73	Coax
Right:Coax3	411	0	-73	Coax
Right:Coax4	411	0	-73	Coax
Right:Coax5	411	0	-73	Coax
Right:Coax6	411	0	-73	Coax
Right:Coax7	411	0	-73	Coax

Detailed Pole Loading Data for Load Case "NESC Heavy L":

Notes: Does not include loads from equipment, arms, guys, braces, etc. or user input loads.  
Wind load is calculated for the undeformed shape of a pole.

Pole Label	Top Joint	Bottom Joint	Section Top Z (ft)	Section Bottom Z (ft)	Section Average Elevation (ft)	Outer Diameter (in)	Reynolds Number	Drag Coef.	Adjusted Wind Pressure (psf)	Adjusted Ice Thickness (in)	Pole Vert. Load (lbs)	Pole Wind Load (lbs)	Pole Ice Vertical Load (lbs)	Pole Ice Wind Load (lbs)	Tran. Wind Load (lbs)	Long. Wind Load (lbs)
Left	Left:t	Left:SW	65.50	65.00	65.25	6.286	2.98e+005	1.600	10.00	0.00	15.44	4.19	0.00	0.00	0.07	4.19
Left	Left:SW	Left:Brace	65.00	63.50	64.25	6.428	3.04e+005	1.600	10.00	0.00	47.35	12.86	0.00	0.00	0.21	12.85
Left	Left:Brace		63.50	60.62	62.06	6.738	3.19e+005	1.600	10.00	0.00	95.15	25.83	0.00	0.00	0.41	25.83
Left		Left:Arm	60.62	57.75	59.19	7.146	3.38e+005	1.600	10.00	0.00	100.91	27.40	0.00	0.00	0.41	27.39
Left	Left:Arm		57.75	54.75	56.25	7.564	3.58e+005	1.600	10.00	0.00	111.44	30.26	0.00	0.00	0.43	30.25
Left		Left:XTP	54.75	51.75	53.25	7.989	3.78e+005	1.600	10.00	0.00	117.72	31.96	0.00	0.00	0.43	31.96
Left	Left:XTP	Left:XTP2	51.75	49.75	50.75	8.345	3.95e+005	1.600	10.00	0.00	81.97	22.25	0.00	0.00	0.29	22.25
Left	Left:XTP2		49.75	44.75	47.25	8.841	4.19e+005	1.600	10.00	0.00	217.12	58.95	0.00	0.00	0.71	58.94
Left			44.75	40.75	42.75	9.480	4.49e+005	1.600	10.00	0.00	186.25	50.57	0.00	0.00	0.57	50.56
Left		Left:XBT	40.75	36.75	38.75	10.049	4.76e+005	1.600	10.00	0.00	197.41	53.59	0.00	0.00	0.57	53.59
Left	Left:XBT	Left:XBT2	36.75	34.75	35.75	10.250	4.85e+005	1.600	10.00	0.00	102.89	27.93	0.00	0.00	0.29	27.93
Left	Left:XBT2		34.75	29.75	32.25	10.250	4.85e+005	1.600	10.00	0.00	269.43	73.15	0.00	0.00	0.71	73.14
Left			29.75	24.75	27.25	10.250	4.85e+005	1.600	10.00	0.00	286.87	77.88	0.00	0.00	0.71	77.88
Left			24.75	19.75	22.25	10.250	4.85e+005	1.600	10.00	0.00	304.30	82.61	0.00	0.00	0.71	82.61
Left			19.75	14.75	17.25	10.250	4.85e+005	1.600	10.00	0.00	321.74	87.35	0.00	0.00	0.71	87.34
Left			14.75	9.75	12.25	10.250	4.85e+005	1.600	10.00	0.00	339.17	92.08	0.00	0.00	0.71	92.08
Left			9.75	4.87	7.31	10.250	4.85e+005	1.600	10.00	0.00	347.48	94.33	0.00	0.00	0.70	94.33
Left		Left:g	4.87	0.00	2.44	10.250	4.85e+005	1.600	10.00	0.00	364.06	98.83	0.00	0.00	0.70	98.83
Right	Right:t	Right:TMo1	84.00	82.00	83.00	12.103	5.73e+005	1.600	10.00	0.00	211.67	32.28	0.00	0.00	0.51	32.27
Right	Right:TMo1		82.00	77.50	79.75	12.436	5.89e+005	1.600	10.00	0.00	489.39	74.63	0.00	0.00	1.14	74.62
Right		Right:TMo2	77.50	73.00	75.25	12.898	6.11e+005	1.600	10.00	0.00	507.57	77.40	0.00	0.00	1.14	77.39
Right	Right:TMo2	Right:Coax1	73.00	70.00	71.50	13.283	6.29e+005	1.600	10.00	0.00	348.48	53.14	0.00	0.00	0.76	53.13
Right	Right:Coax1	Right:SW	70.00	65.00	67.50	13.694	6.48e+005	1.600	10.00	0.00	598.76	91.30	0.00	0.00	1.27	91.29
Right	Right:SW	Right:Brace	65.00	63.50	64.25	14.028	6.64e+005	1.600	10.00	0.00	184.01	28.06	0.00	0.00	0.38	28.06
Right	Right:Brace	Right:Coax2	63.50	60.00	61.75	14.285	6.76e+005	1.600	10.00	0.00	437.21	66.67	0.00	0.00	0.89	66.66
Right	Right:Coax2	Right:Arm	60.00	57.75	58.88	14.580	6.9e+005	1.600	10.00	0.00	286.87	43.74	0.00	0.00	0.57	43.74
Right	Right:Arm		57.75	54.75	56.25	14.849	7.03e+005	1.600	10.00	0.00	389.56	59.40	0.00	0.00	0.76	59.40
Right		Right:XTP	54.75	51.75	53.25	15.157	7.18e+005	1.600	10.00	0.00	397.64	60.63	0.00	0.00	0.76	60.63
Right	Right:XTP	Right:Coax3	51.75	50.00	50.88	15.401	7.29e+005	1.600	10.00	0.00	235.69	35.94	0.00	0.00	0.44	35.94
Right	Right:Coax3	Right:XTP2	50.00	49.75	49.88	15.504	7.34e+005	1.600	10.00	0.00	33.89	5.17	0.00	0.00	0.06	5.17
Right	Right:XTP2		49.75	44.88	47.31	15.767	7.46e+005	1.600	10.00	0.00	672.16	102.49	0.00	0.00	1.24	102.49
Right		Right:Coax4	44.88	40.00	42.44	16.268	7.7e+005	1.600	10.00	0.00	693.50	105.75	0.00	0.00	1.24	105.74

Right	Right:Coax4	Right:XBT	40.00	36.75	38.38	16.685	7.9e+005	1.600	10.00	0.00	474.19	72.31	0.00	0.00	0.83	72.30
Right	Right:XBT	Right:XBT2	36.75	34.75	35.75	16.954	8.03e+005	1.600	10.00	0.00	296.52	45.21	0.00	0.00	0.51	45.21
Right	Right:XBT2	Right:Coax5	34.75	30.00	32.38	17.301	8.19e+005	1.600	10.00	0.00	718.64	109.58	0.00	0.00	1.21	109.57
Right	Right:Coax5		30.00	25.00	27.50	17.801	8.43e+005	1.600	10.00	0.00	778.35	118.68	0.00	0.00	1.27	118.68
Right		Right:Coax6	25.00	20.00	22.50	18.250	8.64e+005	1.600	10.00	0.00	800.79	122.10	0.00	0.00	1.27	122.10
Right	Right:Coax6		20.00	15.00	17.50	18.250	8.64e+005	1.600	10.00	0.00	823.24	125.53	0.00	0.00	1.27	125.52
Right		Right:Coax7	15.00	10.00	12.50	18.250	8.64e+005	1.600	10.00	0.00	845.69	128.95	0.00	0.00	1.27	128.94
Right	Right:Coax7		10.00	5.00	7.50	18.250	8.64e+005	1.600	10.00	0.00	868.14	132.37	0.00	0.00	1.27	132.37
Right		Right:g	5.00	0.00	2.50	18.250	8.64e+005	1.600	10.00	0.00	890.58	135.79	0.00	0.00	1.27	135.79

Point Loads for Load Case "Ext. Wind T":

Joint Label	Vertical Load (lbs)	Transverse Load (lbs)	Longitudinal Load (lbs)	Load Comment
Left:SW	835	398	-50	Shield Wire
Right:SW	785	415	-54	Shield Wire
NESC32:L1	1260	807	-75	Conductor
NESC32:L2V	1260	807	-75	Conductor
NESC32:L3	1260	807	-75	Conductor
Right:TMO1	189	965	0	T-Mobile
Right:TMO2	539	2746	0	T-Mobile
Right:Coax1	97	91	0	Coax
Right:Coax2	97	91	0	Coax
Right:Coax3	97	91	0	Coax
Right:Coax4	97	91	0	Coax
Right:Coax5	97	91	0	Coax
Right:Coax6	97	91	0	Coax
Right:Coax7	97	91	0	Coax

Detailed Pole Loading Data for Load Case "Ext. Wind T":

Notes: Does not include loads from equipment, arms, guys, braces, etc. or user input loads.  
Wind load is calculated for the undeformed shape of a pole.

Pole Label	Top Joint	Bottom Joint	Section Top Z (ft)	Section Bottom Z (ft)	Section Average Elevation (ft)	Outer Diameter (in)	Reynolds Number	Drag Coef.	Adjusted Wind Pressure (psf)	Adjusted Ice Thickness (in)	Pole Vert. Load (lbs)	Pole Wind Load (lbs)	Pole Ice Vertical Load (lbs)	Pole Ice Wind Load (lbs)	Tran. Wind Load (lbs)	Long. Wind Load (lbs)
Left	Left:t	Left:SW	65.50	65.00	65.25	6.286	5.22e+005	1.600	30.73	0.00	10.29	21.00	0.00	0.00	21.00	0.05
Left	Left:SW	Left:Brace	65.00	63.50	64.25	6.428	5.33e+005	1.600	30.73	0.00	31.57	63.00	0.00	0.00	63.00	0.15
Left	Left:Brace		63.50	60.62	62.06	6.738	5.59e+005	1.600	30.73	0.00	63.43	120.76	0.00	0.00	120.76	0.30
Left		Left:Arm	60.62	57.75	59.19	7.146	5.93e+005	1.600	30.73	0.00	67.27	120.76	0.00	0.00	120.76	0.32
Left	Left:Arm		57.75	54.75	56.25	7.564	6.28e+005	1.600	30.73	0.00	74.30	126.01	0.00	0.00	126.01	0.35
Left		Left:XTP	54.75	51.75	53.25	7.989	6.63e+005	1.600	30.73	0.00	78.48	126.01	0.00	0.00	126.01	0.37
Left	Left:XTP	Left:XTP2	51.75	49.75	50.75	8.345	6.93e+005	1.600	30.73	0.00	54.64	84.01	0.00	0.00	84.01	0.26
Left	Left:XTP2		49.75	44.75	47.25	8.841	7.34e+005	1.600	30.73	0.00	144.75	210.02	0.00	0.00	210.01	0.69
Left			44.75	40.75	42.75	9.480	7.87e+005	1.600	30.73	0.00	191.24	210.02	0.00	0.00	210.01	0.59
Left		Left:XBT	40.75	36.75	38.75	10.049	8.34e+005	1.600	30.73	0.00	131.61	168.01	0.00	0.00	168.01	0.63
Left	Left:XBT	Left:XBT2	36.75	34.75	35.75	10.250	8.51e+005	1.600	30.73	0.00	68.59	84.01	0.00	0.00	84.01	0.33
Left	Left:XBT2		34.75	29.75	32.25	10.250	8.51e+005	1.600	30.73	0.00	179.62	210.02	0.00	0.00	210.01	0.86
Left			29.75	24.75	27.25	10.250	8.51e+005	1.600	30.73	0.00	124.17	210.02	0.00	0.00	210.01	0.91
Left			24.75	19.75	22.25	10.250	8.51e+005	1.600	30.73	0.00	202.87	210.02	0.00	0.00	210.01	0.97
Left			19.75	14.75	17.25	10.250	8.51e+005	1.600	30.73	0.00	214.49	210.02	0.00	0.00	210.01	1.02
Left			14.75	9.75	12.25	10.250	8.51e+005	1.600	30.73	0.00	226.12	210.02	0.00	0.00	210.01	1.08
Left			9.75	4.87	7.31	10.250	8.51e+005	1.600	30.73	0.00	231.65	204.77	0.00	0.00	204.76	1.10
Left		Left:g	4.87	0.00	2.44	10.250	8.51e+005	1.600	30.73	0.00	242.70	204.77	0.00	0.00	204.76	1.16

Right	Right:t	Right:TMo1	84.00	82.00	83.00	12.103	1e+006	1.600	30.73	0.00	141.11	149.57	0.00	0.00	149.57	0.38
Right	Right:TMo1		82.00	77.50	79.75	12.436	1.03e+006	1.600	30.73	0.00	326.26	336.54	0.00	0.00	336.53	0.87
Right		Right:TMo2	77.50	73.00	75.25	12.898	1.07e+006	1.600	30.73	0.00	338.38	336.54	0.00	0.00	336.53	0.91
Right	Right:TMo2	Right:Coax1	73.00	70.00	71.50	13.283	1.1e+006	1.600	30.73	0.00	232.32	224.36	0.00	0.00	224.36	0.62
Right	Right:Coax1	Right:SW	70.00	65.00	67.50	13.694	1.14e+006	1.600	30.73	0.00	399.18	373.93	0.00	0.00	373.93	1.07
Right	Right:SW	Right:Brace	65.00	63.50	64.25	14.028	1.16e+006	1.600	30.73	0.00	122.67	112.18	0.00	0.00	112.18	0.33
Right	Right:Brace	Right:Coax2	63.50	60.00	61.75	14.285	1.19e+006	1.600	30.73	0.00	291.47	261.75	0.00	0.00	261.75	0.78
Right	Right:Coax2	Right:Arm	60.00	57.75	58.88	14.580	1.21e+006	1.600	30.73	0.00	191.25	168.27	0.00	0.00	168.27	0.51
Right	Right:Arm		57.75	54.75	56.25	14.849	1.23e+006	1.600	30.73	0.00	259.71	224.36	0.00	0.00	224.36	0.70
Right		Right:XTP	54.75	51.75	53.25	15.157	1.26e+006	1.600	30.73	0.00	265.10	224.36	0.00	0.00	224.36	0.71
Right	Right:XTP	Right:Coax3	51.75	50.00	50.88	15.401	1.28e+006	1.600	30.73	0.00	157.13	130.88	0.00	0.00	130.87	0.42
Right	Right:Coax3	Right:XTP2	50.00	49.75	49.88	15.504	1.29e+006	1.600	30.73	0.00	22.60	18.70	0.00	0.00	18.70	0.06
Right	Right:XTP2		49.75	44.88	47.31	15.767	1.31e+006	1.600	30.73	0.00	448.11	364.58	0.00	0.00	364.58	1.20
Right		Right:Coax4	44.88	40.00	42.44	16.268	1.35e+006	1.600	30.73	0.00	462.33	364.58	0.00	0.00	364.58	1.24
Right	Right:Coax4	Right:XBT	40.00	36.75	38.38	16.685	1.38e+006	1.600	30.73	0.00	316.13	243.05	0.00	0.00	243.05	0.85
Right	Right:XBT	Right:XBT2	36.75	34.75	35.75	16.954	1.41e+006	1.600	30.73	0.00	197.68	149.57	0.00	0.00	149.57	0.53
Right	Right:XBT2	Right:Coax5	34.75	30.00	32.38	17.301	1.44e+006	1.600	30.73	0.00	479.09	355.23	0.00	0.00	355.23	1.28
Right	Right:Coax5		30.00	25.00	27.50	17.801	1.48e+006	1.600	30.73	0.00	518.90	373.93	0.00	0.00	373.93	1.39
Right		Right:Coax6	25.00	20.00	22.50	18.250	1.51e+006	1.600	30.73	0.00	533.86	373.93	0.00	0.00	373.93	1.43
Right	Right:Coax6		20.00	15.00	17.50	18.250	1.51e+006	1.600	30.73	0.00	548.83	373.93	0.00	0.00	373.93	1.47
Right		Right:Coax7	15.00	10.00	12.50	18.250	1.51e+006	1.600	30.73	0.00	563.79	373.93	0.00	0.00	373.93	1.51
Right	Right:Coax7		10.00	5.00	7.50	18.250	1.51e+006	1.600	30.73	0.00	578.76	373.93	0.00	0.00	373.93	1.55
Right		Right:g	5.00	0.00	2.50	18.250	1.51e+006	1.600	30.73	0.00	593.72	373.93	0.00	0.00	373.93	1.59

Point Loads for Load Case "Ext. Wind L":

Joint Label	Vertical Load (lbs)	Transverse Load (lbs)	Longitudinal Load (lbs)	Load Comment
Left:SW	835	0	-50	Shield Wire
Right:SW	785	0	-54	Shield Wire
NESC32:L1	1260	0	-75	Conductor
NESC32:L2V	1260	0	-75	Conductor
NESC32:L3	1260	0	-75	Conductor
Right:TMo1	189	0	-965	T-Mobile
Right:TMo2	539	0	-2746	T-Mobile
Right:Coax1	97	0	-182	Coax
Right:Coax2	97	0	-182	Coax
Right:Coax3	97	0	-182	Coax
Right:Coax4	97	0	-182	Coax
Right:Coax5	97	0	-182	Coax
Right:Coax6	97	0	-182	Coax
Right:Coax7	97	0	-182	Coax

Detailed Pole Loading Data for Load Case "Ext. Wind L":

Notes: Does not include loads from equipment, arms, guys, braces, etc. or user input loads.  
Wind load is calculated for the undeformed shape of a pole.

Pole Label	Top Joint	Bottom Joint	Section Top Z (ft)	Section Bottom Z (ft)	Section Average Elevation (ft)	Outer Diameter (in)	Reynolds Number	Drag Coef.	Adjusted Wind Pressure (psf)	Adjusted Ice Thickness (in)	Pole Vert. Load (lbs)	Pole Wind Load (lbs)	Pole Ice Vertical Load (lbs)	Pole Ice Wind Load (lbs)	Tran. Wind Load (lbs)	Long. Wind Load (lbs)
Left	Left:t	Left:SW	65.50	65.00	65.25	6.286	5.22e+005	1.600	30.73	0.00	10.29	12.88	0.00	0.00	0.08	12.88
Left	Left:SW	Left:Brace	65.00	63.50	64.25	6.428	5.33e+005	1.600	30.73	0.00	31.57	39.51	0.00	0.00	0.24	39.51
Left	Left:Brace		63.50	60.62	62.06	6.738	5.59e+005	1.600	30.73	0.00	63.43	79.39	0.00	0.00	0.46	79.38
Left		Left:Arm	60.62	57.75	59.19	7.146	5.93e+005	1.600	30.73	0.00	67.27	84.19	0.00	0.00	0.46	84.19

Left	Left:Arm		57.75	54.75	56.25	7.564	6.28e+005	1.600	30.73	0.00	74.30	92.98	0.00	0.00	0.48	92.98
Left		Left:XTP	54.75	51.75	53.25	7.989	6.63e+005	1.600	30.73	0.00	78.48	98.22	0.00	0.00	0.48	98.22
Left	Left:XTP	Left:XTP2	51.75	49.75	50.75	8.345	6.93e+005	1.600	30.73	0.00	54.64	68.39	0.00	0.00	0.32	68.39
Left	Left:XTP2		49.75	44.75	47.25	8.841	7.34e+005	1.600	30.73	0.00	144.75	181.16	0.00	0.00	0.80	181.15
Left			44.75	40.75	42.75	9.480	7.87e+005	1.600	30.73	0.00	124.17	155.40	0.00	0.00	0.64	155.40
Left		Left:XBT	40.75	36.75	38.75	10.049	8.34e+005	1.600	30.73	0.00	131.61	164.71	0.00	0.00	0.64	164.71
Left	Left:XBT	Left:XBT2	36.75	34.75	35.75	10.250	8.51e+005	1.600	30.73	0.00	68.59	85.85	0.00	0.00	0.32	85.85
Left	Left:XBT2		34.75	29.75	32.25	10.250	8.51e+005	1.600	30.73	0.00	179.62	224.80	0.00	0.00	0.80	224.80
Left			29.75	24.75	27.25	10.250	8.51e+005	1.600	30.73	0.00	191.24	239.35	0.00	0.00	0.80	239.34
Left			24.75	19.75	22.25	10.250	8.51e+005	1.600	30.73	0.00	202.87	253.89	0.00	0.00	0.80	253.89
Left			19.75	14.75	17.25	10.250	8.51e+005	1.600	30.73	0.00	214.49	268.44	0.00	0.00	0.80	268.44
Left			14.75	9.75	12.25	10.250	8.51e+005	1.600	30.73	0.00	226.12	282.99	0.00	0.00	0.80	282.99
Left			9.75	4.87	7.31	10.250	8.51e+005	1.600	30.73	0.00	231.65	289.92	0.00	0.00	0.78	289.92
Left		Left:g	4.87	0.00	2.44	10.250	8.51e+005	1.600	30.73	0.00	242.70	303.75	0.00	0.00	0.78	303.75
Right	Right:t	Right:TMo1	84.00	82.00	83.00	12.103	1e+006	1.600	30.73	0.00	141.11	99.19	0.00	0.00	0.57	99.19
Right	Right:TMo1		82.00	77.50	79.75	12.436	1.03e+006	1.600	30.73	0.00	326.26	229.33	0.00	0.00	1.28	229.33
Right		Right:TMo2	77.50	73.00	75.25	12.898	1.07e+006	1.600	30.73	0.00	338.38	237.85	0.00	0.00	1.28	237.85
Right	Right:TMo2	Right:Coax1	73.00	70.00	71.50	13.283	1.1e+006	1.600	30.73	0.00	232.32	163.30	0.00	0.00	0.85	163.30
Right	Right:Coax1	Right:SW	70.00	65.00	67.50	13.694	1.14e+006	1.600	30.73	0.00	399.18	280.59	0.00	0.00	1.42	280.58
Right	Right:SW	Right:Brace	65.00	63.50	64.25	14.028	1.16e+006	1.600	30.73	0.00	122.67	86.23	0.00	0.00	0.43	86.23
Right	Right:Brace	Right:Coax2	63.50	60.00	61.75	14.285	1.19e+006	1.600	30.73	0.00	291.47	204.88	0.00	0.00	1.00	204.88
Right	Right:Coax2	Right:Arm	60.00	57.75	58.88	14.580	1.21e+006	1.600	30.73	0.00	191.25	134.43	0.00	0.00	0.64	134.43
Right	Right:Arm		57.75	54.75	56.25	14.849	1.23e+006	1.600	30.73	0.00	259.71	182.55	0.00	0.00	0.85	182.55
Right		Right:XTP	54.75	51.75	53.25	15.157	1.26e+006	1.600	30.73	0.00	265.10	186.34	0.00	0.00	0.85	186.34
Right	Right:XTP	Right:Coax3	51.75	50.00	50.88	15.401	1.28e+006	1.600	30.73	0.00	157.13	110.45	0.00	0.00	0.50	110.45
Right	Right:Coax3	Right:XTP2	50.00	49.75	49.88	15.504	1.29e+006	1.600	30.73	0.00	22.60	15.88	0.00	0.00	0.07	15.88
Right	Right:XTP2		49.75	44.88	47.31	15.767	1.31e+006	1.600	30.73	0.00	448.11	314.98	0.00	0.00	1.39	314.98
Right		Right:Coax4	44.88	40.00	42.44	16.268	1.35e+006	1.600	30.73	0.00	462.33	324.98	0.00	0.00	1.39	324.98
Right	Right:Coax4	Right:XBT	40.00	36.75	38.38	16.685	1.38e+006	1.600	30.73	0.00	316.13	222.21	0.00	0.00	0.93	222.21
Right	Right:XBT	Right:XBT2	36.75	34.75	35.75	16.954	1.41e+006	1.600	30.73	0.00	197.68	138.95	0.00	0.00	0.57	138.95
Right	Right:XBT2	Right:Coax5	34.75	30.00	32.38	17.301	1.44e+006	1.600	30.73	0.00	479.09	336.76	0.00	0.00	1.35	336.75
Right	Right:Coax5		30.00	25.00	27.50	17.801	1.48e+006	1.600	30.73	0.00	518.90	364.74	0.00	0.00	1.42	364.73
Right		Right:Coax6	25.00	20.00	22.50	18.250	1.51e+006	1.600	30.73	0.00	533.86	375.26	0.00	0.00	1.42	375.25
Right	Right:Coax6		20.00	15.00	17.50	18.250	1.51e+006	1.600	30.73	0.00	548.83	385.78	0.00	0.00	1.42	385.77
Right		Right:Coax7	15.00	10.00	12.50	18.250	1.51e+006	1.600	30.73	0.00	563.79	396.29	0.00	0.00	1.42	396.29
Right	Right:Coax7		10.00	5.00	7.50	18.250	1.51e+006	1.600	30.73	0.00	578.76	406.81	0.00	0.00	1.42	406.81
Right		Right:g	5.00	0.00	2.50	18.250	1.51e+006	1.600	30.73	0.00	593.72	417.33	0.00	0.00	1.42	417.33

\*\*\* Analysis Results:

Maximum element usage is 98.54% for X-Arm "NESC32" in load case "Ext. Wind L"  
 Maximum insulator usage is 30.74% for Clamp "C7" in load case "Ext. Wind T"

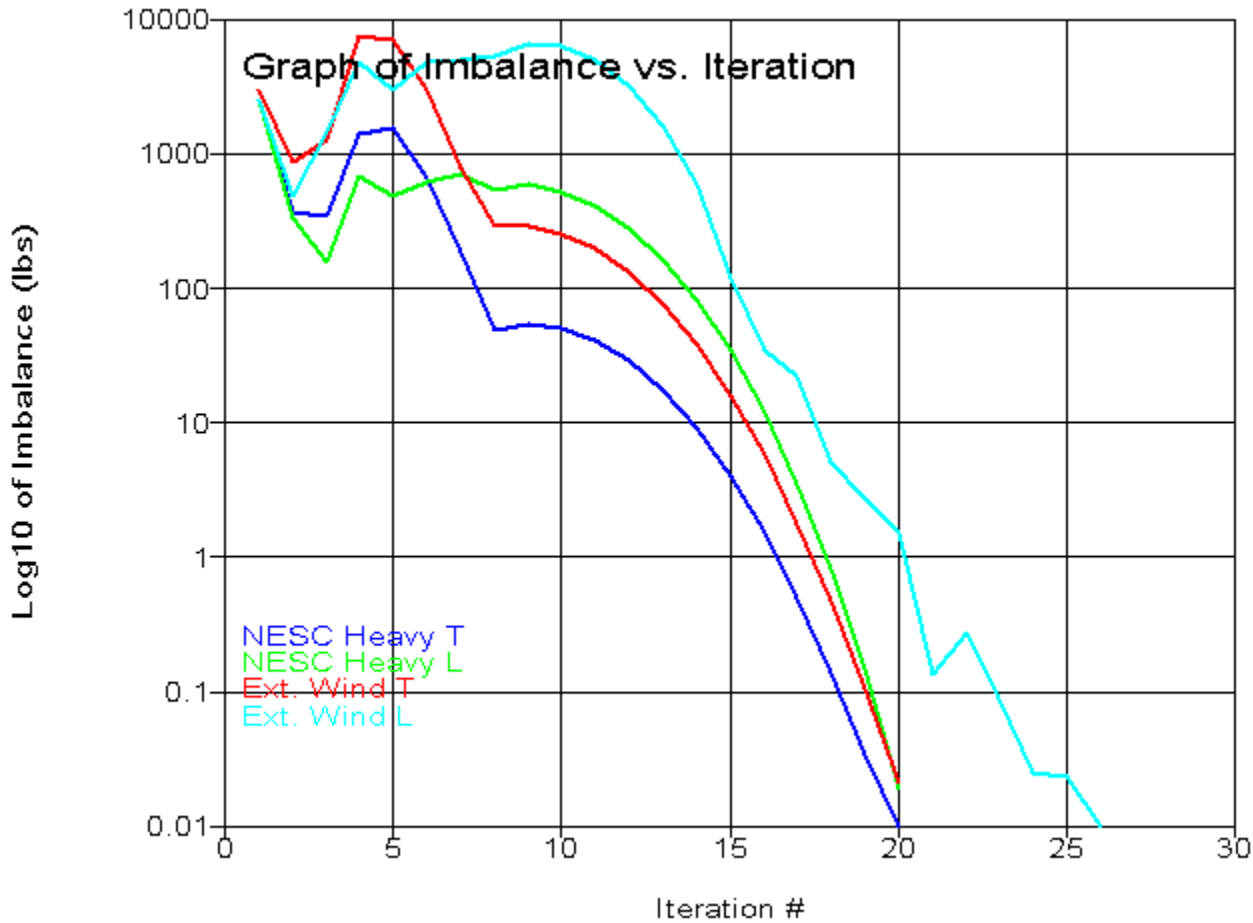

\*\*\* Analysis Results for Load Case No. 1 "NESC Heavy T" - Number of iterations in SAPS 20

Equilibrium Joint Positions and Rotations for Load Case "NESC Heavy T":

Joint Label	X-Displ (ft)	Y-Displ (ft)	Z-Displ (ft)	X-Rot (deg)	Y-Rot (deg)	Z-Rot (deg)	X-Pos (ft)	Y-Pos (ft)	Z-Pos (ft)
Left:g	0	0	0	0.0000	0.0000	0.0000	0	-7.75	0
Left:t	-0.1062	0.2402	-0.0005153	0.4650	-0.1534	-0.0877	-0.1062	-7.51	65.5
Left:SW	-0.1049	0.2443	-0.000497	0.4650	-0.1534	-0.0877	-0.1049	-7.506	65

Left:Brace	-0.1008	0.2565	-0.0004248	0.4732	-0.1531	-0.0877	-0.1008	-7.493	63.5
Left:Arm	-0.08564	0.2783	-0.0001946	-0.2620	-0.1475	-0.0896	-0.08564	-7.472	57.75
Left:XTP	-0.07073	0.2259	0.0001777	-0.3703	-0.1399	-0.0726	-0.07073	-7.524	51.75
Left:XTP2	-0.06592	0.2176	0.000195	-0.0927	-0.1368	-0.0668	-0.06592	-7.532	49.75
Left:XBT	-0.03776	0.2562	-4.287e-005	-0.0017	-0.1103	-0.0394	-0.03776	-7.494	36.75
Left:XBT2	-0.03401	0.2535	-9.874e-005	-0.1569	-0.1055	-0.0364	-0.03401	-7.497	34.75
Right:g	0	0	0	0.0000	0.0000	0.0000	0	7.75	0
Right:t	-0.1154	0.4597	-0.004116	-0.4627	-0.1080	-0.0140	-0.1154	8.21	84
Right:TMol	-0.1116	0.4436	-0.004047	-0.4627	-0.1080	-0.0140	-0.1116	8.194	82
Right:TMo2	-0.09466	0.3721	-0.003727	-0.4398	-0.1080	-0.0140	-0.09466	8.122	73
Right:Coax1	-0.08901	0.3495	-0.003618	-0.4184	-0.1079	-0.0139	-0.08901	8.1	70
Right:SW	-0.07961	0.3154	-0.003456	-0.3547	-0.1079	-0.0138	-0.07961	8.065	65
Right:Brace	-0.07679	0.3065	-0.003411	-0.3290	-0.1078	-0.0138	-0.07679	8.056	63.5
Right:Coax2	-0.07022	0.2883	-0.00328	-0.2654	-0.1074	-0.0136	-0.07022	8.038	60
Right:Arm	-0.06601	0.2787	-0.003204	-0.2230	-0.1069	-0.0135	-0.06601	8.029	57.75
Right:XTP	-0.05496	0.2606	-0.003029	-0.1268	-0.1039	-0.0114	-0.05496	8.011	51.75
Right:Coax3	-0.05181	0.2571	-0.002975	-0.1091	-0.1025	-0.0108	-0.05181	8.007	50
Right:XTP2	-0.05136	0.2566	-0.002967	-0.1071	-0.1023	-0.0107	-0.05136	8.007	49.75
Right:Coax4	-0.03484	0.2358	-0.002623	-0.1848	-0.0910	-0.0080	-0.03484	7.986	40
Right:XBT	-0.02982	0.2233	-0.00249	-0.2625	-0.0859	-0.0073	-0.02982	7.973	36.75
Right:XBT2	-0.02688	0.2131	-0.002384	-0.3192	-0.0825	-0.0069	-0.02688	7.963	34.75
Right:Coax5	-0.02041	0.1817	-0.002055	-0.4276	-0.0737	-0.0059	-0.02041	7.932	30
Right:Coax6	-0.009377	0.09991	-0.001247	-0.4691	-0.0521	-0.0038	-0.009377	7.85	20
Right:Coax7	-0.00241	0.02919	-0.0005231	-0.3092	-0.0272	-0.0019	-0.00241	7.779	9.999
NESC32:O	-0.1006	0.2788	-0.03608	0.2151	-0.1473	-0.1111	-0.1006	-15.72	57.71
NESC32:L1	-0.09961	0.2788	-0.0342	0.2151	-0.1473	-0.1111	-0.09961	-15.22	57.72
NESC32:PL	-0.08564	0.2783	-0.0001946	0.3107	-0.1475	-0.0896	-0.08564	-7.472	57.75
NESC32:L2V	-0.07359	0.2788	-0.03148	-0.0069	-0.1272	-0.0829	-0.07359	0.2788	57.78
NESC32:PR	-0.06601	0.2787	-0.003204	-0.3491	-0.1069	-0.0135	-0.06601	8.029	57.75
NESC32:L3	-0.06584	0.2783	-0.0441	-0.2729	-0.1068	0.0057	-0.06584	15.78	57.71
NESC32:E	-0.06589	0.2783	-0.04648	-0.2729	-0.1068	0.0057	-0.06589	16.28	57.7
TENL:O	-0.1012	0.2565	-0.002673	0.4732	-0.1531	-0.0877	-0.1012	-7.766	63.5
TENR:O	-0.07664	0.3065	-0.006785	-0.3290	-0.1078	-0.0138	-0.07664	8.644	63.49
VEEL:O	-0.1004	0.2565	0.001824	0.4732	-0.1531	-0.0877	-0.1004	-7.221	63.5
VEER:O	-0.07693	0.3065	-3.669e-005	-0.3290	-0.1078	-0.0138	-0.07693	7.469	63.5
X1:O	-0.07029	0.2259	-0.002031	-0.3703	-0.1399	-0.0726	-0.07029	-7.182	51.75
X1:E	-0.02992	0.2233	0.0007269	-0.2625	-0.0859	-0.0073	-0.02992	7.271	36.75
X2:O	-0.05509	0.2606	-0.001617	-0.1268	-0.1039	-0.0114	-0.05509	7.373	51.75
X2:E	-0.03746	0.2562	-5.601e-005	-0.0017	-0.1103	-0.0394	-0.03746	-7.063	36.75
X3:O	-0.06551	0.2176	-0.0003772	-0.0927	-0.1368	-0.0668	-0.06551	-7.179	49.75
X3:E	-0.02697	0.2131	0.001575	-0.3192	-0.0825	-0.0069	-0.02697	7.252	34.75
X4:O	-0.05149	0.2566	-0.001759	-0.1071	-0.1023	-0.0107	-0.05149	7.36	49.75
X4:E	-0.03372	0.2535	-0.00131	-0.1569	-0.1055	-0.0364	-0.03372	-7.054	34.75

Joint Support Reactions for Load Case "NESC Heavy T":

Joint Label	X Force (kips)	X Usage % (kips)	Y Force (kips)	Y Usage % (kips)	H-Shear Usage % (kips)	Z Comp. Force (kips)	Z Usage % (kips)	Uplift Usage % (kips)	Result. Force (kips)	Result. Usage % (ft-k)	X Moment (ft-k)	X-M. Usage % (ft-k)	Y Moment (ft-k)	Y-M. Usage % (ft-k)	H-Bend-M Usage % (ft-k)	Z Moment (ft-k)	Z-M. Usage % (ft-k)	Max. Usage %
Left:g	0.03	0.0	-2.10	0.0	0.0	7.10	0.0	0.0	7.41	0.0	40.75	0.0	1.4	0.0	0.0	0.34	0.0	0.0
Right:g	0.08	0.0	-5.82	0.0	0.0	-39.31	0.0	0.0	39.74	0.0	132.62	0.0	7.9	0.0	0.0	0.44	0.0	0.0

Detailed Laminated Wood Pole Usages for Load Case "NESC Heavy T":

Element Label	Joint Label	Joint Position	Rel. Dist. (ft)	Trans. Defl. (in)	Long. Defl. (in)	Vert. Defl. (in)	Trans. Mom. (ft-k)	Long. Mom. (ft-k)	Tors. Mom. (ft-k)	Axial Force (kips)	Tran. Shear (kips)	Long. Shear (kips)	Usage %

Left	Left:t	Origin	0.00	2.88	-1.27	-0.01	0.00	0.00	0.0	-0.01	0.00	0.00	0.0
Left	Left:SW	End	0.50	2.93	-1.26	-0.01	0.00	0.00	0.0	-0.01	0.00	0.00	0.0
Left	Left:SW	Origin	0.50	2.93	-1.26	-0.01	0.00	0.00	0.0	-1.65	0.45	0.03	0.5
Left	Left:Brace	End	2.00	3.08	-1.21	-0.01	0.67	0.05	0.0	-1.65	0.45	0.03	2.8
Left	Left:Brace	Origin	2.00	3.08	-1.21	-0.01	-0.17	0.05	-0.0	-3.74	-3.53	0.03	1.8
Left	#Left:0	End	4.88	3.32	-1.12	-0.00	-10.30	0.13	-0.0	-3.74	-3.53	0.03	31.7
Left	#Left:0	Origin	4.88	3.32	-1.12	-0.00	-10.30	0.13	-0.0	-3.86	-3.46	0.03	31.7
Left	Left:Arm	End	7.75	3.34	-1.03	-0.00	-20.26	0.22	-0.0	-3.86	-3.46	0.03	54.7
Left	Left:Arm	Origin	7.75	3.34	-1.03	-0.00	-20.25	0.15	-0.3	-3.62	6.35	0.03	54.5
Left	#Left:1	End	10.75	3.04	-0.94	-0.00	-1.20	0.24	-0.3	-3.62	6.35	0.03	4.1
Left	#Left:1	Origin	10.75	3.04	-0.94	-0.00	-1.20	0.24	-0.3	-3.73	6.40	0.03	4.1
Left	Left:XTP	End	13.75	2.71	-0.85	0.00	17.99	0.32	-0.3	-3.73	6.40	0.03	39.4
Left	Left:XTP	Origin	13.75	2.71	-0.85	0.00	16.49	0.32	-0.3	0.55	2.08	0.02	35.5
Left	Left:XTP2	End	15.75	2.61	-0.79	0.00	20.64	0.36	-0.3	0.55	2.08	0.02	41.4
Left	Left:XTP2	Origin	15.75	2.61	-0.79	0.00	18.79	0.36	-0.3	5.66	-2.97	0.02	38.9
Left	#Left:2	End	20.75	2.74	-0.65	0.00	3.95	0.44	-0.3	5.66	-2.97	0.02	8.5
Left	#Left:2	Origin	20.75	2.74	-0.65	0.00	3.95	0.44	-0.3	5.47	-2.89	0.02	8.4
Left	#Left:3	End	24.75	2.97	-0.55	0.00	-7.61	0.51	-0.3	5.47	-2.89	0.02	13.1
Left	#Left:3	Origin	24.75	2.97	-0.55	0.00	-7.61	0.51	-0.3	5.27	-2.85	0.02	13.1
Left	Left:XBT	End	28.75	3.07	-0.45	-0.00	-19.02	0.58	-0.3	5.27	-2.85	0.02	27.1
Left	Left:XBT	Origin	28.75	3.07	-0.45	-0.00	-19.96	0.58	-0.3	7.31	-0.56	0.02	28.7
Left	Left:XBT2	End	30.75	3.04	-0.41	-0.00	-21.07	0.62	-0.3	7.31	-0.56	0.02	28.7
Left	Left:XBT2	Origin	30.75	3.04	-0.41	-0.00	-22.00	0.62	-0.3	9.21	1.61	0.02	30.2
Left	#Left:4	End	35.75	2.71	-0.30	-0.00	-13.93	0.71	-0.3	9.21	1.61	0.02	17.8
Left	#Left:4	Origin	35.75	2.71	-0.30	-0.00	-13.93	0.71	-0.3	8.94	1.65	0.02	17.8
Left	#Left:5	End	40.75	2.16	-0.21	-0.00	-5.68	0.80	-0.3	8.94	1.65	0.02	7.9
Left	#Left:5	Origin	40.75	2.16	-0.21	-0.00	-5.68	0.80	-0.3	8.65	1.71	0.02	7.8
Left	#Left:6	End	45.75	1.53	-0.14	-0.00	2.87	0.90	-0.3	8.65	1.71	0.02	4.7
Left	#Left:6	Origin	45.75	1.53	-0.14	-0.00	2.87	0.90	-0.3	8.33	1.79	0.02	4.7
Left	#Left:7	End	50.75	0.93	-0.08	0.00	11.79	1.01	-0.3	8.33	1.79	0.02	11.4
Left	#Left:7	Origin	50.75	0.93	-0.08	0.00	11.79	1.01	-0.3	8.00	1.87	0.02	11.4
Left	#Left:8	End	55.75	0.43	-0.04	0.00	21.15	1.13	-0.3	8.00	1.87	0.02	17.1
Left	#Left:8	Origin	55.75	0.43	-0.04	0.00	21.15	1.13	-0.3	7.65	1.96	0.02	17.1
Left	#Left:9	End	60.63	0.12	-0.01	0.00	30.72	1.25	-0.3	7.65	1.96	0.02	21.9
Left	#Left:9	Origin	60.63	0.12	-0.01	0.00	30.72	1.25	-0.3	7.29	2.06	0.03	21.8
Left	Left:g	End	65.50	0.00	0.00	0.00	40.75	1.38	-0.3	7.29	2.06	0.03	26.0
Right	Right:t	Origin	0.00	5.52	-1.38	-0.05	0.00	0.00	0.0	-0.11	0.03	0.00	0.0
Right	Right:TMo1	End	2.00	5.32	-1.34	-0.05	0.05	0.00	0.0	-0.11	0.03	0.00	0.0
Right	Right:TMo1	Origin	2.00	5.32	-1.34	-0.05	0.05	0.00	0.0	-0.94	0.44	0.00	0.1
Right	#Right:10	End	6.50	4.89	-1.24	-0.05	2.04	0.01	0.0	-0.94	0.44	0.00	1.1
Right	#Right:10	Origin	6.50	4.89	-1.24	-0.05	2.04	0.01	0.0	-1.44	0.56	0.00	1.1
Right	Right:TMo2	End	11.00	4.46	-1.14	-0.04	4.55	0.01	0.0	-1.44	0.56	0.00	2.2
Right	Right:TMo2	Origin	11.00	4.46	-1.14	-0.04	4.55	0.01	0.0	-3.24	1.55	0.00	2.4
Right	Right:Coax1	End	14.00	4.19	-1.07	-0.04	9.18	0.02	0.0	-3.24	1.55	0.00	4.3
Right	Right:Coax1	Origin	14.00	4.19	-1.07	-0.04	9.18	0.02	0.0	-4.12	1.69	0.01	4.4
Right	Right:SW	End	19.00	3.79	-0.96	-0.04	17.63	0.05	0.0	-4.12	1.69	0.01	7.6
Right	Right:SW	Origin	19.00	3.79	-0.96	-0.04	17.63	0.05	0.0	-6.09	2.39	0.06	7.7
Right	Right:Brace	End	20.50	3.68	-0.92	-0.04	21.21	0.14	0.0	-6.09	2.39	0.06	9.0
Right	Right:Brace	Origin	20.50	3.68	-0.92	-0.04	20.38	0.14	-0.0	-12.82	0.74	0.06	9.2
Right	Right:Coax2	End	24.00	3.46	-0.84	-0.04	22.98	0.36	-0.0	-12.82	0.74	0.06	9.8
Right	Right:Coax2	Origin	24.00	3.46	-0.84	-0.04	22.98	0.36	-0.0	-13.60	0.85	0.06	9.9
Right	Right:Arm	End	26.25	3.34	-0.79	-0.04	24.89	0.50	-0.0	-13.60	0.85	0.06	10.3
Right	Right:Arm	Origin	26.25	3.34	-0.79	-0.04	24.89	0.56	-0.4	-13.70	-0.94	0.15	10.4
Right	#Right:11	End	29.25	3.22	-0.73	-0.04	22.07	1.03	-0.4	-13.70	-0.94	0.15	9.1
Right	#Right:11	Origin	29.25	3.22	-0.73	-0.04	22.07	1.03	-0.4	-14.09	-0.88	0.15	9.1
Right	Right:XTP	End	32.25	3.13	-0.66	-0.04	19.44	1.49	-0.4	-14.09	-0.88	0.15	8.0
Right	Right:XTP	Origin	32.25	3.13	-0.66	-0.04	17.86	1.49	-0.4	-16.89	-3.04	0.15	7.7



Right	Right:Coax3	End	34.00	3.08	-0.62	-0.04	12.55	1.76	-0.4	-16.89	-3.04	0.15	5.8
Right	Right:Coax3	Origin	34.00	3.08	-0.62	-0.04	12.55	1.76	-0.4	-17.43	-2.97	0.15	5.9
Right	Right:XTP2	End	34.25	3.08	-0.62	-0.04	11.80	1.80	-0.4	-17.43	-2.97	0.15	5.6
Right	Right:XTP2	Origin	34.25	3.08	-0.62	-0.04	10.28	1.80	-0.4	-20.14	-5.01	0.15	5.3
Right	#Right:12	End	39.13	2.97	-0.51	-0.03	-14.13	2.55	-0.4	-20.14	-5.01	0.15	6.4
Right	#Right:12	Origin	39.13	2.97	-0.51	-0.03	-14.13	2.55	-0.4	-20.83	-4.87	0.15	6.5
Right	Right:Coax4	End	44.00	2.83	-0.42	-0.03	-37.89	3.29	-0.4	-20.83	-4.87	0.15	13.3
Right	Right:Coax4	Origin	44.00	2.83	-0.42	-0.03	-37.89	3.29	-0.4	-21.83	-4.70	0.15	13.4
Right	Right:XBT	End	47.25	2.68	-0.36	-0.03	-53.16	3.78	-0.4	-21.83	-4.70	0.15	17.4
Right	Right:XBT	Origin	47.25	2.68	-0.36	-0.03	-56.37	3.78	-0.4	-26.79	-0.21	0.14	18.6
Right	Right:XBT2	End	49.25	2.56	-0.32	-0.03	-56.78	4.06	-0.4	-26.79	-0.21	0.14	18.4
Right	Right:XBT2	Origin	49.25	2.56	-0.32	-0.03	-60.61	4.06	-0.4	-32.68	5.12	0.13	19.8
Right	Right:Coax5	End	54.00	2.18	-0.24	-0.02	-36.28	4.69	-0.4	-32.68	5.12	0.13	12.6
Right	Right:Coax5	Origin	54.00	2.18	-0.24	-0.02	-36.28	4.69	-0.4	-33.83	5.34	0.13	12.7
Right	#Right:13	End	59.00	1.70	-0.17	-0.02	-9.59	5.33	-0.4	-33.83	5.34	0.13	5.6
Right	#Right:13	Origin	59.00	1.70	-0.17	-0.02	-9.59	5.33	-0.4	-34.62	5.48	0.12	5.7
Right	Right:Coax6	End	64.00	1.20	-0.11	-0.01	17.80	5.93	-0.4	-34.62	5.48	0.12	7.5
Right	Right:Coax6	Origin	64.00	1.20	-0.11	-0.01	17.80	5.93	-0.4	-35.84	5.63	0.11	7.6
Right	#Right:14	End	69.00	0.73	-0.06	-0.01	45.96	6.49	-0.4	-35.84	5.63	0.11	13.7
Right	#Right:14	Origin	69.00	0.73	-0.06	-0.01	45.96	6.49	-0.4	-36.68	5.71	0.10	13.8
Right	Right:Coax7	End	74.00	0.35	-0.03	-0.01	74.50	7.01	-0.4	-36.68	5.71	0.10	19.3
Right	Right:Coax7	Origin	74.00	0.35	-0.03	-0.01	74.50	7.01	-0.4	-37.96	5.80	0.09	19.4
Right	#Right:15	End	79.00	0.09	-0.01	-0.00	103.51	7.49	-0.4	-37.96	5.80	0.09	24.5
Right	#Right:15	Origin	79.00	0.09	-0.01	-0.00	103.51	7.49	-0.4	-38.86	5.82	0.08	24.6
Right	Right:g	End	84.00	0.00	0.00	0.00	132.62	7.91	-0.4	-38.86	5.82	0.08	29.2

Summary of Brace Forces and Usages for Load Case "NESC Heavy T":

Brace Label	Forces (kips)	Allowable Compression (kips)	Allowable Tension (kips)	Usage %
TENL	4.13	15.37	30.00	21.16
TENR	3.96	15.37	30.00	20.30
VEEL	-0.93	18.88	20.00	7.60
VEER	6.16	18.88	20.00	47.40
X1	-6.26	26.38	25.00	36.54
X2	3.24	26.38	25.00	19.93
X3	-7.41	26.38	25.00	43.21
X4	3.08	26.38	25.00	18.93

Detailed X-Arm Usages for Load Case "NESC Heavy T":

X-Arm Label	Joint Label	Joint Position	Rel. Dist. (ft)	Area (in^2)	X Sect. Modulus (in^3)	Z Sect. Modulus (in^3)	Tran. Defl. (in)	Long. Defl. (in)	Vert. Defl. (in)	X Mom. (ft-k)	Z Mom. (ft-k)	Tors. Mom. (ft-k)	Axial Force (kips)	X Shear (kips)	Z Shear (kips)	P/A (psi)	Mx/Sx (psi)	Mz/Sz (psi)	Max. Usage %
NESC32	NESC32:O	Origin	0.00	38.40	32.83	48.04	3.35	-1.21	-0.43	0.00	-0.00	-0.0	0.00	-0.00	0.00	0.00045	0.000143	1.95e-006	0.0
NESC32	NESC32:L1	End	0.50	38.40	32.83	48.04	3.35	-1.20	-0.41	-0.00	-0.00	-0.0	0.00	-0.00	0.00	0.00045	0.842	0.00129	0.0
NESC32	NESC32:L1	Origin	0.50	38.40	32.83	48.04	3.35	-1.20	-0.41	0.00	0.00	0.0	-3.98	0.09	0.03	1e+002	0.842	0.00129	2.0
NESC32	#gNESC32:O	End	4.38	38.40	32.83	48.04	3.34	-1.11	-0.23	0.34	-0.13	0.0	-3.98	0.09	0.03	1e+002	123	31.5	5.0
NESC32	#gNESC32:O	Origin	4.38	38.40	32.83	48.04	3.34	-1.11	-0.23	-0.34	0.13	0.0	-3.97	0.01	0.03	1e+002	123	31.5	5.0
NESC32	NESC32:PL	End	8.25	38.40	32.83	48.04	3.34	-1.03	-0.00	0.39	-0.25	0.0	-3.97	0.01	0.03	1e+002	141	62.5	5.9
NESC32	NESC32:PL	Origin	8.25	38.40	32.83	48.04	3.34	-1.03	-0.00	-0.38	-0.08	0.1	5.77	-0.30	0.03	1.5e+002	140	19.9	6.0
NESC32	#gNESC32:1	End	12.13	38.40	32.83	48.04	3.34	-0.95	0.25	-0.79	-0.04	0.1	5.77	-0.30	0.03	1.5e+002	290	10.9	8.7
NESC32	#gNESC32:1	Origin	12.13	38.40	32.83	48.04	3.34	-0.95	0.25	0.79	0.04	0.1	5.77	-0.39	0.03	1.5e+002	290	10.9	8.7
NESC32	NESC32:L2V	End	16.00	38.40	32.83	48.04	3.35	-0.88	0.38	-2.31	-0.17	0.1	5.77	-0.39	0.03	1.5e+002	843	42.1	19.9
NESC32	NESC32:L2V	Origin	16.00	38.40	32.83	48.04	3.35	-0.88	0.38	2.31	0.17	0.1	-0.52	0.37	0.06	14	843	42.1	17.3

NESC32	#gNESC32:2	End	19.88	38.40	32.83	48.04	3.34	-0.82	0.24	-0.88	-0.41	0.1	-0.52	0.37	0.06	14	321	104	8.4
NESC32	#gNESC32:2	Origin	19.88	38.40	32.83	48.04	3.34	-0.82	0.24	0.88	0.41	0.1	-0.52	0.30	0.06	14	321	104	8.4
NESC32	NESC32:PR	End	23.75	38.40	32.83	48.04	3.34	-0.79	-0.04	0.28	-0.66	0.1	-0.52	0.30	0.06	14	103	165	5.4
NESC32	NESC32:PR	Origin	23.75	38.40	32.83	48.04	3.34	-0.79	-0.04	-0.28	0.23	-0.0	-2.36	-0.00	-0.03	61	103	56.3	4.2
NESC32	#gNESC32:3	End	27.63	38.40	32.83	48.04	3.34	-0.79	-0.30	0.28	-0.11	-0.0	-2.36	-0.00	-0.03	61	103	28.3	3.7
NESC32	#gNESC32:3	Origin	27.63	38.40	32.83	48.04	3.34	-0.79	-0.30	-0.28	0.11	-0.0	-2.36	-0.07	-0.03	61	103	28.3	3.7
NESC32	NESC32:L3	End	31.50	38.40	32.83	48.04	3.34	-0.79	-0.53	-0.00	-0.00	-0.0	-2.36	-0.07	-0.03	61	0.842	0.000852	1.2
NESC32	NESC32:L3	Origin	31.50	38.40	32.83	48.04	3.34	-0.79	-0.53	0.00	0.00	0.0	0.00	0.00	-0.00	0.00057	0.842	0.000854	0.0
NESC32	NESC32:E	End	32.00	38.40	32.83	48.04	3.34	-0.79	-0.56	0.00	0.00	0.0	0.00	0.00	-0.00	0.00057	7.29e-006	8.62e-007	0.0

Summary of Clamp Capacities and Usages for Load Case "NESC Heavy T":

Clamp Label	Force (kips)	Input Holding Capacity (kips)	Factored Holding Capacity (kips)	Usage %
C1	1.675	10.00	10.00	16.75
C2	1.725	10.00	10.00	17.25
C3	2.443	10.00	10.00	24.43
C4	2.443	10.00	10.00	24.43
C5	2.443	10.00	10.00	24.43
C6	0.638	10.00	10.00	6.38
C7	1.690	10.00	10.00	16.90
C8	0.434	10.00	10.00	4.34
C9	0.426	10.00	10.00	4.26
C10	0.416	10.00	10.00	4.16
C11	0.435	10.00	10.00	4.35
C12	0.442	10.00	10.00	4.42
C13	0.443	10.00	10.00	4.43
C14	0.443	10.00	10.00	4.43

Equilibrium Joint Positions and Rotations for Load Case "NESC Heavy L":

Joint Label	X-Displ (ft)	Y-Displ (ft)	Z-Displ (ft)	X-Rot (deg)	Y-Rot (deg)	Z-Rot (deg)	X-Pos (ft)	Y-Pos (ft)	Z-Pos (ft)
Left:g	0	0	0	0.0000	0.0000	0.0000	0	-7.75	0
Left:t	0.3099	-0.01406	-0.002854	0.1516	0.1185	0.9440	0.3099	-7.764	65.5
Left:SW	0.3088	-0.01276	-0.002852	0.1516	0.1185	0.9440	0.3088	-7.763	65
Left:Brace	0.3056	-0.008839	-0.002826	0.1515	0.1186	0.9440	0.3056	-7.759	63.5
Left:Arm	0.2938	0.001989	-0.002572	0.0349	0.1103	0.9442	0.2938	-7.748	57.75
Left:XTP	0.2813	-0.0007719	-0.002335	-0.0226	0.1417	0.7574	0.2813	-7.751	51.75
Left:XTP2	0.276	-0.001687	-0.002265	-0.0122	0.1654	0.7028	0.276	-7.752	49.75
Left:XBT	0.2178	-0.003302	-0.001735	0.0044	0.3511	0.4198	0.2178	-7.753	36.75
Left:XBT2	0.2051	-0.00338	-0.001638	0.0044	0.3778	0.3851	0.2051	-7.753	34.75
Right:g	0	0	0	0.0000	0.0000	0.0000	0	7.75	0
Right:t	-0.01537	0.0451	-0.001688	-0.1028	-0.1588	0.2519	-0.01537	7.795	84
Right:TMo1	-0.009809	0.04154	-0.001677	-0.1028	-0.1588	0.2519	-0.009809	7.792	82
Right:TMo2	0.01492	0.02551	-0.001608	-0.1026	-0.1532	0.2518	0.01492	7.776	73
Right:Coax1	0.02285	0.02018	-0.001574	-0.1024	-0.1474	0.2518	0.02285	7.77	70
Right:SW	0.03498	0.01131	-0.001515	-0.1019	-0.1270	0.2518	0.03498	7.761	65
Right:Brace	0.03822	0.00866	-0.001493	-0.1017	-0.1185	0.2518	0.03822	7.759	63.5
Right:Coax2	0.0448	0.002771	-0.001423	-0.0872	-0.0947	0.2518	0.0448	7.753	60
Right:Arm	0.04819	-0.0002969	-0.001379	-0.0673	-0.0767	0.2517	0.04819	7.75	57.75
Right:XTP	0.05369	-0.004506	-0.001266	-0.0170	-0.0284	0.2176	0.05369	7.745	51.75
Right:Coax3	0.05435	-0.004871	-0.001232	-0.0072	-0.0151	0.2081	0.05435	7.745	50
Right:XTP2	0.05441	-0.0049	-0.001227	-0.0060	-0.0133	0.2067	0.05441	7.745	49.75
Right:Coax4	0.05104	-0.003364	-0.001031	0.0171	0.0494	0.1568	0.05104	7.747	40
Right:XBT	0.04776	-0.002424	-0.0009601	0.0158	0.0656	0.1415	0.04776	7.748	36.75
Right:XBT2	0.04531	-0.001931	-0.0009125	0.0134	0.0743	0.1322	0.04531	7.748	34.75
Right:Coax5	0.03844	-0.001044	-0.0007973	0.0089	0.0897	0.1110	0.03844	7.749	30
Right:Coax6	0.02159	-0.000135	-0.0005398	0.0027	0.0972	0.0698	0.02159	7.75	20
Right:Coax7	0.006581	3.703e-005	-0.000272	0.0000	0.0681	0.0330	0.006581	7.75	10
NESC32:O	0.4326	0.003485	-0.022	0.1255	0.1100	0.9717	0.4326	-16	57.73
NESC32:L1	0.4241	0.003412	-0.02089	0.1255	0.1100	0.9717	0.4241	-15.5	57.73
NESC32:PL	0.2938	0.001989	-0.002572	0.1375	0.1103	0.9442	0.2938	-7.748	57.75
NESC32:L2V	0.1485	0.0004285	0.01025	-0.0002	0.0165	1.0612	0.1485	0.0004285	57.76
NESC32:PR	0.04819	-0.0002969	-0.001379	-0.1241	-0.0767	0.2517	0.04819	7.75	57.75
NESC32:L3	0.0162	-0.000671	-0.01653	-0.0993	-0.0766	0.2308	0.0162	15.5	57.73
NESC32:E	0.01418	-0.0006758	-0.0174	-0.0994	-0.0766	0.2308	0.01418	16	57.73
TENL:O	0.3101	-0.008801	-0.003546	0.1515	0.1186	0.9440	0.3101	-8.031	63.5
TENR:O	0.03564	0.008653	-0.002536	-0.1017	-0.1185	0.2518	0.03564	8.346	63.5
VEEL:O	0.3011	-0.008877	-0.002106	0.1515	0.1186	0.9440	0.3011	-7.487	63.5
VEER:O	0.0408	0.008666	-0.000449	-0.1017	-0.1185	0.2518	0.0408	7.171	63.5
X1:O	0.2768	-0.0008017	-0.00247	-0.0226	0.1417	0.7574	0.2768	-7.409	51.75
X1:E	0.04949	-0.002422	-0.001154	0.0158	0.0656	0.1415	0.04949	7.045	36.75
X2:O	0.05611	-0.004501	-0.001076	-0.0170	-0.0284	0.2176	0.05611	7.108	51.75
X2:E	0.2146	-0.003314	-0.001702	0.0044	0.3511	0.4198	0.2146	-7.323	36.75
X3:O	0.2717	-0.001714	-0.002341	-0.0122	0.1654	0.7028	0.2717	-7.398	49.75
X3:E	0.04695	-0.001929	-0.001078	0.0134	0.0743	0.1322	0.04695	7.037	34.75
X4:O	0.05674	-0.004896	-0.001159	-0.0060	-0.0133	0.2067	0.05674	7.099	49.75
X4:E	0.2021	-0.00339	-0.001604	0.0044	0.3778	0.3851	0.2021	-7.311	34.75

Joint Support Reactions for Load Case "NESC Heavy L":

Joint	X	X	Y	Y H-Shear	Z Comp.	Uplift	Result.	Result.	X X-M.	Y Y-M.	H-Bend-M	Z Z-M.	Max.
-------	---	---	---	-----------	---------	--------	---------	---------	--------	--------	----------	--------	------

	Label	Force (kips)	Usage % (kips)	Force %	Usage %	Force (kips)	Usage %	Force (kips)	Usage %	Force (kips)	Usage % (ft-k)	Force (kips)	Usage % (ft-k)	Force (kips)	Usage %	Force (kips)	Usage % (ft-k)	Force (kips)	Usage %
Left:g	-0.78	0.0	0.03	0.0	0.0	-9.35	0.0	0.0	9.38	0.0	-0.69	0.0	-14.3	0.0	0.0	-3.42	0.0	0.0	0.0
Right:g	-1.32	0.0	-0.08	0.0	0.0	-22.86	0.0	0.0	22.90	0.0	0.38	0.0	-24.9	0.0	0.0	-7.72	0.0	0.0	0.0

Detailed Laminated Wood Pole Usages for Load Case "NESC Heavy L":

Element Label	Joint Label	Joint Position	Rel. Dist. (ft)	Trans. Defl. (in)	Long. Defl. (in)	Vert. Defl. (in)	Trans. Mom. (ft-k)	Long. Mom. (ft-k)	Tors. Mom. (ft-k)	Axial Force (kips)	Tran. Shear (kips)	Long. Shear (kips)	Usage %
Left	Left:t	Origin	0.00	-0.17	3.72	-0.03	0.00	-0.00	-0.0	-0.01	-0.00	-0.00	0.0
Left	Left:SW	End	0.50	-0.15	3.71	-0.03	-0.00	-0.00	-0.0	-0.01	-0.00	-0.00	0.0
Left	Left:SW	Origin	0.50	-0.15	3.71	-0.03	-0.00	-0.00	-0.0	-1.65	-0.00	0.01	0.5
Left	Left:Brace	End	2.00	-0.11	3.67	-0.03	-0.01	0.02	-0.0	-1.65	-0.00	0.01	0.5
Left	Left:Brace	Origin	2.00	-0.11	3.67	-0.03	-0.11	0.02	0.0	-6.29	-0.53	-0.07	2.3
Left	#Left:0	End	4.88	-0.02	3.60	-0.03	-1.63	-0.17	0.0	-6.29	-0.53	-0.07	6.9
Left	#Left:0	Origin	4.88	-0.02	3.60	-0.03	-1.63	-0.17	0.0	-6.39	-0.52	-0.09	6.9
Left	Left:Arm	End	7.75	0.02	3.53	-0.03	-3.13	-0.43	0.0	-6.39	-0.52	-0.09	10.7
Left	Left:Arm	Origin	7.75	0.02	3.53	-0.03	-3.12	-0.12	3.5	-6.55	0.73	0.39	10.1
Left	#Left:1	End	10.75	0.02	3.46	-0.03	-0.94	1.05	3.5	-6.55	0.73	0.39	5.6
Left	#Left:1	Origin	10.75	0.02	3.46	-0.03	-0.94	1.05	3.5	-6.66	0.73	0.36	5.6
Left	Left:XTP	End	13.75	-0.01	3.38	-0.03	1.24	2.13	3.5	-6.66	0.73	0.36	7.6
Left	Left:XTP	Origin	13.75	-0.01	3.38	-0.03	0.94	2.13	3.5	-5.88	-0.23	0.25	6.8
Left	Left:XTP2	End	15.75	-0.02	3.31	-0.03	0.48	2.63	3.5	-5.88	-0.23	0.25	6.4
Left	Left:XTP2	Origin	15.75	-0.02	3.31	-0.03	0.59	2.63	3.5	-6.32	-0.05	0.12	6.7
Left	#Left:2	End	20.75	-0.03	3.10	-0.02	0.32	3.25	3.5	-6.32	-0.05	0.12	6.5
Left	#Left:2	Origin	20.75	-0.03	3.10	-0.02	0.32	3.25	3.5	-6.52	-0.05	0.06	6.6
Left	#Left:3	End	24.75	-0.04	2.88	-0.02	0.10	3.50	3.5	-6.52	-0.05	0.06	6.2
Left	#Left:3	Origin	24.75	-0.04	2.88	-0.02	0.10	3.50	3.5	-6.71	-0.05	0.00	6.2
Left	Left:XBT	End	28.75	-0.04	2.61	-0.02	-0.12	3.50	3.5	-6.71	-0.05	0.00	5.9
Left	Left:XBT	Origin	28.75	-0.04	2.61	-0.02	-0.19	3.50	3.5	-6.70	0.21	-0.12	6.0
Left	Left:XBT2	End	30.75	-0.04	2.46	-0.02	0.24	3.26	3.5	-6.70	0.21	-0.12	5.6
Left	Left:XBT2	Origin	30.75	-0.04	2.46	-0.02	0.40	3.26	3.4	-7.25	-0.03	-0.26	5.9
Left	#Left:4	End	35.75	-0.04	2.04	-0.02	0.23	1.94	3.4	-7.25	-0.03	-0.26	3.7
Left	#Left:4	Origin	35.75	-0.04	2.04	-0.02	0.23	1.94	3.4	-7.52	-0.03	-0.34	3.8
Left	#Left:5	End	40.75	-0.03	1.58	-0.01	0.07	0.22	3.4	-7.52	-0.03	-0.34	1.5
Left	#Left:5	Origin	40.75	-0.03	1.58	-0.01	0.07	0.22	3.4	-7.82	-0.03	-0.43	1.6
Left	#Left:6	End	45.75	-0.02	1.11	-0.01	-0.10	-1.92	3.4	-7.82	-0.03	-0.43	3.2
Left	#Left:6	Origin	45.75	-0.02	1.11	-0.01	-0.10	-1.92	3.4	-8.13	-0.03	-0.51	3.3
Left	#Left:7	End	50.75	-0.01	0.68	-0.01	-0.25	-4.47	3.4	-8.13	-0.03	-0.51	5.7
Left	#Left:7	Origin	50.75	-0.01	0.68	-0.01	-0.26	-4.47	3.4	-8.46	-0.03	-0.59	5.8
Left	#Left:8	End	55.75	-0.01	0.33	-0.00	-0.41	-7.43	3.4	-8.46	-0.03	-0.59	8.4
Left	#Left:8	Origin	55.75	-0.01	0.33	-0.00	-0.41	-7.43	3.4	-8.81	-0.03	-0.67	8.4
Left	#Left:9	End	60.63	-0.00	0.09	-0.00	-0.55	-10.71	3.4	-8.81	-0.03	-0.67	11.0
Left	#Left:9	Origin	60.63	-0.00	0.09	-0.00	-0.56	-10.71	3.4	-9.16	-0.03	-0.75	11.0
Left	Left:g	End	65.50	0.00	0.00	0.00	-0.68	-14.34	3.4	-9.16	-0.03	-0.75	13.7
Right	Right:t	Origin	0.00	0.54	-0.18	-0.02	0.00	0.00	-0.0	-0.11	0.00	-0.02	0.0
Right	Right:TMo1	End	2.00	0.50	-0.12	-0.02	0.00	-0.03	-0.0	-0.11	0.00	-0.02	0.0
Right	Right:TMo1	Origin	2.00	0.50	-0.12	-0.02	0.00	-0.03	-0.0	-0.94	0.00	0.27	0.1
Right	#Right:10	End	6.50	0.40	0.03	-0.02	0.02	1.16	-0.0	-0.94	0.00	0.27	0.5
Right	#Right:10	Origin	6.50	0.40	0.03	-0.02	0.02	1.16	0.0	-1.44	0.01	0.19	0.5
Right	Right:TMo2	End	11.00	0.31	0.18	-0.02	0.04	2.02	0.0	-1.44	0.01	0.19	0.8
Right	Right:TMo2	Origin	11.00	0.31	0.18	-0.02	0.04	2.02	0.0	-3.25	0.01	1.01	0.9
Right	Right:Coax1	End	14.00	0.24	0.27	-0.02	0.08	5.06	0.0	-3.25	0.01	1.01	1.9
Right	Right:Coax1	Origin	14.00	0.24	0.27	-0.02	0.08	5.06	0.0	-4.13	0.02	1.02	1.9

Right	Right:SW	End	19.00	0.14	0.42	-0.02	0.16	10.15	0.0	-4.13	0.02	1.02	3.4
Right	Right:SW	Origin	19.00	0.14	0.42	-0.02	0.16	10.15	0.0	-6.10	0.02	1.01	3.6
Right	Right:Brace	End	20.50	0.10	0.46	-0.02	0.19	11.66	0.0	-6.10	0.02	1.01	4.0
Right	Right:Brace	Origin	20.50	0.10	0.46	-0.02	1.20	11.66	0.0	-9.67	2.17	0.89	4.7
Right	Right:Coax2	End	24.00	0.03	0.54	-0.02	8.81	14.79	0.0	-9.67	2.17	0.89	8.3
Right	Right:Coax2	Origin	24.00	0.03	0.54	-0.02	8.81	14.79	0.0	-10.45	2.17	0.91	8.4
Right	Right:Arm	End	26.25	-0.00	0.58	-0.02	13.69	16.83	0.0	-10.45	2.17	0.91	10.6
Right	Right:Arm	Origin	26.25	-0.00	0.58	-0.02	13.68	16.53	7.5	-10.82	-0.69	-0.03	10.5
Right	#Right:11	End	29.25	-0.04	0.62	-0.02	11.60	16.43	7.5	-10.82	-0.69	-0.03	9.4
Right	#Right:11	Origin	29.25	-0.04	0.62	-0.02	11.61	16.43	7.5	-11.22	-0.70	-0.10	9.5
Right	Right:XTP	End	32.25	-0.05	0.64	-0.02	9.52	16.14	7.5	-11.22	-0.70	-0.10	8.4
Right	Right:XTP	Origin	32.25	-0.05	0.64	-0.02	9.27	16.14	7.6	-11.92	-0.96	-0.23	8.4
Right	Right:Coax3	End	34.00	-0.06	0.65	-0.01	7.59	15.74	7.6	-11.92	-0.96	-0.23	7.6
Right	Right:Coax3	Origin	34.00	-0.06	0.65	-0.01	7.59	15.74	7.6	-12.46	-0.96	-0.18	7.6
Right	Right:XTP2	End	34.25	-0.06	0.65	-0.01	7.35	15.69	7.6	-12.46	-0.96	-0.18	7.5
Right	Right:XTP2	Origin	34.25	-0.06	0.65	-0.01	7.44	15.69	7.6	-12.67	-0.72	-0.32	7.6
Right	#Right:12	End	39.13	-0.06	0.65	-0.01	3.94	14.16	7.6	-12.67	-0.72	-0.32	5.8
Right	#Right:12	Origin	39.13	-0.06	0.65	-0.01	3.95	14.15	7.6	-13.35	-0.72	-0.43	5.8
Right	Right:Coax4	End	44.00	-0.04	0.61	-0.01	0.44	12.07	7.6	-13.35	-0.72	-0.43	4.0
Right	Right:Coax4	Origin	44.00	-0.04	0.61	-0.01	0.44	12.07	7.6	-14.34	-0.72	-0.45	4.1
Right	Right:XBT	End	47.25	-0.03	0.57	-0.01	-1.90	10.61	7.6	-14.34	-0.72	-0.45	4.1
Right	Right:XBT	Origin	47.25	-0.03	0.57	-0.01	-2.67	10.61	7.7	-15.83	0.24	-0.58	4.4
Right	Right:XBT2	End	49.25	-0.02	0.54	-0.01	-2.19	9.45	7.7	-15.83	0.24	-0.58	3.9
Right	Right:XBT2	Origin	49.25	-0.02	0.54	-0.01	-2.14	9.45	7.7	-16.26	0.07	-0.74	3.9
Right	Right:Coax5	End	54.00	-0.01	0.46	-0.01	-1.83	5.91	7.7	-16.26	0.07	-0.74	2.9
Right	Right:Coax5	Origin	54.00	-0.01	0.46	-0.01	-1.82	5.91	7.7	-17.42	0.07	-0.79	3.0
Right	#Right:13	End	59.00	-0.01	0.36	-0.01	-1.48	1.96	7.7	-17.42	0.07	-0.79	1.9
Right	#Right:13	Origin	59.00	-0.01	0.36	-0.01	-1.48	1.96	7.7	-18.21	0.07	-0.91	1.9
Right	Right:Coax6	End	64.00	-0.00	0.26	-0.01	-1.13	-2.61	7.7	-18.21	0.07	-0.91	1.9
Right	Right:Coax6	Origin	64.00	-0.00	0.26	-0.01	-1.13	-2.61	7.7	-19.43	0.07	-0.96	2.0
Right	#Right:14	End	69.00	0.00	0.16	-0.00	-0.77	-7.44	7.7	-19.43	0.07	-0.96	2.9
Right	#Right:14	Origin	69.00	0.00	0.16	-0.00	-0.77	-7.44	7.7	-20.27	0.07	-1.09	2.9
Right	Right:Coax7	End	74.00	0.00	0.08	-0.00	-0.39	-12.88	7.7	-20.27	0.07	-1.09	3.9
Right	Right:Coax7	Origin	74.00	0.00	0.08	-0.00	-0.39	-12.88	7.7	-21.54	0.08	-1.14	4.0
Right	#Right:15	End	79.00	0.00	0.02	-0.00	-0.01	-18.57	7.7	-21.54	0.08	-1.14	5.0
Right	#Right:15	Origin	79.00	0.00	0.02	-0.00	-0.01	-18.57	7.7	-22.42	0.08	-1.26	5.1
Right	Right:g	End	84.00	0.00	0.00	0.00	0.38	-24.87	7.7	-22.42	0.08	-1.26	6.3

Summary of Brace Forces and Usages for Load Case "NESC Heavy L":

Brace Label	Forces (kips)	Allowable Compression (kips)	Allowable Tension (kips)	Usage %
TENL	4.01	15.37	30.00	20.57
TENR	3.92	15.37	30.00	20.09
VEEL	3.35	18.88	20.00	25.79
VEER	1.16	18.88	20.00	8.92
X1	-1.38	26.38	25.00	8.03
X2	0.38	26.38	25.00	2.36
X3	0.25	26.38	25.00	1.57
X4	-0.36	26.38	25.00	2.07

Detailed X-Arm Usages for Load Case "NESC Heavy L":

X-Arm Label	Joint Label	Joint Position	Rel. Dist. (ft)	Area (in^2)	X Sect. Modulus (in^3)	Z Sect. Modulus (in^3)	Tran. Defl. (in)	Long. Defl. (in)	Vert. Defl. (in)	X Mom. (ft-k)	Z Tors. Mom. (ft-k)	Axial Force (kips)	X Shear (kips)	Z Shear (kips)	P/A (psi)	Mx/Sx (psi)	Mz/Sz (psi)	Max. Usage %
-------------	-------------	----------------	-----------------	-------------	------------------------	------------------------	------------------	------------------	------------------	---------------	---------------------	--------------------	----------------	----------------	-----------	-------------	-------------	--------------

NESC32	NESC32:0	Origin	0.00	38.40	32.83	48.04	0.04	5.19	-0.26	0.00	0.00	0.0	0.00	-0.00	-0.00	0.00027	4.04e-005	1.78e-006	0.0
NESC32	NESC32:L1	End	0.50	38.40	32.83	48.04	0.04	5.09	-0.25	-0.00	0.00	0.0	0.00	-0.00	-0.00	0.00027	0.841	0.313	0.0
NESC32	NESC32:L1	Origin	0.50	38.40	32.83	48.04	0.04	5.09	-0.25	0.00	-0.00	-0.0	-3.18	0.03	-0.03	83	0.841	0.313	1.6
NESC32	#gNESC32:0	End	4.38	38.40	32.83	48.04	0.03	4.30	-0.14	0.10	0.13	-0.0	-3.18	0.03	-0.03	83	37.6	31.4	2.9
NESC32	#gNESC32:0	Origin	4.38	38.40	32.83	48.04	0.03	4.30	-0.14	-0.10	-0.13	-0.0	-3.18	-0.04	-0.07	83	37.6	31.4	2.9
NESC32	NESC32:PL	End	8.25	38.40	32.83	48.04	0.02	3.53	-0.03	-0.07	0.40	-0.0	-3.18	-0.04	-0.07	83	25.7	99.5	4.0
NESC32	NESC32:PL	Origin	8.25	38.40	32.83	48.04	0.02	3.53	-0.03	0.08	3.15	-0.3	-1.94	-0.06	-0.62	50	30.3	786	16.7
NESC32	#gNESC32:1	End	12.13	38.40	32.83	48.04	0.01	2.68	0.07	-0.31	-0.73	-0.3	-1.94	-0.06	-0.62	50	114	183	6.7
NESC32	#gNESC32:1	Origin	12.13	38.40	32.83	48.04	0.01	2.68	0.07	0.31	0.73	-0.3	-1.94	-0.13	-0.66	50	114	183	6.7
NESC32	NESC32:L2V	End	16.00	38.40	32.83	48.04	0.01	1.78	0.12	-0.81	1.84	-0.3	-1.94	-0.13	-0.66	50	298	460	15.6
NESC32	NESC32:L2V	Origin	16.00	38.40	32.83	48.04	0.01	1.78	0.12	0.81	-1.84	-0.3	-0.18	0.14	-0.75	4.8	298	461	14.7
NESC32	#gNESC32:2	End	19.88	38.40	32.83	48.04	-0.00	1.02	0.08	-0.27	4.75	-0.3	-0.18	0.14	-0.75	4.8	100	1.19e+003	24.9
NESC32	#gNESC32:2	Origin	19.88	38.40	32.83	48.04	-0.00	1.02	0.08	0.27	-4.75	-0.3	-0.19	0.07	-0.79	4.9	99.7	1.19e+003	24.8
NESC32	NESC32:PR	End	23.75	38.40	32.83	48.04	-0.00	0.58	-0.02	-0.01	7.81	-0.3	-0.19	0.07	-0.79	4.9	5.12	1.95e+003	37.7
NESC32	NESC32:PR	Origin	23.75	38.40	32.83	48.04	-0.00	0.58	-0.02	0.00	-0.32	0.0	-3.05	0.04	0.06	79	0.403	80.1	3.1
NESC32	#gNESC32:3	End	27.63	38.40	32.83	48.04	-0.01	0.38	-0.11	0.14	0.09	0.0	-3.05	0.04	0.06	79	50.6	21.8	2.9
NESC32	#gNESC32:3	Origin	27.63	38.40	32.83	48.04	-0.01	0.38	-0.11	-0.14	-0.09	0.0	-3.05	-0.04	0.02	79	50.6	21.8	2.9
NESC32	NESC32:L3	End	31.50	38.40	32.83	48.04	-0.01	0.19	-0.20	-0.00	0.00	0.0	-3.05	-0.04	0.02	79	0.842	0.311	1.6
NESC32	NESC32:L3	Origin	31.50	38.40	32.83	48.04	-0.01	0.19	-0.20	0.00	-0.00	-0.0	0.00	0.00	0.00	0.00021	0.842	0.311	0.0
NESC32	NESC32:E	End	32.00	38.40	32.83	48.04	-0.01	0.17	-0.21	0.00	0.00	-0.0	0.00	0.00	0.00	0.00021	4.47e-006	7.55e-007	0.0

Summary of Clamp Capacities and Usages for Load Case "NESC Heavy L":

Clamp Label	Force (kips)	Input Holding Capacity (kips)	Factored Holding Capacity (kips)	Usage %
C1	1.611	10.00	10.00	16.11
C2	1.581	10.00	10.00	15.81
C3	2.338	10.00	10.00	23.38
C4	2.338	10.00	10.00	23.38
C5	2.338	10.00	10.00	23.38
C6	0.562	10.00	10.00	5.62
C7	1.604	10.00	10.00	16.04
C8	0.411	10.00	10.00	4.11
C9	0.411	10.00	10.00	4.11
C10	0.414	10.00	10.00	4.14
C11	0.411	10.00	10.00	4.11
C12	0.413	10.00	10.00	4.13
C13	0.414	10.00	10.00	4.14
C14	0.415	10.00	10.00	4.15

\*\*\* Analysis Results for Load Case No. 3 "Ext. Wind T" - Number of iterations in SAPS 20

Equilibrium Joint Positions and Rotations for Load Case "Ext. Wind T":

Joint Label	X-Displ (ft)	Y-Displ (ft)	Z-Displ (ft)	X-Rot (deg)	Y-Rot (deg)	Z-Rot (deg)	X-Pos (ft)	Y-Pos (ft)	Z-Pos (ft)
Left:g	0	0	0	0.0000	0.0000	0.0000	0	-7.75	0
Left:t	-0.2384	0.4971	-0.001477	0.9189	-0.3280	-0.2328	-0.2384	-7.253	65.5
Left:SW	-0.2355	0.5051	-0.001405	0.9189	-0.3280	-0.2328	-0.2355	-7.245	65
Left:Brace	-0.2268	0.5292	-0.001178	0.9271	-0.3277	-0.2327	-0.2268	-7.221	63.5
Left:Arm	-0.1943	0.5712	-0.0008724	-0.5112	-0.3130	-0.2407	-0.1943	-7.179	57.75
Left:XTP	-0.1632	0.4695	-1.547e-005	-0.7137	-0.2981	-0.1949	-0.1632	-7.28	51.75
Left:XTP2	-0.153	0.4536	-3.889e-005	-0.1674	-0.2936	-0.1783	-0.153	-7.296	49.75
Left:XBT	-0.09144	0.53	-0.000961	-0.0156	-0.2488	-0.1041	-0.09144	-7.22	36.75
Left:XBT2	-0.083	0.5241	-0.001149	-0.3263	-0.2400	-0.0964	-0.083	-7.226	34.75
Right:g	0	0	0	0.0000	0.0000	0.0000	0	7.75	0
Right:t	-0.2457	0.9788	-0.01028	-1.0831	-0.2292	-0.0391	-0.2457	8.729	83.99
Right:TMo1	-0.2378	0.941	-0.009908	-1.0828	-0.2292	-0.0391	-0.2378	8.691	81.99
Right:TMo2	-0.2019	0.7744	-0.008282	-1.0161	-0.2292	-0.0389	-0.2019	8.524	72.99
Right:Coax1	-0.1899	0.7225	-0.007803	-0.9526	-0.2292	-0.0386	-0.1899	8.473	69.99
Right:SW	-0.17	0.6467	-0.00717	-0.7626	-0.2291	-0.0379	-0.17	8.397	64.99
Right:Brace	-0.164	0.6277	-0.007029	-0.6870	-0.2291	-0.0376	-0.164	8.378	63.49
Right:Coax2	-0.15	0.5908	-0.006735	-0.5236	-0.2286	-0.0369	-0.15	8.341	59.99
Right:Arm	-0.1411	0.572	-0.006592	-0.4302	-0.2280	-0.0365	-0.1411	8.322	57.74
Right:XTP	-0.1175	0.5378	-0.00633	-0.2371	-0.2226	-0.0303	-0.1175	8.288	51.74
Right:Coax3	-0.1107	0.5312	-0.006258	-0.2029	-0.2200	-0.0286	-0.1107	8.281	49.99
Right:XTP2	-0.1098	0.5303	-0.006247	-0.1991	-0.2196	-0.0284	-0.1098	8.28	49.74
Right:Coax4	-0.07432	0.4899	-0.00576	-0.3726	-0.1956	-0.0211	-0.07432	8.24	39.99
Right:XBT	-0.06355	0.4645	-0.005532	-0.5362	-0.1846	-0.0192	-0.06355	8.214	36.74
Right:XBT2	-0.05726	0.4437	-0.005322	-0.6545	-0.1772	-0.0182	-0.05726	8.194	34.74
Right:Coax5	-0.04339	0.379	-0.004569	-0.8831	-0.1579	-0.0159	-0.04339	8.129	30
Right:Coax6	-0.01987	0.2093	-0.002499	-0.9778	-0.1110	-0.0105	-0.01987	7.959	20
Right:Coax7	-0.005089	0.06137	-0.0008002	-0.6489	-0.0577	-0.0052	-0.005089	7.811	9.999
NESC32:O	-0.2343	0.5718	-0.06536	0.3726	-0.3115	-0.2987	-0.2343	-15.43	57.68
NESC32:L1	-0.2318	0.5718	-0.0621	0.3726	-0.3115	-0.2987	-0.2318	-14.93	57.69
NESC32:PL	-0.1943	0.5712	-0.0008724	0.6000	-0.3130	-0.2407	-0.1943	-7.179	57.75
NESC32:L2V	-0.1619	0.5724	0.06379	-0.0082	-0.2707	-0.2253	-0.1619	0.5724	57.81
NESC32:PR	-0.1411	0.572	-0.006592	-0.6918	-0.2280	-0.0365	-0.1411	8.322	57.74
NESC32:L3	-0.1406	0.5716	-0.08456	-0.5149	-0.2275	0.0167	-0.1406	16.07	57.67
NESC32:E	-0.1408	0.5715	-0.08905	-0.5149	-0.2275	0.0167	-0.1408	16.57	57.66
TENL:O	-0.2279	0.5292	-0.005583	0.9271	-0.3277	-0.2327	-0.2279	-7.493	63.49
TENR:O	-0.1636	0.6276	-0.01408	0.6870	-0.2291	-0.0376	-0.1636	8.965	63.49
VEEL:O	-0.2257	0.5292	0.003227	0.9271	-0.3277	-0.2327	-0.2257	-6.949	63.5
VEER:O	-0.1644	0.6277	1.788e-005	-0.6870	-0.2291	-0.0376	-0.1644	7.79	63.5
X1:O	-0.162	0.4695	-0.004272	-0.7137	-0.2981	-0.1949	-0.162	-6.939	51.75
X1:E	-0.06381	0.4645	0.001039	-0.5362	-0.1846	-0.0192	-0.06381	7.512	36.75
X2:O	-0.1178	0.5378	-0.00369	-0.2371	-0.2226	-0.0303	-0.1178	7.65	51.75
X2:E	-0.09065	0.53	-0.001078	-0.0156	-0.2488	-0.1041	-0.09065	-6.79	36.75
X3:O	-0.1519	0.4536	-0.001072	-0.1674	-0.2936	-0.1783	-0.1519	-6.943	49.75
X3:E	-0.05751	0.4437	0.002796	-0.6545	-0.1772	-0.0182	-0.05751	7.483	34.75
X4:O	-0.1101	0.5303	-0.004001	-0.1991	-0.2196	-0.0284	-0.1101	7.634	49.75
X4:E	-0.08224	0.5241	-0.003668	-0.3263	-0.2400	-0.0964	-0.08224	-6.784	34.75

Joint Support Reactions for Load Case "Ext. Wind T":

Joint	X	X	Y	Y H-Shear	Z Comp.	Uplift	Result.	Result.	X	X-M.	Y	Y-M.	H-Bend-M	Z	Z-M.	Max.
-------	---	---	---	-----------	---------	--------	---------	---------	---	------	---	------	----------	---	------	------

	Label	Force (kips)	Usage %	Force (kips)	Usage %	Force (kips)	Usage %	Force (kips)	Usage %	Force (kips)	Usage %	Moment (ft-k)	Usage %	Moment (ft-k)	Usage %	Moment (ft-k)	Usage %	Moment (ft-k)	Usage %
Left:g	0.15	0.0	-4.98	0.0	0.0	28.84	0.0	0.0	29.27	0.0	87.33	0.0	4.0	0.0	0.0	0.96	0.0	0.0	
Right:g	0.14	0.0	-12.55	0.0	0.0	-47.15	0.0	0.0	48.79	0.0	279.72	0.0	16.6	0.0	0.0	1.24	0.0	0.0	

Detailed Laminated Wood Pole Usages for Load Case "Ext. Wind T":

Element Label	Joint Label	Joint Position	Rel. Dist. (ft)	Trans. Defl. (in)	Long. Defl. (in)	Vert. Defl. (in)	Trans. Mom. (ft-k)	Long. Mom. (ft-k)	Tors. Mom. (ft-k)	Axial Force (kips)	Tran. Shear (kips)	Long. Shear (kips)	Usage %
Left	Left:t	Origin	0.00	5.97	-2.86	-0.02	0.00	0.00	0.0	-0.01	0.01	0.00	0.0
Left	Left:SW	End	0.50	6.06	-2.83	-0.02	0.01	0.00	0.0	-0.01	0.01	0.00	0.0
Left	Left:SW	Origin	0.50	6.06	-2.83	-0.02	0.01	0.00	0.0	-0.87	0.44	0.06	0.2
Left	Left:Brace	End	2.00	6.35	-2.72	-0.01	0.66	0.08	0.0	-0.87	0.44	0.06	2.3
Left	Left:Brace	Origin	2.00	6.35	-2.72	-0.01	-0.88	0.08	-0.0	1.64	-6.69	0.06	3.1
Left	#Left:0	End	4.88	6.82	-2.52	-0.01	-20.11	0.26	-0.0	1.64	-6.69	0.06	52.2
Left	#Left:0	Origin	4.88	6.82	-2.52	-0.01	-20.11	0.26	-0.0	1.48	-6.59	0.06	52.2
Left	Left:Arm	End	7.75	6.85	-2.33	-0.01	-39.05	0.43	-0.0	1.48	-6.59	0.06	90.1
Left	Left:Arm	Origin	7.75	6.85	-2.33	-0.01	-39.05	0.27	-0.9	2.58	12.28	0.06	90.1
Left	#Left:1	End	10.75	6.27	-2.14	-0.01	-2.22	0.44	-0.9	2.58	12.28	0.06	5.7
Left	#Left:1	Origin	10.75	6.27	-2.14	-0.01	-2.22	0.44	-0.9	2.52	12.40	0.05	5.7
Left	Left:XTP	End	13.75	5.63	-1.96	-0.00	34.98	0.59	-0.9	2.52	12.40	0.05	65.4
Left	Left:XTP	Origin	13.75	5.63	-1.96	-0.00	32.12	0.60	-0.9	10.73	4.42	0.03	61.8
Left	Left:XTP2	End	15.75	5.44	-1.84	-0.00	40.96	0.66	-0.9	10.73	4.42	0.03	73.1
Left	Left:XTP2	Origin	15.75	5.44	-1.84	-0.00	37.00	0.66	-0.9	21.86	-5.96	0.02	68.5
Left	#Left:2	End	20.75	5.71	-1.54	-0.01	7.21	0.74	-0.9	21.86	-5.96	0.02	15.4
Left	#Left:2	Origin	20.75	5.71	-1.54	-0.01	7.21	0.75	-0.9	21.75	-5.67	0.03	15.4
Left	#Left:3	End	24.75	6.15	-1.31	-0.01	-15.46	0.86	-0.9	21.75	-5.67	0.03	24.7
Left	#Left:3	Origin	24.75	6.15	-1.31	-0.01	-15.46	0.85	-0.9	21.60	-5.61	0.03	24.7
Left	Left:XBT	End	28.75	6.36	-1.10	-0.01	-37.89	1.00	-0.9	21.60	-5.61	0.03	48.3
Left	Left:XBT	Origin	28.75	6.36	-1.10	-0.01	-39.67	1.00	-0.9	25.60	-1.42	0.04	51.0
Left	Left:XBT2	End	30.75	6.29	-1.00	-0.01	-42.52	1.08	-0.9	25.60	-1.42	0.04	51.7
Left	Left:XBT2	Origin	30.75	6.29	-1.00	-0.01	-44.64	1.07	-0.9	30.28	3.28	0.04	54.7
Left	#Left:4	End	35.75	5.61	-0.76	-0.02	-28.24	1.29	-0.9	30.28	3.28	0.04	32.9
Left	#Left:4	Origin	35.75	5.61	-0.76	-0.02	-28.25	1.29	-0.9	30.12	3.26	0.05	32.9
Left	#Left:5	End	40.75	4.48	-0.55	-0.01	-11.93	1.56	-0.9	30.12	3.26	0.05	15.8
Left	#Left:5	Origin	40.75	4.48	-0.55	-0.01	-11.93	1.56	-0.9	29.94	3.40	0.07	15.8
Left	#Left:6	End	45.75	3.18	-0.37	-0.00	5.06	1.89	-0.9	29.94	3.40	0.07	9.5
Left	#Left:6	Origin	45.75	3.18	-0.37	-0.00	5.06	1.90	-0.9	29.73	3.64	0.08	9.4
Left	#Left:7	End	50.75	1.94	-0.21	0.00	23.25	2.30	-0.9	29.73	3.64	0.08	21.5
Left	#Left:7	Origin	50.75	1.94	-0.21	0.00	23.24	2.30	-0.9	29.50	3.96	0.10	21.4
Left	#Left:8	End	55.75	0.92	-0.10	0.01	43.04	2.78	-0.9	29.50	3.96	0.10	32.1
Left	#Left:8	Origin	55.75	0.92	-0.10	0.01	43.03	2.79	-0.9	29.25	4.33	0.12	32.1
Left	#Left:9	End	60.63	0.25	-0.03	0.00	64.17	3.35	-0.9	29.25	4.33	0.12	41.7
Left	#Left:9	Origin	60.63	0.25	-0.03	0.00	64.17	3.35	-0.9	28.98	4.75	0.14	41.6
Left	Left:g	End	65.50	0.00	0.00	0.00	87.33	4.01	-0.9	28.98	4.75	0.14	50.6
Right	Right:t	Origin	0.00	11.75	-2.95	-0.12	0.00	0.00	0.0	-0.07	0.08	0.00	0.0
Right	Right:TMo1	End	2.00	11.29	-2.85	-0.12	0.15	0.00	0.0	-0.07	0.08	0.00	0.1
Right	Right:TMo1	Origin	2.00	11.29	-2.85	-0.12	0.15	0.00	0.0	-0.47	1.29	0.00	0.1
Right	#Right:10	End	6.50	10.28	-2.64	-0.11	5.97	0.01	0.0	-0.47	1.29	0.00	2.6
Right	#Right:10	Origin	6.50	10.28	-2.64	-0.11	5.97	0.01	0.0	-0.80	1.63	0.00	2.6
Right	Right:TMo2	End	11.00	9.29	-2.42	-0.10	13.32	0.02	0.0	-0.80	1.63	0.00	5.4
Right	Right:TMo2	Origin	11.00	9.29	-2.42	-0.10	13.32	0.02	0.0	-1.57	4.67	0.01	5.5
Right	Right:Coax1	End	14.00	8.67	-2.28	-0.09	27.34	0.04	0.0	-1.57	4.67	0.01	10.6
Right	Right:Coax1	Origin	14.00	8.67	-2.28	-0.09	27.34	0.04	0.0	-1.99	5.07	0.01	10.6



Right	Right:SW	End	19.00	7.76	-2.04	-0.09	52.67	0.08	0.0	-1.99	5.07	0.01	18.9
Right	Right:SW	Origin	19.00	7.76	-2.04	-0.09	52.67	0.08	0.0	-3.04	5.73	0.07	19.0
Right	Right:Brace	End	20.50	7.53	-1.97	-0.08	61.27	0.18	0.0	-3.04	5.73	0.07	21.6
Right	Right:Brace	Origin	20.50	7.53	-1.97	-0.08	57.84	0.18	-0.0	-11.90	-1.18	0.09	21.0
Right	Right:Coax2	End	24.00	7.09	-1.80	-0.08	53.70	0.49	-0.0	-11.90	-1.18	0.09	18.7
Right	Right:Coax2	Origin	24.00	7.09	-1.80	-0.08	53.70	0.49	-0.0	-12.23	-0.90	0.09	18.7
Right	Right:Arm	End	26.25	6.86	-1.69	-0.08	51.67	0.68	-0.0	-12.23	-0.90	0.09	17.5
Right	Right:Arm	Origin	26.25	6.86	-1.69	-0.08	51.67	0.82	-1.2	-11.70	-2.47	0.35	17.5
Right	#Right:11	End	29.25	6.63	-1.55	-0.08	44.25	1.86	-1.2	-11.70	-2.47	0.35	14.8
Right	#Right:11	Origin	29.25	6.63	-1.55	-0.08	44.25	1.86	-1.2	-11.96	-2.27	0.35	14.8
Right	Right:XTP	End	32.25	6.45	-1.41	-0.08	37.45	2.90	-1.2	-11.96	-2.27	0.35	12.5
Right	Right:XTP	Origin	32.25	6.45	-1.41	-0.08	34.60	2.90	-1.2	-16.63	-6.13	0.35	11.9
Right	Right:Coax3	End	34.00	6.37	-1.33	-0.08	23.88	3.52	-1.2	-16.63	-6.13	0.35	8.7
Right	Right:Coax3	Origin	34.00	6.37	-1.33	-0.08	23.88	3.52	-1.2	-16.82	-5.96	0.35	8.7
Right	Right:XTP2	End	34.25	6.36	-1.32	-0.07	22.39	3.61	-1.2	-16.82	-5.96	0.35	8.3
Right	Right:XTP2	Origin	34.25	6.36	-1.32	-0.07	19.09	3.61	-1.2	-22.15	-10.40	0.36	7.7
Right	#Right:12	End	39.13	6.17	-1.10	-0.07	-31.58	5.36	-1.2	-22.15	-10.40	0.36	11.0
Right	#Right:12	Origin	39.13	6.17	-1.10	-0.07	-31.58	5.36	-1.2	-22.62	-9.99	0.36	11.1
Right	Right:Coax4	End	44.00	5.88	-0.89	-0.07	-80.30	7.10	-1.2	-22.62	-9.99	0.36	23.3
Right	Right:Coax4	Origin	44.00	5.88	-0.89	-0.07	-80.30	7.10	-1.2	-23.13	-9.53	0.35	23.3
Right	Right:XBT	End	47.25	5.57	-0.76	-0.07	-111.28	8.25	-1.2	-23.13	-9.53	0.35	30.3
Right	Right:XBT	Origin	47.25	5.57	-0.76	-0.07	-117.14	8.25	-1.2	-31.75	-0.96	0.32	32.2
Right	Right:XBT2	End	49.25	5.32	-0.69	-0.06	-119.06	8.90	-1.2	-31.75	-0.96	0.32	32.1
Right	Right:XBT2	Origin	49.25	5.32	-0.69	-0.06	-126.93	8.89	-1.2	-43.15	10.44	0.28	34.6
Right	Right:Coax5	End	54.00	4.55	-0.52	-0.05	-77.34	10.24	-1.2	-43.15	10.44	0.28	22.0
Right	Right:Coax5	Origin	54.00	4.55	-0.52	-0.05	-77.34	10.23	-1.2	-43.70	11.03	0.27	22.0
Right	#Right:13	End	59.00	3.55	-0.37	-0.04	-22.16	11.57	-1.2	-43.70	11.03	0.27	9.3
Right	#Right:13	Origin	59.00	3.55	-0.37	-0.04	-22.16	11.56	-1.2	-44.21	11.45	0.25	9.4
Right	Right:Coax6	End	64.00	2.51	-0.24	-0.03	35.10	12.80	-1.2	-44.21	11.45	0.25	11.9
Right	Right:Coax6	Origin	64.00	2.51	-0.24	-0.03	35.10	12.80	-1.2	-44.86	11.88	0.23	11.9
Right	#Right:14	End	69.00	1.54	-0.14	-0.02	94.49	13.93	-1.2	-44.86	11.88	0.23	23.1
Right	#Right:14	Origin	69.00	1.54	-0.14	-0.02	94.49	13.94	-1.2	-45.44	12.13	0.21	23.2
Right	Right:Coax7	End	74.00	0.74	-0.06	-0.01	155.14	14.96	-1.2	-45.44	12.13	0.21	33.5
Right	Right:Coax7	Origin	74.00	0.74	-0.06	-0.01	155.13	14.96	-1.2	-46.16	12.40	0.18	33.5
Right	#Right:15	End	79.00	0.20	-0.02	-0.00	217.14	15.86	-1.2	-46.16	12.40	0.18	43.0
Right	#Right:15	Origin	79.00	0.20	-0.02	-0.00	217.14	15.86	-1.2	-46.82	12.52	0.16	43.1
Right	Right:g	End	84.00	0.00	0.00	0.00	279.72	16.63	-1.2	-46.82	12.52	0.16	51.7

Summary of Brace Forces and Usages for Load Case "Ext. Wind T":

Brace Label	Forces (kips)	Allowable Compression (kips)	Allowable Tension (kips)	Usage %
TENL	2.49	15.37	30.00	11.07
TENR	2.26	15.37	30.00	10.06
VEEL	-6.69	18.88	20.00	47.21
VEER	11.44	18.88	20.00	76.27
X1	-11.72	26.38	25.00	59.25
X2	5.96	26.38	25.00	31.77
X3	-15.58	26.38	25.00	78.75
X4	6.83	26.38	25.00	36.41

Detailed X-Arm Usages for Load Case "Ext. Wind T":

X-Arm Label	Joint Label	Joint Position	Rel. Dist. (ft)	Area (in <sup>2</sup> )	X Sect. Modulus (in <sup>3</sup> )	Z Sect. Modulus (in <sup>3</sup> )	Tran. Defl. (in)	Long. Defl. (in)	Vert. Defl. (in)	X Mom. (ft-k)	Z Tors. Mom. (ft-k)	Axial Force (kips)	X Shear (kips)	Z Shear (kips)	P/A (psi)	Mx/Sx (psi)	Mz/Sz (psi)	Max. Usage %
-------------	-------------	----------------	-----------------	-------------------------	------------------------------------	------------------------------------	------------------	------------------	------------------	---------------	---------------------	--------------------	----------------	----------------	-----------	-------------	-------------	--------------

NESC32	NESC32:O	Origin	0.00	38.40	32.83	48.04	6.86	-2.81	-0.78	0.00	-0.00	-0.0	0.00	-0.00	0.00	0.00052	0.000305	6.59e-006	0.0
NESC32	NESC32:L1	End	0.50	38.40	32.83	48.04	6.86	-2.78	-0.75	-0.00	-0.00	-0.0	0.00	-0.00	0.00	0.00052	0.561	0.0021	0.0
NESC32	NESC32:L1	Origin	0.50	38.40	32.83	48.04	6.86	-2.78	-0.75	0.00	0.00	0.0	-2.79	0.18	0.09	73	0.561	0.00209	1.2
NESC32	#gNESC32:0	End	4.38	38.40	32.83	48.04	6.86	-2.54	-0.43	0.68	-0.34	0.0	-2.79	0.18	0.09	73	249	84.3	6.8
NESC32	#gNESC32:0	Origin	4.38	38.40	32.83	48.04	6.86	-2.54	-0.43	-0.68	0.34	0.0	-2.79	0.12	0.09	73	249	84.3	6.8
NESC32	NESC32:PL	End	8.25	38.40	32.83	48.04	6.85	-2.33	-0.01	1.16	-0.67	0.0	-2.79	0.12	0.09	73	423	167	11.0
NESC32	NESC32:PL	Origin	8.25	38.40	32.83	48.04	6.85	-2.33	-0.01	-1.15	-0.23	0.1	16.00	-0.70	0.09	4.2e+002	421	57	14.9
NESC32	#gNESC32:1	End	12.13	38.40	32.83	48.04	6.86	-2.13	0.50	-1.55	-0.11	0.1	16.00	-0.70	0.09	4.2e+002	568	26.6	16.9
NESC32	#gNESC32:1	Origin	12.13	38.40	32.83	48.04	6.86	-2.13	0.50	1.55	0.11	0.1	16.00	-0.83	0.09	4.2e+002	568	26.8	16.9
NESC32	NESC32:L2V	End	16.00	38.40	32.83	48.04	6.87	-1.94	0.77	-4.76	-0.45	0.1	16.00	-0.83	0.09	4.2e+002	1.74e+003	112	37.8
NESC32	NESC32:L2V	Origin	16.00	38.40	32.83	48.04	6.87	-1.94	0.77	4.76	0.45	0.1	0.83	0.76	0.18	21	1.74e+003	112	31.2
NESC32	#gNESC32:2	End	19.88	38.40	32.83	48.04	6.87	-1.78	0.48	-1.84	-1.13	0.1	0.83	0.76	0.18	21	671	283	16.3
NESC32	#gNESC32:2	Origin	19.88	38.40	32.83	48.04	6.87	-1.78	0.48	1.83	1.13	0.1	0.83	0.70	0.18	22	671	283	16.3
NESC32	NESC32:PR	End	23.75	38.40	32.83	48.04	6.86	-1.69	-0.08	0.89	-1.83	0.1	0.83	0.70	0.18	22	325	456	13.4
NESC32	NESC32:PR	Origin	23.75	38.40	32.83	48.04	6.86	-1.69	-0.08	-0.88	0.62	-0.0	-0.92	-0.09	-0.08	24	323	155	8.4
NESC32	#gNESC32:3	End	27.63	38.40	32.83	48.04	6.86	-1.68	-0.58	0.54	-0.31	-0.0	-0.92	-0.09	-0.08	24	196	77.6	5.0
NESC32	#gNESC32:3	Origin	27.63	38.40	32.83	48.04	6.86	-1.68	-0.58	-0.54	0.31	-0.0	-0.92	-0.14	-0.08	24	196	77.6	5.0
NESC32	NESC32:L3	End	31.50	38.40	32.83	48.04	6.86	-1.69	-1.01	-0.00	-0.00	-0.0	-0.92	-0.14	-0.08	24	0.561	0.00148	0.4
NESC32	NESC32:L3	Origin	31.50	38.40	32.83	48.04	6.86	-1.69	-1.01	0.00	0.00	0.0	0.00	0.00	-0.00	0.00072	0.561	0.00149	0.0
NESC32	NESC32:E	End	32.00	38.40	32.83	48.04	6.86	-1.69	-1.07	0.00	0.00	0.0	0.00	0.00	-0.00	0.00072	1.41e-005	3.39e-006	0.0

Summary of Clamp Capacities and Usages for Load Case "Ext. Wind T":

Clamp Label	Force (kips)	Input Holding Capacity (kips)	Factored Holding Capacity (kips)	Usage %
C1	0.945	10.00	10.00	9.45
C2	1.026	10.00	10.00	10.26
C3	1.498	10.00	10.00	14.98
C4	1.498	10.00	10.00	14.98
C5	1.498	10.00	10.00	14.98
C6	1.223	10.00	10.00	12.23
C7	3.074	10.00	10.00	30.74
C8	0.402	10.00	10.00	4.02
C9	0.321	10.00	10.00	3.21
C10	0.192	10.00	10.00	1.92
C11	0.407	10.00	10.00	4.07
C12	0.466	10.00	10.00	4.66
C13	0.475	10.00	10.00	4.75
C14	0.475	10.00	10.00	4.75

Equilibrium Joint Positions and Rotations for Load Case "Ext. Wind L":

Joint Label	X-Displ (ft)	Y-Displ (ft)	Z-Displ (ft)	X-Rot (deg)	Y-Rot (deg)	Z-Rot (deg)	X-Pos (ft)	Y-Pos (ft)	Z-Pos (ft)
Left:g	0	0	0	0.0000	0.0000	0.0000	0	-7.75	0
Left:t	1.109	0.003624	-0.01183	0.1282	0.6044	2.8471	1.109	-7.746	65.49
Left:SW	1.104	0.004479	-0.0118	0.1282	0.6044	2.8471	1.104	-7.746	64.99
Left:Brace	1.088	0.007041	-0.0117	0.1281	0.6044	2.8471	1.088	-7.743	63.49
Left:Arm	1.028	0.01504	-0.01126	0.0758	0.5776	2.8477	1.028	-7.735	57.74
Left:XTP	0.9651	0.008934	-0.0108	0.0728	0.6638	2.2837	0.9651	-7.741	51.74
Left:XTP2	0.9409	0.008037	-0.01062	0.0842	0.7302	2.1190	0.9409	-7.742	49.74
Left:XBT	0.7181	0.007258	-0.008457	0.0541	1.2406	1.2658	0.7181	-7.743	36.74
Left:XBT2	0.6736	0.006711	-0.007933	0.0427	1.3121	1.1612	0.6736	-7.743	34.74
Right:g	0	0	0	0.0000	0.0000	0.0000	0	7.75	0
Right:t	0.2008	0.01453	-0.001884	-0.0448	-0.2489	0.7562	0.2008	7.765	84
Right:TMO1	0.2095	0.01308	-0.001865	-0.0448	-0.2490	0.7562	0.2095	7.763	82
Right:TMO2	0.2479	0.006563	-0.001769	-0.0445	-0.2333	0.7562	0.2479	7.757	73
Right:Coax1	0.2598	0.004396	-0.001735	-0.0442	-0.2164	0.7562	0.2598	7.754	70
Right:SW	0.2765	0.0007884	-0.001688	-0.0434	-0.1563	0.7561	0.2765	7.751	65
Right:Brace	0.2803	-0.0002929	-0.001674	-0.0431	-0.1311	0.7561	0.2803	7.75	63.5
Right:Coax2	0.2863	-0.002661	-0.001638	-0.0344	-0.0613	0.7560	0.2863	7.747	60
Right:Arm	0.2878	-0.003795	-0.001616	-0.0229	-0.0089	0.7560	0.2878	7.746	57.75
Right:XTP	0.2813	-0.005116	-0.001554	0.0069	0.1294	0.6535	0.2813	7.745	51.75
Right:Coax3	0.2768	-0.005001	-0.00153	0.0125	0.1669	0.6248	0.2768	7.745	50
Right:XTP2	0.2761	-0.004972	-0.001526	0.0132	0.1721	0.6207	0.2761	7.745	49.75
Right:Coax4	0.2314	-0.002563	-0.001314	0.0227	0.3405	0.4710	0.2314	7.747	40
Right:XBT	0.2109	-0.001678	-0.001211	0.0197	0.3804	0.4248	0.2109	7.748	36.75
Right:XBT2	0.1972	-0.001239	-0.001139	0.0168	0.4005	0.3971	0.1972	7.749	34.75
Right:Coax5	0.1626	-0.0005078	-0.0009497	0.0112	0.4309	0.3333	0.1626	7.749	30
Right:Coax6	0.08724	7.638e-005	-0.0005289	0.0035	0.4114	0.2097	0.08724	7.75	20
Right:Coax7	0.02575	6.811e-005	-0.000193	0.0002	0.2707	0.0992	0.02575	7.75	10
NESC32:O	1.446	0.02584	-0.02904	0.0911	0.5773	2.9322	1.446	-15.97	57.72
NESC32:L1	1.421	0.02519	-0.02799	0.0911	0.5773	2.9321	1.421	-15.47	57.72
NESC32:PL	1.028	0.01504	-0.01126	0.0931	0.5776	2.8477	1.028	-7.735	57.74
NESC32:L2V	0.5901	0.002547	0.002917	-0.0100	0.2820	3.1989	0.5901	0.002547	57.75
NESC32:PR	0.2878	-0.003795	-0.001616	-0.0666	-0.0089	0.7560	0.2878	7.746	57.75
NESC32:L3	0.1925	-0.004544	-0.008125	-0.0347	-0.0086	0.6830	0.1925	15.5	57.74
NESC32:E	0.1866	-0.00458	-0.008428	-0.0347	-0.0086	0.6830	0.1866	16	57.74
TENL:O	1.101	0.007377	-0.01231	0.1281	0.6044	2.8471	1.101	-8.015	63.49
TENR:O	0.2725	-0.0003443	-0.002116	-0.0431	-0.1311	0.7561	0.2725	8.337	63.5
VEEL:O	1.074	0.006705	-0.01109	0.1281	0.6044	2.8471	1.074	-7.471	63.49
VEER:O	0.288	-0.0002416	-0.001233	-0.0431	-0.1311	0.7561	0.288	7.162	63.5
X1:O	0.9515	0.008663	-0.01037	0.0728	0.6638	2.2837	0.9515	-7.4	51.74
X1:E	0.2161	-0.001659	-0.001453	0.0197	0.3804	0.4248	0.2161	7.046	36.75
X2:O	0.2886	-0.005074	-0.001631	0.0069	0.1294	0.6535	0.2886	7.107	51.75
X2:E	0.7086	0.007153	-0.008051	0.0541	1.2406	1.2658	0.7086	-7.312	36.74
X3:O	0.9278	0.007795	-0.0101	0.0842	0.7302	2.1190	0.9278	-7.389	49.74
X3:E	0.2022	-0.001222	-0.001347	0.0168	0.4005	0.3971	0.2022	7.038	34.75
X4:O	0.2831	-0.004934	-0.001674	0.0132	0.1721	0.6207	0.2831	7.099	49.75
X4:E	0.6646	0.006621	-0.007603	0.0427	1.3121	1.1612	0.6646	-7.301	34.74

Joint Support Reactions for Load Case "Ext. Wind L":

Joint	X	X	Y	Y H-Shear	Z Comp.	Uplift	Result.	Result.	X	X-M.	Y	Y-M.	H-Bend-M	Z	Z-M.	Max.
-------	---	---	---	-----------	---------	--------	---------	---------	---	------	---	------	----------	---	------	------

	Label	Force (kips)	Usage % (kips)	Force %	Usage %	Force (kips)	Usage %	Force (kips)	Usage %	Force (kips)	Usage % (ft-k)	Force (kips)	Usage % (ft-k)	Force (kips)	Usage % (ft-k)	Force (kips)	Usage %	
Left:g	-2.47	0.0	-0.03	0.0	0.0	-5.25	0.0	0.0	5.80	0.0	-0.16	0.0	-45.8	0.0	0.0	-10.31	0.0	0.0
Right:g	-4.44	0.0	-0.10	0.0	0.0	-13.07	0.0	0.0	13.80	0.0	0.37	0.0	-95.1	0.0	0.0	-23.17	0.0	0.0

Detailed Laminated Wood Pole Usages for Load Case "Ext. Wind L":

Element Label	Joint Label	Joint Position	Rel. Dist. (ft)	Trans. Defl. (in)	Long. Defl. (in)	Vert. Defl. (in)	Trans. Mom. (ft-k)	Long. Mom. (ft-k)	Tors. Mom. (ft-k)	Axial Force (kips)	Tran. Shear (kips)	Long. Shear (kips)	Usage %
Left	Left:t	Origin	0.00	0.04	13.31	-0.14	0.00	-0.00	-0.0	-0.01	-0.00	-0.01	0.0
Left	Left:SW	End	0.50	0.05	13.25	-0.14	-0.00	-0.00	-0.0	-0.01	-0.00	-0.01	0.0
Left	Left:SW	Origin	0.50	0.05	13.25	-0.14	-0.00	-0.00	0.0	-0.86	-0.00	0.01	0.2
Left	Left:Brace	End	2.00	0.08	13.06	-0.14	-0.00	0.01	0.0	-0.86	-0.00	0.01	0.2
Left	Left:Brace	Origin	2.00	0.08	13.06	-0.14	-0.05	0.01	-0.0	-3.43	-0.24	-0.23	1.0
Left	#Left:0	End	4.88	0.14	12.69	-0.14	-0.74	-0.66	-0.0	-3.43	-0.24	-0.23	3.8
Left	#Left:0	Origin	4.88	0.14	12.69	-0.14	-0.74	-0.66	-0.0	-3.49	-0.24	-0.31	3.8
Left	Left:Arm	End	7.75	0.18	12.33	-0.14	-1.45	-1.56	-0.0	-3.49	-0.24	-0.31	6.5
Left	Left:Arm	Origin	7.75	0.18	12.33	-0.14	-1.29	-0.56	10.7	-3.64	0.46	1.14	4.6
Left	#Left:1	End	10.75	0.14	11.97	-0.13	0.07	2.85	10.7	-3.64	0.46	1.14	5.1
Left	#Left:1	Origin	10.75	0.14	11.97	-0.13	0.08	2.84	10.7	-3.71	0.45	1.04	5.1
Left	Left:XTP	End	13.75	0.11	11.58	-0.13	1.40	5.97	10.7	-3.71	0.45	1.04	11.6
Left	Left:XTP	Origin	13.75	0.11	11.58	-0.13	1.20	5.97	10.6	-3.15	-0.25	0.71	11.1
Left	Left:XTP2	End	15.75	0.10	11.29	-0.13	0.68	7.38	10.6	-3.15	-0.25	0.71	11.7
Left	Left:XTP2	Origin	15.75	0.10	11.29	-0.13	0.77	7.38	10.5	-3.43	-0.16	0.33	11.9
Left	#Left:2	End	20.75	0.09	10.43	-0.12	-0.07	9.02	10.5	-3.43	-0.16	0.33	11.9
Left	#Left:2	Origin	20.75	0.09	10.43	-0.12	-0.04	9.02	10.5	-3.56	-0.16	0.15	11.9
Left	#Left:3	End	24.75	0.09	9.59	-0.11	-0.74	9.60	10.5	-3.56	-0.16	0.15	12.8
Left	#Left:3	Origin	24.75	0.09	9.59	-0.11	-0.71	9.60	10.5	-3.68	-0.17	-0.03	12.8
Left	Left:XBT	End	28.75	0.09	8.62	-0.10	-1.42	9.49	10.5	-3.68	-0.17	-0.03	12.7
Left	Left:XBT	Origin	28.75	0.09	8.62	-0.10	-1.57	9.49	10.4	-3.38	0.28	-0.40	12.8
Left	Left:XBT2	End	30.75	0.08	8.08	-0.10	-1.03	8.70	10.4	-3.38	0.28	-0.40	11.0
Left	Left:XBT2	Origin	30.75	0.08	8.08	-0.10	-0.86	8.70	10.3	-3.83	0.01	-0.81	10.9
Left	#Left:4	End	35.75	0.06	6.64	-0.08	-0.81	4.62	10.3	-3.83	0.01	-0.81	6.0
Left	#Left:4	Origin	35.75	0.06	6.64	-0.08	-0.80	4.62	10.3	-4.01	0.01	-1.06	6.0
Left	#Left:5	End	40.75	0.04	5.11	-0.06	-0.72	-0.66	10.3	-4.01	0.01	-1.06	1.8
Left	#Left:5	Origin	40.75	0.04	5.11	-0.06	-0.73	-0.66	10.3	-4.20	0.02	-1.31	1.8
Left	#Left:6	End	45.75	0.02	3.59	-0.04	-0.63	-7.20	10.3	-4.20	0.02	-1.31	7.5
Left	#Left:6	Origin	45.75	0.02	3.59	-0.04	-0.65	-7.20	10.3	-4.41	0.02	-1.56	7.5
Left	#Left:7	End	50.75	0.01	2.20	-0.02	-0.52	-15.02	10.3	-4.41	0.02	-1.56	13.6
Left	#Left:7	Origin	50.75	0.01	2.20	-0.02	-0.56	-15.02	10.3	-4.63	0.02	-1.83	13.7
Left	#Left:8	End	55.75	0.00	1.05	-0.01	-0.39	-24.15	10.3	-4.63	0.02	-1.83	20.3
Left	#Left:8	Origin	55.75	0.00	1.05	-0.01	-0.46	-24.15	10.3	-4.87	0.02	-2.09	20.3
Left	#Left:9	End	60.63	-0.00	0.29	-0.00	-0.26	-34.32	10.3	-4.87	0.02	-2.09	27.1
Left	#Left:9	Origin	60.63	-0.00	0.29	-0.00	-0.35	-34.32	10.3	-5.12	0.03	-2.35	27.2
Left	Left:g	End	65.50	0.00	0.00	0.00	-0.11	-45.76	10.3	-5.12	0.03	-2.35	34.2
Right	Right:t	Origin	0.00	0.17	2.41	-0.02	0.00	0.00	-0.0	-0.07	-0.00	-0.05	0.0
Right	Right:TMo1	End	2.00	0.16	2.51	-0.02	-0.00	-0.10	-0.0	-0.07	-0.00	-0.05	0.0
Right	Right:TMo1	Origin	2.00	0.16	2.51	-0.02	-0.00	-0.10	-0.0	-0.49	0.01	0.75	0.1
Right	#Right:10	End	6.50	0.12	2.75	-0.02	0.05	3.29	-0.0	-0.49	0.01	0.75	1.0
Right	#Right:10	Origin	6.50	0.12	2.75	-0.02	0.05	3.29	0.0	-0.82	0.01	0.52	1.0
Right	Right:TMo2	End	11.00	0.08	2.97	-0.02	0.10	5.63	0.0	-0.82	0.01	0.52	1.6
Right	Right:TMo2	Origin	11.00	0.08	2.97	-0.02	0.10	5.63	0.0	-1.64	0.05	3.07	1.7
Right	Right:Coax1	End	14.00	0.05	3.12	-0.02	0.23	14.84	0.0	-1.64	0.05	3.07	4.2
Right	Right:Coax1	Origin	14.00	0.05	3.12	-0.02	0.23	14.84	-0.0	-2.05	0.05	3.03	4.2

Right	Right:SW	End	19.00	0.01	3.32	-0.02	0.46	29.99	-0.0	-2.05	0.05	3.03	8.0
Right	Right:SW	Origin	19.00	0.01	3.32	-0.02	0.46	29.99	-0.0	-3.10	0.05	2.90	8.1
Right	Right:Brace	End	20.50	-0.00	3.36	-0.02	0.53	34.34	-0.0	-3.10	0.05	2.90	9.2
Right	Right:Brace	Origin	20.50	-0.00	3.36	-0.02	1.10	34.34	0.0	-5.09	1.25	2.56	9.5
Right	Right:Coax2	End	24.00	-0.03	3.44	-0.02	5.46	43.29	0.0	-5.09	1.25	2.56	12.9
Right	Right:Coax2	Origin	24.00	-0.03	3.44	-0.02	5.46	43.29	0.0	-5.43	1.25	2.56	12.9
Right	Right:Arm	End	26.25	-0.05	3.45	-0.02	8.26	49.05	0.0	-5.43	1.25	2.56	15.0
Right	Right:Arm	Origin	26.25	-0.05	3.45	-0.02	8.26	48.09	22.5	-5.68	-0.33	-0.30	14.8
Right	#Right:11	End	29.25	-0.06	3.44	-0.02	7.22	47.19	22.5	-5.68	-0.33	-0.30	13.9
Right	#Right:11	Origin	29.25	-0.06	3.44	-0.02	7.25	47.18	22.5	-5.94	-0.34	-0.49	13.9
Right	Right:XTP	End	32.25	-0.06	3.38	-0.02	6.20	45.71	22.5	-5.94	-0.34	-0.49	12.9
Right	Right:XTP	Origin	32.25	-0.06	3.38	-0.02	5.88	45.70	22.7	-6.69	-0.78	-0.90	12.9
Right	Right:Coax3	End	34.00	-0.06	3.32	-0.02	4.49	44.12	22.7	-6.69	-0.78	-0.90	12.0
Right	Right:Coax3	Origin	34.00	-0.06	3.32	-0.02	4.49	44.12	22.7	-6.87	-0.78	-0.79	12.0
Right	Right:XTP2	End	34.25	-0.06	3.31	-0.02	4.30	43.93	22.7	-6.87	-0.78	-0.79	11.8
Right	Right:XTP2	Origin	34.25	-0.06	3.31	-0.02	4.45	43.92	22.8	-6.90	-0.52	-1.20	11.9
Right	#Right:12	End	39.13	-0.05	3.09	-0.02	1.85	38.07	22.8	-6.90	-0.52	-1.20	9.5
Right	#Right:12	Origin	39.13	-0.05	3.09	-0.02	1.88	38.07	22.8	-7.35	-0.52	-1.53	9.5
Right	Right:Coax4	End	44.00	-0.03	2.78	-0.02	-0.71	30.59	22.8	-7.35	-0.52	-1.53	7.3
Right	Right:Coax4	Origin	44.00	-0.03	2.78	-0.02	-0.69	30.59	22.8	-7.84	-0.52	-1.64	7.3
Right	Right:XBT	End	47.25	-0.02	2.53	-0.01	-2.41	25.27	22.8	-7.84	-0.52	-1.64	6.4
Right	Right:XBT	Origin	47.25	-0.02	2.53	-0.01	-2.95	25.27	23.0	-8.88	0.17	-2.04	6.6
Right	Right:XBT2	End	49.25	-0.01	2.37	-0.01	-2.62	21.19	23.0	-8.88	0.17	-2.04	5.6
Right	Right:XBT2	Origin	49.25	-0.01	2.37	-0.01	-2.59	21.19	23.2	-9.18	0.07	-2.54	5.6
Right	Right:Coax5	End	54.00	-0.01	1.95	-0.01	-2.26	9.13	23.2	-9.18	0.07	-2.54	2.9
Right	Right:Coax5	Origin	54.00	-0.01	1.95	-0.01	-2.25	9.13	23.2	-9.78	0.07	-2.71	2.9
Right	#Right:13	End	59.00	-0.00	1.49	-0.01	-1.87	-4.44	23.2	-9.78	0.07	-2.71	1.8
Right	#Right:13	Origin	59.00	-0.00	1.49	-0.01	-1.87	-4.44	23.2	-10.30	0.08	-3.09	1.8
Right	Right:Coax6	End	64.00	0.00	1.05	-0.01	-1.46	-19.87	23.2	-10.30	0.08	-3.09	4.7
Right	Right:Coax6	Origin	64.00	0.00	1.05	-0.01	-1.48	-19.86	23.2	-10.94	0.08	-3.28	4.7
Right	#Right:14	End	69.00	0.00	0.64	-0.00	-1.03	-36.27	23.2	-10.94	0.08	-3.28	7.6
Right	#Right:14	Origin	69.00	0.00	0.64	-0.00	-1.06	-36.27	23.2	-11.50	0.09	-3.66	7.6
Right	Right:Coax7	End	74.00	0.00	0.31	-0.00	-0.58	-54.58	23.2	-11.50	0.09	-3.66	10.7
Right	Right:Coax7	Origin	74.00	0.00	0.31	-0.00	-0.62	-54.58	23.2	-12.17	0.09	-3.86	10.7
Right	#Right:15	End	79.00	0.00	0.08	-0.00	-0.10	-73.90	23.2	-12.17	0.09	-3.86	13.8
Right	#Right:15	Origin	79.00	0.00	0.08	-0.00	-0.16	-73.90	23.2	-12.77	0.10	-4.25	13.9
Right	Right:g	End	84.00	0.00	0.00	0.00	0.40	-95.14	23.2	-12.77	0.10	-4.25	17.3

Summary of Brace Forces and Usages for Load Case "Ext. Wind L":

Brace Label	Forces (kips)	Allowable Compression (kips)	Allowable Tension (kips)	Usage %
TENL	2.17	15.37	30.00	9.66
TENR	2.15	15.37	30.00	9.57
VEEL	1.88	18.88	20.00	12.51
VEER	0.61	18.88	20.00	4.09
X1	-0.99	26.38	25.00	5.00
X2	0.65	26.38	25.00	3.45
X3	0.15	26.38	25.00	0.80
X4	-0.38	26.38	25.00	1.90

Detailed X-Arm Usages for Load Case "Ext. Wind L":

X-Arm Label	Joint Label	Joint Position	Rel. Dist. (ft)	Area (in^2)	X Sect. Modulus (in^3)	Z Sect. Modulus (in^3)	Tran. Defl. (in)	Long. Defl. (in)	Vert. Defl. (in)	X Mom. (ft-k)	Z Tors. Mom. (ft-k)	Axial Force (kips)	X Shear (kips)	Z Shear (kips)	P/A (psi)	Mx/Sx (psi)	Mz/Sz (psi)	Max. Usage %
-------------	-------------	----------------	-----------------	-------------	------------------------	------------------------	------------------	------------------	------------------	---------------	---------------------	--------------------	----------------	----------------	-----------	-------------	-------------	--------------

NESC32	NESC32:0	Origin	0.00	38.40	32.83	48.04	0.31	17.35	-0.35	0.00	0.00	0.0	0.00	-0.00	-0.01	0.00017	1.48e-005	1.17e-006	0.0
NESC32	NESC32:L1	End	0.50	38.40	32.83	48.04	0.30	17.05	-0.34	-0.00	0.00	0.0	0.00	-0.00	-0.01	0.00017	0.547	0.961	0.0
NESC32	NESC32:L1	Origin	0.50	38.40	32.83	48.04	0.30	17.05	-0.34	0.00	-0.00	-0.0	-1.72	0.01	-0.10	45	0.547	0.961	0.8
NESC32	#gNESC32:0	End	4.38	38.40	32.83	48.04	0.24	14.67	-0.24	0.05	0.39	-0.0	-1.72	0.01	-0.10	45	19.4	96.2	2.7
NESC32	#gNESC32:0	Origin	4.38	38.40	32.83	48.04	0.24	14.67	-0.24	-0.05	-0.39	0.0	-1.72	-0.03	-0.22	45	19.4	96.2	2.7
NESC32	NESC32:PL	End	8.25	38.40	32.83	48.04	0.18	12.33	-0.14	-0.07	1.22	0.0	-1.72	-0.03	-0.22	45	26.6	306	6.3
NESC32	NESC32:PL	Origin	8.25	38.40	32.83	48.04	0.18	12.33	-0.14	0.24	9.47	-1.0	-1.01	-0.00	-1.88	26	85.9	2.37e+003	41.3
NESC32	#gNESC32:1	End	12.13	38.40	32.83	48.04	0.11	9.78	-0.02	-0.24	-2.19	-1.0	-1.01	-0.00	-1.88	26	88	548	11.0
NESC32	#gNESC32:1	Origin	12.13	38.40	32.83	48.04	0.11	9.78	-0.02	0.24	2.19	-1.0	-1.01	-0.05	-2.00	26	89	548	11.0
NESC32	NESC32:L2V	End	16.00	38.40	32.83	48.04	0.03	7.08	0.04	-0.46	5.56	-1.0	-1.01	-0.05	-2.00	26	170	1.39e+003	26.4
NESC32	NESC32:L2V	Origin	16.00	38.40	32.83	48.04	0.03	7.08	0.04	0.46	-5.56	-1.0	-0.01	0.10	-2.27	0.36	167	1.39e+003	25.9
NESC32	#gNESC32:2	End	19.88	38.40	32.83	48.04	-0.03	4.77	0.02	-0.10	14.34	-1.0	-0.01	0.10	-2.27	0.36	35.4	3.58e+003	60.3
NESC32	#gNESC32:2	Origin	19.88	38.40	32.83	48.04	-0.03	4.77	0.02	0.08	-14.34	-1.0	-0.06	0.05	-2.38	1.7	28.2	3.58e+003	60.2
NESC32	NESC32:PR	End	23.75	38.40	32.83	48.04	-0.05	3.45	-0.02	0.05	23.58	-1.0	-0.06	0.05	-2.38	1.7	19.7	5.89e+003	98.5
NESC32	NESC32:PR	Origin	23.75	38.40	32.83	48.04	-0.05	3.45	-0.02	-0.08	-1.09	0.0	-1.68	0.01	0.20	44	30.9	272	5.8
NESC32	#gNESC32:3	End	27.63	38.40	32.83	48.04	-0.05	2.87	-0.07	0.13	0.32	0.0	-1.68	0.01	0.20	44	49.3	79.2	2.9
NESC32	#gNESC32:3	Origin	27.63	38.40	32.83	48.04	-0.05	2.87	-0.07	-0.13	-0.32	0.0	-1.68	-0.04	0.08	44	49.3	79.2	2.9
NESC32	NESC32:L3	End	31.50	38.40	32.83	48.04	-0.05	2.31	-0.10	-0.00	0.00	0.0	-1.68	-0.04	0.08	44	0.561	0.96	0.8
NESC32	NESC32:L3	Origin	31.50	38.40	32.83	48.04	-0.05	2.31	-0.10	0.00	-0.00	-0.0	0.00	0.00	0.01	4.9e-005	0.561	0.96	0.0
NESC32	NESC32:E	End	32.00	38.40	32.83	48.04	-0.05	2.24	-0.10	-0.00	0.00	-0.0	0.00	0.00	0.01	4.9e-005	1.45e-007	2.4e-008	0.0

Summary of Clamp Capacities and Usages for Load Case "Ext. Wind L":

Clamp Label	Force (kips)	Input Holding Capacity (kips)	Factored Holding Capacity (kips)	Usage %
C1	0.835	10.00	10.00	8.35
C2	0.796	10.00	10.00	7.96
C3	1.262	10.00	10.00	12.62
C4	1.262	10.00	10.00	12.62
C5	1.262	10.00	10.00	12.62
C6	0.823	10.00	10.00	8.23
C7	2.602	10.00	10.00	26.02
C8	0.105	10.00	10.00	1.05
C9	0.098	10.00	10.00	0.98
C10	0.153	10.00	10.00	1.53
C11	0.133	10.00	10.00	1.33
C12	0.195	10.00	10.00	1.95
C13	0.221	10.00	10.00	2.21
C14	0.240	10.00	10.00	2.40

\*\*\* Overall summary for all load cases - Usage = Maximum Stress / Allowable Stress

**Summary of Laminated Wood Pole Usages:**

Laminated Wood Pole Label	Maximum Usage %	Load Case	Segment Number	Weight (lbs)
Left	90.08	Ext. Wind T	4	2842.5
Right	51.74	Ext. Wind T	23	9671.7

**Summary of X-Arm Usages:**

X-Arm Label	Maximum Usage %	Load Case	Segment Number	Weight (lbs)
NESC32	98.54	Ext. Wind L	7	393.0

**Summary of Brace Usages:**

Brace Label	Maximum Usage %	Load Case	Weight (lbs)
TENL	21.16	NESC Heavy T	47.0
TENR	20.30	NESC Heavy T	47.0
VEEL	47.21	Ext. Wind T	58.0
VEER	76.27	Ext. Wind T	58.0
X1	59.25	Ext. Wind T	142.0
X2	31.77	Ext. Wind T	142.0
X3	78.75	Ext. Wind T	142.0
X4	36.41	Ext. Wind T	142.0

\*\*\* Maximum Stress Summary for Each Load Case

**Summary of Maximum Usages by Load Case:**

Load Case	Maximum Usage %	Element Label	Element Type
NESC Heavy T	54.71	Left Laminated Wood	
NESC Heavy L	37.71	NESC32 X-Arm	
Ext. Wind T	90.08	Left Laminated Wood	
Ext. Wind L	98.54	NESC32 X-Arm	

**Summary of Laminated Wood Pole Usages by Load Case:**

Load Case	Maximum Usage %	Laminated Wood Pole Label	Segment Number
NESC Heavy T	54.71	Left	4
NESC Heavy L	13.69	Left	18
Ext. Wind T	90.08	Left	4
Ext. Wind L	34.21	Left	18

**Summary of X-Arm Usages by Load Case:**

Load Case	Maximum Usage %	X-Arm Label	Segment Number
NESC Heavy T	19.91	NESC32	5
NESC Heavy L	37.71	NESC32	7
Ext. Wind T	37.83	NESC32	5
Ext. Wind L	98.54	NESC32	7

Summary of Brace Usages by Load Case:

Load Case	Maximum Usage %	Brace Label
NESC Heavy T	47.40	VEER
NESC Heavy L	25.79	VEEL
Ext. Wind T	78.75	X3
Ext. Wind L	12.51	VEEL

Summary of Insulator Usages:

Insulator Label	Insulator Type	Maximum Usage %	Load Case	Weight (lbs)
C1	Clamp	16.75	NESC Heavy T	0.0
C2	Clamp	17.25	NESC Heavy T	0.0
C3	Clamp	24.43	NESC Heavy T	0.0
C4	Clamp	24.43	NESC Heavy T	0.0
C5	Clamp	24.43	NESC Heavy T	0.0
C6	Clamp	12.23	Ext. Wind T	0.0
C7	Clamp	30.74	Ext. Wind T	0.0
C8	Clamp	4.34	NESC Heavy T	0.0
C9	Clamp	4.26	NESC Heavy T	0.0
C10	Clamp	4.16	NESC Heavy T	0.0
C11	Clamp	4.35	NESC Heavy T	0.0
C12	Clamp	4.66	Ext. Wind T	0.0
C13	Clamp	4.75	Ext. Wind T	0.0
C14	Clamp	4.75	Ext. Wind T	0.0

Loads At Insulator Attachments For All Load Cases:

Load Case	Insulator Label	Insulator Type	Structure Attach Label	Structure Attach Load X (kips)	Structure Attach Load Y (kips)	Structure Attach Load Z (kips)	Structure Attach Load Res. (kips)
NESC Heavy T	C1	Clamp	Left:SW	-0.025	0.457	1.611	1.675
NESC Heavy T	C2	Clamp	Right:SW	-0.049	0.689	1.581	1.725
NESC Heavy T	C3	Clamp	NESC32:L1	-0.025	0.707	2.338	2.443
NESC Heavy T	C4	Clamp	NESC32:L2V	-0.025	0.707	2.338	2.443
NESC Heavy T	C5	Clamp	NESC32:L3	-0.025	0.707	2.338	2.443
NESC Heavy T	C6	Clamp	Right:TMo1	0.001	0.411	0.488	0.638
NESC Heavy T	C7	Clamp	Right:TMo2	0.001	0.976	1.379	1.690
NESC Heavy T	C8	Clamp	Right:Coax1	0.001	0.140	0.411	0.434
NESC Heavy T	C9	Clamp	Right:Coax2	0.001	0.113	0.411	0.426
NESC Heavy T	C10	Clamp	Right:Coax3	0.000	0.067	0.411	0.416
NESC Heavy T	C11	Clamp	Right:Coax4	0.001	0.142	0.411	0.435
NESC Heavy T	C12	Clamp	Right:Coax5	0.001	0.162	0.411	0.442



NESC Heavy T	C13	Clamp Right:Coax6	0.001	0.165	0.411	0.443
NESC Heavy T	C14	Clamp Right:Coax7	0.001	0.165	0.411	0.443
NESC Heavy L	C1	Clamp Left:SW	-0.016	0.000	1.611	1.611
NESC Heavy L	C2	Clamp Right:SW	0.010	0.001	1.581	1.581
NESC Heavy L	C3	Clamp NESC32:L1	-0.025	0.000	2.338	2.338
NESC Heavy L	C4	Clamp NESC32:L2V	-0.025	0.000	2.338	2.338
NESC Heavy L	C5	Clamp NESC32:L3	-0.025	0.000	2.338	2.338
NESC Heavy L	C6	Clamp Right:TMo1	-0.279	0.001	0.488	0.562
NESC Heavy L	C7	Clamp Right:TMo2	-0.820	0.001	1.379	1.604
NESC Heavy L	C8	Clamp Right:Coax1	-0.001	0.001	0.411	0.411
NESC Heavy L	C9	Clamp Right:Coax2	-0.018	0.001	0.411	0.411
NESC Heavy L	C10	Clamp Right:Coax3	-0.052	0.000	0.411	0.414
NESC Heavy L	C11	Clamp Right:Coax4	0.016	0.001	0.411	0.411
NESC Heavy L	C12	Clamp Right:Coax5	0.041	0.001	0.411	0.413
NESC Heavy L	C13	Clamp Right:Coax6	0.051	0.001	0.411	0.414
NESC Heavy L	C14	Clamp Right:Coax7	0.058	0.001	0.411	0.415
Ext. Wind T	C1	Clamp Left:SW	-0.050	0.440	0.835	0.945
Ext. Wind T	C2	Clamp Right:SW	-0.053	0.658	0.785	1.026
Ext. Wind T	C3	Clamp NESC32:L1	-0.075	0.807	1.260	1.498
Ext. Wind T	C4	Clamp NESC32:L2V	-0.075	0.807	1.260	1.498
Ext. Wind T	C5	Clamp NESC32:L3	-0.075	0.807	1.260	1.498
Ext. Wind T	C6	Clamp Right:TMo1	0.001	1.208	0.189	1.223
Ext. Wind T	C7	Clamp Right:TMo2	0.001	3.026	0.539	3.074
Ext. Wind T	C8	Clamp Right:Coax1	0.001	0.390	0.097	0.402
Ext. Wind T	C9	Clamp Right:Coax2	0.001	0.306	0.097	0.321
Ext. Wind T	C10	Clamp Right:Coax3	0.000	0.166	0.097	0.192
Ext. Wind T	C11	Clamp Right:Coax4	0.001	0.395	0.097	0.407
Ext. Wind T	C12	Clamp Right:Coax5	0.001	0.456	0.097	0.466
Ext. Wind T	C13	Clamp Right:Coax6	0.001	0.465	0.097	0.475
Ext. Wind T	C14	Clamp Right:Coax7	0.002	0.465	0.097	0.475
Ext. Wind L	C1	Clamp Left:SW	-0.024	0.000	0.835	0.835
Ext. Wind L	C2	Clamp Right:SW	0.129	0.001	0.785	0.796
Ext. Wind L	C3	Clamp NESC32:L1	-0.075	0.000	1.260	1.262
Ext. Wind L	C4	Clamp NESC32:L2V	-0.075	0.000	1.260	1.262
Ext. Wind L	C5	Clamp NESC32:L3	-0.075	0.000	1.260	1.262
Ext. Wind L	C6	Clamp Right:TMo1	-0.801	0.001	0.189	0.823
Ext. Wind L	C7	Clamp Right:TMo2	-2.545	0.001	0.539	2.602
Ext. Wind L	C8	Clamp Right:Coax1	0.040	0.001	0.097	0.105
Ext. Wind L	C9	Clamp Right:Coax2	-0.012	0.001	0.097	0.098
Ext. Wind L	C10	Clamp Right:Coax3	-0.119	0.000	0.097	0.153
Ext. Wind L	C11	Clamp Right:Coax4	0.092	0.001	0.097	0.133
Ext. Wind L	C12	Clamp Right:Coax5	0.169	0.001	0.097	0.195
Ext. Wind L	C13	Clamp Right:Coax6	0.199	0.001	0.097	0.221
Ext. Wind L	C14	Clamp Right:Coax7	0.220	0.001	0.097	0.240

**Overturning Moments For User Input Concentrated Loads:**

Moments are static equivalents based on central axis of 0,0 (i.e. a single pole).

Load Case	Total Tran. Load (kips)	Total Long. Load (kips)	Total Vert. Load (kips)	Transverse Overturning Moment (ft-k)	Longitudinal Overturning Moment (ft-k)	Torsional Moment (ft-k)
NESC Heavy T	4.692	-0.150	14.950	331.335	-9.206	0.194
NESC Heavy L	0.000	-1.878	14.950	36.534	-121.475	13.586
Ext. Wind T	7.582	-0.329	6.807	508.243	-19.754	0.031
Ext. Wind L	0.000	-5.314	6.807	10.517	-350.302	38.665

\*\*\* Weight of structure (lbs):  
Weight of Braces: 778.0  
Weight of X-Arms: 393.0  
Weight of Laminated Wood Poles: 12514.2  
Total: 13685.2

\*\*\* End of Report

**Direct Embed Foundation:**

North Pole

**Input Data:**

Tower Data

Uplift = Uplift := 28.8-kips-1.1 = 32-kips (User Input)

Pole Length = L := 75-ft

Pole Base Width 1 =  $W_{pole1} := 10.25$ -in

Pole Base Width 2 =  $W_{pole2} := 18.5$ -in

Embedment Depth =  $D_e := 9.5$ -ft (User Input)

Material Properties:

Unit Weight of Gravel =  $\gamma_g := 115$ -pcf (User Input)

Depth to Neglect = n := 0-ft (User Input)

Angle of Internal Friction =  $\theta := 25$ -deg

Resisting Width 1 Top =  $R1 := 2 \cdot \tan(\theta) \cdot (D_e - n) + W_{pole1} = 9.71$ -ft (User Input)

Resisting Width 2 Top =  $R2 := 2 \cdot \tan(\theta) \cdot (D_e - n) + W_{pole2} = 10.4$ -ft (User Input)

**Calculated Properties:**

Volume of Resisting Tot =  $V_{tot} := \frac{(D_e - n)}{3} \cdot [R1 \cdot R2 + W_{pole1} \cdot W_{pole2} + \sqrt{(R1 \cdot R2) \cdot (W_{pole1} \cdot W_{pole2})}] = 361$

Volume of Resisting Material =  $V_{res} := V_{tot} - W_{pole1} \cdot W_{pole2} \cdot D_e = 348$ -ft<sup>3</sup>

Weight of Resisting Material =  $W_{T_{res}} := V_{res} \cdot \gamma_g = 40.037$ -kip

**Check Uplift:**

Total Uplift Resistance =  $Uplift_R := W_{T_{res}} = 40$ -kips

Uplift Check =  $\frac{Uplift}{Uplift_R} = 79.13\%$

$Uplift\_Check := \text{if} \left( \frac{Uplift_R}{Uplift} \geq 1.0, \text{"Okay"}, \text{"No Good"} \right)$

Uplift\_Check = "Okay"

**Direct Embed Foundation:**

South Pole

**Input Data:**

Tower Data

Uplift =	Uplift := 28.8-kips·1.1 = 32-kips	(User Input)
Pole Length =	L := 75-ft	
Pole Base Width 1 =	W <sub>pole1</sub> := 10.25-in	
Pole Base Width 2 =	W <sub>pole2</sub> := 18.5-in	
Embedment Depth =	D <sub>e</sub> := 11.8-ft	(User Input)

Material Properties:

Unit Weight of Gravel =	γ <sub>g</sub> := 115-pcf	(User Input)
Depth to Neglect =	n := 0-ft	(User Input)
Angle of Internal Friction =	θ := 25-deg	
Resisting Width 1 Top =	R1 := 2·tan(θ)·(D <sub>e</sub> - n) + W <sub>pole1</sub> = 11.86-ft	(User Input)
Resisting Width 2 Top =	R2 := 2·tan(θ)·(D <sub>e</sub> - n) + W <sub>pole2</sub> = 12.55-ft	(User Input)

**Calculated Properties:**

Volume of Resisting Tot =	$V_{tot} := \frac{(D_e - n)}{3} \cdot [R1 \cdot R2 + W_{pole1} \cdot W_{pole2} + \sqrt{(R1 \cdot R2) \cdot (W_{pole1} \cdot W_{pole2})}] = 64$
Volume of Resisting Material =	$V_{res} := V_{tot} - W_{pole1} \cdot W_{pole2} \cdot D_e = 630\text{-ft}^3$
Weight of Resisting Material =	$WT_{res} := V_{res} \cdot \gamma_g = 72.443\text{-kip}$

**Check Uplift:**

Total Uplift Resistance =	Uplift <sub>R</sub> := WT <sub>res</sub> = 72.4-kips
Uplift Check =	$\frac{\text{Uplift}}{\text{Uplift}_R} = 43.73\%$
	$\text{Uplift\_Check} := \text{if} \left( \frac{\text{Uplift}_R}{\text{Uplift}} \geq 1.0, \text{"Okay"}, \text{"No Good"} \right)$
	Uplift_Check = "Okay"

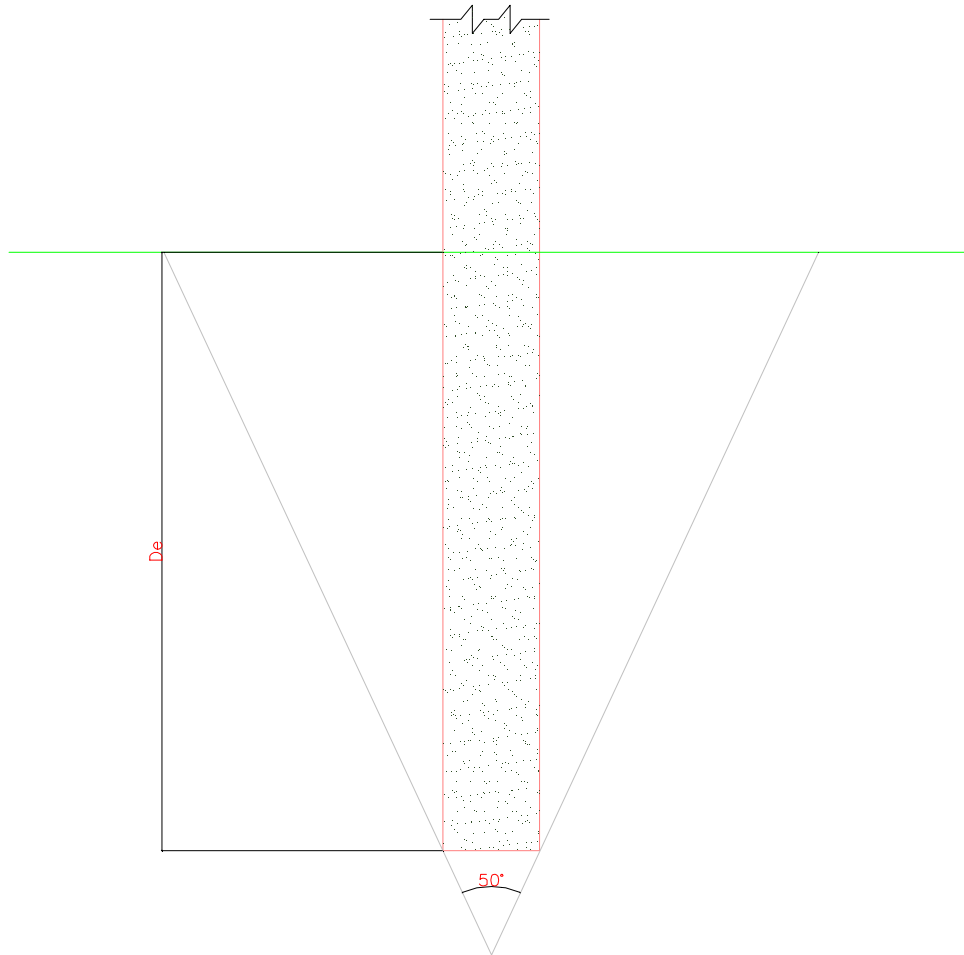

<b>RAN Template:</b> 67D94B Outdoor	<b>A&amp;L Template:</b> 67D94B_1DP+1OP	<b>Power System Template:</b> Custom
--	--	---

CT11135J\_L600\_3.1\_draft

## Section 1 - Site Information

**Site ID:** CT11135J  
**Status:** Draft  
**Version:** 3.1  
**Project Type:** L600  
**Approved:** Not Approved  
**Approved By:** Not Approved  
**Last Modified:** 5/9/2018 3:43:54 PM  
**Last Modified By:** GSM1900\MLucey

**Site Name:** West Hartford/ I-84 X42/M  
**Site Class:** Monopole  
**Site Type:** Structure Non Building  
**Solution Type:**  
**Plan Year:**  
**Market:** CONNECTICUT  
**Vendor:** Ericsson  
**Landlord:** CL&P

**Latitude:** 41.718091000  
**Longitude:** -72.767934000  
**Address:** 40 Maple Ridge Drive  
**City, State:** Farmington, CT  
**Region:** NORTHEAST

<b>RAN Template:</b> 67D94B Outdoor		<b>AL Template:</b> 67D94B_1DP+1OP		
<b>Sector Count:</b> 3	<b>Antenna Count:</b> 6	<b>Coax Line Count:</b> 18	<b>TMA Count:</b> 0	<b>RRU Count:</b> 0

## Section 2 - Existing Template Images

794DB\_RAN\_evolved\_from\_4B.png

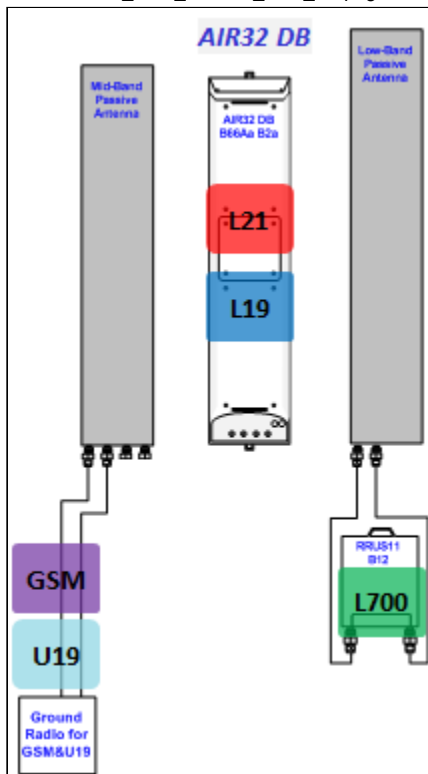

Notes:

Section 3 - Proposed Template Images

67D94DB\_1xAIR+1QP+1OP.JPG

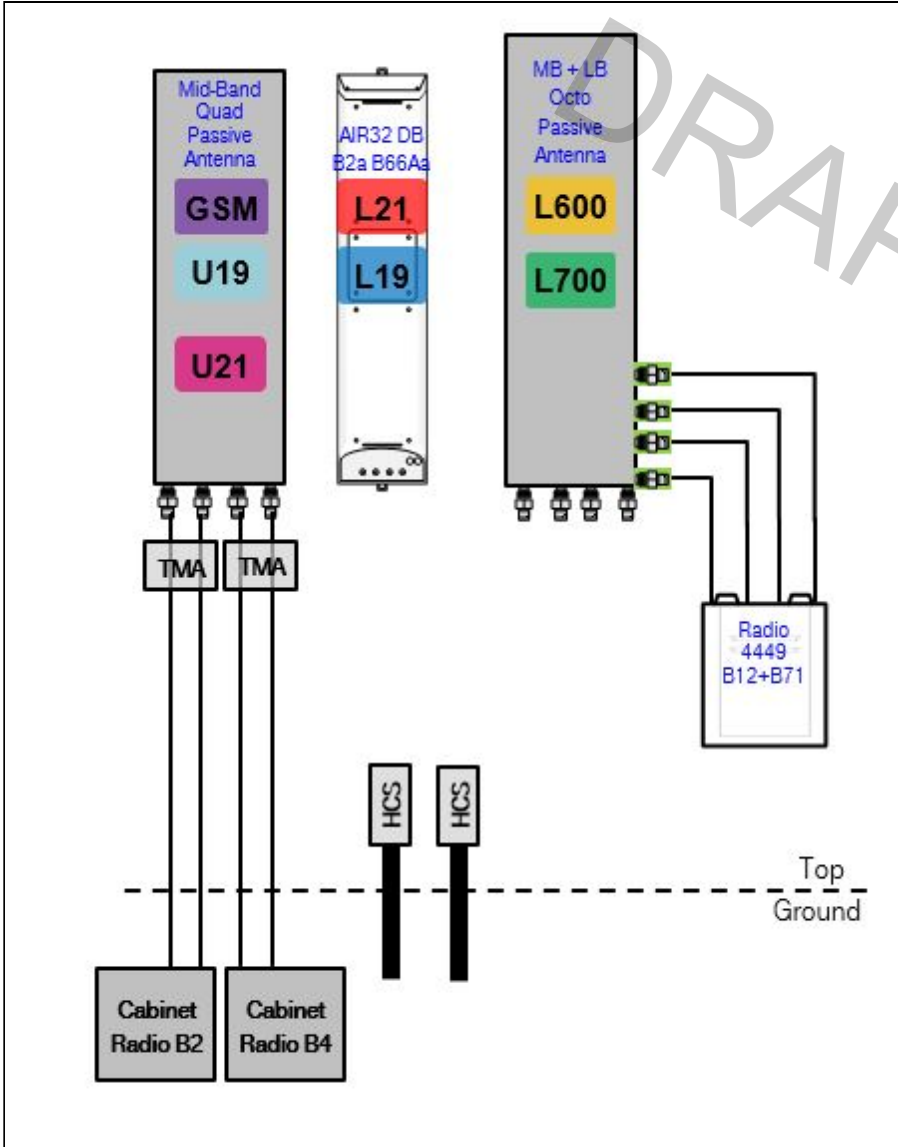

Notes:

67D94DB\_1xAIR+1OP.JPG

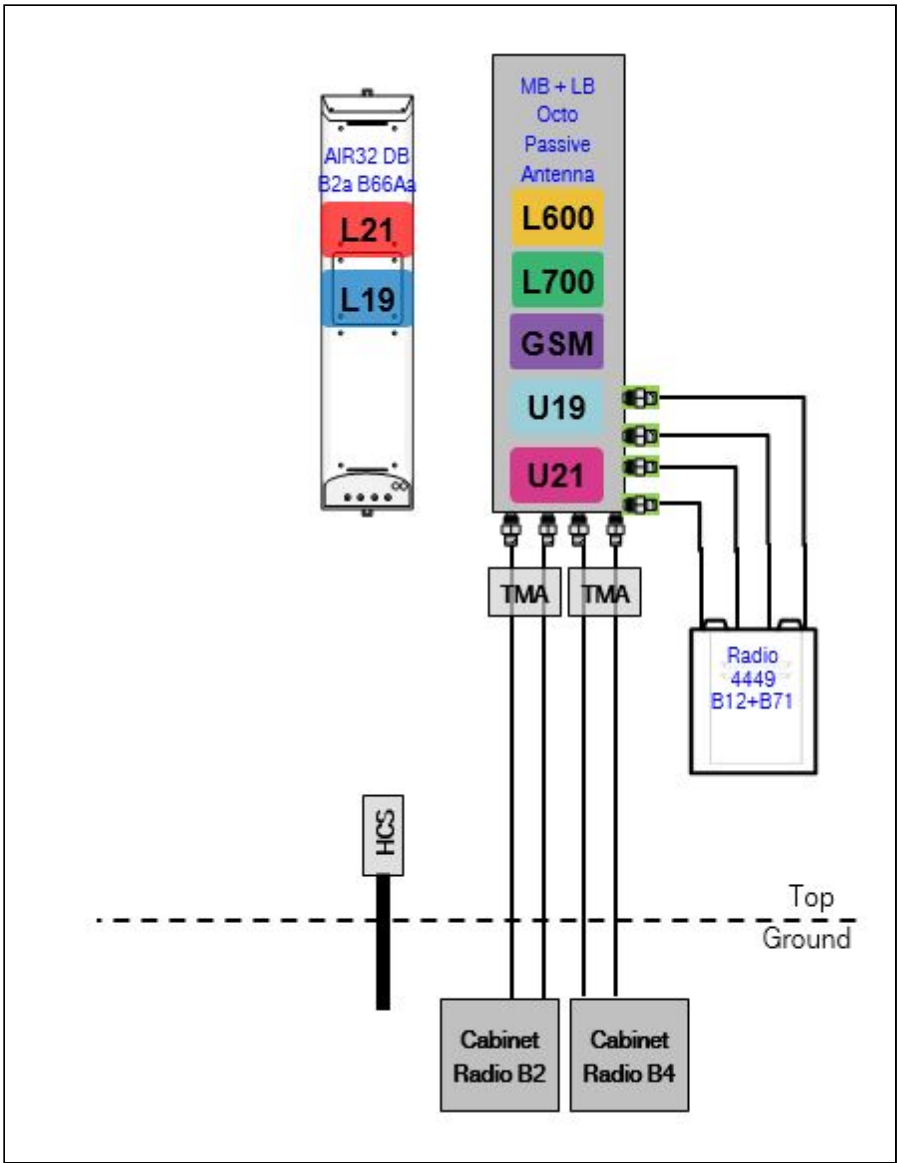

Notes:

67D94B\_1DP+10P.JPG



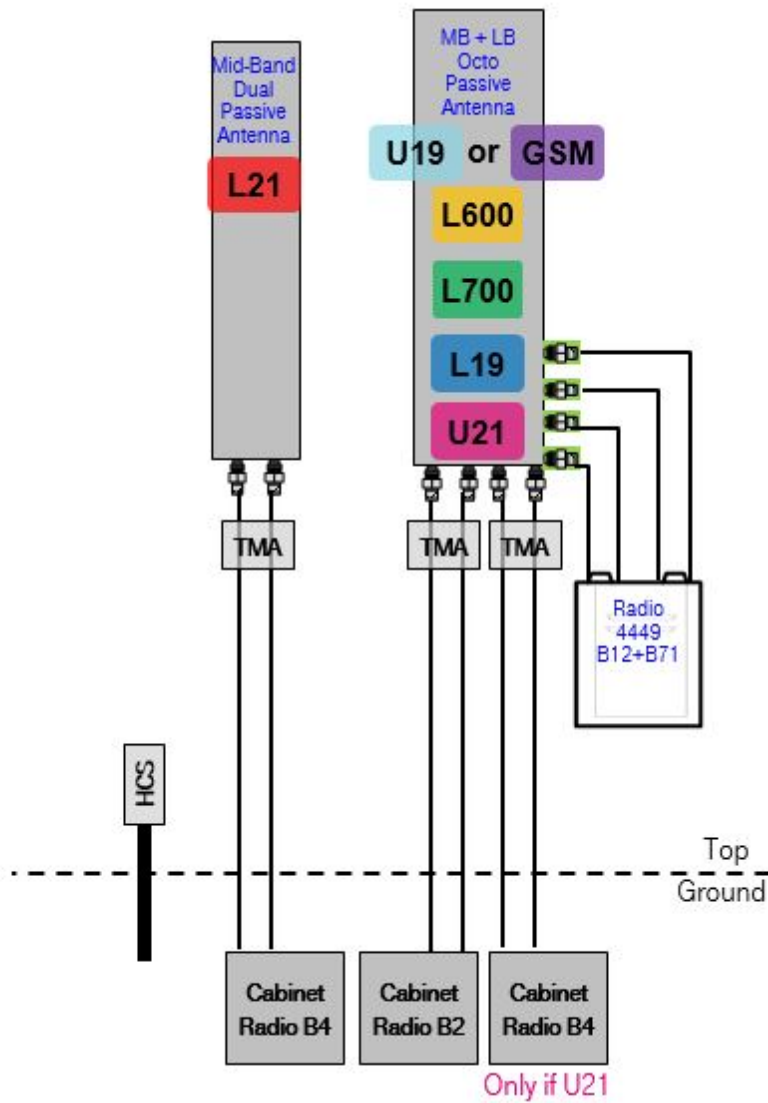

Notes:

Section 4 - Siteplan Images

----- This section is intentionally blank. -----

DRAFT

### Section 5 - RAN Equipment

#### Existing RAN Equipment

Template: 794DB Outdoor (evolved from 4B)

	1	2
<b>Enclosure</b>		
<b>Enclosure Type</b>	RBS 6102	RBS 3106
<b>Baseband</b>	<div style="display: flex; justify-content: space-around; font-size: small;"> <div style="border: 1px solid gray; padding: 2px;">DUS41 L2100</div> <div style="border: 1px solid gray; padding: 2px;">DUW30 U2100</div> <div style="border: 1px solid gray; padding: 2px;">DUG20 G1900</div> </div>	
<b>Multiplexer</b>	<div style="border: 1px solid gray; padding: 2px; font-size: small;">                     XMU L1900 L700                 </div>	
<b>Radio</b>	<div style="display: flex; justify-content: space-around; font-size: small;"> <div style="border: 1px solid gray; padding: 2px;">RUS01 B2 (x3) L1900</div> <div style="border: 1px solid gray; padding: 2px;">RUS01 B2 (x3) L1900 G1900</div> <div style="border: 1px solid gray; padding: 2px;">RUS01 B4 (x3) U2100</div> <div style="border: 1px solid gray; padding: 2px;">RUS01 B4 (x3) L2100</div> </div>	

#### Proposed RAN Equipment

Template: 67D94B Outdoor

	1	2
<b>Enclosure</b>		
<b>Enclosure Type</b>	RBS 6102	Ancillary Equipment
<b>Baseband</b>	<div style="display: flex; justify-content: space-around; font-size: small;"> <div style="border: 1px solid gray; padding: 2px;">BB 5216 L2100 L1900 L700 L600</div> <div style="border: 1px solid gray; padding: 2px;">DUW30 U2100</div> <div style="border: 1px solid gray; padding: 2px;">DUG20 G1900</div> </div>	
<b>Hybrid Cable System</b>		Ericsson 6x12 HCS *Select Length & AWG*
<b>Multiplexer</b>	<div style="border: 1px solid gray; padding: 2px; font-size: small;">XMU</div>	
<b>Radio</b>	<div style="display: flex; justify-content: space-around; font-size: small;"> <div style="border: 1px solid gray; padding: 2px;">RUS01 B2 (x3) G1900</div> <div style="border: 1px solid gray; padding: 2px;">RUS01 B2 (x3) L1900</div> <div style="border: 1px solid gray; padding: 2px;">RUS01 B4 (x3) U2100</div> <div style="border: 1px solid gray; padding: 2px;">RUS01 B4 (x3) L2100</div> </div>	

**RAN Scope of Work:**

<b>RAN Template:</b> 67D94B Outdoor	<b>A&amp;L Template:</b> 67D94B_1DP+1OP	<b>Power System Template:</b> Custom
--	--	---

Section 6 - A&L Equipment

Existing Template: 704A-V2\_1HP  
Proposed Template: 67D94B\_1DP+1OP

Sector 1 (Existing) view from behind

<b>Coverage Type</b>	A - Outdoor Macro		
<b>Antenna</b>	1		2
<b>Antenna Model</b>	RFS - APX16DWV-16DWV-S-E-A20 (Quad)		Andrew - LNX-6515DS-A1M (Dual)
<b>Azimuth</b>	40		40
<b>M. Tilt</b>	0		0
<b>Height</b>	82		73
<b>Ports</b>	P1	P2	P3
<b>Active Tech.</b>	L1900 G1900	U2100 L2100	L700
<b>Dark Tech.</b>			
<b>Restricted Tech.</b>			
<b>Decomm. Tech.</b>			
<b>E. Tilt</b>	5	5	2
<b>Cables</b>	7/8" Coax - 100 ft. (x2)	7/8" Coax - 100 ft. (x2)	7/8" Coax - 100 ft. (x2)
<b>TMA's</b>			
<b>Diplexers / Combiners</b>			
<b>Radio</b>			RRUS11 B12 (At Antenna)
<b>Sector Equipment</b>			

Unconnected Equipment:

Scope of Work:

<b>RAN Template:</b> 67D94B Outdoor	<b>A&amp;L Template:</b> 67D94B_1DP+1OP	<b>Power System Template:</b> Custom
--	--	---

Sector 1 (Proposed) view from behind						
<b>Coverage Type</b>	A - Outdoor Macro					
<b>Antenna</b>	1			2		
<b>Antenna Model</b>	RFS - APX16DWV-16DWV-S-E-A20 (Quad)			RFS - APXVAARR24_43-U-NA20 (Octo)		
<b>Azimuth</b>	40			40		
<b>M. Tilt</b>	0			0		
<b>Height</b>	82			73		
<b>Ports</b>	<b>P1</b>	<b>P2</b>	<b>P3</b>	<b>P4</b>	<b>P5</b>	<b>P6</b>
<b>Active Tech.</b>	U2100 L2100 L1900 G1900		L700 L600	L700 L600		
<b>Dark Tech.</b>						
<b>Restricted Tech.</b>						
<b>Decomm. Tech.</b>						
<b>E. Tilt</b>	5	5	5	5		
<b>Cables</b>	7/8" Coax - 100 ft. (x2)		7/8" Coax - 100 ft. (x2)	7/8" Coax - 100 ft. (x2)		
<b>TMA's</b>						
<b>Diplexers / Combiners</b>	Generic AWS/PCS Diplexer (AtCabinet)					
<b>Radio</b>			Radio 4449 B71+B12 (At Cabinet)			
<b>Sector Equipment</b>						
<b>Unconnected Equipment:</b>						
<b>Scope of Work:</b>						

<b>RAN Template:</b> 67D94B Outdoor	<b>A&amp;L Template:</b> 67D94B_1DP+1OP	<b>Power System Template:</b> Custom
--	--	---

Sector 2 (Existing) view from behind			
<b>Coverage Type</b>	A - Outdoor Macro		
<b>Antenna</b>	1		2
<b>Antenna Model</b>	RFS - APX16DWV-16DWV-S-E-A20 (Quad)		Andrew - LNX-6515DS-A1M (Dual)
<b>Azimuth</b>	160		160
<b>M. Tilt</b>	0		0
<b>Height</b>	82		73
<b>Ports</b>	P1	P2	P3
<b>Active Tech.</b>	L1900 G1900	U2100 L2100	L700
<b>Dark Tech.</b>			
<b>Restricted Tech.</b>			
<b>Decomm. Tech.</b>			
<b>E. Tilt</b>	4	4	2
<b>Cables</b>	7/8" Coax - 100 ft. (x2)	7/8" Coax - 100 ft. (x2)	7/8" Coax - 100 ft. (x2)
<b>TMA's</b>			
<b>Diplexers / Combiners</b>			
<b>Radio</b>			RRUS11 B12 (At Antenna)
<b>Sector Equipment</b>			
<b>Unconnected Equipment:</b>			
<b>Scope of Work:</b>			

<b>RAN Template:</b> 67D94B Outdoor	<b>A&amp;L Template:</b> 67D94B_1DP+1OP	<b>Power System Template:</b> Custom
--	--	---

Sector 2 (Proposed) view from behind						
<b>Coverage Type</b>	A - Outdoor Macro					
<b>Antenna</b>	1			2		
<b>Antenna Model</b>	RFS - APX16DWV-16DWV-S-E-A20 (Quad)			RFS - APXVAARR24_43-U-NA20 (Octo)		
<b>Azimuth</b>	160			160		
<b>M. Tilt</b>	0			0		
<b>Height</b>	82			73		
<b>Ports</b>	<b>P1</b>	<b>P2</b>	<b>P3</b>	<b>P4</b>	<b>P5</b>	<b>P6</b>
<b>Active Tech.</b>	U2100 L2100 L1900 G1900		L700 L600	L700 L600		
<b>Dark Tech.</b>						
<b>Restricted Tech.</b>						
<b>Decomm. Tech.</b>						
<b>E. Tilt</b>	5	5	5	5		
<b>Cables</b>	7/8" Coax - 100 ft. (x2)		7/8" Coax - 100 ft. (x2)	7/8" Coax - 100 ft. (x2)		
<b>TMA's</b>						
<b>Diplexers / Combiners</b>	Generic AWS/PCS Diplexer (AtCabinet)					
<b>Radio</b>			Radio 4449 B71+B12 (At Cabinet)			
<b>Sector Equipment</b>						
<b>Unconnected Equipment:</b>						
<b>Scope of Work:</b>						

<b>RAN Template:</b> 67D94B Outdoor	<b>A&amp;L Template:</b> 67D94B_1DP+1OP	<b>Power System Template:</b> Custom
--	--	---

Sector 3 (Existing) view from behind			
<b>Coverage Type</b>	A - Outdoor Macro		
<b>Antenna</b>	1		2
<b>Antenna Model</b>	RFS - APX16DWV-16DWV-S-E-A20 (Quad)		Andrew - LNX-6515DS-A1M (Dual)
<b>Azimuth</b>	300		300
<b>M. Tilt</b>	0		0
<b>Height</b>	82		73
<b>Ports</b>	P1	P2	P3
<b>Active Tech.</b>	L1900 G1900	U2100 L2100	L700
<b>Dark Tech.</b>			
<b>Restricted Tech.</b>			
<b>Decomm. Tech.</b>			
<b>E. Tilt</b>	2	2	2
<b>Cables</b>	7/8" Coax - 100 ft. (x2)	7/8" Coax - 100 ft. (x2)	7/8" Coax - 100 ft. (x2)
<b>TMA's</b>			
<b>Diplexers / Combiners</b>			
<b>Radio</b>			RRUS11 B12 (At Antenna)
<b>Sector Equipment</b>			
<b>Unconnected Equipment:</b>			
<b>Scope of Work:</b>			



<b>RAN Template:</b> 67D94B Outdoor	<b>A&amp;L Template:</b> 67D94B_1DP+1OP	<b>Power System Template:</b> Custom
--	--	---

Sector 3 (Proposed) view from behind						
<b>Coverage Type</b>	A - Outdoor Macro					
<b>Antenna</b>	1			2		
<b>Antenna Model</b>	RFS - APX16DWV-16DWV-S-E-A20 (Quad)			RFS - APXVAARR24_43-U-NA20 (Octo)		
<b>Azimuth</b>	300			300		
<b>M. Tilt</b>	0			0		
<b>Height</b>	82			73		
<b>Ports</b>	<b>P1</b>	<b>P2</b>	<b>P3</b>	<b>P4</b>	<b>P5</b>	<b>P6</b>
<b>Active Tech.</b>	U2100 L2100 L1900 G1900		L700 L600	L700 L600		
<b>Dark Tech.</b>						
<b>Restricted Tech.</b>						
<b>Decomm. Tech.</b>						
<b>E. Tilt</b>	5	5	5	5		
<b>Cables</b>	7/8" Coax - 100 ft. (x2)		7/8" Coax - 100 ft. (x2)	7/8" Coax - 100 ft. (x2)		
<b>TMA's</b>						
<b>Diplexers / Combiners</b>	Generic AWS/PCS Diplexer (AtCabinet)					
<b>Radio</b>			Radio 4449 B71+B12 (At Cabinet)			
<b>Sector Equipment</b>						
<b>Unconnected Equipment:</b>						
<b>Scope of Work:</b>						

<b>RAN Template:</b> 67D94B Outdoor	<b>A&amp;L Template:</b> 67D94B_1DP+1OP	<b>Power System Template:</b> Custom
--	--	---

**Section 7 - Power Systems Equipment**

**Existing Power Systems Equipment**

----- This section is intentionally blank. -----

**Proposed Power Systems Equipment**

DRAFT



**Dual Slant Polarized Quad Band (8 Port) Antenna, 617-746/617-746/1695-2200/1695-2200MHz, 65deg, 15/15/18/18dBi, 2.4m (8ft), VET, RET, 0-12°/0-12°/2-12°/2-12°**

**FEATURES / BENEFITS**

This antenna provides a 8 Port multi-band flexible platform for advanced use for flexible use in deployment scenarios for encompassing 600MHz, 700MHz, AWS & PCS applications.



- ➔ 24 Inch Width For Easier Zoning
- ➔ Field Replaceable (Integrated) AISG RET platform for reduced environmental exposure and long lasting quality
- ➔ Superior elevation pattern performance across the entire electrical down tilt range
- ➔ Includes three AISG RET motors - Includes 0.5m AISG jumper for optional daisy chain of two high band RET motors for one single AISG point of high band tilt control.
- ➔ Low band arrays driven by a single RET motor

**Technical Features**

**LOW BAND LEFT ARRAY (617-746 MHZ) [R1]**

Frequency Band	MHz	617-698	698-746
Gain	dBi	15.1	15.5
Horizontal Beamwidth @3dB	Deg	65	62
Vertical Beamwidth @3dB	Deg	11.4	10.4
Electrical Downtilt Range	Deg	0-12	0-12
Upper Side Lobe Suppression 0 to +20	dB	19	20
Front-to-Back, at +/-30°, Copolar	dB	25	24
Cross Polar Discrimination (XPD) @ Boresight	dB	19	19
Cross Polar Discrimination (XPD) @ +/-60	dB	5	3
3rd Order PIM 2 x 43dBm	dBc		-153
VSWR	-	1.5:1	1.5:1
Cross Polar Isolation	dB	25	25
Maximum Effective Power per Port	Watt	250	250

**LOW BAND RIGHT ARRAY (617-746 MHZ) [R2]**

Frequency Band	MHz	617-698	698-746
Gain	dBi	14.8	15.1
Horizontal Beamwidth @3dB	Deg	65	62
Vertical Beamwidth @3dB	Deg	11.4	10.3
Electrical Downtilt Range	Deg	0-12	0-12
Upper Side Lobe Suppression 0 to +20	dB	19	20
Front-to-Back, at +/-30°, Copolar	dB	25	23
Cross Polar Discrimination (XPD) @ Boresight	dB	19	19
Cross Polar Discrimination (XPD) @ +/-60	dB	5	3
3rd Order PIM 2 x 43dBm	dBc		-153
VSWR	-	1.5:1	1.5:1
Cross Polar Isolation	dB	25	25
Maximum Effective Power per Port	Watt	250	250



**Dual Slant Polarized Quad Band (8 Port) Antenna, 617-746/617-746/1695-2200/1695-2200MHz, 65deg, 15/15/18/18dBi, 2.4m (8ft), VET, RET, 0-12°/0-12°/2-12°/2-12°**

**ELECTRICAL SPECIFICATIONS**

<b>Impedance</b>	Ohm	50.0
<b>Polarization</b>	Deg	±45°

**MECHANICAL SPECIFICATIONS**

<b>Dimensions - H x W x D</b>	mm (in)	2436 x 609 x 222 (95.9 x 24 x 8.7)
<b>Weight (Antenna Only)</b>	kg (lb)	58 (128)
<b>Weight (Mounting Hardware only)</b>	kg (lb)	11.5 (25.3)
<b>Shipping Weight</b>	kg (lb)	80 (176)
<b>Connector type</b>		8 x 4.3-10 female at bottom + 6 AISG connectors (3 male, 3 female)
<b>Adjustment mechanism</b>		Integrated RET solution AISG compliant (Field Replaceable) + Manual Override + External Tilt Indicator
<b>Mounting Hardware Material</b>		Galvanized steel
<b>Radome Material / Color</b>		Fiber Glass / Light Grey RAL7035

**TESTING AND ENVIRONMENTAL**

<b>Temperature Range</b>	°C (°F)	-40 to 60 (-40 to 140)
<b>Lightning protection</b>		IEC 61000-4-5
<b>Survival/Rated Wind Velocity</b>	km/h	241 (150)
<b>Environmental</b>		ETSI 300-019-2-4 Class 4.1E

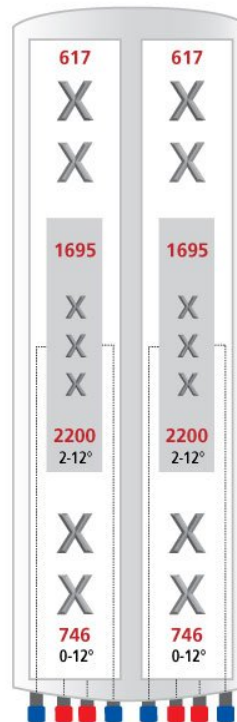
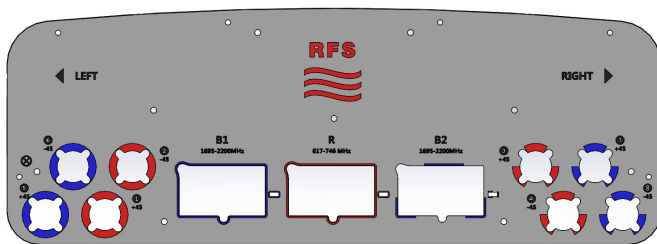

**ORDERING INFORMATION**

Order No.	Configuration	Mounting Hardware	Mounting pipe Diameter	Shipping Weight
APXVAARR24_43-U-NA20	Field Replace RET included (3)	APM40-5E Beam tilt kit (included)	60-120mm	80 Kg



Optimizer® Side-by-Side Dual Polarized Antenna, 1710-2200, 65deg, 18.4dBi, 1.4m, VET, 0-10deg RET

**Product Description**

A combination of two X-Polarized antennas in a single radome, this pair of variable tilt antennas provides exceptional suppression of all upper sidelobes at all downtilt angles. It also features a wide downtilt range. This antenna is optimized for performance across the entire frequency band (1710-2200 MHz). The antenna comes pre-connected with two antenna control units (ACU).

**Features/Benefits**

- Variable electrical downtilt - provides enhanced precision in controlling intercell interference. The tilt is infield adjustable 0-10 deg.
- High Suppression of all Upper Sidelobes (Typically <-20dB).
- Gain tracking – difference between AWS UL (1710-1755 MHz) and DL (2110-2155 MHz) <1dB.
- Two X-Polarised panels in a single radome.
- Azimuth horizontal beamwidth difference <4deg between AWS UL (1710-1755 MHz) and DL (2110-2155 MHz).
- Low profile for low visual impact.
- Dual polarization; Broadband design.
- Includes (2) AISG 2.0 Compatible ACU-A20-N antenna control units.



**Technical Specifications**

**Electrical Specifications**

Frequency Range, MHz	1710-2200
Horizontal Beamwidth, deg	65
Vertical Beamwidth, deg	5.9 to 7.7
Electrical Downtilt, deg	0-10
Gain, dBi (dBd)	18.4 (16.3)
1st Upper Sidelobe Suppression, dB	> 18 (typically > 20)
Upper Sidelobe Suppression, dB	> 18 all (typically > 20)
Front-To-Back Ratio, dB	>26 (typically 28)
Polarization	Dual pol +/-45°
VSWR	< 1.5:1
Isolation between Ports, dB	> 30
3rd Order IMP @ 2 x 43 dBm, dBc	> 150 (155 Typical)
Impedance, Ohms	50
Maximum Power Input, W	300
Lightning Protection	Direct Ground
Connector Type	(4) 7-16 Long Neck Female

**Mechanical Specifications**

Dimensions - HxWxD, mm (in)	1420 x 331 x 80 (55.9 x 13 x 3.15)
Weight w/o Mtg Hardware, kg (lb)	18.5 (40.7)
Survival Wind Speed, km/h (mph)	200 (125)
Rated Wind Speed, km/h (mph)	160 (100)
Max Wind Loading Area, m <sup>2</sup> (ft <sup>2</sup> )	0.47 (5.03)
Front Thrust @ Rated Wind, N (lbf)	756 (170)
Maximum Thrust @ Rated Wind, N (lbf)	756 (170)
Wind Load - Side @ Rated Wind, N (lbf)	231 (52)
Wind Load - Rear @ Rated Wind, N (lbf)	408 (92)
Radome Material	Fiberglass
Radome Color	Light Grey RAL7035
Mounting Hardware Material	Diecasted Aluminum
Shipping Weight, kg (lb)	24.5 (53.9)
Packing Dimensions, HxWxD, mm (in)	1520 x 408 x 198 (59.8 x 16 x 7.8)

**Ordering Information**

Mounting Hardware APM40-2 + APM40-E2

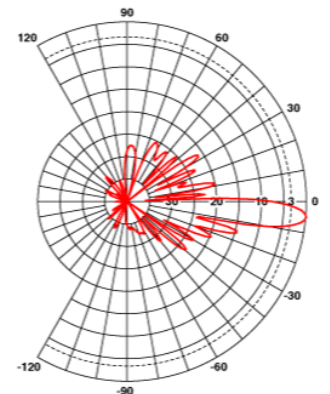

Vertical Pattern

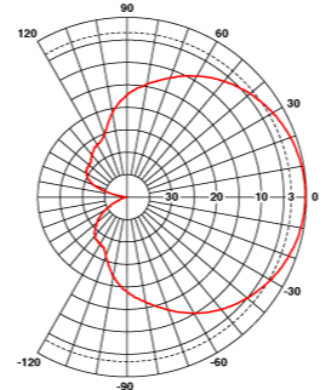

Horizontal Pattern

All information contained in the present datasheet is subject to confirmation at time of ordering

# Exhibit E



## RADIO FREQUENCY EMISSIONS ANALYSIS REPORT EVALUATION OF HUMAN EXPOSURE POTENTIAL TO NON-IONIZING EMISSIONS

T-Mobile Existing Facility

Site ID: CT11135J

West Hartford/ I-84 X42/M  
40 Maple Ridge Drive  
Farmington, CT 06032

**November 12, 2018**

**EBI Project Number: 6218007089**

Site Compliance Summary	
Compliance Status:	<b>COMPLIANT</b>
Site total MPE% of FCC general population allowable limit:	<b>11.41 %</b>



November 12, 2018

T-Mobile USA  
Attn: Jason Overbey, RF Manager  
35 Griffin Road South  
Bloomfield, CT 06002

## Emissions Analysis for Site: **CT11135J – West Hartford/ I-84 X42/M**

EBI Consulting was directed to analyze the proposed T-Mobile facility located at **40 Maple Ridge Drive, Farmington, CT**, for the purpose of determining whether the emissions from the Proposed T-Mobile Antenna Installation located on this property are within specified federal limits.

All information used in this report was analyzed as a percentage of current Maximum Permissible Exposure (% MPE) as listed in the FCC OET Bulletin 65 Edition 97-01 and ANSI/IEEE Std C95.1. The FCC regulates Maximum Permissible Exposure in units of microwatts per square centimeter ( $\mu\text{W}/\text{cm}^2$ ). The number of  $\mu\text{W}/\text{cm}^2$  calculated at each sample point is called the power density. The exposure limit for power density varies depending upon the frequencies being utilized. Wireless Carriers and Paging Services use different frequency bands each with different exposure limits, therefore it is necessary to report results and limits in terms of percent MPE rather than power density.

All results were compared to the FCC (Federal Communications Commission) radio frequency exposure rules, 47 CFR 1.1307(b)(1) – (b)(3), to determine compliance with the Maximum Permissible Exposure (MPE) limits for General Population/Uncontrolled environments as defined below.

General population/uncontrolled exposure limits apply to situations in which the general population may be exposed or in which persons who are exposed as a consequence of their employment may not be made fully aware of the potential for exposure or cannot exercise control over their exposure. Therefore, members of the general population would always be considered under this category when exposure is not employment related, for example, in the case of a telecommunications tower that exposes persons in a nearby residential area.

Public exposure to radio frequencies is regulated and enforced in units of microwatts per square centimeter ( $\mu\text{W}/\text{cm}^2$ ). The general population exposure limits for the 600 MHz and 700 MHz frequency bands are approximately  $400 \mu\text{W}/\text{cm}^2$  and  $467 \mu\text{W}/\text{cm}^2$  respectively. The general population exposure limit for the 1900 MHz (PCS) and 2100 MHz (AWS) frequency bands is  $1000 \mu\text{W}/\text{cm}^2$ . Because each carrier will be using different frequency bands, and each frequency band has different exposure limits, it is necessary to report percent of MPE rather than power density.





Occupational/controlled exposure limits apply to situations in which persons are exposed as a consequence of their employment and in which those persons who are exposed have been made fully aware of the potential for exposure and can exercise control over their exposure. Occupational/controlled exposure limits also apply where exposure is of a transient nature as a result of incidental passage through a location where exposure levels may be above general population/uncontrolled limits (see below), as long as the exposed person has been made fully aware of the potential for exposure and can exercise control over his or her exposure by leaving the area or by some other appropriate means.

Additional details can be found in FCC OET 65.

## CALCULATIONS

Calculations were done for the proposed T-Mobile Wireless antenna facility located at **40 Maple Ridge Drive, Farmington, CT**, using the equipment information listed below. All calculations were performed per the specifications under FCC OET 65. Since T-Mobile is proposing highly focused directional panel antennas, which project most of the emitted energy out toward the horizon, all calculations were performed assuming a lobe representing the maximum gain of the antenna per the antenna manufactures supplied specifications, minus 10 dB for directional panel antennas, was focused at the base of the tower. For this report the sample point is the top of a 6-foot person standing at the base of the tower.

For all calculations, all equipment was calculated using the following assumptions:

- 1) 1 GSM channels (PCS Band - 1900 MHz) was considered for each sector of the proposed installation. These Channels have a transmit power of 15 Watts per Channel.
- 2) 1 UMTS channel (AWS Band – 2100 MHz) was considered for each sector of the proposed installation. These Channels have a transmit power of 40 Watts per Channel.
- 3) 2 LTE channels (PCS Band - 1900 MHz) were considered for each sector of the proposed installation. These Channels have a transmit power of 40 Watts per Channel.
- 4) 2 LTE channels (AWS Band – 2100 MHz) were considered for each sector of the proposed installation. These Channels have a transmit power of 60 Watts per Channel.
- 5) 2 LTE channels (600 MHz Band) were considered for each sector of the proposed installation. These Channels have a transmit power of 40 Watts per Channel.
- 6) 2 LTE channels (700 MHz Band) were considered for each sector of the proposed installation. These Channels have a transmit power of 20 Watts per Channel.



- 7) All radios at the proposed installation were considered to be running at full power and were uncombined in their RF transmissions paths per carrier prescribed configuration. Per FCC OET Bulletin No. 65 - Edition 97-01 recommendations to achieve the maximum anticipated value at each sample point, all power levels emitting from the proposed antenna installation are increased by a factor of 2.56 to account for possible in-phase reflections from the surrounding environment. This is rarely the case, and if so, is never continuous.
- 8) For the following calculations the sample point was the top of a 6-foot person standing at the base of the tower. The maximum gain of the antenna per the antenna manufactures supplied specifications, minus 10 dB for directional panel antennas, was used in this direction. This value is a very conservative estimate as gain reductions for these particular antennas are typically much higher in this direction.
- 9) The antennas used in this modeling are the **RFS APX16DWV-16DWVS-E-A20** for 1900 MHz (PCS) and 2100 MHz (AWS) channels and the **RFS APXVAARR24\_43-U-NA20** for 600 MHz and 700 MHz channels. This is based on feedback from the carrier with regard to anticipated antenna selection. All Antenna gain values and associated transmit power levels are shown in the Site Inventory and Power Data table below. The maximum gain of the antenna per the antenna manufactures supplied specifications, minus 10 dB for directional panel antennas, was used for all calculations. This value is a very conservative estimate as gain reductions for these particular antennas are typically much higher in this direction.
- 10) The antenna mounting height centerlines of the proposed antennas are **73 feet & 82 feet** above ground level (AGL).
- 11) Emissions values for additional carriers were taken from the Connecticut Siting Council active database. Values in this database are provided by the individual carriers themselves.
- 12) All calculations were done with respect to uncontrolled / general population threshold limits.



## T-Mobile Site Inventory and Power Data

Sector:	A	Sector:	B	Sector:	C
Antenna #:	<b>1</b>	Antenna #:	<b>1</b>	Antenna #:	<b>1</b>
Make / Model:	RFS APX16DWV-16DWVS- E-A20	Make / Model:	RFS APX16DWV-16DWVS- E-A20	Make / Model:	RFS APX16DWV-16DWVS- E-A20
Gain:	16.3 dBd	Gain:	16.3 dBd	Gain:	16.3 dBd
Height (AGL):	82 feet	Height (AGL):	82 feet	Height (AGL):	82 feet
Frequency Bands	1900 MHz (PCS) / 2100 MHz (AWS)	Frequency Bands	1900 MHz (PCS) / 2100 MHz (AWS)	Frequency Bands	1900 MHz (PCS) / 2100 MHz (AWS)
Channel Count	6	Channel Count	6	Channel Count	6
Total TX Power(W):	255	Total TX Power(W):	255	Total TX Power(W):	255
ERP (W):	10,877.78	ERP (W):	10,877.78	ERP (W):	10,877.78
Antenna A1 MPE%	<b>6.77</b>	Antenna B1 MPE%	<b>6.77</b>	Antenna C1 MPE%	<b>6.77</b>
Antenna #:	<b>2</b>	Antenna #:	<b>2</b>	Antenna #:	<b>2</b>
Make / Model:	RFS APXVAARR24_43- U-NA20	Make / Model:	RFS APXVAARR24_43-U- NA20	Make / Model:	RFS APXVAARR24_43-U- NA20
Gain:	12.95 / 13.35 dBd	Gain:	12.95 / 13.35 dBd	Gain:	12.95 / 13.35 dBd
Height (AGL):	73 feet	Height (AGL):	73 feet	Height (AGL):	73 feet
Frequency Bands	600 MHz / 700 MHz	Frequency Bands	600 MHz / 700 MHz	Frequency Bands	600 MHz / 700 MHz
Channel Count	4	Channel Count	4	Channel Count	4
Total TX Power(W):	120	Total TX Power(W):	120	Total TX Power(W):	120
ERP (W):	2,443.03	ERP (W):	2,443.03	ERP (W):	2,443.03
Antenna A2 MPE%	<b>4.64</b>	Antenna B2 MPE%	<b>4.64</b>	Antenna C2 MPE%	<b>4.64</b>

Site Composite MPE%	
Carrier	MPE%
T-Mobile (Per Sector Max)	<b>11.41 %</b>
No Additional Carriers Located at this Facility	<b>NA</b>
<b>Site Total MPE %:</b>	<b>11.41 %</b>

T-Mobile Sector A Total:	11.41 %
T-Mobile Sector B Total:	11.41 %
T-Mobile Sector C Total:	11.41 %
<b>Site Total:</b>	
	11.41 %



## T-Mobile Maximum MPE Power Values (Per Sector)

T-Mobile_Frequency Band / Technology (Per Sector)	# Channels	Watts ERP (Per Channel)	Height (feet)	Total Power Density ( $\mu\text{W}/\text{cm}^2$ )	Frequency (MHz)	Allowable MPE ( $\mu\text{W}/\text{cm}^2$ )	Calculated % MPE
T-Mobile PCS - 1900 MHz GSM	1	639.87	82	3.98	PCS - 1900 MHz	1000.00	0.40%
T-Mobile PCS - 1900 MHz LTE	2	1,706.32	82	21.24	PCS - 1900 MHz	1000.00	2.12%
T-Mobile AWS - 2100 MHz UMTS	1	1,706.32	82	10.62	AWS - 2100 MHz	1000.00	1.06%
T-Mobile AWS - 2100 MHz LTE	2	2,559.48	82	31.86	AWS - 2100 MHz	1000.00	3.19%
T-Mobile 600 MHz LTE	2	788.97	73	12.64	600 MHz	400.00	3.16%
T-Mobile 700 MHz LTE	2	432.54	73	6.93	700 MHz	467.00	1.48%
						<b>Total:</b>	<b>11.41%</b>

## Summary

All calculations performed for this analysis yielded results that were **within** the allowable limits for general population exposure to RF Emissions.

The anticipated maximum composite contributions from the T-Mobile facility as well as the site composite emissions value with regards to compliance with FCC's allowable limits for general population exposure to RF Emissions are shown here:

T-Mobile Sector	Power Density Value (%)
Sector A:	11.41 %
Sector B:	11.41 %
Sector C:	11.41 %
T-Mobile Maximum MPE % (Per Sector):	11.41 %
Site Total:	11.41 %
Site Compliance Status:	<b>COMPLIANT</b>

The anticipated composite MPE value for this site assuming all carriers present is **11.41%** of the allowable FCC established general population limit sampled at the ground level. This is based upon values listed in the Connecticut Siting Council database for existing carrier emissions.

FCC guidelines state that if a site is found to be out of compliance (over allowable thresholds), that carriers over a 5% contribution to the composite value will require measures to bring the site into compliance. For this facility, the composite values calculated were well within the allowable 100% threshold standard per the federal government.

# Exhibit F



Mail Processing Center  
Federal Aviation Administration  
Southwest Regional Office  
Obstruction Evaluation Group  
10101 Hillwood Parkway  
Fort Worth, TX 76177

Aeronautical Study No.  
2019-ANE-3335-OE

Issued Date: 07/03/2019

Sheldon Freinle  
Northeast Site Solutions  
420 Main Street  
Sturbridge, MA 01566

**\*\* DETERMINATION OF NO HAZARD TO AIR NAVIGATION \*\***

The Federal Aviation Administration has conducted an aeronautical study under the provisions of 49 U.S.C., Section 44718 and if applicable Title 14 of the Code of Federal Regulations, part 77, concerning:

Structure: Antenna Tower CT11135J  
Location: Farmington, CT  
Latitude: 41-43-05.13N NAD 83  
Longitude: 72-46-04.56W  
Heights: 254 feet site elevation (SE)  
84 feet above ground level (AGL)  
338 feet above mean sea level (AMSL)

This aeronautical study revealed that the structure does not exceed obstruction standards and would not be a hazard to air navigation provided the following condition(s), if any, is(are) met:

Based on this evaluation, marking and lighting are not necessary for aviation safety. However, if marking/lighting are accomplished on a voluntary basis, we recommend it be installed in accordance with FAA Advisory circular 70/7460-1 L Change 2.

This determination expires on 01/03/2021 unless:

- (a) the construction is started (not necessarily completed) and FAA Form 7460-2, Notice of Actual Construction or Alteration, is received by this office.
- (b) extended, revised, or terminated by the issuing office.
- (c) the construction is subject to the licensing authority of the Federal Communications Commission (FCC) and an application for a construction permit has been filed, as required by the FCC, within 6 months of the date of this determination. In such case, the determination expires on the date prescribed by the FCC for completion of construction, or the date the FCC denies the application.

**NOTE: REQUEST FOR EXTENSION OF THE EFFECTIVE PERIOD OF THIS DETERMINATION MUST BE E-FILED AT LEAST 15 DAYS PRIOR TO THE EXPIRATION DATE. AFTER RE-EVALUATION OF CURRENT OPERATIONS IN THE AREA OF THE STRUCTURE TO DETERMINE THAT NO SIGNIFICANT AERONAUTICAL CHANGES HAVE OCCURRED, YOUR DETERMINATION MAY BE ELIGIBLE FOR ONE EXTENSION OF THE EFFECTIVE PERIOD.**

This determination is based, in part, on the foregoing description which includes specific coordinates, heights, frequency(ies) and power. Any changes in coordinates, heights, and frequencies or use of greater power, except those frequencies specified in the Colo Void Clause Coalition; Antenna System Co-Location; Voluntary Best Practices, effective 21 Nov 2007, will void this determination. Any future construction or alteration, including increase to heights, power, or the addition of other transmitters, requires separate notice to the FAA. This determination includes all previously filed frequencies and power for this structure.

If construction or alteration is dismantled or destroyed, you must submit notice to the FAA within 5 days after the construction or alteration is dismantled or destroyed.

This determination does include temporary construction equipment such as cranes, derricks, etc., which may be used during actual construction of the structure. However, this equipment shall not exceed the overall heights as indicated above. Equipment which has a height greater than the studied structure requires separate notice to the FAA.

This determination concerns the effect of this structure on the safe and efficient use of navigable airspace by aircraft and does not relieve the sponsor of compliance responsibilities relating to any law, ordinance, or regulation of any Federal, State, or local government body.

A copy of this determination will be forwarded to the Federal Communications Commission (FCC) because the structure is subject to their licensing authority.

If we can be of further assistance, please contact our office at (817) 222-5922, or [debbie.cardenas@faa.gov](mailto:debbie.cardenas@faa.gov). On any future correspondence concerning this matter, please refer to Aeronautical Study Number 2019-ANE-3335-OE.

**Signature Control No: 409483648-410448067**

( DNE )

Debbie Cardenas  
Technician

Attachment(s)  
Frequency Data

cc: FCC



**Frequency Data for ASN 2019-ANE-3335-OE**

<b>LOW FREQUENCY</b>	<b>HIGH FREQUENCY</b>	<b>FREQUENCY UNIT</b>	<b>ERP</b>	<b>ERP UNIT</b>
6	7	GHz	55	dBW
6	7	GHz	42	dBW
10	11.7	GHz	55	dBW
10	11.7	GHz	42	dBW
17.7	19.7	GHz	55	dBW
17.7	19.7	GHz	42	dBW
21.2	23.6	GHz	55	dBW
21.2	23.6	GHz	42	dBW
614	698	MHz	1000	W
614	698	MHz	2000	W
698	806	MHz	1000	W
806	901	MHz	500	W
806	824	MHz	500	W
824	849	MHz	500	W
851	866	MHz	500	W
869	894	MHz	500	W
896	901	MHz	500	W
901	902	MHz	7	W
929	932	MHz	3500	W
930	931	MHz	3500	W
931	932	MHz	3500	W
932	932.5	MHz	17	dBW
935	940	MHz	1000	W
940	941	MHz	3500	W
1670	1675	MHz	500	W
1710	1755	MHz	500	W
1850	1910	MHz	1640	W
1850	1990	MHz	1640	W
1930	1990	MHz	1640	W
1990	2025	MHz	500	W
2110	2200	MHz	500	W
2305	2360	MHz	2000	W
2305	2310	MHz	2000	W
2345	2360	MHz	2000	W
2496	2690	MHz	500	W

# Exhibit G

July 5, 2019

Mr. Mark Richard  
T-Mobile  
35 Griffin Rd. South  
Bloomfield, CT 06002

RE: T-Mobile Antenna Site CT-11135J, Maple Ridge Drive, Farmington, CT, Eversource Structure 8011

Dear Mr. Richard:

Based on our reviews of the site drawings, the structural analysis and foundation review provided by Centek Engineering, along with a third party review performed by Paul J. Ford and Company, we accept the proposed modification.

Please work with Christopher Gelinias of Eversource Real Estate to process the site lease amendment. Please do not hesitate to contact us with questions or concerns. Christopher can be contacted at 860-665-2008, and I can be contacted at 860-728-4503.

Sincerely,

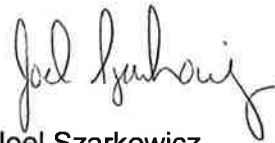

Joel Szarkowicz  
Transmission Line Engineering

Ref: 18098.04 - CT11135J Structural Analysis Rev 2 19.01.09  
18098.04 - CT11135J CD Rev.0 19.04.08 S&S

# Exhibit H



**UNITED STATES  
POSTAL SERVICE®**

**Click-N-Ship®**

**P**

usps.com  
**US POSTAGE**  
 Flat Rate Env  
 \$7.35

9405 5036 9930 0059 2921 27 0073 5000 0010 6032



07/16/2019

Mailed from 06002 062S00000000309

**PRIORITY MAIL 1-DAY™**

Expected Delivery Date: 07/17/19  
 Ref#: 135ZAP  
**0024**

**Carrier -- Leave if No Response**

**R001**

SHIP TO: KATHLEEN A EAGEN  
 FARMINGTON TOWN HALL- TOWN MANAGER  
 1 MONTIETH DR  
 FARMINGTON CT 06032-1082

**USPS TRACKING #**

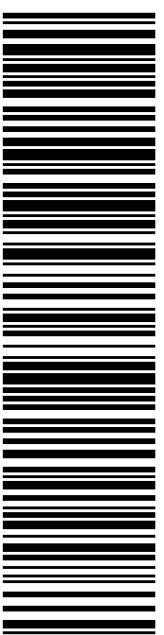

**9405 5036 9930 0059 2921 27**

Electronic Rate Approved #038555749



Cut on dotted line.

### Instructions

1. Each Click-N-Ship® label is unique. Labels are to be used as printed and used only once. DO NOT PHOTO COPY OR ALTER LABEL.
2. Place your label so it does not wrap around the edge of the package.
3. Adhere your label to the package. A self-adhesive label is recommended. If tape or glue is used, DO NOT TAPE OVER BARCODE. Be sure all edges are secure.
4. To mail your package with PC Postage®, you may schedule a Package Pickup online, hand to your letter carrier, take to a Post Office™, or drop in a USPS collection box.
5. Mail your package on the "Ship Date" you selected when creating this label.

### Click-N-Ship® Label Record

**USPS TRACKING # :**  
**9405 5036 9930 0059 2921 27**

Trans. #: 468257198	Priority Mail® Postage: <b>\$7.35</b>
Print Date: 07/15/2019	Total: <b>\$7.35</b>
Ship Date: 07/16/2019	
Expected Delivery Date: 07/17/2019	

**From:** DEBORAH CHASE      Ref#: 135ZAP  
 T-MOBILE/NSS  
 35 GRIFFIN RD S  
 BLOOMFIELD CT 06002-1351

**To:** KATHLEEN A EAGEN  
 FARMINGTON TOWN HALL- TOWN MANAGER  
 1 MONTIETH DR  
 FARMINGTON CT 06032-1082

\* Retail Pricing Priority Mail rates apply. There is no fee for USPS Tracking® service on Priority Mail service with use of this electronic rate shipping label. Refunds for unused postage paid labels can be requested online 30 days from the print date.



Thank you for shipping with the United States Postal Service!  
 Check the status of your shipment on the USPS Tracking® page at usps.com



**UNITED STATES  
POSTAL SERVICE®**

**Click-N-Ship®**

**P**

usps.com  
**US POSTAGE**  
 Flat Rate Env  
 \$7.35

9405 5036 9930 0059 2921 34 0073 5000 0010 6032

07/16/2019

Mailed from 06002 062S0000000315

**PRIORITY MAIL 1-DAY™**

Expected Delivery Date: 07/17/19

0024

Carrier -- Leave if No Response

R001

SHIP TO: WILLIAM WARNER  
 FARMINGTON PLANNING & ZONING DEPT.  
 1 MONTIETH DR  
 FARMINGTON CT 06032-1082

**USPS TRACKING #**

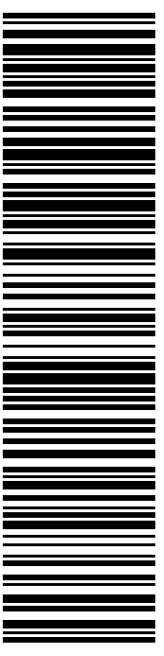

**9405 5036 9930 0059 2921 34**

Electronic Rate Approved #038555749



Cut on dotted line.

### Instructions

1. Each Click-N-Ship® label is unique. Labels are to be used as printed and used only once. DO NOT PHOTO COPY OR ALTER LABEL.
2. Place your label so it does not wrap around the edge of the package.
3. Adhere your label to the package. A self-adhesive label is recommended. If tape or glue is used, DO NOT TAPE OVER BARCODE. Be sure all edges are secure.
4. To mail your package with PC Postage®, you may schedule a Package Pickup online, hand to your letter carrier, take to a Post Office™, or drop in a USPS collection box.
5. Mail your package on the "Ship Date" you selected when creating this label.

### Click-N-Ship® Label Record

**USPS TRACKING # :**  
**9405 5036 9930 0059 2921 34**

Trans. #: 468257198	Priority Mail® Postage: <b>\$7.35</b>
Print Date: 07/15/2019	Total: <b>\$7.35</b>
Ship Date: 07/16/2019	
Expected Delivery Date: 07/17/2019	

**From:** DEBORAH CHASE  
 T-MOBILE USA- NSS  
 35 GRIFFIN RD S  
 BLOOMFIELD CT 06002-1351

**To:** WILLIAM WARNER  
 FARMINGTON PLANNING & ZONING DEPT.  
 1 MONTIETH DR  
 FARMINGTON CT 06032-1082

\* Retail Pricing Priority Mail rates apply. There is no fee for USPS Tracking® service on Priority Mail service with use of this electronic rate shipping label. Refunds for unused postage paid labels can be requested online 30 days from the print date.



Thank you for shipping with the United States Postal Service!  
 Check the status of your shipment on the USPS Tracking® page at usps.com



**UNITED STATES  
POSTAL SERVICE®**

**Click-N-Ship®**

**P**

usps.com  
**US POSTAGE**  
 Flat Rate Env  
 \$7.35

9405 5036 9930 0059 2921 41 0073 5000 0010 6037



07/16/2019

Mailed from 06002 062S00000000309

**PRIORITY MAIL 1-DAY™**

DEBORAH CHASE  
 T-MOBILE USA- NSS  
 35 GRIFFIN RD S  
 BLOOMFIELD CT 06002-1351

Expected Delivery Date: 07/17/19  
 Ref#: 135JZAP  
**0024**

**Carrier -- Leave if No Response**

**C015**

SHIP TO: CHRIS GELINAS  
 EVERSOURCE  
 107 SELDEN ST  
 BERLIN CT 06037-1616

**USPS TRACKING #**

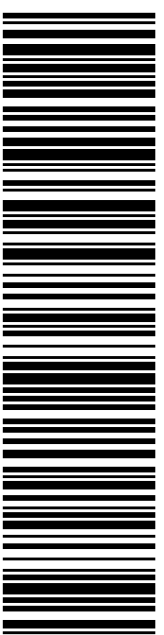

**9405 5036 9930 0059 2921 41**

Electronic Rate Approved #038555749



Cut on dotted line.

### Instructions

1. Each Click-N-Ship® label is unique. Labels are to be used as printed and used only once. DO NOT PHOTO COPY OR ALTER LABEL.
2. Place your label so it does not wrap around the edge of the package.
3. Adhere your label to the package. A self-adhesive label is recommended. If tape or glue is used, DO NOT TAPE OVER BARCODE. Be sure all edges are secure.
4. To mail your package with PC Postage®, you may schedule a Package Pickup online, hand to your letter carrier, take to a Post Office™, or drop in a USPS collection box.
5. Mail your package on the "Ship Date" you selected when creating this label.

### Click-N-Ship® Label Record

**USPS TRACKING # :**  
**9405 5036 9930 0059 2921 41**

Trans. #: 468257198	Priority Mail® Postage: <b>\$7.35</b>
Print Date: 07/15/2019	Total: <b>\$7.35</b>
Ship Date: 07/16/2019	
Expected Delivery Date: 07/17/2019	

**From:** DEBORAH CHASE  
 T-MOBILE USA- NSS  
 35 GRIFFIN RD S  
 BLOOMFIELD CT 06002-1351

Ref#: 135JZAP

**To:** CHRIS GELINAS  
 EVERSOURCE  
 107 SELDEN ST  
 BERLIN CT 06037-1616

\* Retail Pricing Priority Mail rates apply. There is no fee for USPS Tracking® service on Priority Mail service with use of this electronic rate shipping label. Refunds for unused postage paid labels can be requested online 30 days from the print date.



Thank you for shipping with the United States Postal Service!  
 Check the status of your shipment on the USPS Tracking® page at usps.com