



Northeast Site Solutions
Denise Sabo
420 Main Street,
Sturbridge, MA 01566
860-209-4690
denise@northeastsitesolutions.com

July 18, 2018

Members of the Siting Council
Connecticut Siting Council
Ten Franklin Square
New Britain, CT 06051

RE: Notice of Exempt Modification
200 Colt Highway, Farmington CT 06032
Latitude: 41.70088000
Longitude: -72.83218400
T-Mobile Site#: CT11134A_L700 4x2

Dear Ms. Bachman:

T-Mobile is requesting to file an exempt modification for an existing 120-foot Guyed Tower located at 200 Colt Highway, Farmington CT 06032. T-Mobile currently maintains nine (9) antennas at the 103-foot level of the existing 120-foot tower. The guyed tower is owned by WVIT/Outlet Broadcasting Inc. The property is owned by Outlet Broadcasting Inc. T-Mobile now intends to replace six (6) existing antenna with three (3) new 1900/2100 MHz and (3) new 600MHz antenna. The new antennas would be installed at the 103-foot and level of the tower.

Planned Modifications:

Remove:
NONE

Remove and Replace:

(3) AIR21 B2A_B4P Antenna **(Remove)** - (3) AIR 3246 B66 Antenna **(Replace)**
(3) Commscope LNX6515DS A1M **(Remove)** - (3) APXVAARR24-43-U-NA20 Antenna **(Replace)**
(3) RRU **(Remove)** - (3) RRU 4449 B71 + B12 **(Replace)**

Install New:
(1) Hybrid line

Existing to Remain:

(6) 1-1/4" Coax
(2) Hybrid line
(3) AIR32DB B66Aa B2a Antenna
(3) TMA

This facility was approved by the Town of Farmington PZC. The tower was built in the 1980's the original zoning approval file is not available – See attached letter from the Town Planner.

Please accept this letter as notification pursuant to Regulations of Connecticut State Agencies § 16-50j-73, for construction that constitutes an exempt modification pursuant to R.C.S.A. § 16-50j-72(b)(2). In accordance with R.C.S.A. § 16-50j-73, a copy of this letter is being sent to Kathleen Eagen, Town Manager, as Elected Official for the Town of Farmington and William Warner, Town Planner as well as the property owner and the tower owner.

The planned modifications to the facility fall squarely within those activities explicitly provided for in R.C.S.A. § 16-50j-72(b)(2).

1. The proposed modifications will not result in an increase in the height of the existing structure.
2. The proposed modifications will not require the extension of the site boundary.
3. The proposed modifications will not increase noise levels at the facility by six decibels or more, or to levels that exceed state and local criteria.
4. The operation of the replacement antennas will not increase radio frequency emissions at the facility to a level at or above the Federal Communications Commission safety standard.
5. The proposed modifications will not cause a change or alteration in the physical or environmental characteristics of the site.
6. The existing structure and its foundation can support the proposed loading.

For the foregoing reasons, T-Mobile respectfully submits that the proposed modifications to the above referenced telecommunications facility constitute an exempt modification under R.C.S.A. § 16-50j-72(b)(2).

Sincerely,

Denise Sabo

Mobile: 860-209-4690

Fax: 413-521-0558

Office: 420 Main St., Sturbridge, MA 01566

Email: denise@northeastsitesolutions.com

Attachments

cc: Kathleen Eagen – Town Manager - as elected official
William Warner- Town Planner
Outlet Broadcasting Inc. - Tower and property owner

Exhibit A



Denise Sabo
Project Manager, Northeast Site Solutions
54 Main St. Unit 3
Sturbridge, MA 01566

June 8th, 2016

RE : Zoning Compliance Letter for transmission towers at 190 & 200 Colt Highway,
Farmington, CT.

Dear Ms. Sabo

The purpose of this letter is to confirm zoning compliance for the above referenced subject property.

Please be advised the subject property is located in the Residential R80 zone. As you requested we have searched town archives and we have been unable to locate the original zoning approval. As I have indicated the town zoning authority has consistently signed off on building permits for modifications to the towers which indicates zoning compliance. We are not aware of any zoning violations at the subject property at this time.

Thank you.

Sincerely,

William Warner, AICP
Town Planner
Farmington, CT

Exhibit B

The Assessor's office is responsible for the maintenance of records on the ownership of properties. Assessments are computed at 70% of the estimated market value of real property at the time of the last revaluation which was 2012.



Information on the Property Records for the Municipality of Farmington was last updated on 5/4/2017.

Property Summary Information

Parcel Data And Values

Building ▾

Outbuildings

Sales

Google Map

Parcel Information

Location:	200 COLT HIGHWAY	Property Use:	Industrial	Primary Use:	Utility Building
Unique ID:	03750200	Map Block Lot:	0141 7B	Acres:	10.00
490 Acres:	0.00	Zone:	EE	Volume / Page:	0554/0608
Developers Map / Lot:		Census:	4602-02		

Value Information

	Appraised Value	70% Assessed Value
Land	600,000	420,000
Buildings	291,886	204,320

	Appraised Value	70% Assessed Value
Detached Outbuildings	0	0
Total	891,886	624,320

Owner's Information

Owner's Data

OUTLET BROADCASTING INC
E-PROPERTY TAX DEPT 201
ONE COMCAST CENTER,32ND FL
PHILADELPHIA, PA 19103

[Back To Search \(JavaScript>window.history.back\(1\);\)](#)

[Print View \(PrintPage.aspx?towncode=052&uniqueid=03750200\)](#)

Information Published With Permission From The Assessor

Town of Farmington, Connecticut - Assessment Parcel Map

UNIQUE ID: 03750200

Address: 200 COLT HIGHWAY

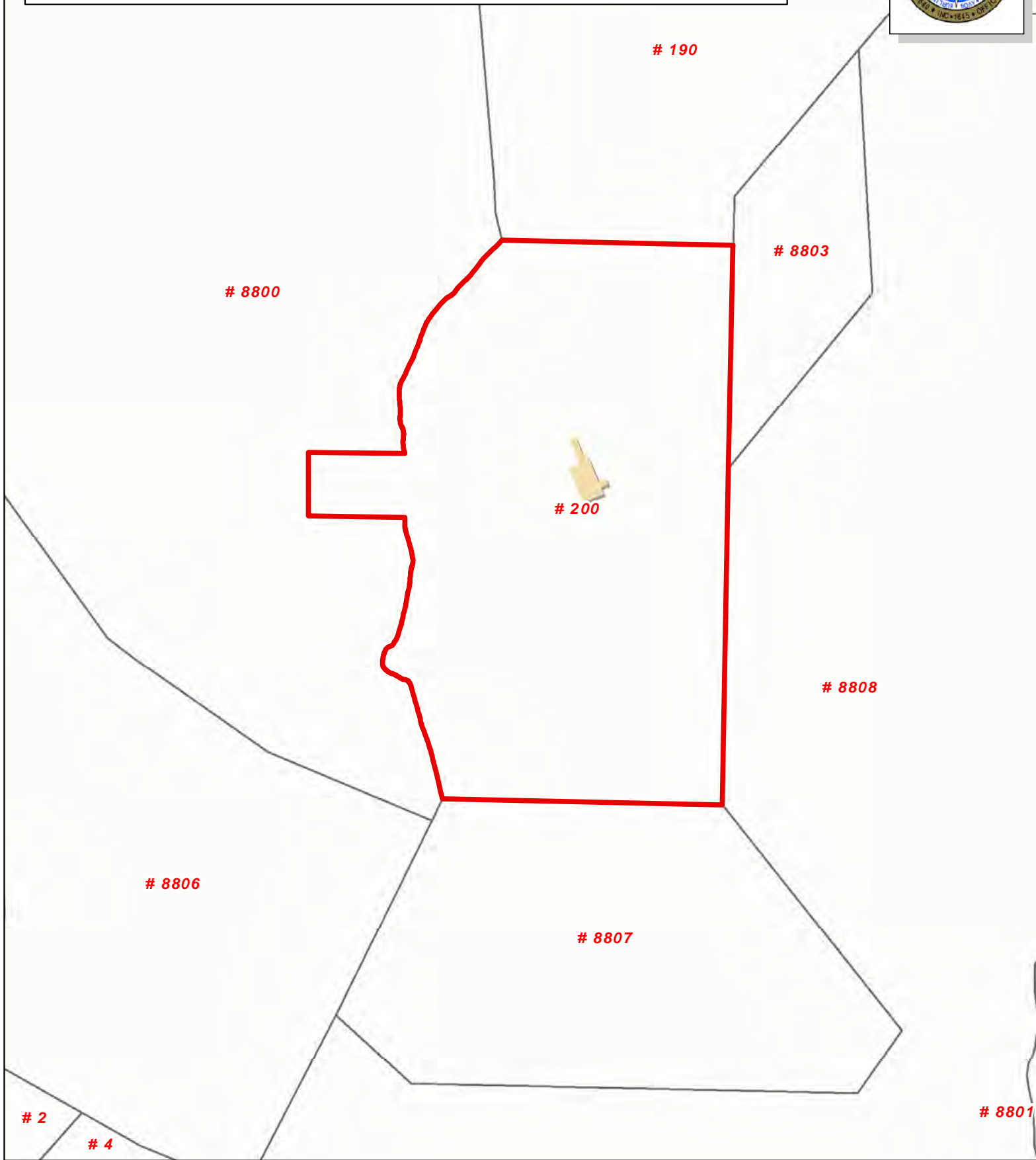

Approximate Scale: 1 inch = 200 feet

Disclaimer: This map is for informational purposes only. All information is subject to verification by any user. The Town of Farmington and its mapping contractors assume no legal responsibility for the information contained herein.

Map Produced Mar 2017

Exhibit C

Copyright © 2018 Foresite LLC all rights reserved. The details, templates, drawing formats or any portion of this document generated by Foresite LLC may not be duplicated, traced or used otherwise for any profit-driven enterprise.

ANTENNA UPGRADES BY

T-Mobile

T-MOBILE NORTHEAST LLC

PROJECT: L700 4X2
SITE NUMBER: CT11134A
SITE NAME: FARMINGTON/ I-84 X 37_1
SITE ADDRESS: 200 COLT HIGHWAY
FARMINGTON, CT 06032
(RF CONFIGURATION 67D92M)

APPLICANT:

T-MOBILE NORTHEAST LLC
 35 GRIFFIN ROAD SOUTH
 BLOOMFIELD, CT 06002
 860-692-7100

PROJECT MANAGER

NSS NORTHEAST
 SITE SOLUTIONS
Turnkey Wireless Development
 420 MAIN STREET, BLDG 4
 STURBRIDGE, MA 01566
 203-275-6669

CONSULTANT:

Architects . Engineers . Surveyors
 462 WALNUT STREET
 NEWTON, MA 02460
 617-212-3123

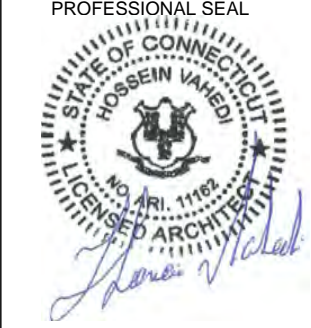
PROFESSIONAL SEAL



THIS DOCUMENT IS THE DESIGN PROPERTY AND COPYRIGHT OF FORESITE, LLC. AND FOR THE EXCLUSIVE USE BY THE TITLE CLIENT. DUPLICATION OR USE WITHOUT THE EXPRESS WRITTEN CONSENT OF THE CREATOR IS STRICTLY PROHIBITED. DRAWING SCALES ARE INTENDED FOR 11"x17" SIZE PRINTED MEDIA ONLY. ALL OTHER PRINTED SIZES ARE DEEMED "NOT TO SCALE".

REV	DESCRIPTION	DATE
A	PRELIMINARY	07/02/18
0	ISSUED FOR PERMIT	07/06/18

SITE NUMBER: CT11134A
 SITE NAME: FARMINGTON/ I-84 X 37_1
 SITE ADDRESS: 200 COLT HIGHWAY
 FARMINGTON, CT 06032

SHEET TITLE:
 T-1: TITLE SHEET

PROJECT SCOPE:
 UPGRADE OF EXISTING WIRELESS FACILITY AS FOLLOWS:
 REPLACE (6) EXISTING ANTENNAS,
 REPLACE(3) REMOTE RADIO UNITS AT ANTENNAS,
 ADD (1) FIBER HYBRID CABLE.

- PROJECT NOTES:**
1. THIS IS AN UNMANNED TELECOMMUNICATION FACILITY AND NOT FOR HUMAN HABITATION:
 HANDICAPPED ACCESS IS NOT REQUIRED.
 POTABLE WATER OR SANITARY SERVICE IS NOT REQUIRED.
 NO OUTDOOR STORAGE OR ANY SOLID WASTE RECEPTACLES REQUIRED.
 2. CONTRACTOR SHALL VERIFY ALL PLANS, EXISTING DIMENSIONS, AND CONDITIONS ON THE JOB SITE. CONTRACTOR SHALL IMMEDIATELY NOTIFY THE ARCHITECT/ENGINEER IN WRITING OF ANY DISCREPANCIES BEFORE PROCEEDING WITH THE WORK. FAILURE TO NOTIFY THE ARCHITECT/ENGINEER PLACES THE RESPONSIBILITY ON THE CONTRACTOR TO CORRECT THE DISCREPANCIES AT THE CONTRACTOR'S EXPENSE.
 3. DEVELOPMENT AND USE OF THE SITE WILL CONFORM TO ALL APPLICABLE CODES, ORDINANCES AND SPECIFICATIONS.
 4. REFER TO STRUCTURAL ANALYSIS REPORT TITLED " STRUCTURAL ANALYSIS REPORT - GUYED TOWER " SITE ID: CT11134A, DATED JUNE 21, 2018, PREPARED BY DESTEK.

APPLICABLE STATE ADOPTION CODES:

2016 CONNECTICUT STATE BUILDING CODE (CSBC).
 ANSITIA-222-G-2005 STRUCTURAL STANDARD FOR ANTENNA SUPPORTING STRUCTURES AND ANTENNAS.
 2014 NATIONAL ELECTRICAL CODE (NFPA 70) FOR POWER AND GROUNDING REQUIREMENTS.

APPROVALS:

FSA CM	DATE
RF ENGINEER	DATE
FOPS	DATE
T-MOBILE ENGINEERING AND DEVELOPMENT	DATE
	DATE
	DATE

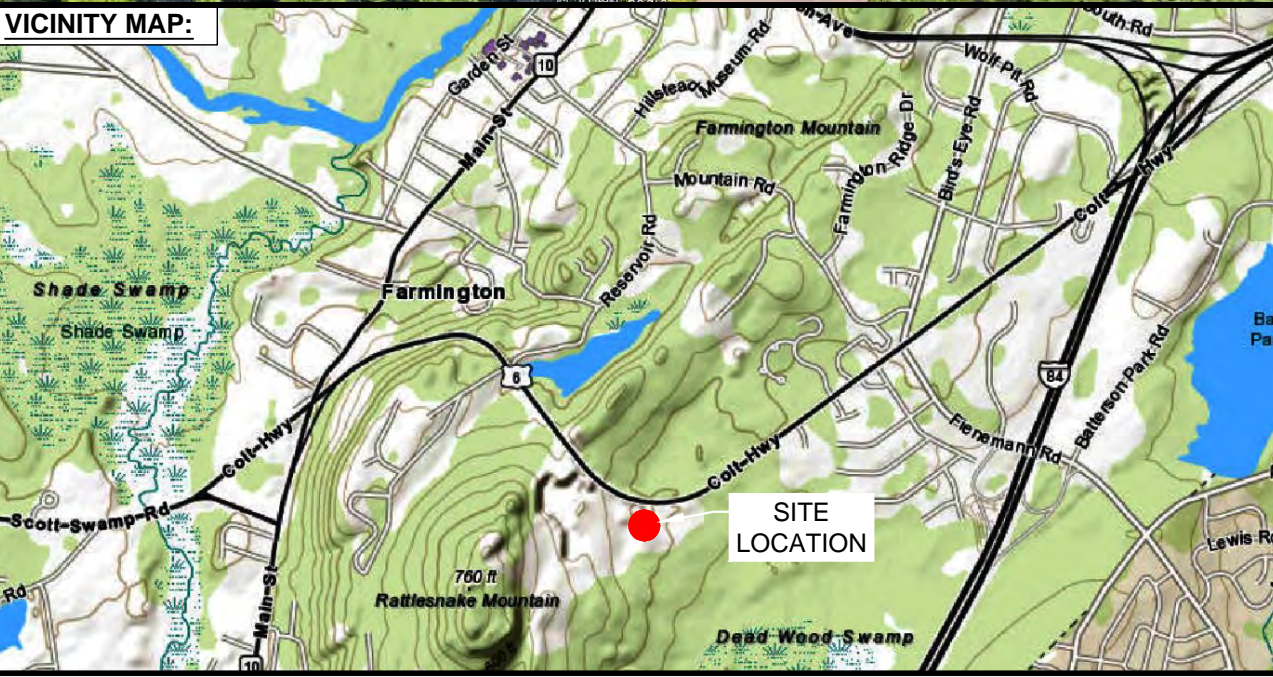

PROJECT INFORMATION:

ADDRESS: 200 COLT HIGHWAY
 FARMINGTON, CT 06032

STRUCTURE TYPE: GUYED TOWER

COORDINATES: 41.7008800 N, -72.832184 W

ZONING DISTRICT: R-80

PARCEL ID: 141 7B

TOWER HEIGHT: 145'-0" AGL

TOP OF T-MOBILE ANTENNAS ELEV: 107'-0" AGL

PROJECT TEAM:

APPLICANT: T-MOBILE NORTHEAST, LLC.
 35 GRIFFIN ROAD SOUTH
 BLOOMFIELD, CT 06002
 860-692-7100

LANDLORD: OUTLET BROADCASTING INC
 ONE COMCAST CENTER, 32ND FL
 PHILADELPHIA PA 19103

PROJECT MANAGER: NORTHEAST SITE SOLUTIONS
 420 MAIN STREET, BLDG 4
 STURBRIDGE, MA 01566
 SHELDON FREINCLE
 SHELDON@NORTHEASTSITE SOLUTIONS.COM
 201-776-8521

CONSULTANTS: FORESITE LLC
 462 WALNUT ST
 NEWTON, MA 02460
 SAEED MOSSAVAT
 SMOSSAVAT@FORESITELLC.COM
 617-212-3123

SHEET INDEX:

T-1:	TITLE SHEET
N-1:	GENERAL NOTES
A-1:	PLAN
A-2:	ELEVATION
A-3:	ANTENNA PLAN
A-4:	ANTENNA DETAILS
E-1:	GROUNDING DETAILS

Copyright © 2018 Foresite LLC all rights reserved. The details, templates, drawing formats or any portion of this document generated by Foresite LLC may not be duplicated, traced or used otherwise for any profit-driven enterprise.

GENERAL NOTES:

1. THE CONTRACTOR SHALL GIVE ALL NOTICES AND COMPLY WITH ALL LAWS, ORDINANCES, RULES, REGULATIONS AND LAWFUL ORDERS OF ANY PUBLIC AUTHORITY, MUNICIPAL AND UTILITY COMPANY SPECIFICATIONS, AND LOCAL AND STATE JURISDICTIONAL CODES BEARING ON THE PERFORMANCE OF THE WORK. THE WORK PERFORMED ON THE PROJECT AND THE MATERIALS INSTALLED SHALL BE IN STRICT ACCORDANCE WITH ALL APPLICABLE CODES, REGULATIONS, AND ORDINANCES.
2. THE ARCHITECT/ENGINEER HAS MADE EVERY EFFORT TO SET FORTH IN THE CONSTRUCTION AND CONTRACT DOCUMENTS THE COMPLETE SCOPE OF WORK. THE CONTRACTOR BIDDING THE JOB IS NEVERTHELESS CAUTIONED THAT MINOR OMISSIONS OR ERRORS IN THE DRAWINGS AND OR SPECIFICATIONS SHALL NOT EXCUSE SAID CONTRACTOR FROM COMPLETING THE PROJECT AND IMPROVEMENTS IN ACCORDANCE WITH THE INTENT OF THESE DOCUMENTS.
3. THE CONTRACTOR OR BIDDER SHALL BEAR THE RESPONSIBILITY OF NOTIFYING (IN WRITING) THE CLIENT'S REPRESENTATIVE OF ANY CONFLICTS, ERRORS, OR OMISSIONS PRIOR TO THE SUBMISSION OF CONTRACTOR'S PROPOSAL OR PERFORMANCE OF WORK.
5. THE CONTRACTOR SHALL VISIT THE JOB SITE PRIOR TO THE SUBMISSION OF BIDS OR PERFORMING WORK TO FAMILIARIZE HIMSELF WITH THE FIELD CONDITIONS AND TO VERIFY THAT THE PROJECT CAN BE CONSTRUCTED IN ACCORDANCE WITH THE CONSTRUCTION DOCUMENTS.
6. THE CONTRACTOR SHALL INSTALL ALL EQUIPMENT AND MATERIALS ACCORDING TO THE MANUFACTURER'S / VENDOR'S SPECIFICATIONS UNLESS NOTED OTHERWISE OR WHERE LOCAL CODES OR ORDINANCES TAKE PRECEDENCE.
7. THE CONTRACTOR SHALL MAKE NECESSARY PROVISIONS TO PROTECT EXISTING IMPROVEMENTS DURING CONSTRUCTION.
8. THE CONTRACTOR SHALL COMPLY WITH ALL PERTINENT SECTIONS OF THE BASIC STATE BUILDING CODE, LATEST EDITION, AND ALL OSHA REQUIREMENTS AS THEY APPLY TO THIS PROJEC
9. THE CONTRACTOR SHALL NOTIFY THE CLIENT'S REPRESENTATIVE IN WRITING WHERE A CONFLICT OCCURS ON ANY OF THE CONTRACT DOCUMENTS. THE CONTRACTOR IS NOT TO ORDER MATERIAL OR CONSTRUCT ANY PORTION OF THE WORK THAT IS IN CONFLICT UNTIL CONFLICT IS RESOLVED BY THE CLIENT'S REPRESENTATIVE.
10. THE WORK SHALL CONFORM TO THE CODES AND STANDARDS OF THE FOLLOWING AGENCIES AS FURTHER CITED HEREIN:
 - A. ASTM: AMERICAN SOCIETY FOR TESTING AND MATERIALS, AS PUBLISHED IN "COMPILATION OF ASTM STANDARDS BUILDING CODES" OR LATEST EDITION.
 - B. AWS: AMERICAN WELDING SOCIETY INC. AS PUBLISHED IN "STANDARD D1.1-08, STRUCTURAL WELDING CODE" OR LATEST EDITION.
 - C. AISC: AMERICAN INSTITUTE FOR STEEL CONSTRUCTION AS PUBLISHED IN "CODE FOR STANDARD PRACTICE FOR STEEL BUILDINGS AND BRIDGES"; "SPECIFICATIONS FOR THE DESIGN, FABRICATION AND ERECTION OF STRUCTURAL STEEL FOR BUILDINGS" (LATEST EDITION).
11. BOLTING:
 - A. BOLTS SHALL BE CONFORMING TO ASTM A325 HIGH STRENGTH, HOT DIP GALVANIZED WITH ASTM A153 HEAVY HEX TYPE NUTS.
 - B. BOLTS SHALL BE 3/4"Ø MINIMUM (UNLESS OTHERWISE NOTED)
 - C. ALL CONNECTIONS SHALL BE 2 BOLTS MINIMUM.
12. FABRICATION:
 - A. FABRICATION OF STEEL SHALL CONFORM TO THE AISC AND AWS STANDARDS AND CODES (LATEST EDITION).
 - B. ALL STRUCTURAL STEEL SHALL BE HOT-DIP GALVANIZED AFTER FABRICATION IN ACCORDANCE WITH ASTM A123 (LATEST EDITION), UNLESS OTHERWISE NOTED.
13. ERECTION OF STEEL:
 - A. PROVIDE ALL ERECTION EQUIPMENT, BRACING, PLANKING, FIELD BOLTS, NUTS, WASHERS, DRIFT PINS, AND SIMILAR MATERIALS WHICH DO NOT FORM A PART OF THE COMPLETED CONSTRUCTION BUT ARE NECESSARY FOR ITS PROPER ERECTION.
 - B. ERECT AND ANCHOR ALL STRUCTURAL STEEL IN ACCORDANCE WITH AISC REFERENCE STANDARDS. ALL WORK SHALL BE ACCURATELY SET TO ESTABLISHED LINES AND ELEVATIONS AND RIGIDLY FASTENED IN PLACE WITH SUITABLE ATTACHMENTS TO THE CONSTRUCTION OF THE BUILDING.
 - C. TEMPORARY BRACING, GUYING AND SUPPORT SHALL BE PROVIDED TO KEEP THE STRUCTURE SAFE AND ALIGNED AT ALL TIMES DURING CONSTRUCTION, AND TO PREVENT DANGER TO PERSONS AND PROPERTY. CHECK ALL TEMPORARY LOADS AND STAY WITHIN SAFE CAPACITY OF ALL BUILDING COMPONENTS.

14. ANTENNA INSTALLATION:
 - A. INSTALL ANTENNAS AS INDICATED ON DRAWINGS AND CLIENT'S REPRESENTATIVE SPECIFICATIONS.
 - B. INSTALL GALVANIZED STEEL ANTENNA MOUNTS AS INDICATED ON DRAWINGS.
 - C. INSTALL COAXIAL / FIBER CABLES AND TERMINATIONS BETWEEN ANTENNAS AND EQUIPMENT PER MANUFACTURER'S RECOMMENDATIONS. WEATHERPROOF ALL CONNECTORS BETWEEN THE ANTENNA AND EQUIPMENT PER MANUFACTURER'S REQUIREMENTS.
15. ANTENNA AND COAXIAL / FIBER CABLE GROUNDING:
 - A. ALL EXTERIOR #6 GREEN GROUND WIRE "DAISY CHAIN" CONNECTIONS ARE TO BE WEATHER SEALED WITH ANDREWS CONNECTOR/SPLICE WEATHERPROOFING KIT TYPE #221213 OR EQUAL.
 - B. ALL COAXIAL / FIBER CABLE GROUNDING KITS ARE TO BE INSTALLED ON STRAIGHT RUNS OF COAXIAL / FIBER CABLE (NOT WITHIN BENDS).
16. RELATED WORK, FURNISH THE FOLLOWING WORK AS SPECIFIED UNDER CONSTRUCTION DOCUMENTS, BUT COORDINATE WITH OTHER TRADES PRIOR TO BID:
 - A. FLASHING OF OPENING INTO OUTSIDE WALLS
 - B. SEALING AND CAULKING ALL OPENINGS
 - C. PAINTING
 - D. CUTTING AND PATCHING
17. REQUIREMENTS OF REGULATORY AGENCIES:
 - A. FURNISH U.L. LISTED EQUIPMENT WHERE SUCH LABEL IS AVAILABLE. INSTALL IN CONFORMANCE WITH U.L. STANDARDS WHERE APPLICABLE.
 - B. INSTALL ANTENNA, ANTENNA CABLES, GROUNDING SYSTEM IN ACCORDANCE WITH DRAWINGS AND SPECIFICATION IN EFFECT AT PROJECT LOCATION AND RECOMMENDATIONS OF STATE AND LOCAL BUILDING CODES, AND SPECIAL CODES HAVING JURISDICTION OVER SPECIFIC PORTIONS OF WORK. THIS WORK INCLUDES BUT IS NOT LIMITED TO THE FOLLOWING:
 - C. TIA-EIA - 222 (LATEST EDITION). STRUCTURAL STANDARDS FOR STEEL ANTENNA TOWERS AND ANTENNA SUPPORTING STRUCTURES.
 - D. FAA - FEDERAL AVIATION ADMINISTRATION ADVISORY CIRCULAR AC 70/7460-IH, OBSTRUCTION MARKING AND LIGHTING.
 - E. FCC - FEDERAL COMMUNICATIONS COMMISSION RULES AND REGULATIONS FORM 715, OBSTRUCTION MARKING AND LIGHTING SPECIFICATION FOR ANTENNA STRUCTURES AND FORM 715A, HIGH INTENSITY OBSTRUCTION LIGHTING SPECIFICATIONS FOR ANTENNA STRUCTURES.
 - F. AISC - AMERICAN INSTITUTE OF STEEL CONSTRUCTION SPECIFICATION FOR STRUCTURAL JOINTS USING ASTM A325 BOLTS (LATEST EDITION).
 - G. NEC - NATIONAL ELECTRICAL CODE - ON TOWER LIGHTING KITS.
 - H. UL - UNDERWRITER'S LABORATORIES APPROVED ELECTRICAL PRODUCTS.
 - I. IN ALL CASES, PART 77 OF THE FAA RULES AND PARTS 17 AND 22 OF THE FCC RULES ARE APPLICABLE AND IN THE EVENT OF CONFLICT, SUPERSEDE ANY OTHER STANDARDS OR SPECIFICATIONS.
 - J. 2009 LIFE SAFETY CODE NFPA - 101.

APPLICANT:

T-MOBILE NORTHEAST LLC
 35 GRIFFIN ROAD SOUTH
 BLOOMFIELD, CT 06002
 860-692-7100

PROJECT MANAGER

NSS NORTHEAST
 SITE SOLUTIONS
Turnkey Wireless Development
 420 MAIN STREET, BLDG 4
 STURBRIDGE, MA 01566
 203-275-6669

CONSULTANT:

Architects . Engineers . Surveyors
 462 WALNUT STREET
 NEWTON, MA 02460
 617-212-3123

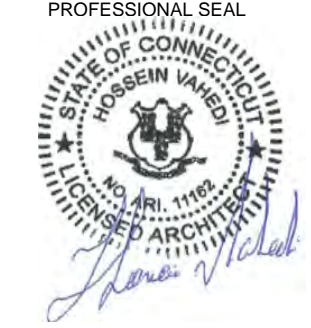
PROFESSIONAL SEAL



THIS DOCUMENT IS THE DESIGN PROPERTY AND COPYRIGHT OF FORESITE, LLC. AND FOR THE EXCLUSIVE USE BY THE TITLE CLIENT. DUPLICATION OR USE WITHOUT THE EXPRESS WRITTEN CONSENT OF THE CREATOR IS STRICTLY PROHIBITED. DRAWING SCALES ARE INTENDED FOR 11"x17" SIZE PRINTED MEDIA ONLY. ALL OTHER PRINTED SIZES ARE DEEMED "NOT TO SCALE".

REV	DESCRIPTION	DATE
A	PRELIMINARY	07/02/18
0	ISSUED FOR PERMIT	07/06/18

SITE NUMBER: CT11134A
 SITE NAME: FARMINGTON/ I-84 X 37_1
 SITE ADDRESS: 200 COLT HIGHWAY
 FARMINGTON, CT 06032

SHEET TITLE:
N-1: NOTES AND DISCLAIMERS

Copyright © 2018 Foresite LLC all rights reserved. The details, templates, drawing formats or any portion of this document generated by Foresite LLC may not be duplicated, traced or used otherwise for any profit-driven enterprise.

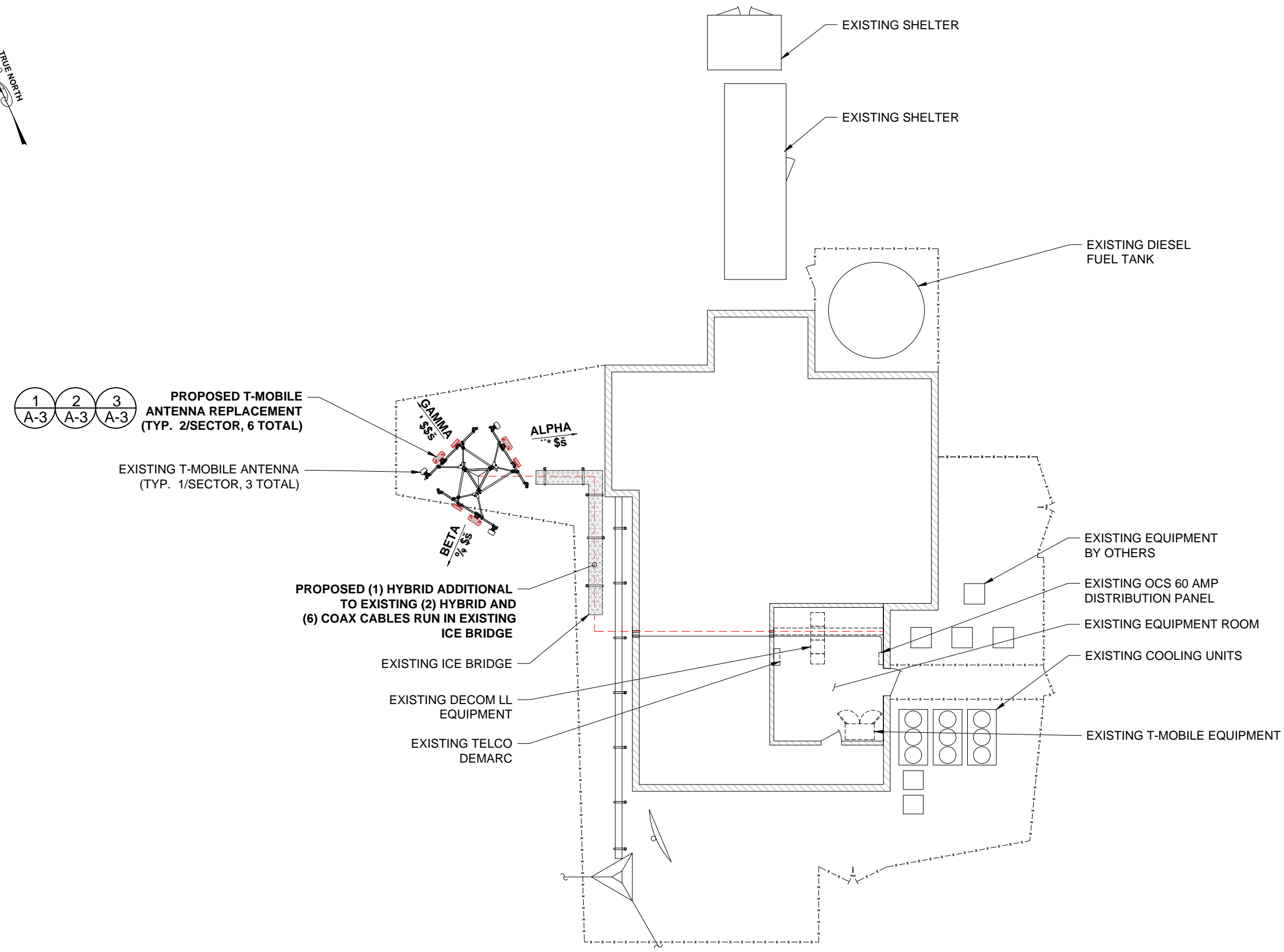

SITE PLAN
SCALE: 1/16" = 1'-0"

1
A-1

APPLICANT:
T-Mobile
T-MOBILE NORTHEAST LLC
35 GRIFFIN ROAD SOUTH
BLOOMFIELD, CT 06002
860-692-7100

PROJECT MANAGER
NSS NORTHEAST
SITE SOLUTIONS
Turkey Wireless Development
420 MAIN STREET, BLDG 4
STURBRIDGE, MA 01566
203-275-6669

CONSULTANT:
FORESITE LLC
Architects . Engineers . Surveyors
462 WALNUT STREET
NEWTON, MA 02460
617-212-3123

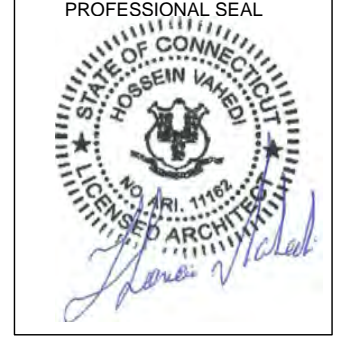

THIS DOCUMENT IS THE DESIGN PROPERTY AND COPYRIGHT OF FORESITE, LLC. AND FOR THE EXCLUSIVE USE BY THE TITLE CLIENT. DUPLICATION OR USE WITHOUT THE EXPRESS WRITTEN CONSENT OF THE CREATOR IS STRICTLY PROHIBITED. DRAWING SCALES ARE INTENDED FOR 11"x17" SIZE PRINTED MEDIA ONLY. ALL OTHER PRINTED SIZES ARE DEEMED "NOT TO SCALE".

REV	DESCRIPTION	DATE
A	PRELIMINARY	07/02/18
0	ISSUED FOR PERMIT	07/06/18

SITE NUMBER: CT11134A
SITE NAME: FARMINGTON/ I-84 X 37_1
SITE ADDRESS: 200 COLT HIGHWAY
FARMINGTON, CT 06032

SHEET TITLE:
A-1: PLAN

Copyright © 2018 Foresite LLC all rights reserved. The details, templates, drawing formats or any portion of this document generated by Foresite LLC may not be duplicated, traced or used otherwise for any profit-driven enterprise.

STRUCTURAL NOTES:
 PRIOR TO COMMENCING CONSTRUCTION, GC SHALL REFER TO TOWER STRUCTURAL ANALYSIS PROVIDED BY DESTEK TO DETERMINE IF THERE ARE ANY SUPPLEMENTAL OR SPECIAL REQUIREMENTS FOR TOWER TOP EQUIPMENT AND FOR CABLE BUNDLING, SHIELDING, MOUNTING OR RELOCATION ARRANGEMENTS.

REFER TO STRUCTURAL ANALYSIS REPORT TITLED "STRUCTURAL ANALYSIS REPORT - GUYED TOWER" SITE ID: CT11134A, DATED JUNE 21, 2018, PREPARED BY DESTEK.

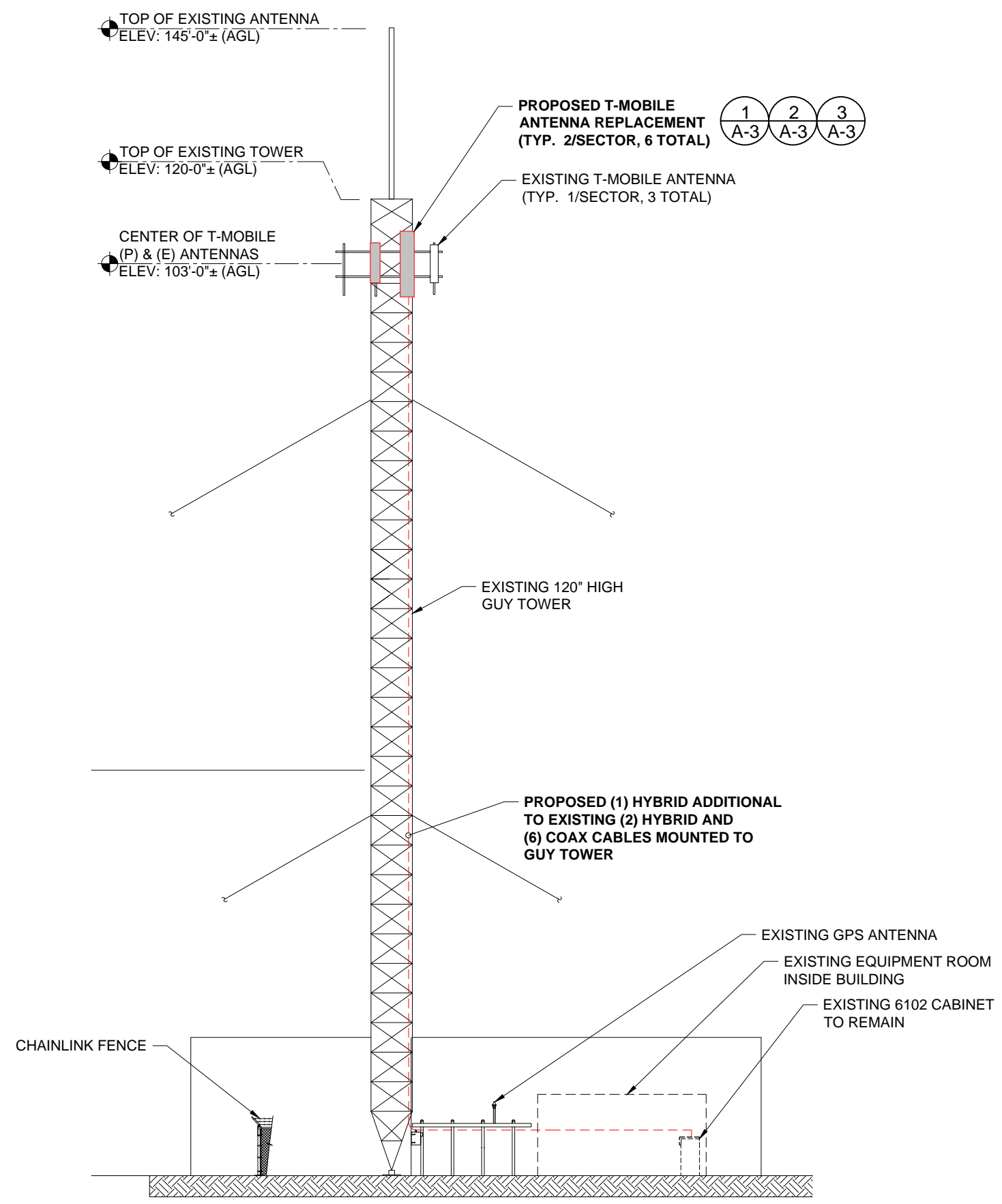

ELEVATION
 SCALE: 1/16" = 1'-0" 1
A-2

APPLICANT:
T-Mobile
T-MOBILE NORTHEAST LLC
 35 GRIFFIN ROAD SOUTH
 BLOOMFIELD, CT 06002
 860-692-7100

PROJECT MANAGER
NSS NORTHEAST
 SITE SOLUTIONS
Turnkey Wireless Development
 420 MAIN STREET, BLDG 4
 STURBRIDGE, MA 01566
 203-275-6669

CONSULTANT:
FORESITE LLC
 Architects . Engineers . Surveyors
 462 WALNUT STREET
 NEWTON, MA 02460
 617-212-3123

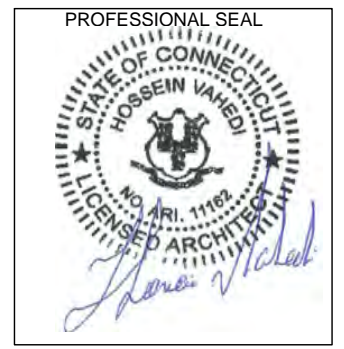

THIS DOCUMENT IS THE DESIGN PROPERTY AND COPYRIGHT OF FORESITE, LLC. AND FOR THE EXCLUSIVE USE BY THE TITLE CLIENT. DUPLICATION OR USE WITHOUT THE EXPRESS WRITTEN CONSENT OF THE CREATOR IS STRICTLY PROHIBITED. DRAWING SCALES ARE INTENDED FOR 11"x17" SIZE PRINTED MEDIA ONLY. ALL OTHER PRINTED SIZES ARE DEEMED "NOT TO SCALE".

REV	DESCRIPTION	DATE
A	PRELIMINARY	07/02/18
0	ISSUED FOR PERMIT	07/06/18

SITE NUMBER: CT11134A
 SITE NAME: FARMINGTON/ I-84 X 37_1
 SITE ADDRESS: 200 COLT HIGHWAY
 FARMINGTON, CT 06032

SHEET TITLE:
 A-2: ELEVATION

Copyright © 2018 Foresite LLC all rights reserved. The details, templates, drawing formats or any portion of this document generated by Foresite LLC may not be duplicated, traced or used otherwise for any profit-driven enterprise.

STRUCTURAL NOTES:
 PRIOR TO COMMENCING CONSTRUCTION, GC SHALL REFER TO TOWER STRUCTURAL ANALYSIS PROVIDED BY DESTEK TO DETERMINE IF THERE ARE ANY SUPPLEMENTAL OR SPECIAL REQUIREMENTS FOR TOWER TOP EQUIPMENT AND FOR CABLE BUNDLING, SHIELDING, MOUNTING OR RELOCATION ARRANGEMENTS.

REFER TO STRUCTURAL ANALYSIS REPORT TITLED "STRUCTURAL ANALYSIS REPORT - GUYED TOWER" SITE ID: CT11134A, DATED JUNE 21, 2018, PREPARED BY DESTEK.

EXISTING ANTENNA PLAN

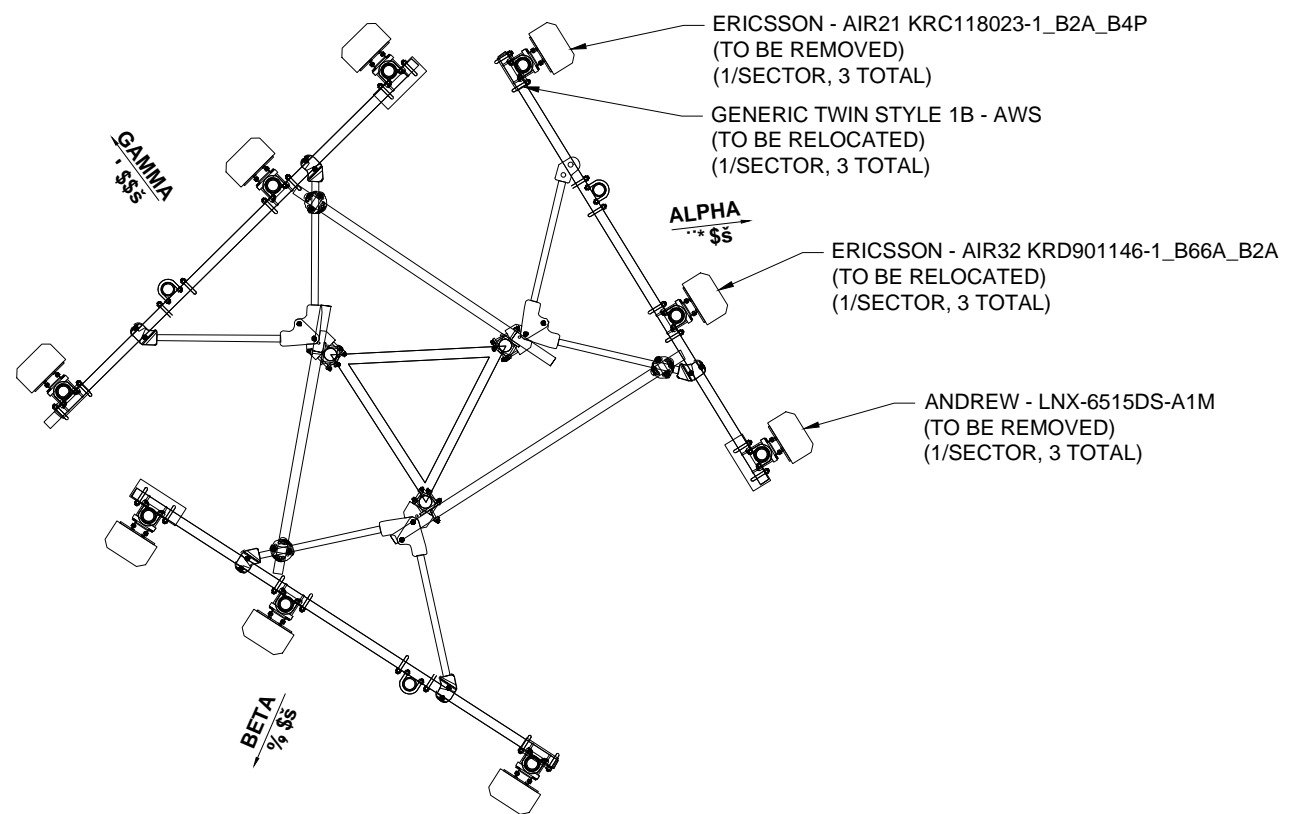

FINAL ANTENNA PLAN

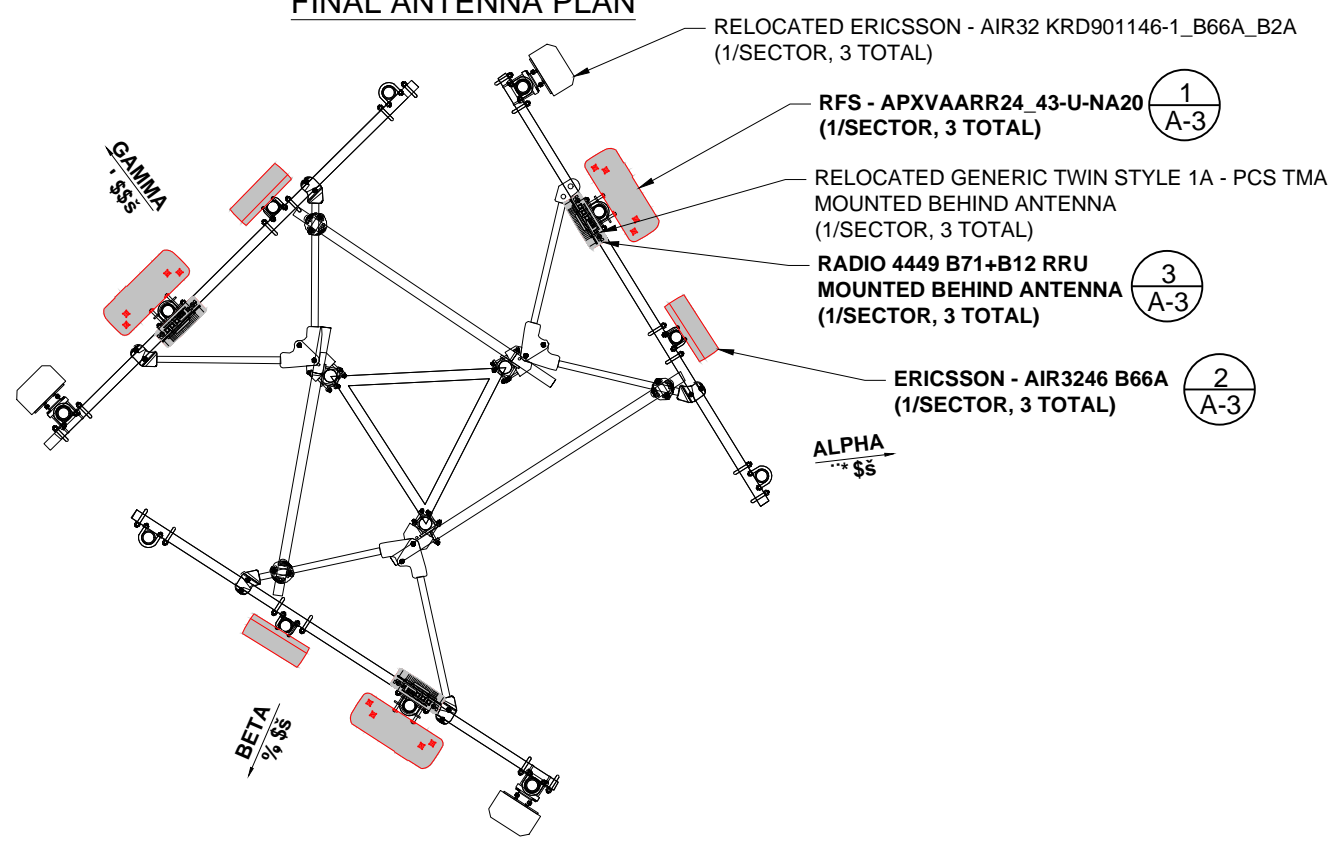

ANTENNA PLAN
 SCALE: NTS

1
A-3

APPLICANT:
T-Mobile
T-MOBILE NORTHEAST LLC
 35 GRIFFIN ROAD SOUTH
 BLOOMFIELD, CT 06002
 860-692-7100

PROJECT MANAGER
NSS NORTHEAST
 SITE SOLUTIONS
Turnkey Wireless Development
 420 MAIN STREET, BLDG 4
 STURBRIDGE, MA 01566
 203-275-6669

CONSULTANT:
FORESITE LLC
 Architects . Engineers . Surveyors
 462 WALNUT STREET
 NEWTON, MA 02460
 617-212-3123

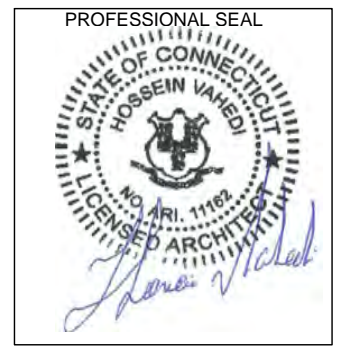

THIS DOCUMENT IS THE DESIGN PROPERTY AND COPYRIGHT OF FORESITE, LLC. AND FOR THE EXCLUSIVE USE BY THE TITLE CLIENT. DUPLICATION OR USE WITHOUT THE EXPRESS WRITTEN CONSENT OF THE CREATOR IS STRICTLY PROHIBITED. DRAWING SCALES ARE INTENDED FOR 11"x17" SIZE PRINTED MEDIA ONLY. ALL OTHER PRINTED SIZES ARE DEEMED "NOT TO SCALE".

REV	DESCRIPTION	DATE
A	PRELIMINARY	07/02/18
0	ISSUED FOR PERMIT	07/06/18

SITE NUMBER: CT11134A
 SITE NAME: FARMINGTON/ I-84 X 37_1
 SITE ADDRESS: 200 COLT HIGHWAY
 FARMINGTON, CT 06032

SHEET TITLE:
 A-3: ANTENNA PLAN AND DETAILS

Copyright © 2018 Foresite LLC all rights reserved. The details, templates, drawing formats or any portion of this document generated by Foresite LLC may not be duplicated, traced or used otherwise for any profit-driven enterprise.

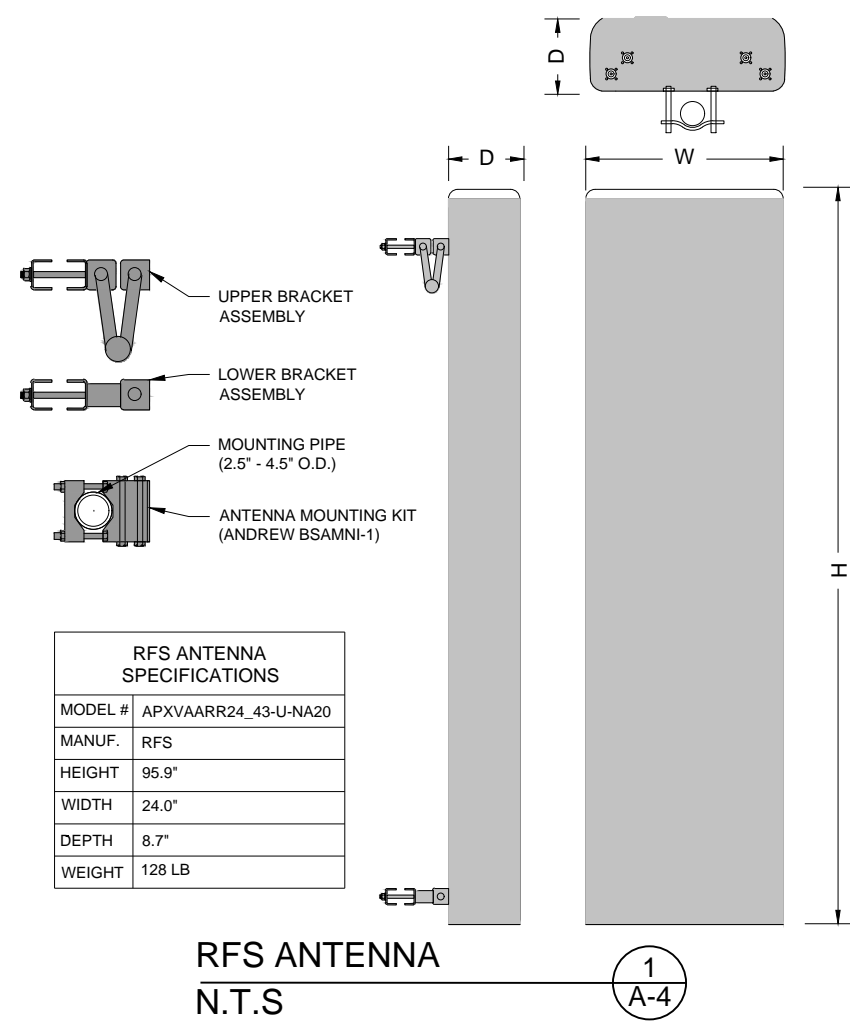

RFS ANTENNA SPECIFICATIONS	
MODEL #	APXVAARR24_43-U-NA20
MANUF.	RFS
HEIGHT	95.9"
WIDTH	24.0"
DEPTH	8.7"
WEIGHT	128 LB

RFS ANTENNA
N.T.S. 1
A-4

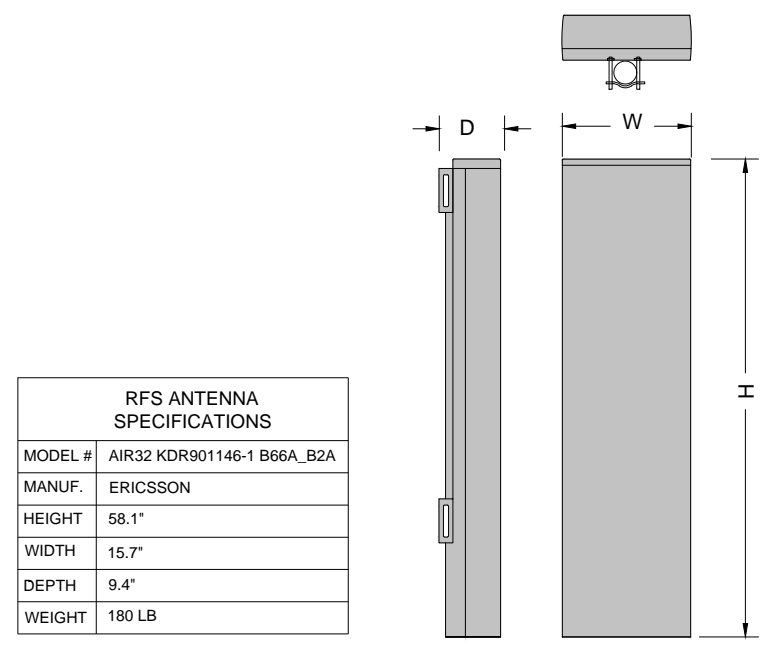

RFS ANTENNA SPECIFICATIONS	
MODEL #	AIR32 KDR901146-1 B66A_B2A
MANUF.	ERICSSON
HEIGHT	58.1"
WIDTH	15.7"
DEPTH	9.4"
WEIGHT	180 LB

ERICSSON ANTENNA
N.T.S. 2
A-4

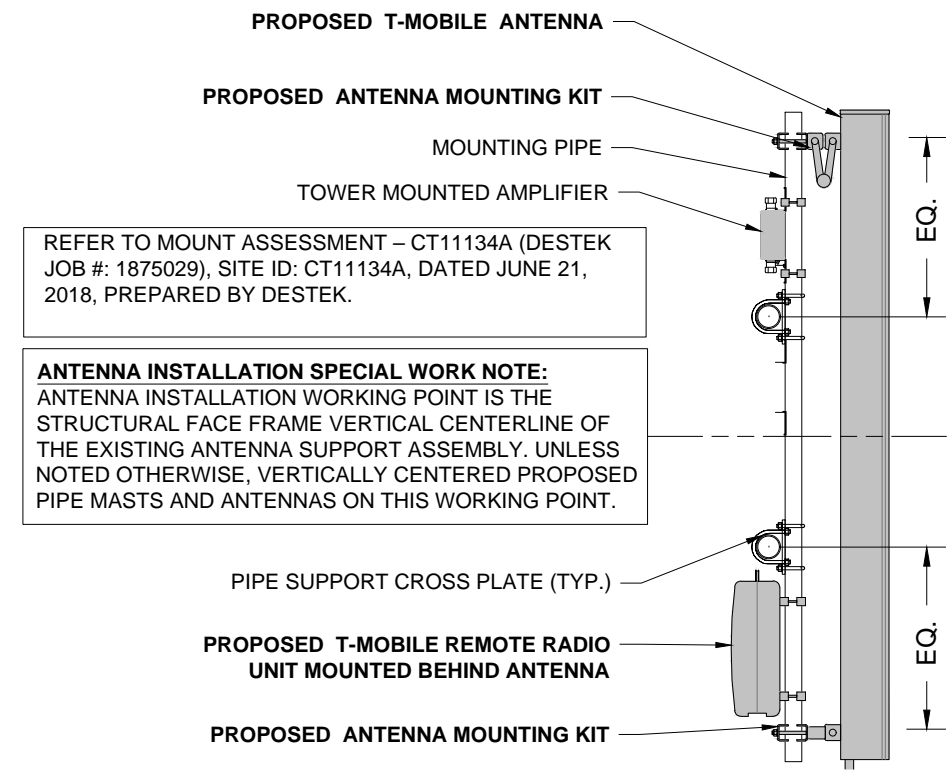

REFER TO MOUNT ASSESSMENT – CT11134A (DESTEK JOB #: 1875029), SITE ID: CT11134A, DATED JUNE 21, 2018, PREPARED BY DESTEK.

ANTENNA INSTALLATION SPECIAL WORK NOTE:
ANTENNA INSTALLATION WORKING POINT IS THE STRUCTURAL FACE FRAME VERTICAL CENTERLINE OF THE EXISTING ANTENNA SUPPORT ASSEMBLY. UNLESS NOTED OTHERWISE, VERTICALLY CENTERED PROPOSED PIPE MASTS AND ANTENNAS ON THIS WORKING POINT.

ANTENNA MOUNTING DETAIL
N.T.S. 4
A-4

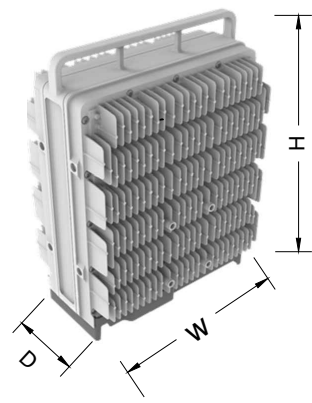

REMOTE RADIO UNIT SPECIFICATIONS	
MODEL #	RADIO 4449 B71+B12
MANUF.	ERICSSON
HEIGHT	14.9"
WIDTH	13.2"
DEPTH	10.4"
WEIGHT	74 LB

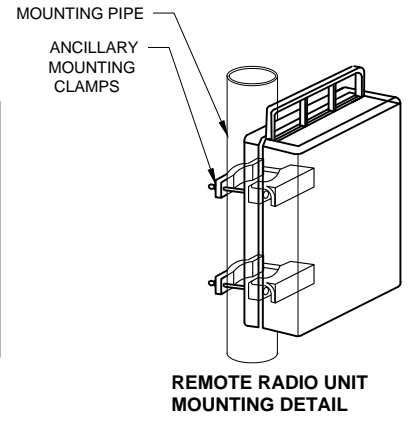

RADIO 4449 B71+B12 REMOTE RADIO UNIT
N.T.S. 3
A-4

APPLICANT:
T-MOBILE
T-MOBILE NORTHEAST LLC
 35 GRIFFIN ROAD SOUTH
 BLOOMFIELD, CT 06002
 860-692-7100

PROJECT MANAGER
NSS **NORTHEAST**
 SITE SOLUTIONS
Turkey Wireless Development
 420 MAIN STREET, BLDG 4
 STURBRIDGE, MA 01566
 203-275-6669

CONSULTANT:
FORESITE **LLC**
 Architects . Engineers . Surveyors
 462 WALNUT STREET
 NEWTON, MA 02460
 617-212-3123

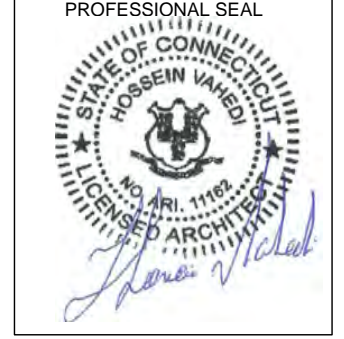

THIS DOCUMENT IS THE DESIGN PROPERTY AND COPYRIGHT OF FORESITE, LLC. AND FOR THE EXCLUSIVE USE BY THE TITLE CLIENT. DUPLICATION OR USE WITHOUT THE EXPRESS WRITTEN CONSENT OF THE CREATOR IS STRICTLY PROHIBITED. DRAWING SCALES ARE INTENDED FOR 11"x17" SIZE PRINTED MEDIA ONLY. ALL OTHER PRINTED SIZES ARE DEEMED "NOT TO SCALE".

REV	DESCRIPTION	DATE
A	PRELIMINARY	07/02/18
0	ISSUED FOR PERMIT	07/06/18

SITE NUMBER: CT11134A
 SITE NAME: FARMINGTON/ I-84 X 37_1
 SITE ADDRESS: 200 COLT HIGHWAY
 FARMINGTON, CT 06032

SHEET TITLE:
 A-4: ANTENNA DETAILS

Copyright © 2018 Foresite LLC all rights reserved. The details, templates, drawing formats or any portion of this document generated by Foresite LLC may not be duplicated, traced or used otherwise for any profit-driven enterprise.

ELECTRICAL & GROUNDING NOTES

1. ALL ELECTRICAL WORK SHALL CONFORM TO THE REQUIREMENTS OF THE NATIONAL ELECTRICAL CODE (NEC) AS WELL AS APPLICABLE STATE AND LOCAL CODES.
2. ALL ELECTRICAL ITEMS SHALL BE U.L. APPROVED OR LISTED AND PRODUCED PER SPECIFICATION REQUIREMENTS.
3. THE ELECTRICAL WORK INCLUDES ALL LABOR AND MATERIAL DESCRIBED BY DRAWINGS AND SPECIFICATION INCLUDING INCIDENTAL WORK TO PROVIDE COMPLETE OPERATING AND APPROVED ELECTRICAL SYSTEM.
4. GENERAL CONTRACTOR SHALL PAY FEES FOR PERMITS, AND RESPONSIBLE FOR OBTAINING SAID PERMITS AND COORDINATION OF INSPECTIONS.
5. ELECTRICAL AND TELCO WIRING OUTSIDE A BUILDING AND EXPOSED TO WEATHER SHALL BE IN WATER TIGHT GALVANIZED RIGID STEEL CONDUITS OR SCHEDULE 80 PVC (AS PERMITTED BY CODE) AND WHERE REQUIRED IN LIQUID TIGHT FLEXIBLE METAL OR NONMETALLIC CONDUITS.
6. RIGID STEEL CONDUITS SHALL BE GROUNDED AT BOTH ENDS.
7. ELECTRICAL WIRING SHALL BE COPPER WITH TYPE XHHW, THWN, OR THIN INSULATION.
8. RUN ELECTRICAL CONDUIT OR CABLING BETWEEN ELECTRICAL ROOM AND PROPOSED CELL SITE ARE PEDESTAL AS INDICATED ON THIS DRAWING. PROVIDE FULL LENGTH PULL ROPE. COORDINATE INSTALLATION WITH UTILITY COMPANY.
9. RUN TELCO CONDUIT OR CABLE BETWEEN TELEPHONE UTILITY DEMARCATION POINT AND PROPOSED CELL SITE TELCOM CABINET AND RBS CABINET AS INDICATED ON DRAWING A -1. PROVIDE FULL LENGTH PULL ROPE INSTALLED TELCO CONDUIT. PROVIDE GREENLEE CONDUIT MEASURING TAPE AT EACH END.
10. ALL EQUIPMENT LOCATED OUTSIDE SHALL HAVE NAME 3R ENCLOSURE.
11. GROUNDING SHALL COMPLY WITH NEC ART. 250.
12. GROUNDING COAX CABLE SHIELDS MINIMUM AT BOTH ENDS USING MANUFACTURES COAX CABLE GROUNDING KITS SUPPLIED BY PROJECT OWNER.
13. USE #6 COPPER STRANDED WIRE WITH GREEN COLOR INSTALLATION FOR ABOVE GRADE GROUNDING (UNLESS OTHERWISE SPECIFIED) AND #2 SOLID TINNED BARE COPPER WIRE FOR BELOW GRADE GROUNDING AS INDICATED ON THE GROUND.
14. ALL GROUND CONNECTION TO BE BURNDY HYGROUND COMPRESSION TYPE CONNECTORS OR CADWELD EXOTHERMIC WELD. DO NOT ALLOW BARE COPPER WIRE TO BE IN CONTACT WITH GALVANIZED STEEL.
15. ROUTE GROUNDING CONDUCTORS ALONG THE SHORTEST AND STRAIGHTEST PATH POSSIBLE, EXCEPT AS OTHERWISE INDICATED. GROUNDING LEADS SHOULD NEVER BE BENT AS RIGHT ANGLE. ALWAYS MAKE AT LEAST 12" RADIUS BENDS. #6 WIRE CAN BE BENT AT 6" RADIUS WHEN NECESSARY BOND ANY METER OBJECTS WITHIN 7 FEET OF PROPOSED EQUIPMENT OR CABINET TO MASTER GROUND BAR.
16. CONNECTIONS TO MGB SHALL BE ARRANGED IN THREE MAIN GROUPS: SURGE PROCEDURES (COAXIAL CABLE GROUND KITS, TELCO AND POWER PANEL GROUND); (GROUNDING ELECTRODE RING OR BUILDING STEEL); NON-SURGING OBJECTS (EGB GROUND IN RBS UNIT).
17. CONNECTIONS TO GROUND BARS SHALL BE MADE WITH TWO HOLE COMPRESSION TYPE COPPER LUGS. APPLY OXIDE INHIBITING COMPOUND TO ALL LOCATIONS.
18. APPLY OXIDE INHIBITING COMPOUND TO ALL COMPRESSION TYPE GROUND CONNECTION.
19. BOND ANTENNA MOUNTING BRACKETS, COAXIAL CABLE GROUND KITS, AND ALNA TO EGB PLACED NEAR THE ANTENNA LOCATION.
20. BOND ANTENNA EGB'S AND MGB TO WATER MAIN.
21. TEST COMPLETED GROUND SYSTEM AND RECORD RESULTS FOR PROJECT CLOSE-OUT DOCUMENTATION.
22. BOND ANY METAL OBJECTS WITHIN 7 FEET OF PROPOSED EQUIPMENT OR CABINET TO MASTER GROUND BAR.
23. VERIFY PROPOSED SERVICE UPGRADE WITH LOCAL UTILITY COMPANY PRIOR TO CONSTRUCTION.

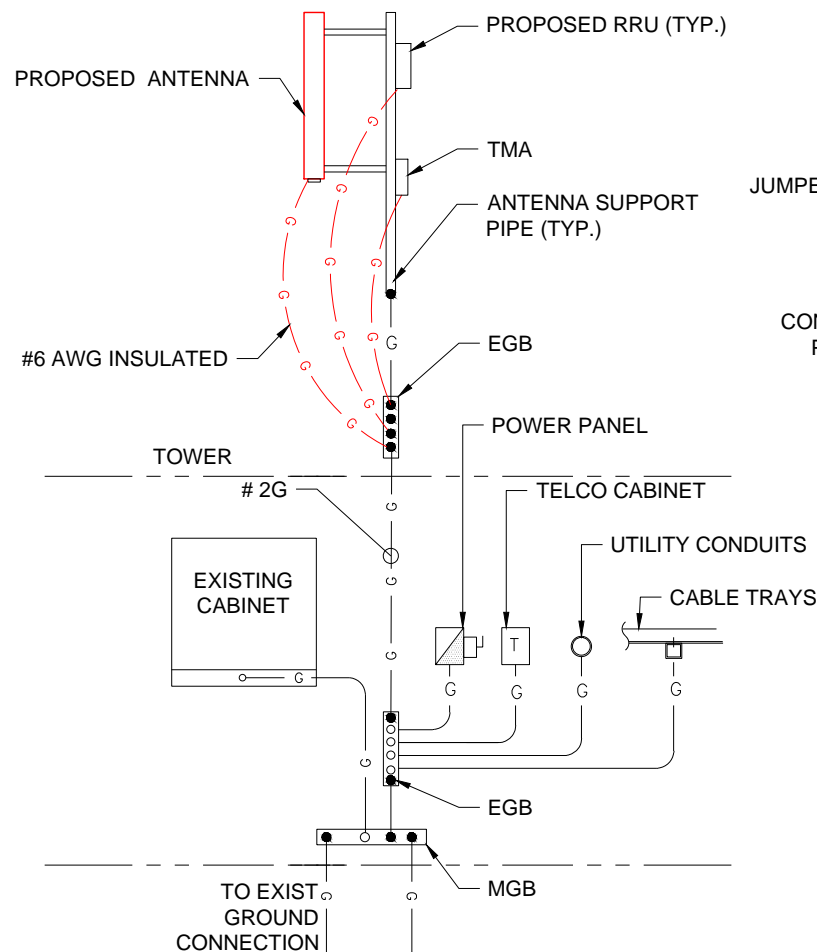

GROUNDING RISER DIAGRAM
SCALE: N.T.S

1
E-1

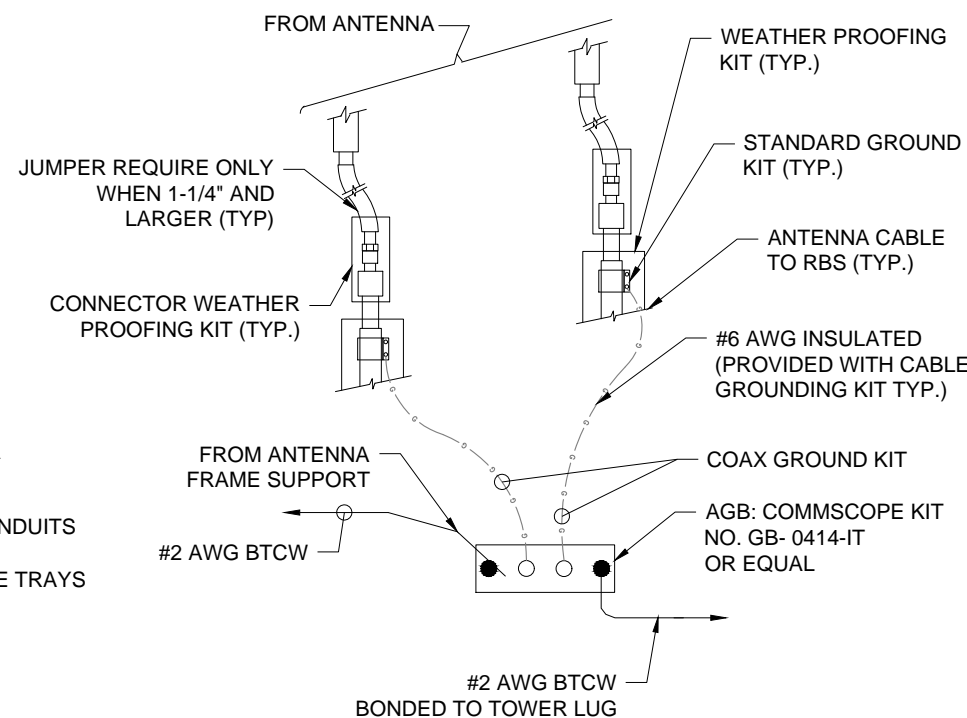

NOTES:
INSTALL CABLE GROUND KIT ABOVE HORIZONTAL BEND AND ALWAYS DIRECT GROUND WIRE DOWN TO AGB/EGB

TOWER TOP CABLE GROUNDING DETAIL
SCALE: N.T.S

2
E-1

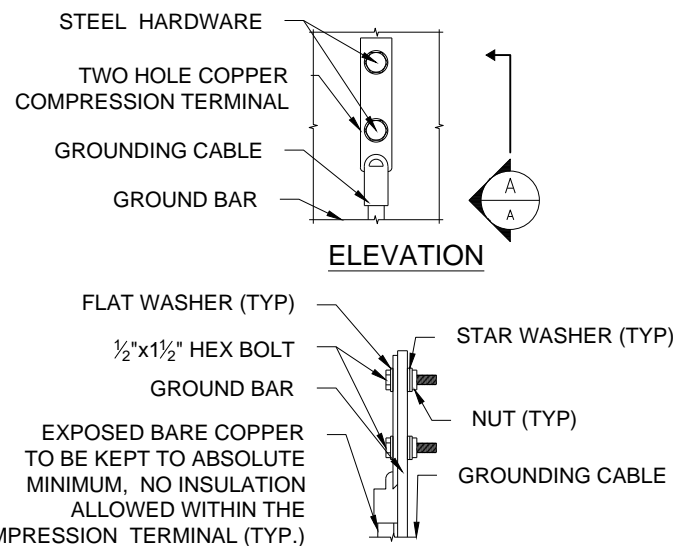

- NOTES:**
1. "DOUBLING UP" OR "STACKING " OF CONNECTIONS IS NOT PERMITTED.
 2. OXIDE INHIBITING COMPOUND TO BE USED AT ALL LOCATIONS.

TYPICAL GROUND BAR CONNECTIONS DETAIL
SCALE: N.T.S

3
E-1

APPLICANT:
T-Mobile
T-MOBILE NORTHEAST LLC

35 GRIFFIN ROAD SOUTH
BLOOMFIELD, CT 06002
860-692-7100

PROJECT MANAGER
NSS NORTHEAST
SITE SOLUTIONS
Turnkey Wireless Development
420 MAIN STREET, BLDG 4
STURBRIDGE, MA 01566
203-275-6669

CONSULTANT:
FORESITE LLC
Architects . Engineers . Surveyors
462 WALNUT STREET
NEWTON, MA 02460
617-212-3123

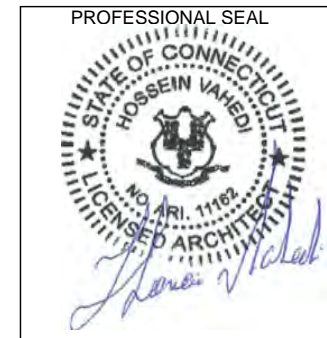

THIS DOCUMENT IS THE DESIGN PROPERTY AND COPYRIGHT OF FORESITE, LLC. AND FOR THE EXCLUSIVE USE BY THE TITLE CLIENT. DUPLICATION OR USE WITHOUT THE EXPRESS WRITTEN CONSENT OF THE CREATOR IS STRICTLY PROHIBITED. DRAWING SCALES ARE INTENDED FOR 11"x17" SIZE PRINTED MEDIA ONLY. ALL OTHER PRINTED SIZES ARE DEEMED "NOT TO SCALE".

REV	DESCRIPTION	DATE
A	PRELIMINARY	07/02/18
0	ISSUED FOR PERMIT	07/06/18

SITE NUMBER: CT11134A
SITE NAME: FARMINGTON/ I-84 X 37_1
SITE ADDRESS: 200 COLT HIGHWAY
FARMINGTON, CT 06032

SHEET TITLE:
E-1: GROUNDING AND ELECTRICAL DETAILS

Exhibit D

**STRUCTURAL ANALYSIS REPORT
GUYED TOWER**



Prepared For:



**T-Mobile Northeast, LLC
35 Griffin Road South
Bloomfield, CT 06002**



Structure Rating

Guyed Tower : Pass(55.6%)

Sincerely,
Destek Engineering, LLC
License No: PEC0001429

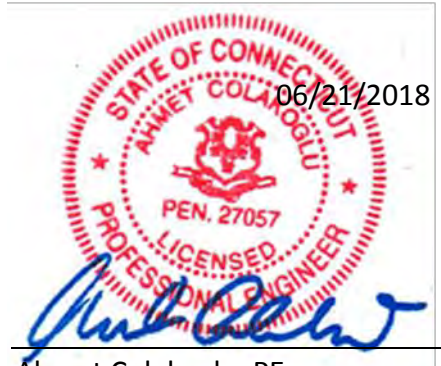

Ahmet Colakoglu, PE
Connecticut Professional Engineer
License No: 27057

**Site ID: CT11134A
Site Name: 200 Colt Highway,
Farmington, CT 06032**

CONTENTS

1.0 – SUBJECT AND REFERENCES

1.1 – STRUCTURE

2.0 – EXISTING AND PROPOSED APPURTENANCES

3.0 - CODES AND LOADING

4.0 - STANDARD CONDITIONS FOR ENGINEERING SERVICES ON EXISTING
STRUCTURES

5.0 - ANALYSIS AND ASSUMPTIONS

6.0 – RESULTS AND CONCLUSION

APPENDIX

A –CALCULATIONS

1.0 SUBJECT AND REFERENCES

The purpose of this analysis is to evaluate the structural capacity of the existing 120 feet tall guyed tower, located at 200 Colt Highway, Farmington, CT 06032 for the additions and alterations proposed by T-Mobile.

The structural analysis of the site is based on the following documents provided to Destek Engineering, LLC (Destek):

- Structural Analysis Report prepared by Destek Engineering, LLC, dated 05/09/2017.
- Construction Drawings prepared by ForeSite, LLC, dated 05/05/2017
- RFDS report provided by TMO, dated 05/09/2018.
- Site Audit pictures, dated 04/20/2017.

1.1 STRUCTURE

The structure is a 120 feet tall, triangular based guyed tower. The tower solid rod legs are X-braced along the elevation with solid rods. The tower is 6 feet wide from top to bottom and guyed at 103.5' with an anchor radius of 250' on ground. Please refer to the software output in Appendix A, for tower geometry, member sizes and other details.

2.0 EXISTING AND PROPOSED APPURTENANCES

This analysis was based on the following existing and proposed appurtenances:

Existing Configuration of T-MOBILE Appurtenances:

RAD CENTER (FT)	ANTENNA & TMA	COAX	MOUNT
103	(3) AIR21 KRC118023-1_B2A/B4P (3) LNX-6515DS-A1M (3) AIR32 KRD901146-1_B66A/B2A (3) RRUS11_B12 (3) Generic Twin Style 1B-AWS TMA	(6) 1-1/4" + (1) 9x18 hybrid + (1) 6x12 hybrid	(3) Sector Mounts

Proposed and Final Configuration of T-MOBILE Appurtenances:

RAD CENTER (FT)	ANTENNA & TMA	COAX	MOUNT
103	(3) APXVAARR24_43-U-NA20 (3)) AIR32 KRD901146-1_B66A/B2A (3) AIR3246 B66 (3) Radio 4449 B12/B71 (3) Generic Twin Style 1B-AWS TMA	(6) 1-1/4" + (1) 9x18 hybrid + (2) 6x12 hybrid	(3) Sector Mounts

Existing and Remaining Appurtenances by Others:

RAD CENTER (FT)	ANTENNA & TMA	COAX	MOUNT
120	(1) TFU-30J	(1) 6-1/8"	-

3.0 CODES AND LOADING

The tower was analyzed per *TIA/EIA-222-G* as referenced by the *2016 Connecticut State Building Code* with all of the adopted Addendums and Supplements. The following wind loading was used in compliance with the standard for Hartford, CT:

- Basic wind speed 97 mph without ice (W_0)
- Basic wind speed 50 mph with 1" escalating ice (W_i)
- Exposure Category B
- Topographic Category 1
- Structure Class II

The following load combinations were used with wind blowing at 0°, 30°, 45°, 60°, and 90° measured from a line normal to the face of the self-support Tower.

- $1.2 D + 1.6 W_0$
- $0.9 D + 1.6 W_0$
- $1.2 D + 1.0 D_i + 1.0 W_i$

D: Dead Load of structure and appurtenances

W_0 : Wind Load, without ice

W_i : Wind Load, with ice

D_i : Weight of Ice

4.0 STANDARD CONDITIONS FOR ENGINEERING SERVICES ON EXISTING STRUCTURES

The analysis is based on the information provided to Destek and is assumed to be current and correct. Unless otherwise noted, the structure and the foundation system are assumed to be in good condition, free of defects and can achieve theoretical strength.

It is assumed that the structure has been maintained and shall be maintained during its service. The superstructure and the foundation system are assumed to be designed with proper engineering practice and fabricated, constructed and erected in accordance with the design documents. Destek will accept no liability which may arise due to any existing deficiency in design, material, fabrication, erection, construction, etc. or lack of maintenance.

The analysis results presented in this report are only applicable for the previously mentioned existing and proposed additions and alterations. Any deviation of the proposed equipment and placement, etc., will require Destek to generate an additional structural analysis.

5.0 ANALYSIS AND ASSUMPTIONS

The tower was analyzed by utilizing tnxTower, a non-linear, three-dimensional, finite element-analysis software package, a product of Tower Numerics, Inc. Software output for this analysis is provided in Appendix A of this report.

All member end connection details are sufficient to resist the maximum supported member loading.

6.0 RESULTS AND CONCLUSION

Based on a structural analysis per ANSI/TIA-222-G, the existing guyed tower **has adequate** structural capacity for the proposed changes by T-Mobile. For the aforementioned load combinations and as a maximum, the tower legs between 12' and 37' are stressed to **30.9%** of capacity. The tower diagonals between 87' and 112' are stressed to **37.4%** of capacity. The guy wires are stressed to **55.6%** of capacity. The existing foundation could not be analyzed as there were no information pertaining to the tower and the guy anchor foundation.

Therefore, the proposed additions and alterations by T-Mobile **can** be implemented as intended with the conditions outlined in this report.

Should you have any questions about this report, please contact us at (770) 693-0835.

**APPENDIX A
CALCULATIONS &
COAX LAYOUT**

Section	T1	T2	T3	T4	T5	T6	
Legs			SR 4 1/2				
Leg Grade			A7-33				
Diagonals			SR 3/4			N.A.	
Diagonal Grade			A7-33			N.A.	
Top Glirts			L 2 1/2x 2 1/2x 1/4			N.A.	
Bottom Glirts			L 2 1/2x 2 1/2x 1/4			N.A.	
Horizontals			L 2 1/2x 2 1/2x 1/4				
Face Width (ft)						6 @ 2	
# Panels @ (ft)			13 @ 8			2.3	
Weight (K)		4.6	4.6	4.6	4.6	2.3	22.3
		1.5					

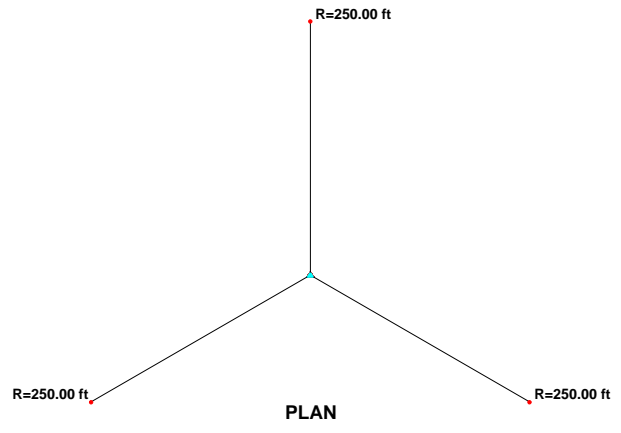
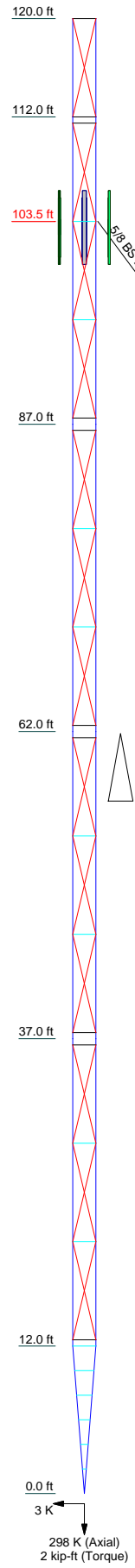

DESIGNED APPURTENANCE LOADING

TYPE	ELEVATION	TYPE	ELEVATION
TFU-30J	120	RADIO 4449 B12/B71	103
AIR -32 B2A/B66AA w/ Mount Pipe	103	RADIO 4449 B12/B71	103
AIR -32 B2A/B66AA w/ Mount Pipe	103	RADIO 4449 B12/B71	103
AIR -32 B2A/B66AA w/ Mount Pipe	103	AIR 3246 B66 w/ Mount Pipe	103
Generic Twin AWS TMA	103	AIR 3246 B66 w/ Mount Pipe	103
Generic Twin AWS TMA	103	AIR 3246 B66 w/ Mount Pipe	103
Generic Twin AWS TMA	103	6'-P2x0.154	103
APXVAARR24_43-U-NA20 w/ Mount Pipe	103	6'-P2x0.154	103
APXVAARR24_43-U-NA20 w/ Mount Pipe	103	6'-P2x0.154	103
APXVAARR24_43-U-NA20 w/ Mount Pipe	103	Sector Mount [SM 502-3]	103
APXVAARR24_43-U-NA20 w/ Mount Pipe	103		

MATERIAL STRENGTH

GRADE	Fy	Fu	GRADE	Fy	Fu
A7-33	33 ksi	60 ksi			

TOWER DESIGN NOTES

1. Tower is located in Hartford County, Connecticut.
2. Tower designed for Exposure B to the TIA-222-G Standard.
3. Tower designed for a 97 mph basic wind in accordance with the TIA-222-G Standard.
4. Tower is also designed for a 50 mph basic wind with 1.00 in ice. Ice is considered to increase in thickness with height.
5. Deflections are based upon a 60 mph wind.
6. Tower Structure Class II.
7. Topographic Category 1 with Crest Height of 0.00 ft
8. TOWER RATING: 55.6%

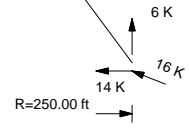

ALL REACTIONS ARE FACTORED

 Destek Engineering, LLC. 1281 Kennestone Cir. Suite#100 Marietta, GA 30066 Phone: (770) 693-0835 FAX:	Job: CT11134A
	Project: 1875029
	Client: ForeSite LLC
	Code: TIA-222-G
	Path: Z:\Projects\2018\75 - ForeSite LLC\1875029 - CT11134A\Calcs\CT11134A.en
Drawn by:	App'd:
Date: 06/20/18	Scale: NTS
	Dwg No. E-1

tnxTower Destek Engineering, LLC. 1281 Kennestone Cir. Suite#100 Marietta, GA 30066 Phone: (770) 693-0835 FAX:	Job CT11134A	Page 1 of 23
	Project 1875029	Date 08:51:12 06/20/18
	Client ForeSite LLC	Designed by Ahmet Colakoglu

Tower Input Data

The main tower is a 3x guyed tower with an overall height of 120.00 ft above the ground line.

The base of the tower is set at an elevation of 0.00 ft above the ground line.

The face width of the tower is 6.00 ft at the top and tapered at the base.

This tower is designed using the TIA-222-G standard.

The following design criteria apply:

Tower is located in Hartford County, Connecticut.

Basic wind speed of 97 mph.

Structure Class II.

Exposure Category B.

Topographic Category 1.

Crest Height 0.00 ft.

Nominal ice thickness of 1.0000 in.

Ice thickness is considered to increase with height.

Ice density of 56 pcf.

A wind speed of 50 mph is used in combination with ice.

Temperature drop of 50 °F.

Deflections calculated using a wind speed of 60 mph.

Pressures are calculated at each section.

Safety factor used in guy design is 1.

Stress ratio used in tower member design is 1.

Local bending stresses due to climbing loads, feed line supports, and appurtenance mounts are not considered.

Options

- | | | |
|--|--|---|
| <ul style="list-style-type: none"> Consider Moments - Legs Consider Moments - Horizontals Consider Moments - Diagonals Use Moment Magnification √ Use Code Stress Ratios √ Use Code Safety Factors - Guys Escalate Ice Always Use Max Kz Use Special Wind Profile √ Include Bolts In Member Capacity √ Leg Bolts Are At Top Of Section √ Secondary Horizontal Braces Leg Use Diamond Inner Bracing (4 Sided) √ SR Members Have Cut Ends SR Members Are Concentric | <ul style="list-style-type: none"> Distribute Leg Loads As Uniform Assume Legs Pinned √ Assume Rigid Index Plate √ Use Clear Spans For Wind Area √ Use Clear Spans For KL/r √ Retension Guys To Initial Tension √ Bypass Mast Stability Checks √ Use Azimuth Dish Coefficients √ Project Wind Area of Appurt. √ Autocalc Torque Arm Areas Add IBC .6D+W Combination √ Sort Capacity Reports By Component √ Triangulate Diamond Inner Bracing Treat Feed Line Bundles As Cylinder | <ul style="list-style-type: none"> Use ASCE 10 X-Brace Ly Rules √ Calculate Redundant Bracing Forces Ignore Redundant Members in FEA √ SR Leg Bolts Resist Compression All Leg Panels Have Same Allowable Offset Girt At Foundation √ Consider Feed Line Torque √ Include Angle Block Shear Check Use TIA-222-G Bracing Resist. Exemption Use TIA-222-G Tension Splice Exemption <li style="text-align: center;">Poles Include Shear-Torsion Interaction Always Use Sub-Critical Flow Use Top Mounted Sockets |
|--|--|---|

tnxTower Destek Engineering, LLC. 1281 Kennestone Cir. Suite#100 Marietta, GA 30066 Phone: (770) 693-0835 FAX:	Job CT11134A	Page 2 of 23
	Project 1875029	Date 08:51:12 06/20/18
	Client ForeSite LLC	Designed by Ahmet Colakoglu

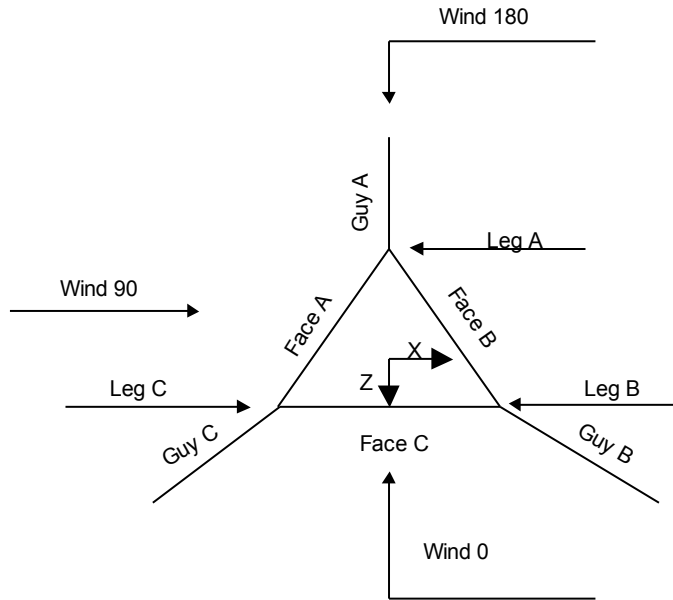

Corner & Starmount Guyed Tower

Tower Section Geometry

Tower Section	Tower Elevation	Assembly Database	Description	Section Width	Number of Sections	Section Length
	ft			ft		ft
T1	120.00-112.00			6.00	1	8.00
T2	112.00-87.00			6.00	1	25.00
T3	87.00-62.00			6.00	1	25.00
T4	62.00-37.00			6.00	1	25.00
T5	37.00-12.00			6.00	1	25.00
T6	12.00-0.00			6.00	1	12.00

Tower Section Geometry (cont'd)

Tower Section	Tower Elevation	Diagonal Spacing	Bracing Type	Has K Brace End Panels	Has Horizontals	Top Girt Offset	Bottom Girt Offset
	ft	ft				in	in
T1	120.00-112.00	8.00	TX Brace	No	Yes	0.0000	0.0000
T2	112.00-87.00	8.00	TX Brace	No	Yes	6.0000	6.0000
T3	87.00-62.00	8.00	TX Brace	No	Yes	6.0000	6.0000
T4	62.00-37.00	8.00	TX Brace	No	Yes	6.0000	6.0000

tnxTower Destek Engineering, LLC. 1281 Kennestone Cir. Suite#100 Marietta, GA 30066 Phone: (770) 693-0835 FAX:	Job	CT11134A	Page	3 of 23
	Project	1875029	Date	08:51:12 06/20/18
	Client	ForeSite LLC	Designed by	Ahmet Colakoglu

Tower Section	Tower Elevation ft	Diagonal Spacing ft	Bracing Type	Has K Brace End Panels	Has Horizontals	Top Girt Offset in	Bottom Girt Offset in
T5	37.00-12.00	8.00	TX Brace	No	Yes	6.0000	6.0000
T6	12.00-0.00	2.00	X Brace	No	Yes	0.0000	0.0000

Tower Section Geometry (cont'd)

Tower Elevation ft	Leg Type	Leg Size	Leg Grade	Diagonal Type	Diagonal Size	Diagonal Grade
T1 120.00-112.00	Solid Round	4 1/2	A7-33 (33 ksi)	Solid Round	3/4	A7-33 (33 ksi)
T2 112.00-87.00	Solid Round	4 1/2	A7-33 (33 ksi)	Solid Round	3/4	A7-33 (33 ksi)
T3 87.00-62.00	Solid Round	4 1/2	A7-33 (33 ksi)	Solid Round	3/4	A7-33 (33 ksi)
T4 62.00-37.00	Solid Round	4 1/2	A7-33 (33 ksi)	Solid Round	3/4	A7-33 (33 ksi)
T5 37.00-12.00	Solid Round	4 1/2	A7-33 (33 ksi)	Solid Round	3/4	A7-33 (33 ksi)
T6 12.00-0.00	Solid Round	4 1/2	A7-33 (33 ksi)	Solid Round	3/4	A7-33 (33 ksi)

Tower Section Geometry (cont'd)

Tower Elevation ft	Top Girt Type	Top Girt Size	Top Girt Grade	Bottom Girt Type	Bottom Girt Size	Bottom Girt Grade
T1 120.00-112.00	Single Angle	L 2 1/2x 2 1/2x 1/4	A7-33 (33 ksi)	Single Angle	L 2 1/2x 2 1/2x 1/4	A7-33 (33 ksi)
T2 112.00-87.00	Single Angle	L 2 1/2x 2 1/2x 1/4	A7-33 (33 ksi)	Single Angle	L 2 1/2x 2 1/2x 1/4	A7-33 (33 ksi)
T3 87.00-62.00	Single Angle	L 2 1/2x 2 1/2x 1/4	A7-33 (33 ksi)	Single Angle	L 2 1/2x 2 1/2x 1/4	A7-33 (33 ksi)
T4 62.00-37.00	Single Angle	L 2 1/2x 2 1/2x 1/4	A7-33 (33 ksi)	Single Angle	L 2 1/2x 2 1/2x 1/4	A7-33 (33 ksi)
T5 37.00-12.00	Single Angle	L 2 1/2x 2 1/2x 1/4	A7-33 (33 ksi)	Single Angle	L 2 1/2x 2 1/2x 1/4	A7-33 (33 ksi)

Tower Section Geometry (cont'd)

Tower Elevation ft	No. of Mid Girts	Mid Girt Type	Mid Girt Size	Mid Girt Grade	Horizontal Type	Horizontal Size	Horizontal Grade
T1 120.00-112.00	None	Flat Bar		A36 (36 ksi)	Single Angle	L 2 1/2x 2 1/2x 1/4	A7-33 (33 ksi)
T2 112.00-87.00	None	Flat Bar		A36 (36 ksi)	Single Angle	L 2 1/2x 2 1/2x 1/4	A7-33 (33 ksi)

tnxTower Destek Engineering, LLC. 1281 Kennestone Cir. Suite#100 Marietta, GA 30066 Phone: (770) 693-0835 FAX:	Job	CT11134A	Page	4 of 23
	Project	1875029	Date	08:51:12 06/20/18
	Client	ForeSite LLC	Designed by	Ahmet Colakoglu

Tower Elevation ft	No. of Mid Girts	Mid Girt Type	Mid Girt Size	Mid Girt Grade	Horizontal Type	Horizontal Size	Horizontal Grade
T3 87.00-62.00	None	Flat Bar		A36 (36 ksi)	Single Angle	L 2 1/2x 2 1/2x 1/4	A7-33 (33 ksi)
T4 62.00-37.00	None	Flat Bar		A36 (36 ksi)	Single Angle	L 2 1/2x 2 1/2x 1/4	A7-33 (33 ksi)
T5 37.00-12.00	None	Flat Bar		A36 (36 ksi)	Single Angle	L 2 1/2x 2 1/2x 1/4	A7-33 (33 ksi)
T6 12.00-0.00	None	Flat Bar		A36 (36 ksi)	Single Angle	L 2 1/2x 2 1/2x 1/4	A7-33 (33 ksi)

Tower Section Geometry (cont'd)

Tower Elevation ft	Gusset Area (per face) ft ²	Gusset Thickness in	Gusset Grade	Adjust. Factor A _f	Adjust. Factor A _r	Weight Mult.	Double Angle Stitch Bolt Spacing Diagonals in	Double Angle Stitch Bolt Spacing Horizontals in	Double Angle Stitch Bolt Spacing Redundants in
T1 120.00-112.00	0.00	0.0000	A36 (36 ksi)	1	1	1	Mid-Pt	Mid-Pt	36.0000
T2 112.00-87.00	0.00	0.0000	A36 (36 ksi)	1	1	1	Mid-Pt	Mid-Pt	36.0000
T3 87.00-62.00	0.00	0.0000	A36 (36 ksi)	1	1	1	Mid-Pt	Mid-Pt	36.0000
T4 62.00-37.00	0.00	0.0000	A36 (36 ksi)	1	1	1	Mid-Pt	Mid-Pt	36.0000
T5 37.00-12.00	0.00	0.0000	A36 (36 ksi)	1	1	1	Mid-Pt	Mid-Pt	36.0000
T6 12.00-0.00	0.00	0.0000	A36 (36 ksi)	1	1	1	Mid-Pt	Mid-Pt	36.0000

Tower Section Geometry (cont'd)

Tower Elevation ft	Calc K Single Angles	Calc K Solid Rounds	Legs	K Factors ¹							
				X Brace Diags	K Brace Diags	Single Diags	Girts	Horiz.	Sec. Horiz.	Inner Brace	
											X Y
T1 120.00-112.00	Yes	Yes	1	1	1	1	1	1	1	1	1
T2 112.00-87.00	Yes	Yes	1	1	1	1	1	1	1	1	1
T3 87.00-62.00	Yes	Yes	1	1	1	1	1	1	1	1	1
T4 62.00-37.00	Yes	Yes	1	1	1	1	1	1	1	1	1
T5 37.00-12.00	Yes	Yes	1	1	1	1	1	1	1	1	1
T6 12.00-0.00	Yes	Yes	0.2	1	1	1	1	1	1	1	1

¹Note: K factors are applied to member segment lengths. K-braces without inner supporting members will have the K factor in the out-of-plane direction applied to the overall length.

tnxTower Destek Engineering, LLC. 1281 Kennestone Cir. Suite#100 Marietta, GA 30066 Phone: (770) 693-0835 FAX:	Job CT11134A	Page 5 of 23
	Project 1875029	Date 08:51:12 06/20/18
	Client ForeSite LLC	Designed by Ahmet Colakoglu

Tower Section Geometry (cont'd)

Tower Elevation ft	Leg		Diagonal		Top Girt		Bottom Girt		Mid Girt		Long Horizontal		Short Horizontal	
	Net Width Deduct in	U	Net Width Deduct in	U	Net Width Deduct in	U	Net Width Deduct in	U	Net Width Deduct in	U	Net Width Deduct in	U	Net Width Deduct in	U
T1 120.00-112.00	0.0000	1	0.0000	0.75	0.0000	0.75	0.0000	0.75	0.0000	0.75	0.0000	0.75	0.0000	0.75
T2 112.00-87.00	0.0000	1	0.0000	0.75	0.0000	0.75	0.0000	0.75	0.0000	0.75	0.0000	0.75	0.0000	0.75
T3 87.00-62.00	0.0000	1	0.0000	0.75	0.0000	0.75	0.0000	0.75	0.0000	0.75	0.0000	0.75	0.0000	0.75
T4 62.00-37.00	0.0000	1	0.0000	0.75	0.0000	0.75	0.0000	0.75	0.0000	0.75	0.0000	0.75	0.0000	0.75
T5 37.00-12.00	0.0000	1	0.0000	0.75	0.0000	0.75	0.0000	0.75	0.0000	0.75	0.0000	0.75	0.0000	0.75
T6 12.00-0.00	0.0000	1	0.0000	0.75	0.0000	0.75	0.0000	0.75	0.0000	0.75	0.0000	0.75	0.0000	0.75

Guy Data

Guy Elevation ft	Guy Grade	Guy Size	Initial Tension K	%	Guy Modulus ksi	Guy Weight plf	L _u ft	Anchor Radius ft	Anchor Azimuth Adj. °	Anchor Elevation ft	End Fitting Efficiency %	
103.5	BS	A	5/8	4.80	10%	24000	0.820	267.17	250.00	0.0000	0.00	100%
		B	5/8	4.80	10%	24000	0.820	267.17	250.00	0.0000	0.00	100%
		C	5/8	4.80	10%	24000	0.820	267.17	250.00	0.0000	0.00	100%

Guy Data(cont'd)

Guy Elevation ft	Mount Type	Torque-Arm Spread ft	Torque-Arm Leg Angle °	Torque-Arm Style	Torque-Arm Grade	Torque-Arm Type	Torque-Arm Size
103.5	Corner						

Guy Data (cont'd)

Guy Elevation ft	Diagonal Grade	Diagonal Type	Upper Diagonal Size	Lower Diagonal Size	Is Strap.	Pull-Off Grade	Pull-Off Type	Pull-Off Size
103.50	A572-50 (50 ksi)	Solid Round				A572-50 (50 ksi)	Solid Round	

tnxTower Destek Engineering, LLC. 1281 Kennestone Cir. Suite#100 Marietta, GA 30066 Phone: (770) 693-0835 FAX:	Job CT11134A	Page 6 of 23
	Project 1875029	Date 08:51:12 06/20/18
	Client ForeSite LLC	Designed by Ahmet Colakoglu

Guy Data (cont'd)

Guy Elevation	Cable Weight	Cable Weight	Cable Weight	Cable Weight	Tower Intercept	Tower Intercept	Tower Intercept	Tower Intercept
ft	A	B	C	D	A	B	C	D
	K	K	K	K	ft	ft	ft	ft
103.5	0.22	0.22	0.22		6.05	6.05	6.05	
					4.2 sec/pulse	4.2 sec/pulse	4.2 sec/pulse	

Guy Data (cont'd)

Guy Elevation	Calc K	Calc K	Torque Arm		Pull Off		Diagonal	
			K _x	K _y	K _x	K _y	K _x	K _y
ft	Single Angles	Solid Rounds						
103.5	No	No			1	1	1	1

Guy Data (cont'd)

Guy Elevation	Torque-Arm				Pull Off				Diagonal			
	Bolt Size	Number	Net Width	U	Bolt Size	Number	Net Width	U	Bolt Size	Number	Net Width	U
ft	in		Deduct		in		Deduct		in		Deduct	
103.5	0.6250	0	0.0000	0.75	0.6250	0	0.0000	0.75	0.6250	0	0.0000	0.75
	A325N				A325N				A325N			

Guy Pressures

Guy Elevation	Guy Location	z	q _z	q _z	Ice Thickness
ft		ft	psf	psf	in
103.5	A	51.75	17	4	2.0920
	B	51.75	17	4	2.0920
	C	51.75	17	4	2.0920

Guy-Mast Forces (Excluding Wind) - No Ice

Guy Elevation	Guy Location	Chord Angle	Guy Tension	F _x	F _y	F _z	M _x	M _y	M _z
ft		°	Top Bottom K	K	K	K	kip-ft	kip-ft	kip-ft
103.5	A	22.7735	4.88 4.80	0.00	1.98	-4.46	-6.87	0.00	0.00
	B	22.7735	4.88 4.80	3.87	1.98	2.23	3.44	0.00	-5.95
	C	22.7735	4.88 4.80	-3.87	1.98	2.23	3.44	-0.00	5.95

tnxTower Destek Engineering, LLC. 1281 Kennestone Cir. Suite#100 Marietta, GA 30066 Phone: (770) 693-0835 FAX:	Job	CT11134A	Page	7 of 23
	Project	1875029	Date	08:51:12 06/20/18
	Client	ForeSite LLC	Designed by	Ahmet Colakoglu

Guy Elevation	Guy Location	Chord Angle	Guy Tension Top Bottom K	F _x	F _y	F _z	M _x	M _y	M _z
ft		°		K	K	K	kip-ft	kip-ft	kip-ft
			Sum:	0.00	5.95	0.00	0.00	0.00	0.00

Guy-Mast Forces (Excluding Wind) - Ice

Guy Elevation	Guy Location	Chord Angle	Guy Tension Top Bottom K	F _x	F _y	F _z	M _x	M _y	M _z
ft		°		K	K	K	kip-ft	kip-ft	kip-ft
103.5	A	22.7735	12.54 11.73	0.00	5.73	-11.15	-19.85	0.00	0.00
	B	22.7735	12.54 11.73	9.66	5.73	5.57	9.92	0.00	-17.19
	C	22.7735	12.54 11.73	-9.66	5.73	5.57	9.92	-0.00	17.19
			Sum:	0.00	17.19	0.00	0.00	0.00	0.00

Guy-Mast Forces (Excluding Wind) - Service

Guy Elevation	Guy Location	Chord Angle	Guy Tension Top Bottom K	F _x	F _y	F _z	M _x	M _y	M _z
ft		°		K	K	K	kip-ft	kip-ft	kip-ft
103.5	A	22.7735	4.88 4.80	0.00	1.98	-4.46	-6.87	0.00	0.00
	B	22.7735	4.88 4.80	3.87	1.98	2.23	3.44	0.00	-5.95
	C	22.7735	4.88 4.80	-3.87	1.98	2.23	3.44	-0.00	5.95
			Sum:	0.00	5.95	0.00	0.00	0.00	0.00

Guy-Tensioning Information

		Temperature At Time Of Tensioning															
Guy Elevation	H	V	0 F		20 F		40 F		60 F		80 F		100 F		120 F		
			Initial Tension	Intercept	Initial Tension	Intercept	Initial Tension	Intercept	Initial Tension	Intercept	Initial Tension	Intercept	Initial Tension	Intercept	Initial Tension	Intercept	
ft	ft	ft	K	ft	K	ft	K	ft	K	ft	K	ft	K	ft	K	ft	
103.5	A	246.54	103.50	6.481	4.49	5.905	4.92	5.343	5.44	4.800	6.05	4.282	6.78	3.798	7.63	3.357	8.62
	B	246.54	103.50	6.481	4.49	5.905	4.92	5.343	5.44	4.800	6.05	4.282	6.78	3.798	7.63	3.357	8.62
	C	246.54	103.50	6.481	4.49	5.905	4.92	5.343	5.44	4.800	6.05	4.282	6.78	3.798	7.63	3.357	8.62

tnxTower Destek Engineering, LLC. 1281 Kennestone Cir. Suite#100 Marietta, GA 30066 Phone: (770) 693-0835 FAX:	Job	CT11134A	Page	8 of 23
	Project	1875029	Date	08:51:12 06/20/18
	Client	ForeSite LLC	Designed by	Ahmet Colakoglu

Feed Line/Linear Appurtenances - Entered As Round Or Flat

Description	Face or Leg	Allow Shield	Component Type	Placement ft	Face Offset in	Lateral Offset (Frac FW)	#	# Per Row	Clear Spacing in	Width or Diameter in	Perimeter in	Weight plf
MACX675A (6-1/8 AIR)	A	No	Ar (CaAa)	120.00 - 10.00	-18.0000	0	1	1	6.0800	6.0800		4.52
Climbing Ladder	C	No	Ar (CaAa)	120.00 - 0.00	0.0000	0.3	2	2	24.0000 0.2500	2.0000		7.90
Feedline Ladder (Af)	B	No	Ar (CaAa)	103.00 - 0.00	-6.0000	0.3	2	2	3.0000	3.0000		8.40
LDF6-50A (1-1/4 FOAM)	B	No	Ar (CaAa)	103.00 - 0.00	-8.0000	0.3	8	4	1.5500	1.5500		0.66
Highcapacity Hybrid for TMO - 1.584"	B	No	Ar (CaAa)	103.00 - 0.00	-2.0000	0.32	1	1	1.5840	1.5840		1.61
Highcapacity Hybrid for TMO - 1.584"	B	No	Ar (CaAa)	103.00 - 0.00	-2.0000	0.34	2	2	1.5840	1.5840		1.61

Feed Line/Linear Appurtenances Section Areas

Tower Section	Tower Elevation ft	Face	A _R ft ²	A _F ft ²	C _{AA} In Face ft ²	C _{AA} Out Face ft ²	Weight K
T1	120.00-112.00	A	0.000	0.000	3.119	0.000	0.04
		B	0.000	0.000	0.000	0.000	0.00
		C	0.000	0.000	3.200	0.000	0.13
T2	112.00-87.00	A	0.000	0.000	9.963	0.000	0.11
		B	0.000	0.000	37.043	0.000	0.43
		C	0.000	0.000	10.000	0.000	0.40
T3	87.00-62.00	A	0.000	0.000	10.383	0.000	0.11
		B	0.000	0.000	57.880	0.000	0.67
		C	0.000	0.000	10.000	0.000	0.40
T4	62.00-37.00	A	0.000	0.000	11.008	0.000	0.11
		B	0.000	0.000	57.880	0.000	0.67
		C	0.000	0.000	10.000	0.000	0.40
T5	37.00-12.00	A	0.000	0.000	11.829	0.000	0.11
		B	0.000	0.000	57.880	0.000	0.67
		C	0.000	0.000	10.000	0.000	0.40
T6	12.00-0.00	A	0.000	0.000	0.946	0.000	0.01
		B	0.000	0.000	27.782	0.000	0.32
		C	0.000	0.000	4.800	0.000	0.19

Feed Line/Linear Appurtenances Section Areas - With Ice

Tower Section	Tower Elevation ft	Face or Leg	Ice Thickness in	A _R ft ²	A _F ft ²	C _{AA} In Face ft ²	C _{AA} Out Face ft ²	Weight K
T1	120.00-112.00	A	2.268	0.000	0.000	8.493	0.000	0.22
		B		0.000	0.000	0.000	0.000	0.00
		C		0.000	0.000	10.457	0.000	0.32
T2	112.00-87.00	A	2.233	0.000	0.000	26.367	0.000	0.68
		B		0.000	0.000	98.181	0.000	2.06
		C		0.000	0.000	32.334	0.000	0.97
T3	87.00-62.00	A	2.170	0.000	0.000	26.048	0.000	0.66

tnxTower Destek Engineering, LLC. 1281 Kennestone Cir. Suite#100 Marietta, GA 30066 Phone: (770) 693-0835 FAX:	Job	CT11134A	Page	9 of 23
	Project	1875029	Date	08:51:12 06/20/18
	Client	ForeSite LLC	Designed by	Ahmet Colakoglu

Tower Section	Tower Elevation ft	Face or Leg	Ice Thickness in	A _R ft ²	A _F ft ²	C _{AA} In Face ft ²	C _{AA} Out Face ft ²	Weight K
T4	62.00-37.00	B		0.000	0.000	151.452	0.000	3.14
		C		0.000	0.000	31.697	0.000	0.95
		A	2.083	0.000	0.000	25.614	0.000	0.63
T5	37.00-12.00	B		0.000	0.000	148.785	0.000	3.04
		C		0.000	0.000	30.828	0.000	0.91
		A	1.941	0.000	0.000	24.907	0.000	0.59
T6	12.00-0.00	B		0.000	0.000	144.450	0.000	2.88
		C		0.000	0.000	29.413	0.000	0.86
		A	1.687	0.000	0.000	1.891	0.000	0.04
		B		0.000	0.000	65.597	0.000	1.25
		C		0.000	0.000	12.895	0.000	0.37

Feed Line Center of Pressure

Section	Elevation ft	CP _x in	CP _z in	CP _x Ice in	CP _z Ice in
T1	120.00-112.00	-0.8374	0.8670	-0.9469	0.9676
T2	112.00-87.00	1.6919	1.7003	0.4624	1.2884
T3	87.00-62.00	2.4162	1.9154	0.9556	1.3543
T4	62.00-37.00	2.3957	1.8990	0.9873	1.3695
T5	37.00-12.00	2.3693	1.8780	1.0415	1.3944
T6	12.00-0.00	1.3992	1.1570	0.6123	0.8146

Shielding Factor Ka

Tower Section	Feed Line Record No.	Description	Feed Line Segment Elev.	K _a No Ice	K _a Ice
T1	1	MACX675A (6-1/8 AIR)	112.00 - 120.00	1.0000	0.5020
T1	2	Climbing Ladder	112.00 - 120.00	0.6000	0.5020
T2	1	MACX675A (6-1/8 AIR)	87.00 - 112.00	1.0000	0.5561
T2	2	Climbing Ladder	87.00 - 112.00	0.6000	0.5561
T2	3	Feedline Ladder (Af)	87.00 - 103.00	0.6000	0.5561
T2	4	LDF6-50A (1-1/4 FOAM)	87.00 - 103.00	0.6000	0.5561
T2	5	Highcapacity Hybrid for TMO - 1.584"	87.00 - 103.00	0.6000	0.5561
T2	6	Highcapacity Hybrid for TMO - 1.584"	87.00 - 103.00	0.6000	0.5561
T3	1	MACX675A (6-1/8 AIR)	62.00 - 87.00	1.0000	0.5635
T3	2	Climbing Ladder	62.00 - 87.00	0.6000	0.5635
T3	3	Feedline Ladder (Af)	62.00 - 87.00	0.6000	0.5635
T3	4	LDF6-50A (1-1/4 FOAM)	62.00 - 87.00	0.6000	0.5635
T3	5	Highcapacity Hybrid for TMO - 1.584"	62.00 - 87.00	0.6000	0.5635
T3	6	Highcapacity Hybrid for TMO - 1.584"	62.00 - 87.00	0.6000	0.5635
T4	1	MACX675A (6-1/8 AIR)	37.00 - 62.00	1.0000	0.5737
T4	2	Climbing Ladder	37.00 - 62.00	0.6000	0.5737
T4	3	Feedline Ladder (Af)	37.00 - 62.00	0.6000	0.5737

tnxTower Destek Engineering, LLC. 1281 Kennestone Cir. Suite#100 Marietta, GA 30066 Phone: (770) 693-0835 FAX:	Job	CT11134A	Page	10 of 23
	Project	1875029	Date	08:51:12 06/20/18
	Client	ForeSite LLC	Designed by	Ahmet Colakoglu

Tower Section	Feed Line Record No.	Description	Feed Line Segment Elev.	K_a No Ice	K_a Ice
T4	4	LDF6-50A (1-1/4 FOAM)	37.00 - 62.00	0.6000	0.5737
T4	5	Highcapacity Hybrid for TMO - 1.584"	37.00 - 62.00	0.6000	0.5737
T4	6	Highcapacity Hybrid for TMO - 1.584"	37.00 - 62.00	0.6000	0.5737
T5	1	MACX675A (6-1/8 AIR)	12.00 - 37.00	1.0000	0.5903
T5	2	Climbing Ladder	12.00 - 37.00	0.6000	0.5903
T5	3	Feedline Ladder (Af)	12.00 - 37.00	0.6000	0.5903
T5	4	LDF6-50A (1-1/4 FOAM)	12.00 - 37.00	0.6000	0.5903
T5	5	Highcapacity Hybrid for TMO - 1.584"	12.00 - 37.00	0.6000	0.5903
T5	6	Highcapacity Hybrid for TMO - 1.584"	12.00 - 37.00	0.6000	0.5903
T6	1	MACX675A (6-1/8 AIR)	10.00 - 12.00	1.0000	0.4205
T6	2	Climbing Ladder	0.00 - 12.00	0.6000	0.4205
T6	3	Feedline Ladder (Af)	0.00 - 12.00	0.6000	0.4205
T6	4	LDF6-50A (1-1/4 FOAM)	0.00 - 12.00	0.6000	0.4205
T6	5	Highcapacity Hybrid for TMO - 1.584"	0.00 - 12.00	0.6000	0.4205
T6	6	Highcapacity Hybrid for TMO - 1.584"	0.00 - 12.00	0.6000	0.4205

Discrete Tower Loads

Description	Face or Leg	Offset Type	Offsets: Horz Lateral Vert	Azimuth Adjustment	Placement	C_{AA} Front	C_{AA} Side	Weight
			ft ft ft	°	ft	ft ²	ft ²	K
120ft								
TFU-30J	B	None		0.0000	120.00	No Ice 1/2" Ice 1" Ice	50.00 53.43 56.86	0.10 0.35 0.62
103ft								
AIR -32 B2A/B66AA w/ Mount Pipe	A	From Leg	4.00 0.00 0.00	0.0000	103.00	No Ice 1/2" Ice 1" Ice	6.75 7.20 7.65	6.07 6.87 7.58
AIR -32 B2A/B66AA w/ Mount Pipe	B	From Leg	4.00 0.00 0.00	0.0000	103.00	No Ice 1/2" Ice 1" Ice	6.75 7.20 7.65	6.07 6.87 7.58
AIR -32 B2A/B66AA w/ Mount Pipe	C	From Leg	4.00 0.00 0.00	0.0000	103.00	No Ice 1/2" Ice 1" Ice	6.75 7.20 7.65	6.07 6.87 7.58
Generic Twin AWS TMA	A	From Leg	4.00 0.00 0.00	0.0000	103.00	No Ice 1/2" Ice 1" Ice	0.64 0.82 1.00	0.64 0.82 1.00
Generic Twin AWS TMA	B	From Leg	4.00 0.00 0.00	0.0000	103.00	No Ice 1/2" Ice 1" Ice	0.64 0.82 1.00	0.64 0.82 1.00
Generic Twin AWS TMA	C	From Leg	4.00 0.00 0.00	0.0000	103.00	No Ice 1/2" Ice 1" Ice	0.64 0.82 1.00	0.64 0.82 1.00
APXVAARR24_43-U-NA20	A	From Leg	4.00	0.0000	103.00	No Ice	20.48	11.02

tnxTower Destek Engineering, LLC. 1281 Kennestone Cir. Suite#100 Marietta, GA 30066 Phone: (770) 693-0835 FAX:	Job	CT11134A	Page	11 of 23
	Project	1875029	Date	08:51:12 06/20/18
	Client	ForeSite LLC	Designed by	Ahmet Colakoglu

Description	Face or Leg	Offset Type	Offsets:		Azimuth Adjustment	Placement	C _{AA} Front	C _{AA} Side	Weight
			Horz	Lateral					
			ft	ft	°	ft	ft ²	ft ²	K
w/ Mount Pipe			0.00			1/2" Ice	21.23	12.55	0.30
			0.00			1" Ice	21.99	14.10	0.44
APXVAARR24_43-U-NA20	B	From Leg	4.00	0.0000	103.00	No Ice	20.48	11.02	0.16
w/ Mount Pipe			0.00			1/2" Ice	21.23	12.55	0.30
			0.00			1" Ice	21.99	14.10	0.44
APXVAARR24_43-U-NA20	C	From Leg	4.00	0.0000	103.00	No Ice	20.48	11.02	0.16
w/ Mount Pipe			0.00			1/2" Ice	21.23	12.55	0.30
			0.00			1" Ice	21.99	14.10	0.44
RADIO 4449 B12/B71	A	From Leg	4.00	0.0000	103.00	No Ice	1.65	1.30	0.08
			0.00			1/2" Ice	1.81	1.44	0.09
			0.00			1" Ice	1.98	1.60	0.11
RADIO 4449 B12/B71	B	From Leg	4.00	0.0000	103.00	No Ice	1.65	1.30	0.08
			0.00			1/2" Ice	1.81	1.44	0.09
			0.00			1" Ice	1.98	1.60	0.11
RADIO 4449 B12/B71	C	From Leg	4.00	0.0000	103.00	No Ice	1.65	1.30	0.08
			0.00			1/2" Ice	1.81	1.44	0.09
			0.00			1" Ice	1.98	1.60	0.11
AIR 3246 B66 w/ Mount Pipe	A	From Leg	4.00	0.0000	103.00	No Ice	8.18	6.56	0.20
			0.00			1/2" Ice	8.66	7.39	0.27
			0.00			1" Ice	9.12	8.13	0.35
AIR 3246 B66 w/ Mount Pipe	B	From Leg	4.00	0.0000	103.00	No Ice	8.18	6.56	0.20
			0.00			1/2" Ice	8.66	7.39	0.27
			0.00			1" Ice	9.12	8.13	0.35
AIR 3246 B66 w/ Mount Pipe	C	From Leg	4.00	0.0000	103.00	No Ice	8.18	6.56	0.20
			0.00			1/2" Ice	8.66	7.39	0.27
			0.00			1" Ice	9.12	8.13	0.35
6'-P2x0.154	A	From Leg	4.00	0.0000	103.00	No Ice	1.43	1.43	0.02
			0.00			1/2" Ice	1.92	1.92	0.03
			0.00			1" Ice	2.29	2.29	0.05
6'-P2x0.154	B	From Leg	4.00	0.0000	103.00	No Ice	1.43	1.43	0.02
			0.00			1/2" Ice	1.92	1.92	0.03
			0.00			1" Ice	2.29	2.29	0.05
6'-P2x0.154	C	From Leg	4.00	0.0000	103.00	No Ice	1.43	1.43	0.02
			0.00			1/2" Ice	1.92	1.92	0.03
			0.00			1" Ice	2.29	2.29	0.05
Sector Mount [SM 502-3]	C	None		0.0000	103.00	No Ice	33.02	33.02	1.67
						1/2" Ice	47.36	47.36	2.22
						1" Ice	61.70	61.70	2.77

Load Combinations

Comb. No.	Description
1	Dead Only
2	1.2 Dead+1.6 Wind 0 deg - No Ice+1.0 Guy
3	1.2 Dead+1.6 Wind 30 deg - No Ice+1.0 Guy
4	1.2 Dead+1.6 Wind 60 deg - No Ice+1.0 Guy
5	1.2 Dead+1.6 Wind 90 deg - No Ice+1.0 Guy
6	1.2 Dead+1.6 Wind 120 deg - No Ice+1.0 Guy
7	1.2 Dead+1.6 Wind 150 deg - No Ice+1.0 Guy
8	1.2 Dead+1.6 Wind 180 deg - No Ice+1.0 Guy

tnxTower Destek Engineering, LLC. 1281 Kennestone Cir. Suite#100 Marietta, GA 30066 Phone: (770) 693-0835 FAX:	Job	CT11134A	Page	12 of 23
	Project	1875029	Date	08:51:12 06/20/18
	Client	ForeSite LLC	Designed by	Ahmet Colakoglu

<i>Comb. No.</i>	<i>Description</i>
9	1.2 Dead+1.6 Wind 210 deg - No Ice+1.0 Guy
10	1.2 Dead+1.6 Wind 240 deg - No Ice+1.0 Guy
11	1.2 Dead+1.6 Wind 270 deg - No Ice+1.0 Guy
12	1.2 Dead+1.6 Wind 300 deg - No Ice+1.0 Guy
13	1.2 Dead+1.6 Wind 330 deg - No Ice+1.0 Guy
14	1.2 Dead+1.0 Ice+1.0 Temp+Guy
15	1.2 Dead+1.0 Wind 0 deg+1.0 Ice+1.0 Temp+1.0 Guy
16	1.2 Dead+1.0 Wind 30 deg+1.0 Ice+1.0 Temp+1.0 Guy
17	1.2 Dead+1.0 Wind 60 deg+1.0 Ice+1.0 Temp+1.0 Guy
18	1.2 Dead+1.0 Wind 90 deg+1.0 Ice+1.0 Temp+1.0 Guy
19	1.2 Dead+1.0 Wind 120 deg+1.0 Ice+1.0 Temp+1.0 Guy
20	1.2 Dead+1.0 Wind 150 deg+1.0 Ice+1.0 Temp+1.0 Guy
21	1.2 Dead+1.0 Wind 180 deg+1.0 Ice+1.0 Temp+1.0 Guy
22	1.2 Dead+1.0 Wind 210 deg+1.0 Ice+1.0 Temp+1.0 Guy
23	1.2 Dead+1.0 Wind 240 deg+1.0 Ice+1.0 Temp+1.0 Guy
24	1.2 Dead+1.0 Wind 270 deg+1.0 Ice+1.0 Temp+1.0 Guy
25	1.2 Dead+1.0 Wind 300 deg+1.0 Ice+1.0 Temp+1.0 Guy
26	1.2 Dead+1.0 Wind 330 deg+1.0 Ice+1.0 Temp+1.0 Guy
27	Dead+Wind 0 deg - Service+Guy
28	Dead+Wind 30 deg - Service+Guy
29	Dead+Wind 60 deg - Service+Guy
30	Dead+Wind 90 deg - Service+Guy
31	Dead+Wind 120 deg - Service+Guy
32	Dead+Wind 150 deg - Service+Guy
33	Dead+Wind 180 deg - Service+Guy
34	Dead+Wind 210 deg - Service+Guy
35	Dead+Wind 240 deg - Service+Guy
36	Dead+Wind 270 deg - Service+Guy
37	Dead+Wind 300 deg - Service+Guy
38	Dead+Wind 330 deg - Service+Guy

Maximum Member Forces

<i>Section No.</i>	<i>Elevation ft</i>	<i>Component Type</i>	<i>Condition</i>	<i>Gov. Load Comb.</i>	<i>Axial K</i>	<i>Major Axis Moment kip-ft</i>	<i>Minor Axis Moment kip-ft</i>		
T1	120 - 112	Leg	Max Tension	1	0.00	0.00	0.00		
			Max. Compression	10	-3.64	-0.37	0.21		
			Max. Mx	5	-0.71	0.42	-0.04		
			Max. My	8	-0.58	0.00	0.45		
			Max. Vy	5	-0.59	-0.00	0.00		
			Max. Vx	2	0.59	0.00	-0.00		
			Diagonal	Max Tension	5	2.12	0.00	0.00	
				Top Girt	Max Tension	2	0.35	0.00	0.00
					Max. Compression	6	-0.73	0.00	0.00
					Max. Mx	19	0.08	-0.09	0.00
		Bottom Girt	Max. My	10	-0.73	0.00	-0.00		
			Max. Vy	19	-0.06	0.00	0.00		
			Max. Vx	10	0.00	0.00	0.00		
			Max Tension	8	0.08	0.00	0.00		
			Max. Compression	5	-0.68	0.00	0.00		
			Max. Mx	19	-0.24	-0.09	0.00		
			Max. My	10	-0.54	0.00	0.00		
			Max. Vy	19	-0.06	0.00	0.00		
T2	112 - 87	Leg	Max. Vx	10	-0.00	0.00	0.00		
			Max Tension	8	2.22	0.00	0.45		
			Max. Compression	17	-88.64	-0.01	0.01		
			Max. Mx	5	-8.41	-1.45	0.02		
			Max. My	8	-8.27	-0.03	-1.45		

tnxTower Destek Engineering, LLC. 1281 Kennestone Cir. Suite#100 Marietta, GA 30066 Phone: (770) 693-0835 FAX:	Job	CT11134A	Page	13 of 23
	Project	1875029	Date	08:51:12 06/20/18
	Client	ForeSite LLC	Designed by	Ahmet Colakoglu

Section No.	Elevation ft	Component Type	Condition	Gov. Load Comb.	Axial K	Major Axis Moment kip-ft	Minor Axis Moment kip-ft
			Max. Vy	5	-1.41	-1.45	0.02
			Max. Vx	2	1.51	0.00	0.68
		Diagonal	Max Tension	7	4.91	0.00	0.00
		Horizontal	Max Tension	6	8.08	0.00	0.00
			Max. Compression	7	-2.87	0.00	0.00
			Max. Mx	19	1.49	-0.09	0.00
			Max. My	10	0.70	0.00	-0.00
			Max. Vy	19	-0.06	0.00	0.00
			Max. Vx	10	0.00	0.00	0.00
		Top Girt	Max Tension	2	0.06	0.00	0.00
			Max. Compression	2	-0.60	0.00	0.00
			Max. Mx	19	-0.01	-0.09	0.00
			Max. My	10	-0.59	0.00	-0.00
			Max. Vy	19	-0.06	0.00	0.00
			Max. Vx	10	0.00	0.00	0.00
		Bottom Girt	Max Tension	6	0.41	0.00	0.00
			Max. Compression	6	-1.49	0.00	0.00
			Max. Mx	19	0.12	-0.09	0.00
			Max. My	10	-1.47	0.00	-0.00
			Max. Vy	19	-0.06	0.00	0.00
			Max. Vx	10	0.00	0.00	0.00
		Guy A	Bottom Tension	21	15.53		
			Top Tension	7	16.01		
			Top Cable Vert	21	7.10		
			Top Cable Norm	21	14.35		
			Top Cable Tan	21	0.00		
			Bot Cable Vert	7	-5.87		
			Bot Cable Norm	7	14.38		
			Bot Cable Tan	7	0.09		
		Guy B	Bottom Tension	25	15.41		
			Top Tension	11	15.59		
			Top Cable Vert	25	6.94		
			Top Cable Norm	25	13.96		
			Top Cable Tan	25	0.00		
			Bot Cable Vert	11	-5.83		
			Bot Cable Norm	11	14.27		
			Bot Cable Tan	11	0.09		
		Guy C	Bottom Tension	17	15.47		
			Top Tension	5	15.86		
			Top Cable Vert	17	7.04		
			Top Cable Norm	17	14.21		
			Top Cable Tan	17	0.00		
			Bot Cable Vert	5	-5.85		
			Bot Cable Norm	5	14.32		
			Bot Cable Tan	5	0.09		
T3	87 - 62	Leg	Max Tension	1	0.00	0.00	0.00
			Max. Compression	17	-97.46	0.01	-0.15
			Max. Mx	5	-25.50	0.75	0.14
			Max. My	2	-24.17	-0.01	-0.82
			Max. Vy	5	-1.35	0.07	0.00
			Max. Vx	2	1.50	-0.00	-0.07
		Diagonal	Max Tension	7	3.82	0.00	0.00
		Horizontal	Max Tension	17	1.68	0.00	0.00
			Max. Compression	9	-1.91	0.00	0.00
			Max. Mx	19	1.60	-0.09	0.00
			Max. My	22	1.65	0.00	0.00
			Max. Vy	19	0.06	0.00	0.00
			Max. Vx	22	-0.00	0.00	0.00
		Top Girt	Max Tension	8	0.30	0.00	0.00
			Max. Compression	9	-1.18	0.00	0.00
			Max. Mx	19	-0.16	-0.09	0.00

tnxTower Destek Engineering, LLC. 1281 Kennestone Cir. Suite#100 Marietta, GA 30066 Phone: (770) 693-0835 FAX:	Job	CT11134A	Page	14 of 23
	Project	1875029	Date	08:51:12 06/20/18
	Client	ForeSite LLC	Designed by	Ahmet Colakoglu

Section No.	Elevation ft	Component Type	Condition	Gov. Load Comb.	Axial K	Major Axis Moment kip-ft	Minor Axis Moment kip-ft		
T4	62 - 37	Bottom Girt	Max. My	10	-0.89	0.00	0.00		
			Max. Vy	19	0.06	0.00	0.00		
			Max. Vx	10	-0.00	0.00	0.00		
			Max Tension	6	0.19	0.00	0.00		
			Max. Compression	10	-0.56	0.00	0.00		
			Max. Mx	19	0.05	-0.09	0.00		
		Leg	Max. My	22	-0.19	0.00	0.00		
			Max. Vy	19	0.06	0.00	0.00		
			Max. Vx	22	-0.00	0.00	0.00		
			Max Tension	1	0.00	0.00	0.00		
			Max. Compression	25	-101.94	-0.18	-0.11		
			Max. Mx	10	-18.78	-0.39	0.12		
		Diagonal Horizontal	Max. My	21	-87.41	0.01	0.47		
			Max. Vy	10	-0.61	-0.08	0.02		
			Max. Vx	2	-0.66	-0.00	-0.10		
			Max Tension	10	1.52	0.00	0.00		
			Max Tension	25	1.77	0.00	0.00		
			Max. Compression	25	-1.77	0.00	0.00		
		Top Girt	Max. Mx	19	1.68	-0.09	0.00		
			Max. My	9	1.00	0.00	0.00		
			Max. Vy	19	-0.06	0.00	0.00		
			Max. Vx	9	-0.00	0.00	0.00		
			Max Tension	23	0.02	0.00	0.00		
			Max. Compression	9	-0.36	0.00	0.00		
		Bottom Girt	Max. Mx	19	-0.07	-0.09	0.00		
			Max. My	22	-0.18	0.00	0.00		
			Max. Vy	19	-0.06	0.00	0.00		
Max. Vx	22		0.00	0.00	0.00				
Max Tension	12		0.06	0.00	0.00				
Max. Compression	4		-0.50	0.00	0.00				
T5	37 - 12	Leg	Max. Mx	19	0.01	-0.09	0.00		
			Max. My	9	-0.20	0.00	0.00		
			Max. Vy	19	-0.06	0.00	0.00		
			Max. Vx	9	-0.00	0.00	0.00		
			Max Tension	1	0.00	0.00	0.00		
			Max. Compression	25	-102.85	0.14	0.08		
		Diagonal Horizontal	Max. Mx	17	-100.76	-4.49	2.57		
			Max. My	21	-100.62	-0.04	-5.18		
			Max. Vy	25	-10.15	4.49	2.55		
			Max. Vx	21	11.46	-0.04	-5.18		
			Max Tension	11	3.73	0.00	0.00		
			Max Tension	25	1.78	0.00	0.00		
		Top Girt	Max. Compression	10	-2.04	0.00	0.00		
			Max. Mx	19	1.73	-0.08	0.00		
			Max. My	9	0.99	0.00	0.00		
			Max. Vy	19	0.05	0.00	0.00		
			Max. Vx	9	-0.00	0.00	0.00		
			Max Tension	6	0.19	0.00	0.00		
		Bottom Girt	Max. Compression	10	-0.77	0.00	0.00		
			Max. Mx	19	0.06	-0.08	0.00		
			Max. My	9	-0.41	0.00	0.00		
			Max. Vy	19	0.05	0.00	0.00		
			Max. Vx	9	-0.00	0.00	0.00		
			Max Tension	19	6.28	0.00	0.00		
		T6	12 - 0	Leg	Max. Compression	1	0.00	0.00	0.00
					Max. Mx	19	6.28	-0.08	0.00
					Max. My	9	2.14	0.00	0.00
Max. Vy	19				0.05	0.00	0.00		
Max. Vx	9				-0.00	0.00	0.00		
Max Tension	1				0.00	0.00	0.00		
Leg	Max. Compression			25	-106.96	-0.45	0.04		

tnxTower Destek Engineering, LLC. 1281 Kennestone Cir. Suite#100 Marietta, GA 30066 Phone: (770) 693-0835 FAX:	Job	CT11134A	Page	15 of 23
	Project	1875029	Date	08:51:12 06/20/18
	Client	ForeSite LLC	Designed by	Ahmet Colakoglu

Section No.	Elevation ft	Component Type	Condition	Gov. Load Comb.	Axial K	Major Axis Moment kip-ft	Minor Axis Moment kip-ft
		Horizontal	Max. Mx	21	-104.20	5.20	-0.05
			Max. My	3	-43.82	0.01	0.67
			Max. Vy	21	3.26	-1.57	0.03
			Max. Vx	3	-0.27	-0.75	0.64
			Max Tension	15	8.52	0.05	-0.01
			Max. Compression	19	-0.51	0.02	0.02
			Max. Mx	3	3.27	0.11	-0.10
			Max. My	3	3.27	-0.09	0.11
			Max. Vy	10	-0.14	0.08	-0.02
			Max. Vx	10	-0.05	-0.00	0.01

Maximum Reactions

Location	Condition	Gov. Load Comb.	Vertical K	Horizontal, X K	Horizontal, Z K	
Mast	Max. Vert	19	298.30	-0.21	0.01	
	Max. H _x	11	127.88	3.13	0.25	
	Max. H _z	2	129.17	0.02	3.11	
	Max. M _x	1	0.00	0.02	0.06	
	Max. M _z	1	0.00	0.02	0.06	
	Max. Torsion	9	1.97	1.42	-2.71	
	Min. Vert	1	104.31	0.02	0.06	
	Min. H _x	5	127.91	-3.08	0.25	
	Min. H _z	8	126.23	0.02	-3.28	
	Min. M _x	1	0.00	0.02	0.06	
	Min. M _z	1	0.00	0.02	0.06	
	Min. Torsion	3	-1.95	-1.69	2.68	
	Guy C @ 250 ft Elev 0 ft Azimuth 240 deg	Max. Vert	10	-0.14	-0.45	0.26
		Max. H _x	10	-0.14	-0.45	0.26
Max. H _z		3	-5.81	-12.29	7.19	
Min. Vert		5	-5.85	-12.45	7.08	
Min. H _x		5	-5.85	-12.45	7.08	
Min. H _z		10	-0.14	-0.45	0.26	
Guy B @ 250 ft Elev 0 ft Azimuth 120 deg	Max. Vert	6	-0.14	0.45	0.26	
	Max. H _x	11	-5.83	12.40	7.06	
	Max. H _z	13	-5.80	12.26	7.18	
	Min. Vert	11	-5.83	12.40	7.06	
	Min. H _x	6	-0.14	0.45	0.26	
	Min. H _z	6	-0.14	0.45	0.26	
Guy A @ 250 ft Elev 0 ft Azimuth 0 deg	Max. Vert	2	-0.15	0.00	-0.53	
	Max. H _x	24	-3.77	0.25	-11.44	
	Max. H _z	2	-0.15	0.00	-0.53	
	Min. Vert	7	-5.87	-0.09	-14.38	
	Min. H _x	18	-3.79	-0.26	-11.49	
	Min. H _z	21	-4.96	-0.00	-14.38	

tnxTower Destek Engineering, LLC. 1281 Kennestone Cir. Suite#100 Marietta, GA 30066 Phone: (770) 693-0835 FAX:	Job	CT11134A	Page	16 of 23
	Project	1875029	Date	08:51:12 06/20/18
	Client	ForeSite LLC	Designed by	Ahmet Colakoglu

Tower Mast Reaction Summary

Load Combination	Vertical	Shear _x	Shear _z	Overturning Moment, M _x	Overturning Moment, M _z	Torque
	K	K	K	kip-ft	kip-ft	kip-ft
Dead Only	104.31	-0.02	-0.06	0.00	0.00	0.06
1.2 Dead+1.6 Wind 0 deg - No Ice+1.0 Guy	129.17	-0.02	-3.11	0.00	0.00	1.21
1.2 Dead+1.6 Wind 30 deg - No Ice+1.0 Guy	127.81	1.69	-2.68	0.00	0.00	1.95
1.2 Dead+1.6 Wind 60 deg - No Ice+1.0 Guy	126.21	2.88	-1.75	0.00	0.00	1.71
1.2 Dead+1.6 Wind 90 deg - No Ice+1.0 Guy	127.91	3.08	-0.25	0.00	0.00	0.98
1.2 Dead+1.6 Wind 120 deg - No Ice+1.0 Guy	129.27	2.60	1.44	0.00	0.00	0.35
1.2 Dead+1.6 Wind 150 deg - No Ice+1.0 Guy	127.91	1.37	2.71	0.00	0.00	-0.28
1.2 Dead+1.6 Wind 180 deg - No Ice+1.0 Guy	126.23	-0.02	3.28	0.00	0.00	-1.22
1.2 Dead+1.6 Wind 210 deg - No Ice+1.0 Guy	127.88	-1.42	2.71	0.00	0.00	-1.97
1.2 Dead+1.6 Wind 240 deg - No Ice+1.0 Guy	129.24	-2.65	1.44	0.00	0.00	-1.69
1.2 Dead+1.6 Wind 270 deg - No Ice+1.0 Guy	127.88	-3.13	-0.25	0.00	0.00	-0.99
1.2 Dead+1.6 Wind 300 deg - No Ice+1.0 Guy	126.20	-2.92	-1.75	0.00	0.00	-0.28
1.2 Dead+1.6 Wind 330 deg - No Ice+1.0 Guy	127.81	-1.73	-2.68	0.00	0.00	0.31
1.2 Dead+1.0 Ice+1.0 Temp+Guy	297.66	-0.19	-0.24	0.00	0.00	0.32
1.2 Dead+1.0 Wind 0 deg+1.0 Ice+1.0 Temp+1.0 Guy	298.20	-0.18	-0.73	0.00	0.00	0.49
1.2 Dead+1.0 Wind 30 deg+1.0 Ice+1.0 Temp+1.0 Guy	298.00	0.10	-0.68	0.00	0.00	0.44
1.2 Dead+1.0 Wind 60 deg+1.0 Ice+1.0 Temp+1.0 Guy	297.86	0.32	-0.55	0.00	0.00	0.10
1.2 Dead+1.0 Wind 90 deg+1.0 Ice+1.0 Temp+1.0 Guy	298.06	0.31	-0.29	0.00	0.00	0.09
1.2 Dead+1.0 Wind 120 deg+1.0 Ice+1.0 Temp+1.0 Guy	298.30	0.21	-0.01	0.00	0.00	0.26
1.2 Dead+1.0 Wind 150 deg+1.0 Ice+1.0 Temp+1.0 Guy	298.07	0.02	0.23	0.00	0.00	0.21
1.2 Dead+1.0 Wind 180 deg+1.0 Ice+1.0 Temp+1.0 Guy	297.88	-0.20	0.36	0.00	0.00	0.13
1.2 Dead+1.0 Wind 210 deg+1.0 Ice+1.0 Temp+1.0 Guy	298.03	-0.42	0.23	0.00	0.00	-0.45
1.2 Dead+1.0 Wind 240 deg+1.0 Ice+1.0 Temp+1.0 Guy	298.23	-0.60	0.01	0.00	0.00	-0.65
1.2 Dead+1.0 Wind 270 deg+1.0 Ice+1.0 Temp+1.0 Guy	298.00	-0.70	-0.28	0.00	0.00	-0.15
1.2 Dead+1.0 Wind 300 deg+1.0 Ice+1.0 Temp+1.0 Guy	297.82	-0.69	-0.54	0.00	0.00	0.14
1.2 Dead+1.0 Wind 330 deg+1.0 Ice+1.0 Temp+1.0 Guy	297.98	-0.47	-0.68	0.00	0.00	-0.11
Dead+Wind 0 deg - Service+Guy	104.46	-0.02	-0.92	0.00	0.00	0.30
Dead+Wind 30 deg - Service+Guy	104.41	0.40	-0.78	0.00	0.00	0.49
Dead+Wind 60 deg - Service+Guy	104.38	0.71	-0.48	0.00	0.00	0.38
Dead+Wind 90 deg -	104.42	0.81	-0.06	0.00	0.00	0.23

tnxTower Destek Engineering, LLC. 1281 Kennestone Cir. Suite#100 Marietta, GA 30066 Phone: (770) 693-0835 FAX:	Job	CT11134A	Page	17 of 23
	Project	1875029	Date	08:51:12 06/20/18
	Client	ForeSite LLC	Designed by	Ahmet Colakoglu

Load Combination	Vertical K	Shear _x K	Shear _z K	Overturing Moment, M _x kip-ft	Overturing Moment, M _z kip-ft	Torque kip-ft
Service+Guy						
Dead+Wind 120 deg -	104.48	0.73	0.37	0.00	0.00	0.14
Service+Guy						
Dead+Wind 150 deg -	104.42	0.40	0.66	0.00	0.00	-0.07
Service+Guy						
Dead+Wind 180 deg -	104.38	-0.02	0.78	0.00	0.00	-0.26
Service+Guy						
Dead+Wind 210 deg -	104.42	-0.43	0.66	0.00	0.00	-0.49
Service+Guy						
Dead+Wind 240 deg -	104.47	-0.76	0.37	0.00	0.00	-0.44
Service+Guy						
Dead+Wind 270 deg -	104.42	-0.85	-0.06	0.00	0.00	-0.24
Service+Guy						
Dead+Wind 300 deg -	104.38	-0.75	-0.48	0.00	0.00	-0.03
Service+Guy						
Dead+Wind 330 deg -	104.41	-0.44	-0.78	0.00	0.00	0.07
Service+Guy						

Solution Summary

Load Comb.	Sum of Applied Forces			Sum of Reactions			% Error
	PX K	PY K	PZ K	PX K	PY K	PZ K	
1	0.00	-99.02	0.00	-0.00	99.02	-0.00	0.000%
2	-0.00	-118.76	-15.50	-0.00	118.76	15.50	0.001%
3	7.58	-118.69	-13.12	-7.58	118.69	13.12	0.001%
4	13.15	-118.62	-7.59	-13.15	118.62	7.60	0.001%
5	15.15	-118.69	0.00	-15.15	118.69	0.00	0.001%
6	13.42	-118.76	7.75	-13.42	118.76	-7.75	0.001%
7	7.58	-118.69	13.12	-7.57	118.69	-13.12	0.001%
8	0.00	-118.62	15.19	0.00	118.62	-15.19	0.000%
9	-7.58	-118.69	13.12	7.57	118.69	-13.12	0.001%
10	-13.42	-118.76	7.75	13.42	118.76	-7.75	0.001%
11	-15.15	-118.69	-0.00	15.15	118.69	0.00	0.001%
12	-13.15	-118.62	-7.59	13.15	118.62	7.60	0.001%
13	-7.58	-118.69	-13.12	7.58	118.69	13.12	0.001%
14	0.00	-286.92	0.00	0.00	286.92	-0.00	0.000%
15	-0.00	-287.00	-5.53	0.00	287.00	5.53	0.001%
16	2.69	-286.92	-4.66	-2.69	286.92	4.66	0.001%
17	4.75	-286.83	-2.74	-4.75	286.83	2.74	0.000%
18	5.38	-286.92	0.00	-5.38	286.92	0.00	0.001%
19	4.78	-287.00	2.76	-4.78	287.00	-2.76	0.000%
20	2.69	-286.92	4.66	-2.69	286.92	-4.66	0.001%
21	0.00	-286.83	5.49	0.00	286.83	-5.48	0.001%
22	-2.69	-286.92	4.66	2.69	286.92	-4.66	0.000%
23	-4.78	-287.00	2.76	4.78	287.00	-2.76	0.001%
24	-5.38	-286.92	-0.00	5.38	286.92	0.00	0.000%
25	-4.75	-286.83	-2.74	4.75	286.83	2.74	0.001%
26	-2.69	-286.92	-4.66	2.69	286.92	4.66	0.000%
27	-0.00	-99.03	-3.71	0.00	99.03	3.71	0.001%
28	1.81	-99.02	-3.14	-1.81	99.02	3.14	0.000%
29	3.15	-99.00	-1.82	-3.15	99.00	1.82	0.000%
30	3.62	-99.02	0.00	-3.62	99.02	0.00	0.001%
31	3.21	-99.03	1.85	-3.21	99.03	-1.85	0.001%
32	1.81	-99.02	3.14	-1.81	99.02	-3.14	0.000%
33	0.00	-99.00	3.63	0.00	99.00	-3.63	0.000%
34	-1.81	-99.02	3.14	1.81	99.02	-3.14	0.000%
35	-3.21	-99.03	1.85	3.21	99.03	-1.85	0.001%

tnxTower Destek Engineering, LLC. 1281 Kennestone Cir. Suite#100 Marietta, GA 30066 Phone: (770) 693-0835 FAX:	Job	CT11134A	Page	18 of 23
	Project	1875029	Date	08:51:12 06/20/18
	Client	ForeSite LLC	Designed by	Ahmet Colakoglu

Load Comb.	Sum of Applied Forces			Sum of Reactions			% Error
	PX K	PY K	PZ K	PX K	PY K	PZ K	
36	-3.62	-99.02	0.00	3.62	99.02	0.00	0.000%
37	-3.15	-99.00	-1.82	3.15	99.00	1.82	0.000%
38	-1.81	-99.02	-3.14	1.81	99.02	3.14	0.000%

Non-Linear Convergence Results

Load Combination	Converged?	Number of Cycles	Displacement Tolerance	Force Tolerance
1	Yes	9	0.0000001	0.00006499
2	Yes	13	0.0000001	0.00008499
3	Yes	13	0.0000001	0.00006934
4	Yes	10	0.0000001	0.00005271
5	Yes	13	0.0000001	0.00006620
6	Yes	13	0.0000001	0.00008402
7	Yes	13	0.0000001	0.00006501
8	Yes	10	0.0000001	0.00003238
9	Yes	13	0.0000001	0.00007082
10	Yes	13	0.0000001	0.00008919
11	Yes	13	0.0000001	0.00006566
12	Yes	10	0.0000001	0.00004030
13	Yes	13	0.0000001	0.00006316
14	Yes	10	0.0000001	0.00002259
15	Yes	15	0.0000001	0.00005844
16	Yes	12	0.0000001	0.00005410
17	Yes	11	0.0000001	0.00004374
18	Yes	12	0.0000001	0.00003336
19	Yes	17	0.0000001	0.00001039
20	Yes	12	0.0000001	0.00003097
21	Yes	10	0.0000001	0.00004700
22	Yes	12	0.0000001	0.00002370
23	Yes	12	0.0000001	0.00003757
24	Yes	12	0.0000001	0.00002545
25	Yes	10	0.0000001	0.00004384
26	Yes	12	0.0000001	0.00002039
27	Yes	9	0.0000001	0.00005239
28	Yes	9	0.0000001	0.00002878
29	Yes	8	0.0000001	0.00005086
30	Yes	8	0.0000001	0.00009773
31	Yes	9	0.0000001	0.00009708
32	Yes	9	0.0000001	0.00004017
33	Yes	8	0.0000001	0.00002480
34	Yes	9	0.0000001	0.00003280
35	Yes	9	0.0000001	0.00007273
36	Yes	9	0.0000001	0.00004050
37	Yes	8	0.0000001	0.00004857
38	Yes	9	0.0000001	0.00003034

Maximum Tower Deflections - Service Wind

Section No.	Elevation ft	Horz. Deflection in	Gov. Load Comb.	Tilt °	Twist °
-------------	-----------------	---------------------------	-----------------------	-----------	------------

tnxTower Destek Engineering, LLC. 1281 Kennestone Cir. Suite#100 Marietta, GA 30066 Phone: (770) 693-0835 FAX:	Job CT11134A	Page 19 of 23
	Project 1875029	Date 08:51:12 06/20/18
	Client ForeSite LLC	Designed by Ahmet Colakoglu

Section No.	Elevation ft	Horz. Deflection in	Gov. Load Comb.	Tilt °	Twist °
T1	120 - 112	1.748	31	0.0666	0.1453
T2	112 - 87	1.628	31	0.0665	0.1456
T3	87 - 62	1.330	31	0.0666	0.1341
T4	62 - 37	1.039	31	0.0701	0.1355
T5	37 - 12	0.658	31	0.0747	0.0858
T6	12 - 0	0.198	31	0.0778	0.0388

Critical Deflections and Radius of Curvature - Service Wind

Elevation ft	Appurtenance	Gov. Load Comb.	Deflection in	Tilt °	Twist °	Radius of Curvature ft
120.00	TFU-30J	31	1.748	0.0666	0.1453	67293
103.50	Guy	31	1.516	0.0663	0.1437	64164
103.00	AIR -32 B2A/B66AA w/ Mount Pipe	31	1.510	0.0663	0.1435	66300

Maximum Tower Deflections - Design Wind

Section No.	Elevation ft	Horz. Deflection in	Gov. Load Comb.	Tilt °	Twist °
T1	120 - 112	13.033	6	0.5020	0.3718
T2	112 - 87	12.157	6	0.5014	0.3723
T3	87 - 62	9.687	6	0.5020	0.3719
T4	62 - 37	7.201	6	0.5170	0.3753
T5	37 - 12	4.419	6	0.5367	0.2722
T6	12 - 0	1.394	6	0.5502	0.1507

Critical Deflections and Radius of Curvature - Design Wind

Elevation ft	Appurtenance	Gov. Load Comb.	Deflection in	Tilt °	Twist °	Radius of Curvature ft
120.00	TFU-30J	6	13.033	0.5020	0.3718	18749
103.50	Guy	6	11.282	0.5007	0.3695	19100
103.00	AIR -32 B2A/B66AA w/ Mount Pipe	6	11.232	0.5007	0.3692	19864

Guy Design Data

Section No.	Elevation ft	Size	Initial Tension K	Breaking Load K	Actual T_u K	Allowable ϕT_n K	Required S.F.	Actual S.F.
T2	103.50 (A) (171)	5/8 BS	4.80	48.00	16.01	28.80	1.000	1.799

tnxTower Destek Engineering, LLC. 1281 Kennestone Cir. Suite#100 Marietta, GA 30066 Phone: (770) 693-0835 FAX:	Job CT11134A	Page 20 of 23
	Project 1875029	Date 08:51:12 06/20/18
	Client ForeSite LLC	Designed by Ahmet Colakoglu

Section No.	Elevation ft	Size	Initial Tension K	Breaking Load K	Actual T_u K	Allowable ϕT_n K	Required S.F.	Actual S.F.
	103.50 (B) (170)	5/8 BS	4.80	48.00	15.59	28.80	1.000	1.847
	103.50 (C) (169)	5/8 BS	4.80	48.00	15.86	28.80	1.000	1.816

Compression Checks

Leg Design Data (Compression)

Section No.	Elevation ft	Size	L ft	L_u ft	Kl/r	A in^2	P_u K	ϕP_n K	Ratio $\frac{P_u}{\phi P_n}$
T1	120 - 112	4 1/2	8.00	8.00	85.3 K=1.00	15.9043	-3.64	332.40	0.011 ¹
T2	112 - 87	4 1/2	25.00	8.00	85.3 K=1.00	15.9043	-88.16	332.40	0.265 ¹
T3	87 - 62	4 1/2	25.00	8.00	85.3 K=1.00	15.9043	-96.93	332.40	0.292 ¹
T4	62 - 37	4 1/2	25.00	8.00	85.3 K=1.00	15.9043	-101.94	332.40	0.307 ¹
T5	37 - 12	4 1/2	25.00	8.00	85.3 K=1.00	15.9043	-102.85	332.40	0.309 ¹
T6	12 - 0	4 1/2	12.49	2.08	4.4 K=0.20	15.9043	-106.96	471.91	0.227 ¹

¹ $P_u / \phi P_n$ controls

Horizontal Design Data (Compression)

Section No.	Elevation ft	Size	L ft	L_u ft	Kl/r	A in^2	P_u K	ϕP_n K	Ratio $\frac{P_u}{\phi P_n}$
T2	112 - 87	L 2 1/2x 2 1/2x 1/4	6.00	5.63	130.7 K=0.95	1.1900	-2.87	15.49	0.186 ¹
T3	87 - 62	L 2 1/2x 2 1/2x 1/4	6.00	5.63	130.7 K=0.95	1.1900	-1.91	15.49	0.123 ¹
T4	62 - 37	L 2 1/2x 2 1/2x 1/4	6.00	5.63	130.7 K=0.95	1.1900	-1.77	15.49	0.114 ¹
T5	37 - 12	L 2 1/2x 2 1/2x 1/4	6.00	5.63	130.7 K=0.95	1.1900	-2.04	15.49	0.132 ¹
T6	12 - 0	L 2 1/2x 2 1/2x 1/4	4.00	3.63	104.3 K=1.18	1.1900	-0.51	20.91	0.024 ¹

¹ $P_u / \phi P_n$ controls

tnxTower Destek Engineering, LLC. 1281 Kennestone Cir. Suite#100 Marietta, GA 30066 Phone: (770) 693-0835 FAX:	Job CT11134A	Page 21 of 23
	Project 1875029	Date 08:51:12 06/20/18
	Client ForeSite LLC	Designed by Ahmet Colakoglu

Top Girt Design Data (Compression)

Section No.	Elevation ft	Size	L ft	L _u ft	Kl/r	A in ²	P _u K	φP _n K	Ratio $\frac{P_u}{\phi P_n}$
T1	120 - 112	L 2 1/2x 2 1/2x 1/4	6.00	5.63	130.7 K=0.95	1.1900	-0.73	15.49	0.047 ¹
T2	112 - 87	L 2 1/2x 2 1/2x 1/4	6.00	5.63	130.7 K=0.95	1.1900	-0.60	15.49	0.038 ¹
T3	87 - 62	L 2 1/2x 2 1/2x 1/4	6.00	5.63	130.7 K=0.95	1.1900	-1.18	15.49	0.076 ¹
T4	62 - 37	L 2 1/2x 2 1/2x 1/4	6.00	5.63	130.7 K=0.95	1.1900	-0.36	15.49	0.023 ¹
T5	37 - 12	L 2 1/2x 2 1/2x 1/4	6.00	5.63	130.7 K=0.95	1.1900	-0.77	15.49	0.050 ¹

¹ P_u / φP_n controls

Bottom Girt Design Data (Compression)

Section No.	Elevation ft	Size	L ft	L _u ft	Kl/r	A in ²	P _u K	φP _n K	Ratio $\frac{P_u}{\phi P_n}$
T1	120 - 112	L 2 1/2x 2 1/2x 1/4	6.00	5.63	130.7 K=0.95	1.1900	-0.68	15.49	0.044 ¹
T2	112 - 87	L 2 1/2x 2 1/2x 1/4	6.00	5.63	130.7 K=0.95	1.1900	-1.49	15.49	0.096 ¹
T3	87 - 62	L 2 1/2x 2 1/2x 1/4	6.00	5.63	130.7 K=0.95	1.1900	-0.56	15.49	0.036 ¹
T4	62 - 37	L 2 1/2x 2 1/2x 1/4	6.00	5.63	130.7 K=0.95	1.1900	-0.50	15.49	0.033 ¹

¹ P_u / φP_n controls

Tension Checks

Leg Design Data (Tension)

Section No.	Elevation ft	Size	L ft	L _u ft	Kl/r	A in ²	P _u K	φP _n K	Ratio $\frac{P_u}{\phi P_n}$
T2	112 - 87	4 1/2	25.00	0.50	5.3	15.9043	2.22	472.36	0.005 ¹

¹ P_u / φP_n controls

Diagonal Design Data (Tension)

tnxTower Destek Engineering, LLC. 1281 Kennestone Cir. Suite#100 Marietta, GA 30066 Phone: (770) 693-0835 FAX:	Job CT11134A	Page 22 of 23
	Project 1875029	Date 08:51:12 06/20/18
	Client ForeSite LLC	Designed by Ahmet Colakoglu

Section No.	Elevation ft	Size	L ft	L _u ft	Kl/r	A in ²	P _u K	φP _n K	Ratio $\frac{P_u}{\phi P_n}$
T1	120 - 112	3/4	10.00	9.38	600.0	0.4418	2.12	13.12	0.161 ¹
T2	112 - 87	3/4	10.00	9.38	600.0	0.4418	4.91	13.12	0.374 ¹
T3	87 - 62	3/4	10.00	9.38	600.0	0.4418	3.82	13.12	0.291 ¹
T4	62 - 37	3/4	10.00	9.38	600.0	0.4418	1.52	13.12	0.116 ¹
T5	37 - 12	3/4	10.00	9.38	600.0	0.4418	3.73	13.12	0.284 ¹

¹ P_u / φP_n controls

Horizontal Design Data (Tension)

Section No.	Elevation ft	Size	L ft	L _u ft	Kl/r	A in ²	P _u K	φP _n K	Ratio $\frac{P_u}{\phi P_n}$
T2	112 - 87	L 2 1/2x 2 1/2x 1/4	6.00	5.63	87.8	1.1900	8.08	35.34	0.228 ¹
T3	87 - 62	L 2 1/2x 2 1/2x 1/4	6.00	5.63	87.8	1.1900	1.68	35.34	0.048 ¹
T4	62 - 37	L 2 1/2x 2 1/2x 1/4	6.00	5.63	87.8	1.1900	1.77	35.34	0.050 ¹
T5	37 - 12	L 2 1/2x 2 1/2x 1/4	6.00	5.63	87.8	1.1900	1.78	35.34	0.050 ¹
T6	12 - 0	L 2 1/2x 2 1/2x 1/4	6.00	5.63	87.8	1.1900	8.52	35.34	0.241 ¹

¹ P_u / φP_n controls

Top Girt Design Data (Tension)

Section No.	Elevation ft	Size	L ft	L _u ft	Kl/r	A in ²	P _u K	φP _n K	Ratio $\frac{P_u}{\phi P_n}$
T1	120 - 112	L 2 1/2x 2 1/2x 1/4	6.00	5.63	87.8	1.1900	0.35	35.34	0.010 ¹
T2	112 - 87	L 2 1/2x 2 1/2x 1/4	6.00	5.63	87.8	1.1900	0.06	35.34	0.002 ¹
T3	87 - 62	L 2 1/2x 2 1/2x 1/4	6.00	5.63	87.8	1.1900	0.30	35.34	0.009 ¹
T4	62 - 37	L 2 1/2x 2 1/2x 1/4	6.00	5.63	87.8	1.1900	0.02	35.34	0.000 ¹
T5	37 - 12	L 2 1/2x 2 1/2x 1/4	6.00	5.63	87.8	1.1900	0.19	35.34	0.005 ¹

¹ P_u / φP_n controls

Bottom Girt Design Data (Tension)

Section No.	Elevation ft	Size	L ft	L _u ft	Kl/r	A in ²	P _u K	φP _n K	Ratio $\frac{P_u}{\phi P_n}$
T1	120 - 112	L 2 1/2x 2 1/2x 1/4	6.00	5.63	87.8	1.1900	0.08	35.34	0.002 ¹
T2	112 - 87	L 2 1/2x 2 1/2x 1/4	6.00	5.63	87.8	1.1900	0.41	35.34	0.012 ¹
T3	87 - 62	L 2 1/2x 2 1/2x 1/4	6.00	5.63	87.8	1.1900	0.19	35.34	0.005 ¹
T4	62 - 37	L 2 1/2x 2 1/2x 1/4	6.00	5.63	87.8	1.1900	0.06	35.34	0.002 ¹
T5	37 - 12	L 2 1/2x 2 1/2x 1/4	6.00	5.63	87.8	1.1900	6.28	35.34	0.178 ¹

tnxTower Destek Engineering, LLC. 1281 Kennestone Cir. Suite#100 Marietta, GA 30066 Phone: (770) 693-0835 FAX:	Job	CT11134A	Page	23 of 23
	Project	1875029	Date	08:51:12 06/20/18
	Client	ForeSite LLC	Designed by	Ahmet Colakoglu

¹ $P_u / \phi P_n$ controls

Section Capacity Table

Section No.	Elevation ft	Component Type	Size	Critical Element	P K	ϕP_{allow} K	% Capacity	Pass Fail	
T1	120 - 112	Leg	4 1/2	1	-3.64	332.40	1.1	Pass	
T2	112 - 87	Leg	4 1/2	16	-88.16	332.40	26.5	Pass	
T3	87 - 62	Leg	4 1/2	49	-96.93	332.40	29.2	Pass	
T4	62 - 37	Leg	4 1/2	83	-101.94	332.40	30.7	Pass	
T5	37 - 12	Leg	4 1/2	116	-102.85	332.40	30.9	Pass	
T6	12 - 0	Leg	4 1/2	149	-106.96	471.91	22.7	Pass	
T1	120 - 112	Diagonal	3/4	10	2.12	13.12	16.1	Pass	
T2	112 - 87	Diagonal	3/4	36	4.91	13.12	37.4	Pass	
T3	87 - 62	Diagonal	3/4	78	3.82	13.12	29.1	Pass	
T4	62 - 37	Diagonal	3/4	92	1.52	13.12	11.6	Pass	
T5	37 - 12	Diagonal	3/4	125	3.73	13.12	28.4	Pass	
T2	112 - 87	Horizontal	L 2 1/2x 2 1/2x 1/4	42	8.08	35.34	22.8	Pass	
T3	87 - 62	Horizontal	L 2 1/2x 2 1/2x 1/4	75	-1.91	15.49	12.3	Pass	
T4	62 - 37	Horizontal	L 2 1/2x 2 1/2x 1/4	98	-1.77	15.49	11.4	Pass	
T5	37 - 12	Horizontal	L 2 1/2x 2 1/2x 1/4	130	-2.04	15.49	13.2	Pass	
T6	12 - 0	Horizontal	L 2 1/2x 2 1/2x 1/4	151	8.52	35.34	24.1	Pass	
T1	120 - 112	Top Girt	L 2 1/2x 2 1/2x 1/4	4	-0.73	15.49	4.7	Pass	
T2	112 - 87	Top Girt	L 2 1/2x 2 1/2x 1/4	21	-0.60	15.49	3.8	Pass	
T3	87 - 62	Top Girt	L 2 1/2x 2 1/2x 1/4	54	-1.18	15.49	7.6	Pass	
T4	62 - 37	Top Girt	L 2 1/2x 2 1/2x 1/4	87	-0.36	15.49	2.3	Pass	
T5	37 - 12	Top Girt	L 2 1/2x 2 1/2x 1/4	118	-0.77	15.49	5.0	Pass	
T1	120 - 112	Bottom Girt	L 2 1/2x 2 1/2x 1/4	7	-0.68	15.49	4.4	Pass	
T2	112 - 87	Bottom Girt	L 2 1/2x 2 1/2x 1/4	23	-1.49	15.49	9.6	Pass	
T3	87 - 62	Bottom Girt	L 2 1/2x 2 1/2x 1/4	57	-0.56	15.49	3.6	Pass	
T4	62 - 37	Bottom Girt	L 2 1/2x 2 1/2x 1/4	88	-0.50	15.49	3.3	Pass	
T5	37 - 12	Bottom Girt	L 2 1/2x 2 1/2x 1/4	123	6.28	35.34	17.8	Pass	
T2	112 - 87	Guy A@103.5	5/8	171	16.01	28.80	55.6	Pass	
T2	112 - 87	Guy B@103.5	5/8	170	15.59	28.80	54.1	Pass	
T2	112 - 87	Guy C@103.5	5/8	169	15.86	28.80	55.1	Pass	
							Summary		
							Leg (T5)	30.9	Pass
							Diagonal (T2)	37.4	Pass
							Horizontal (T6)	24.1	Pass
							Top Girt (T3)	7.6	Pass
							Bottom Girt (T5)	17.8	Pass
							Guy A (T2)	55.6	Pass
							Guy B (T2)	54.1	Pass
							Guy C (T2)	55.1	Pass
							RATING =	55.6	Pass

Feed Line Plan

— Round
 — Flat
 — App In Face
 — App Out Face

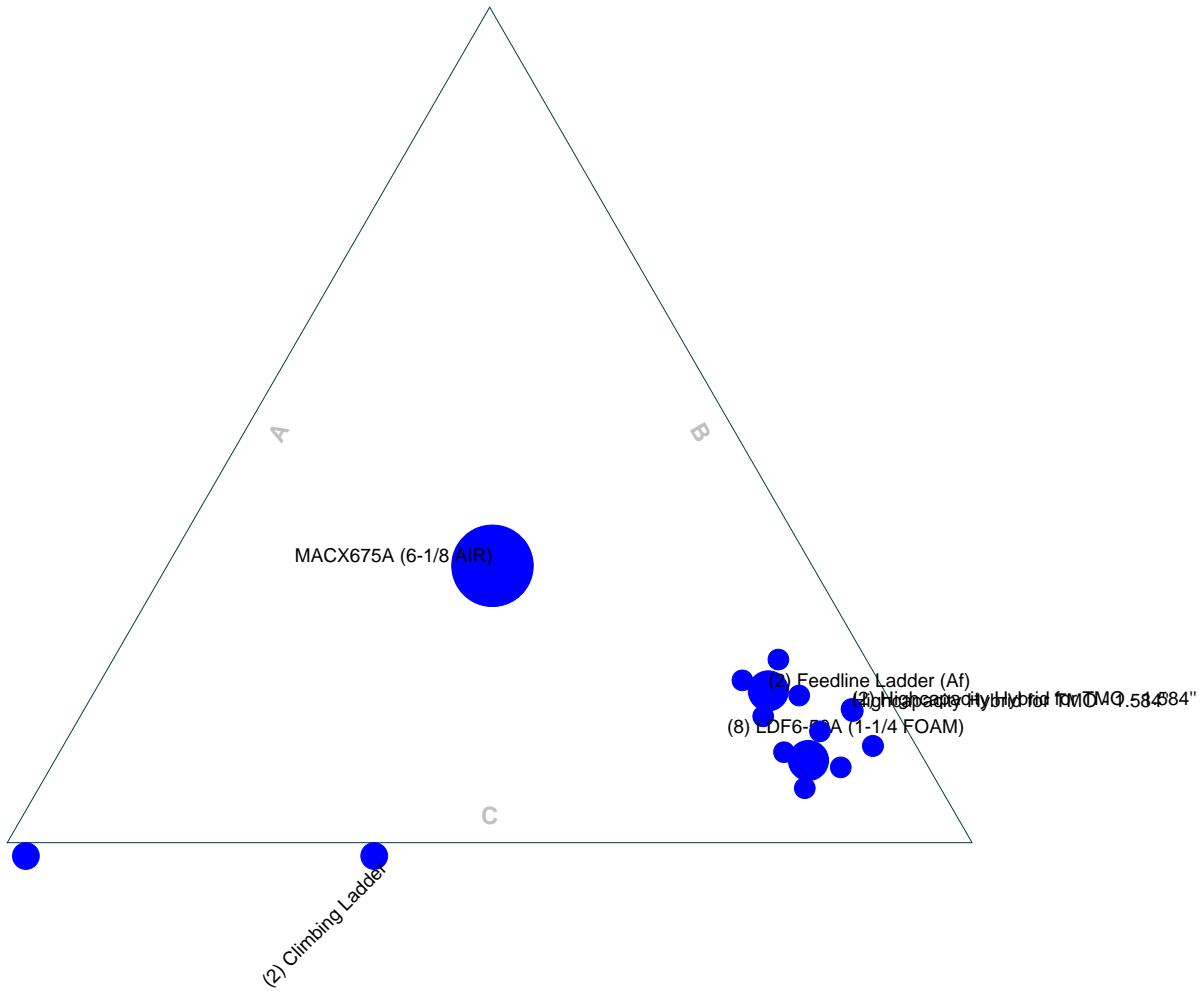

	Destek Engineering, LLC.		Job: CT11134A		
	1281 Kennestone Cir. Suite#100		Project: 1875029		
	Marietta, GA 30066		Client: ForeSite LLC	Drawn by:	App'd:
	Phone: (770) 693-0835		Code: TIA-222-G	Date: 06/20/18	Scale: NTS
	FAX:		Path:	Dwg No. E-7	

Z:\Projects\2018\75 - ForeSite LLC\1875029 - CT11134A\Calcel\CT11134A.dwg

Exhibit E



RADIO FREQUENCY EMISSIONS ANALYSIS REPORT EVALUATION OF HUMAN EXPOSURE POTENTIAL TO NON-IONIZING EMISSIONS

T-Mobile Existing Facility

Site ID: CT11134A

Farmington/ I-84 X 37_1
200 Colt Highway
Farmington, CT 06032

July 10, 2018

EBI Project Number: 6218004978

Site Compliance Summary	
Compliance Status:	COMPLIANT
Site total MPE% of FCC general population allowable limit:	14.51 %



July 10, 2018

T-Mobile USA
Attn: Jason Overbey, RF Manager
35 Griffin Road South
Bloomfield, CT 06002

Emissions Analysis for Site: **CT11134A – Farmington/ I-84 X 37_1**

EBI Consulting was directed to analyze the proposed T-Mobile facility located at **200 Colt Highway, Farmington, CT**, for the purpose of determining whether the emissions from the Proposed T-Mobile Antenna Installation located on this property are within specified federal limits.

All information used in this report was analyzed as a percentage of current Maximum Permissible Exposure (% MPE) as listed in the FCC OET Bulletin 65 Edition 97-01 and ANSI/IEEE Std C95.1. The FCC regulates Maximum Permissible Exposure in units of microwatts per square centimeter ($\mu\text{W}/\text{cm}^2$). The number of $\mu\text{W}/\text{cm}^2$ calculated at each sample point is called the power density. The exposure limit for power density varies depending upon the frequencies being utilized. Wireless Carriers and Paging Services use different frequency bands each with different exposure limits, therefore it is necessary to report results and limits in terms of percent MPE rather than power density.

All results were compared to the FCC (Federal Communications Commission) radio frequency exposure rules, 47 CFR 1.1307(b)(1) – (b)(3), to determine compliance with the Maximum Permissible Exposure (MPE) limits for General Population/Uncontrolled environments as defined below.

General population/uncontrolled exposure limits apply to situations in which the general population may be exposed or in which persons who are exposed as a consequence of their employment may not be made fully aware of the potential for exposure or cannot exercise control over their exposure. Therefore, members of the general population would always be considered under this category when exposure is not employment related, for example, in the case of a telecommunications tower that exposes persons in a nearby residential area.

Public exposure to radio frequencies is regulated and enforced in units of microwatts per square centimeter ($\mu\text{W}/\text{cm}^2$). The general population exposure limits for the 600 MHz and 700 MHz Band are approximately $400 \mu\text{W}/\text{cm}^2$ and $467 \mu\text{W}/\text{cm}^2$ respectively. The general population exposure limit for the 1900 MHz (PCS) and 2100 MHz (AWS) bands is $1000 \mu\text{W}/\text{cm}^2$. Because each carrier will be using different frequency bands, and each frequency band has different exposure limits, it is necessary to report percent of MPE rather than power density.



Occupational/controlled exposure limits apply to situations in which persons are exposed as a consequence of their employment and in which those persons who are exposed have been made fully aware of the potential for exposure and can exercise control over their exposure. Occupational/controlled exposure limits also apply where exposure is of a transient nature as a result of incidental passage through a location where exposure levels may be above general population/uncontrolled limits (see below), as long as the exposed person has been made fully aware of the potential for exposure and can exercise control over his or her exposure by leaving the area or by some other appropriate means.

Additional details can be found in FCC OET 65.

CALCULATIONS

Calculations were done for the proposed T-Mobile Wireless antenna facility located at **200 Colt Highway, Farmington, CT**, using the equipment information listed below. All calculations were performed per the specifications under FCC OET 65. Since T-Mobile is proposing highly focused directional panel antennas, which project most of the emitted energy out toward the horizon, all calculations were performed assuming a lobe representing the maximum gain of the antenna per the antenna manufactures supplied specifications, minus 10 dB for directional panel antennas, was focused at the base of the tower. For this report the sample point is the top of a 6-foot person standing at the base of the tower.

For all calculations, all equipment was calculated using the following assumptions:

- 1) 2 GSM channels (PCS Band - 1900 MHz) were considered for each sector of the proposed installation. These Channels have a transmit power of 30 Watts per Channel.
- 2) 2 UMTS channels (AWS Band – 2100 MHz) were considered for each sector of the proposed installation. These Channels have a transmit power of 30 Watts per Channel.
- 3) 2 LTE channels (PCS Band - 1900 MHz) were considered for each sector of the proposed installation. These Channels have a transmit power of 60 Watts per Channel.
- 4) 4 LTE channels (AWS Band – 2100 MHz) were considered for each sector of the proposed installation. These Channels have a transmit power of 60 Watts per Channel.
- 5) 2 LTE channels (600 MHz Band) were considered for each sector of the proposed installation. These Channels have a transmit power of 30 Watts.
- 6) 2 LTE channels (700 MHz Band) were considered for each sector of the proposed installation. These Channels have a transmit power of 30 Watts.



- 7) All radios at the proposed installation were considered to be running at full power and were uncombined in their RF transmissions paths per carrier prescribed configuration. Per FCC OET Bulletin No. 65 - Edition 97-01 recommendations to achieve the maximum anticipated value at each sample point, all power levels emitting from the proposed antenna installation are increased by a factor of 2.56 to account for possible in-phase reflections from the surrounding environment. This is rarely the case, and if so, is never continuous.
- 8) For the following calculations the sample point was the top of a 6-foot person standing at the base of the tower. The maximum gain of the antenna per the antenna manufactures supplied specifications, minus 10 dB for directional panel antennas, was used in this direction. This value is a very conservative estimate as gain reductions for these particular antennas are typically much higher in this direction.
- 9) The antennas used in this modeling are the **Ericsson AIR3246 B66**, **Ericsson AIR32 B66A/B2A** and the **RFS APXVAARR24_43-U-NA20** for 600 MHz, 700 MHz, 1900 MHz (PCS) and 2100 MHz (AWS) channels. This is based on feedback from the carrier with regard to anticipated antenna selection. All Antenna gain values and associated transmit power levels are shown in the Site Inventory and Power Data table below. The maximum gain of the antenna per the antenna manufactures supplied specifications, minus 10 dB for directional panel antennas, was used for all calculations. This value is a very conservative estimate as gain reductions for these particular antennas are typically much higher in this direction.
- 10) The antenna mounting height centerline of the proposed antennas (both panel antennas and microwave dish) is **103 feet** above ground level (AGL).
- 11) Emissions values for additional carriers were taken from the Connecticut Siting Council active database. Values in this database are provided by the individual carriers themselves. All additional carriers listed are located on an adjacent tower on this property.
- 12) All calculations were done with respect to uncontrolled / general population threshold limits.



T-Mobile Site Inventory and Power Data

Sector:	A	Sector:	B	Sector:	C
Antenna #:	1	Antenna #:	1	Antenna #:	1
Make / Model:	Ericsson AIR3246 B66	Make / Model:	Ericsson AIR3246 B66	Make / Model:	Ericsson AIR3246 B66
Gain:	15.9 dBd	Gain:	15.9 dBd	Gain:	15.9 dBd
Height (AGL):	103	Height (AGL):	103	Height (AGL):	103
Frequency Bands	2100 MHz (AWS)	Frequency Bands	2100 MHz (AWS)	Frequency Bands	2100 MHz (AWS)
Channel Count	4	Channel Count	4	Channel Count	4
Total TX Power(W):	240	Total TX Power(W):	240	Total TX Power(W):	240
ERP (W):	9,337.08	ERP (W):	9,337.08	ERP (W):	9,337.08
Antenna A1 MPE%	3.57	Antenna B1 MPE%	3.57	Antenna C1 MPE%	3.57
Antenna #:	2	Antenna #:	2	Antenna #:	2
Make / Model:	Ericsson AIR32 B66A/B2A	Make / Model:	Ericsson AIR32 B66A/B2A	Make / Model:	Ericsson AIR32 B66A/B2A
Gain:	15.9 dBd	Gain:	15.9 dBd	Gain:	15.9 dBd
Height (AGL):	103	Height (AGL):	103	Height (AGL):	103
Frequency Bands	1900 MHz (PCS)	Frequency Bands	1900 MHz (PCS)	Frequency Bands	1900 MHz (PCS)
Channel Count	4	Channel Count	4	Channel Count	4
Total TX Power(W):	180	Total TX Power(W):	180	Total TX Power(W):	180
ERP (W):	7,002.81	ERP (W):	7,002.81	ERP (W):	7,002.81
Antenna A2 MPE%	2.67	Antenna B2 MPE%	2.67	Antenna C2 MPE%	2.67
Antenna #:	3	Antenna #:	3	Antenna #:	3
Make / Model:	RFS APXVAARR24_43-U-NA20	Make / Model:	RFS APXVAARR24_43-U-NA20	Make / Model:	RFS APXVAARR24_43-U-NA20
Gain:	16.35 / 12.95/ 13.35 dBd	Gain:	16.35 / 12.95/ 13.35 dBd	Gain:	16.35 / 12.95/ 13.35 dBd
Height (AGL):	103	Height (AGL):	103	Height (AGL):	103
Frequency Bands	2100 MHz (AWS) / 600 MHz / 700 MHz	Frequency Bands	2100 MHz (AWS) / 600 MHz / 700 MHz	Frequency Bands	2100 MHz (AWS) / 600 MHz / 700 MHz
Channel Count	6	Channel Count	6	Channel Count	6
Total TX Power(W):	180	Total TX Power(W):	180	Total TX Power(W):	180
ERP (W):	5,070.20	ERP (W):	5,070.20	ERP (W):	5,070.20
Antenna A3 MPE%	3.18	Antenna B3 MPE%	3.18	Antenna C3 MPE%	3.18

Site Composite MPE%	
Carrier	MPE%
T-Mobile (Per Sector Max)	9.42 %
NBC (Adjacent Tower)	0.32 %
MetroPCS (Adjacent Tower)	0.68 %
CNG (Adjacent Tower)	0.39 %
MediaFLO (Adjacent Tower)	0.04 %
Sirius XM Radio (Adjacent Tower)	0.09 %
Verizon Wireless (Adjacent Tower)	2.80 %
Clearwire (Adjacent Tower)	0.05 %
Sprint (Adjacent Tower)	0.72 %
Site Total MPE %:	14.51 %

T-Mobile Sector A Total:	9.42 %
T-Mobile Sector B Total:	9.42 %
T-Mobile Sector C Total:	9.42 %
Site Total:	14.51 %



T-Mobile Max Power Values (Per Sector)

T-Mobile_Max Power Values (per sector)	# Channels	Watts ERP (Per Channel)	Height (feet)	Total Power Density ($\mu\text{W}/\text{cm}^2$)	Frequency (MHz)	Allowable MPE ($\mu\text{W}/\text{cm}^2$)	Calculated % MPE
T-Mobile AWS - 2100 MHz LTE	4	2,334.27	103	35.68	AWS - 2100 MHz	1000	3.57%
T-Mobile PCS - 1900 MHz LTE	2	2,334.27	103	17.84	PCS - 1900 MHz	1000	1.78%
T-Mobile PCS - 1900 MHz GSM	2	1,167.14	103	8.92	PCS - 1900 MHz	1000	0.89%
T-Mobile AWS - 2100 MHz UMTS	2	1,294.56	103	9.89	AWS - 2100 MHz	1000	0.99%
T-Mobile 600 MHz LTE	2	591.73	103	4.52	600 MHz	1000	1.13%
T-Mobile 700 MHz LTE	2	648.82	103	4.96	700 MHz	467	1.06%
						Total:	9.42%



Summary

All calculations performed for this analysis yielded results that were **within** the allowable limits for general population exposure to RF Emissions.

The anticipated maximum composite contributions from the T-Mobile facility as well as the site composite emissions value with regards to compliance with FCC's allowable limits for general population exposure to RF Emissions are shown here:

T-Mobile Sector	Power Density Value (%)
Sector A:	9.42 %
Sector B:	9.42 %
Sector C:	9.42 %
T-Mobile Per Sector Maximum (Per Sector):	9.42 %
Site Total:	14.51 %
Site Compliance Status:	COMPLIANT

The anticipated composite MPE value for this site assuming all carriers present is **14.51%** of the allowable FCC established general population limit sampled at the ground level. This is based upon values listed in the Connecticut Siting Council database for existing carrier emissions.

FCC guidelines state that if a site is found to be out of compliance (over allowable thresholds), that carriers over a 5% contribution to the composite value will require measures to bring the site into compliance. For this facility, the composite values calculated were well within the allowable 100% threshold standard per the federal government.

Exhibit F



**UNITED STATES
POSTAL SERVICE®**

Click-N-Ship®

P

USPS.com
US POSTAGE
 Flat Rate Env
\$6.70

9405 5036 9930 0267 4052 10 0067 0000 0010 6110

07/20/2018

Mailed from 06002 062S00000001311

PRIORITY MAIL 1-DAY™

Expected Delivery Date: 07/21/18
 Ref#: 134ZAPL74X
0024

SHIP TO: JOE DIMAGGIO
 OUTLET BROADCASTING
 1422 NEW BRITAIN AVE
 WEST HARTFORD CT 06110-1632

USPS TRACKING #



9405 5036 9930 0267 4052 10

Carrier -- Leave if No Response

C024

Electronic Rate Approved #038555749



Cut on dotted line.

Instructions

1. Each Click-N-Ship® label is unique. Labels are to be used as printed and used only once. DO NOT PHOTO COPY OR ALTER LABEL.
2. Place your label so it does not wrap around the edge of the package.
3. Adhere your label to the package. A self-adhesive label is recommended. If tape or glue is used, DO NOT TAPE OVER BARCODE. Be sure all edges are secure.
4. To mail your package with PC Postage®, you may schedule a Package Pickup online, hand to your letter carrier, take to a Post Office™, or drop in a USPS collection box.
5. Mail your package on the "Ship Date" you selected when creating this label.

Click-N-Ship® Label Record

USPS TRACKING # :
9405 5036 9930 0267 4052 10

Trans. #: 439916095	Priority Mail® Postage: \$6.70
Print Date: 07/20/2018	Total: \$6.70
Ship Date: 07/20/2018	
Expected Delivery Date: 07/21/2018	

From: DEBORAH CHASE
 T-MOBILE USA- NSS
 35 GRIFFIN RD S
 BLOOMFIELD CT 06002-1351

Ref#: 134ZAPL74X

To: JOE DIMAGGIO
 OUTLET BROADCASTING
 1422 NEW BRITAIN AVE
 WEST HARTFORD CT 06110-1632

* Retail Pricing Priority Mail rates apply. There is no fee for USPS Tracking® service on Priority Mail service with use of this electronic rate shipping label. Refunds for unused postage paid labels can be requested online 30 days from the print date.



Thank you for shipping with the United States Postal Service!
 Check the status of your shipment on the USPS Tracking® page at usps.com

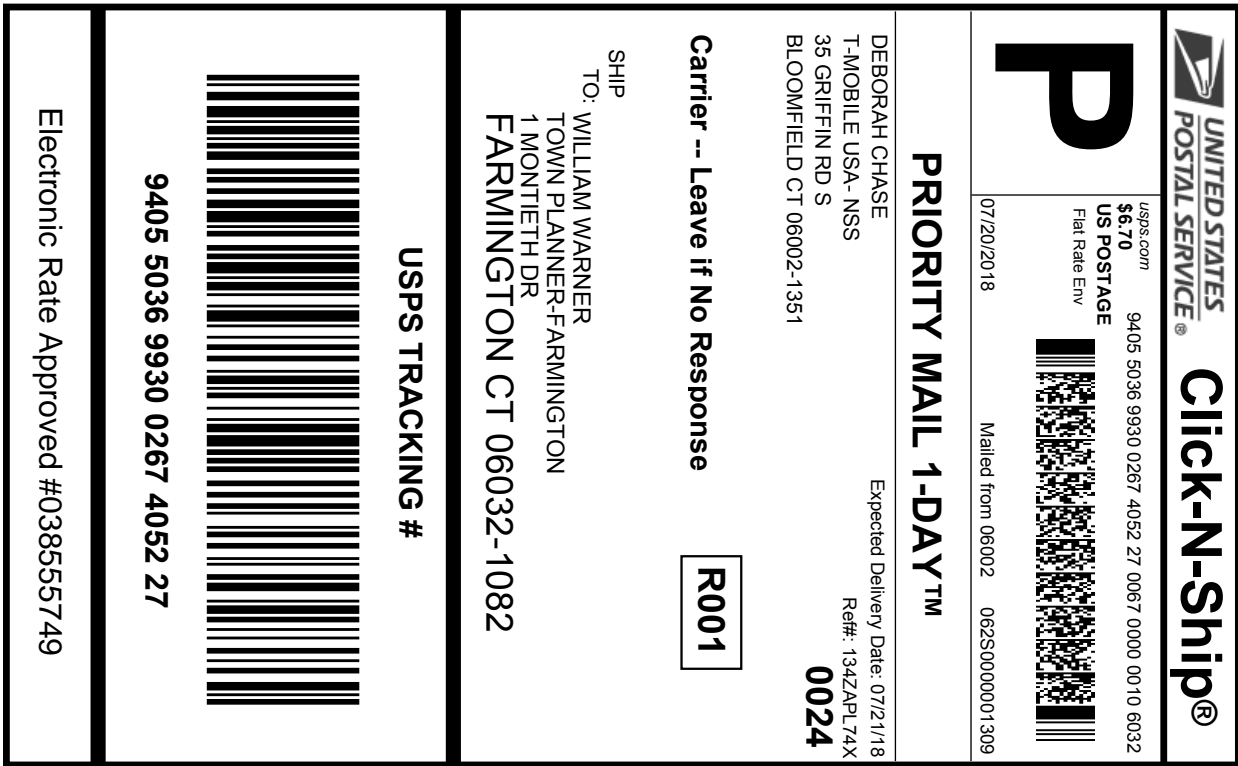

Cut on dotted line.

Instructions

1. Each Click-N-Ship® label is unique. Labels are to be used as printed and used only once. DO NOT PHOTO COPY OR ALTER LABEL.
2. Place your label so it does not wrap around the edge of the package.
3. Adhere your label to the package. A self-adhesive label is recommended. If tape or glue is used, DO NOT TAPE OVER BARCODE. Be sure all edges are secure.
4. To mail your package with PC Postage®, you may schedule a Package Pickup online, hand to your letter carrier, take to a Post Office™, or drop in a USPS collection box.
5. Mail your package on the "Ship Date" you selected when creating this label.

Click-N-Ship® Label Record

USPS TRACKING # :	
9405 5036 9930 0267 4052 27	
Trans. #:	439916095
Print Date:	07/20/2018
Ship Date:	07/20/2018
Expected Delivery Date:	07/21/2018
Priority Mail® Postage:	\$6.70
Total	\$6.70
From:	DEBORAH CHASE T-MOBILE USA- NSS 35 GRIFFIN RD S BLOOMFIELD CT 06002-1351
To:	WILLIAM WARNER TOWN PLANNER-FARMINGTON 1 MONTIETH DR FARMINGTON CT 06032-1082
Ref#:	134ZAPL74X

* Retail Pricing Priority Mail rates apply. There is no fee for USPS Tracking® service on Priority Mail service with use of this electronic rate shipping label. Refunds for unused postage paid labels can be requested online 30 days from the print date.



Thank you for shipping with the United States Postal Service!
Check the status of your shipment on the USPS Tracking® page at usps.com



**UNITED STATES
POSTAL SERVICE®**

Click-N-Ship®

P

USPS.com 9405 5036 9930 0267 4052 41 0067 0000 0010 6032
US POSTAGE
 Flat Rate Env



07/20/2018 Mailed from 06002 062S00000001308

PRIORITY MAIL 1-DAY™

DEBORAH CHASE
 T-MOBILE USA- NSS
 35 GRIFFIN RD S
 BLOOMFIELD CT 06002-1351

Expected Delivery Date: 07/21/18
 Ref#: 134ZAPL74X
0024

Carrier -- Leave if No Response

R001

SHIP TO: KATHLEEN EAGEN
 TOWN MANAGER-FARMINGTON
 1 MONTIETH DR
 FARMINGTON CT 06032-1082

USPS TRACKING #

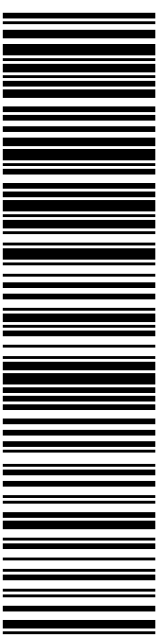

9405 5036 9930 0267 4052 41

Electronic Rate Approved #038555749



Cut on dotted line.

Instructions

1. Each Click-N-Ship® label is unique. Labels are to be used as printed and used only once. DO NOT PHOTO COPY OR ALTER LABEL.
2. Place your label so it does not wrap around the edge of the package.
3. Adhere your label to the package. A self-adhesive label is recommended. If tape or glue is used, DO NOT TAPE OVER BARCODE. Be sure all edges are secure.
4. To mail your package with PC Postage®, you may schedule a Package Pickup online, hand to your letter carrier, take to a Post Office™, or drop in a USPS collection box.
5. Mail your package on the "Ship Date" you selected when creating this label.

Click-N-Ship® Label Record

USPS TRACKING # :
9405 5036 9930 0267 4052 41

Trans. #: 439916095	Priority Mail® Postage:	\$6.70
Print Date: 07/20/2018	Total	\$6.70
Ship Date: 07/20/2018		
Expected Delivery Date: 07/21/2018		

From: DEBORAH CHASE
 T-MOBILE USA- NSS
 35 GRIFFIN RD S
 BLOOMFIELD CT 06002-1351

Ref#: 134ZAPL74X

To: KATHLEEN EAGEN
 TOWN MANAGER-FARMINGTON
 1 MONTIETH DR
 FARMINGTON CT 06032-1082

* Retail Pricing Priority Mail rates apply. There is no fee for USPS Tracking® service on Priority Mail service with use of this electronic rate shipping label. Refunds for unused postage paid labels can be requested online 30 days from the print date.



Thank you for shipping with the United States Postal Service!
 Check the status of your shipment on the USPS Tracking® page at usps.com