



NORTHEAST
SITE SOLUTIONS

Turnkey Wireless Development

Northeast Site Solutions
Denise Sabo
4 Angela's Way, Burlington, CT 06013
860-209-4690
denise@northeastsitesolutions.com

September 18, 2019

Members of the Siting Council
Connecticut Siting Council
Ten Franklin Square
New Britain, CT 06051

RE: Exempt Modification Application
3965 Congress Street
Latitude: 41.1883470 N
Longitude: -73.2990760 W
T-Mobile Site #: CT11077C_L600

Dear Ms. Bachman:

T-Mobile is requesting to file an exempt modification for an existing 150-foot monopole tower located at 3965 Congress Street, Fairfield CT 06824. T-Mobile currently has three (3) antennas at the 116-foot level of the existing 150-foot tower. The tower and property are owned by The Town of Fairfield. T-Mobile now intends to replace three (3) antennas with three (3) new 1900/2100 MHz antennas and add three (3) new 600/700 MHz antennas. The new antenna would be installed at the 116-foot and level of the tower.

Planned Tower Modifications:

Remove: N/A

Remove and Replace:

(3) APX16DWV Antenna (REMOVE) – AIR32 B66A B2A Antenna 1900/2100 MHz (REPLACE)

Install New:

(2) Fiber line

(3) RRU 4449 B71+B12

(3) APXAARR24_43U-NA20 Antenna 600/700 MHz

Handrail Kit (SITEPRO01)

Existing to Remain:

(12) 1-1/4" coax

(6) Twin TMA

Ground:

Upgrade Existing 6102 Cabinet (Internally)

Upgrade existing Breaker

This facility was approved by the Town of Fairfield P&Z on May 25, 1994. This modification complies with this original approval. Please see attached.

Please accept this letter as notification pursuant to Regulations of Connecticut State Agencies § 16-50j-73, for construction that constitutes an exempt modification pursuant to R.C.S.A. § 16-50j-72(b)(2). In accordance with R.C.S.A. § 16-50j-73, a copy of this letter is being sent to First Selectman Michael C. Tetreau, Elected Official and Jim Wendt, Planning Director for the Town of Fairfield, as well as the property owner and the tower owner (Town of Fairfield).

The planned modifications to the facility fall squarely within those activities explicitly provided for in R.C.S.A. § 16-50j-72(b)(2).

1. The proposed modifications will not result in an increase in the height of the existing structure.
2. The proposed modifications will not require the extension of the site boundary.
3. The proposed modifications will not increase noise levels at the facility by six decibels or more, or to levels that exceed state and local criteria.
4. The operation of the replacement antennas will not increase radio frequency emissions at the facility to a level at or above the Federal Communications Commission safety standard.
5. The proposed modifications will not cause a change or alteration in the physical or environmental characteristics of the site.
6. The existing structure and its foundation can support the proposed loading.

For the foregoing reasons, T-Mobile respectfully submits that the proposed modifications to the above referenced telecommunications facility constitute an exempt modification under R.C.S.A. § 16-50j-72(b)(2).

Sincerely,

Denise Sabo
Mobile: 860-209-4690
Fax: 413-521-0558
Office: 4 Angela's Way, Burlington CT 06013
Email: denise@northeastsitesolutions.com

Attachments

cc:

First Selectman Michael C. Tetreau
Sullivan Independence Hall
725 Old Post Road
Fairfield CT 06824

Sullivan Independence Hall
725 Old Post Road
Fairfield CT 06824
Attn: Jim Wendt
Planning Director

Exhibit A



Town of Fairfield

Town Planning and Zoning Department

Zonning Compliance Permit

Hse Num: 3965 Street: Congress Street Map: 170 Parcel: 41 - Unit: 0000 Permit # 23333
Zone: AAA FIRM: Date: 05/25/1994 Occupancy/Use: per plans Receipt # 0

Description: 10' x 30' equipment shelter + 150' antenna
Applicant: Fairfield Town Of

State Fee: \$30.00
Town Fee: \$50.00
Total: \$80.00

Print Date: 07/16/2019



Town of Fairfield

Town Planning and Zoning Department

Zonning Compliance Permit

Hse Num: 3965 Street: Congress Street Map: 170 Parcel: 41 - Unit: 0000 Permit # 26289

Zone: AAA FIRM: Date: 05/27/1998 Occupancy/Use: per plans Receipt # 0

Description: 9 1/2' x 11' concrete equipment pad & 9 new antennas on exist pole

Applicant: Town of Fairfield

State Fee: \$30.00

Town Fee: \$50.00

Total: \$80.00

Print Date: 07/16/2019

Exhibit B

3965 CONGRESS STREET

Location 3965 CONGRESS STREET

Mblu 170/ 41/ / /

Acct# 05308

Owner FAIRFIELD TOWN OF

Assessment \$939,330

Appraisal \$1,341,900

PID 14189

Building Count 1

Current Value

Appraisal			
Valuation Year	Improvements	Land	Total
2017	\$508,400	\$833,500	\$1,341,900

Assessment			
Valuation Year	Improvements	Land	Total
2017	\$355,880	\$583,450	\$939,330

Owner of Record

Owner FAIRFIELD TOWN OF
Co-Owner
Address 725 OLD POST ROAD
FAIRFIELD, CT 06824

Sale Price \$0
Certificate
Book & Page 395/ 523
Sale Date

Ownership History

Ownership History				
Owner	Sale Price	Certificate	Book & Page	Sale Date
FAIRFIELD TOWN OF	\$0		395/ 523	

Building Information

Building 1 : Section 1

Year Built: 1959
Living Area: 3,848
Replacement Cost: \$670,756
Building Percent 60
Good:
Replacement Cost
Less Depreciation: \$402,500

Building Attributes	
Field	Description

STYLE	Fire Station
MODEL	Ind/Comm
Stories:	1
Occupancy	1
Exterior Wall 1	Vinyl Siding
Exterior Wall 2	Brick/Masonry
Roof Structure	Gable/Hip
Roof Cover	Asphalt
Interior Wall 1	Minim/Masonry
Interior Wall 2	Plywood Panel
Interior Floor 1	Concr-Finished
Interior Floor 2	Vinyl/Asphalt
Heating Fuel	Gas
Heating Type	Hot Water
AC Type	None
Bldg Use	Fire Dept
Total Rooms	
Total Bedrms	00
Total Baths	0
Liv Area	
Effect Area	
1st Floor Use:	9032
Heat/AC	None
Frame Type	Masonry
Baths/Plumbing	Average

Building Photo



(<http://images.vgsi.com/photos2/FairfieldCTPhotos/\02\03\13\9>)

Building Layout

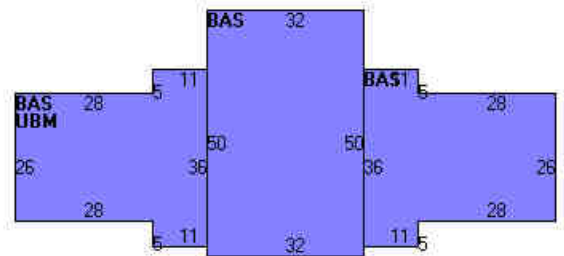

(<http://images.vgsi.com/photos2/FairfieldCTPhotos//Sketches/14>)

Building Sub-Areas (sq ft)			
Code	Description	Gross Area	Living Area
BAS	First Floor	3,848	3,848
UBM	Basement, Unfinished	1,124	0
		4,972	3,848

Extra Features

Extra Features				
Code	Description	Size	Value	Bldg #
SPR1	SPRINKLERS-WET	4972 S.F.	\$6,900	1

Land

Land Use

Use Code 9032
Description Fire Dept

Land Line Valuation

Size (Acres) 1.2
Depth 0

Zone
Neighborhood C6
Alt Land Appr No
Category

Assessed Value \$583,450
Appraised Value \$833,500

Outbuildings

Outbuildings						<u>Legend</u>
Code	Description	Sub Code	Sub Description	Size	Value	Bldg #
PAV1	PAVING-ASPHALT			5000 S.F.	\$15,800	1
LT1	LIGHTS-IN W/PL			1 UNITS	\$700	1
SHD2	W/LIGHTS ETC			80 S.F.	\$1,200	1
GEN1	GENERATOR			1 UNITS	\$10,000	1
SHD5	CELL SHED			300 SF	\$16,200	1
SHD5	CELL SHED			300 SF	\$16,200	1
SHD5	CELL SHED			300 SF	\$16,200	1
SHD5	CELL SHED			300 SF	\$16,200	1
FN4	FENCE-8' CHAIN			600 L.F.	\$6,500	1

Valuation History

Appraisal			
Valuation Year	Improvements	Land	Total
2018	\$508,400	\$833,500	\$1,341,900
2017	\$508,400	\$833,500	\$1,341,900
2016	\$508,400	\$833,500	\$1,341,900

Assessment			
Valuation Year	Improvements	Land	Total
2018	\$355,880	\$583,450	\$939,330
2017	\$355,880	\$583,450	\$939,330
2016	\$355,880	\$583,450	\$939,330

4009

1700400000
DOUGLAS MARY O/EST, C/O PETER D DOUGLAS
4009 CONGRESS STREET

3958

1700160000
JOHNSON TIMOTHY
3958 CONGRESS ST

7109-00

Fairfield Fire
Department
Station 5

3965

1700410000
FAIRFIELD TOWN OF
3965 CONGRESS STREET

170039A0000
O'HARA MARGARET
3965 CROSS HIGHWAY

1700420000
3931 CONGRESS LLC
3931 CONGRESS STREET

CONGRESS ST



Exhibit C

..T..Mobile..

NORTHEAST, LLC.

PROJECT: L600

SITE I.D. NUMBER:

CT11077C

SITE NAME:

FAIRFIELD FIRE RESCUE #5

SITE ADDRESS:

3965 CONGRESS STREET
FAIRFIELD, CT 06824

Tectonic

Practical Solutions. Exceptional Service.
Tectonic Engineering & Surveying Consultants P.C.
70 Pleasant Hill Road Phone: (845) 534-5959
P.O. Box 37 (800) 529-6531
Mountainville, NY 10953 www.tectonicengineering.com
Project Contact Info
1279 Route 300
Newburgh, NY 12550 Phone: (845) 567-6656

..T..Mobile..

NORTHEAST, LLC.

35 GRIFFIN ROAD SOUTH
BLOOMFIELD, CT 06002



NSS NORTHEAST
SITE SOLUTIONS
Turnkey Wireless Development

APPROVALS

LANDLORD _____
RF _____
CONSTRUCTION _____
OPERATIONS _____
SITE ACQ. _____

PROJECT NUMBER 9927.CT11077C DESIGNED BY JV

REV.	DATE	DESCRIPTION	DRAWN BY
△	07/19/19	ISSUED FOR CONSTRUCTION	BWY
△	07/22/19	REVISED PER COMMENTS	MB
△	08/09/19	REVISED PER COMMENTS	BWY
△	09/17/19	REVISED PER COMMENTS	BWY

ISSUED BY _____ DATE _____

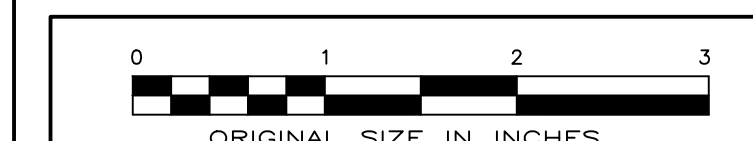

SITE INFORMATION

FAIRFIELD FIRE RESCUE #5
CT11077C
3965 CONGRESS STREET
FAIRFIELD COUNTY
FAIRFIELD, CT
06824

SHEET TITLE

TITLE SHEET

SHEET NUMBER

T-1

PROJECT INDEX

SITE NUMBER: CT11077C	PROJECT CLIENT: NORTHEAST SITE SOLUTIONS, LLC SHELDON FREINCLE (201) 776-8521
SITE NAME: FAIRFIELD FIRE RESCUE #5	CONTACT: SHELDON FREINCLE (201) 776-8521
SITE ADDRESS: 3965 CONGRESS STREET FAIRFIELD COUNTY FAIRFIELD, CT 06824	ENGINEER/ STRUCTURAL ENG: TECTONIC ENGINEERING CONSULTANTS, P.C. EDWARD IAMICELI (845) 567-6656x2811
PROPERTY OWNER: TOWN OF FAIRFIELD 725 OLD POST ROAD FAIRFIELD, CT 06824	CONTACT: EDWARD IAMICELI (845) 567-6656x2811
APPLICANT: T-MOBILE NORTHEAST LLC 35 GRIFFIN ROAD SOUTH BLOOMFIELD, CT 06002	
STRUCTURE TYPE: MONOPOLE	
LATTITUDE (NAD83): 41.1883470° N	
LONGITUDE (NAD83): 73.2990760° W	
GRADE ELEVATION: 277' (AMSL, PER GOOGLE MAPS)	

VICINITY MAP (NTS)

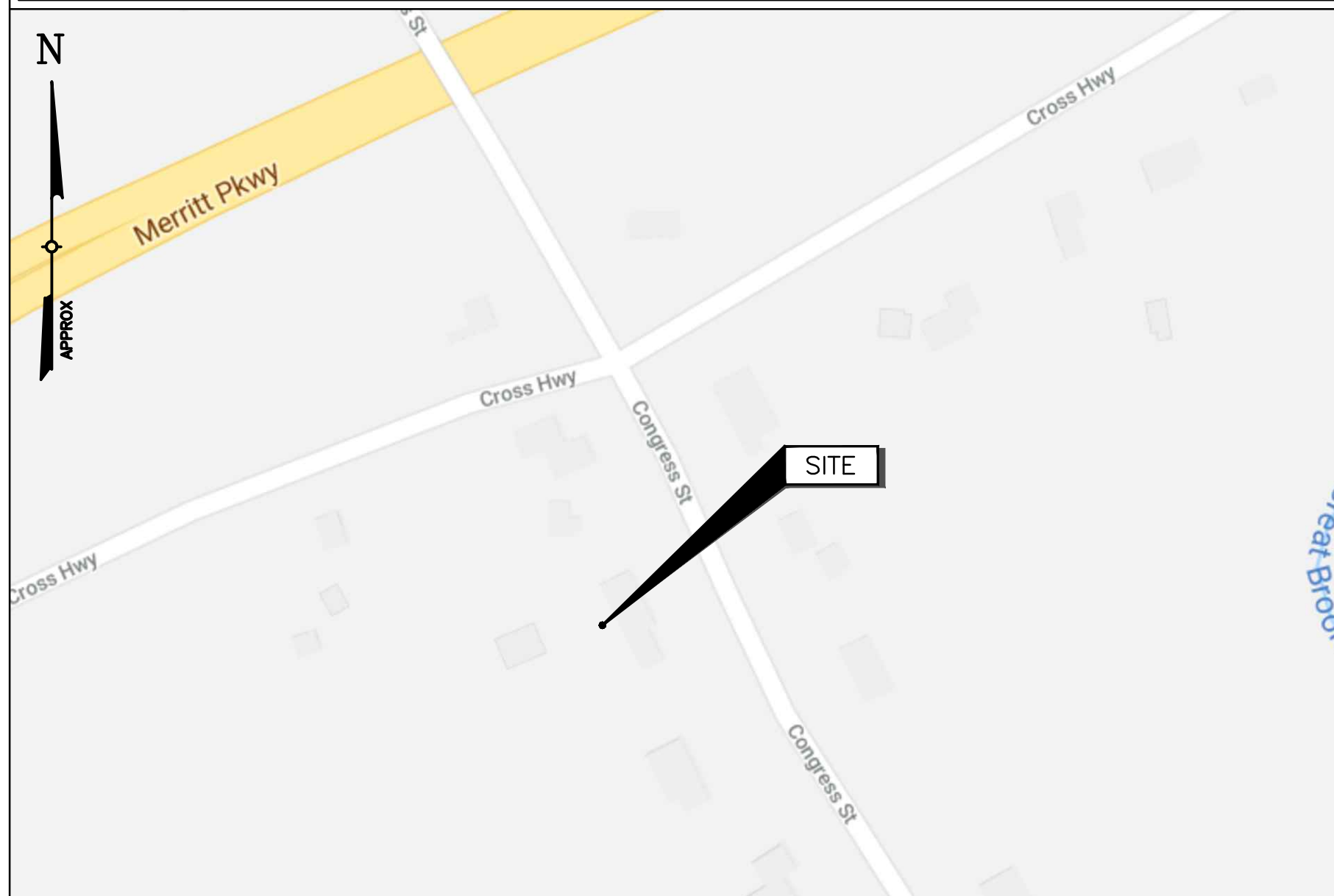

SHEET INDEX

SHEET NO	DESCRIPTION	REVISION	DATE
T-1	TITLE SHEET	3	09/17/19
A-1	SITE PLAN & T-MOBILE EQUIPMENT PLAN	3	09/17/19
A-2	MONOPOLE ELEVATION	3	09/17/19
A-3	EXIST/NEW T-MOBILE ANTENNA PLANS & ANTENNA SCHEDULE	3	09/17/19
A-4	DETAILS & ANTENNA SCHEMATIC	3	09/17/19
A-5	NOTES	3	09/17/19
E-1	ELECTRICAL NOTES & ONE-LINE DIAGRAM	3	09/17/19
G-1	GROUNDING DETAILS & NOTES	3	09/17/19

CODE COMPLIANCE

CODE INFORMATION

- STATE OF CONNECTICUT BUILDING CODE, LATEST EDITION
- ANSI/TIA-222-G
- NATIONAL ELECTRIC CODE, LATEST EDITION

RFDS DESIGN

DESIGN BASED ON RFDS DATED 07/18/2019, VERSION 5.2.
RAN TEMPLATE: 67D94DB HYBRID (EVOLVED FROM 4B)
A&L TEMPLATE: 67D94DB_1xAIR+10P

STRUCTURAL NOTE

REFER TO THE STRUCTURAL ANALYSIS REPORT BY TECTONIC ENGINEERING & SURVEYING CONSULTANTS P.C. DATED AUGUST 23, 2019 REV 4.

COPIES OF THIS DOCUMENT WITHOUT A FACSIMILE OF THE SIGNATURE & AN ORIGINAL EMBOSSED SEAL OR ORIGINAL STAMP IN BLUE OR BLACK INK OF THE PROFESSIONAL ENGINEER OR LAND SURVEYOR SHALL NOT BE CONSIDERED VALID COPIES.
THIS DOCUMENT IS PREPARED SPECIFICALLY FOR THE CLIENT AND PROJECT DESIGNATED HEREON. MODIFICATION, ALTERATION, REVISION, DUPLICATION, OR USE WITHOUT THE CONSENT OF TECTONIC IS STRICTLY PROHIBITED. COPYRIGHT 2019 TECTONIC. ALL RIGHTS RESERVED.

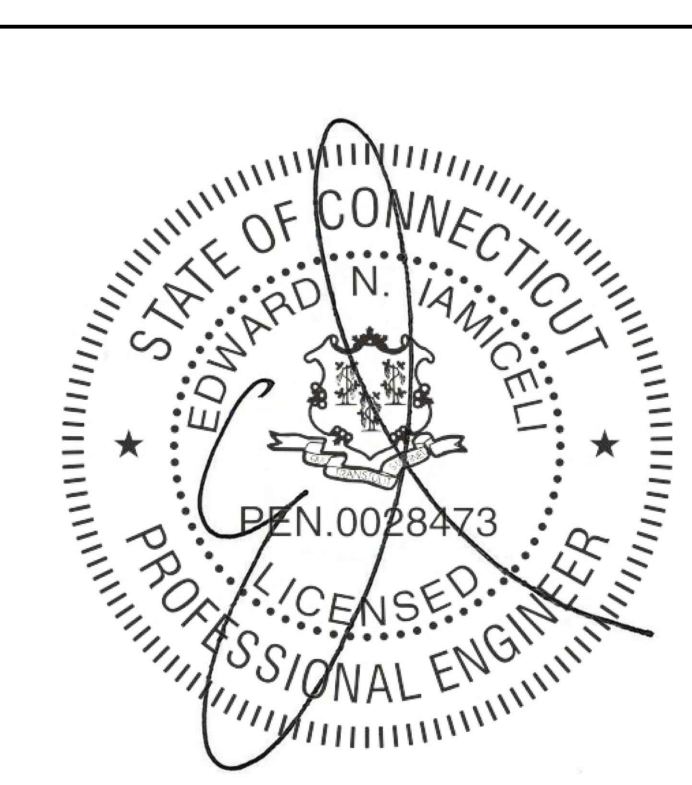

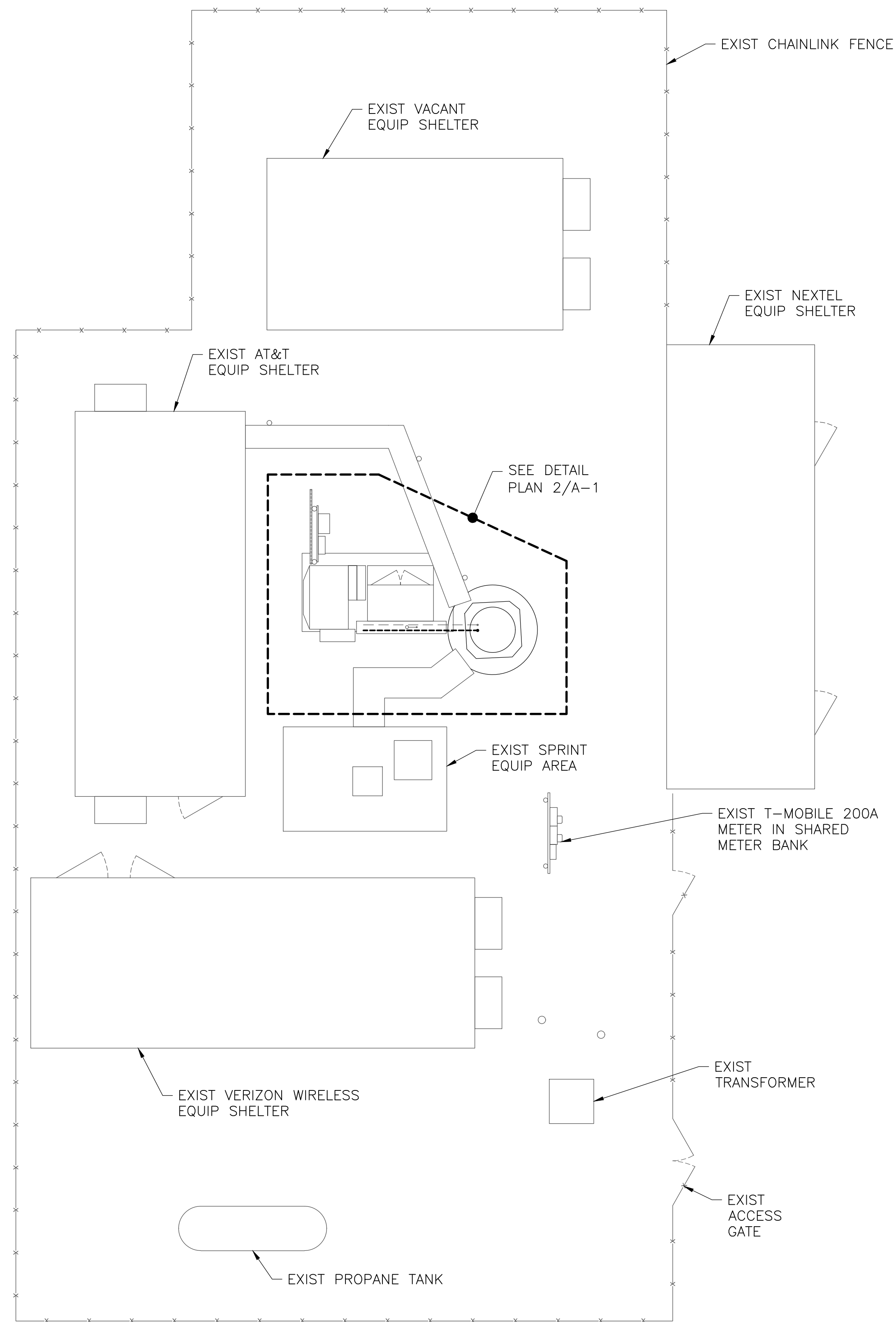
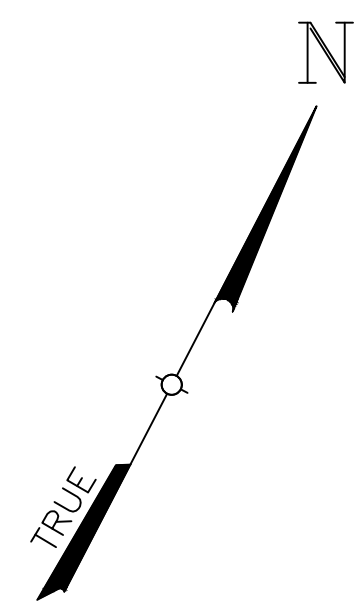

1 SITE PLAN
A-1 SCALE: 3/16" = 1'-0"

RAN SCOPE NOTES

1. REPLACE (1) DUS41 WITH (1) BB6630 FOR LTE.
2. INSTALL (1) BB630 FOR FUTURE 5G N600.
3. ADD (2) 6x12 HCS
4. EXIST (12) 1-2/8" COAX CABLES
5. REMOVE BATTERIES FROM CABINET
6. ADD (1) BBU.

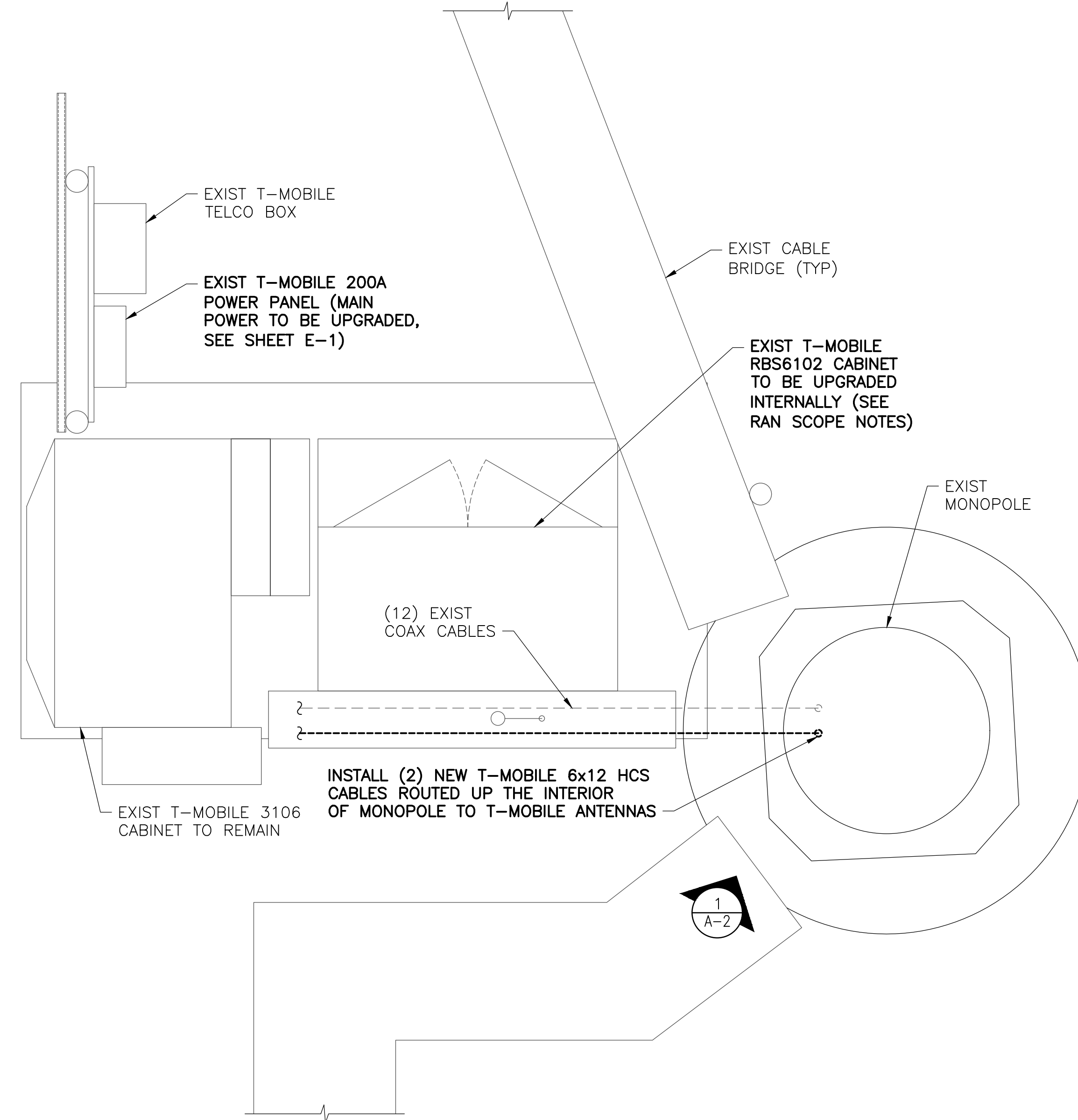

2 T-MOBILE EQUIPMENT AREA PLAN
A-1 SCALE: 3/4" = 1'-0"

Tectonic
PRACTICAL SOLUTIONS. EXCEPTIONAL SERVICE.
Tectonic Engineering & Surveying Consultants P.C.
70 Pleasant Hill Road Phone: (845) 534-5959
P.O. Box 37 (800) 529-6531
Mountainville, NY 10953 www.tectonicengineering.com
Project Contact Info
1279 Route 300
Newburgh, NY 12550 Phone: (845) 567-6656

T-Mobile
NORTHEAST, LLC.
35 GRIFFIN ROAD SOUTH
BLOOMFIELD, CT 06002

NSS NORTHEAST
SITE SOLUTIONS
Turnkey Wireless Development

APPROVALS

LANDLORD _____
RF _____
CONSTRUCTION _____
OPERATIONS _____
SITE ACQ. _____

PROJECT NUMBER 9927.CT11077C
DESIGNED BY JV

REV.	DATE	DESCRIPTION	DRAWN BY
△	07/19/19	ISSUED FOR CONSTRUCTION	BWY
△	07/22/19	REVISED PER COMMENTS	MB
△	08/09/19	REVISED PER COMMENTS	BWY
△	09/17/19	REVISED PER COMMENTS	BWY

ISSUED BY _____ DATE _____

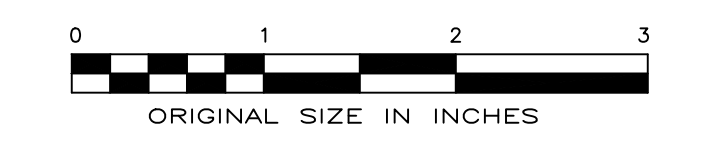

SITE INFORMATION

FAIRFIELD FIRE RESCUE #5
CT11077C
3965 CONGRESS STREET
FAIRFIELD COUNTY
FAIRFIELD, CT
06824

SHEET TITLE
SITE PLAN & T-MOBILE
EQUIPMENT AREA PLAN

SHEET NUMBER

A-1

COPIES OF THIS DOCUMENT WITHOUT A FACSIMILE OF THE SIGNATURE & AN ORIGINAL EMBOSSED SEAL OR ORIGINAL STAMP IN BLUE OR BLACK INK OF THE PROFESSIONAL ENGINEER OR LAND SURVEYOR SHALL NOT BE CONSIDERED VALID COPIES.

THIS DOCUMENT IS PREPARED SPECIFICALLY FOR THE CLIENT AND PROJECT DESIGNATED HEREON. MODIFICATION, ALTERATION, REVISION, DUPLICATION, OR USE WITHOUT THE CONSENT OF TECTONIC IS STRICTLY PROHIBITED. COPYRIGHT 2019 TECTONIC. ALL RIGHTS RESERVED.

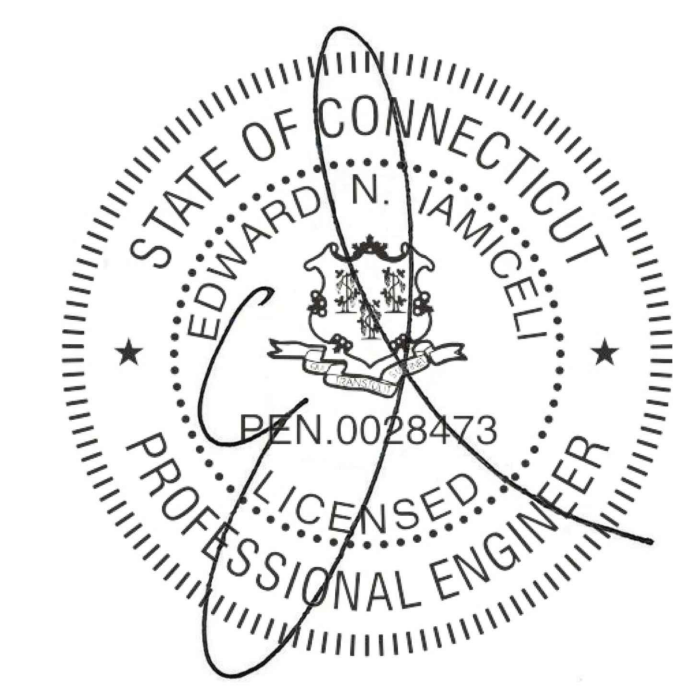

STRUCTURAL NOTE:
REFER TO THE STRUCTURAL ANALYSIS REPORT
BY TECTONIC ENGINEERING & SURVEYING
CONSULTANTS P.C. DATED AUGUST 23, 2019 REV 4.

Tectonic
PRACTICAL SOLUTIONS. EXCEPTIONAL SERVICE.
Tectonic Engineering & Surveying Consultants P.C.
70 Pleasant Hill Road Phone: (845) 534-5959
P.O. Box 37 (800) 529-6531
Mountainville, NY 10953 www.tectonicing.com
Project Contact Info
1279 Route 300
Newburgh, NY 12550 Phone: (845) 567-6656

Mobile
NORTHEAST, LLC.
35 GRIFFIN ROAD SOUTH
BLOOMFIELD, CT 06002

NSS NORTHEAST
SITE SOLUTIONS
Turnkey Wireless Development

APPROVALS

LANDLORD _____
RF _____
CONSTRUCTION _____
OPERATIONS _____
SITE ACQ. _____

PROJECT NUMBER 9927.CT11077C DESIGNED BY JV

REV.	DATE	DESCRIPTION	DRAWN BY
△	07/19/19	ISSUED FOR CONSTRUCTION	BWY
△	07/22/19	REVISED PER COMMENTS	MB
△	08/09/19	REVISED PER COMMENTS	BWY
△	09/17/19	REVISED PER COMMENTS	BWY

ISSUED BY _____ DATE _____

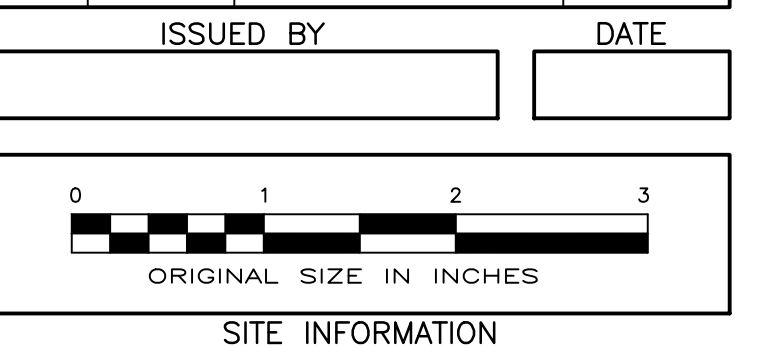

SITE INFORMATION

FAIRFIELD FIRE RESCUE #5
CT11077C
3965 CONGRESS STREET
FAIRFIELD COUNTY
FAIRFIELD, CT
06824

SHEET TITLE

MONOPOLE ELEVATION

SHEET NUMBER

A-2

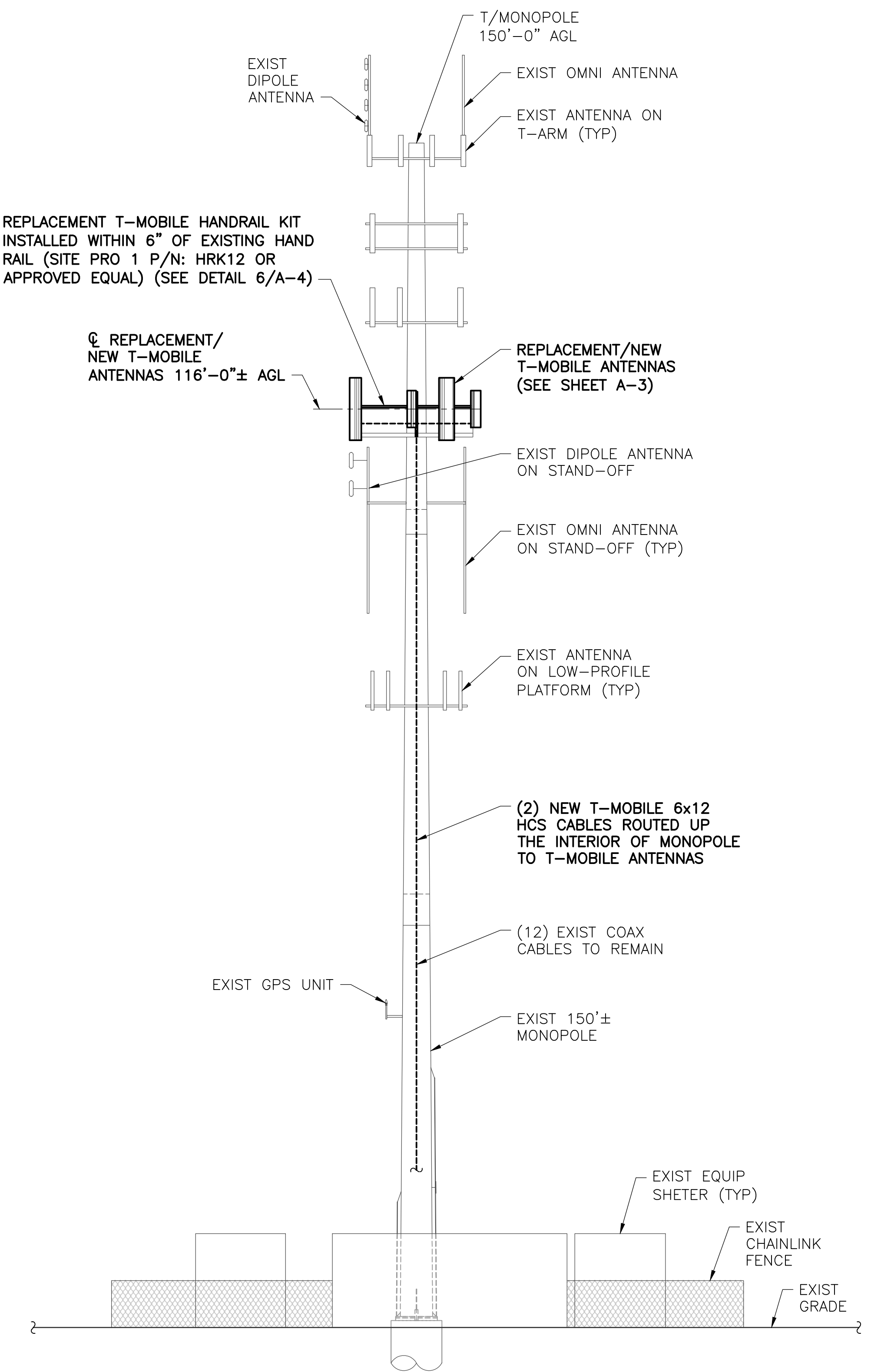

NOTE: NOT ALL SITE FEATURES SHOWN FOR CLARITY.

1 MONOPOLE ELEVATION
A-2 SCALE: 3/32" = 1'-0"

COPIES OF THIS DOCUMENT WITHOUT A FACSIMILE OF THE SIGNATURE & AN ORIGINAL EMBOSSED SEAL OR ORIGINAL STAMP IN BLUE OR BLACK INK OF THE PROFESSIONAL ENGINEER OR LAND SURVEYOR SHALL NOT BE CONSIDERED VALID COPIES.

THIS DOCUMENT IS PREPARED SPECIFICALLY FOR THE CLIENT AND PROJECT DESIGNATED HEREON. MODIFICATION, ALTERATION, REVISION, DUPLICATION, OR USE WITHOUT THE CONSENT OF TECTONIC IS STRICTLY PROHIBITED. COPYRIGHT 2019 TECTONIC. ALL RIGHTS RESERVED.

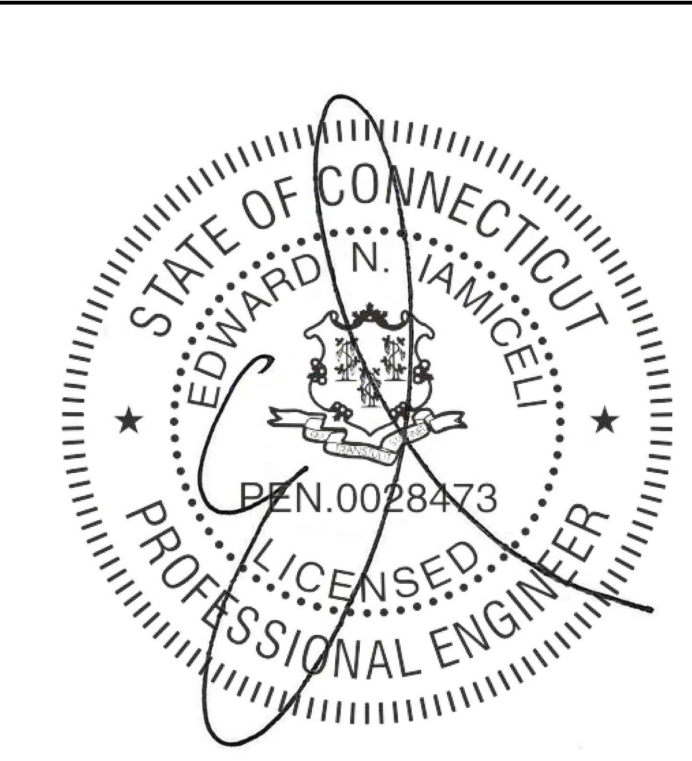

ANTENNA AND COAXIAL CABLE SCHEDULE

SECTOR MARK	ANTENNA MODEL	AZIMUTH	ELEC. DOWNTILT	MECH. DOWNTILT	ANTENNA CENTERLINE	SECTOR	STATUS	TMA/RRU	CABLE	JUMPER TYPE	CABLE LENGTH
A-1 LTE	ERICSSON AIR32 B66A/B2A	150°	6°	0°	116'-0"±	LEFT ALPHA	REPLACED	0/0	NEW 6x12 HCS	FIBER	160'-0"
A-2 LTE/GSM/UMTS	RFS APXVAARR24-43-U-NA20	150°	6°	0°	116'-0"±	RIGHT ALPHA	NEW	2/1	NEW 6x12 HCS & (4) EXIST 1 5/8" COAX	FIBER	160'-0"
B-1 LTE	ERICSSON AIR32 B66A/B2A	240°	5°	0°	116'-0"±	LEFT BETA	REPLACED	0/0	NEW 6x12 HCS	FIBER	160'-0"
B-2 LTE/GSM/UMTS	RFS APXVAARR24-43-U-NA20	240°	5°	0°	116'-0"±	RIGHT BETA	NEW	2/1	NEW 6x12 HCS & (4) EXIST 1 5/8" COAX	COAX	160'-0"
C-1 LTE	ERICSSON AIR32 B66A/B2A	320°	4°	0°	116'-0"±	LEFT GAMMA	REPLACED	0/0	NEW 6x12 HCS	FIBER	160'-0"
C-2 LTE/GSM/UMTS	RFS APXVAARR24-43-U-NA20	320°	4°	0°	116'-0"±	RIGHT GAMMA	NEW	2/1	NEW 6x12 HCS & (4) EXIST 1 5/8" COAX	FIBER	160'-0"
										COAX	160'-0"

STRUCTURAL NOTE:
REFER TO THE STRUCTURAL ANALYSIS REPORT
BY TECTONIC ENGINEERING & SURVEYING
CONSULTANTS P.C. DATED AUGUST 23, 2019 REV 4.

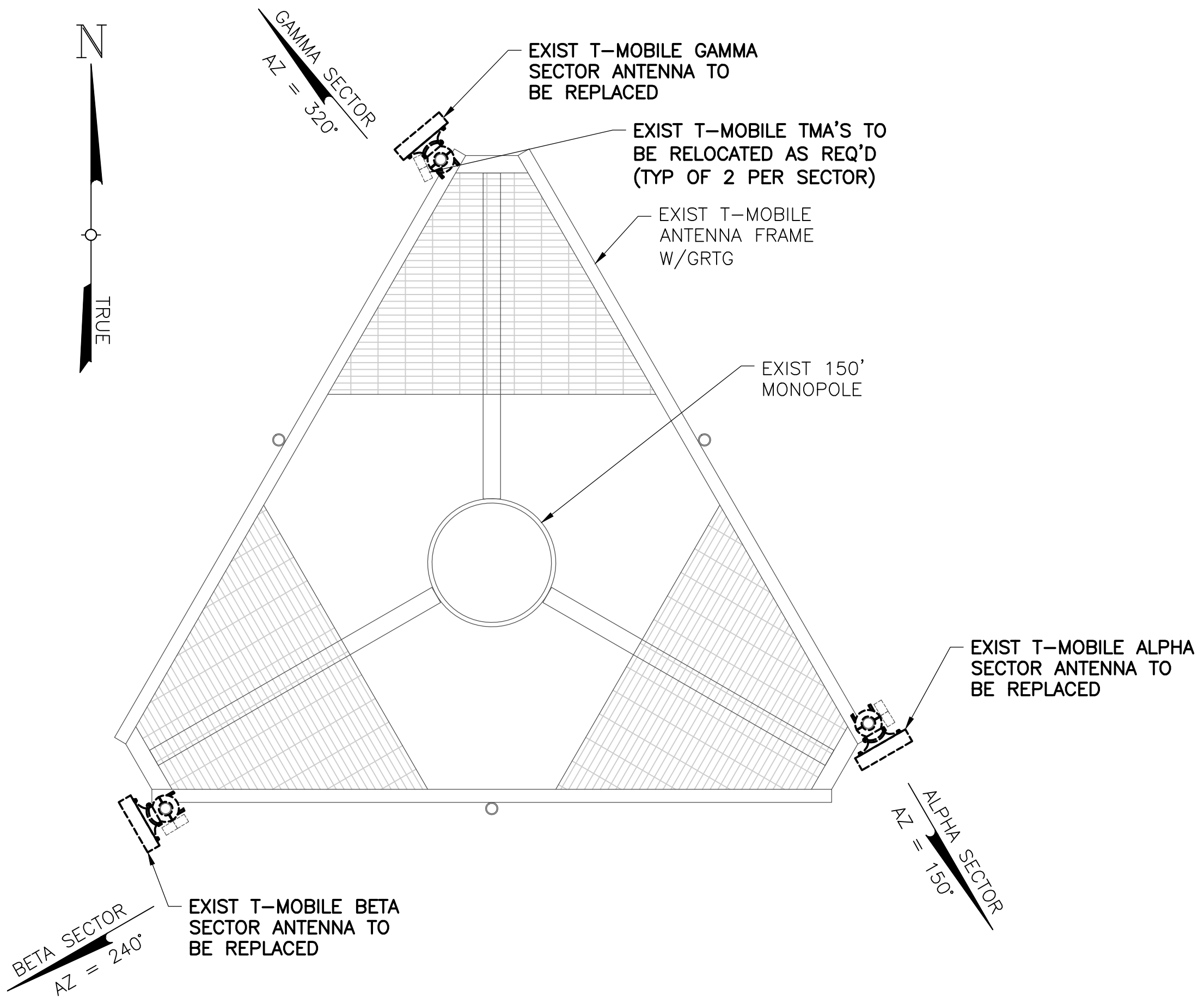
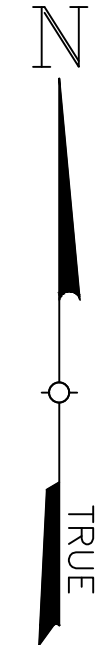

1
A-3
EXISTING T-MOBILE ANTENNA PLAN
SCALE: 1/2" = 1'-0"

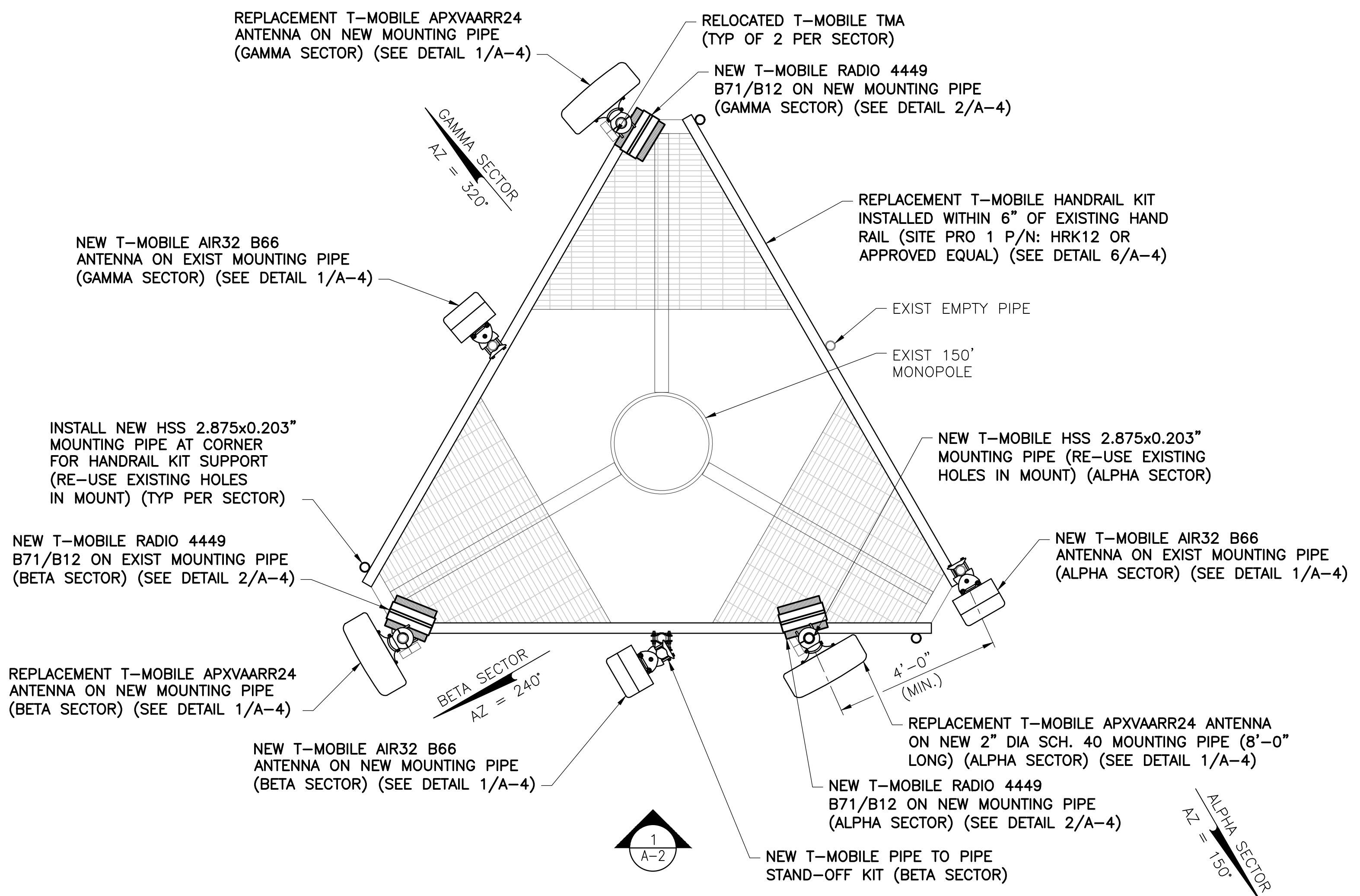

2
A-3
NEW T-MOBILE ANTENNA PLAN
SCALE: 1/2" = 1'-0"

COPIES OF THIS DOCUMENT WITHOUT A FACSIMILE OF THE SIGNATURE & AN ORIGINAL EMBOSSED SEAL OR ORIGINAL STAMP IN BLUE OR BLACK INK OF THE PROFESSIONAL ENGINEER OR LAND SURVEYOR SHALL NOT BE CONSIDERED VALID COPIES.

THIS DOCUMENT IS PREPARED SPECIFICALLY FOR THE CLIENT AND PROJECT DESIGNATED HEREON. MODIFICATION, ALTERATION, REVISION, DUPLICATION, OR USE WITHOUT THE CONSENT OF TECTONIC IS STRICTLY PROHIBITED. COPYRIGHT 2019 TECTONIC. ALL RIGHTS RESERVED.

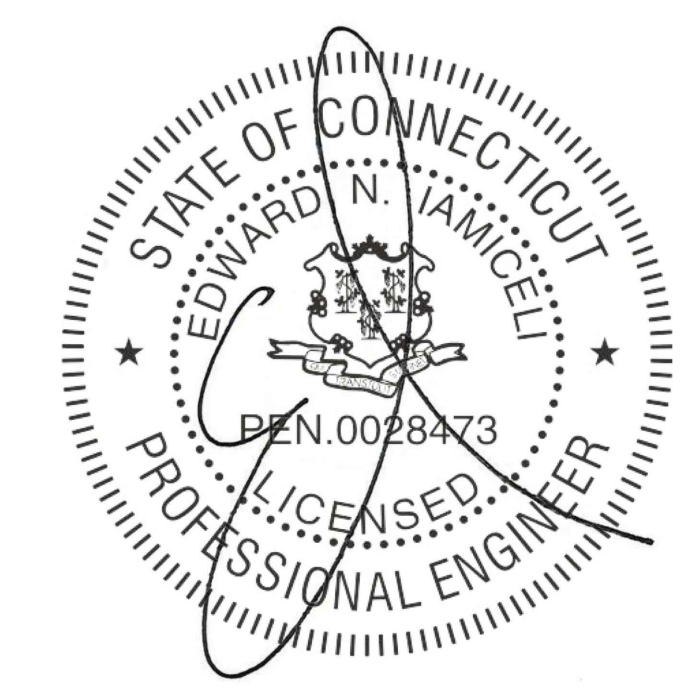

Tectonic
PRACTICAL SOLUTIONS. EXCEPTIONAL SERVICE.
Tectonic Engineering & Surveying Consultants P.C.
70 Pleasant Hill Road Phone: (845) 534-5959
P.O. Box 37 (800) 529-6531
Mountainville, NY 10953 www.tectonicing.com
Project Contact Info
1279 Route 300
Newburgh, NY 12550 Phone: (845) 567-6656

T-Mobile
NORTHEAST, LLC.
35 GRIFFIN ROAD SOUTH
BLOOMFIELD, CT 06002

NSS NORTHEAST
SITE SOLUTIONS
Turnkey Wireless Development

APPROVALS

LANDLORD _____
RF _____
CONSTRUCTION _____
OPERATIONS _____
SITE ACQ. _____

PROJECT NUMBER 9927.CT11077C DESIGNED BY JV

REV.	DATE	DESCRIPTION	DRAWN BY
1	07/19/19	ISSUED FOR CONSTRUCTION	BWY
2	07/22/19	REVISED PER COMMENTS	MB
3	08/09/19	REVISED PER COMMENTS	BWY
4	09/17/19	REVISED PER COMMENTS	BWY

ISSUED BY _____ DATE _____

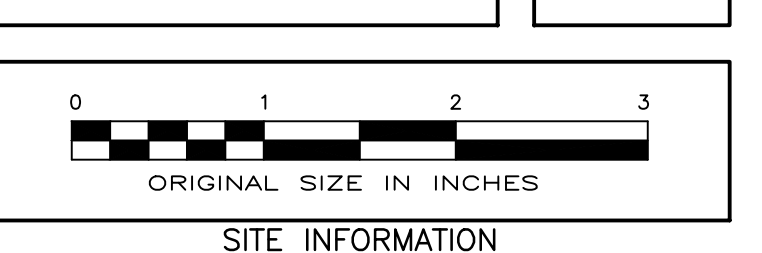

SITE INFORMATION

FAIRFIELD FIRE RESCUE #5
CT11077C
3965 CONGRESS STREET
FAIRFIELD COUNTY
FAIRFIELD, CT
06824

SHEET TITLE

EXISTING/NEW
T-MOBILE ANTENNA PLANS
& ANTENNA SCHEDULE

SHEET NUMBER

A-3

STRUCTURAL NOTE:
REFER TO THE STRUCTURAL ANALYSIS REPORT
BY TECTONIC ENGINEERING & SURVEYING
CONSULTANTS P.C. DATED AUGUST 23, 2019 REV 4.

Tectonic
PRACTICAL SOLUTIONS. EXCEPTIONAL SERVICE.
Tectonic Engineering & Surveying Consultants P.C.
70 Pleasant Hill Road Phone: (845) 534-5959
P.O. Box 37 (800) 529-6531
Mountainville, NY 10953 www.tectonicengineering.com
Project Contact Info
1279 Route 300
Newburgh, NY 12550 Phone: (845) 567-6656

Mobile
NORTHEAST, LLC.
35 GRIFFIN ROAD SOUTH
BLOOMFIELD, CT 06002

NSS NORTHEAST
SITE SOLUTIONS
Turnkey Wireless Development

APPROVALS

LANDLORD _____
RF _____
CONSTRUCTION _____
OPERATIONS _____
SITE ACQ. _____

PROJECT NUMBER 9927.CT11077C DESIGNED BY JV

REV.	DATE	DESCRIPTION	DRAWN BY
1	07/19/19	ISSUED FOR CONSTRUCTION	BWY
2	07/22/19	REVISED PER COMMENTS	MB
3	08/09/19	REVISED PER COMMENTS	BWY
4	09/17/19	REVISED PER COMMENTS	BWY

ISSUED BY _____ DATE _____

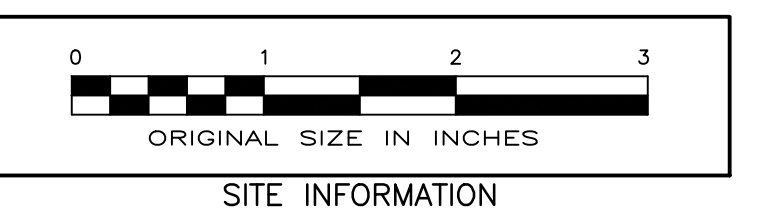

SITE INFORMATION

FAIRFIELD FIRE RESCUE #5
CT11077C
3965 CONGRESS STREET
FAIRFIELD COUNTY
FAIRFIELD, CT
06824

SHEET TITLE
DETAILS & ANTENNA SCHEMATIC

SHEET NUMBER
A-4

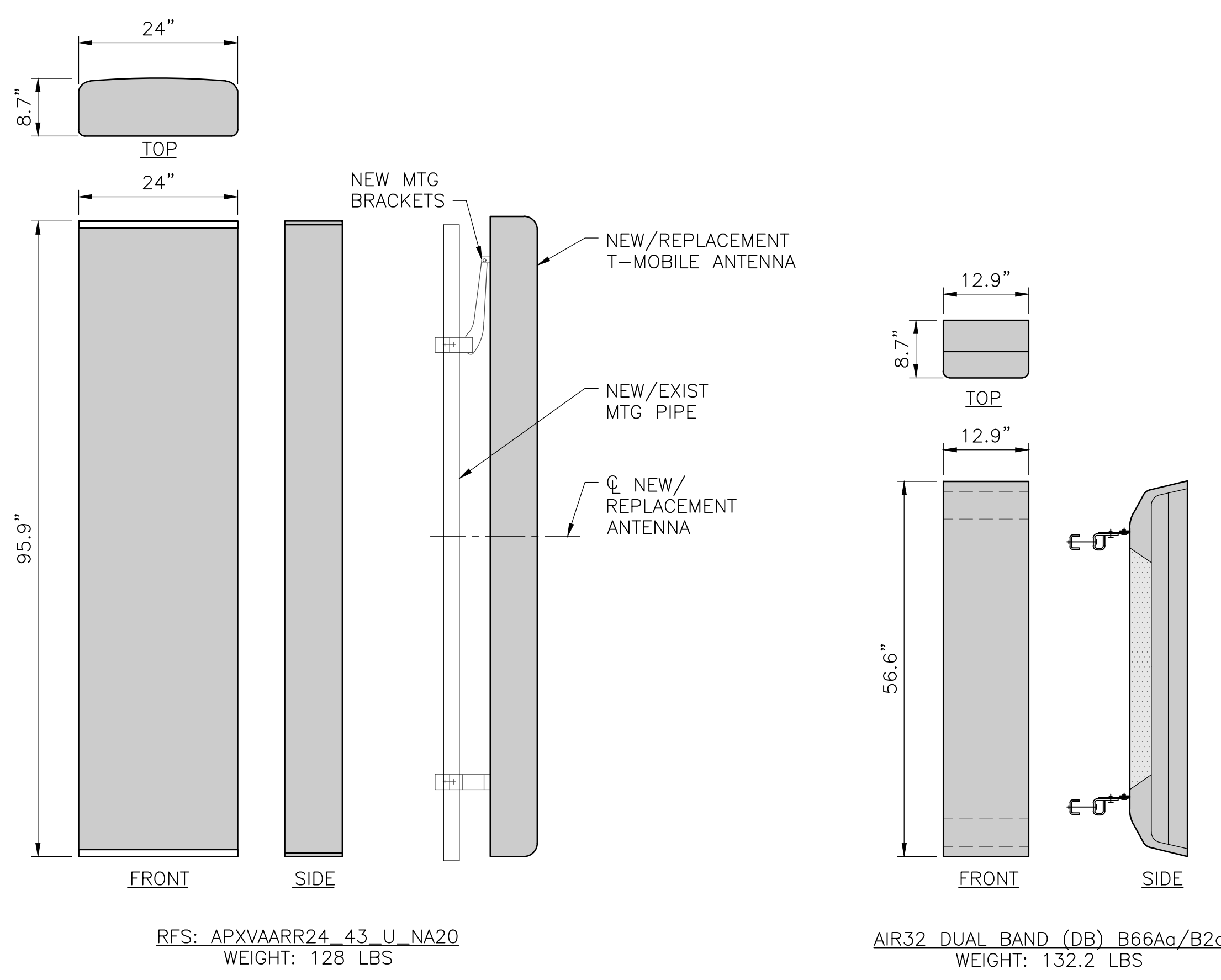

RFS: APXVAARR24_43_U_NA20
WEIGHT: 128 LBS

1 ANTENNA DETAILS
A-4 SCALE: 3/4" = 1'-0"

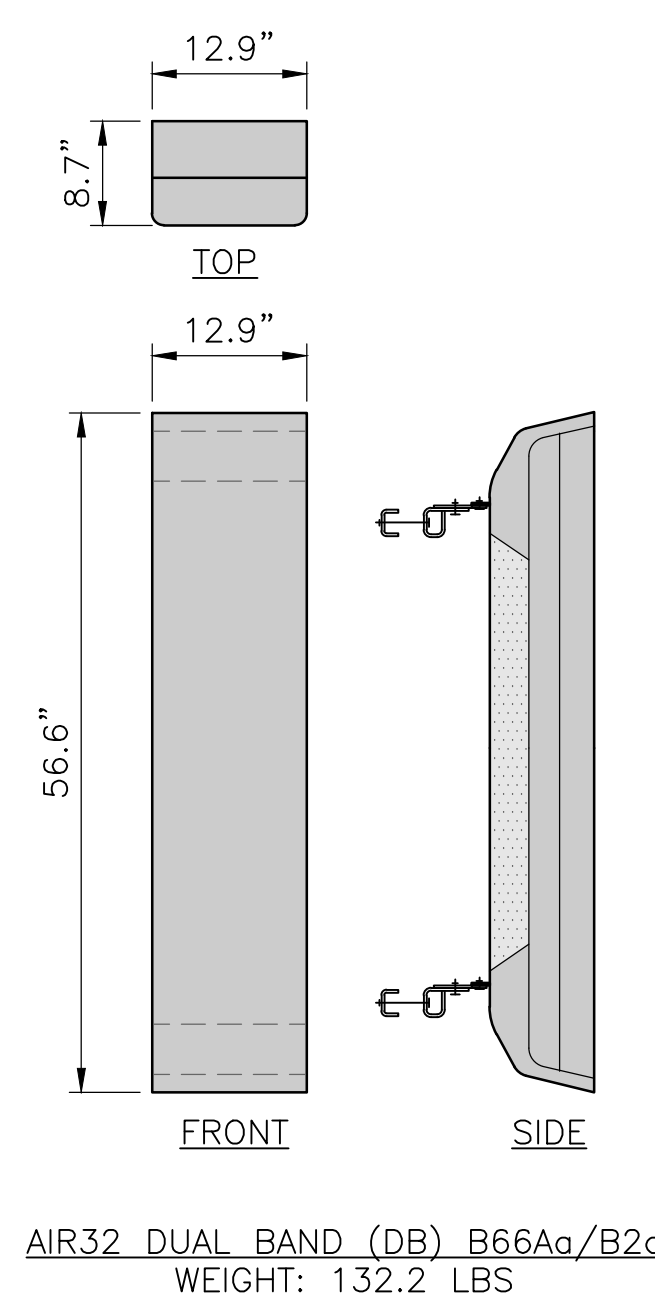

AIR32 DUAL BAND (DB) B66Aa/B2a
WEIGHT: 132.2 LBS

2 RADIO MOUNTING DETAIL
A-4 SCALE: 1" = 1'-0"

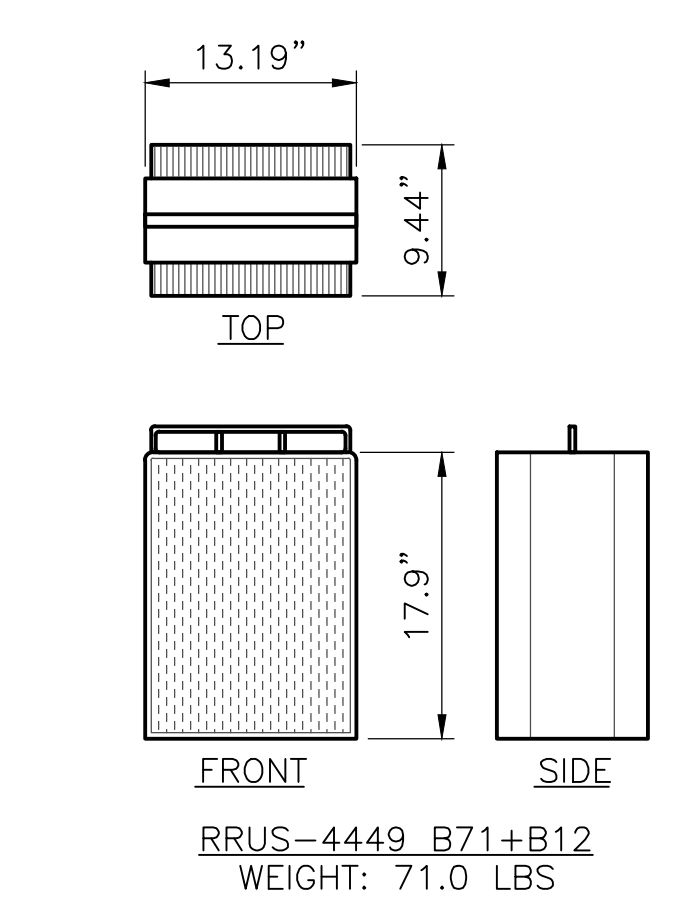

3 RADIO DETAIL
A-4 SCALE: 1" = 1'-0"

NOTE: MOUNTING OF RADIO TO MOUNTING PIPE, INCLUDING MOUNTING BRACKET ASSEMBLY SHALL BE PER MANUFACTURER DIRECTION.

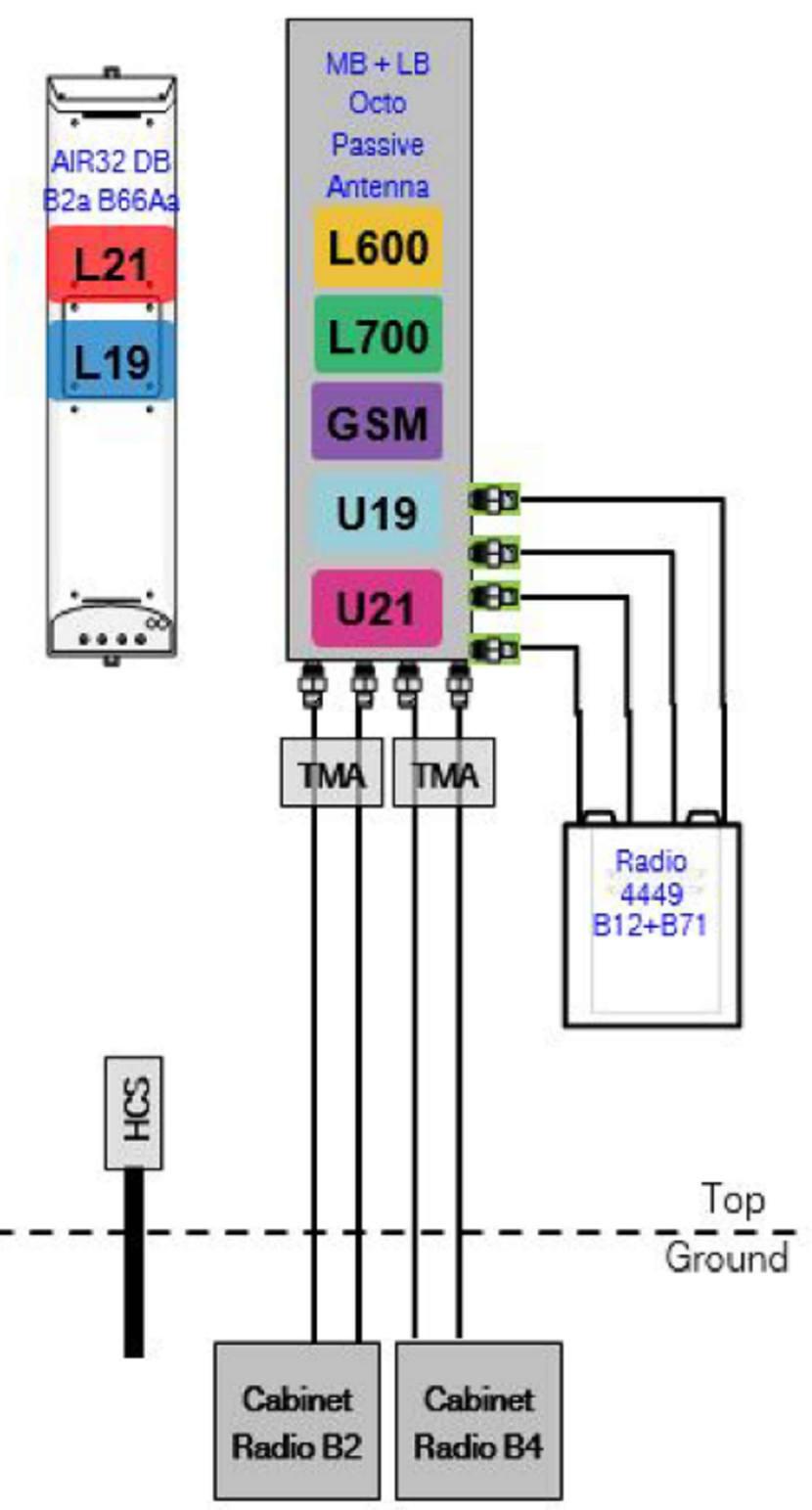

TYP ALL SECTORS

4 ANTENNA SCHEMATIC
A-4 SCALE: NTS

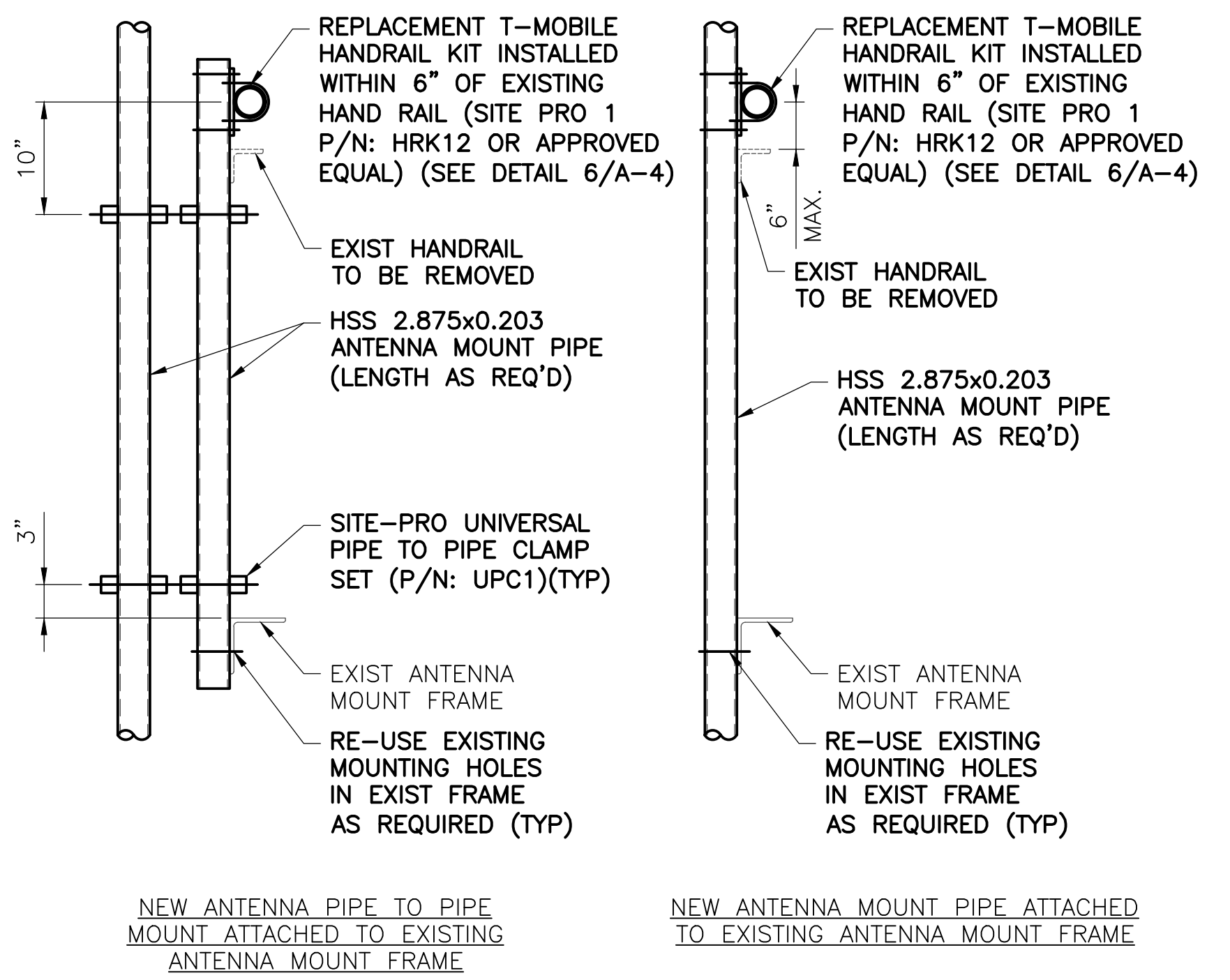

- NOTES:
- PANEL ANTENNAS AND ASSOCIATED EQUIPMENT AND CABLES NOT SHOWN FOR CLARITY.
 - EXISTING HAND RAIL TO BE REMOVED ONCE NEW HANDRAIL KIT HAS BEEN INSTALLED

5 ANTENNA MOUNT DETAILS
A-4 SCALE: 1" = 1'-0"

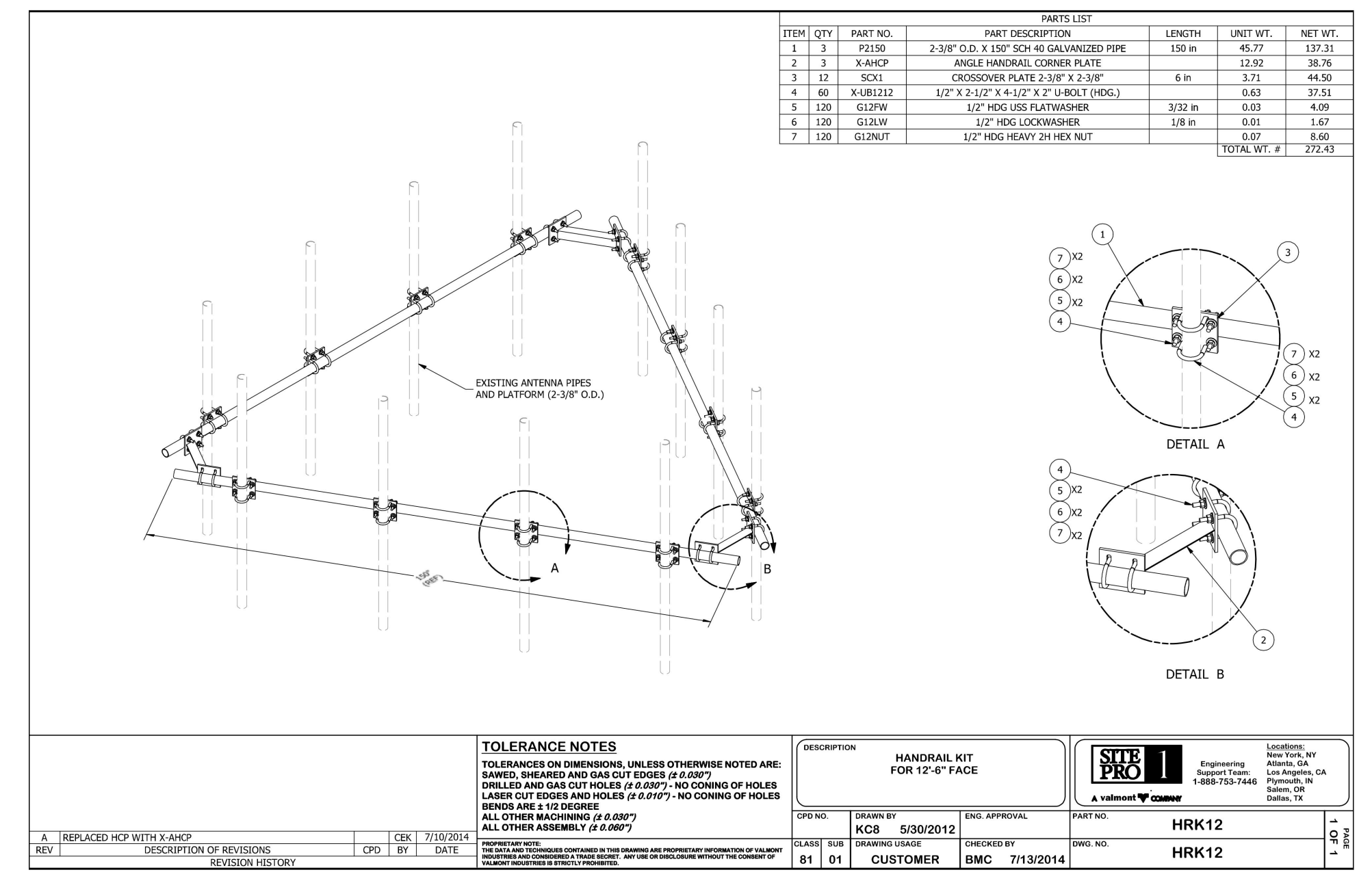

6 HANDRAIL KIT DETAIL
A-4 SCALE: NTS

COPIES OF THIS DOCUMENT WITHOUT A FACSIMILE OF THE SIGNATURE & AN ORIGINAL EMBOSSED SEAL OR ORIGINAL STAMP IN BLUE OR BLACK INK OF THE PROFESSIONAL ENGINEER OR LAND SURVEYOR SHALL NOT BE CONSIDERED VALID COPIES.

THIS DOCUMENT IS PREPARED SPECIFICALLY FOR THE CLIENT AND PROJECT DESIGNATED HEREON. MODIFICATION, ALTERATION, REVISION, DUPLICATION, OR USE WITHOUT THE CONSENT OF TECTONIC IS STRICTLY PROHIBITED. COPYRIGHT 2019 TECTONIC. ALL RIGHTS RESERVED.

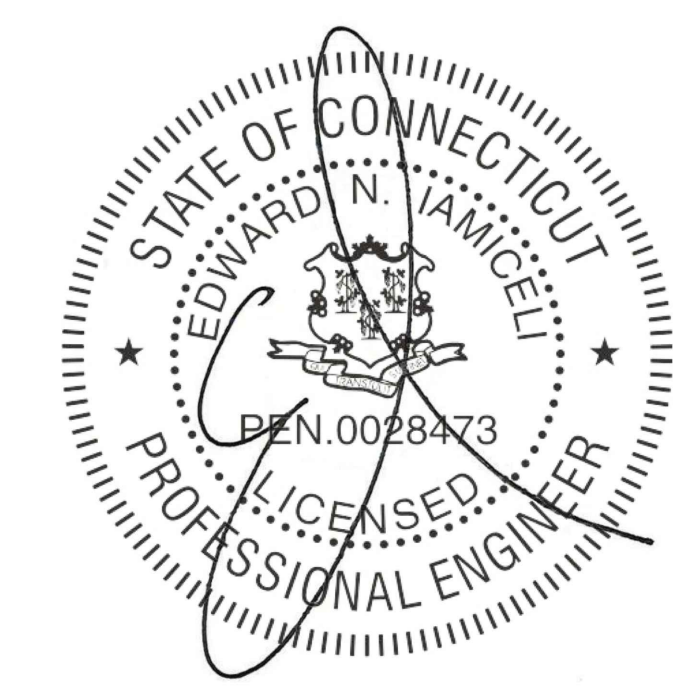

GENERAL NOTES

- ALL WORK SHALL CONFORM TO THE REQUIREMENTS OF THE STATE OF CONNECTICUT BUILDING CODE, LATEST VERSION AND ALL OTHER APPLICABLE CODES AND ORDINANCES.
- CONTRACTOR SHALL VISIT THE JOB SITE AND FAMILIARIZE HIMSELF WITH ALL CONDITIONS AFFECTING THE PROPOSED WORK AND MAKE PROVISIONS AS TO THE COST THEREOF. CONTRACTOR SHALL BE RESPONSIBLE FOR FAMILIARIZING HIMSELF WITH ALL CONTRACT DOCUMENTS, FIELD CONDITIONS AND DIMENSIONS AND CONFIRMING THAT THE WORK MAY BE ACCOMPLISHED AS SHOWN PRIOR TO PROCEEDING WITH CONSTRUCTION. ANY DISCREPANCIES SHALL BE BROUGHT TO THE ATTENTION OF THE ENGINEER PRIOR TO THE COMMENCEMENT OF WORK.
- PLANS ARE NOT TO BE SCALED. THESE PLANS ARE INTENDED TO BE A DIAGRAMMATIC OUTLINE ONLY, UNLESS OTHERWISE NOTED. THE WORK SHALL INCLUDE FURNISHING MATERIALS, EQUIPMENT, APPURTENANCES, AND LABOR NECESSARY TO EFFECT ALL INSTALLATIONS AS INDICATED ON THE DRAWINGS.
- DIMENSIONS SHOWN ARE TO FINISH SURFACES, UNLESS OTHERWISE NOTED. SPACING BETWEEN EQUIPMENT IS REQUIRED CLEARANCE. THEREFORE, IT IS CRITICAL TO FIELD VERIFY DIMENSIONS. SHOULD THERE BE ANY QUESTIONS REGARDING THE CONTRACT DOCUMENTS, EXISTING CONDITIONS AND/OR DESIGN INTENT, THE CONTRACTOR SHALL BE RESPONSIBLE FOR OBTAINING A CLARIFICATION FROM THE AUTHORIZED REPRESENTATIVE OR THE ENGINEER PRIOR TO PROCEEDING WITH THE WORK.
- DETAILS ARE INTENDED TO SHOW END RESULT OF DESIGN. MINOR MODIFICATIONS MAY BE REQUIRED TO SUIT JOB DIMENSIONS OR CONDITIONS, AND SUCH MODIFICATIONS SHALL BE INCLUDED AS PART OF THE WORK.
- CONTRACTOR SHALL RECEIVE CLARIFICATION IN WRITING, AND SHALL RECEIVE IN WRITING AUTHORIZATION TO PROCEED BEFORE STARTING WORK ON ANY ITEMS NOT CLEARLY DEFINED OR IDENTIFIED BY THE CONTRACT DOCUMENTS.
- ONCE THE CONTRACTOR HAS RECEIVED AND ACCEPTED THE "NOTICE TO PROCEED," CONTRACTOR WILL CONTACT THE CONSTRUCTION MANAGER OF RECORD A MINIMUM OF 48 HOURS PRIOR TO WORK START.
- CONTRACTOR SHALL NOTIFY THE CONSTRUCTION MANAGER OF ALL PRODUCTS OR ITEMS NOTED AS "EXISTING" WHICH ARE NOT FOUND TO BE IN THE FIELD.
- CONTRACTOR SHALL SUPERVISE AND DIRECT THE WORK USING THE BEST CONSTRUCTION SKILLS AND ATTENTION. CONTRACTOR SHALL BE SOLELY RESPONSIBLE FOR CONSTRUCTION MEANS, METHODS, TECHNIQUES, SEQUENCES, PROCEDURES, AND FOR COORDINATING ALL PORTIONS OF THE WORK UNDER CONTRACT, UNLESS OTHERWISE NOTED.
- ERECTION SHALL BE DONE IN A WORKMANLIKE MANNER BY COMPETENT EXPERIENCED WORKMEN IN ACCORDANCE WITH APPLICABLE CODES AND THE BEST ACCEPTED PRACTICE. ALL MEMBERS SHALL BE LAID PLUMB AND TRUE AS INDICATED ON THE DRAWINGS.
- CONTRACTOR SHALL BE RESPONSIBLE FOR THE SAFETY OF THE WORK AREA, ADJACENT AREAS, AND BUILDING OCCUPANTS THAT ARE LIKELY TO BE AFFECTED BY THE WORK UNDER THIS CONTRACT. WORK SHALL CONFORM TO ALL OSHA REQUIREMENTS.
- CONTRACTOR SHALL COORDINATE HIS WORK AND SCHEDULE HIS ACTIVITIES AND WORKING HOURS IN ACCORDANCE WITH THE REQUIREMENTS OF THE OWNER.
- CONTRACTOR SHALL BE RESPONSIBLE FOR COORDINATING HIS WORK WITH THE WORK OF OTHERS AS IT MAY RELATE TO RADIO EQUIPMENT, ANTENNAS AND ANY OTHER PORTIONS OF THE WORK.
- CONTRACTOR SHALL MAINTAIN LIABILITY INSURANCE TO PROTECT THE OWNER.
- INSTALL ALL EQUIPMENT AND MATERIALS IN ACCORDANCE WITH MANUFACTURER'S RECOMMENDATIONS UNLESS SPECIFICALLY INDICATED OR WHERE LOCAL CODES OR REGULATIONS TAKE PRECEDENCE.
- MAKE NECESSARY PROVISIONS TO PROTECT EXISTING SURFACES, EQUIPMENT, IMPROVEMENTS, AND PIPING. REPAIR ANY DAMAGE THAT OCCURS DURING CONSTRUCTION.
- REPAIR ALL EXISTING SURFACES DAMAGED DURING CONSTRUCTION SUCH THAT THEY MATCH AND BLEND WITH ADJACENT SURFACES.
- KEEP CONTRACT AREA CLEAN, HAZARD FREE, AND DISPOSE OF ALL DEBRIS AND RUBBISH. EQUIPMENT NOT SPECIFIED AS REMAINING ON THE PROPERTY OF THE OWNER SHALL BE REMOVED. LEAVE PREMISES IN CLEAN CONDITION AND FREE FROM PAINT SPOTS, DUST, OR SMUDGES OF ANY NATURE. CONTRACTOR SHALL BE RESPONSIBLE FOR MAINTAINING ALL ITEMS UNTIL COMPLETION OF CONSTRUCTION.
- CONTRACTOR SHALL VERIFY ALL DIMENSIONS AND CONDITIONS IN THE FIELD PRIOR TO FABRICATION AND ERECTION OF ANY MATERIAL. ANY UNUSUAL CONDITIONS SHALL BE REPORTED TO THE ATTENTION OF THE ENGINEER.
- PROVIDE 48 HOURS WRITTEN NOTICE TO THE ENGINEER PRIOR TO THE COMMENCEMENT OF WORK.
- ALL BROCHURES, OPERATING AND MAINTENANCE MANUALS, CATALOGS, SHOP DRAWINGS AND OTHER DOCUMENTATION SHALL BE TURNED OVER TO AT COMPLETION OF CONSTRUCTION.
- COMPLETE JOB SHALL BE GUARANTEED FOR A PERIOD OF ONE (1) YEAR AFTER DATE OF ACCEPTANCE BY. ANY WORK, MATERIALS OR EQUIPMENT FOUND TO BE DEFECTIVE DURING THAT PERIOD SHALL BE CORRECTED IMMEDIATELY UPON WRITTEN NOTIFICATION AT NO ADDITIONAL COST TO T-MOBILE.

STRUCTURAL NOTES

- CONTRACTOR SHALL VERIFY ALL DIMENSIONS AND CONDITIONS IN THE FIELD PRIOR TO FABRICATION AND ERECTION OF ANY MATERIAL. ANY UNUSUAL CONDITIONS SHALL BE REPORTED TO THE ATTENTION OF THE ENGINEER.
- DESIGN AND CONSTRUCTION OF STRUCTURAL STEEL SHALL CONFORM TO THE AMERICAN INSTITUTE OF STEEL CONSTRUCTION "SPECIFICATION FOR THE DESIGN, FABRICATION AND ERECTION OF STRUCTURAL STEEL FOR BUILDINGS", LATEST EDITION.
- STRUCTURAL STEEL BEAMS SHALL CONFORM TO ASTM A992 (Fy=50ksi). STRUCTURAL STEEL PLATES AND ANGLES SHALL CONFORM TO ASTM A36.
- ROUND AND SQUARE HOLLOW STRUCTURAL SECTIONS (HSS) CONFORM TO ASTM A500 "COLD-FORMED WELDED & SEAMLESS CARBON STEEL STRUCTURAL TUBING", GRADE C.
- STEEL PIPE SHALL CONFORM TO ASTM A500 "COLD-FORMED WELDED & SEAMLESS CARBON STEEL STRUCTURAL TUBING", GRADE B, OR ASTM A53 "PIPE, STEEL, BLACK AND HOT-DIPPED, ZINC-COATED WELDED AND SEAMLESS", TYPE E OR S, GRADE B.
- CONNECTIONS: WELD OR BOLT CONNECTIONS, AS INDICATED:
 - CONNECTIONS NOT DETAILED ON THE DRAWINGS SHALL CONFORM TO THE REQUIREMENTS OF THE CITED AISC SPECIFICATION.
 - STRUCTURAL BOLTS SHALL CONFORM TO THE LATEST ASTM A325 "HIGH STRENGTH BOLTS FOR STRUCTURAL JOINTS, INCLUDING SUITABLE NUTS AND PLAIN HARDENED WASHERS".
 - WHERE THE REACTION VALUES OF BEAMS, BRACING, STRUTS, ETC., ARE NOT SHOWN ON THE DRAWINGS THE CONNECTIONS SHALL BE DESIGNED TO SUPPORT THE END REACTION DERIVED FROM THE TABLES AND FORMULA OF UNIFORM LOAD CONSTANTS IN PART 2, NINTH EDITION, OF THE AISC MANUAL OF STEEL CONSTRUCTION FOR THE GIVEN MEMBER SIZE, SPAN AND YIELD STRENGTH.
 - MINIMUM 3/16" FILLET E70-XX WELD SHALL APPLY UNLESS NOTED.
 - MINIMUM 1/2" DIA. A325 BOLTS SHALL APPLY UNLESS NOTED.
 - MINIMUM SIZE OF CLIP ANGLES SHALL BE L3x3x3/8" UNLESS NOTED.
 - ALL GUSSET PLATES SHALL BE 3/8" THICK UNLESS NOTED.
 - ALL HOLES FOR BOLTS SHALL BE 1/16 INCH LARGER THAN THE BOLT DIAMETER WITH AN EDGE DISTANCE OF AT LEAST 1 1/2 TIMES THE BOLT DIAMETER AND A SPACING OF AT LEAST 3 TIMES THE BOLT DIAMETER. ALL BOLTS SHALL BE PROVIDED WITH PALNUTS OR LOCK NUTS.
- STRUCTURAL CONNECTION BOLTS SHALL BE HIGH STRENGTH BOLTS AND CONFORM TO ASTM A325 "HIGH STRENGTH BOLTS FOR STRUCTURAL JOINTS, INCLUDING SUITABLE NUTS AND PLAIN HARDENED WASHERS", LATEST EDITION. BOLTS SHALL BE 3/4 INCH DIA. UNLESS OTHERWISE NOTED.
- CONTRACTOR SHALL COMPLY WITH AWS CODE FOR PROCEDURES, APPEARANCE AND QUALITY OF WELDS AND FOR METHODS USED IN CORRECTING WELDING. ALL WELDERS AND WELDING PROCESSES SHALL BE QUALIFIED IN ACCORDANCE WITH AWS "STANDARD QUALIFICATION PROCEDURES".
- ALL STEEL MATERIALS SHALL BE GALVANIZED AFTER FABRICATION IN ACCORDANCE WITH ASTM A123 "ZINC (HOT-DIP GALVANIZED) COATINGS ON IRON AND STEEL PRODUCTS", UNLESS OTHERWISE NOTED.
- DAMAGED GALVANIZED SURFACES SHALL BE REPAIRED BY COLD GALVANIZING IN ACCORDANCE WITH ASTM A780.
- ALL BOLTS, ANCHORS AND MISCELLANEOUS HARDWARE SHALL BE GALVANIZED IN ACCORDANCE WITH ASTM A153 "ZINC-COATING (HOT-DIP) ON IRON AND STEEL HARDWARE", UNLESS OTHERWISE NOTED.
- ALL STEEL SUPPORTS SHALL BE INSTALLED WITH DOUBLE NUTS AND SHALL BE INSTALLED SNUG TIGHT.
- SLEEVE ANCHORS SHALL CONFORM TO FEDERAL SPECIFICATION FF-S-325, GROUP II, TYPE 3, CLASS 3, AS MANUFACTURED BY HILTI FASTENING SYSTEMS OR APPROVED EQUAL. INSTALLATION SHALL BE IN ACCORDANCE WITH THE MANUFACTURER'S RECOMMENDATIONS. MINIMUM EMBEDMENT SHALL BE THREE (3) INCHES.
- EXPANSION BOLTS SHALL CONFORM TO FEDERAL SPECIFICATION FF-S-325, GROUP II, TYPE 4, CLASS 1, HILTI KWIK BOLT II OR APPROVED EQUAL. INSTALLATION SHALL BE IN ACCORDANCE WITH THE MANUFACTURER'S RECOMMENDATIONS. MINIMUM EMBEDMENT SHALL BE FOUR (4) INCHES.
- EPOXY ANCHORING SYSTEM SHALL BE THE HILTI HY-270 FOR MASONRY CONSTRUCTION WITH HOLLOW BRICK OR BLOCK & THE HILTI HIT HY200 INJECTION ADHESIVE ANCHOR FOR GROUT FILLED CONCRETE MASONRY UNITS AND CONCRETE. EPOXY ANCHOR ASSEMBLY SHALL CONSIST OF 1/2"Ø STAINLESS STEEL ANCHOR ROD W/NUTS & WASHERS, AN INTERNALLY THREADED INSERT, A SCREEN TUBE FOR THE HY-270 ONLY & AN EPOXY ADHESIVE (6" MIN EMBEDMENT). THE INSTALLATION PROCEDURE SHALL BE AS FOLLOWS
 - DRILL THE HOLE USING MANUFACTURER RECOMMENDED DRILL BIT UP TO SPECIFIED DEPTH. HAMMERING IS NOT PERMITTED.
 - CLEAN THE HOLE USING NYLON BRUSH AND/OR COMPRESSED AIR. THE HOLE SHOULD BE CLEAR OF ANY LOOSE MATERIAL. IF WET, THE MASONRY SHOULD BE ALLOWED TO DRY FULLY BEFORE ANCHOR INSTALLATION.
 - INSERT SPECIFIED SCREEN TUBE INTO THE HOLE.
 - FILL THE SCREEN TUBE COMPLETELY WITH ADHESIVE, BEGINNING AT THE BOTTOM END.
 - INSERT ANCHOR ROD OR INTERNALLY THREADED INSERT INTO THE ADHESIVE-FILLED SCREEN TUBE, TWISTING SLIGHTLY.
 - LOAD FASTENER ONLY AFTER MANUFACTURER SPECIFIED CURE TIME HAS ELAPSED.
- GRATING SHALL BE GALVANIZED WELDED STEEL BAR GRATING TYPE W/BA WITH 1-1/4" BEARING BARS AT 1-3/16" OC. FASTEN TO SUPPORTING MEMBERS WITH SADDLE-TYPE CLIPS AT 2'-0" O.C. AND BAND ALL EXPOSED EDGES.
- SUBMIT DRAWINGS OF ALL STRUCTURAL AND MISCELLANEOUS STEEL TO THE ENGINEER FOR APPROVAL AND INCORPORATE ALL COMMENTS PRIOR TO FABRICATION.
- INCORRECTLY FABRICATED, DAMAGED OR OTHERWISE MISFITTING OR NONCONFORMING MATERIALS OR CONDITIONS SHALL BE REPORTED TO THE ENGINEER PRIOR TO REMEDIAL OR CORRECTIVE ACTION. ANY SUCH ACTION SHALL REQUIRE ENGINEER APPROVAL.
- ALL WORK SHALL BE INSPECTED BY THE ENGINEER DURING AND AT THE COMPLETION OF CONSTRUCTION.
- CONTRACTOR TO REMOVE MASTIC ON THE EXISTING WALL/PARAPET AT EVERY STEEL SUPPORT ATTACHMENT AND REPOINT MASONRY AS REQUIRED. A BED OF SILICONE SHALL BE APPLIED BEHIND AND ALL AROUND THE STEEL SUPPORT ATTACHMENT TO MAKE IT WEATHERPROOF.
- HAMMER DRILLS ARE NOT TO BE USED WHEN DRILLING HOLES FOR SLEEVE OR EXPANSION BOLTS INSTALLED IN MASONRY BLOCKS/BRICKS.
- ALL HOLES TO BE ADDED IN THE FIELD SHALL BE PUNCHED OR DRILLED. NO HOLE BURNING SHALL BE ALLOWED.
- NOTES ARE NOT PROJECT SPECIFIC.

SITE NOTES

- ALL SITE WORK SHALL BE AS INDICATED ON THE DRAWING.
- RUBBISH, STUMPS, DEBRIS, STICKS, STONES AND OTHER REFUSE SHALL BE REMOVED FROM THE SITE AND DISPOSED OF LEGALLY.
- THE SITE SHALL BE GRADED TO CAUSE SURFACE WATER TO FLOW AWAY FROM THE BTS EQUIPMENT AND TOWER AREAS.
- NO FILL OR EMBANKMENT MATERIAL SHALL BE PLACED ON FROZEN GROUND. FROZEN MATERIALS, SNOW OR ICE SHALL NOT BE PLACED IN ANY FILL OR EMBANKMENT.
- THE SUBGRADE SHALL BE COMPACTED AND BROUGHT TO A SMOOTH UNIFORM GRADE PRIOR TO FINISHED SURFACE APPLICATION.
- ALL EXISTING ACTIVE SEWER, WATER, GAS, ELECTRIC, AND OTHER UTILITIES WHERE ENCOUNTERED IN THE WORK, SHALL BE PROTECTED AT ALL TIMES, AND WHERE REQUIRED FOR THE PROPER EXECUTION OF THE WORK, SHALL BE RELOCATED AS DIRECTED BY ENGINEERS. EXTREME CAUTION SHOULD BE USED BY THE CONTRACTOR WHEN EXCAVATING OR PIER DRILLING AROUND OR NEAR UTILITIES.
- ALL EXISTING INACTIVE SEWER, WATER, GAS, ELECTRIC AND OTHER UTILITIES, WHICH INTERFERE WITH THE EXECUTION OF THE WORK, SHALL BE REMOVED AND/OR CAPPED, PLUGGED OR OTHERWISE DISCONTINUED AT POINTS WHICH WILL NOT INTERFERE WITH THE EXECUTION OF THE WORK, SUBJECT TO THE APPROVAL OF ENGINEER.
- THE AREAS OF THE OWNERS PROPERTY DISTURBED BY THE WORK SHALL BE GRADED TO A UNIFORM SLOPE, FERTILIZED, SEEDED, AND COVERED WITH MULCH.
- CONTRACTOR SHALL MINIMIZE DISTURBANCE TO EXISTING SITE DURING CONSTRUCTION. EROSION CONTROL MEASURES, IF REQUIRED DURING CONSTRUCTION, SHALL BE IN CONFORMANCE WITH THE LOCAL GUIDELINES FOR EROSION AND SEDIMENT CONTROL.
- CARE SHALL BE TAKEN TO RETAIN NATURAL GROWTH AND PREVENT DAMAGE TO TREES WITHIN AND OUTSIDE THE LIMITS OF CONSTRUCTION AND SPECIFIED WORK AREAS CAUSED BY EQUIPMENT AND MATERIALS. ANY DAMAGE TO THIS NATURAL GROWTH SHALL BE RESTORED AT THE EXPENSE OF THE CONTRACTOR.
- ALL AREAS DISTURBED BY THE CONTRACTOR WITHOUT AUTHORIZATION SHALL BE RESTORED BY THE CONTRACTOR.
- IN THE EVENT THE CONTRACTOR DAMAGES AN EXISTING UTILITY SERVICE CAUSING AN INTERRUPTION IN SAID SERVICE, HE SHALL IMMEDIATELY COMMENCE WORK TO RESTORE SERVICE AND MAY NOT CEASE HIS WORK OPERATION UNTIL SERVICE IS RESTORED.

COPIES OF THIS DOCUMENT WITHOUT A FACSIMILE OF THE SIGNATURE & AN ORIGINAL EMBOSSED SEAL OR ORIGINAL STAMP IN BLUE OR BLACK INK OF THE PROFESSIONAL ENGINEER OR LAND SURVEYOR SHALL NOT BE CONSIDERED VALID COPIES.

THIS DOCUMENT IS PREPARED SPECIFICALLY FOR THE CLIENT AND PROJECT DESIGNATED HEREON. MODIFICATION, ALTERATION, REVISION, DUPLICATION, OR USE WITHOUT THE CONSENT OF TECTONIC IS STRICTLY PROHIBITED. COPYRIGHT 2019 TECTONIC. ALL RIGHTS RESERVED.

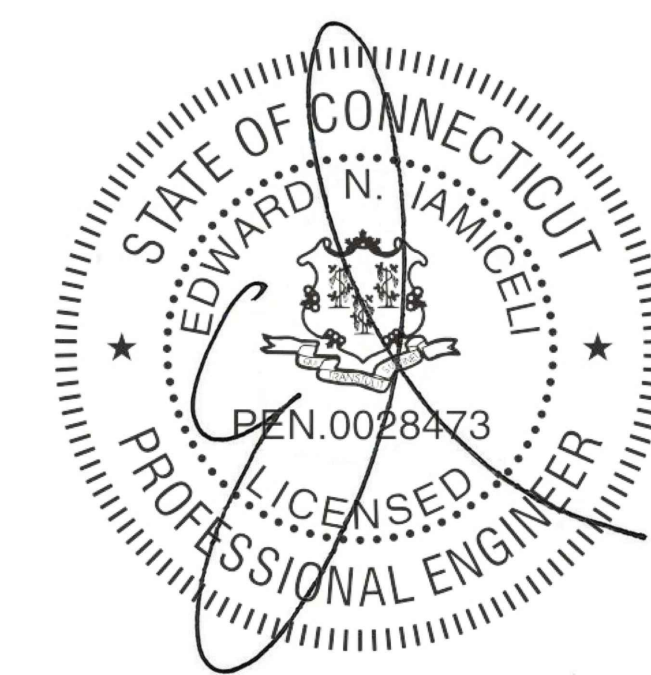

Tectonic
 PRACTICAL SOLUTIONS. EXCEPTIONAL SERVICE.
 Tectonic Engineering & Surveying Consultants P.C.
 70 Pleasant Hill Road Phone: (845) 534-5959
 P.O. Box 37 (800) 529-6531
 Mountaintop, NY 10953 www.tectonicingeering.com
 Project Contact Info
 1279 Route 300
 Newburgh, NY 12550 Phone: (845) 567-6656

Mobile
 NORTEAST, LLC.
 35 GRIFFIN ROAD SOUTH
 BLOOMFIELD, CT 06002

NSS NORTEAST
 SITE SOLUTIONS
 Turnkey Wireless Development

APPROVALS

LANDLORD _____

RF _____

CONSTRUCTION _____

OPERATIONS _____

SITE ACQ. _____

PROJECT NUMBER	DESIGNED BY
9927.CT11077C	JV

REV.	DATE	DESCRIPTION	DRAWN BY
△	07/19/19	ISSUED FOR CONSTRUCTION	BWY
△	07/22/19	REVISED PER COMMENTS	MB
△	08/09/19	REVISED PER COMMENTS	BWY
△	09/17/19	REVISED PER COMMENTS	BWY

ISSUED BY _____ DATE _____

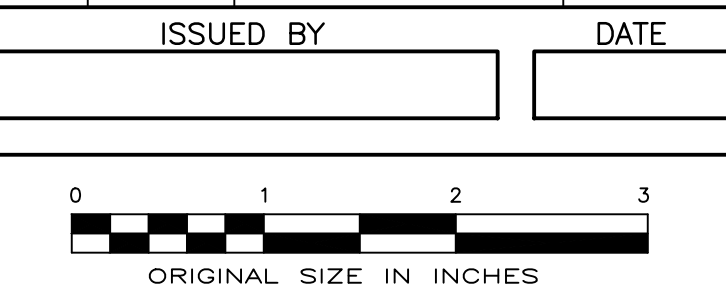

SITE INFORMATION

FAIRFIELD FIRE RESCUE #5
 CT11077C
 3965 CONGRESS STREET
 FAIRFIELD COUNTY
 FAIRFIELD, CT
 06824

SHEET TITLE

NOTES

SHEET NUMBER

A-5

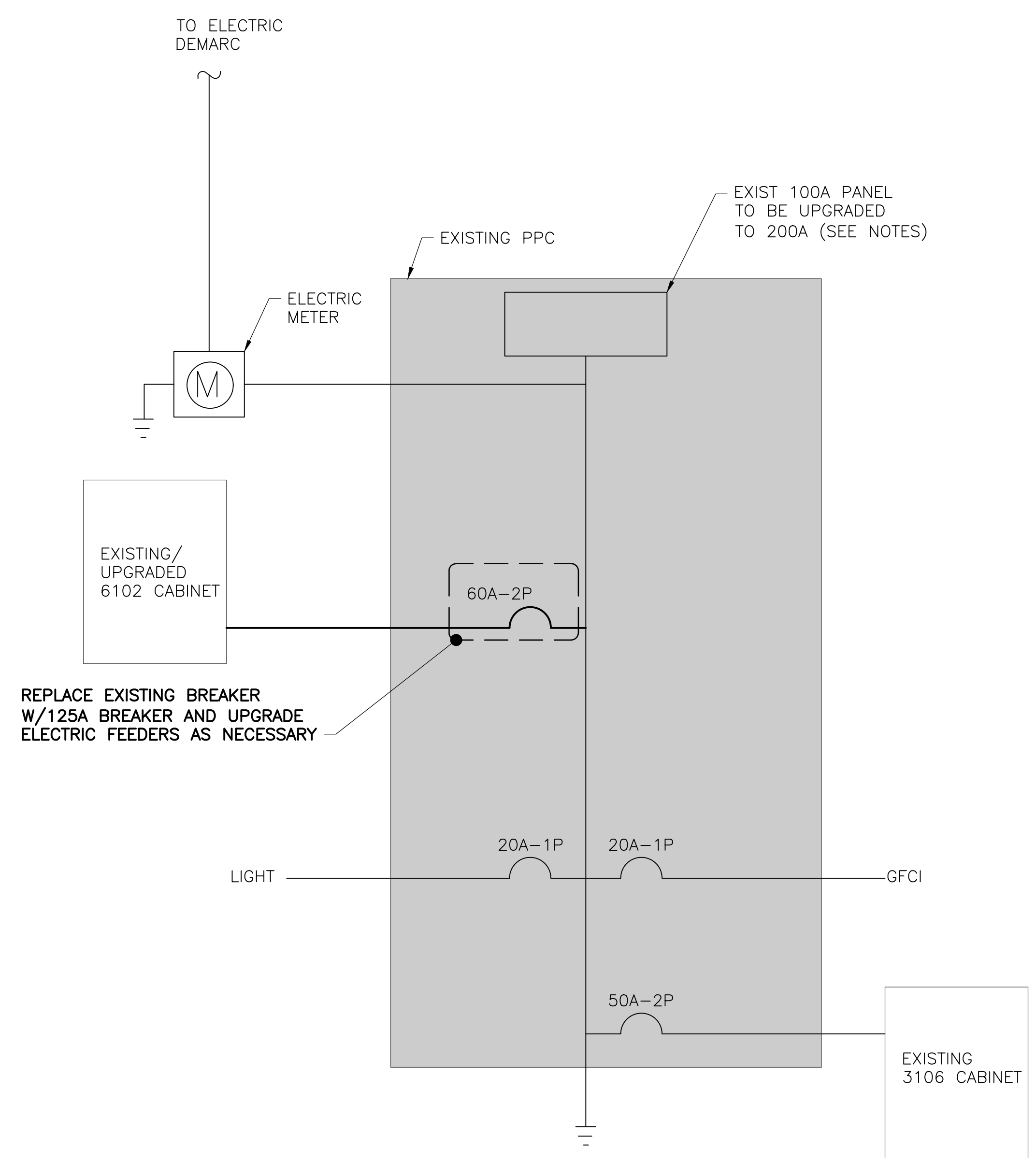

- NOTES:
1. THE ABOVE DIAGRAM IS GENERIC AND ANY ELECTRICAL WORK SHALL BE COMPLETED BY A LICENSED ELECTRICIAN IN ACCORDANCE WITH NEC STANDARDS.
 2. ELECTRICAL IS REQUIRED TO BE UPGRADED TO 200A PANEL. ELECTRICAL CONSULT SHALL BE PERFORMED TO CONSTRUCTION. ADDITIONAL TRENCHING AND CONSTRUCTION MAY BE REQUIRED FOR UPGRADE.

1 ONE-LINE DIAGRAM
E-1 SCALE: NTS

GENERAL ELECTRICAL NOTES

1. CONTRACTOR SHALL PERFORM ALL VERIFICATION OBSERVATION TESTS, AND EXAMINATION WORK PRIOR TO THE ORDERING OF THE ELECTRICAL EQUIPMENT AND THE ACTUAL CONSTRUCTION. CONTRACTOR SHALL ISSUE A WRITTEN NOTICE OF ALL FINDINGS TO THE ENGINEER LISTING ALL MALFUNCTIONS, FAULTY EQUIPMENT AND DISCREPANCIES.
2. CONTRACTOR SHALL PROVIDE ALL LABOR, MATERIALS, INSURANCE, EQUIPMENT, INSTALLATION, CONSTRUCTION TOOLS, TRANSPORTATION, ETC., FOR A COMPLETE AND PROPERLY OPERATIVE SYSTEM ENERGIZED THROUGHOUT AND AS INDICATED ON DRAWINGS, AS SPECIFIED HEREIN AND/OR AS OTHERWISE REQUIRED.
3. ALL MATERIALS AND EQUIPMENT SHALL BE NEW AND IN PERFECT CONDITION WHEN INSTALLED AND SHALL BE OF THE BEST GRADE AND OF THE SAME MANUFACTURER THROUGHOUT FOR EACH CLASS OR GROUP OF EQUIPMENT. MATERIALS SHALL BE LISTED AND APPROVED BY UNDERWRITER'S LABORATORIES (U.L.) AND SHALL BEAR THE INSPECTION LABEL "J" WHERE SUBJECT TO SUCH APPROVAL. MATERIALS SHALL MEET WITH APPROVAL OF ALL GOVERNING BODIES HAVING JURISDICTION. AND SHALL BE MANUFACTURED IN ACCORDANCE WITH APPLICABLE STANDARDS ESTABLISHED BY ANSI, NEMA AND NBFU.
4. CONTRACTOR TO COORDINATE WITH SITE OWNER FOR CONNECTION OF TEMPORARY AND PERMANENT POWER TO THE SITE. THE TEMPORARY POWER AND ALL HOOKUP COSTS TO BE PAID BY CONTRACTOR.
5. ALL CIRCUIT BREAKERS, FUSES AND ELECTRICAL EQUIPMENT SHALL HAVE AN INTERRUPTING RATING NOT LESS THAN THE MAXIMUM SHORT CIRCUIT CURRENT TO WHICH THEY MAY BE SUBJECTED, AND A MINIMUM OF 10,000 A.I.C.
6. ALL ELECTRICAL EQUIPMENT SHALL BE LABELED WITH PERMANENT ENGRAVED PLASTIC LABELS.
7. METER SOCKETS AMPERES, VOLTAGE AND NUMBER OF PHASES SHALL BE NOTED AND SHALL BE MANUFACTURED BY SQUARE "D" COMPANY, SANGAMO OR APPROVED EQUAL. METER SOCKET SHALL BE APPROVED BY UTILITY COMPANY PRIOR TO INSTALLATION.
8. WIRE AND CABLE CONDUCTORS SHALL BE COPPER #12 AWG MINIMUM WITH TYPE THHN INSULATION UNLESS SPECIFICALLY NOTED OTHERWISE.
9. ALL CONDUCTORS SHALL BE COPPER.
10. USE T-TAP CONNECTIONS ON ALL MULTI-CIRCUITS WITH COMMON NEUTRAL CONDUCTOR FOR LIGHTING FIXTURES.
11. EACH CONDUCTOR OF EVERY SYSTEM SHALL BE PERMANENTLY TAGGED IN EACH PANEL BOARD, PULLBOX, J-BOX, SWITCH BOX, ETC., IN COMPLIANCE WITH THE OCCUPATIONAL SAFETY AND HEALTH ACT (O.S.H.A.)
12. CONDUIT:
 - A. RIGID CONDUIT SHALL BE U.L. LABEL GALVANIZED ZINC COATED WITH ZINC INTERIOR AND SHALL BE USED WHEN INSTALLED IN OR UNDER CONCRETE SLABS, IN CONTACT WITH THE EARTH, UNDER PUBLIC ROADWAYS, IN MASONRY WALLS OR EXPOSED ON BUILDING EXTERIOR.
 - B. INTERMEDIATE METAL CONDUIT SHALL BE U.L. LABEL, FITTINGS SHALL BE THREADED ALUMINUM OR STEEL AND SHALL BE USED FOR ALL EXTERIOR RUNS. THREADLESS COUPLINGS AND CONNECTORS SHALL NOT BE USED.
 - C. ELECTRICAL METALLIC TUBING (EMT) SHALL HAVE U.L. LABEL, FITTINGS SHALL BE NO SET SCREW OR CRIMP TYPE FITTINGS SHALL BE USED. GLAND RING COMPRESSION TYPE. EMT SHALL BE USED ONLY FOR INTERIOR RUNS.
 - D. FLEXIBLE METALLIC CONDUIT SHALL HAVE U.L. LISTED LABEL AND MAY BE USED WHERE PERMITTED BY CODE. FITTINGS SHALL BE "JAKE" OR "SQUEEZE" TYPE, SEAL TIGHT FLEXIBLE CONDUIT. ALL CONDUIT IN EXCESS OF SIX FEET IN LENGTH SHALL HAVE FULL SIZE GROUND WIRE.
 - E. CONDUIT SHALL BE SIZED PER THE NEC AND AS SHOWN.
 - F. CONDUIT RUNS MAY BE SURFACE MOUNTED IN CEILINGS OR WALLS UNLESS INDICATED OTHERWISE. CONDUIT INDICATED SHALL RUN PARALLEL OR AT RIGHT ANGLES TO CEILING, FLOOR OR BEAMS. VERIFY EXACT ROUTING OF ALL EXPOSED CONDUIT WITH OWNER PRIOR TO INSTALLING.
 - G. ALL CONDUIT ONLY (C.O.) RUNS SHALL HAVE A PULL WIRE OR ROPE.
13. COVERPLATES SHALL BE BRUSHED STAINLESS STEEL FOR ALL SWITCHES, RECEPTACLES, TELEPHONE AND BLANKED OUTLETS, AND SHALL HAVE ENGRAVED LETTERING WHERE INDICATED WEATHERPROOF RECEPTACLES SHALL HAVE SIERRA #WPD-8 LIFT COVERPLATES.
14. REFER TO MANUFACTURERS MANUAL FOR RECOMMENDED FUSE AND WIRE SIZES.
15. ALL FINAL CONNECTIONS TO THE EQUIPMENT ARE TO BE OF FLEXIBLE WEATHERPROOF CONDUIT TO MEET APPLICABLE CODES.
16. THE ENTIRE ELECTRICAL INSTALLATION SHALL BE GROUNDED AS REQUIRED BY ALL APPLICABLE CODES.
17. GROUNDING CONDUCTORS SHALL BE SOLID TINNED COPPER AND ANNEALED #2, UNLESS OTHERWISE NOTED.
18. UPON COMPLETION OF WORK, CONDUCT CONTINUITY, SHORT CIRCUIT, AND FALL OF POTENTIAL GROUNDING TESTS FOR APPROVAL. SUBMIT TEST REPORTS TO THE CONSTRUCTION MANAGER. CLEAN PREMISES OF ALL DEBRIS RESULTING FROM WORK AND LEAVE WORK IN A COMPLETE AND UNDAIMAGED CONDITION.
19. PROVIDE CONSTRUCTION MANAGER WITH ONE SET OF COMPLETE ELECTRICAL "AS INSTALLED" DRAWINGS AT THE COMPLETION OF THE JOB, SHOWING ACTUAL DIMENSIONS, ROUTINGS, AND CIRCUITS.
20. CONTRACTOR SHALL BE RESPONSIBLE FOR COORDINATING WITH GAINING APPROVALS AND PAYING ALL FEES ASSESSED BY UTILITY COMPANY FOR ELECTRICAL SERVICE.

COPIES OF THIS DOCUMENT WITHOUT A FACSIMILE OF THE SIGNATURE & AN ORIGINAL EMBOSSED SEAL OR ORIGINAL STAMP IN BLUE OR BLACK INK OF THE PROFESSIONAL ENGINEER OR LAND SURVEYOR SHALL NOT BE CONSIDERED VALID COPIES.

THIS DOCUMENT IS PREPARED SPECIFICALLY FOR THE CLIENT AND PROJECT DESIGNATED HEREON. MODIFICATION, ALTERATION, REVISION, DUPLICATION, OR USE WITHOUT THE CONSENT OF TECTONIC IS STRICTLY PROHIBITED. COPYRIGHT 2019 TECTONIC. ALL RIGHTS RESERVED.

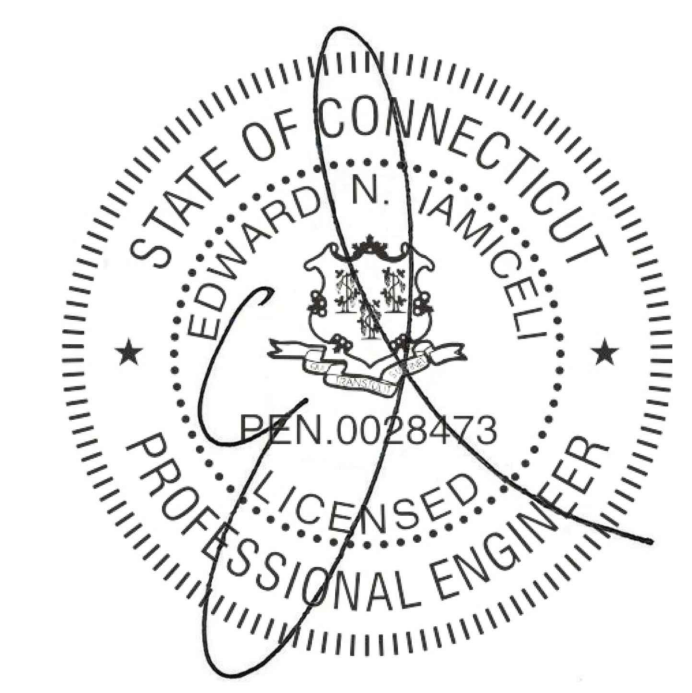

Tectonic
 PRACTICAL SOLUTIONS. EXCEPTIONAL SERVICE.
 Tectonic Engineering & Surveying Consultants P.C.
 70 Pleasant Hill Road Phone: (845) 534-5959
 P.O. Box 37 (800) 529-6531
 Mountainville, NY 10953 www.tectonicengineering.com
 Project Contact Info
 1279 Route 300
 Newburgh, NY 12550 Phone: (845) 567-6656

Mobile
 NORTEAST, LLC.
 35 GRIFFIN ROAD SOUTH
 BLOOMFIELD, CT 06002

NSS NORTEAST
 SITE SOLUTIONS
 Turnkey Wireless Development

APPROVALS

LANDLORD _____

RF _____

CONSTRUCTION _____

OPERATIONS _____

SITE ACQ. _____

PROJECT NUMBER 9927.CT11077C DESIGNED BY JV

REV.	DATE	DESCRIPTION	DRAWN BY
△	07/19/19	ISSUED FOR CONSTRUCTION	BWY
△	07/22/19	REVISED PER COMMENTS	MB
△	08/09/19	REVISED PER COMMENTS	BWY
△	09/17/19	REVISED PER COMMENTS	BWY

ISSUED BY _____ DATE _____

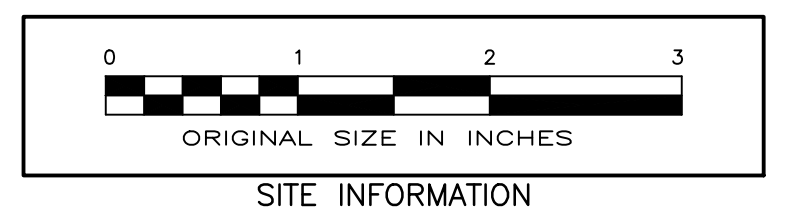

SITE INFORMATION

FAIRFIELD FIRE RESCUE #5
 CT11077C
 3965 CONGRESS STREET
 FAIRFIELD COUNTY
 FAIRFIELD, CT
 06824

SHEET TITLE

ELECTRICAL NOTES
 & ONE-LINE DIAGRAM

SHEET NUMBER

E-1

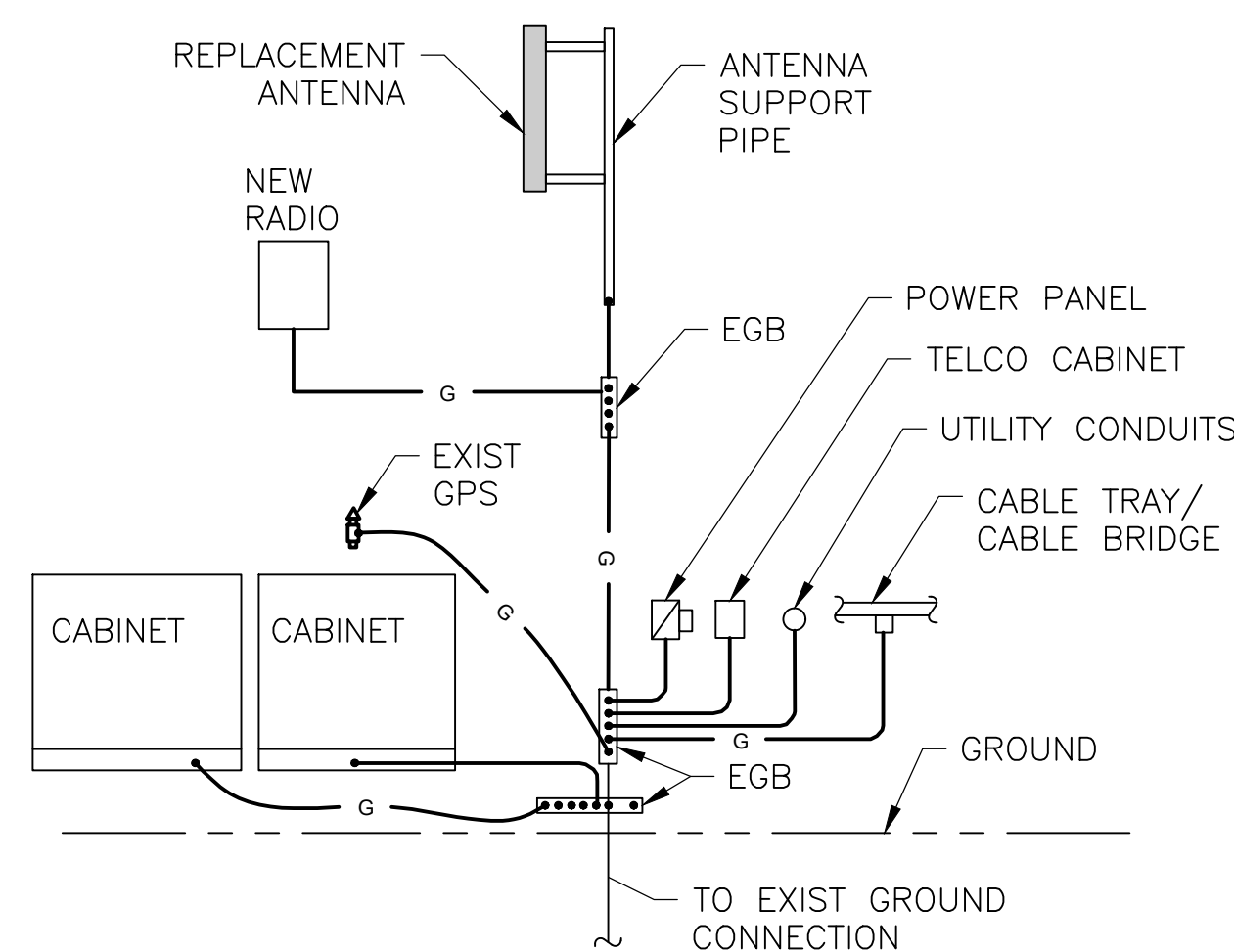

NOTE: CONTRACTOR SHALL CONFIRM ALL EQUIPMENT IS GROUNDED. IF NOT, CONTRACTOR SHALL GROUND EQUIPMENT AS SHOWN AND AS REQUIRED.

1 GROUNDING RISER DIAGRAM
G-1 SCALE: NTS

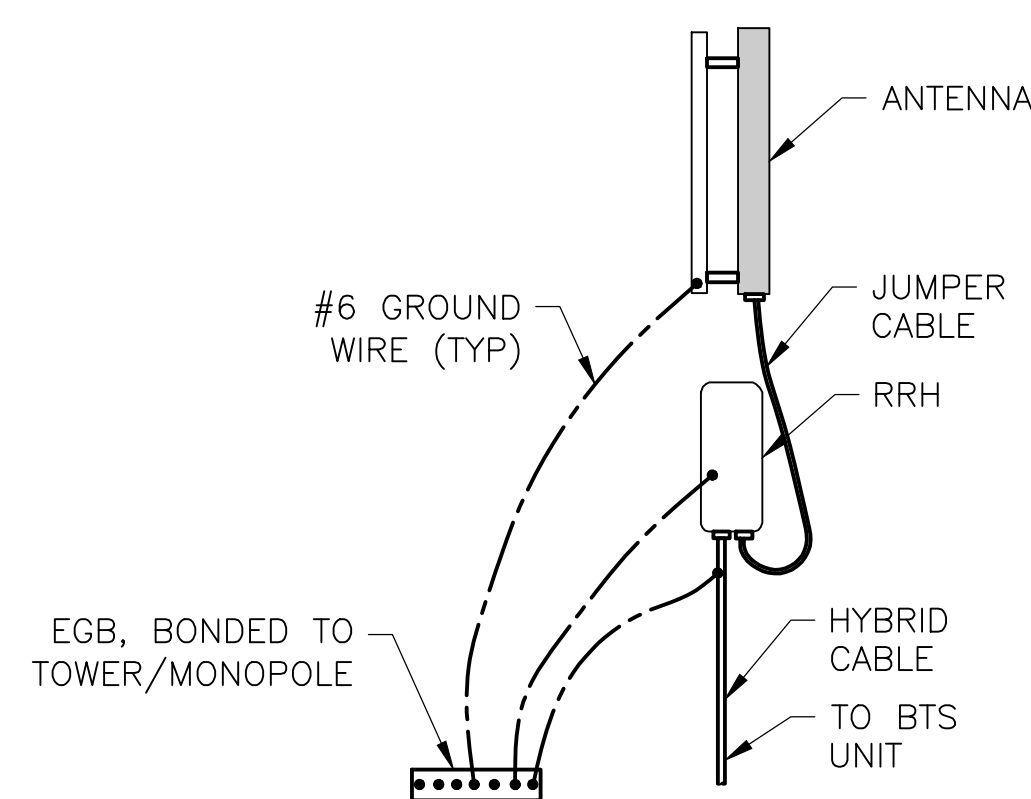

2 HYBRID CABLE CONNECTION DETAIL
G-1 SCALE: NTS

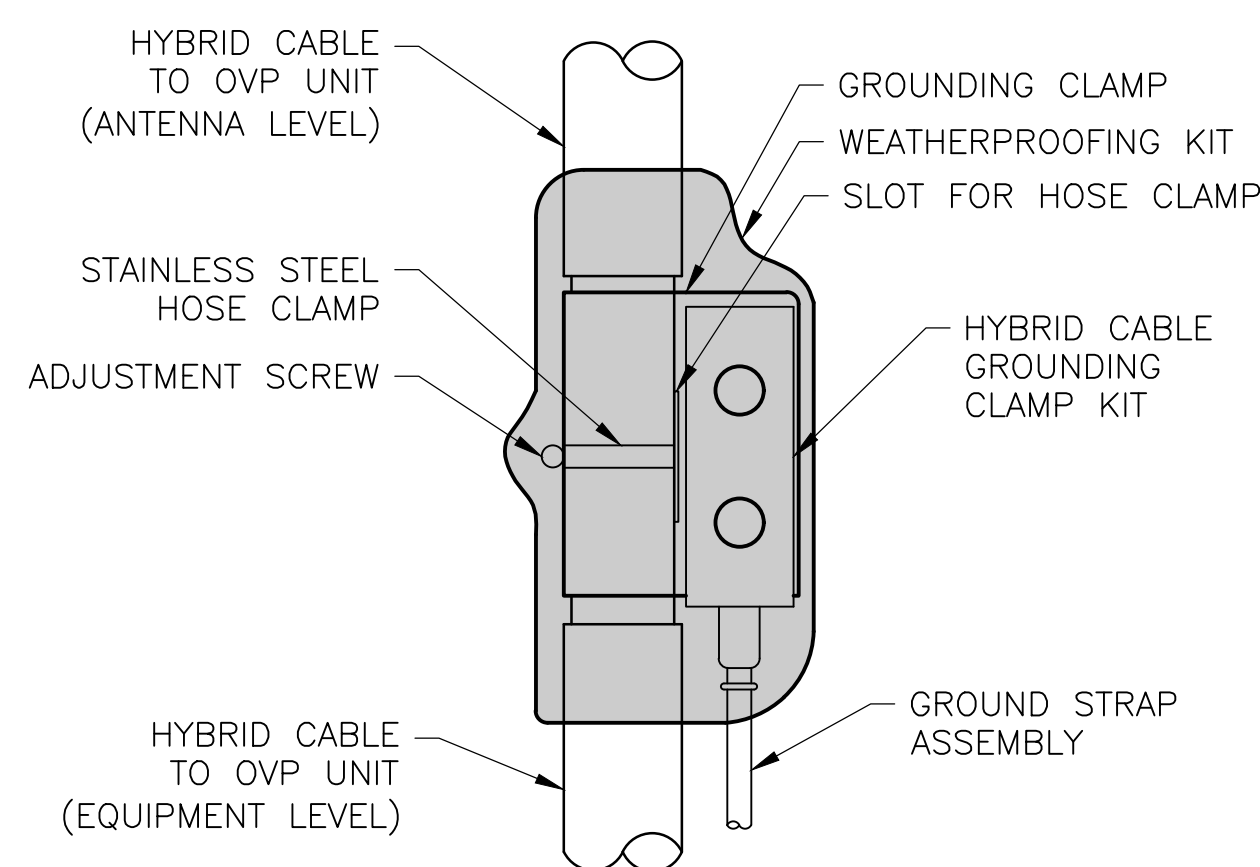

3 HYBRID CABLE GROUNDING DETAIL
G-1 SCALE: NTS

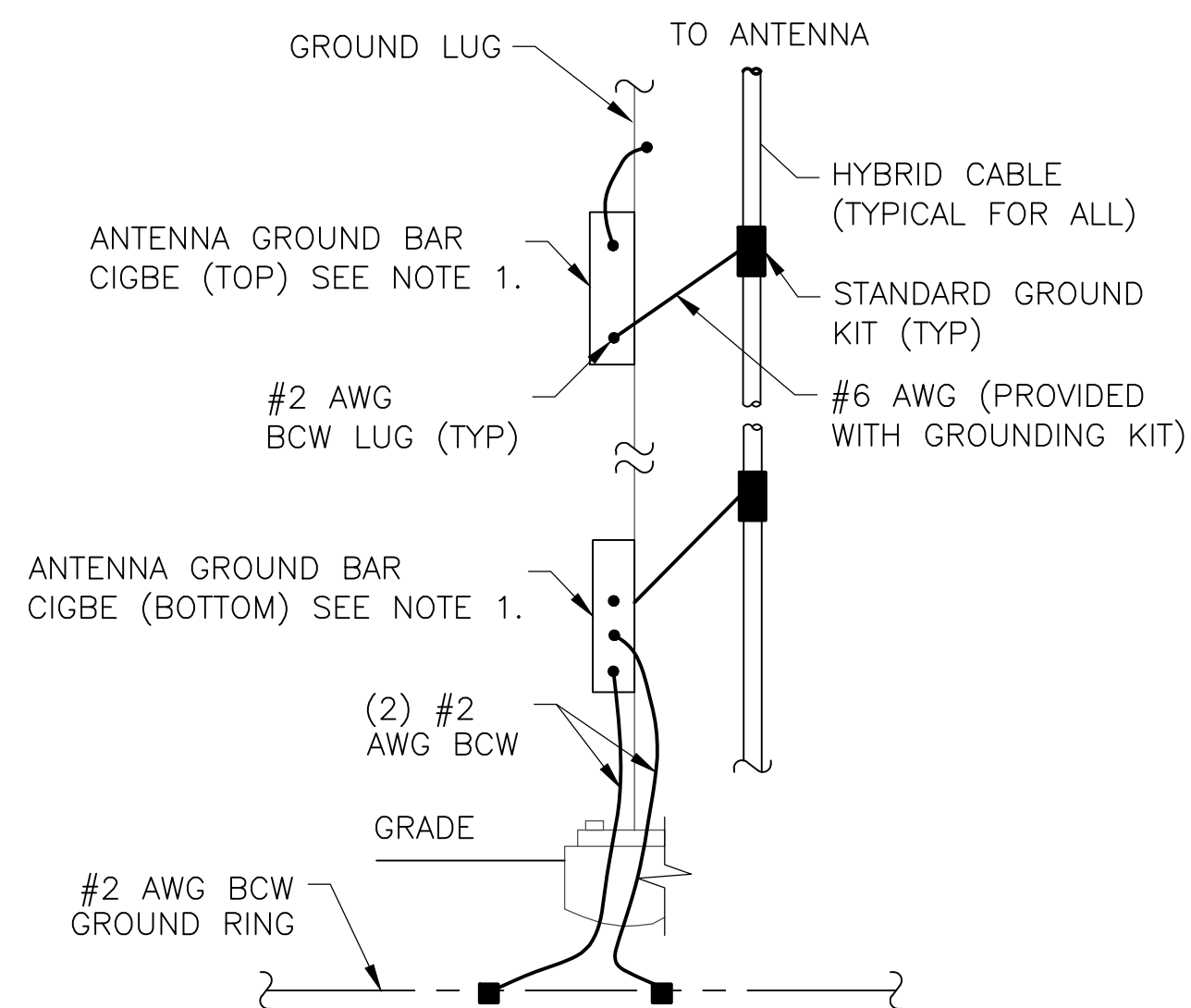

NOTES:
1. NUMBER OF GROUND BARS MAY VARY DEPENDING ON THE TYPE OF TOWER, ANTENNA LOCATION AND CONNECTION ANTENNA LOCATION AND CONNECTION ORIENTATION. PROVIDE AS REQUIRED.
2. A SEPARATE GROUND BAR TO BE USED FOR GPS UNIT IF REQUIRED.

4 ANTENNA CABLE GROUNDING
G-1 SCALE: NTS

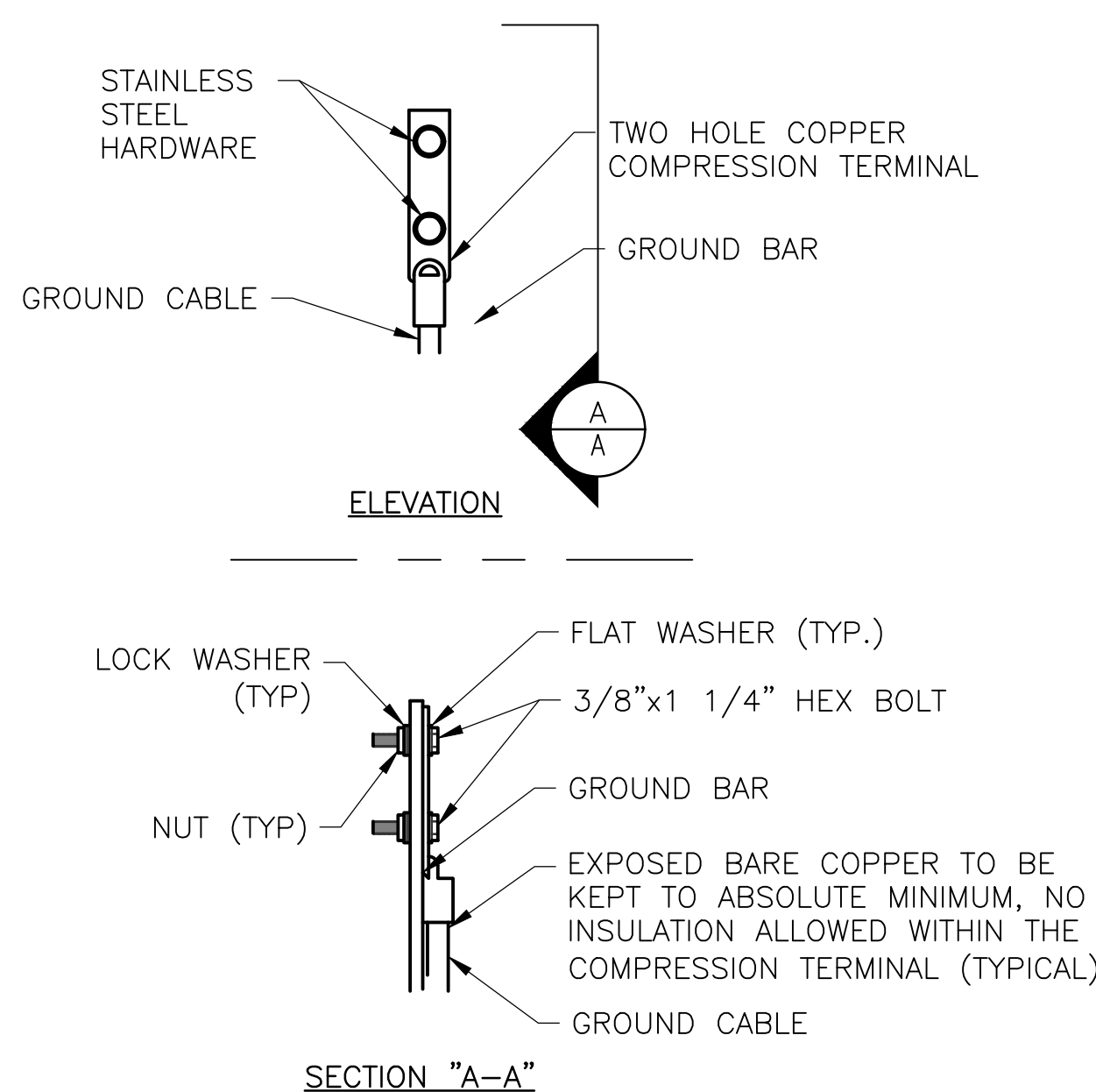

NOTES:
1. "DOUBLING UP" OR "STACKING" OF CONNECTION IS NOT PERMITTED.
2. OXIDE INHIBITING COMPOUND TO BE USED AT ALL LOCATIONS.
3. CADWELD DOWNLEADS FROM UPPER EGB, LOWER EGB AND MGB.
4. ALL GROUND LUGS MUST NE HEAT SHRUNK AT WIRE/LUG CONNECTION.

5 GROUND BAR CONNECTION DETAIL
G-1 SCALE: NTS

GROUNDING NOTES

1. THE ENTIRE ELECTRICAL INSTALLATION SHALL BE GROUNDED AS REQUIRED BY ALL APPLICABLE CODES.
2. ALL GROUNDING WORK SHALL BE IN ACCORDANCE WITH T-MOBILE STANDARD PRACTICE.
3. ALL BUS CONNECTORS SHALL BE TWO-HOLE, LONG-BARREL TYPE COMPRESSION LUGS, T&B OR EQUAL, UNLESS OTHERWISE NOTED ON DRAWINGS. ALL LUGS SHALL BE ATTACHED TO BUSES USING BOLTS, NUTS, AND LOCK WASHERS. NO WASHERS ARE ALLOWED BETWEEN THE ITEMS BEING GROUNDED.
4. ALL CONNECTORS SHALL BE CRIMPED USING HYDRAULIC CRIMPING TOOLS, T&B #TBM 8 OR EQUIVALENT.
5. ALL CONNECTIONS SHALL BE MADE TO BARE METAL. ALL PAINTED SURFACES SHALL BE FILED TO ENSURE PROPER CONTACT. NO WASHERS ARE ALLOWED BETWEEN THE ITEMS BEING GROUNDED. ALL CONNECTIONS ARE TO HAVE A NON-OXIDIZING AGENT APPLIED PRIOR TO INSTALLATION.
6. ALL COPPER BUSES SHALL BE CLEANED, POLISHED, AND A NON-OXIDIZING AGENT APPLIED. NO FINGERPRINTS OR DISCOLORED COPPER WILL BE PERMITTED.
7. ALL BENDS SHALL BE AS SHALLOW AS POSSIBLE, WITH NO TURN SHORTER THAN AN 8-INCH NOMINAL RADIUS.
8. GROUNDING CONDUCTORS SHALL BE SOLID TINNED COPPER AND ANNEALED #2. ALL GROUNDING CONDUCTORS SHALL RUN THROUGH PVC SLEEVES WHEREVER CONDUCTORS RUN THROUGH WALLS, FLOORS, OR CEILINGS. IF CONDUCTORS MUST RUN THROUGH EMT, BOTH ENDS OF CONDUIT SHALL BE GROUNDED. SEAL BOTH ENDS OF CONDUIT WITH SILICONE CAULK.
9. GROUNDING SYSTEM RESISTANCE SHALL NOT EXCEED 10 OHMS. IF THE RESISTANCE VALUE IS EXCEEDED, NOTIFY THE PROJECT MANAGER FOR FURTHER INSTRUCTION ON METHODS FOR REDUCING THE RESISTANCE VALUE.
10. ALL ROOF TOP ANTENNA MOUNTS SHALL BE GROUNDED WITH A #2 GROUND WIRE CONNECTED TO THE NEAREST GROUND BUS. ALL CONNECTIONS ARE TO BE CAD-WELDED IF POSSIBLE.
11. UPON COMPLETION OF WORK, CONDUCT CONTINUITY, SHORT CIRCUIT, AND FALL OF POTENTIAL GROUNDING TESTS FOR APPROVAL. SUBMIT TEST REPORTS TO THE PROJECT MANAGER.
12. GROUNDING CONNECTION TO TRAVEL IN A DOWNWARD DIRECTION.
13. ALL EXPOSED #2 WIRE MUST BE TINN NOT BTW.
14. TECTONIC TAKES NO RESPONSIBILITY OR LIABILITY FOR THE GROUNDING SYSTEM AS SHOWN ON THIS SITE. THIS IS A STANDARD GROUNDING SYSTEM.

COPIES OF THIS DOCUMENT WITHOUT A FACSIMILE OF THE SIGNATURE & AN ORIGINAL EMBOSSED SEAL OR ORIGINAL STAMP IN BLUE OR BLACK INK OF THE PROFESSIONAL ENGINEER OR LAND SURVEYOR SHALL NOT BE CONSIDERED VALID COPIES.
THIS DOCUMENT IS PREPARED SPECIFICALLY FOR THE CLIENT AND PROJECT DESIGNATED HEREON. MODIFICATION, ALTERATION, REVISION, DUPLICATION, OR USE WITHOUT THE CONSENT OF TECTONIC IS STRICTLY PROHIBITED. COPYRIGHT 2019 TECTONIC. ALL RIGHTS RESERVED.

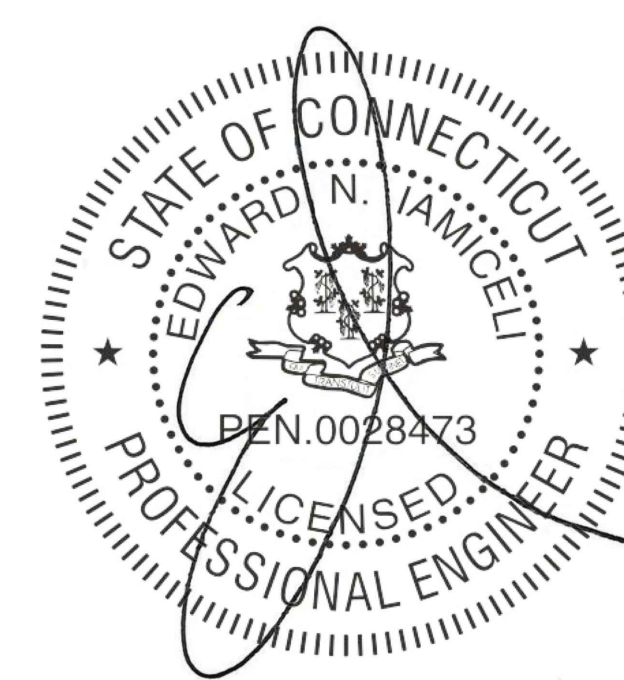

Tectonic
PRACTICAL SOLUTIONS. EXCEPTIONAL SERVICE.
Tectonic Engineering & Surveying Consultants P.C.
70 Pleasant Hill Road Phone: (845) 534-5959
P.O. Box 37 (800) 529-6531
Mountainville, NY 10953 www.tectonicengineering.com
Project Contact Info
1279 Route 300
Newburgh, NY 12550 Phone: (845) 567-6656

Mobile
NORTHEAST, LLC.
35 GRIFFIN ROAD SOUTH
BLOOMFIELD, CT 06002

NSS NORTHEAST
SITE SOLUTIONS
Turnkey Wireless Development

APPROVALS

LANDLORD _____
RF _____
CONSTRUCTION _____
OPERATIONS _____
SITE ACQ. _____

PROJECT NUMBER	DESIGNED BY
9927.CT11077C	JV

REV.	DATE	DESCRIPTION	DRAWN BY
△	07/19/19	ISSUED FOR CONSTRUCTION	BWY
△	07/22/19	REVISED PER COMMENTS	MB
△	08/09/19	REVISED PER COMMENTS	BWY
△	09/17/19	REVISED PER COMMENTS	BWY

ISSUED BY _____ DATE _____

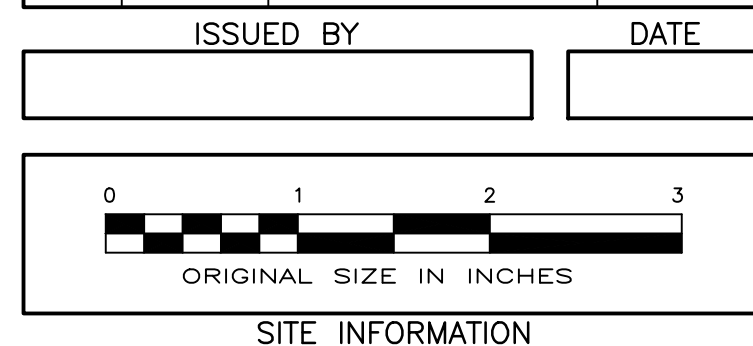

FAIRFIELD FIRE RESCUE #5
CT11077C
3965 CONGRESS STREET
FAIRFIELD COUNTY
FAIRFIELD, CT
06824

SHEET TITLE
GROUNDING DETAILS & NOTES

SHEET NUMBER
G-1

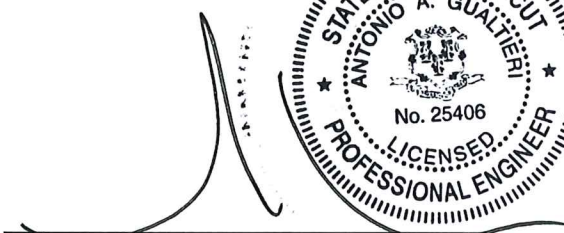

Exhibit D

STRUCTURAL ANALYSIS REPORT

TECTONIC WORK ORDER #: 9927.CT11077C
PROJECT SCOPE OF WORK: T-MOBILE "L600 SCOPE"
SITE TYPE: ANTENNA MOUNT ON 150' MONOPOLE
DATE: August 23, 2019
REVISION #: 4
SITE ID #: CT11077C
SITE NAME: FAIRFIELD FIRE RESCUE #5
SITE ADDRESS: 3965 CONGRESS STREET,
FAIRFIELD, CT 06824

PREPARED FOR: NORTHEAST SITE SOLUTIONS

PASS PASS WITH MODS FAIL
86% UTILIZATION

APPROVED BY:   8-23-19.
ANTONIO A. GUALTIERI, P.E.

Tectonic Engineering & Surveying Consultants P.C.

1279 Route 300 | Newburgh, NY 12550
845.567.6656 Tel | 845.567.8703 Fax

tectonicengineering.com
Equal Opportunity Employer

dba, Tectonic Engineering & Surveying Consultants P.C.
70 Pleasant Hill Road, PO Box 37 | Mountainville, NY 10953

Project Information

P.O. Number: 020CT11000C
 Client: T-Mobile Northeast Site Solutions
 Site Name: Fairfield Fire Rescue #
 Owner: Town of Fairfield
 Address: 300 Congress Street
 City, State, Zip: Fairfield, CT 06424
 FCC Registration Number:
 County: Fairfield
 Report Date: 8/23/18
 Revision: 4

Structure Information

Structure Type: Monopole
 Structure Height: 100 ft
 Manufacturer: Valmont
 Year Built: 1004
 Original Drawings: Structure: 0, Foundation: 0
 Previous Analysis: Yes
 Documents provided:

Item	By	Date
Original Tower and Foundation Design Report	Paul Ford Company	3/28/14 R2
Previous Structural Analysis Report	Paul Ford Company	4/21/12, 12/1/13
Version Wireless Load Letter	Robinson Cole	1/22/11
Previous Structural Analysis Report	DeBerry Engineers, Inc.	1/2/11
Antenna/Coax Verification / Mount Mapping Report	Hightower Solutions	CT1100C
RFDS	T-Mobile	CT1100C
Construction Drawings Rev 1	Tectonic Engineering	020CT11000C

Inspection

Type: Limited visual inspection from ground.
 Tower Climb
 Date: 1/1/18
 General Condition:
 Tower: Good
 Foundation: Good
 Observations: None
 Finish: Galvanized
 Condition: Intact

Existing T-Mobile Installation

Height (ft.)	Carrier	Qty	Manuf.	Model	Mount	Comment
11	T-Mobile	3	Ericsson	APX16DWV-16DWV-S-E-A20	LoProfile Platform	To Be Removed
				Tin Style TM		To Remain

Height (ft.)	Qty	Com. Size	Location/Support
11	12	1 1/4" Coax	Existing to remain along the exterior of the pole

Proposed T-Mobile Installation

T-Mobile is proposing to replace all three (3) of the existing panel antennas with six (6) newer model antennas and associated appurtenances. The final T-Mobile configuration upon this installation will be as follows:

Height (ft.)	Carrier	Qty	Manuf.	Model	Mount	Location
11	T-Mobile	3	Ericsson	AIR32 KRD901146-1_B66A_B2A	Existing LoProfile Platform w/ Handrail Kit (SitePro1 HRK12 or approved equal)	Face A, B, and C
				Tin Style TM		
		3	RFS	APXVAARR24_43-U-NA20		
		3	Ericsson	RRU 4449 B71+B12		

Height (ft.)	Qty	Com. Size	Location/Support
11	12	1 1/4" Coax	Existing to remain along the exterior of the pole
11	2	6x12 Hybriflex	Proposed to be routed along the exterior of the pole

Project Number: 2019CT11000C	Report Date: 8/23/19
Client: T-Mobile Northeast Site Solutions	Revision: 4
Site Name: Fairfield Fire Rescue #	

Analysis Criteria

Design Standard: ASCE 7-10
 Building Code: 2018 Connecticut State Building Code

	Capacity (no ice)	Capacity with ice	Service
Wind Speed	120 mph	120 mph	120 mph
Basic Ice Thickness	0 inch	0 inch	0 inch

This analysis has been performed in accordance with the 2018 Connecticut State Building Code based upon an ultimate 3-second gust wind speed of 120 mph converted to a nominal 3-second gust wind speed of 100 mph per Section 1609.3 and Appendix A as required for use in the ASCE 7-10 Standard per Exception #1 of Section 1609.1.1. Exposure Category C with a maximum topographic factor, K_t, of 1.0 and Risk Category II was used in this analysis.

Structure Class: 2 Seismic: 0
 Exposure Category: B
 Topo Category: 1 Crest Height: 0 ft

- Assumptions:
- The monopole and foundation were designed, manufactured, and constructed in accordance with the approved design drawings and applicable codes and standards in effect at the time.
 - The slip jointed splices were assembled in accordance with the manufacturer's specs.
 - The tower and foundation have been properly maintained in accordance with industry standards.
 - The tower is considered to be used for non-emergency services and therefore, structure class II has been used for the analysis.
 - The weight and wind area of certain appurtenances have been estimated.
 - The existing tower modifications have been installed in accordance with the original design drawings. The connections have been adequately designed to develop the full capacity of the reinforcing members.
 - The foundation geometry and geotechnical values are based solely on the previous analysis report by Paul J. Ford Company, referenced above.
 - The reserved T₁T loading at the 120 level is based on the previous analysis report by DeBerry, referenced above.
 - The reserved Verizon wireless loading at the 80 level is based on the letter by Robinson Cole and the previous analysis report by Paul J. Ford Company, referenced above.

Analysis Results

Tower Members

Element	% Usage
Pole Shaft	4
Pole Reinforcement	8
Anchor Bolts	8
Base Plate	4
Base Foundation	4
Base Foundation Soil Interaction	8
Loop Profile Platform	83
Platform Connections	4

Service Load Deformations (Max)

Type	Actual	Allowable	% of Allowable
Tower Horizontal (in)	2.00	4.00	38%
Tilt or Sway (deg)	1.11	4.00	28%

Foundation Reactions (Envelope)

Axial	2 kips
Shear	44 kips
Moment	412 k-ft

For detailed information, see the attached tnxTower output.

Conclusions

Based on our analysis, the existing tower and its foundation **have adequate capacity** to support the proposed T-Mobile installation and the reserved T₁T and Verizon loading as described herein in accordance with current code requirements.

The existing loop profile platform and its connections **will have adequate capacity** to support the proposed T-Mobile installation as described herein in accordance with current code requirements. **In order for the results of this analysis to be valid, a handrail kit (SitePro1 #HRK12, or approved equal) and new HSS2.875x0.203 corner mounting pipes must be installed prior to the installation of the proposed equipment. See Construction Drawings by Tectonic for more details.**

This analysis is based on a limited visual inspection from the ground, an antenna/coax verification mount mapping report, and the information provided by the client. Any further changes to the antenna configuration or other appurtenances should be reviewed with respect to their effect on structural loads prior to implementation. If the existing conditions are not as represented in this report, the design engineer should be immediately notified prior to construction.

Prepared by: Ian Marinaccio, PE
 Project Engineer

Submitted By: Antonio A. Gualtieri
 Antonio A. Gualtieri, P.E.
 Executive Vice President

Date: 8/23/19

(APPENDIX N) MUNICIPALITY - SPECIFIC STRUCTURAL DESIGN PARAMETERS

Municipality	Ground Snow Load (psf)	MCE Spectral Acceleration s (%g)		Wind Design Parameters								
		S _s	S ₁	Ultimate Design Wind Speeds, V _{ult} (mph)			Nominal Design Wind Speeds, V _{asd} (mph)			Wind-Borne Debris Regions ¹		Hurricane-Prone Regions
				Risk Cat. I	Risk Cat. II	Risk Cat III-IV	Risk Cat. I	Risk Cat. II	Risk Cat. III-IV	Risk Cat. II & III except Occup I-2	Risk Cat III Occup I-2 & Risk Cat. IV	
East Hampton	30	0.177	0.062	120	130	140	93	101	108			Yes
East Hartford	30	0.180	0.064	115	125	135	89	97	105			Yes
East Haven	30	0.182	0.062	120	130	140	93	101	108		Type B	Yes
East Lyme	30	0.164	0.059	125	135	145	97	105	112	Type B	Type A	Yes
Easton	30	0.215	0.066	110	120	130	85	93	101			Yes
East Windsor	35	0.177	0.064	115	125	135	89	97	105			Yes
Ellington	35	0.176	0.064	115	125	135	89	97	105			Yes
Enfield	35	0.176	0.065	110	125	130	85	97	101			Yes
Essex	30	0.168	0.059	120	135	145	93	105	112		Type A	Yes
Fairfield	30	0.215	0.065	115	125	135	89	97	105		Type B	Yes
Farmington	35	0.183	0.064	115	125	135	89	97	105			Yes
Franklin	30	0.171	0.061	120	130	140	93	101	108		Type A	Yes
Glastonbury	30	0.180	0.063	115	125	135	89	97	105			Yes
Goshen	40	0.181	0.065	105	115	125	81	89	97			
Granby	35	0.176	0.065	110	120	130	85	93	101			Yes
Greenwich	30	0.259	0.070	110	120	130	85	93	101			Yes
Griswold	30	0.168	0.060	125	135	145	97	105	112		Type A	Yes
Groton	30	0.160	0.058	125	135	145	97	105	112	Type B	Type A	Yes
Guilford	30	0.176	0.061	120	130	140	93	101	108		Type B	Yes
Haddam	30	0.175	0.061	120	130	140	93	101	108			Yes
Hamden	30	0.185	0.063	115	125	135	89	97	105			Yes
Hampton	35	0.172	0.062	120	130	140	93	101	108			Yes
Hartford	30	0.181	0.064	115	125	135	89	97	105			Yes
Hartland	40	0.175	0.065	110	120	125	85	93	97			Yes
Harwinton	35	0.183	0.065	110	120	130	85	93	101			Yes
Hebron	30	0.177	0.063	120	130	140	93	101	108			Yes
Kent	40	0.188	0.065	105	115	120	81	89	93			
Killingly	40	0.171	0.062	120	130	140	93	101	108			Yes
Killingworth	30	0.173	0.061	120	130	140	93	101	108			Yes
Lebanon	30	0.173	0.062	120	130	140	93	101	108			Yes
Ledyard	30	0.163	0.059	125	135	145	97	105	112		Type A	Yes
Lisbon	30	0.169	0.061	125	135	145	97	105	112		Type A	Yes
Litchfield	40	0.184	0.065	110	120	125	85	93	97			Yes
Lyme	30	0.164	0.059	125	135	145	97	105	112		Type A	Yes
Madison	30	0.173	0.060	120	130	140	93	101	108		Type B	Yes
Manchester	30	0.178	0.064	115	125	135	89	97	105			Yes
Mansfield	35	0.173	0.062	120	130	140	93	101	108			Yes
Marlborough	30	0.177	0.062	120	130	140	93	101	108			Yes
Meriden	30	0.183	0.063	115	125	135	89	97	105			Yes
Middlebury	35	0.191	0.064	110	120	130	85	93	101			Yes
Middlefield	30	0.181	0.063	115	125	135	89	97	105			Yes
Middletown	30	0.180	0.063	115	130	135	89	101	105			Yes
Milford	30	0.194	0.063	115	125	135	89	97	105		Type B	Yes
Monroe	30	0.205	0.065	110	120	130	85	93	101			Yes

TOWER ANALYSIS

DESIGNED APPURTENANCE LOADING

TYPE	ELEVATION	TYPE	ELEVATION
10' x 1.5" Dia Dipole	149	RADIO 4415 B30	127
10' x 1.5" Dia Dipole	149	RRUS 4449 B5/B12	127
12' x 3" Dia Omni	149	RRUS 4449 B5/B12	127
13' T-Arms	149	RRUS 4449 B5/B12	127
(4) 2" STD Pipe (2.375 OD)x6'-0"	149	DC6-48-60-18-8F	127
(4) 2" STD Pipe (2.375 OD)x6'-0"	149	AIR 32 B66Aa B2a w/ Mount Pipe	116
(4) 2" STD Pipe (2.375 OD)x6'-0"	149	AIR 32 B66Aa B2a w/ Mount Pipe	116
RRUS A2 B13	138	SitePro1 HRK12 Handrail kit	116
RRUS A2 B13	138	13' Low-Profile Platform	116
RRUS A2 B13	138	(2) RADIO 4449 B12/B71	116
RRUS 32 B30	138	RADIO 4449 B12/B71	116
RRUS 32 B30	138	(4) Twin Style TMA	116
RRUS 32 B30	138	(2) Twin Style TMA	116
DT465B-2XR-V2 w/ Mount Pipe	138	(2) APXVARR24_43-C-NA20 w/ Mount Pipe	116
DT465B-2XR-V2 w/ Mount Pipe	138	APXVARR24_43-C-NA20 w/ Mount Pipe	116
DT465B-2XR-V2 w/ Mount Pipe	138	AIR 32 B66Aa B2a w/ Mount Pipe	116
APXVSPP18-C-A20_TIA w/ Mount Pipe	138	(2) Collar Mount	106
APXVSPP18-C-A20_TIA w/ Mount Pipe	138	(2) Collar Mount	105
APXVSPP18-C-A20_TIA w/ Mount Pipe	138	6' Standoff	104
APXVSPP18-C-A20_TIA w/ Mount Pipe	138	6' Standoff	104
FD-RRH-2x50-800	138	8' x 2" Dia Dipole	104
FD-RRH-2x50-800	138	15'x1.25" Dia Whips	104
FD-RRH-2x50-800	138	20' x 2" Dia Whips	104
RRH4X45-19	138	20' x 2" Dia Whips	104
RRH4X45-19	138	6' Standoff	104
RRH4X45-19	138	6' Standoff	104
13' Low-Profile Platform	138	B13 RRH4X30-4R	80
2" STD Pipe (2.375 OD)x6'-0"	138	B25 RRH4X30	80
2" STD Pipe (2.375 OD)x6'-0"	138	B25 RRH4X30	80
2" STD Pipe (2.375 OD)x6'-0"	138	B25 RRH4X30	80
DC6-48-60-18-8F	129	B66A RRH4X45	80
RRUS 11	129	B66A RRH4X45	80
RRUS 11	129	B66A RRH4X45	80
RRUS 11	129	RC3DC-3315-PF-48	80
RRUS 12	129	RC3DC-3315-PF-48	80
RRUS 12	129	13' Low Profile Platform	80
RRUS 12	129	BXA-70063-6CF-EDIN-X w/ Mount Pipe	80
RRU A2	129	(2) NHH-65B-R2B_TIA w/ Mount Pipe	80
RRU A2	129	(2) NHH-65B-R2B_TIA w/ Mount Pipe	80
Collar Mount	129	(2) NHH-65B-R2B_TIA w/ Mount Pipe	80
HPA-65R-BUU-H6_TIA w/ Mount Pipe	127	B13 RRH4X30-4R	80
HPA-65R-BUU-H6_TIA w/ Mount Pipe	127	B13 RRH4X30-4R	80
HPA-65R-BUU-H6_TIA w/ Mount Pipe	127	BXA-171063-8BF-EDIN-X w/ Mount Pipe	80
(2) 7770.00 w/ Mount Pipe	127	BXA-171063-8BF-EDIN-X w/ Mount Pipe	80
(2) 7770.00 w/ Mount Pipe	127	BXA-171063-8BF-EDIN-X w/ Mount Pipe	80
(2) 7770.00 w/ Mount Pipe	127	BXA-171063-8BF-EDIN-X w/ Mount Pipe	80
LGP214nn	127	BXA-70063-6CF-EDIN-X w/ Mount Pipe	80
LGP214nn	127	BXA-70063-6CF-EDIN-X w/ Mount Pipe	80
LGP214nn	127	BXA-70063-6CF-EDIN-X w/ Mount Pipe	80
13' Low-Profile Platform	127	BXA-70063-6CF-EDIN-X w/ Mount Pipe	80
80010965_TIA w/ Mount Pipe	127	3' Stand Off	40
80010965_TIA w/ Mount Pipe	127	GPS_A	40
80010965_TIA w/ Mount Pipe	127		
RADIO 4415 B30	127		
RADIO 4415 B30	127		

MATERIAL STRENGTH

GRADE	Fy	Fu	GRADE	Fy	Fu
A572-65	65 ksi	80 ksi			

TOWER DESIGN NOTES

1. Tower designed for Exposure B to the TIA-222-G Standard.
2. Tower designed for a 97 mph basic wind in accordance with the TIA-222-G Standard.
3. Tower is also designed for a 50 mph basic wind with 0.75 in ice. Ice is considered to increase in thickness with height.
4. Deflections are based upon a 60 mph wind.
5. Tower Structure Class II.
6. Topographic Category 1 with Crest Height of 0.00 ft
7. TOWER RATING: 73.9%

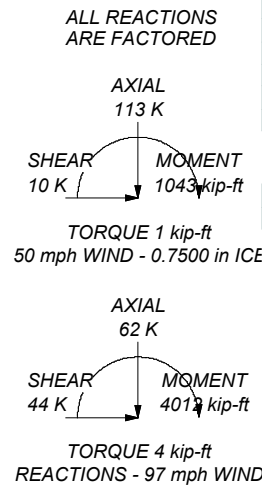

Section	Length (ft)	Number of Sides	Thickness (in)	Socket Length (ft)	Top Dia (in)	Bot Dia (in)	Grade	Weight (K)
1	20.00	12	0.2813		23.6100	27.2500		1.6
2	20.00	12	0.2813		27.2500	30.8900		1.8
3	14.17	12	0.2813	5.17	30.8900	33.4690	A572-65	1.4
4	20.00	12	0.3750		31.9655	35.6055		2.7
5	20.00	12	0.3750		35.6055	39.2455		3.0
6	13.17	12	0.3750	6.17	39.2455	41.6425		2.2
7	20.00	12	0.4375		39.7695	43.4095		3.9
8	4.42	12	0.4375		43.4095	44.2134		0.9
9	14.91	12	0.5800		44.2134	46.9276		4.3
10	14.67	12	0.7000		46.9276	49.5976		5.4
								27.2

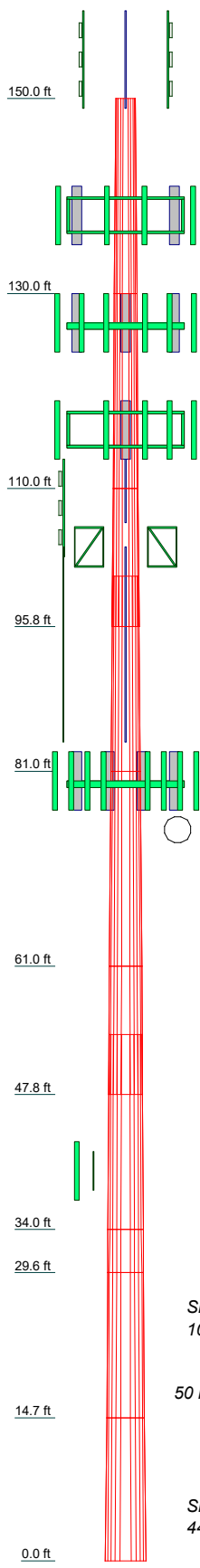

Equivalent Thickness of Reinforced Sections

Tectonic
PRACTICAL SOLUTIONS. EXCEPTIONAL SERVICE.

Tectonic
1279 Route 300
Newburgh, NY 12550
Phone: (845) 567-6656
FAX: (845) 567-8703

Job: **9927.CT11077C, Revision 4**

Project: **150' Monopole**

Client: T-Mobile	Drawn by: Ian Marinaccio	App'd:
Code: TIA-222-G	Date: 08/23/19	Scale: NTS
Path:		Dwg No. E-1

© Newburgh/Phoenix/9927 NSS4-600 proj=CT11077C/Rev 4_VZW/9927.CT11077C_Reinforced.dwg

 <p>Tectonic PRACTICAL SOLUTIONS. EXCEPTIONAL SERVICE.</p> <p>1279 Route 300 Newburgh, NY 12550 Phone: (845) 567-6656 FAX: (845) 567-8703</p>	Job 02CT11C, Revision 4	Page 1 of 23
	Project 1 Monopole	Date 8/23/11
	Client T-Mobile	Designed by Ian Marinaccio

Tower Input Data

The tower is a monopole.

This tower is designed using the TIA-222-G standard.

The following design criteria apply:

- Basic wind speed of 97 mph.
- Structure Class II.
- Exposure Category B.
- Topographic Category 1.
- Crest Height 0.00 ft.
- Nominal ice thickness of 0.7500 in.
- Ice thickness is considered to increase with height.
- Ice density of 56 pcf.
- A wind speed of 50 mph is used in combination with ice.
- Temperature drop of 50 °F.
- Deflections calculated using a wind speed of 60 mph.
- A non-linear (P-delta) analysis was used.
- Pressures are calculated at each section.
- Stress ratio used in pole design is 1.
- Local bending stresses due to climbing loads, feed line supports, and appurtenance mounts are not considered.

Options

- | | | |
|--------------------------------------------------------------------------------------------------------------------------------------------------------------------------------------------------------------------------------------------------------------------------------------------------------------------------------------------------------------------------------------------------------------------------------------------------------------------------------------------------------------------------------------------------------------------------------------------------------|---------------------------------------------------------------------------------------------------------------------------------------------------------------------------------------------------------------------------------------------------------------------------------------------------------------------------------------------------------------------------------------------------------------------------------------------------------------------------------------------------------------------------------------------------------------------------------------------------------------------------------------------------------|-------------------------------------------------------------------------------------------------------------------------------------------------------------------------------------------------------------------------------------------------------------------------------------------------------------------------------------------------------------------------------------------------------------------------------------------------------------------------------------------------------------------------------------------------------------------------------------------------------------------------------------------------------------------------------------------------------------------------------------------------------------------------------------|
| <ul style="list-style-type: none"> Consider Moments - Legs Consider Moments - Horizontals Consider Moments - Diagonals Use Moment Magnification √ Use Code Stress Ratios √ Use Code Safety Factors - Guys Escalate Ice Always Use Max Kz Use Special Wind Profile Include Bolts In Member Capacity Leg Bolts Are At Top Of Section Secondary Horizontal Braces Leg Use Diamond Inner Bracing (4 Sided) SR Members Have Cut Ends SR Members Are Concentric | <ul style="list-style-type: none"> Distribute Leg Loads As Uniform Assume Legs Pinned √ Assume Rigid Index Plate √ Use Clear Spans For Wind Area Use Clear Spans For KL/r Retention Guys To Initial Tension √ Bypass Mast Stability Checks √ Use Azimuth Dish Coefficients √ Project Wind Area of Appurt. Autocalc Torque Arm Areas Add IBC .6D+W Combination Sort Capacity Reports By Component Triangulate Diamond Inner Bracing Treat Feed Line Bundles As Cylinder Ignore KL/ry For 60 Deg. Angle Legs | <ul style="list-style-type: none"> Use ASCE 10 X-Brace Ly Rules Calculate Redundant Bracing Forces Ignore Redundant Members in FEA SR Leg Bolts Resist Compression All Leg Panels Have Same Allowable Offset Girt At Foundation √ Consider Feed Line Torque Include Angle Block Shear Check Use TIA-222-G Bracing Resist. Exemption Use TIA-222-G Tension Splice Exemption <li style="text-align: center;">Poles √ Include Shear-Torsion Interaction Always Use Sub-Critical Flow Use Top Mounted Sockets Pole Without Linear Attachments Pole With Shroud Or No Appurtenances Outside and Inside Corner Radii Are Known |
|--------------------------------------------------------------------------------------------------------------------------------------------------------------------------------------------------------------------------------------------------------------------------------------------------------------------------------------------------------------------------------------------------------------------------------------------------------------------------------------------------------------------------------------------------------------------------------------------------------|---------------------------------------------------------------------------------------------------------------------------------------------------------------------------------------------------------------------------------------------------------------------------------------------------------------------------------------------------------------------------------------------------------------------------------------------------------------------------------------------------------------------------------------------------------------------------------------------------------------------------------------------------------|-------------------------------------------------------------------------------------------------------------------------------------------------------------------------------------------------------------------------------------------------------------------------------------------------------------------------------------------------------------------------------------------------------------------------------------------------------------------------------------------------------------------------------------------------------------------------------------------------------------------------------------------------------------------------------------------------------------------------------------------------------------------------------------|

Tapered Pole Section Geometry

Section	Elevation ft	Section Length ft	Splice Length ft	Number of Sides	Top Diameter in	Bottom Diameter in	Wall Thickness in	Bend Radius in	Pole Grade
L1	150.00-130.00	20.00	0.00	12	23.6100	27.2500	0.2813	1.1252	A572-65 (65 ksi)

Job	0020CT11000C, Revision 4	Page	2 of 23
Project	1000Monopole	Date	08/23/10
Client	T-Mobile	Designed by	Ian Marinaccio

Section	Elevation ft	Section Length ft	Splice Length ft	Number of Sides	Top Diameter in	Bottom Diameter in	Wall Thickness in	Bend Radius in	Pole Grade
L2	130.00-110.00	20.00	0.00	12	27.2500	30.8900	0.2813	1.1252	A572-65 (65 ksi)
L3	110.00-95.83	14.17	5.17	12	30.8900	33.4690	0.2813	1.1252	A572-65 (65 ksi)
L4	95.83-81.00	20.00	0.00	12	31.9655	35.6055	0.3750	1.5000	A572-65 (65 ksi)
L5	81.00-61.00	20.00	0.00	12	35.6055	39.2455	0.3750	1.5000	A572-65 (65 ksi)
L6	61.00-47.83	13.17	6.17	12	39.2455	41.6425	0.3750	1.5000	A572-65 (65 ksi)
L7	47.83-34.00	20.00	0.00	12	39.7695	43.4095	0.4375	1.7500	A572-65 (65 ksi)
L8	34.00-29.58	4.42	0.00	12	43.4095	44.2134	0.4375	1.7500	A572-65 (65 ksi)
L9	29.58-14.67	14.91	0.00	12	44.2134	46.9276	0.5800	2.3200	A572-65 (65 ksi)
L10	14.67-0.00	14.67		12	46.9276	49.5976	0.7000	2.8000	A572-65 (65 ksi)

Equivalent thickness of reinforced section

Tapered Pole Properties

Section	Tip Dia. in	Area in ²	I in ⁴	r in	C in	I/C in ³	J in ⁴	It/Q in ²	w in	w/t
L1	24.3436	21.1308	1467.8550	8.3517	12.2300	120.0211	2974.2723	10.3999	5.5736	19.814
	28.1121	24.4279	2267.7368	9.6548	14.1155	160.6557	4595.0496	12.0227	6.5491	23.282
L2	28.1121	24.4279	2267.7368	9.6548	14.1155	160.6557	4595.0496	12.0227	6.5491	23.282
	31.8805	27.7250	3315.4927	10.9579	16.0010	207.2048	6718.0872	13.6454	7.5246	26.75
L3	31.8805	27.7250	3315.4927	10.9579	16.0010	207.2048	6718.0872	13.6454	7.5246	26.75
	34.5504	30.0610	4226.1315	11.8812	17.3369	243.7645	8563.2881	14.7951	8.2158	29.207
L4	33.9349	38.1455	4858.9305	11.3094	16.5581	293.4473	9845.5105	18.7740	7.5617	20.165
	36.7292	42.5408	6739.5146	12.6125	18.4436	365.4114	13656.0838	20.9373	8.5373	22.766
L5	36.7292	42.5408	6739.5146	12.6125	18.4436	365.4114	13656.0838	20.9373	8.5373	22.766
	40.4976	46.9361	9051.7677	13.9156	20.3292	445.2601	18341.3354	23.1005	9.5128	25.367
L6	40.4976	46.9361	9051.7677	13.9156	20.3292	445.2601	18341.3354	23.1005	9.5128	25.367
	42.9792	49.8304	10831.6861	14.7737	21.5708	502.1460	21947.9327	24.5250	10.1552	27.08
L7	42.1806	55.4090	10941.0287	14.0809	20.6006	531.1023	22169.4904	27.2706	9.4857	21.682
	44.7865	60.5368	14268.4704	15.3840	22.4861	634.5453	28911.7893	29.7944	10.4613	23.911
L8	44.7865	60.5368	14268.4704	15.3840	22.4861	634.5453	28911.7893	29.7944	10.4613	23.911
	45.6187	61.6693	15084.2698	15.6718	22.9025	658.6291	30564.8202	30.3517	10.6767	24.404
L9	45.5684	81.4897	19802.7790	15.6207	22.9025	864.6548	40125.7991	40.1067	10.2948	17.75
	48.3784	86.5588	23732.9550	16.5924	24.3085	976.3232	48089.4011	42.6016	11.0222	19.004
L10	48.3361	104.1970	28421.3139	16.5495	24.3085	1169.1924	57589.2875	51.2826	10.7006	15.287
	51.1002	110.2151	33635.7844	17.5053	25.6915	1309.2164	68155.2183	54.2445	11.4161	16.309

Tower Elevation ft	Gusset Area (per face) ft ²	Gusset Thickness in	Gusset Grade	Adjust. Factor A _f	Adjust. Factor A _r	Weight Mult.	Double Angle Stitch Bolt Spacing Diagonals in	Double Angle Stitch Bolt Spacing Horizontal in	Double Angle Stitch Bolt Spacing Redundants in
L1 150.00-130.00				1	1	1			
L2 130.00-110.00				1	1	1			
L3 110.00-95.83				1	1	1			
L4 95.83-81.00				1	1	1			

Job	0020CT11000C, Revision 4	Page	3 of 23
Project	1000Monopole	Date	082310
Client	T-Mobile	Designed by	Ian Marinaccio

Tower Elevation	Gusset Area (per face)	Gusset Thickness	Gusset Grade	Adjust. Factor A_f	Adjust. Factor A_r	Weight Mult.	Double Angle Stitch Bolt Spacing Diagonals in	Double Angle Stitch Bolt Spacing Horizontals in	Double Angle Stitch Bolt Spacing Redundants in
ft	ft ²	in							
L5 81.00-61.00				1	1	1			
L6 61.00-47.83				1	1	1			
L7 47.83-34.00				1	1	1			
L8 34.00-29.58				1	1	1			
L9 29.58-14.67				1	1	1			
L10 14.67-0.00				1	1	1			

Feed Line/Linear Appurtenances - Entered As Round Or Flat

Description	Sector	Exclude From Torque Calculation	Component Type	Placement ft	Total Number	Number Per Row	Start/End Position	Width or Diameter in	Perimeter in	Weight plf
Black Cable .4"	C	No	Surface Ar (CaAa)	127.00 - 0.00	1	1	0.000 0.000	0.5200		0.14
PWRT-608-S(13/16")	C	No	Surface Ar (CaAa)	127.00 - 0.00	2	2	0.000 0.000	0.8200		0.62
RG-6(1/2")	C	No	Surface Ar (CaAa)	127.00 - 0.00	1	1	0.000 0.000	0.5840		0.15
RG-6(1/2")	C	No	Surface Ar (CaAa)	127.00 - 0.00	1	1	0.000 0.000	0.5840		0.15
*										
RF 1 5/8 inch-50(1-5/8")	C	No	Surface Ar (CaAa)	80.00 - 0.00	12	6	-0.500 -0.300	1.9700		0.97
FLC 114-50J(1-1/4")	C	No	Surface Ar (CaAa)	80.00 - 0.00	2	2	-0.300 -0.000	1.5800		0.70

LCF114-50J(1-1/4")	A	No	Surface Ar (CaAa)	127.00 - 116.00	12	12	-0.250 0.250	1.5800		0.70
LCF114-50J(1-1/4")	A	No	Surface Ar (CaAa)	116.00 - 0.00	24	12	-0.250 0.250	1.5800		0.70
HCS 6X12 4AWG(1-5/8)	A	No	Surface Ar (CaAa)	116.00 - 0.00	2	2	0.000 0.000	1.6600		2.40
Black Cable .32"	A	No	Surface Ar (CaAa)	116.00 - 0.00	1	1	0.000 0.000	0.3150		0.07
**										
Step Bolts	C	No	Surface Ar (CaAa)	140.00 - 12.25	1	1	0.000 0.000	0.3750		2.00
Safety Line 3/8	C	No	Surface Ar (CaAa)	150.00 - 12.25	1	1	0.000 0.000	0.3750		0.22
**										
WT6x25 Reinforcement	A	No	Surface Ar (CaAa)	15.94 - 0.00	1	1	0.000 0.000	8.0000		25.00
WT6x25 Reinforcement	A	No	Surface Ar (CaAa)	15.94 - 0.00	1	1	0.500 0.500	8.0000		25.00
WT6x25 Reinforcement	B	No	Surface Ar (CaAa)	15.94 - 0.00	1	1	0.250 0.250	8.0000		25.00
WT6x25 Reinforcement	C	No	Surface Ar (CaAa)	15.94 - 0.00	1	1	0.000 0.000	8.0000		25.00
WT6x25 Reinforcement	A	No	Surface Ar (CaAa)	31.00 - 0.00	1	1	-0.250 -0.250	8.0000		25.00
WT6x25 Reinforcement	A	No	Surface Ar (CaAa)	31.00 - 0.00	1	1	0.250 0.250	8.0000		25.00
WT6x25 Reinforcement	B	No	Surface Ar (CaAa)	31.00 - 0.00	1	1	0.000 0.000	8.0000		25.00

Job	0020CT11000C, Revision 4	Page	4 of 23
Project	1000Monopole	Date	082310
Client	T-Mobile	Designed by	Ian Marinaccio

Description	Sector	Exclude From Torque Calculation	Component Type	Placement ft	Total Number	Number Per Row	Start/End Position	Width or Diameter in	Perimeter in	Weight plf
WT6x25 Reinforcement	C	No	Surface Ar (CaAa)	31.00 - 0.00	1	1	0.250 0.250	8.0000		25.00

Feed Line/Linear Appurtenances - Entered As Area

Description	Face or Leg	Allow Shield	Exclude From Torque Calculation	Component Type	Placement ft	Total Number		CAAA ft ² /ft	Weight plf
*									
AVA5-50(7/8")	C	No	No	Inside Pole	104.00 - 0.00	3	No Ice 1/2" Ice 1" Ice	0.00 0.00 0.00	0.30 0.30 0.30
AVA5-50(7/8")	C	No	No	Inside Pole	149.00 - 0.00	2	No Ice 1/2" Ice 1" Ice	0.00 0.00 0.00	0.30 0.30 0.30
LCF114-50J(1-1/4")	C	No	No	Inside Pole	149.00 - 0.00	1	No Ice 1/2" Ice 1" Ice	0.00 0.00 0.00	0.70 0.70 0.70
*									
FLC 12-50J(1/2")	C	No	No	Inside Pole	138.00 - 0.00	1	No Ice 1/2" Ice 1" Ice	0.00 0.00 0.00	0.17 0.17 0.17
1" Rigid Conduit	C	No	No	Inside Pole	138.00 - 0.00	1	No Ice 1/2" Ice 1" Ice	0.00 0.00 0.00	0.50 0.50 0.50
FLC 114-50J(1-1/4")	C	No	No	Inside Pole	138.00 - 0.00	3	No Ice 1/2" Ice 1" Ice	0.00 0.00 0.00	0.70 0.70 0.70

Feed Line/Linear Appurtenances Section Areas

Tower Section	Tower Elevation ft	Face	A _R ft ²	A _F ft ²	C _A A _A In Face ft ²	C _A A _A Out Face ft ²	Weight K
L1	150.00-130.00	A	0.000	0.000	0.000	0.000	0.00
		B	0.000	0.000	0.000	0.000	0.00
		C	0.000	0.000	1.125	0.000	0.07
L2	130.00-110.00	A	0.000	0.000	34.413	0.000	0.22
		B	0.000	0.000	0.000	0.000	0.00
		C	0.000	0.000	7.158	0.000	0.15
L3	110.00-95.83	A	0.000	0.000	32.017	0.000	0.31
		B	0.000	0.000	0.000	0.000	0.00
		C	0.000	0.000	5.779	0.000	0.12
L4	95.83-81.00	A	0.000	0.000	33.508	0.000	0.32
		B	0.000	0.000	0.000	0.000	0.00
		C	0.000	0.000	6.048	0.000	0.13
L5	81.00-61.00	A	0.000	0.000	45.190	0.000	0.43
		B	0.000	0.000	0.000	0.000	0.00
		C	0.000	0.000	36.618	0.000	0.43
L6	61.00-47.83	A	0.000	0.000	29.758	0.000	0.29

Job	02CT11C, Revision 4	Page	1 of 23
Project	1 Monopole	Date	8/23/11
Client	T-Mobile	Designed by	Ian Marinaccio

Tower Section	Tower Elevation ft	Face	A _R ft ²	A _F ft ²	C _{AA} In Face ft ²	C _{AA} Out Face ft ²	Weight K
L7	47.83-34.00	B	0.000	0.000	0.000	0.000	0.00
		C	0.000	0.000	25.099	0.000	0.29
		A	0.000	0.000	31.249	0.000	0.30
L8	34.00-29.58	B	0.000	0.000	0.000	0.000	0.00
		C	0.000	0.000	26.357	0.000	0.30
		A	0.000	0.000	12.246	0.000	0.17
L9	29.58-14.67	B	0.000	0.000	1.133	0.000	0.04
		C	0.000	0.000	9.551	0.000	0.13
		A	0.000	0.000	59.590	0.000	1.13
L10	14.67-0.00	B	0.000	0.000	12.947	0.000	0.40
		C	0.000	0.000	41.368	0.000	0.73
		A	0.000	0.000	80.091	0.000	1.78
		B	0.000	0.000	23.472	0.000	0.73
		C	0.000	0.000	50.511	0.000	1.03

Feed Line/Linear Appurtenances Section Areas - With Ice

Tower Section	Tower Elevation ft	Face or Leg	Ice Thickness in	A _R ft ²	A _F ft ²	C _{AA} In Face ft ²	C _{AA} Out Face ft ²	Weight K
L1	150.00-130.00	A	1.733	0.000	0.000	0.000	0.000	0.00
		B		0.000	0.000	0.000	0.000	0.00
		C		0.000	0.000	11.523	0.000	0.21
L2	130.00-110.00	A	1.706	0.000	0.000	54.829	0.000	0.88
		B		0.000	0.000	0.000	0.000	0.00
		C		0.000	0.000	46.163	0.000	0.68
L3	110.00-95.83	A	1.681	0.000	0.000	56.579	0.000	1.01
		B		0.000	0.000	0.000	0.000	0.00
		C		0.000	0.000	36.126	0.000	0.52
L4	95.83-81.00	A	1.655	0.000	0.000	59.214	0.000	1.06
		B		0.000	0.000	0.000	0.000	0.00
		C		0.000	0.000	37.809	0.000	0.55
L5	81.00-61.00	A	1.619	0.000	0.000	78.997	0.000	1.39
		B		0.000	0.000	0.000	0.000	0.00
		C		0.000	0.000	100.412	0.000	1.61
L6	61.00-47.83	A	1.577	0.000	0.000	51.629	0.000	0.89
		B		0.000	0.000	0.000	0.000	0.00
		C		0.000	0.000	66.911	0.000	1.06
L7	47.83-34.00	A	1.532	0.000	0.000	54.217	0.000	0.94
		B		0.000	0.000	0.000	0.000	0.00
		C		0.000	0.000	70.265	0.000	1.11
L8	34.00-29.58	A	1.494	0.000	0.000	20.173	0.000	0.41
		B		0.000	0.000	1.557	0.000	0.06
		C		0.000	0.000	23.360	0.000	0.40
L9	29.58-14.67	A	1.441	0.000	0.000	92.263	0.000	2.30
		B		0.000	0.000	17.610	0.000	0.67
		C		0.000	0.000	89.829	0.000	1.78
L10	14.67-0.00	A	1.289	0.000	0.000	116.635	0.000	3.19
		B		0.000	0.000	31.038	0.000	1.16
		C		0.000	0.000	90.956	0.000	2.05

Feed Line Center of Pressure



1279 Route 300
Newburgh, NY 12550
Phone: (845) 567-6656
FAX: (845) 567-8703

Job	002 CT11 C, Revision 4	Page	1 of 23
Project	1 Monopole	Date	8/23/11
Client	T-Mobile	Designed by	Ian Marinaccio

Section	Elevation	CP _x	CP _z	CP _x	CP _z
	ft	in	in	Ice in	Ice in
L1	150.00-130.00	0.0000	0.3275	0.0000	2.1212
L2	130.00-110.00	-5.1274	-1.7913	-3.9104	1.3412
L3	110.00-95.83	-6.3146	-2.4148	-5.0222	0.5888
L4	95.83-81.00	-6.4781	-2.4725	-5.2297	0.6257
L5	81.00-61.00	-2.7583	0.9179	-2.2306	2.9768
L6	61.00-47.83	-2.7038	1.0937	-2.2292	3.1991
L7	47.83-34.00	-2.7608	1.1137	-2.2963	3.2922
L8	34.00-29.58	-3.0793	0.5809	-2.7647	2.7804
L9	29.58-14.67	-3.8289	-0.1898	-3.4432	1.8359
L10	14.67-0.00	-3.0376	-0.9197	-2.9451	0.4563

Note: For pole sections, center of pressure calculations do not consider feed line shielding.

Shielding Factor Ka

Tower Section	Feed Line Record No.	Description	Feed Line Segment Elev.	K _a No Ice	K _a Ice
L1	22	Step Bolts	130.00 - 140.00	1.0000	1.0000
L1	23	Safety Line 3/8	130.00 - 150.00	1.0000	1.0000
L2	1	Black Cable .4"	110.00 - 127.00	1.0000	1.0000
L2	2	PWRT-608-S(13/16")	110.00 - 127.00	1.0000	1.0000
L2	3	RG-6(1/2")	110.00 - 127.00	1.0000	1.0000
L2	4	RG-6(1/2")	110.00 - 127.00	1.0000	1.0000
L2	17	LCF114-50J(1-1/4")	116.00 - 127.00	1.0000	1.0000
L2	18	LCF114-50J(1-1/4")	110.00 - 116.00	1.0000	1.0000
L2	19	HCS 6X12 4AWG(1-5/8)	110.00 - 116.00	1.0000	1.0000
L2	20	Black Cable .32"	110.00 - 116.00	1.0000	1.0000
L2	22	Step Bolts	110.00 - 130.00	1.0000	1.0000
L2	23	Safety Line 3/8	110.00 - 130.00	1.0000	1.0000
L3	1	Black Cable .4"	95.83 - 110.00	1.0000	1.0000
L3	2	PWRT-608-S(13/16")	95.83 - 110.00	1.0000	1.0000
L3	3	RG-6(1/2")	95.83 - 110.00	1.0000	1.0000
L3	4	RG-6(1/2")	95.83 - 110.00	1.0000	1.0000
L3	18	LCF114-50J(1-1/4")	95.83 - 110.00	1.0000	1.0000
L3	19	HCS 6X12 4AWG(1-5/8)	95.83 - 110.00	1.0000	1.0000
L3	20	Black Cable .32"	95.83 - 110.00	1.0000	1.0000
L3	22	Step Bolts	95.83 - 110.00	1.0000	1.0000
L3	23	Safety Line 3/8	95.83 - 110.00	1.0000	1.0000
L5	1	Black Cable .4"	61.00 - 81.00	1.0000	1.0000
L5	2	PWRT-608-S(13/16")	61.00 - 81.00	1.0000	1.0000
L5	3	RG-6(1/2")	61.00 - 81.00	1.0000	1.0000
L5	4	RG-6(1/2")	61.00 - 81.00	1.0000	1.0000



PRACTICAL SOLUTIONS. EXCEPTIONAL SERVICE.

1279 Route 300
Newburgh, NY 12550
Phone: (845) 567-6656
FAX: (845) 567-8703

Job	0020CT11000C, Revision 4	Page	0 of 23
Project	1000Monopole	Date	08/23/10
Client	T-Mobile	Designed by	Ian Marinaccio

Tower Section	Feed Line Record No.	Description	Feed Line Segment Elev.	K _a No Ice	K _a Ice
L5	10	RF 1 5/8 inch-50(1-5/8")	61.00 - 80.00	1.0000	1.0000
L5	11	FLC 114-50J(1-1/4")	61.00 - 80.00	1.0000	1.0000
L5	18	LCF114-50J(1-1/4")	61.00 - 81.00	1.0000	1.0000
L5	19	HCS 6X12 4AWG(1-5/8)	61.00 - 81.00	1.0000	1.0000
L5	20	Black Cable .32"	61.00 - 81.00	1.0000	1.0000
L5	22	Step Bolts	61.00 - 81.00	1.0000	1.0000
L5	23	Safety Line 3/8	61.00 - 81.00	1.0000	1.0000
L6	1	Black Cable .4"	47.83 - 61.00	1.0000	1.0000
L6	2	PWRT-608-S(13/16")	47.83 - 61.00	1.0000	1.0000
L6	3	RG-6(1/2")	47.83 - 61.00	1.0000	1.0000
L6	4	RG-6(1/2")	47.83 - 61.00	1.0000	1.0000
L6	10	RF 1 5/8 inch-50(1-5/8")	47.83 - 61.00	1.0000	1.0000
L6	11	FLC 114-50J(1-1/4")	47.83 - 61.00	1.0000	1.0000
L6	18	LCF114-50J(1-1/4")	47.83 - 61.00	1.0000	1.0000
L6	19	HCS 6X12 4AWG(1-5/8)	47.83 - 61.00	1.0000	1.0000
L6	20	Black Cable .32"	47.83 - 61.00	1.0000	1.0000
L6	22	Step Bolts	47.83 - 61.00	1.0000	1.0000
L6	23	Safety Line 3/8	47.83 - 61.00	1.0000	1.0000
L8	1	Black Cable .4"	29.58 - 34.00	1.0000	1.0000
L8	2	PWRT-608-S(13/16")	29.58 - 34.00	1.0000	1.0000
L8	3	RG-6(1/2")	29.58 - 34.00	1.0000	1.0000
L8	4	RG-6(1/2")	29.58 - 34.00	1.0000	1.0000
L8	10	RF 1 5/8 inch-50(1-5/8")	29.58 - 34.00	1.0000	1.0000
L8	11	FLC 114-50J(1-1/4")	29.58 - 34.00	1.0000	1.0000
L8	18	LCF114-50J(1-1/4")	29.58 - 34.00	1.0000	1.0000
L8	19	HCS 6X12 4AWG(1-5/8)	29.58 - 34.00	1.0000	1.0000
L8	20	Black Cable .32"	29.58 - 34.00	1.0000	1.0000
L8	22	Step Bolts	29.58 - 34.00	1.0000	1.0000
L8	23	Safety Line 3/8	29.58 - 34.00	1.0000	1.0000
L8	29	WT6x25 Reinforcement	29.58 - 31.00	1.0000	1.0000
L8	30	WT6x25 Reinforcement	29.58 - 31.00	1.0000	1.0000
L8	31	WT6x25 Reinforcement	29.58 - 31.00	1.0000	1.0000
L8	32	WT6x25 Reinforcement	29.58 - 31.00	1.0000	1.0000
L9	1	Black Cable .4"	14.67 - 29.58	1.0000	1.0000
L9	2	PWRT-608-S(13/16")	14.67 - 29.58	1.0000	1.0000
L9	3	RG-6(1/2")	14.67 - 29.58	1.0000	1.0000
L9	4	RG-6(1/2")	14.67 - 29.58	1.0000	1.0000
L9	10	RF 1 5/8 inch-50(1-5/8")	14.67 - 29.58	1.0000	1.0000
L9	11	FLC 114-50J(1-1/4")	14.67 - 29.58	1.0000	1.0000
L9	18	LCF114-50J(1-1/4")	14.67 - 29.58	1.0000	1.0000
L9	19	HCS 6X12 4AWG(1-5/8)	14.67 - 29.58	1.0000	1.0000
L9	20	Black Cable .32"	14.67 - 29.58	1.0000	1.0000
L9	22	Step Bolts	14.67 - 29.58	1.0000	1.0000
L9	23	Safety Line 3/8	14.67 - 29.58	1.0000	1.0000
L9	25	WT6x25 Reinforcement	14.67 - 15.94	1.0000	1.0000
L9	26	WT6x25 Reinforcement	14.67 - 15.94	1.0000	1.0000
L9	27	WT6x25 Reinforcement	14.67 - 15.94	1.0000	1.0000
L9	28	WT6x25 Reinforcement	14.67 - 15.94	1.0000	1.0000
L9	29	WT6x25 Reinforcement	14.67 - 29.58	1.0000	1.0000
L9	30	WT6x25 Reinforcement	14.67 - 29.58	1.0000	1.0000
L9	31	WT6x25 Reinforcement	14.67 - 29.58	1.0000	1.0000
L9	32	WT6x25 Reinforcement	14.67 - 29.58	1.0000	1.0000
L10	1	Black Cable .4"	0.00 - 14.67	1.0000	1.0000
L10	2	PWRT-608-S(13/16")	0.00 - 14.67	1.0000	1.0000
L10	3	RG-6(1/2")	0.00 - 14.67	1.0000	1.0000
L10	4	RG-6(1/2")	0.00 - 14.67	1.0000	1.0000
L10	10	RF 1 5/8 inch-50(1-5/8")	0.00 - 14.67	1.0000	1.0000
L10	11	FLC 114-50J(1-1/4")	0.00 - 14.67	1.0000	1.0000
L10	18	LCF114-50J(1-1/4")	0.00 - 14.67	1.0000	1.0000
L10	19	HCS 6X12 4AWG(1-5/8)	0.00 - 14.67	1.0000	1.0000
L10	20	Black Cable .32"	0.00 - 14.67	1.0000	1.0000
L10	22	Step Bolts	12.25 - 14.67	1.0000	1.0000

Job	02 CT11 C, Revision 4	Page	8 of 23
Project	1 Monopole	Date	8/23/11
Client	T-Mobile	Designed by	Ian Marinaccio

Tower Section	Feed Line Record No.	Description	Feed Line Segment Elev.	K _a No Ice	K _a Ice
L10	23	Safety Line 3/8	12.25 - 14.67	1.0000	1.0000
L10	25	WT6x25 Reinforcement	0.00 - 14.67	1.0000	1.0000
L10	26	WT6x25 Reinforcement	0.00 - 14.67	1.0000	1.0000
L10	27	WT6x25 Reinforcement	0.00 - 14.67	1.0000	1.0000
L10	28	WT6x25 Reinforcement	0.00 - 14.67	1.0000	1.0000
L10	29	WT6x25 Reinforcement	0.00 - 14.67	1.0000	1.0000
L10	30	WT6x25 Reinforcement	0.00 - 14.67	1.0000	1.0000
L10	31	WT6x25 Reinforcement	0.00 - 14.67	1.0000	1.0000
L10	32	WT6x25 Reinforcement	0.00 - 14.67	1.0000	1.0000

Discrete Tower Loads

Description	Face or Leg	Offset Type	Offsets: Horz Lateral Vert ft ft ft	Azimuth Adjustment °	Placement ft	C _A A _A Front ft ²	C _A A _A Side ft ²	Weight K	
GPS_A	C	From Leg	4.00	0.0000	40.00	No Ice	0.26	0.26	0.00
			0.00			1/2" Ice	0.32	0.32	0.00
			0.00			1" Ice	0.39	0.39	0.01
3' Stand Off	C	From Leg	2.00	0.0000	40.00	No Ice	0.85	1.67	0.07
			0.00			1/2" Ice	1.14	2.34	0.08
			0.00			1" Ice	1.43	3.01	0.09

BXA-171063-8BF-EDIN-X w/ Mount Pipe	A	From Leg	4.00	0.0000	80.00	No Ice	3.18	3.35	0.03
			0.00			1/2" Ice	3.56	3.97	0.06
			0.00			1" Ice	3.93	4.60	0.10
BXA-171063-8BF-EDIN-X w/ Mount Pipe	B	From Leg	4.00	0.0000	80.00	No Ice	3.18	3.35	0.03
			0.00			1/2" Ice	3.56	3.97	0.06
			0.00			1" Ice	3.93	4.60	0.10
BXA-171063-8BF-EDIN-X w/ Mount Pipe	C	From Leg	4.00	0.0000	80.00	No Ice	3.18	3.35	0.03
			0.00			1/2" Ice	3.56	3.97	0.06
			0.00			1" Ice	3.93	4.60	0.10
BXA-70063-6CF-EDIN-X w/ Mount Pipe	A	From Leg	4.00	0.0000	80.00	No Ice	7.81	5.80	0.04
			0.00			1/2" Ice	8.36	6.95	0.10
			0.00			1" Ice	8.87	7.82	0.17
BXA-70063-6CF-EDIN-X w/ Mount Pipe	B	From Leg	4.00	0.0000	80.00	No Ice	7.81	5.80	0.04
			0.00			1/2" Ice	8.36	6.95	0.10
			0.00			1" Ice	8.87	7.82	0.17
BXA-70063-6CF-EDIN-X w/ Mount Pipe	C	From Leg	4.00	0.0000	80.00	No Ice	7.81	5.80	0.04
			0.00			1/2" Ice	8.36	6.95	0.10
			0.00			1" Ice	8.87	7.82	0.17
(2) NHH-65B-R2B_TIA w/ Mount Pipe	A	From Leg	4.00	0.0000	80.00	No Ice	8.32	7.00	0.07
			0.00			1/2" Ice	8.88	8.19	0.14
			0.00			1" Ice	9.40	9.08	0.21
(2) NHH-65B-R2B_TIA w/ Mount Pipe	B	From Leg	4.00	0.0000	80.00	No Ice	8.32	7.00	0.07
			0.00			1/2" Ice	8.88	8.19	0.14
			0.00			1" Ice	9.40	9.08	0.21
(2) NHH-65B-R2B_TIA w/ Mount Pipe	C	From Leg	4.00	0.0000	80.00	No Ice	8.32	7.00	0.07
			0.00			1/2" Ice	8.88	8.19	0.14
			0.00			1" Ice	9.40	9.08	0.21
B13 RRH4X30-4R	A	From Leg	4.00	0.0000	80.00	No Ice	2.16	1.62	0.06
			0.00			1/2" Ice	2.35	1.79	0.08

Job	0020CT11000C, Revision 4	Page	0 of 23
Project	1000Monopole	Date	08/23/10
Client	T-Mobile	Designed by	Ian Marinaccio

Description	Face or Leg	Offset Type	Offsets:		Azimuth Adjustment	Placement	C _{AA} Front	C _{AA} Side	Weight	
			Horz	Vert						
			ft	ft	°	ft	ft ²	ft ²	K	
B13 RRH4X30-4R	B	From Leg	0.00		0.0000	80.00	1" Ice	2.55	1.97	0.10
			4.00				No Ice	2.16	1.62	0.06
			0.00				1/2" Ice	2.35	1.79	0.08
			0.00				1" Ice	2.55	1.97	0.10
B13 RRH4X30-4R	C	From Leg	4.00		0.0000	80.00	No Ice	2.16	1.62	0.06
			0.00				1/2" Ice	2.35	1.79	0.08
			0.00				1" Ice	2.55	1.97	0.10
			0.00				1" Ice	2.55	1.97	0.10
B25 RRH4X30	A	From Leg	4.00		0.0000	80.00	No Ice	2.20	1.74	0.06
			0.00				1/2" Ice	2.39	1.92	0.08
			0.00				1" Ice	2.59	2.11	0.10
			0.00				1" Ice	2.59	2.11	0.10
B25 RRH4X30	B	From Leg	4.00		0.0000	80.00	No Ice	2.20	1.74	0.06
			0.00				1/2" Ice	2.39	1.92	0.08
			0.00				1" Ice	2.59	2.11	0.10
			0.00				1" Ice	2.59	2.11	0.10
B25 RRH4X30	C	From Leg	4.00		0.0000	80.00	No Ice	2.20	1.74	0.06
			0.00				1/2" Ice	2.39	1.92	0.08
			0.00				1" Ice	2.59	2.11	0.10
			0.00				1" Ice	2.59	2.11	0.10
B66A RRH4X45	A	From Leg	4.00		0.0000	80.00	No Ice	2.58	1.63	0.06
			0.00				1/2" Ice	2.79	1.81	0.08
			0.00				1" Ice	3.01	2.00	0.10
			0.00				1" Ice	3.01	2.00	0.10
B66A RRH4X45	B	From Leg	4.00		0.0000	80.00	No Ice	2.58	1.63	0.06
			0.00				1/2" Ice	2.79	1.81	0.08
			0.00				1" Ice	3.01	2.00	0.10
			0.00				1" Ice	3.01	2.00	0.10
B66A RRH4X45	C	From Leg	4.00		0.0000	80.00	No Ice	2.58	1.63	0.06
			0.00				1/2" Ice	2.79	1.81	0.08
			0.00				1" Ice	3.01	2.00	0.10
			0.00				1" Ice	3.01	2.00	0.10
RC3DC-3315-PF-48	A	From Leg	4.00		0.0000	80.00	No Ice	3.79	2.51	0.03
			0.00				1/2" Ice	4.04	2.72	0.06
			0.00				1" Ice	4.30	2.94	0.10
			0.00				1" Ice	4.30	2.94	0.10
RC3DC-3315-PF-48	C	From Leg	4.00		0.0000	80.00	No Ice	3.79	2.51	0.03
			0.00				1/2" Ice	4.04	2.72	0.06
			0.00				1" Ice	4.30	2.94	0.10
			0.00				1" Ice	4.30	2.94	0.10
13' Low Profile Platform	C	None			0.0000	80.00	No Ice	24.33	24.33	1.65
							1/2" Ice	30.22	30.22	2.03
							1" Ice	36.11	36.11	2.41
							1" Ice	36.11	36.11	2.41

8' x 2" Dia Dipole	C	From Leg	6.00		0.0000	104.00	No Ice	1.60	1.60	0.02
			0.00				1/2" Ice	2.42	2.42	0.03
			4.00				1" Ice	3.24	3.24	0.05
			0.00				1" Ice	3.24	3.24	0.05
15'x1.25" Dia Whips	A	From Leg	6.00		0.0000	104.00	No Ice	1.88	1.88	0.02
			0.00				1/2" Ice	3.39	3.39	0.04
			7.50				1" Ice	4.93	4.93	0.06
			0.00				1" Ice	4.93	4.93	0.06
20' x 2" Dia Whips	C	From Leg	6.00		0.0000	104.00	No Ice	4.00	4.00	0.02
			0.00				1/2" Ice	6.03	6.03	0.05
			-10.00				1" Ice	8.07	8.07	0.09
			0.00				1" Ice	8.07	8.07	0.09
20' x 2" Dia Whips	A	From Leg	6.00		0.0000	104.00	No Ice	4.00	4.00	0.02
			0.00				1/2" Ice	6.03	6.03	0.05
			-10.00				1" Ice	8.07	8.07	0.09
			0.00				1" Ice	8.07	8.07	0.09
6' Standoff	A	From Leg	3.00		0.0000	104.00	No Ice	0.85	1.67	0.07
			0.00				1/2" Ice	1.14	2.34	0.08
			0.00				1" Ice	1.43	3.01	0.09
			0.00				1" Ice	1.43	3.01	0.09
6' Standoff	B	From Leg	3.00		0.0000	104.00	No Ice	0.85	1.67	0.07
			0.00				1/2" Ice	1.14	2.34	0.08
			0.00				1" Ice	1.43	3.01	0.09
			0.00				1" Ice	1.43	3.01	0.09
6' Standoff	C	From Leg	3.00		0.0000	104.00	No Ice	0.85	1.67	0.07
			0.00				1/2" Ice	1.14	2.34	0.08
			0.00				1" Ice	1.43	3.01	0.09
			0.00				1" Ice	1.43	3.01	0.09
6' Standoff	C	From Face	3.00		0.0000	104.00	No Ice	0.85	1.67	0.07
							1/2" Ice	1.14	2.34	0.08
							1" Ice	1.43	3.01	0.09
							1" Ice	1.43	3.01	0.09

Job	0020CT11000C, Revision 4	Page	1 of 23
Project	1000Monopole	Date	08/23/10
Client	T-Mobile	Designed by	Ian Marinaccio

Description	Face or Leg	Offset Type	Offsets:			Azimuth Adjustment	Placement	C _{AA} Front	C _{AA} Side	Weight
			Horz	Vert	Lateral					
			0.00				1/2" Ice	1.14	2.34	0.08
			0.00				1" Ice	1.43	3.01	0.09
(2) Collar Mount	C	None			0.0000	105.00	No Ice	1.14	1.14	0.32
							1/2" Ice	1.49	1.49	0.34
							1" Ice	1.91	1.91	0.37
(2) Collar Mount	C	None			0.0000	106.00	No Ice	1.14	1.14	0.32
							1/2" Ice	1.49	1.49	0.34
							1" Ice	1.91	1.91	0.37

(2) RADIO 4449 B12/B71	B	From Leg	4.00		0.0000	116.00	No Ice	1.65	1.16	0.07
			0.00				1/2" Ice	1.81	1.30	0.09
			0.00				1" Ice	1.98	1.45	0.11
RADIO 4449 B12/B71	C	From Leg	4.00		0.0000	116.00	No Ice	1.65	1.16	0.07
			0.00				1/2" Ice	1.81	1.30	0.09
			0.00				1" Ice	1.98	1.45	0.11
(4) Twin Style TMA	B	From Leg	4.00		0.0000	116.00	No Ice	6.68	3.48	0.07
			0.00				1/2" Ice	7.07	4.12	0.12
			0.00				1" Ice	7.48	4.78	0.18
(2) Twin Style TMA	C	From Leg	4.00		0.0000	116.00	No Ice	6.68	3.48	0.07
			0.00				1/2" Ice	7.07	4.12	0.12
			0.00				1" Ice	7.48	4.78	0.18
(2)	B	From Leg	4.00		0.0000	116.00	No Ice	17.38	10.88	0.12
APXVARR24_43-C-NA20			0.00				1/2" Ice	18.11	12.41	0.24
w/ Mount Pipe			0.00				1" Ice	18.85	13.96	0.37
APXVARR24_43-C-NA20	C	From Leg	4.00		0.0000	116.00	No Ice	17.38	10.88	0.12
w/ Mount Pipe			0.00				1/2" Ice	18.11	12.41	0.24
			0.00				1" Ice	18.85	13.96	0.37
AIR 32 B66Aa B2a w/ Mount Pipe	A	From Leg	4.00		0.0000	116.00	No Ice	6.81	6.14	0.15
			0.00				1/2" Ice	7.30	6.99	0.22
			0.00				1" Ice	7.76	7.73	0.28
AIR 32 B66Aa B2a w/ Mount Pipe	B	From Leg	4.00		0.0000	116.00	No Ice	6.81	6.14	0.15
			0.00				1/2" Ice	7.30	6.99	0.22
			0.00				1" Ice	7.76	7.73	0.28
AIR 32 B66Aa B2a w/ Mount Pipe	C	From Leg	4.00		0.0000	116.00	No Ice	6.81	6.14	0.15
			0.00				1/2" Ice	7.30	6.99	0.22
			0.00				1" Ice	7.76	7.73	0.28
SitePro1 HRK12 Handrail kit	C	None			0.0000	116.00	No Ice	4.80	4.80	0.25
							1/2" Ice	6.70	6.70	0.29
							1" Ice	8.60	8.60	0.34
13' Low-Profile Platform	C	None			0.0000	116.00	No Ice	32.03	32.03	1.34
							1/2" Ice	38.71	38.71	1.80
							1" Ice	45.39	45.39	2.26

HPA-65R-BUU-H6_TIA w/ Mount Pipe	A	From Leg	4.00		0.0000	127.00	No Ice	9.72	7.15	0.07
			0.00				1/2" Ice	10.30	8.34	0.15
			0.00				1" Ice	10.84	9.24	0.23
HPA-65R-BUU-H6_TIA w/ Mount Pipe	B	From Leg	4.00		0.0000	127.00	No Ice	9.72	7.15	0.07
			0.00				1/2" Ice	10.30	8.34	0.15
			0.00				1" Ice	10.84	9.24	0.23
HPA-65R-BUU-H6_TIA w/ Mount Pipe	C	From Leg	4.00		0.0000	127.00	No Ice	9.72	7.15	0.07
			0.00				1/2" Ice	10.30	8.34	0.15
			0.00				1" Ice	10.84	9.24	0.23
(2) 7770.00 w/ Mount Pipe	A	From Leg	4.00		0.0000	127.00	No Ice	5.75	4.25	0.06
			0.00				1/2" Ice	6.18	5.01	0.10
			0.00				1" Ice	6.61	5.71	0.16
(2) 7770.00 w/ Mount Pipe	B	From Leg	4.00		0.0000	127.00	No Ice	5.75	4.25	0.06
			0.00				1/2" Ice	6.18	5.01	0.10

Job	02CT11C, Revision 4	Page	11 of 23
Project	1 Monopole	Date	8/23/11
Client	T-Mobile	Designed by	Ian Marinaccio

Description	Face or Leg	Offset Type	Offsets:		Azimuth Adjustment	Placement	C _{AA} Front	C _{AA} Side	Weight	
			Horz	Vert						
			ft	ft	°	ft	ft ²	ft ²	K	
(2) 7770.00 w/ Mount Pipe	C	From Leg	0.00	4.00	0.0000	127.00	1" Ice	6.61	5.71	0.16
			0.00	0.00			No Ice	5.75	4.25	0.06
			0.00	0.00			1/2" Ice	6.18	5.01	0.10
			0.00	0.00			1" Ice	6.61	5.71	0.16
LGP214nn	A	From Leg	4.00	0.00	0.0000	127.00	No Ice	1.10	0.35	0.01
			0.00	0.00			1/2" Ice	1.24	0.44	0.02
			0.00	0.00			1" Ice	1.38	0.54	0.03
			4.00	0.00			No Ice	1.10	0.35	0.01
LGP214nn	B	From Leg	4.00	0.00	0.0000	127.00	No Ice	1.10	0.35	0.01
			0.00	0.00			1/2" Ice	1.24	0.44	0.02
			0.00	0.00			1" Ice	1.38	0.54	0.03
			4.00	0.00			No Ice	1.10	0.35	0.01
LGP214nn	C	From Leg	4.00	0.00	0.0000	127.00	No Ice	1.10	0.35	0.01
			0.00	0.00			1/2" Ice	1.24	0.44	0.02
			0.00	0.00			1" Ice	1.38	0.54	0.03
			4.00	0.00			No Ice	1.10	0.35	0.01
13' Low-Profile Platform	C	None	0.00	0.00	0.0000	127.00	No Ice	24.53	24.53	1.34
			0.00	0.00			1/2" Ice	29.94	29.94	1.65
			0.00	0.00			1" Ice	35.35	35.35	1.96
			4.00	0.00			No Ice	14.05	7.63	0.14
80010965_TIA w/ Mount Pipe	A	From Leg	4.00	0.00	0.0000	127.00	No Ice	14.05	7.63	0.14
			0.00	0.00			1/2" Ice	14.69	8.90	0.23
			0.00	0.00			1" Ice	15.30	9.96	0.34
			4.00	0.00			No Ice	14.05	7.63	0.14
80010965_TIA w/ Mount Pipe	B	From Leg	4.00	0.00	0.0000	127.00	No Ice	14.05	7.63	0.14
			0.00	0.00			1/2" Ice	14.69	8.90	0.23
			0.00	0.00			1" Ice	15.30	9.96	0.34
			4.00	0.00			No Ice	14.05	7.63	0.14
80010965_TIA w/ Mount Pipe	C	From Leg	4.00	0.00	0.0000	127.00	No Ice	14.05	7.63	0.14
			0.00	0.00			1/2" Ice	14.69	8.90	0.23
			0.00	0.00			1" Ice	15.30	9.96	0.34
			4.00	0.00			No Ice	1.64	0.64	0.04
RADIO 4415 B30	A	From Leg	4.00	0.00	0.0000	127.00	No Ice	1.64	0.64	0.04
			0.00	0.00			1/2" Ice	1.80	0.75	0.05
			0.00	0.00			1" Ice	1.97	0.87	0.07
			4.00	0.00			No Ice	1.64	0.64	0.04
RADIO 4415 B30	B	From Leg	4.00	0.00	0.0000	127.00	No Ice	1.64	0.64	0.04
			0.00	0.00			1/2" Ice	1.80	0.75	0.05
			0.00	0.00			1" Ice	1.97	0.87	0.07
			4.00	0.00			No Ice	1.64	0.64	0.04
RADIO 4415 B30	C	From Leg	4.00	0.00	0.0000	127.00	No Ice	1.64	0.64	0.04
			0.00	0.00			1/2" Ice	1.80	0.75	0.05
			0.00	0.00			1" Ice	1.97	0.87	0.07
			4.00	0.00			No Ice	1.97	1.41	0.07
RRUS 4449 B5/B12	A	From Leg	4.00	0.00	0.0000	127.00	No Ice	1.97	1.41	0.07
			0.00	0.00			1/2" Ice	2.14	1.56	0.09
			0.00	0.00			1" Ice	2.33	1.73	0.11
			4.00	0.00			No Ice	1.97	1.41	0.07
RRUS 4449 B5/B12	B	From Leg	4.00	0.00	0.0000	127.00	No Ice	1.97	1.41	0.07
			0.00	0.00			1/2" Ice	2.14	1.56	0.09
			0.00	0.00			1" Ice	2.33	1.73	0.11
			4.00	0.00			No Ice	1.97	1.41	0.07
RRUS 4449 B5/B12	C	From Leg	4.00	0.00	0.0000	127.00	No Ice	1.97	1.41	0.07
			0.00	0.00			1/2" Ice	2.14	1.56	0.09
			0.00	0.00			1" Ice	2.33	1.73	0.11
			4.00	0.00			No Ice	0.92	0.92	0.02
DC6-48-60-18-8F	A	From Leg	4.00	0.00	0.0000	127.00	No Ice	0.92	0.92	0.02
			0.00	0.00			1/2" Ice	1.46	1.46	0.04
			0.00	0.00			1" Ice	1.64	1.64	0.06
			4.00	0.00			No Ice	0.92	0.92	0.02
* DC6-48-60-18-8F	C	From Leg	4.00	0.00	0.0000	129.00	No Ice	0.92	0.92	0.02
			0.00	0.00			1/2" Ice	1.46	1.46	0.04
			0.00	0.00			1" Ice	1.64	1.64	0.06
			4.00	0.00			No Ice	2.78	1.19	0.05
RRUS 11	A	From Leg	4.00	0.00	0.0000	129.00	No Ice	2.78	1.19	0.05
			0.00	0.00			1/2" Ice	2.99	1.33	0.07
			0.00	0.00			1" Ice	3.21	1.49	0.10
			4.00	0.00			No Ice	2.78	1.19	0.05
RRUS 11	B	From Leg	4.00	0.00	0.0000	129.00	No Ice	2.78	1.19	0.05
			0.00	0.00			1/2" Ice	2.99	1.33	0.07
			0.00	0.00			1" Ice	3.21	1.49	0.10
			4.00	0.00			No Ice	2.78	1.19	0.05
RRUS 11	C	From Leg	4.00	0.00	0.0000	129.00	No Ice	2.78	1.19	0.05
			0.00	0.00			1/2" Ice	2.99	1.33	0.07
			0.00	0.00			1" Ice	3.21	1.49	0.10
			4.00	0.00			No Ice	2.78	1.19	0.05

Job	02CT11C, Revision 4	Page	12 of 23
Project	1 Monopole	Date	8/23/11
Client	T-Mobile	Designed by	Ian Marinaccio

Description	Face or Leg	Offset Type	Offsets:		Azimuth Adjustment	Placement	C _{AA} Front	C _{AA} Side	Weight
			Horz	Vert					
			ft	ft	°	ft	ft ²	ft ²	K
			0.00			1/2" Ice	2.99	1.33	0.07
			0.00			1" Ice	3.21	1.49	0.10
RRUS 12	A	From Leg	4.00		0.0000	No Ice	3.15	1.29	0.06
			0.00			1/2" Ice	3.36	1.44	0.08
			0.00			1" Ice	3.59	1.60	0.11
RRUS 12	B	From Leg	4.00		0.0000	No Ice	3.15	1.29	0.06
			0.00			1/2" Ice	3.36	1.44	0.08
			0.00			1" Ice	3.59	1.60	0.11
RRUS 12	C	From Leg	4.00		0.0000	No Ice	3.15	1.29	0.06
			0.00			1/2" Ice	3.36	1.44	0.08
			0.00			1" Ice	3.59	1.60	0.11
RRU A2	A	From Leg	4.00		0.0000	No Ice	2.07	0.50	0.02
			0.00			1/2" Ice	2.25	0.61	0.03
			0.00			1" Ice	2.43	0.73	0.05
RRU A2	B	From Leg	4.00		0.0000	No Ice	2.07	0.50	0.02
			0.00			1/2" Ice	2.25	0.61	0.03
			0.00			1" Ice	2.43	0.73	0.05
RRU A2	C	From Leg	4.00		0.0000	No Ice	2.07	0.50	0.02
			0.00			1/2" Ice	2.25	0.61	0.03
			0.00			1" Ice	2.43	0.73	0.05
Collar Mount	C	None			0.0000	No Ice	1.14	1.14	0.32
						1/2" Ice	1.49	1.49	0.34
						1" Ice	1.91	1.91	0.37

RRUS A2 B13	A	From Leg	4.00		0.0000	No Ice	2.79	1.72	0.08
			0.00			1/2" Ice	3.00	1.90	0.10
			0.00			1" Ice	3.21	2.07	0.13
RRUS A2 B13	B	From Leg	4.00		0.0000	No Ice	2.79	1.72	0.08
			0.00			1/2" Ice	3.00	1.90	0.10
			0.00			1" Ice	3.21	2.07	0.13
RRUS A2 B13	C	From Leg	4.00		0.0000	No Ice	2.79	1.72	0.08
			0.00			1/2" Ice	3.00	1.90	0.10
			0.00			1" Ice	3.21	2.07	0.13
RRUS 32 B30	A	From Leg	4.00		0.0000	No Ice	2.69	1.57	0.06
			0.00			1/2" Ice	2.91	1.76	0.08
			0.00			1" Ice	3.14	1.95	0.10
RRUS 32 B30	B	From Leg	4.00		0.0000	No Ice	2.69	1.57	0.06
			0.00			1/2" Ice	2.91	1.76	0.08
			0.00			1" Ice	3.14	1.95	0.10
RRUS 32 B30	C	From Leg	4.00		0.0000	No Ice	2.69	1.57	0.06
			0.00			1/2" Ice	2.91	1.76	0.08
			0.00			1" Ice	3.14	1.95	0.10
DT465B-2XR-V2 w/ Mount Pipe	A	From Leg	4.00		0.0000	No Ice	5.50	4.38	0.09
			0.00			1/2" Ice	5.97	4.84	0.16
			0.00			1" Ice	6.45	5.30	0.25
DT465B-2XR-V2 w/ Mount Pipe	B	From Leg	4.00		0.0000	No Ice	5.50	4.38	0.09
			0.00			1/2" Ice	5.97	4.84	0.16
			0.00			1" Ice	6.45	5.30	0.25
DT465B-2XR-V2 w/ Mount Pipe	C	From Leg	4.00		0.0000	No Ice	5.50	4.38	0.09
			0.00			1/2" Ice	5.97	4.84	0.16
			0.00			1" Ice	6.45	5.30	0.25
APXVSP18-C-A20_TIA w/ Mount Pipe	A	From Leg	4.00		0.0000	No Ice	8.26	7.47	0.10
			0.00			1/2" Ice	8.82	8.66	0.17
			0.00			1" Ice	9.35	9.56	0.24
APXVSP18-C-A20_TIA w/ Mount Pipe	B	From Leg	4.00		0.0000	No Ice	8.26	7.47	0.10
			0.00			1/2" Ice	8.82	8.66	0.17
			0.00			1" Ice	9.35	9.56	0.24

Job	0020CT11000C, Revision 4	Page	13 of 23
Project	1000Monopole	Date	08/23/10
Client	T-Mobile	Designed by	Ian Marinaccio

Description	Face or Leg	Offset Type	Offsets:		Azimuth Adjustment	Placement	C _{AA} Front	C _{AA} Side	Weight
			Horz	Vert					
			ft	ft	°	ft	ft ²	ft ²	K
APXVSP18-C-A20_TIA w/ Mount Pipe	C	From Leg	4.00	0.0000	138.00	No Ice	8.26	7.47	0.10
			0.00			1/2" Ice	8.82	8.66	0.17
			0.00			1" Ice	9.35	9.56	0.24
FD-RRH-2x50-800	A	From Leg	4.00	0.0000	138.00	No Ice	1.36	3.01	0.05
			0.00			1/2" Ice	1.52	3.22	0.08
			0.00			1" Ice	1.68	3.45	0.10
FD-RRH-2x50-800	B	From Leg	4.00	0.0000	138.00	No Ice	1.36	3.01	0.05
			0.00			1/2" Ice	1.52	3.22	0.08
			0.00			1" Ice	1.68	3.45	0.10
FD-RRH-2x50-800	C	From Leg	4.00	0.0000	138.00	No Ice	1.36	3.01	0.05
			0.00			1/2" Ice	1.52	3.22	0.08
			0.00			1" Ice	1.68	3.45	0.10
RRH4X45-19	A	From Leg	4.00	0.0000	138.00	No Ice	2.31	2.38	0.09
			0.00			1/2" Ice	2.52	2.58	0.11
			0.00			1" Ice	2.73	2.79	0.14
RRH4X45-19	B	From Leg	4.00	0.0000	138.00	No Ice	2.31	2.38	0.09
			0.00			1/2" Ice	2.52	2.58	0.11
			0.00			1" Ice	2.73	2.79	0.14
RRH4X45-19	C	From Leg	4.00	0.0000	138.00	No Ice	2.31	2.38	0.09
			0.00			1/2" Ice	2.52	2.58	0.11
			0.00			1" Ice	2.73	2.79	0.14
13' Low-Profile Platform	C	None		0.0000	138.00	No Ice	44.21	44.21	1.77
						1/2" Ice	53.97	53.97	2.32
						1" Ice	63.73	63.73	2.87
2" STD Pipe (2.375 OD)x6'-0"	A	From Leg	4.00	0.0000	138.00	No Ice	1.43	1.43	0.02
			0.00			1/2" Ice	1.92	1.92	0.03
			0.00			1" Ice	2.29	2.29	0.05
2" STD Pipe (2.375 OD)x6'-0"	B	From Leg	4.00	0.0000	138.00	No Ice	1.43	1.43	0.02
			0.00			1/2" Ice	1.92	1.92	0.03
			0.00			1" Ice	2.29	2.29	0.05
2" STD Pipe (2.375 OD)x6'-0"	C	From Leg	4.00	0.0000	138.00	No Ice	1.43	1.43	0.02
			0.00			1/2" Ice	1.92	1.92	0.03
			0.00			1" Ice	2.29	2.29	0.05

10' x 1.5" Dia Dipole	B	From Leg	4.00	0.0000	149.00	No Ice	2.00	2.00	0.02
			0.00			1/2" Ice	3.02	3.02	0.04
			5.00			1" Ice	4.07	4.07	0.06
10' x 1.5" Dia Dipole	C	From Leg	4.00	0.0000	149.00	No Ice	2.00	2.00	0.02
			0.00			1/2" Ice	3.02	3.02	0.04
			5.00			1" Ice	4.07	4.07	0.06
12' x 3" Dia Omni	A	From Leg	4.00	0.0000	149.00	No Ice	3.60	3.60	0.04
			0.00			1/2" Ice	4.83	4.83	0.07
			5.00			1" Ice	6.08	6.08	0.10
13' T-Arms	C	None		0.0000	149.00	No Ice	11.59	11.59	0.77
						1/2" Ice	15.44	15.44	0.99
						1" Ice	19.29	19.29	1.21
(4) 2" STD Pipe (2.375 OD)x6'-0"	A	From Leg	4.00	0.0000	149.00	No Ice	1.43	1.43	0.02
			0.00			1/2" Ice	1.92	1.92	0.03
			0.00			1" Ice	2.29	2.29	0.05
(4) 2" STD Pipe (2.375 OD)x6'-0"	B	From Leg	4.00	0.0000	149.00	No Ice	1.43	1.43	0.02
			0.00			1/2" Ice	1.92	1.92	0.03
			0.00			1" Ice	2.29	2.29	0.05
(4) 2" STD Pipe (2.375 OD)x6'-0"	C	From Leg	4.00	0.0000	149.00	No Ice	1.43	1.43	0.02
			0.00			1/2" Ice	1.92	1.92	0.03
			0.00			1" Ice	2.29	2.29	0.05

Job	02 CT11 C, Revision 4	Page	14 of 23
Project	1 Monopole	Date	8/23/11
Client	T-Mobile	Designed by	Ian Marinaccio

Load Combinations

Comb. No.	Description
1	Dead Only
2	1.2 Dead+1.6 Wind 0 deg - No Ice
3	0.9 Dead+1.6 Wind 0 deg - No Ice
4	1.2 Dead+1.6 Wind 30 deg - No Ice
5	0.9 Dead+1.6 Wind 30 deg - No Ice
6	1.2 Dead+1.6 Wind 60 deg - No Ice
7	0.9 Dead+1.6 Wind 60 deg - No Ice
8	1.2 Dead+1.6 Wind 90 deg - No Ice
9	0.9 Dead+1.6 Wind 90 deg - No Ice
10	1.2 Dead+1.6 Wind 120 deg - No Ice
11	0.9 Dead+1.6 Wind 120 deg - No Ice
12	1.2 Dead+1.6 Wind 150 deg - No Ice
13	0.9 Dead+1.6 Wind 150 deg - No Ice
14	1.2 Dead+1.6 Wind 180 deg - No Ice
15	0.9 Dead+1.6 Wind 180 deg - No Ice
16	1.2 Dead+1.6 Wind 210 deg - No Ice
17	0.9 Dead+1.6 Wind 210 deg - No Ice
18	1.2 Dead+1.6 Wind 240 deg - No Ice
19	0.9 Dead+1.6 Wind 240 deg - No Ice
20	1.2 Dead+1.6 Wind 270 deg - No Ice
21	0.9 Dead+1.6 Wind 270 deg - No Ice
22	1.2 Dead+1.6 Wind 300 deg - No Ice
23	0.9 Dead+1.6 Wind 300 deg - No Ice
24	1.2 Dead+1.6 Wind 330 deg - No Ice
25	0.9 Dead+1.6 Wind 330 deg - No Ice
26	1.2 Dead+1.0 Ice+1.0 Temp
27	1.2 Dead+1.0 Wind 0 deg+1.0 Ice+1.0 Temp
28	1.2 Dead+1.0 Wind 30 deg+1.0 Ice+1.0 Temp
29	1.2 Dead+1.0 Wind 60 deg+1.0 Ice+1.0 Temp
30	1.2 Dead+1.0 Wind 90 deg+1.0 Ice+1.0 Temp
31	1.2 Dead+1.0 Wind 120 deg+1.0 Ice+1.0 Temp
32	1.2 Dead+1.0 Wind 150 deg+1.0 Ice+1.0 Temp
33	1.2 Dead+1.0 Wind 180 deg+1.0 Ice+1.0 Temp
34	1.2 Dead+1.0 Wind 210 deg+1.0 Ice+1.0 Temp
35	1.2 Dead+1.0 Wind 240 deg+1.0 Ice+1.0 Temp
36	1.2 Dead+1.0 Wind 270 deg+1.0 Ice+1.0 Temp
37	1.2 Dead+1.0 Wind 300 deg+1.0 Ice+1.0 Temp
38	1.2 Dead+1.0 Wind 330 deg+1.0 Ice+1.0 Temp
39	Dead+Wind 0 deg - Service
40	Dead+Wind 30 deg - Service
41	Dead+Wind 60 deg - Service
42	Dead+Wind 90 deg - Service
43	Dead+Wind 120 deg - Service
44	Dead+Wind 150 deg - Service
45	Dead+Wind 180 deg - Service
46	Dead+Wind 210 deg - Service
47	Dead+Wind 240 deg - Service
48	Dead+Wind 270 deg - Service
49	Dead+Wind 300 deg - Service
50	Dead+Wind 330 deg - Service

Maximum Member Forces

Job	0020CT11000C, Revision 4	Page	1 of 23
Project	1000Monopole	Date	08/23/10
Client	T-Mobile	Designed by	Ian Marinaccio

Section No.	Elevation ft	Component Type	Condition	Gov. Load Comb.	Axial K	Major Axis Moment kip-ft	Minor Axis Moment kip-ft
L1	150 - 130	Pole	Max Tension	48	0.00	-0.00	0.00
			Max. Compression	26	-15.21	0.01	0.03
			Max. Mx	20	-6.44	89.58	0.05
			Max. My	2	-6.46	0.03	89.49
			Max. Vy	20	-8.35	89.58	0.05
			Max. Vx	14	8.33	-0.05	-89.35
			Max. Torque	8			0.37
L2	130 - 110	Pole	Max Tension	1	0.00	0.00	0.00
			Max. Compression	26	-39.02	-4.49	-10.74
			Max. Mx	8	-15.80	-405.57	-4.01
			Max. My	14	-15.90	-2.51	-402.46
			Max. Vy	20	-21.34	402.81	-1.38
			Max. Vx	14	20.64	-2.51	-402.46
			Max. Torque	18			5.55
L3	110 - 95.83	Pole	Max Tension	1	0.00	0.00	0.00
			Max. Compression	26	-44.78	-1.87	-10.19
			Max. Mx	8	-19.09	-602.65	-5.97
			Max. My	14	-19.19	-3.82	-593.80
			Max. Vy	20	-23.20	601.11	0.28
			Max. Vx	14	22.47	-3.82	-593.80
			Max. Torque	18			5.55
L4	95.83 - 81	Pole	Max Tension	1	0.00	0.00	0.00
			Max. Compression	26	-52.85	0.27	-10.45
			Max. Mx	8	-23.89	-1089.49	-9.88
			Max. My	14	-23.97	-7.18	-1066.39
			Max. Vy	20	-25.50	1089.36	4.47
			Max. Vx	14	24.77	-7.18	-1066.39
			Max. Torque	18			4.56
L5	81 - 61	Pole	Max Tension	1	0.00	0.00	0.00
			Max. Compression	26	-69.55	3.33	-11.83
			Max. Mx	20	-32.15	1703.23	7.96
			Max. My	14	-32.24	-9.99	-1660.42
			Max. Vy	20	-32.13	1703.23	7.96
			Max. Vx	14	30.94	-9.99	-1660.42
			Max. Torque	18			4.55
L6	61 - 47.83	Pole	Max Tension	1	0.00	0.00	0.00
			Max. Compression	26	-72.59	4.18	-12.48
			Max. Mx	20	-34.05	1931.14	9.14
			Max. My	14	-34.14	-10.99	-1879.31
			Max. Vy	20	-32.94	1931.14	9.14
			Max. Vx	14	31.60	-10.99	-1879.31
			Max. Torque	18			4.10
L7	47.83 - 34	Pole	Max Tension	1	0.00	0.00	0.00
			Max. Compression	26	-84.04	7.13	-14.60
			Max. Mx	20	-41.58	2615.84	12.40
			Max. My	14	-41.65	-13.61	-2532.38
			Max. Vy	20	-35.31	2615.84	12.40
			Max. Vx	14	33.57	-13.61	-2532.38
			Max. Torque	20			4.16
L8	34 - 29.5833	Pole	Max Tension	1	0.00	0.00	0.00
			Max. Compression	26	-86.44	7.79	-14.91
			Max. Mx	20	-43.21	2773.26	13.22
			Max. My	14	-43.27	-14.18	-2681.56
			Max. Vy	20	-35.89	2773.26	13.22
			Max. Vx	14	34.01	-14.18	-2681.56
			Max. Torque	20			4.17
L9	29.5833 - 14.67	Pole	Max Tension	1	0.00	0.00	0.00
			Max. Compression	26	-98.03	11.03	-15.24
			Max. Mx	20	-51.40	3327.88	16.37

Job	02CT11C, Revision 4	Page	1 of 23
Project	1 Monopole	Date	8/23/11
Client	T-Mobile	Designed by	Ian Marinaccio

Section No.	Elevation ft	Component Type	Condition	Gov. Load Comb.	Axial K	Major Axis Moment kip-ft	Minor Axis Moment kip-ft
L10	14.67 - 0	Pole	Max. My	14	-51.43	-15.40	-3206.58
			Max. Vy	20	-38.31	3327.88	16.37
			Max. Vx	14	36.48	-15.40	-3206.58
			Max. Torque	20			4.17
			Max Tension	1	0.00	0.00	0.00
			Max. Compression	26	-112.74	15.41	-14.56
			Max. Mx	20	-62.41	3915.30	20.00
			Max. My	14	-62.41	-15.66	-3762.91
			Max. Vy	20	-41.47	3915.30	20.00
			Max. Vx	14	39.52	-15.66	-3762.91
			Max. Torque	20			4.15

Maximum Reactions

Location	Condition	Gov. Load Comb.	Vertical K	Horizontal, X K	Horizontal, Z K
Pole	Max. Vert	26	112.74	0.00	-0.00
	Max. H _x	20	62.42	41.46	0.19
	Max. H _z	2	62.42	0.19	39.50
	Max. M _x	2	3758.10	0.19	39.50
	Max. M _z	8	3901.90	-41.46	-0.19
	Max. Torsion	20	3.97	41.46	0.19
	Min. Vert	13	46.81	-19.99	-33.86
	Min. H _x	8	62.42	-41.46	-0.19
	Min. H _z	14	62.42	-0.19	-39.50
	Min. M _x	14	-3762.91	-0.19	-39.50
	Min. M _z	20	-3915.30	41.46	0.19
	Min. Torsion	8	-3.97	-41.46	-0.19

Tower Mast Reaction Summary

Load Combination	Vertical K	Shear _x K	Shear _z K	Overturning Moment, M _x kip-ft	Overturning Moment, M _z kip-ft	Torque kip-ft
Dead Only	52.02	-0.00	0.00	1.90	5.51	-0.00
1.2 Dead+1.6 Wind 0 deg - No Ice	62.42	-0.19	-39.50	-3758.10	29.11	0.17
0.9 Dead+1.6 Wind 0 deg - No Ice	46.81	-0.19	-39.50	-3718.48	27.15	0.14
1.2 Dead+1.6 Wind 30 deg - No Ice	62.42	21.97	-37.67	-3455.01	-2017.24	1.37
0.9 Dead+1.6 Wind 30 deg - No Ice	46.81	21.97	-37.67	-3419.56	-1997.80	1.31
1.2 Dead+1.6 Wind 60 deg - No Ice	62.42	37.83	-21.40	-1956.71	-3479.50	3.26
0.9 Dead+1.6 Wind 60 deg - No Ice	46.81	37.83	-21.40	-1936.89	-3444.72	3.19
1.2 Dead+1.6 Wind 90 deg - No Ice	62.42	41.46	0.19	24.77	-3901.90	3.97
0.9 Dead+1.6 Wind 90 deg - No Ice	46.81	41.46	0.19	23.87	-3862.05	3.91
1.2 Dead+1.6 Wind 120 deg - No Ice	62.42	34.27	19.56	1896.70	-3322.55	3.27

Job	02 CT11 C, Revision 4	Page	1 of 23
Project	1 Monopole	Date	8/23/11
Client	T-Mobile	Designed by	Ian Marinaccio

Load Combination	Vertical K	Shear _x K	Shear _z K	Overturning Moment, M _x kip-ft	Overturning Moment, M _z kip-ft	Torque kip-ft
No Ice						
0.9 Dead+1.6 Wind 120 deg - No Ice	46.81	34.27	19.56	1875.72	-3288.48	3.23
1.2 Dead+1.6 Wind 150 deg - No Ice	62.42	19.99	33.86	3264.92	-1930.59	1.72
0.9 Dead+1.6 Wind 150 deg - No Ice	46.81	19.99	33.86	3229.28	-1911.49	1.71
1.2 Dead+1.6 Wind 180 deg - No Ice	62.42	0.19	39.50	3762.91	-15.66	-0.17
0.9 Dead+1.6 Wind 180 deg - No Ice	46.81	0.19	39.50	3721.99	-17.12	-0.14
1.2 Dead+1.6 Wind 210 deg - No Ice	62.42	-21.97	37.67	3459.79	2030.69	-1.37
0.9 Dead+1.6 Wind 210 deg - No Ice	46.81	-21.97	37.67	3423.06	2007.83	-1.31
1.2 Dead+1.6 Wind 240 deg - No Ice	62.42	-37.83	21.40	1961.47	3492.94	-3.26
0.9 Dead+1.6 Wind 240 deg - No Ice	46.81	-37.83	21.40	1940.36	3454.74	-3.19
1.2 Dead+1.6 Wind 270 deg - No Ice	62.42	-41.46	-0.19	-20.00	3915.30	-3.97
0.9 Dead+1.6 Wind 270 deg - No Ice	46.81	-41.46	-0.19	-20.40	3872.06	-3.91
1.2 Dead+1.6 Wind 300 deg - No Ice	62.42	-34.27	-19.56	-1891.91	3335.94	-3.28
0.9 Dead+1.6 Wind 300 deg - No Ice	46.81	-34.27	-19.56	-1872.22	3298.48	-3.23
1.2 Dead+1.6 Wind 330 deg - No Ice	62.42	-19.99	-33.86	-3260.11	1944.00	-1.72
0.9 Dead+1.6 Wind 330 deg - No Ice	46.81	-19.99	-33.86	-3225.77	1921.50	-1.71
1.2 Dead+1.0 Ice+1.0 Temp	112.74	-0.00	0.00	14.56	15.41	-0.00
1.2 Dead+1.0 Wind 0 deg+1.0 Ice+1.0 Temp	112.74	-0.02	-9.30	-967.10	18.28	-0.06
1.2 Dead+1.0 Wind 30 deg+1.0 Ice+1.0 Temp	112.74	5.05	-8.70	-868.90	-498.38	0.43
1.2 Dead+1.0 Wind 60 deg+1.0 Ice+1.0 Temp	112.74	8.64	-4.93	-490.35	-871.28	0.99
1.2 Dead+1.0 Wind 90 deg+1.0 Ice+1.0 Temp	112.74	9.58	0.02	17.45	-981.01	1.10
1.2 Dead+1.0 Wind 120 deg+1.0 Ice+1.0 Temp	112.74	8.02	4.61	507.14	-844.02	0.91
1.2 Dead+1.0 Wind 150 deg+1.0 Ice+1.0 Temp	112.74	4.67	7.99	865.62	-482.79	0.55
1.2 Dead+1.0 Wind 180 deg+1.0 Ice+1.0 Temp	112.74	0.02	9.30	996.41	12.69	0.05
1.2 Dead+1.0 Wind 210 deg+1.0 Ice+1.0 Temp	112.74	-5.05	8.70	898.21	529.35	-0.43
1.2 Dead+1.0 Wind 240 deg+1.0 Ice+1.0 Temp	112.74	-8.64	4.93	519.65	902.25	-0.99
1.2 Dead+1.0 Wind 270 deg+1.0 Ice+1.0 Temp	112.74	-9.58	-0.02	11.86	1011.97	-1.11
1.2 Dead+1.0 Wind 300 deg+1.0 Ice+1.0 Temp	112.74	-8.02	-4.61	-477.83	874.99	-0.92
1.2 Dead+1.0 Wind 330 deg+1.0 Ice+1.0 Temp	112.74	-4.67	-7.99	-836.31	513.76	-0.56
Dead+Wind 0 deg - Service	52.02	-0.04	-8.45	-797.74	10.34	0.03
Dead+Wind 30 deg - Service	52.02	4.70	-8.06	-733.44	-424.93	0.29
Dead+Wind 60 deg - Service	52.02	8.09	-4.58	-414.73	-735.96	0.70
Dead+Wind 90 deg - Service	52.02	8.87	0.04	6.74	-825.73	0.85
Dead+Wind 120 deg - Service	52.02	7.33	4.19	404.84	-702.45	0.70

Job	CT11C, Revision 4	Page	18 of 23
Project	1 Monopole	Date	8/21
Client	T-Mobile	Designed by	Ian Marinaccio

Load Combination	Vertical K	Shear _x K	Shear _z K	Overturning Moment, M _x kip-ft	Overturning Moment, M _z kip-ft	Torque kip-ft
Dead+Wind 150 deg - Service	52.02	4.28	7.24	695.81	-406.42	0.37
Dead+Wind 180 deg - Service	52.02	0.04	8.45	801.70	0.82	-0.03
Dead+Wind 210 deg - Service	52.02	-4.70	8.06	737.40	436.09	-0.29
Dead+Wind 240 deg - Service	52.02	-8.09	4.58	418.70	747.12	-0.70
Dead+Wind 270 deg - Service	52.02	-8.87	-0.04	-2.78	836.88	-0.85
Dead+Wind 300 deg - Service	52.02	-7.33	-4.19	-400.88	713.61	-0.70
Dead+Wind 330 deg - Service	52.02	-4.28	-7.24	-691.85	417.57	-0.37

Solution Summary

Load Comb.	Sum of Applied Forces			Sum of Reactions			% Error
	PX K	PY K	PZ K	PX K	PY K	PZ K	
1	0.00	-52.02	0.00	0.00	52.02	-0.00	0.000%
2	-0.19	-62.42	-39.50	0.19	62.42	39.50	0.000%
3	-0.19	-46.81	-39.50	0.19	46.81	39.50	0.000%
4	21.97	-62.42	-37.67	-21.97	62.42	37.67	0.000%
5	21.97	-46.81	-37.67	-21.97	46.81	37.67	0.000%
6	37.83	-62.42	-21.40	-37.83	62.42	21.40	0.000%
7	37.83	-46.81	-21.40	-37.83	46.81	21.40	0.000%
8	41.46	-62.42	0.19	-41.46	62.42	-0.19	0.000%
9	41.46	-46.81	0.19	-41.46	46.81	-0.19	0.000%
10	34.27	-62.42	19.56	-34.27	62.42	-19.56	0.000%
11	34.27	-46.81	19.56	-34.27	46.81	-19.56	0.000%
12	19.99	-62.42	33.86	-19.99	62.42	-33.86	0.000%
13	19.99	-46.81	33.86	-19.99	46.81	-33.86	0.000%
14	0.19	-62.42	39.50	-0.19	62.42	-39.50	0.000%
15	0.19	-46.81	39.50	-0.19	46.81	-39.50	0.000%
16	-21.97	-62.42	37.67	21.97	62.42	-37.67	0.000%
17	-21.97	-46.81	37.67	21.97	46.81	-37.67	0.000%
18	-37.83	-62.42	21.40	37.83	62.42	-21.40	0.000%
19	-37.83	-46.81	21.40	37.83	46.81	-21.40	0.000%
20	-41.46	-62.42	-0.19	41.46	62.42	0.19	0.000%
21	-41.46	-46.81	-0.19	41.46	46.81	0.19	0.000%
22	-34.27	-62.42	-19.56	34.27	62.42	19.56	0.000%
23	-34.27	-46.81	-19.56	34.27	46.81	19.56	0.000%
24	-19.99	-62.42	-33.86	19.99	62.42	33.86	0.000%
25	-19.99	-46.81	-33.86	19.99	46.81	33.86	0.000%
26	0.00	-112.74	0.00	0.00	112.74	-0.00	0.000%
27	-0.02	-112.74	-9.30	0.02	112.74	9.30	0.000%
28	5.05	-112.74	-8.70	-5.05	112.74	8.70	0.000%
29	8.64	-112.74	-4.93	-8.64	112.74	4.93	0.000%
30	9.58	-112.74	0.02	-9.58	112.74	-0.02	0.000%
31	8.02	-112.74	4.61	-8.02	112.74	-4.61	0.000%
32	4.67	-112.74	7.99	-4.67	112.74	-7.99	0.000%
33	0.02	-112.74	9.30	-0.02	112.74	-9.30	0.000%
34	-5.05	-112.74	8.70	5.05	112.74	-8.70	0.000%
35	-8.64	-112.74	4.93	8.64	112.74	-4.93	0.000%
36	-9.58	-112.74	-0.02	9.58	112.74	0.02	0.000%
37	-8.02	-112.74	-4.61	8.02	112.74	4.61	0.000%
38	-4.67	-112.74	-7.99	4.67	112.74	7.99	0.000%
39	-0.04	-52.02	-8.45	0.04	52.02	8.45	0.000%
40	4.70	-52.02	-8.06	-4.70	52.02	8.06	0.000%
41	8.09	-52.02	-4.58	-8.09	52.02	4.58	0.000%
42	8.87	-52.02	0.04	-8.87	52.02	-0.04	0.000%
43	7.33	-52.02	4.19	-7.33	52.02	-4.19	0.000%
44	4.28	-52.02	7.24	-4.28	52.02	-7.24	0.000%
45	0.04	-52.02	8.45	-0.04	52.02	-8.45	0.000%

Job	02CT11C, Revision 4	Page	1 of 23
Project	1 Monopole	Date	8/21
Client	T-Mobile	Designed by	Ian Marinaccio

Load Comb.	Sum of Applied Forces			Sum of Reactions			% Error
	PX K	PY K	PZ K	PX K	PY K	PZ K	
46	-4.70	-52.02	8.06	4.70	52.02	-8.06	0.000%
47	-8.09	-52.02	4.58	8.09	52.02	-4.58	0.000%
48	-8.87	-52.02	-0.04	8.87	52.02	0.04	0.000%
49	-7.33	-52.02	-4.19	7.33	52.02	4.19	0.000%
50	-4.28	-52.02	-7.24	4.28	52.02	7.24	0.000%

Non-Linear Convergence Results

Load Combination	Converged?	Number of Cycles	Displacement Tolerance	Force Tolerance
1	Yes	4	0.0000001	0.0000605
2	Yes	5	0.0000001	0.00011521
3	Yes	5	0.0000001	0.00005351
4	Yes	6	0.0000001	0.00022814
5	Yes	6	0.0000001	0.00007378
6	Yes	6	0.0000001	0.00020070
7	Yes	6	0.0000001	0.00006429
8	Yes	5	0.0000001	0.00054524
9	Yes	5	0.0000001	0.00025127
10	Yes	6	0.0000001	0.00022577
11	Yes	6	0.0000001	0.00007358
12	Yes	6	0.0000001	0.00021219
13	Yes	6	0.0000001	0.00006886
14	Yes	5	0.0000001	0.00023119
15	Yes	5	0.0000001	0.00010800
16	Yes	6	0.0000001	0.00020959
17	Yes	6	0.0000001	0.00006694
18	Yes	6	0.0000001	0.00023191
19	Yes	6	0.0000001	0.00007512
20	Yes	5	0.0000001	0.00041977
21	Yes	5	0.0000001	0.00019358
22	Yes	6	0.0000001	0.00020516
23	Yes	6	0.0000001	0.00006636
24	Yes	6	0.0000001	0.00021592
25	Yes	6	0.0000001	0.00007034
26	Yes	4	0.0000001	0.00031431
27	Yes	6	0.0000001	0.00016836
28	Yes	6	0.0000001	0.00022562
29	Yes	6	0.0000001	0.00021985
30	Yes	6	0.0000001	0.00017623
31	Yes	6	0.0000001	0.00023675
32	Yes	6	0.0000001	0.00023103
33	Yes	6	0.0000001	0.00017754
34	Yes	6	0.0000001	0.00023732
35	Yes	6	0.0000001	0.00024471
36	Yes	6	0.0000001	0.00017841
37	Yes	6	0.0000001	0.00022055
38	Yes	6	0.0000001	0.00022354
39	Yes	4	0.0000001	0.00022468
40	Yes	5	0.0000001	0.00005930
41	Yes	4	0.0000001	0.00090467
42	Yes	4	0.0000001	0.00051194
43	Yes	5	0.0000001	0.00005796
44	Yes	4	0.0000001	0.00099218
45	Yes	4	0.0000001	0.00024457
46	Yes	4	0.0000001	0.00098394

Job	02 CT11 C, Revision 4	Page	2 of 23
Project	1 Monopole	Date	8/23/11
Client	T-Mobile	Designed by	Ian Marinaccio

47	Yes	5	0.00000001	0.00006487
48	Yes	4	0.00000001	0.00048984
49	Yes	4	0.00000001	0.00090963
50	Yes	5	0.00000001	0.00005014

Maximum Tower Deflections - Service Wind

Section No.	Elevation ft	Horz. Deflection in	Gov. Load Comb.	Tilt °	Twist °
L1	150 - 130	20.555	46	1.1116	0.0043
L2	130 - 110	15.920	46	1.0938	0.0046
L3	110 - 95.83	11.503	46	0.9982	0.0039
L4	101 - 81	9.690	46	0.9224	0.0029
L5	81 - 61	6.110	46	0.7664	0.0019
L6	61 - 47.83	3.332	46	0.5545	0.0011
L7	54 - 34	2.578	46	0.4737	0.0009
L8	34 - 29.5833	0.939	46	0.2853	0.0005
L9	29.5833 - 14.67	0.698	46	0.2355	0.0004
L10	14.67 - 0	0.163	46	0.1064	0.0001

Critical Deflections and Radius of Curvature - Service Wind

Elevation ft	Appurtenance	Gov. Load Comb.	Deflection in	Tilt °	Twist °	Radius of Curvature ft
149.00	10' x 1.5" Dia Dipole	46	20.322	1.1114	0.0044	115045
138.00	RRUS A2 B13	46	17.764	1.1063	0.0045	47935
129.00	DC6-48-60-18-8F	46	15.691	1.0915	0.0046	24379
127.00	HPA-65R-BUU-H6_TIA w/ Mount Pipe	46	15.235	1.0860	0.0046	20145
116.00	(2) RADIO 4449 B12/B71	46	12.781	1.0386	0.0044	9250
106.00	(2) Collar Mount	46	10.682	0.9653	0.0035	7759
105.00	(2) Collar Mount	46	10.481	0.9567	0.0034	7927
104.00	8' x 2" Dia Dipole	46	10.281	0.9480	0.0033	8091
80.00	BXA-171063-8BF-EDIN-X w/ Mount Pipe	46	5.951	0.7575	0.0019	5761
40.00	GPS_A	46	1.341	0.3447	0.0006	5297

Maximum Tower Deflections - Design Wind

Section No.	Elevation ft	Horz. Deflection in	Gov. Load Comb.	Tilt °	Twist °
L1	150 - 130	96.212	18	5.2140	0.0207
L2	130 - 110	74.524	18	5.1295	0.0218
L3	110 - 95.83	53.868	16	4.6811	0.0185
L4	101 - 81	45.388	16	4.3266	0.0137
L5	81 - 61	28.628	16	3.5933	0.0090
L6	61 - 47.83	15.613	16	2.5998	0.0052
L7	54 - 34	12.080	16	2.2204	0.0042

Job	02CT11C, Revision 4	Page	21 of 23
Project	1 Monopole	Date	8/23/11
Client	T-Mobile	Designed by	Ian Marinaccio

Section No.	Elevation ft	Horz. Deflection in	Gov. Load Comb.	Tilt °	Twist °
L8	34 - 29.5833	4.397	16	1.3369	0.0022
L9	29.5833 - 14.67	3.268	16	1.1034	0.0017
L10	14.67 - 0	0.766	16	0.4984	0.0007

Critical Deflections and Radius of Curvature - Design Wind

Elevation ft	Appurtenance	Gov. Load Comb.	Deflection in	Tilt °	Twist °	Radius of Curvature ft
149.00	10' x 1.5" Dia Dipole	18	95.122	5.2131	0.0208	25236
138.00	RRUS A2 B13	18	83.151	5.1882	0.0215	10514
129.00	DC6-48-60-18-8F	18	73.453	5.1183	0.0218	5299
127.00	HPA-65R-BUU-H6_TIA w/ Mount Pipe	18	71.319	5.0928	0.0218	4349
116.00	(2) RADIO 4449 B12/B71	16	59.845	4.8705	0.0206	2019
106.00	(2) Collar Mount	16	50.029	4.5273	0.0164	1692
105.00	(2) Collar Mount	16	49.087	4.4870	0.0159	1727
104.00	8' x 2" Dia Dipole	16	48.153	4.4465	0.0154	1761
80.00	BXA-171063-8BF-EDIN-X w/ Mount Pipe	16	27.879	3.5517	0.0089	1235
40.00	GPS_A	16	6.281	1.6157	0.0028	1132

Compression Checks

Pole Design Data

Section No.	Elevation ft	Size	L ft	L _u ft	Kl/r	A in ²	P _u K	φP _n K	Ratio P _u / φP _n
L1	150 - 130 (1)	TP27.25x23.61x0.2813	20.00	0.00	0.0	24.4279	-6.44	1743.92	0.004
L2	130 - 110 (2)	TP30.89x27.25x0.2813	20.00	0.00	0.0	27.7250	-15.81	1884.92	0.008
L3	110 - 95.83 (3)	TP33.469x30.89x0.2813	14.17	0.00	0.0	29.2087	-19.10	1941.05	0.010
L4	95.83 - 81 (4)	TP35.6055x31.9655x0.375	20.00	0.00	0.0	42.5408	-23.90	3058.53	0.008
L5	81 - 61 (5)	TP39.2455x35.6055x0.375	20.00	0.00	0.0	46.9361	-32.15	3254.69	0.010
L6	61 - 47.83 (6)	TP41.6425x39.2455x0.375	13.17	0.00	0.0	48.4745	-34.05	3318.04	0.010
L7	47.83 - 34 (7)	TP43.4095x39.7695x0.4375	20.00	0.00	0.0	60.5368	-41.52	4284.32	0.010
L8	34 - 29.5833 (8)	TP44.2134x43.4095x0.4375	4.42	0.00	0.0	61.6693	-43.16	4334.66	0.010
L9	29.5833 - 14.67 (9)	TP46.9276x44.2134x0.58	14.91	0.00	0.0	86.5588	-51.38	6380.25	0.008
L10	14.67 - 0 (10)	TP49.5976x46.9276x0.7	14.67	0.00	0.0	110.215	-62.41	8123.96	0.008

Pole Bending Design Data

Job	0020CT11000C, Revision 4	Page	22 of 23
Project	1000Monopole	Date	08/23/10
Client	T-Mobile	Designed by	Ian Marinaccio

Section No.	Elevation ft	Size	M_{ux} kip-ft	ϕM_{rx} kip-ft	Ratio $\frac{M_{ux}}{\phi M_{rx}}$	M_{uy} kip-ft	ϕM_{ry} kip-ft	Ratio $\frac{M_{uy}}{\phi M_{ry}}$
L1	150 - 130 (1)	TP27.25x23.61x0.2813	89.64	955.77	0.094	0.00	955.77	0.000
L2	130 - 110 (2)	TP30.89x27.25x0.2813	406.70	1173.93	0.346	0.00	1173.93	0.000
L3	110 - 95.83 (3)	TP33.469x30.89x0.2813	603.80	1274.16	0.474	0.00	1274.16	0.000
L4	95.83 - 81 (4)	TP35.6055x31.9655x0.375	1090.26	2189.32	0.498	0.00	2189.32	0.000
L5	81 - 61 (5)	TP39.2455x35.6055x0.375	1703.25	2572.97	0.662	0.00	2572.97	0.000
L6	61 - 47.83 (6)	TP41.6425x39.2455x0.375	1931.17	2709.85	0.713	0.00	2709.85	0.000
L7	47.83 - 34 (7)	TP43.4095x39.7695x0.4375	2643.87	3742.35	0.706	0.00	3742.35	0.000
L8	34 - 29.5833 (8)	TP44.2134x43.4095x0.4375	2809.88	3857.86	0.728	0.00	3857.86	0.000
L9	29.5833 - 14.67 (9)	TP46.9276x44.2134x0.58	3394.54	5997.07	0.566	0.00	5997.07	0.000
L10	14.67 - 0 (10)	TP49.5976x46.9276x0.7	4011.72	8041.86	0.499	0.00	8041.86	0.000

Reactions used to check reinforcing members

Pole Shear Design Data

Section No.	Elevation ft	Size	Actual V_u K	ϕV_n K	Ratio $\frac{V_u}{\phi V_n}$	Actual T_u kip-ft	ϕT_n kip-ft	Ratio $\frac{T_u}{\phi T_n}$
L1	150 - 130 (1)	TP27.25x23.61x0.2813	8.34	871.96	0.010	0.19	1944.85	0.000
L2	130 - 110 (2)	TP30.89x27.25x0.2813	21.34	942.46	0.023	2.69	2387.76	0.001
L3	110 - 95.83 (3)	TP33.469x30.89x0.2813	23.18	970.52	0.024	2.85	2591.24	0.001
L4	95.83 - 81 (4)	TP35.6055x31.9655x0.375	25.48	1529.27	0.017	2.84	4455.24	0.001
L5	81 - 61 (5)	TP39.2455x35.6055x0.375	32.13	1627.35	0.020	4.05	5234.23	0.001
L6	61 - 47.83 (6)	TP41.6425x39.2455x0.375	32.94	1659.02	0.020	4.05	5512.11	0.001
L7	47.83 - 34 (7)	TP43.4095x39.7695x0.4375	37.26	2142.16	0.017	2.50	7614.46	0.000
L8	34 - 29.5833 (8)	TP44.2134x43.4095x0.4375	37.90	2167.33	0.017	2.43	7848.99	0.000
L9	29.5833 - 14.67 (9)	TP46.9276x44.2134x0.58	40.48	3190.12	0.013	1.98	12211.58	0.000
L10	14.67 - 0 (10)	TP49.5976x46.9276x0.7	43.63	4061.98	0.011	1.41	16385.17	0.000

Pole Interaction Design Data

Section No.	Elevation ft	Ratio P_u ϕP_n	Ratio M_{ux} ϕM_{rx}	Ratio M_{uy} ϕM_{ry}	Ratio V_u ϕV_n	Ratio T_u ϕT_n	Comb. Stress Ratio	Allow. Stress Ratio	Criteria
L1	150 - 130 (1)	0.004	0.094	0.000	0.010	0.000	0.098	1.000	4.8.2 ✓
L2	130 - 110 (2)	0.008	0.346	0.000	0.023	0.001	0.355	1.000	4.8.2 ✓
L3	110 - 95.83 (3)	0.010	0.474	0.000	0.024	0.001	0.484	1.000	4.8.2 ✓
L4	95.83 - 81 (4)	0.008	0.498	0.000	0.017	0.001	0.506	1.000	4.8.2 ✓
L5	81 - 61 (5)	0.010	0.662	0.000	0.020	0.001	0.672	1.000	4.8.2 ✓
L6	61 - 47.83 (6)	0.010	0.713	0.000	0.020	0.001	0.723	1.000	4.8.2 ✓

Job	0020CT11000C, Revision 4	Page	23 of 23
Project	1000Monopole	Date	082310
Client	T-Mobile	Designed by	Ian Marinaccio

Section No.	Elevation ft	Ratio P_u	Ratio M_{ux}	Ratio M_{uy}	Ratio V_u	Ratio T_u	Comb. Stress Ratio	Allow. Stress Ratio	Criteria
		ϕP_n	ϕM_{nx}	ϕM_{ny}	ϕV_n	ϕT_n			
L7	47.83 - 34 (7)	0.010	0.706	0.000	0.017	0.000	0.716	1.000	4.8.2 ✓
L8	34 - 29.5833 (8)	0.010	0.728	0.000	0.017	0.000	0.739	1.000	4.8.2 ✓
L9	29.5833 - 14.67 (9)	0.008	0.566	0.000	0.013	0.000	0.574	1.000	4.8.2 ✓
L10	14.67 - 0 (10)	0.008	0.499	0.000	0.011	0.000	0.507	1.000	4.8.2 ✓

Section Capacity Table

Section No.	Elevation ft	Component Type	Size	Critical Element	P K	ϕP_{allow} K	% Capacity	Pass Fail	
L1	150 - 130	Pole	TP27.25x23.61x0.2813	1	-6.44	1743.92	9.8	Pass	
L2	130 - 110	Pole	TP30.89x27.25x0.2813	2	-15.81	1884.92	35.5	Pass	
L3	110 - 95.83	Pole	TP33.469x30.89x0.2813	3	-19.10	1941.05	48.4	Pass	
L4	95.83 - 81	Pole	TP35.6055x31.9655x0.375	4	-23.90	3058.53	50.6	Pass	
L5	81 - 61	Pole	TP39.2455x35.6055x0.375	5	-32.15	3254.69	67.2	Pass	
L6	61 - 47.83	Pole	TP41.6425x39.2455x0.375	6	-34.05	3318.04	72.3	Pass	
L7	47.83 - 34	Pole	TP43.4095x39.7695x0.4375	7	-41.52	4284.32	71.6	Pass	
L8	34 - 29.5833	Pole	TP44.2134x43.4095x0.4375	8	-43.16	4334.66	73.9	Pass	
L9	29.5833 - 14.67	Pole	TP46.9276x44.2134x0.58	9	-51.38	6380.25	85.5	Pass	
L10	14.67 - 0	Pole	TP49.5976x46.9276x0.7	10	-62.41	8123.96	74.7	Pass	
							Summary		
							Pole (L8)	73.9	Pass
							RATING =	85.5	Pass

Reinforcing member capacity governs over pole shaft. See attached calculations.

W.O.	9927.CT11077C	Report Date:	8/23/2019
Client:	T-Mobile / Northeast Site Solutions	Revision:	4
Site Name:	Fairfield Fire Rescue #5	Prepared By:	IM

CHECK FOR REINFORCING MEMBER

SECTION	0'-14.67'		
Fy	65 ksi	Reinf. Member	(8) WT6x25
Moment @ Base	4011.7 kip-ft	Area	7.30 in ²
Y _{POLE} @ Bottom	24.81 in	Capacity	327.6 kips
Y _{REINF} @ Bottom	30.13 in		

POLE ELEVATION	Moment of Inertia (in ⁴)		
	w/o Reinforcement	w/Reinforcement	Reinforcement
Base	21396	43283	21887

Moment distribution within the pole and the reinforcing plates

AT BASE	Ratios of the moments	Approx Moment Distribution (kip-ft)	Axial Force in Plate (kips)
Pole Section	0.49	1983	
Reinforcing Plate	0.51	2029	

Max Percentage Stress of the reinforcing member = 74.7% Pass

W.O.	9927.CT11077C	Report Date:	8/23/2019
Client:	T-Mobile / Northeast Site Solutions	Revision:	4
Site Name:	Fairfield Fire Rescue #5	Prepared By:	IM

CHECK FOR REINFORCING MEMBER

SECTION	14.67'-31'		
Fy	65 ksi	Reinf. Member	(4) WT6x25
Moment @ Base	3394.5 kip-ft	Area	7.30 in ²
Y _{POLE} @ Bottom	23.4375 in	Capacity	327.6 kips
Y _{REINF} @ Bottom	28.50 in		

POLE ELEVATION	Moment of Inertia (in ⁴)		
	w/o Reinforcement	w/Reinforcement	Reinforcement
@ 14.67	18084	30239	12155

Moment distribution within the pole and the reinforcing plates

AT BASE	Ratios of the moments	Approx Moment Distribution (kip-ft)	Axial Force in Plate (kips)
Pole Section	0.60	2030	
Reinforcing Plate	0.40	1364	280

Max Percentage Stress of the reinforcing member = 85.5% Pass

Monopole Base Plate Connection



Site Info	
Site #	CT11077C
Site Name	Fairfield Fire Rescue #5
WO #	9927.CT11077C, Rev 4

Analysis Considerations	
TIA-222 Revision	G
Grout Considered	Yes
l_{ar} (in)	<input type="checkbox"/>
Eta Factor, η	<input type="checkbox"/> <input type="checkbox"/>

Applied Loads	
Moment (kip-ft)	4011.71
Axial Force (kips)	62.41
Shear Force (kips)	43.63

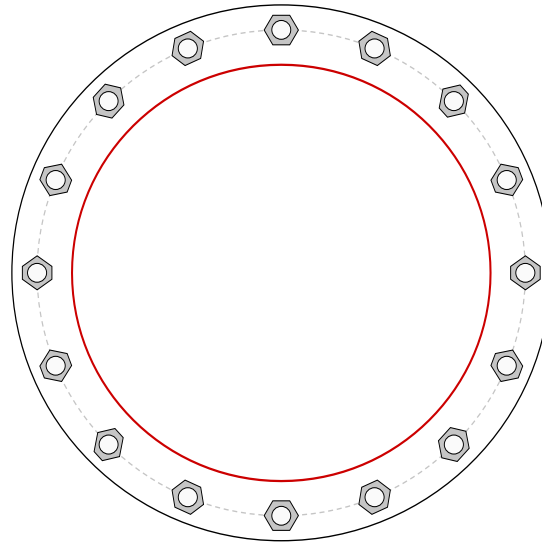

Connection Properties	Analysis Results
-----------------------	------------------

Anchor Rod Data	
(16) 2-1/4" ϕ bolts (A615-75 N; Fy=75 ksi, Fu=100 ksi) on 57.85" BC	
Base Plate Data	
63.85" OD x 2.75" Plate (A633 Gr. E; Fy=60 ksi, Fu=75 ksi)	
Stiffener Data	
N/A	
Pole Data	
49.597565" x 0.7" 12-sided pole (A572-65; Fy=65 ksi, Fu=80 ksi)	

Anchor Rod Summary		<i>(units of kips, kip-in)</i>
Pu_t = 204.01	$\phi Pn_t = 260$	Stress Rating
Vu = 2.73	$\phi Vn = n/a$	80.4%
Mu = n/a	$\phi Mn = n/a$	Pass
Base Plate Summary		
Max Stress (ksi):	28.92	(Flexural)
Allowable Stress (ksi):	54	
Stress Rating:	53.6%	Pass

Drilled Pier Foundation



BU #: CT1100C
 Site Name: Fairfield Fire Rescue #
 Order Number: 020CT1100C, Rev 4

TI0222 Revision: G
 Tower Type: Monopole

Applied Loads	
	Comp. Uplift
Moment (kip-ft)	411.1
Axial Force (kips)	2.41
Shear Force (kips)	43.3

Material Properties	
Concrete Strength, f _c	3 ksi
Rebar Strength, F _y	ksi

Pier Design Data	
Depth	20 ft
Ext. Above Grade	1 ft
Pier Section 1	
<i>From 1' above grade to 26.5' below grade</i>	
Pier Diameter	ft
Rebar Quantity	4
Rebar Size	11
Clear Cover to Ties	4 in
Tie Size	4

Analysis Results		
Soil Lateral Capacity		
D _{v=0} (ft from TOC)	0.1	
Soil Safety Factor	1.0	
Max Moment (kip-ft)	421.0	
Rating	78.1%	-
Soil Vertical Capacity		
Skin Friction (kips)	22.4	
End Bearing (kips)		
Weight of Concrete (kips)	12.8	
Total Capacity (kips)	22.4	
Axial (kips)	12.3	
Rating	73.3%	-
Reinforced Concrete Capacity		
Critical Depth (ft from TOC)		
Critical Moment (kip-ft)	421.23	
Critical Moment Capacity	11.3	
Rating	46.7%	-
Soil Interaction Rating		78.1%
Structural Foundation Rating		46.7%

Check Limitation	
Load Normalization	<input checked="" type="checkbox"/>

Soil Profile		
Groundwater Depth	ft	# of Layers 3

Layer	Top (ft)	Bottom (ft)	Thickness (ft)	γ _{soil} (pcf)	γ _{concrete} (pcf)	Cohesion (ksf)	Angle of Friction (degrees)	Calculated Ultimate Skin Friction Comp (ksf)	Calculated Ultimate Skin Friction Uplift (ksf)	Ultimate Skin Friction Comp Override (ksf)	Ultimate Skin Friction Uplift Override (ksf)	Ult. Gross Bearing Capacity (ksf)	SPT Blow Count	Soil Type
1	0	4	4	12	1									Cohesionless
2	4		1	12	1		3	8	8				2	Cohesionless
3		2	21	42	8		3						1	Cohesionless

MOUNT ANALYSIS



Job No. 9927.CT11077C, Revision 4

Sheet No.	1	of	3
Calculated By	IM	Date :	08/23/19
Checked By	EI	Date :	08/23/19

WIND AND ICE LOADS PER TIA-222-G

W.O.	9927.CT11077C, Revision 3
Project Name	Fairfield Fire Rescue #5
Location	3965 Congress Street, Fairfield, CT 06824
County	Fairfield

Tower Type	MP	Monopole
Structure Class	2	Substantial hazard
Exposure Category	B	Suburban/wooded/obstructed
Topo Category	1	Flat or rolling terrain
Height of crest	0	ft

Basic Wind Speed (3-sec gust):		
Without ice	97	mph*
With ice	50	mph
Maintenance	40	mph
Ice thickness	0.75	in

*Nominal converted from 125 mph ultimate risk cat. 2

Importance Factor	
Wind only	1.00
Wind with ice	1.00
Ice thickness	1.00
Supporting Data:	
K_e	0.90
K_t	N/A
f	N/A
z_g	1200
α	7
$K_{z,min}$	0.7
K_d	0.95
G_h	1.00

Height	z (ft)	116
	K_h	N/A
	K_{zt}	1.00
	K_z	1.03
	K_{iz}	1.13
Wind Pressure, q_z (psf)	No Ice	23.59
	With Ice	6.27
	Service	4.01
(tiz)	Ice Thk	1.70
Appurtenances ($q_z G_h$)	No Ice	23.59
	With Ice	6.27
	Service	4.01

Appurtenance Information

Effective Projected Area for Appurtenance $(EPA)_A = \text{Max}((EPA)_N, (EPA)_T)$

$(EPA)_T = \sum(C_a A_a)_T$

$(EPA)_N = \sum(C_a A_a)_N$

Reduction Factor = 0.9

Wind Only Load Combinations

Antenna Configuration	(E) or (P)	Qty per Sector	z (ft)	Length or Diameter (ft)	Width (in)	Depth (in)	Flat or Cylindrical?	Antenna $(C_a)_T$	Antenna $(C_a)_N$	Side Face $(A_a)_T$ (ft ²)	Wind ward Side Face $(CaA_a)_T$ (ft ²)	Face Normal $(A_a)_N$ (ft ²)	Windward face Normal $(CaA_a)_N$ (ft ²)	Normal Antenna Wind Load Each (lb)	Transverse Antenna Wind Load Each (lb)	Antenna Weight (lb)	Total Weight (lb)
RRU 4449 B71+B12	P	1	116	1.25	13.20	10.40	Flat	1.20	1.20	1.08	1.17	1.38	1.49	35	28	75.0	75.0
TMA	E	2	116	1.32	14.00	3.10	Flat	1.32	1.20	0.34	0.81	1.54	3.32	39	10	33.0	66.0
AIR-32 B2A/B66A	P	1	116	4.72	12.90	8.70	Flat	1.38	1.28	3.42	4.24	5.07	5.86	138	100	132.2	132.2
APXVAARR24_43-U-NA20	P	1	116	7.99	24.00	8.70	Flat	1.53	1.27	5.79	8.00	15.98	18.22	430	189	153.3	153.3
										$\sum(C_a A_a)_T$	14.22	$\sum(C_a A_a)_N$	28.88				427

Wind with Ice Load Combinations

Ice Thk= 1.70 in

Antenna Configuration	(E) or (P)	Qty per Sector	z (ft)	Length or Diameter (ft)	Width (in)	Depth (in)	Flat or Cylindrical?	Antenna $(C_a)_T$	Antenna $(C_a)_N$	Side Face $(A_a)_T$ (ft ²)	Windward Side Face $(CaA_a)_T$ (ft ²)	Face Normal $(A_a)_N$ (ft ²)	Windward Face Normal $(CaA_a)_N$ (ft ²)	Normal Antenna Wind Load Each (lb)	Transverse Antenna Wind Load Each (lb)	Ice Area for Weight (ft ²)	Ice Weight Alone (lbs)
RRU 4449 B71+B12	P	1	116	1.53	16.60	13.80	Cylindrical	0.7	0.7	1.76	1.11	2.12	1.34	8	7	4.9	39.0
TMA	E	2	116	1.60	17.40	6.50	Cylindrical	0.7	0.7	0.87	1.09	2.32	2.92	9	3	3.8	29.8
AIR-32 B2A/B66A	P	1	116	5.00	16.30	12.10	Cylindrical	0.73	0.73	5.04	3.30	6.79	4.44	28	21	17.0	134.8
APXVAARR24_43-U-NA20	P	1	116	8.28	27.40	12.10	Cylindrical	0.72	0.72	8.35	5.45	18.90	12.33	77	34	43.6	345.7
										$\sum(C_a A_a)_T$	10.94	$\sum(C_a A_a)_N$	21.03				549

Maintenance Load Combinations

Antenna Configuration	(E) or (P)	Qty per Sector	z (ft)	Length or Diameter (ft)	Width (in)	Depth (in)	Flat or Cylindrical?	Antenna $(C_a)_T$	Antenna $(C_a)_N$	Side Face $(A_a)_T$ (ft ²)	Windward Side Face $(CaA_a)_T$ (ft ²)	Face Normal $(A_a)_N$ (ft ²)	Windward Face Normal $(CaA_a)_N$ (ft ²)	Normal Antenna Wind Load Each (lb)	Transverse Antenna Wind Load Each (lb)
RRU 4449 B71+B12	P	1	116	1.25	13.20	10.40	Flat	1.20	1.20	1.08	1.17	1.38	1.49	6	5
TMA	E	2	116	1.32	14.00	3.10	Flat	1.32	1.20	0.34	0.81	1.54	3.32	7	2
AIR-32 B2A/B66A	P	1	116	4.72	12.90	8.70	Flat	1.38	1.28	3.42	4.24	5.07	5.86	24	17
APXVAARR24_43-U-NA20	P	1	116	7.99	24.00	8.70	Flat	1.53	1.27	5.79	8.00	15.98	18.22	73	32



Job No. 9927.CT11077C, Revision 4
 Sheet No. 3 of 3
 Calculated By IM Date : 08/23/19
 Checked By Date :

Existing Low-Profile Platform

Mount Center Line= 116 ft

Member lengths and widths based on mapping report by Hightower Solutions, dated 6/6/19.

Reduction Factor = 0.9

Mount Part	Quantity	Length (ft)	Projected Width (in)	Depth (in)	Flat or Cylindrical ?	Drag Factor	Projected Area (ft^2)	Wind Force (lbs/ft)	Ice Weight Area (ft^2)	Ice Weight (lbs/ft)	Projected Area with Ice (ft^2)	Wind Force Ice (lbs/ft)	Maintenance Wind Force (lbs/ft)
C5x9 - Face Horizontal	3	13.25	5.00	1.89	Flat	2	33.13	17.7	45.65	9.1	55.66	7.9	3.0
L2.5x2.5 - Exisit Handrail	3	13.25	2.50	2.50	Flat	2	16.56	8.8	33.13	6.6	39.10	5.5	1.5
2.38" OD Pipe - Mount Pipe	6	4.00	2.38	2.38	Cylindrical	1.2	5.71	5.1	14.95	4.9	13.88	3.3	0.9
2.38" OD Pipe - New Handrail	3	12.00	2.38	2.38	Cylindrical	1.2	8.57	5.1	22.42	4.9	20.81	3.3	0.9
2.38" OD Pipe - New Mount Pipe	3	8.00	2.38	2.38	Cylindrical	1.2	5.71	5.1	14.95	4.9	13.88	3.3	0.9
L4x4 - Grating Support	3	5.58	4.00	4.00	Flat	2	11.16	14.2	22.32	10.6	20.65	7.0	2.4
HSS 4x4 -Standoof	3	5.83	4.00	4.00	Cylindrical	1.2	7.00	8.5	18.31	8.3	12.95	4.2	1.4



Section Sets	
L2.5x2.5	
C300	
L4x4	
4Ttube	
2.375" Pipe	
New HSe 2.875 x .203	
Flat	

(P) SitePro1 Handrail Kit for 12" face (Part #HRK12) or approved equal to replace existing handrail. Install within 1" of the exiting rail.

Existing handrail to be removed once new pipe railing and corner pipes have been installed.

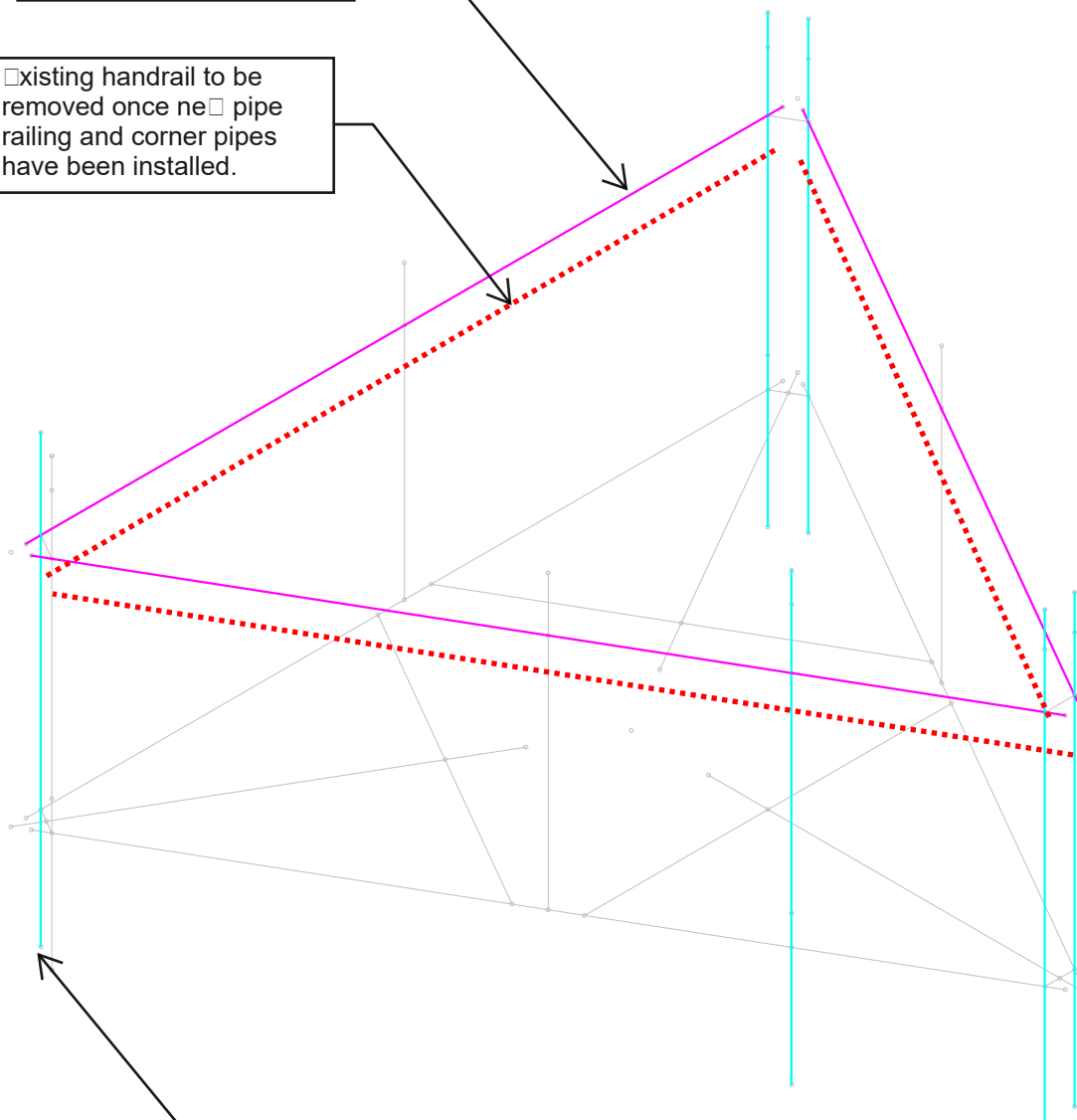

Corner pipes to be replaced with larger HSS 2.875 x .203 pipe (typ of 4)

Tectonic	Low-Profile Platform	
Ian Marinaccio		
9927.CT11077C, Rev 4		9927.CT11077C_Mod.r3.r3d

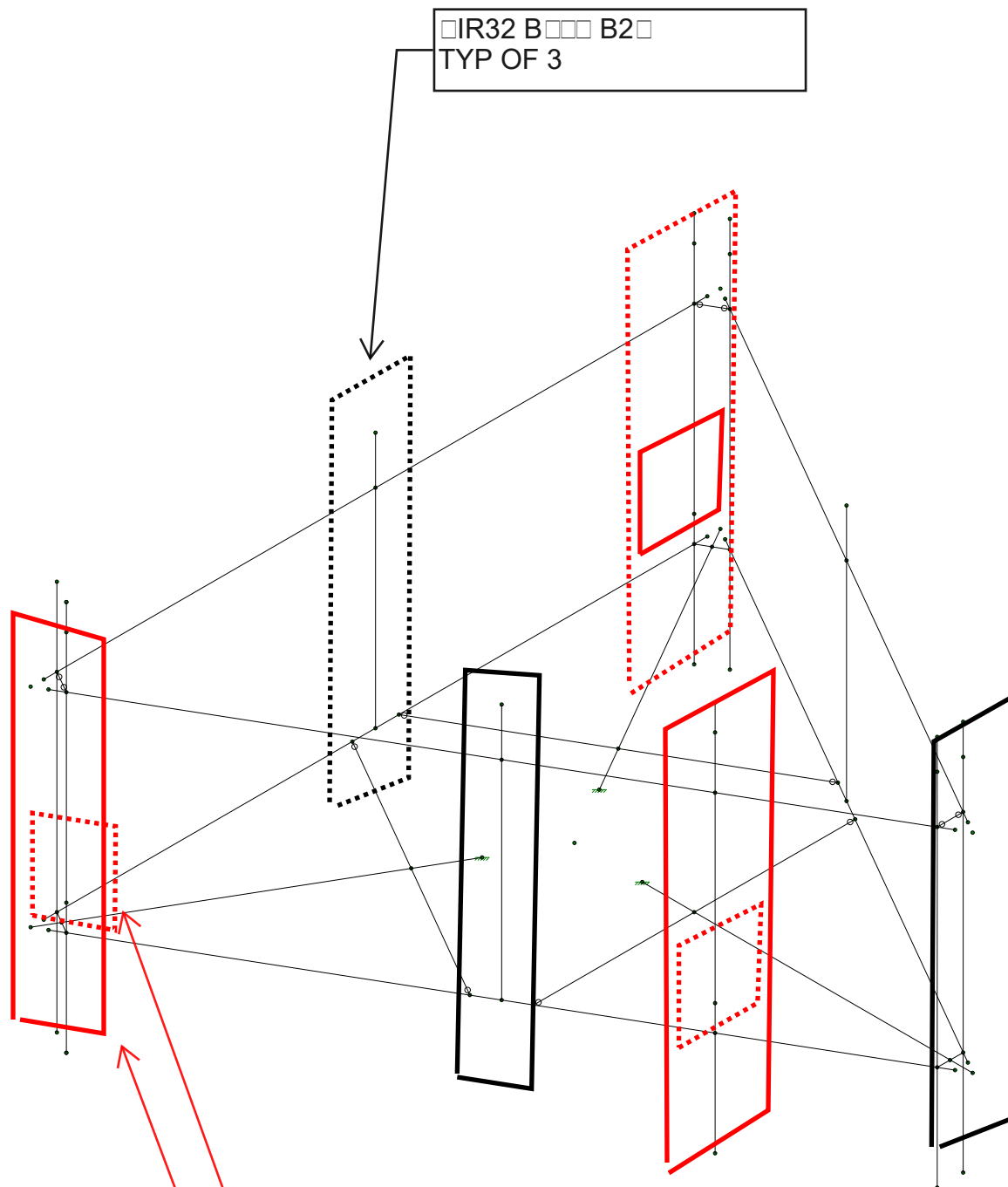

IR32 B B2
TYP OF 3

RADIO 444 B1 B12
BHI D T
TYP OF 3

PXV RR24 O
HSS 2.38 x 2.3 PIP
TYP OF 3

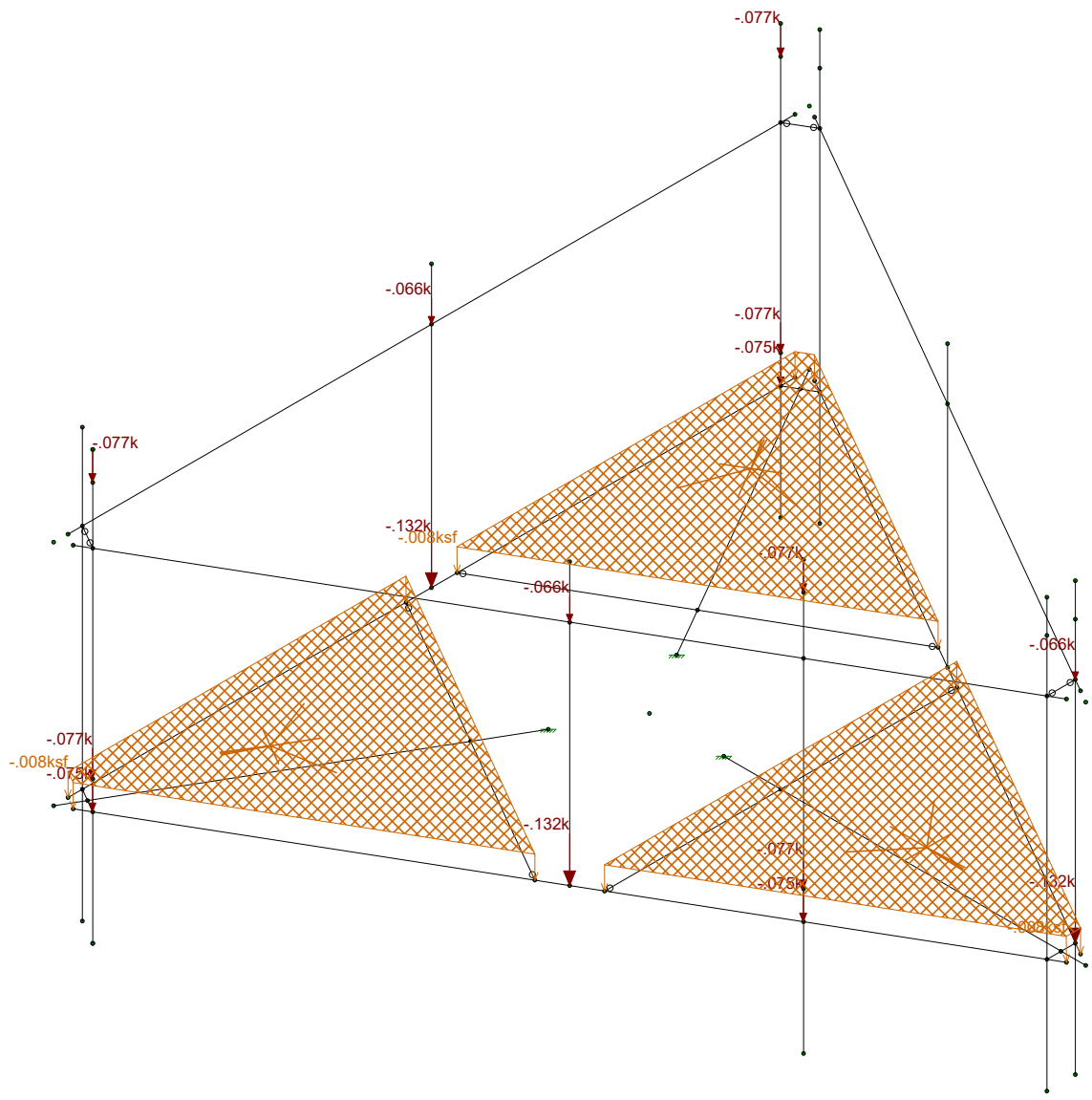

Loads: BLC 1, DL

Tectonic	Low-Profile Platform	
Ian Marinaccio		
9927.CT11077C, Rev 4		9927.CT11077C_Mod.r3.r3d

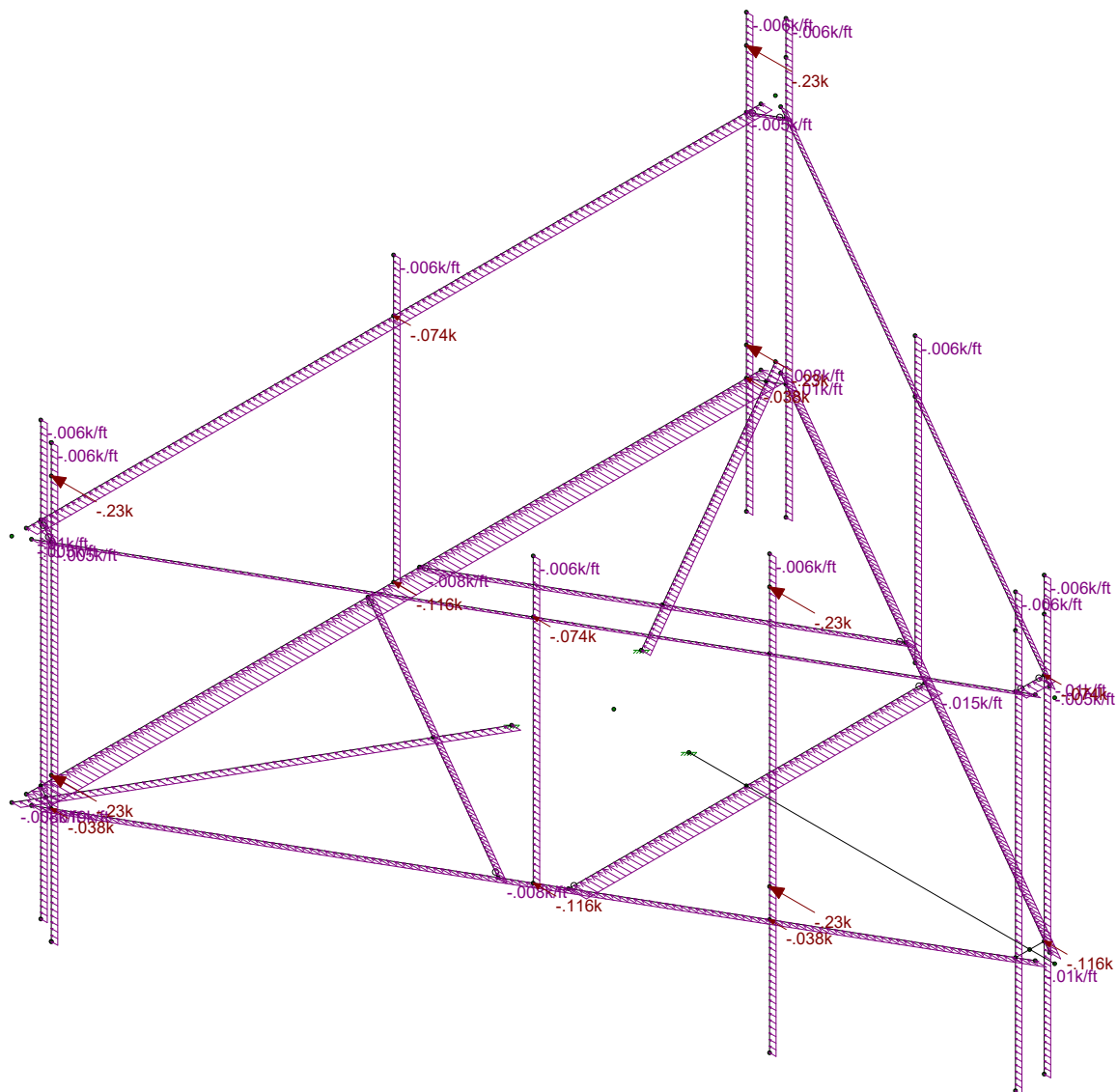

Loads: BLC 2, WLX

Tectonic	Low-Profile Platform	
Ian Marinaccio		
9927.CT11077C, Rev 4		9927.CT11077C_Mod.r3.r3d

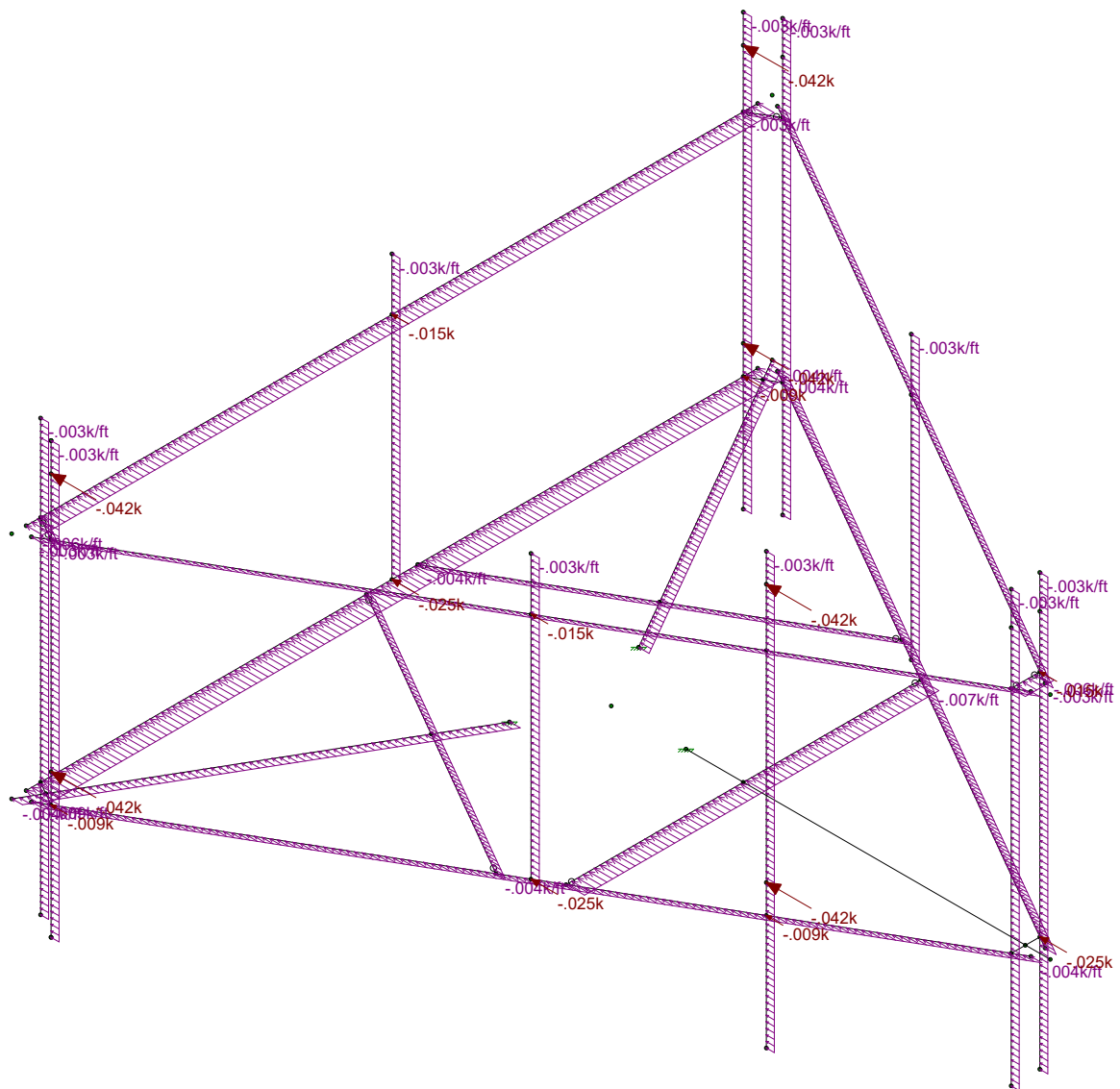

Loads: BLC 5, WLX (ICE)

Tectonic	Low-Profile Platform	
Ian Marinaccio		
9927.CT11077C, Rev 4		9927.CT11077C_Mod.r3.r3d

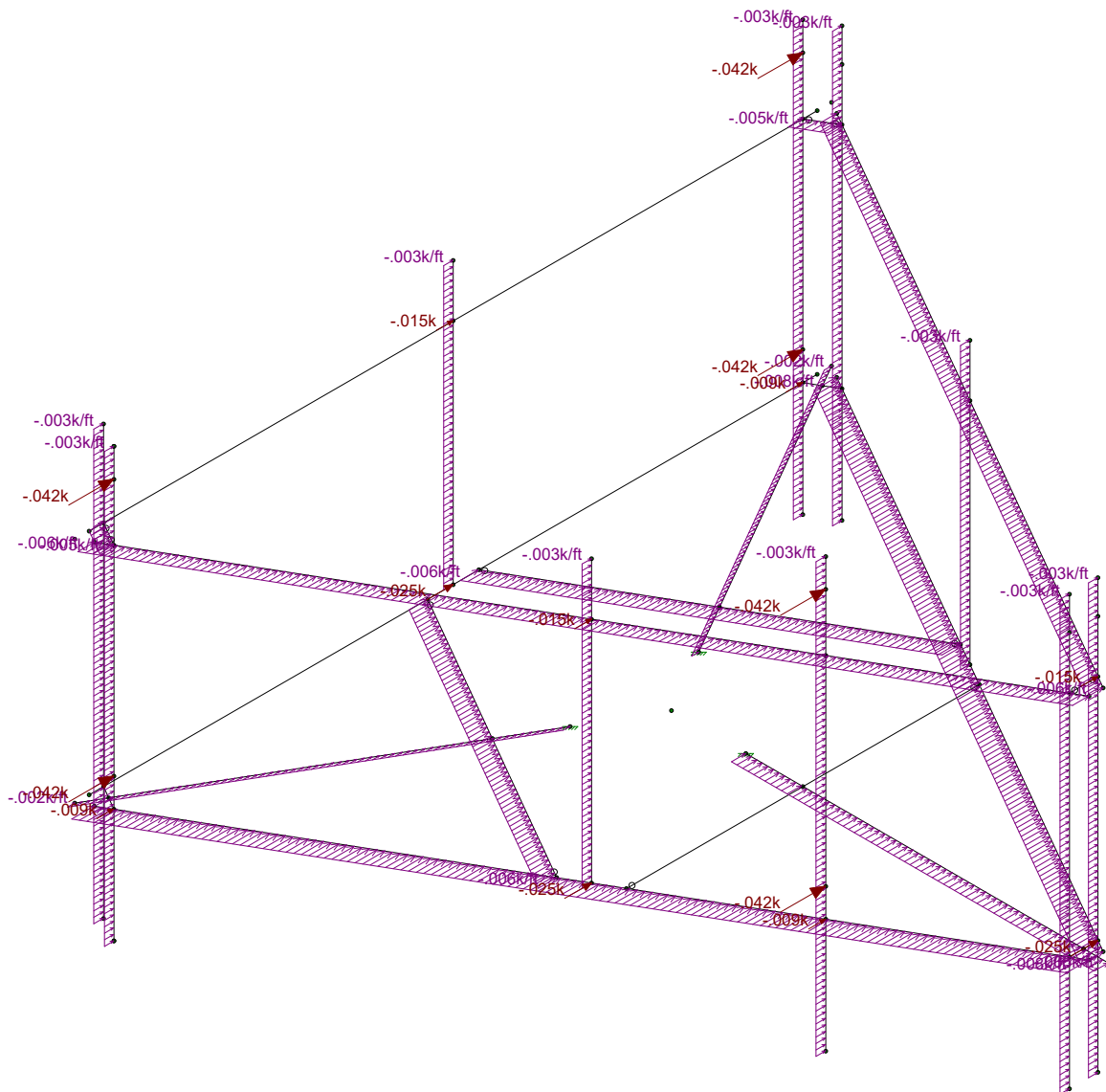

Loads: BLC 6, WLZ (ICE)

Tectonic	Low-Profile Platform	
Ian Marinaccio		
9927.CT11077C, Rev 4		9927.CT11077C_Mod.r3.r3d

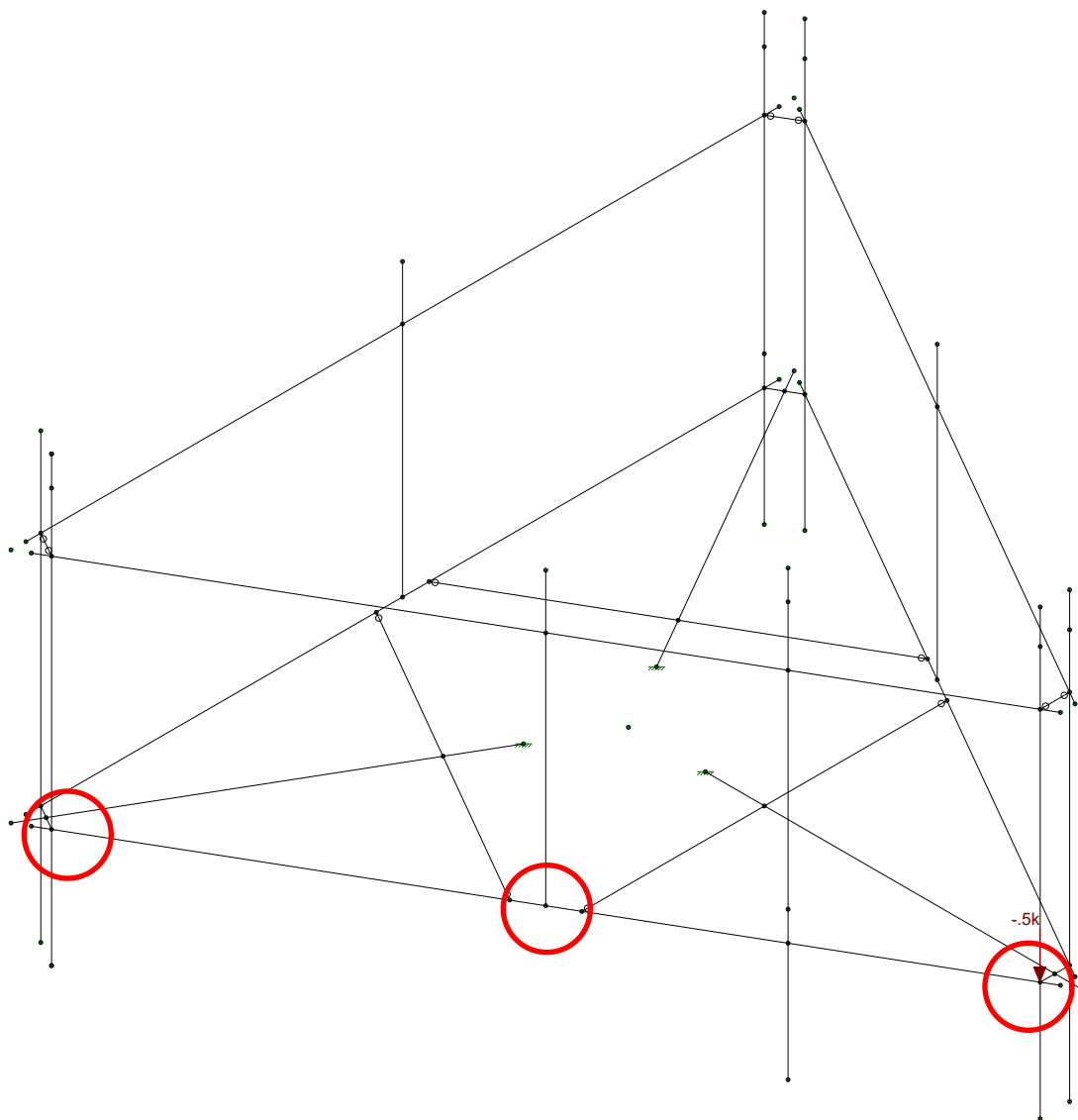

□□□ lb Man Load
Typ of 3 locations

Loads: BLC 9, Lm1

Tectonic	Low-Profile Platform	
Ian Marinaccio		
9927.CT11077C, Rev 4		9927.CT11077C_Mod.r3.r3d



Code Check (Etr)	
■	No Calc
■	> 1.0
■	50-1.0
■	75-90
■	80-75
■	0-50

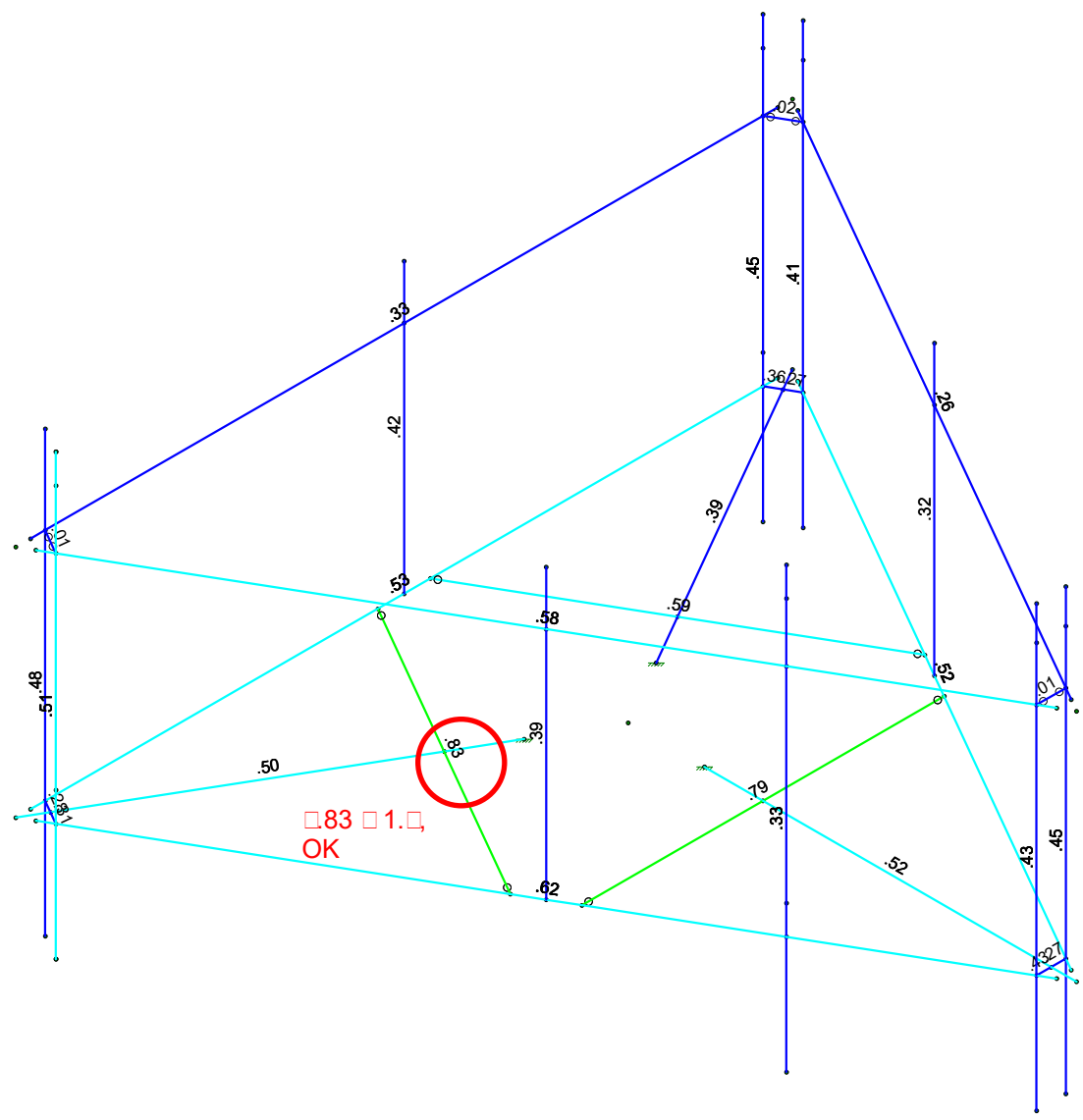

Member Code Checks Displayed (Enveloped)
Envelope Only Solution

Tectonic	Low-Profile Platform	
Ian Marinaccio		
9927.CT11077C, Rev 4		9927.CT11077C_Mod.r3.r3d



Company : Tectonic
 Designer : Ian Marinaccio
 Job Number : 9927.CT11077C, Rev 4
 Model Name : Low-Profile Platform

Checked By: _____

Hot Rolled Steel Properties

	Label	E [ksi]	G [ksi]	Nu	Therm (1...	Density[k/f...	Yield[ksi]	Ry	Fu[ksi]	Rt
1	A992	29000	11154	.3	.65	.49	50	1.1	65	1.1
2	A36 Gr.36	29000	11154	.3	.65	.49	36	1.5	58	1.2
3	A572 Gr.50	29000	11154	.3	.65	.49	50	1.1	65	1.1
4	A500 Gr.B RND	29000	11154	.3	.65	.527	42	1.4	58	1.3
5	A500 Gr.B Rect	29000	11154	.3	.65	.527	46	1.4	58	1.3
6	A53 Gr.B	29000	11154	.3	.65	.49	35	1.6	60	1.2
7	A1085	29000	11154	.3	.65	.49	50	1.4	65	1.3

Basic Load Cases

	BLC Description	Category	X Gravi...	Y Gravi...	Z Gravity	Joint	Point	Distrib...	Area(Memb...	Surface(...
1	DL	DL		-1.05		18			3	
2	WLX	WL+X				18		25		
3	WLZ	WL+Z				18		25		
4	DL (ICE)	SL				18		25		
5	WLX (ICE)	WL+X				18		25		
6	WLZ (ICE)	WL+Z				18		25		
7	WLX (MAINT)	WL+X				18		25		
8	WLZ (MAINT)	WL+Z				18		25		
9	Lm1	OL1				1				
10	Lm2	OL2				1				
11	Lm3	OL3				1				
12	BLC 1 Transient Area Loa...	None						66		

Load Combinations

	Description	Sol..P...	SRSS	BLCFa...	B...	Factor	BLC	Factor	B...	Fact..B...	Fa..B...	Fa.....
1	1.4D	Yes Y		1	1.4							
2	1.2D+1.6WLX	Yes Y		1	1.2	2	1.6					
3	1.2D+1.6WLZ	Yes Y		1	1.2	3	1.6					
4	1.2D+1.6(WLX+WLZ) - 0 Deg	Yes Y		1	1.2	2	1.6					
5	1.2D+1.6(WLX+WLZ) - 30 Deg	Yes Y		1	1.2	2	1.385	3	.8			
6	1.2D+1.6(WLX+WLZ) - 60 Deg	Yes Y		1	1.2	2	.8	3	1.385			
7	1.2D+1.6(WLX+WLZ) - 90 Deg	Yes Y		1	1.2	2		3	1.6			
8	1.2D+1.6(WLX+WLZ) - 120 Deg	Yes Y		1	1.2	2	-.8	3	1.385			
9	1.2D+1.6(WLX+WLZ) - 150 Deg	Yes Y		1	1.2	2	-1.385	3	.8			
10	1.2D+1.6(WLX+WLZ) - 180 Deg	Yes Y		1	1.2	2	-1.6	3				
11	1.2D+1.6(WLX+WLZ) - 210 Deg	Yes Y		1	1.2	2	-1.385	3	-.8			
12	1.2D+1.6(WLX+WLZ) - 240 Deg	Yes Y		1	1.2	2	-.8	3	-1.385			
13	1.2D+1.6(WLX+WLZ) - 270 Deg	Yes Y		1	1.2	2		3	-1.6			
14	1.2D+1.6(WLX+WLZ) - 300 Deg	Yes Y		1	1.2	2	.8	3	-1.385			
15	1.2D+1.6(WLX+WLZ) - 330 Deg	Yes Y		1	1.2	2	1.385	3	-.8			
16	**Wind Load with Ice**											
17	1.2D+1.0Di+1.0WLXi	Yes Y		1	1.2	4	1	5	1			
18	1.2D+1.0Di+1.0WLZi	Yes Y		1	1.2	4	1		6	1		
19	1.2D+1.0Di+1.0(WLXi+WLZi) - 0 Deg	Yes Y		1	1.2	4	1	5	1	6		
20	1.2D+1.0Di+1.0(WLXi+WLZi) - 30 Deg	Yes Y		1	1.2	4	1	5	.87	6	.5	
21	1.2D+1.0Di+1.0(WLXi+WLZi) - 60 Deg	Yes Y		1	1.2	4	1	5	.5	6	.87	
22	1.2D+1.0Di+1.0(WLXi+WLZi) - 90 Deg	Yes Y		1	1.2	4	1	5		6	1	
23	1.2D+1.0Di+1.0(WLXi+WLZi) - 120 Deg	Yes Y		1	1.2	4	1	5	-.5	6	.87	
24	1.2D+1.0Di+1.0(WLXi+WLZi) - 150 Deg	Yes Y		1	1.2	4	1	5	-.87	6	.5	
25	1.2D+1.0Di+1.0(WLXi+WLZi) - 180 Deg	Yes Y		1	1.2	4	1	5	-1	6		
26	1.2D+1.0Di+1.0(WLXi+WLZi) - 210 Deg	Yes Y		1	1.2	4	1	5	-.87	6	-.5	
27	1.2D+1.0Di+1.0(WLXi+WLZi) - 240 Deg	Yes Y		1	1.2	4	1	5	-.5	6	-.87	
28	1.2D+1.0Di+1.0(WLXi+WLZi) - 270 Deg	Yes Y		1	1.2	4	1	5		6	-1	



Load Combinations (Continued)

	Description	Sol.	P...	SRSS	BLC	Fa...	B...	Factor	BLC	Factor	B...	Fact...	B...	Fa...	B...	Fa...
29	1.2D+1.0Di+1.0(WLXi+WLZi) - 300 Deg	Yes	Y		1	1.2	4	1	5	.5	6	-87				
30	1.2D+1.0Di+1.0(WLXi+WLZi) - 330 Deg	Yes	Y		1	1.2	4	1	5	.87	6	-5				
31	**Maintenance Load (With Service Load)**...		Y													
32	1.2D+1.5Lm1+1.0WLX (service)	Yes	Y		1	1.2	9	1.5	7	1	8					
33	1.2D+1.5Lm1+1.0WLZ (service)	Yes	Y		1	1.2	9	1.5	7		8	1				
34	1.2D+1.5Lm1+1.0(WLX+WLZ, Service) - 0...	Yes	Y		1	1.2	9	1.5	7	1	8					
35	1.2D+1.5Lm1+1.0(WLX+WLZ, Service) - 3...	Yes	Y		1	1.2	9	1.5	7	.87	8	.5				
36	1.2D+1.5Lm1+1.0(WLX+WLZ, Service) - 6...	Yes	Y		1	1.2	9	1.5	7	.5	8	.87				
37	1.2D+1.5Lm1+1.0(WLX+WLZ, Service) - 9...	Yes	Y		1	1.2	9	1.5	7		8	1				
38	1.2D+1.5Lm1+1.0(WLX+WLZ, Service) - 1...	Yes	Y		1	1.2	9	1.5	7	-5	8	.87				
39	1.2D+1.5Lm1+1.0(WLX+WLZ, Service) - 1...	Yes	Y		1	1.2	9	1.5	7	-87	8	.5				
40	1.2D+1.5Lm1+1.0(WLX+WLZ, Service) - 1...	Yes	Y		1	1.2	9	1.5	7	-1	8					
41	1.2D+1.5Lm1+1.0(WLX+WLZ, Service) - 2...	Yes	Y		1	1.2	9	1.5	7	-87	8	-5				
42	1.2D+1.5Lm1+1.0(WLX+WLZ, Service) - 2...	Yes	Y		1	1.2	9	1.5	7	-5	8	-87				
43	1.2D+1.5Lm1+1.0(WLX+WLZ, Service) - 2...	Yes	Y		1	1.2	9	1.5	7		8	-1				
44	1.2D+1.5Lm1+1.0(WLX+WLZ, Service) - 3...	Yes	Y		1	1.2	9	1.5	7	.5	8	-87				
45	1.2D+1.5Lm1+1.0(WLX+WLZ, Service) - 3...	Yes	Y		1	1.2	9	1.5	7	.87	8	-5				
46	**Maintenance Load (With Service Load)**...		Y													
47	1.2D+1.5Lm2+1.0WLX (service)	Yes	Y		1	1.2	10	1.5	7	1	8					
48	1.2D+1.5Lm2+1.0WLZ (service)	Yes	Y		1	1.2	10	1.5	7		8	1				
49	1.2D+1.5Lm2+1.0(WLX+WLZ, Service) - 0...	Yes	Y		1	1.2	10	1.5	7	1	8					
50	1.2D+1.5Lm2+1.0(WLX+WLZ, Service) - 3...	Yes	Y		1	1.2	10	1.5	7	.87	8	.5				
51	1.2D+1.5Lm2+1.0(WLX+WLZ, Service) - 6...	Yes	Y		1	1.2	10	1.5	7	.5	8	.87				
52	1.2D+1.5Lm2+1.0(WLX+WLZ, Service) - 9...	Yes	Y		1	1.2	10	1.5	7		8	1				
53	1.2D+1.5Lm2+1.0(WLX+WLZ, Service) - 1...	Yes	Y		1	1.2	10	1.5	7	-5	8	.87				
54	1.2D+1.5Lm2+1.0(WLX+WLZ, Service) - 1...	Yes	Y		1	1.2	10	1.5	7	-87	8	.5				
55	1.2D+1.5Lm2+1.0(WLX+WLZ, Service) - 1...	Yes	Y		1	1.2	10	1.5	7	-1	8					
56	1.2D+1.5Lm2+1.0(WLX+WLZ, Service) - 2...	Yes	Y		1	1.2	10	1.5	7	-87	8	-5				
57	1.2D+1.5Lm2+1.0(WLX+WLZ, Service) - 2...	Yes	Y		1	1.2	10	1.5	7	-5	8	-87				
58	1.2D+1.5Lm2+1.0(WLX+WLZ, Service) - 2...	Yes	Y		1	1.2	10	1.5	7		8	-1				
59	1.2D+1.5Lm2+1.0(WLX+WLZ, Service) - 3...	Yes	Y		1	1.2	10	1.5	7	.5	8	-87				
60	1.2D+1.5Lm2+1.0(WLX+WLZ, Service) - 3...	Yes	Y		1	1.2	10	1.5	7	.87	8	-5				
61	**Maintenance Load (With Service Load)**...		Y													
62	1.2D+1.5Lm3+1.0WLX (service)	Yes	Y		1	1.2	11	1.5	7	1	8					
63	1.2D+1.5Lm3+1.0WLZ (service)	Yes	Y		1	1.2	11	1.5	7		8	1				
64	1.2D+1.5Lm3+1.0(WLX+WLZ, Service) - 0...	Yes	Y		1	1.2	11	1.5	7	1	8					
65	1.2D+1.5Lm3+1.0(WLX+WLZ, Service) - 3...	Yes	Y		1	1.2	11	1.5	7	.87	8	.5				
66	1.2D+1.5Lm3+1.0(WLX+WLZ, Service) - 6...	Yes	Y		1	1.2	11	1.5	7	.5	8	.87				
67	1.2D+1.5Lm3+1.0(WLX+WLZ, Service) - 9...	Yes	Y		1	1.2	11	1.5	7		8	1				
68	1.2D+1.5Lm3+1.0(WLX+WLZ, Service) - 1...	Yes	Y		1	1.2	11	1.5	7	-5	8	.87				
69	1.2D+1.5Lm3+1.0(WLX+WLZ, Service) - 1...	Yes	Y		1	1.2	11	1.5	7	-87	8	.5				
70	1.2D+1.5Lm3+1.0(WLX+WLZ, Service) - 1...	Yes	Y		1	1.2	11	1.5	7	-1	8					
71	1.2D+1.5Lm3+1.0(WLX+WLZ, Service) - 2...	Yes	Y		1	1.2	11	1.5	7	-87	8	-5				
72	1.2D+1.5Lm3+1.0(WLX+WLZ, Service) - 2...	Yes	Y		1	1.2	11	1.5	7	-5	8	-87				
73	1.2D+1.5Lm3+1.0(WLX+WLZ, Service) - 2...	Yes	Y		1	1.2	11	1.5	7		8	-1				
74	1.2D+1.5Lm3+1.0(WLX+WLZ, Service) - 3...	Yes	Y		1	1.2	11	1.5	7	.5	8	-87				
75	1.2D+1.5Lm3+1.0(WLX+WLZ, Service) - 3...	Yes	Y		1	1.2	11	1.5	7	.87	8	-5				

Hot Rolled Steel Section Sets

	Label	Shape	Type	Design List	Material	Desig...	A [in2]	Iyy [i...	Izz [i...	J [in4]
1	L2.5x2.5	L2.5x2.5x3	None	None	A36 Gr.36	Typical	.901	.535	.535	.011
2	C5x9	C5X9	None	None	A36 Gr.36	Typical	2.64	.624	8.89	.109
3	L4x4	L4X4X4	None	None	A36 Gr.36	Typical	1.93	3	3	.044
4	4"Tube	HSS4X4X3	None	None	A500 Gr.B R...	Typical	2.58	6.21	6.21	10
5	2.375" Pipe	HSS2.375X0.154	None	None	A53 Gr.B	Typical	1	.627	.627	1.25



Company : Tectonic
 Designer : Ian Marinaccio
 Job Number : 9927.CT11077C, Rev 4
 Model Name : Low-Profile Platform

Checked By: _____

Hot Rolled Steel Section Sets (Continued)

	Label	Shape	Type	Design List	Material	Desig...	A [in ²]	I _{yy} [i...]	I _{zz} [i...]	J [in ⁴]
6	New HSs 2.875 x 2...	HSS2.875X0.203	None	None	A53 Gr.B	Typical	1.59	1.45	1.45	2.89
7	Flat	10	None	None	A36 Gr.36	Typical	5	.104	41.667	.404

Envelope Joint Reactions

	Joint	X [k]	LC	Y [k]	LC	Z [k]	LC	MX [k-ft]	LC	MY [k-ft]	LC	MZ [k-ft]	LC	
1	N34A	max	1.606	15	2.621	29	2.129	8	1.205	7	1.319	5	1.418	10
2		min	-2.086	9	.165	8	-1.34	14	-5.247	13	-1.459	11	-3.254	2
3	N33A	max	3.4	4	2.466	25	1.54	7	2.037	7	1.488	13	5.674	10
4		min	-2.488	10	.182	2	-1.53	13	-2.619	13	-1.313	3	-1.03	2
5	N32A	max	.944	6	1.984	21	2.116	6	3.763	7	.481	8	1.674	10
6		min	-1.384	12	-.089	12	-2.924	12	-1.179	13	-.533	14	-3.39	2
7	Totals:	max	5.555	4	6.47	30	5.379	7						
8		min	-5.555	10	3.448	2	-5.379	13						

Envelope AISC 15th(360-16): LRFD Steel Code Checks

Member	Shape	Co...	Loc[ft]	LC	Shear ...	Loc[ft]	Dir	LC	phi*...	phi*...	phi*Mn y-y [k-ft]	phi*...	Eqn	
1	M1	C5X9	.535	5.844	4	.090	5.977	z	10	6.022	85.5...	1.909	11.0...	H1-
2	M2	C5X9	.521	6.906	9	.066	6.375	y	13	6.022	85.5...	1.909	10.6...	H1-
3	M3	C5X9	.621	3.453	12	.128	3.32	y	6	6.022	85.5...	1.909	11.8...	H1-
4	M4	HSS2.375X0.1...	.332	12.484	13	.135	6.375		14	6.051	31.5	1.872	1.872	H1-
5	M5	HSS2.375X0.1...	.259	12.484	11	.171	6.375		6	6.051	31.5	1.872	1.872	H1-
6	M6	HSS2.375X0.1...	.577	9.43	6	.218	12.484		12	6.051	31.5	1.872	1.872	H1-
7	M12	HSS2.375X0.1...	.320	4.917	5	.154	4.917		5	23.7...	31.5	1.872	1.872	H1-
8	M16A	HSS4X4X3	.387	6.35	6	.244	6.35	y	4	90.8...	106...	12.662	12.6...	H1-
9	M17A	HSS4X4X3	.517	6.35	9	.299	6.35	z	13	90.8...	106...	12.662	12.6...	H1-
10	M18A	HSS4X4X3	.503	6.35	12	.302	6.35	y	12	90.8...	106...	12.662	12.6...	H3-6
11	M19	L4X4X4	.794	3.089	26	.096	3.089	y	12	39.0...	62.5...	3.138	6.028	H2-1
12	M20	L4X4X4	.591	3.089	21	.076	3.024	y	5	39.0...	62.5...	3.138	6.003	H2-1
13	M21	L4X4X4	.829	3.089	29	.095	3.089	y	12	39.0...	62.5...	3.138	6.008	H2-1
14	M26	L2.5x2.5x3	.014	.25	11	.361	0	y	6	28.0...	29.1...	.873	1.972	H2-1
15	M26A	10	.268	0	13	.759	0	y	4	158...	162	1.688	33.75	H1-
16	M27A	10	.267	.25	9	.814	.25	y	12	158...	162	1.688	33.75	H1-
17	M28	10	.427	0	5	.914	0	y	7	158...	162	1.688	33.2...	H1-
18	M30	10	.278	0	4	.927	0	y	12	158...	162	1.688	33.75	H1-
19	M31	HSS2.375X0.1...	.416	4.917	13	.135	4.917		7	23.7...	31.5	1.872	1.872	H1-
20	M29A	HSS2.875X0.2...	.447	5.469	10	.108	5.469		11	31.7...	50.0...	3.596	3.596	H1-
21	M29B	L2.5x2.5x3	.015	.26	5	.351	.5	z	10	28.0...	29.1...	.873	1.972	H2-1
22	M30A	10	.358	.25	11	.751	.25	y	10	158...	162	1.688	33.6...	H1-
23	M31A	HSS2.875X0.2...	.331	5.469	15	.222	5.469		6	31.7...	50.0...	3.596	3.596	H1-
24	M31B	HSS2.375X0.1...	.390	4.917	9	.091	4.917		9	23.7...	31.5	1.872	1.872	H1-
25	M29	L2.5x2.5x3	.014	.271	13	.429	.5	y	6	28.0...	29.1...	.873	1.972	H2-1
26	M30B	10	.314	.25	7	.946	.25	y	5	158...	162	1.688	33.6...	H1-
27	M31C	HSS2.875X0.2...	.484	5.469	6	.105	5.469		10	31.7...	50.0...	3.596	3.596	H1-
28	M28A	HSS2.875X0.2...	.453	5.469	6	.096	5.469		5	31.7...	50.0...	3.596	3.596	H1-
29	M29C	HSS2.875X0.2...	.409	5.469	10	.102	5.469		11	31.7...	50.0...	3.596	3.596	H1-
30	M30C	HSS2.875X0.2...	.512	5.469	6	.144	5.469		6	31.7...	50.0...	3.596	3.596	H1-
31	M31D	HSS2.875X0.2...	.431	5.469	6	.220	5.469		6	31.7...	50.0...	3.596	3.596	H1-

Maximum member stress is at 83% of its capacity; therefore, the existing mount members are adequate to support the proposed installation. In order for the results of this analysis to be valid, a handrail kit (SitePro1 #HRK12, or approved equal) must be installed prior to the installation of the proposed equipment.

Design connection per AISC Steel Manual [LRFD]

Connection Details

Bolts	
Quantity =	4
Diameter =	0.625
Vertical Spacing =	6 in (assumed)
Horizontal Spacing =	6 in (assumed)
Grade =	A325
F_{nt} =	90 ksi
F_{nv} =	54 ksi

Loading Details

Node N33A	
Shear, Z =	1.54 k
Shear, Y =	2.466 k
Tension, X =	2.488 k
Mz =	5.674 k-ft
My =	1.488 k-ft
Mx =	2.619 k-ft
	[Table J3.2]
	[Table J3.2]

1 - Tensile Capacity

$$\phi R_{nt} = F_{nt} A_b \quad \text{[Eqn. J3-1]}$$

ϕ =	0.75
F_{nt} =	90 ksi
A_b =	0.307 in ²
ϕR_{nt} =	20.72 k
T_{max} =	7.78 k

Rnt > Tmax

38%

OK

2 - Shear Capacity

$$\phi R_{nv} = F_{nv} A_b \quad \text{[Eqn. J3-1]}$$

ϕ =	0.75
F_{nv} =	54 ksi
A_b =	0.307 in ²
ϕR_{nv} =	12.43 k
V_{max} =	4.43 k

Rnv > Vmax

36%

OK

3 - Combined Tension and Shear Capacity

$$\phi R'_{nt} = F'_{nt} A_b \quad \text{[Eqn. J3-2]}$$

$$F'_{nt} = 1.3F_{nt} - \frac{F_{nt}}{\phi F_{nv}} f_{rv} \leq F_{nt} \quad \text{[Eqn. J3-3a]}$$

ϕ =	0.75
F'_{nt} =	85 ksi
A_b =	0.307 in ²
$\phi R'_{nt}$ =	19.55 k
T_{max} =	7.78 k

R'nt > Tmax

40%

OK

Exhibit E



RADIO FREQUENCY EMISSIONS ANALYSIS REPORT EVALUATION OF HUMAN EXPOSURE POTENTIAL TO NON-IONIZING EMISSIONS

T-Mobile Existing Facility

Site ID: CT11077C

Fairfield Fire Rescue #5
3965 Congress Street
Fairfield, Connecticut 06824

May 22, 2019

EBI Project Number: 6219001727

Site Compliance Summary	
Compliance Status:	COMPLIANT
Site total MPE% of FCC general population allowable limit:	24.19%

May 22, 2019

T-Mobile

Attn: Jason Overbey, RF Manager
35 Griffin Road South
Bloomfield, Connecticut 06002

Emissions Analysis for Site: CT11077C - Fairfield Fire Rescue #5

EBI Consulting was directed to analyze the proposed T-Mobile facility located at **3965 Congress Street** in **Fairfield, Connecticut** for the purpose of determining whether the emissions from the Proposed T-Mobile Antenna Installation located on this property are within specified federal limits.

All information used in this report was analyzed as a percentage of current Maximum Permissible Exposure (% MPE) as listed in the FCC OET Bulletin 65 Edition 97-01 and ANSI/IEEE Std C95.1. The FCC regulates Maximum Permissible Exposure in units of microwatts per square centimeter ($\mu\text{W}/\text{cm}^2$). The number of $\mu\text{W}/\text{cm}^2$ calculated at each sample point is called the power density. The exposure limit for power density varies depending upon the frequencies being utilized. Wireless Carriers and Paging Services use different frequency bands each with different exposure limits; therefore, it is necessary to report results and limits in terms of percent MPE rather than power density.

All results were compared to the FCC (Federal Communications Commission) radio frequency exposure rules, 47 CFR 1.1307(b)(1) – (b)(3), to determine compliance with the Maximum Permissible Exposure (MPE) limits for General Population/Uncontrolled environments as defined below.

General population/uncontrolled exposure limits apply to situations in which the general population may be exposed or in which persons who are exposed as a consequence of their employment may not be made fully aware of the potential for exposure or cannot exercise control over their exposure. Therefore, members of the general population would always be considered under this category when exposure is not employment related, for example, in the case of a telecommunications tower that exposes persons in a nearby residential area.

Public exposure to radio frequencies is regulated and enforced in units of microwatts per square centimeter ($\mu\text{W}/\text{cm}^2$). The general population exposure limits for the 600 MHz and 700 MHz frequency bands are approximately $400 \mu\text{W}/\text{cm}^2$ and $467 \mu\text{W}/\text{cm}^2$, respectively. The general population exposure limit for the 1900 MHz (PCS), 2100 MHz (AWS) and 11 GHz frequency bands is $1000 \mu\text{W}/\text{cm}^2$. Because each carrier will be using different frequency bands, and each frequency band has different exposure limits, it is necessary to report percent of MPE rather than power density.

Occupational/controlled exposure limits apply to situations in which persons are exposed as a consequence of their employment and in which those persons who are exposed have been made fully aware of the potential for exposure and can exercise control over their exposure. Occupational/controlled exposure limits also apply where exposure is of a transient nature as a result of incidental passage through a location where exposure levels may be above general population/uncontrolled limits (see below), as long as the exposed person has been made fully aware of the potential for exposure and can exercise control over his or her exposure by leaving the area or by some other appropriate means.

Additional details can be found in FCC OET 65.

CALCULATIONS

Calculations were done for the proposed T-Mobile Wireless antenna facility located at 3965 Congress Street in Fairfield, Connecticut using the equipment information listed below. All calculations were performed per the specifications under FCC OET 65. Since T-Mobile is proposing highly focused directional panel antennas, which project most of the emitted energy out toward the horizon, all calculations were performed assuming a lobe representing the maximum gain of the antenna per the antenna manufacturer's supplied specifications, minus 10 dB for directional panel antennas and 20 dB for highly focused parabolic microwave dishes, was focused at the base of the tower. For this report, the sample point is the top of a 6-foot person standing at the base of the tower.

For all calculations, all equipment was calculated using the following assumptions:

- 1) 2 LTE channels (600 MHz Band) were considered for each sector of the proposed installation. These Channels have a transmit power of 30 Watts per Channel.
- 2) 2 LTE channels (700 MHz Band) were considered for each sector of the proposed installation. These Channels have a transmit power of 30 Watts per Channel.
- 3) 4 GSM channels (PCS Band - 1900 MHz) were considered for each sector of the proposed installation. These Channels have a transmit power of 30 Watts per Channel.
- 4) 2 LTE channels (PCS Band - 1900 MHz) were considered for each sector of the proposed installation. These Channels have a transmit power of 60 Watts per Channel.
- 5) 2 UMTS channels (AWS Band - 2100 MHz) were considered for each sector of the proposed installation. These Channels have a transmit power of 30 Watts per Channel.

- 6) 2 LTE channels (AWS Band – 2100 MHz) were considered for each sector of the proposed installation. These Channels have a transmit power of 60 Watts per Channel.
- 7) All radios at the proposed installation were considered to be running at full power and were uncombined in their RF transmissions paths per carrier prescribed configuration. Per FCC OET Bulletin No. 65 - Edition 97-01 recommendations to achieve the maximum anticipated value at each sample point, all power levels emitting from the proposed antenna installation are increased by a factor of 2.56 to account for possible in-phase reflections from the surrounding environment. This is rarely the case, and if so, is never continuous.
- 8) For the following calculations, the sample point was the top of a 6-foot person standing at the base of the tower. The maximum gain of the antenna per the antenna manufacturer's supplied specifications, minus 10 dB for directional panel antennas and 20 dB for highly focused parabolic microwave dishes, was used in this direction. This value is a very conservative estimate as gain reductions for these particular antennas are typically much higher in this direction.
- 9) The antennas used in this modeling are the Ericsson AIR32 B66A_B2A for the 2100 MHz / 1900 MHz channel(s), the RFS APXVAARR24_43-U-NA20 for the 600 MHz / 700 MHz / 1900 MHz channel(s) in Sector A, the Ericsson AIR32 B66A_B2A for the 2100 MHz / 1900 MHz channel(s), the RFS APXVAARR24_43-U-NA20 for the 600 MHz / 700 MHz / 1900 MHz / 2100 MHz channel(s) in Sector B, the Ericsson AIR32 B66A_B2A for the 2100 MHz / 1900 MHz channel(s), the RFS APXVAARR24_43-U-NA20 for the 600 MHz / 700 MHz / 1900 MHz / 2100 MHz channel(s) in Sector C. This is based on feedback from the carrier with regard to anticipated antenna selection. All Antenna gain values and associated transmit power levels are shown in the Site Inventory and Power Data table below. The maximum gain of the antenna per the antenna manufacturer's supplied specifications, minus 10 dB for directional panel antennas and 20 dB for highly focused parabolic microwave dishes, was used for all calculations. This value is a very conservative estimate as gain reductions for these particular antennas are typically much higher in this direction.
- 10) The antenna mounting height centerline of the proposed antennas is 116 feet above ground level (AGL).
- 11) Emissions values for additional carriers were taken from the Connecticut Siting Council active database. Values in this database are provided by the individual carriers themselves.
- 12) All calculations were done with respect to uncontrolled / general population threshold limits.

T-Mobile Site Inventory and Power Data

Sector:	A	Sector:	B	Sector:	C
Antenna #:	1	Antenna #:	1	Antenna #:	1
Make / Model:	Ericsson AIR32 B66A_B2A	Make / Model:	Ericsson AIR32 B66A_B2A	Make / Model:	Ericsson AIR32 B66A_B2A
Frequency Bands:	2100 MHz / 1900 MHz	Frequency Bands:	2100 MHz / 1900 MHz	Frequency Bands:	2100 MHz / 1900 MHz
Gain:	15.85 dBd / 15.35 dBd	Gain:	15.85 dBd / 15.35 dBd	Gain:	15.85 dBd / 15.35 dBd
Height (AGL):	116 feet	Height (AGL):	116 feet	Height (AGL):	116 feet
Channel Count:	4	Channel Count:	4	Channel Count:	4
Total TX Power (W):	240 Watts	Total TX Power (W):	240 Watts	Total TX Power (W):	240 Watts
ERP (W):	8,728.31	ERP (W):	8,728.31	ERP (W):	8,728.31
Antenna A1 MPE %:	2.33%	Antenna B1 MPE %:	2.33%	Antenna C1 MPE %:	2.33%
Antenna #:	2	Antenna #:	2	Antenna #:	2
Make / Model:	RFS APXVAARR24_43-U-NA20	Make / Model:	RFS APXVAARR24_43-U-NA20	Make / Model:	RFS APXVAARR24_43-U-NA20
Frequency Bands:	600 MHz / 700 MHz / 1900 MHz	Frequency Bands:	600 MHz / 700 MHz / 1900 MHz / 2100 MHz	Frequency Bands:	600 MHz / 700 MHz / 1900 MHz / 2100 MHz
Gain:	12.95 dBd / 13.35 dBd / 15.65 dBd / 16.35 dBd	Gain:	12.95 dBd / 13.35 dBd / 15.65 dBd / 16.35 dBd	Gain:	12.95 dBd / 13.35 dBd / 15.65 dBd / 16.35 dBd
Height (AGL):	116 feet	Height (AGL):	116 feet	Height (AGL):	116 feet
Channel Count:	10	Channel Count:	10	Channel Count:	10
Total TX Power (W):	300 Watts	Total TX Power (W):	300 Watts	Total TX Power (W):	300 Watts
ERP (W):	9,477.59	ERP (W):	9,477.59	ERP (W):	9,477.59
Antenna A2 MPE %:	3.40%	Antenna B2 MPE %:	3.40%	Antenna C2 MPE %:	3.40%

Site Composite MPE %	
Carrier	MPE %
T-Mobile (Max at Sector A):	5.73%
AT&T	2.35%
Sprint	3.58%
Nextel	0.51%
Town	0.13%
Verizon	11.89%
Site Total MPE % :	24.19%

T-Mobile Sector A Total:	5.73%
T-Mobile Sector B Total:	5.73%
T-Mobile Sector C Total:	5.73%
Site Total:	24.19%

T-Mobile Maximum MPE Power Values (Sector A)

T-Mobile Frequency Band / Technology (Sector A)	# Channels	Watts ERP (Per Channel)	Height (feet)	Total Power Density ($\mu\text{W}/\text{cm}^2$)	Frequency (MHz)	Allowable MPE ($\mu\text{W}/\text{cm}^2$)	Calculated % MPE
T-Mobile 2100 MHz LTE AWS	2	2307.55	116.0	12.33	2100 MHz LTE AWS	1000	1.23%
T-Mobile 1900 MHz LTE PCS	2	2056.61	116.0	10.99	1900 MHz LTE PCS	1000	1.10%
T-Mobile 600 MHz LTE	2	591.73	116.0	3.16	600 MHz LTE	400	0.79%
T-Mobile 700 MHz LTE	2	648.82	116.0	3.47	700 MHz LTE	467	0.74%
T-Mobile 1900 MHz GSM	4	1101.85	116.0	11.78	1900 MHz GSM	1000	1.18%
T-Mobile 2100 MHz UMTS	2	1294.56	116.0	6.92	2100 MHz UMTS	1000	0.69%
						Total:	5.73%

• NOTE: Totals may vary by approximately 0.01% due to summation of remainders in calculations.

Summary

All calculations performed for this analysis yielded results that were **within** the allowable limits for general population exposure to RF Emissions.

The anticipated maximum composite contributions from the T-Mobile facility as well as the site composite emissions value with regards to compliance with FCC's allowable limits for general population exposure to RF Emissions are shown here:

T-Mobile Sector	Power Density Value (%)
Sector A:	5.73%
Sector B:	5.73%
Sector C:	5.73%
T-Mobile Maximum MPE % (Sector A):	5.73%
Site Total:	24.19%
Site Compliance Status:	COMPLIANT

The anticipated composite MPE value for this site assuming all carriers present is **24.19%** of the allowable FCC established general population limit sampled at the ground level. This is based upon values listed in the Connecticut Siting Council database for existing carrier emissions.

FCC guidelines state that if a site is found to be out of compliance (over allowable thresholds), that carriers over a 5% contribution to the composite value will require measures to bring the site into compliance. For this facility, the composite values calculated were well within the allowable 100% threshold standard per the federal government.

Exhibit F



**UNITED STATES
POSTAL SERVICE®**

Click-N-Ship®

P

usps.com
US POSTAGE
Flat Rate Env

09/21/2019

Mailed from 06002 062S0000001310

9405 5036 9930 0115 4968 72

0020 6824

PRIORITY MAIL 2-DAY™

Expected Delivery Date: 09/23/19
 Ref#: 077C-ZAP2
0004

Carrier -- Leave if No Response

C005

SHIP TO: MICHAEL C TETREAU
 FIRST SELECTMAN- TOWN OF FAIRFIELD
 611 OLD POST RD
 FAIRFIELD CT 06824-6646

USPS TRACKING #

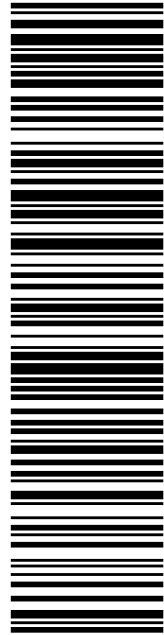

9405 5036 9930 0115 4968 72

Electronic Rate Approved #038555749



Cut on dotted line.

Instructions

1. Each Click-N-Ship® label is unique. Labels are to be used as printed and used only once. DO NOT PHOTO COPY OR ALTER LABEL.
2. Place your label so it does not wrap around the edge of the package.
3. Adhere your label to the package. A self-adhesive label is recommended. If tape or glue is used, DO NOT TAPE OVER BARCODE. Be sure all edges are secure.
4. To mail your package with PC Postage®, you may schedule a Package Pickup online, hand to your letter carrier, take to a Post Office™, or drop in a USPS collection box.
5. Mail your package on the "Ship Date" you selected when creating this label.

Click-N-Ship® Label Record

USPS TRACKING # :
9405 5036 9930 0115 4968 72

Trans. #: 472883371	Priority Mail® Postage: \$7.35
Print Date: 09/19/2019	Total: \$7.35
Ship Date: 09/21/2019	
Expected Delivery Date: 09/23/2019	

From: DEBORAH CHASE
 T-MOBILE/NSS
 35 GRIFFIN RD S
 BLOOMFIELD CT 06002-1351

Ref#: 077C-ZAP2

To: MICHAEL C TETREAU
 FIRST SELECTMAN- TOWN OF FAIRFIELD
 611 OLD POST RD
 FAIRFIELD CT 06824-6646

* Retail Pricing Priority Mail rates apply. There is no fee for USPS Tracking® service on Priority Mail service with use of this electronic rate shipping label. Refunds for unused postage paid labels can be requested online 30 days from the print date.



Thank you for shipping with the United States Postal Service!
 Check the status of your shipment on the USPS Tracking® page at usps.com



UNITED STATES POSTAL SERVICE®

Click-N-Ship®

P

usps.com
US POSTAGE
 Flat Rate Env
 \$7.35

9405 5036 9930 0115 4968 89 0073 5000 0020 6824



09/21/2019

Mailed from 06002 062S0000000312

PRIORITY MAIL 2-DAY™

Expected Delivery Date: 09/23/19
 Ref#: 077C ZAP2
0004

DEBORAH CHASE
 T-MOBILE/NSS
 35 GRIFFIN RD S
 BLOOMFIELD CT 06002-1351

Carrier -- Leave if No Response

C005

SHIP TO: JIM WENDT
 PLANNING DIRECTOR-TOWN OF FAIRFIELD
 725 OLD POST RD
 SULLIVAN INDEPENDENCE HALL
 FAIRFIELD CT 06824-6684

USPS TRACKING #

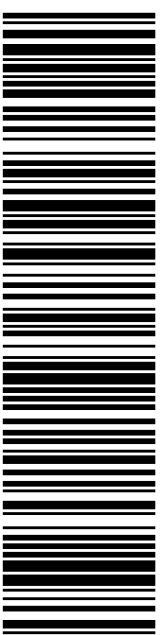

9405 5036 9930 0115 4968 89

Electronic Rate Approved #038555749



Cut on dotted line.

Instructions

1. Each Click-N-Ship® label is unique. Labels are to be used as printed and used only once. DO NOT PHOTO COPY OR ALTER LABEL.
2. Place your label so it does not wrap around the edge of the package.
3. Adhere your label to the package. A self-adhesive label is recommended. If tape or glue is used, DO NOT TAPE OVER BARCODE. Be sure all edges are secure.
4. To mail your package with PC Postage®, you may schedule a Package Pickup online, hand to your letter carrier, take to a Post Office™, or drop in a USPS collection box.
5. Mail your package on the "Ship Date" you selected when creating this label.

Click-N-Ship® Label Record

USPS TRACKING # :
9405 5036 9930 0115 4968 89

Trans. #: 472883371 Print Date: 09/19/2019 Ship Date: 09/21/2019 Expected Delivery Date: 09/23/2019	Priority Mail® Postage: \$7.35 Total: \$7.35
--------------------------------------------------------------------------------------------------------------	---------------------------------------------------------------

From: DEBORAH CHASE
 T-MOBILE/NSS
 35 GRIFFIN RD S
 BLOOMFIELD CT 06002-1351

Ref#: 077C ZAP2

To: JIM WENDT
 PLANNING DIRECTOR-TOWN OF FAIRFIELD
 725 OLD POST RD
 SULLIVAN INDEPENDENCE HALL
 FAIRFIELD CT 06824-6684

* Retail Pricing Priority Mail rates apply. There is no fee for USPS Tracking® service on Priority Mail service with use of this electronic rate shipping label. Refunds for unused postage paid labels can be requested online 30 days from the print date.



Thank you for shipping with the United States Postal Service!
 Check the status of your shipment on the USPS Tracking® page at usps.com