



PAUL J. FORD AND COMPANY  
 STRUCTURAL ENGINEERS  
 250 East Broad Street • Suite 1500 • Columbus, Ohio 43215-3708

Date: July 24, 2012

Steve Tuttle  
 Crown Castle USA Inc.  
 The Piano Works 349 West Commercial Street  
 East Rochester, NY 14445  
 (585) 899-3445

Paul J. Ford and Company  
 250 East Broad Street, Suite 1500  
 Columbus, Ohio 43215  
 (614) 221-6679  
 kthorpe@pjfweb.com

**Subject: Structural Modification Report**

**Carrier Designation:** AT&T Mobility Co-Locate  
**Carrier Site Number:** CT5154  
**Carrier Site Name:** AWE-Enfield

**Crown Castle Designation:** Crown Castle BU Number: 806373  
 Crown Castle Site Name: HRT 101 943232  
 Crown Castle JDE Job Number: 183413  
 Crown Castle Work Order Number: 509202  
 Crown Castle Application Number: 145016 Rev. 4

**Engineering Firm Designation:** Paul J. Ford and Company Project Number: 37512-1571 BP

**Site Data:** 4 Oliver Road, ENFIELD, Hartford County, CT  
 Latitude 41° 57' 36.2", Longitude -72° 35' 32.3"  
 160 Foot - Monopole Tower w/ Replacement 10' Extension

Dear Steve Tuttle,

Paul J. Ford and Company is pleased to submit this "Structural Modification Report" to determine the structural integrity of the above mentioned tower. This analysis has been performed in accordance with the Crown Castle Structural 'Statement of Work' and the terms of Crown Castle Purchase Order Number 474530, in accordance with application 145016, revision 4.

The purpose of the analysis is to determine acceptability of the tower stress level. Based on our analysis we have determined the tower stress level for the structure and foundation, under the following load case, to be:

LC4.5: Modified Structure w/ Existing + Proposed **Sufficient Capacity**  
 Note: See Table I and Table II for the proposed and existing loading, respectively.

The structural analysis was performed for this tower in accordance with the requirements of the 2005 Connecticut Building Code and the TIA/EIA-222-F Structural Standards for Steel Antenna Towers and Antenna Supporting Structures using a fastest mile wind speed of 80 mph with no ice, 37.6 mph with 1 inch ice thickness and 50 mph under service loads.

All modifications and equipment proposed in this report shall be installed in accordance with the attached drawings for the determined available structural capacity to be effective.

We at Paul J. Ford and Company appreciate the opportunity of providing our continuing professional services to you and Crown Castle USA Inc. If you have any questions or need further assistance on this or any other projects please give us a call.

Respectfully submitted by:

  
 Kyle Thorpe, E.I.  
 Structural Engineer

tnxTower Report - version 6.0.3.0

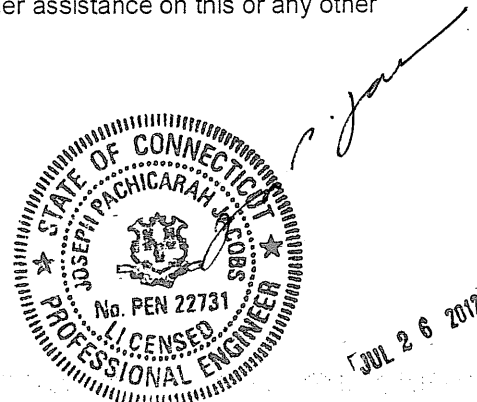



PAUL J. FORD AND COMPANY  
STRUCTURAL ENGINEERS  
250 East Broad Street • Suite 1500 • Columbus, Ohio 43215-3708

Date: **July 24, 2012**

Steve Tuttle  
Crown Castle USA Inc.  
The Piano Works 349 West Commercial Street  
East Rochester, NY 14445  
(585) 899-3445

Paul J. Ford and Company  
250 East Broad Street, Suite 1500  
Columbus, Ohio 43215  
(614) 221-6679  
kthorpe@pjfweb.com

**Subject: Structural Modification Report**

**Carrier Designation:** **AT&T Mobility Co-Locate**  
**Carrier Site Number:** CT5154  
**Carrier Site Name:** AWE-Enfield

**Crown Castle Designation:** **Crown Castle BU Number:** 806373  
**Crown Castle Site Name:** HRT 101 943232  
**Crown Castle JDE Job Number:** 183413  
**Crown Castle Work Order Number:** 509202  
**Crown Castle Application Number:** 145016 Rev. 4

**Engineering Firm Designation:** **Paul J. Ford and Company Project Number:** 37512-1571 BP

**Site Data:** **4 Oliver Road, ENFIELD, Hartford County, CT**  
**Latitude 41° 57' 36.2", Longitude -72° 35' 32.3"**  
**150 Foot - Monopole Tower w/ Replacement 10' Extension**

Dear Steve Tuttle,

Paul J. Ford and Company is pleased to submit this "Structural Modification Report" to determine the structural integrity of the above mentioned tower. This analysis has been performed in accordance with the Crown Castle Structural 'Statement of Work' and the terms of Crown Castle Purchase Order Number 474530, in accordance with application 145016, revision 4.

The purpose of the analysis is to determine acceptability of the tower stress level. Based on our analysis we have determined the tower stress level for the structure and foundation, under the following load case, to be:

LC4.5: Modified Structure w/ Existing + Proposed

**Sufficient Capacity**

Note: See Table I and Table II for the proposed and existing loading, respectively.

The structural analysis was performed for this tower in accordance with the requirements of the 2005 Connecticut Building Code and the TIA/EIA-222-F Structural Standards for Steel Antenna Towers and Antenna Supporting Structures using a fastest mile wind speed of 80 mph with no ice, 37.6 mph with 1 inch ice thickness and 50 mph under service loads.

All modifications and equipment proposed in this report shall be installed in accordance with the attached drawings for the determined available structural capacity to be effective.

We at Paul J. Ford and Company appreciate the opportunity of providing our continuing professional services to you and Crown Castle USA Inc. If you have any questions or need further assistance on this or any other projects please give us a call.

Respectfully submitted by:

Kyle Thorpe, E.I.  
Structural Engineer

## TABLE OF CONTENTS

### 1) INTRODUCTION

### 2) ANALYSIS CRITERIA

Table 1 - Proposed Antenna and Cable Information

Table 2 - Existing and Reserved Antenna and Cable Information

### 3) ANALYSIS PROCEDURE

Table 3 - Documents Provided

3.1) Analysis Method

3.2) Assumptions

### 4) ANALYSIS RESULTS

Table 4 – Section Capacity (Summary)

Table 5 - Tower Component Stresses vs. Capacity – LC4.5

4.1) Recommendations

### 5) APPENDIX A

tnxTower Output

### 6) APPENDIX B

Base Level Drawing

### 7) APPENDIX C

Additional Calculations

## 1) INTRODUCTION

This tower is a 160 ft Monopole tower designed by VALMONT in November of 1991. The tower was originally designed for a wind speed of 90 mph per TIA/EIA-222-E.

## 2) ANALYSIS CRITERIA

The structural analysis was performed for this tower in accordance with the requirements of the 2005 Connecticut Building Code and the TIA/EIA-222-F Structural Standards for Steel Antenna Towers and Antenna Supporting Structures using a fastest mile wind speed of 80 mph with no ice, 37.6 mph with 1 inch ice thickness and 50 mph under service loads.

**Table 1 - Proposed Antenna and Cable Information**

Mounting Level (ft)	Center Line Elevation (ft)	Number of Antennas	Antenna Manufacturer	Antenna Model	Number of Feed Lines	Feed Line Size (in)	Note
158.0	158.0	3	andrew	SBNH-1D6565C w/ Mount Pipe	2 1	3/4 3/8	-
		6	ericsson	RRUS-11			
		6	powerwave technologies	7770.00 w/ Mount Pipe			
		1	raycap	DC6-48-60-18-8F			
		1	tower mounts	Platform Mount [LP 301-1]			
50.0	50.0	1	symmetricom	58532A	1	1/2	-
		1	tower mounts	Platform Mount [LP 301-1]			

**Table 2 - Existing and Reserved Antenna and Cable Information**

Mounting Level (ft)	Center Line Elevation (ft)	Number of Antennas	Antenna Manufacturer	Antenna Model	Number of Feed Lines	Feed Line Size (in)	Note
158.0	161.0	6	powerwave technologies	LGP13519	12	7/8	3
		6		LGP21401			
151.0	151.0	1	tower mounts	Side Arm Mount [SO 101-3]	-	-	2
		1		Side Arm Mount [SO 701-3]			
149.0	149.0	1	antel	BXA-185063/8CF w/ Mount Pipe	12	7/8	1
		2		BXA-185090/8CFx2 w/ Mount Pipe			
		2		BXA-70063/6CFx4 w/ Mount Pipe			
		1		BXA-70063/6CFx6 w/ Mount Pipe			
		2		LPA-80063/4CF w/ Mount Pipe			
		4		LPA-80080/4CF w/ Mount Pipe			
		6		rfs celwave			
		1	tower mounts	Platform Mount [LP 602-1]			

Mounting Level (ft)	Center Line Elevation (ft)	Number of Antennas	Antenna Manufacturer	Antenna Model	Number of Feed Lines	Feed Line Size (in)	Note
135.0	139.0	2	andrew	VHLP2.5-11	6 6 3	1-5/8 1/4 1/2	1
		2	dragonwave	HORIZON COMPACT			
	135.0	3	argus technologies	LLPX310R-V1 w/ Mount Pipe			
		6	decibel	DB980H90E-M w/ Mount Pipe			
		1	motorola	TIMING 2000			
		3	samsung telecommunications	WIMAX DAP HEAD			
1	tower mounts	Platform Mount [LP 602-1]					
126.0	127.0	9	decibel	DB844H90E-XY w/ Mount Pipe	9	7/8	1
	126.0	1	tower mounts	T-Arm Mount [TA 901-3]			
116.0	117.0	3	andrew	ONEBASE TWIN DUAL DUPLEX TMA	6 6	1-1/4 1-5/8	1
		3	ems wireless	RR90-17-02DP w/ Mount Pipe			
		3	ericsson	KRY 112 71/1			
		3	rfs celwave	APX16DWV-16DWV-S-E-ACU w/ Mount Pipe			
	116.0	1	tower mounts	Side Arm Mount [SO 103-3]			
		1		Side Arm Mount [SO 701-3]			
106.0	108.0	3	andrew	ATM200-A20	6 1	7/8 5/16	1
		3		HBX-6516DS-VTM w/ Mount Pipe			
	106.0	1	tower mounts	T-Arm Mount [TA 602-3]			
47.0	48.0	1	lucent	KS24019-L112A	1	1/2	1
	47.0	1	tower mounts	Side Arm Mount [SO 701-1]			

Notes:

- 1) Existing Equipment
- 2) Equipment To Be Removed
- 3) Existing equipment to be relocated to the 158-ft level from the 151' level.

### 3) ANALYSIS PROCEDURE

**Table 3 - Documents Provided**

Document	Remarks	Reference	Source
4-GEOTECHNICAL REPORTS	FDH Engineering 07/26/2007	821582	CCISITES
4-TOWER FOUNDATION DRAWINGS/DESIGN/SPECS	SAC Engineering, Inc. 11/16/1991	821581	CCISITES
4-TOWER MANUFACTURER DRAWINGS	Valmont 11/09/1991	822743	CCISITES
4-TOWER STRUCTURAL ANALYSIS REPORTS	PJF, 37512-1571, 05/30/2012	3195408	CCISITES

#### 3.1) Analysis Method

tnxTower (version 6.0.3.0), a commercially available analysis software package, was used to create a three-dimensional model of the tower and calculate member stresses for various loading cases. Selected output from the analysis is included in Appendix A.

#### 3.2) Assumptions

- 1) Tower and structures were built in accordance with the manufacturer's specifications.
- 2) The tower and structures have been maintained in accordance with the manufacturer's specification.
- 3) The configuration of antennas, transmission cables, mounts and other appurtenances are as specified in Tables 1 and 2 and the referenced drawings.
- 4) Monopole will be reinforced in conformance with the attached proposed modification drawings.

This analysis may be affected if any assumptions are not valid or have been made in error. Paul J. Ford and Company should be notified to determine the effect on the structural integrity of the tower.

#### 4) ANALYSIS RESULTS

**Table 4 - Section Capacity (Summary)**

Section No.	Elevation (ft)	Component Type	Size	Critical Element	P (K)	SF*P_allow (K)	% Capacity	Pass / Fail
L1	160 - 150.5	Pole	TP20x20x0.25	1	-2.42	434.22	24.0	Pass
L2	150.5 - 150	Pole	TP20.3x20x0.25	2	-2.45	440.81	24.9	Pass
L3	150 - 119	Pole	TP26.6545x20.3x0.25	3	-8.34	1105.02	86.8	Pass
L4	119 - 97.1667	Pole	TP31.13x26.6545x0.3512	4	-12.29	1695.47	89.1	Pass
L5	97.1667 - 90.5	Pole	TP31.9973x29.4368x0.472	5	-15.14	2414.52	79.0	Pass
L6	90.5 - 60.5	Pole	TP38.149x31.9973x0.4827	6	-22.24	2943.93	93.1	Pass
L7	60.5 - 55	Pole	TP39.2768x38.149x0.5056	7	-23.73	3281.19	88.0	Pass
L8	55 - 30.5	Pole	TP43.5485x39.2768x0.5553	8	-32.89	3996.63	89.4	Pass
L9	30.5 - 0	Pole	TP49.8x43.5485x0.5594	9	-43.45	4610.85	92.6	Pass
							Summary	
						Pole (L6)	93.1	Pass
						RATING =	93.1	Pass

**Table 5 - Tower Component Stresses vs. Capacity - LC4.5**

Notes	Component	Elevation (ft)	% Capacity	Pass / Fail
1	Anchor Rods	0	93.9	Pass
1	Base Plate	0	63.9	Pass
1	Base Foundation Structural Steel	0	67.6	Pass
1,2	Base Foundation Soil Interaction	0	85.1	Pass
1	Extension Connection	150	26.8	Pass

<b>Structure Rating (max from all components) =</b>	<b>93.9%</b>
---	--------------

Notes:

- 1) See additional documentation in "Appendix C – Additional Calculations" for calculations supporting the % capacity consumed.
- 2) According to the procedures prescribed and agreed to by the Crown Castle Engineering Foundation Committee, held in January 2010, the existing caisson foundation was analyzed using the methodology in the software 'PLS-Caisson' (Version 8.10, or newer, by Power Line Systems, Inc.). Per the methods in PLS-Caisson, the soil reactions of cohesive soils are calculated using 8CD independent of the depth of the soil layer. The depth of soil to be ignored at the top of the caisson is the greater of the geotechnical report's recommendation, the frost depth of the site or half of the caisson diameter.

#### 4.1) Recommendations

See attached proposed modification drawings.

## APPENDIX A

### TNXTOWER OUTPUT

### Tower Input Data

There is a pole section.

This tower is designed using the TIA/EIA-222-F standard.

The following design criteria apply:

Tower is located in Hartford County, Connecticut.

Basic wind speed of 80.00 mph.

Nominal ice thickness of 1.0000 in.

Ice thickness is considered to increase with height.

Ice density of 56.00 pcf.

A wind speed of 37.60 mph is used in combination with ice.

Temperature drop of 50.00 °F.

Deflections calculated using a wind speed of 50.00 mph.

A non-linear (P-delta) analysis was used.

Pressures are calculated at each section.

Stress ratio used in pole design is 1.333.

Local bending stresses due to climbing loads, feedline supports, and appurtenance mounts are not considered.

### Options

- |  |  |   |
|--|--|---|
| <ul style="list-style-type: none"> <li>Consider Moments - Legs</li> <li>Consider Moments - Horizontals</li> <li>Consider Moments - Diagonals</li> <li>Use Moment Magnification</li> <li>√ Use Code Stress Ratios</li> <li>√ Use Code Safety Factors - Guys</li> <li>√ Escalate Ice</li> <li>Always Use Max Kz</li> <li>Use Special Wind Profile</li> <li>Include Bolts In Member Capacity</li> <li>Leg Bolts Are At Top Of Section</li> <li>Secondary Horizontal Braces Leg</li> <li>Use Diamond Inner Bracing (4 Sided)</li> <li>Add IBC .6D+W Combination</li> </ul> | <ul style="list-style-type: none"> <li>Distribute Leg Loads As Uniform</li> <li>Assume Legs Pinned</li> <li>√ Assume Rigid Index Plate</li> <li>√ Use Clear Spans For Wind Area</li> <li>Use Clear Spans For KL/r</li> <li>Retension Guys To Initial Tension</li> <li>√ Bypass Mast Stability Checks</li> <li>√ Use Azimuth Dish Coefficients</li> <li>√ Project Wind Area of Appurt.</li> <li>Autocalc Torque Arm Areas</li> <li>SR Members Have Cut Ends</li> <li>Sort Capacity Reports By Component</li> <li>Triangulate Diamond Inner Bracing</li> </ul> | <ul style="list-style-type: none"> <li>Treat Feedline Bundles As Cylinder</li> <li>Use ASCE 10 X-Brace Ly Rules</li> <li>Calculate Redundant Bracing Forces</li> <li>Ignore Redundant Members in FEA</li> <li>SR Leg Bolts Resist Compression</li> <li>All Leg Panels Have Same Allowable</li> <li>Offset Girt At Foundation</li> <li>√ Consider Feedline Torque</li> <li>Include Angle Block Shear Check</li> <li style="text-align: center;">Poles</li> <li>√ Include Shear-Torsion Interaction</li> <li>Always Use Sub-Critical Flow</li> <li>Use Top Mounted Sockets</li> </ul> |
|--|--|---|

### Tapered Pole Section Geometry

Section	Elevation ft	Section Length ft	Splice Length ft	Number of Sides	Top Diameter in	Bottom Diameter in	Wall Thickness in	Bend Radius in	Pole Grade
L1	160.0000- 150.5000	9.5000	0.00	Round	20.0000	20.0000	0.2500		A53-B-35 (35 ksi)
L2	150.5000- 150.0000	0.5000	0.00	Round	20.0000	20.3000	0.2500		A53-B-35 (35 ksi)
L3	150.0000- 119.0000	31.0000	0.00	12	20.3000	26.6545	0.2500	1.0000	A572-65 (65 ksi)
L4	119.0000- 97.1667	21.8333	4.83	12	26.6545	31.1300	0.3512	1.4048	Reinf 62.93 ksi (63 ksi)
L5	97.1667- 90.5000	11.5000	0.00	12	29.4368	31.9973	0.4720	1.8879	Reinf 63.01 ksi (63 ksi)
L6	90.5000- 60.5000	30.0000	0.00	12	31.9973	38.1490	0.4827	1.9309	Reinf 62.87 ksi (63 ksi)
L7	60.5000-	5.5000	0.00	12	38.1490	39.2768	0.5056	2.0222	Reinf 65.00 ksi



Section	Elevation ft	Section Length ft	Splice Length ft	Number of Sides	Top Diameter in	Bottom Diameter in	Wall Thickness in	Bend Radius in	Pole Grade
L8	55.0000 55.0000-30.5000	24.5000	0.00	12	39.2768	43.5485	0.5553	2.2213	(65 ksi) Reinf 65.00 ksi (65 ksi)
L9	30.5000-0.0000	30.5000		12	43.5485	49.8000	0.5594	2.2375	Reinf 65.00 ksi (65 ksi)

### Tapered Pole Properties

Section	Tip Dia. in	Area in <sup>2</sup>	I in <sup>4</sup>	r in	C in	I/C in <sup>3</sup>	J in <sup>4</sup>	It/Q in <sup>2</sup>	w in	w/t
L1	20.0000	15.5116	756.8919	6.9915	10.0000	75.6892	1511.7218	7.7512	0.0000	0
L2	20.0000	15.5116	756.8919	6.9915	10.0000	75.6892	1511.7218	7.7512	0.0000	0
L3	20.0000	15.5116	756.8919	6.9915	10.0000	75.6892	1511.7218	7.7512	0.0000	0
L3	20.3000	15.7472	791.9097	7.0977	10.1500	78.0207	1581.6621	7.8689	0.0000	0
L3	21.0161	16.1403	828.1804	7.1779	10.5154	78.7588	1678.1181	7.9437	4.7704	19.082
L3	27.5948	21.2556	1891.5449	9.4528	13.8070	136.9986	3832.7829	10.4614	6.4734	25.894
L4	27.5948	29.7455	2626.8062	9.4166	13.8070	190.2512	5322.6215	14.6398	6.2022	17.66
L4	32.2281	34.8066	4208.7330	11.0188	16.1253	261.0012	8528.0342	17.1308	7.4016	21.075
L5	31.5894	44.0201	4713.8930	10.3694	15.2483	309.1425	9551.6252	21.6653	6.6242	14.035
L5	33.1261	47.9115	6077.7827	11.2861	16.5746	366.6922	12315.235	23.5806	7.3104	15.489
L6	33.1261	48.9850	6209.7330	11.2822	16.5746	374.6532	12582.602	24.1089	7.2816	15.085
L6	39.4947	58.5468	10602.149	13.4845	19.7612	536.5145	21482.829	28.8150	8.9302	18.5
L7	39.4947	61.2798	11083.605	13.4763	19.7612	560.8782	22458.389	30.1601	8.8690	17.543
L7	40.6623	63.1157	12109.938	13.8801	20.3454	595.2188	24538.017	31.0636	9.1713	18.141
L8	40.6623	69.2390	13250.714	13.8623	20.3454	651.2894	26849.540	34.0773	9.0379	16.275
L8	45.0847	76.8774	18137.768	15.3916	22.5581	804.0460	36752.035	37.8367	10.1827	18.337
L9	45.0847	77.4322	18265.199	15.3901	22.5581	809.6950	37010.246	38.1098	10.1719	18.184
L9	51.5568	88.6924	27448.542	17.6281	25.7964	1064.0455	55618.189	43.6517	11.8473	21.179

Tower Elevation ft	Gusset Area (per face) ft <sup>2</sup>	Gusset Thickness in	Gusset Grade	Adjust. Factor A <sub>r</sub>	Adjust. Factor A <sub>r</sub>	Weight Mult.	Double Angle Stitch Bolt Spacing Diagonals in	Double Angle Stitch Bolt Spacing Horizontals in
L1 160.0000-150.5000				1	1	1		
L2 150.5000-150.0000				1	1	1		
L3 150.0000-119.0000				1	1	1		
L4 119.0000-97.1667				1	1	1		
L5 97.1667-90.5000				1	1	1		
L6 90.5000-60.5000				1	1	1		
L7 60.5000-55.0000				1	1	1		
L8 55.0000-30.5000				1	1	1		
L9 30.5000-0.0000				1	1	1		

**Feed Line/Linear Appurtenances - Entered As Area**

Description	Face or Leg	Allow Shield	Component Type	Placement ft	Total Number	C <sub>A</sub> A <sub>A</sub>		Weight
						ft <sup>2</sup> /ft	plf	
FB-L98B-002-75000(3/8")	C	No	CaAa (Out Of Face)	158.0000 - 0.0000	1	No Ice	0.0000	0.06
						1/2" Ice	0.0000	0.60
						1" Ice	0.0000	1.76
						2" Ice	0.0000	5.91
						4" Ice	0.0000	21.53
WR-VG86ST-BRD(3/4)	C	No	CaAa (Out Of Face)	158.0000 - 0.0000	2	No Ice	0.0000	0.59
						1/2" Ice	0.0000	1.37
						1" Ice	0.0000	2.76
						2" Ice	0.0000	7.37
						4" Ice	0.0000	23.92
LDF7-50A(1-5/8")	C	No	CaAa (Out Of Face)	158.0000 - 0.0000	3	No Ice	0.1980	0.82
						1/2" Ice	0.2980	2.33
						1" Ice	0.3980	4.46
						2" Ice	0.5980	10.54
						4" Ice	0.9980	30.04
LDF7-50A(1-5/8")	C	No	CaAa (Out Of Face)	158.0000 - 0.0000	9	No Ice	0.0000	0.82
						1/2" Ice	0.0000	2.33
						1" Ice	0.0000	4.46
						2" Ice	0.0000	10.54
						4" Ice	0.0000	30.04
**								
LDF5-50A(7/8")	C	No	Inside Pole	149.0000 - 0.0000	12	No Ice	0.0000	0.33
						1/2" Ice	0.0000	0.33
						1" Ice	0.0000	0.33
						2" Ice	0.0000	0.33
						4" Ice	0.0000	0.33
**								
FSJ4-50B(1/2")	C	No	CaAa (Out Of Face)	135.0000 - 0.0000	3	No Ice	0.0000	0.14
						1/2" Ice	0.0000	0.76
						1" Ice	0.0000	2.00
						2" Ice	0.0000	6.30
						4" Ice	0.0000	22.23
LDF1-50A(1/4")	C	No	Inside Pole	135.0000 - 0.0000	6	No Ice	0.0000	0.06
						1/2" Ice	0.0000	0.06
						1" Ice	0.0000	0.06
						2" Ice	0.0000	0.06
						4" Ice	0.0000	0.06
2" Conduit	C	No	CaAa (Out Of Face)	135.0000 - 0.0000	1	No Ice	0.2000	0.95
						1/2" Ice	0.3000	2.48
						1" Ice	0.4000	4.62
						2" Ice	0.6000	10.72
						4" Ice	1.0000	30.27
LDF7-50A(1-5/8")	C	No	Inside Pole	135.0000 - 0.0000	6	No Ice	0.0000	0.82
						1/2" Ice	0.0000	0.82
						1" Ice	0.0000	0.82
						2" Ice	0.0000	0.82
						4" Ice	0.0000	0.82
**								
LDF5-50A(7/8")	C	No	CaAa (Out Of Face)	126.0000 - 0.0000	9	No Ice	0.0000	0.33
						1/2" Ice	0.0000	1.30
						1" Ice	0.0000	2.88
						2" Ice	0.0000	7.88
						4" Ice	0.0000	25.20
**								
LDF7-50A(1-5/8")	C	No	CaAa (Out Of Face)	116.0000 - 0.0000	6	No Ice	0.0000	0.82
						1/2" Ice	0.0000	2.33
						1" Ice	0.0000	4.46
						2" Ice	0.0000	10.54
						4" Ice	0.0000	30.04
LDF6-50A(1-1/4")	C	No	CaAa (Out Of Face)	116.0000 - 0.0000	6	No Ice	0.0000	0.66
						1/2" Ice	0.0000	1.91
						1" Ice	0.0000	3.78
						2" Ice	0.0000	9.33
						4" Ice	0.0000	27.78
**								

Description	Face or Leg	Allow Shield	Component Type	Placement ft	Total Number		C <sub>A</sub> A <sub>A</sub> ft <sup>2</sup> /ft	Weight plf
FXL 780 PE(7/8)	C	No	CaAa (Out Of Face)	106.0000 - 0.0000	6	No Ice	0.0000	0.25
						1/2" Ice	0.0000	1.22
						1" Ice	0.0000	2.80
						2" Ice	0.0000	7.80
						4" Ice	0.0000	25.12
ATCB-B01(5/16)	C	No	CaAa (Out Of Face)	106.0000 - 0.0000	1	No Ice	0.0000	0.07
						1/2" Ice	0.0000	0.57
						1" Ice	0.0000	1.68
						2" Ice	0.0000	5.73
						4" Ice	0.0000	21.16
** FLC 12-50J(1/2")	C	No	CaAa (Out Of Face)	50.0000 - 0.0000	1	No Ice	0.0000	0.17
1/2" Ice						0.0000	0.87	
1" Ice						0.0000	2.17	
2" Ice						0.0000	6.62	
4" Ice						0.0000	22.85	
** LDF4-50A(1/2")	C	No	CaAa (Out Of Face)	47.0000 - 0.0000	1	No Ice	0.0000	0.15
1/2" Ice						0.0000	0.84	
1" Ice						0.0000	2.14	
2" Ice						0.0000	6.58	
4" Ice						0.0000	22.78	
*****								
***								
***								
1" Flat Reinforcement	C	No	CaAa (Out Of Face)	90.5000 - 0.0000	1	No Ice	0.1667	0.00
						1/2" Ice	0.2778	0.00
						1" Ice	0.3889	0.00
						2" Ice	0.6111	0.00
						4" Ice	1.0556	0.00
3/4" Flat Reinforcement	C	No	CaAa (Out Of Face)	120.5000 - 90.5000	1	No Ice	0.1250	0.00
						1/2" Ice	0.2361	0.00
						1" Ice	0.3472	0.00
						2" Ice	0.5694	0.00
						4" Ice	1.0139	0.00

### Feed Line/Linear Appurtenances Section Areas

Tower Section	Tower Elevation ft	Face	A <sub>R</sub> ft <sup>2</sup>	A <sub>F</sub> ft <sup>2</sup>	C <sub>A</sub> A <sub>A</sub> In Face ft <sup>2</sup>	C <sub>A</sub> A <sub>A</sub> Out Face ft <sup>2</sup>	Weight K
L1	160.0000-150.5000	A	0.000	0.000	0.000	0.000	0.00
		B	0.000	0.000	0.000	0.000	0.00
		C	0.000	0.000	0.000	4.455	0.08
L2	150.5000-150.0000	A	0.000	0.000	0.000	0.000	0.00
		B	0.000	0.000	0.000	0.000	0.00
		C	0.000	0.000	0.000	0.297	0.01
L3	150.0000-119.0000	A	0.000	0.000	0.000	0.000	0.00
		B	0.000	0.000	0.000	0.000	0.00
		C	0.000	0.000	0.000	21.802	0.59
L4	119.0000-97.1667	A	0.000	0.000	0.000	0.000	0.00
		B	0.000	0.000	0.000	0.000	0.00
		C	0.000	0.000	0.000	20.065	0.72
L5	97.1667-90.5000	A	0.000	0.000	0.000	0.000	0.00
		B	0.000	0.000	0.000	0.000	0.00
		C	0.000	0.000	0.000	6.127	0.23
L6	90.5000-60.5000	A	0.000	0.000	0.000	0.000	0.00
		B	0.000	0.000	0.000	0.000	0.00
		C	0.000	0.000	0.000	28.820	1.05
L7	60.5000-55.0000	A	0.000	0.000	0.000	0.000	0.00
		B	0.000	0.000	0.000	0.000	0.00
		C	0.000	0.000	0.000	5.284	0.19
L8	55.0000-30.5000	A	0.000	0.000	0.000	0.000	0.00
		B	0.000	0.000	0.000	0.000	0.00
		C	0.000	0.000	0.000	23.536	0.87
L9	30.5000-0.0000	A	0.000	0.000	0.000	0.000	0.00

Tower Section n	Tower Elevation ft	Face	A <sub>R</sub> ft <sup>2</sup>	A <sub>F</sub> ft <sup>2</sup>	C <sub>A</sub> A <sub>A</sub> In Face ft <sup>2</sup>	C <sub>A</sub> A <sub>A</sub> Out Face ft <sup>2</sup>	Weight K
		B	0.000	0.000	0.000	0.000	0.00
		C	0.000	0.000	0.000	29.300	1.08

### Feed Line/Linear Appurtenances Section Areas - With Ice

Tower Section n	Tower Elevation ft	Face or Leg	Ice Thickness in	A <sub>R</sub> ft <sup>2</sup>	A <sub>F</sub> ft <sup>2</sup>	C <sub>A</sub> A <sub>A</sub> In Face ft <sup>2</sup>	C <sub>A</sub> A <sub>A</sub> Out Face ft <sup>2</sup>	Weight K
L1	160.0000-150.5000	A	1.204	0.000	0.000	0.000	0.000	0.00
		B		0.000	0.000	0.000	0.000	0.00
		C		0.000	0.000	0.000	9.874	0.59
L2	150.5000-150.0000	A	1.199	0.000	0.000	0.000	0.000	0.00
		B		0.000	0.000	0.000	0.000	0.00
		C		0.000	0.000	0.000	0.657	0.04
L3	150.0000-119.0000	A	1.183	0.000	0.000	0.000	0.000	0.00
		B		0.000	0.000	0.000	0.000	0.00
		C		0.000	0.000	0.000	47.987	3.04
L4	119.0000-97.1667	A	1.153	0.000	0.000	0.000	0.000	0.00
		B		0.000	0.000	0.000	0.000	0.00
		C		0.000	0.000	0.000	45.790	4.17
L5	97.1667-90.5000	A	1.134	0.000	0.000	0.000	0.000	0.00
		B		0.000	0.000	0.000	0.000	0.00
		C		0.000	0.000	0.000	13.982	1.42
L6	90.5000-60.5000	A	1.104	0.000	0.000	0.000	0.000	0.00
		B		0.000	0.000	0.000	0.000	0.00
		C		0.000	0.000	0.000	62.665	6.03
L7	60.5000-55.0000	A	1.069	0.000	0.000	0.000	0.000	0.00
		B		0.000	0.000	0.000	0.000	0.00
		C		0.000	0.000	0.000	11.296	1.06
L8	55.0000-30.5000	A	1.031	0.000	0.000	0.000	0.000	0.00
		B		0.000	0.000	0.000	0.000	0.00
		C		0.000	0.000	0.000	49.356	4.55
L9	30.5000-0.0000	A	1.000	0.000	0.000	0.000	0.000	0.00
		B		0.000	0.000	0.000	0.000	0.00
		C		0.000	0.000	0.000	60.478	5.45

### Feed Line Center of Pressure

Section	Elevation ft	CP <sub>x</sub> in	CP <sub>z</sub> in	CP <sub>x</sub> Ice in	CP <sub>z</sub> Ice in
L1	160.0000-150.5000	-0.4754	0.2745	-0.7742	0.4470
L2	150.5000-150.0000	-0.5700	0.3291	-0.8975	0.5182
L3	150.0000-119.0000	-0.6792	0.3921	-1.0746	0.6204
L4	119.0000-97.1667	-0.8640	0.4988	-1.3965	0.8063
L5	97.1667-90.5000	-0.8825	0.5095	-1.4500	0.8371
L6	90.5000-60.5000	-0.9392	0.5423	-1.5265	0.8813
L7	60.5000-55.0000	-0.9616	0.5552	-1.5770	0.9105
L8	55.0000-30.5000	-0.9762	0.5636	-1.6020	0.9249
L9	30.5000-0.0000	-1.0008	0.5778	-1.6590	0.9578

### Discrete Tower Loads

Description	Face or Leg	Offset Type	Offsets:		Azimuth Adjustment	Placement	C <sub>AA</sub> <sub>Front</sub>	C <sub>AA</sub> <sub>Side</sub>	Weight	
			Horz	Lateral						Vert
			ft	ft	°	ft	ft <sup>2</sup>	ft <sup>2</sup>	K	
SBNH-1D6565C w/ Mount Pipe	A	From Face	4.0000	0.0000	0.0000	158.0000	No Ice	11.5561	9.7151	0.09
			0.00				1/2"	12.2227	11.1857	0.18
			0.00				Ice	12.8929	12.5942	0.28
							1" Ice	14.2911	14.8689	0.51
							2" Ice	17.4280	19.6184	1.14
SBNH-1D6565C w/ Mount Pipe	B	From Face	4.0000	0.0000	0.0000	158.0000	No Ice	11.5561	9.7151	0.09
			0.00				1/2"	12.2227	11.1857	0.18
			0.00				Ice	12.8929	12.5942	0.28
							1" Ice	14.2911	14.8689	0.51
							2" Ice	17.4280	19.6184	1.14
SBNH-1D6565C w/ Mount Pipe	C	From Face	4.0000	0.0000	0.0000	158.0000	No Ice	11.5561	9.7151	0.09
			0.00				1/2"	12.2227	11.1857	0.18
			0.00				Ice	12.8929	12.5942	0.28
							1" Ice	14.2911	14.8689	0.51
							2" Ice	17.4280	19.6184	1.14
(2) 7770.00 w/ Mount Pipe	A	From Face	4.0000	0.0000	0.0000	158.0000	No Ice	6.1194	4.2543	0.06
			0.00				1/2"	6.6258	5.0137	0.10
			0.00				Ice	7.1283	5.7109	0.16
							1" Ice	8.1643	7.1553	0.29
							2" Ice	10.3599	10.4117	0.66
(2) 7770.00 w/ Mount Pipe	B	From Face	4.0000	0.0000	0.0000	158.0000	No Ice	6.1194	4.2543	0.06
			0.00				1/2"	6.6258	5.0137	0.10
			0.00				Ice	7.1283	5.7109	0.16
							1" Ice	8.1643	7.1553	0.29
							2" Ice	10.3599	10.4117	0.66
(2) 7770.00 w/ Mount Pipe	C	From Face	4.0000	0.0000	0.0000	158.0000	No Ice	6.1194	4.2543	0.06
			0.00				1/2"	6.6258	5.0137	0.10
			0.00				Ice	7.1283	5.7109	0.16
							1" Ice	8.1643	7.1553	0.29
							2" Ice	10.3599	10.4117	0.66
DC6-48-60-18-8F	A	From Face	4.0000	0.0000	0.0000	158.0000	No Ice	2.5667	4.3167	0.02
			0.00				1/2"	2.7978	4.5965	0.05
			0.00				Ice	3.0377	4.8849	0.09
							1" Ice	3.5432	5.4877	0.17
							2" Ice	4.6580	6.7969	0.38
(2) RRUS-11	A	From Face	4.0000	0.0000	0.0000	158.0000	No Ice	4.4236	1.1855	0.05
			0.00				1/2"	4.7079	1.3512	0.07
			0.00				Ice	5.0009	1.5256	0.10
							1" Ice	5.6127	1.9002	0.17
							2" Ice	6.9402	2.7532	0.36
(2) RRUS-11	B	From Face	4.0000	0.0000	0.0000	158.0000	No Ice	4.4236	1.1855	0.05
			0.00				1/2"	4.7079	1.3512	0.07
			0.00				Ice	5.0009	1.5256	0.10
							1" Ice	5.6127	1.9002	0.17
							2" Ice	6.9402	2.7532	0.36
(2) RRUS-11	C	From Face	4.0000	0.0000	0.0000	158.0000	No Ice	4.4236	1.1855	0.05
			0.00				1/2"	4.7079	1.3512	0.07
			0.00				Ice	5.0009	1.5256	0.10
							1" Ice	5.6127	1.9002	0.17
							2" Ice	6.9402	2.7532	0.36
(2) LGP13519	A	From Face	4.0000	0.0000	0.0000	158.0000	No Ice	0.3379	0.2074	0.01
			0.00				1/2"	0.4220	0.2804	0.01
			3.00				Ice	0.5147	0.3621	0.01
							1" Ice	0.7260	0.5513	0.02
							2" Ice	1.2523	1.0335	0.07

Description	Face or Leg	Offset Type	Offsets:			Azimuth Adjustment	Placement	C <sub>AA</sub> <sub>Front</sub>	C <sub>AA</sub> <sub>Side</sub>	Weight
			Horz	Lateral	Vert					
			ft	ft	ft	°	ft	ft <sup>2</sup>	ft <sup>2</sup>	K
(2) LGP13519	B	From Face	4.0000	0.0000	158.0000	0.0000	4" Ice			
							No Ice	0.3379	0.2074	0.01
							1/2"	0.4220	0.2804	0.01
							Ice	0.5147	0.3621	0.01
							1" Ice	0.7260	0.5513	0.02
(2) LGP13519	C	From Face	4.0000	0.0000	158.0000	0.0000	2" Ice	1.2523	1.0335	0.07
							4" Ice			
							No Ice	0.3379	0.2074	0.01
							1/2"	0.4220	0.2804	0.01
							Ice	0.5147	0.3621	0.01
(2) LGP21401	A	From Face	4.0000	0.0000	158.0000	0.0000	1" Ice	0.7260	0.5513	0.02
							2" Ice	1.2523	1.0335	0.07
							4" Ice			
							No Ice	1.2880	0.2326	0.01
							1/2"	1.4453	0.3134	0.02
(2) LGP21401	B	From Face	4.0000	0.0000	158.0000	0.0000	Ice	1.6112	0.4028	0.03
							1" Ice	1.9690	0.6076	0.05
							2" Ice	2.7882	1.1210	0.14
							4" Ice			
							No Ice	1.2880	0.2326	0.01
(2) LGP21401	C	From Face	4.0000	0.0000	158.0000	0.0000	1/2"	1.4453	0.3134	0.02
							Ice	1.6112	0.4028	0.03
							1" Ice	1.9690	0.6076	0.05
							2" Ice	2.7882	1.1210	0.14
							4" Ice			
Platform Mount [LP 301-1]	C	None			0.0000	158.0000	No Ice	30.1000	30.1000	1.59
							1/2"	40.8000	40.8000	2.03
							Ice	51.5000	51.5000	2.47
							1" Ice	72.9000	72.9000	3.35
							2" Ice	115.7000	115.7000	5.11
(2) LPA-80063/4CF w/ Mount Pipe	A	From Face	4.0000	0.0000	149.0000	0.0000	4" Ice			
							No Ice	7.2481	7.2599	0.04
							1/2"	7.7190	7.9574	0.10
							Ice	8.2003	8.6723	0.18
							1" Ice	9.1945	10.1556	0.34
(2) LPA-80080/4CF w/ Mount Pipe	B	From Face	4.0000	0.0000	149.0000	0.0000	2" Ice	11.3199	13.3910	0.80
							4" Ice			
							No Ice	2.8561	7.2274	0.03
							1/2"	3.2195	7.9217	0.07
							Ice	3.5922	8.6338	0.13
(2) LPA-80080/4CF w/ Mount Pipe	C	From Face	4.0000	0.0000	149.0000	0.0000	1" Ice	4.4498	10.1119	0.25
							2" Ice	6.3182	13.3391	0.61
							4" Ice			
							No Ice	2.8561	7.2274	0.03
							1/2"	3.2195	7.9217	0.07
BXA-70063/6CFx6 w/ Mount Pipe	A	From Face	4.0000	0.0000	149.0000	0.0000	Ice	3.5922	8.6338	0.13
							1" Ice	4.4498	10.1119	0.25
							2" Ice	6.3182	13.3391	0.61
							4" Ice			
							No Ice	7.9686	5.3981	0.04
BXA-70063/6CFx4 w/ Mount Pipe	B	From Face	4.0000	0.0000	149.0000	0.0000	1/2"	8.6091	6.5465	0.10
							Ice	9.2158	7.4089	0.17
							1" Ice	10.4591	9.1837	0.33
							2" Ice	13.0655	12.9333	0.79
							4" Ice			

Description	Face or Leg	Offset Type	Offsets: Horz Lateral Vert ft ft ft	Azimuth Adjustment °	Placement ft	C <sub>AA</sub> Front ft <sup>2</sup>	C <sub>AA</sub> Side ft <sup>2</sup>	Weight K	
						1" Ice	10.4591	9.1837	0.33
						2" Ice	13.0655	12.9333	0.79
						4" Ice			
BXA-70063/6CFx4 w/ Mount Pipe	C	From Face	4.0000 0.00 0.00	0.0000	149.0000	No Ice	7.9686	5.3981	0.04
						1/2" Ice	8.6091 9.2158	6.5465 7.4089	0.10 0.17
						1" Ice	10.4591	9.1837	0.33
						2" Ice	13.0655	12.9333	0.79
						4" Ice			
BXA-185063/8CF w/ Mount Pipe	A	From Face	4.0000 0.00 0.00	0.0000	149.0000	No Ice	3.1811	2.9966	0.03
						1/2" Ice	3.5589 3.9627	3.6145 4.2361	0.06 0.09
						1" Ice	4.8550	5.5293	0.19
						2" Ice	6.7735	8.4233	0.47
						4" Ice			
BXA-185090/8CFx2 w/ Mount Pipe	B	From Face	4.0000 0.00 0.00	0.0000	149.0000	No Ice	3.1574	3.3303	0.03
						1/2" Ice	3.5312 3.9415	3.9423 4.5633	0.06 0.10
						1" Ice	4.8273	5.8553	0.19
						2" Ice	6.7342	8.8407	0.49
						4" Ice			
BXA-185090/8CFx2 w/ Mount Pipe	C	From Face	4.0000 0.00 0.00	0.0000	149.0000	No Ice	3.1574	3.3303	0.03
						1/2" Ice	3.5312 3.9415	3.9423 4.5633	0.06 0.10
						1" Ice	4.8273	5.8553	0.19
						2" Ice	6.7342	8.8407	0.49
						4" Ice			
(2) FD9R6004/2C-3L	A	From Face	4.0000 0.00 0.00	0.0000	149.0000	No Ice	0.3665	0.0846	0.00
						1/2" Ice	0.4506 0.5433	0.1362 0.1965	0.01 0.01
						1" Ice	0.7546	0.3430	0.02
						2" Ice	1.2808	0.7396	0.06
						4" Ice			
(2) FD9R6004/2C-3L	B	From Face	4.0000 0.00 0.00	0.0000	149.0000	No Ice	0.3665	0.0846	0.00
						1/2" Ice	0.4506 0.5433	0.1362 0.1965	0.01 0.01
						1" Ice	0.7546	0.3430	0.02
						2" Ice	1.2808	0.7396	0.06
						4" Ice			
(2) FD9R6004/2C-3L	C	From Face	4.0000 0.00 0.00	0.0000	149.0000	No Ice	0.3665	0.0846	0.00
						1/2" Ice	0.4506 0.5433	0.1362 0.1965	0.01 0.01
						1" Ice	0.7546	0.3430	0.02
						2" Ice	1.2808	0.7396	0.06
						4" Ice			
Platform Mount [LP 602-1]	C	None		0.0000	149.0000	No Ice	32.0300	32.0300	1.34
						1/2" Ice	38.7100 45.3900	38.7100 45.3900	1.80 2.26
						1" Ice	58.7500	58.7500	3.17
						2" Ice	85.4700	85.4700	5.00
						4" Ice			
***									
LLPX310R-V1 w/ Mount Pipe	A	From Face	4.0000 0.00 0.00	0.0000	135.0000	No Ice	5.0651	2.9834	0.05
						1/2" Ice	5.4798 5.9052	3.5263 4.0859	0.08 0.13
						1" Ice	6.7881	5.3127	0.23
						2" Ice	8.7045	8.1308	0.54
						4" Ice			
LLPX310R-V1 w/ Mount Pipe	B	From Face	4.0000 0.00 0.00	0.0000	135.0000	No Ice	5.0651	2.9834	0.05
						1/2" Ice	5.4798 5.9052	3.5263 4.0859	0.08 0.13
						1" Ice	6.7881	5.3127	0.23
						2" Ice	8.7045	8.1308	0.54
						4" Ice			
LLPX310R-V1 w/ Mount	C	From Face	4.0000	0.0000	135.0000	No Ice	5.0651	2.9834	0.05

Description	Face or Leg	Offset Type	Offsets: Horz Lateral Vert ft ft ft	Azimuth Adjustment °	Placement ft	C <sub>AA</sub> Front ft <sup>2</sup>	C <sub>AA</sub> Side ft <sup>2</sup>	Weight K	
Pipe			0.00 0.00			1/2" Ice 1" Ice 2" Ice 4" Ice	5.4798 5.9052 6.7881 8.7045	3.5263 4.0859 5.3127 8.1308	0.08 0.13 0.23 0.54
WIMAX DAP HEAD	A	From Face	4.0000 0.00 0.00	0.0000	135.0000	No Ice 1/2" Ice 1" Ice 2" Ice 4" Ice	1.8044 1.9877 2.1795 2.5891 3.5121	0.7778 0.9182 1.0673 1.3914 2.1432	0.03 0.04 0.06 0.09 0.20
WIMAX DAP HEAD	B	From Face	4.0000 0.00 0.00	0.0000	135.0000	No Ice 1/2" Ice 1" Ice 2" Ice 4" Ice	1.8044 1.9877 2.1795 2.5891 3.5121	0.7778 0.9182 1.0673 1.3914 2.1432	0.03 0.04 0.06 0.09 0.20
WIMAX DAP HEAD	C	From Face	4.0000 0.00 0.00	0.0000	135.0000	No Ice 1/2" Ice 1" Ice 2" Ice 4" Ice	1.8044 1.9877 2.1795 2.5891 3.5121	0.7778 0.9182 1.0673 1.3914 2.1432	0.03 0.04 0.06 0.09 0.20
HORIZON COMPACT	A	From Face	4.0000 0.00 4.00	0.0000	135.0000	No Ice 1/2" Ice 1" Ice 2" Ice 4" Ice	0.8409 0.9658 1.0993 1.3922 2.0819	0.4295 0.5249 0.6289 0.8629 1.4345	0.01 0.02 0.03 0.05 0.12
HORIZON COMPACT	C	From Face	4.0000 0.00 4.00	0.0000	135.0000	No Ice 1/2" Ice 1" Ice 2" Ice 4" Ice	0.8409 0.9658 1.0993 1.3922 2.0819	0.4295 0.5249 0.6289 0.8629 1.4345	0.01 0.02 0.03 0.05 0.12
TIMING 2000	A	From Face	4.0000 0.00 0.00	0.0000	135.0000	No Ice 1/2" Ice 1" Ice 2" Ice 4" Ice	0.1258 0.1771 0.2370 0.3827 0.7778	0.1258 0.1771 0.2370 0.3827 0.7778	0.00 0.00 0.01 0.01 0.05
(2) DB980H90E-M w/ Mount Pipe	A	From Face	4.0000 0.00 0.00	0.0000	135.0000	No Ice 1/2" Ice 1" Ice 2" Ice 4" Ice	4.0361 4.4987 4.9468 5.8700 8.0460	3.6194 4.4808 5.2186 6.7442 9.9954	0.03 0.06 0.11 0.22 0.55
(2) DB980H90E-M w/ Mount Pipe	B	From Face	4.0000 0.00 0.00	0.0000	135.0000	No Ice 1/2" Ice 1" Ice 2" Ice 4" Ice	4.0361 4.4987 4.9468 5.8700 8.0460	3.6194 4.4808 5.2186 6.7442 9.9954	0.03 0.06 0.11 0.22 0.55
(2) DB980H90E-M w/ Mount Pipe	C	From Face	4.0000 0.00 0.00	0.0000	135.0000	No Ice 1/2" Ice 1" Ice 2" Ice 4" Ice	4.0361 4.4987 4.9468 5.8700 8.0460	3.6194 4.4808 5.2186 6.7442 9.9954	0.03 0.06 0.11 0.22 0.55
Platform Mount [LP 602-1]	C	None		0.0000	135.0000	No Ice 1/2" Ice 1" Ice 2" Ice 4" Ice	32.0300 38.7100 45.3900 58.7500 85.4700	32.0300 38.7100 45.3900 58.7500 85.4700	1.34 1.80 2.26 3.17 5.00



Description	Face or Leg	Offset Type	Offsets: Horz Lateral Vert ft ft ft	Azimuth Adjustment °	Placement ft		C <sub>AA</sub> Front ft <sup>2</sup>	C <sub>AA</sub> Side ft <sup>2</sup>	Weight K
***									
(3) DB844H90E-XY w/ Mount Pipe	A	From Face	4.0000 0.00 1.00	0.0000	126.0000	No Ice	3.2986	4.9208	0.03
						1/2" Ice	3.6900	5.5962	0.07
						Ice	4.1185	6.2837	0.12
						1" Ice	5.0070	7.7123	0.23
						2" Ice	6.9197	10.8330	0.56
(3) DB844H90E-XY w/ Mount Pipe	B	From Face	4.0000 0.00 1.00	0.0000	126.0000	No Ice	3.2986	4.9208	0.03
						1/2" Ice	3.6900	5.5962	0.07
						Ice	4.1185	6.2837	0.12
						1" Ice	5.0070	7.7123	0.23
						2" Ice	6.9197	10.8330	0.56
(3) DB844H90E-XY w/ Mount Pipe	C	From Face	4.0000 0.00 1.00	0.0000	126.0000	No Ice	3.2986	4.9208	0.03
						1/2" Ice	3.6900	5.5962	0.07
						Ice	4.1185	6.2837	0.12
						1" Ice	5.0070	7.7123	0.23
						2" Ice	6.9197	10.8330	0.56
T-Arm Mount [TA 901-3]	C	None		0.0000	126.0000	No Ice	17.5000	17.5000	0.75
						1/2" Ice	20.7000	20.7000	1.00
						Ice	23.9000	23.9000	1.26
						1" Ice	30.3000	30.3000	1.76
						2" Ice	43.1000	43.1000	2.76
***									
APX16DWV-16DWV-S-E- ACU w/ Mount Pipe	A	From Face	4.0000 0.00 1.00	0.0000	116.0000	No Ice	6.9361	3.2893	0.06
						1/2" Ice	7.4389	3.9953	0.10
						Ice	7.9415	4.6615	0.16
						1" Ice	8.9779	6.0439	0.28
						2" Ice	11.1750	9.0230	0.65
APX16DWV-16DWV-S-E- ACU w/ Mount Pipe	B	From Face	4.0000 0.00 1.00	0.0000	116.0000	No Ice	6.9361	3.2893	0.06
						1/2" Ice	7.4389	3.9953	0.10
						Ice	7.9415	4.6615	0.16
						1" Ice	8.9779	6.0439	0.28
						2" Ice	11.1750	9.0230	0.65
APX16DWV-16DWV-S-E- ACU w/ Mount Pipe	C	From Face	4.0000 0.00 1.00	0.0000	116.0000	No Ice	6.9361	3.2893	0.06
						1/2" Ice	7.4389	3.9953	0.10
						Ice	7.9415	4.6615	0.16
						1" Ice	8.9779	6.0439	0.28
						2" Ice	11.1750	9.0230	0.65
RR90-17-02DP w/ Mount Pipe	A	From Face	4.0000 0.00 1.00	0.0000	116.0000	No Ice	4.5931	3.3194	0.03
						1/2" Ice	5.0883	4.0888	0.07
						Ice	5.5778	4.7844	0.11
						1" Ice	6.5876	6.2255	0.22
						2" Ice	8.7306	9.3076	0.56
RR90-17-02DP w/ Mount Pipe	B	From Face	4.0000 0.00 1.00	0.0000	116.0000	No Ice	4.5931	3.3194	0.03
						1/2" Ice	5.0883	4.0888	0.07
						Ice	5.5778	4.7844	0.11
						1" Ice	6.5876	6.2255	0.22
						2" Ice	8.7306	9.3076	0.56
RR90-17-02DP w/ Mount Pipe	C	From Face	4.0000 0.00 1.00	0.0000	116.0000	No Ice	4.5931	3.3194	0.03
						1/2" Ice	5.0883	4.0888	0.07
						Ice	5.5778	4.7844	0.11
						1" Ice	6.5876	6.2255	0.22
						2" Ice	8.7306	9.3076	0.56
KRY 112 71/1	A	From Face	4.0000 0.00 1.00	0.0000	116.0000	No Ice	0.6806	0.4497	0.01
						1/2" Ice	0.8022	0.5590	0.02
						Ice	0.9325	0.6769	0.03

Description	Face or Leg	Offset Type	Offsets:		Azimuth Adjustment	Placement	C <sub>AA</sub> <sub>Front</sub>	C <sub>AA</sub> <sub>Side</sub>	Weight	
			Horz	Lateral						Vert
			ft	ft	°	ft	ft <sup>2</sup>	ft <sup>2</sup>	K	
KRY 112 71/1	B	From Face	4.0000	0.0000	0.0000	116.0000	1" Ice	1.2190	0.9388	0.04
							2" Ice	1.8956	1.5662	0.11
							4" Ice			
							No Ice	0.6806	0.4497	0.01
							1/2" Ice	0.8022	0.5590	0.02
							1" Ice	0.9325	0.6769	0.03
							2" Ice	1.2190	0.9388	0.04
KRY 112 71/1	C	From Face	4.0000	0.0000	0.0000	116.0000	2" Ice	1.8956	1.5662	0.11
							4" Ice			
							No Ice	0.6806	0.4497	0.01
							1/2" Ice	0.8022	0.5590	0.02
							1" Ice	0.9325	0.6769	0.03
							1" Ice	1.2190	0.9388	0.04
							2" Ice	1.8956	1.5662	0.11
ONEBASE TWIN DUAL DUPLEX TMA	A	From Face	4.0000	0.0000	0.0000	116.0000	4" Ice			
							No Ice	0.6737	0.3063	0.01
							1/2" Ice	0.7863	0.3916	0.02
							1" Ice	0.9075	0.4856	0.02
							1" Ice	1.1758	0.6995	0.04
							2" Ice	1.8162	1.2309	0.10
							4" Ice			
ONEBASE TWIN DUAL DUPLEX TMA	B	From Face	4.0000	0.0000	0.0000	116.0000	No Ice	0.6737	0.3063	0.01
							1/2" Ice	0.7863	0.3916	0.02
							1" Ice	0.9075	0.4856	0.02
							1" Ice	1.1758	0.6995	0.04
							2" Ice	1.8162	1.2309	0.10
							4" Ice			
							No Ice	0.6737	0.3063	0.01
ONEBASE TWIN DUAL DUPLEX TMA	C	From Face	4.0000	0.0000	0.0000	116.0000	1/2" Ice	0.7863	0.3916	0.02
							1" Ice	0.9075	0.4856	0.02
							1" Ice	1.1758	0.6995	0.04
							2" Ice	1.8162	1.2309	0.10
							4" Ice			
							No Ice	0.6737	0.3063	0.01
							1/2" Ice	0.7863	0.3916	0.02
Side Arm Mount [SO 103-3]	C	None			0.0000	116.0000	No Ice	9.5000	9.5000	0.22
							1/2" Ice	11.8000	11.8000	0.32
							1" Ice	14.1000	14.1000	0.41
							1" Ice	18.7000	18.7000	0.60
							2" Ice	27.9000	27.9000	0.97
							4" Ice			
							No Ice	2.8300	2.8300	0.20
Side Arm Mount [SO 701-3]	C	None			0.0000	116.0000	1/2" Ice	3.9200	3.9200	0.24
							1" Ice	5.0100	5.0100	0.28
							1" Ice	7.1900	7.1900	0.36
							2" Ice	11.5500	11.5500	0.53
							4" Ice			
							No Ice	2.8300	2.8300	0.20
							1/2" Ice	3.9200	3.9200	0.24
HBX-6516DS-VTM w/ Mount Pipe	A	From Face	4.0000	0.0000	0.0000	106.0000	No Ice	3.5975	3.2406	0.03
							1/2" Ice	3.9981	3.9135	0.06
							1" Ice	4.4346	4.5638	0.10
							1" Ice	5.3677	5.9143	0.20
							2" Ice	7.3611	8.8773	0.50
							4" Ice			
							No Ice	3.5975	3.2406	0.03
HBX-6516DS-VTM w/ Mount Pipe	B	From Face	4.0000	0.0000	0.0000	106.0000	1/2" Ice	3.9981	3.9135	0.06
							1" Ice	4.4346	4.5638	0.10
							1" Ice	5.3677	5.9143	0.20
							2" Ice	7.3611	8.8773	0.50
							4" Ice			
							No Ice	3.5975	3.2406	0.03
							1/2" Ice	3.9981	3.9135	0.06
HBX-6516DS-VTM w/ Mount Pipe	C	From Face	4.0000	0.0000	0.0000	106.0000	1" Ice	4.4346	4.5638	0.10
							1" Ice	5.3677	5.9143	0.20
							2" Ice	7.3611	8.8773	0.50
							4" Ice			
							No Ice	3.5975	3.2406	0.03
							1/2" Ice	3.9981	3.9135	0.06
							1" Ice	4.4346	4.5638	0.10
ATM200-A20	A	From Face	4.0000	0.0000	0.0000	106.0000	1" Ice	5.3677	5.9143	0.20
							2" Ice	7.3611	8.8773	0.50
							4" Ice			
							No Ice	0.2178	0.1633	0.00

Description	Face or Leg	Offset Type	Offsets: Horz Lateral Vert ft ft ft	Azimuth Adjustment °	Placement ft	C <sub>AA</sub> Front ft <sup>2</sup>	C <sub>AA</sub> Side ft <sup>2</sup>	Weight K	
			0.00			1/2"	0.2921	0.2331	0.00
			2.00			Ice	0.3751	0.3115	0.01
						1" Ice	0.5669	0.4943	0.02
						2" Ice	1.0543	0.9636	0.06
						4" Ice			
ATM200-A20	B	From Face	4.0000	0.0000	106.0000	No Ice	0.2178	0.1633	0.00
			0.00			1/2"	0.2921	0.2331	0.00
			2.00			Ice	0.3751	0.3115	0.01
						1" Ice	0.5669	0.4943	0.02
						2" Ice	1.0543	0.9636	0.06
						4" Ice			
ATM200-A20	C	From Face	4.0000	0.0000	106.0000	No Ice	0.2178	0.1633	0.00
			0.00			1/2"	0.2921	0.2331	0.00
			2.00			Ice	0.3751	0.3115	0.01
						1" Ice	0.5669	0.4943	0.02
						2" Ice	1.0543	0.9636	0.06
						4" Ice			
T-Arm Mount [TA 602-3]	C	None		0.0000	106.0000	No Ice	11.5900	11.5900	0.77
						1/2"	15.4400	15.4400	0.99
						Ice	19.2900	19.2900	1.21
						1" Ice	26.9900	26.9900	1.64
						2" Ice	42.3900	42.3900	2.50
						4" Ice			
***									
58532A	C	From Face	2.0000	0.0000	50.0000	No Ice	0.2209	0.2209	0.00
			0.00			1/2"	0.2897	0.2897	0.00
			0.00			Ice	0.3672	0.3672	0.01
						1" Ice	0.5481	0.5481	0.02
						2" Ice	1.0137	1.0137	0.06
						4" Ice			
Platform Mount [LP 301-1]	C	None		0.0000	50.0000	No Ice	30.1000	30.1000	1.59
						1/2"	40.8000	40.8000	2.03
						Ice	51.5000	51.5000	2.47
						1" Ice	72.9000	72.9000	3.35
						2" Ice	115.7000	115.7000	5.11
						4" Ice			
***									
KS24019-L112A	B	From Face	2.0000	0.0000	47.0000	No Ice	0.1556	0.1556	0.01
			0.00			1/2"	0.2247	0.2247	0.01
			1.00			Ice	0.3025	0.3025	0.01
						1" Ice	0.4840	0.4840	0.02
						2" Ice	0.9506	0.9506	0.06
						4" Ice			
Side Arm Mount [SO 701-1]	B	None		0.0000	47.0000	No Ice	0.8500	1.6700	0.07
						1/2"	1.1400	2.3400	0.08
						Ice	1.4300	3.0100	0.09
						1" Ice	2.0100	4.3500	0.12
						2" Ice	3.1700	7.0300	0.18
						4" Ice			

### Dishes

Description	Face or Leg	Dish Type	Offset Type	Offsets: Horz Lateral Vert ft ft ft	Azimuth Adjustment °	3 dB Beam Width °	Elevation ft	Outside Diameter ft	Aperture Area ft <sup>2</sup>	Weight K	
VHLP2.5-11	A	Paraboloid w/Shroud (HP)	From Face	4.0000 0.00	0.0000		135.0000	2.9167	No Ice 1/2" Ice	6.6800 7.0700	0.05 0.08

Description	Face or Leg	Dish Type	Offset Type	Offsets: Horz Lateral Vert ft	Azimuth Adjustment °	3 dB Beam Width °	Elevation ft	Outside Diameter ft	Aperture Area ft <sup>2</sup>	Weight K
				4.00					1" Ice 7.4600	0.12
									2" Ice 8.2300	0.19
									4" Ice 9.7800	0.34
VHLP2.5-11	C	Paraboloid w/Shroud (HP)	From Face	4.0000 0.00 4.00	0.0000		135.0000	2.9167	No Ice 6.6800	0.05
									1/2" Ice 7.0700	0.08
									1" Ice 7.4600	0.12
									2" Ice 8.2300	0.19
									4" Ice 9.7800	0.34

### Load Combinations

Comb. No.	Description
1	Dead Only
2	Dead+Wind 0 deg - No Ice
3	Dead+Wind 30 deg - No Ice
4	Dead+Wind 60 deg - No Ice
5	Dead+Wind 90 deg - No Ice
6	Dead+Wind 120 deg - No Ice
7	Dead+Wind 150 deg - No Ice
8	Dead+Wind 180 deg - No Ice
9	Dead+Wind 210 deg - No Ice
10	Dead+Wind 240 deg - No Ice
11	Dead+Wind 270 deg - No Ice
12	Dead+Wind 300 deg - No Ice
13	Dead+Wind 330 deg - No Ice
14	Dead+Ice+Temp
15	Dead+Wind 0 deg+Ice+Temp
16	Dead+Wind 30 deg+Ice+Temp
17	Dead+Wind 60 deg+Ice+Temp
18	Dead+Wind 90 deg+Ice+Temp
19	Dead+Wind 120 deg+Ice+Temp
20	Dead+Wind 150 deg+Ice+Temp
21	Dead+Wind 180 deg+Ice+Temp
22	Dead+Wind 210 deg+Ice+Temp
23	Dead+Wind 240 deg+Ice+Temp
24	Dead+Wind 270 deg+Ice+Temp
25	Dead+Wind 300 deg+Ice+Temp
26	Dead+Wind 330 deg+Ice+Temp
27	Dead+Wind 0 deg - Service
28	Dead+Wind 30 deg - Service
29	Dead+Wind 60 deg - Service
30	Dead+Wind 90 deg - Service
31	Dead+Wind 120 deg - Service
32	Dead+Wind 150 deg - Service
33	Dead+Wind 180 deg - Service
34	Dead+Wind 210 deg - Service
35	Dead+Wind 240 deg - Service
36	Dead+Wind 270 deg - Service
37	Dead+Wind 300 deg - Service
38	Dead+Wind 330 deg - Service

### Maximum Member Forces

Section No.	Elevation ft	Component Type	Condition	Gov. Load Comb.	Force K	Major Axis Moment kip-ft	Minor Axis Moment kip-ft
L1	160 - 150.5	Pole	Max Tension	11	0.00	-0.00	-0.00
			Max. Compression	14	-7.21	0.92	-0.03
			Max. Mx	11	-2.42	45.12	-0.27
			Max. My	2	-2.42	-0.16	45.27

Section No.	Elevation ft	Component Type	Condition	Gov. Load Comb.	Force K	Major Axis Moment kip-ft	Minor Axis Moment kip-ft
L2	150.5 - 150	Pole	Max. Vy	5	6.13	-44.84	0.17
			Max. Vx	2	-6.17	-0.16	45.27
			Max. Torque	9			-0.91
			Max Tension	1	0.00	0.00	0.00
			Max. Compression	14	-7.29	0.96	-0.05
			Max. Mx	11	-2.45	48.20	-0.29
			Max. My	2	-2.45	-0.16	48.36
			Max. Vy	11	-6.17	48.20	-0.29
			Max. Vx	8	6.21	0.29	-48.33
L3	150 - 119	Pole	Max. Torque	9			-0.92
			Max Tension	1	0.00	0.00	0.00
			Max. Compression	14	-24.62	5.22	-1.88
			Max. Mx	11	-8.37	506.11	5.06
			Max. My	2	-8.38	7.16	503.38
			Max. Vy	5	20.25	-505.92	-7.35
			Max. Vx	2	-20.16	7.16	503.38
			Max. Torque	2			1.73
			Max Tension	1	0.00	0.00	0.00
L4	119 - 97.1667	Pole	Max. Compression	14	-33.90	8.91	-3.98
			Max. Mx	5	-12.31	-898.93	-12.68
			Max. My	2	-12.33	12.14	895.00
			Max. Vy	5	25.20	-898.93	-12.68
			Max. Vx	2	-25.10	12.14	895.00
			Max. Torque	2			1.88
			Max Tension	1	0.00	0.00	0.00
			Max. Compression	14	-39.34	11.70	-5.56
			Max. Mx	5	-15.16	-1198.24	-16.31
L5	97.1667 - 90.5	Pole	Max. My	2	-15.18	15.54	1193.37
			Max. Vy	5	26.87	-1198.24	-16.31
			Max. Vx	2	-26.78	15.54	1193.37
			Max. Torque	2			2.00
			Max Tension	1	0.00	0.00	0.00
			Max. Compression	14	-52.36	19.77	-10.19
			Max. Mx	5	-22.26	-2062.66	-25.87
			Max. My	2	-22.27	24.55	2055.41
			Max. Vy	5	30.92	-2062.66	-25.87
L6	90.5 - 60.5	Pole	Max. Vx	2	-30.82	24.55	2055.41
			Max. Torque	2			2.31
			Max Tension	1	0.00	0.00	0.00
			Max. Compression	14	-54.87	21.30	-11.07
			Max. Mx	5	-23.74	-2234.37	-27.63
			Max. My	2	-23.75	26.21	2226.69
			Max. Vy	5	31.62	-2234.37	-27.63
			Max. Vx	2	-31.53	26.21	2226.69
			Max. Torque	2			2.37
L7	60.5 - 55	Pole	Max Tension	1	0.00	0.00	0.00
			Max. Compression	14	-69.48	28.20	-15.06
			Max. Mx	5	-32.89	-3064.52	-35.42
			Max. My	2	-32.90	33.61	3054.97
			Max. Vy	5	35.64	-3064.52	-35.42
			Max. Vx	2	-35.54	33.61	3054.97
			Max. Torque	2			2.62
			Max Tension	1	0.00	0.00	0.00
			Max. Compression	14	-85.38	37.10	-20.18
L8	55 - 30.5	Pole	Max. Mx	5	-43.45	-4200.73	-45.03
			Max. My	2	-43.45	42.80	4188.98
			Max. Vy	5	39.03	-4200.73	-45.03
			Max. Vx	2	-38.94	42.80	4188.98
			Max. Torque	2			2.97
			Max Tension	1	0.00	0.00	0.00
			Max. Compression	14	-85.38	37.10	-20.18
			Max. Mx	5	-43.45	-4200.73	-45.03
			Max. My	2	-43.45	42.80	4188.98
L9	30.5 - 0	Pole	Max. Vy	5	39.03	-4200.73	-45.03
			Max. Vx	2	-38.94	42.80	4188.98
			Max. Torque	2			2.97
			Max Tension	1	0.00	0.00	0.00
			Max. Compression	14	-85.38	37.10	-20.18
			Max. Mx	5	-43.45	-4200.73	-45.03
			Max. My	2	-43.45	42.80	4188.98
			Max. Vy	5	39.03	-4200.73	-45.03
			Max. Vx	2	-38.94	42.80	4188.98

**Maximum Reactions**

Location	Condition	Gov. Load Comb.	Vertical K	Horizontal, X K	Horizontal, Z K
Pole	Max. Vert	14	85.38	-0.00	0.00
	Max. H <sub>x</sub>	11	43.47	38.93	0.20
	Max. H <sub>z</sub>	2	43.47	0.25	38.91
	Max. M <sub>x</sub>	2	4188.98	0.25	38.91
	Max. M <sub>z</sub>	5	4200.73	-39.00	-0.28
	Max. Torsion	2	2.97	0.25	38.91
	Min. Vert	11	43.47	38.93	0.20
	Min. H <sub>x</sub>	5	43.47	-39.00	-0.28
	Min. H <sub>z</sub>	8	43.47	-0.32	-38.86
	Min. M <sub>x</sub>	8	-4186.44	-0.32	-38.86
	Min. M <sub>z</sub>	11	-4200.61	38.93	0.20
	Min. Torsion	7	-2.80	-19.68	-33.78

### Tower Mast Reaction Summary

Load Combination	Vertical	Shear <sub>x</sub>	Shear <sub>z</sub>	Overtuning Moment, M <sub>x</sub>	Overtuning Moment, M <sub>z</sub>	Torque
	K	K	K	kip-ft	kip-ft	kip-ft
Dead Only	43.47	0.00	-0.00	2.69	5.00	-0.00
Dead+Wind 0 deg - No Ice	43.47	-0.25	-38.91	-4188.98	42.80	-2.97
Dead+Wind 30 deg - No Ice	43.47	19.26	-33.65	-3619.96	-2061.38	-2.39
Dead+Wind 60 deg - No Ice	43.47	33.66	-19.28	-2066.14	-3619.42	-0.72
Dead+Wind 90 deg - No Ice	43.47	39.00	0.28	45.03	-4200.73	1.14
Dead+Wind 120 deg - No Ice	43.47	33.84	19.68	2131.23	-3647.26	2.25
Dead+Wind 150 deg - No Ice	43.47	19.68	33.78	3645.28	-2125.08	2.80
Dead+Wind 180 deg - No Ice	43.47	0.32	38.86	4186.44	-42.00	2.79
Dead+Wind 210 deg - No Ice	43.47	-19.29	33.55	3610.96	2077.03	2.38
Dead+Wind 240 deg - No Ice	43.47	-33.63	19.26	2069.47	3625.88	0.72
Dead+Wind 270 deg - No Ice	43.47	-38.93	-0.20	-27.57	4200.61	-1.13
Dead+Wind 300 deg - No Ice	43.47	-33.77	-19.71	-2130.15	3646.26	-2.08
Dead+Wind 330 deg - No Ice	43.47	-19.65	-33.80	-3642.77	2130.14	-2.80
Dead+Ice+Temp	85.38	0.00	-0.00	20.18	37.10	-0.00
Dead+Wind 0 deg+Ice+Temp	85.38	-0.06	-11.77	-1330.34	46.79	-1.11
Dead+Wind 30 deg+Ice+Temp	85.38	5.83	-10.18	-1147.63	-630.40	-0.82
Dead+Wind 60 deg+Ice+Temp	85.38	10.18	-5.84	-648.24	-1130.73	-0.19
Dead+Wind 90 deg+Ice+Temp	85.38	11.79	0.07	31.06	-1316.67	0.49
Dead+Wind 120 deg+Ice+Temp	85.38	10.22	5.94	703.87	-1137.78	0.92
Dead+Wind 150 deg+Ice+Temp	85.38	5.94	10.21	1192.99	-646.65	1.12
Dead+Wind 180 deg+Ice+Temp	85.38	0.08	11.75	1368.78	25.06	1.07
Dead+Wind 210 deg+Ice+Temp	85.38	-5.84	10.15	1184.20	706.19	0.82
Dead+Wind 240 deg+Ice+Temp	85.38	-10.17	5.84	688.11	1204.07	0.19
Dead+Wind 270 deg+Ice+Temp	85.38	-11.77	-0.05	12.58	1388.38	-0.48
Dead+Wind 300 deg+Ice+Temp	85.38	-10.20	-5.94	-664.57	1209.14	-0.88
Dead+Wind 330 deg+Ice+Temp	85.38	-5.93	-10.21	-1153.32	719.64	-1.12
Dead+Wind 0 deg - Service	43.47	-0.10	-15.20	-1637.52	19.94	-1.18
Dead+Wind 30 deg - Service	43.47	7.52	-13.15	-1414.98	-803.54	-0.95
Dead+Wind 60 deg - Service	43.47	13.15	-7.53	-806.88	-1413.30	-0.29
Dead+Wind 90 deg - Service	43.47	15.23	0.11	19.34	-1640.67	0.45
Dead+Wind 120 deg - Service	43.47	13.22	7.69	835.84	-1424.28	0.89
Dead+Wind 150 deg - Service	43.47	7.69	13.20	1428.39	-828.52	1.11
Dead+Wind 180 deg - Service	43.47	0.12	15.18	1640.13	-13.26	1.10

Load Combination	Vertical K	Shear <sub>x</sub> K	Shear <sub>z</sub> K	Overturning Moment, M <sub>x</sub> kip-ft	Overturning Moment, M <sub>z</sub> kip-ft	Torque kip-ft
Service						
Dead+Wind 210 deg - Service	43.47	-7.54	13.11	1414.86	816.04	0.94
Dead+Wind 240 deg - Service	43.47	-13.14	7.52	811.60	1422.20	0.29
Dead+Wind 270 deg - Service	43.47	-15.21	-0.08	-9.08	1647.18	-0.45
Dead+Wind 300 deg - Service	43.47	-13.19	-7.70	-831.99	1430.26	-0.82
Dead+Wind 330 deg - Service	43.47	-7.67	-13.20	-1423.99	836.88	-1.11

### Solution Summary

Load Comb.	Sum of Applied Forces			Sum of Reactions			% Error
	PX K	PY K	PZ K	PX K	PY K	PZ K	
1	0.00	-43.47	0.00	-0.00	43.47	0.00	0.003%
2	-0.25	-43.47	-38.92	0.25	43.47	38.91	0.002%
3	19.26	-43.47	-33.65	-19.26	43.47	33.65	0.000%
4	33.66	-43.47	-19.28	-33.66	43.47	19.28	0.000%
5	39.00	-43.47	0.28	-39.00	43.47	-0.28	0.002%
6	33.84	-43.47	19.68	-33.84	43.47	-19.68	0.000%
7	19.68	-43.47	33.78	-19.68	43.47	-33.78	0.000%
8	0.32	-43.47	38.86	-0.32	43.47	-38.86	0.009%
9	-19.29	-43.47	33.55	19.29	43.47	-33.55	0.000%
10	-33.63	-43.47	19.26	33.63	43.47	-19.26	0.000%
11	-38.94	-43.47	-0.20	38.93	43.47	0.20	0.009%
12	-33.77	-43.47	-19.71	33.77	43.47	19.71	0.000%
13	-19.65	-43.47	-33.80	19.65	43.47	33.80	0.000%
14	0.00	-85.38	0.00	-0.00	85.38	0.00	0.001%
15	-0.06	-85.38	-11.77	0.06	85.38	11.77	0.001%
16	5.83	-85.38	-10.18	-5.83	85.38	10.18	0.000%
17	10.18	-85.38	-5.84	-10.18	85.38	5.84	0.000%
18	11.79	-85.38	0.07	-11.79	85.38	-0.07	0.001%
19	10.22	-85.38	5.94	-10.22	85.38	-5.94	0.000%
20	5.94	-85.38	10.21	-5.94	85.38	-10.21	0.000%
21	0.08	-85.38	11.75	-0.08	85.38	-11.75	0.001%
22	-5.84	-85.38	10.15	5.84	85.38	-10.15	0.000%
23	-10.17	-85.38	5.84	10.17	85.38	-5.84	0.000%
24	-11.77	-85.38	-0.05	11.77	85.38	0.05	0.001%
25	-10.20	-85.38	-5.94	10.20	85.38	5.94	0.000%
26	-5.93	-85.38	-10.21	5.93	85.38	10.21	0.000%
27	-0.10	-43.47	-15.20	0.10	43.47	15.20	0.005%
28	7.52	-43.47	-13.15	-7.52	43.47	13.15	0.001%
29	13.15	-43.47	-7.53	-13.15	43.47	7.53	0.001%
30	15.24	-43.47	0.11	-15.23	43.47	-0.11	0.005%
31	13.22	-43.47	7.69	-13.22	43.47	-7.69	0.001%
32	7.69	-43.47	13.20	-7.69	43.47	-13.20	0.001%
33	0.12	-43.47	15.18	-0.12	43.47	-15.18	0.005%
34	-7.54	-43.47	13.11	7.54	43.47	-13.11	0.001%
35	-13.14	-43.47	7.52	13.14	43.47	-7.52	0.001%
36	-15.21	-43.47	-0.08	15.21	43.47	0.08	0.005%
37	-13.19	-43.47	-7.70	13.19	43.47	7.70	0.001%
38	-7.67	-43.47	-13.20	7.67	43.47	13.20	0.001%

### Non-Linear Convergence Results

Load Combination	Converged?	Number of Cycles	Displacement Tolerance	Force Tolerance
1	Yes	6	0.00000001	0.00000995
2	Yes	18	0.00002147	0.00013922

3	Yes	22	0.00000001	0.00011578
4	Yes	22	0.00000001	0.00011986
5	Yes	18	0.00002145	0.00007991
6	Yes	22	0.00000001	0.00012614
7	Yes	22	0.00000001	0.00012150
8	Yes	16	0.00008419	0.00013753
9	Yes	22	0.00000001	0.00012185
10	Yes	22	0.00000001	0.00011822
11	Yes	16	0.00008412	0.00010703
12	Yes	22	0.00000001	0.00012283
13	Yes	22	0.00000001	0.00012656
14	Yes	14	0.00000001	0.00004896
15	Yes	19	0.00004857	0.00009958
16	Yes	20	0.00000001	0.00008753
17	Yes	20	0.00000001	0.00009007
18	Yes	19	0.00004857	0.00009642
19	Yes	20	0.00000001	0.00009801
20	Yes	20	0.00000001	0.00009341
21	Yes	19	0.00004853	0.00010106
22	Yes	20	0.00000001	0.00010333
23	Yes	20	0.00000001	0.00010071
24	Yes	19	0.00004854	0.00010145
25	Yes	20	0.00000001	0.00009817
26	Yes	20	0.00000001	0.00010246
27	Yes	16	0.00009107	0.00010316
28	Yes	19	0.00000001	0.00008093
29	Yes	19	0.00000001	0.00008789
30	Yes	16	0.00009107	0.00006415
31	Yes	19	0.00000001	0.00009479
32	Yes	19	0.00000001	0.00008671
33	Yes	16	0.00009107	0.00007345
34	Yes	19	0.00000001	0.00009237
35	Yes	19	0.00000001	0.00008548
36	Yes	16	0.00009106	0.00005408
37	Yes	19	0.00000001	0.00008901
38	Yes	19	0.00000001	0.00009623

### Maximum Tower Deflections - Service Wind

Section No.	Elevation ft	Horz. Deflection in	Gov. Load Comb.	Tilt °	Twist °
L1	160 - 150.5	52.924	37	3.0428	0.0097
L2	150.5 - 150	46.889	37	3.0174	0.0085
L3	150 - 119	46.573	37	3.0141	0.0084
L4	119 - 97.1667	28.585	37	2.4090	0.0040
L5	102 - 90.5	20.725	37	1.9942	0.0027
L6	90.5 - 60.5	16.136	37	1.7890	0.0023
L7	60.5 - 55	6.970	37	1.1286	0.0012
L8	55 - 30.5	5.736	37	1.0142	0.0010
L9	30.5 - 0	1.726	37	0.5489	0.0005

### Critical Deflections and Radius of Curvature - Service Wind

Elevation ft	Appurtenance	Gov. Load Comb.	Deflection in	Tilt °	Twist °	Radius of Curvature ft
158.0000	SBNH-1D6565C w/ Mount Pipe	37	51.650	3.0409	0.0097	18597
149.0000	(2) LPA-80063/4CF w/ Mount Pipe	37	45.943	3.0066	0.0085	6591
139.0000	VHLP2.5-11	37	39.777	2.8743	0.0070	3601
135.0000	LLPX310R-V1 w/ Mount Pipe	37	37.396	2.7973	0.0063	3094
126.0000	(3) DB844H90E-XY w/ Mount Pipe	37	32.281	2.5897	0.0051	2350



Elevation ft	Appurtenance	Gov. Load Comb.	Deflection in	Tilt °	Twist °	Radius of Curvature ft
116.0000	APX16DWV-16DWV-S-E-ACU w/ Mount Pipe	37	27.088	2.3299	0.0039	2115
106.0000	HBX-6516DS-VTM w/ Mount Pipe	37	22.449	2.0800	0.0031	2709
50.0000	58532A	37	4.715	0.9145	0.0010	3095
47.0000	KS24019-L112A	37	4.148	0.8562	0.0009	2958

### Maximum Tower Deflections - Design Wind

Section No.	Elevation ft	Horz. Deflection in	Gov. Load Comb.	Tilt °	Twist °
L1	160 - 150.5	134.502	6	7.7417	0.0246
L2	150.5 - 150	119.217	6	7.6777	0.0214
L3	150 - 119	118.417	6	7.6693	0.0211
L4	119 - 97.1667	72.795	6	6.1379	0.0103
L5	102 - 90.5	52.812	6	5.0837	0.0070
L6	90.5 - 60.5	41.133	6	4.5615	0.0058
L7	60.5 - 55	17.782	6	2.8794	0.0030
L8	55 - 30.5	14.635	6	2.5875	0.0027
L9	30.5 - 0	4.405	6	1.4008	0.0013

### Critical Deflections and Radius of Curvature - Design Wind

Elevation ft	Appurtenance	Gov. Load Comb.	Deflection in	Tilt °	Twist °	Radius of Curvature ft
158.0000	SBNH-1D6565C w/ Mount Pipe	6	131.275	7.7370	0.0245	7589
149.0000	(2) LPA-80063/4CF w/ Mount Pipe	6	116.822	7.6504	0.0214	2690
139.0000	VHLP2.5-11	6	101.196	7.3157	0.0173	1465
135.0000	LLPX310R-V1 w/ Mount Pipe	6	95.160	7.1210	0.0157	1257
126.0000	(3) DB844H90E-XY w/ Mount Pipe	6	82.182	6.5959	0.0125	951
116.0000	APX16DWV-16DWV-S-E-ACU w/ Mount Pipe	6	68.991	5.9372	0.0096	852
106.0000	HBX-6516DS-VTM w/ Mount Pipe	6	57.198	5.3020	0.0076	1084
50.0000	58532A	6	12.030	2.3335	0.0025	1218
47.0000	KS24019-L112A	6	10.584	2.1849	0.0023	1164

### Compression Checks

### Pole Design Data

Section No.	Elevation ft	Size	L ft	L <sub>u</sub> ft	Kl/r	F <sub>a</sub> ksi	A in <sup>2</sup>	Actual P K	Allow. P <sub>a</sub> K	Ratio P P <sub>a</sub>
L1	160 - 150.5 (1)	TP20x20x0.25	9.5000	0.0000	0.0	21.000	15.5116	-2.42	325.74	0.007
L2	150.5 - 150 (2)	TP20.3x20x0.25	0.5000	0.0000	0.0	21.000	15.7472	-2.45	330.69	0.007
L3	150 - 119 (3)	TP26.6545x20.3x0.25	31.0000	0.0000	0.0	39.000	21.2556	-8.34	828.97	0.010
L4	119 - 97.1667 (4)	TP31.13x26.6545x0.3512	21.8333	0.0000	0.0	37.758	33.6862	-12.29	1271.92	0.010
L5	97.1667 - 90.5	TP31.9973x29.4368x0.472	11.5000	0.0000	0.0	37.806	47.9115	-15.14	1811.34	0.008

Section No.	Elevation ft	Size	L ft	L <sub>u</sub> ft	Kl/r	F <sub>a</sub> ksi	A in <sup>2</sup>	Actual P K	Allow. P <sub>a</sub> K	Ratio P P <sub>a</sub>
	(5)									
L6	90.5 - 60.5 (6)	TP38.149x31.9973x0.4827	30.0000	0.0000	0.0	37.722	58.5468	-22.24	2208.50	0.010
L7	60.5 - 55 (7)	TP39.2768x38.149x0.5056	5.5000	0.0000	0.0	39.000	63.1157	-23.73	2461.51	0.010
L8	55 - 30.5 (8)	TP43.5485x39.2768x0.555	24.5000	0.0000	0.0	39.000	76.8774	-32.89	2998.22	0.011
		3								
L9	30.5 - 0 (9)	TP49.8x43.5485x0.5594	30.5000	0.0000	0.0	39.000	88.6924	-43.45	3459.00	0.013

### Pole Bending Design Data

Section No.	Elevation ft	Size	Actual M <sub>x</sub> kip-ft	Actual f <sub>bx</sub> ksi	Allow. F <sub>bx</sub> ksi	Ratio f <sub>bx</sub> F <sub>bx</sub>	Actual M <sub>y</sub> kip-ft	Actual f <sub>by</sub> ksi	Allow. F <sub>by</sub> ksi	Ratio f <sub>by</sub> F <sub>by</sub>
L1	160 - 150.5 (1)	TP20x20x0.25	45.45	7.205	23.100	0.312	0.00	0.000	23.100	0.000
L2	150.5 - 150 (2)	TP20.3x20x0.25	48.55	7.468	23.100	0.323	0.00	0.000	23.100	0.000
L3	150 - 119 (3)	TP26.6545x20.3x0.25	509.88	44.662	39.000	1.145	0.00	0.000	39.000	0.000
L4	119 - 97.1667 (4)	TP31.13x26.6545x0.3512	905.56	44.467	37.758	1.178	0.00	0.000	37.758	0.000
L5	97.1667 - 90.5 (5)	TP31.9973x29.4368x0.47	1206.7	39.491	37.806	1.045	0.00	0.000	37.806	0.000
		2								
L6	90.5 - 60.5 (6)	TP38.149x31.9973x0.482	2076.1	46.436	37.722	1.231	0.00	0.000	37.722	0.000
		7								
L7	60.5 - 55 (7)	TP39.2768x38.149x0.505	2248.7	45.337	39.000	1.162	0.00	0.000	39.000	0.000
		6								
L8	55 - 30.5 (8)	TP43.5485x39.2768x0.55	3083.0	46.012	39.000	1.180	0.00	0.000	39.000	0.000
		53								
L9	30.5 - 0 (9)	TP49.8x43.5485x0.5594	4224.3	47.640	39.000	1.222	0.00	0.000	39.000	0.000
		0								

### Pole Shear Design Data

Section No.	Elevation ft	Size	Actual V K	Actual f <sub>v</sub> ksi	Allow. F <sub>v</sub> ksi	Ratio f <sub>v</sub> F <sub>v</sub>	Actual T kip-ft	Actual f <sub>vt</sub> ksi	Allow. F <sub>vt</sub> ksi	Ratio f <sub>vt</sub> F <sub>vt</sub>
L1	160 - 150.5 (1)	TP20x20x0.25	6.19	0.399	14.000	0.057	0.91	0.072	14.000	0.005
L2	150.5 - 150 (2)	TP20.3x20x0.25	6.24	0.396	14.000	0.057	0.92	0.070	14.000	0.005
L3	150 - 119 (3)	TP26.6545x20.3x0.25	20.35	0.957	26.000	0.075	0.80	0.033	26.000	0.001
L4	119 - 97.1667 (4)	TP31.13x26.6545x0.3512	25.35	0.753	25.172	0.061	1.14	0.026	25.172	0.001
L5	97.1667 - 90.5 (5)	TP31.9973x29.4368x0.47	27.03	0.564	25.204	0.045	1.25	0.019	25.204	0.001
		2								
L6	90.5 - 60.5 (6)	TP38.149x31.9973x0.482	31.07	0.531	25.148	0.043	1.57	0.017	25.148	0.001
		7								
L7	60.5 - 55 (7)	TP39.2768x38.149x0.505	31.78	0.503	26.000	0.039	1.63	0.015	26.000	0.001
		6								
L8	55 - 30.5 (8)	TP43.5485x39.2768x0.55	35.79	0.465	26.000	0.036	1.90	0.013	26.000	0.001
		53								
L9	30.5 - 0 (9)	TP49.8x43.5485x0.5594	39.17	0.442	26.000	0.035	2.25	0.012	26.000	0.000

### Pole Interaction Design Data

Section No.	Elevation ft	Ratio P $P_a$	Ratio $f_{bx}$ $F_{bx}$	Ratio $f_{by}$ $F_{by}$	Ratio $f_v$ $F_v$	Ratio $f_{vt}$ $F_{vt}$	Comb. Stress Ratio	Allow. Stress Ratio	Criteria
L1	160 - 150.5 (1)	0.007	0.312	0.000	0.057	0.005	0.320	1.333	H1-3+VT ✓
L2	150.5 - 150 (2)	0.007	0.323	0.000	0.057	0.005	0.332	1.333	H1-3+VT ✓
L3	150 - 119 (3)	0.010	1.145	0.000	0.075	0.001	1.157	1.333	H1-3+VT ✓
L4	119 - 97.1667 (4)	0.010	1.178	0.000	0.061	0.001	1.188	1.333	H1-3+VT ✓
L5	97.1667 - 90.5 (5)	0.008	1.045	0.000	0.045	0.001	1.053	1.333	H1-3+VT ✓
L6	90.5 - 60.5 (6)	0.010	1.231	0.000	0.043	0.001	1.242	1.333	H1-3+VT ✓
L7	60.5 - 55 (7)	0.010	1.162	0.000	0.039	0.001	1.173	1.333	H1-3+VT ✓
L8	55 - 30.5 (8)	0.011	1.180	0.000	0.036	0.001	1.191	1.333	H1-3+VT ✓
L9	30.5 - 0 (9)	0.013	1.222	0.000	0.035	0.000	1.234	1.333	H1-3+VT ✓

### Section Capacity Table

Section No.	Elevation ft	Component Type	Size	Critical Element	P K	SF* $P_{allow}$ K	% Capacity	Pass Fail	
L1	160 - 150.5	Pole	TP20x20x0.25	1	-2.42	434.22	24.0	Pass	
L2	150.5 - 150	Pole	TP20.3x20x0.25	2	-2.45	440.81	24.9	Pass	
L3	150 - 119	Pole	TP26.6545x20.3x0.25	3	-8.34	1105.02	86.8	Pass	
L4	119 - 97.1667	Pole	TP31.13x26.6545x0.3512	4	-12.29	1695.47	89.1	Pass	
L5	97.1667 - 90.5	Pole	TP31.9973x29.4368x0.472	5	-15.14	2414.52	79.0	Pass	
L6	90.5 - 60.5	Pole	TP38.149x31.9973x0.4827	6	-22.24	2943.93	93.1	Pass	
L7	60.5 - 55	Pole	TP39.2768x38.149x0.5056	7	-23.73	3281.19	88.0	Pass	
L8	55 - 30.5	Pole	TP43.5485x39.2768x0.5553	8	-32.89	3996.63	89.4	Pass	
L9	30.5 - 0	Pole	TP49.8x43.5485x0.5594	9	-43.45	4610.85	92.6	Pass	
							Summary		
							Pole (L6)	93.1	Pass
							<b>RATING =</b>	<b>93.1</b>	<b>Pass</b>

### APPENDIX B BASE LEVEL DRAWING

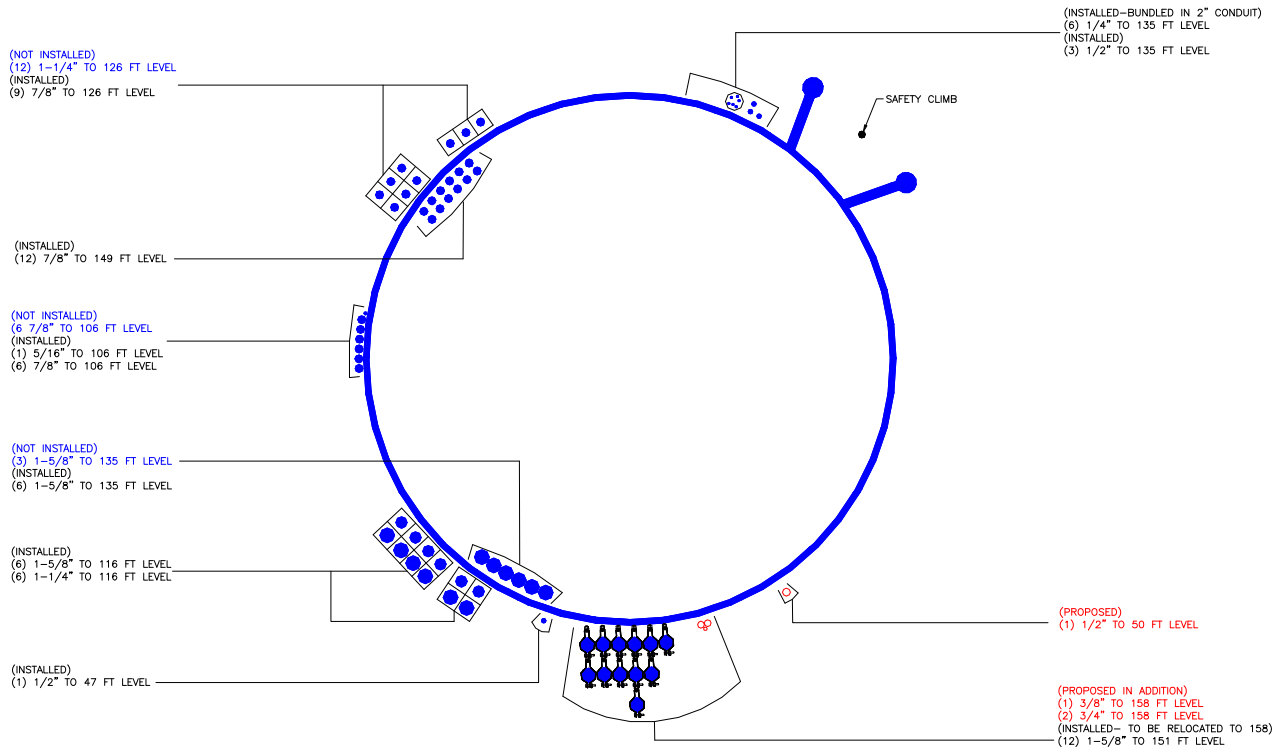

**APPENDIX C**  
**ADDITIONAL CALCULATIONS**

---

Section	1	2	3	4	5	6	7	8	9	28.1		
Length (ft)	0.9000	0.9000	31.0000	21.8333	11.5000	30.0000	5.5000	24.5000	30.5000	28.1		
Number of Sides	1	1	12	12	12	12	12	12	12	12		
Thickness (in)	0.2500	0.2500	0.2500	0.3512	0.4720	0.4827	0.5056	0.5553	0.5594	0.5594		
Socket Length (ft)				4.8333								
Top Dia (in)	20.0000	20.0000	20.3000	26.6545	29.4368	31.9973	38.1490	39.2768	43.5485	49.8000		
Bot Dia (in)	20.3000	20.3000	20.6545	31.1300	31.9973	38.1490	39.2768	43.5485	49.8000	49.8000		
Grade	A53-B-35		A572-65		Reinf 62.93 ksi		Reinf 63.01 ksi		Reinf 62.87 ksi		Reinf 65.00 ksi	
Weight (K)	0.0	0.0	2.0	2.4	1.8	5.5	1.2	6.1	8.6	28.1		

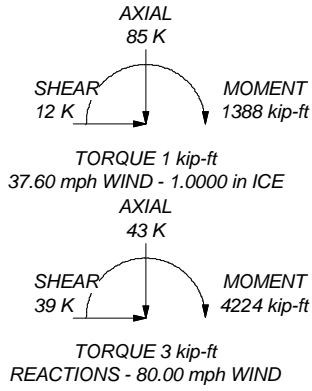
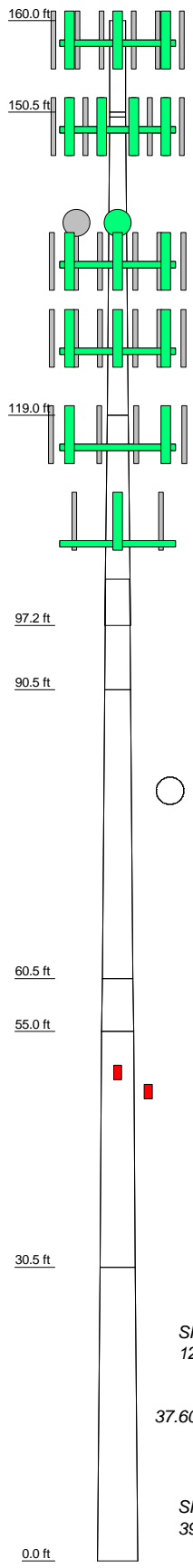

### DESIGNED APPURTENANCE LOADING

TYPE	ELEVATION	TYPE	ELEVATION
SBNH-1D6565C w/ Mount Pipe	158	(2) DB980H90E-M w/ Mount Pipe	135
SBNH-1D6565C w/ Mount Pipe	158	(2) DB980H90E-M w/ Mount Pipe	135
SBNH-1D6565C w/ Mount Pipe	158	(2) DB980H90E-M w/ Mount Pipe	135
(2) 7770.00 w/ Mount Pipe	158	Platform Mount [LP 602-1]	135
(2) 7770.00 w/ Mount Pipe	158	VHLP2.5-11	135
(2) 7770.00 w/ Mount Pipe	158	VHLP2.5-11	135
DC6-48-60-18-8F	158	(3) DB844H90E-XY w/ Mount Pipe	126
(2) RRUS-11	158	T-Arm Mount [TA 901-3]	126
(2) RRUS-11	158	(3) DB844H90E-XY w/ Mount Pipe	126
(2) RRUS-11	158	(3) DB844H90E-XY w/ Mount Pipe	126
(2) LGP13519	158	APX16DWV-16DWV-S-E-ACU w/ Mount Pipe	116
(2) LGP13519	158	RR90-17-02DP w/ Mount Pipe	116
(2) LGP13519	158	RR90-17-02DP w/ Mount Pipe	116
(2) LGP21401	158	RR90-17-02DP w/ Mount Pipe	116
(2) LGP21401	158	RR90-17-02DP w/ Mount Pipe	116
(2) LGP21401	158	KRY 112 71/1	116
Platform Mount [LP 301-1]	158	KRY 112 71/1	116
(2) LPA-80063/4CF w/ Mount Pipe	149	KRY 112 71/1	116
(2) LPA-80080/4CF w/ Mount Pipe	149	ONEBASE TWIN DUAL DUPLEX TMA	116
(2) LPA-80080/4CF w/ Mount Pipe	149	ONEBASE TWIN DUAL DUPLEX TMA	116
BXA-70063/6CFx6 w/ Mount Pipe	149	ONEBASE TWIN DUAL DUPLEX TMA	116
BXA-70063/6CFx4 w/ Mount Pipe	149	Side Arm Mount [SO 103-3]	116
BXA-70063/6CFx4 w/ Mount Pipe	149	Side Arm Mount [SO 701-3]	116
BXA-185063/8CF w/ Mount Pipe	149	APX16DWV-16DWV-S-E-ACU w/ Mount Pipe	116
BXA-185090/8CFx2 w/ Mount Pipe	149	APX16DWV-16DWV-S-E-ACU w/ Mount Pipe	116
BXA-185090/8CFx2 w/ Mount Pipe	149	APX16DWV-16DWV-S-E-ACU w/ Mount Pipe	116
(2) FD9R6004/2C-3L	149	HBX-6516DS-VTM w/ Mount Pipe	106
(2) FD9R6004/2C-3L	149	ATM200-A20	106
(2) FD9R6004/2C-3L	149	ATM200-A20	106
Platform Mount [LP 602-1]	149	ATM200-A20	106
LLPX310R-V1 w/ Mount Pipe	135	T-Arm Mount [TA 602-3]	106
LLPX310R-V1 w/ Mount Pipe	135	HBX-6516DS-VTM w/ Mount Pipe	106
LLPX310R-V1 w/ Mount Pipe	135	HBX-6516DS-VTM w/ Mount Pipe	106
WIMAX DAP HEAD	135	58532A	50
WIMAX DAP HEAD	135	Platform Mount [LP 301-1]	50
WIMAX DAP HEAD	135	KS24019-L112A	47
HORIZON COMPACT	135	Side Arm Mount [SO 701-1]	47
HORIZON COMPACT	135		
TIMING 2000	135		

### MATERIAL STRENGTH

GRADE	Fy	Fu	GRADE	Fy	Fu
A53-B-35	35 ksi	63 ksi	Reinf 63.01 ksi	63 ksi	79 ksi
A572-65	65 ksi	80 ksi	Reinf 62.87 ksi	63 ksi	79 ksi
Reinf 62.93 ksi	63 ksi	79 ksi	Reinf 65.00 ksi	65 ksi	65 ksi

### TOWER DESIGN NOTES

1. Tower is located in Hartford County, Connecticut.
2. Tower designed for a 80.00 mph basic wind in accordance with the TIA/EIA-222-F Standard.
3. Tower is also designed for a 37.60 mph basic wind with 1.00 in in ice. Ice is considered to increase in thickness with height.
4. Deflections are based upon a 50.00 mph wind.
5. TOWER RATING: 93.1%



**Paul J. Ford and Company**  
250 East Broad Street, Suite 1500  
Columbus, Ohio 43215  
Phone: (614) 221-6679  
FAX: (614) 448-4118

**Job: 160' Monopole / HRT 101 943232**

Project: **PJF 37512-1571 BP / BU 806373**

Client: Crown Castle	Drawn by: Kyle Thorpe	App'd:
Code: TIA/EIA-222-F	Date: 07/25/12	Scale: NTS
Path:		Dwg No. E-1

G:\TOWER\375\_Crown\_Castle\2012\37512-1571\_BP\_BU\_806373\BP - WID 500022 BU 806373\Drawn\37512-1571\_BP\_CROWN.dwg



**Stilt Extension Connection**

@ 150' elevation

Assume 3 legs w/ 22.54 " Channel Circle

**Reactions from TNXTower:**

Moment = 48.55 k-ft  
Axial = 2.45 kips  
Shear = 6.24 kips

Revision = F  
Unbraced length = 12 in.  
K = 1  
Top Pole Shaft Diameter = 20.3 in.  
Number of Bolt Rows (N) = 6 Even Number  
Bolt Spacing (S) = 3  
Allowable Stress Increase = 1.33333

$$I = \frac{N * (B.C.)^2}{8}$$

I = 190.5 in<sup>2</sup>  
My/I = 34.5 kips  
Axial/leg = 0.8167 kips

T = 33.6 kips  
C = 35.3 kips  
M = 74.88 k-in

x = 1.12 in  
A = 8.37 in<sup>2</sup>  
r = 1.16 in  
S = 3.99 in<sup>3</sup>  
Z = 7.59 in<sup>3</sup>  
I = 11.3 in<sup>4</sup>

Using MC10X28.5 Fy = 50 ksi

**Available Strength in Axial Compression**

Kl/r = 10.34 C<sub>c</sub> = 107.00  
Kl/rC<sub>c</sub> = 0.097  
C<sub>A</sub> = 0.551 Use Table 3 on page 5-119 of Green Book  
F<sub>a</sub> = 36.73 ksi F<sub>a</sub> = 4/3 \* Fy \* C<sub>c</sub>  
P = 34.46 kips P = T + Axial / #legs  
f<sub>a</sub> = 4.12 ksi f<sub>a</sub> = P/A  
Ratio = 11.2%

**Available Flexural Strength**

F<sub>b</sub> = 40.00 ksi F<sub>b</sub> = 4/3 \* 0.6 \* Fy  
M<sub>b</sub> = 24.96 kip\*in M<sub>b</sub> = Shear \* lu / # legs  
f<sub>b</sub> = 6.26 ksi f<sub>b</sub> = M<sub>b</sub> / S  
Ratio = 15.6%

**Combined Strength**

fa/Fa = 0.11 < 0.15 Use H1-3 of Green Book  
Fe' = 1860.559 ksi  
Eqn H1-1  
Eqn H1-2  
Eqn H1-3 0.2685  
Ratio = 26.8%

**Bolt Check**

Tension Force (T<sub>applied</sub>) = 34.46 kips  
Eccentricity (e) = 1.12 in.  
V<sub>allow</sub> (Ajax Bolt) = 31.0 kips  
T<sub>allow</sub> (Ajax Bolt) = 12.0 kips  
Sum r<sup>2</sup> = 157.5 in.<sup>2</sup>  
Ry (Shear Force) = 5.744 kips  
Rx (Tension Force) = 3.027 kips  
Stress Ratio = 16.1%



**PAUL J. FORD AND COMPANY**  
**STRUCTURAL ENGINEERS**  
 250 East Broad Street • Suite 1500 • Columbus, Ohio 43215-3708  
 Phone 614-221-6679 • Fax 614-448-4105 • www.PJFweb.com

Date: 7/24/2012  
 PJF Project: 37512-1571 BP CROWN  
 Client Ref. # BU 806373  
 Site Name: HRT 101 943232  
 Description: 151-ft pole w/ 10-ft propped extension  
 Owner: CROWN  
 Engineer: KAT

v4.1 - Effective 7-3-12

**Asymmetric Anchor Rod Analysis**

Moment = 4224 k-ft  
 Axial = 43.0 kips  
 Shear = 39.0 kips  
 Anchor Qty = 19

TIA Ref. = F  
 ASIF = 1.3333  
 Max Ratio = 95.0%

Location = Base Plate  
 η = N/A for BP, Rev. G Sect. 4.9.9  
 Threads = N/A for FP, Rev. G

**\*\* For Post Installed Anchors: Check anchors for embedment, epoxy/grout bond, and capacity based on proof load. \*\***

Item	Nominal Anchor Dia, in	Spec	Fy, ksi	Fu, ksi	Location, degrees	Anchor Circle, in	Area Override, in <sup>2</sup>	Area, in <sup>2</sup>	Max Net Compression, kips	Max Net Tension, kips	Load for Capacity Calc, kips	Capacity Override, kips	Capacity, kips	Capacity Ratio
1	2.250	#18J A615 Gr 75	75	100	0.0	58.06	0.00	3.98	183.01	178.48	178.48	0.00	195.00	91.5%
2	2.250	#18J A615 Gr 75	75	100	22.5	58.06	0.00	3.98	179.24	174.72	174.72	0.00	195.00	89.6%
3	2.250	#18J A615 Gr 75	75	100	45.0	58.06	0.00	3.98	177.02	172.49	172.49	0.00	195.00	88.5%
4	2.250	#18J A615 Gr 75	75	100	67.5	58.06	0.00	3.98	177.32	172.79	172.79	0.00	195.00	88.6%
5	2.250	#18J A615 Gr 75	75	100	90.0	58.06	0.00	3.98	179.55	175.03	175.03	0.00	195.00	89.8%
6	2.250	#18J A615 Gr 75	75	100	112.5	58.06	0.00	3.98	182.05	177.53	177.53	0.00	195.00	91.0%
7	2.250	#18J A615 Gr 75	75	100	135.0	58.06	0.00	3.98	183.15	178.62	178.62	0.00	195.00	91.6%
8	2.250	#18J A615 Gr 75	75	100	157.5	58.06	0.00	3.98	182.14	177.61	177.61	0.00	195.00	91.1%
9	2.250	#18J A615 Gr 75	75	100	180.0	58.06	0.00	3.98	179.67	175.15	175.15	0.00	195.00	89.8%
10	2.250	#18J A615 Gr 75	75	100	202.5	58.06	0.00	3.98	177.39	172.86	172.86	0.00	195.00	88.6%
11	2.250	#18J A615 Gr 75	75	100	225.0	58.06	0.00	3.98	176.98	172.45	172.45	0.00	195.00	88.4%
12	2.250	#18J A615 Gr 75	75	100	247.5	58.06	0.00	3.98	179.10	174.57	174.57	0.00	195.00	89.5%
13	2.250	#18J A615 Gr 75	75	100	270.0	58.06	0.00	3.98	182.83	178.30	178.30	0.00	195.00	91.4%
14	2.250	#18J A615 Gr 75	75	100	292.5	58.06	0.00	3.98	186.29	181.76	181.76	0.00	195.00	93.2%
15	2.250	#18J A615 Gr 75	75	100	315.0	58.06	0.00	3.98	187.72	183.19	183.19	0.00	195.00	93.9%
16	2.250	#18J A615 Gr 75	75	100	337.5	58.06	0.00	3.98	186.40	181.88	181.88	0.00	195.00	93.3%
17	2.250	A193 Gr B7	105	125	22.5	63.00	0.00	3.98	194.03	189.51	189.51	0.00	218.68	86.7%
18	2.250	A193 Gr B7	105	125	135.5	63.00	0.00	3.98	198.54	194.02	194.02	0.00	218.68	88.7%
19	2.250	A193 Gr B7	105	125	248.5	63.00	0.00	3.98	194.03	189.51	189.51	0.00	218.68	86.7%

75.61



# Stiffened or Unstiffened, UngROUTed, Circular Base Plate - Any Rod Material

## TIA Rev F

### Site Data

BU#: 806373
Site Name: HRT 101 943232
App #:
Pole Manufacturer: <i>Other</i>

### Reactions

Moment:	3589.1	ft-kips	Reactions modified to account for post-installed anchors
Axial:	36.2	kips	
Shear:	32.8	kips	

### Anchor Rod Data

Qty:	16	
Diam:	2.25	in
Rod Material:	A615-J	
Strength (Fu):	100	ksi
Yield (Fy):	75	ksi
Bolt Circle:	58.06	in

If No stiffeners, Criteria: **AISC ASD** <-Only Applicable to Unstiffened Cases

### Anchor Rod Results

Maximum Rod Tension:	183.2 Kips
Allowable Tension:	195.0 Kips
Anchor Rod Stress Ratio:	94.0% <b>Pass</b>

Rigid
Service, ASD
Fty*ASIF

### Plate Data

Diam:	64.06	in
Thick:	2.75	in
Grade:	60	ksi
Single-Rod B-eff:	10.01	in

### Base Plate Results

Base Plate Stress:	38.3 ksi	Flexural Check
Allowable Plate Stress:	60.0 ksi	
Base Plate Stress Ratio:	63.9% <b>Pass</b>	

Rigid
Service ASD
0.75*Fy*ASIF
Y.L. Length:
29.85

### Stiffener Data (Welding at both sides)

Config:	0	*
Weld Type:		
Groove Depth:		in **
Groove Angle:		degrees
Fillet H. Weld:		<-- Disregard
Fillet V. Weld:		in
Width:		in
Height:		in
Thick:		in
Notch:		in
Grade:		ksi
Weld str.:		ksi

n/a

### Stiffener Results

Horizontal Weld :	n/a
Vertical Weld:	n/a
Plate Flex+Shear, fb/Fb+(fv/Fv)^2:	n/a
Plate Tension+Shear, ft/Ft+(fv/Fv)^2:	n/a
Plate Comp. (AISC Bracket):	n/a

### Pole Results

Pole Punching Shear Check:	n/a
----------------------------	-----

### Pole Data

Diam:	49.8	in
Thick:	0.4375	in
Grade:	65	ksi
# of Sides:	12	"0" IF Round
Fu	80	ksi
Reinf. Fillet Weld	0	"0" if None

### Stress Increase Factor

ASIF:	1.333
-------	-------

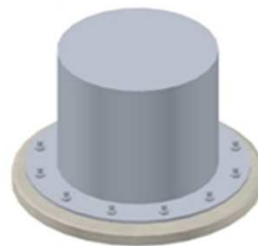
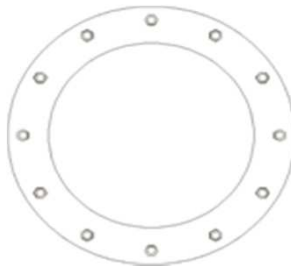

\* 0 = none, 1 = every bolt, 2 = every 2 bolts, 3 = 2 per bolt

\*\* Note: for complete joint penetration groove welds the groove depth must be exactly 1/2 the stiffener thickness for calculation purposes



**DRILLED PIER SOIL AND STEEL ANALYSIS - TIA/EIA-222-F**

**Unfactored Base Reactions from RISA**

	Comp. (+)	Tension (-)	
Moment, M =	4224.0		k-ft
Shear, V =	39.0		kips
Axial Load, P =	43.0		kips
OTM =	4263.0	0.0	k-ft @ Ground

**Safety Factors / Load Factors /  $\Phi$  Factors**

Tower Type =	Monopole DP
ACI Code =	ACI 318-02
Seismic Design Category =	D
Reference Standard =	TIA/EIA-222-F
Use 1.3 Load Factor?	Yes
Load Factor =	1.30

**Drilled Pier Parameters**

Diameter =	7	ft
Height Above Grade =	1	ft
Depth Below Grade =	24.5	ft
fc' =	3	ksi
εc =	0.003	in/in
Mat Ftdn. Cap Width =		ft
Mat Ftdn. Cap Length =		ft
Depth Below Grade =		ft

	<b>Safety Factor</b>	<b><math>\Phi</math> Factor</b>
Soil Lateral Resistance =	2.00	0.75
Skin Friction =	2.00	0.75
End Bearing =	2.00	0.75
Concrete Wt. Resist Uplift =	1.25	

**Load Combinations Checked per TIA/EIA-222-F**

- Ult. Skin Friction/2.00 + Ult. End Bearing/2.00 + Effective Soil Wt. - Buoyant Conc. Wt. ≥ Compression
- Ult. Skin Friction/2.00 + Buoyant Conc. Wt./1.25 ≥ Uplift
- Ult. Skin Friction/1.50 + Buoyant Conc. Wt./1.50 ≥ Uplift

**Steel Parameters**

Number of Bars =	36	
Rebar Size =	#11	
Rebar Fy =	60	ksi
Rebar MOE =	29000	ksi
Tie Size =	#4	
Side Clear Cover to Ties =	3	in

**Soil Parameters**

Water Table Depth =	5.00	ft
Depth to Ignore Soil =	3.50	ft
Depth to Full Cohesion =	0	ft
Full Cohesion Starts at?	Ground	
<i>Above Full Cohesion Lateral Resistance = 4(Cohesion)(Dia)(H)</i>		
<i>Below Full Cohesion Lateral Resistance = 8(Cohesion)(Dia)(H)</i>		

**Direct Embed Pole Shaft Parameters**

Dia @ Grade =		in
Dia @ Depth Below Grade =		in
Number of Sides =		
Thickness =		in
Fy =		ksi
Backfill Condition =		

**Maximum Capacity Ratios**

Maximum Soil Ratio =	100.0%
Maximum Steel Ratio =	100.0%

**Define Soil Layers**

Note: Cohesion = Undrained Shear Strength = Unconfined Compressive Strength / 2

Layer	Thickness ft	Unit Weight pcf	Cohesion psf	Friction Angle degrees	Soil Type	Ultimate End Bearing psf	Comp. Ult. Skin Friction psf	Tension Ult. Skin Friction psf	Depth ft
1	3.5	100							3.5
2	0.5	100	0	28	Sand	78000			4
3	1	125	0	42	Sand	78000			5
4	26.5	127.4	0	42	Sand	78000			31.5
5									
6									
7									
8									
9									
10									
11									
12									

**Soil Results: Overturning**

Depth to COR =	17.36	ft, from Grade
Bending Moment, M =	4939.86	k-ft, from COR
Resisting Moment, Ma =	5807.48	k-ft, from COR

Shear, V =	39.00	kips
Resisting Shear, Va =	45.85	kips

**MOMENT RATIO = 85.1% OK**

**SHEAR RATIO = 85.1% OK**

**Soil Results: Uplift**

Uplift, T =	0.00	kips
Allowable Uplift Cap., Ta =	80.30	kips

**UPLIFT RATIO = 0.0% OK**

**Soil Results: Compression**

Compression, C =	43.00	kips
Allowable Comp. Cap., Ca =	1469.50	kips

**COMPRESSION RATIO = 2.9% OK**

**Steel Results (ACI 318-02):**

Minimum Steel Area =	18.47	sq in
Actual Steel Area =	56.16	sq in

Axial Load, P =	78.48	kips @ 5.25 ft Below Grade
Moment, M =	4444.91	k-ft @ 5.25 ft Below Grade
Allowable Moment, Ma =	6570.89	k-ft

Allowable Min Axial, Pa =	-2332.80	kips, Where Ma = 0 k-ft
Allowable Max Axial, Pa =	6943.16	kips, Where Ma = 0 k-ft

**MOMENT RATIO = 67.6% OK**

# Moment Capacity of Drilled Concrete Shaft (Caisson) for TIA Rev F or G

**Note:** Shaft assumed to have ties, not spiral, transverse reinforcing

## Site Data

BU#: 806373  
 Site Name: HRT 101 943232  
 App #:

Enter Load Factors Below:		
For M (WL)	1.3	<---- Enter Factor
For P (DL)	1.3	<---- Enter Factor

Pier Properties	
<b>Concrete:</b>	
Pier Diameter =	7.0 ft
Concrete Area =	5541.8 in <sup>2</sup>
<b>Reinforcement:</b>	
Clear Cover to Tie=	3.00 in
Horiz. Tie Bar Size=	4
Vert. Cage Diameter =	6.30 ft
Vert. Cage Diameter =	75.59 in
Vertical Bar Size =	11
Bar Diameter =	1.41 in
Bar Area =	1.56 in <sup>2</sup>
Number of Bars =	36
As Total=	56.16 in <sup>2</sup>
A s/ Aconc, Rho:	0.0101 1.01%

ACI 10.5 , ACI 21.10.4, and IBC 1810.

Min As for Flexural, Tension Controlled, Shafts:

$$(3) * (\text{Sqrt}(f'c) / F_y) = 0.0027$$

$$200 / F_y = 0.0033$$

Minimum Rho Check:

Actual Req'd Min. Rho:	0.33%	Flexural
Provided Rho:	1.01%	<b>OK</b>

Ref. Shaft Max Axial Capacities, $\phi$ Max(Pn or Tn):		
Max Pu = ( $\phi=0.65$ ) Pn.		
Pn per ACI 318 (10-2)	9026.11	kips
at Mu=( $\phi=0.65$ )Mn=	5472.88	ft-kips
Max Tu, ( $\phi=0.9$ ) Tn =	3032.64	kips
at Mu= $\phi=(0.90)$ Mn=	0.00	ft-kips

Maximum Shaft Superimposed Forces		
TIA Revision:	F	
Max. Service Shaft M:	4444.91	ft-kips (* Note)
Max. Service Shaft P:	78.48	kips
Max Axial Force Type:	Comp.	

(\* Note: Max Shaft Superimposed Moment does not necessarily equal to the shaft top reaction moment

Load Factor	Shaft Factored Loads	
1.30	Mu:	5778.383 ft-kips
1.30	Pu:	102.024 kips

Material Properties		
Concrete Comp. strength, f'c =	3000	psi
Reinforcement yield strength, Fy =	60	ksi
Reinforcing Modulus of Elasticity, E =	29000	ksi
Reinforcement yield strain =	0.00207	
Limiting compressive strain =	0.003	
ACI 318 Code		
Select Analysis ACI Code=	2002	
Seismic Properties		
Seismic Design Category =	D	
Seismic Risk =	High	

Solve (Run) <-- Press Upon Completing All Input

## Results:

Governing Orientation Case: 2

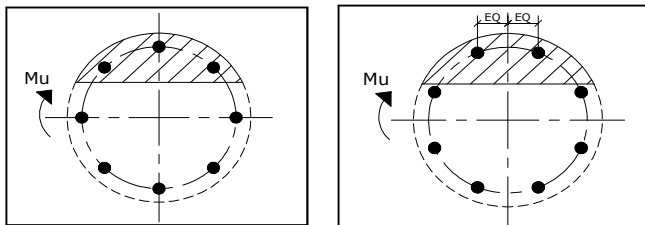

Case 1

Case 2

Dist. From Edge to Neutral Axis: 17.65 in

Extreme Steel Strain,  $\epsilon_t$ : 0.0105

**$\epsilon_t > 0.0050$ , Tension Controlled**

Reduction Factor,  $\phi$ : 0.900

Output Note: Negative Pu=Tension  
 For Axial Compression,  $\phi$  Pn = Pu: 102.02 kips  
 Drilled Shaft Moment Capacity,  $\phi$ Mn: 8542.16 ft-kips  
 Drilled Shaft Superimposed Mu: 5778.38 ft-kips

**(Mu/ $\phi$ Mn, Drilled Shaft Flexure CSR: 67.6%**

CROWN CASTLE PROJECT - BU #806373; HRT 101 943232; ENFIELD, CT  
MONOPOLE RETROFIT PROJECT MASTER NOTES DOCUMENT (REV. 2, 1/22/2009)

UPON THE SUCCESSFUL AND COMPLETE INSTALLATION OF THE REINFORCING SYSTEM SPECIFIED IN THESE STANDARDS, THE REINFORCED POLE MEETS THE WIND DESIGN RECOMMENDATIONS OF THE TIA/EIA-222-F-1996 STANDARD FOR WIND SPEEDS OF 80 MPH AND 37.6 MPH + 1" RADIAL ICE

**A. GENERAL NOTES**

- IT SHALL BE THE RESPONSIBILITY OF THE CONTRACTOR TO FIELD VERIFY ALL EXISTING CONDITIONS AND DIMENSIONS PRIOR TO FABRICATION AND CONSTRUCTION. THESE DRAWINGS WERE PREPARED FROM INFORMATION AND DOCUMENTS PROVIDED TO PAUL J. FORD & COMPANY BY CROWN CASTLE. THIS INFORMATION PROVIDED HAS NOT BEEN FIELD VERIFIED BY PAUL J. FORD & COMPANY FOR ACCURACY AND THEREFORE DISCREPANCIES BETWEEN THESE DRAWINGS AND ACTUAL SITE CONDITIONS SHOULD BE ANTICIPATED. ANY DISCREPANCIES AND/OR CHANGES BETWEEN THE INFORMATION CONTAINED IN THESE DRAWINGS AND THE ACTUAL VERIFIED SITE CONDITIONS SHALL BE IMMEDIATELY BROUGHT TO THE ATTENTION OF CROWN CASTLE AND PAUL J. FORD & COMPANY SO THAT ANY CHANGES AND/OR ADJUSTMENTS, IF NECESSARY, CAN BE MADE TO THE DESIGN AND DRAWINGS.
- THE EXISTING UNREINFORCED MONOPOLE STRUCTURE DOES NOT HAVE THE STRUCTURAL CAPACITY TO CARRY ALL OF THE ANTENNA AND PLATFORM LOADS SHOWN ON THESE DRAWINGS AT THE REQUIRED MINIMUM TIA/EIA-222-F BASIC WIND SPEEDS. DO NOT INSTALL ANY ADDITIONAL OR NEW ANTENNA AND PLATFORM LOADS UNTIL THE MONOPOLE REINFORCING SYSTEM IS COMPLETELY AND SUCCESSFULLY INSTALLED.
- IF MATERIALS, QUANTITIES, STRENGTHS OR SIZES INDICATED BY THE DRAWINGS OR SPECIFICATIONS ARE NOT IN AGREEMENT WITH THESE NOTES, THE BETTER QUALITY AND/OR GREATER QUANTITY, STRENGTH OR SIZE INDICATED, SPECIFIED OR NOTED SHALL BE PROVIDED.
- THIS STRUCTURE IS DESIGNED TO BE SELF-SUPPORTING AND STABLE AFTER THE INSTALLATION OF THE REINFORCING REPAIR SYSTEM HAS BEEN PROPERLY AND ADEQUATELY COMPLETED. IT IS THE CONTRACTOR'S SOLE RESPONSIBILITY TO INSURE THE SAFETY AND STABILITY OF THE MONOPOLE AND ITS COMPONENT PARTS DURING FIELD MODIFICATIONS. THIS INCLUDES, BUT IS NOT LIMITED TO, THE ADDITION OF WHATEVER TEMPORARY BRACING, GUYS OR TIE DOWNS THAT MAY BE NECESSARY. SUCH MATERIAL SHALL BE REMOVED AND SHALL REMAIN THE PROPERTY OF THE CONTRACTOR AFTER THE COMPLETION OF THE PROJECT. IMPORTANT CUTTING, WELDING AND SAFETY GUIDELINES: THE CONTRACTOR SHALL FOLLOW ALL CROWN CASTLE CUTTING, WELDING, FIRE PREVENTION AND SAFETY GUIDELINES. PRIOR TO CONSTRUCTION, THE CONTRACTOR SHALL OBTAIN A COPY OF THE CURRENT CROWN CASTLE GUIDELINES FROM CROWN CASTLE. PER THE 12-01-2005 CROWN CASTLE DIRECTIVE: "ALL CUTTING AND WELDING ACTIVITIES SHALL BE CONDUCTED IN ACCORDANCE WITH CROWN CASTLE POLICY CUTTING AND WELDING PLAN" (DOC # ENG-PLN-10015) ON AN ONGOING BASIS THROUGHOUT THE ENTIRE LIFE OF THE PROJECT.
- THE STRUCTURAL CONTRACT DOCUMENTS DO NOT INDICATE THE METHOD OR MEANS OF CONSTRUCTION. THE CONTRACTOR SHALL SUPERVISE AND DIRECT THE WORK AND SHALL BE SOLELY RESPONSIBLE FOR ALL CONSTRUCTION MEANS, METHODS, TECHNIQUES, SEQUENCES, AND PROCEDURES. OBSERVATION VISITS TO THE SITE BY THE OWNER AND/OR THE ENGINEER SHALL NOT INCLUDE INSPECTIONS OF THE PROTECTIVE MEASURES OR THE CONSTRUCTION PROCEDURES.
- ANY SUPPORT SERVICES PERFORMED BY THE ENGINEER DURING CONSTRUCTION SHALL BE DISTINGUISHED FROM CONTINUOUS AND DETAILED INSPECTION SERVICES WHICH ARE FURNISHED BY THE INSPECTION/TESTING AGENCY. THESE SUPPORT SERVICES PERFORMED BY THE ENGINEER ARE SOLELY FOR THE PURPOSE OF ASSISTING IN QUALITY CONTROL AND IN ACHIEVING CONFORMANCE WITH CONTRACT DOCUMENTS. THEY DO NOT GUARANTEE CONTRACTOR'S PERFORMANCE AND SHALL NOT BE CONSTRUCTED AS SUPERVISION OF CONSTRUCTION.
- ALL MATERIALS AND EQUIPMENT FURNISHED WILL BE NEW AND OF GOOD QUALITY. FREE FROM FAULTS AND DEFECTS AND IN CONFORMANCE WITH THE CONTRACT DOCUMENTS. ANY AND ALL SUBSTITUTIONS MUST BE PROPERLY APPROVED AND AUTHORIZED IN WRITING BY THE OWNER AND ENGINEER PRIOR TO INSTALLATION. THE CONTRACTOR SHALL FURNISH SATISFACTORY EVIDENCE AS TO THE KIND AND QUALITY OF MATERIALS AND EQUIPMENT BEING SUBSTITUTED.
- THE CONTRACTOR SHALL BE RESPONSIBLE FOR INITIATING, MAINTAINING, AND SUPERVISING ALL SAFETY PRECAUTIONS AND PROGRAMS IN CONNECTION WITH THE WORK. THE CONTRACTOR IS RESPONSIBLE TO INSURE THAT THIS PROJECT AND RELATED WORK COMPLIES WITH ALL APPLICABLE LOCAL, STATE, AND FEDERAL SAFETY CODES AND REGULATIONS GOVERNING THIS WORK AS WELL AS CROWN CASTLE SAFETY GUIDELINES.
- THE CONTRACTOR SHALL BE RESPONSIBLE FOR PROTECTING ALL EXISTING AND NEW COAXIAL CABLES AND OTHER EQUIPMENT DURING CONSTRUCTION.
- ANY EXISTING ATTACHMENTS AND/OR PROJECTIONS ON THE POLE THAT MAY INTERFERE WITH THE INSTALLATION OF THE REINFORCING SYSTEM WILL HAVE TO BE REMOVED, AND/OR RELOCATED, AND/OR REPLACED AND RE-INSTALLED AFTER THE REINFORCING IS SUCCESSFULLY COMPLETED. THE CONTRACTOR SHALL IDENTIFY AND COORDINATE THESE ITEMS PRIOR TO CONSTRUCTION WITH THE OWNER, TESTING AGENCY, AND ENGINEER.
- ANY AND ALL EXISTING PLATFORMS THAT ARE LOCATED IN AREAS OF THE POLE SHAFT WHERE SHAFT REINFORCING MUST BE APPLIED SHALL BE TEMPORARILY REMOVED OR OTHERWISE SUPPORTED TO PERMIT NEW CONTINUOUS REINFORCEMENT TO BE ATTACHED. AFTER THE CONTRACTOR HAS SUCCESSFULLY INSTALLED THE MONOPOLE REINFORCEMENT SYSTEM, THE CONTRACTOR SHALL RE-INSTALL THE PLATFORMS. IN NO CASE SHALL ANY NEW AND/OR ADDITIONAL PLATFORMS AND/OR ANTENNAS AND/OR COAX CABLES AND/OR OTHER EQUIPMENT BE INSTALLED ON THE MONOPOLE UNTIL THE CONTRACTOR HAS SUCCESSFULLY COMPLETED THE INSTALLATION OF ALL OF THE REQUIRED STRUCTURAL REINFORCING SYSTEM COMPONENTS.

**B. "LOW HEAT" WELDING PROCEDURES - (NOT REQUIRED)**

**C. SPECIAL INSPECTION AND TESTING**

- ALL WORK SHALL BE SUBJECT TO REVIEW AND OBSERVATION BY THE OWNER'S REPRESENTATIVE AND THE OWNER'S AUTHORIZED INDEPENDENT INSPECTION AND TESTING AGENCY. REFER TO CROWN CASTLE DOCUMENT ENG-SOW-10066 FOR SPECIFICATION.
- ANY SUPPORT SERVICES PERFORMED BY THE ENGINEER DURING CONSTRUCTION SHALL BE DISTINGUISHED FROM CONTINUOUS AND DETAILED INSPECTION SERVICES WHICH ARE FURNISHED BY OTHERS. THESE SUPPORT SERVICES PERFORMED BY THE ENGINEER ARE PERFORMED SOLELY FOR THE PURPOSE OF ASSISTING IN QUALITY CONTROL AND IN ACHIEVING CONFORMANCE WITH CONTRACT DOCUMENTS. THEY DO NOT GUARANTEE CONTRACTOR'S PERFORMANCE AND SHALL NOT BE CONSTRUCTED AS SUPERVISION OF CONSTRUCTION.
- OBSERVED DISCREPANCIES BETWEEN THE WORK AND THE CONTRACT DOCUMENTS SHALL BE CORRECTED BY THE CONTRACTOR AT NO ADDITIONAL COST.
- AN INDEPENDENT QUALIFIED INSPECTION/TESTING AGENCY SHALL BE SELECTED, RETAINED AND PAID FOR BY THE OWNER FOR THE SOLE PURPOSE OF INSPECTING, TESTING, DOCUMENTING, AND APPROVING ALL WELDING AND FIELD WORK PERFORMED BY THE CONTRACTOR.
  - ACCESS TO ANY PLACE WHERE WORK IS BEING DONE SHALL BE PERMITTED AT ALL TIMES.
  - THE INSPECTION AGENCY SHALL SO SCHEDULE THIS WORK AS TO CAUSE A MINIMUM OF INTERRUPTION TO, AND COORDINATE WITH, THE WORK IN PROGRESS. IT IS THE CONTRACTOR'S RESPONSIBILITY TO COORDINATE THE WORK SCHEDULE WITH THE TESTING AGENCY. THE CONTRACTOR SHALL ALLOW FOR ADEQUATE TIME AND ACCESS FOR THE TESTING AGENCY TO PERFORM THEIR DUTIES.
- THE INSPECTION AND TESTING AGENCY SHALL BE RESPONSIBLE TO PERFORM THE FOLLOWING SERVICES FOR THE OWNER. THE TESTING AGENCY SHALL INSPECT THE FOLLOWING ITEMS IN ACCORDANCE WITH THE CONSTRUCTION DRAWINGS. THE TESTING AGENCY SHALL INSPECT ITEMS ON THIS LIST AND OTHER ITEMS AS NECESSARY TO FULFILL THEIR RESPONSIBILITY. THE TESTING AGENCY SHALL UTILIZE EXPERIENCED, TRAINED INSPECTORS INCLUDING AWS CERTIFIED WELDING INSPECTORS (CWI). INSPECTORS SHALL HAVE THE TRAINING, CREDENTIALS, AND EXPERIENCE APPROPRIATE FOR AND COMMENSURATE WITH THE SCOPE AND TYPE OF INSPECTION WORK TO BE PERFORMED.
  - PERFORM CONTINUOUS ON-SITE OBSERVATION, INSPECTION, VERIFICATION, AND TESTING DURING THE TIME THE CONTRACTOR IS WORKING ON-SITE. AGENCY SHALL NOTIFY OWNER IMMEDIATELY WHEN FIELD PROBLEMS OR DISCREPANCIES OCCUR.
- FOUNDATIONS, CONCRETE, AND SOIL PREPARATION - (NOT REQUIRED)
- CONCRETE TESTING PER ACI - (NOT REQUIRED)
- STRUCTURAL STEEL
  - CHECK THE STEEL ON THE JOB WITH THE PLANS.
  - CHECK MILL CERTIFICATIONS.
  - CHECK GRADE OF STEEL MEMBERS, AND BOLTS FOR CONFORMANCE WITH DRAWINGS.
  - INSPECT STEEL MEMBERS FOR DISTORTION, EXCESSIVE RUST, FLAWS AND BURNED HOLES.
  - CALL FOR LABORATORY TEST REPORTS WHEN IN DOUBT.
  - CHECK STEEL MEMBERS FOR SIZES, SWEEP AND DIMENSIONAL TOLERANCES.
  - CHECK FOR SURFACE FINISH SPECIFIED, GALVANIZED.
  - CHECK BOLT TIGHTENING ACCORDING TO AISC "TURN OF THE NUT" METHOD.
- WELDING:
  - VERIFY FIELD WELDING PROCEDURES, WELDERS, AND WELDING OPERATORS, NOT DEEMED PREQUALIFIED, IN ACCORDANCE WITH AWS D1.1.
  - INSPECT FIELD WELDED CONNECTIONS IN ACCORDANCE WITH THE REQUIREMENTS SPECIFIED AND IN ACCORDANCE WITH AWS D1.1.
  - APPROVE FIELD WELDING SEQUENCE.
    - A PROGRAM OF THE APPROVED SEQUENCES SHALL BE SUBMITTED TO THE OWNER BEFORE WELDING BEGINS. NO CHANGE IN APPROVED SEQUENCES MAY BE MADE WITHOUT PERMISSION FROM THE OWNER.
  - INSPECT WELDED CONNECTIONS AS FOLLOWS AND IN ACCORDANCE WITH AWS D1.1:
    - INSPECT WELDING EQUIPMENT FOR CAPACITY, MAINTENANCE AND WORKING CONDITIONS.
    - VERIFY SPECIFIED ELECTRODES AND HANDLING AND STORAGE OF ELECTRODES FOR CONFORMANCE TO SPECIFICATIONS.
    - INSPECT PREHEATING AND INTERPASS TEMPERATURES FOR CONFORMANCE WITH AWS D1.1.
    - VISUALLY INSPECT ALL WELDS AND VERIFY THAT QUALITY OF WELDS MEETS THE REQUIREMENTS OF AWS D1.1.
    - SPOT TEST AT LEAST ONE FILLET WELD OF EACH MEMBER USING MAGNETIC PARTICLE OR DYE PENETRANT.
    - VERIFY THAT THE BASE METAL CONFORMS TO THE DRAWINGS.
    - VERIFY THE REPORTS BY TESTING LABS.
    - REVIEW TO SEE THAT WELDS ARE CLEAN AND FREE FROM SLAG.
    - INSPECT RUST PROTECTION OF WELDS AS PER SPECIFICATIONS.
    - CHECK THAT DEFECTIVE WELDS ARE CLEARLY MARKED AND HAVE BEEN ADEQUATELY REPAIRED.
- SPECIAL INSPECTION OF EXISTING SHAFT-TO-FLANGE WELD CONNECTIONS:
  - PRIOR TO CONSTRUCTION, TESTING AGENCY SHALL INSPECT CONDITION OF EXISTING SHAFT-TO-BASE-PLATE WELD CONNECTION. ALSO INSPECT EXISTING STIFFENERS IF PRESENT. THE INSPECTOR SHALL USE THE FOLLOWING INSPECTION METHODS, OR COMBINATION OF METHODS, AS REQUIRED TO IDENTIFY ANY CRACKS: VISUAL, MAGNETIC PARTICLE, AND/OR ULTRA-SONIC. IN ADDITION, OTHER TEST METHODS MAY ALSO BE USED AT THE RECOMMENDATION OF THE TESTING AGENCY AND UPON THE APPROVAL OF THE OWNER AND THE ENGINEER. THE TESTING AGENCY SHALL PROVIDE CAREFUL AND THOROUGH DOCUMENTATION OF THIS INSPECTION TO THE OWNER AND THE ENGINEER. TESTING AGENCY SHALL COORDINATE THESE INSPECTION ACTIVITIES WITH THE OWNER'S REQUIRED PROCESSES AND PROCEDURES. IMPORTANT: THE TESTING AGENCY SHALL IMMEDIATELY REPORT ANY INDICATIONS OF CRACKS, FRACTURES, DISTRESS, AND/OR CORROSION TO THE OWNER AND ENGINEER.
  - AFTER CONSTRUCTION, TESTING AGENCY SHALL INSPECT ANY AND ALL FIELD REPAIRS IMPLEMENTED AS REQUIRED BY THE OWNER FROM THE RESULTS OF THE INSPECTION IN THE PREVIOUS NOTE 5.F.(1) ABOVE.
    - REFER TO CROWN CASTLE DOCUMENTS ENG-SOW-10033 AND ENG-BUL-10051 FOR SPECIFICATIONS.
- REPORTS:
  - COMPLETE AND PERIODICALLY SUBMIT DAILY INSPECTION REPORTS TO THE OWNER.
- THE INSPECTION PLAN OUTLINED HEREIN IS INTENDED AS A DESCRIPTION OF GENERAL AND SPECIFIC ITEMS OF CONCERN. IT IS NOT INTENDED TO BE ALL-INCLUSIVE. IT DOES NOT LIMIT THE TESTING AND INSPECTION AGENCY TO THE ITEMS LISTED. ADDITIONAL TESTING, INSPECTION, AND CHECKING MAY BE REQUIRED AND SHOULD BE ANTICIPATED. THE TESTING AGENCY SHALL USE THEIR PROFESSIONAL JUDGMENT AND KNOWLEDGE OF THE JOB SITE CONDITIONS AND THE CONTRACTOR'S PERFORMANCE TO DECIDE WHAT OTHER ITEMS REQUIRE ADDITIONAL ATTENTION. THE TESTING AGENCY'S JUDGMENT MUST PREVAIL ON ITEMS NOT SPECIFICALLY COVERED. ANY DISCREPANCIES AND PROBLEMS SHALL BE BROUGHT IMMEDIATELY TO THE OWNER'S ATTENTION. RESOLUTIONS ARE NOT TO BE MADE WITHOUT THE OWNER'S REVIEW AND SPECIFIC WRITTEN CONSENT. THE OWNER RESERVES THE RIGHT TO DETERMINE WHAT IS AN ACCEPTABLE RESOLUTION OF DISCREPANCIES AND PROBLEMS.
- AFTER EACH INSPECTION, THE TESTING AGENCY WILL PREPARE A WRITTEN ACCEPTANCE OR REJECTION WHICH WILL BE GIVEN TO THE CONTRACTOR AND FILED AS DAILY REPORTS TO THE OWNER. THIS WRITTEN ACTION WILL GIVE THE CONTRACTOR A LIST OF ITEMS TO BE CORRECTED, PRIOR TO CONTINUING CONSTRUCTION, AND/OR LOADING OF STRUCTURAL ITEMS.
- RESPONSIBILITY: THE TESTING AGENCY DOES NOT RELIEVE THE CONTRACTOR'S CONTRACTUAL OR STATUTORY OBLIGATIONS. THE CONTRACTOR HAS THE SOLE RESPONSIBILITY FOR ANY DEVIATIONS FROM THE OFFICIAL CONTRACT DOCUMENTS. THE TESTING AGENCY WILL NOT REPLACE THE CONTRACTOR'S QUALITY CONTROL PERSONNEL.

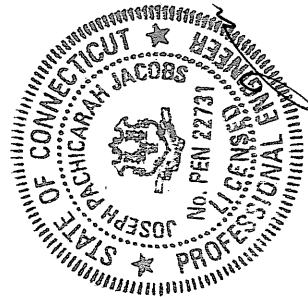

**PAUL J. FORD AND COMPANY**  
STRUCTURAL ENGINEERS  
250 East Broad Street - Suite 1500 - Columbus, Ohio 43215  
(614) 221-6679 www.pjfweb.com

**CROWN CASTLE**

THE PIANO WORKS349 WEST, EAST ROCHESTER, NY 14445  
PH: (585) 899-3445 FAX: (585) 899-3448

© Copyright 2012, by Paul J. Ford and Company, All Rights Reserved. This document and the data contained herein, is proprietary to Paul J. Ford and Company, issued in strict confidence and shall not, without the prior written permission of Paul J. Ford and Company, be reproduced, copied or used for any purpose other than the intended use for this specific project.

PROJECT No:  
37512-1571  
DRAWN BY:  
S.S.  
CHECKED BY:  
K.A.T.  
APPROVED BY:

BU #806373; HRT 101 943232

ENFIELD, CT  
MONOPOLE REINFORCEMENT AND RETROFIT PROJECT

ISSUE DATE OF  
PERMIT: 7-24-2012

DATE:  
7-24-2012

S-1



- D. STRUCTURAL STEEL**
1. STRUCTURAL STEEL MATERIALS, FABRICATION, DETAILING, AND WORKMANSHIP SHALL CONFORM TO THE LATEST EDITION OF THE FOLLOWING REFERENCE STANDARDS:
    - A. BY THE AMERICAN INSTITUTE OF STEEL CONSTRUCTION (AISC):
      - (A) "SPECIFICATION FOR THE DESIGN, FABRICATION AND ERECTION OF STRUCTURAL STEEL FOR BUILDINGS"
      - (B) "SPECIFICATION FOR STRUCTURAL JOINTS USING ASTM A325 OR A490 BOLTS," AS APPROVED BY THE RESEARCH COUNCIL ON STRUCTURAL CONNECTIONS OF THE ENGINEERING FOUNDATION.
      - (C) "CODE OF STANDARD PRACTICE FOR STEEL BUILDINGS AND BRIDGES" (PARAGRAPH 4.2.1 SPECIFICALLY EXCLUDED).
    - B. BY THE AMERICAN WELDING SOCIETY (AWS):
      - (A) "STRUCTURAL WELDING CODE - STEEL D1.1."
      - (B) "SYMBOLS FOR WELDING AND NON-DESTRUCTIVE TESTING"
  2. ANY MATERIAL OR WORKMANSHIP WHICH IS OBSERVED TO BE DEFECTIVE OR INCONSISTENT WITH THE CONTRACT DOCUMENTS SHALL BE CORRECTED, MODIFIED, OR REPLACED AT THE CONTRACTOR'S EXPENSE.
  3. TIGHTEN ALL STRUCTURAL BOLTS, INCLUDING THE AJAX M20 BOLTS WITH SHEAR SLEEVES, ACCORDING TO THE REQUIREMENTS OF THE AISC "TURN OF THE NUT" METHOD. TIGHTEN BOLTS 1/3 TURN PAST THE SNUG TIGHT CONDITION AS DEFINED BY AISC.
  4. WELDED CONNECTIONS SHALL CONFORM TO THE LATEST REVISED CODE OF THE AMERICAN WELDING SOCIETY, AWS D1.1. ALL WELD ELECTRODES SHALL BE E60XX UNLESS NOTED OTHERWISE ON THE DRAWINGS.
  5. ALL WELDED CONNECTIONS SHALL BE MADE BY WELDERS CERTIFIED BY AWS. CONTRACTOR SHALL SUBMIT WELDERS' CERTIFICATION AND QUALIFICATION DOCUMENTATION TO THE OWNER'S TESTING AGENCY FOR REVIEW AND APPROVAL PRIOR TO CONSTRUCTION.
  6. STRUCTURAL STEEL PLATES SHALL CONFORM TO ASTM A572 GRADE 65 (FY = 65 KSI MIN.) UNLESS NOTED OTHERWISE ON THE DRAWINGS.
  7. SURFACES OF EXISTING STEEL SHALL BE PREPARED AS REQUIRED FOR FIELD WELDING PER AWS. SEE SECTION I NOTES REGARDING TOUCH-UP OF GALVANIZED SURFACES DAMAGED DURING TRANSPORTATION OR ERECTION AND ASSEMBLY AS WELL AS HOT-DIP GALVANIZING.
  8. UNLESS OTHERWISE NOTED, ALL STEEL MEMBERS SHALL BE HOT-DIP GALVANIZED AFTER FABRICATION, IN ACCORDANCE WITH ASTM A123. SEE SECTION J FOR FURTHER NOTES AND FOR EXCEPTIONS (IF ANY).
  9. ALL WELDS SHALL BE VISUALLY INSPECTED BY THE OWNER'S APPROVED TESTING AGENCY. OTHER TESTS MAY ALSO BE PERFORMED ON THE WELDS BY THE TESTING AGENCY IN ORDER FOR THEM TO PERFORM THEIR DUTIES FOR THIS PROJECT. THE CONTRACTOR SHALL COOPERATE WITH THE TESTING AGENCY IN THEIR TESTING EFFORTS.
  10. NO WELDING SHALL BE DONE TO THE EXISTING STRUCTURE WITHOUT THE PRIOR APPROVAL AND SUPERVISION OF THE TESTING AGENCY.
  11. FIELD CUTTING OF STEEL:
    - (A) PRIOR TO ANY FIELD CUTTING, THE CONTRACTOR SHALL MARK THE CUT OUTLINES ON THE STEEL AND THE INSPECTION/TESTING AGENCY SHALL VERIFY PROPOSED LAYOUT, LOCATION, AND DIMENSIONS.
    - (B) ANY REQUIRED CUTS IN THE STEEL SHALL BE CAREFULLY CUT BY MECHANICAL METHODS SUCH AS DRILLING, SAW CUTTING, AND GRINDING. THE CONTRACTOR IS RESPONSIBLE TO PREVENT ANY DAMAGE TO THE COAX CABLES, AND/OR OTHER EQUIPMENT AND/OR THE STRUCTURE, DURING THE CUTTING WORK. ANY DAMAGE TO THE COAX CABLES, AND/OR OTHER EQUIPMENT AND/OR THE STRUCTURE, RESULTING FROM THE CONTRACTOR'S ACTIVITIES SHALL BE REPAIRED AT THE CONTRACTOR'S EXPENSE. THE INSPECTION/TESTING AGENCY SHALL CLOSELY AND CONTINUOUSLY MONITOR THIS ACTIVITY.
    - (C) ALL REQUIRED CUTS SHALL BE CUT WITHIN THE DIMENSIONS SHOWN ON THE DRAWINGS. NO CUTS SHALL EXTEND BEYOND THE OUTLINE OF THE DIMENSIONS SHOWN ON THE DRAWINGS. ALL CUT EDGES SHALL BE GROUND SMOOTH AND DE-BURRED. CUT EDGES THAT ARE TO BE FIELD WELDED SHALL BE PREPARED FOR FIELD WELDING PER AWS D1.1 AND AS SHOWN ON THE DRAWINGS. IT MAY BE NECESSARY TO DRILL STARTER HOLES AS REQUIRED TO MAKE THE CUTS. THE INSPECTION/TESTING AGENCY SHALL CLOSELY AND CONTINUOUSLY MONITOR THIS ACTIVITY.

- E. BASE PLATE GROUT**
1. NEW GROUT FOR THE POLE BASE SHALL BE NON-SHRINK, NON-METALLIC, GROUT (EUCONS GROUT BY EUCLID, OR APPROVED EQUAL) WITH A 7500 PSI MINIMUM COMPRESSIVE STRENGTH. PVC DRAINAGE PIPES SHALL BE PROVIDED FROM INSIDE THE POLE SHAFT OUT THROUGH THE GROUT SPACE UNDER THE BASE PLATE IN ORDER TO ALLOW MOISTURE TO ADEQUATELY DRAIN FROM THE INTERIOR OF THE POLE SHAFT. CONTRACTOR SHALL SUBMIT PROPOSED GROUT SPECIFICATION INFORMATION TO THE OWNER FOR REVIEW AND APPROVAL PRIOR TO CONSTRUCTION. CONTRACTOR SHALL FOLLOW GROUT MANUFACTURER'S SPECIFICATIONS FOR COLD WEATHER GROUTING PROCEDURES (IF NECESSARY) AND THE TESTING AGENCY SHALL PREPARE GROUT SAMPLE SPECIMENS FOR COMPRESSIVE STRENGTH TESTING AND VERIFICATION.
  2. GROUT SHALL BE INSTALLED TIGHT UNDER BASE PLATE WITH NO VOIDS REMAINING BETWEEN TOP OF EXISTING CONCRETE AND UNDERSIDE OF EXISTING BASE PLATE (EXCEPT FOR DRAIN PIPES). GROUT COMPLETELY SOLID (EXCEPT FOR DRAIN PIPES) UNDER ENTIRE SURFACE OF BASE PLATE FROM OUTSIDE EDGE TO INSIDE EDGE.
- F. FOUNDATION WORK - (NOT REQUIRED)**

**G. CAST-IN-PLACE CONCRETE - (NOT REQUIRED)**

- H. EPOXY GROUTED REINFORCING ANCHOR RODS**
1. UNLESS OTHERWISE NOTED, REINFORCING ANCHOR RODS SHALL BE 150 KSI ALL-THREAD BAR CONFORMING TO ASTM A722. RECOMMENDED MANUFACTURERS/SUPPLIERS OF 150 KSI ALL-THREAD BAR ARE WILLIAMS FORM ENGINEERING CORPORATION AND DYWIDAG SYSTEMS INTERNATIONAL.
  2. ALL REINFORCING ANCHOR RODS SHALL BE HOT DIP GALVANIZED PER ASTM A153. ALTERNATIVELY, ALL REINFORCING ANCHOR RODS MAY BE EPOXY COATED PER ASTM A775.
  3. THE CORE-DRILLED HOLES IN THE CONCRETE FOR THE ANCHOR RODS SHALL BE CLEAN AND DRY, AND OTHERWISE PROPERLY PREPARED ACCORDING TO THE ANCHOR ROD AND EPOXY MANUFACTURERS' INSTRUCTIONS, PRIOR TO PLACEMENT OF ANCHOR RODS AND EPOXY. CONTRACTOR SHALL FOLLOW ALL ANCHOR ROD AND EPOXY MANUFACTURER RECOMMENDATIONS REGARDING HANDLING OF RODS, EPOXY, ACCEPTABLE AMBIENT TEMPERATURE RANGE DURING INSTALLATION AND POST-INSTALLATION CURING, THE EFFECT OF TEMPERATURE ON EPOXY CURING TIME, PREPARATION OF HOLE, ETC.
  4. ULTRABOND 1, HILTI HIT RE-500 OR ANCHORTITE EPOXY SHALL BE USED TO ANCHOR THE 150 KSI ALL-THREAD BAR IN THE DRILL HOLES. IF CONTRACTOR WISHES TO USE A DIFFERENT EPOXY, A REQUEST INCLUDING THE EPOXY TECHNICAL DATA SHEET(S) SHALL BE SUBMITTED TO PAUL J FORD AND COMPANY FOR REVIEW PRIOR TO CONSTRUCTION. AS NOTED ABOVE, FOLLOW ALL EPOXY MANUFACTURER RECOMMENDATIONS REGARDING HANDLING OF EPOXY, ACCEPTABLE AMBIENT TEMPERATURE RANGE DURING INSTALLATION AND POST-INSTALLATION CURING, THE EFFECT OF TEMPERATURE ON EPOXY CURING TIME, PREPARATION OF HOLE, ETC.
  5. ONCE THE REINFORCING ANCHOR RODS HAVE BEEN INSTALLED AND ALL EPOXY AND GROUT HAVE CURED (IF BASE PLATE AND/OR BEARING PLATES HAVE BEEN GROUTED PRIOR TO TESTING), ALL REINFORCING ANCHOR RODS SHALL BE LOAD TESTED PER CROWN CASTLE ENGINEERING DOCUMENT #ENG-PRC-10119. REFER TO THE NEW ANCHOR & BRACKET DETAIL ON FOLLOWING DRAWING SHEETS FOR SPECIFIED ANCHOR ROD LOAD.
  6. ONCE THE REINFORCING ANCHOR RODS HAVE BEEN SUCCESSFULLY LOAD TESTED AND APPROVED AND BASE PLATE / BEARING PLATE GROUT HAS CURED (IF BASE PLATE AND/OR BEARING PLATES HAVE BEEN GROUTED AFTER TESTING), CONTRACTOR SHALL TIGHTEN ALL HEAVY HEX ANCHOR NUTS TO SNUG TIGHT PLUS 1/8 TURN OF NUT.

**I. TOUCH UP OF GALVANIZING**

1. THE CONTRACTOR SHALL TOUCH UP ANY AND/OR ALL AREAS OF GALVANIZING ON THE EXISTING STRUCTURE OR NEW COMPONENTS THAT ARE DAMAGED OR ABRADED DURING CONSTRUCTION. GALVANIZED SURFACES DAMAGED DURING TRANSPORTATION OR ERECTION AND ASSEMBLY AS WELL AS ANY AND ALL ABRASIONS, CUTS, FIELD DRILLING, AND ALL FIELD WELDING SHALL BE TOUCHED UP WITH TWO (2) COATS OF ZRC-BRAND, ZINC-RICH COLD GALVANIZING COMPOUND. FILM THICKNESS PER COAT SHALL BE: WET 3.0 MILS; DRY 1.5 MILS. APPLY PER ZRC (MANUFACTURER) RECOMMENDED PROCEDURES. CONTACT ZRC AT 1-800-831-3275 FOR PRODUCT INFORMATION.
2. CONTRACTOR SHALL CLEAN AND PREPARE ALL FIELD WELDS ON GALVANIZED AND PRIME PAINTED SURFACES FOR TOUCH-UP COATING IN ACCORDANCE WITH AWS D1.1. THE OWNER'S TESTING AGENCY SHALL VERIFY THE PREPARED SURFACE PRIOR TO APPLICATION OF THE TOUCH-UP COATING.
3. THE OWNER'S TESTING AGENCY SHALL TEST AND VERIFY THE COATING THICKNESS AFTER THE CONTRACTOR HAS APPLIED THE ZRC COLD GALVANIZING COMPOUND AND IT HAS SUFFICIENTLY DRIED. AREAS FOUND TO BE INADEQUATELY COATED, SHALL BE RE-COATED BY THE CONTRACTOR AND RE-TESTED BY THE TESTING AGENCY.

**J. HOT DIP GALVANIZING**

1. HOT-DIP GALVANIZE ALL STRUCTURAL STEEL MEMBERS AND ALL STEEL ACCESSORIES, BOLTS, WASHERS, ETC. PER ASTM A123 OR PER ASTM A153, AS APPROPRIATE.
2. PROPERLY PREPARE STEEL ITEMS FOR GALVANIZING.
3. DRILL OR PUNCH WEEP AND/OR DRAINAGE HOLES AS REQUIRED.
4. ALL GALVANIZING SHALL BE DONE AFTER FABRICATION IS COMPLETED AND PRIOR TO FIELD INSTALLATION.

**K. PERPETUAL INSPECTION AND MAINTENANCE BY THE OWNER**

1. AFTER THE CONTRACTOR HAS SUCCESSFULLY COMPLETED THE INSTALLATION OF THE MONOPOLE REINFORCING SYSTEM AND THE WORK HAS BEEN ACCEPTED BY THE OWNER, THE OWNER WILL BE RESPONSIBLE FOR THE LONG TERM AND PERPETUAL INSPECTION AND MAINTENANCE OF THE POLE AND REINFORCING SYSTEM.
2. THE MONOPOLE REINFORCING SYSTEM INDICATED IN THESE DOCUMENTS USES REINFORCING COMPONENTS THAT INVOLVE FIELD WELDING STEEL MEMBERS TO THE EXISTING GALVANIZED STEEL POLE STRUCTURE. THESE FIELD WELDED CONNECTIONS ARE SUBJECT TO CORROSION DAMAGE AND DETERIORATION IF THEY ARE NOT PROPERLY MAINTAINED AND COVERED WITH CORROSION PREVENTIVE COATING SUCH AS THE ZRC GALVANIZING COMPOUND SPECIFIED PREVIOUSLY. THE STRUCTURAL LOAD CARRYING CAPACITY OF THE REINFORCED POLE SYSTEM IS DEPENDENT UPON THE INSTALLED SIZE AND QUALITY, MAINTAINED SOUND CONDITION AND STRENGTH OF THESE FIELD WELDED CONNECTIONS. ANY CORROSION OF, DAMAGE TO, FATIGUE, FRACTURE, AND/OR DETERIORATION OF THESE WELDS AND/OR THE CONNECTED COMPONENTS WILL RESULT IN THE LOSS OF STRUCTURAL LOAD CARRYING CAPACITY AND MAY LEAD TO FAILURE OF THE STRUCTURAL SYSTEM. THEREFORE, IT IS IMPERATIVE THAT THE OWNER REGULARLY INSPECTS, MAINTAINS, AND REPAIRS AS NECESSARY, ALL OF THESE WELDS, CONNECTIONS, AND COMPONENTS FOR THE LIFE OF THE STRUCTURE.
3. THE OWNER SHALL REFER TO TIA/EIA-222-F-1996, SECTION 14 AND ANNEX E FOR RECOMMENDATIONS FOR MAINTENANCE AND INSPECTION. THE FREQUENCY OF THE INSPECTION AND MAINTENANCE INTERVALS IS TO BE DETERMINED BY THE OWNER BASED UPON ACTUAL SITE AND ENVIRONMENTAL CONDITIONS. PAUL J. FORD & COMPANY RECOMMENDS THAT A COMPLETE AND THOROUGH INSPECTION OF THE ENTIRE REINFORCED MONOPOLE STRUCTURAL SYSTEM BE PERFORMED YEARLY AND/OR AS FREQUENTLY AS CONDITIONS WARRANT. ACCORDING TO TIA/EIA-222-F-1996 SECTION 14.1, NOTE 1: "IT IS RECOMMENDED THAT THE STRUCTURE BE INSPECTED AFTER SEVERE WIND AND/OR ICE STORMS OR OTHER EXTREME LOADING CONDITIONS".

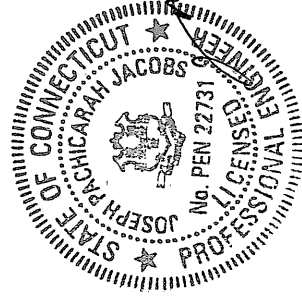
**D. STRUCTURAL STEEL**

1. STRUCTURAL STEEL MATERIALS, FABRICATION, DETAILING, AND WORKMANSHIP SHALL CONFORM TO THE LATEST EDITION OF THE FOLLOWING REFERENCE STANDARDS:
  - A. BY THE AMERICAN INSTITUTE OF STEEL CONSTRUCTION (AISC):
    - (A) "SPECIFICATION FOR THE DESIGN, FABRICATION AND ERECTION OF STRUCTURAL STEEL FOR BUILDINGS"
    - (B) "SPECIFICATION FOR STRUCTURAL JOINTS USING ASTM A325 OR A490 BOLTS," AS APPROVED BY THE RESEARCH COUNCIL ON STRUCTURAL CONNECTIONS OF THE ENGINEERING FOUNDATION.
    - (C) "CODE OF STANDARD PRACTICE FOR STEEL BUILDINGS AND BRIDGES" (PARAGRAPH 4.2.1 SPECIFICALLY EXCLUDED).
  - B. BY THE AMERICAN WELDING SOCIETY (AWS):
    - (A) "STRUCTURAL WELDING CODE - STEEL D1.1."
    - (B) "SYMBOLS FOR WELDING AND NON-DESTRUCTIVE TESTING"
2. ANY MATERIAL OR WORKMANSHIP WHICH IS OBSERVED TO BE DEFECTIVE OR INCONSISTENT WITH THE CONTRACT DOCUMENTS SHALL BE CORRECTED, MODIFIED, OR REPLACED AT THE CONTRACTOR'S EXPENSE.
3. TIGHTEN ALL STRUCTURAL BOLTS, INCLUDING THE AJAX M20 BOLTS WITH SHEAR SLEEVES, ACCORDING TO THE REQUIREMENTS OF THE AISC "TURN OF THE NUT" METHOD. TIGHTEN BOLTS 1/3 TURN PAST THE SNUG TIGHT CONDITION AS DEFINED BY AISC.
4. WELDED CONNECTIONS SHALL CONFORM TO THE LATEST REVISED CODE OF THE AMERICAN WELDING SOCIETY, AWS D1.1. ALL WELD ELECTRODES SHALL BE E60XX UNLESS NOTED OTHERWISE ON THE DRAWINGS.
5. ALL WELDED CONNECTIONS SHALL BE MADE BY WELDERS CERTIFIED BY AWS. CONTRACTOR SHALL SUBMIT WELDERS' CERTIFICATION AND QUALIFICATION DOCUMENTATION TO THE OWNER'S TESTING AGENCY FOR REVIEW AND APPROVAL PRIOR TO CONSTRUCTION.
6. STRUCTURAL STEEL PLATES SHALL CONFORM TO ASTM A572 GRADE 65 (FY = 65 KSI MIN.) UNLESS NOTED OTHERWISE ON THE DRAWINGS.
7. SURFACES OF EXISTING STEEL SHALL BE PREPARED AS REQUIRED FOR FIELD WELDING PER AWS. SEE SECTION I NOTES REGARDING TOUCH-UP OF GALVANIZED SURFACES DAMAGED DURING TRANSPORTATION OR ERECTION AND ASSEMBLY AS WELL AS HOT-DIP GALVANIZING.
8. UNLESS OTHERWISE NOTED, ALL STEEL MEMBERS SHALL BE HOT-DIP GALVANIZED AFTER FABRICATION, IN ACCORDANCE WITH ASTM A123. SEE SECTION J FOR FURTHER NOTES AND FOR EXCEPTIONS (IF ANY).
9. ALL WELDS SHALL BE VISUALLY INSPECTED BY THE OWNER'S APPROVED TESTING AGENCY. OTHER TESTS MAY ALSO BE PERFORMED ON THE WELDS BY THE TESTING AGENCY IN ORDER FOR THEM TO PERFORM THEIR DUTIES FOR THIS PROJECT. THE CONTRACTOR SHALL COOPERATE WITH THE TESTING AGENCY IN THEIR TESTING EFFORTS.
10. NO WELDING SHALL BE DONE TO THE EXISTING STRUCTURE WITHOUT THE PRIOR APPROVAL AND SUPERVISION OF THE TESTING AGENCY.
11. FIELD CUTTING OF STEEL:
  - (A) PRIOR TO ANY FIELD CUTTING, THE CONTRACTOR SHALL MARK THE CUT OUTLINES ON THE STEEL AND THE INSPECTION/TESTING AGENCY SHALL VERIFY PROPOSED LAYOUT, LOCATION, AND DIMENSIONS.
  - (B) ANY REQUIRED CUTS IN THE STEEL SHALL BE CAREFULLY CUT BY MECHANICAL METHODS SUCH AS DRILLING, SAW CUTTING, AND GRINDING. THE CONTRACTOR IS RESPONSIBLE TO PREVENT ANY DAMAGE TO THE COAX CABLES, AND/OR OTHER EQUIPMENT AND/OR THE STRUCTURE, DURING THE CUTTING WORK. ANY DAMAGE TO THE COAX CABLES, AND/OR OTHER EQUIPMENT AND/OR THE STRUCTURE, RESULTING FROM THE CONTRACTOR'S ACTIVITIES SHALL BE REPAIRED AT THE CONTRACTOR'S EXPENSE. THE INSPECTION/TESTING AGENCY SHALL CLOSELY AND CONTINUOUSLY MONITOR THIS ACTIVITY.
  - (C) ALL REQUIRED CUTS SHALL BE CUT WITHIN THE DIMENSIONS SHOWN ON THE DRAWINGS. NO CUTS SHALL EXTEND BEYOND THE OUTLINE OF THE DIMENSIONS SHOWN ON THE DRAWINGS. ALL CUT EDGES SHALL BE GROUND SMOOTH AND DE-BURRED. CUT EDGES THAT ARE TO BE FIELD WELDED SHALL BE PREPARED FOR FIELD WELDING PER AWS D1.1 AND AS SHOWN ON THE DRAWINGS. IT MAY BE NECESSARY TO DRILL STARTER HOLES AS REQUIRED TO MAKE THE CUTS. THE INSPECTION/TESTING AGENCY SHALL CLOSELY AND CONTINUOUSLY MONITOR THIS ACTIVITY.

- E. BASE PLATE GROUT**
1. NEW GROUT FOR THE POLE BASE SHALL BE NON-SHRINK, NON-METALLIC, GROUT (EUCONS GROUT BY EUCLID, OR APPROVED EQUAL) WITH A 7500 PSI MINIMUM COMPRESSIVE STRENGTH. PVC DRAINAGE PIPES SHALL BE PROVIDED FROM INSIDE THE POLE SHAFT OUT THROUGH THE GROUT SPACE UNDER THE BASE PLATE IN ORDER TO ALLOW MOISTURE TO ADEQUATELY DRAIN FROM THE INTERIOR OF THE POLE SHAFT. CONTRACTOR SHALL SUBMIT PROPOSED GROUT SPECIFICATION INFORMATION TO THE OWNER FOR REVIEW AND APPROVAL PRIOR TO CONSTRUCTION. CONTRACTOR SHALL FOLLOW GROUT MANUFACTURER'S SPECIFICATIONS FOR COLD WEATHER GROUTING PROCEDURES (IF NECESSARY) AND THE TESTING AGENCY SHALL PREPARE GROUT SAMPLE SPECIMENS FOR COMPRESSIVE STRENGTH TESTING AND VERIFICATION.
  2. GROUT SHALL BE INSTALLED TIGHT UNDER BASE PLATE WITH NO VOIDS REMAINING BETWEEN TOP OF EXISTING CONCRETE AND UNDERSIDE OF EXISTING BASE PLATE (EXCEPT FOR DRAIN PIPES). GROUT COMPLETELY SOLID (EXCEPT FOR DRAIN PIPES) UNDER ENTIRE SURFACE OF BASE PLATE FROM OUTSIDE EDGE TO INSIDE EDGE.
- F. FOUNDATION WORK - (NOT REQUIRED)**

**G. CAST-IN-PLACE CONCRETE - (NOT REQUIRED)**

- H. EPOXY GROUTED REINFORCING ANCHOR RODS**
1. UNLESS OTHERWISE NOTED, REINFORCING ANCHOR RODS SHALL BE 150 KSI ALL-THREAD BAR CONFORMING TO ASTM A722. RECOMMENDED MANUFACTURERS/SUPPLIERS OF 150 KSI ALL-THREAD BAR ARE WILLIAMS FORM ENGINEERING CORPORATION AND DYWIDAG SYSTEMS INTERNATIONAL.
  2. ALL REINFORCING ANCHOR RODS SHALL BE HOT DIP GALVANIZED PER ASTM A153. ALTERNATIVELY, ALL REINFORCING ANCHOR RODS MAY BE EPOXY COATED PER ASTM A775.
  3. THE CORE-DRILLED HOLES IN THE CONCRETE FOR THE ANCHOR RODS SHALL BE CLEAN AND DRY, AND OTHERWISE PROPERLY PREPARED ACCORDING TO THE ANCHOR ROD AND EPOXY MANUFACTURERS' INSTRUCTIONS, PRIOR TO PLACEMENT OF ANCHOR RODS AND EPOXY. CONTRACTOR SHALL FOLLOW ALL ANCHOR ROD AND EPOXY MANUFACTURER RECOMMENDATIONS REGARDING HANDLING OF RODS, EPOXY, ACCEPTABLE AMBIENT TEMPERATURE RANGE DURING INSTALLATION AND POST-INSTALLATION CURING, THE EFFECT OF TEMPERATURE ON EPOXY CURING TIME, PREPARATION OF HOLE, ETC.
  4. ULTRABOND 1, HILTI HIT RE-500 OR ANCHORTITE EPOXY SHALL BE USED TO ANCHOR THE 150 KSI ALL-THREAD BAR IN THE DRILL HOLES. IF CONTRACTOR WISHES TO USE A DIFFERENT EPOXY, A REQUEST INCLUDING THE EPOXY TECHNICAL DATA SHEET(S) SHALL BE SUBMITTED TO PAUL J FORD AND COMPANY FOR REVIEW PRIOR TO CONSTRUCTION. AS NOTED ABOVE, FOLLOW ALL EPOXY MANUFACTURER RECOMMENDATIONS REGARDING HANDLING OF EPOXY, ACCEPTABLE AMBIENT TEMPERATURE RANGE DURING INSTALLATION AND POST-INSTALLATION CURING, THE EFFECT OF TEMPERATURE ON EPOXY CURING TIME, PREPARATION OF HOLE, ETC.
  5. ONCE THE REINFORCING ANCHOR RODS HAVE BEEN INSTALLED AND ALL EPOXY AND GROUT HAVE CURED (IF BASE PLATE AND/OR BEARING PLATES HAVE BEEN GROUTED PRIOR TO TESTING), ALL REINFORCING ANCHOR RODS SHALL BE LOAD TESTED PER CROWN CASTLE ENGINEERING DOCUMENT #ENG-PRC-10119. REFER TO THE NEW ANCHOR & BRACKET DETAIL ON FOLLOWING DRAWING SHEETS FOR SPECIFIED ANCHOR ROD LOAD.
  6. ONCE THE REINFORCING ANCHOR RODS HAVE BEEN SUCCESSFULLY LOAD TESTED AND APPROVED AND BASE PLATE / BEARING PLATE GROUT HAS CURED (IF BASE PLATE AND/OR BEARING PLATES HAVE BEEN GROUTED AFTER TESTING), CONTRACTOR SHALL TIGHTEN ALL HEAVY HEX ANCHOR NUTS TO SNUG TIGHT PLUS 1/8 TURN OF NUT.

**I. TOUCH UP OF GALVANIZING**

1. THE CONTRACTOR SHALL TOUCH UP ANY AND/OR ALL AREAS OF GALVANIZING ON THE EXISTING STRUCTURE OR NEW COMPONENTS THAT ARE DAMAGED OR ABRADED DURING CONSTRUCTION. GALVANIZED SURFACES DAMAGED DURING TRANSPORTATION OR ERECTION AND ASSEMBLY AS WELL AS ANY AND ALL ABRASIONS, CUTS, FIELD DRILLING, AND ALL FIELD WELDING SHALL BE TOUCHED UP WITH TWO (2) COATS OF ZRC-BRAND, ZINC-RICH COLD GALVANIZING COMPOUND. FILM THICKNESS PER COAT SHALL BE: WET 3.0 MILS; DRY 1.5 MILS. APPLY PER ZRC (MANUFACTURER) RECOMMENDED PROCEDURES. CONTACT ZRC AT 1-800-831-3275 FOR PRODUCT INFORMATION.
2. CONTRACTOR SHALL CLEAN AND PREPARE ALL FIELD WELDS ON GALVANIZED AND PRIME PAINTED SURFACES FOR TOUCH-UP COATING IN ACCORDANCE WITH AWS D1.1. THE OWNER'S TESTING AGENCY SHALL VERIFY THE PREPARED SURFACE PRIOR TO APPLICATION OF THE TOUCH-UP COATING.
3. THE OWNER'S TESTING AGENCY SHALL TEST AND VERIFY THE COATING THICKNESS AFTER THE CONTRACTOR HAS APPLIED THE ZRC COLD GALVANIZING COMPOUND AND IT HAS SUFFICIENTLY DRIED. AREAS FOUND TO BE INADEQUATELY COATED, SHALL BE RE-COATED BY THE CONTRACTOR AND RE-TESTED BY THE TESTING AGENCY.

**J. HOT DIP GALVANIZING**

1. HOT-DIP GALVANIZE ALL STRUCTURAL STEEL MEMBERS AND ALL STEEL ACCESSORIES, BOLTS, WASHERS, ETC. PER ASTM A123 OR PER ASTM A153, AS APPROPRIATE.
2. PROPERLY PREPARE STEEL ITEMS FOR GALVANIZING.
3. DRILL OR PUNCH WEEP AND/OR DRAINAGE HOLES AS REQUIRED.
4. ALL GALVANIZING SHALL BE DONE AFTER FABRICATION IS COMPLETED AND PRIOR TO FIELD INSTALLATION.

**K. PERPETUAL INSPECTION AND MAINTENANCE BY THE OWNER**

1. AFTER THE CONTRACTOR HAS SUCCESSFULLY COMPLETED THE INSTALLATION OF THE MONOPOLE REINFORCING SYSTEM AND THE WORK HAS BEEN ACCEPTED BY THE OWNER, THE OWNER WILL BE RESPONSIBLE FOR THE LONG TERM AND PERPETUAL INSPECTION AND MAINTENANCE OF THE POLE AND REINFORCING SYSTEM.
2. THE MONOPOLE REINFORCING SYSTEM INDICATED IN THESE DOCUMENTS USES REINFORCING COMPONENTS THAT INVOLVE FIELD WELDING STEEL MEMBERS TO THE EXISTING GALVANIZED STEEL POLE STRUCTURE. THESE FIELD WELDED CONNECTIONS ARE SUBJECT TO CORROSION DAMAGE AND DETERIORATION IF THEY ARE NOT PROPERLY MAINTAINED AND COVERED WITH CORROSION PREVENTIVE COATING SUCH AS THE ZRC GALVANIZING COMPOUND SPECIFIED PREVIOUSLY. THE STRUCTURAL LOAD CARRYING CAPACITY OF THE REINFORCED POLE SYSTEM IS DEPENDENT UPON THE INSTALLED SIZE AND QUALITY, MAINTAINED SOUND CONDITION AND STRENGTH OF THESE FIELD WELDED CONNECTIONS. ANY CORROSION OF, DAMAGE TO, FATIGUE, FRACTURE, AND/OR DETERIORATION OF THESE WELDS AND/OR THE CONNECTED COMPONENTS WILL RESULT IN THE LOSS OF STRUCTURAL LOAD CARRYING CAPACITY AND MAY LEAD TO FAILURE OF THE STRUCTURAL SYSTEM. THEREFORE, IT IS IMPERATIVE THAT THE OWNER REGULARLY INSPECTS, MAINTAINS, AND REPAIRS AS NECESSARY, ALL OF THESE WELDS, CONNECTIONS, AND COMPONENTS FOR THE LIFE OF THE STRUCTURE.
3. THE OWNER SHALL REFER TO TIA/EIA-222-F-1996, SECTION 14 AND ANNEX E FOR RECOMMENDATIONS FOR MAINTENANCE AND INSPECTION. THE FREQUENCY OF THE INSPECTION AND MAINTENANCE INTERVALS IS TO BE DETERMINED BY THE OWNER BASED UPON ACTUAL SITE AND ENVIRONMENTAL CONDITIONS. PAUL J. FORD & COMPANY RECOMMENDS THAT A COMPLETE AND THOROUGH INSPECTION OF THE ENTIRE REINFORCED MONOPOLE STRUCTURAL SYSTEM BE PERFORMED YEARLY AND/OR AS FREQUENTLY AS CONDITIONS WARRANT. ACCORDING TO TIA/EIA-222-F-1996 SECTION 14.1, NOTE 1: "IT IS RECOMMENDED THAT THE STRUCTURE BE INSPECTED AFTER SEVERE WIND AND/OR ICE STORMS OR OTHER EXTREME LOADING CONDITIONS".

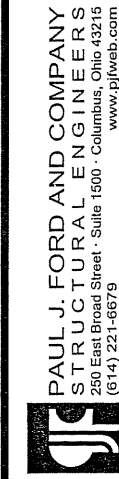

**CROWN CASTLE**

THE PIANO WORKS349 WEST, EAST ROCHESTER, NY 14445  
PH: (585) 899-3445 FAX: (585) 899-3448

© Copyright 2012, by Paul J. Ford and Company. All Rights Reserved. This document and the data contained herein, is proprietary to Paul J. Ford and Company, issued in strict confidence and shall not, without the prior written permission of Paul J. Ford and Company, be reproduced, copied or used for any purpose other than the intended use for this specific project.

BU #806373; HRT 101 943232

ENFIELD, CT

MONOPOLE REINFORCEMENT AND RETROFIT PROJECT

PROJECT No:  
37512-1571

DRAWN BY:  
S.S.

CHECKED BY:  
K.A.T.

APPROVED BY:

DATE:  
7-24-2012

ISSUE DATE OF  
PERMIT: 7-24-2012

S-2

AJAX BOLT NOTE SHEET: REV. 1.2, 01-23-2012

- NOTES:
- ALL STRUCTURAL BOLTS SHALL BE INSTALLED AND TIGHTENED TO THE PRETENSIONED CONDITION ACCORDING TO THE REQUIREMENTS OF THE AISC 'SPECIFICATION FOR STRUCTURAL JOINTS USING HIGH-STRENGTH BOLTS', DEC. 31, 2009.
  - ALL STRUCTURAL BOLTS SHALL BE INSPECTED ACCORDING TO THE REQUIREMENTS OF THE AISC 'SPECIFICATION FOR STRUCTURAL JOINTS USING HIGH-STRENGTH BOLTS', DEC. 31, 2009.
  - ALL AJAX M20 BOLTS WITH SHEAR SLEEVES SHALL BE PRETENSIONED AND TIGHTENED UNTIL THE DIRECT TENSION INDICATOR (DTI) WASHERS SHOW THAT THE PROPER BOLT TENSION HAS BEEN REACHED. SEE NOTES AND DETAIL BELOW FOR THE USE OF DIRECT TENSION INDICATOR (DTI) WASHERS WITH THE AJAX M20 BOLTS.
  - ALL AJAX BOLTS SHALL BE INSTALLED USING DIRECT TENSION INDICATORS (DTI'S) AND HARDENED WASHERS. DTI'S SHALL BE THE SQUIRTER® STYLE, MADE TO ASTM F959 LATEST REVISION; AND HARDENED WASHERS SHALL CONFORM TO ASTM F436 AND HAVE A HARDNESS OF RC 38 OR HIGHER.

NOTES FOR AJAX M20 'ONE-SIDE' BOLTS WITH DIRECT TENSION INDICATORS (DTI'S):

DTI'S REQUIRED: DTI'S SHALL BE "SELF-INDICATING" SQUIRTER® STYLE DTI'S MADE WITH SILICONE EMBEDDED IN THEM, INSPECTED BY MEANS OF THE VISUAL EJECTION OF SILICONE AS THE DTI PROTRUSIONS COMPRESS. SQUIRTER® DTI'S SHALL BE CALIBRATED PER MANUFACTURER'S INSTRUCTIONS PRIOR TO USE.

THE DIRECT TENSION INDICATOR (DTI) WASHERS SHALL BE THE "SQUIRTER® STYLE" AS MANUFACTURED BY:

APPLIED BOLTING TECHNOLOGY PRODUCTS, INC.  
1413 ROCKINGHAM ROAD BELLOW'S FALLS, VERMONT, USA 05101  
PHONE 1-800-552-1999  
WEBSITE: [WWW.APPLIEDBOLTING.COM](http://WWW.APPLIEDBOLTING.COM)

DISTRIBUTORS OF SQUIRTER® DTI'S:

[HTTP://WWW.APPLIEDBOLTING.COM/APPLIED-BOLTING-DISTRIBUTORS.HTML](http://WWW.APPLIEDBOLTING.COM/APPLIED-BOLTING-DISTRIBUTORS.HTML)

DTI: USE DIRECT TENSION INDICATOR (DTI) WASHERS COMPATIBLE WITH 3/4" NOMINAL A325 BOLTS FOR THE AJAX M20 BOLTS. DTI'S SHALL NOT BE HOT-DIP GALVANIZED. DTI'S SHALL BE MECHANICALLY GALVANIZED (MG) BY THE COLD MECHANICAL PROCESS ONLY AS PROVIDED BY THE DTI MANUFACTURER.

HARDENED WASHERS REQUIRED: USE A HARDENED WASHER FOR A 3/4" NOMINAL BOLT BETWEEN THE TOP OF THE DIRECT TENSION INDICATOR (DTI) WASHER AND THE NUT OF THE AJAX M20 BOLTS. HARDENED WASHERS SHALL CONFORM TO ASTM F436 AND HAVE A MINIMUM HARDNESS OF RC 38 OR HIGHER. THE HARDENED WASHERS SHALL BE MECHANICALLY GALVANIZED BY THE COLD MECHANICAL PROCESS. ALTERNATIVELY, CORRECTLY MADE HOT DIP GALVANIZED HARDENED FLAT WASHERS HAVING A MINIMUM HARDNESS OF RC 38 CAN BE USED; CONTRACTOR SHALL PROVIDE DOCUMENTATION OF WASHER SPECIFICATION AND HARDNESS.

NUT LUBRICATION REQUIRED: PROPERLY LUBRICATE THE THREADS OF THE NUT OF THE AJAX BOLT SO THAT IT CAN BE PROPERLY TIGHTENED WITHOUT GALLING AND/OR LOCKING UP ON THE BOLT THREADS. CONTRACTOR SHALL FOLLOW DTI MANUFACTURER INSTRUCTIONS FOR PROPER LUBRICATION AND TIGHTENING.

NOTE: COMPLETELY COMPRESSED DTI'S SHOWING NO VISIBLE REMAINING GAP ARE ACCEPTABLE. DTI WASHERS SHALL BE PLACED DIRECTLY AGAINST THE OUTER AJAX WASHER WITH THE DTI BUMPS FACING AWAY FROM THE AJAX WASHER. PLACE A HARDENED WASHER BETWEEN THE DTI AND THE AJAX NUT. THE DTI BUMPS SHALL BEAR AGAINST THE UNDERSIDE OF A HARDENED FLAT WASHER, NEVER DIRECTLY AGAINST THE NUT.

CONTRACTOR SHALL FOLLOW DTI MANUFACTURER'S INSTRUCTIONS FOR INSTALLATION, LUBRICATION, TIGHTENING AND INSPECTION.

INSPECTION REQUIRED: ALL AJAX BOLTS SHALL BE INSPECTED ACCORDING TO THE REQUIREMENTS OF THE AISC 'SPECIFICATION FOR STRUCTURAL JOINTS USING HIGH-STRENGTH BOLTS', DEC. 31, 2009, BY A QUALIFIED BOLT INSPECTOR. DURING INSTALLATION, THE BOLT INSPECTOR SHALL VERIFY AND DOCUMENT: THE SHOP-DRILLED AND FIELD-DRILLED HOLE SIZES; THE INSTALLATION OF THE AJAX BOLT ASSEMBLY, INCLUDING THE SHEAR SLEEVE PLACEMENT AND NUT LUBRICATION; AND THE CONTRACTOR'S TENSIONING PROCEDURE. IN ADDITION, ALL AJAX BOLTS AND DTI'S SHALL BE VISUALLY INSPECTED ACCORDING TO THE DTI MANUFACTURER'S INSTRUCTIONS. THE BOLT INSPECTOR SHALL PROVIDE COMPLETE PHOTO DOCUMENTATION OF ALL BOLTS AFTER TIGHTENING CLEARLY SHOWING THE CONDITION OF THE DTI'S.

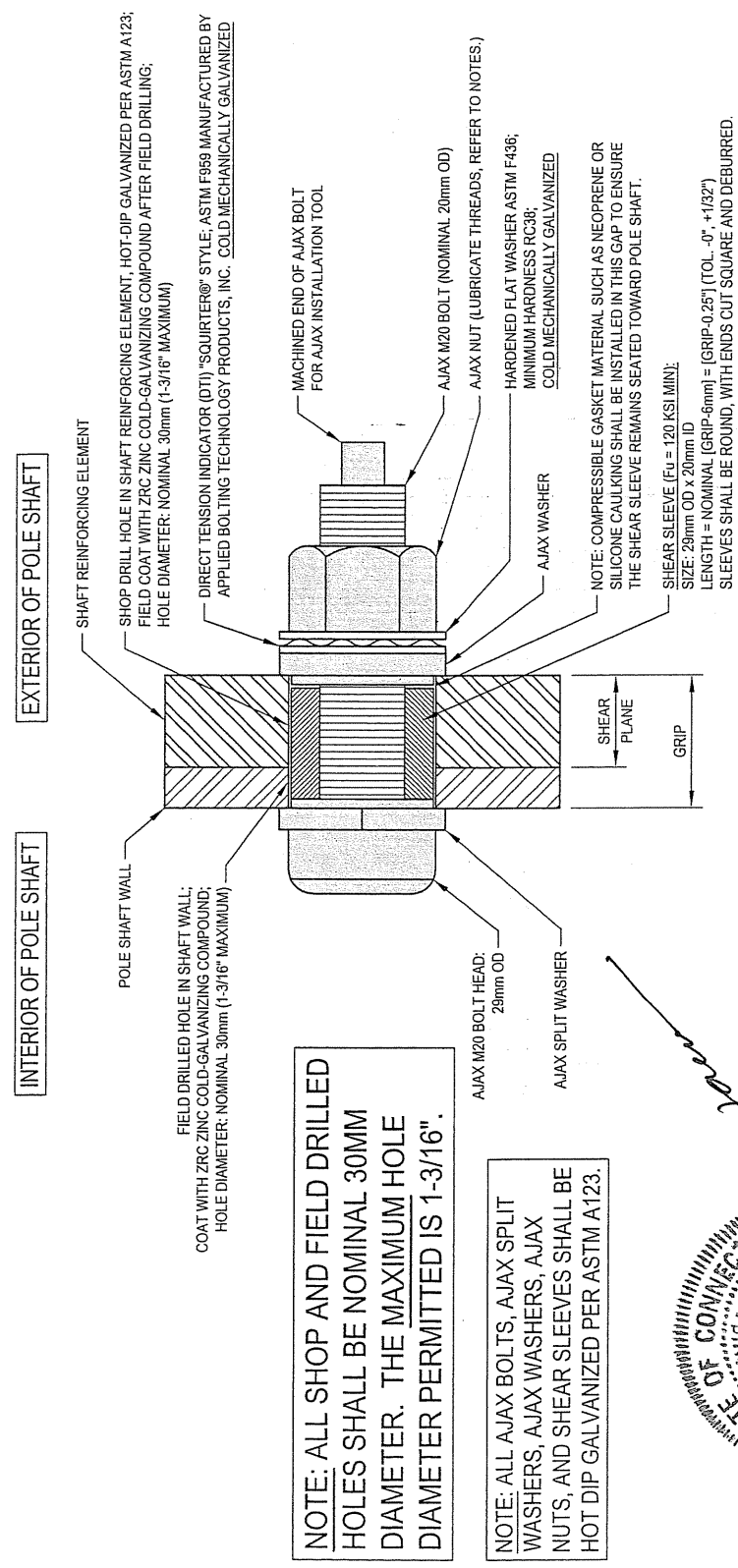

TYPICAL AJAX BOLT DETAIL 1 S-3

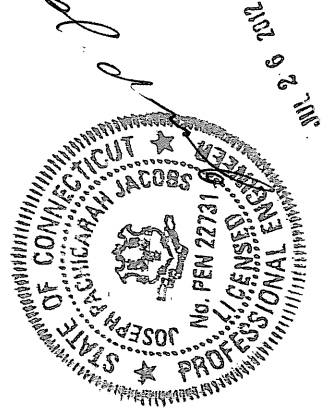

© Copyright 2012, by Paul J. Ford and Company, All Rights Reserved. This document and the data contained herein, is proprietary to Paul J. Ford and Company, issued in strict confidence and shall not, without the prior written permission of Paul J. Ford and Company, be reproduced, copied or used for any purpose other than the intended use for this specific project.

**Paul J. Ford and Company**  
STRUCTURAL ENGINEERS  
250 East Broad Street · Suite 1500 · Columbus, Ohio 43215  
(614) 221-6679  
[www.pjfweb.com](http://www.pjfweb.com)

**CROWN CASTLE**

THE PIANO WORKS349 WEST, EAST ROCHESTER, NY 14445  
PH: (685) 899-3445  
FAX: (685) 899-3448

BU #806373; HRT 101 943232  
ENFIELD, CT

MONOPOLE REINFORCEMENT AND RETROFIT PROJECT

PROJECT No:  
37512-1571

DRAWN BY:  
S.S.

CHECKED BY:  
K.A.T.

APPROVED BY:

DATE:  
7-24-2012

ISSUE DATE OF  
PERMIT: 7-24-2012

S-3

**NOTE: NO DETAILED INFORMATION REGARDING INTERFERENCES WAS PROVIDED. THEREFORE, CONTRACTOR SHALL FIELD VERIFY ALL EXISTING CONDITIONS AND DIMENSIONS BEFORE PROCEEDING WITH THE WORK. REPORT ANY AND ALL DISCREPANCIES TO PAUL J. FORD AND COMPANY AND CROWN CASTLE FIELD PERSONNEL IMMEDIATELY.**

THIS POLE REINFORCEMENT DRAWING IS FOR THE POLE DESIGN AND ANTENNA LOADING DOCUMENTED IN THE PJF CO-LOCATION ANALYSIS FOR THIS SITE (PJF#37512-1571), DATED 7-24-2012.

POLE SPECIFICATIONS	
POLE SHAPE TYPE:	12-SIDED POLYGON; ROUND
TAPER:	0.2716667 IN/FT
SHAFT STEEL:	ASTM A572 GRADE 65
BASE PL STEEL:	ASTM A633 GR. E (60 KSI)
ANCHOR RODS:	2 1/4" Ø #18J ASTM A615 GRADE 75

SHAFT SECTION	SHAFT SECTION DATA		DIAMETER ACROSS FLATS (IN)	
	SECTION LENGTH (FT)	PLATE THICKNESS (IN)	LAP SPLICE (IN)	@ TOP @ BOTTOM
1	10.00	0.2500	58.00	20.000 20.000
2	52.83	0.2500	71.00	20.300 31.130
3	52.92	0.3750		29.639 40.490
4	55.00	0.4360		38.527 49.800

NOTE: DIMENSIONS SHOWN DO NOT INCLUDE GALVANIZING TOLERANCES

CONTRACTOR SHALL PROVIDE ASTM A36 SHIM PLATES BELOW SLIP JOINTS. THE SHIM PLATES SHALL BE PLACED BETWEEN THE NEW SHAFT REINFORCEMENT AND THE EXISTING POLE SHAFT FROM THE SLIP JOINT TO THE NEW SHAFT REINFORCEMENT SPLICE LOCATION AND AN EXTRA LONG "SPLICE SHIM" SHALL BE PLACED BETWEEN THE NEW UPPER AND LOWER SHAFT REINFORCEMENT PLATES AT THE SHAFT REINFORCEMENT SPLICE PLATE LOCATION.

**NOTES:**

- ALL STRUCTURAL BOLTS SHALL BE INSTALLED AND TIGHTENED TO THE PRETENSIONED CONDITION ACCORDING TO THE REQUIREMENTS OF THE AISC "SPECIFICATION FOR STRUCTURAL JOINTS USING HIGH-STRENGTH BOLTS", DEC. 31, 2009.
- ALL STRUCTURAL BOLTS SHALL BE INSPECTED ACCORDING TO THE REQUIREMENTS OF THE AISC "SPECIFICATION FOR STRUCTURAL JOINTS USING HIGH-STRENGTH BOLTS", DEC. 31, 2009.
- ALL AJAX M20 BOLTS WITH SHEAR SLEEVES SHALL BE PRETENSIONED AND TIGHTENED UNTIL THE DIRECT TENSION INDICATOR (DTI) WASHERS SHOW THAT THE PROPER BOLT TENSION HAS BEEN REACHED. SEE NOTES AND DETAIL ON SHEET S-3 FOR THE USE OF DIRECT TENSION INDICATOR (DTI) WASHERS WITH THE AJAX M20 BOLTS.
- DTIS REQUIRED: \* ALL AJAX BOLTS SHALL BE INSTALLED USING DIRECT TENSION INDICATORS (DTIS) AND HARDENED WASHERS. DTIS SHALL BE THE SQUIRTER® STYLE, MADE TO ASTM F959 LATEST REVISION; AND HARDENED WASHERS SHALL CONFORM TO ASTM F436 AND HAVE A HARDNESS OF RC 38 OR HIGHER.
- NUT LUBRICATION REQUIRED: \* PROPERLY LUBRICATE THE THREADS OF THE NUT OF THE AJAX BOLT SO THAT IT CAN BE PROPERLY TIGHTENED WITHOUT GALLING AND/OR LOCKING UP ON THE BOLT THREADS. CONTRACTOR SHALL FOLLOW DTI MANUFACTURER INSTRUCTIONS FOR PROPER LUBRICATION AND TIGHTENING. REFER TO SHEET S-3.
- AJAX BOLT HOLE SIZE: ALL SHOP- AND FIELD-DRILLED HOLES SHALL BE NOMINAL 30MM DIAMETER. THE MAXIMUM HOLE DIAMETER PERMITTED IS 1-3/16". REFER TO SHEET S-3.

\* AS OF 5/30/2012, UNTIL FURTHER NOTICE, CROWN CASTLE WILL ACCEPT AJAX BOLTS TIGHTENED USING AISC "TURN-OF-THE-NUT" METHODOLOGY. INSTALLERS SHALL FOLLOW CROWN GUIDELINES FOR AISC "TURN-OF-THE-NUT" METHOD AND ALSO PROVIDE COMPLETE INSPECTION DOCUMENTATION IN THE PMI.

NDE OF THE CIRCUMFERENTIAL WELD OF THE BASE PLATE TO SHAFT CONNECTION IS REQUIRED. PLEASE SEE ENG-SOW-1033 : TOWER BASE PLATE NDE AND ENG-BUL-10051 : NDE REQUIREMENTS FOR MONOPOLE BASE PLATE TO PREVENT CONNECTION FAILURE. NOTIFY THE EOR AND CROWN ENGINEERING IMMEDIATELY IF ANY CRACKS ARE SUSPECTED OR HAVE BEEN IDENTIFIED. THE NDE SHALL INCLUDE ALL EXISTING REINFORCEMENTS THAT HAVE BEEN WELDED TO THE BASE PLATE. FULL PENETRATION WELDING TO THE BASE PLATE REQUIRED AS PART OF THIS ACTIVE REINFORCEMENT DESIGN SHALL BE INCLUDED IN THE NDE SCOPE OF WORK.

**NEW AEROSOLUTIONS MP3 REINFORCING (OPTION #1)**

ELEVATION	FLAT #	NO. OF END BOLTS (PER END)	INTERMEDIATE BOLT SPACING	MP3
0'-6" TO 30'-6"	1,5 & 9	13	24"	MP306
30'-6" TO 60'-6"	1,5 & 9	9	16"	MP305
60'-6" TO 90'-6"	1,5 & 9	9	18"	MP305
90'-6" TO 120'-6"	1,5 & 9	6	18"	MP304

ALL BOLTS SHALL BE AJAX M20 BOLTS WITH HIGH STRENGTH SHEAR SLEEVES (ASTM A519 WITH MIN. Fu=105 KSI). CONTACT SUPPLIER FOR MATERIAL (PLATE & BOLTS) AND INSTALLATION PROCEDURES.

**NEW SABRE FLAT PLATE REINFORCING (OPTION #2)**

ELEVATION	FLAT #	NO. OF END BOLTS (PER END)	INTERMEDIATE BOLT SPACING	FLAT PLATE
0'-6" TO 30'-6"	1,5 & 9	15	17 1/4"	MS-850
30'-6" TO 60'-6"	1,5 & 9	11	19 1/4"	MS-650
60'-6" TO 90'-6"	1,5 & 9	11	19 1/4"	MS-650
90'-6" TO 120'-6"	1,5 & 9	8	16 3/8"	MS-600

ALL BOLTS SHALL BE AJAX M20 BOLTS WITH HIGH STRENGTH SHEAR SLEEVES (ASTM A519 WITH MIN. Fu=105 KSI). CONTACT SUPPLIER FOR MATERIAL (PLATE & BOLTS) AND INSTALLATION PROCEDURES.

**NEW CCI FLAT PLATE REINFORCING (OPTION #3)**

ELEVATION	FLAT #	NO. OF END BOLTS (PER END)	INTERMEDIATE BOLT SPACING	FLAT PLATE
0'-6" TO 30'-6"	1,5 & 9	12	17"	ISP-UR-1006
30'-6" TO 60'-6"	1,5 & 9	9	18"	ISP-UR-1005
60'-6" TO 90'-6"	1,5 & 9	7	20"	ISP-UR-1004
90'-6" TO 120'-6"	1,5 & 9	5	15"	ISP-UR-0754

ALL BOLTS SHALL BE AJAX M20 BOLTS WITH HIGH STRENGTH SHEAR SLEEVES (ASTM A519 WITH MIN. Fu=105 KSI). CONTACT SUPPLIER FOR MATERIAL (PLATE & BOLTS) AND INSTALLATION PROCEDURES.

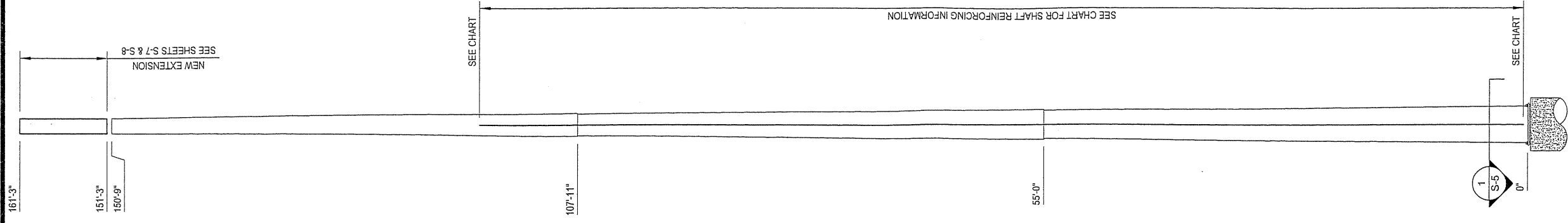

POLE ELEVATION 1  
S-4

**PAUL J. FORD AND COMPANY**  
STRUCTURAL ENGINEERS  
250 East Broad Street - Suite 1500 - Columbus, Ohio 43215  
(614) 221-6679  
www.pjfweb.com

**CROWN CASTLE**  
THE PIANO WORKS349 WEST, EAST ROCHESTER, NY 14445  
PH: (585) 899-3445 FAX: (585) 899-3448

© Copyright 2012, by Paul J. Ford and Company, All Rights Reserved. This document and the data contained herein, is proprietary to Paul J. Ford and Company, issued in strict confidence and shall not, without the prior written permission of Paul J. Ford and Company, be reproduced, copied or used for any purpose other than the intended use for this specific project.

BU #806373; HRT 101 943232  
ENFIELD, CT  
MONOPOLE REINFORCEMENT AND RETROFIT PROJECT

PROJECT No: 37512-1571  
DRAWN BY: S.S.  
CHECKED BY: K.A.T.  
APPROVED BY:  
DATE: 7-24-2012

ISSUE DATE OF PERMIT: 7-24-2012

S-4

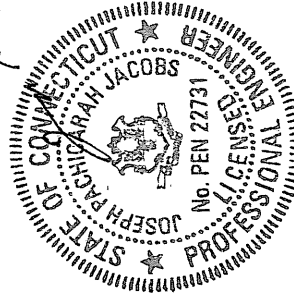

JUL 26 2012

SPECIAL INSPECTION OF EXISTING SHAFT-TO-FLANGE WELD CONNECTIONS:  
 (1) PRIOR TO CONSTRUCTION, CONTRACTOR'S INSPECTION AGENCY SHALL INSPECT CONDITION OF EXISTING SHAFT-TO-BASE-PLATE WELD CONNECTION. ALSO INSPECT EXISTING STIFFENERS IF PRESENT. THE CONTRACTOR'S INSPECTION AGENCY SHALL USE THE FOLLOWING INSPECTION METHODS, OR COMBINATION OF METHODS, AS REQUIRED TO IDENTIFY ANY CRACKS: VISUAL, MAGNETIC PARTICLE, AND/OR ULTRA-SOUND. IN ADDITION, OTHER TEST METHODS MAY ALSO BE USED AT THE RECOMMENDATION OF THE TESTING AGENCY AND UPON THE APPROVAL OF THE OWNER AND THE ENGINEER. CONTRACTOR SHALL PROVIDE CAREFUL AND THOROUGH DOCUMENTATION OF THIS INSPECTION TO THE OWNER AND THE ENGINEER BEFORE PROCEEDING WITH WORK. CONTRACTOR SHALL COORDINATE THESE INSPECTION ACTIVITIES WITH THE OWNERS REQUIRED PROCESSES AND PROCEDURES. IMPORTANT: THE TESTING AGENCY SHALL IMMEDIATELY REPORT ANY INDICATIONS OF CRACKS, FRACTURES, DISTRESS, AND/OR CORROSION TO THE OWNER AND ENGINEER.  
 (2) AFTER CONSTRUCTION, TESTING AGENCY SHALL INSPECT ANY AND ALL FIELD WELDS AND FIELD REPAIRS IMPLEMENTED AS REQUIRED BY THE OWNER FROM THE RESULTS OF THE INSPECTION IN THE PREVIOUS NOTE (1) ABOVE.

GENERAL NOTES:  
 1. AJAX BOLTS ARE TO BE 20 mm Ø WITH CORRESPONDING 29 mm Ø SHEAR SLEEVE WITH MATCHING STEEL GRADE. DRILLED HOLE DIAMETERS IN REINFORCING STEEL AND EXISTING SHAFT SHALL BE 1 3/16" Ø MAX.  
 2. ALL STEEL SHALL BE HOT-DIP GALVANIZED AFTER FABRICATION IN ACCORDANCE WITH ASTM A123. ALTERNATIVELY, ALL NEW STIFFENER PLATE STEEL REINFORCING MAY BE COLD GALVANIZED AS FOLLOWS: APPLY A MINIMUM OF TWO COATS OF ZRC-BRAND ZINC-RICH COLD GALVANIZING COMPOUND. FILM THICKNESS PER COAT SHALL BE: WET 3.0 MILS; DRY 1.5 MILS. APPLY PER ZRC (MANUFACTURER) RECOMMENDED PROCEDURES. CONTACT ZRC AT 1-800-831-3275 FOR PRODUCT INFORMATION.  
 3. EPOXY MUST BE HILTI RE-500.

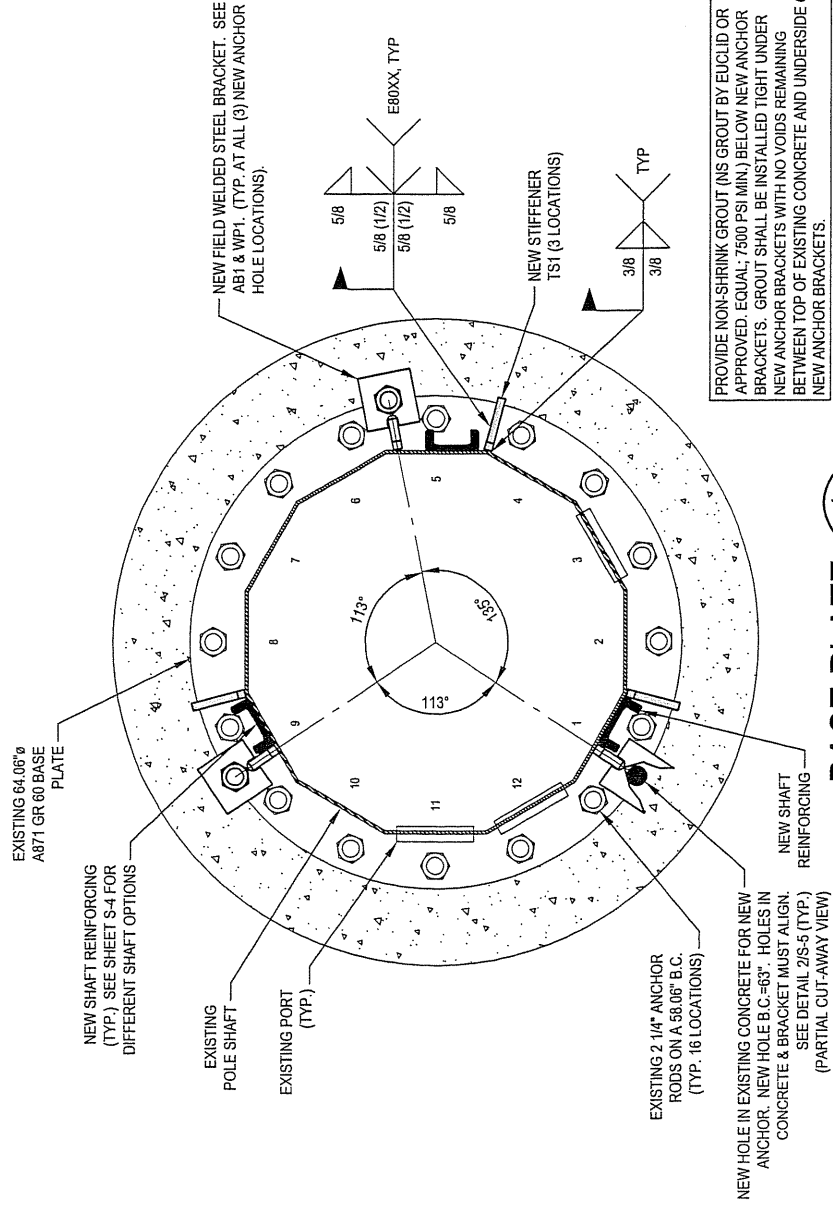

**BASE PLATE** 1  
S-5

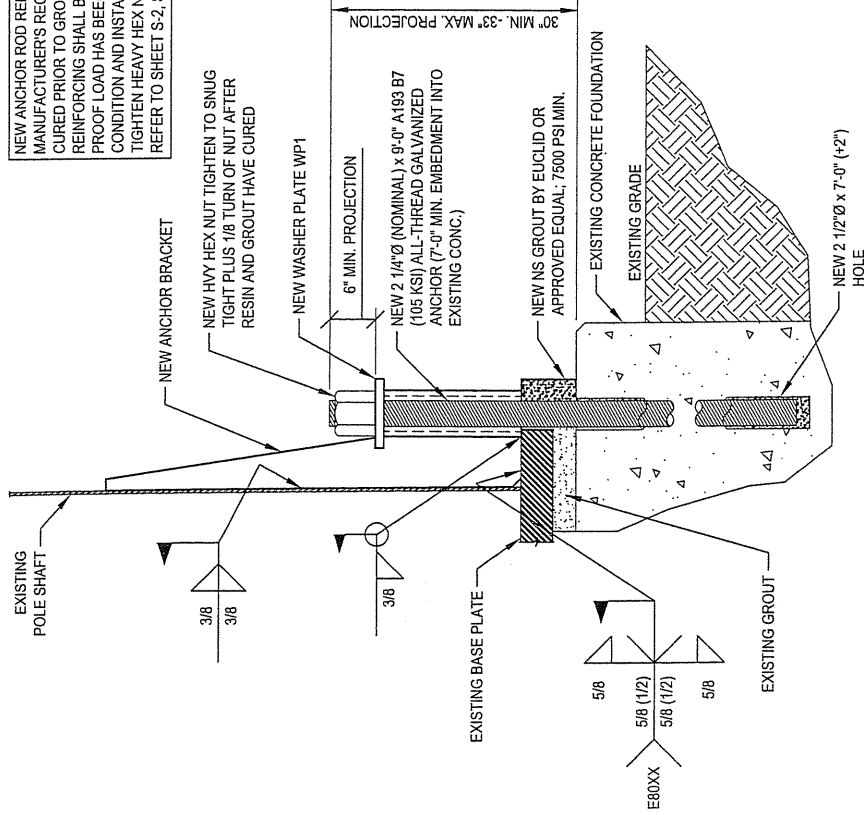

NEW ANCHOR ROD REINFORCING SHALL BE INSTALLED PER MANUFACTURER'S RECOMMENDATIONS. ONCE ALL RESIN HAS CURED PRIOR TO GROUTING, ALL NEW ANCHOR ROD REINFORCING SHALL BE PROOF LOADED TO 273 KIIPS. ONCE THE PROOF LOAD HAS BEEN RELEASED, TIGHTEN NUT TO SNUG TIGHT CONDITION AND INSTALL GROUT. AFTER GROUT HAS CURED, TIGHTEN HEAVY HEX NUT TO SNUG TIGHT PLUS 1/8 TURN OF NUT. REFER TO SHEET S-2, SECTION H FOR ADDITIONAL INFORMATION.

**NEW ANCHOR & BRACKET DETAIL** 2  
S-5

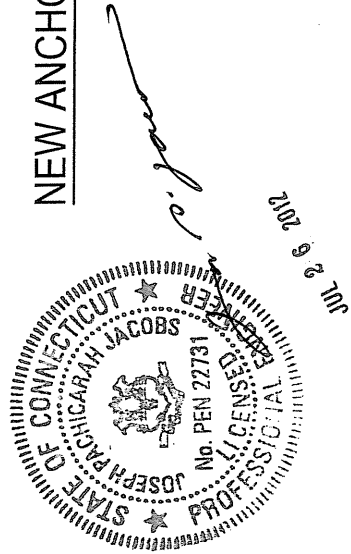

**PAUL J. FORD AND COMPANY**  
 STRUCTURAL ENGINEERS  
 250 East Broad Street - Suite 1500 - Columbus, Ohio 43215  
 (614) 221-6679 www.pjfweb.com

**CROWN CASTLE**  
 THE PIANO WORKS 349 WEST, EAST ROCHESTER, NY 14445  
 PH: (585) 899-3445 FAX: (585) 899-3446

© Copyright 2012, by Paul J. Ford and Company, All Rights Reserved. This document and the data contained herein, is proprietary to Paul J. Ford and Company, issued in strict confidence and shall not, without the prior written permission of Paul J. Ford and Company, be reproduced, copied or used for any purpose other than the intended use for this specific project.

**BU #806373; HRT 101 943232**  
**ENFIELD, CT**  
**MONOPOLE REINFORCEMENT AND RETROFIT PROJECT**

PROJECT No: 37512-1571  
 DRAWN BY: S.S.  
 CHECKED BY: K.A.T.  
 APPROVED BY:  
 DATE: 7-24-2012

**S-5**

ISSUE DATE OF PERMIT: 7-24-2012



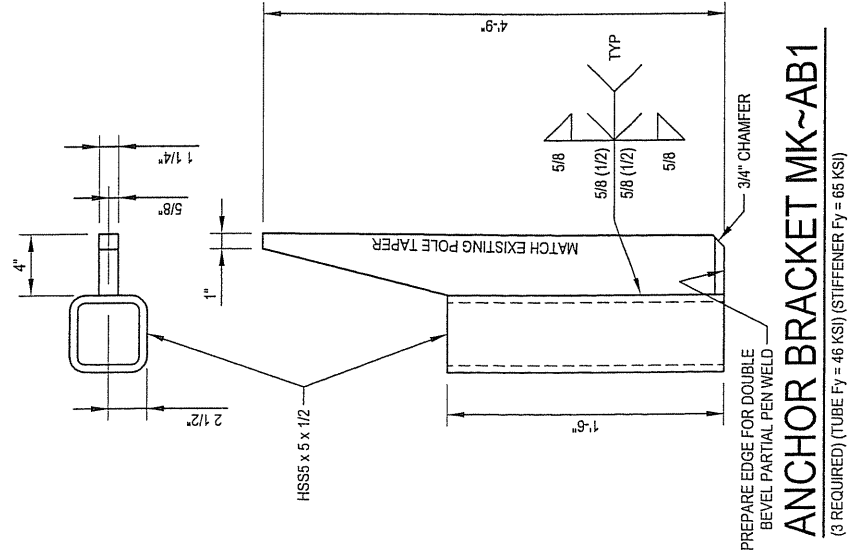

**ANCHOR BRACKET MK~AB1**

(3 REQUIRED) (TUBE Fy = 46 KSI) (STIFFENER Fy = 65 KSI)

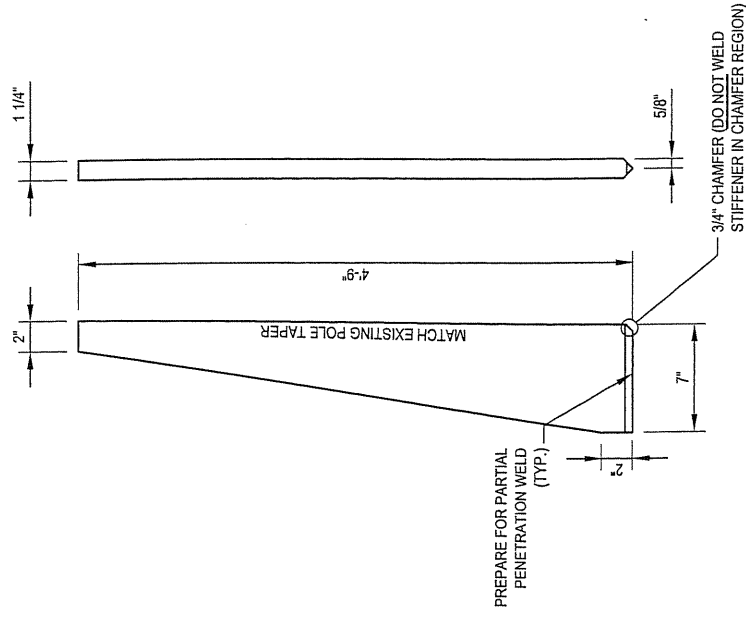

**TRANSITION STIFFENER MK~TS1**

(3 REQUIRED) (Fy = 65 KSI)

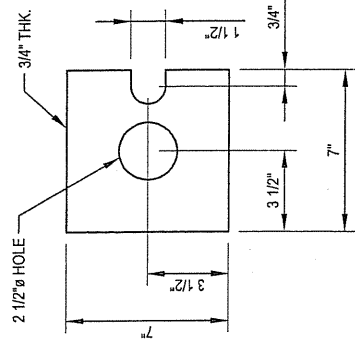

**WASHER PLATE MK~WP1**

(3 REQUIRED) (Fy = 50 KSI)

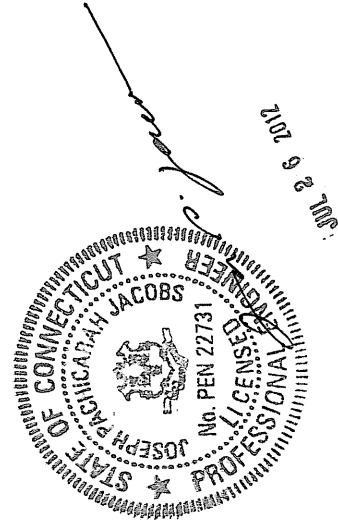

**PAUL J. FORD AND COMPANY**  
 STRUCTURAL ENGINEERS  
 250 East Ebrod Street - Suite 1500 - Columbus, Ohio 43215  
 (614) 221-6679 www.pjfweb.com

**CROWN CASTLE**  
 THE PIANO WORKS349 WEST, EAST ROCHESTER, NY 14445  
 PH: (585) 899-3445 FAX: (585) 899-3448

© Copyright 2012, by Paul J. Ford and Company, All Rights Reserved. This document and the data contained herein, is proprietary to Paul J. Ford and Company, issued in strict confidence and shall not, without the prior written permission of Paul J. Ford and Company, be reproduced, copied or used for any purpose other than the intended use for this specific project.

**BU #806373; HRT 101 943232**  
**ENFIELD, CT**

**MONOPOLE REINFORCEMENT AND RETROFIT PROJECT**

PROJECT No: 37512-1571	DRAWN BY: S.S.	CHECKED BY: K.A.T.	APPROVED BY:
ISSUE DATE OF PERMIT: 7-24-2012	DATE: 7-24-2012	S-6	

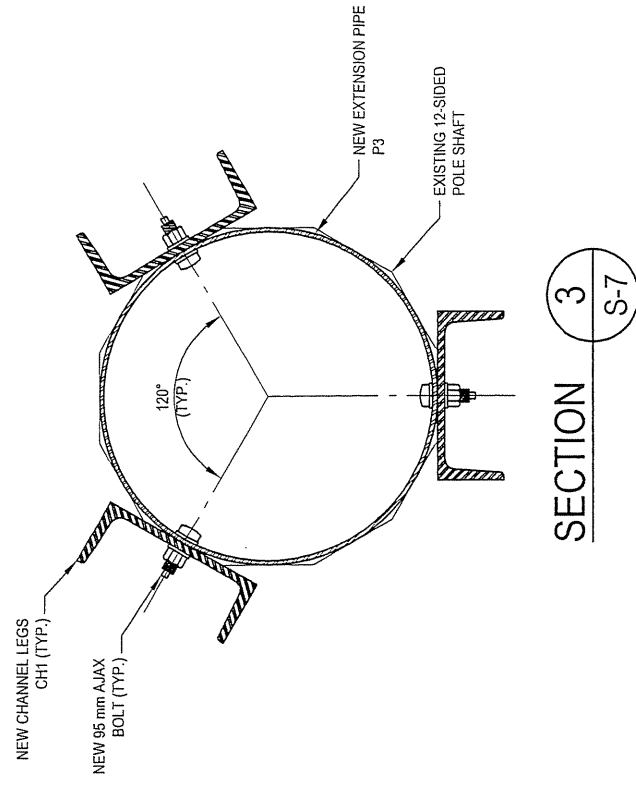
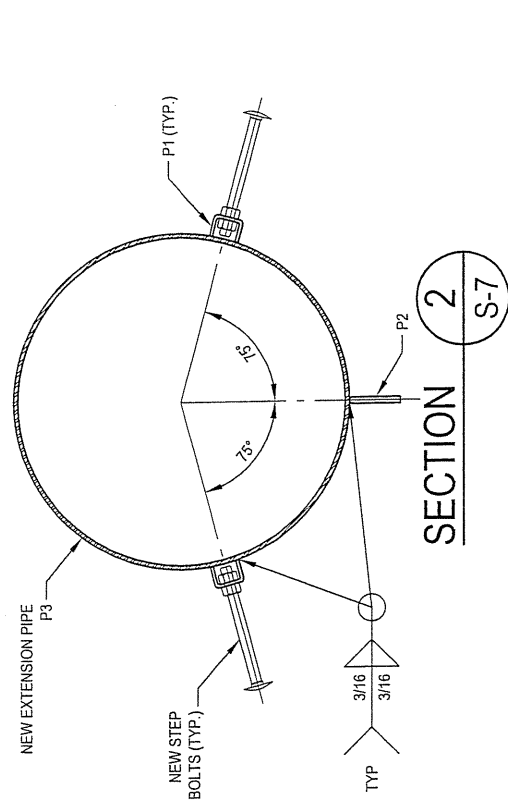

NOTE: CONTRACTOR TO VERIFY THAT EXISTING MOUNT DOES NOT INTERFERE WITH NEW REINFORCEMENT. NOTIFY PAUL J. FORD AND COMPANY IF A CONFLICT EXISTS.

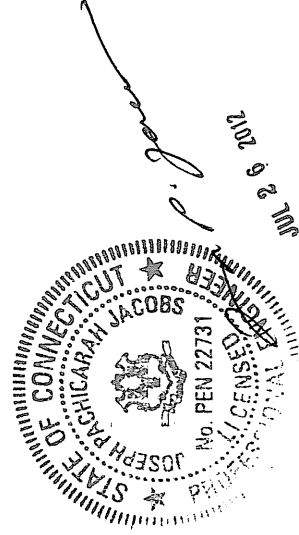
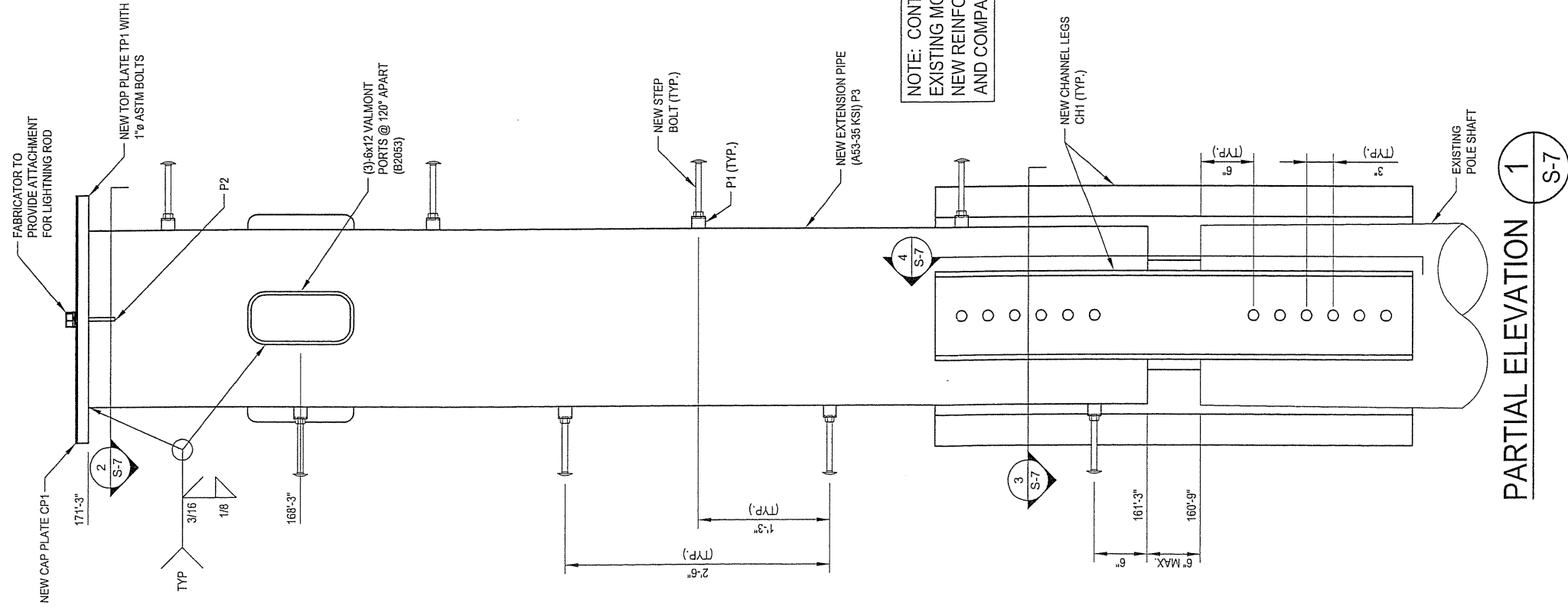
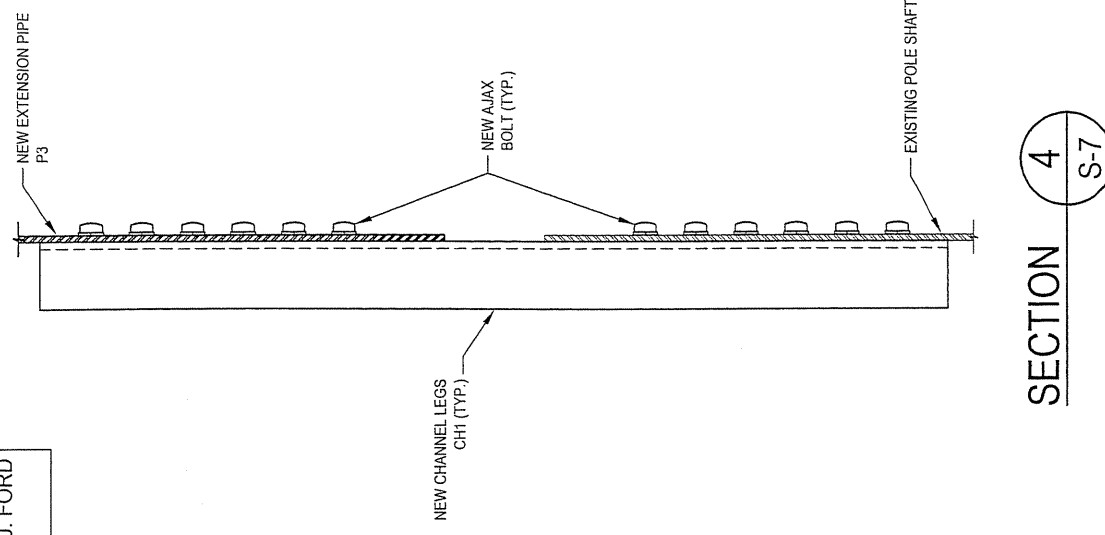

**PAUL J. FORD AND COMPANY**  
 STRUCTURAL ENGINEERS  
 250 East Broad Street - Suite 1500 - Columbus, Ohio 43215  
 (614) 221-6679 www.pjfweb.com

**CROWN CASTLE**  
 THE PIANO WORKS 349 WEST, EAST ROCHESTER, NY 14445  
 PH: (585) 899-3445 FAX: (585) 899-3448

© Copyright 2012, by Paul J. Ford and Company, All Rights Reserved. This document and the data contained herein, is proprietary to Paul J. Ford and Company, issued in strict confidence and shall not, without the prior written permission of Paul J. Ford and Company, be reproduced, copied or used for any purpose other than the intended use for this specific project.

**BU #806373; HRT 101 943232**  
**ENFIELD, CT**

**MONOPOLE REINFORCEMENT AND RETROFIT PROJECT**

PROJECT No: 37512-1571	ISSUE DATE OF PERMIT: 7-24-2012
DRAWN BY: S.S.	
CHECKED BY: K.A.T.	
APPROVED BY:	
DATE: 7-24-2012	

**S-7**

**MONOPOLE EXTENSION MATERIAL LIST**

MARK	QTY	MATERIAL	APPROX. LENGTH	STEEL WEIGHT
CH1	3	CHANNEL MC10 x 28.5	4'-3"	126
CP1	1	CAP PLATE 3/16" x 28" Ø		33
P1	8	PLATE 3/16" x 1 1/2"	0'-4 5/8"	3
P2	1	PLATE 3/8" x 3"	0'-3"	1
P3	1	EXTENSION PIPE 20" Ø x 1/4"	10'-0"	
TP1	1	TOP PLATE 1 1/2" x 28" Ø		177
	18	AJAX BOLT SLEEVE	1/2"	
	8	5/8" Ø STEP BOLT	7"	
	16	LOCK WASHERS AND NUTS FOR 5/8" Ø BOLTS		
	36	20mm Ø STANDARD AJAX BOLT	95 mm	
<b>TOTAL (LBS)</b>				<b>181</b>

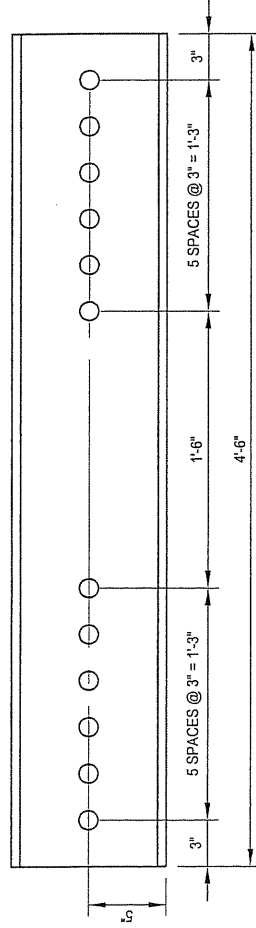

**CHANNEL LEG MK~CH1**  
(3 REQUIRED) (Fy = 60 KSI)

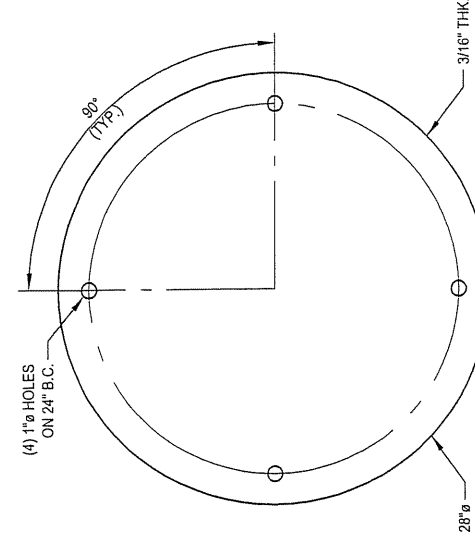

**CAP PLATE MK~CP1**  
(1 REQUIRED) (Fy = 36 KSI)

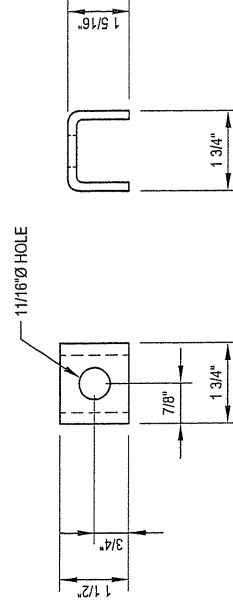

**PLATE MK~P1**  
(8 REQUIRED) (Fy = 36 KSI)

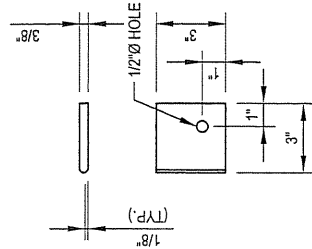

**PLATE MK~P2**  
(1 REQUIRED) (Fy = 36 KSI)

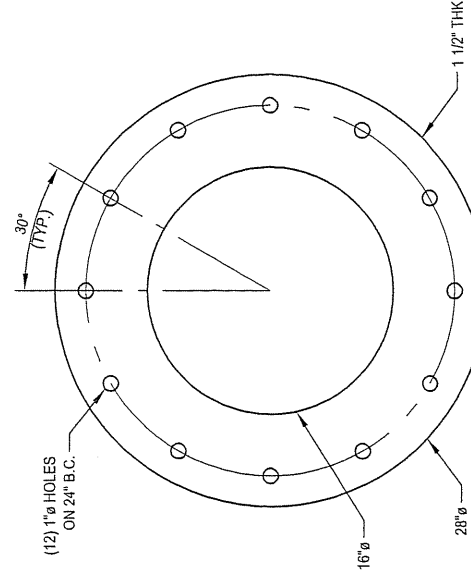

**TOP PLATE MK~TP1**  
(1 REQUIRED) (Fy = 50 KSI)

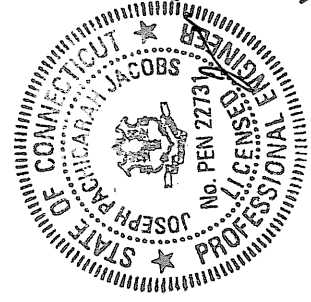

**Paul J. Ford and Company**  
STRUCTURAL ENGINEERS  
250 East Broad Street - Suite 1500 - Columbus, Ohio 43215  
(614) 221-6679 www.pjfweb.com

**CROWN CASTLE**  
THE PIANO WORKS 349 WEST, EAST ROCHESTER, NY 14445  
PH: (585) 899-3445 FAX: (585) 899-3448

**BU #806373; HRT 101 943232**

**ENFIELD, CT**

**MONOPOLE REINFORCEMENT AND RETROFIT PROJECT**

PROJECT No: 37512-1571  
DRAWN BY: S.S.  
CHECKED BY: K.A.T.  
APPROVED BY:  
DATE: 7-24-2012

ISSUE DATE OF PERMIT: 7-24-2012

**S-8**

**MODIFICATION INSPECTION NOTES:**

**GENERAL**

THE MODIFICATION INSPECTION (MI) IS A VISUAL INSPECTION OF TOWER MODIFICATIONS AND A REVIEW OF CONSTRUCTION INSPECTIONS AND OTHER REPORTS TO ENSURE THE INSTALLATION WAS CONSTRUCTED IN ACCORDANCE WITH THE CONTRACT DOCUMENTS, NAMELY THE MODIFICATION DRAWINGS, AS DESIGNED BY THE ENGINEER OF RECORD (EOR).

THE MI IS TO CONFIRM INSTALLATION CONFIGURATION AND WORKMANSHIP ONLY AND IS NOT A REVIEW OF THE MODIFICATION DESIGN ITSELF, NOR DOES THE MI INSPECTOR TAKE OWNERSHIP OF THE MODIFICATION DESIGN. OWNERSHIP OF THE STRUCTURAL MODIFICATION DESIGN EFFECTIVENESS AND INTEGRITY RESIDES WITH THE EOR AT ALL TIMES.

ALL MTS SHALL BE CONDUCTED BY A CROWN ENGINEERING VENDOR (AEV) OR ENGINEERING SERVICE VENDOR (AESV) THAT IS APPROVED TO PERFORM ELEVATED WORK FOR CROWN. SEE ENG-BUL-10773 LIST OF APPROVED MI VENDORS.

TO ENSURE THAT THE REQUIREMENTS OF THE MI ARE MET, IT IS VITAL THAT THE GENERAL CONTRACTOR (GC) AND THE MI INSPECTOR BEGIN COMMUNICATING AND COORDINATING AS SOON AS A PO IS RECEIVED. IT IS EXPECTED THAT EACH PARTY WILL BE PROACTIVE IN REACHING OUT TO THE OTHER PARTY. IF CONTACT INFORMATION IS NOT KNOWN, CONTACT YOUR CROWN POINT OF CONTACT (POC).

REFER TO ENG-SOW-10007 : MODIFICATION INSPECTION SOW FOR FURTHER DETAILS AND REQUIREMENTS.

**MI INSPECTOR**

THE MI INSPECTOR IS REQUIRED TO CONTACT THE GC AS SOON AS RECEIVING A PO FOR THE MI TO, AT A MINIMUM:

- REVIEW THE REQUIREMENTS OF THE MI CHECKLIST
- WORK WITH THE GC TO DEVELOP A SCHEDULE TO CONDUCT ON-SITE INSPECTIONS, INCLUDING FOUNDATION INSPECTIONS TO CROWN.

THE MI INSPECTOR IS RESPONSIBLE FOR COLLECTING ALL GENERAL CONTRACTOR (GC) INSPECTION AND TEST REPORTS, REVIEWING THE DOCUMENTS FOR ADHERENCE TO THE CONTRACT DOCUMENTS, CONDUCTING THE IN-FIELD INSPECTIONS, AND SUBMITTING THE MI REPORT TO CROWN.

**GENERAL CONTRACTOR**

THE GC IS REQUIRED TO CONTACT THE MI INSPECTOR AS SOON AS RECEIVING A PO FOR THE MODIFICATION INSTALLATION OR TURNKEY PROJECT TO, AT A MINIMUM:

- REVIEW THE REQUIREMENTS OF THE MI CHECKLIST
- WORK WITH THE MI INSPECTOR TO DEVELOP A SCHEDULE TO CONDUCT ON-SITE INSPECTIONS, INCLUDING FOUNDATION INSPECTIONS
- BETTER UNDERSTAND ALL INSPECTION AND TESTING REQUIREMENTS

THE GC SHALL PERFORM AND RECORD THE TEST AND INSPECTION RESULTS IN ACCORDANCE WITH THE REQUIREMENTS OF THE MI CHECKLIST AN ENG-SOW-10007.

**RECOMMENDATIONS**

THE FOLLOWING RECOMMENDATIONS AND SUGGESTIONS ARE OFFERED TO ENHANCE THE EFFICIENCY AND EFFECTIVENESS OF DELIVERING A MI REPORT:

- IT IS SUGGESTED THAT THE GC PROVIDE A MINIMUM OF 5 BUSINESS DAYS NOTICE, PREFERABLE 10, TO THE MI INSPECTOR AS TO WHEN THE SITE WILL BE READY FOR THE MI TO BE CONDUCTED.
- THE GC AND MI INSPECTOR COORDINATE CLOSELY THROUGHOUT THE ENTIRE PROJECT.
- WHEN POSSIBLE, IT IS PREFERRED TO HAVE THE GC AND MI INSPECTOR ON-SITE SIMULTANEOUSLY FOR ANY GUY WIRE TENSIONING OR RE-TENSIONING OPERATIONS
- IT MAY BE BENEFICIAL TO INSTALL ALL TOWER MODIFICATIONS PRIOR TO CONDUCTING THE FOUNDATION INSPECTIONS TO ALLOW FOUNDATION AND MI INSPECTIONS(S) TO COMMENCE WITH ONE SITE VISIT.
- WHEN POSSIBLE, IT IS PREFERRED TO HAVE THE GC AND MI INSPECTOR ON-SITE DURING THE MI TO HAVE ANY DEFICIENCIES CORRECTED DURING THE INITIAL MI. THEREFORE, THE GC MAY CHOOSE TO COORDINATE THE MI CAREFULLY TO ENSURE ALL CONSTRUCTION FACILITIES ARE AT THEIR DISPOSAL WHEN THE MI INSPECTOR IS ON-SITE.

**CANCELLATION OR DELAYS IN SCHEDULED MI**

IF THE GC AND MI INSPECTOR AGREE TO A DATE ON WHICH THE MI WILL BE CONDUCTED, AND EITHER PARTY CANCELS OR DELAYS, CROWN SHALL NOT BE RESPONSIBLE FOR ANY COSTS, FEES, LOSS OF DEPOSITS AND/OR OTHER PENALTIES RELATED TO THE CANCELLATION OR DELAY INCURRED BY EITHER PARTY FOR ANY TIME (E.G. TRAVEL AND LODGING, COSTS OF KEEPING EQUIPMENT ON-SITE, ETC.). IF CROWN CONTRACTS DIRECTLY FOR A THIRD PARTY MI, EXCEPTIONS MAY BE MADE IN THE EVENT THAT THE DELAY/CANCELLATION IS CAUSED BY WEATHER OR OTHER CONDITIONS THAT MAY COMPROMISE THE SAFETY OF THE PARTIES INVOLVED.

**CORRECTION OF FAILING MTS**

IF THE MODIFICATION INSTALLATION WOULD FAIL THE MI ("FAILED MI"), THE GC SHALL WORK WITH CROWN TO COORDINATE A REMEDIATION PLAN IN ONE OF TWO WAYS:

- CORRECT FAILING ISSUES TO COMPLY WITH THE SPECIFICATIONS CONTAINED IN THE ORIGINAL CONTRACT DOCUMENTS AND COORDINATE A SUPPLEMENT MI
- OR, WITH CROWN'S APPROVAL, THE GC MAY WORK WITH THE EOR TO RE-ANALYZE THE MODIFICATION/REINFORCEMENT USING THE AS-BUILT CONDITION

**MI VERIFICATION INSPECTIONS**

CROWN RESERVES THE RIGHT TO CONDUCT A MI VERIFICATION INSPECTION TO VERIFY THE ACCURACY AND COMPLETENESS OF PREVIOUSLY COMPLETED MI INSPECTIONS(S) ON TOWER MODIFICATION PROJECTS.

ALL VERIFICATION INSPECTIONS SHALL BE HELD TO THE SAME SPECIFICATIONS AND REQUIREMENTS IN THE CONTRACT DOCUMENTS AND IN ACCORDANCE WITH ENG-SOW-10007.

VERIFICATION INSPECTION MAY BE CONDUCTED BY AN INDEPENDENT AEA/AESV FIRM AFTER A MODIFICATION PROJECT IS COMPLETED, AS MARKED BY THE DATE OF AN ACCEPTED "PASSING MI" OR "PASS AS NOTED MI" REPORT FOR THE ORIGINAL PROJECT.

**PHOTOGRAPHS**

BETWEEN THE GC AND THE MI INSPECTOR THE FOLLOWING PHOTOGRAPHS, AT A MINIMUM, ARE TO BE TAKEN AND INCLUDED IN THE MI REPORT:

- PRE-CONSTRUCTION GENERAL SITE CONDITION
- PHOTOGRAPHS DURING THE REINFORCEMENT MODIFICATION CONSTRUCTION/RESECTION AND INSPECTION
- RAW MATERIALS
- PHOTOS OF ALL CRITICAL DETAILS
- FOUNDATION MODIFICATIONS
- WELD PREPARATION
- BOLT INSTALLATION AND TORQUE
- FINAL INSTALLED CONDITION
- SURFACE COATING REPAIR
- POST CONSTRUCTION PHOTOGRAPHS
- FINAL INFELD CONDITION

PHOTOS OF ELEVATED MODIFICATIONS TAKEN FROM THE GROUND SHALL BE CONSIDERED INADEQUATE.

THIS IS NOT A COMPLETE LIST OF REQUIRED PHOTOS, PLEASE REFER TO ENG-SOW-10007.

MI CHECKLIST	
CONSTRUCTION/INSTALLATION INSPECTIONS AND TESTING REQUIRED (COMPLETED BY EOR)	REPORT ITEM
<b>PRE-CONSTRUCTION</b>	
X	MI CHECKLIST DRAWINGS
X	EOR APPROVED SHOP DRAWINGS
X	FABRICATION INSPECTION
NA	FABRICATOR CERTIFIED WELD INSPECTION
X	MATERIAL TEST REPORT (MTR)
NA	FABRICATOR NDE INSPECTION
X	NDE REPORT OF MONOPOLE BASE PLATE (AS REQUIRED)
X	PACKING SLIPS
ADDITIONAL TESTING AND INSPECTIONS:	
-----	
<b>CONSTRUCTION</b>	
X	CONSTRUCTION INSPECTIONS
NA	FOUNDATION INSPECTIONS
NA	CONCRETE COMP. STRENGTH AND SLUMP TESTS
X	POST INSTALLED ANCHOR ROD VERIFICATION
X	BASE PLATE GROUT VERIFICATION
X	CONTRACTOR'S CERTIFIED WELD INSPECTION
NA	EARTHWORK: LIFT AND DENSITY
X	ON SITE COLD GALVANIZING VERIFICATION
NA	GUY WIRE TENSION REPORT
X	GC AS-BUILT DOCUMENTS
X	INSPECTION OF BOLT PRETENSION PER AISC BOLT SPEC.
X	INSPECTION OF A/JAX BOLTS AND DTIS PER REQUIREMENTS ON SHEET S-3
ADDITIONAL TESTING AND INSPECTIONS:	
-----	
<b>POST-CONSTRUCTION</b>	
X	MI INSPECTOR REDLINE OR RECORD DRAWING(S)
X	POST INSTALLED ANCHOR ROD PULL-OUT TESTING
X	PHOTOGRAPHS
ADDITIONAL TESTING AND INSPECTIONS:	
-----	

NOTE: X DENOTES A DOCUMENT NEEDED FOR THE PMI REPORT  
 NA DENOTES A DOCUMENT THAT IS NOT REQUIRED FOR THE PMI REPORT

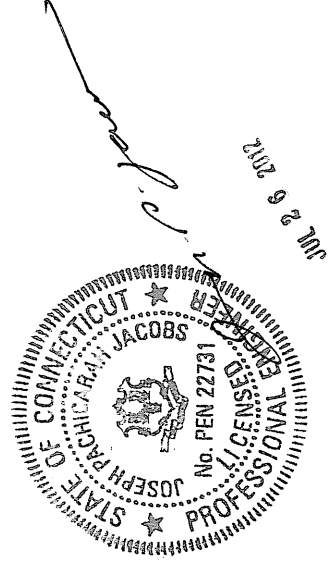

**PAUL J. FORD AND COMPANY**  
 STRUCTURAL ENGINEERS  
 250 East Broad Street · Suite 1500 · Columbus, Ohio 43215  
 (614) 221-6679 www.pjfweb.com

**CROWN CASTLE**  
 THE PIANO WORKS 349 WEST, EAST ROCHESTER, NY 14445  
 Ph: (585) 899-9446 FAX: (585) 899-3448

© Copyright 2012, by Paul J. Ford and Company, All Rights Reserved. This document and the data contained herein, is proprietary to Paul J. Ford and Company, issued in strict confidence and shall not, without the prior written permission of Paul J. Ford and Company, be reproduced, copied or used for any purpose other than the intended use for this specific project.

**BU #806373; HRT 101 943232**  
**ENFIELD, CT**  
**MONOPOLE REINFORCEMENT AND RETROFIT PROJECT**

PROJECT No: 37512-1571  
 DRAWN BY: S.S.  
 CHECKED BY: K.A.T.  
 APPROVED BY:  
 DATE: 7-24-2012  
 ISSUE DATE OF PERMIT: 7-24-2012