



10 INDUSTRIAL AVE,
SUITE 3
MAHWAH NJ 07430

PHONE: 201.684.0055
FAX: 201.684.0066

October 28, 2019

Members of the Siting Council
Connecticut Siting Council
Ten Franklin Square
New Britain, CT 06051

RE: Notice of Exempt Modification
45 Saltonstall Road East Haven, CT 06512
Latitude: 41.293624
Longitude: -72.857369
Sprint Site#: CT52XC125 – DO Macro

Dear Ms. Bachman:

Clearwire currently maintains three (3) panel antennas and (2) microwave antennas at the 85-foot level of the existing 100-foot lattice tower at 45 Saltonstall Road East Haven, CT. The 100-foot lattice tower and property are owned by The South Central Connecticut Regional Water Authority. Clearwire now intends to replace three (3) of its existing antennas with three (3) new 800/1900 MHz antennas and add three (3) new 2500 MHz antennas and assorted equipment. The new antennas will be installed at the same 85-foot level of the tower.

Planned Modifications:

Tower:

Remove

N/A

Remove and Replace:

- (3) CW Wimax antennas (Remove) - CommScope NNVV-65B-R4 antennas (Replace) 800/1900 MHz
- (3) CW RRHs (Remove) – (3) ALU 1900MHz 4X45W RRH (Replace)
- (6) Beldin 7919A cables (Remove) – (4) Hybriflex Cables (Replace)

Install New:

- (6) ALU 800 MHZ 2x50W RRHs
- (3) Nokia AAHC antennas 2500 MHz

Existing to Remain:

- (2) Andrew VILP2-I8 MW antennas
- (2) EUPEN EC4-50 cables

Ground:

Remove and Replace: Existing Clearwire Cabinet (Remove) – Eltek E-Cab, Eltek I-Cab, and Eltek B-Cab (replace)

This facility was approved by the CSC for Sprint use in TS-Clearwire-044-101109 dated December 2, 2010. This modification complies with this approval. The original tower share approval is unavailable on the CSC website, please see the enclosed first exempt modification request after tower share approval with its reference and the approval of that modification request by the CSC.

Please accept this letter as notification pursuant to Regulations of Connecticut State Agencies § 16-50j-73, for construction that constitutes an exempt modification pursuant to R.C.S.A. § 16-50j-72(b)(2). In accordance with R.C.S.A. § 16-50j-73, a copy of this letter is being sent to Mayor – Joseph Maturo Jr., Elected Official, and Christopher Soto, Zoning Enforcement Officer for the Town of East Haven, as well as the owner.

The planned modifications to the facility fall squarely within those activities explicitly provided for in R.C.S.A. § 16-50j-72(b)(2).

1. The proposed modifications will not result in an increase in the height of the existing structure.
2. The proposed modifications will not require the extension of the site boundary.
3. The proposed modifications will not increase noise levels at the facility by six decibels or more, or to levels that exceed state and local criteria.
4. The operation of the replacement antennas will not increase radio frequency emissions at the facility to a level at or above the Federal Communications Commission safety standard.
5. The proposed modifications will not cause a change or alteration in the physical or environmental characteristics of the site.
6. The existing structure and its foundation can support the proposed loading.

For the foregoing reasons, Sprint respectfully submits that the proposed modifications to the above referenced telecommunications facility constitute an exempt modification under R.C.S.A. § 16-50j-72(b)(2).

Sincerely,

Jake Shappy

Transcend Wireless

Cell: 845-553-3330

Email: jshappy@transcendwireless.com

Attachments

cc: Joseph Maturo Jr. – Town of East Haven Mayor

Christopher Soto – Town of East Haven Zoning Enforcement Officer

The South Central Connecticut Regional Water Authority – tower and property owner

clearwire®
wireless broadband

Transcend Wireless, LLC
C/O Clearwire, LLC
147 Austing Ryer Ln
Branford, CT 06405
Phone: (203)-410-4531
Douglas Talmadge
Real Estate Consultant

March 23, 2012

Ms. Linda Roberts
Executive Director
Connecticut Siting Council
10 Franklin Square
New Britain, CT 06051

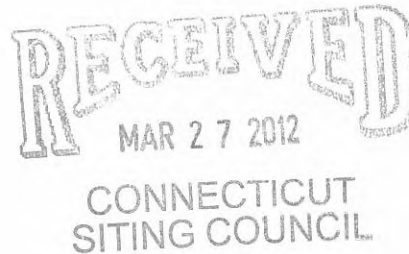

RE: Clearwire LLC notice of intent to modify an existing telecommunications facility located at 45 Saltonstall Rd, East haven, CT 06512. Clearwire site CT-NHN0095.

Dear Ms. Roberts:

In order to accommodate technological changes, implement 4G Worldwide Interoperability for Microwave Access (“WiMAX”) to wirelessly deliver high-speed internet service to a large geographical area and enhance system performance in the state of Connecticut, Clearwire, LLC plans to modify the equipment originally approved for a Tower Share on Dec. 2, 2010 Doc. TS-Clearwire-044-101109. The build was put on hold by Clearwire shortly after the approval. Clearwire is continuing with the original build and since it has been over a one (1) year time frame since the original approval and the equipment may very slightly Clearwire is requesting approval for an Exempt Modification. Please accept this letter and attachments as notification, pursuant to R.C.S.A. Section 16-50j-73, of construction which constitutes an exempt modification pursuant to R.C.S.A. Section 16-50j-72(b)(2). In compliance with R.C.S.A. Section 16-50j-73, a copy of this letter and its attachments is being sent to the chief elected official of the municipality in which affected cell site is located.

4G Worldwide Interoperability for Microwave Access (“WiMAX”) is a communication technology for wirelessly delivering high-speed Internet service to large geographical areas. WiMAX can provide at-home or mobile internet access across whole cities or countries. In many cases this has resulted in competition in markets which typically only had access through an existing incumbent DSL (or similar) operator.

Attached is a summary of the planned modifications, including power density calculations reflecting the modifications of Clearwire's equipment at the site and a structural assessment of the tower to accommodate the revised antenna configuration.

The changes to the facility do not constitute modification as defined Connecticut General Statutes ("C.G.S.") Section 16-50i(d) because the general physical characteristics of the facility will not be significantly changed or altered. Rather, the planned changes to the facility fall squarely within those activities explicitly provided for the R.C.S.A. Section 16-50j-72(b)(2).

1. The height of the overall structure will not be affected.
2. The proposed changes will not extend the site boundaries. The equipment will be located within the existing fenced in compound.
3. The proposed changes will not increase the noise level at the existing facility by 6 decibels or more.
4. Radio Frequency power density may increase due to the use of WiMAX. . However, the changes will not increase the calculated "worst case" power density for the combined operations at the site to a level at or above the applicable standard for uncontrolled environments as calculated for a mixed frequency site.

For the foregoing reasons Clearwire, LLC respectfully submits that the proposed changes at the referenced site constitute exempt modifications under R.C.S.A. Section 16-50j-72(b)(2).

Please feel free to call me at (203)-410-4531 with questions concerning this matter. Thank you for your consideration.

Sincerely,

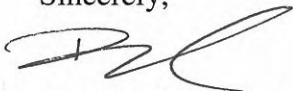

Douglas Talmadge
Real Estate Consultant

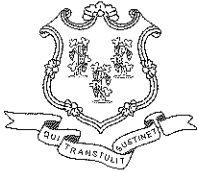

STATE OF CONNECTICUT

CONNECTICUT SITING COUNCIL

Ten Franklin Square, New Britain, CT 06051

Phone: (860) 827-2935 Fax: (860) 827-2950

E-Mail: siting.council@ct.gov

www.ct.gov/csc

August 9, 2012

Douglas Talmadge, Real Estate Consultant
Transcend Wireless, LLC
c/o Clearwire, LLC
147 Austin Ryer Lane
Branford, CT 06405

RE: **EM-CLEARWIRE-044-120720** – Clearwire LLC notice of intent to modify an existing telecommunications facility located at 45 Saltonstall Road, East Haven, Connecticut.

Dear Mr. Talmadge:

The Connecticut Siting Council (Council) hereby acknowledges your notice to modify this existing telecommunications facility, pursuant to Section 16-50j-73 of the Regulations of Connecticut State Agencies with the following conditions:

- Any deviation from the proposed modification as specified in this notice and supporting materials with Council shall render this acknowledgement invalid;
- Any material changes to this modification as proposed shall require the filing of a new notice with the Council;
- Not less than 45 days after completion of construction, the Council shall be notified in writing that construction has been completed;
- The validity of this action shall expire one year from the date of this letter; and
- The applicant may file a request for an extension of time beyond the one year deadline provided that such request is submitted to the Council not less than 60 days prior to the expiration;

The proposed modifications including the placement of all necessary equipment and shelters within the tower compound are to be implemented as specified here and in your notice dated July 19, 2012. The modifications are in compliance with the exception criteria in Section 16-50j-72 (b) of the Regulations of Connecticut State Agencies as changes to an existing facility site that would not increase tower height, extend the boundaries of the tower site, increase noise levels at the tower site boundary by six decibels, and increase the total radio frequencies electromagnetic radiation power density measured at the tower site boundary to or above the standard adopted by the State Department of Environmental Protection pursuant to General Statutes § 22a-162. This facility has also been carefully modeled to ensure that radio frequency emissions are conservatively below State and federal standards applicable to the frequencies now used on this tower.

This decision is under the exclusive jurisdiction of the Council. Please be advised that the validity of this action shall expire one year from the date of this letter. Any additional change to this facility will require explicit notice to this agency pursuant to Regulations of Connecticut State Agencies Section 16-50j-73. Such notice shall include all relevant information regarding the proposed change with cumulative worst-case modeling of radio frequency exposure at the closest point of uncontrolled access to the tower base, consistent with Federal Communications Commission, Office of Engineering and Technology, Bulletin 65. Thank you for your attention and cooperation.

Very truly yours,

Linda Roberts
Executive Director

LR/CDM/jbw

c: The Honorable Joseph Maturo, Jr., Mayor, Town of East Haven
George Mingione, Zoning Enforcement Officer, Town of East Haven
South Central CT Regional Water Authority





Town of East Haven, Connecticut. Assessment Parcel Map

MBL: 240-2920-001

ADDRESS: 75 SALTONSTALL PL

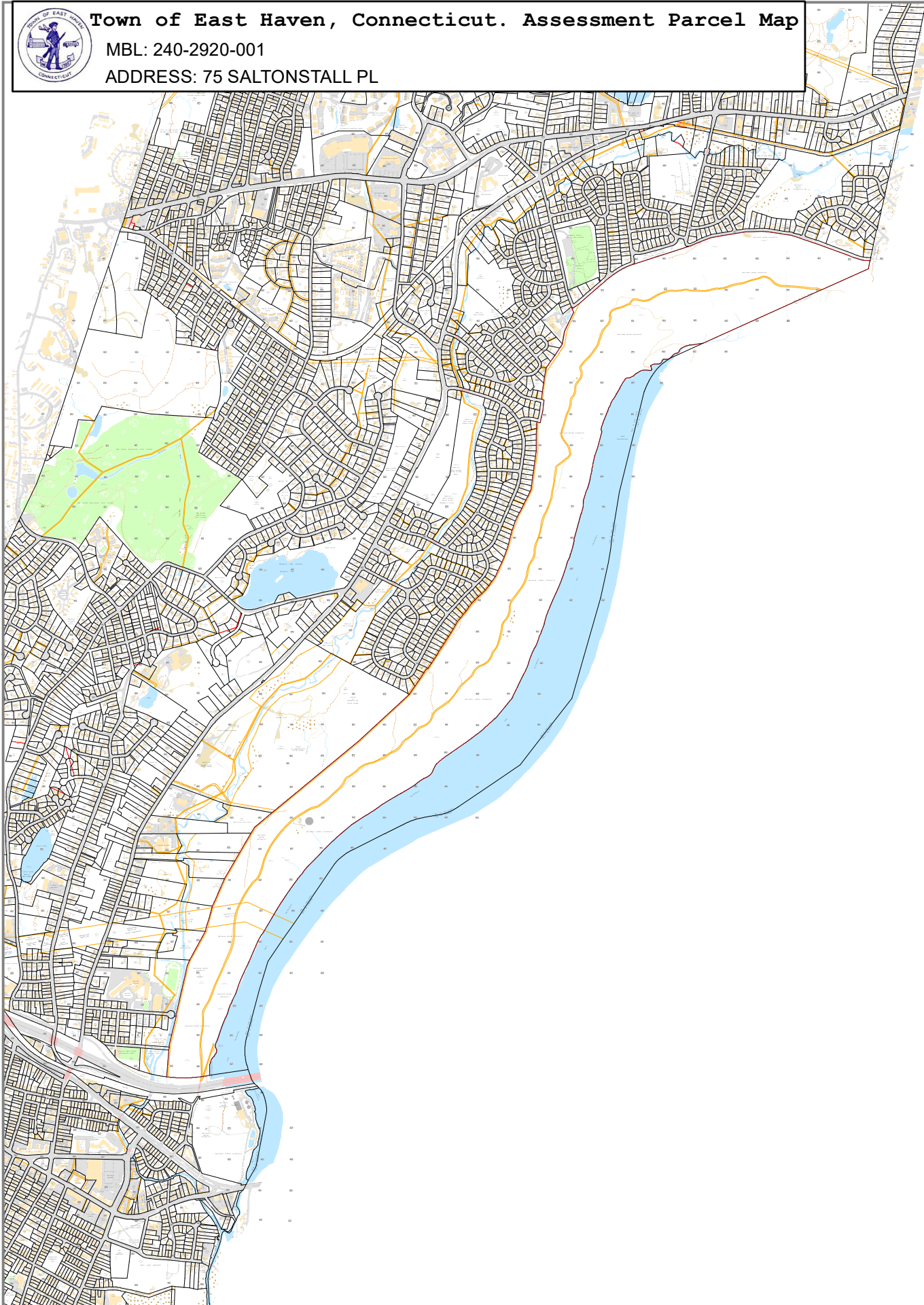

1 inch = 2,100 feet

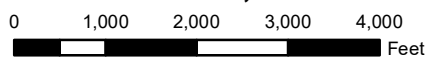

Disclaimer:
This map is for informational purposes only All information is subject to verification by any user. The Town of East Haven and its mapping contractors assume no legal responsibility for the information contained herein.

Map Produced: 10/2019

The Assessor's office is responsible for the maintenance of records on the ownership of properties. Assessments are computed at 70% of the estimated market value of real property at the time of the last revaluation which was 2016.



TOWN of EAST HAVEN ASSESSOR



Information on the Property Records for the Municipality of East Haven was last updated on 10/9/2019.

Parcel Information

Location:	75 SALTONSTALL PL	Property Use:	Public Use	Primary Use:	Water Treatment Plant
Unique ID:	W9007002	Map Block Lot:	240 2920 001	Acres:	705.30
490 Acres:	579.00	Zone:	RA-1	Volume / Page:	0073/506B
Developers Map / Lot:		Census:	1803000		

Value Information

	Appraised Value	Assessed Value
Land	2,018,460	1,412,920
Buildings	123,104	86,170
Detached Outbuildings	2,586	1,810
Total	2,144,150	1,500,900

Owner's Information

Owner's Data

SOUTH CENTRAL CONN REGIONAL WATER AUTHOR
90 SARGENT DR
NEW HAVEN CT 06511

Building 1

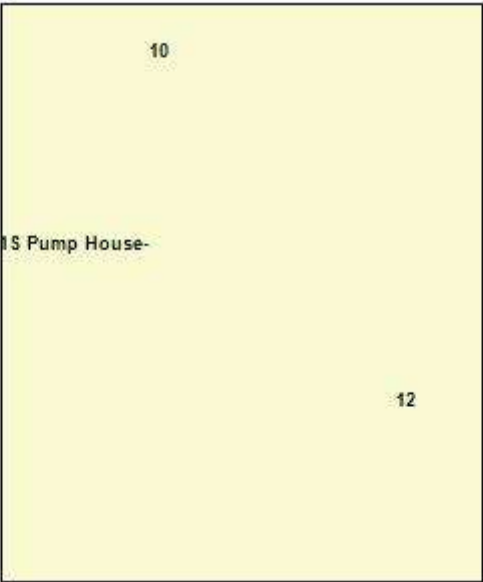

Category:	Industrial	Use:	Pump House	GLA:	120
Stories:	1.00	Construction:	Masonry and Wood Frame	Year Built:	1980

Heating:		Fuel:		Cooling Percent:	0
Siding:		Roof Material:		Beds/Units:	0

Special Features

Attached Components

Building 2



15 Cell Tower-

Lat 41.29362

Long 72.8573

Type - Lattice Tower

Hgt - RF 85' AGL (x3)

MV 90' AGL (x2)

12

22

Category:	Cell Tower	Use:	Cell Site	GLA:	1
Stories:	10.00	Construction:	Metal	Year Built:	2013
Heating:		Fuel:		Cooling Percent:	0
Siding:	Metal	Roof Material:		Beds/Units:	0

Special Features

Attached Components

Building 3

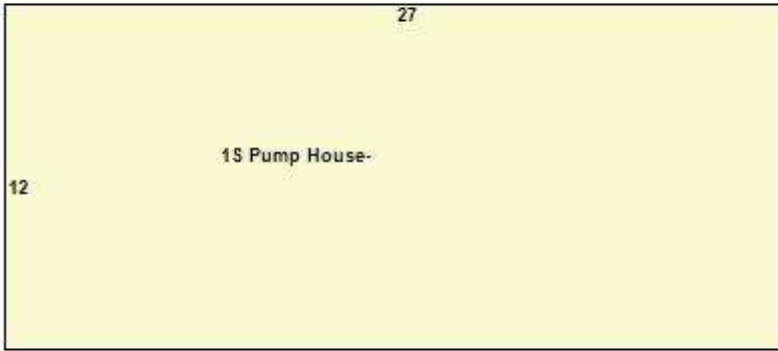

Category:	Industrial	Use:	Pump House	GLA:	324
Stories:	0.00	Construction:	Masonry and Wood Frame	Year Built:	2016
Heating:		Fuel:		Cooling Percent:	0
Siding:		Roof Material:		Beds/Units:	0

Special Features

Attached Components

Detached Outbuildings

Type:	Year Built:	Length:	Width:	Area:
Concrete Pad	2016	20.00	20.00	400
Paving	1980	0.00	0.00	1,500
Average Shed	2012	0.00	0.00	200
Water Tanks	1974	0.00	0.00	1

Building Permits

Permit Number	Permit Type	Date Opened	Date Closed	Permit Status	Reason
1282	Certificate of Completion	12/27/2016		Closed	
65453	Building	04/19/2015		Closed	

Information Published With Permission From The Assessor

UPS Internet Shipping: View/Print Label

- 1. **Ensure there are no other shipping or tracking labels attached to your package.** Select the Print button on the print dialog box that appears. Note: If your browser does not support this function select Print from the File menu to print the label.
- 2. **Fold the printed label at the solid line below.** Place the label in a UPS Shipping Pouch. If you do not have a pouch, affix the folded label using clear plastic shipping tape over the entire label.
- 3. **GETTING YOUR SHIPMENT TO UPS**
Customers with a Daily Pickup
 Your driver will pickup your shipment(s) as usual.

Customers without a Daily Pickup

Take your package to any location of The UPS Store®, UPS Access Point(TM) location, UPS Drop Box, UPS Customer Center, Staples® or Authorized Shipping Outlet near you. Items sent via UPS Return Services(SM) (including via Ground) are also accepted at Drop Boxes. To find the location nearest you, please visit the 'Find Locations' Quick link at ups.com.



Schedule a same day or future day Pickup to have a UPS driver pickup all of your Internet Shipping packages. Hand the package to any UPS driver in your area.

UPS Access Point™
MICHAELS STORE # 7773
75 INTERSTATE SHOP CTR
RAMSEY ,NJ 07446

UPS Access Point™
THE UPS STORE
115 FRANKLIN TPKE
MAHWAH ,NJ 07430

UPS Access Point™
THE UPS STORE
120 E MAIN ST
RAMSEY ,NJ 07446

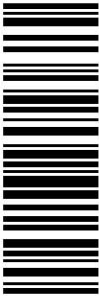
FOLD HERE

<p style="text-align: right;">1 OF 1</p> <p>2 LBS DWT: 12.9,2</p> <p>SHIP TO: JAKE SHAPPY 845533330 TRANSCEND WIRELESS 10 INDUSTRIAL AVE MAHWAH NJ 074302284</p> <p>MELANIE A. BACHMAN CONNECTICUT SITING COUNCIL 10 FRANKLIN SQUARE NEW BRITAIN CT 06051-2655</p>	<p style="font-size: 2em;">CT 067 9-06</p> 	<p>UPS GROUND</p> <p>TRACKING #: 1Z V25 742 03 9140 1620</p> 	<p style="text-align: right;"></p> <p style="text-align: right; font-size: 0.8em;">UPS 21.5-47. WNTINV50 17.0A 09/2019</p> <p>Reference# 1: CTS2XC125</p> <p style="text-align: right;">BILLING: P/P</p>
---	---	---	--

UPS Internet Shipping: View/Print Label

- 1. Ensure there are no other shipping or tracking labels attached to your package.** Select the Print button on the print dialog box that appears. Note: If your browser does not support this function select Print from the File menu to print the label.
- 2. Fold the printed label at the solid line below.** Place the label in a UPS Shipping Pouch. If you do not have a pouch, affix the folded label using clear plastic shipping tape over the entire label.
- 3. GETTING YOUR SHIPMENT TO UPS**
Customers with a Daily Pickup
 Your driver will pickup your shipment(s) as usual.

Customers without a Daily Pickup

Take your package to any location of The UPS Store®, UPS Access Point(TM) location, UPS Drop Box, UPS Customer Center, Staples® or Authorized Shipping Outlet near you. Items sent via UPS Return Services(SM) (including via Ground) are also accepted at Drop Boxes. To find the location nearest you, please visit the 'Find Locations' Quick link at ups.com.

Schedule a same day or future day Pickup to have a UPS driver pickup all of your Internet Shipping packages. Hand the package to any UPS driver in your area.

UPS Access Point™
MICHAELS STORE # 7773
75 INTERSTATE SHOP CTR
RAMSEY ,NJ 07446

UPS Access Point™
THE UPS STORE
115 FRANKLIN TPKE
MAHWAH ,NJ 07430

UPS Access Point™
THE UPS STORE
120 E MAIN ST
RAMSEY ,NJ 07446

FOLD HERE

<p>1 LBS 1 OF 1</p> <p>DWT: 14.9,1</p> <p>SHIP TO: JAKE SHAPPY 845533330 TRANSCEND WIRELESS 10 INDUSTRIAL AVE MAHWAH NJ 074302284</p> <p>SOUTH CENTRAL CONNECTICUT WATER AUT 90 SARGENT DRIVE NEW HAVEN CT 06511-5918</p>	<p>CT 064 7-01</p> 	<p>UPS GROUND</p> <p>TRACKING #: 1Z V25 742 03 9306 3591</p> 	<p>BILLING: P/P</p> <p>Reference# 1: CTS2XC125</p> <p style="text-align: right;">  <small>UPS 21.5-47. WNTINV50 17.0A 09/2019</small> </p>
---	---	---	--

UPS Internet Shipping: View/Print Label

- 1. **Ensure there are no other shipping or tracking labels attached to your package.** Select the Print button on the print dialog box that appears. Note: If your browser does not support this function select Print from the File menu to print the label.
- 2. **Fold the printed label at the solid line below.** Place the label in a UPS Shipping Pouch. If you do not have a pouch, affix the folded label using clear plastic shipping tape over the entire label.
- 3. **GETTING YOUR SHIPMENT TO UPS**
Customers with a Daily Pickup
 Your driver will pickup your shipment(s) as usual.

Customers without a Daily Pickup

Take your package to any location of The UPS Store®, UPS Access Point(TM) location, UPS Drop Box, UPS Customer Center, Staples® or Authorized Shipping Outlet near you. Items sent via UPS Return Services(SM) (including via Ground) are also accepted at Drop Boxes. To find the location nearest you, please visit the 'Find Locations' Quick link at ups.com.



Schedule a same day or future day Pickup to have a UPS driver pickup all of your Internet Shipping packages. Hand the package to any UPS driver in your area.

UPS Access Point™
MICHAELS STORE # 7773
75 INTERSTATE SHOP CTR
RAMSEY ,NJ 07446

UPS Access Point™
THE UPS STORE
115 FRANKLIN TPKE
MAHWAH ,NJ 07430

UPS Access Point™
THE UPS STORE
120 E MAIN ST
RAMSEY ,NJ 07446

FOLD HERE

<p>1 LBS 1 OF 1</p> <p>DWT: 14.9,1</p> <p>SHIP TO: JAKE SHAPPY 845533330 TRANSCEND WIRELESS 10 INDUSTRIAL AVE MAHWAH NJ 074302284</p> <p>MAYOR JOSEPH MATURO JR. TOWN OF EAST HAVEN UPPER LEVEL 250 MAIN STREET EAST HAVEN CT 06512-3004</p>	<p style="font-size: 2em; font-weight: bold;">CT 064 7-01</p> 	<p style="font-weight: bold; font-size: 1.5em;">UPS GROUND</p> <p>TRACKING #: 1Z V25 742 03 9350 5603</p> 	<p>BILLING: P/P</p> <p>Reference# 1: CTS2XC125</p> <p style="text-align: right;">  <small>UPS 21.5-47. WNTINV50 17.0A 09/2019</small> </p>
--	---	---	--

UPS Internet Shipping: View/Print Label

- 1. Ensure there are no other shipping or tracking labels attached to your package.** Select the Print button on the print dialog box that appears. Note: If your browser does not support this function select Print from the File menu to print the label.
- 2. Fold the printed label at the solid line below.** Place the label in a UPS Shipping Pouch. If you do not have a pouch, affix the folded label using clear plastic shipping tape over the entire label.
- 3. GETTING YOUR SHIPMENT TO UPS**
Customers with a Daily Pickup
 Your driver will pickup your shipment(s) as usual.

Customers without a Daily Pickup

Take your package to any location of The UPS Store®, UPS Access Point(TM) location, UPS Drop Box, UPS Customer Center, Staples® or Authorized Shipping Outlet near you. Items sent via UPS Return Services(SM) (including via Ground) are also accepted at Drop Boxes. To find the location nearest you, please visit the 'Find Locations' Quick link at ups.com.



Schedule a same day or future day Pickup to have a UPS driver pickup all of your Internet Shipping packages. Hand the package to any UPS driver in your area.

UPS Access Point™
MICHAELS STORE # 7773
75 INTERSTATE SHOP CTR
RAMSEY ,NJ 07446

UPS Access Point™
THE UPS STORE
115 FRANKLIN TPKE
MAHWAH ,NJ 07430

UPS Access Point™
THE UPS STORE
120 E MAIN ST
RAMSEY ,NJ 07446

FOLD HERE

<p>1 LBS 1 OF 1</p> <p>DWT: 14.9,1</p> <p>SHIP TO: JAKE SHAPPY 845533330 TRANSCEND WIRELESS 10 INDUSTRIAL AVE MAHWAH NJ 074302284</p> <p>CHRISTOPHER SOTO TOWN OF EAST HAVEN LOWER LEVEL PLANNING AND ZONING DEPARTMENT 250 MAIN STREET EAST HAVEN CT 06512-3004</p>	<p>CT 064 7-01</p> 	<p>UPS GROUND</p> <p>TRACKING #: 1Z V25 742 03 9075 1610</p> 	<p>BILLING: P/P</p> <p>Reference# 1: CTS2XC125</p> <p style="text-align: right;">  <small>UPS 21.5-47. WNTINV50 17.0A 09/2019</small> </p>
---	---	---	--

RADIO FREQUENCY EMISSIONS ANALYSIS REPORT
EVALUATION OF HUMAN EXPOSURE POTENTIAL
TO NON-IONIZING EMISSIONS

Sprint Existing Facility

Site ID: CT52XC125

Saltonstall Place
12 Saltonstall Place
East Haven, Connecticut 06512

October 22, 2019

EBI Project Number: 6219005411

Site Compliance Summary	
Compliance Status:	COMPLIANT
Site total MPE% of FCC general population allowable limit:	10.01%

October 22, 2019

Sprint

Attn: RF Engineering Manager

1 International Boulevard, Suite 800

Mahwah, New Jersey 07495

Emissions Analysis for Site: CT52XC125 - Saltonstall Place

EBI Consulting was directed to analyze the proposed Sprint facility located at **12 Saltonstall Place in East Haven, Connecticut** for the purpose of determining whether the emissions from the Proposed Sprint Antenna Installation located on this property are within specified federal limits.

All information used in this report was analyzed as a percentage of current Maximum Permissible Exposure (% MPE) as listed in the FCC OET Bulletin 65 Edition 97-01 and ANSI/IEEE Std C95.1. The FCC regulates Maximum Permissible Exposure in units of microwatts per square centimeter ($\mu\text{W}/\text{cm}^2$). The number of $\mu\text{W}/\text{cm}^2$ calculated at each sample point is called the power density. The exposure limit for power density varies depending upon the frequencies being utilized. Wireless Carriers and Paging Services use different frequency bands each with different exposure limits; therefore, it is necessary to report results and limits in terms of percent MPE rather than power density.

All results were compared to the FCC (Federal Communications Commission) radio frequency exposure rules, 47 CFR 1.1307(b)(1) – (b)(3), to determine compliance with the Maximum Permissible Exposure (MPE) limits for General Population/Uncontrolled environments as defined below.

General population/uncontrolled exposure limits apply to situations in which the general population may be exposed or in which persons who are exposed as a consequence of their employment may not be made fully aware of the potential for exposure or cannot exercise control over their exposure. Therefore, members of the general population would always be considered under this category when exposure is not employment related, for example, in the case of a telecommunications tower that exposes persons in a nearby residential area.

Public exposure to radio frequencies is regulated and enforced in units of microwatts per square centimeter ($\mu\text{W}/\text{cm}^2$). The general population exposure limits for the 600 MHz and 700 MHz frequency bands are approximately $400 \mu\text{W}/\text{cm}^2$ and $467 \mu\text{W}/\text{cm}^2$, respectively. The general population exposure limit for the 1900 MHz (PCS), 2100 MHz (AWS) and 11 GHz frequency bands is $1000 \mu\text{W}/\text{cm}^2$. Because each carrier will be using different frequency bands, and each frequency band has different exposure limits, it is necessary to report percent of MPE rather than power density.

Occupational/controlled exposure limits apply to situations in which persons are exposed as a consequence of their employment and in which those persons who are exposed have been made fully aware of the potential for exposure and can exercise control over their exposure. Occupational/controlled exposure limits also apply where exposure is of a transient nature as a result of incidental passage through a location where exposure levels may be above general population/uncontrolled limits (see below), as long as the exposed person has been made fully aware of the potential for exposure and can exercise control over his or her exposure by leaving the area or by some other appropriate means.

Additional details can be found in FCC OET 65.

CALCULATIONS

Calculations were done for the proposed Sprint Wireless antenna facility located at 12 Saltonstall Place in East Haven, Connecticut using the equipment information listed below. All calculations were performed per the specifications under FCC OET 65. Since Sprint is proposing highly focused directional panel antennas, which project most of the emitted energy out toward the horizon, all calculations were performed assuming a lobe representing the maximum gain of the antenna per the antenna manufacturer's supplied specifications, minus 10 dB for directional panel antennas and 20 dB for highly focused parabolic microwave dishes, was focused at the base of the tower. For this report, the sample point is the top of a 6-foot person standing at the base of the tower.

For all calculations, all equipment was calculated using the following assumptions:

- 1) 4 CDMA channels (800 MHz Band) were considered for each sector of the proposed installation. These Channels have a transmit power of 50 Watts per Channel.
- 2) 4 PCS channels (1900 MHz Band) were considered for each sector of the proposed installation. These Channels have a transmit power of 45 Watts per Channel.
- 3) 3 BRS channels (2500 MHz Band) were considered for each sector of the proposed installation. These Channels have a transmit power of 40 Watts per Channel.
- 4) All radios at the proposed installation were considered to be running at full power and were uncombined in their RF transmissions paths per carrier prescribed configuration. Per FCC OET Bulletin No. 65 - Edition 97-01 recommendations to achieve the maximum anticipated value at each sample point, all power levels emitting from the proposed antenna installation are increased by a factor of 2.56 to account for possible in-phase reflections from the surrounding environment. This is rarely the case, and if so, is never continuous.

- 5) For the following calculations, the sample point was the top of a 6-foot person standing at the base of the tower. The maximum gain of the antenna per the antenna manufacturer's supplied specifications, minus 10 dB for directional panel antennas and 20 dB for highly focused parabolic microwave dishes, was used in this direction. This value is a very conservative estimate as gain reductions for these particular antennas are typically much higher in this direction.
- 6) The antennas used in this modeling are the Nokia AAHC for the 2500 MHz channel(s), the Commscope NNVV-65B-R4 for the 800 MHz / 1900 MHz channel(s) in Sector A, the Nokia AAHC for the 2500 MHz channel(s), the Commscope NNVV-65B-R4 for the 800 MHz / 1900 MHz channel(s) in Sector B, the Nokia AAHC for the 2500 MHz channel(s), the Commscope NNVV-65B-R4 for the 800 MHz / 1900 MHz channel(s) in Sector C. This is based on feedback from the carrier with regard to anticipated antenna selection. All Antenna gain values and associated transmit power levels are shown in the Site Inventory and Power Data table below. The maximum gain of the antenna per the antenna manufacturer's supplied specifications, minus 10 dB for directional panel antennas and 20 dB for highly focused parabolic microwave dishes, was used for all calculations. This value is a very conservative estimate as gain reductions for these particular antennas are typically much higher in this direction.
- 7) The antenna mounting height centerline of the proposed antennas is 85 feet above ground level (AGL).
- 8) Emissions values for additional carriers were taken from the Connecticut Siting Council active database. Values in this database are provided by the individual carriers themselves.
- 9) All calculations were done with respect to uncontrolled / general population threshold limits.

Sprint Site Inventory and Power Data

Sector:	A	Sector:	B	Sector:	C
Antenna #:	1	Antenna #:	1	Antenna #:	1
Make / Model:	Nokia AAHC	Make / Model:	Nokia AAHC	Make / Model:	Nokia AAHC
Frequency Bands:	2500 MHz	Frequency Bands:	2500 MHz	Frequency Bands:	2500 MHz
Gain:	13.05 dBd	Gain:	13.05 dBd	Gain:	13.05 dBd
Height (AGL):	85 feet	Height (AGL):	85 feet	Height (AGL):	85 feet
Channel Count:	3	Channel Count:	3	Channel Count:	3
Total TX Power (W):	120 Watts	Total TX Power (W):	120 Watts	Total TX Power (W):	120 Watts
ERP (W):	2,422.04	ERP (W):	2,422.04	ERP (W):	2,422.04
Antenna A1 MPE %:	1.21%	Antenna B1 MPE %:	1.21%	Antenna C1 MPE %:	1.21%
Antenna #:	2	Antenna #:	2	Antenna #:	2
Make / Model:	Commscope NNVV-65B-R4	Make / Model:	Commscope NNVV-65B-R4	Make / Model:	Commscope NNVV-65B-R4
Frequency Bands:	800 MHz / 1900 MHz	Frequency Bands:	800 MHz / 1900 MHz	Frequency Bands:	800 MHz / 1900 MHz
Gain:	12.35 dBd / 15.05 dBd	Gain:	12.35 dBd / 15.05 dBd	Gain:	12.35 dBd / 15.05 dBd
Height (AGL):	85 feet	Height (AGL):	85 feet	Height (AGL):	85 feet
Channel Count:	8	Channel Count:	8	Channel Count:	8
Total TX Power (W):	380 Watts	Total TX Power (W):	380 Watts	Total TX Power (W):	380 Watts
ERP (W):	9,193.83	ERP (W):	9,193.83	ERP (W):	9,193.83
Antenna A2 MPE %:	6.07%	Antenna B2 MPE %:	6.07%	Antenna C2 MPE %:	6.07%

Site Composite MPE %	
Carrier	MPE %
Sprint (Max at Sector A):	7.28%
East Haven PD	1.81%
East Haven DPW	0.26%
HAM Radio	0.66%
Site Total MPE % :	10.01%

Sprint MPE % Per Sector	
Sprint Sector A Total:	7.28%
Sprint Sector B Total:	7.28%
Sprint Sector C Total:	7.28%
Site Total MPE % :	10.01%

Sprint Maximum MPE Power Values (Sector A)							
Sprint Frequency Band / Technology (Sector A)	# Channels	Watts ERP (Per Channel)	Height (feet)	Total Power Density ($\mu\text{W}/\text{cm}^2$)	Frequency (MHz)	Allowable MPE ($\mu\text{W}/\text{cm}^2$)	Calculated % MPE
Sprint 2500 MHz BRS	3	807.35	85.0	12.05	2500 MHz BRS	1000	1.21%
Sprint 800 MHz CDMA	4	858.95	85.0	17.10	800 MHz CDMA	533	3.21%
Sprint 1900 MHz PCS	4	1439.50	85.0	28.65	1900 MHz PCS	1000	2.87%
						Total:	7.28%

• NOTE: Totals may vary by approximately 0.01% due to summation of remainders in calculations.

Summary

All calculations performed for this analysis yielded results that were **within** the allowable limits for general population exposure to RF Emissions.

The anticipated maximum composite contributions from the Sprint facility as well as the site composite emissions value with regards to compliance with FCC's allowable limits for general population exposure to RF Emissions are shown here:

Sprint Sector	Power Density Value (%)
Sector A:	7.28%
Sector B:	7.28%
Sector C:	7.28%
Sprint Maximum MPE % (Sector A):	7.28%
Site Total:	10.01%
Site Compliance Status:	COMPLIANT

The anticipated composite MPE value for this site assuming all carriers present is **10.01%** of the allowable FCC established general population limit sampled at the ground level. This is based upon values listed in the Connecticut Siting Council database for existing carrier emissions.

FCC guidelines state that if a site is found to be out of compliance (over allowable thresholds), that carriers over a 5% contribution to the composite value will require measures to bring the site into compliance. For this facility, the composite values calculated were well within the allowable 100% threshold standard per the federal government.

PROJECT INFORMATION:

SITE INFORMATION SITE ADDRESS: 12 SALTONSTALL PLACE EAST HAVEN, CT 06512 LAT: 41.293624 LONG: -72.857369 ELEV: 100' (A.G.L.) STRUCTURE HEIGHT SITE TYPE: EXISTING LATTICE TOWER COUNTY: NEW HAVEN	APPLICANT SPRINT 1 INTERNATIONAL BLVD., SUITE 800 MAHWAH, NJ 07495
EQUIPMENT LIST COMPANY FURNISHED MATERIALS: (6) 800 RRHS (3) 1900 RRHS (3) 800/1900 PANEL ANTENNAS (3) 2500 MIMO PANEL ANTENNAS (3) HYBRIFLEX CABLE (1) AUXILIARY HYBRIFLEX CABLE RF JUMPERS ELTEK CABINETS (1) PPC CABINET	LANDLORD REGIONAL WATER AUTHORITY
A&E FIRM RAMAKER & ASSOCIATES, INC. 855 COMMUNITY DRIVE SAUK CITY, WI 53583 PHONE: (608) 643-4100	SITE ACQUISITION TRANSCEND WIRELESS CONTACT: VINCENT GRANESE EMAIL: VGRANESE@TRANSCENDWIRELESS.COM

**** GENERAL CONTRACTOR IS RESPONSIBLE FOR ANY ADDITIONAL MATERIALS****

NOTE: SEE SPRINT STANDARDS FOR COLOR CODE CHARTS, DC WIRING DIAGRAMS, ANTENNA / RRU MOUNTING DETAILS AND GROUNDING SPECIFICATIONS.



SHEET INDEX:

SHEET NUMBER	SHEET DESCRIPTION	REVISION
T-1	COVER SHEET & SITE PLAN	0
SP-1	SPECIFICATIONS	0
SP-2	SPECIFICATIONS	0
A-1	EQUIPMENT LAYOUT & TOWER ELEVATION	0
A-2	ANTENNA LAYOUTS & SCHEDULES	0
A-3	EQUIPMENT DETAILS	0
A-4	EQUIPMENT DETAILS & SCHEDULES	0
A-5	CABLE SPECS & MARKING NOTES	0
A-6	CABLE MARKING NOTES	0
A-7	CABINET SPEC	0
A-8	EQUIPMENT MOUNTING DETAILS & PLUMBING DIAGRAM	0
E-1	ELECTRICAL DETAILS	0
G-1	GROUNDING DETAILS	0
S-1	STRUCTURAL DETAILS	0
S-2	STRUCTURAL DETAILS	0
S-3	STRUCTURAL DETAILS	0
S-4	STRUCTURAL DETAILS	0
S-5	STRUCTURAL DETAILS	0

CODE COMPLIANCE:

ALL WORK SHALL BE PERFORMED AND MATERIALS INSTALLED IN ACCORDANCE WITH THE CURRENT EDITIONS OF THE FOLLOWING CODES AS ADOPTED BY THE LOCAL GOVERNING AUTHORITIES. NOTHING IN THESE PLANS IS TO BE CONSTRUED TO PERMIT WORK NOT CONFORMING TO THESE CODES.

- INTERNATIONAL BUILDING CODE
- INTERNATIONAL MECHANICAL CODE
- ANSI/TIA-222 STRUCTURAL STANDARD
- NFPA 780 - LIGHTNING PROTECTION CODE
- UNIFORM PLUMBING CODE
- 2017 NATIONAL ELECTRICAL CODE

SCOPE OF WORK:

- REMOVE (3) EXISTING CW ANTENNAS AND (3) DAP HEADS
- REMOVE (1) EXISTING CW EQUIPMENT CABINET
- ADD (3) NEW 2500 MIMO ANTENNAS ON NEW MOUNTS
- ADD (3) NEW 800/1900 ANTENNAS ON NEW MOUNTS
- ADD (3) NEW 1900 RRHS
- ADD (6) NEW 800 RRHS
- ADD (1) NEW EQUIPMENT CABINET ON EXISTING PLATFORM
- ADD (1) NEW PPC CABINET ON EXISTING PLATFORM
- ADD (4) HYBRIFLEX CABLES

DO MACRO UPGRADE

SITE CASCADE: CT52XC125

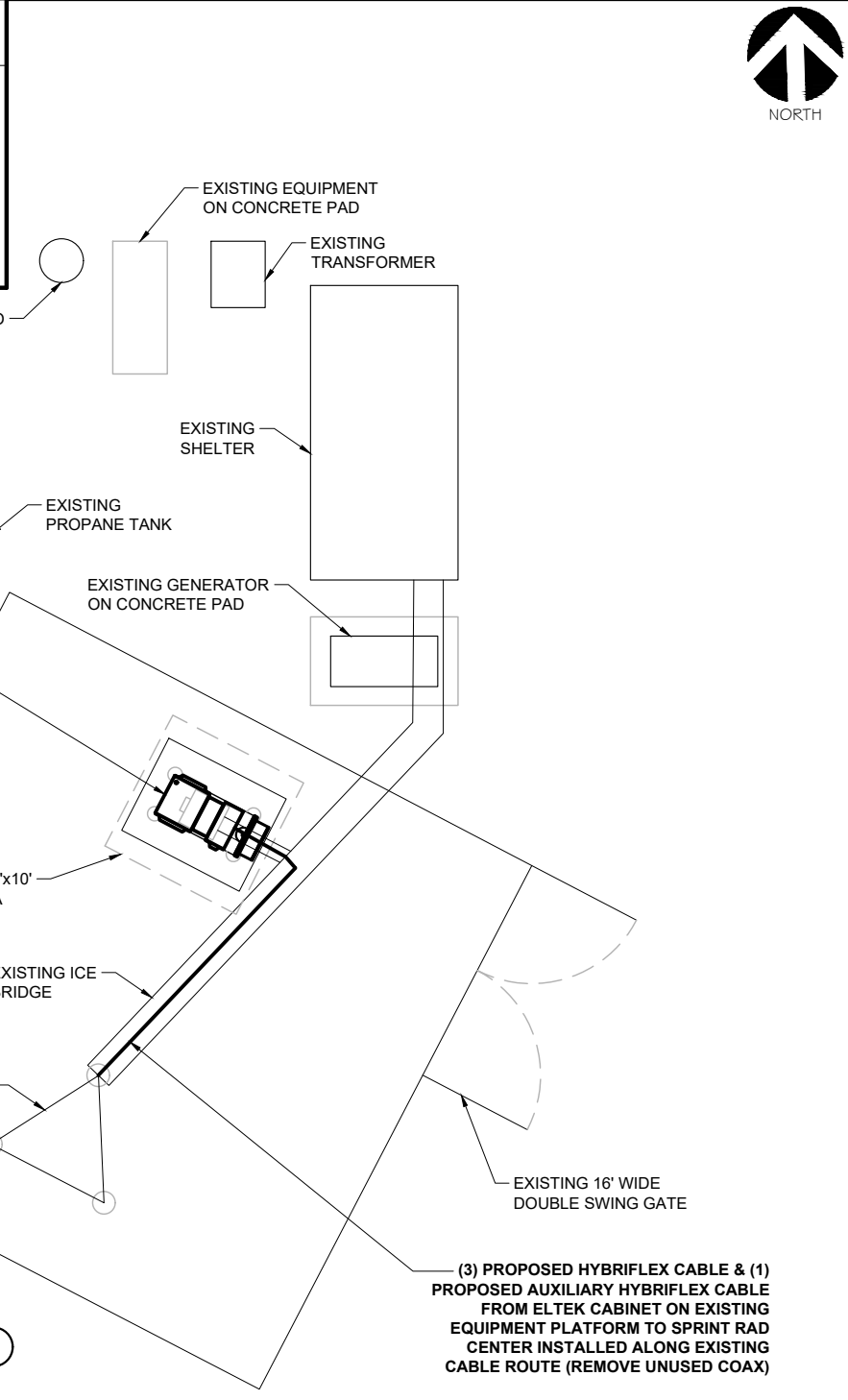

OVERALL SITE PLAN
 SCALE: 1" = 12.5'

1 INTERNATIONAL BLVD. SUITE 800
 MAHWAH, NJ 07495

10 INDUSTRIAL AVE., SUITE 3
 MAHWAH, NJ 07430

100% EMPLOYEE-OWNED
 855 Community Dr, Sauk City, WI 53583
 608-643-4100 www.Ramaker.com
 Sauk City, WI • Willmar, MN
 Woodcliff Lake, NJ • Bayamon, PR

Certification & Seal:
 I hereby certify that this plan, specification, or report was prepared by me or under my direct supervision and that I am a duly Licensed Professional Engineer under the laws of the State of Connecticut.

Signature: *James R. Skowronski* Date: 2/12/2019

MARK	DATE	DESCRIPTION
0	02/12/19	FINAL CDs ISSUED

ISSUE PHASE: FINAL DATE ISSUED: 02/12/2019

PROJECT TITLE:
**SALTONSTALL PLACE
 CT52XC125**

PROJECT INFORMATION:
 12 SALTONSTALL PLACE
 EAST HAVEN, CT 06512
 NEW HAVEN COUNTY

SHEET TITLE:
COVER SHEET & SITE PLAN

11" x 17" - 1" = 12.5'
 22" x 34" - 1" = 6.25'

PROJECT NUMBER: 37621
 SHEET NUMBER: T-1

SECTION 01 100 - SCOPE OF WORK

THE WORK:
 SHALL COMPLY WITH ALL APPLICABLE ADOPTED CODES AND STANDARDS, AND PORTIONS THEREOF.

PRECEDENCE:
 SHOULD CONFLICTS OCCUR BETWEEN THE STANDARD CONSTRUCTION SPECIFICATIONS FOR WIRELESS SITES INCLUDING THE STANDARD CONSTRUCTION DETAILS FOR WIRELESS SITES AND THE CONSTRUCTION DRAWINGS, INFORMATION ON THE CONSTRUCTION DRAWINGS SHALL TAKE PRECEDENCE.

SITE FAMILIARITY:
 CONTRACTOR SHALL BE RESPONSIBLE FOR FAMILIARIZING THEMSELVES WITH ALL CONTRACT DOCUMENTS, FIELD CONDITIONS AND DIMENSIONS PRIOR TO PROCEEDING WITH CONSTRUCTION.

ON-SITE SUPERVISION:
 THE CONTRACTOR SHALL SUPERVISE AND DIRECT THE WORK AND SHALL BE RESPONSIBLE FOR CONSTRUCTION MEANS, METHODS, TECHNIQUES, SEQUENCES, AND PROCEDURES IN ACCORDANCE WITH THE CONTRACT DOCUMENTS.

DRAWINGS, SPECIFICATIONS AND DETAILS REQUIRED AT JOBSITE:
 THE CONSTRUCTION CONTRACTOR SHALL MAINTAIN A FULL SET OF THE CONSTRUCTION DRAWINGS AT THE JOBSITE FROM MOBILIZATION THROUGH CONSTRUCTION COMPLETION.

- A. DETAILS ARE INTENDED TO SHOW DESIGN INTENT. PROVIDE ALL MATERIALS AND LABOR AS REQUIRED TO PROVIDE A COMPLETE AND FUNCTIONING SYSTEM. MODIFICATIONS MAY BE REQUIRED TO SUIT JOB DIMENSIONS OR CONDITIONS, AND SUCH MODIFICATIONS SHALL BE INCLUDED AS PART OF THE WORK.
- B. CONTRACTOR SHALL NOTIFY SPRINT CONSTRUCTION MANAGER OF ANY VARIATIONS PRIOR TO PROCEEDING WITH THE WORK. DIMENSIONS SHOWN ARE TO FINISH SURFACES UNLESS NOTED OTHERWISE. MODIFICATIONS MAY BE REQUIRED TO SUIT JOB DIMENSIONS OR CONDITIONS, AND SUCH MODIFICATIONS SHALL BE INCLUDED AS PART OF THE WORK.
- C. MARK THE FIELD SET OF DRAWINGS IN RED, DOCUMENTING ANY CHANGES FROM THE CONSTRUCTION DOCUMENTS.

METHODS OF PROCEDURE (MOPS) FOR CONSTRUCTION:
 CONTRACTOR SHALL PERFORM WORK AS DESCRIBED IN:

- A. COAX COLOR CODING SWEEPS AND FIBER TESTING TS-0200 AND EL-0568
- B. CABLE LABELING EN-2012-00
- C. APPLICABLE INSTALLATION MOPS IDENTIFIED ELSEWHERE IN THE CONTRACT DOCUMENTS

SECTION 01 200 - COMPANY FURNISHED MATERIAL AND EQUIPMENT

- A. COMPANY FURNISHED MATERIAL AND EQUIPMENT IS IDENTIFIED ON THE RF DATA SHEET IN THE CONSTRUCTION DRAWINGS.
- B. CONTRACTOR IS RESPONSIBLE FOR SPRINT PROVIDED MATERIAL AND EQUIPMENT TO ENSURE IT IS PROTECTED AND HANDLED PROPERLY THROUGHOUT THE CONSTRUCTION DURATION.
- C. CONTRACTOR IS RESPONSIBLE FOR RECEIPT OF SPRINT FURNISHED EQUIPMENT AT CELL SITE OR CONTRACTORS LOCATION. CONTRACTOR TO COMPLETE SHIPPING AND RECEIPT DOCUMENTATION IN ACCORDANCE WITH COMPANY PRACTICE.

SECTION 01 300 - CELL SITE CONSTRUCTION

NOTICE TO PROCEED:
 NO WORK SHALL COMMENCE PRIOR TO COMPANY'S WRITTEN NOTICE TO PROCEED AND THE ISSUANCE OF WORK ORDER.

SITE CLEANLINESS:
 CONTRACTOR SHALL KEEP THE SITE FREE FROM ACCUMULATING WASTE MATERIAL, DEBRIS, AND TRASH. AT THE COMPLETION OF THE WORK, CONTRACTOR SHALL REMOVE FROM THE SITE ALL REMAINING RUBBISH, IMPLEMENTS, TEMPORARY FACILITIES, AND SURPLUS MATERIALS.

SECTION 01 400 - SUBMITTALS & TESTS

ALTERNATES:
 AT THE COMPANY'S REQUEST, ANY ALTERNATIVES TO THE MATERIALS OR METHODS SPECIFIED SHALL BE SUBMITTED TO SPRINT'S CONSTRUCTION MANAGER FOR APPROVAL. SPRINT WILL REVIEW AND APPROVE ONLY THOSE REQUESTS MADE IN WRITING. NO VERBAL APPROVALS WILL BE CONSIDERED.

TESTS AND INSPECTIONS:

- A. THE CONTRACTOR SHALL BE RESPONSIBLE FOR ALL CONSTRUCTION TESTS, INSPECTIONS AND PROJECT DOCUMENTATION.
- B. CONTRACTOR SHALL ACCOMPLISH TESTING INCLUDING BUT NOT LIMITED TO THE FOLLOWING:
 - 1. COAX SWEEPS AND FIBER TESTS PER TS-0200 REV 4 ANTENNA LINE ACCEPTANCE STANDARDS.
 - 2. AGL, AZIMUTH AND DOWNTILT: PROVIDE AN AUTOMATED REPORT UPLOADED TO SITERRA USING A COMMERCIAL MADE-FOR THE PURPOSE ELECTRONIC ANTENNA ALIGNMENT TOOL (AAT). INSTALLED AZIMUTH, CENTERLINE AND DOWNTILT MUST CONFORM WITH RF CONFIGURATION DATA.
 - 3. CONTRACTOR SHALL BE RESPONSIBLE FOR ANY AND ALL CORRECTIONS TO ANY WORK IDENTIFIED AS UNACCEPTABLE IN SITE INSPECTION ACTIVITIES AND/OR AS A RESULT OF TESTING.
 - 4. ALL TESTING REQUIRED BY APPLICABLE INSTALLATION MOPS.
- C. REQUIRED CLOSEOUT DOCUMENTATION INCLUDES, BUT IS NOT LIMITED TO THE FOLLOWING:
 - 1. AZIMUTH, DOWNTILT, AGL FROM SUNSIGHT INSTRUMENTS - ANTENNALIGN ALIGNMENT TOOL (AAT).
 - 2. SWEEP AND FIBER TESTS.
 - 3. SCALABLE BARCODE PHOTOGRAPHS OF TOWER TOP AND INACCESSIBLE SERIALIZED EQUIPMENT.
 - 4. ALL AVAILABLE JURISDICTIONAL PERMIT AND OCCUPANCY INFORMATION.
 - 5. PDF SCAN OF REDLINES PRODUCED IN FIELD.
 - 6. A PDF SCAN OF REDLINE MARK-UPS SUITABLE FOR USE IN ELECTRONIC AS-BUILT DRAWING PRODUCTION.
 - 7. LIEN WAIVERS.
 - 8. FINAL PAYMENT APPLICATION.
 - 9. REQUIRED FINAL CONSTRUCTION PHOTOS.
 - 10. CONSTRUCTION AND COMMISSIONING CHECKLIST COMPLETE WITH NO DEFICIENT ITEMS.
 - 11. APPLICABLE POST NTP TASKS INCLUDING DOCUMENT UPLOADS COMPLETED IN SITERRA (SPRINT'S DOCUMENT REPOSITORY OF RECORD).
 - 12. CLOSEOUT PHOTOGRAPHS AND CLOSEOUT CHECKLIST: SPRINT WILL PROVIDE SEPARATE GUIDANCE.

SECTION 11 700 - ANTENNA ASSEMBLY, REMOTE RADIO UNITS AND CABLE INSTALLATION

SUMMARY:
 THIS SECTION SPECIFIES INSTALLATION OF ANTENNAS, RRU'S, AND CABLE EQUIPMENT, INSTALLATION, AND TESTING OF COAXIAL FIBER CABLE.

ANTENNAS AND RRU'S:
 THE NUMBER AND TYPE OF ANTENNAS AND RRU'S TO BE INSTALLED IS DETAILED ON THE CONSTRUCTION DRAWINGS.

HYBRID CABLE:
 HYBRID CABLE WILL BE DC/FIBER AND FURNISHED FOR INSTALLATION AT EACH SITE. CABLE SHALL BE INSTALLED PER THE CONSTRUCTION DRAWINGS AND THE APPLICABLE MANUFACTURER'S REQUIREMENTS.

JUMPERS AND CONNECTORS:
 FURNISH AND INSTALL 1/2" COAX JUMPER CABLES BETWEEN THE RRU'S AND ANTENNAS. JUMPERS SHALL BE TYPE LDF 4, FLC 12-50, CR 540, OR FXL 540. SUPER-FLEX CABLES ARE NOT ACCEPTABLE. JUMPERS BETWEEN THE RRU'S AND ANTENNAS OR TOWER TOP AMPLIFIERS SHALL CONSIST OF 1/2 INCH FOAM DIELECTRIC, OUTDOOR RATED COAXIAL CABLE, MIN. LENGTH FOR JUMPER SHALL BE 10'-0".

REMOTE ELECTRICAL TILT (RET) CABLES:

MISCELLANEOUS:
 INSTALL SPLITTERS, COMBINERS, FILTERS PER RF DATA SHEET, FURNISHED BY SPRINT.

ANTENNA INSTALLATION:
 THE CONTRACTOR SHALL ASSEMBLE ALL ANTENNAS ONSITE IN ACCORDANCE WITH THE INSTRUCTIONS SUPPLIED BY THE MANUFACTURER. ANTENNA HEIGHT, AZIMUTH, AND FEED ORIENTATION INFORMATION SHALL BE A DESIGNATED ON THE CONSTRUCTION DRAWINGS.

- A. THE CONTRACTOR SHALL POSITION THE ANTENNA ON TOWER PIPE MOUNTS SO THAT THE BOTTOM STRUT IS LEVEL. THE PIPE MOUNTS SHALL BE PLUMB TO WITHIN 1 DEGREE.
- B. ANTENNA MOUNTING REQUIREMENTS: PROVIDE ANTENNA MOUNTING HARDWARE AS INDICATED ON THE DRAWINGS.

HYBRID CABLE INSTALLATION:

- A. THE CONTRACTOR SHALL ROUTE, TEST, AND INSTALL ALL CABLES AS INDICATED ON THE CONSTRUCTION DRAWINGS AND IN ACCORDANCE WITH THE MANUFACTURER'S RECOMMENDATIONS.
- B. THE INSTALLED RADIUS OF THE CABLES SHALL NOT BE LESS THAN THE MANUFACTURER'S SPECIFICATIONS FOR BENDING RADII.
- C. EXTREME CARE SHALL BE TAKEN TO AVOID DAMAGE TO THE CABLES DURING HANDLING AND INSTALLATION.
 - 1. FASTENING MAIN HYBRID CABLES: ALL CABLES SHALL BE INSTALLED INSIDE MONOPOLE WITH CABLE SUPPORT GRIPS AS REQUIRED BY THE MANUFACTURER.
 - 2. FASTENING INDIVIDUAL FIBER AND DC CABLES ABOVE BREAKOUT ENCLOSURE (MEDUSA), WITHIN THE MMBS CABINET AND ANY INTERMEDIATE DISTRIBUTION BOXES:
 - a. FIBER: SUPPORT FIBER BUNDLES USING 1/2" VELCRO STRAPS OF THE REQUIRED LENGTH AT 18" O.C. STRAPS SHALL BE UV, OIL AND WATER RESISTANT AND SUITABLE FOR INDUSTRIAL INSTALLATIONS AS MANUFACTURED BY TEXTOL OR APPROVED EQUAL.
 - b. DC: SUPPORT DC BUNDLES WITH ZIP TIES OF THE ADEQUATE LENGTH. ZIP TIES TO BE UV STABILIZED, BLACK NYLON, WITH TENSILE STRENGTH AT 12,000 PSI AS MANUFACTURED BY NELCO PRODUCTS OR EQUAL.
 - 3. FASTENING JUMPERS: SECURE JUMPERS TO THE SIDE ARMS OR HEAD FRAMES USING STAINLESS STEEL TIE WRAPS OR STAINLESS STEEL BUTTERFLY CLIPS.
 - 4. CABLE INSTALLATION:
 - a. INSPECT CABLE PRIOR TO USE FOR SHIPPING DAMAGE, NOTIFY THE CONSTRUCTION MANAGER.
 - b. CABLE ROUTING: CABLE INSTALLATION SHALL BE PLANNED TO ENSURE THAT THE LINES WILL BE PROPERLY ROUTED IN THE CABLE ENVELOP AS INDICATED ON THE DRAWINGS. AVOID TWISTING AND CROSSOVERS.
 - c. HOIST CABLE USING PROPER HOISTING GRIPS. DO NOT EXCEED MANUFACTURER'S RECOMMENDED MAXIMUM BEND RADIUS.
 - 5. GROUNDING OF TRANSMISSION LINES: ALL TRANSMISSION LINES SHALL BE GROUNDED AS INDICATED ON DRAWINGS.
 - 6. HYBRID CABLE COLOR CODING: ALL COLOR CODING SHALL BE AS REQUIRED IN TS 0200 REV 4.
 - 7. HYBRID CABLE LABELING: INDIVIDUAL HYBRID AND DC BUNDLES SHALL BE LABELED ALPHA-NUMERICALLY ACCORDING TO SPRINT CELL SITE ENGINEERING NOTICE - EN 2012-001, REV 1

WEATHERPROOFING EXTERIOR CONNECTORS AND HYBRID CABLE GROUND KITS:

- A. ALL FIBER & COAX CONNECTORS AND GROUND KITS SHALL BE WEATHERPROOFED.
- B. WEATHERPROOFED USING ONE OF THE FOLLOWING METHODS. ALL INSTALLATIONS MUST BE DONE IN ACCORDANCE WITH THE MANUFACTURER'S RECOMMENDATIONS AND INDUSTRY BEST PRACTICES.
 - 1. COLD SHRINK: ENCOMPASS CONNECTOR IN COLD SHRINK TUBING AND PROVIDE A DOUBLE WRAP OF 2" ELECTRICAL TAPE EXTENDING 2" BEYOND TUBING. PROVIDE 3M COLD SHRINK CXS SERIES OR EQUAL.
 - 2. SELF-AMALGAMATING TAPE: CLEAN SURFACES. APPLY A DOUBLE WRAP OF SELF-AMALGAMATING TAPE 2" BEYOND CONNECTOR. APPLY A SECOND WRAP OF SELF-AMALGAMATING TAPE IN OPPOSITE DIRECTION. APPLY DOUBLE WRAP OF 2" WIDE ELECTRICAL TAPE EXTENDING 2" BEYOND THE SELF-AMALGAMATING TAPE.
 - 3. 3M SLIM LOCK CLOSURE 716: SUBSTITUTIONS WILL NOT BE ALLOWED.
 - 4. OPEN FLAME ON JOB SITE IS NOT ACCEPTABLE



1 INTERNATIONAL BLVD. SUITE 800
 MAHWAH, NJ 07495



10 INDUSTRIAL AVE., SUITE 3
 MAHWAH, NJ 07430



100% EMPLOYEE-OWNED
 855 Community Dr, Sauk City, WI 53583
 608-643-4100 www.Ramaker.com
 Sauk City, WI • Willmar, MN
 Woodcliff Lake, NJ • Bayamon, PR

Certification & Seal:
 I hereby certify that this plan, specification, or report was prepared by me or under my direct supervision and that I am a duly Licensed Professional Engineer under the laws of the State of Connecticut.

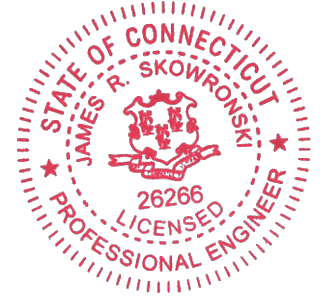

James R. Skowronski
 Signature: _____ Date: 2/12/2019

0	02/12/19	FINAL CDs ISSUED
---	----------	------------------

MARK	DATE	DESCRIPTION
ISSUE PHASE	FINAL	DATE ISSUED 02/12/2019

PROJECT TITLE:
**SALTONSTALL PLACE
 CT52XC125**

PROJECT INFORMATION:
 12 SALTONSTALL PLACE
 EAST HAVEN, CT 06512
 NEW HAVEN COUNTY

SHEET TITLE:
 SPECIFICATIONS

PROJECT NUMBER	37621
SHEET NUMBER	SP-1

SECTION 11 800 - INSTALLATION OF MULTIMODAL BASE STATIONS (MMBS) AND RELATED EQUIPMENT

SUMMARY:

- A. THIS SECTION SPECIFIES MMBS CABINETS, POWER CABINETS, AND INTERNAL EQUIPMENT INCLUDING BY NOT LIMITED TO RECTIFIERS, POWER DISTRIBUTION UNITS, BASE BAND UNITS, SURGE ARRESTORS, BATTERIES, AND SIMILAR EQUIPMENT FURNISHED BY THE COMPANY FOR INSTALLATION BY THE CONTRACTOR (OFCI).
- B. CONTRACTOR SHALL PROVIDE AND INSTALL ALL MISCELLANEOUS MATERIALS AND PROVIDE ALL LABOR REQUIRED FOR INSTALLATION EQUIPMENT IN EXISTING CABINET OR NEW CABINET AS SHOWN ON DRAWINGS AND AS REQUIRED BY THE APPLICABLE INSTALLATION MOPS.
- C. COMPLY WITH MANUFACTURER'S INSTALLATION AND START-UP REQUIREMENTS.

DC CIRCUIT BREAKER LABELING

- A. NEW DC CIRCUIT IS REQUIRED IN MMBS CABINET SHALL BE CLEARLY IDENTIFIED AS TO RRU BEING SERVICED.

SECTION 26 100 - BASIC ELECTRICAL REQUIREMENTS

SUMMARY:

THIS SECTION SPECIFIES BASIC ELECTRICAL REQUIREMENTS FOR SYSTEMS AND COMPONENTS.

QUALITY ASSURANCE:

- A. ALL EQUIPMENT FURNISHED UNDER DIVISION 26 SHALL CARRY UL LABELS AND LISTINGS WHERE SUCH LABELS AND LISTINGS ARE AVAILABLE IN THE INDUSTRY.
- B. MANUFACTURERS OF EQUIPMENT SHALL HAVE A MINIMUM OF THREE YEARS EXPERIENCE WITH THEIR EQUIPMENT INSTALLED AND OPERATING IN THE FIELD IN A USE SIMILAR TO THE PROPOSED USE FOR THIS PROJECT.
- C. **MATERIALS AND EQUIPMENT:** ALL MATERIALS AND EQUIPMENT SPECIFIED IN DIVISION 26 OF THE SAME TYPE SHALL BE OF THE SAME MANUFACTURER AND SHALL BE NEW, OF THE BEST QUALITY AND DESIGN, AND FREE FROM DEFECTS.

SUPPORTING DEVICES:

- A. MANUFACTURED STRUCTURAL SUPPORT MATERIALS: SUBJECT TO COMPLIANCE WITH REQUIREMENTS, PROVIDE PRODUCTS BY THE FOLLOWING:
 - 1. ALLIED TUBE AND CONDUIT.
 - 2. B-LINE SYSTEM.
 - 3. UNISTRUT DIVERSIFIED PRODUCTS.
 - 4. THOMAS & BETTS.
- B. FASTENERS: TYPES, MATERIALS, AND CONSTRUCTION FEATURES AS FOLLOWS:
 - 1. EXPANSION ANCHORS: CARBON STEEL WEDGE OR SLEEVE TYPE.
 - 2. POWER-DRIVEN THREADED STUDS: HEAT-TREATED STEEL, DESIGNED SPECIFICALLY FOR THE INTENDED SERVICE.
 - 3. FASTEN BY MEANS OF WOOD SCREWS ON WOOD.
 - 4. TOGGLE BOLTS ON HOLLOW MASONRY UNITS.
 - 5. CONCRETE INSERTS OR EXPANSION BOLTS ON CONCRETE OR SOLID MASONRY.
 - 6. MACHINE SCREWS, WELDED THREADED STUDS, OR SPRING-TENSION CLAMPS ON STEEL.
 - 7. EXPLOSIVE DEVICES FOR ATTACHING HANGERS TO STRUCTURE SHALL NOT BE PERMITTED.
 - 8. DO NOT WELD CONDUIT, PIPE STRAPS, OR ITEMS OTHER THAN THREADED STUDS TO STEEL STRUCTURES.
 - 9. IN PARTITIONS OF LIGHT STEEL CONSTRUCTION, USE SHEET METAL SCREWS.

SUPPORTING DEVICES:

- A. INSTALL SUPPORTING DEVICES TO FASTEN ELECTRICAL COMPONENTS SECURELY AND PERMANENTLY IN ACCORDANCE WITH NEC.
- B. COORDINATE WITH THE BUILDING STRUCTURAL SYSTEM AND WITH OTHER TRADES.
- C. UNLESS OTHERWISE INDICATED ON THE DRAWINGS, FASTEN ELECTRICAL ITEMS AND THEIR SUPPORTING HARDWARE SECURELY TO THE STRUCTURE IN ACCORDANCE WITH THE FOLLOWING:
 - 1. ENSURE THAT THE LOAD APPLIED BY ANY FASTENER DOES NOT EXCEED 25 PERCENT OF THE PROOF TEST LOAD.
 - 2. USE VIBRATION AND SHOCK-RESISTANT FASTENERS FOR ATTACHMENTS TO CONCRETE SLABS.

ELECTRICAL IDENTIFICATION:

- A. UPDATE AND PROVIDE TYPED CIRCUIT BREAKER SCHEDULES IN THE MOUNTING BRACKET, INSIDE DOORS OF AC PANEL BOARDS WITH ANY CHANGES MADE TO THE AC SYSTEM.
- B. BRANCH CIRCUITS FEEDING AVIATION OBSTRUCTION LIGHTING EQUIPMENT SHALL BE CLEARLY IDENTIFIED AS SUCH AT THE BRANCH CIRCUIT PANELBOARD.

SECTION 26 200 - ELECTRICAL MATERIALS AND EQUIPMENT

CONDUIT:

- A. RIGID GALVANIZED STEEL (RGS) CONDUIT SHALL BE USED FOR EXTERIOR LOCATIONS ABOVE GROUND AND IN UNFINISHED INTERIOR LOCATIONS AND FOR UNDERGROUND RUNS. RIGID CONDUIT AND FITTINGS SHALL BE STEEL, COATED WITH ZINC EXTERIOR AND INTERIOR BY THE HOT DIP GALVANIZING PROCESS. CONDUIT SHALL BE PRODUCED TO ANSI SPECIFICATIONS C80.1, FEDERAL SPECIFICATION WW-C-581 AND SHALL BE LISTED WITH THE UNDERWRITERS' LABORATORIES. FITTINGS SHALL BE THREADED - SET SCREW OR COMPRESSION FITTINGS WILL NOT BE ACCEPTABLE. RGS CONDUITS SHALL BE MANUFACTURED BY ALLIED, REPUBLIC OR WHEATLAND.
- B. UNDERGROUND CONDUIT IN CONCRETE SHALL BE POLYVINYLCHLORIDE (PVC) SUITABLE FOR DIRECT BURIAL AS APPLICABLE. JOINTS SHALL BE BELLED, AND FLUSH SOLVENT WELDED IN ACCORDANCE WITH MANUFACTURER'S INSTRUCTIONS. CONDUIT SHALL BE CARLON ELECTRICAL PRODUCTS OR APPROVED EQUAL.
- C. TRANSITIONS BETWEEN PVC AND RIGID (RGS) SHALL BE MADE WITH PVC COATED METALLIC LONG SWEEP RADIUS ELBOWS.
- D. EMT OR RIGID GALVANIZED STEEL CONDUIT MAY BE USED IN FINISHED SPACES CONCEALED IN WALLS AND CEILINGS. EMT SHALL BE MILD STEEL, ELECTRICALLY WELDED, ELECTRO-GALVANIZED OR HOT-DIPPED GALVANIZED AND PRODUCED TO ANSI SPECIFICATION C80.3, FEDERAL SPECIFICATION WW-C-563, AND SHALL BE UL LISTED. EMT SHALL BE MANUFACTURED BY ALLIED, REPUBLIC OR WHEATLAND, OR APPROVED EQUAL. FITTINGS SHALL BE METALLIC COMPRESSION. SET SCREW CONNECTIONS SHALL NOT BE ACCEPTABLE.
- E. LIQUID TIGHT FLEXIBLE METALLIC CONDUIT SHALL BE USED FOR FINAL CONNECTION TO EQUIPMENT. FITTINGS SHALL BE METALLIC GLAND TYPE COMPRESSION FITTINGS, MAINTAINING THE INTEGRITY OF CONDUIT SYSTEM. SET SCREW CONNECTIONS SHALL NOT BE ACCEPTABLE. MAXIMUM LENGTH OF FLEXIBLE CONDUIT SHALL NOT EXCEED 6-FEET. LFMC SHALL BE PROTECTED AND SUPPORTED AS REQUIRED BY NEC. MANUFACTURERS OF FLEXIBLE CONDUITS SHALL BE CAROL, ANACONDA METAL HOSE OR UNIVERSAL METAL HOSE, OR APPROVED EQUAL.
- F. MINIMUM SIZE CONDUIT SHALL BE 3/4 INCH (21MM).

HUBS AND BOXES:

- A. AT ENTRANCES TO CABINETS OR OTHER EQUIPMENT NOT HAVING INTEGRAL THREADED HUBS PROVIDE METALLIC THREADED HUBS OF THE SIZE AND CONFIGURATION REQUIRED. HUB SHALL INCLUDE LOCKNUT AND NEOPRENE O-RING SEAL. PROVIDE IMPACT RESISTANT 105 DEGREE C PLASTIC BUSHINGS TO PROTECT CABLE INSULATION.
- B. CABLE TERMINATION FITTINGS FOR CONDUIT
 - 1. CABLE TERMINATORS FOR RGS CONDUITS SHALL BE TYPE CRC BY O-Z/GEDNEY OR EQUAL BY ROXTEC.
 - 2. CABLE TERMINATORS FOR LFMC SHALL BE ETCO - CL2075; OR MADE FOR THE PURPOSE PRODUCTS BY ROXTEC.
- C. EXTERIOR PULL BOXES AND PULL BOXES IN INTERIOR INDUSTRIAL AREAS SHALL BE PLATED CAST ALLOY, HEAVY DUTY, WEATHERPROOF, DUST PROOF, WITH GASKET, PLATED IRON ALLOY COVER AND STAINLESS STEEL COVER SCREWS, CROUSE-HINDS WAB SERIES OR EQUAL.
- D. CONDUIT OUTLET BODIES SHALL BE PLATED CAST ALLOY WITH SIMILAR GASKET COVERS. OUTLET BODIES SHALL BE OF THE CONFIGURATION AND SIZE SUITABLE FOR THE APPLICATION. PROVIDE CROUSE-HINDS FORM 8 OR EQUAL.
- E. MANUFACTURER FOR BOXES AND COVERS SHALL BE HOFFMAN, SQUARE "D", CROUSE-HINDS, COOPER, ADALET, APPLETON, O-Z GEDNEY, RACO, OR APPROVED EQUAL.

SUPPLEMENTAL GROUNDING SYSTEM:

- A. FURNISH AND INSTALL A SUPPLEMENTAL GROUNDING SYSTEM TO THE EXTENT INDICATED ON THE DRAWINGS. SUPPORT SYSTEM WITH NON-MAGNETIC STAINLESS STEEL CLIPS WITH RUBBER GROMMETS. GROUNDING CONNECTORS SHALL BE TINNED COPPER WIRE, SIZES AS INDICATED ON THE DRAWINGS. PROVIDE STRANDED OR SOLID BARE OR INSULATED CONDUCTORS EXCEPT AS OTHERWISE NOTED.
- B. SUPPLEMENTAL GROUNDING SYSTEM: ALL CONNECTIONS TO BE MADE WITH CAD WELDS, EXCEPT AT EQUIPMENT USE LUGS OR OTHER AVAILABLE GROUNDING MEANS AS REQUIRED BY MANUFACTURER; AT GROUND BARS USE TWO HOLE SPADES WITH NO-OX.
- C. STOLEN GROUND-BARS: IN THE EVENT OF STOLEN GROUND BARS, CONTACT SPRINT CM FOR REPLACEMENT INSTRUCTION USING THREADED ROD KITS.

EXISTING STRUCTURE:

- A. EXISTING EXPOSED WIRING AND ALL EXPOSED OUTLETS, RECEPTACLES, SWITCHES, DEVICES, BOXES, AND OTHER EQUIPMENT THAT ARE NOT TO BE UTILIZED IN THE COMPLETED PROJECT SHALL BE REMOVED OR DE-ENERGIZED AND CAPPED IN THE WALL, CEILING, OR FLOOR SO THAT THEY ARE CONCEALED AND SAFE. WALL, CEILING, OR FLOOR SHALL BE PATCHED TO MATCH THE ADJACENT CONSTRUCTION.

CONDUIT AND CONDUCTOR INSTALLATION:

- A. CONDUITS SHALL BE FASTENED SECURELY IN PLACE WITH APPROVED NON-PERFORATED STRAPS AND HANGERS. EXPLOSIVE DEVICES FOR ATTACHING HANGERS TO STRUCTURE WILL NOT BE PERMITTED. CLOSELY FOLLOW THE LINES OF THE STRUCTURE, MAINTAIN CLOSE PROXIMITY TO THE STRUCTURE AND KEEP CONDUITS IN TIGHT ENVELOPES. CHANGES IN DIRECTION TO ROUTE AROUND OBSTACLES SHALL BE MADE WITH CONDUIT OUTLET BODIES. CONDUIT SHALL BE INSTALLED IN A NEAT AND WORKMANLIKE MANNER, PARALLEL AND PERPENDICULAR TO STRUCTURE WALL AND CEILING LINES. ALL CONDUIT SHALL BE FISHED TO CLEAR OBSTRUCTIONS. ENDS OF CONDUITS SHALL BE TEMPORARILY CAPPED TO PREVENT CONCRETE, PLASTER OR DIRT FROM ENTERING. CONDUITS SHALL BE RIGIDLY CLAMPED TO BOXES BY GALVANIZED MALLEABLE IRON BUSHING ON INSIDE AND GALVANIZED MALLEABLE IRON LOCKNUT ON OUTSIDE AND INSIDE.
- B. CONDUCTORS SHALL BE PULLED IN ACCORDANCE WITH ACCEPTED GOOD PRACTICE.



1 INTERNATIONAL BLVD. SUITE 800
 MAHWAH, NJ 07495



10 INDUSTRIAL AVE., SUITE 3
 MAHWAH, NJ 07430



100% EMPLOYEE-OWNED
 855 Community Dr, Sauk City, WI 53583
 608-643-4100 www.Ramaker.com
 Sauk City, WI • Willmar, MN
 Woodcliff Lake, NJ • Bayamon, PR

Certification & Seal:
 I hereby certify that this plan, specification, or report was prepared by me or under my direct supervision and that I am a duly Licensed Professional Engineer under the laws of the State of Connecticut.

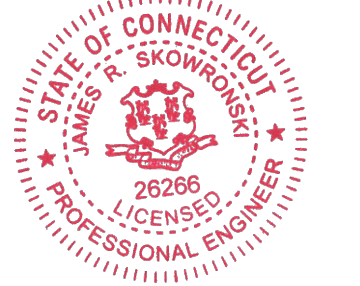

Signature: *James R. Skowronski* Date: 2/12/2019

MARK	DATE	DESCRIPTION
0	02/12/19	FINAL CDs ISSUED
ISSUE PHASE	FINAL	DATE ISSUED 02/12/2019

PROJECT TITLE:
**SALTONSTALL PLACE
 CT52XC125**

PROJECT INFORMATION:
 12 SALTONSTALL PLACE
 EAST HAVEN, CT 06512
 NEW HAVEN COUNTY

SHEET TITLE:
 SPECIFICATIONS

PROJECT NUMBER	37621
SHEET NUMBER	SP-2

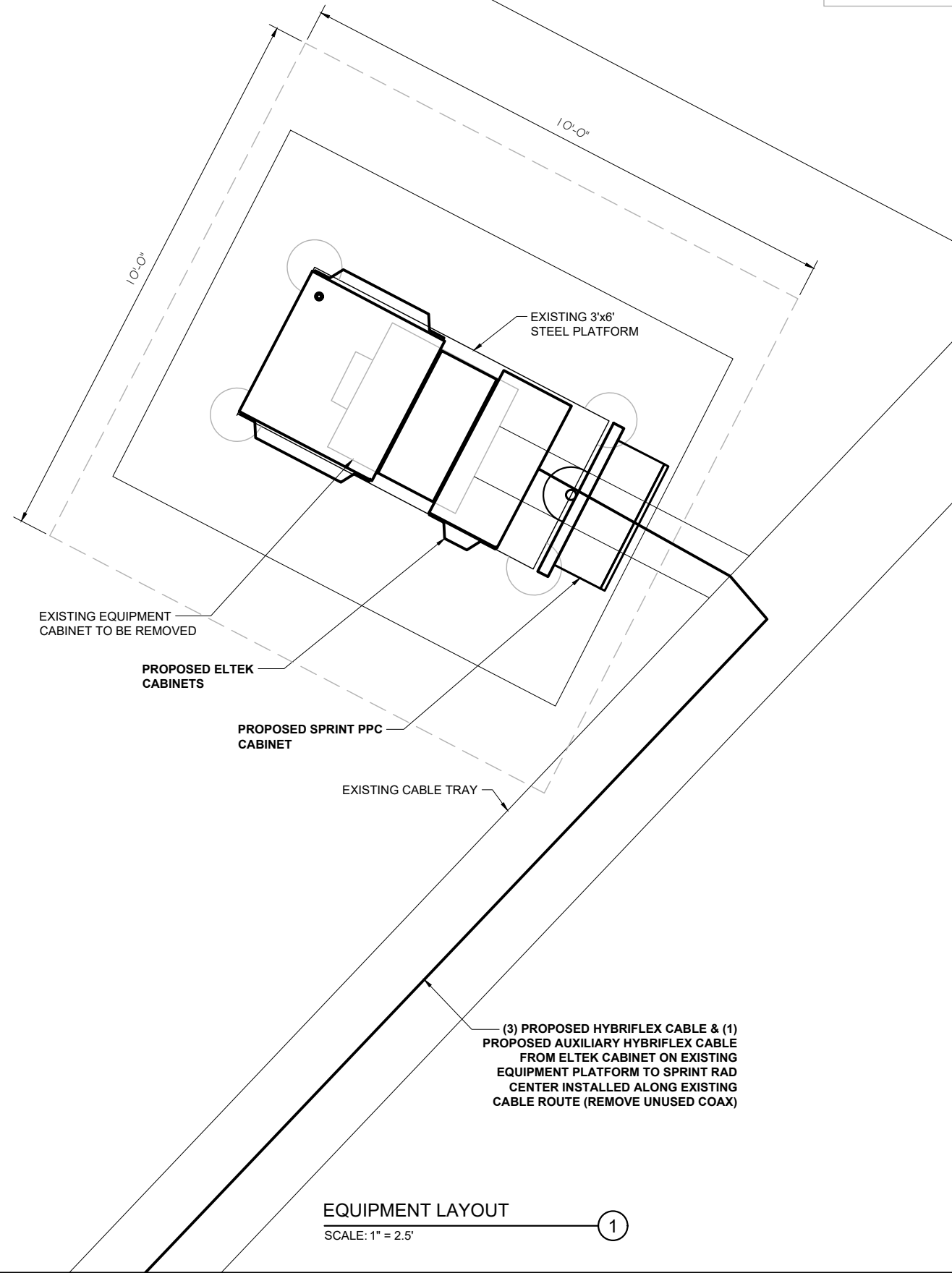

EQUIPMENT LAYOUT
 SCALE: 1" = 2.5' 1

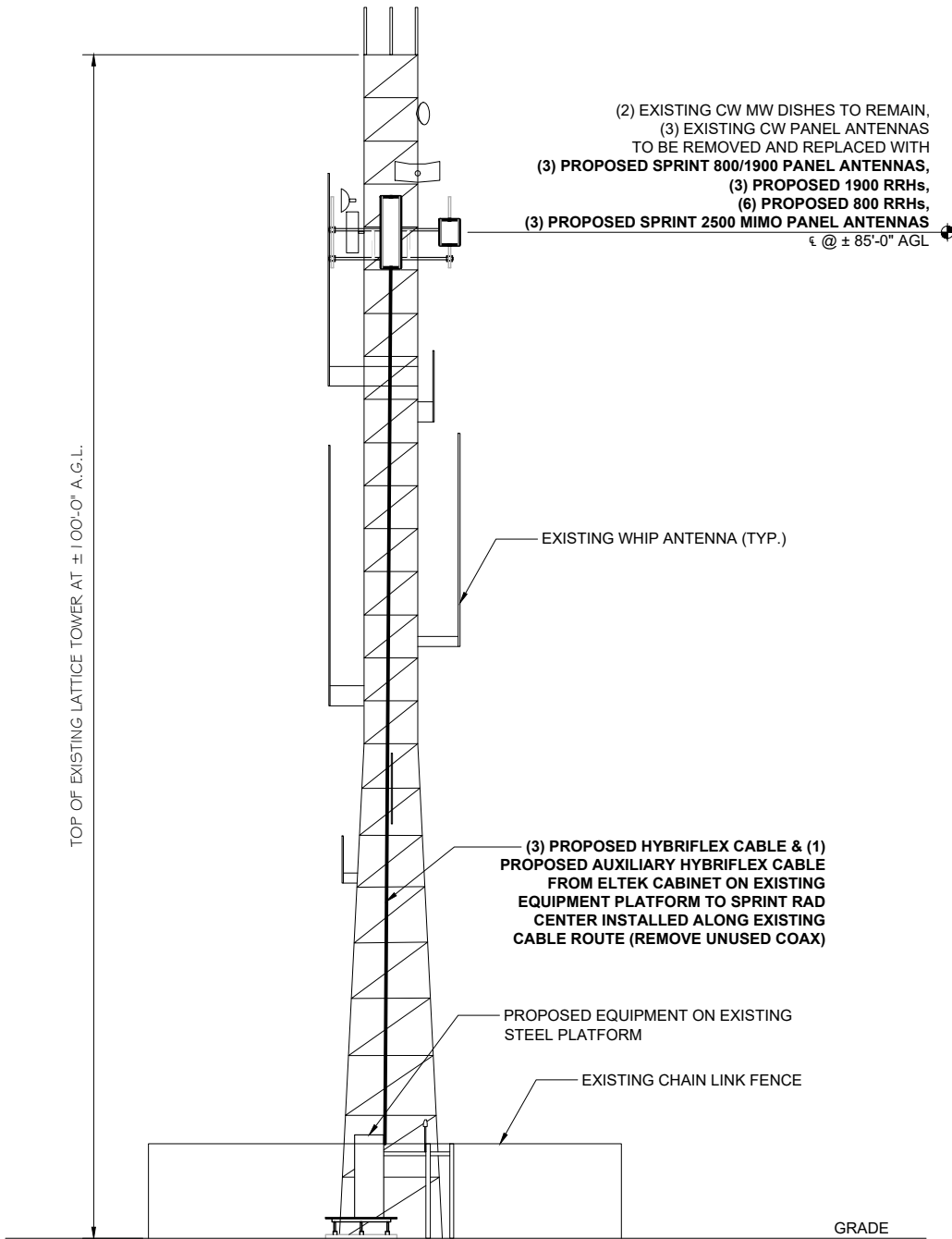

TOWER ELEVATION
 SCALE: 1" = 15' 2



1 INTERNATIONAL BLVD. SUITE 800
 MAHWAH, NJ 07495



10 INDUSTRIAL AVE., SUITE 3
 MAHWAH, NJ 07430



100% EMPLOYEE-OWNED
 855 Community Dr, Sauk City, WI 53583
 608-643-4100 www.Ramaker.com
 Sauk City, WI • Willmar, MN
 Woodcliff Lake, NJ • Bayamon, PR

Certification & Seal:
 I hereby certify that this plan, specification, or report was prepared by me or under my direct supervision and that I am a duly Licensed Professional Engineer under the laws of the State of Connecticut.

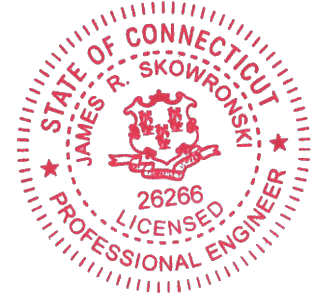

James R. Skowronski
 Signature: _____ Date: 2/12/2019

MARK	DATE	DESCRIPTION
0	02/12/19	FINAL CDs ISSUED
ISSUE PHASE	FINAL	DATE ISSUED 02/12/2019

**SALTONSTALL PLACE
 CT52XC125**

PROJECT INFORMATION:
 12 SALTONSTALL PLACE
 EAST HAVEN, CT 06512
 NEW HAVEN COUNTY

SHEET TITLE:
**EQUIPMENT LAYOUT &
 TOWER ELEVATION**

SCALE:
 AS NOTED

PROJECT NUMBER: 37621
 SHEET NUMBER: A-1

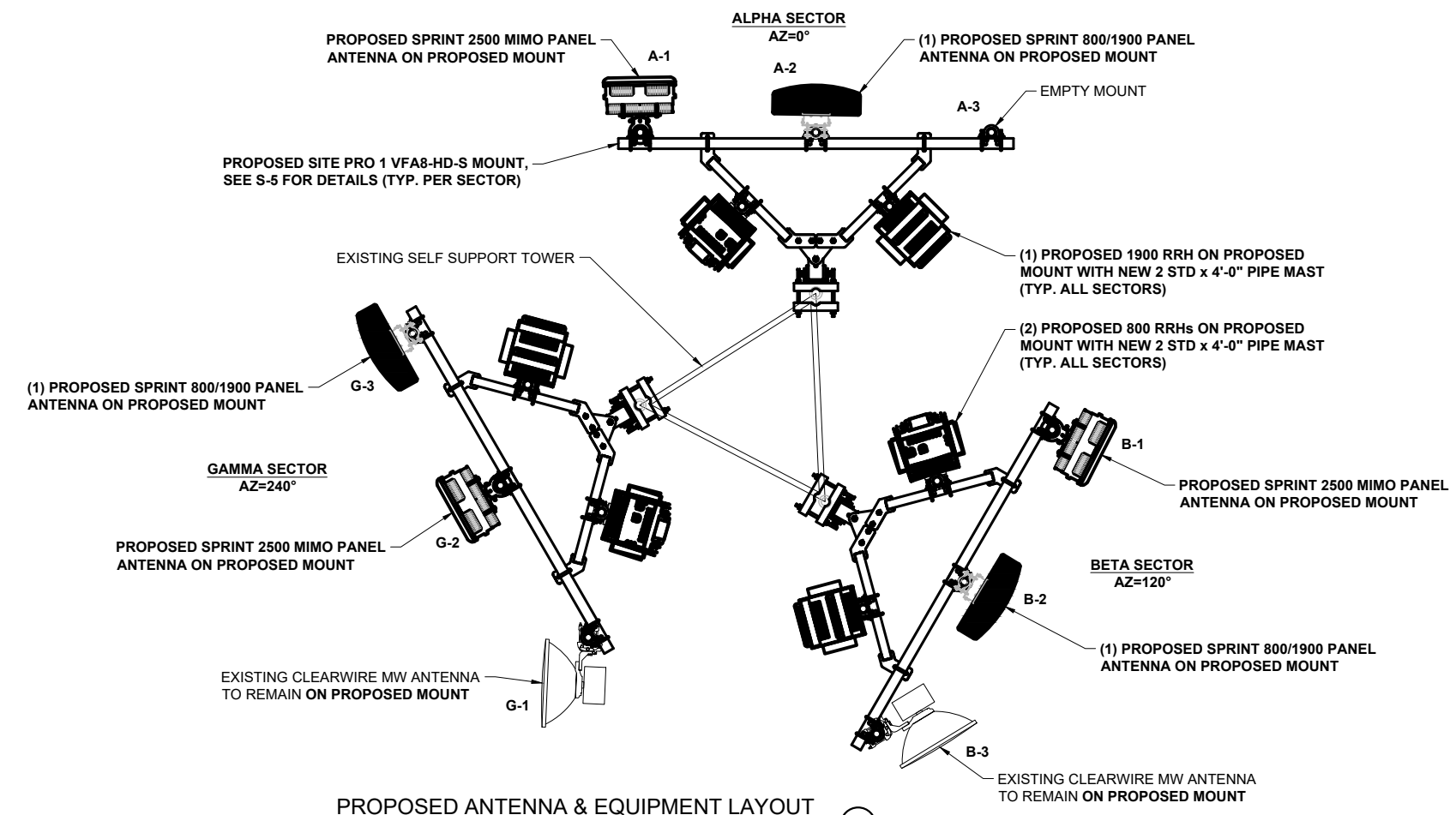
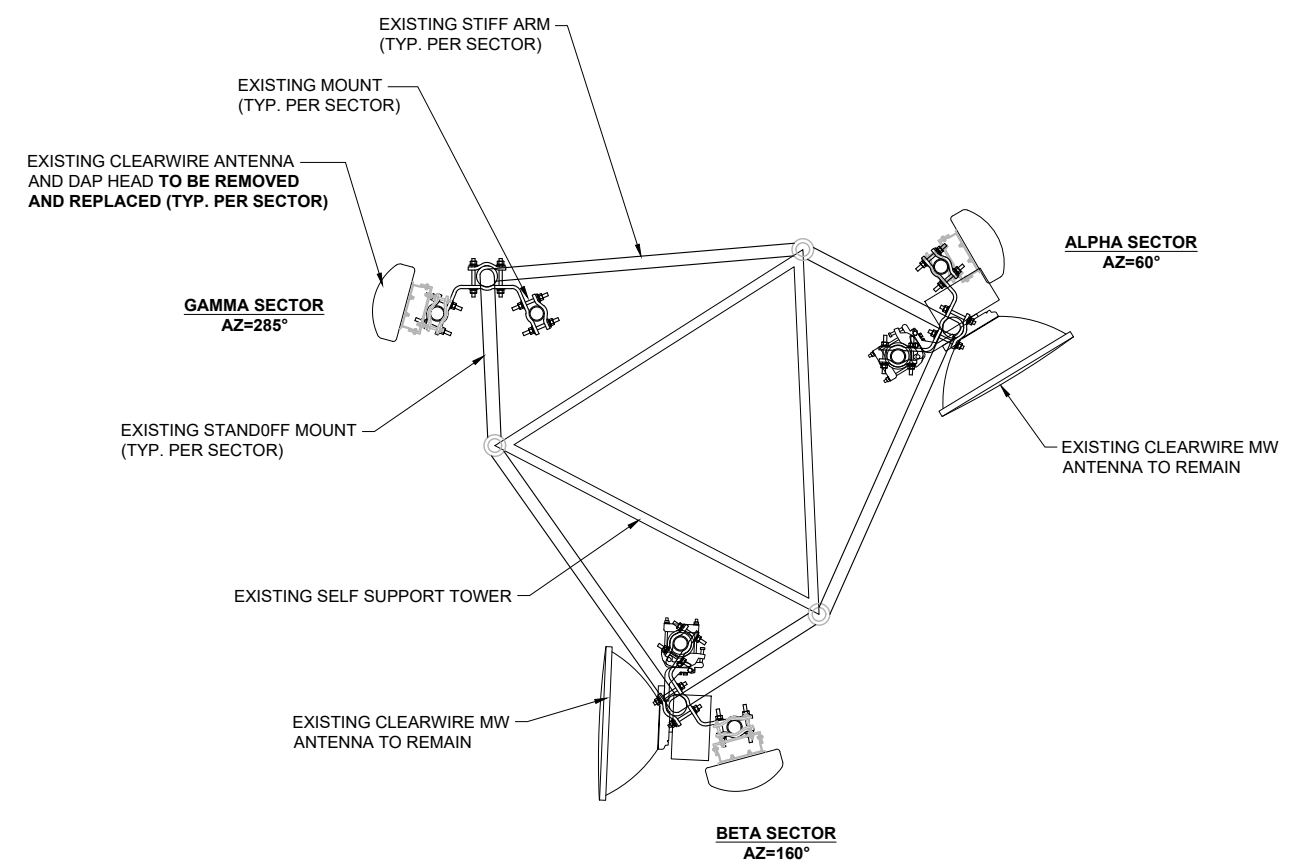

1 INTERNATIONAL BLVD. SUITE 800
 MAHWAH, NJ 07495



10 INDUSTRIAL AVE., SUITE 3
 MAHWAH, NJ 07430



100% EMPLOYEE-OWNED
 855 Community Dr, Sauk City, WI 53583
 608-643-4100 www.Ramaker.com
 Sauk City, WI • Willmar, MN
 Woodcliff Lake, NJ • Bayamon, PR

Certification & Seal:
 I hereby certify that this plan, specification, or report was prepared by me or under my direct supervision and that I am a duly Licensed Professional Engineer under the laws of the State of Connecticut.

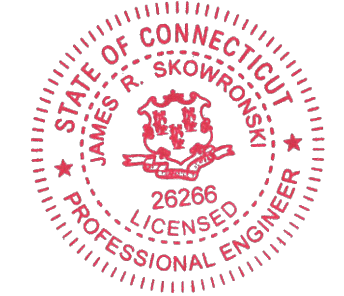

Signature: *James R. Skowronski* Date: 2/12/2019

MARK	DATE	DESCRIPTION
0	02/12/19	FINAL CDs ISSUED
ISSUE PHASE	FINAL	DATE ISSUED 02/12/2019

PROJECT TITLE:
SALTONSTALL PLACE CT52XC125

PROJECT INFORMATION:
 12 SALTONSTALL PLACE
 EAST HAVEN, CT 06512
 NEW HAVEN COUNTY

SHEET TITLE:
 ANTENNA LAYOUTS

SCALE:
 AS NOTED

PROJECT NUMBER: 37621
 SHEET NUMBER: A-2

MECHANICAL	
DIMENSION (HxWxD)	25.6" x 19.7" x 9.64"
WEIGHT	103.7 lbs

ANTENNA MODEL: NOKIA #AAHC - ANTENNA SPECS

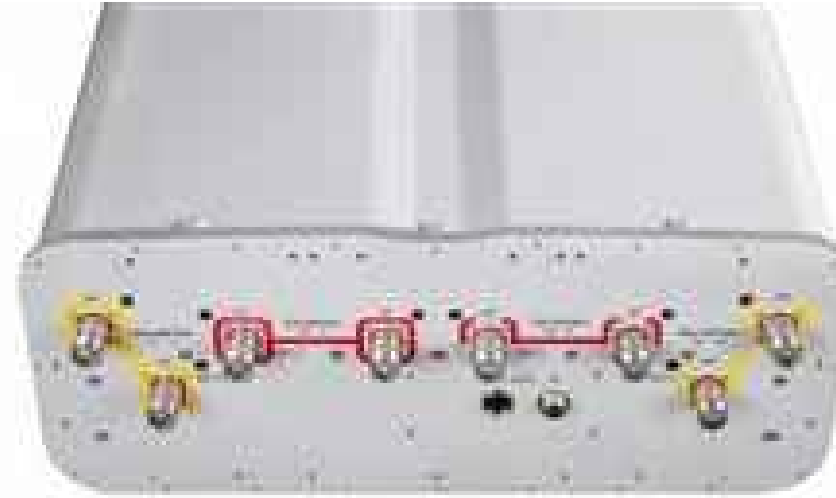
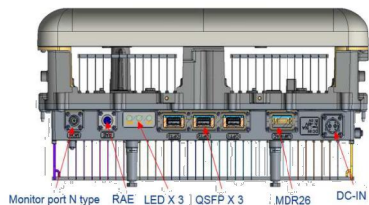

MECHANICAL	
DIMENSION (HxWxD)	72.0" x 19.6" x 7.8"
WEIGHT	77.4 lbs

ANTENNA MODEL: COMMSCOPE #NNVV-65B-R4 - ANTENNA SPECS

800MHz 2X50W Remote Radio Head (RRH)

- Simultaneous CDMA & LTE Multi technology RRH 862-869 MHz
- Any combination of CDMA and LTE carriers supported by 100W RF Power
 - 2 CPRI-like Optical Connections for daisy chaining
 - Software Switchable External Filter for use before Public Safety is cleared
- Dimensions: w/o Filter w/ Filter
- Height: 480 mm (19") 480 mm (19")
 - Width: 330 mm (13") 330 mm (13")
 - Depth: 218 mm (8.6") 310 (12.2")
 - Weight: 24 kg (53 lbs) 29 kg (64 lbs)
 - 49 liters, <29kg
- Power Supply: -48 VDC
 Power Consumption: <400W Typical
 Operating Temp range -40° C to +55° C
 Option to mount on Ground at tower base

Front/Top View



Bottom View

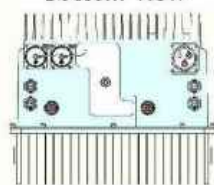

Alcatel-Lucent's 800 RRH satisfies Sprint's requirements.

MECHANICAL	
DIMENSION (HxWxD)	19" x 13" x 12.2"
WEIGHT	64 lbs

RRH MODEL: ALU #800 MHz 2x50W - RADIO SPECS

1900MHz Remote Radio Head (RRH)

Capacity & Features

- CDMA / LTE Multi technology RRH 65MHz bandwidth (PCS A-G Band)
- Sprint is free to deploy any combination of CDMA (1XRTT or EVDO) and LTE carriers in Sprint's spectrum up to 160 Watts of RF power
 - E.g. "A block" and "G block" both with 4 branch MIMO (4Tx & 4Rx)
 - 2 CPRI Optical Connections for multi-carrier LTE and CDMA (1X & DO)
- Power Supply: -48 VDC
 Power Consumption: 700W Typical
- Dimensions:
- Size: 282 x 271.5 x 637mm (11.1" x 10.69" x 25.1")
 - Volume: 49 Liter
 - 56 liters with solar shield & mounting OD
- Weight: 27 kg (59.5 lbs)
 Operating Temp range -40° C/+55° C

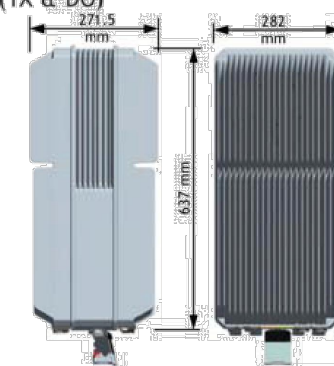
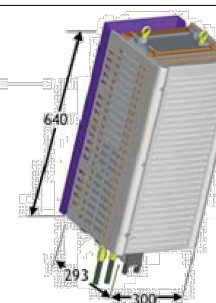

Alcatel-Lucent's 65MHz RRH satisfies Sprint's requirements.

MECHANICAL	
DIMENSION (HxWxD)	25.2"x11.8"x11.5"
WEIGHT	59.5 lbs

RRH MODEL: ALU #1900 MHz 4x45W - RADIO SPECS



1 INTERNATIONAL BLVD. SUITE 800
 MAHWAH, NJ 07495



10 INDUSTRIAL AVE., SUITE 3
 MAHWAH, NJ 07430



100% EMPLOYEE-OWNED
 855 Community Dr, Sauk City, WI 53583
 608-643-4100 www.Ramaker.com
 Sauk City, WI • Willmar, MN
 Woodcliff Lake, NJ • Bayamon, PR

Certification & Seal:
 I hereby certify that this plan, specification, or report was prepared by me or under my direct supervision and that I am a duly Licensed Professional Engineer under the laws of the State of Connecticut.



Signature: *James R. Skowronski* Date: 2/12/2019

MARK	DATE	DESCRIPTION
0	02/12/19	FINAL CDs ISSUED
ISSUE PHASE	FINAL	DATE ISSUED 02/12/2019

PROJECT TITLE:
**SALTONSTALL PLACE
 CT52XC125**

PROJECT INFORMATION:
 12 SALTONSTALL PLACE
 EAST HAVEN, CT 06512
 NEW HAVEN COUNTY

SHEET TITLE:
EQUIPMENT DETAILS

SCALE:
 AS NOTED

PROJECT NUMBER	37621
SHEET NUMBER	A-3

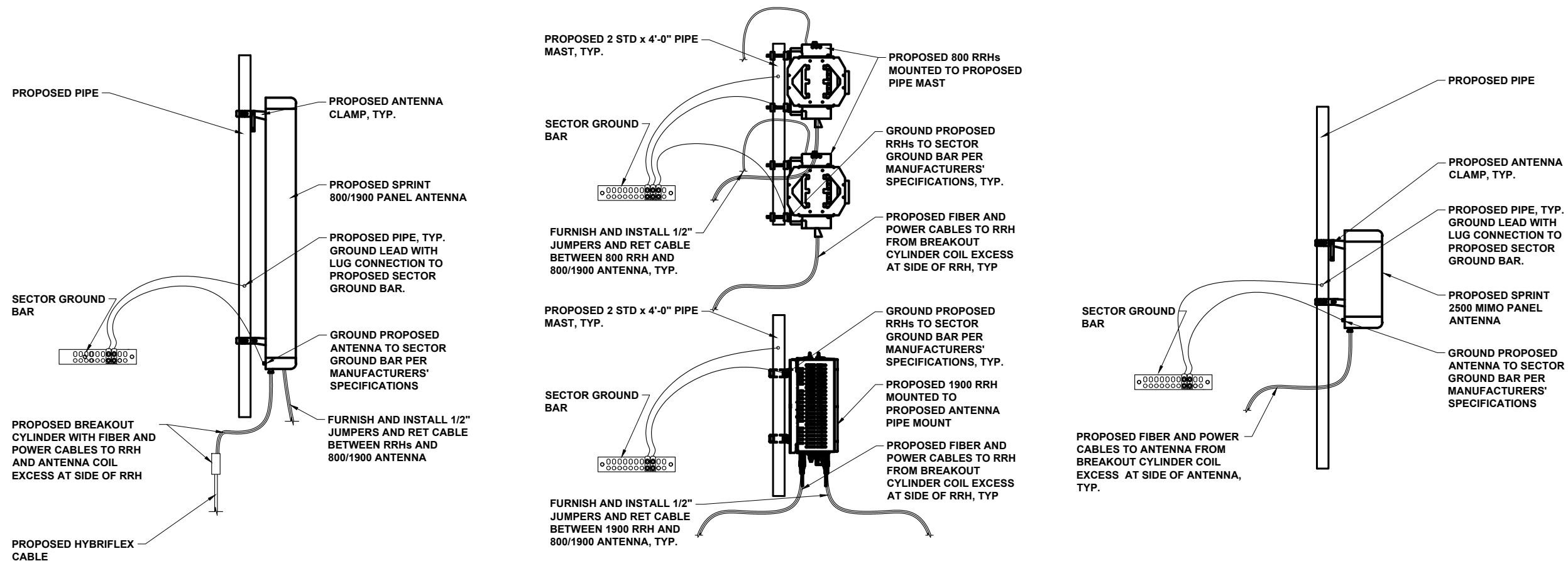

EQUIPMENT MOUNTING DETAIL 1
 SCALE: NTS



1 INTERNATIONAL BLVD. SUITE 800
 MAHWAH, NJ 07495



10 INDUSTRIAL AVE., SUITE 3
 MAHWAH, NJ 07430



100% EMPLOYEE-OWNED
 855 Community Dr, Sauk City, WI 53583
 608-643-4100 www.Ramaker.com
 Sauk City, WI • Willmar, MN
 Woodcliff Lake, NJ • Bayamon, PR

Certification & Seal:
 I hereby certify that this plan, specification, or report was prepared by me or under my direct supervision and that I am a duly Licensed Professional Engineer under the laws of the State of Connecticut.



Signature: *James R. Skowronski* Date: 2/12/2019

MARK	DATE	DESCRIPTION
0	02/12/19	FINAL CDs ISSUED
ISSUE PHASE	FINAL	DATE ISSUED 02/12/2019

PROJECT TITLE:
SALTONSTALL PLACE CT52XC125

PROJECT INFORMATION:
 12 SALTONSTALL PLACE
 EAST HAVEN, CT 06512
 NEW HAVEN COUNTY

SHEET TITLE:
EQUIPMENT DETAILS & SCHEDULE

SCALE:
 AS NOTED

PROJECT NUMBER: 37621
 SHEET NUMBER: A-4

800/1900/2500 EQUIPMENT SCHEDULE								
SECTOR	POSITION	ANTENNA MAKE/MODEL	AZIMUTH	CENTERLINE	RRH	CABLE TYPE	CABLE LENGTH	JUMPER TYPE
ALPHA	1	PROPOSED 2500 MIMO PANEL ANTENNA (NOKIA AAHC)	0°	85'-0"	2500 RRH INTERGRATED WITH MIMO ANTENNA	(1) PROPOSED HYBRIFLEX	147'	8' HYBRID
	2	PROPOSED 800/1900 PANEL ANTENNA (COMMSCOPE NNVV-65B-R4)	0°	85'-0"	(1) PROPOSED RRH 1900 4X45 65 MHz & (2) PROPOSED RRH 800 MHz 2x50W			
	3	EMPTY MOUNT	-	-	-			
BETA	1	PROPOSED 2500 MIMO PANEL ANTENNA (NOKIA AAHC)	120°	85'-0"	2500 RRH INTERGRATED WITH MIMO ANTENNA	(1) PROPOSED HYBRIFLEX	147'	8' HYBRID
	2	PROPOSED 800/1900 PANEL ANTENNA (COMMSCOPE NNVV-65B-R4)	120°	85'-0"	(1) PROPOSED RRH 1900 4X45 65 MHz & (2) PROPOSED RRH 800 MHz 2x50W			
	3	EXISTING CLEARWIRE MW ANTENNA	-	-	-			
GAMMA	1	EXISTING CLEARWIRE MW ANTENNA	-	-	-	(1) PROPOSED HYBRIFLEX & (1) PROPOSED AUXILIARY HYBRIFLEX	147'	8' HYBRID
	2	PROPOSED 2500 MIMO PANEL ANTENNA (NOKIA AAHC)	240°	85'-0"	2500 RRH INTERGRATED WITH MIMO ANTENNA			
	3	PROPOSED 800/1900 PANEL ANTENNA (COMMSCOPE NNVV-65B-R4)	240°	85'-0"	(1) PROPOSED RRH 1900 4X45 65 MHz & (2) PROPOSED RRH 800 MHz 2x50W			

ANTENNA & EQUIPMENT SCHEDULES 2
 SCALE: N.T.S.

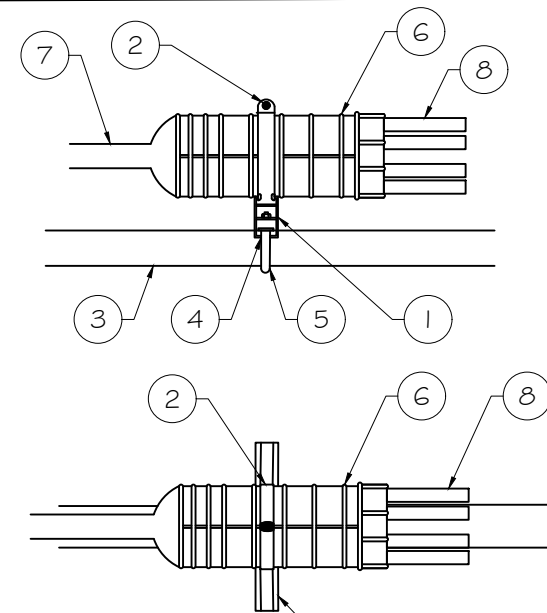

- NOTES:
- 1 1/2" x 1 5/8" UNISTRUT, 6" LONG
 - 4" PIPE HANGER
 - EXISTING SUPPORT PIPE
 - NEW STANDOFF BRACKET ANDREW PART NO. 30848-4. CONTRACTOR TO SUPPLY 3/8" CONNECTION HARDWARE
 - NEW ROUND MEMBER ADAPTED SIZED FOR PIPE SUPPORT
 - NEW CABLE BREAKOUT UNIT
 - NEW HYBRID CABLE
 - NEW FIBER & POWER CABLES FROM BREAKOUT

HYBRID BREAKOUT DETAIL 3
 SCALE: NTS

CABLE TYPE REQUIRED FOR THIS SITE
(± 130'-0")

Ref. Hybrid cable type (sort by length)					
	Type 1	Type 2	Type 3	Type 4	Type 5
Total Length	~35 m	~55 m	~65 m	~80 m	~100 m
Hybrid Power Cable configuration	AWG 10 1 pair, AWG 12 3 pair	AWG 8 1 pair, AWG 10 3 pair	AWG 6 1 pair, AWG 8 1 pair, AWG 10 2 pair	AWG 6 1 pair, AWG 8 3 pair	AWG 4 1 pair, AWG 6 1 pair, AWG 8 2 pair
Cable diameter	25mm	27mm	30mm	30/32mm ¹⁾	32mm
Bending radius	300mm	330mm	390mm	450mm	450mm
Optic cable	LC/PC-to-LC/PC, Single mode				
DU cabinet (power cable terminal max size AWG 4)	2 pair power and optic cable With PE pipe				
RRU Power cable Spec	AWG 8, 14.7~15.4 mm AWG 10, 11.5~12.4 mm				
Non use Power and optic cable protection	2 pair power and optic cable With PE pipe	2 pair power and optic cable With PE pipe	2 pair power and optic cable With PE pipe	2 pair power and optic cable With PE pipe	

HYBRID CABLE SPECIFICATIONS ①
 SCALE: NTS

CABLE TYPE REQUIRED FOR THIS SITE
(± 130'-0")

	#8 AWG	#6 AWG	#4 AWG
Distance Range	30 ft – 135 ft	136 ft – 225 ft	226 ft – 390 ft
Wire Size / count	#8 / 3 pairs	#6 / 3 pairs	#4 / 3 pairs
Fiber Count	24 fibers	24 fibers	24 fibers
Fiber breakout top	4 sets of 6 fibers MFC connector	4 sets of 6 fibers MFC connector	4 sets of 6 fibers MFC connector
Fiber breakout bottom	4 sets of 6, LC connector	4 sets of 6, LC connector	4 sets of 6, LC connector
Diameter*	~1.13 inch	~1.2 inch	1.4 inch
Weight per foot*	~0.725 lb/ft(2.38lb/m)	~0.97 lb/ft (3.17 lb/m)	~ 1.36 lb/ft (4.47 lb/m)
Bend radius*	16.9 in	18 in	21 in
Ratings	UL and UV	UL and UV	UL and UV
Outer Sheath (thickness)	1.6 mm	1.6 mm	1.6 mm
Al Conduit (thickness)	0.4 mm	0.4 mm	0.4 mm

AUXILIARY HYBRID CABLE SPECIFICATIONS ②
 SCALE: NTS

Hybrid Cable Color Map(Legacy NV cable only)				
ID	NV HFC (One per sector)			
Freq	1.9 GHz	800 MHz	800 MHz or 1.9MHz 2nd RRH ***	2.5 GHz
Circuit(Eltek)	C*12,13,14	NC*13,14,15	NC16,17,18	NC10,11,12
Return STA	White/Red Stripe	White/Black Stripe	**White/Blue Stripe White/Brown Stripe	**White/Blue Stripe White/Brown Stripe
-48VDC STA	Red	Black	Blue/Brown	Blue/Brown
ID	Aux HFC-STA ONLY			
Freq	2.5 GHz-S1	2.5 GHz-S2	2.5 GHz-S3	
Circuit	NC10	NC11	NC12	
Return	White/Red Stripe	White/Black Stripe	White/Blue stripe	
-48VDC	Red	Black	Blue	

*C=Critical, NC=NonCritical Buss
 **STA Bi-Wired Pairs. Either 1.9, 800 2nd RRH or 2.5 can use this dual pair.
 *** Use only one freq band RRH. To deploy more than 4 RRHs/sector a second Ecab must be deployed.

HYBRID CABLE COLOR CODING ③
 SCALE: NTS



1 INTERNATIONAL BLVD. SUITE 800
 MAHWAH, NJ 07495



10 INDUSTRIAL AVE., SUITE 3
 MAHWAH, NJ 07430



100% EMPLOYEE-OWNED
 855 Community Dr, Sauk City, WI 53583
 608-643-4100 www.Ramaker.com
 Sauk City, WI • Willmar, MN
 Woodcliff Lake, NJ • Bayamon, PR

Certification & Seal:
 I hereby certify that this plan, specification, or report was prepared by me or under my direct supervision and that I am a duly Licensed Professional Engineer under the laws of the State of Connecticut.

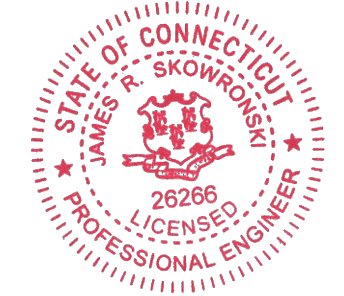

Signature: *James R. Skowronski* Date: 2/12/2019

MARK	DATE	DESCRIPTION
0	02/12/19	FINAL CDs ISSUED
ISSUE PHASE	FINAL	DATE ISSUED 02/12/2019

PROJECT TITLE:
**SALTONSTALL PLACE
 CT52XC125**

PROJECT INFORMATION:
 12 SALTONSTALL PLACE
 EAST HAVEN, CT 06512
 NEW HAVEN COUNTY

SHEET TITLE:
 CABLE SPECS & MARKING NOTES

SCALE:
 AS NOTED

PROJECT NUMBER	37621
SHEET NUMBER	A-5

RRH-1800							
Sector #	Radio Port #	First Ring	Second Ring	Third Ring	Space	Sector #	Frequency-Radio #
1	1	Green	No tape	No tape		Yellow	Green
1	2		No tape	No tape		Yellow	Green
Sector #	Cable #	First Ring	Second Ring	Third Ring	Space	Sector #	Frequency-Radio #
2	1	Green	Green	No tape		Yellow	Green
2	2			No tape		Yellow	Green
Sector #	Radio Port #	First Ring	Second Ring	Third Ring	Space	Sector #	Frequency-Radio #
3	1	Green	Green	Green		Yellow	Green
3	2					Yellow	Green

RRH-2800							
Sector #	Radio Port #	First Ring	Second Ring	Third Ring	Space	Sector #	Frequency-Radio #
1	1	Green	No tape	No tape		Yellow	Orange
1	2		No tape	No tape		Yellow	Orange
Sector #	Radio Port #	First Ring	Second Ring	Third Ring	Space	Sector #	Frequency-Radio #
2	1	Green	Green	No tape		Yellow	Orange
2	2			No tape		Yellow	Orange
Sector #	Radio Port #	First Ring	Second Ring	Third Ring	Space	Sector #	Frequency-Radio #
3	1	Green	Green	Green		Yellow	Orange
3	2					Yellow	Orange

RRH-1900							
Sector #	Radio Port #	First Ring	Second Ring	Third Ring	Space	Sector #	Frequency-Radio #
1	1	Green	No tape	No tape		Yellow	Red
1	2		No tape	No tape		Yellow	Red
1	3	Brown	No tape	No tape		Yellow	Red
1	4	White	No tape	No tape		Yellow	Red
Sector #	Radio Port #	First Ring	Second Ring	Third Ring	Space	Sector #	Frequency-Radio #
2	1	Green	Green	No tape		Yellow	Red
2	2			No tape		Yellow	Red
2	3	Brown	Brown	No tape		Yellow	Red
2	4	White	White	No tape		Yellow	Red
Sector #	Radio Port #	First Ring	Second Ring	Third Ring	Space	Sector #	Frequency-Radio #
3	1	Green	Green	Green		Yellow	Red
3	2					Yellow	Red
3	3	Brown	Brown	Brown		Yellow	Red
3	4	White	White	White		Yellow	Red

RRH-2900							
Sector #	Radio Port #	First Ring	Second Ring	Third Ring	Space	Sector #	Frequency-Radio #
1	1	Green	No tape	No tape		Yellow	Brown
1	2		No tape	No tape		Yellow	Brown
1	3	Brown	No tape	No tape		Yellow	Brown
1	4	White	No tape	No tape		Yellow	Brown
Sector #	Radio Port #	First Ring	Second Ring	Third Ring	Space	Sector #	Frequency-Radio #
2	1	Green	Green	No tape		Yellow	Brown
2	2			No tape		Yellow	Brown
2	3	Brown	Brown	No tape		Yellow	Brown
2	4	White	White	No tape		Yellow	Brown
Sector #	Radio Port #	First Ring	Second Ring	Third Ring	Space	Sector #	Frequency-Radio #
3	1	Green	Green	Green		Yellow	Brown
3	2					Yellow	Brown
3	3	Brown	Brown	Brown		Yellow	Brown
3	4	White	White	White		Yellow	Brown

RRH-3900							
Sector #	Radio Port #	First Ring	Second Ring	Third Ring	Space	Sector #	Frequency-Radio #
1	1	Green	No tape	No tape		Yellow	
1	2		No tape	No tape		Yellow	
1	3	Brown	No tape	No tape		Yellow	
1	4	White	No tape	No tape		Yellow	
Sector #	Radio Port #	First Ring	Second Ring	Third Ring	Space	Sector #	Frequency-Radio #
2	1	Green	Green	No tape		Yellow	
2	2			No tape		Yellow	
2	3	Brown	Brown	No tape		Yellow	
2	4	White	White	No tape		Yellow	
Sector #	Radio Port #	First Ring	Second Ring	Third Ring	Space	Sector #	Frequency-Radio #
3	1	Green	Green	Green		Yellow	
3	2					Yellow	
3	3	Brown	Brown	Brown		Yellow	
3	4	White	White	White		Yellow	

RRH-12500							
Sector #	Radio Port #	First Ring	Second Ring	Third Ring	Space	Sector #	Frequency-Radio #
1	1	Green	No tape	No tape		Yellow	White
1	2		No tape	No tape		Yellow	White
1	3	Brown	No tape	No tape		Yellow	White
1	4	White	No tape	No tape		Yellow	White
1	5	Red	No tape	No tape		Yellow	White
1	6	Gray	No tape	No tape		Yellow	White
1	7		No tape	No tape		Yellow	White
1	8	Orange	No tape	No tape		Yellow	White
Sector #	Radio Port #	First Ring	Second Ring	Third Ring	Space	Sector #	Frequency-Radio #
2	1	Green	Green	No tape		Yellow	White
2	2			No tape		Yellow	White
2	3	Brown	Brown	No tape		Yellow	White
2	4	White	White	No tape		Yellow	White
2	5	Red	Red	No tape		Yellow	White
2	6	Gray	Gray	No tape		Yellow	White
2	7		No tape	No tape		Yellow	White
2	8	Orange	Orange	No tape		Yellow	White
Sector #	Radio Port #	First Ring	Second Ring	Third Ring	Space	Sector #	Frequency-Radio #
3	1	Green	Green	Green		Yellow	White
3	2					Yellow	White
3	3	Brown	Brown	Brown		Yellow	White
3	4	White	White	White		Yellow	White
3	5	Red	Red	Red		Yellow	White
3	6	Gray	Gray	Gray		Yellow	White
3	7		No tape	No tape		Yellow	White
3	8	Orange	Orange	Orange		Yellow	White

RRH-22500							
Sector #	Radio Port #	First Ring	Second Ring	Third Ring	Space	Sector #	Frequency-Radio #
1	1	Green	No tape	No tape		Yellow	
1	2		No tape	No tape		Yellow	
1	3	Brown	No tape	No tape		Yellow	
1	4	White	No tape	No tape		Yellow	
1	5	Red	No tape	No tape		Yellow	
1	6	Gray	No tape	No tape		Yellow	
1	7		No tape	No tape		Yellow	
1	8	Orange	No tape	No tape		Yellow	
Sector #	Radio Port #	First Ring	Second Ring	Third Ring	Space	Sector #	Frequency-Radio #
2	1	Green	Green	No tape		Yellow	
2	2			No tape		Yellow	
2	3	Brown	Brown	No tape		Yellow	
2	4	White	White	No tape		Yellow	
2	5	Red	Red	No tape		Yellow	
2	6	Gray	Gray	No tape		Yellow	
2	7		No tape	No tape		Yellow	
2	8	Orange	Orange	No tape		Yellow	
Sector #	Radio Port #	First Ring	Second Ring	Third Ring	Space	Sector #	Frequency-Radio #
3	1	Green	Green	Green		Yellow	
3	2					Yellow	
3	3	Brown	Brown	Brown		Yellow	
3	4	White	White	White		Yellow	
3	5	Red	Red	Red		Yellow	
3	6	Gray	Gray	Gray		Yellow	
3	7		No tape	No tape		Yellow	
3	8	Orange	Orange	Orange		Yellow	

RRH-32500							
Sector #	Radio Port #	First Ring	Second Ring	Third Ring	Space	Sector #	Frequency-Radio #
1	1	Green	No tape	No tape		Yellow	Gray
1	2		No tape	No tape		Yellow	Gray
1	3	Brown	No tape	No tape		Yellow	Gray
1	4	White	No tape	No tape		Yellow	Gray
1	5	Red	No tape	No tape		Yellow	Gray
1	6	Gray	No tape	No tape		Yellow	Gray
1	7		No tape	No tape		Yellow	Gray
1	8	Orange	No tape	No tape		Yellow	Gray
Sector #	Radio Port #	First Ring	Second Ring	Third Ring	Space	Sector #	Frequency-Radio #
2	1	Green	Green	No tape		Yellow	Gray
2	2			No tape		Yellow	Gray
2	3	Brown	Brown	No tape		Yellow	Gray
2	4	White	White	No tape		Yellow	Gray
2	5	Red	Red	No tape		Yellow	Gray
2	6	Gray	Gray	No tape		Yellow	Gray
2	7		No tape	No tape		Yellow	Gray
2	8	Orange	Orange	No tape		Yellow	Gray
Sector #	Radio Port #	First Ring	Second Ring	Third Ring	Space	Sector #	Frequency-Radio #
3	1	Green	Green	Green		Yellow	Gray
3	2					Yellow	Gray
3	3	Brown	Brown	Brown		Yellow	Gray
3	4	White	White	White		Yellow	Gray
3	5	Red	Red	Red		Yellow	Gray
3	6	Gray	Gray	Gray		Yellow	Gray
3	7		No tape	No tape		Yellow	Gray
3	8	Orange	Orange	Orange		Yellow	Gray



1 INTERNATIONAL BLVD. SUITE 800
 MAHWAH, NJ 07495



10 INDUSTRIAL AVE., SUITE 3
 MAHWAH, NJ 07430



100% EMPLOYEE-OWNED
 855 Community Dr, Sauk City, WI 53583
 608-643-4100 www.Ramaker.com
 Sauk City, WI • Willmar, MN
 Woodcliff Lake, NJ • Bayamon, PR

Certification & Seal:
 I hereby certify that this plan, specification, or report was prepared by me or under my direct supervision and that I am a duly Licensed Professional Engineer under the laws of the State of Connecticut.

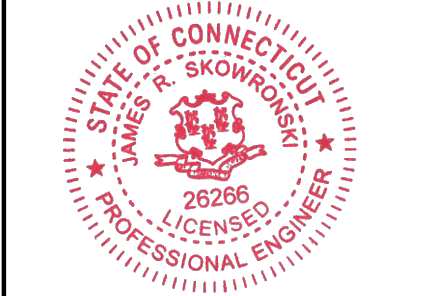

Signature: *James R. Skowronski* Date: 2/12/2019

MARK	DATE	DESCRIPTION
0	02/12/19	FINAL CDs ISSUED

ISSUE PHASE: FINAL DATE ISSUED: 02/12/2019

PROJECT TITLE:
SALTONSTALL PLACE
CT52XC125
 PROJECT INFORMATION:
 12 SALTONSTALL PLACE
 EAST HAVEN, CT 06512
 NEW HAVEN COUNTY

SHEET TITLE:
CABLE MARKING NOTES

SCALE:
 AS NOTED

PROJECT NUMBER: 37621
 SHEET NUMBER: A-6

JUMPER COLOR CODING
 SCALE: NTS 1

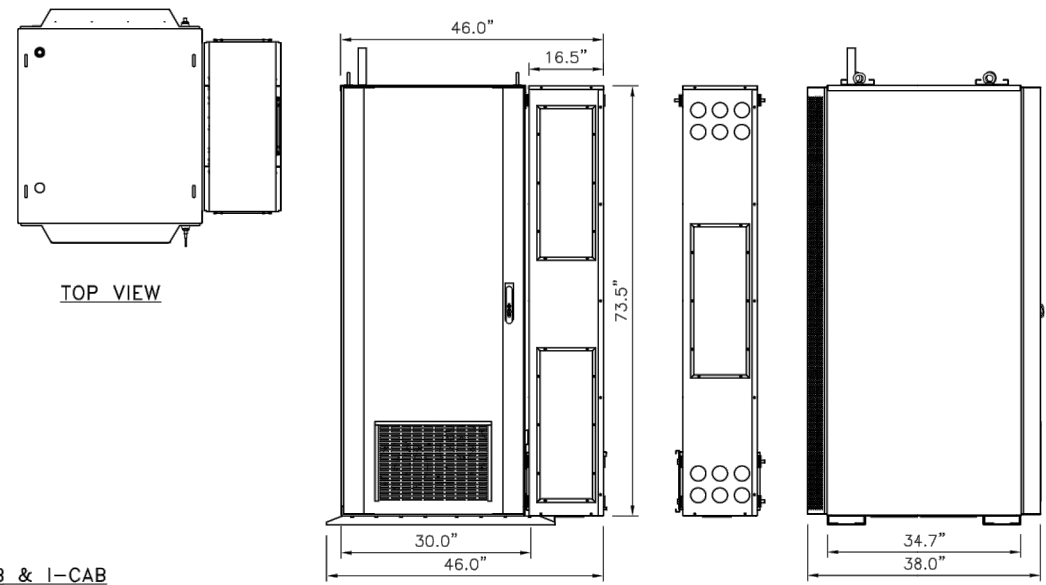

E-CAB & I-CAB
 DIMENSIONS HxWxD: 73.5"x30.0"x38.0"
 EMPTY WEIGHT: 505lbs
 FULLY LOADED WEIGHT: 1,381lbs

ELTEK E-CAB & I-CAB
 SCALE: NTS ①

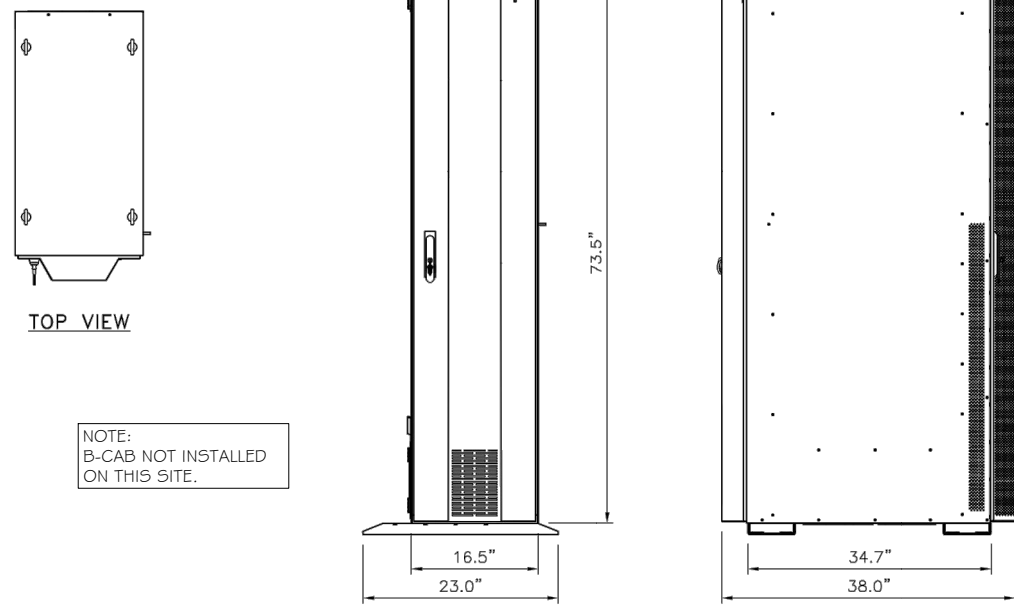

NOTE:
 B-CAB NOT INSTALLED
 ON THIS SITE.

B-CAB
 DIMENSIONS HxWxD: 73.5"x16.5"x38.0"
 EMPTY WEIGHT: 330lbs
 FULLY LOADED WEIGHT: 1,386lbs

ELTEK B-CAB
 SCALE: NTS ②

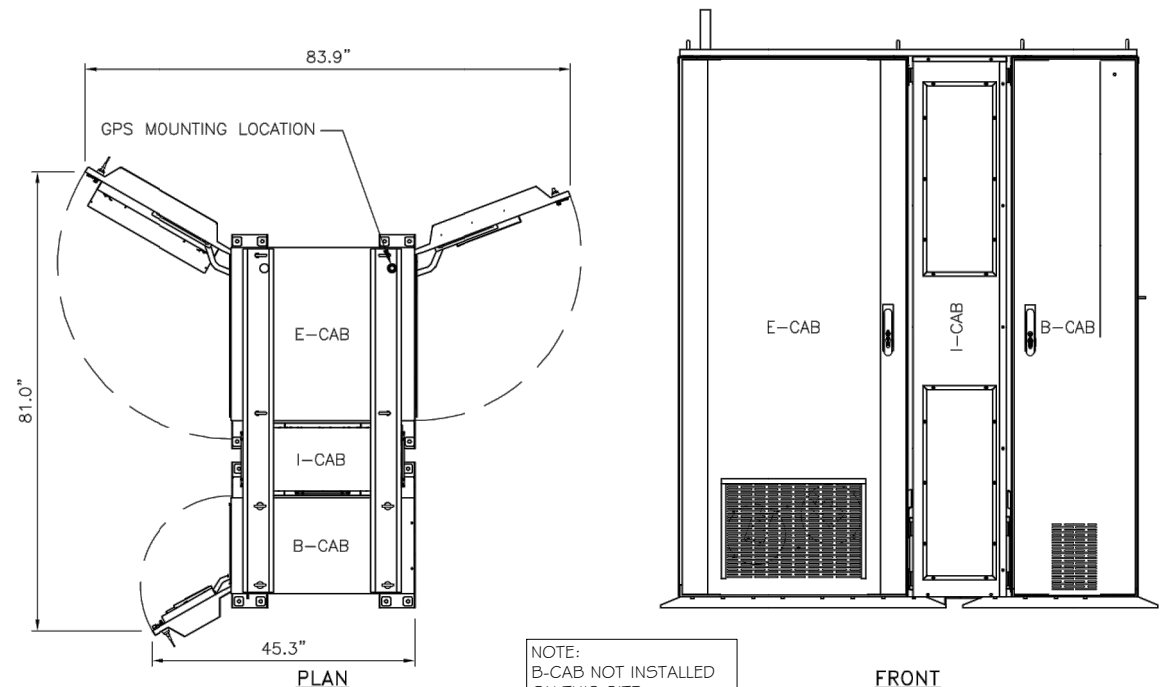

NOTE:
 B-CAB NOT INSTALLED
 ON THIS SITE.

ELTEK E-CAB, I-CAB & B-CAB
 SCALE: NTS ③

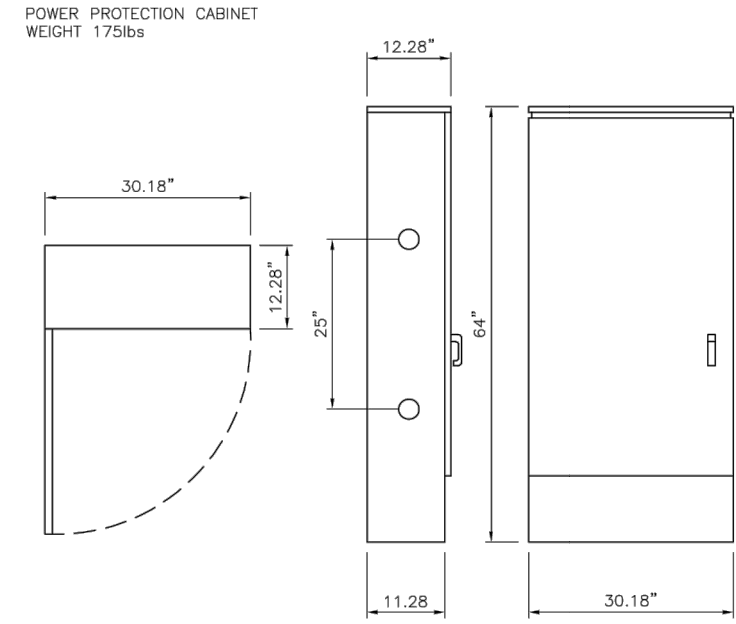

PPC CABINET DETAIL
 SCALE: NTS ④



1 INTERNATIONAL BLVD. SUITE 800
 MAHWAH, NJ 07495



10 INDUSTRIAL AVE., SUITE 3
 MAHWAH, NJ 07430



100% EMPLOYEE-OWNED
 855 Community Dr, Sauk City, WI 53583
 608-643-4100 www.Ramaker.com
 Sauk City, WI • Willmar, MN
 Woodcliff Lake, NJ • Bayamon, PR

Certification & Seal:
 I hereby certify that this plan, specification, or report was prepared by me or under my direct supervision and that I am a duly Licensed Professional Engineer under the laws of the State of Connecticut.

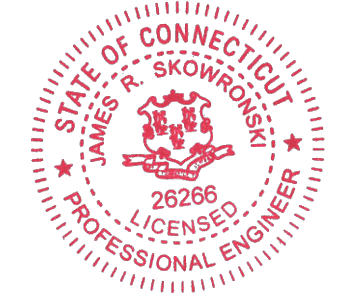

Signature: *James R. Skowronski* Date: 2/12/2019

MARK	DATE	DESCRIPTION
0	02/12/19	FINAL CDs ISSUED
ISSUE PHASE	FINAL	DATE ISSUED 02/12/2019

PROJECT TITLE:
**SALTONSTALL PLACE
 CT52XC125**

PROJECT INFORMATION:
 12 SALTONSTALL PLACE
 EAST HAVEN, CT 06512
 NEW HAVEN COUNTY

SHEET TITLE:
CABINET SPECS

SCALE:
 AS NOTED

PROJECT NUMBER: 37621
 SHEET NUMBER: A-7

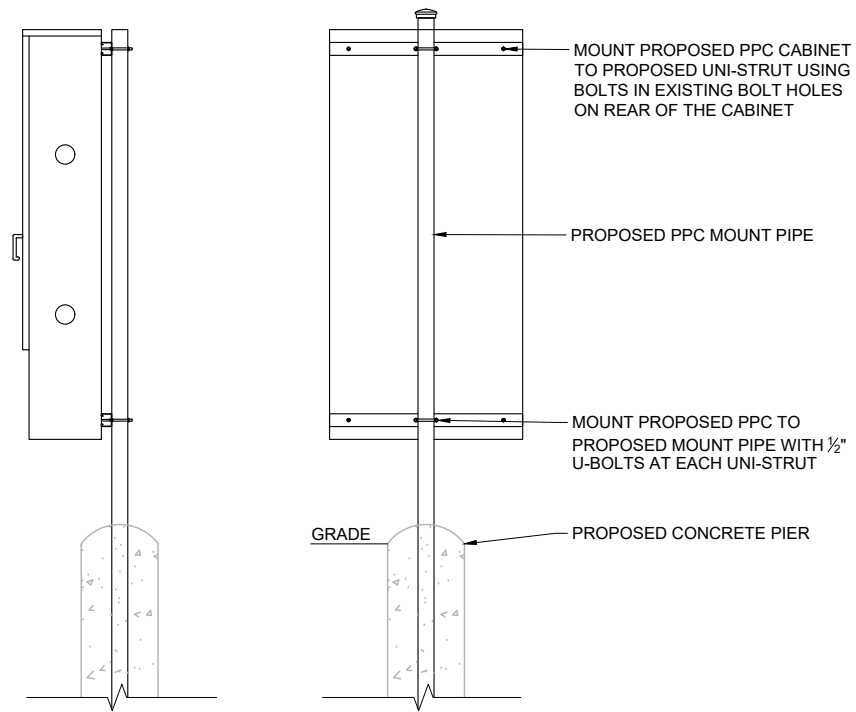

PPC MOUNTING DETAILS
 SCALE: 1" = 2.5' ①

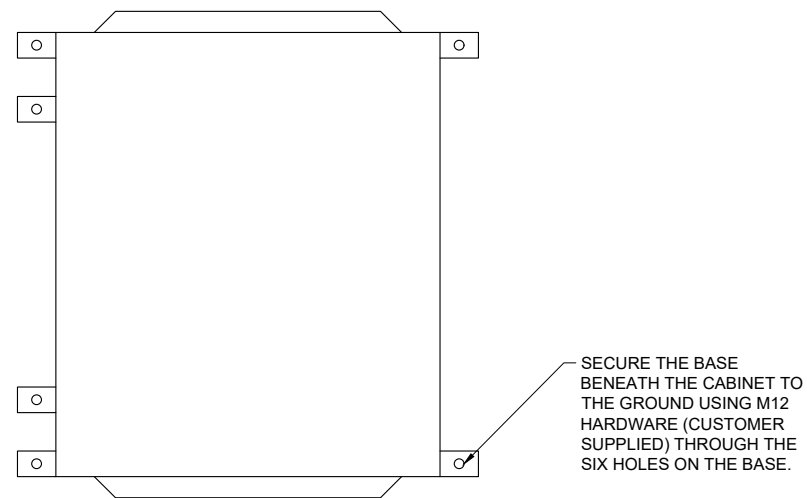

NOTE:
 MOUNTING WASHERS (P/N 331847700) ARE SUPPLIED. THEY ARE ON TOP OF THE MOUNTING BRACKETS, WHEN SECURING THE BASE TO THE GROUND.

ECAB MOUNTING DETAIL
 SCALE: 1" = 1.25' ②

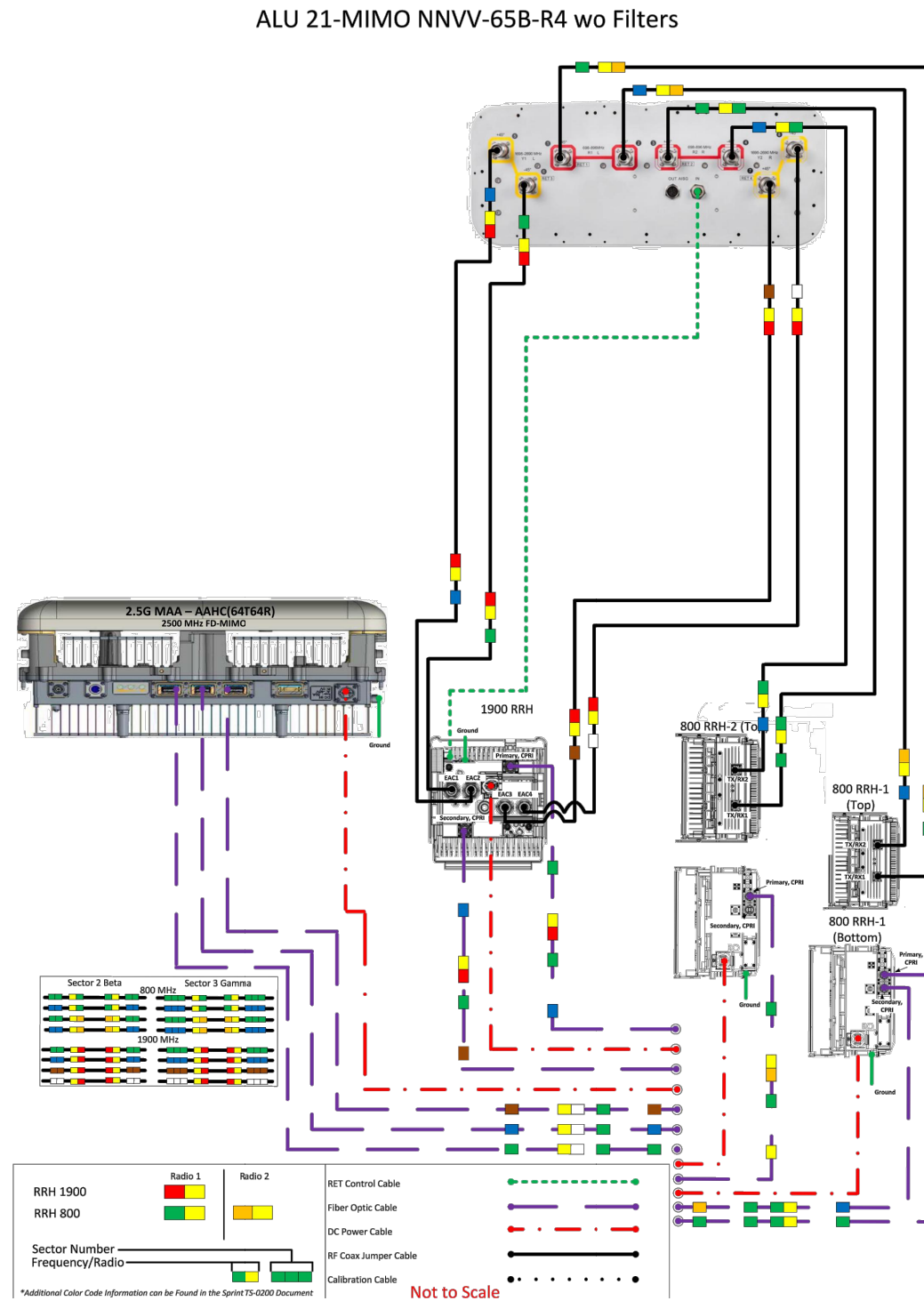

PLUMBING DIAGRAM
 SCALE: NTS ③



1 INTERNATIONAL BLVD. SUITE 800
 MAHWAH, NJ 07495



10 INDUSTRIAL AVE., SUITE 3
 MAHWAH, NJ 07430



100% EMPLOYEE-OWNED
 855 Community Dr, Sauk City, WI 53583
 608-643-4100 www.Ramaker.com
 Sauk City, WI • Willmar, MN
 Woodcliff Lake, NJ • Bayamon, PR

Certification & Seal:
 I hereby certify that this plan, specification, or report was prepared by me or under my direct supervision and that I am a duly Licensed Professional Engineer under the laws of the State of Connecticut.



Signature: *James R. Skowronski* Date: 2/12/2019

MARK	DATE	DESCRIPTION
0	02/12/19	FINAL CDs ISSUED
ISSUE PHASE	FINAL	DATE ISSUED 02/12/2019

PROJECT TITLE:
**SALTONSTALL PLACE
 CT52XC125**

PROJECT INFORMATION:
 12 SALTONSTALL PLACE
 EAST HAVEN, CT 06512
 NEW HAVEN COUNTY

SHEET TITLE:
 EQUIPMENT MOUNTING
 DETAILS & PLUMBING DIAGRAM

SCALE:
 AS NOTED

PROJECT NUMBER	37621
SHEET NUMBER	A-8

SYMBOL LEGEND	
■	EXOTHERMIC CONNECTION
▲	MECHANICAL CONNECTION

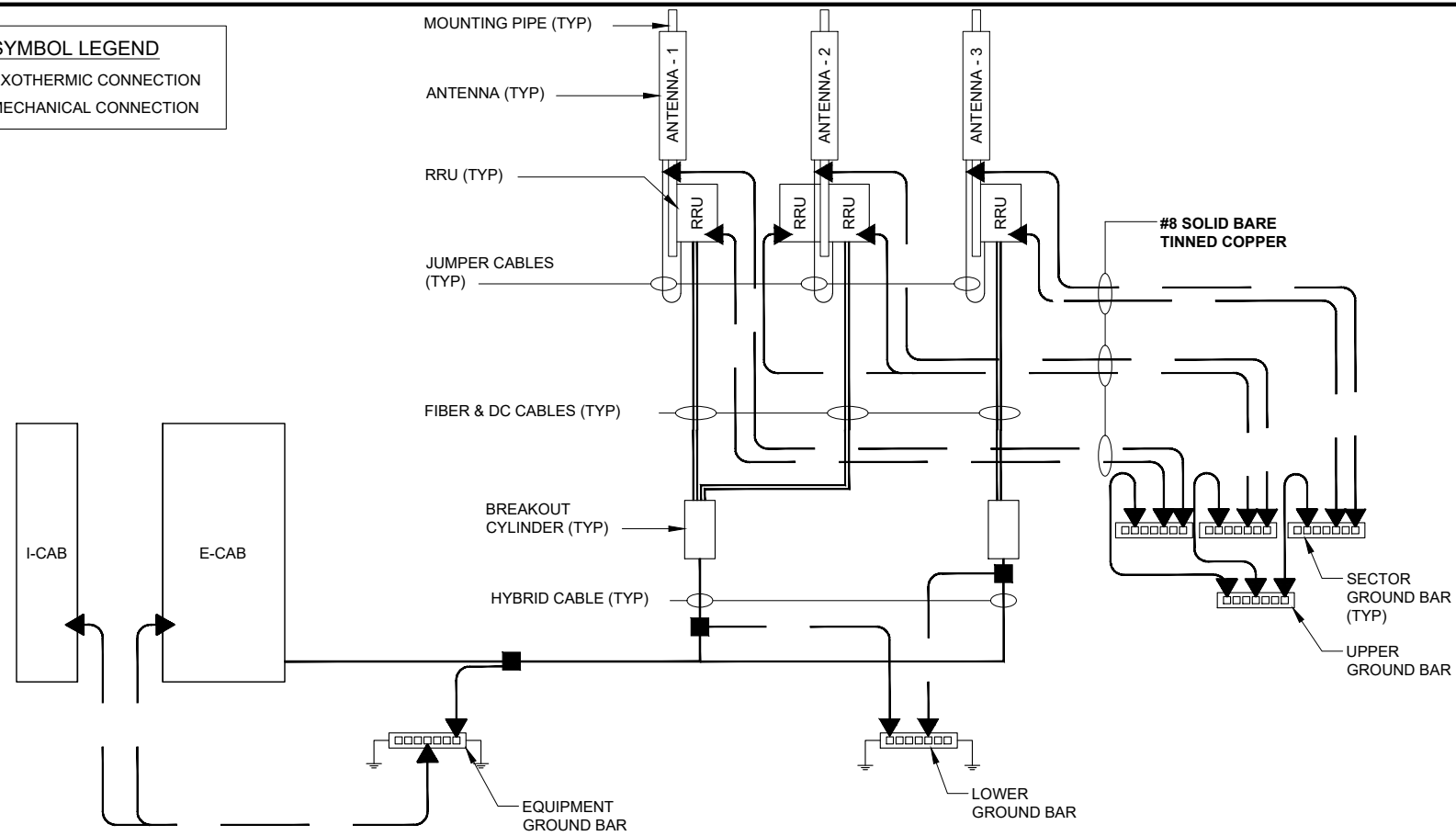

GROUNDING RISER DIAGRAM (TYP.)

SCALE: NTS

1

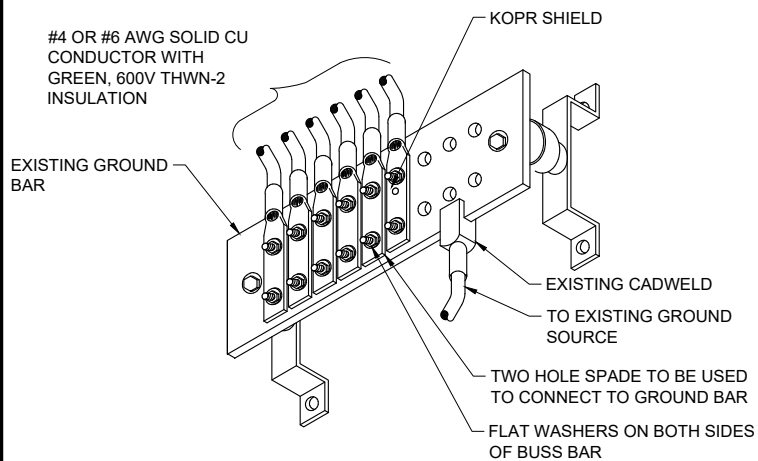

- NOTES:
1. APPLY NO-OX TO LUG AND GROUND BAR CONTACT SURFACE. DO NOT COAT INLINE LUG.
 2. IF STOLEN GROUND BARS ARE ENCOUNTERED, CONTACT SPRINT CM FOR REPLACEMENT THREADED ROD KIT.

GROUNDING CONDUCTOR INSTALLATION

SCALE: NTS

1

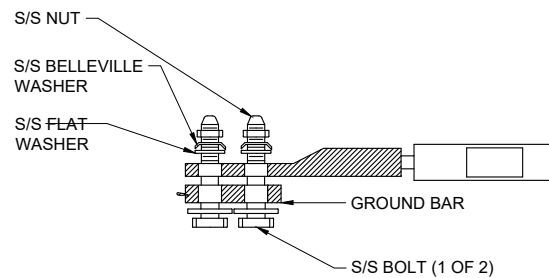

NOTES:

1. PROVIDE 2-HOLE, LONG BARREL, TINNED SOLID COPPER LUGS WHEREVER LUGS ARE SHOWN. ERICO B-122-CE PREFERRED WITH CADWELD TYPE GL CONNECTION. THOMAS AND BETTS 54800BE SERIES WHERE CRIMP CONNECTOR IS REQUIRED.
2. ALL CRIMP CONNECTIONS MUST BE MADE USING HYDRAULIC TOOLS AND THREE POINT HEXAGONAL COMPRESSION MOLDS ON LONG BARREL LUGS.
3. ALL MECHANICAL CONNECTIONS MUST BE MADE USING THOMAS AND BETTS "KOPR-SHIELD". COAT ALL WIRES BEFORE LUGGING. COAT ALL SURFACES BEFORE CONNECTING.
4. ALL HARDWARE 18/8 STAINLESS STEEL INCLUDING BELLEVILLE, COAT ALL SURFACES WITH "KOPR-SHIELD" BEFORE MATING.
5. FOR GROUNDING BOND TO STEEL ONLY: INSERT A DRAGON TOOTH WASHER BETWEEN LUG AND STEEL, COAT ALL SURFACES WITH "KOPR-SHIELD".
6. NO SLOTTED HOLES ON BUS BAR OR LUGS ARE PERMITTED.
7. ALL LUG SHANKS AND LEAD JOINTS SHALL HAVE HEAT SHRINK MATERIAL

TWO-HOLE LUG

SCALE: NTS

2



1 INTERNATIONAL BLVD. SUITE 800
 MAHWAH, NJ 07495



10 INDUSTRIAL AVE., SUITE 3
 MAHWAH, NJ 07430



100% EMPLOYEE-OWNED
 855 Community Dr, Sauk City, WI 53583
 608-643-4100 www.Ramaker.com
 Sauk City, WI • Willmar, MN
 Woodcliff Lake, NJ • Bayamon, PR

Certification & Seal:
 I hereby certify that this plan, specification, or report was prepared by me or under my direct supervision and that I am a duly Licensed Professional Engineer under the laws of the State of Connecticut.



Signature: *James R. Skowronski* Date: 2/12/2019

MARK	DATE	DESCRIPTION
0	02/12/19	FINAL CDs ISSUED

PROJECT TITLE:
**SALTONSTALL PLACE
 CT52XC125**

PROJECT INFORMATION:
 12 SALTONSTALL PLACE
 EAST HAVEN, CT 06512
 NEW HAVEN COUNTY

SHEET TITLE:
 GROUNDING DETAILS

SCALE:
 AS NOTED

PROJECT NUMBER: 37621
 SHEET NUMBER: G-1

GENERAL NOTES:

- ALL WORK PRESENTED ON THESE DRAWINGS MUST BE COMPLETED BY THE CONTRACTOR UNLESS NOTED OTHERWISE. THE CONTRACTOR MUST HAVE CONSIDERABLE EXPERIENCE IN PERFORMANCE OF WORK SIMILAR TO THAT DESCRIBED HEREIN. BY ACCEPTANCE OF THIS ASSIGNMENT, THE CONTRACTOR IS ATTESTING THAT HE DOES HAVE SUFFICIENT EXPERIENCE AND ABILITY, THAT HE IS KNOWLEDGEABLE OF THE WORK TO BE PERFORMED AND THAT HE IS PROPERLY LICENSED AND PROPERLY REGISTERED TO DO THIS WORK IN THE STATE.
- WORK SHALL BE COMPLETED IN ACCORDANCE WITH THE CURRENT STATE BUILDING CODE.
- UNLESS SHOWN OR NOTED OTHERWISE ON THE CONTRACT DRAWINGS, OR IN THE SPECIFICATIONS, THE FOLLOWING NOTES SHALL APPLY TO THE MATERIALS LISTED HEREIN, AND TO THE PROCEDURES TO BE USED ON THIS PROJECT.
- ALL HARDWARE ASSEMBLY MANUFACTURER'S INSTRUCTIONS SHALL BE FOLLOWED EXACTLY AND SHALL SUPERSEDE ANY CONFLICTING NOTES ENCLOSED HEREIN.
- IT IS THE CONTRACTOR'S SOLE RESPONSIBILITY TO DETERMINE THE ERECTION PROCEDURE AND SEQUENCE TO INSURE THE SAFETY OF THE STRUCTURE AND ITS COMPONENT PARTS DURING ERECTION AND/OR FIELD MODIFICATIONS. THIS INCLUDES, BUT IS NOT LIMITED TO, THE ADDITION OF TEMPORARY BRACING, GUYS, OR TIE DOWNS THAT MAY BE NECESSARY. SUCH MATERIAL SHALL BE REMOVED AND SHALL REMAIN THE PROPERTY OF THE CONTRACTOR AFTER THE COMPLETION OF THE PROJECT.
- ALL DIMENSIONS, ELEVATIONS, AND EXISTING CONDITIONS SHOWN ON THE DRAWINGS SHALL BE FIELD VERIFIED BY THE CONTRACTOR PRIOR TO BEGINNING ANY MATERIALS ORDERING, FABRICATION, OR CONSTRUCTION WORK ON THIS PROJECT. CONTRACTOR SHALL NOT SCALE CONTRACT DRAWINGS IN LIEU OF FIELD VERIFICATIONS. ANY DISCREPANCIES SHALL BE IMMEDIATELY BROUGHT TO THE ATTENTION OF THE OWNER AND THE OWNER'S ENGINEER. THE DISCREPANCIES MUST BE RESOLVED BEFORE THE CONTRACTOR IS TO PROCEED WITH THE WORK. THE CONTRACT DOCUMENTS DO NOT INDICATE THE METHOD OF CONSTRUCTION. THE CONTRACTOR SHALL SUPERVISE AND DIRECT THE WORK AND SHALL BE SOLELY RESPONSIBLE FOR ALL CONSTRUCTION MEANS, METHODS, TECHNIQUES, SEQUENCES, AND PROCEDURES. OBSERVATION VISITS TO THE SITE BY THE OWNER AND/OR THE ENGINEER SHALL NOT INCLUDE INSPECTION OF THE PROTECTIVE MEASURES OR THE PROCEDURES.
- ALL MATERIALS AND EQUIPMENT FURNISHED SHALL BE NEW AND OF GOOD QUALITY, FREE FROM FAULTS AND DEFECTS, AND IN CONFORMANCE WITH THE CONTRACT DOCUMENTS. ANY AND ALL SUBSTITUTIONS MUST BE PROPERLY APPROVED AND AUTHORIZED IN WRITING BY THE OWNER AND ENGINEER PRIOR TO INSTALLATION. THE CONTRACTOR SHALL FURNISH SATISFACTORY EVIDENCE AS TO THE KIND AND QUALITY OF THE MATERIALS AND EQUIPMENT BEING SUBSTITUTED.
- THE CONTRACTOR SHALL BE RESPONSIBLE FOR INITIATING, MAINTAINING, AND SUPERVISING ALL SAFETY PRECAUTIONS AND PROGRAMS IN CONNECTION WITH THE WORK. THE CONTRACTOR IS RESPONSIBLE FOR ENSURING THAT THIS PROJECT AND RELATED WORK COMPLIES WITH ALL APPLICABLE LOCAL, STATE, AND FEDERAL SAFETY CODES AND REGULATIONS GOVERNING THIS WORK.
- THE CONTRACTOR SHALL COORDINATE ACCESS AND CONSTRUCTION ACTIVITY, INCLUDING WORK SCHEDULE AND MATERIALS ACCESS, WITH THE LEASING AGENT FOR APPROVAL.
- ALL PERMITS THAT MUST BE OBTAINED ARE THE RESPONSIBILITY OF THE CONTRACTOR. THE CONTRACTOR WILL BE RESPONSIBLE FOR ABIDING BY ALL CONDITIONS AND REQUIREMENTS OF THE PERMITS.
- 24 HOURS PRIOR TO THE BEGINNING OF ANY CONSTRUCTION, THE CONTRACTOR MUST NOTIFY THE APPLICABLE JURISDICTIONAL (STATE, COUNTY, OR CITY) ENGINEER.
- ALL MATERIALS AND WORKMANSHIP SHALL BE WARRANTED FOR ONE YEAR FROM ACCEPTANCE DATE.
- ALL TOWER DIMENSIONS SHALL BE VERIFIED WITH THE PLANS (LATEST REVISION) PRIOR TO COMMENCING CONSTRUCTION. NOTIFY THE ENGINEER IMMEDIATELY IF ANY DISCREPANCIES ARE DISCOVERED. THE OWNER SHALL HAVE A SET OF APPROVED PLANS AVAILABLE AT THE SITE AT ALL TIMES WHILE WORK IS BEING PERFORMED. A DESIGNATED RESPONSIBLE EMPLOYEE SHALL BE AVAILABLE FOR CONTACT BY THE GOVERNING AGENCY INSPECTORS.
- ALL TOWER MODIFICATION WORK SHALL BE IN ACCORDANCE WITH TIA-1019-A-2012, "STANDARD FOR INSTALLATION, ALTERATION AND MAINTENANCE OF ANTENNA SUPPORTING STRUCTURES AND ANTENNAS."
- THE CLIMBING FACILITIES, SAFETY CLIMB, AND ALL PARTS THEREOF SHALL NOT BE IMPEDED, MODIFIED, OR ALTERED WITHOUT THE EXPRESS WRITTEN APPROVAL OF THE TOWER OWNER OR ENGINEER OF RECORD.
- ALL CONSTRUCTION MEANS AND METHODS, INCLUDING BUT NOT LIMITED TO, ERECTION PLANS, RIGGING PLANS, CLIMBING PLANS, AND RESCUE PLANS SHALL BE THE RESPONSIBILITY OF THE GENERAL CONTRACTOR. EXECUTION OF THE WORK CONTAINED HEREIN AND SHALL MEET THE ANSI/TIA-1019-A, OSHA, AND GENERAL INDUSTRY STANDARDS. ALL RIGGING PLANS SHALL ADHERE TO ANSI/TIA-1019-A, INCLUDING THE REQUIRED INVOLVEMENT OF A QUALIFIED ENGINEER FOR CLASS IV CONSTRUCTION.
- ANTENNAS AND OTHER APPURTENANCES MAY NEED TO BE TEMPORARILY RELOCATED DURING THE INSTALLATION OF MODIFICATIONS. THE CONTRACTOR SHALL BE RESPONSIBLE FOR PROTECTING ALL EXISTING AND NEW COAXIAL CABLES AND OTHER EQUIPMENT DURING CONSTRUCTION.

STRUCTURAL STEEL NOTES:

- STRUCTURAL STEEL MATERIALS, FABRICATION, DETAILING, AND WORKMANSHIP SHALL CONFORM TO THE LATEST EDITION OF THE AISC SPECIFICATION FOR STRUCTURAL STEEL BUILDINGS, THE RCSC SPECIFICATION FOR STRUCTURAL JOINTS USING HIGH-STRENGTH BOLTS, AND THE CODE OF STANDARD PRACTICE FOR STEEL BUILDINGS AND BRIDGES.
- UNLESS OTHERWISE NOTED, ALL STRUCTURAL ELEMENTS SHALL CONFORM TO THE FOLLOWING REQUIREMENTS:
 - A. ANGLE: ASTM A36
 - B. PIPE/TUBE: ASTM A500-46
 - C. PLATE: ASTM A36 (SELF-SUPPORTING AND GUYED TOWERS)
 - D. PLATE: ASTM A572-65 (MONOPOLES)
 - E. BOLTS: ASTM A325 TYPE 1 GALVANIZED HIGH STRENGTH BOLTS
 - F. U-BOLTS: ASTM A193 GRADE B7
 - G. NUTS: ASTM A563 CARBON AND ALLOY STEEL NUTS
 - H. WASHERS: ASTM F436 HARDENED STEEL WASHERS
- ALL CONNECTIONS NOT FULLY DETAILED IN THESE PLANS SHALL BE DETAILED BY THE STEEL FABRICATOR IN ACCORDANCE WITH THE LATEST AISC STEEL CONSTRUCTION MANUAL.
- HOLES SHALL NOT BE FLAME CUT THROUGH STEEL UNLESS APPROVED BY THE ENGINEER.
- HOT-DIP GALVANIZE ALL ITEMS UNLESS OTHERWISE NOTED, AFTER FABRICATION WHERE PRACTICABLE. GALVANIZING: ASTM A123, ASTM, A153/A153M OR ASTM A653/A653M, G90, AS APPLICABLE. ADDITIONALLY, ALL NEW STEEL SHALL BE PAINTED TO MATCH EXISTING STEEL. CONTRACTOR SHALL OBTAIN WRITTEN PERMISSION TO PROTECT STEEL BY ANY OTHER MEANS.
- REPAIR DAMAGED SURFACES WITH GALVANIZING REPAIR METHOD AND PAINT CONFORMING TO ASTM A780 OR BY APPLICATION OF STICK OR THICK PASTED MATERIAL SPECIFICALLY DESIGNED FOR REPAIR OF GALVANIZING. CLEAN AREAS TO BE REPAIRED AND REMOVE SLAG FROM WELDS. HEAT SURFACES TO WHICH STICK OR PASTE MATERIAL IS APPLIED. WITH A TORCH TO A TEMPERATURE SUFFICIENT TO MELT THE METALLICS IN STICK OR PASTED; SPREAD MOLTEN MATERIAL UNIFORMLY OVER SURFACES TO BE COATED AND WIPE OFF EXCESS MATERIAL. AFTER REPAIR, STEEL SHALL BE REPAINTED TO MATCH EXISTING FINISH (IF APPLICABLE).
- A NUT LOCKING DEVICE SHALL BE INSTALLED ON ALL PROPOSED AND/OR REPLACED BOLTS. GALVANIZED ASTM A325 BOLTS SHALL NOT BE REUSED.
- ALL PROPOSED AND /OR REPLACED BOLTS SHALL BE OF SUFFICIENT LENGTH SUCH THAT THE END OF THE BOLT BE AT LEAST FLUSH WITH THE FACE OF THE NUT. IT IS NOT PERMITTED FOR THE BOLT END TO BE BELOW THE FACE OF THE NUT AFTER TIGHTENING IS COMPLETED.

WELDING NOTES:

- ALL WELDING SHALL BE IN ACCORDANCE WITH THE LATEST AWS D1.1/D1.1M: "STRUCTURAL STEEL CODE - STEEL".
- ALL WELDING SHALL BE PERFORMED BY AWS CERTIFIED WELDERS.
- CONTRACTOR SHALL RETAIN AN AWS CERTIFIED WELD INSPECTOR TO PERFORM VISUAL INSPECTIONS ON FIELD WELDS. A LETTER AND REPORT SHALL BE ISSUED TO THE CONTRACTOR. CONTRACTOR SHALL SUBMIT A LETTER AND REPORT TO RAMAKER.
- GRIND THE SURFACE ADJACENT TO THE WELD FOR A DISTANCE OF 2" MINIMUM ALL AROUND. GRIND THE SURFACE OF THE ROD TO BE INSTALLED FOR A DISTANCE OF 2" MINIMUM ALL AROUND THE AREA TO BE WELDED. ENSURE BOTH AREAS ARE 100% FREE OF ALL GALVANIZING. SURFACES TO BE WELDED SHALL BE FREE FROM SCALE, SLAG, RUST, MOISTURE, GREASE OR ANY OTHER FOREIGN MATERIAL THAT WOULD PREVENT PROPER WELDING.
- DO NOT WELD IF THE TEMPERATURE OF THE STEEL IN THE VICINITY OF THE WELD AREA IS BELOW 0 DEG F. THE MINIMUM PREHEAT AND INTERPASS TEMPERATURE REQUIREMENTS SHALL COMPLY WITH SECTION 3.5.1 AND TABLE 3.2 OF THE AWS D1.1/D1.1M.
- DO NOT WELD ON WET OR FROST-COVERED SURFACES AND PROVIDE ADEQUATE PROTECTION FROM HIGH WINDS.
- USE 70 KSI LOW HYDROGEN ELECTRODES FOR ALL WELDING. POLYGONAL MONOPOLE REINFORCEMENT SHALL USE 80 KSI ELECTRODES. THE ELECTRODES SHALL BE APPROPRIATE FOR THE WELDING POSITION REQUIRED TO MAKE THE JOINT.
- AFTER FINAL INSPECTION, THE AREA OF THE WELDS AND ALL SURFACES DAMAGED BY WELDING OR GRINDING SHALL RECEIVE AT LEAST TWO (2) COATS OF ZRC COLD GALVANIZING COMPOUND. THIS COATING SHALL BE APPLIED BY BRUSH. OTHER APPROVED GALVANIZING COMPOUNDS SHALL CONTAIN A MINIMUM OF 95% ± PURE ZINC. THE FINISHED COATING SHALL BE A MINIMUM THICKNESS OF 3 MILS. CONTACT ZRC AT 1-800-831-3275 FOR PRODUCT INFORMATION.
- FOR MONOPOLE TOWERS FULL PENETRATION WELDS IN THE VICINITY OF THE BASE OF THE TOWER ARE REQUIRED TO BE 100% NDE INSPECTED BY ULTRASONIC TESTING (UT) IN ACCORDANCE WITH AWS D1.1.
- FOR MONOPOLE TOWERS PARTIAL PENETRATION AND FILLET WELDS IN THE VICINITY OF THE BASE OF THE TOWER ARE REQUIRED TO BE 50% NDE INSPECTED BY MAGNETIC PARTICLE (MT) IN ACCORDANCE WITH AWS D1.1.

BOLT TIGHTENING PROCEDURE:

- CONNECTION BOLTS SUBJECT TO DIRECT TENSION SHALL BE INSTALLED AND TIGHTENED AS PER SECTION 8.2.1 OF THE AISC SPECIFICATION FOR STRUCTURAL JOINTS USING HIGH-STRENGTH BOLTS, LOCATED IN THE AISC MANUAL OF STEEL CONSTRUCTION. ALL OTHER BOLTED CONNECTIONS SHALL BE BROUGHT TO A SNUG TIGHT CONDITION AS DEFINED IN SECTION 8.1 OF THE SPECIFICATION.
- PRETENSIONED JOINTS SHALL BE UTILIZE PROPERLY ALIGNED HOLES AND FASTENERS SHALL BE TIGHTENED BY ONE OF THE METHODS FROM SECTIONS 8.2.1 THROUGH 8.2.4.

8.1. SNUG-TIGHTENED JOINTS

ALL BOLT HOLES SHALL BE ALIGNED TO PERMIT INSERTION OF THE BOLTS WITHOUT UNDUE DAMAGE TO THE THREADS. BOLTS SHALL BE PLACED IN ALL HOLES WITH WASHERS POSITIONED AS REQUIRED IN SECTION 6.1 AND NUTS THREADED TO COMPLETE THE ASSEMBLY. COMPACTING THE JOINT TO THE SNUG-TIGHT CONDITION SHALL PROGRESS SYSTEMATICALLY FROM THE MOST RIGID PART OF THE JOINT. THE SNUG TIGHTENED CONDITION IS THE TIGHTNESS THAT IS ATTAINED WITH A FEW IMPACTS OF AN IMPACT WRENCH OR THE FULL EFFORT OF AN IRONWORKER USING AN ORDINARY SPUD WRENCH TO BRING THE PLIES INTO FIRM CONTACT.

8.2.1. TURN-OF-THE-NUT PRETENSIONING

ALL BOLTS SHALL BE INSTALLED IN ACCORDANCE WITH THE REQUIREMENTS IN SECTION 8.1, WITH WASHERS POSITIONED AS REQUIRED IN SECTION 6.2. SUBSEQUENTLY, THE NUT OR HEAD ROTATION SPECIFIED IN TABLE 8.2 SHALL BE APPLIED TO ALL FASTENER ASSEMBLIES IN THE JOINT, PROGRESSING SYSTEMATICALLY FROM THE MOST RIGID PART OF THE JOINT IN A MANNER THAT WILL MINIMIZE RELAXATION OF PREVIOUSLY PRETENSIONED BOLTS. THE PART NOT TURNED BY THE WRENCH SHALL BE PREVENTED FROM ROTATING DURING THIS OPERATION. UPON COMPLETION OF THE APPLICATION OF THE REQUIRED NUT ROTATION FOR PRETENSIONING, IT IS NOT PERMITTED TO TURN THE NUT IN THE LOOSENING DIRECTION EXCEPT FOR THE PURPOSE OF COMPLETE REMOVAL OF THE INDIVIDUAL FASTENER ASSEMBLY.

PROVIDE NUT ROTATION FROM THE SNUG-TIGHT CONDITION TO TURN-OF-NUT PRETENSIONING, USING THE CHART BELOW (PARTIAL RCSC TABLE 8.2):

BOLT LENGTHS UP TO AND INCLUDING FOUR DIAMETERS:

1/2" BOLT	LENGTH ≤ 2.0 INCHES	+ 1/3 TURN BEYOND SNUG TIGHT
5/8" BOLT	LENGTH ≤ 2.5 INCHES	+ 1/3 TURN BEYOND SNUG TIGHT
3/4" BOLT	LENGTH ≤ 3.0 INCHES	+ 1/3 TURN BEYOND SNUG TIGHT
7/8" BOLT	LENGTH ≤ 3.5 INCHES	+ 1/3 TURN BEYOND SNUG TIGHT
1" BOLT	LENGTH ≤ 4.0 INCHES	+ 1/3 TURN BEYOND SNUG TIGHT

BOLT LENGTHS OVER FOUR DIAMETERS BUT NOT EXCEEDING EIGHT DIAMETERS:1

1/2" BOLT	LENGTH = 2.25 TO 4.0 INCHES	+ 1/2 TURN BEYOND SNUG TIGHT
5/8" BOLT	LENGTH = 2.75 TO 5.0 INCHES	+ 1/2 TURN BEYOND SNUG TIGHT
3/4" BOLT	LENGTH = 3.25 TO 6.0 INCHES	+ 1/2 TURN BEYOND SNUG TIGHT
7/8" BOLT	LENGTH = 3.75 TO 7.0 INCHES	+ 1/2 TURN BEYOND SNUG TIGHT
1" BOLT	LENGTH = 4.25 TO 8.0 INCHES	+ 1/2 TURN BEYOND SNUG TIGHT

8.2.2 CALIBRATED WRENCH PRETENSIONING

THE PRE-INSTALLATION VERIFICATION PROCEDURES IN SECTION 7 SHALL BE PERFORMED DAILY FOR THE CALIBRATION OF THE INSTALLATION WRENCH. TORQUE VALUES DETERMINED FROM TABLES OR FROM EQUATIONS THAT CLAIM TO RELATE TORQUE TO PRETENSION WITHOUT VERIFICATION SHALL NOT BE USED. ALL BOLTS SHALL BE INSTALLED IN ACCORDANCE WITH THE REQUIREMENTS IN SECTION 8.1, WITH WASHERS POSITIONED AS REQUIRED IN SECTION 6.2. SUBSEQUENTLY, THE INSTALLATION TORQUE DETERMINED IN THE PRE-INSTALLATION VERIFICATION OF THE FASTENER ASSEMBLY (SECTION 7) SHALL BE APPLIED TO ALL BOLTS IN THE JOINT, PROGRESSING SYSTEMATICALLY FROM THE MOST RIGID PART OF THE JOINT IN A MANNER THAT WILL MINIMIZE RELAXATION OF PREVIOUSLY PRETENSIONED BOLTS. THE PART NOT TURNED BY THE WRENCH SHALL BE PREVENTED FROM ROTATING DURING THIS OPERATION. APPLICATION OF THE INSTALLATION TORQUE NEED NOT PRODUCE A RELATIVE ROTATION BETWEEN THE BOLT AND NUT THAT IS GREATER THAN THE ROTATION SPECIFIED IN TABLE 8.2.

8.2.3. TWIST-OFF-TYPE TENSION-CONTROL BOLT PRETENSIONING

TWIST-OFF-TYPE TENSION CONTROL BOLT ASSEMBLIES THAT MEET THE REQUIREMENTS OF ASTM F1852 OR F2280 SHALL BE USED. ALL FASTENER ASSEMBLIES SHALL BE INSTALLED IN ACCORDANCE WITH THE REQUIREMENTS IN SECTION 8.1 WITHOUT SEVERING THE SPLINED END AND WITH WASHERS POSITIONED AS REQUIRED IN SECTION 6.2. IF A SPLINED END IS SEVERED DURING THIS OPERATION, THE FASTENER ASSEMBLY SHALL BE REMOVED AND REPLACED. SUBSEQUENTLY, ALL BOLTS IN THE JOINT SHALL BE PRETENSIONED WITH THE TWIST-OFF-TYPE TENSION-CONTROL BOLT INSTALLATION WRENCH, PROGRESSING SYSTEMATICALLY FROM THE MOST RIGID PART OF THE JOINT IN A MANNER THAT WILL MINIMIZE RELAXATION OF PREVIOUSLY PRETENSIONED BOLTS.

8.2.4. DIRECT-TENSION-INDICATOR PRETENSIONING

DIRECT TENSION INDICATORS THAT MEET THE REQUIREMENTS OF ASTM F959 SHALL BE USED. THE PRE-INSTALLATION VERIFICATION PROCEDURES SPECIFIED IN SECTION 7 SHALL DEMONSTRATE THAT, WHEN THE PRETENSION IN THE BOLT REACHES THAT REQUIRED IN TABLE 7.1, THE GAP IS NOT LESS THAN THE JOB INSPECTION GAP IN ACCORDANCE WITH ASTM F959. ALL BOLTS SHALL BE INSTALLED IN ACCORDANCE WITH THE REQUIREMENTS IN SECTION 8.1, WITH WASHERS POSITIONED AS REQUIRED IN SECTION 6.2. THE INSTALLER SHALL VERIFY THAT THE DIRECT-TENSION-INDICATOR PROTRUSIONS HAVE NOT BEEN COMPRESSED TO A GAP THAT IS LESS THAN THE JOB INSPECTION GAP DURING THIS OPERATION, AND IF THIS HAS OCCURRED, THE DIRECT TENSION INDICATOR SHALL BE REMOVED AND REPLACED. SUBSEQUENTLY, ALL BOLTS IN THE JOINT SHALL BE PRETENSIONED, PROGRESSING SYSTEMATICALLY FROM THE MOST RIGID PART OF THE JOINT IN A MANNER THAT WILL MINIMIZE RELAXATION OF PREVIOUSLY PRETENSIONED BOLTS. THE INSTALLER SHALL VERIFY THAT THE DIRECT TENSION INDICATOR PROTRUSIONS HAVE BEEN COMPRESSED TO A GAP THAT IS LESS THAN THE JOB INSPECTION GAP.



**1 INTERNATIONAL BLVD. SUITE 800
MAHWAH, NJ 07495**



**10 INDUSTRIAL AVE., SUITE 3
MAHWAH, NJ 07430**



100% EMPLOYEE-OWNED
855 Community Dr, Sauk City, WI 53583
608-643-4100 www.Ramaker.com
 Sauk City, WI • Willmar, MN
 Woodcliff Lake, NJ • Bayamon, PR

Certification & Seal:
 I hereby certify that this plan, specification, or report was prepared by me or under my direct supervision and that I am a duly Licensed Professional Engineer under the laws of the State of Connecticut.



Signature: *James R. Skowronski* Date: 2/12/2019

0	02/12/19	FINAL CDs ISSUED
MARK	DATE	DESCRIPTION
ISSUE PHASE	FINAL	DATE ISSUED 02/12/2019

PROJECT TITLE:
**SALTONSTALL PLACE
CT52XC125**

PROJECT INFORMATION:
**12 SALTONSTALL PLACE
EAST HAVEN, CT 06512
NEW HAVEN COUNTY**

SHEET TITLE:
STRUCTURAL DETAILS

SCALE:
AS NOTED

PROJECT NUMBER	37621
SHEET NUMBER	S-1

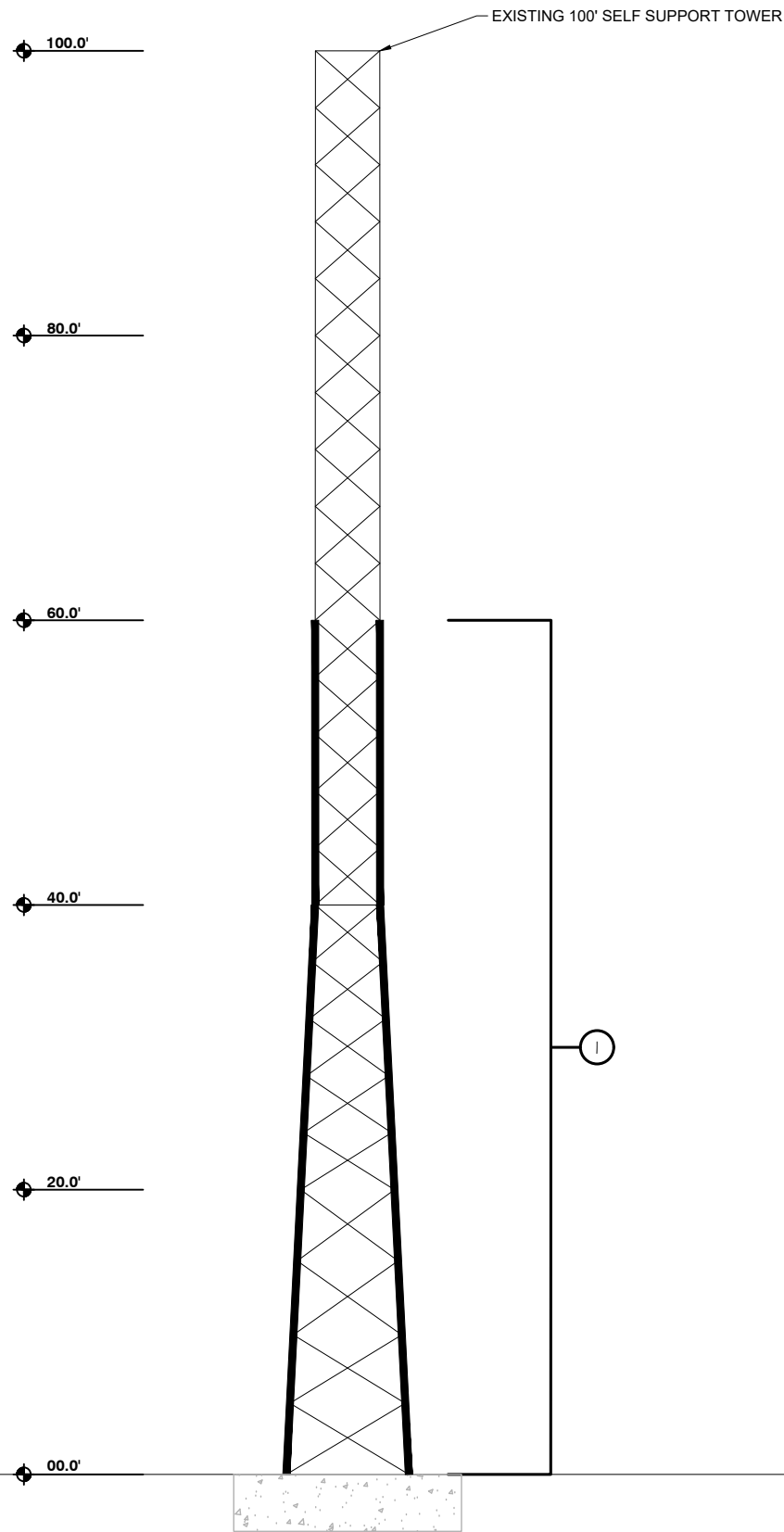

MODIFIED TOWER ELEVATION
 SCALE: NTS

1

NO.	ELEVATION (FT)	TOWER MODIFICATION SCHEDULE	REFERENCE DETAIL/SHEET
1	0' - 80'	REINFORCE TOWER LEGS WITH HALF SLEEVES.	S-3

NOTES:
 1. ALL PROPOSED STEEL AND HARDWARE TO BE HOT-DIPPED GALVANIZED.
 2. ALL PROPOSED BOLTS TO BE GRADE A325, UNLESS NOTED OTHERWISE.
 3. DO NOT REUSE EXISTING BOLTS, INSTALL NEW BOLTS.
 4. CONTRACTOR SHALL BE RESPONSIBLE FOR THE STABILITY OF THE TOWER DURING CONSTRUCTION.
 5. SEE STRUCTURAL NOTES ON PAGES S-1 AND S-2

NOMINAL HOLE DIMENSIONS		
BOLT DIA.	STANDARD HOLE	SHORT SLOT
1/2	5/8	5/8 x 1 1/8
3/8	1/2	1/2 x 7/8
3/4	1 3/8	1 3/8 x 1
7/8	1 5/8	1 5/8 x 1 1/8
1	1 1/4	1 1/4 x 1 5/8

NOTE: DIMENSIONS GIVEN IN INCHES

BOLT EDGE AND SPACING		
BOLT DIA.	MIN. EDGE	SPACING
1/2	7/8	1 1/2
3/8	1/2	1 1/8
3/4	1/4	2 1/4
7/8	1/2	2 3/8
1	1 3/4	3

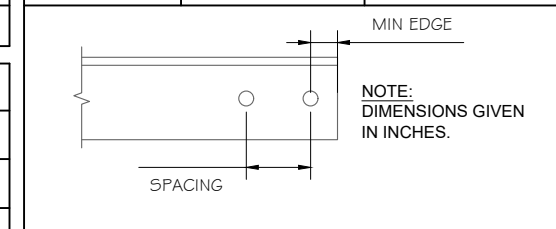

WORKABLE GAGES						
LEG	4	3 1/2	3	2 1/2	2	1 3/4
G	2 1/2	2	1 3/4	1 3/8	1 1/8	1

NOTE:
 • WORKABLE GAGES GIVEN IN INCHES
 • MATCH EXISTING WHEN APPLICABLE

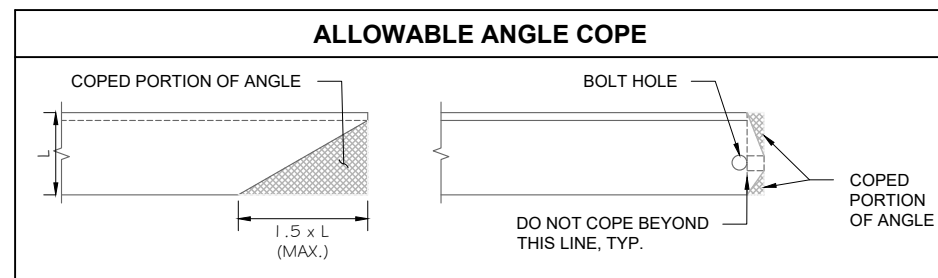

1 INTERNATIONAL BLVD. SUITE 800
 MAHWAH, NJ 07495



10 INDUSTRIAL AVE., SUITE 3
 MAHWAH, NJ 07430



100% EMPLOYEE-OWNED
 855 Community Dr, Sauk City, WI 53583
 608-643-4100 www.Ramaker.com
 Sauk City, WI • Willmar, MN
 Woodcliff Lake, NJ • Bayamon, PR

Certification & Seal:
 I hereby certify that this plan, specification, or report was prepared by me or under my direct supervision and that I am a duly Licensed Professional Engineer under the laws of the State of Connecticut.



Signature: *James R. Skowronski* Date: 2/12/2019

MARK	DATE	DESCRIPTION
0	02/12/19	FINAL CDs ISSUED

ISSUE PHASE: FINAL DATE ISSUED: 02/12/2019

PROJECT TITLE:
**SALTONSTALL PLACE
 CT52XC125**

PROJECT INFORMATION:
 12 SALTONSTALL PLACE
 EAST HAVEN, CT 06512
 NEW HAVEN COUNTY

SHEET TITLE:
 STRUCTURAL DETAILS

SCALE:
 AS NOTED

PROJECT NUMBER	37621
SHEET NUMBER	S-2

HALF PIPE WELD SCHEDULE

ELEVATIONS (FT)	EXISTING	PROPOSED (A500-46)	TOTAL LENGTH (FT)	STITCH SPACING	WELD SIZE
40' - 60'	2.5 STD (2.875x0.203)	HSS 3.5x0.300	20'±	12"	$\frac{3}{16}$
20' - 40'	2.5XS STD (2.875x0.276)	HSS 3.5x0.300	20'±	12"	$\frac{3}{16}$
0' - 20'	2.5XS STD (2.875x0.276)	HSS 3.5x0.300	20'±	12"	$\frac{3}{16}$

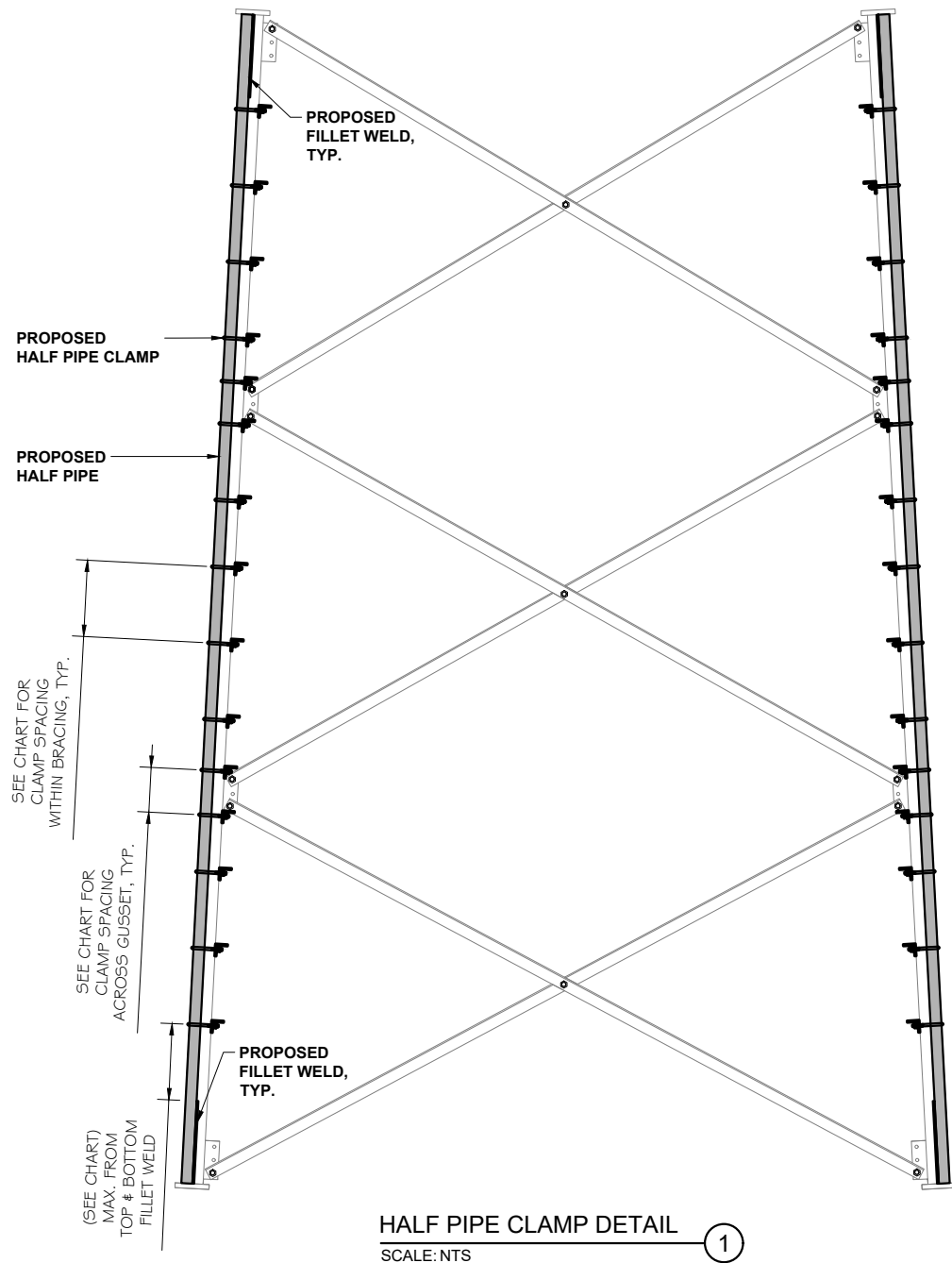

HALF PIPE CLAMP DETAIL
 SCALE: NTS

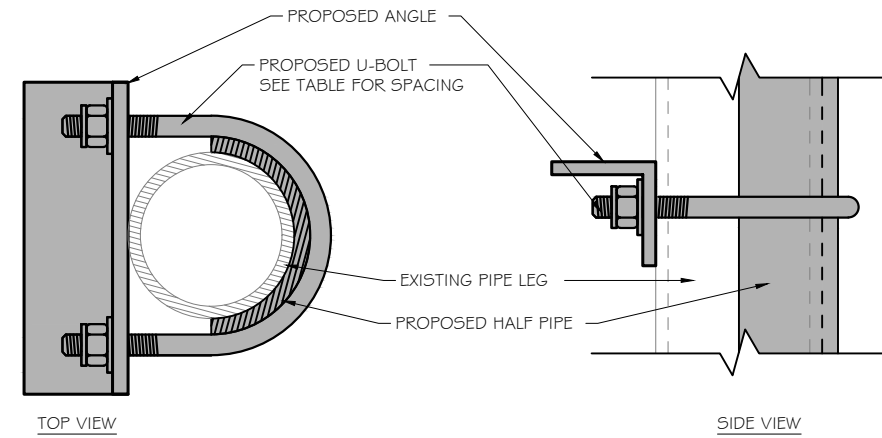

NOTE:
 - $\frac{1}{2}$ " U-BOLTS WITH $\angle 2 \times 2 \times \frac{1}{4}$ (A572-50) FOR HALF PIPES UP TO 5.0 x 0.375.
 - $\frac{1}{2}$ " U-BOLTS WITH $\angle 3 \times 3 \times \frac{1}{4}$ (A572-50) FOR HALF PIPES LARGER THAN 5.0 x 0.375.

HALF PIPE CLAMP DETAIL
 SCALE: NTS

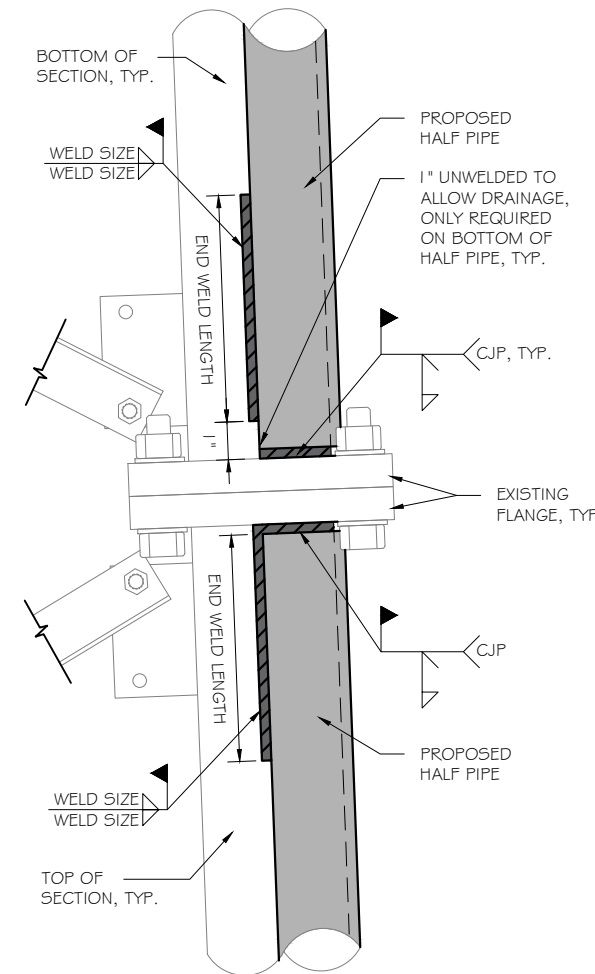

HALF PIPE WELD AT FLANGE DETAIL
 SCALE: NTS



1 INTERNATIONAL BLVD. SUITE 800
 MAHWAH, NJ 07495



10 INDUSTRIAL AVE., SUITE 3
 MAHWAH, NJ 07430



100% EMPLOYEE-OWNED
 855 Community Dr, Sauk City, WI 53583
 608-643-4100 www.Ramaker.com
 Sauk City, WI • Willmar, MN
 Woodcliff Lake, NJ • Bayamon, PR

Certification & Seal:
 I hereby certify that this plan, specification, or report was prepared by me or under my direct supervision and that I am a duly Licensed Professional Engineer under the laws of the State of Connecticut.

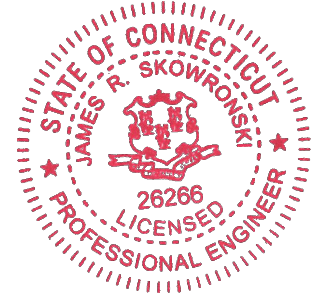

Signature: *James R. Skowronski* Date: 2/12/2019

MARK	DATE	DESCRIPTION
0	02/12/19	FINAL CDs ISSUED
ISSUE PHASE	FINAL	DATE ISSUED 02/12/2019

PROJECT TITLE:
**SALTONSTALL PLACE
 CT52XC125**

PROJECT INFORMATION:
 12 SALTONSTALL PLACE
 EAST HAVEN, CT 06512
 NEW HAVEN COUNTY

SHEET TITLE:
 STRUCTURAL DETAILS

SCALE:
 AS NOTED

PROJECT NUMBER: 37621
 SHEET NUMBER: 5-3



1 INTERNATIONAL BLVD. SUITE 800
 MAHWAH, NJ 07495



10 INDUSTRIAL AVE., SUITE 3
 MAHWAH, NJ 07430



100% EMPLOYEE-OWNED
 855 Community Dr, Sauk City, WI 53583
 608-643-4100 www.Ramaker.com
 Sauk City, WI • Willmar, MN
 Woodcliff Lake, NJ • Bayamon, PR

Certification & Seal:
 I hereby certify that this plan, specification, or report was prepared by me or under my direct supervision and that I am a duly Licensed Professional Engineer under the laws of the State of Connecticut.

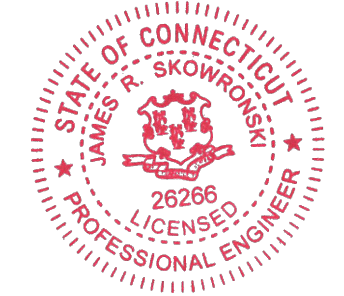

James R. Skowronski 2/12/2019
 Signature: Date:

MARK	DATE	DESCRIPTION
0	02/12/19	FINAL CDs ISSUED
ISSUE PHASE	FINAL	DATE ISSUED 02/12/2019

PROJECT TITLE:
**SALTONSTALL PLACE
 CT52XC125**

PROJECT INFORMATION:
 12 SALTONSTALL PLACE
 EAST HAVEN, CT 06512
 NEW HAVEN COUNTY

SHEET TITLE:
STRUCTURAL DETAILS

SCALE:
 AS NOTED

PROJECT NUMBER 37621
 SHEET NUMBER 5-4

- NOTES:**
- CLEAN GALVANIZING FROM EXISTING WELD AND ALL WELD CONTACT SURFACES.
 - INSTALL PROPOSED HALF PIPE.

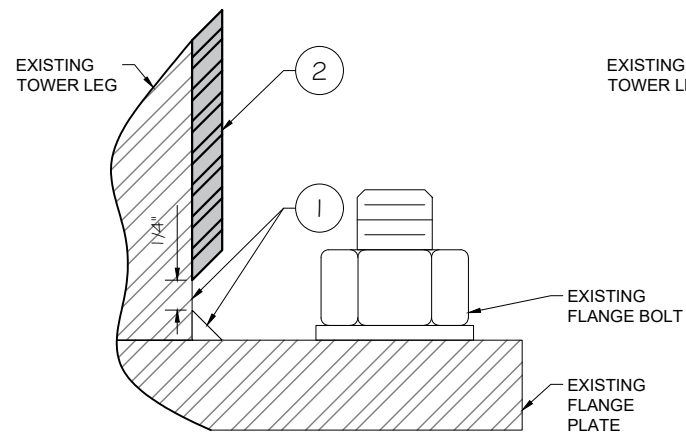

- NOTES:**
- BUILD A PLATFORM WITH WELD (BUTTER) TO MATCH THE HEIGHT OF THE EXISTING FILLET WELD PER SECTION 5.22.4.3 OF AWS D1.1/D1.1M: 2010. ENGINEERING APPROVAL IS PROVIDED FOR CORRECTING ROOT OPENINGS GREATER THAN THOSE PERMITTED IN SECTION 5.22.4.3 IN ACCORDANCE WITH SECTION 5.22.4.4.

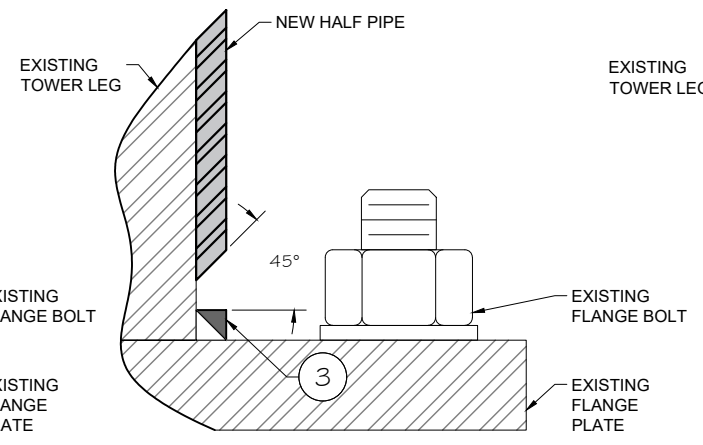

- NOTES:**
- PERFORM A CJP WELD USING THE EXISTING TOWER LEG AS A BACKING BAR.

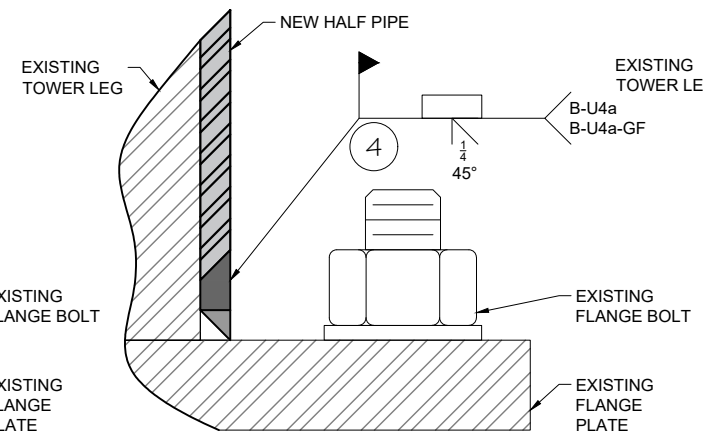

- NOTES:**
- REINFORCING FILLET WELD SIZED TO MATCH EXISTING FILLET WELD. PRIOR TO CONSTRUCTION CONTRACTOR SHALL VERIFY THAT THERE IS ADEQUATE CLEARANCE BETWEEN THE PROPOSED WELD AND THE EXISTING FLANGE BOLTS. IF INTERFERENCE OCCURS AN ALTERNATIVE SLEEVE TERMINATION DETAIL MAY BE REQUIRED.

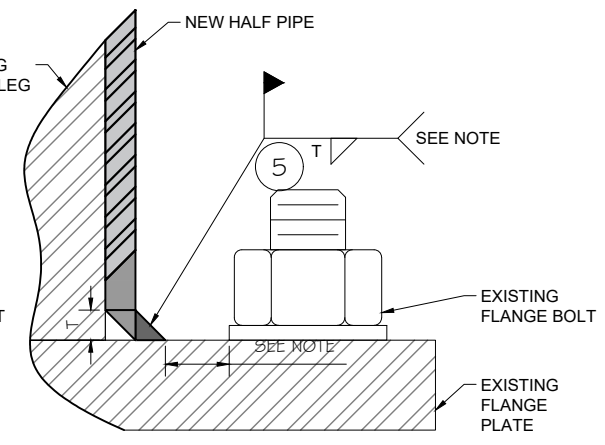

HALF PIPE WELD DETAIL, OPTION 1
 SCALE: NTS

- DESIGN CONSIDERATIONS AND DRAWING REQUIREMENTS:**
- THE DETAILED PRE-QUALIFIED WELD PROCESS SHALL BE USED IF THE ORIGINAL LEG TO FLANGE CONNECTION IS BUTT WELDED. IF THE ORIGINAL LEG TO FLANGE WELD IS A LAP CONNECTION THEN BRIDGE STIFFENERS SHALL BE USED INSTEAD.
 - SPLIT PIPE THICKNESS 1/4" OR LESS DO NOT REQUIRE BEVELING THE JOINT DESIGNATION IS B-L1a/B-L1a-GF.
 - IF ALTERNATIVE WELD DETAILS ARE USED, THE EOR SHALL SPECIFY THE JOINT INFORMATION AND DETAILS.

- NOTES:**
- CLEAN GALVANIZING FROM EXISTING WELD AND ALL WELD CONTACT SURFACES.
 - PARTIALLY GRIND THE HEIGHT OF THE EXISTING FILLET WELD TO FORM A PLATFORM WITH TOP WIDTH TO MATCH THE HALF PIPE THICKNESS.

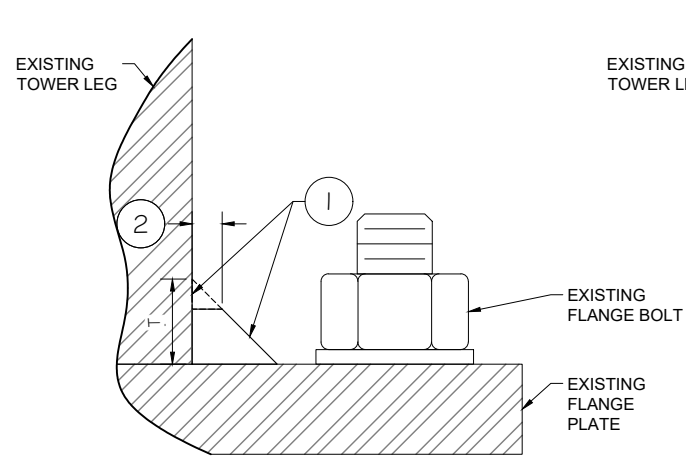

- NOTES:**
- INSTALL PROPOSED HALF PIPE.

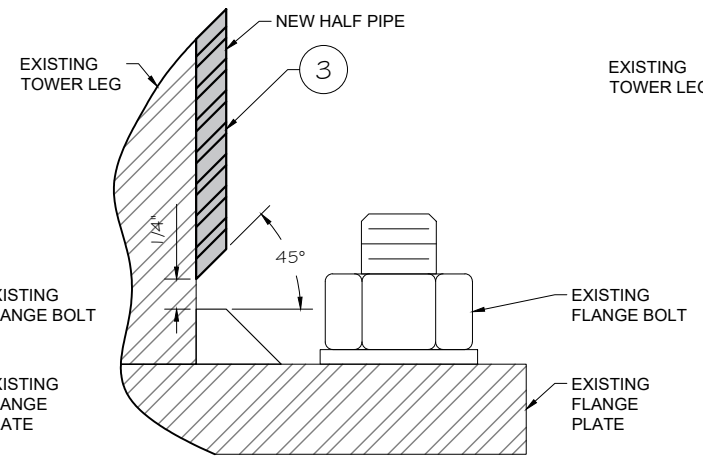

- NOTES:**
- PERFORM A CJP WELD USING THE EXISTING TOWER LEG AS A BACKING BAR.

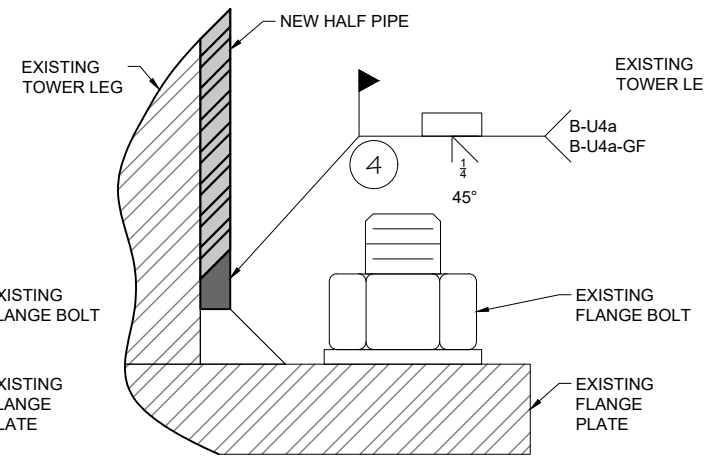

- NOTES:**
- BUILD UP FILLET WELD TO MATCH EXISTING FILLET WELD. PRIOR TO CONSTRUCTION CONTRACTOR SHALL VERIFY THAT THERE IS ADEQUATE CLEARANCE BETWEEN THE PROPOSED WELD AND THE EXISTING FLANGE BOLTS. IF INTERFERENCE OCCURS AN ALTERNATIVE SLEEVE TERMINATION DETAIL MAY BE REQUIRED.

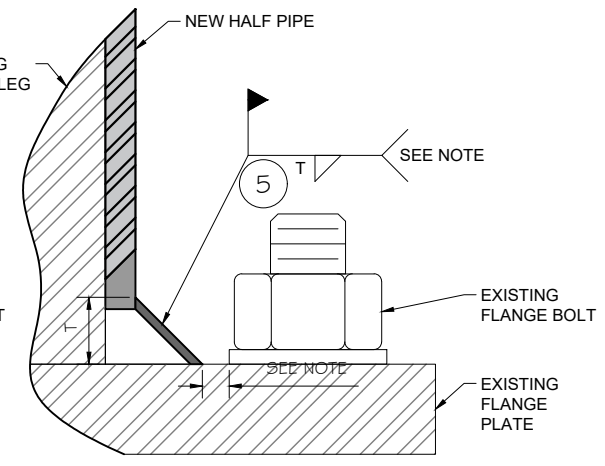

HALF PIPE WELD DETAIL, OPTION 2
 SCALE: NTS

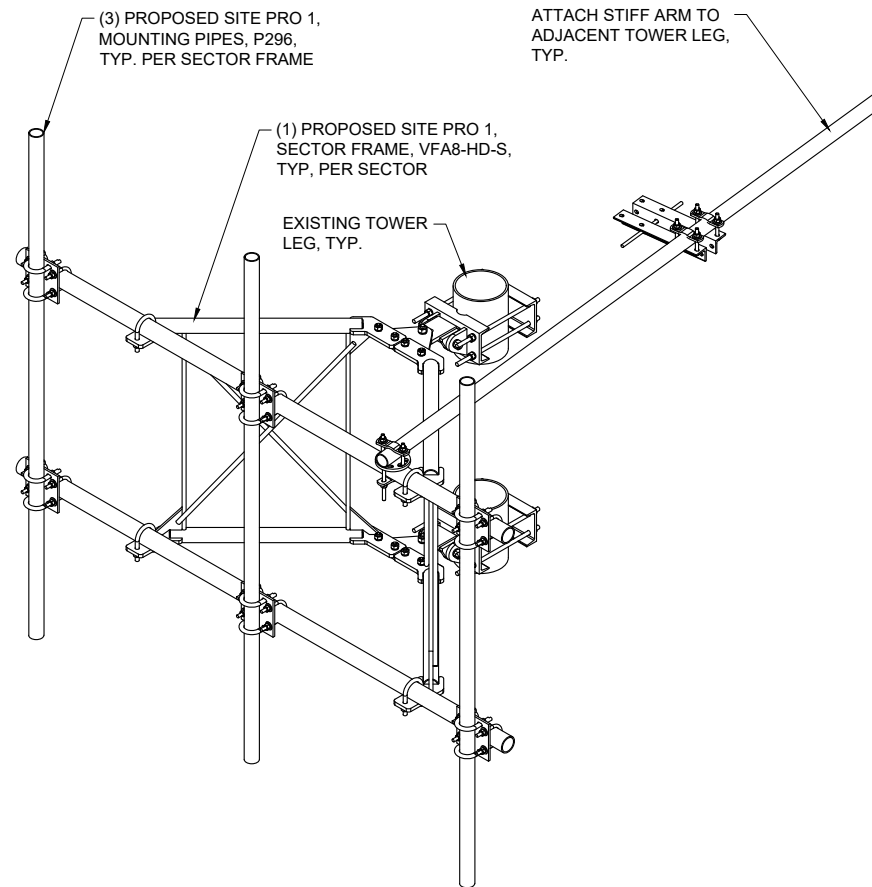

PROPOSED SECTOR FRAME DETAIL ①
 SCALE: NTS



1 INTERNATIONAL BLVD. SUITE 800
 MAHWAH, NJ 07495



10 INDUSTRIAL AVE., SUITE 3
 MAHWAH, NJ 07430



100% EMPLOYEE-OWNED
 855 Community Dr, Sauk City, WI 53583
 608-643-4100 www.Ramaker.com
 Sauk City, WI • Willmar, MN
 Woodcliff Lake, NJ • Bayamon, PR

Certification & Seal:
 I hereby certify that this plan, specification, or report was prepared by me or under my direct supervision and that I am a duly Licensed Professional Engineer under the laws of the State of Connecticut.

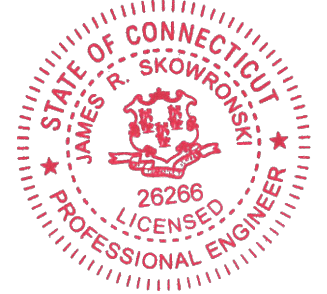

Signature: *James R. Skowronski* Date: 2/12/2019

MARK	DATE	DESCRIPTION
0	02/12/19	FINAL CDs ISSUED

ISSUE PHASE: FINAL DATE ISSUED: 02/12/2019

PROJECT TITLE:
**SALTONSTALL PLACE
 CT52XC125**

PROJECT INFORMATION:
 12 SALTONSTALL PLACE
 EAST HAVEN, CT 06512
 NEW HAVEN COUNTY

SHEET TITLE:
 STRUCTURAL DETAILS

SCALE:
 AS NOTED

PROJECT NUMBER	37621
SHEET NUMBER	S-5

January 16, 2019

Mike Kithcart
Transcend Wireless
10 Industrial Avenue, Suite 3
Mahwah, NJ 07430

Ramaker & Associates, Inc.
855 Community Drive
Sauk City, WI 53583

**SUBJECT: STRUCTURAL ASSESSMENT
 100-FOOT SELF-SUPPORT TOWER**

CARRIER: SPRINT

**SITE: SALTONSTALL PLACE (CT52XC125)
 12 SALTONSTALL PLACE
 EAST HAVEN, NEW HAVEN COUNTY, CONNECTICUT 06512
 RAMAKER & ASSOCIATES PROJECT NUMBER: 37621**

**RESULTS: TOWER: 98.5% PASS WITH MODIFICATIONS
 FOUNDATION: 67.8% PASS**

Dear Mike Kithcart:

Ramaker & Associates, Inc. (RAMAKER) respectfully submits this structural assessment for the above-mentioned site. The purpose of this report is to determine the structural integrity of the existing structure with the existing and proposed loading. Engineering recommendations regarding the analysis results are provided in the following pages.

RAMAKER developed a finite element model of the tower using tnxTower analysis software. All information contained herein is valid only for the described structure configuration and loading conditions. RAMAKER reserves the right to modify our recommendations should alterations to the tower loading occur.

If you have any questions or comments, please do not hesitate to contact our office.

Sincerely,

RAMAKER & ASSOCIATES, INC.

Thomas E. Moore
Thomas E. Moore
Project Engineer

James R. Skowronski
James R. Skowronski, P.E.
Supervising Engineer



ANALYSIS CRITERIA

State Building Code	2016 CT State Building Code
Adopted Building Code	2012 IBC
Referenced Standard	TIA-222-G
Risk Category	II
Ultimate Design Wind Speed, V_{ult}	130 mph (3 sec. gust)
Nominal Design Wind Speed, V_{asd}	101 mph (3 sec. gust)
Design Wind Speed w/ Ice	50 mph (3 sec. gust)
Ice Thickness	3/4 inch
Exposure Category	C
Topographic Feature	None

SUPPORTING DOCUMENTATION

- Foundation mapping by TEP, job number 147093.197061, dated December 14, 2018
- Geotechnical report by TEP, job number 147093.197062, dated December 13, 2018
- Structural analysis by CHA Consulting, Inc., job number 20621-1065-28000 Rev. 4, dated May 23, 2012
- Construction drawings by RAMAKER, project number 37621
- Site visit(s) conducted by RAMAKER
- Other pertinent data procured or assumed by RAMAKER during site due diligence activities

TOWER LOADING

RAMAKER understands that the loading to be used for this analysis will consist of the antenna equipment, mount, and cable configurations as shown in the following chart:

Elevation	Appurtenance	Mount	Coax	Owner	Status
100	(1) 4' Omni	Top of Tower	(3) 1/2	--	Existing
	(2) 10' Omni				
96	(1) 2' Dish	Tower Leg	(1) 1/2	--	
85	(3) Argus LLPX310R	(3) Site Pro 1 VFA8-HD-S	(1) 2" Conduit	Sprint	Remove
	(3) Clearwire RRU				Existing
	(3) Junction Box				Proposed
	(2) Andrew VHLP2-18				
	(3) Commscope NNVV-65B-R4				
	(3) Nokia AAHC				
	(6) ALU 800MHz 2x50W RRH				
(3) ALU 1900MHz 4x45W RRH					
72	(1) 5' Omni	(1) 8' Standoff	(1) 1/2	--	Existing
70	(1) 10' Dipole	(1) 8' Standoff	(1) 1/2		
60	(1) 10' Dipole	(1) 4' Standoff	(1) 1/2		
50	(1) 15' Omni	(1) 4' Standoff	(1) 1/2		
48	(1) 6' Omni	(1) 4' Standoff	(1) 1/2		
41	(1) 8' Dipole	Tower Leg	(1) 1/2		

TOWER RESULTS

The maximum tower member stress capacities under the loading conditions previously described are as follows:

Component Type	Percent Capacity	Pass/Fail
Leg	98.5	Pass
Diagonal	82.2	Pass
Top Girt	4.4	Pass
Bolt	91.4	Pass
Anchor Rod	87.0	Pass
RATING	98.5	PASS

Results of the analysis show that the modified tower will be stressed to a maximum of 98.5 percent of capacity. Therefore, the modified tower will pass the TIA-222-G analysis requirements under proposed loading conditions. Details of the tower modifications are contained within the associated RAMAKER Construction Drawings.

DISH TWIST/SWAY RESULTS

The twist/sway results for a 60-mph service wind speed are as follows:

Elevation	Dish	Deflection (in)	Tilt (deg)	Twist (deg)
96	(1) 2' Dish	2.794	0.2493	0.0434
85	(1) Andrew VHLP2-18	2.221	0.2470	0.0438

FOUNDATION RESULTS

The maximum foundation stress capacities are as follows:

Component Type	Percent Capacity	Pass/Fail
Unit Base - Soil Interaction	67.8	Pass
Unit Base - Structural	11.0	Pass
RATING	67.8	PASS

The foundations were analyzed utilizing the foundation mapping and geotechnical report referenced above. Results of the analysis show that the existing foundation will be stressed to a maximum of 67.8 percent of capacity. Therefore, the existing foundation will pass the TIA-222-G analysis requirements under proposed loading conditions.

LIMITATIONS

The recommendations contained within this report were developed using the supporting documentation as previously described. All recommendations pertain only to the proposed antenna installation activities as described in this report. RAMAKER assumes no responsibility for failures caused by factors beyond our control. These include but are not limited to the following:

- Missing, corroding, and/or deteriorating members
- Improper manufacturing and/or construction
- Improper maintenance

RAMAKER assumes no responsibility for modifications completed prior to or hereafter in which RAMAKER was not directly involved. These modifications include but are not limited to the following:

- Replacing or strengthening bracing members
- Reinforcing or extending vertical members
- Installing or removing antenna mounting gates or side arms
- Changing loading configurations

The tower owner is responsible for verifying that the existing loading on the structure is consistent with the loading applied to the structure within this report. If there is any information contrary to that contained herein, or if there are any defects arising from the original design, material, fabrication and erection deficiencies, this report should be disregarded and RAMAKER should be contacted immediately. RAMAKER is not liable for any representation, recommendation, or conclusion not expressly stated herein.

This analysis pertains only to the tower structure, and no analyses or conclusions were made regarding the antenna and equipment mounting structure(s). Analysis and certification of the antenna and equipment mounting structure(s) is performed and submitted separately.

ATTACHMENTS

- Analysis Figures
- Analysis Calculations

DESIGNED APPURTENANCE LOADING

TYPE	ELEVATION	TYPE	ELEVATION
10' Omni	100	SitePro1 VFA8-HD-S (1)	85
10' Omni	100	SitePro1 VFA8-HD-S (1)	85
4' Omni	100	NNVV-65B-R4 w/Mount Pipe	85
2 FT DISH	96	VHLP2-18	85
NNVV-65B-R4 w/Mount Pipe	85	VHLP2-18	85
NNVV-65B-R4 w/Mount Pipe	85	5' Omni	72
AAHC	85	8' Standoff	72
AAHC	85	8' Standoff	70
AAHC	85	10' Dipole	70
1900MHz 4x45W RRH	85	Side Arm Mount [SO 306-1]	60
1900MHz 4x45W RRH	85	10' Dipole	60
1900MHz 4x45W RRH	85	Side Arm Mount [SO 702-1]	50
(2) 800MHz 2x50W RRH	85	15' Omni	50
(2) 800MHz 2x50W RRH	85	Side Arm Mount [SO 306-1]	48
(2) 800MHz 2x50W RRH	85	6' Omni	48
SitePro1 VFA8-HD-S (1)	85	8' Dipole	41

MATERIAL STRENGTH

GRADE	Fy	Fu	GRADE	Fy	Fu
A572-50	50 ksi	65 ksi	A500-46	46 ksi	62 ksi
A36	36 ksi	58 ksi			

TOWER DESIGN NOTES

1. Tower is located in New Haven County, Connecticut.
2. Tower designed for Exposure C to the TIA-222-G Standard.
3. Tower designed for a 101 mph basic wind in accordance with the TIA-222-G Standard.
4. Tower is also designed for a 50 mph basic wind with 0.75 in ice. Ice is considered to increase in thickness with height.
5. Deflections are based upon a 60 mph wind.
6. Tower Structure Class II.
7. Topographic Category 1 with Crest Height of 0.00 ft
8. TOWER RATING: 98.5%

100.0 ft
80.0 ft
60.0 ft
40.0 ft
20.0 ft
0.0 ft

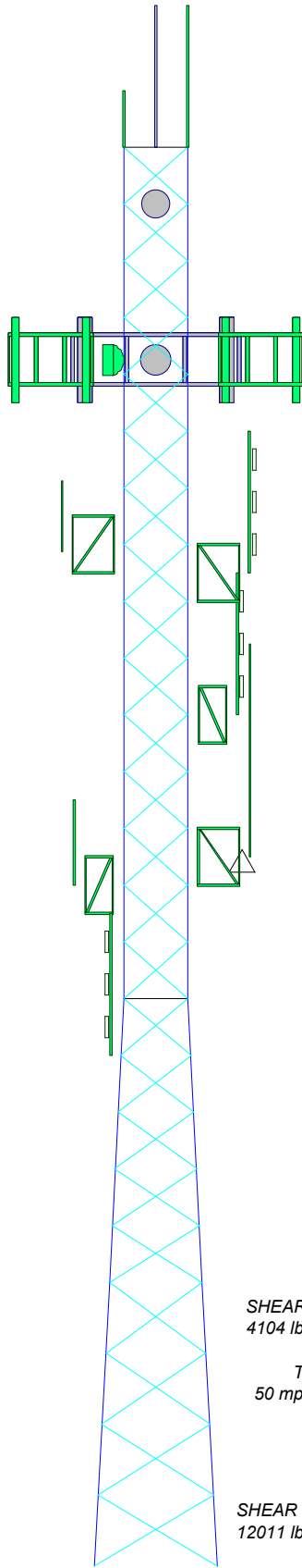

ALL REACTIONS
ARE FACTORED

MAX. CORNER REACTIONS AT BASE:

DOWN: 100532 lb
SHEAR: 7855 lb

UPLIFT: -91371 lb
SHEAR: 7160 lb

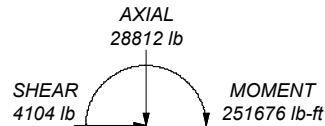

TORQUE 2830 lb-ft
50 mph WIND - 0.7500 in ICE

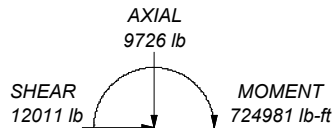

TORQUE 5465 lb-ft
REACTIONS - 101 mph WIND

Section	T1	T2	T3	T4	T5
Legs	ROHN 2 STD		P2.5STD + Half P3XS		P2.5XS + Half P3XS
Leg Grade	A572-50			A500-46	
Diagonals	L1 1/2x1 1/2x1/8		L1 1/2x1 1/2x3/16		L1 1/2x1 1/2x1/8
Diagonal Grade			A36		
Top Girts	L1 1/2x1 1/2x1/8			L1 1/2x1 1/2x1/8	
Face Width (ft)	4.52083		4.5625		6.5625
# Panels @ (ft)		20 @ 4			4 @ 5
Weight (lb)	487.4	441.4	982.4	1037.7	1036.1

 <p>Ramaker & Associates, Inc 855 Community Drive Sauk City, WI 53583 Phone: (608) 643-4100 FAX: (608) 643-7999</p>	Job: Saltonstall Place CT52XC125		
	Project: 37621		
	Client: Transcend/Sprint	Drawn by: TEM	App'd:
	Code: TIA-222-G	Date: 01/16/19	Scale: NTS
	Path: I:\37600\37621\Structural\TX\37621 rev2.eri		Dwg No. E-1

tnxTower Ramaker & Associates, Inc 855 Community Drive Sauk City, WI 53583 Phone: (608) 643-4100 FAX: (608) 643-7999	Job Saltonstall Place CT52XC125	Page 1 of 22
	Project 37621	Date 09:42:20 01/16/19
	Client Transcend/Sprint	Designed by TEM

Tower Input Data

The main tower is a 3x free standing tower with an overall height of 100.00 ft above the ground line.

The base of the tower is set at an elevation of 0.00 ft above the ground line.

The face width of the tower is 4.52 ft at the top and 8.60 ft at the base.

This tower is designed using the TIA-222-G standard.

The following design criteria apply:

Tower is located in New Haven County, Connecticut.

ASCE 7-10 Wind Data is used (wind speeds converted to nominal values).

Basic wind speed of 101 mph.

Structure Class II.

Exposure Category C.

Topographic Category 1.

Crest Height 0.00 ft.

Nominal ice thickness of 0.7500 in.

Ice thickness is considered to increase with height.

Ice density of 56 pcf.

A wind speed of 50 mph is used in combination with ice.

Temperature drop of 50 °F.

Deflections calculated using a wind speed of 60 mph.

A non-linear (P-delta) analysis was used.

Pressures are calculated at each section.

Stress ratio used in tower member design is 1.

Local bending stresses due to climbing loads, feed line supports, and appurtenance mounts are not considered.

Options

<ul style="list-style-type: none"> Consider Moments - Legs Consider Moments - Horizontals Consider Moments - Diagonals Use Moment Magnification √ Use Code Stress Ratios √ Use Code Safety Factors - Guys Escalate Ice Always Use Max Kz Use Special Wind Profile Include Bolts In Member Capacity Leg Bolts Are At Top Of Section √ Secondary Horizontal Braces Leg Use Diamond Inner Bracing (4 Sided) SR Members Have Cut Ends SR Members Are Concentric 	<ul style="list-style-type: none"> Distribute Leg Loads As Uniform Assume Legs Pinned √ Assume Rigid Index Plate √ Use Clear Spans For Wind Area √ Use Clear Spans For KL/r Retension Guys To Initial Tension √ Bypass Mast Stability Checks √ Use Azimuth Dish Coefficients √ Project Wind Area of Appurt. Autocalc Torque Arm Areas Add IBC .6D+W Combination Sort Capacity Reports By Component √ Triangulate Diamond Inner Bracing Treat Feed Line Bundles As Cylinder Ignore KL/ry For 60 Deg. Angle Legs 	<ul style="list-style-type: none"> Use ASCE 10 X-Brace Ly Rules √ Calculate Redundant Bracing Forces Ignore Redundant Members in FEA SR Leg Bolts Resist Compression √ All Leg Panels Have Same Allowable Offset Girt At Foundation √ Consider Feed Line Torque √ Include Angle Block Shear Check Use TIA-222-G Bracing Resist. Exemption Use TIA-222-G Tension Splice Exemption <li style="text-align: center;">Poles Include Shear-Torsion Interaction Always Use Sub-Critical Flow Use Top Mounted Sockets Pole Without Linear Attachments Pole With Shroud Or No Appurtenances Outside and Inside Corner Radii Are Known
--	---	---

tnxTower Ramaker & Associates, Inc 855 Community Drive Sauk City, WI 53583 Phone: (608) 643-4100 FAX: (608) 643-7999	Job Saltonstall Place CT52XC125	Page 2 of 22
	Project 37621	Date 09:42:20 01/16/19
	Client Transcend/Sprint	Designed by TEM

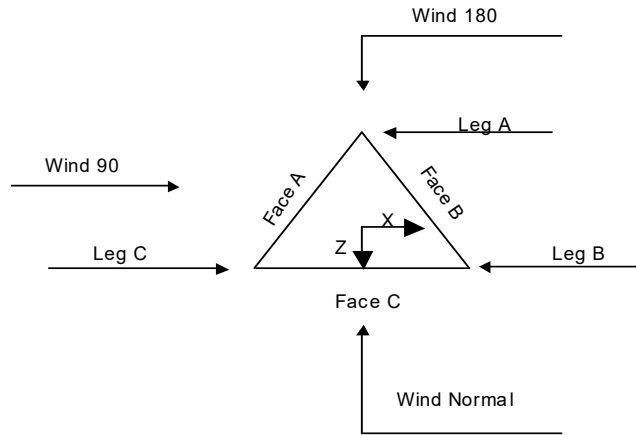

Triangular Tower

Tower Section Geometry

Tower Section	Tower Elevation	Assembly Database	Description	Section Width	Number of Sections	Section Length
	<i>ft</i>			<i>ft</i>		<i>ft</i>
T1	100.00-80.00			4.52	1	20.00
T2	80.00-60.00			4.52	1	20.00
T3	60.00-40.00			4.56	1	20.00
T4	40.00-20.00			4.56	1	20.00
T5	20.00-0.00			6.56	1	20.00

Tower Section Geometry (cont'd)

Tower Section	Tower Elevation	Diagonal Spacing	Bracing Type	Has K Brace End Panels	Has Horizontals	Top Girt Offset	Bottom Girt Offset
	<i>ft</i>	<i>ft</i>				<i>in</i>	<i>in</i>
T1	100.00-80.00	4.00	X Brace	No	No	0.0000	0.0000
T2	80.00-60.00	4.00	X Brace	No	No	0.0000	0.0000
T3	60.00-40.00	4.00	X Brace	No	Yes	0.0000	0.0000
T4	40.00-20.00	4.00	X Brace	No	Yes	0.0000	0.0000
T5	20.00-0.00	5.00	X Brace	No	Yes	0.0000	0.0000

Tower Section Geometry (cont'd)

tnxTower Ramaker & Associates, Inc 855 Community Drive Sauk City, WI 53583 Phone: (608) 643-4100 FAX: (608) 643-7999	Job Saltonstall Place CT52XC125	Page 3 of 22
	Project 37621	Date 09:42:20 01/16/19
	Client Transcend/Sprint	Designed by TEM

Tower Elevation ft	Leg Type	Leg Size	Leg Grade	Diagonal Type	Diagonal Size	Diagonal Grade
T1 100.00-80.00	Pipe	ROHN 2 STD	A572-50 (50 ksi)	Equal Angle	L1 1/2x1 1/2x1/8	A36 (36 ksi)
T2 80.00-60.00	Pipe	ROHN 2 STD	A572-50 (50 ksi)	Equal Angle	L1 1/2x1 1/2x1/8	A36 (36 ksi)
T3 60.00-40.00	Arbitrary Shape	P2.5STD + Half P3XS	A500-46 (46 ksi)	Equal Angle	L1 1/2x1 1/2x3/16	A36 (36 ksi)
T4 40.00-20.00	Arbitrary Shape	P2.5XS + Half P3XS	A500-46 (46 ksi)	Equal Angle	L1 1/2x1 1/2x1/8	A36 (36 ksi)
T5 20.00-0.00	Arbitrary Shape	P2.5XS + Half P3XS	A500-46 (46 ksi)	Equal Angle	L1 1/2x1 1/2x1/8	A36 (36 ksi)

Tower Section Geometry (cont'd)

Tower Elevation ft	Top Girt Type	Top Girt Size	Top Girt Grade	Bottom Girt Type	Bottom Girt Size	Bottom Girt Grade
T1 100.00-80.00	Equal Angle	L1 1/2x1 1/2x1/8	A36 (36 ksi)	Equal Angle		A36 (36 ksi)
T4 40.00-20.00	Equal Angle	L1 1/2x1 1/2x1/8	A36 (36 ksi)	Equal Angle		A36 (36 ksi)

Tower Section Geometry (cont'd)

Tower Elevation ft	Gusset Area (per face) ft ²	Gusset Thickness in	Gusset Grade	Adjust. Factor A _f	Adjust. Factor A _r	Weight Mult.	Double Angle Stitch Bolt Spacing Diagonals in	Double Angle Stitch Bolt Spacing Horizontals in	Double Angle Stitch Bolt Spacing Redundants in
T1 100.00-80.00	0.00	0.0000	A36 (36 ksi)	1	1	1	36.0000	36.0000	36.0000
T2 80.00-60.00	0.00	0.0000	A36 (36 ksi)	1	1	1	36.0000	36.0000	36.0000
T3 60.00-40.00	0.00	0.0000	A36 (36 ksi)	1	1	1	36.0000	36.0000	36.0000
T4 40.00-20.00	0.00	0.0000	A36 (36 ksi)	1	1	1	36.0000	36.0000	36.0000
T5 20.00-0.00	0.00	0.0000	A36 (36 ksi)	1	1	1	36.0000	36.0000	36.0000

Tower Section Geometry (cont'd)

Tower Elevation ft	Calc K Single Angles	Calc K Solid Rounds	Legs	K Factors ^l						
				X Brace Diags X Y	K Brace Diags X Y	Single Diags X Y	Girts X Y	Horiz. X Y	Sec. Horiz. X Y	Inner Brace X Y
				X	X	X	X	X	X	X
				Y	Y	Y	Y	Y	Y	Y

tnxTower Ramaker & Associates, Inc 855 Community Drive Sauk City, WI 53583 Phone: (608) 643-4100 FAX: (608) 643-7999	Job Saltonstall Place CT52XC125	Page 4 of 22
	Project 37621	Date 09:42:20 01/16/19
	Client Transcend/Sprint	Designed by TEM

Tower Elevation ft	Calc K Single Angles	Calc K Solid Rounds	Legs	K Factors ¹								
				X Brace Diags	K Brace Diags	Single Diags	Girts	Horiz.	Sec. Horiz.	Inner Brace		
				X Y	X Y	X Y	X Y	X Y	X Y	X Y		
T1 100.00-80.00	Yes	No	1	1	1	1	1	1	1	1	1	1
T2 80.00-60.00	Yes	No	1	1	1	1	1	1	1	1	1	1
T3 60.00-40.00	Yes	No	1.10161	1	1	1	1	1	1	1	1	1
T4 40.00-20.00	Yes	No	1.10235	1	1	1	1	1	1	1	1	1
T5 20.00-0.00	Yes	No	1.06663	1	1	1	1	1	1	1	1	1

¹Note: K factors are applied to member segment lengths. K-braces without inner supporting members will have the K factor in the out-of-plane direction applied to the overall length.

Tower Section Geometry (cont'd)

Tower Elevation ft	Leg		Diagonal		Top Girt		Bottom Girt		Mid Girt		Long Horizontal		Short Horizontal	
	Net Width Deduct in	U	Net Width Deduct in	U	Net Width Deduct in	U	Net Width Deduct in	U	Net Width Deduct in	U	Net Width Deduct in	U	Net Width Deduct in	U
T1 100.00-80.00	0.0000	1	0.0000	0.75	0.0000	0.75	0.0000	0.75	0.0000	0.75	0.0000	0.75	0.0000	0.75
T2 80.00-60.00	0.0000	1	0.0000	0.75	0.0000	0.75	0.0000	0.75	0.0000	0.75	0.0000	0.75	0.0000	0.75
T3 60.00-40.00	0.0000	1	0.0000	0.75	0.0000	0.75	0.0000	0.75	0.0000	0.75	0.0000	0.75	0.0000	0.75
T4 40.00-20.00	0.0000	1	0.0000	0.75	0.0000	0.75	0.0000	0.75	0.0000	0.75	0.0000	0.75	0.0000	0.75
T5 20.00-0.00	0.0000	1	0.0000	0.75	0.0000	0.75	0.0000	0.75	0.0000	0.75	0.0000	0.75	0.0000	0.75

Tower Section Geometry (cont'd)

Tower Elevation ft	Leg Connection Type	Leg		Diagonal		Top Girt		Bottom Girt		Mid Girt		Long Horizontal		Short Horizontal	
		Bolt Size in	No.	Bolt Size in	No.	Bolt Size in	No.	Bolt Size in	No.	Bolt Size in	No.	Bolt Size in	No.	Bolt Size in	No.
T1 100.00-80.00	Flange	0.6250	4	0.5000	1	0.5000	1	0.6250	0	0.6250	0	0.6250	0	0.6250	0
		A325N		A325N		A325N		A325N		A325N		A325N		A325N	
T2 80.00-60.00	Flange	0.6250	4	0.5000	1	0.5000	0	0.6250	0	0.6250	0	0.6250	0	0.6250	0
		A325N		A325N		A325N		A325N		A325N		A325N		A325N	
T3 60.00-40.00	Flange	0.6250	4	0.5000	1	0.5000	0	0.6250	0	0.6250	0	0.6250	0	0.6250	0
		A325N		A325N		A325N		A325N		A325N		A325N		A325N	
T4 40.00-20.00	Flange	0.7500	4	0.5000	1	0.5000	1	0.6250	0	0.6250	0	0.6250	0	0.6250	0
		A325N		A325N		A325N		A325N		A325N		A325N		A325N	
T5 20.00-0.00	Flange	0.7500	0	0.5000	1	0.5000	0	0.6250	0	0.6250	0	0.6250	0	0.6250	0
		A325N		A325N		A325N		A325N		A325N		A325N		A325N	

Feed Line/Linear Appurtenances - Entered As Round Or Flat

tnxTower Ramaker & Associates, Inc 855 Community Drive Sauk City, WI 53583 Phone: (608) 643-4100 FAX: (608) 643-7999	Job Saltonstall Place CT52XC125	Page 5 of 22
	Project 37621	Date 09:42:20 01/16/19
	Client Transcend/Sprint	Designed by TEM

Description	Face or Leg	Allow Shield	Exclude From Torque Calculation	Component Type	Placement ft	Face Offset in	Lateral Offset (Frac FW)	#	# Per Row	Clear Spacing in	Width or Diameter in	Perimeter in	Weight plf

Safety Line 1/2 (100)	A	No	No	Ar (CaAa)	100.00 - 0.00	3.0000	0.5	1	1	0.5000	0.5000		0.35
Step Bolts (100)	A	No	No	Ar (CaAa)	100.00 - 0.00	0.0000	0.5	1	1	0.4000	0.4000		1.00
T-Bracket (100)	A	No	No	Af (CaAa)	100.00 - 0.00	-2.0000	-0.46	1	1	1.0000	1.0000		1.50

1/2 (100)	A	No	No	Ar (CaAa)	100.00 - 0.00	-5.0000	-0.35	3	2	0.5800	0.5800		0.25

1/2 (96)	A	No	No	Ar (CaAa)	96.00 - 0.00	-4.0000	-0.37	1	1	0.5800	0.5800		0.25

1 (85)	A	No	No	Ar (CaAa)	85.00 - 0.00	-3.0000	-0.39	2	2	1.2500	1.2500		0.58
1 (85)	A	No	No	Ar (CaAa)	85.00 - 0.00	-2.0000	-0.41	2	2	1.2500	1.2500		0.58
1/2 (85)	A	No	No	Ar (CaAa)	85.00 - 0.00	-1.0000	-0.43	2	1	0.5800	0.5800		0.25

1/2 (72)	C	No	No	Ar (CaAa)	72.00 - 0.00	-1.0000	0.43	1	1	0.5800	0.5800		0.25

1/2 (70)	C	No	No	Ar (CaAa)	70.00 - 0.00	-2.0000	0.41	1	1	0.5800	0.5800		0.25

1/2 (60)	C	No	No	Ar (CaAa)	60.00 - 0.00	-3.0000	0.39	1	1	0.5800	0.5800		0.25

1/2 (50)	C	No	No	Ar (CaAa)	50.00 - 0.00	-4.0000	0.37	1	1	0.5800	0.5800		0.25

1/2 (48)	C	No	No	Ar (CaAa)	48.00 - 0.00	-5.0000	0.35	1	1	0.5800	0.5800		0.25

1/2 (41)	C	No	No	Ar (CaAa)	41.00 - 0.00	-5.0000	0.35	1	1	0.5800	0.5800		0.25

Feed Line/Linear Appurtenances Section Areas

Tower Section	Tower Elevation ft	Face	A _R ft ²	A _F ft ²	C _A A _A In Face ft ²	C _A A _A Out Face ft ²	Weight lb
T1	100.00-80.00	A	0.000	0.000	12.621	0.000	90.10
		B	0.000	0.000	0.000	0.000	0.00
		C	0.000	0.000	0.000	0.000	0.00
T2	80.00-60.00	A	0.000	0.000	22.093	0.000	133.40
		B	0.000	0.000	0.000	0.000	0.00
		C	0.000	0.000	1.276	0.000	5.50
T3	60.00-40.00	A	0.000	0.000	22.093	0.000	133.40

tnxTower Ramaker & Associates, Inc 855 Community Drive Sauk City, WI 53583 Phone: (608) 643-4100 FAX: (608) 643-7999	Job Saltonstall Place CT52XC125	Page 6 of 22
	Project 37621	Date 09:42:20 01/16/19
	Client Transcend/Sprint	Designed by TEM

Tower Section	Tower Elevation ft	Face	A_R ft ²	A_F ft ²	C_{AA} In Face ft ²	C_{AA} Out Face ft ²	Weight lb
T4	40.00-20.00	B	0.000	0.000	0.000	0.000	0.00
		C	0.000	0.000	4.582	0.000	19.75
		A	0.000	0.000	22.093	0.000	133.40
		B	0.000	0.000	0.000	0.000	0.00
T5	20.00-0.00	C	0.000	0.000	6.960	0.000	30.00
		A	0.000	0.000	22.093	0.000	133.40
		B	0.000	0.000	0.000	0.000	0.00
		C	0.000	0.000	6.960	0.000	30.00

Feed Line/Linear Appurtenances Section Areas - With Ice

Tower Section	Tower Elevation ft	Face or Leg	Ice Thickness in	A_R ft ²	A_F ft ²	C_{AA} In Face ft ²	C_{AA} Out Face ft ²	Weight lb
T1	100.00-80.00	A	1.658	0.000	0.000	63.652	0.000	747.96
		B		0.000	0.000	0.000	0.000	0.00
		C		0.000	0.000	0.000	0.000	0.00
T2	80.00-60.00	A	1.617	0.000	0.000	106.925	0.000	1199.59
		B		0.000	0.000	0.000	0.000	0.00
		C		0.000	0.000	8.391	0.000	101.00
T3	60.00-40.00	A	1.564	0.000	0.000	104.577	0.000	1146.78
		B		0.000	0.000	0.000	0.000	0.00
		C		0.000	0.000	29.288	0.000	343.26
T4	40.00-20.00	A	1.486	0.000	0.000	101.160	0.000	1072.21
		B		0.000	0.000	0.000	0.000	0.00
		C		0.000	0.000	42.619	0.000	479.98
T5	20.00-0.00	A	1.331	0.000	0.000	94.384	0.000	932.24
		B		0.000	0.000	0.000	0.000	0.00
		C		0.000	0.000	38.909	0.000	402.99

Feed Line Center of Pressure

Section	Elevation ft	CP_x in	CP_z in	CP_x Ice in	CP_z Ice in
T1	100.00-80.00	-2.8759	1.0024	-5.0892	0.0572
T2	80.00-60.00	-5.6606	2.7998	-8.7828	2.8240
T3	60.00-40.00	-5.8526	2.9643	-9.6045	3.6438
T4	40.00-20.00	-7.0334	3.5729	-12.1402	4.9132
T5	20.00-0.00	-9.3372	4.6588	-15.9027	6.5379

Shielding Factor K_a

Tower Section	Feed Line Record No.	Description	Feed Line Segment Elev.	K_a No Ice	K_a Ice
T1	2	Safety Line 1/2	80.00 - 100.00	0.6000	0.5608
T1	3	Step Bolts	80.00 - 100.00	0.6000	0.5608
T1	4	T-Bracket	80.00 - 100.00	0.6000	0.5608

Job	Saltonstall Place CT52XC125	Page	7 of 22
Project	37621	Date	09:42:20 01/16/19
Client	Transcend/Sprint	Designed by	TEM

Tower Section	Feed Line Record No.	Description	Feed Line Segment Elev.	K _a No Ice	K _a Ice
T1	6	1/2	80.00 - 100.00	0.6000	0.5608
T1	8	1/2	80.00 - 96.00	0.6000	0.5608
T1	10	1	80.00 - 85.00	0.6000	0.5608
T1	11	1	80.00 - 85.00	0.6000	0.5608
T1	12	1/2	80.00 - 85.00	0.6000	0.5608
T2	2	Safety Line 1/2	60.00 - 80.00	0.6000	0.5854
T2	3	Step Bolts	60.00 - 80.00	0.6000	0.5854
T2	4	T-Bracket	60.00 - 80.00	0.6000	0.5854
T2	6	1/2	60.00 - 80.00	0.6000	0.5854
T2	8	1/2	60.00 - 80.00	0.6000	0.5854
T2	10	1	60.00 - 80.00	0.6000	0.5854
T2	11	1	60.00 - 80.00	0.6000	0.5854
T2	12	1/2	60.00 - 80.00	0.6000	0.5854
T2	14	1/2	60.00 - 72.00	0.6000	0.5854
T2	16	1/2	60.00 - 70.00	0.6000	0.5854
T3	2	Safety Line 1/2	40.00 - 60.00	0.6000	0.5672
T3	3	Step Bolts	40.00 - 60.00	0.6000	0.5672
T3	4	T-Bracket	40.00 - 60.00	0.6000	0.5672
T3	6	1/2	40.00 - 60.00	0.6000	0.5672
T3	8	1/2	40.00 - 60.00	0.6000	0.5672
T3	10	1	40.00 - 60.00	0.6000	0.5672
T3	11	1	40.00 - 60.00	0.6000	0.5672
T3	12	1/2	40.00 - 60.00	0.6000	0.5672
T3	14	1/2	40.00 - 60.00	0.6000	0.5672
T3	16	1/2	40.00 - 60.00	0.6000	0.5672
T3	18	1/2	40.00 - 60.00	0.6000	0.5672
T3	20	1/2	40.00 - 50.00	0.6000	0.5672
T3	22	1/2	40.00 - 48.00	0.6000	0.5672
T3	24	1/2	40.00 - 41.00	0.6000	0.5672
T4	2	Safety Line 1/2	20.00 - 40.00	0.6000	0.6000
T4	3	Step Bolts	20.00 - 40.00	0.6000	0.6000
T4	4	T-Bracket	20.00 - 40.00	0.6000	0.6000
T4	6	1/2	20.00 - 40.00	0.6000	0.6000
T4	8	1/2	20.00 - 40.00	0.6000	0.6000
T4	10	1	20.00 - 40.00	0.6000	0.6000
T4	11	1	20.00 - 40.00	0.6000	0.6000
T4	12	1/2	20.00 - 40.00	0.6000	0.6000
T4	14	1/2	20.00 - 40.00	0.6000	0.6000
T4	16	1/2	20.00 - 40.00	0.6000	0.6000
T4	18	1/2	20.00 - 40.00	0.6000	0.6000
T4	20	1/2	20.00 - 40.00	0.6000	0.6000
T4	22	1/2	20.00 - 40.00	0.6000	0.6000
T4	24	1/2	20.00 - 40.00	0.6000	0.6000
T5	2	Safety Line 1/2	0.00 - 20.00	0.6000	0.6000
T5	3	Step Bolts	0.00 - 20.00	0.6000	0.6000
T5	4	T-Bracket	0.00 - 20.00	0.6000	0.6000
T5	6	1/2	0.00 - 20.00	0.6000	0.6000
T5	8	1/2	0.00 - 20.00	0.6000	0.6000
T5	10	1	0.00 - 20.00	0.6000	0.6000
T5	11	1	0.00 - 20.00	0.6000	0.6000
T5	12	1/2	0.00 - 20.00	0.6000	0.6000
T5	14	1/2	0.00 - 20.00	0.6000	0.6000
T5	16	1/2	0.00 - 20.00	0.6000	0.6000
T5	18	1/2	0.00 - 20.00	0.6000	0.6000
T5	20	1/2	0.00 - 20.00	0.6000	0.6000
T5	22	1/2	0.00 - 20.00	0.6000	0.6000
T5	24	1/2	0.00 - 20.00	0.6000	0.6000

Job	Saltonstall Place CT52XC125	Page	8 of 22
Project	37621	Date	09:42:20 01/16/19
Client	Transcend/Sprint	Designed by	TEM

Discrete Tower Loads

Description	Face or Leg	Offset Type	Offsets:		Azimuth Adjustment	Placement	C _{AA} Front	C _{AA} Side	Weight	
			Horz	Vert						
			ft	ft	°	ft	ft ²	ft ²	lb	

10' Omni	A	From Leg	0.00	0.00	0.0000	100.00	No Ice	2.75	2.75	30.00
			0.00	0.00			1/2" Ice	3.78	3.78	50.21
			5.00	0.00			1" Ice	4.83	4.83	76.96
10' Omni	B	From Leg	0.00	0.00	0.0000	100.00	No Ice	2.75	2.75	30.00
			0.00	0.00			1/2" Ice	3.78	3.78	50.21
			5.00	0.00			1" Ice	4.83	4.83	76.96
4' Omni	C	From Leg	0.00	0.00	0.0000	100.00	No Ice	1.00	1.00	20.00
			0.00	0.00			1/2" Ice	1.25	1.25	28.96
			2.00	0.00			1" Ice	1.50	1.50	40.82

NNVV-65B-R4 w/Mount Pipe	A	From Leg	0.00	-4.00	0.0000	85.00	No Ice	12.51	7.41	102.95
			0.00	0.00			1/2" Ice	13.11	8.60	193.58
			0.00	0.00			1" Ice	13.67	9.50	292.74
NNVV-65B-R4 w/Mount Pipe	B	From Leg	0.00	-4.00	0.0000	85.00	No Ice	12.51	7.41	102.95
			0.00	0.00			1/2" Ice	13.11	8.60	193.58
			0.00	0.00			1" Ice	13.67	9.50	292.74
NNVV-65B-R4 w/Mount Pipe	C	From Leg	0.00	-4.00	0.0000	85.00	No Ice	12.51	7.41	102.95
			0.00	0.00			1/2" Ice	13.11	8.60	193.58
			0.00	0.00			1" Ice	13.67	9.50	292.74
AAHC	A	From Leg	0.00	4.00	0.0000	85.00	No Ice	4.20	2.07	103.70
			0.00	0.00			1/2" Ice	4.46	2.26	136.01
			0.00	0.00			1" Ice	4.72	2.46	172.07
AAHC	B	From Leg	0.00	4.00	0.0000	85.00	No Ice	4.20	2.07	103.70
			0.00	0.00			1/2" Ice	4.46	2.26	136.01
			0.00	0.00			1" Ice	4.72	2.46	172.07
AAHC	C	From Leg	0.00	4.00	0.0000	85.00	No Ice	4.20	2.07	103.70
			0.00	0.00			1/2" Ice	4.46	2.26	136.01
			0.00	0.00			1" Ice	4.72	2.46	172.07
1900MHz 4x45W RRH	A	From Leg	0.00	0.00	0.0000	85.00	No Ice	2.32	2.24	59.50
			0.00	0.00			1/2" Ice	2.53	2.44	82.62
			0.00	0.00			1" Ice	2.74	2.65	108.98
1900MHz 4x45W RRH	B	From Leg	0.00	0.00	0.0000	85.00	No Ice	2.32	2.24	59.50
			0.00	0.00			1/2" Ice	2.53	2.44	82.62
			0.00	0.00			1" Ice	2.74	2.65	108.98
1900MHz 4x45W RRH	C	From Leg	0.00	0.00	0.0000	85.00	No Ice	2.32	2.24	59.50
			0.00	0.00			1/2" Ice	2.53	2.44	82.62
			0.00	0.00			1" Ice	2.74	2.65	108.98
(2) 800MHz 2x50W RRH	A	From Leg	0.00	0.00	0.0000	85.00	No Ice	2.06	1.93	64.00
			0.00	0.00			1/2" Ice	2.24	2.11	86.12
			0.00	0.00			1" Ice	2.43	2.29	111.30
(2) 800MHz 2x50W RRH	B	From Leg	0.00	0.00	0.0000	85.00	No Ice	2.06	1.93	64.00
			0.00	0.00			1/2" Ice	2.24	2.11	86.12
			0.00	0.00			1" Ice	2.43	2.29	111.30
(2) 800MHz 2x50W RRH	C	From Leg	0.00	0.00	0.0000	85.00	No Ice	2.06	1.93	64.00
			0.00	0.00			1/2" Ice	2.24	2.11	86.12
			0.00	0.00			1" Ice	2.43	2.29	111.30
SitePro1 VFA8-HD-S (1)	A	From Leg	0.00	0.00	0.0000	85.00	No Ice	10.90	7.00	530.00
			0.00	0.00			1/2" Ice	15.90	11.30	623.00
			0.00	0.00			1" Ice	19.70	15.30	761.00
SitePro1 VFA8-HD-S (1)	B	From Leg	0.00	0.00	0.0000	85.00	No Ice	10.90	7.00	530.00
			0.00	0.00			1/2" Ice	15.90	11.30	623.00

tnxTower Ramaker & Associates, Inc 855 Community Drive Sauk City, WI 53583 Phone: (608) 643-4100 FAX: (608) 643-7999	Job	Saltonstall Place CT52XC125	Page	9 of 22
	Project	37621	Date	09:42:20 01/16/19
	Client	Transcend/Sprint	Designed by	TEM

<i>Description</i>	<i>Face or Leg</i>	<i>Offset Type</i>	<i>Offsets: Horz Lateral Vert</i> <i>ft ft ft</i>	<i>Azimuth Adjustment</i> <i>°</i>	<i>Placement</i> <i>ft</i>	<i>Ice</i>	<i>C_{AA} Front</i> <i>ft²</i>	<i>C_{AA} Side</i> <i>ft²</i>	<i>Weight</i> <i>lb</i>
SitePro1 VFA8-HD-S (1)	C	From Leg	0.00 0.00 0.00 0.00	0.0000	85.00	1" Ice No Ice 1/2" Ice 1" Ice	19.70 10.90 15.90 19.70	15.30 7.00 11.30 15.30	761.00 530.00 623.00 761.00

5' Omni	C	From Leg	5.00 0.00 2.00	0.0000	72.00	No Ice 1/2" Ice 1" Ice	1.23 1.53 1.84	1.23 1.53 1.84	25.00 34.47 47.41
8' Standoff	C	From Leg	2.50 0.00 0.00	0.0000	72.00	No Ice 1/2" Ice 1" Ice	1.59 2.30 3.01	3.96 5.63 7.29	73.20 108.83 144.46

10' Dipole	B	From Leg	5.00 0.00 5.00	0.0000	70.00	No Ice 1/2" Ice 1" Ice	3.00 4.03 5.03	3.00 4.03 5.03	30.00 51.79 80.14
8' Standoff	B	From Leg	2.50 0.00 0.00	0.0000	70.00	No Ice 1/2" Ice 1" Ice	1.59 2.30 3.01	3.96 5.63 7.29	73.20 108.83 144.46

10' Dipole	B	From Leg	4.00 0.00 5.00	0.0000	60.00	No Ice 1/2" Ice 1" Ice	3.00 4.03 5.03	3.00 4.03 5.03	30.00 51.79 80.14
Side Arm Mount [SO 306-1]	B	From Leg	2.00 0.00 0.00	0.0000	60.00	No Ice 1/2" Ice 1" Ice	0.98 1.70 2.42	2.18 3.80 5.42	42.00 62.37 82.75

15' Omni	B	From Leg	5.00 0.00 7.50	0.0000	50.00	No Ice 1/2" Ice 1" Ice	4.13 5.66 7.20	4.13 5.66 7.20	40.00 70.14 109.87
Side Arm Mount [SO 702-1]	B	From Leg	2.50 0.00 0.00	0.0000	50.00	No Ice 1/2" Ice 1" Ice	1.00 1.25 1.50	1.43 2.05 2.67	27.00 38.00 49.00

6' Omni	C	From Leg	4.00 0.00 3.00	0.0000	48.00	No Ice 1/2" Ice 1" Ice	2.11 2.60 3.11	2.11 2.60 3.11	37.30 56.00 79.69
Side Arm Mount [SO 306-1]	C	From Leg	2.00 0.00 0.00	0.0000	48.00	No Ice 1/2" Ice 1" Ice	0.98 1.70 2.42	2.18 3.80 5.42	42.00 62.37 82.75

8' Dipole	C	From Leg	1.00 0.00 0.00	0.0000	41.00	No Ice 1/2" Ice 1" Ice	2.80 3.41 3.89	2.80 3.41 3.89	45.00 65.06 90.52

Dishes

tnxTower Ramaker & Associates, Inc 855 Community Drive Sauk City, WI 53583 Phone: (608) 643-4100 FAX: (608) 643-7999	Job Saltonstall Place CT52XC125	Page 10 of 22
	Project 37621	Date 09:42:20 01/16/19
	Client Transcend/Sprint	Designed by TEM

Description	Face or Leg	Dish Type	Offset Type	Offsets: Horiz Lateral Vert	Azimuth Adjustment °	3 dB Beam Width °	Elevation ft	Outside Diameter ft	Aperture Area ft ²	Weight lb	

2 FT DISH	A	Paraboloid w/o Radome	From Leg	0.00 0.00 0.00	0.0000		96.00	2.00	No Ice 1/2" Ice 1" Ice	3.14 3.41 3.68	70.00 87.50 105.01

VHLP2-18	A	Paraboloid w/Shroud (HP)	From Leg	0.00 0.00 0.00	0.0000		85.00	2.18	No Ice 1/2" Ice 1" Ice	3.72 4.01 4.30	27.00 54.00 81.00
VHLP2-18	C	Paraboloid w/Shroud (HP)	From Leg	0.00 0.00 0.00	0.0000		85.00	2.18	No Ice 1/2" Ice 1" Ice	3.72 4.01 4.30	27.00 54.00 81.00

Force Totals

Load Case	Vertical Forces lb	Sum of Forces X lb	Sum of Forces Z lb	Sum of Overturning Moments, M _x lb-ft	Sum of Overturning Moments, M _z lb-ft	Sum of Torques lb-ft
Leg Weight	2633.11					
Bracing Weight	1321.90					
Total Member Self-Weight	3955.02					
Total Weight	8105.12			1398.70	1116.91	
Wind 0 deg - No Ice		58.74	-7506.62	-449779.11	-3812.17	-1616.88
Wind 30 deg - No Ice		3475.09	-6080.17	-368443.61	-210163.37	184.40
Wind 60 deg - No Ice		6023.91	-3575.18	-216045.01	-362420.85	1559.08
Wind 90 deg - No Ice		7110.59	-49.03	-2715.05	-426028.57	2830.35
Wind 120 deg - No Ice		6399.42	3845.55	235149.91	-380789.09	3391.28
Wind 150 deg - No Ice		3498.49	6342.50	386618.33	-207516.03	3094.62
Wind 180 deg - No Ice		-38.29	7131.36	435302.27	4308.42	1653.65
Wind 210 deg - No Ice		-3432.40	6144.79	377372.56	208423.27	-288.67
Wind 240 deg - No Ice		-6354.64	3887.52	239257.12	380278.64	-1671.74
Wind 270 deg - No Ice		-7089.20	21.97	3192.95	426444.15	-2838.45
Wind 300 deg - No Ice		-6035.99	-3537.93	-212339.36	364619.30	-3315.39
Wind 330 deg - No Ice		-3541.08	-6253.23	-375594.70	213715.37	-2982.25
Member Ice	8827.33					
Total Weight Ice	27190.99			7784.36	11009.43	
Wind 0 deg - Ice		20.74	-4064.81	-227852.04	9302.65	-1981.11
Wind 30 deg - Ice		1963.99	-3443.21	-192571.92	-103182.04	-800.24
Wind 60 deg - Ice		3393.63	-2005.47	-109061.63	-185582.21	528.22
Wind 90 deg - Ice		3993.35	-17.75	6328.15	-219233.26	1832.52
Wind 120 deg - Ice		3527.42	2096.89	129653.03	-191495.96	2733.90
Wind 150 deg - Ice		1976.78	3539.79	213420.26	-102416.40	2793.71
Wind 180 deg - Ice		-14.44	4000.86	240880.53	12180.91	1992.43
Wind 210 deg - Ice		-1950.61	3463.54	210070.56	123954.53	767.35
Wind 240 deg - Ice		-3450.89	2076.65	129604.28	210016.81	-563.48
Wind 270 deg - Ice		-3986.76	9.40	8524.76	240691.96	-1835.01
Wind 300 deg - Ice		-3460.08	-2027.17	-109234.09	210242.75	-2709.96
Wind 330 deg - Ice		-1990.13	-3511.86	-195276.30	125679.06	-2758.32
Total Weight	8105.12			1398.70	1116.91	
Wind 0 deg - Service		20.73	-2649.13	-158148.54	-1935.22	-570.61
Wind 30 deg - Service		1226.38	-2145.73	-129444.71	-74757.92	65.07
Wind 60 deg - Service		2125.88	-1261.70	-75662.24	-128490.58	550.21
Wind 90 deg - Service		2509.38	-17.30	-376.69	-150938.17	998.85
Wind 120 deg - Service		2258.40	1357.12	83567.41	-134972.86	1196.81
Wind 150 deg - Service		1234.64	2238.31	137021.62	-73823.65	1092.11

tnxTower Ramaker & Associates, Inc 855 Community Drive Sauk City, WI 53583 Phone: (608) 643-4100 FAX: (608) 643-7999	Job Saltonstall Place CT52XC125	Page 11 of 22
	Project 37621	Date 09:42:20 01/16/19
	Client Transcend/Sprint	Designed by TEM

Load Case	Vertical Forces lb	Sum of Forces X lb	Sum of Forces Z lb	Sum of Overturning Moments, M_x lb-ft	Sum of Overturning Moments, M_z lb-ft	Sum of Torques lb-ft
Wind 180 deg - Service		-13.51	2516.70	154202.50	930.59	583.58
Wind 210 deg - Service		-1211.32	2168.54	133758.72	72964.06	-101.87
Wind 240 deg - Service		-2242.59	1371.93	85016.87	133612.95	-589.97
Wind 270 deg - Service		-2501.83	7.75	1708.28	149905.06	-1001.71
Wind 300 deg - Service		-2130.14	-1248.56	-74354.49	128086.67	-1170.02
Wind 330 deg - Service		-1249.67	-2206.81	-131968.38	74831.68	-1052.46

Load Combinations

Comb. No.	Description
1	Dead Only
2	1.2 Dead+1.6 Wind 0 deg - No Ice
3	1.2D+1.6W (pattern 1) 0 deg - No Ice
4	1.2D+1.6W (pattern 2) 0 deg - No Ice
5	0.9 Dead+1.6 Wind 0 deg - No Ice
6	1.2 Dead+1.6 Wind 30 deg - No Ice
7	1.2D+1.6W (pattern 1) 30 deg - No Ice
8	1.2D+1.6W (pattern 2) 30 deg - No Ice
9	0.9 Dead+1.6 Wind 30 deg - No Ice
10	1.2 Dead+1.6 Wind 60 deg - No Ice
11	1.2D+1.6W (pattern 1) 60 deg - No Ice
12	1.2D+1.6W (pattern 2) 60 deg - No Ice
13	0.9 Dead+1.6 Wind 60 deg - No Ice
14	1.2 Dead+1.6 Wind 90 deg - No Ice
15	1.2D+1.6W (pattern 1) 90 deg - No Ice
16	1.2D+1.6W (pattern 2) 90 deg - No Ice
17	0.9 Dead+1.6 Wind 90 deg - No Ice
18	1.2 Dead+1.6 Wind 120 deg - No Ice
19	1.2D+1.6W (pattern 1) 120 deg - No Ice
20	1.2D+1.6W (pattern 2) 120 deg - No Ice
21	0.9 Dead+1.6 Wind 120 deg - No Ice
22	1.2 Dead+1.6 Wind 150 deg - No Ice
23	1.2D+1.6W (pattern 1) 150 deg - No Ice
24	1.2D+1.6W (pattern 2) 150 deg - No Ice
25	0.9 Dead+1.6 Wind 150 deg - No Ice
26	1.2 Dead+1.6 Wind 180 deg - No Ice
27	1.2D+1.6W (pattern 1) 180 deg - No Ice
28	1.2D+1.6W (pattern 2) 180 deg - No Ice
29	0.9 Dead+1.6 Wind 180 deg - No Ice
30	1.2 Dead+1.6 Wind 210 deg - No Ice
31	1.2D+1.6W (pattern 1) 210 deg - No Ice
32	1.2D+1.6W (pattern 2) 210 deg - No Ice
33	0.9 Dead+1.6 Wind 210 deg - No Ice
34	1.2 Dead+1.6 Wind 240 deg - No Ice
35	1.2D+1.6W (pattern 1) 240 deg - No Ice
36	1.2D+1.6W (pattern 2) 240 deg - No Ice
37	0.9 Dead+1.6 Wind 240 deg - No Ice
38	1.2 Dead+1.6 Wind 270 deg - No Ice
39	1.2D+1.6W (pattern 1) 270 deg - No Ice
40	1.2D+1.6W (pattern 2) 270 deg - No Ice
41	0.9 Dead+1.6 Wind 270 deg - No Ice
42	1.2 Dead+1.6 Wind 300 deg - No Ice
43	1.2D+1.6W (pattern 1) 300 deg - No Ice
44	1.2D+1.6W (pattern 2) 300 deg - No Ice
45	0.9 Dead+1.6 Wind 300 deg - No Ice

tnxTower Ramaker & Associates, Inc 855 Community Drive Sauk City, WI 53583 Phone: (608) 643-4100 FAX: (608) 643-7999	Job Saltonstall Place CT52XC125	Page 12 of 22
	Project 37621	Date 09:42:20 01/16/19
	Client Transcend/Sprint	Designed by TEM

Comb. No.	Description
46	1.2 Dead+1.6 Wind 330 deg - No Ice
47	1.2D+1.6W (pattern 1) 330 deg - No Ice
48	1.2D+1.6W (pattern 2) 330 deg - No Ice
49	0.9 Dead+1.6 Wind 330 deg - No Ice
50	1.2 Dead+1.0 Ice+1.0 Temp
51	1.2 Dead+1.0 Wind 0 deg+1.0 Ice+1.0 Temp
52	1.2 Dead+1.0 Wind 30 deg+1.0 Ice+1.0 Temp
53	1.2 Dead+1.0 Wind 60 deg+1.0 Ice+1.0 Temp
54	1.2 Dead+1.0 Wind 90 deg+1.0 Ice+1.0 Temp
55	1.2 Dead+1.0 Wind 120 deg+1.0 Ice+1.0 Temp
56	1.2 Dead+1.0 Wind 150 deg+1.0 Ice+1.0 Temp
57	1.2 Dead+1.0 Wind 180 deg+1.0 Ice+1.0 Temp
58	1.2 Dead+1.0 Wind 210 deg+1.0 Ice+1.0 Temp
59	1.2 Dead+1.0 Wind 240 deg+1.0 Ice+1.0 Temp
60	1.2 Dead+1.0 Wind 270 deg+1.0 Ice+1.0 Temp
61	1.2 Dead+1.0 Wind 300 deg+1.0 Ice+1.0 Temp
62	1.2 Dead+1.0 Wind 330 deg+1.0 Ice+1.0 Temp
63	Dead+Wind 0 deg - Service
64	Dead+Wind 30 deg - Service
65	Dead+Wind 60 deg - Service
66	Dead+Wind 90 deg - Service
67	Dead+Wind 120 deg - Service
68	Dead+Wind 150 deg - Service
69	Dead+Wind 180 deg - Service
70	Dead+Wind 210 deg - Service
71	Dead+Wind 240 deg - Service
72	Dead+Wind 270 deg - Service
73	Dead+Wind 300 deg - Service
74	Dead+Wind 330 deg - Service

Maximum Member Forces

Section No.	Elevation ft	Component Type	Condition	Gov. Load Comb.	Axial lb	Major Axis Moment lb-ft	Minor Axis Moment lb-ft
T1	100 - 80	Leg	Max Tension	29	5771.48	13.85	-307.79
			Max. Compression	2	-8380.95	-0.19	-63.31
			Max. Mx	14	-1394.87	500.24	8.27
			Max. My	26	-2966.83	38.67	491.23
			Max. Vy	14	732.35	-281.78	47.74
			Max. Vx	26	756.47	13.82	-307.80
		Diagonal	Max Tension	6	2120.15	0.00	0.00
			Max. Compression	6	-2135.79	0.00	0.00
			Max. Mx	61	551.38	9.90	-0.38
			Max. My	6	-2132.80	-1.99	4.26
			Max. Vy	61	-13.64	9.90	-0.38
			Max. Vx	6	1.41	0.00	0.00
		Top Girt	Max Tension	35	54.41	0.00	0.00
			Max. Compression	11	-66.97	0.00	0.00
			Max. Mx	50	-15.20	-23.31	0.00
			Max. My	56	-16.45	0.00	0.00
			Max. Vy	50	20.63	0.00	0.00
			Max. Vx	56	-0.00	0.00	0.00
T2	80 - 60	Leg	Max Tension	29	32718.12	-33.43	-20.22
			Max. Compression	34	-36279.50	106.82	0.70
			Max. Mx	34	-36279.50	106.82	0.70
			Max. My	7	-1420.97	-4.13	172.25
			Max. Vy	3	98.97	38.83	-42.76
			Max. Vx	42	237.72	13.70	89.88

tnxTower Ramaker & Associates, Inc 855 Community Drive Sauk City, WI 53583 Phone: (608) 643-4100 FAX: (608) 643-7999	Job Saltonstall Place CT52XC125	Page 13 of 22
	Project 37621	Date 09:42:20 01/16/19
	Client Transcend/Sprint	Designed by TEM

Section No.	Elevation ft	Component Type	Condition	Gov. Load Comb.	Axial lb	Major Axis Moment lb-ft	Minor Axis Moment lb-ft
T3	60 - 40	Diagonal	Max Tension	14	2857.03	0.00	0.00
			Max. Compression	14	-2951.15	0.00	0.00
			Max. Mx	34	2395.02	18.44	-0.34
			Max. My	14	-2782.63	-8.25	-4.42
			Max. Vy	59	-15.33	15.78	-0.22
			Max. Vx	14	1.46	-8.25	-4.42
		Leg	Max Tension	29	69274.71	-57.96	-24.72
			Max. Compression	34	-74703.08	411.31	9.33
			Max. Mx	34	-74703.08	411.31	9.33
			Max. My	22	-4930.64	-16.95	-513.85
			Max. Vy	34	-141.46	411.31	9.33
			Max. Vx	30	215.63	3.69	63.37
		Diagonal	Max Tension	14	4137.65	0.00	0.00
			Max. Compression	38	-4273.50	0.00	0.00
Max. Mx	34		3275.08	19.95	-0.52		
Max. My	22		-3417.46	-10.66	-7.02		
Max. Vy	59		-15.89	16.32	-0.39		
Max. Vx	22		2.32	-10.66	-7.02		
T4	40 - 20	Leg	Max Tension	29	82394.76	-156.51	-5.80
			Max. Compression	2	-89671.37	167.38	7.99
			Max. Mx	34	-80357.56	411.31	9.31
			Max. My	22	-5288.47	-15.31	-432.49
			Max. Vy	18	110.52	410.36	-26.97
			Max. Vx	22	138.26	-15.31	-432.49
		Diagonal	Max Tension	43	1531.18	0.00	0.00
			Max. Compression	18	-1732.33	0.00	0.00
			Max. Mx	57	135.82	13.61	-1.91
			Max. My	14	-1511.39	-6.04	-5.23
			Max. Vy	57	16.60	13.35	-1.87
			Max. Vx	14	1.82	0.00	0.00
		Top Girt	Max Tension	21	47.01	0.00	0.00
			Max. Compression	26	-132.64	0.00	0.00
Max. Mx	50		-75.64	-20.85	0.00		
Max. My	56		-77.62	0.00	0.60		
Max. Vy	50		18.28	0.00	0.00		
Max. Vx	56		-0.53	0.00	0.00		
T5	20 - 0	Leg	Max Tension	29	90399.06	-127.68	-12.10
			Max. Compression	2	-99277.85	-0.00	-0.04
			Max. Mx	55	-40866.70	242.01	3.15
			Max. My	22	-6006.96	-8.82	-348.57
			Max. Vy	53	-90.88	-233.89	0.82
			Max. Vx	22	-107.01	-8.82	-348.57
		Diagonal	Max Tension	15	1620.13	0.00	0.00
			Max. Compression	18	-1809.10	0.00	0.00
			Max. Mx	57	-103.24	21.52	-2.83
			Max. My	61	-872.30	18.66	3.47
			Max. Vy	57	18.81	21.52	-2.83
			Max. Vx	61	-1.24	0.00	0.00

Maximum Reactions

Location	Condition	Gov. Load Comb.	Vertical lb	Horizontal, X lb	Horizontal, Z lb
Leg C	Max. Vert	34	100190.88	6847.64	-3740.81
	Max. H _x	34	100190.88	6847.64	-3740.81
	Max. H _z	13	-88763.80	-6158.94	3354.94

Job	Saltonstall Place CT52XC125	Page	14 of 22
Project	37621	Date	09:42:20 01/16/19
Client	Transcend/Sprint	Designed by	TEM

Location	Condition	Gov. Load Comb.	Vertical lb	Horizontal, X lb	Horizontal, Z lb
Leg B	Min. Vert	13	-88763.80	-6158.94	3354.94
	Min. H _x	13	-88763.80	-6158.94	3354.94
	Min. H _z	34	100190.88	6847.64	-3740.81
	Max. Vert	18	99947.25	-6945.78	-3590.53
	Max. H _x	45	-88591.54	6246.26	3184.75
	Max. H _z	45	-88591.54	6246.26	3184.75
Leg A	Min. Vert	45	-88591.54	6246.26	3184.75
	Min. H _x	18	99947.25	-6945.78	-3590.53
	Min. H _z	18	99947.25	-6945.78	-3590.53
	Max. Vert	2	100532.28	-168.38	7853.23
	Max. H _x	24	-58567.74	214.58	-4531.17
	Max. H _z	2	100532.28	-168.38	7853.23
	Min. Vert	29	-91370.52	179.84	-7157.71
	Min. H _x	4	74792.43	-206.45	5760.51
Min. H _z	29	-91370.52	179.84	-7157.71	

Tower Mast Reaction Summary

Load Combination	Vertical lb	Shear _x lb	Shear _z lb	Overturning Moment, M _x lb-ft	Overturning Moment, M _z lb-ft	Torque lb-ft
Dead Only	8105.12	0.00	-0.00	1398.70	1116.91	-0.00
1.2 Dead+1.6 Wind 0 deg - No Ice	9726.14	93.97	-12010.59	-724951.31	-6592.48	-2595.92
1.2D+1.6W (pattern 1) 0 deg - No Ice	9726.14	93.97	-11463.06	-674971.76	-6593.46	-2595.18
1.2D+1.6W (pattern 2) 0 deg - No Ice	9726.14	56.39	-8674.76	-533152.68	-3413.58	-3138.41
0.9 Dead+1.6 Wind 0 deg - No Ice	7294.61	93.98	-12010.59	-724169.79	-6915.74	-2594.07
1.2 Dead+1.6 Wind 30 deg - No Ice	9726.14	5560.15	-9728.28	-593983.84	-338955.69	299.63
1.2D+1.6W (pattern 1) 30 deg - No Ice	9726.14	5316.48	-9301.62	-555050.81	-316735.04	357.60
1.2D+1.6W (pattern 2) 30 deg - No Ice	9726.14	3984.23	-6964.19	-432414.77	-246857.78	-766.42
0.9 Dead+1.6 Wind 30 deg - No Ice	7294.61	5560.15	-9728.28	-593413.20	-338722.50	299.48
1.2 Dead+1.6 Wind 60 deg - No Ice	9726.14	9638.26	-5720.28	-348520.24	-584173.92	2506.09
1.2D+1.6W (pattern 1) 60 deg - No Ice	9726.14	9240.27	-5481.32	-326707.53	-547933.13	2575.53
1.2D+1.6W (pattern 2) 60 deg - No Ice	9726.14	6978.43	-4131.57	-254686.83	-428531.03	1228.52
0.9 Dead+1.6 Wind 60 deg - No Ice	7294.61	9638.25	-5720.28	-348360.52	-583534.12	2503.36
1.2 Dead+1.6 Wind 90 deg - No Ice	9726.14	11376.95	-78.45	-4926.11	-686601.72	4543.71
1.2D+1.6W (pattern 1) 90 deg - No Ice	9726.14	10910.43	-77.89	-4873.39	-644176.73	4597.98
1.2D+1.6W (pattern 2) 90 deg - No Ice	9726.14	8253.07	-47.63	-2332.83	-504736.49	3401.12
0.9 Dead+1.6 Wind 90 deg - No Ice	7294.61	11376.95	-78.45	-5339.46	-685794.48	4539.07
1.2 Dead+1.6 Wind 120 deg - No Ice	9726.14	10239.08	6152.88	378201.27	-613713.42	5444.25
1.2D+1.6W (pattern 1) 120 deg - No Ice	9726.14	9796.84	5825.78	348045.15	-573523.15	5465.00
1.2D+1.6W (pattern 2) 120 deg - No Ice	9726.14	7407.81	4493.49	282990.54	-451592.35	4686.66
0.9 Dead+1.6 Wind 120 deg - No Ice	7294.61	10239.07	6152.89	377142.26	-613031.39	5438.85
1.2 Dead+1.6 Wind 150 deg - No Ice	9726.14	5597.58	10148.00	622148.80	-334647.35	4969.58
1.2D+1.6W (pattern 1) 150 deg - No Ice	9726.14	5373.99	9684.18	579616.25	-314372.73	4960.01
1.2D+1.6W (pattern 2) 150 deg - No Ice	9726.14	4062.34	7384.34	460571.27	-245970.54	4798.73
0.9 Dead+1.6 Wind 150 deg - No Ice	7294.61	5597.58	10148.00	620682.68	-334429.12	4965.40
1.2 Dead+1.6 Wind 180 deg - No Ice	9726.14	-61.27	11410.18	700557.44	6497.83	2654.41
1.2D+1.6W (pattern 1) 180 deg - No Ice	9726.14	-61.27	10901.95	653998.57	6496.89	2653.60
1.2D+1.6W (pattern 2) 180 deg - No Ice	9726.14	-36.76	8275.20	516447.27	4438.56	3173.07
0.9 Dead+1.6 Wind 180 deg - No Ice	7294.61	-61.27	11410.18	698959.41	6149.88	2652.12
1.2 Dead+1.6 Wind 210 deg - No Ice	9726.14	-5491.84	9831.67	607269.19	335230.84	-464.08
1.2D+1.6W (pattern 1) 210 deg - No Ice	9726.14	-5268.24	9367.85	564737.17	314954.63	-456.00
1.2D+1.6W (pattern 2) 210 deg - No Ice	9726.14	-3923.18	7063.40	445338.68	243760.67	601.21
0.9 Dead+1.6 Wind 210 deg - No Ice	7294.61	-5491.84	9831.67	605824.00	334335.62	-464.03
1.2 Dead+1.6 Wind 240 deg - No Ice	9726.14	-10167.42	6220.03	384816.48	611990.34	-2682.46
1.2D+1.6W (pattern 1) 240 deg - No Ice	9726.14	-9725.18	5892.93	354661.23	571799.46	-2704.18
1.2D+1.6W (pattern 2) 240 deg - No Ice	9726.14	-7340.19	4519.56	286160.77	450256.05	-1383.13

tnxTower Ramaker & Associates, Inc 855 Community Drive Sauk City, WI 53583 Phone: (608) 643-4100 FAX: (608) 643-7999	Job Saltonstall Place CT52XC125	Page 15 of 22
	Project 37621	Date 09:42:20 01/16/19
	Client Transcend/Sprint	Designed by TEM

Load Combination	Vertical	Shear _x	Shear _y	Overturing Moment, M _x	Overturing Moment, M _y	Torque
	lb	lb	lb	lb-ft	lb-ft	lb-ft
0.9 Dead+1.6 Wind 240 deg - No Ice	7294.61	-10167.42	6220.03	383745.35	610639.84	-2680.22
1.2 Dead+1.6 Wind 270 deg - No Ice	9726.14	-11342.73	35.14	4594.71	686365.41	-4556.12
1.2D+1.6W (pattern 1) 270 deg - No Ice	9726.14	-10876.20	35.70	4647.56	643939.67	-4610.63
1.2D+1.6W (pattern 2) 270 deg - No Ice	9726.14	-8232.54	20.53	3379.48	505673.05	-3408.64
0.9 Dead+1.6 Wind 270 deg - No Ice	7294.61	-11342.73	35.14	4164.11	684887.12	-4551.52
1.2 Dead+1.6 Wind 300 deg - No Ice	9726.14	-9657.59	-5660.70	-342541.96	586812.80	-5324.77
1.2D+1.6W (pattern 1) 300 deg - No Ice	9726.14	-9259.61	-5421.73	-320730.10	550571.52	-5393.45
1.2D+1.6W (pattern 2) 300 deg - No Ice	9726.14	-7014.66	-4110.04	-251895.81	432575.42	-4565.91
0.9 Dead+1.6 Wind 300 deg - No Ice	7294.61	-9657.59	-5660.70	-342393.44	585497.05	-5319.74
1.2 Dead+1.6 Wind 330 deg - No Ice	9726.14	-5665.74	-10005.18	-605476.49	343767.94	-5792.23
1.2D+1.6W (pattern 1) 330 deg - No Ice	9726.14	-5422.07	-9578.52	-566544.48	321546.03	-4848.90
1.2D+1.6W (pattern 2) 330 deg - No Ice	9726.14	-4123.30	-7261.48	-445612.47	254466.45	-4625.60
0.9 Dead+1.6 Wind 330 deg - No Ice	7294.61	-5665.74	-10005.18	-604891.62	342858.15	-4788.04
1.2 Dead+1.0 Ice+1.0 Temp	28812.01	0.00	-0.00	8240.27	11427.51	-0.01
1.2 Dead+1.0 Wind 0 deg+1.0 Ice+1.0 Temp	28812.01	20.74	-4064.81	-231716.28	9694.33	-2008.49
1.2 Dead+1.0 Wind 30 deg+1.0 Ice+1.0 Temp	28812.01	1963.99	-3443.21	-195792.37	-104861.45	-811.30
1.2 Dead+1.0 Wind 60 deg+1.0 Ice+1.0 Temp	28812.01	3393.62	-2005.47	-110744.64	-188773.80	535.62
1.2 Dead+1.0 Wind 90 deg+1.0 Ice+1.0 Temp	28812.01	3993.35	-17.75	6766.43	-223032.26	1856.83
1.2 Dead+1.0 Wind 120 deg+1.0 Ice+1.0 Temp	28812.01	3527.42	2096.89	132368.79	-194777.98	2769.65
1.2 Dead+1.0 Wind 150 deg+1.0 Ice+1.0 Temp	28812.01	1976.77	3539.79	217669.76	-104068.71	2829.79
1.2 Dead+1.0 Wind 180 deg+1.0 Ice+1.0 Temp	28812.01	-14.44	4000.86	245636.77	12624.86	2019.59
1.2 Dead+1.0 Wind 210 deg+1.0 Ice+1.0 Temp	28812.01	-1950.61	3463.54	214262.13	126447.89	779.08
1.2 Dead+1.0 Wind 240 deg+1.0 Ice+1.0 Temp	28812.01	-3450.89	2076.65	132318.14	214085.70	-570.07
1.2 Dead+1.0 Wind 270 deg+1.0 Ice+1.0 Temp	28812.01	-3986.76	9.40	8996.14	245323.13	-1859.22
1.2 Dead+1.0 Wind 300 deg+1.0 Ice+1.0 Temp	28812.01	-3460.08	-2027.17	-110918.75	214319.55	-2744.78
1.2 Dead+1.0 Wind 330 deg+1.0 Ice+1.0 Temp	28812.01	-1990.13	-3511.86	-198537.48	128211.29	-2794.38
Dead+Wind 0 deg - Service	8105.12	20.73	-2649.13	-158698.31	-626.69	-572.50
Dead+Wind 30 deg - Service	8105.12	1226.38	-2145.73	-129835.86	-73855.42	65.27
Dead+Wind 60 deg - Service	8105.12	2125.88	-1261.70	-75754.25	-127885.01	552.29
Dead+Wind 90 deg - Service	8105.12	2509.38	-17.30	-50.63	-150454.08	1002.25
Dead+Wind 120 deg - Service	8105.12	2258.40	1357.12	84366.59	-134399.77	1200.74
Dead+Wind 150 deg - Service	8105.12	1234.64	2238.31	138113.40	-72910.96	1095.28
Dead+Wind 180 deg - Service	8105.12	-13.51	2516.70	155389.82	2255.73	585.29
Dead+Wind 210 deg - Service	8105.12	-1211.32	2168.54	134833.86	74687.35	-101.96
Dead+Wind 240 deg - Service	8105.12	-2242.59	1371.93	85825.07	135670.91	-591.99
Dead+Wind 270 deg - Service	8105.12	-2501.83	7.75	2046.87	152052.78	-1005.08
Dead+Wind 300 deg - Service	8105.12	-2130.14	-1248.56	-74432.18	130114.75	-1173.72
Dead+Wind 330 deg - Service	8105.12	-1249.67	-2206.81	-132370.61	76566.00	-1055.74

Solution Summary

Load Comb.	Sum of Applied Forces			Sum of Reactions			% Error
	PX lb	PY lb	PZ lb	PX lb	PY lb	PZ lb	
1	0.00	-8105.12	-0.00	-0.00	8105.12	0.00	0.000%
2	93.98	-9726.14	-12010.59	-93.97	9726.14	12010.59	0.000%
3	93.98	-9726.14	-11463.06	-93.97	9726.14	11463.06	0.000%
4	56.39	-9726.14	-8674.76	-56.39	9726.14	8674.76	0.000%
5	93.98	-7294.61	-12010.59	-93.98	7294.61	12010.59	0.000%
6	5560.15	-9726.14	-9728.28	-5560.15	9726.14	9728.28	0.000%
7	5316.48	-9726.14	-9301.62	-5316.48	9726.14	9301.62	0.000%
8	3984.23	-9726.14	-6964.19	-3984.23	9726.14	6964.19	0.000%
9	5560.15	-7294.61	-9728.28	-5560.15	7294.61	9728.28	0.000%
10	9638.25	-9726.14	-5720.28	-9638.25	9726.14	5720.28	0.000%
11	9240.27	-9726.14	-5481.32	-9240.27	9726.14	5481.32	0.000%
12	6978.43	-9726.14	-4131.57	-6978.43	9726.14	4131.57	0.000%
13	9638.25	-7294.61	-5720.28	-9638.25	7294.61	5720.28	0.000%
14	11376.95	-9726.14	-78.45	-11376.95	9726.14	78.45	0.000%

Job	Saltonstall Place CT52XC125	Page	16 of 22
Project	37621	Date	09:42:20 01/16/19
Client	Transcend/Sprint	Designed by	TEM

Load Comb.	Sum of Applied Forces			Sum of Reactions			% Error
	PX lb	PY lb	PZ lb	PX lb	PY lb	PZ lb	
15	10910.43	-9726.14	-77.89	-10910.43	9726.14	77.89	0.000%
16	8253.07	-9726.14	-47.63	-8253.07	9726.14	47.63	0.000%
17	11376.95	-7294.61	-78.45	-11376.95	7294.61	78.45	0.000%
18	10239.08	-9726.14	6152.88	-10239.08	9726.14	-6152.88	0.000%
19	9796.84	-9726.14	5825.78	-9796.84	9726.14	-5825.78	0.000%
20	7407.81	-9726.14	4493.48	-7407.81	9726.14	-4493.48	0.000%
21	10239.08	-7294.61	6152.88	-10239.07	7294.61	-6152.89	0.000%
22	5597.58	-9726.14	10148.00	-5597.58	9726.14	-10148.00	0.000%
23	5373.99	-9726.14	9684.17	-5373.99	9726.14	-9684.18	0.000%
24	4062.34	-9726.14	7384.34	-4062.34	9726.14	-7384.34	0.000%
25	5597.58	-7294.61	10148.00	-5597.58	7294.61	-10148.00	0.000%
26	-61.27	-9726.14	11410.17	61.27	9726.14	-11410.18	0.000%
27	-61.27	-9726.14	10901.95	61.27	9726.14	-10901.95	0.000%
28	-36.76	-9726.14	8275.20	36.76	9726.14	-8275.20	0.000%
29	-61.27	-7294.61	11410.17	61.27	7294.61	-11410.18	0.000%
30	-5491.84	-9726.14	9831.67	5491.84	9726.14	-9831.67	0.000%
31	-5268.24	-9726.14	9367.84	5268.24	9726.14	-9367.85	0.000%
32	-3923.18	-9726.14	7063.40	3923.18	9726.14	-7063.40	0.000%
33	-5491.84	-7294.61	9831.67	5491.84	7294.61	-9831.67	0.000%
34	-10167.42	-9726.14	6220.03	10167.42	9726.14	-6220.03	0.000%
35	-9725.18	-9726.14	5892.92	9725.18	9726.14	-5892.93	0.000%
36	-7340.19	-9726.14	4519.56	7340.19	9726.14	-4519.56	0.000%
37	-10167.42	-7294.61	6220.03	10167.42	7294.61	-6220.03	0.000%
38	-11342.72	-9726.14	35.15	11342.73	9726.14	-35.14	0.000%
39	-10876.20	-9726.14	35.71	10876.20	9726.14	-35.70	0.000%
40	-8232.54	-9726.14	20.53	8232.54	9726.14	-20.53	0.000%
41	-11342.72	-7294.61	35.15	11342.73	7294.61	-35.14	0.000%
42	-9657.59	-9726.14	-5660.70	9657.59	9726.14	5660.70	0.000%
43	-9259.61	-9726.14	-5421.73	9259.61	9726.14	5421.73	0.000%
44	-7014.66	-9726.14	-4110.04	7014.66	9726.14	4110.04	0.000%
45	-9657.59	-7294.61	-5660.70	9657.59	7294.61	5660.70	0.000%
46	-5665.73	-9726.14	-10005.18	5665.74	9726.14	10005.18	0.000%
47	-5422.07	-9726.14	-9578.52	5422.07	9726.14	9578.52	0.000%
48	-4123.30	-9726.14	-7261.48	4123.30	9726.14	7261.48	0.000%
49	-5665.73	-7294.61	-10005.18	5665.74	7294.61	10005.18	0.000%
50	0.00	-28812.01	-0.00	0.00	28812.01	0.00	0.000%
51	20.74	-28812.01	-4064.81	-20.74	28812.01	4064.81	0.000%
52	1963.99	-28812.01	-3443.21	-1963.99	28812.01	3443.21	0.000%
53	3393.63	-28812.01	-2005.47	-3393.62	28812.01	2005.47	0.000%
54	3993.35	-28812.01	-17.75	-3993.35	28812.01	17.75	0.000%
55	3527.42	-28812.01	2096.89	-3527.42	28812.01	-2096.89	0.000%
56	1976.78	-28812.01	3539.79	-1976.77	28812.01	-3539.79	0.000%
57	-14.44	-28812.01	4000.86	14.44	28812.01	-4000.86	0.000%
58	-1950.61	-28812.01	3463.54	1950.61	28812.01	-3463.54	0.000%
59	-3450.89	-28812.01	2076.65	3450.89	28812.01	-2076.65	0.000%
60	-3986.76	-28812.01	9.40	3986.76	28812.01	-9.40	0.000%
61	-3460.08	-28812.01	-2027.17	3460.08	28812.01	2027.17	0.000%
62	-1990.13	-28812.01	-3511.86	1990.13	28812.01	3511.86	0.000%
63	20.73	-8105.12	-2649.13	-20.73	8105.12	2649.13	0.000%
64	1226.38	-8105.12	-2145.73	-1226.38	8105.12	2145.73	0.000%
65	2125.88	-8105.12	-1261.70	-2125.88	8105.12	1261.70	0.000%
66	2509.38	-8105.12	-17.30	-2509.38	8105.12	17.30	0.000%
67	2258.40	-8105.12	1357.12	-2258.40	8105.12	-1357.12	0.000%
68	1234.64	-8105.12	2238.31	-1234.64	8105.12	-2238.31	0.000%
69	-13.51	-8105.12	2516.70	13.51	8105.12	-2516.70	0.000%
70	-1211.32	-8105.12	2168.54	1211.32	8105.12	-2168.54	0.000%
71	-2242.59	-8105.12	1371.93	2242.59	8105.12	-1371.93	0.000%
72	-2501.83	-8105.12	7.75	2501.83	8105.12	-7.75	0.000%
73	-2130.14	-8105.12	-1248.56	2130.14	8105.12	1248.56	0.000%
74	-1249.67	-8105.12	-2206.81	1249.67	8105.12	2206.81	0.000%

tnxTower Ramaker & Associates, Inc 855 Community Drive Sauk City, WI 53583 Phone: (608) 643-4100 FAX: (608) 643-7999	Job Saltonstall Place CT52XC125	Page 17 of 22
	Project 37621	Date 09:42:20 01/16/19
	Client Transcend/Sprint	Designed by TEM

Non-Linear Convergence Results

<i>Load Combination</i>	<i>Converged?</i>	<i>Number of Cycles</i>	<i>Displacement Tolerance</i>	<i>Force Tolerance</i>
1	Yes	4	0.00000001	0.00000001
2	Yes	4	0.00000001	0.00000001
3	Yes	4	0.00000001	0.00000001
4	Yes	4	0.00000001	0.00000001
5	Yes	4	0.00000001	0.00000001
6	Yes	4	0.00000001	0.00000229
7	Yes	4	0.00000001	0.00000001
8	Yes	4	0.00000001	0.00000001
9	Yes	4	0.00000001	0.00000207
10	Yes	4	0.00000001	0.00000210
11	Yes	4	0.00000001	0.00000001
12	Yes	4	0.00000001	0.00000001
13	Yes	4	0.00000001	0.00000001
14	Yes	4	0.00000001	0.00000205
15	Yes	4	0.00000001	0.00000001
16	Yes	4	0.00000001	0.00000001
17	Yes	4	0.00000001	0.00000001
18	Yes	4	0.00000001	0.00000001
19	Yes	4	0.00000001	0.00000001
20	Yes	4	0.00000001	0.00000001
21	Yes	4	0.00000001	0.00000001
22	Yes	4	0.00000001	0.00000281
23	Yes	4	0.00000001	0.00000233
24	Yes	4	0.00000001	0.00000001
25	Yes	4	0.00000001	0.00000254
26	Yes	4	0.00000001	0.00000215
27	Yes	4	0.00000001	0.00000001
28	Yes	4	0.00000001	0.00000001
29	Yes	4	0.00000001	0.00000001
30	Yes	4	0.00000001	0.00000235
31	Yes	4	0.00000001	0.00000001
32	Yes	4	0.00000001	0.00000001
33	Yes	4	0.00000001	0.00000213
34	Yes	4	0.00000001	0.00000001
35	Yes	4	0.00000001	0.00000001
36	Yes	4	0.00000001	0.00000001
37	Yes	4	0.00000001	0.00000001
38	Yes	4	0.00000001	0.00000001
39	Yes	4	0.00000001	0.00000001
40	Yes	4	0.00000001	0.00000001
41	Yes	4	0.00000001	0.00000001
42	Yes	4	0.00000001	0.00000210
43	Yes	4	0.00000001	0.00000001
44	Yes	4	0.00000001	0.00000001
45	Yes	4	0.00000001	0.00000001
46	Yes	4	0.00000001	0.00000268
47	Yes	4	0.00000001	0.00000225
48	Yes	4	0.00000001	0.00000001
49	Yes	4	0.00000001	0.00000242
50	Yes	4	0.00000001	0.00000001
51	Yes	4	0.00000001	0.00002135
52	Yes	4	0.00000001	0.00002147
53	Yes	4	0.00000001	0.00002181
54	Yes	4	0.00000001	0.00002154
55	Yes	4	0.00000001	0.00002151

tnxTower Ramaker & Associates, Inc 855 Community Drive Sauk City, WI 53583 Phone: (608) 643-4100 FAX: (608) 643-7999	Job	Saltonstall Place CT52XC125	Page	18 of 22
	Project	37621	Date	09:42:20 01/16/19
	Client	Transcend/Sprint	Designed by	TEM

56	Yes	4	0.00000001	0.00002212
57	Yes	4	0.00000001	0.00002244
58	Yes	4	0.00000001	0.00002205
59	Yes	4	0.00000001	0.00002167
60	Yes	4	0.00000001	0.00002197
61	Yes	4	0.00000001	0.00002241
62	Yes	4	0.00000001	0.00002199
63	Yes	4	0.00000001	0.00000001
64	Yes	4	0.00000001	0.00000001
65	Yes	4	0.00000001	0.00000001
66	Yes	4	0.00000001	0.00000001
67	Yes	4	0.00000001	0.00000001
68	Yes	4	0.00000001	0.00000001
69	Yes	4	0.00000001	0.00000001
70	Yes	4	0.00000001	0.00000001
71	Yes	4	0.00000001	0.00000001
72	Yes	4	0.00000001	0.00000001
73	Yes	4	0.00000001	0.00000001
74	Yes	4	0.00000001	0.00000001

Maximum Tower Deflections - Service Wind

Section No.	Elevation ft	Horz. Deflection in	Gov. Load Comb.	Tilt °	Twist °
T1	100 - 80	3.005	71	0.2475	0.0430
T2	80 - 60	1.968	71	0.2390	0.0433
T3	60 - 40	1.062	71	0.1676	0.0371
T4	40 - 20	0.447	71	0.1087	0.0271
T5	20 - 0	0.111	71	0.0488	0.0109

Critical Deflections and Radius of Curvature - Service Wind

Elevation ft	Appurtenance	Gov. Load Comb.	Deflection in	Tilt °	Twist °	Radius of Curvature ft
100.00	10' Omni	71	3.005	0.2475	0.0430	172071
96.00	2 FT DISH	71	2.794	0.2493	0.0434	172071
85.00	VHLP2-18	71	2.221	0.2470	0.0438	57357
72.00	5' Omni	71	1.579	0.2145	0.0415	23693
70.00	10' Dipole	71	1.487	0.2068	0.0409	21233
60.00	10' Dipole	71	1.062	0.1676	0.0371	14529
50.00	15' Omni	71	0.716	0.1362	0.0329	15760
48.00	6' Omni	71	0.656	0.1307	0.0319	16172
41.00	8' Dipole	71	0.470	0.1116	0.0278	17687

Maximum Tower Deflections - Design Wind

Section No.	Elevation ft	Horz. Deflection in	Gov. Load Comb.	Tilt °	Twist °
-------------	-----------------	------------------------	-----------------	-----------	------------

tnxTower Ramaker & Associates, Inc 855 Community Drive Sauk City, WI 53583 Phone: (608) 643-4100 FAX: (608) 643-7999	Job Saltonstall Place CT52XC125	Page 19 of 22
	Project 37621	Date 09:42:20 01/16/19
	Client Transcend/Sprint	Designed by TEM

Section No.	Elevation ft	Horz. Deflection in	Gov. Load Comb.	Tilt °	Twist °
T1	100 - 80	13.519	2	1.1139	0.1973
T2	80 - 60	8.861	2	1.0748	0.1983
T3	60 - 40	4.788	2	0.7540	0.1696
T4	40 - 20	2.018	2	0.4893	0.1235
T5	20 - 0	0.503	2	0.2198	0.0495

Critical Deflections and Radius of Curvature - Design Wind

Elevation ft	Appurtenance	Gov. Load Comb.	Deflection in	Tilt °	Twist °	Radius of Curvature ft
100.00	10' Omni	2	13.519	1.1139	0.1973	38968
96.00	2 FT DISH	2	12.572	1.1214	0.1989	38968
85.00	VHLP2-18	2	9.999	1.1108	0.2004	12989
72.00	5' Omni	2	7.114	0.9646	0.1897	5268
70.00	10' Dipole	2	6.698	0.9303	0.1868	4724
60.00	10' Dipole	2	4.788	0.7540	0.1696	3237
50.00	15' Omni	2	3.232	0.6132	0.1500	3508
48.00	6' Omni	2	2.964	0.5883	0.1455	3599
41.00	8' Dipole	2	2.125	0.5020	0.1267	3933

Bolt Design Data

Section No.	Elevation ft	Component Type	Bolt Grade	Bolt Size in	Number Of Bolts	Maximum Load per Bolt lb	Allowable Load per Bolt lb	Ratio Load Allowable	Allowable Ratio	Criteria	
T1	100	Leg	A325N	0.6250	4	1442.87	20708.70	0.070	✓	1	Bolt Tension
		Diagonal	A325N	0.5000	1	2120.15	3126.56	0.678	✓	1	Member Block Shear
		Top Girt	A325N	0.5000	1	54.41	3126.56	0.017	✓	1	Member Block Shear
T2	80	Leg	A325N	0.6250	4	8179.53	20708.70	0.395	✓	1	Bolt Tension
		Diagonal	A325N	0.5000	1	2857.03	3126.56	0.914	✓	1	Member Block Shear
T3	60	Leg	A325N	0.6250	4	17318.70	20708.70	0.836	✓	1	Bolt Tension
		Diagonal	A325N	0.5000	1	4137.65	4689.84	0.882	✓	1	Member Block Shear
T4	40	Leg	A325N	0.7500	4	20598.70	29820.60	0.691	✓	1	Bolt Tension
		Diagonal	A325N	0.5000	1	1531.18	3126.56	0.490	✓	1	Member Block Shear
		Top Girt	A325N	0.5000	1	132.64	6960.00	0.019	✓	1	Member Bearing
T5	20	Diagonal	A325N	0.5000	1	1620.13	3126.56	0.518	✓	1	Member Block Shear

Compression Checks

Leg Design Data (Compression)

tnxTower Ramaker & Associates, Inc 855 Community Drive Sauk City, WI 53583 Phone: (608) 643-4100 FAX: (608) 643-7999	Job Saltonstall Place CT52XC125	Page 20 of 22
	Project 37621	Date 09:42:20 01/16/19
	Client Transcend/Sprint	Designed by TEM

Section No.	Elevation ft	Size	L ft	L _u ft	Kl/r	A in ²	P _u lb	φP _n lb	Ratio $\frac{P_u}{\phi P_n}$
T1	100 - 80	ROHN 2 STD	20.00	4.00	61.0 K=1.00	1.0745	-8380.95	36842.30	0.227 ¹
T2	80 - 60	ROHN 2 STD	20.00	4.00	61.0 K=1.00	1.0745	-36279.50	36842.20	0.985 ¹
T3	60 - 40	P2.5STD + Half P3XS	20.00	4.00	57.5 K=1.10	3.2120	-74703.10	106472.00	0.702 ¹
T4	40 - 20	P2.5XS + Half P3XS	20.03	4.01	57.3 K=1.10	3.7615	-89671.40	124860.00	0.718 ¹
T5	20 - 0	P2.5XS + Half P3XS	20.03	5.01	69.3 K=1.07	3.7615	-99277.90	112719.00	0.881 ¹

¹ P_u / φP_n controls

Diagonal Design Data (Compression)

Section No.	Elevation ft	Size	L ft	L _u ft	Kl/r	A in ²	P _u lb	φP _n lb	Ratio $\frac{P_u}{\phi P_n}$
T1	100 - 80	L1 1/2x1 1/2x1/8	6.04	2.78	114.5 K=1.02	0.3594	-2135.79	5836.98	0.366 ¹
T2	80 - 60	L1 1/2x1 1/2x1/8	6.06	2.80	115.1 K=1.01	0.3594	-2951.15	5799.98	0.509 ¹
T3	60 - 40	L1 1/2x1 1/2x3/16	6.07	2.74	113.9 K=1.02	0.5273	-4273.50	8627.09	0.495 ¹
T4	40 - 20	L1 1/2x1 1/2x1/8	7.52	3.60	145.8 K=1.00	0.3594	-1531.34	3816.68	0.401 ¹
T5	20 - 0	L1 1/2x1 1/2x1/8	9.73	4.74	192.1 K=1.00	0.3594	-1809.10	2200.49	0.822 ¹

¹ P_u / φP_n controls

Top Girt Design Data (Compression)

Section No.	Elevation ft	Size	L ft	L _u ft	Kl/r	A in ²	P _u lb	φP _n lb	Ratio $\frac{P_u}{\phi P_n}$
T1	100 - 80	L1 1/2x1 1/2x1/8	4.52	4.11	166.7 K=1.00	0.3594	-66.97	2921.51	0.023 ¹
T4	40 - 20	L1 1/2x1 1/2x1/8	4.56	4.06	164.6 K=1.00	0.3594	-132.64	2996.89	0.044 ¹

¹ P_u / φP_n controls

tnxTower Ramaker & Associates, Inc 855 Community Drive Sauk City, WI 53583 Phone: (608) 643-4100 FAX: (608) 643-7999	Job Saltonstall Place CT52XC125	Page 21 of 22
	Project 37621	Date 09:42:20 01/16/19
	Client Transcend/Sprint	Designed by TEM

Tension Checks

Leg Design Data (Tension)

Section No.	Elevation <i>ft</i>	Size	L <i>ft</i>	L _u <i>ft</i>	Kl/r	A <i>in</i> ²	P _u <i>lb</i>	φP _n <i>lb</i>	Ratio $\frac{P_u}{\phi P_n}$
T1	100 - 80	ROHN 2 STD	20.00	4.00	61.0	1.0745	5771.48	48353.90	0.119 ¹
T2	80 - 60	ROHN 2 STD	20.00	4.00	61.0	1.0745	32718.10	48353.90	0.677 ¹
T3	60 - 40	P2.5STD + Half P3XS	20.00	4.00	52.2	3.2120	69274.70	132977.00	0.521 ¹
T4	40 - 20	P2.5XS + Half P3XS	20.03	4.01	52.0	3.7615	82394.80	155726.00	0.529 ¹
T5	20 - 0	P2.5XS + Half P3XS	20.03	5.01	65.0	3.7615	90399.10	155726.00	0.581 ¹

¹ P_u / φP_n controls

Diagonal Design Data (Tension)

Section No.	Elevation <i>ft</i>	Size	L <i>ft</i>	L _u <i>ft</i>	Kl/r	A <i>in</i> ²	P _u <i>lb</i>	φP _n <i>lb</i>	Ratio $\frac{P_u}{\phi P_n}$
T1	100 - 80	L1 1/2x1 1/2x1/8	6.04	2.78	74.5	0.2109	2120.15	9175.78	0.231 ¹
T2	80 - 60	L1 1/2x1 1/2x1/8	6.06	2.80	74.9	0.2109	2857.03	9175.78	0.311 ¹
T3	60 - 40	L1 1/2x1 1/2x3/16	6.07	2.74	74.6	0.3076	4137.65	13381.30	0.309 ¹
T4	40 - 20	L1 1/2x1 1/2x1/8	6.22	2.96	79.2	0.2109	1531.18	9175.78	0.167 ¹
T5	20 - 0	L1 1/2x1 1/2x1/8	9.73	4.74	125.0	0.2109	1620.13	9175.78	0.177 ¹

¹ P_u / φP_n controls

Top Girt Design Data (Tension)

Section No.	Elevation <i>ft</i>	Size	L <i>ft</i>	L _u <i>ft</i>	Kl/r	A <i>in</i> ²	P _u <i>lb</i>	φP _n <i>lb</i>	Ratio $\frac{P_u}{\phi P_n}$
T1	100 - 80	L1 1/2x1 1/2x1/8	4.52	4.11	111.5	0.2109	54.41	9175.78	0.006 ¹
T4	40 - 20	L1 1/2x1 1/2x1/8	4.56	4.06	110.2	0.2109	47.01	9175.78	0.005 ¹

tnxTower Ramaker & Associates, Inc 855 Community Drive Sauk City, WI 53583 Phone: (608) 643-4100 FAX: (608) 643-7999	Job Saltonstall Place CT52XC125	Page 22 of 22
	Project 37621	Date 09:42:20 01/16/19
	Client Transcend/Sprint	Designed by TEM

¹ $P_u / \phi P_n$ controls

Section Capacity Table

Section No.	Elevation ft	Component Type	Size	Critical Element	P lb	ϕP_{allow} lb	% Capacity	Pass Fail	
T1	100 - 80	Leg	ROHN 2 STD	3	-8380.95	36842.30	22.7	Pass	
		Diagonal	L1 1/2x1 1/2x1/8	11	-2135.79	5836.98	36.6	Pass	
		Top Girt	L1 1/2x1 1/2x1/8	5	-66.97	2921.51	2.3	Pass	
T2	80 - 60	Leg	ROHN 2 STD	37	-36279.50	36842.20	98.5	Pass	
		Diagonal	L1 1/2x1 1/2x1/8	41	-2951.15	5799.98	50.9	Pass	
T3	60 - 40	Leg	P2.5STD + Half P3XS	70	-74703.10	106472.00	70.2	Pass	
		Diagonal	L1 1/2x1 1/2x3/16	73	-4273.50	8627.09	49.5	Pass	
T4	40 - 20	Leg	P2.5XS + Half P3XS	105	-89671.40	124860.00	71.8	Pass	
		Diagonal	L1 1/2x1 1/2x1/8	110	-1531.34	3816.68	40.1	Pass	
		Top Girt	L1 1/2x1 1/2x1/8	106	-132.64	2996.89	4.4	Pass	
T5	20 - 0	Leg	P2.5XS + Half P3XS	141	-99277.90	112719.00	88.1	Pass	
		Diagonal	L1 1/2x1 1/2x1/8	143	-1809.10	2200.49	82.2	Pass	
							Summary		
							Leg (T2)	98.5	Pass
							Diagonal (T5)	82.2	Pass
							Top Girt (T4)	4.4	Pass
							Bolt Checks	91.4	Pass
							RATING =	98.5	Pass

Project Information	
Project #	37621
Site Name	CT52XC125

Tower Information	
Tower Type	Self Support
TIA-222 Rev	G

Applied Loads		
	Comp.	Uplift
Axial (k)	100.53	91.37
Shear (k)	7.85	7.16

Anchor Rod Data	
Quantity:	4
Diameter (in):	0.75
Material Grade:	A354-BC
Grout Considered:	No
l_{ar} (in):	0.75
Eta Factor, η :	0.5
Thread Type:	N-Included
Configuration:	Symmetrical

Fy=109 ksi Fu=125 ksi

Anchor Rod Results	
Axial, Pu_c (kips)	25.13
Shear, Vu (kips)	1.96
Moment, Mu (kip-in)	-
Axial Cap., ϕPn_t (kips)	33.40
Shear Cap., ϕVn (kips)	-
Moment Cap., ϕMn (kip-in)	-
Stress Rating	87.0%

Pass

SST Unit Base Foundation

Project #: 37621
 Site Name: CT52XC125

TIA-222 Revision: G

Top & Bot. Pad Rein. Different?:	<input type="checkbox"/>
Tower Centroid Offset?:	<input type="checkbox"/>
Block Foundation?:	<input checked="" type="checkbox"/>

Superstructure Analysis Reactions		
Global Moment, M :	724.98	ft-kips
Global Axial, P :	9.73	kips
Global Shear, V :	12.01	kips
Leg Compression, P_{comp} :	100.53	kips
Leg Comp. Shear, V_{u,comp} :	7.86	kips
Leg Uplift, P_{uplift} :	91.37	kips
Leg Uplift. Shear, V_{u,uplift} :	7.16	kips
Tower Height, H :	100	ft
Base Face Width, BW :	8.604	ft
BP Dist. Above Fdn, bp_{dist} :	2	in
Anchor Bolt Circle, BC :	8	in

Foundation Analysis Checks				
	Capacity	Demand	Rating	Check
<i>Lateral (Sliding) (kips)</i>	70.78	12.01	17.0%	Pass
<i>Bearing Pressure (ksf)</i>	35.55	3.02	8.5%	Pass
<i>Overtuning (kip*ft)</i>	1142.40	775.02	67.8%	Pass
<i>Pad Flexure (kip*ft)</i>	2430.23	266.27	11.0%	Pass
<i>Pad Shear - 1-way (kips)</i>	686.19	37.57	5.5%	Pass
<i>Pad Shear - Comp 2-way (ksi)</i>	0.164	0.014	8.5%	Pass

Soil Rating:	67.8%
Structural Rating:	11.0%

Pad Properties		
Depth, D :	4.00	ft
Pad Width, W :	16.00	ft
Pad Thickness, T :	4.00	ft
Pad Rebar Size (Bottom), Sp :	8	
Pad Rebar Quantity (Bottom), mp :	16	
Pad Clear Cover, cc_{pad} :	3	in

Material Properties		
Rebar Grade, Fy :	60000	psi
Concrete Compressive Strength, F'c :	3000	psi
Dry Concrete Density, δc :	150	pcf

Soil Properties		
Total Soil Unit Weight, γ :	109	pcf
Ultimate Gross Bearing, Qult :	47.400	ksf
Cohesion, Cu :		ksf
Friction Angle, φ :	42	degrees
SPT Blow Count, N_{blows} :	29	
Base Friction, μ :	0.5	
Neglected Depth, N :	3.33	ft
Foundation Bearing on Rock?	Yes	
Groundwater Depth, gw :	N/A	ft

<-- Toggle between Gross and Net