

UPS CampusShip: View/Print Label

1. **Ensure there are no other shipping or tracking labels attached to your package.** Select the Print button on the print dialog box that appears. Note: If your browser does not support this function select Print from the File menu to print the label.
2. **Fold the printed label at the solid line below.** Place the label in a UPS Shipping Pouch. If you do not have a pouch, affix the folded label using clear plastic shipping tape over the entire label.
3. **GETTING YOUR SHIPMENT TO UPS**
Customers with a Daily Pickup
Your driver will pickup your shipment(s) as usual.

Customers without a Daily Pickup



Take your package to any location of The UPS Store®, UPS Access Point™ location, UPS Drop Box, UPS Customer Center, Staples® or Authorized Shipping Outlet near you. Items sent via UPS Return Services(SM) (including via Ground) are also accepted at Drop Boxes. To find the location nearest you, please visit the Resources area of CampusShip and select UPS Locations.
Schedule a same day or future day Pickup to have a UPS driver pickup all your CampusShip packages.
Hand the package to any UPS driver in your area.

UPS Access Point™
CVS STORE # 972
555 WASHINGTON ST
SOUTH EASTON ,MA 02375

UPS Access Point™
CVS STORE # 7232
689 DEPOT ST
NORTH EASTON ,MA 02356

UPS Access Point™
TOWN LINE GENERAL STORE
450 E CENTER ST
WEST BRIDGEWATER ,MA 02379

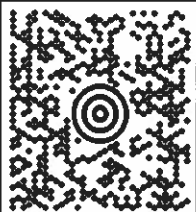
FOLD HERE

<p>PATRICIA NOWAK 508-265-5599 CENTERLINE COMMUNICATIONS, LLC 750 WEST CENTER STREET WEST BRIDGEWATER MA 02379</p> <p>SHIP TO: MAYOR MARCIA A. LECLERC TOWN OF EAST HARTFORD MAYOR'S OFFICE 740 MAIN STREET EAST HARTFORD CT 06108-3140</p>	<p>CT 061 9-01</p>  	<p>UPS NEXT DAY AIR TRACKING #: 1Z 9Y4 503 01 1173 1662</p> <p>1</p>		<p>BILLING: P/P</p> <p>Reference # 1: CT3438 - Mayor</p> <p>CS 22.0.11. WINTNVS0 26-0A 04/2020</p> 
--	---	--	---	---

UPS CampusShip: View/Print Label

1. **Ensure there are no other shipping or tracking labels attached to your package.** Select the Print button on the print dialog box that appears. Note: If your browser does not support this function select Print from the File menu to print the label.
2. **Fold the printed label at the solid line below.** Place the label in a UPS Shipping Pouch. If you do not have a pouch, affix the folded label using clear plastic shipping tape over the entire label.
3. **GETTING YOUR SHIPMENT TO UPS**
Customers with a Daily Pickup
Your driver will pickup your shipment(s) as usual.

Customers without a Daily Pickup

Take your package to any location of The UPS Store®, UPS Access Point™ location, UPS Drop Box, UPS Customer Center, Staples® or Authorized Shipping Outlet near you. Items sent via UPS Return Services(SM) (including via Ground) are also accepted at Drop Boxes. To find the location nearest you, please visit the Resources area of CampusShip and select UPS Locations.



Schedule a same day or future day Pickup to have a UPS driver pickup all your CampusShip packages. Hand the package to any UPS driver in your area.

UPS Access Point™
CVS STORE # 972
555 WASHINGTON ST
SOUTH EASTON ,MA 02375

UPS Access Point™
CVS STORE # 7232
889 DEPOT ST
NORTH EASTON ,MA 02356

UPS Access Point™
TOWN LINE GENERAL STORE
450 E CENTER ST
WEST BRIDGEWATER ,MA 02379

FOLD HERE

<p>PATRICIA NOWAK 508-265-5599 CENTERLINE COMMUNICATIONS, LLC 750 WEST CENTER STREET WEST BRIDGEWATER MA 02379</p> <p>SHIP TO: JEFFREY CORMIER TOWN OF EAST HARTFORD TOWN PLANNER 740 MAIN STREET EAST HARTFORD CT 06108-3140</p>	<p>CT 061 9-01</p> 	<p>UPS NEXT DAY AIR</p> <p>TRACKING #: 1Z 9Y4 503 01 1806 6673</p> <p>1</p>		<p>BILLING: P/P</p> <p>Reference # 1: CT3438 - Town Planner</p> <p>CS 22-011 WNTNVS0 28.0A 04/2020</p> 
--	---	---	---	---

April 27, 2020

VIA ELECTRONIC MAIL

Melanie A. Bachman
Executive Director
Connecticut Siting Council
10 Franklin Square
New Britain, CT 06051

Regarding: Notice of Exempt Modification – AT&T Site CT3438
Address: 100 Sunset Ridge, East Hartford, CT 06108

Dear Ms. Bachman:

New Cingular Wireless, PCS, LLC (hereinafter “AT&T”) currently maintains a wireless telecommunications facility on an existing 140’ Self Support Tower (the “Tower”) at the above-referenced address, latitude 41.7719400, longitude -72.5903500. Said Tower is owned by the Town of East Hartford, Connecticut.

AT&T desires to modify its existing telecommunications facility on the Tower by adding (6) antennas, adding (6) remote radio units, swapping (6) remote radio heads, swapping (3) surge arrestors, adding (5) dc power lines and swapping (3) fiber lines, as more particularly detailed and described in the enclosed Construction Drawings prepared by Centerline Communications LLC, dated February 21, 2020 and last revised April 10, 2020. Enclosed please also find a Mount Analysis prepared by Hudson Design Group LLC dated February 21, 2020 and last revised April 15, 2020. The centerline height of the antennas will be at 110 feet.

The Town of East Hartford, CT does not have the original site plan approval for the Tower. The Council approved AT&T’s original request to share the Tower on September 14, 2017 under the identification number TS-CING-043-170821. Please find the above-mentioned Tower share decision enclosed.

Please accept this letter as notification pursuant to R.C.S.A §16-50j-73 for construction that constitutes an exempt modification pursuant to R.C.S.A. § 16-50j-72(b)(2). In accordance with R.C.S.A. § 16-50j-73, a copy of this letter is being sent to the following individuals: The Honorable Marcia A. Leclerc, Mayor of the Town of East Hartford and Jeffrey Cormier, Town Planner of the Town of East Hartford, CT. The Town of East Hartford, Connecticut is the property owner and the Tower owner. Enclosed please find a property card and GIS map of the property.

The planned modifications to the facility fall squarely within those activities explicitly provided for in R.C.S.A. § 16-50j-72(b)(2). Specifically:

1. The proposed modifications will not result in an increase in the height of the existing structure.
2. The proposed modifications will not require an extension of the site boundary.
3. The proposed modifications will not increase noise levels at the facility by six decibels or more, or to levels that exceed state and local criteria.
4. The operation of the modified facility will not increase radio frequency emissions at the facility to a level at or above the Federal Communications Commission safety standard. *Please see the RF Emissions Analysis Report for AT&T's modified facility enclosed herewith.*
5. The proposed modifications will not cause an ineligible change or alteration in the physical or environmental characteristics of the site.
6. The existing structure and its foundation can support the proposed loading. *Please see the Structural Analysis Report dated April 16, 2020 and prepared by Centerline Communications enclosed herewith.*

For the foregoing reasons, AT&T respectfully submits that the proposed modifications to the above referenced telecommunications facility constitute an exempt modification under R.C.S.A. § 16-50j-72(b)(2).

Sincerely,



Patricia Nowak
Site Acquisition Consultant
Centerline Communications, LLC
750 West Center Street, Suite 301
West Bridgewater, MA 02379
pnowak@clinellc.com

Enclosures: Exhibit 1 - Construction Drawings
 Exhibit 2 - Mount Analysis
 Exhibit 3 - CSC Tower Share Decision
 Exhibit 4 - Property Card and GIS Map
 Exhibit 5 - RF Emissions Analysis Report
 Exhibit 6 - Structural Analysis

cc: The Honorable Marcia A. Leclerc, Mayor of the Town of East Hartford, CT
 Jeffrey Cormier, Town Planner of the Town of East Hartford, CT

EXHIBIT 1

PROJECT INFORMATION

SITE NAME: EAST HARTFORD SUNSET RIDGE
 SITE ADDRESS: 100 SUNSET RIDGE EAST HARTFORD, CT 06108
 LATITUDE: 41° 46' 18.98"
 LONGITUDE: -72° 35' 25.26"
 TOWER HEIGHT: 140'-0"± AGL
 RAD CENTER: 110'-0"± AGL
 ZONING JURISDICTION: TOWN OF EAST HARTFORD
 COUNTY: HARTFORD

DESCRIPTION OF WORK:
TELECOMMUNICATIONS FACILITY UPGRADE (LTE 5C, 6C, 7C, 4TX4RX, 5G NR & BWE):

SELF SUPPORT TOWER:

- INSTALL:
- (3) DMP65R-BU8DA ANTENNAS (ONE PER SECTOR)
 - (3) OPA65R-BU8DA ANTENNAS (ONE PER SECTOR)
 - (6) 4449 B5/B12 RRUS (ONE PER SECTOR)
 - (3) 8843 B2/B66A RRUS (ONE PER SECTOR)
 - (3) 4478 B14 RRUS (ONE PER SECTOR)
 - (3) RRUS E2 B29 (ONE PER SECTOR)
 - (3) DC9-48-60-24-8C-EV SURGE ARRESTORS
 - (5) DC POWER LINES
 - (3) FIBER LINES

- REMOVE:
- (3) RRUS-11 B12 (ONE PER SECTOR)
 - (3) RRUS-11 B5 (ONE PER SECTOR)
 - (3) DC6-48-60-18-8C SURGE ARRESTORS
 - (2) FIBER LINES

- EXISTING TO REMAIN:
- (3) 800-10799 ANTENNA (ONE PER SECTOR)
 - (3) 4415 B25 RRUS (ONE PER SECTOR)
 - (3) RRUS-32 B30 (ONE PER SECTOR)
 - (4) DC LINES

EQUIPMENT AREA/GROUND:

- INSTALL:
- (2) 6630
 - (1) IDLE

- REMOVE:
- (1) XMU

PROJECT DIRECTORY

A&E / PROJECT MANAGER:
 CENTERLINE COMMUNICATIONS
 750 WEST CENTER ST, SUITE 301
 WEST BRIDGEWATER, MA 02379
 CONTACT: DAVID FORD
 PHONE 844.748.8878

APPLICANT:
 at&t MOBILITY CORP.
 500 ENTERPRISE DRIVE
 ROCKY HILL, CT 06067



SITE NUMBER: CT3438
FA# 10578403
SITE NAME: EAST HARTFORD SUNSET RIDGE
PACE ID: 5C-MRCTB045175, 6C-MRCTB045156, 7C-MRCTB045193,
4TXRX-MRCTB045279, 5G NR-MRCTB045300 & BWE-MRCTB045310
PROJECT: LTE 5C, 6C, 7C, 4TX4RX, 5G NR & BWE
ABC_XXX.vsd

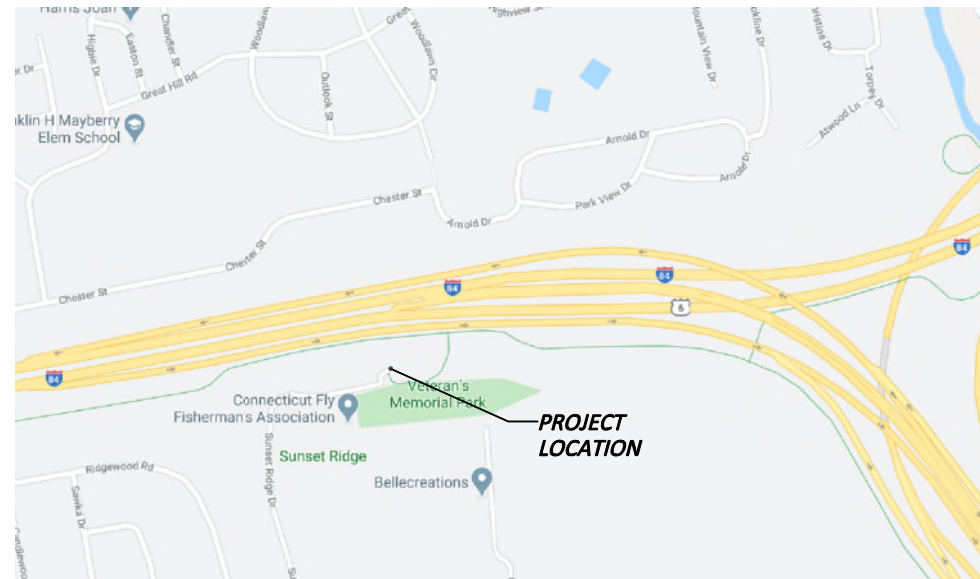

VICINITY MAP
 NOT TO SCALE



LOCATION MAP
 NOT TO SCALE

DIRECTIONS:

HEAD NORTHEAST ON ENTERPRISE DR TOWARD CAPITAL BLVD. // TURN LEFT ON CAPITAL BLVD. // TURN LEFT ONTO WEST ST // MERGE ONTO I-91 N VIA THE RAMP ON THE LEFT TOWARD HARTFORD // MERGE ONTO CT-15 N VIA EXIST 29 TOWARD BOSTON/EAST HARTFORD/I-84E // TAKE EXIT 91 AND MERGE ONTO SILVER LN. // TURN LEFT ONTO WESTVIEW DR. // TAKE THE FIRST RIGHT ONTO RIDGEWOOD RD. // 100 SUNSET RIDGE DR. ON THE RIGHT.

GENERAL NOTES:

1. THIS DOCUMENT IS THE CREATION, DESIGN, PROPERTY AND COPYRIGHTED WORK OF AT&T. ANY DUPLICATION OR USE WITHOUT EXPRESS WRITTEN CONSENT IS STRICTLY PROHIBITED. DUPLICATION AND USE BY GOVERNMENT AGENCIES FOR THE PURPOSE OF CONDUCTING THEIR LAWFULLY AUTHORIZED REGULATORY AND ADMINISTRATIVE FUNCTIONS IS SPECIFICALLY ALLOWED.
2. THE FACILITY IS AN UNMANNED PRIVATE AND SECURED EQUIPMENT INSTALLATION. IT IS ONLY ACCESSED BY TRAINED TECHNICIANS FOR PERIODIC ROUTINE MAINTENANCE AND THEREFORE DOES NOT REQUIRE ANY WATER OR SANITARY SEWER SERVICE. THE FACILITY IS NOT GOVERNED BY REGULATIONS REQUIRING PUBLIC ACCESS PER ADA REQUIREMENTS.
3. CONTRACTOR SHALL VERIFY ALL PLANS AND EXISTING DIMENSIONS AND CONDITIONS ON THE JOB SITE AND SHALL IMMEDIATELY NOTIFY THE AT&T REPRESENTATIVE IN WRITING OF DISCREPANCIES BEFORE PROCEEDING WITH THE WORK OR BE RESPONSIBLE FOR SAME.

DRAWING INDEX

NO.	DESCRIPTION	REV.	DATE
T-1	TITLE SHEET	1	04/10/20
GN-1	GENERAL NOTES	1	04/10/20
A-1	COMPOUND & EQUIPMENT PLANS	1	04/10/20
A-2	ANTENNA LAYOUT & ELEVATIONS	1	04/10/20
A-3	DETAILS	1	04/10/20
SN-1	STRUCTURAL NOTES	1	04/10/20
RF-1	RF PLUMBING DIAGRAM	1	04/10/20
G-1	GROUNDING DETAILS	1	04/10/20



REVISIONS		
NO.	DATE	DESCRIPTION
1	04/10/20	ISSUED FOR CONSTRUCTION
0	02/21/20	ISSUED FOR REVIEW

DESIGNED BY: AA APPROVED BY: DC



IT IS A VIOLATION OF LAW FOR ANY PERSON UNLESS THEY ARE ACTING UNDER THE DIRECTION OF A LICENSED PROFESSIONAL ENGINEER TO ALTER THIS DOCUMENT, UNLESS EXPLICITLY AGREED TO BY THE ENGINEER IN WRITING. THE ENGINEER DISCLAIMS ALL LIABILITY ASSOCIATED WITH THE REUSE, ALTERATION OR MODIFICATION OF THE CONTENTS HEREIN.



SITE NAME: EAST HARTFORD SUNSET RIDGE
 SITE NUMBER: CT3438
 SITE ADDRESS: 100 SUNSET RIDGE EAST HARTFORD, CT 06108
 PROJECT TYPE: LTE 5C, 6C, 7C, 4TX4RX, 5G NR & BWE

SHEET TITLE: TITLE SHEET
 DRAWING #: T-1 REVISION: 1

GENERAL NOTES

- FOR THE PURPOSE OF CONSTRUCTION DRAWING, THE FOLLOWING DEFINITIONS SHALL APPLY:
 CONTRACTOR – CENTERLINE COMMUNICATIONS
 SUBCONTRACTOR – GENERAL CONTRACTOR (CONSTRUCTION)
 OWNER – AT&T MOBILITY
- PRIOR TO THE SUBMISSION OF BIDS, THE BIDDING SUBCONTRACTOR SHALL VISIT THE CELL SITE TO FAMILIARIZE WITH THE EXISTING CONDITIONS AND TO CONFIRM THAT THE WORK CAN BE ACCOMPLISHED AS SHOWN ON THE CONSTRUCTION DRAWINGS. ANY DISCREPANCY FOUND SHALL BE BROUGHT TO THE ATTENTION OF CONTRACTOR.
- ALL MATERIALS FURNISHED AND INSTALLED SHALL BE IN STRICT ACCORDANCE WITH ALL APPLICABLE CODES, REGULATIONS, AND ORDINANCES. SUBCONTRACTOR SHALL ISSUE ALL APPROPRIATE NOTICES AND COMPLY WITH ALL LAWS, ORDINANCES, RULES, REGULATIONS, AND LAWFUL ORDERS OF ANY PUBLIC AUTHORITY REGARDING THE PERFORMANCE OF THE WORK. ALL WORK CARRIED OUT SHALL COMPLY WITH ALL APPLICABLE MUNICIPAL AND UTILITY COMPANY SPECIFICATIONS AND LOCAL JURISDICTIONAL CODES, ORDINANCES AND APPLICABLE REGULATIONS.
- DRAWINGS PROVIDED HERE ARE NOT TO BE SCALED AND ARE INTENDED TO SHOW OUTLINE ONLY.
- UNLESS NOTED OTHERWISE, THE WORK SHALL INCLUDE FURNISHING MATERIALS, EQUIPMENT, APPURTENANCES, AND LABOR NECESSARY TO COMPLETE ALL INSTALLATIONS AS INDICATED ON THE DRAWINGS.
- "KITTING LIST" SUPPLIED WITH THE BID PACKAGE IDENTIFIES ITEMS THAT WILL BE SUPPLIED BY CONTRACTOR. ITEMS NOT INCLUDED IN THE BILL OF MATERIALS AND KITTING LIST SHALL BE SUPPLIED BY THE SUBCONTRACTOR.
- THE SUBCONTRACTOR SHALL INSTALL ALL EQUIPMENT AND MATERIALS IN ACCORDANCE WITH MANUFACTURER'S RECOMMENDATIONS UNLESS SPECIFICALLY STATED OTHERWISE.
- IF THE SPECIFIED EQUIPMENT CANNOT BE INSTALLED AS SHOWN ON THESE DRAWINGS, THE SUBCONTRACTOR SHALL PROPOSE AN ALTERNATIVE INSTALLATION SPACE FOR APPROVAL BY THE CONTRACTOR.
- SUBCONTRACTOR SHALL DETERMINE ACTUAL ROUTING OF CONDUIT, POWER AND T1 CABLES, GROUNDING CABLES AS SHOWN ON THE POWER, GROUNDING AND TELCO PLAN DRAWING. SUBCONTRACTOR SHALL UTILIZE EXISTING TRAYS AND/OR SHALL ADD NEW TRAYS AS NECESSARY. SUBCONTRACTOR SHALL CONFIRM THE ACTUAL ROUTING WITH THE CONTRACTOR.
- THE SUBCONTRACTOR SHALL PROTECT EXISTING IMPROVEMENTS, PAVEMENTS, CURBS, LANDSCAPING AND STRUCTURES. ANY DAMAGED PART SHALL BE REPAIRED AT SUBCONTRACTOR'S EXPENSE TO THE SATISFACTION OF OWNER.
- SUBCONTRACTOR SHALL LEGALLY AND PROPERLY DISPOSE OF ALL SCRAP MATERIALS SUCH AS COAXIAL CABLES AND OTHER ITEMS REMOVED FROM THE EXISTING FACILITY. ANTENNAS REMOVED SHALL BE RETURNED TO THE OWNER'S DESIGNATED LOCATION.
- SUBCONTRACTOR SHALL LEAVE PREMISES IN CLEAN CONDITION.
- ALL CONCRETE REPAIR WORK SHALL BE DONE IN ACCORDANCE WITH AMERICAN CONCRETE INSTITUTE (ACI) 301.
- ANY NEW CONCRETE NEEDED FOR THE CONSTRUCTION SHALL BE AIR-ENTRAINED AND SHALL HAVE 4000 PSI STRENGTH AT 28 DAYS. ALL CONCRETE WORK SHALL BE DONE IN ACCORDANCE WITH ACI 318 CODE REQUIREMENTS.

- ALL STRUCTURAL STEEL WORK SHALL BE DETAILED, FABRICATED AND ERECTED IN ACCORDANCE WITH AISC SPECIFICATIONS. ALL STRUCTURAL STEEL SHALL BE ASTM A36 (Fy = 36 ksi) UNLESS OTHERWISE NOTED. PIPES SHALL BE ASTM A53 TYPE E (Fy = 36 ksi). ALL STEEL EXPOSED TO WEATHER SHALL BE HOT DIPPED GALVANIZED. TOUCHUP ALL SCRATCHES AND OTHER MARKS IN THE FIELD AFTER STEEL IS ERECTED USING A COMPATIBLE ZINC RICH PAINT.
- CONSTRUCTION SHALL COMPLY WITH SPECIFICATIONS AND "GENERAL CONSTRUCTION SERVICES FOR CONSTRUCTION OF AT&T MOBILITY SITES."
- SUBCONTRACTOR SHALL VERIFY ALL EXISTING DIMENSIONS AND CONDITIONS PRIOR TO COMMENCING ANY WORK. ALL DIMENSIONS OF EXISTING CONSTRUCTION SHOWN ON THE DRAWINGS MUST BE VERIFIED. SUBCONTRACTOR SHALL NOTIFY THE CONTRACTOR OF ANY DISCREPANCIES PRIOR TO ORDERING MATERIAL OR PROCEEDING WITH CONSTRUCTION.
- THE EXISTING CELL SITE IS IN FULL COMMERCIAL OPERATION. ANY CONSTRUCTION WORK BY SUBCONTRACTOR SHALL NOT DISRUPT THE EXISTING NORMAL OPERATION. ANY WORK ON EXISTING EQUIPMENT MUST BE COORDINATED WITH CONTRACTOR. ALSO, WORK SHOULD BE SCHEDULED FOR AN APPROPRIATE MAINTENANCE WINDOW USUALLY IN LOW TRAFFIC PERIODS AFTER MIDNIGHT.
- SINCE THE CELL SITE IS ACTIVE, ALL SAFETY PRECAUTIONS MUST BE TAKEN WHEN WORKING AROUND HIGH LEVELS OF ELECTROMAGNETIC RADIATION. EQUIPMENT SHOULD BE SHUTDOWN PRIOR TO PERFORMING ANY WORK THAT COULD EXPOSE THE WORKERS TO DANGER. PERSONAL RF EXPOSURE MONITORS ARE ADVISED TO BE WORN TO ALERT OF ANY DANGEROUS EXPOSURE LEVELS.
- APPLICABLE BUILDING CODES:
 SUBCONTRACTOR'S WORK SHALL COMPLY WITH ALL APPLICABLE NATIONAL, STATE, AND LOCAL CODES AS ADOPTED BY THE LOCAL AUTHORITY HAVING JURISDICTION (AHJ) FOR THE LOCATION. THE EDITION OF THE AHJ ADOPTED CODES AND STANDARDS IN EFFECT ON THE DATE OF CONTRACT AWARD SHALL GOVERN THE DESIGN.
 BUILDING CODE: IBC 2015 (2018 CT STATE BUILDING CODE)
 ELECTRICAL CODE: 2017 NATIONAL ELECTRICAL CODE
 LIGHTNING CODE: NFPA 70-2017
 SUBCONTRACTOR'S WORK SHALL COMPLY WITH THE LATEST EDITION OF THE FOLLOWING STANDARDS:
 AMERICAN CONCRETE INSTITUTE (ACI) 318; BUILDING CODE REQUIREMENTS FOR STRUCTURAL CONCRETE;
 AMERICAN INSTITUTE OF STEEL CONSTRUCTION (AISC) MANUAL OF STEEL CONSTRUCTION, ASD, FOURTEENTH EDITION;
 TELECOMMUNICATIONS INDUSTRY ASSOCIATION (TIA) 222-G, STRUCTURAL STANDARDS FOR STEEL
 ANTENNA TOWER AND ANTENNA SUPPORTING STRUCTURES; REFER TO ELECTRICAL DRAWINGS FOR SPECIFIC ELECTRICAL STANDARDS.

FOR ANY CONFLICTS BETWEEN SECTIONS OF LISTED CODES AND STANDARDS REGARDING MATERIAL, METHODS OF CONSTRUCTION, OR OTHER REQUIREMENTS, THE MOST RESTRICTIVE REQUIREMENT SHALL GOVERN. WHERE THERE IS CONFLICT BETWEEN A GENERAL REQUIREMENT AND A SPECIFIC REQUIREMENT, THE SPECIFIC REQUIREMENT SHALL GOVERN.

RF NOTES

- ACTUAL LENGTHS SHALL BE DETERMINED PER SITE CONDITION BY SUBCONTRACTOR
- THE DESIGN IS BASED ON RF DATA SHEETS, SIGNED AND APPROVED.
- RADIO SIGNAL CABLE AND RACEWAY SHALL COMPLY WITH THE REQUIREMENTS OF THE NATIONAL ELECTRICAL CODE (NEC, NFPA 70), CHAPTER 8.
- ALL SPECIFIED MATERIAL FOR EACH LOCATION (E.G. OUT DOORS--OCCUPIED, INDOORS--UNOCCUPIED, PLENUMS, RISER SHAFTS, ETC.) SHALL BE APPROVED, LISTED, OR LABELED AS REQUIRED BY THE NEC.
- RADIO SIGNAL CABLE SHALL BE SUPPORTED AT MINIMUM OF EVERY THREE (3) FEET EXCEPT INSIDE MONOPOLES OR MONOPOLES WHERE CABLE AND CONNECTOR MANUFACTURERS SUPPORT RECOMMENDATIONS SHALL BE FOLLOWED. MANUFACTURER RECOMMENDATION CABLES SUPPORT ACCESSORIES SHALL BE USED.
- THE OUTDOOR CABLE SUPPORT SYSTEM SHALL BE PROVIDED WITH AN ICE SHIELD TO SUPPORT AND PROTECT ANTENNA CABLE RUNS.
- DRIP LOOPS SHALL BE REQUIRED ON ALL OUTSIDE CABLES. CABLES SHALL BE SLOPED AWAY FROM BUILDING OR OUTDOOR BTS CABINETS TO PREVENT WATER FROM ENTERING THROUGH THE COAXIAL CABLE PORT.
- ALL FEEDER LINE AND JUMPER CONNECTORS SHALL BE 7/16 DIN CABLE CONNECTORS THAT MEET IP68 STANDARDS.
- 7/16 DIN CONNECTORS REQUIRE NO ADDITIONAL WEATHER PROOFING IN INDOOR APPLICATIONS IF INSTALLED AND TORQUED PROPERLY. IN OUTDOOR APPLICATIONS WEATHER PROOFING IS REQUIRED AND THE FOLLOWING PROCEDURE SHOULD BE FOLLOWED.
- USING WEATHERPROOFING KIT APPROVED BY CABLE MANUFACTURER AND CONTRACTOR START TAPE APPROXIMATELY 5 INCHES FROM THE CONNECTOR, AND WRAP 2 INCHES TOWARD THE CONNECTOR, THEN REVERSE THE TAPE SO THAT THE STICKY SIDE IS UP. TAPE OVER THE CONNECTOR OR SURGE ARRESTOR UNTIL THREE (3) TO FOUR (4) INCHES BEYOND THE CONNECTOR AND REVERSE AGAIN WITH THE STICKY SIDE DOWN FOR ANOTHER INCH OR TWO. PASS THE BUTYL RUBBER AND FINISH WITH A FINAL LAYER OF TAPE.
- ANTENNAS SHALL BE PAINTED, WHEN REQUIRED, BY THE LANDLORD OR AUTHORITY OF HAVING JURISDICTION IN ACCORDANCE WITH ANTENNA MANUFACTURERS' SURFACES PREPARATION AND PAINTING REQUIREMENTS.
- CABLE SHIELDS AND TOWER CONDUITS SHALL BE GROUNDED AT THE TOP OF THE TOWER WITHIN 10 FEET OF THEIR CONNECTORS, AND AT THE BOTTOM OF THE TOWER ABOUT 6 INCHES BEFORE THEY TURN TOWARD THE FACILITY. THEY SHALL BE GROUNDED AT THE MIDPOINT OF THE TOWERS THAT ARE BETWEEN 60 FEET AND 200 FEET HIGH, AND AT INTERVALS OF 60 FEET OR LESS ON TOWERS THAT ARE HIGHER THAN 200 FEET.

ANTENNA CABLE AND SCHEDULING NOTES

- SUBCONTRACTOR SHALL VERIFY THE ACTUAL LENGTH IN THE FIELD BEFORE INSTALLATION.
- TAG AND COLOR CODE ALL MAIN CABLES AT LOCATIONS PER AT&T ANTENNA CABLE MARKING STANDARD:
 - TOP OF TOWER END OF MAIN COAX
 - BOTTOM OF TOWER END OF MAIN COAX
 - DIRECTLY BEFORE AND AFTER RF EQUIPMENT
 - END OF JUMPERS AT BTS EQUIPMENT
- ANTENNAS SHALL BE PROCURED AND INSTALLED WITH DOWN TILT MOUNTING BRACKETS SUPPLIED BY ANTENNA MANUFACTURER.
- PRIOR APPROVAL IS REQUIRED BEFORE PERFORMING ANY WORK ON EXISTING CELL SITE EQUIPMENT.

ABBREVIATIONS

AGL	ABOVE GRADE LEVEL	G.C.	GENERAL CONTRACTOR	RF	RADIO FREQUENCY
AWG	AMERICAN WIRE GAUGE	MGB	MASTER GROUND BUS		
BCW	BARE COPPER WIRE	MIN	MINIMUM	TBD	TO BE DETERMINED
BTS	BASE TRANSCIVER STATION	PROPOSED	NEW	TBR	TO BE REMOVED
EXISTING	EXISTING	N.T.S.	NOT TO SCALE	TBRR	TO BE REMOVED AND REPLACED
EG	EQUIPMENT GROUND	REF	REFERENCE	TYP	TYPICAL
EGR	EQUIPMENT GROUND RING	REQ	REQUIRED		



REVISIONS		
NO.	DATE	DESCRIPTION
1	04/10/20	ISSUED FOR CONSTRUCTION
0	02/21/20	ISSUED FOR REVIEW

DESIGNED BY: AA	APPROVED BY: DC
--------------------	--------------------

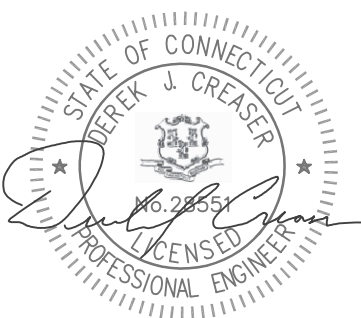

IT IS A VIOLATION OF LAW FOR ANY PERSON UNLESS THEY ARE ACTING UNDER THE DIRECTION OF A LICENSED PROFESSIONAL ENGINEER TO ALTER THIS DOCUMENT, UNLESS EXPLICITLY AGREED TO BY THE ENGINEER IN WRITING. THE ENGINEER DISCLAIMS ALL LIABILITY ASSOCIATED WITH THE REUSE, ALTERATION OR MODIFICATION OF THE CONTENTS HEREIN.

SITE NAME: EAST HARTFORD SUNSET RIDGE	
SITE NUMBER: CT3438	
SITE ADDRESS: 100 SUNSET RIDGE EAST HARTFORD, CT 06108	
PROJECT TYPE: LTE 5C, 6C, 7C, 4TX4RX, 5G NR & BWE	
SHEET TITLE: GENERAL NOTES	
DRAWING #: GN-1	REVISION: 1

REVISIONS		
NO.	DATE	DESCRIPTION
1	04/10/20	ISSUED FOR CONSTRUCTION
0	02/21/20	ISSUED FOR REVIEW

DESIGNED BY: AA
APPROVED BY: DC



IT IS A VIOLATION OF LAW FOR ANY PERSON UNLESS THEY ARE ACTING UNDER THE DIRECTION OF A LICENSED PROFESSIONAL ENGINEER TO ALTER THIS DOCUMENT, UNLESS EXPLICITLY AGREED TO BY THE ENGINEER IN WRITING. THE ENGINEER DISCLAIMS ALL LIABILITY ASSOCIATED WITH THE REUSE, ALTERATION OR MODIFICATION OF THE CONTENTS HEREIN.

SITE NAME:
EAST HARTFORD SUNSET RIDGE

SITE NUMBER:
CT3438

SITE ADDRESS:
100 SUNSET RIDGE
EAST HARTFORD, CT 06108

PROJECT TYPE:
LTE 5C, 6C, 7C, 4TX4RX,
5G NR & BWE

SHEET TITLE:
ANTENNA LAYOUT & ELEVATIONS

DRAWING #: A-2
REVISION: 1

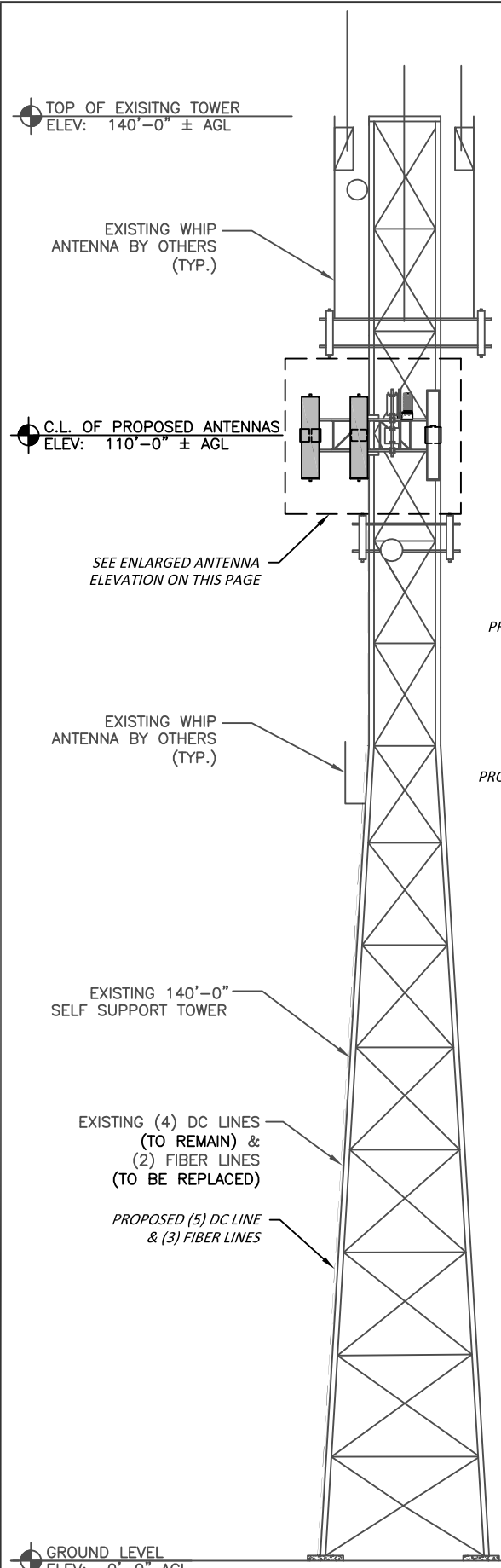

TOWER ELEVATION
SCALE: 1/4" = 1'-0" (22"X34")
1/8" = 1'-0" (11"X17")

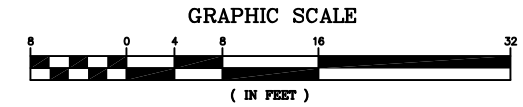

- NOTES:**
1. REFERENCE LATEST STRUCTURAL ANALYSIS BY CENTERLINE COMMUNICATIONS FOR FURTHER INFORMATION REGARDING THE CAPACITY OF THE TOWER AND ANTENNA MOUNTS TO SUPPORT THIS EQUIPMENT UPGRADE.
 2. REFER TO THE FINAL RF DATA SHEET FOR FINAL ANTENNA SETTINGS.

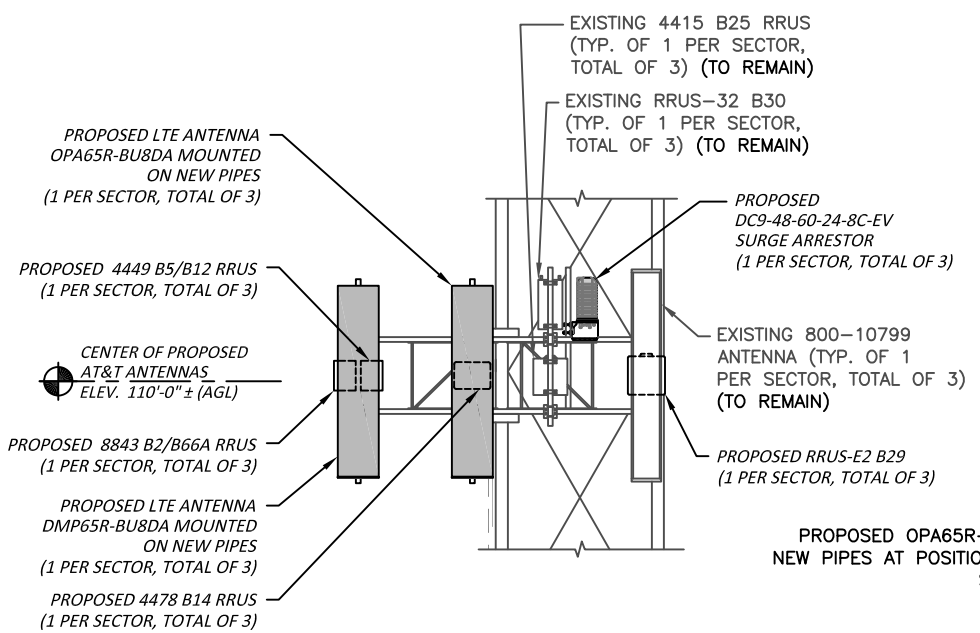

ENLARGED ANTENNA ELEVATION
SCALE: N.T.S

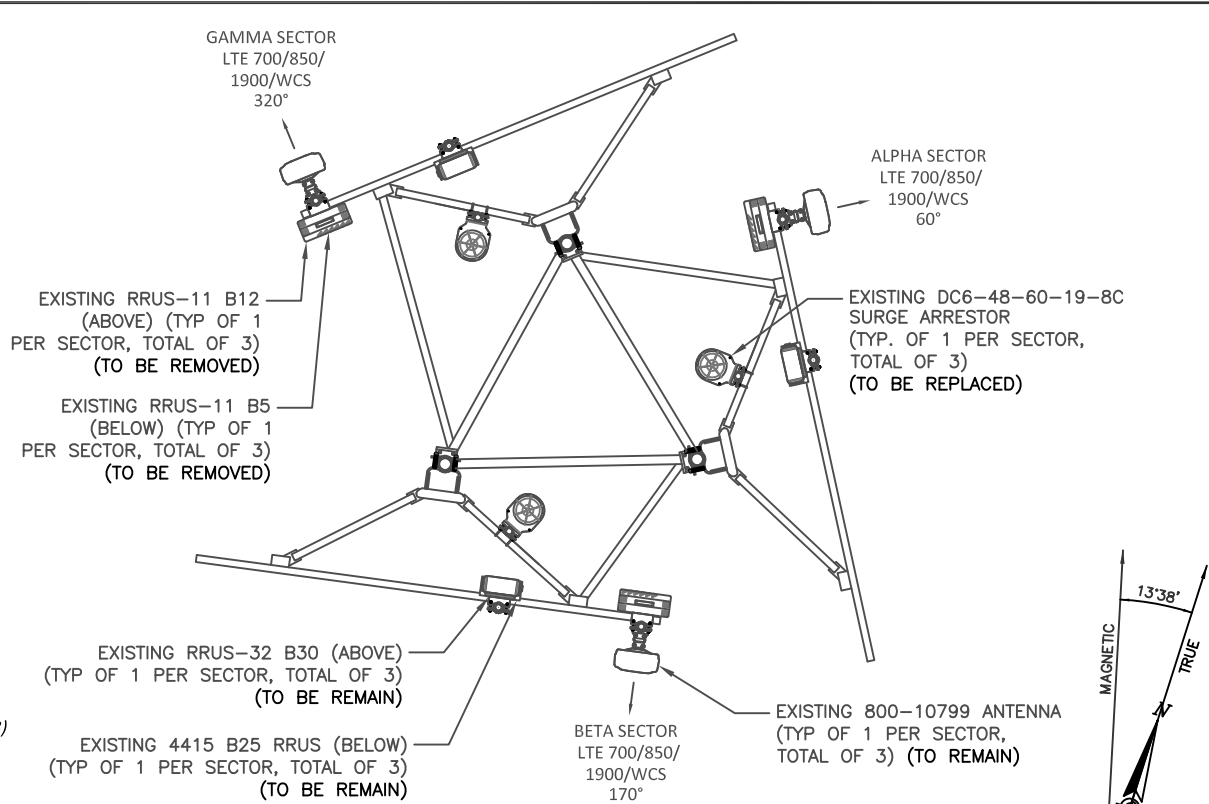

EXISTING ANTENNA CONFIGURATION
SCALE: N.T.S

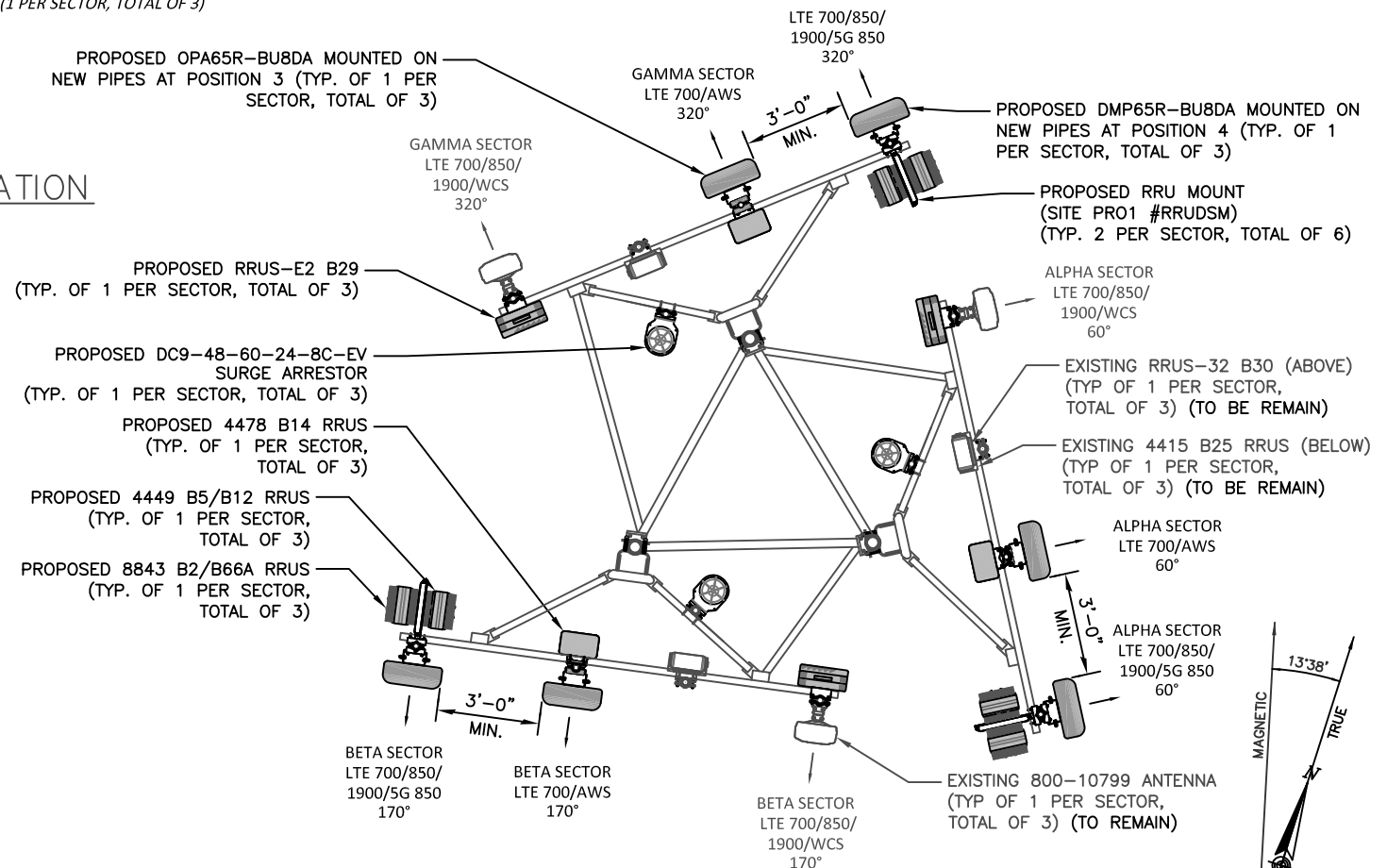

PROPOSED ANTENNA CONFIGURATION
SCALE: N.T.S

ANTENNA SCHEDULE- RFDS: CT3438 (11/23/2019)

SECTOR	EXISTING/ PROPOSED	BAND	ANTENNA	SIZE (INCHES) (L x W x D)	ANTENNA CL. HEIGHT	AZIMUTH	TMA/ DIPLEXER	RRU	SIZE (INCHES) (L x W x D)	FEEDER	RAYCAP
A1	EXISTING	LTE 700/ WCS/1900	800-10799	106X14.8X6.7	±110'	60°	-	(P) (1) RRUS-E2 B29 (E) (1) 4415 B25 (E) (1) RRUS-32 B30	20.4x18.5x7.5 16.5x13.4x5.9 26.7x12.1x6.7	(E) (2) DC POWER, (P) (1) DC POWER & (P) (1) FIBER	--
A2	-	-	-	-	-	-	-	-	-	-	(P) (1) RAYCAP DC9-48-60-24-8C-EY
A3	PROPOSED	LTE 700/AWS	OPA65R-BU8DA	96.0X21X7.8	±110'	60°	-	(P) (1) 4478 B14 RRUS	18.1x13.4x8.26	-	-
A4	PROPOSED	LTE 700/850/ 1900/5G 850	DMP65R-BU8DA	96.0X20.7X7.7	±110'	60°	-	(P) (1) 8843 B2/B66A RRUS (P) (1) 4449 B5/B12 RRUS	14.9X13.2X10.9 15x13.2x10.4	-	-
B1	EXISTING	LTE 700/ WCS/1900	800-10799	106X14.8X6.7	±110'	170°	-	(P) (1) RRUS-E2 B29 (E) (1) 4415 B25 (E) (1) RRUS-32 B30	20.4x18.5x7.5 16.5x13.4x5.9 26.7x12.1x6.7	(E) (2) DC POWER, (P) (1) DC POWER & (P) (1) FIBER	--
B2	-	-	-	-	-	-	-	-	-	-	(P) (1) RAYCAP DC9-48-60-24-8C-EY
B3	PROPOSED	LTE 700/AWS	OPA65R-BU8DA	96.0X21X7.8	±110'	170°	-	(P) (1) 4478 B14 RRUS	18.1x13.4x8.26	-	-
B4	PROPOSED	LTE 700/850/ 1900/5G 850	DMP65R-BU8DA	96.0X20.7X7.7	±110'	170°	-	(P) (1) 8843 B2/B66A RRUS (P) (1) 4449 B5/B12 RRUS	14.9X13.2X10.9 15x13.2x10.4	-	-
C1	EXISTING	LTE 700/ WCS/1900	800-10799	106X14.8X6.7	±110'	320°	-	(P) (1) RRUS-E2 B29 (E) (1) 4415 B25 (E) (1) RRUS-32 B30	20.4x18.5x7.5 16.5x13.4x5.9 26.7x12.1x6.7	(P) (3) DC POWER & (P) (1) FIBER	--
C2	-	-	-	-	-	-	-	-	-	-	(P) (1) RAYCAP DC9-48-60-24-8C-EY
C3	PROPOSED	LTE 700/AWS	OPA65R-BU8DA	96.0X21X7.8	±110'	320°	-	(P) (1) 4478 B14 RRUS	18.1x13.4x8.26	-	-
C4	PROPOSED	LTE 700/850/ 1900/5G 850	DMP65R-BU8DA	96.0X20.7X7.7	±110'	320°	-	(P) (1) 8843 B2/B66A RRUS (P) (1) 4449 B5/B12 RRUS	14.9X13.2X10.9 15x13.2x10.4	-	-

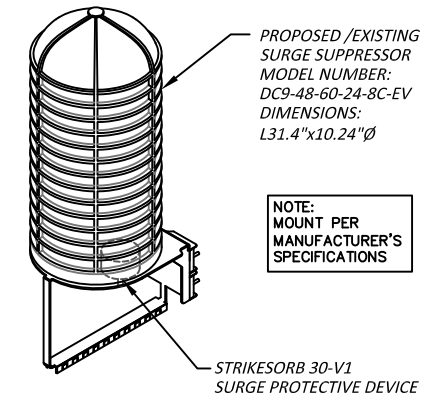

**DC SURGE
SUPPRESSOR DETAIL**
N.T.S.

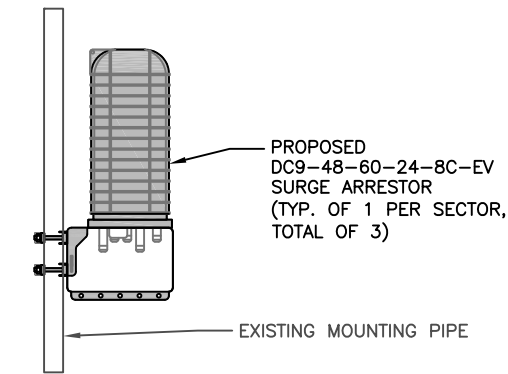

**DC SURGE ARRESTOR
MOUNTING DETAIL**
N.T.S.



REVISIONS		
NO.	DATE	DESCRIPTION
1	04/10/20	ISSUED FOR CONSTRUCTION
0	02/21/20	ISSUED FOR REVIEW

DESIGNED BY: AA	APPROVED BY: DC
--------------------	--------------------



RRU CHART				
QUANTITY	MODEL	L	W	D
3(P)	4449 B5/B12	15.0"	13.2"	10.4"
3(P)	4478 B14	18.1"	13.4"	8.3"
3(P)	8843 B2/B66A	14.9"	13.2"	10.9"
3(P)	RRUS-E2 B29	20.4"	18.5"	7.5"
3(E)	4415 B25	16.5"	13.4"	5.9"
3(E)	RRUS-32 B30	26.7"	12.1"	6.7"

NOTE:
MOUNT PER MANUFACTURER'S SPECIFICATIONS.

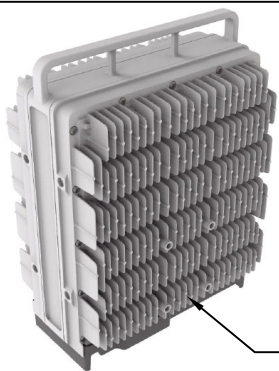

RRUS DETAIL
N.T.S.
REFER TO THE FINAL RFDS AND TABLE FOR THE PROPOSED RRUS MODEL, QUANTITY, AND DIMENSIONS

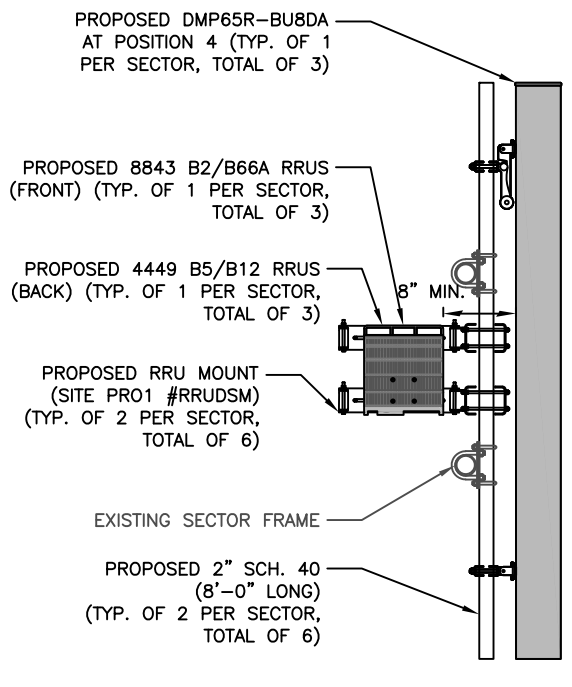
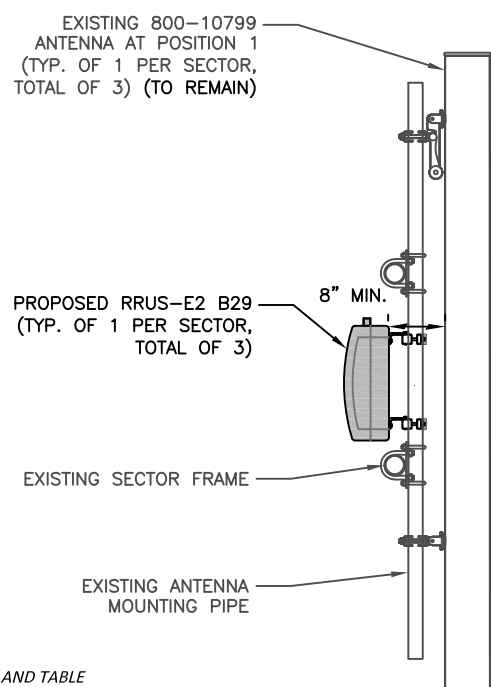

ANTENNA & RRU MOUNTING DETAIL
N.T.S.

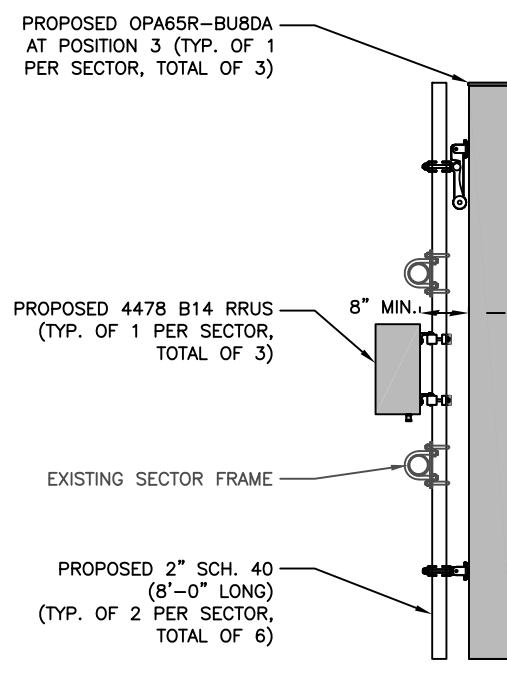

- NOTES:**
- REFERENCE LATEST STRUCTURAL ANALYSIS BY CENTERLINE COMMUNICATIONS FOR FURTHER INFORMATION REGARDING THE CAPACITY OF THE TOWER AND ANTENNA MOUNTS TO SUPPORT THIS EQUIPMENT UPGRADE.
 - REFER TO THE FINAL RF DATA SHEET FOR FINAL ANTENNA SETTINGS.

IT IS A VIOLATION OF LAW FOR ANY PERSON UNLESS THEY ARE ACTING UNDER THE DIRECTION OF A LICENSED PROFESSIONAL ENGINEER TO ALTER THIS DOCUMENT, UNLESS EXPLICITLY AGREED TO BY THE ENGINEER IN WRITING. THE ENGINEER DISCLAIMS ALL LIABILITY ASSOCIATED WITH THE REUSE, ALTERATION OR MODIFICATION OF THE CONTENTS HEREIN.

SITE NAME: EAST HARTFORD SUNSET RIDGE
SITE NUMBER: CT3438
SITE ADDRESS: 100 SUNSET RIDGE EAST HARTFORD, CT 06108
PROJECT TYPE: LTE 5C, 6C, 7C, 4TX4RX, 5G NR & BWE

SHEET TITLE: DETAILS	
DRAWING #: A-3	REVISION: 1



at&t MOBILITY CORP.
500 ENTERPRISE DRIVE
ROCKY HILL, CT 06067



REVISIONS

NO.	DATE	DESCRIPTION
1	04/10/20	ISSUED FOR CONSTRUCTION
0	02/21/20	ISSUED FOR REVIEW

DESIGNED BY: AA
APPROVED BY: DC

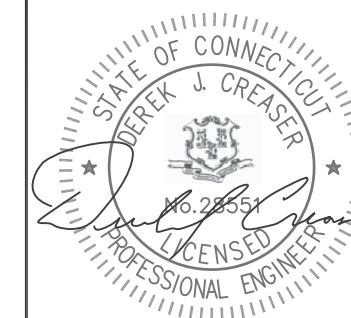

IT IS A VIOLATION OF LAW FOR ANY PERSON UNLESS THEY ARE ACTING UNDER THE DIRECTION OF A LICENSED PROFESSIONAL ENGINEER TO ALTER THIS DOCUMENT, UNLESS EXPLICITLY AGREED TO BY THE ENGINEER IN WRITING. THE ENGINEER DISCLAIMS ALL LIABILITY ASSOCIATED WITH THE REUSE, ALTERATION OR MODIFICATION OF THE CONTENTS HEREIN.

SITE NAME:
EAST HARTFORD SUNSET RIDGE

SITE NUMBER:
CT3438

SITE ADDRESS:
100 SUNSET RIDGE
EAST HARTFORD, CT 06108

PROJECT TYPE:
LTE 5C, 6C, 7C, 4TX4RX,
5G NR & BWE

SHEET TITLE:
COMPOUND & EQUIPMENT PLANS

DRAWING #: A-1
REVISION: 1

NOTES:

1. REFERENCE LATEST STRUCTURAL ANALYSIS BY CENTERLINE COMMUNICATIONS FOR FURTHER INFORMATION REGARDING THE CAPACITY OF THE TOWER AND ANTENNA MOUNTS TO SUPPORT THIS EQUIPMENT UPGRADE.
2. REFER TO THE FINAL RF DATA SHEET FOR FINAL ANTENNA SETTINGS.

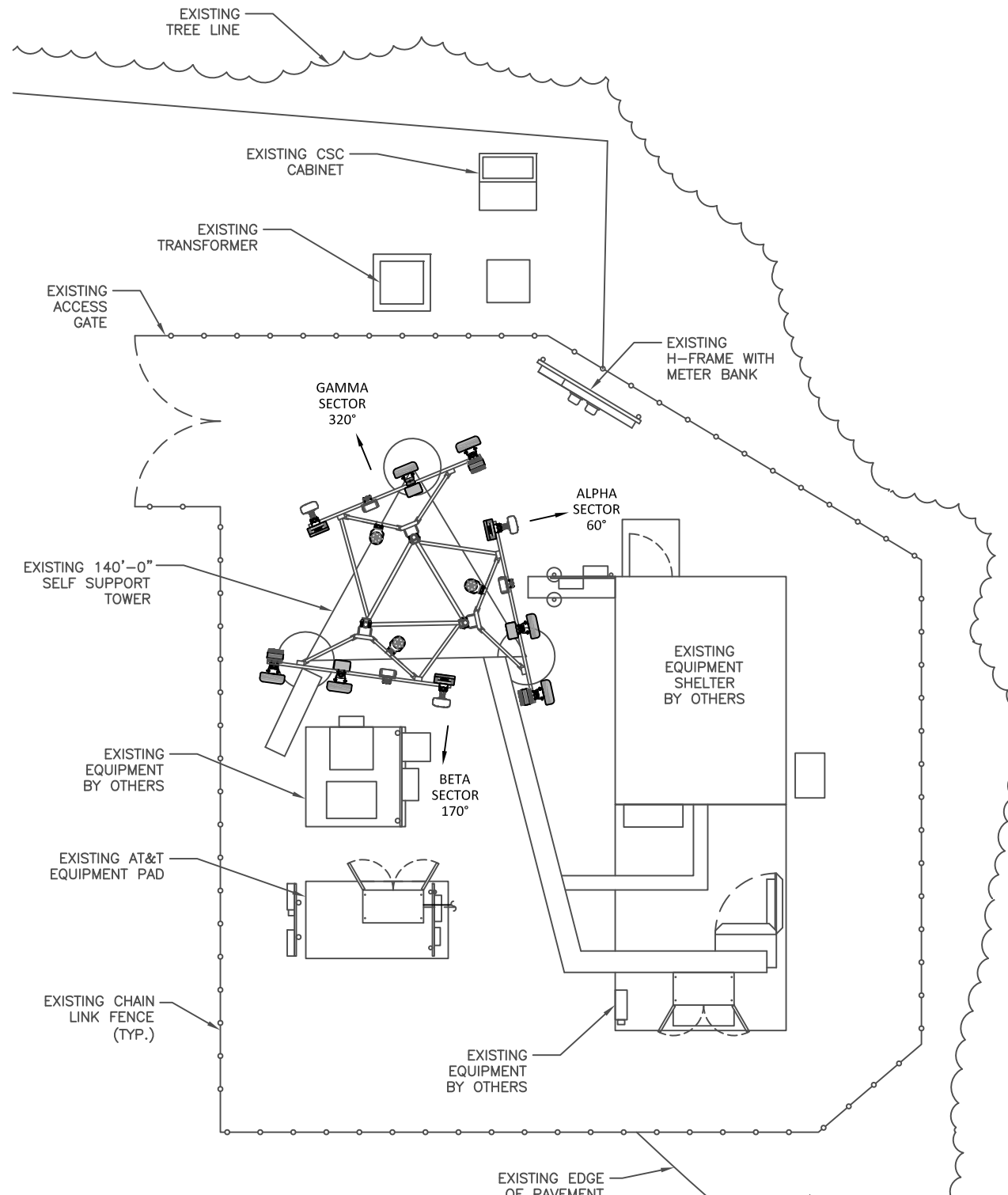

COMPOUND PLAN

SCALE: 3/8" = 1'-0" (22"X34")
3/16" = 1'-0" (11"X17")

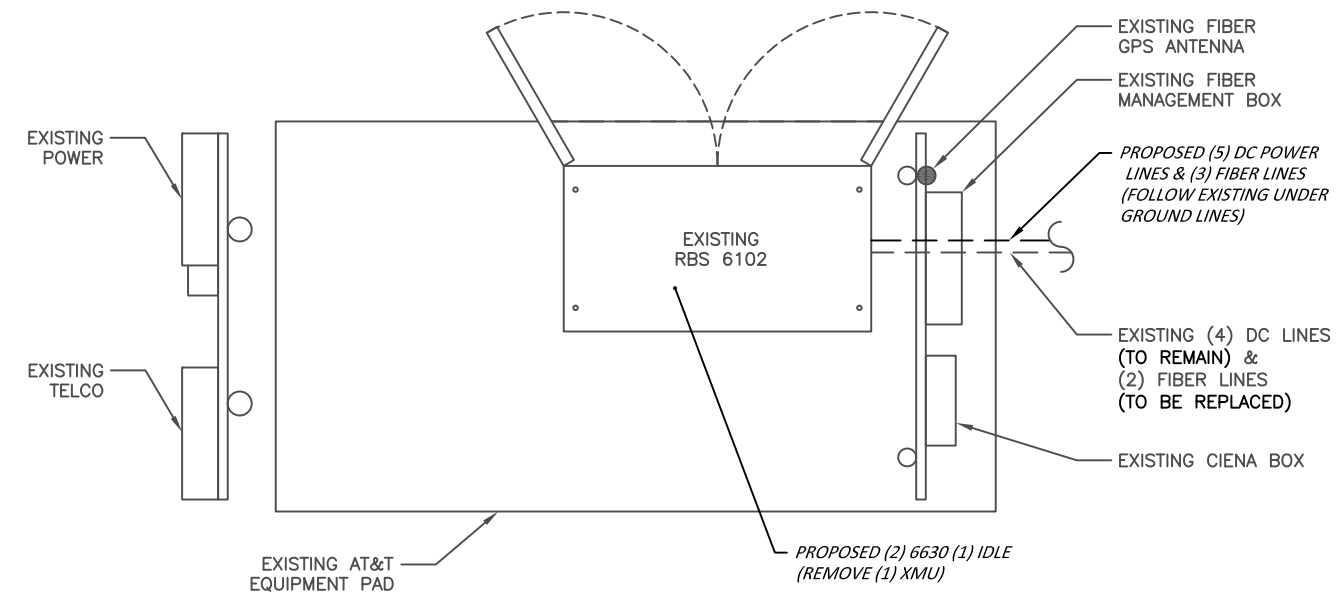
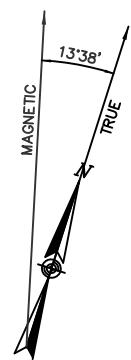

EQUIPMENT PLAN

SCALE: 1-1/2" = 1'-0" (22"X34")
3/4" = 1'-0" (11"X17")

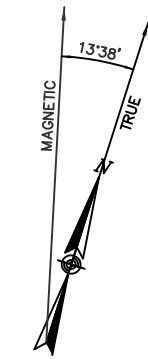
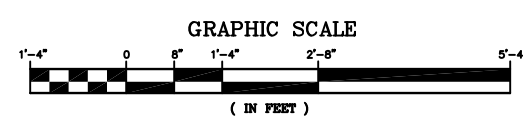

STRUCTURAL NOTES:

- DESIGN REQUIREMENTS ARE PER STATE BUILDING CODE AND APPLICABLE SUPPLEMENTS, INTERNATIONAL BUILDING CODE, EIA/TIA-222-G STRUCTURAL STANDARDS FOR STEEL ANTENNA, TOWERS AND ANTENNA SUPPORTING STRUCTURES.
- CONTRACTOR SHALL VERIFY ALL DIMENSIONS AND CONDITIONS IN THE FIELD PRIOR TO FABRICATION AND ERECTION OF ANY MATERIAL. ANY UNUSUAL CONDITIONS SHALL BE REPORTED TO THE ATTENTION OF THE CONSTRUCTION MANAGER AND ENGINEER OF RECORD.
- DESIGN AND CONSTRUCTION OF STRUCTURAL STEEL SHALL CONFORM TO THE AMERICAN INSTITUTE OF STEEL CONSTRUCTION "SPECIFICATION FOR THE DESIGN, FABRICATION AND ERECTION OF STRUCTURAL STEEL FOR BUILDINGS".
- STRUCTURAL STEEL SHALL CONFORM TO ASTM A992 (Fy=50 ksi), MISCELLANEOUS STEEL SHALL CONFORM TO ASTM A36 UNLESS OTHERWISE INDICATED.
- STEEL PIPE SHALL CONFORM TO ASTM A500 "COLD-FORMED WELDED & SEAMLESS CARBON STEEL STRUCTURAL TUBING", GRADE B, OR ASTM A53 PIPE STEEL BLACK AND HOT-DIPPED ZINC-COATED WELDED AND SEAMLESS TYPE E OR S, GRADE B. PIPE SIZES INDICATED ARE NOMINAL. ACTUAL OUTSIDE DIAMETER IS LARGER.
- STRUCTURAL CONNECTION BOLTS SHALL BE HIGH STRENGTH BOLTS (BEARING TYPE) AND CONFORM TO ASTM A325 TYPE-X "HIGH STRENGTH BOLTS FOR STRUCTURAL JOINTS, INCLUDING SUITABLE NUTS AND PLAIN HARDENED WASHERS". ALL BOLTS SHALL BE 3/4" DIA UON.
- ALL STEEL MATERIALS SHALL BE GALVANIZED AFTER FABRICATION IN ACCORDANCE WITH ASTM A123 "ZINC (HOT-DIP GALVANIZED) COATINGS ON IRON AND STEEL PRODUCTS", UNLESS OTHERWISE NOTED.
- ALL BOLTS, ANCHORS AND MISCELLANEOUS HARDWARE SHALL BE GALVANIZED IN ACCORDANCE WITH ASTM A153 "ZINC-COATING (HOT-DIP) ON IRON AND STEEL HARDWARE", UNLESS OTHERWISE NOTED.
- FIELD WELDS, DRILL HOLES, SAW CUTS AND ALL DAMAGED GALVANIZED SURFACES SHALL BE REPAIRED WITH AN ORGANIC ZINC REPAIR PAINT COMPLYING WITH REQUIREMENTS OF ASTM A780. GALVANIZING REPAIR PAINT SHALL HAVE 65 PERCENT ZINC BY WEIGHT, ZIRP BY DUNCAN GALVANIZING, GALVA BRIGHT PREMIUM BY CROWN OR EQUAL. THICKNESS OF APPLIED GALVANIZING REPAIR PAINT SHALL BE NOT LESS THAN 4 COATS (ALLOW TIME TO DRY BETWEEN COATS) WITH A RESULTING COATING THICKNESS REQUIRED BY ASTM A123 OR A153 AS APPLICABLE.
- CONTRACTOR SHALL COMPLY WITH AWS CODE FOR PROCEDURES, APPEARANCE AND QUALITY OF WELDS, AND FOR METHODS USED IN CORRECTING WELDING. ALL WELDERS AND WELDING PROCESSES SHALL BE QUALIFIED IN ACCORDANCE WITH AWS "STANDARD QUALIFICATION PROCEDURES". ALL WELDING SHALL BE DONE USING E70XX ELECTRODES AND WELDING SHALL CONFORM TO AISC AND D.I. WHERE FILLET WELD SIZES ARE NOT SHOWN, PROVIDE THE MINIMUM SIZE PER TABLE J2.4 IN THE AISC "STEEL CONSTRUCTION MANUAL". 14TH EDITION.
- INCORRECTLY FABRICATED, DAMAGED OR OTHERWISE MISFITTING OR NON-CONFORMING MATERIALS OR CONDITIONS SHALL BE REPORTED TO THE CONSTRUCTION MANAGER PRIOR TO REMEDIAL OR CORRECTIVE ACTION. ANY SUCH ACTION SHALL REQUIRE CONSTRUCTION MANAGER APPROVAL.
- UNISTRUT SHALL BE FORMED STEEL CHANNEL STRUT FRAMING AS MANUFACTURED BY UNISTRUT CORP., WAYNE, MI OR EQUAL. STRUT MEMBERS SHALL BE 1 5/8"x1 5/8"x12GA, UNLESS OTHERWISE NOTED, AND SHALL BE HOT-DIP GALVANIZED AFTER FABRICATION.
- EPOXY ANCHOR ASSEMBLY SHALL CONSIST OF STAINLESS STEEL ANCHOR ROD WITH NUTS & WASHERS. AN INTERNALLY THREADED INSERT, A SCREEN TUBE AND A EPOXY ADHESIVE. THE ANCHORING SYSTEM SHALL BE THE HILTI-HIT HY-270 AND OR HY-200 SYSTEMS (AS SPECIFIED IN DWG.) OR ENGINEERS APPROVED EQUAL.
- EXPANSION BOLTS SHALL CONFORM TO FEDERAL SPECIFICATION FF-S-325, GROUP II, TYPE 4, CLASS I, HILTI KWIK BOLT III OR APPROVED EQUAL. INSTALLATION SHALL BE IN ACCORDANCE WITH THE MANUFACTURER'S RECOMMENDATIONS.
- LUMBER SHALL COMPLY WITH THE REQUIREMENTS OF THE AMERICAN INSTITUTE OF TIMBER CONSTRUCTION AND THE NATIONAL FOREST PRODUCTS ASSOCIATION'S NATIONAL DESIGN SPECIFICATION FOR WOOD CONSTRUCTION. ALL LUMBER SHALL BE PRESSURE TREATED AND SHALL BE STRUCTURAL GRADE NO. 2 OR BETTER.
- WHERE ROOF PENETRATIONS ARE REQUIRED, THE CONTRACTOR SHALL CONTACT AND COORDINATE RELATED WORK WITH THE BUILDING OWNER AND THE EXISTING ROOF INSTALLER. WORK SHALL BE PERFORMED IN SUCH A MANNER AS TO NOT VOID THE EXISTING ROOF WARRANTY. ROOF SHALL BE WATERTIGHT.
- ALL FIBERGLASS MEMBERS USED ARE AS MANUFACTURED BY STRONGWELL COMPANY OF BRISTOL, VA 24203. ALL DESIGN CRITERIA FOR THESE MEMBERS IS BASED ON INFORMATION PROVIDED IN THE DESIGN MANUAL. ALL REQUIREMENTS PUBLISHED IN SAID MANUAL MUST BE STRICTLY ADHERED TO.
- NO MATERIALS TO BE ORDERED AND NO WORK TO BE COMPLETED UNTIL SHOP DRAWINGS HAVE BEEN REVIEWED AND APPROVED IN WRITING.
- SUBCONTRACTOR SHALL FIREPROOF ALL STEEL TO PRE-EXISTING CONDITIONS.

SPECIAL INSPECTIONS (REFERENCE IBC CHAPTER 17):

GENERAL: WHERE APPLICATION IS MADE FOR CONSTRUCTION, THE OWNER OR THE REGISTERED DESIGN PROFESSIONAL IN RESPONSIBLE CHARGE ACTING AS THE OWNER'S AGENT SHALL EMPLOY ONE OR MORE APPROVED AGENCIES TO PERFORM INSPECTIONS DURING CONSTRUCTION ON THE TYPES OF WORK LISTED IN THE INSPECTION CHECKLIST ABOVE.

THE REGISTERED DESIGN PROFESSIONAL IN RESPONSIBLE CHARGE AND ENGINEERS OF RECORD INVOLVED IN THE DESIGN OF THE PROJECT ARE PERMITTED TO ACT AS THE APPROVED AGENCY AND THEIR PERSONNEL ARE PERMITTED TO ACT AS THE SPECIAL INSPECTOR FOR THE WORK DESIGNED BY THEM, PROVIDED THOSE PERSONNEL MEET THE QUALIFICATION REQUIREMENTS.

STATEMENT OF SPECIAL INSPECTIONS: THE APPLICANT SHALL SUBMIT A STATEMENT OF SPECIAL INSPECTIONS PREPARED BY THE REGISTERED DESIGN PROFESSIONAL IN RESPONSIBLE CHARGE IN ACCORDANCE WITH SECTION 107.1 AS A CONDITION FOR ISSUANCE. THIS STATEMENT SHALL BE IN ACCORDANCE WITH SECTION 1705.

REPORT REQUIREMENT: SPECIAL INSPECTORS SHALL KEEP RECORDS OF INSPECTIONS. THE SPECIAL INSPECTOR SHALL FURNISH INSPECTION REPORTS TO THE BUILDING OFFICIAL, AND TO THE REGISTERED DESIGN PROFESSIONAL IN RESPONSIBLE CHARGE. REPORTS SHALL INDICATE THAT WORK INSPECTED WAS OR WAS NOT COMPLETED IN CONFORMANCE TO APPROVED CONSTRUCTION DOCUMENTS. DISCREPANCIES SHALL BE BROUGHT TO THE IMMEDIATE ATTENTION OF THE CONTRACTOR FOR CORRECTION. IF THEY ARE NOT CORRECTED, THE DISCREPANCIES SHALL BE BROUGHT TO THE ATTENTION OF THE BUILDING OFFICIAL AND TO THE REGISTERED DESIGN PROFESSIONAL IN RESPONSIBLE CHARGE. A FINAL REPORT DOCUMENTING REQUIRED SPECIAL INSPECTIONS SHALL BE SUBMITTED.

SPECIAL INSPECTION CHECKLIST	
BEFORE CONSTRUCTION	
CONSTRUCTION/INSTALLATION INSPECTIONS AND TESTING REQUIRED (COMPLETED BY ENGINEER OF RECORD)	REPORT ITEM
N/A	ENGINEER OF RECORD APPROVED SHOP DRAWINGS ¹
N/A	MATERIAL SPECIFICATIONS REPORT ²
N/A	FABRICATOR NDE INSPECTION
N/A	PACKING SLIPS ³
ADDITIONAL TESTING AND INSPECTIONS:	
DURING CONSTRUCTION	
CONSTRUCTION/INSTALLATION INSPECTIONS AND TESTING REQUIRED (COMPLETED BY ENGINEER OF RECORD)	REPORT ITEM
REQUIRED	STEEL INSPECTIONS
N/A	HIGH STRENGTH BOLT INSPECTIONS
N/A	HIGH WIND ZONE INSPECTIONS ⁴
N/A	FOUNDATION INSPECTIONS
N/A	CONCRETE COMP. STRENGTH, SLUMP TESTS AND PLACEMENT
N/A	POST INSTALLED ANCHOR VERIFICATION ⁵
N/A	GROUT VERIFICATION
N/A	CERTIFIED WELD INSPECTION
N/A	EARTHWORK: LIFT AND DENSITY
N/A	ON SITE COLD GALVANIZING VERIFICATION
N/A	GUY WIRE TENSION REPORT
ADDITIONAL TESTING AND INSPECTIONS:	
AFTER CONSTRUCTION	
CONSTRUCTION/INSTALLATION INSPECTIONS AND TESTING REQUIRED (COMPLETED BY ENGINEER OF RECORD)	REPORT ITEM
REQUIRED	MODIFICATION INSPECTOR REDLINE OR RECORD DRAWINGS ⁶
N/A	POST INSTALLED ANCHOR PULL-OUT TESTING
REQUIRED	PHOTOGRAPHS
ADDITIONAL TESTING AND INSPECTIONS:	

NOTES:

- REQUIRED FOR ANY NEW SHOP FABRICATED FRP OR STEEL.
- PROVIDED BY MANUFACTURER, REQUIRED IF HIGH STRENGTH BOLTS OR STEEL.
- PROVIDED BY GENERAL CONTRACTOR; PROOF OF MATERIALS.
- HIGH WIND ZONE INSPECTION CATB 120MPH OR CAT C,D 110MPH INSPECT FRAMING OF WALLS, ANCHORING, FASTENING SCHEDULE.
- ADHESIVE FOR REBAR AND ANCHORS SHALL HAVE BEEN TESTED IN ACCORDANCE WITH ACI 355.4 AND ICC-ES AC308 FOR CRACKED CONCRETE AND SEISMIC APPLICATIONS. DESIGN ADHESIVE BOND STRENGTH HAS BEEN BASED ON ACI 355.4 TEMPERATURE CATEGORY B WITH INSTALLATIONS INTO DRY HOLES DRILLED USING A CARBIDE BIT INTO CRACKED CONCRETE THAT HAS CURED FOR AT LEAST 21 DAYS. ADHESIVE ANCHORS REQUIRING CERTIFIED INSTALLATIONS SHALL BE INSTALLED BY A CERTIFIED ADHESIVE ANCHOR INSTALLER PER ACI 318-11 D.9.2.2. INSTALLATIONS REQUIRING CERTIFIED INSTALLERS SHALL BE INSPECTED PER ACI 318-11 D.8.2.4.
- AS REQUIRED; FOR ANY FIELD CHANGES TO THE ITEMS IN THIS TABLE.

NOTES:

- ALL CONNECTIONS TO BE SHOP WELDED & FIELD BOLTED USING 3/4" A325-X BOLTS, UNLESS OTHERWISE NOTIFIED.
- SHOP DRAWING ENGINEER REVIEW & APPROVAL REQUIRED BEFORE ORDERING MATERIAL.
- SHOP DRAWING ENGINEER REVIEW & APPROVAL REQUIRED PRIOR TO STEEL FABRICATION.
- VERIFICATION OF EXISTING ROOF CONSTRUCTION IS REQUIRED PRIOR TO THE INSTALLATION OF THE ROOF PLATFORM. ENGINEER OF RECORD IS TO APPROVE EXISTING CONDITIONS IN ORDER TO MOVE FORWARD.
- CENTERLINE OF PROPOSED STEEL PLATFORM SUPPORT COLUMNS TO BE CENTRALLY LOCATED OVER THE EXISTING BUILDING COLUMNS.
- EXISTING BRICK MASONRY COLUMNS/BEARING TO BE REPAIRED/REPLACED AT ALL PROPOSED PLATFORM SUPPORT POINTS. ENGINEER OF RECORD TO REVIEW AND APPROVE.

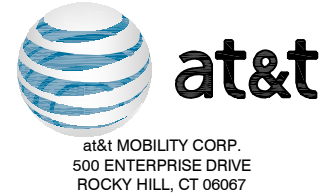

REVISIONS		
NO.	DATE	DESCRIPTION
1	04/10/20	ISSUED FOR CONSTRUCTION
0	02/21/20	ISSUED FOR REVIEW

DESIGNED BY: AA	APPROVED BY: DC
--------------------	--------------------

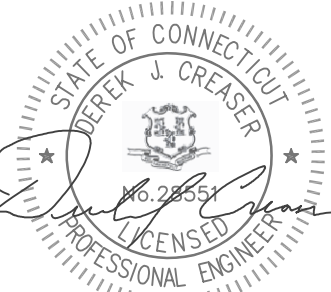

IT IS A VIOLATION OF LAW FOR ANY PERSON UNLESS THEY ARE ACTING UNDER THE DIRECTION OF A LICENSED PROFESSIONAL ENGINEER TO ALTER THIS DOCUMENT, UNLESS EXPLICITLY AGREED TO BY THE ENGINEER IN WRITING. THE ENGINEER DISCLAIMS ALL LIABILITY ASSOCIATED WITH THE REUSE, ALTERATION OR MODIFICATION OF THE CONTENTS HEREIN.

SITE NAME: EAST HARTFORD SUNSET RIDGE
SITE NUMBER: CT3438
SITE ADDRESS: 100 SUNSET RIDGE EAST HARTFORD, CT 06108
PROJECT TYPE: LTE 5C, 6C, 7C, 4TX4RX, 5G NR & BWE
SHEET TITLE: STRUCTURAL NOTES
DRAWING #: SN-1 REVISION: 1

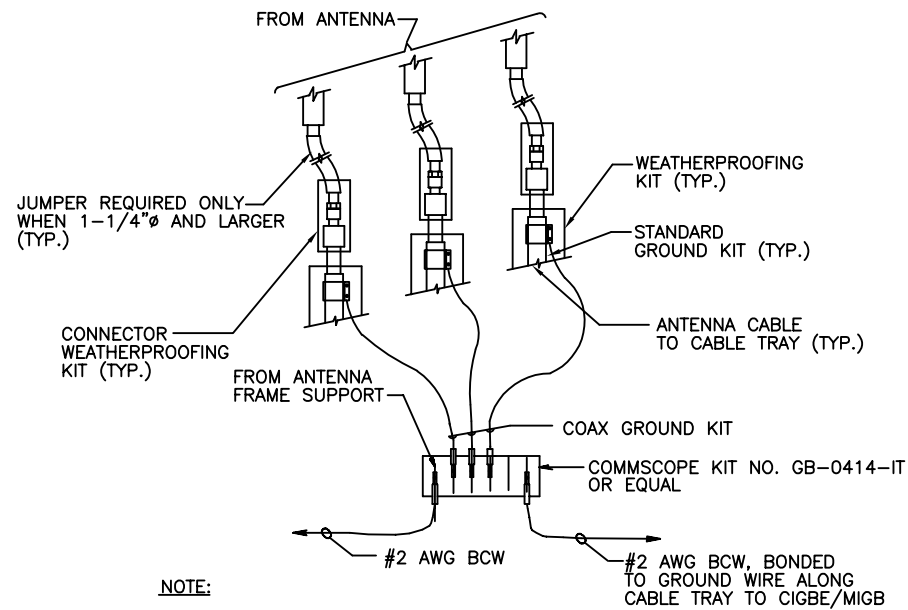

NOTE:

- DO NOT INSTALL CABLE GROUND KIT AT A BEND AND ALWAYS DIRECT GROUND WIRE DOWN TO CIGBE.

GROUNDING RISER DIAGRAM

N.T.S.

EACH GROUND CONDUCTOR TERMINATING ON ANY GROUND BAR SHALL HAVE AN IDENTIFICATION TAG ATTACHED AT EACH END THAT WILL IDENTIFY ITS ORIGIN AND DESTINATION.

SECTION "P" - SURGE PRODUCERS

- CABLE ENTRY PORTS (HATCH PLATES) (#2)
- GENERATOR FRAMEWORK (IF AVAILABLE) (#2)
- TELCO GROUND BAR
- COMMERCIAL POWER COMMON NEUTRAL/GROUND BOND (#2)
- +24V POWER SUPPLY RETURN BAR (#2)
- 48V POWER SUPPLY RETURN BAR (#2)
- RECTIFIER FRAMES.

SECTION "A" - SURGE ABSORBERS

- INTERIOR GROUND RING (#2)
- EXTERNAL EARTH GROUND FIELD (BURIED GROUND RING) (#2)
- METALLIC COLD WATER PIPE (IF AVAILABLE) (#2)
- BUILDING STEEL (IF AVAILABLE) (#2)

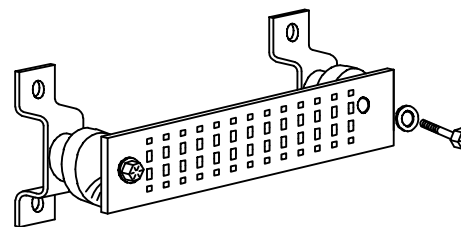

GROUND BAR DETAIL

N.T.S.

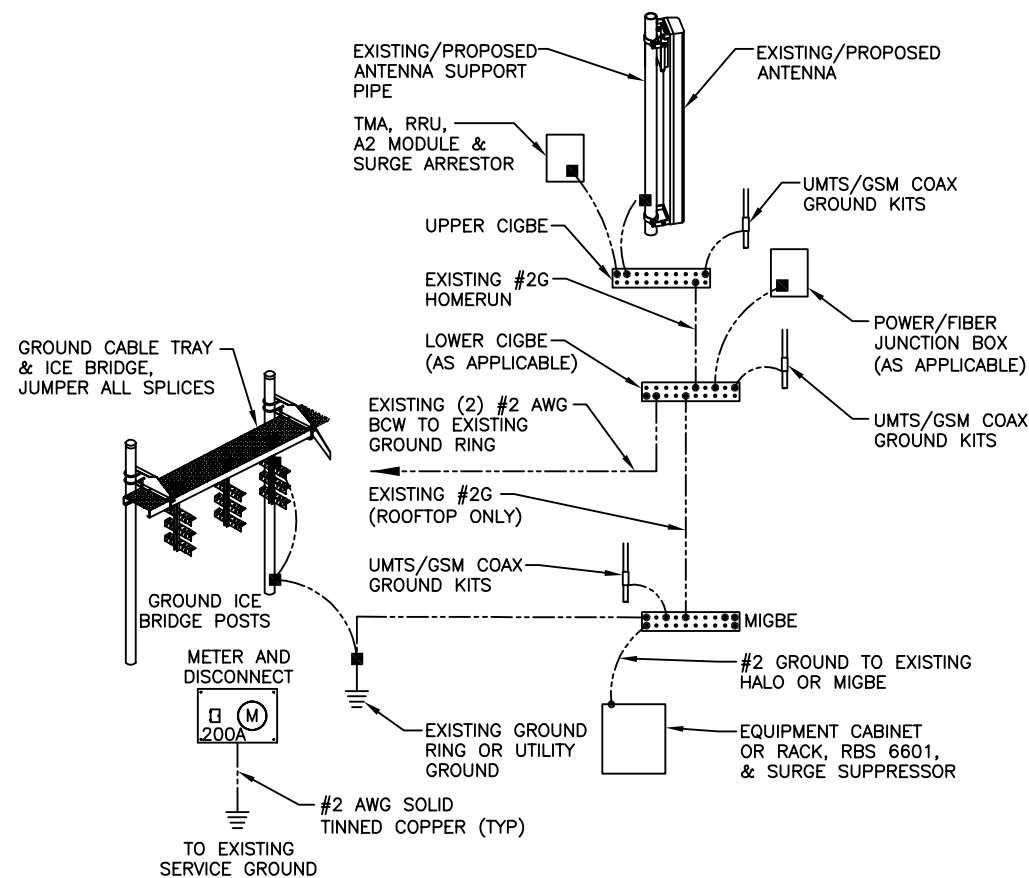

GROUNDING RISER DIAGRAM

N.T.S.

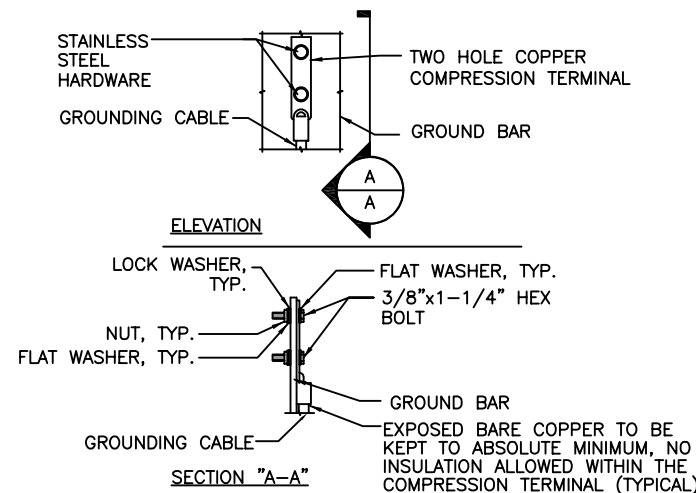

NOTE:

- "DOUBLING UP" OR "STACKING" OF CONNECTION IS NOT PERMITTED.
- OXIDE INHIBITING COMPOUND TO BE USED AT ALL LOCATION.
- CADWELD DOWNLEADS FROM UPPER EGB, LOWER EGB, AND MGB

GROUND BAR CONNECTION DETAIL

N.T.S.



at&t MOBILITY CORP.
500 ENTERPRISE DRIVE
ROCKY HILL, CT 06067



750 WEST CENTER ST, SUITE 301
WEST BRIDGEWATER, MA 02379
PHONE: 781.713.4725

REVISIONS

NO.	DATE	DESCRIPTION
1	04/10/20	ISSUED FOR CONSTRUCTION
0	02/21/20	ISSUED FOR REVIEW

DESIGNED BY: AA
APPROVED BY: DC

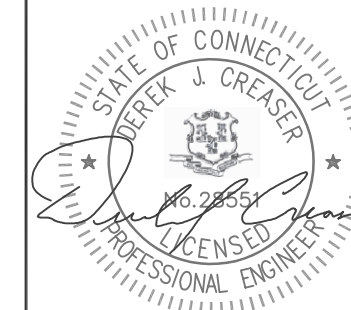

IT IS A VIOLATION OF LAW FOR ANY PERSON UNLESS THEY ARE ACTING UNDER THE DIRECTION OF A LICENSED PROFESSIONAL ENGINEER TO ALTER THIS DOCUMENT, UNLESS EXPLICITLY AGREED TO BY THE ENGINEER IN WRITING. THE ENGINEER DISCLAIMS ALL LIABILITY ASSOCIATED WITH THE REUSE, ALTERATION OR MODIFICATION OF THE CONTENTS HEREIN.

SITE NAME:
EAST HARTFORD SUNSET RIDGE

SITE NUMBER:
CT3438

SITE ADDRESS:
100 SUNSET RIDGE
EAST HARTFORD, CT 06108

PROJECT TYPE:
LTE 5C, 6C, 7C, 4TX4RX,
5G NR & BWE

SHEET TITLE:
GROUNDING DETAILS

DRAWING #: G-1 REVISION: 1

EXHIBIT 2

Revised Mount Analysis Report

Site Name	East Hartford Sunset Ridge
Site Number	CT3438
Project	LTE 5C, 6C, 7C, 4TX4RX, 5G NR & BWE
Pace ID	5C-MRCTB045175, 6C-MRCTB045156, 7C-MRCTB045193, 4TX4RX-MRCTB045279, 5G NR-MRCTB045300, & BWE-MRCTB045310
PTN	2051A0SRTQ, 2051A0SRQM, 2051A0SRSF, 2051A0SRSJ, 2051A0SRNA & 2051A0SRL0
Site Location	100 Sunset Ridge East Hartford, CT, 06108
Design Codes	TIA-222-H Standards International Building Code 2018 ASCE 7-16 Connecticut State Building Code 2018
Mount Centerline	110 ft.
Mount Classification	Sector Mounts

	Stress Ratio	Overall Result
Existing Mount	72%	PASS

Client:

at&t Mobility Corp.
 500 Enterprise Drive
 Rocky Hill, CT 06067



Date: 4/15/2020 (Rev.1)
 2/21/2020

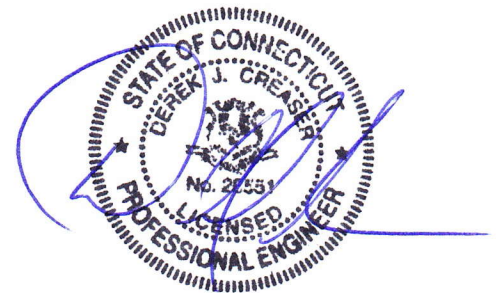

Scope of Work:

Centerline Communications was authorized by AT&T to perform a mount analysis of the existing sector mounts to determine their capacity to support the proposed and existing AT&T equipment listed in this report. This mount was analyzed using RAM Elements version 16.1.0.

Proposed Appurtenances:

Elevation (ft)	Position #	Azimuth	Quantity	Appurtenance
166	1	60°	1	Kathrein 800-10799
166	1	60°	1	DC9-48-60-24-8C-EV Squid
166	4	60°	1	CCI DMP65R-BU8DA
166	3	60°	1	CCI OPA65R-BU8DA
166	1	60°	1	Ericsson RRUS-E2 B29
166	4	60°	1	Ericsson RRUS 4449 B5/12
166	4	60°	1	Ericsson RRUS 8843 B2/B66A
166	3	60°	1	Ericsson RRUS 4478 B14
166	1	60°	1	Ericsson RRUS 4415 B25
166	1	60°	1	Ericsson RRUS-32 B30
166	1	170°	1	Kathrein 800-10799
166	1	170°	1	DC9-48-60-24-8C-EV Squid
166	3	170°	1	CCI OPA65R-BU8DA
166	4	170°	1	CCI DMP65R-BU8DA
166	1	170°	1	Ericsson RRUS-E2 B29
166	4	170°	1	Ericsson RRUS 4449 B5/12
166	4	170°	1	Ericsson RRUS 8843 B2/B66A
166	3	170°	1	Ericsson RRUS 4478 B14
166	1	170°	1	Ericsson RRUS 4415 B25
166	1	170°	1	Ericsson RRUS-32 B30
166	1	320°	1	Kathrein 800-10799
166	1	320°	1	DC9-48-60-24-8C-EV Squid
166	3	320°	1	CCI OPA65R-BU8DA
166	4	320°	1	CCI DMP65R-BU8DA
166	1	320°	1	Ericsson RRUS-E2 B29
166	4	320°	1	Ericsson RRUS 4449 B5/12
166	4	320°	1	Ericsson RRUS 8843 B2/B66A
166	3	320°	1	Ericsson RRUS 4478 B14
166	1	320°	1	Ericsson RRUS 4415 B25
166	1	320°	1	Ericsson RRUS-32 B30

Design Codes:

TIA-222-H Standards
 International Building Code 2018
 ASCE 7-16
 Connecticut State Building Code 2018

Wind Speed (Municipality Requirement)	125 mph
Wind Speed with Ice	50 mph
Ice Thickness	1.5 in.
Exposure Category	B
Topographic Category	1
Structure Classification	II
Importance Factor	1
Site Soil Class (assumed)	D – Stiff Soil
Seismic Design Category	B
Spectral Response Acceleration Parameter at a Short Periods, S_s	0.19
Spectral Response Acceleration Parameter at a Period of 1 Second, S_1	0.055
Short Period Site Coefficient, F_A	1.6
Long Period Site Coefficient, F_V	2.4

***See calculations for additional design criteria.**

Conclusion:

The results of the analysis concluded that the existing AT&T mounts are structurally adequate to support the proposed and existing AT&T equipment loading.

	Stress Ratio	Overall Result
Existing Mount	72%	PASS

Reference Documents:

- Construction Drawings by Advanced Engineering Group dated 5/4/17.
- Sabre Industries 12' V-Boom Assembly, #C10857001C, dated 12/22/15 (assumed mount used in this analysis).

Assumptions and Limitations:

- The calculations performed by Centerline Communications are limited to the structural members in these calculations only.
- Structural calculations in this report do not check the adequacy of the supporting tower, other mounts, or coax mounting attachments.

Design Calculations



ASCE 7 Hazards Report

Address:
100 Sunset Ridge Dr
East Hartford, Connecticut
06118

Standard: ASCE/SEI 7-16
Risk Category: II
Soil Class: D - Stiff Soil

Elevation: 191.52 ft (NAVD 88)
Latitude: 41.771604
Longitude: -72.592505

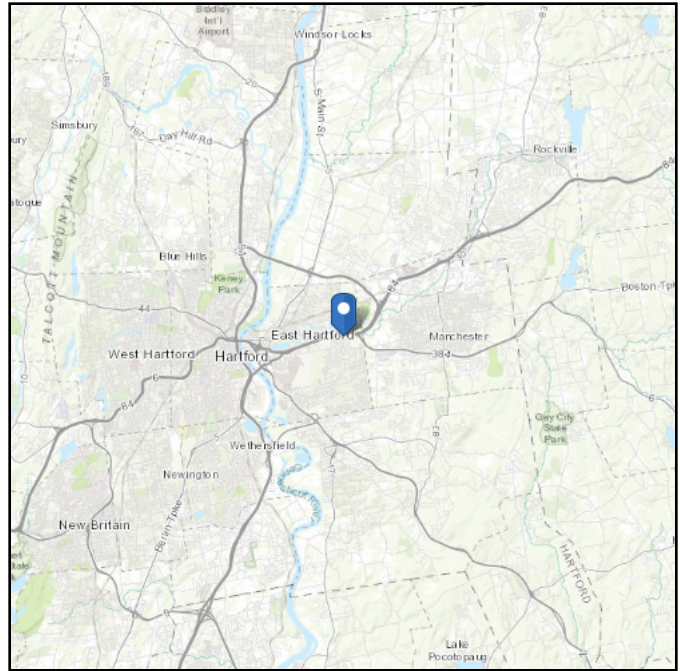
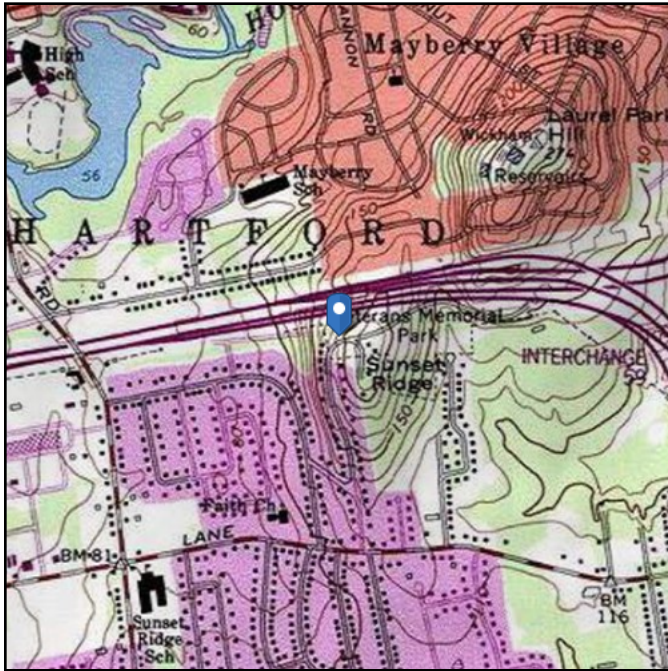

Wind

Results:

Wind Speed:	118 Vmph
10-year MRI	75 Vmph
25-year MRI	84 Vmph
50-year MRI	90 Vmph
100-year MRI	97 Vmph

Data Source: ASCE/SEI 7-16, Fig. 26.5-1B and Figs. CC.2-1–CC.2-4

Date Accessed: Fri Apr 10 2020

Value provided is 3-second gust wind speeds at 33 ft above ground for Exposure C Category, based on linear interpolation between contours. Wind speeds are interpolated in accordance with the 7-16 Standard. Wind speeds correspond to approximately a 7% probability of exceedance in 50 years (annual exceedance probability = 0.00143, MRI = 700 years).

Site is in a hurricane-prone region as defined in ASCE/SEI 7-16 Section 26.2. Glazed openings need not be protected against wind-borne debris.

Mountainous terrain, gorges, ocean promontories, and special wind regions should be examined for unusual wind conditions.

Site Soil Class: D - Stiff Soil

Results:

S_s :	0.19	S_{D1} :	0.088
S_1 :	0.055	T_L :	6
F_a :	1.6	PGA :	0.103
F_v :	2.4	PGA _M :	0.164
S_{MS} :	0.304	F_{PGA} :	1.595
S_{M1} :	0.132	I_e :	1
S_{DS} :	0.203	C_v :	0.7

Seismic Design Category B

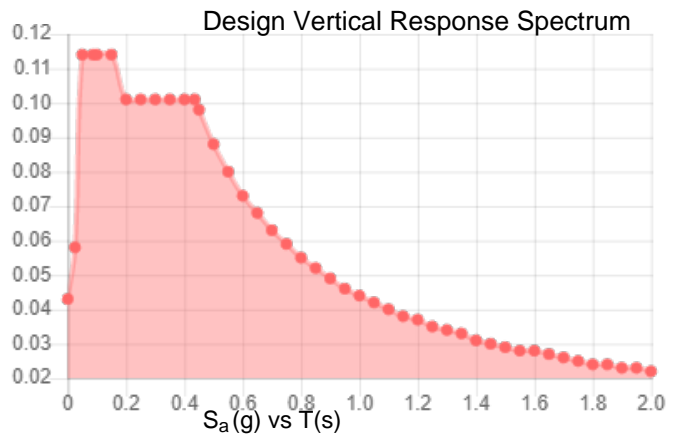
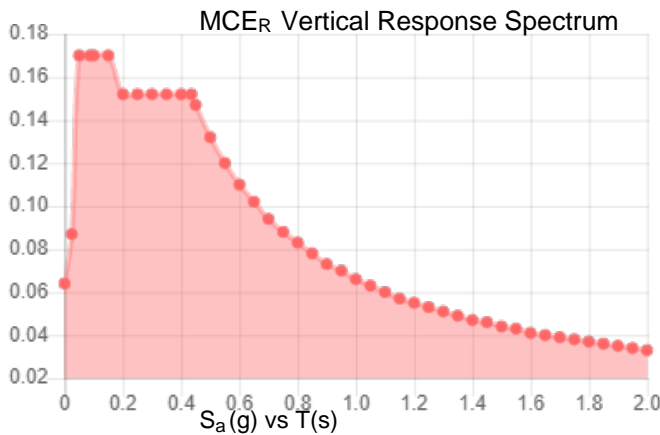
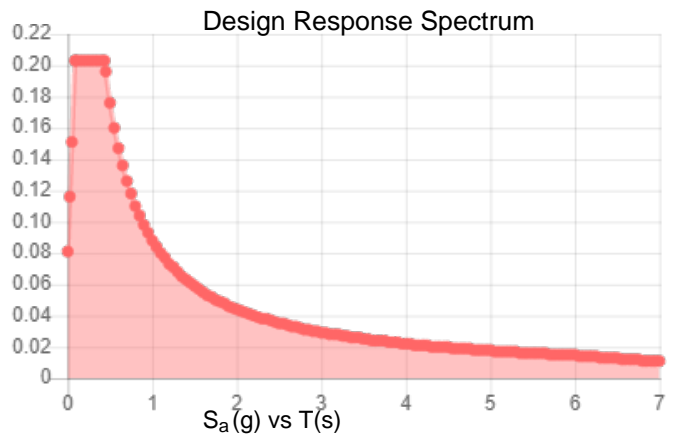
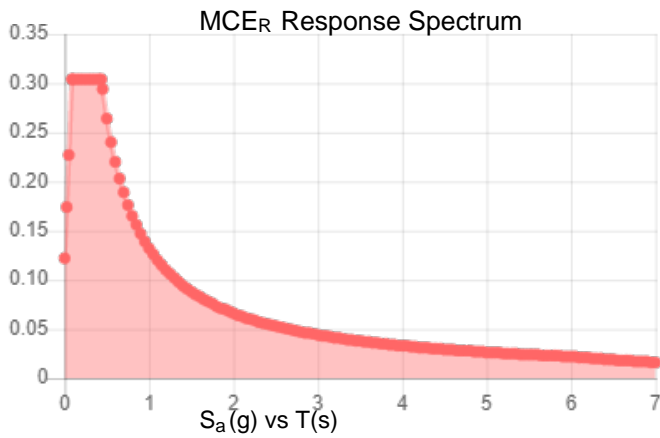

Data Accessed:

Fri Apr 10 2020

Date Source:

USGS Seismic Design Maps based on ASCE/SEI 7-16 and ASCE/SEI 7-16 Table 1.5-2. Additional data for site-specific ground motion procedures in accordance with ASCE/SEI 7-16 Ch. 21 are available from USGS.

Ice

Results:

Ice Thickness: 1.50 in.

Concurrent Temperature: 5 F

Gust Speed: 50 mph

Data Source: Standard ASCE/SEI 7-16, Figs. 10-2 through 10-8

Date Accessed: Fri Apr 10 2020

Ice thicknesses on structures in exposed locations at elevations higher than the surrounding terrain and in valleys and gorges may exceed the mapped values.

Values provided are equivalent radial ice thicknesses due to freezing rain with concurrent 3-second gust speeds, for a 500-year mean recurrence interval, and temperatures concurrent with ice thicknesses due to freezing rain. Thicknesses for ice accretions caused by other sources shall be obtained from local meteorological studies. Ice thicknesses in exposed locations at elevations higher than the surrounding terrain and in valleys and gorges may exceed the mapped values.

The ASCE 7 Hazard Tool is provided for your convenience, for informational purposes only, and is provided “as is” and without warranties of any kind. The location data included herein has been obtained from information developed, produced, and maintained by third party providers; or has been extrapolated from maps incorporated in the ASCE 7 standard. While ASCE has made every effort to use data obtained from reliable sources or methodologies, ASCE does not make any representations or warranties as to the accuracy, completeness, reliability, currency, or quality of any data provided herein. Any third-party links provided by this Tool should not be construed as an endorsement, affiliation, relationship, or sponsorship of such third-party content by or from ASCE.

ASCE does not intend, nor should anyone interpret, the results provided by this Tool to replace the sound judgment of a competent professional, having knowledge and experience in the appropriate field(s) of practice, nor to substitute for the standard of care required of such professionals in interpreting and applying the contents of this Tool or the ASCE 7 standard.

In using this Tool, you expressly assume all risks associated with your use. Under no circumstances shall ASCE or its officers, directors, employees, members, affiliates, or agents be liable to you or any other person for any direct, indirect, special, incidental, or consequential damages arising from or related to your use of, or reliance on, the Tool or any information obtained therein. To the fullest extent permitted by law, you agree to release and hold harmless ASCE from any and all liability of any nature arising out of or resulting from any use of data provided by the ASCE 7 Hazard Tool.

SITE NUMBER: CT3438
 SITE NAME: East Hartford
 DATE: 4/10/20
 BY: LP CHECKED BY: DC



ANSI/TIA-222-H WIND CALCULATIONS:

Design Criteria:

Height above ground level at the base of the structure, z=	110	ft	
Mean elevation of base of structure above sea level, z _s =	192	ft	(ASCE 7 Hazards Report)
Height of structure, h=	140	ft	
Basic Wind Speed, V (mph) =	125		(CSBC 2018)
30 mph Wind Speed, V ₃₀ (mph) =	30		(Section 16)
Basic Wind Speed with ice, V _i (mph) =	50		(Annex B, Figure B-9)
Max. Design Ice Thickness, t _i (in.)=	1.5		(Annex B, Figure B-9)
Exposure Category =	B		(2.6.5.1)
Topographic Category =	1		(2.6.6.2.1)
Risk Category	II		(Table 2-1)
Wind Direction Prob. Factor, K _d =	0.95		(Table 2-2)
Importance Factor, I =	1		(Table 2-3)
Velocity Pressure Coefficient, K _z =	1.02		(2.6.5.2)
Topographic Factor, K _{zt} =	1		(2.6.6.2.1)
Rooftop Wind Speed-Up Factor, K _s =	1		(2.6.7)
Ground Elevation Factor, K _e =	0.99		(2.6.8)
Gust Effect Factor G _h =	1		(2.6.9)
Factored thickness of radial glazed ice at z, t _{iz} =	1.69	in	(2.6.10)

Calculate Velocity Pressure:

$$q_z = 0.00256 K_z K_{zt} K_s K_e K_d V^2 \text{ (lb/ft}^2\text{)} \quad (2.6.11.6)$$

$$q_z = \mathbf{38.32}$$

$$q_{z(30)} = \mathbf{2.21}$$

Calculate Velocity Pressure with Ice:

$$q_{zi} = 0.00256 K_z K_{zt} K_s K_e K_d V^2 \text{ (lb/ft}^2\text{)} \quad (2.6.11.6)$$

$$q_{zi} = \mathbf{6.13}$$

SITE NUMBER: CT3438
 SITE NAME: East Hartford
 DATE: 4/10/20
 BY: LP CHECKED BY: DC



ANSI/TIA-222-H WIND CALCULATIONS (Cont.):

Appurtenance/Equipment Properties:

Appurtenance/Equip.	Height (in)	Width (in)	Depth (in)	Normal Flat Area (ft ²)	Aspect Ratio	Force Coef., C _a	Side Flat Area (ft ²)	Aspect Ratio	Force Coef., C _a	EPA Normal Flat Area (ft ²)	EPA Side Flat Area (ft ²)
800-10799 Antenna	106.00	14.80	6.70	10.89	7.16	1.41	4.93	15.82	1.69	15.36	8.33
OPA65R-BU8D Antenna	96.00	21.00	7.80	14.00	4.57	1.29	5.20	12.31	1.58	18.06	8.22
DMP65R-BU8DA Antenna	96.00	20.70	7.70	13.80	4.64	1.30	5.13	12.47	1.58	17.94	8.11
RRUS E2 B29	20.40	18.50	7.50	2.62	1.10	1.20	1.06	2.72	1.21	3.15	1.29
4449 B5/B12 RRU	14.96	13.19	10.43	1.37	1.13	1.20	1.08	1.43	1.20	1.64	1.30
4478 B14 RRU	18.10	13.40	8.26	1.68	1.35	1.20	1.04	2.19	1.20	2.02	1.25
4415 B25 RRU	16.50	13.40	5.90	1.54	1.23	1.20	0.68	2.80	1.21	1.84	0.82
8843 RRU	14.90	13.20	10.90	1.37	1.13	1.20	1.13	1.37	1.20	1.64	1.35
RRUS 32 B30	26.70	12.10	6.70	2.24	2.21	1.20	1.24	3.99	1.27	2.69	1.58
DC6-48-60-0-8CEV Squid	24.00	9.70	9.70	1.62	2.47	0.70	1.62	2.47	0.70	1.13	1.13

Appurtenance/Equipment Properties with Ice:

t_{iz} (in) = 1.69

Appurtenance/Equip.	Height w/ice (in)	Width w/ice (in)	Depth w/ice (in)	Normal Flat Area (ft ²)	Aspect Ratio	Force Coef., C _a	Side Flat Area (ft ²)	Aspect Ratio	Force Coef., C _a	EPA Normal Flat Area (ft ²)	EPA Side Flat Area (ft ²)
800-10799 Antenna	109.38	18.18	10.08	13.81	6.02	1.36	7.66	10.85	1.53	18.79	11.72
OPA65R-BU8D Antenna	99.38	24.38	11.18	16.83	4.08	1.27	7.72	8.89	1.46	21.37	11.27
DMP65R-BU8DA Antenna	99.38	24.08	11.08	16.62	4.13	1.27	7.65	8.97	1.47	21.11	11.25
RRUS E2 B29	23.78	21.88	10.88	3.61	1.09	1.20	1.80	2.19	1.20	4.34	2.16
4449 B5/B12 RRU	18.34	16.57	13.81	2.11	1.11	1.20	1.76	1.33	1.20	2.53	2.11
4478 B14 RRU	21.48	16.78	11.64	2.50	1.28	1.20	1.74	1.85	1.20	3.00	2.08
4415 B25 RRU	19.88	16.78	9.28	2.32	1.18	1.20	1.28	2.14	1.20	2.78	1.54
8843 RRU	18.28	16.58	14.28	2.11	1.10	1.20	1.81	1.28	1.20	2.53	2.18
RRUS 32 B30	30.08	15.48	10.08	3.23	1.94	1.20	2.11	2.98	1.22	3.88	2.57
DC6-48-60-0-8CEV Squid	27.38	13.08	13.08	2.49	2.09	0.70	2.49	2.09	0.70	1.74	1.74

SITE NUMBER: CT3438
 SITE NAME: East Hartford
 DATE: 4/10/20
 BY: LP CHECKED BY: DC



ANSI/TIA-222-H WIND CALCULATIONS (Cont.):

Calculate Design Wind Force on Appurtenances:

$$(EPA)_A = k_a ((EPA)_N * \cos^2(\omega) + (EPA)_T * \sin^2(\omega)) \quad (\text{Section 2.6.11.2})$$

$$k_a = 1$$

$$F = q_z G_r (EPA)_A \quad (2.6.9.2)$$

Appurtenance/Equip.	Wind Direction								
	0° & 180°			30° & 210°			60° & 240°		
	F (lbs.)	F _{ice} (lbs.)	F ₃₀ (lbs.)	F (lbs.)	F _{ice} (lbs.)	F ₃₀ (lbs.)	F (lbs.)	F _{ice} (lbs.)	F ₃₀ (lbs.)
800-10799 Antenna	589	115	34	521	104	30	387	83	22
OPA65R-BU8D Antenna	692	131	40	598	116	34	409	85	24
DMP65R-BU8DA Antenna	687	129	40	593	114	34	405	84	23
RRUS E2 B29	121	27	7	103	23	6	67	17	4
4449 B5/B12 RRU	63	16	4	60	15	3	53	14	3
4478 B14 RRU	77	18	4	70	17	4	55	14	3
4415 B25 RRU	71	17	4	61	15	4	41	11	2
8843 RRU	63	15	4	60	15	3	55	14	3
RRUS 32 B30	103	24	6	92	22	5	71	18	4
DC6-48-60-0-8CEV Squid	43	11	2	43	11	2	43	11	2

Appurtenance/Equip.	Wind Direction								
	90° & 270°			120° & 300°			150° & 330°		
	F (lbs.)	F _{ice} (lbs.)	F ₃₀ (lbs.)	F (lbs.)	F _{ice} (lbs.)	F ₃₀ (lbs.)	F (lbs.)	F _{ice} (lbs.)	F ₃₀ (lbs.)
800-10799 Antenna	319	72	18	387	83	22	521	104	30
OPA65R-BU8D Antenna	315	69	18	409	85	24	598	116	34
DMP65R-BU8DA Antenna	311	69	18	405	84	23	593	114	34
RRUS E2 B29	49	13	3	67	17	4	103	23	6
4449 B5/B12 RRU	50	13	3	53	14	3	60	15	3
4478 B14 RRU	48	13	3	55	14	3	70	17	4
4415 B25 RRU	31	9	2	41	11	2	61	15	4
8843 RRU	52	13	3	55	14	3	60	15	3
RRUS 32 B30	60	16	3	71	18	4	92	22	5
DC6-48-60-0-8CEV Squid	43	11	2	43	11	2	43	11	2

SITE NUMBER: CT3438
 SITE NAME: East Hartford
 DATE: 4/10/20
 BY: LP CHECKED BY: DC



ANSI/TIA-222-H WIND CALCULATIONS (Cont.):

Calculate Design Wind Force on Mounting Members:

Mount Member	Height (in)	Width (in)	Normal Flat Area (ft ²)	Aspect Ratio	Force Coef., C _a	EPA Normal Flat Area (ft ²)
2 STD Pipe	2.38	12.00	0.20	0.20	1.20	0.24
3/4 Round Bar	0.75	12.00	0.06	0.06	1.20	0.08

Mount Member	Height w/ice (in)	Width (in)	Normal Flat Area (ft ²)	Aspect Ratio	Force Coef., C _a	EPA Normal Flat Area (ft ²)
2 STD Pipe	5.76	12.00	0.48	0.48	1.20	0.58
3/4 Round Bar	4.13	12.00	0.34	0.34	1.20	0.41

Mount Member	F (lbs.)	F _{ice} (lbs.)	F ₃₀ (lbs.)
2 STD Pipe	9	4	1
3/4 Round Bar	3	3	0

SITE NUMBER: CT3438
 SITE NAME: East Hartford
 DATE: 4/10/20
 BY: LP CHECKED BY: DC



ICE LOAD CALCULATIONS:

Unit Weight of Glaze Ice (lb/ft³) = 56

Factored thickness of radial glazed ice at z, t_{iz} (in) = 1.69

Appurtenances/Equip.	Height w/ice (in)	Width w/ice (in)	Depth w/ice (in)	Weight (lbs.)	Weight of Ice (lbs.)	Total Weight (lbs.)
800-10799 Antenna	109.38	18.18	10.08	108.00	309.36	417.36
OPA65R-BU8D Antenna	99.38	24.38	11.18	76.50	368.72	445.22
DMP65R-BU8DA Antenna	99.38	24.08	11.08	95.70	363.88	459.58
RRUS E2 B29	23.78	21.88	10.88	60.00	91.85	151.85
4449 B5/B12 RRU	18.34	16.57	13.81	73.00	69.41	142.41
4478 B14 RRU	21.48	16.78	11.64	59.40	71.14	130.54
4415 B25 RRU	19.88	16.78	9.28	46.00	58.13	104.13
8843 RRU	18.28	16.58	14.28	72.00	70.88	142.88
RRUS 32 B30	30.08	15.48	10.08	60.00	82.08	142.08
DC6-48-60-0-8CEV Squid	27.38	13.08	13.08	33.00	78.74	111.74

Member Properties for: Pipe 2 STD

Outside Diameter, OD = 2.375 in.
 Inside Diameter, ID = 2.070 in.
 Nominal Wall Thickness, t = 0.154 in.

Design Parameters:

Ice Height Factor, k_{iz} =	1.13		$K_{iz} = (z/33)^{0.10}$
Design Ice Thickness, t_{iz} =	1.69	in.	$t_{iz} = t_i * k_{iz} * (K_{zt})^{0.35}$
Density of Ice, I_d =	56	pcf	$I_d = (\text{assumed} = 56 \text{ pcf})$
Weight of Ice (for t_{iz}) W_i =	7.90	psf	$W_i = (t_{iz}/12) I_d$

Ice Load on Circumscribing Diameter of Member per Code:

Circumscribing Dia., D_c =	2.38	in.	$D_c = OD$
Area of Ice (for t_{iz}), A_i =	21.62	in ²	$A_i = \pi * t_{iz} * (D_c + t_{iz})$
Unif. Distributed Ice Load, w_i =	8.41	plf	$w_i = (A_i/144) * I_d$

SITE NUMBER: CT3438
 SITE NAME: East Hartford
 DATE: 4/10/20
 BY: LP CHECKED BY: DC



ICE LOAD CALCULATIONS (Cont.):

Member Properties for:		3/4" Round Bar
Outside Diameter, OD =	0.750	in.
Design Parameters:		
Ice Height Factor, K_{iz} =	1.13	$K_{iz} = (z/33)^{0.10}$
Design Ice Thickness, t_{iz} =	1.69	in. $t_{iz} = t_i * I * K_{iz} * (K_{zt})^{0.35}$
Density of Ice, I_d =	56	pcf $I_d = (\text{assumed} = 56 \text{ pcf})$
Weight of Ice (for t_{iz}) W_i =	7.90	psf $W_i = (t_{iz}/12) I_d$
Ice Load on Circumscribing Diameter of Member per Code:		
Circumscribing Dia., D_c =	0.75	in. $D_c = OD$
Area of Ice (for t_{iz}), A_i =	12.98	in ² $A_i = \pi * t_{iz} * (D_c + t_{iz})$
Unif. Distributed Ice Load, w_i =	5.05	plf $w_i = (A_i/144) * I_d$

SITE NUMBER: CT3438
 SITE NAME: East Hartford
 DATE: 4/10/20
 BY: LP CHECKED BY: DC



ANSI/TIA-222-H SEISMIC CALCULATIONS:

Design Spectral Response Acceleration Parameters: (Reference ASCE 7 Hazards Report)

Site Soil Class: **D-Stiff Soil** (Assumed)

Importance Factor, I = **1**

Spectral Response Acceleration Parameter at Short Periods, S_s = **0.19**

Spectral Response Acceleration Parameter at a Period of 1 Second, S_1 = **0.055**

Short Period Site Coefficient, F_a = **1.6**

Long Period Site Coefficient, F_v = **2.4**

Design Spectral Response Acceleration Parameter at Short Periods, S_{DS} = **0.203**

Design Spectral Response Acceleration Parameter at a Period of 1 Second, S_{D1} = **0.088**

Appurtenances/Equip.	Weight (lbs.)	E_v (lbs.)	E_H (lbs.)
800-10799 Antenna	108.00	4.38	10.96
OPA65R-BU8D Antenna	76.50	3.11	7.76
DMP65R-BU8DA Antenna	95.70	3.89	9.71
RRUS E2 B29	60.00	2.44	6.09
4449 B5/B12 RRU	73.00	2.96	7.41
4478 B14 RRU	59.40	2.41	6.03
4415 B25 RRU	46.00	1.87	4.67
8843 RRU	72.00	2.92	7.31
RRUS 32 B30	60.00	2.44	6.09
DC6-48-60-0-8CEV Squid	33.00	1.34	3.35

Mount Member	Weight (lbs./ft)	E_v (lbs./ft)	E_H (lbs./ft)
2 STD Pipe	3.66	0.15	0.37
3/4 Round Bar	1.50	0.06	0.15

Existing Mount Results



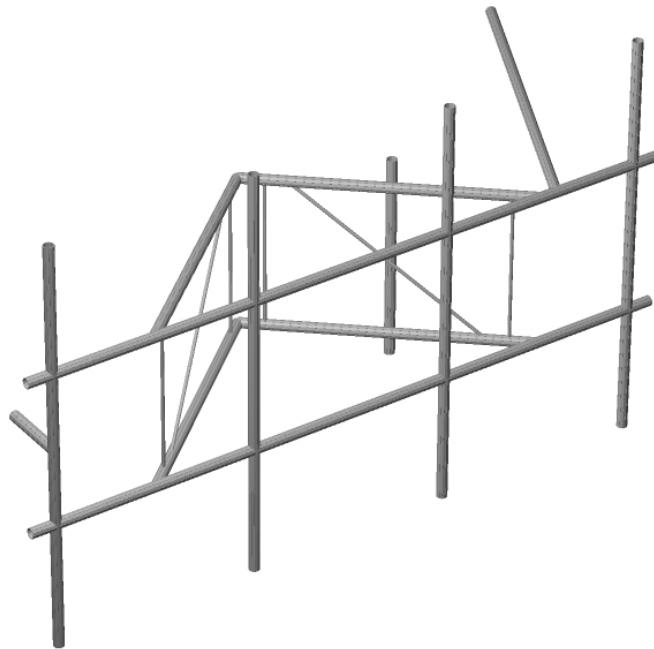

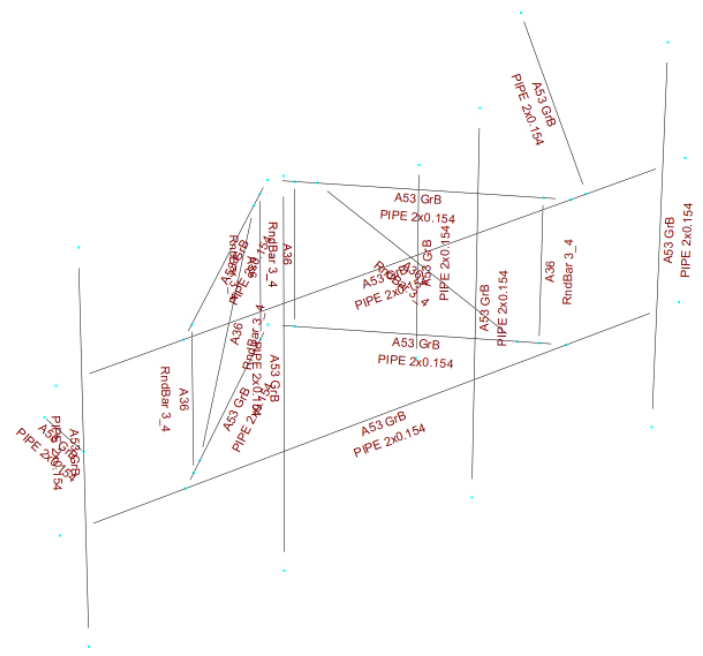



Current Date: 4/10/2020 1:15 PM

Units system: English

File name: C:\Users\Lee Peringer\Centerline Communications\Derek Creaser - Centerline Engineering\Projects\AT&T\NEW ENGLAND\CT\CT3438 - EAST HARTFORD - SST\LTE 6C\Structural\Working Files\RAM\CT3438 Tower.ret

Geometry data

GLOSSARY

- Cb22, Cb33 : Moment gradient coefficients
- Cm22, Cm33 : Coefficients applied to bending term in interaction formula
- d0 : Tapered member section depth at J end of member
- DJX : Rigid end offset distance measured from J node in axis X
- DJY : Rigid end offset distance measured from J node in axis Y
- DJZ : Rigid end offset distance measured from J node in axis Z
- DKX : Rigid end offset distance measured from K node in axis X
- DKY : Rigid end offset distance measured from K node in axis Y
- DKZ : Rigid end offset distance measured from K node in axis Z
- dL : Tapered member section depth at K end of member
- Ig factor : Inertia reduction factor (Effective Inertia/Gross Inertia) for reinforced concrete members
- K22 : Effective length factor about axis 2
- K33 : Effective length factor about axis 3
- L22 : Member length for calculation of axial capacity
- L33 : Member length for calculation of axial capacity
- LB pos : Lateral unbraced length of the compression flange in the positive side of local axis 2
- LB neg : Lateral unbraced length of the compression flange in the negative side of local axis 2
- RX : Rotation about X
- RY : Rotation about Y
- RZ : Rotation about Z
- TO : 1 = Tension only member 0 = Normal member
- TX : Translation in X
- TY : Translation in Y
- TZ : Translation in Z

Nodes

Node	X [in]	Y [in]	Z [in]	Rigid Floor
1	-6.00	0.00	0.00	0
2	0.00	-30.00	0.00	0
4	24.00	0.00	0.00	0
5	48.00	-30.00	0.00	0
6	144.00	-30.00	0.00	0
7	150.00	0.00	0.00	0
8	72.00	0.00	-42.00	0
10	96.00	-30.00	0.00	0
11	120.00	0.00	0.00	0
12	-6.00	36.00	0.00	0
13	0.00	66.00	0.00	0
15	24.00	36.00	0.00	0
16	48.00	66.00	0.00	0
17	144.00	66.00	0.00	0
18	150.00	36.00	0.00	0
19	72.00	36.00	-42.00	0
21	96.00	66.00	0.00	0
22	120.00	36.00	0.00	0
23	115.6364	36.00	-3.8182	0
32	76.3636	36.00	-38.1818	0
33	115.6364	0.00	-3.8182	0

42	76.3636	0.00	-38.1818	0
43	28.3636	0.00	-3.8182	0
52	67.6364	0.00	-38.1818	0
53	28.3636	36.00	-3.8182	0
62	67.6364	36.00	-38.1818	0
63	96.00	42.00	-21.00	0
64	158.00	36.00	-70.00	0
65	124.00	36.00	0.00	0
66	96.00	-6.00	-21.00	0
67	64.0661	36.00	-35.0579	0
68	79.9339	36.00	-35.0579	0
69	112.0661	0.00	-6.9421	0
79	31.9339	0.00	-6.9421	0
80	0.00	18.00	0.00	0
81	0.00	18.00	-15.00	0

Restraints

Node	TX	TY	TZ	RX	RY	RZ
8	1	1	1	1	1	1
19	1	1	1	1	1	1
64	1	1	1	0	0	0

Members

Member	NJ	NK	Description	Section	Material	d0 [in]	dL [in]	Ig factor
1	1	7	Horz. Pipe	PIPE 2x0.154	A53 GrB	0.00	0.00	0.00
3	4	8	stand off	PIPE 2x0.154	A53 GrB	0.00	0.00	0.00
4	11	8	stand off	PIPE 2x0.154	A53 GrB	0.00	0.00	0.00
5	12	18	Horz. Pipe	PIPE 2x0.154	A53 GrB	0.00	0.00	0.00
7	15	19	stand off	PIPE 2x0.154	A53 GrB	0.00	0.00	0.00
8	22	19	stand off	PIPE 2x0.154	A53 GrB	0.00	0.00	0.00
9	13	2	antenna pipe	PIPE 2x0.154	A53 GrB	0.00	0.00	0.00
10	16	5	antenna pipe	PIPE 2x0.154	A53 GrB	0.00	0.00	0.00
11	21	10	antenna pipe	PIPE 2x0.154	A53 GrB	0.00	0.00	0.00
12	17	6	antenna pipe	PIPE 2x0.154	A53 GrB	0.00	0.00	0.00
13	33	23	rnd bar	RndBar 3_4	A36	0.00	0.00	0.00
14	42	32	rnd bar	RndBar 3_4	A36	0.00	0.00	0.00
15	52	62	rnd bar	RndBar 3_4	A36	0.00	0.00	0.00
16	43	53	rnd bar	RndBar 3_4	A36	0.00	0.00	0.00
19	65	64	Tie Back	PIPE 2x0.154	A53 GrB	0.00	0.00	0.00
21	66	63	squid pipe	PIPE 2x0.154	A53 GrB	0.00	0.00	0.00
22	79	67	rnd bar	RndBar 3_4	A36	0.00	0.00	0.00
23	69	68	rnd bar	RndBar 3_4	A36	0.00	0.00	0.00
24	80	81	RRU Rack	PIPE 2x0.154	A53 GrB	0.00	0.00	0.00

Rigid end offsets

Member	DJX [in]	DJY [in]	DJZ [in]	DKX [in]	DKY [in]	DKZ [in]
21	1.50	0.00	-1.00	1.50	0.00	-1.00



Current Date: 4/10/2020 1:15 PM

Units system: English

File name: C:\Users\Lee Peringer\Centerline Communications\Derek Creaser - Centerline Engineering\Projects\AT&T\NEW ENGLAND\CT\CT3438 - EAST HARTFORD - SST\LTE 6C\Structural\Working Files\RAM\CT3438 Tower.ret

Load data

GLOSSARY

Comb : Indicates if load condition is a load combination

Load Conditions

Condition	Description	Comb.	Category
DL	Dead Load	No	DL
W1	Wind Load (0, 180 degrees)	No	WIND
W2	Wind Load (30, 150, 210, 330 degrees)	No	WIND
W3	Wind Load (60, 120, 240, 300 degrees)	No	WIND
W4	Wind Load (90, 270 degrees)	No	WIND
Di	Ice Load	No	LL
Wi1	Ice Wind Load (0, 180 degrees)	No	WIND
Wi2	Ice Wind Load (30, 150, 210, 330 Degrees)	No	WIND
Wi3	Ice Wind Load (60, 120, 240, 300 Degrees)	No	WIND
Wi4	Ice Wind Load (90, 270 degrees)	No	WIND
w1	Wind Load 30 mph (0, 180 degrees)	No	WIND
w2	Wind Load 30 mph (30, 150, 210, 330 Degrees)	No	WIND
w3	Wind Load 30 mph (60, 120, 240, 300 Degrees)	No	WIND
w4	Wind Load 30 mph (90, 270 degrees)	No	WIND
Ev	Vertical Seismic Load Y-Direction	No	EQ
Ehx	Horizontal Seismic Load X-Direction	No	EQ
Ehz	Horizontal Seismic Load Z-Direction	No	EQ
SL1	Service Live Load at Position 1 (500lb)	No	LL
SL2	Service Live Load at Position 2 (500lb)	No	LL
SL3	Service Live Load at Position 3 (500lb)	No	LL
SL4	Service Live Load at Position 4 (500lb)	No	LL
SLC	Service Live Load at Center of Mount (250lb)	No	LL
SLE1	Service Live Load at End of Mount (250lb)	No	LL
SLE2	Service Live Load at End of Mount (250lb)	No	LL
LC1	1.2DL+W1	Yes	
LC2	1.2DL+W2	Yes	
LC3	1.2DL+W3	Yes	
LC4	1.2DL+W4	Yes	
LC5	1.2DL-W1	Yes	
LC6	1.2DL-W2	Yes	
LC7	1.2DL-W3	Yes	
LC8	1.2DL-W4	Yes	
LC9	0.9DL+W1	Yes	
LC10	0.9DL+W2	Yes	
LC11	0.9DL+W3	Yes	
LC12	0.9DL+W4	Yes	
LC13	0.9DL-W1	Yes	
LC14	0.9DL-W2	Yes	
LC15	0.9DL-W3	Yes	
LC16	0.9DL-W4	Yes	
LC17	1.2DL+Di+Wi1	Yes	
LC18	1.2DL+Di+Wi2	Yes	
LC19	1.2DL+Di+Wi3	Yes	
LC20	1.2DL+Di+Wi4	Yes	

LC21	1.2DL+Di-Wi1	Yes
LC22	1.2DL+Di-Wi2	Yes
LC23	1.2DL+Di-Wi3	Yes
LC24	1.2DL+Di-Wi4	Yes
LC26	1.2DL+1.5SLC	Yes
LC27	1.2DL+1.5SLE1	Yes
LC28	1.2DL+1.5SLE2	Yes
LC29	1.2DL+w1+1.5SL1	Yes
LC30	1.2DL+w2+1.5SL1	Yes
LC31	1.2DL+w3+1.5SL1	Yes
LC32	1.2DL+w4+1.5SL1	Yes
LC33	1.2DL-w1+1.5SL1	Yes
LC34	1.2DL-w2+1.5SL1	Yes
LC35	1.2DL-w3+1.5SL1	Yes
LC36	1.2DL-w4+1.5SL1	Yes
LC37	1.2DL+w1+1.5SL2	Yes
LC38	1.2DL+w2+1.5SL2	Yes
LC39	1.2DL+w3+1.5SL2	Yes
LC40	1.2DL+w4+1.5SL2	Yes
LC41	1.2DL-w1+1.5SL2	Yes
LC42	1.2DL-w2+1.5SL2	Yes
LC43	1.2DL-w3+1.5SL2	Yes
LC44	1.2DL-w4+1.5SL2	Yes
LC45	1.2DL+w1+1.5SL3	Yes
LC46	1.2DL+w2+1.5SL3	Yes
LC47	1.2DL+w3+1.5SL3	Yes
LC48	1.2DL+w4+1.5SL3	Yes
LC49	1.2DL-w1+1.5SL3	Yes
LC50	1.2DL-w2+1.5SL3	Yes
LC51	1.2DL-w3+1.5SL3	Yes
LC52	1.2DL-w4+1.5SL3	Yes
LC53	1.2DL+w1+1.5SL4	Yes
LC54	1.2DL+w2+1.5SL4	Yes
LC55	1.2DL+w3+1.5SL4	Yes
LC56	1.2DL+w4+1.5SL4	Yes
LC57	1.2DL-w1+1.5SL4	Yes
LC58	1.2DL-w2+1.5SL4	Yes
LC59	1.2DL-w3+1.5SL4	Yes
LC60	1.2DL-w4+1.5SL4	Yes
LC61	1.2DL+Ev+Ehx	Yes
LC62	0.9DL-Ev+Ehx	Yes
LC63	1.2DL+Ev+Ehz	Yes
LC64	0.9DL-Ev+Ehz	Yes

Distributed force on members

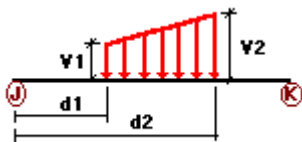

Condition	Member	Dir1	Val1 [Kip/ft]	Val2 [Kip/ft]	Dist1 [in]	%	Dist2 [in]	%
W1	1	Z	-0.009	-0.009	0.00	Yes	100.00	Yes
	3	Z	-0.009	-0.009	0.00	Yes	100.00	Yes
	4	Z	-0.009	-0.009	0.00	Yes	100.00	Yes
	5	Z	-0.009	-0.009	0.00	Yes	100.00	Yes
	7	Z	-0.009	-0.009	0.00	Yes	100.00	Yes
	8	Z	-0.009	-0.009	0.00	Yes	100.00	Yes
	11	Z	-0.009	-0.009	0.00	Yes	100.00	Yes
	13	Z	-0.003	-0.003	0.00	Yes	100.00	Yes
	14	Z	-0.003	-0.003	0.00	Yes	100.00	Yes
	15	Z	-0.003	-0.003	0.00	Yes	100.00	Yes
	16	Z	-0.003	-0.003	0.00	Yes	100.00	Yes
	19	Z	-0.009	-0.009	0.00	Yes	100.00	Yes
	21	Z	-0.009	-0.009	0.00	Yes	100.00	Yes
	22	Z	-0.003	-0.003	0.00	Yes	100.00	Yes
23	Z	-0.003	-0.003	0.00	Yes	100.00	Yes	
W2	1	X	-0.009	-0.009	0.00	Yes	100.00	Yes
	3	X	-0.009	-0.009	0.00	Yes	100.00	Yes
	4	X	-0.009	-0.009	0.00	Yes	100.00	Yes
	5	X	-0.009	-0.009	0.00	Yes	100.00	Yes
	7	X	-0.009	-0.009	0.00	Yes	100.00	Yes
	8	X	-0.009	-0.009	0.00	Yes	100.00	Yes
	9	X	-0.009	-0.009	0.00	Yes	100.00	Yes
	10	X	-0.009	-0.009	0.00	Yes	100.00	Yes
	11	X	-0.009	-0.009	0.00	Yes	100.00	Yes
	12	X	-0.009	-0.009	0.00	Yes	100.00	Yes
	13	X	-0.003	-0.003	0.00	Yes	100.00	Yes
	14	X	-0.003	-0.003	0.00	Yes	100.00	Yes
	15	X	-0.003	-0.003	0.00	Yes	100.00	Yes
	16	X	-0.003	-0.003	0.00	Yes	100.00	Yes
19	X	-0.009	-0.009	0.00	Yes	100.00	Yes	
21	X	-0.009	-0.009	0.00	Yes	100.00	Yes	
22	X	-0.003	-0.003	0.00	Yes	100.00	Yes	
23	X	-0.003	-0.003	0.00	Yes	100.00	Yes	
W3	1	Z	-0.009	-0.009	0.00	Yes	100.00	Yes
	3	Z	-0.009	-0.009	0.00	Yes	100.00	Yes
	4	Z	-0.009	-0.009	0.00	Yes	100.00	Yes
	5	Z	-0.009	-0.009	0.00	Yes	100.00	Yes
	7	Z	-0.009	-0.009	0.00	Yes	100.00	Yes
	8	Z	-0.009	-0.009	0.00	Yes	100.00	Yes
	9	Z	-0.009	-0.009	0.00	Yes	100.00	Yes
	10	Z	-0.009	-0.009	0.00	Yes	100.00	Yes
	11	Z	-0.009	-0.009	0.00	Yes	100.00	Yes
	12	Z	-0.009	-0.009	0.00	Yes	100.00	Yes
	13	Z	-0.003	-0.003	0.00	Yes	100.00	Yes
	14	Z	-0.003	-0.003	0.00	Yes	100.00	Yes
	15	Z	-0.003	-0.003	0.00	Yes	100.00	Yes
	16	Z	-0.003	-0.003	0.00	Yes	100.00	Yes
19	Z	-0.009	-0.009	0.00	Yes	100.00	Yes	
21	Z	-0.009	-0.009	0.00	Yes	100.00	Yes	
22	Z	-0.003	-0.003	0.00	Yes	100.00	Yes	
23	Z	-0.003	-0.003	0.00	Yes	100.00	Yes	
W4	3	X	-0.009	-0.009	0.00	Yes	100.00	Yes
	4	X	-0.009	-0.009	0.00	Yes	100.00	Yes
	7	X	-0.009	-0.009	0.00	Yes	100.00	Yes
	8	X	-0.009	-0.009	0.00	Yes	100.00	Yes
	9	X	-0.009	-0.009	0.00	Yes	100.00	Yes
	10	X	-0.009	-0.009	0.00	Yes	100.00	Yes
	11	X	-0.009	-0.009	0.00	Yes	100.00	Yes
12	X	-0.009	-0.009	0.00	Yes	100.00	Yes	
13	X	-0.003	-0.003	0.00	Yes	100.00	Yes	

	14	X	-0.003	-0.003	0.00	Yes	100.00	Yes
	15	X	-0.003	-0.003	0.00	Yes	100.00	Yes
	16	X	-0.003	-0.003	0.00	Yes	100.00	Yes
	19	X	-0.009	-0.009	0.00	Yes	100.00	Yes
	21	X	-0.009	-0.009	0.00	Yes	100.00	Yes
	22	X	-0.003	-0.003	0.00	Yes	100.00	Yes
	23	X	-0.003	-0.003	0.00	Yes	100.00	Yes
Di	1	Y	-0.0084	-0.0084	0.00	Yes	100.00	Yes
	3	Y	-0.0084	-0.0084	0.00	Yes	100.00	Yes
	4	Y	-0.0084	-0.0084	0.00	Yes	100.00	Yes
	5	Y	-0.0084	-0.0084	0.00	Yes	100.00	Yes
	7	Y	-0.0084	-0.0084	0.00	Yes	100.00	Yes
	8	Y	-0.0084	-0.0084	0.00	Yes	100.00	Yes
	9	Y	-0.0084	-0.0084	0.00	Yes	100.00	Yes
	10	Y	-0.0084	-0.0084	0.00	Yes	100.00	Yes
	11	Y	-0.0084	-0.0084	0.00	Yes	100.00	Yes
	12	Y	-0.0084	-0.0084	0.00	Yes	100.00	Yes
	13	Y	-0.005	-0.005	0.00	Yes	100.00	Yes
	14	Y	-0.005	-0.005	0.00	Yes	100.00	Yes
	15	Y	-0.005	-0.005	0.00	Yes	100.00	Yes
	16	Y	-0.005	-0.005	0.00	Yes	100.00	Yes
	19	Y	-0.0084	-0.0084	0.00	Yes	100.00	Yes
	21	Y	-0.0084	-0.0084	0.00	Yes	100.00	Yes
	22	Y	-0.005	-0.005	0.00	Yes	100.00	Yes
	23	Y	-0.005	-0.005	0.00	Yes	100.00	Yes
Wi1	1	Z	-0.004	-0.004	0.00	Yes	100.00	Yes
	3	Z	-0.004	-0.004	0.00	Yes	100.00	Yes
	4	Z	-0.004	-0.004	0.00	Yes	100.00	Yes
	5	Z	-0.004	-0.004	0.00	Yes	100.00	Yes
	7	Z	-0.004	-0.004	0.00	Yes	100.00	Yes
	8	Z	-0.004	-0.004	0.00	Yes	100.00	Yes
	11	Z	-0.004	-0.004	0.00	Yes	100.00	Yes
	13	Z	-0.003	-0.003	0.00	Yes	100.00	Yes
	14	Z	-0.003	-0.003	0.00	Yes	100.00	Yes
	15	Z	-0.003	-0.003	0.00	Yes	100.00	Yes
	16	Z	-0.003	-0.003	0.00	Yes	100.00	Yes
	19	Z	-0.004	-0.004	0.00	Yes	100.00	Yes
	21	Z	-0.004	-0.004	0.00	Yes	100.00	Yes
	22	Z	-0.003	-0.003	0.00	Yes	100.00	Yes
	23	Z	-0.003	-0.003	0.00	Yes	100.00	Yes
Wi2	1	X	-0.004	-0.004	0.00	Yes	100.00	Yes
	3	X	-0.004	-0.004	0.00	Yes	100.00	Yes
	4	X	-0.004	-0.004	0.00	Yes	100.00	Yes
	5	X	-0.004	-0.004	0.00	Yes	100.00	Yes
	7	X	-0.004	-0.004	0.00	Yes	100.00	Yes
	8	X	-0.004	-0.004	0.00	Yes	100.00	Yes
	9	X	-0.004	-0.004	0.00	Yes	100.00	Yes
	10	X	-0.004	-0.004	0.00	Yes	100.00	Yes
	11	X	-0.004	-0.004	0.00	Yes	100.00	Yes
	12	X	-0.004	-0.004	0.00	Yes	100.00	Yes
	13	X	-0.003	-0.003	0.00	Yes	100.00	Yes
	14	X	-0.003	-0.003	0.00	Yes	100.00	Yes
	15	X	-0.003	-0.003	0.00	Yes	100.00	Yes
	16	X	-0.003	-0.003	0.00	Yes	100.00	Yes
	19	X	-0.004	-0.004	0.00	Yes	100.00	Yes
	21	X	-0.004	-0.004	0.00	Yes	100.00	Yes
	22	X	-0.003	-0.003	0.00	Yes	100.00	Yes
	23	X	-0.003	-0.003	0.00	Yes	100.00	Yes
Wi3	1	Z	-0.004	-0.004	0.00	Yes	100.00	Yes
	3	Z	-0.004	-0.004	0.00	Yes	100.00	Yes

	4	Z	-0.004	-0.004	0.00	Yes	100.00	Yes
	5	Z	-0.004	-0.004	0.00	Yes	100.00	Yes
	7	Z	-0.004	-0.004	0.00	Yes	100.00	Yes
	8	Z	-0.004	-0.004	0.00	Yes	100.00	Yes
	9	Z	-0.004	-0.004	0.00	Yes	100.00	Yes
	10	Z	-0.004	-0.004	0.00	Yes	100.00	Yes
	11	Z	-0.004	-0.004	0.00	Yes	100.00	Yes
	12	Z	-0.004	-0.004	0.00	Yes	100.00	Yes
	13	Z	-0.003	-0.003	0.00	Yes	100.00	Yes
	14	Z	-0.003	-0.003	0.00	Yes	100.00	Yes
	15	Z	-0.003	-0.003	0.00	Yes	100.00	Yes
	16	Z	-0.003	-0.003	0.00	Yes	100.00	Yes
	19	Z	-0.004	-0.004	0.00	Yes	100.00	Yes
	21	Z	-0.004	-0.004	0.00	Yes	100.00	Yes
	22	Z	-0.003	-0.003	0.00	Yes	100.00	Yes
	23	Z	-0.003	-0.003	0.00	Yes	100.00	Yes
Wi4	3	X	-0.004	-0.004	0.00	Yes	100.00	Yes
	4	X	-0.004	-0.004	0.00	Yes	100.00	Yes
	7	X	-0.004	-0.004	0.00	Yes	100.00	Yes
	8	X	-0.004	-0.004	0.00	Yes	100.00	Yes
	9	X	-0.004	-0.004	0.00	Yes	100.00	Yes
	10	X	-0.004	-0.004	0.00	Yes	100.00	Yes
	11	X	-0.004	-0.004	0.00	Yes	100.00	Yes
	12	X	-0.004	-0.004	0.00	Yes	100.00	Yes
	13	X	-0.003	-0.003	0.00	Yes	100.00	Yes
	14	X	-0.003	-0.003	0.00	Yes	100.00	Yes
	15	X	-0.003	-0.003	0.00	Yes	100.00	Yes
	16	X	-0.003	-0.003	0.00	Yes	100.00	Yes
	19	X	-0.004	-0.004	0.00	Yes	100.00	Yes
	21	X	-0.004	-0.004	0.00	Yes	100.00	Yes
	22	X	-0.003	-0.003	0.00	Yes	100.00	Yes
	23	X	-0.003	-0.003	0.00	Yes	100.00	Yes
wl1	1	Z	-0.001	-0.001	0.00	Yes	100.00	Yes
	3	Z	-0.001	-0.001	0.00	Yes	100.00	Yes
	4	Z	-0.001	-0.001	0.00	Yes	100.00	Yes
	5	Z	-0.001	-0.001	0.00	Yes	100.00	Yes
	7	Z	-0.001	-0.001	0.00	Yes	100.00	Yes
	8	Z	-0.001	-0.001	0.00	Yes	100.00	Yes
	11	Z	-0.001	-0.001	0.00	Yes	100.00	Yes
	19	Z	-0.001	-0.001	0.00	Yes	100.00	Yes
	21	Z	-0.001	-0.001	0.00	Yes	100.00	Yes
wl2	1	X	-0.001	-0.001	0.00	Yes	100.00	Yes
	3	X	-0.001	-0.001	0.00	Yes	100.00	Yes
	4	X	-0.001	-0.001	0.00	Yes	100.00	Yes
	5	X	-0.001	-0.001	0.00	Yes	100.00	Yes
	7	X	-0.001	-0.001	0.00	Yes	100.00	Yes
	8	X	-0.001	-0.001	0.00	Yes	100.00	Yes
	9	X	-0.001	-0.001	0.00	Yes	100.00	Yes
	10	X	-0.001	-0.001	0.00	Yes	100.00	Yes
	11	X	-0.001	-0.001	0.00	Yes	100.00	Yes
	12	X	-0.001	-0.001	0.00	Yes	100.00	Yes
	19	X	-0.001	-0.001	0.00	Yes	100.00	Yes
	21	X	-0.001	-0.001	0.00	Yes	100.00	Yes
wl3	1	Z	-0.001	-0.001	0.00	Yes	100.00	Yes
	3	Z	-0.001	-0.001	0.00	Yes	100.00	Yes
	4	Z	-0.001	-0.001	0.00	Yes	100.00	Yes
	5	Z	-0.001	-0.001	0.00	Yes	100.00	Yes
	7	Z	-0.001	-0.001	0.00	Yes	100.00	Yes
	8	Z	-0.001	-0.001	0.00	Yes	100.00	Yes
	9	Z	-0.001	-0.001	0.00	Yes	100.00	Yes

	10	Z	-0.001	-0.001	0.00	Yes	100.00	Yes
	11	Z	-0.001	-0.001	0.00	Yes	100.00	Yes
	12	Z	-0.001	-0.001	0.00	Yes	100.00	Yes
	19	Z	-0.001	-0.001	0.00	Yes	100.00	Yes
	21	Z	-0.001	-0.001	0.00	Yes	100.00	Yes
wl4	3	X	-0.001	-0.001	0.00	Yes	100.00	Yes
	4	X	-0.001	-0.001	0.00	Yes	100.00	Yes
	7	X	-0.001	-0.001	0.00	Yes	100.00	Yes
	8	X	-0.001	-0.001	0.00	Yes	100.00	Yes
	9	X	-0.001	-0.001	0.00	Yes	100.00	Yes
	10	X	-0.001	-0.001	0.00	Yes	100.00	Yes
	11	X	-0.001	-0.001	0.00	Yes	100.00	Yes
	12	X	-0.001	-0.001	0.00	Yes	100.00	Yes
	19	X	-0.001	-0.001	0.00	Yes	100.00	Yes
	21	X	-0.001	-0.001	0.00	Yes	100.00	Yes
Ev	1	Y	-0.0002	-0.0002	0.00	Yes	100.00	Yes
	3	Y	-0.0002	-0.0002	0.00	Yes	100.00	Yes
	4	Y	-0.0002	-0.0002	0.00	Yes	100.00	Yes
	5	Y	-0.0002	-0.0002	0.00	Yes	100.00	Yes
	7	Y	-0.0002	-0.0002	0.00	Yes	100.00	Yes
	8	Y	-0.0002	-0.0002	0.00	Yes	100.00	Yes
	9	Y	-0.0002	-0.0002	0.00	Yes	100.00	Yes
	10	Y	-0.0002	-0.0002	0.00	Yes	100.00	Yes
	11	Y	-0.0002	-0.0002	0.00	Yes	100.00	Yes
	12	Y	-0.0002	-0.0002	0.00	Yes	100.00	Yes
	13	Y	-6.00E-05	-6.00E-05	0.00	Yes	100.00	Yes
	14	Y	-6.00E-05	-6.00E-05	0.00	Yes	100.00	Yes
	15	Y	-6.00E-05	-6.00E-05	0.00	Yes	100.00	Yes
	16	Y	-6.00E-05	-6.00E-05	0.00	Yes	100.00	Yes
	19	Y	-0.0002	-0.0002	0.00	Yes	100.00	Yes
	21	Y	-0.0002	-0.0002	0.00	Yes	100.00	Yes
	22	Y	-6.00E-05	-6.00E-05	0.00	Yes	100.00	Yes
	23	Y	-6.00E-05	-6.00E-05	0.00	Yes	100.00	Yes
Ehx	1	X	-0.0004	-0.0004	0.00	Yes	100.00	Yes
	3	X	-0.0004	-0.0004	0.00	Yes	100.00	Yes
	4	X	-0.0004	-0.0004	0.00	Yes	100.00	Yes
	5	X	-0.0004	-0.0004	0.00	Yes	100.00	Yes
	7	X	-0.0004	-0.0004	0.00	Yes	100.00	Yes
	8	X	-0.0004	-0.0004	0.00	Yes	100.00	Yes
	9	X	-0.0004	-0.0004	0.00	Yes	100.00	Yes
	10	X	-0.0004	-0.0004	0.00	Yes	100.00	Yes
	11	X	-0.0004	-0.0004	0.00	Yes	100.00	Yes
	12	X	-0.0004	-0.0004	0.00	Yes	100.00	Yes
	13	X	-0.0002	-0.0002	0.00	Yes	100.00	Yes
	14	X	-0.0002	-0.0002	0.00	Yes	100.00	Yes
	15	X	-0.0002	-0.0002	0.00	Yes	100.00	Yes
	16	X	-0.0002	-0.0002	0.00	Yes	100.00	Yes
	19	X	-0.0004	-0.0004	0.00	Yes	100.00	Yes
	21	X	-0.0004	-0.0004	0.00	Yes	100.00	Yes
	22	X	-0.0002	-0.0002	0.00	Yes	100.00	Yes
	23	X	-0.0002	-0.0002	0.00	Yes	100.00	Yes
Ehz	1	Z	-0.0004	-0.0004	0.00	Yes	100.00	Yes
	3	Z	-0.0004	-0.0004	0.00	Yes	100.00	Yes
	4	Z	-0.0004	-0.0004	0.00	Yes	100.00	Yes
	5	Z	-0.0004	-0.0004	0.00	Yes	100.00	Yes
	7	Z	-0.0004	-0.0004	0.00	Yes	100.00	Yes
	8	Z	-0.0004	-0.0004	0.00	Yes	100.00	Yes
	9	Z	-0.0004	-0.0004	0.00	Yes	100.00	Yes
	10	Z	-0.0004	-0.0004	0.00	Yes	100.00	Yes
	11	Z	-0.0004	-0.0004	0.00	Yes	100.00	Yes

12	Z	-0.0004	-0.0004	0.00	Yes	100.00	Yes
13	Z	-0.0002	-0.0002	0.00	Yes	100.00	Yes
14	Z	-0.0002	-0.0002	0.00	Yes	100.00	Yes
15	Z	-0.0002	-0.0002	0.00	Yes	100.00	Yes
16	Z	-0.0002	-0.0002	0.00	Yes	100.00	Yes
19	Z	-0.0004	-0.0004	0.00	Yes	100.00	Yes
21	Z	-0.0004	-0.0004	0.00	Yes	100.00	Yes
22	Z	-0.0002	-0.0002	0.00	Yes	100.00	Yes
23	Z	-0.0002	-0.0002	0.00	Yes	100.00	Yes

Concentrated forces on members

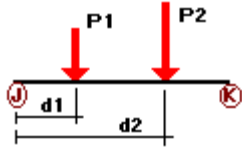

Condition	Member	Dir1	Value1 [Kip]	Dist1 [in]	%
<hr/>					
DL	9	Y	-0.048	12.00	No
		Y	-0.048	84.00	No
	10	Y	-0.0383	12.00	No
		Y	-0.0383	84.00	No
	11	Y	-0.0594	48.00	No
		Y	-0.046	50.00	Yes
	12	Y	-0.06	50.00	Yes
		Y	-0.054	87.50	Yes
		Y	-0.054	12.50	Yes
		Y	-0.06	50.00	Yes
	21	Y	-0.033	50.00	Yes
	24	Y	-0.145	15.00	No
W1	9	Z	-0.344	12.00	No
		Z	-0.344	84.00	No
	10	Z	-0.346	12.00	No
		Z	-0.346	84.00	No
	11	Z	-0.174	50.00	Yes
		Z	-0.295	87.50	Yes
	12	Z	-0.295	12.50	Yes
		Z	-0.043	50.00	Yes
		Z	-0.043	50.00	Yes
		Z	-0.043	50.00	Yes
	21	Z	-0.043	50.00	Yes
	W2	9	X	-0.267	12.00
X			-0.267	84.00	No
10		X	-0.299	12.00	No
		X	-0.299	84.00	No
11		X	-0.07	48.00	No
		X	-0.061	50.00	Yes
12		X	-0.092	50.00	Yes
		X	-0.261	87.50	Yes
		X	-0.261	12.50	Yes
		X	-0.103	48.00	No
21		X	-0.043	24.00	No
24		X	-0.108	15.00	No
W3	9	Z	-0.203	12.00	No
		Z	-0.203	84.00	No
	10	Z	-0.2045	12.00	No
		Z	-0.2045	84.00	No

		Z	-0.055	48.00	No
	11	Z	-0.041	50.00	Yes
		Z	-0.071	50.00	Yes
	12	Z	-0.194	87.50	Yes
		Z	-0.194	12.50	Yes
		Z	-0.067	48.00	No
	21	Z	-0.043	24.00	No
	24	Z	-0.06	15.00	No
W4	9	X	-0.156	12.00	No
		X	-0.156	84.00	No
	10	X	-0.1575	12.00	No
		X	-0.1575	84.00	No
		X	-0.048	48.00	No
	11	X	-0.06	50.00	Yes
	12	X	-0.16	84.00	No
		X	-0.16	12.00	No
		X	-0.049	48.00	No
	21	X	-0.043	24.00	No
	24	X	-0.063	15.00	No
Di	9	Y	-0.182	12.00	No
		Y	-0.182	84.00	No
	10	Y	-0.1844	12.00	No
		Y	-0.1844	84.00	No
		Y	-0.0711	48.00	No
	11	Y	-0.058	50.00	Yes
		Y	-0.082	50.00	Yes
	12	Y	-0.155	87.50	Yes
		Y	-0.155	12.50	Yes
		Y	-0.092	48.00	No
	21	Y	-0.0787	24.00	No
	24	Y	-0.14	15.00	No
Wi1	9	Z	-0.065	84.00	No
		Z	-0.065	12.00	No
	10	Z	-0.0655	84.00	No
		Z	-0.0655	12.00	No
	11	Z	-0.041	50.00	Yes
	12	Z	-0.058	84.00	No
		Z	-0.058	12.00	No
	21	Z	-0.011	24.00	No
Wi2	9	X	-0.057	84.00	No
		X	-0.057	12.00	No
	10	X	-0.058	84.00	No
		X	-0.058	12.00	No
		X	-0.017	48.00	No
	11	X	-0.037	48.00	No
	12	X	-0.052	84.00	No
		X	-0.052	12.00	No
		X	-0.023	48.00	No
	21	X	-0.011	24.00	No
	24	X	-0.028	15.00	No
Wi3	9	Z	-0.042	84.00	No
		Z	-0.042	12.00	No
	10	Z	-0.0425	84.00	No
		Z	-0.0425	12.00	No
		Z	-0.014	48.00	No
	11	Z	-0.029	48.00	No
	12	Z	-0.042	84.00	No
		Z	-0.042	12.00	No
		Z	-0.017	48.00	No
	21	Z	-0.011	24.00	No

Wi4	24	Z	-0.015	15.00	No
	9	X	-0.035	12.00	No
		X	-0.035	84.00	No
	10	X	-0.035	84.00	No
		X	-0.035	12.00	No
	11	X	-0.013	48.00	No
		X	-0.016	48.00	No
	12	X	-0.036	84.00	No
		X	-0.036	12.00	No
	wl1	21	X	-0.013	48.00
X			-0.011	24.00	No
24		X	-0.016	15.00	No
		Z	-0.02	12.00	No
9		Z	-0.02	84.00	No
		Z	-0.02	84.00	No
10		Z	-0.02	12.00	No
		Z	-0.01	48.00	No
11		Z	-0.017	84.00	No
		Z	-0.017	12.00	No
wl2	21	Z	-0.002	24.00	No
		X	-0.017	12.00	No
	9	X	-0.017	84.00	No
		X	-0.017	84.00	No
	10	X	-0.017	84.00	No
		X	-0.017	12.00	No
	11	X	-0.004	48.00	No
		X	-0.009	48.00	No
	12	X	-0.015	84.00	No
		X	-0.015	12.00	No
wl3	21	X	-0.007	48.00	No
		X	-0.002	24.00	No
	24	X	-0.006	15.00	No
		Z	-0.012	12.00	No
	9	Z	-0.012	84.00	No
		Z	-0.012	84.00	No
	10	Z	-0.012	12.00	No
		Z	-0.003	48.00	No
	11	Z	-0.006	48.00	No
		Z	-0.011	84.00	No
wl4	12	Z	-0.011	12.00	No
		Z	-0.004	48.00	No
	21	Z	-0.002	24.00	No
		Z	-0.003	15.00	No
	24	X	-0.009	12.00	No
		X	-0.009	84.00	No
	9	X	-0.009	84.00	No
		X	-0.009	12.00	No
	10	X	-0.003	48.00	No
		X	-0.005	48.00	No
Ev	11	X	-0.009	84.00	No
		X	-0.009	12.00	No
	12	X	-0.003	48.00	No
		X	-0.002	24.00	No
	21	X	-0.004	15.00	No
		Y	-0.0019	12.00	No
	24	Y	-0.0019	84.00	No
		Y	-0.0016	12.00	No
	9	Y	-0.0016	84.00	No
		Y	-0.0024	48.00	No
10	Y	-0.0043	48.00	No	
	Y	-0.0022	84.00	No	

		Y	-0.0022	12.00	No
		Y	-0.0024	48.00	No
	21	Y	-0.0013	50.00	Yes
	24	Y	-0.0059	15.00	No
Ehx	9	X	-0.0049	12.00	No
		X	-0.0049	84.00	No
	10	X	-0.0039	12.00	No
		X	-0.0039	84.00	No
		X	-0.006	48.00	No
	11	X	-0.0108	48.00	No
	12	X	-0.0055	12.00	No
		X	-0.0055	84.00	No
		X	-0.0061	48.00	No
	21	X	-0.0034	50.00	Yes
	24	X	-0.0147	15.00	No
Ehz	9	Z	-0.0049	12.00	No
		Z	-0.0049	84.00	No
	10	Z	-0.0039	12.00	No
		Z	-0.0039	84.00	No
		Z	-0.006	48.00	No
	11	Z	-0.0108	48.00	No
	12	Z	-0.0055	12.00	No
		Z	-0.0055	84.00	No
		Z	-0.0061	48.00	No
	21	Z	-0.0034	50.00	Yes
	24	Z	-0.0147	15.00	No
SL1	1	Y	-0.50	150.00	No
SL2	1	Y	-0.50	102.00	No
SL3	1	Y	-0.50	54.00	No
SL4	1	Y	-0.50	6.00	No
SLC	1	Y	-0.25	50.00	Yes
SLE1	1	Y	-0.25	0.00	No
SLE2	1	Y	-0.25	100.00	Yes

Self weight multipliers for load conditions

Condition	Description	Self weight multiplier			
		Comb.	MultX	MultY	MultZ
DL	Dead Load	No	0.00	-1.00	0.00
W1	Wind Load (0, 180 degrees)	No	0.00	0.00	0.00
W2	Wind Load (30, 150, 210, 330 degrees)	No	0.00	0.00	0.00
W3	Wind Load (60, 120, 240, 300 degrees)	No	0.00	0.00	0.00
W4	Wind Load (90, 270 degrees)	No	0.00	0.00	0.00
Di	Ice Load	No	0.00	0.00	0.00
Wi1	Ice Wind Load (0, 180 degrees)	No	0.00	0.00	0.00
Wi2	Ice Wind Load (30, 150, 210, 330 Degrees)	No	0.00	0.00	0.00
Wi3	Ice Wind Load (60, 120, 240, 300 Degrees)	No	0.00	0.00	0.00
Wi4	Ice Wind Load (90, 270 degrees)	No	0.00	0.00	0.00
wl1	Wind Load 30 mph (0, 180 degrees)	No	0.00	0.00	0.00
wl2	Wind Load 30 mph (30, 150, 210, 330 Degrees)	No	0.00	0.00	0.00
wl3	Wind Load 30 mph (60, 120, 240, 300 Degrees)	No	0.00	0.00	0.00
wl4	Wind Load 30 mph (90, 270 degrees)	No	0.00	0.00	0.00
Ev	Vertical Seismic Load Y-Direction	No	0.00	0.00	0.00
Ehx	Horizontal Seismic Load X-Direction	No	0.00	0.00	0.00
Ehz	Horizontal Seismic Load Z-Direction	No	0.00	0.00	0.00

SL1	Service Live Load at Position 1 (500lb)	No	0.00	0.00	0.00
SL2	Service Live Load at Position 2 (500lb)	No	0.00	0.00	0.00
SL3	Service Live Load at Position 3 (500lb)	No	0.00	0.00	0.00
SL4	Service Live Load at Position 4 (500lb)	No	0.00	0.00	0.00
SLC	Service Live Load at Center of Mount (250lb)	No	0.00	0.00	0.00
SLE1	Service Live Load at End of Mount (250lb)	No	0.00	0.00	0.00
SLE2	Service Live Load at End of Mount (250lb)	No	0.00	0.00	0.00
LC1	1.2DL+W1	Yes	0.00	0.00	0.00
LC2	1.2DL+W2	Yes	0.00	0.00	0.00
LC3	1.2DL+W3	Yes	0.00	0.00	0.00
LC4	1.2DL+W4	Yes	0.00	0.00	0.00
LC5	1.2DL-W1	Yes	0.00	0.00	0.00
LC6	1.2DL-W2	Yes	0.00	0.00	0.00
LC7	1.2DL-W3	Yes	0.00	0.00	0.00
LC8	1.2DL-W4	Yes	0.00	0.00	0.00
LC9	0.9DL+W1	Yes	0.00	0.00	0.00
LC10	0.9DL+W2	Yes	0.00	0.00	0.00
LC11	0.9DL+W3	Yes	0.00	0.00	0.00
LC12	0.9DL+W4	Yes	0.00	0.00	0.00
LC13	0.9DL-W1	Yes	0.00	0.00	0.00
LC14	0.9DL-W2	Yes	0.00	0.00	0.00
LC15	0.9DL-W3	Yes	0.00	0.00	0.00
LC16	0.9DL-W4	Yes	0.00	0.00	0.00
LC17	1.2DL+Di+Wi1	Yes	0.00	0.00	0.00
LC18	1.2DL+Di+Wi2	Yes	0.00	0.00	0.00
LC19	1.2DL+Di+Wi3	Yes	0.00	0.00	0.00
LC20	1.2DL+Di+Wi4	Yes	0.00	0.00	0.00
LC21	1.2DL+Di-Wi1	Yes	0.00	0.00	0.00
LC22	1.2DL+Di-Wi2	Yes	0.00	0.00	0.00
LC23	1.2DL+Di-Wi3	Yes	0.00	0.00	0.00
LC24	1.2DL+Di-Wi4	Yes	0.00	0.00	0.00
LC26	1.2DL+1.5SLC	Yes	0.00	0.00	0.00
LC27	1.2DL+1.5SLE1	Yes	0.00	0.00	0.00
LC28	1.2DL+1.5SLE2	Yes	0.00	0.00	0.00
LC29	1.2DL+w1+1.5SL1	Yes	0.00	0.00	0.00
LC30	1.2DL+w2+1.5SL1	Yes	0.00	0.00	0.00
LC31	1.2DL+w3+1.5SL1	Yes	0.00	0.00	0.00
LC32	1.2DL+w4+1.5SL1	Yes	0.00	0.00	0.00
LC33	1.2DL-w1+1.5SL1	Yes	0.00	0.00	0.00
LC34	1.2DL-w2+1.5SL1	Yes	0.00	0.00	0.00
LC35	1.2DL-w3+1.5SL1	Yes	0.00	0.00	0.00
LC36	1.2DL-w4+1.5SL1	Yes	0.00	0.00	0.00
LC37	1.2DL+w1+1.5SL2	Yes	0.00	0.00	0.00
LC38	1.2DL+w2+1.5SL2	Yes	0.00	0.00	0.00
LC39	1.2DL+w3+1.5SL2	Yes	0.00	0.00	0.00
LC40	1.2DL+w4+1.5SL2	Yes	0.00	0.00	0.00
LC41	1.2DL-w1+1.5SL2	Yes	0.00	0.00	0.00
LC42	1.2DL-w2+1.5SL2	Yes	0.00	0.00	0.00
LC43	1.2DL-w3+1.5SL2	Yes	0.00	0.00	0.00
LC44	1.2DL-w4+1.5SL2	Yes	0.00	0.00	0.00
LC45	1.2DL+w1+1.5SL3	Yes	0.00	0.00	0.00
LC46	1.2DL+w2+1.5SL3	Yes	0.00	0.00	0.00
LC47	1.2DL+w3+1.5SL3	Yes	0.00	0.00	0.00
LC48	1.2DL+w4+1.5SL3	Yes	0.00	0.00	0.00
LC49	1.2DL-w1+1.5SL3	Yes	0.00	0.00	0.00
LC50	1.2DL-w2+1.5SL3	Yes	0.00	0.00	0.00
LC51	1.2DL-w3+1.5SL3	Yes	0.00	0.00	0.00
LC52	1.2DL-w4+1.5SL3	Yes	0.00	0.00	0.00
LC53	1.2DL+w1+1.5SL4	Yes	0.00	0.00	0.00

LC54	1.2DL+w2+1.5SL4	Yes	0.00	0.00	0.00
LC55	1.2DL+w3+1.5SL4	Yes	0.00	0.00	0.00
LC56	1.2DL+w4+1.5SL4	Yes	0.00	0.00	0.00
LC57	1.2DL-w1+1.5SL4	Yes	0.00	0.00	0.00
LC58	1.2DL-w2+1.5SL4	Yes	0.00	0.00	0.00
LC59	1.2DL-w3+1.5SL4	Yes	0.00	0.00	0.00
LC60	1.2DL-w4+1.5SL4	Yes	0.00	0.00	0.00
LC61	1.2DL+Ev+Ehx	Yes	0.00	0.00	0.00
LC62	0.9DL-Ev+Ehx	Yes	0.00	0.00	0.00
LC63	1.2DL+Ev+Ehz	Yes	0.00	0.00	0.00
LC64	0.9DL-Ev+Ehz	Yes	0.00	0.00	0.00

Earthquake (Dynamic analysis only)

Condition	a/g	Ang. [Deg]	Damp. [%]
DL	0.00	0.00	0.00
W1	0.00	0.00	0.00
W2	0.00	0.00	0.00
W3	0.00	0.00	0.00
W4	0.00	0.00	0.00
Di	0.00	0.00	0.00
Wi1	0.00	0.00	0.00
Wi2	0.00	0.00	0.00
Wi3	0.00	0.00	0.00
Wi4	0.00	0.00	0.00
w1	0.00	0.00	0.00
w2	0.00	0.00	0.00
w3	0.00	0.00	0.00
w4	0.00	0.00	0.00
Ev	0.00	0.00	0.00
Ehx	0.00	0.00	0.00
Ehz	0.00	0.00	0.00
SL1	0.00	0.00	0.00
SL2	0.00	0.00	0.00
SL3	0.00	0.00	0.00
SL4	0.00	0.00	0.00
SLC	0.00	0.00	0.00
SLE1	0.00	0.00	0.00
SLE2	0.00	0.00	0.00
LC1	0.00	0.00	0.00
LC2	0.00	0.00	0.00
LC3	0.00	0.00	0.00
LC4	0.00	0.00	0.00
LC5	0.00	0.00	0.00
LC6	0.00	0.00	0.00
LC7	0.00	0.00	0.00
LC8	0.00	0.00	0.00
LC9	0.00	0.00	0.00
LC10	0.00	0.00	0.00
LC11	0.00	0.00	0.00
LC12	0.00	0.00	0.00
LC13	0.00	0.00	0.00
LC14	0.00	0.00	0.00
LC15	0.00	0.00	0.00

LC16	0.00	0.00	0.00
LC17	0.00	0.00	0.00
LC18	0.00	0.00	0.00
LC19	0.00	0.00	0.00
LC20	0.00	0.00	0.00
LC21	0.00	0.00	0.00
LC22	0.00	0.00	0.00
LC23	0.00	0.00	0.00
LC24	0.00	0.00	0.00
LC26	0.00	0.00	0.00
LC27	0.00	0.00	0.00
LC28	0.00	0.00	0.00
LC29	0.00	0.00	0.00
LC30	0.00	0.00	0.00
LC31	0.00	0.00	0.00
LC32	0.00	0.00	0.00
LC33	0.00	0.00	0.00
LC34	0.00	0.00	0.00
LC35	0.00	0.00	0.00
LC36	0.00	0.00	0.00
LC37	0.00	0.00	0.00
LC38	0.00	0.00	0.00
LC39	0.00	0.00	0.00
LC40	0.00	0.00	0.00
LC41	0.00	0.00	0.00
LC42	0.00	0.00	0.00
LC43	0.00	0.00	0.00
LC44	0.00	0.00	0.00
LC45	0.00	0.00	0.00
LC46	0.00	0.00	0.00
LC47	0.00	0.00	0.00
LC48	0.00	0.00	0.00
LC49	0.00	0.00	0.00
LC50	0.00	0.00	0.00
LC51	0.00	0.00	0.00
LC52	0.00	0.00	0.00
LC53	0.00	0.00	0.00
LC54	0.00	0.00	0.00
LC55	0.00	0.00	0.00
LC56	0.00	0.00	0.00
LC57	0.00	0.00	0.00
LC58	0.00	0.00	0.00
LC59	0.00	0.00	0.00
LC60	0.00	0.00	0.00
LC61	0.00	0.00	0.00
LC62	0.00	0.00	0.00
LC63	0.00	0.00	0.00
LC64	0.00	0.00	0.00

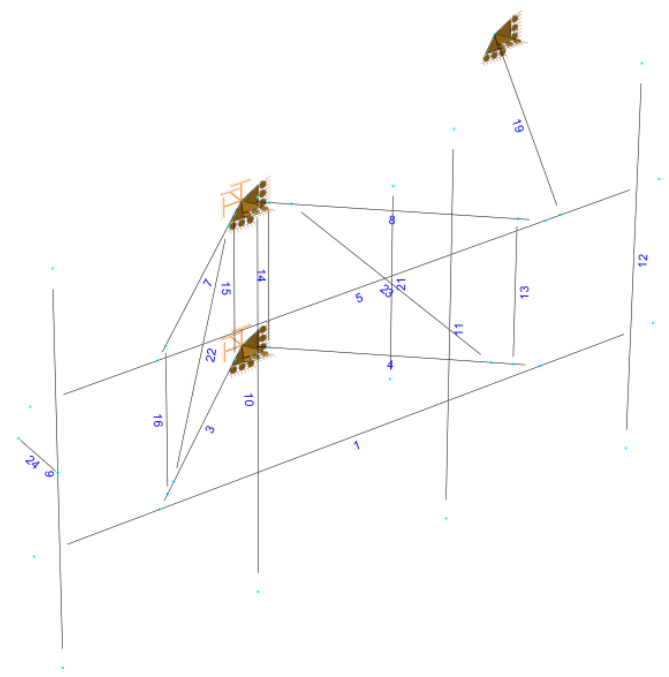

Design status

- Not designed
- Error on design
- Design O.K.
- With warnings

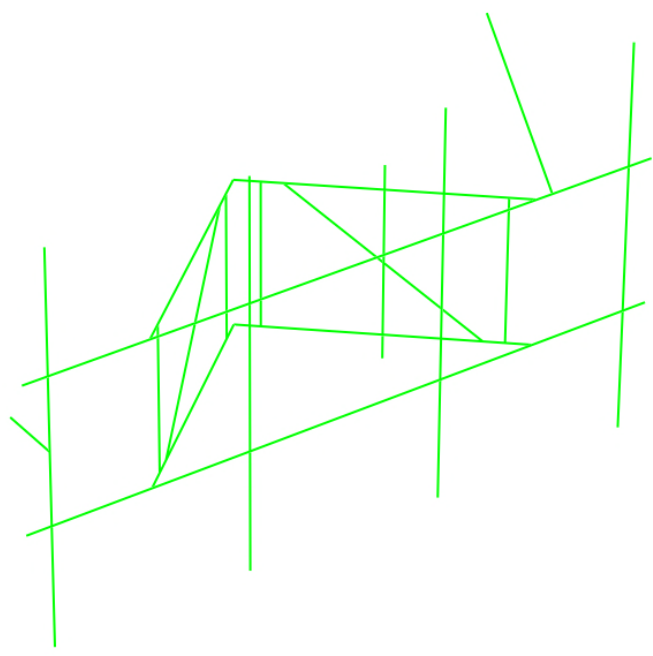



Current Date: 4/10/2020 1:16 PM

Units system: English

File name: C:\Users\Lee Peringer\Centerline Communications\Derek Creaser - Centerline Engineering\Projects\AT&T\NEW ENGLAND\CT\CT3438 - EAST HARTFORD - SST\LTE 6C\Structural\Working Files\RAM\CT3438 Tower.ret

Steel Code Check

Report: Summary - For all selected load conditions

Load conditions to be included in design :

LC1=1.2DL+W1
LC2=1.2DL+W2
LC3=1.2DL+W3
LC4=1.2DL+W4
LC5=1.2DL-W1
LC6=1.2DL-W2
LC7=1.2DL-W3
LC8=1.2DL-W4
LC9=0.9DL+W1
LC10=0.9DL+W2
LC11=0.9DL+W3
LC12=0.9DL+W4
LC13=0.9DL-W1
LC14=0.9DL-W2
LC15=0.9DL-W3
LC16=0.9DL-W4
LC17=1.2DL+Di+Wi1
LC18=1.2DL+Di+Wi2
LC19=1.2DL+Di+Wi3
LC20=1.2DL+Di+Wi4
LC21=1.2DL+Di-Wi1
LC22=1.2DL+Di-Wi2
LC23=1.2DL+Di-Wi3
LC24=1.2DL+Di-Wi4
LC26=1.2DL+1.5SLC
LC27=1.2DL+1.5SLE1
LC28=1.2DL+1.5SLE2
LC29=1.2DL+w1+1.5SL1
LC30=1.2DL+w2+1.5SL1
LC31=1.2DL+w3+1.5SL1
LC32=1.2DL+w4+1.5SL1
LC33=1.2DL-w1+1.5SL1
LC34=1.2DL-w2+1.5SL1
LC35=1.2DL-w3+1.5SL1
LC36=1.2DL-w4+1.5SL1
LC37=1.2DL+w1+1.5SL2
LC38=1.2DL+w2+1.5SL2
LC39=1.2DL+w3+1.5SL2
LC40=1.2DL+w4+1.5SL2
LC41=1.2DL-w1+1.5SL2
LC42=1.2DL-w2+1.5SL2
LC43=1.2DL-w3+1.5SL2
LC44=1.2DL-w4+1.5SL2
LC45=1.2DL+w1+1.5SL3
LC46=1.2DL+w2+1.5SL3
LC47=1.2DL+w3+1.5SL3
LC48=1.2DL+w4+1.5SL3
LC49=1.2DL-w1+1.5SL3
LC50=1.2DL-w2+1.5SL3
LC51=1.2DL-w3+1.5SL3
LC52=1.2DL-w4+1.5SL3
LC53=1.2DL+w1+1.5SL4

LC54=1.2DL+w2+1.5SL4
 LC55=1.2DL+w3+1.5SL4
 LC56=1.2DL+w4+1.5SL4
 LC57=1.2DL-w1+1.5SL4
 LC58=1.2DL-w2+1.5SL4
 LC59=1.2DL-w3+1.5SL4
 LC60=1.2DL-w4+1.5SL4
 LC61=1.2DL+Ev+Ehx
 LC62=0.9DL-Ev+Ehx
 LC63=1.2DL+Ev+Ehz
 LC64=0.9DL-Ev+Ehz

Description	Section	Member	Ctrl Eq.	Ratio	Status	Reference
<u>antenna pipe</u>	<i>PIPE 2x0.154</i>	9	LC1 at 67.19%	0.35	OK	
			LC10 at 31.25%	0.24	OK	
			LC11 at 67.19%	0.24	OK	
			LC12 at 31.25%	0.17	OK	
			LC13 at 31.25%	0.31	OK	
			LC14 at 68.75%	0.23	OK	
			LC15 at 31.25%	0.24	OK	
			LC16 at 67.19%	0.16	OK	
			LC17 at 67.19%	0.39	OK	
			LC18 at 31.25%	0.39	OK	
			LC19 at 67.19%	0.38	OK	
			LC2 at 31.25%	0.27	OK	
			LC20 at 31.25%	0.38	OK	
			LC21 at 31.25%	0.40	OK	
			LC22 at 67.19%	0.37	OK	
			LC23 at 31.25%	0.39	OK	
			LC24 at 67.19%	0.36	OK	
			LC26 at 31.25%	0.13	OK	
			LC27 at 67.19%	0.32	OK	
			LC28 at 31.25%	0.14	OK	
			LC29 at 67.19%	0.14	OK	
			LC3 at 67.19%	0.27	OK	
			LC30 at 31.25%	0.14	OK	
			LC31 at 67.19%	0.14	OK	
			LC32 at 31.25%	0.14	OK	
			LC33 at 31.25%	0.15	OK	
			LC34 at 67.19%	0.14	OK	
			LC35 at 31.25%	0.15	OK	
			LC36 at 67.19%	0.14	OK	
			LC37 at 67.19%	0.14	OK	
			LC38 at 31.25%	0.14	OK	
			LC39 at 67.19%	0.14	OK	
			LC4 at 31.25%	0.19	OK	
			LC40 at 31.25%	0.13	OK	
			LC41 at 31.25%	0.14	OK	
			LC42 at 67.19%	0.13	OK	
			LC43 at 31.25%	0.14	OK	
			LC44 at 67.19%	0.13	OK	
			LC45 at 67.19%	0.14	OK	
			LC46 at 31.25%	0.13	OK	
			LC47 at 67.19%	0.13	OK	
			LC48 at 31.25%	0.13	OK	
			LC49 at 31.25%	0.14	OK	
			LC5 at 31.25%	0.35	OK	
			LC50 at 67.19%	0.13	OK	
			LC51 at 31.25%	0.14	OK	
			LC52 at 67.19%	0.13	OK	
			LC53 at 31.25%	0.41	OK	
			LC54 at 31.25%	0.43	OK	
			LC55 at 31.25%	0.42	OK	
			LC56 at 31.25%	0.43	OK	

LC57 at 31.25%	0.44	OK
LC58 at 31.25%	0.42	OK
LC59 at 31.25%	0.43	OK
LC6 at 68.75%	0.23	OK
LC60 at 31.25%	0.42	OK
LC61 at 31.25%	0.15	OK
LC62 at 31.25%	0.10	OK
LC63 at 67.19%	0.14	OK
LC64 at 67.19%	0.10	OK
LC7 at 31.25%	0.28	OK
LC8 at 67.19%	0.19	OK
LC9 at 31.25%	0.31	OK

10

LC1 at 68.75%	0.28	OK
LC10 at 31.25%	0.31	OK
LC11 at 68.75%	0.18	OK
LC12 at 31.25%	0.17	OK
LC13 at 68.75%	0.28	OK
LC14 at 31.25%	0.37	OK
LC15 at 68.75%	0.18	OK
LC16 at 31.25%	0.23	OK
LC17 at 66.67%	0.15	OK
LC18 at 66.67%	0.06	OK
LC19 at 66.67%	0.14	OK
LC2 at 31.25%	0.30	OK
LC20 at 66.67%	0.09	OK
LC21 at 31.25%	0.14	OK
LC22 at 31.25%	0.19	OK
LC23 at 31.25%	0.13	OK
LC24 at 31.25%	0.16	OK
LC26 at 66.67%	0.13	OK
LC27 at 66.67%	0.06	OK
LC28 at 66.67%	0.03	OK
LC29 at 66.67%	0.06	OK
LC3 at 68.75%	0.18	OK
LC30 at 31.25%	0.07	OK
LC31 at 66.67%	0.06	OK
LC32 at 31.25%	0.06	OK
LC33 at 31.25%	0.05	OK
LC34 at 66.67%	0.04	OK
LC35 at 31.25%	0.05	OK
LC36 at 66.67%	0.04	OK
LC37 at 66.67%	0.15	OK
LC38 at 66.67%	0.13	OK
LC39 at 66.67%	0.15	OK
LC4 at 31.25%	0.16	OK
LC40 at 66.67%	0.14	OK
LC41 at 31.25%	0.16	OK
LC42 at 31.25%	0.17	OK
LC43 at 31.25%	0.16	OK
LC44 at 31.25%	0.16	OK
LC45 at 66.67%	0.14	OK
LC46 at 66.67%	0.12	OK
LC47 at 66.67%	0.14	OK
LC48 at 66.67%	0.13	OK
LC49 at 31.25%	0.15	OK
LC5 at 68.75%	0.28	OK
LC50 at 31.25%	0.16	OK
LC51 at 31.25%	0.14	OK
LC52 at 31.25%	0.15	OK
LC53 at 66.67%	0.08	OK
LC54 at 66.67%	0.05	OK
LC55 at 66.67%	0.07	OK
LC56 at 66.67%	0.06	OK

LC57 at 31.25%	0.06	OK
LC58 at 66.67%	0.08	OK
LC59 at 66.67%	0.06	OK
LC6 at 31.25%	0.38	OK
LC60 at 66.67%	0.07	OK
LC61 at 66.67%	0.04	OK
LC62 at 66.67%	0.03	OK
LC63 at 66.67%	0.05	OK
LC64 at 66.67%	0.03	OK
LC7 at 68.75%	0.18	OK
LC8 at 31.25%	0.24	OK
LC9 at 68.75%	0.28	OK

11

LC1 at 66.67%	0.10	OK
LC10 at 31.25%	0.30	OK
LC11 at 66.67%	0.06	OK
LC12 at 31.25%	0.17	OK
LC13 at 31.25%	0.11	OK
LC14 at 31.25%	0.31	OK
LC15 at 31.25%	0.07	OK
LC16 at 31.25%	0.18	OK
LC17 at 66.67%	0.06	OK
LC18 at 31.25%	0.12	OK
LC19 at 66.67%	0.06	OK
LC2 at 31.25%	0.30	OK
LC20 at 31.25%	0.08	OK
LC21 at 31.25%	0.04	OK
LC22 at 66.67%	0.09	OK
LC23 at 31.25%	0.04	OK
LC24 at 66.67%	0.07	OK
LC26 at 66.67%	0.09	OK
LC27 at 31.25%	0.07	OK
LC28 at 66.67%	0.03	OK
LC29 at 66.67%	0.05	OK
LC3 at 66.67%	0.06	OK
LC30 at 31.25%	0.04	OK
LC31 at 66.67%	0.05	OK
LC32 at 66.67%	0.04	OK
LC33 at 31.25%	0.06	OK
LC34 at 31.25%	0.07	OK
LC35 at 31.25%	0.06	OK
LC36 at 31.25%	0.06	OK
LC37 at 66.67%	0.09	OK
LC38 at 31.25%	0.11	OK
LC39 at 66.67%	0.09	OK
LC4 at 31.25%	0.17	OK
LC40 at 31.25%	0.10	OK
LC41 at 31.25%	0.09	OK
LC42 at 66.67%	0.07	OK
LC43 at 31.25%	0.09	OK
LC44 at 66.67%	0.08	OK
LC45 at 66.67%	0.11	OK
LC46 at 31.25%	0.13	OK
LC47 at 66.67%	0.11	OK
LC48 at 31.25%	0.12	OK
LC49 at 31.25%	0.11	OK
LC5 at 31.25%	0.12	OK
LC50 at 66.67%	0.09	OK
LC51 at 31.25%	0.11	OK
LC52 at 66.67%	0.10	OK
LC53 at 31.25%	0.11	OK
LC54 at 31.25%	0.08	OK
LC55 at 31.25%	0.10	OK
LC56 at 31.25%	0.09	OK

LC57 at 31.25%	0.10	OK
LC58 at 31.25%	0.12	OK
LC59 at 31.25%	0.10	OK
LC6 at 31.25%	0.31	OK
LC60 at 31.25%	0.12	OK
LC61 at 66.67%	0.02	OK
LC62 at 66.67%	0.01	OK
LC63 at 66.67%	0.02	OK
LC64 at 66.67%	0.02	OK
LC7 at 31.25%	0.07	OK
LC8 at 31.25%	0.18	OK
LC9 at 66.67%	0.09	OK

12

LC1 at 66.67%	0.24	OK
LC10 at 68.75%	0.23	OK
LC11 at 31.25%	0.18	OK
LC12 at 68.75%	0.14	OK
LC13 at 68.75%	0.24	OK
LC14 at 31.25%	0.30	OK
LC15 at 31.25%	0.19	OK
LC16 at 31.25%	0.20	OK
LC17 at 66.67%	0.27	OK
LC18 at 66.67%	0.26	OK
LC19 at 66.67%	0.26	OK
LC2 at 68.75%	0.23	OK
LC20 at 31.25%	0.25	OK
LC21 at 31.25%	0.29	OK
LC22 at 31.25%	0.29	OK
LC23 at 31.25%	0.29	OK
LC24 at 31.25%	0.27	OK
LC26 at 31.25%	0.08	OK
LC27 at 31.25%	0.11	OK
LC28 at 31.25%	0.26	OK
LC29 at 31.25%	0.37	OK
LC3 at 31.25%	0.20	OK
LC30 at 31.25%	0.38	OK
LC31 at 31.25%	0.37	OK
LC32 at 31.25%	0.38	OK
LC33 at 31.25%	0.39	OK
LC34 at 31.25%	0.38	OK
LC35 at 31.25%	0.39	OK
LC36 at 31.25%	0.38	OK
LC37 at 66.67%	0.08	OK
LC38 at 66.67%	0.08	OK
LC39 at 66.67%	0.08	OK
LC4 at 68.75%	0.14	OK
LC40 at 66.67%	0.08	OK
LC41 at 31.25%	0.08	OK
LC42 at 31.25%	0.07	OK
LC43 at 31.25%	0.08	OK
LC44 at 31.25%	0.07	OK
LC45 at 66.67%	0.08	OK
LC46 at 66.67%	0.08	OK
LC47 at 66.67%	0.08	OK
LC48 at 66.67%	0.08	OK
LC49 at 31.25%	0.09	OK
LC5 at 66.67%	0.25	OK
LC50 at 31.25%	0.08	OK
LC51 at 31.25%	0.09	OK
LC52 at 31.25%	0.08	OK
LC53 at 31.25%	0.13	OK
LC54 at 31.25%	0.11	OK
LC55 at 31.25%	0.13	OK
LC56 at 31.25%	0.11	OK

LC57 at 31.25%	0.11	OK
LC58 at 31.25%	0.14	OK
LC59 at 31.25%	0.11	OK
LC6 at 31.25%	0.32	OK
LC60 at 31.25%	0.13	OK
LC61 at 31.25%	0.09	OK
LC62 at 31.25%	0.06	OK
LC63 at 31.25%	0.09	OK
LC64 at 31.25%	0.06	OK
LC7 at 31.25%	0.21	OK
LC8 at 31.25%	0.22	OK
LC9 at 68.75%	0.24	OK

Horz. Pipe

1

LC1 at 18.75%	0.38	OK
LC10 at 4.46%	0.28	OK
LC11 at 81.25%	0.32	OK
LC12 at 4.46%	0.19	OK
LC13 at 19.64%	0.46	OK
LC14 at 95.54%	0.27	OK
LC15 at 19.64%	0.36	OK
LC16 at 95.54%	0.19	OK
LC17 at 19.64%	0.38	OK
LC18 at 19.64%	0.31	OK
LC19 at 19.64%	0.39	OK
LC2 at 4.46%	0.30	OK
LC20 at 19.64%	0.32	OK
LC21 at 19.64%	0.40	OK
LC22 at 19.64%	0.37	OK
LC23 at 19.64%	0.39	OK
LC24 at 19.64%	0.36	OK
LC26 at 19.64%	0.16	OK
LC27 at 19.64%	0.20	OK
LC28 at 80.36%	0.18	OK
LC29 at 95.54%	0.31	OK
LC3 at 81.25%	0.33	OK
LC30 at 95.54%	0.30	OK
LC31 at 95.54%	0.31	OK
LC32 at 95.54%	0.31	OK
LC33 at 95.54%	0.32	OK
LC34 at 95.54%	0.33	OK
LC35 at 95.54%	0.31	OK
LC36 at 95.54%	0.32	OK
LC37 at 80.36%	0.24	OK
LC38 at 80.36%	0.24	OK
LC39 at 80.36%	0.24	OK
LC4 at 4.46%	0.21	OK
LC40 at 80.36%	0.23	OK
LC41 at 80.36%	0.22	OK
LC42 at 80.36%	0.22	OK
LC43 at 80.36%	0.22	OK
LC44 at 80.36%	0.23	OK
LC45 at 19.64%	0.26	OK
LC46 at 19.64%	0.24	OK
LC47 at 19.64%	0.26	OK
LC48 at 19.64%	0.25	OK
LC49 at 19.64%	0.24	OK
LC5 at 19.64%	0.49	OK
LC50 at 19.64%	0.26	OK
LC51 at 19.64%	0.24	OK
LC52 at 19.64%	0.26	OK
LC53 at 4.46%	0.34	OK
LC54 at 4.46%	0.35	OK
LC55 at 4.46%	0.34	OK
LC56 at 4.46%	0.35	OK

LC57 at 4.46%	0.34	OK
LC58 at 4.46%	0.33	OK
LC59 at 4.46%	0.34	OK
LC6 at 95.54%	0.28	OK
LC60 at 4.46%	0.34	OK
LC61 at 19.64%	0.12	OK
LC62 at 19.64%	0.09	OK
LC63 at 19.64%	0.12	OK
LC64 at 19.64%	0.09	OK
LC7 at 19.64%	0.39	OK
LC8 at 95.54%	0.21	OK
LC9 at 18.75%	0.37	OK

5

LC1 at 18.75%	0.50	OK
LC10 at 80.47%	0.22	OK
LC11 at 18.75%	0.39	OK
LC12 at 80.47%	0.15	OK
LC13 at 18.75%	0.44	OK
LC14 at 3.91%	0.20	OK
LC15 at 18.75%	0.35	OK
LC16 at 3.91%	0.15	OK
LC17 at 19.53%	0.40	OK
LC18 at 19.53%	0.33	OK
LC19 at 19.53%	0.39	OK
LC2 at 80.47%	0.24	OK
LC20 at 19.53%	0.34	OK
LC21 at 19.53%	0.40	OK
LC22 at 19.53%	0.38	OK
LC23 at 19.53%	0.40	OK
LC24 at 19.53%	0.37	OK
LC26 at 19.53%	0.18	OK
LC27 at 3.91%	0.29	OK
LC28 at 96.09%	0.24	OK
LC29 at 96.09%	0.34	OK
LC3 at 18.75%	0.41	OK
LC30 at 96.09%	0.35	OK
LC31 at 96.09%	0.34	OK
LC32 at 96.09%	0.35	OK
LC33 at 96.09%	0.34	OK
LC34 at 96.09%	0.34	OK
LC35 at 96.09%	0.34	OK
LC36 at 96.09%	0.34	OK
LC37 at 80.47%	0.22	OK
LC38 at 80.47%	0.24	OK
LC39 at 80.47%	0.22	OK
LC4 at 80.47%	0.17	OK
LC40 at 80.47%	0.23	OK
LC41 at 80.47%	0.24	OK
LC42 at 80.47%	0.23	OK
LC43 at 80.47%	0.24	OK
LC44 at 80.47%	0.23	OK
LC45 at 19.53%	0.25	OK
LC46 at 19.53%	0.25	OK
LC47 at 19.53%	0.25	OK
LC48 at 19.53%	0.26	OK
LC49 at 19.53%	0.27	OK
LC5 at 18.75%	0.46	OK
LC50 at 19.53%	0.26	OK
LC51 at 19.53%	0.27	OK
LC52 at 19.53%	0.26	OK
LC53 at 3.91%	0.39	OK
LC54 at 3.91%	0.39	OK
LC55 at 3.91%	0.39	OK
LC56 at 3.91%	0.39	OK

LC57 at 3.91%	0.39	OK
LC58 at 3.91%	0.40	OK
LC59 at 3.91%	0.39	OK
LC6 at 3.91%	0.23	OK
LC60 at 3.91%	0.39	OK
LC61 at 3.91%	0.14	OK
LC62 at 3.91%	0.10	OK
LC63 at 18.75%	0.13	OK
LC64 at 18.75%	0.10	OK
LC7 at 18.75%	0.38	OK
LC8 at 3.91%	0.17	OK
LC9 at 18.75%	0.47	OK

rnd bar

RndBar 3_4

13

LC1 at 0.00%	0.13	OK
LC10 at 100.00%	0.31	OK
LC11 at 0.00%	0.10	OK
LC12 at 0.00%	0.15	OK
LC13 at 0.00%	0.10	OK
LC14 at 100.00%	0.15	OK
LC15 at 100.00%	0.09	OK
LC16 at 100.00%	0.10	OK
LC17 at 0.00%	0.45	OK
LC18 at 0.00%	0.48	OK
LC19 at 0.00%	0.45	OK
LC2 at 100.00%	0.32	OK
LC20 at 0.00%	0.47	OK
LC21 at 0.00%	0.42	OK
LC22 at 0.00%	0.39	OK
LC23 at 0.00%	0.43	OK
LC24 at 0.00%	0.40	OK
LC26 at 0.00%	0.14	OK
LC27 at 0.00%	0.10	OK
LC28 at 0.00%	0.33	OK
LC29 at 0.00%	0.46	OK
LC3 at 0.00%	0.13	OK
LC30 at 0.00%	0.47	OK
LC31 at 0.00%	0.46	OK
LC32 at 0.00%	0.47	OK
LC33 at 0.00%	0.46	OK
LC34 at 0.00%	0.45	OK
LC35 at 0.00%	0.46	OK
LC36 at 0.00%	0.46	OK
LC37 at 0.00%	0.19	OK
LC38 at 0.00%	0.20	OK
LC39 at 0.00%	0.19	OK
LC4 at 0.00%	0.17	OK
LC40 at 0.00%	0.20	OK
LC41 at 0.00%	0.19	OK
LC42 at 0.00%	0.18	OK
LC43 at 0.00%	0.19	OK
LC44 at 0.00%	0.19	OK
LC45 at 0.00%	0.13	OK
LC46 at 0.00%	0.13	OK
LC47 at 0.00%	0.13	OK
LC48 at 0.00%	0.13	OK
LC49 at 0.00%	0.12	OK
LC5 at 0.00%	0.11	OK
LC50 at 0.00%	0.12	OK
LC51 at 0.00%	0.12	OK
LC52 at 0.00%	0.12	OK
LC53 at 100.00%	0.10	OK
LC54 at 0.00%	0.10	OK
LC55 at 100.00%	0.10	OK
LC56 at 100.00%	0.10	OK

LC57 at 100.00%	0.10	OK
LC58 at 100.00%	0.10	OK
LC59 at 100.00%	0.10	OK
LC6 at 100.00%	0.16	OK
LC60 at 100.00%	0.10	OK
LC61 at 0.00%	0.11	OK
LC62 at 0.00%	0.08	OK
LC63 at 0.00%	0.11	OK
LC64 at 0.00%	0.08	OK
LC7 at 100.00%	0.11	OK
LC8 at 100.00%	0.11	OK
LC9 at 0.00%	0.11	OK

14

LC1 at 0.00%	0.09	OK
LC10 at 0.00%	0.12	OK
LC11 at 0.00%	0.07	OK
LC12 at 0.00%	0.10	OK
LC13 at 0.00%	0.08	OK
LC14 at 0.00%	0.03	OK
LC15 at 0.00%	0.08	OK
LC16 at 0.00%	0.05	OK
LC17 at 0.00%	0.36	OK
LC18 at 0.00%	0.38	OK
LC19 at 0.00%	0.36	OK
LC2 at 0.00%	0.15	OK
LC20 at 0.00%	0.37	OK
LC21 at 100.00%	0.37	OK
LC22 at 100.00%	0.35	OK
LC23 at 100.00%	0.37	OK
LC24 at 100.00%	0.36	OK
LC26 at 0.00%	0.13	OK
LC27 at 0.00%	0.09	OK
LC28 at 0.00%	0.19	OK
LC29 at 100.00%	0.33	OK
LC3 at 0.00%	0.09	OK
LC30 at 100.00%	0.33	OK
LC31 at 100.00%	0.33	OK
LC32 at 100.00%	0.33	OK
LC33 at 100.00%	0.33	OK
LC34 at 100.00%	0.32	OK
LC35 at 100.00%	0.33	OK
LC36 at 100.00%	0.33	OK
LC37 at 100.00%	0.25	OK
LC38 at 100.00%	0.25	OK
LC39 at 100.00%	0.25	OK
LC4 at 0.00%	0.13	OK
LC40 at 100.00%	0.25	OK
LC41 at 100.00%	0.25	OK
LC42 at 0.00%	0.24	OK
LC43 at 100.00%	0.25	OK
LC44 at 0.00%	0.24	OK
LC45 at 0.00%	0.13	OK
LC46 at 0.00%	0.13	OK
LC47 at 0.00%	0.13	OK
LC48 at 0.00%	0.13	OK
LC49 at 0.00%	0.13	OK
LC5 at 0.00%	0.10	OK
LC50 at 0.00%	0.12	OK
LC51 at 0.00%	0.13	OK
LC52 at 0.00%	0.13	OK
LC53 at 0.00%	0.08	OK
LC54 at 0.00%	0.08	OK
LC55 at 0.00%	0.08	OK
LC56 at 0.00%	0.08	OK

LC57 at 0.00%	0.08	OK
LC58 at 0.00%	0.07	OK
LC59 at 0.00%	0.08	OK
LC6 at 0.00%	0.05	OK
LC60 at 0.00%	0.08	OK
LC61 at 0.00%	0.10	OK
LC62 at 0.00%	0.07	OK
LC63 at 0.00%	0.10	OK
LC64 at 0.00%	0.07	OK
LC7 at 0.00%	0.10	OK
LC8 at 0.00%	0.07	OK
LC9 at 0.00%	0.07	OK

15

LC1 at 0.00%	0.26	OK
LC10 at 0.00%	0.07	OK
LC11 at 0.00%	0.17	OK
LC12 at 0.00%	0.11	OK
LC13 at 0.00%	0.12	OK
LC14 at 0.00%	0.26	OK
LC15 at 0.00%	0.13	OK
LC16 at 0.00%	0.20	OK
LC17 at 100.00%	0.66	OK
LC18 at 100.00%	0.65	OK
LC19 at 100.00%	0.66	OK
LC2 at 0.00%	0.12	OK
LC20 at 100.00%	0.66	OK
LC21 at 100.00%	0.67	OK
LC22 at 100.00%	0.68	OK
LC23 at 100.00%	0.67	OK
LC24 at 100.00%	0.67	OK
LC26 at 100.00%	0.29	OK
LC27 at 100.00%	0.39	OK
LC28 at 0.00%	0.18	OK
LC29 at 0.00%	0.17	OK
LC3 at 0.00%	0.25	OK
LC30 at 0.00%	0.17	OK
LC31 at 0.00%	0.17	OK
LC32 at 0.00%	0.17	OK
LC33 at 0.00%	0.17	OK
LC34 at 0.00%	0.18	OK
LC35 at 0.00%	0.17	OK
LC36 at 0.00%	0.17	OK
LC37 at 100.00%	0.28	OK
LC38 at 100.00%	0.27	OK
LC39 at 100.00%	0.28	OK
LC4 at 0.00%	0.16	OK
LC40 at 100.00%	0.28	OK
LC41 at 100.00%	0.28	OK
LC42 at 100.00%	0.29	OK
LC43 at 100.00%	0.28	OK
LC44 at 100.00%	0.28	OK
LC45 at 100.00%	0.42	OK
LC46 at 100.00%	0.42	OK
LC47 at 100.00%	0.42	OK
LC48 at 100.00%	0.42	OK
LC49 at 100.00%	0.42	OK
LC5 at 0.00%	0.17	OK
LC50 at 100.00%	0.43	OK
LC51 at 100.00%	0.42	OK
LC52 at 100.00%	0.43	OK
LC53 at 100.00%	0.55	OK
LC54 at 100.00%	0.54	OK
LC55 at 100.00%	0.55	OK
LC56 at 100.00%	0.55	OK

LC57 at 100.00%	0.55	OK
LC58 at 100.00%	0.56	OK
LC59 at 100.00%	0.55	OK
LC6 at 0.00%	0.32	OK
LC60 at 100.00%	0.55	OK
LC61 at 100.00%	0.23	OK
LC62 at 0.00%	0.14	OK
LC63 at 100.00%	0.24	OK
LC64 at 0.00%	0.14	OK
LC7 at 0.00%	0.18	OK
LC8 at 0.00%	0.28	OK
LC9 at 0.00%	0.18	OK

16

LC1 at 0.00%	0.22	OK
LC10 at 100.00%	0.15	OK
LC11 at 0.00%	0.16	OK
LC12 at 100.00%	0.12	OK
LC13 at 100.00%	0.13	OK
LC14 at 100.00%	0.20	OK
LC15 at 100.00%	0.12	OK
LC16 at 0.00%	0.17	OK
LC17 at 0.00%	0.70	OK
LC18 at 0.00%	0.65	OK
LC19 at 0.00%	0.70	OK
LC2 at 100.00%	0.17	OK
LC20 at 0.00%	0.65	OK
LC21 at 0.00%	0.66	OK
LC22 at 0.00%	0.72	OK
LC23 at 0.00%	0.66	OK
LC24 at 0.00%	0.71	OK
LC26 at 0.00%	0.30	OK
LC27 at 0.00%	0.45	OK
LC28 at 0.00%	0.16	OK
LC29 at 0.00%	0.15	OK
LC3 at 0.00%	0.20	OK
LC30 at 0.00%	0.15	OK
LC31 at 0.00%	0.15	OK
LC32 at 0.00%	0.15	OK
LC33 at 0.00%	0.15	OK
LC34 at 0.00%	0.15	OK
LC35 at 0.00%	0.15	OK
LC36 at 0.00%	0.15	OK
LC37 at 0.00%	0.20	OK
LC38 at 0.00%	0.19	OK
LC39 at 0.00%	0.20	OK
LC4 at 100.00%	0.14	OK
LC40 at 0.00%	0.19	OK
LC41 at 0.00%	0.19	OK
LC42 at 0.00%	0.20	OK
LC43 at 0.00%	0.19	OK
LC44 at 0.00%	0.20	OK
LC45 at 0.00%	0.40	OK
LC46 at 0.00%	0.39	OK
LC47 at 0.00%	0.40	OK
LC48 at 0.00%	0.39	OK
LC49 at 0.00%	0.39	OK
LC5 at 100.00%	0.17	OK
LC50 at 0.00%	0.40	OK
LC51 at 0.00%	0.39	OK
LC52 at 0.00%	0.40	OK
LC53 at 0.00%	0.62	OK
LC54 at 0.00%	0.61	OK
LC55 at 0.00%	0.62	OK
LC56 at 0.00%	0.61	OK

LC57 at 0.00%	0.61	OK
LC58 at 0.00%	0.62	OK
LC59 at 0.00%	0.62	OK
LC6 at 0.00%	0.33	OK
LC60 at 0.00%	0.62	OK
LC61 at 0.00%	0.17	OK
LC62 at 0.00%	0.12	OK
LC63 at 0.00%	0.18	OK
LC64 at 0.00%	0.12	OK
LC7 at 100.00%	0.16	OK
LC8 at 0.00%	0.22	OK
LC9 at 0.00%	0.18	OK

22

LC1 at 0.00%	0.16	OK
LC10 at 100.00%	0.08	OK
LC11 at 0.00%	0.13	OK
LC12 at 100.00%	0.08	OK
LC13 at 0.00%	0.10	OK
LC14 at 0.00%	0.13	OK
LC15 at 0.00%	0.09	OK
LC16 at 0.00%	0.12	OK
LC17 at 0.00%	0.42	OK
LC18 at 0.00%	0.37	OK
LC19 at 0.00%	0.42	OK
LC2 at 100.00%	0.09	OK
LC20 at 0.00%	0.38	OK
LC21 at 0.00%	0.40	OK
LC22 at 0.00%	0.43	OK
LC23 at 0.00%	0.40	OK
LC24 at 0.00%	0.42	OK
LC26 at 0.00%	0.11	OK
LC27 at 0.00%	0.17	OK
LC28 at 0.00%	0.09	OK
LC29 at 0.00%	0.09	OK
LC3 at 0.00%	0.15	OK
LC30 at 0.00%	0.09	OK
LC31 at 0.00%	0.09	OK
LC32 at 0.00%	0.09	OK
LC33 at 0.00%	0.09	OK
LC34 at 0.00%	0.09	OK
LC35 at 0.00%	0.09	OK
LC36 at 0.00%	0.09	OK
LC37 at 0.00%	0.11	OK
LC38 at 0.00%	0.11	OK
LC39 at 0.00%	0.11	OK
LC4 at 100.00%	0.09	OK
LC40 at 0.00%	0.11	OK
LC41 at 0.00%	0.11	OK
LC42 at 0.00%	0.11	OK
LC43 at 0.00%	0.11	OK
LC44 at 0.00%	0.11	OK
LC45 at 0.00%	0.17	OK
LC46 at 0.00%	0.16	OK
LC47 at 0.00%	0.17	OK
LC48 at 0.00%	0.16	OK
LC49 at 0.00%	0.16	OK
LC5 at 0.00%	0.12	OK
LC50 at 0.00%	0.17	OK
LC51 at 0.00%	0.16	OK
LC52 at 0.00%	0.16	OK
LC53 at 0.00%	0.32	OK
LC54 at 0.00%	0.32	OK
LC55 at 0.00%	0.32	OK
LC56 at 0.00%	0.32	OK

LC57 at 0.00%	0.32	OK
LC58 at 0.00%	0.32	OK
LC59 at 0.00%	0.32	OK
LC6 at 0.00%	0.15	OK
LC60 at 0.00%	0.32	OK
LC61 at 0.00%	0.10	OK
LC62 at 0.00%	0.07	OK
LC63 at 0.00%	0.10	OK
LC64 at 0.00%	0.07	OK
LC7 at 0.00%	0.12	OK
LC8 at 0.00%	0.14	OK
LC9 at 0.00%	0.14	OK

23

LC1 at 0.00%	0.11	OK
LC10 at 0.00%	0.08	OK
LC11 at 0.00%	0.08	OK
LC12 at 0.00%	0.07	OK
LC13 at 0.00%	0.07	OK
LC14 at 46.88%	0.06	OK
LC15 at 0.00%	0.07	OK
LC16 at 46.88%	0.04	OK
LC17 at 0.00%	0.20	OK
LC18 at 0.00%	0.29	OK
LC19 at 0.00%	0.20	OK
LC2 at 0.00%	0.10	OK
LC20 at 6.25%	0.26	OK
LC21 at 46.88%	0.19	OK
LC22 at 46.88%	0.19	OK
LC23 at 46.88%	0.19	OK
LC24 at 46.88%	0.19	OK
LC26 at 46.88%	0.09	OK
LC27 at 0.00%	0.06	OK
LC28 at 46.88%	0.13	OK
LC29 at 46.88%	0.19	OK
LC3 at 0.00%	0.10	OK
LC30 at 46.88%	0.20	OK
LC31 at 46.88%	0.19	OK
LC32 at 46.88%	0.20	OK
LC33 at 46.88%	0.19	OK
LC34 at 0.00%	0.19	OK
LC35 at 46.88%	0.19	OK
LC36 at 46.88%	0.19	OK
LC37 at 46.88%	0.14	OK
LC38 at 46.88%	0.14	OK
LC39 at 46.88%	0.14	OK
LC4 at 0.00%	0.08	OK
LC40 at 46.88%	0.14	OK
LC41 at 46.88%	0.13	OK
LC42 at 46.88%	0.13	OK
LC43 at 46.88%	0.13	OK
LC44 at 46.88%	0.13	OK
LC45 at 46.88%	0.08	OK
LC46 at 46.88%	0.09	OK
LC47 at 46.88%	0.08	OK
LC48 at 46.88%	0.09	OK
LC49 at 46.88%	0.08	OK
LC5 at 0.00%	0.09	OK
LC50 at 46.88%	0.08	OK
LC51 at 46.88%	0.08	OK
LC52 at 46.88%	0.08	OK
LC53 at 0.00%	0.06	OK
LC54 at 0.00%	0.06	OK
LC55 at 0.00%	0.06	OK
LC56 at 0.00%	0.06	OK

LC57 at 0.00%	0.06	OK
LC58 at 0.00%	0.06	OK
LC59 at 0.00%	0.06	OK
LC6 at 46.88%	0.07	OK
LC60 at 0.00%	0.06	OK
LC61 at 46.88%	0.07	OK
LC62 at 46.88%	0.05	OK
LC63 at 46.88%	0.07	OK
LC64 at 46.88%	0.05	OK
LC7 at 0.00%	0.08	OK
LC8 at 46.88%	0.06	OK
LC9 at 0.00%	0.09	OK

RRU Rack

PIPE 2x0.154

24

LC1 at 0.00%	0.12	OK
LC10 at 0.00%	0.16	OK
LC11 at 0.00%	0.09	OK
LC12 at 0.00%	0.13	OK
LC13 at 0.00%	0.09	OK
LC14 at 0.00%	0.16	OK
LC15 at 0.00%	0.09	OK
LC16 at 0.00%	0.13	OK
LC17 at 0.00%	0.21	OK
LC18 at 0.00%	0.23	OK
LC19 at 0.00%	0.21	OK
LC2 at 0.00%	0.19	OK
LC20 at 0.00%	0.22	OK
LC21 at 0.00%	0.21	OK
LC22 at 0.00%	0.23	OK
LC23 at 0.00%	0.21	OK
LC24 at 0.00%	0.22	OK
LC26 at 0.00%	0.12	OK
LC27 at 0.00%	0.12	OK
LC28 at 0.00%	0.12	OK
LC29 at 0.00%	0.12	OK
LC3 at 0.00%	0.12	OK
LC30 at 0.00%	0.12	OK
LC31 at 0.00%	0.12	OK
LC32 at 0.00%	0.12	OK
LC33 at 0.00%	0.12	OK
LC34 at 0.00%	0.12	OK
LC35 at 0.00%	0.12	OK
LC36 at 0.00%	0.12	OK
LC37 at 0.00%	0.12	OK
LC38 at 0.00%	0.12	OK
LC39 at 0.00%	0.12	OK
LC4 at 0.00%	0.16	OK
LC40 at 0.00%	0.12	OK
LC41 at 0.00%	0.12	OK
LC42 at 0.00%	0.12	OK
LC43 at 0.00%	0.12	OK
LC44 at 0.00%	0.12	OK
LC45 at 0.00%	0.12	OK
LC46 at 0.00%	0.12	OK
LC47 at 0.00%	0.12	OK
LC48 at 0.00%	0.12	OK
LC49 at 0.00%	0.12	OK
LC5 at 0.00%	0.12	OK
LC50 at 0.00%	0.12	OK
LC51 at 0.00%	0.12	OK
LC52 at 0.00%	0.12	OK
LC53 at 0.00%	0.12	OK
LC54 at 0.00%	0.12	OK
LC55 at 0.00%	0.12	OK
LC56 at 0.00%	0.12	OK

LC57 at 0.00%	0.12	OK
LC58 at 0.00%	0.12	OK
LC59 at 0.00%	0.12	OK
LC6 at 0.00%	0.19	OK
LC60 at 0.00%	0.12	OK
LC61 at 0.00%	0.13	OK
LC62 at 0.00%	0.09	OK
LC63 at 0.00%	0.12	OK
LC64 at 0.00%	0.08	OK
LC7 at 0.00%	0.12	OK
LC8 at 0.00%	0.16	OK
LC9 at 0.00%	0.09	OK

squid pipe

21

LC1 at 85.94%	0.02	OK
LC10 at 12.50%	0.04	OK
LC11 at 48.44%	0.02	OK
LC12 at 12.50%	0.02	OK
LC13 at 12.50%	0.03	OK
LC14 at 12.50%	0.04	OK
LC15 at 12.50%	0.03	OK
LC16 at 12.50%	0.03	OK
LC17 at 12.50%	0.04	OK
LC18 at 12.50%	0.04	OK
LC19 at 12.50%	0.04	OK
LC2 at 12.50%	0.03	OK
LC20 at 12.50%	0.04	OK
LC21 at 12.50%	0.05	OK
LC22 at 12.50%	0.04	OK
LC23 at 12.50%	0.05	OK
LC24 at 12.50%	0.04	OK
LC26 at 85.94%	0.01	OK
LC27 at 12.50%	0.02	OK
LC28 at 48.44%	0.05	OK
LC29 at 48.44%	0.09	OK
LC3 at 48.44%	0.02	OK
LC30 at 48.44%	0.09	OK
LC31 at 48.44%	0.09	OK
LC32 at 48.44%	0.09	OK
LC33 at 48.44%	0.09	OK
LC34 at 48.44%	0.09	OK
LC35 at 48.44%	0.09	OK
LC36 at 48.44%	0.09	OK
LC37 at 85.94%	0.03	OK
LC38 at 85.94%	0.03	OK
LC39 at 85.94%	0.03	OK
LC4 at 12.50%	0.02	OK
LC40 at 85.94%	0.03	OK
LC41 at 85.94%	0.03	OK
LC42 at 85.94%	0.03	OK
LC43 at 85.94%	0.03	OK
LC44 at 85.94%	0.03	OK
LC45 at 85.94%	0.01	OK
LC46 at 85.94%	0.02	OK
LC47 at 85.94%	0.01	OK
LC48 at 85.94%	0.01	OK
LC49 at 85.94%	0.01	OK
LC5 at 12.50%	0.04	OK
LC50 at 85.94%	0.01	OK
LC51 at 85.94%	0.01	OK
LC52 at 85.94%	0.01	OK
LC53 at 12.50%	0.02	OK
LC54 at 12.50%	0.02	OK
LC55 at 12.50%	0.02	OK
LC56 at 12.50%	0.02	OK

LC57 at 12.50%	0.02	OK
LC58 at 12.50%	0.02	OK
LC59 at 12.50%	0.02	OK
LC6 at 12.50%	0.05	OK
LC60 at 12.50%	0.02	OK
LC61 at 12.50%	0.02	OK
LC62 at 12.50%	0.01	OK
LC63 at 12.50%	0.01	OK
LC64 at 12.50%	0.01	OK
LC7 at 12.50%	0.03	OK
LC8 at 12.50%	0.03	OK
LC9 at 85.94%	0.02	OK

stand off

3

LC1 at 17.19%	0.25	OK
LC10 at 100.00%	0.17	OK
LC11 at 17.19%	0.19	OK
LC12 at 100.00%	0.13	OK
LC13 at 0.00%	0.29	OK
LC14 at 100.00%	0.30	OK
LC15 at 0.00%	0.23	OK
LC16 at 100.00%	0.21	OK
LC17 at 17.19%	0.41	OK
LC18 at 17.19%	0.41	OK
LC19 at 17.19%	0.40	OK
LC2 at 100.00%	0.20	OK
LC20 at 17.19%	0.40	OK
LC21 at 17.19%	0.39	OK
LC22 at 17.19%	0.40	OK
LC23 at 17.19%	0.40	OK
LC24 at 17.19%	0.40	OK
LC26 at 17.19%	0.16	OK
LC27 at 17.19%	0.25	OK
LC28 at 17.19%	0.14	OK
LC29 at 17.19%	0.14	OK
LC3 at 17.19%	0.22	OK
LC30 at 17.19%	0.14	OK
LC31 at 17.19%	0.14	OK
LC32 at 17.19%	0.14	OK
LC33 at 17.19%	0.14	OK
LC34 at 17.19%	0.14	OK
LC35 at 17.19%	0.14	OK
LC36 at 17.19%	0.14	OK
LC37 at 17.19%	0.16	OK
LC38 at 17.19%	0.16	OK
LC39 at 17.19%	0.16	OK
LC4 at 100.00%	0.16	OK
LC40 at 17.19%	0.16	OK
LC41 at 17.19%	0.16	OK
LC42 at 17.19%	0.16	OK
LC43 at 17.19%	0.16	OK
LC44 at 17.19%	0.16	OK
LC45 at 0.00%	0.23	OK
LC46 at 0.00%	0.23	OK
LC47 at 0.00%	0.23	OK
LC48 at 0.00%	0.23	OK
LC49 at 0.00%	0.24	OK
LC5 at 0.00%	0.31	OK
LC50 at 0.00%	0.24	OK
LC51 at 0.00%	0.24	OK
LC52 at 0.00%	0.24	OK
LC53 at 17.19%	0.38	OK
LC54 at 17.19%	0.37	OK
LC55 at 17.19%	0.38	OK
LC56 at 17.19%	0.37	OK

LC57 at 17.19%	0.37	OK
LC58 at 17.19%	0.37	OK
LC59 at 17.19%	0.37	OK
LC6 at 100.00%	0.33	OK
LC60 at 17.19%	0.37	OK
LC61 at 17.19%	0.15	OK
LC62 at 17.19%	0.10	OK
LC63 at 17.19%	0.14	OK
LC64 at 17.19%	0.10	OK
LC7 at 0.00%	0.25	OK
LC8 at 100.00%	0.24	OK
LC9 at 17.19%	0.22	OK

4

LC1 at 17.50%	0.24	OK
LC10 at 100.00%	0.31	OK
LC11 at 17.50%	0.19	OK
LC12 at 100.00%	0.22	OK
LC13 at 0.00%	0.23	OK
LC14 at 100.00%	0.21	OK
LC15 at 0.00%	0.20	OK
LC16 at 100.00%	0.16	OK
LC17 at 17.50%	0.35	OK
LC18 at 17.50%	0.35	OK
LC19 at 17.50%	0.36	OK
LC2 at 100.00%	0.33	OK
LC20 at 17.50%	0.35	OK
LC21 at 17.50%	0.35	OK
LC22 at 17.50%	0.36	OK
LC23 at 17.50%	0.36	OK
LC24 at 17.50%	0.36	OK
LC26 at 100.00%	0.16	OK
LC27 at 100.00%	0.12	OK
LC28 at 17.50%	0.25	OK
LC29 at 17.50%	0.39	OK
LC3 at 17.50%	0.22	OK
LC30 at 17.50%	0.39	OK
LC31 at 17.50%	0.39	OK
LC32 at 17.50%	0.39	OK
LC33 at 17.50%	0.38	OK
LC34 at 17.50%	0.38	OK
LC35 at 17.50%	0.38	OK
LC36 at 17.50%	0.38	OK
LC37 at 100.00%	0.24	OK
LC38 at 100.00%	0.24	OK
LC39 at 100.00%	0.24	OK
LC4 at 100.00%	0.24	OK
LC40 at 100.00%	0.24	OK
LC41 at 100.00%	0.24	OK
LC42 at 100.00%	0.25	OK
LC43 at 100.00%	0.24	OK
LC44 at 100.00%	0.25	OK
LC45 at 100.00%	0.15	OK
LC46 at 100.00%	0.14	OK
LC47 at 100.00%	0.15	OK
LC48 at 100.00%	0.14	OK
LC49 at 100.00%	0.15	OK
LC5 at 0.00%	0.24	OK
LC50 at 100.00%	0.16	OK
LC51 at 100.00%	0.15	OK
LC52 at 100.00%	0.15	OK
LC53 at 100.00%	0.13	OK
LC54 at 100.00%	0.12	OK
LC55 at 100.00%	0.13	OK
LC56 at 100.00%	0.13	OK

LC57 at 100.00%	0.13	OK
LC58 at 100.00%	0.14	OK
LC59 at 100.00%	0.13	OK
LC6 at 100.00%	0.24	OK
LC60 at 100.00%	0.14	OK
LC61 at 17.50%	0.12	OK
LC62 at 17.50%	0.08	OK
LC63 at 17.50%	0.12	OK
LC64 at 17.50%	0.08	OK
LC7 at 0.00%	0.21	OK
LC8 at 100.00%	0.19	OK
LC9 at 17.50%	0.21	OK

7

LC1 at 0.00%	0.27	OK
LC10 at 7.81%	0.06	OK
LC11 at 0.00%	0.19	OK
LC12 at 100.00%	0.09	OK
LC13 at 7.81%	0.20	OK
LC14 at 100.00%	0.23	OK
LC15 at 9.38%	0.15	OK
LC16 at 100.00%	0.19	OK
LC17 at 100.00%	0.48	OK
LC18 at 100.00%	0.46	OK
LC19 at 100.00%	0.48	OK
LC2 at 100.00%	0.09	OK
LC20 at 100.00%	0.46	OK
LC21 at 100.00%	0.49	OK
LC22 at 100.00%	0.52	OK
LC23 at 100.00%	0.49	OK
LC24 at 100.00%	0.51	OK
LC26 at 100.00%	0.22	OK
LC27 at 100.00%	0.27	OK
LC28 at 100.00%	0.15	OK
LC29 at 100.00%	0.14	OK
LC3 at 0.00%	0.20	OK
LC30 at 100.00%	0.14	OK
LC31 at 100.00%	0.14	OK
LC32 at 100.00%	0.14	OK
LC33 at 100.00%	0.14	OK
LC34 at 100.00%	0.15	OK
LC35 at 100.00%	0.14	OK
LC36 at 100.00%	0.15	OK
LC37 at 100.00%	0.21	OK
LC38 at 100.00%	0.20	OK
LC39 at 100.00%	0.21	OK
LC4 at 100.00%	0.12	OK
LC40 at 100.00%	0.21	OK
LC41 at 100.00%	0.21	OK
LC42 at 100.00%	0.22	OK
LC43 at 100.00%	0.21	OK
LC44 at 100.00%	0.22	OK
LC45 at 100.00%	0.32	OK
LC46 at 100.00%	0.31	OK
LC47 at 100.00%	0.32	OK
LC48 at 100.00%	0.31	OK
LC49 at 100.00%	0.32	OK
LC5 at 7.81%	0.21	OK
LC50 at 100.00%	0.33	OK
LC51 at 100.00%	0.32	OK
LC52 at 100.00%	0.32	OK
LC53 at 100.00%	0.36	OK
LC54 at 100.00%	0.36	OK
LC55 at 100.00%	0.36	OK
LC56 at 100.00%	0.36	OK

LC57 at 100.00%	0.36	OK
LC58 at 100.00%	0.37	OK
LC59 at 100.00%	0.36	OK
LC6 at 100.00%	0.27	OK
LC60 at 100.00%	0.37	OK
LC61 at 100.00%	0.17	OK
LC62 at 100.00%	0.12	OK
LC63 at 100.00%	0.17	OK
LC64 at 100.00%	0.12	OK
LC7 at 100.00%	0.18	OK
LC8 at 100.00%	0.23	OK
LC9 at 0.00%	0.25	OK

8

LC1 at 0.00%	0.20	OK
LC10 at 100.00%	0.25	OK
LC11 at 0.00%	0.17	OK
LC12 at 100.00%	0.19	OK
LC13 at 8.75%	0.16	OK
LC14 at 100.00%	0.13	OK
LC15 at 8.75%	0.14	OK
LC16 at 100.00%	0.13	OK
LC17 at 100.00%	0.38	OK
LC18 at 100.00%	0.42	OK
LC19 at 100.00%	0.38	OK
LC2 at 100.00%	0.28	OK
LC20 at 100.00%	0.41	OK
LC21 at 100.00%	0.39	OK
LC22 at 100.00%	0.40	OK
LC23 at 100.00%	0.39	OK
LC24 at 100.00%	0.39	OK
LC26 at 100.00%	0.18	OK
LC27 at 100.00%	0.11	OK
LC28 at 100.00%	0.23	OK
LC29 at 100.00%	0.33	OK
LC3 at 0.00%	0.17	OK
LC30 at 100.00%	0.33	OK
LC31 at 100.00%	0.33	OK
LC32 at 100.00%	0.33	OK
LC33 at 100.00%	0.33	OK
LC34 at 100.00%	0.33	OK
LC35 at 100.00%	0.33	OK
LC36 at 100.00%	0.33	OK
LC37 at 100.00%	0.28	OK
LC38 at 100.00%	0.29	OK
LC39 at 100.00%	0.28	OK
LC4 at 100.00%	0.22	OK
LC40 at 100.00%	0.29	OK
LC41 at 100.00%	0.28	OK
LC42 at 100.00%	0.28	OK
LC43 at 100.00%	0.28	OK
LC44 at 100.00%	0.28	OK
LC45 at 100.00%	0.17	OK
LC46 at 100.00%	0.18	OK
LC47 at 100.00%	0.17	OK
LC48 at 100.00%	0.18	OK
LC49 at 100.00%	0.17	OK
LC5 at 8.75%	0.17	OK
LC50 at 100.00%	0.17	OK
LC51 at 100.00%	0.17	OK
LC52 at 100.00%	0.17	OK
LC53 at 100.00%	0.10	OK
LC54 at 100.00%	0.11	OK
LC55 at 100.00%	0.10	OK
LC56 at 100.00%	0.11	OK

LC57 at 100.00%	0.10	OK
LC58 at 100.00%	0.10	OK
LC59 at 100.00%	0.10	OK
LC6 at 100.00%	0.16	OK
LC60 at 100.00%	0.10	OK
LC61 at 100.00%	0.14	OK
LC62 at 100.00%	0.10	OK
LC63 at 100.00%	0.13	OK
LC64 at 100.00%	0.09	OK
LC7 at 100.00%	0.16	OK
LC8 at 100.00%	0.16	OK
LC9 at 0.00%	0.20	OK

Tie Back

19

LC1 at 0.00%	0.11	OK
LC10 at 12.50%	0.12	OK
LC11 at 0.00%	0.09	OK
LC12 at 31.25%	0.08	OK
LC13 at 0.00%	0.12	OK
LC14 at 0.00%	0.15	OK
LC15 at 0.00%	0.10	OK
LC16 at 0.00%	0.09	OK
LC17 at 50.00%	0.04	OK
LC18 at 43.75%	0.06	OK
LC19 at 43.75%	0.05	OK
LC2 at 18.75%	0.12	OK
LC20 at 50.00%	0.05	OK
LC21 at 50.00%	0.04	OK
LC22 at 56.25%	0.05	OK
LC23 at 50.00%	0.04	OK
LC24 at 56.25%	0.04	OK
LC26 at 0.00%	0.02	OK
LC27 at 0.00%	0.02	OK
LC28 at 12.50%	0.04	OK
LC29 at 0.00%	0.07	OK
LC3 at 0.00%	0.09	OK
LC30 at 0.00%	0.07	OK
LC31 at 0.00%	0.07	OK
LC32 at 0.00%	0.07	OK
LC33 at 0.00%	0.07	OK
LC34 at 0.00%	0.07	OK
LC35 at 0.00%	0.07	OK
LC36 at 0.00%	0.07	OK
LC37 at 0.00%	0.04	OK
LC38 at 0.00%	0.04	OK
LC39 at 0.00%	0.04	OK
LC4 at 31.25%	0.08	OK
LC40 at 0.00%	0.04	OK
LC41 at 0.00%	0.04	OK
LC42 at 0.00%	0.04	OK
LC43 at 0.00%	0.04	OK
LC44 at 0.00%	0.04	OK
LC45 at 0.00%	0.02	OK
LC46 at 0.00%	0.01	OK
LC47 at 0.00%	0.02	OK
LC48 at 0.00%	0.01	OK
LC49 at 0.00%	0.02	OK
LC5 at 0.00%	0.13	OK
LC50 at 0.00%	0.02	OK
LC51 at 0.00%	0.02	OK
LC52 at 0.00%	0.02	OK
LC53 at 0.00%	0.03	OK
LC54 at 0.00%	0.03	OK
LC55 at 0.00%	0.03	OK
LC56 at 0.00%	0.03	OK

LC57 at 0.00%	0.03	OK
LC58 at 0.00%	0.04	OK
LC59 at 0.00%	0.03	OK
LC6 at 0.00%	0.16	OK
LC60 at 0.00%	0.04	OK
LC61 at 50.00%	0.01	OK
LC62 at 50.00%	0.01	OK
LC63 at 50.00%	0.01	OK
LC64 at 50.00%	0.01	OK
LC7 at 0.00%	0.10	OK
LC8 at 0.00%	0.09	OK
LC9 at 0.00%	0.11	OK

EXHIBIT 3



STATE OF CONNECTICUT

CONNECTICUT SITING COUNCIL

Ten Franklin Square, New Britain, CT 06051

Phone: (860) 827-2935 Fax: (860) 827-2950

E-Mail: siting.council@ct.gov

www.ct.gov/csc

September 14, 2017

Tim Whalen
Real Estate Consultant
95 Ryan Drive, Suite 1
Raynham, MA 02767

RE: **TS-CING-043-170821** – New Cingular Wireless PCS, LLC request for an order to approve tower sharing at an existing telecommunications facility located at 100 Sunset Ridge, East Hartford, Connecticut.

Dear Mr. Whalen:

At a public meeting held on September 14, 2017, the Connecticut Siting Council (Council) ruled that the shared use of this existing tower site is technically, legally, environmentally, and economically feasible and meets public safety concerns, and therefore, in compliance with General Statutes § 16-50aa, the Council has ordered the shared use of this facility to avoid the unnecessary proliferation of tower structures with the following conditions:

1. Any deviation from the proposed installation as specified in the original tower share request and supporting materials with the Council shall render this decision invalid;
2. Any material changes to the proposed installation as specified in the original tower share request and supporting materials filed with the Council shall require an explicit request for modification to the Council pursuant to Connecticut General Statutes § 16-50aa, including all relevant information regarding the proposed change with cumulative worst-case modeling of radio frequency exposure at the closest point of uncontrolled access to the tower base, consistent with Federal Communications Commission, Office of Engineering and Technology, Bulletin 65;
3. Not less than 45 days after completion of the proposed installation, the Council shall be notified in writing that the installation has been completed;
4. Any nonfunctioning antenna and associated antenna mounting equipment on this facility owned and operated by New Cingular Wireless PCS, LLC shall be removed within 60 days of the date the antenna ceased to function;
5. The validity of this action shall expire one year from the date of this letter; and
6. The applicant may file a request for an extension of time beyond the one year deadline provided that such request is submitted to the Council not less than 60 days prior to the expiration.

This decision is under the exclusive jurisdiction of the Council and applies only to this request for tower sharing dated August 11, 2017. This facility has been carefully modeled to ensure that radio frequency emissions are conservatively below State and federal standards applicable to the frequencies now used on this tower. Any deviation from the approved tower sharing request is enforceable under the provisions of Connecticut General Statutes § 16-50u.



CONNECTICUT SITING COUNCIL

Affirmative Action / Equal Opportunity Employer

The proposed shared use is to be implemented as specified in your letter dated August 11, 2017, including the placement of all necessary equipment and shelters within the tower compound.

Please be advised that the validity of this action shall expire one year from the date of this letter.

Thank you for your attention and cooperation.

Very truly yours,

Robert Stein
Chairman

RS/MAB/bm

c: The Honorable Marcia A. Leclerc, Mayor, Town of East Hartford
Jeffrey Cormier, Town Planner, Town of East Hartford

EXHIBIT 4

Town of East Hartford Property Summary Report

100 SUNSET RIDGE DR

MAP LOT:	57-134A	CAMA PID:	13740
LOCATION:	100 SUNSET RIDGE DR		
OWNER NAME:	TOWN OF EAST HARTFORD / VETERANS MEMORIAL CLUBHSE		

OWNER OF RECORD
TOWN OF EAST HARTFORD VETERANS MEMORIAL CLUBHSE 740 MAIN STREET EAST HARTFORD, CT 06108

LIVING AREA:	6169	ZONING:	R2	ACREAGE:	1.64
---------------------	------	----------------	----	-----------------	------

SALES HISTORY

OWNER	BOOK / PAGE	SALE DATE	SALE PRICE
TOWN OF EAST HARTFORD VETERANS MEMORIAL CLUBHSE	0159/0039	30-Dec-1899	\$0.00

CURRENT PARCEL ASSESSMENT

TOTAL:	\$836,930.00	IMPROVEMENTS:	\$738,230.00	LAND:	\$98,700.00
---------------	--------------	----------------------	--------------	--------------	-------------

ASSESSING HISTORY

FISCAL YEAR	TOTAL VALUE	IMPROVEMENT VALUE	LAND VALUE
2019	\$836,930.00	\$738,230.00	\$98,700.00
2018	\$836,930.00	\$738,230.00	\$98,700.00
2017	\$836,930.00	\$738,230.00	\$98,700.00
2016	\$836,930.00	\$738,230.00	\$98,700.00
2015	\$807,050.00	\$708,350.00	\$98,700.00

Town of East Hartford Property Summary Report

100 SUNSET RIDGE DR

MAP LOT:	57-134A	CAMA PID:	13740
LOCATION:	100 SUNSET RIDGE DR		
OWNER NAME:	TOWN OF EAST HARTFORD / VETERANS MEMORIAL CLUBHSE		

BUILDING # 1

YEAR BUILT	1930	EXT WALL 1	Stone/Masonry
STYLE	Cultural Facility	INT WALLS 1	Plaster
MODEL	Comm/Ind	HEAT FUEL	Other
STORIES	1.0	HEAT TYPE	Steam
OCCUPANCY	Exempt	AC TYPE	None
ROOF	Drmrs/Ex Gable	BEDROOMS	
ROOF COVER	Asphalt	FULL BATHS	15
FLOOR COVER 1	Hardwood	HALF BATHS	
% BSMT	null	TOTAL ROOMS	0
% FIN BSMT	null	% REC RM	null
% SEMI FIN	null	% ATTIC FINISH	null
BSMT GARAGE	null	FIREPLACES	null



13740 03/24/2016

EXTRA FEATURES

DESCRIPTION	CODE	UNITS
Fireplace	FPL	1.00 UNITS
Fin Bsmt	FBM	1567.00 S.F.

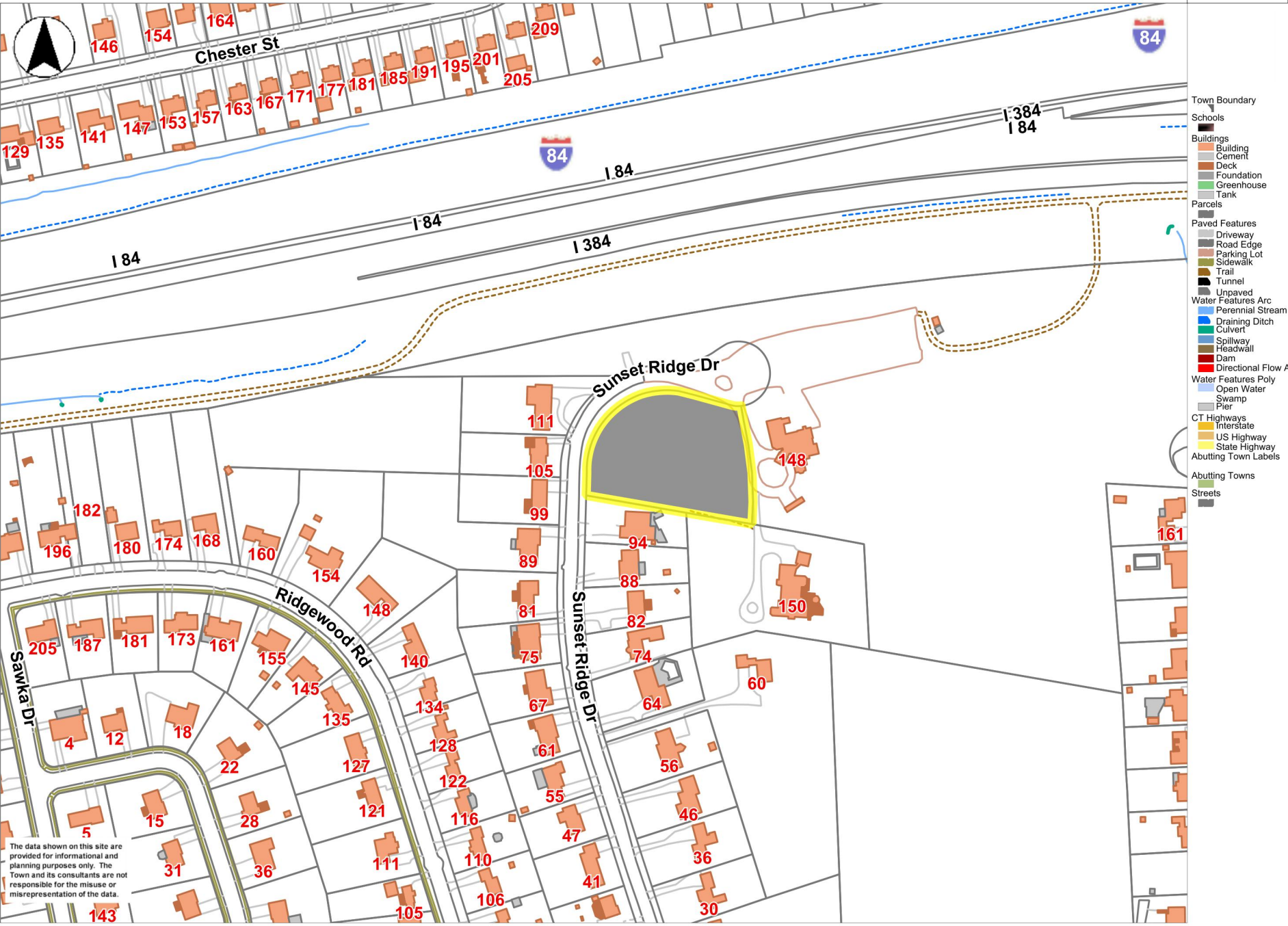

The data shown on this site are provided for informational and planning purposes only. The Town and its consultants are not responsible for the misuse or misrepresentation of the data.

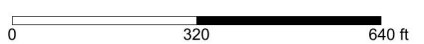

Printed on 04/27/2020 at 01:00 PM

EXHIBIT 5



Radio Frequency Emissions Analysis Report

Site Name: **CT3438**

100 Sunset Ridge
East Hartford, Connecticut 06108

April 22, 2020

Centerline Communications Project Number: 950010-152

Site Compliance Summary	
Compliance Status:	Compliant
Site total MPE% of FCC general population allowable limit:	33.09%
AT&T total MPE% of FCC general population allowable limit:	29.29%



April 22, 2020

AT&T Mobility – New England
Attn: John Benedetto, RF Manager
550 Cochituate Road
Suite 550 – 13&14
Framingham, MA 01701

Emissions Analysis for Site: **CT3438**

Centerline Communications, LLC (“Centerline”) was directed to analyze the proposed AT&T facility to be located on a **monopole at 100 Sunset Ridge, East Hartford Connecticut 06108** for the purpose of determining whether the emissions from the proposed facility are within specified federal limits.

All information used in this report was analyzed as a percentage of current Maximum Permissible Exposure (% MPE) as listed in the FCC OET Bulletin 65 Edition 97-01 and ANSI/IEEE Std C95.1. The FCC regulates Maximum Permissible Exposure in units of microwatts per square centimeter ($\mu\text{W}/\text{cm}^2$). The number of $\mu\text{W}/\text{cm}^2$ calculated at each sample point is called the power density. The exposure limit for power density varies depending upon the frequencies being utilized. Wireless Carriers and Paging Services use different frequency bands each with different exposure limits, therefore it is necessary to report results and limits in terms of percent MPE rather than power density.

All results were compared to the FCC (Federal Communications Commission) radio frequency exposure rules, 47 CFR 1.1307(b)(1) – (b)(3), to determine compliance with the Maximum Permissible Exposure (MPE) limits for General Population/Uncontrolled environments as defined below.

General population/uncontrolled exposure limits apply to situations in which the general population may be exposed or in which persons who are exposed as a consequence of their employment may not be made fully aware of the potential for exposure or cannot exercise control over their exposure. Therefore, members of the general population would always be considered under this category when exposure is not employment related, for example, in the case of a telecommunications tower that exposes persons in a nearby residential area.

Population exposure to radio frequencies is regulated and enforced in units of microwatts per square centimeter ($\mu\text{W}/\text{cm}^2$). The general population exposure limits for the 700MHz, 850MHz, 1900 MHz (PCS), 2300MHz (WCS) and 5 GHz (B46) bands is $1000 \mu\text{W}/\text{cm}^2$.



Occupational/controlled exposure limits apply to situations in which persons are exposed as a consequence of their employment and in which those persons who are exposed have been made fully aware of the potential for exposure and can exercise control over their exposure. Occupational/controlled exposure limits also apply where exposure is of a transient nature as a result of incidental passage through a location where exposure levels may be above general population/uncontrolled limits, as long as the exposed person has been made fully aware of the potential for exposure and can exercise control over his or her exposure by leaving the area or by some other appropriate means.

Additional details can be found in FCC OET 65.



CALCULATIONS

Calculations were performed for the proposed facility using the equipment information listed below. All calculations were performed per the specifications under FCC OET 65. Since AT&T is proposing focused omnidirectional antennas, which project most of the emitted energy out toward the horizon, all calculations were performed assuming a lobe representing the maximum gain of the antenna per the antenna manufactures supplied specifications, minus 10 dB, was focused at the base of the tower. This is a very conservative estimate since the gain reduction in actual applications is typically greater than 10 dB in the direction of ground immediately surrounding the facility. Real world emissions values from this facility are expected to be lower than values listed in this report at ground level. For this report the sample point is the top of a 6-foot person standing at the base of the tower.

Per FCC OET Bulletin No. 65 - Edition 97-01 recommendations to achieve the maximum anticipated value at each sample point, all power levels emitting from the proposed antenna installation are increased by a factor of 2.56 to account for possible in-phase reflections from the surrounding environment. All power values expressed and analyzed are maximum power levels expected to be used on all radios.

For each sector the following channel counts, frequency bands and power levels were utilized as shown in *Table 1*:

Antenna	Technology	Frequency Band	Channel Count	Transmit Power per Channel (W)
ATT A1	LTE	700	2	40
ATT A1	LTE	2300	4	25
ATT A1	LTE	1900	4	40
ATT A2	LTE	700	2	40
ATT A2	LTE	2100	4	40
ATT A3	LTE	700	2	40
ATT A3	LTE	850	2	40
ATT A3	LTE	1900	2	40
ATT A3	LTE	1900	2	40
ATT A3	5G	850	2	40
ATT B1	LTE	700	2	40
ATT B1	LTE	2300	4	25
ATT B1	LTE	1900	4	40
ATT B2	LTE	700	2	40
ATT B2	LTE	2100	4	40
ATT B3	LTE	700	2	40
ATT B3	LTE	850	2	40
ATT B3	LTE	1900	2	40
ATT B3	LTE	1900	2	40
ATT B3	5G	850	2	40

ATT C1	LTE	700	2	40
ATT C1	LTE	2300	4	25
ATT C1	LTE	1900	4	40
ATT C2	LTE	700	2	40
ATT C2	LTE	2100	4	40
ATT C3	LTE	700	2	40
ATT C3	LTE	850	2	40
ATT C3	LTE	1900	2	40
ATT C3	LTE	1900	2	40
ATT C3	5G	850	2	40

Table 1: Channel Data Table



The following antennas listed in *Table 2* were used in the modeling for transmission in the 700MHz, 850MHz, 1900 MHz (PCS), 2100 MHz (AWS), 2300MHz (WCS) and 5 GHz (Band 46) frequency bands. This is based on information from the carrier with regard to anticipated antenna selection. Maximum gain values for all antennas are listed in the AT&T Antenna Inventory & Power Levels table (Table 3) below in the Results section. The maximum gain of the antenna per the antenna manufactures supplied specifications, minus 10 dB, was used for all calculations. This value is a very conservative estimate as gain reductions for these particular antennas are typically much higher in this direction.

Sector	Antenna Number	Antenna Make / Model	Antenna Centerline (ft)
A	1	Kathrein 800-10799	110
A	2	CCI OPA65R-BU8DA	110
A	3	CCI DMP65R-BU8DA	110
B	4	Kathrein 800-10799	110
B	5	CCI OPA65R-BU8DA	110
B	6	CCI DMP65R-BU8DA	110
C	7	Kathrein 800-10799	110
C	8	CCI OPA65R-BU8DA	110
C	9	CCI DMP65R-BU8DA	110

Table 2: Antenna Data

All calculations were done with respect to uncontrolled / general population threshold limits.



RESULTS

Per the calculations completed for the proposed AT&T configurations *Table 3* shows resulting emissions power levels and percentages of the FCC’s allowable general population limit.

Antenna ID	Antenna Make / Model	Frequency Bands	Antenna Gain (dBd)	Antenna Height (ft)	Channel Count	Total TX Power (W)	ERP (W)	MPE %
ATT A1	Kathrein 800-10799	700	13.29	110	2	40	1706.44	1.0857%
ATT A1	Kathrein 800-10799	2300	14.21	110	4	25	2636.33	0.7833%
ATT A1	Kathrein 800-10799	1900	14.83	110	4	40	4865.42	1.4456%
ATT A2	CCI OPA65R-BU8DA	700	12.95	110	2	40	1343.04	0.8545%
ATT A2	CCI OPA65R-BU8DA	2100	15.35	110	4	40	5237.45	1.5561%
ATT A3	CCI DMP65R-BU8DA	700	12.25	110	2	40	1343.04	0.8545%
ATT A3	CCI DMP65R-BU8DA	850	12.55	110	2	40	1439.10	0.7541%
ATT A3	CCI DMP65R-BU8DA	1900	14.35	110	2	40	2178.16	0.6472%
ATT A3	CCI DMP65R-BU8DA	1900	14.35	110	2	40	2178.16	0.6472%
ATT A3	CCI DMP65R-BU8DA	850	12.55	110	2	40	1439.10	0.7541%
ATT B1	Kathrein 800-10799	700	13.29	110	2	40	1706.44	1.0857%
ATT B1	Kathrein 800-10799	2300	14.21	110	4	25	2636.33	0.7833%
ATT B1	Kathrein 800-10799	1900	14.83	110	4	40	4865.42	1.4456%
ATT B2	CCI OPA65R-BU8DA	700	12.95	110	2	40	1343.04	0.8545%
ATT B2	CCI OPA65R-BU8DA	2100	15.35	110	4	40	5237.45	1.5561%
ATT B3	CCI DMP65R-BU8DA	700	12.25	110	2	40	1343.04	0.8545%
ATT B3	CCI DMP65R-BU8DA	850	12.55	110	2	40	1439.10	0.7541%
ATT B3	CCI DMP65R-BU8DA	1900	14.35	110	2	40	2178.16	0.6472%
ATT B3	CCI DMP65R-BU8DA	1900	14.35	110	2	40	2178.16	0.6472%
ATT B3	CCI DMP65R-BU8DA	850	12.55	110	2	40	1439.10	0.7541%
ATT C1	Kathrein 800-10799	700	13.29	110	2	40	1706.44	1.0857%
ATT C1	Kathrein 800-10799	2300	14.21	110	4	25	2636.33	0.7833%

ATT C1	Kathrein 800-10799	1900	14.83	110	1	40	4865.42	1.4456%
ATT C2	CCI OPA65R-BU8DA	700	12.95	110	1	40	1343.04	0.8545%
ATT C2	CCI OPA65R-BU8DA	2100	15.35	110	4	40	5237.45	1.5561%
ATT C3	CCI DMP65R-BU8DA	700	12.25	110	2	40	1343.04	0.8545%
ATT C3	CCI DMP65R-BU8DA	850	12.55	110	1	40	1439.10	0.7541%
ATT C3	CCI DMP65R-BU8DA	1900	14.35	110	2	40	2178.16	0.6472%
ATT C3	CCI DMP65R-BU8DA	1900	14.35	110	2	40	2178.16	0.6472%
ATT C3	CCI DMP65R-BU8DA	850	12.55	110	1	40	1439.10	0.7541%
All Sectors Composite MPE%								29.29 %



FCC OET 65 specifies that for carriers utilizing directional antennas that the highest recorded sector value be used for composite site MPE values due to their greatly reduced emissions contributions in the directions of the adjacent sectors. *Table 6* below details a breakdown by frequency band and technology for the MPE power values for the maximum calculated AT&T sector(s). Since this proposed facility is utilizing an omnidirectional antenna there is only one sector for this site (Sector A).

AT&T Frequency Band / Technology	# Channels	Watts ERP (Per Channel)	Height (feet)	Total Power Density (µW/cm ²)	Frequency (MHz)	Allowable MPE (µW/cm ²)	Calculated % MPE
AT&T 700 MHz	2	40	110	5.0702	700 MHz LTE	1000	1.0857%
AT&T 2300 MHz	4	25	110	7.8331	2300 MHz LTE	1000	0.7833%
AT&T 1900 MHz	4	40	110	14.4561	1900 MHz LTE	1000	1.4456%
AT&T 700 MHz	2	40	110	4.6884	700 MHz LTE	1000	1.0039%
AT&T 2100 MHz	4	40	110	16.2949	2100 MHz LTE	1000	1.6295%
AT&T 700 MHz	2	40	110	3.9904	700 MHz LTE	1000	0.8545%
AT&T 850 MHz	2	40	110	4.2758	850 MHz LTE	1000	0.7541%
AT&T 1900 MHz	2	40	110	7.2614	1900 MHz LTE	1000	0.7261%
AT&T 1900 MHz	2	40	110	7.2614	1900 MHz LTE	1000	0.7261%
AT&T 850 MHz	2	40	110	4.2758	850 MHz LTE	1000	0.7541%
AT&T 700 MHz	2	40	110	5.0702	700 MHz LTE	1000	1.0857%
AT&T 2300 MHz	4	25	110	7.8331	2300 MHz LTE	1000	0.7833%
AT&T 1900 MHz	4	40	110	14.4561	1900 MHz LTE	1000	1.4456%
AT&T 700 MHz	2	40	110	4.6884	700 MHz LTE	1000	1.0039%
AT&T 2100 MHz	4	40	110	16.2949	2100 MHz LTE	1000	1.6295%
AT&T 700 MHz	2	40	110	3.9904	700 MHz LTE	1000	0.8545%
AT&T 850 MHz	2	40	110	4.2758	850 MHz LTE	1000	0.7541%
AT&T 1900 MHz	2	40	110	7.2614	1900 MHz LTE	1000	0.7261%
AT&T 1900 MHz	2	40	110	7.2614	1900 MHz LTE	1000	0.7261%
AT&T 850 MHz	2	40	110	4.2758	850 MHz LTE	1000	0.7541%
AT&T 700 MHz	2	40	110	5.0702	700 MHz LTE	1000	1.0857%
AT&T 2300 MHz	4	25	110	7.8331	2300 MHz LTE	1000	0.7833%
AT&T 1900 MHz	4	40	110	14.4561	1900 MHz LTE	1000	1.4456%
AT&T 700 MHz	2	40	110	4.6884	700 MHz LTE	1000	1.0039%
AT&T 2100 MHz	4	40	110	16.2949	2100 MHz LTE	1000	1.6295%
AT&T 700 MHz	2	40	110	3.9904	700 MHz LTE	1000	0.8545%
AT&T 850 MHz	2	40	110	4.2758	850 MHz LTE	1000	0.7541%
AT&T 1900 MHz	2	40	110	7.2614	1900 MHz LTE	1000	0.7261%
AT&T 1900 MHz	2	40	110	7.2614	1900 MHz LTE	1000	0.7261%
AT&T 850 MHz	2	40	110	4.2758	850 MHz LTE	1000	0.7541%
All Sectors						Total:	29.29%

Table 6: AT&T Maximum Sector MPE Power Values



Summary

All calculations performed for this analysis yielded results that were **within** the allowable limits for general population exposure to RF Emissions.

The anticipated maximum composite contributions from the AT&T facility as well as the site composite emissions value with regards to compliance with FCC's allowable limits for general population exposure to RF Emissions are shown here:

AT&T Sector	Power Density Value (%)
AT&T All Sectors:	29.29%
Unknown Carriers:	3.8%
AT&T Maximum Site Total:	29.29%
Site Total:	33.09%
Site Compliance Status:	Compliant

The anticipated composite MPE value for this site assuming all carriers present is **33.09%** of the allowable FCC established general population limit sampled at the ground level.

FCC guidelines state that if a site is found to be out of compliance (over allowable thresholds), that carriers over a 5% contribution to the composite value will require measures to bring the site into compliance. For this facility, the composite values calculated were well within the allowable 100% threshold standard per the federal government.

A handwritten signature in black ink that reads 'Michelle L. Stone'.

Michelle L. Stone
RF Compliance Consultant
Centerline Communications, LLC

750 West Center St. Suite 301
West Bridgewater, MA 02379

EXHIBIT 6

Structural Analysis Report

SITE NUMBER	CT3438
FA NUMBER	10578403
SITE NAME	EAST HARTFORD SUNSET RIDGE
PROJECT	LTE 5C, 6C, 7C, 4TX4RX, 5G NR & BWE
SITE ADDRESS	100 SUNSET RIDGE EAST HARTFORD, CT 06108
Design Codes	TIA-222-G Standard International Building Code 2015 2018 Connecticut State Building Code
Tower Classification	Self Support Tower

	Stress Ratio	Overall Result
Structure Rating	78.1%	PASS

Client:

at&t Mobility Corp.
500 Enterprise Drive
Rocky Hill, CT 06067



at&t

Date: 4/16/2020



1) INTRODUCTION

Centerline Communications was authorized by AT&T to perform a structural analysis of the existing 140 ft self support tower to determine the capacity to support the proposed and existing AT&T equipment listed in this report. This tower was analyzed using TNX Tower version 8.0.

2) ANALYSIS CRITERIA

Design Codes	TIA-222-G Standard International Building Code 2015 2018 Connecticut State Building Code
Wind Speed	97 mph
Wind Speed with Ice	50 mph
Ice Thickness	1.0 in.
Exposure Category	B
Topographic Category	1
Structure Class	II
Importance Factor	1.0

Existing & Proposed Antenna and Cable Information

Carrier	Center Line Elevation (ft)	Number of Antennas	Antenna Model	Feed Lines	Note
	137	3	Omni 2"x8'	(3) 7/8"	1
	137	1	Omni 2 1/2"x20'	(1) 7/8"	1
	133	1	2' Dish	(1) 1/2"	1
	120	6	AIR 21 Antennas	(12) 1 5/8"	1
		3	TMA		1
	120	3	Omni 2 1/2"x20'	(3) 7/8"	1
AT&T	110	3	800 10799 Antennas	(4) DC Power Cables	1
		3	4415 B25		1
		3	RRUS-32		1
		3	OPA65R-BU8DA Antennas	(5) DC Power Cables (3) Fiber Cables	2
		3	DMP65R-BU8DA Antennas		2
		3	RRUS-E2		2
		3	8843 B2/B66A		2
		3	4478 B14		2
		3	4449 B5/B12		2
		3	DC9-48-60-24-8C-EV		2
	100	3	6' Panel Antennas	(2) 2" Conduits (2) 1/2"	1
		1	3' Dish		1
		1	2' Dish		1
	80	1	Omni 2"x8'	(1) 1/2"	1

Notes:

1. Existing Equipment
2. Proposed Equipment

3) ANALYSIS PROCEDURE

Documents Provided

Source	Document	Reference
AT&T	RFDS	11/23/2019
ADVANCED ENGINEERING GROUP	Structural Analysis Report	5/4/2017
ADVANCED ENGINEERING GROUP	Construction Drawings	5/4/2017
CENTERLINE COMMUNICATIONS	Construction Drawings	4/10/2020

3.1) Analysis Method

tnxTower (version 8.0.), a commercially available analysis software package, was used to create a three-dimensional model of the tower and calculate member stresses for various loading cases. Selected input/output from the tower analysis is included in Appendix A.

3.2) Assumptions and Limitations:

- 1) Tower and structures were built in accordance with the manufacturer's specifications.
- 2) Tower and structures have been maintained in accordance with the manufacturer's specification.
- 3) The configuration of antennas, transmission cables, mounts and other appurtenances are as specified in Existing & Proposed Antenna and Cable Information in this report.
- 4) All connections of the members are assumed to have been designed to meet or exceed the load carrying capacity of the connected members.

This analysis may be affected if any assumptions are not valid or have been made in error. Centerline Communications should be notified to determine the effect on the structural integrity of the tower.

4) ANALYSIS RESULTS

Section Capacity (Summary)

Component Type	Controlling Elevation (ft)	% Capacity	Pass / Fail	Comment
Leg (T4)	60 - 80	56.7	Pass	
Diagonal (T2)	100 - 120	78.1	Pass	
Top Girt (T1)	120 - 140	0.9	Pass	

Structure Rating (max from all components) =	78.1%
---	--------------

4.1) Conclusion & Recommendations

The tower has sufficient capacity to carry the existing and proposed loadings. No modifications are required at this time.

APPENDIX A
TNX Tower Input/Output

DESIGNED APPURTENANCE LOADING

TYPE	ELEVATION	TYPE	ELEVATION
Pirot 4' Side Mount Standoff (1)	137	OPA65R-BU8DA w/mount pipe	110
Pirot 4' Side Mount Standoff (1)	137	OPA65R-BU8DA w/mount pipe	110
Pirot 4' Side Mount Standoff (1)	137	DMP65R-BU8DA w/mount pipe	110
Omni 2"x8'	137	DMP65R-BU8DA w/mount pipe	110
Omni 2 1/2"x20'	137	DMP65R-BU8DA w/mount pipe	110
Omni 2"x8'	137	RRUS-E2 B29	110
Omni 2"x8'	137	RRUS-E2 B29	110
P2F-52	133	RRUS-E2 B29	110
PIROD 12' T-Frame	120	8843 B2/B66A	110
PIROD 12' T-Frame	120	8843 B2/B66A	110
(2) AIR 21 w/ Mount Pipe	120	8843 B2/B66A	110
(2) AIR 21 w/ Mount Pipe	120	4478 B14	110
(2) AIR 21 w/ Mount Pipe	120	4478 B14	110
Omni 2 1/2"x20'	120	4478 B14	110
Omni 2 1/2"x20'	120	4449 B5/B12	110
Omni 2 1/2"x20'	120	4449 B5/B12	110
RFS ATMAA1412D-1A20	120	4449 B5/B12	110
RFS ATMAA1412D-1A20	120	DC9-48-60-24-8C-EV	110
RFS ATMAA1412D-1A20	120	DC9-48-60-24-8C-EV	110
PIROD 12' T-Frame	120	DC9-48-60-24-8C-EV	110
Sabre 12' V-Boom	110	Sabre 12' V-Boom (ATI - existing)	110
Sabre 12' V-Boom	110	Pirot 4' Side Mount Standoff (1)	100
800 10799 w/ Mount Pipe	110	Pirot 4' Side Mount Standoff (1)	100
800 10799 w/ Mount Pipe	110	Panel Antenna 72"x12" w/mount pipe	100
800 10799 w/ Mount Pipe	110	Panel Antenna 72"x12" w/mount pipe	100
4415 B25	110	Panel Antenna 72"x12" w/mount pipe	100
4415 B25	110	Pirot 4' Side Mount Standoff (1)	100
4415 B25	110	P3F-52	100
RRUS-32 B30	110	P2F-52	100
RRUS-32 B30	110	Omni 2"x8'	80
RRUS-32 B30	110	Pirot 4' Side Mount Standoff (1)	80
OPA65R-BU8DA w/mount pipe (ATI - proposed)	110		

MATERIAL STRENGTH

GRADE	Fy	Fu	GRADE	Fy	Fu
A572-50	50 ksi	65 ksi	A36	36 ksi	58 ksi

TOWER DESIGN NOTES

1. Tower is located in Hartford County, Connecticut.
2. Tower designed for Exposure B to the TIA-222-G Standard.
3. Tower designed for a 97 mph basic wind in accordance with the TIA-222-G Standard.
4. Tower is also designed for a 50 mph basic wind with 1.00 in ice. Ice is considered to increase in thickness with height.
5. Deflections are based upon a 60 mph wind.
6. Tower Structure Class II.
7. Topographic Category 1 with Crest Height of 0.00 ft

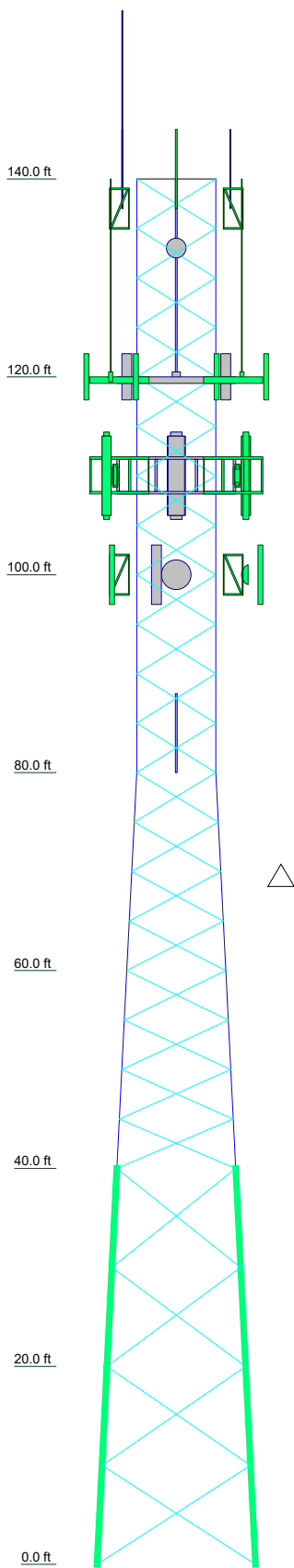

Section	T1	T2	T3	T4	T5	T6	T7
Legs	SR 2 1/4	SR 2 3/4	SR 3	SR 3 1/4	SR 3 1/4	Pirot 105218	Pirot 105219
Leg Grade	L1 3/4x1 3/4x1/8	L1 3/4x1 3/4x1/4	A572-50	A36	L2 1/2x2 1/2x5/16	L3x3x5/16	L3x3x5/16
Diagonals	L3x3x3/8						
Diagonal Grade							
Top Girts							
Face Width (ft)	8	10	12	14	16	18	20
# Panels @ (ft)	20 @ 5	20 @ 5	20 @ 5	20 @ 5	20 @ 5	20 @ 5	20 @ 5
Weight (lb) 18260.6	1306.1	1437.8	2337.5	2673.7	3137.6	3361.8	4013.0

CENTERLINE COMMUNICATIONS		Job: CT3438	
750 West Center Street, Suite 301 West Bridgewater, MA 02379 Phone: 781.713.4725 FAX:			
Project: 140 ft Self Supporting Tower		Client: AT&T	
Code: TIA-222-G		Date: 04/15/20	
Path:		Scale: NTS	
© KENNY/DENKOP/KENNY WORK 2009/CENTERLINE 2009/CT3438 East Hartford Rev 11/05/11/CT3438 Rev 1/CT3438		Dwg No. E-1	

tnxTower CENTERLINE COMMUNICATIONS 750 West Center Street, Suite 301 West Bridgewater, MA 02379 Phone: 781.713.4725 FAX:	Job CT3438	Page 1 of 12
	Project 140 ft Self Supporting Tower	Date 15:48:53 04/15/20
	Client AT&T	Designed by TC

Tower Input Data

The main tower is a 3x free standing tower with an overall height of 140.00 ft above the ground line.

The base of the tower is set at an elevation of 0.00 ft above the ground line.

The face width of the tower is 8.00 ft at the top and 16.00 ft at the base.

This tower is designed using the TIA-222-G standard.

The following design criteria apply:

Tower is located in Hartford County, Connecticut.

Basic wind speed of 97 mph.

Structure Class II.

Exposure Category B.

Topographic Category 1.

Crest Height 0.00 ft.

Nominal ice thickness of 1.0000 in.

Ice thickness is considered to increase with height.

Ice density of 56 pcf.

A wind speed of 50 mph is used in combination with ice.

Temperature drop of 50 °F.

Deflections calculated using a wind speed of 60 mph.

A non-linear (P-delta) analysis was used.

Pressures are calculated at each section.

Stress ratio used in tower member design is 1.

Local bending stresses due to climbing loads, feed line supports, and appurtenance mounts are not considered.

Tower Section Geometry

Tower Section	Tower Elevation	Assembly Database	Description	Section Width	Number of Sections	Section Length
	ft			ft		ft
T1	140.00-120.00			8.00	1	20.00
T2	120.00-100.00			8.00	1	20.00
T3	100.00-80.00			8.00	1	20.00
T4	80.00-60.00			8.00	1	20.00
T5	60.00-40.00			10.00	1	20.00
T6	40.00-20.00			12.00	1	20.00
T7	20.00-0.00			14.00	1	20.00

Tower Section Geometry (cont'd)

Tower Section	Tower Elevation	Diagonal Spacing	Bracing Type	Has K Brace End Panels	Has Horizontals	Top Girt Offset	Bottom Girt Offset
	ft	ft				in	in
T1	140.00-120.00	5.00	X Brace	No	No	0.0000	0.0000
T2	120.00-100.00	5.00	X Brace	No	No	0.0000	0.0000
T3	100.00-80.00	5.00	X Brace	No	No	0.0000	0.0000
T4	80.00-60.00	5.00	X Brace	No	No	0.0000	0.0000
T5	60.00-40.00	5.00	X Brace	No	No	0.0000	0.0000

tnxTower CENTERLINE COMMUNICATIONS 750 West Center Street, Suite 301 West Bridgewater, MA 02379 Phone: 781.713.4725 FAX:	Job	CT3438	Page	2 of 12
	Project	140 ft Self Supporting Tower	Date	15:48:53 04/15/20
	Client	AT&T	Designed by	TC

Tower Section	Tower Elevation	Diagonal Spacing	Bracing Type	Has K Brace End Panels	Has Horizontals	Top Girt Offset	Bottom Girt Offset
	ft	ft				in	in
T6	40.00-20.00	10.00	X Brace	No	No	0.0000	0.0000
T7	20.00-0.00	10.00	X Brace	No	No	0.0000	0.0000

Tower Section Geometry (cont'd)

Tower Elevation	Leg Type	Leg Size	Leg Grade	Diagonal Type	Diagonal Size	Diagonal Grade
ft						
T1 140.00-120.00	Solid Round	2 1/4	A572-50 (50 ksi)	Equal Angle	L1 3/4x1 3/4x1/8	A36 (36 ksi)
T2 120.00-100.00	Solid Round	2 1/4	A572-50 (50 ksi)	Equal Angle	L1 3/4x1 3/4x1/4	A36 (36 ksi)
T3 100.00-80.00	Solid Round	2 3/4	A572-50 (50 ksi)	Equal Angle	L2 1/2x2 1/2x5/16	A36 (36 ksi)
T4 80.00-60.00	Solid Round	3	A572-50 (50 ksi)	Equal Angle	L2 1/2x2 1/2x5/16	A36 (36 ksi)
T5 60.00-40.00	Solid Round	3 1/4	A572-50 (50 ksi)	Equal Angle	L2 1/2x2 1/2x5/16	A36 (36 ksi)
T6 40.00-20.00	Truss Leg	Pirod 105218	A572-50 (50 ksi)	Equal Angle	L3x3x5/16	A36 (36 ksi)
T7 20.00-0.00	Truss Leg	Pirod 105219	A572-50 (50 ksi)	Equal Angle	L3x3x5/16	A36 (36 ksi)

Tower Section Geometry (cont'd)

Tower Elevation	Top Girt Type	Top Girt Size	Top Girt Grade	Bottom Girt Type	Bottom Girt Size	Bottom Girt Grade
ft						
T1 140.00-120.00	Equal Angle	L3x3x3/8	A36 (36 ksi)	Equal Angle		A36 (36 ksi)

Feed Line/Linear Appurtenances - Entered As Round Or Flat

Description	Face or Leg	Allow Shield	Exclude From Torque Calculation	Component Type	Placement	Face Offset	Lateral Offset	#	# Per Row	Clear Spacing	Width or Diameter	Perimeter	Weight
					ft	in	(Frac FW)			in	in	in	plf
1 5/8	A	No	No	Ar (CaAa)	120.00 - 6.00	-2.0000	0.45	12	6	1.9800	1.9800		1.04
7/8	B	No	No	Ar (CaAa)	137.00 - 6.00	-3.0000	-0.4	4	4	1.1100	1.1100		0.54
7/8	B	No	No	Ar (CaAa)	120.00 - 6.00	-3.0000	-0.35	3	3	1.1100	1.1100		0.54
1/2	B	No	No	Ar (CaAa)	133.00 - 6.00	2.0000	0.35	1	1	0.5800	0.5800		0.25
1/2	B	No	No	Ar (CaAa)	100.00 - 6.00	2.0000	0.4	2	2	0.5800	0.5800		0.25
1/2	B	No	No	Ar (CaAa)	80.00 - 6.00	2.0000	0.42	1	1	0.5800	0.5800		0.25
2" Rigid Conduit	B	No	No	Ar (CaAa)	100.00 - 6.00	2.0000	0.45	2	2	2.0000	2.0000		2.80

tnxTower CENTERLINE COMMUNICATIONS 750 West Center Street, Suite 301 West Bridgewater, MA 02379 Phone: 781.713.4725 FAX:	Job	CT3438	Page	3 of 12
	Project	140 ft Self Supporting Tower	Date	15:48:53 04/15/20
	Client	AT&T	Designed by	TC

Description	Face or Leg	Allow Shield	Exclude From Torque Calculation	Component Type	Placement ft	Face Offset in	Lateral Offset (Frac FW)	#	# Per Row	Clear Spacing in	Width or Diameter in	Perimeter in	Weight plf
***** WR-VG122S T-BRDA (AT&T - existing) *****	C	No	No	Ar (CaAa)	110.00 - 6.00	0.0000	0.2	4	4	0.0000	0.4000		0.25
WR-VG122S T-BRDA (AT&T - proposed)	C	No	No	Ar (CaAa)	110.00 - 6.00	0.0000	0.1	5	5	0.0000	0.4000		0.25
FB-L98B-002	C	No	No	Ar (CaAa)	110.00 - 6.00	0.0000	0	3	3	0.0000	0.4000		0.25

Discrete Tower Loads

Description	Face or Leg	Offset Type	Offsets: Horz Lateral Vert	Azimuth Adjustment °	Placement ft	CAAA Front ft ²	CAAA Side ft ²	Weight lb
Pirod 4' Side Mount Standoff (1)	A	From Leg	2.00 0.00 0.00	0.0000	137.00	No Ice 1/2" Ice 1" Ice	2.72 4.91 7.10	50.00 89.00 128.00
Pirod 4' Side Mount Standoff (1)	B	From Leg	2.00 0.00 0.00	0.0000	137.00	No Ice 1/2" Ice 1" Ice	2.72 4.91 7.10	50.00 89.00 128.00
Pirod 4' Side Mount Standoff (1)	C	From Leg	2.00 0.00 0.00	0.0000	137.00	No Ice 1/2" Ice 1" Ice	2.72 4.91 7.10	50.00 89.00 128.00
Omni 2"x8'	A	From Face	4.00 0.00 4.00	0.0000	137.00	No Ice 1/2" Ice 1" Ice	1.60 2.42 3.24	35.00 47.45 65.14
Omni 2 1/2"x20'	A	From Face	4.00 0.00 10.00	0.0000	137.00	No Ice 1/2" Ice 1" Ice	5.00 7.03 9.07	40.00 76.96 126.55
Omni 2"x8'	B	From Face	4.00 0.00 4.00	0.0000	137.00	No Ice 1/2" Ice 1" Ice	1.60 2.42 3.24	35.00 47.45 65.14
Omni 2"x8'	C	From Face	4.00 0.00 4.00	0.0000	137.00	No Ice 1/2" Ice 1" Ice	1.60 2.42 3.24	35.00 47.45 65.14
***** PiROD 12' T-Frame	A	From Leg	2.00 0.00 0.00	0.0000	120.00	No Ice 1/2" Ice 1" Ice	12.20 17.60 23.00	360.00 490.00 620.00
PiROD 12' T-Frame	B	From Leg	2.00 0.00 0.00	0.0000	120.00	No Ice 1/2" Ice 1" Ice	12.20 17.60 23.00	360.00 490.00 620.00
PiROD 12' T-Frame	C	From Leg	2.00 0.00 0.00	0.0000	120.00	No Ice 1/2" Ice 1" Ice	12.20 17.60 23.00	360.00 490.00 620.00
(2) AIR 21 w/ Mount Pipe	A	From Leg	3.00 0.00 0.00	0.0000	120.00	No Ice 1/2" Ice 1" Ice	6.29 6.73 7.17	111.68 168.60 232.26

tnxTower CENTERLINE COMMUNICATIONS 750 West Center Street, Suite 301 West Bridgewater, MA 02379 Phone: 781.713.4725 FAX:	Job	CT3438	Page	4 of 12
	Project	140 ft Self Supporting Tower	Date	15:48:53 04/15/20
	Client	AT&T	Designed by	TC

Description	Face or Leg	Offset Type	Offsets:		Azimuth Adjustment	Placement	C _{AA} Front	C _{AA} Side	Weight
			Horz	Vert					
			ft	ft	°	ft	ft ²	ft ²	lb
(2) AIR 21 w/ Mount Pipe	B	From Leg	3.00	0.0000		120.00	No Ice 6.29	5.70	111.68
			0.00				1/2" Ice 6.73	6.48	168.60
			0.00				1" Ice 7.17	7.19	232.26
(2) AIR 21 w/ Mount Pipe	C	From Leg	3.00	0.0000		120.00	No Ice 6.29	5.70	111.68
			0.00				1/2" Ice 6.73	6.48	168.60
			0.00				1" Ice 7.17	7.19	232.26
Omni 2 1/2"x20'	A	From Leg	3.00	0.0000		120.00	No Ice 5.00	5.00	40.00
			0.00				1/2" Ice 7.03	7.03	76.96
			10.00				1" Ice 9.07	9.07	126.55
Omni 2 1/2"x20'	B	From Leg	3.00	0.0000		120.00	No Ice 5.00	5.00	40.00
			0.00				1/2" Ice 7.03	7.03	76.96
			10.00				1" Ice 9.07	9.07	126.55
Omni 2 1/2"x20'	C	From Leg	3.00	0.0000		120.00	No Ice 5.00	5.00	40.00
			0.00				1/2" Ice 7.03	7.03	76.96
			10.00				1" Ice 9.07	9.07	126.55
RFS ATMAA1412D-1A20	A	From Leg	3.00	0.0000		120.00	No Ice 1.00	0.41	13.00
			0.00				1/2" Ice 1.13	0.50	20.62
			0.00				1" Ice 1.26	0.59	30.11
RFS ATMAA1412D-1A20	B	From Leg	3.00	0.0000		120.00	No Ice 1.00	0.41	13.00
			0.00				1/2" Ice 1.13	0.50	20.62
			0.00				1" Ice 1.26	0.59	30.11
RFS ATMAA1412D-1A20	C	From Leg	3.00	0.0000		120.00	No Ice 1.00	0.41	13.00
			0.00				1/2" Ice 1.13	0.50	20.62
			0.00				1" Ice 1.26	0.59	30.11

Sabre 12' V-Boom (AT&T - existing)	A	From Leg	2.00	0.0000		110.00	No Ice 15.40	14.00	558.00
			0.00				1/2" Ice 21.30	20.81	741.00
			0.00				1" Ice 27.20	27.62	924.00
Sabre 12' V-Boom	B	From Leg	2.00	0.0000		110.00	No Ice 15.40	14.00	558.00
			0.00				1/2" Ice 21.30	20.81	741.00
			0.00				1" Ice 27.20	27.62	924.00
Sabre 12' V-Boom	C	From Leg	2.00	0.0000		110.00	No Ice 15.40	14.00	558.00
			0.00				1/2" Ice 21.30	20.81	741.00
			0.00				1" Ice 27.20	27.62	924.00
800 10799 w/ Mount Pipe	A	From Leg	3.50	0.0000		110.00	No Ice 15.36	10.94	165.11
			0.00				1/2" Ice 16.05	12.52	274.28
			0.00				1" Ice 16.73	13.92	395.35
800 10799 w/ Mount Pipe	B	From Leg	3.50	0.0000		110.00	No Ice 15.36	10.94	165.11
			0.00				1/2" Ice 16.05	12.52	274.28
			0.00				1" Ice 16.73	13.92	395.35
800 10799 w/ Mount Pipe	C	From Leg	3.50	0.0000		110.00	No Ice 15.36	10.94	165.11
			0.00				1/2" Ice 16.05	12.52	274.28
			0.00				1" Ice 16.73	13.92	395.35
4415 B25	A	From Leg	2.50	0.0000		110.00	No Ice 1.84	0.82	46.00
			0.00				1/2" Ice 2.01	0.94	60.07
			0.00				1" Ice 2.19	1.07	76.66
4415 B25	B	From Leg	2.50	0.0000		110.00	No Ice 1.84	0.82	46.00
			0.00				1/2" Ice 2.01	0.94	60.07
			0.00				1" Ice 2.19	1.07	76.66
4415 B25	C	From Leg	2.50	0.0000		110.00	No Ice 1.84	0.82	46.00
			0.00				1/2" Ice 2.01	0.94	60.07
			0.00				1" Ice 2.19	1.07	76.66
RRUS-32 B30	A	From Leg	2.50	0.0000		110.00	No Ice 2.72	1.67	53.00
			0.00				1/2" Ice 2.94	1.86	74.00
			0.00				1" Ice 3.17	2.05	98.19
RRUS-32 B30	B	From Leg	2.50	0.0000		110.00	No Ice 2.72	1.67	53.00
			0.00				1/2" Ice 2.94	1.86	74.00

tnxTower CENTERLINE COMMUNICATIONS 750 West Center Street, Suite 301 West Bridgewater, MA 02379 Phone: 781.713.4725 FAX:	Job	CT3438	Page	5 of 12
	Project	140 ft Self Supporting Tower	Date	15:48:53 04/15/20
	Client	AT&T	Designed by	TC

Description	Face or Leg	Offset Type	Offsets:		Azimuth Adjustment	Placement	C _{AA} Front	C _{AA} Side	Weight	
			Horz	Vert						
			ft	ft	°	ft	ft ²	ft ²	lb	
RRUS-32 B30	C	From Leg	0.00		0.0000	110.00	1" Ice	3.17	2.05	98.19
			2.50				No Ice	2.72	1.67	53.00
			0.00				1/2" Ice	2.94	1.86	74.00
			0.00				1" Ice	3.17	2.05	98.19

OPA65R-BU8DA w/mount pipe (AT&T - proposed)	A	From Leg	3.50		0.0000	110.00	No Ice	18.38	10.79	132.11
			0.00				1/2" Ice	19.11	12.31	259.03
			0.00				1" Ice	19.84	13.66	397.67
			0.00				1" Ice	19.84	13.66	397.67
OPA65R-BU8DA w/mount pipe	B	From Leg	3.50		0.0000	110.00	No Ice	18.38	10.79	132.11
			0.00				1/2" Ice	19.11	12.31	259.03
			0.00				1" Ice	19.84	13.66	397.67
			0.00				1" Ice	19.84	13.66	397.67
OPA65R-BU8DA w/mount pipe	C	From Leg	3.50		0.0000	110.00	No Ice	18.38	10.79	132.11
			0.00				1/2" Ice	19.11	12.31	259.03
			0.00				1" Ice	19.84	13.66	397.67
			0.00				1" Ice	19.84	13.66	397.67
DMP65R-BU8DA w/mount pipe	A	From Leg	3.50		0.0000	110.00	No Ice	18.16	10.71	148.11
			0.00				1/2" Ice	18.89	12.24	273.63
			0.00				1" Ice	19.61	13.58	410.85
			0.00				1" Ice	19.61	13.58	410.85
DMP65R-BU8DA w/mount pipe	B	From Leg	3.50		0.0000	110.00	No Ice	18.16	10.71	148.11
			0.00				1/2" Ice	18.89	12.24	273.63
			0.00				1" Ice	19.61	13.58	410.85
			0.00				1" Ice	19.61	13.58	410.85
DMP65R-BU8DA w/mount pipe	C	From Leg	3.50		0.0000	110.00	No Ice	18.16	10.71	148.11
			0.00				1/2" Ice	18.89	12.24	273.63
			0.00				1" Ice	19.61	13.58	410.85
			0.00				1" Ice	19.61	13.58	410.85
RRUS-E2 B29	A	From Leg	2.50		0.0000	110.00	No Ice	3.15	1.29	53.00
			0.00				1/2" Ice	3.36	1.44	76.22
			0.00				1" Ice	3.59	1.60	102.64
			0.00				1" Ice	3.59	1.60	102.64
RRUS-E2 B29	B	From Leg	2.50		0.0000	110.00	No Ice	3.15	1.29	53.00
			0.00				1/2" Ice	3.36	1.44	76.22
			0.00				1" Ice	3.59	1.60	102.64
			0.00				1" Ice	3.59	1.60	102.64
RRUS-E2 B29	C	From Leg	2.50		0.0000	110.00	No Ice	3.15	1.29	53.00
			0.00				1/2" Ice	3.36	1.44	76.22
			0.00				1" Ice	3.59	1.60	102.64
			0.00				1" Ice	3.59	1.60	102.64
8843 B2/B66A	A	From Leg	2.50		0.0000	110.00	No Ice	1.64	1.35	74.00
			0.00				1/2" Ice	1.80	1.50	91.60
			0.00				1" Ice	1.97	1.65	111.91
			0.00				1" Ice	1.97	1.65	111.91
8843 B2/B66A	B	From Leg	2.50		0.0000	110.00	No Ice	1.64	1.35	74.00
			0.00				1/2" Ice	1.80	1.50	91.60
			0.00				1" Ice	1.97	1.65	111.91
			0.00				1" Ice	1.97	1.65	111.91
8843 B2/B66A	C	From Leg	2.50		0.0000	110.00	No Ice	1.64	1.35	74.00
			0.00				1/2" Ice	1.80	1.50	91.60
			0.00				1" Ice	1.97	1.65	111.91
			0.00				1" Ice	1.97	1.65	111.91
4478 B14	A	From Leg	2.50		0.0000	110.00	No Ice	2.02	1.25	59.40
			0.00				1/2" Ice	2.20	1.40	77.06
			0.00				1" Ice	2.39	1.56	97.48
			0.00				1" Ice	2.39	1.56	97.48
4478 B14	B	From Leg	2.50		0.0000	110.00	No Ice	2.02	1.25	59.40
			0.00				1/2" Ice	2.20	1.40	77.06
			0.00				1" Ice	2.39	1.56	97.48
			0.00				1" Ice	2.39	1.56	97.48
4478 B14	C	From Leg	2.50		0.0000	110.00	No Ice	2.02	1.25	59.40
			0.00				1/2" Ice	2.20	1.40	77.06
			0.00				1" Ice	2.39	1.56	97.48
			0.00				1" Ice	2.39	1.56	97.48
4449 B5/B12	A	From Leg	2.50		0.0000	110.00	No Ice	1.64	1.29	74.00
			0.00				1/2" Ice	1.80	1.44	91.12
			0.00				1" Ice	1.97	1.59	110.94
			0.00				1" Ice	1.97	1.59	110.94
4449 B5/B12	B	From Leg	2.50		0.0000	110.00	No Ice	1.64	1.29	74.00
			0.00				1/2" Ice	1.80	1.44	91.12
			0.00				1" Ice	1.97	1.59	110.94
			0.00				1" Ice	1.97	1.59	110.94
4449 B5/B12	C	From Leg	2.50		0.0000	110.00	No Ice	1.64	1.29	74.00
			0.00				1/2" Ice	1.80	1.44	91.12
			0.00				1" Ice	1.97	1.59	110.94
			0.00				1" Ice	1.97	1.59	110.94

tnxTower CENTERLINE COMMUNICATIONS 750 West Center Street, Suite 301 West Bridgewater, MA 02379 Phone: 781.713.4725 FAX:	Job	CT3438	Page	6 of 12
	Project	140 ft Self Supporting Tower	Date	15:48:53 04/15/20
	Client	AT&T	Designed by	TC

Description	Face or Leg	Offset Type	Offsets: Horz Lateral Vert ft ft ft	Azimuth Adjustment °	Placement ft	C _{AA} Front ft ²	C _{AA} Side ft ²	Weight lb	
			0.00			1/2" Ice 1.80	1.44	91.12	
			0.00			1" Ice 1.97	1.59	110.94	
DC9-48-60-24-8C-EV	A	From Leg	2.50	0.0000	110.00	No Ice 0.81	0.81	33.00	
			0.00			1/2" Ice 1.30	1.30	48.38	
			0.00			1" Ice 1.48	1.48	66.11	
DC9-48-60-24-8C-EV	B	From Leg	2.50	0.0000	110.00	No Ice 0.81	0.81	33.00	
			0.00			1/2" Ice 1.30	1.30	48.38	
			0.00			1" Ice 1.48	1.48	66.11	
DC9-48-60-24-8C-EV	C	From Leg	2.50	0.0000	110.00	No Ice 0.81	0.81	33.00	
			0.00			1/2" Ice 1.30	1.30	48.38	
			0.00			1" Ice 1.48	1.48	66.11	

Pirot 4' Side Mount Standoff (1)	A	From Leg	2.00	0.0000	100.00	No Ice 2.72	2.72	50.00	
			0.00			1/2" Ice 4.91	4.91	89.00	
			0.00			1" Ice 7.10	7.10	128.00	
Pirot 4' Side Mount Standoff (1)	B	From Leg	2.00	0.0000	100.00	No Ice 2.72	2.72	50.00	
			0.00			1/2" Ice 4.91	4.91	89.00	
			0.00			1" Ice 7.10	7.10	128.00	
Pirot 4' Side Mount Standoff (1)	C	From Leg	2.00	0.0000	100.00	No Ice 2.72	2.72	50.00	
			0.00			1/2" Ice 4.91	4.91	89.00	
			0.00			1" Ice 7.10	7.10	128.00	
Panel Antenna 72"x12" w/mount pipe	A	From Leg	4.00	0.0000	100.00	No Ice 8.37	7.53	65.55	
			-2.00			1/2" Ice 8.93	8.72	136.83	
			0.00			1" Ice 9.46	9.62	216.16	
Panel Antenna 72"x12" w/mount pipe	B	From Leg	4.00	0.0000	100.00	No Ice 8.37	7.53	65.55	
			-2.00			1/2" Ice 8.93	8.72	136.83	
			0.00			1" Ice 9.46	9.62	216.16	
Panel Antenna 72"x12" w/mount pipe	C	From Leg	4.00	0.0000	100.00	No Ice 8.37	7.53	65.55	
			-2.00			1/2" Ice 8.93	8.72	136.83	
			0.00			1" Ice 9.46	9.62	216.16	
Pirot 4' Side Mount Standoff (1)	A	From Leg	2.00	0.0000	80.00	No Ice 2.72	2.72	50.00	
			0.00			1/2" Ice 4.91	4.91	89.00	
			0.00			1" Ice 7.10	7.10	128.00	
Omni 2"x8'	A	From Leg	4.00	0.0000	80.00	No Ice 1.60	1.60	35.00	
			0.00			1/2" Ice 2.42	2.42	47.45	
			0.00			1" Ice 3.24	3.24	65.14	

Dishes

Description	Face or Leg	Dish Type	Offset Type	Offsets: Horz Lateral Vert ft ft ft	Azimuth Adjustment °	3 dB Beam Width °	Elevation ft	Outside Diameter ft	Aperture Area ft ²	Weight lb
P2F-52	A	Paraboloid w/o Radome	From Leg	3.00	0.0000		133.00	2.00	No Ice 3.10	17.00
				0.00					1/2" Ice 3.41	34.49
				0.00					1" Ice 3.71	51.98
P3F-52	A	Paraboloid w/o Radome	From Leg	3.00	0.0000		100.00	3.00	No Ice 7.10	90.00
				0.00					1/2" Ice 7.46	128.31
				0.00					1" Ice 7.83	166.62
P2F-52	B	Paraboloid w/o Radome	From Leg	3.00	0.0000		100.00	2.00	No Ice 3.10	17.00
				0.00					1/2" Ice 3.41	34.49
				0.00					1" Ice 3.71	51.98

tnxTower CENTERLINE COMMUNICATIONS 750 West Center Street, Suite 301 West Bridgewater, MA 02379 Phone: 781.713.4725 FAX:	Job	CT3438	Page	7 of 12
	Project	140 ft Self Supporting Tower	Date	15:48:53 04/15/20
	Client	AT&T	Designed by	TC

Maximum Reactions

Location	Condition	Gov. Load Comb.	Vertical lb	Horizontal, X lb	Horizontal, Z lb
Leg C	Max. Vert	18	179439.20	15613.43	-9520.72
	Max. H _x	18	179439.20	15613.43	-9520.72
	Max. H _z	7	-152008.94	-13352.81	8227.23
	Min. Vert	7	-152008.94	-13352.81	8227.23
	Min. H _x	7	-152008.94	-13352.81	8227.23
	Min. H _z	18	179439.20	15613.43	-9520.72
Leg B	Max. Vert	10	187219.70	-16236.58	-10317.12
	Max. H _x	23	-159616.29	14011.74	9051.70
	Max. H _z	23	-159616.29	14011.74	9051.70
	Min. Vert	23	-159616.29	14011.74	9051.70
	Min. H _x	10	187219.70	-16236.58	-10317.12
	Min. H _z	10	187219.70	-16236.58	-10317.12
Leg A	Max. Vert	2	180648.73	96.57	18311.54
	Max. H _x	21	9526.87	1580.72	763.45
	Max. H _z	2	180648.73	96.57	18311.54
	Min. Vert	15	-152879.36	-95.57	-15830.46
	Min. H _x	9	9000.07	-1561.75	715.00
	Min. H _z	15	-152879.36	-95.57	-15830.46

Tower Mast Reaction Summary

Load Combination	Vertical lb	Shear _x lb	Shear _z lb	Overturning Moment, M _x lb-ft	Overturning Moment, M _z lb-ft	Torque lb-ft
Dead Only	28033.55	-0.00	-0.00	-9044.17	-2760.89	-0.00
1.2 Dead+1.6 Wind 0 deg - No Ice	33640.26	-111.45	-26990.25	-2347764.54	7860.97	2558.98
0.9 Dead+1.6 Wind 0 deg - No Ice	25230.47	-111.40	-26990.50	-2342788.81	8680.71	2558.52
1.2 Dead+1.6 Wind 30 deg - No Ice	33640.26	12638.88	-21917.06	-1930335.72	-1109829.02	-3301.78
0.9 Dead+1.6 Wind 30 deg - No Ice	25230.20	12638.88	-21917.07	-1925751.41	-1107930.91	-3299.64
1.2 Dead+1.6 Wind 60 deg - No Ice	33640.27	21962.37	-12719.12	-1123675.99	-1922829.09	-12599.19
0.9 Dead+1.6 Wind 60 deg - No Ice	25230.20	21962.37	-12719.12	-1119870.19	-1920146.64	-12590.34
1.2 Dead+1.6 Wind 90 deg - No Ice	33640.26	27129.29	0.76	-10910.19	-2339414.46	-25089.60
0.9 Dead+1.6 Wind 90 deg - No Ice	25230.20	27129.29	0.76	-8175.32	-2336347.31	-25077.13
1.2 Dead+1.6 Wind 120 deg - No Ice	33640.26	24511.91	14586.31	1245930.87	-2096761.94	-22605.72
0.9 Dead+1.6 Wind 120 deg - No Ice	25230.20	24511.91	14586.31	1247464.42	-2093933.34	-22591.17
1.2 Dead+1.6 Wind 150 deg - No Ice	33640.26	13173.17	23271.53	2008216.42	-1139860.40	-10678.81
0.9 Dead+1.6 Wind 150 deg - No Ice	25230.20	13173.17	23271.53	2009016.54	-1137940.15	-10673.37
1.2 Dead+1.6 Wind 180 deg - No Ice	33640.29	14.27	25644.00	2234320.51	-4760.16	-2736.85
0.9 Dead+1.6 Wind 180 deg - No Ice	25230.20	14.27	25644.00	2234891.86	-3925.88	-2734.34

tnxTower CENTERLINE COMMUNICATIONS 750 West Center Street, Suite 301 West Bridgewater, MA 02379 Phone: 781.713.4725 FAX:	Job	CT3438	Page	8 of 12
	Project	140 ft Self Supporting Tower	Date	15:48:53 04/15/20
	Client	AT&T	Designed by	TC

<i>Load Combination</i>	<i>Vertical lb</i>	<i>Shear_x lb</i>	<i>Shear_z lb</i>	<i>Overturning Moment, M_x lb-ft</i>	<i>Overturning Moment, M_z lb-ft</i>	<i>Torque lb-ft</i>
No Ice						
1.2 Dead+1.6 Wind 210 deg - No Ice	33640.26	-12515.68	22143.00	1933612.72	1089529.60	2257.52
0.9 Dead+1.6 Wind 210 deg - No Ice	25230.20	-12515.68	22143.00	1934468.74	1089309.51	2258.66
1.2 Dead+1.6 Wind 240 deg - No Ice	33640.26	-23238.69	13722.53	1185233.94	2007317.27	12133.62
0.9 Dead+1.6 Wind 240 deg - No Ice	25230.20	-23238.69	13722.52	1186815.19	2006219.58	12124.69
1.2 Dead+1.6 Wind 270 deg - No Ice	33640.26	-27169.01	-71.99	-18217.80	2336754.79	25389.45
0.9 Dead+1.6 Wind 270 deg - No Ice	25230.20	-27169.01	-71.99	-15474.93	2335349.38	25376.94
1.2 Dead+1.6 Wind 300 deg - No Ice	33640.28	-23351.11	-13537.35	-1179839.76	2010557.80	23246.90
0.9 Dead+1.6 Wind 300 deg - No Ice	25230.20	-23351.09	-13537.37	-1175988.92	2009464.13	23236.17
1.2 Dead+1.6 Wind 330 deg - No Ice	33640.26	-13370.34	-23048.76	-2005270.25	1154273.02	11420.13
0.9 Dead+1.6 Wind 330 deg - No Ice	25230.20	-13370.34	-23048.76	-2000627.12	1153997.64	11414.61
1.2 Dead+1.0 Ice+1.0 Temp	109182.60	-0.00	0.00	-74140.90	-19252.79	-0.69
1.2 Dead+1.0 Wind 0 deg+1.0 Ice+1.0 Temp	109182.60	-26.71	-9002.60	-861714.13	-16561.28	1885.79
1.2 Dead+1.0 Wind 30 deg+1.0 Ice+1.0 Temp	109182.60	4475.61	-7757.53	-752936.00	-410744.12	331.14
1.2 Dead+1.0 Wind 60 deg+1.0 Ice+1.0 Temp	109182.60	7893.80	-4565.56	-472203.85	-706879.85	-2644.38
1.2 Dead+1.0 Wind 90 deg+1.0 Ice+1.0 Temp	109182.60	9253.72	0.26	-74236.40	-822277.35	-5596.47
1.2 Dead+1.0 Wind 120 deg+1.0 Ice+1.0 Temp	109182.60	8031.76	4731.01	338466.52	-715683.33	-5652.65
1.2 Dead+1.0 Wind 150 deg+1.0 Ice+1.0 Temp	109182.60	4447.96	7802.23	609269.69	-407463.84	-3477.13
1.2 Dead+1.0 Wind 180 deg+1.0 Ice+1.0 Temp	109182.60	3.42	8842.44	702825.22	-19619.96	-1927.94
1.2 Dead+1.0 Wind 210 deg+1.0 Ice+1.0 Temp	109182.60	-4448.94	7806.39	609975.45	369180.98	-556.32
1.2 Dead+1.0 Wind 240 deg+1.0 Ice+1.0 Temp	109182.60	-8057.52	4715.04	337010.44	680033.75	2549.19
1.2 Dead+1.0 Wind 270 deg+1.0 Ice+1.0 Temp	109182.60	-9263.24	-17.18	-76008.91	784703.53	5668.50
1.2 Dead+1.0 Wind 300 deg+1.0 Ice+1.0 Temp	109182.60	-7895.73	-4570.62	-472557.52	668255.07	5790.08
1.2 Dead+1.0 Wind 330 deg+1.0 Ice+1.0 Temp	109182.60	-4492.37	-7754.13	-752308.87	373742.74	3630.31
Dead+Wind 0 deg - Service	28033.55	-26.65	-6454.25	-567565.88	-94.78	611.47
Dead+Wind 30 deg - Service	28033.55	3022.37	-5241.09	-467781.77	-267200.29	-789.85
Dead+Wind 60 deg - Service	28033.55	5251.92	-3041.56	-275004.17	-461470.19	-3010.61
Dead+Wind 90 deg - Service	28033.55	6487.50	0.18	-9071.19	-561054.29	-5996.97
Dead+Wind 120 deg - Service	28033.55	5861.60	3488.06	291294.96	-503071.36	-5404.00
Dead+Wind 150 deg - Service	28033.55	3150.14	5564.99	473451.83	-274375.96	-2554.19
Dead+Wind 180 deg - Service	28033.55	3.41	6132.32	527488.54	-3110.77	-654.10
Dead+Wind 210 deg - Service	28033.55	-2992.91	5295.12	455618.76	258400.58	540.74
Dead+Wind 240 deg - Service	28033.55	-5557.13	3281.51	276789.22	477753.18	2899.78
Dead+Wind 270 deg - Service	28033.55	-6497.00	-17.22	-10817.25	556471.01	6068.68
Dead+Wind 300 deg - Service	28033.55	-5584.01	-3237.23	-288426.34	478491.55	5556.72
Dead+Wind 330 deg - Service	28033.55	-3197.29	-5511.71	-485691.13	273876.64	2731.58

tnxTower CENTERLINE COMMUNICATIONS 750 West Center Street, Suite 301 West Bridgewater, MA 02379 Phone: 781.713.4725 FAX:	Job CT3438	Page 9 of 12
	Project 140 ft Self Supporting Tower	Date 15:48:53 04/15/20
	Client AT&T	Designed by TC

Maximum Tower Deflections - Service Wind

Section No.	Elevation ft	Horz. Deflection in	Gov. Load Comb.	Tilt °	Twist °
T1	140 - 120	2.186	43	0.1163	0.0251
T2	120 - 100	1.699	43	0.1154	0.0236
T3	100 - 80	1.207	43	0.1074	0.0205
T4	80 - 60	0.771	43	0.0885	0.0164
T5	60 - 40	0.434	43	0.0647	0.0112
T6	40 - 20	0.191	43	0.0435	0.0062
T7	20 - 0	0.050	43	0.0187	0.0029

Critical Deflections and Radius of Curvature - Service Wind

Elevation ft	Appurtenance	Gov. Load Comb.	Deflection in	Tilt °	Twist °	Radius of Curvature ft
137.00	PiROD 4' Side Mount Standoff (1)	43	2.114	0.1164	0.0249	883858
133.00	P2F-52	43	2.017	0.1164	0.0247	631340
120.00	PiROD 12' T-Frame	43	1.699	0.1154	0.0236	275523
110.00	Sabre 12' V-Boom	43	1.450	0.1127	0.0222	221371
100.00	P3F-52	43	1.207	0.1074	0.0205	77676
80.00	PiROD 4' Side Mount Standoff (1)	43	0.771	0.0885	0.0164	42806

Compression Checks

Leg Design Data (Compression)

Section No.	Elevation ft	Size	L ft	L _u ft	Kl/r	A in ²	P _u lb	φP _n lb	Ratio $\frac{P_u}{\phi P_n}$
T1	140 - 120	2 1/4	20.00	5.00	106.7 K=1.00	3.9761	-4376.32	77870.40	0.056 ¹
T2	120 - 100	2 1/4	20.00	5.00	106.7 K=1.00	3.9761	-31183.10	77870.40	0.400 ¹
T3	100 - 80	2 3/4	20.00	5.00	87.3 K=1.00	5.9396	-78756.00	153147.00	0.514 ¹
T4	80 - 60	3	20.03	5.01	80.1 K=1.00	7.0686	-112858.00	198902.00	0.567 ¹
T5	60 - 40	3 1/4	20.03	5.01	74.0 K=1.00	8.2958	-139536.00	250223.00	0.558 ¹
T6	40 - 20	PiROD 105218	20.03	10.02	32.4 K=1.00	7.2158	-159110.00	300681.00	0.529 ¹
T7	20 - 0	PiROD 105219	20.03	10.02	28.4 K=1.00	9.4248	-180751.00	399868.00	0.452 ¹

¹ P_u / φP_n controls

tnxTower CENTERLINE COMMUNICATIONS 750 West Center Street, Suite 301 West Bridgewater, MA 02379 Phone: 781.713.4725 FAX:	Job CT3438	Page 10 of 12
	Project 140 ft Self Supporting Tower	Date 15:48:53 04/15/20
	Client AT&T	Designed by TC

Truss-Leg Diagonal Data

Section No.	Elevation ft	Diagonal Size	L_d ft	Kl/r	ϕP_n lb	A in ²	V_u lb	ϕV_n lb	Stress Ratio
T6	40 - 20	0.5	1.46	140.0	324713.00	0.1963	556.57	2532.16	0.220
T7	20 - 0	0.625	1.45	111.1	424115.00	0.3068	826.52	5809.85	0.142

Diagonal Design Data (Compression)

Section No.	Elevation ft	Size	L ft	L_u ft	Kl/r	A in ²	P_u lb	ϕP_n lb	Ratio $\frac{P_u}{\phi P_n}$
T1	140 - 120	L1 3/4x1 3/4x1/8	9.43	4.61	159.4 K=1.00	0.4219	-1188.20	3751.65	0.317 ¹
T2	120 - 100	L1 3/4x1 3/4x1/4	9.43	4.61	161.9 K=1.00	0.8125	-5466.62	6999.86	0.781 ¹
T3	100 - 80	L2 1/2x2 1/2x5/16	9.43	4.58	114.3 K=1.02	1.4600	-7159.04	23771.20	0.301 ¹
T4	80 - 60	L2 1/2x2 1/2x5/16	10.52	5.26	129.1 K=1.00	1.4600	-4880.07	19680.00	0.248 ¹
T5	60 - 40	L2 1/2x2 1/2x5/16	12.31	6.15	150.8 K=1.00	1.4600	-5020.21	14501.70	0.346 ¹
T6	40 - 20	L3x3x5/16	16.80	8.09	164.8 K=1.00	1.7800	-6002.07	14801.00	0.406 ¹
T7	20 - 0	L3x3x5/16	18.45	8.93	181.9 K=1.00	1.7800	-7151.48	12157.80	0.588 ¹

¹ $P_u / \phi P_n$ controls

Top Girt Design Data (Compression)

Section No.	Elevation ft	Size	L ft	L_u ft	Kl/r	A in ²	P_u lb	ϕP_n lb	Ratio $\frac{P_u}{\phi P_n}$
T1	140 - 120	L3x3x3/8	8.00	7.81	159.7 K=1.00	2.1100	-162.80	18687.70	0.009 ¹

¹ $P_u / \phi P_n$ controls

Tension Checks

Leg Design Data (Tension)

tnxTower CENTERLINE COMMUNICATIONS 750 West Center Street, Suite 301 West Bridgewater, MA 02379 Phone: 781.713.4725 FAX:	Job CT3438	Page 11 of 12
	Project 140 ft Self Supporting Tower	Date 15:48:53 04/15/20
	Client AT&T	Designed by TC

Section No.	Elevation ft	Size	L ft	L _u ft	Kl/r	A in ²	P _u lb	φP _n lb	Ratio $\frac{P_u}{\phi P_n}$
T1	140 - 120	2 1/4	20.00	5.00	106.7	3.9761	2415.09	178924.00	0.013 ¹
T2	120 - 100	2 1/4	20.00	5.00	106.7	3.9761	23701.20	178924.00	0.132 ¹ ✓
T3	100 - 80	2 3/4	20.00	5.00	87.3	5.9396	67687.60	267281.00	0.253 ¹ ✓
T4	80 - 60	3	20.03	5.01	80.1	7.0686	97933.20	318086.00	0.308 ¹ ✓
T5	60 - 40	3 1/4	20.03	5.01	74.0	8.2958	120704.00	373310.00	0.323 ¹ ✓
T6	40 - 20	Pirod 105218	20.03	10.02	32.4	7.2158	137004.00	324713.00	0.422 ¹ ✓
T7	20 - 0	Pirod 105219	20.03	10.02	28.4	9.4248	154548.00	424115.00	0.364 ¹ ✓

¹ P_u / φP_n controls

Truss-Leg Diagonal Data

Section No.	Elevation ft	Diagonal Size	L _d ft	Kl/r	φP _n lb	A in ²	V _u lb	φV _n lb	Stress Ratio
T6	40 - 20	0.5	1.46	140.0	324713.00	0.1963	556.57	2532.16	0.220
T7	20 - 0	0.625	1.45	111.1	424115.00	0.3068	826.52	5809.85	0.142 ✓

Diagonal Design Data (Tension)

Section No.	Elevation ft	Size	L ft	L _u ft	Kl/r	A in ²	P _u lb	φP _n lb	Ratio $\frac{P_u}{\phi P_n}$
T1	140 - 120	L1 3/4x1 3/4x1/8	9.43	4.61	101.3	0.4219	1085.64	13668.80	0.079 ¹ ✓
T2	120 - 100	L1 3/4x1 3/4x1/4	9.43	4.61	104.5	0.8125	5422.63	26325.00	0.206 ¹ ✓
T3	100 - 80	L2 1/2x2 1/2x5/16	9.43	4.58	72.3	1.4600	6963.96	47304.00	0.147 ¹ ✓
T4	80 - 60	L2 1/2x2 1/2x5/16	10.08	5.04	79.5	1.4600	4959.26	47304.00	0.105 ¹ ✓
T5	60 - 40	L2 1/2x2 1/2x5/16	12.77	6.37	100.5	1.4600	4887.85	47304.00	0.103 ¹ ✓
T6	40 - 20	L3x3x5/16	16.80	8.09	105.3	1.7800	5598.55	57672.00	0.097 ¹ ✓
T7	20 - 0	L3x3x5/16	18.45	8.93	116.2	1.7800	6424.66	57672.00	0.111 ¹ ✓

¹ P_u / φP_n controls

tnxTower CENTERLINE COMMUNICATIONS 750 West Center Street, Suite 301 West Bridgewater, MA 02379 Phone: 781.713.4725 FAX:	Job CT3438	Page 12 of 12
	Project 140 ft Self Supporting Tower	Date 15:48:53 04/15/20
	Client AT&T	Designed by TC

Top Girt Design Data (Tension)

Section No.	Elevation ft	Size	L ft	L _u ft	Kl/r	A in ²	P _u lb	φP _n lb	Ratio $\frac{P_u}{\phi P_n}$
T1	140 - 120	L3x3x3/8	8.00	7.81	102.7	2.1100	123.27	68364.00	0.002 ¹



¹ P_u / φP_n controls

Section Capacity Table

Section No.	Elevation ft	Component Type	Size	Critical Element	P lb	φP _{allow} lb	% Capacity	Pass Fail	
T1	140 - 120	Leg	2 1/4	3	-4376.32	77870.40	5.6	Pass	
T2	120 - 100	Leg	2 1/4	33	-31183.10	77870.40	40.0	Pass	
T3	100 - 80	Leg	2 3/4	59	-78756.00	153147.00	51.4	Pass	
T4	80 - 60	Leg	3	86	-112858.00	198902.00	56.7	Pass	
T5	60 - 40	Leg	3 1/4	113	-139536.00	250223.00	55.8	Pass	
T6	40 - 20	Leg	Pirod 105218	140	-159110.00	300681.00	52.9	Pass	
T7	20 - 0	Leg	Pirod 105219	155	-180751.00	399868.00	45.2	Pass	
T1	140 - 120	Diagonal	L1 3/4x1 3/4x1/8	12	-1188.20	3751.65	31.7	Pass	
T2	120 - 100	Diagonal	L1 3/4x1 3/4x1/4	38	-5466.62	6999.86	78.1	Pass	
T3	100 - 80	Diagonal	L2 1/2x2 1/2x5/16	64	-7159.04	23771.20	30.1	Pass	
T4	80 - 60	Diagonal	L2 1/2x2 1/2x5/16	96	-4880.07	19680.00	24.8	Pass	
T5	60 - 40	Diagonal	L2 1/2x2 1/2x5/16	123	-5020.21	14501.70	34.6	Pass	
T6	40 - 20	Diagonal	L3x3x5/16	144	-6002.07	14801.00	40.6	Pass	
T7	20 - 0	Diagonal	L3x3x5/16	159	-7151.48	12157.80	58.8	Pass	
T1	140 - 120	Top Girt	L3x3x3/8	6	-162.80	18687.70	0.9	Pass	
							Summary		
							Leg (T4)	56.7	Pass
							Diagonal (T2)	78.1	Pass
							Top Girt (T1)	0.9	Pass
							RATING =	78.1	Pass