



INDUSTRIAL AVE,  
SUITE 3  
MORRISTOWN NJ 07430

PHONE: 201.684.0055  
FAX: 201.684.0066

August 16, 2021

Members of the Siting Council  
Connecticut Siting Council  
10 Franklin Square  
New Britain, CT 06051

RE: Notice of Exempt Modification  
148 Roberts Street, East Hartford, CT 06108  
Latitude: 41.77330556  
Longitude: -72.61341667  
T-Mobile Site#: CTHA505A - Anchor/L600

Dear Ms. Bachman:

T-Mobile currently maintains six (6) antennas at the 100' level of the 130' monopole located at 148 Roberts Street in East Hartford, CT. The monopole is owned by American Tower and the property is owned by Greater Hartford Transit District. T-Mobile now intends to replace three (3) of its existing antennas with six (6) L700/L600/N600/L1900/L2100/U2100/L2500/N2500 antennas. The new antennas would be installed at the same 100' level of the tower. The new antennas support 5G services.

**Planned Modifications:**

**Tower:**

Install New:

- (3) Ericsson AIR6449 B41 Antennas
- (3) RFS APXVAALL24 43-U-NA20 Antennas
- (3) Radio 4449 B71 B85
- (3) Radio 4415 B66
- (3) SDX 1926Q-43 Diplexers
- (3) 1 5/8" Hybrid Cables

To Be Removed:

- (3) Ericsson AIR21 KRC118023-1 Antennas
- (1) 1 5/8" Hybrid Cable

To Remain:

(3) AIR32 B66A/B2A Antennas

(6) 7/8" Coax Cables

Ground Work:

**Install** (1) 6160 Equipment Cabinet, (1) Battery Cabinet B160, and (2) BB6648

This facility was approved by the Connecticut Siting Council in Docket No. 228 on November 7, 2002. The Docket is attached. None of the modifications break the conditions given.

Please accept this letter as notification pursuant to Regulations of Connecticut State Agencies § 16-50j-73, for construction that constitutes an exempt modification pursuant to R.C.S.A. § 16-50j-72(b)(2). In accordance with R.C.S.A. § 16-50j-73, a copy of this letter is being sent to Mayor Marcia Leclerc, Elected Official, and The Planning and Zoning Department of Madison, as well as the property and tower owner.

The planned modifications to the facility fall squarely within those activities explicitly provided for in R.C.S.A. § 16-50j-72(b)(2).

1. The proposed modifications will not result in an increase in the height of the existing structure.
2. The proposed modifications will not require the extension of the site boundary.
3. The proposed modifications will not increase noise levels at the facility by six decibels or more, or to levels that exceed state and local criteria.
4. The operation of the replacement antennas will not increase radio frequency emissions at the facility to a level at or above the Federal Communications Commission safety standard.
5. The proposed modifications will not cause a change or alteration in the physical or environmental characteristics of the site.
6. The existing structure and its foundation can support the proposed loading.

For the foregoing reasons, T-Mobile respectfully submits that the proposed modifications to the above referenced telecommunications facility constitute an exempt modification under R.C.S.A. § 16-50j-72(b)(2).

Sincerely,

**Eric Breun**

Transcend Wireless

Cell: 201-658-7728

Email: [ebreun@transcendwireless.com](mailto:ebreun@transcendwireless.com)

Attachments

cc: Marcia Leclerc - Mayor of East Hartford

Jeffrey Cormier - Town Planner

Greater Hartford Transit District - Property Owner

American Towers - Tower Owner

ERIC BREUN  
2016587728  
10 INDUSTRIAL AVE  
MAHWAH NJ 07430

1 LBS

1 OF 1

**SHIP TO:**  
TOWN PLANNER  
JEFFREY CORMIER  
740 MAIN STREET  
EAST HARTFORD CT 06108



**CT 061 9-01**

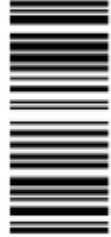

**UPS GROUND**

TRACKING #: 1Z V25 742 03 9306 9899

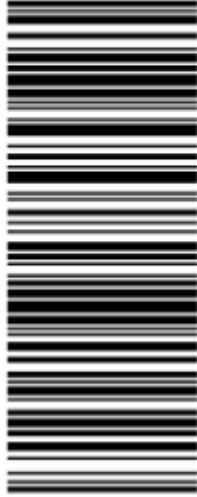

BILLING: P/P

Reference #1: CTHA505A

XOL 21.07.05 NV49 32.0A 06/2021\*



TM

ERIC BREUN  
2016587728  
10 INDUSTRIAL AVE  
MAHWAH NJ 07430

1 LBS

1 OF 1

**SHIP TO:**  
MAYOR MARCIA LECLERC  
740 MAIN STREET  
EAST HARTFORD CT 06108



**CT 061 9-01**

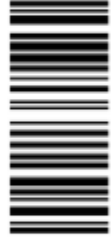

**UPS GROUND**

TRACKING #: 1Z V25 742 03 9331 1885

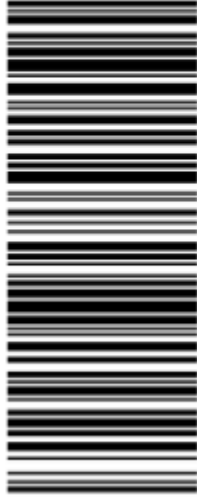

BILLING: P/P

Reference #1: CTHA505A

XOL 21.07.05 NV49 32.0A 06/2021\*



TM

ERIC BREUN  
2016587728  
10 INDUSTRIAL AVE  
MAHWAH NJ 07430

1 LBS

1 OF 1

**SHIP TO:**  
GREATER HARTFORD TRANSIT DISTRICT  
1 UNION PLACE  
**HARTFORD CT 06103**



**CT 061 9-03**

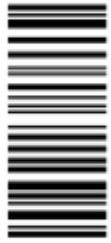

**UPS GROUND**

TRACKING #: 1Z V25 742 03 9674 5125

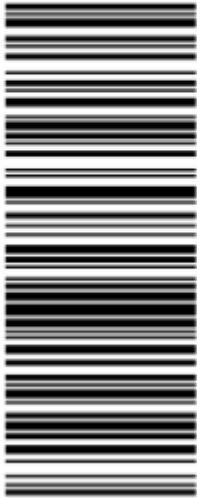

BILLING: P/P

Reference #1: CTHA505A

XOL 21.07.05 NV45 32.0A 08/2021\*



ERIC BREUN  
2016587728  
10 INDUSTRIAL AVE  
MAHWAH NJ 07430

1 LBS

1 OF 1

**SHIP TO:**  
AMERICAN TOWER CORPORATION  
10 PRESIDENTIAL WAY  
**WOBURN MA 01801**



**MA 018 9-04**



**UPS GROUND**

TRACKING #: 1Z V25 742 03 9103 1904

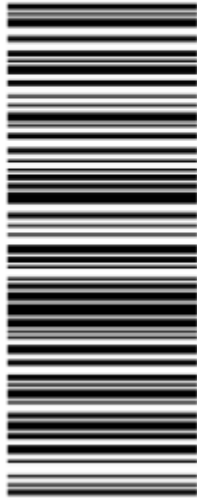

BILLING: P/P

Reference #1: CTHA505A

XOL 21.07.05 NV45 32.0A 08/2021\*





**Hello, your package has been delivered.**

**Delivery Date:** Thursday, 08/12/2021

**Delivery Time:** 3:49 PM

**Left At:** FRONT DESK

**Signed by:** MICHELLE

## **TRANSCEND WIRELESS**

<b>Tracking Number:</b>	<a href="#"><u>1ZV257420393311885</u></a>
<b>Ship To:</b>	MAYOR MARCIA LECLERC 740 MAIN STREET EAST HARTFORD, CT 06108 US
<b>Number of Packages:</b>	1
<b>UPS Service:</b>	UPS Ground
<b>Package Weight:</b>	1.0 LBS
<b>Reference Number:</b>	CTHA505A

**Hello, your package has been delivered.**

**Delivery Date:** Monday, 08/16/2021

**Delivery Time:** 12:02 PM

**Left At:** INSIDE DELIV

**Signed by:** ANCRI

## **TRANSCEND WIRELESS**

<b>Tracking Number:</b>	<a href="#"><u>1ZV257420391031904</u></a>
<b>Ship To:</b>	AMERICAN TOWER CORPORATION 10 PRESIDENTIAL WAY WOBURN, MA 01801 US
<b>Number of Packages:</b>	1
<b>UPS Service:</b>	UPS Ground
<b>Package Weight:</b>	1.0 LBS
<b>Reference Number:</b>	CTHA505A

**Hello, your package has been delivered.**

**Delivery Date:** Friday, 08/13/2021

**Delivery Time:** 1:20 PM

**Left At:** OFFICE

**Signed by:** AT DOOR

**TRANSCEND WIRELESS**

**Tracking Number:** [1ZV257420396745125](#)

**Ship To:** GREATER HARTFORD TRANSIT DISTRICT  
1 UNION PLACE  
HARTFORD, CT 06103  
US

**Number of Packages:** 1

**UPS Service:** UPS Ground

**Package Weight:** 1.0 LBS

**Reference Number:** CTHA505A

**Hello, your package has been delivered.**

**Delivery Date:** Friday, 08/13/2021

**Delivery Time:** 11:50 AM

**Left At:** FRONT DESK

**Signed by:** MICHILLE

**TRANSCEND WIRELESS**

**Tracking Number:** [1ZV257420393069899](#)

**Ship To:** JEFFREY CORMIER  
740 MAIN STREET  
EAST HARTFORD, CT 06108  
US

**Number of Packages:** 1

**UPS Service:** UPS Ground

**Package Weight:** 1.0 LBS

**Reference Number:** CTHA505A

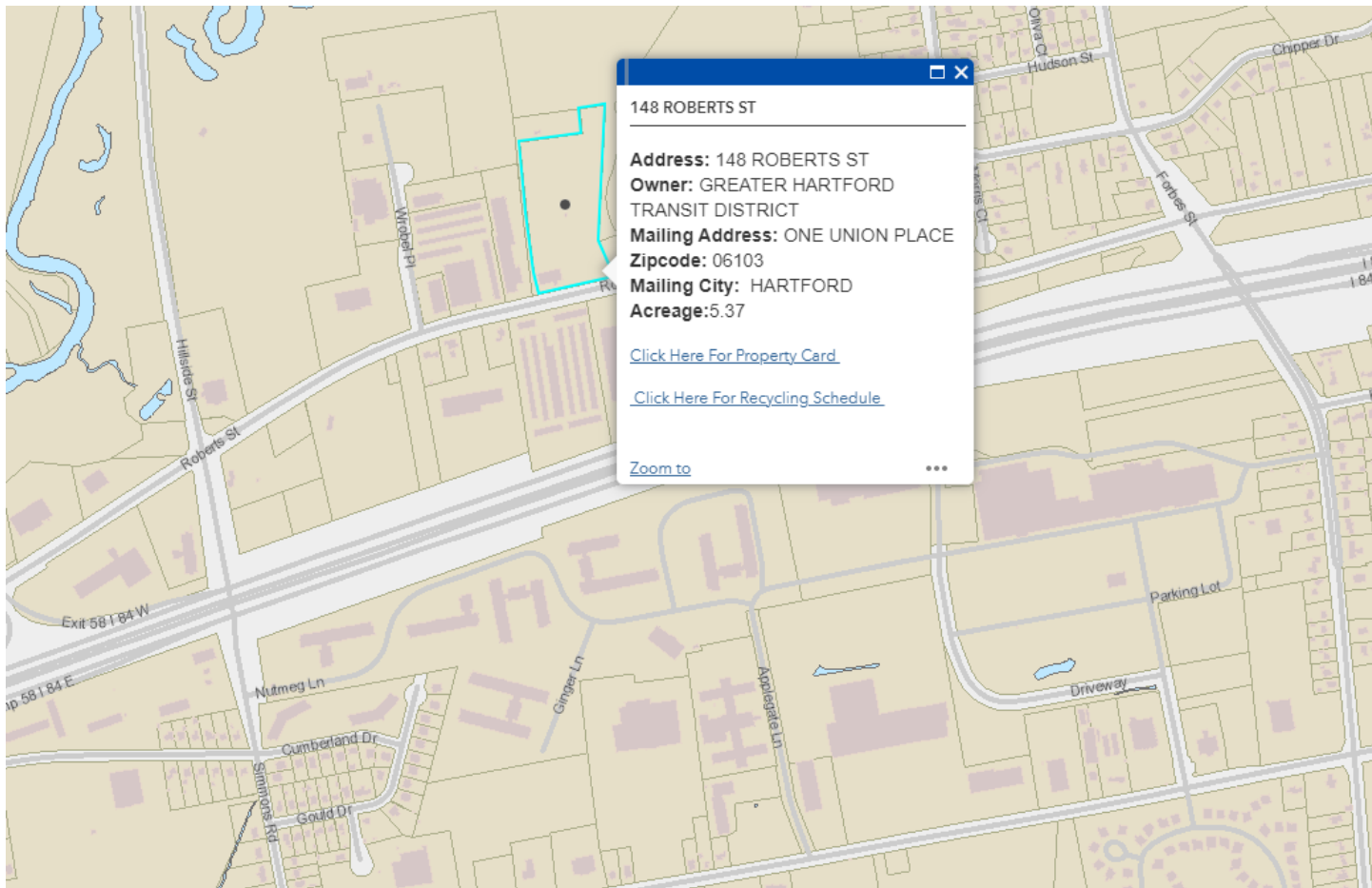

148 ROBERTS ST

---

**Address:** 148 ROBERTS ST  
**Owner:** GREATER HARTFORD  
TRANSIT DISTRICT  
**Mailing Address:** ONE UNION PLACE  
**Zipcode:** 06103  
**Mailing City:** HARTFORD  
**Acreage:** 5.37

[Click Here For Property Card](#)

[Click Here For Recycling Schedule](#)

[Zoom to](#) ...

# Town of East Hartford Property Summary Report

## 148 ROBERTS ST

<b>MAP LOT:</b>	35-18	<b>CAMA PID:</b>	12045
<b>LOCATION:</b>	148 ROBERTS ST		
<b>OWNER NAME:</b>	GREATER HARTFORD TRANSIT DISTRICT		

<b>OWNER OF RECORD</b>
GREATER HARTFORD TRANSIT DISTRICT
ONE UNION PLACE
HARTFORD, CT 06103

<b>LIVING AREA:</b>	37064	<b>ZONING:</b>	I2	<b>ACREAGE:</b>	5.37
---------------------	-------	----------------	----	-----------------	------

### SALES HISTORY

OWNER	BOOK / PAGE	SALE DATE	SALE PRICE
GREATER HARTFORD TRANSIT DISTRICT	3394/0102	03-Jun-2013	\$1,000,000.00
DOUBLE E PROPERTIES OF EAST HARTFORD LLC C/O CARMINE	3205/0125	05-Oct-2010	\$0.00
THE MASTERS CLUB L L C	2969/0212	02-Dec-2007	\$1,200,000.00
ELKS BENEVOLENT	0365/0358	30-Dec-1899	\$0.00

### CURRENT PARCEL ASSESSMENT

<b>TOTAL:</b>	\$3,194,630.00	<b>IMPROVEMENTS:</b>	\$2,956,920.00	<b>LAND:</b>	\$237,710.00
---------------	----------------	----------------------	----------------	--------------	--------------

### ASSESSING HISTORY

FISCAL YEAR	TOTAL VALUE	IMPROVEMENT VALUE	LAND VALUE
2019	\$3,194,630.00	\$2,956,920.00	\$237,710.00
2018	\$3,194,630.00	\$2,956,920.00	\$237,710.00
2017	\$3,194,630.00	\$2,956,920.00	\$237,710.00
2016	\$1,005,290.00	\$767,580.00	\$237,710.00
2015	\$303,730.00	\$66,020.00	\$237,710.00

# Town of East Hartford Property Summary Report

## 148 ROBERTS ST

<b>MAP LOT:</b>	35-18	<b>CAMA PID:</b>	12045
<b>LOCATION:</b>	148 ROBERTS ST		
<b>OWNER NAME:</b>	GREATER HARTFORD TRANSIT DISTRICT		

### BUILDING # 1

<b>YEAR BUILT</b>	2017	<b>EXT WALL 1</b>	Concr/Cinder
<b>STYLE</b>	Office	<b>INT WALLS 1</b>	Typical
<b>MODEL</b>	Comm/Ind	<b>HEAT FUEL</b>	Other
<b>STORIES</b>	2	<b>HEAT TYPE</b>	Other
<b>OCCUPANCY</b>	Exempt	<b>AC TYPE</b>	Partial
<b>ROOF</b>	Flat	<b>BEDROOMS</b>	
<b>ROOF COVER</b>	Metal	<b>FULL BATHS</b>	
<b>FLOOR COVER 1</b>	Mixed	<b>HALF BATHS</b>	
<b>% BSMT</b>	null	<b>TOTAL ROOMS</b>	
<b>% FIN BSMT</b>	null	<b>% REC RM</b>	null
<b>% SEMI FIN</b>		<b>% ATTIC FINISH</b>	null
<b>BSMT GARAGE</b>	null	<b>FIREPLACES</b>	null



### EXTRA FEATURES

DESCRIPTION	CODE	UNITS
Elevator Pass	ELV1	1.00 UNITS
Sprinklers-Wet	SPR1	23648.00 S.F.
Sprinklers-Dry	SPR3	13416.00 S.F.

### EXTRA FEATURES

DESCRIPTION	CODE	UNITS
Paving	PAV1	154000.00 SF
Concrete Slab-Reinforced	PAV3	84.00 S.F.
Concrete Slab-Reinforced	PAV3	420.00 S.F.



# CONNECTICUT SITING COUNCIL

[Home](#) [About Us](#) [Pending Matters](#) [Decisions](#) [Forms](#) [Contact Us](#)



**Robert Stein**  
Chairman

- [Filing Guides](#)
- [Meetings & Minutes](#)
- [Public Participation](#)
- [Audio Link to New Britain Hearing Rooms](#)
- [Programs & Services](#)
- [Telecommunications Database](#)
- [Publications](#)
- [Other Resources](#)
- [Statutes & Regulations](#)
- [Electric Transmission Upgrade Projects](#)
- [Frequently Asked Questions](#)



[Robert Stein](#)  
Chairman

Melanie Bachman,  
Acting Executive Director

### NOTICE TO USERS

The Connecticut Siting Council posts filed documents to this site as a public service. The Council disclaims any liability for the content of submissions made by parties, intervenors, public officials, and the general public. Further, while the Council seeks to be complete in its postings, the Council urges users of this site to confirm with the submitter the completeness of the postings made. The posting of any

## Decisions

[Printable Version](#)

**DOCKET NO. 228** – The Marcus Group, LLC application } Connecticut  
 for a Certificate of Environmental Compatibility and Public }  
 Need for the construction, maintenance and operation of a } Siting  
 cellular telecommunications facility at 148 Roberts Street, } Council  
 East Hartford, Connecticut. }  
 } November 7, 2002

### Decision and Order

Pursuant to the foregoing Findings of Fact and Opinion, the Connecticut Siting Council (Council) finds that the effects associated with the construction, operation, and maintenance of a telecommunications facility including effects on the natural environment; ecological integrity and balance; public health and safety; scenic, historic, and recreational values; forests and parks; air and water purity; and fish and wildlife are not disproportionate either alone or cumulatively with other effects when compared to need, are not in conflict with the policies of the State concerning such effects, and are not sufficient reason to deny the application and therefore directs that a Certificate of Environmental Compatibility and Public Need, as provided by General Statutes § 16-50k, be issued to The Marcus Group (Marcus) for the construction, maintenance and operation of a wireless telecommunications facility at the proposed prime site located at 148 Roberts Street, East Hartford, Connecticut.

The facility shall be constructed, operated, and maintained substantially as specified in the Council's record in this matter, and subject to the following conditions:

1. The tower shall be constructed as a monopole, no taller than necessary to provide the proposed telecommunications services, sufficient to accommodate the antennas of AT&T Wireless LLC, Celco Partnership b/b/a Verizon Wireless, Nextel Communications of the Mid-Atlantic, and other entities, both public and private, but such tower shall not exceed a height of 120 feet above ground level. The access road to the facility shall be finished with gravel. The north edge of the facility compound shall be a minimum distance of 52 feet to the nearest wetland area.
2. The Certificate Holder shall prepare a Development and Management (D&M) Plan for this site in compliance with Sections 16-50j-75 through 16-50j-77 of the Regulations of Connecticut State Agencies. The D&M Plan shall be submitted to and approved by the Council prior to the commencement of facility construction and shall include: a final site plan(s) for site development to include the location and specifications for the tower, tower foundation, antennas, equipment buildings, security fence, access road, utility line, and landscaping plan. The D&M Plan shall also include construction plans to be submitted prior to construction for site clearing, water drainage, and erosion and sedimentation control consistent with the Connecticut Guidelines for Soil Erosion and Sediment Control, as amended.
3. The Certificate Holder shall, prior to the commencement of operation, provide the Council worst-case modeling of electromagnetic radio frequency power density of all proposed entities' antennas at the closest point of uncontrolled access to the tower base, consistent with Federal Communications Commission, Office of Engineering and Technology, Bulletin No. 65, August 1997. The Certificate Holder shall provide a recalculated report of electromagnetic radio frequency power density if and when circumstances in operation cause a change in power density above the levels calculated and provided pursuant to this Decision and Order.
4. Upon the establishment of any new state or federal radio frequency standards applicable to frequencies of this facility, the facility granted herein shall be brought into compliance with such standards.
5. The Certificate Holder shall permit public or private entities to share space on the proposed tower for fair consideration, or shall provide any requesting entity with specific legal, technical, environmental, or economic reasons precluding such tower sharing.
6. If the facility does not initially provide, or permanently ceases to provide wireless services following completion of construction, this Decision and Order shall be void, and the Certificate Holder shall dismantle the tower and remove all associated equipment or reapply for any continued or new use to the Council before any such use is made.
7. Any antenna that becomes obsolete and ceases to function shall be removed within 60

document does not constitute or imply endorsement by the Connecticut Siting Council. Finally, the Connecticut Siting Council assumes no responsibility for the use of documents posted on this site.

For further information about the proper use of material posted on this site, please see the State of Connecticut [disclaimer](#).

days after such antennas become obsolete and ceases to function.

- 8. Unless otherwise approved by the Council, this Decision and Order shall be void if the facility authorized herein is not operational within one year of the effective date of this Decision and Order or within one year after all appeals to this Decision and Order have been resolved.

Pursuant to General Statutes § 16-50p, we hereby direct that a copy of the Findings of Fact, Opinion, and Decision and Order be served on each person listed below, and notice of issuance shall be published in The Hartford Courant, and The East Hartford Gazette.

By this Decision and Order, the Council disposes of the legal rights, duties, and privileges of each party named or admitted to the proceeding in accordance with Section 16-50j-17 of the Regulations of Connecticut State Agencies.

The parties and intervenors to this proceeding are:

**Applicant**

The Marcus Group, LLC

**Its Representative**

Julie Donaldson Kohler, Esq.  
Hurwitz & Sagarin, LLC  
147 N. Broad Street  
Milford, CT 06460  
(203) 877-8000

**Intervenor**

Cellco Partnership  
d/b/a Verizon Wireless

**Its Representative**

Kenneth C. Baldwin, Esq.  
Robinson & Cole LLP  
280 Trumbull Street  
Hartford, CT 06103-3597  
(860) 275-8200

Content Last Modified on 11/18/2002 9:22:37 AM

Ten Franklin Square New Britain, CT 06051 / 860- 827-2935

[Home](#) | [CT.gov Home](#) | [Send Feedback](#) | [Login](#) | [Register](#)  
State of Connecticut [Disclaimer](#), [Privacy Policy](#), and [Web Site Accessibility Policy](#). Copyright © 2002-2016 State of Connecticut.





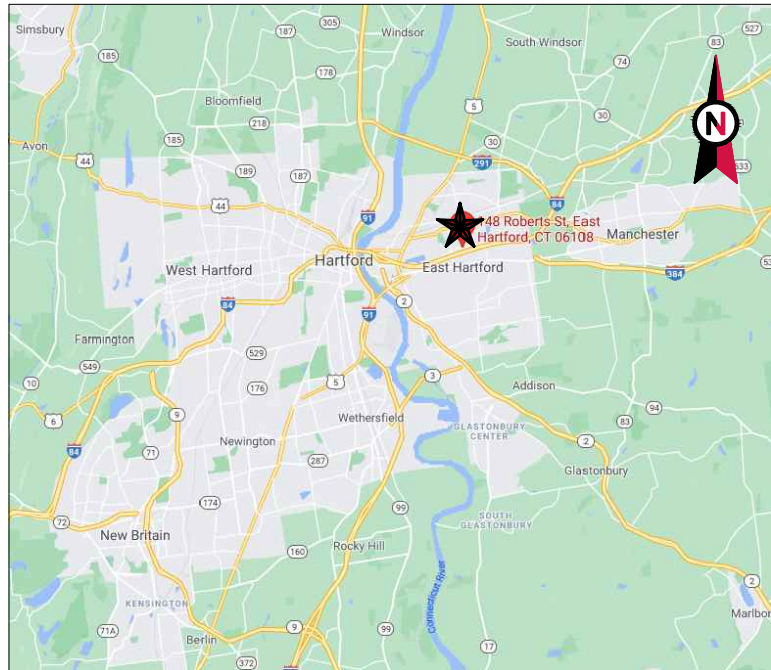

VICINITY MAP



**AMERICAN TOWER®**

ATC SITE NAME: EAST HARTFORD  
 ATC SITE NUMBER: 370626  
 T-MOBILE SITE NAME: CROWN E. HARTFORD  
 MONOPOLE  
 T-MOBILE SITE NUMBER: CTHA505A  
 SITE ADDRESS: 148 ROBERTS ST.

EAST HARTFORD, CT, 06108  
 T-MOBILE ANCHOR ANTENNA AMENDMENT PLAN  
 67D5997DB\_2XAIR+1OP CONFIGURATION



LOCATION MAP



**Kimley»Horn**

COA: 17166  
 421 FAYETTEVILLE ST, SUITE 600  
 RALEIGH, NC 27601

REV.	DESCRIPTION	BY	DATE
A	PRELIM	ARC	06/11/21
0	ISSUED FOR CONSTRUCTION	RCG	07/12/21

ATC SITE NUMBER:  
**370626**  
 ATC SITE NAME:  
**EAST HARTFORD**  
 T-MOBILE SITE NAME:  
**CROWN E. HARTFORD**  
**MONOPOLE**  
 SITE ADDRESS:  
 148 ROBERTS ST.  
 EAST HARTFORD, CT, 06108

SEAL:

DocuSigned by:  
 Kyle Frechart  
 D8BEE252A3804C1...



DATE DRAWN:	07/12/21
ATC JOB NO:	13677849
CUSTOMER ID:	CROWN E. HARTFORD MONOPOLE
CUSTOMER #:	CTHA505A

TITLE SHEET

SHEET NUMBER:  
**G-001**

REVISION:  
**0**

COMPLIANCE CODE	PROJECT SUMMARY	PROJECT DESCRIPTION	SHEET INDEX				
ALL WORK SHALL BE PERFORMED AND MATERIALS INSTALLED IN ACCORDANCE WITH THE CURRENT EDITIONS OF THE FOLLOWING CODES AS ADOPTED BY THE LOCAL GOVERNMENT AUTHORITIES. NOTHING IN THESE PLANS IS TO BE CONSTRUED TO PERMIT WORK NOT CONFORMING TO THESE CODES.  1. 2015 INTERNATIONAL BUILDING CODE (IBC) 2. 2017 NATIONAL ELECTRIC CODE (NEC) 3. LOCAL BUILDING CODE 4. CITY/COUNTY ORDINANCES	<u>SITE ADDRESS:</u> 148 ROBERTS ST. EAST HARTFORD, CT, 06108 COUNTY: HARTFORD <u>GEOGRAPHIC COORDINATES:</u> LATITUDE: 41.77330556 LONGITUDE: -72.61341667 GROUND ELEVATION: 50' AMSL	THE PROPOSED PROJECT INCLUDES MODIFYING GROUND BASED AND TOWER MOUNTED EQUIPMENT AS INDICATED PER BELOW: <u>TOWER WORK:</u> REMOVE (3) AIR21 KRC118046-1_B2P_B4A ANTENNA(s) AND (1) 9X18 (1 5/8") HYBRID CABLE(s)  INSTALL (3) AIR6449 B41 ANTENNA(s),(3) APXVAALL24 43-U-NA20 ANTENNA(s), (3) RADIO 4449 B71 B85A RRH(s),(3) 4415 B66 RRH(s), (3) SDX 1926Q-43 DIPLEXER(s) AND (3) 9X18 (1 5/8") HYBRID CABLE(s)  EXISTING (3) AIR32 B66AA/B2A ANTENNA(s), AND (6) 3X6 (7/8") COAX CABLE(s) TO REMAIN  <u>GROUND WORK:</u> INSTALL (1) ENCLOSURE 6160 CABINET, (1) B160 CABINET AND (2) BB6648  EXISTING (1) RBS 6201 ODE CABINET, (1) DUW30 AND (1) BB6648 TO REMAIN	SHEET NO:	DESCRIPTION:	REV:	DATE:	BY:
	<u>PROJECT TEAM</u>  <u>TOWER OWNER:</u> AMERICAN TOWER 10 PRESIDENTIAL WAY WOBURN, MA 01801  <u>ENGINEER:</u> KIMLEY-HORN & ASSOCIATES, INC. 421 FAYETTEVILLE ST, STE 600 RALEIGH, NC 27601 COA: 17166  <u>PROPERTY OWNER:</u> CARO LLC C/O PROPERTY TAX DEPT PO BOX 723597 ATLANTA, GA, 33139	THE PROPOSED PROJECT DOES NOT INCLUDE ELECTRICAL SCOPE  <u>PROJECT NOTES</u> 1. THE FACILITY IS UNMANNED. 2. A TECHNICIAN WILL VISIT THE SITE APPROXIMATELY ONCE A MONTH FOR ROUTINE INSPECTION AND MAINTENANCE. 3. THE PROJECT WILL NOT RESULT IN ANY SIGNIFICANT LAND DISTURBANCE OR EFFECT OF STORM WATER DRAINAGE. 4. NO SANITARY SEWER, POTABLE WATER OR TRASH DISPOSAL IS REQUIRED. 5. HANDICAP ACCESS IS NOT REQUIRED.	G-001	TITLE SHEET	0	07/12/21	RCG
<u>UTILITY COMPANIES</u>  POWER COMPANY: EVER SOURCE PHONE: (877) 659-6326  TELEPHONE COMPANY: FRONTEIR COMMUNICATION PHONE: (800) 376- 6843	<u>PROJECT TEAM</u>  <u>APPLICANT:</u> T-MOBILE SUE EMERY SUSAN.EMERY@T-MOBILE.COM	<u>PROJECT LOCATION DIRECTIONS</u> FROM HARTFORD: PROCEED FROM HARTFORD, CT. HEAD NORTH ON MAIN ST TOWARD GOLD ST 0.2 MI TURN RIGHT ONTO CENTRAL ROW 341 FT BEAR RIGHT ONTO AMERICAN ROW, THEN KEEP LEFT TO GET ONTO STATE ST 0.1 MI TAKE THE RAMP ON THE LEFT FOR CT-2 EAST AND HEAD TOWARD NEW LONDON / NORWICH 0.5 MI AT EXIT 2, HEAD RIGHT ON THE RAMP FOR I-84 EAST TOWARD BOSTON / E HARTFORD 1.6 MI AT EXIT 58, HEAD RIGHT ON THE RAMP FOR ROBERTS ST TOWARD BURNSIDE AVE / SILVER LANE 0.2 MI TURN LEFT ONTO ROBERTS ST 0.9 MI ARRIVE AT ROBERTS ST	G-002	GENERAL NOTES	0	07/12/21	RCG
			C-101	DETAILED SITE PLAN	0	07/12/21	RCG
			C-102	DETAILED GROUND PLAN	0	07/12/21	RCG
			C-201	TOWER ELEVATION	0	07/12/21	RCG
			C-401	ANTENNA INFORMATION & SCHEDULE	0	07/12/21	RCG
			C-501	CONSTRUCTION DETAILS	0	07/12/21	RCG
			E-501	GROUNDING DETAILS	0	07/12/21	RCG
			R-601	SUPPLEMENTAL			
			R-602	SUPPLEMENTAL			
			R-603	SUPPLEMENTAL			
			R-604	SUPPLEMENTAL			
			R-605	SUPPLEMENTAL			



**GENERAL CONSTRUCTION NOTES:**

1. OWNER FURNISHED MATERIALS, T-MOBILE "THE COMPANY" WILL PROVIDE AND THE CONTRACTOR WILL INSTALL
  - A. BTS EQUIPMENT FRAME (PLATFORM) AND ICEBRIDGE SHELTER (GROUND BUILD/CO-LOCATE ONLY)
  - B. AC/TELCO INTERFACE BOX (PPC)
  - C. ICE BRIDGE (CABLE TRAY WITH COVER) (GROUND BUILD/CO-LOCATE ONLY, GC TO FURNISH AND INSTALL FOR ROOFTOP INSTALLATION)
  - D. TOWERS, MONOPOLES
  - E. TOWER LIGHTING
  - F. GENERATORS & LIQUID PROPANE TANK
  - G. ANTENNA STANDARD BRACKETS, FRAMES AND PIPES FOR MOUNTING
  - H. ANTENNAS (INSTALLED BY OTHERS)
  - I. TRANSMISSION LINE
  - J. TRANSMISSION LINE JUMPERS
  - K. TRANSMISSION LINE CONNECTORS WITH WEATHERPROOFING KITS
  - L. TRANSMISSION LINE GROUND KITS
  - M. HANGERS
  - N. HOISTING GRIPS
  - O. BTS EQUIPMENT
2. THE CONTRACTOR IS RESPONSIBLE TO PROVIDE ALL OTHER MATERIALS FOR THE COMPLETE INSTALLATION OF THE SITE INCLUDING, BUT NOT LIMITED TO, SUCH MATERIALS AS FENCING, STRUCTURAL STEEL SUPPORTING SUB-FRAME FOR PLATFORM, ROOFING LABOR AND MATERIALS, GROUNDING RINGS, GROUNDING WIRES, COPPER-CLAD OR XIT CHEMICAL GROUND ROD(S), BUSS BARS, TRANSFORMERS AND DISCONNECT SWITCHES WHERE APPLICABLE, TEMPORARY ELECTRICAL POWER, CONDUIT, LANDSCAPING COMPOUND STONE, CRANES, CORE DRILLING, SLEEPERS AND RUBBER MATTING, REBAR, CONCRETE CAISSONS, PADS AND/OR AUGER MOUNTS, MISCELLANEOUS FASTENERS, CABLE TRAYS, NON-STANDARD ANTENNA FRAMES AND ALL OTHER MATERIAL AND LABOR REQUIRED TO COMPLETE THE JOB ACCORDING TO THE DRAWINGS AND SPECIFICATIONS. IT IS THE POSITION OF T-MOBILE TO APPLY FOR PERMITTING AND CONTRACTOR RESPONSIBLE FOR PICKUP AND PAYMENT OF REQUIRED PERMITS.
3. ALL WORK SHALL CONFORM TO ALL CURRENT APPLICABLE FEDERAL, STATE, AND LOCAL CODES, INCLUDING ANSIEIA/ITIA-222, AND COMPLY WITH ATC CONSTRUCTION SPECIFICATIONS.
4. CONTRACTOR SHALL CONTACT LOCAL 811 FOR IDENTIFICATION OF UNDERGROUND UTILITIES PRIOR TO START OF CONSTRUCTION.
5. CONTRACTOR SHALL BE RESPONSIBLE FOR COORDINATING ALL REQUIRED INSPECTIONS.
6. ALL DIMENSIONS TO, OF, AND ON EXISTING BUILDINGS, DRAINAGE STRUCTURES, AND SITE IMPROVEMENTS SHALL BE VERIFIED IN FIELD BY CONTRACTOR WITH ALL DISCREPANCIES REPORTED TO THE ENGINEER.
7. DO NOT CHANGE SIZE OR SPACING OF STRUCTURAL ELEMENTS.
8. DETAILS SHOWN ARE TYPICAL; SIMILAR DETAILS APPLY TO SIMILAR CONDITIONS UNLESS OTHERWISE NOTED.
9. THESE DRAWINGS DO NOT INCLUDE NECESSARY COMPONENTS FOR CONSTRUCTION SAFETY WHICH SHALL BE THE SOLE RESPONSIBILITY OF THE CONTRACTOR.
10. CONTRACTOR SHALL BRACE STRUCTURES UNTIL ALL STRUCTURAL ELEMENTS NEEDED FOR STABILITY ARE INSTALLED. THESE ELEMENTS ARE AS FOLLOWS: LATERAL BRACING, ANCHOR BOLTS, ETC.
11. CONTRACTOR SHALL DETERMINE EXACT LOCATION OF EXISTING UTILITIES, GROUNDS DRAINS, DRAIN PIPES, VENTS, ETC. BEFORE COMMENCING WORK.
12. INCORRECTLY FABRICATED, DAMAGED, OR OTHERWISE MISFITTING OR NONCONFORMING MATERIALS OR CONDITIONS SHALL BE REPORTED TO THE T-MOBILE REP PRIOR TO REMEDIAL OR CORRECTIVE ACTION. ANY SUCH REMEDIAL ACTION SHALL REQUIRE WRITTEN APPROVAL BY THE T-MOBILE REP PRIOR TO PROCEEDING.
13. EACH CONTRACTOR SHALL COOPERATE WITH THE T-MOBILE REP, AND COORDINATE HIS WORK WITH THE WORK OF OTHERS.
14. CONTRACTOR SHALL REPAIR ANY DAMAGE CAUSED BY CONSTRUCTION OF THIS PROJECT TO MATCH EXISTING PRE-CONSTRUCTION CONDITIONS TO THE SATISFACTION OF THE T-MOBILE CONSTRUCTION MANAGER.
15. ALL CABLE/CONDUIT ENTRY/EXIT PORTS SHALL BE WEATHERPROOFED DURING INSTALLATION USING A SILICONE SEALANT.
16. WHERE EXISTING CONDITIONS DO NOT MATCH THOSE SHOWN IN THIS PLAN SET, CONTRACTOR SHALL NOTIFY THE T-MOBILE REP AND ENGINEER OF RECORD IMMEDIATELY.
17. CONTRACTOR SHALL ENSURE ALL SUBCONTRACTORS ARE PROVIDED WITH A COMPLETE AND CURRENT SET OF DRAWINGS AND SPECIFICATIONS FOR THIS PROJECT.
18. CONTRACTOR SHALL REMOVE ALL RUBBISH AND DEBRIS FROM THE SITE AT THE END OF EACH DAY.
19. CONTRACTOR SHALL COORDINATE WORK SCHEDULE WITH AMERICAN TOWER CORPORATION (ATC) AND TAKE PRECAUTIONS TO MINIMIZE IMPACT AND DISRUPTION OF OTHER OCCUPANTS OF THE FACILITY.
20. CONTRACTOR SHALL FURNISH T-MOBILE AND AMERICAN TOWER CORPORATION (ATC) WITH A PDF MARKED UP AS-BUILT SET OF DRAWINGS UPON COMPLETION OF WORK.
21. PRIOR TO SUBMISSION OF BID, CONTRACTOR SHALL COORDINATE WITH T-MOBILE REP TO DETERMINE WHAT, IF ANY, ITEMS WILL BE PROVIDED. ALL ITEMS NOT PROVIDED SHALL BE PROVIDED AND INSTALLED BY THE CONTRACTOR. CONTRACTOR WILL INSTALL ALL ITEMS PROVIDED.

22. PRIOR TO SUBMISSION OF BID, CONTRACTOR SHALL COORDINATE WITH T-MOBILE REP TO DETERMINE IF ANY PERMITS WILL BE OBTAINED BY CONTRACTOR. ALL REQUIRED PERMITS NOT OBTAINED BY T-MOBILE MUST BE OBTAINED, AND PAID FOR, BY THE CONTRACTOR.
23. CONTRACTOR SHALL INSTALL ALL SITE SIGNAGE IN ACCORDANCE WITH T-MOBILE SPECIFICATIONS AND REQUIREMENTS.
24. CONTRACTOR SHALL SUBMIT ALL SHOP DRAWINGS TO T-MOBILE FOR REVIEW AND APPROVAL PRIOR TO FABRICATION.
25. ALL EQUIPMENT SHALL BE INSTALLED ACCORDING TO MANUFACTURER'S SPECIFICATIONS AND LOCATED ACCORDING TO T-MOBILE SPECIFICATIONS, AND AS SHOWN IN THESE PLANS.
26. THE CONTRACTOR SHALL SUPERVISE AND DIRECT THE PROJECT DESCRIBED HEREIN. THE CONTRACTOR SHALL BE SOLELY RESPONSIBLE FOR ALL THE CONSTRUCTION MEANS, METHODS, TECHNIQUES, SEQUENCES AND PROCEDURES AND FOR COORDINATING ALL PORTIONS OF THE WORK UNDER THE CONTRACT.
27. CONTRACTOR SHALL NOTIFY T-MOBILE REP A MINIMUM OF 48 HOURS IN ADVANCE OF POURING CONCRETE OR BACKFILLING ANY UNDERGROUND UTILITIES, FOUNDATIONS OR SEALING ANY WALL, FLOOR OR ROOF PENETRATIONS FOR ENGINEERING REVIEW AND APPROVAL.
28. CONTRACTOR SHALL BE RESPONSIBLE FOR SITE SAFETY INCLUDING COMPLIANCE WITH ALL APPLICABLE OSHA STANDARDS AND RECOMMENDATIONS AND SHALL PROVIDE ALL NECESSARY SAFETY DEVICES INCLUDING PPE AND PPM AND CONSTRUCTION DEVICES SUCH AS WELDING AND FIRE PREVENTION, TEMPORARY SHORING, SCAFFOLDING, TRENCH BOXES/SLOPING, BARRIERS, ETC.
29. THE CONTRACTOR SHALL PROTECT AT HIS OWN EXPENSE, ALL EXISTING FACILITIES AND SUCH OF HIS NEW WORK LIABLE TO INJURY DURING THE CONSTRUCTION PERIOD. ANY DAMAGE CAUSED BY NEGLIGENCE ON THE PART OF THIS CONTRACTOR OR HIS REPRESENTATIVES, OR BY THE ELEMENTS DUE TO NEGLIGENCE ON THE PART OF THIS CONTRACTOR OR HIS REPRESENTATIVES, EITHER TO THE EXISTING WORK, OR TO HIS WORK OR THE WORK OF ANY OTHER CONTRACTOR, SHALL BE REPAIRED AT HIS EXPENSE TO THE OWNER'S SATISFACTION.
30. ALL WORK SHALL BE INSTALLED IN A FIRST CLASS, NEAT AND WORKMANLIKE MANNER BY MECHANICS SKILLED IN THE TRADE INVOLVED. THE QUALITY OF WORKMANSHIP SHALL BE SUBJECT TO THE APPROVAL OF THE T-MOBILE REP. ANY WORK FOUND BY THE T-MOBILE REP TO BE OF INFERIOR QUALITY AND/OR WORKMANSHIP SHALL BE REPLACED AND/OR REWORKED AT CONTRACTOR EXPENSE UNTIL APPROVAL IS OBTAINED.
31. IN ORDER TO ESTABLISH STANDARDS OF QUALITY AND PERFORMANCE, ALL TYPES OF MATERIALS LISTED HEREINAFTER BY MANUFACTURER'S NAMES AND/OR MANUFACTURER'S CATALOG NUMBER SHALL BE PROVIDED BY THESE MANUFACTURERS AS SPECIFIED.
32. T-MOBILE FURNISHED EQUIPMENT SHALL BE PICKED-UP AT THE T-MOBILE WAREHOUSE, NO LATER THAN 48HR AFTER BEING NOTIFIED INSURED, STORED, UNCRATE, PROTECTED AND INSTALLED BY THE CONTRACTOR WITH ALL APPURTENANCES REQUIRED TO PLACE THE EQUIPMENT IN OPERATION, READY FOR USE. THE CONTRACTOR SHALL BE RESPONSIBLE FOR THE EQUIPMENT AFTER PICKING IT UP.
33. T-MOBILE OR HIS ARCHITECT/ENGINEER RESERVES THE RIGHT TO REJECT ANY EQUIPMENT OR MATERIALS WHICH, IN HIS OWN OPINION ARE NOT IN COMPLIANCE WITH THE CONTRACT DOCUMENTS, EITHER BEFORE OR AFTER INSTALLATION AND THE EQUIPMENT SHALL BE REPLACED WITH EQUIPMENT CONFORMING TO THE REQUIREMENTS OF THE CONTRACT DOCUMENTS BY THE CONTRACTOR AT NO COST TO T-MOBILE OR THEIR ARCHITECT/ENGINEER.

**SPECIAL CONSTRUCTION**

**ANTENNA INSTALLATION NOTES:**

1. WORK INCLUDED:
  - A. ANTENNA AND COAXIAL CABLES ARE FURNISHED BY T-MOBILE UNDER A SEPARATE CONTRACT. THE CONTRACTOR SHALL ASSIST ANTENNA INSTALLATION CONTRACTOR IN TERMS OF COORDINATION AND SITE ACCESS. ERECTION SUBCONTRACTOR SHALL BE RESPONSIBLE FOR THE PROTECTION OF PERSONNEL.
  - B. INSTALL ANTENNA AS INDICATED ON DRAWINGS AND T-MOBILE SPECIFICATIONS.
  - C. INSTALL GALVANIZED STEEL ANTENNA MOUNTS AS INDICATED ON DRAWINGS.
  - D. INSTALL FURNISHED GALVANIZED STEEL OR ALUMINUM WAVEGUIDE.
  - E. CONTRACTOR SHALL PROVIDE FOUR (4) SETS OF SWEEP TESTS USING ANRITZU-PACKARD 8713B RF SCALAR NETWORK ANALYZER. SUBMIT FREQUENCY DOMAIN REFLECTOMETER(FDR) TESTS RESULTS TO THE PROJECT MANAGER. SWEEP TESTS SHALL BE AS PER ATTACHED RFS "MINIMUM FIELD TESTING RECOMMENDED FOR ANTENNA AND HELIAX COAXIAL CABLE SYSTEMS" DATED 10/5/93. TESTING SHALL BE PERFORMED BY AN INDEPENDENT TESTING SERVICE AND BE BOUND AND SUBMITTED WITHIN ONE WEEK OF WORK COMPLETION.
  - F. INSTALL COAXIAL CABLES AND TERMINATING BETWEEN ANTENNAS AND EQUIPMENT PER MANUFACTURER'S RECOMMENDATIONS. WEATHERPROOF ALL CONNECTIONS BETWEEN THE ANTENNA AND EQUIPMENT PER MANUFACTURER'S REQUIREMENTS. TERMINATE ALL COAXIAL CABLE THREE (3) FEET IN EXCESS OF ENTRY PORT LOCATION UNLESS OTHERWISE STATED.
  - G. ANTENNA AND COAXIAL CABLE GROUNDING:
    - i. ALL EXTERIOR #6 GREEN GROUND WIRE "DAISY CHAIN" CONNECTIONS ARE TO BE WEATHER SEALED WITH RFS CONNECTORS/SPLICE WEATHERPROOFING KIT #221213 OR EQUAL.
    - ii. ALL COAXIAL CABLE GROUNDING KITS ARE TO BE INSTALLED ON STRAIGHT RUNS OF COAXIAL CABLE (NOT WITHIN BENDS).

**ALL DISCREPANCIES FROM WHAT IS SHOWN ON THESE CONSTRUCTION DRAWINGS SHALL BE COMMUNICATED TO ATC ENGINEERING IMMEDIATELY FOR CORRECTION OR RE-DESIGN. FAILURE TO COMMUNICATE DIRECTLY WITH ATC ENGINEERING OR ANY CHANGES FROM THE DESIGN CONDUCTED WITHOUT PRIOR APPROVAL FROM ATC ENGINEERING SHALL BE THE SOLE RESPONSIBILITY OF THE GENERAL CONTRACTOR.**



**Kimley»Horn**

**COA: 17166  
421 FAYETTEVILLE ST, SUITE 600  
RALEIGH, NC 27601**

REV.	DESCRIPTION	BY	DATE
A	PRELIM	ARC	06/11/21
0	ISSUED FOR CONSTRUCTION	RCG	07/12/21

ATC SITE NUMBER:  
**370626**  
ATC SITE NAME:  
**EAST HARTFORD**  
T-MOBILE SITE NAME:  
**CROWN E. HARTFORD**  
**MONOPOLE**  
SITE ADDRESS:  
148 ROBERTS ST.  
EAST HARTFORD, CT, 06108

SEAL:

DocuSigned by:  
*Kyle Frechart*  
D8BEE252A3804C1...



DATE DRAWN:	07/12/21
ATC JOB NO:	13677849
CUSTOMER ID:	CROWN E. HARTFORD MONOPOLE
CUSTOMER #:	CTHA505A

**GENERAL NOTES**

SHEET NUMBER: <b>G-002</b>	REVISION: <b>0</b>
-------------------------------	-----------------------

Copyright © 2021 ATC IP LLC, All Rights Reserved.

**SITE PLAN NOTES:**

1. THIS SITE PLAN REPRESENTS THE BEST PRESENT KNOWLEDGE AVAILABLE TO THE ENGINEER AT THE TIME OF THIS DESIGN. THE CONTRACTOR SHALL VISIT THE SITE PRIOR TO CONSTRUCTION AND VERIFY ALL EXISTING CONDITIONS RELATED TO THE SCOPE OF WORK FOR THIS PROJECT.
2. ICE BRIDGE, CABLE LADDER, COAX PORT, AND COAX CABLE ARE SHOWN FOR REFERENCE ONLY. CONTRACTOR SHALL CONFIRM THE EXACT LOCATION OF ALL PROPOSED AND EXISTING EQUIPMENT AND STRUCTURES DEPICTED ON THIS PLAN. BEFORE UTILIZING EXISTING CABLE SUPPORTS, COAX PORTS, INSTALLING NEW PORTS OR ANY OTHER EQUIPMENT, CONTRACTOR SHALL VERIFY ALL ASPECTS OF THE COMPONENTS MEET THE ATC SPECIFICATIONS.
3. NO ELECTRICAL SCOPE IS INCLUDED IN THIS PROJECT.

LEGEND	
⊗	GROUNDING TEST WELL
ATS	AUTOMATIC TRANSFER SWITCH
B	BOLLARD
CSC	CELL SITE CABINET
D	DISCONNECT
E	ELECTRICAL
F	FIBER
GEN	GENERATOR
G	GENERATOR RECEPTACAL
HH, V	HAND HOLE, VAULT
IB	ICE BRIDGE
K	KENTROX BOX
LC	LIGHTING CONTROL
M	METER
PB	PULL BOX
PP	POWER POLE
T	TELCO
TRN	TRANSFORMER
—x—	CHAINLINK FENCE

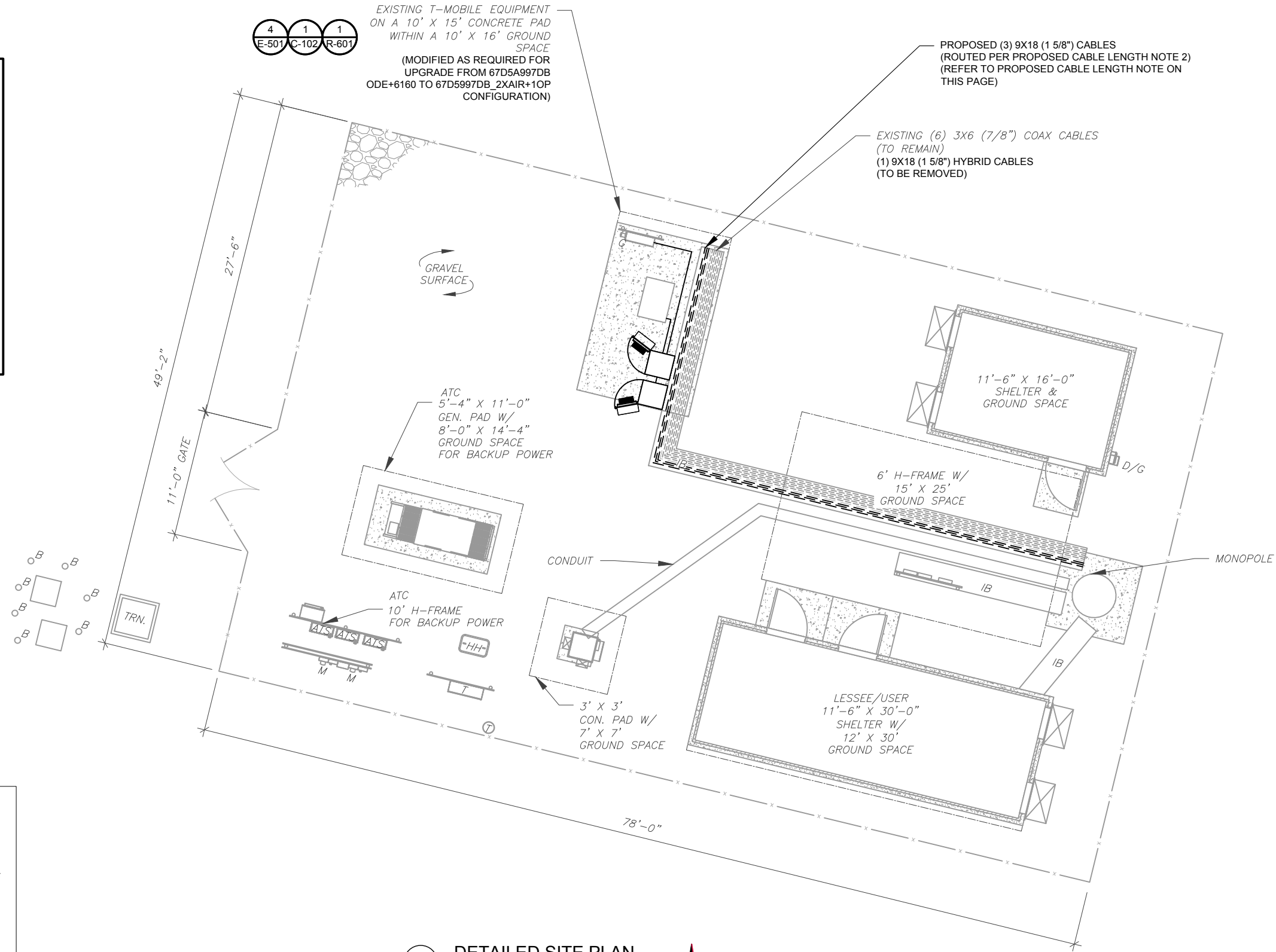

**PROPOSED CABLE LENGTH:**

1. ESTIMATED LENGTH OF PROPOSED CABLE IS 67'. ESTIMATED LENGTH OF CABLE WAS PROVIDED BY CUSTOMER OR CALCULATED BY ADDING THE RAD CENTER AND THE DISTANCE FROM THE SHELTER ENTRY PLATE TO THE TOWER (ALONG THE ICE BRIDGE) AND A SAFETY FACTOR MEASUREMENT OF 15% (OF THE TWO PREVIOUS VALUES), CDS DEFER TO GREATEST CABLE LENGTH.
2. ROUTE PROPOSED CABLES ALONG SAME PATH AS EXISTING CABLES AND IN ACCORDANCE WITH STRUCTURAL ANALYSIS. IF ADEQUATE SPACE EXISTS, ROUTE CABLES THROUGH ENTRY PORT HOLE, UP INSIDE OF MONOPOLE, AND THROUGH EXIT PORT HOLE. IF ROUTING OUTSIDE THE MONOPOLE, ATTACH CABLES USING STAND-OFF ADAPTERS MOUNTED TO TOWER USING STAINLESS STEEL BANDING. ADEQUATELY SECURE CABLES USING EITHER APPROPRIATELY SIZED STAINLESS STEEL SNAP-INS OR MOUNTING HARDWARE AND BRACKETS AS SPECIFIED BY CABLE MANUFACTURER.

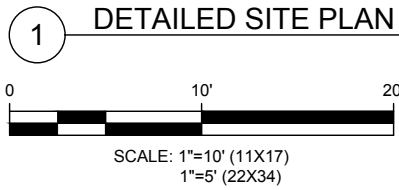

**Kimley»Horn**

COA: 17166  
421 FAYETTEVILLE ST, SUITE 600  
RALEIGH, NC 27601

REV.	DESCRIPTION	BY	DATE
A	PRELIM	ARC	06/11/21
0	ISSUED FOR CONSTRUCTION	RCG	07/12/21

ATC SITE NUMBER:  
**370626**  
ATC SITE NAME:  
**EAST HARTFORD**  
T-MOBILE SITE NAME:  
**CROWN E. HARTFORD**  
MONOPOLE  
SITE ADDRESS:  
148 ROBERTS ST.  
EAST HARTFORD, CT, 06108

SEAL:

DocuSigned by:  
*Kyle Freehart*  
D8BEE252A3804C1...



DATE DRAWN:	07/12/21
ATC JOB NO:	13677849
CUSTOMER ID:	CROWN E. HARTFORD MONOPOLE
CUSTOMER #:	CTHA505A

**DETAILED SITE PLAN**

SHEET NUMBER:	REVISION:
<b>C-101</b>	<b>0</b>

Copyright © 2021 ATC IP, LLC, All Rights Reserved.

**SITE PLAN NOTES:**

1. CONTRACTOR TO VERIFY THERE IS NO LIVE AAV FIBER RUNNING THROUGH EXISTING DEAD EQUIPMENT. IF SO, THIS WILL NEED TO BE RERUN THROUGH CONDUIT PRIOR TO REMOVING DEAD 2G (6201 CABS) EQUIPMENT.
2. REMOVE EXISTING 2G CABINETS, AND POWER / TELCO WHIPS ASSOCIATED WITH THE DEAD EQUIPMENT IF APPLICABLE.
3. ALL OPEN PORTS NEED TO BE SEALED / WEATHERPROOFED PROPERLY
4. ALL UNNEEDED / EXCESS EQUIPMENT AND GARBAGE TO BE REMOVED FROM EQUIPMENT AREA. DISPOSE OF MATERIALS PROPERLY OFF SITE.

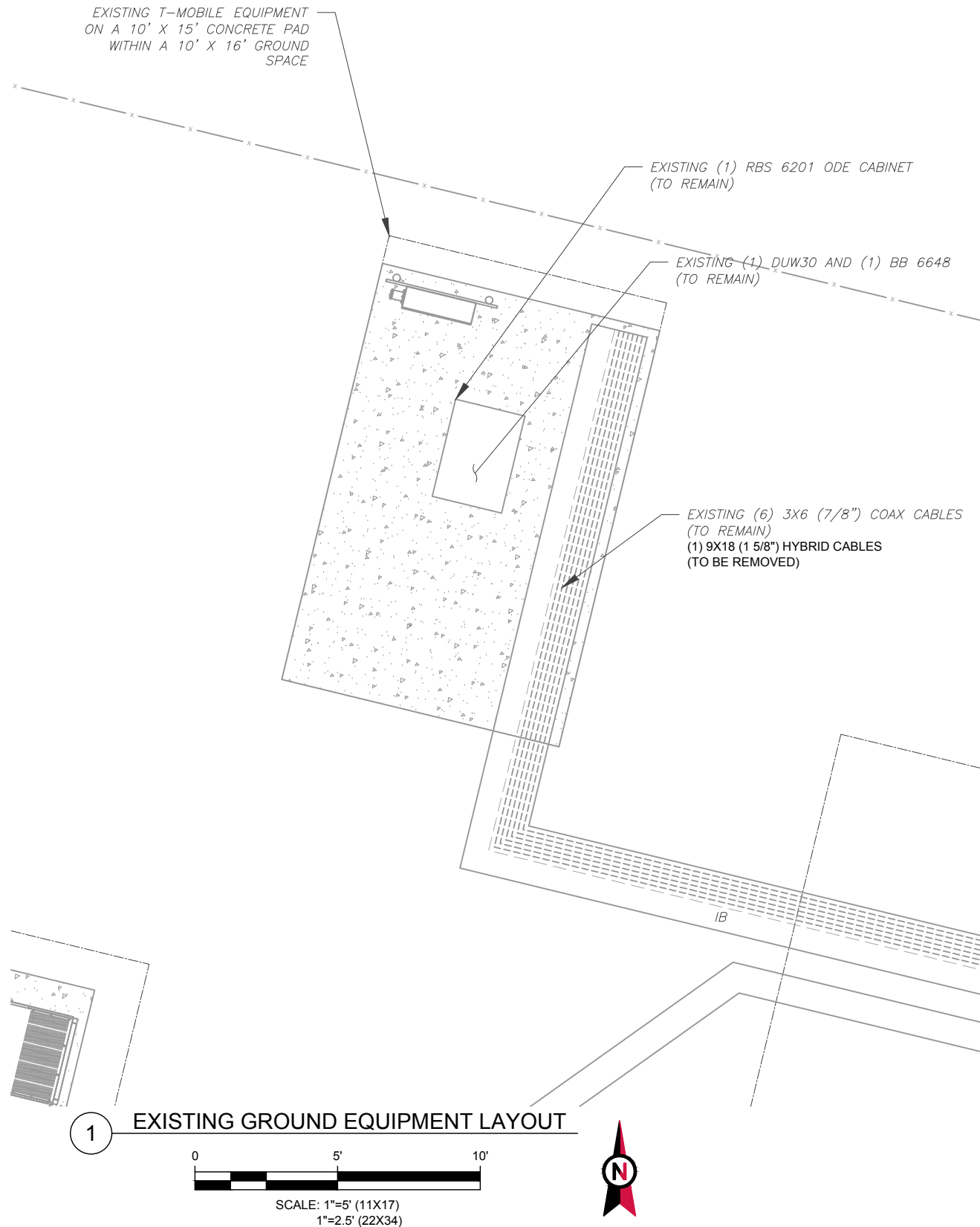

T-MOBILE CM APPROVAL REQUIRED BEFORE INSTALLING CABINETS

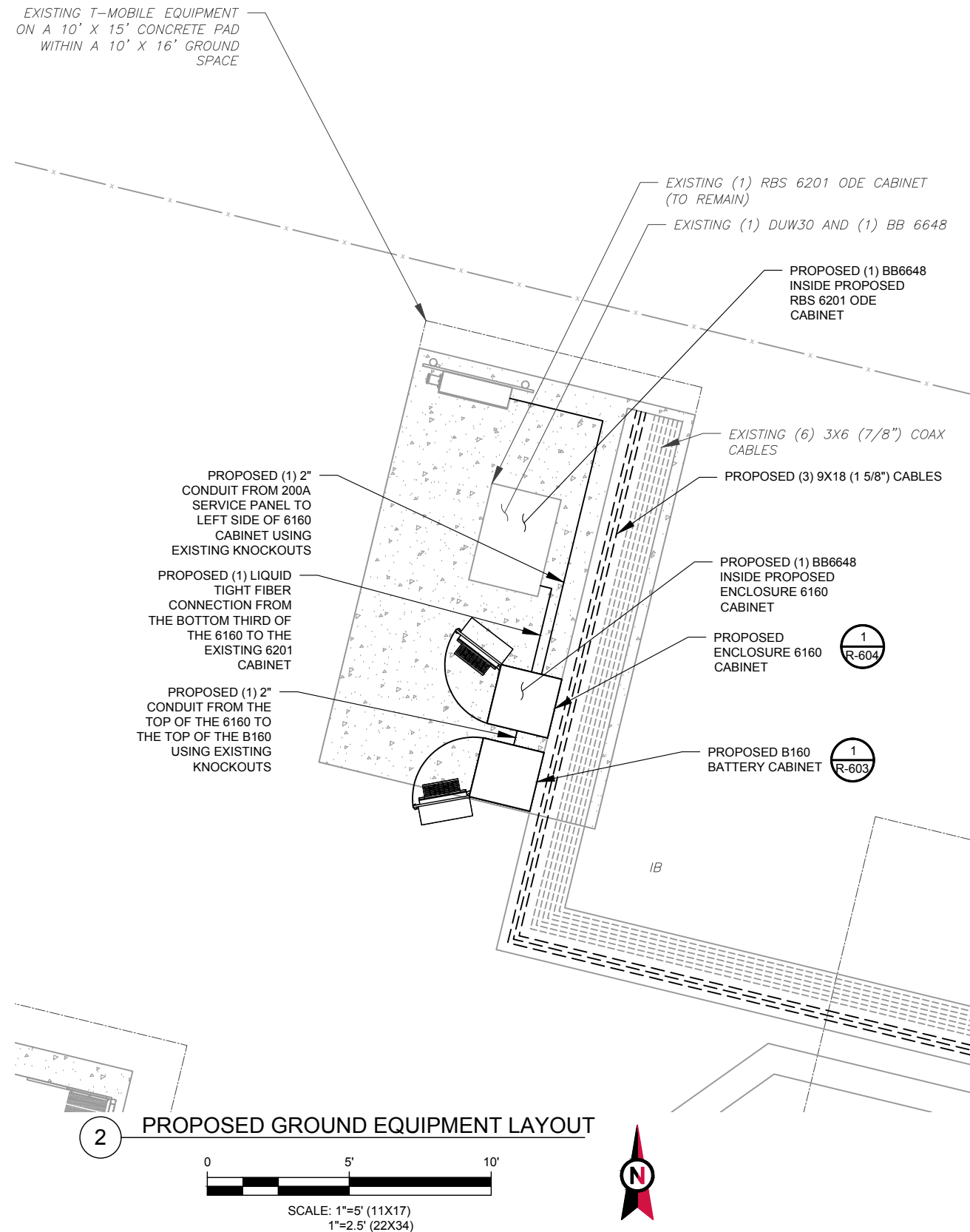

**Kimley»Horn**

COA: 17166  
421 FAYETTEVILLE ST, SUITE 600  
RALEIGH, NC 27601

REV.	DESCRIPTION	BY	DATE
A	PRELIM	ARC	06/11/21
0	ISSUED FOR CONSTRUCTION	RCG	07/12/21

ATC SITE NUMBER:  
**370626**

ATC SITE NAME:  
**EAST HARTFORD**

T-MOBILE SITE NAME:  
**CROWN E. HARTFORD MONOPOLE**

SITE ADDRESS:  
148 ROBERTS ST.  
EAST HARTFORD, CT, 06108

SEAL:

DocuSigned by:  
*Kyle Frechart*  
D8BEE252A3804C1...



DATE DRAWN:	07/12/21
ATC JOB NO:	13677849
CUSTOMER ID:	CROWN E. HARTFORD MONOPOLE
CUSTOMER #:	CTHA505A

**DETAILED GROUND PLAN**

SHEET NUMBER:	REVISION:
<b>C-102</b>	<b>0</b>

Copyright © 2021 ATC IP, LLC, All Rights Reserved.





**Kimley»Horn**

COA: 17166  
421 FAYETTEVILLE ST, SUITE 600  
RALEIGH, NC 27601

REV.	DESCRIPTION	BY	DATE
A	PRELIM	ARC	06/11/21
0	ISSUED FOR CONSTRUCTION	RCG	07/12/21

ATC SITE NUMBER:  
**370626**  
ATC SITE NAME:  
**EAST HARTFORD**  
T-MOBILE SITE NAME:  
**CROWN E. HARTFORD**  
MONOPOLE  
SITE ADDRESS:  
148 ROBERTS ST.  
EAST HARTFORD, CT, 06108

SEAL:

DocuSigned by:  
*Kyle Freehart*  
D8BEE252A3804C1



DATE DRAWN:	07/12/21
ATC JOB NO:	13677849
CUSTOMER ID:	CROWN E. HARTFORD MONOPOLE
CUSTOMER #:	CTHA505A

**TOWER ELEVATION**

SHEET NUMBER: <b>C-201</b>	REVISION: <b>0</b>
-------------------------------	-----------------------

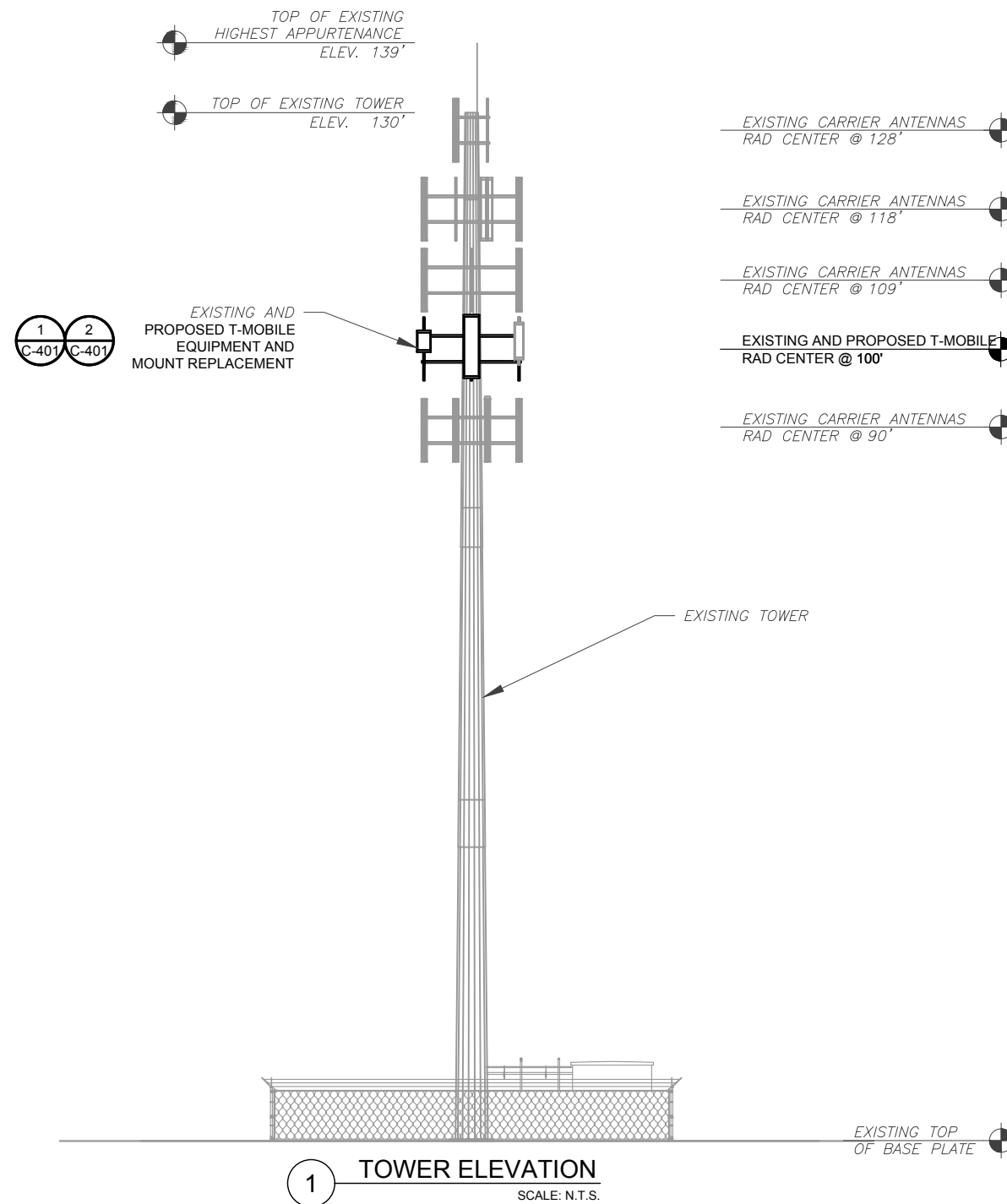

PER MOUNT ANALYSIS COMPLETED BY ATC, DATED 06/02/21, THE PROPOSED MOUNT CAN ADEQUATELY SUPPORT THE PROPOSED LOADING.

- TOWER NOTE:**
- IT IS THE CONTRACTOR'S RESPONSIBILITY TO CONFIRM WITH THE PROJECT MANAGER THAT THEY HAVE THE MOST RECENT VERSION OF THE STRUCTURAL ANALYSIS BEFORE COMMENCING WORK. EXISTING AND PROPOSED TOWER APPURTENANCES, MOUNTS, AND ANTENNAS ARE SHOWN BASED ON THE STRUCTURAL ANALYSIS.
  - WHERE APPLICABLE, ALL NEW ANTENNAS, EQUIPMENT, MOUNTS, CABLING, ETC. SHALL BE PAINTED/SOCKED TO MATCH EXISTING EQUIPMENT IN ACCORDANCE WITH FAA, JURISDICTION, AND/OR OTHER LOCAL REQUIREMENTS.
  - ROUTE PROPOSED CABLES ALONG SAME PATH AS EXISTING CABLES AND IN ACCORDANCE WITH STRUCTURAL ANALYSIS. IF ADEQUATE SPACE EXISTS, ROUTE CABLES THROUGH ENTRY PORT HOLE, UP INSIDE OF MONOPOLE, AND THROUGH EXIT PORT HOLE. IF ROUTING OUTSIDE THE MONOPOLE, ATTACH CABLES USING STAND-OFF ADAPTERS MOUNTED TO TOWER USING STAINLESS STEEL BANDING. ADEQUATELY SECURE CABLES USING EITHER APPROPRIATELY SIZED STAINLESS STEEL SNAP-INS OR MOUNTING HARDWARE AND BRACKETS AS SPECIFIED BY CABLE MANUFACTURER.
  - TOWER ELEVATIONS ARE MEASURED FROM TOP OF BASE PLATE TO MATCH STRUCTURAL ANALYSIS. ELEVATIONS DO NOT REFLECT TRUE ABOVE GROUND LEVEL (A.G.L.)

**1 TOWER ELEVATION**  
SCALE: N.T.S.

Copyright © 2021 ATC IP, LLC. All Rights Reserved.

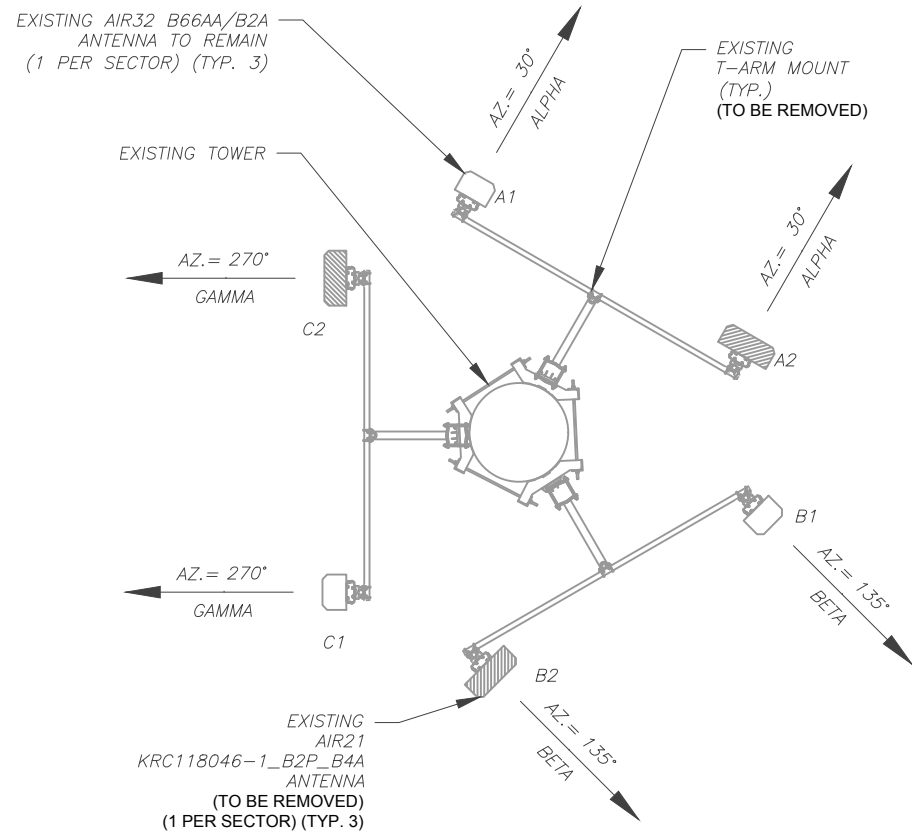

**1 EXISTING ANTENNA PLAN**  
SCALE: N.T.S.

PER MOUNT ANALYSIS COMPLETED BY ATC, DATED 06/02/21, THE PROPOSED MOUNT CAN ADEQUATELY SUPPORT THE PROPOSED LOADING.

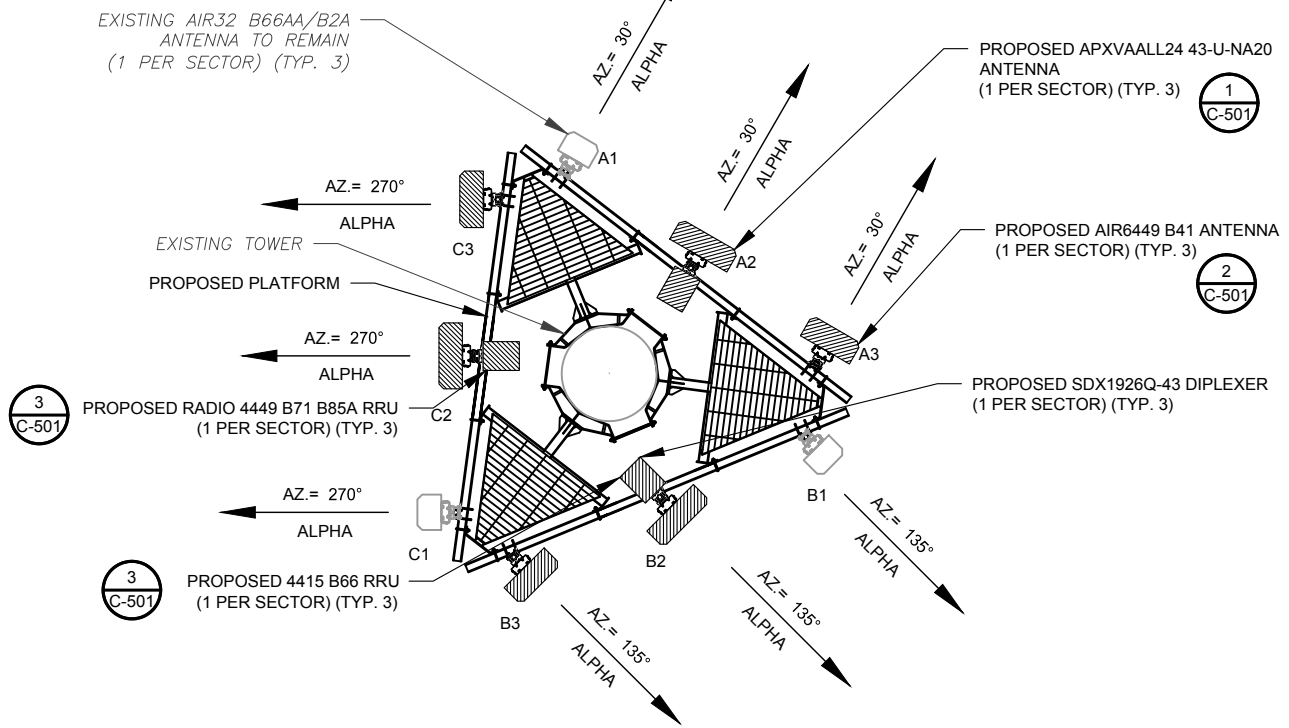

**2 FINAL ANTENNA PLAN**  
SCALE: N.T.S.

CONTRACTOR SHALL RE-ORIENT ANTENNA MOUNT(S) AS NECESSARY TO ACHIEVE PROPOSED ANTENNA AZIMUTHS

EXISTING ANTENNA SCHEDULE									
LOCATION		ANTENNA SUMMARY						NON ANTENNA SUMMARY	
SECTOR	RAD	AZ	POS	ANTENNA	BAND	MECH/ELEC D-TILT	STATUS	ADDITIONAL TOWER MOUNTED EQUIPMENT	STATUS
ALPHA	100'	30°	A1	AIR32 B66AA/B2A	L2100/L1900	0°/2'	REL	-	-
			A2	AIR21 KRC118046-1_B2P_B4A	U2100	0°/2'	RMV	-	-
BETA	100'	135°	B1	AIR32 B66AA/B2A	L2100/L1900	0°/2'	REL	-	-
			B2	AIR21 KRC118046-1_B2P_B4A	U2100	0°/2'	RMV	-	-
GAMMA	100'	270°	C1	AIR32 B66AA/B2A	L2100/L1900	0°/2'	REL	-	-
			C2	AIR21 KRC118046-1_B2P_B4A	U2100	0°/2'	RMV	-	-

**NOTES**

- CONFIRM WITH T-MOBILE REP FOR APPLICABLE UPDATES/REVISIONS AND MOST RECENT RFDS FOR NSN CONFIGURATION (CONFIG). GC TO CAP ALL UNUSED PORTS.
- CONFIRM SPACING OF PROPOSED EQUIP DOES NOT CAUSE TOWER CONFLICTS NOR IMPEDE TOWER CLIMBING PEGS.
- ROUTE HYBRID JUMPERS TO AVOID DAMAGE FROM BEING STEPPED UPON.

**STATUS ABBREVIATIONS**

RMV: TO BE REMOVED  
RMN: TO REMAIN  
REL: TO BE RELOCATED  
ADD: TO BE ADDED

**CABLE LENGTHS FOR JUMPERS**

JUNCTION BOX TO RRU: 15'  
RRU TO ANTENNA: 10'

FINAL ANTENNA SCHEDULE									
LOCATION		ANTENNA SUMMARY						NON ANTENNA SUMMARY	
SECTOR	RAD	AZ	POS	ANTENNA	BAND	MECH/ELEC D-TILT	STATUS	ADDITIONAL TOWER MOUNTED EQUIPMENT	STATUS
ALPHA	100'	30°	A1	AIR32 B66AA/B2A	L2100/L1900	0°/2'	RMN	-	-
			A2	APXVAALL21 43-U-NA20	L700/L600/N600/L1900 /U2100	0°/-	ADD	RADIO 4449 B71 B85A 4415 B66 SDX1926Q-43	ADD ADD ADD
			A3	AIR6449 B41	L2500/N2500	0°/-	ADD	-	-
BETA	100'	135°	B1	AIR32 B66AA/B2A	L2100/L1900	0°/2'	RMN	-	-
			B2	APXVAALL21 43-U-NA20	L700/L600/N600/L1900 /U2100	0°/-	ADD	RADIO 4449 B71 B85A 4415 B66 SDX1926Q-43	ADD ADD ADD
			B3	AIR6449 B41	L2500/N2500	0°/-	ADD	-	-
GAMMA	100'	270°	C1	AIR32 B66AA/B2A	L2100/L1900	0°/2'	RMN	-	-
			C2	APXVAALL21 43-U-NA20	L700/L600/N600/L1900 /U2100	0°/-	ADD	RADIO 4449 B71 B85A 4415 B66 SDX1926Q-43	ADD ADD ADD
			C3	AIR6449 B41	L2500/N2500	0°/-	ADD	-	-

EXISTING FIBER DISTRIBUTION/OVP BOX		EXISTING CABLING SUMMARY		
MODEL NUMBER	STATUS	COAX	HYBRID	STATUS
-	-	(6) 3X6 (7/8")	-	RMN
-	-	-	(6) 9X18 (1 5/8")	RMV

**3 EQUIPMENT SCHEDULES**

FINAL FIBER DISTRIBUTION / OVP BOX		FINAL CABLING SUMMARY		
MODEL NUMBER	STATUS	COAX	HYBRID	STATUS
-	-	(6) 3X6 (7/8")	-	RMN
-	-	-	(3) 9X18 (1 5/8")	ADD



**Kimley»Horn**

COA: 17166  
421 FAYETTEVILLE ST, SUITE 600  
RALEIGH, NC 27601

REV.	DESCRIPTION	BY	DATE
A	PRELIM	ARC	06/11/21
0	ISSUED FOR CONSTRUCTION	RCG	07/12/21

ATC SITE NUMBER:  
**370626**

ATC SITE NAME:  
**EAST HARTFORD**

T-MOBILE SITE NAME:  
**CROWN E. HARTFORD**

MONOPOLE  
SITE ADDRESS:  
148 ROBERTS ST.  
EAST HARTFORD, CT, 06108

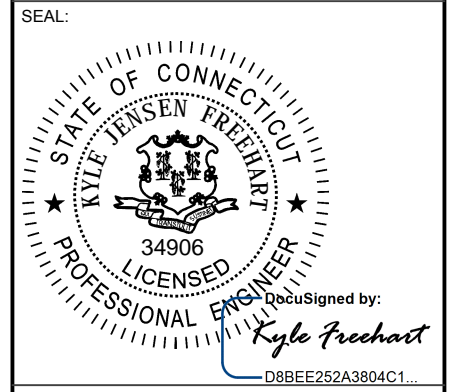

DATE DRAWN:	07/12/21
ATC JOB NO:	13677849
CUSTOMER ID:	CROWN E. HARTFORD MONOPOLE
CUSTOMER #:	CTHA505A

**ANTENNA INFORMATION & SCHEDULE**

SHEET NUMBER: <b>C-401</b>	REVISION: <b>0</b>
-------------------------------	-----------------------

Copyright © 2021 ATC IP, LLC. All Rights Reserved.

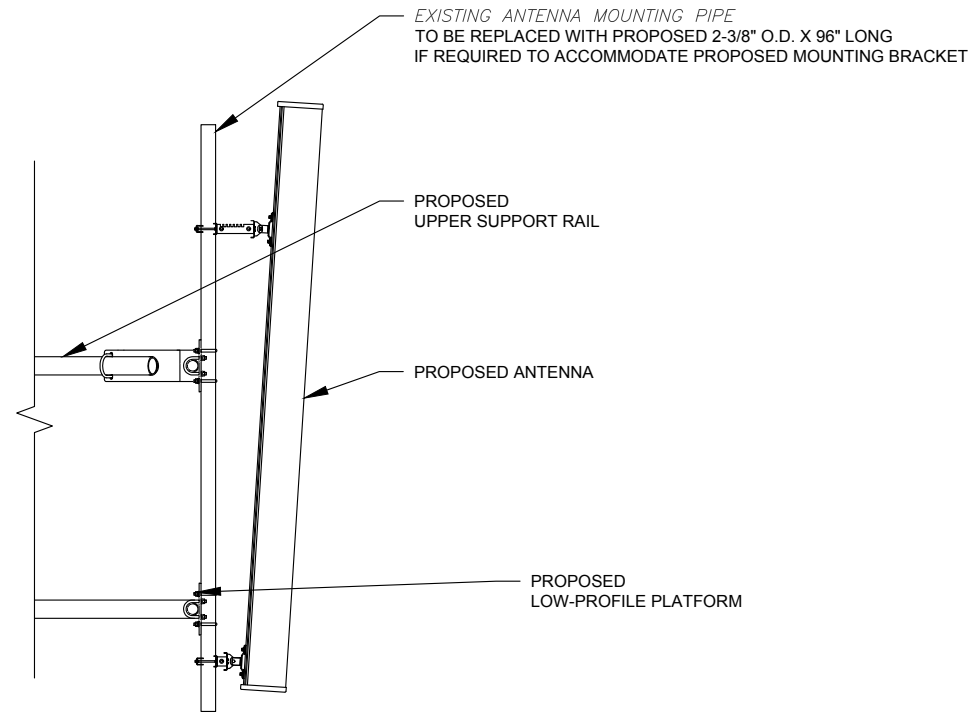

1 PROPOSED ANTENNA MOUNTING DETAIL - TYPICAL  
SCALE: N.T.S.

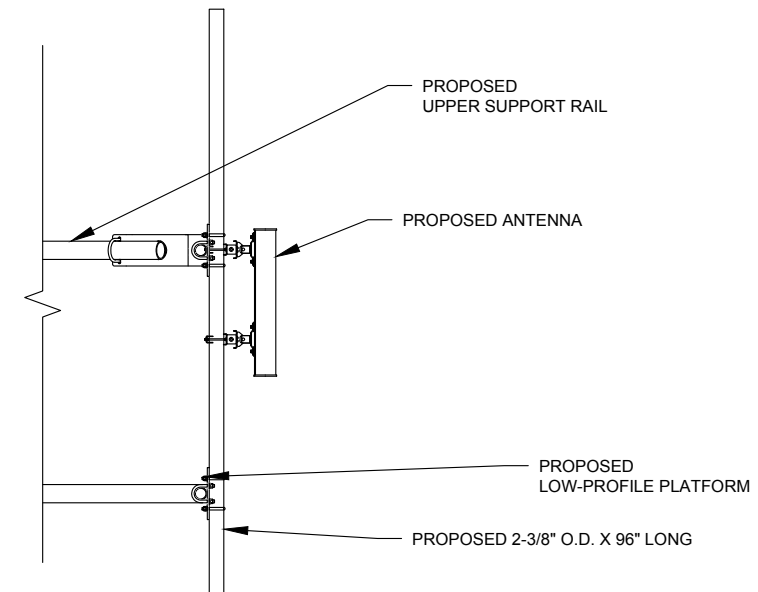

2 PROPOSED 5G ANTENNA MOUNTING DETAIL - TYPICAL  
SCALE: N.T.S.

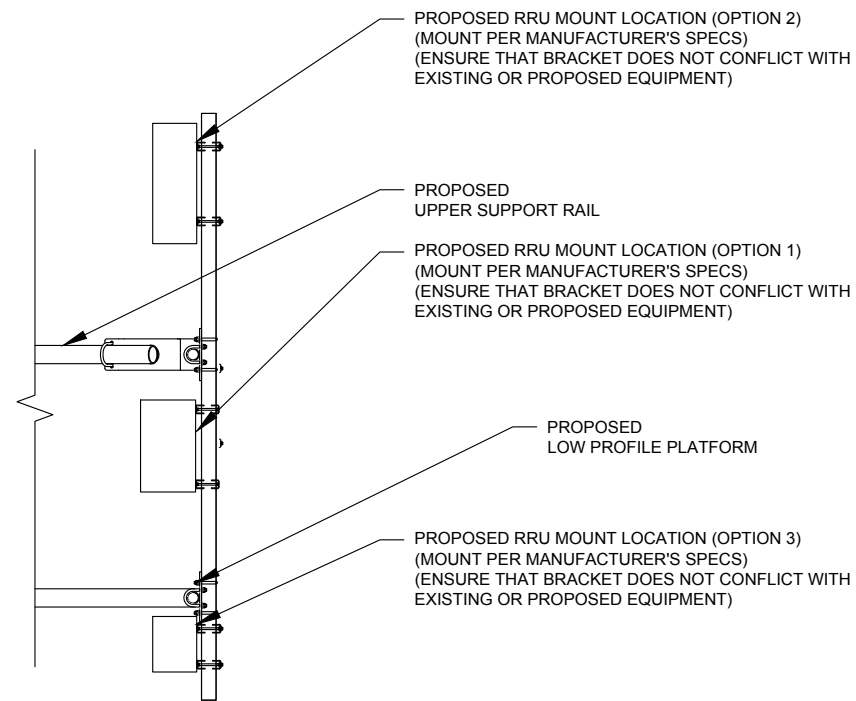

3 PROPOSED RRU MOUNTING DETAIL - TYPICAL  
SCALE: N.T.S.

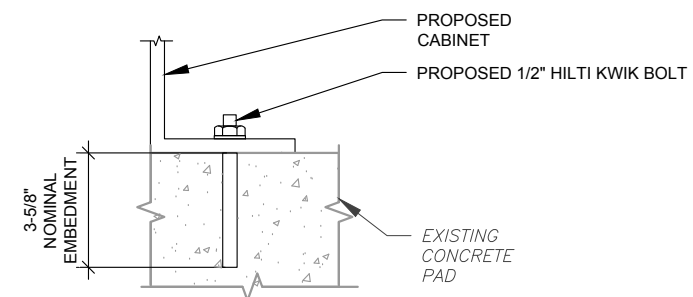

NOTE:  
INSTALL HILTI KWIK BOLT ANCHORS STRICTLY PER INSTALLATION INSTRUCTIONS INCLUDED WITH PRODUCT OR FOUND ONLINE AT WWW.US.HILTI.COM. PROPER INSTALLATION IS CRITICAL FOR FULL PERFORMANCE.

4 CABINET ATTACHMENT DETAIL  
SCALE: NOT TO SCALE



Kimley»Horn

COA: 17166  
421 FAYETTEVILLE ST, SUITE 600  
RALEIGH, NC 27601

REV.	DESCRIPTION	BY	DATE
A	PRELIM	ARC	06/11/21
0	ISSUED FOR CONSTRUCTION	RCG	07/12/21

ATC SITE NUMBER:

370626

ATC SITE NAME:

EAST HARTFORD

T-MOBILE SITE NAME:  
CROWN E. HARTFORD

MONOPOLE

SITE ADDRESS:

148 ROBERTS ST.  
EAST HARTFORD, CT, 06108

SEAL:

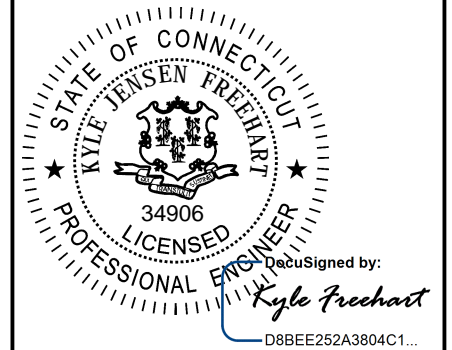

T-Mobile

DATE DRAWN:	07/12/21
ATC JOB NO:	13677849
CUSTOMER ID:	CROWN E. HARTFORD MONOPOLE
CUSTOMER #:	CTHA505A

CONSTRUCTION  
DETAILS

SHEET NUMBER:	REVISION:
C-501	0

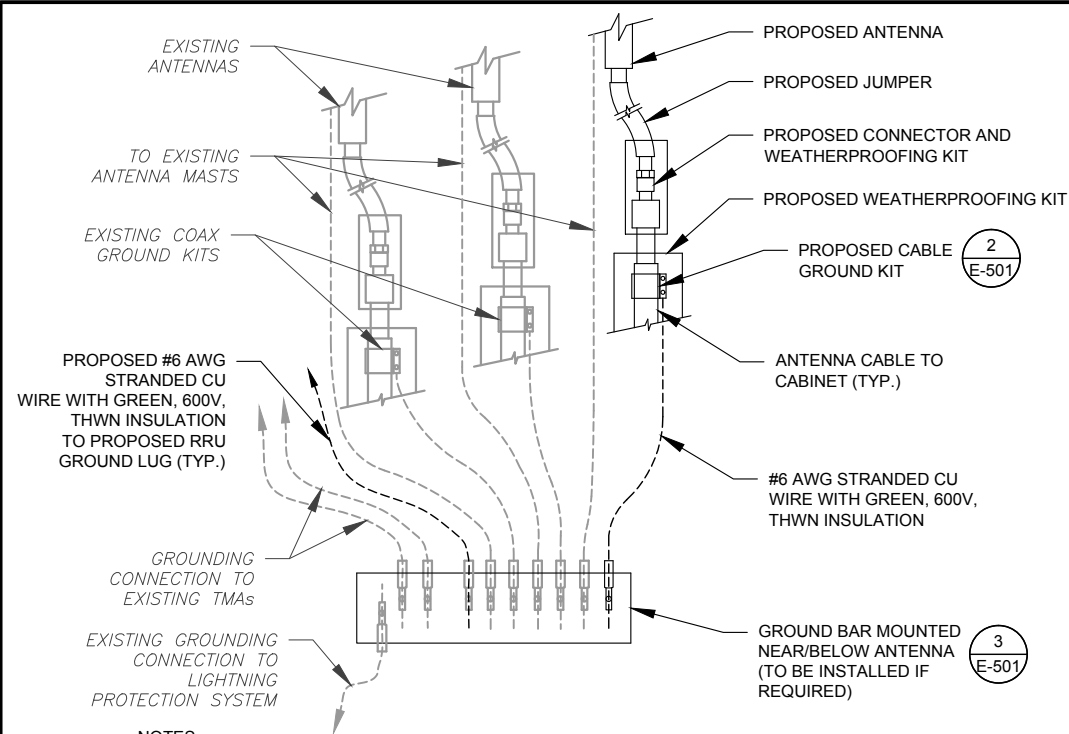

**NOTES:**

1. THIS DETAIL IS INTENDED TO SHOW THE GENERAL GROUNDING REQUIREMENTS. SLIGHT ADJUSTMENTS MAY BE REQUIRED BASED ON EXISTING SITE CONDITIONS. THE CONTRACTOR SHALL MAKE FIELD ADJUSTMENTS AS NEEDED AND INFORM THE CONSTRUCTION MANAGER OF ANY CONFLICTS.
2. SITE GROUNDING SHALL COMPLY WITH T-MOBILE GROUNDING STANDARDS, LATEST EDITION, AND COMPLY WITH T-MOBILE GROUNDING CHECKLIST, LATEST VERSION. WHEN NATIONAL AND LOCAL GROUNDING CODES ARE MORE STRINGENT THEY SHALL GOVERN.

**1** TYPICAL ANTENNA GROUNDING DIAGRAM  
SCALE: N.T.S.

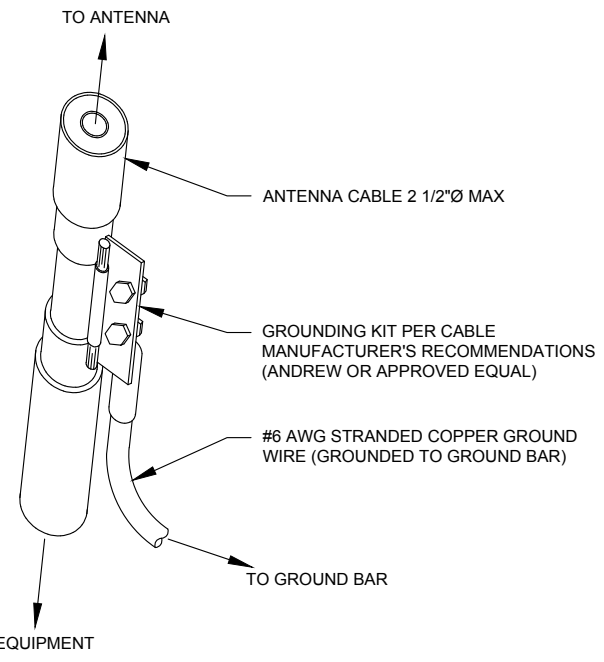

**GROUND KIT NOTES:**

1. DO NOT INSTALL CABLE GROUND KIT AT A BEND AND ALWAYS DIRECT GROUND WIRE DOWN TO GROUND BAR.
2. CONTRACTOR SHALL PROVIDE WEATHERPROOFING KIT (ANDREW PART NUMBER 221213) AND INSTALL/TAPE PER MANUFACTURER'S SPECIFICATIONS.

**2** CABLE GROUND KIT CONNECTION DETAIL  
SCALE: N.T.S.

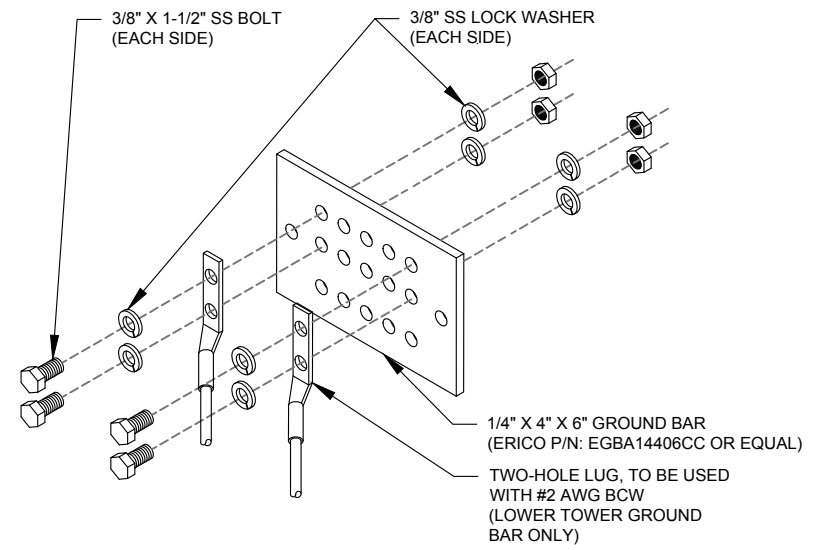

**GROUND BAR NOTES:**

1. GROUND BAR KITS COME WITH ALL HARDWARE, NUTS, BOLTS, WASHERS, ETC. EXCEPT THE STRUCTURAL MOUNTING MEMBER(S).
2. GROUND BAR TO BE BONDED DIRECTLY TO TOWER.

**3** TOWER GROUND BAR DETAIL  
SCALE: N.T.S.

**ELECTRICAL NOTES:**

1. IT IS THE RESPONSIBILITY OF THE CONTRACTOR TO COORDINATE WITH THE T-MOBILE REPRESENTATIVE AND LOCAL UTILITY COMPANY FOR THE INSTALLATION OF CONDUITS, CONDUCTORS, BREAKERS, DISCONNECTS, OR ANY OTHER EQUIPMENT REQUIRED FOR ELECTRICAL SERVICE. ALL ELECTRICAL WORK SHALL BE PERFORMED IN ACCORDANCE WITH LATEST EDITION OF THE STATE AND NATIONAL CODES, ORDINANCES AND REGULATIONS APPLICABLE TO THIS PROJECT.
2. ATC HAS NOT VERIFIED ANY EXISTING T-MOBILE GROUND EQUIPMENT OR ELECTRICAL LOADING. PROPOSED WORK BASED ON INSTALLATION CONFIGURATION PROVIDED BY T-MOBILE. CONTRACTOR TO VERIFY EXISTING T-MOBILE PANEL HAS SUFFICIENT SPACE FOR PROPOSED BREAKER. PROPOSED CABLE AND CONDUIT SHALL BE MINIMUM SIZE PER BELOW IN CHART.
3. FOR SPECIFIC CABINET / ANCILLARY EQUIPMENT WIRING REQUIREMENTS, THE T-MOBILE CONTRACTOR SHOULD REFERENCE DESIGN DOCUMENTS PROVIDED BY T-MOBILE FOR THIS CURRENT PROJECT CONFIGURATION, IN ACCORDANCE WITH LOCAL JURISDICTION REQUIREMENTS & NEC STANDARDS & PRACTICES.

OCPD SIZE	WIRE SIZE	GROUND SIZE	CONDUIT SIZE
80A/2P	2#3 AWG	#8 AWG	1-1/4"
100/2P	2#2 AWG	#8 AWG	1-1/4"
125A/2P	2#1 AWG	#8 AWG	1-1/2"
150A/2P	2#1/0 AWG	#8 AWG	1-1/2"

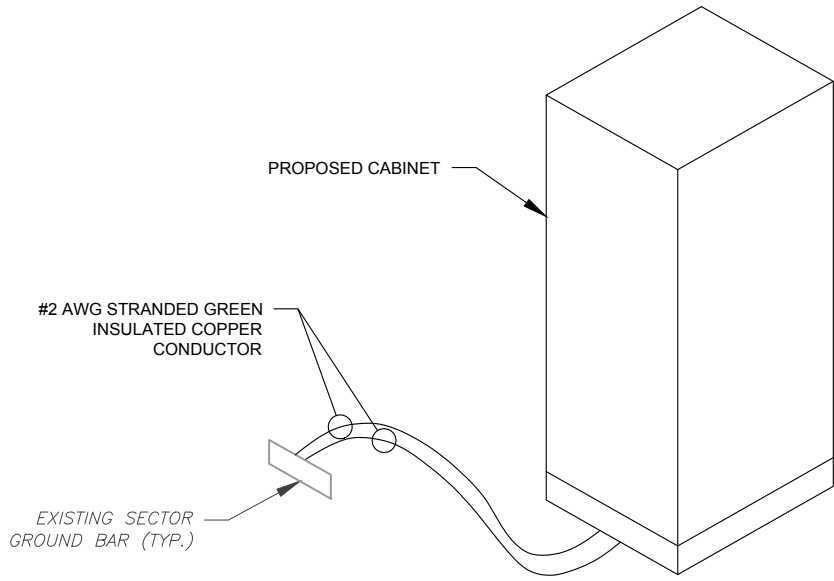

**4** CABINET GROUNDING DETAIL  
SCALE: N.T.S.



**Kimley»Horn**

COA: 17166  
421 FAYETTEVILLE ST, SUITE 600  
RALEIGH, NC 27601

REV.	DESCRIPTION	BY	DATE
A	PRELIM	ARC	06/11/21
0	ISSUED FOR CONSTRUCTION	RCG	07/12/21

ATC SITE NUMBER:  
**370626**

ATC SITE NAME:  
**EAST HARTFORD**

T-MOBILE SITE NAME:  
**CROWN E. HARTFORD MONOPOLE**

SITE ADDRESS:  
148 ROBERTS ST.  
EAST HARTFORD, CT, 06108

SEAL:

DocuSigned by:  
*Kyle Freehart*  
D8BEE252A3804C1...



DATE DRAWN:	07/12/21
ATC JOB NO:	13677849
CUSTOMER ID:	CROWN E. HARTFORD MONOPOLE
CUSTOMER #:	CTHA505A

**GROUNDING DETAILS**

SHEET NUMBER:	REVISION:
<b>E-501</b>	<b>0</b>

Copyright © 2021 ATC IP, LLC. All Rights Reserved.



Section 5 - RAN Equipment

Existing RAN Equipment		
Template: 95ADB		
Enclosure	1	2
Enclosure Type	RBS 6201 ODE	Ancillary Equipment (Ericsson)
Baseband	DJUW30 U2100	BB 6630 L2100 L1900
Hybrid Cable System		Ericsson 9x18 HCS *Select Length* Ericsson 6x12 HCS *Select Length & AWG*

Proposed RAN Equipment			
Template: 67D5A997DB ODE+6160			
Enclosure	1	2	3
Enclosure Type	RBS 6201 ODE	Enclosure 6160	B160
Baseband	DJUW30 U2100	BB 6648 L2100 L700 L600 N600	BB 6648 L2500 N2500
Hybrid Cable System	Ericsson Hybrid Trunk 6/24 4AWG 40m (x 2)	Ericsson Hybrid Trunk 6/24 4AWG 40m	
Transport System		PSU 4813	
		CSR IXRe V2 (Gen2)	

1 CABINET CONFIGURATION  
SCALE: NOT TO SCALE

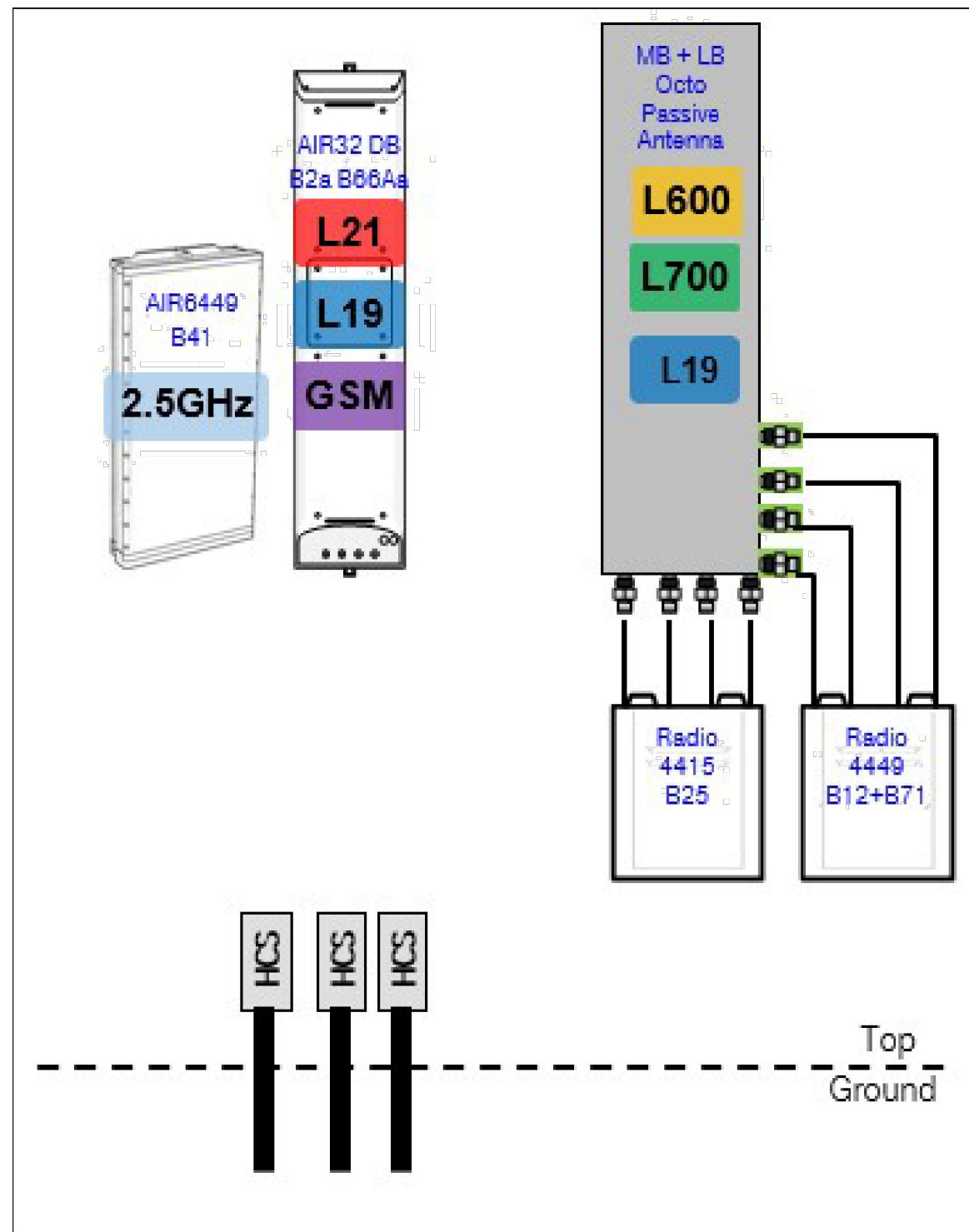

2 ANTENNA CONFIGURATION  
SCALE: NOT TO SCALE

NOTE: THIS SHEET CREATED BY OTHERS AND PROVIDED BY REQUEST OF CUSTOMER WITHOUT EDIT.

SUPPLEMENTAL

SHEET NUMBER:

R-601

REVISION:

0



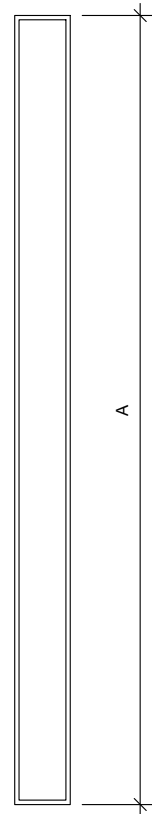

FRONT VIEW

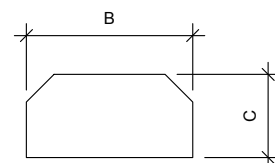

TOP VIEW

**1 ANTENNA SPECIFICATIONS**  
FOR ILLUSTRATIVE PURPOSES ONLY - NOT TO SCALE

ANTENNA SPECIFICATIONS				
ANTENNA MODEL	A	B	C	WEIGHT (LBS)
AIR6449 B41	33.1"	20.6"	8.6"	104.0
APXVAALL24 43-U-NA20	95.9"	12.9"	8.7"	122.8

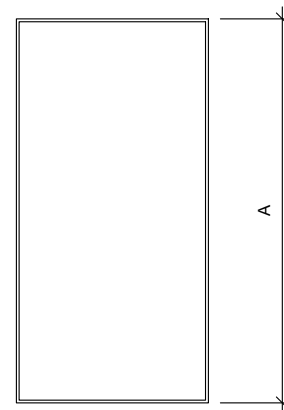

FRONT VIEW

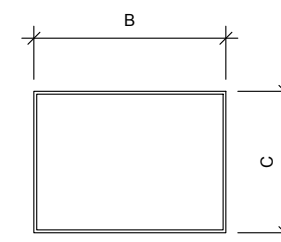

TOP VIEW

**2 RRU SPECIFICATIONS**  
FOR ILLUSTRATIVE PURPOSES ONLY - NOT TO SCALE

RRU SPECIFICATIONS				
RRU MODEL	A	B	C	WEIGHT (LBS)
RADIO 4449 B71 B85A	15.0"	13.2"	10.5"	75
4415 B66	15.0"	13.2"	5.4"	46

SUPPLEMENTAL

SHEET NUMBER:  
**R-602**

REVISION:  
**0**

# Enclosure B160

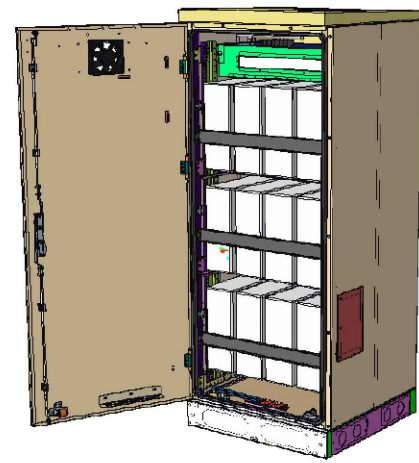

Enclosure B160  
AirCon + VRLA

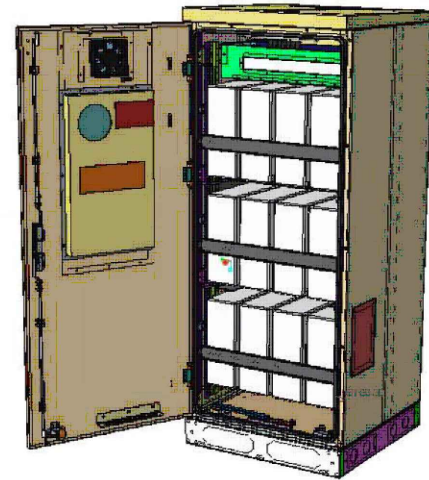

Enclosure B160  
AirCon + Li-Ion

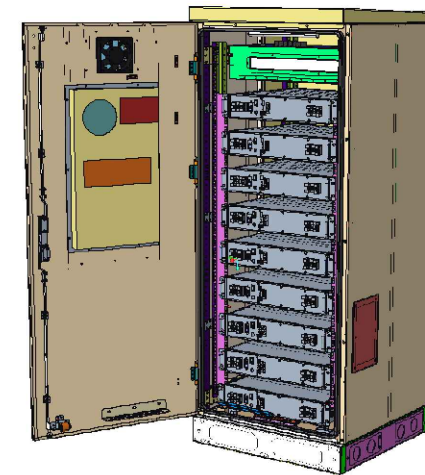

Enclosure B160  
Convection Cooling  
+ VRLA

PA1 | 2019-02-03 | Ericsson Confidential | Page 1

# Enclosure B160

## Capacity

- VRLA 12V: 100Ah / 150Ah / 170Ah / 190Ah / 210Ah
- Li-Ion: 24U 19" / 23"
- Sodium-Nickel: 3x FIAMM

## Electrical specification

- DC Output: -48VDC/200A
- Battery breakers: 2x 125/2p
- Alarms: Door open, Climate failure, MCB Connection

## Mechanical specification

- Weight: 134kg
- Dimensions: 63 x 26 x 26 in. (incl. Base frame)
- Base frame height: 6 in.
- Material: Galvanized steel (180g/m<sup>2</sup>)
- Color: Powder paint NCS 2002-B
- Door: Front access
- Locking type: Pad lock / cylinder

## Environmental specification

- Ingress protection: VRLA/Sodium IP44  
Li-Ion IP55
- Relative humidity: 15-100%
- Climate system
- Air Conditioner
- Fan type: DC
- Cooling capacity: 500W @L35/L35
- Convection cooling
- Emergency fan

PA1 | 2019-02-03 | Ericsson Confidential | Page 2

SUPPLEMENTAL

SHEET NUMBER:

R-603

REVISION:

0

NOTE: THIS SHEET WAS CREATED BY OTHERS AND PROVIDED AT THE REQUEST OF THE CUSTOMER WITHOUT EDIT.



# Enclosure 6160 AC

The Enclosure 6160 is a multi-purpose site cabinet designed to support a multitude of equipment such as ERS Baseband, Transport, Li-Ion battery and 3PP vendor equipment. It also provides a highly capable power system and battery back-up - all in a streamlined design and minimized footprint to support cost efficient expansion of mobile broadband.

Being an all-in-one enclosure, the Enclosure 6160 is a very fitting choice for all types of sites where the capacity need is large or room for future expansion is needed. It is ideally used for modernizing existing sites or in greenfield scenarios to match both current and future needs.

With a robust design, IP65 compliance and a sealed Heat Exchanger (HEX) climate system the Enclosure 6160 ensures optimal environmental protection of the active equipment - enabling them for a long-lasting service. The complete system is also integrated and verified for the entire Ericsson Radio System and ensures best-in-class service.

The power system offers 31,5kW of power in total and provides 24kW of -48V DC power for both internal and external consumers.

The equipment space allows 19U of rack space ensuring well enough capacity for existing need and future expansion.

One of the main advantages of the Enclosure 6160 is its default integration with ENM - allowing for advanced remote monitoring and control such a fault management (alams), inventory management and performance measurements. The cabinet also provides an open O&M interface for integration to 3PP O&M systems.



## Preliminary technical specification for Enclosure 6160 AC

### CAPACITY

Rack space user equipment	19U (19" rack)
Hardware capabilities	Power and CPRI support for multi-standard remote radios (RRU or AIR) ERS Baseband and Transport units Li-Ion batteries 3PP equipment Additional power feed available as option

### MECHANICAL SPECIFICATION

Weight	145 kg (excluding active equipment) 320 lbs (excluding active equipment)
Dimension (H x W x D)	1600 x 650 x 650 mm (incl. Base frame) 63 x 26 x 26 in. (incl. Base frame)
Base frame height	150 mm 6 in.
Mounting position	Ground
Enclosure material	Aluminum
Color	Power paint NCS 2002-B
Door	Front access
Rack type	19" (IEC 60297-3-100)
Locking type	Pad lock or Cylinder

### POWER SYSTEM

Input voltage	3P+N+PE: 346/200-415/240 VAC 2P+N+PE: 208/120-220/127 VAC 1P+N+PE: 200-250 VAC
Input power	<33kW
Output load (-48VDC)	24kW
Total capacity (-48VDC)	31.5kW
AC SPD	Class 2/Type 2
DC SPD	Class 2/Type 2
PSU Slots	9x
Service outlet	Optional
Priority load	8x Circuit Breaker
LLVD 1	6x Circuit Breaker
LLVD 2	6x Circuit Breaker
CB ratings	3A / 5A / 10A / 15A / 20A / 25A / 30A / 40A / 50A / 60A / 80A / 100A
Battery Interface	2x Circuit Breaker
Battery Circuit Breaker rating	125A 2pol (200A)
PSU capacity	3500W

SUPPLEMENTAL

SHEET NUMBER: <b>R-604</b>	REVISION: <b>0</b>
-------------------------------	-----------------------

NOTE: THIS SHEET WAS CREATED BY OTHERS AND PROVIDED AT THE REQUEST OF THE CUSTOMER WITHOUT EDIT.



This report was prepared for American Tower Corporation by



### Antenna Mount Analysis Report

**ATC Site Name** : East Hartford  
**ATC Site Number** : 370626  
**Engineering Number** : 13677849\_C8\_02  
**Mount Elevation** : 100 ft  
**Carrier** : T-MOBILE  
**Carrier Site Name** : Crown E. Hartford Monopole  
**Carrier Site Number** : CTHA505A  
**Site Location** : 148 Roberts St.  
 East Hartford, CT 06108  
 41.77330556, -72.61341667  
**County** : Hartford  
**Date** : June 2, 2021  
**Max Usage** : 65%  
**Result** : Pass

Prepared By:  
Saja Alkhafaji  
E.I.T

Reviewed By:  
Brian Brewer  
P.E.

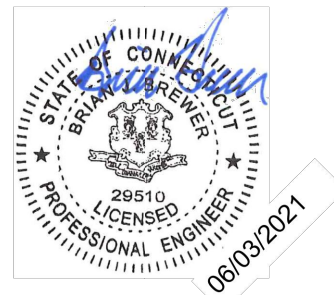

Kimley-Horn and Associates, Inc.  
COA #PEC.0000738

Kimley-Horn and Associates, Inc. – 421 Fayetteville St., Suite 600 – Raleigh, NC 27601 – 919.677.2000 Office - www.kimley-horn.com



Eng. Number 13677849\_C8\_02  
June 2, 2021  
Page 1

#### Introduction

The purpose of this report is to summarize results of the antenna mount analysis performed for T-MOBILE at 100 ft.

#### Supporting Documents

Spec Sheet	SitePro1 Drawing #RMQP-4XX, dated 07/09/2015 SitePro1 Drawing # HRK12, dated 07/13/2014
Tower Analysis	ATC by TEP Engineering Number 12948437_C3_02, dated 08/22/2019
RFDS	T-MOBILE CTHA505A_Anchor_5_draft, dated 04/27/2021
Photos	Site Photos, dated 11/11/2019

#### Analysis

This antenna mount was analyzed using RISA-3D v17 analysis software and Kimley-Horn's Mount Analysis Program.

Basic Wind Speed:	118 mph (3-Second Gust)
Basic Wind Speed w/ Ice:	50 mph (3-Second Gust) w/ 1.5" radial ice concurrent
Codes:	ANSI/TIA-222-H
Exposure Category:	B
Risk Category:	II
Topographic Factor Procedure:	Method 2
Feature:	Flat
Crest Height (H):	0 ft
Crest Length (L):	0 ft
Spectral Response:	Ss = 0.189, S1 = 0.055
Site Class:	D - Stiff soil.
Live Loads:	Lm = 500 lbs., Lv = 250 lbs.

#### Conclusion

Based on the analysis results, the antenna mount meets the requirements per the applicable codes listed above. The mount can support the equipment as described in this report.

Install new SitePro1 RMQP platform mount with HRK12 handrail kit at 100-ft.

If you have any questions or require additional information, please contact American Tower via email at [Engineering@americantower.com](mailto:Engineering@americantower.com). Please include the American Tower site name, site number, and engineering number in the subject line for any questions.

Kimley-Horn and Associates, Inc. – 421 Fayetteville St., Suite 600 – Raleigh, NC 27601 – 919.677.2000 Office - www.kimley-horn.com

NOTE: THIS SHEET WAS CREATED BY OTHERS AND PROVIDED AT THE REQUEST OF THE CUSTOMER WITHOUT EDIT. PLEASE REFERENCE THE MOUNT ANALYSIS REPORT FOR COMPLETE MOUNT ANALYSIS CALCULATIONS AND DETAILS. SUPPLEMENTAL PAGES INCLUDED IN THE CONSTRUCTION DRAWINGS ARE FOR REFERENCE ONLY. GENERAL CONTRACTOR IS TO VERIFY THEY HAVE THE MOST RECENT MOUNT ANALYSIS PRIOR TO CONSTRUCTION.

SUPPLEMENTAL

SHEET NUMBER: <b>R-605</b>	REVISION: <b>0</b>
-------------------------------	-----------------------





**AMERICAN TOWER®**  
CORPORATION

This report was prepared for American Tower Corporation by

**Kimley»»Horn**

---

## Antenna Mount Analysis Report

**ATC Site Name** : East Hartford  
**ATC Site Number** : 370626  
**Engineering Number** : 13677849\_C8\_02  
**Mount Elevation** : 100 ft  
**Carrier** : T-MOBILE  
**Carrier Site Name** : Crown E. Hartford Monopole  
**Carrier Site Number** : CTHA505A  
**Site Location** : 148 Roberts St.  
East Hartford, CT 06108  
41.77330556, -72.61341667  
**County** : Hartford  
**Date** : June 2, 2021  
**Max Usage** : 65%  
**Result** : Pass

Prepared By:  
Saja Alkhafaji  
E.I.T

Reviewed By:  
Brian Brewer  
P.E.



**Kimley-Horn and Associates, Inc.**  
**COA #PEC.0000738**



**Table of Contents**

Introduction..... 1

Supporting Documents..... 1

Analysis..... 1

Conclusion ..... 1

Antenna Loading..... 2

Structure Usages..... 2

Standard Conditions .....3

Calculations..... Attached



## Introduction

The purpose of this report is to summarize results of the antenna mount analysis performed for T-MOBILE at 100 ft.

## Supporting Documents

<b>Spec Sheet</b>	SitePro1 Drawing #RMQP-4XX, dated 07/09/2015 SitePro1 Drawing # HRK12, dated 07/13/2014
<b>Tower Analysis</b>	ATC by TEP Engineering Number 12948437_C3_02, dated 08/22/2019
<b>RFDS</b>	T-MOBILE CTHA505A_Anchor_5_draft, dated 04/27/2021
<b>Photos</b>	Site Photos, dated 11/11/2019

## Analysis

This antenna mount was analyzed using RISA-3D v17 analysis software and Kimley-Horn's Mount Analysis Program.

<b>Basic Wind Speed:</b>	118 mph (3-Second Gust)
<b>Basic Wind Speed w/ Ice:</b>	50 mph (3-Second Gust) w/ 1.5" radial ice concurrent
<b>Codes:</b>	ANSI/TIA-222-H
<b>Exposure Category:</b>	B
<b>Risk Category:</b>	II
<b>Topographic Factor Procedure:</b>	Method 2
<b>Feature:</b>	Flat
<b>Crest Height (H):</b>	0 ft
<b>Crest Length (L):</b>	0 ft
<b>Spectral Response:</b>	$S_s = 0.189$ , $S_1 = 0.055$
<b>Site Class:</b>	D - Stiff soil.
<b>Live Loads:</b>	$L_m = 500$ lbs., $L_v = 250$ lbs.

## Conclusion

Based on the analysis results, the antenna mount meets the requirements per the applicable codes listed above. The mount can support the equipment as described in this report.

Install new SitePro1 RMQP platform mount with HRK12 handrail kit at 100-ft.

If you have any questions or require additional information, please contact American Tower via email at [Engineering@americantower.com](mailto:Engineering@americantower.com). Please include the American Tower site name, site number, and engineering number in the subject line for any questions.



**Antenna Loading**

Mount Centerline (ft)	Antenna Centerline (ft)	Qty	Antenna Model
100	100	3	Ericsson Air6449 B41
		3	RFS APXVAALL24 43-U-NA20
		3	Ericsson AIR32 B66Aa/B2a
		3	Commscope SDX1926Q-43
		3	Ericsson Radio 4449 B71 B85A
		3	Ericsson RRUS 4415 B66
		3	Ericsson RRUS 4415 B25

**Structure Usages**

Structural Component	Controlling Usage	Pass/Fail
Connection Plates	65%	Pass
Mount Pipes	55%	Pass
Stand-Off Horizontals	53%	Pass
Support Rails	27%	Pass
Corner Plates	26%	Pass
Face Horizontals	23%	Pass
Grating Angles	11%	Pass





## Standard Conditions

### Analysis Method

RISA-3D (version 17.02.00), a commercially available analysis software package, was used to create a three-dimensional model of the antenna mounting system and calculate member stresses for various loading cases.

A proprietary tool internally developed by Kimley-Horn was used to calculate wind loading on all appurtenances, dishes, and mount members for various load cases. Selected output from the analysis is included.

### Assumptions

- 1) The antenna mounting system (including any considered modifications) was properly fabricated, installed and maintained in good condition in accordance with its original design, TIA standards, and manufacturer's specifications.
- 2) The configuration of antennas, mounts, and other appurtenances are as specified in the Antenna Loading Table and the provided reference information.
- 3) All member connections are assumed to have been designed to meet or exceed the load carrying capacity of the connected member unless otherwise specified in this report.
- 4) The analysis will be required to be revised if the existing conditions in the field differ from those shown in the above-referenced documents or assumed in this analysis. No allowance was made for any damaged, missing, or rusted members that could not be verified at this time.
- 5) Steel grades have been assumed as follows, unless noted otherwise:

Channel, Solid Round, Angle, Plate	ASTM A36 (Gr. 36)
HSS (Rectangular)	ASTM A36 (Gr. 36)
Pipe	ASTM A53 (Gr. B-35)
Threaded Rods	ASTM A36 (Gr. 36)
Connection Bolts	ASTM A325

This analysis may be affected if any assumptions are not valid or have been made in error. Kimley-Horn should be notified to determine the effect on the structural integrity of the antenna mounting system.

Date	May 25, 2021
Client	American Tower
Site #	370626
Site Name	EAST HARTFORD
Project #	011916045

General Criteria	
TIA Standard	H
IBC Edition	2018
Structure Class	-
Risk Category	II

Wind Summary	
Basic Wind Speed w/o Ice, V (mph)	118.00
Velocity Pressure Coeff., K <sub>z</sub>	0.99
Velocity Pressure, q <sub>z</sub> (w/o Ice) (psf)	33.40

Site-Specific Criteria	
Exposure Category	B
Topographic Factor, K <sub>zt</sub>	1.00
Structure Base Elev. (AMSL), z <sub>s</sub> (ft)	50.42
Ground Effect Factor, K <sub>e</sub>	1.00

Ice Load Summary	
Basic Wind Speed w/ Ice, V <sub>i</sub> (mph)	50.00
Design Ice Thick. (ASCE 7-16), t <sub>i</sub> (in)	1.5
Velocity Pressure, q <sub>z</sub> (w/ Ice) (psf)	6.00
Escalated Ice Thick. @ Mount, t <sub>iz</sub> (in)	1.68

Mount & Structure Criteria	
Mount Elevation (AGL) (ft)	100.00
Structure Height (ft)	130.50
Structure Type	Monopole

Seismic Load Summary	
Spectral Response (Short Periods), S <sub>s</sub>	0.189
Spectral Response (1-Sec. Period), S <sub>1</sub>	0.055
Site Class	D
Seismic Design Category	B
Seismic Risk Category	II

Constants	
Wind Direction Probability Factor, K <sub>d</sub>	0.95
Gust Effect Factor, G <sub>f</sub>	1
Shielding Factor, K <sub>s</sub> (antenna)	0.9
Shielding Factor, K <sub>s</sub> (mount)	0.9

Snow Load Summary	
Ground Snow Load, p <sub>g</sub> (psf)	-
Snow Load on Flat Roofs, p <sub>f</sub> (psf)	-

532

35

Antenna Name	Qty	Shape	Dimensions (in)			Weight (lb)	Joint Labels				EPA (ft <sup>2</sup> )		Wind Force, F <sub>A</sub> (lb)					
			H	W	D		Alpha	Beta	Gamma	Delta	Front	Side	No Ice		With Ice			
													Front	Side	Front	Side		
Air6449 B41	3	Flat	33.1	20.6	8.6	104	A3B	A3T	B3B	B3T	G3B	G3T	5.68	2.49	170.82	74.88	39.27	20
APXVAALL24 43-U-NA20	3	Flat	95.9	24	8.5	122.8	A2B	A2T	B2B	B2T	G2B	G2T	20.24	8.73	608.56	262.55	127.22	63.75
AIR32 B66Aa/B2a	3	Flat	56.6	12.9	8.7	132.2	A1B	A1T	B1B	B1T	G1B	G1T	6.51	4.71	195.71	141.67	45.76	35.48
SDX1926Q-43	3	Flat	4.2	6.9	2.9	6.2	N1323C		N1297B		N1335B		0.12	0.1	3.63	3.05	1.74	2.12
Radio 4449 B71 B85A	3	Flat	15	13.2	10.5	75	N1321C		N1295B		N1333B		0.66	0.83	19.73	24.8	5.72	6.83
RRUS 4415 B66	3	Flat	15	13.2	5.4	46	A2R		N1281B		N1319B		0.83	0.68	24.8	20.5	6.83	7.22
RRUS 4415 B25	3	Flat	16.5	13.4	5.9	46	N1320C		N1294B		N1332B		0.92	0.82	27.7	24.66	7.48	8.26

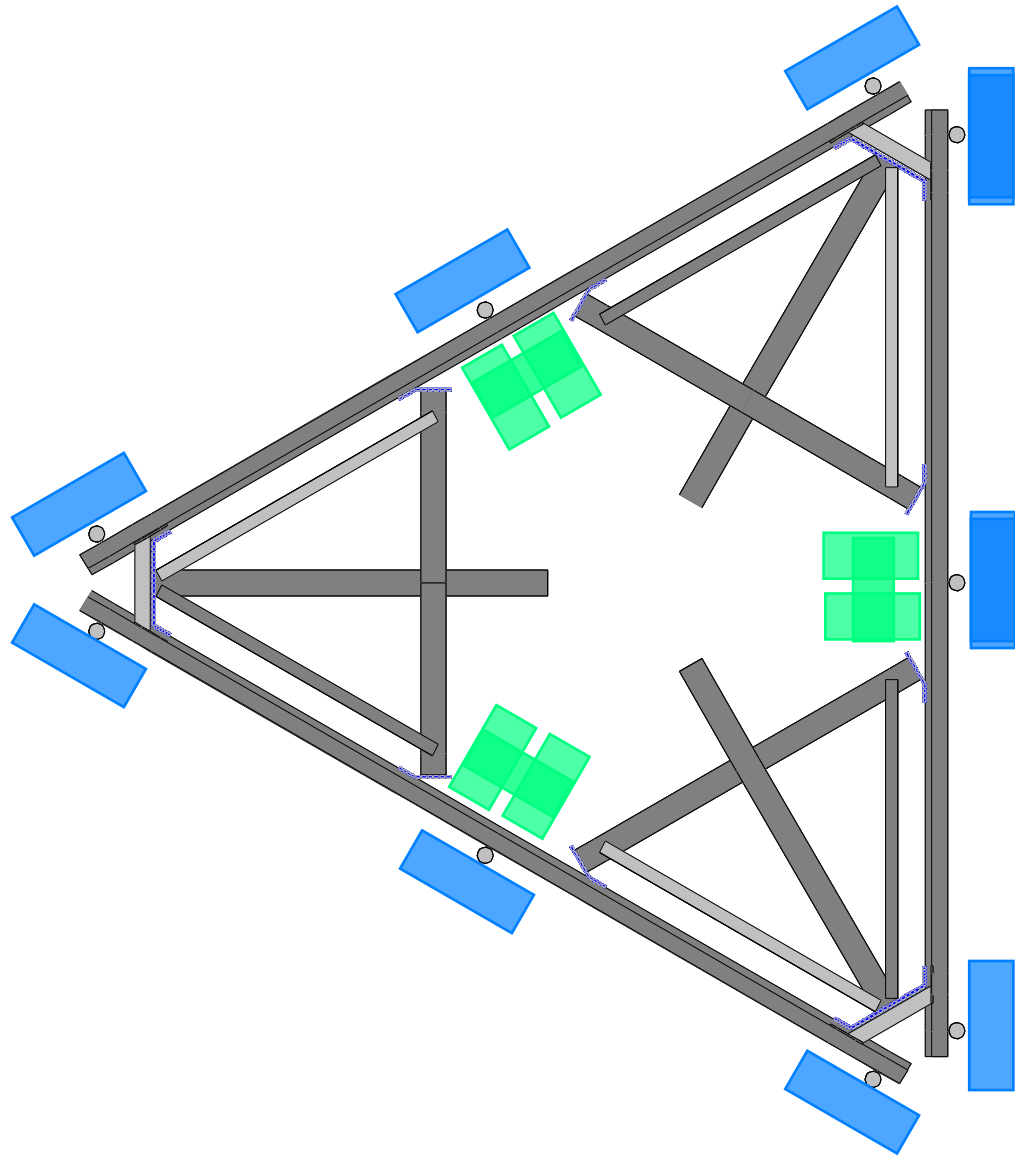

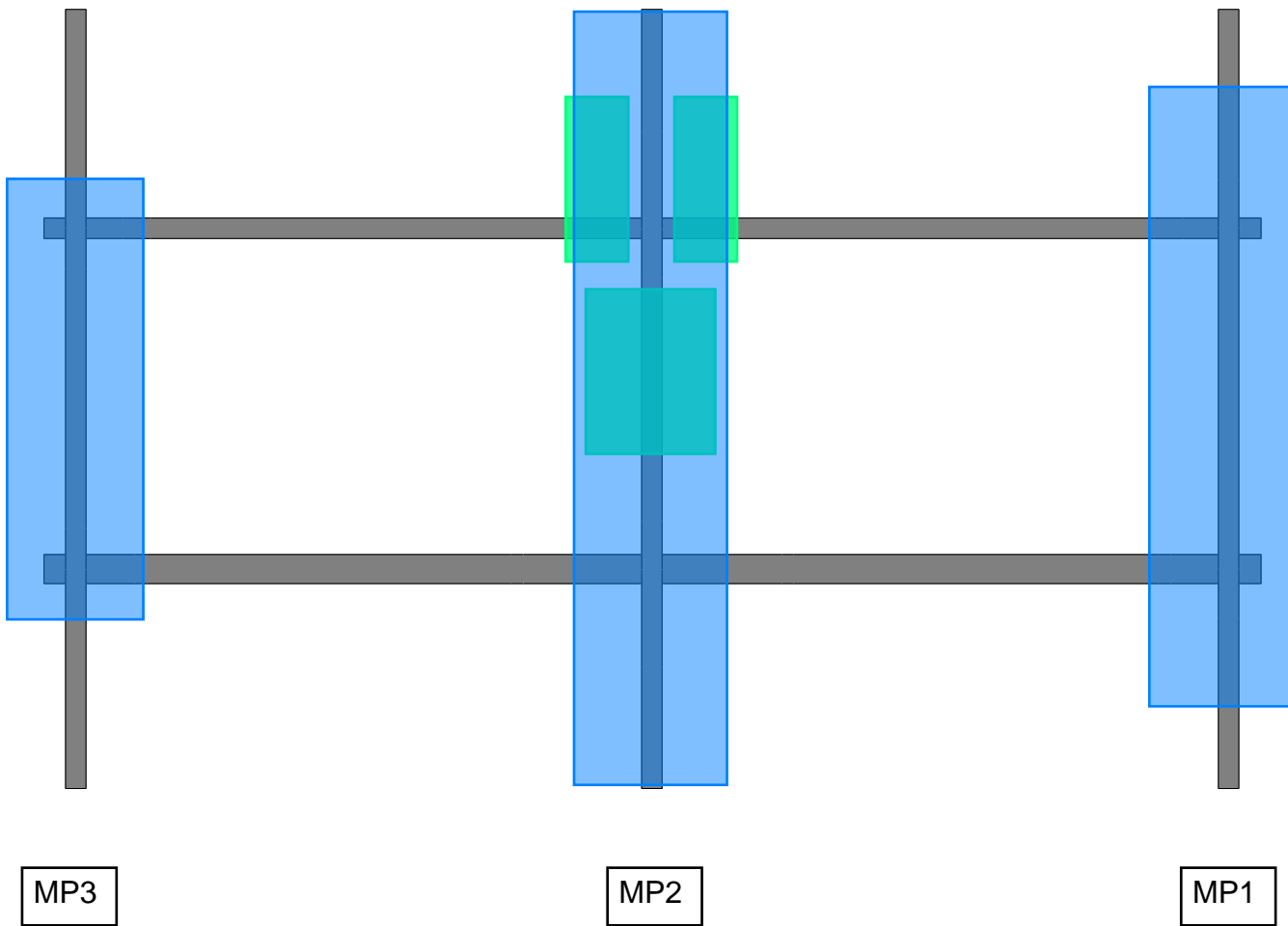

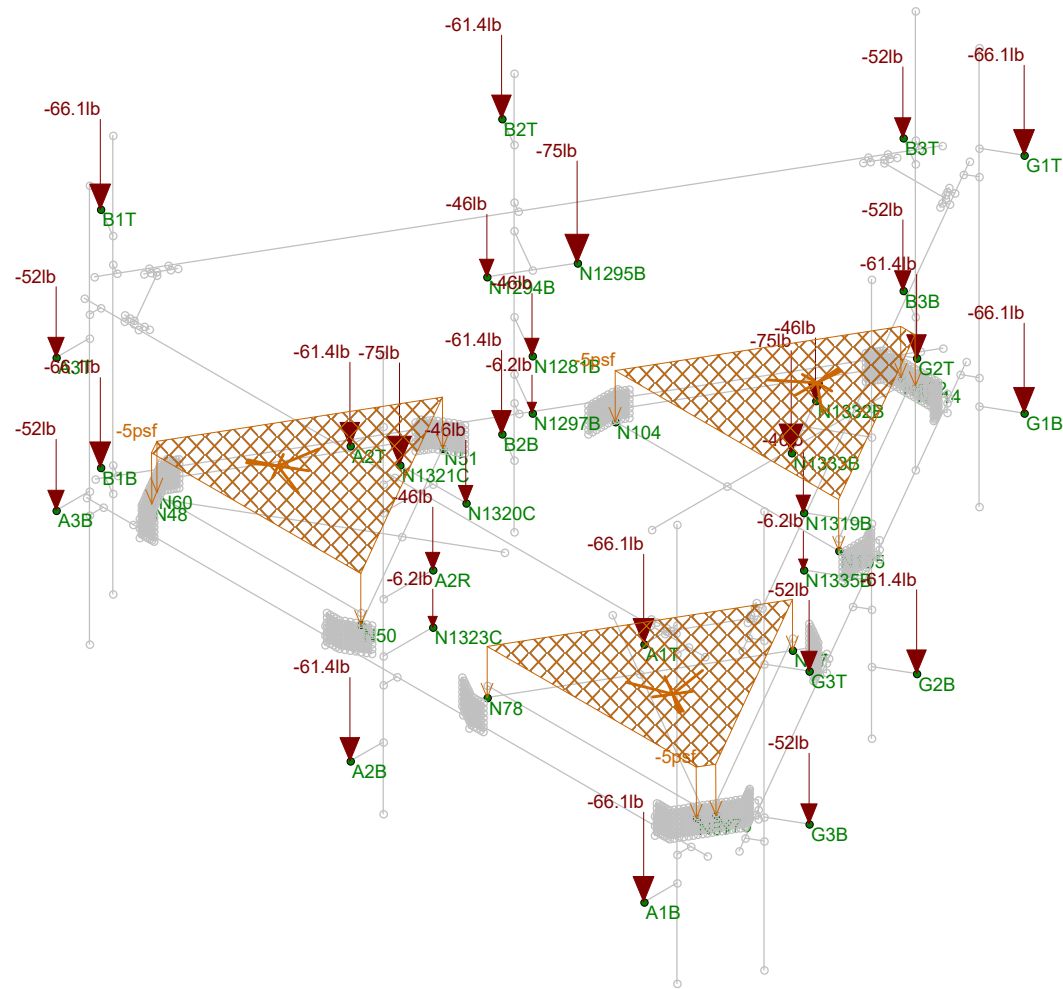
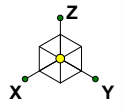

Loads: DL - Dead Load

Kimley-Horn and Associates, Inc.

SSA

011916045

370626

SK - 1

May 25, 2021 at 6:32 PM

370626.r3d

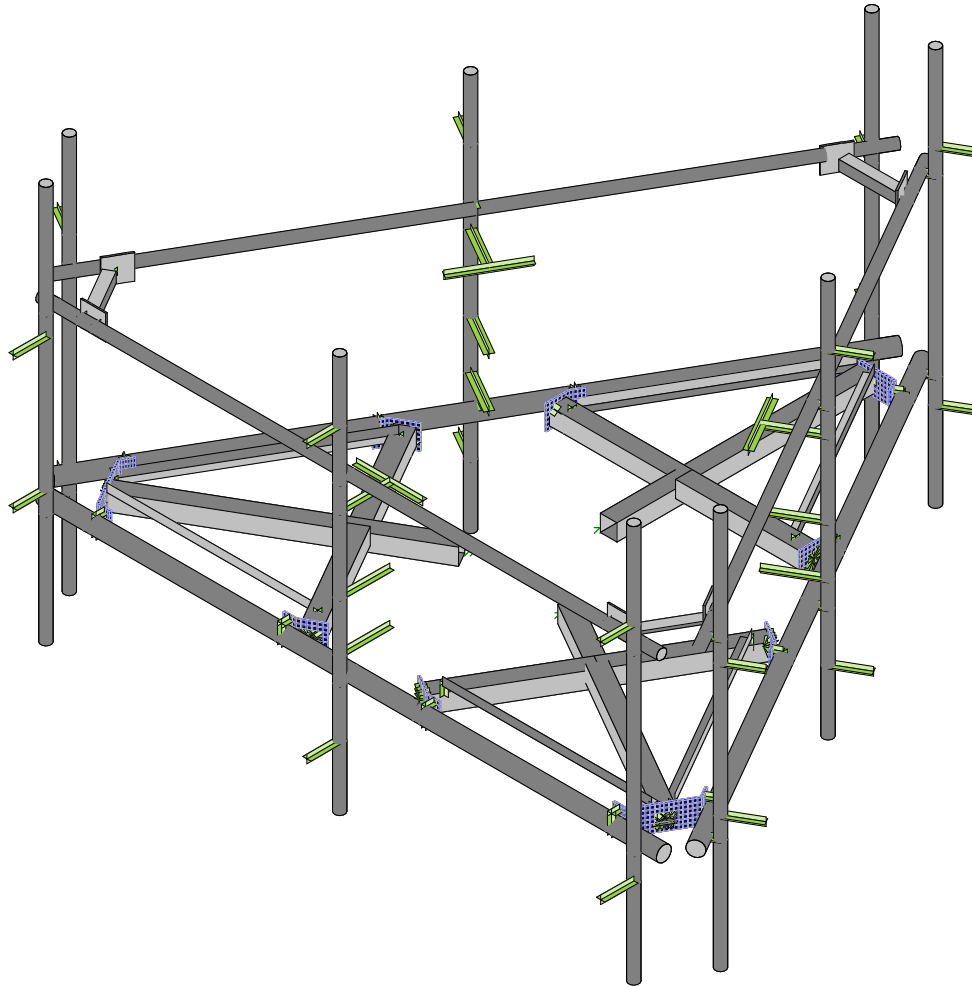
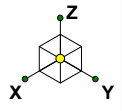

Envelope Only Solution

Kimley-Horn and Associates, Inc.

SSA

011916045

370626

SK - 2

May 25, 2021 at 6:46 PM

370626.r3d

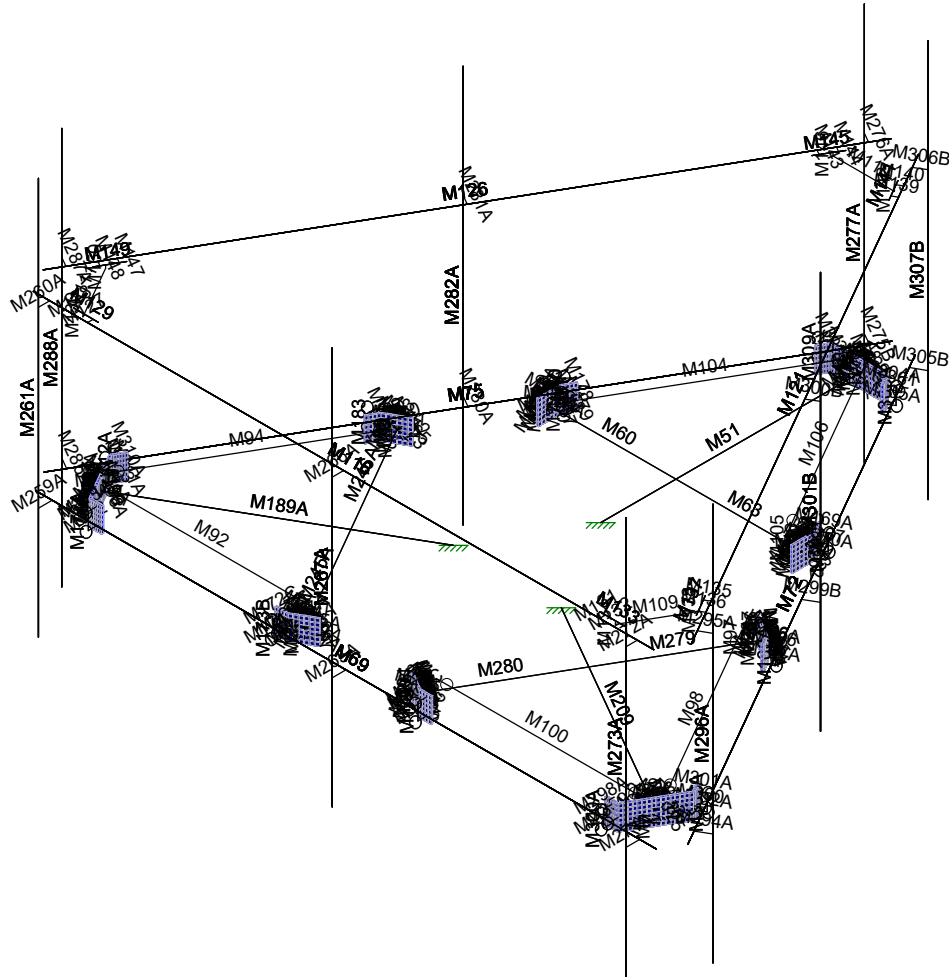
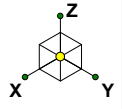

Envelope Only Solution

Kimley-Horn and Associates, Inc.

SSA

011916045

370626

SK - 3

May 25, 2021 at 6:48 PM

370626.r3d

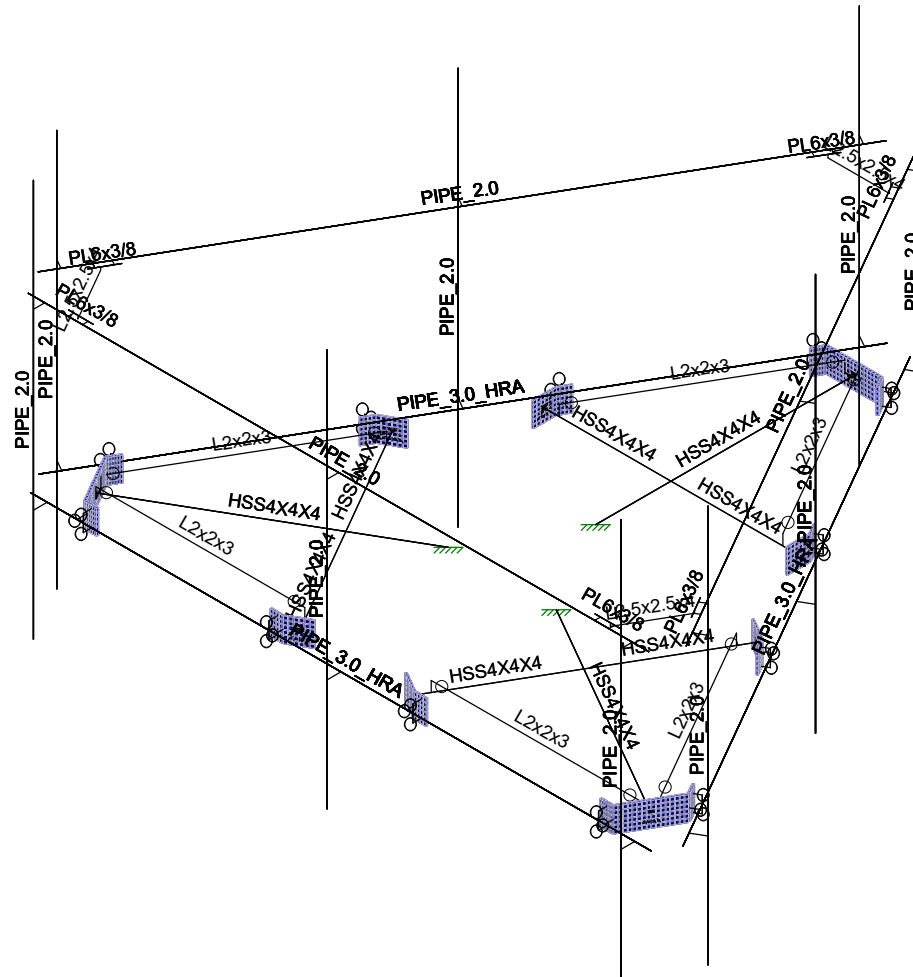
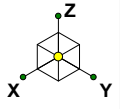

Envelope Only Solution

Kimley-Horn and Associates, Inc.

SSA

011916045

370626

SK - 4

May 25, 2021 at 6:48 PM

370626.r3d



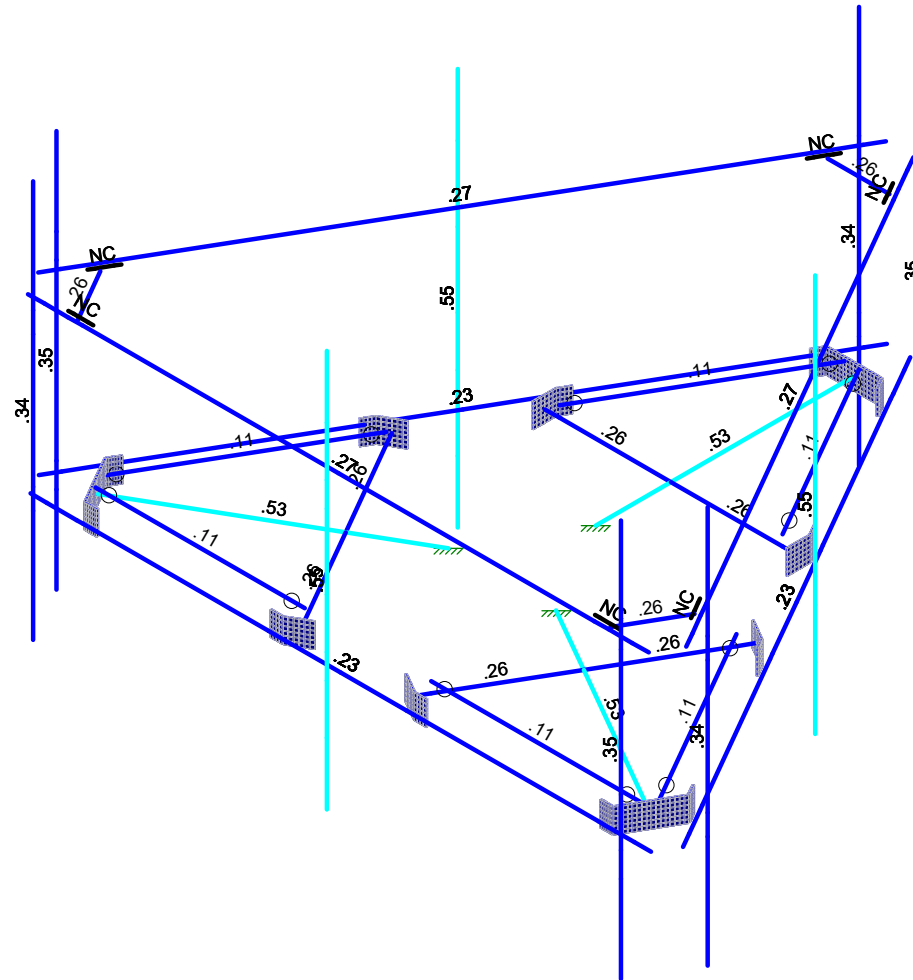
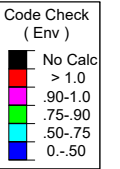
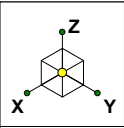

Member Code Checks Displayed (Enveloped)  
Envelope Only Solution

Kimley-Horn and Associates, Inc.
SSA
011916045

370626
--------

SK - 5
May 25, 2021 at 6:49 PM
370626.r3d

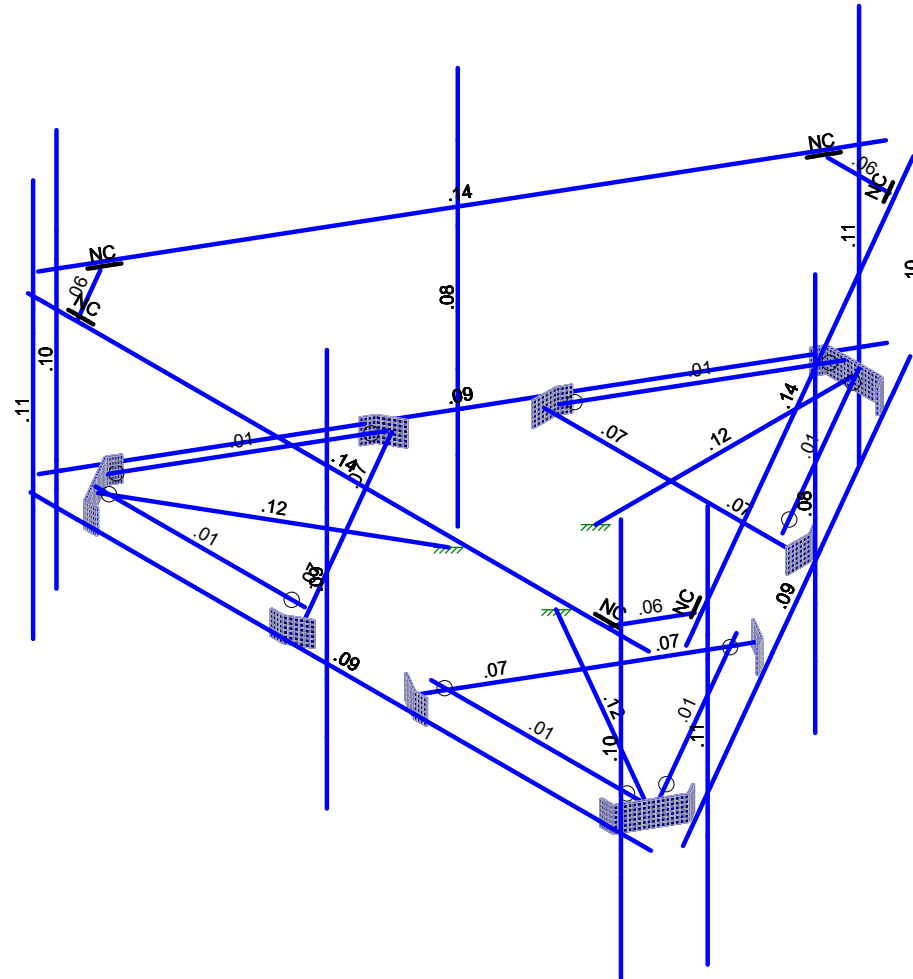
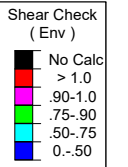
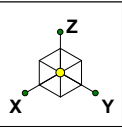

Member Shear Checks Displayed (Enveloped)  
Envelope Only Solution

Kimley-Horn and Associates, Inc.  
SSA  
011916045

370626

SK - 6  
May 25, 2021 at 6:49 PM  
370626.r3d





































## Mount Analysis Square Plate Connection

<b>TIA Revision:</b>	TIA-222-H	Select
----------------------	-----------	--------

SITE DATA	
<b>Site Number:</b>	370626
<b>Site Name:</b>	East Hartford
<b>Project Number:</b>	11916045

REACTIONS		
<b>Moment:</b>	6.495	kip-ft
<b>Axial:</b>	1.649	kips
<b>Shear:</b>	3.009	kips

BOLT DATA		
<b>Quantity:</b>	4	
<b>Diameter:</b>	0.625	in
<b>Material:</b>	A325	Select
<b>Fy:</b>	92	ksi
<b>Fu:</b>	120	ksi
<b>Bolt Spacing:</b>	6	in

<b>Load Combination</b>	24
-------------------------	----

BOLT RESULTS		
<b>Max Bolt (<math>C_u + V_u/\eta</math>):</b>	9.60	kips
<b>Axial Design Strength:</b>	21.70	kips
<b>Stress Ratio</b>	44.24%	

PLATE DATA		
<b>Width:</b>	8	in
<b>Thickness:</b>	0.75	in
<b>Fy:</b>	36	ksi

PLATE RESULTS		
<b>Base Plate Stress:</b>	20.93	ksi
<b>Bending Strength:</b>	32.40	ksi
<b>Stress Ratio:</b>	64.59%	

SUPPORT ARM DATA		
<b>Type:</b>	HSST	Select
<b>Diameter/Width:</b>	4	in
<b>Thickness</b>	0.25	in
<b>Fy:</b>	36	ksi
<b>Number of Sides:</b>	4	



**AMERICAN TOWER®**  
CORPORATION

---

## Structural Analysis Report

**Structure** : 130 ft Monopole  
**ATC Site Name** : East Hartford, CT  
**ATC Asset Number** : 370626  
**Engineering Number** : 13677849\_C3\_03  
**Proposed Carrier** : T-MOBILE  
**Carrier Site Name** : Crown E. Hartford Monopole  
**Carrier Site Number** : CTHA505A  
**Site Location** : 148 Roberts St.  
East Hartford, CT 06108-0000  
41.773300,-72.613400  
**County** : Hartford  
**Date** : June 14, 2021  
**Max Usage** : 67%  
**Result** : Pass

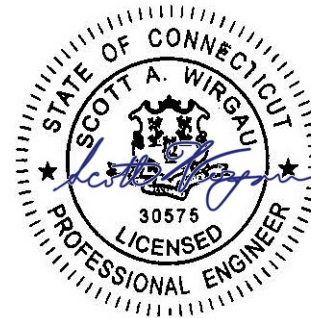

Prepared By:  
Lyle Morin  
Structural Engineer I

Reviewed By:

Authorized by "EOR"  
14 Jun 2021 04:19:19

COA: PEC.0001553



**Table of Contents**

Introduction .....	1
Supporting Documents .....	1
Analysis .....	1
Conclusion.....	1
Existing and Reserved Equipment.....	2
Equipment to be Removed.....	2
Proposed Equipment .....	3
Structure Usages .....	3
Foundations .....	3
Deflection and Sway .....	3
Standard Conditions .....	4
Calculations .....	Attached



## Introduction

The purpose of this report is to summarize results of a structural analysis performed on the 130 ft monopole to reflect the change in loading by T-MOBILE.

## Supporting Documents

<b>Tower Drawings</b>	Glen Martin Engineering Drawing #MP1400800-0001, dated August 20, 2003
<b>Foundation Drawing</b>	Glen Martin Engineering Drawing #GME-03309, dated August 26, 2003
<b>Geotechnical Report</b>	Geotechnical Engineering Project Name: The Marcus Group, dated April 25, 2003
<b>Mount Analysis</b>	ATC Engineering #13677849_C8_02, dated June 2, 2021

## Analysis

The tower was analyzed using American Tower Corporation's tower analysis software. This program considers an elastic three-dimensional model and second-order effects per ANSI/TIA-222.

<b>Basic Wind Speed:</b>	118 mph (3-Second Gust)
<b>Basic Wind Speed w/ Ice:</b>	50 mph (3-Second Gust) w/ 1 1/2" radial ice concurrent
<b>Code:</b>	ANSI/TIA-222-H / 2015 IBC / 2018 Connecticut State Building Code
<b>Exposure Category:</b>	B
<b>Risk Category:</b>	II
<b>Topographic Factor Procedure:</b>	Method 1
<b>Topographic Category:</b>	1
<b>Crest Height (H):</b>	0 ft
<b>Spectral Response:</b>	$S_s = 0.19, S_1 = 0.05$
<b>Site Class:</b>	D - Stiff Soil

## Conclusion

Based on the analysis results, the structure meets the requirements per the applicable codes listed above. The tower and foundation can support the equipment as described in this report.

If you have any questions or require additional information, please contact American Tower via email at [Engineering@americantower.com](mailto:Engineering@americantower.com). Please include the American Tower site name, site number, and engineering number in the subject line for any questions.



**Existing and Reserved Equipment**

Elev. <sup>1</sup> (ft)	Qty	Equipment	Mount Type	Lines	Carrier
128.0	3	DragonWave A-ANT-18G-2-C	T-Arm	(2) 0.41" (10.3mm) Fiber (3) 1 1/4" Hybriflex Cable (1) 1.7" (43.2mm) Hybrid (3) 1/2" Coax (2) 2" Carflex Non-Metallic Conduit (3) 5/8" Coax	CLEARWIRE CORPORATION
	3	Argus LLPX310R			
	3	Nokia 2.5G MAA - AAHC(64T64R)			
	3	Alcatel-Lucent 1900 MHz 4X45 RRH			
	6	Alcatel-Lucent RRH2x50-08			
	3	DragonWave Horizon Compact (11.5 lbs)			
	3	Commscope NNVV-65B-R4			
118.0	3	Andrew LNX-6513DS-A1M (32.6lb)	Platform w/ Handrails	(6) 1 5/8" Coax (2) 1 5/8" Hybriflex	VERIZON WIRELESS
	2	RFS DB-T1-6Z-8AB-OZ			
	3	Samsung MT6407-77A			
	3	Samsung B5/B13 RRH-BR04C			
	3	Samsung B2/B66A RRH-BR049			
	3	Samsung RT4401-48A			
	3	Commscope NHHSS-65B-R2BT4			
	3	Commscope NHH-65B-R2B			
110.0	3	Generic 48" x 12" Panel	Low Profile Platform	(9) 1 5/8" Coax	SPRINT NEXTEL
100.0	-	-	Triangular Platform with Handrails	(2) 1 5/8" Hybriflex (6) 7/8" Coax	T-MOBILE
90.0	3	Ericsson RRUS 4478 B14	Platform with Handrails	(3) 0.35" (9mm) Fiber (2) 0.39" (10mm) Fiber Trunk (8) 0.76" (19.2mm) 8 AWG 6 (8) 0.78" (19.7mm) 8 AWG 6 (3) 1/2" Coax (6) 2" conduit	AT&T MOBILITY
	3	Ericsson RRUS 32 B2			
	3	Ericsson RRUS 32 B66			
	3	Ericsson RRUS E2 B29			
	6	Ericsson RRUS-11			
	12	CCI HPA-65R-BUU-H8			
	2	Raycap DC6-48-60-18-8F			
	2	Raycap DC6-48-60-0-8F			
	3	Ericsson RRUS-32 (77 lbs)			
70.0	1	Generic 2' Std. Dish	Flush	(1) 1 5/8" Coax	SPRINT NEXTEL
50.0	1	Generic GPS	Side Arm	(1) 1/2" Coax	

**Equipment to be Removed**

Elev. <sup>1</sup> (ft)	Qty	Equipment	Mount Type	Lines	Carrier
100.0	3	Ericsson AIR-32 B2A/B66Aa	-	(6) 7/8" Coax	T-MOBILE
	3	Ericsson AIR 21, 1.3M, B2A B4P (91.5 lbs)			



**Proposed Equipment**

Elev. <sup>1</sup> (ft)	Qty	Equipment	Mount Type	Lines	Carrier
100.0	3	Commscope SDX1926Q-43	Triangular Platform with Handrails	(1) 1 5/8" Hybriflex	T-MOBILE
	3	Ericsson Radio 4449 B71 B85A			
	3	Ericsson RRUS 4415 B66			
	3	Ericsson RRUS 4415 B25			
	3	Ericsson Air6449 B41			
	3	Ericsson AIR32 B66Aa/B2a			
	3	RFS APXVAALL24 43-U-NA20			

<sup>1</sup> Contracted elevations are shown for appurtenances within contracted installation tolerances. Appurtenances outside of contract limits are shown at installed elevations.

Install proposed lines inside the pole shaft.

**Structure Usages**

Structural Component	Controlling Usage	Pass/Fail
Anchor Bolts	52%	Pass
Shaft	62%	Pass
Base Plate	23%	Pass
Flange	11%	Pass

**Foundations**

Reaction Component	Original Design Reactions	Factored Design Reactions*	Analysis Reactions	% of Design
Moment (Kips-Ft)	2,740.2	3,699.3	2,373.6	64%
Shear (Kips)	28.5	38.4	25.6	67%

\* The design reactions are factored by 1.35 per ANSI/TIA-222-H, Sec. 15.6.2

The structure base reactions resulting from this analysis are acceptable when compared to those shown on the original structure drawings, therefore no modification or reinforcement of the foundation will be required.

**Deflection and Sway\***

Antenna Elevation (ft)	Antenna	Carrier	Deflection (ft)	Sway (Rotation) (°)
128.0	DragonWave A-ANT-18G-2-C	CLEARWIRE CORPORATION	1.283	0.996
100.0	Commscope SDX1926Q-43	T-MOBILE	0.810	0.911
	Ericsson Radio 4449 B71 B85A			
	Ericsson RRUS 4415 B66			
	Ericsson RRUS 4415 B25			
	Ericsson Air6449 B41			
	Ericsson AIR32 B66Aa/B2a			
70.0	Generic 2' Std. Dish	SPRINT NEXTEL	0.393	0.665

\*Deflection and Sway was evaluated considering a design wind speed of 60 mph (3-Second Gust) per ANSI/TIA-222-H



## Standard Conditions

All engineering services performed by A.T. Engineering Service, PLLC are prepared on the basis that the information used is current and correct. This information may consist of, but is not limited to the following:

- Information supplied by the client regarding antenna, mounts and feed line loading
- Information from drawings, design and analysis documents, and field notes in the possession of A.T. Engineering Service, PLLC

It is the responsibility of the client to ensure that the information provided to A.T. Engineering Service, PLLC and used in the performance of our engineering services is correct and complete.

All assets of American Tower Corporation, its affiliates and subsidiaries (collectively "American Tower") are inspected at regular intervals. Based upon these inspections and in the absence of information to the contrary, American Tower assumes that all structures were constructed in accordance with the drawings and specifications.

Unless explicitly agreed by both the client and A.T. Engineering Service, PLLC, all services will be performed in accordance with the current revision of ANSI/TIA-222.

All services are performed, results obtained, and recommendations made in accordance with generally accepted engineering principles and practices. A.T. Engineering Service, PLLC is not responsible for the conclusions, opinions and recommendations made by others based on the information supplied herein.



Job Information		
Client : T-MOBILE	Code: ANSI/TIA-222-H	
Pole : 370626	Location : East Hartford, CT	
Description : 130 ft. Monopole	Risk Category : II	Exposure : B
Shape : 16 Sides	Height : 130.00 (ft)	Topo Method : Method 1
Base Elev (ft): 0.00	Topographic Category : 1	
Taper: 0.233192in/ft)		

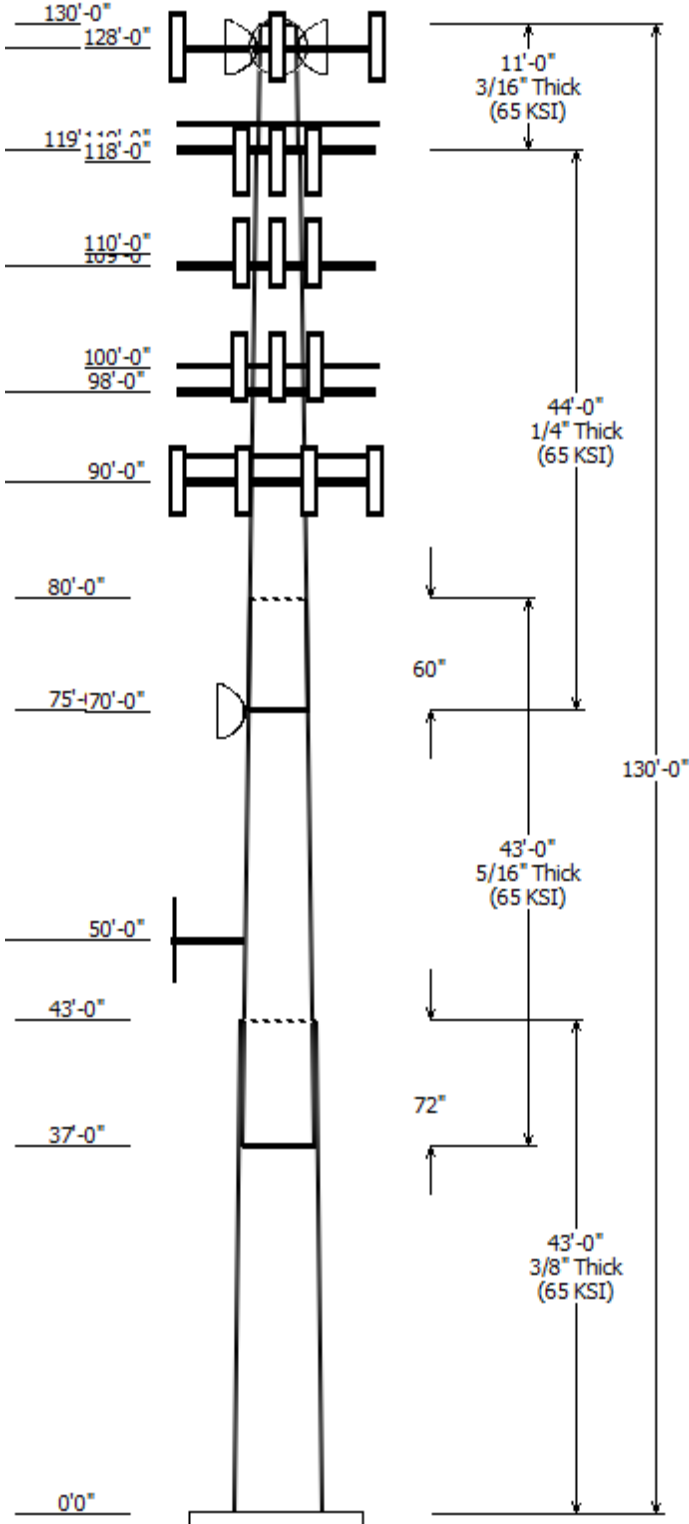

Sections Properties							
Shaft Section	Length (ft)	Diameter (in)		Thick (in)	Joint Type	Overlap Length (in)	Steel Grade (ksi)
		Top	Bottom				
1	43.000	39.16	49.19	0.375		0.000	16 Sides 65
2	43.000	31.16	41.18	0.313	Slip Joint	72.000	16 Sides 65
3	44.000	22.56	32.82	0.250	Slip Joint	60.000	16 Sides 65
4	11.000	20.00	22.56	0.188	Butt Joint	0.000	16 Sides 65

Discrete Appurtenance			
Attach Elev (ft)	Force Elev (ft)	Qty	Description
128.000	128.000	3	Infinity T-Arm CT52XC030
128.000	128.000	3	Commscope NNVV-65B-R4
128.000	128.000	3	DragonWave A-ANT-18G-2-C
128.000	128.000	3	Argus LLPX310R
128.000	128.000	3	Alcatel-Lucent 1900 MHz 4X45
128.000	128.000	6	Alcatel-Lucent RRH2x50-08
128.000	128.000	3	DragonWave Horizon Compact
128.000	128.000	3	Nokia 2.5G MAA -
119.000	119.000	1	Round Platform w/ Handrails
118.000	118.000	3	Commscope NHHSS-65B-
118.000	118.000	3	Andrew LNX-6513DS-A1M
118.000	118.000	3	Commscope NHH-65B-R2B
118.000	120.000	2	RFS DB-T1-6Z-8AB-0Z
118.000	118.000	3	Samsung MT6407-77A
118.000	118.000	3	Samsung B5/B13 RRH-BR04C
118.000	118.000	3	Samsung B2/B66A RRH-BR049
118.000	118.000	3	Samsung RT4401-48A
110.000	110.000	3	Generic 48" x 12" Panel
109.000	109.000	1	Round Low Profile Platform
100.000	100.000	3	RFS APXVAALL24 43-U-NA20
100.000	100.000	3	Ericsson AIR32 B66Aa/B2a
100.000	100.000	3	Ericsson Air6449 B41
100.000	100.000	3	Ericsson RRUS 4415 B25
100.000	100.000	3	Ericsson RRUS 4415 B66
100.000	100.000	3	Ericsson Radio 4449 B71 B85A
100.000	100.000	3	Commscope SDX1926Q-43
98.000	98.000	1	PerfectVision PV-RP14M-HR-9-
90.000	90.000	1	Round Platform w/ Handrails
90.000	90.000	6	Ericsson RRUS-11
90.000	90.000	3	Ericsson RRUS-32 (77 lbs)
90.000	90.000	3	Ericsson RRUS E2 B29
90.000	90.000	12	CCI HPA-65R-BUU-H8
90.000	90.000	3	Ericsson RRUS 32 B66
90.000	90.000	3	Ericsson RRUS 32 B2
90.000	90.000	3	Ericsson RRUS 4478 B14
90.000	90.000	2	Raycap DC6-48-60-18-8F
90.000	90.000	2	Raycap DC6-48-60-0-8F
70.000	70.000	1	Generic 2' Std. Dish
50.000	50.000	1	Round Side Arm
50.000	50.000	1	Generic GPS

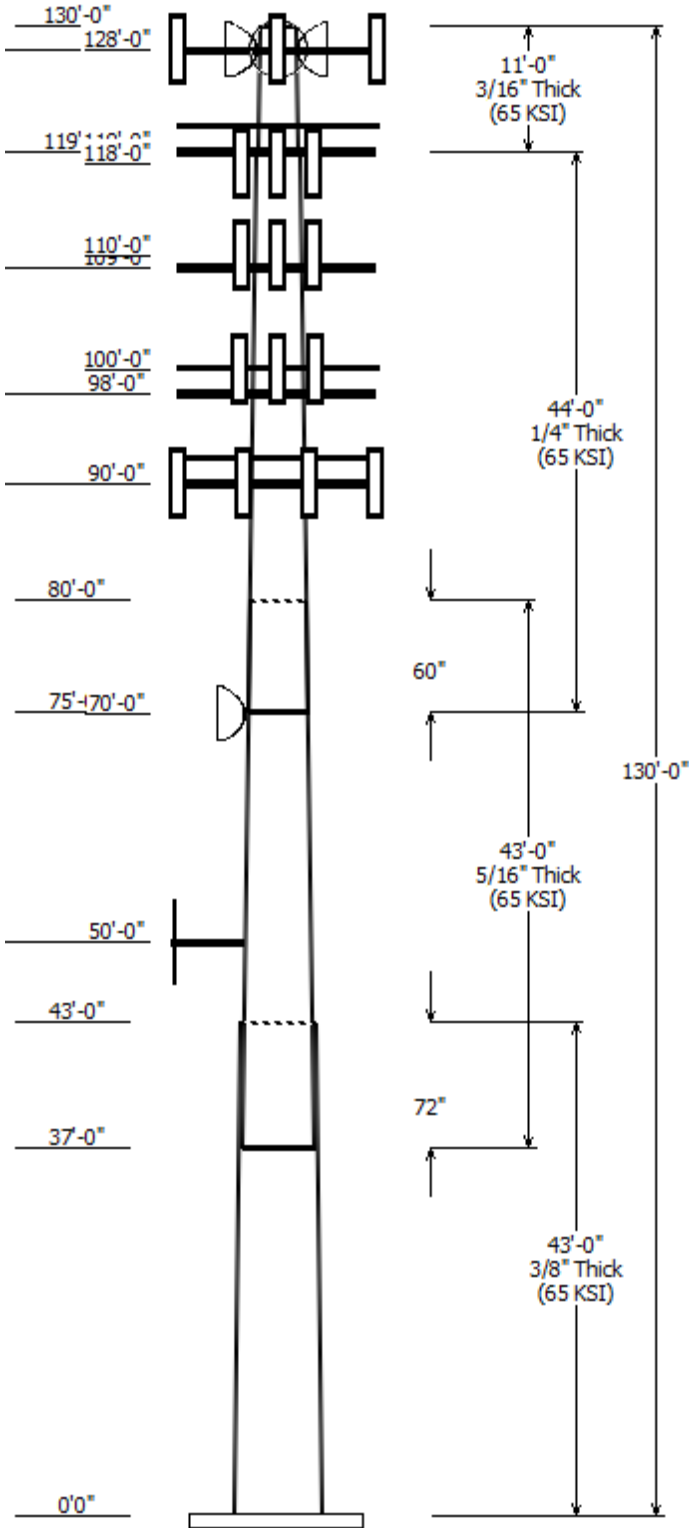

Linear Appurtenance			
Elev (ft)		Description	Exposed To Wind
From	To		
0.000	50.000	1/2" Coax	No
0.000	70.000	1 5/8" Coax	Yes
0.000	90.000	0.35" (9mm) Fiber	No
0.000	90.000	0.39" (10mm)	No
0.000	90.000	0.76" (19.2mm) 8	No
0.000	90.000	0.78" (19.7mm) 8	No
0.000	90.000	1/2" Coax	No
0.000	90.000	2" conduit	No
0.000	100.0	1 5/8" Hybriflex	No
0.000	100.0	1 5/8" Hybriflex	No
0.000	100.0	7/8" Coax	No
0.000	110.0	1 5/8" Coax	No
0.000	118.0	1 5/8" Coax	Yes
0.000	118.0	1 5/8" Hybriflex	Yes
0.000	128.0	0.41" (10.3mm)	No
0.000	128.0	1 1/4" Hybriflex	No
0.000	128.0	1.7" (43.2mm)	No
0.000	128.0	1/2" Coax	No
0.000	128.0	2" Carflex Non-	No
0.000	128.0	5/8" Coax	No

Load Cases	
1.2D + 1.0W	118 mph with No Ice
0.9D + 1.0W	118 mph with No Ice (Reduced DL)
1.2D + 1.0Di + 1.0Wi	50 mph with 1.50 in Radial Ice
1.2D + 1.0Ev + 1.0Eh	Seismic
0.9D - 1.0Ev + 1.0Eh	Seismic (Reduced DL)
1.0D + 1.0W	Serviceability 60 mph

Reactions			
Load Case	Moment (kip-ft)	Shear (kip)	Axial (kip)
1.2D + 1.0W	2373.61	25.61	44.97
0.9D + 1.0W	2345.89	25.59	33.72
1.2D + 1.0Di + 1.0Wi	651.92	6.81	72.35
1.2D + 1.0Ev + 1.0Eh	117.09	1.13	44.93
0.9D - 1.0Ev + 1.0Eh	115.36	1.13	31.14
1.0D + 1.0W	545.20	5.92	37.51

Dish Deflections			
Load Case	Attach Elev (ft)	Deflection (in)	Rotation (deg)
1.0D + 1.0W	70.00	4.714	0.665
1.0D + 1.0W	128.00	15.392	0.996

Load Case : 1.2D + 1.0W  
Max Ratio 61.63% at 43.0 ft

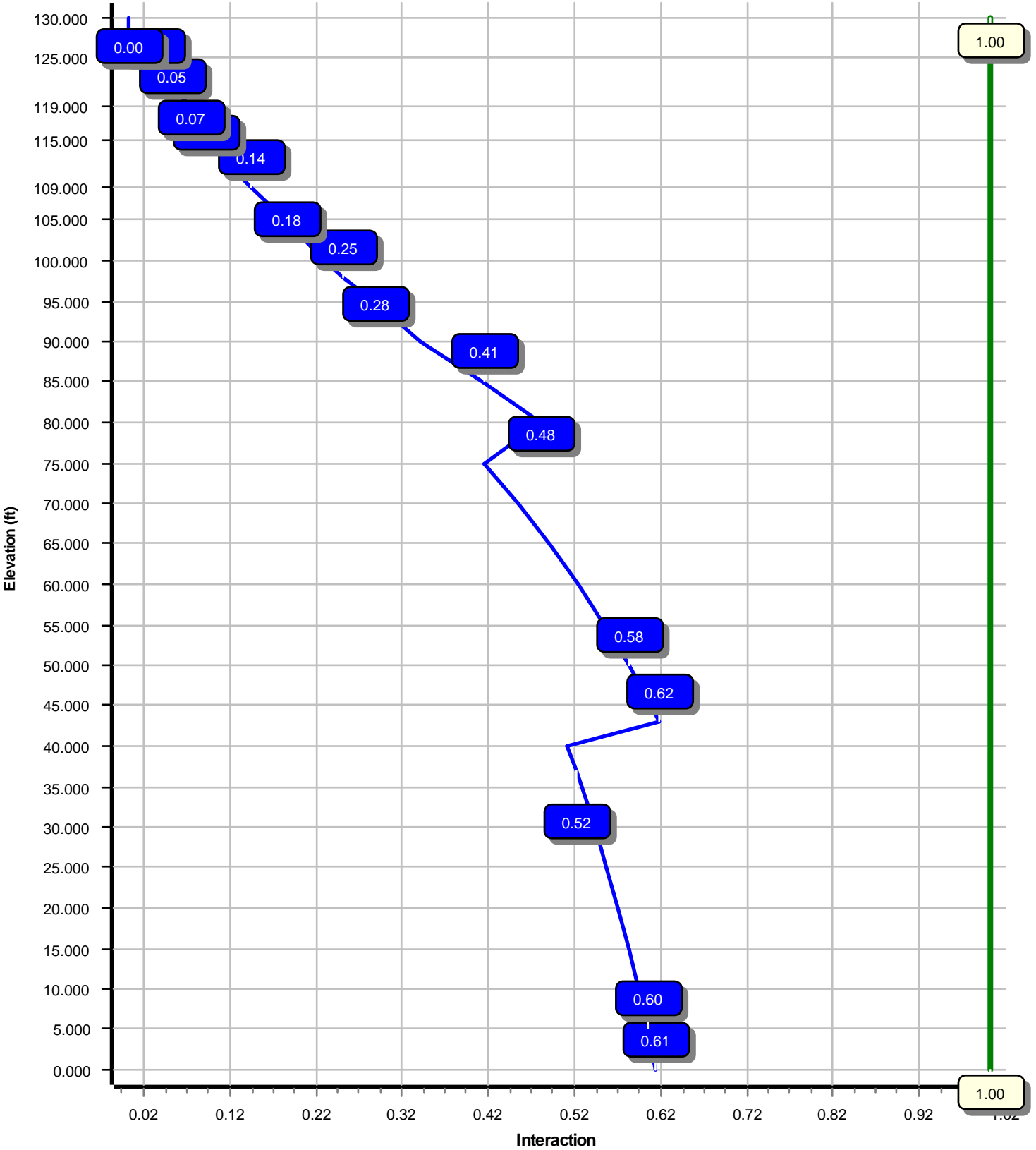

Site Number: 370626

Code: ANSI/TIA-222-H

© 2007 - 2021 by ATC IP LLC. All rights reserved.

Site Name: East Hartford, CT

Engineering Number:13677849\_C3\_03

6/14/2021 3:32:29 PM

Customer: T-MOBILE

**Analysis Parameters**

Location :	Hartford County, CT	Height (ft) :	130
Code :	ANSI/TIA-222-H	Base Diameter (in) :	49.19
Shape :	16 Sides	Top Diameter (in) :	20.00
Pole Type :	Taper	Taper (in/ft) :	0.233
Pole Manufacturer :	Glen Martin	Rotation (deg) :	0.00
Kd (non-service) :	0.95	Ke :	1.00

**Ice & Wind Parameters**

Exposure Category:	B	Design Wind Speed Without Ice:	118 mph
Risk Category:	II	Design Wind Speed With Ice:	50 mph
Topographic Factor Procedure:	Method 1	Operational Wind Speed:	60 mph
Topographic Category:	1	Design Ice Thickness:	1.50 in
Crest Height:	0 ft	HMSL:	49.00 ft

**Seismic Parameters**

Analysis Method:	Equivalent Lateral Force Method		
Site Class:	D - Stiff Soil		
Period Based on Rayleigh Method (sec):	2.18		
T <sub>L</sub> (sec):	6	p:	1
S <sub>s</sub> :	0.189	S <sub>1</sub> :	0.055
F <sub>a</sub> :	1.600	F <sub>v</sub> :	2.400
S <sub>ds</sub> :	0.202	S <sub>d1</sub> :	0.088
		C <sub>s</sub> :	0.030
		C <sub>s</sub> Max:	0.030
		C <sub>s</sub> Min:	0.030

**Load Cases**

1.2D + 1.0W	118 mph with No Ice
0.9D + 1.0W	118 mph with No Ice (Reduced DL)
1.2D + 1.0Di + 1.0Wi	50 mph with 1.50 in Radial Ice
1.2D + 1.0Ev + 1.0Eh	Seismic
0.9D - 1.0Ev + 1.0Eh	Seismic (Reduced DL)
1.0D + 1.0W	Serviceability 60 mph

Site Number: 370626

Code: ANSI/TIA-222-H

© 2007 - 2021 by ATC IP LLC. All rights reserved.

Site Name: East Hartford, CT

Engineering Number:13677849\_C3\_03

6/14/2021 3:32:29 PM

Customer: T-MOBILE

**Shaft Section Properties**

Sect Info	Length (ft)	Thick (in)	Fy (ksi)	Joint Type	Joint Len (in)	Weight (lb)	Bottom					Top					Taper (in/ft)		
							Dia (in)	Elev (ft)	Area (in <sup>2</sup> )	Ix (in <sup>4</sup> )	W/t Ratio	D/t Ratio	Dia (in)	Elev (ft)	Area (in <sup>2</sup> )	Ix (in <sup>4</sup> )		W/t Ratio	D/t Ratio
1-16	43.000	0.3750	65		0.00	7,667	49.19	0.00	58.39	17579.1	24.10	131.17	39.16	43.00	46.40	8819.0	18.78	104.43	0.233192
2-16	43.000	0.3125	65	Slip	72.00	5,231	41.18	37.00	40.75	8600.2	24.23	131.80	31.16	80.00	30.75	3696.6	17.84	99.71	0.233192
3-16	44.000	0.2500	65	Slip	60.00	3,277	32.82	75.00	25.98	3482.7	24.13	131.30	22.56	119.00	17.80	1119.5	15.96	90.26	0.233192
4-16	11.000	0.1875	65	Butt	0.00	472	22.56	119.00	13.38	846.7	21.95	120.35	20.00	130.00	11.85	587.7	19.23	106.67	0.233192
Shaft Weight						16,647													

**Discrete Appurtenance Properties**

Attach Elev (ft)	Description	Qty	Ka	Vert Ecc (ft)	Weight (lb)	No Ice EPAa (sf)	Orientation Factor	Weight (lb)	Ice EPAa (sf)	Orientation Factor
128.00	DragonWave Horizon Compact	3	0.80	0.000	11.50	0.721	0.50	33.65	1.282	0.50
128.00	Alcatel-Lucent RRH2x50-08	6	0.80	0.000	52.90	1.701	0.50	111.28	2.551	0.50
128.00	Alcatel-Lucent 1900 MHz 4X45	3	0.80	0.000	60.00	2.322	0.50	139.39	3.387	0.50
128.00	Nokia 2.5G MAA - AAHC(64T64R)	3	0.80	0.000	103.60	4.203	0.64	214.66	5.524	0.64
128.00	Argus LLPX310R	3	0.80	0.000	28.60	4.292	0.63	117.38	5.921	0.63
128.00	DragonWave A-ANT-18G-2-C	3	1.00	0.000	27.10	4.688	1.00	123.24	5.943	1.00
128.00	Infinity T-Arm CT52XC030	3	0.75	0.000	250.00	9.700	0.67	455.89	17.822	0.67
128.00	Commscope NNVV-65B-R4	3	0.80	0.000	77.40	12.271	0.64	324.93	15.033	0.64
119.00	Round Platform w/ Handrails	1	1.00	0.000	2,000.00	27.200	1.00	3,268.19	51.124	1.00
118.00	Samsung RT4401-48A	3	0.80	0.000	18.60	0.996	0.50	44.98	1.664	0.50
118.00	Samsung B2/B66A RRH-BR049	3	0.80	0.000	84.40	1.875	0.50	146.73	2.757	0.50
118.00	Samsung B5/B13 RRH-BR04C	3	0.80	0.000	70.30	1.875	0.50	126.19	2.757	0.50
118.00	Samsung MT6407-77A	3	0.80	0.000	81.60	4.709	0.61	181.19	6.193	0.61
118.00	RFS DB-T1-6Z-8AB-0Z	2	0.75	2.000	44.00	4.800	0.72	166.97	6.189	0.72
118.00	Andrew LNX-6513DS-A1M	3	0.80	0.000	32.60	5.846	0.69	164.78	7.911	0.69
118.00	Commscope NHHSS-65B-R2BT4	3	0.80	0.000	51.00	8.079	0.69	220.82	10.812	0.69
118.00	Commscope NHH-65B-R2B	3	0.80	0.000	43.70	8.079	0.69	214.05	10.801	0.69
110.00	Generic 48" x 12" Panel	3	0.80	0.000	30.00	5.067	0.66	139.93	6.884	0.66
109.00	Round Low Profile Platform	1	1.00	0.000	1,500.00	21.700	1.00	2,127.66	40.300	1.00
100.00	Commscope SDX1926Q-43	3	0.75	0.000	6.20	0.242	0.50	14.47	0.580	0.50
100.00	Ericsson Radio 4449 B71 B85A	3	0.75	0.000	75.00	1.650	0.50	132.81	2.467	0.50
100.00	Ericsson RRUS 4415 B66	3	0.75	0.000	46.00	1.650	0.50	87.62	2.467	0.50
100.00	Ericsson RRUS 4415 B25	3	0.75	0.000	46.00	1.842	0.50	93.13	2.704	0.50
100.00	Ericsson Air6449 B41	3	0.75	0.000	104.00	5.682	0.63	235.00	7.208	0.63
100.00	Ericsson AIR32 B66Aa/B2a	3	0.75	0.000	132.20	6.510	0.71	285.62	8.616	0.71
100.00	RFS APXVAALL24 43-U-NA20	3	0.75	0.000	122.80	20.243	0.63	497.22	23.808	0.63
98.00	PerfectVision PV-RP14M-HR-9-	1	1.00	0.000	2,000.00	27.200	1.00	3,242.41	50.637	1.00
90.00	Raycap DC6-48-60-18-8F	2	0.75	0.000	20.00	1.260	1.00	69.99	1.885	1.00
90.00	Raycap DC6-48-60-0-8F	2	0.75	0.000	32.80	1.360	1.00	87.99	1.990	1.00
90.00	Ericsson RRUS 4478 B14	3	0.75	0.000	59.40	2.021	0.50	117.67	2.917	0.50
90.00	Ericsson RRUS 32 B2	3	0.75	0.000	53.00	2.743	0.50	122.83	3.853	0.50
90.00	Ericsson RRUS 32 B66	3	0.75	0.000	53.00	2.743	0.50	122.83	3.853	0.50
90.00	Ericsson RRUS E2 B29	3	0.75	0.000	60.00	3.145	0.50	136.79	4.245	0.50
90.00	Ericsson RRUS-32 (77 lbs)	3	0.75	0.000	77.00	3.314	0.50	169.34	4.533	0.50
90.00	Ericsson RRUS-11	6	0.75	0.000	55.00	3.792	0.50	140.24	5.011	0.50
90.00	CCI HPA-65R-BUU-H8	12	0.75	0.000	68.00	12.976	0.67	311.97	16.375	0.67
90.00	Round Platform w/ Handrails	1	1.00	0.000	2,000.00	27.200	1.00	3,230.31	50.409	1.00
70.00	Generic 2' Std. Dish	1	1.00	0.000	14.00	5.228	1.00	65.26	6.660	1.00
50.00	Generic GPS	1	1.00	0.000	10.00	0.900	1.00	36.13	1.471	1.00
50.00	Round Side Arm	1	1.00	0.000	150.00	5.200	1.00	215.34	7.627	1.00
<b>Totals</b>	<b>Num Loadings:40</b>	<b>118</b>			<b>14,746.00</b>			<b>32,077.38</b>		

Site Number: 370626

Code: ANSI/TIA-222-H

© 2007 - 2021 by ATC IP LLC. All rights reserved.

Site Name: East Hartford, CT

Engineering Number:13677849\_C3\_03

6/14/2021 3:32:29 PM

Customer: T-MOBILE

**Linear Appurtenance Properties**      **Load Case Azimuth (deg) :**

Elev From (ft)	Elev To (ft)	Qty	Description	Coax Dia (in)	Coax Wt (lb/ft)	Max Coax / Flat Row	Dist Between Rows (in)	Dist Between Cols (in)	Azimuth (deg)	Dist From Face (in)	Exposed To Wind	Carrier
0.00	128.00	2	0.41" (10.3mm) Fiber	0.41	0.09	N 0	0.00	0.00	0	0.00	N	CLEARWIRE
0.00	128.00	3	1 1/4" Hybriflex Cable	1.54	1.00	N 0	0.00	0.00	0	0.00	N	CLEARWIRE
0.00	128.00	1	1.7" (43.2mm) Hybrid	1.70	1.78	N 0	0.00	0.00	0	0.00	N	CLEARWIRE
0.00	128.00	3	1/2" Coax	0.63	0.15	N 0	0.00	0.00	0	0.00	N	CLEARWIRE
0.00	128.00	2	2" Carflex Non-	2.36	0.68	N 0	0.00	0.00	0	0.00	N	CLEARWIRE
0.00	128.00	3	5/8" Coax	0.86	0.15	N 0	0.00	0.00	0	0.00	N	CLEARWIRE
0.00	118.00	6	1 5/8" Coax	1.98	0.82	N 5	1.00	1.00	270	1.00	Y	VERIZON WIRELESS
0.00	118.00	2	1 5/8" Hybriflex	1.98	1.30	N 2	1.00	1.00	250	1.00	Y	VERIZON WIRELESS
0.00	110.00	9	1 5/8" Coax	1.98	0.82	N 0	0.00	0.00	0	0.00	N	SPRINT NEXTEL
0.00	100.00	2	1 5/8" Hybriflex	1.98	1.30	N 0	0.00	0.00	0	0.00	N	T-MOBILE
0.00	100.00	1	1 5/8" Hybriflex	1.98	1.30	N 0	0.00	0.00	0	0.00	N	T-MOBILE
0.00	100.00	6	7/8" Coax	1.09	0.33	N 0	0.00	0.00	0	0.00	N	T-MOBILE
0.00	90.00	3	0.35" (9mm) Fiber	0.35	0.05	N 0	0.00	0.00	0	0.00	N	AT&T MOBILITY
0.00	90.00	2	0.39" (10mm) Fiber	0.39	0.06	N 0	0.00	0.00	0	0.00	N	AT&T MOBILITY
0.00	90.00	8	0.76" (19.2mm) 8 AWG	0.76	0.53	N 0	0.00	0.00	0	0.00	N	AT&T MOBILITY
0.00	90.00	8	0.78" (19.7mm) 8 AWG	0.78	0.59	N 0	0.00	0.00	0	0.00	N	AT&T MOBILITY
0.00	90.00	3	1/2" Coax	0.63	0.15	N 0	0.00	0.00	0	0.00	N	AT&T MOBILITY
0.00	90.00	6	2" conduit	2.38	3.65	N 0	0.00	0.00	0	0.00	N	AT&T MOBILITY
0.00	70.00	1	1 5/8" Coax	1.98	0.82	N 1	0.00	0.00	300	0.00	Y	SPRINT NEXTEL
0.00	50.00	1	1/2" Coax	0.63	0.15	N 0	0.00	0.00	0	0.00	N	SPRINT NEXTEL



Site Number: 370626

Code: ANSI/TIA-222-H

© 2007 - 2021 by ATC IP LLC. All rights reserved.

Site Name: East Hartford, CT

Engineering Number:13677849\_C3\_03

6/14/2021 3:32:29 PM

Customer: T-MOBILE

**Segment Properties** (Max Len : 5. ft)

Seg Top Elev (ft)	Description	Thick (in)	Flat Dia (in)	Area (in <sup>2</sup> )	Ix (in <sup>4</sup> )	W/t Ratio	D/t Ratio	F'y (ksi)	S (in <sup>3</sup> )	Z (in <sup>3</sup> )	Weight (lb)
0.00		0.3750	49.190	58.395	17,579.1	24.10	131.17	75.3	701.0	0.0	0.0
5.00		0.3750	48.024	57.000	16,349.3	23.48	128.06	76.0	667.8	0.0	981.7
10.00		0.3750	46.858	55.605	15,178.2	22.87	124.95	76.7	635.4	0.0	957.9
15.00		0.3750	45.692	54.211	14,064.5	22.25	121.85	77.4	603.8	0.0	934.2
20.00		0.3750	44.526	52.816	13,006.6	21.63	118.74	78.1	573.0	0.0	910.5
25.00		0.3750	43.360	51.421	12,003.1	21.01	115.63	78.8	543.0	0.0	886.7
30.00		0.3750	42.194	50.026	11,052.6	20.39	112.52	79.5	513.8	0.0	863.0
35.00		0.3750	41.028	48.631	10,153.7	19.77	109.41	80.2	485.4	0.0	839.3
37.00	Bot - Section 2	0.3750	40.562	48.074	9,808.2	19.53	108.17	80.5	474.3	0.0	329.1
40.00		0.3750	39.862	47.237	9,304.8	19.16	106.30	80.9	457.9	0.0	898.9
43.00	Top - Section 1	0.3125	39.788	39.352	7,746.9	23.34	127.32	76.2	381.9	0.0	883.2
45.00		0.3125	39.321	38.887	7,475.6	23.04	125.83	76.5	372.9	0.0	266.2
50.00		0.3125	38.155	37.725	6,825.1	22.30	122.10	77.3	350.9	0.0	651.7
55.00		0.3125	36.989	36.562	6,213.5	21.56	118.37	78.2	329.5	0.0	632.0
60.00		0.3125	35.823	35.400	5,639.5	20.81	114.64	79.0	308.8	0.0	612.2
65.00		0.3125	34.657	34.238	5,102.1	20.07	110.90	79.9	288.8	0.0	592.4
70.00		0.3125	33.492	33.075	4,599.9	19.33	107.17	80.7	269.4	0.0	572.6
75.00	Bot - Section 3	0.3125	32.326	31.913	4,131.8	18.59	103.44	81.5	250.7	0.0	552.9
80.00	Top - Section 2	0.2500	31.660	25.049	3,122.0	23.20	126.64	76.3	193.4	0.0	967.2
85.00		0.2500	30.494	24.119	2,787.1	22.27	121.97	77.4	179.3	0.0	418.3
90.00		0.2500	29.328	23.189	2,477.0	21.35	117.31	78.4	165.7	0.0	402.5
95.00		0.2500	28.162	22.260	2,190.8	20.42	112.65	79.5	152.6	0.0	386.6
98.00		0.2500	27.462	21.702	2,030.2	19.86	109.85	80.1	145.0	0.0	224.4
100.0		0.2500	26.996	21.330	1,927.6	19.49	107.98	80.5	140.1	0.0	146.4
105.0		0.2500	25.830	20.400	1,686.3	18.56	103.32	81.6	128.1	0.0	355.0
109.0		0.2500	24.897	19.656	1,508.5	17.82	99.59	82.4	118.8	0.0	272.6
110.0		0.2500	24.664	19.470	1,466.1	17.63	98.66	82.6	116.6	0.0	66.6
115.0		0.2500	23.498	18.540	1,265.9	16.71	93.99	82.6	105.7	0.0	323.4
118.0		0.2500	22.798	17.982	1,155.0	16.15	91.19	82.6	99.4	0.0	186.4
119.0	Top - Section 3	0.2500	22.565	17.796	1,119.5	15.96	90.26	82.6	97.3	0.0	60.9
119.0	Bot - Section 4	0.1875	22.565	13.385	846.7	21.95	120.35	77.7	73.6	0.0	
120.0		0.1875	22.332	13.245	820.5	21.70	119.10	78.0	72.1	0.0	45.3
125.0		0.1875	21.166	12.548	697.6	20.47	112.89	79.4	64.7	0.0	219.4
128.0		0.1875	20.466	12.129	630.1	19.72	109.15	80.3	60.4	0.0	126.0
130.0		0.1875	20.000	11.850	587.7	19.23	106.67	80.8	57.6	0.0	81.6
											16,646.8

<b>Load Case: 1.2D + 1.0W</b>	<b>118 mph with No Ice</b>	<b>23 Iterations</b>
Gust Response Factor :1.10		
Dead Load Factor :1.20		
Wind Load Factor :1.00		

**Applied Segment Forces Summary**

Seg Elev (ft)	Description	Shaft Forces		Discrete Forces			Linear Forces		Sum of Forces				
		Wind FX (lb)	Dead Load (lb)	Wind FX (lb)	Torsion MY (lb-ft)	Moment MZ (lb-ft)	Dead Load (lb)	Wind FX (lb)	Dead Load (lb)	Wind FX (lb)	Dead Load (lb)	Torsion MY (lb-ft)	Moment MZ (lb)
0.00		201.6	0.0					0.0	0.0	201.6	0.0	0.0	0.0
5.00		401.3	1,178.0					0.0	363.3	401.3	1,541.3	0.0	0.0
10.00		397.6	1,149.5					0.0	363.3	397.6	1,512.8	0.0	0.0
15.00		393.8	1,121.0					0.0	363.3	393.8	1,484.3	0.0	0.0
20.00		390.1	1,092.6					0.0	363.3	390.1	1,455.9	0.0	0.0
25.00		386.4	1,064.1					0.0	363.3	386.4	1,427.4	0.0	0.0
30.00		387.4	1,035.6					0.0	363.3	387.4	1,398.9	0.0	0.0
35.00		274.9	1,007.1					0.0	363.3	274.9	1,370.4	0.0	0.0
37.00	Bot - Section 2	203.2	394.9					0.0	145.3	203.2	540.2	0.0	0.0
40.00		248.8	1,078.7					0.0	218.0	248.8	1,296.6	0.0	0.0
43.00	Top - Section 1	209.1	1,059.9					0.0	218.0	209.1	1,277.8	0.0	0.0
45.00		296.2	319.5					0.0	145.3	296.2	464.8	0.0	0.0
50.00	Appurtenance(s)	429.3	782.1	183.9	0.0	0.0	192.0	0.0	363.3	613.2	1,337.4	0.0	0.0
55.00		437.3	758.3					0.0	362.4	437.3	1,120.7	0.0	0.0
60.00		444.4	734.6					0.0	362.4	444.4	1,097.0	0.0	0.0
65.00		450.9	710.9					0.0	362.4	450.9	1,073.3	0.0	0.0
70.00	Appurtenance(s)	456.7	687.2	173.5	0.0	0.0	16.8	0.0	362.4	630.2	1,066.4	0.0	0.0
75.00	Bot - Section 3	465.8	663.4					0.0	357.5	465.8	1,020.9	0.0	0.0
80.00	Top - Section 2	471.6	1,160.6					0.0	357.5	471.6	1,518.1	0.0	0.0
85.00		473.4	501.9					0.0	357.5	473.4	859.4	0.0	0.0
90.00	Appurtenance(s)	473.9	482.9	4,764.3	0.0	0.0	4,990.6	0.0	357.5	5,238.2	5,831.0	0.0	0.0
95.00		373.9	464.0					0.2	168.0	374.1	632.0	0.0	0.0
98.00	Appurtenance(s)	228.2	269.3	993.7	0.0	0.0	2,400.0	0.3	100.8	1,222.2	2,770.1	0.0	0.0
100.00	Appurtenance(s)	310.3	175.7	1,955.1	0.0	0.0	1,915.9	0.3	67.2	2,265.7	2,158.8	0.0	0.0
105.00		389.8	426.0					0.9	132.7	390.7	558.7	0.0	0.0
109.00	Appurtenance(s)	211.3	327.1	817.3	0.0	0.0	1,800.0	1.0	106.2	1,029.6	2,233.3	0.0	0.0
110.00	Appurtenance(s)	243.8	79.9	303.1	0.0	0.0	108.0	0.3	26.5	547.2	214.4	0.0	0.0
115.00		319.1	388.0					1.7	88.4	320.8	476.5	0.0	0.0
118.00	Appurtenance(s)	144.7	223.7	2,089.5	0.0	401.4	1,481.5	1.2	53.1	2,235.4	1,758.3	0.0	0.0
119.00	Top - Section 3	55.5	73.0	1,050.4	0.0	0.0	2,400.0	0.0	8.7	1,105.9	2,481.7	0.0	0.0
120.00		162.6	54.4					0.0	8.7	162.6	63.0	0.0	0.0
125.00		213.1	263.3					0.0	43.3	213.1	306.6	0.0	0.0
128.00	Appurtenance(s)	122.4	151.1	2,689.8	0.0	0.0	2,390.4	0.0	26.0	2,812.1	2,567.5	0.0	0.0
130.00		44.2	97.9					0.0	0.0	44.2	97.9	0.0	0.0
<b>Totals:</b>									<b>25,738.7</b>	<b>45,013.5</b>	<b>0.00</b>	<b>0.00</b>	

Site Number: 370626

Code: ANSI/TIA-222-H

© 2007 - 2021 by ATC IP LLC. All rights reserved.

Site Name: East Hartford, CT

Engineering Number:13677849\_C3\_03

6/14/2021 3:32:32 PM

Customer: T-MOBILE

**Load Case: 1.2D + 1.0W**

118 mph with No Ice

23 Iterations

Gust Response Factor :1.10

Dead Load Factor :1.20

Wind Load Factor :1.00

**Calculated Forces**

Seg Elev (ft)	Pu FY (-) (kips)	Vu FX (-) (kips)	Tu MY (ft-kips)	Mu MZ (ft-kips)	Mu MX (ft-kips)	Resultant Moment (ft-kips)	phi Pn (kips)	phi Vn (kips)	phi Tn (ft-kips)	phi Mn (ft-kips)	Total Deflect (in)	Rotation (deg)	Ratio
0.00	-44.97	-25.61	0.00	-2,373.61	0.00	2,373.61	3,957.37	1,024.83	4,561.65	3,958.89	0.00	0.00	0.612
5.00	-43.35	-25.35	0.00	-2,245.56	0.00	2,245.56	3,898.74	1,000.35	4,346.37	3,806.37	0.10	-0.19	0.602
10.00	-41.75	-25.09	0.00	-2,118.81	0.00	2,118.81	3,838.36	975.87	4,136.30	3,655.00	0.40	-0.38	0.591
15.00	-40.19	-24.82	0.00	-1,993.39	0.00	1,993.39	3,776.22	951.40	3,931.42	3,504.92	0.90	-0.57	0.580
20.00	-38.65	-24.54	0.00	-1,869.31	0.00	1,869.31	3,712.32	926.92	3,731.76	3,356.23	1.60	-0.76	0.568
25.00	-37.15	-24.26	0.00	-1,746.61	0.00	1,746.61	3,646.67	902.44	3,537.29	3,209.08	2.51	-0.96	0.555
30.00	-35.67	-23.97	0.00	-1,625.30	0.00	1,625.30	3,579.26	877.96	3,348.03	3,063.58	3.62	-1.16	0.541
35.00	-34.25	-23.75	0.00	-1,505.44	0.00	1,505.44	3,510.10	853.48	3,163.97	2,919.87	4.95	-1.36	0.526
37.00	-33.67	-23.60	0.00	-1,457.93	0.00	1,457.93	3,481.94	843.69	3,091.80	2,862.92	5.54	-1.45	0.520
40.00	-32.33	-23.39	0.00	-1,387.14	0.00	1,387.14	3,439.17	829.00	2,985.11	2,778.07	6.49	-1.57	0.510
43.00	-31.02	-23.20	0.00	-1,316.98	0.00	1,316.98	2,697.55	690.63	2,485.92	2,181.75	7.51	-1.69	0.616
45.00	-30.50	-22.97	0.00	-1,270.59	0.00	1,270.59	2,677.43	682.47	2,427.54	2,139.70	8.24	-1.78	0.606
50.00	-29.09	-22.43	0.00	-1,155.75	0.00	1,155.75	2,625.91	662.07	2,284.61	2,035.31	10.23	-2.01	0.580
55.00	-27.90	-22.06	0.00	-1,043.60	0.00	1,043.60	2,572.64	641.67	2,146.02	1,932.08	12.46	-2.24	0.552
60.00	-26.74	-21.68	0.00	-933.29	0.00	933.29	2,517.61	621.27	2,011.77	1,830.13	14.92	-2.46	0.522
65.00	-25.61	-21.28	0.00	-824.90	0.00	824.90	2,460.82	600.87	1,881.85	1,729.60	17.62	-2.69	0.489
70.00	-24.50	-20.69	0.00	-718.51	0.00	718.51	2,402.27	580.47	1,756.27	1,630.62	20.55	-2.90	0.452
75.00	-23.43	-20.25	0.00	-615.08	0.00	615.08	2,341.97	560.07	1,635.02	1,533.30	23.70	-3.11	0.412
80.00	-21.88	-19.77	0.00	-513.83	0.00	513.83	1,720.57	439.61	1,259.08	1,107.20	27.06	-3.30	0.479
85.00	-20.98	-19.31	0.00	-415.01	0.00	415.01	1,679.48	423.29	1,167.35	1,040.33	30.62	-3.48	0.413
90.00	-15.45	-13.76	0.00	-318.46	0.00	318.46	1,636.64	406.98	1,079.09	974.39	34.37	-3.67	0.337
95.00	-14.82	-13.38	0.00	-249.64	0.00	249.64	1,592.04	390.66	994.30	909.51	38.30	-3.83	0.285
98.00	-12.12	-11.99	0.00	-209.50	0.00	209.50	1,564.44	380.86	945.09	871.14	40.73	-3.92	0.249
100.00	-10.11	-9.60	0.00	-185.52	0.00	185.52	1,545.69	374.34	912.98	845.81	42.38	-3.98	0.227
105.00	-9.56	-9.18	0.00	-137.54	0.00	137.54	1,497.58	358.02	835.13	783.43	46.61	-4.09	0.183
109.00	-7.40	-8.00	0.00	-100.80	0.00	100.80	1,457.82	344.96	775.35	734.55	50.08	-4.18	0.143
110.00	-7.22	-7.45	0.00	-92.80	0.00	92.80	1,446.53	341.70	760.75	721.90	50.95	-4.19	0.134
115.00	-6.76	-7.10	0.00	-55.56	0.00	55.56	1,377.44	325.38	689.83	654.26	55.38	-4.27	0.090
118.00	-5.18	-4.74	0.00	-33.87	0.00	33.87	1,335.99	315.59	648.95	615.27	58.07	-4.30	0.059
119.00	-2.78	-3.45	0.00	-29.13	0.00	29.13	1,322.18	312.33	635.60	602.54	58.97	-4.30	0.051
119.00	-2.78	-3.45	0.00	-29.13	0.00	29.13	936.41	234.90	479.32	429.14	58.97	-4.30	0.071
120.00	-2.73	-3.28	0.00	-25.68	0.00	25.68	929.99	232.45	469.38	421.71	59.87	-4.31	0.064
125.00	-2.44	-3.05	0.00	-9.25	0.00	9.25	896.83	220.21	421.26	385.08	64.40	-4.34	0.027
128.00	-0.09	-0.05	0.00	-0.10	0.00	0.10	876.09	212.87	393.64	363.52	67.13	-4.35	0.000
130.00	0.00	-0.04	0.00	0.00	0.00	0.00	861.91	207.97	375.75	349.34	68.95	-4.35	0.000

Site Number: 370626

Code: ANSI/TIA-222-H

© 2007 - 2021 by ATC IP LLC. All rights reserved.

Site Name: East Hartford, CT

Engineering Number:13677849\_C3\_03

6/14/2021 3:32:32 PM

Customer: T-MOBILE

<b>Load Case: 0.9D + 1.0W</b>	<b>118 mph with No Ice (Reduced DL)</b>	<b>23 Iterations</b>
Gust Response Factor :1.10		
Dead Load Factor :0.90		
Wind Load Factor :1.00		

**Applied Segment Forces Summary**

Seg Elev (ft)	Description	Shaft Forces		Discrete Forces			Linear Forces		Sum of Forces					
		Wind FX (lb)	Dead Load (lb)	Wind FX (lb)	Torsion MY (lb-ft)	Moment MZ (lb-ft)	Dead Load (lb)	Wind FX (lb)	Dead Load (lb)	Wind FX (lb)	Dead Load (lb)	Torsion MY (lb-ft)	Moment MZ (lb)	
0.00		201.6	0.0					0.0	0.0	201.6	0.0	0.0	0.0	
5.00		401.3	883.5					0.0	272.5	401.3	1,156.0	0.0	0.0	
10.00		397.6	862.1					0.0	272.5	397.6	1,134.6	0.0	0.0	
15.00		393.8	840.8					0.0	272.5	393.8	1,113.3	0.0	0.0	
20.00		390.1	819.4					0.0	272.5	390.1	1,091.9	0.0	0.0	
25.00		386.4	798.1					0.0	272.5	386.4	1,070.5	0.0	0.0	
30.00		387.4	776.7					0.0	272.5	387.4	1,049.2	0.0	0.0	
35.00		274.9	755.3					0.0	272.5	274.9	1,027.8	0.0	0.0	
37.00	Bot - Section 2	203.2	296.2					0.0	109.0	203.2	405.1	0.0	0.0	
40.00		248.8	809.0					0.0	163.5	248.8	972.5	0.0	0.0	
43.00	Top - Section 1	209.1	794.9					0.0	163.5	209.1	958.4	0.0	0.0	
45.00		296.2	239.6					0.0	109.0	296.2	348.6	0.0	0.0	
50.00	Appurtenance(s)	429.3	586.6	183.9	0.0	0.0	144.0	0.0	272.5	613.2	1,003.0	0.0	0.0	
55.00		437.3	568.8					0.0	271.8	437.3	840.6	0.0	0.0	
60.00		444.4	551.0					0.0	271.8	444.4	822.8	0.0	0.0	
65.00		450.9	533.2					0.0	271.8	450.9	805.0	0.0	0.0	
70.00	Appurtenance(s)	456.7	515.4	173.5	0.0	0.0	12.6	0.0	271.8	630.2	799.8	0.0	0.0	
75.00	Bot - Section 3	465.8	497.6					0.0	268.1	465.8	765.7	0.0	0.0	
80.00	Top - Section 2	471.6	870.5					0.0	268.1	471.6	1,138.6	0.0	0.0	
85.00		473.4	376.4					0.0	268.1	473.4	644.6	0.0	0.0	
90.00	Appurtenance(s)	473.9	362.2	4,764.3	0.0	0.0	3,742.9	0.0	268.1	5,238.2	4,373.2	0.0	0.0	
95.00		373.9	348.0					0.2	126.0	374.1	474.0	0.0	0.0	
98.00	Appurtenance(s)	228.2	201.9	993.7	0.0	0.0	1,800.0	0.3	75.6	1,222.2	2,077.5	0.0	0.0	
100.00	Appurtenance(s)	310.3	131.8	1,955.1	0.0	0.0	1,436.9	0.3	50.4	2,265.7	1,619.1	0.0	0.0	
105.00		389.8	319.5					0.9	99.5	390.7	419.0	0.0	0.0	
109.00	Appurtenance(s)	211.3	245.3	817.3	0.0	0.0	1,350.0	1.0	79.6	1,029.6	1,675.0	0.0	0.0	
110.00	Appurtenance(s)	243.8	59.9	303.1	0.0	0.0	81.0	0.3	19.9	547.2	160.8	0.0	0.0	
115.00		319.1	291.0					1.7	66.3	320.8	357.3	0.0	0.0	
118.00	Appurtenance(s)	144.7	167.8	2,089.5	0.0	401.4	1,111.1	1.2	39.8	2,235.4	1,318.7	0.0	0.0	
119.00	Top - Section 3	55.5	54.8	1,050.4	0.0	0.0	1,800.0	0.0	6.5	1,105.9	1,861.3	0.0	0.0	
120.00		162.6	40.8					0.0	6.5	162.6	47.3	0.0	0.0	
125.00		213.1	197.5					0.0	32.5	213.1	230.0	0.0	0.0	
128.00	Appurtenance(s)	122.4	113.4	2,689.8	0.0	0.0	1,792.8	0.0	19.5	2,812.1	1,925.7	0.0	0.0	
130.00		44.2	73.4					0.0	0.0	44.2	73.4	0.0	0.0	
							<b>Totals:</b>				<b>25,738.7</b>	<b>33,760.1</b>	<b>0.00</b>	<b>0.00</b>

Site Number: 370626

Code: ANSI/TIA-222-H

© 2007 - 2021 by ATC IP LLC. All rights reserved.

Site Name: East Hartford, CT

Engineering Number:13677849\_C3\_03

6/14/2021 3:32:35 PM

Customer: T-MOBILE

**Load Case: 0.9D + 1.0W**

118 mph with No Ice (Reduced DL)

23 Iterations

Gust Response Factor :1.10

Dead Load Factor :0.90

Wind Load Factor :1.00

**Calculated Forces**

Seg Elev (ft)	Pu FY (-) (kips)	Vu FX (-) (kips)	Tu MY (ft-kips)	Mu MZ (ft-kips)	Mu MX (ft-kips)	Resultant Moment (ft-kips)	phi Pn (kips)	phi Vn (kips)	phi Tn (ft-kips)	phi Mn (ft-kips)	Total Deflect (in)	Rotation (deg)	Ratio
0.00	-33.72	-25.59	0.00	-2,345.89	0.00	2,345.89	3,957.37	1,024.83	4,561.65	3,958.89	0.00	0.00	0.602
5.00	-32.48	-25.29	0.00	-2,217.93	0.00	2,217.93	3,898.74	1,000.35	4,346.37	3,806.37	0.10	-0.18	0.592
10.00	-31.27	-24.99	0.00	-2,091.46	0.00	2,091.46	3,838.36	975.87	4,136.30	3,655.00	0.39	-0.37	0.581
15.00	-30.07	-24.69	0.00	-1,966.49	0.00	1,966.49	3,776.22	951.40	3,931.42	3,504.92	0.89	-0.56	0.570
20.00	-28.90	-24.39	0.00	-1,843.03	0.00	1,843.03	3,712.32	926.92	3,731.76	3,356.23	1.58	-0.75	0.558
25.00	-27.76	-24.08	0.00	-1,721.09	0.00	1,721.09	3,646.67	902.44	3,537.29	3,209.08	2.47	-0.95	0.545
30.00	-26.63	-23.77	0.00	-1,600.69	0.00	1,600.69	3,579.26	877.96	3,348.03	3,063.58	3.57	-1.15	0.531
35.00	-25.55	-23.53	0.00	-1,481.86	0.00	1,481.86	3,510.10	853.48	3,163.97	2,919.87	4.88	-1.35	0.516
37.00	-25.11	-23.36	0.00	-1,434.80	0.00	1,434.80	3,481.94	843.69	3,091.80	2,862.92	5.46	-1.43	0.509
40.00	-24.10	-23.14	0.00	-1,364.71	0.00	1,364.71	3,439.17	829.00	2,985.11	2,778.07	6.40	-1.55	0.499
43.00	-23.10	-22.95	0.00	-1,295.29	0.00	1,295.29	2,697.55	690.63	2,485.92	2,181.75	7.41	-1.67	0.603
45.00	-22.70	-22.70	0.00	-1,249.40	0.00	1,249.40	2,677.43	682.47	2,427.54	2,139.70	8.13	-1.75	0.594
50.00	-21.63	-22.14	0.00	-1,135.90	0.00	1,135.90	2,625.91	662.07	2,284.61	2,035.31	10.09	-1.98	0.567
55.00	-20.72	-21.75	0.00	-1,025.20	0.00	1,025.20	2,572.64	641.67	2,146.02	1,932.08	12.28	-2.20	0.540
60.00	-19.84	-21.35	0.00	-916.43	0.00	916.43	2,517.61	621.27	2,011.77	1,830.13	14.71	-2.43	0.510
65.00	-18.98	-20.94	0.00	-809.66	0.00	809.66	2,460.82	600.87	1,881.85	1,729.60	17.37	-2.64	0.477
70.00	-18.13	-20.34	0.00	-704.97	0.00	704.97	2,402.27	580.47	1,756.27	1,630.62	20.26	-2.86	0.441
75.00	-17.33	-19.89	0.00	-603.29	0.00	603.29	2,341.97	560.07	1,635.02	1,533.30	23.36	-3.06	0.402
80.00	-16.15	-19.41	0.00	-503.84	0.00	503.84	1,720.57	439.61	1,259.08	1,107.20	26.66	-3.25	0.466
85.00	-15.48	-18.95	0.00	-406.80	0.00	406.80	1,679.48	423.29	1,167.35	1,040.33	30.16	-3.42	0.402
90.00	-11.39	-13.48	0.00	-312.06	0.00	312.06	1,636.64	406.98	1,079.09	974.39	33.85	-3.61	0.328
95.00	-10.92	-13.10	0.00	-244.64	0.00	244.64	1,592.04	390.66	994.30	909.51	37.71	-3.77	0.277
98.00	-8.91	-11.76	0.00	-205.32	0.00	205.32	1,564.44	380.86	945.09	871.14	40.11	-3.85	0.242
100.00	-7.44	-9.40	0.00	-181.81	0.00	181.81	1,545.69	374.34	912.98	845.81	41.73	-3.91	0.220
105.00	-7.03	-8.99	0.00	-134.82	0.00	134.82	1,497.58	358.02	835.13	783.43	45.89	-4.03	0.177
109.00	-5.43	-7.85	0.00	-98.85	0.00	98.85	1,457.82	344.96	775.35	734.55	49.30	-4.10	0.139
110.00	-5.30	-7.30	0.00	-91.00	0.00	91.00	1,446.53	341.70	760.75	721.90	50.16	-4.12	0.130
115.00	-4.96	-6.96	0.00	-54.51	0.00	54.51	1,377.44	325.38	689.83	654.26	54.51	-4.19	0.087
118.00	-3.81	-4.63	0.00	-33.24	0.00	33.24	1,335.99	315.59	648.95	615.27	57.16	-4.22	0.057
119.00	-2.03	-3.39	0.00	-28.61	0.00	28.61	1,322.18	312.33	635.60	602.54	58.04	-4.23	0.049
119.00	-2.03	-3.39	0.00	-28.61	0.00	28.61	936.41	234.90	479.32	429.14	58.04	-4.23	0.069
120.00	-2.00	-3.23	0.00	-25.22	0.00	25.22	929.99	232.45	469.38	421.71	58.93	-4.24	0.062
125.00	-1.78	-3.00	0.00	-9.09	0.00	9.09	896.83	220.21	421.26	385.08	63.38	-4.27	0.026
128.00	-0.07	-0.05	0.00	-0.10	0.00	0.10	876.09	212.87	393.64	363.52	66.06	-4.27	0.000
130.00	0.00	-0.04	0.00	0.00	0.00	0.00	861.91	207.97	375.75	349.34	67.85	-4.27	0.000

Site Number: 370626

Code: ANSI/TIA-222-H

© 2007 - 2021 by ATC IP LLC. All rights reserved.

Site Name: East Hartford, CT

Engineering Number:13677849\_C3\_03

6/14/2021 3:32:36 PM

Customer: T-MOBILE

**Load Case: 1.2D + 1.0Di + 1.0Wi**

**50 mph with 1.50 in Radial Ice**

**23 Iterations**

Gust Response Factor :1.10

Ice Dead Load Factor :1.00

Dead Load Factor :1.20

Ice Importance Factor :1.00

Wind Load Factor :1.00

**Applied Segment Forces Summary**

Seg Elev (ft)	Description	Shaft Forces		Discrete Forces			Linear Forces		Sum of Forces				
		Wind FX (lb)	Dead Load (lb)	Wind FX (lb)	Torsion MY (lb-ft)	Moment MZ (lb-ft)	Dead Load (lb)	Wind FX (lb)	Dead Load (lb)	Wind FX (lb)	Dead Load (lb)	Torsion MY (lb-ft)	Moment MZ (lb)
0.00		60.6	0.0					0.0	0.0	60.6	0.0	0.0	0.0
5.00		120.1	1,538.3					0.0	484.4	120.1	2,022.7	0.0	0.0
10.00		117.8	1,543.2					0.0	496.3	117.8	2,039.5	0.0	0.0
15.00		115.3	1,525.9					0.0	502.5	115.3	2,028.4	0.0	0.0
20.00		112.7	1,501.3					0.0	506.7	112.7	2,008.0	0.0	0.0
25.00		110.1	1,472.9					0.0	510.0	110.1	1,982.9	0.0	0.0
30.00		108.7	1,442.1					0.0	512.8	108.7	1,954.9	0.0	0.0
35.00		76.3	1,409.7					0.0	515.1	76.3	1,924.8	0.0	0.0
37.00	Bot - Section 2	55.7	555.8					0.0	206.6	55.7	762.4	0.0	0.0
40.00		67.5	1,321.3					0.0	310.5	67.5	1,631.8	0.0	0.0
43.00	Top - Section 1	56.5	1,300.3					0.0	311.1	56.5	1,611.5	0.0	0.0
45.00		79.5	479.0					0.0	207.8	79.5	686.7	0.0	0.0
50.00	Appurtenance(s)	113.7	1,172.5	49.2	0.0	0.0	268.8	0.0	520.5	162.9	1,961.8	0.0	0.0
55.00		113.6	1,141.2					0.0	521.1	113.6	1,662.4	0.0	0.0
60.00		113.2	1,109.5					0.4	522.5	113.6	1,632.0	0.0	0.0
65.00		112.4	1,077.2					1.3	523.8	113.7	1,601.0	0.0	0.0
70.00	Appurtenance(s)	111.3	1,044.5	39.7	0.0	0.0	60.1	2.3	524.9	153.3	1,629.6	0.0	0.0
75.00	Bot - Section 3	110.8	1,011.5					3.3	507.3	114.1	1,518.8	0.0	0.0
80.00	Top - Section 2	110.0	1,504.3					4.3	508.2	114.3	2,012.5	0.0	0.0
85.00		108.3	835.7					4.9	509.1	113.2	1,344.8	0.0	0.0
90.00	Appurtenance(s)	106.3	806.6	1,204.0	0.0	0.0	10,067.3	6.0	509.9	1,316.3	11,383.8	0.0	0.0
95.00		83.7	777.3					7.1	321.2	90.8	1,098.5	0.0	0.0
98.00	Appurtenance(s)	51.5	453.7	332.2	0.0	0.0	3,456.4	4.8	193.1	388.5	4,103.2	0.0	0.0
100.00	Appurtenance(s)	70.8	297.0	441.9	0.0	0.0	3,992.4	3.4	128.9	516.1	4,418.3	0.0	0.0
105.00		89.6	717.9					9.4	287.4	99.0	1,005.4	0.0	0.0
109.00	Appurtenance(s)	49.0	553.8	272.5	0.0	0.0	2,334.7	8.3	230.4	329.9	3,118.9	0.0	0.0
110.00	Appurtenance(s)	57.4	136.2	73.9	0.0	0.0	389.0	2.2	57.7	133.5	582.9	0.0	0.0
115.00		75.6	657.9					11.7	244.5	87.3	902.4	0.0	0.0
118.00	Appurtenance(s)	37.1	381.7	506.9	0.0	92.9	3,525.2	7.6	147.0	551.6	4,053.8	0.0	0.0
119.00	Top - Section 3	18.3	125.3	354.5	0.0	0.0	3,482.2	0.0	8.7	372.8	3,616.2	0.0	0.0
120.00		53.9	106.2					0.0	8.7	53.9	114.8	0.0	0.0
125.00		70.8	510.4					0.0	43.3	70.8	553.7	0.0	0.0
128.00	Appurtenance(s)	41.7	295.3	686.4	0.0	0.0	4,870.5	0.0	26.0	728.1	5,191.8	0.0	0.0
130.00		15.7	192.2					0.0	0.0	15.7	192.2	0.0	0.0
<b>Totals:</b>									<b>6,833.98</b>	<b>72,352.3</b>	<b>0.00</b>	<b>0.00</b>	



Site Number: 370626

Code: ANSI/TIA-222-H

© 2007 - 2021 by ATC IP LLC. All rights reserved.

Site Name: East Hartford, CT

Engineering Number:13677849\_C3\_03

6/14/2021 3:32:39 PM

Customer: T-MOBILE

**Load Case: 1.2D + 1.0Di + 1.0Wi**

50 mph with 1.50 in Radial Ice

23 Iterations

Gust Response Factor :1.10

Ice Dead Load Factor :1.00

Dead Load Factor :1.20

Ice Importance Factor :1.00

Wind Load Factor :1.00

**Calculated Forces**

Seg Elev (ft)	Pu FY (-) (kips)	Vu FX (-) (kips)	Tu MY (ft-kips)	Mu MZ (ft-kips)	Mu MX (ft-kips)	Resultant Moment (ft-kips)	phi Pn (kips)	phi Vn (kips)	phi Tn (ft-kips)	phi Mn (ft-kips)	Total Deflect (in)	Rotation (deg)	Ratio
0.00	-72.35	-6.81	0.00	-651.92	0.00	651.92	3,957.37	1,024.83	4,561.65	3,958.89	0.00	0.00	0.183
5.00	-70.32	-6.75	0.00	-617.89	0.00	617.89	3,898.74	1,000.35	4,346.37	3,806.37	0.03	-0.05	0.180
10.00	-68.27	-6.69	0.00	-584.14	0.00	584.14	3,838.36	975.87	4,136.30	3,655.00	0.11	-0.10	0.178
15.00	-66.24	-6.63	0.00	-550.69	0.00	550.69	3,776.22	951.40	3,931.42	3,504.92	0.25	-0.16	0.175
20.00	-64.23	-6.58	0.00	-517.53	0.00	517.53	3,712.32	926.92	3,731.76	3,356.23	0.44	-0.21	0.172
25.00	-62.24	-6.52	0.00	-484.65	0.00	484.65	3,646.67	902.44	3,537.29	3,209.08	0.69	-0.27	0.168
30.00	-60.28	-6.46	0.00	-452.07	0.00	452.07	3,579.26	877.96	3,348.03	3,063.58	1.00	-0.32	0.164
35.00	-58.35	-6.41	0.00	-419.79	0.00	419.79	3,510.10	853.48	3,163.97	2,919.87	1.37	-0.38	0.160
37.00	-57.58	-6.38	0.00	-406.97	0.00	406.97	3,481.94	843.69	3,091.80	2,862.92	1.53	-0.40	0.159
40.00	-55.95	-6.33	0.00	-387.84	0.00	387.84	3,439.17	829.00	2,985.11	2,778.07	1.79	-0.44	0.156
43.00	-54.33	-6.29	0.00	-368.85	0.00	368.85	2,697.55	690.63	2,485.92	2,181.75	2.08	-0.47	0.189
45.00	-53.64	-6.25	0.00	-356.27	0.00	356.27	2,677.43	682.47	2,427.54	2,139.70	2.28	-0.49	0.187
50.00	-51.68	-6.12	0.00	-325.04	0.00	325.04	2,625.91	662.07	2,284.61	2,035.31	2.83	-0.56	0.179
55.00	-50.01	-6.05	0.00	-294.43	0.00	294.43	2,572.64	641.67	2,146.02	1,932.08	3.45	-0.62	0.172
60.00	-48.37	-5.97	0.00	-264.18	0.00	264.18	2,517.61	621.27	2,011.77	1,830.13	4.14	-0.69	0.164
65.00	-46.77	-5.89	0.00	-234.33	0.00	234.33	2,460.82	600.87	1,881.85	1,729.60	4.89	-0.75	0.155
70.00	-45.13	-5.76	0.00	-204.90	0.00	204.90	2,402.27	580.47	1,756.27	1,630.62	5.71	-0.81	0.145
75.00	-43.61	-5.67	0.00	-176.11	0.00	176.11	2,341.97	560.07	1,635.02	1,533.30	6.59	-0.87	0.134
80.00	-41.59	-5.56	0.00	-147.78	0.00	147.78	1,720.57	439.61	1,259.08	1,107.20	7.53	-0.93	0.158
85.00	-40.25	-5.46	0.00	-119.98	0.00	119.98	1,679.48	423.29	1,167.35	1,040.33	8.53	-0.98	0.139
90.00	-28.88	-3.97	0.00	-92.68	0.00	92.68	1,636.64	406.98	1,079.09	974.39	9.58	-1.03	0.113
95.00	-27.78	-3.88	0.00	-72.82	0.00	72.82	1,592.04	390.66	994.30	909.51	10.69	-1.08	0.098
98.00	-23.69	-3.42	0.00	-61.19	0.00	61.19	1,564.44	380.86	945.09	871.14	11.37	-1.10	0.085
100.00	-19.28	-2.83	0.00	-54.35	0.00	54.35	1,545.69	374.34	912.98	845.81	11.84	-1.12	0.077
105.00	-18.28	-2.72	0.00	-40.22	0.00	40.22	1,497.58	358.02	835.13	783.43	13.03	-1.16	0.064
109.00	-15.16	-2.33	0.00	-29.36	0.00	29.36	1,457.82	344.96	775.35	734.55	14.01	-1.18	0.050
110.00	-14.58	-2.18	0.00	-27.03	0.00	27.03	1,446.53	341.70	760.75	721.90	14.26	-1.18	0.048
115.00	-13.68	-2.08	0.00	-16.10	0.00	16.10	1,377.44	325.38	689.83	654.26	15.51	-1.21	0.035
118.00	-9.64	-1.45	0.00	-9.76	0.00	9.76	1,335.99	315.59	648.95	615.27	16.27	-1.21	0.023
119.00	-6.03	-1.00	0.00	-8.32	0.00	8.32	1,322.18	312.33	635.60	602.54	16.53	-1.22	0.018
119.00	-6.03	-1.00	0.00	-8.32	0.00	8.32	936.41	234.90	479.32	429.14	16.53	-1.22	0.026
120.00	-5.92	-0.94	0.00	-7.32	0.00	7.32	929.99	232.45	469.38	421.71	16.78	-1.22	0.024
125.00	-5.37	-0.86	0.00	-2.62	0.00	2.62	896.83	220.21	421.26	385.08	18.06	-1.23	0.013
128.00	-0.19	-0.02	0.00	-0.04	0.00	0.04	876.09	212.87	393.64	363.52	18.83	-1.23	0.000
130.00	0.00	-0.02	0.00	0.00	0.00	0.00	861.91	207.97	375.75	349.34	19.35	-1.23	0.000

Site Number: 370626

Code: ANSI/TIA-222-H

© 2007 - 2021 by ATC IP LLC. All rights reserved.

Site Name: East Hartford, CT

Engineering Number:13677849\_C3\_03

6/14/2021 3:32:39 PM

Customer: T-MOBILE

**Load Case: 1.0D + 1.0W**

**Serviceability 60 mph**

**22 Iterations**

Gust Response Factor :1.10

Dead Load Factor :1.00

Wind Load Factor :1.00

**Applied Segment Forces Summary**

Seg Elev (ft)	Description	Shaft Forces		Discrete Forces			Linear Forces		Sum of Forces				
		Wind FX (lb)	Dead Load (lb)	Wind FX (lb)	Torsion MY (lb-ft)	Moment MZ (lb-ft)	Dead Load (lb)	Wind FX (lb)	Dead Load (lb)	Wind FX (lb)	Dead Load (lb)	Torsion MY (lb-ft)	Moment MZ (lb)
0.00		46.6	0.0					0.0	0.0	46.6	0.0	0.0	0.0
5.00		92.8	981.7					0.0	302.7	92.8	1,284.4	0.0	0.0
10.00		92.0	957.9					0.0	302.7	92.0	1,260.7	0.0	0.0
15.00		91.1	934.2					0.0	302.7	91.1	1,236.9	0.0	0.0
20.00		90.2	910.5					0.0	302.7	90.2	1,213.2	0.0	0.0
25.00		89.4	886.7					0.0	302.7	89.4	1,189.5	0.0	0.0
30.00		89.6	863.0					0.0	302.7	89.6	1,165.8	0.0	0.0
35.00		63.6	839.3					0.0	302.7	63.6	1,142.0	0.0	0.0
37.00	Bot - Section 2	47.0	329.1					0.0	121.1	47.0	450.2	0.0	0.0
40.00		57.5	898.9					0.0	181.7	57.5	1,080.5	0.0	0.0
43.00	Top - Section 1	48.4	883.2					0.0	181.7	48.4	1,064.9	0.0	0.0
45.00		68.5	266.2					0.0	121.1	68.5	387.3	0.0	0.0
50.00	Appurtenance(s)	99.3	651.7	42.5	0.0	0.0	160.0	0.0	302.7	141.8	1,114.5	0.0	0.0
55.00		101.2	632.0					0.0	302.0	101.2	934.0	0.0	0.0
60.00		102.8	612.2					0.0	302.0	102.8	914.2	0.0	0.0
65.00		104.3	592.4					0.0	302.0	104.3	894.4	0.0	0.0
70.00	Appurtenance(s)	105.7	572.6	40.1	0.0	0.0	14.0	0.0	302.0	145.8	888.6	0.0	0.0
75.00	Bot - Section 3	107.8	552.9					0.0	297.9	107.8	850.8	0.0	0.0
80.00	Top - Section 2	109.1	967.2					0.0	297.9	109.1	1,265.1	0.0	0.0
85.00		109.5	418.3					0.0	297.9	109.5	716.2	0.0	0.0
90.00	Appurtenance(s)	109.6	402.5	1,102.1	0.0	0.0	4,158.8	0.0	297.9	1,211.8	4,859.2	0.0	0.0
95.00		86.5	386.6					0.0	140.0	86.5	526.6	0.0	0.0
98.00	Appurtenance(s)	52.8	224.4	229.9	0.0	0.0	2,000.0	0.1	84.0	282.7	2,308.4	0.0	0.0
100.00	Appurtenance(s)	71.8	146.4	452.3	0.0	0.0	1,596.6	0.1	56.0	524.1	1,799.0	0.0	0.0
105.00		90.2	355.0					0.2	110.6	90.4	465.6	0.0	0.0
109.00	Appurtenance(s)	48.9	272.6	189.1	0.0	0.0	1,500.0	0.2	88.5	238.2	1,861.1	0.0	0.0
110.00	Appurtenance(s)	56.4	66.6	70.1	0.0	0.0	90.0	0.1	22.1	126.6	178.7	0.0	0.0
115.00		73.8	323.4					0.4	73.7	74.2	397.1	0.0	0.0
118.00	Appurtenance(s)	33.5	186.4	483.4	0.0	92.8	1,234.6	0.3	44.2	517.1	1,465.2	0.0	0.0
119.00	Top - Section 3	12.8	60.9	243.0	0.0	0.0	2,000.0	0.0	7.2	255.8	2,068.1	0.0	0.0
120.00		37.6	45.3					0.0	7.2	37.6	52.5	0.0	0.0
125.00		49.3	219.4					0.0	36.1	49.3	255.5	0.0	0.0
128.00	Appurtenance(s)	28.3	126.0	622.2	0.0	0.0	1,992.0	0.0	21.7	650.5	2,139.6	0.0	0.0
130.00		10.2	81.6					0.0	0.0	10.2	81.6	0.0	0.0
								<b>Totals:</b>	5,954.17	37,511.2	0.00	0.00	

Site Number: 370626

Code: ANSI/TIA-222-H

© 2007 - 2021 by ATC IP LLC. All rights reserved.

Site Name: East Hartford, CT

Engineering Number:13677849\_C3\_03

6/14/2021 3:32:42 PM

Customer: T-MOBILE

**Load Case: 1.0D + 1.0W**

**Serviceability 60 mph**

**22 Iterations**

Gust Response Factor :1.10

Dead Load Factor :1.00

Wind Load Factor :1.00

**Calculated Forces**

Seg Elev (ft)	Pu FY (-) (kips)	Vu FX (-) (kips)	Tu MY (ft-kips)	Mu MZ (ft-kips)	Mu MX (ft-kips)	Resultant Moment (ft-kips)	phi Pn (kips)	phi Vn (kips)	phi Tn (ft-kips)	phi Mn (ft-kips)	Total Deflect (in)	Rotation (deg)	Ratio
0.00	-37.51	-5.92	0.00	-545.20	0.00	545.20	3,957.37	1,024.83	4,561.65	3,958.89	0.00	0.00	0.147
5.00	-36.22	-5.86	0.00	-515.59	0.00	515.59	3,898.74	1,000.35	4,346.37	3,806.37	0.02	-0.04	0.145
10.00	-34.96	-5.79	0.00	-486.31	0.00	486.31	3,838.36	975.87	4,136.30	3,655.00	0.09	-0.09	0.142
15.00	-33.71	-5.72	0.00	-457.37	0.00	457.37	3,776.22	951.40	3,931.42	3,504.92	0.21	-0.13	0.139
20.00	-32.50	-5.65	0.00	-428.76	0.00	428.76	3,712.32	926.92	3,731.76	3,356.23	0.37	-0.18	0.137
25.00	-31.30	-5.59	0.00	-400.50	0.00	400.50	3,646.67	902.44	3,537.29	3,209.08	0.58	-0.22	0.133
30.00	-30.13	-5.51	0.00	-372.57	0.00	372.57	3,579.26	877.96	3,348.03	3,063.58	0.83	-0.27	0.130
35.00	-28.99	-5.46	0.00	-345.00	0.00	345.00	3,510.10	853.48	3,163.97	2,919.87	1.14	-0.31	0.126
37.00	-28.54	-5.42	0.00	-334.08	0.00	334.08	3,481.94	843.69	3,091.80	2,862.92	1.27	-0.33	0.125
40.00	-27.45	-5.37	0.00	-317.80	0.00	317.80	3,439.17	829.00	2,985.11	2,778.07	1.49	-0.36	0.122
43.00	-26.39	-5.33	0.00	-301.68	0.00	301.68	2,697.55	690.63	2,485.92	2,181.75	1.72	-0.39	0.148
45.00	-26.00	-5.27	0.00	-291.03	0.00	291.03	2,677.43	682.47	2,427.54	2,139.70	1.89	-0.41	0.146
50.00	-24.88	-5.15	0.00	-264.65	0.00	264.65	2,625.91	662.07	2,284.61	2,035.31	2.35	-0.46	0.140
55.00	-23.94	-5.06	0.00	-238.92	0.00	238.92	2,572.64	641.67	2,146.02	1,932.08	2.86	-0.51	0.133
60.00	-23.02	-4.97	0.00	-213.62	0.00	213.62	2,517.61	621.27	2,011.77	1,830.13	3.42	-0.56	0.126
65.00	-22.13	-4.87	0.00	-188.78	0.00	188.78	2,460.82	600.87	1,881.85	1,729.60	4.04	-0.62	0.118
70.00	-21.23	-4.74	0.00	-164.41	0.00	164.41	2,402.27	580.47	1,756.27	1,630.62	4.71	-0.66	0.110
75.00	-20.38	-4.64	0.00	-140.72	0.00	140.72	2,341.97	560.07	1,635.02	1,533.30	5.44	-0.71	0.101
80.00	-19.11	-4.52	0.00	-117.55	0.00	117.55	1,720.57	439.61	1,259.08	1,107.20	6.21	-0.76	0.117
85.00	-18.40	-4.42	0.00	-94.93	0.00	94.93	1,679.48	423.29	1,167.35	1,040.33	7.02	-0.80	0.102
90.00	-13.55	-3.15	0.00	-72.84	0.00	72.84	1,636.64	406.98	1,079.09	974.39	7.88	-0.84	0.083
95.00	-13.03	-3.06	0.00	-57.10	0.00	57.10	1,592.04	390.66	994.30	909.51	8.78	-0.88	0.071
98.00	-10.72	-2.74	0.00	-47.93	0.00	47.93	1,564.44	380.86	945.09	871.14	9.34	-0.90	0.062
100.00	-8.93	-2.19	0.00	-42.44	0.00	42.44	1,545.69	374.34	912.98	845.81	9.72	-0.91	0.056
105.00	-8.47	-2.10	0.00	-31.47	0.00	31.47	1,497.58	358.02	835.13	783.43	10.69	-0.94	0.046
109.00	-6.61	-1.83	0.00	-23.07	0.00	23.07	1,457.82	344.96	775.35	734.55	11.48	-0.96	0.036
110.00	-6.43	-1.70	0.00	-21.24	0.00	21.24	1,446.53	341.70	760.75	721.90	11.68	-0.96	0.034
115.00	-6.04	-1.62	0.00	-12.72	0.00	12.72	1,377.44	325.38	689.83	654.26	12.70	-0.98	0.024
118.00	-4.58	-1.08	0.00	-7.76	0.00	7.76	1,335.99	315.59	648.95	615.27	13.32	-0.98	0.016
119.00	-2.52	-0.79	0.00	-6.67	0.00	6.67	1,322.18	312.33	635.60	602.54	13.52	-0.99	0.013
119.00	-2.52	-0.79	0.00	-6.67	0.00	6.67	936.41	234.90	479.32	429.14	13.52	-0.99	0.018
120.00	-2.46	-0.75	0.00	-5.88	0.00	5.88	929.99	232.45	469.38	421.71	13.73	-0.99	0.017
125.00	-2.21	-0.70	0.00	-2.12	0.00	2.12	896.83	220.21	421.26	385.08	14.77	-0.99	0.008
128.00	-0.08	-0.01	0.00	-0.02	0.00	0.02	876.09	212.87	393.64	363.52	15.39	-1.00	0.000
130.00	0.00	-0.01	0.00	0.00	0.00	0.00	861.91	207.97	375.75	349.34	15.81	-1.00	0.000

Site Number: 370626

Code: ANSI/TIA-222-H

© 2007 - 2021 by ATC IP LLC. All rights reserved.

Site Name: East Hartford, CT

Engineering Number:13677849\_C3\_03

6/14/2021 3:32:42 PM

Customer: T-MOBILE

**Equivalent Lateral Forces Method Analysis**

Spectral Response Acceleration for Short Period ( $S_s$ ):	0.19
Spectral Response Acceleration at 1.0 Second Period ( $S_{d1}$ ):	0.05
Long-Period Transition Period ( $T_L$ ):	6
Importance Factor ( $I_E$ ):	1.00
Site Coefficient $F_a$ :	1.60
Site Coefficient $F_v$ :	2.40
Response Modification Coefficient (R):	1.50
Design Spectral Response Acceleration at Short Period ( $S_{ds}$ ):	0.20
Design Spectral Response Acceleration at 1.0 Second Period ( $S_{d1}$ ):	0.09
Seismic Response Coefficient ( $C_s$ ):	0.03
Upper Limit $C_s$	0.03
Lower Limit $C_s$	0.03
Period based on Rayleigh Method (sec):	2.18
Redundancy Factor (p):	1.00
Seismic Force Distribution Exponent (k):	1.84
Total Unfactored Dead Load:	37.51 k
Seismic Base Shear (E):	1.13 k

**Load Case 1.2D + 1.0Ev + 1.0Eh**

**Seismic**

Segment	Height Above Base (ft)	Weight (lb)	$W_z$ (lb-ft)	$C_{vx}$	Horizontal Force (lb)	Vertical Force (lb)
33	129.00	82	626	0.005	6	101
32	126.50	148	1,092	0.009	10	183
31	122.50	256	1,781	0.015	17	317
30	119.50	53	350	0.003	3	65
29	118.50	68	447	0.004	4	84
28	116.50	231	1,466	0.012	14	286
27	112.50	397	2,367	0.020	22	492
26	109.50	89	503	0.004	5	110
25	107.00	361	1,963	0.016	18	448
24	102.50	466	2,338	0.019	22	577
23	99.00	202	954	0.008	9	251
22	96.50	308	1,386	0.012	13	382
21	92.50	527	2,189	0.018	21	653
20	87.50	700	2,629	0.022	25	869
19	82.50	716	2,412	0.020	23	888
18	77.50	1,265	3,798	0.032	36	1,569
17	72.50	851	2,259	0.019	21	1,055
16	67.50	875	2,036	0.017	19	1,085
15	62.50	894	1,807	0.015	17	1,109
14	57.50	914	1,584	0.013	15	1,134
13	52.50	934	1,369	0.011	13	1,158
12	47.50	954	1,164	0.010	11	1,184
11	44.00	387	410	0.003	4	480
10	41.50	1,065	1,013	0.008	9	1,321
9	38.50	1,081	895	0.007	8	1,340

Site Number: 370626

Code: ANSI/TIA-222-H

© 2007 - 2021 by ATC IP LLC. All rights reserved.

Site Name: East Hartford, CT

Engineering Number:13677849\_C3\_03

6/14/2021 3:32:42 PM

Customer: T-MOBILE

8	36.00	450	330	0.003	3	558
7	32.50	1,142	692	0.006	6	1,416
6	27.50	1,166	520	0.004	5	1,446
5	22.50	1,189	367	0.003	3	1,475
4	17.50	1,213	235	0.002	2	1,505
3	12.50	1,237	129	0.001	1	1,534
2	7.50	1,261	51	0.000	0	1,564
1	2.50	1,284	7	0.000	0	1,593
DragonWave Horizon C	128.00	34	261	0.002	2	43
Alcatel-Lucent RRH2x	128.00	317	2,399	0.020	22	394
Alcatel-Lucent 1900	128.00	180	1,361	0.011	13	223
Nokia 2.5G MAA - AAH	128.00	311	2,349	0.020	22	385
Argus LLPX310R	128.00	86	649	0.005	6	106
DragonWave A-ANT-18G	128.00	81	615	0.005	6	101
Infinity T-Arm CT52X	128.00	750	5,669	0.047	53	930
Commscope NNVV-65B-R	128.00	232	1,755	0.015	16	288
Round Platform w/ Ha	119.00	2,000	13,220	0.110	124	2,481
Samsung RT4401-48A	118.00	56	363	0.003	3	69
Samsung B2/B66A RRH-	118.00	253	1,648	0.014	15	314
Samsung B5/B13 RRH-B	118.00	211	1,373	0.011	13	262
Samsung MT6407-77A	118.00	245	1,593	0.013	15	304
RFS DB-T1-6Z-8AB-0Z	118.00	88	573	0.005	5	109
Andrew LNX-6513DS-A1	118.00	98	636	0.005	6	121
Commscope NHHSS-65B-	118.00	153	996	0.008	9	190
Commscope NHH-65B-R2	118.00	131	853	0.007	8	163
Generic 48" x 12" Pa	110.00	90	515	0.004	5	112
Round Low Profile PI	109.00	1,500	8,436	0.070	79	1,860
Commscope SDX1926Q-4	100.00	19	89	0.001	1	23
Ericsson Radio 4449	100.00	225	1,080	0.009	10	279
Ericsson RRUS 4415 B	100.00	138	662	0.006	6	171
Ericsson RRUS 4415 B	100.00	138	662	0.006	6	171
Ericsson Air6449 B41	100.00	312	1,497	0.012	14	387
Ericsson AIR32 B66Aa	100.00	397	1,903	0.016	18	492
RFS APXVAALL24 43-U-	100.00	368	1,768	0.015	17	457
PerfectVision PV-RP1	98.00	2,000	9,247	0.077	87	2,481
Raycap DC6-48-60-18-	90.00	40	158	0.001	1	50
Raycap DC6-48-60-0-8	90.00	66	259	0.002	2	81
Ericsson RRUS 4478 B	90.00	178	704	0.006	7	221
Ericsson RRUS 32 B2	90.00	159	629	0.005	6	197
Ericsson RRUS 32 B66	90.00	159	629	0.005	6	197
Ericsson RRUS E2 B29	90.00	180	712	0.006	7	223
Ericsson RRUS-32 (77	90.00	231	913	0.008	9	287
Ericsson RRUS-11	90.00	330	1,304	0.011	12	409
CCI HPA-65R-BUU-H8	90.00	816	3,226	0.027	30	1,012
Round Platform w/ Ha	90.00	2,000	7,906	0.066	74	2,481
Generic 2' Std. Dish	70.00	14	35	0.000	0	17
Generic GPS	50.00	10	13	0.000	0	12
Round Side Arm	50.00	150	201	0.002	2	186
		37,511	120,027	1.000	1,125	46,526

**Load Case 0.9D - 1.0Ev + 1.0Eh**

**Seismic (Reduced DL)**

Segment	Height Above Base (ft)	Weight (lb)	W <sub>z</sub> (lb-ft)	C <sub>vx</sub>	Horizontal Force (lb)	Vertical Force (lb)
33	129.00	82	626	0.005	6	70
32	126.50	148	1,092	0.009	10	127
31	122.50	256	1,781	0.015	17	220
30	119.50	53	350	0.003	3	45
29	118.50	68	447	0.004	4	59
28	116.50	231	1,466	0.012	14	198
27	112.50	397	2,367	0.020	22	341

Site Number: 370626

Code: ANSI/TIA-222-H

© 2007 - 2021 by ATC IP LLC. All rights reserved.

Site Name: East Hartford, CT

Engineering Number:13677849\_C3\_03

6/14/2021 3:32:42 PM

Customer: T-MOBILE

26	109.50	89	503	0.004	5	76
25	107.00	361	1,963	0.016	18	310
24	102.50	466	2,338	0.019	22	400
23	99.00	202	954	0.008	9	174
22	96.50	308	1,386	0.012	13	265
21	92.50	527	2,189	0.018	21	453
20	87.50	700	2,629	0.022	25	602
19	82.50	716	2,412	0.020	23	616
18	77.50	1,265	3,798	0.032	36	1,088
17	72.50	851	2,259	0.019	21	731
16	67.50	875	2,036	0.017	19	752
15	62.50	894	1,807	0.015	17	769
14	57.50	914	1,584	0.013	15	786
13	52.50	934	1,369	0.011	13	803
12	47.50	954	1,164	0.010	11	821
11	44.00	387	410	0.003	4	333
10	41.50	1,065	1,013	0.008	9	915
9	38.50	1,081	895	0.007	8	929
8	36.00	450	330	0.003	3	387
7	32.50	1,142	692	0.006	6	982
6	27.50	1,166	520	0.004	5	1,002
5	22.50	1,189	367	0.003	3	1,023
4	17.50	1,213	235	0.002	2	1,043
3	12.50	1,237	129	0.001	1	1,063
2	7.50	1,261	51	0.000	0	1,084
1	2.50	1,284	7	0.000	0	1,104
DragonWave Horizon C	128.00	34	261	0.002	2	30
Alcatel-Lucent RRH2x	128.00	317	2,399	0.020	22	273
Alcatel-Lucent 1900	128.00	180	1,361	0.011	13	155
Nokia 2.5G MAA - AAH	128.00	311	2,349	0.020	22	267
Argus LLPX310R	128.00	86	649	0.005	6	74
DragonWave A-ANT-18G	128.00	81	615	0.005	6	70
Infinity T-Arm CT52X	128.00	750	5,669	0.047	53	645
Commscope NNVV-65B-R	128.00	232	1,755	0.015	16	200
Round Platform w/ Ha	119.00	2,000	13,220	0.110	124	1,719
Samsung RT4401-48A	118.00	56	363	0.003	3	48
Samsung B2/B66A RRH-	118.00	253	1,648	0.014	15	218
Samsung B5/B13 RRH-B	118.00	211	1,373	0.011	13	181
Samsung MT6407-77A	118.00	245	1,593	0.013	15	210
RFS DB-T1-6Z-8AB-0Z	118.00	88	573	0.005	5	76
Andrew LNX-6513DS-A1	118.00	98	636	0.005	6	84
Commscope NHHSS-65B-	118.00	153	996	0.008	9	132
Commscope NHH-65B-R2	118.00	131	853	0.007	8	113
Generic 48" x 12" Pa	110.00	90	515	0.004	5	77
Round Low Profile PI	109.00	1,500	8,436	0.070	79	1,290
Commscope SDX1926Q-4	100.00	19	89	0.001	1	16
Ericsson Radio 4449	100.00	225	1,080	0.009	10	193
Ericsson RRUS 4415 B	100.00	138	662	0.006	6	119
Ericsson RRUS 4415 B	100.00	138	662	0.006	6	119
Ericsson Air6449 B41	100.00	312	1,497	0.012	14	268
Ericsson AIR32 B66Aa	100.00	397	1,903	0.016	18	341
RFS APXVAALL24 43-U-	100.00	368	1,768	0.015	17	317
PerfectVision PV-RP1	98.00	2,000	9,247	0.077	87	1,719
Raycap DC6-48-60-18-	90.00	40	158	0.001	1	34
Raycap DC6-48-60-0-8	90.00	66	259	0.002	2	56
Ericsson RRUS 4478 B	90.00	178	704	0.006	7	153
Ericsson RRUS 32 B2	90.00	159	629	0.005	6	137
Ericsson RRUS 32 B66	90.00	159	629	0.005	6	137
Ericsson RRUS E2 B29	90.00	180	712	0.006	7	155
Ericsson RRUS-32 (77	90.00	231	913	0.008	9	199
Ericsson RRUS-11	90.00	330	1,304	0.011	12	284
CCI HPA-65R-BUU-H8	90.00	816	3,226	0.027	30	701
Round Platform w/ Ha	90.00	2,000	7,906	0.066	74	1,719
Generic 2' Std. Dish	70.00	14	35	0.000	0	12



---

---

Site Number: 370626

Code: ANSI/TIA-222-H

© 2007 - 2021 by ATC IP LLC. All rights reserved.

Site Name: East Hartford, CT

Engineering Number:13677849\_C3\_03

6/14/2021 3:32:42 PM

Customer: T-MOBILE

---

---

Generic GPS	50.00	10	13	0.000	0	9
Round Side Arm	50.00	150	201	0.002	2	129
		37,511	120,027	1.000	1,125	32,248

Site Number: 370626

Code: ANSI/TIA-222-H

© 2007 - 2021 by ATC IP LLC. All rights reserved.

Site Name: East Hartford, CT

Engineering Number:13677849\_C3\_03

6/14/2021 3:32:42 PM

Customer: T-MOBILE

**Load Case 1.2D + 1.0Ev + 1.0Eh**

**Seismic**

**Calculated Forces**

Seg Elev (ft)	Pu FY (-) (kips)	Vu FX (-) (kips)	Tu MY (ft-kips)	Mu MZ (ft-kips)	Mu MX (ft-kips)	Resultant Moment (ft-kips)	phi Pn (kips)	phi Vn (kips)	phi Tn (ft-kips)	phi Mn (ft-kips)	Total Deflect (in)	Rotation (deg)	Ratio
0.00	-44.93	-1.13	0.00	-117.09	0.00	117.09	3,957.37	1,024.83	4,561.65	3,958.89	0.00	0.00	0.041
5.00	-43.37	-1.13	0.00	-111.45	0.00	111.45	3,898.74	1,000.35	4,346.37	3,806.37	0.00	-0.01	0.040
10.00	-41.83	-1.14	0.00	-105.77	0.00	105.77	3,838.36	975.87	4,136.30	3,655.00	0.02	-0.02	0.040
15.00	-40.33	-1.14	0.00	-100.07	0.00	100.07	3,776.22	951.40	3,931.42	3,504.92	0.04	-0.03	0.039
20.00	-38.85	-1.15	0.00	-94.35	0.00	94.35	3,712.32	926.92	3,731.76	3,356.23	0.08	-0.04	0.039
25.00	-37.41	-1.15	0.00	-88.62	0.00	88.62	3,646.67	902.44	3,537.29	3,209.08	0.12	-0.05	0.038
30.00	-35.99	-1.15	0.00	-82.88	0.00	82.88	3,579.26	877.96	3,348.03	3,063.58	0.18	-0.06	0.037
35.00	-35.43	-1.15	0.00	-77.15	0.00	77.15	3,510.10	853.48	3,163.97	2,919.87	0.25	-0.07	0.037
37.00	-34.09	-1.14	0.00	-74.86	0.00	74.86	3,481.94	843.69	3,091.80	2,862.92	0.28	-0.07	0.036
40.00	-32.77	-1.13	0.00	-71.44	0.00	71.44	3,439.17	829.00	2,985.11	2,778.07	0.32	-0.08	0.035
43.00	-32.29	-1.13	0.00	-68.04	0.00	68.04	2,697.55	690.63	2,485.92	2,181.75	0.38	-0.09	0.043
45.00	-31.11	-1.12	0.00	-65.78	0.00	65.78	2,677.43	682.47	2,427.54	2,139.70	0.41	-0.09	0.042
50.00	-29.75	-1.11	0.00	-60.17	0.00	60.17	2,625.91	662.07	2,284.61	2,035.31	0.51	-0.10	0.041
55.00	-28.62	-1.10	0.00	-54.61	0.00	54.61	2,572.64	641.67	2,146.02	1,932.08	0.63	-0.11	0.039
60.00	-27.51	-1.09	0.00	-49.10	0.00	49.10	2,517.61	621.27	2,011.77	1,830.13	0.75	-0.13	0.038
65.00	-26.42	-1.07	0.00	-43.67	0.00	43.67	2,460.82	600.87	1,881.85	1,729.60	0.89	-0.14	0.036
70.00	-25.35	-1.05	0.00	-38.32	0.00	38.32	2,402.27	580.47	1,756.27	1,630.62	1.04	-0.15	0.034
75.00	-23.78	-1.02	0.00	-33.06	0.00	33.06	2,341.97	560.07	1,635.02	1,533.30	1.20	-0.16	0.032
80.00	-22.89	-1.00	0.00	-27.98	0.00	27.98	1,720.57	439.61	1,259.08	1,107.20	1.38	-0.17	0.039
85.00	-22.02	-0.97	0.00	-23.00	0.00	23.00	1,679.48	423.29	1,167.35	1,040.33	1.56	-0.18	0.035
90.00	-16.21	-0.78	0.00	-18.14	0.00	18.14	1,636.64	406.98	1,079.09	974.39	1.76	-0.19	0.029
95.00	-15.83	-0.77	0.00	-14.24	0.00	14.24	1,592.04	390.66	994.30	909.51	1.96	-0.20	0.026
98.00	-13.10	-0.66	0.00	-11.93	0.00	11.93	1,564.44	380.86	945.09	871.14	2.09	-0.21	0.022
100.00	-10.54	-0.56	0.00	-10.60	0.00	10.60	1,545.69	374.34	912.98	845.81	2.17	-0.21	0.019
105.00	-10.09	-0.54	0.00	-7.79	0.00	7.79	1,497.58	358.02	835.13	783.43	2.40	-0.22	0.017
109.00	-8.12	-0.45	0.00	-5.62	0.00	5.62	1,457.82	344.96	775.35	734.55	2.58	-0.22	0.013
110.00	-7.52	-0.42	0.00	-5.17	0.00	5.17	1,446.53	341.70	760.75	721.90	2.63	-0.22	0.012
115.00	-7.23	-0.41	0.00	-3.05	0.00	3.05	1,377.44	325.38	689.83	654.26	2.86	-0.22	0.010
118.00	-5.62	-0.32	0.00	-1.82	0.00	1.82	1,335.99	315.59	648.95	615.27	3.00	-0.23	0.007
119.00	-3.07	-0.19	0.00	-1.50	0.00	1.50	1,322.18	312.33	635.60	602.54	3.05	-0.23	0.005
119.00	-3.07	-0.19	0.00	-1.50	0.00	1.50	936.41	234.90	479.32	429.14	3.05	-0.23	0.007
120.00	-2.75	-0.17	0.00	-1.31	0.00	1.31	929.99	232.45	469.38	421.71	3.10	-0.23	0.006
125.00	-2.57	-0.16	0.00	-0.47	0.00	0.47	896.83	220.21	421.26	385.08	3.33	-0.23	0.004
128.00	0.00	0.00	0.00	0.00	0.00	0.00	876.09	212.87	393.64	363.52	3.48	-0.23	0.000
130.00	0.00	0.00	0.00	0.00	0.00	0.00	861.91	207.97	375.75	349.34	3.57	-0.23	0.000

Site Number: 370626

Code: ANSI/TIA-222-H

© 2007 - 2021 by ATC IP LLC. All rights reserved.

Site Name: East Hartford, CT

Engineering Number:13677849\_C3\_03

6/14/2021 3:32:42 PM

Customer: T-MOBILE

**Load Case 0.9D - 1.0Ev + 1.0Eh**

**Seismic (Reduced DL)**

**Calculated Forces**

Seg Elev (ft)	Pu FY (-) (kips)	Vu FX (-) (kips)	Tu MY (ft-kips)	Mu MZ (ft-kips)	Mu MX (ft-kips)	Resultant Moment (ft-kips)	phi Pn (kips)	phi Vn (kips)	phi Tn (ft-kips)	phi Mn (ft-kips)	Total Deflect (in)	Rotation (deg)	Ratio
0.00	-31.14	-1.13	0.00	-115.36	0.00	115.36	3,957.37	1,024.83	4,561.65	3,958.89	0.00	0.00	0.037
5.00	-30.06	-1.13	0.00	-109.73	0.00	109.73	3,898.74	1,000.35	4,346.37	3,806.37	0.00	-0.01	0.037
10.00	-29.00	-1.13	0.00	-104.07	0.00	104.07	3,838.36	975.87	4,136.30	3,655.00	0.02	-0.02	0.036
15.00	-27.95	-1.14	0.00	-98.39	0.00	98.39	3,776.22	951.40	3,931.42	3,504.92	0.04	-0.03	0.035
20.00	-26.93	-1.14	0.00	-92.71	0.00	92.71	3,712.32	926.92	3,731.76	3,356.23	0.08	-0.04	0.035
25.00	-25.93	-1.14	0.00	-87.02	0.00	87.02	3,646.67	902.44	3,537.29	3,209.08	0.12	-0.05	0.034
30.00	-24.95	-1.13	0.00	-81.34	0.00	81.34	3,579.26	877.96	3,348.03	3,063.58	0.18	-0.06	0.034
35.00	-24.56	-1.13	0.00	-75.67	0.00	75.67	3,510.10	853.48	3,163.97	2,919.87	0.24	-0.07	0.033
37.00	-23.63	-1.13	0.00	-73.41	0.00	73.41	3,481.94	843.69	3,091.80	2,862.92	0.27	-0.07	0.032
40.00	-22.71	-1.12	0.00	-70.03	0.00	70.03	3,439.17	829.00	2,985.11	2,778.07	0.32	-0.08	0.032
43.00	-22.38	-1.12	0.00	-66.68	0.00	66.68	2,697.55	690.63	2,485.92	2,181.75	0.37	-0.08	0.039
45.00	-21.56	-1.11	0.00	-64.45	0.00	64.45	2,677.43	682.47	2,427.54	2,139.70	0.41	-0.09	0.038
50.00	-20.62	-1.09	0.00	-58.92	0.00	58.92	2,625.91	662.07	2,284.61	2,035.31	0.51	-0.10	0.037
55.00	-19.83	-1.08	0.00	-53.45	0.00	53.45	2,572.64	641.67	2,146.02	1,932.08	0.62	-0.11	0.035
60.00	-19.06	-1.07	0.00	-48.05	0.00	48.05	2,517.61	621.27	2,011.77	1,830.13	0.74	-0.12	0.034
65.00	-18.31	-1.05	0.00	-42.71	0.00	42.71	2,460.82	600.87	1,881.85	1,729.60	0.88	-0.13	0.032
70.00	-17.57	-1.03	0.00	-37.46	0.00	37.46	2,402.27	580.47	1,756.27	1,630.62	1.02	-0.15	0.030
75.00	-16.48	-0.99	0.00	-32.32	0.00	32.32	2,341.97	560.07	1,635.02	1,533.30	1.18	-0.16	0.028
80.00	-15.87	-0.97	0.00	-27.34	0.00	27.34	1,720.57	439.61	1,259.08	1,107.20	1.35	-0.17	0.034
85.00	-15.26	-0.95	0.00	-22.48	0.00	22.48	1,679.48	423.29	1,167.35	1,040.33	1.53	-0.18	0.031
90.00	-11.24	-0.76	0.00	-17.74	0.00	17.74	1,636.64	406.98	1,079.09	974.39	1.72	-0.19	0.025
95.00	-10.97	-0.75	0.00	-13.92	0.00	13.92	1,592.04	390.66	994.30	909.51	1.92	-0.20	0.022
98.00	-9.08	-0.65	0.00	-11.67	0.00	11.67	1,564.44	380.86	945.09	871.14	2.05	-0.20	0.019
100.00	-7.30	-0.55	0.00	-10.37	0.00	10.37	1,545.69	374.34	912.98	845.81	2.13	-0.20	0.017
105.00	-6.99	-0.53	0.00	-7.62	0.00	7.62	1,497.58	358.02	835.13	783.43	2.35	-0.21	0.014
109.00	-5.63	-0.44	0.00	-5.50	0.00	5.50	1,457.82	344.96	775.35	734.55	2.53	-0.22	0.011
110.00	-5.21	-0.41	0.00	-5.05	0.00	5.05	1,446.53	341.70	760.75	721.90	2.58	-0.22	0.011
115.00	-5.01	-0.40	0.00	-2.98	0.00	2.98	1,377.44	325.38	689.83	654.26	2.80	-0.22	0.008
118.00	-3.89	-0.32	0.00	-1.78	0.00	1.78	1,335.99	315.59	648.95	615.27	2.94	-0.22	0.006
119.00	-2.13	-0.18	0.00	-1.47	0.00	1.47	1,322.18	312.33	635.60	602.54	2.99	-0.22	0.004
119.00	-2.13	-0.18	0.00	-1.47	0.00	1.47	936.41	234.90	479.32	429.14	2.99	-0.22	0.006
120.00	-1.91	-0.16	0.00	-1.28	0.00	1.28	929.99	232.45	469.38	421.71	3.04	-0.22	0.005
125.00	-1.78	-0.15	0.00	-0.46	0.00	0.46	896.83	220.21	421.26	385.08	3.27	-0.22	0.003
128.00	0.00	0.00	0.00	0.00	0.00	0.00	876.09	212.87	393.64	363.52	3.41	-0.22	0.000
130.00	0.00	0.00	0.00	0.00	0.00	0.00	861.91	207.97	375.75	349.34	3.50	-0.22	0.000

Site Number: 370626

Code: ANSI/TIA-222-H

© 2007 - 2021 by ATC IP LLC. All rights reserved.

Site Name: East Hartford, CT

Engineering Number:13677849\_C3\_03

6/14/2021 3:32:43 PM

Customer: T-MOBILE

### Analysis Summary

Load Case	Reactions						Max Usage	
	Shear FX (kips)	Shear FZ (kips)	Axial FY (kips)	Moment MX (ft-kips)	Moment MY (ft-kips)	Moment MZ (ft-kips)	Elev (ft)	Interaction Ratio
1.2D + 1.0W	25.61	0.00	44.97	0.00	0.00	2373.61	43.00	0.62
0.9D + 1.0W	25.59	0.00	33.72	0.00	0.00	2345.89	43.00	0.60
1.2D + 1.0Di + 1.0Wi	6.81	0.00	72.35	0.00	0.00	651.92	43.00	0.19
1.2D + 1.0Ev + 1.0Eh	1.13	0.00	44.93	0.00	0.00	117.09	43.00	0.04
0.9D - 1.0Ev + 1.0Eh	1.13	0.00	31.14	0.00	0.00	115.36	43.00	0.04
1.0D + 1.0W	5.92	0.00	37.51	0.00	0.00	545.20	43.00	0.15



## Base Plate & Anchor Rod Analysis

Pole Dimensions		
Number of Sides	16	-
Diameter	49.19	in
Thickness	3/8	in
Orientation Offset	0	°

Base Reactions		
Moment, Mu	2,373.6	k-ft
Axial, Pu	45.0	k
Shear, Vu	25.6	k
Neutral Axis	198	°

Report Capacities		
Component	Capacity	Result
Base Plate	23%	Pass
Anchor Rods	52%	Pass
Dwyidag	-	-

Base Plate		
Shape	Round	-
Diameter, $\phi$	67	in
Thickness	2 1/2	in
Grade	A572-55	
Yield Strength, Fy	55	ksi
Tensile Strength, Fu	70	ksi
Clip	N/A	in
Orientation Offset	0	°
Anchor Rod Detail	d	$\eta=0.5$
Clear Distance	3	in
Applied Moment, Mu	514.7	k
Bending Stress, $\phi Mn$	2236.3	k

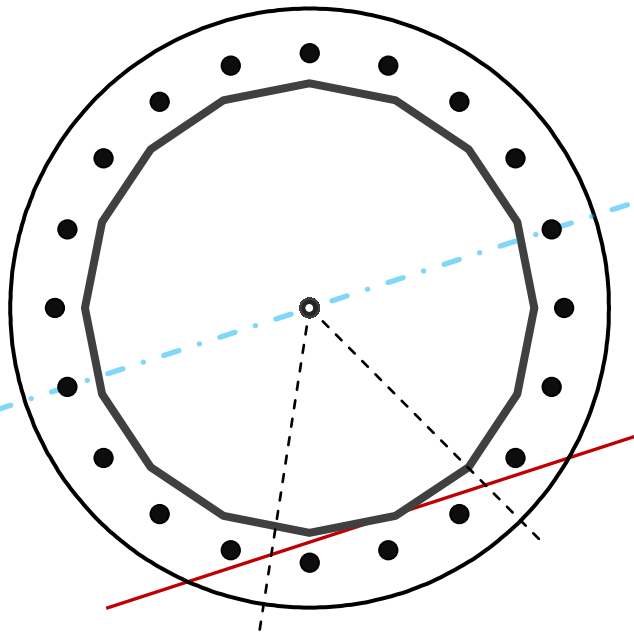

Original Anchor Rods		
Arrangement	Radial	-
Quantity	20	-
Diameter, $\phi$	2 1/2	in
Bolt Circle	57	in
Grade	Other	
Yield Strength, Fy	55	ksi
Tensile Strength, Fu	70	ksi
Spacing	9.0	in
Orientation Offset	0	°
Applied Force, Pu	106.9	k
Anchor Rods, $\phi Pn$	209.9	k

# Calculations for Monopole Base Plate & Anchor Rod Analysis

## Reaction Distribution

Reaction	Shear Vu	Moment Mu	Factor
-	k	k-ft	-
Base Forces	25.6	2373.6	1.00
Anchor Rod Forces	25.6	2373.6	1.00
Additional Bolt (Grp1) Forces	0.0	0.0	0.00
Additional Bolt (Grp2) Forces	0.0	0.0	0.00
Dywidag Forces	0.0	0.0	0.00
Stiffener Forces	0.0	0.0	0.00

## Geometric Properties

Section	Gross Area	Net Area	Individual Inertia	Threads per Inch	Moment of Inertia
-	in <sup>2</sup>	in <sup>2</sup>	in <sup>4</sup>	#	in <sup>4</sup>
Pole	57.1400	3.5713	0.1680		17022.58
Bolt	4.9087	3.9988	1.2725	4	29583.19
Bolt1	0.0000	0.0000	0.0000	0	0.00
Bolt2	0.0000	0.0000	0.0000	0	0.00
Dywidag	0.0000	0.0000	0.0000		0.00
Stiffener	0.0000	0.0000	0.0000		0.00

### Base Plate

Shape	Round	-
Diameter, D	67	in
Thickness, t	2.5	in
Yield Strength, Fy	55	ksi
Tensile Strength, Fu	70	ksi
Base Plate Chord	45.490	in
Detail Type	d	-
Detail Factor	0.50	-
Clear Distance	3	-

### Anchor Rods

Anchor Rod Quantity, N	20	-
Rod Diameter, d	2.5	in
Bolt Circle, BC	57	in
Yield Strength, Fy	55	ksi
Tensile Strength, Fu	70	ksi
Applied Axial, Pu	106.9	k
Applied Shear, Vu	0.6	k
Compressive Capacity, $\phi P_n$	209.9	k
Tensile Capacity, $\phi R_n$	0.509	OK
Interaction Capacity	0.515	OK

### External Base Plate

Chord Length AA	33.736	in
Additional AA	5.000	in
Section Modulus, Z	60.524	in <sup>3</sup>
Applied Moment, Mu	514.7	k-ft
Bending Capacity, $\phi M_n$	2996.0	k-ft
Capacity, Mu/ $\phi M_n$	0.172	OK

Chord Length AB	32.278	in
Additional AB	5.000	in
Section Modulus, Z	58.247	in <sup>3</sup>
Applied Moment, Mu	364.7	k-ft
Bending Capacity, $\phi M_n$	2883.2	k-ft
Capacity, Mu/ $\phi M_n$	0.126	OK

Bend Line Length	28.914	in
Additional Bend Line	0.000	in
Section Modulus, Z	45.178	in <sup>3</sup>
Applied Moment, Mu	514.7	k-ft
Bending Capacity, $\phi M_n$	2236.3	k-ft
Capacity, Mu/ $\phi M_n$	0.230	OK

### Internal Base Plate

Arc Length	0.000	in
Section Modulus, Z	0.000	in <sup>3</sup>
Moment Arm	0.000	in
Applied Moment, Mu	0.0	k-ft
Bending Capacity, $\phi M_n$	0.0	k-ft
Capacity, Mu/ $\phi M_n$		



# Flange Plate Analysis

Flange Plate	Plate Type	<b>Flange</b>	<b>@ 119 ft</b>
	Pole Diameter	22	in
	Pole Thickness	0.1875	in
	Plate Diameter	31	in
	Plate Thickness	1	in
	Plate Fy	36	ksi
	Weld Length	0.3125	in
	f <sub>s</sub> Resistance Applied	61.38	k-in
		9.95	k-in

Code Rev. **H**

Date	6/14/2021
Engineer	L. Morin
Site #	370626
Carrier	T-MOBILE

Moment 29.1 k-ft  
Axial 2.8 k

Required Flange Thickness:  
0.40 in OK

Stiffeners	#	
------------	---	--

Bolts	#	<b>8</b>	
	Bolt Circle (R)adial / (S)quare	27	in
	Bolt Gap	R	
	Diameter	6	in
	Hole Diameter	1	in
	Type	1.125	in
	Fy	A325	
	Fu	92	ksi
	f <sub>s</sub> Resistance Applied	120	ksi
		54.52	k
	6.12	k	

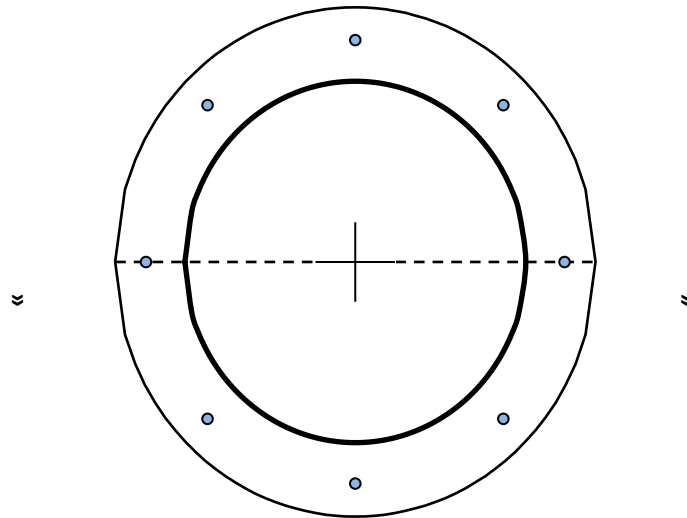

Reinforcement	#	
---------------	---	--

**Plate Stress Ratio:**  
16% Pass

**Bolt Stress Ratio:**  
11% Pass

Extra Bolts	O	#	
-------------	---	---	--

<b>RAN Template:</b> 67D5A997DB ODE+6160	<b>A&amp;L Template:</b> 67D5997DB_2xAIR+1OP (U21 Market)
---	--

### CTHA505A\_Anchor\_5\_draft

**Print Name:** Preliminary (RFDS\_for\_Scoping)  
**PORs:** Anchor\_Phase 3  
 L600\_CMP5

## Section 1 - Site Information

**Site ID:** CTHA505A  
**Status:** Draft  
**Version:** 5  
**Project Type:** Anchor  
**Approved:** Not Approved  
**Approved By:** Not Approved  
**Last Modified:** 4/18/2021 9:44:22 PM  
**Last Modified By:** Dominic.Kallas2@T-Mobile.com

**Site Name:** Crown E. Hartford Monopole  
**Site Class:** Monopole  
**Site Type:** Structure Non Building  
**Plan Year:** 2021  
**Market:** CONNECTICUT CT  
**Vendor:** Ericsson  
**Landlord:** <undefined>

**Latitude:** 41.77330000  
**Longitude:** -72.61350000  
**Address:** 148 Roberts Street  
**City, State:** East Hartford, CT  
**Region:** NORTHEAST

<b>RAN Template:</b> 67D5A997DB ODE+6160		<b>AL Template:</b> 67D5997DB_2xAIR+1OP (U21 Market)		
<b>Sector Count:</b> 3	<b>Antenna Count:</b> 9	<b>Coax Line Count:</b> 0	<b>TMA Count:</b> 0	<b>RRU Count:</b> 9

## Section 2 - Existing Template Images

----- This section is intentionally blank. -----

Section 3 - Proposed Template Images

67D5A997DB\_2xAIR+1xOP.jpg

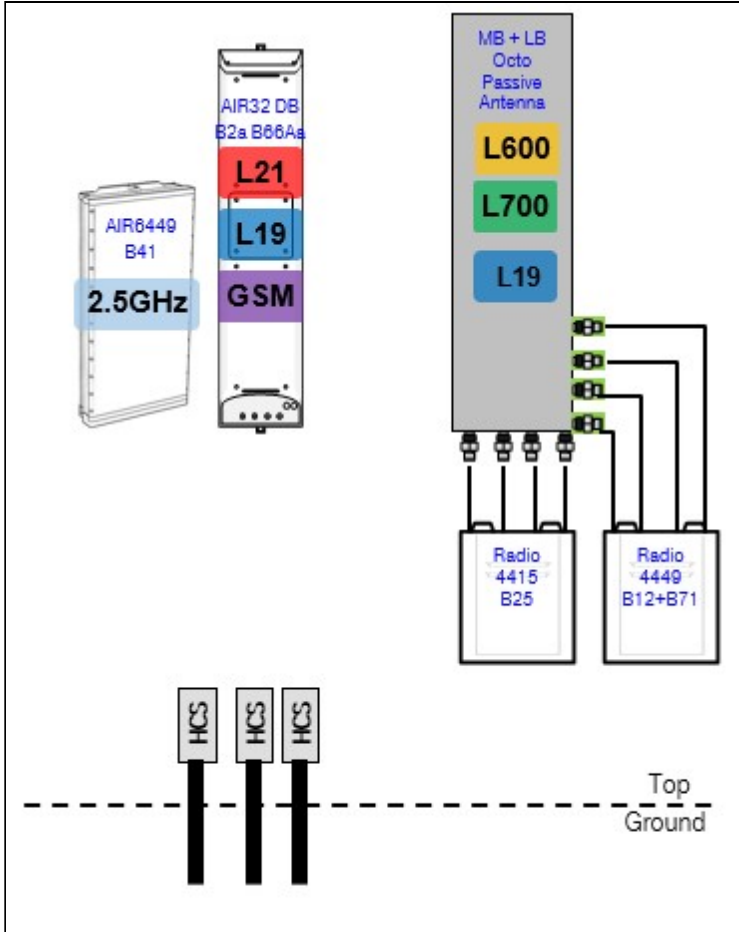

Notes:

67D5997DB\_2xAIR+1OP.JPG

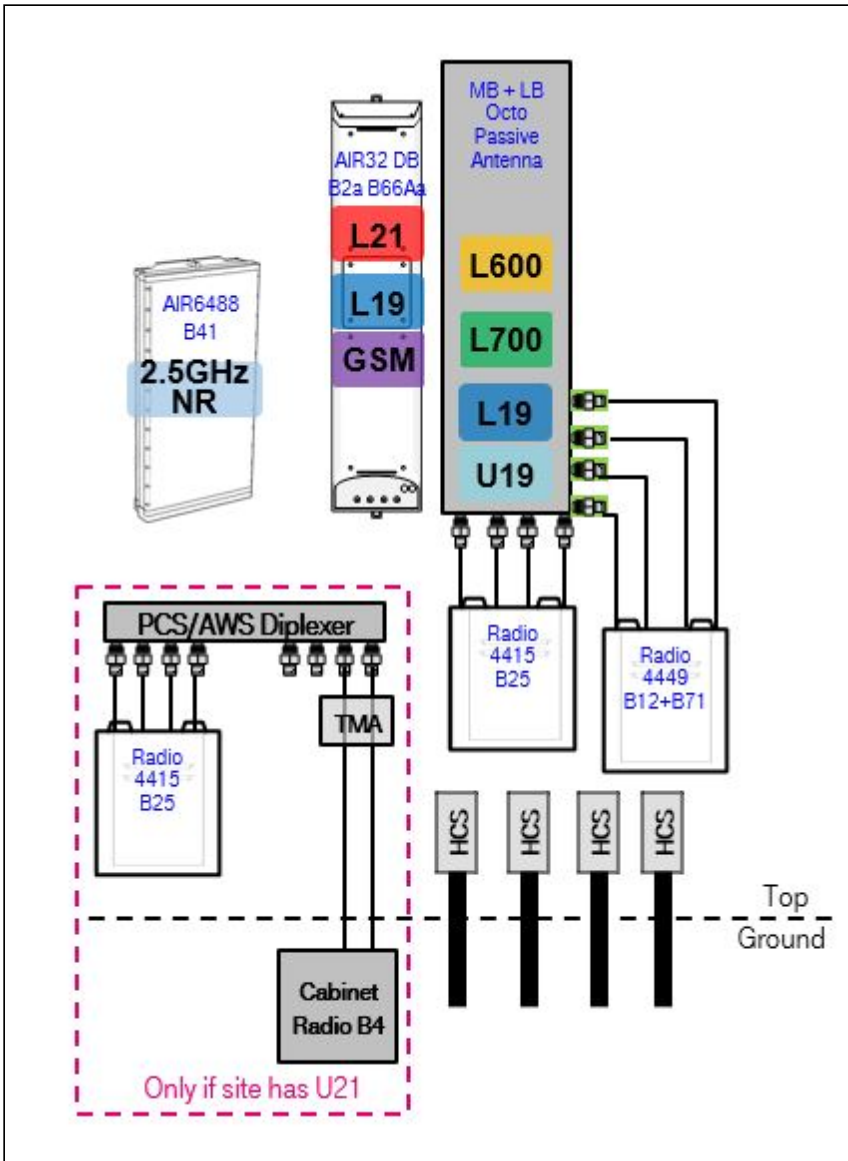

Notes:

**Section 4 - Siteplan Images**

----- This section is intentionally blank. -----

<b>RAN Template:</b> 67D5A997DB ODE+6160	<b>A&amp;L Template:</b> 67D5997DB_2xAIR+1OP (U21 Market)
---	--

**Section 5 - RAN Equipment**

**Existing RAN Equipment**

Template: 95ADB

Enclosure	1	2
<b>Enclosure Type</b>	RBS 6201 ODE	Ancillary Equipment (Ericsson)
<b>Baseband</b>	DUW30 U2100 BB 6630 L2100 L1900	
<b>Hybrid Cable System</b>		Ericsson 9x18 HCS *Select Length* Ericsson 6x12 HCS *Select Length & AWG*

**Proposed RAN Equipment**

Template: 67D5A997DB ODE+6160

Enclosure	1	2	3
<b>Enclosure Type</b>	RBS 6201 ODE	Enclosure 6160	B160
<b>Baseband</b>	DUW30 U2100 BB 6648 L2100 L1900 BB 6648 L700 L600 N600	BB 6648 L2500 N2500	
<b>Hybrid Cable System</b>	Ericsson Hybrid Trunk 6/24 4AWG 40m (x 2)	Ericsson Hybrid Trunk 6/24 4AWG 40m PSU 4813	
<b>Transport System</b>		CSR IXRe V2 (Gen2)	

**RAN Scope of Work:**

- Add (1) BB6648 for L600, L700, and N600 (MMBB - Mixed Mode Baseband) to existing RBS6201 ODE base station cabinet.
- Add (1) Enclosure 6160.
- Add (1) Battery Cabinet B160.
- Add (1) iXRe Router to new Enclosure 6160.
- Add (1) BB6648 for L2500 and N2500 (MMBB - Mixed Mode Baseband) to new Enclosure 6160.
- Add (1) PSU4813 Voltage Booster to new Enclosure 6160.
- Existing: (6) coaxial lines; (1) 9X18 HCS
- Remove all coaxial lines.
- Remove 9X18 HCS.
- Add (3) 6X24 HCS as follows: (2) terminating at the ODE; (1) terminating at the Enclosure 6160 (Connect DC for AIR6449 B41 to the PSU4813 Voltage Booster).

<b>RAN Template:</b> 67D5A997DB ODE+6160	<b>A&amp;L Template:</b> 67D5997DB_2xAIR+1OP (U21 Market)
---	--

**Section 6 - A&L Equipment**

**Existing Template:** 95ADB\_2xAIR  
**Proposed Template:** 67D5997DB\_2xAIR+1OP (U21 Market)

**Sector 1 (Existing) view from behind**

<b>Coverage Type</b>	A - Outdoor Macro					
<b>Antenna</b>	1			2		
<b>Antenna Model</b>	Ericsson - AIR32 KRD901146-1_B66A_B2A (Octo)			Ericsson - AIR21 KRC118046-1_B2P_B4A (Quad)		
<b>Azimuth</b>	30			30		
<b>M. Tilt</b>	0			0		
<b>Height</b>	100			100		
<b>Ports</b>	<b>P1</b>	<b>P2</b>	<b>P3</b>	<b>P4</b>	<b>P5</b>	<b>P6</b>
<b>Active Tech.</b>	L2100	L2100	L1900	L1900	U2100	
<b>Dark Tech.</b>						
<b>Restricted Tech.</b>						
<b>Decomm. Tech.</b>						
<b>E. Tilt</b>	2	2	2	2	2	
<b>Cables</b>	Fiber Jumper - 15 ft.		Fiber Jumper - 15 ft.		Fiber Jumper (x2)	
<b>TMA's</b>						
<b>Diplexers / Combiners</b>						
<b>Radio</b>						
<b>Sector Equipment</b>						

**Unconnected Equipment:**

**Scope of Work:**



<b>RAN Template:</b> 67D5A997DB ODE+6160	<b>A&amp;L Template:</b> 67D5997DB_2xAIR+1OP (U21 Market)
---	--

### CTHA505A\_Anchor\_5\_draft

**Print Name:** Preliminary (RFDS\_for\_Scoping)  
**PORs:** Anchor\_Phase 3  
L600\_CMP5

**Sector 1 (Proposed) view from behind**

<b>Coverage Type</b>	A - Outdoor Macro									
<b>Antenna</b>	1				2				3	
<b>Antenna Model</b>	Ericsson - AIR32 KRD901146-1_B66A_B2A (Octo)				RFS - APXVAALL24_43-U-NA20 (Octo)				Ericsson - AIR6449 B41 (Active Antenna - Massive MIMO)	
<b>Azimuth</b>	30				30				30	
<b>M. Tilt</b>	0				0				0	
<b>Height</b>	100				100				100	
<b>Ports</b>	<b>P1</b>	<b>P2</b>	<b>P3</b>	<b>P4</b>	<b>P5</b>	<b>P6</b>	<b>P7</b>	<b>P8</b>	<b>P9</b>	<b>P10</b>
<b>Active Tech.</b>	L2100	L2100	L1900	L1900	L700 L600 N600	L700 L600 N600	L1900	L1900 U2100	L2500 N2500	L2500 N2500
<b>Dark Tech.</b>										
<b>Restricted Tech.</b>										
<b>Decomm. Tech.</b>										
<b>E. Tilt</b>										
<b>Cables</b>	Fiber Jumper	Fiber Jumper	Fiber Jumper	Fiber Jumper	Coax Jumper (x2) Fiber Jumper	Coax Jumper (x2) Fiber Jumper	Coax Jumper (x2) Fiber Jumper (x2)	Coax Jumper (x2) Fiber Jumper (x2)	Fiber Jumper (x2)	Fiber Jumper (x2)
<b>TMA's</b>										
<b>Diplexers / Combiners</b>							Comms cope - SDX19 26Q-43 (E14F0 5P86) (AtAntenna)	SHARED Comms cope - SDX19 26Q-43 (E14F0 5P86) (AtAntenna)		
<b>Radio</b>					Radio 4449 B71+B85 (At Antenna)	SHARED Radio 4449 B71+B85 (At Antenna)	Radio 4415 B25 (At Antenna)	SHARED Radio 4415 B25 (At Antenna) Radio 4415 B66A (At Antenna)		
<b>Sector Equipment</b>										

**Unconnected Equipment:**

**Scope of Work:**

New Platform with three mounts per sector.  
 Add handrail kit.  
 Keep AIR32 B66A/B2A Dual Band for L2100 and L1900 1st Carrier in Position 1.  
 Remove AIR21 B2A/B4P from Position 2.  
 Install (1) Low-Band/Mid-Band Octo in Position 2.  
 Add (1) Radio 4449 B71+B85 for L600, L700, and N600 in Position 2 at antenna, and connect its ports to the Low-Band ports of the Octo Antenna.  
 Add (1) PCS/AWS 8:4 diplexer to Position 2 at antenna, and connect its four common ports to the Mid-Band ports of the Octo Antenna.  
 Add (1) Radio 4415 B25 for L1900 2nd Carrier to Position 2 near antenna, and connect its ports to the four PCS ports of the diplexer.  
 Add (1) Radio 4415 B66 for U2100, to Position 2 near antenna, and connect two of its ports to two AWS ports of the diplexer.

Make sure to install metal caps on all empty ports of AWS/PCS diplexer for load balancing.

Install (1) AIR6449 B41 for L2500 and N2500 in Position 3.

Ensure RET control is enabled for all technology layers according to the Design Documents.

\*A dashed border indicates shared equipment. Any connected equipment is denoted with the SHARED keyword.

<b>RAN Template:</b> 67D5A997DB ODE+6160	<b>A&amp;L Template:</b> 67D5997DB_2xAIR+1OP (U21 Market)
---	--

Sector 2 (Existing) view from behind						
<b>Coverage Type</b>	A - Outdoor Macro					
<b>Antenna</b>	1			2		
<b>Antenna Model</b>	Ericsson - AIR32 KRD901146-1_B66A_B2A (Octo)			Ericsson - AIR21 KRC118046-1_B2P_B4A (Quad)		
<b>Azimuth</b>	135			135		
<b>M. Tilt</b>	0			0		
<b>Height</b>	100			100		
<b>Ports</b>	<b>P1</b>	<b>P2</b>	<b>P3</b>	<b>P4</b>	<b>P5</b>	<b>P6</b>
<b>Active Tech.</b>	L2100	L2100	L1900	L1900	U2100	
<b>Dark Tech.</b>						
<b>Restricted Tech.</b>						
<b>Decomm. Tech.</b>						
<b>E. Tilt</b>	2	2	2	2	4	
<b>Cables</b>	Fiber Jumper - 15 ft.		Fiber Jumper - 15 ft.		Fiber Jumper - 15 ft. (x2)	
<b>TMAs</b>						
<b>Diplexers / Combiners</b>						
<b>Radio</b>						
<b>Sector Equipment</b>						
<b>Unconnected Equipment:</b>						
<b>Scope of Work:</b>						

<b>RAN Template:</b> 67D5A997DB ODE+6160	<b>A&amp;L Template:</b> 67D5997DB_2xAIR+1OP (U21 Market)
---	--

### CTHA505A\_Anchor\_5\_draft

**Print Name:** Preliminary (RFDS\_for\_Scoping)  
**PORs:** Anchor\_Phase 3  
L600\_CMP5

**Sector 2 (Proposed) view from behind**

<b>Coverage Type</b>	A - Outdoor Macro									
<b>Antenna</b>	1				2				3	
<b>Antenna Model</b>	Ericsson - AIR32 KRD901146-1_B66A_B2A (Octo)				RFS - APXVAALL24_43-U-NA20 (Octo)				Ericsson - AIR6449 B41 (Active Antenna - Massive MIMO)	
<b>Azimuth</b>	135				135				135	
<b>M. Tilt</b>	0				0				0	
<b>Height</b>	100				100				100	
<b>Ports</b>	<b>P1</b>	<b>P2</b>	<b>P3</b>	<b>P4</b>	<b>P5</b>	<b>P6</b>	<b>P7</b>	<b>P8</b>	<b>P9</b>	<b>P10</b>
<b>Active Tech.</b>	L2100	L2100	L1900	L1900	L700 L600 N600	L700 L600 N600	L1900	L1900 U2100	L2500 N2500	L2500 N2500
<b>Dark Tech.</b>										
<b>Restricted Tech.</b>										
<b>Decomm. Tech.</b>										
<b>E. Tilt</b>										
<b>Cables</b>	Fiber Jumper	Fiber Jumper	Fiber Jumper	Fiber Jumper	Coax Jumper (x2) Fiber Jumper	Coax Jumper (x2) Fiber Jumper	Coax Jumper (x2) Fiber Jumper (x2)	Coax Jumper (x2) Fiber Jumper (x2)	Fiber Jumper (x2)	Fiber Jumper (x2)
<b>TMA's</b>										
<b>Diplexers / Combiners</b>							Comms cope - SDX19 26Q-43 (E14F0 5P86) (AtAntenna)	SHARED Comms cope - SDX19 26Q-43 (E14F0 5P86) (AtAntenna)		
<b>Radio</b>					Radio 4449 B71+B85 (At Antenna)	SHARED Radio 4449 B71+B85 (At Antenna)	Radio 4415 B25 (At Antenna)	SHARED Radio 4415 B25 (At Antenna) Radio 4415 B66A (At Antenna)		
<b>Sector Equipment</b>										

**Unconnected Equipment:**

**Scope of Work:**

New Platform with three mounts per sector.  
 Add handrail kit.  
 Keep AIR32 B66A/B2A Dual Band for L2100 and L1900 1st Carrier in Position 1.  
 Remove AIR21 B2A/B4P from Position 2.  
 Install (1) Low-Band/Mid-Band Octo in Position 2.  
 Add (1) Radio 4449 B71+B85 for L600, L700, and N600 in Position 2 at antenna, and connect its ports to the Low-Band ports of the Octo Antenna.  
 Add (1) PCS/AWS 8:4 diplexer to Position 2 at antenna, and connect its four common ports to the Mid-Band ports of the Octo Antenna.  
 Add (1) Radio 4415 B25 for L1900 2nd Carrier to Position 2 near antenna, and connect its ports to the four PCS ports of the diplexer.  
 Add (1) Radio 4415 B66 for U2100, to Position 2 near antenna, and connect two of its ports to two AWS ports of the diplexer.

Make sure to install metal caps on all empty ports of AWS/PCS diplexer for load balancing.

Install (1) AIR6449 B41 for L2500 and N2500 in Position 3.

Ensure RET control is enabled for all technology layers according to the Design Documents.

\*A dashed border indicates shared equipment. Any connected equipment is denoted with the SHARED keyword.



<b>RAN Template:</b> 67D5A997DB ODE+6160	<b>A&amp;L Template:</b> 67D5997DB_2xAIR+1OP (U21 Market)
---	--

Sector 3 (Existing) view from behind						
<b>Coverage Type</b>	A - Outdoor Macro					
<b>Antenna</b>	1			2		
<b>Antenna Model</b>	Ericsson - AIR32 KRD901146-1_B66A_B2A (Octo)			Ericsson - AIR21 KRC118046-1_B2P_B4A (Quad)		
<b>Azimuth</b>	270			270		
<b>M. Tilt</b>	0			0		
<b>Height</b>	100			100		
<b>Ports</b>	<b>P1</b>	<b>P2</b>	<b>P3</b>	<b>P4</b>	<b>P5</b>	<b>P6</b>
<b>Active Tech.</b>	L2100	L2100	L1900	L1900	U2100	
<b>Dark Tech.</b>						
<b>Restricted Tech.</b>						
<b>Decomm. Tech.</b>						
<b>E. Tilt</b>	2	2	2	2	2	
<b>Cables</b>	Fiber Jumper - 15 ft.		Fiber Jumper - 15 ft.		Fiber Jumper - 15 ft. (x2)	
<b>TMA's</b>						
<b>Diplexers / Combiners</b>						
<b>Radio</b>						
<b>Sector Equipment</b>						
<b>Unconnected Equipment:</b>						
<b>Scope of Work:</b>						

<b>RAN Template:</b> 67D5A997DB ODE+6160	<b>A&amp;L Template:</b> 67D5997DB_2xAIR+1OP (U21 Market)
---	--

### CTHA505A\_Anchor\_5\_draft

**Print Name:** Preliminary (RFDS\_for\_Scoping)  
**PORs:** Anchor\_Phase 3  
L600\_CMP5

**Sector 3 (Proposed) view from behind**

<b>Coverage Type</b>	A - Outdoor Macro									
<b>Antenna</b>	1				2				3	
<b>Antenna Model</b>	Ericsson - AIR32 KRD901146-1_B66A_B2A (Octo)				RFS - APXVAALL24_43-U-NA20 (Octo)				Ericsson - AIR6449 B41 (Active Antenna - Massive MIMO)	
<b>Azimuth</b>	270				270				270	
<b>M. Tilt</b>	0				0				0	
<b>Height</b>	100				100				100	
<b>Ports</b>	<b>P1</b>	<b>P2</b>	<b>P3</b>	<b>P4</b>	<b>P5</b>	<b>P6</b>	<b>P7</b>	<b>P8</b>	<b>P9</b>	<b>P10</b>
<b>Active Tech.</b>	L2100	L2100	L1900	L1900	L700 L600 N600	L700 L600 N600	L1900	L1900 U2100	L2500 N2500	L2500 N2500
<b>Dark Tech.</b>										
<b>Restricted Tech.</b>										
<b>Decomm. Tech.</b>										
<b>E. Tilt</b>										
<b>Cables</b>	Fiber Jumper	Fiber Jumper	Fiber Jumper	Fiber Jumper	Coax Jumper (x2) Fiber Jumper	Coax Jumper (x2) Fiber Jumper	Coax Jumper (x2) Fiber Jumper (x2)	Coax Jumper (x2) Fiber Jumper (x2)	Fiber Jumper (x2)	Fiber Jumper (x2)
<b>TMA's</b>										
<b>Diplexers / Combiners</b>							Comms cope - SDX19 26Q-43 (E14F0 5P86) (AtAntenna)	SHARED Comms cope - SDX19 26Q-43 (E14F0 5P86) (AtAntenna)		
<b>Radio</b>					Radio 4449 B71+B85 (At Antenna)	SHARED Radio 4449 B71+B85 (At Antenna)	Radio 4415 B25 (At Antenna)	SHARED Radio 4415 B25 (At Antenna) Radio 4415 B66A (At Antenna)		
<b>Sector Equipment</b>										

**Unconnected Equipment:**

**Scope of Work:**

New Platform with three mounts per sector.  
 Add handrail kit.  
 Keep AIR32 B66A/B2A Dual Band for L2100 and L1900 1st Carrier in Position 1.  
 Remove AIR21 B2A/B4P from Position 2.  
 Install (1) Low-Band/Mid-Band Octo in Position 2.  
 Add (1) Radio 4449 B71+B85 for L600, L700, and N600 in Position 2 at antenna, and connect its ports to the Low-Band ports of the Octo Antenna.  
 Add (1) PCS/AWS 8:4 diplexer to Position 2 at antenna, and connect its four common ports to the Mid-Band ports of the Octo Antenna.  
 Add (1) Radio 4415 B25 for L1900 2nd Carrier to Position 2 near antenna, and connect its ports to the four PCS ports of the diplexer.  
 Add (1) Radio 4415 B66 for U2100, to Position 2 near antenna, and connect two of its ports to two AWS ports of the diplexer.

Make sure to install metal caps on all empty ports of AWS/PCS diplexer for load balancing.

Install (1) AIR6449 B41 for L2500 and N2500 in Position 3.

Ensure RET control is enabled for all technology layers according to the Design Documents.

\*A dashed border indicates shared equipment. Any connected equipment is denoted with the SHARED keyword.

<b>RAN Template:</b> 67D5A997DB ODE+6160	<b>A&amp;L Template:</b> 67D5997DB_2xAIR+1OP (U21 Market)
---	--

**Section 7 - Power Systems Equipment**

**Existing Power Systems Equipment**

----- This section is intentionally blank. -----

**Proposed Power Systems Equipment**

RADIO FREQUENCY EMISSIONS ANALYSIS REPORT  
EVALUATION OF HUMAN EXPOSURE POTENTIAL  
TO NON-IONIZING EMISSIONS

T-Mobile Existing Facility

Site ID: CTHA505A

Crown E. Hartford Monopole  
148 Roberts Street  
East Hartford, Connecticut 06108

**June 28, 2021**

**EBI Project Number: 6221003244**

Site Compliance Summary	
Compliance Status:	<b>COMPLIANT</b>
Site total MPE% of FCC general population allowable limit:	<b>52.56%</b>

June 28, 2021

T-Mobile

Attn: Jason Overbey, RF Manager  
35 Griffin Road South  
Bloomfield, Connecticut 06002

Emissions Analysis for Site: CTHA505A - Crown E. Hartford Monopole

EBI Consulting was directed to analyze the proposed T-Mobile facility located at **148 Roberts Street in East Hartford, Connecticut** for the purpose of determining whether the emissions from the Proposed T-Mobile Antenna Installation located on this property are within specified federal limits.

All information used in this report was analyzed as a percentage of current Maximum Permissible Exposure (% MPE) as listed in the FCC OET Bulletin 65 Edition 97-01 and ANSI/IEEE Std C95.1. The FCC regulates Maximum Permissible Exposure in units of microwatts per square centimeter ( $\mu\text{W}/\text{cm}^2$ ). The number of  $\mu\text{W}/\text{cm}^2$  calculated at each sample point is called the power density. The exposure limit for power density varies depending upon the frequencies being utilized. Wireless Carriers and Paging Services use different frequency bands each with different exposure limits; therefore, it is necessary to report results and limits in terms of percent MPE rather than power density.

All results were compared to the FCC (Federal Communications Commission) radio frequency exposure rules, 47 CFR 1.1307(b)(1) – (b)(3), to determine compliance with the Maximum Permissible Exposure (MPE) limits for General Population/Uncontrolled environments as defined below.

General population/uncontrolled exposure limits apply to situations in which the general population may be exposed or in which persons who are exposed as a consequence of their employment may not be made fully aware of the potential for exposure or cannot exercise control over their exposure. Therefore, members of the general population would always be considered under this category when exposure is not employment related, for example, in the case of a telecommunications tower that exposes persons in a nearby residential area.

Public exposure to radio frequencies is regulated and enforced in units of microwatts per square centimeter ( $\mu\text{W}/\text{cm}^2$ ). The general population exposure limits for the 600 MHz and 700 MHz frequency bands are approximately  $400 \mu\text{W}/\text{cm}^2$  and  $467 \mu\text{W}/\text{cm}^2$ , respectively. The general population exposure limit for the 1900 MHz (PCS), 2100 MHz (AWS) and 11 GHz frequency bands is  $1000 \mu\text{W}/\text{cm}^2$ . Because each carrier will be using different frequency bands, and each frequency band has different exposure limits, it is necessary to report percent of MPE rather than power density.



Occupational/controlled exposure limits apply to situations in which persons are exposed as a consequence of their employment and in which those persons who are exposed have been made fully aware of the potential for exposure and can exercise control over their exposure. Occupational/controlled exposure limits also apply where exposure is of a transient nature as a result of incidental passage through a location where exposure levels may be above general population/uncontrolled limits (see below), as long as the exposed person has been made fully aware of the potential for exposure and can exercise control over his or her exposure by leaving the area or by some other appropriate means.

Additional details can be found in FCC OET 65.

## **CALCULATIONS**

Calculations were done for the proposed T-Mobile Wireless antenna facility located at 148 Roberts Street in East Hartford, Connecticut using the equipment information listed below. All calculations were performed per the specifications under FCC OET 65. Since T-Mobile is proposing highly focused directional panel antennas, which project most of the emitted energy out toward the horizon, all calculations were performed assuming a lobe representing the maximum gain of the antenna per the antenna manufacturer's supplied specifications, minus 10 dB for directional panel antennas and 20 dB for highly focused parabolic microwave dishes, was focused at the base of the tower. For this report, the sample point is the top of a 6-foot person standing at the base of the tower. For power density calculations, the broadcast footprint of the AIR6449 antenna has been considered. Due to the beamforming nature of this antenna, the actual beam locations vary depending on demand and are narrow in nature. Using the broadcast footprint accounts for the potential location of beams at any given time.

For all calculations, all equipment was calculated using the following assumptions:

- 1) 2 LTE channels (600 MHz Band) were considered for each sector of the proposed installation. These Channels have a transmit power of 30 Watts per Channel.
- 2) 1 NR channel (600 MHz Band) was considered for each sector of the proposed installation. This Channel has a transmit power of 80 Watts.
- 3) 2 LTE channels (700 MHz Band) were considered for each sector of the proposed installation. These Channels have a transmit power of 30 Watts per Channel.
- 4) 4 LTE channels (PCS Band - 1900 MHz) were considered for each sector of the proposed installation. These Channels have a transmit power of 60 Watts per Channel.
- 5) 2 UMTS channels (AWS Band - 2100 MHz) were considered for each sector of the proposed installation. These Channels have a transmit power of 30 Watts per Channel.

- 6) 2 LTE channels (AWS Band – 2100 MHz) were considered for each sector of the proposed installation. These Channels have a transmit power of 60 Watts per Channel.
- 7) 1 LTE Traffic channel (LTE IC and 2C BRS Band - 2500 MHz) was considered for each sector of the proposed installation. This Channel has a transmit power of 60 Watts.
- 8) 1 LTE Broadcast channel (LTE IC and 2C BRS Band - 2500 MHz) was considered for each sector of the proposed installation. This Channel has a transmit power of 20 Watts.
- 9) 1 NR Traffic channel (BRS Band - 2500 MHz) was considered for each sector of the proposed installation. This Channel has a transmit power of 120 Watts.
- 10) 1 NR Broadcast channel (BRS Band - 2500 MHz) was considered for each sector of the proposed installation. This Channel has a transmit power of 40 Watts.
- 11) All radios at the proposed installation were considered to be running at full power and were uncombined in their RF transmissions paths per carrier prescribed configuration. Per FCC OET Bulletin No. 65 - Edition 97-01 recommendations to achieve the maximum anticipated value at each sample point, all power levels emitting from the proposed antenna installation are increased by a factor of 2.56 to account for possible in-phase reflections from the surrounding environment. This is rarely the case, and if so, is never continuous.
- 12) For the following calculations, the sample point was the top of a 6-foot person standing at the base of the tower. The maximum gain of the antenna per the antenna manufacturer's supplied specifications, minus 10 dB for directional panel antennas and 20 dB for highly focused parabolic microwave dishes, was used in this direction. This value is a very conservative estimate as gain reductions for these particular antennas are typically much higher in this direction.
- 13) The antennas used in this modeling are the Ericsson AIR 32 for the 1900 MHz / 2100 MHz channel(s), the RFS APXVAALL24\_43-U-NA20 for the 600 MHz / 600 MHz / 700 MHz / 1900 MHz / 2100 MHz channel(s), the Ericsson AIR 6449 for the 2500 MHz / 2500 MHz / 2500 MHz / 2500 MHz channel(s) in Sector A, the Ericsson AIR 32 for the 1900 MHz / 2100 MHz channel(s), the RFS APXVAALL24\_43-U-NA20 for the 600 MHz / 600 MHz / 700 MHz / 1900 MHz / 2100 MHz channel(s), the Ericsson AIR 6449 for the 2500 MHz / 2500 MHz / 2500 MHz / 2500 MHz channel(s) in Sector B, the Ericsson AIR 32 for the 1900 MHz / 2100 MHz channel(s), the RFS APXVAALL24\_43-U-NA20 for the 600 MHz / 600 MHz / 700 MHz / 1900 MHz / 2100 MHz channel(s), the Ericsson AIR 6449 for the 2500 MHz / 2500 MHz / 2500 MHz / 2500 MHz channel(s) in Sector C. This is based on feedback from the carrier with regard to anticipated antenna selection. All Antenna gain values and associated transmit power

levels are shown in the Site Inventory and Power Data table below. The maximum gain of the antenna per the antenna manufacturer's supplied specifications, minus 10 dB for directional panel antennas and 20 dB for highly focused parabolic microwave dishes, was used for all calculations. This value is a very conservative estimate as gain reductions for these particular antennas are typically much higher in this direction.

- 14) The antenna mounting height centerline of the proposed antennas is 100 feet above ground level (AGL).
- 15) Emissions values for additional carriers were taken from the Connecticut Siting Council active database. Values in this database are provided by the individual carriers themselves.
- 16) All calculations were done with respect to uncontrolled / general population threshold limits.

## T-Mobile Site Inventory and Power Data

Sector:	A	Sector:	B	Sector:	C
Antenna #:	1	Antenna #:	1	Antenna #:	1
Make / Model:	Ericsson AIR 32	Make / Model:	Ericsson AIR 32	Make / Model:	Ericsson AIR 32
Frequency Bands:	1900 MHz / 2100 MHz	Frequency Bands:	1900 MHz / 2100 MHz	Frequency Bands:	1900 MHz / 2100 MHz
Gain:	15.35 dBd / 15.85 dBd	Gain:	15.35 dBd / 15.85 dBd	Gain:	15.35 dBd / 15.85 dBd
Height (AGL):	100 feet	Height (AGL):	100 feet	Height (AGL):	100 feet
Channel Count:	4	Channel Count:	4	Channel Count:	4
Total TX Power (W):	240 Watts	Total TX Power (W):	240 Watts	Total TX Power (W):	240 Watts
ERP (W):	8,728.31	ERP (W):	8,728.31	ERP (W):	8,728.31
Antenna A1 MPE %:	<b>3.55%</b>	Antenna B1 MPE %:	<b>3.55%</b>	Antenna C1 MPE %:	<b>3.55%</b>
Antenna #:	2	Antenna #:	2	Antenna #:	2
Make / Model:	RFS APXVAALL24_43-U-NA20	Make / Model:	RFS APXVAALL24_43-U-NA20	Make / Model:	RFS APXVAALL24_43-U-NA20
Frequency Bands:	600 MHz / 600 MHz / 700 MHz / 1900 MHz / 2100 MHz	Frequency Bands:	600 MHz / 600 MHz / 700 MHz / 1900 MHz / 2100 MHz	Frequency Bands:	600 MHz / 600 MHz / 700 MHz / 1900 MHz / 2100 MHz
Gain:	12.95 dBd / 12.95 dBd / 13.65 dBd / 15.45 dBd / 16.45 dBd	Gain:	12.95 dBd / 12.95 dBd / 13.65 dBd / 15.45 dBd / 16.45 dBd	Gain:	12.95 dBd / 12.95 dBd / 13.65 dBd / 15.45 dBd / 16.45 dBd
Height (AGL):	100 feet	Height (AGL):	100 feet	Height (AGL):	100 feet
Channel Count:	9	Channel Count:	9	Channel Count:	9
Total TX Power (W):	380 Watts	Total TX Power (W):	380 Watts	Total TX Power (W):	380 Watts
ERP (W):	11,010.27	ERP (W):	11,010.27	ERP (W):	11,010.27
Antenna A2 MPE %:	<b>6.81%</b>	Antenna B2 MPE %:	<b>6.81%</b>	Antenna C2 MPE %:	<b>6.81%</b>
Antenna #:	3	Antenna #:	3	Antenna #:	3
Make / Model:	Ericsson AIR 6449	Make / Model:	Ericsson AIR 6449	Make / Model:	Ericsson AIR 6449
Frequency Bands:	2500 MHz / 2500 MHz / 2500 MHz / 2500 MHz	Frequency Bands:	2500 MHz / 2500 MHz / 2500 MHz / 2500 MHz	Frequency Bands:	2500 MHz / 2500 MHz / 2500 MHz / 2500 MHz
Gain:	22.65 dBd / 17.3 dBd / 22.65 dBd / 17.3 dBd	Gain:	22.65 dBd / 17.3 dBd / 22.65 dBd / 17.3 dBd	Gain:	22.65 dBd / 17.3 dBd / 22.65 dBd / 17.3 dBd
Height (AGL):	100 feet	Height (AGL):	100 feet	Height (AGL):	100 feet
Channel Count:	4	Channel Count:	4	Channel Count:	4
Total TX Power (W):	240 Watts	Total TX Power (W):	240 Watts	Total TX Power (W):	240 Watts
ERP (W):	36,356.09	ERP (W):	36,356.09	ERP (W):	36,356.09
Antenna A3 MPE %:	<b>14.79%</b>	Antenna B3 MPE %:	<b>14.79%</b>	Antenna C3 MPE %:	<b>14.79%</b>

Site Composite MPE %	
Carrier	MPE %
T-Mobile (Max at Sector A):	25.15%
Verizon	6.69%
Sprint	7.14%
AT&T	13.58%
<b>Site Total MPE % :</b>	<b>52.56%</b>

T-Mobile MPE % Per Sector	
T-Mobile Sector A Total:	25.15%
T-Mobile Sector B Total:	25.15%
T-Mobile Sector C Total:	25.15%
<b>Site Total MPE % :</b>	<b>52.56%</b>

T-Mobile Maximum MPE Power Values (Sector A)							
T-Mobile Frequency Band / Technology (Sector A)	# Channels	Watts ERP (Per Channel)	Height (feet)	Total Power Density ( $\mu\text{W}/\text{cm}^2$ )	Frequency (MHz)	Allowable MPE ( $\mu\text{W}/\text{cm}^2$ )	Calculated % MPE
T-Mobile 1900 MHz LTE	2	2056.61	100.0	16.74	1900 MHz LTE	1000	1.67%
T-Mobile 2100 MHz LTE	2	2307.55	100.0	18.78	2100 MHz LTE	1000	1.88%
T-Mobile 600 MHz LTE	2	591.73	100.0	4.82	600 MHz LTE	400	1.20%
T-Mobile 600 MHz NR	1	1577.94	100.0	6.42	600 MHz NR	400	1.61%
T-Mobile 700 MHz LTE	2	695.22	100.0	5.66	700 MHz LTE	467	1.21%
T-Mobile 1900 MHz LTE	2	2104.51	100.0	17.13	1900 MHz LTE	1000	1.71%
T-Mobile 2100 MHz UMTS	2	1324.71	100.0	10.78	2100 MHz UMTS	1000	1.08%
T-Mobile 2500 MHz LTE IC & 2C Traffic	1	11044.63	100.0	44.94	2500 MHz LTE IC & 2C Traffic	1000	4.49%
T-Mobile 2500 MHz LTE IC & 2C Broadcast	1	1074.06	100.0	4.37	2500 MHz LTE IC & 2C Broadcast	1000	0.44%
T-Mobile 2500 MHz NR Traffic	1	22089.26	100.0	89.88	2500 MHz NR Traffic	1000	8.99%
T-Mobile 2500 MHz NR Broadcast	1	2148.13	100.0	8.74	2500 MHz NR Broadcast	1000	0.87%
						<b>Total:</b>	<b>25.15%</b>

• NOTE: Totals may vary by approximately 0.01% due to summation of remainders in calculations.

## Summary

All calculations performed for this analysis yielded results that were **within** the allowable limits for general population exposure to RF Emissions.

The anticipated maximum composite contributions from the T-Mobile facility as well as the site composite emissions value with regards to compliance with FCC's allowable limits for general population exposure to RF Emissions are shown here:

T-Mobile Sector	Power Density Value (%)
Sector A:	25.15%
Sector B:	25.15%
Sector C:	25.15%
T-Mobile Maximum MPE % (Sector A):	25.15%
Site Total:	52.56%
Site Compliance Status:	<b>COMPLIANT</b>

The anticipated composite MPE value for this site assuming all carriers present is **52.56%** of the allowable FCC established general population limit sampled at the ground level. This is based upon values listed in the Connecticut Siting Council database for existing carrier emissions.

FCC guidelines state that if a site is found to be out of compliance (over allowable thresholds), that carriers over a 5% contribution to the composite value will require measures to bring the site into compliance. For this facility, the composite values calculated were well within the allowable 100% threshold standard per the federal government.