



Crown Castle
3 Corporate Park Drive, Suite 101
Clifton Park, NY 12065

September 20, 2018

Melanie A. Bachman
Acting Executive Director
Connecticut Siting Council
10 Franklin Square
New Britain, CT 06051

RE: Notice of Exempt Modification for Sprint DO Macro: 806364
Sprint Site ID: CT03XC168
143 R Old Blue Hill Rd., Durham Connecticut 06422
Latitude: 41° 27' 33.67"/ Longitude: 72° 39' 45.83"

Dear Ms. Bachman:

Sprint currently maintains six (6) antennas at the 87-foot level of the existing 120-foot monopole tower at 149 R Old Blue Hill Rd., Durham CT. The tower is owned by Crown Castle. The property is owned by Francis E. Behrens Jr.. Sprint now intends to replace six (6) antennas with nine (9) new antennas. These antennas would be installed at the 87-foot level of the tower. Sprint also intends to install twelve (12) RRHs, one (1) new platform, one (1) hand rail kit, one (1) platform reinforcement kit, and swap six (6) existing coax cables with three (4) hybrid cables.

The Connecticut Siting Council approved this facility, an email was sent on 09/20/2018 to the Town of Durham Planning and Zoning Office to ascertain the original zoning approval documents and date.

Please accept this letter as notification pursuant to Regulations of Connecticut State Agencies § 16-50j-73, for construction that constitutes an exempt modification pursuant to R.C.S.A. § 16-50j-72(b)(2). In accordance with R.S.C.A. § 16-50j-73, a copy of this letter is being sent to First Selectman Laura L. Francis, Town of Durham, Geoffrey L. Colegrove, Planning & Zoning Officer, Town of Durham, as well as the property owner, and Crown Castle is the tower owner.

1. The proposed modifications will not result in an increase in the height of the existing tower.
2. The proposed modifications will not require the extension of the site boundary.
3. The proposed modification will not increase noise levels at the facility by six decibels or more, or to levels that exceed state and local criteria.
4. The operation of the replacement antennas will not increase radio frequency emissions at the facility to a level at or above the Federal Communication Commission safety standard.

The Foundation for a Wireless World.

CrownCastle.com

Melanie A. Bachman

September 21, 2018

Page 2

5. The proposed modifications will not cause a change or alteration in the physical or environmental characteristics of the site.
6. The existing structure and its foundation can support the proposed loading.

For the foregoing reasons, Sprint respectfully submits that the proposed modifications to the above-reference telecommunications facility constitutes an exempt modification under R.C.S.A. § 16-50j-72(b)(2). Please send approval/rejection letter to Attn: Jeffrey Barbadora.

Sincerely,

Jeffrey Barbadora
Real Estate Specialist
12 Gill Street, Suite 5800, Woburn, MA 01801
781-729-0053
Jeff.Barbadora@crowncastle.com

Attachments:

- Tab 1: Exhibit-1: Compound plan and elevation depicting the planned changes
- Tab 2: Exhibit-2: Structural Modification Report
- Tab 3: Exhibit-3: General Power Density Table Report (RF Emissions Analysis Report)

cc: The Honorable Laura L. Francis
Town Hall, 30 Town House Road
P.O. Box 428
Durham, Connecticut 06422

Geoffrey Colegrove, Planning & Zoning Officer
30 Town House Road
P.O. Box 428
Durham, Connecticut 06422

Francis E. Behrens
109 Old Blue Hills Rd.
Durham, CT 06422-3005



Property Card: OLD BLUE HILLS RD
 Town of Durham, CT



Parcel ID: 69-12
Account #: B0016900

Owner: BEHRENS FRANCIS E JR
Mailing Address: 109 OLD BLUE HILLS RD
 DURHAM, CT 06422-3005

General Information	Assessed Value
State Class: 130 Class: R Census-Tract: 5851 District No.: M Neighborhood: 80 Zone: FR Total Acres: 6.31	Land: \$126,400 Buildings: \$0 Total: \$2,030
Sale History	
Book/Page: 100-255 Deed Date: 19840824 Sale Date: Sale Type: 0 Sale Price: 0	
Building Details	
Living Units: 0 Style: 0 Year Built: 0 Effective Year Built: 0 Ture TLA: 0 Stories: 0 Total Rooms: 0 Total Bedrooms: 0 Number Full Baths: 0 Number Half Baths: 0 WB/FP Openings: 0 Heating Type: 0 Heating Fuel Type: 0	Basement: 0 FBLA Size: 0 Attic: 0 Exterior Walls: 0 Basement / Garage: 0



www.cai-tech.com

Data shown on this report is provided for planning and informational purposes only. The municipality and CAI Technologies are not responsible for any use for other purposes or misuse or misrepresentation of this report.

BUILDING SKETCH

	<u>Descriptor/Area</u>



www.cai-tech.com

Data shown on this report is provided for planning and informational purposes only. The municipality and CAI Technologies are not responsible for any use for other purposes or misuse or misrepresentation of this report.

Old Blue Hills Rd
Durham, CT 06422

Directions

SAVE NEARBY SEND TO YOUR PHONE SHARE

Add a missing place

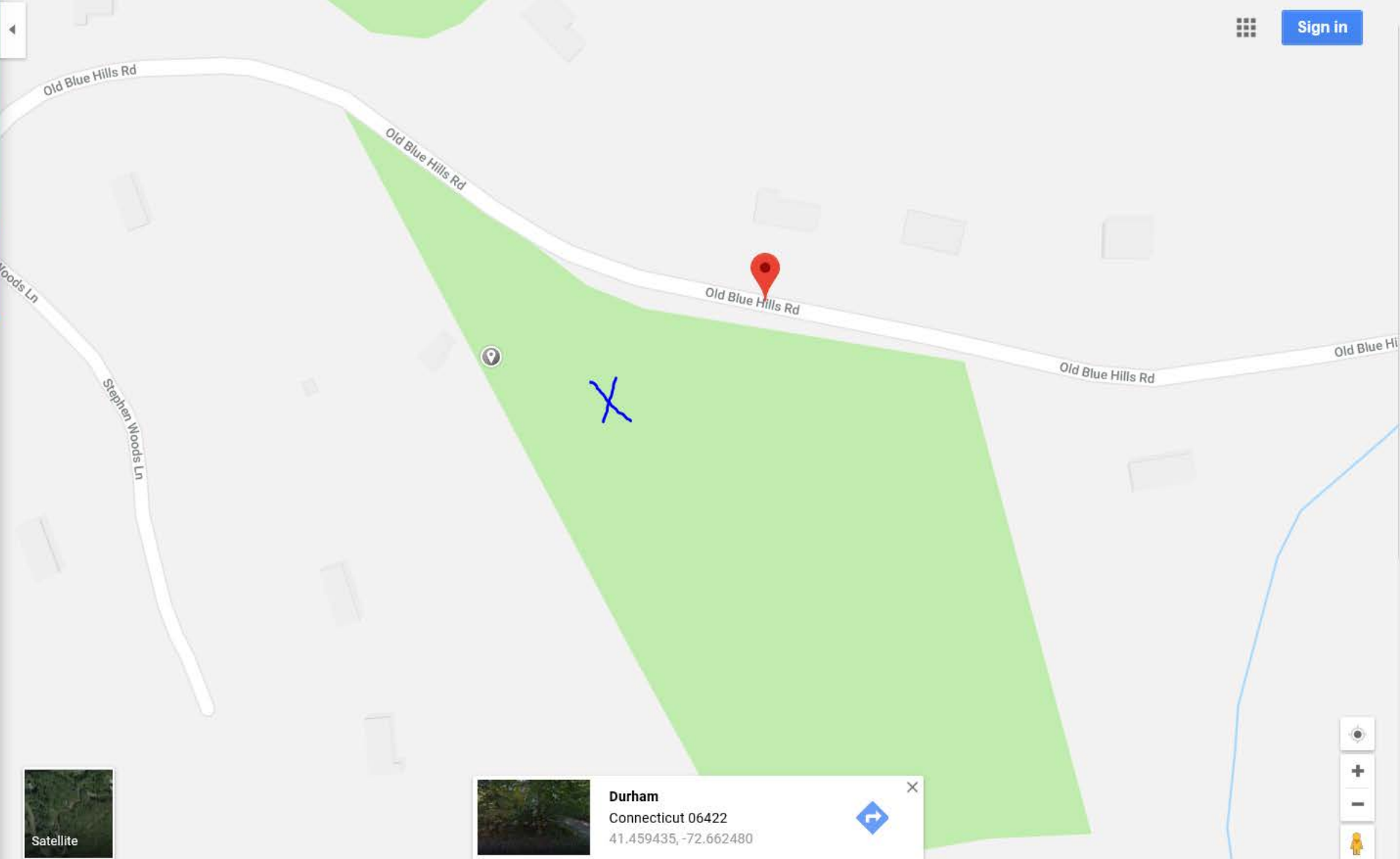

Durham
Connecticut 06422
41.459435, -72.662480

Directions

Map navigation controls: compass, zoom in (+), zoom out (-), and street view person icon.

SPECIAL CONSTRUCTION NOTE:
 SPRINT WORK IS CONTINGENT ON THE FOLLOWING:
 * COMPLETION OF A GLOBAL STRUCTURAL STABILITY ANALYSIS.
 * COMPLETION OF AN ANTENNA/RRH MOUNT STRUCTURAL ASSESSMENT.
 * GC SHALL FURNISH, INSTALL AND COMPLETE ALL REQUIRED STRUCTURAL MODIFICATIONS AS INDICATED IN BEFORE-MENTIONED ANALYSIS AND ASSESSMENT.



PROJECT: DO MACRO UPGRADE (800 3G/4G & 2.5)
SITE NAME: HRT 106(B) 943202
SITE CASCADE: CT03XC168
MARKET: NE
SITE ADDRESS: 143 R OLD BLUE HILL ROAD
 DURHAM, CT 06422
SITE TYPE: MONOPOLE



NOTE:
 OWNER AND TENANT MAY, FROM TIME TO TIME AT TENANT'S OPTION, REPLACE THIS EXHIBIT WITH AN EXHIBIT SETTING FORTH THE LEGAL DESCRIPTION OF THE SITE, OR WITH ENGINEERED OR AS-BUILT DRAWING DEPICTING THE SITE OR ILLUSTRATING STRUCTURAL MODIFICATIONS OR CONSTRUCTION PLANS OF THE SITE. ANY VISUAL OR TEXTUAL REPRESENTATION OF THE EQUIPMENT LOCATED WITHIN THE SITE CONTAINED IN THESE OTHER DOCUMENTS IS ILLUSTRATIVE ONLY, AND DOES NOT LIMIT THE RIGHTS OF SPRINT AS PROVIDED FOR IN THE AGREEMENT. THE LOCATIONS OF ANY ACCESS AND UTILITY EASEMENTS ARE ILLUSTRATIVE ONLY. ACTUAL LOCATIONS MAY BE DETERMINED BY TENANT AND/OR THE SERVICING UTILITY COMPANY IN COMPLIANCE WITH LOCAL LAWS AND REGULATIONS.

STRUCTURAL NOTE:
 PRIOR TO COMMENCING CONSTRUCTION, GC SHALL REFER TO TOWER STRUCTURAL ANALYSIS REPORT PROVIDED BY CROWN CASTLE DATED JUNE 29, 2018 AND MOUNT STRUCTURAL ANALYSIS BY HUDSON DESIGN GROUP DATED JUNE 14, 2018 (REV. 1) TO DETERMINE IF THERE ANY SUPPLEMENTAL OR SPECIAL INSTALLATION REQUIREMENTS, OR RELOCATION ARRANGEMENTS.



CROWN CASTLE SITE #: 806364
CROWN CASTLE SITE NAME: HRT 106(B) 943202

VICINITY MAP N.T.S.

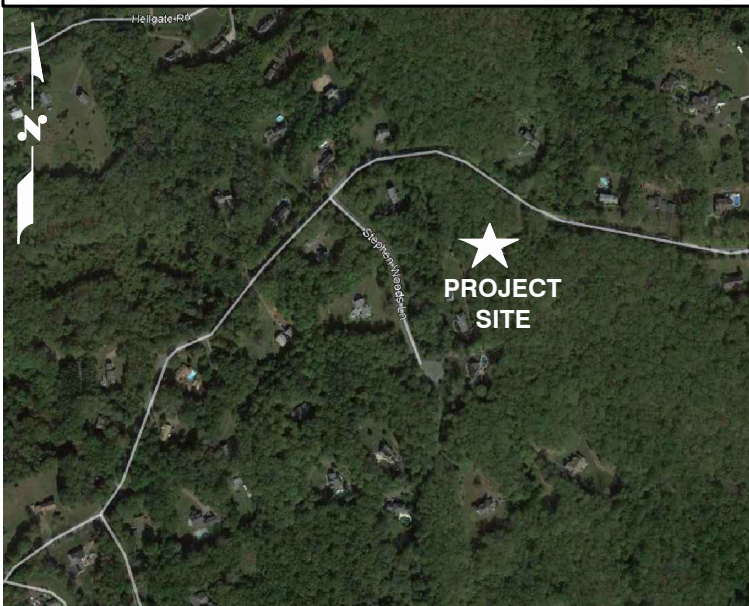

PROJECT INFORMATION

SITE INFORMATION:
 SPRINT EQUIPMENT MODIFICATIONS REQUIRED TO SUPPORT MODERNIZATION OF AN EXISTING WIRELESS COMMUNICATIONS FACILITY AND UTILIZATION OF FCC BROADBAND SPECTRUM LICENSE FOR DO_MACRO UPGRADE, INCLUDING INSTALLATION OF:
 GROUND-LEVEL RAN EQUIPMENT, CONSISTING OF:
 * NO CHANGES
 TOWER EQUIPMENT, INCLUDING INSTALLATION OF:
 * (1) NEW LOW PROFILE PLATFORM
 * (1) NEW HANDRAIL KIT
 * (1) NEW PLATFORM REINFORCEMENT KIT
 * (9) PANEL ANTENNAS TO REPLACE (6) EXISTING ANTENNAS
 * (12) REMOTE RADIO HEADS (RRH), (3) RELOCATED TO TOWER TOP FROM GROUND LEVEL
 * (4) HYBRID CABLES

LATITUDE: N 41° 27' 33.67"
 LONGITUDE: W 72° 39' 45.83"
 GROUND ELEVATION: 540'± AMSL (PER GOOGLE EARTH)
 STRUCTURE HEIGHT: 120'± AGL (TYPE: MONOPOLE)
 ZONING JURISDICTION: DURHAM

DRAWING INDEX

SHEET NO.	DESCRIPTION	REV.
T-1	TITLE SHEET	1
SP-1	OUTLINE SPECIFICATIONS	1
SP-2	OUTLINE SPECIFICATIONS	1
SP-3	OUTLINE SPECIFICATIONS	1
A-1	COMPOUND PLAN & EQUIPMENT PLAN	1
A-2	ANTENNA PLANS & ELEVATION	1
A-3	EQUIPMENT DETAILS	1
A-4	MOUNTING DETAILS	1
RF-1	RF DATA SHEET	1
RF-2	WIRING DIAGRAMS	1
G-1	ONE LINE DIAGRAM, GROUNDING DETAILS & NOTES	1

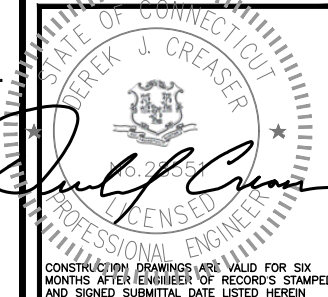

CHECKED BY: BB

APPROVED BY: DJC

SUBMITTALS

REV.	DATE	DESCRIPTION	BY
1	08/13/18	CONSTRUCTION FINAL	BB
0	07/24/18	ISSUED FOR CONSTRUCTION	GA

APPROVALS

PROJECT MANAGER	DATE
CONSTRUCTION	DATE
RF ENGINEERING	DATE
ZONING / SITE ACQ.	DATE
OPERATIONS	DATE
TOWER OWNER	DATE

APPLICANT:
 SPRINT
 1 INTERNATIONAL BLVD, SUITE 800
 MAHWAH, NJ 07495

PROPERTY OWNER:
 UNKNOWN

TOWER OWNER:
 CROWN CASTLE
 12 GILL STREET
 SUITE 5800
 WOBURN, MA 01801

SPRINT CONSTRUCTION MANAGER:
 MIKE DURKIN
 PHONE: 401-363-9923
 michael.durkin@sprint.com

SPRINT MARKET MANAGER:
 RONALD HIBBARD
 PHONE: 774-269-8812
 ronald.hibbard@sprint.com

CROWN CASTLE PROJECT MANAGER:
 WILL STONE
 PHONE: 518-373-3543
 william.stone@crowncastle.com

SPECIAL ZONING NOTE

BASED ON INFORMATION PROVIDED BY SPRINT REGULATORY COMPLIANCE PROFESSIONALS AND LEGAL COUNSEL, THIS TELECOMMUNICATIONS EQUIPMENT DEPLOYMENT IS CONSIDERED AN ELIGIBLE FACILITY UNDER THE TAX RELIEF ACT OF 2012, 47 USC 1455(A), AND IS SUBJECT TO AN EXPEDITED ELIGIBLE FACILITIES REQUEST/REVIEW AND ZONING PRE-EMPTION FOR LOCAL DISCRETIONARY PERMITS (VARIANCE, SPECIAL PERMIT, SITE PLAN REVIEW, ADMINISTRATIVE REVIEW).

GENERAL NOTES

- THIS IS AN UNMANNED TELECOMMUNICATION FACILITY AND NOT FOR HUMAN HABITATION:
 - ADA COMPLIANCE NOT REQUIRED.
 - POTABLE WATER OR SANITARY SERVICE IS NOT REQUIRED.
 - NO OUTDOOR STORAGE OR ANY SOLID WASTE RECEPTACLES REQUIRED.
- CONTRACTOR SHALL VERIFY ALL PLANS, EXISTING DIMENSIONS, AND CONDITIONS ON JOB SITE. CONTRACTOR SHALL IMMEDIATELY NOTIFY THE ARCHITECT/ENGINEER IN WRITING OF ANY DISCREPANCIES BEFORE PROCEEDING WITH THE WORK. FAILURE TO NOTIFY THE ARCHITECT/ENGINEER PLACE THE RESPONSIBILITY ON THE CONTRACTOR TO CORRECT THE DISCREPANCIES AT THE CONTRACTOR'S EXPENSE.
- CONSTRUCTION DRAWINGS ARE VALID FOR SIX MONTHS AFTER ENGINEER OF RECORD'S STAMPED AND SIGNED SUBMITTAL DATE LISTED HEREIN.
- NEW CONSTRUCTION WILL CONFORM TO ALL APPLICABLE CODES AND ORDINANCES.
 BUILDING CODE: INTERNATIONAL BUILDING CODE 2012 WITH 2016 CT STATE BUILDING CODE AMENDMENTS
 ELECTRICAL CODE: NFPA 70 2014 - NATIONAL ELECTRIC CODE
 STRUCTURAL CODE: TIA/EIA-222-G STRUCTURAL STANDARDS FOR ANTENNA SUPPORTING STRUCTURES AND ANTENNAS.

SITE NUMBER:
 CT03XC168
 SITE NAME:
 HRT 106(B) 943202
 CROWN BU NUMBER:
 806364
 SITE ADDRESS:
 143 R OLD BLUE HILL ROAD
 DURHAM, CT 06422
 MIDDLESEX COUNTY

SHEET TITLE
 TITLE SHEET
 (DO MACRO)

SHEET NUMBER
 T-1

THESE OUTLINE SPECIFICATIONS IN CONJUNCTION WITH THE SPRINT STANDARD CONSTRUCTION SPECIFICATIONS, INCLUDING CONTRACT DOCUMENTS AND THE CONSTRUCTION DRAWINGS DESCRIBE THE WORK TO BE PERFORMED BY THE CONTRACTOR.

SECTION 01 100 – SCOPE OF WORK

PART 1 – GENERAL

1.1 **THE WORK:** THESE STANDARD CONSTRUCTION SPECIFICATIONS IN CONJUNCTION WITH THE SPRINT CONSTRUCTION STANDARDS FOR WIRELESS SITES, CONTRACT DOCUMENTS AND THE CONSTRUCTION DRAWINGS DESCRIBE THE WORK TO BE PERFORMED BY THE CONTRACTOR.

1.2 **RELATED DOCUMENTS:**

- A. THE REQUIREMENTS OF THIS SECTION APPLY TO ALL SECTIONS IN THIS SPECIFICATION.
- B. SPRINT "STANDARD CONSTRUCTION DETAILS FOR WIRELESS SITES" ARE INCLUDED IN AND MADE A PART OF THESE SPECIFICATIONS HEREWITH.

1.3 **PRECEDENCE:** SHOULD CONFLICTS OCCUR BETWEEN THE STANDARD CONSTRUCTION SPECIFICATIONS FOR WIRELESS SITES INCLUDING THE STANDARD CONSTRUCTION DETAILS FOR WIRELESS SITES AND THE CONSTRUCTION DRAWINGS, INFORMATION ON THE CONSTRUCTION DRAWINGS SHALL TAKE PRECEDENCE. NOTIFY SPRINT CONSTRUCTION MANAGER IF THIS OCCURS.

1.4 **NATIONALLY RECOGNIZED CODES AND STANDARDS:**

- A. THE WORK SHALL COMPLY WITH APPLICABLE NATIONAL AND LOCAL CODES AND STANDARDS, LATEST EDITION, AND PORTIONS THEREOF, INCLUDED BUT NOT LIMITED TO THE FOLLOWING:
 1. GR-78-CORE GENERIC REQUIREMENTS FOR THE PHYSICAL DESIGN AND MANUFACTURE OF TELECOMMUNICATIONS EQUIPMENT.
 2. GR-1089 CORE, ELECTROMAGNETIC COMPATIBILITY AND ELECTRICAL SAFETY –GENERIC CRITERIA FOR NETWORK TELECOMMUNICATIONS EQUIPMENT.
 3. NATIONAL FIRE PROTECTION ASSOCIATION CODES AND STANDARDS (NFPA) INCLUDING NFPA 70 (NATIONAL ELECTRICAL CODE – "NEC") AND NFPA 101 (LIFE SAFETY CODE).
 4. AMERICAN SOCIETY FOR TESTING OF MATERIALS (ASTM)
 5. INSTITUTE OF ELECTRONIC AND ELECTRICAL ENGINEERS (IEEE)
 6. AMERICAN CONCRETE INSTITUTE (ACI)
 7. AMERICAN WIRE PRODUCERS ASSOCIATION (AWPA)
 8. CONCRETE REINFORCING STEEL INSTITUTE (CRSI)
 9. AMERICAN ASSOCIATION OF STATE HIGHWAY AND TRANSPORTATION OFFICIALS (AASHTO)
 10. PORTLAND CEMENT ASSOCIATION (PCA)
 11. NATIONAL CONCRETE MASONRY ASSOCIATION (NCMA)
 12. BRICK INDUSTRY ASSOCIATION (BIA)
 13. AMERICAN WELDING SOCIETY (AWS)
 14. NATIONAL ROOFING CONTRACTORS ASSOCIATION (NRCA)
 15. SHEET METAL AND AIR CONDITIONING CONTRACTORS' NATIONAL ASSOCIATION (SMACNA)
 16. DOOR AND HARDWARE INSTITUTE (DHI)
 17. OCCUPATIONAL SAFETY AND HEALTH ACT (OSHA)
 18. APPLICABLE BUILDING CODES INCLUDING UNIFORM BUILDING CODE, SOUTHERN BUILDING CODE, BOCA, AND THE INTERNATIONAL BUILDING CODE.

1.5 **DEFINITIONS:**

- A. WORK: THE SUM OF TASKS AND RESPONSIBILITIES IDENTIFIED IN THE CONTRACT DOCUMENTS.
- B. COMPANY: SPRINT CORPORATION
- C. ENGINEER: SYNONYMOUS WITH ARCHITECT & ENGINEER AND "A&E". THE DESIGN PROFESSIONAL HAVING PROFESSIONAL RESPONSIBILITY FOR DESIGN OF THE PROJECT.
- D. CONTRACTOR: CONSTRUCTION CONTRACTOR; CONSTRUCTION VENDOR; INDIVIDUAL OR ENTITY WHO AFTER EXECUTION OF A CONTRACT IS BOUND TO ACCOMPLISH THE WORK.
- E. THIRD PARTY VENDOR OR AGENCY: A VENDOR OR AGENCY ENGAGED SEPARATELY BY THE COMPANY, A&E, OR CONTRACTOR TO PROVIDE MATERIALS OR TO ACCOMPLISH SPECIFIC TASKS RELATED TO BUT NOT INCLUDED IN THE WORK.
- F. OFCI: OWNER FURNISHED, CONTRACTOR INSTALLED EQUIPMENT.
- G. CONSTRUCTION MANAGER – ALL PROJECTS RELATED COMMUNICATION TO FLOW THROUGH SPRINT REPRESENTATIVE IN CHARGE OF PROJECT...

1.6 **SITE FAMILIARITY:** CONTRACTOR SHALL BE RESPONSIBLE FOR FAMILIARIZING HIMSELF WITH ALL CONTRACT DOCUMENTS, FIELD CONDITIONS AND DIMENSIONS PRIOR TO PROCEEDING WITH CONSTRUCTION. ANY DISCREPANCIES SHALL BE BROUGHT TO THE ATTENTION OF THE SPRINT CONSTRUCTION MANAGER PRIOR TO THE COMMENCEMENT OF WORK. NO COMPENSATION WILL BE AWARDED BASED ON CLAIM OF LACK OF KNOWLEDGE OR FIELD CONDITIONS.

1.7 **POINT OF CONTACT:** COMMUNICATION BETWEEN SPRINT AND THE CONTRACTOR SHALL FLOW THROUGH THE SINGLE SPRINT CONSTRUCTION MANAGER APPOINTED TO MANAGE THE PROJECT FOR SPRINT.

1.8 **ON-SITE SUPERVISION:** THE CONTRACTOR SHALL SUPERVISE AND DIRECT THE WORK AND SHALL BE RESPONSIBLE FOR CONSTRUCTION MEANS, METHODS, TECHNIQUES, SEQUENCES, AND PROCEDURES IN ACCORDANCE WITH THE CONTRACT DOCUMENTS. THE CONTRACTOR SHALL EMPLOY A COMPETENT SUPERINTENDENT WHO SHALL BE IN ATTENDANCE AT THE SITE AT ALL TIMES DURING PERFORMANCE OF THE WORK.

1.9 **DRAWINGS, SPECIFICATIONS AND DETAILS REQUIRED AT JOBSITE:** THE CONSTRUCTION CONTRACTOR SHALL MAINTAIN A FULL SET OF THE CONSTRUCTION DRAWINGS, STANDARD CONSTRUCTION DETAILS FOR WIRELESS SITES AND THE STANDARD CONSTRUCTION SPECIFICATIONS FOR WIRELESS SITES AT THE JOBSITE FROM MOBILIZATION THROUGH CONSTRUCTION COMPLETION.

- A. THE JOBSITE DRAWINGS, SPECIFICATIONS AND DETAILS SHALL BE CLEARLY MARKED DAILY IN RED PENCIL WITH ANY CHANGES IN CONSTRUCTION OVER WHAT IS DEPICTED IN THE DOCUMENTS. AT CONSTRUCTION COMPLETION, THIS JOBSITE MARKUP SET SHALL BE DELIVERED TO THE COMPANY OR COMPANY'S DESIGNATED REPRESENTATIVE TO BE FORWARDED TO THE COMPANY'S A&E VENDOR FOR PRODUCTION OF "AS-BUILT" DRAWINGS.
- B. DETAILS ARE INTENDED TO SHOW DESIGN INTENT. MODIFICATIONS MAY BE REQUIRED TO SUIT JOB DIMENSIONS OR CONDITIONS, AND SUCH MODIFICATIONS SHALL BE INCLUDED AS PART OF THE WORK. CONTRACTOR SHALL NOTIFY SPRINT CONSTRUCTION MANAGER OF ANY VARIATIONS PRIOR TO PROCEEDING WITH THE WORK.
- C. DIMENSIONS SHOWN ARE TO FINISH SURFACES UNLESS NOTED OTHERWISE. SPACING BETWEEN EQUIPMENT IS THE REQUIRED CLEARANCE. SHOULD THERE BE ANY QUESTIONS REGARDING THE CONTRACT DOCUMENTS, EXISTING CONDITIONS AND/OR DESIGN INTENT, THE CONTRACTOR SHALL BE RESPONSIBLE FOR OBTAINING A CLARIFICATION FROM THE SPRINT CONSTRUCTION MANAGER PRIOR TO PROCEEDING WITH THE WORK.

1.10 **USE OF JOB SITE:** THE CONTRACTOR SHALL CONFINE ALL CONSTRUCTION AND RELATED OPERATIONS INCLUDING STAGING AND STORAGE OF MATERIALS AND EQUIPMENT, PARKING, TEMPORARY FACILITIES, AND WASTE STORAGE TO THE LEASE PARCEL UNLESS OTHERWISE PERMITTED BY THE CONTRACT DOCUMENTS.

1.11 **UTILITIES SERVICES:** WHERE NECESSARY TO CUT EXISTING PIPES, ELECTRICAL WIRES, CONDUITS, CABLES, ETC., OF UTILITY SERVICES, OR OF FIRE PROTECTION OR COMMUNICATIONS SYSTEMS, THEY SHALL BE CUT AND CAPPED AT SUITABLE PLACES OR WHERE SHOWN. ALL SUCH ACTIONS SHALL BE COORDINATED WITH THE UTILITY COMPANY INVOLVED:

1.12 **PERMITS / FEES:** WHEN REQUIRED THAT A PERMIT OR CONNECTION FEE BE PAID TO A PUBLIC UTILITY PROVIDER FOR NEW SERVICE TO THE CONSTRUCTION PROJECT, PAYMENT OF SUCH FEE SHALL BE THE RESPONSIBILITY OF THE CONTRACTOR.

1.13 CONTRACTOR SHALL TAKE ALL MEASURES AND PROVIDE ALL MATERIAL NECESSARY FOR PROTECTING EXISTING EQUIPMENT AND PROPERTY.

1.14 **METHODS OF PROCEDURE (MOPS) FOR CONSTRUCTION:** CONTRACTOR SHALL PERFORM WORK AS DESCRIBED IN THE FOLLOWING INSTALLATION AND COMMISSIONING MOPS.

- A. TOP HAT
- B. HOW TO INSTALL A NEW CABINET
- C. BASE BAND UNIT IN EXISTING UNIT
- D. INSTALLATION OF BATTERIES
- E. INSTALLATION OF HYBRID CABLE
- F. INSTALLATION OF RRH'S
- G. CABLING
- H. SPRINT TS-0200 (CURRENT VERSION) – ANTENNA LINE ACCEPTANCE STANDARDS
- I. SPRINT CELL SITE ENGINEERING NOTICE – EN 2012-001, REV 1.
- J. COMMISSIONING MOPS
- K. SPRINT CELL SITE ENGINEERING NOTICE – EN-2013-002
- L. SPRINT ENGINEERING LETTER – EL-0504
- M. SPRINT ENGINEERING LETTER – EL-0568
- N. SPRINT TECHNICAL SPECIFICATION – TS-0193

1.15 **USE OF ELECTRONIC PROJECT MANAGEMENT SYSTEMS:**

- A. CONTRACTOR WILL UTILIZE ITS BEST EFFORTS TO WORK WITH SPRINT ELECTRONIC PROJECT MANAGEMENT SYSTEMS. CONTRACTOR UNDERSTANDS THAT SUFFICIENT INTERNET ACCESS, EQUIVALENT TO "BROADBAND" OR BETTER, IS REQUIRED TO TIMELY AND EFFECTIVELY UTILIZE SPRINT DATA AND DOCUMENT MANAGEMENT SYSTEMS AND AGREES TO MAINTAIN APPROPRIATE CONNECTIONS FOR CONTRACTOR'S STAFF AND OFFICES THAT ARE COMPATIBLE WITH SPRINT DATA AND DOCUMENT MANAGEMENT SYSTEMS

PART 2 – PRODUCTS (NOT USED)

PART 3 – EXECUTION

3.1 **TEMPORARY UTILITIES AND FACILITIES:** THE CONTRACTOR SHALL BE RESPONSIBLE FOR ALL TEMPORARY UTILITIES AND FACILITIES NECESSARY EXCEPT AS OTHERWISE INDICATED IN THE CONSTRUCTION DOCUMENTS. TEMPORARY UTILITIES AND FACILITIES INCLUDE POTABLE WATER, HEAT, HVAC, ELECTRICITY, SANITARY FACILITIES, WASTE DISPOSAL FACILITIES, AND TELEPHONE/COMMUNICATION SERVICES. PROVIDE TEMPORARY UTILITIES AND FACILITIES IN ACCORDANCE WITH OSHA AND THE AUTHORITY HAVING JURISDICTION. CONTRACTOR MAY UTILIZE THE COMPANY ELECTRICAL SERVICE IN THE COMPLETION OF THE WORK WHEN IT BECOMES AVAILABLE. USE OF THE LESSORS OR SITE OWNER'S UTILITIES OR FACILITIES IS EXPRESSLY FORBIDDEN EXCEPT AS OTHERWISE ALLOWED IN THE CONTRACT DOCUMENTS.

3.2 **ACCESS TO WORK:** THE CONTRACTOR SHALL PROVIDE ACCESS TO THE JOB SITE FOR AUTHORIZED COMPANY PERSONNEL AND AUTHORIZED REPRESENTATIVES OF THE ARCHITECT/ENGINEER DURING ALL PHASES OF THE WORK.

3.3 **TESTING: REQUIREMENTS FOR TESTING BY THIS CONTRACTOR SHALL BE AS INDICATED HEREWITH, ON THE CONSTRUCTION DRAWINGS, AND IN THE INDIVIDUAL SECTIONS OF THESE SPECIFICATIONS.** SHOULD COMPANY CHOOSE TO ENGAGE ANY THIRD-PARTY TO CONDUCT ADDITIONAL TESTING, THE CONTRACTOR SHALL COOPERATE WITH AND PROVIDE A WORK AREA FOR COMPANY'S TEST AGENCY.

3.4 **DIMENSIONS:** VERIFY DIMENSIONS INDICATED ON DRAWINGS WITH FIELD DIMENSIONS BEFORE FABRICATION OR ORDERING OF MATERIALS. DO NOT SCALE DRAWINGS.

3.5 **EXISTING CONDITIONS:** NOTIFY THE SPRINT CONSTRUCTION MANAGER OF EXISTING CONDITIONS DIFFERING FROM THOSE INDICATED ON THE DRAWINGS. DO NOT REMOVE OR ALTER STRUCTURAL COMPONENTS WITHOUT PRIOR WRITTEN APPROVAL FROM THE ARCHITECT AND ENGINEER.

SECTION 01 200 – COMPANY FURNISHED MATERIAL AND EQUIPMENT

PART 1 – GENERAL

1.1 **THE WORK:** THESE STANDARD CONSTRUCTION SPECIFICATIONS IN CONJUNCTION WITH THE OTHER CONTRACT DOCUMENTS AND THE CONSTRUCTION DRAWINGS DESCRIBE THE WORK TO BE PERFORMED BY THE CONTRACTOR.

1.2 **RELATED DOCUMENTS:**

- A. THE REQUIREMENTS OF THIS SECTION APPLY TO ALL SECTIONS IN THIS SPECIFICATION.
- B. SPRINT "STANDARD CONSTRUCTION DETAILS FOR WIRELESS SITES" ARE INCLUDED IN AND MADE A PART OF THESE SPECIFICATIONS HEREWITH.

PART 2 – PRODUCTS (NOT USED)

PART 3 – EXECUTION

3.1 **RECEIPT OF MATERIAL AND EQUIPMENT:**

- A. COMPANY FURNISHED MATERIAL AND EQUIPMENT IS IDENTIFIED ON THE RF DATA SHEET IN THE CONSTRUCTION DOCUMENTS.
- B. THE CONTRACTOR IS RESPONSIBLE FOR SPRINT PROVIDED MATERIAL AND EQUIPMENT AND UPON RECEIPT SHALL:
 1. ACCEPT DELIVERIES AS SHIPPED AND TAKE RECEIPT.
 2. VERIFY COMPLETENESS AND CONDITION OF ALL DELIVERIES.
 3. TAKE RESPONSIBILITY FOR EQUIPMENT AND PROVIDE INSURANCE PROTECTION AS REQUIRED IN AGREEMENT.
 4. RECORD ANY DEFECTS OR DAMAGES AND WITHIN TWENTY-FOUR HOURS AFTER RECEIPT, REPORT TO SPRINT OR ITS DESIGNATED PROJECT REPRESENTATIVE OF SUCH.
 5. PROVIDE SECURE AND NECESSARY WEATHER PROTECTED WAREHOUSING.
 6. COORDINATE SAFE AND SECURE TRANSPORTATION OF MATERIAL AND EQUIPMENT, DELIVERING AND OFF-LOADING FROM CONTRACTOR'S WAREHOUSE TO SITE.

3.2 **DELIVERABLES:**

- A. COMPLETE SHIPPING AND RECEIPT DOCUMENTATION IN ACCORDANCE WITH COMPANY PRACTICE.
- B. IF APPLICABLE, COMPLETE LOST/STOLEN/DAMAGED DOCUMENTATION REPORT AS NECESSARY IN ACCORDANCE WITH COMPANY PRACTICE, AND AS DIRECTED BY COMPANY.
- C. UPLOAD DOCUMENTATION INTO SPRINT SITE MANAGEMENT SYSTEM (SMS) AND/OR PROVIDE HARD COPY DOCUMENTATION AS REQUESTED.

SECTION 01 300 – CELL SITE CONSTRUCTION

PART 1 – GENERAL

1.1 **THE WORK:** THESE STANDARD CONSTRUCTION SPECIFICATIONS IN CONJUNCTION WITH THE OTHER CONTRACT DOCUMENTS AND THE CONSTRUCTION DRAWINGS DESCRIBE THE WORK TO BE PERFORMED BY THE CONTRACTOR.

1.2 **RELATED DOCUMENTS:**

- A. THE REQUIREMENTS OF THIS SECTION APPLY TO ALL SECTIONS IN THIS SPECIFICATION.
- B. SPRINT "STANDARD CONSTRUCTION DETAILS FOR WIRELESS SITES" ARE INCLUDED IN AND MADE A PART OF THESE SPECIFICATIONS HEREWITH.

1.3 **NOTICE TO PROCEED:**

- A. NO WORK SHALL COMMENCE PRIOR TO COMPANY'S WRITTEN NOTICE TO PROCEED AND THE ISSUANCE OF THE WORK ORDER.
- B. UPON RECEIVING NOTICE TO PROCEED, CONTRACTOR SHALL FULLY PERFORM ALL WORK NECESSARY TO PROVIDE SPRINT WITH AN OPERATIONAL WIRELESS FACILITY.

PART 2 – PRODUCTS (NOT USED)

PART 3 – EXECUTION

3.1 **FUNCTIONAL REQUIREMENTS:**

- A. THE ACTIVITIES DESCRIBED IN THIS PARAGRAPH REPRESENT MINIMUM ACTIONS AND PROCESSES REQUIRED TO SUCCESSFULLY COMPLETE THE WORK. THE ACTIVITIES DESCRIBED ARE NOT EXHAUSTIVE, AND CONTRACTOR SHALL TAKE ANY AND ALL ACTIONS AS NECESSARY TO SUCCESSFULLY COMPLETE THE CONSTRUCTION OF A FULLY FUNCTIONING WIRELESS FACILITY AT THE SITE IN ACCORDANCE WITH COMPANY PROCESSES.
- B. SUBMIT SPECIFIC DOCUMENTATION AS INDICATED HEREIN, AND OBTAIN REQUIRED APPROVALS WHILE THE WORK IS BEING PERFORMED.
- C. MANAGE AND CONDUCT ALL FIELD CONSTRUCTION SERVICE RELATED ACTIVITIES
- D. PROVIDE CONSTRUCTION ACTIVITIES TO THE EXTENT REQUIRED BY THE CONTRACT DOCUMENTS, INCLUDING BUT NOT LIMITED TO THE FOLLOWING:
 1. PERFORM ANY REQUIRED SITE ENVIRONMENTAL MITIGATION.
 2. PREPARE GROUND SITES; PROVIDE DE-GRUBBING; AND ROUGH AND FINAL GRADING, AND COMPOUND SURFACE TREATMENTS.
 3. MANAGE AND CONDUCT ALL ACTIVITIES FOR INSTALLATION OF UTILITIES INCLUDING ELECTRICAL AND TELCO BACKHAUL.
 4. INSTALL UNDERGROUND FACILITIES INCLUDING UNDERGROUND POWER AND COMMUNICATIONS CONDUITS, AND UNDERGROUND GROUNDING SYSTEM.
 5. INSTALL ABOVE GROUND GROUNDING SYSTEMS.
 6. PROVIDE NEW HVAC INSTALLATIONS AND MODIFICATIONS.
 7. INSTALL "H-FRAMES", CABINETS AND SHELTERS AS INDICATED.
 8. INSTALL ROADS, ACCESS WAYS, CURBS AND DRAINS AS INDICATED.
 9. ACCOMPLISH REQUIRED MODIFICATION OF EXISTING FACILITIES.
 10. PROVIDE ANTENNA SUPPORT STRUCTURE FOUNDATIONS.
 11. PROVIDE SLABS AND EQUIPMENT PLATFORMS.
 12. INSTALL COMPOUND FENCING, SIGHT SHIELDING, LANDSCAPING AND ACCESS BARRIERS.
 13. PERFORM INSPECTION AND MATERIAL TESTING AS REQUIRED HEREINAFTER.
 14. CONDUCT SITE RESISTANCE TO EARTH TESTING AS REQUIRED HEREINAFTER
 15. INSTALL FIXED GENERATOR SETS AND OTHER STANDBY POWER SOLUTIONS.
 16. INSTALL TOWERS, ANTENNA SUPPORT STRUCTURES AND PLATFORMS ON EXISTING TOWERS AS REQUIRED.
 17. INSTALL CELL SITE RADIOS, MICROWAVE, GPS, COAXIAL MAINLINE, ANTENNAS, CROSS BAND COUPLERS, TOWER TOP AMPLIFIERS, LOW NOISE AMPLIFIERS AND RELATED EQUIPMENT.
 18. PERFORM, DOCUMENT, AND CLOSE OUT ANY CONSTRUCTION CONTROL DOCUMENTS THAT MAY BE REQUIRED BY GOVERNMENT AGENCIES AND LANDLORDS.
 19. PERFORM ANTENNAL AND COAX SWEEP TESTING AND MAKE ANY AND ALL NECESSARY CORRECTIONS.
 20. REMAIN ON SITE MOBILIZED THROUGHOUT HAND-OFF AND INTEGRATION TO ASSIST AS NEEDED UNTIL SITE IS DEEMED SUBSTANTIALLY COMPLETE AND PLACED "ON AIR."

3.2 **GENERAL REQUIREMENTS FOR CIVIL CONSTRUCTION:**

- A. CONTRACTOR SHALL KEEP THE SITE FREE FROM ACCUMULATING WASTE MATERIAL, DEBRIS, AND TRASH. AT THE COMPLETION OF THE WORK, CONTRACTOR SHALL REMOVE FROM THE SITE ALL REMAINING RUBBISH, IMPLEMENTS, TEMPORARY FACILITIES, AND SURPLUS MATERIALS.
- B. EQUIPMENT ROOMS SHALL AT ALL TIMES BE MAINTAINED "BROOM CLEAN" AND CLEAR OF DEBRIS.
- C. CONTRACTOR SHALL TAKE ALL REASONABLE PRECAUTIONS TO DISCOVER AND LOCATE ANY HAZARDOUS CONDITION.
 1. IN THE EVENT CONTRACTOR ENCOUNTERS ANY HAZARDOUS CONDITION WHICH HAS NOT BEEN ABATED OR OTHERWISE MITIGATED, CONTRACTOR AND ALL OTHER PERSONS SHALL IMMEDIATELY STOP WORK IN THE AFFECTED AREA AND NOTIFY COMPANY IN WRITING. THE WORK IN THE AFFECTED AREA SHALL NOT BE RESUMED EXCEPT BY WRITTEN NOTIFICATION BY COMPANY.
 2. CONTRACTOR AGREES TO USE CARE WHILE ON THE SITE AND SHALL NOT TAKE ANY ACTION THAT WILL OR MAY RESULT IN OR CAUSE THE HAZARDOUS CONDITION TO BE FURTHER RELEASED IN THE ENVIRONMENT, OR TO FURTHER EXPOSE INDIVIDUALS TO THE HAZARD.

- D. CONTRACTOR'S ACTIVITIES SHALL BE RESTRICTED TO THE PROJECT LIMITS. SHOULD AREAS OUTSIDE THE PROJECT LIMITS BE AFFECTED BY CONTRACTOR'S ACTIVITIES, CONTRACTOR SHALL IMMEDIATELY RETURN THEM TO ORIGINAL CONDITION
- E. CONDUCT TESTING AS REQUIRED HEREIN.

3.3 **DELIVERABLES:**

- A. CONTRACTOR SHALL REVIEW, APPROVE, AND SUBMIT TO SPRINT SHOP DRAWINGS, PRODUCT DATA, SAMPLES, AND SIMILAR SUBMITTALS AS REQUIRED HEREINAFTER
- B. PROVIDE DOCUMENTATION INCLUDING, BUT NOT LIMITED TO, THE FOLLOWING. DOCUMENTATION SHALL BE FORWARDED IN ORIGINAL FORMAT AND/OR UPLOADED INTO SMS.
 1. ALL CORRESPONDENCE AND PRELIMINARY CONSTRUCTION REPORTS.
 2. PROJECT PROGRESS REPORTS.
 3. CIVIL CONSTRUCTION START DATE (POPULATE FIELD IN SMS AND/OR FORWARD NOTIFICATION).
 4. ELECTRICAL SERVICE COMPLETION DATE (POPULATE FIELD IN SMS AND/OR FORWARD NOTIFICATION).
 5. LINES AND ANTENNA INSTALL DATE (POPULATE FIELD IN SMS AND/OR FORWARD NOTIFICATION).
 6. POWER INSTALL DATE (POPULATE FIELD IN SMS AND/OR FORWARD NOTIFICATION).
 7. TELCO READY DATE (POPULATE FIELD IN SMS AND/OR FORWARD NOTIFICATION).
 8. PPC (OR SHELTER) INSTALL DATE (POPULATE FIELD IN SMS AND/OR FORWARD NOTIFICATION).
 9. TOWER CONSTRUCTION START DATE (POPULATE FIELD IN SMS AND/OR FORWARD NOTIFICATION).
 10. TOWER CONSTRUCTION COMPLETE DATE (POPULATE FIELD IN SMS AND/OR FORWARD NOTIFICATION).
 11. BTS AND RADIO EQUIPMENT DELIVERED AT SITE DATE (POPULATE FIELD IN SMS AND/OR FORWARD NOTIFICATION).
 12. NETWORK OPERATIONS HANDOFF CHECKLIST (HOC WALK) COMPLETE (UPLOAD FORM IN SMS)
 13. CIVIL CONSTRUCTION COMPLETE DATE (POPULATE FIELD IN SMS AND/OR FORWARD NOTIFICATION).
 14. SITE CONSTRUCTION PROGRESS PHOTOS UNLOADED INTO SMS. **CONTINUE SHEET SP-2**

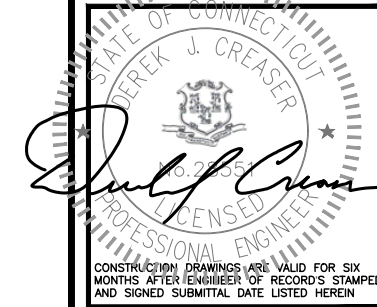
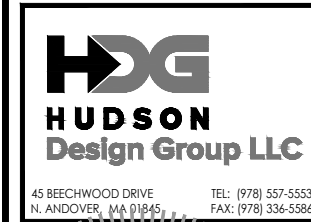

CHECKED BY: BB

APPROVED BY: DJC

SUBMITTALS			
REV.	DATE	DESCRIPTION	BY
1	08/13/18	CONSTRUCTION FINAL	BB
0	07/24/18	ISSUED FOR CONSTRUCTION	GA

SITE NUMBER:
CT03XC168
SITE NAME:
HRT 106(B) 943202
CROWN BU NUMBER:
806364
SITE ADDRESS:
143 R OLD BLUE HILL ROAD
DURHAM, CT 06422
MIDDLESEX COUNTY

SHEET TITLE
OUTLINE SPECIFICATIONS
(DO MACRO)

SHEET NUMBER
SP-1

CONTINUED FROM SP-1:

SECTION 01 400 - SUBMITTALS, TESTS, AND INSPECTIONS

PART 1 - GENERAL

1.1 THE WORK: THESE STANDARD CONSTRUCTION SPECIFICATIONS IN CONJUNCTION WITH THE OTHER CONTRACT DOCUMENTS AND THE CONSTRUCTION DRAWINGS DESCRIBE THE WORK TO BE PERFORMED BY THE CONTRACTOR.

1.2 RELATED DOCUMENTS:

- A. THE REQUIREMENTS OF THIS SECTION APPLY TO ALL SECTIONS IN THIS SPECIFICATION.
B. SPRINT "STANDARD CONSTRUCTION DETAILS FOR WIRELESS SITES" ARE INCLUDED IN AND MADE A PART OF THESE SPECIFICATIONS HERewith.

1.3 SUBMITTALS:

- A. THE WORK IN ALL ASPECTS SHALL COMPLY WITH THE CONSTRUCTION DRAWINGS AND THESE SPECIFICATIONS.
B. SUBMIT THE FOLLOWING TO COMPANY REPRESENTATIVE FOR APPROVAL.
1. CONCRETE MIX-DESIGNS FOR TOWER FOUNDATIONS, ANCHORS PIERS, AND CONCRETE PAVING.
2. CONCRETE BREAK TESTS AS SPECIFIED HEREIN.
3. SPECIAL FINISHES FOR INTERIOR SPACES, IF ANY.
4. ALL EQUIPMENT AND MATERIALS SO IDENTIFIED ON THE CONSTRUCTION DRAWINGS.
5. CHEMICAL GROUNDING DESIGN.
C. ALTERNATES: AT THE COMPANY'S REQUEST, ANY ALTERNATIVES TO THE MATERIALS OR METHODS SPECIFIED SHALL BE SUBMITTED TO SPRINT'S CONSTRUCTION MANAGER FOR APPROVAL PRIOR TO BEING SHIPPED TO SITE.

1.4 TESTS AND INSPECTIONS:

- A. THE CONTRACTOR SHALL BE RESPONSIBLE FOR ALL CONSTRUCTION TESTS, INSPECTIONS AND PROJECT DOCUMENTATION.
B. CONTRACTOR SHALL ACCOMPLISH TESTING INCLUDING BUT NOT LIMITED TO THE FOLLOWING:
1. COAX SWEEPS AND FIBER TESTS PER SPRINT TS-0200 (CURRENT VERSION) ANTENNA LINE ACCEPTANCE STANDARDS.
2. AGL, AZIMUTH AND DOWNTILT USING ELECTRONIC COMMERCIAL MADE-FOR-THE-PURPOSE ANTENNA ALIGNMENT TOOL.
3. CONTRACTOR SHALL BE RESPONSIBLE FOR ANY AND ALL CORRECTIONS TO ANY WORK IDENTIFIED AS UNACCEPTABLE IN SITE INSPECTION ACTIVITIES AND/OR AS A RESULT OF TESTING.
C. REQUIRED CLOSEOUT DOCUMENTATION INCLUDES, BUT IS NOT LIMITED TO THE FOLLOWING:
1. AZIMUTH, DOWNTILT, AGL - UPLOAD REPORT FROM ANTENNA ALIGNMENT TOOL TO SITERRA TASK 465.
2. SCANABLE BARCODE PHOTOGRAPHS OF TOWER TOP AND INACCESSIBLE SERIALIZED EQUIPMENT
3. ALL AVAILABLE JURISDICTIONAL INFORMATION
4. PDF SCAN OF REDLINES PRODUCED IN FIELD
5. ELECTRONIC AS-BUILT DRAWINGS IN AUTOCAD AND PDF FORMATS.
6. LIEN WAIVERS
7. FINAL PAYMENT APPLICATION
8. REQUIRED FINAL CONSTRUCTION PHOTOS
9. CONSTRUCTION AND COMMISSIONING CHECKLIST COMPLETE WITH NO DEFICIENT ITEMS
10. ALL POST NTP TASKS INCLUDING DOCUMENT UPLOADS COMPLETED IN SITERRA

1.5 COMMISSIONING: PERFORM ALL COMMISSIONING AS REQUIRED BY APPLICABLE MOPS

1.6 INTEGRATION: PERFORM ALL INTEGRATION ACTIVITIES AS REQUIRED BY APPLICABLE MOPS

PART 2 - PRODUCTS (NOT USED)

PART 3 - EXECUTION

3.1 REQUIREMENTS FOR TESTING:

- A. THIRD PARTY TESTING AGENCY: WHEN THE USE OF A THIRD PARTY INDEPENDENT TESTING AGENCY IS REQUIRED, THE AGENCY THAT IS SELECTED MUST PERFORM SUCH WORK ON A REGULAR BASIS IN THE STATE WHERE THE PROJECT IS LOCATED AND HAVE A THOROUGH UNDERSTANDING OF LOCAL AVAILABLE MATERIALS, INCLUDING THE SOIL, ROCK, AND GROUNDWATER CONDITIONS.
1. THE THIRD PARTY TESTING AGENCY IS TO BE FAMILIAR WITH THE APPLICABLE REQUIREMENTS FOR THE TESTS TO BE DONE, EQUIPMENT TO BE USED, AND ASSOCIATED HEALTH AND SAFETY ISSUES.
2. EXPERIENCE IN SOILS, CONCRETE, MASONRY, AGGREGATE, AND ASPHALT TESTING USING ASTM, AASJTO, AND OTHER METHODS IS NEEDED.
3. EXPERIENCE IN SOILS, CONCRETE, MASONRY, AGGREGATE, AND ASPHALT TESTING USING ASTM, AASJTO, AND OTHER METHODS IS NEEDED.

3.2 REQUIRED TESTS:

- A. CONTRACTOR SHALL ACCOMPLISH TESTING INCLUDING BUT NOT LIMITED TO THE FOLLOWING:
1. CONCRETE CYLINDER BREAK TESTS FOR THE TOWER AND ANCHOR FOUNDATIONS AS SPECIFIED IN SECTION: PORTLAND CEMENT CONCRETE PAVING.
2. ASPHALT ROADWAY COMPACTED THICKNESS, SURFACE SMOOTHNESS, AND COMPACTED DENSITY TESTING AS SPECIFIED IN SECTION: HOT MIX ASPHALT PAVING.
3. FIELD QUALITY CONTROL TESTING AS SPECIFIED IN SECTION: PORTLAND CEMENT CONCRETE PAVING.
4. TESTING REQUIRED UNDER SECTION: AGGREGATE BASE FOR ACCESS ROADS, PADS AND ANCHOR LOCATIONS
5. STRUCTURAL BACKFILL COMPACTION TESTS FOR THE TOWER FOUNDATION.
6. SITE RESISTANCE TO EARTH TESTING PER EXHIBIT: CELL SITE GROUNDING SYSTEM DESIGN.
7. ANTENNA AND COAX SWEEP TESTS PER EXHIBIT: ANTENNA TRANSMISSION LINE ACCEPTANCE STANDARDS.
8. GROUNDING AT ANTENNA MASTS FOR GPS AND ANTENNAS
9. ALL OTHER TESTS REQUIRED BY COMPANY OR JURISDICTION.

3.3 REQUIRED INSPECTIONS:

- A. SCHEDULE INSPECTIONS WITH COMPANY REPRESENTATIVE.
B. CONDUCT INSPECTIONS INCLUDING BUT NOT LIMITED TO THE FOLLOWING:
1. GROUNDING SYSTEM INSTALLATION PRIOR TO EARTH CONCEALMENT DOCUMENTED WITH DIGITAL PHOTOGRAPHS BY CONTRACTOR, APPROVED BY A&E OR SPRINT REPRESENTATIVE.
2. FORMING FOR CONCRETE AND REBAR PLACEMENT PRIOR TO POUR DOCUMENTED WITH DIGITAL PHOTOGRAPHS BY CONTRACTOR, APPROVED BY A&E OR SPRINT REPRESENTATIVE.
3. COMPACTION OF BACKFILL MATERIALS; AGGREGATE BASE FOR ROADS, PADS, AND ANCHORS; ASPHALT PAVING; AND SHAFT BACKFILL FOR CONCRETE AND WOOD POLES, BY INDEPENDENT THIRD PARTY AGENCY.
4. PRE- AND POST-CONSTRUCTION ROOFTOP AND STRUCTURAL INSPECTIONS ON EXISTING FACILITIES.
5. TOWER ERECTION SECTION STACKING AND PLATFORM ATTACHMENT DOCUMENTED BY DIGITAL PHOTOGRAPHS BY THIRD PARTY AGENCY.
6. ANTENNA AZIMUTH, DOWN TILT AND PER SUNLIGHT TOOL SUNSIGHT INSTRUMENTS - ANTENNALIGN ALIGNMENT TOOL (AAT)
7. VERIFICATION DOCUMENTED WITH THE ANTENNA CHECKLIST REPORT, BY A&E, SITE DEVELOPMENT REP, OR RF REP.
8. FINAL INSPECTION CHECKLIST AND HANDOFF WALK (HOC), SIGNED FORM SHOWING ACCEPTANCE BY FIELD OPS IS TO BE UPLOADED INTO SMS.
9. COAX SWEEP AND FIBER TESTING DOCUMENTS SUBMITTED VIA SMS FOR RF APPROVAL.
10. SCAN-ABLE BARCODE PHOTOGRAPHS OF TOWER TOP AND INACCESSIBLE SERIALIZED EQUIPMENT
11. ALL AVAILABLE JURISDICTIONAL INFORMATION
12. PDF SCAN OF REDLINES PRODUCED IN FIELD
E. THE CONTRACTOR SHALL BE RESPONSIBLE FOR ANY AND ALL CORRECTIONS TO ANY WORK IDENTIFIED AS UNACCEPTABLE IN SITE INSPECTION ACTIVITIES AND/OR AS A RESULT OF TESTING.
F. CONSTRUCTION INSPECTIONS AND CORRECTIVE MEASURES SHALL BE DOCUMENTED BY THE CONTRACTOR WITH WRITTEN REPORTS AND PHOTOGRAPHS. PHOTOGRAPHS MUST BE DIGITAL AND OF SUFFICIENT QUALITY TO CLEARLY SHOW THE SITE CONSTRUCTION. PHOTOGRAPHS MUST CLEARLY IDENTIFY THE PHOTOGRAPHED ITEM AND BE LABELED WITH THE SITE CASCADE NUMBER, SITE NAME, DESCRIPTION, AND DATE.

3.4 DELIVERABLES: TEST AND INSPECTION REPORTS AND CLOSEOUT DOCUMENTATION SHALL BE UPLOADED TO THE SMS AND/OR FORWARDED TO SPRINT FOR INCLUSION INTO THE PERMANENT SITE FILES.

- A. THE FOLLOWING TEST AND INSPECTION REPORTS SHALL BE PROVIDED AS APPLICABLE.
1. CONCRETE MIX AND CYLINDER BREAK REPORTS.
2. STRUCTURAL BACKFILL COMPACTION REPORTS.
3. SITE RESISTANCE TO EARTH TEST.
4. ANTENNA AZIMUTH AND DOWN TILT VERIFICATION
5. TOWER ERECTION INSPECTIONS AND MEASUREMENTS DOCUMENTING TOWER INSTALLED PER SUPPLIER'S REQUIREMENTS AND THE APPLICABLE SECTIONS HEREIN.
6. COAX CABLE SWEEP TESTS PER COMPANY'S "ANTENNA LINE ACCEPTANCE STANDARDS".
B. REQUIRED CLOSEOUT DOCUMENTATION INCLUDES THE FOLLOWING:
1. TEST WELLS AND TRENCHES: PHOTOGRAPHS OF ALL TEST WELLS; PHOTOGRAPHS SHOWING ALL OPEN EXCAVATIONS AND TRENCHING PRIOR TO BACKFILLING SHOWING A TAPE MEASURE VISIBLE IN THE EXCAVATIONS INDICATING DEPTH.
2. CONDUITS, CONDUCTORS AND GROUNDING: PHOTOGRAPHS SHOWING TYPICAL INSTALLATION OF CONDUCTORS AND CONNECTORS; PHOTOGRAPHS SHOWING TYPICAL BEND RADIUS OF INSTALLED GROUND WIRES AND GROUND ROD SPACING;
3. CONCRETE FORMS AND REINFORCING: CONCRETE FORMING AT TOWER AND EQUIPMENT/SHELTER PAD/FOUNDATIONS - PHOTOGRAPHS SHOWING ALL REINFORCING STEEL, UTILITY AND CONDUIT STUB OUTS; PHOTOGRAPHS SHOWING CONCRETE POUR OF SHELTER SLAB/FOUNDATION, TOWER FOUNDATION AND GUY ANCHORS WITH VIBRATOR IN USE; PHOTOGRAPHS SHOWING EACH ANCHOR ON GUYED TOWERS, BEFORE CONCRETE POUR.
4. TOWER, ANTENNAS AND MAINLINE: INSPECTION AND PHOTOGRAPHS OF SECTION STACKING; INSPECTION AND PHOTOGRAPHS OF PLATFORM COMPONENT ATTACHMENT POINTS; PHOTOGRAPHS OF TOWER TOP GROUNDING; PHOTOS OF TOWER COAX LINE COLOR CODING AT THE TOP AND AT GROUND LEVEL; INSPECTION AND PHOTOGRAPHS OF OPERATIONAL OF TOWER LIGHTING, AND PLACEMENT OF FAA REGISTRATION SIGN; PHOTOGRAPHS SHOWING ADDITIONAL GROUNDING POINTS FOR TOWERS GREATER THAN 200 FEET.; PHOTOS OF ANTENNA GROUND BAR, EQUIPMENT GROUND BAR, AND MASTER GROUND BAR; PHOTOS OF GPS ANTENNA(S); PHOTOS OF EACH SECTOR OF ANTENNAS; ONE PHOTOGRAPH LOOKING AT THE SECTOR AND ONE FROM BEHIND SHOWING THE PROJECTED COVERAGE AREA; PHOTOS OF COAX WEATHERPROOFING - TOP AND BOTTOM; PHOTOS OF COAX GROUNDING--TOP AND BOTTOM; PHOTOS OF ANTENNA AND MAST GROUNDING; PHOTOS OF COAX CABLE ENTRY INTO SHELTER; PHOTOS OF PLATFORM MECHANICAL CONNECTIONS TO TOWER/MONOPOLE.
5. ROOF TOPS: PRE-CONSTRUCTION AND POST-CONSTRUCTION VISUAL INSPECTION AND PHOTOGRAPHS OF THE ROOF AND INTERIOR TO DETERMINE AND DOCUMENT CONDITIONS; ROOF TOP CONSTRUCTION INSPECTIONS AS REQUIRED BY THE JURISDICTION; PHOTOGRAPHS OF CABLE TRAY AND/OR ICE BRIDGE; PHOTOGRAPHS OF DOGHOUSE/CABLE EXIT FROM ROOF;
6. SITE LAYOUT - PHOTOGRAPHS OF THE OVERALL COMPOUND, INCLUDING EQUIPMENT PLATFORM FROM ALL FOUR CORNERS.
7. FINISHED UTILITIES: CLOSE-UP PHOTOGRAPHS OF THE PPC BREAKER PANEL; CLOSE-UP PHOTOGRAPH OF THE INSIDE OF THE TELCO PANEL AND NIU; CLOSE-UP PHOTOGRAPH OF THE POWER METER AND DISCONNECT; PHOTOS OF POWER AND TELCO ENTRANCE TO COMPANY ENCLOSURE; PHOTOGRAPHS AT METER BOX AND/OR FACILITY DISTRIBUTION PANEL.
8. REQUIRED MATERIALS CERTIFICATIONS: CONCRETE MIX DESIGNS; MILL CERTIFICATION FOR ALL REINFORCING AND STRUCTURAL STEEL; AND ASPHALT PAVING MIX DESIGN.
9. ANY AND ALL SUBMITTALS BY THE JURISDICTION OR COMPANY.

SECTION 01 500 - PROJECT REPORTING

PART 1 - GENERAL

1.1 THE WORK: THESE STANDARD CONSTRUCTION SPECIFICATIONS IN CONJUNCTION WITH THE OTHER CONTRACT DOCUMENTS AND THE CONSTRUCTION DRAWINGS DESCRIBE THE WORK TO BE PERFORMED BY THE CONTRACTOR.

1.2 RELATED DOCUMENTS:

- A. THE REQUIREMENTS OF THIS SECTION APPLY TO ALL SECTIONS IN THIS SPECIFICATION.
B. SPRINT "STANDARD CONSTRUCTION DETAILS FOR WIRELESS SITES" ARE INCLUDED IN AND MADE A PART OF THESE SPECIFICATIONS HERewith.

PART 2 - PRODUCTS (NOT USED)

PART 3 - EXECUTION

3.1 WEEKLY REPORTS:

- A. CONTRACTOR SHALL PROVIDE SPRINT WITH WEEKLY REPORTS SHOWING PROJECT STATUS. THIS STATUS REPORT FORMAT WILL BE PROVIDED TO THE CONTRACTOR BY SPRINT. THE REPORT WILL CONTAIN SITE ID NUMBER, THE MILESTONES FOR EACH SITE, INCLUDING THE BASELINE DATE, ESTIMATED COMPLETION DATE AND ACTUAL COMPLETION DATE.

B. REPORT INFORMATION WILL BE TRANSMITTED TO SPRINT VIA ELECTRONIC MEANS AS REQUIRED. THIS INFORMATION WILL PROVIDE A BASIS FOR PROGRESS MONITORING AND PAYMENT.

3.2 PROJECT CONFERENCE CALLS:

- A. SPRINT MAY HOLD WEEKLY PROJECT CONFERENCE CALLS. CONTRACTOR WILL BE REQUIRED TO COMMUNICATE SITE STATUS, MILESTONE COMPLETIONS AND UPCOMING MILESTONE PROJECTIONS, AND ANSWER ANY OTHER SITE STATUS QUESTIONS AS NECESSARY.

3.3 PROJECT TRACKING IN SMS:

- A. CONTRACTOR SHALL PROVIDE SCHEDULE UPDATES AND PROJECTIONS IN THE SMS SYSTEM ON A WEEKLY BASIS.

3.4 ADDITIONAL REPORTING:

- A. ADDITIONAL OR ALTERNATE REPORTING REQUIREMENTS MAY BE ADDED TO THE REPORT AS DETERMINED TO BE REASONABLY NECESSARY BY COMPANY.

3.5 PROJECT PHOTOGRAPHS:

- A. FILE DIGITAL PHOTOGRAPHS OF COMPLETED SITE IN JPEG FORMAT IN THE SMS PHOTO LIBRARY FOR THE RESPECTIVE SITE. PHOTOGRAPHS SHALL BE CLEARLY LABELED WITH SITE NUMBER, NAME AND DESCRIPTION, AND SHALL INCLUDE AT A MINIMUM THE FOLLOWING AS APPLICABLE:
1. SHELTER AND TOWER OVERVIEW.
2. TOWER FOUNDATION(S) - FORMS AND STEEL BEFORE POUR (EACH ANCHOR ON GUYED TOWERS).
3. TOWER FOUNDATION(S) POUR WITH VIBRATOR IN USE (EACH ANCHOR ON GUYED TOWERS).
4. TOWER STEEL AS BEING INSTALLED INTO HOLE (SHOW ANCHOR STEEL ON GUYED TOWERS).
5. PHOTOS OF TOWER SECTION STACKING.
6. CONCRETE TESTING / SAMPLES.
7. PLACING OF ANCHOR BOLTS IN TOWER FOUNDATION.
8. BUILDING/WATER TANK FROM ROAD FOR TENANT IMPROVEMENTS OR COMMENTS.
9. SHELTER FOUNDATION--FORMS AND STEEL BEFORE POURING.
10. SHELTER FOUNDATION POUR WITH VIBRATOR IN USE.
11. COAX CABLE ENTRY INTO SHELTER.
12. PLATFORM MECHANICAL CONNECTIONS TO TOWER/MONOPOLE.
13. ROOFTOP PRE AND POST CONSTRUCTION PHOTOS TO INCLUDE PENETRATIONS AND INTERIOR CEILING.
14. PHOTOS OF TOWER TOP COAX LINE COLOR CODING AND COLOR CODING AT GROUND LEVEL.
15. PHOTOS OF ALL APPROPRIATE COMPANY OR REGULATORY SIGNAGE.
16. PHOTOS OF EQUIPMENT BOLT DOWN INSIDE SHELTER.
17. POWER AND TELCO ENTRANCE TO COMPANY ENCLOSURE AND POWER AND TELCO SUPPLY LOCATIONS INCLUDING METER/DISCONNECT.
18. ELECTRICAL TRENCH(S) WITH ELECTRICAL / CONDUIT BEFORE BACKFILL.
19. ELECTRICAL TRENCH(S) WITH FOIL-BACKED TAPE BEFORE FURTHER BACKFILL.
20. TELCO TRENCH WITH TELEPHONE / CONDUIT BEFORE BACKFILL.
21. TELCO TRENCH WITH FOIL-BACKED TAPE BEFORE FURTHER BACKFILL.
22. SHELTER GROUND-RING TRENCH WITH GROUND-WIRE BEFORE BACKFILL (SHOW ALL CAD WELDS AND BEND RADII).
23. TOWER GROUND-RING TRENCH WITH GROUND-WIRE BEFORE BACKFILL (SHOW ALL CAD WELDS AND BEND RADII).
24. FENCE GROUND-RING TRENCH WITH GROUND-WIRE BEFORE BACKFILL (SHOW ALL CAD WELDS AND BEND RADII).
25. ALL BTS GROUND CONNECTIONS.
26. ALL GROUND TEST WELLS.
27. ANTENNA GROUND BAR AND EQUIPMENT GROUND BAR.
28. ADDITIONAL GROUNDING POINTS ON TOWERS ABOVE 200'.
29. HVAC UNITS INCLUDING CONDENSERS ON SPLIT SYSTEMS.
30. GPS ANTENNAS.
31. CABLE TRAY AND/OR WAVEGUIDE BRIDGE.
32. DOGHOUSE/CABLE EXIT FROM ROOF.
33. EACH SECTOR OF ANTENNAS; ONE PHOTOGRAPH LOOKING AT THE SECTOR AND ONE FROM BEHIND SHOWING THE PROJECTED COVERAGE AREA.
34. MASTER BUS BAR.
35. TELCO BOARD AND NIU.
36. ELECTRICAL DISTRIBUTION WALL.
37. CABLE ENTRY WITH SURGE SUPPRESSION.
38. ENTRANCE TO EQUIPMENT ROOM.
39. COAX WEATHERPROOFING--TOP AND BOTTOM OF TOWER.
40. COAX GROUNDING --TOP AND BOTTOM OF TOWER.
41. ANTENNA AND MAST GROUNDING.
42. LANDSCAPING - WHERE APPLICABLE.

3.6 FINAL PROJECT ACCEPTANCE: COMPLETE ALL REQUIRED REPORTING TASKS PER CONTRACT, CONTRACT DOCUMENTS OR THE SPRINT INTEGRATED CONSTRUCTION STANDARDS FOR WIRELESS SITES AND UPLOAD INTO SITERRA.

SECTION 07 500 - ROOF CUTTING, PATCHING AND REPAIR

SUMMARY:

THIS SECTION SPECIFIES CUTTING AND PATCHING EXISTING ROOFING SYSTEMS WHERE CONDUIT OR CABLES EXIT THE BUILDING ONTO THE ROOF OR BUILDING-MOUNTED ANTENNAS, AND AS REQUIRED FOR WATERTIGHT PERFORMANCE. ROOFTOP ENTRY OPENINGS IN MEMBRANE ROOFTOPS SHALL BE CONSTRUCTED TO COMPLY WITH LANDLORD, ANY EXISTING WARRANTY, AND LOCAL JURISDICTIONAL STANDARDS.

1.4 SUBMITTALS:

A. PRE-CONSTRUCTION ROOF PHOTOS: COMPLETE A ROOF INSPECTION PRIOR TO THE INSTALLATION OF SPRINT EQUIPMENT ON ANY ROOFTOP BUILD. AT A MINIMUM INSPECT AND PHOTOGRAPH (MINIMUM 3 EA.) ALL AREAS IMPACTED BY THE ADDITION OF THE SPRINT EQUIPMENT.

B. PROVIDE SIMILAR PHOTOGRAPHS SHOWING ROOF CONDITIONS AFTER CONSTRUCTION (MINIMUM 3 EA.)

C. ROOF INSPECTION PHOTOGRAPHS SHOULD BE UPLOADED WITH CLOSEOUT PHOTOGRAPHS.

SECTION 09 900 - PAINTING

QUALITY ASSURANCE:

A. COMPLY WITH GOVERNING CODES AND REGULATIONS. PROVIDE PRODUCTS OF ACCEPTABLE MANUFACTURERS WHICH HAVE BEEN IN SATISFACTORY USE IN SIMILAR SERVICE FOR THREE YEARS. USE EXPERIENCED INSTALLERS. DELIVER, HANDLE, AND STORE MATERIALS IN ACCORDANCE WITH MANUFACTURER'S INSTRUCTIONS.

B. COMPLY WITH ALL ENVIRONMENTAL REGULATIONS FOR VOLATILE ORGANIC COMPOUNDS.

CONTINUE SHEET SP-3



1 INTERNATIONAL BLVD, SUITE 800 MAHWAH, NJ 07495 TEL: (800) 357-7641



CROWN CASTLE 12 GILL STREET, SUITE 5800 WOBURN, MA 01801



45 BEECHWOOD DRIVE N. ANDOVER, MA 01845 TEL: (978) 557-5553 FAX: (978) 336-5586

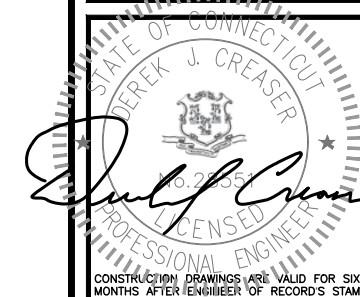

CHECKED BY: BB

APPROVED BY: DJC

SUBMITTALS

Table with columns: REV., DATE, DESCRIPTION, BY. Row 1: 1, 08/13/18, CONSTRUCTION FINAL, BB. Row 2: 0, 07/24/18, ISSUED FOR CONSTRUCTION, GA.

SITE NUMBER: CT03XC168

SITE NAME: HRT 106(B) 943202

CROWN BU NUMBER: 806364

SITE ADDRESS: 143 R OLD BLUE HILL ROAD DURHAM, CT 06422 MIDDLESEX COUNTY

SHEET TITLE

OUTLINE SPECIFICATIONS (DO MACRO)

SHEET NUMBER

SP-2

CONTINUED FROM SP-2:

MATERIALS:

A. MANUFACTURERS: BENJAMIN MOORE, ICI DEVOE COATINGS, PPG, SHERWIN WILLIAMS OR APPROVED EQUAL. PROVIDE PREMIUM GRADE, PROFESSIONAL-QUALITY PRODUCTS FOR COATING SYSTEMS.

PAINT SCHEDULE:

A. EXTERIOR ANTENNAE AND ANTENNA MOUNTING HARDWARE: ONE COAT OF PRIMER AND TWO FINISH COATS. PAINT FOR ANTENNAE SHALL BE NON-METALLIC BASED AND CONTAIN NO METALLIC PARTICLES. PROVIDE COLORS AND PATTERNS AS REQUIRED TO MASK APPEARANCE OF ANTENNAE ON ADJACENT BUILDING SURFACES AND AS ACCEPTABLE TO THE OWNER. REFER TO ANTENNA MANUFACTURER'S INSTRUCTIONS WHENEVER POSSIBLE.

B. ROOF TOP CONSTRUCTION: TOUCH UP - PREPARE SURFACES TO BE REPAIRED. FOLLOW INDUSTRY STANDARDS AND REQUIREMENTS OF OWNER TO MATCH EXISTING COATING AND FINISH.

PAINTING APPLICATION:

1. INSPECT SURFACES, REPORT UNSATISFACTORY CONDITIONS IN WRITING; BEGINNING WORK MEANS ACCEPTANCE OF SUBSTRATE.
2. COMPLY WITH MANUFACTURER'S INSTRUCTIONS AND RECOMMENDATIONS FOR PREPARATION, PRIMING AND COATING WORK. COORDINATE WITH WORK OF OTHER SECTIONS.
3. MATCH APPROVED MOCK-UPS FOR COLOR, TEXTURE, AND PATTERN. RE-COAT OR REMOVE AND REPLACE WORK WHICH DOES NOT MATCH OR SHOWS LOSS OF ADHESION.
4. CLEAN UP, TOUCH UP AND PROTECT WORK.

TOUCHUP PAINTING:

1. GALVANIZING DAMAGE AND ALL BOLTS AND NUTS SHALL BE TOUCHED UP AFTER TOWER ERECTION WITH "GALVANOX," "DRY GALV," OR "ZINC-IT."
2. FIELD TOUCHUP PAINT SHALL BE DONE IN ACCORDANCE WITH THE MANUFACTURER'S WRITTEN INSTRUCTIONS.
3. ALL METAL COMPONENTS SHALL BE HANDLED WITH CARE TO PREVENT DAMAGE TO THE COMPONENTS, THEIR PRESERVATIVE TREATMENT, OR THEIR PROTECTIVE COATINGS.

SECTION 11 700 - ANTENNA ASSEMBLY, REMOTE RADIO HEADS AND CABLE INSTALLATION

SUMMARY:

THIS SECTION SPECIFIES INSTALLATION OF ANTENNAS, RRH'S, AND CABLE EQUIPMENT, INSTALLATION, AND TESTING OF COAXIAL FIBER CABLE.

ANTENNAS AND RRH'S:

THE NUMBER AND TYPE OF ANTENNAS AND RRH'S TO BE INSTALLED IS DETAILED ON THE CONSTRUCTION DRAWINGS.

HYBRID CABLE:

HYBRID CABLE WILL BE DC/FIBER AND FURNISHED FOR INSTALLATION AT EACH SITE. CABLE SHALL BE INSTALLED PER THE CONSTRUCTION DRAWINGS AND THE APPLICABLE MANUFACTURER'S REQUIREMENTS.

JUMPERS AND CONNECTORS:

FURNISH AND INSTALL 1/2" COAX JUMPER CABLES BETWEEN THE RRH'S AND ANTENNAS. JUMPERS SHALL BE TYPE LDF 4, FLC 12-50, CR 540, OR FXL 540. SUPER-FLEX CABLES ARE NOT ACCEPTABLE. JUMPERS BETWEEN THE RRH'S AND ANTENNAS OR TOWER TOP AMPLIFIERS SHALL CONSIST OF 1/2 INCH FOAM DIELECTRIC, OUTDOOR RATED COAXIAL CABLE. DO NOT USE SUPERFLEX OUTDOORS. JUMPERS SHALL BE FACTORY FABRICATED IN APPROPRIATE LENGTHS WITH A MAXIMUM OF 4 FEET EXCESS PER JUMPER AND HAVE CONNECTORS AT EACH END, MANUFACTURED BY SUPPLIER. IF JUMPERS ARE FIELD FABRICATED, FOLLOW MANUFACTURER'S REQUIREMENTS FOR INSTALLATION OF CONNECTORS

REMOTE ELECTRICAL TILT (RET) CABLES:

MISCELLANEOUS:

INSTALL SPLITTERS, COMBINERS, FILTERS PER RF DATA SHEET, FURNISHED BY SPRINT.

ANTENNA INSTALLATION:

THE CONTRACTOR SHALL ASSEMBLE ALL ANTENNAS ONSITE IN ACCORDANCE WITH THE INSTRUCTIONS SUPPLIED BY THE MANUFACTURER. ANTENNA HEIGHT, AZIMUTH, AND FEED ORIENTATION INFORMATION SHALL BE A DESIGNATED ON THE CONSTRUCTION DRAWINGS.

A. THE CONTRACTOR SHALL POSITION THE ANTENNA ON TOWER PIPE MOUNTS SO THAT THE BOTTOM STRUT IS LEVEL. THE PIPE MOUNTS SHALL BE PLUMB TO WITHIN 1 DEGREE.

B. ANTENNA MOUNTING REQUIREMENTS: PROVIDE ANTENNA MOUNTING HARDWARE AS INDICATED ON THE DRAWINGS.

HYBRID CABLES INSTALLATION:

A. THE CONTRACTOR SHALL ROUTE, TEST, AND INSTALL ALL CABLES AS INDICATED ON THE CONSTRUCTION DRAWINGS AND IN ACCORDANCE WITH THE MANUFACTURER'S RECOMMENDATIONS.

B. THE INSTALLED RADIUS OF THE CABLES SHALL NOT BE LESS THAN THE MANUFACTURER'S SPECIFICATIONS FOR BENDING RADI. C. EXTREME CARE SHALL BE TAKEN TO AVOID DAMAGE TO THE CABLES DURING HANDLING AND INSTALLATION.

1. FASTENING MAIN HYBRID CABLES: ALL CABLES SHALL BE PERMANENTLY FASTENED TO THE COAX LADDER AT 4'-0" OC USING NON-MAGNETIC STAINLESS STEEL CLIPS.
2. FASTENING INDIVIDUAL FIBER AND DC CABLES ABOVE BREAKOUT ENCLOSURE (MEDUSA), WITHIN THE MMBTS CABINET AND ANY INTERMEDIATE DISTRIBUTION BOXES:
 - a. FIBER: SUPPORT FIBER BUNDLES USING 1/2" VELCRO STRAPS OF THE REQUIRED LENGTH @ 18" OC. STRAPS SHALL BE UV, OIL AND WATER RESISTANT AND SUITABLE FOR INDUSTRIAL INSTALLATIONS AS MANUFACTURED BY TETOL OR APPROVED EQUAL.
 - b. DC: SUPPORT DC BUNDLES WITH ZIP TIES OF THE ADEQUATE LENGTH. ZIP TIES TO BE UV STABILIZED, BLACK NYLON, WITH TENSILE STRENGTH AT 12,000 PSI AS MANUFACTURED BY NELCO PRODUCTS OR EQUAL.
3. FASTENING JUMPERS: SECURE JUMPERS TO THE SIDE ARMS OR HEAD FRAMES USING STAINLESS STEEL TIE WRAPS OR STAINLESS STEEL BUTTERFLY CLIPS.
4. CABLE INSTALLATION:
 - a. INSPECT CABLE PRIOR TO USE FOR SHIPPING DAMAGE, NOTIFY THE CONSTRUCTION MANAGER.
 - b. CABLE ROUTING: CABLE INSTALLATION SHALL BE PLANNED TO ENSURE THAT THE LINES WILL BE PROPERLY ROUTED IN THE CABLE ENVELOP AS INDICATED ON THE DRAWINGS. AVOID TWISTING AND CROSSOVERS.
 - c. HOIST CABLE USING PROPER HOISTING GRIPS. DO NOT EXCEED MANUFACTURER'S RECOMMENDED MAXIMUM BEND RADIUS.

5. GROUNDING OF TRANSMISSION LINES: ALL TRANSMISSION LINES SHALL BE GROUNDED AS INDICATED ON DRAWINGS.

6. HYBRID CABLE COLOR CODING: ALL COLOR CODING SHALL BE AS REQUIRED IN TS 0200 REV 4.

7. HYBRID CABLE LABELING: INDIVIDUAL HYBRID AND DC BUNDLES SHALL BE LABELED ALPHA-NUMERICALLY ACCORDING TO SPRINT CELL SITE ENGINEERING NOTICE - EN 2012-001, REV 1

WEATHERPROOFING EXTERIOR CONNECTORS AND HYBRID CABLE GROUND KITS:

A. ALL FIBER & COAX CONNECTORS AND GROUND KITS SHALL BE WEATHERPROOFED.

B. WEATHERPROOFED USING ONE OF THE FOLLOWING METHODS. ALL INSTALLATIONS MUST BE DONE IN ACCORDANCE WITH THE MANUFACTURER'S RECOMMENDATIONS AND INDUSTRY BEST PRACTICES.

1. COLD SHRINK: ENCOMPASS CONNECTOR IN COLD SHRINK TUBING AND PROVIDE A DOUBLE WRAP OF 2" ELECTRICAL TAPE EXTENDING 2" BEYOND TUBING. PROVIDE 3M COLD SHRINK CXS SERIES OR EQUAL.
2. SELF-AMALGAMATING TAPE: CLEAN SURFACES. APPLY A DOUBLE WRAP OF SELF-AMALGAMATING TAPE 2" BEYOND CONNECTOR. APPLY A SECOND WRAP OF SELF-AMALGAMATING TAPE IN OPPOSITE DIRECTION. APPLY DOUBLE WRAP OF 2" WIDE ELECTRICAL TAPE EXTENDING 2" BEYOND THE SELF-AMALGAMATING TAPE.
3. 3M SLIM LOCK CLOSURE 716: SUBSTITUTIONS WILL NOT BE ALLOWED.
4. OPEN FLAME ON JOB SITE IS NOT ACCEPTABLE

SECTION 11 800 - INSTALLATION OF MULTIMODAL BASE STATIONS (MMBTS) AND RELATED EQUIPMENT

SUMMARY:

A. THIS SECTION SPECIFIES MMBTS CABINETS, POWER CABINETS, AND INTERNAL EQUIPMENT INCLUDING BY NOT LIMITED TO RECTIFIERS, POWER DISTRIBUTION UNITS, BASE BAND UNITS, SURGE ARRESTORS, BATTERIES, AND SIMILAR EQUIPMENT FURNISHED BY THE COMPANY FOR INSTALLATION BY THE CONTRACTOR (OFCI).

B. CONTRACTOR SHALL PROVIDE AND INSTALL ALL MISCELLANEOUS MATERIALS AND PROVIDE ALL LABOR REQUIRED FOR INSTALLATION EQUIPMENT IN EXISTING CABINET OR NEW CABINET AS SHOWN ON DRAWINGS AND AS REQUIRE BY THE APPLICABLE INSTALLATION MOPS.

C. COMPLY WITH MANUFACTURERS INSTALLATION AND START-UP REQUIREMENTS

DC CIRCUIT BREAKER LABELING

A. LABEL CIRCUIT BREAKERS ACCORDING TO SPRINT CELL SITE ENGINEERING NOTICE - EN 2012-001, REV 1.

SECTION 11 800 - INSTALLATION OF MULTIMODAL BASE TRANSCIEVER STATIONS (MMBTS) AND RELATED EQUIPMENT

SUMMARY:

A. THIS SECTION SPECIFIES MMBTS CABINETS, POWER CABINETS, AND INTERNAL EQUIPMENT INCLUDING BY NOT LIMITED TO RECTIFIERS, POWER DISTRIBUTION UNITS, BASE BAND UNITS, SURGE ARRESTORS, BATTERIES, AND SIMILAR EQUIPMENT FURNISHED BY THE COMPANY FOR INSTALLATION BY THE CONTRACTOR (OFCI).

B. CONTRACTOR SHALL PROVIDE AND INSTALL ALL MISCELLANEOUS MATERIALS AND PROVIDE ALL LABOR REQUIRED FOR INSTALLATION EQUIPMENT IN EXISTING CABINET OR NEW CABINET AS SHOWN ON DRAWINGS AND AS REQUIRE BY THE APPLICABLE INSTALLATION MOPS.

C. COMPLY WITH MANUFACTURERS INSTALLATION AND START-UP REQUIREMENTS

SUPPORTING DEVICES:

A. MANUFACTURED STRUCTURAL SUPPORT MATERIALS: SUBJECT TO COMPLIANCE WITH REQUIREMENTS, PROVIDE PRODUCTS BY THE FOLLOWING:

1. ALLIED TUBE AND CONDUIT
2. B-LINE SYSTEM
3. UNISTRUT DIVERSIFIED PRODUCTS
4. THOMAS & BETTS

B. FASTENERS: TYPES, MATERIALS, AND CONSTRUCTION FEATURES AS FOLLOWS:

1. EXPANSION ANCHORS: CARBON STEEL WEDGE OR SLEEVE TYPE.
2. POWER-DRIVEN THREADED STUDS: HEAT-TREATED STEEL, DESIGNED SPECIFICALLY FOR THE INTENDED SERVICE.
3. FASTEN BY MEANS OF WOOD SCREWS ON WOOD.
4. TOGGLE BOLTS ON HOLLOW MASONRY UNITS.
5. CONCRETE INSERTS OR EXPANSION BOLTS ON CONCRETE OR SOLID MASONRY.
6. MACHINE SCREWS, WELDED THREADED STUDS, OR SPRING-TENSION CLAMPS ON STEEL.
7. EXPLOSIVE DEVICES FOR ATTACHING HANGERS TO STRUCTURE SHALL NOT BE PERMITTED.
8. DO NOT WELD CONDUIT, PIPE STRAPS, OR ITEMS OTHER THAN THREADED STUDS TO STEEL STRUCTURES.
9. IN PARTITIONS OF LIGHT STEEL CONSTRUCTION, USE SHEET METAL SCREWS.

SUPPORTING DEVICES:

- A. INSTALL SUPPORTING DEVICES TO FASTEN ELECTRICAL COMPONENTS SECURELY AND PERMANENTLY IN ACCORDANCE WITH NEC.
- B. COORDINATE WITH THE BUILDING STRUCTURAL SYSTEM AND WITH OTHER TRADES.
- C. UNLESS OTHERWISE INDICATED ON THE DRAWINGS, FASTEN ELECTRICAL ITEMS AND THEIR SUPPORTING HARDWARE SECURELY TO THE STRUCTURE IN ACCORDANCE WITH THE FOLLOWING:
- D. ENSURE THAT THE LOAD APPLIED BY ANY FASTENER DOES NOT EXCEED 25 PERCENT OF THE PROOF TEST LOAD.
- E. USE VIBRATION AND SHOCK-RESISTANT FASTENERS FOR ATTACHMENTS TO CONCRETE SLABS.

ELECTRICAL IDENTIFICATION:

- A. UPDATE AND PROVIDE TYPED CIRCUIT BREAKER SCHEDULES IN THE MOUNTING BRACKET, INSIDE DOORS OF AC PANEL BOARDS WITH ANY CHANGES MADE TO THE AC SYSTEM.
- B. BRANCH CIRCUITS FEEDING AVIATION OBSTRUCTION LIGHTING EQUIPMENT SHALL BE CLEARLY IDENTIFIED AS SUCH AT THE BRANCH CIRCUIT PANELBOARD.

SECTION 26 200 - ELECTRICAL MATERIALS AND EQUIPMENT

CONDUIT:

A. RIGID GALVANIZED STEEL (RGS) CONDUIT SHALL BE USED FOR EXTERIOR LOCATIONS ABOVE GROUND AND IN UNFINISHED INTERIOR LOCATIONS AND FOR ENCASED RUNS IN CONCRETE. RIGID CONDUIT AND FITTINGS SHALL BE STEEL, COATED WITH ZINC EXTERIOR AND INTERIOR BY THE HOT DIP GALVANIZING PROCESS. CONDUIT SHALL BE PRODUCED TO ANSI SPECIFICATIONS C80.1, FEDERAL SPECIFICATION WW-C-581 AND SHALL BE LISTED WITH THE UNDERWRITERS' LABORATORIES. FITTINGS SHALL BE THREADED - SET SCREW OR COMPRESSION FITTINGS WILL NOT BE ACCEPTABLE. RGS CONDUITS SHALL BE MANUFACTURED BY ALLIED, REPUBLIC OR WHEATLAND.

B. UNDERGROUND CONDUIT IN CONCRETE SHALL BE POLYVINYLCHLORIDE (PVC) SUITABLE FOR DIRECT BURIAL AS APPLICABLE. JOINTS SHALL BE BELLED, AND FLUSH SOLVENT WELDED IN ACCORDANCE WITH MANUFACTURER'S INSTRUCTIONS. CONDUIT SHALL BE CARLON ELECTRICAL PRODUCTS OR APPROVED EQUAL.

C. TRANSITIONS BETWEEN PVC AND RIGID (RGS) SHALL BE MADE WITH PVC COATED METALLIC LONG SWEEP RADIUS ELBOWS.

D. EMT OR RIGID GALVANIZED STEEL CONDUIT MAY BE USED IN FINISHED SPACES CONCEALED IN WALLS AND CEILINGS. EMT SHALL BE MILD STEEL, ELECTRICALLY WELDED, ELECTRO-GALVANIZED OR HOT-DIPPED GALVANIZED AND PRODUCED TO ANSI SPECIFICATION C80.3, FEDERAL SPECIFICATION WW-C-563, AND SHALL BE UL LISTED. EMT SHALL BE MANUFACTURED BY ALLIED, REPUBLIC OR WHEATLAND, OR APPROVED EQUAL. FITTINGS SHALL BE METALLIC COMPRESSION. SET SCREW CONNECTIONS SHALL NOT BE ACCEPTABLE.

E. LIQUID TIGHT FLEXIBLE METALLIC CONDUIT SHALL BE USED FOR FINAL CONNECTION TO EQUIPMENT. FITTINGS SHALL BE METALLIC GLAND TYPE COMPRESSION FITTINGS, MAINTAINING THE INTEGRITY OF CONDUIT SYSTEM. SET SCREW CONNECTIONS SHALL NOT BE ACCEPTABLE. MAXIMUM LENGTH OF FLEXIBLE CONDUIT SHALL NOT EXCEED 6- FEET. LFMC SHALL BE PROTECTED AND SUPPORTED AS REQUIRE BY NEC. MANUFACTURERS OF FLEXIBLE CONDUITS SHALL BE CAROL, ANACONDA METAL HOSE OR UNIVERSAL METAL HOSE, OR APPROVED EQUAL.

F. MINIMUM SIZE CONDUIT SHALL BE 3/4 INCH (21MM).

HUBS AND BOXES:

A. AT ENTRANCES TO CABINETS OR OTHER EQUIPMENT NOT HAVING INTEGRAL THREADED HUBS PROVIDE METALLIC THREADED HUBS OF THE SIZE AND CONFIGURATION REQUIRED. HUB SHALL INCLUDE LOCKNUT AND NEOPRENE O-RING SEAL. PROVIDE IMPACT RESISTANT 105 DEGREE C PLASTIC BUSHINGS TO PROTECT CABLE INSULATION.

B. CABLE TERMINATION FITTINGS FOR CONDUIT

1. CABLE TERMINATORS FOR RGS CONDUITS SHALL BE TYPE CRC BY O-Z/GEDNEY OR EQUAL.
2. CABLE TERMINATORS FOR LFMC SHALL BE ETCO - CL2075; OR MADE FOR THE PURPOSE PRODUCTS BY ROXTEC.

C. EXTERIOR PULL BOXES AND PULL BOXES IN INTERIOR INDUSTRIAL AREAS SHALL BE PLATED CAST ALLOY, HEAVY DUTY, WEATHERPROOF, DUST PROOF, WITH GASKET, PLATED IRON ALLOY COVER AND STAINLESS STEEL COVER SCREWS, CROUSE-HINDS WAB SERIES OR EQUAL.

D. CONDUIT OUTLET BODIES SHALL BE PLATED CAST ALLOY WITH SIMILAR GASKETED COVERS. OUTLET BODIES SHALL BE OF THE CONFIGURATION AND SIZE SUITABLE FOR THE APPLICATION. PROVIDE CROUSE-HINDS FORM 8 OR EQUAL.

E. MANUFACTURER FOR BOXES AND COVERS SHALL BE HOFFMAN, SQUARE "D", CROUSE-HINDS, COOPER, ADALET, APPLETON, O-Z GEDNEY, RACO, OR APPROVED EQUAL.

SUPPLEMENTAL GROUNDING SYSTEM

A. FURNISH AND INSTALL A SUPPLEMENTAL GROUNDING SYSTEM AS INDICATED ON THE DRAWINGS. SUPPORT SYSTEM WITH NON-MAGNETIC STAINLESS STEEL CLIPS WITH RUBBER GROMMETS. GROUNDING CONNECTORS SHALL BE TINNED COPPER WIRE, SIZES AS INDICATED ON THE DRAWINGS. PROVIDE STRANDED OR SOLID BARE OR INSULATED CONDUCTORS AS INDICATED.

B. SUPPLEMENTAL GROUNDING SYSTEM: ALL CONNECTIONS TO BE MADE WITH CAD WELDS, EXCEPT AT EQUIPMENT USE LUGS OR OTHER AVAILABLE GROUNDING MEANS AS REQUIRED BY MANUFACTURER; AT GROUND BARS USE TWO HOLE SPADES WITH NO OX.

C. STOLEN GROUND-BARS: IN THE EVENT OF STOLEN GROUND BARS, CONTACT SPRINT CM FOR REPLACEMENT INSTRUCTION USING THREADED ROD KITS.

EXISTING STRUCTURE:

A. EXISTING EXPOSED WIRING AND ALL EXPOSED OUTLETS, RECEPTACLES, SWITCHES, DEVICES, BOXES, AND OTHER EQUIPMENT THAT ARE NOT TO BE UTILIZED IN THE COMPLETED PROJECT SHALL BE REMOVED OR DE-ENERGIZED AND CAPPED IN THE WALL, CEILING, OR FLOOR SO THAT THEY ARE CONCEALED AND SAFE. WALL, CEILING, OR FLOOR SHALL BE PATCHED TO MATCH THE ADJACENT CONSTRUCTION.

CONDUIT AND CONDUCTOR INSTALLATION:

A. CONDUITS SHALL BE FASTENED SECURELY IN PLACE WITH APPROVED NON-PERFORATED STRAPS AND HANGERS. EXPLOSIVE DEVICES FOR ATTACHING HANGERS TO STRUCTURE WILL NOT BE PERMITTED. CLOSELY FOLLOW THE LINES OF THE STRUCTURE, MAINTAIN CLOSE PROXIMITY TO THE STRUCTURE AND KEEP CONDUITS IN TIGHT ENVELOPES. CHANGES IN DIRECTION TO ROUTE AROUND OBSTACLES SHALL BE MADE WITH CONDUIT OUTLET BODIES. CONDUIT SHALL BE INSTALLED IN A NEAT AND WORKMANLIKE MANNER, PARALLEL AND PERPENDICULAR TO STRUCTURE WALL AND CEILING LINES. ALL CONDUIT SHALL BE FISHED TO CLEAR OBSTRUCTIONS. ENDS OF CONDUITS SHALL BE TEMPORARILY CAPPED TO PREVENT CONCRETE, PLASTER OR DIRT FROM ENTERING. CONDUITS SHALL BE RIGIDLY CLAMPED TO BOXES BY GALVANIZED MALLEABLE IRON BUSHING ON INSIDE AND GALVANIZED MALLEABLE IRON LOCKNUT ON OUTSIDE AND INSIDE.

B. CONDUCTORS SHALL BE PULLED IN ACCORDANCE WITH ACCEPTED GOOD PRACTICE.



1 INTERNATIONAL BLVD, SUITE 800
MAHWAH, NJ 07495
TEL: (800) 357-7641



CROWN CASTLE
12 GILL STREET, SUITE 5800
WOBRURN, MA 01801



45 BEECHWOOD DRIVE
N. ANDOVER, MA 01845
TEL: (978) 557-5553
FAX: (978) 336-5586

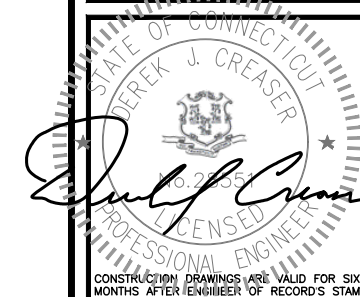

CONSTRUCTION DRAWINGS ARE VALID FOR SIX MONTHS AFTER THE DATE OF RECORD'S STAMP AND SIGNED SUBMITTAL DATE LISTED HEREIN

CHECKED BY: BB

APPROVED BY: DJC

SUBMITTALS			
REV.	DATE	DESCRIPTION	BY
1	08/13/18	CONSTRUCTION FINAL	BB
0	07/24/18	ISSUED FOR CONSTRUCTION	GA

SITE NUMBER:
CT03XC168
SITE NAME:
HRT 106(B) 943202
CROWN BU NUMBER:
806364
SITE ADDRESS:
143 R OLD BLUE HILL ROAD
DURHAM, CT 06422
MIDDLESEX COUNTY

SHEET TITLE
OUTLINE
SPECIFICATIONS
(DO MACRO)

SHEET NUMBER
SP-3

NOTE:
REFER TO THE FINAL RF DATA SHEET FOR FINAL ANTENNA SETTINGS.

STRUCTURAL NOTE:
PRIOR TO COMMENCING CONSTRUCTION, GC SHALL REFER TO TOWER STRUCTURAL ANALYSIS REPORT PROVIDED BY CROWN CASTLE DATED JUNE 29, 2018 AND MOUNT STRUCTURAL ANALYSIS BY HUDSON DESIGN GROUP DATED JUNE 14, 2018 (REV. 1) TO DETERMINE IF THERE ANY SUPPLEMENTAL OR SPECIAL INSTALLATION REQUIREMENTS, OR RELOCATION ARRANGEMENTS.

Sprint
1 INTERNATIONAL BLVD, SUITE 800
MAHWAH, NJ 07495
TEL: (800) 357-7641

CROWN CASTLE
CROWN CASTLE
12 GILL STREET, SUITE 5800
WOBURN, MA 01801

HDG HUDSON Design Group LLC
45 BEECHWOOD DRIVE
N. ANDOVER, MA 01845
TEL: (978) 557-5553
FAX: (978) 336-5866

STATE OF CONNECTICUT
Derek J. Creaser
16.27.35
LICENSED PROFESSIONAL ENGINEER
CONSTRUCTION DRAWINGS ARE VALID FOR SIX MONTHS AFTER THE DATE OF RECORD'S STAMP AND SIGNED SUBMITTAL DATE LISTED HEREIN

CHECKED BY: BB

APPROVED BY: DJC

SUBMITTALS

REV.	DATE	DESCRIPTION	BY
1	08/13/18	CONSTRUCTION FINAL	BB
0	07/24/18	ISSUED FOR CONSTRUCTION	GA

SITE NUMBER:
CT03XC168
SITE NAME:
HRT 106(B) 943202
CROWN BU NUMBER:
806364
SITE ADDRESS:
143 R OLD BLUE HILL ROAD
DURHAM, CT 06422
MIDDLESEX COUNTY

SHEET TITLE
COMPOUND PLAN &
EQUIPMENT PLAN
(DO MACRO)

SHEET NUMBER
A-1

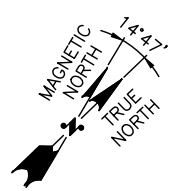
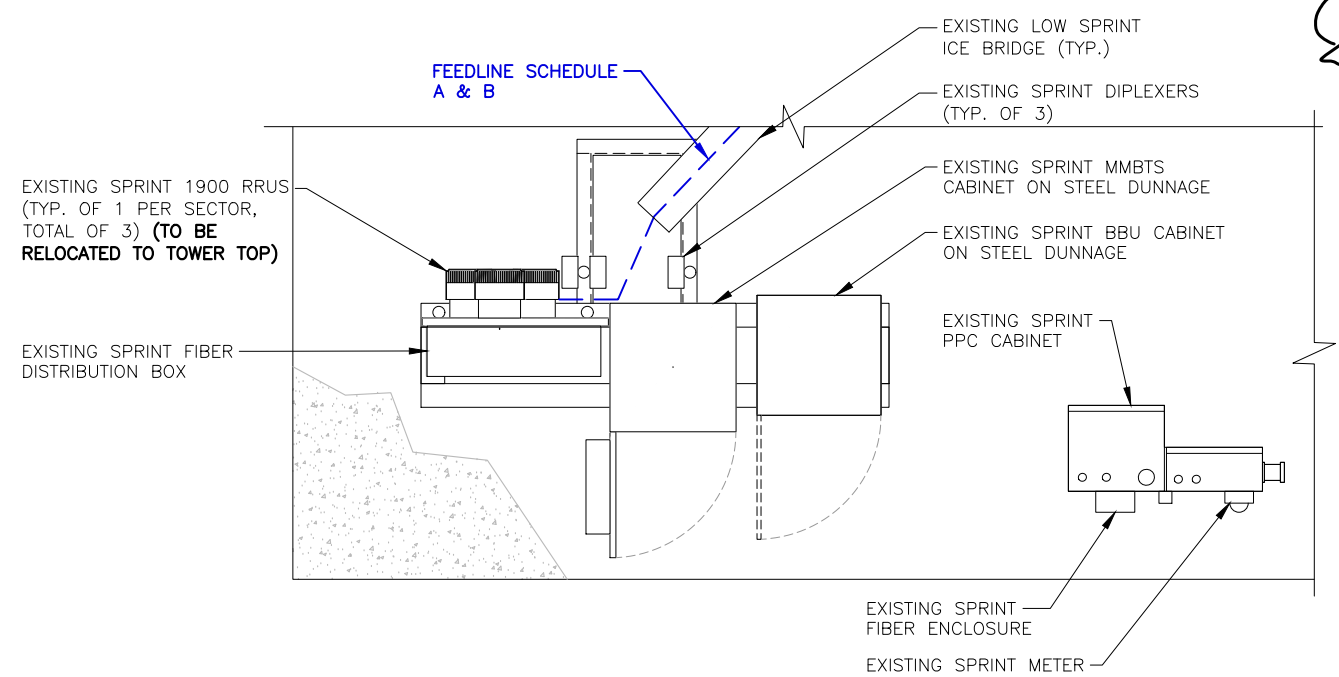
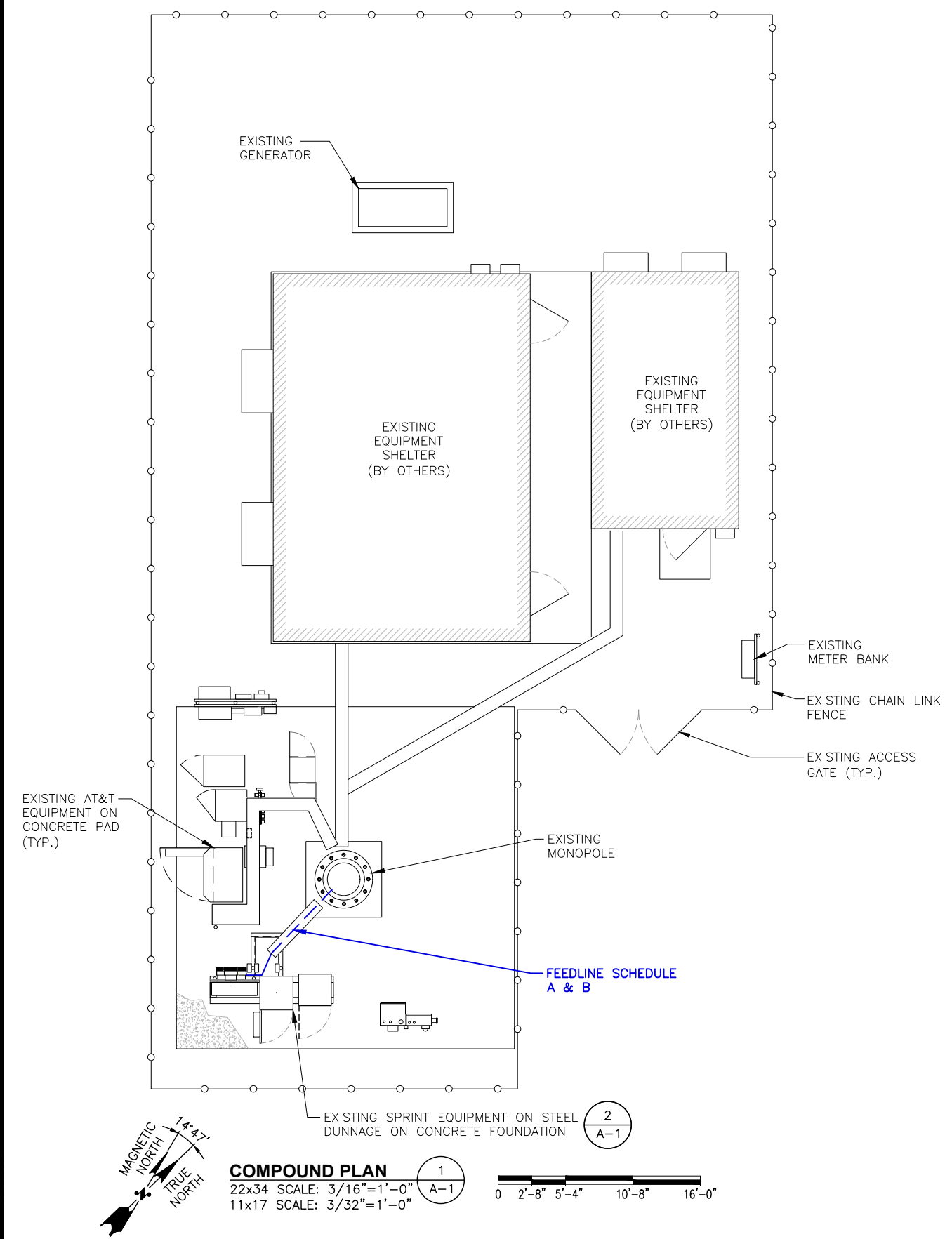

COMPOUND PLAN
22x34 SCALE: 3/16"=1'-0"
11x17 SCALE: 3/32"=1'-0"

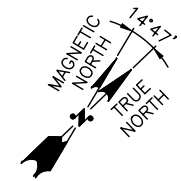
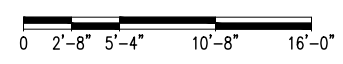

EQUIPMENT PLAN
22x34 SCALE: 1/2"=1'-0"
11x17 SCALE: 1/4"=1'-0"

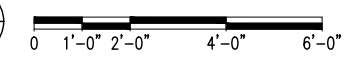

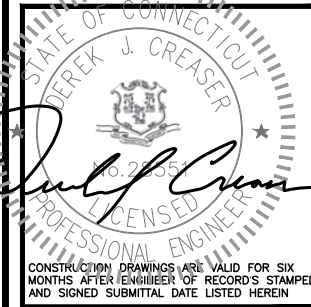

CHECKED BY: BB
APPROVED BY: DJC

SUBMITTALS			
REV.	DATE	DESCRIPTION	BY
1	08/13/18	CONSTRUCTION FINAL	BB
0	07/24/18	ISSUED FOR CONSTRUCTION	GA

SITE NUMBER: CT03XC168
SITE NAME: HRT 106(B) 943202
CROWN BU NUMBER: 806364
SITE ADDRESS: 143 R OLD BLUE HILL ROAD DURHAM, CT 06422 MIDDLESEX COUNTY

SHEET TITLE: ANTENNA PLANS & ELEVATION (DO MACRO)

SHEET NUMBER: A-2

STRUCTURAL NOTE:
DESIGN LIMITATIONS AND ASSUMPTIONS:
1. EQUIPMENT AND LOCATIONS SHOULD NOT DEVIATE FROM THE CONSTRUCTION DRAWINGS WITHOUT WRITTEN APPROVAL OF THE ENGINEER.
2. HDG IS NOT RESPONSIBLE FOR ANY MODIFICATIONS COMPLETED PRIOR TO AND HEREAFTER WHICH HDG WAS NOT INVOLVED.
3. ALL STRUCTURAL MEMBERS AND THEIR CONNECTIONS ARE ASSUMED TO BE IN GOOD CONDITION AND ARE FREE FROM DEFECTS WITH NO DETERIORATION TO ITS MEMBER CAPACITIES. CONTRACTOR IS TO PERFORM A PRE-INSPECTION TO CONFIRM.
4. ALL ANTENNAS, COAX CABLES AND WAVEGUIDE CABLES ARE ASSUMED TO BE PROPERLY INSTALLED AND SUPPORTED AS PER THE MANUFACTURER'S REQUIREMENTS.
5. ALL COMPONENTS SUPPORTING THE SPRINT EQUIPMENT ARE ASSUMED TO BE DESIGNED TO ALL APPLICABLE CODES AND DESIGNED FOR IDENTICAL TO OR GREATER THAN THE CURRENT LOADS.

NOTE:
REFER TO THE FINAL RF DATA SHEET FOR FINAL ANTENNA SETTINGS.

SCOPE NOTE:
PROPOSED DESIGN IS BASED OFF OF CROWN APPLICATION REV 0 DATED 05/21/18

STRUCTURAL NOTE:
PRIOR TO COMMENCING CONSTRUCTION, GC SHALL REFER TO TOWER STRUCTURAL ANALYSIS REPORT PROVIDED BY CROWN CASTLE DATED JUNE 29, 2018 AND MOUNT STRUCTURAL ANALYSIS BY HUDSON DESIGN GROUP DATED JUNE 14, 2018 (REV. 1) TO DETERMINE IF THERE ANY SUPPLEMENTAL OR SPECIAL INSTALLATION REQUIREMENTS, OR RELOCATION ARRANGEMENTS.

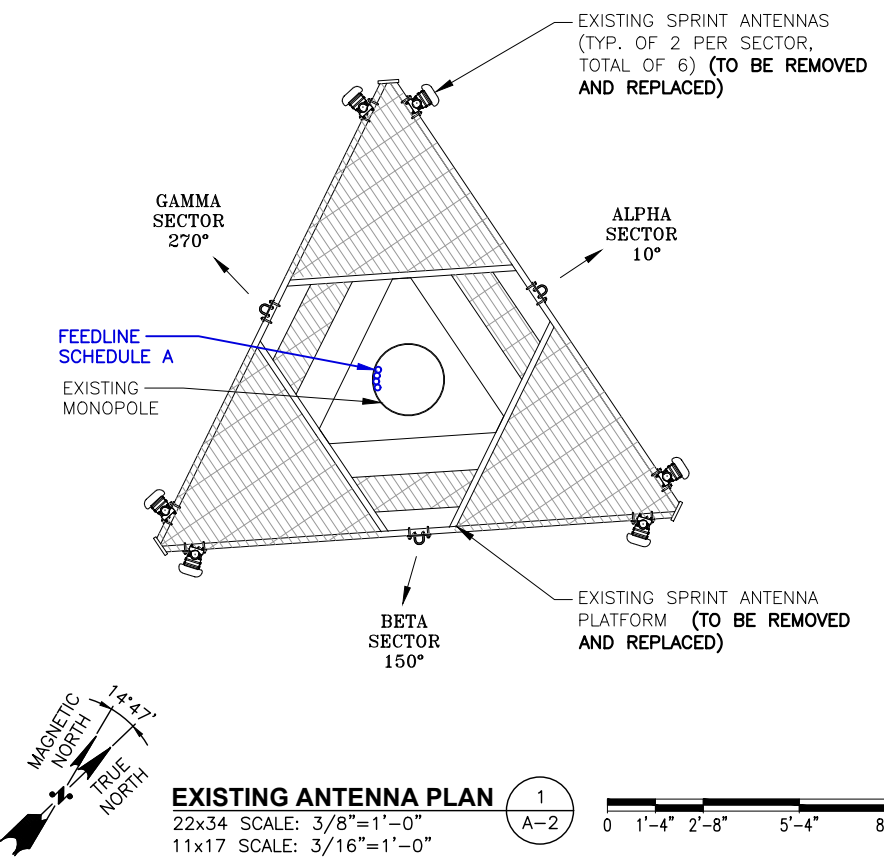

EXISTING ANTENNA PLAN (1) A-2
22x34 SCALE: 3/8"=1'-0"
11x17 SCALE: 3/16"=1'-0"

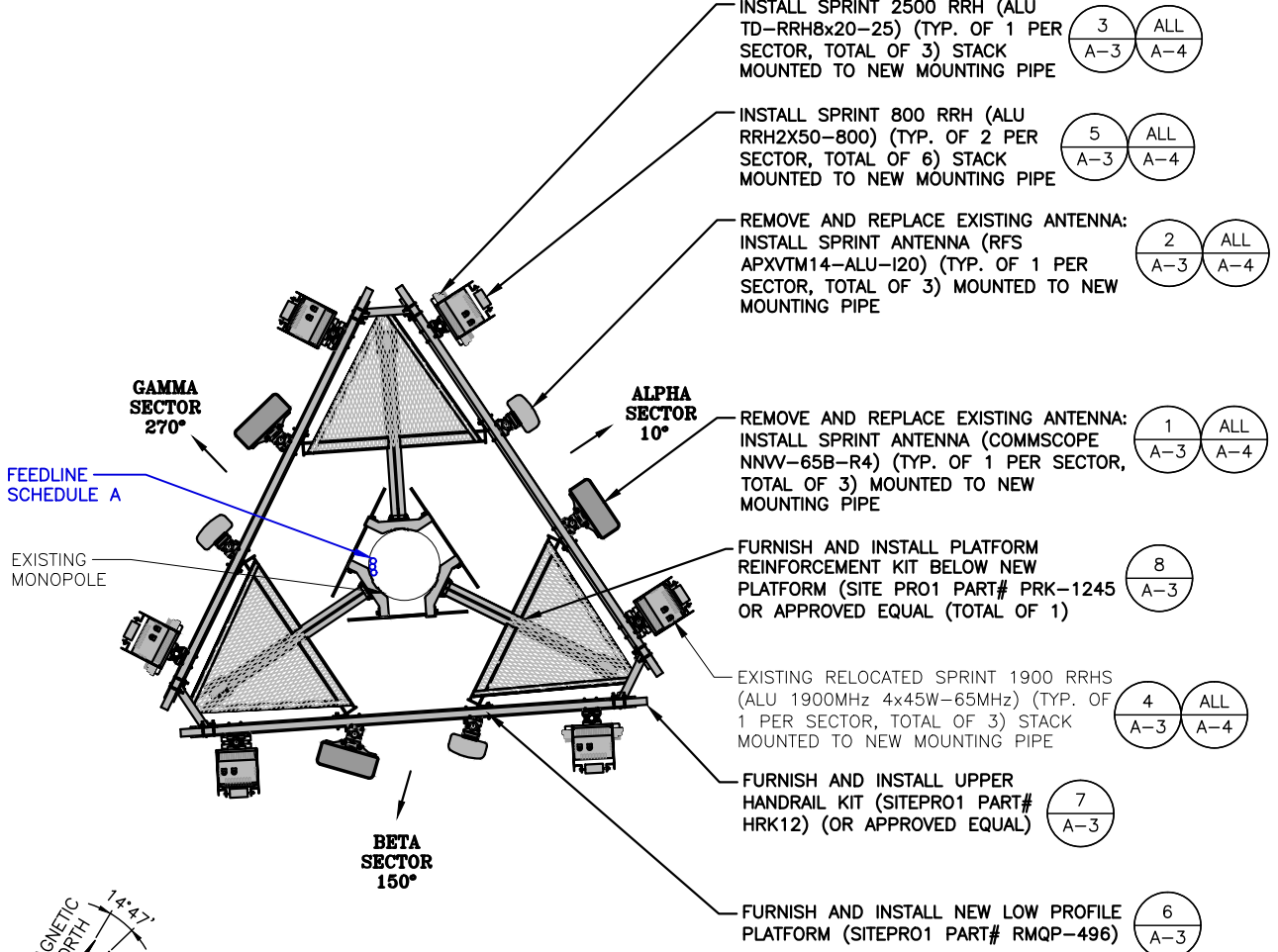

PROPOSED ANTENNA PLAN (2) A-2
22x34 SCALE: 3/8"=1'-0"
11x17 SCALE: 3/16"=1'-0"

FEEDLINES			
FEEDLINE SCHEDULE	FEEDLINE DESCRIPTION	LOCATION	LENGTH
A	EXISTING TO BE REMOVED: (6) 1-5/8" COAX EXISTING TO REMAIN: (1) 1/2" COAX	ROUTED ON EXTERIOR MONOPOLE FACE PER TOWER SA	ALPHA: 139'± BETA: 139'± GAMMA: 139'±
B	PROPOSED (3) 1-1/4" AND (1) 7/8" HYBRID TRUNKS		

NOTE:
EXISTING SPRINT EQUIPMENT FEEDLINE INVENTORY BASED ON OBSERVED FIELD CONDITIONS, RFDS AND FEEDLINE LEASING ENTITLEMENTS MAY DIFFER.

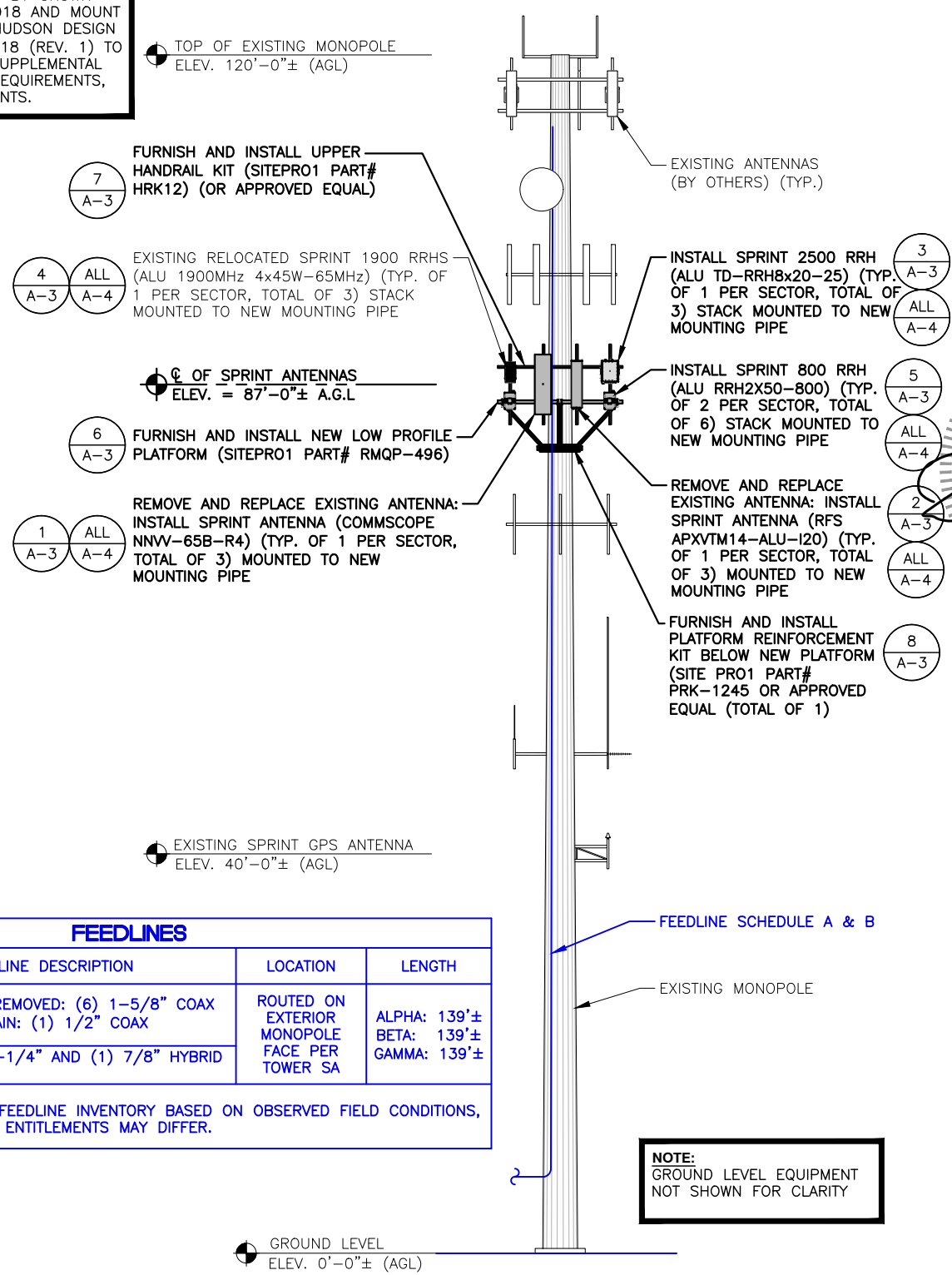

ELEVATION (3) A-2
22x34 SCALE: 1/8"=1'-0"
11x17 SCALE: 1/16"=1'-0"

NOTE:
GROUND LEVEL EQUIPMENT NOT SHOWN FOR CLARITY

800/1900 MHZ ANTENNA DIMENSIONS	
MODEL #	NNV-65B-R4
MANUF.	COMMSCOPE
HEIGHT	72.0"
WIDTH	19.6"
DEPTH	7.8"
WEIGHT	77.4 LBS

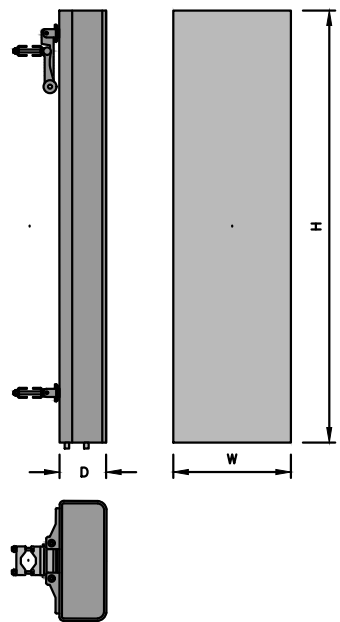

800/1900 MHZ ANTENNA DETAIL 1
SCALE: N.T.S. A-3

2500 MHZ ANTENNA DIMENSIONS	
MODEL #	APXVTM14-ALU-120
MANUF.	RFS
HEIGHT	56.3"
WIDTH	12.6"
DEPTH	6.3"
WEIGHT	56.2 LBS

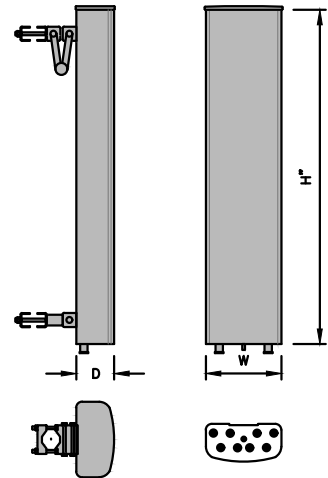

2500 MHZ ANTENNA DETAIL 2
SCALE: N.T.S. A-3

2500 MHZ RRH DIMENSIONS	
MODEL #	TD-RRH8X20-25
MANUF.	ALCATEL-LUCENT
LENGTH	25.4"
WIDTH	17.5"
DEPTH	5.7"
WEIGHT	66 LBS

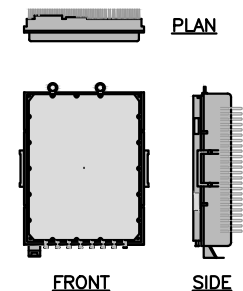

2500 MHz RRH DETAIL 3
SCALE: N.T.S. A-3

1900MHZ RRH DIMENSIONS	
MODEL #	1900MHZ 4X45W-65MHZ
MANUF.	ALCATEL-LUCENT
LENGTH	25"
WIDTH	11.1"
DEPTH	10.7"
WEIGHT	60 LBS

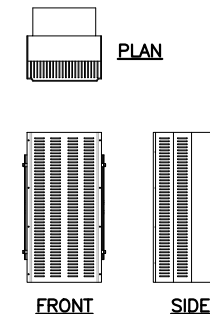

1900 MHZ RRH DETAIL 4
SCALE: N.T.S. A-3

800MHZ RRH DIMENSIONS	
MODEL #	RRH2X50-800
MANUF.	ALCATEL-LUCENT
LENGTH	19.7"
WIDTH	13"
DEPTH	10.8"
WEIGHT	53 LBS

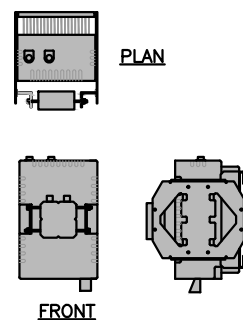

800 MHZ RRH DETAIL 5
SCALE: N.T.S. A-3

FURNISH AND INSTALL NEW 2" STD (2-3/8" O.D.) X84" MOUNTING PIPE (TYP. OF 3 PER SECTOR, TOTAL OF 9) (INCLUDED WITH LOW PROFILE PLATFORM KIT)

FURNISH AND INSTALL NEW LOW PROFILE PLATFORM (SITEPRO1 PART# RMQP-496)

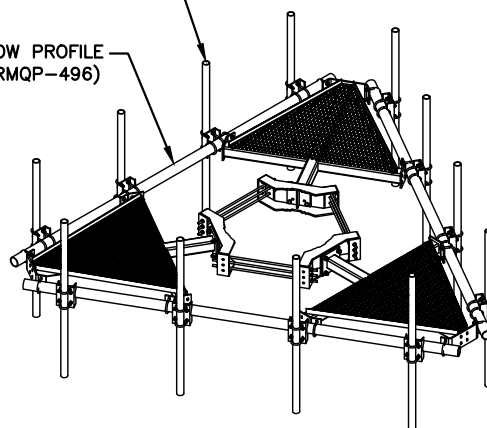

LOW PROFILE PLATFORM KIT DETAIL 6
SCALE: N.T.S. A-3

FURNISH AND INSTALL UPPER HANDRAIL KIT (SITEPRO1 PART# HRK12) (OR APPROVED EQUAL)

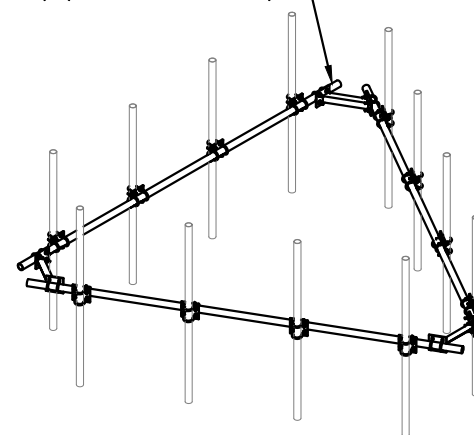

HANDRAIL KIT DETAIL 7
SCALE: N.T.S. A-3

FURNISH AND INSTALL PLATFORM REINFORCEMENT KIT BELOW EXISTING PLATFORM (SITE PRO1 PART# PRK-1245) (OR APPROVED EQUAL) (TOTAL OF 1)

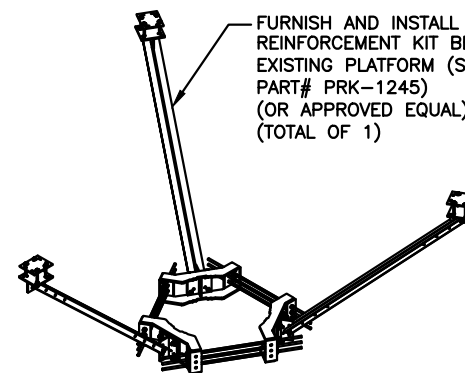

PLATFORM REINFORCEMENT KIT DETAIL 8
SCALE: N.T.S. A-3

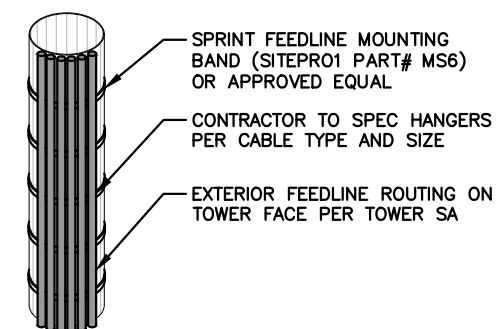

EXTERIOR FEEDLINE ROUTING 9
SCALE: N.T.S. A-3

Sprint
1 INTERNATIONAL BLVD, SUITE 800
MAHWAH, NJ 07495
TEL: (800) 357-7641

CROWN CASTLE
CROWN CASTLE
12 GILL STREET, SUITE 5800
WOBURN, MA 01801

HG HUDSON Design Group LLC
45 BEECHWOOD DRIVE
N. ANDOVER, MA 01845
TEL: (978) 557-5553
FAX: (978) 336-5886

STATE OF CONNECTICUT
Derek J. Creaser
Professional Engineer
CONSTRUCTION DRAWINGS ARE VALID FOR SIX MONTHS AFTER ENGINEER OF RECORD'S STAMPED AND SIGNED SUBMITTAL DATE LISTED HEREIN

CHECKED BY: BB

APPROVED BY: DJC

SUBMITTALS			
REV.	DATE	DESCRIPTION	BY
1	08/13/18	CONSTRUCTION FINAL	BB
0	07/24/18	ISSUED FOR CONSTRUCTION	GA

SITE NUMBER:
CT03XC168
SITE NAME:
HRT 106(B) 943202
CROWN BU NUMBER:
806364
SITE ADDRESS:
143 R OLD BLUE HILL ROAD
DURHAM, CT 06422
MIDDLESEX COUNTY

SHEET TITLE
EQUIPMENT DETAILS
(DO MACRO)

SHEET NUMBER
A-3

STRUCTURAL NOTE:

DESIGN LIMITATIONS AND ASSUMPTIONS:
 1. EQUIPMENT AND LOCATIONS SHOULD NOT DEVIATE FROM THE CONSTRUCTION DRAWINGS WITHOUT WRITTEN APPROVAL OF THE ENGINEER.
 2. HDG IS NOT RESPONSIBLE FOR ANY MODIFICATIONS COMPLETED PRIOR TO AND HEREAFTER WHICH HDG WAS NOT INVOLVED.
 3. ALL STRUCTURAL MEMBERS AND THEIR CONNECTIONS ARE ASSUMED TO BE IN GOOD CONDITION AND ARE FREE FROM DEFECTS WITH NO DETERIORATION TO ITS MEMBER CAPACITIES. CONTRACTOR IS TO PERFORM A PRE-INSPECTION TO CONFIRM.
 4. ALL ANTENNAS, COAX CABLES AND WAVEGUIDE CABLES ARE ASSUMED TO BE PROPERLY INSTALLED AND SUPPORTED AS PER THE MANUFACTURER'S REQUIREMENTS.
 5. ALL COMPONENTS SUPPORTING THE SPRINT EQUIPMENT ARE ASSUMED TO BE DESIGNED TO ALL APPLICABLE CODES AND DESIGNED FOR IDENTICAL TO OR GREATER THAN THE CURRENT LOADS.

STRUCTURAL NOTE:

PRIOR TO COMMENCING CONSTRUCTION, GC SHALL REFER TO TOWER STRUCTURAL ANALYSIS REPORT PROVIDED BY CROWN CASTLE DATED JUNE 29, 2018 AND MOUNT STRUCTURAL ANALYSIS BY HUDSON DESIGN GROUP DATED JUNE 14, 2018 (REV. 1) TO DETERMINE IF THERE ANY SUPPLEMENTAL OR SPECIAL INSTALLATION REQUIREMENTS, OR RELOCATION ARRANGEMENTS.

NOTE:

REFER TO THE FINAL RF DATA SHEET FOR FINAL ANTENNA SETTINGS.

SCOPE NOTE:

PROPOSED DESIGN IS BASED OFF OF CROWN APPLICATION REV 0 DATED 05/21/18

MAJOR RF EQUIPMENT LIST				
(GC SHALL FURNISH AND INSTALL ALL OTHER MATERIALS AND EQUIPMENT NOT SUPPLIED BY SPRINT)				
DESCRIPTION	QUANTITY	UNITS	MAKE/MODEL/MATERIAL	PROVIDED BY
ANTENNA	3	EA	COMMSCOPE NNVV-65B-R4	SPRINT
ANTENNA	3	EA	RFS APXVTM14-ALU-120	SPRINT
800 RRH	6	EA	ALCATEL-LUCENT 800MHZ RRH2X50-800	SPRINT
1900 RRH	3	EA	ALCATEL-LUCENT PCS 1900MHZ 4X45W-65MHZ	EXISTING TO REMAIN
2500 RRH	3	EA	ALCATEL-LUCENT TD-RRH8X20-25	SPRINT
COAX CABLE	1	139 LF ±	RFS HB114-08U3M12-XXXF	SPRINT
RET CABLE	3	139 LF ±	RFS HB114-1-0813U4-M5J	SPRINT

SPRINT-PROVIDED EQUIPMENT SCHEDULE (3 A-4)
 SCALE: N.T.S.

(1 A-3) (2 A-2) REMOVE AND REPLACE EXISTING ANTENNA: INSTALL SPRINT ANTENNA (COMMSCOPE NNVV-65B-R4) (TYP. OF 1 PER SECTOR, TOTAL OF 3) MOUNTED TO NEW MOUNTING PIPE

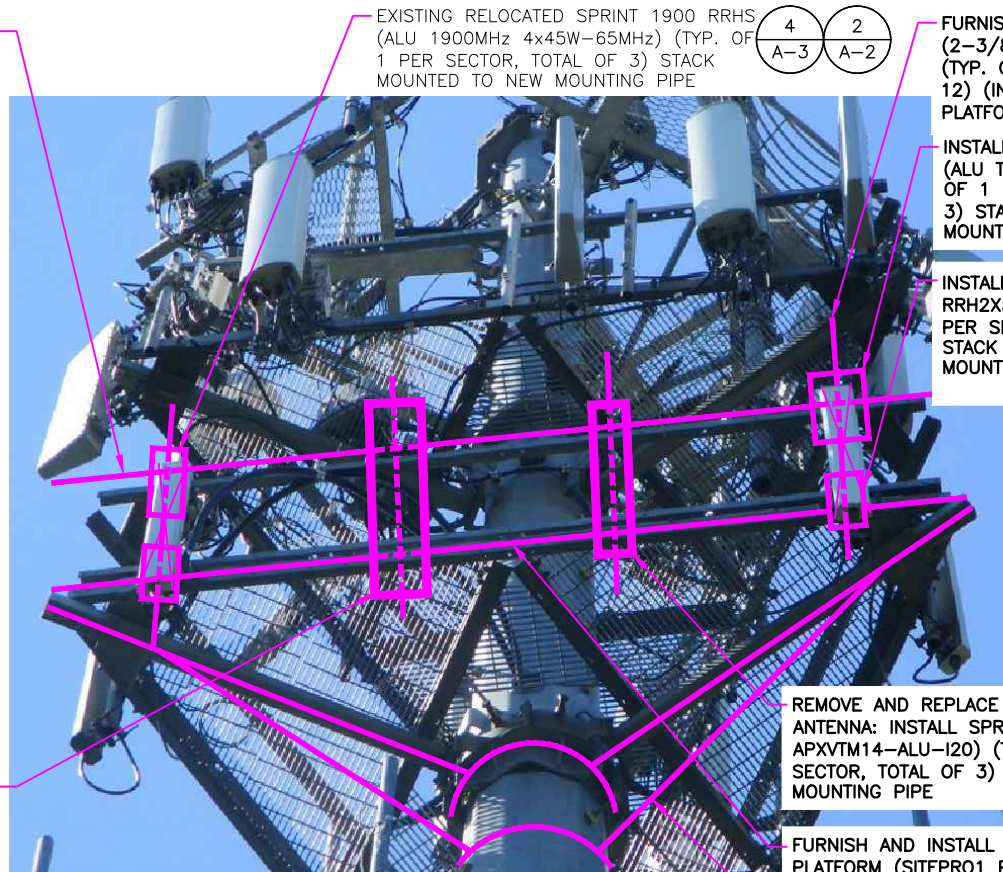

(4 A-3) (2 A-2) FURNISH AND INSTALL NEW 2" STD (2-3/8" O.D.) X84" MOUNTING PIPE (TYP. OF 4 PER SECTOR, TOTAL OF 12) (INCLUDED WITH LOW PROFILE PLATFORM KIT)

(3 A-3) (2 A-2) INSTALL SPRINT 2500 RRH (ALU TD-RRH8x20-25) (TYP. OF 1 PER SECTOR, TOTAL OF 3) STACK MOUNTED TO NEW MOUNTING PIPE

(5 A-3) (2 A-2) INSTALL SPRINT 800 RRH (ALU RRH2X50-800) (TYP. OF 2 PER SECTOR, TOTAL OF 6) STACK MOUNTED TO NEW MOUNTING PIPE

(2 A-3) (2 A-2) REMOVE AND REPLACE EXISTING ANTENNA: INSTALL SPRINT ANTENNA (RFS APXVTM14-ALU-120) (TYP. OF 1 PER SECTOR, TOTAL OF 3) MOUNTED TO NEW MOUNTING PIPE

(6 A-3) FURNISH AND INSTALL NEW LOW PROFILE PLATFORM (SITEPRO1 PART# RMQP-496)

(8 A-3) FURNISH AND INSTALL PLATFORM REINFORCEMENT KIT BELOW NEW PLATFORM (SITE PRO1 PART# PRK-1245 OR APPROVED EQUAL (TOTAL OF 1))

ANTENNA & RRH MOUNT PHOTO DETAIL (2 A-4)
 SCALE: N.T.S.

(6 A-3) FURNISH AND INSTALL NEW LOW PROFILE PLATFORM (SITEPRO1 PART# RMQP-496)

(7 A-3) FURNISH AND INSTALL UPPER HANDRAIL KIT (SITEPRO1 PART# HRK12) (OR APPROVED EQUAL)

(1 A-3) (2 A-2) REMOVE AND REPLACE EXISTING ANTENNA: INSTALL SPRINT ANTENNA (COMMSCOPE NNVV-65B-R4) (TYP. OF 1 PER SECTOR, TOTAL OF 3) MOUNTED TO NEW MOUNTING PIPE

(7 A-3) FURNISH AND INSTALL UPPER HANDRAIL KIT (SITEPRO1 PART# HRK12) (OR APPROVED EQUAL)

(2 A-3) (2 A-2) REMOVE AND REPLACE EXISTING ANTENNA: INSTALL SPRINT ANTENNA (RFS APXVTM14-ALU-120) (TYP. OF 1 PER SECTOR, TOTAL OF 3) MOUNTED TO NEW MOUNTING PIPE

FURNISH AND INSTALL NEW 2" STD (2-3/8" O.D.) X84" MOUNTING PIPE (TYP. OF 4 PER SECTOR, TOTAL OF 12) (INCLUDED WITH LOW PROFILE PLATFORM KIT)

(3 A-3) (2 A-2) INSTALL SPRINT 2500 RRH (ALU TD-RRH8x20-25) (TYP. OF 1 PER SECTOR, TOTAL OF 3) STACK MOUNTED TO NEW MOUNTING PIPE

(5 A-3) (2 A-2) INSTALL SPRINT 800 RRH (ALU RRH2X50-800) (TYP. OF 2 PER SECTOR, TOTAL OF 6) STACK MOUNTED TO NEW MOUNTING PIPE

FURNISH AND INSTALL NEW 2" STD (2-3/8" O.D.) X84" MOUNTING PIPE (TYP. OF 4 PER SECTOR, TOTAL OF 12) (INCLUDED WITH LOW PROFILE PLATFORM KIT)

FURNISH AND INSTALL NEW 2" STD (2-3/8" O.D.) X84" MOUNTING PIPE (TYP. OF 4 PER SECTOR, TOTAL OF 12) (INCLUDED WITH LOW PROFILE PLATFORM KIT)

PROPOSED ANTENNA & RRH MOUNTING ELEVATION (1 A-4)
 22x34 SCALE: 3/4"=1'-0"
 11x17 SCALE: 3/8"=1'-0"

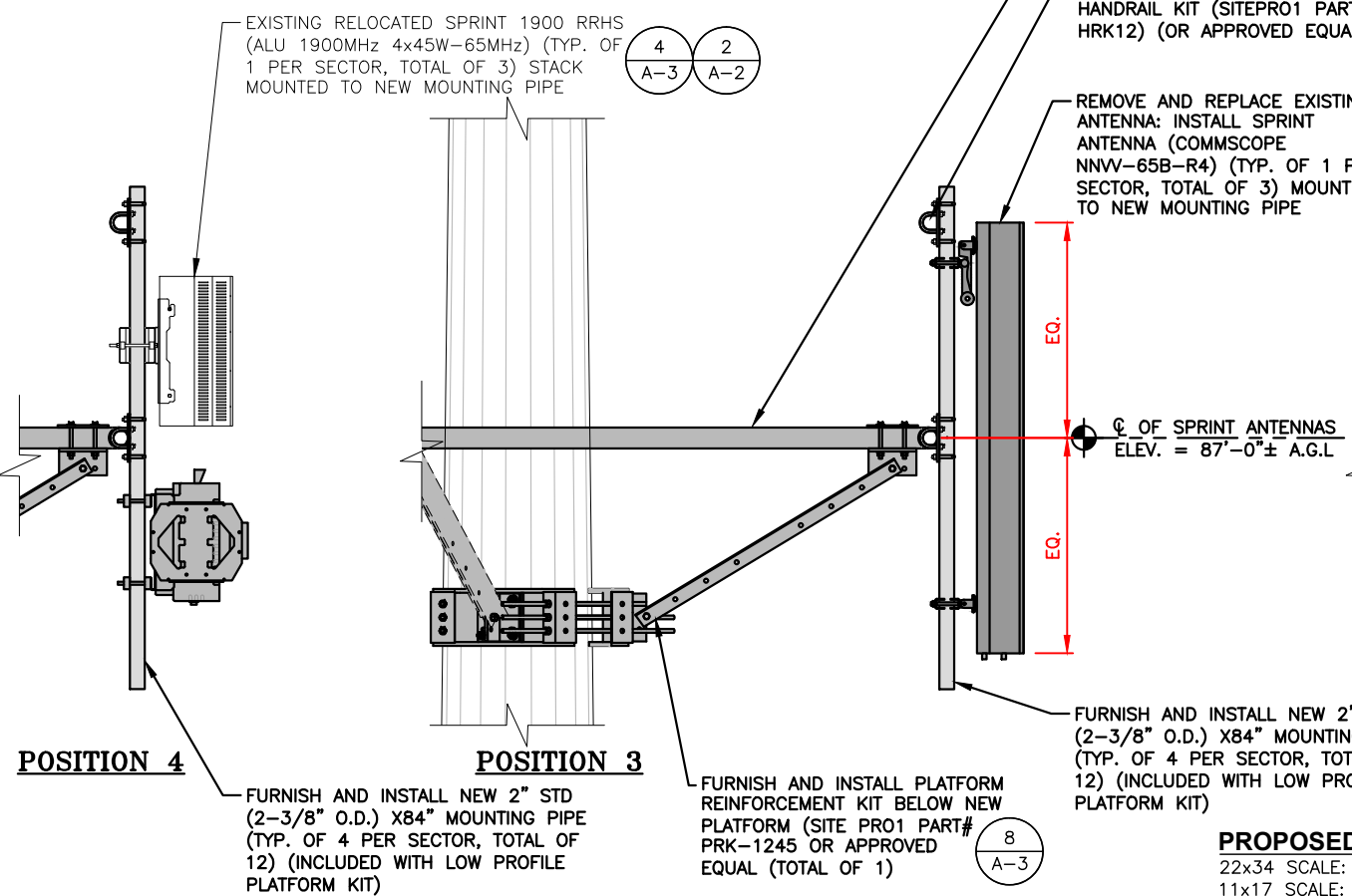

Sprint
 1 INTERNATIONAL BLVD, SUITE 800
 MAHWAH, NJ 07495
 TEL: (800) 357-7641

CROWN CASTLE
 CROWN CASTLE
 12 GILL STREET, SUITE 5800
 WOBURN, MA 01801

HDG HUDSON Design Group LLC
 45 BEECHWOOD DRIVE
 N. ANDOVER, MA 01845
 TEL: (978) 557-5553
 FAX: (978) 336-5986

STATE OF CONNECTICUT
 DEREK J. CREASER
 LICENSED PROFESSIONAL ENGINEER
 CONSTRUCTION DRAWINGS ARE VALID FOR SIX MONTHS AFTER THE DATE OF RECORD'S STAMP AND SIGNED SUBMITTAL DATE LISTED HEREIN

CHECKED BY: BB

APPROVED BY: DJC

SUBMITTALS			
REV.	DATE	DESCRIPTION	BY
1	08/13/18	CONSTRUCTION FINAL	BB
0	07/24/18	ISSUED FOR CONSTRUCTION	GA

SITE NUMBER: CT03XC168
 SITE NAME: HRT 106(B) 943202
 CROWN BU NUMBER: 806364
 SITE ADDRESS: 143 R OLD BLUE HILL ROAD
 DURHAM, CT 06422
 MIDDLESEX COUNTY

SHEET TITLE
 MOUNTING DETAILS
 (DO MACRO)

SHEET NUMBER
A-4



1 INTERNATIONAL BLVD, SUITE 800
MAHWAH, NJ 07495
TEL: (800) 357-7641



CROWN CASTLE
12 GILL STREET, SUITE 5800
WOBURN, MA 01801



45 BEECHWOOD DRIVE TEL: (978) 557-5553
N. ANDOVER, MA 01845 FAX: (978) 336-5986

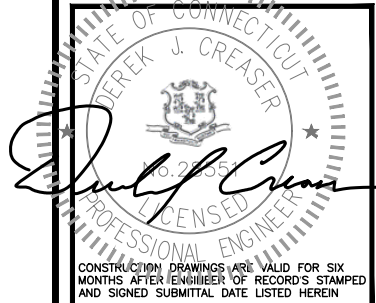

CONSTRUCTION DRAWINGS ARE VALID FOR SIX MONTHS AFTER ENGINEER OF RECORD'S STAMPED AND SIGNED SUBMITTAL DATE LISTED HEREIN

CHECKED BY: BB

APPROVED BY: DJC

SUBMITTALS

REV.	DATE	DESCRIPTION	BY
1	08/13/18	CONSTRUCTION FINAL	BB
0	07/24/18	ISSUED FOR CONSTRUCTION	GA

SITE NUMBER:
CT03XC168
SITE NAME:
HRT 106(B) 943202
CROWN BU NUMBER:
806364
SITE ADDRESS:
143 R OLD BLUE HILL ROAD
DURHAM, CT 06422
MIDDLESEX COUNTY

SHEET TITLE
RF DATA SHEET
(DO MACRO)

SHEET NUMBER
RF-1

NOTE:
RFDS HAS NOT BEEN PROVIDED BY CROWN CASTLE,
REFER TO CROWN APP REV #0 DATED 05/21/18

NOTE:
SPRINT CM SHALL CONFIRM HYBRID CABLE LENGTH,
COAX JUMPER LENGTH AND AISG CABLE LENGTH BEFORE
PREPARING BOM. A&E RECOMMENDED HYBRID CABLE
LENGTH BASED ON NV 2.5 EQUIPMENT AUDIT PLUS 20
FEET FOR (2) 10-FOOT COILS AT EACH END OF THE
FIBER TRUNK.

NOTE:
GENERAL CONTRACTOR/TOWER CREW SHALL VERIFY THAT
THE LATEST RF DATA SHEET IS USED FOR EQUIPMENT
INSTALLATION.

SPECIAL WORK NOTE:
JUMPERS (COAX/AISG) FROM THE 2.5 RRH TO THE 2.5
ANTENNA CANNOT EXCEED 15'. NOTIFY SPRINT
CONSTRUCTION MANAGER OF ANY DISCREPANCY.

RF DATA SHEET
SCALE: N.T.S



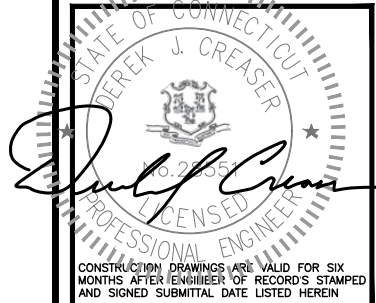

CHECKED BY: BB

APPROVED BY: DJC

SUBMITTALS

REV.	DATE	DESCRIPTION	BY
1	08/13/18	CONSTRUCTION FINAL	BB
0	07/24/18	ISSUED FOR CONSTRUCTION	GA

SITE NUMBER:
CT03XC168
SITE NAME:
HRT 106(B) 943202
CROWN BU NUMBER:
806364
SITE ADDRESS:
**143 R OLD BLUE HILL ROAD
DURHAM, CT 06422
MIDDLESEX COUNTY**

SHEET TITLE

WIRING DIAGRAM

(DO MACRO)

SHEET NUMBER

RF-2

Prepared By Mark Elliott	Revision Date March 13, 2018	Revision Number R1	
Approved By RAN Hardware & Antenna Teams	Approval Date Final-Macro Generated		

ALU 211 APXVTM14-ALU-I20 & NNVV-65B-R4 wo Filters

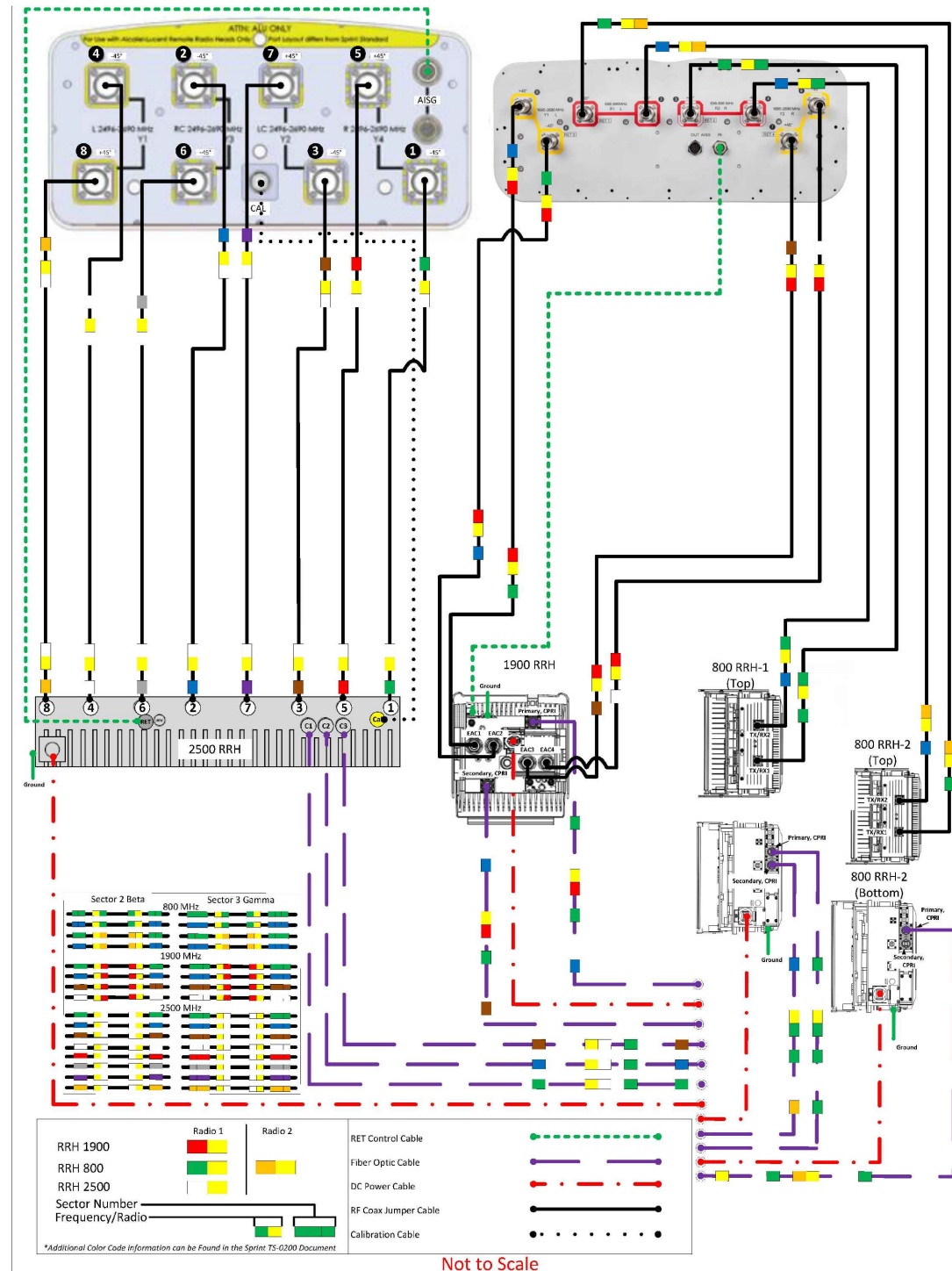

PLUMBING DIAGRAM
SCALE: N.T.S

1
RF-2

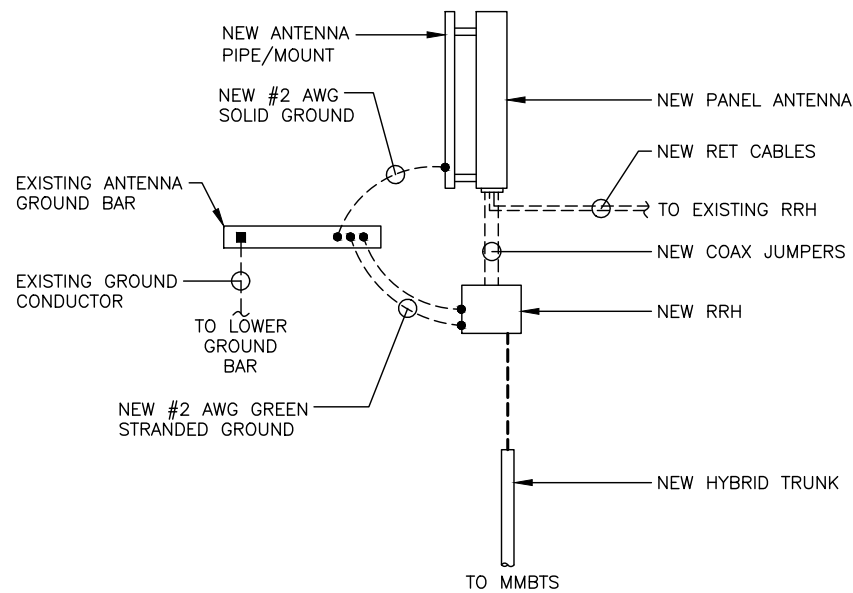

EQUIPMENT GROUNDING SCHEMATIC 1
 SCALE: N.T.S. G-1

PROTECTIVE GROUNDING SYSTEMS GENERAL NOTES:

- GROUNDING SHALL BE IN ACCORDANCE WITH NEC ARTICLE 250—GROUNDING AND BONDING.
- GROUNDING SHALL BE IN ACCORDANCE WITH SPRINT SSEO DOCUMENTS 3.018.02.004 "BONDING, GROUNDING AND TRANSIENT PROTECTION FOR CELL SITES" AND 3.018.10.002 "SITE RESISTANCE TO EARTH TESTING".
- PROVIDE GROUND CONNECTIONS FOR ALL METALLIC STRUCTURES, ENCLOSURES, RACEWAYS AND OTHER CONDUCTIVE ITEMS ASSOCIATED WITH THE INSTALLATION OF CARRIER'S EQUIPMENT.
- GROUND CONNECTIONS: CLEAN SURFACES THOROUGHLY BEFORE APPLYING GROUND LUGS OR CLAMPS. IF SURFACE IS COATED, REMOVE THE COATING, APPLY A NON-CORROSIVE APPROVED COMPOUND TO CLEAN SURFACE AND INSTALL LUGS OR CLAMPS. WHERE GALVANIZING IS REMOVED FROM METAL, IT SHALL BE PAINTED OR TOUCHED UP WITH "GALVAMOX" OR EQUAL.
- ALL GROUNDING WIRES SHALL PROVIDE A STRAIGHT, DOWNWARD PATH TO GROUND WITH GRADUAL BENDS AS REQUIRED. GROUND WIRES SHALL NOT BE LOOPED OR SHARPLY BENT.
- ALL CLAMPS AND SUPPORTS USED TO SUPPORT THE GROUNDING SYSTEM CONDUCTORS AND PVC CONDUITS SHALL BE PVC TYPE (NON CONDUCTIVE). DO NOT USE METAL BRACKETS OR SUPPORTS WHICH WOULD FORM A COMPLETE RING AROUND ANY GROUNDING CONDUCTOR.
- ALL GROUND WIRES SHALL BE #2 SOLID TINNED BCW UNLESS NOTED OTHERWISE.
- PROVIDE DEDICATED #2 AWG COPPER GROUND WIRE FROM EACH ANTENNA MOUNTING PIPE TO ASSOCIATED CIGBE.
- GROUND ANTENNA BASES, FRAMES, CABLE RACKS, AND OTHER METALLIC COMPONENTS WITH #2 INSULATED TINNED STRANDED COPPER GROUNDING CONDUCTORS AND CONNECT TO INSULATED SURFACE MOUNTED GROUND BARS. CONNECTION DETAILS SHALL FOLLOW MANUFACTURER'S SPECIFICATIONS FOR GROUNDING.
- EACH EQUIPMENT CABINET SHALL BE CONNECTED TO THE MASTER ISOLATION GROUND BAR (MGB) WITH #2 SOLID TINNED BCW EQUIPMENT CABINETS WALL HAVE (2) CONNECTIONS.
- GROUND HYBRIFLEX SHIELD AT TOP, BOTTOM AND AT TRANSITION TO HYBRIFLEX JUMPER CABLES AT EQUIPMENT CABINET ENTRANCE USING MANUFACTURER'S GUIDELINES. WHEN HYBRIFLEX CABLE EXCEEDS 200', GROUND AT INTERVALS NOT EXCEEDING 100'.
- THE CONTRACTOR SHALL VERIFY THAT THE EXISTING GROUND BARS HAVE ENOUGH SPACE/HOLES FOR ADDITIONAL TWO HOLE LUGS.
- EXOTHERMIC WELDING IS RECOMMENDED FOR GROUNDING CONNECTION WHERE PRACTICAL OTHERWISE. THE CONNECTION SHALL BE MADE USING COMPRESSION TYPE-2 HOLES, LONG BARREL LUGS OR DOUBLE CRIMP "C" CLAMP. THE COPPER CABLES SHALL BE COATED WITH AN ANTI-OXIDANT (THOMAS BETTS KOPR-SHILD) BEFORE MAKING THE CRIMP CONNECTIONS THE CONTRACTOR SHALL FOLLOW MANUFACTURER'S RECOMMENDED TORQUES ON THE BOLT ASSEMBLY TO SECURE CONNECTIONS.
- AT ALL TERMINATIONS AT EQUIPMENT ENCLOSURES, PANEL, AND FRAMES OF EQUIPMENT AND WHERE EXPOSED FOR GROUNDING, CONDUCTOR TERMINATION SHALL BE PERFORMED UTILIZING TWO HOLE BOLTED TONGUE COMPRESSION TYPE LUGS WITH STAINLESS STEEL SELF-TAPPING SCREWS.
- THE MASTER GROUND BAR (MGB) SHALL BE MADE OF BARE 1/4"x2" COPPER (FOR OUTDOOR APPLICATIONS IT SHALL BE TINNED COPPER) AND LARGE ENOUGH TO ACCOMMODATE THE REQUIRED NUMBER OF GROUND CONNECTIONS. THE HARDWARE SECURING THE MGB SHALL ELECTRICAL INSULATE THE MGB FROM ANY STRUCTURE TO WHICH IT IS FASTENED.
- ALL BOLTS, WASHERS, AND NUTS USED ON GROUNDING CONNECTIONS SHALL BE STAINLESS STEEL.
- ALL GROUNDING CONNECTIONS SHALL BE COATED WITH A COPPER SHIELD ANTI-CORROSIVE AGENT SUCH AS T&B KOPR SHIELD. VERIFY PRODUCT WITH SPRINT CONSTRUCTION MANAGER.
- FOR NEW OR REPAIRED GROUNDING EQUIPMENT. REFER TO SPRINT GROUNDING STANDARDS AND FOLLOWING (SUPPLEMENTS):
 -ANTI-THEFT UPDATE TO SPRINT GROUNDING DATED: 08-24-12 (OR CURRENT VERSION)
 -SPRINT ENGINEERING LETTER EL-0504 DATED: 04-20-12 (OR CURRENT VERSION)

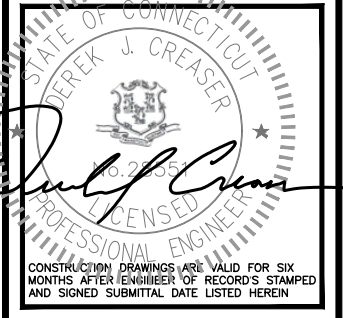
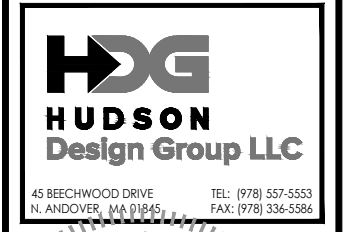

CONSTRUCTION DRAWINGS ARE VALID FOR SIX MONTHS AFTER ENGINEER OF RECORD'S STAMPED AND SIGNED SUBMITTAL DATE LISTED HEREIN

CHECKED BY: BB

APPROVED BY: DJC

SUBMITTALS

REV.	DATE	DESCRIPTION	BY
1	08/13/18	CONSTRUCTION FINAL	BB
0	07/24/18	ISSUED FOR CONSTRUCTION	GA

SITE NUMBER: CT03XC168
 SITE NAME: HRT 106(B) 943202
 CROWN BU NUMBER: 806364
 SITE ADDRESS: 143 R OLD BLUE HILL ROAD DURHAM, CT 06422 MIDDLESEX COUNTY

SHEET TITLE
ONE LINE DIAGRAM, GROUNDING DETAILS & NOTES
 (DO MACRO)

SHEET NUMBER
G-1

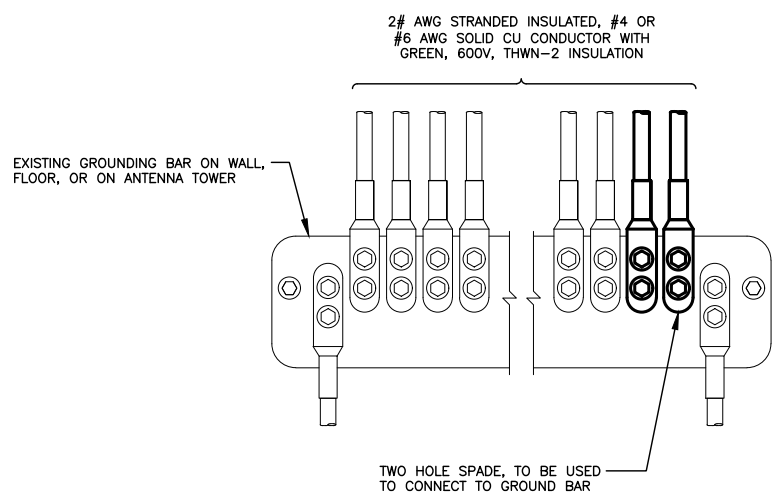

- NOTES**
- APPLY NO-OX TO LUG AND BAR CONTACT SURFACE. DO NOT COAT INLINE LUG.
 - IF STOLEN GROUND BARS ARE ENCOUNTERED, CONTACT SPRINT CM FOR REPLACEMENT THREADED ROD KIT.

INSTALLATION OF GROUNDING CONDUCTOR TO GROUNDING BAR 2
 SCALE: N.T.S. G-1

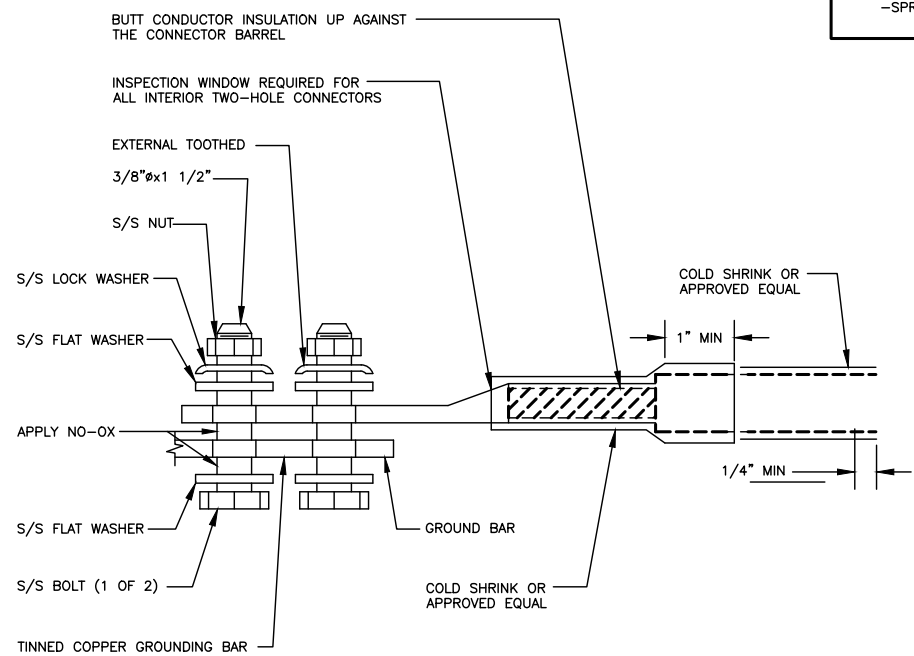

TWO HOLE LUG 3
 SCALE: N.T.S. G-1



McKay, Kristian

planningandzoning@townofdurhamct.org

Thu 12:59 PM

RE: Original zoning Approvals Cell Tower

Hello Zoning Department,

I work for Crown Castle and have an inquiry regarding the original zoning documents for a tower and I am hoping your office can provide more information.

We are applying for CSC Zoning Approval for Sprint to modify their antennas and new requirements ask that we procure original zoning documents from the jurisdiction, if possible. However, if these documents are not available, please let me know.

The tower is located on Old Blue Hill Rd. and according to lease documents it would have been constructed sometime in late 1993 or early 1994. Francis E. Behrens Jr. owned the property at the time and continues to do so.

If you have any questions, please don't hesitate to call or e-mail me.

Thank you,

Kristian McKay

Real Estate Specialist – East Area

T: (704) 405-6612 | M: (704) 713-5728 | F: (724) 416-6496

CROWN CASTLE

3530 Toringdon Way, Suite 300, Charlotte, NC 28277

Crowncastle.com

From: McKay, Kristian

Sent: Thursday, September 20, 2018 12:58 PM

To: planningandzoning@townofdurhamct.org

Subject: Original zoning Approvals Cell Tower

Date: **June 29, 2018**

Denice Nicholson
Crown Castle
3 Corporate Park Drive, Suite 101
Clifton Park, NY 12065



Crown Castle
2000 Corporate Drive
Canonsburg, PA 15317
(724) 416-2000

Subject: **Structural Analysis Report**

Carrier Designation: **Sprint PCS Co-Locate**
Carrier Site Number: CT03XC168
Carrier Site Name: CT03XC168

Crown Castle Designation: **Crown Castle BU Number:** 806364
Crown Castle Site Name: HRT 106(B) 943202
Crown Castle JDE Job Number: 505811
Crown Castle Work Order Number: 1595001
Crown Castle Order Number: 441307 Rev. 0

Engineering Firm Designation: **Crown Castle Project Number:** 1595001

Site Data: **143 R Old Blue Hill Road, DURHAM, Middlesex County, CT**
Latitude 41° 27' 33.67", Longitude -72° 39' 45.83"
120 Foot - Monopole Tower

Dear Denice Nicholson,

Crown Castle is pleased to submit this "**Structural Analysis Report**" to determine the structural integrity of the above mentioned tower. This analysis has been performed in accordance with the Crown Castle Structural 'Statement of Work' and the terms of Crown Castle Purchase Order Number 1595001, in accordance with order 441307, revision 0.

The purpose of the analysis is to determine acceptability of the tower stress level. Based on our analysis we have determined the tower stress level for the structure and foundation, under the following load case, to be:

LC7: Existing + Reserved + Proposed Equipment

Sufficient Capacity

Note: See Table I and Table II for the proposed and existing/reserved loading, respectively.

This analysis has been performed in accordance with the 2016 Connecticut State Building Code based upon an ultimate 3-second gust wind speed of 130 mph converted to a nominal 3-second gust wind speed of 101 mph per Section 1609.3 and Appendix N as required for use in the TIA-222-G Standard per Exception #5 of Section 1609.1.1. Exposure Category B and Risk Category II were used in this analysis.

All modifications and equipment proposed in this report shall be installed in accordance with the attached drawings for the determined available structural capacity to be effective.

We at *Crown Castle* appreciate the opportunity of providing our continuing professional services to you and Crown Castle. If you have any questions or need further assistance on this or any other projects please give us a call.

Structural analysis prepared by: Emma McCarty / SCK

Respectfully submitted by:

Maribel Dentinger, P.E.
Senior Project Engineer

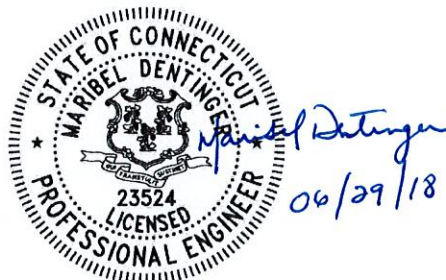

TABLE OF CONTENTS

1) INTRODUCTION

2) ANALYSIS CRITERIA

Table 1 - Proposed Antenna and Cable Information

Table 2 - Existing and Reserved Antenna and Cable Information

Table 3 - Design Antenna and Cable Information

3) ANALYSIS PROCEDURE

Table 4 - Documents Provided

3.1) Analysis Method

3.2) Assumptions

4) ANALYSIS RESULTS

Table 5 - Section Capacity (Summary)

Table 6 – Tower Component Stresses vs. Capacity – LC7

4.1) Recommendations

5) APPENDIX A

tnxTower Output

6) APPENDIX B

Base Level Drawing

7) APPENDIX C

Additional Calculations

1) INTRODUCTION

This tower is a 120 ft Monopole tower designed by VALMONT in March of 1994. The tower was originally designed for a wind speed of 90 mph per TIA/EIA-222-E.

2) ANALYSIS CRITERIA

The structural analysis was performed for this tower in accordance with the requirements of TIA-222-G Structural Standards for Steel Antenna Towers and Antenna Supporting Structures using a 3-second gust wind speed of 101 mph with no ice, 50 mph with 0.75 inch ice thickness and 60 mph under service loads, exposure category B.

Table 1 - Proposed Antenna and Cable Information

Mounting Level (ft)	Center Line Elevation (ft)	Number of Antennas	Antenna Manufacturer	Antenna Model	Number of Feed Lines	Feed Line Size (in)	Note
87.0	89.0	3	alcatel lucent	PCS 1900MHZ 4X45W-65MHZ	1 3	7/8 1-1/4	-
		6	alcatel lucent	RRH2X50-800			
		3	alcatel lucent	TD-RRH8X20-25			
		3	commscope	NNVV-65B-R4			
		3	rfs celwave	APXVTM14-ALU-I20			
	87.0	1	site pro1	RMQP-496			
		1	site pro1	HRK12			
		1	site pro1	PRK-1245			

Table 2 - Existing and Reserved Antenna and Cable Information

Mounting Level (ft)	Center Line Elevation (ft)	Number of Antennas	Antenna Manufacturer	Antenna Model	Number of Feed Lines	Feed Line Size (in)	Note
119.0	125.0	1	decibel	DB809MT3-XT	2	7/8	1
	123.0	1	decibel	DB201-A			
	119.0	2	tower mounts	Side Arm Mount [SO 701-1]			
116.0	116.0	9	andrew	SBNHH-1D65A w/ Mount Pipe	12 2 4	7/8 3/8 3/4	2
		3	ericsson	RRUS 11			
		3	ericsson	RRUS 32			
		3	ericsson	RRUS 32 B2			
		1	tower mounts	Miscellaneous [NA 507-1]			
		1	tower mounts	Platform Mount [LP 601-1]			
		1	tower mounts	Side Arm Mount [SO 102-3]			
	110.0	3	ericsson	RRUS 32 B2			
		1	raycap	DC6-48-60-18-8C			
		1	raycap	DC6-48-60-18-8F			
107.0	107.0	1	gabriel electronics	GLF6-450	1	7/8	1
		1	tower mounts	Pipe Mount [PM 601-1]			
98.0	100.0	3	alcatel lucent	B13 RRH4X30-4R	1	1/2	1

Mounting Level (ft)	Center Line Elevation (ft)	Number of Antennas	Antenna Manufacturer	Antenna Model	Number of Feed Lines	Feed Line Size (in)	Note
		3	alcatel lucent	B25 RRH4X30	12	7/8	
		3	alcatel lucent	B66A RRH4X45			
		6	andrew	SBNHH-1D65B w/ Mount Pipe			
		6	antel	LPA-80080/6CF w/ Mount Pipe			
		2	raycap	RXXDC-3315-PF-48			
	98.0	1	tower mounts	Platform Mount [LP 602-1]			
87.0	89.0	6	decibel	DB980H90E-M w/ Mount Pipe	6	1-1/4	3
	87.0	1	tower mounts	Platform Mount [LP 602-1]			
73.0	79.0	1	decibel	DB636-C	1	7/8	1
	73.0	1	commscope	SHP2-13	4	1-5/8 1/2	2
		3	ericsson	AIR 21 B2A/B4P			
		3	ericsson	AIR32 DB B66Aa B2a			
		3	ericsson	KRY 112 144/1			
		3	ericsson	RADIO 4449			
		3	rfs celwave	APXVAA24_43-U-A20			
1	Site pro1	RMQP-496-HK Mount					
50.0	57.0	1	rfs celwave	PD1142-1	3	1/2 7/8	1
	54.0	1	decibel	ASP-655			
	53.0	1	rfs celwave	PD1121-6			
	50.0	1	decibel	DB492A			
		2	tower mounts	Side Arm Mount [SO 701-1]			
40.0	41.0	1	tekelec systemes	EPSILON GPS ANTENNA 35 DB	1	1/2 Conduit	1
	40.0	1	tower mounts	Side Arm Mount [SO 701-1]	1		

Notes:

- 1) Existing Equipment
- 2) Reserved Equipment
- 3) Equipment to be Removed; Not Considered in Analysis

Table 3 - Design Antenna and Cable Information

Mounting Level (ft)	Center Line Elevation (ft)	Number of Antennas	Antenna Manufacturer	Antenna Model	Number of Feed Lines	Feed Line Size (in)
97	97	12	-	8RL41OC4R105	-	-
87	87	9	-	8RL41OC4R105	-	-
75	75	1	-	ASP710	-	-
		1	Telewave	450F6 Antenna		
50	50	1	-	ASP701	-	-
		1	-	ASP710		

3) ANALYSIS PROCEDURE

Table 4 - Documents Provided

Document	Remarks	Reference	Source
4-GEOTECHNICAL REPORTS	Clarence Welti Assoc., Inc.	262150	CCISITES
4-TOWER FOUNDATION DRAWINGS/DESIGN/SPECS	SAC Engineering, Inc.	297341	CCISITES
4-TOWER MANUFACTURER DRAWINGS	Valmont	262153	CCISITES
4-TOWER STRUCTURAL ANALYSIS REPORTS	Valmont Microflect (20' extension design)	942187	CCISITES

3.1) Analysis Method

tnxTower (version 7.0.5.1), a commercially available analysis software package, was used to create a three-dimensional model of the tower and calculate member stresses for various loading cases. Selected output from the analysis is included in Appendix A.

3.2) Assumptions

- 1) Tower and structures were built in accordance with the manufacturer's specifications.
- 2) The tower and structures have been maintained in accordance with the manufacturer's specification.
- 3) The configuration of antennas, transmission cables, mounts and other appurtenances are as specified in Tables 1 and 2 and the referenced drawings.
- 4) The existing base plate grout was not considered in this analysis.

This analysis may be affected if any assumptions are not valid or have been made in error. Crown Castle should be notified to determine the effect on the structural integrity of the tower.

4) ANALYSIS RESULTS

Table 5 - Section Capacity (Summary)

Section No.	Elevation (ft)	Component Type	Size	Critical Element	P (K)	SF*P_allow (K)	% Capacity	Pass / Fail
L1	120 - 100	Pole	TP20.263x15.403x0.1875	1	-4.04	829.59	33.6	Pass
L2	100 - 47.0833	Pole	TP33.13x20.263x0.2813	2	-21.22	1920.74	94.7	Pass
L3	47.0833 - 0	Pole	TP44x31.372x0.375	3	-35.20	3477.10	89.5	Pass
							Summary	
						Pole (L2)	94.7	Pass
						Rating =	94.7	Pass

Table 6 - Tower Component Stresses vs. Capacity – LC7

Notes	Component	Elevation (ft)	% Capacity	Pass / Fail
1	Flange Bolts	100	49.5	Pass
1	Flange Plates		13.4	Pass
1	Anchor Rods	0	83.9	Pass
1	Base Plate	0	45.5	Pass
1	Base Foundation (Structure)	0	10.5	Pass
1	Base Foundation (Soil Interaction)	0	40.8	Pass

Structure Rating (max from all components) =	94.7%
---	--------------

Notes:

- 1) See additional documentation in "Appendix C – Additional Calculations" for calculations supporting the % capacity consumed.

4.1) Recommendations

The tower and its foundation have sufficient capacity to carry the proposed load configuration. No modifications are required at this time.



RADIO FREQUENCY EMISSIONS ANALYSIS REPORT EVALUATION OF HUMAN EXPOSURE POTENTIAL TO NON-IONIZING EMISSIONS

SPRINT Existing Facility

Site ID: CT03XC168

HRT 106(B) 943202
143 R Old Blue Hill Road
Durham, CT 06422

September 17, 2018

EBI Project Number: 6218006112

Site Compliance Summary	
Compliance Status:	COMPLIANT
Site total MPE% of FCC general population allowable limit:	41.54 %



September 17, 2018

SPRINT

Attn: RF Engineering Manager
1 International Boulevard, Suite 800
Mahwah, NJ 07495

Emissions Analysis for Site: **CT03XC168 – HRT 106(B) 943202**

EBI Consulting was directed to analyze the proposed SPRINT facility located at **143 R Old Blue Hill Road, Durham, CT**, for the purpose of determining whether the emissions from the Proposed SPRINT Antenna Installation located on this property are within specified federal limits.

All information used in this report was analyzed as a percentage of current Maximum Permissible Exposure (% MPE) as listed in the FCC OET Bulletin 65 Edition 97-01 and ANSI/IEEE Std C95.1. The FCC regulates Maximum Permissible Exposure in units of microwatts per square centimeter ($\mu\text{W}/\text{cm}^2$). The number of $\mu\text{W}/\text{cm}^2$ calculated at each sample point is called the power density. The exposure limit for power density varies depending upon the frequencies being utilized. Wireless Carriers and Paging Services use different frequency bands each with different exposure limits, therefore it is necessary to report results and limits in terms of percent MPE rather than power density.

All results were compared to the FCC (Federal Communications Commission) radio frequency exposure rules, 47 CFR 1.1307(b)(1) – (b)(3), to determine compliance with the Maximum Permissible Exposure (MPE) limits for General Population/Uncontrolled environments as defined below.

General population/uncontrolled exposure limits apply to situations in which the general population may be exposed or in which persons who are exposed as a consequence of their employment may not be made fully aware of the potential for exposure or cannot exercise control over their exposure. Therefore, members of the general population would always be considered under this category when exposure is not employment related, for example, in the case of a telecommunications tower that exposes persons in a nearby residential area.

General population exposure to radio frequencies is regulated and enforced in units of microwatts per square centimeter ($\mu\text{W}/\text{cm}^2$). The general population exposure limits for the 850 MHz Band is approximately $567 \mu\text{W}/\text{cm}^2$. The general population exposure limit for the 1900 MHz (PCS) and 2500 MHz (BRS) bands is $1000 \mu\text{W}/\text{cm}^2$. Because each carrier will be using different frequency bands, and each frequency band has different exposure limits, it is necessary to report percent of MPE rather than power density.



Occupational/controlled exposure limits apply to situations in which persons are exposed as a consequence of their employment and in which those persons who are exposed have been made fully aware of the potential for exposure and can exercise control over their exposure. Occupational/controlled exposure limits also apply where exposure is of a transient nature as a result of incidental passage through a location where exposure levels may be above general population/uncontrolled limits (see below), as long as the exposed person has been made fully aware of the potential for exposure and can exercise control over his or her exposure by leaving the area or by some other appropriate means.

Additional details can be found in FCC OET 65.

CALCULATIONS

Calculations were done for the proposed SPRINT Wireless antenna facility located at **143 R Old Blue Hill Road, Durham, CT**, using the equipment information listed below. All calculations were performed per the specifications under FCC OET 65. Since SPRINT is proposing highly focused directional panel antennas, which project most of the emitted energy out toward the horizon, all calculations were performed assuming a lobe representing the maximum gain of the antenna per the antenna manufactures supplied specifications, minus 10 dB for directional panel antennas, was focused at the base of the tower. For this report the sample point is the top of a 6-foot person standing at the base of the tower.

For all calculations, all equipment was calculated using the following assumptions:

- 1) 1 CDMA channels (850 MHz) were considered for each sector of the proposed installation. These Channels have a transmit power of 20 Watts per Channel.
- 2) 2 LTE channels (850 MHz) were considered for each sector of the proposed installation. These Channels have a transmit power of 50 Watts per Channel.
- 3) 5 CDMA channels (1900 MHz (PCS)) were considered for each sector of the proposed installation. These Channels have a transmit power of 16 Watts per Channel.
- 4) 2 LTE channels (1900 MHz (PCS)) were considered for each sector of the proposed installation. These Channels have a transmit power of 40 Watts per Channel.
- 5) 8 LTE channels (2500 MHz (BRS)) were considered for each sector of the proposed installation. These Channels have a transmit power of 20 Watts per Channel.



- 6) All radios at the proposed installation were considered to be running at full power and were uncombined in their RF transmissions paths per carrier prescribed configuration. Per FCC OET Bulletin No. 65 - Edition 97-01 recommendations to achieve the maximum anticipated value at each sample point, all power levels emitting from the proposed antenna installation are increased by a factor of 2.56 to account for possible in-phase reflections from the surrounding environment. This is rarely the case, and if so, is never continuous.
- 7) For the following calculations, the sample point was the top of a 6-foot person standing at the base of the tower. The maximum gain of the antenna per the antenna manufactures supplied specifications, minus 10 dB for directional panel antennas, was used in this direction. This value is a very conservative estimate as gain reductions for these particular antennas are typically much higher in this direction.
- 8) The antennas used in this modeling are the **Commscope NNVV-65B-R4 and the RFS APXVTM14-ALU-I20** for transmission in the 850 MHz, 1900 MHz (PCS) and 2500 MHz (BRS) frequency bands. This is based on feedback from the carrier with regards to anticipated antenna selection. Maximum gain values for all antennas are listed in the Inventory and Power Data table below. The maximum gain of the antenna per the antenna manufactures supplied specifications, minus 10 dB for directional panel antennas, was used for all calculations. This value is a very conservative estimate as gain reductions for these particular antennas are typically much higher in this direction.
- 9) The antenna mounting height centerlines of the proposed panel antennas are **89 feet** above ground level (AGL) for **Sector A**, **89 feet** above ground level (AGL) for **Sector B** and **89 feet** above ground level (AGL) for Sector C.
- 10) Emissions values for additional carriers were taken from the Connecticut Siting Council active database. Values in this database are provided by the individual carriers themselves.

All calculations were done with respect to uncontrolled / general population threshold limits.



SPRINT Site Inventory and Power Data by Antenna

Sector:	A	Sector:	B	Sector:	C
Antenna #:	1	Antenna #:	1	Antenna #:	1
Make / Model:	Commscope NNVV-65B-R4	Make / Model:	Commscope NNVV-65B-R4	Make / Model:	Commscope NNVV-65B-R4
Gain:	12.75 / 15.05 dBd	Gain:	12.75 / 15.05 dBd	Gain:	12.75 / 15.05 dBd
Height (AGL):	89 feet	Height (AGL):	89 feet	Height (AGL):	89 feet
Frequency Bands	850 MHz / 1900 MHz (PCS)	Frequency Bands	850 MHz / 1900 MHz (PCS)	Frequency Bands	850 MHz / 1900 MHz (PCS)
Channel Count	10	Channel Count	10	Channel Count	10
Total TX Power(W):	280 Watts	Total TX Power(W):	280 Watts	Total TX Power(W):	280 Watts
ERP (W):	7,378.61	ERP (W):	7,378.61	ERP (W):	7,378.61
Antenna A1 MPE%	4.75 %	Antenna B1 MPE%	4.75 %	Antenna C1 MPE%	4.75 %
Antenna #:	2	Antenna #:	2	Antenna #:	2
Make / Model:	RFS APXVTM14-ALU-I20	Make / Model:	RFS APXVTM14-ALU-I20	Make / Model:	RFS APXVTM14-ALU-I20
Gain:	15.9 dBd	Gain:	15.9 dBd	Gain:	15.9 dBd
Height (AGL):	89 feet	Height (AGL):	89 feet	Height (AGL):	89 feet
Frequency Bands	2500 MHz (BRS)	Frequency Bands	2500 MHz (BRS)	Frequency Bands	2500 MHz (BRS)
Channel Count	8	Channel Count	8	Channel Count	8
Total TX Power(W):	160 Watts	Total TX Power(W):	160 Watts	Total TX Power(W):	160 Watts
ERP (W):	6,224.72	ERP (W):	6,224.72	ERP (W):	6,224.72
Antenna A2 MPE%	3.25 %	Antenna B2 MPE%	3.25 %	Antenna C2 MPE%	3.25 %

Site Composite MPE%	
Carrier	MPE%
SPRINT – Max per sector	8.00 %
T-Mobile	15.57 %
AT&T	5.84 %
Verizon Wireless	8.10 %
Town	4.03 %
Site Total MPE %:	41.54 %

SPRINT Sector A Total:	8.00 %
SPRINT Sector B Total:	8.00 %
SPRINT Sector C Total:	8.00 %
Site Total:	41.54 %

SPRINT _ Frequency Band / Technology (Per Sector)	# Channels	Watts ERP (Per Channel)	Height (feet)	Total Power Density ($\mu\text{W}/\text{cm}^2$)	Frequency (MHz)	Allowable MPE ($\mu\text{W}/\text{cm}^2$)	Calculated % MPE
Sprint 850 MHz CDMA	1	376.73	89	1.95	850 MHz	567	0.34%
Sprint 850 MHz LTE	2	941.82	89	9.83	850 MHz	567	1.73%
Sprint 1900 MHz (PCS) CDMA	5	511.82	89	13.35	1900 MHz (PCS)	1000	1.34%
Sprint 1900 MHz (PCS) LTE	2	1,279.56	89	13.35	1900 MHz (PCS)	1000	1.34%
Sprint 2500 MHz (BRS) LTE	8	778.09	89	32.48	2500 MHz (BRS)	1000	3.25%
						Total:	8.00%



Summary

All calculations performed for this analysis yielded results that were **within** the allowable limits for general population exposure to RF Emissions.

The anticipated maximum composite contributions from the SPRINT facility as well as the site composite emissions value with regards to compliance with FCC's allowable limits for general population exposure to RF Emissions are shown here:

SPRINT Sector	Power Density Value (%)
Sector A:	8.00 %
Sector B:	8.00 %
Sector C:	8.00 %
SPRINT Maximum MPE % (per sector):	8.00 %
Site Total:	41.54 %
Site Compliance Status:	COMPLIANT

The anticipated composite MPE value for this site assuming all carriers present is **41.54 %** of the allowable FCC established general population limit sampled at the ground level. This is based upon values listed in the Connecticut Siting Council database for existing carrier emissions.

FCC guidelines state that if a site is found to be out of compliance (over allowable thresholds), that carriers over a 5% contribution to the composite value will require measures to bring the site into compliance. For this facility, the composite values calculated were well within the allowable 100% threshold standard per the federal government.

773285322723 

Delivered
Friday 9/21/2018 at 9:58 am

**DELIVERED**

Signed for by: M.JANETTE

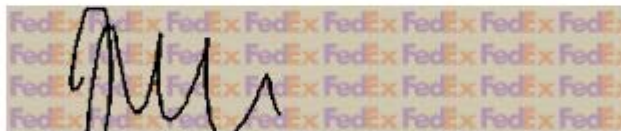
[GET STATUS UPDATES](#)[OBTAIN PROOF OF DELIVERY](#)**FROM**

Kristian McKay
STE 300
3530 Toringdon Way
CHARLOTTE, NC US 28277
704 405-6612

TO

Durham Town Hall
Geoffrey Colegrove
30 Town House Rd.
DURHAM, CT US 06422
704 405-6612

773285360404 

Delivered
Friday 9/21/2018 at 9:58 am

**DELIVERED**

Signature not required

[GET STATUS UPDATES](#)[OBTAIN PROOF OF DELIVERY](#)**FROM**

Kristian McKay
STE 300
3530 Toringdon Way
CHARLOTTE, NC US 28277
704 405-6612

TO

Francis E Behrens Jr.
109 Old Blue Hill Rd.
DURHAM, CT US 06422
704 405-6612

[Travel History](#)[Shipment Facts](#)

773285285162 

Delivered
Friday 9/21/2018 at 9:58 am

**DELIVERED**

Signed for by: M.JANETTE

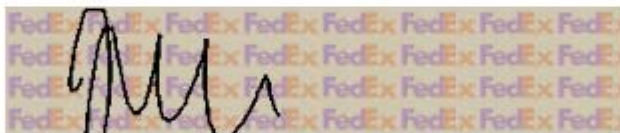
[GET STATUS UPDATES](#)[OBTAIN PROOF OF DELIVERY](#)**FROM**

Kristian McKay
STE 300
3530 Toringdon Way
CHARLOTTE, NC US 28277
704 405-6612

TO

Durham Town Hall
Laura L. Francis
30 Town House Rd.
DURHAM, CT US 06422
704 405-6612