



QC Development

PO Box 916

Storrs, CT 06268

860-670-9068

Mark.Roberts@QCDevelopment.net

April 14, 2017

Melanie A. Bachman
Acting Executive Director
Connecticut Siting Council
10 Franklin Square
New Britain, CT 06051

Notice of Exempt Modification – New Cingular Wireless PCS, LLC (AT&T) – CT5841
143R Old Blue Hills Road, Durham, CT 06422
N 41-27-33.69
W 72-39-45.82

Dear Ms. Bachman:

AT&T currently maintains nine (9) antennas at the 74-foot level of the existing 120-foot Monopole at 143R Old Blue Hills Road, Durham, CT. The tower is owned by Crown Castle. The property is owned by Frances E. Behrens Jr. and Marie C. Castano. AT&T now intends to remove its antenna equipment from the 74-foot level of the monopole and install six (6) new Andrew antennas on a new platform mount at the 114-foot level. This level of the tower was previously occupied by Nextel antennas, which have now been decommissioned and removed. AT&T will also install three (3) Ericsson RRUS-11 and three (4) Ericsson RRUS-B2 units on the same platform mount.

This facility was approved by the Connecticut Siting Council in Docket # 161 on March 11, 1994 and later approved for extension of the monopole to 120' AGL (132' with appurtenances) per Petition # 697 on May 11, 2005. Since no further modification to the overall facility height is proposed, this modification therefore complies with the aforementioned approvals.

Please accept this letter as notification pursuant to Regulations of Connecticut State Agencies § 16-50j-73, for construction that constitutes an exempt modification pursuant to R.C.S.A. § 16-50j-72(b)(2). In accordance with R.C.S.A. § 16-50j-73, a copy of this letter is being sent to Laura L.

Francis, First Selectman of the Town of Durham, the Durham Building & Zoning Department as well as the property owner and the tower owner.

The planned modifications to the facility fall squarely within those activities explicitly provided for in R.C.S.A. § 16-50j-72(b)(2).

1. The proposed modifications will not result in an increase in the height of the existing structure.
2. The proposed modifications will not require the extension of the site boundary.
3. The proposed modifications will not increase noise levels at the facility by six decibels or more, or to levels that exceed state and local criteria.
4. The operation of the replacement antennas will not increase radio frequency emissions at the facility to a level at or above the Federal Communications Commission safety standard.
5. The proposed modifications will not cause a change or alteration in the physical or environmental characteristics of the site.
6. The existing structure and its foundation can support the proposed loading.

For the foregoing reasons, AT&T respectfully submits that the proposed modifications to the above-referenced telecommunications facility constitute an exempt modification under R.C.S.A. § 16-50j-72(b)(2).

Please feel free to call me at (860) 670-9068 with any questions regarding this matter. Thank you for your consideration.

Sincerely,

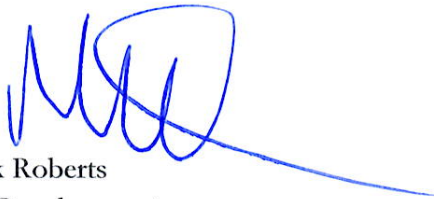

Mark Roberts
QC Development
Consultant for AT&T

Attachments

cc: Laura L. Francis- as elected official (via e-mail)
Dick McManus – Building Inspector (via e-mail)
Crown Castle - as tower owner (via e-mail)
Frances E. Behrens Jr. and Marie C. Castano - as property owners

Power Density

Existing Loading on Tower

Carrier	# of Channels	ERP/Ch (W)	Antenna Centerline Height (ft)	Power Density (mW/cm ²)	Freq. Band (MHz ^{**})	Limit S (mW/cm ²)	%MPE
Other Carriers*							19.47%
AT&T GSM	1	283	74	0.0220	880	0.5867	0.38%
AT&T GSM	2	875	74	0.1361	1900	1.0000	1.36%
AT&T UMTS	2	565	74	0.0879	880	0.5867	1.50%
AT&T LTE	1	1313	74	0.1021	734	0.4933	2.09%
AT&T LTE	4	525	74	0.1633	1900	1.0000	1.63%
Site Total							26.42%

*Per CSC Records (available upon request, includes calculation formulas)

** If a range of frequencies are used, such as 880-894, enter the lowest value, i.e. 880

Proposed Loading on Tower

Carrier	# of Channels	ERP/Ch (W)	Antenna Centerline Height (ft)	Power Density (mW/cm ²)	Freq. Band (MHz ^{**})	Limit S (mW/cm ²)	%MPE
Other Carriers*							18.88%
AT&T UMTS	2	299	114	0.0184	880	0.5867	0.31%
AT&T LTE	2	1119	114	0.0690	734	0.4893	1.41%
AT&T LTE	2	3304	74	0.2037	1900	1.0000	2.04%
Site Total							22.64%

*Per CSC Records (available upon request, includes calculation formulas) but with NEXTEL removed.

** If a range of frequencies are used, such as 880-894, enter the lowest value, i.e. 880



at&t Mobility

**SITE NAME: DURHAM CENTRAL
AT&T SITE NUMBER: CT5841
CROWN CASTLE BU #: 806364
143R OLD BLUE HILLS ROAD
DURHAM, CT 06422**

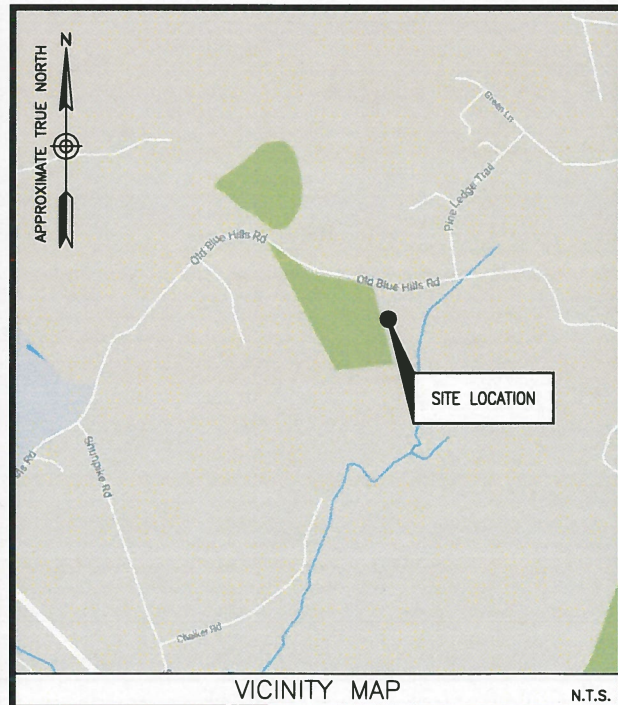

DIRECTIONS FROM 500 ENTERPRISE DRIVE, ROCKY HILL, CT:
HEAD NORTHEAST ON ENTERPRISE DR TOWARD CAPITAL BLVD. TURN LEFT ONTO CAPITAL BLVD. USE THE LEFT 2 LANES TO TURN LEFT ONTO STATE HWY 411. TURN LEFT TO MERGE ONTO I-91 S. USE THE LEFT LANE TO TAKE EXIT 22S TO MERGE ONTO CT-9 S TOWARD MIDDLETOWN/OLD SAYBROOK. TAKE EXIT 13 FOR STATE ROUTE 17 S TOWARD NEW HAVEN. CONTINUE ONTO CT-17 S. TURN LEFT ONTO MADISON RD. TURN LEFT ONTO OLD BLUE HILLS RD. SITE WILL BE ON THE RIGHT.

SITE COORDINATES:
LATITUDE: 41°-27'-33.71" N (NAD83)
LONGITUDE: 72°-39'-45.90" W (NAD83)
(PER GOOGLE EARTH)

ELEVATION DATA:
GRADE ELEVATION AT TOWER = 540'± A.M.S.L.
(PER GOOGLE EARTH)

SITE INFORMATION

- REMOVE ALL EXISTING TOWER MOUNTED EQUIPMENT AT A CENTERLINE ELEVATION OF 75'-0"± A.G.L., INCLUDING COAX CABLES & INNERDUCT.
 - INSTALL NEW ANTENNA PLATFORM WITH HANDRAIL AT A NEW CENTERLINE ELEVATION OF 114'-0"± A.G.L.
 - INSTALL NEW ANTENNAS (TYP.-2 PER SECTOR) (6 TOTAL)
 - RELOCATE EXISTING RRUS-11 TO NEW ANTENNA PLATFORM (TYP.-1 PER SECTOR) (3 TOTAL)
 - INSTALL NEW 1900 RRUS-32 B2 (TYP.-1 PER SECTOR) (3 TOTAL)
 - INSTALL NEW (6) 1-5/8"Ø COAX CABLES & (1) FIBER, (2) DC CABLES AND (3) RET CABLES HOUSED IN FLEX INNERDUCT
- PROJECT DESCRIPTION

SITE NAME:
DURHAM CENTRAL
AT&T SITE NUMBER:
CT5841
CROWN CASTLE BU #:
806364
SITE ADDRESS:
143R OLD BLUE HILLS ROAD
DURHAM, CT 06422
MIDDLESEX COUNTY
TOWER OWNER:
CROWN CASTLE
12 GILL STREET, SUITE 5800
WOBURN, MA 01801
APPLICANT/LESSEE:
AT&T MOBILITY
500 ENTERPRISE DRIVE, SUITE 3A
ROCKY HILL, CT 06067

PROJECT INFORMATION

THIS DOCUMENT WAS DEVELOPED TO REFLECT A SPECIFIC SITE AND ITS SITE CONDITIONS AND IS NOT TO BE USED FOR ANOTHER SITE OR WHEN OTHER CONDITIONS PERTAIN. REUSE OF THIS DOCUMENT IS AT THE SOLE RISK OF THE USER.

A.D.A. COMPLIANCE:
FACILITY IS UNMANNED AND NOT FOR HUMAN HABITATION.

SHEET NUMBER	DESCRIPTION
T-1	TITLE SHEET
G-1	GENERAL NOTES
C-1	COMPOUND PLAN
C-2	EXISTING & PROPOSED EQUIPMENT LAYOUTS
C-3	ANTENNA LAYOUTS & ELEVATIONS
C-4	CONSTRUCTION DETAILS
E-1	GROUNDING NOTES & DETAILS

SHEET INDEX



500 ENTERPRISE DRIVE SUITE 3A
ROCKY HILL, CT 06067



27 NORTHWESTERN DRIVE
SALEM, NH 03079

**CT5841
DURHAM CENTRAL
CROWN BU #: 806364**

CONSTRUCTION DRAWINGS	
0	04/07/17 ISSUED FOR CONSTRUCTION
A	03/17/17 ISSUED FOR REVIEW

Dewberry[®]
Dewberry Engineers Inc.
800 PARSIPPANY ROAD
SUITE 301
PARSIPPANY, NJ 07054
PHONE: 973.739.9400
FAX: 973.739.9710



DRAWN BY: BJR
REVIEWED BY: BSH
CHECKED BY: GHN
PROJECT NUMBER: 50055106
JOB NUMBER: 50065688
SITE ADDRESS:

143R OLD BLUE HILLS RD
DURHAM, CT 06422
MIDDLESEX COUNTY

SHEET TITLE:
TITLE SHEET
SHEET NUMBER:

T-1

GENERAL NOTES:

- FOR THE PURPOSE OF CONSTRUCTION DRAWING, THE FOLLOWING DEFINITIONS SHALL APPLY:
PROJECT MANAGEMENT - SAI COMMUNICATIONS, INC.
CONTRACTOR - GENERAL CONTRACTOR (CONSTRUCTION)
OWNER - AT&T MOBILITY
OEM - ORIGINAL EQUIPMENT MANUFACTURER
- PRIOR TO THE SUBMISSION OF BIDS, THE BIDDING CONTRACTOR SHALL VISIT THE CELL SITE TO FAMILIARIZE WITH THE EXISTING CONDITIONS AND TO CONFIRM THAT THE WORK CAN BE ACCOMPLISHED AS SHOWN ON THE CONSTRUCTION DRAWINGS. ANY DISCREPANCY FOUND SHALL BE BROUGHT TO THE ATTENTION OF PROJECT MANAGEMENT.
- ALL MATERIALS FURNISHED AND INSTALLED SHALL BE IN STRICT ACCORDANCE WITH ALL APPLICABLE CODES, REGULATIONS, AND ORDINANCES. CONTRACTOR SHALL ISSUE ALL APPROPRIATE NOTICES AND COMPLY WITH ALL LAWS, ORDINANCES, RULES, REGULATIONS, AND LAWFUL ORDERS OF ANY PUBLIC AUTHORITY REGARDING THE PERFORMANCE OF THE WORK.
- ALL WORK CARRIED OUT SHALL COMPLY WITH ALL APPLICABLE MUNICIPAL AND UTILITY COMPANY SPECIFICATIONS AND LOCAL JURISDICTIONAL CODES, ORDINANCES AND APPLICABLE REGULATIONS.
- DRAWINGS PROVIDED HERE ARE NOT TO SCALE UNLESS OTHERWISE NOTED AND ARE INTENDED TO SHOW OUTLINE ONLY.
- UNLESS NOTED OTHERWISE, THE WORK SHALL INCLUDE FURNISHING MATERIALS, EQUIPMENT, APPURTENANCES, AND LABOR NECESSARY TO COMPLETE ALL INSTALLATIONS AS INDICATED ON THE DRAWINGS.
- THE CONTRACTOR SHALL INSTALL ALL EQUIPMENT AND MATERIALS IN ACCORDANCE WITH MANUFACTURER'S RECOMMENDATIONS UNLESS SPECIFICALLY STATED OTHERWISE.
- IF THE SPECIFIED EQUIPMENT CANNOT BE INSTALLED AS SHOWN ON THESE DRAWINGS, THE CONTRACTOR SHALL PROPOSE AN ALTERNATIVE INSTALLATION FOR APPROVAL BY PROJECT MANAGEMENT.
- CONTRACTOR SHALL DETERMINE ACTUAL ROUTING OF CONDUIT, POWER AND T1 CABLES, GROUNDING CABLES AS SHOWN ON THE POWER, GROUNDING AND TELCO PLAN DRAWING. CONTRACTOR SHALL UTILIZE EXISTING TRAYS AND/OR SHALL ADD NEW TRAYS AS NECESSARY. CONTRACTOR SHALL CONFIRM THE ACTUAL ROUTING WITH PROJECT MANAGEMENT.
- THE CONTRACTOR SHALL PROTECT EXISTING IMPROVEMENTS, PAVEMENTS, CURBS, LANDSCAPING AND STRUCTURES. ANY DAMAGED PART SHALL BE REPAIRED AT CONTRACTOR'S EXPENSE TO THE SATISFACTION OF THE OWNER.
- CONTRACTOR SHALL LEGALLY AND PROPERLY DISPOSE OF ALL SCRAP MATERIALS SUCH AS COAXIAL CABLES AND OTHER ITEMS REMOVED FROM THE EXISTING FACILITY. ANTENNAS REMOVED SHALL BE RETURNED TO THE OWNER'S DESIGNATED LOCATION.
- CONTRACTOR SHALL LEAVE PREMISES IN CLEAN CONDITION.
- THE CONTRACTOR SHALL SUPERVISE AND DIRECT THE PROJECT DESCRIBED HEREIN. THE CONTRACTOR SHALL BE SOLELY RESPONSIBLE FOR ALL CONSTRUCTION MEANS, METHODS, TECHNIQUES, SEQUENCES, AND PROCEDURES AND FOR COORDINATING ALL PORTIONS OF THE WORK UNDER THE CONTRACT.
- CONTRACTOR SHALL NOTIFY DEWBERRY 48 HOURS IN ADVANCE OF POURING CONCRETE, OR BACKFILLING TRENCHES, SEALING ROOF AND WALL PENETRATIONS & POST DOWNS, FINISHING NEW WALLS OR FINAL ELECTRICAL CONNECTIONS FOR ENGINEER REVIEW.
- CONTRACTOR SHALL VERIFY ALL EXISTING DIMENSIONS AND CONDITIONS PRIOR TO COMMENCING ANY WORK. ALL DIMENSIONS OF EXISTING CONSTRUCTION SHOWN ON THE DRAWINGS MUST BE VERIFIED. CONTRACTOR SHALL NOTIFY PROJECT MANAGEMENT & ENGINEER OF ANY DISCREPANCIES PRIOR TO ORDERING MATERIAL OR PROCEEDING WITH CONSTRUCTION.
- THE EXISTING CELL SITE IS IN FULL COMMERCIAL OPERATION. ANY CONSTRUCTION WORK BY CONTRACTOR SHALL NOT DISRUPT THE EXISTING NORMAL OPERATION. ANY WORK ON EXISTING EQUIPMENT MUST BE COORDINATED WITH LAND LORD. ALSO, WORK SHOULD BE SCHEDULED FOR AN APPROPRIATE MAINTENANCE WINDOW USUALLY IN LOW TRAFFIC PERIODS AFTER MIDNIGHT.
- SINCE THE CELL SITE IS ACTIVE, ALL SAFETY PRECAUTIONS MUST BE TAKEN WHEN WORKING AROUND HIGH LEVELS OF ELECTROMAGNETIC RADIATION. EQUIPMENT SHOULD BE SHUTDOWN PRIOR TO PERFORMING ANY WORK THAT COULD EXPOSE THE WORKERS TO DANGER. PERSONAL RF EXPOSURE MONITORS ARE ADVISED TO BE WORN TO ALERT OF ANY DANGEROUS EXPOSURE LEVELS.

SITE WORK GENERAL NOTES:

- THE CONTRACTOR SHALL CONTACT UTILITY LOCATING SERVICES PRIOR TO THE START OF CONSTRUCTION.
- ALL EXISTING ACTIVE SEWER, WATER, GAS, ELECTRIC, AND OTHER UTILITIES WHERE ENCOUNTERED IN THE WORK, SHALL BE PROTECTED AT ALL TIMES, AND WHERE REQUIRED FOR THE PROPER EXECUTION OF THE WORK, SHALL BE RELOCATED AS DIRECTED BY CONTRACTOR. EXTREME CAUTION SHOULD BE USED BY THE CONTRACTOR WHEN EXCAVATING OR DRILLING PIERS AROUND OR NEAR UTILITIES. CONTRACTOR SHALL PROVIDE SAFETY TRAINING FOR THE WORKING CREW. THIS WILL INCLUDE BUT NOT BE LIMITED TO:
A) FALL PROTECTION
B) CONFINED SPACE
C) ELECTRICAL SAFETY
D) TRENCHING & EXCAVATION.
- ALL SITE WORK SHALL BE AS INDICATED ON THE DRAWINGS AND PROJECT SPECIFICATIONS.
- IF NECESSARY, RUBBISH, STUMPS, DEBRIS, STICKS, STONES, TOP SOIL AND OTHER REFUSE SHALL BE REMOVED FROM THE SITE AND DISPOSED OF LEGALLY.
- ALL EXISTING INACTIVE SEWER, WATER, GAS, ELECTRIC AND OTHER UTILITIES, WHICH INTERFERE WITH THE EXECUTION OF THE WORK, SHALL BE REMOVED AND/OR CAPPED, PLUGGED OR OTHERWISE DISCONTINUED AT POINTS WHICH WILL NOT INTERFERE WITH THE EXECUTION OF THE WORK, SUBJECT TO THE APPROVAL OF CONTRACTOR, OWNER AND/OR LOCAL UTILITIES.
- CONTRACTOR SHALL MINIMIZE DISTURBANCE TO EXISTING SITE DURING CONSTRUCTION.
- THE CONTRACTOR SHALL PROVIDE SITE SIGNAGE IN ACCORDANCE WITH THE AT&T SPECIFICATION FOR SITE SIGNAGE.
- THE SITE SHALL BE GRADED TO CAUSE SURFACE WATER TO FLOW AWAY FROM THE TRANSMISSION EQUIPMENT AND TOWER AREAS.
- NO FILL OR EMBANKMENT MATERIAL SHALL BE PLACED ON FROZEN GROUND. FROZEN MATERIALS, SNOW OR ICE SHALL NOT BE PLACED IN ANY FILL OR EMBANKMENT.
- THE SUB GRADE SHALL BE COMPACTED AND BROUGHT TO A SMOOTH UNIFORM GRADE PRIOR TO FINISHED SURFACE APPLICATION, SEE SOIL COMPACTION NOTES.
- THE AREAS OF THE OWNER'S PROPERTY DISTURBED BY THE WORK AND NOT COVERED BY THE TOWER, EQUIPMENT OR DRIVEWAY, SHALL BE GRADED TO A UNIFORM SLOPE, AND STABILIZED TO PREVENT EROSION.
- EROSION CONTROL MEASURES, IF REQUIRED DURING CONSTRUCTION, SHALL BE IN CONFORMANCE WITH THE LOCAL JURISDICTION'S GUIDELINES FOR EROSION AND SEDIMENT CONTROL.

CONCRETE AND REINFORCING STEEL NOTES:

- ALL CONCRETE WORK SHALL BE IN ACCORDANCE WITH THE ACI 301, ACI 318, ACI 336, ASTM A184, ASTM A185 AND THE DESIGN AND CONSTRUCTION SPECIFICATION FOR CAST-IN-PLACE CONCRETE.
- ALL CONCRETE SHALL HAVE A MINIMUM COMPRESSIVE STRENGTH OF 4000 PSI AT 28 DAYS, UNLESS NOTED OTHERWISE. A HIGHER STRENGTH (4000 PSI) MAY BE USED. ALL CONCRETING WORK SHALL BE DONE IN ACCORDANCE WITH ACI 318 CODE REQUIREMENTS.
- REINFORCING STEEL SHALL CONFORM TO ASTM A 615, GRADE 60, DEFORMED UNLESS NOTED OTHERWISE. WELDED WIRE FABRIC SHALL CONFORM TO ASTM A 185 WELDED STEEL WIRE FABRIC UNLESS NOTED OTHERWISE (UNO). SPLICES SHALL BE CLASS "B" AND ALL HOOKS SHALL BE STANDARD, UNO.
- THE FOLLOWING MINIMUM CONCRETE COVER SHALL BE PROVIDED FOR REINFORCING STEEL UNLESS SHOWN OTHERWISE ON DRAWINGS:
CONCRETE CAST AGAINST EARTH.....3 IN.
CONCRETE EXPOSED TO EARTH OR WEATHER:
#6 AND LARGER2 IN.
#5 AND SMALLER & WWF.....1 1/2 IN.
CONCRETE NOT EXPOSED TO EARTH OR WEATHER OR NOT CAST AGAINST THE GROUND:
SLAB AND WALL3/4 IN.
BEAMS AND COLUMNS.....1 1/2 IN.
- A CHAMFER 3/4" SHALL BE PROVIDED AT ALL EXPOSED EDGES OF CONCRETE, UNO, IN ACCORDANCE WITH ACI 301 SECTION 4.2.4.
- INSTALLATION OF CONCRETE EXPANSION/WEDGE ANCHOR, SHALL BE PER MANUFACTURER'S WRITTEN RECOMMENDED PROCEDURE. THE ANCHOR BOLT, DOWEL OR ROD SHALL CONFORM TO MANUFACTURER'S RECOMMENDATION FOR EMBEDMENT DEPTH OR AS SHOWN ON THE DRAWINGS. NO REBAR SHALL BE CUT WITHOUT PRIOR CONTRACTOR APPROVAL WHEN DRILLING HOLES IN CONCRETE. SPECIAL INSPECTIONS, REQUIRED BY GOVERNING CODES, SHALL BE PERFORMED IN ORDER TO MAINTAIN MANUFACTURER'S MAXIMUM ALLOWABLE LOADS. ALL EXPANSION/WEDGE ANCHORS SHALL BE STAINLESS STEEL OR HOT DIPPED GALVANIZED. EXPANSION BOLTS SHALL BE PROVIDED BY RAMSET/REDHEAD OR APPROVED EQUAL.
- CONCRETE CYLINDER TEST IS NOT REQUIRED FOR SLAB ON GRADE WHEN CONCRETE IS LESS THAN 50 CUBIC YARDS (IBC 1905.6.2.3) IN THAT EVENT THE FOLLOWING RECORDS SHALL BE PROVIDED BY THE CONCRETE SUPPLIER:
(A) RESULTS OF CONCRETE CYLINDER TESTS PERFORMED AT THE SUPPLIER'S PLANT.
(B) CERTIFICATION OF MINIMUM COMPRESSIVE STRENGTH FOR THE CONCRETE GRADE SUPPLIED.
FOR GREATER THAN 50 CUBIC YARDS THE GC SHALL PERFORM THE CONCRETE CYLINDER TEST.
- AS AN ALTERNATIVE TO ITEM 7, TEST CYLINDERS SHALL BE TAKEN INITIALLY AND THEREAFTER FOR EVERY 50 YARDS OF CONCRETE FROM EACH DIFFERENT BATCH PLANT.
- EQUIPMENT SHALL NOT BE PLACED ON NEW PADS FOR SEVEN DAYS AFTER PAD IS POURED, UNLESS IT IS VERIFIED BY CYLINDER TESTS THAT COMPRESSIVE STRENGTH HAS BEEN ATTAINED.

STRUCTURAL STEEL NOTES:

- ALL STEEL WORK SHALL BE PAINTED OR GALVANIZED IN ACCORDANCE WITH THE DRAWINGS UNLESS NOTED OTHERWISE. STRUCTURAL STEEL SHALL BE ASTM-A-36 UNLESS OTHERWISE NOTED ON THE SITE SPECIFIC DRAWINGS. STEEL DESIGN, INSTALLATION AND BOLTING SHALL BE PERFORMED IN ACCORDANCE WITH THE AMERICAN INSTITUTE OF STEEL CONSTRUCTION (AISC) "MANUAL OF STEEL CONSTRUCTION".
- ALL WELDING SHALL BE PERFORMED USING E70XX ELECTRODES AND WELDING SHALL CONFORM TO AISC. WHERE FILET WELD SIZES ARE NOT SHOWN, PROVIDE THE MINIMUM SIZE PER TABLE J2.4 IN THE AISC "MANUAL OF STEEL CONSTRUCTION". PAINTED SURFACES SHALL BE TOUCHED UP.
- BOLTED CONNECTIONS SHALL BE ASTM A325 BEARING TYPE (3/4") CONNECTIONS AND SHALL HAVE MINIMUM OF TWO BOLTS UNLESS NOTED OTHERWISE.
- NON-STRUCTURAL CONNECTIONS FOR STEEL GRATING MAY USE 5/8" DIA. ASTM A 307 BOLTS UNLESS NOTED OTHERWISE.
- INSTALLATION OF CONCRETE EXPANSION/WEDGE ANCHOR, SHALL BE PER MANUFACTURER'S WRITTEN RECOMMENDED PROCEDURE. THE ANCHOR BOLT, DOWEL OR ROD SHALL CONFORM TO MANUFACTURER'S RECOMMENDATION FOR EMBEDMENT DEPTH OR AS SHOWN ON THE DRAWINGS. NO REBAR SHALL BE CUT WITHOUT PRIOR CONTRACTOR APPROVAL WHEN DRILLING HOLES IN CONCRETE. SPECIAL INSPECTIONS, REQUIRED BY GOVERNING CODES, SHALL BE PERFORMED IN ORDER TO MAINTAIN MANUFACTURER'S MAXIMUM ALLOWABLE LOADS. ALL EXPANSION/WEDGE ANCHORS SHALL BE STAINLESS STEEL OR HOT DIPPED GALVANIZED. EXPANSION BOLTS SHALL BE PROVIDED BY RAMSET/REDHEAD OR APPROVED EQUAL.
- CONTRACTOR SHALL SUBMIT SHOP DRAWINGS FOR ENGINEER REVIEW & APPROVAL ON PROJECTS REQUIRING STRUCTURAL STEEL.
- ALL STRUCTURAL STEEL WORK SHALL BE DONE IN ACCORDANCE WITH AISC SPECIFICATIONS.

SOIL COMPACTION NOTES FOR SLAB ON GRADE:

- EXCAVATE AS REQUIRED TO REMOVE VEGETATION & TOPSOIL EXPOSE UNDISTURBED NATURAL SUBGRADE AND PLACE CRUSHED STONE AS REQUIRED.
- COMPACTION CERTIFICATION: AN INSPECTION AND WRITTEN CERTIFICATION BY A QUALIFIED GEOTECHNICAL TECHNICIAN OR ENGINEER IS ACCEPTABLE.
- AS AN ALTERNATIVE TO INSPECTION AND WRITTEN CERTIFICATION, THE "UNDISTURBED SOIL" BASE SHALL BE COMPACTED WITH "COMPACTION EQUIPMENT", LISTED BELOW, TO AT LEAST 90% MODIFIED PROCTOR MAXIMUM DENSITY PER ASTM D 1557 METHOD C.
- COMPACTED SUBBASE SHALL BE UNIFORM & LEVELLED. PROVIDE 6" MINIMUM CRUSHED STONE OR GRAVEL COMPACTED IN 3" LIFTS ABOVE COMPACTED SOIL. GRAVEL SHALL BE NATURAL OR CRUSHED WITH 100% PASSING 1" SIEVE.
- AS AN ALTERNATIVE TO ITEMS 2 AND 3 PROOFROLL THE SUBGRADE SOILS WITH 5 PASSES OF A MEDIUM SIZED VIBRATORY PLATE COMPACTOR (SUCH AS BOMAG BPR 30/38) OR HAND-OPERATED SINGLE DRUM VIBRATORY ROLLER (SUCH AS BOMAG BW 55E). ANY SOFT AREAS THAT ARE ENCOUNTERED SHOULD BE REMOVED AND REPLACED WITH A WELL-GRADED GRANULAR FILL, AND COMPACTED AS STATED ABOVE.

COMPACTION EQUIPMENT:

- HAND OPERATED DOUBLE DRUM, VIBRATORY ROLLER, VIBRATORY PLATE COMPACTOR OR JUMPING JACK COMPACTOR.

CONSTRUCTION NOTES:

- FIELD VERIFICATION: CONTRACTOR SHALL FIELD VERIFY SCOPE OF WORK, AT&T ANTENNA PLATFORM LOCATION AND ANTENNAS TO BE REPLACED.
- COORDINATION OF WORK: CONTRACTOR SHALL COORDINATE RF WORK AND PROCEDURES WITH PROJECT MANAGEMENT.
- CABLE LADDER RACK: CONTRACTOR SHALL FURNISH AND INSTALL CABLE LADDER RACK, CABLE TRAY, AND CONDUIT AS REQUIRED TO SUPPORT CABLES TO THE NEW BTS LOCATION.

ELECTRICAL INSTALLATION NOTES:

- ALL ELECTRICAL WORK SHALL BE PERFORMED IN ACCORDANCE WITH THE PROJECT SPECIFICATIONS, NEC AND ALL APPLICABLE LOCAL CODES.
- CONTRACTOR SHALL MODIFY EXISTING CABLE TRAY SYSTEM AS REQUIRED TO SUPPORT RF AND TRANSPORT CABLING TO THE NEW BTS EQUIPMENT. CONTRACTOR SHALL SUBMIT MODIFICATIONS TO PROJECT MANAGEMENT FOR APPROVAL.
- CONDUIT ROUTINGS ARE SCHEMATIC. CONTRACTOR SHALL INSTALL CONDUITS SO THAT ACCESS TO EQUIPMENT IS NOT BLOCKED.
- WIRING, RACEWAY AND SUPPORT METHODS AND MATERIALS SHALL COMPLY WITH THE REQUIREMENTS OF THE NEC.
- ALL CIRCUITS SHALL BE SEGREGATED AND MAINTAIN MINIMUM CABLE SEPARATION AS REQUIRED BY THE NEC.
- CABLES SHALL NOT BE ROUTED THROUGH LADDER-STYLE CABLE TRAY RUNGS.
- EACH END OF EVERY POWER, POWER PHASE CONDUCTOR (I.E., HOTS), GROUNDING, AND T1 CONDUCTOR AND CABLE SHALL BE LABELED WITH COLOR-CODED INSULATION OR ELECTRICAL TAPE (3M BRAND, 1/2 INCH PLASTIC ELECTRICAL TAPE WITH UV PROTECTION, OR EQUAL). THE IDENTIFICATION METHOD SHALL CONFORM WITH NEC & OSHA, AND MATCH EXISTING INSTALLATION REQUIREMENTS.
- ALL ELECTRICAL COMPONENTS SHALL BE CLEARLY LABELED WITH ENGRAVED LAMACOID PLASTIC LABELS. ALL EQUIPMENT SHALL BE LABELED WITH THEIR VOLTAGE RATING, PHASE CONFIGURATION, WIRE CONFIGURATION, POWER OR AMPACITY RATING, AND BRANCH CIRCUIT ID NUMBERS (I.E., PANELBOARD AND CIRCUIT ID'S).
- PANELBOARDS (ID NUMBERS) AND INTERNAL CIRCUIT BREAKERS (CIRCUIT ID NUMBERS) SHALL BE CLEARLY LABELED WITH ENGRAVED LAMACOID PLASTIC LABELS.
- ALL TIE WRAPS SHALL BE CUT FLUSH WITH APPROVED CUTTING TOOL TO REMOVE SHARP EDGES.
- POWER, CONTROL, AND EQUIPMENT GROUND WIRING IN TUBING OR CONDUIT SHALL BE SINGLE CONDUCTOR (SIZE 14 AWG OR LARGER), 600V, OIL RESISTANT THHN OR THWN-2, CLASS B STRANDED COPPER CABLE RATED FOR 90 °C (WET AND DRY) OPERATION; LISTED OR LABELED FOR THE LOCATION AND RACEWAY SYSTEM USED, UNLESS OTHERWISE SPECIFIED.
- POWER PHASE CONDUCTORS (I.E., HOTS) SHALL BE LABELED WITH COLOR-CODED INSULATION OR ELECTRICAL TAPE (3M BRAND, 1/2 INCH PLASTIC ELECTRICAL TAPE WITH UV PROTECTION, OR EQUAL). PHASE CONDUCTOR COLOR CODES SHALL CONFORM WITH THE NEC & OSHA AND MATCH EXISTING INSTALLATION REQUIREMENTS.
- SUPPLEMENTAL EQUIPMENT GROUND WIRING LOCATED INDOORS SHALL BE SINGLE CONDUCTOR (SIZE 6 AWG OR LARGER), 600V, OIL RESISTANT THHN OR THWN-2 GREEN INSULATION, CLASS B STRANDED COPPER CABLE RATED FOR 90°C (WET AND DRY) OPERATION; LISTED OR LABELED FOR THE LOCATION AND RACEWAY SYSTEM USED, UNLESS OTHERWISE SPECIFIED.
- SUPPLEMENTAL EQUIPMENT GROUND WIRING LOCATED OUTDOORS, OR BELOW GRADE, SHALL BE SINGLE CONDUCTOR #2 AWG SOLID TINNED COPPER CABLE, UNLESS OTHERWISE SPECIFIED.
- POWER AND CONTROL WIRING, NOT IN TUBING OR CONDUIT, SHALL BE MULTI-CONDUCTOR, TYPE TC CABLE (SIZE 14 AWG OR LARGER), 600V, OIL RESISTANT THHN OR THWN-2, CLASS B STRANDED COPPER CABLE RATED FOR 90°C (WET AND DRY) OPERATION; WITH OUTER JACKET; LISTED OR LABELED FOR THE LOCATION USED, UNLESS OTHERWISE SPECIFIED.
- ALL POWER AND POWER GROUNDING CONNECTIONS SHALL BE CRIMP-STYLE, COMPRESSION WIRE LUGS AND WIRENUTS BY THOMAS AND BETTS (OR EQUAL). LUGS AND WIRENUTS SHALL BE RATED FOR OPERATION AT NO LESS THAN 75°C (90°C IF AVAILABLE).
- RACEWAY AND CABLE TRAY SHALL BE LISTED OR LABELED FOR ELECTRICAL USE IN ACCORDANCE WITH NEMA, UL, ANSI/IEEC, AND NEC.
- NEW RACEWAY OR CABLE TRAY WILL MATCH THE EXISTING INSTALLATION WHERE POSSIBLE.
- ELECTRICAL METALLIC TUBING (EMT) OR RIGID NONMETALLIC CONDUIT (I.E., RIGID PVC SCHEDULE 40, OR RIGID PVC SCHEDULE 80 FOR LOCATIONS SUBJECT TO PHYSICAL DAMAGE) SHALL BE USED FOR EXPOSED INDOOR LOCATIONS.
- ELECTRICAL METALLIC TUBING (EMT), ELECTRICAL NONMETALLIC TUBING (ENT), OR RIGID NONMETALLIC CONDUIT (RIGID PVC, SCHEDULE 40) SHALL BE USED FOR CONCEALED INDOOR LOCATIONS.
- GALVANIZED STEEL INTERMEDIATE METALLIC CONDUIT (IMC) SHALL BE USED FOR OUTDOOR LOCATIONS ABOVE GRADE.
- RIGID NONMETALLIC CONDUIT (I.E., RIGID PVC SCHEDULE 40 OR RIGID PVC SCHEDULE 80) SHALL BE USED UNDERGROUND; DIRECT BURIED, IN AREAS OF OCCASIONAL LIGHT VEHICLE TRAFFIC OR ENCASED IN REINFORCED CONCRETE IN AREAS OF HEAVY VEHICLE TRAFFIC.
- LIQUID-TIGHT FLEXIBLE METALLIC CONDUIT (LIQUID-TITE FLEX) SHALL BE USED INDOORS AND OUTDOORS, WHERE VIBRATION OCCURS OR FLEXIBILITY IS NEEDED.
- CONDUIT AND TUBING FITTINGS SHALL BE THREADED OR COMPRESSION-TYPE AND APPROVED FOR THE LOCATION USED. SETSCREW FITTINGS ARE NOT ACCEPTABLE.
- CABINETS, BOXES, AND WIREWAYS SHALL BE LISTED OR LABELED FOR ELECTRICAL USE IN ACCORDANCE WITH NEMA, UL, ANSI/IEEC, AND NEC.
- CABINETS, BOXES, AND WIREWAYS TO MATCH THE EXISTING INSTALLATION WHERE POSSIBLE.
- WIREWAYS SHALL BE EPOXY-COATED (GRAY) AND INCLUDE A HINGED COVER, DESIGNED TO SWING OPEN DOWNWARD; SHALL BE PANDUIT TYPE E (OR EQUAL); AND RATED NEMA 1 (OR BETTER) INDOORS, OR NEMA 3R (OR BETTER) OUTDOORS.
- EQUIPMENT CABINETS, TERMINAL BOXES, JUNCTION BOXES, AND PULL BOXES SHALL BE GALVANIZED OR EPOXY-COATED SHEET STEEL, SHALL MEET OR EXCEED UL 50, AND RATED NEMA 1 (OR BETTER) INDOORS, OR NEMA 3R (OR BETTER) OUTDOORS.
- METAL RECEPTACLE, SWITCH, AND DEVICE BOXES SHALL BE GALVANIZED, EPOXY-COATED, OR NON-CORRODING; SHALL MEET OR EXCEED UL 514A AND NEMA OS 1; AND RATED NEMA 1 (OR BETTER) INDOORS, OR WEATHER PROTECTED (WP OR BETTER) OUTDOORS.
- NONMETALLIC RECEPTACLE, SWITCH, AND DEVICE BOXES SHALL MEET OR EXCEED NEMA OS 2; AND RATED NEMA 1 (OR BETTER) INDOORS, OR WEATHER PROTECTED (WP OR BETTER) OUTDOORS.
- THE CONTRACTOR SHALL NOTIFY AND OBTAIN NECESSARY AUTHORIZATION FROM PROJECT MANAGEMENT BEFORE COMMENCING WORK ON THE AC POWER DISTRIBUTION PANELS.
- THE CONTRACTOR SHALL PROVIDE NECESSARY TAGGING ON THE BREAKERS, CABLES AND DISTRIBUTION PANELS IN ACCORDANCE WITH THE APPLICABLE CODES AND STANDARDS TO SAFEGUARD AGAINST LIFE AND PROPERTY.



500 ENTERPRISE DRIVE SUITE 3A
ROCKY HILL, CT 06067



27 NORTHWESTERN DRIVE
SALEM, NH 03079

**CT5841
DURHAM CENTRAL
CROWN BU #: 806364**

CONSTRUCTION DRAWINGS

0	04/07/17	ISSUED FOR CONSTRUCTION	
A	03/17/17	ISSUED FOR REVIEW	



Dewberry Engineers Inc.
600 PARSIPPANY ROAD
SUITE 301
PARSIPPANY, NJ 07054
PHONE: 973.739.9400
FAX: 973.739.9710



CONNECTICUT LICENSE NO. 0023222
IT IS A VIOLATION OF LAW FOR ANY PERSON, UNLESS THEY ARE ACTING UNDER THE DIRECTION OF A LICENSED PROFESSIONAL ENGINEER TO ALTER THIS DOCUMENT.

DRAWN BY: BJR
REVIEWED BY: BSH
CHECKED BY: GHN
PROJECT NUMBER: 50055106
JOB NUMBER: 50065688
SITE ADDRESS:

143R OLD BLUE HILLS RD
DURHAM, CT 06422
MIDDLESEX COUNTY

SHEET TITLE
GENERAL NOTES
SHEET NUMBER

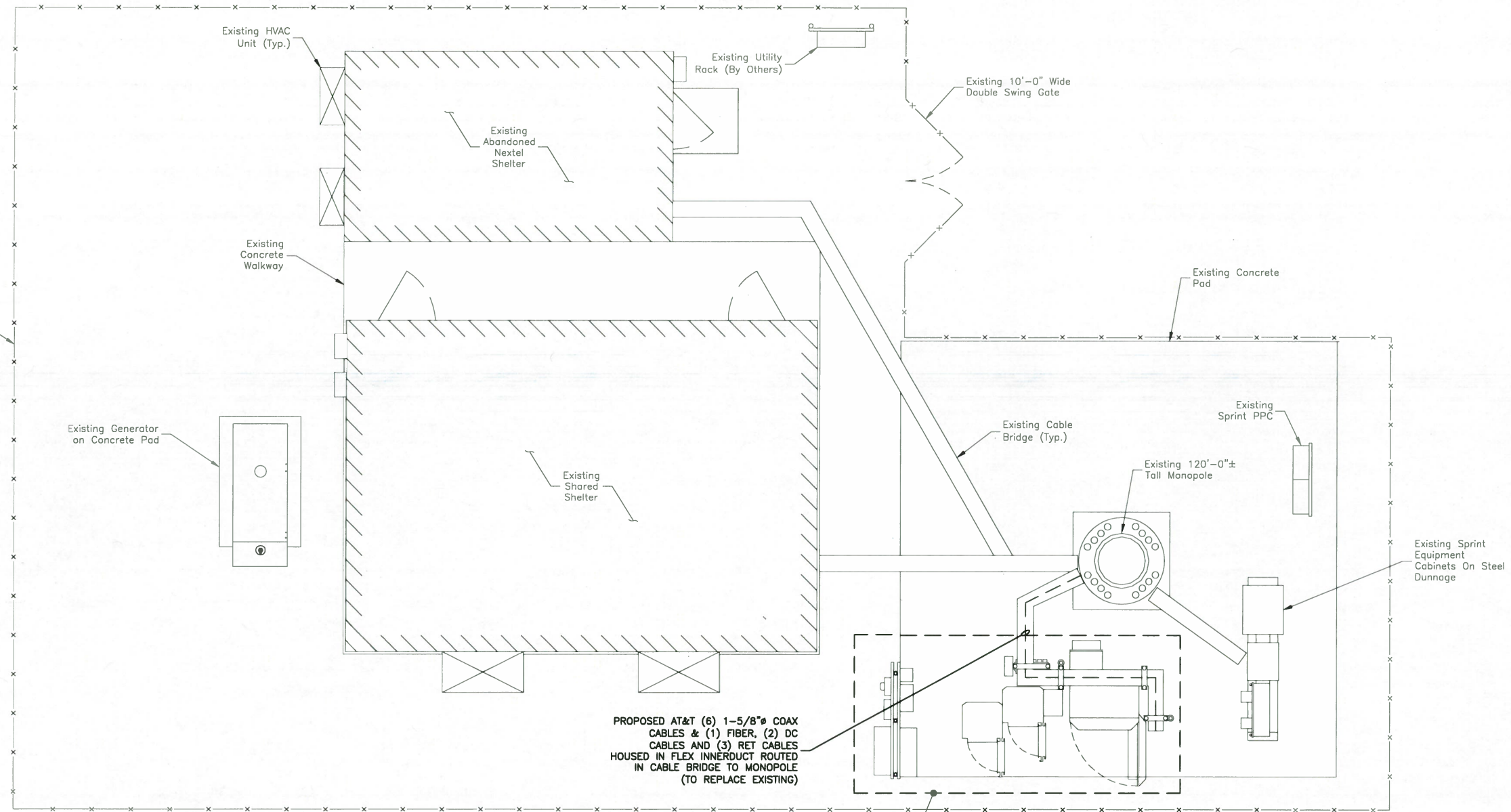

PROPOSED AT&T (6) 1-5/8" COAX CABLES & (1) FIBER, (2) DC CABLES AND (3) RET CABLES HOUSED IN FLEX INNERDUCT ROUTED IN CABLE BRIDGE TO MONOPOLE (TO REPLACE EXISTING)

1 2
C-2 C-2 Existing AT&T Equipment Area

3
C-3

COMPOUND PLAN 1

SCALE: 1/8"=1' FOR 11"x17"
1/4"=1' FOR 22"x34"

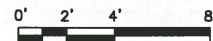

NOTES:

1. NORTH SHOWN AS APPROXIMATE.
2. NOT ALL INFORMATION IS SHOWN FOR CLARITY.
3. ALL PROPOSED EQUIPMENT, INCLUDING ANTENNAS, COAX, SURGE ARRESTORS, TMA'S, RRU'S, ETC., SHALL BE MOUNTED IN ACCORDANCE WITH THE TOWER STRUCTURAL ANALYSIS BY CROWN CASTLE DATED MARCH 22, 2017.



500 ENTERPRISE DRIVE SUITE 3A
ROCKY HILL, CT 06067



27 NORTHWESTERN DRIVE
SALEM, NH 03079

**CT5841
DURHAM CENTRAL
CROWN BU #: 806364**

CONSTRUCTION DRAWINGS

D 04/07/17 ISSUED FOR CONSTRUCTION
A 03/17/17 ISSUED FOR REVIEW



Dewberry Engineers Inc.
800 PARSIPPANY ROAD
SUITE 301
PARSIPPANY, NJ 07054
PHONE: 973.739.9400
FAX: 973.739.9710

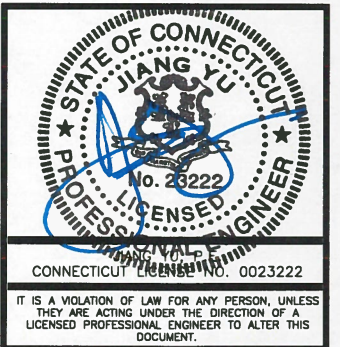

DRAWN BY: BJR

REVIEWED BY: BSH

CHECKED BY: GHN

PROJECT NUMBER: 50055106

JOB NUMBER: 50065688

SITE ADDRESS:

143R OLD BLUE HILLS RD
DURHAM, CT 06422
MIDDLESEX COUNTY

SHEET TITLE

COMPOUND PLAN

SHEET NUMBER

C-1



500 ENTERPRISE DRIVE SUITE 3A
ROCKY HILL, CT 06067



27 NORTHWESTERN DRIVE
SALEM, NH 03079

CT5841
DURHAM CENTRAL
CROWN BU #: 806364

CONSTRUCTION DRAWINGS

0 04/07/17 ISSUED FOR CONSTRUCTION
A 03/17/17 ISSUED FOR REVIEW



Dewberry Engineers Inc.
600 PARSIPPANY ROAD
SUITE 301
PARSIPPANY, NJ 07054
PHONE: 973.739.9400
FAX: 973.739.9710

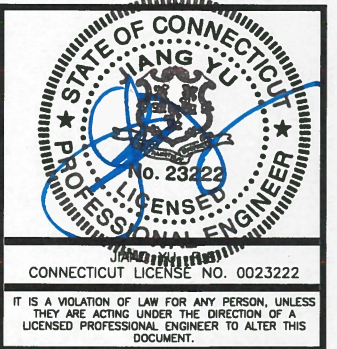

IT IS A VIOLATION OF LAW FOR ANY PERSON, UNLESS THEY ARE ACTING UNDER THE DIRECTION OF A LICENSED PROFESSIONAL ENGINEER TO ALTER THIS DOCUMENT.

DRAWN BY:
REVIEWED BY:
CHECKED BY:
PROJECT NUMBER: 50055106
JOB NUMBER: 50065688
SITE ADDRESS:

143R OLD BLUE HILLS RD
DURHAM, CT 06422
MIDDLESEX COUNTY

SHEET TITLE:
SHEET NUMBER:

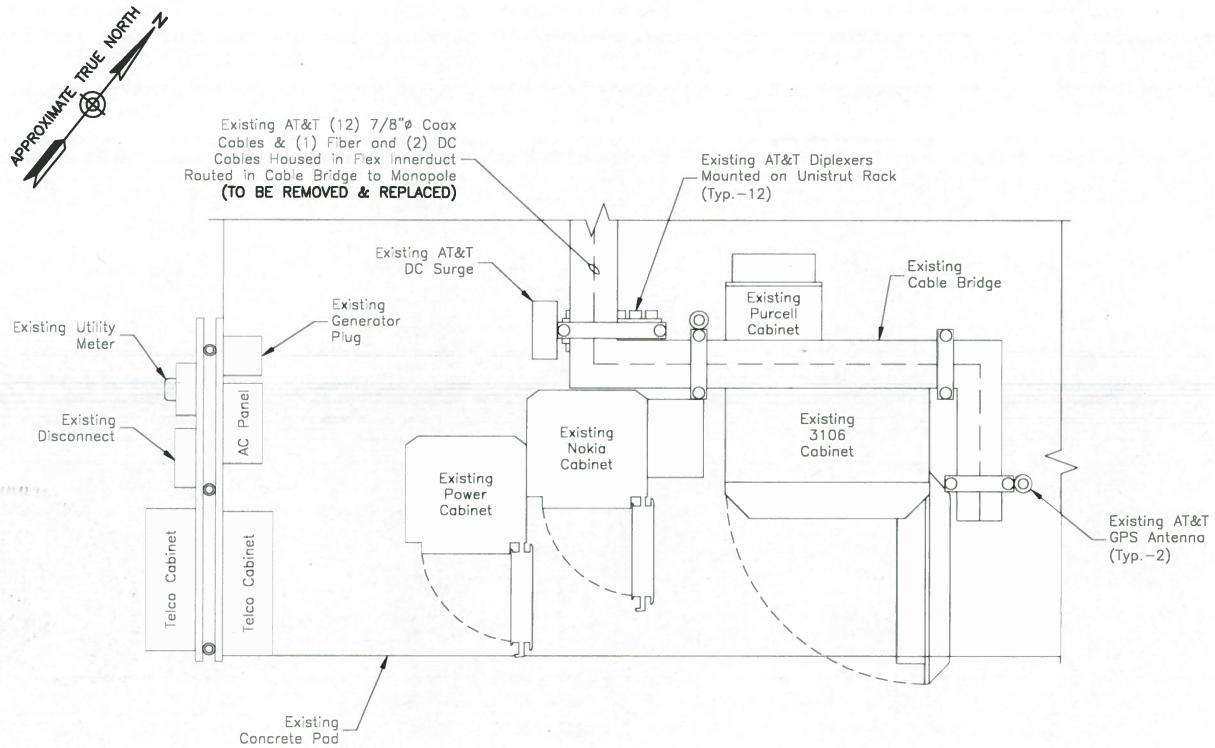

EXISTING EQUIPMENT LAYOUT ①

SCALE: 1/4"=1' FOR 11"x17"
1/2"=1' FOR 22"x34"

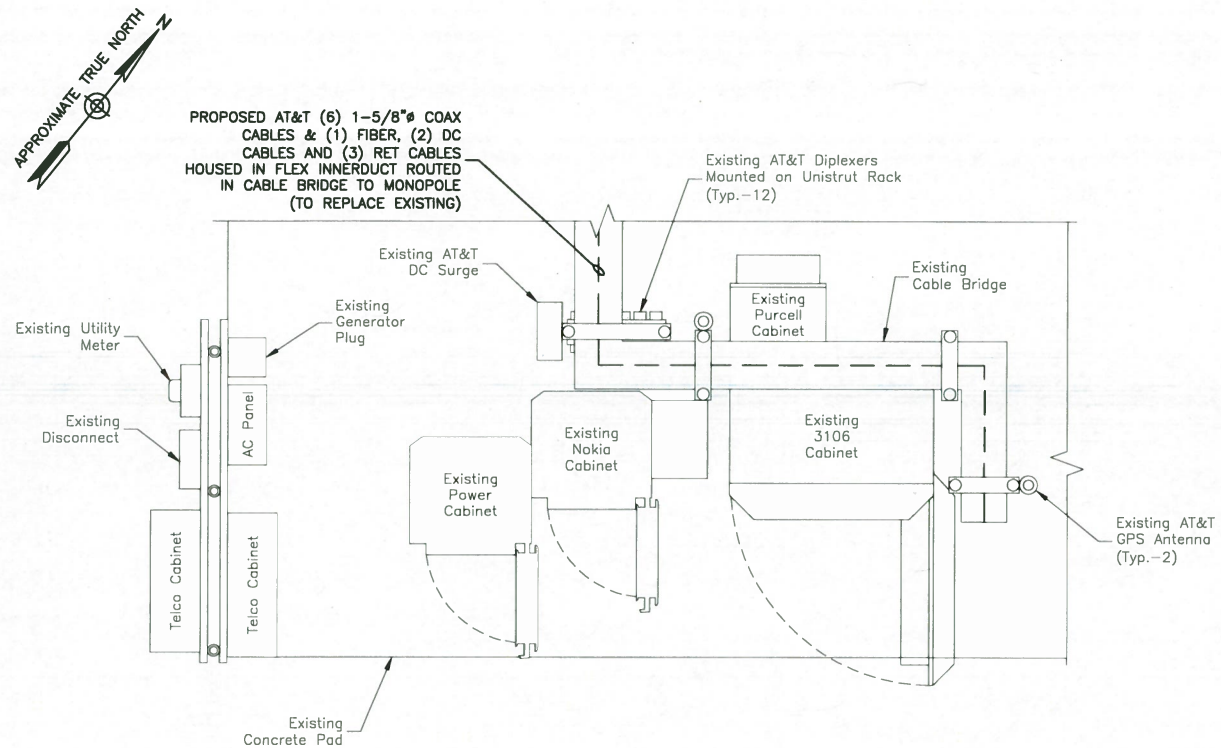
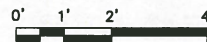

PROPOSED EQUIPMENT LAYOUT ②

SCALE: 1/4"=1' FOR 11"x17"
1/2"=1' FOR 22"x34"

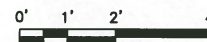



500 ENTERPRISE DRIVE SUITE 3A
ROCKY HILL, CT 06067



27 NORTHWESTERN DRIVE
SALEM, NH 03079

CT5841
DURHAM CENTRAL
CROWN BU #: 806364

CONSTRUCTION DRAWINGS

O	04/07/17	ISSUED FOR CONSTRUCTION
A	03/17/17	ISSUED FOR REVIEW



Dewberry Engineers Inc.
600 PARSIPPANY ROAD
SUITE 301
PARSIPPANY, NJ 07054
PHONE: 973.739.9400
FAX: 973.739.9710



IT IS A VIOLATION OF LAW FOR ANY PERSON, UNLESS THEY ARE ACTING UNDER THE DIRECTION OF A LICENSED PROFESSIONAL ENGINEER TO ALTER THIS DOCUMENT.

DRAWN BY:	BJR
REVIEWED BY:	BSH
CHECKED BY:	GHN
PROJECT NUMBER:	50055106
JOB NUMBER:	50065688
SITE ADDRESS:	

143R OLD BLUE HILLS RD
DURHAM, CT 06422
MIDDLESEX COUNTY

SHEET TITLE

ANTENNA LAYOUTS
& ELEVATIONS

SHEET NUMBER

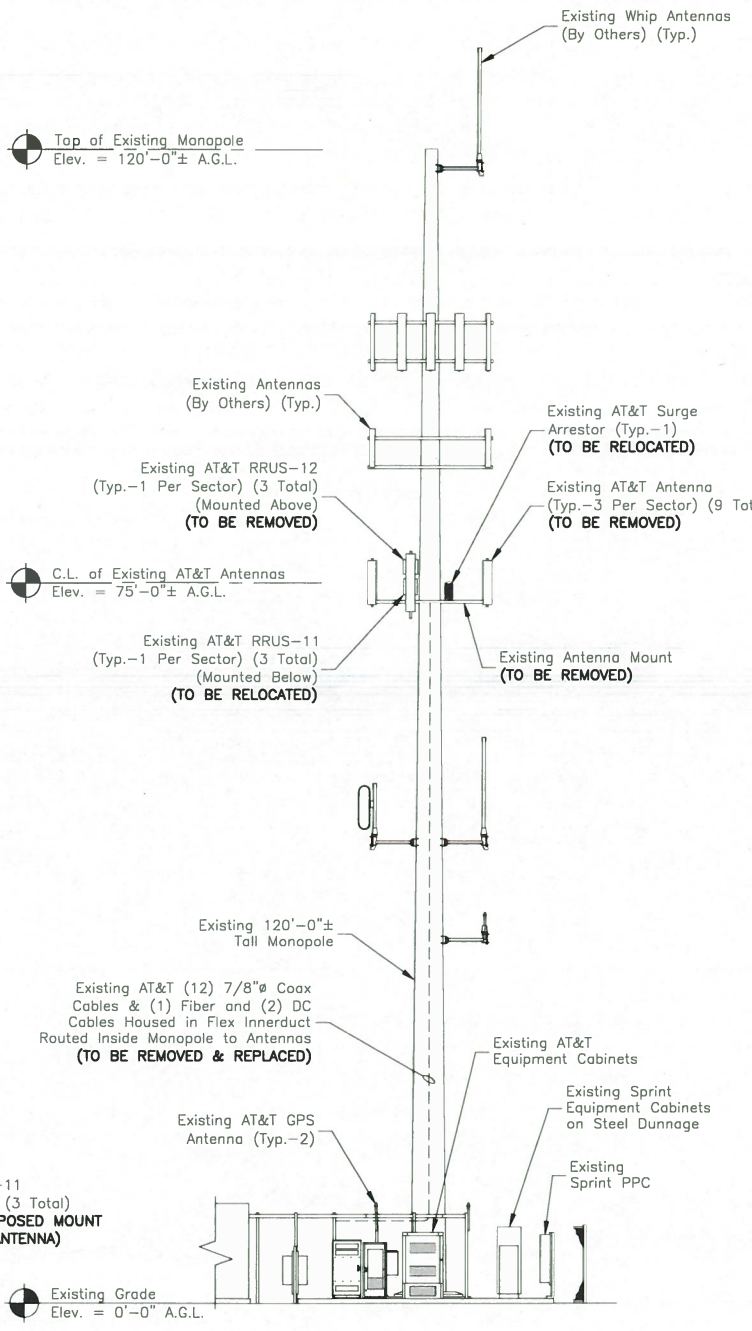
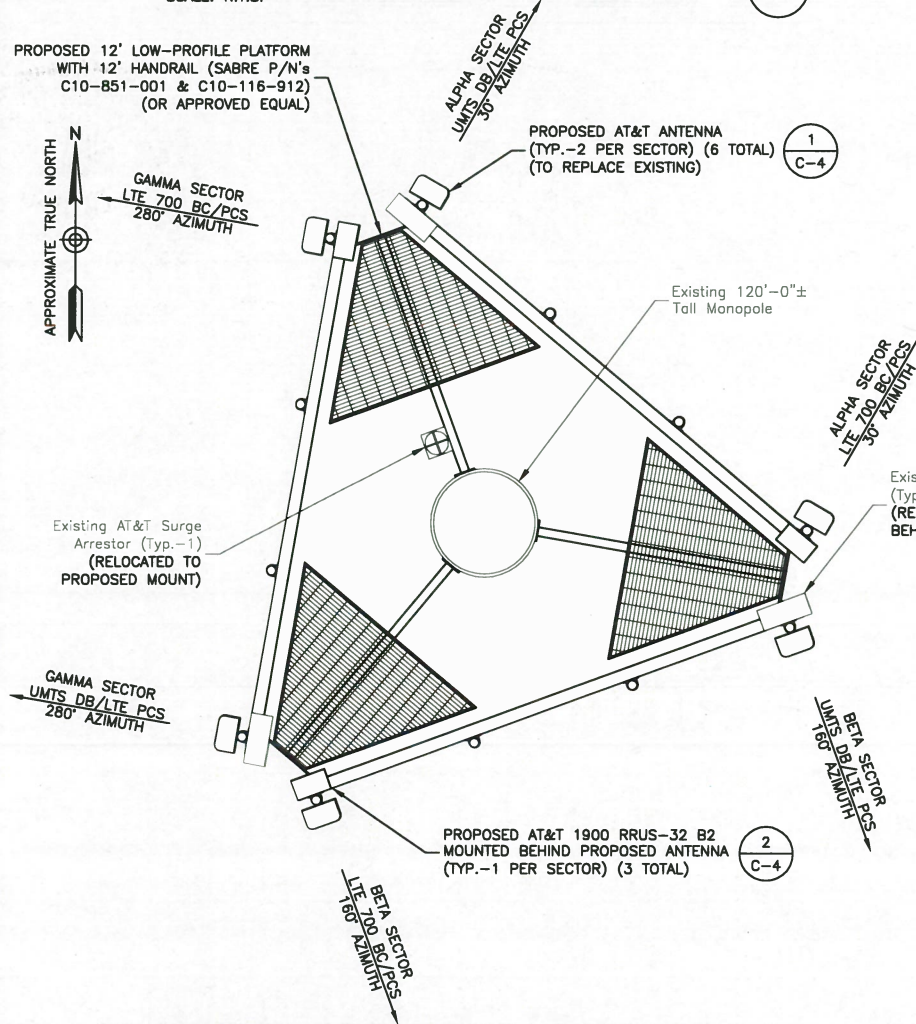
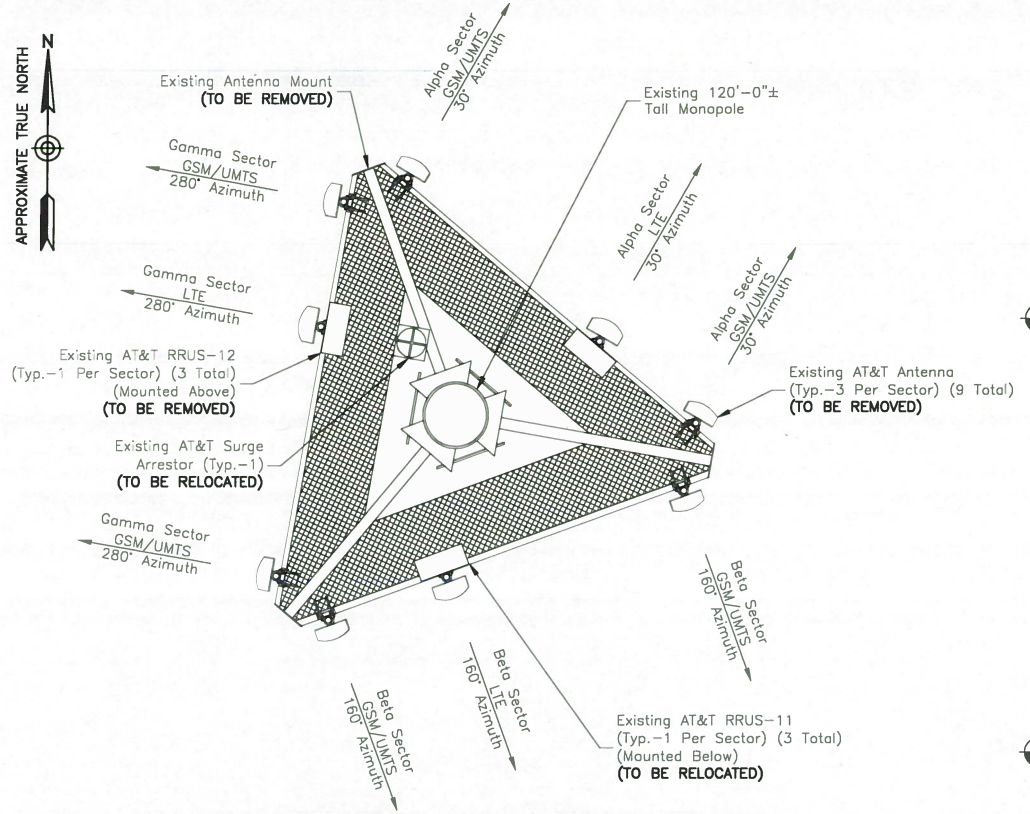

EXISTING SOUTHWEST ELEVATION
SCALE: 1"=20' FOR 11"x17"
1"=10' FOR 22"x34"

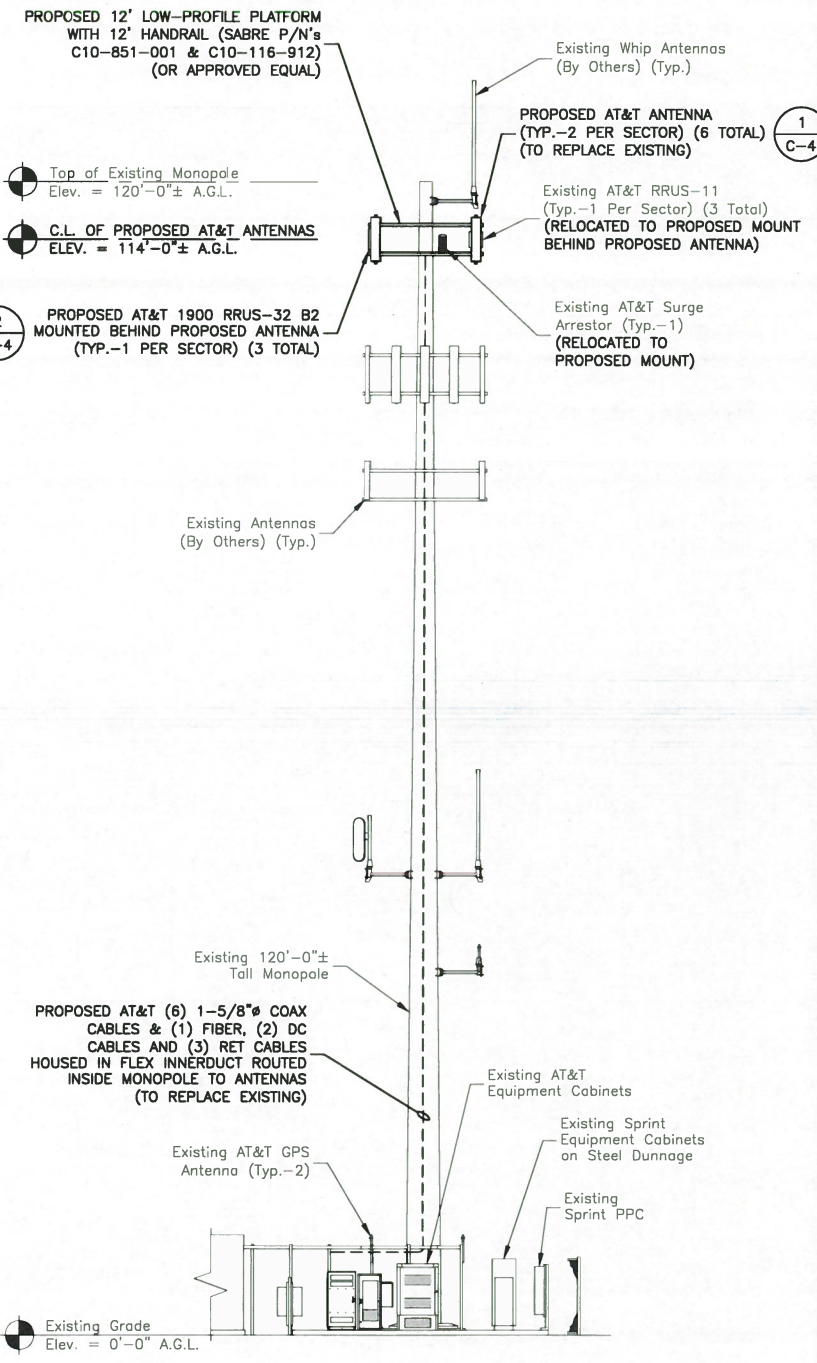

PROPOSED SOUTHWEST ELEVATION
SCALE: 1"=20' FOR 11"x17"
1"=10' FOR 22"x34"

NOTE:
1. ALL PROPOSED EQUIPMENT, INCLUDING ANTENNAS, COAX, SURGE ARRESTORS, TMA'S, RRUS, ETC., SHALL BE MOUNTED IN ACCORDANCE WITH THE TOWER STRUCTURAL ANALYSIS BY CROWN CASTLE DATED MARCH 22, 2017.

GROUNDING NOTES:

- THE CONTRACTOR SHALL REVIEW AND INSPECT THE EXISTING FACILITY GROUNDING SYSTEM AND LIGHTNING PROTECTION SYSTEM (AS DESIGNED AND INSTALLED) FOR STRICT COMPLIANCE WITH THE NEC (AS ADOPTED BY THE AHJ). THE SITE-SPECIFIC (UL, LPI, OR NFPA) LIGHTING PROTECTION CODE, AND GENERAL COMPLIANCE WITH TELCORDIA AND TIA GROUNDING STANDARDS. THE CONTRACTOR SHALL REPORT ANY VIOLATIONS OR ADVERSE FINDINGS TO THE ENGINEER FOR RESOLUTION.
- ALL GROUND ELECTRODE SYSTEMS (INCLUDING TELECOMMUNICATION, RADIO, LIGHTNING PROTECTION, AND AC POWER GESS) SHALL BE BONDED TOGETHER, AT OR BELOW GRADE, BY TWO OR MORE COPPER BONDING CONDUCTORS. ALL AVAILABLE GROUNDING ELECTRODES SHALL BE CONNECTED TOGETHER IN ACCORDANCE WITH THE NEC.
- THE CONTRACTOR SHALL PERFORM IEEE FALL-OF-POTENTIAL RESISTANCE TO EARTH TESTING (PER IEEE 1100 AND 81) FOR GROUND ELECTRODE SYSTEMS. USE OF OTHER METHODS MUST BE PRE-APPROVED BY THE ENGINEER IN WRITING.
- THE CONTRACTOR SHALL FURNISH AND INSTALL SUPPLEMENTAL GROUND ELECTRODES AS NEEDED TO ACHIEVE A TEST RESULT OF 5 OHMS OR LESS ON TOWER SITES AND 10 OHMS OR LESS ON ROOFTOP SITES. WHEN ADDING ELECTRODES, CONTRACTOR SHALL MAINTAIN A MINIMUM DISTANCE BETWEEN THE ADDED ELECTRODE AND ANY OTHER EXISTING ELECTRODE EQUAL TO THE BURIED LENGTH OF THE ROD. IDEALLY, CONTRACTOR SHALL STRIVE TO KEEP THE SEPARATION DISTANCE EQUAL TO TWICE THE BURIED LENGTH OF THE RODS.
- THE CONTRACTOR IS RESPONSIBLE FOR PROPERLY SEQUENCING GROUNDING AND UNDERGROUND CONDUIT INSTALLATION AS TO PREVENT ANY LOSS OF CONTINUITY IN THE GROUNDING SYSTEM OR DAMAGE TO THE CONDUIT.
- METAL CONDUIT AND TRAY SHALL BE GROUNDED AND MADE ELECTRICALLY CONTINUOUS WITH LISTED BONDING FITTINGS OR BY BONDING ACROSS THE DISCONTINUITY WITH 6 AWG COPPER WIRE AND UL APPROVED GROUNDING TYPE CONDUIT CLAMPS.
- METAL RACEWAY SHALL NOT BE USED AS THE NEC REQUIRED EQUIPMENT GROUND CONDUCTOR. STRANDED COPPER CONDUCTORS WITH GREEN INSULATION, SIZED IN ACCORDANCE WITH THE NEC, SHALL BE FURNISHED AND INSTALLED WITH THE POWER CIRCUITS TO TRANSMISSION EQUIPMENT.
- CONNECTIONS TO THE GROUND BUS SHALL NOT BE DOUBLED UP OR STACKED. BACK-TO-BACK CONNECTIONS ON OPPOSITE SIDES OF THE GROUND BUS ARE PERMITTED.
- ALUMINUM CONDUCTOR OR COPPER CLAD STEEL CONDUCTOR SHALL NOT BE USED FOR GROUNDING CONNECTIONS.
- USE OF 90° BENDS IN THE PROTECTION GROUNDING CONDUCTORS SHALL BE AVOIDED WHEN 45° BENDS CAN BE ADEQUATELY SUPPORTED. IN ALL CASES, BENDS SHALL BE MADE WITH A MINIMUM BEND RADIUS OF 8 INCHES.
- EACH INTERIOR TRANSMISSION CABINET FRAME/PLINTH SHALL BE DIRECTLY CONNECTED TO THE MASTER GROUND BAR WITH 6 AWG STRANDED, GREEN INSULATED SUPPLEMENTAL EQUIPMENT GROUND WIRE UNLESS NOTED OTHERWISE IN THE DETAILS. EACH OUTDOOR CABINET FRAME/PLINTH SHALL BE DIRECTLY CONNECTED TO THE BURIED GROUND RING WITH 2 AWG SOLID TIN-PLATED COPPER WIRE UNLESS NOTED OTHERWISE IN THE DETAILS.
- ALL EXTERIOR GROUND CONDUCTORS BETWEEN EQUIPMENT/GROUND BARS AND THE GROUND RING, SHALL BE 2 AWG SOLID TIN-PLATED COPPER UNLESS OTHERWISE INDICATED.
- EXOTHERMIC WELDS SHALL BE USED FOR ALL GROUNDING CONNECTIONS BELOW GRADE. CONNECTIONS TO ABOVE GRADE UNITS SHALL BE MADE WITH EXOTHERMIC WELDS WHERE PRACTICAL OR WITH 2-HOLE MECHANICAL TYPE BRASS CONNECTORS WITH STAINLESS STEEL HARDWARE, INCLUDING SET SCREWS. HIGH PRESSURE CRIMP CONNECTORS MAY ONLY BE USED WITH WRITTEN PERMISSION FROM SAI MARKET REPRESENTATIVE.
- EXOTHERMIC WELDS SHALL BE PERMITTED ON TOWERS ONLY WITH THE EXPRESS APPROVAL OF THE TOWER MANUFACTURER OR THE CONTRACTORS STRUCTURAL ENGINEER.
- ALL WIRE TO WIRE GROUND CONNECTIONS TO THE INTERIOR GROUND RING SHALL BE FORMED USING HIGH PRESS CRIMPS OR SPLIT BOLT CONNECTORS WHERE INDICATED IN THE DETAILS.
- ON ROOFTOP SITES WHERE EXOTHERMIC WELDS ARE A FIRE HAZARD COPPER COMPRESSION CAP CONNECTORS MAY BE USED FOR WIRE TO WIRE CONNECTORS. 2 HOLE MECHANICAL TYPE BRASS CONNECTORS WITH STAINLESS STEEL HARDWARE, INCLUDING SET SCREWS SHALL BE USED FOR CONNECTION TO ALL ROOFTOP TRANSMISSION EQUIPMENT AND STRUCTURAL STEEL.
- COAX BRIDGE BONDING CONDUCTORS SHALL BE EXOTHERMICALLY BONDED OR BOLTED TO THE BRIDGE AND THE TOWER GROUND BAR USING TWO-HOLE MECHANICAL TYPE BRASS CONNECTORS AND STAINLESS STEEL HARDWARE.
- APPROVED ANTIOXIDANT COATINGS (I.E., CONDUCTIVE GEL OR PASTE) SHALL BE USED ON ALL COMPRESSION AND BOLTED GROUND CONNECTIONS.
- ALL EXTERIOR GROUND CONNECTIONS SHALL BE COATED WITH A CORROSION RESISTANT MATERIAL.
- MISCELLANEOUS ELECTRICAL AND NON-ELECTRICAL METAL BOXES, FRAMES AND SUPPORTS SHALL BE BONDED TO THE GROUND RING, IN ACCORDANCE WITH THE NEC.
- BOND ALL METALLIC OBJECTS WITHIN 6 FT OF THE BURIED GROUND RING WITH 2 AWG SOLID TIN-PLATED COPPER GROUND CONDUCTOR. DURING EXCAVATION FOR NEW GROUND CONDUCTORS, IF EXISTING GROUND CONDUCTORS ARE ENCOUNTERED, BOND EXISTING GROUND CONDUCTORS TO NEW CONDUCTORS.
- GROUND CONDUCTORS USED IN THE FACILITY GROUND AND LIGHTNING PROTECTION SYSTEMS SHALL NOT BE ROUTED THROUGH METALLIC OBJECTS THAT FORM A RING AROUND THE CONDUCTOR, SUCH AS METALLIC CONDUITS, METAL SUPPORT CLIPS OR SLEEVES THROUGH WALLS OR FLOORS. WHEN IT IS REQUIRED TO BE HOUSED IN CONDUIT TO MEET CODE REQUIREMENTS OR LOCAL CONDITIONS, NON-METALLIC MATERIAL SUCH AS PVC PLASTIC CONDUIT SHALL BE USED. WHERE USE OF METAL CONDUIT IS UNAVOIDABLE (E.G., NON-METALLIC CONDUIT PROHIBITED BY LOCAL CODE) THE GROUND CONDUCTOR SHALL BE BONDED TO EACH END OF THE METAL CONDUIT WITH LISTED BONDING FITTINGS.

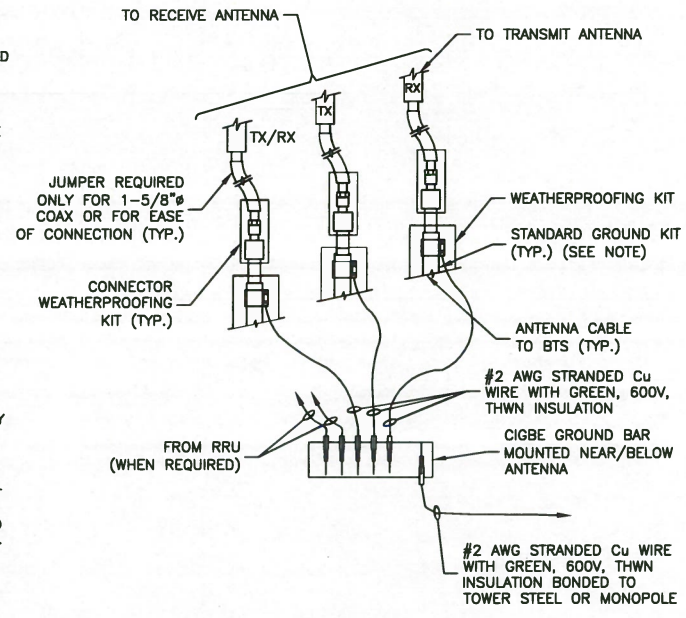

NOTE:
1. DO NOT INSTALL CABLE GROUND KIT AT A BEND AND ALWAYS DIRECT GROUND WIRE DOWN TO CIGBE.

CONNECTION OF GROUND WIRES TO GROUNDING BAR (CIGBE)

SCALE: N.T.S. 1

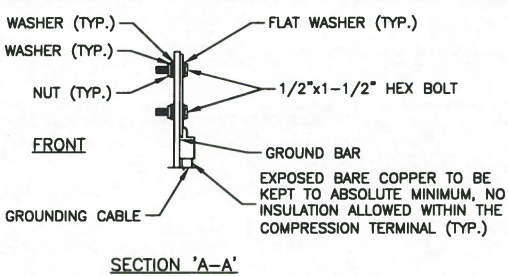
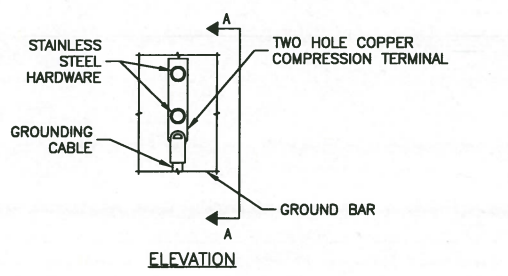

NOTES:
1. DOUBLING UP OR STACKING OF CONNECTIONS IS NOT PERMITTED.
2. OXIDE INHIBITING COMPOUND TO BE USED AT ALL LOCATIONS.

TYPICAL GROUND BAR MECHANICAL CONNECTION DETAIL

SCALE: N.T.S. 2

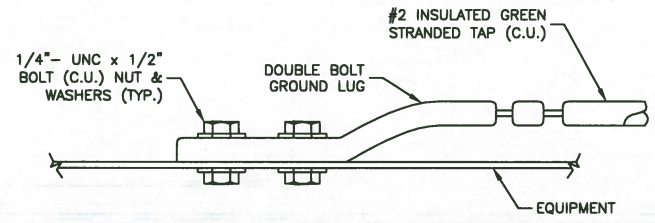

CONNECTION TO EQUIPMENT DETAIL

SCALE: N.T.S. 3

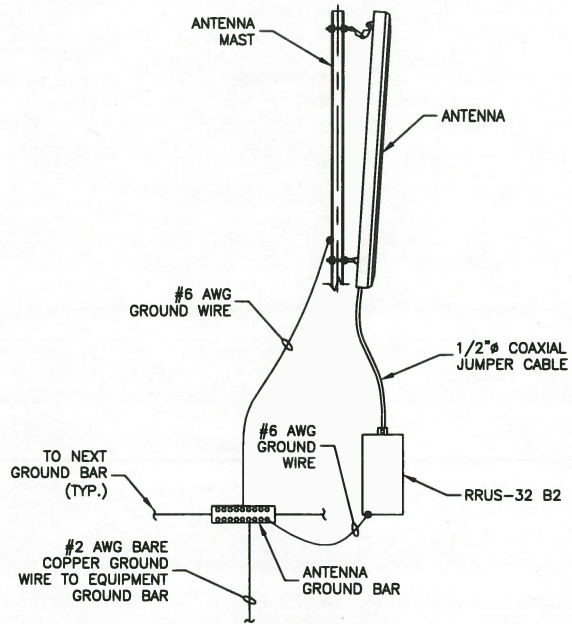

TYPICAL ANTENNA GROUNDING DETAIL

SCALE: N.T.S. 4

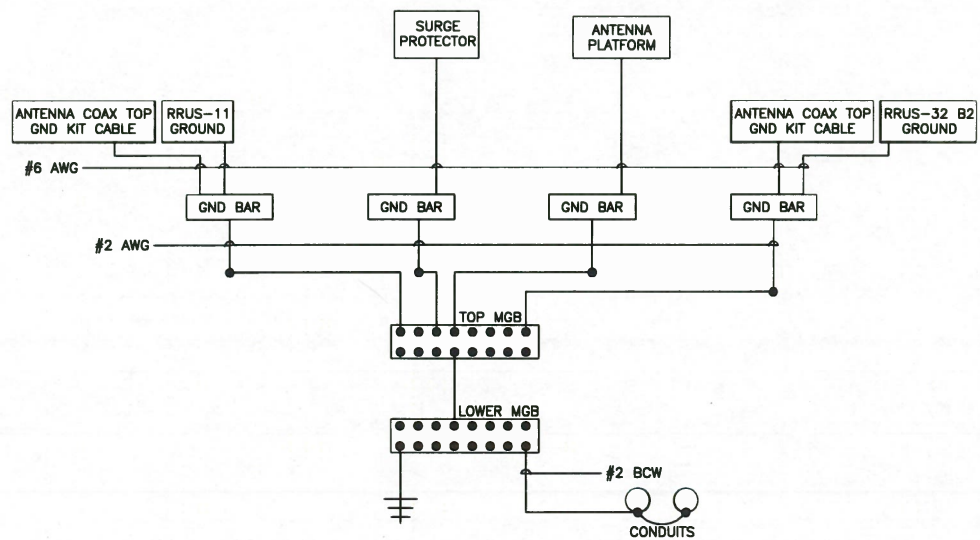

NOTES:
1. BOND ANTENNA GROUNDING KIT CABLE TO TOP CIGBE
2. BOND ANTENNA GROUNDING KIT CABLE TO BOTTOM CIGBE.
3. SCHEMATIC GROUNDING DIAGRAM IS TYPICAL FOR EACH SECTOR.
4. GROUND ALL EQUIPMENT PER MANUFACTURER RECOMMENDATIONS.

SCHEMATIC GROUNDING DIAGRAM

SCALE: N.T.S. 5



500 ENTERPRISE DRIVE SUITE 3A
ROCKY HILL, CT 06067



27 NORTHWESTERN DRIVE
SALEM, NH 03079

CT5841
DURHAM CENTRAL
CROWN BU #: 806364

CONSTRUCTION DRAWINGS

0	04/07/17	ISSUED FOR CONSTRUCTION
A	03/17/17	ISSUED FOR REVIEW



Dewberry Engineers Inc.
600 PARSIPPANY ROAD
SUITE 301
PARSIPPANY, NJ 07054
PHONE: 973.739.8400
FAX: 973.739.9710

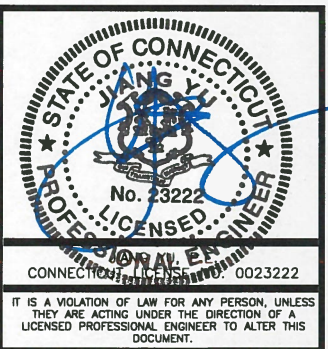

DRAWN BY:	BJR
REVIEWED BY:	BSH
CHECKED BY:	GHN
PROJECT NUMBER:	50055106
JOB NUMBER:	50065688
SITE ADDRESS:	

143R OLD BLUE HILLS RD
DURHAM, CT 06422
MIDDLESEX COUNTY

SHEET TITLE

GROUNDING NOTES & DETAILS

SHEET NUMBER

Date: **March 22, 2017**

Charles McGuirt
Crown Castle
3530 Toringdon Way, Suite 300
Charlotte, NC 28277



Crown Castle
2000 Corporate Drive
Canonsburg, PA, 15317
(724) 416-9160

Subject: **Structural Analysis Report**

Carrier Designation: **AT&T Mobility Co-Locate**
Carrier Site Number: CT5841
Carrier Site Name: Durham Central

Crown Castle Designation: **Crown Castle BU Number:** 806364
Crown Castle Site Name: HRT 106(B) 943202
Crown Castle JDE Job Number: 430682
Crown Castle Work Order Number: 1378401
Crown Castle Application Number: 383797 Rev. 1

Engineering Firm Designation: **Crown Castle Project Number:** 1378401

Site Data: **143 R Old Blue Hill Road, DURHAM, Middlesex County, CT**
Latitude 41° 27' 33.67", Longitude -72° 39' 45.83"
120 Foot - Monopole Tower

Dear Charles McGuirt,

Crown Castle is pleased to submit this "**Structural Analysis Report**" to determine the structural integrity of the above mentioned tower. This analysis has been performed in accordance with the Crown Castle Structural 'Statement of Work' and the terms of Crown Castle Purchase Order Number 1378401, in accordance with application 383797, revision 1.

The purpose of the analysis is to determine acceptability of the tower stress level. Based on our analysis we have determined the tower stress level for the structure and foundation, under the following load case, to be:

LC7: Existing + Reserved + Proposed Equipment

Sufficient Capacity

Note: See Table I and Table II for the proposed and existing/reserved loading, respectively.

This analysis has been performed in accordance with the 2016 Connecticut State Building Code based upon an ultimate 3-second gust wind speed of 130 mph converted to a nominal 3-second gust wind speed of 101 mph per Section 1609.3 and Appendix N as required for use in the TIA-222-G Standard per Exception #5 of Section 1609.1.1. Exposure Category B and Risk Category II were used in this analysis.

All modifications and equipment proposed in this report shall be installed in accordance with the attached drawings for the determined available structural capacity to be effective.

We at *Crown Castle* appreciate the opportunity of providing our continuing professional services to you and Crown Castle. If you have any questions or need further assistance on this or any other projects, please give us a call.

Structural analysis prepared by: Michael Lopienski, E.I.T. / AGH

Respectfully submitted by:

Bradley E. Byrom, P.E., S.E.
Senior Project Engineer

tnxTower Report - version 7.0.5.1

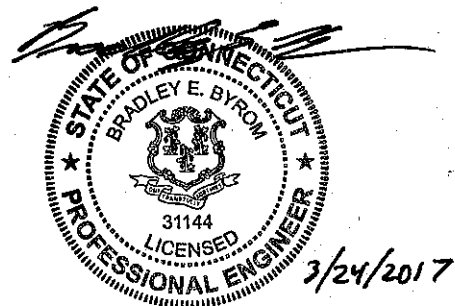

TABLE OF CONTENTS

1) INTRODUCTION

2) ANALYSIS CRITERIA

Table 1 - Proposed Antenna and Cable Information

Table 2 - Existing and Reserved Antenna and Cable Information

Table 3 - Design Antenna and Cable Information

3) ANALYSIS PROCEDURE

Table 4 - Documents Provided

3.1) Analysis Method

3.2) Assumptions

4) ANALYSIS RESULTS

Table 5 - Section Capacity (Summary)

Table 6 – Tower Components vs. Capacity – LC7

4.1) Recommendations

5) APPENDIX A

tnxTower Output

6) APPENDIX B

Base Level Drawing

7) APPENDIX C

Additional Calculations

1) INTRODUCTION

This tower is a 120 ft Monopole tower designed by VALMONT in March of 1994. The tower was originally designed for a wind speed of 90 mph per TIA/EIA-222-E.

2) ANALYSIS CRITERIA

The structural analysis was performed for this tower in accordance with the requirements of TIA-222-G Structural Standards for Steel Antenna Towers and Antenna Supporting Structures using a 3-second gust wind speed of 101 mph with no ice, 50 mph with 0.75 inch ice thickness and 60 mph under service loads, exposure category B.

Table 1 - Proposed Antenna and Cable Information

Mounting Level (ft)	Center Line Elevation (ft)	Number of Antennas	Antenna Manufacturer	Antenna Model	Number of Feed Lines	Feed Line Size (in)	Note
114.0	114.0	6	andrew	SBNHH-1D65A w/ Mount Pipe	4 2 6	3/8 3/4 1-5/8	-
		3	ericsson	RRUS 11			
		3	ericsson	RRUS 32 B2			
		1	raycap	DC6-48-60-18-8C			
		1	tower mounts	Sabre-C10-116-912			
		1	tower mounts	Sabre-C10-851-001			
		1	tower mounts	Sabre-C10-112-300			

Table 2 - Existing and Reserved Antenna and Cable Information

Mounting Level (ft)	Center Line Elevation (ft)	Number of Antennas	Antenna Manufacturer	Antenna Model	Number of Feed Lines	Feed Line Size (in)	Note
118.0	125.0	1	decibel	DB809MT3-XT	3	7/8	1
	123.0	1	decibel	DB201-A			
	118.0	2	tower mounts	Side Arm Mount [SO 701-1]			
107.0	107.0	1	gabriel electronics	GLF6-450	1	7/8	1
		1	tower mounts	Pipe Mount [PM 601-1]			
98.0	100.0	3	alcatel lucent	B13 RRH4X30-4R	12 1	1-5/8	2
		3	alcatel lucent	B66A RRH4X45			
		6	andrew	SBNHH-1D65B w/ Mount Pipe			
		1	antel	LPA-80080/6CF w/ Mount Pipe			
		2	raycap	RXXDC-3315-PF-48			
		3	alcatel lucent	RRH2X60-PCS			
	5	antel	LPA-80080/6CF w/ Mount Pipe				
98.0	1	tower mounts	Platform Mount [LP 602-1]				
87.0	89.0	6	decibel	DB980H90E-M w/ Mount Pipe	6	1-1/4	1
	87.0	1	tower mounts	Platform Mount [LP 602-1]			

Mounting Level (ft)	Center Line Elevation (ft)	Number of Antennas	Antenna Manufacturer	Antenna Model	Number of Feed Lines	Feed Line Size (in)	Note
73.0	79.0	1	decibel	DB636-C	1	7/8	1
	74.0	6	ericsson	RRUS 11	1 2 12 1	3/8 3/4 7/8 2" Conduit	3
		3	kmw communications	AM-X-CD-16-65-00T-RET w/ Mount Pipe			
		6	powerwave technologies	7770.00 w/ Mount Pipe			
		6	powerwave technologies	LGP21401			
		6	powerwave technologies	LGP21903			
	1	raycap	DC6-48-60-18-8F				
73.0	1	tower mounts	Platform Mount [LP 1201-1]	-	-	1	
50.0	57.0	1	rfs celwave	PD1142-1	1 3	1/2 7/8	1
	54.0	1	decibel	ASP-655			
	53.0	1	celwave	PD1121-6			
	50.0	1	decibel	DB492A			
		1	tower mounts	Side Arm Mount [SO 701-3]			
40.0	41.0	1	tekelec systemes	EPSILON GPS ANTENNA 35 DB	1 1	1/2 2" conduit	1
	40.0	1	tower mounts	Side Arm Mount [SO 701-1]			

- Notes:
 1) Existing Equipment
 2) Reserved Equipment
 3) Equipment to be Removed, Not Considered in this Analysis

Table 3 - Design Antenna and Cable Information

Mounting Level (ft)	Center Line Elevation (ft)	Number of Antennas	Antenna Manufacturer	Antenna Model	Number of Feed Lines	Feed Line Size (in)
97	97	12	-	8RL41OC4R105	-	-
87	87	9	-	8RL41OC4R105	-	-
75	75	1	-	ASP710	-	-
		1	Telewave	450F6 Antenna		
50	50	1	-	ASP701	-	-
		1	-	ASP710		

3) ANALYSIS PROCEDURE

Table 4 - Documents Provided

Document	Remarks	Reference	Source
4-GEOTECHNICAL REPORTS	Clarence Welti	262150	CCISITES
4-TOWER FOUNDATION DRAWINGS/DESIGN/SPECS	SAC	297341	CCISITES
4-TOWER MANUFACTURER DRAWINGS	Valmont	262153	CCISITES
4-TOWER EXTENSION DESIGN	Valmont	942187	CCISITES

3.1) Analysis Method

tnxTower (version 7.0.5.1), a commercially available analysis software package, was used to create a three-dimensional model of the tower and calculate member stresses for various loading cases. Selected output from the analysis is included in Appendix A.

3.2) Assumptions

- 1) Tower and structures were built in accordance with the manufacturer's specifications.
- 2) The tower and structures have been maintained in accordance with the manufacturer's specification.
- 3) The configuration of antennas, transmission cables, mounts and other appurtenances are as specified in Tables 1 and 2 and the referenced drawings.
- 4) The existing base plate grout was not considered in this analysis.

This analysis may be affected if any assumptions are not valid or have been made in error. Crown Castle should be notified to determine the effect on the structural integrity of the tower.

4) ANALYSIS RESULTS

Table 5 - Section Capacity (Summary)

Section No.	Elevation (ft)	Component Type	Size	Critical Element	P (K)	SF*P_allow (K)	% Capacity	Pass / Fail
L1	120 - 100	Pole	TP20.263x15.0403x0.1875	1	-3.63	829.59	25.0	Pass
L2	100 - 47.0833	Pole	TP33.13x20.263x0.2813	2	-16.63	1920.74	71.0	Pass
L3	47.0833 - 0	Pole	TP44x31.372x0.375	3	-29.31	3477.10	66.5	Pass
							Summary	
						Pole (L2)	71.0	Pass
						Rating =	71.0	Pass

Table 6 - Tower Component Stresses vs. Capacity – LC7

Notes	Component	Elevation (ft)	% Capacity	Pass / Fail
1	Flange Bolts	100.0	36.6	Pass
1	Flange Plate		10.0	Pass
1	Anchor Rods	0	62.4	Pass
1	Base Plate	0	33.8	Pass
1	Base Foundation	0	24.3	Pass
1	Base Foundation Soil Interaction	0	26.7	Pass

Structure Rating (max from all components) =	71.0%
---	--------------

Notes:

- 1) See additional documentation in "Appendix C – Additional Calculations" for calculations supporting the % capacity consumed.

4.1) Recommendations

The tower and its foundation have sufficient capacity to carry the existing, reserved, and proposed loads. No modifications are required at this time.

APPENDIX A
TNXTOWER OUTPUT

DESIGNED APPURTENANCE LOADING

TYPE	ELEVATION	TYPE	ELEVATION
DB809MT3-XT	118	(2) SBNHH-1D65B w/ Mount Pipe	98
DB201-A	118	(2) SBNHH-1D65B w/ Mount Pipe	98
6' x 2" Mount Pipe	118	LPA-80080/6CF w/ Mount Pipe	98
6' x 2" Mount Pipe	118	B13 RRH4X30-4R	98
Side Arm Mount [SO 102-3]	118	B13 RRH4X30-4R	98
Side Arm Mount [SO 701-1]	118	B13 RRH4X30-4R	98
Side Arm Mount [SO 701-1]	118	B66A RRH4X45	98
(2) SBNHH-1D65A w/ Mount Pipe	114	B66A RRH4X45	98
(2) SBNHH-1D65A w/ Mount Pipe	114	B66A RRH4X45	98
(2) SBNHH-1D65A w/ Mount Pipe	114	(2) RXXDC-3315-PF-48	98
RRUS 11	114	Platform Mount [LP 602-1]	98
RRUS 11	114	(2) LPA-80080/6CF w/ Mount Pipe	98
RRUS 11	114	(2) DB980H90E-M w/ Mount Pipe	87
RRUS 32 B2	114	(2) DB980H90E-M w/ Mount Pipe	87
RRUS 32 B2	114	6' x 2" Mount Pipe	87
RRUS 32 B2	114	Platform Mount [LP 602-1]	87
DC6-48-60-18-8C	114	(2) DB980H90E-M w/ Mount Pipe	87
Miscellaneous [NA 507-1]	114	6' x 2" Mount Pipe	73
Side Arm Mount [SO 102-3]	114	Platform Mount [LP 1201-1]	73
Platform Mount [LP 601-1]	114	DB636-C	73
Pipe Mount [PM 601-1]	107	DB492A	50
GLF6-450	107	ASP-655	50
(2) LPA-80080/6CF w/ Mount Pipe	98	PD1121-6	50
LPA-80080/6CF w/ Mount Pipe	98	Side Arm Mount [SO 701-3]	50
RRH2X60-PCS	98	PD1142-1	50
RRH2X60-PCS	98	Side Arm Mount [SO 701-1]	40
RRH2X60-PCS	98	EPSILON GPS ANTENNA 35 DB	40
(2) SBNHH-1D65B w/ Mount Pipe	98		

MATERIAL STRENGTH

GRADE	Fy	Fu	GRADE	Fy	Fu
A572-65	65 ksi	80 ksi			

TOWER DESIGN NOTES

1. Tower is located in Middlesex County, Connecticut.
2. Tower designed for Exposure B to the TIA-222-G Standard.
3. Tower designed for a 101 mph basic wind in accordance with the TIA-222-G Standard.
4. Tower is also designed for a 50 mph basic wind with 0.75 in ice. Ice is considered to increase in thickness with height.
5. Deflections are based upon a 60 mph wind.
6. Tower Structure Class II.
7. Topographic Category 1 with Crest Height of 0.00 ft
8. TOWER RATING: 71%

Section	1	2	3
Length (ft)	20.00	52.92	52.00
Number of Sides	12	12	12
Thickness (in)	0.1875	0.2813	0.3750
Socket Length (ft)		4.92	31.3720
Top Dia (in)	15.0403	20.2630	44.0000
Bot Dia (in)	20.2630	33.1300	
Grade		A572-65	
Weight (K)	0.7	4.3	8.0

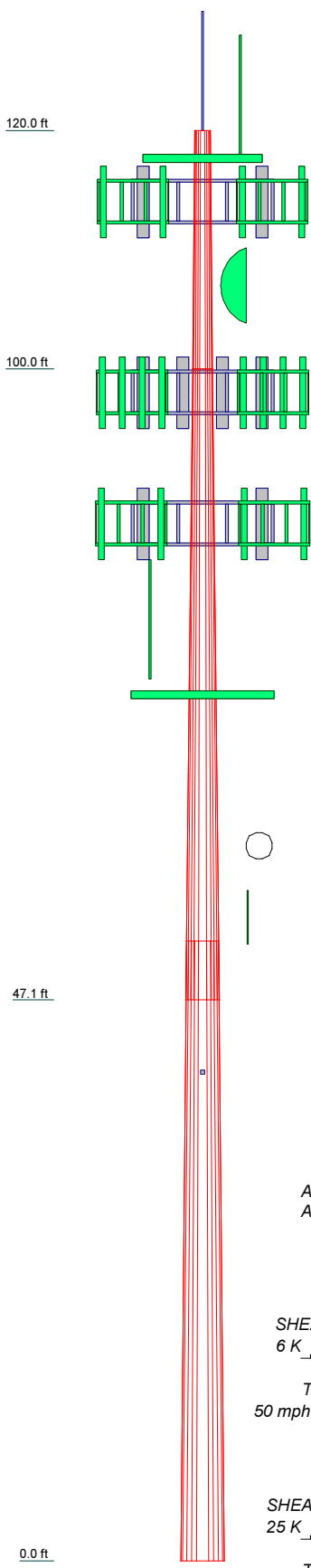

ALL REACTIONS ARE FACTORED

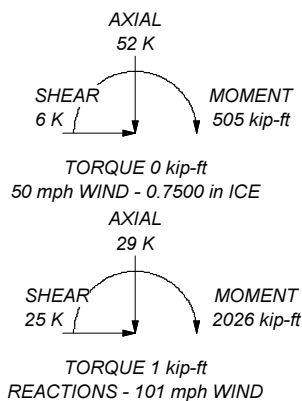

Crown Castle
 2000 Corporate Drive
 Canonsburg, PA, 15317
 Phone: (724) 416-9160
 FAX:

Job: BU# 806364		
Project:	Client: CCI	App'd:
Code: TIA-222-G	Drawn by: MLopienski	Scale: NTS
Path:	Date: 03/22/17	Dwg No. E-1

R:\SA Models - Letters\Work Area\MLopienski\WPI\806364 WO 1378401\806364.dwg

Tower Input Data

There is a pole section.

This tower is designed using the TIA-222-G standard.

The following design criteria apply:

- 4) Tower is located in Middlesex County, Connecticut.
- 5) Basic wind speed of 101 mph.
- 6) Structure Class II.
- 7) Exposure Category B.
- 8) Topographic Category 1.
- 9) Crest Height 0.00 ft.
- 10) Nominal ice thickness of 0.7500 in.
- 11) Ice thickness is considered to increase with height.
- 12) Ice density of 56.00 pcf.
- 13) A wind speed of 50 mph is used in combination with ice.
- 14) Deflections calculated using a wind speed of 60 mph.
- 15) A non-linear (P-delta) analysis was used.
- 16) Pressures are calculated at each section.
- 17) Stress ratio used in pole design is 1.
- 18) Local bending stresses due to climbing loads, feed line supports, and appurtenance mounts are not considered.

Options

Consider Moments - Legs Consider Moments - Horizontals Consider Moments - Diagonals Use Moment Magnification ✓ Use Code Stress Ratios ✓ Use Code Safety Factors - Guys Escalate Ice Always Use Max Kz Use Special Wind Profile Include Bolts In Member Capacity Leg Bolts Are At Top Of Section Secondary Horizontal Braces Leg Use Diamond Inner Bracing (4 Sided) SR Members Have Cut Ends SR Members Are Concentric	Distribute Leg Loads As Uniform Assume Legs Pinned ✓ Assume Rigid Index Plate ✓ Use Clear Spans For Wind Area Use Clear Spans For KL/r Retension Guys To Initial Tension ✓ Bypass Mast Stability Checks ✓ Use Azimuth Dish Coefficients ✓ Project Wind Area of Appurt. Autocalc Torque Arm Areas Add IBC .6D+W Combination ✓ Sort Capacity Reports By Component Triangulate Diamond Inner Bracing Treat Feed Line Bundles As Cylinder	Use ASCE 10 X-Brace Ly Rules Calculate Redundant Bracing Forces Ignore Redundant Members in FEA SR Leg Bolts Resist Compression All Leg Panels Have Same Allowable Offset Girt At Foundation ✓ Consider Feed Line Torque Include Angle Block Shear Check Use TIA-222-G Bracing Resist. Exemption Use TIA-222-G Tension Splice Exemption <div style="text-align: center; background-color: #e0e0e0; padding: 2px;">Poles</div> ✓ Include Shear-Torsion Interaction Always Use Sub-Critical Flow Use Top Mounted Sockets
--	--	---

Tapered Pole Section Geometry

Section	Elevation <i>ft</i>	Section Length <i>ft</i>	Splice Length <i>ft</i>	Number of Sides	Top Diameter <i>in</i>	Bottom Diameter <i>in</i>	Wall Thickness <i>in</i>	Bend Radius <i>in</i>	Pole Grade
L1	120.00-100.00	20.00	0.00	12	15.0403	20.2630	0.1875	0.7500	A572-65 (65 ksi)
L2	100.00-47.08	52.92	4.92	12	20.2630	33.1300	0.2813	1.1250	A572-65 (65 ksi)
L3	47.08-0.00	52.00		12	31.3720	44.0000	0.3750	1.5000	A572-65 (65 ksi)

Tapered Pole Properties

Section	Tip Dia. in	Area in ²	I in ⁴	r in	C in	I/C in ³	J in ⁴	It/Q in ²	w in	w/t
L1	15.5709	8.9674	252.5039	5.3173	7.7909	32.4102	511.6414	4.4135	3.5283	18.818
	20.9778	12.1206	623.5083	7.1870	10.4962	59.4030	1263.3968	5.9654	4.9280	26.283
L2	20.9778	18.0960	922.2208	7.1535	10.4962	87.8621	1868.6694	8.9063	4.6767	16.628
	34.2987	29.7486	4097.2352	11.7599	17.1613	238.7480	8302.1094	14.6414	8.1251	28.889
L3	33.7148	37.4288	4590.1943	11.0969	16.2507	282.4616	9300.9781	18.4213	7.4027	19.741
	45.5522	52.6772	12796.152	15.6177	22.7920	561.4318	25928.474	25.9261	10.7870	28.765

6

3

Tower Elevation	Gusset Area (per face)	Gusset Thickness	Gusset Grade	Adjust. Factor A _r	Adjust. Factor A _r	Weight Mult.	Double Angle Stitch Bolt Spacing Diagonals	Double Angle Stitch Bolt Spacing Horizontals	Double Angle Stitch Bolt Spacing Redundants
ft	ft ²	in					in	in	in
L1 120.00-100.00				1	1	1			
L2 100.00-47.08				1	1	1			
L3 47.08-0.00				1	1	1			

Feed Line/Linear Appurtenances - Entered As Round Or Flat

Description	Sector	Component Type	Placement	Total Number	Number Per Row	Start/End Position	Width or Diameter	Perimeter	Weight
			ft				in	in	klf
2" Rigid Conduit	C	Surface Ar (CaAa)	40.00 - 0.00	1	1	0.200 0.500	2.0000		0.00

Feed Line/Linear Appurtenances - Entered As Area

Description	Face or Leg	Allow Shield	Component Type	Placement	Total Number		C _A A _A	Weight
				ft			ft ² /ft	klf
LDF5-50A(7/8")	A	No	Inside Pole	118.00 - 0.00	3	No Ice 1/2" Ice 1" Ice	0.00 0.00 0.00	0.00 0.00 0.00

VXL5-50(7/8")	A	No	Inside Pole	107.00 - 0.00	1	No Ice 1/2" Ice 1" Ice	0.00 0.00 0.00	0.00 0.00 0.00

LDF5-50A(7/8")	C	No	Inside Pole	98.00 - 0.00	12	No Ice 1/2" Ice 1" Ice	0.00 0.00 0.00	0.00 0.00 0.00
HB158-1-08U8-S8J18(1-5/8)	C	No	Inside Pole	98.00 - 0.00	2	No Ice 1/2" Ice 1" Ice	0.00 0.00 0.00	0.00 0.00 0.00

LDF6-50A(1-1/4")	C	No	Inside Pole	87.00 - 0.00	6	No Ice 1/2" Ice 1" Ice	0.00 0.00 0.00	0.00 0.00 0.00

VXL5-50(7/8")	A	No	Inside Pole	73.00 - 0.00	1	No Ice 1/2" Ice 1" Ice	0.00 0.00 0.00	0.00 0.00 0.00

LDF4-50A(1/2")	A	No	Inside Pole	50.00 - 0.00	1	No Ice 1/2" Ice 1" Ice	0.00 0.00 0.00	0.00 0.00 0.00
LDF5-50A(7/8")	A	No	Inside Pole	50.00 - 0.00	3	No Ice 1/2" Ice 1" Ice	0.00 0.00 0.00	0.00 0.00 0.00

Description	Face or Leg	Allow Shield	Component Type	Placement ft	Total Number		C _A A _A ft ² /ft	Weight klf

LDF4-50A(1/2")	C	No	Inside Pole	40.00 - 0.00	1	No Ice 1/2" Ice 1" Ice	0.00 0.00 0.00	0.00 0.00 0.00
*								
LDF2-50(3/8)	A	No	Inside Pole	110.00 - 0.00	3	No Ice 1/2" Ice 1" Ice	0.00 0.00 0.00	0.00 0.00 0.00
LDF7-50A(1-5/8)	A	No	Inside Pole	110.00 - 0.00	6	No Ice 1/2" Ice 1" Ice	0.00 0.00 0.00	0.00 0.00 0.00
FB-L98B-034-XXX(3/8)	A	No	Inside Pole	110.00 - 0.00	1	No Ice 1/2" Ice 1" Ice	0.00 0.00 0.00	0.00 0.00 0.00
WR-VG86ST-BRD(3/4)	A	No	Inside Pole	110.00 - 0.00	2	No Ice 1/2" Ice 1" Ice	0.00 0.00 0.00	0.00 0.00 0.00

Feed Line/Linear Appurtenances Section Areas

Tower Sectio n	Tower Elevation ft	Face	A _R ft ²	A _F ft ²	C _A A _A In Face ft ²	C _A A _A Out Face ft ²	Weight K
L1	120.00-100.00	A	0.000	0.000	0.000	0.000	0.08
		B	0.000	0.000	0.000	0.000	0.00
		C	0.000	0.000	0.000	0.000	0.00
L2	100.00-47.08	A	0.000	0.000	0.000	0.000	0.42
		B	0.000	0.000	0.000	0.000	0.00
		C	0.000	0.000	0.000	0.000	0.49
L3	47.08-0.00	A	0.000	0.000	0.000	0.000	0.43
		B	0.000	0.000	0.000	0.000	0.00
		C	0.000	0.000	8.000	0.000	0.61

Feed Line/Linear Appurtenances Section Areas - With Ice

Tower Sectio n	Tower Elevation ft	Face or Leg	Ice Thickness in	A _R ft ²	A _F ft ²	C _A A _A In Face ft ²	C _A A _A Out Face ft ²	Weight K
L1	120.00-100.00	A	1.691	0.000	0.000	0.000	0.000	0.08
		B		0.000	0.000	0.000	0.000	0.00
		C		0.000	0.000	0.000	0.000	0.00
L2	100.00-47.08	A	1.622	0.000	0.000	0.000	0.000	0.42
		B		0.000	0.000	0.000	0.000	0.00
		C		0.000	0.000	0.000	0.000	0.49
L3	47.08-0.00	A	1.444	0.000	0.000	0.000	0.000	0.43
		B		0.000	0.000	0.000	0.000	0.00
		C		0.000	0.000	20.975	0.000	0.90

Feed Line Center of Pressure

Section	Elevation ft	CP _x in	CP _z in	CP _x Ice in	CP _z Ice in
L1	120.00-100.00	0.0000	0.0000	0.0000	0.0000
L2	100.00-47.08	0.0000	0.0000	0.0000	0.0000
L3	47.08-0.00	-0.1684	0.1870	-0.3815	0.4237

Shielding Factor Ka

Tower Section	Feed Line Record No.	Description	Feed Line Segment Elev.	K_a No Ice	K_a Ice
L2	21	2" Rigid Conduit	47.08 - 40.00	1.0000	1.0000

Discrete Tower Loads

Description	Face or Leg	Offset Type	Offsets: Horz Lateral	Azimuth Adjustment	Placement		C_{AA} Front	C_{AA} Side	Weight
			Vert ft	°	ft		ft ²	ft ²	K
DB809MT3-XT	A	From Leg	3.00	0.00	118.00	No Ice	2.84	2.84	0.03
			0.00			1/2"	4.29	4.29	0.05
			7.00			Ice	5.75	5.75	0.08
DB201-A	B	From Leg	3.00	0.00	118.00	No Ice	1.10	1.10	0.03
			0.00			1/2"	1.98	1.98	0.03
			5.00			Ice	2.86	2.86	0.04
6' x 2" Mount Pipe	A	From Leg	3.00	0.00	118.00	No Ice	1.43	1.43	0.02
			0.00			1/2"	1.92	1.92	0.03
			0.00			Ice	2.29	2.29	0.05
6' x 2" Mount Pipe	B	From Leg	3.00	0.00	118.00	No Ice	1.43	1.43	0.02
			0.00			1/2"	1.92	1.92	0.03
			0.00			Ice	2.29	2.29	0.05
Side Arm Mount [SO 102-3]	B	None		0.00	118.00	No Ice	3.00	3.00	0.08
						1/2"	3.48	3.48	0.11
						Ice	3.96	3.96	0.14
Side Arm Mount [SO 701-1]	A	From Leg	0.00	0.00	118.00	No Ice	0.85	1.67	0.07
			0.00			1/2"	1.14	2.34	0.08
			0.00			Ice	1.43	3.01	0.09
Side Arm Mount [SO 701-1]	B	From Leg	0.00	0.00	118.00	No Ice	0.85	1.67	0.07
			0.00			1/2"	1.14	2.34	0.08
			0.00			Ice	1.43	3.01	0.09

(2) SBNHH-1D65A w/ Mount Pipe	A	From Leg	4.00	0.00	114.00	No Ice	5.95	5.19	0.06
			0.00			1/2"	6.39	5.96	0.11
			0.00			Ice	6.82	6.66	0.17
(2) SBNHH-1D65A w/ Mount Pipe	B	From Leg	4.00	0.00	114.00	No Ice	5.95	5.19	0.06
			0.00			1/2"	6.39	5.96	0.11
			0.00			Ice	6.82	6.66	0.17
(2) SBNHH-1D65A w/ Mount Pipe	C	From Leg	4.00	0.00	114.00	No Ice	5.95	5.19	0.06
			0.00			1/2"	6.39	5.96	0.11
			0.00			Ice	6.82	6.66	0.17
RRUS 11	A	From Leg	4.00	0.00	114.00	No Ice	2.78	1.19	0.05
			0.00			1/2"	2.99	1.33	0.07
			0.00			Ice	3.21	1.49	0.09
RRUS 11	B	From Leg	4.00	0.00	114.00	No Ice	2.78	1.19	0.05
			0.00			1/2"	2.99	1.33	0.07
			0.00			Ice	3.21	1.49	0.09
RRUS 11	C	From Leg	4.00	0.00	114.00	No Ice	2.78	1.19	0.05

Description	Face or Leg	Offset Type	Offsets:		Azimuth Adjustment	Placement	C _{AA} Front	C _{AA} Side	Weight	
			Horz	Lateral						Vert
			ft	ft	°	ft	ft ²	ft ²	K	
			0.00			1/2"	2.99	1.33	0.07	
			0.00			Ice	3.21	1.49	0.09	
RRUS 32 B2	A	From Leg	4.00		0.00	114.00	1" Ice	2.73	1.67	0.05
			0.00				No Ice	2.95	1.86	0.07
			0.00				1/2"	3.18	2.05	0.10
							Ice			
							1" Ice			
RRUS 32 B2	B	From Leg	4.00		0.00	114.00	No Ice	2.73	1.67	0.05
			0.00				1/2"	2.95	1.86	0.07
			0.00				Ice	3.18	2.05	0.10
							1" Ice			
RRUS 32 B2	C	From Leg	4.00		0.00	114.00	No Ice	2.73	1.67	0.05
			0.00				1/2"	2.95	1.86	0.07
			0.00				Ice	3.18	2.05	0.10
							1" Ice			
DC6-48-60-18-8C	A	From Leg	4.00		0.00	114.00	No Ice	2.74	2.74	0.03
			0.00				1/2"	2.96	2.96	0.05
			0.00				Ice	3.20	3.20	0.08
							1" Ice			
Miscellaneous [NA 507-1]	A	None			0.00	114.00	No Ice	4.80	4.80	0.25
							1/2"	6.70	6.70	0.29
							Ice	8.60	8.60	0.34
							1" Ice			
Side Arm Mount [SO 102-3]	A	None			0.00	114.00	No Ice	3.00	3.00	0.08
							1/2"	3.48	3.48	0.11
							Ice	3.96	3.96	0.14
							1" Ice			
Platform Mount [LP 601-1]	A	None			0.00	114.00	No Ice	28.47	28.47	1.12
							1/2"	33.59	33.59	1.51
							Ice	38.71	38.71	1.91
							1" Ice			
*										
Pipe Mount [PM 601-1]	B	None			0.00	107.00	No Ice	3.00	0.90	0.07
							1/2"	3.74	1.12	0.08
							Ice	4.48	1.34	0.09
							1" Ice			

(2) LPA-80080/6CF w/ Mount Pipe	A	From Leg	4.00		0.00	98.00	No Ice	4.56	10.26	0.05
			0.00				1/2"	5.11	11.43	0.11
			2.00				Ice	5.61	12.31	0.19
							1" Ice			
(2) LPA-80080/6CF w/ Mount Pipe	B	From Leg	4.00		0.00	98.00	No Ice	4.56	10.26	0.05
			0.00				1/2"	5.11	11.43	0.11
			2.00				Ice	5.61	12.31	0.19
							1" Ice			
LPA-80080/6CF w/ Mount Pipe	C	From Leg	4.00		0.00	98.00	No Ice	4.56	10.26	0.05
			0.00				1/2"	5.11	11.43	0.11
			2.00				Ice	5.61	12.31	0.19
							1" Ice			
RRH2X60-PCS	A	From Leg	4.00		0.00	98.00	No Ice	2.20	1.72	0.06
			0.00				1/2"	2.39	1.90	0.08
			2.00				Ice	2.59	2.09	0.10
							1" Ice			
RRH2X60-PCS	B	From Leg	4.00		0.00	98.00	No Ice	2.20	1.72	0.06
			0.00				1/2"	2.39	1.90	0.08
			2.00				Ice	2.59	2.09	0.10
							1" Ice			
RRH2X60-PCS	C	From Leg	4.00		0.00	98.00	No Ice	2.20	1.72	0.06
			0.00				1/2"	2.39	1.90	0.08
			2.00				Ice	2.59	2.09	0.10
							1" Ice			
(2) SBNHH-1D65B w/ Mount Pipe	A	From Leg	4.00		0.00	98.00	No Ice	8.39	7.08	0.08
			0.00				1/2"	8.95	8.28	0.15
			2.00				Ice	9.48	9.19	0.22
							1" Ice			

Description	Face or Leg	Offset Type	Offsets:		Azimuth Adjustment	Placement	C _{AA} Front	C _{AA} Side	Weight	
			Horz	Lateral						Vert
			ft	ft	°	ft	ft ²	ft ²	K	
(2) SBNHH-1D65B w/ Mount Pipe	B	From Leg	4.00	0.00	0.00	98.00	No Ice	8.39	7.08	0.08
			0.00				1/2"	8.95	8.28	0.15
			2.00				Ice	9.48	9.19	0.22
							1" Ice			
(2) SBNHH-1D65B w/ Mount Pipe	C	From Leg	4.00	0.00	0.00	98.00	No Ice	8.39	7.08	0.08
			0.00				1/2"	8.95	8.28	0.15
			2.00				Ice	9.48	9.19	0.22
							1" Ice			
LPA-80080/6CF w/ Mount Pipe	C	From Leg	4.00	0.00	0.00	98.00	No Ice	4.56	10.26	0.05
			0.00				1/2"	5.11	11.43	0.11
			2.00				Ice	5.61	12.31	0.19
							1" Ice			
B13 RRH4X30-4R	A	From Leg	4.00	0.00	0.00	98.00	No Ice	2.16	1.62	0.06
			0.00				1/2"	2.35	1.79	0.08
			2.00				Ice	2.55	1.97	0.10
							1" Ice			
B13 RRH4X30-4R	B	From Leg	4.00	0.00	0.00	98.00	No Ice	2.16	1.62	0.06
			0.00				1/2"	2.35	1.79	0.08
			2.00				Ice	2.55	1.97	0.10
							1" Ice			
B13 RRH4X30-4R	C	From Leg	4.00	0.00	0.00	98.00	No Ice	2.16	1.62	0.06
			0.00				1/2"	2.35	1.79	0.08
			2.00				Ice	2.55	1.97	0.10
							1" Ice			
B66A RRH4X45	A	From Leg	4.00	0.00	0.00	98.00	No Ice	2.58	1.63	0.07
			0.00				1/2"	2.79	1.81	0.09
			2.00				Ice	3.01	2.00	0.11
							1" Ice			
B66A RRH4X45	B	From Leg	4.00	0.00	0.00	98.00	No Ice	2.58	1.63	0.07
			0.00				1/2"	2.79	1.81	0.09
			2.00				Ice	3.01	2.00	0.11
							1" Ice			
B66A RRH4X45	C	From Leg	4.00	0.00	0.00	98.00	No Ice	2.58	1.63	0.07
			0.00				1/2"	2.79	1.81	0.09
			2.00				Ice	3.01	2.00	0.11
							1" Ice			
(2) RXXDC-3315-PF-48	C	From Leg	4.00	0.00	0.00	98.00	No Ice	3.01	1.96	0.02
			0.00				1/2"	3.23	2.15	0.05
			2.00				Ice	3.46	2.35	0.08
							1" Ice			
Platform Mount [LP 602-1]	C	None			0.00	98.00	No Ice	32.03	32.03	1.34
							1/2"	38.71	38.71	1.80
							Ice	45.39	45.39	2.26
							1" Ice			

(2) DB980H90E-M w/ Mount Pipe	A	From Leg	4.00	0.00	0.00	87.00	No Ice	4.04	3.62	0.03
			0.00				1/2"	4.50	4.48	0.07
			2.00				Ice	4.95	5.22	0.11
							1" Ice			
(2) DB980H90E-M w/ Mount Pipe	B	From Leg	4.00	0.00	0.00	87.00	No Ice	4.04	3.62	0.03
			0.00				1/2"	4.50	4.48	0.07
			2.00				Ice	4.95	5.22	0.11
							1" Ice			
(2) DB980H90E-M w/ Mount Pipe	C	From Leg	4.00	0.00	0.00	87.00	No Ice	4.04	3.62	0.03
			0.00				1/2"	4.50	4.48	0.07
			2.00				Ice	4.95	5.22	0.11
							1" Ice			
6' x 2" Mount Pipe	C	From Leg	0.00	0.00	0.00	87.00	No Ice	1.43	1.43	0.02
			0.00				1/2"	1.92	1.92	0.03
			0.00				Ice	2.29	2.29	0.05
							1" Ice			
Platform Mount [LP 602-1]	C	None			0.00	87.00	No Ice	32.03	32.03	1.34
							1/2"	38.71	38.71	1.80
							Ice	45.39	45.39	2.26
							1" Ice			

Description	Face or Leg	Offset Type	Offsets:		Azimuth Adjustment	Placement	C _{AA} _{Front}	C _{AA} _{Side}	Weight	
			Horz	Lateral						ft

DB636-C	C	From Leg	4.00		0.00	73.00	No Ice	2.51	2.51	0.03
			0.00				1/2"	3.59	3.59	0.05
			6.00				Ice	4.68	4.68	0.07
6' x 2" Mount Pipe	C	From Leg	4.00		0.00	73.00	No Ice	1.43	1.43	0.02
			0.00				1/2"	1.92	1.92	0.03
			3.00				Ice	2.29	2.29	0.05
Platform Mount [LP 1201-1]	C	None			0.00	73.00	No Ice	23.10	23.10	2.10
							1/2"	26.80	26.80	2.50
							Ice	30.50	30.50	2.90

PD1142-1	A	From Leg	3.00		0.00	50.00	No Ice	1.32	1.32	0.01
			0.00				1/2"	3.21	3.21	0.02
			7.00				Ice	5.12	5.12	0.05
DB492A	A	From Leg	3.00		0.00	50.00	No Ice	1.10	1.10	0.01
			0.00				1/2"	1.98	1.98	0.01
			0.00				Ice	2.86	2.86	0.01
ASP-655	B	From Leg	3.00		0.00	50.00	No Ice	0.56	0.56	0.00
			0.00				1/2"	1.02	1.02	0.01
			4.00				Ice	1.30	1.30	0.01
PD1121-6	C	From Leg	3.00		0.00	50.00	No Ice	0.23	0.23	0.00
			0.00				1/2"	0.41	0.41	0.00
			3.00				Ice	0.60	0.60	0.00
Side Arm Mount [SO 701-3]	C	None			0.00	50.00	No Ice	2.83	2.83	0.20
							1/2"	3.92	3.92	0.24
							Ice	5.01	5.01	0.28

EPSILON GPS ANTENNA 35 DB	A	From Leg	3.00		0.00	40.00	No Ice	0.11	0.11	0.00
			0.00				1/2"	0.16	0.16	0.00
			1.00				Ice	0.21	0.21	0.00
Side Arm Mount [SO 701-1]	A	None			0.00	40.00	No Ice	0.85	1.67	0.07
							1/2"	1.14	2.34	0.08
							Ice	1.43	3.01	0.09
*										

Dishes

Description	Face or Leg	Dish Type	Offset Type	Offsets:		Azimuth Adjustment	3 dB Beam Width	Elevation	Outside Diameter	Aperture Area	Weight	
				Horz	Lateral							ft
GLF6-450	B	Grid	From Leg	1.00		0.00		107.00	6.40	No Ice	32.17	0.20
				0.00						1/2" Ice	33.01	0.37
				0.00						1" Ice	33.86	0.54

Load Combinations

Comb. No.	Description
1	Dead Only
2	1.2 Dead+1.6 Wind 0 deg - No Ice
3	0.9 Dead+1.6 Wind 0 deg - No Ice
4	1.2 Dead+1.6 Wind 30 deg - No Ice
5	0.9 Dead+1.6 Wind 30 deg - No Ice
6	1.2 Dead+1.6 Wind 60 deg - No Ice
7	0.9 Dead+1.6 Wind 60 deg - No Ice
8	1.2 Dead+1.6 Wind 90 deg - No Ice
9	0.9 Dead+1.6 Wind 90 deg - No Ice
10	1.2 Dead+1.6 Wind 120 deg - No Ice
11	0.9 Dead+1.6 Wind 120 deg - No Ice
12	1.2 Dead+1.6 Wind 150 deg - No Ice
13	0.9 Dead+1.6 Wind 150 deg - No Ice
14	1.2 Dead+1.6 Wind 180 deg - No Ice
15	0.9 Dead+1.6 Wind 180 deg - No Ice
16	1.2 Dead+1.6 Wind 210 deg - No Ice
17	0.9 Dead+1.6 Wind 210 deg - No Ice
18	1.2 Dead+1.6 Wind 240 deg - No Ice
19	0.9 Dead+1.6 Wind 240 deg - No Ice
20	1.2 Dead+1.6 Wind 270 deg - No Ice
21	0.9 Dead+1.6 Wind 270 deg - No Ice
22	1.2 Dead+1.6 Wind 300 deg - No Ice
23	0.9 Dead+1.6 Wind 300 deg - No Ice
24	1.2 Dead+1.6 Wind 330 deg - No Ice
25	0.9 Dead+1.6 Wind 330 deg - No Ice
26	1.2 Dead+1.0 Ice
27	1.2 Dead+1.0 Wind 0 deg+1.0 Ice
28	1.2 Dead+1.0 Wind 30 deg+1.0 Ice
29	1.2 Dead+1.0 Wind 60 deg+1.0 Ice
30	1.2 Dead+1.0 Wind 90 deg+1.0 Ice
31	1.2 Dead+1.0 Wind 120 deg+1.0 Ice
32	1.2 Dead+1.0 Wind 150 deg+1.0 Ice
33	1.2 Dead+1.0 Wind 180 deg+1.0 Ice
34	1.2 Dead+1.0 Wind 210 deg+1.0 Ice
35	1.2 Dead+1.0 Wind 240 deg+1.0 Ice
36	1.2 Dead+1.0 Wind 270 deg+1.0 Ice
37	1.2 Dead+1.0 Wind 300 deg+1.0 Ice
38	1.2 Dead+1.0 Wind 330 deg+1.0 Ice
39	Dead+Wind 0 deg - Service
40	Dead+Wind 30 deg - Service
41	Dead+Wind 60 deg - Service
42	Dead+Wind 90 deg - Service
43	Dead+Wind 120 deg - Service
44	Dead+Wind 150 deg - Service
45	Dead+Wind 180 deg - Service
46	Dead+Wind 210 deg - Service
47	Dead+Wind 240 deg - Service
48	Dead+Wind 270 deg - Service
49	Dead+Wind 300 deg - Service
50	Dead+Wind 330 deg - Service

Maximum Member Forces

Section No.	Elevation ft	Component Type	Condition	Gov. Load Comb.	Axial K	Major Axis Moment kip-ft	Minor Axis Moment kip-ft
L1	120 - 100	Pole	Max Tension	36	0.00	0.00	-0.00
			Max. Compression	26	-9.59	-1.77	0.55
			Max. Mx	8	-3.64	-82.71	-0.26
			Max. My	2	-3.67	-0.11	80.30
			Max. Vy	8	6.50	-82.71	-0.26
			Max. Vx	14	6.28	-1.10	-80.22
			Max. Torque	24			
L2	100 -	Pole	Max Tension	1	0.00	0.00	0.00

Section No.	Elevation ft	Component Type	Condition	Gov. Load Comb.	Axial K	Major Axis Moment kip-ft	Minor Axis Moment kip-ft
	47.0833		Max. Compression	26	-35.09	0.29	-0.63
			Max. Mx	8	-16.63	-863.33	-2.57
			Max. My	14	-16.66	-4.87	-848.84
			Max. Vy	20	-19.67	863.14	-0.34
			Max. Vx	14	19.41	-4.87	-848.84
			Max. Torque	24			-1.81
L3	47.0833 - 0	Pole	Max Tension	1	0.00	0.00	0.00
			Max. Compression	26	-51.55	0.69	-0.71
			Max. Mx	20	-29.31	2019.52	-0.65
			Max. My	14	-29.31	-9.08	-1991.56
			Max. Vy	20	-24.58	2019.52	-0.65
			Max. Vx	14	24.32	-9.08	-1991.56
			Max. Torque	24			-0.66

Maximum Reactions

Location	Condition	Gov. Load Comb.	Vertical K	Horizontal, X K	Horizontal, Z K
Pole	Max. Vert	36	51.55	5.66	0.18
	Max. H _x	20	29.34	24.55	-0.00
	Max. H _z	3	22.00	0.04	24.28
	Max. M _x	2	1989.07	0.04	24.28
	Max. M _z	8	2019.38	-24.55	-0.04
	Max. Torsion	12	0.58	-12.31	-21.14
	Min. Vert	5	22.00	-12.18	20.87
	Min. H _x	8	29.34	-24.55	-0.04
	Min. H _z	15	22.00	-0.08	-24.29
	Min. M _x	14	-1991.56	-0.08	-24.29
	Min. M _z	20	-2019.52	24.55	-0.00
	Min. Torsion	24	-0.66	12.27	21.17

Tower Mast Reaction Summary

Load Combination	Vertical K	Shear _x K	Shear _z K	Overturning Moment, M _x kip-ft	Overturning Moment, M _z kip-ft	Torque kip-ft
Dead Only	24.45	0.00	0.00	0.23	0.06	0.00
1.2 Dead+1.6 Wind 0 deg - No Ice	29.34	-0.04	-24.28	-1989.07	4.64	0.50
0.9 Dead+1.6 Wind 0 deg - No Ice	22.00	-0.04	-24.28	-1971.78	4.58	0.49
1.2 Dead+1.6 Wind 30 deg - No Ice	29.34	12.18	-20.87	-1705.05	-999.77	0.09
0.9 Dead+1.6 Wind 30 deg - No Ice	22.00	12.18	-20.87	-1690.26	-991.05	0.08
1.2 Dead+1.6 Wind 60 deg - No Ice	29.34	21.17	-12.08	-987.43	-1739.43	0.25
0.9 Dead+1.6 Wind 60 deg - No Ice	22.00	21.17	-12.08	-978.88	-1724.24	0.25
1.2 Dead+1.6 Wind 90 deg - No Ice	29.34	24.55	0.04	4.86	-2019.38	0.19
0.9 Dead+1.6 Wind 90 deg - No Ice	22.00	24.55	0.04	4.75	-2001.73	0.19
1.2 Dead+1.6 Wind 120 deg - No Ice	29.34	21.33	12.26	1008.70	-1757.02	-0.22
0.9 Dead+1.6 Wind 120 deg - No Ice	22.00	21.33	12.26	999.81	-1741.66	-0.21
1.2 Dead+1.6 Wind 150 deg - No Ice	29.34	12.31	21.14	1736.46	-1013.64	-0.58

Load Combination	Vertical K	Shear _x K	Shear _z K	Overturning Moment, M _x kip-ft	Overturning Moment, M _z kip-ft	Torque kip-ft
0.9 Dead+1.6 Wind 150 deg - No Ice	22.00	12.31	21.14	1721.21	-1004.78	-0.56
1.2 Dead+1.6 Wind 180 deg - No Ice	29.34	0.08	24.29	1991.56	-9.08	-0.48
0.9 Dead+1.6 Wind 180 deg - No Ice	22.00	0.08	24.29	1974.10	-9.00	-0.46
1.2 Dead+1.6 Wind 210 deg - No Ice	29.34	-12.06	20.94	1713.60	986.06	-0.09
0.9 Dead+1.6 Wind 210 deg - No Ice	22.00	-12.06	20.94	1698.58	977.45	-0.08
1.2 Dead+1.6 Wind 240 deg - No Ice	29.34	-21.14	12.10	990.98	1735.61	-0.28
0.9 Dead+1.6 Wind 240 deg - No Ice	22.00	-21.14	12.10	982.26	1720.43	-0.27
1.2 Dead+1.6 Wind 270 deg - No Ice	29.34	-24.55	0.00	0.65	2019.52	-0.27
0.9 Dead+1.6 Wind 270 deg - No Ice	22.00	-24.55	0.00	0.58	2001.85	-0.27
1.2 Dead+1.6 Wind 300 deg - No Ice	29.34	-21.26	-12.22	-1003.54	1749.19	0.22
0.9 Dead+1.6 Wind 300 deg - No Ice	22.00	-21.26	-12.22	-994.84	1733.87	0.21
1.2 Dead+1.6 Wind 330 deg - No Ice	29.34	-12.27	-21.17	-1738.38	1009.49	0.66
0.9 Dead+1.6 Wind 330 deg - No Ice	22.00	-12.27	-21.17	-1723.26	1000.65	0.64
1.2 Dead+1.0 Ice	51.55	0.00	0.00	0.71	0.69	0.00
1.2 Dead+1.0 Wind 0 deg+1.0 Ice	51.55	-0.30	-5.57	-489.73	35.25	-0.11
1.2 Dead+1.0 Wind 30 deg+1.0 Ice	51.55	2.72	-4.69	-408.14	-237.36	0.08
1.2 Dead+1.0 Wind 60 deg+1.0 Ice	51.55	4.78	-2.71	-236.07	-418.71	0.05
1.2 Dead+1.0 Wind 90 deg+1.0 Ice	51.55	5.55	-0.00	0.71	-486.76	-0.04
1.2 Dead+1.0 Wind 120 deg+1.0 Ice	51.55	4.84	2.78	245.12	-425.30	-0.27
1.2 Dead+1.0 Wind 150 deg+1.0 Ice	51.55	2.77	4.78	420.21	-242.99	-0.43
1.2 Dead+1.0 Wind 180 deg+1.0 Ice	51.55	0.03	5.48	480.01	-2.50	-0.32
1.2 Dead+1.0 Wind 210 deg+1.0 Ice	51.55	-2.72	4.69	409.98	238.21	-0.08
1.2 Dead+1.0 Wind 240 deg+1.0 Ice	51.55	-5.00	2.53	216.12	445.55	0.39
1.2 Dead+1.0 Wind 270 deg+1.0 Ice	51.55	-5.66	-0.18	-19.95	500.98	0.44
1.2 Dead+1.0 Wind 300 deg+1.0 Ice	51.55	-4.94	-2.84	-250.39	438.53	0.27
1.2 Dead+1.0 Wind 330 deg+1.0 Ice	51.55	-2.98	-4.79	-419.35	268.82	0.03
Dead+Wind 0 deg - Service	24.45	-0.01	-4.79	-390.52	0.95	0.10
Dead+Wind 30 deg - Service	24.45	2.40	-4.12	-334.73	-196.33	0.02
Dead+Wind 60 deg - Service	24.45	4.18	-2.38	-193.78	-341.63	0.05
Dead+Wind 90 deg - Service	24.45	4.84	0.01	1.14	-396.63	0.04
Dead+Wind 120 deg - Service	24.45	4.21	2.42	198.32	-345.09	-0.04
Dead+Wind 150 deg - Service	24.45	2.43	4.17	341.27	-199.07	-0.11
Dead+Wind 180 deg - Service	24.45	0.02	4.79	391.37	-1.74	-0.09
Dead+Wind 210 deg - Service	24.45	-2.38	4.13	336.77	193.72	-0.02
Dead+Wind 240 deg - Service	24.45	-4.17	2.39	194.83	340.96	-0.05
Dead+Wind 270 deg - Service	24.45	-4.84	0.00	0.31	396.73	-0.05
Dead+Wind 300 deg - Service	24.45	-4.20	-2.41	-196.95	343.63	0.04

Load Combination	Vertical K	Shear _x K	Shear _z K	Overturning Moment, M _x kip-ft	Overturning Moment, M _z kip-ft	Torque kip-ft
Dead+Wind 330 deg - Service	24.45	-2.42	-4.18	-341.29	198.33	0.13

Solution Summary

Load Comb.	Sum of Applied Forces			Sum of Reactions			% Error
	PX K	PY K	PZ K	PX K	PY K	PZ K	
1	0.00	-24.45	0.00	0.00	24.45	0.00	0.000%
2	-0.04	-29.34	-24.28	0.04	29.34	24.28	0.000%
3	-0.04	-22.00	-24.28	0.04	22.00	24.28	0.000%
4	12.18	-29.34	-20.87	-12.18	29.34	20.87	0.000%
5	12.18	-22.00	-20.87	-12.18	22.00	20.87	0.000%
6	21.17	-29.34	-12.08	-21.17	29.34	12.08	0.000%
7	21.17	-22.00	-12.08	-21.17	22.00	12.08	0.000%
8	24.55	-29.34	0.04	-24.55	29.34	-0.04	0.000%
9	24.55	-22.00	0.04	-24.55	22.00	-0.04	0.000%
10	21.33	-29.34	12.26	-21.33	29.34	-12.26	0.000%
11	21.33	-22.00	12.26	-21.33	22.00	-12.26	0.000%
12	12.31	-29.34	21.14	-12.31	29.34	-21.14	0.000%
13	12.31	-22.00	21.14	-12.31	22.00	-21.14	0.000%
14	0.08	-29.34	24.29	-0.08	29.34	-24.29	0.000%
15	0.08	-22.00	24.29	-0.08	22.00	-24.29	0.000%
16	-12.06	-29.34	20.94	12.06	29.34	-20.94	0.000%
17	-12.06	-22.00	20.94	12.06	22.00	-20.94	0.000%
18	-21.14	-29.34	12.10	21.14	29.34	-12.10	0.000%
19	-21.14	-22.00	12.10	21.14	22.00	-12.10	0.000%
20	-24.55	-29.34	0.00	24.55	29.34	-0.00	0.000%
21	-24.55	-22.00	0.00	24.55	22.00	-0.00	0.000%
22	-21.26	-29.34	-12.22	21.26	29.34	12.22	0.000%
23	-21.26	-22.00	-12.22	21.26	22.00	12.22	0.000%
24	-12.27	-29.34	-21.17	12.27	29.34	21.17	0.000%
25	-12.27	-22.00	-21.17	12.27	22.00	21.17	0.000%
26	0.00	-51.55	0.00	0.00	51.55	0.00	0.000%
27	-0.30	-51.55	-5.57	0.30	51.55	5.57	0.000%
28	2.72	-51.55	-4.69	-2.72	51.55	4.69	0.000%
29	4.78	-51.55	-2.71	-4.78	51.55	2.71	0.000%
30	5.55	-51.55	-0.00	-5.55	51.55	0.00	0.000%
31	4.84	-51.55	2.78	-4.84	51.55	-2.78	0.000%
32	2.77	-51.55	4.78	-2.77	51.55	-4.78	0.000%
33	0.03	-51.55	5.48	-0.03	51.55	-5.48	0.000%
34	-2.72	-51.55	4.69	2.72	51.55	-4.69	0.000%
35	-5.00	-51.55	2.53	5.00	51.55	-2.53	0.000%
36	-5.66	-51.55	-0.18	5.66	51.55	0.18	0.000%
37	-4.94	-51.55	-2.84	4.94	51.55	2.84	0.000%
38	-2.98	-51.55	-4.79	2.98	51.55	4.79	0.000%
39	-0.01	-24.45	-4.79	0.01	24.45	4.79	0.000%
40	2.40	-24.45	-4.12	-2.40	24.45	4.12	0.000%
41	4.18	-24.45	-2.38	-4.18	24.45	2.38	0.000%
42	4.84	-24.45	0.01	-4.84	24.45	-0.01	0.000%
43	4.21	-24.45	2.42	-4.21	24.45	-2.42	0.000%
44	2.43	-24.45	4.17	-2.43	24.45	-4.17	0.000%
45	0.02	-24.45	4.79	-0.02	24.45	-4.79	0.000%
46	-2.38	-24.45	4.13	2.38	24.45	-4.13	0.000%
47	-4.17	-24.45	2.39	4.17	24.45	-2.39	0.000%
48	-4.84	-24.45	0.00	4.84	24.45	-0.00	0.000%
49	-4.20	-24.45	-2.41	4.20	24.45	2.41	0.000%
50	-2.42	-24.45	-4.18	2.42	24.45	4.18	0.000%

Non-Linear Convergence Results

Load Combination	Converged?	Number of Cycles	Displacement Tolerance	Force Tolerance
1	Yes	4	0.00000001	0.00000001
2	Yes	5	0.00000001	0.00005547
3	Yes	4	0.00000001	0.00081193
4	Yes	5	0.00000001	0.00067728
5	Yes	5	0.00000001	0.00028692
6	Yes	5	0.00000001	0.00065972
7	Yes	5	0.00000001	0.00027746
8	Yes	4	0.00000001	0.00035553
9	Yes	4	0.00000001	0.00020043
10	Yes	5	0.00000001	0.00067540
11	Yes	5	0.00000001	0.00028190
12	Yes	5	0.00000001	0.00072431
13	Yes	5	0.00000001	0.00030572
14	Yes	5	0.00000001	0.00006761
15	Yes	4	0.00000001	0.00098584
16	Yes	5	0.00000001	0.00064123
17	Yes	5	0.00000001	0.00027097
18	Yes	5	0.00000001	0.00068386
19	Yes	5	0.00000001	0.00028907
20	Yes	4	0.00000001	0.00035123
21	Yes	4	0.00000001	0.00019842
22	Yes	5	0.00000001	0.00070643
23	Yes	5	0.00000001	0.00029753
24	Yes	5	0.00000001	0.00064956
25	Yes	5	0.00000001	0.00027121
26	Yes	4	0.00000001	0.00000001
27	Yes	4	0.00000001	0.00029700
28	Yes	5	0.00000001	0.00011958
29	Yes	4	0.00000001	0.00097449
30	Yes	4	0.00000001	0.00025946
31	Yes	5	0.00000001	0.00010403
32	Yes	5	0.00000001	0.00015198
33	Yes	4	0.00000001	0.00062526
34	Yes	4	0.00000001	0.00090321
35	Yes	4	0.00000001	0.00089951
36	Yes	4	0.00000001	0.00062018
37	Yes	5	0.00000001	0.00014516
38	Yes	5	0.00000001	0.00012113
39	Yes	4	0.00000001	0.00007000
40	Yes	4	0.00000001	0.00019285
41	Yes	4	0.00000001	0.00016943
42	Yes	4	0.00000001	0.00001778
43	Yes	4	0.00000001	0.00017471
44	Yes	4	0.00000001	0.00023222
45	Yes	4	0.00000001	0.00007169
46	Yes	4	0.00000001	0.00016021
47	Yes	4	0.00000001	0.00019364
48	Yes	4	0.00000001	0.00001887
49	Yes	4	0.00000001	0.00020915
50	Yes	4	0.00000001	0.00016327

Maximum Tower Deflections - Service Wind

Section No.	Elevation ft	Horz. Deflection in	Gov. Load Comb.	Tilt °	Twist °
L1	120 - 100	14.98	43	1.08	0.01
L2	100 - 47.0833	10.54	43	1.01	0.00
L3	52 - 0	2.69	43	0.49	0.00

Critical Deflections and Radius of Curvature - Service Wind

Elevation ft	Appurtenance	Gov. Load Comb.	Deflection in	Tilt °	Twist °	Radius of Curvature ft
118.00	DB809MT3-XT	43	14.53	1.08	0.01	31255
114.00	(2) SBNHH-1D65A w/ Mount Pipe	43	13.62	1.07	0.00	26046
107.00	GLF6-450	43	12.06	1.05	0.00	12021
98.00	(2) LPA-80080/6CF w/ Mount Pipe	43	10.12	1.00	0.00	7560
87.00	(2) DB980H90E-M w/ Mount Pipe	43	7.92	0.91	0.00	6226
73.00	DB636-C	43	5.47	0.75	0.00	5101
50.00	PD1142-1	43	2.49	0.46	0.00	4197
40.00	EPSILON GPS ANTENNA 35 DB	43	1.64	0.36	0.00	5217

Maximum Tower Deflections - Design Wind

Section No.	Elevation ft	Horz. Deflection in	Gov. Load Comb.	Tilt °	Twist °
L1	120 - 100	76.17	10	5.49	0.03
L2	100 - 47.0833	53.62	10	5.16	0.01
L3	52 - 0	13.68	10	2.49	0.00

Critical Deflections and Radius of Curvature - Design Wind

Elevation ft	Appurtenance	Gov. Load Comb.	Deflection in	Tilt °	Twist °	Radius of Curvature ft
118.00	DB809MT3-XT	10	73.86	5.47	0.03	6344
114.00	(2) SBNHH-1D65A w/ Mount Pipe	10	69.26	5.43	0.02	5286
107.00	GLF6-450	10	61.32	5.32	0.02	2438
98.00	(2) LPA-80080/6CF w/ Mount Pipe	10	51.48	5.10	0.01	1529
87.00	(2) DB980H90E-M w/ Mount Pipe	10	40.33	4.63	0.01	1247
73.00	DB636-C	10	27.86	3.82	0.00	1014
50.00	PD1142-1	10	12.65	2.37	0.00	826
40.00	EPSILON GPS ANTENNA 35 DB	10	8.37	1.81	0.00	1026

Compression Checks

Pole Design Data

Section No.	Elevation ft	Size	L ft	L _u ft	KI/r	A in ²	P _u K	φP _n K	Ratio $\frac{P_u}{\phi P_n}$
L1	120 - 100 (1)	TP20.263x15.0403x0.187 5	20.00	0.00	0.0	12.120 6	-3.63	829.59	0.004
L2	100 - 47.0833 (2)	TP33.13x20.263x0.2813	52.92	0.00	0.0	28.666 0	-16.63	1920.74	0.009
L3	47.0833 - 0 (3)	TP44x31.372x0.375	52.00	0.00	0.0	52.677 2	-29.31	3477.10	0.008

Pole Bending Design Data

Section No.	Elevation ft	Size	M_{ux}	ϕM_{nx}	Ratio	M_{uy}	ϕM_{ny}	Ratio
			kip-ft	kip-ft	$\frac{M_{ux}}{\phi M_{nx}}$	kip-ft	kip-ft	$\frac{M_{uy}}{\phi M_{ny}}$
L1	120 - 100 (1)	TP20.263x15.0403x0.187 5	83.05	338.82	0.245	0.00	338.82	0.000
L2	100 - 47.0833 (2)	TP33.13x20.263x0.2813	866.78	1237.43	0.700	0.00	1237.43	0.000
L3	47.0833 - 0 (3)	TP44x31.372x0.375	2025.98	3088.23	0.656	0.00	3088.23	0.000

Pole Shear Design Data

Section No.	Elevation ft	Size	Actual	ϕV_n	Ratio	Actual	ϕT_n	Ratio
			V_u K	K	$\frac{V_u}{\phi V_n}$	T_u kip-ft	kip-ft	$\frac{T_u}{\phi T_n}$
L1	120 - 100 (1)	TP20.263x15.0403x0.187 5	6.60	414.80	0.016	1.09	687.02	0.002
L2	100 - 47.0833 (2)	TP33.13x20.263x0.2813	19.73	960.37	0.021	0.09	2509.12	0.000
L3	47.0833 - 0 (3)	TP44x31.372x0.375	24.63	1738.55	0.014	0.22	6261.97	0.000

Pole Interaction Design Data

Section No.	Elevation ft	Ratio	Ratio	Ratio	Ratio	Ratio	Comb. Stress Ratio	Allow. Stress Ratio	Criteria
		$\frac{P_u}{\phi P_n}$	$\frac{M_{ux}}{\phi M_{nx}}$	$\frac{M_{uy}}{\phi M_{ny}}$	$\frac{V_u}{\phi V_n}$	$\frac{T_u}{\phi T_n}$			
L1	120 - 100 (1)	0.004	0.245	0.000	0.016	0.002	0.250	1.000	4.8.2 ✓
L2	100 - 47.0833 (2)	0.009	0.700	0.000	0.021	0.000	0.710	1.000	4.8.2 ✓
L3	47.0833 - 0 (3)	0.008	0.656	0.000	0.014	0.000	0.665	1.000	4.8.2 ✓

Section Capacity Table

Section No.	Elevation ft	Component Type	Size	Critical Element	P K	ϕP_{allow} K	% Capacity	Pass Fail	
L1	120 - 100	Pole	TP20.263x15.0403x0.1875	1	-3.63	829.59	25.0	Pass	
L2	100 - 47.0833	Pole	TP33.13x20.263x0.2813	2	-16.63	1920.74	71.0	Pass	
L3	47.0833 - 0	Pole	TP44x31.372x0.375	3	-29.31	3477.10	66.5	Pass	
							Summary		
							Pole (L2)	71.0	Pass
							RATING =	71.0	Pass

APPENDIX B
BASE LEVEL DRAWING



(INSTALLED)
(1) 7/8" TO 73 FT LEVEL

(PROPOSED)
(4) 3/8" TO 114 FT LEVEL
(2) 3/4" TO 114 FT LEVEL
(6) 1-5/8" TO 114 FT LEVEL
(INSTALLED-IN CONDUIT-TO BE REMOVED)
(1) 3/8" TO 73 FT LEVEL
(2) 3/4" TO 73 FT LEVEL
(INSTALLED-TO BE REMOVED)
(12) 7/8" TO 73 FT LEVEL

(INSTALLED)
(1) 1/2" TO 50 FT LEVEL
(3) 7/8" TO 50 FT LEVEL
(1) 7/8" TO 107 FT LEVEL
(3) 7/8" TO 118 FT LEVEL

(RESERVED)
(1) 1-5/8" TO 98 FT LEVEL

(INSTALLED)
(12) 7/8" TO 98 FT LEVEL
(1) 1-5/8" TO 98 FT LEVEL

(INSTALLED-IN CONDUIT)
(1) 1/2" TO 40 FT LEVEL
(INSTALLED)
(6) 1-1/4" TO 87 FT LEVEL

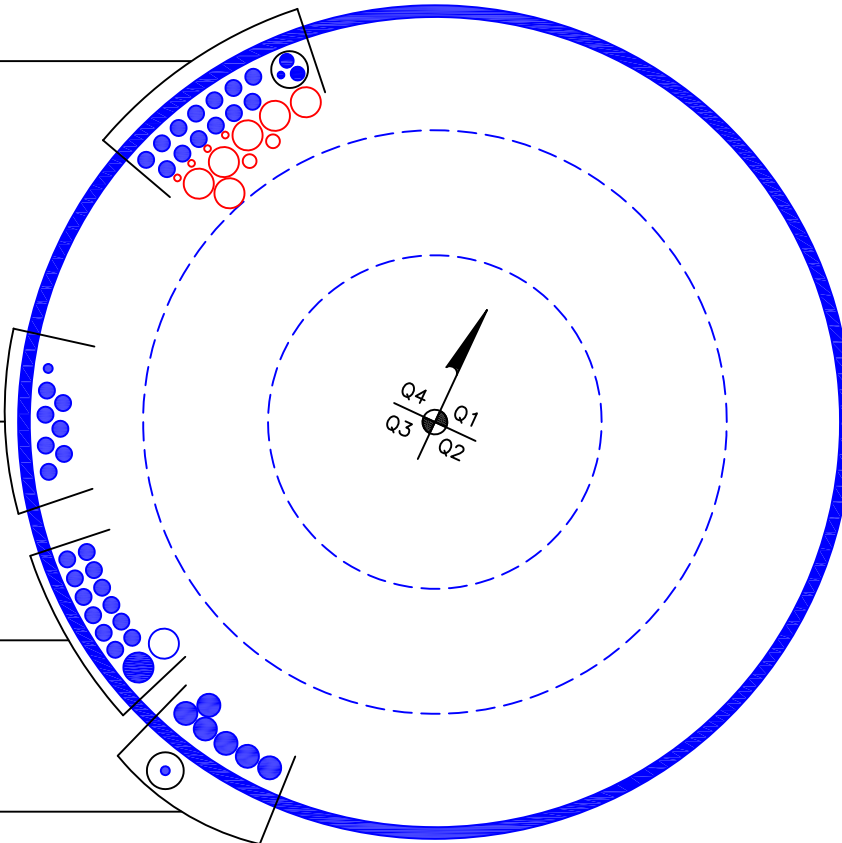

APPENDIX C
ADDITIONAL CALCULATIONS

Stiffened or Unstiffened, UngROUTed, Circular Base Plate - Any Rod Material

TIA Rev G

Assumption: Clear space between bottom of leveling nut and top of concrete **not** exceeding (1)*(Rod Diameter)

Site Data

BU#: 806364

Site Name: HRT 106(B) 943202

App #: 383797 Rev. 1

Pole Manufacturer: *Other*

Anchor Rod Data

Qty:	12	
Diam:	2.25	in
Rod Material:	A615-J	
Strength (Fu):	100	ksi
Yield (Fy):	75	ksi
Bolt Circle:	52.05	in

Plate Data

Diam:	58.05	in
Thick:	2.75	in
Grade:	60	ksi
Single-Rod B-eff:	11.79	in

Stiffener Data (Welding at both sides)

Config:	0	*
Weld Type:		
Groove Depth:		<-- Disregard
Groove Angle:		<-- Disregard
Fillet H. Weld:		in
Fillet V. Weld:		in
Width:		in
Height:		in
Thick:		in
Notch:		in
Grade:		ksi
Weld str.:		ksi

Pole Data

Diam:	44	in
Thick:	0.375	in
Grade:	65	ksi
# of Sides:	12	"0" IF Round
Fu	80	ksi
Reinf. Fillet Weld	0	"0" if None

Reactions

Mu:	2026	ft-kips
Axial, Pu:	29	kips
Shear, Vu:	25	kips
Eta Factor, η	0.5	TIA G (Fig. 4-4)

If No stiffeners, Criteria: **AISC LRFD** <-Only Applicable to Unstiffened Cases

Anchor Rod Results

Max Rod ($C_u + V_u/\eta$): 162.2 Kips
 Allowable Axial, $\Phi^*F_u \cdot A_{net}$: 260.0 Kips
 Anchor Rod Stress Ratio: 62.4% **Pass**

Rigid

AISC LRFD

ϕ^*T_n

Base Plate Results

Base Plate Stress: 18.2 ksi
 Allowable Plate Stress: 54.0 ksi
 Base Plate Stress Ratio: 33.8% **Pass**

Flexural Check

Rigid

AISC LRFD

ϕ^*F_y

Y.L. Length:

27.81

n/a

Stiffener Results

Horizontal Weld : n/a
 Vertical Weld: n/a
 Plate Flex+Shear, $f_b/F_b + (f_v/F_v)^2$: n/a
 Plate Tension+Shear, $f_t/F_t + (f_v/F_v)^2$: n/a
 Plate Comp. (AISC Bracket): n/a

Pole Results

Pole Punching Shear Check: n/a

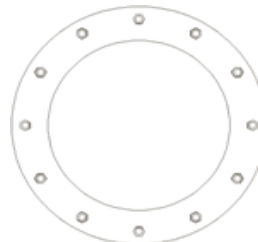

* 0 = none, 1 = every bolt, 2 = every 2 bolts, 3 = 2 per bolt

** Note: for complete joint penetration groove welds the groove depth must be exactly 1/2 the stiffener thickness for calculation purposes

Stiffened or Unstiffened, Exterior Flange Plate - Any Bolt Material TIA Rev G

Site Data

BU#: 806364
 Site Name: HRT 106(B) 943202
 App #: 383797 Rev. 1

Reactions		
Mu	83.05	ft-kips
Axial, Pu:	3.63	kips
Shear, Vu:	6.60	kips
Elevation:	100	feet

Bolt Threads:
X-Excluded
$\phi V_n = \phi(0.55 A_b F_u)$
$\phi = 0.75, \phi V_n$ (kips):
38.88

Pole Manufacturer:	Other
--------------------	-------

If No stiffeners, Criteria: TIA G <-Only Applicable to Unstiffened Cases

Bolt Data		
Qty:	8	
Diameter (in.):	1	Bolt Fu: 120
Bolt Material:	A325	Bolt Fy: 92
N/A:	100	<-- Disregard
N/A:	75	<-- Disregard
Circle (in.):	24.41	

Flange Bolt Results
 Bolt Tension Capacity, $\phi^*T_n, B1$: 54.54 kips
 Adjusted ϕ^*T_n (due to $V_u = V_u/Qty$), **B**: 54.53 kips
 Max Bolt directly applied T_u : 19.96 Kips
 Min. PL "tc" for **B cap. w/o Pry**: 0.799 in
 Min PL "treq" for actual **T w/ Pry**: 0.354 in
 Min PL "t1" for actual **T w/o Pry**: 0.483 in
 T allowable w/o Prying: 54.54 kips
 Prying Force, q: 0.00 kips
 Total Bolt Tension= T_u+q : 19.96 kips
 Non-Prying Bolt Stress Ratio, T_u/B : 36.6% **Pass**

Rigid
ϕ^*T_n
$\phi T_n [(1 - (V_u/\phi V_n)^2)^{0.5}]$

Plate Data		
Diam:	26.91	in
Thick, t:	1.5	in
Grade (Fy):	60	ksi
Strength, Fu:	75	ksi
Single-Rod B-eff:	8.14	in

Exterior Flange Plate Results Flexural Check
 Compression Side Plate Stress: 5.4 ksi
 Allowable Plate Stress: 54.0 ksi
 Compression Plate Stress Ratio: 10.0% **Pass**
No Prying
 Tension Side Stress Ratio, $(treq/t)^2$: 5.6% **Pass**

Rigid
TIA G
ϕ^*F_y
Comp. Y.L. Length: 13.61

Stiffener Data (Welding at Both Sides)		
Config:	0	*
Weld Type:		
Groove Depth:		<-- Disregard
Groove Angle:		<-- Disregard
Fillet H. Weld:		in
Fillet V. Weld:		in
Width:		in
Height:		in
Thick:		in
Notch:		in
Grade:		ksi
Weld str.:		ksi

Stiffener Results
 Horizontal Weld: n/a
 Vertical Weld: n/a
 Plate Flex+Shear, $f_b/F_b + (f_v/F_v)^2$: n/a
 Plate Tension+Shear, $f_t/F_t + (f_v/F_v)^2$: n/a
 Plate Comp. (AISC Bracket): n/a
Pole Results
 Pole Punching Shear Check: n/a

Pole Data		
Diam:	20.263	in
Thick:	0.1875	in
Grade:	65	ksi
# of Sides:	12	"0" IF Round
Fu	80	ksi
Reinf. Fillet Weld	0	"0" if None

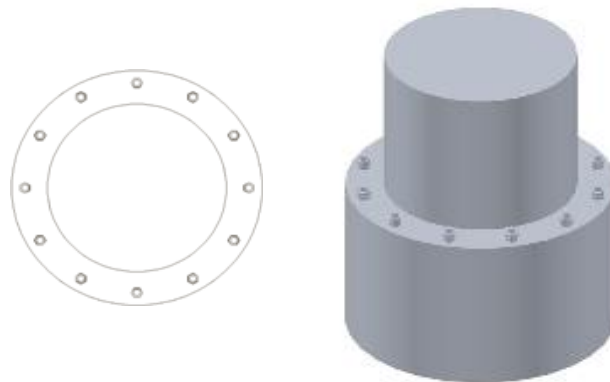

* 0 = none, 1 = every bolt, 2 = every 2 bolts, 3 = 2 per bolt

** Note: for complete joint penetration groove welds the groove depth must be exactly 1/2 the stiffener thickness for calculation purposes

Monopole Block Foundation

Checks capacity of monolithic block foundation for a monopole tower per TIA-222-G



BU #: 806364
 Site Name: HRT 106(B) 943202
 App No.: 383797 Rev. 1

Factored Design Reactions		
Shear, S:	25.00	kips
Moment, M:	2026.00	ft*kips
Height, H:	120.00	ft
Weight, Wt:	29.00	kips
Base Diameter, BD:	44.0	in

Foundation Dimensions		
Depth, D:	6.0	ft
Block Width, W:	27.0	ft
Neglected Depth, N:	3.3	ft
Ext. Above Grade, E:	0.0	ft
Anchor Steel Length, Lst:	97.0	in
Clear Cover, cc:	4.0	in

Soil Properties		
Soil Unit Weight, γ:	0.125	kcf
Ultimate Bearing, Bc:	8.000	ksf
Int. Angle of Friction, Φ:	34.00	deg
Cohesion, Co:	0.000	ksf
Passive Pressure, Pp:	0.000	kcf
Base Friction, μ:	0.2	
Seismic Zone, z:	1	

Material Properties		
Rebar Yield Strength, Fy:	60000	psi
Concrete Strength, F'c:	3000	psi
Concrete Density, δc:	0.150	kcf

Rebar Properties		
Pad Rebar Size, sp:	11	
Rebar Quantity, mp:	26	14

Design Checks				
	Capacity/Availability	Demands/Limits	Check	% Capacity
Shear (ksf)	102.77	25.00	OK	24.33
Overturning (ft*kips)	9285.13	2176.00	OK	23.44
Bearing (ksf)	6.00	1.60	OK	26.72
Shear - 1-Way (kips)	102.77	25.00	OK	24.33
Pad Rebar Area (in ²)	40.60	21.00	OK	
Bar Spacing (in)	11.17	18 > Bs > 2	OK	
Development Length (in)	158.00	60.24	OK	

Modification Checks			
	Capacity/Availability	Demands/Limits	Check
Minimum Extra Thickness (in)	0.00	0.00	Not Used
Pad Rebar Area-short (in ²)	8.84	0.00	Not Used
Pad Rebar Area-long (in2)	2.21	0.00	Not Used
Pad Rebar Spacing-short (in2)	15.84	18 > Bs > 2	Not Used
Pad Rebar Spacing-long (in2)	78.06	18 > Bs > 2	Not Used
End Cap Width (in)	0.00	0.00	Not Used
End Cap Rebar Area (in2)	4.81	0.00	Not Used
EC Rebar Spacing (in)	-2.02	18 > Bs > 2	Not Used
Tie Spacing (in)	16.13	316 > s > 4.5	Not Used
Dowel Area (in2)	8.84	0.00	Not Used
Dowel Embedment (in)	6.00	6.00	Not Used
Shear Strength of Cone (kips)	9.87	23.86	Not Used
Dowel Edge Distance (in)	12.00	5.19	Not Used
Dowel Spacing (in)	33.33	12.00	Not Used
Dowel Edge Distance (vert) (in)	36.00	5.19	Not Used
Dowel Devel. Length (in)	-4.00	15.38	Not Used

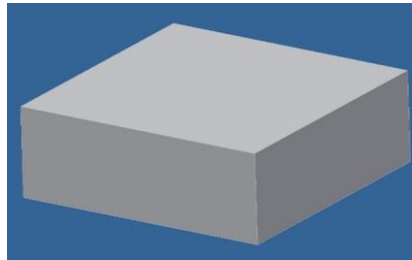

Modifications					
Pad Thickness, Te:	0	in	End Cap Width, Wec:	0	in
Revised Pad Thickness, Tx:	6	ft	Revised Width, Wx:	27	ft
Pad Rebar Size, Se:	6		EC Rebar Size, Sec:	7	per side, top & bottom
Rebar Quantity (long), me:	20	0	EC Rebar Quantity, mec:	8	0
Rebar Quantity (short), mex:	5	0	EC Tie Size, Sect:	4	per side
Dowel Size, Sed:	7		Tie Quantity, mect:	20	0
Dowel Quantity, med:	20	0	EC Dowel Size, Secd:	6	per side
			Dowel Quantity, mecd:	20	0
			Rows of Dowels, Nd:	2	
			Dowel Depth, dec:	6	in
			Edge Distance, eccd:	12	in

USGS Design Maps Summary Report

User-Specified Input

Report Title 806364
Tue October 4, 2016 18:04:22 UTC

Building Code Reference Document 2012/2015 International Building Code
(which utilizes USGS hazard data available in 2008)

Site Coordinates 41.45935°N, 72.66273°W

Site Soil Classification Site Class D – “Stiff Soil”

Risk Category I/II/III



USGS-Provided Output

$S_s = 0.179 \text{ g}$	$S_{MS} = 0.286 \text{ g}$	$S_{DS} = 0.191 \text{ g}$
$S_1 = 0.062 \text{ g}$	$S_{M1} = 0.148 \text{ g}$	$S_{D1} = 0.099 \text{ g}$

For information on how the S_s and S_1 values above have been calculated from probabilistic (risk-targeted) and deterministic ground motions in the direction of maximum horizontal response, please return to the application and select the “2009 NEHRP” building code reference document.

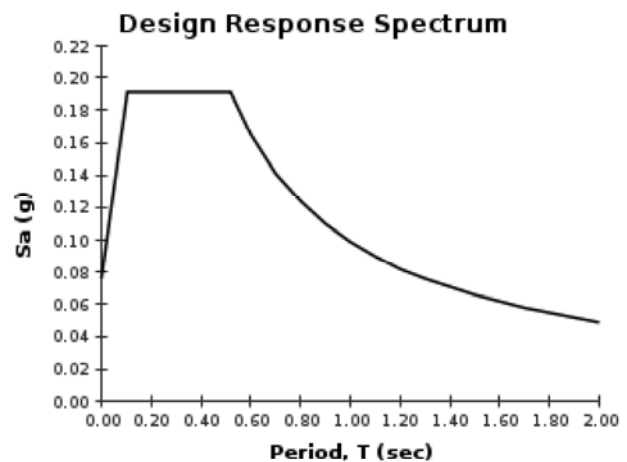
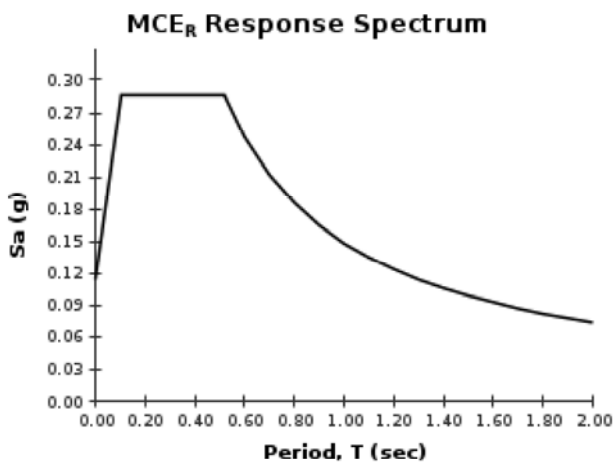

CCISeismic - Design Category

Per 2012/2015 IBC

Site BU: 806364
 Work Order: 1378401
 Application: 383797 Rev. 1



	Degrees	Minutes	Seconds		
Site Latitude =	41	27	33.67	41.4594	degrees
Site Longitude =	-72	39	45.83	-72.6627	degrees
Ground Supported Structure =	Yes				
Structure Class =	II				(Table 2-1)
Site Class =	D - Stiff Soil				(Table 2-11)
Spectral response acceleration short periods, S_S =	0.179				USGS Seismic Tool
Spectral response acceleration 1 s period, S_1 =	0.062				
Importance Factor, I =	1.0				(Table 2-3)
Acceleration-based site coefficient, F_a =	1.6				(Table 2-12)
Velocity-based site coefficient, F_v =	2.4				(Table 2-13)
Design spectral response acceleration short period, S_{DS} =	0.191				(2.7.6)
Design spectral response acceleration 1 s period, S_{D1} =	0.099				(2.7.6)
Seismic Design Category - Short Period Response =	B				ASCE 7-05 Table 11.6-1
Seismic Design Category - 1s Period Response =	B				ASCE 7-05 Table 11.6-2
Worst Case Seismic Design Category =	B				ASCE 7-05 Tables 11.6-1 and 6-2

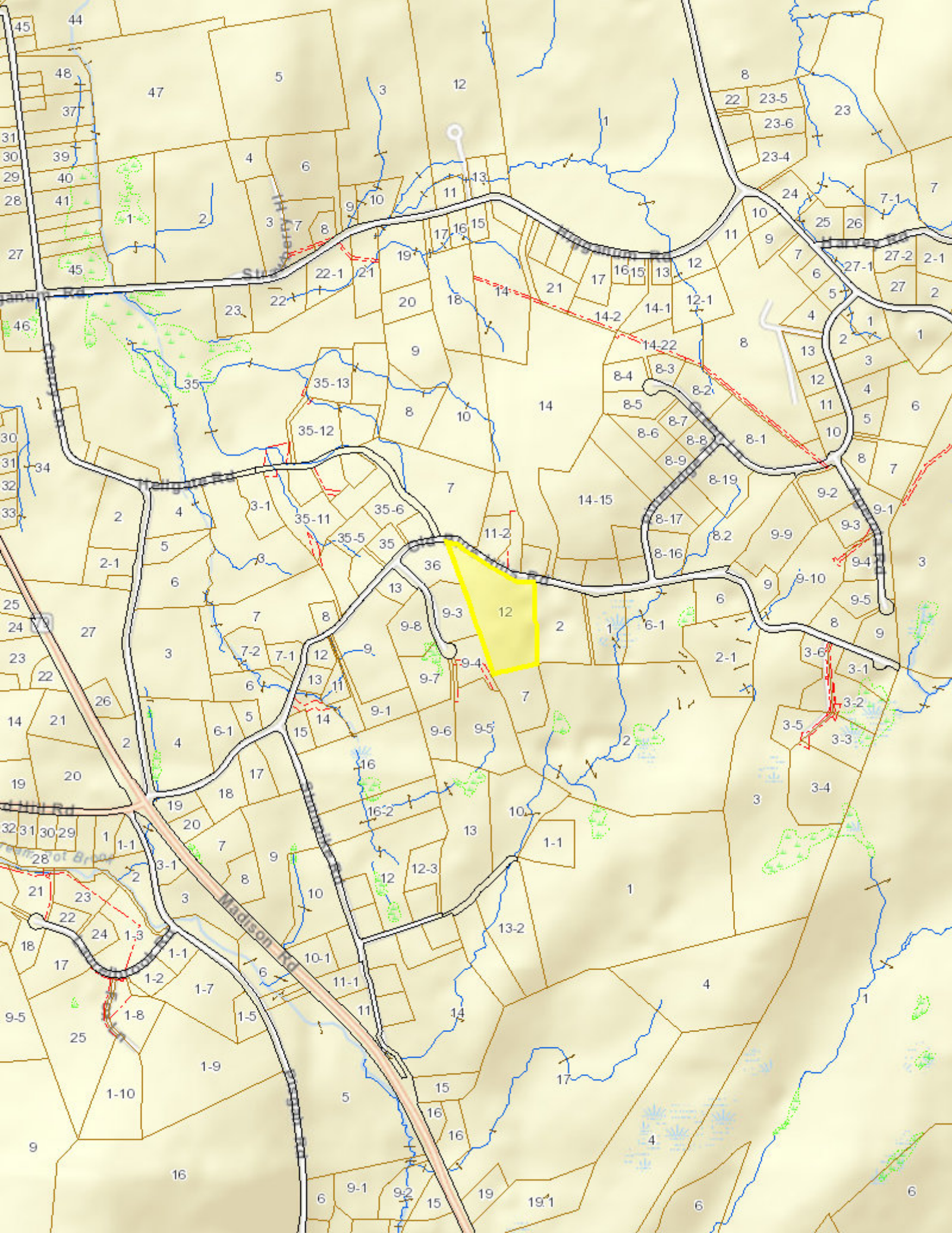

Durham, CT : Residential Property Record Card

[[Back to Search Results](#)]

[[Start a New Search](#)] [[Help with Printing](#)]

Search For Properties

Parcel ID <input type="text"/>	Name <input type="text"/>	Street Name <input type="text" value="BLUE HILLS RD"/>	<input type="button" value="Search"/>	<input type="button" value="Reset"/>
--	-------------------------------------	--	---------------------------------------	--------------------------------------

Parcel ID	Card	Routing No	Location	Zoning	State Class	Acres
B0016900	1	69 12	143R OLD BLUE HILLS RD	FR	130 - Developable Land	6.310
Living Units						
0						

Owner Information

Behrens Francis E Jr Castano Marie C
109 Old Blue Hills Rd
Durham CT 06422-3005

Property Picture



Deed Information

Book/Page: 100/255
Deed Date: 1984/08/24

Dwelling Information

Style:
Story Height: 0
Attic:
Basement:
Year Built: 0
Ground Flr Area: 0
Tot Living Area: 0
Rooms: 0
Bedrooms: 0
Full Baths: 0
Half Baths: 0

Valuation

Land: \$126,400
Building: \$0
Total: \$2,900
Net Assessment: \$2,030

Sales History

Book/Page	Date	Price	Type	Validity
-----------	------	-------	------	----------

Out Building Information

Type	Qty	Year	Size1	Size2	Grade	Cond
------	-----	------	-------	-------	-------	------

Building Sketch

	<u>Descriptor/Area</u>
--	------------------------

Notice

The information delivered through this on-line database is provided in the spirit of open access to government information and is intended as an enhanced service and convenience for citizens of Durham, CT.

The providers of this database: CLT, Big Room Studios, and Durham, CT assume no liability for any error or omission in the information provided here.

Currently All Values Have Not Been Finalized and Are Subject To Change.

Comments regarding this service should be directed to: jphilip@townofdurhamct.org

