



445 Hamilton Avenue, 14th Floor
White Plains, New York 10601
T 914 761 1300
F 914 761 5372
cuddyfeder.com

Lucia Chiocchio
lchiocchio@cuddyfeder.com

3/18/20

BY OVERNIGHT FED EX

Melanie A. Bachman
Executive Director
Connecticut Siting Council
10 Franklin Square
New Britain, CT 06051

Re: New Cingular Wireless PCS, LLC ("AT&T")
Notice of Exempt Modification
Emergency Back-up Generator
143 R Old Blue Hills Road, Durham, CT 06422
Lat.: 41.45949190°; Long.: -72.66269890°

Dear Ms. Bachman:

This letter and enclosures are respectfully submitted on behalf of New Cingular Wireless PCS, LLC ("AT&T"). AT&T currently maintains its wireless telecommunications facility at 143 R Old Blue Hills Road in the Town of Durham, Connecticut. Bell Atlantic Nynex Behrens is the owner of the underlying property and Crown Castle is the owner of the tower. AT&T submits this letter and enclosures to the Connecticut Siting Council ("Council") to notify the Council of AT&T's intent to perform modifications to the existing facility that do not have substantial adverse environmental effects and thus do not require a certificate pursuant to Section 16-50k of the Connecticut General Statutes.

AT&T intends to install one (1) new Generac 20kW Diesel Generator within the existing grade-level fenced equipment compound as demonstrated on the plans enclosed as Attachment 1. AT&T's existing facility supports its FirstNet program which provides first responders with priority access to AT&T's network to ensure adequate communication capabilities in the event of emergency. AT&T's proposed generator will ensure that critical communication capability for first responders and the public are not lost in the event of a loss of power.

AT&T's proposed generator will also advance the State's goal of natural disaster and emergency preparedness. As discussed in the Council's Docket 432 Findings and Report and Docket 440 proceedings and Findings of Fact (Nos. 76- 77), in response to two significant storm events in

2011, the State formed a Two Storm Panel (the “Panel”) that evaluated Connecticut’s approach to planning and mitigation of impacts associated with emergencies and natural disasters. The Panel found that “wireless telecommunications service providers were not prepared to serve residential and business customers during a power outage” because certain companies had limited backup generator capacity.¹ The Panel also noted that “[t]he failure of a large portion of Connecticut’s telecommunications system during the two storms is a life safety issue.” The Panel recommended that State regulatory bodies review “telecommunications services currently in place to verify that the vendors have sufficient generator and backhaul capacity to meet the emergency needs of consumers and businesses” and that the “Connecticut Siting Council should require continuity of service plans for any cellular tower to be erected.”² The planned modifications will ensure continuity of services by reinforcing AT&T’s back-up power and backhaul capacity to meet the emergency needs of first responders, consumers and businesses in the event of a power outage.

The planned modifications to the facility fall squarely within the activities explicitly provided for in R.C.S.A. § 16-50j-72(b)(2) as the planned modifications:

- Will not result in an increase in the height of the existing structure;
- Will not require the extension of the site boundary;
- Will not increase noise levels at the facility by more than six decibels or more, or to levels that exceed state or local criteria since emergency backup generators are exempt from noise regulations as “noise created as a result of, or relating to, an emergency”;³
- Will not increase radio frequency emission at the facility to a level at or above the Federal Communications Commission safety standards;
- Will not cause a change or alteration in the physical or environmental characteristics of the site; and
- Will not impair the structural integrity of the facility.

This facility was originally approved by the Council in 1994 by Docket No. 161 as illustrated by the Decision and Order dated March 11, 1994 enclosed as Attachment 2. This modification complies with the conditions of the aforementioned approval.

The proposed modifications will have no impact on the existing tower structure itself or the radio-frequency emissions as the proposed modifications only consist of the addition of one new

¹ See Council Administrative Notice Item No. 39

² See Council Administrative Notice Item No. 39.

³ R.C.S.A. § 22a-69-1.8.



3/18/20
Page -3-

generator within the grade-level fenced equipment compound. Thus, AT&T respectfully requests a waiver from submission of information relating to the existing tower structure or the radio-frequency emissions.

Please accept this letter as notification pursuant to R.C.S.A. § 16-50j-73 for construction that constitutes an exempt modification pursuant to R.C.S.A. § 16-50j-73. In accordance with R.C.S.A. § 16-50j-73, a copy of this letter and enclosure are being sent to the Town First Selectwoman Laura L. Francis as well as the property owner and structure owner identified above. Proof of notification is enclosed as Attachment 3.

For the foregoing reasons, AT&T respectfully submits that the proposed modification to the above referenced wireless telecommunications facility constitutes an exempt modification under R.C.S.A. § 16-50j-72(b)(2).

Very truly yours,

A handwritten signature in cursive script that reads 'Lucia Chiochio'. The ink is dark and the signature is fluid and legible.

Lucia Chiochio

Attachments

cc: First Selectwoman Laura L. Francis, Town of Durham
Crown Castle, Tower Owner
Bell Atlantic Nynex Behrens, Property Owner
AT&T
General Dynamics Information Technology
Daniel Patrick, Esq. & Julie Durkin, Cuddy & Feder, LLP

ATTACHMENT 1



at&t Mobility

SITE NAME: DURHAM CENTRAL
FA LOCATION CODE: 10071003
CROWN BUN: 806364

GENERATOR PROJECT
20KW GENERAC DIESEL GENERATOR
200A GENERAC ATS

143 R OLD BLUE HILLS ROAD
DURHAM, CT 06422

RAMAKER & ASSOCIATES, INC.
 100% EMPLOYEE-OWNED
 855 Community Dr, Sauk City, WI 53583
 608-643-4100 www.Ramaker.com
 Sauk City, WI • Willmar, MN
 Woodcliff Lake, NJ • Bayamon, PR

PREPARED FOR:
at&t Mobility

CONSULTANT:
GENERAL DYNAMICS
 Information Technology, Inc.
 GENERAL DYNAMICS
 661 MOORE RD STE 110
 KING OF PRUSSIA, PA 19406

Certification & Seal:
 I hereby certify that this plan, specification, or report was prepared by me or under my direct supervision and that I am a duly Licensed Professional Engineer under the laws of the State of Connecticut.

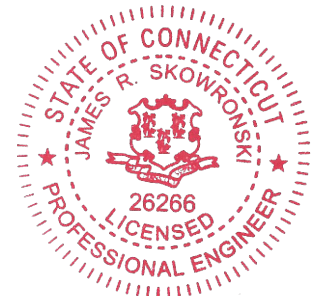

James R. Skowronski Signature: _____ Date: 3/12/2020

VICINITY MAP

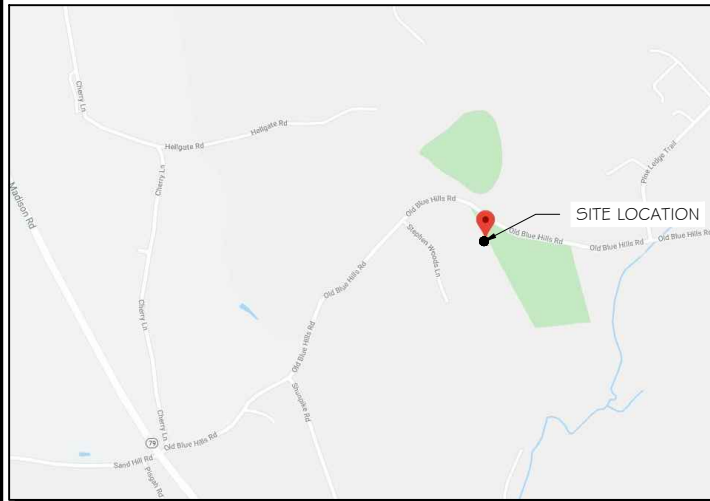

SCOPE OF WORK

ADD STANDBY GENERATOR, ASSOCIATED CONCRETE PAD, AND UTILITY EQUIPMENT TO EXISTING AT&T EQUIPMENT AREA. THERE WILL BE NO CHANGE IN THE SIZE OR HEIGHT OF THE TOWER OR ANTENNAS.

APPLICABLE BUILDING CODE & STANDARDS

ALL WORK AND MATERIALS SHALL BE PERFORMED AND INSTALLED IN ACCORDANCE WITH THE CURRENT EDITION OF THE FOLLOWING CODES AS ADOPTED BY THE GOVERNING LOCAL AUTHORITIES. NOTHING IN THESE PLANS ARE TO BE CONSTRUCTED TO PERMIT WORK NOT CONFORMING TO THESE CODES:

- INTERNATIONAL BUILDING CODE 2015
- NATIONAL ELECTRIC CODE 2017
- AMERICAN CONCRETE INSTITUTE (ACI) 318, BUILDING CODE REQUIREMENTS FOR STRUCTURAL CONCRETE
- AMERICAN INSTITUTE OF STEEL CONSTRUCTION (AISC), MANUAL OF STEEL CONSTRUCTION
- TELECOMMUNICATIONS INDUSTRY ASSOCIATION (TIA) 222-G, STRUCTURAL STANDARDS FOR STEEL TOWER AND ANTENNA SUPPORTING STRUCTURES
- TIA 607, COMMERCIAL BUILDING GROUNDING AND BONDING REQUIREMENTS FOR TELECOMMUNICATIONS

MEMBER

 TO OBTAIN LOCATION OF PARTICIPANTS' UNDERGROUND FACILITIES BEFORE YOU DIG IN CONNECTICUT
CALL BEFORE YOU DIG
811 OR 1-800-922-4455
 CONNECTICUT PUBLIC ACT 87-71 REQUIRES MIN. 2 WORKING DAYS NOTICE BEFORE YOU EXCAVATE.

AERIAL VIEW OF SITE



PROJECT INFORMATION

PROJECT MANAGER:
 JOE JARVIS
 MARKET LEAD
 GENERAL DYNAMICS WIRELESS SERVICES
 661 MOORE RD STE 110
 KING OF PRUSSIA, PA 19406
 EMAIL: joseph.jarvis@gdit.com

ENGINEER:
 RAMAKER & ASSOCIATES, INC.
 855 COMMUNITY DRIVE
 SAUK CITY, WI 53583
 PH.: (608) 643-4100
 FAX: (608) 643-7999
 CONTACT: TYLER BEATTY
 EMAIL: tbeatty@ramaker.com

APPLICANT INFORMATION:
 AT&T MOBILITY
 7150 STANDARD DR.
 HANOVER, MD 21076

SITE DATA:
 SITE NAME: DURHAM CENTRAL
 FA NUMBER: 10071003

TOWER OWNER:
 CROWN CASTLE
 2000 CORPORATE DRIVE
 CANONSBURG, PA 15317

PROPERTY OWNER:
 FRANCIS E. BEHRENS, JR. AND MARIE C. BEHRENS
 101 R. OLD BLUE HILLS ROAD
 DURHAM, CT 06422

ADDRESS:
 143 R OLD BLUE HILLS ROAD
 DURHAM, CT 06422

COUNTY: MIDDLESEX

LAT.: 41.45949190°
LONG.: -72.66269890°

GROUND ELEVATION: 540 FT AMSL

DO NOT SCALE DRAWINGS:
 CONTRACTOR SHALL VERIFY ALL PLANS & EXISTING DIMENSIONS & CONDITIONS ON THE JOB SITE & SHALL IMMEDIATELY NOTIFY THE ENGINEER IN WRITING OF ANY DISCREPANCIES BEFORE PROCEEDING WITH THE WORK OR BE RESPONSIBLE FOR SAME.

THE INFORMATION CONTAINED IN THIS SET OF DOCUMENTS IS PROPRIETARY BY NATURE. ANY USE OR DISCLOSURE OTHER THAN THAT WHICH RELATES TO THE CLIENT IS STRICTLY PROHIBITED.

SHEET INDEX

GENERAL:
 T-1 TITLE SHEET

NOTES:
 N-1 GENERAL NOTES

SITE:
 A-1 SITE PLAN
 S-1 FOUNDATION DETAILS

ELECTRICAL & GROUNDING:
 E-1 WIRING DETAILS
 E-2 PANEL AND PENETRATION DETAILS
 E-3 ATS, CONDUIT & GROUND ROD DETAILS
 E-4 GENERAC GENERATOR SPECIFICATIONS
 E-4.1 GENERAC GENERATOR SPECIFICATIONS
 E-4.2 GENERAC GENERATOR SPECIFICATIONS
 E-5 GENERAC ATS SPECIFICATIONS
 E-5.1 GENERAC ATS SPECIFICATIONS

SIGNATURE BLOCK

AT&T MGR.	DATE
GENERAL DYNAMICS CONSTRUCTION MGR.	DATE
SITE ACQUISITION	DATE

MARK	DATE	REVISED CD#	DESCRIPTION
1	3/12/20		
ISSUE PHASE	FINAL	DATE ISSUED	02/24/2020
PROJECT TITLE: DURHAM CENTRAL FA ID # 10071003			
PROJECT INFORMATION: 143 R OLD BLUE HILLS ROAD DURHAM, CT 06422			
SHEET TITLE: TITLE SHEET			
SCALE: NONE			
PROJECT NUMBER	45808		
SHEET NUMBER	T-1		

NOTES TO SUBCONTRACTOR:

1. THE GENERAL SUBCONTRACTOR MUST VERIFY ALL DIMENSIONS, CONDITIONS AND ELEVATIONS BEFORE PROCEEDING WITH THE WORK. ALL WORK SHALL BE PERFORMED IN A WORKMANLIKE MANNER IN ACCORDANCE WITH ACCEPTED CONSTRUCTION PRACTICES.
2. IT IS THE INTENTION OF THESE DRAWINGS TO SHOW THE COMPLETED INSTALLATION. THE SUBCONTRACTOR SHALL BE RESPONSIBLE FOR ALL TEMPORARY BRACING, SHORING, TIES, FORM WORK, ETC. IN ACCORDANCE WITH ALL NATIONAL, STATE, AND LOCAL ORDINANCES, TO SAFELY EXECUTE ALL WORK AND SHALL BE RESPONSIBLE FOR SAME. ALL WORK SHALL BE IN ACCORDANCE WITH LOCAL CODES.
3. THE SUBCONTRACTOR SHALL USE ADEQUATE NUMBER OF SKILLED WORKMAN WHO ARE THOROUGHLY TRAINED AND EXPERIENCED IN THE NECESSARY CRAFTS AND WHO ARE COMPLETELY FAMILIAR WITH THE SPECIFIED REQUIREMENTS AND METHOD NEEDED FOR PROPER PERFORMANCE OF THE WORK.
4. CONSTRUCTION SUBCONTRACTOR AGREES THAT IN ACCORDANCE WITH GENERALLY ACCEPTED CONSTRUCTION PRACTICES, CONSTRUCTION SUBCONTRACTOR WILL BE REQUIRED TO ASSUME SOLE AND COMPLETE RESPONSIBILITY FOR JOB SITE CONDITIONS DURING THE COURSE OF CONSTRUCTION OF THE PROJECT, INCLUDING THE SAFETY OF ALL PERSONS AND PROPERTY, THAT THIS REQUIREMENT SHALL BE MADE TO APPLY CONTINUOUSLY AND NOT BE LIMITED TO NORMAL WORKING HOURS AND CONSTRUCTION SUBCONTRACTOR FURTHER AGREES TO INDEMNIFY AND HOLD DESIGN ENGINEER HARMLESS FROM ANY AND ALL LIABILITY, REAL OR ALLEGED, IN CONNECTION WITH PERFORMANCE OF WORK ON THIS PROJECT.
5. SITE GROUNDING SHALL COMPLY WITH AT&T WIRELESS SERVICES TECHNICAL SPECIFICATIONS FOR FACILITY GROUNDING FOR CELL SITE STANDARDS, LATEST EDITION, AND COMPLY WITH AT&T TOWERS GROUNDING CHECKLIST, LATEST VERSION. WHEN NATIONAL AND LOCAL GROUNDING CODES ARE MORE STRINGENT THEY SHALL GOVERN. GROUNDING SHALL BE COMPLETED BEFORE ERECTION OF TOWER.
6. ALL WORK SHALL COMPLY WITH OSHA AND STATE SAFETY REQUIREMENTS. PROCEDURES FOR THE PROTECTION OF EXCAVATIONS, EXISTING CONSTRUCTION AND UTILITIES SHALL BE ESTABLISHED PRIOR TO FOUNDATION INSTALLATION, IF TEMPORARY LIGHTING AND MARKING IS REQUIRED BY THE FEDERAL AVIATION ADMINISTRATION (FAA), IT IS THE SUBCONTRACTOR'S RESPONSIBILITY TO MAINTAIN THE NECESSARY LIGHTS AND NOTIFY THE PROPER AUTHORITIES IN THE EVENT OF A PROBLEM.
7. ALL WORK SHALL BE ACCOMPLISHED IN ACCORDANCE WITH ALL LOCAL, STATE, AND FEDERAL CODES OR ORDINANCES. THE MOST STRINGENT CODE WILL APPLY IN THE CASE OF DISCREPANCIES OR DIFFERENCES IN THE CODE REQUIREMENTS.
8. ANY DAMAGE TO THE ADJACENT PROPERTIES WILL BE CORRECTED AT THE SUBCONTRACTOR'S EXPENSE TO THE SATISFACTION OF THE LANDOWNER AND THE ENGINEER.
9. THE COMPLETE BID PACKAGE INCLUDES THESE CONSTRUCTION DRAWINGS ALONG WITH THE SPECIFICATIONS. SUBCONTRACTOR IS RESPONSIBLE FOR REVIEW OF TOTAL BID PACKAGE PRIOR TO BID SUBMITTAL..
10. SUBCONTRACTOR SHALL VERIFY LOCATION OF ALL EXISTING UTILITIES WITHIN CONSTRUCTION LIMITS PRIOR TO CONSTRUCTION.
11. THE SUBCONTRACTOR IS RESPONSIBLE FOR MAINTAINING POSITIVE DRAINAGE ON THE SITE AT ALL TIMES. SILT AND EROSION CONTROL SHALL BE MAINTAINED ON THE DOWNSTREAM SIDE OF THE SITE AT ALL TIMES. ANY DAMAGE TO ADJACENT PROPERTIES WILL BE CORRECTED AT THE SUBCONTRACTOR'S EXPENSE.
12. CLEARING OF TREES AND VEGETATION ON THE SITE SHOULD BE HELD TO A MINIMUM. ONLY THE TREES NECESSARY FOR CONSTRUCTION OF THE FACILITIES SHALL BE REMOVED. ANY DAMAGE TO THE PROPERTY OUTSIDE THE LEASED PROPERTY SHALL BE REPAIRED BY THE SUBCONTRACTOR.
13. ALL SUITABLE BORROW MATERIAL FOR BACK FILL OF THE SITE SHALL BE INCLUDED IN THE BID. EXCESS TOPSOIL AND UNSUITABLE MATERIAL SHALL BE DISPOSED OF OFF SITE AT LOCATIONS APPROVED BY GOVERNING AGENCIES PRIOR TO DISPOSAL.
14. SEEDING AND MULCHING OF THE SITE WILL BE ACCOMPLISHED AS SOON AS POSSIBLE AFTER COMPLETION OF THE SITE DEVELOPMENT. THE SUBCONTRACTOR IS RESPONSIBLE FOR PROVIDING AND MAINTAIN AN ADEQUATE COVER OF VEGETATION OVER THE SITE FOR A ONE YEAR PERIOD.
15. PERMITS: THE SUBCONTRACTOR SHALL BE RESPONSIBLE FOR OBTAINING AND INCURRING THE COST OF ALL REQUIRED PERMITS, INSPECTIONS, CERTIFICATES, ETC.
16. RECORD DRAWINGS: MAINTAIN A RECORD OF ALL CHANGES, SUBSTITUTIONS BETWEEN WORK AS SPECIFIED AND INSTALLED. RECORD CHANGES ON A CLEAN SET OF CONTRACT DRAWINGS WHICH SHALL BE TURNED OVER TO THE CONSTRUCTION MANAGER UPON COMPLETION OF THE PROJECT.
17. THE PLANS SHOW SOME KNOWN SUBSURFACE STRUCTURES, ABOVE GROUND STRUCTURES AND/OR EXISTING UTILITIES BELIEVED TO BE IN THE WORKING AREA. IT IS THE RESPONSIBILITY OF THE SUBCONTRACTOR TO VERIFY ALL UTILITIES, PIPELINES AND OTHER STRUCTURES SHOWN OR NOT SHOWN ON THESE PLANS. THE SUBCONTRACTOR SHALL CONTACT THE LOCAL JURISDICTION'S DIGGER'S HOTLINE BEFORE DIGGING OR DRILLING. ANY DAMAGE TO EXISTING UTILITIES SHALL BE REPAIRED TO THE SATISFACTION OF THE OWNER AND ENGINEER AT THE SUBCONTRACTOR'S EXPENSE.

GENERAL NOTES:

1. THIS PROPOSAL IS FOR THE ADDITION OF A NEW GENERATOR ON A CONCRETE PAD TO AN EXISTING UNMANNED TELECOMMUNICATIONS FACILITY CONSISTING OF AN EQUIPMENT SHELTER AND TOWER.
2. THE PROPOSED FACILITY WILL BE UNMANNED AND DOES NOT REQUIRE POTABLE WATER OR SEWER SERVICE.
3. THE PROPOSED FACILITY IS UNMANNED AND IS NOT FOR HUMAN HABITAT. (NO HANDICAP

ACCESS IS REQUIRED)

4. OCCUPANCY IS LIMITED TO PERIODIC MAINTENANCE AND INSPECTION, APPROXIMATELY 2 TIMES PER MONTH BY AT&T TECHNICIANS.
5. OUTDOOR STORAGE AND SOLID WASTE CONTAINERS ARE NOT PROPOSED.
6. ALL MATERIAL SHALL BE FURNISHED AND WORK SHALL BE PERFORMED IN ACCORDANCE WITH THE PROJECT SPECIFICATIONS.
7. SUBCONTRACTOR SHALL BE RESPONSIBLE FOR REPAIRING ANY DAMAGE CAUSED BY THE CONSTRUCTION OPERATION.
8. SUBCONTRACTOR SHALL BE RESPONSIBLE FOR OBTAINING ALL PERMITS AND INSPECTION REQUIRED FOR CONSTRUCTION.
9. SUBCONTRACTOR SHALL REMOVE ALL TRASH AND DEBRIS FROM THE SITE ON A DAILY BASIS.

ELECTRICAL NOTES:

A. GENERAL

1. COORDINATE LOCATION AND POWER REQUIREMENTS OF ALL EQUIPMENT WITH AT&T AND EQUIPMENT SUPPLIER PRIOR TO INSTALLATION.
2. COORDINATE LOCATION AND REQUIREMENTS FOR ELECTRICAL AND TELEPHONE SERVICES WITH THE PROPERTY REPRESENTATIVE, AT&T AND UTILITY COMPANIES. ROUTING OF CONDUITS MAY BE MODIFIED TO MEET SITE REQUIREMENTS. EXACT CONDUIT ROUTING TO BE DETERMINED IN THE FIELD.
3. ALL WIRING AND EQUIPMENT SHOWN ON ELECTRICAL SHEETS SHALL BE FURNISHED AND INSTALLED UNDER ELECTRICAL PORTION OF CONTRACT UNLESS OTHERWISE NOTED
4. UNINTERRUPTED ELECTRICAL SERVICE FOR EXISTING EQUIPMENT SHALL BE MAINTAINED DURING THE INSTALLATION OF THE WORK DESCRIBED UNDER THESE DOCUMENTS. TEMPORARY EQUIPMENT, CABLES AND WHATEVER ELSE IS NECESSARY SHALL BE PROVIDED AS REQUIRED TO MAINTAIN ELECTRICAL SERVICE. TEMPORARY SERVICE FACILITIES, IF REQUIRED AT ANY TIME, SHALL NOT BE DISCONNECTED OR REMOVED UNTIL NEW SERVICE EQUIPMENT IS IN PROPER OPERATION. IF ANY SERVICE OR SYSTEM MUST BE INTERRUPTED, THE CONTRACTOR SHALL REQUEST PERMISSION IN WRITING STATING THE DATE, TIME, ETC. THE SERVICE WILL BE INTERRUPTED AND THE AREAS AFFECTED. THIS REQUEST SHALL BE MADE IN SUFFICIENT TIME FOR PROPER ARRANGEMENTS TO BE MADE. WRITTEN PERMISSION SHALL BE OBTAINED FROM THE OWNER BEFORE INTERRUPTING ELECTRICAL SERVICE.
5. COORDINATE NEW WORK WITH OTHER TRADES AND VERIFY EXISTING CONDITIONS TO AVOID INTERFERENCE. IN CASE OF INTERFERENCE, AT&T'S REPRESENTATIVE WILL DECIDE WHICH WORK IS TO BE RELOCATED, REGARDLESS OF WHICH WAS FIRST INSTALLED.
6. THE INSTALLATION MUST COMPLY WITH NEC AND ALL FEDERAL, STATE AND LOCAL RULES AND REGULATIONS.
7. THE DRAWINGS ARE DIAGRAMMATIC AND INDICATE THE GENERAL ARRANGEMENT OF SYSTEMS AND EQUIPMENT UNLESS OTHERWISE DEFINED BY DIMENSIONS OR DETAILS. EXACT EQUIPMENT LOCATIONS AND RACEWAY ROUTING SHALL BE GOVERNED BY ACTUAL FIELD CONDITIONS AND/OR DIRECTIONS FROM AT&T'S REPRESENTATIVE.
8. CONTRACTOR SHALL PAY ALL PERMITS AND FEES REQUIRED.
9. ALL MATERIALS SHALL BE FURNISHED AND WORK SHALL BE PERFORMED IN ACCORDANCE WITH THE APPLICABLE SECTIONS OF THE STANDARDS REFERENCED BELOW:
 - a. ANSI (AMERICAN NATIONAL STANDARDS INSTITUTE)
 - b. ASTM (AMERICAN SOCIETY FOR TESTING MATERIALS)
 - c. ETL (ELECTRICAL TESTING LABORATORY)
 - d. ICEA (INSULATED CABLE ENGINEERS ASSOCIATION)
 - e. IEEE (INSTITUTE OF ELECTRICAL AND ELECTRONIC ENGINEERS)
 - f. MBFU (NATIONAL BOARD OF FIRE UNDERWRITERS)
 - g. NESC (NATIONAL ELECTRICAL SAFETY CODE)
 - h. NEMA (NATIONAL ELECTRICAL MANUFACTURER'S ASSOCIATION)
 - i. NFPA (NATIONAL FIRE PROTECTION ASSOCIATION)
 - j. UL (UNDERWRITER'S LABORATORY)
10. CONTRACTOR SHALL REVIEW PLANS, DETAILS AND SPECIFICATIONS IN DETAIL AND ADJUST WORK TO CONFORM WITH ACTUAL SITE CONDITIONS SO THAT ELECTRICAL DEVICES AND EQUIPMENT WILL BE LOCATED AND READILY ACCESSIBLE. QUANTITIES LISTED IN MATERIAL LISTS ON THE DRAWINGS ARE FOR INFORMATION ONLY. THE CONTRACTOR SHALL PROVIDE HIS OWN TAKEOFF FOR MATERIAL QUANTITY AND TYPES BASED ON ACTUAL SITE CONDITIONS. IN ADDITION, CONTRACTOR SHALL PROVIDE ALL NECESSARY MATERIALS TO INSTALL EQUIPMENT FURNISHED BY AT&T OR ITS SUPPLIERS. ALL ITEMS NOT SPECIFICALLY MENTIONED HEREIN OR SHOWN ON THE DRAWINGS, BUT WHICH ARE OBVIOUSLY NECESSARY TO MAKE A COMPLETE WORKING INSTALLATION, SHALL BE INCLUDED.

11. THE CONTRACTOR OR BIDDER SHALL BEAR THE RESPONSIBILITY OF NOTIFYING (IN WRITING) AT&T'S REPRESENTATIVE OF ANY CONFLICTS PRIOR TO THE SUBMISSION OF CONTRACTOR'S PROPOSAL OR PERFORMANCE OF WORK, IN THE EVENT OF DISCREPANCIES THE CONTRACTOR SHALL PRICE THE MORE COSTLY OR EXTENSIVE WORK, UNLESS DIRECTED IN WRITING OTHERWISE.

12. ALL FLOORS WHERE PENETRATIONS ARE REQUIRED IN BUILDING ARE TO BE CORE DRILLED AND THEN FIREPROOFED.

B. WIRING/CONDUIT

1. PROVIDE PULL BOXES AND JUNCTION BOXES WHERE SHOWN OR AS REQUIRED BY CODE SUCH THAT NO MORE THAN THE EQUIVALENT OF FOUR QUARTER BENDS (360 DEGREES TOTAL) EXIST IN A CONDUIT RUN.
2. ALL POWER AND CONTROL/INDICATION WIRING SHALL BE TYPE THHN/THWN 800V RATED 75 DEGREES CELSIUS, UNLESS NOTED OTHERWISE.

3. SCHEDULE 80 PVC CONDUIT SHALL BE USED ABOVE GROUND, WHERE ABOVE GRADE IS DEFINED AS THE GROUND OF THE TURN-UP
4. BELL END OR TERMINAL ADAPTER MUST BE INSTALLED ON END OF PVC CONDUIT PER NEC 352.46. 300.4 F, (3)
5. CONDUIT BENDS SHALL BE MADE IN ACCORDANCE WITH NEC TABLE 346-10. NO RIGHT ANGLE DEVICE OTHER THAN STANDARD CONDUIT ELBOWS WITH 1 2" MINIMUM INSIDE SWEEPS FOR ALL CONDUITS 2" OR LARGER.
6. POWER WIRING SIZE SHALL NOT BE SMALLER THAN #12 AWG.
7. ALL WIRING SHALL BE COPPER. ALUMINUM WILL NOT BE ACCEPTABLE ALL POWER CIRCUITS SHALL CONTAIN A GROUND WIRE.
8. PHASE MARKINGS TO BE USED AT POWER CONDUCTOR TERMINATIONS.
9. CONTRACTOR SHALL ENSURE INTEGRITY IS MAINTAINED WHEN INSTALLING CONDUIT AND WIRING.
10. INSTALL PULL STRING IN ALL CONDUIT.

11. FOR ROOFTOP INSTALLS AND BUILD-OUTS, CONDUITS INSIDE BUILDING AND ON ROOF SHALL BE RGS, UNLESS OTHERWISE NOTED. FOR RAW LAND SITES AND CO-LOCATES, PVC SCHEDULE 80 SHALL BE UTILIZED UNLESS NOTED OTHERWISE.
12. MAINTAIN MINIMUM 1'-0" VERTICAL AND 1'-0" HORIZONTAL SEPARATIONS FROM ANY MECHANICAL GAS PIPING.
13. ALL WIRING Routed IN PLENUM TO BE RATED OR IN METALLIC FLEX (LIQUIDITE) CONDUIT.

C. EQUIPMENT

1. EQUIPMENT/PARTS CONNECTED TO EXISTING PANELS, DUCTS, ETC. SHALL MATCH THE CHARACTERISTICS (A/C, V, A) OF THAT EQUIPMENT.
2. ALL ELECTRICAL EQUIPMENT OUTSIDE SHALL BE NEMA OR 3R RATED.

D. GROUNDING

1. ALL GROUND CONNECTIONS TO BUILDING SHALL BE MADE USING TWO-HOLE CONNECTORS. PROVIDE STAINLESS STEEL BOLTS AND LOCK WASHERS ON ALL MECHANICAL GROUND CONNECTIONS.
2. ALL EQUIPMENT SURFACES TO BE BONDED TO GROUNDING SYSTEM SHALL BE STRIPPED OF ALL PAINT AND DIRT. CONNECTIONS TO VARIOUS METALS SHALL BE OF A TYPE AS TO CAUSE A GALVANIC OR CORROSIVE REACTION. AREA SHALL BE REPAINTED FOLLOWING BONDING.
3. ANY METALLIC ITEM WITHIN 6' OF GROUND CONDUCTORS MUST BE CONNECTED TO THE GROUNDING SYSTEM.
4. EXTERIOR, ABOVE GRADE GROUND CONNECTIONS SHALL BE FURNISHED WITH A LIBERAL PROTECTIVE COATING OF ANTI-OXIDE COMPOUND.
5. ALL MATERIALS AND LABOR REQUIRED FOR THE GROUNDING SYSTEM AS INDICATED ON THE PLANS AND DETAILS, AND AS DESCRIBED HEREIN SHALL BE FURNISHED BY THIS CONTRACTOR UNLESS OTHERWISE NOTED.
6. EXACT LOCATION OF GROUND CONNECTION POINTS SHALL BE DETERMINED IN FIELD. ADJUST LOCATIONS INDICATED ON PLANS ACCORDING TO ACTUAL EQUIPMENT LOCATIONS TO KEEP THE GROUND CONNECTION CABLES AS SHORT AS PRACTICAL.
7. PROVIDE ALL ELECTRICAL SYSTEM AND EQUIPMENT GROUNDS AS REQUIRED BY THE CURRENT EDITION OF THE NATIONAL ELECTRIC CODE (1999) AND THE CURRENT EDITION OF THE NATIONAL ELECTRICAL SAFETY CODE. BONDING JUMPERS WITH APPROVED GROUND FITTINGS SHALL BE INSTALLED AT ALL RACEWAYS, EQUIPMENT ENCLOSURES, PULL BOXES, ETC. TO MAINTAIN GROUND CONTINUITY WHERE REQUIRED BY CODE.
8. ALL EQUIPMENT GROUND CONDUCTORS SHALL BE TIN COATED, #2 AWG COPPER UNLESS NOTED OTHERWISE ON THE DRAWINGS.
9. PROVIDE PRE AND POST GROUND TEST RESULTS, USING CLAMP-ON TESTER. TEST RESULTS SHALL BE PHOTOS WITH DIGITAL TIME AND GPS STAMPED/EMBEDDED.

E. INSPECTION/DOCUMENTATION

1. THE CONTRACTOR, UPON COMPLETION OF HIS WORK, SHALL PROVIDE AS-BUILT DRAWINGS. INFORMATION SHOULD BE GIVEN TO THE GENERAL CONTRACTOR FOR INCLUSION IN FINAL AS-BUILT SURVEY DOCUMENTS TO BE GIVEN TO THE OWNER.
2. CONTRACTOR SHALL SUPPLY DOCUMENTATION ATTESTING TO THE COMPLETE GROUND SYSTEM'S RECEPTIVITY (MAX. 5 OHMS).
3. AN ELECTRICAL INSPECTION SHALL BE MADE BY AND INSPECTING AGENCY APPROVED BY AT&T'S REPRESENTATIVE. CONTRACTOR SHALL COORDINATE ALL INSPECTIONS AND OBTAIN POWER COMPANY APPROVAL.
4. CONTRACTOR SHALL HAVE ATS AND GENERATOR RELAY INSTALLATION AND CONNECTIONS INSPECTED BY OTHERS TO ENSURE THAT UL LISTING FOR THAT EQUIPMENT IS NOT VOIDED.

PREPARED FOR:

CONSULTANT:
GENERAL DYNAMICS
 Information Technology, Inc.
 GENERAL DYNAMICS
 661 MOORE RD STE 110
 KING OF PRUSSIA, PA 19406

Certification & Seal:
 I hereby certify that this plan, specification, or report was prepared by me or under my direct supervision and that I am a duly Licensed Professional Engineer under the laws of the State of Connecticut.

1	3/12/20	REVISED CDs
MARK	DATE	DESCRIPTION
ISSUE	FINAL	DATE ISSUED 02/24/2020

PROJECT TITLE:
DURHAM CENTRAL
FA ID # 10071003

PROJECT INFORMATION:
 143 R OLD BLUE HILLS ROAD
 DURHAM, CT 06422

SHEET TITLE:
GENERAL NOTES

SCALE: NONE

PROJECT NUMBER	45808
SHEET NUMBER	N-1

SCOPE OF WORK DETAILS

- GENERAL:**
- NEW GENERAC DIESEL GENERATOR PROVIDED BY GENERAL DYNAMICS & INSTALLED BY GENERAL CONTRACTOR, SEE E-4.
 - NEW 4'-0" X 5'-0" CONCRETE PAD PROVIDED & INSTALLED BY GENERAL CONTRACTOR (AS REQUIRED) SEE S-1
 - NEW GENERAC AUTOMATIC TRANSFER SWITCH PROVIDED BY GENERAL DYNAMICS & INSTALLED BY CONTRACTOR (AS REQUIRED) SEE E-3 & E-5.
 - CONTRACTOR TO VERIFY ALL EXISTING UTILITIES PRIOR TO CONSTRUCTION
 - CONTRACTOR SHALL RESTORE & REPAIR ANY DAMAGED AREAS CAUSED BY CONSTRUCTION TO ORIGINAL OR BETTER CONDITION
- CONDUITS:**
- INSTALL PULL STRING IN EACH CONDUIT
 - (1) NEW 2" AND (1) NEW 1" ELECTRICAL CONDUITS WITH CONDUCTORS TO RUN FROM NEW GENERATOR TO NEW ATS. CONDUIT PROVIDED AND INSTALLED BY GENERAL CONTRACTOR. SEE E-1, E-2 & E-3.
 - (2) NEW 1" ELECTRICAL CONDUIT WITH CONDUCTORS TO RUN FROM NEW GENERATOR TO AC PANEL. CONDUIT PROVIDED & INSTALLED BY GENERAL CONTRACTOR. SEE E-1, E-2 & E-3.
 - (1) NEW 1" ALARM CONDUIT & CABLING PROVIDED & INSTALLED BY GENERAL CONTRACTOR. SEE E-1, E-2 & E-3.
- GROUNDING:**
- NEW EXOTHERMIC CONNECTION FROM EXISTING GROUND RING TO NEW MECHANICAL CONNECTION AT GENERATOR CHASSIS. GENERAL CONTRACTOR TO VERIFY LOCATION IN FIELD. LOCATE GROUND RODS NO MORE THAN 8'-0" APART.
- H-FRAME:**
- PROVIDE NEW H-FRAME IF REQUIRED, MATCH EXISTING H-FRAME MATERIAL FOR CONSTRUCTION OF NEW H-FRAME. USE ALL GALVANIZED COMPONENTS, WHITE PLASTIC END CAPS ON UNISTRUTS, WEATHER CAPS ON TOPS OF PIPE AND CONCRETE SUPPORTS BELOW FROST LINE. TOP OF FOOTING SHOULD BE AT LEAST 2" ABOVE EXISTING GROUND LEVEL. SLOPE THE GROUND AWAY FROM THE H-FRAME FOR POSITIVE WATER DRAINAGE OFF THE FORM.

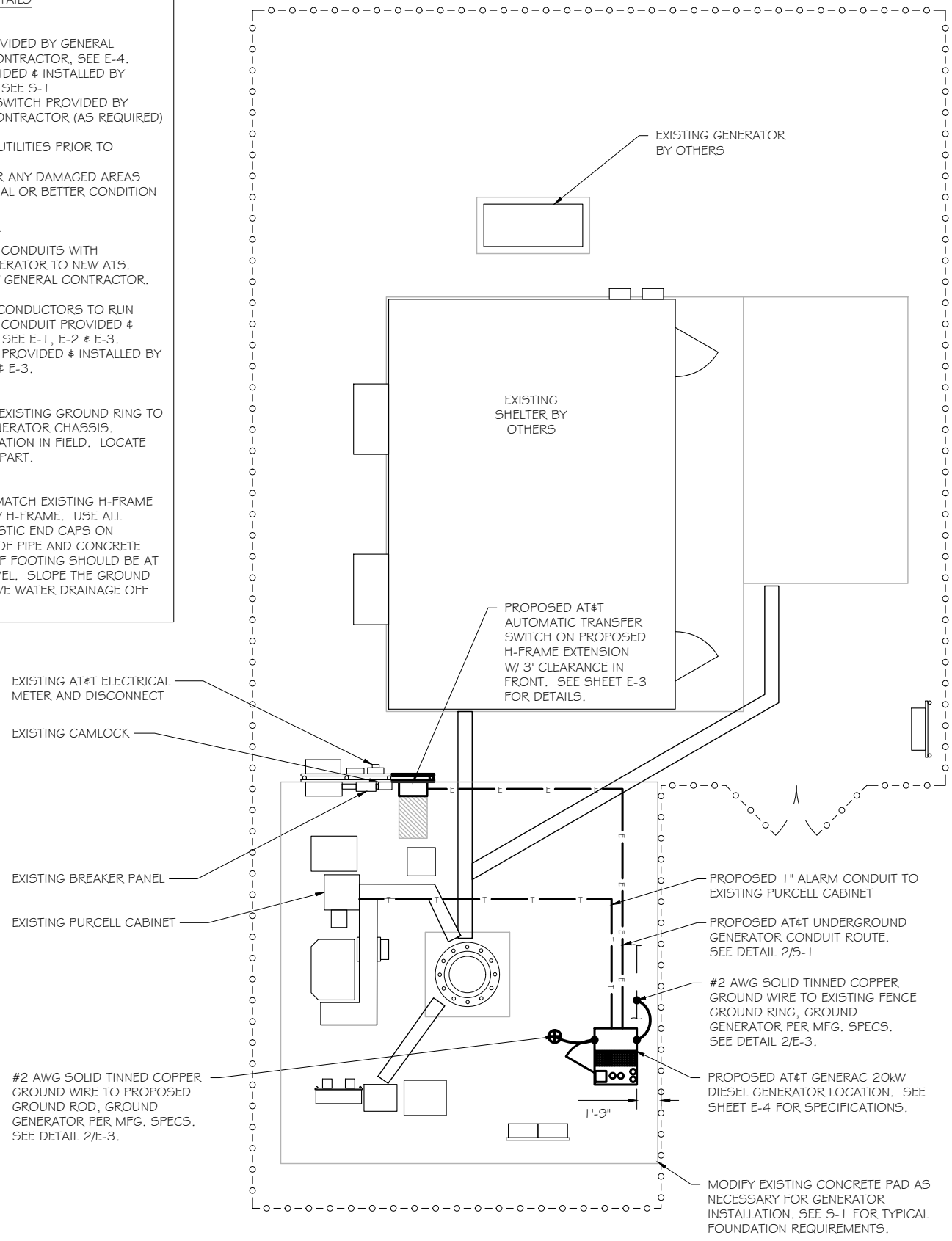

SITE PLAN
 SCALE: 1" = 10'

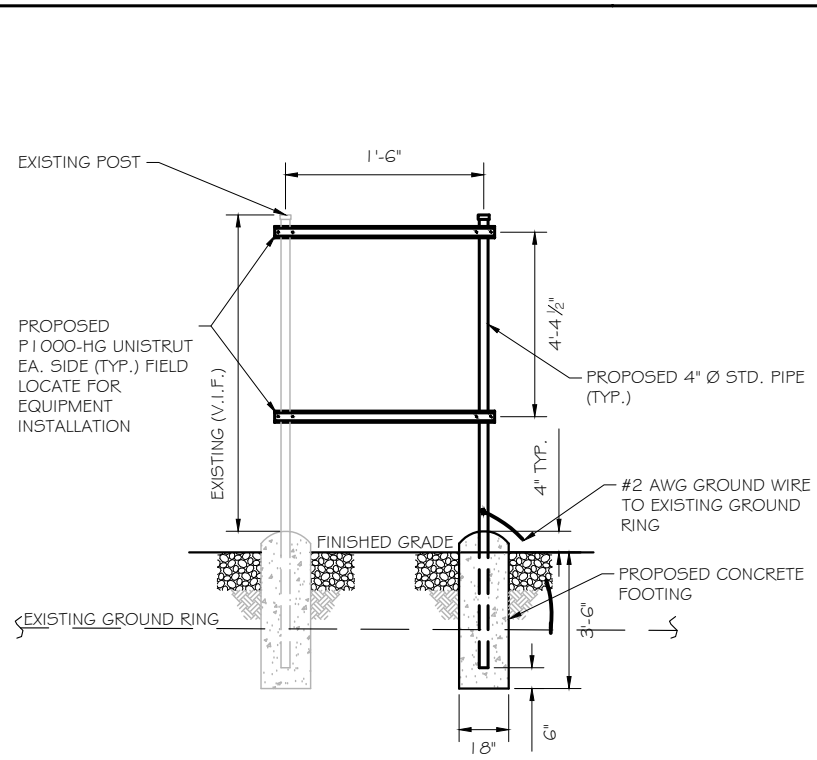

H-FRAME EXTENSION DETAIL
 SCALE: NTS



RAMAKER & ASSOCIATES, INC.
 100% EMPLOYEE-OWNED
 855 Community Dr, Sauk City, WI 53583
 608-643-4100 www.Ramaker.com
 Sauk City, WI • Willmar, MN
 Woodcliff Lake, NJ • Bayamon, PR

PREPARED FOR:

at&t
 Mobility

CONSULTANT:
GENERAL DYNAMICS
 Information Technology, Inc.
 GENERAL DYNAMICS
 661 MOORE RD STE 110
 KING OF PRUSSIA, PA 19406

Certification & Seal:
 I hereby certify that this plan, specification, or report was prepared by me or under my direct supervision and that I am a duly Licensed Professional Engineer under the laws of the State of Connecticut.



Signature: *James R. Skowronski* Date: 3/12/2020

MARK	DATE	REVISIONS	DESCRIPTION
1	3/12/20	REVISED CD's	

ISSUE PHASE: FINAL DATE ISSUED: 02/24/2020

PROJECT TITLE:
DURHAM CENTRAL
 FA ID # 10071003

PROJECT INFORMATION:
 143 R OLD BLUE HILLS ROAD
 DURHAM, CT 06422

SHEET TITLE:
 SITE PLAN

0 5' 10' 20'

11" x 17" - 1" = 10'
 22" x 34" - 1" = 5'

PROJECT NUMBER: 45808
 SHEET NUMBER: A-1

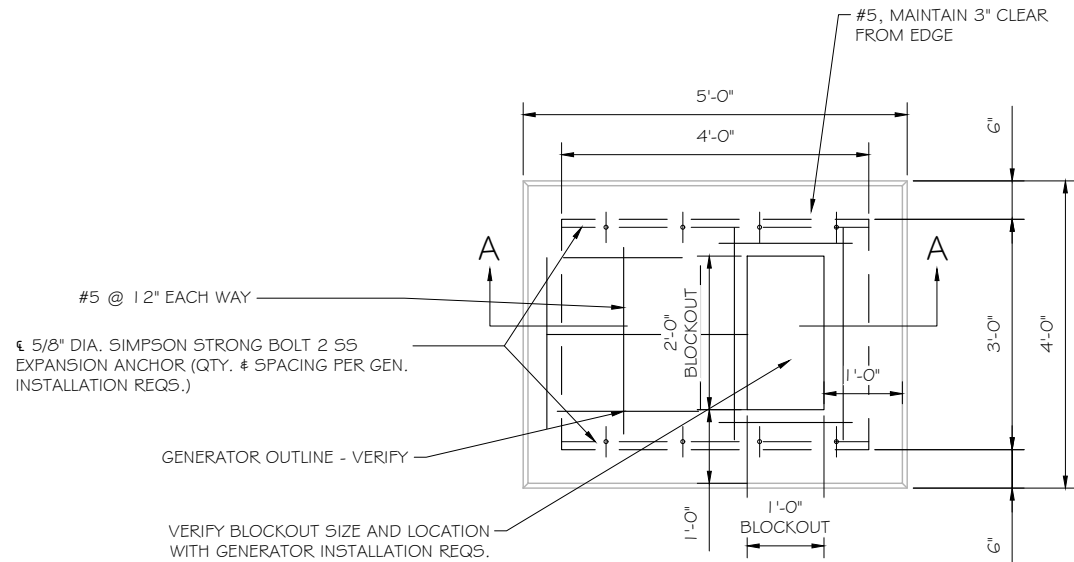

TYPICAL FOUNDATION PLAN (1)
 SCALE: NTS

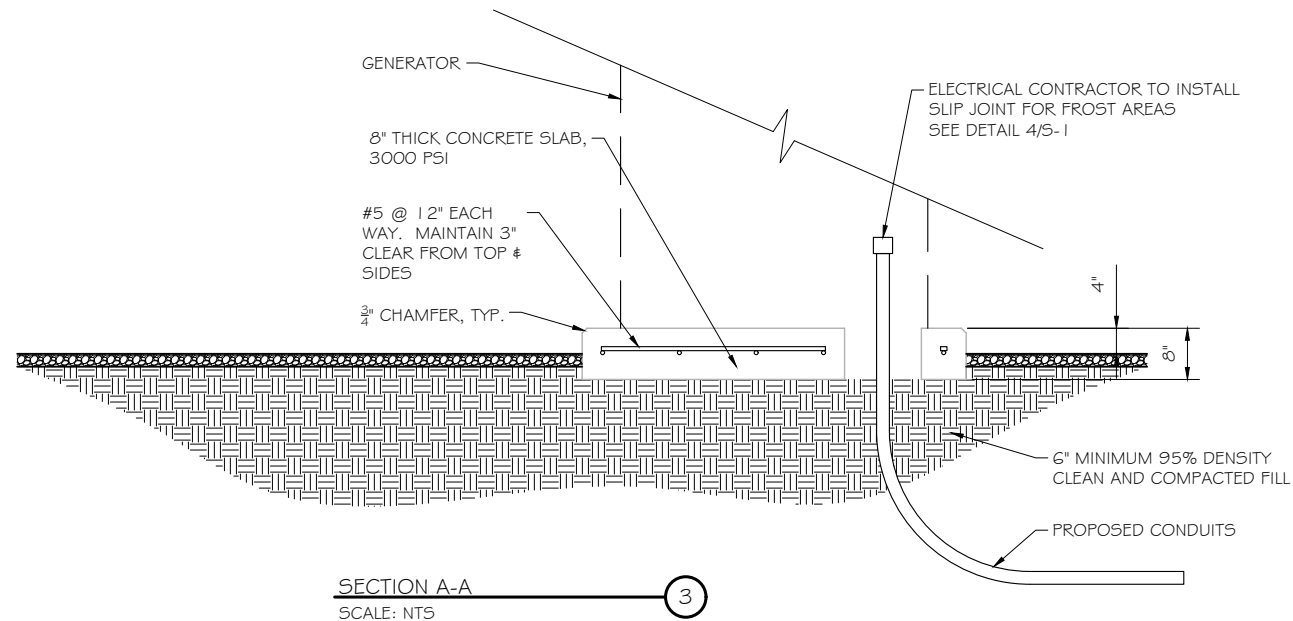

SECTION A-A (3)
 SCALE: NTS

DOUBLE WALL FUEL TANK BASE SPECIFICATION

REF: ATT 30KW GENERATOR PACKAGE
 UL REGISTRATION NUMBER: MH18459
 U.L. 142 DOUBLE WALL FUEL TANK BASE SPECIFICATION
 FUEL TANK BASE CONSTRUCTION:

- BE CONSTRUCTED IN ACCORDANCE WITH UNDERWRITERS LABORATORIES STANDARD UL-142. BE CONSTRUCTED IN ACCORDANCE WITH FLAMMABLE & COMBUSTIBLE LIQUIDS CODE, NFPA 30; THE STANDARD FOR INSTALLATION & USE OF STATIONARY COMBUSTIBLE ENGINE & GAS TURBINES, NFPA 37; AND THE STANDARD FOR EMERGENCY & STANDBY POWER SYSTEMS, NFPA 110.
- ANCHORS MINIMUM (4) @ 5/8" FOR GEN-SET MOUNTING
- SUB BASE TANK TESTING: PRIMARY TANK & SECONDARY CONTAINMENT BASIN SECTIONS SHALL BE PRESSURIZED AT 3-5 PSI AND LEAK-CHECKED TO ENSURE INTEGRITY OF SUB BASE WELD SEAMS PER UL-142 STANDARDS
- FUEL FILL: 5 GALLON SPILL CONTAINMENT WITH ALARM
 - 40% REMAINING FOR ALARM
 - 20% REMAINING FOR SHUT-DOWN
- FACTORY PRE-SET AT 95% FULL FOR ALARM
- FUEL CONTAINMENT BASIN: SUB BASE TANK SHALL INCLUDE A WELDED STEEL CONTAINMENT BASIN, SIZED AT A MINIMUM OF 110% OF THE TANK CAPACITY TO PREVENT ESCAPE OF FUEL INTO THE ENVIRONMENT IN THE EVENT OF A TANK RUPTURE. A FUEL CONTAINMENT BASIN LEAK DETECTOR SWITCH SHALL BE PROVIDED.

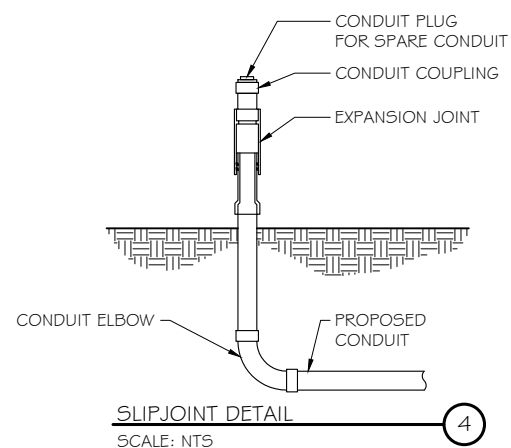

SLIPJOINT DETAIL (4)
 SCALE: NTS

NOTE:

VERIFY WIRE AND CONDUIT QUANTITY & SIZES WITH GENERATOR MAKE & MODEL # PRIOR TO INSTALLATION. VERIFY ELECTRICAL REQUIREMENTS WITH LOCAL UTILITY PROVIDER.

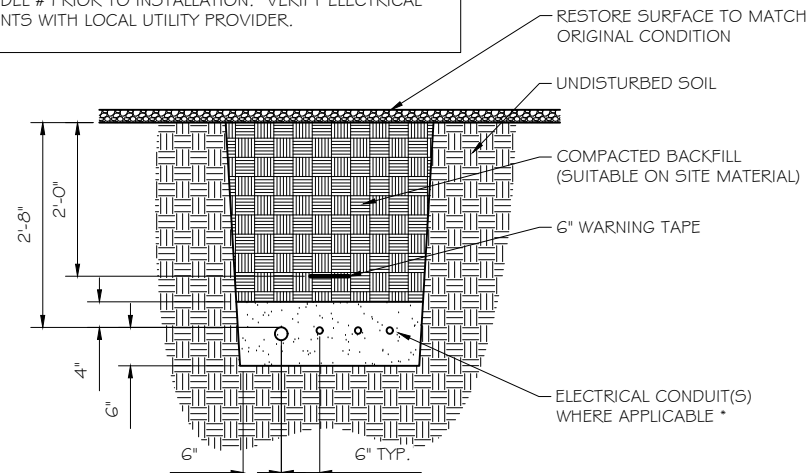

* SEPARATION DIMENSION TO BE VERIFIED WITH LOCAL UTILITY COMPANY REQUIREMENTS

NOTES:

- PROVIDE PVC CONDUIT BELOW GRADE EXCEPT AS NOTED BELOW.
- PROVIDE RGS CONDUIT AND ELBOWS AT STUB UP LOCATIONS (I.E. SERVICE POLE, BTS EQUIPMENT, ETC.)
- INSTALL UTILITY PULLBOXES PER NEC.

UTILITY CONDUIT TRENCH (2)
 SCALE: NTS

NOTE:

-EXISTING CONCRETE PAD TO BE MODIFIED AS REQUIRED.
 -FOUNDATION DETAILS ARE FOR REFERENCE ONLY.

RAMAKER & ASSOCIATES, INC.
 100% EMPLOYEE-OWNED
 855 Community Dr, Sauk City, WI 53583
 608-643-4100 www.Ramaker.com
 Sauk City, WI • Willmar, MN
 Woodcliff Lake, NJ • Bayamon, PR

PREPARED FOR:



CONSULTANT:
GENERAL DYNAMICS
 Information Technology, Inc.
 GENERAL DYNAMICS
 661 MOORE RD STE 110
 KING OF PRUSSIA, PA 19406

Certification & Seal:
 I hereby certify that this plan, specification, or report was prepared by me or under my direct supervision and that I am a duly Licensed Professional Engineer under the laws of the State of Connecticut.

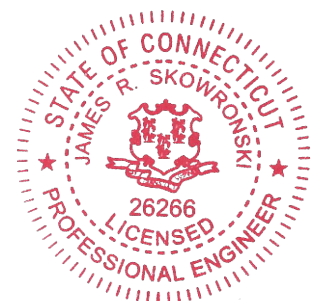

Signature: *James R. Skowronski* Date: 3/12/2020

MARK	DATE	REVISIONS
1	3/12/20	REVISED CD's

ISSUE PHASE: FINAL DATE ISSUED: 02/24/2020
 PROJECT TITLE:
DURHAM CENTRAL
FA ID # 10071003

PROJECT INFORMATION:
 143 R OLD BLUE HILLS ROAD
 DURHAM, CT 06422

SHEET TITLE:
FOUNDATION DETAILS

SCALE: NONE

PROJECT NUMBER: 45808
 SHEET NUMBER: S-1

DIAGRAM CIRCUIT SCHEDULE

NO.	FROM	TO	WIRES	GROUND	CONDUIT SIZE	FUNCTION
1	NORMAL POWER SOURCE	AUTOMATIC TRANSFER SWITCH	(3) 3/0	(1) #4	2"	NORMAL POWER FEEDER TO ATS (CUT BACK EXISTING)
2	AUTOMATIC TRANSFER SWITCH	LOAD CENTER	(3) 3/0	(1) #4	2"	POWER FEEDER FROM ATS TO PANEL
3	GENERATOR	AUTOMATIC TRANSFER SWITCH	(3) #3	(1) #8	1 1/4"	EMERGENCY POWER FEEDER TO ATS
4	AUTOMATIC TRANSFER SWITCH	GENERATOR	(2) #10	(1) #10	1"	START CIRCUIT
5	LOAD CENTER (DISTRIBUTION CENTER)	GENERATOR, ATS	(2) #12 (2) #12 (2) #12	(1) #12 (1) #12 (1) #12	1" 1" 1"	CIRCUIT FOR GENERATOR BLOCK HEATER & BATTERY HEATER CIRCUIT FOR BATTERY CHARGER CIRCUIT FOR ATS
6	GENERATOR	AUTOMATIC TRANSFER SWITCH	1 2-PAIR 24 AWG OR 2EA 6-PAIR CAT5	N/A	1"	ALARM CABLES (1) 1 2 PAIR 24 AWG. PROVIDE 24" OF SLACK CABLE. FINAL PUNCH DOWN IS BY AT&T TECH. LABEL ALL WIRES
7	AUTOMATIC TRANSFER SWITCH	ALARM BLOCK	1 2-PAIR 24 AWG OR 2EA 6-PAIR CAT5	N/A	1"	ALARM CABLES (1) 1 2 PAIR 24 AWG (RUN TO PURCELL CABINET & INTO ALARM BOX). PROVIDE 24" OF SLACK CABLE. FINAL PUNCH DOWN IS BY AT&T TECH. LABEL ALL WIRES

CIRCUIT DETAIL
 SCALE: NTS

1

ALARM WIRE IDENTIFICATION CHART

WIRE	ALARM
BROWN / WHITE	GENERATOR RUNNING
GREEN / WHITE	CRITICAL FAULT
BLUE / WHITE	MINOR FAULT
ORANGE / WHITE	LOW FUEL
BROWN *	FUEL LEAK
BROWN / WHITE *	

*CAT5 CABLE ONLY, FROM 2ND CAT5 CABLE

ALARM WIRING IDENTIFICATION CHART
 SCALE: NTS

2

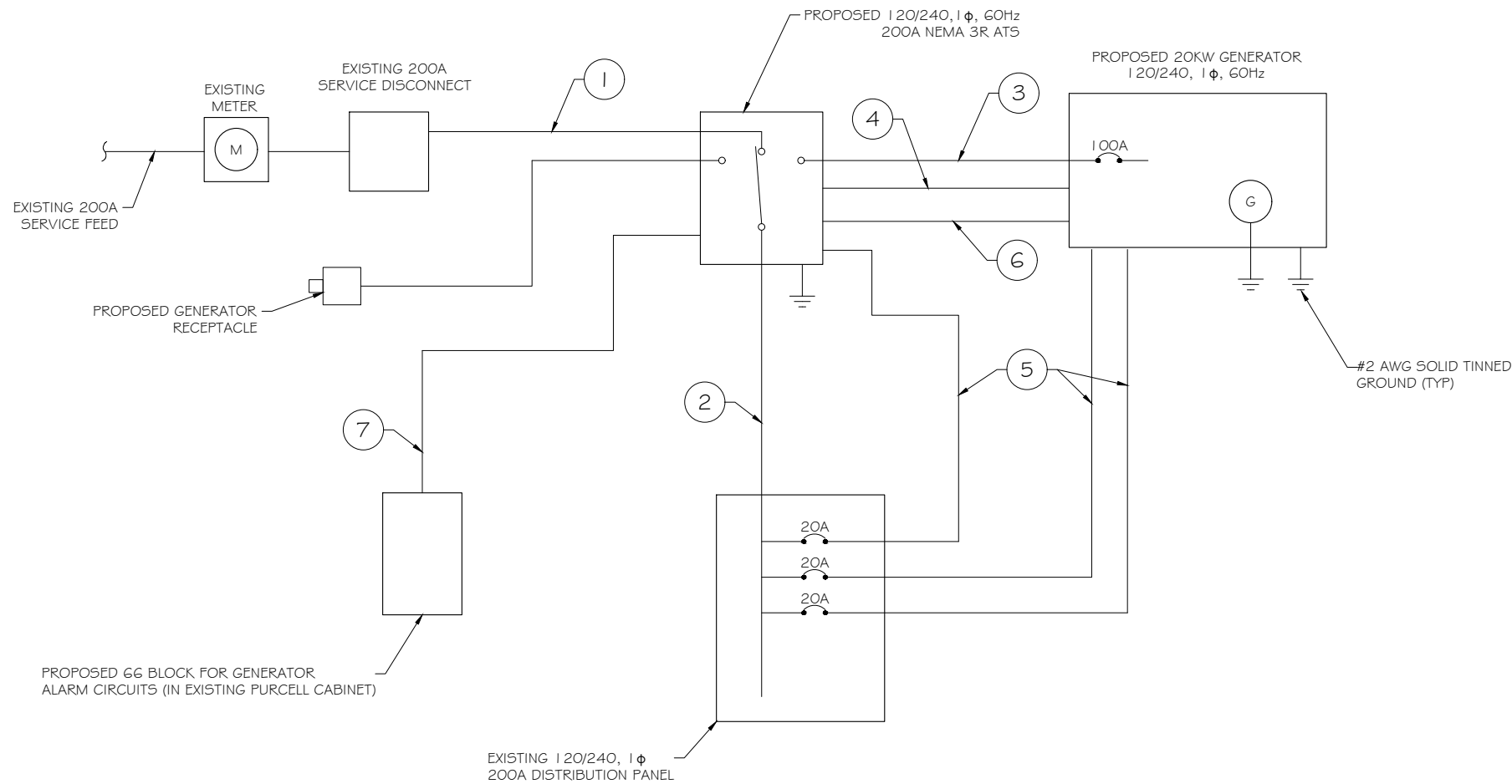

PROPOSED WIRING DIAGRAM
 SCALE: NTS

3

RAMAKER & ASSOCIATES, INC.
 100% EMPLOYEE-OWNED
 855 Community Dr, Sauk City, WI 53583
 608-643-4100 www.Ramaker.com
 Sauk City, WI • Willmar, MN
 Woodcliff Lake, NJ • Bayamon, PR

PREPARED FOR:



CONSULTANT:
GENERAL DYNAMICS
 Information Technology, Inc.
 GENERAL DYNAMICS
 661 MOORE RD STE 110
 KING OF PRUSSIA, PA 19406

Certification & Seal:
 I hereby certify that this plan, specification, or report was prepared by me or under my direct supervision and that I am a duly Licensed Professional Engineer under the laws of the State of Connecticut.



Signature: *James R. Skowronski* Date: 3/12/2020

MARK	DATE	REVISIONS	DESCRIPTION
1	3/12/20	REVISED CD's	

ISSUE PHASE: FINAL DATE ISSUED: 02/24/2020

PROJECT TITLE:
DURHAM CENTRAL
 FA ID # 10071003

PROJECT INFORMATION:
 143 R OLD BLUE HILLS ROAD
 DURHAM, CT 06422

SHEET TITLE:
WIRING DETAILS

SCALE: NONE

PROJECT NUMBER: 45808
 SHEET NUMBER: E-1

U.L. SYSTEM NO. C-AJ-1150
 CONDUIT THROUGH BEARING WALL SIMILAR TO U.L. DESIGN NO. U902
 F RATING = 3 HR
 T RATING = 0 HR

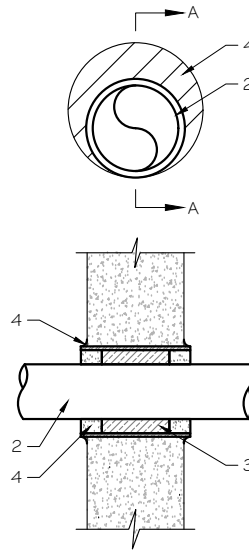

- FLOOR OR WALL ASSEMBLY : MINIMUM 4- 1/2" THICK REINFORCED LIGHTWEIGHT OR NORMAL WEIGHT (100-150 PCF) CONCRETE. WALL MAY ALSO BE CONSTRUCTED OF ANY UL CLASSIFIED CONCRETE BLOCKS*. MAX DIAMETER OF OPENING IS 4". SEE CONCRETE BLOCKS (CATZ) CATEGORY IN THE FIRE RESISTANCE DIRECTORY FOR NAMES OF MANUFACTURERS.
- THROUGH PENETRATIONS : ONE METALLIC PIPE OR CONDUIT TO BE RIGIDLY SUPPORTED ON BOTH SIDES OF FLOOR OR WALL ASSEMBLY. THE ANNULAR SPACE SHALL BE MINIMUM 0". (POINT CONTACT) TO MAXIMUM 1 - 3/8". THE FOLLOWING TYPES AND SIZES OF METALLIC PIPES OR CONDUITS MAY BE USED:
 - STEEL PIPE-NOMINAL 6" DIAMETER (OR SMALLER) SCHEDULE 40 (OR HEAVIER) STEEL PIPE.
 - IRON PIPE-NOMINAL 6" DIAMETER (OR SMALLER) CAST OR DUCTILE IRON PIPE.
 - CONDUIT - NOMINAL 4" DIAMETER (OR SMALLER) STEEL ELECTRICAL METALLIC TUBING OR NOMINAL 3- 1/2" DIAMETER (OR SMALLER) STEEL CONDUIT.
- PACKING MATERIAL: MINIMUM 6" THICKNESS OF MIN 4.0 PCF MINERAL WOOL BATTING INSULATION FIRMLY PACKED INTO OPENING AS A PERMANENT FORM. PACKING MATERIAL TO BE RECESSED FROM TOP SURFACE OF FLOOR OR FROM BOTH SURFACES OF WALL AS REQUIRED TO ACCOMMODATE THE REQUIRED THICKNESS OF FILL MATERIAL.
- FILL, VOID, OR CAVITY MATERIAL*: SEALANT: MINIMUM 1/4" THICKNESS OF FILL MATERIAL APPLIED WITHIN THE ANNULUS, FLUSH WITH TOP SURFACE OF FLOOR AND WITH BOTH SURFACES OF WALL. AT THE POINT CONTACT LOCATION BETWEEN PIPE AND CONCRETE, A MINIMUM 1/2" DIAMETER BEAD OF FILL MATERIAL SHALL BE APPLIED AT THE CONCRETE/PIPE INTERFACE ON THE TOP SURFACE OF FLOOR AND ON BOTH SURFACES OF WALL. W RATING APPLIES ONLY WHEN CP6015 OR CP604 SEALANT IS USED.

HILTI CONSTRUCTION CHEMICALS, DIV OF HILTI INC. : CP6015, CP604, CP606, OR FS-ONE SEALANT.

* BEARING THE UL CLASSIFICATION MARK

EXISTING PANEL SCHEDULE INFORMATION WAS NOT AVAILABLE AT THE TIME OF DRAWING CREATION.

SCOPE OF WORK REQUIRES (3) PROPOSED SINGLE POLE, 20A BREAKERS, ONE EACH FOR CALLOUT NUMBER 5 ON DETAILS 1/E-1 AND 3/E-1. UTILIZE EMPTY OR SPARE SPACES ON EXISTING PANELBOARD IF POSSIBLE.

IF SUFFICIENT SPACES ARE NOT PRESENT IN MAIN PANEL, PROVIDE NEW SUBPANEL FED WITH NEW TWO-POLE, 100A BREAKER IN MAIN PANELBOARD. RELOCATE EXISTING CIRCUITS TO SUBPANEL WHERE REQUIRED. SQUARE D QO LOAD CENTER RECOMMENDED AS NECESSARY.

- NOTE:
- IF EXISTING CONSTRUCTION VARIES FROM THIS DETAIL, AN EQUAL 3-HR U.L. PENETRATION APPROPRIATE FOR THE EXISTING WALL TYPE SHALL BE CONSTRUCTED
 - GC SHALL USE NON-SHRINKING CAULK TO WEATHERSEAL ALL PENETRATIONS INTO OR THRU SHELTER WALL.

OUTER WALL PENETRATION DETAIL
 (IF APPLICABLE)

SCALE: NTS

2

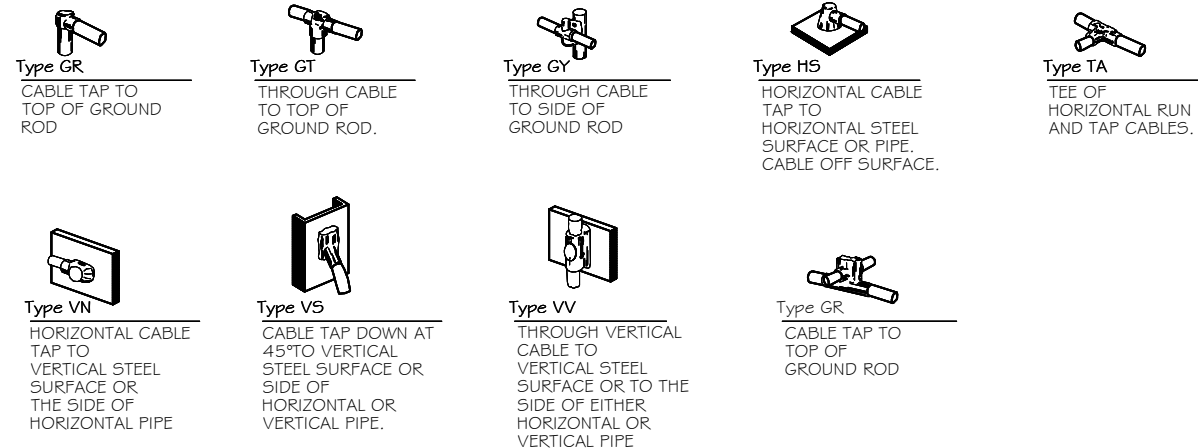

NOTE:
 CONTRACTOR TO LABEL WIRES WITH P-TOUCH OR SIMILAR LABELS ONLY. ABSOLUTELY NO HANDWRITTEN LABELS.

*CONTRACTOR TO UTILIZE NEXT AVAILABLE IN SEQUENCE SINGLE BREAKER POSITION FOR GENERATOR, BATTERY CHARGER, BATTERY HEATER AND BLOCK HEATER

CADWELD DETAILS
 SCALE: NTS

3

RAMAKER & ASSOCIATES, INC.

100% EMPLOYEE-OWNED

855 Community Dr, Sauk City, WI 53583
 608-643-4100 www.Ramaker.com

Sauk City, WI • Willmar, MN
 Woodcliff Lake, NJ • Bayamon, PR

PREPARED FOR:



CONSULTANT:
GENERAL DYNAMICS
 Information Technology, Inc.
 GENERAL DYNAMICS
 661 MOORE RD STE 110
 KING OF PRUSSIA, PA 19406

Certification & Seal:
 I hereby certify that this plan, specification, or report was prepared by me or under my direct supervision and that I am a duly Licensed Professional Engineer under the laws of the State of Connecticut.

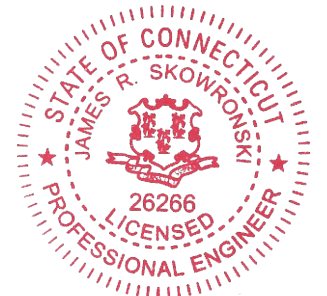

Signature: *James R. Skowronski* Date: 3/12/2020

MARK	DATE	REVISIONS	DESCRIPTION
1	3/12/20	REVISED CDs	
ISSUE PHASE	FINAL	DATE ISSUED	02/24/2020

PROJECT TITLE:
DURHAM CENTRAL
 FA ID # 10071003

PROJECT INFORMATION:
 143 R OLD BLUE HILLS ROAD
 DURHAM, CT 06422

SHEET TITLE:
PANEL AND PENETRATION DETAILS

SCALE: NONE

PROJECT NUMBER: 45808
 SHEET NUMBER: E-2

- 1 CONDUIT (TYP)
- 2 BUTTERFLY CLAMP AS REQUIRED
- 3 EXISTING WALL/CEILING
- 4 VERTICAL "UNISTRUT" P1000 T' SERIES LENGTH BASED ON NUMBER OF CONDUIT TO BE MOUNTED

WALL CONSTRUCTION TYPE	USE
HOLLOW	3/8" DIA. TOGGLE BOLT
HOLLOW, AT STUD	3/8" DIA. LAG SCREW
CONCRETE BLOCK (HOLLOW)	3/8" DIA. HILTI HY-20 WITH SCREEN, MINIMUM EMBEDMENT 2-1/2"
CONCRETE (SOLID)	3/8" DIA. HILTI HY-150 WITH SCREEN, MINIMUM EMBEDMENT 2-1/2"

NOTE: USE GALVANIZED OR STAINLESS STEEL HARDWARE FOR WALL MOUNT & CONNECTIONS OF CHANNELS SPACE UNITS @ 5'-0" O.C. LENGTH OF RUN

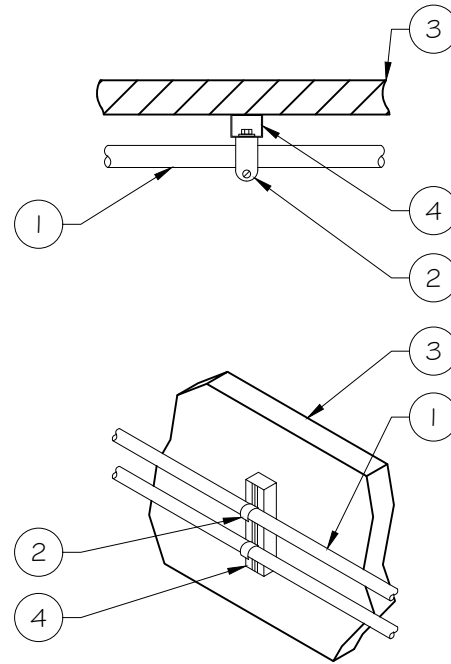

CONDUIT WALL MOUNT
 SCALE: NTS

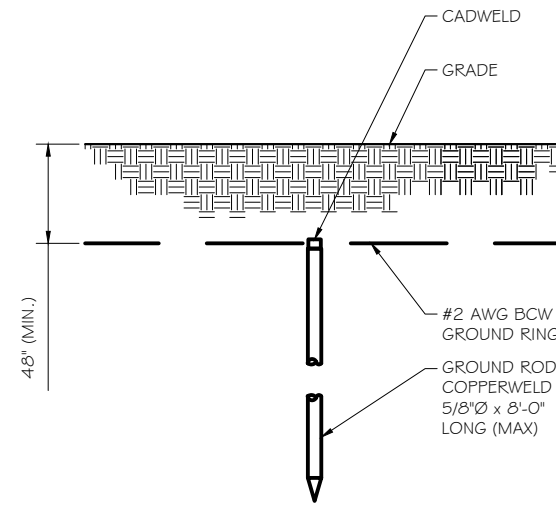

GROUND ROD DETAIL
 SCALE: NTS

- NOTE:
- GROUND RODS MAY BE:
 - COPPER CLAD STEEL
 - SOLID COPPER
 - GROUND RODS SHALL HAVE A MAXIMUM SPACING TWICE THE LENGTH OF ROD
 - SEE RESISTIVITY REPORT FOR VERIFICATION AS AVAILABLE
 - A LARGER CONDUCTOR SHALL BE REQUIRED IN AREAS HIGHLY PRONE TO LIGHTNING AND/OR AREAS WITH HIGHLY ACIDIC SOIL
 - GROUND RODS INSTALLED WITHIN CLOSE PROXIMITY TO TOWER OR WHEN SOIL IS AT OR BELOW 2,000 OHM-CM, SHALL BE GALVANIZED TO PREVENT GALVANIC CORROSION OF TOWER. (SEE ANSI/TIA-EIA-222-G)
 - PROVIDE (1) GROUND LEAD TO EACH SIDE OF THE GENERATOR

WALL CONSTRUCTION TYPE	USE
HOLLOW	3/8" DIA. TOGGLE BOLT
HOLLOW, AT STUD	3/8" DIA. LAG SCREW
CONCRETE BLOCK (HOLLOW)	7/16" DIA. HILTI HY-20 WITH SCREEN MINIMUM EMBEDMENT 2-1/2"
CONCRETE (SOLID)	7/16" DIA. HILTI HY-150 WITH SCREEN MINIMUM EMBEDMENT 2-1/2"

- NOTE:
- USE GALVANIZED OR STAINLESS STEEL HARDWARE FOR WALL MOUNT AND CONNECTION OF CHANNELS
 - GC SHALL USE NON-SHRINKING CAULK TO WEATHER SEAL ALL PENETRATIONS INTO OR THROUGH SHELTER WALL

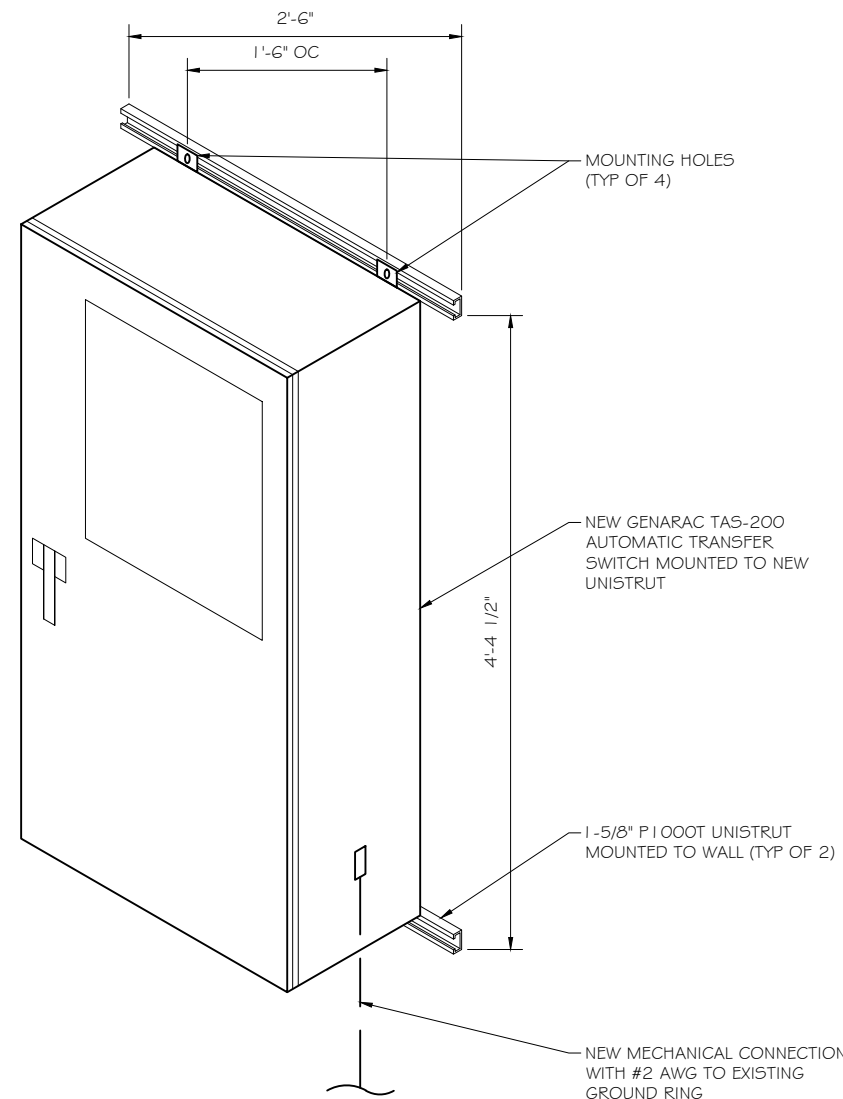

GENERAC ATS MOUNTING DETAIL
 SCALE: NTS

RAMAKER & ASSOCIATES, INC.
 100% EMPLOYEE-OWNED
 855 Community Dr, Sauk City, WI 53583
 608-643-4100 www.Ramaker.com
 Sauk City, WI • Willmar, MN
 Woodcliff Lake, NJ • Bayamon, PR

PREPARED FOR:

CONSULTANT:
GENERAL DYNAMICS
 Information Technology, Inc.
 GENERAL DYNAMICS
 661 MOORE RD STE 110
 KING OF PRUSSIA, PA 19406

Certification & Seal:
 I hereby certify that this plan, specification, or report was prepared by me or under my direct supervision and that I am a duly Licensed Professional Engineer under the laws of the State of Connecticut.

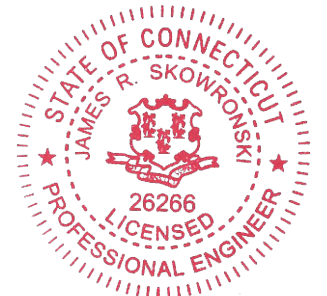

Signature: *James R. Skowronski* Date: 3/12/2020

MARK	DATE	DESCRIPTION
1	3/12/20	REVISED CD's

ISSUE PHASE: FINAL DATE ISSUED: 02/24/2020
 PROJECT TITLE:
DURHAM CENTRAL
FA ID # 10071003

PROJECT INFORMATION:
 143 R OLD BLUE HILLS ROAD
 DURHAM, CT 06422

SHEET TITLE:
ATS, CONDUIT & GROUND ROD
DETAILS

SCALE: NONE

PROJECT NUMBER	45808
SHEET NUMBER	E-3

SDC20 | 2.5L | 20 kW - AC
INDUSTRIAL DIESEL GENERATOR SET

EPA Certified Stationary Emergency



Model G007098-0 (Steel)

Standby Power Rating
 20 kW AC, 60 Hz



Image used for illustration purposes only



Codes and Standards

Generac products are designed to the following standards:

- UL2200, UL508, UL142, UL489
- NFPA 37, 70, 99, 110
- NEMA ICS10, MG1, 250, ICS6, AB1
- ANSI C62.41
- ISO 3046, 7637, 8528, 9001
- NEMA ICS10, MG1, 250, ICS6, AB1
- ANSI C62.41

Powering Ahead

For over 50 years, Generac has provided innovative design and superior manufacturing.

Generac ensures superior quality by designing and manufacturing most of its generator components, including alternators, enclosures and base tanks, control systems and communications software.

Generac gensets utilize a wide variety of options, configurations and arrangements, allowing us to meet the standby power needs of practically every application.

Generac searched globally to ensure the most reliable engines power our generators. We choose only engines that have already been proven in heavy-duty industrial applications under adverse conditions.

Generac is committed to ensuring our customers' service support continues after their generator purchase.

SPEC SHEET

1 of 5

SDC20 | 2.5L | 20 kW - AC
INDUSTRIAL DIESEL GENERATOR SET

EPA Certified Stationary Emergency



Model G007098-0 (Steel)

STANDARD FEATURES

ENGINE SYSTEM

- Oil Drain Extension
- Air Cleaner with Service Indicator
- Fan Guard
- Stainless Steel Flexible Exhaust Connection
- Exhaust Silencer with Drain
- Factory Filled Oil & Coolant

Fuel System

- Primary Fuel Filter

Cooling System

- 120V AC Coolant Heater
- Closed Coolant Recovery System
- UV/Ozone Resistant Hoses
- Factory-Installed Radiator
- 50/50 Ethylene Glycol Antifreeze
- Radiator Drain Extension

Electrical System

- Battery Charging Alternator
- AGM Spill Proof Battery
- Battery Cables
- Sealed/Rubber-Booted Engine Electrical Connections
- Solenoid Activated Starter Motor
- Output Circuit Breaker

CONTROL SYSTEM

- Digital H Control Panel - Dual 4x20 Display
- Programmable Crank Limiter
- 7-Day Programmable Exerciser
- Special Applications Programmable PLC
- RS-232/485 Communications
- All-Phase Sensing Voltage Regulator
- Full System Status
- 2-Wire Start Compatible
- Power Output (kW)
- Power Factor
- kW Hours, Total & Last Run
- Real/Reactive/Apparent Power
- All Phase AC Voltage
- All Phase Currents
- Oil Pressure
- Coolant Temperature
- Coolant Level
- Engine Speed
- Battery Voltage

MODEL OPTIONS

CONTROL SYSTEM

- 21 Light Annunciator- Shipped Loose Kit and Field Installed
- External E-Stop-Shipped Loose Kit and Field Installed

ALTERNATOR SYSTEM

- Class H Insulation Material
- Vented Rotor
- 2/3 Pitch
- Skewed Stator
- Amortisseur Winding
- Brushless Excitation
- Sealed Bearings
- Rotor Dynamically Spin Balanced
- Full Load Capacity Alternator
- Protective Thermal Shutdown

GENERATOR SET

- Single Side Service
- Internal Genset Vibration Isolators
- Separation of Circuits- High/Low Voltage
- Silencer Heat Shield
- High Heat Wrapped Exhaust Piping
- Silencer Enclosed Within Generator
- 5 Year Extended Warranty
- Extended Factory Testing
- 12 Gallon System Spill Containment
- 2.5 Gallon Fuel Fill Spill Containment

Alarms

- Frequency
- Date/Time Fault History (Event Log)
- Isochronous Governor Control
- Waterproof/Sealed Connectors
- Audible Alarms and Shutdowns
- Not in Auto (Flashing Light)
- Auto/Off/Manual Switch
- E-Stop (Red Mushroom-Type)
- NFPA110 Level I and II (Programmable)
- Customizable Alarms, Warnings, and Events
- Modbus protocol
- Predictive Maintenance Algorithm
- Sealed Boards
- Password Parameter Adjustment Protection
- Single Point Ground Connections
- 15 Channel Data Logging
- 0.2 msec High Speed Data Logging
- Alarm Information Automatically Comes Up On the Display

ENCLOSURE

- Aluminum Enclosure
- Extreme Cold Weather Kit - Shipped Loose Kit and Field Installed

ENCLOSURE

- Serviceable Items Accessible Though Lift-Off Door
- High Performance Sound-Absorbing Material
- Gasketed Door
- Stamped Air-Intake Louvers
- Single Door Latch Lockable with Key & Padlock
- Rhino Coat™ - Textured Polyester Powder Coat
- 150 MPH Wind Rating
- 36" Snow Rating

FUEL TANK

- UL 142 Compliant
- Double Wall Construction
- Factory Pressure Tested (5 psi)
- Rupture Basin Alarm
- Fuel Level Gauge and Sender
- Check Valve in Supply Line
- Rhino Coat™ - Textured Polyester Powder Coat
- Stainless Steel Hardware
- Integrated Fork Pockets

TANKS

- External Fuel Vent- Shipped Loose Kit and Field Installed



100% EMPLOYEE-OWNED

855 Community Dr, Sauk City, WI 53583

608-643-4100 www.Ramaker.com

Sauk City, WI • Willmar, MN
 Woodcliff Lake, NJ • Bayamon, PR

PREPARED FOR:



CONSULTANT:
GENERAL DYNAMICS
 Information Technology, Inc.

GENERAL DYNAMICS
 661 MOORE RD STE 110
 KING OF PRUSSIA, PA 19406

Certification & Seal:
 I hereby certify that this plan, specification, or report was prepared by me or under my direct supervision and that I am a duly Licensed Professional Engineer under the laws of the State of Connecticut.

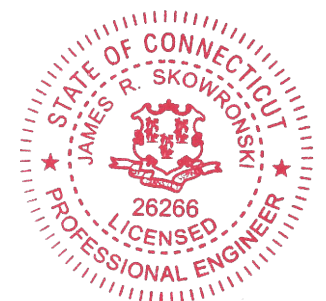

Signature: *James R. Skowronski* Date: 3/12/2020

MARK	DATE	DESCRIPTION
1	3/12/20	REVISED CD's
ISSUE PHASE	FINAL	DATE ISSUED 02/24/2020

PROJECT TITLE:
DURHAM CENTRAL
FA ID # 10071003

PROJECT INFORMATION:
 143 R OLD BLUE HILLS ROAD
 DURHAM, CT 06422

SHEET TITLE:
GENERAC 20KW GENERATOR
SPECIFICATIONS

SCALE: NONE

PROJECT NUMBER: 45808
 SHEET NUMBER: E-4

SPEC SHEET

2 of 5

SDC20 | 2.5L | 20 kW - AC
INDUSTRIAL DIESEL GENERATOR SET

EPA Certified Stationary Emergency

APPLICATION AND ENGINEERING DATA

ENGINE SPECIFICATIONS

General	
Make	Mitsubishi
EPA Emissions Compliance	Interim Tier 4
Cylinder #	4
Type	In-Line
Displacement - L (Cu In)	2.5 (158)
Bore - mm (in)	88 (3.5)
Stroke - mm (in)	103 (4.1)
Compression Ratio	22:1
Intake Air Method	Naturally Aspirated
Engine Governing	
Governor	Electronic Isochronous
Frequency Regulation (Steady State)	± 0.25%
Lubrication System	
Oil Pump Type	Trochoid Gear Pump
Oil Filter Type	Filtering Paper, Full Flow
Crankcase Capacity - L (qts)	6.5 (6.9)

ALTERNATOR SPECIFICATIONS

Standard Model	Mecc Alte ECP 28-2L/4
Poles	4
Field Type	Revolving
Insulation Class - Rotor	H
Insulation Class - Stator	H
Total Harmonic Distortion	<5%
Telephone Interference Factor (TIF)	<45
Standard Excitation	Brushless

RATING DEFINITIONS

Standby - Applicable for a varying emergency load for the duration of a utility power outage with no overload capability.

GENERAC INDUSTRIAL POWER

Model G007098-0 (Steel)

Cooling System	
Cooling System Type	Forced Circulation
Water Pump Type	Centrifugal Pump
Fan Type	Pusher
Fan Speed (rpm)	2100
Fan Diameter - mm (in)	431.8 (17)
Coolant Heater Wattage	1000
Coolant Heater Voltage	120
Fuel System	
Fuel Type	Ultra Low Sulfur Diesel #2
Fuel Specifications	ASTM
Fuel Filtering (microns)	6
Fuel Inject Pump Make	Bosch
Injector Type	Engine Driven Gear
Engine Type	Diesel
Fuel Supply Line - mm (in.)	6.6 (0.26)
Engine Electrical System	
System Voltage	12 VDC
Battery Charger Alternator	12V-50A
Battery Size	650 CCA
Battery Group	35
Battery Voltage	12 VDC
Ground Polarity	Negative

Bearings	Dual Sealed
Coupling	Belt, Pulley
Load Capacity - Standby	100%
Prototype Short Circuit Test	Yes
Voltage Regulator Type	Digital
Number of Sensed Phases	All
Regulation Accuracy (Steady State)	±0.5%

SPEC SHEET

3 of 5

SDC20 | 2.5L | 20 kW - AC
INDUSTRIAL DIESEL GENERATOR SET

EPA Certified Stationary Emergency

OPERATING DATA

POWER RATINGS

Single-Phase 120/240 VAC @1.0pf	20 kW	Amps: 83
Circuit Breaker Size	100A	

FUEL CONSUMPTION RATES*

Diesel - gph (lph)		
Percent Load	Standby	
25%	0.74 (2.80)	
50%	0.99 (3.75)	
75%	1.41 (5.30)	
100%	1.90 (7.19)	

* Fuel supply installation must accommodate fuel consumption rates at 100% load.

COOLING

Coolant Flow per Minute	gpm (lpm)	Standby
Coolant System Capacity	gal (L)	3.5 (13.2)
Heat Rejection to Coolant	BTU/hr	238,200
Inlet Air	cfm (m ³ /min)	2365 (67)
Max. Operating Ambient Temperature (Before Derate)	°F (°C)	77° (25°)
Maximum Radiator Backpressure	in H ₂ O	0.50

COMBUSTION AIR REQUIREMENTS

Flow at Rated Power cfm (m ³ /min)	Standby
	88 (2.49)

ENGINE

Rated Engine Speed	rpm	Standby
Horsepower at Rated kW**	hp	1800
Piston Speed	ft/min	33.5
BMEP	psi	1220.47
		96.5

EXHAUST

Exhaust Flow (Rated Output)	cfm (m ³ /min)	Standby
Max. Backpressure (Post Silencer)	inHg (kPa)	193 (328)
Exhaust Temp (Rated Output - Post Silencer)	°F (°C)	1.38 (4.67)
		928 (497.7)

** Refer to "Emissions Data Sheet" for maximum bHP for EPA and SCAQMD permitting purposes.

Deration - Operational characteristics consider maximum ambient conditions. Derate factors may apply under atypical site conditions. Please consult a Generac Power Systems Industrial Dealer for additional details. All performance ratings in accordance with ISO3046, BS5514, ISO8528 and DIN6271 standards.

SPEC SHEET

4 of 5

GENERAC 20KW GENERATOR
SPECIFICATIONS
SCALE: NTS



RAMAKER & ASSOCIATES, INC.

100% EMPLOYEE-OWNED

855 Community Dr, Sauk City, WI 53583
608-643-4100 www.Ramaker.com
Sauk City, WI • Willmar, MN
Woodcliff Lake, NJ • Bayamon, PR

PREPARED FOR:



CONSULTANT:
GENERAL DYNAMICS
Information Technology, Inc.
GENERAL DYNAMICS
661 MOORE RD STE 110
KING OF PRUSSIA, PA 19406

Certification & Seal:
I hereby certify that this plan, specification, or report was prepared by me or under my direct supervision and that I am a duly Licensed Professional Engineer under the laws of the State of Connecticut.

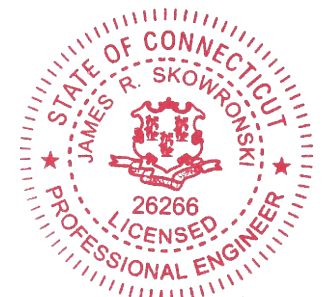

Signature: *James R. Skowronski* Date: 3/12/2020

MARK	DATE	REVISED CD's
1	3/12/20	

ISSUE PHASE: FINAL DATE ISSUED: 02/24/2020

PROJECT TITLE:
DURHAM CENTRAL
FA ID # 10071003

PROJECT INFORMATION:
143 R OLD BLUE HILLS ROAD
DURHAM, CT 06422

SHEET TITLE:
GENERAC 20KW GENERATOR
SPECIFICATIONS

SCALE: NONE

PROJECT NUMBER: 45808
SHEET NUMBER: E-4.1

SDC20 | 2.5L | 20 kW - AC
INDUSTRIAL DIESEL GENERATOR SET

EPA Certified Stationary Emergency

DIMENSIONS AND WEIGHTS*



Model G007098-0 (Steel)

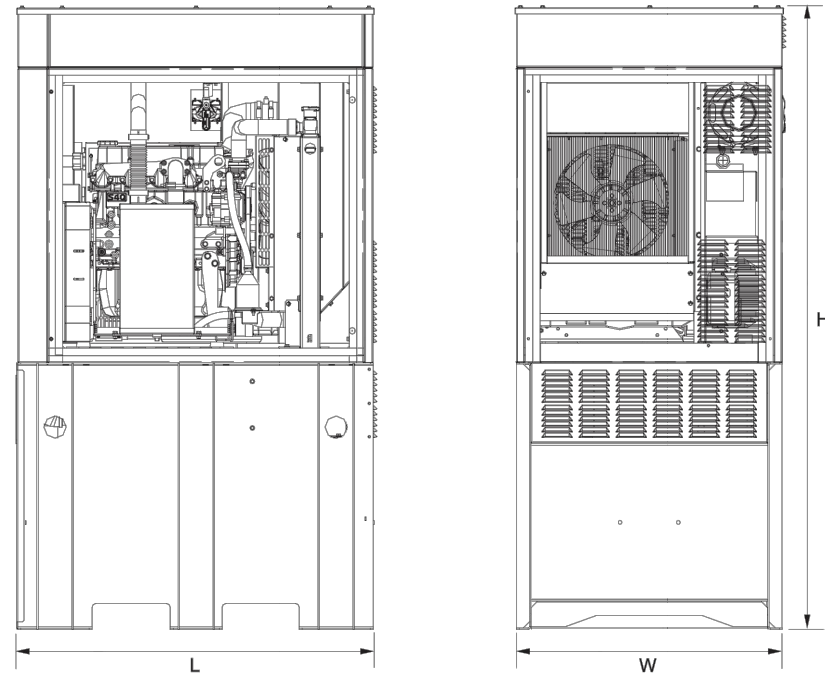

Level 2 Sound Attenuation Enclosure

Run Time Hours	48
Usable Capacity Gal (L)	92 (348.2)
L x W x H in (mm)	48 x 36 x 90 (1219.2 x 914.4 x 2286)
Weight lbs (kg)	2400 (1089)
Sound Level	71 dBA

* All measurements are approximate and for estimation purposes only.

YOUR FACTORY RECOGNIZED GENERAC INDUSTRIAL DEALER

Specification characteristics may change without notice. Dimensions and weights are for preliminary purposes only. Please consult a Generac Power Systems Industrial Dealer for detailed installation drawings.

Generac Power Systems, Inc. | P.O.Box 8 | Waukesha, WI 53189
 P: (262) 544-4811 ©2016 Generac Power Systems, Inc. All rights reserved. All specifications are subject to change without notice.

Document No. 1000009019
 Rev. WIP 11/04/16

GENERAC 20KW GENERATOR SPECIFICATIONS
 SCALE: NTS

SPEC SHEET

5 of 5

SDC20 | 2.5L | 20 kW - AC
INDUSTRIAL DIESEL GENERATOR SET

EPA Certified Stationary Emergency



Model G007098-0 (Steel)

RAMAKER & ASSOCIATES, INC.

100% EMPLOYEE-OWNED

855 Community Dr, Sauk City, WI 53583
 608-643-4100 www.Ramaker.com

Sauk City, WI • Willmar, MN
 Woodcliff Lake, NJ • Bayamon, PR

PREPARED FOR:



CONSULTANT:
GENERAL DYNAMICS
 Information Technology, Inc.
 GENERAL DYNAMICS
 661 MOORE RD STE 110
 KING OF PRUSSIA, PA 19406

Certification & Seal:
 I hereby certify that this plan, specification, or report was prepared by me or under my direct supervision and that I am a duly Licensed Professional Engineer under the laws of the State of Connecticut.

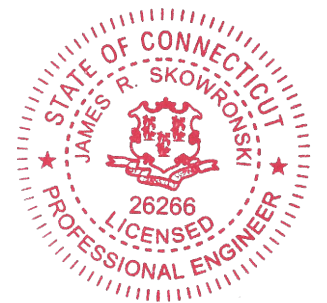

James R. Skowronski 3/12/2020
 Signature: Date:

MARK	DATE	DESCRIPTION
1	3/12/20	REVISED CD's
ISSUE PHASE	FINAL	DATE ISSUED 02/24/2020

PROJECT TITLE:
DURHAM CENTRAL
FA ID # 10071003

PROJECT INFORMATION:
 143 R OLD BLUE HILLS ROAD
 DURHAM, CT 06422

SHEET TITLE:
GENERAC 20KW GENERATOR SPECIFICATIONS

SCALE: NONE

PROJECT NUMBER 45808
 SHEET NUMBER E-4.2

SPEC SHEET

6 of 5

**TTS Series
Switches**
**200 Amps
600 VAC**

GENERAC | **INDUSTRIAL
POWER**

TAS200
200A Automatic Transfer Switch

TAS200
TAS200
1 of 3 2 of 3

The Generac TAS200 Automatic Transfer Switch

- Flexibility for multiple application installations
- Multiple generator support with 3 source panel
- Designed with a 6 inch touch screen controller for improved user interface
- Camlock functionality for mobile generator sources



Image used for illustration purposes only.

Features

- **STEEL CONSTRUCTION**
- **NEMA 3R ENCLOSURE WITH HINGED "PADLOCKING" DOORS**
- **STAINLESS STEEL HARDWARE**
- **CAMLOCK "QUICK CONNECT" CAPABILITY**
- **OPERATIONAL STATUS VIEW VIA 6 INCH TOUCH SCREEN**
- **TEST FUNCTION - FAST TEST & NORMAL TEST**
- **UL1008 LISTED - FOR EMERGENCY SYSTEMS**

Optional Features

- **EXTENDED WARRANTY**
- **THREE-PHASE VOLTAGE CONFIGURATIONS**

Codes and Standards

Generac products are designed to the following standards:



UL1008,
UL508,
UL50,
CSA C22.2 No. 178



NEC 700, 701 and 702



NEMA 250

Application and Engineering Data

Cabinet Specifications	
Dimensions	24"W x 12"D x 48"H
Weight	210 lbs.
Construction	Single Chamber with Main Door
	Steel
	UL Type / NEMA 3R Rated
	Powder Coat Finish for Corrosion Resistance
	C-UL-US Listed - Automatic Transfer Switch
	Stainless Steel Hardware
Mounting Options	3-Point Latching System with Pad-Lockable Handles
	Wall
Installed	H-frame
	Pre-wired alarm terminal strip

Electrical Specifications	
Voltage/Phase/Amps	120/240 Single-Phase, 200A 120/208 3-Phase, 200A 120/240 3-Phase, 200A
Breaker	Eaton 200 amp Utility Breaker Eaton 200 amp Generator Breaker
Maximum RMS Symmetrical Fault Current - Amps	25k AIC Rated
Protective Device Continuous Rating (Max) Amp	200
Input to Generator	350MCM - #6 AWG
Output to Site	350MCM - #6 AWG
Generator Annunciator Connector	Deutsch DTM04-12PA-L012
Alarm Terminal Board	Generator Run Alarm
	Generator Fail – Shutdown Alarm
	Generator Fail – Non Shutdown Alarm
	Low Fuel Alarm
	Generator Theft Alarm
	AC Utility Fail Alarm

Camlock Component	
Camlock Component	Shipped loose for multiple installation options
Dimensions	9" W x 9.4" D x 24.25" H
200A Camlock Generator Connection	Single-Phase: Black L1, Red L2, White-Neutral, Green-Ground
	3-Phase: Black L1, Red L2, Blue L3, White-Neutral, Green-Ground
	Uses 4 CH E1016 Male Connectors
	Mating Connector – CH E1016 Female



RAMAKER
& ASSOCIATES, INC.

100% EMPLOYEE-OWNED
855 Community Dr, Sauk City, WI 53583
608-643-4100 www.Ramaker.com
Sauk City, WI • Willmar, MN
Woodcliff Lake, NJ • Bayamon, PR

PREPARED FOR:



CONSULTANT:
GENERAL DYNAMICS
Information Technology, Inc.
GENERAL DYNAMICS
661 MOORE RD STE 110
KING OF PRUSSIA, PA 19406

Certification & Seal:
I hereby certify that this plan, specification, or report was prepared by me or under my direct supervision and that I am a duly Licensed Professional Engineer under the laws of the State of Connecticut.

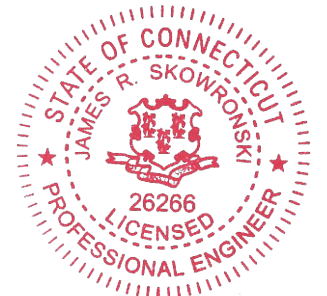

Signature: *James R. Skowronski* Date: 3/12/2020

MARK	DATE	DESCRIPTION
1	3/12/20	REVISED CD's
ISSUE PHASE	FINAL	DATE ISSUED 02/24/2020

PROJECT TITLE:
**DURHAM CENTRAL
FA ID # 10071003**

PROJECT INFORMATION:
143 R OLD BLUE HILLS ROAD
DURHAM, CT 06422

SHEET TITLE:
GENERAC ATS SPECIFICATIONS

SCALE: NONE

PROJECT NUMBER: 45808
SHEET NUMBER: E-5

TTS Control Systems

TAS200

3 of 3

Touch Screen Interface



INDICATORS AND BUTTONS

<ul style="list-style-type: none"> System Ready indicator Standby Operating indicator Utility Available indicator GEN/UTIL Switch Position indicator TVSS status 	<ul style="list-style-type: none"> Normal Test button Fast Test button Return to Normal button Reset button Exercising indicator
---	---

DETAILS SCREEN

<p>System Settings:</p> <ul style="list-style-type: none"> System Voltage/Phases: <ul style="list-style-type: none"> 120/240V single phase (standard) 120/208V three phase (optional) 120/240V three phase (optional) Utility Fail Monitor: <ul style="list-style-type: none"> Under Voltage: 75-95% of nominal voltage Over Voltage: 105%-125% of nominal voltage Pickup (hysteresis): fixed at 5 volts Delay time: 0-60s Utility Interrupt Delay: 0-60s Return to Utility Timer: 1-30 minutes Transfer: <ul style="list-style-type: none"> In-phase, or Time-Delay-Neutral at 0.0-10.0s in 1 second increments 	<p>Exercise Settings:</p> <ul style="list-style-type: none"> Time of day Day of week Exercise: <ul style="list-style-type: none"> Exercise with/without load Exercise once every 1, 2, or 4 weeks. Exercise time-of-day Exercise day of week Exercise duration: 15-30 minutes
	<p>Screen Settings:</p> <ul style="list-style-type: none"> Brightness & Contrast button Screen Calibration button Startup/Clean screen
	<p>Diagnostics:</p> <ul style="list-style-type: none"> Digital I/O bits status Voltage A/D readings
<p>Engine Settings:</p> <ul style="list-style-type: none"> Engine Warm-up timer: 0-20 minutes Generator Load Accept: <ul style="list-style-type: none"> Time-Delay-Neutral at 0.0-10.0s in 1 second increments Voltage: 85-95% of nominal Frequency: 85-95% of nominal Engine Minimum Run Timer: 5-30 minutes Engine Cooldown Timer: 0-20 minutes 	<p>Mimic Diagram:</p> <ul style="list-style-type: none"> System Ready Transfer switch position Utility available Standby available Maintenance/Auto switch position Generator source TS position TVSS status

Generac Power Systems, Inc. • S45 W29290 HWY. 59, Waukesha, WI 53189 • generac.com

©2013 Generac Power Systems, Inc. All rights reserved. All specifications are subject to change without notice. Bulletin 01956705BY-B / Printed in U.S.A. 03/13/13

100% EMPLOYEE-OWNED

855 Community Dr, Sauk City, WI 53583
 608-643-4100 www.Ramaker.com

Sauk City, WI • Willmar, MN
 Woodcliff Lake, NJ • Bayamon, PR

PREPARED FOR:



CONSULTANT:
GENERAL DYNAMICS
 Information Technology, Inc.

GENERAL DYNAMICS
 661 MOORE RD STE 110
 KING OF PRUSSIA, PA 19406

Certification & Seal:
 I hereby certify that this plan, specification, or report was prepared by me or under my direct supervision and that I am a duly Licensed Professional Engineer under the laws of the State of Connecticut.

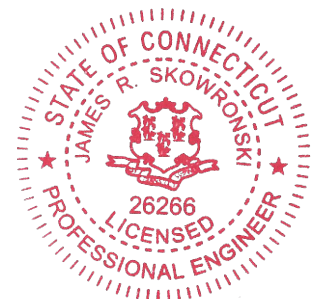

James R. Skowronski 3/12/2020
 Signature: Date:

MARK	DATE	DESCRIPTION
1	3/12/20	REVISED CD's

ISSUE PHASE: FINAL DATE ISSUED: 02/24/2020
 PROJECT TITLE:
**DURHAM CENTRAL
 FA ID # 10071003**

PROJECT INFORMATION:
 143 R OLD BLUE HILLS ROAD
 DURHAM, CT 06422

SHEET TITLE:
GENERAC ATS SPECIFICATIONS

SCALE: NONE

PROJECT NUMBER: 45808
 SHEET NUMBER: E-5.1

Parcel ID	Card	Routing No	Location	Zoning	State Class	Acres
M0162401	1	69 12A	143R OLD BLUE HILLS RD	FR	504 - n/a	2.750

Living Units

0

Owner Information

Bell Atlantic Nynex Behrens
Pmb353
4017 Washington Rd
Mcmurray PA 15317

Deed Information

Book/Page: 0

Deed Date: 1984/08/24

Building Information

Building No: 1

Year Built: 1994

No of Units: 1

Structure Type: Radio/Tv Transmitting Building

Grade: C+

Identical Units: 1

Valuation

Land: \$144,000

Building: \$156,600

Total: \$300,600

Net Assessment: \$210,420

Property Picture



Sales History

Book/Page	Date	Price	Type	Validity
-----------	------	-------	------	----------

Out Building Information

ATTACHMENT 2

DOCKET NO. 161 - An application of Metro Mobile CTS of Hartford Inc., for a Certificate of Environmental Compatibility and Public Need for the construction, maintenance, and operation of a cellular telecommunications facility. The proposed prime site is located off of Old Blue Hills Road approximately 2,000 feet from the end of the improved portion of the road in Durham, Connecticut. The proposed alternate sites are located at 199R Cherry Lane and 100 New Haven Road, Durham, Connecticut.

Connecticut

Siting

Council

March 11, 1994

Decision and Order

Pursuant to the foregoing Findings of Fact, and Opinion, the Connecticut Siting Council (Council) finds that the effects associated with the construction, operation, and maintenance of a cellular telecommunications tower and equipment building at the proposed prime site in Durham, Connecticut, including effects on the natural environment; ecological integrity and balance; public health and safety; scenic, historic, and recreational values; forests and parks; air and water purity; and fish and wildlife are not disproportionate either alone or cumulatively with other effects when compared to need, are not in conflict with the policies of the State concerning such effects, and are not sufficient reason to deny the application and therefore directs that a Certificate of Environmental Compatibility and Public Need as provided by section 16-50k of the Connecticut General Statutes (CGS), be issued to Metro Mobile CTS of Hartford, Inc. (Metro Mobile), for the construction, operation, and maintenance of a cellular telecommunications tower, associated equipment, and building at the proposed prime site located off of Old Blue Hills Road, Durham, Connecticut. We find the effects on scenic resources and adjacent land uses of the alternative sites to be significant, and therefore deny certification of these sites.

The facility shall be constructed, operated, and maintained substantially as specified in the Council's record in this matter, and subject to the following conditions:

1. The self-supporting monopole tower shall be no taller than necessary to provide the proposed communications service and the tower shall not exceed a total height of 113 feet above ground level (AGL), with antennas and appurtenances.
2. The road design and drainage system for improvements on approximately 1,600 feet of the Old Blue Hills Road right-of-way shall be subject to approval by the Town of Durham.

3. The Certificate Holder shall prepare a Development and Management (D&M) plan for this site in compliance with sections 16-50j-75 through 16-50j-77 of the Regulations of State Agencies. The D&M plan shall include detailed plans of the tower, antenna placement on the tower including entities sharing tower space, tower foundation, equipment building, access road, utility connection, security fence, and erosion and sedimentation controls consistent with the Connecticut Guidelines for Soil Erosion and Sedimentation Control (as amended).
4. The Certificate Holder shall make provision for a Phase I archaeological reconnaissance survey, subject to the consent of the landowner, at the Merwin Cave site, due within six months after the commencement of construction. A final report of this survey shall be provided to the Council upon completion. The Certificate Holder shall not be liable for any site protection, collection and exhibition of artifacts, or other actions beyond a Phase I reconnaissance survey.
5. The Certificate Holder shall comply with any existing and future radio frequency (RF) standard promulgated by State or federal regulatory agencies. Upon the establishment of any new governmental RF standards, the facility granted herein shall be brought into compliance with such standards.
6. The Certificate Holder shall provide the Council a recalculated report of electromagnetic radio frequency power density if and when circumstances in operation cause a change in power density above the levels originally calculated and provided in the application.
7. The Certificate Holder shall permit public or private entities to share space on the proposed tower for fair consideration, or shall provide any requesting entity with specific legal, technical, environmental, or economic reasons precluding such tower sharing.
8. If the facility does not initially provide, or permanently ceases to provide cellular or other services following completion of construction, this Decision and Order shall be void, and the Certificate holder shall dismantle the tower and remove all associated equipment or reapplication for any continued or new use shall be made to the Council before any such use is made.
9. Unless otherwise approved by the Council, this Decision and Order shall be void if all construction authorized herein is not completed within three years of the effective date of this Decision and Order or within three years after all appeals to this Decision and Order have been resolved.

Pursuant to CGS section 16-50p, we hereby direct that a copy of the Findings of Fact, Opinion, and Decision and Order be served on each person listed below, and notice of issuance shall be published in the Hartford Courant and Middletown Press.

By this Decision and Order, the Council disposes of the legal rights, duties, and privileges of each party named or admitted to the proceeding in accordance with section 16-50j-17 of the Regulations of State Agencies.

The parties and intervenors to this proceeding are:

APPLICANT

Metro Mobile CTS of
Hartford, Inc.

ITS REPRESENTATIVES

Metro Mobile CTS of
Hartford, Inc.
20 Alexander Drive
Wallingford, CT 06492
Attn: David S. Malko, P.E.
Manager, Engineering and
Regulatory Services

Robinson & Cole
One Commercial Plaza
Hartford, CT 06103-3597
Attn: Brian C. S. Freeman, Esq.

PARTY

Town of Durham

ITS REPRESENTATIVE

Henry A. Robinson
First Selectman
30 Town House Road
P.O. Box 428
Durham, CT 06422

INTERVENOR

Springwich Cellular
Limited Partnership

ITS REPRESENTATIVE

Peter J. Tyrrell
Senior Attorney
Springwich Cellular
Limited Partnership
227 Church Street
New Haven, CT 06506

CERTIFICATION

The undersigned members of the Connecticut Siting Council (Council) hereby certify that they have heard this case, or read the record thereof, in Docket No. 161 - Certificate of Environmental Compatibility and Public Need for the construction, maintenance, and operation of a cellular telecommunications facility, in Durham, Connecticut, and voted as follows to approve the proposed prime site located off of Old Blue Hills Road:

Council Members

Vote Cast

Mortimer A. Gelston
Chairman

YES

Commissioner Reginald J. Smith
Designee: Gerald J. Heffernan

YES

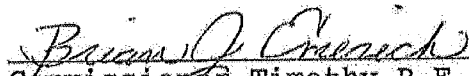
Commissioner Timothy R.E. Keeney
Designee: Brian Emerick

YES

Harry E. Covey

ABSENT

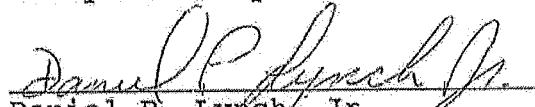
Daniel P. Lynch, Jr.

YES

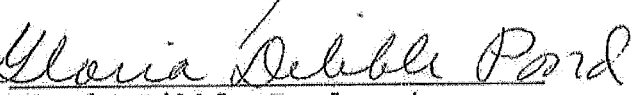
Gloria Dibble Pond

YES

William H. Smith

YES

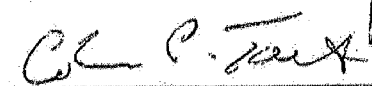
Colin C. Tait

YES

Dana J. Wright

ABSENT

Dated at New Britain, Connecticut, March 11, 1994.
7697E

STATE OF CONNECTICUT)
 :
ss. New Britain, Connecticut
COUNTY OF HARTFORD)

I hereby certify that the foregoing is a true and correct copy of the Findings of Fact, Opinion, and Decision and Order issued by the Connecticut Siting Council, State of Connecticut.

ATTEST:

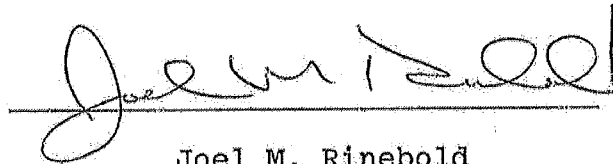

Joel M. Rinebold
Executive Director
Connecticut Siting Council

I certify that a copy of the Findings of Fact, Opinion, and Decision and Order in Docket 161 have been forwarded by Certified First Class Return Receipt Requested mail on March 11, 1994, to all parties and intervenors of record as listed on the attached service list, dated December 7, 1993.

ATTEST:



Stanley J. Modzelesky
Executive Assistant
Connecticut Siting Council

ATTACHMENT 3



Shipment Receipt

Address Information

Ship to:

Laura L. Francis
First Selectwoman
Town of Durham
30 Townhouse Road
DURHAM, CT
06422
US
914-760-1300

Ship from:

Lucia Chiochio, Esq.
Cuddy & Feder LLP
445 Hamilton Avenue
Suite 1400
White Plains, NY
10601
US
9147611300

Shipment Information:

Tracking no.: 770052483206
Ship date: 03/18/2020
Estimated shipping charges: 15.57 USD

Package Information

Pricing option: FedEx Standard Rate
Service type: Priority Overnight
Package type: FedEx Envelope
Number of packages: 1
Total weight: 1 LBS
Declared Value: 0.00 USD
Special Services:
Pickup/Drop-off: Use an already scheduled pickup at my location

Billing Information:

Bill transportation to: CuddyFeder-963
Your reference: 1844-3530
P.O. no.:
Invoice no.:
Department no.:

Thank you for shipping online with FedEx ShipManager at fedex.com.

Please Note

FedEx will not be responsible for any claim in excess of \$100 per package, whether the result of loss, damage, delay, non-delivery, misdelivery, or misinformation, unless you declare a higher value, pay an additional charge, document your actual loss and file a timely claim. Limitations found in the current FedEx Service Guide apply. Your right to recover from FedEx for any loss, including intrinsic value of the package, loss of sales, income interest, profit, attorney's fees, costs, and other forms of damage whether direct, incidental, consequential, or special is limited to the greater of \$100 or the authorized declared value. Recovery cannot exceed actual documented loss. Maximum for items of extraordinary value is \$1000, e.g., jewelry, precious metals, negotiable instruments and other items listed in our Service Guide. Written claims must be filed within strict time limits; Consult the applicable FedEx Service Guide for details.

The estimated shipping charge may be different than the actual charges for your shipment. Differences may occur based on actual weight, dimensions, and other factors. Consult the applicable [FedEx Service Guide](#) or the FedEx Rate Sheets for details on how shipping charges are calculated.



Shipment Receipt

Address Information

Ship to:

Robin Newton, Town Planner
Town of Durham
30 Town House Road

DURHAM, CT
06422
US
914-761-1300

Ship from:

Lucia Chiocchio, Esq.
Cuddy & Feder LLP
445 Hamilton Avenue
Suite 1400

White Plains, NY
10601
US
9147611300

Shipment Information:

Tracking no.: 770054348465

Ship date: 03/18/2020

Estimated shipping charges: 13.40 USD

Package Information

Pricing option: FedEx Standard Rate

Service type: FedEx Express Saver

Package type: FedEx Envelope

Number of packages: 1

Total weight: 1 LBS

Declared Value: 0.00 USD

Special Services:

Pickup/Drop-off: Use an already scheduled pickup at my location

Billing Information:

Bill transportation to: CuddyFeder-963

Your reference: 1844-3530

P.O. no.:

Invoice no.:

Department no.:

Thank you for shipping online with FedEx ShipManager at fedex.com.

Please Note

FedEx will not be responsible for any claim in excess of \$100 per package, whether the result of loss, damage, delay, non-delivery, misdelivery, or misinformation, unless you declare a higher value, pay an additional charge, document your actual loss and file a timely claim. Limitations found in the current FedEx Service Guide apply. Your right to recover from FedEx for any loss, including intrinsic value of the package, loss of sales, income interest, profit, attorney's fees, costs, and other forms of damage whether direct, incidental, consequential, or special is limited to the greater of \$100 or the authorized declared value. Recovery cannot exceed actual documented loss. Maximum for items of extraordinary value is \$1000, e.g., jewelry, precious metals, negotiable instruments and other items listed in our Service Guide. Written claims must be filed within strict time limits; Consult the applicable FedEx Service Guide for details.

The estimated shipping charge may be different than the actual charges for your shipment. Differences may occur based on actual weight, dimensions, and other factors. Consult the applicable [FedEx Service Guide](#) or the FedEx Rate Sheets for details on how shipping charges are calculated.



Shipment Receipt

Address Information

Ship to:

Crown Castle
2000 Corporate Drive
CANONSBURG, PA
15317
US
914-760-1300

Ship from:

Lucia Chiochio, Esq.
Cuddy & Feder LLP
445 Hamilton Avenue
Suite 1400
White Plains, NY
10601
US
9147611300

Shipment Information:

Tracking no.: 770052505811
Ship date: 03/18/2020
Estimated shipping charges: 13.11 USD

Package Information

Pricing option: FedEx Standard Rate
Service type: Priority Overnight
Package type: FedEx Envelope
Number of packages: 1
Total weight: 1 LBS
Declared Value: 0.00 USD
Special Services:
Pickup/Drop-off: Use an already scheduled pickup at my location

Billing Information:

Bill transportation to: CuddyFeder-963
Your reference: 1844-3530
P.O. no.:
Invoice no.:
Department no.:

Thank you for shipping online with FedEx ShipManager at fedex.com.

Please Note

FedEx will not be responsible for any claim in excess of \$100 per package, whether the result of loss, damage, delay, non-delivery, misdelivery, or misinformation, unless you declare a higher value, pay an additional charge, document your actual loss and file a timely claim. Limitations found in the current FedEx Service Guide apply. Your right to recover from FedEx for any loss, including intrinsic value of the package, loss of sales, income interest, profit, attorney's fees, costs, and other forms of damage whether direct, incidental, consequential, or special is limited to the greater of \$100 or the authorized declared value. Recovery cannot exceed actual documented loss. Maximum for items of extraordinary value is \$1000, e.g., jewelry, precious metals, negotiable instruments and other items listed in our Service Guide. Written claims must be filed within strict time limits; Consult the applicable FedEx Service Guide for details.

The estimated shipping charge may be different than the actual charges for your shipment. Differences may occur based on actual weight, dimensions, and other factors. Consult the applicable [FedEx Service Guide](#) or the FedEx Rate Sheets for details on how shipping charges are calculated.



Shipment Receipt

Address Information

Ship to:

Bell Atlantic Nynex Behrens
Bell Atlantic Nynex Behrens
pmb353
4017 Washington Rd
MC MURRAY, PA
15317
US
914-760-1300

Ship from:

Lucia Chiochio, Esq.
Cuddy & Feder LLP
445 Hamilton Avenue
Suite 1400
White Plains, NY
10601
US
9147611300

Shipment Information:

Tracking no.: 770052587362

Ship date: 03/18/2020

Estimated shipping charges: 13.11 USD

Package Information

Pricing option: FedEx Standard Rate

Service type: Priority Overnight

Package type: FedEx Envelope

Number of packages: 1

Total weight: 1 LBS

Declared Value: 0.00 USD

Special Services:

Pickup/Drop-off: Use an already scheduled pickup at my location

Billing Information:

Bill transportation to: CuddyFeder-963

Your reference: 1844-3530

P.O. no.:

Invoice no.:

Department no.:

Thank you for shipping online with FedEx ShipManager at fedex.com.

Please Note

FedEx will not be responsible for any claim in excess of \$100 per package, whether the result of loss, damage, delay, non-delivery, misdelivery, or misinformation, unless you declare a higher value, pay an additional charge, document your actual loss and file a timely claim. Limitations found in the current FedEx Service Guide apply. Your right to recover from FedEx for any loss, including intrinsic value of the package, loss of sales, income interest, profit, attorney's fees, costs, and other forms of damage whether direct, incidental, consequential, or special is limited to the greater of \$100 or the authorized declared value. Recovery cannot exceed actual documented loss. Maximum for items of extraordinary value is \$1000, e.g., jewelry, precious metals, negotiable instruments and other items listed in our Service Guide. Written claims must be filed within strict time limits; Consult the applicable FedEx Service Guide for details.

The estimated shipping charge may be different than the actual charges for your shipment. Differences may occur based on actual weight, dimensions, and other factors. Consult the applicable [FedEx Service Guide](#) or the FedEx Rate Sheets for details on how shipping charges are calculated.