

RACHEL A. SCHWARTZMAN

Please Reply To: Bridgeport
Writer's Direct Dial: (203) 337-4110
E-Mail: rschwartzman@cohenandwolf.com

August 27, 2014

Attorney Melanie Bachman
Acting Executive Director
Connecticut Siting Council
Ten Franklin Square
New Britain, CT 06501

RECEIVED
AUG 29 2014

CONNECTICUT
SITING COUNCIL

ORIGINAL

**Re: EM-T-MOBILE-034-130528
T-Mobile Site ID CT11796G
52 Stadley Rough Road, Danbury, CT
Notice of Compliance with Conditions and Construction Completion**

Dear Attorney Bachman:

The Connecticut Siting Council ("Council") acknowledged the above referenced T-Mobile Northeast LLC ("T-Mobile") notice of exempt modification on June 27, 2013.

The Council imposed the following condition in its acknowledgment:

- The proposed coax lines and accessory equipment shall be installed in accordance with the recommendation made in the Structural Analysis Report prepared by FDH Engineering dated April 30, 2013 and stamped by Christopher Murphy;
- Within 45 days following completion of the antenna installation, T-Mobile shall provide documentation certified by a professional engineer that its installation complied with the recommendation of the structural analysis.

T-Mobile has complied with each of these conditions as evidenced by the PE Close Out Letter, dated August 25, 2014, attached hereto.

In addition, T-Mobile hereby notifies the Council that construction of the acknowledged modifications were complete as of December 18, 2013.

Please don't hesitate to contact me with any questions.

August 27, 2014
CT11796G
Page 2

Sincerely,



Rachel A. Schwartzman, Esq.

cc: Samuel Simons, T-Mobile
Mark Richard, T-Mobile
Alex Giannaras, HPC Wireless
Julie Kohler, Esq.



500 North
Broadway East
Providence, RI 02914
Phone: 401-354-2403
Fax: 401-633-6354

August 25, 2014

Mr. Samuel Simons
Engineering Development - Connecticut
T-Mobile
35 Griffin Road South
Bloomfield, CT 06002
sam.simons@t-mobile.com

RE: PE Close Out Letter
EM-T-MOBILE-034-130528 / T-Mobile Site ID #CT11796G

Mr. Simons:

Advanced Engineering Group, P.C. has completed its post-construction review of the above-referenced site to determine whether T-Mobile complied with conditions imposed by the Connecticut Siting Council's (the "Council") acknowledgment letter, dated 6/27/13 ("the Acknowledgment Letter"). Our compliance review included the following: the Acknowledgment Letter, the approved tower Structural Analysis report by FDH dated 4/30/13 (the "Structural Analysis"), and the approved design plans by this office entitled "CT11796G, Optasite Candle FT", Rev 0, dated 5/2/13.

On behalf of Advanced Engineering Group, P.C., based on my review of the information, I, Marc Chretien, licensed professional engineer number 28307, certify that to the best of my knowledge, T-Mobile's work complied with the recommendations of the approved Structural Analysis. Specifically, as required by the Acknowledgment Letter, T-Mobile's work complied with the following structural conditions imposed by the Council:

- The coax lines and accessory equipment shall be installed in accordance with the recommendations made in the Structural Analysis Report prepared by FDH Engineering dated, April 30, 2013 and stamped by Christopher Murphy;

Should you have any questions regarding the foregoing review, please contact me directly at 401-354-2403 or email to mchretien@aegpc.net.

Very truly yours

Marc R. Chretien, P.E.
Advanced Engineering Group, P.C.

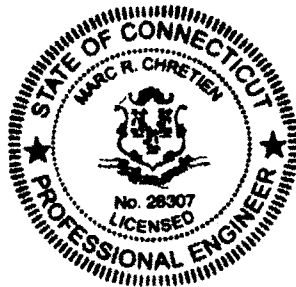



EM-T-MOBILE-034-130528

May 23, 2013

David Martin and
Members of the Siting Council
Connecticut Siting Council
Ten Franklin Square
New Britain, CT 06051

ORIGINAL

RECEIVED
MAY 28 2013

CONNECTICUT
SITING COUNCIL

RE: Notice of Exempt Modification
52 Stadley Rough Road
Danbury, CT 06811
N 41° 25' 59"
W -73° 25' 55"

Dear Mr. Martin and Members of the Siting Council:

On behalf of T-Mobile, SBA Communications is submitting an exempt modification application to the Connecticut Siting council for modification of existing equipment at a tower facility located at 52 Stadley Rough Road, Danbury, CT.

The 52 Stadley Rough Road facility consists of a 139' MONOPOLE Tower owned and operated by SBA Towers II LLC. In order to accommodate technological changes and enhance system performance in the State of Connecticut, T-Mobile plans to modify the equipment configurations at many of its existing cell sites. Please accept this letter and attachments as notification, pursuant to R.C.S.A. Section 16-50j-73, of construction which constitutes an exempt modification pursuant to R.C.S.A. Section 16-50j-72(b)(2). In compliance with R.C.S.A. Section 16-50j-73, a copy of this letter and attachments is being sent to the chief elected official of the municipality in which the affected cell site is located.

As part of T-Mobile's modernization project, T-Mobile desires to upgrade their equipment to meet the new standards of 4G technology. The new equipment will allow customers to download files and browse the internet at a high rate of speed while also allowing their phones to be compatible with the latest 4G technology.

Attached is a summary of the planned modifications, including power density calculations reflecting the change in T-Mobile's operations at the site along with the required fee of \$625.

The changes to the facility do not constitute modifications as defined in Connecticut General Statutes ("C.G.S.") Section 16-50i(d) because the general physical characteristics of the facility will not be



significantly changed or altered. Rather, the planned changes to the facility fall squarely within those activities explicitly provided for in R.C.S.A. Section 16-50j-72(b)(2).

1. The overall height of the structure will be unaffected.
2. The proposed changes will not extend the site boundaries. There will be no effect on the site compound other than the new equipment cabinets.
3. The proposed changes will not increase the noise level at the existing facility by six decibels or more.
4. The changes in radio frequency power density will not increase the calculated "worst case" power density for the combined operations at the site to a level at or above the applicable standard for uncontrolled environments as calculated for a mixed frequency site.

For the foregoing reasons, SBA Communications on behalf of T-Mobile, respectfully submits that he proposed changes at the referenced site constitute exempt modifications under R.C.S.A. Section 16-50j-72(b)(2).

Please feel free to call me at (508) 614-0389 with any questions you may have concerning this matter.

Thank you,

A handwritten signature in blue ink, appearing to read "Rick Woods", is written over a light blue background.

Rick Woods
SBA Communications Corporation
33 Boston Post Road West Suite 320
Marlborough, MA 01752
508-251-1691 x 319 + T
508-251-1755 + F
508-614-0389 + C
rwoods@sbsite.com



T-Mobile Equipment Modification

52 Stadley Rough Road, Danbury, CT
Site number CT11796G

Tower Owner: SBA Towers II LLC

Equipment Configuration: Monopole Tower

Current and/or approved:

- (6) RFS APX16PV-16VL-E
- (12) 1-5/8" Coax

Planned Modifications:

- (3) Ericsson AIR 21 B2A/B4P
- (3) Ericsson KRY 112 144/1 TMAs
- (12) 1-5/8" Coax
- (1) 1-5/8" Fiber

Structural Information:

The attached structural analysis demonstrates that the tower and foundation will have adequate structural capacity to accommodate the proposed modifications.

Power Density:

The anticipated Maximum Composite contributions from the T-Mobile facility are .538% of the allowable FCC established general public limit. The anticipated composite MPE value for this site assuming all carriers present is 50.148% of the allowable FCC established general public limit sampled at the ground level.

Site Composite MPE %	
Carrier	MPE %
T-Mobile	0.538%
Clearwire	1.600%
MetroPCS	3.500%
Verizon Wireless	44.510%
Total Site MPE %	50.148%



May 23, 2013

Mark D. Boughton, Mayor
City of Danbury
155 Deer Hill Avenue
Danbury, CT 06810

RE: Telecommunications Facility @ 52 Stadley Rough Road

Dear Mayor Boughton,

In order to accommodate technological changes and enhance system performance in the State of Connecticut, T-Mobile will be changing its equipment configuration at certain cell sites.

As required by Regulations of Connecticut State Agencies (R.C.S.A.) Section 16-50j-73, the Connecticut Siting Council has been notified of the changes and will review T-Mobile's proposal. Please accept this letter as notification under Section 16-50j-73 of construction which constitutes an exempt modification pursuant to R.C.S.A. Section 16-50j-72(b)(2).

The accompanying letter to the Siting Council fully describes T-Mobile's proposal for the referenced cell site. However, if you have any questions or require any further information on our plans or the Siting Council's procedures, please call me at (508) 614-0389.

Thank you,

A handwritten signature in blue ink, appearing to read "Rick Woods", is written over the "Thank you," text.

Rick Woods
SBA Communications Company
33 Boston Post Road West Suite 320
Marlborough, MA 01752
508-251-1691 x 319 + T
508-251-1755 + F
508-614-0389 + C
rwoods@sbsite.com



FDH Engineering, Inc., 6521 Meridien Drive Raleigh, NC 27616, Ph. 919.755.1012

**Structural Analysis for
SBA Network Services, Inc.**

139' Monopole Tower

**SBA Site Name: Danbury 1
SBA Site ID: CT13549-S-01
T-Mobile Site ID: CT11796G**

FDH Project Number 1327681400

Analysis Results

Tower Components	68.2%	Sufficient
Foundation	72.3%	Sufficient

Prepared By:

Adam Bryan, EI
Project Engineer

Reviewed By:

Christopher M Murphy, PE
President
CT PE License No. 25842

FDH Engineering, Inc.
6521 Meridien Drive
Raleigh, NC 27616
(919) 755-1012
info@fdh-inc.com



April 30, 2013

Prepared pursuant to TIA/EIA-222-F Structural Standards for Steel Antenna Towers and Antenna Supporting Structures and 2005 Connecticut State Building Code (CBC)

TABLE OF CONTENTS

EXECUTIVE SUMMARY 3

 Conclusions..... 3

 Recommendations 3

APPURTENANCE LISTING 4

RESULTS 5

GENERAL COMMENTS 6

LIMITATIONS 6

APPENDIX 7

EXECUTIVE SUMMARY

At the request of SBA Network Services, Inc., FDH Engineering, Inc. performed a structural analysis of the monopole located in Danbury, CT to determine whether the tower is structurally adequate to support both the existing and proposed loads pursuant to the *Structural Standards for Steel Antenna Towers and Antenna Supporting Structures, TIA/EIA-222-F* and *2005 Connecticut Building Code (CBC)*. Information pertaining to the existing/proposed antenna loading, current tower geometry, foundation dimensions, geotechnical data, and member sizes was obtained from:

- Sabre Towers & Poles (Job No. 10-01206) Structural Design Report dated January 28, 2010
- Tower Engineering Professionals (Project 091184.01) Subsurface Exploration Report dated May 13, 2009
- SBA Network Services, Inc.

The *basic design wind speed* per the *TIA/EIA-222-F* standards and *2005 CBC* is 85 mph without ice and 38 mph with 3/4" radial ice. Ice is considered to increase in thickness with height.

Conclusions

With the existing and proposed antennas from T-Mobile in place at 137 ft, the tower meets the requirements of the *TIA/EIA-222-F* standards and *2005 CBC* provided the **Recommendations** listed below are satisfied. Furthermore, provided the foundation is designed and constructed to support the original design reactions (see Sabre Job No. 10-01206), the foundation should have the necessary capacity to support the reserved and proposed loading. For a more detailed description of the analysis of the tower, see the **Results** section of this report.

Our structural analysis has been performed assuming all information provided to FDH Engineering, Inc. is accurate (i.e., the steel data, tower layout, existing antenna loading, and proposed antenna loading) and that the tower has been properly erected and maintained per the original design drawings.

Recommendations

To ensure the requirements of the *TIA/EIA-222-F* standards and *2005 CBC* are met with the existing and proposed loading in place, we have the following recommendations:

1. The proposed coax should be installed inside the monopole's shaft.
2. The proposed TMAs should be installed directly behind the proposed panel antennas.

APPURTENANCE LISTING

The proposed and existing antennas with their corresponding cables/coax lines are shown in **Table 1**. *If the actual layout determined in the field deviates from the layout, FDH Engineering, Inc. should be contacted to perform a revised analysis.*

Table 1 - Appurtenance Loading

Existing Loading:

Antenna Elevation (ft)	Description	Coax and Lines ¹	Carrier	Mount Elevation (ft)	Mount Type
137	(6) RFS APX16PV-16VL-E	(12) 1-5/8"	T-Mobile	137	Flush
127	(6) Decibel DB848H90E-XY	(12) 1-5/8"	Sprint	127	Flush
117	(3) Kathrein 800-10504 (3) Kathrein 742-351	(12) 1-5/8"	Metro PCS	117	Flush
109	(2) Dragonwave A-ANT-23G-2-C Dishes	(6) 5/16" (2) 1/2"	Cleanwire	109	Flush
107	(3) Argus LLPX310R (3) Samsung FDD-R6-RRH BTSs			107	Flush
97	(3) Decibel DB856DG65E-XY (3) Antel BXA-70063/6CF	(12) 1-5/8"	Verizon	97	Flush

1. Coax installed inside pole's shaft unless otherwise noted.

Proposed Loading:

Antenna Elevation (ft)	Description	Coax and Lines	Carrier	Mount Elevation (ft)	Mount Type
137	(3) Ericsson Air 21 B2A/B4P (3) Ericsson KRY 112 144/1 TMAs	(12) 1-5/8" (1) 1-5/8" Fiber	T-Mobile	137	Flush

RESULTS

The following yield strength of steel for individual members was used for analysis:

Table 2 - Material Strength

Member Type	Yield Strength
Tower Shaft Sections	65 ksi
Base Plate	50 ksi
Anchor Bolts	75 ksi

Table 3 displays the summary of the ratio (as a percentage) of force in the member to their capacities. Values greater than 100% indicate locations where the maximum force in the member exceeds its capacity. *Note: Capacities up to 100% are considered acceptable.* **Table 4** displays the maximum foundation reactions. **Table 5** displays maximum antenna rotations at service wind speeds.

If the assumptions outlined in this report differ from actual field conditions, FDH Engineering, Inc. should be contacted to perform a revised analysis. Furthermore, as no information pertaining to the allowable twist and sway requirements for the existing or proposed appurtenances was provided, deflection and rotation were not taken into consideration when performing this analysis.

See the **Appendix** for detailed modeling information.

Table 3 - Summary of Working Percentage of Structural Components

Section No.	Elevation ft	Component Type	Size	% Capacity*	Pass Fail
L1	139 - 98.75	Pole	TP25.3x16x0.1875	42.0	Pass
L2	98.75 - 48.5	Pole	TP36.53x24.1741x0.25	68.2	Pass
L3	48.5 - 0	Pole	TP47.23x34.933x0.3125	65.1	Pass
		Anchor Bolts	(12) 2.25" Ø w/ BC = 53.5"	42.4	Pass
		Base Plate	51.5" SQ PL x 2.75" thk.	56.0	Pass

*Capacities include 1/3 allowable increase for wind.

Table 4 - Maximum Base Reactions

Base Reactions	Current Analysis (TIA/EIA-222-F)	Original Design (TIA/EIA-222-F)
Axial	21 k	22 k
Shear	17 k	21 k
Moment	1,499 k-ft	2,074 k-ft

Table 5 – Maximum Antenna Rotations at Service Wind Speeds

Centerline Elevation (ft)	Dish	Tilt (deg)*	Twist (deg)*
109	(2) Dragonwave A-ANT-23G-2-C Dishes	1.4133	0.0007

*Allowable tilt and twist values to be reviewed by the carrier.

GENERAL COMMENTS

This engineering analysis is based upon the theoretical capacity of the structure. It is not a condition assessment of the tower and its foundation. It is the responsibility of SBA Network Services, Inc. to verify that the tower modeled and analyzed is the correct structure (with accurate antenna loading information) modeled. If there are substantial modifications to be made or the assumptions made in this analysis are not accurate, FDH Engineering, Inc. should be notified immediately to perform a revised analysis.

LIMITATIONS

All opinions and conclusions are considered accurate to a reasonable degree of engineering certainty based upon the evidence available at the time of this report. All opinions and conclusions are subject to revision based upon receipt of new or additional/updated information. All services are provided exercising a level of care and diligence equivalent to the standard and care of our profession. No other warranty or guarantee, expressed or implied, is offered. Our services are confidential in nature and we will not release this report to any other party without the client's consent. The use of this engineering work is limited to the express purpose for which it was commissioned and it may not be reused, copied, or distributed for any other purpose without the written consent of FDH Engineering, Inc.

APPENDIX

Section	1	2	3
Length (ft)	40.25	53.50	53.25
Number of Sides	18	18	18
Thickness (in)	0.1875	0.2500	0.3125
Socket Length (ft)	3.25	4.75	34.9330
Top Dia (in)	16.0000	24.1741	47.2300
Bot Dia (in)	25.3000	36.5300	7.3
Grade	A572-65	A572-65	A572-65
Weight (K)	1.7	4.3	7.3

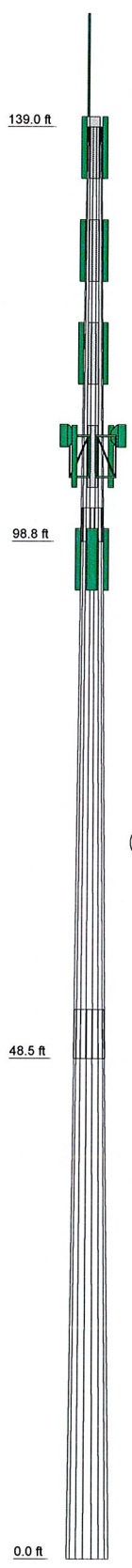

DESIGNED APPURTENANCE LOADING

TYPE	ELEVATION	TYPE	ELEVATION
Lightning Rod	140	A-ANT-23G-2-C Dish	109
AIR 21 B2A/B4P w/Mount Pipe	137	8'-6" x 4" Pipe Mount	107
AIR 21 B2A/B4P w/Mount Pipe	137	LLPX310R	107
AIR 21 B2A/B4P w/Mount Pipe	137	LLPX310R	107
KRY 112 144/1	137	LLPX310R	107
KRY 112 144/1	137	FDD-R6-RRH BTS	107
KRY 112 144/1	137	FDD-R6-RRH BTS	107
(2) DB848H90E-XY w/ mount pipe	127	FDD-R6-RRH BTS	107
(2) DB848H90E-XY w/ mount pipe	127	8'-6" x 4" Pipe Mount	107
(2) DB848H90E-XY w/ mount pipe	127	8'-6" x 4" Pipe Mount	107
800-10504 w/ mount pipe	117	BXA-70063/6CF w/ mount pipe	97
800-10504 w/ mount pipe	117	DB856DG65E-XY w/ mount pipe	97
800-10504 w/ mount pipe	117	DB856DG65E-XY w/ mount pipe	97
742-351 w/ mount pipe	117	DB856DG65E-XY w/ mount pipe	97
742-351 w/ mount pipe	117	BXA-70063/6CF w/ mount pipe	97
742-351 w/ mount pipe	117	BXA-70063/6CF w/ mount pipe	97
A-ANT-23G-2-C Dish	109		

MATERIAL STRENGTH

GRADE	Fy	Fu	GRADE	Fy	Fu
A572-65	65 ksi	80 ksi			

TOWER DESIGN NOTES

1. Tower is located in Fairfield County, Connecticut.
2. Tower designed for a 85 mph basic wind in accordance with the TIA/EIA-222-F Standard.
3. Tower is also designed for a 38 mph basic wind with 0.75 in ice. Ice is considered to increase in thickness with height.
4. Deflections are based upon a 50 mph wind.
5. TIA-G Addendum 2, Table 4-8 was used in this analysis.
6. TOWER RATING: 68.2%

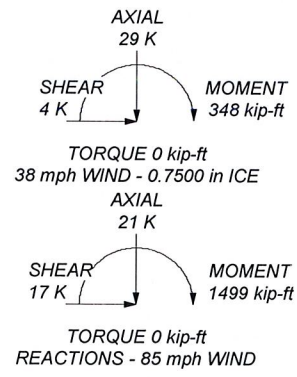

 FDH Engineering, Inc. 6521 Meridien Drive, Suite 107 Raleigh, NC 27616 Phone: 919-7551012 FAX: 919-7551031	Job: Danbury 1, CT13549-S-01
	Project: 1327681400
	Client: SBA Network Services, Inc. Drawn by: Adam Bryan App'd:
	Code: TIA/EIA-222-F Date: 04/30/13 Scale: NTS Path: Dwg No. E-1

RADIO FREQUENCY EMISSIONS ANALYSIS REPORT
EVALUATION OF HUMAN EXPOSURE POTENTIAL
TO NON-IONIZING EMISSIONS

T-Mobile Existing Facility

Site ID: CT11796G

Optasite Candle FT
52 Stadley Rough Road
Danbury, CT 06811

May 21, 2013



May 21, 2013

T-Mobile USA
Attn: Jason Overbey, RF Manager
35 Griffin Road South
Bloomfield, CT 06002

Re: Emissions Values for Site: **CT11796G - Optasite Candle FT**

EBI Consulting was directed to analyze the proposed T-Mobile facility located at 52 Stadley Rough Road, Danbury, CT, for the purpose of determining whether the emissions from the Proposed T-Mobile Antenna Installation located on this property are within specified federal limits.

All information used in this report was analyzed as a percentage of current Maximum Permissible Exposure (% MPE) as listed in the FCC OET Bulletin 65 Edition 97-01 and ANSI/IEEE Std C95.1. The FCC regulates Maximum Permissible Exposure in units of microwatts per square centimeter ($\mu\text{W}/\text{cm}^2$). The number of $\mu\text{W}/\text{cm}^2$ calculated at each sample point is called the power density. The exposure limit for power density varies depending upon the frequencies being utilized. Wireless Carriers and Paging Services use different frequency bands each with different exposure limits, therefore it is necessary to report results and limits in terms of percent MPE rather than power density.

All results were compared to the FCC (Federal Communications Commission) radio frequency exposure rules, 47 CFR 1.1307(b)(1) – (b)(3), to determine compliance with the Maximum Permissible Exposure (MPE) limits for General Population/Uncontrolled environments as defined below.

General population/uncontrolled exposure limits apply to situations in which the general public may be exposed or in which persons who are exposed as a consequence of their employment may not be made fully aware of the potential for exposure or cannot exercise control over their exposure. Therefore, members of the general public would always be considered under this category when exposure is not employment related, for example, in the case of a telecommunications tower that exposes persons in a nearby residential area.

Public exposure to radio frequencies is regulated and enforced in units of microwatts per square centimeter ($\mu\text{W}/\text{cm}^2$). The general population exposure limit for the cellular band is $567 \mu\text{W}/\text{cm}^2$, and the general population exposure limit for the PCS band is $1000 \mu\text{W}/\text{cm}^2$. Because each carrier will be using different frequency bands, and each frequency band has different exposure limits, it is necessary to report percent of MPE rather than power density.

Occupational/controlled exposure limits apply to situations in which persons are exposed as a consequence of their employment and in which those persons who are exposed have been made fully aware of the potential for exposure and can exercise control over their exposure. Occupational/controlled exposure limits also apply where exposure is of a transient nature as a result of incidental passage through a location where exposure levels may be above general population/uncontrolled limits (see below), as long as the exposed person has been made fully aware of the potential for exposure and can exercise control over his or her exposure by leaving the area or by some other appropriate means.

Additional details can be found in FCC OET 65.

CALCULATIONS

Calculations were done for the proposed T-Mobile Wireless antenna facility located at 52 Stadley Rough Road, Danbury, CT, using the equipment information listed below. All calculations were performed per the specifications under FCC OET 65. Since T-Mobile is proposing highly focused directional panel antennas, which project most of the emitted energy out toward the horizon, the actual antenna pattern gain value in the direction of the sample area was used. For this report the sample point is a 6 foot person standing at the base of the tower

For all calculations, all equipment was calculated using the following assumptions:

- 1) 2 GSM channels (1940.000 MHz—to 1950.000 MHz) were considered for each sector of the proposed installation.
- 2) 2 UMTS channels (2110.000 MHz to 2120.000 MHz / 2140.000 MHz to 2145.000 MHz) were considered for each sector of the proposed installation
- 3) 2 LTE channels (2110.000 MHz to 2120.000 MHz / 2140.000 MHz to 2145.000 MHz) were considered for each sector of the proposed installation
- 4) All radios at the proposed installation were considered to be running at full power and were uncombined in their RF transmissions paths per carrier prescribed configuration. Per FCC OET Bulletin No. 65 - Edition 97-01 recommendations to achieve the maximum anticipated value at each sample point, all power levels emitting from the proposed antenna installation are increased by a factor of 2.56 to account for possible in-phase reflections from the surrounding environment. This is rarely the case, and if so, is never continuous.
- 5) For the following calculations the sample point was the top of a six foot person standing at the base of the tower. The actual gain in this direction was used per the manufactures supplied specifications.
- 6) The antenna used in this modeling is the Ericsson AIR21 for LTE, UMTS and GSM. This is based on feedback from the carrier with regards to anticipated antenna selection. This antenna has a 15.6 dBd gain value at its main lobe. Actual antenna gain values were used for all calculations as per the manufacturers specifications



EBI Consulting

environmental | engineering | due diligence

- 7) The antenna mounting height centerline of the proposed antennas is **137 feet** above ground level (AGL)
- 8) Emissions values for additional carriers were taken from the Connecticut Siting Council active database. Values in this database are provided by the individual carriers themselves.

All calculation were done with respect to uncontrolled / general public threshold limits

Site ID	CT11796G - Optasite Candle FT
Site Address	52 Stadley Rough Road, Danbury, CT 06811
Site Type	Monopole

Sector 1																		
Antenna Number	Antenna Make	Antenna Model	Status	Frequency Band	Technology	Power Out Per Channel (Watts)	Number of Channels	Composite Power	Antenna Gain in direction of sample point (dBd)	Antenna Height (ft)	Antenna analysis height	Cable Size	Cable Loss (dB)	Additional Loss	ERP	Power Density Value	Power Density Percentage	
1a	RFS	APX16DWW-16DWW	Passive	PCS - 1950 MHz	GSM / UMTS	30	4	120	-3.95	137	131	7/8"	1.2	0	36.659053	0.767971	0.07680%	
1B	RFS	APX16DWW-16DWW	Passive	AWS - 2100 MHz	UMTS/LTE	40	4	160	-3.95	137	131	7/8"	1.2	0	48.878738	1.023961	0.10240%	
Sector total Power Density Value:													0.179%					
Sector 2																		
Antenna Number	Antenna Make	Antenna Model	Status	Frequency Band	Technology	Power Out Per Channel (Watts)	Number of Channels	Composite Power	Antenna Gain in direction of sample point (dBd)	Antenna Height (ft)	Antenna analysis height	Cable Size	Cable Loss (dB)	Additional Loss	ERP	Power Density Value	Power Density Percentage	
1a	RFS	APX16DWW-16DWW	Passive	PCS - 1950 MHz	GSM / UMTS	30	4	120	-3.95	137	131	7/8"	1.2	0	36.659053	0.767971	0.07680%	
1B	RFS	APX16DWW-16DWW	Passive	AWS - 2100 MHz	UMTS/LTE	40	4	160	-3.95	137	131	1-5/8"	1.2	0	48.878738	1.023961	0.10240%	
Sector total Power Density Value:													0.179%					
Sector 3																		
Antenna Number	Antenna Make	Antenna Model	Status	Frequency Band	Technology	Power Out Per Channel (Watts)	Number of Channels	Composite Power	Antenna Gain in direction of sample point (dBd)	Antenna Height (ft)	Antenna analysis height	Cable Size	Cable Loss (dB)	Additional Loss	ERP	Power Density Value	Power Density Percentage	
1a	RFS	APX16DWW-16DWW	Passive	PCS - 1950 MHz	GSM / UMTS	30	4	120	-3.95	137	131	7/8"	1.2	0	36.659053	0.767971	0.07680%	
1B	RFS	APX16DWW-16DWW	Passive	AWS - 2100 MHz	UMTS/LTE	40	4	160	-3.95	137	131	1-5/8"	1.2	0	48.878738	1.023961	0.10240%	
Sector total Power Density Value:													0.179%					

Site Composite MPE %	
Carrier	MPE %
T-Mobile	0.538%
Clearwire	1.600%
MetroPCS	3.500%
Verizon Wireless	44.510%
Total Site MPE %	50.148%



Summary

All calculations performed for this analysis yielded results that were well within the allowable limits for general public exposure to RF Emissions.

The anticipated Maximum Composite contributions from the T-Mobile facility are **0.538% (0.179% from each sector)** of the allowable FCC established general public limit considering all three sectors simultaneously.

The anticipated composite MPE value for this site assuming all carriers present is **50.148%** of the allowable FCC established general public limit. This is based upon values listed in the Connecticut Siting Council database for existing carrier emissions

FCC guidelines state that if a site is found to be out of compliance (over allowable thresholds), that carriers over a 5% contribution to the composite value will require measures to bring the site into compliance. For this facility, the composite values calculated were within the allowable 100% threshold standard per the federal government

Scott Heffernan
RF Engineering Director

EBI Consulting

21 B Street
Burlington, MA 01803

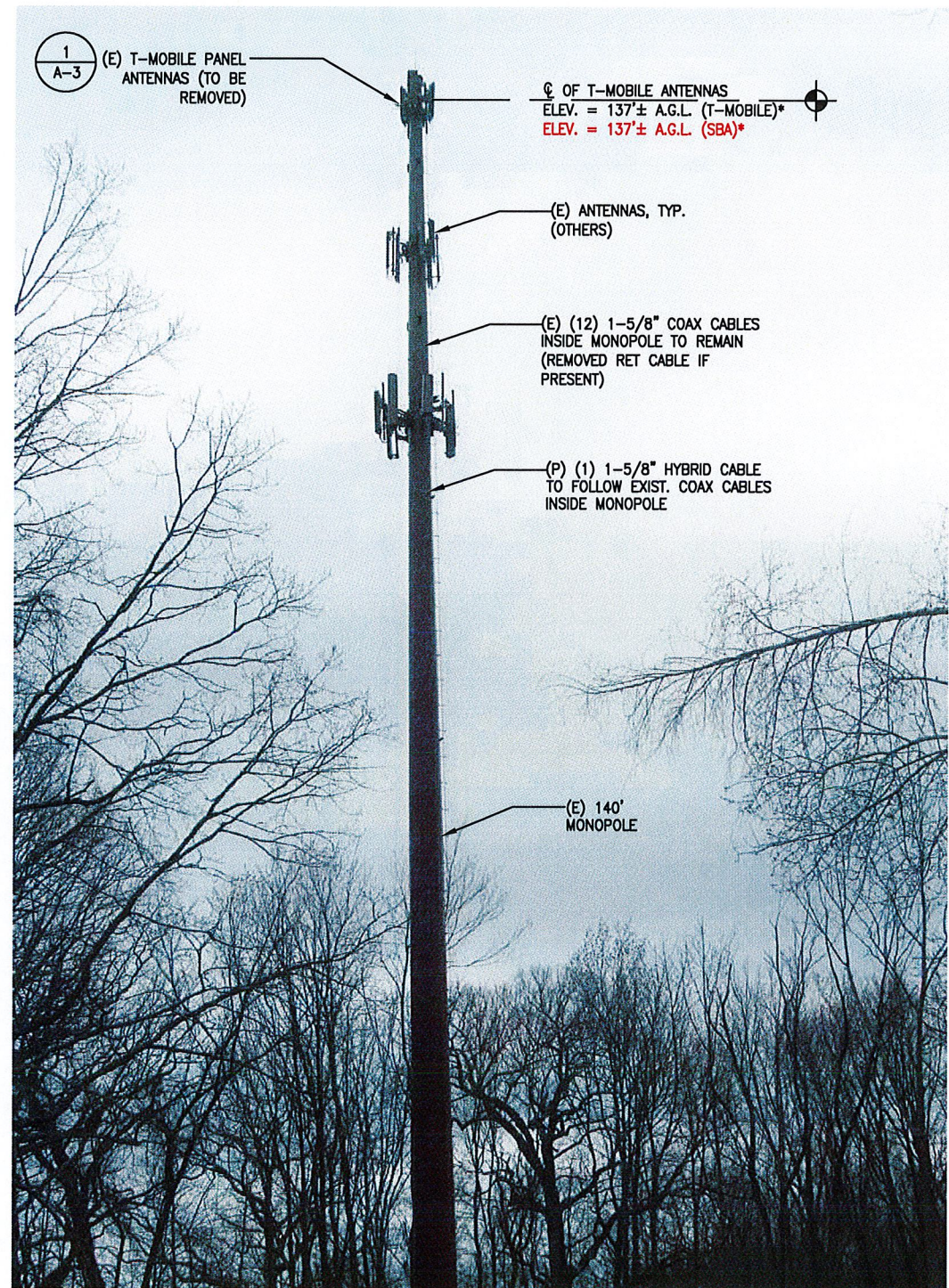
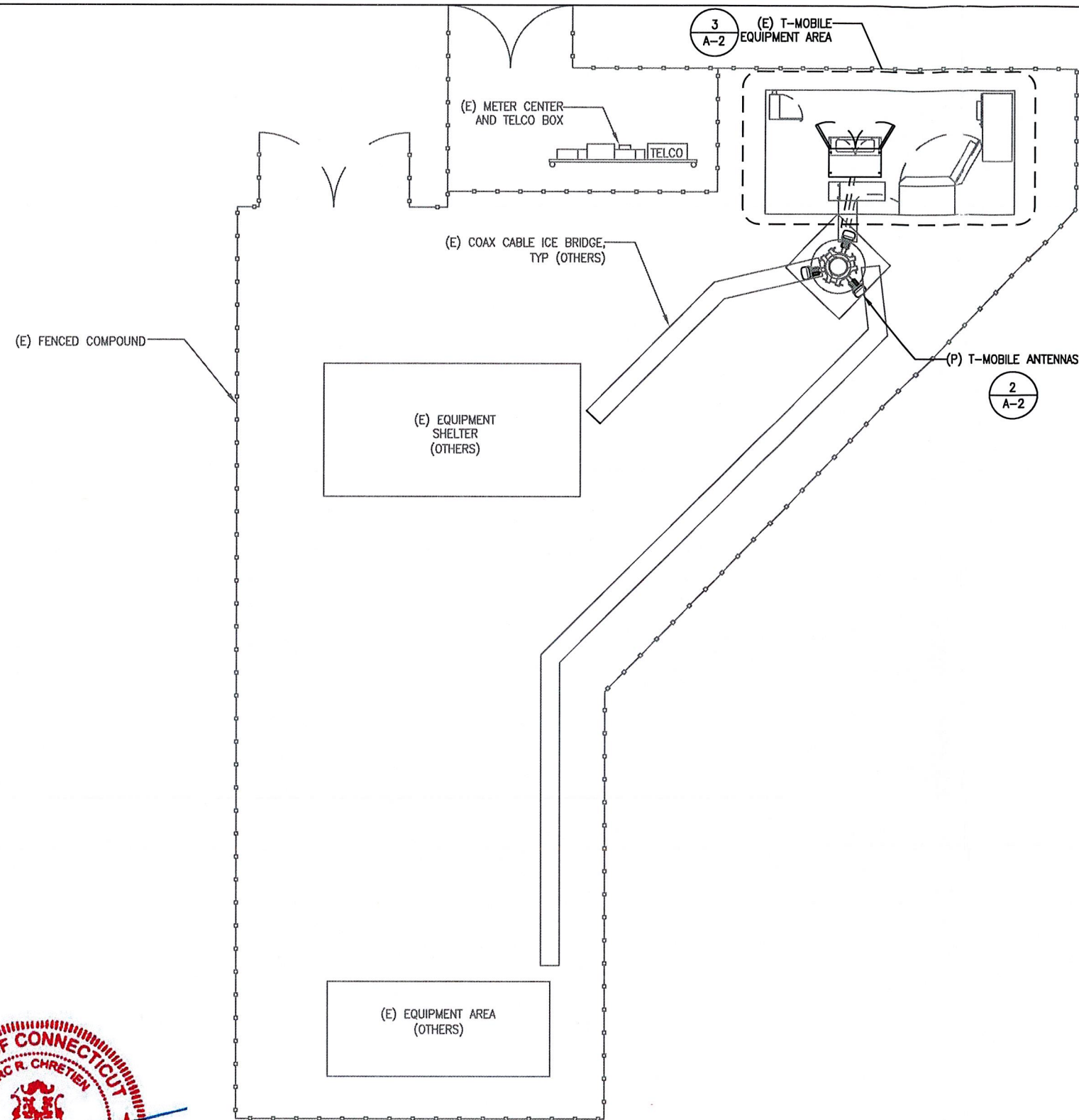

NOTE:
GROUND EQUIPMENT NOT SHOWN FOR
CLARITY

2
A-1 **EXISTING ELEVATION**
SCALE: NTS

*NOTE:
ANTENNA ELEVATION BASED ON
CLIENT-PROVIDED INFORMATION



1
A-1 **COMPOUND PLAN**
SCALE: 3/32"=1'-0"
0' 5'-4" 10'-8" 21'-4"

EG ADVANCED
ENGINEERING GROUP, P.C.
Civil Engineering - Site Development Surveying - Telecommunications
500 NORTH BROADWAY
EAST PROVIDENCE, RI 02814
Ph: (401) 354-2403
FAX: (401) 633-6354

SBA
SBA COMMUNICATIONS CORPORATION
33 BOSTON POST ROAD WEST, SUITE 320
MARLBOROUGH, MA 01752
PHONE: 508-366-5505

SITE NUMBER: CT11796G
SITE NAME: OPTASITE CANDLE FT
52 STADLEY ROUGH ROAD
DANBURY, CT 06811

T-MOBILE NORTHEAST LLC
35 GRIFFIN ROAD SOUTH
BLOOMFIELD, CT 06002
OFFICE: (860) 648-1116

T-MOBILE									
COMPOUND PLAN AND ELEVATION									
NO.	DATE	REVISIONS	BY	CHK	APP'D	JOB NUMBER	DRAWING NUMBER		REV
0	05/02/13	CONSTRUCTION	BDJ	MRC	MRC	CT11796G	A-1		0
SCALE: AS SHOWN			DESIGNED BY: MRC		DRAWN BY: BDJ				

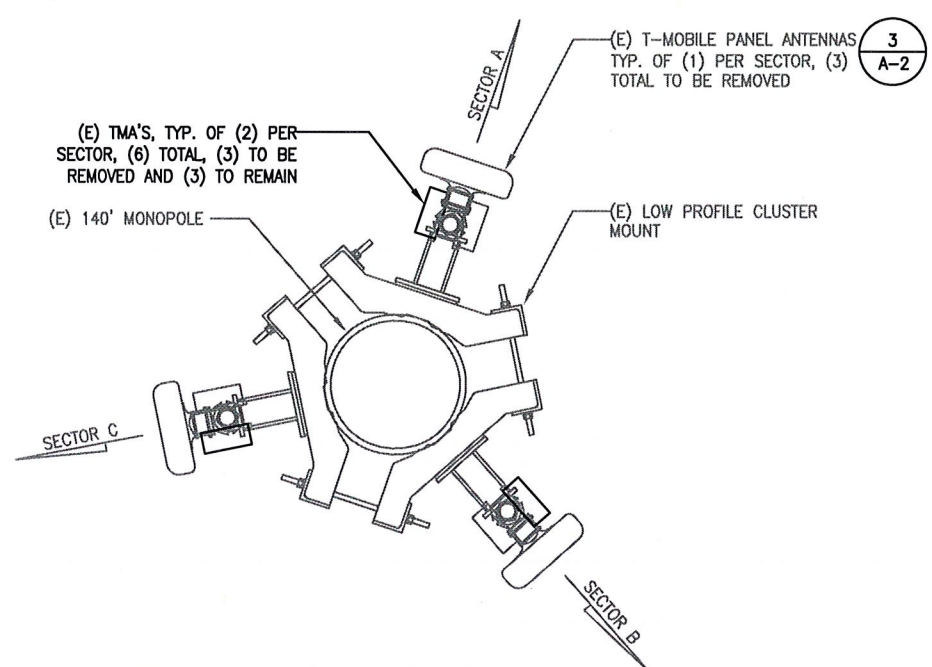

EXISTING ANTENNA PLAN
 SCALE: 1/4"=1'-0"
 (1) A-2

EXISTING ANTENNA SCHEDULE			
SECTOR	MAKE	MODEL#	SIZE (INCHES)
SECTOR A:	RFS	APX16DWV-16DWV-S	13x3.15x59.9
SECTOR B:	RFS	APX16DWV-16DWV-S	13x3.15x59.9
SECTOR C:	RFS	APX16DWV-16DWV-S	13x3.15x59.9

PROPOSED ANTENNA SCHEDULE			
SECTOR	MAKE	MODEL#	SIZE (INCHES)
SECTOR A:	ERICSSON	AIR21 B2A/B4P	12x8x56
SECTOR B:	ERICSSON	AIR21 B2A/B4P	12x8x56
SECTOR C:	ERICSSON	AIR21 B2A/B4P	12x8x56

NOTE:
 1. REFER TO FINAL RF DATA SHEET FOR FINAL ANTENNA SETTINGS.

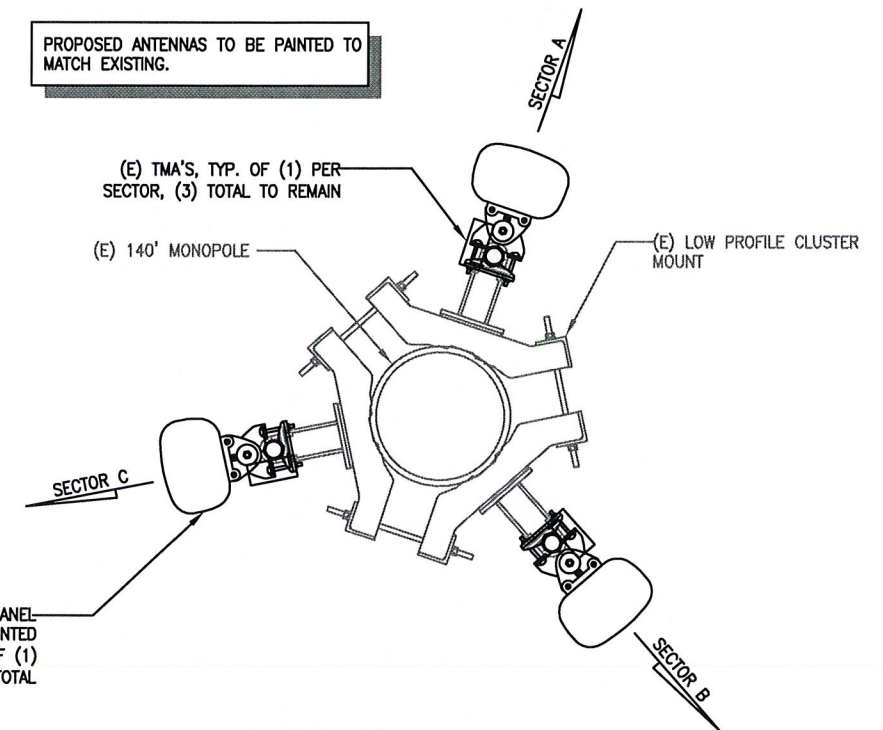

PROPOSED ANTENNA PLAN
 SCALE: 1/4"=1'-0"
 (2) A-2

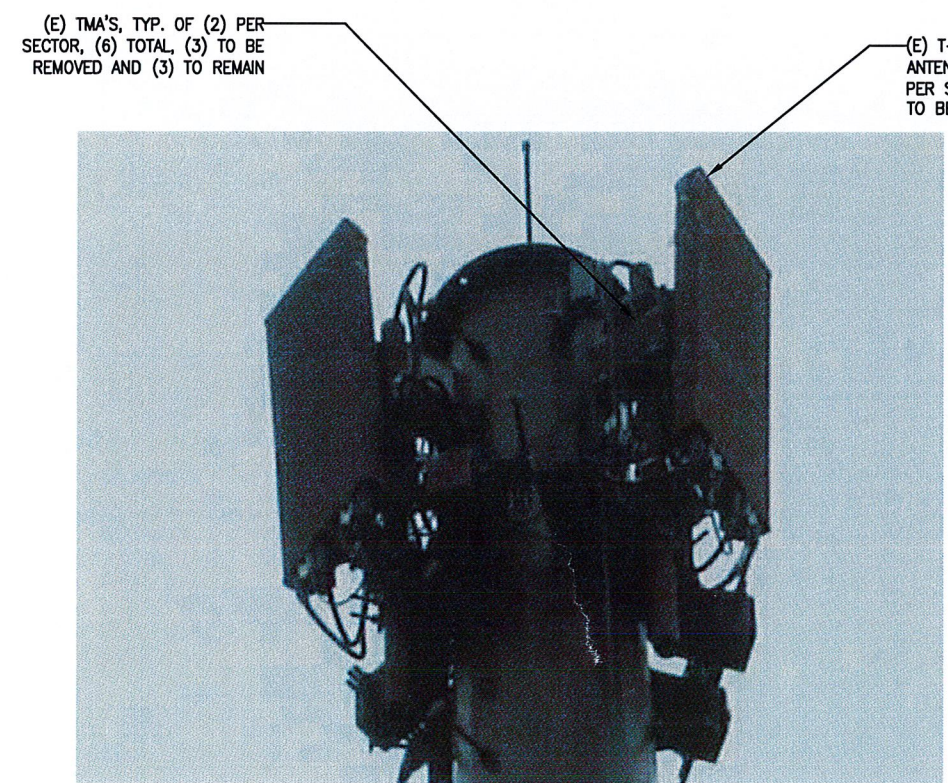

EXISTING ANTENNA MOUNT TYP.
 N.T.S.
 (3) A-2

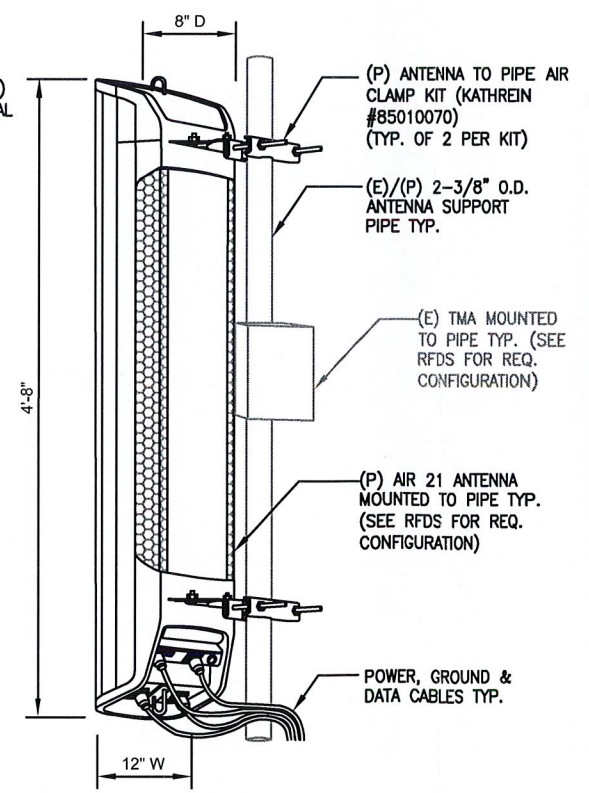

AIR21 ANTENNA MOUNT TYP.
 SCALE: N.T.S.
 (4) A-2

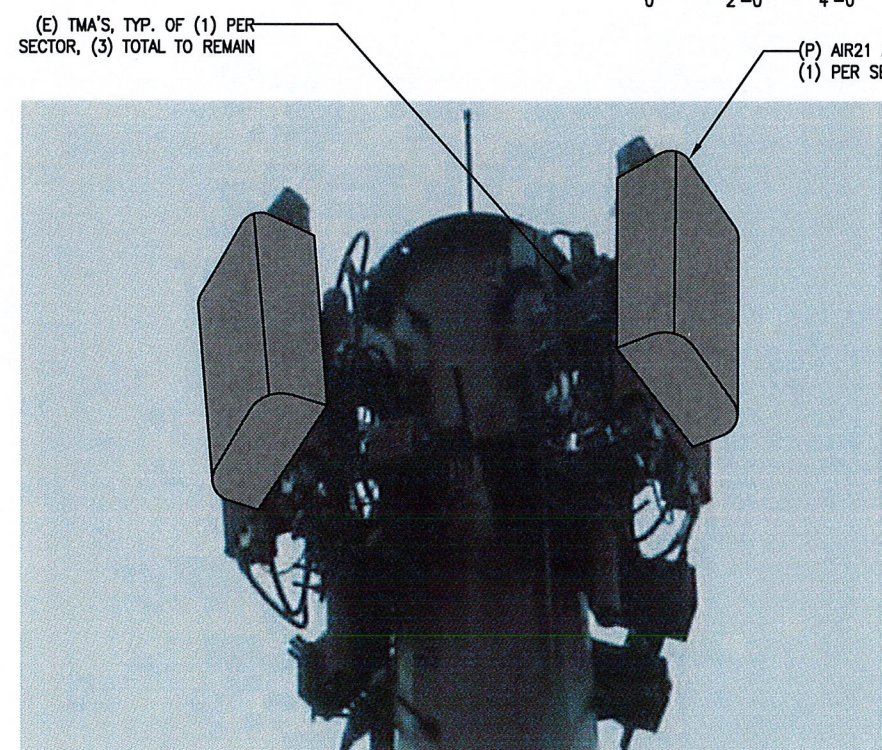

PROPOSED ANTENNA MOUNT TYP.
 N.T.S.
 (5) A-2

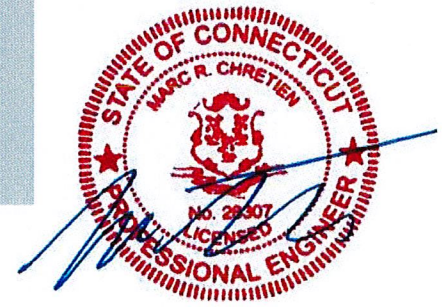

NO.	DATE	REVISIONS	BY	CHK	APP'D
0	05/02/13	CONSTRUCTION	BDJ	MRC	MRC

SCALE: AS SHOWN DESIGNED BY: MRC DRAWN BY: BDJ

T-MOBILE		
PLANS AND ANTENNA SCHEDULES		
JOB NUMBER	DRAWING NUMBER	REV
CT11796G	A-2	0