

TS-CING-034-13/015

**CUDDY &
FEDER** ^{LLP}

445 Hamilton Avenue, 14th Floor
White Plains, New York 10601
Tel 914.761.1300 Fax 914.761.5372
www.cuddyfeder.com

January 2, 2014

VIA ELECTRONIC MAIL

Melanie Bachman
Executive Director
Connecticut Siting Council
10 Franklin Square
New Britain, CT 06051

RECEIVED
JAN - 6 2014
CONNECTICUT
SITING COUNCIL

ORIGINAL

Re: AT&T Tower Share Request
Certificated Site – Docket No. 366
52 Stadley Rough Road, Danbury, Connecticut

Dear Executive Director Bachman:

On behalf of New Cingular Wireless PCS, LLC (“AT&T”), we respectfully withdraw its tower share application, without prejudice, for re-filing at a later date. Additional information regarding the proposed generator is being developed in accordance with a stipulation related to the Council’s Decision & Order in Docket 366. AT&T anticipates re-filing at a later date. Thank you for your assistance in this regard.

Very truly yours,

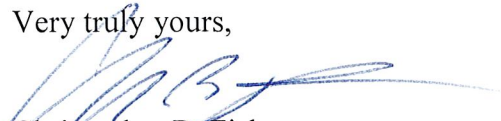

Christopher B. Fisher

cc: Eric Dahl (edahl@comcast.net)
Michele Briggs, AT&T (MC3185@att.com)

November 26, 2013

VIA ELECTRONIC MAIL

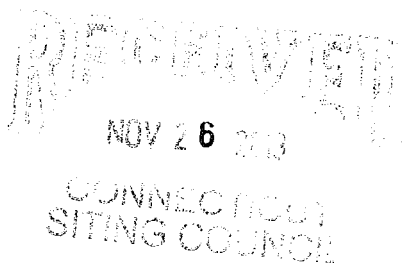
Mr. David Martin
Siting Analyst
Connecticut Siting Council
10 Franklin Square
New Britain, CT 06051



Re: AT&T Tower Share Request
Certificated Site – Docket No. 366
52 Stadley Rough Road, Danbury, Connecticut

Dear Mr. Martin:

On behalf of New Cingular Wireless PCS, LLC (“AT&T”), we understand that AT&T’s filing is not yet complete. Specifically, that before the Council can act on AT&T’s tower share request, additional information is required regarding the proposed generator in accordance with certain requirements for the tower site and as it relates to a stipulation with the City of Danbury, which confirmed the Council’s Decision & Order in Docket 366. AT&T is currently working on the information regarding the generator and anticipates filing same in December. To facilitate the timing for completion of this information and the Council’s review, AT&T has authorized and we hereby grant on their behalf an extension of time for the Council to decide its tower sharing application through January 31, 2014. Thank you for your assistance in this regard.

Very truly yours,

Christopher B. Fisher

cc: Melanie Bachman, Esq., Executive Director (Melanie.Bachman@ct.gov)
Michele Briggs, AT&T (MC3185@att.com)

HPC Wireless Services
 22 Shelter Rock Lane
 Building C
 Danbury, CT, 06810
 P.: 203.797.1112



October 9, 2013

VIA OVERNIGHT DELIVERY

Connecticut Siting Council
 10 Franklin Square
 New Britain, Connecticut 06051
 Attn: Ms. Melanie Bachman, Acting Executive Director

Re: New Cingular Wireless PCS, LLC – Tower Share Request
52 Stadley Rough Road, Danbury, Connecticut

Dear Ms. Bachman:



Pursuant to Connecticut General Statutes §16-50aa, as amended, and on behalf of New Cingular Wireless PCS, LLC (“AT&T”), this letter and associated documentation is submitted as a request for an order from the Connecticut Siting Council (“Council”) to approve the proposed shared use by AT&T of a tower at 52 Stadley Rough Road, Danbury, Connecticut (coordinates 41°-25’-59.17”, 73°-25’-54.9”). The tower is owned by SBA Communications, and currently supports antennas of a number of wireless carriers.

AT&T proposes to install six (6) panel antennas, approximately 78” long, on a low profile mount at 107’ centerline AGL on the existing 120’ tower. Additionally, AT&T proposes to install fifteen (15) RRH’s and three (3) surge arrestors on the tower. Six (6) RRH’s will be installed on a collar mount at 102’ AGL and six (6) will be installed on a collar mount at 112’ AGL. The three (3) surge arrestors and three (3) remaining RRH’s will be mounted behind the proposed panel antennas. Two (2) ½” fiber cables and eight (8) ¾” DC power cables will also be installed up the tower to the antennas. AT&T will install a 12’ x 30’ pre-fabricated shelter for its equipment cabinets and 50 kW natural gas generator within the existing fenced equipment compound. Based on the following, AT&T requests that the Council find that the proposed shared use of the tower satisfies the criteria stated in Connecticut General Statutes §16-50aa and issue an order approving the proposed use.

C.G.S. §16-50aa(c)(1) provides that, upon written request for approval of a proposed shared use, “if the council finds that the proposed shared use of the facility is technically, legally, environmentally and economically feasible and meets public safety concerns, the council shall issue an order approving such shared use.” The shared use of the tower satisfies those criteria as follows:

A. Technical Feasibility. Attached is documentation of the structural sufficiency of the existing tower to support the proposed AT&T loading. The proposed shared use of this tower therefore is technically feasible.

B. Legal Feasibility. Under C.G.S. §16-50aa, the Council has been authorized to issue orders approving the proposed shared use of a tower facility such as the Danbury facility. In addition, §16-50aa directs the Council to “give such consideration to other state laws and municipal regulations as it shall deem appropriate” in ruling on requests for the shared use of tower facilities. There is no legal impediment to the shared use of the facility.

C. Environmental Feasibility. The overall environmental effect of the proposed shared use is positive. The effect on the facility itself is minimal, for the following reasons:

1. The proposed installation would have an insignificant incremental visual impact, and would not cause any significant change or alteration in the physical or environmental characteristics of the site. In particular, the proposed installation would not increase the height of the approved tower, and would not extend the boundaries of the tower site outside the limits of the approved site compound.

2. The proposed installation would not increase the noise levels at the facility by six decibels or more.

3. Addition of AT&T’s antennas at this site would not result in a total radio frequency (RF) electromagnetic radiation power density level in excess of that adopted by the Federal Communications Commission.

4. The proposed installation would not require any water or sanitary facilities, or generate air emissions or discharges to water bodies. After construction is complete, the proposed installation will not generate any traffic other than for occasional maintenance.

The proposed use of facility would, therefore, have a minimal adverse effect, and is environmentally feasible.

E. Economic Feasibility. The parties have entered into an agreement to share the use of the existing tower on terms mutually agreeable to the parties. The proposed tower sharing is therefore economically feasible.

F. Public Safety Concerns. AT&T is not aware of any public safety concerns relative to the proposed sharing of the tower. As stated above, the tower is structurally capable of supporting the proposed and existing antennas. The proposed shared use will not interfere with municipal public safety activities. The increased availability of quality wireless communications service enhances the ability of the public to report public safety concerns.

Conclusion

For the reasons set forth above, the proposed shared use of the tower at Stadley Rough Road, Danbury, Connecticut satisfies the criteria stated in C.G.S. § 16-50aa and advances the General

Assembly's and the Council's goal of preventing the proliferation of towers in Connecticut. AT&T, therefore, requests that the Council issue an order approving the proposed use.

Please feel free to contact me by phone at (860) 227-1975 or by e-mail at edahl@comcast.net with questions concerning this matter. Thank you for your consideration.

Respectfully yours,



Eric Dahl

Attachments

cc: Honorable Mark D. Boughton, Mayor
Christ the Shepherd Church PCA



CT2312
SBA TOWER
CT13549

LEASE EXHIBIT	
1	08/13/13 ISSUED FOR LEASE
0	08/27/13 ISSUED FOR LEASE
4	08/14/13 PRELIMINARY SUBMISSION

Dewberry
Dewberry Engineers Inc.
800 PARSONS ROAD
WESTPORT, NJ 07564
PHONE: 973 739-8400
FAX: 973 739-8400
CONTRACT NO. 13040001700

ROBERT J. POLEY, P.E. CT LICENSE No. PE0028056
IF A HOLDER OF ONE OR ANY PERSON, UNLESS LICENSED PROFESSIONAL ENGINEER TO ACT IN THIS CAPACITY.
DRAWN BY: J.C.
REVIEWED BY: O.H.N.
CHECKED BY: O.H.N.
PROJECT NUMBER: 50000100
JOB NUMBER: 50001002
SITE ADDRESS:

52 STADLEY ROUGH ROAD
DANBURY, CT 06811

SHEET TITLE
CONCEPTUAL SITE PLAN &
ELEVATION
SHEET NUMBER

LE-1

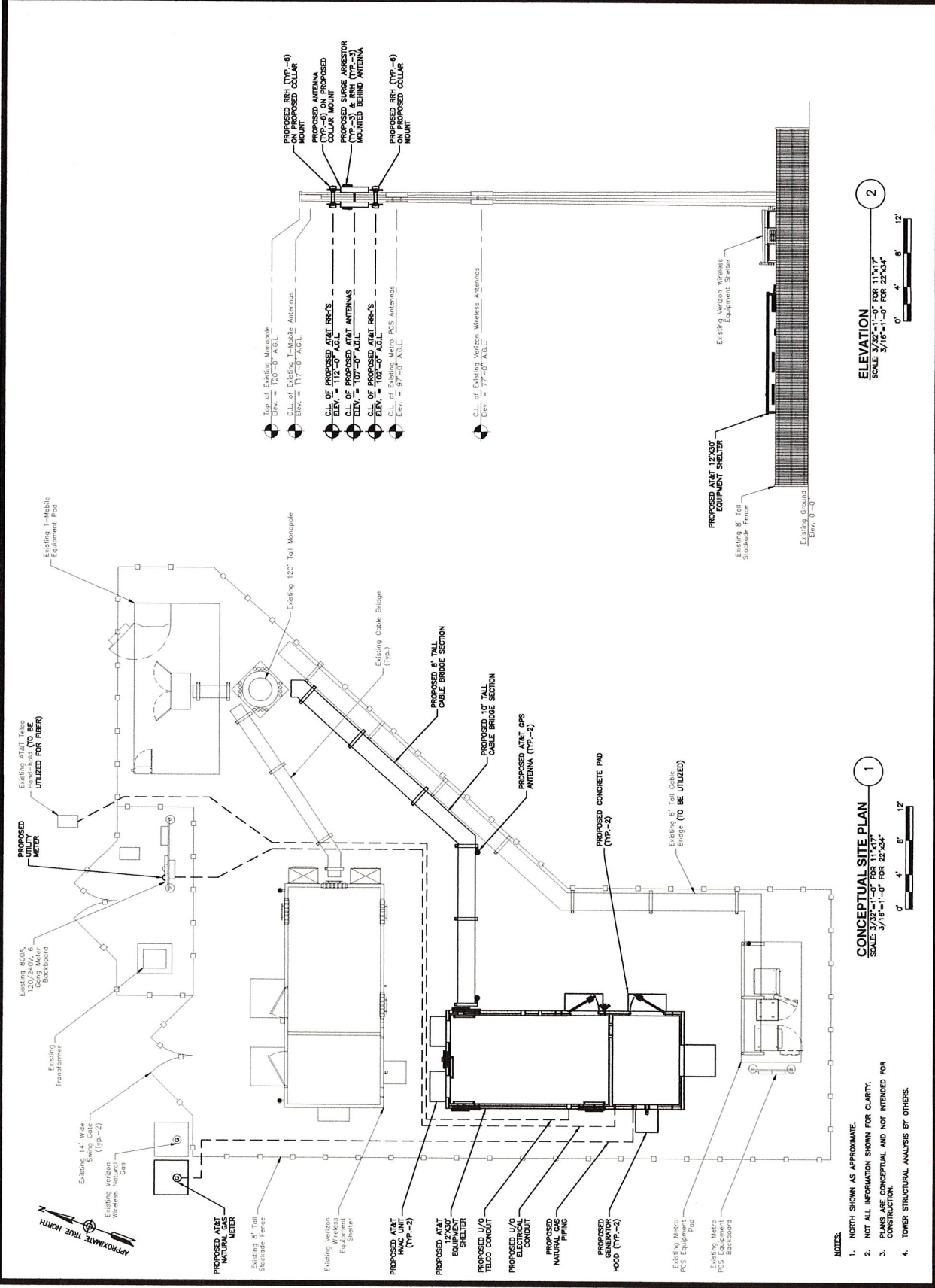

CONCEPTUAL SITE PLAN
SCALE 3/16"=1'-0" FOR 11'x17"
SCALE 3/16"=1'-0" FOR 22'x34"

ELEVATION
SCALE 3/16"=1'-0" FOR 11'x17"
SCALE 3/16"=1'-0" FOR 22'x34"

- NOTES:
1. NORTH SHOWN AS APPROXIMATE.
 2. NOT ALL INFORMATION SHOWN FOR CLARITY.
 3. PLANS ARE CONCEPTUAL AND NOT INTENDED FOR CONSTRUCTION.
 4. TOWER STRUCTURAL ANALYSIS BY OTHERS.

Michael Lawton
 SAI Communications
 260 Cedar Hill St.
 Marlborough, MA 01752
Mike.Lawton@sai-comm.com



October 4, 2013

Connecticut Siting Council

Subject: AT&T Wireless, CT2312 – Danbury Pinnacle Way

Dear Connecticut Siting Council:

At the request of AT&T Wireless, SAI Communications has performed a cumulative assessment of the RF Power Density at the proposed site located at 52 Stadley Rough Road, Danbury, CT. Calculations were done in compliance with FCC OET Bulletin 65. This report provides an FCC compliance assessment based on a "worst-case" analysis that all transmitters are simultaneously operating at full power and pointing directly at the ground.

FCC OET Bulletin 65 formula:

$$S = \frac{2.56 * 1.64 * ERP}{4 * \pi * R^2}$$

Transmission Mode	Antenna Centerline AGL (ft)	Frequency (MHz)	Number of Channels	Effective Radiated Power per Channel (Watts)	Power Density (mW/cm ²)	Standard Limits (mW/cm ²)	% MPE (Uncontrolled/General Public)
T-Mobile GSM/UMTS	137	1950	4	10.80	0.0008	1	0.08%
T-Mobile UMTS/LTE	137	2100	4	12.00	0.0009	1	0.09%
MetroPCS	117	2140	3	443.61	0.0350	1	3.50%
Verizon PCS	97	1970	11	274.00	0.1152	1	11.52%
Verizon cellular	97	869	9	273.00	0.0939	0.5793	16.21%
Verizon AWS	97	2145	1	670.00	0.0256	1	2.56%
Verizon LTE	97	698	2	866.00	0.0662	0.4653	14.22%
AT&T UMTS	107	850	2	500.00	0.0314	0.5667	5.54%
AT&T UMTS	107	1900	2	500.00	0.0314	1	3.14%
AT&T LTE	107	700	2	500.00	0.0314	0.4667	6.73%
AT&T LTE	107	2100	2	500.00	0.0314	1	3.14%
Total							66.74%

Conclusion: AT&T's proposed antenna installation is calculated to be within 66.74% of FCC Standard for General Public/Uncontrolled Maximum Permissible Exposure (MPE).

Sincerely,

Michael Lawton
 SAI Communications



FDH Engineering, Inc., 6521 Meridien Drive Raleigh, NC 27616, Ph. 919.755.1012

**Structural Analysis for
SBA Network Services, Inc.**

139' Monopole Tower

**SBA Site Name: Danbury 1
SBA Site ID: CT13549-S-00
New Cingular Site Name: Danbury 1**

FDH Project Number 13SCNN1400

Analysis Results

Tower Components	77.5%	Sufficient
Foundation	81.5%	Sufficient

Prepared By:

Logan Poe, EI
Project Engineer

Reviewed By:

Christopher M Murphy, PE
President
CT PE License No. 25842

FDH Engineering, Inc.
6521 Meridien Drive
Raleigh, NC 27616
(919) 755-1012
info@fdh-inc.com



September 23, 2013

Prepared pursuant to TIA/EIA-222-F Structural Standards for Steel Antenna Towers and Antenna Supporting Structures and 2005 Connecticut State Building Code (CBC)

TABLE OF CONTENTS

EXECUTIVE SUMMARY 3

 Conclusions..... 3

 Recommendations 3

APPURTENANCE LISTING 4

RESULTS 5

GENERAL COMMENTS 6

LIMITATIONS..... 6

APPENDIX 7

EXECUTIVE SUMMARY

At the request of SBA Network Services, Inc., FDH Engineering, Inc. performed a structural analysis of the monopole located in Danbury, CT to determine whether the tower is structurally adequate to support both the existing and proposed loads pursuant to the *Structural Standards for Steel Antenna Towers and Antenna Supporting Structures, TIA/EIA-222-F* and *2005 Connecticut Building Code (CBC)*. Information pertaining to the existing/proposed antenna loading, current tower geometry, foundation dimensions, geotechnical data, and member sizes was obtained from:

- Sabre Towers & Poles (Job No. 10-01206) Structural Design Report dated January 28, 2010
- Tower Engineering Professionals (Project 091184.01) Subsurface Exploration Report dated May 13, 2009
- SBA Network Services, Inc.

The *basic design wind speed* per the *TIA/EIA-222-F* standards and *2005 CBC* is 85 mph without ice and 38 mph with 3/4" radial ice. Ice is considered to increase in thickness with height.

Conclusions

With the existing and proposed antennas from New Cingular in place at 107 ft, the tower meets the requirements of the *TIA/EIA-222-F* standards and *2005 CBC* provided the **Recommendations** listed below are satisfied. Furthermore, provided the foundation is designed and constructed to support the original design reactions (see Sabre Job No. 10-01206), the foundation should have the necessary capacity to support the reserved and proposed loading. For a more detailed description of the analysis of the tower, see the **Results** section of this report.

Our structural analysis has been performed assuming all information provided to FDH Engineering, Inc. is accurate (i.e., the steel data, tower layout, existing antenna loading, and proposed antenna loading) and that the tower has been properly erected and maintained per the original design drawings.

Recommendations

To ensure the requirements of the *TIA/EIA-222-F* standards and *2005 CBC* are met with the existing and proposed loading in place, we have the following recommendations:

1. The proposed coax should be installed inside the monopole's shaft.
2. RRU/RRH Stipulation: The equipment may be installed in any arrangement as determined by the client.

APPURTENANCE LISTING

The proposed and existing antennas with their corresponding cables/coax lines are shown in **Table 1**. *If the actual layout determined in the field deviates from the layout, FDH Engineering, Inc. should be contacted to perform a revised analysis.*

Table 1 - Appurtenance Loading

Existing Loading:

Antenna Elevation (ft)	Description	Coax and Lines ¹	Carrier	Mount Elevation (ft)	Mount Type
137	(3) Ericsson Air 21 B2A/B4P (3) Ericsson KRY 112 144/1 TMAs	(12) 1-5/8" (1) 1-5/8" Fiber	T-Mobile	137	Flush
127	(6) Decibel DB848H90E-XY	(12) 1-5/8"	Sprint	127	Flush
117	(3) Kathrein 800-10504 (3) Kathrein 742-351	(12) 1-5/8"	Metro PCS	117	Flush
97	(3) Decibel DB856DG65E-XY (3) Antel BXA-70063/6CF	(12) 1-5/8"	Verizon	97	Flush

1. Coax installed inside pole's shaft unless otherwise noted.

Proposed Loading:

Antenna Elevation (ft)	Description	Coax and Lines	Carrier	Mount Elevation (ft)	Mount Type
107	(3) Andrew SBNHH-1D6565B (3) Ericsson KRC 118 005/1 (15) Ericsson RRUS (3) Raycap DC6-48-60-18-8F Surge Suppressors	(8) 3/4" DC Power Cables (2) 1/2" Fiber Cables	New Cingular	107	(1) Commscope MC-HPM1250-B Standoff Mount (1) Commscope RR-RM1560 Collar Mount

RESULTS

The following yield strength of steel for individual members was used for analysis:

Table 2 - Material Strength

Member Type	Yield Strength
Tower Shaft Sections	65 ksi
Base Plate	50 ksi
Anchor Bolts	75 ksi

Table 3 displays the summary of the ratio (as a percentage) of force in the member to their capacities. Values greater than 100% indicate locations where the maximum force in the member exceeds its capacity. *Note: Capacities up to 100% are considered acceptable.* **Table 4** displays the maximum foundation reactions.

If the assumptions outlined in this report differ from actual field conditions, FDH Engineering, Inc. should be contacted to perform a revised analysis. Furthermore, as no information pertaining to the allowable twist and sway requirements for the existing or proposed appurtenances was provided, deflection and rotation were not taken into consideration when performing this analysis.

See the **Appendix** for detailed modeling information.

Table 3 - Summary of Working Percentage of Structural Components

Section No.	Elevation ft	Component Type	Size	% Capacity*	Pass Fail
L1	139 - 98.75	Pole	TP25.3x16x0.1875	44.4	Pass
L2	98.75 - 48.5	Pole	TP36.53x24.1741x0.25	77.5	Pass
L3	48.5 - 0	Pole	TP47.23x34.933x0.3125	73.3	Pass
		Anchor Bolts	(12) 2.25" Ø w/ BC = 53.5"	47.9	Pass
		Base Plate	51.5" SQ PL x 2.75" thk.	63.1	Pass

*Capacities include 1/3 allowable increase for wind.

Table 4 - Maximum Base Reactions

Base Reactions	Current Analysis (TIA/EIA-222-F)	Original Design (TIA/EIA-222-F)
Axial	22 k	22 k
Shear	18 k	21 k
Moment	1,690 k-ft	2,074 k-ft

GENERAL COMMENTS

This engineering analysis is based upon the theoretical capacity of the structure. It is not a condition assessment of the tower and its foundation. It is the responsibility of SBA Network Services, Inc. to verify that the tower modeled and analyzed is the correct structure (with accurate antenna loading information) modeled. If there are substantial modifications to be made or the assumptions made in this analysis are not accurate, FDH Engineering, Inc. should be notified immediately to perform a revised analysis.

LIMITATIONS

All opinions and conclusions are considered accurate to a reasonable degree of engineering certainty based upon the evidence available at the time of this report. All opinions and conclusions are subject to revision based upon receipt of new or additional/updated information. All services are provided exercising a level of care and diligence equivalent to the standard and care of our profession. No other warranty or guarantee, expressed or implied, is offered. Our services are confidential in nature and we will not release this report to any other party without the client's consent. The use of this engineering work is limited to the express purpose for which it was commissioned and it may not be reused, copied, or distributed for any other purpose without the written consent of FDH Engineering, Inc.

APPENDIX

Section	1	2	3
Length (ft)	40.25	53.50	53.25
Number of Sides	18	18	18
Thickness (in)	0.1875	0.2500	0.3125
Socket Length (ft)	3.25	4.75	
Top Dia (in)	16.0000	24.1741	34.9330
Bot Dia (in)	25.3000	36.5300	47.2300
Grade		A572-65	
Weight (K)	1.7	4.3	7.3

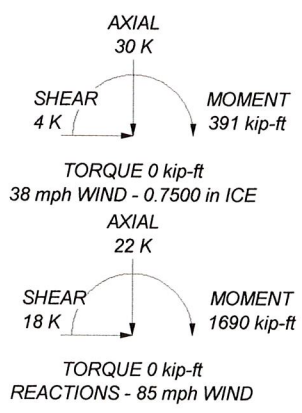
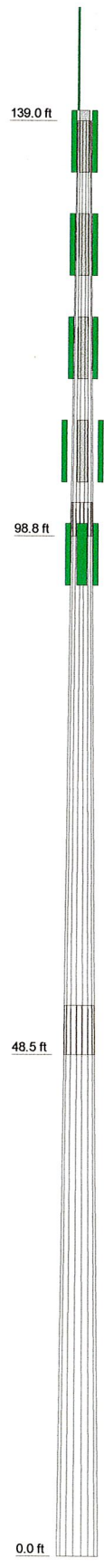

DESIGNED APPURTENANCE LOADING

TYPE	ELEVATION	TYPE	ELEVATION
Lightning Rod	140	SBNHH-1D6565B w/Mount Pipe	107
AIR 21 B2A/B4P w/Mount Pipe	137	KRC 118 005/1 w/ Mount Pipe	107
AIR 21 B2A/B4P w/Mount Pipe	137	KRC 118 005/1 w/ Mount Pipe	107
AIR 21 B2A/B4P w/Mount Pipe	137	KRC 118 005/1 w/ Mount Pipe	107
KRY 112 144/1	137	RRUS 01	107
KRY 112 144/1	137	RRUS 01	107
KRY 112 144/1	137	RRUS 01	107
(2) DB848H90E-XY w/ mount pipe	127	DC6-48-60-18-8F Surge Arrestor	107
(2) DB848H90E-XY w/ mount pipe	127	DC6-48-60-18-8F Surge Arrestor	107
(2) DB848H90E-XY w/ mount pipe	127	DC6-48-60-18-8F Surge Arrestor	107
800-10504 w/ mount pipe	117	Commscope MC-HPM1250-B	107
800-10504 w/ mount pipe	117	Commscope RR-RM1560	107
800-10504 w/ mount pipe	117	BXA-70063/6CF w/ mount pipe	97
742-351 w/ mount pipe	117	BXA-70063/6CF w/ mount pipe	97
742-351 w/ mount pipe	117	BXA-70063/6CF w/ mount pipe	97
742-351 w/ mount pipe	117	DB856DG65E-XY w/ mount pipe	97
SBNHH-1D6565B w/Mount Pipe	107	DB856DG65E-XY w/ mount pipe	97
SBNHH-1D6565B w/Mount Pipe	107	DB856DG65E-XY w/ mount pipe	97

MATERIAL STRENGTH

GRADE	Fy	Fu	GRADE	Fy	Fu
A572-65	65 ksi	80 ksi			

TOWER DESIGN NOTES

1. Tower is located in Fairfield County, Connecticut.
2. Tower designed for a 85 mph basic wind in accordance with the TIA/EIA-222-F Standard.
3. Tower is also designed for a 38 mph basic wind with 0.75 in ice. Ice is considered to increase in thickness with height.
4. Deflections are based upon a 50 mph wind.
5. TIA-G Addendum 2, Table 4-8 was used in this analysis.
6. TOWER RATING: 77.5%

 FDH Engineering, Inc. 6521 Meridien Drive Raleigh, NC 27616 Phone: 919-7551012 FAX: 919-7552031	Job: Danbury 1, CT13549-S-00
	Project: 13SCNN1400 Client: SBA Network Services, Inc. Drawn by: Logan Poe App'd: Code: TIA/EIA-222-F Date: 09/23/13 Scale: N Path: