



Aaron Meyers, Site Acquisition
c/o New Cingular Wireless, PCS LLC (AT&T)
Centerline Communications, LLC
750 W. Center St., Floor 3
West Bridgewater, MA 02379
Mobile: (774) 420-4202
ameyers@clinellc.com

DATE October 10, 2018

Melanie A. Bachman
Acting Executive Director
Connecticut Siting Council
10 Franklin Square
New Britain, CT 06051

**RE: Notice of Exempt Modification // Site Number: CT2312
52 Stadley Rough Road, Danbury, CT 06811 (Site Name: Danbury1)
N 41.433102// W -73.431916**

Dear Ms. Bachman:

New Cingular Wireless, PCS, LLC (“AT&T”) currently maintains six (6) antennas at the 107-foot level of the existing 140-foot Monopole tower at 57 Stadley Rough Road, Danbury, CT 06811. The tower is owned by SBA Communications Corp.. The property is owned by Christ the Shepherd Church PCA. AT&T now intends to replace three (3) Antennas, add three (9) Remote Radio Units, and add one (1) Surge Arrestor for its LTE upgrade. These Antennas and Remote Radio Units would be installed at the 140-foot level of the tower.

Please accept this letter as notification pursuant to Regulations of Connecticut State Agencies § 16-50j-73, for construction that constitutes an exempt modification pursuant to R.C.S.A. § 16-50j-72(b)(2). In accordance with R.C.S.A. § 16-50j-73, a copy of this letter is being sent to Mark Boughton, Mayor of Danbury, as well as the tower owner, SBA Communications Corp., and the ground owner, Christ the Shepherd Church PCA.

The planned modifications to the facility fall squarely within those activities explicitly provided for in R.C.S.A. § 16-50j-72(b)(2).

Attached to accommodate this filing are construction drawings dated August 30, 2018 by Dewberry Engineers Inc., a structural analysis dated September 26, 2018 by Tower Engineering Solutions, a mount analysis dated August 21, 2018 by B+T Group, and an Emissions Analysis Report dated October 3, 2018 by Centerline Communications, LLC.

1. The proposed modifications will not result in an increase in the height of the existing structure.

2. The proposed modifications will not require the extension of the site boundary.
3. The proposed modifications will not increase noise levels at the facility by six decibels or more, or to levels that exceed state and local criteria.
4. The operation of the replacement antennas will not increase radio frequency emissions at the facility to a level at or above the Federal Communications Commission safety standard.
5. The proposed modifications will not cause a change or alteration in the physical or environmental characteristics of the site.
6. The existing structure and its foundation can support the proposed loading as shown in the attached structural analysis by Tower Engineering Solutions, dated September 26, 2018

For the foregoing reasons, AT&T respectfully submits that the proposed modifications to the above referenced telecommunications facility constitute an exempt modification under R.C.S.A. § 16-50j-72(b)(2).

Sincerely,

Aaron Meyers, Site Acquisition
c/o New Cingular Wireless, PCS LLC (AT&T)
Centerline Communications, LLC
750 W. Center St., Floor 3
West Bridgewater, MA 02379
Mobile: (774) 420-4202
ameyers@centerlincommunications.com

Attachments

cc: Mark Boughton, Mayor of Danbury - as elected official
SBA Communications Corp. – as tower owner
Christ the Shepherd Church PCA – as property owner
Sharon Calitro, AICP, Director of Planning & Zoning – as town Planner



Radio Frequency Emissions Analysis Report

AT&T Existing Facility

Site ID: CT2312

FA#: 12676398

Danbury Stadley Rough Road
52 Stadley Rough Road
Danbury, CT 06811

October 3, 2018

Centerline Communications Project Number: 950012-174

Site Compliance Summary	
Compliance Status:	COMPLIANT
Site total MPE% of FCC general population allowable limit:	16.47 %



October 3, 2018

AT&T Mobility – New England
Attn: John Benedetto, RF Manager
550 Cochituate Road
Suite 550 – 13&14
Framingham, MA 06040

Emissions Analysis for Site: **CT2312 – Danbury Stadley Rough Road**

Centerline Communications, LLC (“Centerline”) was directed to analyze the proposed AT&T facility located at **52 Stadley Rough Road, Danbury, CT**, for the purpose of determining whether the emissions from the Proposed AT&T Antenna Installation located on this property are within specified federal limits.

All information used in this report was analyzed as a percentage of current Maximum Permissible Exposure (% MPE) as listed in the FCC OET Bulletin 65 Edition 97-01 and ANSI/IEEE Std C95.1. The FCC regulates Maximum Permissible Exposure in units of microwatts per square centimeter ($\mu\text{W}/\text{cm}^2$). The number of $\mu\text{W}/\text{cm}^2$ calculated at each sample point is called the power density. The exposure limit for power density varies depending upon the frequencies being utilized. Wireless Carriers and Paging Services use different frequency bands each with different exposure limits, therefore it is necessary to report results and limits in terms of percent MPE rather than power density.

All results were compared to the FCC (Federal Communications Commission) radio frequency exposure rules, 47 CFR 1.1307(b)(1) – (b)(3), to determine compliance with the Maximum Permissible Exposure (MPE) limits for General Population/Uncontrolled environments as defined below.

General population/uncontrolled exposure limits apply to situations in which the general population may be exposed or in which persons who are exposed as a consequence of their employment may not be made fully aware of the potential for exposure or cannot exercise control over their exposure. Therefore, members of the general population would always be considered under this category when exposure is not employment related, for example, in the case of a telecommunications tower that exposes persons in a nearby residential area.

Population exposure to radio frequencies is regulated and enforced in units of microwatts per square centimeter ($\mu\text{W}/\text{cm}^2$). The general population exposure limits for the 700 and 850 MHz Bands are approximately $467 \mu\text{W}/\text{cm}^2$ and $567 \mu\text{W}/\text{cm}^2$ respectively. The general population exposure limit for the 1900 MHz (PCS), 2100 MHz (AWS) and 2300 MHz (WCS) bands is $1000 \mu\text{W}/\text{cm}^2$. Because each carrier will be using different frequency bands, and each frequency band has different exposure limits, it is necessary to report percent of MPE rather than power density.



Occupational/controlled exposure limits apply to situations in which persons are exposed as a consequence of their employment and in which those persons who are exposed have been made fully aware of the potential for exposure and can exercise control over their exposure. Occupational/controlled exposure limits also apply where exposure is of a transient nature as a result of incidental passage through a location where exposure levels may be above general population/uncontrolled limits (see below), as long as the exposed person has been made fully aware of the potential for exposure and can exercise control over his or her exposure by leaving the area or by some other appropriate means.

Additional details can be found in FCC OET 65.



CALCULATIONS

Calculations were performed for the proposed AT&T Wireless antenna facility located at **52 Stadley Rough Road, Danbury, CT**, using the equipment information listed below. All calculations were performed per the specifications under FCC OET 65. Since AT&T is proposing highly focused directional panel antennas, which project most of the emitted energy out toward the horizon, all calculations were performed assuming a lobe representing the maximum gain of the antenna per the antenna manufactures supplied specifications, minus 10 dB, was focused at the base of the tower. For this report the sample point is the top of a 6-foot person standing at the base of the tower.

Per FCC OET Bulletin No. 65 - Edition 97-01 recommendations to achieve the maximum anticipated value at each sample point, all power levels emitting from the proposed antenna installation are increased by a factor of 2.56 to account for possible in-phase reflections from the surrounding environment. All power values expressed and analyzed are maximum power levels expected to be used on all radios.

All emissions values for additional carriers were taken from the Connecticut Siting Council (CSC) active MPE database. Values in this database are provided by the individual carriers themselves

For each sector the following channel counts, frequency bands and power levels were utilized as shown in *Table 1*:

Technology	Frequency Band	Channel Count	Transmit Power per Channel (W)
LTE	850 MHz	2	40
5G	850 MHz	2	40
LTE	2100 MHz (AWS)	4	30
LTE	1900 MHz (PCS)	4	40
LTE	700 MHz	2	40
UMTS	850 MHz	2	30
LTE	2300 MHz (WCS)	4	30

Table 1: Channel Data Table



The following antennas listed in *Table 2* were used in the modeling for transmission in the 700 MHz, 850 MHz, 1900 MHz (PCS), 2100 MHz (AWS) and 2300 MHz (WCS) frequency bands. This is based on feedback from the carrier with regards to anticipated antenna selection. Maximum gain values for all antennas are listed in the Inventory and Power Data table below. The maximum gain of the antenna per the antenna manufactures supplied specifications, minus 10 dB, was used for all calculations. This value is a very conservative estimate as gain reductions for these particular antennas are typically much higher in this direction.

Sector	Antenna Number	Antenna Make / Model	Antenna Centerline (ft)
A	1	KMW EPBQ-654L8H6-L2	107
A	2	CCI OPA-65R-LCUU-H6	107
B	1	KMW EPBQ-654L8H6-L2	107
B	2	CCI OPA-65R-LCUU-H6	107
C	1	KMW EPBQ-654L8H6-L2	107
C	2	CCI OPA-65R-LCUU-H6	107

Table 2: Antenna Data

All calculations were done with respect to uncontrolled / general population threshold limits.



RESULTS

Per the calculations completed for the proposed AT&T configurations *Table 3* shows resulting emissions power levels and percentages of the FCC's allowable general population limit.

Antenna ID	Antenna Make / Model	Frequency Bands	Antenna Gain (dBd)	Channel Count	Total TX Power (W)	ERP (W)	MPE %
Antenna A1	KMW EPBQ-654L8H6-L2	850 MHz / 2100 MHz (AWS) / 1900 MHz (PCS)	12.45 / 14.95/15.05	12	440	11,682.21	4.88
Antenna A2	CCI OPA-65R-LCUU-H6	700 MHz / 850 MHz / 2300 MHz (WCS)	11.65 / 12.45 / 15.45	8	260	6,433.52	3.02
Sector A Composite MPE%							7.90
Antenna B1	KMW EPBQ-654L8H6-L2	850 MHz / 2100 MHz (AWS) / 1900 MHz (PCS)	12.45 / 14.95/15.05	12	440	11,682.21	4.88
Antenna B2	CCI OPA-65R-LCUU-H6	700 MHz / 850 MHz / 2300 MHz (WCS)	11.65 / 12.45 / 15.45	8	260	6,433.52	3.02
Sector B Composite MPE%							7.90
Antenna C1	KMW EPBQ-654L8H6-L2	850 MHz / 2100 MHz (AWS) / 1900 MHz (PCS)	12.45 / 14.95/15.05	12	440	11,682.21	4.88
Antenna C2	CCI OPA-65R-LCUU-H6	700 MHz / 850 MHz / 2300 MHz (WCS)	11.65 / 12.45 / 15.45	8	260	6,433.52	3.02
Sector C Composite MPE%							7.90

Table 3: AT&T Emissions Levels



The Following table (*table 4*) shows all additional carriers on site and their MPE% as recorded in the CSC active MPE database for this facility along with the newly calculated maximum AT&T MPE contributions per this report. FCC OET 65 specifies that for carriers utilizing directional antennas that the highest recorded sector value be used for composite site MPE values due to their greatly reduced emissions contributions in the directions of the adjacent sectors. For this site, all three sectors have the same configuration yielding the same results on all three sectors. *Table 5* below shows a summary for each AT&T Sector as well as the composite MPE value for the site.

Site Composite MPE%	
Carrier	MPE%
AT&T – Max Sector Value	7.90 %
T-Mobile	2.27 %
Clearwire	0.18 %
MetroPCS	0.39 %
Verizon Wireless	5.73 %
Site Total MPE %:	16.47 %

Table 4: All Carrier MPE Contributions

AT&T Sector A Total:	7.90 %
AT&T Sector B Total:	7.90 %
AT&T Sector C Total:	7.90 %
Site Total:	16.47 %

Table 5: Site MPE Summary



FCC OET 65 specifies that for carriers utilizing directional antennas that the highest recorded sector value be used for composite site MPE values due to their greatly reduced emissions contributions in the directions of the adjacent sectors. *Table 6* below details a breakdown by frequency band and technology for the MPE power values for the maximum calculated AT&T sector(s). For this site, all three sectors have the same configuration yielding the same results on all three sectors.

AT&T _ Frequency Band / Technology Max Power Values (Per Sector)	# Channels	Watts ERP (Per Channel)	Height (feet)	Total Power Density ($\mu\text{W}/\text{cm}^2$)	Frequency (MHz)	Allowable MPE ($\mu\text{W}/\text{cm}^2$)	Calculated % MPE
AT&T 850 MHz LTE – Antenna 1	2	703.17	107	4.97	850 MHz	567	0.88%
AT&T 850 MHz 5G – Antenna 1	2	703.17	107	4.97	850 MHz	567	0.88%
AT&T 2100 MHz (AWS) LTE – Antenna 1	4	937.82	107	13.22	2100 MHz (AWS)	1000	1.32%
AT&T 1900 MHz (PCS) LTE – Antenna 1	4	1,279.56	107	18.04	1900 MHz (PCS)	1000	1.80%
AT&T 700 MHz LTE – Antenna 2	2	584.87	107	4.12	700 MHz	467	0.88%
AT&T 850 MHz UMTS – Antenna 2	2	527.38	107	3.72	850 MHz	567	0.66%
AT&T 2300 MHz (WCS) LTE – Antenna 2	4	1,052.26	107	14.83	2300 MHz (WCS)	1000	1.48%
						Total:	7.90%

Table 6: AT&T Maximum Sector MPE Power Values



Summary

All calculations performed for this analysis yielded results that were **within** the allowable limits for general population exposure to RF Emissions.

The anticipated maximum composite contributions from the AT&T facility as well as the site composite emissions value with regards to compliance with FCC's allowable limits for general population exposure to RF Emissions are shown here:

AT&T Sector	Power Density Value (%)
Sector A:	7.90 %
Sector B:	7.90 %
Sector C:	7.90 %
AT&T Maximum Total (per sector):	7.90 %
Site Total:	16.47 %
Site Compliance Status:	COMPLIANT

The anticipated composite MPE value for this site assuming all carriers present is **16.47 %** of the allowable FCC established general population limit sampled at the ground level. This is based upon values listed in the Connecticut Siting Council database for existing carrier emissions.

FCC guidelines state that if a site is found to be out of compliance (over allowable thresholds), that carriers over a 5% contribution to the composite value will require measures to bring the site into compliance. For this facility, the composite values calculated were well within the allowable 100% threshold standard per the federal government.

A handwritten signature in black ink, appearing to read 'Scott Heffernan', is positioned above the contact information.

Scott Heffernan
RF Engineering Director
Centerline Communications, LLC
95 Ryan Drive, Suite 1
Raynham, MA 02767



August 21, 2018

Meredith Paynter
Centerline Communications LLC
95 Ryan Drive, Suite 1
Raynham, MA 02767
(508) 386-0863

B+T Group
1717 S. Boulder, Suite 300
Tulsa, OK 74119
(918) 587-4630
btwo@btgrp.com

Subject: Appurtenance Mount Analysis Report

Carrier Designation: **Site Number:** CT-2312D/12676398
Site Name: Danbury

Engineering Firm Designation: **B+T Group Project Number:** 127404.002.01

Site Data: **52 Stadley Rough Road, Danbury, CT, 06811, Fairfield County**
Latitude 41.43310°, Longitude -73.43191°
Monopole
(3) 5.5' T-Arm Mount

Dear Mr. Paynter,

B+T Group is pleased to submit this “Appurtenance Mount Analysis Report” to determine the structural integrity of the antenna mount on the above-mentioned structure.

The purpose of the analysis is to determine acceptability of the mount’s stress level. Based on our analysis we have determined the stress level for the mount under the following load case to be:

Existing + Proposed Equipment

Note: See Table 1 for the final loading configuration

Sufficient Capacity
(Passing at 88.0%)

This analysis has been performed in accordance with the 2012 International Building Code based upon an ultimate 3-second gust wind speed of 120 mph converted to a nominal 3-second gust wind speed of 93 mph per section 1609.3.1 as required for use in the ANSI/TIA-222-G Standard per Exception #5 of Section 1609.1.1. Exposure Category C and Risk Category II were used in this analysis.

All the equipment proposed in this report shall be installed in accordance with the drawings for the determined available structural capacity to be effective.

We at B+T Group appreciate the opportunity of providing our continuing professional services to you and Centerline Communications LLC. If you have any questions or need further assistance on this or any other projects, please give us a call.

Mount structural analysis prepared by: Suman Rana, E.I.T

Respectfully submitted by: B&T Engineering, Inc.
COA: PEC.0001564 Expires: 02/10/2019

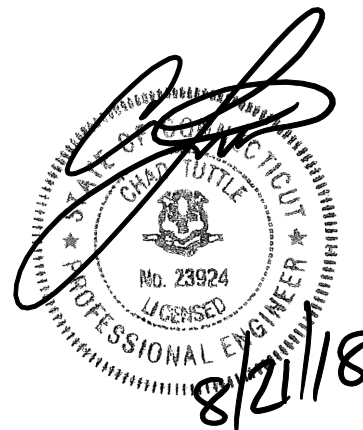

Chad E. Tuttle, P.E.

TABLE OF CONTENTS

1) INTRODUCTION

2) ANALYSIS CRITERIA

Table 1 - Proposed and Existing Equipment Information

Table 2 - Documents Provided

3) ANALYSIS PROCEDURE

3.1) Analysis Method

3.2) Assumptions

4) ANALYSIS RESULTS

Table 3 – Mount Component Stresses vs. Capacity

5) RECOMMENDATIONS

6) APPENDIX A

RISA-3D Output

1) INTRODUCTION

The appurtenance mount consists of T-Arm mounts at 109 ft., attached to monopole at 52 Stadley Rough Road, Danbury, CT, 06811, Fairfield County. The proposed antenna loading information was obtained from Centerline Communications LLC. All information provided to B+T Group was assumed accurate and complete.

2) ANALYSIS CRITERIA

The structural analysis was performed for this mount in accordance with the ANSI/TIA-222-G-2-2005 Structural Standard for Antenna Supporting Structures and Antennas – Addendum 2 using a 3-second gust nominal wind speed of 93 mph with no ice and 50 mph with 0.75 in radial ice. The mount was analyzed under 30° increments in the wind direction. The analyzed loading is detailed in Table 1.

Table 1 – Proposed and Existing Equipment Information

Loading	RAD Center Elev. (ft.)	Position	Qty.	Manufacturer	Model / Type	Note
Proposed	110	1	3	KMW	EPBQ-654L8H6-L2	1
			3	Ericsson	B5/B12 4449	2
			3	Ericsson	4426 B66	
		2	3	Ericsson	RRUS-32	--
		--	2	Raycap	DC6-48-60-18-8F	
Existing	110	2	3	CCI	OPA-65R-LCUU-H6	3
			3	CCI	DTMABP7819VG12A	
			6	CCI	TPX-070821	
		--	3	Ericsson	RRUS-12+RRUS-A2	4
			3	Ericsson	RRUS-11	
			1	Raycap	DC6-48-60-18-8F	

Note:

- (1) Proposed Antenna to be installed on the existing Mount Pipe.
- (2) Proposed Equipment to be installed directly behind the Antenna.
- (3) Existing Equipment installed on the Mount.
- (4) Existing Equipment installed on the Tower.

Table 2 - Documents Provided

Documents	Remarks	Reference	Source
RFDS	Existing Loading Proposed Loading	Date: 05/01/2018	Centerline Communications LLC.
Mount Mapping	B+T Group	Date: 08/09/2018	On file

3) ANALYSIS PROCEDURE

3.1) Analysis Method

RISA-3D (Version 16.0.5), a commercially available analysis software package, was used to create a three-dimensional model of the mount and calculate member stresses and deflections for various loading cases. Selected output from the analysis is included in Appendix A.

3.2) Assumptions

1. The mount was built in accordance with the manufacturer's specifications.
2. The mount has been maintained in accordance with the manufacturer's specifications and is free of damage.
3. The configuration of antennas and other appurtenances are as specified in Table 1.
4. All mount components have been assumed to be in sufficient condition to carry their full design capacity for the analysis.
5. Mount areas and weights are determined from field measurements, standard material properties, and/or manufacturer product data.
6. Serviceability with respect to antenna twist, tilt, roll or lateral translation is not checked and is left to the carrier or tower owner to ensure conformance.
7. All prior structural modifications, if any are assumed to be correctly installed and fully effective.
8. All member connections are assumed to have been designed to meet or exceed the load carrying capacity of the connected member unless otherwise specified in this report.
9. The following material grades were assumed (Unless Noted Otherwise):
 - a) Connection Bolts : ASTM A325
 - b) Steel Pipe : ASTM A53 (GR. 35)
 - c) HSS (Round) : ASTM 500 (GR. B-42)
 - d) HSS (Rectangular) : ASTM 500 (GR. B-46)
 - e) Channel : ASTM A36 (GR. 36)
 - f) Steel Solid Rod : ASTM A36 (GR. 36)
 - g) Steel Plate : ASTM A36 (GR. 36)
 - h) Steel Angle : ASTM A36 (GR. 36)
 - i) UNISTRUT : ASTM A570 (GR. 33)

This analysis may be affected if any assumptions are not valid or have been made in error. B+T Group should be notified to determine the effect on the structural integrity of the antenna mounting system.

4) ANALYSIS RESULTS

Table 3 – Mount Component Stresses vs. Capacity

Notes	Component	Elevation (ft.)	% Capacity	Pass / Fail
-	Face Horizontal	109	18.0	Pass
-	Support Tube	109	24.7	Pass
-	Mount Pipes	109	88.0	Pass

5) RECOMMENDATIONS

The mount has sufficient capacity to carry the existing and proposed loads and is in compliance with the ANSI/TIA-222-G standard for the proposed and existing loading. (Refer to the RISA output for the specific members).

APPENDIX A

(RISA-3D Output)

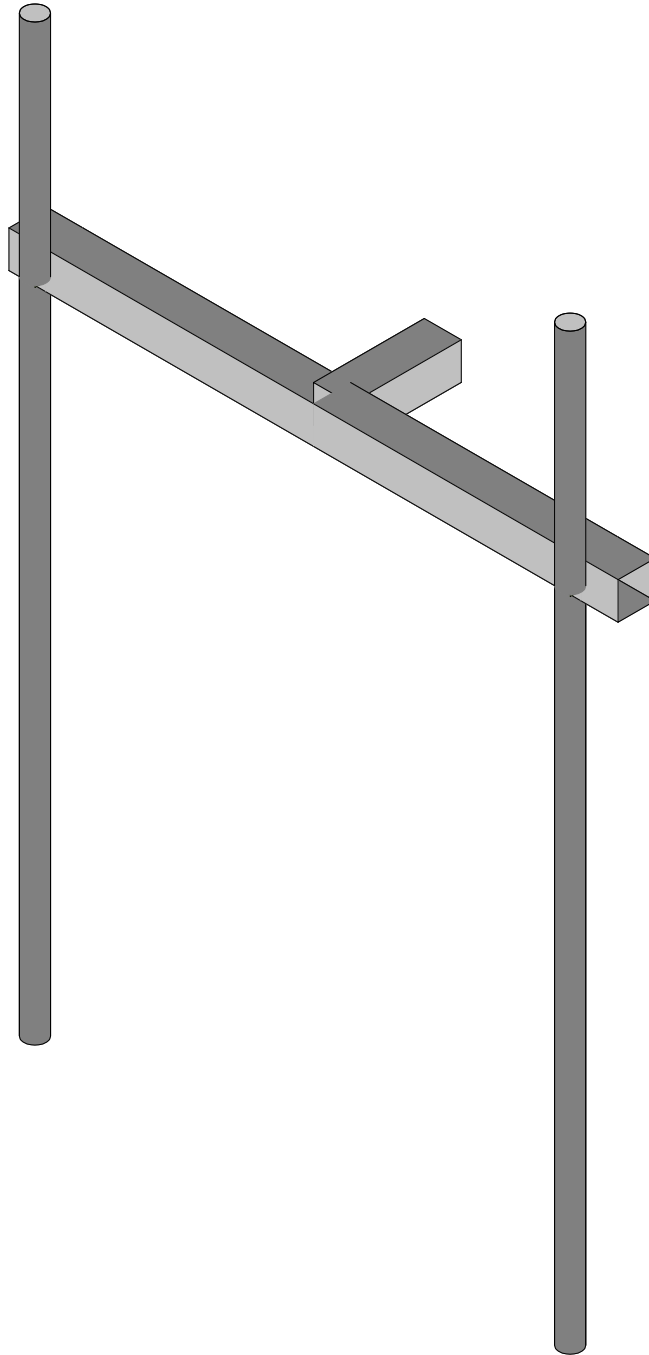
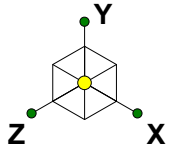

Loads: BLC 20,
Envelope Only Solution

B+T Group
SR
127404.002.01

CT-2312D - Danbury

SK - 1
Aug 21, 2018 at 4:30 PM
127404_002_01_Danbury_CT.R3D

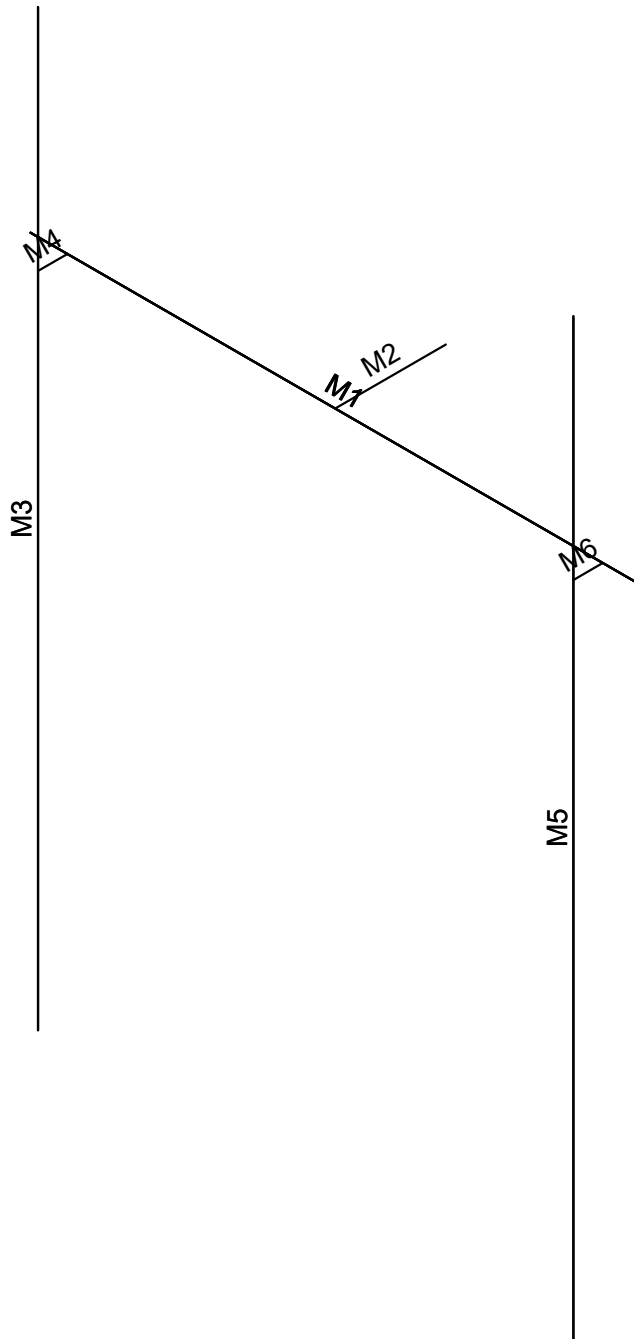
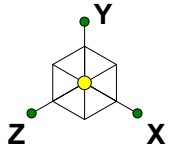

Loads: BLC 20,
Envelope Only Solution

B+T Group
SR
127404.002.01

CT-2312D - Danbury

SK - 2
Aug 21, 2018 at 4:30 PM
127404_002_01_Danbury_CT.R3D

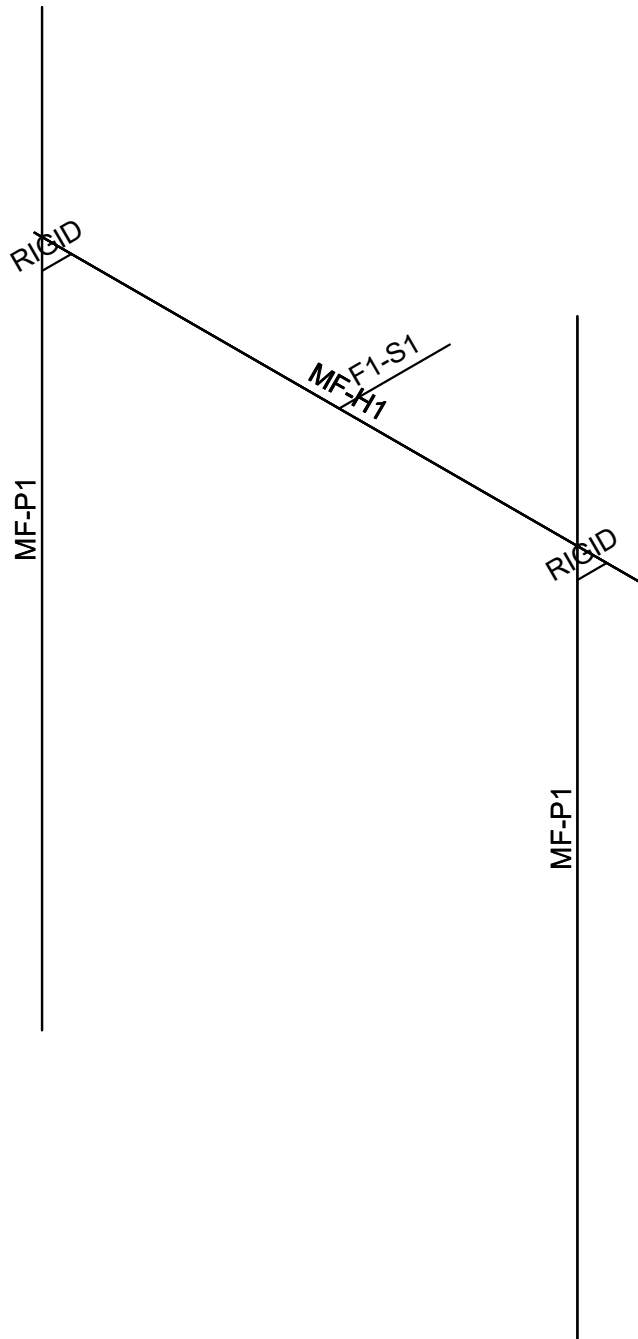
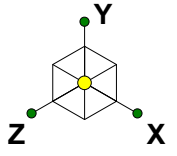

Loads: BLC 20,
Envelope Only Solution

B+T Group
SR
127404.002.01

CT-2312D - Danbury

SK - 4
Aug 21, 2018 at 4:30 PM
127404_002_01_Danbury_CT.R3D

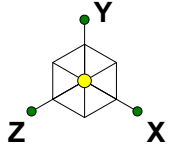

Code Check (Env)	
Black	No Calc
Red	> 1.0
Magenta	.90-1.0
Green	.75-.90
Cyan	.50-.75
Blue	0.-.50

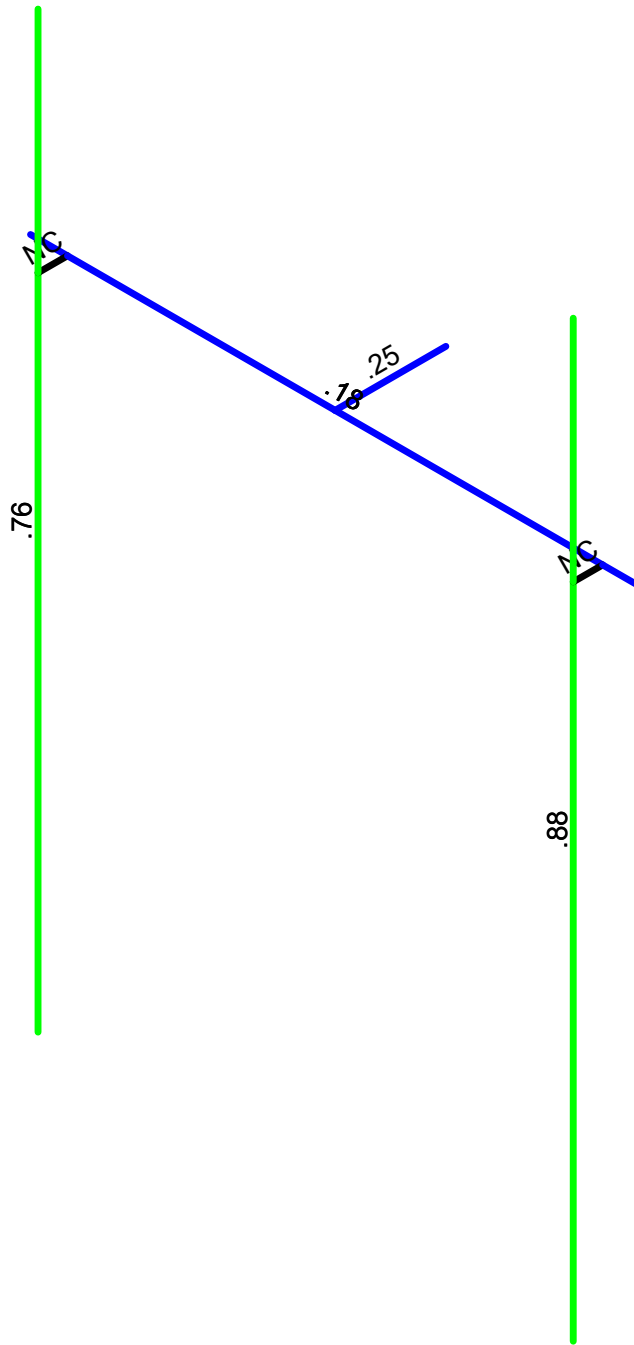

Member Code Checks Displayed (Enveloped)
 Loads: BLC 20,
 Envelope Only Solution

B+T Group	CT-2312D - Danbury	SK - 5
SR		Aug 21, 2018 at 4:30 PM
127404.002.01		127404_002_01_Danbury_CT.R3D

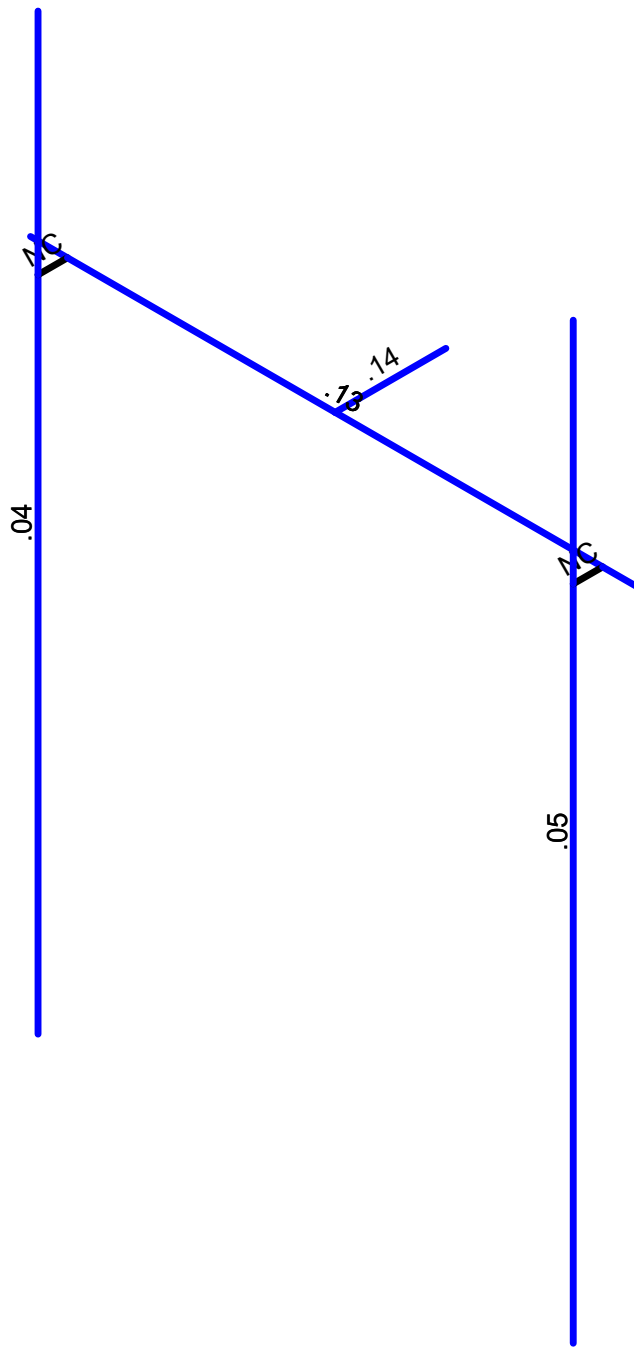
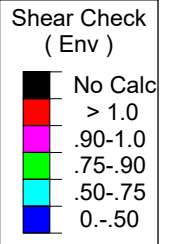
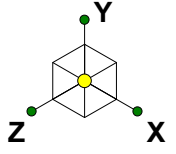

Member Shear Checks Displayed (Enveloped)
 Loads: BLC 20,
 Envelope Only Solution

B+T Group	CT-2312D - Danbury	SK - 6
SR		Aug 21, 2018 at 4:31 PM
127404.002.01		127404_002_01_Danbury_CT.R3D



Hot Rolled Steel Section Sets

	Label	Shape	Type	Design List	Material	Design Ru...	A [in2]	Iyy [in4]	Izz [in4]	J [in4]
1	MF-H1	HSS4x4x4	Beam	Tube	A500 Gr.B Rect	Typical	3.37	7.8	7.8	12.8
2	MF-P1	PIPE 2.0	Column	Pipe	A53 Gr.B	Typical	1.02	.627	.627	1.25
3	F1-S1	HSS4x4x4	Beam	Tube	A500 Gr.B Rect	Typical	3.37	7.8	7.8	12.8

Member Primary Data

	Label	I Joint	J Joint	K Joint	Rotate(deg)	Section/Shape	Type	Design List	Material	Design Rules
1	M1	N1	N2			MF-H1	Beam	Tube	A500 Gr.B...	Typical
2	M2	N3	N4			F1-S1	Beam	Tube	A500 Gr.B...	Typical
3	M3	N5	N6			MF-P1	Column	Pipe	A53 Gr.B	Typical
4	M4	N7	N8			RIGID	None	None	RIGID	Typical
5	M5	N9	N10			MF-P1	Column	Pipe	A53 Gr.B	Typical
6	M6	N11	N12			RIGID	None	None	RIGID	Typical

Basic Load Cases

	BLC Description	Category	X Gravity	Y Gravity	Z Gravity	Joint	Point	Distributed Area(Me...	Surface(P...
1	Dead	DL		-1			15		
2	0 Wind - No Ice	WLZ					15	4	
3	90 Wind - No Ice	WLX					15	4	
4	0 Wind - Ice	WLZ					15	4	
5	90 Wind - Ice	WLX					15	4	
6	0 Wind - Service	WLZ					15	4	
7	90 Wind - Service	WLX					15	4	
8	Ice	OL1					15	4	
9	Live Load a	LL							
10	Live Load b	LL							
11	Live Load c	LL							
12	Live Load d	LL							
13	Maint LL 1	LL							
14	Maint LL 2	LL							
15	Maint LL 3	LL							
16	Maint LL 4	LL							
17	Maint LL 5	LL							
18	Maint LL 6	LL							

Load Combinations

	Description	S...	PDelta	S...B...Factor	B...F...	B...F...	B...F...	B...F...	B...F...	B...F...	B...F...	B...F...	B...F...	B...F...
1	1.4 Dead	Y...	Y	1	1.4									
2	0.9 D + 1.6 - 0 W	Y...	Y	1	.9	2	1.6							
3	0.9 D + 1.6 - 30 W	Y...	Y	1	.9	2	1...	3	.8					
4	0.9 D + 1.6 - 60 W	Y...	Y	1	.9	3	1...	2	.8					
5	0.9 D + 1.6 - 90 W	Y...	Y	1	.9	3	1.6							
6	0.9 D + 1.6 - 120 W	Y...	Y	1	.9	3	1...	2	-.8					
7	0.9 D + 1.6 - 150 W	Y...	Y	1	.9	2	-1...	3	.8					
8	0.9 D + 1.6 - 180 W	Y...	Y	1	.9	2	-1.6							
9	0.9 D + 1.6 - 210 W	Y...	Y	1	.9	2	-1...	3	-.8					
10	0.9 D + 1.6 - 240 W	Y...	Y	1	.9	3	-1...	2	-.8					
11	0.9 D + 1.6 - 270 W	Y...	Y	1	.9	3	-1.6							
12	0.9 D + 1.6 - 300 W	Y...	Y	1	.9	3	-1...	2	.8					
13	0.9 D + 1.6 - 330 W	Y...	Y	1	.9	2	1...	3	-.8					
14	1.2 D + 1.6 - 0 W	Y...	Y	1	1.2	2	1.6							
15	1.2 D + 1.6 - 30 W	Y...	Y	1	1.2	2	1...	3	.8					



Company : B+T Group
 Designer : SR
 Job Number : 127404.002.01
 Model Name : CT-2312D - Danbury

Aug 21, 2018
 4:31 PM
 Checked By: _____

Load Combinations (Continued)

Description	S...	PDelta	S...B...Factor	B...F...	B...F...	B...F...	B...F...	B...F...	B...F...	B...F...	B...F...	B...F...	B...F...	B...F...	B...F...
16	1.2 D + 1.6 - 60 W	Y...	Y	1	1.2	3	1...	2	.8						
17	1.2 D + 1.6 - 90 W	Y...	Y	1	1.2	3	1.6								
18	1.2 D + 1.6 - 120 W	Y...	Y	1	1.2	3	1...	2	-.8						
19	1.2 D + 1.6 - 150 W	Y...	Y	1	1.2	2	-1...	3	.8						
20	1.2 D + 1.6 - 180 W	Y...	Y	1	1.2	2	-1.6								
21	1.2 D + 1.6 - 210 W	Y...	Y	1	1.2	2	-1...	3	-.8						
22	1.2 D + 1.6 - 240 W	Y...	Y	1	1.2	3	-1...	2	-.8						
23	1.2 D + 1.6 - 270 W	Y...	Y	1	1.2	3	-1.6								
24	1.2 D + 1.6 - 300 W	Y...	Y	1	1.2	3	-1...	2	.8						
25	1.2 D + 1.6 - 330 W	Y...	Y	1	1.2	2	1...	3	-.8						
26	0.9 D + 1.6 - 0 W/Ice	Y...	Y	1	.9	4	1.6			8	1				
27	0.9 D + 1.6 - 30 W/Ice	Y...	Y	1	.9	4	1...	5	.8	8	1				
28	0.9 D + 1.6 - 60 W/Ice	Y...	Y	1	.9	5	1...	4	.8	8	1				
29	0.9 D + 1.6 - 90 W/Ice	Y...	Y	1	.9	5	1.6			8	1				
30	0.9 D + 1.6 - 120 W/Ice	Y...	Y	1	.9	5	1...	4	-.8	8	1				
31	0.9 D + 1.6 - 150 W/Ice	Y...	Y	1	.9	4	-1...	5	.8	8	1				
32	0.9 D + 1.6 - 180 W/Ice	Y...	Y	1	.9	4	-1.6			8	1				
33	0.9 D + 1.6 - 210 W/Ice	Y...	Y	1	.9	4	-1...	5	-.8	8	1				
34	0.9 D + 1.6 - 240 W/Ice	Y...	Y	1	.9	5	-1...	4	-.8	8	1				
35	0.9 D + 1.6 - 270 W/Ice	Y...	Y	1	.9	5	-1.6			8	1				
36	0.9 D + 1.6 - 300 W/Ice	Y...	Y	1	.9	5	-1...	4	.8	8	1				
37	0.9 D + 1.6 - 330 W/Ice	Y...	Y	1	.9	4	1...	5	-.8	8	1				
38	1.2 D + 1.0 - 0 W/Ice	Y...	Y	1	1.2	4	1			8	1				
39	1.2 D + 1.0 - 30 W/Ice	Y...	Y	1	1.2	4	.8...	5	.5	8	1				
40	1.2 D + 1.0 - 60 W/Ice	Y...	Y	1	1.2	5	.8...	4	.5	8	1				
41	1.2 D + 1.0 - 90 W/Ice	Y...	Y	1	1.2	5	1			8	1				
42	1.2 D + 1.0 - 120 W/Ice	Y...	Y	1	1.2	5	.8...	4	-.5	8	1				
43	1.2 D + 1.0 - 150 W/Ice	Y...	Y	1	1.2	4	----	5	.5	8	1				
44	1.2 D + 1.0 - 180 W/Ice	Y...	Y	1	1.2	4	-1			8	1				
45	1.2 D + 1.0 - 210 W/Ice	Y...	Y	1	1.2	4	----	5	-.5	8	1				
46	1.2 D + 1.0 - 240 W/Ice	Y...	Y	1	1.2	5	----	4	-.5	8	1				
47	1.2 D + 1.0 - 270 W/Ice	Y...	Y	1	1.2	5	-1			8	1				
48	1.2 D + 1.0 - 300 W/Ice	Y...	Y	1	1.2	5	----	4	.5	8	1				
49	1.2 D + 1.0 - 330 W/Ice	Y...	Y	1	1.2	4	.8...	5	-.5	8	1				
50	1.2 D + 1.5 LL a + Service - 0 W	Y...	Y	1	1.2	6	1			9	1.5				
51	1.2 D + 1.5 LL a + Service - 30 W	Y...	Y	1	1.2	6	.8...	7	.5	9	1.5				
52	1.2 D + 1.5 LL a + Service - 60 W	Y...	Y	1	1.2	7	.8...	6	.5	9	1.5				
53	1.2 D + 1.5 LL a + Service - 90 W	Y...	Y	1	1.2	7	1			9	1.5				
54	1.2 D + 1.5 LL a + Service - 120 W	Y...	Y	1	1.2	7	.8...	6	-.5	9	1.5				
55	1.2 D + 1.5 LL a + Service - 150 W	Y...	Y	1	1.2	6	----	7	.5	9	1.5				
56	1.2 D + 1.5 LL a + Service - 180 W	Y...	Y	1	1.2	6	-1			9	1.5				
57	1.2 D + 1.5 LL a + Service - 210 W	Y...	Y	1	1.2	6	----	7	-.5	9	1.5				
58	1.2 D + 1.5 LL a + Service - 240 W	Y...	Y	1	1.2	7	----	6	-.5	9	1.5				
59	1.2 D + 1.5 LL a + Service - 270 W	Y...	Y	1	1.2	7	-1			9	1.5				
60	1.2 D + 1.5 LL a + Service - 300 W	Y...	Y	1	1.2	7	----	6	.5	9	1.5				
61	1.2 D + 1.5 LL a + Service - 330 W	Y...	Y	1	1.2	6	.8...	7	-.5	9	1.5				
62	1.2 D + 1.5 LL b + Service - 0 W	Y...	Y	1	1.2	6	1			10	1.5				
63	1.2 D + 1.5 LL b + Service - 30 W	Y...	Y	1	1.2	6	.8...	7	.5	10	1.5				
64	1.2 D + 1.5 LL b + Service - 60 W	Y...	Y	1	1.2	7	.8...	6	.5	10	1.5				
65	1.2 D + 1.5 LL b + Service - 90 W	Y...	Y	1	1.2	7	1			10	1.5				
66	1.2 D + 1.5 LL b + Service - 120 W	Y...	Y	1	1.2	7	.8...	6	-.5	10	1.5				
67	1.2 D + 1.5 LL b + Service - 150 W	Y...	Y	1	1.2	6	----	7	.5	10	1.5				
68	1.2 D + 1.5 LL b + Service - 180 W	Y...	Y	1	1.2	6	-1			10	1.5				
69	1.2 D + 1.5 LL b + Service - 210 W	Y...	Y	1	1.2	6	----	7	-.5	10	1.5				
70	1.2 D + 1.5 LL b + Service - 240 W	Y...	Y	1	1.2	7	----	6	-.5	10	1.5				
71	1.2 D + 1.5 LL b + Service - 270 W	Y...	Y	1	1.2	7	-1			10	1.5				
72	1.2 D + 1.5 LL b + Service - 300 W	Y...	Y	1	1.2	7	----	6	.5	10	1.5				



Load Combinations (Continued)

Description	S...	PDelta	S...B...	Factor	B...F...	B...F...	B...F...	B...F...	B...F...	B...F...	B...F...	B...F...	B...F...	B...F...	B...F...
73	1.2 D + 1.5 LL b + Service - 330 W	Y...	Y	1	1.2	6	.8...	7	-.5	10	1.5				
74	1.2 D + 1.5 LL c + Service - 0 W	Y...	Y	1	1.2	6	1			11	1.5				
75	1.2 D + 1.5 LL c + Service - 30 W	Y...	Y	1	1.2	6	.8...	7	.5	11	1.5				
76	1.2 D + 1.5 LL c + Service - 60 W	Y...	Y	1	1.2	7	.8...	6	.5	11	1.5				
77	1.2 D + 1.5 LL c + Service - 90 W	Y...	Y	1	1.2	7	1			11	1.5				
78	1.2 D + 1.5 LL c + Service - 120 W	Y...	Y	1	1.2	7	.8...	6	-.5	11	1.5				
79	1.2 D + 1.5 LL c + Service - 150 W	Y...	Y	1	1.2	6	----	7	.5	11	1.5				
80	1.2 D + 1.5 LL c + Service - 180 W	Y...	Y	1	1.2	6	-1			11	1.5				
81	1.2 D + 1.5 LL c + Service - 210 W	Y...	Y	1	1.2	6	----	7	-.5	11	1.5				
82	1.2 D + 1.5 LL c + Service - 240 W	Y...	Y	1	1.2	7	----	6	-.5	11	1.5				
83	1.2 D + 1.5 LL c + Service - 270 W	Y...	Y	1	1.2	7	-1			11	1.5				
84	1.2 D + 1.5 LL c + Service - 300 W	Y...	Y	1	1.2	7	----	6	.5	11	1.5				
85	1.2 D + 1.5 LL c + Service - 330 W	Y...	Y	1	1.2	6	.8...	7	-.5	11	1.5				
86	1.2 D + 1.5 LL d + Service - 0 W	Y...	Y	1	1.2	6	1			12	1.5				
87	1.2 D + 1.5 LL d + Service - 30 W	Y...	Y	1	1.2	6	.8...	7	.5	12	1.5				
88	1.2 D + 1.5 LL d + Service - 60 W	Y...	Y	1	1.2	7	.8...	6	.5	12	1.5				
89	1.2 D + 1.5 LL d + Service - 90 W	Y...	Y	1	1.2	7	1			12	1.5				
90	1.2 D + 1.5 LL d + Service - 120 W	Y...	Y	1	1.2	7	.8...	6	-.5	12	1.5				
91	1.2 D + 1.5 LL d + Service - 150 W	Y...	Y	1	1.2	6	----	7	.5	12	1.5				
92	1.2 D + 1.5 LL d + Service - 180 W	Y...	Y	1	1.2	6	-1			12	1.5				
93	1.2 D + 1.5 LL d + Service - 210 W	Y...	Y	1	1.2	6	----	7	-.5	12	1.5				
94	1.2 D + 1.5 LL d + Service - 240 W	Y...	Y	1	1.2	7	----	6	-.5	12	1.5				
95	1.2 D + 1.5 LL d + Service - 270 W	Y...	Y	1	1.2	7	-1			12	1.5				
96	1.2 D + 1.5 LL d + Service - 300 W	Y...	Y	1	1.2	7	----	6	.5	12	1.5				
97	1.2 D + 1.5 LL d + Service - 330 W	Y...	Y	1	1.2	6	.8...	7	-.5	12	1.5				
98	1.2 D + 1.5 LL Maint (1)	Y...	Y	1	1.2					13	1.5				
99	1.2 D + 1.5 LL Maint (2)	Y...	Y	1	1.2					14	1.5				
100	1.2 D + 1.5 LL Maint (3)	Y...	Y	1	1.2					15	1.5				
101	1.2 D + 1.5 LL Maint (4)	Y...	Y	1	1.2					16	1.5				
102	1.2 D + 1.5 LL Maint (5)	Y...	Y	1	1.2					17	1.5				
103	1.2 D + 1.5 LL Maint (6)	Y...	Y	1	1.2					18	1.5				

Member Point Loads (BLC 1 : Dead)

Member Label	Direction	Magnitude[k,k-ft]	Location[in,%]	
1	M5	Y	-036	%15
2	M5	Y	-036	%85
3	M5	Y	-075	%40
4	M5	Y	-048	%40
5	M5	Y	0	0
6	M3	Y	-044	%20
7	M3	Y	-044	%80
8	M3	Y	-055	%40
9	M3	Y	-019	%70
10	M3	Y	-015	%60
11	M1	Y	-033	%20
12	M1	Y	0	0
13	M1	Y	0	0
14	M1	Y	0	0
15	M1	Y	0	0

Member Point Loads (BLC 2 : 0 Wind - No Ice)

Member Label	Direction	Magnitude[k,k-ft]	Location[in,%]	
1	M5	Z	-18	%15
2	M5	Z	-18	%85
3	M5	Z	-046	%40



Member Point Loads (BLC 2 : 0 Wind - No Ice) (Continued)

	Member Label	Direction	Magnitude[k,k-ft]	Location[in, %]
4	M5	Z	-.02	%40
5	M5	Z	0	0
6	M3	Z	-.131	%20
7	M3	Z	-.131	%80
8	M3	Z	-.048	%40
9	M3	Z	-.026	%70
10	M3	Z	-.025	%60
11	M1	Z	-.033	%20
12	M1	Z	0	0
13	M1	Z	0	0
14	M1	Z	0	0
15	M1	Z	0	0

Member Point Loads (BLC 3 : 90 Wind - No Ice)

	Member Label	Direction	Magnitude[k,k-ft]	Location[in, %]
1	M5	X	-.054	%15
2	M5	X	-.054	%85
3	M5	X	-.054	%40
4	M5	X	-.045	%40
5	M5	X	0	0
6	M3	X	-.08	%20
7	M3	X	-.08	%80
8	M3	X	-.081	%40
9	M3	X	-.009	%70
10	M3	X	-.005	%60
11	M1	X	-.033	%20
12	M1	X	0	0
13	M1	X	0	0
14	M1	X	0	0
15	M1	X	0	0

Member Point Loads (BLC 4 : 0 Wind - Ice)

	Member Label	Direction	Magnitude[k,k-ft]	Location[in, %]
1	M5	Z	-.063	%15
2	M5	Z	-.063	%85
3	M5	Z	-.021	%40
4	M5	Z	-.011	%40
5	M5	Z	0	0
6	M3	Z	-.048	%20
7	M3	Z	-.048	%80
8	M3	Z	-.023	%40
9	M3	Z	-.013	%70
10	M3	Z	-.016	%60
11	M1	Z	-.014	%20
12	M1	Z	0	0
13	M1	Z	0	0
14	M1	Z	0	0
15	M1	Z	0	0

Member Point Loads (BLC 5 : 90 Wind - Ice)

	Member Label	Direction	Magnitude[k,k-ft]	Location[in, %]
1	M5	X	-.025	%15
2	M5	X	-.025	%85
3	M5	X	-.023	%40
4	M5	X	-.02	%40



Member Point Loads (BLC 5 : 90 Wind - Ice) (Continued)

	Member Label	Direction	Magnitude[k,k-ft]	Location[in, %]
5	M5	X	0	0
6	M3	X	-.033	%20
7	M3	X	-.033	%80
8	M3	X	-.033	%40
9	M3	X	-.007	%70
10	M3	X	-.006	%60
11	M1	X	-.014	%20
12	M1	X	0	0
13	M1	X	0	0
14	M1	X	0	0
15	M1	X	0	0

Member Point Loads (BLC 6 : 0 Wind - Service)

	Member Label	Direction	Magnitude[k,k-ft]	Location[in, %]
1	M5	Z	-.019	%15
2	M5	Z	-.019	%85
3	M5	Z	-.005	%40
4	M5	Z	-.002	%40
5	M5	Z	0	0
6	M3	Z	-.013	%20
7	M3	Z	-.013	%80
8	M3	Z	-.005	%40
9	M3	Z	-.003	%70
10	M3	Z	-.003	%60
11	M1	Z	-.003	%20
12	M1	Z	0	0
13	M1	Z	0	0
14	M1	Z	0	0
15	M1	Z	0	0

Member Point Loads (BLC 7 : 90 Wind - Service)

	Member Label	Direction	Magnitude[k,k-ft]	Location[in, %]
1	M5	X	-.006	%15
2	M5	X	-.006	%85
3	M5	X	-.006	%40
4	M5	X	-.005	%40
5	M5	X	0	0
6	M3	X	-.008	%20
7	M3	X	-.008	%80
8	M3	X	-.008	%40
9	M3	X	-.0009	%70
10	M3	X	-.0006	%60
11	M1	X	-.003	%20
12	M1	X	0	0
13	M1	X	0	0
14	M1	X	0	0
15	M1	X	0	0

Member Point Loads (BLC 8 : Ice)

	Member Label	Direction	Magnitude[k,k-ft]	Location[in, %]
1	M5	Y	-.148	%15
2	M5	Y	-.148	%85
3	M5	Y	-.059	%40
4	M5	Y	-.042	%40
5	M5	Y	0	0



Member Point Loads (BLC 8 : Ice) (Continued)

	Member Label	Direction	Magnitude[k,k-ft]	Location[in, %]
6	M3	Y	-.118	%20
7	M3	Y	-.118	%80
8	M3	Y	-.077	%40
9	M3	Y	-.024	%70
10	M3	Y	-.023	%60
11	M1	Y	-.068	%20
12	M1	Y	0	0
13	M1	Y	0	0
14	M1	Y	0	0
15	M1	Y	0	0

Member Distributed Loads (BLC 2 : 0 Wind - No Ice)

	Member Label	Direction	Start Magnitude[k/ft,...	End Magnitude[k/ft,F...	Start Location[in, %]	End Location[in, %]
1	M1	Z	-.015	-.015	0	0
2	M2	Z	-.011	-.011	0	0
3	M3	Z	-.006	-.006	0	0
4	M5	Z	-.006	-.006	0	0

Member Distributed Loads (BLC 3 : 90 Wind - No Ice)

	Member Label	Direction	Start Magnitude[k/ft,...	End Magnitude[k/ft,F...	Start Location[in, %]	End Location[in, %]
1	M1	X	-.015	-.015	0	0
2	M2	X	-.011	-.011	0	0
3	M3	X	-.006	-.006	0	0
4	M5	X	-.006	-.006	0	0

Member Distributed Loads (BLC 4 : 0 Wind - Ice)

	Member Label	Direction	Start Magnitude[k/ft,...	End Magnitude[k/ft,F...	Start Location[in, %]	End Location[in, %]
1	M1	Z	-.009	-.009	0	0
2	M2	Z	-.007	-.007	0	0
3	M3	Z	-.002	-.002	0	0
4	M5	Z	-.002	-.002	0	0

Member Distributed Loads (BLC 5 : 90 Wind - Ice)

	Member Label	Direction	Start Magnitude[k/ft,...	End Magnitude[k/ft,F...	Start Location[in, %]	End Location[in, %]
1	M1	X	-.009	-.009	0	0
2	M2	X	-.007	-.007	0	0
3	M3	X	-.002	-.002	0	0
4	M5	X	-.002	-.002	0	0

Member Distributed Loads (BLC 6 : 0 Wind - Service)

	Member Label	Direction	Start Magnitude[k/ft,...	End Magnitude[k/ft,F...	Start Location[in, %]	End Location[in, %]
1	M1	Z	-.002	-.002	0	0
2	M2	Z	-.001	-.001	0	0
3	M3	Z	-.0003	-.0003	0	0
4	M5	Z	-.0003	-.0003	0	0

Member Distributed Loads (BLC 7 : 90 Wind - Service)

	Member Label	Direction	Start Magnitude[k/ft,...	End Magnitude[k/ft,F...	Start Location[in, %]	End Location[in, %]
1	M1	X	-.002	-.002	0	0
2	M2	X	-.001	-.001	0	0
3	M3	X	-.0003	-.0003	0	0
4	M5	X	-.0003	-.0003	0	0



Member Distributed Loads (BLC 8 : Ice)

	Member Label	Direction	Start Magnitude[k/ft,...	End Magnitude[k/ft,F...	Start Location[in, %]	End Location[in, %]
1	M1	Y	-015	-015	0	0
2	M2	Y	-015	-015	0	0
3	M3	Y	-008	-008	0	0
4	M5	Y	-008	-008	0	0

Joint Loads and Enforced Displacements

Joint Label	L,D,M	Direction	Magnitude[(k,k-ft), (in,rad), (k*s^2/i...
No Data to Print ...			

Envelope Joint Reactions

Joint	X [k]	LC	Y [k]	LC	Z [k]	LC	MX [k-ft]	LC	MY [k-ft]	LC	MZ [k-ft]	LC
No Data to Print ...												

Envelope AISC 13th(360-05): LRFD Steel Code Checks

Member	Shape	Code Check	Loc[in]	LC	Shear C...	Loc[in]	Dir	LC	phi*...	phi*...	phi*...	phi*...	Eqn	
1	M2	HSS4x4x4	.247	12	25	.142	12	z	11	138....	139....	16.1....	16.1....	H1-...



Tower Engineering Solutions

Phone (972) 483-0607, Fax (972) 975-9615
1320 Greenway Drive, Suite 600, Irving, Texas 75038

Structural Analysis Report

Existing 139 ft SABRE Monopole

Customer Name: SBA Communications Corp

Customer Site Number: CT13549-S

Customer Site Name: Danbury 1

Carrier Name: AT&T

Carrier Site ID / Name: CT2312 / Danbury SBA Tower

Site Location: 52 Stadley Rough Road

Danbury, Connecticut

Fairfield County

Latitude: 41.433102

Longitude: -73.431916

Analysis Result:

Max Structural Usage: 70.4% [Pass]

Max Foundation Usage: 97.0% [Pass]

Additional Usage Caused by New Mount/Mount Modification: N/A

Report Prepared By : Dipika Dhungana



AJY
9/26/18



Tower Engineering Solutions

Phone (972) 483-0607, Fax (972) 975-9615
1320 Greenway Drive, Suite 600, Irving, Texas 75038

Structural Analysis Report

Existing 139 ft SABRE Monopole

Customer Name: SBA Communications Corp

Customer Site Number: CT13549-S

Customer Site Name: Danbury 1

Carrier Name: AT&T

Carrier Site ID / Name: CT2312 / Danbury SBA Tower

Site Location: 52 Stadley Rough Road

Danbury, Connecticut

Fairfield County

Latitude: 41.433102

Longitude: -73.431916

Analysis Result:

Max Structural Usage: 70.4% [Pass]

Max Foundation Usage: 97.0% [Pass]

Additional Usage Caused by New Mount/Mount Modification: N/A

Report Prepared By : Dipika Dhungana

Introduction

The purpose of this report is to summarize the analysis results on the 139 ft SABRE Monopole to support the proposed antennas and transmission lines in addition to those currently installed. Any modification listed under Sources of Information was assumed completed and was included in this analysis.

Sources of Information

Tower Drawings	Tower Drawings prepared by Sabre Towers and Poles, Job # 10-01206 Dated 01/28/2010
Foundation Drawing	Foundation Drawings prepared by Sabre Towers and Poles, Job # 10-01206 Dated 01/28/2010
Geotechnical Report	Geotechnical Report prepared by Tower Engineering Professionals Project # 091184.01 Dated 05/13/2009
Modification Drawings	N/A

Analysis Criteria

The rigorous analysis was performed in accordance with the requirements and stipulations of the ANSI/TIA/EIA 222-G. In accordance with this standard, the structure was analyzed using **TESPoles**, a proprietary analysis software. The program considers the structure as an elastic 3-D model with second-order effects and temperature effects incorporated in the analysis. The analysis was performed using multiple wind directions.

Wind Speed Used in the Analysis:	Ultimate Design Wind Speed Vult = 125 mph (3-Sec. Gust)/ Nominal Design Wind Speed V _{asd} = 97.0 mph (3-Sec. Gust)
Wind Speed with Ice:	50 mph (3-Sec. Gust) with 3/4" radial ice concurrent
Operational Wind Speed:	60 mph + 0" Radial ice
Standard/Codes:	ANSI/TIA/EIA 222-G / 2012 IBC / 2016 Connecticut State Building Code
Exposure Category:	C
Structure Class:	II
Topographic Category:	1
Crest Height:	0 ft
Seismic Parameters:	S _s = 0.215, S ₁ = 0.056

This structural analysis is based upon the tower being classified as a Structure Class II; however, if a different classification is required subsequent to the date hereof, the tower classification will be changed to meet such requirement and a new structural analysis will be run.

Existing Antennas, Mounts and Transmission Lines

The table below summarizes the antennas, mounts and transmission lines that were considered in the analysis as existing on the tower.

Items	Elevation (ft.)	Qty.	Antenna Descriptions	Mount Type & Qty.	Transmission Lines	Owner
1	137.0	3	AIR 21 B2A/B4P - Panel	(3) T-Arms (SitePro-UDS-NP)	(12) 1 5/8" (1) 1 5/8" Fiber	T-Mobile
2		3	AIR 21 B4A/B12P - Panel			
3		3	Ericsson - KRY 112 144/1 - TMA			
4		3	Ericsson - S11B12 - RRU			
5	117.0	3	Kathrein - 800 10504 - Panel	(1) Flush Mount	(12) 1 5/8"	Metro PCS
6		3	Kathrein - 742 351 - Panel			
7	107.0	3	CCI OPA-65R-LCUU-H6	(1) Commscope MC-HPM1250-B (1) Commscope RR-RM1560	(6) 3/4" DC Power (2) 3/8" Fiber (6) 7/8" Coax	AT&T
8		3	CCI HPA-65R-BUU-H6			
9		3	CCI DTMABP7819VG12A TMA			
10		3	Ericsson RRUS-11 700MHz			
11		3	Ericsson RRUS-12			
12		3	Ericsson RRUS-32			
13		3	Ericsson RRUS-E2			
14		3	Ericsson RRUS-A2			
15		3	Kaelus DBC2055F1V1			
16		2	Raycap DC6-48-60-18-8F			
17	97.0	3	Antel - BXA-70063/6CF - Panel	(1) Flush Mount	(12) 1 5/8" (1) 1 5/8" Fiber	Verizon
18		3	Antel - BXA-171063/12CF - Panel			
19		3	Andrew - DBXNH-6565A-VTM - Panel			
20		3	Alcatel - RRH2x40-AWS - RRH			
21		6	RFS - FD9R6004/2C-3L - Diplexer			
22		1	RFS - DB-T1-6Z-8AB-0Z - Junction Box			

Proposed Carrier's Final Configuration of Antennas, Mounts and Transmission Lines

Information pertaining to the proposed carrier's final configuration of antennas and transmission lines was provided by SBA Communications Corp. The proposed antennas and lines are listed below.

Items	Elevation (ft)	Qty.	Antenna Descriptions	Mount Type & Qty.	Transmission Lines	Owner
23	107.0	3	CCI OPA-65R-LCUU-H6	(1) Commscope MC-HPM1250-B (1) Commscope RR-RM1560	(6) 3/4" DC Power (2) 3/8" Fiber (6) 7/8" Coax	AT&T
24		3	KMW EPBQ-652L8H6-L2			
25		3	CCI DTMAPB7819VG12A TMA			
26		3	Ericsson RRUS-11 700MHz			
27		3	Ericsson RRUS-12			
28		3	Ericsson RRUS-32			
29		3	Ericsson RRUS 4449 B5/B12			
30		3	Ericsson RRUS 4426 B66			
31		3	Ericsson RRUS-A2			
32		3	Kaelus DBC2055F1V1			
33		3	Raycap DC6-48-60-18-8F			

All transmission lines are considered running inside of the pole shafts.

Analysis Results

The results of the structural analysis, performed for the wind and ice loading and antenna equipment as defined above, are summarized as the following:

	Pole shafts	Anchor Bolts	Base Plate
Max. Usage:	70.4%	57.0%	56.0%
Pass/Fail	Pass	Pass	Pass

Foundations

	Moment (Kip-Ft)	Shear (Kips)	Axial (Kips)
Original Design Reactions	2074.0	20.7	21.7
Analysis Reactions	1968.0	21.2	45.1

The foundation has been investigated using the supplied documents and soils report and was found adequate. Therefore, no modification to the foundation will be required.

Operational Condition (Rigidity):

Operational characteristics of the tower are found to be within the limits prescribed by ANSI/TIA/EIA 222-G for the installed antennas. The maximum twist/sway at the elevation of the proposed equipment is 1.2294 degrees under the operational wind speed as specified in the Analysis Criteria.

Conclusions

Based on the analysis results, the existing structure and its foundation were found to be adequate to safely support the existing and proposed equipment and meet the minimum requirements per the ANSI/TIA/EIA 222-G Standard under the design basic wind speed as specified in the Analysis Criteria.

Standard Conditions

1. This analysis was performed based on the information supplied to **(TES) Tower Engineering Solutions, LLC**. Verification of the information provided was not included in the Scope of Work for **TES**. The accuracy of the analysis is dependent on the accuracy of the information provided.
2. The analysis is based on the presumption that the tower members and components along with any existing reinforcement items have been correctly and properly designed, manufactured, installed and maintained.
3. All the existing structural members were assumed to be in good condition with no physical damage or deterioration associated with corrosion.
4. An initial tension of 10% of the break strength on all the existing guy wires was assumed in all the structural analyses of guyed towers unless different values were provided by the client. **TES** cannot take responsibility for the deviations in the analysis results because of differences in the initial tension forces of the existing guy wires.
5. Secondary component or connection secondary components, welds and bolts are assumed to be able to carry their intended original design loads. **TES** cannot take responsibility for verification of the adequacy on the connections, bolts and welds present in the structure.
6. The analyses will be performed based on the codes as specified by the client or based on the best knowledge of the engineering staff of **TES**. In the absence of information to the contrary, all work will be performed in accordance with the latest relevant revision of ANSI/TIA-222. If wind speed and/or ice loads are different from the minimum values recommended by the EIA/TIA-222 standard or other codes, **TES** should be notified in writing and the applicable minimum values provided by the client.
7. The configuration of the existing mounts, antennas, coax and other appurtenances were supplied by the customer for the current structural analysis. **TES** has not visited the tower site to verify the adequacy of the information provided. If there is any discrepancy found in the report regarding the existing conditions, **TES** should be notified immediately to evaluate the effect of the discrepancy on the analysis results.
8. The client will assume responsibility for rework associated with the differences in initially provided information, including tower and foundation information, existing and/or proposed equipment and transmission lines.
9. If a feasibility analysis was performed, final acceptance of changed conditions shall be based upon a rigorous structural analysis.

Usage Diagram - Max Ratio 70.41% at 53.3ft

Structure: CT13549-S-SBA
Site Name: Danbury 1
Height: 139.00 (ft)
Base Elev: 0.000 (ft)

Code: EIA/TIA-222-G
Exposure: C
Gh: 1.1

9/26/2018



Page: 1

Dead Load Factor: 1.20
Wind Load Factor: 1.60

Load Case : 1.2D + 1.6W 97 mph Wind

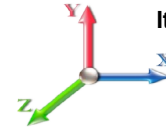

Iterations: 26

Copyright © 2018 by Tower Engineering Solutions, LLC. All rights reserved.

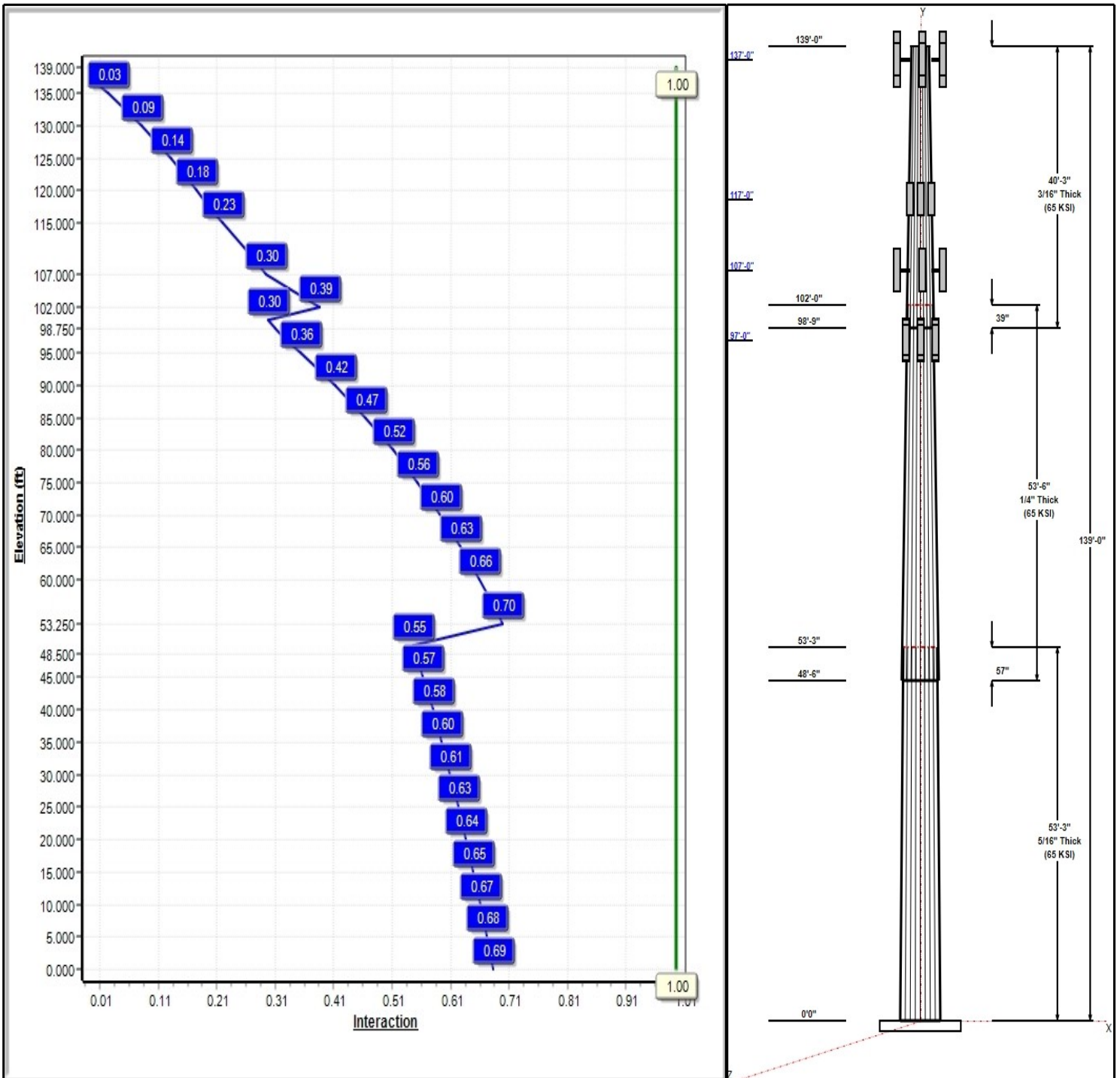

Structure: CT13549-S-SBA

Type: Tapered
Site Name: Danbury 1
Height: 139.00 (ft)
Base Elev: 0.00 (ft)

Base Shape: 18 Sided
Taper: 0.23097

9/26/2018

Page: 2



Shaft Properties

Seq	Length (ft)	Top (in)	Bottom (in)	Thick (in)	Joint Type	Taper	Grade (ksi)
1	53.25	34.93	47.23	0.313		0.23097	65
2	53.50	24.17	36.53	0.250	Slip	0.23097	65
3	40.25	16.00	25.30	0.188	Slip	0.23097	65

Discrete Appurtenances

Attach Elev (ft)	Force Elev (ft)	Qty	Description	Carrier
139.00	139.00	1	6' Lightning rod	T-Mobile
137.00	137.00	3	T-Arms	T-Mobile
137.00	137.00	3	AIR 21, 1.3M, B2A B4P	T-Mobile
137.00	137.00	3	KRY 112 144/1	T-Mobile
137.00	137.00	3	S11B12	T-Mobile
137.00	137.00	3	AIR 21 B4A/B12P	T-Mobile
117.00	117.00	3	800 10504	Metro PCS
117.00	117.00	3	742 351	Metro PCS
117.00	117.00	1	Flush Mount	Metro PCS
107.00	107.00	3	RRUS-11 700MHz	AT&T
107.00	107.00	3	RRUS 12	AT&T
107.00	107.00	3	RRUS A2	AT&T
107.00	107.00	3	RRUS-32	AT&T
107.00	107.00	3	DC6-48-60-18-8F	AT&T
107.00	107.00	3	OPA-65R-LCUU-H6	AT&T
107.00	107.00	3	EPBQ-652L8H6-L2	AT&T
107.00	107.00	3	DBC20056F1V1	AT&T
107.00	107.00	3	DTMABP7819VG12A	AT&T
107.00	107.00	3	RRUS-E2	AT&T
107.00	107.00	1	Collar Mount Commscope	AT&T
107.00	107.00	3	T-Arm Commscope	AT&T
107.00	107.00	3	RRUS 4449 B5/B12	AT&T
97.00	97.00	3	BXA-70063/6CF	Verizon
97.00	97.00	3	BXA-171063/12CF	Verizon
97.00	97.00	3	DBXNH-6565A-VTM	Verizon
97.00	97.00	3	RRH2x40-AWS	Verizon
97.00	97.00	6	FD9R6004/2C-3L (3.1 lbs)	Verizon
97.00	97.00	1	DB-T1-6Z-8AB-OZ	Verizon
97.00	97.00	1	Flush Mount	Verizon

Linear Appurtenances

Elev From (ft)	Elev To (ft)	Placement	Description	Carrier
0.00	137.00	Inside	1 5/8" Coax	T-Mobile
0.00	137.00	Inside	1 5/8" Hybrid	T-Mobile
0.00	117.00	Inside	1 5/8" Coax	Metro PCS
0.00	107.00	Inside	3/4" DC	AT&T
0.00	107.00	Inside	3/8" Fiber	AT&T
0.00	107.00	Inside	7/8" Coax	AT&T
0.00	97.00	Inside	1 5/8" Coax	Verizon
0.00	97.00	Inside	1 5/8" Hybrid	Verizon

Anchor Bolts

Qty	Specifications	Grade (ksi)	Arrangement
12	2.25" 18J	75.0	Cluster

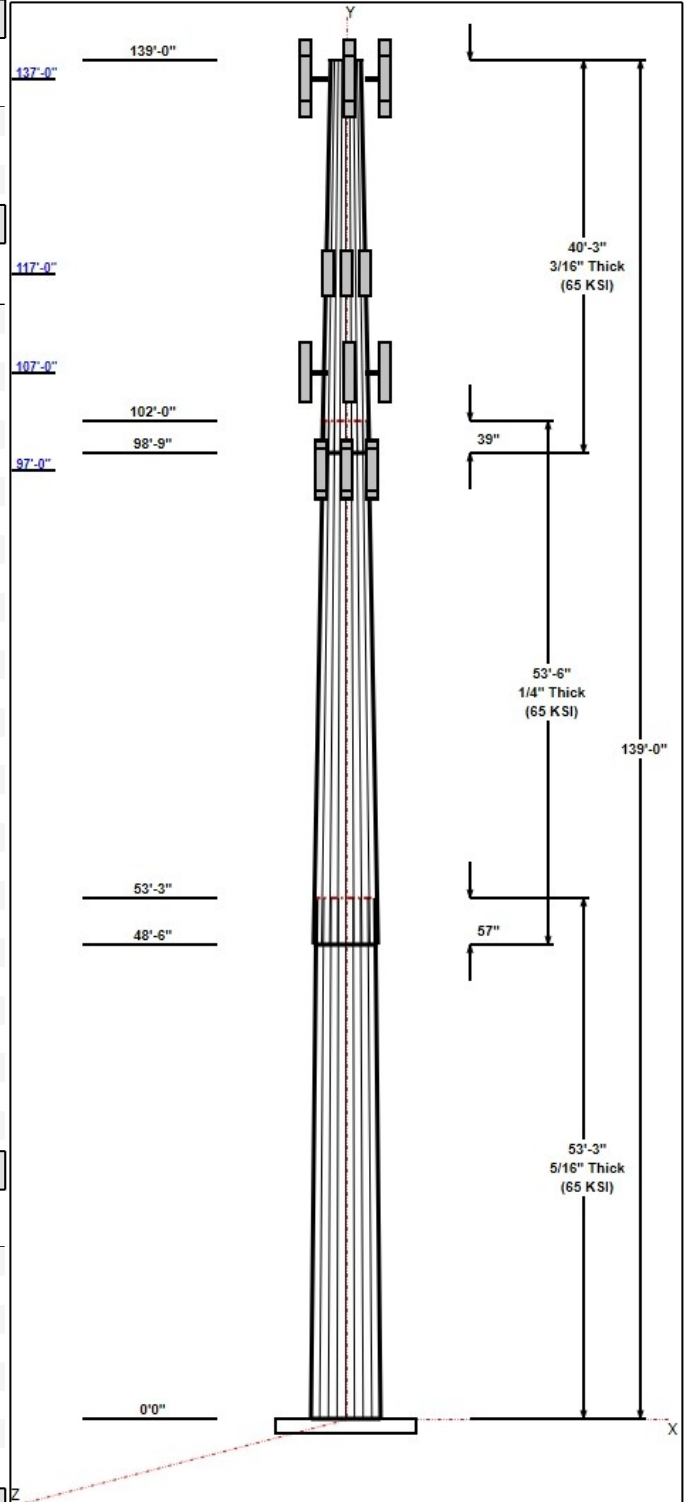

Structure: CT13549-S-SBA

Type: Tapered
Site Name: Danbury 1
Height: 139.00 (ft)
Base Elev: 0.00 (ft)

Base Shape: 18 Sided
Taper: 0.23097

9/26/2018

Page: 3



Base Plate

Thickness (in)	Specifications (in)	Grade (ksi)	Geometry
2.7500	51.5	50.0	Clipped

Reactions

Load Case	Moment (FT-Kips)	Shear (Kips)	Axial (Kips)
1.2D + 1.6W 97 mph Wind	1968.0	21.2	28.9
0.9D + 1.6W 97 mph Wind	1947.6	21.2	21.6
1.2D + 1.0Di + 1.0Wi 50 mph Wind	569.2	6.2	45.1
1.2D + 1.0E	107.6	1.0	28.9
0.9D + 1.0E	106.3	1.0	21.7
1.0D + 1.0W 60 mph Wind	467.9	5.1	24.1

Structure: CT13549-S-SBA - Coax Line Placement

Type: Monopole
Site Name: Danbury 1
Height: 139.00 (ft)

9/26/2018



Page: 4

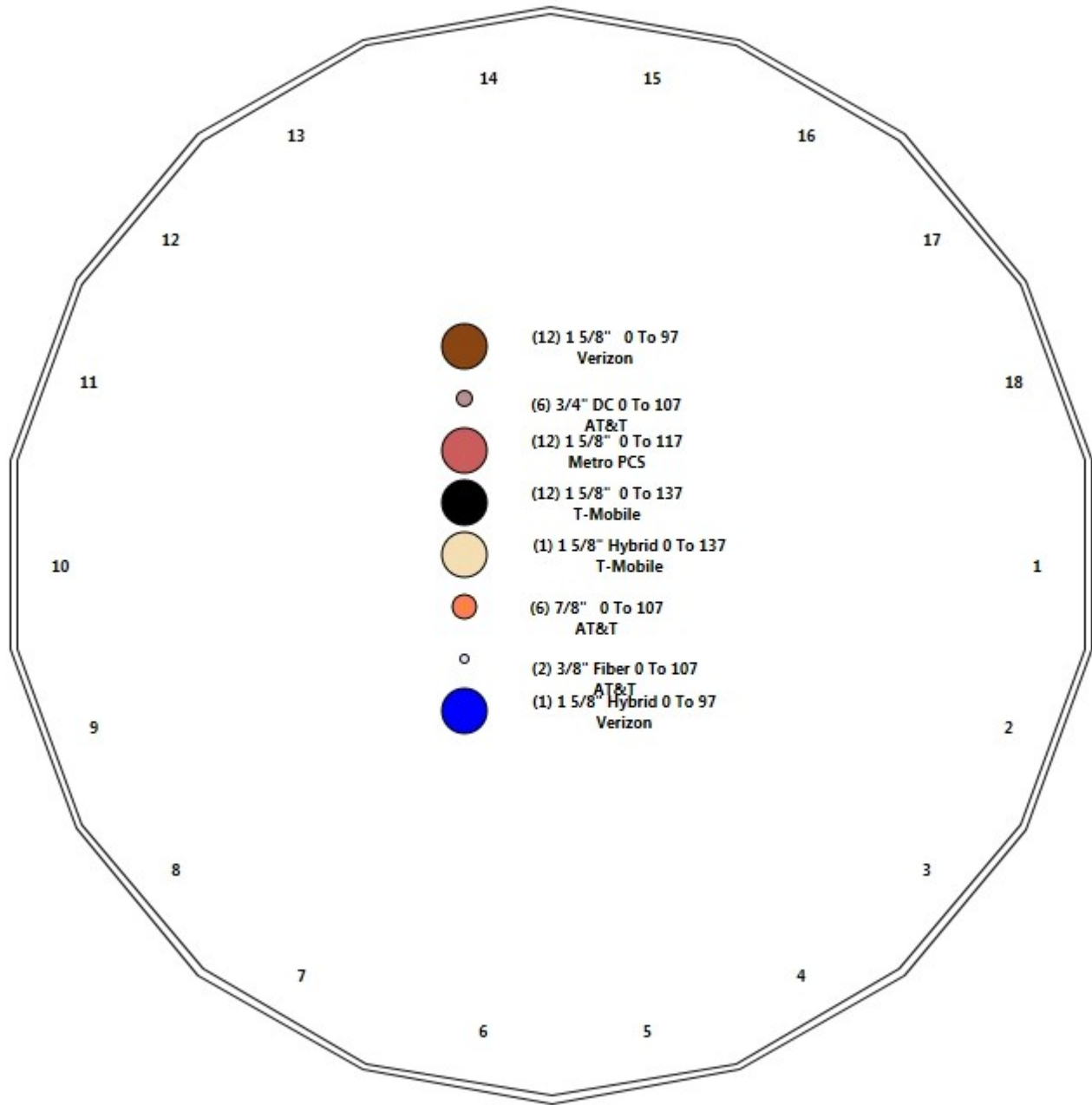

Shaft Properties

Structure: CT13549-S-SBA	Code: EIA/TIA-222-G	9/26/2018
Site Name: Danbury 1	Exposure: C	
Height: 139.00 (ft)	Crest Height: 0.00	
Base Elev: 0.000 (ft)	Site Class: D - Stiff Soil	
Gh: 1.1	Topography: 1	Struct Class: II



Page: 5

Sec. No.	Shape	Length (ft)	Thick (in)	Fy (ksi)	Joint Type	Overlap (in)	Weight (lb)
1	18	53.250	0.3125	65		0.00	7,327
2	18	53.500	0.2500	65	Slip	57.00	4,348
3	18	40.250	0.1875	65	Slip	39.00	1,668
Total Shaft Weight:							13,342

Bottom

Top

Sec. No.	Dia (in)	Elev (ft)	Area (sqin)	Ix (in^4)	W/t Ratio	D/t Ratio	Dia (in)	Elev (ft)	Area (sqin)	Ix (in^4)	W/t Ratio	D/t Ratio	Taper
1	47.23	0.00	46.53	12941.93	25.24	151.14	34.93	53.25	34.34	5198.89	18.30	111.7	0.230971
2	36.53	48.50	28.79	4786.42	24.35	146.11	24.17	102.00	18.98	1372.20	15.64	96.68	0.230971
3	25.30	98.75	14.94	1190.25	22.38	134.92	16.00	139.00	9.41	297.27	13.64	85.33	0.230971

Load Summary

Structure: CT13549-S-SBA	Code: EIA/TIA-222-G	9/26/2018
Site Name: Danbury 1	Exposure: C	
Height: 139.00 (ft)	Crest Height: 0.00	
Base Elev: 0.000 (ft)	Site Class: D - Stiff Soil	
Gh: 1.1	Topography: 1	Struct Class: II



Page: 6

Discrete Appurtenances

No.	Elev (ft)	Description	Qty	No Ice			Ice			Hor. Ecc. (ft)	Vert Ecc (ft)
				Weight (lb)	CaAa (sf)	CaAa Factor	Weight (lb)	CaAa (sf)	CaAa Factor		
1	139.00	6' Lightning rod	1	6.50	0.38	1.00	42.53	1.459	1.00	0.00	0.00
2	137.00	T-Arms	3	350.00	8.00	0.50	592.13	14.918	0.50	0.00	0.00
3	137.00	AIR 21, 1.3M, B2A B4P	3	91.50	6.09	0.86	258.57	7.177	0.86	0.00	0.00
4	137.00	KRY 112 144/1	3	11.00	0.41	0.70	21.68	0.881	0.70	0.00	0.00
5	137.00	S11B12	3	51.00	2.83	0.70	119.97	3.496	0.70	0.00	0.00
6	137.00	AIR 21 B4A/B12P	3	126.00	11.54	0.89	408.26	13.183	0.89	0.00	0.00
7	117.00	800 10504	3	17.60	3.34	0.72	78.99	5.109	0.72	0.00	0.00
8	117.00	742 351	3	29.80	5.38	0.61	122.76	7.318	0.61	0.00	0.00
9	117.00	Flush Mount	1	350.00	5.00	1.00	636.00	8.405	1.00	0.00	0.00
10	107.00	RRUS-11 700MHz	3	50.70	2.52	0.76	136.29	3.148	0.76	0.00	0.00
11	107.00	RRUS 12	3	58.00	3.15	0.70	149.55	3.838	0.70	0.00	0.00
12	107.00	RRUS A2	3	21.20	1.86	0.62	56.11	2.801	0.62	0.00	0.00
13	107.00	RRUS-32	3	77.00	3.87	0.87	186.06	4.078	0.87	0.00	0.00
14	107.00	DC6-48-60-18-8F	3	31.80	1.47	1.00	91.57	2.147	1.00	0.00	0.00
15	107.00	OPA-65R-LCUU-H6	3	80.00	9.66	0.79	302.78	10.978	0.79	0.00	0.00
16	107.00	EPBQ-652L8H6-L2	3	72.80	9.66	0.85	343.47	14.704	0.85	0.00	0.00
17	107.00	DBC20056F1V1	3	6.60	0.41	0.80	19.83	0.720	0.80	0.00	0.00
18	107.00	DTMABP7819VG12A	3	19.20	1.14	0.67	43.87	1.884	0.67	0.00	0.00
19	107.00	RRUS-E2	3	77.00	1.65	0.70	123.37	2.209	0.70	0.00	0.00
20	107.00	Collar Mount Commscope	1	122.40	5.00	1.00	411.53	13.436	1.00	0.00	0.00
21	107.00	T-Arm Commscope MC-HPM1250-B	3	178.00	10.00	0.75	298.13	18.436	0.75	0.00	0.00
22	107.00	RRUS 4449 B5/B12	3	85.00	1.65	0.70	198.76	4.261	0.70	0.00	0.00
23	97.00	BXA-70063/6CF	3	17.00	7.57	0.70	152.66	10.216	0.70	0.00	0.00
24	97.00	BXA-171063/12CF	3	15.00	4.78	0.84	106.74	7.038	0.84	0.00	0.00
25	97.00	DBXNH-6565A-VTM	3	34.20	5.37	0.80	155.54	7.261	0.80	0.00	0.00
26	97.00	RRH2x40-AWS	3	44.00	2.52	0.82	102.13	3.691	0.82	0.00	0.00
27	97.00	FD9R6004/2C-3L (3.1 lbs)	6	3.10	0.36	1.00	10.78	0.784	1.00	0.00	0.00
28	97.00	DB-T1-6Z-8AB-OZ	1	18.90	4.80	0.71	155.45	5.634	0.71	0.00	0.00
29	97.00	Flush Mount	1	350.00	5.00	0.50	630.69	8.341	0.50	0.00	0.00
Totals:			80	5,499.60			14,148.57				

Linear Appurtenances

Bottom Elev. (ft)	Top Elev. (ft)	Description	Exposed Width	Exposed
0.00	137.00	(12) 1 5/8" Coax	0.00	Inside
0.00	137.00	(1) 1 5/8" Hybrid	0.00	Inside
0.00	117.00	(12) 1 5/8" Coax	0.00	Inside
0.00	107.00	(6) 3/4" DC	0.00	Inside
0.00	107.00	(2) 3/8" Fiber	0.00	Inside
0.00	107.00	(6) 7/8" Coax	0.00	Inside
0.00	97.00	(12) 1 5/8" Coax	0.00	Inside
0.00	97.00	(1) 1 5/8" Hybrid	0.00	Inside

Shaft Section Properties

Structure: CT13549-S-SBA	Code: EIA/TIA-222-G	9/26/2018
Site Name: Danbury 1	Exposure: C	
Height: 139.00 (ft)	Crest Height: 0.00	
Base Elev: 0.000 (ft)	Site Class: D - Stiff Soil	
Gh: 1.1	Topography: 1	Struct Class: II



Page: 7

Increment Length: 5 (ft)

Elev (ft)	Description	Thick (in)	Dia (in)	Area (in ²)	Ix (in ⁴)	W/t Ratio	D/t Ratio	Fpy (ksi)	S (in ³)	Weight (lb)
0.00		0.3125	47.230	46.535	12941.9	25.24	151.14	71.7	539.7	0.0
5.00		0.3125	46.075	45.389	12009.6	24.59	147.44	72.5	513.4	782.0
10.00		0.3125	44.920	44.244	11123.1	23.94	143.74	73.2	487.7	762.5
15.00		0.3125	43.765	43.098	10281.4	23.28	140.05	74.0	462.7	743.0
20.00		0.3125	42.611	41.953	9483.2	22.63	136.35	74.8	438.3	723.5
25.00		0.3125	41.456	40.807	8727.5	21.98	132.66	75.5	414.7	704.0
30.00		0.3125	40.301	39.662	8013.0	21.33	128.96	76.3	391.6	684.5
35.00		0.3125	39.146	38.517	7338.6	20.68	125.27	77.1	369.2	665.1
40.00		0.3125	37.991	37.371	6703.2	20.03	121.57	77.8	347.5	645.6
45.00		0.3125	36.836	36.226	6105.5	19.37	117.88	78.6	326.5	626.1
48.50	Bot - Section 2	0.3125	36.028	35.424	5709.0	18.92	115.29	79.1	312.1	426.7
50.00		0.3125	35.681	35.080	5544.5	18.72	114.18	79.4	306.1	326.2
53.25	Top - Section 1	0.2500	35.431	27.915	4365.2	23.58	141.72	0.0	0.0	695.8
55.00		0.2500	35.027	27.594	4216.4	23.29	140.11	74.0	237.1	165.3
60.00		0.2500	33.872	26.678	3810.2	22.48	135.49	75.0	221.6	461.7
65.00		0.2500	32.717	25.762	3430.9	21.66	130.87	75.9	206.5	446.1
70.00		0.2500	31.562	24.845	3077.6	20.85	126.25	76.9	192.1	430.5
75.00		0.2500	30.407	23.929	2749.5	20.04	121.63	77.8	178.1	414.9
80.00		0.2500	29.252	23.012	2445.6	19.22	117.01	78.8	164.7	399.3
85.00		0.2500	28.097	22.096	2164.9	18.41	112.39	79.8	151.8	383.7
90.00		0.2500	26.943	21.180	1906.6	17.59	107.77	80.7	139.4	368.1
95.00		0.2500	25.788	20.263	1669.7	16.78	103.15	81.7	127.5	352.6
97.00		0.2500	25.326	19.897	1580.7	16.45	101.30	82.1	122.9	136.7
98.75	Bot - Section 3	0.2500	24.922	19.576	1505.5	16.17	99.69	82.4	119.0	117.5
100.00		0.2500	24.633	19.347	1453.2	15.96	98.53	82.5	116.2	146.0
102.00	Top - Section 2	0.1875	24.546	14.496	1086.7	21.67	130.91	0.0	0.0	230.0
105.00		0.1875	23.853	14.083	996.5	21.02	127.22	76.7	82.3	145.9
107.00		0.1875	23.391	13.809	939.3	20.59	124.75	77.2	79.1	94.9
110.00		0.1875	22.698	13.396	857.7	19.93	121.06	78.0	74.4	138.9
115.00		0.1875	21.543	12.709	732.3	18.85	114.90	79.2	67.0	222.1
117.00		0.1875	21.081	12.434	685.8	18.41	112.43	79.7	64.1	85.6
120.00		0.1875	20.388	12.022	619.8	17.76	108.74	80.5	59.9	124.8
125.00		0.1875	19.234	11.334	519.5	16.68	102.58	81.8	53.2	198.7
130.00		0.1875	18.079	10.647	430.6	15.59	96.42	82.5	46.9	187.0
135.00		0.1875	16.924	9.960	352.5	14.50	90.26	82.5	41.0	175.3
137.00		0.1875	16.462	9.685	324.1	14.07	87.80	82.5	38.8	66.8
139.00		0.1875	16.000	9.410	297.3	13.64	85.33	82.5	36.6	65.0

13342.3

Wind Loading - Shaft

Structure: CT13549-S-SBA	Code: EIA/TIA-222-G	9/26/2018
Site Name: Danbury 1	Exposure: C	
Height: 139.00 (ft)	Crest Height: 0.00	
Base Elev: 0.000 (ft)	Site Class: D - Stiff Soil	
Gh: 1.1	Topography: 1	Struct Class: II



Load Case: 1.2D + 1.6W 97 mph Wind

Dead Load Factor 1.20
Wind Load Factor 1.60

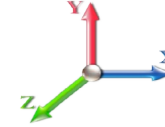

Iterations 26

Elev (ft)	Description	Kzt	Kz	qz (psf)	qzGh (psf)	C (mph-ft)	Cf	Ice Thick (in)	Tributary (ft)	Aa (sf)	CfAa (sf)	Wind Force X (lb)	Dead Load Ice (lb)	Tot Dead Load (lb)
0.00		1.00	0.85	19.450	21.40	357.41	0.650	0.000	0.00	0.000	0.00	0.0	0.0	0.0
5.00		1.00	0.85	19.450	21.40	348.67	0.650	0.000	5.00	19.738	12.83	439.2	0.0	938.4
10.00		1.00	0.85	19.450	21.40	339.93	0.650	0.000	5.00	19.250	12.51	428.3	0.0	915.0
15.00		1.00	0.85	19.450	21.40	331.19	0.650	0.000	5.00	18.761	12.19	417.5	0.0	891.6
20.00		1.00	0.90	20.638	22.70	332.15	0.650	0.000	5.00	18.273	11.88	431.4	0.0	868.2
25.00		1.00	0.95	21.630	23.79	330.83	0.650	0.000	5.00	17.784	11.56	440.1	0.0	844.8
30.00		1.00	0.98	22.477	24.72	327.84	0.650	0.000	5.00	17.295	11.24	444.7	0.0	821.5
35.00		1.00	1.01	23.218	25.54	323.66	0.650	0.000	5.00	16.807	10.92	446.4	0.0	798.1
40.00		1.00	1.04	23.880	26.27	318.56	0.650	0.000	5.00	16.318	10.61	445.8	0.0	774.7
45.00		1.00	1.07	24.479	26.93	312.72	0.650	0.000	5.00	15.830	10.29	443.3	0.0	751.3
48.50	Bot - Section 2	1.00	1.09	24.869	27.36	308.28	0.650	0.000	3.50	10.790	7.01	307.0	0.0	512.0
50.00		1.00	1.09	25.029	27.53	306.30	0.650	0.000	1.50	4.614	3.00	132.1	0.0	391.4
53.25	Top - Section 1	1.00	1.11	25.363	27.90	301.85	0.650	0.000	3.25	9.847	6.40	285.7	0.0	835.0
55.00		1.00	1.12	25.536	28.09	303.71	0.650	0.000	1.75	5.217	3.39	152.4	0.0	198.3
60.00		1.00	1.14	26.008	28.61	296.40	0.650	0.000	5.00	14.575	9.47	433.7	0.0	554.0
65.00		1.00	1.16	26.450	29.09	288.71	0.650	0.000	5.00	14.087	9.16	426.2	0.0	535.3
70.00		1.00	1.17	26.866	29.55	280.70	0.650	0.000	5.00	13.598	8.84	417.9	0.0	516.6
75.00		1.00	1.19	27.259	29.98	272.40	0.650	0.000	5.00	13.109	8.52	408.8	0.0	497.9
80.00		1.00	1.21	27.632	30.39	263.85	0.650	0.000	5.00	12.621	8.20	399.0	0.0	479.2
85.00		1.00	1.22	27.987	30.79	255.05	0.650	0.000	5.00	12.132	7.89	388.4	0.0	460.5
90.00		1.00	1.24	28.325	31.16	246.04	0.650	0.000	5.00	11.644	7.57	377.3	0.0	441.8
95.00		1.00	1.25	28.650	31.51	236.84	0.650	0.000	5.00	11.155	7.25	365.6	0.0	423.1
97.00	Appurtenance(s)	1.00	1.26	28.776	31.65	233.11	0.650	0.000	2.00	4.325	2.81	142.4	0.0	164.0
98.75	Bot - Section 3	1.00	1.26	28.884	31.77	229.82	0.650	0.000	1.75	3.720	2.42	122.9	0.0	141.0
100.00		1.00	1.27	28.961	31.86	227.46	0.650	0.000	1.25	2.660	1.73	88.1	0.0	175.2
102.00	Top - Section 2	1.00	1.27	29.082	31.99	223.66	0.650	0.000	2.00	4.193	2.73	139.5	0.0	276.0
105.00		1.00	1.28	29.260	32.19	221.39	0.650	0.000	3.00	6.143	3.99	205.6	0.0	175.0
107.00	Appurtenance(s)	1.00	1.28	29.376	32.31	217.54	0.650	0.000	2.00	3.998	2.60	134.3	0.0	113.9
110.00		1.00	1.29	29.548	32.50	211.71	0.650	0.000	3.00	5.850	3.80	197.7	0.0	166.6
115.00		1.00	1.30	29.826	32.81	201.88	0.650	0.000	5.00	9.359	6.08	319.3	0.0	266.5
117.00	Appurtenance(s)	1.00	1.31	29.934	32.93	197.91	0.650	0.000	2.00	3.607	2.34	123.5	0.0	102.7
120.00		1.00	1.32	30.094	33.10	191.92	0.650	0.000	3.00	5.264	3.42	181.2	0.0	149.8
125.00		1.00	1.33	30.354	33.39	181.82	0.650	0.000	5.00	8.382	5.45	291.1	0.0	238.4
130.00		1.00	1.34	30.605	33.67	171.61	0.650	0.000	5.00	7.893	5.13	276.4	0.0	224.4
135.00		1.00	1.35	30.850	33.93	161.29	0.650	0.000	5.00	7.405	4.81	261.3	0.0	210.4
137.00	Appurtenance(s)	1.00	1.35	30.945	34.04	157.13	0.650	0.000	2.00	2.825	1.84	100.0	0.0	80.2
139.00	Appurtenance(s)	1.00	1.36	31.040	34.14	152.96	0.650	0.000	2.00	2.747	1.79	97.5	0.0	78.0
Totals:									139.00			10,711.9		16,010.8

Discrete Appurtenance Forces

Structure: CT13549-S-SBA	Code: EIA/TIA-222-G	9/26/2018
Site Name: Danbury 1	Exposure: C	
Height: 139.00 (ft)	Crest Height: 0.00	
Base Elev: 0.000 (ft)	Site Class: D - Stiff Soil	
Gh: 1.1	Topography: 1	Struct Class: II



Page: 9

Load Case: 1.2D + 1.6W 97 mph Wind

Dead Load Factor 1.20
Wind Load Factor 1.60

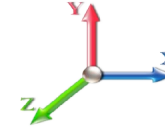

Iterations 26

No.	Elev (ft)	Description	Qty	qz (psf)	qzGh (psf)	CaAa x Ka	Ka	Total CaAa (sf)	Dead Load (lb)	Horiz Ecc (ft)	Vert Ecc (ft)	Wind FX (lb)	Mom Y (lb-ft)	Mom Z (lb-ft)
1	139.00	6' Lightning rod	1	31.040	34.144	1.00	1.00	0.38	7.80	0.000	0.000	20.76	0.00	0.00
2	137.00	AIR 21 B4A/B12P	3	30.945	34.040	0.67	0.75	23.11	453.60	0.000	0.000	1258.59	0.00	0.00
3	137.00	S11B12	3	30.945	34.040	0.52	0.75	4.46	183.60	0.000	0.000	242.76	0.00	0.00
4	137.00	KRY 112 144/1	3	30.945	34.040	0.52	0.75	0.65	39.60	0.000	0.000	35.17	0.00	0.00
5	137.00	AIR 21, 1.3M, B2A B4P	3	30.945	34.040	0.65	0.75	11.78	329.40	0.000	0.000	641.81	0.00	0.00
6	137.00	T-Arms	3	30.945	34.040	0.45	0.90	10.80	1260.00	0.000	0.000	588.21	0.00	0.00
7	117.00	800 10504	3	29.934	32.927	0.54	0.75	5.41	63.36	0.000	0.000	285.06	0.00	0.00
8	117.00	Flush Mount	1	29.934	32.927	1.00	1.00	5.00	420.00	0.000	0.000	263.42	0.00	0.00
9	117.00	742 351	3	29.934	32.927	0.46	0.75	7.38	107.28	0.000	0.000	389.02	0.00	0.00
10	107.00	RRUS 4449 B5/B12	3	29.376	32.314	0.52	0.75	2.60	306.00	0.000	0.000	134.36	0.00	0.00
11	107.00	T-Arm Commscope	3	29.376	32.314	0.56	0.75	16.88	640.80	0.000	0.000	872.47	0.00	0.00
12	107.00	Collar Mount Commscope	1	29.376	32.314	1.00	1.00	5.00	146.88	0.000	0.000	258.51	0.00	0.00
13	107.00	RRUS-E2	3	29.376	32.314	0.52	0.75	2.60	277.20	0.000	0.000	134.36	0.00	0.00
14	107.00	DTMABP7819VG12A	3	29.376	32.314	0.50	0.75	1.72	69.12	0.000	0.000	88.85	0.00	0.00
15	107.00	DBC20056F1V1	3	29.376	32.314	0.60	0.75	0.74	23.76	0.000	0.000	38.16	0.00	0.00
16	107.00	RRUS A2	3	29.376	32.314	0.46	0.75	2.59	76.32	0.000	0.000	134.15	0.00	0.00
17	107.00	RRUS-11 700MHz	3	29.376	32.314	0.57	0.75	4.31	182.52	0.000	0.000	222.79	0.00	0.00
18	107.00	RRUS 12	3	29.376	32.314	0.52	0.75	4.96	208.80	0.000	0.000	256.51	0.00	0.00
19	107.00	EPBQ-652L8H6-L2	3	29.376	32.314	0.64	0.75	18.47	262.08	0.000	0.000	955.18	0.00	0.00
20	107.00	RRUS-32	3	29.376	32.314	0.65	0.75	7.58	277.20	0.000	0.000	391.67	0.00	0.00
21	107.00	DC6-48-60-18-8F	3	29.376	32.314	0.67	0.67	2.95	114.48	0.000	0.000	152.76	0.00	0.00
22	107.00	OPA-65R-LCUU-H6	3	29.376	32.314	0.59	0.75	17.17	288.00	0.000	0.000	887.76	0.00	0.00
23	97.00	Flush Mount	1	28.776	31.653	0.50	1.00	2.50	420.00	0.000	0.000	126.61	0.00	0.00
24	97.00	DB-T1-6Z-8AB-OZ	1	28.776	31.653	0.71	1.00	3.41	22.68	0.000	0.000	172.60	0.00	0.00
25	97.00	FD9R6004/2C-3L (3.1 lbs)	6	28.776	31.653	0.75	0.75	1.62	22.32	0.000	0.000	82.05	0.00	0.00
26	97.00	RRH2x40-AWS	3	28.776	31.653	0.61	0.75	4.65	158.40	0.000	0.000	235.47	0.00	0.00
27	97.00	DBXNH-6565A-VTM	3	28.776	31.653	0.60	0.75	9.67	123.12	0.000	0.000	489.54	0.00	0.00
28	97.00	BXA-171063/12CF	3	28.776	31.653	0.63	0.75	9.03	54.00	0.000	0.000	457.54	0.00	0.00
29	97.00	BXA-70063/6CF	3	28.776	31.653	0.52	0.75	11.92	61.20	0.000	0.000	603.83	0.00	0.00
Totals:									6,599.52			10,419.97		

Total Applied Force Summary

Structure: CT13549-S-SBA	Code: EIA/TIA-222-G	9/26/2018
Site Name: Danbury 1	Exposure: C	
Height: 139.00 (ft)	Crest Height: 0.00	
Base Elev: 0.000 (ft)	Site Class: D - Stiff Soil	
Gh: 1.1	Topography: 1	Struct Class: II



Page: 10

Load Case: 1.2D + 1.6W 97 mph Wind

Dead Load Factor 1.20
Wind Load Factor 1.60



Iterations 26

Elev (ft)	Description	Lateral FX (-) (lb)	Axial FY (-) (lb)	Torsion MY (lb-ft)	Moment MZ (lb-ft)
0.00		0.00	0.00	0.00	0.00
5.00		439.20	1210.07	0.00	0.00
10.00		428.33	1186.68	0.00	0.00
15.00		417.46	1163.30	0.00	0.00
20.00		431.40	1139.91	0.00	0.00
25.00		440.06	1116.53	0.00	0.00
30.00		444.72	1093.14	0.00	0.00
35.00		446.41	1069.75	0.00	0.00
40.00		445.79	1046.37	0.00	0.00
45.00		443.30	1022.98	0.00	0.00
48.50		306.97	702.17	0.00	0.00
50.00		132.12	472.89	0.00	0.00
53.25		285.71	1011.60	0.00	0.00
55.00		152.40	293.42	0.00	0.00
60.00		433.66	825.71	0.00	0.00
65.00		426.24	807.00	0.00	0.00
70.00		417.93	788.29	0.00	0.00
75.00		408.80	769.58	0.00	0.00
80.00		398.95	750.87	0.00	0.00
85.00		388.43	732.16	0.00	0.00
90.00		377.30	713.46	0.00	0.00
95.00		365.61	694.75	0.00	0.00
97.00	(20) attachments	2310.01	1134.38	0.00	0.00
98.75		122.93	207.60	0.00	0.00
100.00		88.14	222.72	0.00	0.00
102.00		139.51	352.09	0.00	0.00
105.00		205.63	289.17	0.00	0.00
107.00	(37) attachments	4661.90	3063.13	0.00	0.00
110.00		197.75	260.44	0.00	0.00
115.00		319.34	422.85	0.00	0.00
117.00	(7) attachments	1061.02	755.85	0.00	0.00
120.00		181.22	198.68	0.00	0.00
125.00		291.06	319.91	0.00	0.00
130.00		276.37	305.87	0.00	0.00
135.00		261.33	291.84	0.00	0.00
137.00	(15) attachments	2866.54	2379.01	0.00	0.00
139.00	(1) attachments	118.30	85.77	0.00	0.00
Totals:		21,131.84	28,899.95	0.00	0.00

Calculated Forces

Structure: CT13549-S-SBA	Code: EIA/TIA-222-G	9/26/2018
Site Name: Danbury 1	Exposure: C	
Height: 139.00 (ft)	Crest Height: 0.00	
Base Elev: 0.000 (ft)	Site Class: D - Stiff Soil	
Gh: 1.1	Topography: 1	Struct Class: II



Page: 11

Load Case: 1.2D + 1.6W 97 mph Wind

Iterations 26

Dead Load Factor 1.20
Wind Load Factor 1.60

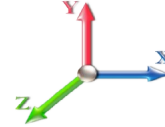

Seg Elev (ft)	Pu FY (-) (kips)	Vu FX (-) (kips)	Tu MY (-) (ft-kips)	Mu MZ (ft-kips)	Mu MX (ft-kips)	Resultant Moment (ft-kips)	phi Pn (kips)	phi Vn (kips)	phi Tn (ft-kips)	phi Mn (ft-kips)	Total Deflect (in)	Rotation Sway (deg)	Rotation Twist (deg)	Stress Ratio
0.00	-28.86	-21.19	0.00	-1967.9	0.00	1967.98	3003.53	1501.76	5797.25	2902.93	0.00	0.000	0.000	0.688
5.00	-27.57	-20.85	0.00	-1862.0	0.00	1862.06	2960.91	1480.45	5573.38	2790.83	0.11	-0.210	0.000	0.677
10.00	-26.31	-20.51	0.00	-1757.8	0.00	1757.83	2916.70	1458.35	5350.68	2679.32	0.45	-0.425	0.000	0.665
15.00	-25.08	-20.18	0.00	-1655.2	0.00	1655.28	2870.92	1435.46	5129.40	2568.51	1.01	-0.643	0.000	0.653
20.00	-23.86	-19.83	0.00	-1554.3	0.00	1554.38	2823.56	1411.78	4909.74	2458.52	1.80	-0.865	0.000	0.641
25.00	-22.68	-19.46	0.00	-1455.2	0.00	1455.25	2774.61	1387.31	4691.94	2349.46	2.83	-1.091	0.000	0.628
30.00	-21.52	-19.08	0.00	-1357.9	0.00	1357.97	2724.09	1362.04	4476.23	2241.44	4.10	-1.320	0.000	0.614
35.00	-20.38	-18.69	0.00	-1262.5	0.00	1262.59	2671.99	1335.99	4262.83	2134.58	5.60	-1.553	0.000	0.599
40.00	-19.27	-18.29	0.00	-1169.1	0.00	1169.16	2618.30	1309.15	4051.97	2029.00	7.36	-1.788	0.000	0.584
45.00	-18.20	-17.88	0.00	-1077.7	0.00	1077.71	2563.04	1281.52	3843.87	1924.79	9.36	-2.027	0.000	0.567
48.50	-17.48	-17.58	0.00	-1015.1	0.00	1015.13	2523.41	1261.71	3699.97	1852.74	10.91	-2.198	0.000	0.555
50.00	-16.97	-17.47	0.00	-988.76	0.00	988.76	2506.19	1253.10	3638.77	1822.09	11.61	-2.272	0.000	0.550
53.25	-15.94	-17.17	0.00	-931.99	0.00	931.99	1850.79	925.39	2677.47	1340.72	13.21	-2.433	0.000	0.704
55.00	-15.59	-17.06	0.00	-901.93	0.00	901.93	1837.85	918.92	2627.99	1315.95	14.12	-2.520	0.000	0.694
60.00	-14.70	-16.67	0.00	-816.63	0.00	816.63	1799.82	899.91	2487.54	1245.62	16.92	-2.810	0.000	0.664
65.00	-13.84	-16.27	0.00	-733.30	0.00	733.30	1760.21	880.10	2348.61	1176.05	20.02	-3.100	0.000	0.632
70.00	-13.00	-15.87	0.00	-651.97	0.00	651.97	1719.02	859.51	2211.45	1107.37	23.42	-3.387	0.000	0.597
75.00	-12.18	-15.47	0.00	-572.61	0.00	572.61	1676.25	838.13	2076.26	1039.67	27.11	-3.670	0.000	0.558
80.00	-11.38	-15.08	0.00	-495.24	0.00	495.24	1631.90	815.95	1943.29	973.09	31.10	-3.946	0.000	0.516
85.00	-10.62	-14.69	0.00	-419.84	0.00	419.84	1585.97	792.99	1812.75	907.72	35.38	-4.212	0.000	0.470
90.00	-9.87	-14.30	0.00	-346.39	0.00	346.39	1538.46	769.23	1684.87	843.69	39.92	-4.464	0.000	0.417
95.00	-9.17	-13.91	0.00	-274.89	0.00	274.89	1489.37	744.69	1559.88	781.10	44.72	-4.696	0.000	0.358
97.00	-8.21	-11.52	0.00	-247.07	0.00	247.07	1469.29	734.65	1510.75	756.50	46.71	-4.785	0.000	0.332
98.75	-8.01	-11.39	0.00	-226.91	0.00	226.91	1451.52	725.76	1468.18	735.18	48.47	-4.859	0.000	0.314
100.00	-7.78	-11.29	0.00	-212.67	0.00	212.67	1437.39	718.70	1436.71	719.42	49.75	-4.911	0.000	0.301
102.00	-7.42	-11.14	0.00	-190.08	0.00	190.08	990.34	495.17	991.38	496.43	51.82	-4.990	0.000	0.391
105.00	-7.13	-10.92	0.00	-156.68	0.00	156.68	971.88	485.94	945.01	473.21	54.99	-5.098	0.000	0.339
107.00	-4.49	-6.01	0.00	-134.84	0.00	134.84	959.26	479.63	914.39	457.88	57.14	-5.181	0.000	0.299
110.00	-4.23	-5.80	0.00	-116.82	0.00	116.82	939.85	469.93	868.93	435.11	60.43	-5.295	0.000	0.273
115.00	-3.83	-5.45	0.00	-87.83	0.00	87.83	906.24	453.12	794.52	397.85	66.06	-5.465	0.000	0.225
117.00	-3.18	-4.32	0.00	-76.93	0.00	76.93	892.36	446.18	765.27	383.21	68.36	-5.529	0.000	0.204
120.00	-2.99	-4.13	0.00	-63.96	0.00	63.96	871.06	435.53	722.01	361.54	71.86	-5.617	0.000	0.180
125.00	-2.69	-3.81	0.00	-43.32	0.00	43.32	834.29	417.15	651.64	326.30	77.80	-5.740	0.000	0.136
130.00	-2.41	-3.51	0.00	-24.25	0.00	24.25	791.03	395.51	580.02	290.44	83.86	-5.832	0.000	0.087
135.00	-2.15	-3.22	0.00	-6.70	0.00	6.70	739.97	369.98	507.20	253.97	89.99	-5.884	0.000	0.029
137.00	-0.07	-0.13	0.00	-0.25	0.00	0.25	719.55	359.77	479.43	240.07	92.45	-5.889	0.000	0.001
139.00	0.00	-0.12	0.00	0.00	0.00	0.00	699.12	349.56	452.45	226.56	94.91	-5.889	0.000	0.000

Wind Loading - Shaft

Structure: CT13549-S-SBA	Code: EIA/TIA-222-G	9/26/2018
Site Name: Danbury 1	Exposure: C	
Height: 139.00 (ft)	Crest Height: 0.00	
Base Elev: 0.000 (ft)	Site Class: D - Stiff Soil	
Gh: 1.1	Topography: 1	Struct Class: II



Page: 12

Load Case: 0.9D + 1.6W 97 mph Wind

Dead Load Factor 0.90
Wind Load Factor 1.60

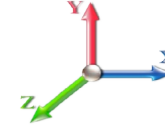

Iterations 26

Elev (ft)	Description	Kzt	Kz	qz (psf)	qzGh (psf)	C (mph-ft)	Cf	Ice Thick (in)	Tributary (ft)	Aa (sf)	CfAa (sf)	Wind Force X (lb)	Dead Load Ice (lb)	Tot Dead Load (lb)
0.00		1.00	0.85	19.450	21.40	357.41	0.650	0.000	0.00	0.000	0.00	0.0	0.0	0.0
5.00		1.00	0.85	19.450	21.40	348.67	0.650	0.000	5.00	19.738	12.83	439.2	0.0	703.8
10.00		1.00	0.85	19.450	21.40	339.93	0.650	0.000	5.00	19.250	12.51	428.3	0.0	686.3
15.00		1.00	0.85	19.450	21.40	331.19	0.650	0.000	5.00	18.761	12.19	417.5	0.0	668.7
20.00		1.00	0.90	20.638	22.70	332.15	0.650	0.000	5.00	18.273	11.88	431.4	0.0	651.2
25.00		1.00	0.95	21.630	23.79	330.83	0.650	0.000	5.00	17.784	11.56	440.1	0.0	633.6
30.00		1.00	0.98	22.477	24.72	327.84	0.650	0.000	5.00	17.295	11.24	444.7	0.0	616.1
35.00		1.00	1.01	23.218	25.54	323.66	0.650	0.000	5.00	16.807	10.92	446.4	0.0	598.6
40.00		1.00	1.04	23.880	26.27	318.56	0.650	0.000	5.00	16.318	10.61	445.8	0.0	581.0
45.00		1.00	1.07	24.479	26.93	312.72	0.650	0.000	5.00	15.830	10.29	443.3	0.0	563.5
48.50	Bot - Section 2	1.00	1.09	24.869	27.36	308.28	0.650	0.000	3.50	10.790	7.01	307.0	0.0	384.0
50.00		1.00	1.09	25.029	27.53	306.30	0.650	0.000	1.50	4.614	3.00	132.1	0.0	293.5
53.25	Top - Section 1	1.00	1.11	25.363	27.90	301.85	0.650	0.000	3.25	9.847	6.40	285.7	0.0	626.3
55.00		1.00	1.12	25.536	28.09	303.71	0.650	0.000	1.75	5.217	3.39	152.4	0.0	148.7
60.00		1.00	1.14	26.008	28.61	296.40	0.650	0.000	5.00	14.575	9.47	433.7	0.0	415.5
65.00		1.00	1.16	26.450	29.09	288.71	0.650	0.000	5.00	14.087	9.16	426.2	0.0	401.5
70.00		1.00	1.17	26.866	29.55	280.70	0.650	0.000	5.00	13.598	8.84	417.9	0.0	387.5
75.00		1.00	1.19	27.259	29.98	272.40	0.650	0.000	5.00	13.109	8.52	408.8	0.0	373.4
80.00		1.00	1.21	27.632	30.39	263.85	0.650	0.000	5.00	12.621	8.20	399.0	0.0	359.4
85.00		1.00	1.22	27.987	30.79	255.05	0.650	0.000	5.00	12.132	7.89	388.4	0.0	345.4
90.00		1.00	1.24	28.325	31.16	246.04	0.650	0.000	5.00	11.644	7.57	377.3	0.0	331.3
95.00		1.00	1.25	28.650	31.51	236.84	0.650	0.000	5.00	11.155	7.25	365.6	0.0	317.3
97.00	Appurtenance(s)	1.00	1.26	28.776	31.65	233.11	0.650	0.000	2.00	4.325	2.81	142.4	0.0	123.0
98.75	Bot - Section 3	1.00	1.26	28.884	31.77	229.82	0.650	0.000	1.75	3.720	2.42	122.9	0.0	105.8
100.00		1.00	1.27	28.961	31.86	227.46	0.650	0.000	1.25	2.660	1.73	88.1	0.0	131.4
102.00	Top - Section 2	1.00	1.27	29.082	31.99	223.66	0.650	0.000	2.00	4.193	2.73	139.5	0.0	207.0
105.00		1.00	1.28	29.260	32.19	221.39	0.650	0.000	3.00	6.143	3.99	205.6	0.0	131.3
107.00	Appurtenance(s)	1.00	1.28	29.376	32.31	217.54	0.650	0.000	2.00	3.998	2.60	134.3	0.0	85.4
110.00		1.00	1.29	29.548	32.50	211.71	0.650	0.000	3.00	5.850	3.80	197.7	0.0	125.0
115.00		1.00	1.30	29.826	32.81	201.88	0.650	0.000	5.00	9.359	6.08	319.3	0.0	199.9
117.00	Appurtenance(s)	1.00	1.31	29.934	32.93	197.91	0.650	0.000	2.00	3.607	2.34	123.5	0.0	77.0
120.00		1.00	1.32	30.094	33.10	191.92	0.650	0.000	3.00	5.264	3.42	181.2	0.0	112.3
125.00		1.00	1.33	30.354	33.39	181.82	0.650	0.000	5.00	8.382	5.45	291.1	0.0	178.8
130.00		1.00	1.34	30.605	33.67	171.61	0.650	0.000	5.00	7.893	5.13	276.4	0.0	168.3
135.00		1.00	1.35	30.850	33.93	161.29	0.650	0.000	5.00	7.405	4.81	261.3	0.0	157.8
137.00	Appurtenance(s)	1.00	1.35	30.945	34.04	157.13	0.650	0.000	2.00	2.825	1.84	100.0	0.0	60.2
139.00	Appurtenance(s)	1.00	1.36	31.040	34.14	152.96	0.650	0.000	2.00	2.747	1.79	97.5	0.0	58.5
Totals:									139.00			10,711.9		12,008.1

Discrete Appurtenance Forces

Structure: CT13549-S-SBA	Code: EIA/TIA-222-G	9/26/2018
Site Name: Danbury 1	Exposure: C	
Height: 139.00 (ft)	Crest Height: 0.00	
Base Elev: 0.000 (ft)	Site Class: D - Stiff Soil	
Gh: 1.1	Topography: 1	Struct Class: II



Page: 13

Load Case: 0.9D + 1.6W 97 mph Wind

Dead Load Factor 0.90
Wind Load Factor 1.60

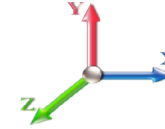

Iterations 26

No.	Elev (ft)	Description	Qty	qz (psf)	qzGh (psf)	CaAa x Ka	Ka	Total CaAa (sf)	Dead Load (lb)	Horiz Ecc (ft)	Vert Ecc (ft)	Wind FX (lb)	Mom Y (lb-ft)	Mom Z (lb-ft)
1	139.00	6' Lightning rod	1	31.040	34.144	1.00	1.00	0.38	5.85	0.000	0.000	20.76	0.00	0.00
2	137.00	AIR 21 B4A/B12P	3	30.945	34.040	0.67	0.75	23.11	340.20	0.000	0.000	1258.59	0.00	0.00
3	137.00	S11B12	3	30.945	34.040	0.52	0.75	4.46	137.70	0.000	0.000	242.76	0.00	0.00
4	137.00	KRY 112 144/1	3	30.945	34.040	0.52	0.75	0.65	29.70	0.000	0.000	35.17	0.00	0.00
5	137.00	AIR 21, 1.3M, B2A B4P	3	30.945	34.040	0.65	0.75	11.78	247.05	0.000	0.000	641.81	0.00	0.00
6	137.00	T-Arms	3	30.945	34.040	0.45	0.90	10.80	945.00	0.000	0.000	588.21	0.00	0.00
7	117.00	800 10504	3	29.934	32.927	0.54	0.75	5.41	47.52	0.000	0.000	285.06	0.00	0.00
8	117.00	Flush Mount	1	29.934	32.927	1.00	1.00	5.00	315.00	0.000	0.000	263.42	0.00	0.00
9	117.00	742 351	3	29.934	32.927	0.46	0.75	7.38	80.46	0.000	0.000	389.02	0.00	0.00
10	107.00	RRUS 4449 B5/B12	3	29.376	32.314	0.52	0.75	2.60	229.50	0.000	0.000	134.36	0.00	0.00
11	107.00	T-Arm Commscope	3	29.376	32.314	0.56	0.75	16.88	480.60	0.000	0.000	872.47	0.00	0.00
12	107.00	Collar Mount Commscope	1	29.376	32.314	1.00	1.00	5.00	110.16	0.000	0.000	258.51	0.00	0.00
13	107.00	RRUS-E2	3	29.376	32.314	0.52	0.75	2.60	207.90	0.000	0.000	134.36	0.00	0.00
14	107.00	DTMABP7819VG12A	3	29.376	32.314	0.50	0.75	1.72	51.84	0.000	0.000	88.85	0.00	0.00
15	107.00	DBC20056F1V1	3	29.376	32.314	0.60	0.75	0.74	17.82	0.000	0.000	38.16	0.00	0.00
16	107.00	RRUS A2	3	29.376	32.314	0.46	0.75	2.59	57.24	0.000	0.000	134.15	0.00	0.00
17	107.00	RRUS-11 700MHz	3	29.376	32.314	0.57	0.75	4.31	136.89	0.000	0.000	222.79	0.00	0.00
18	107.00	RRUS 12	3	29.376	32.314	0.52	0.75	4.96	156.60	0.000	0.000	256.51	0.00	0.00
19	107.00	EPBQ-652L8H6-L2	3	29.376	32.314	0.64	0.75	18.47	196.56	0.000	0.000	955.18	0.00	0.00
20	107.00	RRUS-32	3	29.376	32.314	0.65	0.75	7.58	207.90	0.000	0.000	391.67	0.00	0.00
21	107.00	DC6-48-60-18-8F	3	29.376	32.314	0.67	0.67	2.95	85.86	0.000	0.000	152.76	0.00	0.00
22	107.00	OPA-65R-LCUU-H6	3	29.376	32.314	0.59	0.75	17.17	216.00	0.000	0.000	887.76	0.00	0.00
23	97.00	Flush Mount	1	28.776	31.653	0.50	1.00	2.50	315.00	0.000	0.000	126.61	0.00	0.00
24	97.00	DB-T1-6Z-8AB-OZ	1	28.776	31.653	0.71	1.00	3.41	17.01	0.000	0.000	172.60	0.00	0.00
25	97.00	FD9R6004/2C-3L (3.1 lbs)	6	28.776	31.653	0.75	0.75	1.62	16.74	0.000	0.000	82.05	0.00	0.00
26	97.00	RRH2x40-AWS	3	28.776	31.653	0.61	0.75	4.65	118.80	0.000	0.000	235.47	0.00	0.00
27	97.00	DBXNH-6565A-VTM	3	28.776	31.653	0.60	0.75	9.67	92.34	0.000	0.000	489.54	0.00	0.00
28	97.00	BXA-171063/12CF	3	28.776	31.653	0.63	0.75	9.03	40.50	0.000	0.000	457.54	0.00	0.00
29	97.00	BXA-70063/6CF	3	28.776	31.653	0.52	0.75	11.92	45.90	0.000	0.000	603.83	0.00	0.00

Totals: 4,949.64 10,419.97

Total Applied Force Summary

Structure: CT13549-S-SBA	Code: EIA/TIA-222-G	9/26/2018
Site Name: Danbury 1	Exposure: C	
Height: 139.00 (ft)	Crest Height: 0.00	
Base Elev: 0.000 (ft)	Site Class: D - Stiff Soil	
Gh: 1.1	Topography: 1	Struct Class: II



Page: 14

Load Case: 0.9D + 1.6W 97 mph Wind

Dead Load Factor 0.90
Wind Load Factor 1.60

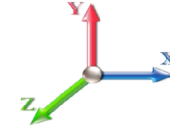

Iterations 26

Elev (ft)	Description	Lateral FX (-) (lb)	Axial FY (-) (lb)	Torsion MY (lb-ft)	Moment MZ (lb-ft)
0.00		0.00	0.00	0.00	0.00
5.00		439.20	907.55	0.00	0.00
10.00		428.33	890.01	0.00	0.00
15.00		417.46	872.47	0.00	0.00
20.00		431.40	854.93	0.00	0.00
25.00		440.06	837.39	0.00	0.00
30.00		444.72	819.85	0.00	0.00
35.00		446.41	802.32	0.00	0.00
40.00		445.79	784.78	0.00	0.00
45.00		443.30	767.24	0.00	0.00
48.50		306.97	526.63	0.00	0.00
50.00		132.12	354.67	0.00	0.00
53.25		285.71	758.70	0.00	0.00
55.00		152.40	220.06	0.00	0.00
60.00		433.66	619.28	0.00	0.00
65.00		426.24	605.25	0.00	0.00
70.00		417.93	591.22	0.00	0.00
75.00		408.80	577.19	0.00	0.00
80.00		398.95	563.15	0.00	0.00
85.00		388.43	549.12	0.00	0.00
90.00		377.30	535.09	0.00	0.00
95.00		365.61	521.06	0.00	0.00
97.00	(20) attachments	2310.01	850.79	0.00	0.00
98.75		122.93	155.70	0.00	0.00
100.00		88.14	167.04	0.00	0.00
102.00		139.51	264.07	0.00	0.00
105.00		205.63	216.88	0.00	0.00
107.00	(37) attachments	4661.90	2297.35	0.00	0.00
110.00		197.75	195.33	0.00	0.00
115.00		319.34	317.14	0.00	0.00
117.00	(7) attachments	1061.02	566.89	0.00	0.00
120.00		181.22	149.01	0.00	0.00
125.00		291.06	239.93	0.00	0.00
130.00		276.37	229.41	0.00	0.00
135.00		261.33	218.88	0.00	0.00
137.00	(15) attachments	2866.54	1784.26	0.00	0.00
139.00	(1) attachments	118.30	64.33	0.00	0.00
Totals:		21,131.84	21,674.96	0.00	0.00

Calculated Forces

Structure: CT13549-S-SBA	Code: EIA/TIA-222-G	9/26/2018
Site Name: Danbury 1	Exposure: C	
Height: 139.00 (ft)	Crest Height: 0.00	
Base Elev: 0.000 (ft)	Site Class: D - Stiff Soil	
Gh: 1.1	Topography: 1	Struct Class: II



Page: 15

Load Case: 0.9D + 1.6W 97 mph Wind

Iterations 26

Dead Load Factor 0.90
Wind Load Factor 1.60

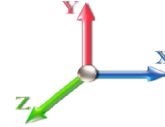

Seg Elev (ft)	Pu FY (-) (kips)	Vu FX (-) (kips)	Tu MY (-) (ft-kips)	Mu MZ (ft-kips)	Mu MX (ft-kips)	Resultant Moment (ft-kips)	phi Pn (kips)	phi Vn (kips)	phi Tn (ft-kips)	phi Mn (ft-kips)	Total Deflect (in)	Rotation Sway (deg)	Rotation Twist (deg)	Stress Ratio
0.00	-21.64	-21.17	0.00	-1947.6	0.00	1947.65	3003.53	1501.76	5797.25	2902.93	0.00	0.000	0.000	0.678
5.00	-20.65	-20.81	0.00	-1841.7	0.00	1841.79	2960.91	1480.45	5573.38	2790.83	0.11	-0.208	0.000	0.667
10.00	-19.69	-20.45	0.00	-1737.7	0.00	1737.76	2916.70	1458.35	5350.68	2679.32	0.44	-0.420	0.000	0.656
15.00	-18.74	-20.09	0.00	-1635.5	0.00	1635.53	2870.92	1435.46	5129.40	2568.51	1.00	-0.636	0.000	0.643
20.00	-17.82	-19.72	0.00	-1535.0	0.00	1535.07	2823.56	1411.78	4909.74	2458.52	1.78	-0.855	0.000	0.631
25.00	-16.91	-19.33	0.00	-1436.4	0.00	1436.47	2774.61	1387.31	4691.94	2349.46	2.80	-1.078	0.000	0.618
30.00	-16.03	-18.93	0.00	-1339.8	0.00	1339.82	2724.09	1362.04	4476.23	2241.44	4.05	-1.304	0.000	0.604
35.00	-15.16	-18.53	0.00	-1245.1	0.00	1245.15	2671.99	1335.99	4262.83	2134.58	5.54	-1.534	0.000	0.589
40.00	-14.32	-18.12	0.00	-1152.5	0.00	1152.51	2618.30	1309.15	4051.97	2029.00	7.27	-1.766	0.000	0.574
45.00	-13.50	-17.70	0.00	-1061.9	0.00	1061.92	2563.04	1281.52	3843.87	1924.79	9.25	-2.001	0.000	0.557
48.50	-12.95	-17.40	0.00	-999.97	0.00	999.97	2523.41	1261.71	3699.97	1852.74	10.78	-2.169	0.000	0.545
50.00	-12.57	-17.28	0.00	-973.88	0.00	973.88	2506.19	1253.10	3638.77	1822.09	11.47	-2.243	0.000	0.540
53.25	-11.78	-16.99	0.00	-917.72	0.00	917.72	1850.79	925.39	2677.47	1340.72	13.05	-2.401	0.000	0.691
55.00	-11.52	-16.86	0.00	-887.99	0.00	887.99	1837.85	918.92	2627.99	1315.95	13.95	-2.487	0.000	0.681
60.00	-10.83	-16.46	0.00	-803.67	0.00	803.67	1799.82	899.91	2487.54	1245.62	16.71	-2.773	0.000	0.652
65.00	-10.17	-16.05	0.00	-721.39	0.00	721.39	1760.21	880.10	2348.61	1176.05	19.76	-3.057	0.000	0.620
70.00	-9.53	-15.65	0.00	-641.13	0.00	641.13	1719.02	859.51	2211.45	1107.37	23.12	-3.340	0.000	0.585
75.00	-8.90	-15.25	0.00	-562.89	0.00	562.89	1676.25	838.13	2076.26	1039.67	26.76	-3.618	0.000	0.547
80.00	-8.30	-14.85	0.00	-486.66	0.00	486.66	1631.90	815.95	1943.29	973.09	30.70	-3.890	0.000	0.506
85.00	-7.72	-14.46	0.00	-412.40	0.00	412.40	1585.97	792.99	1812.75	907.72	34.91	-4.151	0.000	0.460
90.00	-7.15	-14.07	0.00	-340.11	0.00	340.11	1538.46	769.23	1684.87	843.69	39.39	-4.398	0.000	0.408
95.00	-6.62	-13.69	0.00	-269.74	0.00	269.74	1489.37	744.69	1559.88	781.10	44.12	-4.626	0.000	0.350
97.00	-5.95	-11.32	0.00	-242.37	0.00	242.37	1469.29	734.65	1510.75	756.50	46.07	-4.713	0.000	0.325
98.75	-5.79	-11.19	0.00	-222.56	0.00	222.56	1451.52	725.76	1468.18	735.18	47.81	-4.786	0.000	0.307
100.00	-5.62	-11.10	0.00	-208.57	0.00	208.57	1437.39	718.70	1436.71	719.42	49.07	-4.837	0.000	0.294
102.00	-5.35	-10.94	0.00	-186.37	0.00	186.37	990.34	495.17	991.38	496.43	51.11	-4.915	0.000	0.381
105.00	-5.14	-10.73	0.00	-153.54	0.00	153.54	971.88	485.94	945.01	473.21	54.23	-5.020	0.000	0.330
107.00	-3.25	-5.89	0.00	-132.08	0.00	132.08	959.26	479.63	914.39	457.88	56.35	-5.102	0.000	0.292
110.00	-3.06	-5.68	0.00	-114.41	0.00	114.41	939.85	469.93	868.93	435.11	59.59	-5.214	0.000	0.266
115.00	-2.76	-5.34	0.00	-86.00	0.00	86.00	906.24	453.12	794.52	397.85	65.13	-5.380	0.000	0.219
117.00	-2.29	-4.23	0.00	-75.32	0.00	75.32	892.36	446.18	765.27	383.21	67.40	-5.443	0.000	0.199
120.00	-2.15	-4.04	0.00	-62.62	0.00	62.62	871.06	435.53	722.01	361.54	70.84	-5.528	0.000	0.176
125.00	-1.94	-3.73	0.00	-42.41	0.00	42.41	834.29	417.15	651.64	326.30	76.69	-5.649	0.000	0.132
130.00	-1.73	-3.44	0.00	-23.75	0.00	23.75	791.03	395.51	580.02	290.44	82.65	-5.740	0.000	0.084
135.00	-1.54	-3.16	0.00	-6.56	0.00	6.56	739.97	369.98	507.20	253.97	88.68	-5.790	0.000	0.028
137.00	-0.05	-0.12	0.00	-0.25	0.00	0.25	719.55	359.77	479.43	240.07	91.10	-5.795	0.000	0.001
139.00	0.00	-0.12	0.00	0.00	0.00	0.00	699.12	349.56	452.45	226.56	93.53	-5.795	0.000	0.000

Wind Loading - Shaft

Structure: CT13549-S-SBA	Code: EIA/TIA-222-G	9/26/2018
Site Name: Danbury 1	Exposure: C	
Height: 139.00 (ft)	Crest Height: 0.00	
Base Elev: 0.000 (ft)	Site Class: D - Stiff Soil	
Gh: 1.1	Topography: 1	Struct Class: II



Page: 16

Load Case: 1.2D + 1.0Di + 1.0Wi 50 mph Wind

Dead Load Factor 1.20
Wind Load Factor 1.00

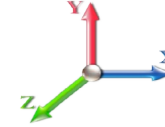

Iterations 25

Elev (ft)	Description	Kzt	Kz	qz (psf)	qzGh (psf)	C (mph-ft)	Cf	Ice Thick (in)	Tributary (ft)	Aa (sf)	CfAa (sf)	Wind Force X (lb)	Dead Load Ice (lb)	Tot Dead Load (lb)
0.00		1.00	0.85	5.168	5.68	0.00	1.200	0.000	0.00	0.000	0.00	0.0	0.0	0.0
5.00		1.00	0.85	5.168	5.68	0.00	1.200	1.242	5.00	20.773	24.93	141.7	368.1	1306.5
10.00		1.00	0.85	5.168	5.68	0.00	1.200	1.331	5.00	20.359	24.43	138.9	385.7	1300.7
15.00		1.00	0.85	5.168	5.68	0.00	1.200	1.386	5.00	19.916	23.90	135.9	392.1	1283.7
20.00		1.00	0.90	5.483	6.03	0.00	1.200	1.427	5.00	19.462	23.35	140.9	393.5	1261.8
25.00		1.00	0.95	5.747	6.32	0.00	1.200	1.459	5.00	19.000	22.80	144.1	392.1	1237.0
30.00		1.00	0.98	5.972	6.57	0.00	1.200	1.486	5.00	18.534	22.24	146.1	388.9	1210.3
35.00		1.00	1.01	6.169	6.79	0.00	1.200	1.509	5.00	18.064	21.68	147.1	384.2	1182.3
40.00		1.00	1.04	6.345	6.98	0.00	1.200	1.529	5.00	17.592	21.11	147.3	378.5	1153.2
45.00		1.00	1.07	6.504	7.15	0.00	1.200	1.547	5.00	17.119	20.54	147.0	371.9	1123.2
48.50	Bot - Section 2	1.00	1.09	6.608	7.27	0.00	1.200	1.559	3.50	11.699	14.04	102.0	256.9	768.9
50.00		1.00	1.09	6.650	7.32	0.00	1.200	1.564	1.50	5.005	6.01	43.9	110.9	502.3
53.25	Top - Section 1	1.00	1.11	6.739	7.41	0.00	1.200	1.574	3.25	10.699	12.84	95.2	237.0	1072.0
55.00		1.00	1.12	6.785	7.46	0.00	1.200	1.579	1.75	5.677	6.81	50.8	126.7	325.0
60.00		1.00	1.14	6.910	7.60	0.00	1.200	1.592	5.00	15.902	19.08	145.1	353.7	907.7
65.00		1.00	1.16	7.028	7.73	0.00	1.200	1.605	5.00	15.424	18.51	143.1	345.0	880.3
70.00		1.00	1.17	7.138	7.85	0.00	1.200	1.617	5.00	14.946	17.93	140.8	336.0	852.6
75.00		1.00	1.19	7.243	7.97	0.00	1.200	1.628	5.00	14.466	17.36	138.3	326.6	824.5
80.00		1.00	1.21	7.342	8.08	0.00	1.200	1.639	5.00	13.987	16.78	135.5	317.0	796.2
85.00		1.00	1.22	7.436	8.18	0.00	1.200	1.649	5.00	13.506	16.21	132.6	307.1	767.6
90.00		1.00	1.24	7.526	8.28	0.00	1.200	1.658	5.00	13.025	15.63	129.4	297.0	738.7
95.00		1.00	1.25	7.612	8.37	0.00	1.200	1.667	5.00	12.544	15.05	126.0	286.6	709.7
97.00	Appurtenance(s)	1.00	1.26	7.646	8.41	0.00	1.200	1.671	2.00	4.882	5.86	49.3	113.0	276.9
98.75	Bot - Section 3	1.00	1.26	7.675	8.44	0.00	1.200	1.674	1.75	4.209	5.05	42.6	97.5	238.6
100.00		1.00	1.27	7.695	8.46	0.00	1.200	1.676	1.25	3.010	3.61	30.6	70.0	245.2
102.00	Top - Section 2	1.00	1.27	7.727	8.50	0.00	1.200	1.679	2.00	4.753	5.70	48.5	110.3	386.3
105.00		1.00	1.28	7.774	8.55	0.00	1.200	1.684	3.00	6.985	8.38	71.7	161.5	336.6
107.00	Appurtenance(s)	1.00	1.28	7.805	8.59	0.00	1.200	1.687	2.00	4.560	5.47	47.0	106.0	219.8
110.00		1.00	1.29	7.851	8.64	0.00	1.200	1.692	3.00	6.696	8.04	69.4	155.0	321.6
115.00		1.00	1.30	7.925	8.72	0.00	1.200	1.699	5.00	10.775	12.93	112.7	247.3	513.7
117.00	Appurtenance(s)	1.00	1.31	7.954	8.75	0.00	1.200	1.702	2.00	4.174	5.01	43.8	97.1	199.8
120.00		1.00	1.32	7.996	8.80	0.00	1.200	1.707	3.00	6.117	7.34	64.6	141.6	291.4
125.00		1.00	1.33	8.065	8.87	0.00	1.200	1.714	5.00	9.810	11.77	104.4	224.7	463.1
130.00		1.00	1.34	8.132	8.95	0.00	1.200	1.720	5.00	9.327	11.19	100.1	213.2	437.6
135.00		1.00	1.35	8.197	9.02	0.00	1.200	1.727	5.00	8.844	10.61	95.7	201.6	411.9
137.00	Appurtenance(s)	1.00	1.35	8.222	9.04	0.00	1.200	1.729	2.00	3.402	4.08	36.9	78.7	159.0
139.00	Appurtenance(s)	1.00	1.36	8.247	9.07	0.00	1.200	1.732	2.00	3.324	3.99	36.2	76.9	154.8
Totals:									139.00			3,625.3		24,860.5

Discrete Appurtenance Forces

Structure: CT13549-S-SBA	Code: EIA/TIA-222-G	9/26/2018
Site Name: Danbury 1	Exposure: C	
Height: 139.00 (ft)	Crest Height: 0.00	
Base Elev: 0.000 (ft)	Site Class: D - Stiff Soil	
Gh: 1.1	Topography: 1	Struct Class: II



Page: 17

Load Case: 1.2D + 1.0Di + 1.0Wi 50 mph Wind

Dead Load Factor 1.20
Wind Load Factor 1.00



Iterations 25

No.	Elev (ft)	Description	Qty	qz (psf)	qzGh (psf)	CaAa x Ka	Ka	Total CaAa (sf)	Dead Load (lb)	Horiz Ecc (ft)	Vert Ecc (ft)	Wind FX (lb)	Mom Y (lb-ft)	Mom Z (lb-ft)
1	139.00	6' Lightning rod	1	8.247	9.072	1.00	1.00	1.46	38.53	0.000	0.000	13.24	0.00	0.00
2	137.00	AIR 21 B4A/B12P	3	8.222	9.044	0.67	0.75	26.40	1300.38	0.000	0.000	238.77	0.00	0.00
3	137.00	S11B12	3	8.222	9.044	0.52	0.75	5.51	342.22	0.000	0.000	49.80	0.00	0.00
4	137.00	KRY 112 144/1	3	8.222	9.044	0.52	0.75	1.39	62.35	0.000	0.000	12.55	0.00	0.00
5	137.00	AIR 21, 1.3M, B2A B4P	3	8.222	9.044	0.65	0.75	13.89	830.61	0.000	0.000	125.60	0.00	0.00
6	137.00	T-Arms	3	8.222	9.044	0.45	0.90	20.14	1776.38	0.000	0.000	182.15	0.00	0.00
7	117.00	800 10504	3	7.954	8.749	0.54	0.75	8.28	193.22	0.000	0.000	72.42	0.00	0.00
8	117.00	Flush Mount	1	7.954	8.749	1.00	1.00	8.40	606.00	0.000	0.000	73.53	0.00	0.00
9	117.00	742 351	3	7.954	8.749	0.46	0.75	10.04	304.26	0.000	0.000	87.87	0.00	0.00
10	107.00	RRUS 4449 B5/B12	3	7.805	8.586	0.52	0.75	6.71	647.28	0.000	0.000	57.62	0.00	0.00
11	107.00	T-Arm Commscope	3	7.805	8.586	0.56	0.75	31.11	875.20	0.000	0.000	267.12	0.00	0.00
12	107.00	Collar Mount Commscope	1	7.805	8.586	1.00	1.00	13.44	398.01	0.000	0.000	115.36	0.00	0.00
13	107.00	RRUS-E2	3	7.805	8.586	0.52	0.75	3.48	416.30	0.000	0.000	29.87	0.00	0.00
14	107.00	DTMABP7819VG12A	3	7.805	8.586	0.50	0.75	2.84	121.24	0.000	0.000	24.38	0.00	0.00
15	107.00	DBC20056F1V1	3	7.805	8.586	0.60	0.75	1.30	55.05	0.000	0.000	11.13	0.00	0.00
16	107.00	RRUS A2	3	7.805	8.586	0.46	0.75	3.91	150.45	0.000	0.000	33.55	0.00	0.00
17	107.00	RRUS-11 700MHz	3	7.805	8.586	0.57	0.75	5.38	439.28	0.000	0.000	46.22	0.00	0.00
18	107.00	RRUS 12	3	7.805	8.586	0.52	0.75	6.05	483.44	0.000	0.000	51.91	0.00	0.00
19	107.00	EPBQ-652L8H6-L2	3	7.805	8.586	0.64	0.75	28.12	1074.08	0.000	0.000	241.45	0.00	0.00
20	107.00	RRUS-32	3	7.805	8.586	0.65	0.75	7.98	604.39	0.000	0.000	68.54	0.00	0.00
21	107.00	DC6-48-60-18-8F	3	7.805	8.586	0.67	0.67	4.31	240.69	0.000	0.000	37.05	0.00	0.00
22	107.00	OPA-65R-LCUU-H6	3	7.805	8.586	0.59	0.75	19.51	956.35	0.000	0.000	167.54	0.00	0.00
23	97.00	Flush Mount	1	7.646	8.410	0.50	1.00	4.17	600.69	0.000	0.000	35.08	0.00	0.00
24	97.00	DB-T1-6Z-8AB-OZ	1	7.646	8.410	0.71	1.00	4.00	159.23	0.000	0.000	33.64	0.00	0.00
25	97.00	FD9R6004/2C-3L (3.1 lbs)	6	7.646	8.410	0.75	0.75	3.53	54.62	0.000	0.000	29.69	0.00	0.00
26	97.00	RRH2x40-AWS	3	7.646	8.410	0.61	0.75	6.81	280.60	0.000	0.000	57.27	0.00	0.00
27	97.00	DBXNH-6565A-VTM	3	7.646	8.410	0.60	0.75	13.07	378.25	0.000	0.000	109.93	0.00	0.00
28	97.00	BXA-171063/12CF	3	7.646	8.410	0.63	0.75	13.30	247.01	0.000	0.000	111.88	0.00	0.00
29	97.00	BXA-70063/6CF	3	7.646	8.410	0.52	0.75	16.09	346.39	0.000	0.000	135.32	0.00	0.00

Totals: 13,982.49

2,520.45

Total Applied Force Summary

Structure: CT13549-S-SBA	Code: EIA/TIA-222-G	9/26/2018
Site Name: Danbury 1	Exposure: C	
Height: 139.00 (ft)	Crest Height: 0.00	
Base Elev: 0.000 (ft)	Site Class: D - Stiff Soil	
Gh: 1.1	Topography: 1	Struct Class: II



Page: 18

Load Case: 1.2D + 1.0Di + 1.0Wi 50 mph Wind

Dead Load Factor 1.20
Wind Load Factor 1.00



Iterations 25

Elev (ft)	Description	Lateral FX (-) (lb)	Axial FY (-) (lb)	Torsion MY (lb-ft)	Moment MZ (lb-ft)
0.00		0.00	0.00	0.00	0.00
5.00		141.71	1578.21	0.00	0.00
10.00		138.89	1572.35	0.00	0.00
15.00		135.87	1555.36	0.00	0.00
20.00		140.87	1533.45	0.00	0.00
25.00		144.14	1508.67	0.00	0.00
30.00		146.10	1482.00	0.00	0.00
35.00		147.10	1453.95	0.00	0.00
40.00		147.34	1424.85	0.00	0.00
45.00		146.98	1394.92	0.00	0.00
48.50		102.04	959.04	0.00	0.00
50.00		43.94	583.78	0.00	0.00
53.25		95.18	1248.63	0.00	0.00
55.00		50.85	420.08	0.00	0.00
60.00		145.06	1179.37	0.00	0.00
65.00		143.09	1152.01	0.00	0.00
70.00		140.83	1124.28	0.00	0.00
75.00		138.30	1096.23	0.00	0.00
80.00		135.55	1067.88	0.00	0.00
85.00		132.57	1039.27	0.00	0.00
90.00		129.40	1010.41	0.00	0.00
95.00		126.05	981.34	0.00	0.00
97.00	(20) attachments	562.08	2452.42	0.00	0.00
98.75		42.63	305.15	0.00	0.00
100.00		30.57	292.71	0.00	0.00
102.00		48.48	462.37	0.00	0.00
105.00		71.68	450.71	0.00	0.00
107.00	(37) attachments	1198.71	6757.67	0.00	0.00
110.00		69.39	415.44	0.00	0.00
115.00		112.72	670.11	0.00	0.00
117.00	(7) attachments	277.65	1365.80	0.00	0.00
120.00		64.56	340.30	0.00	0.00
125.00		104.44	544.58	0.00	0.00
130.00		100.12	519.05	0.00	0.00
135.00		95.69	493.40	0.00	0.00
137.00	(15) attachments	645.77	4503.50	0.00	0.00
139.00	(1) attachments	49.43	193.37	0.00	0.00
Totals:		6,145.75	45,132.64	0.00	0.00

Calculated Forces

Structure: CT13549-S-SBA	Code: EIA/TIA-222-G	9/26/2018
Site Name: Danbury 1	Exposure: C	
Height: 139.00 (ft)	Crest Height: 0.00	
Base Elev: 0.000 (ft)	Site Class: D - Stiff Soil	
Gh: 1.1	Topography: 1	Struct Class: II



Page: 19

Load Case: 1.2D + 1.0Di + 1.0Wi 50 mph Wind

Iterations 25

Dead Load Factor 1.20
Wind Load Factor 1.00

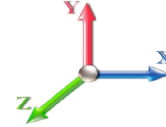

Seg Elev (ft)	Pu FY (-) (kips)	Vu FX (-) (kips)	Tu MY (-) (ft-kips)	Mu MZ (ft-kips)	Mu MX (ft-kips)	Resultant Moment (ft-kips)	phi Pn (kips)	phi Vn (kips)	phi Tn (ft-kips)	phi Mn (ft-kips)	Total Deflect (in)	Rotation Sway (deg)	Rotation Twist (deg)	Stress Ratio
0.00	-45.13	-6.17	0.00	-569.16	0.00	569.16	3003.53	1501.76	5797.25	2902.93	0.00	0.000	0.000	0.211
5.00	-43.54	-6.07	0.00	-538.31	0.00	538.31	2960.91	1480.45	5573.38	2790.83	0.03	-0.061	0.000	0.208
10.00	-41.97	-5.98	0.00	-507.95	0.00	507.95	2916.70	1458.35	5350.68	2679.32	0.13	-0.123	0.000	0.204
15.00	-40.40	-5.88	0.00	-478.06	0.00	478.06	2870.92	1435.46	5129.40	2568.51	0.29	-0.186	0.000	0.200
20.00	-38.87	-5.78	0.00	-448.64	0.00	448.64	2823.56	1411.78	4909.74	2458.52	0.52	-0.250	0.000	0.196
25.00	-37.35	-5.67	0.00	-419.75	0.00	419.75	2774.61	1387.31	4691.94	2349.46	0.82	-0.315	0.000	0.192
30.00	-35.86	-5.56	0.00	-391.39	0.00	391.39	2724.09	1362.04	4476.23	2241.44	1.18	-0.381	0.000	0.188
35.00	-34.40	-5.44	0.00	-363.61	0.00	363.61	2671.99	1335.99	4262.83	2134.58	1.62	-0.448	0.000	0.183
40.00	-32.97	-5.32	0.00	-336.40	0.00	336.40	2618.30	1309.15	4051.97	2029.00	2.13	-0.516	0.000	0.178
45.00	-31.58	-5.19	0.00	-309.80	0.00	309.80	2563.04	1281.52	3843.87	1924.79	2.70	-0.585	0.000	0.173
48.50	-30.61	-5.10	0.00	-291.63	0.00	291.63	2523.41	1261.71	3699.97	1852.74	3.15	-0.634	0.000	0.170
50.00	-30.03	-5.07	0.00	-283.98	0.00	283.98	2506.19	1253.10	3638.77	1822.09	3.35	-0.655	0.000	0.168
53.25	-28.78	-4.97	0.00	-267.52	0.00	267.52	1850.79	925.39	2677.47	1340.72	3.81	-0.701	0.000	0.215
55.00	-28.35	-4.95	0.00	-258.81	0.00	258.81	1837.85	918.92	2627.99	1315.95	4.08	-0.726	0.000	0.212
60.00	-27.17	-4.82	0.00	-234.09	0.00	234.09	1799.82	899.91	2487.54	1245.62	4.88	-0.810	0.000	0.203
65.00	-26.01	-4.70	0.00	-209.97	0.00	209.97	1760.21	880.10	2348.61	1176.05	5.77	-0.892	0.000	0.193
70.00	-24.88	-4.58	0.00	-186.47	0.00	186.47	1719.02	859.51	2211.45	1107.37	6.75	-0.975	0.000	0.183
75.00	-23.78	-4.45	0.00	-163.58	0.00	163.58	1676.25	838.13	2076.26	1039.67	7.82	-1.056	0.000	0.172
80.00	-22.71	-4.33	0.00	-141.32	0.00	141.32	1631.90	815.95	1943.29	973.09	8.97	-1.134	0.000	0.159
85.00	-21.67	-4.20	0.00	-119.68	0.00	119.68	1585.97	792.99	1812.75	907.72	10.20	-1.210	0.000	0.146
90.00	-20.66	-4.08	0.00	-98.68	0.00	98.68	1538.46	769.23	1684.87	843.69	11.50	-1.282	0.000	0.130
95.00	-19.68	-3.94	0.00	-78.30	0.00	78.30	1489.37	744.69	1559.88	781.10	12.88	-1.348	0.000	0.113
97.00	-17.24	-3.33	0.00	-70.42	0.00	70.42	1469.29	734.65	1510.75	756.50	13.45	-1.373	0.000	0.105
98.75	-16.93	-3.28	0.00	-64.59	0.00	64.59	1451.52	725.76	1468.18	735.18	13.96	-1.395	0.000	0.100
100.00	-16.64	-3.25	0.00	-60.49	0.00	60.49	1437.39	718.70	1436.71	719.42	14.33	-1.409	0.000	0.096
102.00	-16.18	-3.20	0.00	-53.99	0.00	53.99	990.34	495.17	991.38	496.43	14.92	-1.432	0.000	0.125
105.00	-15.73	-3.12	0.00	-44.39	0.00	44.39	971.88	485.94	945.01	473.21	15.83	-1.462	0.000	0.110
107.00	-9.00	-1.76	0.00	-38.14	0.00	38.14	959.26	479.63	914.39	457.88	16.45	-1.486	0.000	0.093
110.00	-8.59	-1.68	0.00	-32.87	0.00	32.87	939.85	469.93	868.93	435.11	17.39	-1.518	0.000	0.085
115.00	-7.92	-1.56	0.00	-24.46	0.00	24.46	906.24	453.12	794.52	397.85	19.01	-1.566	0.000	0.070
117.00	-6.56	-1.24	0.00	-21.35	0.00	21.35	892.36	446.18	765.27	383.21	19.67	-1.584	0.000	0.063
120.00	-6.22	-1.17	0.00	-17.62	0.00	17.62	871.06	435.53	722.01	361.54	20.67	-1.608	0.000	0.056
125.00	-5.68	-1.06	0.00	-11.76	0.00	11.76	834.29	417.15	651.64	326.30	22.38	-1.642	0.000	0.043
130.00	-5.16	-0.94	0.00	-6.49	0.00	6.49	791.03	395.51	580.02	290.44	24.11	-1.667	0.000	0.029
135.00	-4.67	-0.83	0.00	-1.78	0.00	1.78	739.97	369.98	507.20	253.97	25.86	-1.680	0.000	0.013
137.00	-0.19	-0.06	0.00	-0.11	0.00	0.11	719.55	359.77	479.43	240.07	26.57	-1.682	0.000	0.001
139.00	0.00	-0.05	0.00	0.00	0.00	0.00	699.12	349.56	452.45	226.56	27.27	-1.682	0.000	0.000

Seismic Segment Forces (Factored)

Structure: CT13549-S-SBA	Code: EIA/TIA-222-G	9/26/2018
Site Name: Danbury 1	Exposure: C	
Height: 139.00 (ft)	Crest Height: 0.00	
Base Elev: 0.000 (ft)	Site Class: D - Stiff Soil	
Gh: 1.1	Topography: 1	Struct Class: II



Page: 20

Load Case: 1.2D + 1.0E				Iterations 23
Gust Response Factor	1.10	Sds	0.23	Ss 0.21
Dead Load Factor	1.20	Seismic Load Factor	1.00	S1 0.06
Wind Load Factor	0.00	Structure Frequency	0.37	SA 0.03
				Seismic Importance Factor 1.00

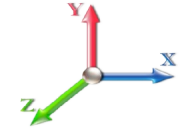

Top Elev (ft)	Description	Wz (lb)	a	b	c	Lateral Fs (lb)	R: 1.50
0.00		0.00	0.00	0.00	0.00	0.00	
5.00		781.99	0.00	0.03	0.02	20.57	
10.00		762.50	0.01	0.05	0.03	27.77	
15.00		743.01	0.02	0.07	0.04	30.45	
20.00		723.53	0.04	0.07	0.04	31.26	
25.00		704.04	0.06	0.07	0.04	31.37	
30.00		684.55	0.09	0.07	0.04	31.31	
35.00		665.06	0.12	0.07	0.03	31.24	
40.00		645.57	0.16	0.07	0.03	31.05	
45.00		626.08	0.20	0.06	0.02	30.43	
48.50	Bot - Section 2	426.66	0.23	0.06	0.02	20.52	
50.00		326.16	0.24	0.06	0.02	15.51	
53.25	Top - Section 1	695.84	0.28	0.05	0.01	31.60	
55.00		165.27	0.30	0.05	0.01	7.21	
60.00		461.69	0.35	0.03	0.01	16.22	
65.00		446.10	0.41	0.01	0.01	9.32	
70.00		430.51	0.48	-0.01	0.01	0.61	
75.00		414.92	0.55	-0.03	0.01	-8.23	
80.00		399.33	0.63	-0.06	0.02	-15.13	
85.00		383.74	0.71	-0.09	0.03	-18.92	
90.00		368.15	0.79	-0.11	0.05	-19.50	
95.00		352.56	0.88	-0.12	0.08	-17.30	
97.00	Appurtenance(s)	854.76	0.92	-0.12	0.10	-38.89	
98.75	Bot - Section 3	117.53	0.95	-0.12	0.11	-4.87	
100.00		145.97	0.98	-0.11	0.12	-5.55	
102.00	Top - Section 2	230.01	1.02	-0.11	0.14	-7.29	
105.00		145.87	1.08	-0.08	0.17	-2.94	
107.00	Appurtenance(s)	2489.2	1.12	-0.06	0.20	-27.66	
110.00		138.86	1.18	-0.01	0.24	0.62	
115.00		222.07	1.29	0.11	0.33	7.98	
117.00	Appurtenance(s)	577.76	1.34	0.18	0.37	29.14	
120.00		124.83	1.41	0.30	0.44	9.28	
125.00		198.69	1.53	0.57	0.58	23.80	
130.00		187.00	1.65	0.95	0.74	32.27	
135.00		175.30	1.78	1.46	0.95	40.82	
137.00	Appurtenance(s)	1955.3	1.84	1.71	1.04	506.66	
139.00	Appurtenance(s)	71.48	1.89	1.98	1.14	20.49	
Totals:		18,841.9				871.2	Total Wind: 21,131.8

Seismic Base Shear is Less Than 50% of Wind Force - An Analysis is NOT Required

Calculated Forces

Structure: CT13549-S-SBA	Code: EIA/TIA-222-G	9/26/2018
Site Name: Danbury 1	Exposure: C	
Height: 139.00 (ft)	Crest Height: 0.00	
Base Elev: 0.000 (ft)	Site Class: D - Stiff Soil	
Gh: 1.1	Topography: 1	Struct Class: II



Page: 21

Load Case: 1.2D + 1.0E						Iterations 23
Gust Response Factor	1.10		Sds	0.23		Ss 0.21
Dead Load Factor	1.20	Seismic Load Factor	1.00	Sd1	0.09	S1 0.06
Wind Load Factor	0.00	Structure Frequency	0.37	SA	0.03	Seismic Importance Factor 1.00

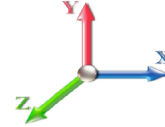

Seg Elev (ft)	Pu FY (-) (kips)	Vu FX (-) (kips)	Tu MY (-) (ft-kips)	Mu MZ (ft-kips)	Mu MX (ft-kips)	Resultant Moment (ft-kips)	phi Pn (kips)	phi Vn (kips)	phi Tn (ft-kips)	phi Mn (ft-kips)	Total Deflect (in)	Rotation Sway (deg)	Rotation Twist (deg)	Stress Ratio
0.00	-28.90	-1.04	0.00	-107.60	0.00	107.60	3003.53	1501.76	5797.25	2902.93	0.00	0.00	0.00	0.047
5.00	-27.69	-1.02	0.00	-102.40	0.00	102.40	2960.91	1480.45	5573.38	2790.83	0.01	-0.01	0.046	
10.00	-26.50	-1.00	0.00	-97.28	0.00	97.28	2916.70	1458.35	5350.68	2679.32	0.02	-0.02	0.045	
15.00	-25.34	-0.98	0.00	-92.27	0.00	92.27	2870.92	1435.46	5129.40	2568.51	0.06	-0.04	0.045	
20.00	-24.20	-0.95	0.00	-87.40	0.00	87.40	2823.56	1411.78	4909.74	2458.52	0.10	-0.05	0.044	
25.00	-23.08	-0.92	0.00	-82.65	0.00	82.65	2774.61	1387.31	4691.94	2349.46	0.16	-0.06	0.043	
30.00	-21.99	-0.89	0.00	-78.04	0.00	78.04	2724.09	1362.04	4476.23	2241.44	0.23	-0.07	0.043	
35.00	-20.92	-0.87	0.00	-73.57	0.00	73.57	2671.99	1335.99	4262.83	2134.58	0.31	-0.09	0.042	
40.00	-19.87	-0.84	0.00	-69.24	0.00	69.24	2618.30	1309.15	4051.97	2029.00	0.41	-0.10	0.042	
45.00	-18.85	-0.81	0.00	-65.04	0.00	65.04	2563.04	1281.52	3843.87	1924.79	0.52	-0.12	0.041	
48.50	-18.15	-0.79	0.00	-62.21	0.00	62.21	2523.41	1261.71	3699.97	1852.74	0.61	-0.13	0.041	
50.00	-17.67	-0.78	0.00	-61.02	0.00	61.02	2506.19	1253.10	3638.77	1822.09	0.65	-0.13	0.041	
53.25	-16.66	-0.74	0.00	-58.50	0.00	58.50	1850.79	925.39	2677.47	1340.72	0.74	-0.14	0.053	
55.00	-16.37	-0.74	0.00	-57.19	0.00	57.19	1837.85	918.92	2627.99	1315.95	0.80	-0.15	0.052	
60.00	-15.54	-0.73	0.00	-53.49	0.00	53.49	1799.82	899.91	2487.54	1245.62	0.96	-0.16	0.052	
65.00	-14.74	-0.72	0.00	-49.86	0.00	49.86	1760.21	880.10	2348.61	1176.05	1.14	-0.18	0.051	
70.00	-13.95	-0.72	0.00	-46.25	0.00	46.25	1719.02	859.51	2211.45	1107.37	1.35	-0.20	0.050	
75.00	-13.18	-0.72	0.00	-42.64	0.00	42.64	1676.25	838.13	2076.26	1039.67	1.57	-0.22	0.049	
80.00	-12.43	-0.73	0.00	-39.03	0.00	39.03	1631.90	815.95	1943.29	973.09	1.82	-0.25	0.048	
85.00	-11.69	-0.73	0.00	-35.40	0.00	35.40	1585.97	792.99	1812.75	907.72	2.08	-0.27	0.046	
90.00	-10.98	-0.73	0.00	-31.76	0.00	31.76	1538.46	769.23	1684.87	843.69	2.38	-0.29	0.045	
95.00	-10.29	-0.73	0.00	-28.13	0.00	28.13	1489.37	744.69	1559.88	781.10	2.69	-0.31	0.043	
97.00	-9.15	-0.72	0.00	-26.67	0.00	26.67	1469.29	734.65	1510.75	756.50	2.82	-0.32	0.041	
98.75	-8.94	-0.72	0.00	-25.41	0.00	25.41	1451.52	725.76	1468.18	735.18	2.94	-0.33	0.041	
100.00	-8.72	-0.72	0.00	-24.51	0.00	24.51	1437.39	718.70	1436.71	719.42	3.03	-0.33	0.040	
102.00	-8.37	-0.72	0.00	-23.06	0.00	23.06	990.34	495.17	991.38	496.43	3.17	-0.34	0.055	
105.00	-8.08	-0.72	0.00	-20.90	0.00	20.90	971.88	485.94	945.01	473.21	3.39	-0.36	0.052	
107.00	-5.02	-0.70	0.00	-19.45	0.00	19.45	959.26	479.63	914.39	457.88	3.54	-0.37	0.048	
110.00	-4.75	-0.70	0.00	-17.34	0.00	17.34	939.85	469.93	868.93	435.11	3.78	-0.39	0.045	
115.00	-4.33	-0.69	0.00	-13.83	0.00	13.83	906.24	453.12	794.52	397.85	4.20	-0.41	0.040	
117.00	-3.58	-0.66	0.00	-12.44	0.00	12.44	892.36	446.18	765.27	383.21	4.38	-0.42	0.036	
120.00	-3.38	-0.65	0.00	-10.46	0.00	10.46	871.06	435.53	722.01	361.54	4.65	-0.44	0.033	
125.00	-3.06	-0.62	0.00	-7.21	0.00	7.21	834.29	417.15	651.64	326.30	5.11	-0.46	0.026	
130.00	-2.75	-0.59	0.00	-4.09	0.00	4.09	791.03	395.51	580.02	290.44	5.60	-0.47	0.018	
135.00	-2.46	-0.55	0.00	-1.14	0.00	1.14	739.97	369.98	507.20	253.97	6.10	-0.48	0.008	
137.00	-0.09	-0.02	0.00	-0.04	0.00	0.04	719.55	359.77	479.43	240.07	6.30	-0.48	0.000	
139.00	0.00	-0.02	0.00	0.00	0.00	0.00	699.12	349.56	452.45	226.56	6.50	-0.48	0.000	

Seismic Segment Forces (Factored)

Structure: CT13549-S-SBA	Code: EIA/TIA-222-G	9/26/2018
Site Name: Danbury 1	Exposure: C	
Height: 139.00 (ft)	Crest Height: 0.00	
Base Elev: 0.000 (ft)	Site Class: D - Stiff Soil	
Gh: 1.1	Topography: 1	Struct Class: II



Page: 22

Load Case: 0.9D + 1.0E				Iterations 23
Gust Response Factor	1.10	Sds	0.23	Ss 0.21
Dead Load Factor	0.90	Seismic Load Factor	1.00	S1 0.06
Wind Load Factor	0.00	Structure Frequency	0.37	SA 0.03
				Seismic Importance Factor 1.00

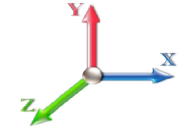

Top Elev (ft)	Description	Wz (lb)	a	b	c	Lateral Fs (lb)	R: 1.50
0.00		0.00	0.00	0.00	0.00	0.00	
5.00		781.99	0.00	0.03	0.02	20.57	
10.00		762.50	0.01	0.05	0.03	27.77	
15.00		743.01	0.02	0.07	0.04	30.45	
20.00		723.53	0.04	0.07	0.04	31.26	
25.00		704.04	0.06	0.07	0.04	31.37	
30.00		684.55	0.09	0.07	0.04	31.31	
35.00		665.06	0.12	0.07	0.03	31.24	
40.00		645.57	0.16	0.07	0.03	31.05	
45.00		626.08	0.20	0.06	0.02	30.43	
48.50	Bot - Section 2	426.66	0.23	0.06	0.02	20.52	
50.00		326.16	0.24	0.06	0.02	15.51	
53.25	Top - Section 1	695.84	0.28	0.05	0.01	31.60	
55.00		165.27	0.30	0.05	0.01	7.21	
60.00		461.69	0.35	0.03	0.01	16.22	
65.00		446.10	0.41	0.01	0.01	9.32	
70.00		430.51	0.48	-0.01	0.01	0.61	
75.00		414.92	0.55	-0.03	0.01	-8.23	
80.00		399.33	0.63	-0.06	0.02	-15.13	
85.00		383.74	0.71	-0.09	0.03	-18.92	
90.00		368.15	0.79	-0.11	0.05	-19.50	
95.00		352.56	0.88	-0.12	0.08	-17.30	
97.00	Appurtenance(s)	854.76	0.92	-0.12	0.10	-38.89	
98.75	Bot - Section 3	117.53	0.95	-0.12	0.11	-4.87	
100.00		145.97	0.98	-0.11	0.12	-5.55	
102.00	Top - Section 2	230.01	1.02	-0.11	0.14	-7.29	
105.00		145.87	1.08	-0.08	0.17	-2.94	
107.00	Appurtenance(s)	2489.2	1.12	-0.06	0.20	-27.66	
110.00		138.86	1.18	-0.01	0.24	0.62	
115.00		222.07	1.29	0.11	0.33	7.98	
117.00	Appurtenance(s)	577.76	1.34	0.18	0.37	29.14	
120.00		124.83	1.41	0.30	0.44	9.28	
125.00		198.69	1.53	0.57	0.58	23.80	
130.00		187.00	1.65	0.95	0.74	32.27	
135.00		175.30	1.78	1.46	0.95	40.82	
137.00	Appurtenance(s)	1955.3	1.84	1.71	1.04	506.66	
139.00	Appurtenance(s)	71.48	1.89	1.98	1.14	20.49	
Totals:		18,841.9				871.2	Total Wind: 21,131.8

Seismic Base Shear is Less Than 50% of Wind Force - An Analysis is NOT Required

Calculated Forces

Structure: CT13549-S-SBA	Code: EIA/TIA-222-G	9/26/2018
Site Name: Danbury 1	Exposure: C	
Height: 139.00 (ft)	Crest Height: 0.00	
Base Elev: 0.000 (ft)	Site Class: D - Stiff Soil	
Gh: 1.1	Topography: 1	Struct Class: II



Page: 23

Load Case: 0.9D + 1.0E						Iterations 23
Gust Response Factor	1.10			Sds	0.23	Ss 0.21
Dead Load Factor	0.90	Seismic Load Factor	1.00	Sd1	0.09	S1 0.06
Wind Load Factor	0.00	Structure Frequency	0.37	SA	0.03	Seismic Importance Factor 1.00

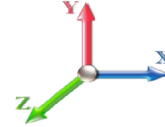

Seg Elev (ft)	Pu FY (-) (kips)	Vu FX (-) (kips)	Tu MY (-) (ft-kips)	Mu MZ (ft-kips)	Mu MX (ft-kips)	Resultant Moment (ft-kips)	phi Pn (kips)	phi Vn (kips)	phi Tn (ft-kips)	phi Mn (ft-kips)	Total Deflect (in)	Rotation Sway (deg)	Rotation Twist (deg)	Stress Ratio
0.00	-21.67	-1.04	0.00	-106.32	0.00	106.32	3003.53	1501.76	5797.25	2902.93	0.00	0.00	0.00	0.044
5.00	-20.77	-1.02	0.00	-101.13	0.00	101.13	2960.91	1480.45	5573.38	2790.83	0.01	-0.01	0.043	
10.00	-19.88	-1.00	0.00	-96.02	0.00	96.02	2916.70	1458.35	5350.68	2679.32	0.02	-0.02	0.043	
15.00	-19.00	-0.97	0.00	-91.03	0.00	91.03	2870.92	1435.46	5129.40	2568.51	0.05	-0.04	0.042	
20.00	-18.15	-0.94	0.00	-86.17	0.00	86.17	2823.56	1411.78	4909.74	2458.52	0.10	-0.05	0.041	
25.00	-17.31	-0.91	0.00	-81.46	0.00	81.46	2774.61	1387.31	4691.94	2349.46	0.15	-0.06	0.041	
30.00	-16.49	-0.89	0.00	-76.88	0.00	76.88	2724.09	1362.04	4476.23	2241.44	0.22	-0.07	0.040	
35.00	-15.69	-0.86	0.00	-72.45	0.00	72.45	2671.99	1335.99	4262.83	2134.58	0.31	-0.09	0.040	
40.00	-14.90	-0.83	0.00	-68.16	0.00	68.16	2618.30	1309.15	4051.97	2029.00	0.40	-0.10	0.039	
45.00	-14.14	-0.80	0.00	-64.02	0.00	64.02	2563.04	1281.52	3843.87	1924.79	0.52	-0.11	0.039	
48.50	-13.61	-0.78	0.00	-61.22	0.00	61.22	2523.41	1261.71	3699.97	1852.74	0.60	-0.12	0.038	
50.00	-13.26	-0.77	0.00	-60.05	0.00	60.05	2506.19	1253.10	3638.77	1822.09	0.64	-0.13	0.038	
53.25	-12.50	-0.73	0.00	-57.56	0.00	57.56	1850.79	925.39	2677.47	1340.72	0.73	-0.14	0.050	
55.00	-12.28	-0.73	0.00	-56.27	0.00	56.27	1837.85	918.92	2627.99	1315.95	0.79	-0.14	0.049	
60.00	-11.66	-0.71	0.00	-52.63	0.00	52.63	1799.82	899.91	2487.54	1245.62	0.95	-0.16	0.049	
65.00	-11.05	-0.71	0.00	-49.06	0.00	49.06	1760.21	880.10	2348.61	1176.05	1.13	-0.18	0.048	
70.00	-10.46	-0.71	0.00	-45.52	0.00	45.52	1719.02	859.51	2211.45	1107.37	1.33	-0.20	0.047	
75.00	-9.88	-0.71	0.00	-41.98	0.00	41.98	1676.25	838.13	2076.26	1039.67	1.55	-0.22	0.046	
80.00	-9.32	-0.71	0.00	-38.43	0.00	38.43	1631.90	815.95	1943.29	973.09	1.79	-0.24	0.045	
85.00	-8.77	-0.71	0.00	-34.87	0.00	34.87	1585.97	792.99	1812.75	907.72	2.05	-0.26	0.044	
90.00	-8.23	-0.71	0.00	-31.31	0.00	31.31	1538.46	769.23	1684.87	843.69	2.34	-0.28	0.042	
95.00	-7.71	-0.71	0.00	-27.75	0.00	27.75	1489.37	744.69	1559.88	781.10	2.65	-0.31	0.041	
97.00	-6.86	-0.71	0.00	-26.32	0.00	26.32	1469.29	734.65	1510.75	756.50	2.78	-0.32	0.039	
98.75	-6.71	-0.71	0.00	-25.08	0.00	25.08	1451.52	725.76	1468.18	735.18	2.90	-0.32	0.039	
100.00	-6.54	-0.71	0.00	-24.20	0.00	24.20	1437.39	718.70	1436.71	719.42	2.98	-0.33	0.038	
102.00	-6.28	-0.71	0.00	-22.78	0.00	22.78	990.34	495.17	991.38	496.43	3.13	-0.34	0.052	
105.00	-6.06	-0.71	0.00	-20.66	0.00	20.66	971.88	485.94	945.01	473.21	3.34	-0.35	0.050	
107.00	-3.76	-0.69	0.00	-19.24	0.00	19.24	959.26	479.63	914.39	457.88	3.49	-0.36	0.046	
110.00	-3.57	-0.69	0.00	-17.16	0.00	17.16	939.85	469.93	868.93	435.11	3.73	-0.38	0.043	
115.00	-3.25	-0.69	0.00	-13.69	0.00	13.69	906.24	453.12	794.52	397.85	4.14	-0.41	0.038	
117.00	-2.68	-0.65	0.00	-12.31	0.00	12.31	892.36	446.18	765.27	383.21	4.31	-0.42	0.035	
120.00	-2.53	-0.64	0.00	-10.36	0.00	10.36	871.06	435.53	722.01	361.54	4.58	-0.43	0.032	
125.00	-2.29	-0.62	0.00	-7.14	0.00	7.14	834.29	417.15	651.64	326.30	5.04	-0.45	0.025	
130.00	-2.06	-0.58	0.00	-4.05	0.00	4.05	791.03	395.51	580.02	290.44	5.52	-0.47	0.017	
135.00	-1.84	-0.54	0.00	-1.13	0.00	1.13	739.97	369.98	507.20	253.97	6.01	-0.47	0.007	
137.00	-0.06	-0.02	0.00	-0.04	0.00	0.04	719.55	359.77	479.43	240.07	6.21	-0.48	0.000	
139.00	0.00	-0.02	0.00	0.00	0.00	0.00	699.12	349.56	452.45	226.56	6.41	-0.48	0.000	

Wind Loading - Shaft

Structure: CT13549-S-SBA	Code: EIA/TIA-222-G	9/26/2018
Site Name: Danbury 1	Exposure: C	
Height: 139.00 (ft)	Crest Height: 0.00	
Base Elev: 0.000 (ft)	Site Class: D - Stiff Soil	
Gh: 1.1	Topography: 1	Struct Class: II



Page: 24

Load Case: 1.0D + 1.0W 60 mph Wind

Dead Load Factor 1.00
Wind Load Factor 1.00

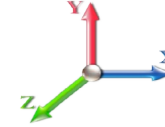

Iterations 25

Elev (ft)	Description	Kzt	Kz	qz (psf)	qzGh (psf)	C (mph-ft)	Cf	Ice Thick (in)	Tributary (ft)	Aa (sf)	CfAa (sf)	Wind Force X (lb)	Dead Load Ice (lb)	Tot Dead Load (lb)
0.00		1.00	0.85	7.442	8.19	221.08	0.650	0.000	0.00	0.000	0.00	0.0	0.0	0.0
5.00		1.00	0.85	7.442	8.19	215.67	0.650	0.000	5.00	19.738	12.83	105.0	0.0	782.0
10.00		1.00	0.85	7.442	8.19	210.27	0.650	0.000	5.00	19.250	12.51	102.4	0.0	762.5
15.00		1.00	0.85	7.442	8.19	204.86	0.650	0.000	5.00	18.761	12.19	99.8	0.0	743.0
20.00		1.00	0.90	7.896	8.69	205.45	0.650	0.000	5.00	18.273	11.88	103.2	0.0	723.5
25.00		1.00	0.95	8.276	9.10	204.63	0.650	0.000	5.00	17.784	11.56	105.2	0.0	704.0
30.00		1.00	0.98	8.600	9.46	202.79	0.650	0.000	5.00	17.295	11.24	106.3	0.0	684.5
35.00		1.00	1.01	8.883	9.77	200.20	0.650	0.000	5.00	16.807	10.92	106.8	0.0	665.1
40.00		1.00	1.04	9.137	10.05	197.04	0.650	0.000	5.00	16.318	10.61	106.6	0.0	645.6
45.00		1.00	1.07	9.366	10.30	193.44	0.650	0.000	5.00	15.830	10.29	106.0	0.0	626.1
48.50	Bot - Section 2	1.00	1.09	9.515	10.47	190.69	0.650	0.000	3.50	10.790	7.01	73.4	0.0	426.7
50.00		1.00	1.09	9.576	10.53	189.46	0.650	0.000	1.50	4.614	3.00	31.6	0.0	326.2
53.25	Top - Section 1	1.00	1.11	9.704	10.67	186.71	0.650	0.000	3.25	9.847	6.40	68.3	0.0	695.8
55.00		1.00	1.12	9.770	10.75	187.86	0.650	0.000	1.75	5.217	3.39	36.4	0.0	165.3
60.00		1.00	1.14	9.951	10.95	183.34	0.650	0.000	5.00	14.575	9.47	103.7	0.0	461.7
65.00		1.00	1.16	10.120	11.13	178.59	0.650	0.000	5.00	14.087	9.16	101.9	0.0	446.1
70.00		1.00	1.17	10.279	11.31	173.63	0.650	0.000	5.00	13.598	8.84	99.9	0.0	430.5
75.00		1.00	1.19	10.430	11.47	168.50	0.650	0.000	5.00	13.109	8.52	97.8	0.0	414.9
80.00		1.00	1.21	10.572	11.63	163.20	0.650	0.000	5.00	12.621	8.20	95.4	0.0	399.3
85.00		1.00	1.22	10.708	11.78	157.76	0.650	0.000	5.00	12.132	7.89	92.9	0.0	383.7
90.00		1.00	1.24	10.838	11.92	152.19	0.650	0.000	5.00	11.644	7.57	90.2	0.0	368.1
95.00		1.00	1.25	10.962	12.06	146.50	0.650	0.000	5.00	11.155	7.25	87.4	0.0	352.6
97.00	Appurtenance(s)	1.00	1.26	11.010	12.11	144.19	0.650	0.000	2.00	4.325	2.81	34.0	0.0	136.7
98.75	Bot - Section 3	1.00	1.26	11.051	12.16	142.16	0.650	0.000	1.75	3.720	2.42	29.4	0.0	117.5
100.00		1.00	1.27	11.081	12.19	140.70	0.650	0.000	1.25	2.660	1.73	21.1	0.0	146.0
102.00	Top - Section 2	1.00	1.27	11.127	12.24	138.35	0.650	0.000	2.00	4.193	2.73	33.4	0.0	230.0
105.00		1.00	1.28	11.195	12.31	136.94	0.650	0.000	3.00	6.143	3.99	49.2	0.0	145.9
107.00	Appurtenance(s)	1.00	1.28	11.240	12.36	134.56	0.650	0.000	2.00	3.998	2.60	32.1	0.0	94.9
110.00		1.00	1.29	11.305	12.44	130.95	0.650	0.000	3.00	5.850	3.80	47.3	0.0	138.9
115.00		1.00	1.30	11.412	12.55	124.87	0.650	0.000	5.00	9.359	6.08	76.4	0.0	222.1
117.00	Appurtenance(s)	1.00	1.31	11.453	12.60	122.42	0.650	0.000	2.00	3.607	2.34	29.5	0.0	85.6
120.00		1.00	1.32	11.514	12.67	118.71	0.650	0.000	3.00	5.264	3.42	43.3	0.0	124.8
125.00		1.00	1.33	11.614	12.78	112.47	0.650	0.000	5.00	8.382	5.45	69.6	0.0	198.7
130.00		1.00	1.34	11.710	12.88	106.15	0.650	0.000	5.00	7.893	5.13	66.1	0.0	187.0
135.00		1.00	1.35	11.803	12.98	99.77	0.650	0.000	5.00	7.405	4.81	62.5	0.0	175.3
137.00	Appurtenance(s)	1.00	1.35	11.840	13.02	97.19	0.650	0.000	2.00	2.825	1.84	23.9	0.0	66.8
139.00	Appurtenance(s)	1.00	1.36	11.876	13.06	94.61	0.650	0.000	2.00	2.747	1.79	23.3	0.0	65.0
Totals:									139.00			2,561.6		13,342.3

Discrete Appurtenance Forces

Structure: CT13549-S-SBA	Code: EIA/TIA-222-G	9/26/2018
Site Name: Danbury 1	Exposure: C	
Height: 139.00 (ft)	Crest Height: 0.00	
Base Elev: 0.000 (ft)	Site Class: D - Stiff Soil	
Gh: 1.1	Topography: 1	Struct Class: II



Page: 25

Load Case: 1.0D + 1.0W 60 mph Wind

Dead Load Factor 1.00
Wind Load Factor 1.00



Iterations 25

No.	Elev (ft)	Description	Qty	qz (psf)	qzGh (psf)	CaAa x Ka	Ka	Total CaAa (sf)	Dead Load (lb)	Horiz Ecc (ft)	Vert Ecc (ft)	Wind FX (lb)	Mom Y (lb-ft)	Mom Z (lb-ft)	
1	139.00	6' Lightning rod	1	11.876	13.064	1.00	1.00	0.38	6.50	0.000	0.000	4.96	0.00	0.00	
2	137.00	AIR 21 B4A/B12P	3	11.840	13.024	0.67	0.75	23.11	378.00	0.000	0.000	300.97	0.00	0.00	
3	137.00	S11B12	3	11.840	13.024	0.52	0.75	4.46	153.00	0.000	0.000	58.05	0.00	0.00	
4	137.00	KRY 112 144/1	3	11.840	13.024	0.52	0.75	0.65	33.00	0.000	0.000	8.41	0.00	0.00	
5	137.00	AIR 21, 1.3M, B2A B4P	3	11.840	13.024	0.65	0.75	11.78	274.50	0.000	0.000	153.48	0.00	0.00	
6	137.00	T-Arms	3	11.840	13.024	0.45	0.90	10.80	1050.00	0.000	0.000	140.66	0.00	0.00	
7	117.00	800 10504	3	11.453	12.598	0.54	0.75	5.41	52.80	0.000	0.000	68.17	0.00	0.00	
8	117.00	Flush Mount	1	11.453	12.598	1.00	1.00	5.00	350.00	0.000	0.000	62.99	0.00	0.00	
9	117.00	742 351	3	11.453	12.598	0.46	0.75	7.38	89.40	0.000	0.000	93.03	0.00	0.00	
10	107.00	RRUS 4449 B5/B12	3	11.240	12.364	0.52	0.75	2.60	255.00	0.000	0.000	32.13	0.00	0.00	
11	107.00	T-Arm Commscope	3	11.240	12.364	0.56	0.75	16.88	534.00	0.000	0.000	208.64	0.00	0.00	
12	107.00	Collar Mount Commscope	1	11.240	12.364	1.00	1.00	5.00	122.40	0.000	0.000	61.82	0.00	0.00	
13	107.00	RRUS-E2	3	11.240	12.364	0.52	0.75	2.60	231.00	0.000	0.000	32.13	0.00	0.00	
14	107.00	DTMABP7819VG12A	3	11.240	12.364	0.50	0.75	1.72	57.60	0.000	0.000	21.25	0.00	0.00	
15	107.00	DBC20056F1V1	3	11.240	12.364	0.60	0.75	0.74	19.80	0.000	0.000	9.12	0.00	0.00	
16	107.00	RRUS A2	3	11.240	12.364	0.46	0.75	2.59	63.60	0.000	0.000	32.08	0.00	0.00	
17	107.00	RRUS-11 700MHz	3	11.240	12.364	0.57	0.75	4.31	152.10	0.000	0.000	53.28	0.00	0.00	
18	107.00	RRUS 12	3	11.240	12.364	0.52	0.75	4.96	174.00	0.000	0.000	61.34	0.00	0.00	
19	107.00	EPBQ-652L8H6-L2	3	11.240	12.364	0.64	0.75	18.47	218.40	0.000	0.000	228.42	0.00	0.00	
20	107.00	RRUS-32	3	11.240	12.364	0.65	0.75	7.58	231.00	0.000	0.000	93.66	0.00	0.00	
21	107.00	DC6-48-60-18-8F	3	11.240	12.364	0.67	0.67	2.95	95.40	0.000	0.000	36.53	0.00	0.00	
22	107.00	OPA-65R-LCUU-H6	3	11.240	12.364	0.59	0.75	17.17	240.00	0.000	0.000	212.29	0.00	0.00	
23	97.00	Flush Mount	1	11.010	12.111	0.50	1.00	2.50	350.00	0.000	0.000	30.28	0.00	0.00	
24	97.00	DB-T1-6Z-8AB-OZ	1	11.010	12.111	0.71	1.00	3.41	18.90	0.000	0.000	41.27	0.00	0.00	
25	97.00	FD9R6004/2C-3L (3.1 lbs)	6	11.010	12.111	0.75	0.75	1.62	18.60	0.000	0.000	19.62	0.00	0.00	
26	97.00	RRH2x40-AWS	3	11.010	12.111	0.61	0.75	4.65	132.00	0.000	0.000	56.31	0.00	0.00	
27	97.00	DBXNH-6565A-VTM	3	11.010	12.111	0.60	0.75	9.67	102.60	0.000	0.000	117.06	0.00	0.00	
28	97.00	BXA-171063/12CF	3	11.010	12.111	0.63	0.75	9.03	45.00	0.000	0.000	109.41	0.00	0.00	
29	97.00	BXA-70063/6CF	3	11.010	12.111	0.52	0.75	11.92	51.00	0.000	0.000	144.40	0.00	0.00	
Totals:									5,499.60						2,491.76

Total Applied Force Summary

Structure: CT13549-S-SBA	Code: EIA/TIA-222-G	9/26/2018
Site Name: Danbury 1	Exposure: C	
Height: 139.00 (ft)	Crest Height: 0.00	
Base Elev: 0.000 (ft)	Site Class: D - Stiff Soil	
Gh: 1.1	Topography: 1	Struct Class: II



Page: 26

Load Case: 1.0D + 1.0W 60 mph Wind

Dead Load Factor 1.00
Wind Load Factor 1.00

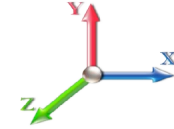

Iterations 25

Elev (ft)	Description	Lateral FX (-) (lb)	Axial FY (-) (lb)	Torsion MY (lb-ft)	Moment MZ (lb-ft)
0.00		0.00	0.00	0.00	0.00
5.00		105.03	1008.39	0.00	0.00
10.00		102.43	988.90	0.00	0.00
15.00		99.83	969.41	0.00	0.00
20.00		103.16	949.93	0.00	0.00
25.00		105.23	930.44	0.00	0.00
30.00		106.35	910.95	0.00	0.00
35.00		106.75	891.46	0.00	0.00
40.00		106.60	871.97	0.00	0.00
45.00		106.01	852.48	0.00	0.00
48.50		73.41	585.14	0.00	0.00
50.00		31.60	394.08	0.00	0.00
53.25		68.32	843.00	0.00	0.00
55.00		36.44	244.51	0.00	0.00
60.00		103.70	688.09	0.00	0.00
65.00		101.93	672.50	0.00	0.00
70.00		99.94	656.91	0.00	0.00
75.00		97.76	641.32	0.00	0.00
80.00		95.40	625.73	0.00	0.00
85.00		92.89	610.14	0.00	0.00
90.00		90.23	594.55	0.00	0.00
95.00		87.43	578.96	0.00	0.00
97.00	(20) attachments	552.40	945.32	0.00	0.00
98.75		29.40	173.00	0.00	0.00
100.00		21.08	185.60	0.00	0.00
102.00		33.36	293.41	0.00	0.00
105.00		49.17	240.97	0.00	0.00
107.00	(37) attachments	1114.81	2552.61	0.00	0.00
110.00		47.29	217.04	0.00	0.00
115.00		76.36	352.37	0.00	0.00
117.00	(7) attachments	253.72	629.88	0.00	0.00
120.00		43.33	165.57	0.00	0.00
125.00		69.60	266.59	0.00	0.00
130.00		66.09	254.90	0.00	0.00
135.00		62.49	243.20	0.00	0.00
137.00	(15) attachments	685.48	1982.51	0.00	0.00
139.00	(1) attachments	28.29	71.48	0.00	0.00
Totals:		5,053.31	24,083.29	0.00	0.00

Calculated Forces

Structure: CT13549-S-SBA	Code: EIA/TIA-222-G	9/26/2018
Site Name: Danbury 1	Exposure: C	
Height: 139.00 (ft)	Crest Height: 0.00	
Base Elev: 0.000 (ft)	Site Class: D - Stiff Soil	
Gh: 1.1	Topography: 1	Struct Class: II



Page: 27

Load Case: 1.0D + 1.0W 60 mph Wind

Iterations 25

Dead Load Factor 1.00
Wind Load Factor 1.00

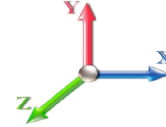

Seg Elev (ft)	Pu FY (-) (kips)	Vu FX (-) (kips)	Tu MY (-) (ft-kips)	Mu MZ (ft-kips)	Mu MX (ft-kips)	Resultant Moment (ft-kips)	phi Pn (kips)	phi Vn (kips)	phi Tn (ft-kips)	phi Mn (ft-kips)	Total Deflect (in)	Rotation Sway (deg)	Rotation Twist (deg)	Stress Ratio
0.00	-24.08	-5.06	0.00	-467.92	0.00	467.92	3003.53	1501.76	5797.25	2902.93	0.00	0.000	0.000	0.169
5.00	-23.07	-4.98	0.00	-442.61	0.00	442.61	2960.91	1480.45	5573.38	2790.83	0.03	-0.050	0.000	0.166
10.00	-22.08	-4.89	0.00	-417.72	0.00	417.72	2916.70	1458.35	5350.68	2679.32	0.11	-0.101	0.000	0.163
15.00	-21.10	-4.81	0.00	-393.24	0.00	393.24	2870.92	1435.46	5129.40	2568.51	0.24	-0.153	0.000	0.160
20.00	-20.15	-4.72	0.00	-369.19	0.00	369.19	2823.56	1411.78	4909.74	2458.52	0.43	-0.206	0.000	0.157
25.00	-19.21	-4.63	0.00	-345.57	0.00	345.57	2774.61	1387.31	4691.94	2349.46	0.67	-0.259	0.000	0.154
30.00	-18.30	-4.54	0.00	-322.40	0.00	322.40	2724.09	1362.04	4476.23	2241.44	0.97	-0.314	0.000	0.151
35.00	-17.40	-4.44	0.00	-299.70	0.00	299.70	2671.99	1335.99	4262.83	2134.58	1.33	-0.369	0.000	0.147
40.00	-16.53	-4.35	0.00	-277.47	0.00	277.47	2618.30	1309.15	4051.97	2029.00	1.75	-0.425	0.000	0.143
45.00	-15.67	-4.25	0.00	-255.73	0.00	255.73	2563.04	1281.52	3843.87	1924.79	2.22	-0.481	0.000	0.139
48.50	-15.09	-4.18	0.00	-240.86	0.00	240.86	2523.41	1261.71	3699.97	1852.74	2.59	-0.522	0.000	0.136
50.00	-14.69	-4.15	0.00	-234.60	0.00	234.60	2506.19	1253.10	3638.77	1822.09	2.76	-0.540	0.000	0.135
53.25	-13.85	-4.08	0.00	-221.11	0.00	221.11	1850.79	925.39	2677.47	1340.72	3.14	-0.578	0.000	0.172
55.00	-13.60	-4.05	0.00	-213.97	0.00	213.97	1837.85	918.92	2627.99	1315.95	3.36	-0.598	0.000	0.170
60.00	-12.91	-3.96	0.00	-193.71	0.00	193.71	1799.82	899.91	2487.54	1245.62	4.02	-0.667	0.000	0.163
65.00	-12.23	-3.86	0.00	-173.92	0.00	173.92	1760.21	880.10	2348.61	1176.05	4.75	-0.736	0.000	0.155
70.00	-11.57	-3.77	0.00	-154.62	0.00	154.62	1719.02	859.51	2211.45	1107.37	5.56	-0.804	0.000	0.146
75.00	-10.93	-3.67	0.00	-135.79	0.00	135.79	1676.25	838.13	2076.26	1039.67	6.44	-0.871	0.000	0.137
80.00	-10.30	-3.58	0.00	-117.43	0.00	117.43	1631.90	815.95	1943.29	973.09	7.39	-0.937	0.000	0.127
85.00	-9.69	-3.48	0.00	-99.55	0.00	99.55	1585.97	792.99	1812.75	907.72	8.40	-1.000	0.000	0.116
90.00	-9.09	-3.39	0.00	-82.12	0.00	82.12	1538.46	769.23	1684.87	843.69	9.48	-1.059	0.000	0.103
95.00	-8.51	-3.30	0.00	-65.16	0.00	65.16	1489.37	744.69	1559.88	781.10	10.62	-1.114	0.000	0.089
97.00	-7.58	-2.73	0.00	-58.56	0.00	58.56	1469.29	734.65	1510.75	756.50	11.10	-1.135	0.000	0.083
98.75	-7.40	-2.70	0.00	-53.77	0.00	53.77	1451.52	725.76	1468.18	735.18	11.51	-1.153	0.000	0.078
100.00	-7.22	-2.68	0.00	-50.40	0.00	50.40	1437.39	718.70	1436.71	719.42	11.82	-1.165	0.000	0.075
102.00	-6.92	-2.64	0.00	-45.04	0.00	45.04	990.34	495.17	991.38	496.43	12.31	-1.184	0.000	0.098
105.00	-6.68	-2.59	0.00	-37.12	0.00	37.12	971.88	485.94	945.01	473.21	13.06	-1.210	0.000	0.085
107.00	-4.15	-1.42	0.00	-31.94	0.00	31.94	959.26	479.63	914.39	457.88	13.57	-1.229	0.000	0.074
110.00	-3.94	-1.37	0.00	-27.67	0.00	27.67	939.85	469.93	868.93	435.11	14.36	-1.256	0.000	0.068
115.00	-3.59	-1.29	0.00	-20.80	0.00	20.80	906.24	453.12	794.52	397.85	15.69	-1.297	0.000	0.056
117.00	-2.96	-1.02	0.00	-18.22	0.00	18.22	892.36	446.18	765.27	383.21	16.24	-1.312	0.000	0.051
120.00	-2.80	-0.98	0.00	-15.15	0.00	15.15	871.06	435.53	722.01	361.54	17.07	-1.333	0.000	0.045
125.00	-2.53	-0.90	0.00	-10.26	0.00	10.26	834.29	417.15	651.64	326.30	18.48	-1.362	0.000	0.034
130.00	-2.28	-0.83	0.00	-5.75	0.00	5.75	791.03	395.51	580.02	290.44	19.92	-1.384	0.000	0.023
135.00	-2.04	-0.76	0.00	-1.59	0.00	1.59	739.97	369.98	507.20	253.97	21.38	-1.396	0.000	0.009
137.00	-0.07	-0.03	0.00	-0.06	0.00	0.06	719.55	359.77	479.43	240.07	21.96	-1.397	0.000	0.000
139.00	0.00	-0.03	0.00	0.00	0.00	0.00	699.12	349.56	452.45	226.56	22.55	-1.397	0.000	0.000

Final Analysis Summary

Structure: CT13549-S-SBA	Code: EIA/TIA-222-G	9/26/2018
Site Name: Danbury 1	Exposure: C	
Height: 139.00 (ft)	Crest Height: 0.00	
Base Elev: 0.000 (ft)	Site Class: D - Stiff Soil	
Gh: 1.1	Topography: 1	Page: 28
	Struct Class: II	



Reactions

Load Case	Shear FX (kips)	Shear FZ (kips)	Axial FY (kips)	Moment MX (ft-kips)	Moment MY (ft-kips)	Moment MZ (ft-kips)
1.2D + 1.6W 97 mph Wind	21.2	0.00	28.86	0.00	0.00	1967.98
0.9D + 1.6W 97 mph Wind	21.2	0.00	21.64	0.00	0.00	1947.65
1.2D + 1.0Di + 1.0Wi 50 mph Wind	6.2	0.00	45.13	0.00	0.00	569.16
1.2D + 1.0E	1.0	0.00	28.90	0.00	0.00	107.60
0.9D + 1.0E	1.0	0.00	21.67	0.00	0.00	106.32
1.0D + 1.0W 60 mph Wind	5.1	0.00	24.08	0.00	0.00	467.92

Max Stresses

Load Case	Pu FY (-) (kips)	Vu FX (-) (kips)	Tu MY (-) (ft-kips)	Mu MZ (ft-kips)	Mu MX (ft-kips)	Resultant Moment (ft-kips)	phi Pn (kips)	phi Vn (kips)	phi Tn (ft-kips)	phi Mn (ft-kips)	Elev (ft)	Stress Ratio
1.2D + 1.6W 97 mph Wind	-15.94	-17.17	0.00	-931.99	0.00	-931.99	1850.79	925.39	2677.47	1340.72	53.25	0.704
0.9D + 1.6W 97 mph Wind	-11.78	-16.99	0.00	-917.72	0.00	-917.72	1850.79	925.39	2677.47	1340.72	53.25	0.691
1.2D + 1.0Di + 1.0Wi 50 mph Wind	-28.78	-4.97	0.00	-267.52	0.00	-267.52	1850.79	925.39	2677.47	1340.72	53.25	0.215
1.2D + 1.0E	-8.37	-0.72	0.00	-23.06	0.00	-23.06	990.34	495.17	991.38	496.43	102.00	0.055
0.9D + 1.0E	-6.28	-0.71	0.00	-22.78	0.00	-22.78	990.34	495.17	991.38	496.43	102.00	0.052
1.0D + 1.0W 60 mph Wind	-13.85	-4.08	0.00	-221.11	0.00	-221.11	1850.79	925.39	2677.47	1340.72	53.25	0.172

Base Plate Summary

Structure: CT13549-S-SB	Code: EIA/TIA-222-G	9/26/2018
Site Name: Danbury 1	Exposure: C	
Height: 139.00 (ft)	Crest Height: 0.00	
Base Elev: 0.000 (ft)	Site Class: D - Stiff Soil	
Gh: 1.1	Topography: 1	Struct Class: II
		Page: 29



Reactions	Base Plate	Anchor Bolts
Original Design	Yield (ksi): 50.00	Bolt Circle: 53.50
Moment (kip-ft): 2074.00	Width (in): 51.50	Number Bolts: 12.00
Axial (kip): 21.70	Style: Clipped	Bolt Type: 2.25" 18J
Shear (kip): 20.70	Polygon Sides: 4.00	Bolt Diameter (in): 2.25
Analysis	Clip Length (in): 9.00	Yield (ksi): 75.00
Moment (kip-ft): 1967.98	Effective Len (in): 9.88	Ultimate (ksi): 100.00
Axial (kip): 45.13	Moment (kip-in): 473.07	Arrangement: Clustered
Shear (kip): 21.19	Allow Stress (ksi): 67.50	Cluster Dist (in): 6.00
	Applied Stress (ksi): 0.00	Start Angle (deg): 45.00
Moment Design %: 94.89	Stress Ratio: 0.56	Compression
		Force (kip): 150.90
		Allowable (kip): 260.00
		Ratio: 0.59
		Tension
		Force (kip): 143.38
		Allowable (kip): 260.00
		Ratio: 0.57



Monopole Mat Foundation Design

Date

9/26/2018

Customer Name:	AT&T	EIA/TIA Standard:	EIA-222-G
Site Name:		Structure Height (Ft.):	139
Site Number:	CT13549-S-SBA	Engineer Name:	J. Chen
Engr. Number:	61583	Engineer Login ID:	

Foundation Info Obtained from:

Drawings/Calculations

Structure Type:

Monopole

Analysis or Design?

Analysis

Base Reactions (Factored):

Axial Load (Kips):	45.1	Shear Force (Kips):	21.2
Uplift Force (Kips):	0.0	Moment (Kips-ft):	1968.0

Allowable overstress %: 5.0%

Foundation Geometries:

		Mods required -Yes/No ?:	No
Diameter of Pier (ft.):	5.5	Depth of Base BG (ft.):	6.5
Pier Height A. G. (ft.):	0.50	Thickness of Pad (ft):	5.00
Length of Pad (ft.):	19	Width of Pad (ft.):	19
Final Length of pad (ft)	19.0	Final width of pad (ft):	19.0
Control Value for Cell D18:	0	Control Value for Cell F18:	0

Material Properties and Rebar Info:

Concrete Strength (psi):	4000	Steel Elastic Modulus:	29000	ksi
Vertical bar yield (ksi)	60	Tie steel yield (ksi):	60	
Vertical Rebar Size #:	9	Tie / Stirrup Size #:	4	
Qty. of Vertical Rebars:	24	Tie Spacing (in):	12.0	
Pad Rebar Yield (Ksi):	60	Pad Steel Rebar Size (#):	8	
Concrete Cover (in.):	3	Unit Weight of Concrete:	150.0	pcf
Rebar at the bottom of the concrete pad:				
Qty. of Rebar in Pad (L):	30	Qty. of Rebar in Pad (W):	30	
Rebar at the top of the concrete pad:				
Qty. of Rebar in Pad (L):	30	Qty. of Rebar in Pad (W):	30	

Apply 1.35 factor for e/w Per G: 1.35

Soil Design Parameters:

Soil Unit Weight (pcf):	115.0	Soil Buoyant Weight:	50.0	Pcf
Water Table B.G.S. (ft):	15.0	Unit Weight of Water:	62.4	pcf
Ultimate Bearing Pressure (psf):	4300	Ultimate Skin Friction:	0	Psf
Consider Friction for O.T.M. (Y/N):	No	Consider Friction for bearing (Y/N):	No	
Consider soil hor. resist. for OTM.:	Yes	Reduction factor on the maximum soil bearing pressure:	1.00	
		Angle from Top of Pad:	30	
		Angle from Bottm of Pad:	25	
		Angle from Bottm of Pad:	25	

Foundation Analysis and Design:

Uplift Strength Reduction Factor:	0.75	Compression Strength Reduction Factor:	0.75
Total Dry Soil Volume (cu. Ft.):	505.86	Total Dry Soil Weight (Kips):	58.17
Total Buoyant Soil Volume (cu. Ft.):	0.00	Total Buoyant Soil Weight (Kips):	0.00
Total Effective Soil Weight (Kips):	58.17	Weight from the Concrete Block at Top (K):	0.00
Total Dry Concrete Volume (cu. Ft.):	1852.52	Total Dry Concrete Weight (Kips):	277.88
Total Buoyant Concrete Volume (cu. Ft.):	0.00	Total Buoyant Concrete Weight (Kips):	0.00
Total Effective Concrete Weight (Kips):	277.88	Total Vertical Load on Base (Kips):	381.15

Check Soil Capacities:

Calculated Maxium Net Soil Pressure under the base (psf):	3122	<	Allowable Factored Soil Bearing (psf):	3225	0.97	OK!
Allowable Foundation Overturning Resistance (kips-ft.):	3301.7	>	Design Factored Momont (kips-ft):	1931	0.58	OK!
Factor of Safety Against Overturning (O. R. Moment/Design Moment):	1.71					OK!

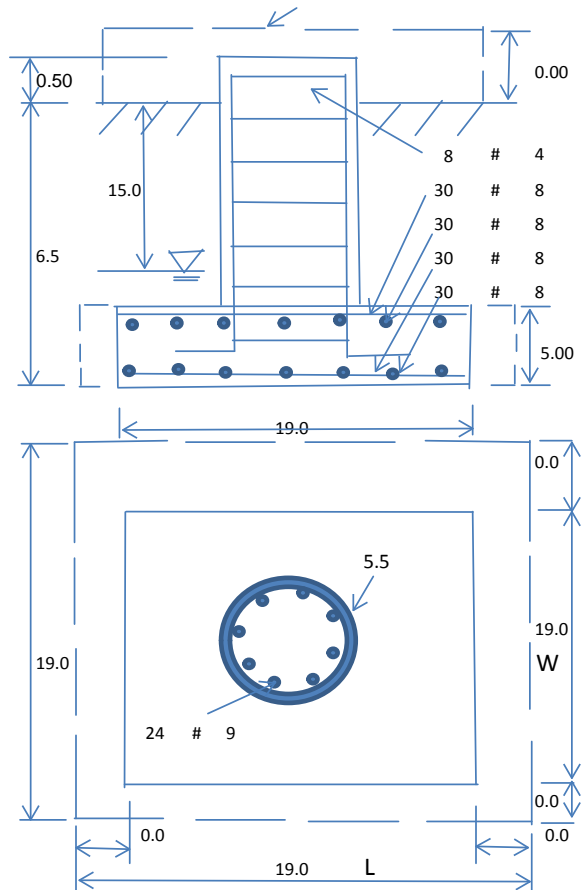

Check the capacities of Reinforcing Concrete:

Strength reduction factor (Flexure and axial tension):	0.90	Strength reduction factor (Shear):	0.75
Strength reduction factor (Axial compression):	0.65	Wind Load Factor on Concrete Design:	1.00

Load/
Capacity
Ratio**(1) Concrete Pier:**

Vertical Steel Rebar Area (sq. in./each):	1.00	Tie / Stirrup Area (sq. in./each):	0.20		
Calculated Moment Capacity (Mn,Kips-Ft):	3146.1	>	Design Factored Moment (Mu, Kips-Ft)	2010.4	0.64 OK!
Calculated Shear Capacity (Kips):	430.2	>	Design Factored Shear (Kips):	21.2	0.05 OK!
Calculated Tension Capacity (Tn, Kips):	1296.0	>	Design Factored Tension (Tu Kips):	0.0	0.00 OK!
Calculated Compression Capacity (Pn, Kips):	6006.2	>	Design Factored Axial Load (Pu Kips):	45.1	0.01 OK!
Moment & Axial Strength Combination:	0.64	OK!	Check Tie Spacing (Design/Required):	1	OK!
Pier Reinforcement Ratio:	0.007		Reinforcement Ratio is satisfied per ACI		

(2).Concrete Pad:

One-Way Design Shear Capacity (L-Direction, Kips):	1222.1	>	One-Way Factored Shear (L-D. Kips):	82.4	0.07 OK!
One-Way Design Shear Capacity (W-Direction, Kips):	1222.1	>	One-Way Factored Shear (W-D., Kips)	82.4	0.07 OK!
One-Way Design Shear Capacity (Corner-Corner. Kips):	768.9	>	One-Way Factored Shear (C-C, Kips):	85.3	0.11 OK!
Lower Steel Pad Reinforcement Ratio (L-Direct.):	0.0018	OK!	Lower Steel Pad Reinf. Ratio (W-Direc	0.0018	
Lower Steel Pad Moment Capacity (L-Direction. Kips-ft):	5927.9	>	Moment at Bottom (L-Dir. K-Ft):	672.2	0.11 OK!
Lower Steel Pad Moment Capacity (W-Direction. Kips-ft):	5927.9	>	Moment at Bottom (W-Dir. K-Ft):	672.2	0.11 OK!
Lower Steel Pad Moment Capacity (Corner-Corner,K-ft):	8347.7	>	Moment at Bottom (C-C Dir. K-Ft):	950.6	0.11 OK!
Upper Steel Pad Reinforcement Ratio (L-Direct.):	0.0018	OK!	Upper Steel Reinf. Ratio (W-Dir.):	0.0018	
Upper Steel Pad Moment Capacity (L-Direc. Kips-ft):	5927.9	>	Moment at the top (L-Dir K-Ft):	280.3	0.05 OK!
Upper Steel Pad Moment Capacity (W-Direc. Kips-ft):	5927.9	>	Moment at the top (W-Dir K-Ft):	280.3	0.05 OK!
Upper Steel Pad Moment Capacity (Corner-Corner. K-ft):	8347.7	>	Moment at the top (C-C Dir. K-Ft):	263.3	0.03 OK!

(3).Check Punching Shear Capacity due to Moment in the Pier:

Moment transferred by punching shear:	787.2	k-ft.	Max. factored shear stress $v_{u,CD}$:	1.9	Psi
Max. factored shear stress $v_{u,AB}$:	4.8	Psi	Factored shear Strength ϕv_n :	189.7	Psi
Max. factored shear stress v_u :	4.8	Psi	Check Usage of Punching Shear Capacity:	0.03	OK!

PROJECT INFORMATION

SCOPE OF WORK: TOWER: REPLACE (3) EXISTING ANTENNAS WITH (3) 6' TALL 12 PORT ANTENNAS. ADD (3) 4426 B66 RADIOS AND (3) B5/12 4449 RADIOS TO PROPOSED ANTENNA IN POSITION 1. ADD (3) RRUS 32 RADIOS TO EXISTING ANTENNA IN POSITION 4. INSTALL (1) DC/FIBER SQUID AND (1) DC ONLY SQUID.

SHELTER: ADD (4) DC CABLES, (1) FIBER, (2) ALARM CABLES (PAINT TO MATCH). SWAP DUS WITH 5216, ADD (1) XMU, (1) 6630, (1) FIBER DRAWER, (1) 6601 AND (1) FIBER MANAGEMENT BOX.

SITE ADDRESS: 52 STADLEY ROUGH ROAD DANBURY, CT 06811

LATITUDE: 41° 25' 58.41" N (NAD 83)*

LONGITUDE: 73° 25' 54.58" W (NAD 83)*
*PER FAA-1A

NAME OF APPLICANT: AT&T MOBILITY
550 COCHITUATE ROAD
SUITES 13 & 14
FRAMINGHAM, MA 01701

TOWER OWNER: SBA COMMUNICATIONS CORPORATION

TOWER NUMBER: N/A



at&t
Mobility

SITE NAME: SBA TOWER - DANBURY
SITE NUMBER: CT2312 3C/4C/5C
PACE NO.: MRCTB031225 (3C) / MRCTB032095 (4C) / MRCTB031829 (5C)
FA LOCATION CODE: 12676398

DRAWING INDEX

REV

T01	TITLE SHEET	A
G01	GENERAL NOTES	A
C01	PROPOSED SITE PLAN & ELEVATION	A
C02	PROPOSED EQUIPMENT CONFIGURATION	A
C03	EQUIPMENT PLUMBING DIAGRAM	A
E01	GROUNDING DETAILS	A

VICINITY MAP

DIRECTIONS: TURN LEFT TO MERGE ONTO I-91 S. TAKE EXIT 18 TO MERGE ONTO I-691 W TOWARD MERIDEN/WATERBURY. TAKE EXIT 1 ON THE LEFT FOR I-84 W TOWARD WATERBURY/DANBURY. MERGE ONTO I-84. TAKE EXIT 7 TO MERGE ONTO US-202. E/WHITE TURKEY RD EXD. TURN LEFT ONTO US-202 E/WHITE TURKEY RD EXD. CONTINUE ONTO CANDLEWOOD LAKE RD. TURN LEFT ONTO N NABBY RD. TURN LEFT ONTO FORTY ACRE MOUNTAIN RD. TURN LEFT ONTO FORTY ACRE MOUNTAIN RD. CONTINUE ONTO STADLEY RD. DESTINATION WILL BE ON THE RIGHT.

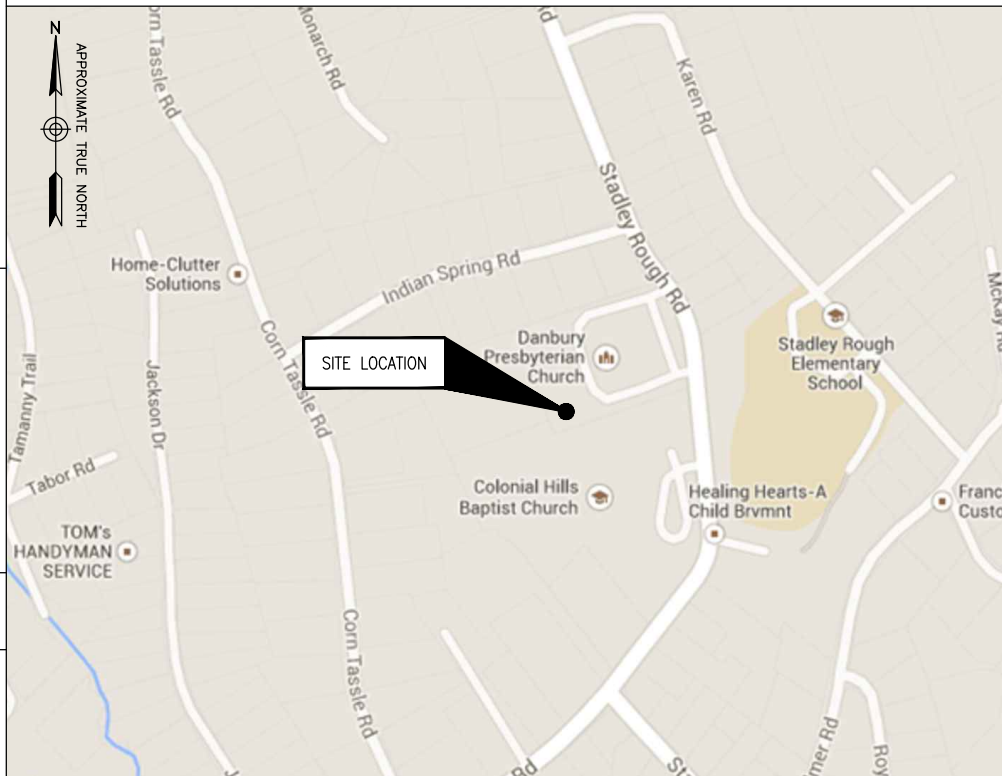

APPLICABLE BUILDING CODES & STANDARDS

CONTRACTOR'S WORK SHALL COMPLY WITH PROJECT STANDARD NOTES, SYMBOLS & DETAILS (SEE DRAWING INDEX FOR STANDARD NOTES & DETAILS INCLUDED WITH TYPICAL DRAWING PACKAGE). CONTRACTOR WORK SHALL COMPLY WITH ALL APPLICABLE NATIONAL, STATE, & LOCAL CODES AS ADOPTED BY THE LOCAL AUTHORITY HAVING JURISDICTION (AHJ) FOR THE LOCATION. THE EDITION OF THE AHJ ADOPTED CODES & STANDARDS IN EFFECT ON THE DATE OF CONTRACT AWARD SHALL GOVERN THE DESIGN.

BUILDING CODE: INTERNATIONAL BUILDING CODE (IBC) WITH CONNECTICUT AMENDMENTS (780 CMR)

ELECTRICAL CODE: NATIONAL ELECTRICAL CODE (NEC)

CONTRACTOR'S WORK SHALL COMPLY WITH THE LATEST EDITION OF THE FOLLOWING STANDARDS. AMERICAN CONCRETE INSTITUTE (ACI) 318, BUILDING CODE REQUIREMENTS FOR STRUCTURAL CONCRETE AMERICAN INSTITUTE OF STEEL CONSTRUCTION (AISC) MANUAL OF STEEL CONSTRUCTION, ASD, 9TH EDITION TELECOMMUNICATIONS INDUSTRY ASSOCIATION (TIA) 222-G, STRUCTURAL STANDARDS FOR STEEL ANTENNA TOWER & ANTENNA SUPPORTING STRUCTURES; TIA 607, COMMERCIAL BUILDING GROUNDING & BONDING REQUIREMENTS FOR TELECOMMUNICATIONS

INSTITUTE FOR ELECTRICAL & ELECTRONICS ENGINEERS (IEEE) 81, GUIDE FOR MEASURING EARTH RESISTIVITY, GROUND IMPEDANCE, & EARTH SURFACE POTENTIALS OF A GROUND SYSTEM IEEE 1100 (1999) RECOMMENDED PRACTICE FOR POWERING & GROUNDING OF ELECTRONIC EQUIPMENT IEEE 62.41, RECOMMENDED PRACTICES ON SURGE VOLTAGES IN LOW VOLTAGE AC POWER CIRCUITS (FOR LOCATION CATEGORY "C3" & "HIGH SYSTEM EXPOSURE")

TELCORDIA GR-1503, COAXIAL CABLE CONNECTIONS

ANSI T1.311, FOR TELECOM - DC POWER SYSTEMS - TELECOM, ENVIRONMENTAL PROTECTION

FOR ANY CONFLICTS BETWEEN SECTIONS OF LISTED CODES & STANDARDS REGARDING MATERIAL, METHODS OF CONSTRUCTION, OR OTHER REQUIREMENTS, THE MOST RESTRICTIVE REQUIREMENT SHALL GOVERN. WHERE THERE IS CONFLICT BETWEEN A GENERAL REQUIREMENT & A SPECIFIC REQUIREMENT, THE SPECIFIC REQUIREMENT SHALL GOVERN.

THIS DOCUMENT WAS DEVELOPED TO REFLECT A SPECIFIC SITE & ITS SITE CONDITIONS & IS NOT TO BE USED FOR ANOTHER SITE OR WHEN OTHER CONDITIONS PERTAIN. REUSE OF THIS DOCUMENT IS AT THE SOLE RISK OF THE USER.

STRUCTURAL NOTE:

- AS REQUIRED UNDER TIA/EIA 222-G - STANDARD, CENTERLINE COMMUNICATIONS SHALL PROVIDE A STRUCTURAL ANALYSIS OF THE TOWER PREPARED BY A LICENSED CONNECTICUT STRUCTURAL ENGINEER CERTIFYING THAT, THE EXISTING TOWER & ANY REQUIRED IMPROVEMENTS & REINFORCEMENTS HAVE SUFFICIENT CAPACITY TO SUPPORT ALL EXISTING & PROPOSED ANTENNAS, SUPPORTS & APPURTENANCES & COMPLIES WITH THE CURRENT LOCAL BUILDING CODE & EIA/TIA CRITERIA. THE CONTRACTOR IS RESPONSIBLE TO CONFIRM THAT ANY IMPROVEMENTS & REINFORCEMENTS REQUIRED BY THE STRUCTURAL ANALYSIS CERTIFICATION ARE PROPERLY INSTALLED PRIOR TO THE ADDITION OF ANTENNAS, SUPPORTS & APPURTENANCES PROPOSED ON THESE DRAWINGS OR OTHERWISE NOTED IN THE STRUCTURAL ANALYSIS.

CONTACT INFORMATION

<u>CONTACT</u>	<u>CONTACT</u>	<u>COMPANY</u>	<u>PHONE NO.</u>
ENGINEERING:	BENJAMIN REVETTE, P.E.	DEWBERRY ENGINEERS INC.	(617) 531-0800
SAC:	DAVID FORD	CENTERLINE COMMUNICATIONS	(508) 821-6509

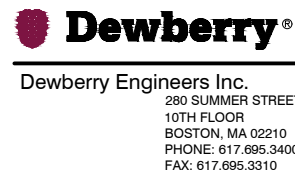

SBA TOWER DANBURY
SITE NO.: CT2312 3C/4C/5C

52 STADLEY ROAD
DANBURY, CT 06811

NO.	DATE	ISSUED FOR REVIEW	AJB	CDH	DAS
SCALE: AS SHOWN		DESIGNED BY: CDH	DRAWN BY: AJB		

AT&T MOBILITY
FRAMINGHAM, MA 01701

TITLE SHEET

DEWBERRY NO.	DRAWING NUMBER	REV
50093723/50096349	T01	A

GENERAL NOTES:

- FOR THE PURPOSE OF CONSTRUCTION DRAWING, THE FOLLOWING DEFINITIONS SHALL APPLY:
PROJECT MANAGEMENT – CENTERLINE COMMUNICATIONS
CONTRACTOR – GENERAL CONTRACTOR (CONSTRUCTION)
OWNER – AT&T MOBILITY
OEM – ORIGINAL EQUIPMENT MANUFACTURER
- PRIOR TO THE SUBMISSION OF BIDS, THE BIDDING CONTRACTOR SHALL VISIT THE CELL SITE TO FAMILIARIZE WITH THE EXISTING CONDITIONS & TO CONFIRM THAT THE WORK CAN BE ACCOMPLISHED AS SHOWN ON THE CONSTRUCTION DRAWINGS. ANY DISCREPANCY FOUND SHALL BE BROUGHT TO THE ATTENTION OF PROJECT MANAGEMENT.
- ALL MATERIALS FURNISHED & INSTALLED SHALL BE IN STRICT ACCORDANCE WITH ALL APPLICABLE CODES, REGULATIONS, & ORDINANCES. CONTRACTOR SHALL ISSUE ALL APPROPRIATE NOTICES & COMPLY WITH ALL LAWS, ORDINANCES, RULES, REGULATIONS, & LAWFUL ORDERS OF ANY PUBLIC AUTHORITY REGARDING THE PERFORMANCE OF THE WORK.
- ALL WORK CARRIED OUT SHALL COMPLY WITH ALL APPLICABLE MUNICIPAL & UTILITY COMPANY SPECIFICATIONS & LOCAL JURISDICTIONAL CODES, ORDINANCES & APPLICABLE REGULATIONS.
- DRAWINGS PROVIDED HERE ARE NOT TO SCALE UNLESS OTHERWISE NOTED & ARE INTENDED TO SHOW OUTLINE ONLY.
- UNLESS NOTED OTHERWISE, THE WORK SHALL INCLUDE FURNISHING MATERIALS, EQUIPMENT, APPURTENANCES, & LABOR NECESSARY TO COMPLETE ALL INSTALLATIONS AS INDICATED ON THE DRAWINGS.
- THE CONTRACTOR SHALL INSTALL ALL EQUIPMENT & MATERIALS IN ACCORDANCE WITH MANUFACTURER'S RECOMMENDATIONS UNLESS SPECIFICALLY STATED OTHERWISE.
- IF THE SPECIFIED EQUIPMENT CANNOT BE INSTALLED AS SHOWN ON THESE DRAWINGS, THE CONTRACTOR SHALL PROPOSE AN ALTERNATIVE INSTALLATION FOR APPROVAL BY PROJECT MANAGEMENT.
- CONTRACTOR SHALL DETERMINE ACTUAL ROUTING OF CONDUIT, POWER & T1 CABLES, GROUNDING CABLES AS SHOWN ON THE POWER, GROUNDING & TELCO PLAN DRAWING. CONTRACTOR SHALL UTILIZE EXISTING TRAYS AND/OR SHALL ADD NEW TRAYS AS NECESSARY. CONTRACTOR SHALL CONFIRM THE ACTUAL ROUTING WITH PROJECT MANAGEMENT.
- THE CONTRACTOR SHALL PROTECT EXISTING & PROPOSED IMPROVEMENTS, PAVEMENTS, CURBS, LANDSCAPING & STRUCTURES. ANY DAMAGED PART SHALL BE REPAIRED AT CONTRACTOR'S EXPENSE TO THE SATISFACTION OF THE OWNER.
- CONTRACTOR SHALL LEGALLY & PROPERLY DISPOSE OF ALL SCRAP MATERIALS SUCH AS COAXIAL CABLES & OTHER ITEMS REMOVED FROM THE EXISTING FACILITY. ANTENNAS REMOVED SHALL BE RETURNED TO THE OWNER'S DESIGNATED LOCATION.
- CONTRACTOR SHALL LEAVE PREMISES IN CLEAN CONDITION.
- THE CONTRACTOR SHALL SUPERVISE & DIRECT THE PROJECT DESCRIBED HEREIN. THE CONTRACTOR SHALL BE SOLELY RESPONSIBLE FOR ALL CONSTRUCTION MEANS, METHODS, TECHNIQUES, SEQUENCES, & PROCEDURES & FOR COORDINATING ALL PORTIONS OF THE WORK UNDER THE CONTRACT.
- CONTRACTOR SHALL NOTIFY DEWBERRY 48 HOURS IN ADVANCE OF POURING CONCRETE, OR BACKFILLING TRENCHES, SEALING ROOF & WALL PENETRATIONS & POST DOWNS, FINISHING NEW WALLS OR FINAL ELECTRICAL CONNECTIONS FOR ENGINEER REVIEW.
- CONTRACTOR SHALL VERIFY ALL EXISTING DIMENSIONS & CONDITIONS PRIOR TO COMMENCING ANY WORK. ALL DIMENSIONS OF EXISTING CONSTRUCTION SHOWN ON THE DRAWINGS MUST BE VERIFIED. CONTRACTOR SHALL NOTIFY PROJECT MANAGEMENT OF ANY DISCREPANCIES PRIOR TO ORDERING MATERIAL OR PROCEEDING WITH CONSTRUCTION.
- THE EXISTING CELL SITE IS IN FULL COMMERCIAL OPERATION. ANY CONSTRUCTION WORK BY CONTRACTOR SHALL NOT DISRUPT THE EXISTING NORMAL OPERATION. ANY WORK ON EXISTING EQUIPMENT MUST BE COORDINATED WITH CONTRACTOR. ALSO, WORK SHOULD BE SCHEDULED FOR AN APPROPRIATE MAINTENANCE WINDOW USUALLY IN LOW TRAFFIC PERIODS AFTER MIDNIGHT.
- SINCE THE CELL SITE IS ACTIVE, ALL SAFETY PRECAUTIONS MUST BE TAKEN WHEN WORKING AROUND HIGH LEVELS OF ELECTROMAGNETIC RADIATION. EQUIPMENT SHOULD BE SHUTDOWN PRIOR TO PERFORMING ANY WORK THAT COULD EXPOSE THE WORKERS TO DANGER. PERSONAL RF EXPOSURE MONITORS ARE ADVISED TO BE WORN TO ALERT OF ANY DANGEROUS EXPOSURE LEVELS.
- CONTRACTOR SHALL BE RESPONSIBLE FOR SITE SAFETY INCLUDING COMPLIANCE WITH ALL APPLICABLE OSHA STANDARDS & RECOMMENDATIONS & SHALL PROVIDE ALL NECESSARY SAFETY DEVICES INCLUDING PPE & PPM & CONSTRUCTION DEVICES SUCH AS WELDING & FIRE PREVENTION, TEMPORARY SHORING, SCAFFOLDING, TRENCH BOXES/SLOPING, BARRIERS, ETC.

SITE WORK GENERAL NOTES:

- THE CONTRACTOR SHALL CONTACT UTILITY LOCATING SERVICES PRIOR TO THE START OF CONSTRUCTION.
- ALL EXISTING ACTIVE SEWER, WATER, GAS, ELECTRIC, & OTHER UTILITIES WHERE ENCOUNTERED IN THE WORK, SHALL BE PROTECTED AT ALL TIMES, & WHERE REQUIRED FOR THE PROPER EXECUTION OF THE WORK, SHALL BE RELOCATED AS DIRECTED BY CONTRACTOR. EXTREME CAUTION SHOULD BE USED BY THE CONTRACTOR WHEN EXCAVATING OR DRILLING PIERS AROUND OR NEAR UTILITIES. CONTRACTOR SHALL PROVIDE SAFETY TRAINING FOR THE WORKING CREW. THIS WILL INCLUDE BUT NOT BE LIMITED TO:
A) FALL PROTECTION
B) CONFINED SPACE
C) ELECTRICAL SAFETY
D) TRENCHING & EXCAVATION.
- ALL SITE WORK SHALL BE AS INDICATED ON THE DRAWINGS & PROJECT SPECIFICATIONS.
- IF NECESSARY, RUBBISH, STUMPS, DEBRIS, STICKS, STONES, TOP SOIL & OTHER REFUSE SHALL BE REMOVED FROM THE SITE & DISPOSED OF LEGALLY.
- ALL EXISTING INACTIVE SEWER, WATER, GAS, ELECTRIC & OTHER UTILITIES, WHICH INTERFERE WITH THE EXECUTION OF THE WORK, SHALL BE REMOVED AND/OR CAPPED, PLUGGED OR OTHERWISE DISCONTINUED AT POINTS WHICH WILL NOT INTERFERE WITH THE EXECUTION OF THE WORK, SUBJECT TO THE APPROVAL OF CONTRACTOR, OWNER AND/OR LOCAL UTILITIES.
- CONTRACTOR SHALL MINIMIZE DISTURBANCE TO EXISTING SITE DURING CONSTRUCTION.
- THE CONTRACTOR SHALL PROVIDE SITE SIGNAGE IN ACCORDANCE WITH THE AT&T SPECIFICATION FOR SITE SIGNAGE.
- THE SITE SHALL BE GRADED TO CAUSE SURFACE WATER TO FLOW AWAY FROM THE TRANSMISSION EQUIPMENT & TOWER AREAS.
- NO FILL OR EMBANKMENT MATERIAL SHALL BE PLACED ON FROZEN GROUND. FROZEN MATERIALS, SNOW OR ICE SHALL NOT BE PLACED IN ANY FILL OR EMBANKMENT.
- THE SUB GRADE SHALL BE COMPACTED & BROUGHT TO A SMOOTH UNIFORM GRADE PRIOR TO FINISHED SURFACE APPLICATION, SEE SOIL COMPACTION NOTES.
- THE AREAS OF THE OWNER'S PROPERTY DISTURBED BY THE WORK & NOT COVERED BY THE TOWER, EQUIPMENT OR DRIVEWAY, SHALL BE GRADED TO A UNIFORM SLOPE, & STABILIZED TO PREVENT EROSION.
- EROSION CONTROL MEASURES, IF REQUIRED DURING CONSTRUCTION, SHALL BE IN CONFORMANCE WITH THE LOCAL JURISDICTION'S GUIDELINES FOR EROSION & SEDIMENT CONTROL.

CONCRETE & REINFORCING STEEL NOTES:

- ALL CONCRETE WORK SHALL BE IN ACCORDANCE WITH THE ACI 301, ACI 318, ACI 336, ASTM A184, ASTM A185 & THE DESIGN & CONSTRUCTION SPECIFICATION FOR CAST-IN-PLACE CONCRETE.
- ALL CONCRETE SHALL HAVE A MINIMUM COMPRESSIVE STRENGTH OF 4000 PSI AT 28 DAYS, UNLESS NOTED OTHERWISE. A HIGHER STRENGTH (4000 PSI) MAY BE USED. ALL CONCRETING WORK SHALL BE DONE IN ACCORDANCE WITH ACI 318 CODE REQUIREMENTS.
- REINFORCING STEEL SHALL CONFORM TO ASTM A 615, GRADE 60, DEFORMED UNLESS NOTED OTHERWISE. WELDED WIRE FABRIC SHALL CONFORM TO ASTM A 185 WELDED STEEL WIRE FABRIC UNLESS NOTED OTHERWISE (UNO). SPLICES SHALL BE CLASS "B" & ALL HOOKS SHALL BE STANDARD, UNO.
- THE FOLLOWING MINIMUM CONCRETE COVER SHALL BE PROVIDED FOR REINFORCING STEEL UNLESS SHOWN OTHERWISE ON DRAWINGS:
CONCRETE CAST AGAINST EARTH.....3 IN.
CONCRETE EXPOSED TO EARTH OR WEATHER:
#6 & LARGER2 IN.
#5 & SMALLER & WWF1 1/2 IN.
CONCRETE NOT EXPOSED TO EARTH OR WEATHER OR NOT CAST AGAINST THE GROUND:
SLAB & WALL3/4 IN.
BEAMS & COLUMNS1 1/2 IN.
- A CHAMFER 3/4" SHALL BE PROVIDED AT ALL EXPOSED EDGES OF CONCRETE, UNO, IN ACCORDANCE WITH ACI 301 SECTION 4.2.4.
- INSTALLATION OF CONCRETE EXPANSION/WEDGE ANCHOR, SHALL BE PER MANUFACTURER'S WRITTEN RECOMMENDED PROCEDURE. THE ANCHOR BOLT, DOWEL OR ROD SHALL CONFORM TO MANUFACTURER'S RECOMMENDATION FOR EMBEDMENT DEPTH OR AS SHOWN ON THE DRAWINGS. NO REBAR SHALL BE CUT WITHOUT PRIOR CONTRACTOR APPROVAL WHEN DRILLING HOLES IN CONCRETE. SPECIAL INSPECTIONS, REQUIRED BY GOVERNING CODES, SHALL BE PERFORMED IN ORDER TO MAINTAIN MANUFACTURER'S MAXIMUM ALLOWABLE LOADS. ALL EXPANSION/WEDGE ANCHORS SHALL BE STAINLESS STEEL OR HOT DIPPED GALVANIZED. EXPANSION BOLTS SHALL BE PROVIDED BY RAMSET/REDHEAD OR APPROVED EQUAL.
- CONCRETE CYLINDER TEST IS NOT REQUIRED FOR SLAB ON GRADE WHEN CONCRETE IS LESS THAN 50 CUBIC YARDS (IBC 1905.6.2.3) IN THAT EVENT THE FOLLOWING RECORDS SHALL BE PROVIDED BY THE CONCRETE SUPPLIER;
(A) RESULTS OF CONCRETE CYLINDER TESTS PERFORMED AT THE SUPPLIER'S PLANT,
(B) CERTIFICATION OF MINIMUM COMPRESSIVE STRENGTH FOR THE CONCRETE GRADE SUPPLIED.
FOR GREATER THAN 50 CUBIC YARDS THE GC SHALL PERFORM THE CONCRETE CYLINDER TEST.
- AS AN ALTERNATIVE TO ITEM 7, TEST CYLINDERS SHALL BE TAKEN INITIALLY & THEREAFTER FOR EVERY 50 YARDS OF CONCRETE FROM EACH DIFFERENT BATCH PLANT.
- EQUIPMENT SHALL NOT BE PLACED ON NEW PADS FOR SEVEN DAYS AFTER PAD IS POURED, UNLESS IT IS VERIFIED BY CYLINDER TESTS THAT COMPRESSIVE STRENGTH HAS BEEN ATTAINED.

STRUCTURAL STEEL NOTES:

- ALL STEEL WORK SHALL BE PAINTED OR GALVANIZED IN ACCORDANCE WITH THE DRAWINGS UNLESS NOTED OTHERWISE. STRUCTURAL STEEL SHALL BE ASTM-A-36 UNLESS OTHERWISE NOTED ON THE SITE SPECIFIC DRAWINGS. STEEL DESIGN, INSTALLATION & BOLTING SHALL BE PERFORMED IN ACCORDANCE WITH THE AMERICAN INSTITUTE OF STEEL CONSTRUCTION (AISC) "MANUAL OF STEEL CONSTRUCTION".
- ALL WELDING SHALL BE PERFORMED USING E70XX ELECTRODES & WELDING SHALL CONFORM TO AISC. WHERE FILLET WELD SIZES ARE NOT SHOWN, PROVIDE THE MINIMUM SIZE PER TABLE J2.4 IN THE AISC "MANUAL OF STEEL CONSTRUCTION". PAINTED SURFACES SHALL BE TOUCHED UP.
- BOLTED CONNECTIONS SHALL BE ASTM A325 BEARING TYPE 3/4"Ø CONNECTIONS & SHALL HAVE MINIMUM OF TWO BOLTS UNLESS NOTED OTHERWISE.
- NON-STRUCTURAL CONNECTIONS FOR STEEL GRATING MAY USE 5/8" DIA. ASTM A 307 BOLTS UNLESS NOTED OTHERWISE.
- INSTALLATION OF CONCRETE EXPANSION/WEDGE ANCHOR, SHALL BE PER MANUFACTURER'S WRITTEN RECOMMENDED PROCEDURE. THE ANCHOR BOLT, DOWEL OR ROD SHALL CONFORM TO MANUFACTURER'S RECOMMENDATION FOR EMBEDMENT DEPTH OR AS SHOWN ON THE DRAWINGS. NO REBAR SHALL BE CUT WITHOUT PRIOR CONTRACTOR APPROVAL WHEN DRILLING HOLES IN CONCRETE. SPECIAL INSPECTIONS, REQUIRED BY GOVERNING CODES, SHALL BE PERFORMED IN ORDER TO MAINTAIN MANUFACTURER'S MAXIMUM ALLOWABLE LOADS. ALL EXPANSION/WEDGE ANCHORS SHALL BE STAINLESS STEEL OR HOT DIPPED GALVANIZED. EXPANSION BOLTS SHALL BE PROVIDED BY RAMSET/REDHEAD OR APPROVED EQUAL.
- CONTRACTOR SHALL SUBMIT SHOP DRAWINGS FOR ENGINEER REVIEW & APPROVAL ON PROJECTS REQUIRING STRUCTURAL STEEL.
- ALL STRUCTURAL STEEL WORK SHALL BE DONE IN ACCORDANCE WITH AISC SPECIFICATIONS.

SOIL COMPACTION NOTES FOR SLAB ON GRADE:

- EXCAVATE AS REQUIRED TO REMOVE VEGETATION & TOPSOIL EXPOSE UNDISTURBED NATURAL SUBGRADE & PLACE CRUSHED STONE AS REQUIRED.
- COMPACTION CERTIFICATION: AN INSPECTION & WRITTEN CERTIFICATION BY A QUALIFIED GEOTECHNICAL TECHNICIAN OR ENGINEER IS ACCEPTABLE.
- AS AN ALTERNATIVE TO INSPECTION & WRITTEN CERTIFICATION, THE "UNDISTURBED SOIL" BASE SHALL BE COMPACTED WITH "COMPACTION EQUIPMENT", LISTED BELOW, TO AT LEAST 90% MODIFIED PROCTOR MAXIMUM DENSITY PER ASTM D 1557 METHOD C.
- COMPACTED SUBBASE SHALL BE UNIFORM & LEVELED. PROVIDE 6" MINIMUM CRUSHED STONE OR GRAVEL COMPACTED IN 3" LIFTS ABOVE COMPACTED SOIL. GRAVEL SHALL BE NATURAL OR CRUSHED WITH 100% PASSING 1" SIEVE.
- AS AN ALTERNATIVE TO ITEMS 2 & 3 PROOFROLL THE SUBGRADE SOILS WITH 5 PASSES OF A MEDIUM SIZED VIBRATORY PLATE COMPACTOR (SUCH AS BOMAG BPR 30/38) OR HAND-OPERATED SINGLE DRUM VIBRATORY ROLLER (SUCH AS BOMAG BW 55E). ANY SOFT AREAS THAT ARE ENCOUNTERED SHOULD BE REMOVED & REPLACED WITH A WELL-GRADED GRANULAR FILL, & COMPACTED AS STATED ABOVE.

COMPACTION EQUIPMENT:

- HAND OPERATED DOUBLE DRUM, VIBRATORY ROLLER, VIBRATORY PLATE COMPACTOR OR JUMPING JACK COMPACTOR.

CONSTRUCTION NOTES:

- FIELD VERIFICATION:
CONTRACTOR SHALL FIELD VERIFY SCOPE OF WORK, AT&T ANTENNA PLATFORM LOCATION & ANTENNAS TO BE REPLACED.
- COORDINATION OF WORK:
CONTRACTOR SHALL COORDINATE RF WORK & PROCEDURES WITH PROJECT MANAGEMENT.
- CABLE LADDER RACK:
CONTRACTOR SHALL FURNISH & INSTALL CABLE LADDER RACK, CABLE TRAY, & CONDUIT AS REQUIRED TO SUPPORT CABLES TO ANY NEW BTS LOCATION.

ELECTRICAL INSTALLATION NOTES:

- ALL ELECTRICAL WORK SHALL BE PERFORMED IN ACCORDANCE WITH THE PROJECT SPECIFICATIONS, NEC & ALL APPLICABLE LOCAL CODES.
- CONTRACTOR SHALL MODIFY EXISTING CABLE TRAY SYSTEM AS REQUIRED TO SUPPORT RF & TRANSPORT CABLING TO NEW BTS EQUIPMENT. CONTRACTOR SHALL SUBMIT MODIFICATIONS TO PROJECT MANAGEMENT FOR APPROVAL.
- CONDUIT ROUTINGS ARE SCHEMATIC. CONTRACTOR SHALL INSTALL CONDUITS SO THAT ACCESS TO EQUIPMENT IS NOT BLOCKED.
- WIRING, RACEWAY & SUPPORT METHODS & MATERIALS SHALL COMPLY WITH THE REQUIREMENTS OF THE NEC & TELCORDIA.
- ALL CIRCUITS SHALL BE SEGREGATED & MAINTAIN MINIMUM CABLE SEPARATION AS REQUIRED BY THE NEC & TELCORDIA.
- CABLES SHALL NOT BE ROUTED THROUGH LADDER-STYLE CABLE TRAY RUNGS.
- EACH END OF EVERY POWER, POWER PHASE CONDUCTOR (I.E., HOTS), GROUNDING, & T1 CONDUCTOR & CABLE SHALL BE LABELED WITH COLOR-CODED INSULATION OR ELECTRICAL TAPE (3M BRAND, 1/2 INCH PLASTIC ELECTRICAL TAPE WITH UV PROTECTION, OR EQUAL). THE IDENTIFICATION METHOD SHALL CONFORM WITH NEC & OSHA, & MATCH EXISTING INSTALLATION REQUIREMENTS.
- ALL ELECTRICAL COMPONENTS SHALL BE CLEARLY LABELED WITH ENGRAVED LAMACOID PLASTIC LABELS. ALL EQUIPMENT SHALL BE LABELED WITH THEIR VOLTAGE RATING, PHASE CONFIGURATION, WIRE CONFIGURATION, POWER OR AMPACITY RATING, & BRANCH CIRCUIT ID NUMBERS (I.E., PANELBOARD & CIRCUIT ID'S).
- PANELBOARDS (ID NUMBERS) & INTERNAL CIRCUIT BREAKERS (CIRCUIT ID NUMBERS) SHALL BE CLEARLY LABELED WITH ENGRAVED LAMACOID PLASTIC LABELS.
- ALL TIE WRAPS SHALL BE CUT FLUSH WITH APPROVED CUTTING TOOL TO REMOVE SHARP EDGES.
- POWER, CONTROL, & EQUIPMENT GROUND WIRING IN TUBING OR CONDUIT SHALL BE SINGLE CONDUCTOR (SIZE 14 AWG OR LARGER), 600V, OIL RESISTANT THHN OR THWN-2, CLASS B STRANDED COPPER CABLE RATED FOR 90 °C (WET & DRY) OPERATION; LISTED OR LABELED FOR THE LOCATION & RACEWAY SYSTEM USED, UNLESS OTHERWISE SPECIFIED.
- POWER PHASE CONDUCTORS (I.E., HOTS) SHALL BE LABELED WITH COLOR-CODED INSULATION OR ELECTRICAL TAPE (3M BRAND, 1/2 INCH PLASTIC ELECTRICAL TAPE WITH UV PROTECTION, OR EQUAL.) PHASE CONDUCTOR COLOR CODES SHALL CONFORM WITH THE NEC & OSHA & MATCH EXISTING INSTALLATION REQUIREMENTS.
- SUPPLEMENTAL EQUIPMENT GROUND WIRING LOCATED INDOORS SHALL BE SINGLE CONDUCTOR (SIZE 6 AWG OR LARGER), 600V, OIL RESISTANT THHN OR THWN-2 GREEN INSULATION, CLASS B STRANDED COPPER CABLE RATED FOR 90°C (WET & DRY) OPERATION; LISTED OR LABELED FOR THE LOCATION & RACEWAY SYSTEM USED, UNLESS OTHERWISE SPECIFIED.
- SUPPLEMENTAL EQUIPMENT GROUND WIRING LOCATED OUTDOORS, OR BELOW GRADE, SHALL BE SINGLE CONDUCTOR #2 AWG SOLID TINNED COPPER CABLE, UNLESS OTHERWISE SPECIFIED.
- POWER & CONTROL WIRING, NOT IN TUBING OR CONDUIT, SHALL BE MULTI-CONDUCTOR, TYPE TC CABLE (SIZE 14 AWG OR LARGER), 600V, OIL RESISTANT THHN OR THWN-2, CLASS B STRANDED COPPER CABLE RATED FOR 90°C (WET & DRY) OPERATION; WITH OUTER JACKET; LISTED OR LABELED FOR THE LOCATION USED, UNLESS OTHERWISE SPECIFIED.
- ALL POWER & POWER GROUNDING CONNECTIONS SHALL BE CRIMP-STYLE, COMPRESSION WIRE LUGS & WIRENUTS BY THOMAS & BETTS (OR EQUAL). LUGS & WIRENUTS SHALL BE RATED FOR OPERATION AT NO LESS THAN 75°C (90°C IF AVAILABLE).
- RACEWAY & CABLE TRAY SHALL BE LISTED OR LABELED FOR ELECTRICAL USE IN ACCORDANCE WITH NEMA, UL, ANSI/IEEE, & NEC.
- NEW RACEWAY OR CABLE TRAY WILL MATCH THE EXISTING INSTALLATION WHERE POSSIBLE.
- ELECTRICAL METALLIC TUBING (EMT) OR RIGID NONMETALLIC CONDUIT (I.E., RIGID PVC SCHEDULE 40, OR RIGID PVC SCHEDULE 80 FOR LOCATIONS SUBJECT TO PHYSICAL DAMAGE) SHALL BE USED FOR EXPOSED INDOOR LOCATIONS.
- ELECTRICAL METALLIC TUBING (EMT), ELECTRICAL NONMETALLIC TUBING (ENT), OR RIGID NONMETALLIC CONDUIT (RIGID PVC, SCHEDULE 40) SHALL BE USED FOR CONCEALED INDOOR LOCATIONS.
- GALVANIZED STEEL INTERMEDIATE METALLIC CONDUIT (IMC) SHALL BE USED FOR OUTDOOR LOCATIONS ABOVE GRADE.
- RIGID NONMETALLIC CONDUIT (I.E., RIGID PVC SCHEDULE 40 OR RIGID PVC SCHEDULE 80) SHALL BE USED UNDERGROUND; DIRECT BURIED, IN AREAS OF OCCASIONAL LIGHT VEHICLE TRAFFIC OR ENCASED IN REINFORCED CONCRETE IN AREAS OF HEAVY VEHICLE TRAFFIC.
- LIQUID-TIGHT FLEXIBLE METALLIC CONDUIT (LIQUID-TITE FLEX) SHALL BE USED INDOORS & OUTDOORS, WHERE VIBRATION OCCURS OR FLEXIBILITY IS NEEDED.
- CONDUIT & TUBING FITTINGS SHALL BE THREADED OR COMPRESSION-TYPE & APPROVED FOR THE LOCATION USED. SETSCREW FITTINGS ARE NOT ACCEPTABLE.
- CABINETS, BOXES, & WIREWAYS SHALL BE LISTED OR LABELED FOR ELECTRICAL USE IN ACCORDANCE WITH NEMA, UL, ANSI/IEEE, & NEC.
- CABINETS, BOXES, & WIREWAYS TO MATCH THE EXISTING INSTALLATION WHERE POSSIBLE.
- WIREWAYS SHALL BE EPOXY-COATED (GRAY) & INCLUDE A HINGED COVER, DESIGNED TO SWING OPEN DOWNWARD; SHALL BE PANDUIT TYPE E (OR EQUAL); & RATED NEMA 1 (OR BETTER) INDOORS, OR NEMA 3R (OR BETTER) OUTDOORS.
- EQUIPMENT CABINETS, TERMINAL BOXES, JUNCTION BOXES, & PULL BOXES SHALL BE GALVANIZED OR EPOXY-COATED SHEET STEEL, SHALL MEET OR EXCEED UL 50, & RATED NEMA 1 (OR BETTER) INDOORS, OR NEMA 3R (OR BETTER) OUTDOORS.
- METAL RECEPTACLE, SWITCH, & DEVICE BOXES SHALL BE GALVANIZED, EPOXY-COATED, OR NON-CORRODING; SHALL MEET OR EXCEED UL 514A & NEMA OS 1; & RATED NEMA 1 (OR BETTER) INDOORS, OR WEATHER PROTECTED (WP OR BETTER) OUTDOORS.
- NONMETALLIC RECEPTACLE, SWITCH, & DEVICE BOXES SHALL MEET OR EXCEED NEMA OS 2; & RATED NEMA 1 (OR BETTER) INDOORS, OR WEATHER PROTECTED (WP OR BETTER) OUTDOORS.
- THE CONTRACTOR SHALL NOTIFY & OBTAIN NECESSARY AUTHORIZATION FROM PROJECT MANAGEMENT BEFORE COMMENCING WORK ON THE AC POWER DISTRIBUTION PANELS.
- THE CONTRACTOR SHALL PROVIDE NECESSARY TAGGING ON THE BREAKERS, CABLES & DISTRIBUTION PANELS IN ACCORDANCE WITH THE APPLICABLE CODES & STANDARDS TO SAFEGUARD AGAINST LIFE & PROPERTY.



Dewberry
Dewberry Engineers Inc.
280 SUMMER STREET
10TH FLOOR
BOSTON, MA 02210
PHONE: 617.695.3400
FAX: 617.695.3310



CENTERLINE
COMMUNICATIONS
95 RYAN DRIVE, SUITE 1
RAYNHAM, MA 02767



at&t
Mobility
550 COCHITUATE ROAD
SUITES 13 & 14
FRAMINGHAM, MA 01701

SBA TOWER DANBURY
SITE NO.: CT2312 3C/4C/5C

52 STADLEY ROAD
DANBURY, CT 06811

A	08/30/18	ISSUED FOR REVIEW	AJB	CDH	DAS
NO.	DATE	REVISIONS	BY	CHK	APP'D
SCALE: AS SHOWN		DESIGNED BY: CDH	DRAWN BY: AJB		

AT&T MOBILITY
FRAMINGHAM, MA 01701

GENERAL NOTES

DEWBERRY NO.	DRAWING NUMBER	REV
50093723/50096349	G01	A

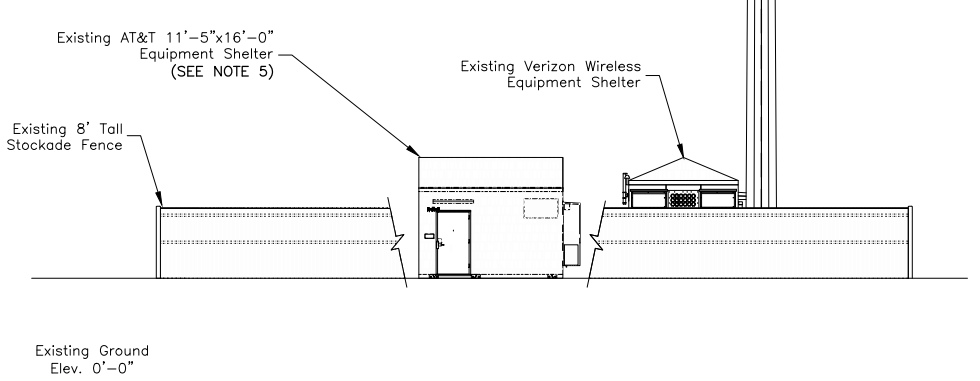
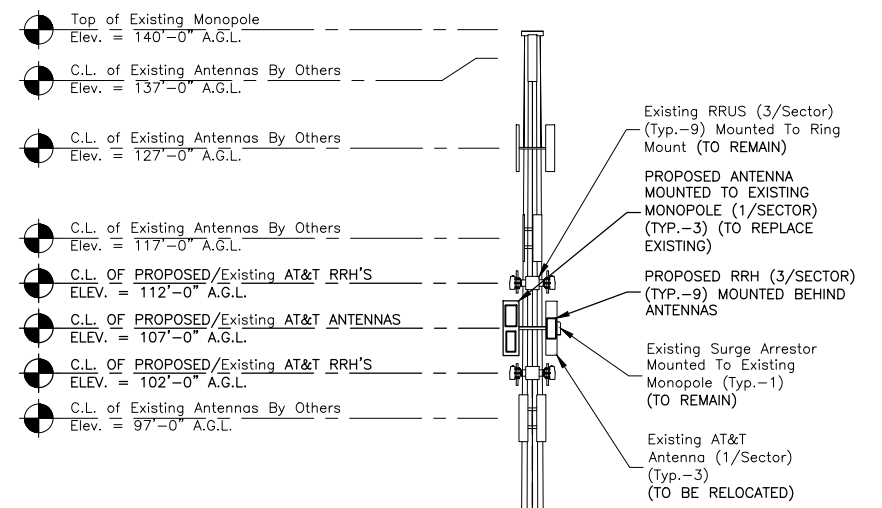
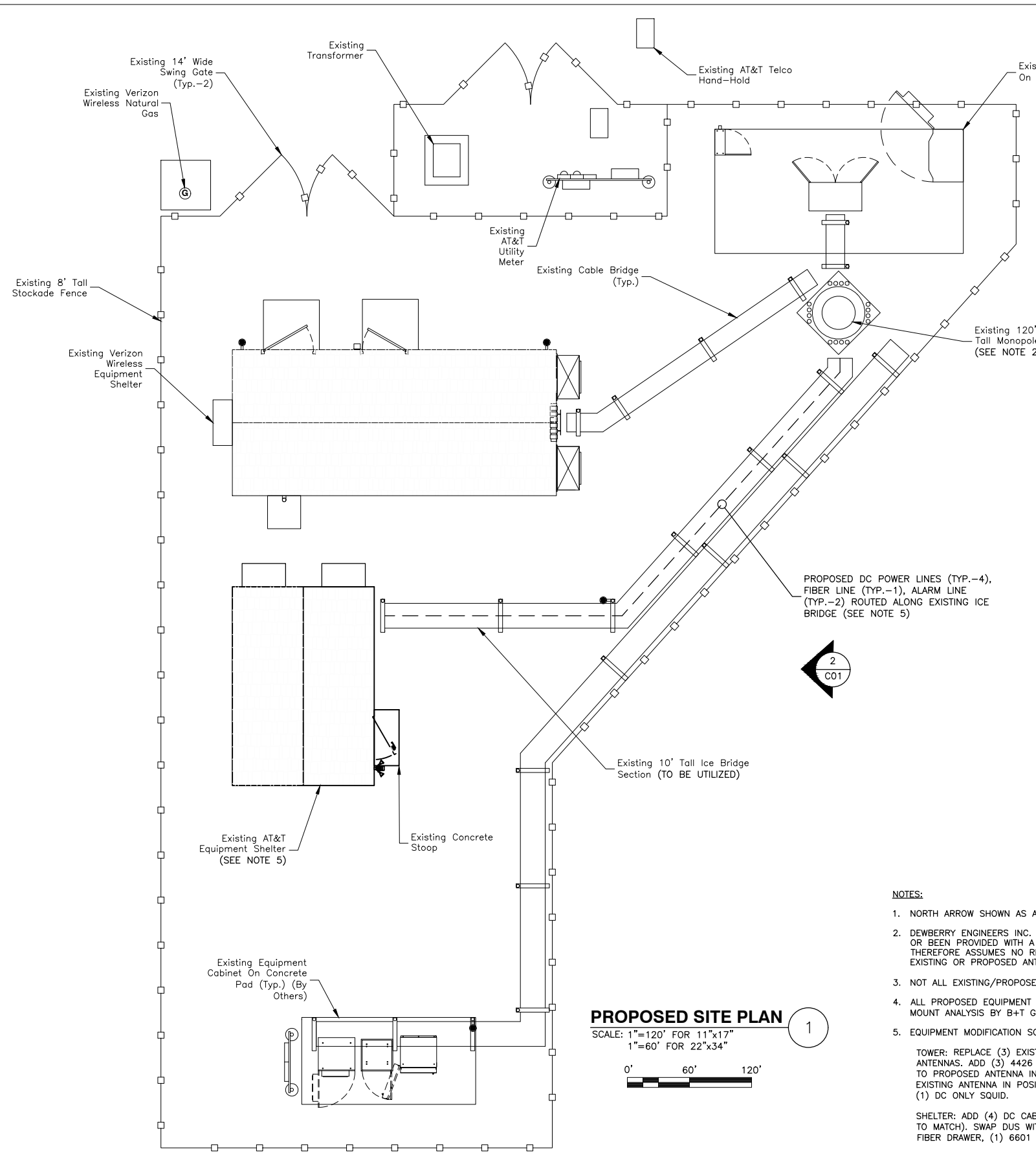

PROPOSED SITE PLAN
SCALE: 1"=120' FOR 11"x17"
1"=60' FOR 22"x34"
0' 60' 120'

PROPOSED ELEVATION
SCALE: 3/64"=1' FOR 11"x17"
3/32"=1' FOR 22"x34"
0' 8' 16' 24'

- NOTES:**
- NORTH ARROW SHOWN AS APPROXIMATE.
 - DEWBERRY ENGINEERS INC. HAS NOT BEEN CONTRACTED TO PREPARE OR BEEN PROVIDED WITH A TOWER STRUCTURAL ANALYSIS AND THEREFORE ASSUMES NO RESPONSIBILITY FOR THE TOWER OR ITS EXISTING OR PROPOSED ANTENNA INSTALLATIONS.
 - NOT ALL EXISTING/PROPOSED INFORMATION SHOWN FOR CLARITY
 - ALL PROPOSED EQUIPMENT SHALL BE MOUNTED IN ACCORDANCE TO MOUNT ANALYSIS BY B+T GROUP DATED 08/21/2018.
 - EQUIPMENT MODIFICATION SCOPE:
TOWER: REPLACE (3) EXISTING ANTENNAS WITH (3) 6' TALL 12 PORT ANTENNAS. ADD (3) 4426 B66 RADIOS AND (3) B5/12 4449 RADIOS TO PROPOSED ANTENNA IN POSITION 1. ADD (3) RRUS 32 RADIOS TO EXISTING ANTENNA IN POSITION 4. INSTALL (1) DC/FIBER SQUID AND (1) DC ONLY SQUID.
SHELTER: ADD (4) DC CABLES, (1) FIBER, (2) ALARM CABLES (PAINT TO MATCH). SWAP DUS WITH 5216, ADD (1) XMU, (1) 6630, (1) FIBER DRAWER, (1) 6601 AND (1) FIBER MANAGEMENT BOX.

A.G.L. = ABOVE GRADE LEVEL
C.L. = CENTER LINE

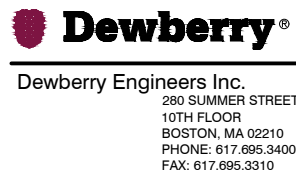

SBA TOWER DANBURY
SITE NO.: CT2312 3C/4C/5C
52 STADLEY ROAD
DANBURY, CT 06811

NO.	DATE	REVISIONS	BY	CHK	APP'D
A	08/30/18	ISSUED FOR REVIEW	AJB	CDH	DAS
SCALE: AS SHOWN		DESIGNED BY: CDH	DRAWN BY: AJB		

AT&T MOBILITY FRAMINGHAM, MA 01701		
PROPOSED SITE PLAN & ELEVATION		
DEWBERRY NO.	DRAWING NUMBER	REV
50093723/50096349	C01	A

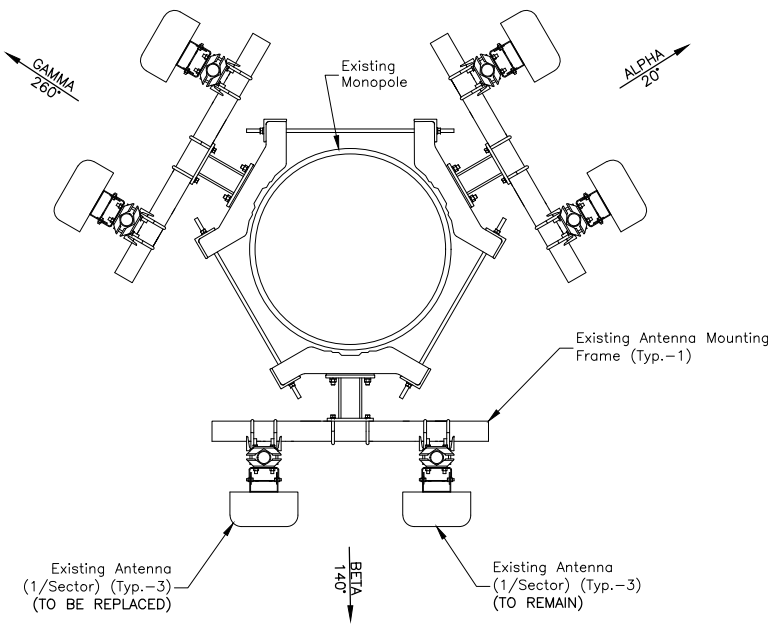

PROPOSED ANTENNA LAYOUT 1
SCALE: N.T.S.

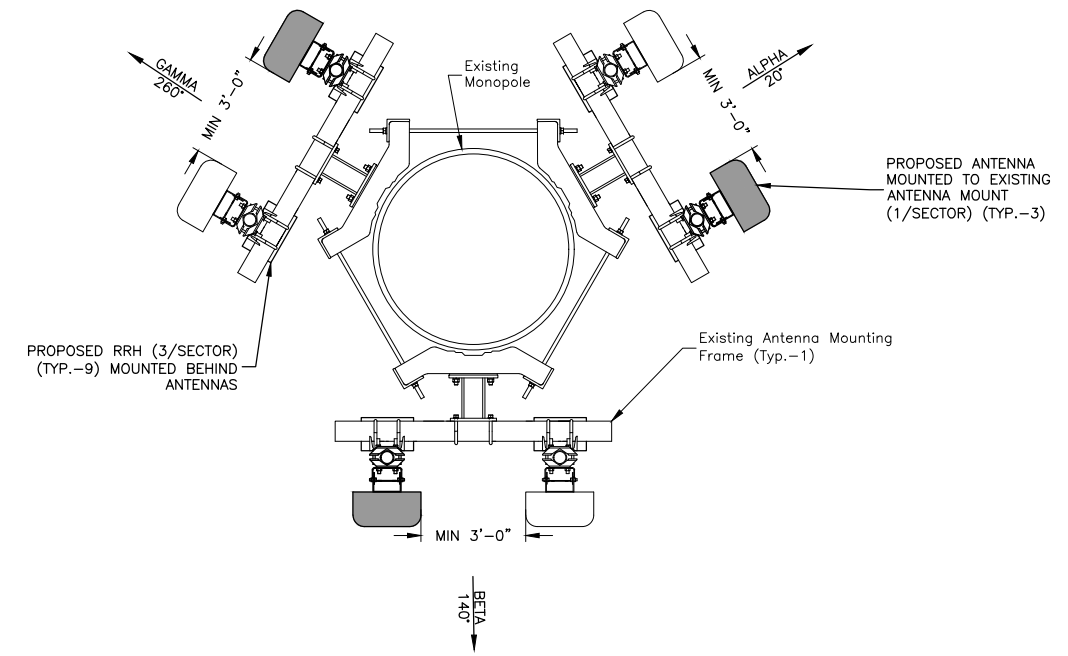

PROPOSED ANTENNA LAYOUT 2
SCALE: N.T.S.

FINAL EQUIPMENT CONFIGURATION											
SECTOR	BAND	ANTENNA	SIZE (INCHES) (LxWxD)	RAD. CENTER	AZIMUTH	TMA	COMBINERS	RRU	SIZE (INCHES) (LxWxD)	FEEDERS	FIBER
ALPHA	LTE 850/AWS/PCS	(P) EPBQ-654L8H6-L2	73.0x21.0x6.3	107'-0"	20°	-	-	(P) B5/B12 4449 (850) (P) 4426 B66 (AWS) (E) RRUS-12 (1900) (E) RRUS-A2 (1900)	28.0 x 15.0 x 10.0 27.2 x 12.1 x 7.0 20.4 x 18.5 x 7.5 16.4 x 15.1 x 3.4	-	(P) 1
	-	-	-	-	-	-	-	-	-	-	-
	UMTS 850 / LTE 700/1900/WCS	(E) OPA-65R-LCUU-H6	72.0x14.8x9.0	107'-0"	20°	(E) TMABPD7823VG12A	-	(E) RRUS-11 (700) (P) RRUS-32 (WCS)	19.7 x 17.0 x 7.2 27.2 x 12.1 x 7.0	E (2)	-
BETA	LTE 850/AWS/PCS	(P) EPBQ-654L8H6-L2	73.0x21.0x6.3	107'-0"	140°	-	-	(P) B5/B12 4449 (850) (P) 4426 B66 (AWS) (E) RRUS-12 (1900) (E) RRUS-A2 (1900)	28.0 x 15.0 x 10.0 27.2 x 12.1 x 7.0 20.4 x 18.5 x 7.5 16.4 x 15.1 x 3.4	-	(P) 1
	-	-	-	-	-	-	-	-	-	-	-
	UMTS 850 / LTE 700/1900/WCS	(E) OPA-65R-LCUU-H6	72.0x14.8x9.0	107'-0"	140°	(E) TMABPD7823VG12A	-	(E) RRUS-11 (700) (P) RRUS-32 (WCS)	19.7 x 17.0 x 7.2 27.2 x 12.1 x 7.0	E (2)	-
GAMMA	LTE 850/AWS/PCS	(P) EPBQ-654L8H6-L2	73.0x21.0x6.3	107'-0"	260°	-	-	(P) B5/B12 4449 (850) (P) 4426 B66 (AWS) (E) RRUS-12 (1900) (E) RRUS-A2 (1900)	28.0 x 15.0 x 10.0 27.2 x 12.1 x 7.0 20.4 x 18.5 x 7.5 16.4 x 15.1 x 3.4	-	(P) 1
	-	-	-	-	-	-	-	-	-	-	-
	UMTS 850 / LTE 700/1900/WCS	(E) OPA-65R-LCUU-H6	72.0x14.8x9.0	107'-0"	260°	(E) TMABPD7823VG12A	-	(E) RRUS-11 (700) (P) RRUS-32 (WCS)	19.7 x 17.0 x 7.2 27.2 x 12.1 x 7.0	E (2)	-

NOTES:

- NORTH ARROW SHOWN AS APPROXIMATE.
- DEWBERRY ENGINEERS INC. HAS NOT BEEN CONTRACTED TO PREPARE OR BEEN PROVIDED WITH A TOWER STRUCTURAL ANALYSIS AND THEREFORE ASSUMES NO RESPONSIBILITY FOR THE TOWER OR ITS EXISTING OR PROPOSED ANTENNA INSTALLATIONS.
- NOT ALL EXISTING/PROPOSED INFORMATION SHOWN FOR CLARITY
- ALL PROPOSED EQUIPMENT SHALL BE MOUNTED IN ACCORDANCE TO MOUNT ANALYSIS BY B+T GROUP DATED 08/21/2018.
- EQUIPMENT MODIFICATION SCOPE:
TOWER: REPLACE (3) EXISTING ANTENNAS WITH (3) 6' TALL 12 PORT ANTENNAS. ADD (3) 4426 B66 RADIOS AND (3) B5/12 4449 RADIOS TO PROPOSED ANTENNA IN POSITION 1. ADD (3) RRUS 32 RADIOS TO EXISTING ANTENNA IN POSITION 4. INSTALL (1) DC/FIBER SQUID AND (1) DC ONLY SQUID.
SHELTER: ADD (4) DC CABLES, (1) FIBER, (2) ALARM CABLES (PAINT TO MATCH). SWAP DUS WITH 5216, ADD (1) XMU, (1) 6630, (1) FIBER DRAWER, (1) 6601 AND (1) FIBER MANAGEMENT BOX.

EXISTING/PROPOSED FINAL EQUIPMENT CONFIGURATION 3
SCALE: N.T.S.

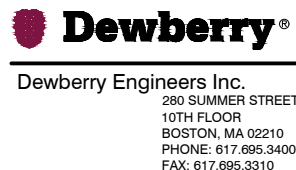

SBA TOWER DANBURY
SITE NO.: CT2312 3C/4C/5C
52 STADLEY ROAD
DANBURY, CT 06811

NO.	DATE	ISSUED FOR REVIEW	AJB	CDH	DAS
SCALE: AS SHOWN		DESIGNED BY: CDH	DRAWN BY: AJB		

AT&T MOBILITY FRAMINGHAM, MA 01701		
PROPOSED EQUIPMENT CONFIGURATION		
DEWBERRY NO.	DRAWING NUMBER	REV
50093723/50096349	C02	A

Diagram - Sector A Diagram File Name - CT2312_ABC_Multicarrier_5G.vsd
 Atoll Site Name - CT2312 Location Name - DANBURY STADLEY ROUGH ROAD Market - CONNECTICUT Market Cluster - NEW ENGLAND
 Comments: Important Note: For detailed radio to antenna wiring refer to the latest 4T4R Antenna/ radio Port connections Field Notice (RF-HW-2016-265)

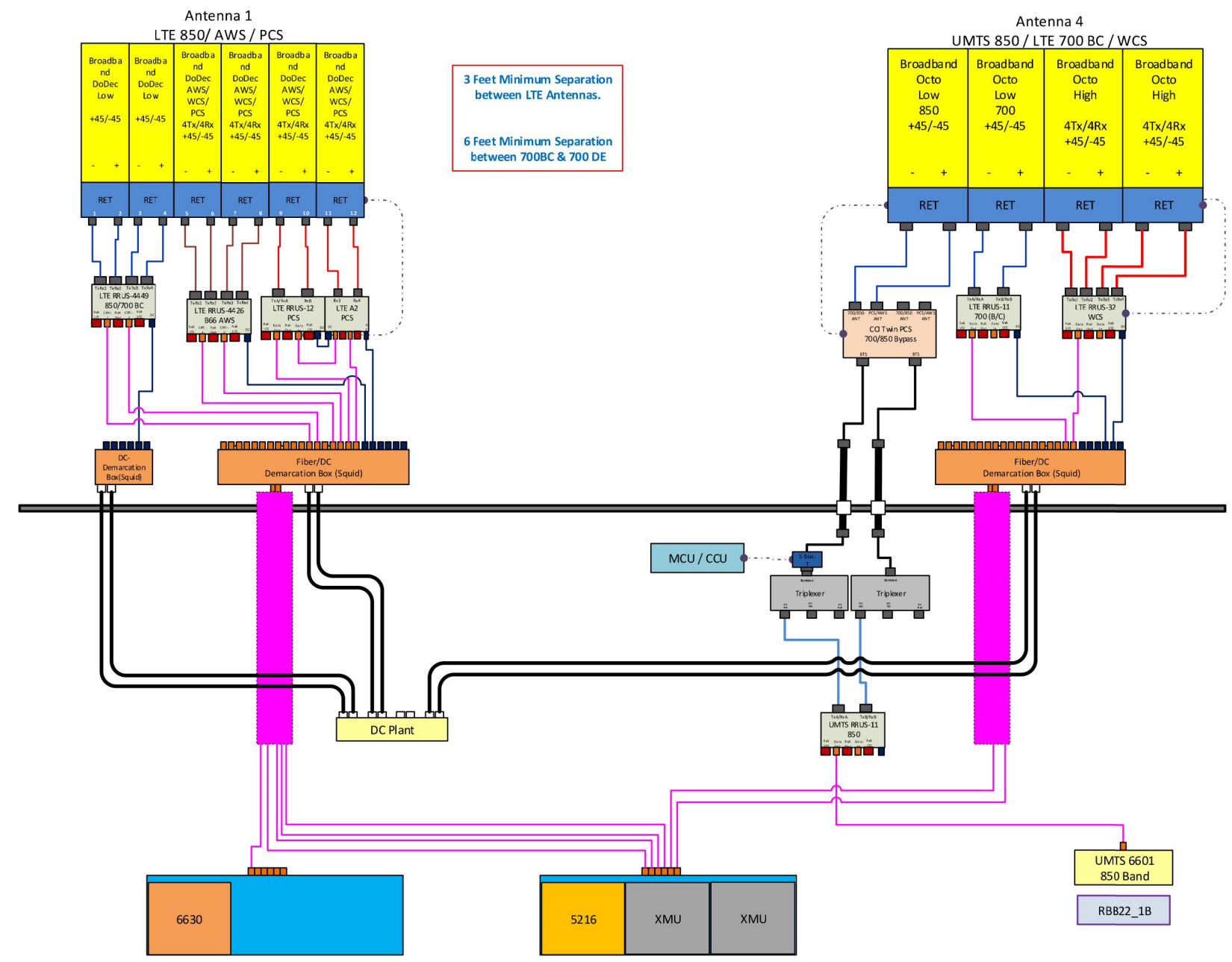

3 Feet Minimum Separation between LTE Antennas.
 6 Feet Minimum Separation between 700BC & 700 DE

PLUMBING DIAGRAM
 SCALE: N.T.S. 1

- NOTES:**
- EQUIPMENT PLUMBING DIAGRAM PER RFDS VERSION 1 DATED 05/01/18.
 - CONTRACTOR TO VERIFY FINAL EQUIPMENT CONFIGURATION & SEPARATIONS WITH AT&T PRIOR TO CONSTRUCTION.

Dewberry
 Dewberry Engineers Inc.
 280 SUMMER STREET
 10TH FLOOR
 BOSTON, MA 02210
 PHONE: 617.695.3400
 FAX: 617.695.3310

CENTERLINE
 COMMUNICATIONS
 95 RYAN DRIVE, SUITE 1
 RAYNHAM, MA 02767

at&t
 Mobility
 550 COCHITUATE ROAD
 SUITES 13 & 14
 FRAMINGHAM, MA 01701

SBA TOWER DANBURY
 SITE NO.: CT2312 3C/4C/5C
 52 STADLEY ROAD
 DANBURY, CT 06811

NO.	DATE	ISSUED FOR REVIEW	AJB	CDH	DAS
		REVISIONS	BY	CHK	APP'D
SCALE: AS SHOWN		DESIGNED BY: CDH	DRAWN BY: AJB		

AT&T MOBILITY FRAMINGHAM, MA 01701		
EQUIPMENT PLUMBING DIAGRAM		
DEWBERRY NO.	DRAWING NUMBER	REV
50093723/50096349	C03	A

GROUNDING NOTES:

- THE CONTRACTOR SHALL REVIEW & INSPECT THE EXISTING FACILITY GROUNDING SYSTEM & LIGHTNING PROTECTION SYSTEM (AS DESIGNED & INSTALLED) FOR STRICT COMPLIANCE WITH THE NEC (AS ADOPTED BY THE AHJ), THE SITE-SPECIFIC (UL, LPI, OR NFPA) LIGHTNING PROTECTION CODE, & GENERAL COMPLIANCE WITH TELCORDIA & TIA GROUNDING STANDARDS. THE CONTRACTOR SHALL REPORT ANY VIOLATIONS OR ADVERSE FINDINGS TO THE CONTRACTOR FOR RESOLUTION.
- ALL GROUND ELECTRODE SYSTEMS (INCLUDING TELECOMMUNICATION, RADIO, LIGHTNING PROTECTION, & AC POWER GES'S) SHALL BE BONDED TOGETHER, AT OR BELOW GRADE, BY TWO OR MORE COPPER BONDING CONDUCTORS. ALL AVAILABLE GROUNDING ELECTRODES SHALL BE CONNECTED TOGETHER IN ACCORDANCE WITH THE NEC.
- THE CONTRACTOR SHALL PERFORM IEEE FALL-OF-POTENTIAL RESISTANCE TO EARTH TESTING (PER IEEE 1100 & 81) FOR GROUND ELECTRODE SYSTEMS. USE OF OTHER METHODS MUST BE PRE-APPROVED BY CONTRACTOR IN WRITING.
- THE CONTRACTOR SHALL FURNISH & INSTALL SUPPLEMENTAL GROUND ELECTRODES AS NEEDED TO ACHIEVE A TEST RESULT OF 5 OHMS OR LESS ON TOWER SITES & 10 OHMS OR LESS ON ROOFTOP SITES. WHEN ADDING ELECTRODES, CONTRACTOR SHALL MAINTAIN A MINIMUM DISTANCE BETWEEN THE ADDED ELECTRODE & ANY OTHER EXISTING ELECTRODE EQUAL TO THE BURIED LENGTH OF THE ROD. IDEALLY, CONTRACTOR SHALL STRIVE TO KEEP THE SEPARATION DISTANCE EQUAL TO TWICE THE BURIED LENGTH OF THE RODS.
- THE CONTRACTOR IS RESPONSIBLE FOR PROPERLY SEQUENCING GROUNDING & UNDERGROUND CONDUIT INSTALLATION AS TO PREVENT ANY LOSS OF CONTINUITY IN THE GROUNDING SYSTEM OR DAMAGE TO THE CONDUIT.
- METAL CONDUIT & TRAY SHALL BE GROUNDED & MADE ELECTRICALLY CONTINUOUS WITH LISTED BONDING FITTINGS OR BY BONDING ACROSS THE DISCONTINUITY WITH 6 AWG COPPER WIRE & UL APPROVED GROUNDING TYPE CONDUIT CLAMPS.
- METAL RACEWAY SHALL NOT BE USED AS THE NEC REQUIRED EQUIPMENT GROUND CONDUCTOR. STRANDED COPPER CONDUCTORS WITH GREEN INSULATION, SIZED IN ACCORDANCE WITH THE NEC, SHALL BE FURNISHED & INSTALLED WITH THE POWER CIRCUITS TO TRANSMISSION EQUIPMENT.
- CONNECTIONS TO THE GROUND BUS SHALL NOT BE DOUBLED UP OR STACKED. BACK-TO-BACK CONNECTIONS ON OPPOSITE SIDES OF THE GROUND BUS ARE PERMITTED.
- ALUMINUM CONDUCTOR OR COPPER CLAD STEEL CONDUCTOR SHALL NOT BE USED FOR GROUNDING CONNECTIONS.
- USE OF 90° BENDS IN THE PROTECTION GROUNDING CONDUCTORS SHALL BE AVOIDED WHEN 45° BENDS CAN BE ADEQUATELY SUPPORTED. IN ALL CASES, BENDS SHALL BE MADE WITH A MINIMUM BEND RADIUS OF 8 INCHES.
- EACH INTERIOR TRANSMISSION CABINET FRAME/PLINTH SHALL BE DIRECTLY CONNECTED TO THE MASTER GROUND BAR WITH 6 AWG STRANDED, GREEN INSULATED SUPPLEMENTAL EQUIPMENT GROUND WIRE UNLESS NOTED OTHERWISE IN THE DETAILS. EACH OUTDOOR CABINET FRAME/PLINTH SHALL BE DIRECTLY CONNECTED TO THE BURIED GROUND RING WITH 2 AWG SOLID TIN-PLATED COPPER WIRE UNLESS NOTED OTHERWISE IN THE DETAILS.
- ALL EXTERIOR GROUND CONDUCTORS BETWEEN EQUIPMENT/GROUND BARS & THE GROUND RING, SHALL BE 2 AWG SOLID TIN-PLATED COPPER UNLESS OTHERWISE INDICATED.
- EXOTHERMIC WELDS SHALL BE USED FOR ALL GROUNDING CONNECTIONS BELOW GRADE. CONNECTIONS TO ABOVE GRADE UNITS SHALL BE MADE WITH EXOTHERMIC WELDS WHERE PRACTICAL OR WITH 2 HOLE MECHANICAL TYPE BRASS CONNECTORS WITH STAINLESS STEEL HARDWARE, INCLUDING SET SCREWS. HIGH PRESSURE CRIMP CONNECTORS MAY ONLY BE USED WITH WRITTEN PERMISSION FROM CENTERLINE COMMUNICATIONS MARKET REPRESENTATIVE.
- EXOTHERMIC WELDS SHALL BE PERMITTED ON TOWERS ONLY WITH THE EXPRESS APPROVAL OF THE TOWER MANUFACTURER OR THE CONTRACTORS STRUCTURAL ENGINEER.
- ALL WIRE TO WIRE GROUND CONNECTIONS TO THE INTERIOR GROUND RING SHALL BE FORMED USING HIGH PRESS CRIMPS OR SPLIT BOLT CONNECTORS WHERE INDICATED IN THE DETAILS.
- ON ROOFTOP SITES WHERE EXOTHERMIC WELDS ARE A FIRE HAZARD COPPER COMPRESSION CAP CONNECTORS MAY BE USED FOR WIRE TO WIRE CONNECTORS. 2 HOLE MECHANICAL TYPE BRASS CONNECTORS WITH STAINLESS STEEL HARDWARE, INCLUDING SET SCREWS SHALL BE USED FOR CONNECTION TO ALL ROOFTOP TRANSMISSION EQUIPMENT & STRUCTURAL STEEL.
- COAX BRIDGE BONDING CONDUCTORS SHALL BE EXOTHERMICALLY BONDED OR BOLTED TO THE BRIDGE & THE TOWER GROUND BAR USING TWO-HOLE MECHANICAL TYPE BRASS CONNECTORS & STAINLESS STEEL HARDWARE.
- APPROVED ANTIOXIDANT COATINGS (I.E., CONDUCTIVE GEL OR PASTE) SHALL BE USED ON ALL COMPRESSION & BOLTED GROUND CONNECTIONS.
- ALL EXTERIOR GROUND CONNECTIONS SHALL BE COATED WITH A CORROSION RESISTANT MATERIAL.
- MISCELLANEOUS ELECTRICAL & NON-ELECTRICAL METAL BOXES, FRAMES & SUPPORTS SHALL BE BONDED TO THE GROUND RING, IN ACCORDANCE WITH THE NEC.
- BOND ALL METALLIC OBJECTS WITHIN 6 FT OF THE BURIED GROUND RING WITH 2 AWG SOLID TIN-PLATED COPPER GROUND CONDUCTOR. DURING EXCAVATION FOR NEW GROUND CONDUCTORS, IF EXISTING GROUND CONDUCTORS ARE ENCOUNTERED, BOND EXISTING GROUND CONDUCTORS TO NEW CONDUCTORS.
- GROUND CONDUCTORS USED IN THE FACILITY GROUND & LIGHTNING PROTECTION SYSTEMS SHALL NOT BE ROUTED THROUGH METALLIC OBJECTS THAT FORM A RING AROUND THE CONDUCTOR, SUCH AS METALLIC CONDUITS, METAL SUPPORT CLIPS OR SLEEVES THROUGH WALLS OR FLOORS WHEN IT IS REQUIRED TO BE HOUSED IN CONDUIT TO MEET CODE REQUIREMENTS OR LOCAL CONDITIONS. NON-METALLIC MATERIAL SUCH AS PVC PLASTIC CONDUIT SHALL BE USED. WHERE USE OF METAL CONDUIT IS UNAVOIDABLE (E.G., NON-METALLIC CONDUIT PROHIBITED BY LOCAL CODE) THE GROUND CONDUCTOR SHALL BE BONDED TO EACH END OF THE METAL CONDUIT WITH LISTED BONDING FITTINGS.

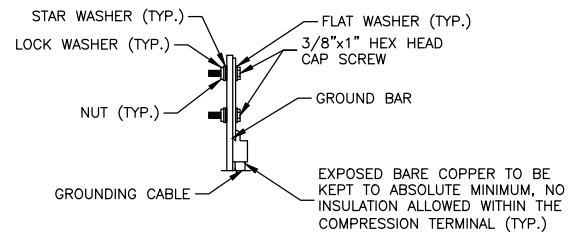
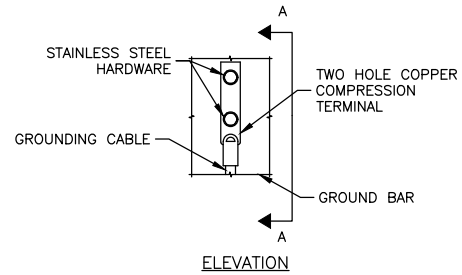

NOTES:

- DOUBLING UP OR STACKING OF CONNECTIONS IS NOT PERMITTED.
- OXIDE INHIBITING COMPOUND TO BE USED AT ALL LOCATIONS.

TYPICAL GROUND BAR MECHANICAL CONNECTION DETAIL

SCALE: N.T.S.

1

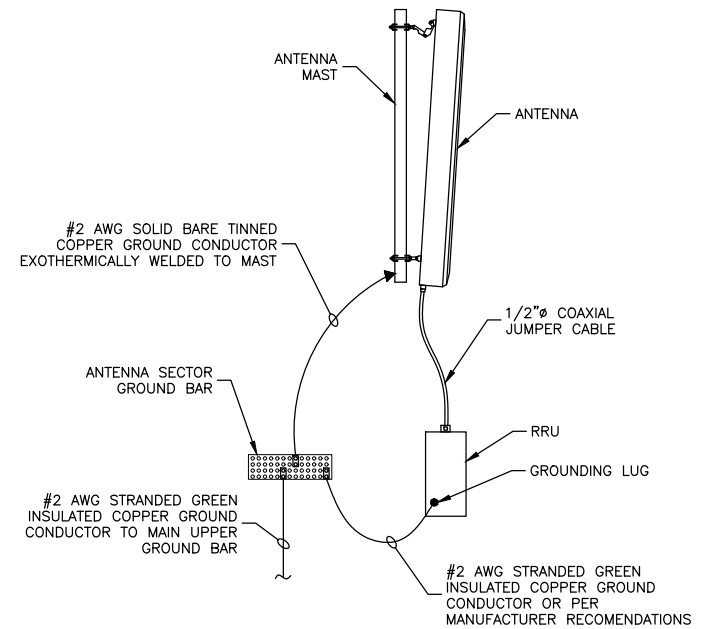

NOTES:

- VERIFY EXISTING GROUNDING SYSTEM IS INSTALLED PER AT&T STANDARDS.
- BOND NEW EQUIPMENT INTO EXISTING GROUND SYSTEM IN ACCORDANCE WITH AT&T STANDARDS & MANUFACTURER RECOMMENDATIONS.

TYPICAL ANTENNA/RRU GROUNDING DETAIL

SCALE: N.T.S.

2

Dewberry
Dewberry Engineers Inc.
280 SUMMER STREET
10TH FLOOR
BOSTON, MA 02210
PHONE: 617.695.3400
FAX: 617.695.3310

CENTERLINE
COMMUNICATIONS
95 RYAN DRIVE, SUITE 1
RAYNHAM, MA 02767

at&t
Mobility
550 COCHITUATE ROAD
SUITES 13 & 14
FRAMINGHAM, MA 01701

SBA TOWER DANBURY
SITE NO.: CT2312 3C/4C/5C

52 STADLEY ROAD
DANBURY, CT 06811

NO.	DATE	REVISIONS	BY	CHK	APP'D
A	08/30/18	ISSUED FOR REVIEW	AJB	CDH	DAS
SCALE: AS SHOWN		DESIGNED BY: CDH	DRAWN BY: AJB		

AT&T MOBILITY
FRAMINGHAM, MA 01701

GROUNDING DETAILS

DEWBERRY NO.	DRAWING NUMBER	REV
50093723/50096349	E01	A

AARON MEYERS
(774) 420-4202
CENTERLINE COMMUNICATIONS, LLC
750 WEST CENTER STREET
WEST BRIDGEWATER MA 02379

1 LBS

1 OF 1

SHIP TO:
MARK BOUGHTON
MAYOR OF DANBURY
155 DEER HILL AVE
DANBURY CT 06810

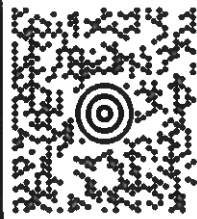

CT 068 0-01



UPS GROUND

TRACKING #: 1Z 9Y4 503 03 1666 5427



BILLING: P/P



XDL 18.09.09 NV45 03.0A 07/2018

AARON MEYERS
(774) 420-4202
CENTERLINE COMMUNICATIONS, LLC
750 WEST CENTER STREET
WEST BRIDGEWATER MA 02379

1 LBS

1 OF 1

SHIP TO:
CHRIST THE SHEPHERD CHURCH
52 STADLEY ROUGH ROAD
DANBURY CT 06810

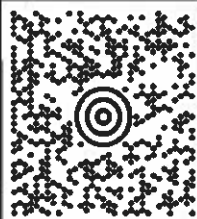

CT 068 0-01



UPS GROUND

TRACKING #: 1Z 9Y4 503 03 2704 6807



BILLING: P/P



XOL 18.09.09 NY-15 03.0A 07/2018

AARON MEYERS
(774) 420-4202
CENTERLINE COMMUNICATIONS, LLC
750 WEST CENTER STREET
WEST BRIDGEWATER MA 02379

1 LBS

1 OF 1

SHIP TO:

CARLA SHORTER
SBA COMMUNICATIONS CORPORATION
8051 CONGRESS AVENUE
BOCA RATON FL 33487-1307

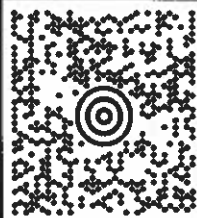

FL 332 6-07



UPS GROUND

TRACKING #: 1Z 9Y4 503 03 0024 1440



BILLING: P/P



XDL 18 09 09 NY45 03 0A 07 /D18

1 OF 1

1 LBS

AARON MEYERS
(774) 420-4202
CENTERLINE COMMUNICATIONS, LLC
750 WEST CENTER STREET
WEST BRIDGEWATER MA 02379

SHIP TO:
SHARON CALITRO, AICP
DIRECTOR
155 DEER HILL AVE
DANBURY CT 06810

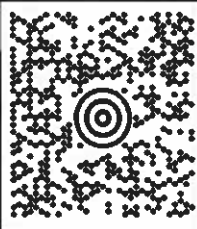

CT 068 0-01



UPS GROUND

TRACKING #: 1Z 9Y4 503 03 0975 2435

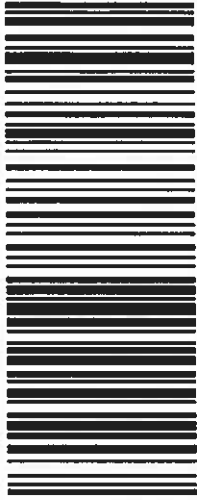

BILLING: P/P



XDL18 09 09 NY45 03 0A 07/2018