



445 Hamilton Avenue, 14th Floor
White Plains, New York 10601
T 914 761 1300
F 914 761 5372
cuddyfeder.com

Daniel Patrick
dpatrick@cuddyfeder.com

July 21, 2022

VIA ELECTRONIC MAIL AND OVERNIGHT MAIL

Melanie A. Bachman
Executive Director
Connecticut Siting Council
10 Franklin Square
New Britain, CT 06051

Re: New Cingular Wireless PCS, LLC (“AT&T”)
Notice of Exempt Modification
Emergency Back-up Generator
52 Stadley Rough Road, Danbury, CT 06811
Lat.: 41.43310280°; Long.: -73.43191670°

Dear Ms. Bachman:

This letter and enclosures are respectfully submitted on behalf of New Cingular Wireless PCS, LLC (“AT&T”). AT&T currently maintains its wireless telecommunications facility on the existing tower located at 52 Stadley Rough Road in the City of Danbury, Connecticut. The underlying property is owned by Christ the Shephard Church PCA and SBA Towers is the tower owner. AT&T submits this letter and enclosures to the Connecticut Siting Council (“Council”) to notify the Council of AT&T’s intent to perform modifications to the existing facility that do not have substantial adverse environmental effects and thus do not require a certificate pursuant to Section 16-50k of the Connecticut General Statutes.

AT&T intends to install one (1) new Generac 30kW Diesel Generator within the existing grade-level fenced equipment compound as demonstrated on the plans enclosed as **Attachment 1**. AT&T’s existing facility supports its FirstNet program which provides first responders with priority access to AT&T’s network to ensure adequate communication capabilities in the event of emergency. AT&T’s proposed generator will ensure that critical communication capability for first responders and the public are not lost in the event of a loss of power.

AT&T’s proposed generator will also advance the State’s goal of natural disaster and emergency preparedness. As discussed in the Council’s Docket 432 Findings and Report and Docket 440 proceedings and Findings of Fact (Nos. 76- 77), in response to two significant storm events in 2011, the State formed a Two Storm Panel (the “Panel”) that evaluated Connecticut’s approach to planning and mitigation of impacts associated with emergencies and natural disasters. The Panel found that “wireless telecommunications service providers were not prepared to serve residential and business customers during a power outage” because certain companies had limited backup generator capacity.



July 21, 2022

Page 2

The Panel also noted that “[t]he failure of a large portion of Connecticut’s telecommunications system during the two storms is a life safety issue.” The Panel recommended that State regulatory bodies review “telecommunications services currently in place to verify that the vendors have sufficient generator and backhaul capacity to meet the emergency needs of consumers and businesses” and that the “Connecticut Siting Council should require continuity of service plans for any cellular tower to be erected.” The planned modifications will ensure continuity of services by reinforcing AT&T’s back-up power and backhaul capacity to meet the emergency needs of first responders, consumers and businesses in the event of a power outage.

The planned modifications to the facility fall squarely within the activities explicitly provided for in R.C.S.A. § 16-50j-72(b)(2) as the planned modifications:

- Will not result in an increase in the height of the existing structure;
- Will not require the extension of the site boundary;
- Will not increase noise levels at the facility by more than six decibels or more, or to levels that exceed state or local criteria since emergency backup generators are exempt from noise regulations as “noise created as a result of, or relating to, an emergency”;
- Will not increase radio frequency emission at the facility to a level at or above the Federal Communications Commission safety standards;
- Will not cause a change or alteration in the physical or environmental characteristics of the site; and
- Will not impair the structural integrity of the facility.

The existing tower was approved by the Siting Council in Docket No. 366 on April 23, 2009. A copy of the Council’s Decision and Order from Docket No. 366 is enclosed in **Attachment 2**. The Siting Council’s decision in Docket No. 366 was thereafter subject to an appeal to State of Connecticut Superior Court, Judicial Branch in Docket No.: CV-09-4021287-S. The following have been provided or performed in compliance with the Superior Court’s Stipulation for Judgment:

- A written statement prepared by AT&T, enclosed as **Attachment 3**, explaining the reasons why fuel cell technology is not a feasible backup power source for AT&T’s facility.
- Plans enclosed as **Attachment 1** demonstrating that the proposed backup generator will be baffled using the proposed 12’x12’ cedar-shingle siding generator enclosure with a pitched roof designed to match the existing enclosures at the facility. The enclosure will include 6” insulation sound barriers within the walls and 10” insulation



July 21, 2022

Page 3

- sound barriers within the roof/ceiling. The generator will also be equipped with the manufacturer's high performance sound attenuation enclosure.
- A note on the plans enclosed as **Attachment 1** specifying that "testing and cycling will only occur between 9am-5pm on weekdays."

The proposed modifications will have no impact on the existing tower structure itself or the radio-frequency emissions as the proposed modifications only consist of the addition of one new generator within the grade-level fenced equipment compound. Thus, AT&T respectfully requests a waiver from submission of information relating to the existing tower structure or the radio-frequency emissions.

Please accept this letter as notification pursuant to R.C.S.A. § 16-50j-73 for construction that constitutes an exempt modification pursuant to R.C.S.A. § 16-50j-73. In accordance with R.C.S.A. § 16-50j-73, a copy of this letter and enclosures are being sent to the City of Danbury Mayor Dean Esposito as well as the property owner and structure owner identified above. A copy of this letter and enclosures are also being sent to the City of Danbury Assistant Corporation Counsel Robin L. Edwards, Esq and Jose & Christina Carvalheiro and their legal counsel, Daniel Casagrande, Esq. Certificate of Mailing is enclosed as **Attachment 4**.

For the foregoing reasons, AT&T respectfully submits that the proposed modification to the above referenced wireless telecommunications facility constitutes an exempt modification under R.C.S.A. § 16-50j-72(b)(2).

Very truly yours,

A handwritten signature in blue ink, appearing to read 'DP', is written over a light blue horizontal line.

Daniel Patrick

Attachments

cc: City of Danbury Mayor Dean Esposito
Director Sharon B. Calitro, City of Danbury Planning & Zoning Department
Robin L. Edwards, Esq., City of Danbury Assistant Corporation Counsel
Jose and Christina Carvalheiro
Daniel Casagrande, Esq., Cramer & Anderson, LLP
Christ the Shephard Church PCA (Property Owner)
SBA Communications (Tower Owner)
AT&T
General Dynamics Wireless Services
Lucia Chiochio, Esq.
Meyling Nuñez

ATTACHMENT 1



at&t Mobility

SITE NAME: DANBURY STADLEY ROUGH ROAD
FA LOCATION CODE: 12676398
SITE ID #: CT13549

GENERATOR PROJECT
30KW GENERAC DIESEL GENERATOR
200A GENERAC ATS

52 STADLEY ROUGH ROAD
DANBURY, CT 06811



PREPARED FOR:
GENERAL DYNAMICS
Information Technology, Inc.

GENERAL DYNAMICS
101 STATION DR
WESTWOOD, MA 02090

Certification & Seal:
I hereby certify that this plan, specification, or report was prepared by me or under my direct supervision and that I am a duly Licensed Professional Engineer under the laws of the State of Connecticut.

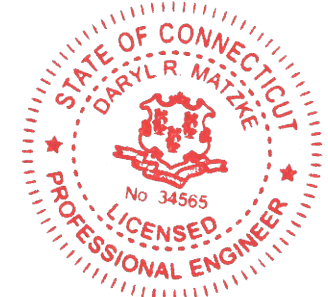

Signature: _____ Date: 4/21/2022

MARK	DATE	DESCRIPTION
4	04/21/22	REVISE GENERATOR FOOT PRINT
3	04/20/22	ADD GENERATOR SHELTER TO CDs
2	12/03/21	REVISED CDs
1	05/25/21	REVISED CDs

ISSUE PHASE: FINAL DATE ISSUED: 02/05/2021
PROJECT TITLE:
DANBURY STADLEY ROUGH ROAD
FA ID # 12676398

PROJECT INFORMATION:
52 STADLEY ROUGH ROAD
DANBURY, CT 06811

SHEET TITLE:
TITLE SHEET
SCALE: NONE
PROJECT NUMBER: 50175
SHEET NUMBER: T-1

VICINITY MAP

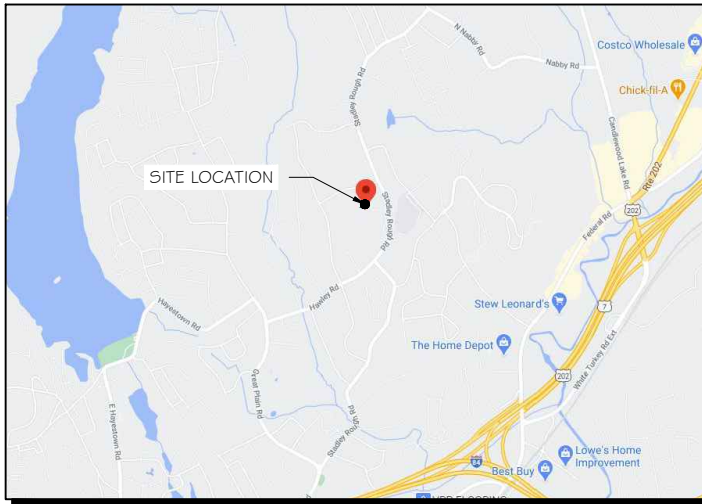

SCOPE OF WORK

ADD STANDBY GENERATOR, ASSOCIATED CONCRETE PAD, AND UTILITY EQUIPMENT TO EXISTING AT&T EQUIPMENT AREA. THERE WILL BE NO CHANGE IN THE SIZE OR HEIGHT OF THE TOWER OR ANTENNAS.

APPLICABLE BUILDING CODE & STANDARDS

ALL WORK AND MATERIALS SHALL BE PERFORMED AND INSTALLED IN ACCORDANCE WITH THE CURRENT EDITION OF THE FOLLOWING CODES AS ADOPTED BY THE GOVERNING LOCAL AUTHORITIES. NOTHING IN THESE PLANS ARE TO BE CONSTRUCTED TO PERMIT WORK NOT CONFORMING TO THESE CODES:

- INTERNATIONAL BUILDING CODE 2015
- NATIONAL ELECTRIC CODE 2014
- AMERICAN CONCRETE INSTITUTE (ACI) 318, BUILDING CODE REQUIREMENTS FOR STRUCTURAL CONCRETE
- AMERICAN INSTITUTE OF STEEL CONSTRUCTION (AISC), MANUAL OF STEEL CONSTRUCTION
- TELECOMMUNICATIONS INDUSTRY ASSOCIATION (TIA) 222-G, STRUCTURAL STANDARDS FOR STEEL TOWER AND ANTENNA SUPPORTING STRUCTURES
- TIA 607, COMMERCIAL BUILDING GROUNDING AND BONDING REQUIREMENTS FOR TELECOMMUNICATIONS

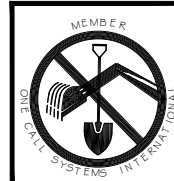

TO OBTAIN LOCATION OF PARTICIPANTS' UNDERGROUND FACILITIES BEFORE YOU DIG IN CONNECTICUT

CALL BEFORE YOU DIG
811 OR 1-800-922-4455

CONNECTICUT PUBLIC ACT 87-71 REQUIRES MIN. 2 WORKING DAYS NOTICE BEFORE YOU EXCAVATE.

AERIAL VIEW OF SITE

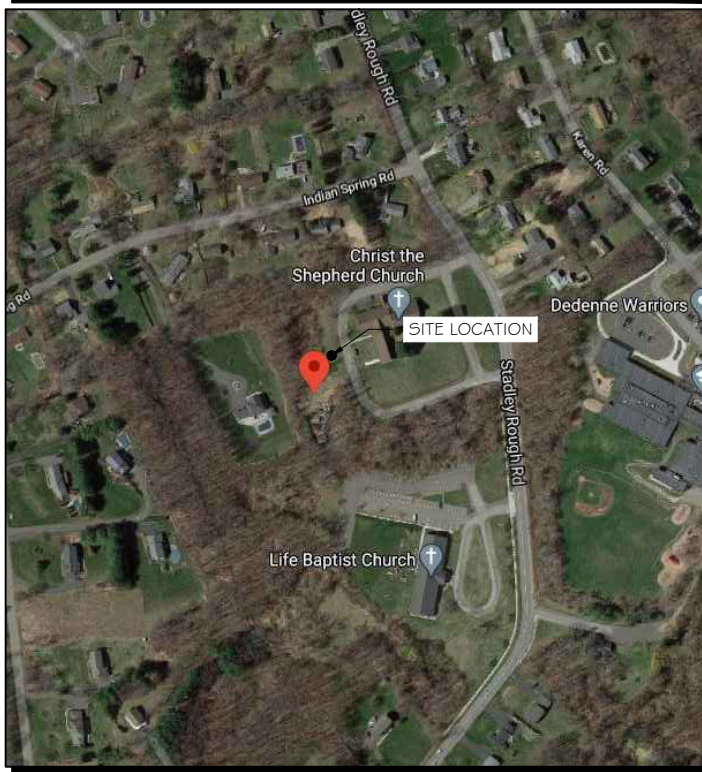

PROJECT INFORMATION

PROJECT MANAGER:
BRIAN K SILBERT
SR. REGIONAL MANAGER
GENERAL DYNAMICS WIRELESS SERVICES
101 STATION DR
WESTWOOD, MA 02090
EMAIL: Brian.Silbert@gdit.com

ENGINEER:
RAMAKER & ASSOCIATES, INC.
855 COMMUNITY DRIVE
SAUK CITY, WI 53583
PH.: (608) 643-4100
FAX: (608) 643-7999
CONTACT: TYLER BEATTY
EMAIL: tbeatty@ramaker.com

SITE DATA:
SITE NAME: DANBURY STADLEY ROUGH ROAD
FA NUMBER: 12676398

PROPERTY OWNER:
SBA TOWERS
805 I CONGRESS AVENUE
BOCA RATON, FL 33487

ADDRESS:
52 STADLEY ROUGH ROAD
DANBURY, CT 06811

COUNTY: FAIRFIELD

LAT.: 41.43310280°
LONG.: -73.43191670°

GROUND ELEVATION: 551 FT AMSL

APPLICANT INFORMATION:
AT&T MOBILITY
7150 STANDARD DR
HANOVER, MD 21076

DO NOT SCALE DRAWINGS:
CONTRACTOR SHALL VERIFY ALL PLANS & EXISTING DIMENSIONS & CONDITIONS ON THE JOB SITE & SHALL IMMEDIATELY NOTIFY THE ENGINEER IN WRITING OF ANY DISCREPANCIES BEFORE PROCEEDING WITH THE WORK OR BE RESPONSIBLE FOR SAME.

THE INFORMATION CONTAINED IN THIS SET OF DOCUMENTS IS PROPRIETARY BY NATURE. ANY USE OR DISCLOSURE OTHER THAN THAT WHICH RELATES TO THE CLIENT IS STRICTLY PROHIBITED.

SHEET INDEX

- GENERAL:**
- T-1 TITLE SHEET
- NOTES:**
- N-1 GENERAL NOTES
- SITE:**
- A-1 SITE PLAN
 - A-2 SHELTER EQUIPMENT LAYOUT
 - A-3 SHELTER ELECTRICAL PLAN
 - S-1 SHELTER FOUNDATION DETAILS
 - S-2 SHELTER FOUNDATION DETAILS
 - S-3 SHELTER FLOOR PLAN
 - S-4 SHELTER ELEVATIONS
 - S-5 SHELTER SECTION DETAILS
 - S-6 SHELTER SECTIONS & LOUVER SPECS.
 - S-7 DOOR SPECS. & SECTION DETAILS
 - S-8 DAMPER SPECIFICATIONS
 - S-9 WEATHER HOOD SPECIFICATIONS
 - S-10 MARSEAL LINING SPECIFICATIONS

- ELECTRICAL & GROUNDING:**
- E-1 WIRING DETAILS
 - E-2 PANEL AND PENETRATION DETAILS
 - E-3 ATS, CONDUIT & GROUND ROD DETAILS
 - E-4 GENERAC GENERATOR SPECIFICATIONS
 - E-4.1 GENERAC GENERATOR SPECIFICATIONS
 - E-4.2 GENERAC GENERATOR SPECIFICATIONS
 - E-5 GENERAC ATS SPECIFICATIONS
 - E-5.1 GENERAC ATS SPECIFICATIONS

SIGNATURE BLOCK

AT&T MGR.	DATE
GENERAL DYNAMICS CONSTRUCTION MGR.	DATE
SITE ACQUISITION	DATE

NOTES TO SUBCONTRACTOR:

1. THE GENERAL SUBCONTRACTOR MUST VERIFY ALL DIMENSIONS, CONDITIONS AND ELEVATIONS BEFORE PROCEEDING WITH THE WORK. ALL WORK SHALL BE PERFORMED IN A WORKMANLIKE MANNER IN ACCORDANCE WITH ACCEPTED CONSTRUCTION PRACTICES.
 2. IT IS THE INTENTION OF THESE DRAWINGS TO SHOW THE COMPLETED INSTALLATION. THE SUBCONTRACTOR SHALL BE RESPONSIBLE FOR ALL TEMPORARY BRACING, SHORING, TIES, FORM WORK, ETC. IN ACCORDANCE WITH ALL NATIONAL, STATE, AND LOCAL ORDINANCES, TO SAFELY EXECUTE ALL WORK AND SHALL BE RESPONSIBLE FOR SAME. ALL WORK SHALL BE IN ACCORDANCE WITH LOCAL CODES.
 3. THE SUBCONTRACTOR SHALL USE ADEQUATE NUMBER OF SKILLED WORKMAN WHO ARE THOROUGHLY TRAINED AND EXPERIENCED IN THE NECESSARY CRAFTS AND WHO ARE COMPLETELY FAMILIAR WITH THE SPECIFIED REQUIREMENTS AND METHOD NEEDED FOR PROPER PERFORMANCE OF THE WORK.
 4. CONSTRUCTION SUBCONTRACTOR AGREES THAT IN ACCORDANCE WITH GENERALLY ACCEPTED CONSTRUCTION PRACTICES, CONSTRUCTION SUBCONTRACTOR WILL BE REQUIRED TO ASSUME SOLE AND COMPLETE RESPONSIBILITY FOR JOB SITE CONDITIONS DURING THE COURSE OF CONSTRUCTION OF THE PROJECT, INCLUDING THE SAFETY OF ALL PERSONS AND PROPERTY, THAT THIS REQUIREMENT SHALL BE MADE TO APPLY CONTINUOUSLY AND NOT BE LIMITED TO NORMAL WORKING HOURS AND CONSTRUCTION SUBCONTRACTOR FURTHER AGREES TO INDEMNIFY AND HOLD DESIGN ENGINEER HARMLESS FROM ANY AND ALL LIABILITY, REAL OR ALLEGED, IN CONNECTION WITH PERFORMANCE OF WORK ON THIS PROJECT.
 5. SITE GROUNDING SHALL COMPLY WITH AT&T WIRELESS SERVICES TECHNICAL SPECIFICATIONS FOR FACILITY GROUNDING FOR CELL SITE STANDARDS, LATEST EDITION, AND COMPLY WITH AT&T TOWERS GROUNDING CHECKLIST, LATEST VERSION. WHEN NATIONAL AND LOCAL GROUNDING CODES ARE MORE STRINGENT THEY SHALL GOVERN. GROUNDING SHALL BE COMPLETED BEFORE ERECTION OF TOWER.
 6. ALL WORK SHALL COMPLY WITH OSHA AND STATE SAFETY REQUIREMENTS. PROCEDURES FOR THE PROTECTION OF EXCAVATIONS, EXISTING CONSTRUCTION AND UTILITIES SHALL BE ESTABLISHED PRIOR TO FOUNDATION INSTALLATION. IF TEMPORARY LIGHTING AND MARKING IS REQUIRED BY THE FEDERAL AVIATION ADMINISTRATION (FAA), IT IS THE SUBCONTRACTOR'S RESPONSIBILITY TO MAINTAIN THE NECESSARY LIGHTS AND NOTIFY THE PROPER AUTHORITIES IN THE EVENT OF A PROBLEM.
 7. ALL WORK SHALL BE ACCOMPLISHED IN ACCORDANCE WITH ALL LOCAL, STATE, AND FEDERAL CODES OR ORDINANCES. THE MOST STRINGENT CODE WILL APPLY IN THE CASE OF DISCREPANCIES OR DIFFERENCES IN THE CODE REQUIREMENTS.
 8. ANY DAMAGE TO THE ADJACENT PROPERTIES WILL BE CORRECTED AT THE SUBCONTRACTOR'S EXPENSE TO THE SATISFACTION OF THE LANDOWNER AND THE ENGINEER.
 9. THE COMPLETE BID PACKAGE INCLUDES THESE CONSTRUCTION DRAWINGS ALONG WITH THE SPECIFICATIONS. SUBCONTRACTOR IS RESPONSIBLE FOR REVIEW OF TOTAL BID PACKAGE PRIOR TO BID SUBMITTAL.
 10. SUBCONTRACTOR SHALL VERIFY LOCATION OF ALL EXISTING UTILITIES WITHIN CONSTRUCTION LIMITS PRIOR TO CONSTRUCTION.
 11. THE SUBCONTRACTOR IS RESPONSIBLE FOR MAINTAINING POSITIVE DRAINAGE ON THE SITE AT ALL TIMES. SILT AND EROSION CONTROL SHALL BE MAINTAINED ON THE DOWNSTREAM SIDE OF THE SITE AT ALL TIMES. ANY DAMAGE TO ADJACENT PROPERTIES WILL BE CORRECTED AT THE SUBCONTRACTOR'S EXPENSE.
 12. CLEARING OF TREES AND VEGETATION ON THE SITE SHOULD BE HELD TO A MINIMUM. ONLY THE TREES NECESSARY FOR CONSTRUCTION OF THE FACILITIES SHALL BE REMOVED. ANY DAMAGE TO THE PROPERTY OUTSIDE THE LEASED PROPERTY SHALL BE REPAIRED BY THE SUBCONTRACTOR.
 13. ALL SUITABLE BORROW MATERIAL FOR BACK FILL OF THE SITE SHALL BE INCLUDED IN THE BID. EXCESS TOPSOIL AND UNSUITABLE MATERIAL SHALL BE DISPOSED OF OFF SITE AT LOCATIONS APPROVED BY GOVERNING AGENCIES PRIOR TO DISPOSAL.
 14. SEEDING AND MULCHING OF THE SITE WILL BE ACCOMPLISHED AS SOON AS POSSIBLE AFTER COMPLETION OF THE SITE DEVELOPMENT. THE SUBCONTRACTOR IS RESPONSIBLE FOR PROVIDING AND MAINTAIN AN ADEQUATE COVER OF VEGETATION OVER THE SITE FOR A ONE YEAR PERIOD.
 15. PERMITS: THE SUBCONTRACTOR SHALL BE RESPONSIBLE FOR OBTAINING AND INCURRING THE COST OF ALL REQUIRED PERMITS, INSPECTIONS, CERTIFICATES, ETC.
 16. RECORD DRAWINGS: MAINTAIN A RECORD OF ALL CHANGES, SUBSTITUTIONS BETWEEN WORK AS SPECIFIED AND INSTALLED. RECORD CHANGES ON A CLEAN SET OF CONTRACT DRAWINGS WHICH SHALL BE TURNED OVER TO THE CONSTRUCTION MANAGER UPON COMPLETION OF THE PROJECT.
 17. THE PLANS SHOW SOME KNOWN SUBSURFACE STRUCTURES, ABOVE GROUND STRUCTURES AND/OR EXISTING UTILITIES BELIEVED TO BE IN THE WORKING AREA. IT IS THE RESPONSIBILITY OF THE SUBCONTRACTOR TO VERIFY ALL UTILITIES, PIPELINES AND OTHER STRUCTURES SHOWN OR NOT SHOWN ON THESE PLANS. THE SUBCONTRACTOR SHALL CONTACT THE LOCAL JURISDICTION'S DIGGERS' HOTLINE BEFORE DIGGING OR DRILLING. ANY DAMAGE TO EXISTING UTILITIES SHALL BE REPAIRED TO THE SATISFACTION OF THE OWNER AND ENGINEER AT THE SUBCONTRACTOR'S EXPENSE.
- GENERAL NOTES:
1. THIS PROPOSAL IS FOR THE ADDITION OF A NEW GENERATOR IN A NEW SHELTER ON A NEW CONCRETE FROST WALL FOUNDATION TO AN EXISTING UNMANNED TELECOMMUNICATIONS FACILITY CONSISTING OF AN EQUIPMENT SHELTER AND TOWER.
 2. THE PROPOSED FACILITY WILL BE UNMANNED AND DOES NOT REQUIRE POTABLE WATER OR SEWER SERVICE.
 3. THE PROPOSED FACILITY IS UNMANNED AND IS NOT FOR HUMAN HABITAT. (NO HANDICAP

- ACCESS IS REQUIRED)
4. OCCUPANCY IS LIMITED TO PERIODIC MAINTENANCE AND INSPECTION, APPROXIMATELY 2 TIMES PER MONTH BY AT&T TECHNICIANS.
 5. OUTDOOR STORAGE AND SOLID WASTE CONTAINERS ARE NOT PROPOSED.
 6. ALL MATERIAL SHALL BE FURNISHED AND WORK SHALL BE PERFORMED IN ACCORDANCE WITH THE PROJECT SPECIFICATIONS.
 7. SUBCONTRACTOR SHALL BE RESPONSIBLE FOR REPAIRING ANY DAMAGE CAUSED BY THE CONSTRUCTION OPERATION.
 8. SUBCONTRACTOR SHALL BE RESPONSIBLE FOR OBTAINING ALL PERMITS AND INSPECTION REQUIRED FOR CONSTRUCTION.
 9. SUBCONTRACTOR SHALL REMOVE ALL TRASH AND DEBRIS FROM THE SITE ON A DAILY BASIS.
- ELECTRICAL NOTES:
- A. GENERAL
1. COORDINATE LOCATION AND POWER REQUIREMENTS OF ALL EQUIPMENT WITH AT&T AND EQUIPMENT SUPPLIER PRIOR TO INSTALLATION.
 2. COORDINATE LOCATION AND REQUIREMENTS FOR ELECTRICAL AND TELEPHONE SERVICES WITH THE PROPERTY REPRESENTATIVE, AT&T AND UTILITY COMPANIES. ROUTING OF CONDUITS MAY BE MODIFIED TO MEET SITE REQUIREMENTS. EXACT CONDUIT ROUTING TO BE DETERMINED IN THE FIELD.
 3. ALL WIRING AND EQUIPMENT SHOWN ON ELECTRICAL SHEETS SHALL BE FURNISHED AND INSTALLED UNDER ELECTRICAL PORTION OF CONTRACT UNLESS OTHERWISE NOTED
 4. UNINTERRUPTED ELECTRICAL SERVICE FOR EXISTING EQUIPMENT SHALL BE MAINTAINED DURING THE INSTALLATION OF THE WORK DESCRIBED UNDER THESE DOCUMENTS. TEMPORARY EQUIPMENT, CABLES AND WHATEVER ELSE IS NECESSARY SHALL BE PROVIDED AS REQUIRED TO MAINTAIN ELECTRICAL SERVICE. TEMPORARY SERVICE FACILITIES, IF REQUIRED AT ANY TIME, SHALL NOT BE DISCONNECTED OR REMOVED UNTIL NEW SERVICE EQUIPMENT IS IN PROPER OPERATION. IF ANY SERVICE OR SYSTEM MUST BE INTERRUPTED, THE CONTRACTOR SHALL REQUEST PERMISSION IN WRITING STATING THE DATE, TIME, ETC. THE SERVICE WILL BE INTERRUPTED AND THE AREAS AFFECTED. THIS REQUEST SHALL BE MADE IN SUFFICIENT TIME FOR PROPER ARRANGEMENTS TO BE MADE. WRITTEN PERMISSION SHALL BE OBTAINED FROM THE OWNER BEFORE INTERRUPTING ELECTRICAL SERVICE.
 5. COORDINATE NEW WORK WITH OTHER TRADES AND VERIFY EXISTING CONDITIONS TO AVOID INTERFERENCE. IN CASE OF INTERFERENCE, AT&T'S REPRESENTATIVE WILL DECIDE WHICH WORK IS TO BE RELOCATED, REGARDLESS OF WHICH WAS FIRST INSTALLED.
 6. THE INSTALLATION MUST COMPLY WITH NEC AND ALL FEDERAL, STATE AND LOCAL RULES AND REGULATIONS.
 7. THE DRAWINGS ARE DIAGRAMMATIC AND INDICATE THE GENERAL ARRANGEMENT OF SYSTEMS AND EQUIPMENT UNLESS OTHERWISE DEFINED BY DIMENSIONS OR DETAILS. EXACT EQUIPMENT LOCATIONS AND RACEWAY ROUTING SHALL BE GOVERNED BY ACTUAL FIELD CONDITIONS AND/OR DIRECTIONS FROM AT&T'S REPRESENTATIVE.
 8. CONTRACTOR SHALL PAY ALL PERMITS AND FEES REQUIRED.
 9. ALL MATERIALS SHALL BE FURNISHED AND WORK SHALL BE PERFORMED IN ACCORDANCE WITH THE APPLICABLE SECTIONS OF THE STANDARDS REFERENCED BELOW:
 - a. ANSI (AMERICAN NATIONAL STANDARDS INSTITUTE)
 - b. ASTM (AMERICAN SOCIETY FOR TESTING MATERIALS)
 - c. ETL (ELECTRICAL TESTING LABORATORY)
 - d. ICEA (INSULATED CABLE ENGINEERS ASSOCIATION)
 - e. IEEE (INSTITUTE OF ELECTRICAL AND ELECTRONIC ENGINEERS)
 - f. MBFU (NATIONAL BOARD OF FIRE UNDERWRITERS)
 - g. NESC (NATIONAL ELECTRICAL SAFETY CODE)
 - h. NEMA (NATIONAL ELECTRICAL MANUFACTURER'S ASSOCIATION)
 - i. NFPA (NATIONAL FIRE PROTECTION ASSOCIATION)
 - j. UL (UNDERWRITER'S LABORATORY)
 10. CONTRACTOR SHALL REVIEW PLANS, DETAILS AND SPECIFICATIONS IN DETAIL AND ADJUST WORK TO CONFORM WITH ACTUAL SITE CONDITIONS SO THAT ELECTRICAL DEVICES AND EQUIPMENT WILL BE LOCATED AND READILY ACCESSIBLE. QUANTITIES LISTED IN MATERIAL LISTS ON THE DRAWINGS ARE FOR INFORMATION ONLY. THE CONTRACTOR SHALL PROVIDE HIS OWN TAKEOFF FOR MATERIAL QUANTITY AND TYPES BASED ON ACTUAL SITE CONDITIONS. IN ADDITION, CONTRACTOR SHALL PROVIDE ALL NECESSARY MATERIALS TO INSTALL EQUIPMENT FURNISHED BY AT&T OR ITS SUPPLIERS. ALL ITEMS NOT SPECIFICALLY MENTIONED HEREIN OR SHOWN ON THE DRAWINGS, BUT WHICH ARE OBVIOUSLY NECESSARY TO MAKE A COMPLETE WORKING INSTALLATION, SHALL BE INCLUDED.
 11. THE CONTRACTOR OR BIDDER SHALL BEAR THE RESPONSIBILITY OF NOTIFYING (IN WRITING) AT&T'S REPRESENTATIVE OF ANY CONFLICTS PRIOR TO THE SUBMISSION OF CONTRACTOR'S PROPOSAL OR PERFORMANCE OF WORK, IN THE EVENT OF DISCREPANCIES THE CONTRACTOR SHALL PRICE THE MORE COSTLY OR EXTENSIVE WORK, UNLESS DIRECTED IN WRITING OTHERWISE.
 12. ALL FLOORS WHERE PENETRATIONS ARE REQUIRED IN BUILDING ARE TO BE CORE DRILLED AND THEN FIREPROOFED.
- B. WIRING/CONDUIT
1. PROVIDE PULL BOXES AND JUNCTION BOXES WHERE SHOWN OR AS REQUIRED BY CODE SUCH THAT NO MORE THAN THE EQUIVALENT OF FOUR QUARTER BENDS (380 DEGREES TOTAL) EXIST IN A CONDUIT RUN.
 2. ALL POWER AND CONTROL/INDICATION WIRING SHALL BE TYPE THHN/THWN 800V RATED 75 DEGREES CELSIUS, UNLESS NOTED OTHERWISE.

3. SCHEDULE 80 PVC CONDUIT SHALL BE USED ABOVE GROUND, WHERE ABOVE GRADE IS DEFINED AS THE GROUND OF THE TURN-UP
 4. BELL END OR TERMINAL ADAPTER MUST BE INSTALLED ON END OF PVC CONDUIT PER NEC 352.4G. 300.4 F. (3)
 5. CONDUIT BENDS SHALL BE MADE IN ACCORDANCE WITH NEC TABLE 346-10. NO RIGHT ANGLE DEVICE OTHER THAN STANDARD CONDUIT ELBOWS WITH 1/2" MINIMUM INSIDE SWEEPS FOR ALL CONDUITS 2" OR LARGER.
 6. POWER WIRING SIZE SHALL NOT BE SMALLER THAN #12 AWG.
 7. ALL WIRING SHALL BE COPPER. ALUMINUM WILL NOT BE ACCEPTABLE ALL POWER CIRCUITS SHALL CONTAIN A GROUND WIRE.
 8. PHASE MARKINGS TO BE USED AT POWER CONDUCTOR TERMINATIONS.
 9. CONTRACTOR SHALL ENSURE INTEGRITY IS MAINTAINED WHEN INSTALLING CONDUIT AND WIRING.
 10. INSTALL PULL STRING IN ALL CONDUIT.
 11. FOR ROOFTOP INSTALLS AND BUILD-OUTS, CONDUITS INSIDE BUILDING AND ON ROOF SHALL BE RGS, UNLESS OTHERWISE NOTED. FOR RAW LAND SITES AND CO-LOCATES, PVC SCHEDULE 80 SHALL BE UTILIZED UNLESS NOTED OTHERWISE.
 12. MAINTAIN MINIMUM 1'-0" VERTICAL AND 1'-0" HORIZONTAL SEPARATIONS FROM ANY MECHANICAL GAS PIPING.
 13. ALL WIRING ROUTED IN PLENUM TO BE RATED OR IN METALLIC FLEX (LIQUIDITE) CONDUIT.
- C. EQUIPMENT
1. EQUIPMENT/PARTS CONNECTED TO EXISTING PANELS, DUCTS, ETC. SHALL MATCH THE CHARACTERISTICS (AVC, V, A) OF THAT EQUIPMENT.
 2. ALL ELECTRICAL EQUIPMENT OUTSIDE SHALL BE NEMA OR 3R RATED.
- D. GROUNDING
1. ALL GROUND CONNECTIONS TO BUILDING SHALL BE MADE USING TWO-HOLE CONNECTORS. PROVIDE STAINLESS STEEL BOLTS AND LOCK WASHERS ON ALL MECHANICAL GROUND CONNECTIONS.
 2. ALL EQUIPMENT SURFACES TO BE BONDED TO GROUNDING SYSTEM SHALL BE STRIPPED OF ALL PAINT AND DIRT. CONNECTIONS TO VARIOUS METALS SHALL BE OF A TYPE AS TO CAUSE A GALVANIC OR CORROSIVE REACTION. AREA SHALL BE REPAINTED FOLLOWING BONDING.
 3. ANY METALLIC ITEM WITHIN 6' OF GROUND CONDUCTORS MUST BE CONNECTED TO THE GROUNDING SYSTEM.
 4. EXTERIOR, ABOVE GRADE GROUND CONNECTIONS SHALL BE FURNISHED WITH A LIBERAL PROTECTIVE COATING OF ANTI-OXIDE COMPOUND.
 5. ALL MATERIALS AND LABOR REQUIRED FOR THE GROUNDING SYSTEM AS INDICATED ON THE PLANS AND DETAILS, AND AS DESCRIBED HEREIN SHALL BE FURNISHED BY THIS CONTRACTOR UNLESS OTHERWISE NOTED.
 6. EXACT LOCATION OF GROUND CONNECTION POINTS SHALL BE DETERMINED IN FIELD. ADJUST LOCATIONS INDICATED ON PLANS ACCORDING TO ACTUAL EQUIPMENT LOCATIONS TO KEEP THE GROUND CONNECTION CABLES AS SHORT AS PRACTICAL.
 7. PROVIDE ALL ELECTRICAL SYSTEM AND EQUIPMENT GROUNDS AS REQUIRED BY THE CURRENT EDITION OF THE NATIONAL ELECTRIC CODE (1999) AND THE CURRENT EDITION OF THE NATIONAL ELECTRICAL SAFETY CODE. BONDING JUMPERS WITH APPROVED GROUND FITTINGS SHALL BE INSTALLED AT ALL RACEWAYS, EQUIPMENT ENCLOSURES, PULL BOXES, ETC. TO MAINTAIN GROUND CONTINUITY WHERE REQUIRED BY CODE.
 8. ALL EQUIPMENT GROUND CONDUCTORS SHALL BE TIN COATED, #2 AWG COPPER UNLESS NOTED OTHERWISE ON THE DRAWINGS.
 9. PROVIDE PRE AND POST GROUND TEST RESULTS, USING CLAMP-ON TESTER. TEST RESULTS SHALL BE PHOTOS WITH DIGITAL TIME AND GPS STAMPED/EMBEDDED.
- E. INSPECTION/DOCUMENTATION
1. THE CONTRACTOR, UPON COMPLETION OF HIS WORK, SHALL PROVIDE AS-BUILT DRAWINGS. INFORMATION SHOULD BE GIVEN TO THE GENERAL CONTRACTOR FOR INCLUSION IN FINAL AS-BUILT SURVEY DOCUMENTS TO BE GIVEN TO THE OWNER.
 2. CONTRACTOR SHALL SUPPLY DOCUMENTATION ATTESTING TO THE COMPLETE GROUND SYSTEM'S RECEPTIVITY (MAX. 5 OHMS).
 3. AN ELECTRICAL INSPECTION SHALL BE MADE BY AND INSPECTING AGENCY APPROVED BY AT&T'S REPRESENTATIVE. CONTRACTOR SHALL COORDINATE ALL INSPECTIONS AND OBTAIN POWER COMPANY APPROVAL.
 4. CONTRACTOR SHALL HAVE ATS AND GENERATOR RELAY INSTALLATION AND CONNECTIONS INSPECTED BY OTHERS TO ENSURE THAT UL LISTING FOR THAT EQUIPMENT IS NOT VOIDED.

PREPARED FOR:

CONSULTANT:
GENERAL DYNAMICS
 Information Technology, Inc.
 GENERAL DYNAMICS
 101 STATION DR
 WESTWOOD, MA 02090

Certification & Seal:
 I hereby certify that this plan, specification, or report was prepared by me or under my direct supervision and that I am a duly Licensed Professional Engineer under the laws of the State of Connecticut.

Signature: _____ Date: 4/21/2022

MARK	DATE	DESCRIPTION
4	04/21/22	REVISE GENERATOR FOOT PRINT
3	04/20/22	ADD GENERATOR SHELTER TO CDs
2	12/03/21	REVISED CDs
1	05/25/21	REVISED CDs
ISSUE PHASE	FINAL	DATE ISSUED 02/05/2021

PROJECT TITLE:
**DANBURY STADLEY
 ROUGH ROAD
 FA ID # 12676398**

PROJECT INFORMATION:
 52 STADLEY ROUGH ROAD
 DANBURY, CT 06811

SHEET TITLE:
GENERAL NOTES

SCALE: NONE

PROJECT NUMBER: 50175
 SHEET NUMBER: N-1

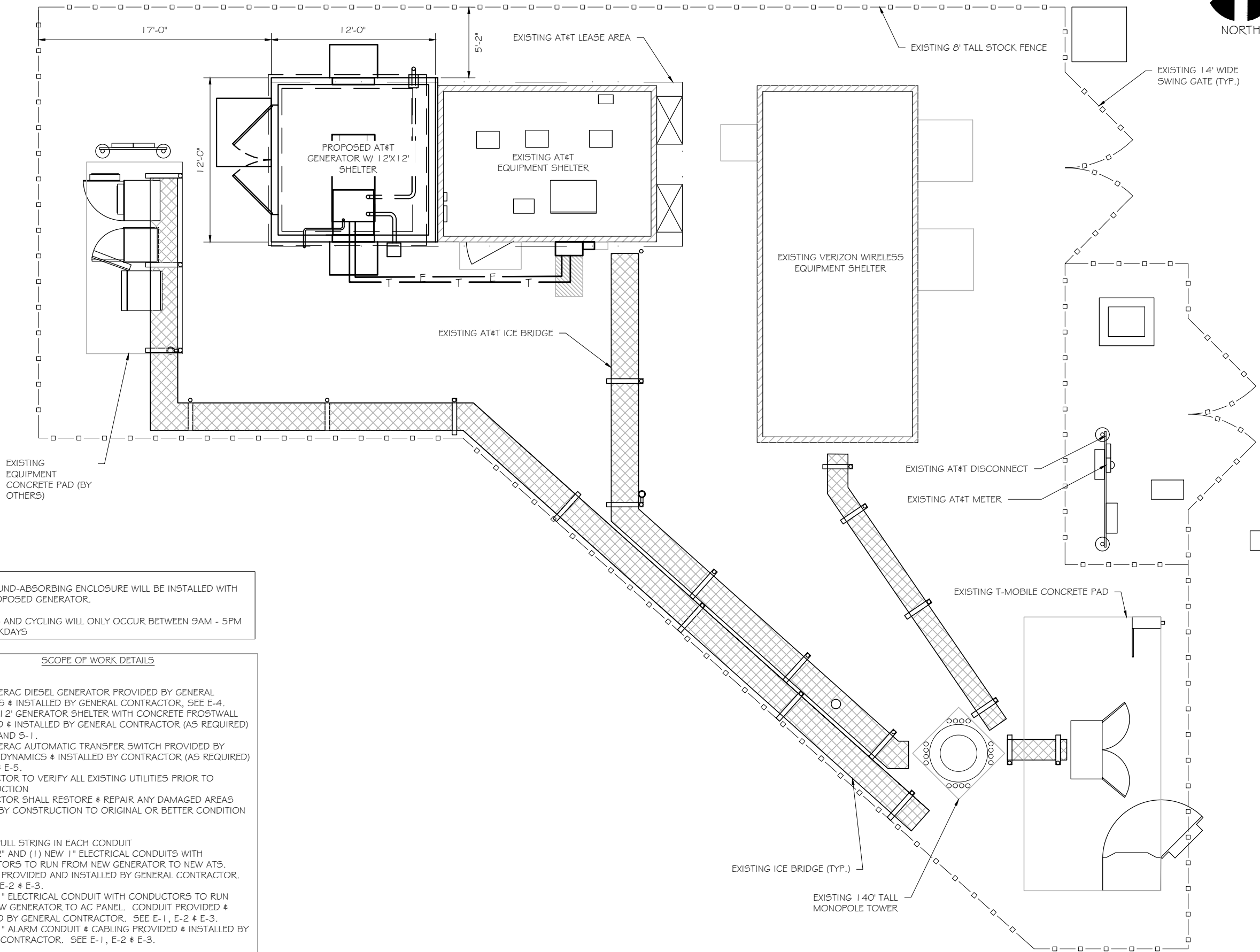

NOTE:

- THE SOUND-ABSORBING ENCLOSURE WILL BE INSTALLED WITH THE PROPOSED GENERATOR.
- TESTING AND CYCLING WILL ONLY OCCUR BETWEEN 9AM - 5PM ON WEEKDAYS

SCOPE OF WORK DETAILS

GENERAL:

- NEW GENERAC DIESEL GENERATOR PROVIDED BY GENERAL DYNAMICS & INSTALLED BY GENERAL CONTRACTOR, SEE E-4.
- NEW 12'x12' GENERATOR SHELTER WITH CONCRETE FROSTWALL PROVIDED & INSTALLED BY GENERAL CONTRACTOR (AS REQUIRED) SEE A-2 AND S-1.
- NEW GENERAC AUTOMATIC TRANSFER SWITCH PROVIDED BY GENERAL DYNAMICS & INSTALLED BY CONTRACTOR (AS REQUIRED) SEE E-3 & E-5.
- CONTRACTOR TO VERIFY ALL EXISTING UTILITIES PRIOR TO CONSTRUCTION
- CONTRACTOR SHALL RESTORE & REPAIR ANY DAMAGED AREAS CAUSED BY CONSTRUCTION TO ORIGINAL OR BETTER CONDITION

CONDUITS:

- INSTALL PULL STRING IN EACH CONDUIT
- (1) NEW 2" AND (1) NEW 1" ELECTRICAL CONDUITS WITH CONDUCTORS TO RUN FROM NEW GENERATOR TO NEW ATS. CONDUIT PROVIDED AND INSTALLED BY GENERAL CONTRACTOR. SEE E-1, E-2 & E-3.
- (1) NEW 1" ELECTRICAL CONDUIT WITH CONDUCTORS TO RUN FROM NEW GENERATOR TO AC PANEL. CONDUIT PROVIDED & INSTALLED BY GENERAL CONTRACTOR. SEE E-1, E-2 & E-3.
- (1) NEW 1" ALARM CONDUIT & CABLING PROVIDED & INSTALLED BY GENERAL CONTRACTOR. SEE E-1, E-2 & E-3.

GROUNDING:

- NEW EXOTHERMIC CONNECTION FROM EXISTING GROUND RING TO NEW MECHANICAL CONNECTION AT GENERATOR CHASSIS. GENERAL CONTRACTOR TO VERIFY LOCATION IN FIELD. LOCATE GROUND RODS NO MORE THAN 8'-0" APART.

SITE PLAN
SCALE: 1" = 7.5'





RAMAKER
 employee-owned
 (608) 643-4100 www.ramaker.com

PREPARED FOR:

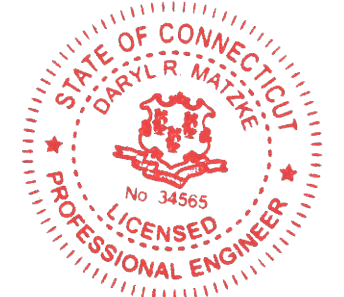

CONSULTANT:
GENERAL DYNAMICS
 Information Technology, Inc.
 GENERAL DYNAMICS
 101 STATION DR
 WESTWOOD, MA 02090

Certification & Seal:
 I hereby certify that this plan, specification, or report was prepared by me or under my direct supervision and that I am a duly Licensed Professional Engineer under the laws of the State of Connecticut.



Signature: _____ Date: 4/21/2022

MARK	DATE	DESCRIPTION
4	04/21/22	REVISE GENERATOR FOOT PRINT
3	04/20/22	ADD GENERATOR SHELTER TO CDs
2	12/03/21	REVISED CDs
1	05/25/21	REVISED CDs

ISSUE PHASE: FINAL DATE ISSUED: 02/05/2021

PROJECT TITLE:
DANBURY STADLEY ROUGH ROAD
FA ID # 12676398

PROJECT INFORMATION:
 52 STADLEY ROUGH ROAD
 DANBURY, CT 06811

SHEET TITLE:
SITE PLAN

0 3.75' 7.5' 15'

1 1" x 17" - 1" = 7.5'
 22" x 34" - 1" = 3.75'

PROJECT NUMBER: 50175
 SHEET NUMBER: A-1



RAMAKER
employee-owned
(608) 643-4100 www.ramaker.com



PREPARED FOR:
GENERAL DYNAMICS
Information Technology, Inc.
GENERAL DYNAMICS
101 STATION DR
WESTWOOD, MA 02090

Certification & Seal:
I hereby certify that this plan, specification, or report was prepared by me or under my direct supervision and that I am a duly Licensed Professional Engineer under the laws of the State of Connecticut.

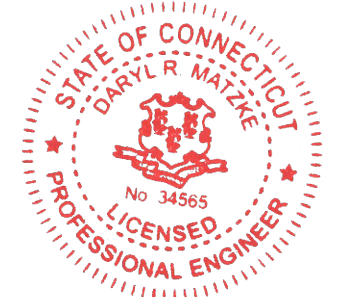

Signature: _____ Date: 4/21/2022

MARK	DATE	DESCRIPTION
4	04/21/22	REVISE GENERATOR FOOT PRINT
3	04/20/22	ADD GENERATOR SHELTER TO CDs
2	12/03/21	REVISED CDs
1	05/25/21	REVISED CDs

ISSUE PHASE	DATE ISSUED
FINAL	02/05/2021

PROJECT TITLE:
DANBURY STADLEY ROUGH ROAD
FA ID # 12676398

PROJECT INFORMATION:
52 STADLEY ROUGH ROAD
DANBURY, CT 06811

SHEET TITLE:
SHELTER EQUIPMENT LAYOUT

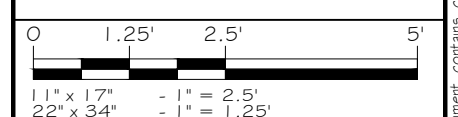

PROJECT NUMBER: 50175
SHEET NUMBER: A-2

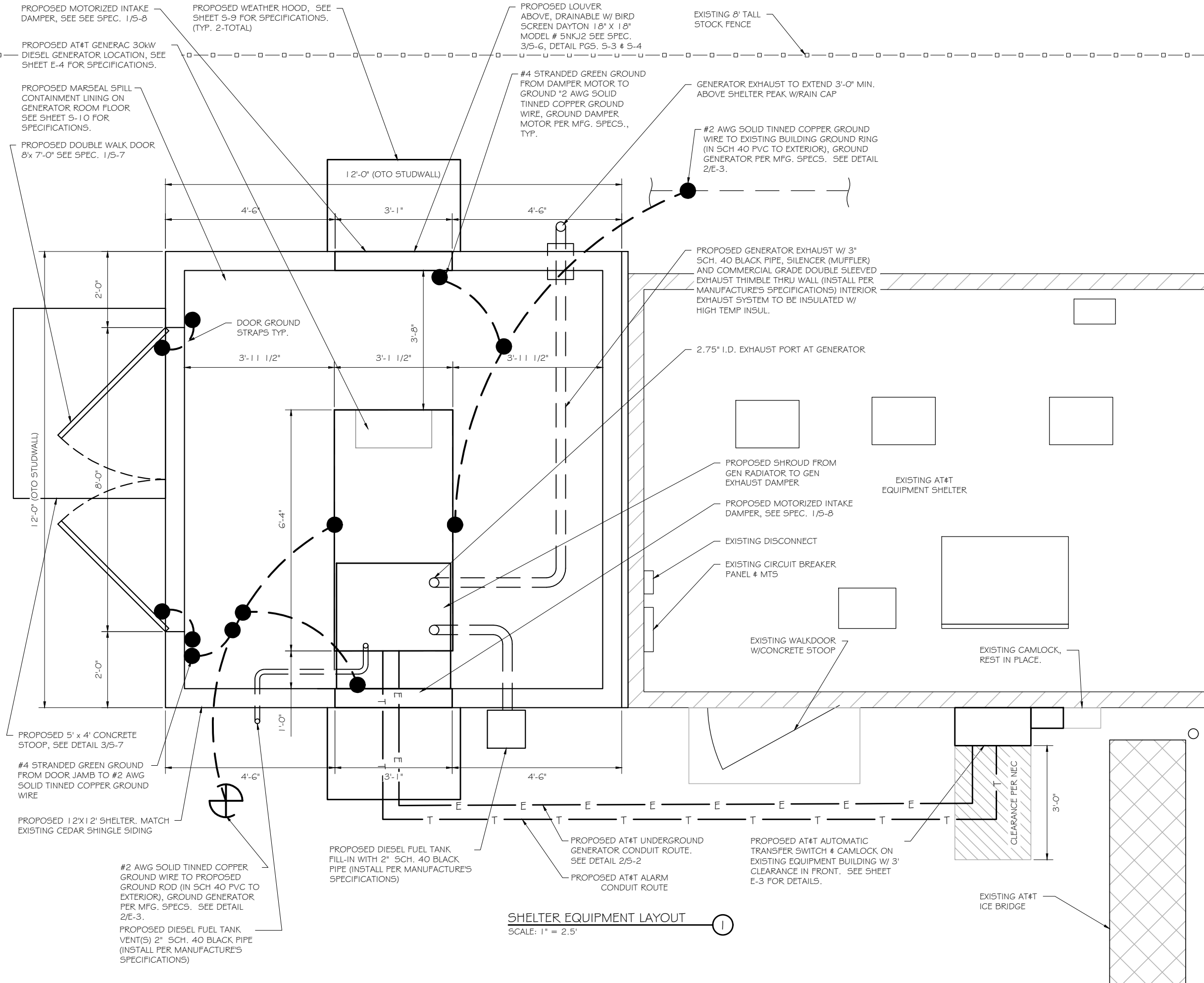

SHELTER EQUIPMENT LAYOUT
SCALE: 1" = 2.5'

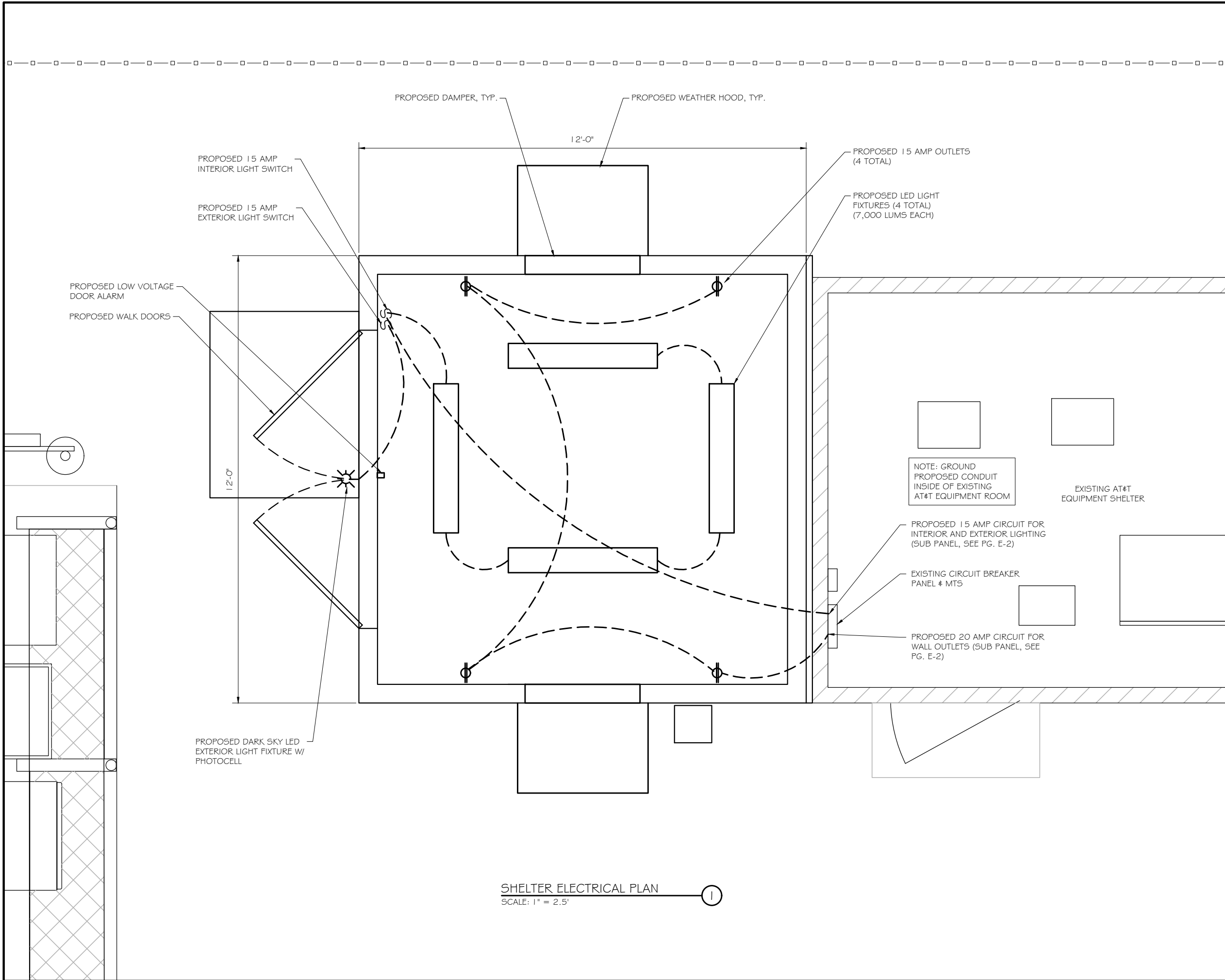

SHELTER ELECTRICAL PLAN
 SCALE: 1" = 2.5'



RAMAKER
 employee-owned
 (608) 643-4100 www.ramaker.com

PREPARED FOR:

CONSULTANT:
GENERAL DYNAMICS
 Information Technology, Inc.
 GENERAL DYNAMICS
 101 STATION DR
 WESTWOOD, MA 02090

Certification & Seal:
 I hereby certify that this plan, specification, or report was prepared by me or under my direct supervision and that I am a duly Licensed Professional Engineer under the laws of the State of Connecticut.

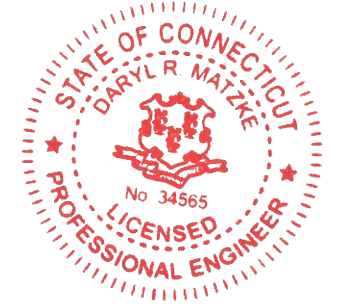

Signature: _____ Date: 4/21/2022

MARK	DATE	DESCRIPTION
4	04/21/22	REVISE GENERATOR FOOT PRINT
3	04/20/22	ADD GENERATOR SHELTER TO CDs
2	12/03/21	REVISED CDs
1	05/25/21	REVISED CDs

ISSUE PHASE	DATE ISSUED
FINAL	02/05/2021

PROJECT TITLE:
DANBURY STADLEY ROUGH ROAD
FA ID # 12676398

PROJECT INFORMATION:
 52 STADLEY ROUGH ROAD
 DANBURY, CT 06811

SHEET TITLE:
SHELTER ELECTRICAL PLAN

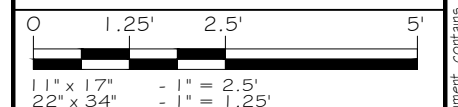

PROJECT NUMBER	50175
SHEET NUMBER	A-3

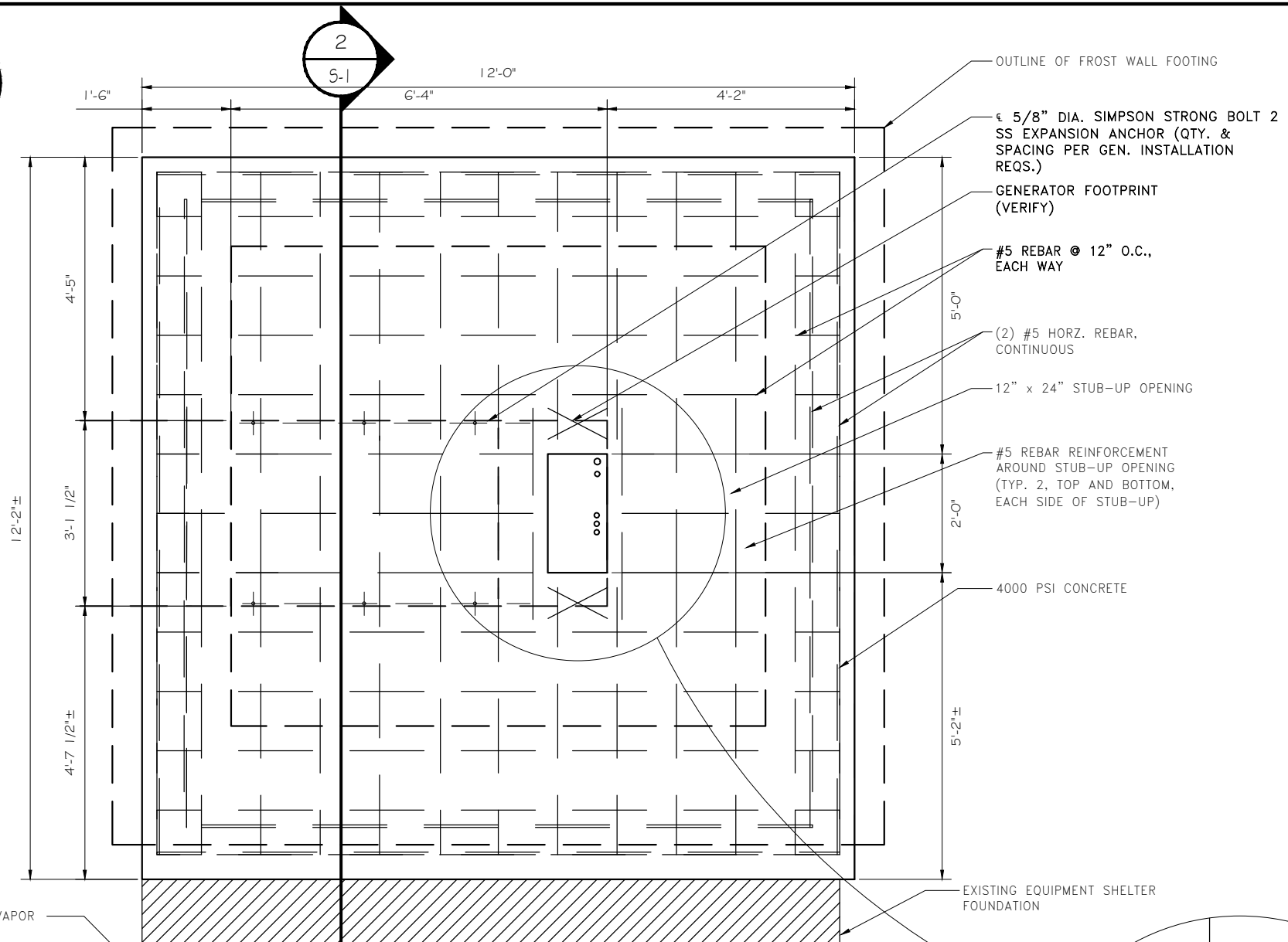

SHELTER FOUNDATION PLAN VIEW
SCALE: NTS

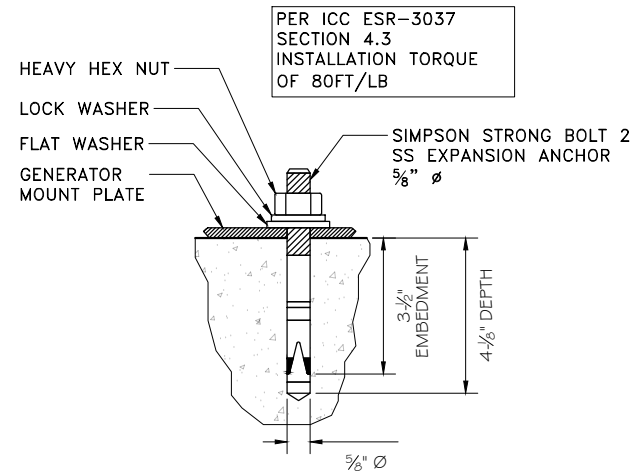

ANCHOR BOLT DETAIL
SCALE: NTS

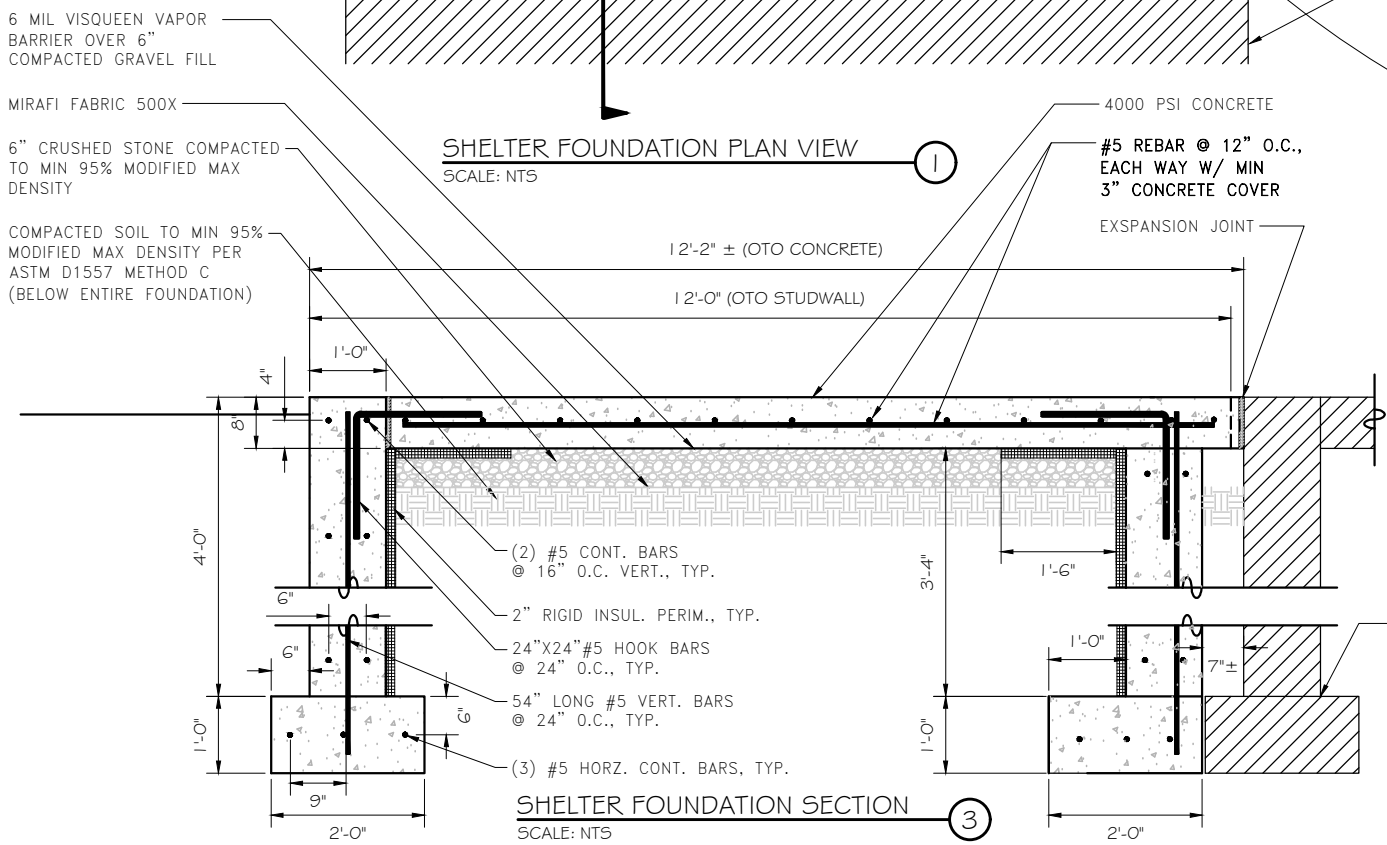

SHELTER FOUNDATION SECTION
SCALE: NTS

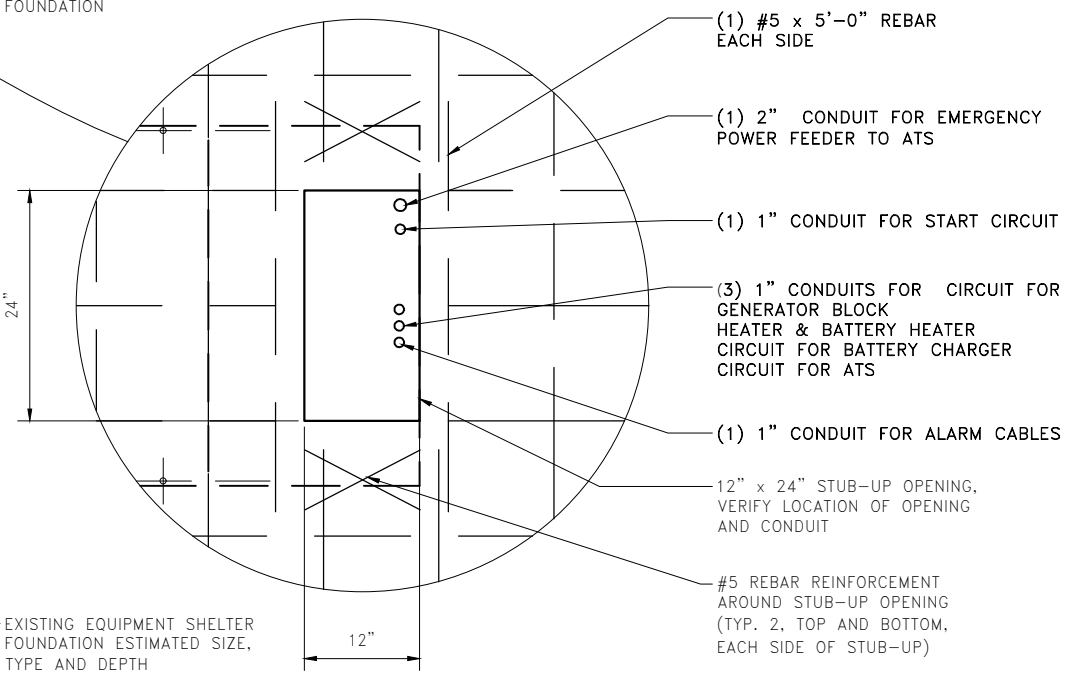

GENERATOR STUB-UP OPENING DETAIL
SCALE: NTS

PREPARED FOR:

CONSULTANT:
GENERAL DYNAMICS
 Information Technology, Inc.
 GENERAL DYNAMICS
 101 STATION DR
 WESTWOOD, MA 02090

Certification & Seal:
 I hereby certify that this plan, specification, or report was prepared by me or under my direct supervision and that I am a duly Licensed Professional Engineer under the laws of the State of Connecticut.

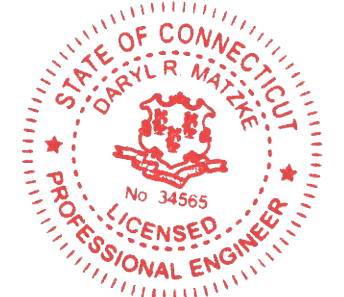

Signature: _____ Date: 4/21/2022

MARK	DATE	DESCRIPTION
4	04/21/22	REVISE GENERATOR FOOT PRINT
3	04/20/22	ADD GENERATOR SHELTER TO CDs
2	12/03/21	REVISED CDs
1	05/25/21	REVISED CDs

ISSUE PHASE: FINAL DATE ISSUED: 02/05/2021
 PROJECT TITLE:
DANBURY STADLEY ROUGH ROAD
FA ID # 12676398

PROJECT INFORMATION:
 52 STADLEY ROUGH ROAD
 DANBURY, CT 06811

SHEET TITLE:
SHELTER FOUNDATION DETAILS

SCALE: NONE

PROJECT NUMBER: 50175
 SHEET NUMBER: S-1

NOTE:
 VERIFY WIRE AND CONDUIT QUANTITY & SIZES WITH GENERATOR MAKE & MODEL # PRIOR TO INSTALLATION. VERIFY ELECTRICAL REQUIREMENTS WITH LOCAL UTILITY PROVIDER.

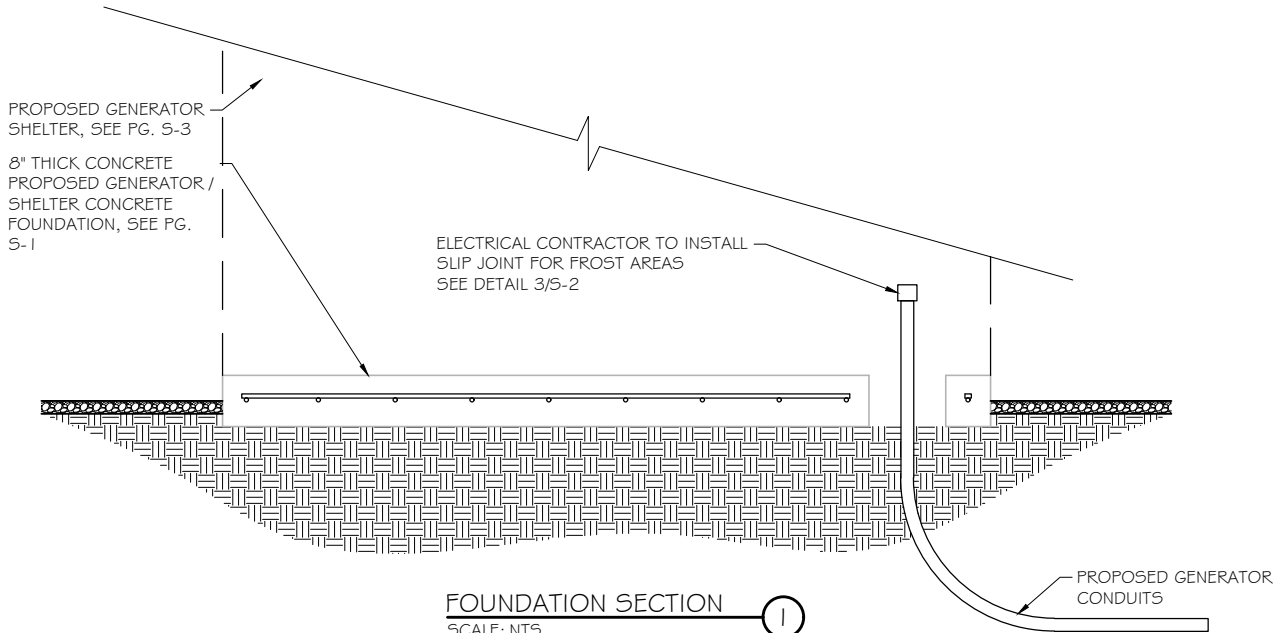

FOUNDATION SECTION 1
 SCALE: NTS

DOUBLE WALL FUEL TANK BASE SPECIFICATION

REF: ATT 30KW GENERATOR PACKAGE
 UL REGISTRATION NUMBER: MH18459
 U.L. 142 DOUBLE WALL FUEL TANK BASE SPECIFICATION
 FUEL TANK BASE CONSTRUCTION:

- BE CONSTRUCTED IN ACCORDANCE WITH UNDERWRITERS LABORATORIES STANDARD UL-142. BE CONSTRUCTED IN ACCORDANCE WITH FLAMMABLE & COMBUSTIBLE LIQUIDS CODE, NFPA 30; THE STANDARD FOR INSTALLATION & USE OF STATIONARY COMBUSTIBLE ENGINE & GAS TURBINES, NFPA 37; AND THE STANDARD FOR EMERGENCY & STANDBY POWER SYSTEMS, NFPA 110.
- ANCHORS MINIMUM (4) @ 5/8" FOR GEN-SET MOUNTING

SUB BASE TANK TESTING: PRIMARY TANK & SECONDARY CONTAINMENT BASIN SECTIONS SHALL BE PRESSURIZED AT 3-5 PSI AND LEAK-CHECKED TO ENSURE INTEGRITY OF SUB BASE WELD SEAMS PER UL-142 STANDARDS

FUEL FILL: 5 GALLON SPILL CONTAINMENT WITH ALARM

- 40% REMAINING FOR ALARM
- 20% REMAINING FOR SHUT-DOWN

FACTORY PRE-SET AT 95% FULL FOR ALARM

FUEL CONTAINMENT BASIN: SUB BASE TANK SHALL INCLUDE A WELDED STEEL CONTAINMENT BASIN, SIZED AT A MINIMUM OF 110% OF THE TANK CAPACITY TO PREVENT ESCAPE OF FUEL INTO THE ENVIRONMENT IN THE EVENT OF A TANK RUPTURE. A FUEL CONTAINMENT BASIN LEAK DETECTOR SWITCH SHALL BE PROVIDED.

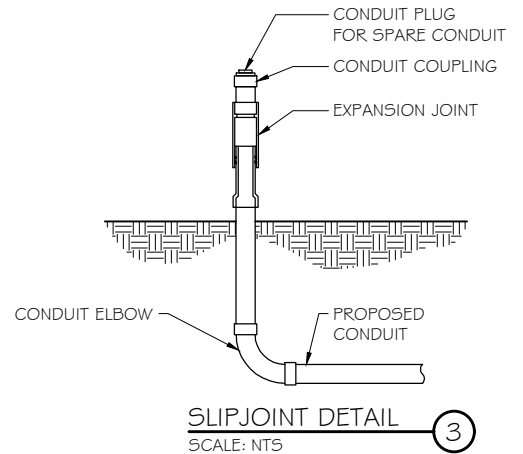

SLIPJOINT DETAIL 3
 SCALE: NTS

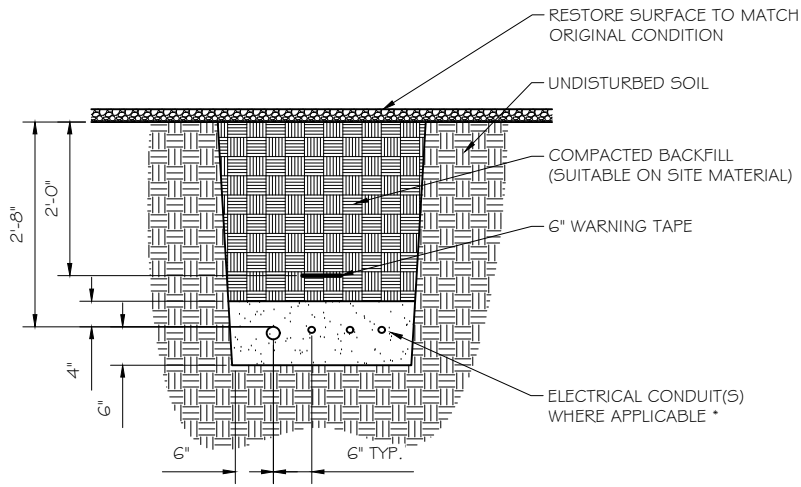

UTILITY CONDUIT TRENCH 2
 SCALE: NTS

- NOTES:**
- PROVIDE PVC CONDUIT BELOW GRADE EXCEPT AS NOTED BELOW.
 - PROVIDE RGS CONDUIT AND ELBOWS AT STUB UP LOCATIONS (I.E. SERVICE POLE, BTS EQUIPMENT, ETC.)
 - INSTALL UTILITY PULLBOXES PER NEC.

STRUCTURAL GENERAL NOTES

- 1.0 GENERAL CONDITIONS
- DESIGN & CONSTRUCTION OF ALL WORK SHALL CONFORM TO LOCAL BUILDING CODES, ACI 318-11. IN CASE OF CONFLICT BETWEEN THE CODES, STANDARDS, REGULATIONS, SPECIFICATIONS, GENERAL NOTES AND/OR MANUFACTURER'S REQUIREMENTS, USE THE MOST STRINGENT PROVISIONS.
 - IT IS THE EXPRESS INTENT OF PARTIES INVOLVED IN THIS PROJECT THAT THE CONTRACTOR OR SUBCONTRACTOR OR INDEPENDENT CONTRACTOR OR THE RESPECTIVE EMPLOYEES SHALL EXCULPATE THE ARCHITECT, THE ENGINEER, TECH. CONSTRUCTION MANAGER, THE OWNER, & THEIR AGENTS FROM ANY LIABILITY WHATSOEVER & HOLD THEM HARMLESS AGAINST LOSS, DAMAGES, LIABILITY OR ANY EXPENSE ARISING IN ANY MATTER FROM THE WRONGFUL OR NEGLIGENT ACT, OR FAILURE TO CARRY METHODS, TECHNIQUES OR PROCEDURES OR FAILURE TO CONFORM TO THE STATE SCAFFOLDING ACT IN CONNECTIONS WITH THE WORK.
 - DO NOT SCALE DRAWINGS
 - VERIFY ALL EQUIPMENT MOUNTING DIMENSIONS PER MANUFACTURER DRAWINGS
 - DESIGN LOADS ARE (GENERAC):

LIVE LOAD	: 100 PSF
EQUIPMENT SIZE	: 81.1" H, 106" W, 38" D
WEIGHT WITH WOODEN SHIPPING SKID ENCLOSED GENERATOR	: 2560 LBS
- 2.0 FOR DESIGN & ANALYSIS OF THE FOUNDATION, THE MINIMUM NET SOIL BEARING CAPACITY SHALL BE ASSUMED TO BE 2000 PSF.
- 3.0 CONCRETE
- 3.1 MEET OR EXCEED THE FOLLOWING CODES & STANDARDS:
- | | |
|-----------------|--|
| DESIGN | : ACI 318-11 |
| CONSTRUCTION | : ACI 301 |
| DETAILING | : CRSI MANUAL OF STANDARD PRACTICE |
| REINF. STEEL | : ASTM A 615 GRADE 60, DEFORMED |
| MIXING | : ASTM C 94. READY MIX CONCRETE |
| AIR ENTRAINMENT | : ACI 318 AND ASTM C-260 |
| AGGREGATE | : ASTM C 33 AND C 330 (FOR LIGHT WEIGHT) |
- CONCRETE STRENGTH AT 28 DAYS SHALL BE 4000 PSI MINIMUM
 - DO NOT FIELD BEND OR WELD TO GRADE 60 REINFORCED STEEL
 - PROVIDE AIR ENTRAINED CONCRETE WITH AIR CONTENT OF 5 TO 7% FOR ALL CONCRETE EXPOSED TO EARTH OR WEATHER.
 - MAXIMUM AGGREGATE SIZE: 3/4"
 - DO NOT USE IN ADMIXTURE, WATER OR OTHER CONSTITUENTS OF CONCRETE WHICH HAS CALCIUM CHLORIDE.
 - MINIMUM COVER FOR REINFORCING STEEL SHALL BE AS SHOWN ON PLAN.
- 4.0 FOUNDATION & EXCAVATION NOTES
- SLAB SHALL BE CONSTRUCTED UPON UNDISTURBED, NATURAL SUBGRADE OR COMPACTED GRANULAR FILL WITH AN ASSUMED MINIMUM NET ALLOWABLE BEARING CAPACITY OF 1800 PSF.
 - ALL ORGANIC AND/OR OTHER UNSUITABLE MATERIAL SHALL BE REMOVED FROM FOUNDATION & SLAB SUBGRADE & BACKFILL AREAS, & THEN BACKFILLED WITH ACCEPTABLE GRANULAR FILL COMPACTED TO 95% OF MAXIMUM DENSITY AT OPTIMUM MOISTURE CONTENT (ASTM D 1557).
 - THE CONTRACTOR SHALL PROVIDE ALL NECESSARY MEASURES TO PREVENT ANY WATER, FROST, OR ICE FROM PENETRATING ANY FOOTING OR STRUCTURAL SUBGRADE BEFORE & AFTER PLACING OF CONCRETE, AND UNTIL SUCH CONCRETE HAS FULLY CURED.

RAMAKER
 employee-owned
 (608) 643-4100 www.ramaker.com

PREPARED FOR:

CONSULTANT:
GENERAL DYNAMICS
 Information Technology, Inc.
 GENERAL DYNAMICS
 101 STATION DR
 WESTWOOD, MA 02090

Certification & Seal:
 I hereby certify that this plan, specification, or report was prepared by me or under my direct supervision and that I am a duly Licensed Professional Engineer under the laws of the State of Connecticut.

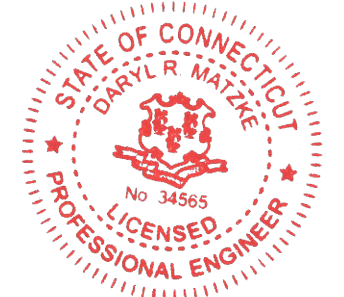

Signature: _____ Date: 4/21/2022

MARK	DATE	DESCRIPTION
4	04/21/22	REVISE GENERATOR FOOT PRINT
3	04/20/22	ADD GENERATOR SHELTER TO CDs
2	12/03/21	REVISED CDs
1	05/25/21	REVISED CDs

ISSUE PHASE: FINAL DATE ISSUED: 02/05/2021

PROJECT TITLE:
DANBURY STADLEY ROUGH ROAD
FA ID # 12676398

PROJECT INFORMATION:
 52 STADLEY ROUGH ROAD
 DANBURY, CT 06811

SHEET TITLE:
SHELTER FOUNDATION DETAILS

SCALE: NONE

PROJECT NUMBER: 50175
 SHEET NUMBER: S-2

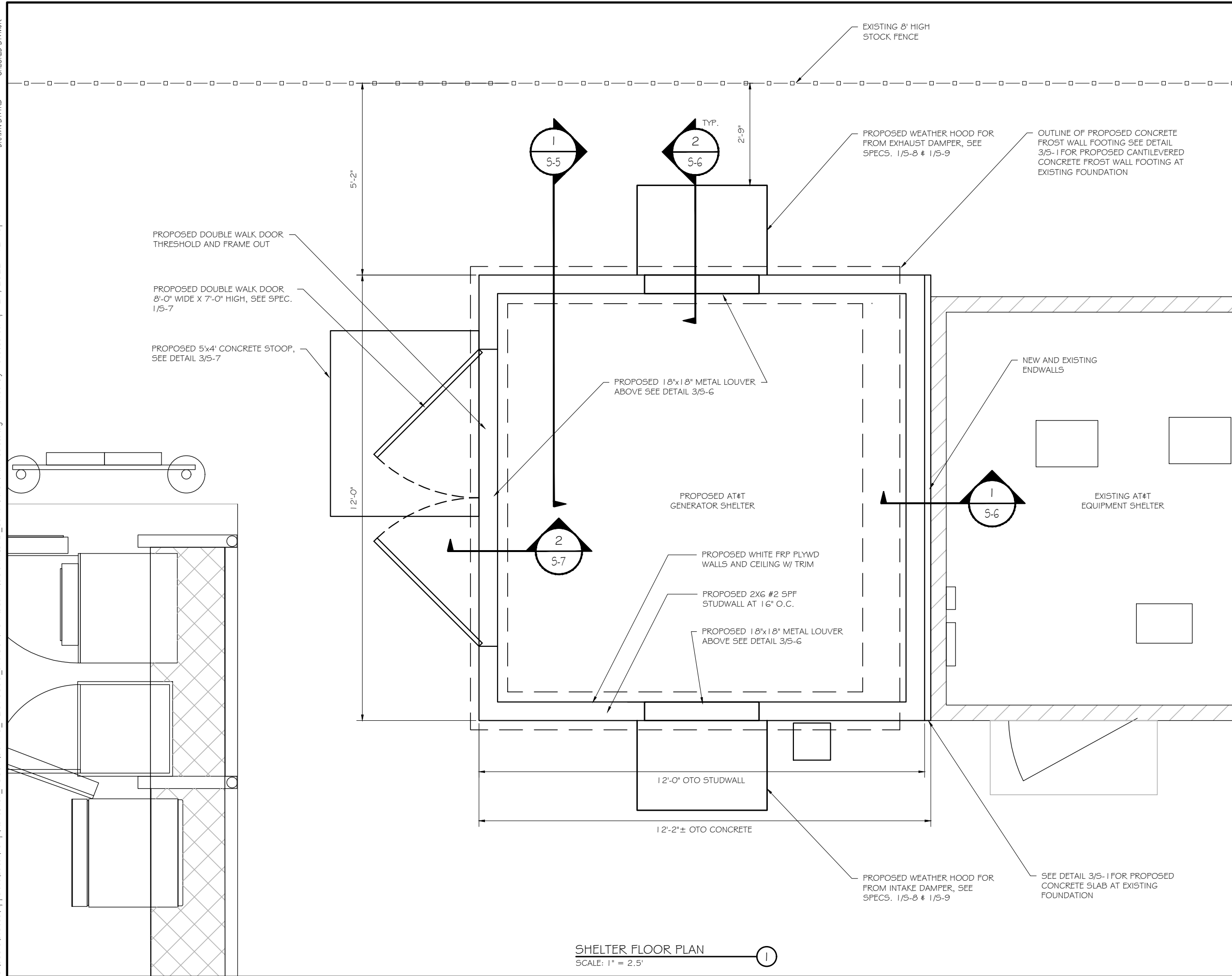

RAMAKER
 employee-owned
 (608) 643-4100 www.ramaker.com

PREPARED FOR:

CONSULTANT:
GENERAL DYNAMICS
 Information Technology, Inc.
 GENERAL DYNAMICS
 101 STATION DR
 WESTWOOD, MA 02090

Certification & Seal:
 I hereby certify that this plan, specification, or report was prepared by me or under my direct supervision and that I am a duly Licensed Professional Engineer under the laws of the State of Connecticut.

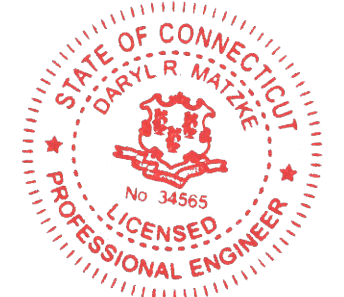

Signature: _____ Date: 4/21/2022

MARK	DATE	DESCRIPTION
4	04/21/22	REVISE GENERATOR FOOT PRINT
3	04/20/22	ADD GENERATOR SHELTER TO CDs
2	12/03/21	REVISED CDs
1	05/25/21	REVISED CDs

ISSUE PHASE	DATE ISSUED
FINAL	02/05/2021

PROJECT TITLE:
DANBURY STADLEY ROUGH ROAD
FA ID # 12676398

PROJECT INFORMATION:
 52 STADLEY ROUGH ROAD
 DANBURY, CT 06811

SHEET TITLE:
SHELTER FLOOR PLAN

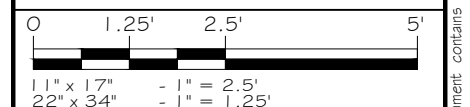

PROJECT NUMBER	50175
SHEET NUMBER	S-3

SHELTER FLOOR PLAN
 SCALE: 1" = 2.5'

VERIFY EXISTING ROOF PITCH AND MATCH

18x18 LOUVERS, SEE SPEC. DETAIL 2/5-6

PROPOSED OVERHANG, MATCH EXISTING

36x36 DAMPERS W/ WEATHER HOODS, SEE SPECS. 1/5-8 & 12/5-9

DOUBLE STEEL DOORS 8'-0" x 7'-0" LEFT SIDE ACTIVE, LEVER HANDLES AND AT&T LOCK OF CHOICE, MATCH COLOR OF EXISTING SEE SPEC. DETAIL 1/5-7

PROPOSED VENTED RIDGE

PROPOSED ASPHALT SHINGLES, MATCH EXISTING COLOR

GENERATOR FUEL TANK VENT(S) THRU WALL (INSTALL PER MANUFACTURER'S SPECIFICATIONS)

GENERATOR EXHAUST 3' MIN. ABOVE ROOF PEAK (INSTALL PER MANUFACTURER'S SPECIFICATIONS)

PROPOSED ROOF FLASHING

EXISTING ASPHALT SHINGLES

EXISTING OVERHANG

EXISTING CEDAR SHINGLE SIDING

EXISTING AT&T EQUIPMENT SHELTER

EXISTING WALK DOOR

PROPOSED CEDAR SHINGLE SIDING (MATCH EXISTING)

GENERATOR EXTERIOR TANK FILL (INSTALL PER MANUFACTURER'S SPECIFICATIONS)

PROVIDE WEATHER PROOF SIDING JOINT

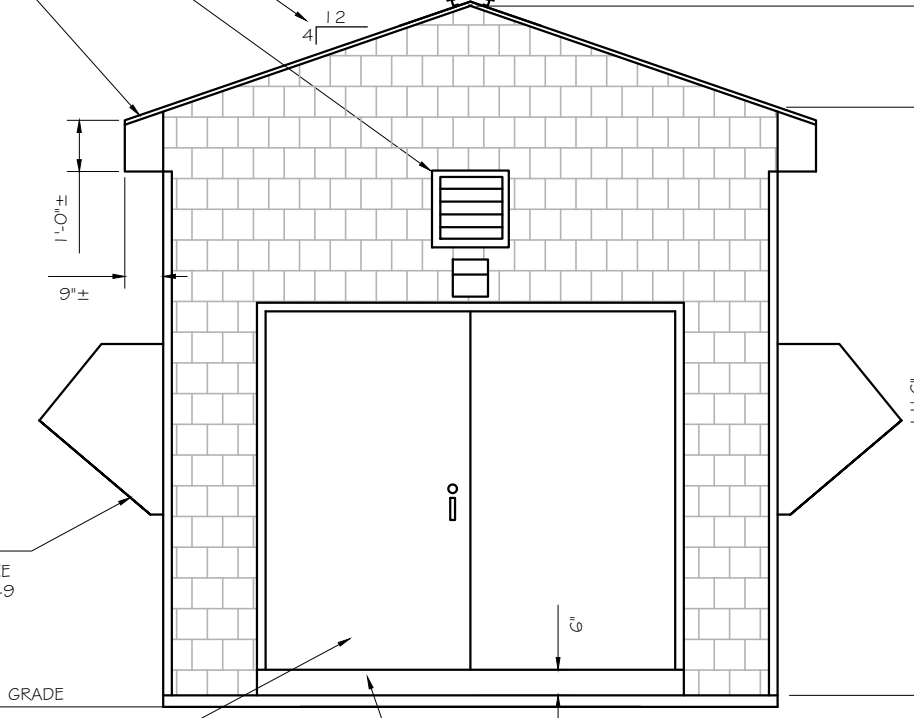

SHELTER WEST ELEVATION ①
SCALE: 1" = 3.75'

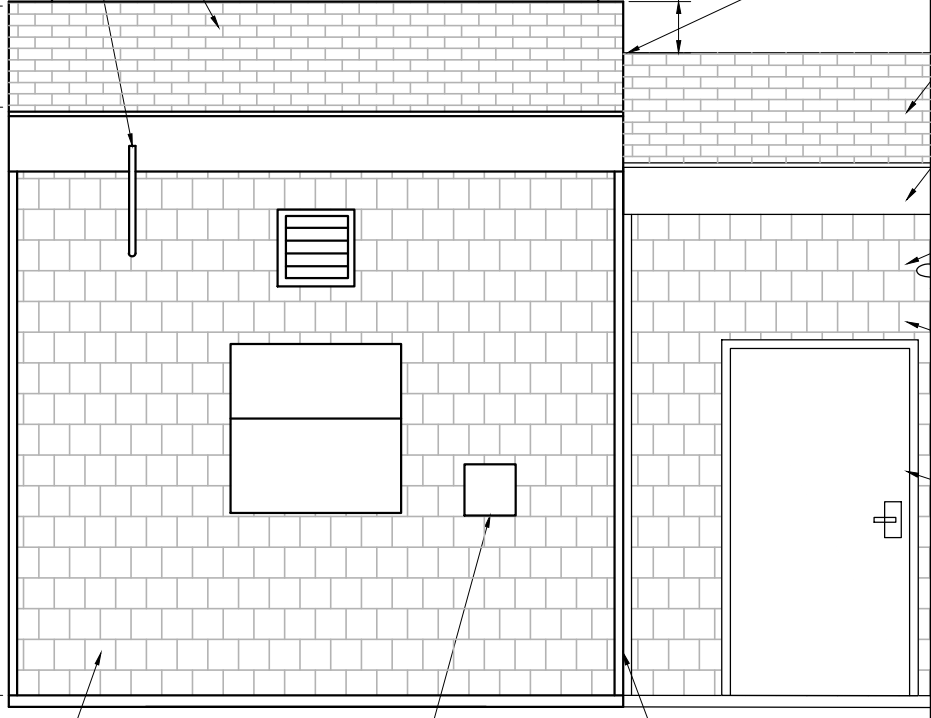

SHELTER SOUTH ELEVATION ②
SCALE: 1" = 3.75'

RAMAKER
employee-owned
(608) 643-4100 www.ramaker.com

PREPARED FOR:

CONSULTANT:
GENERAL DYNAMICS
Information Technology, Inc.
GENERAL DYNAMICS
101 STATION DR
WESTWOOD, MA 02090

Certification & Seal:
I hereby certify that this plan, specification, or report was prepared by me or under my direct supervision and that I am a duly Licensed Professional Engineer under the laws of the State of Connecticut.

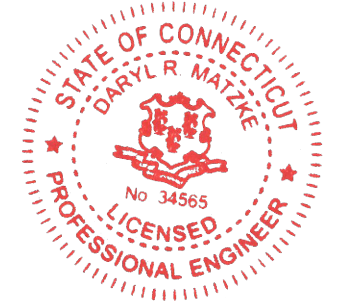

Signature: _____ Date: 4/21/2022

MARK	DATE	DESCRIPTION
4	04/21/22	REVISE GENERATOR FOOT PRINT
3	04/20/22	ADD GENERATOR SHELTER TO CDs
2	12/03/21	REVISED CDs
1	05/25/21	REVISED CDs

ISSUE PHASE	FINAL	DATE ISSUED	02/05/2021
-------------	-------	-------------	------------

PROJECT TITLE:
DANBURY STADLEY ROUGH ROAD
FA ID # 12676398

PROJECT INFORMATION:
52 STADLEY ROUGH ROAD
DANBURY, CT 06811

SHEET TITLE:
SHELTER ELEVATIONS

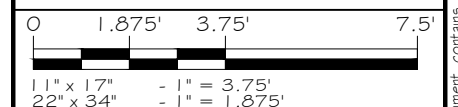

PROJECT NUMBER: 50175
SHEET NUMBER: S-4

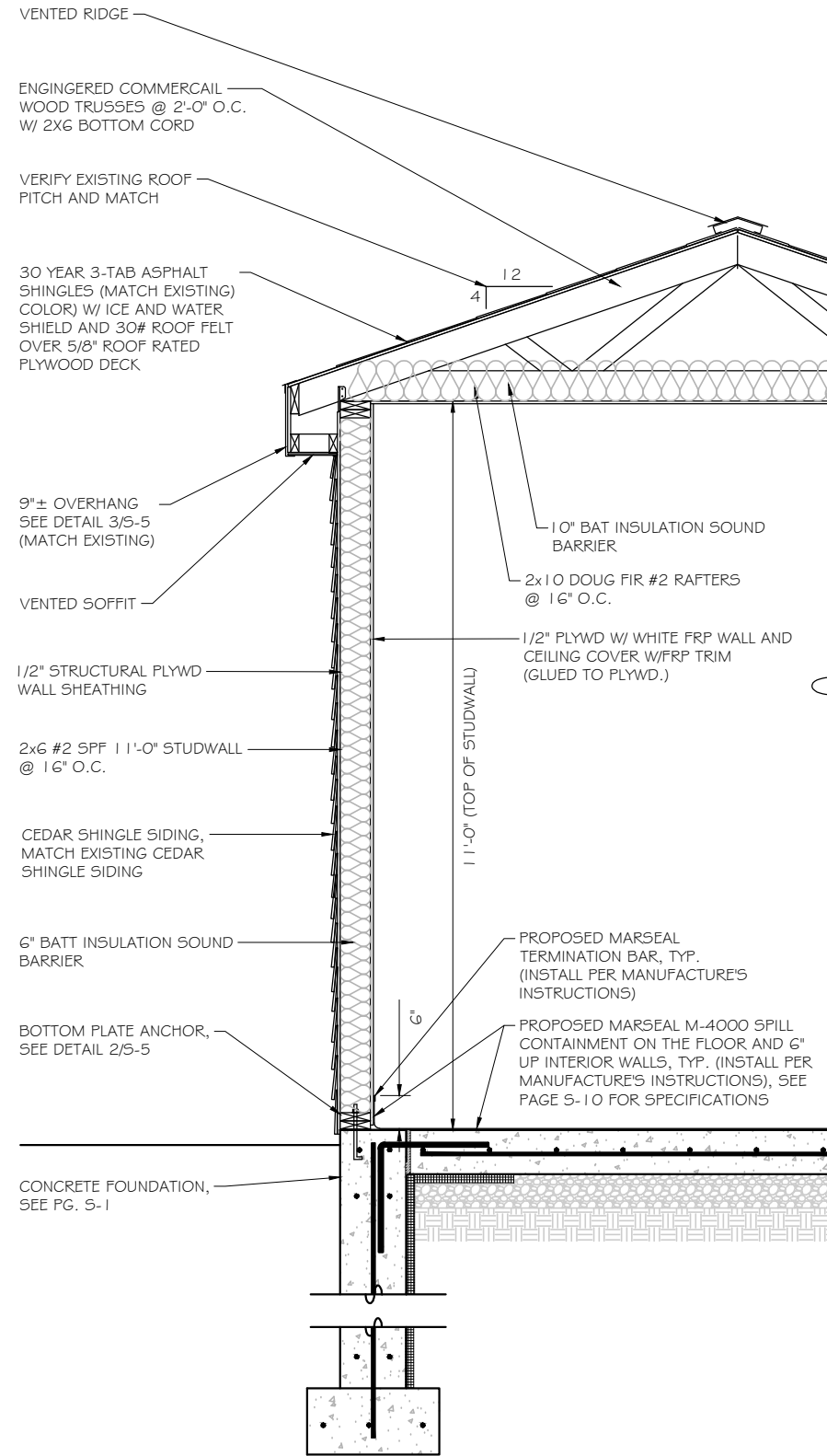

SHELTER SECTION DETAIL
SCALE: 3/8" = 1'-0" (1)

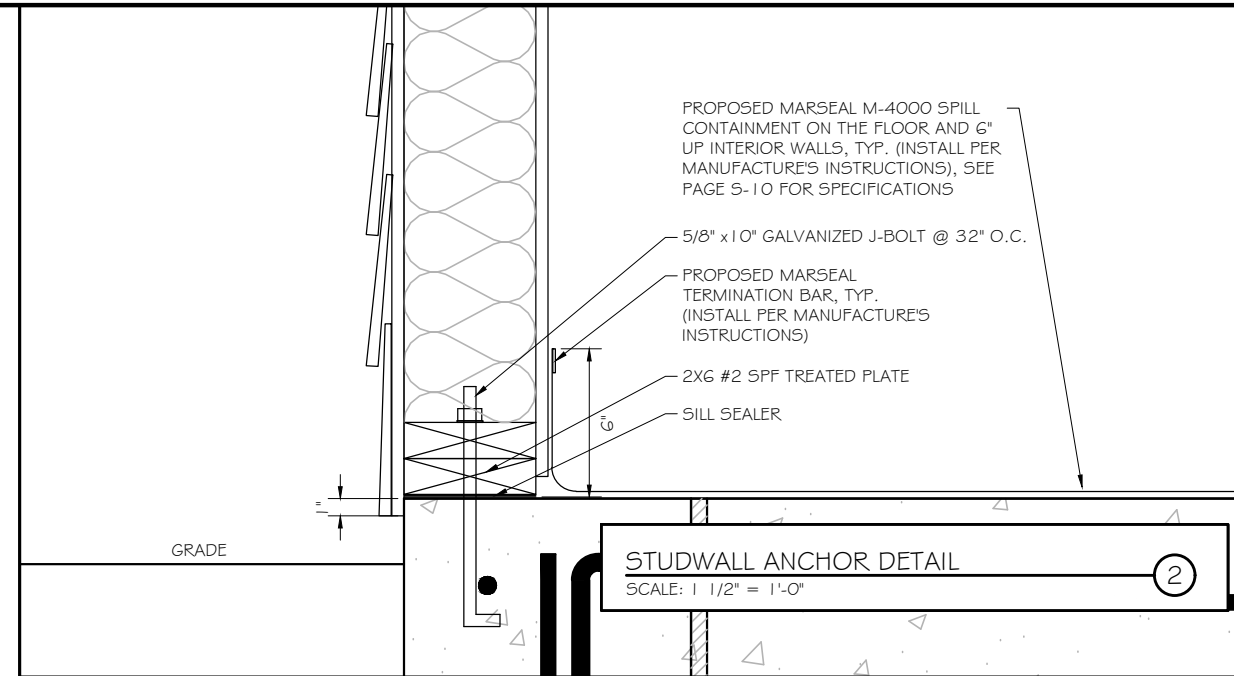

STUDWALL ANCHOR DETAIL
SCALE: 1 1/2" = 1'-0" (2)

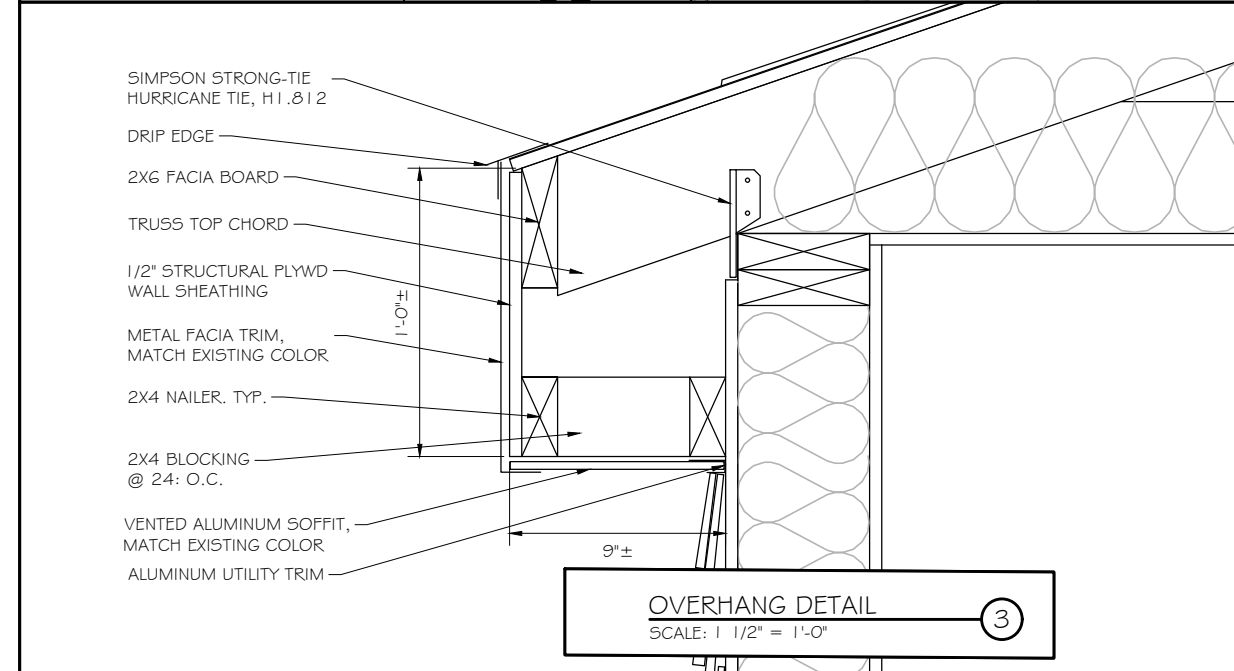

OVERHANG DETAIL
SCALE: 1 1/2" = 1'-0" (3)

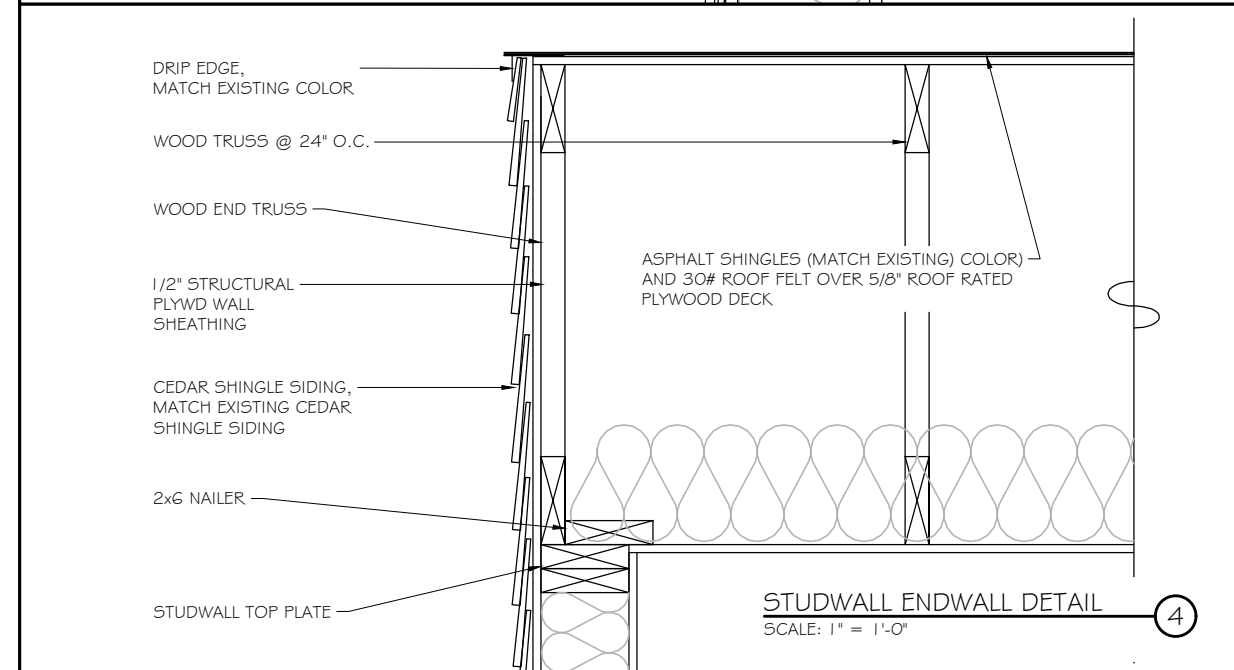

STUDWALL ENDWALL DETAIL
SCALE: 1" = 1'-0" (4)

PREPARED FOR:

CONSULTANT:
GENERAL DYNAMICS
 Information Technology, Inc.
 GENERAL DYNAMICS
 101 STATION DR
 WESTWOOD, MA 02090

Certification & Seal:
 I hereby certify that this plan, specification, or report was prepared by me or under my direct supervision and that I am a duly Licensed Professional Engineer under the laws of the State of Connecticut.

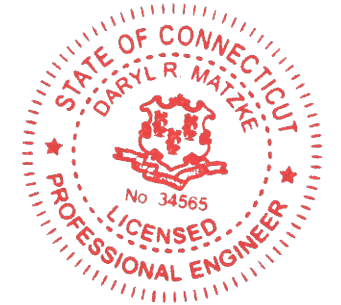

Signature: _____ Date: 4/21/2022

4	04/21/22	REVISE GENERATOR FOOT PRINT
3	04/20/22	ADD GENERATOR SHELTER TO CDs
2	12/03/21	REVISED CDs
1	05/25/21	REVISED CDs

ISSUE	FINAL	DATE	02/05/2021
PHASE		ISSUED	

PROJECT TITLE:
**DANBURY STADLEY
 ROUGH ROAD
 FA ID # 12676398**

PROJECT INFORMATION:
 52 STADLEY ROUGH ROAD
 DANBURY, CT 06811

SHEET TITLE:
SHELTER SECTION DETAILS

SCALE:
 AS NOTED

PROJECT NUMBER	50175
SHEET NUMBER	S-5

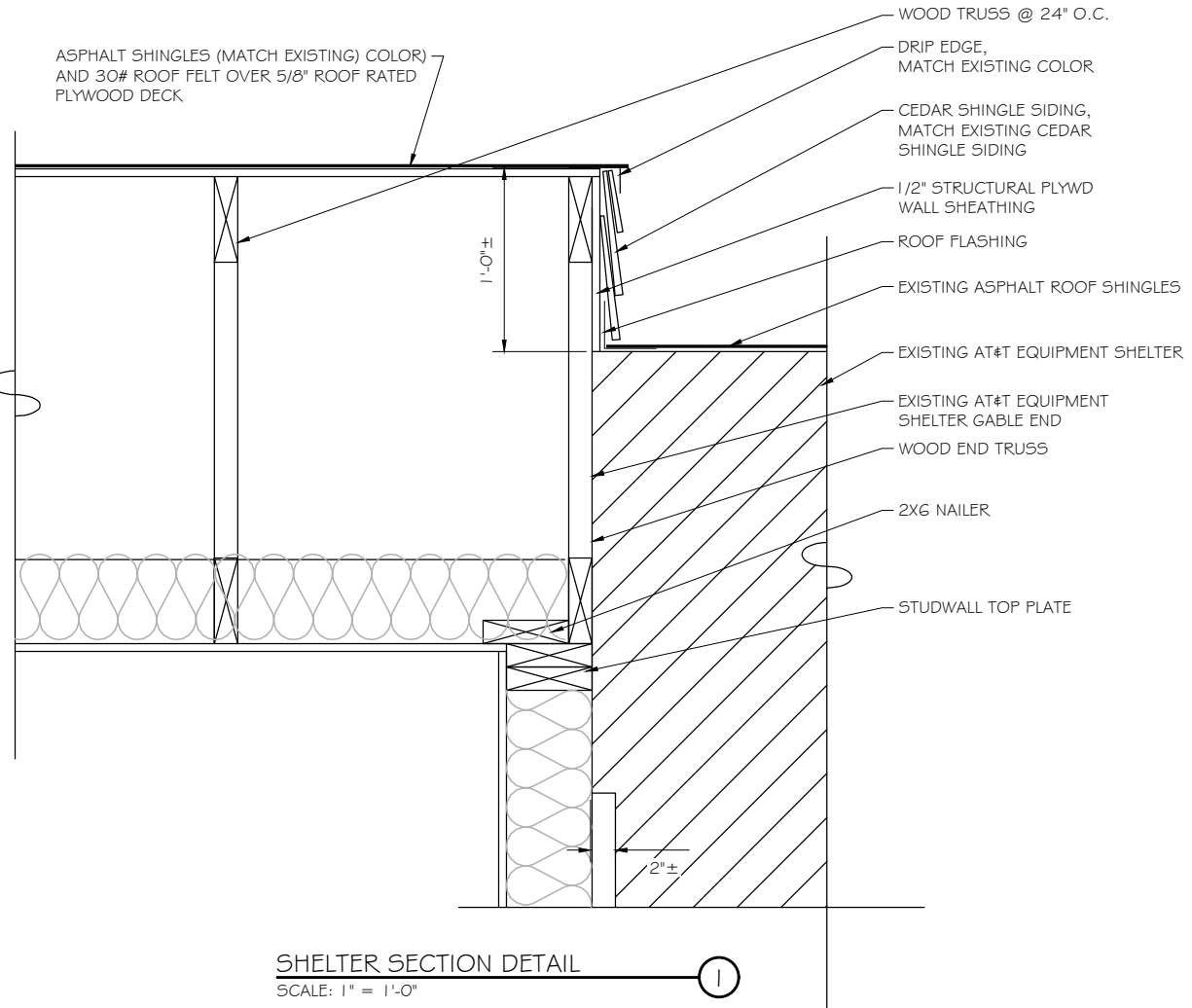

SHELTER SECTION DETAIL
SCALE: 1" = 1'-0"

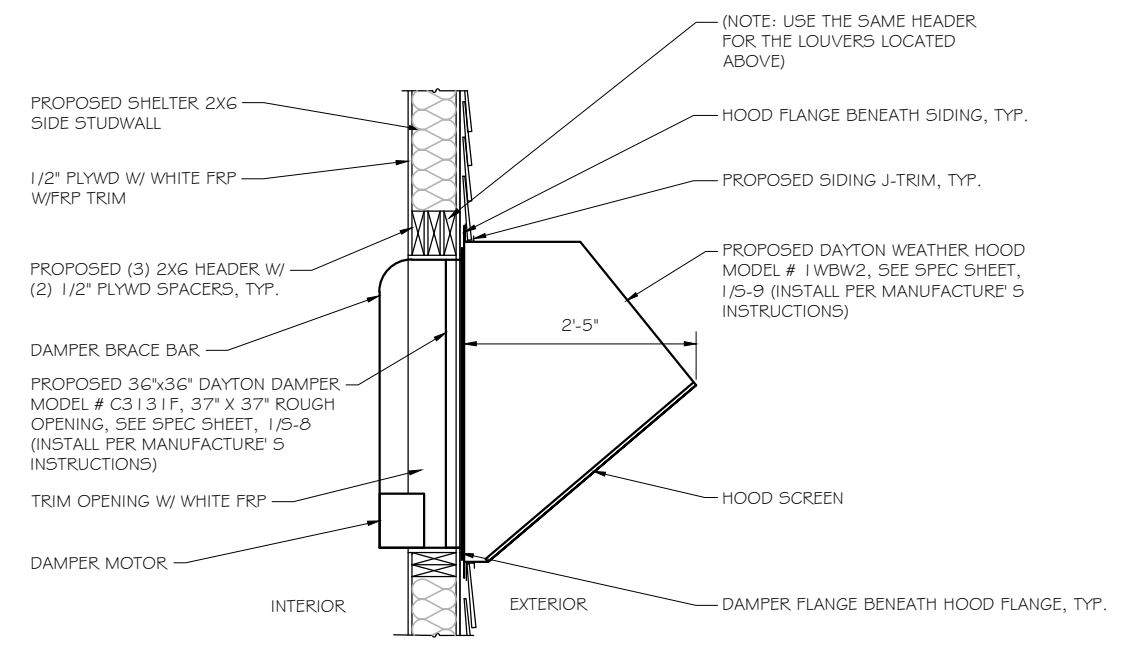

DAMPER & HOOD DETAIL
SCALE: 1/2" = 1'-0"

Dayton®

FIXED LOUVERS

HVAC/R fact sheet

FIXED INTAKE/EXHAUST LOUVERS

Modular louvers provide good protection from rain and weather at an economical price. The channel frame is 4" deep with K-style non-drainable 45 degree blades. Available in Aluminum or Galvaneal and comes standard with a birdscreen on the back.
Single Panel Sizes - 12"W x 12"H to 48"W x 72"H

OUTSIDE H (IN.)	OUTSIDE W (IN.)	MIN. WALL OPENING (IN.)	GALVANEAL STEEL ITEM NO.	ALUMINUM ITEM NO.	OUTSIDE H (IN.)	OUTSIDE W (IN.)	MIN. WALL OPENING (IN.)	GALVANEAL STEEL ITEM NO.	ALUMINUM ITEM NO.
17 1/2	17 1/2	18H x 18W	4FZG3	4ZF3	35 1/2	35 1/2	36H x 36W	4FZG8	4ZF8
23 1/2	23 1/2	24H x 24W	4FZG4	4ZF4	35 1/2	47 1/2	36H x 48W	4FZH1	4FZG1
23 1/2	35 1/2	24H x 36W	4FZG7	4ZF7	47 1/2	35 1/2	48H x 36W	4FZG9	4ZF9
29 1/2	29 1/2	30H x 30W	4FZG6	4ZF6	47 1/2	47 1/2	48H x 48W	4FZH2	4FZG2
35 1/2	23 1/2	36H x 24W	4FZG5	4ZF5					



4FZG4

FIXED-HEIGHT ADJUSTABLE-WIDTH INTAKE/EXHAUST LOUVERS

Adjustable-Width Louvers are a unique design that provides good protection from rain and weather but also gives you the flexibility to adjust the louver width during installation. The height remains fixed while the width can be adjusted to your opening size. The frame is 4" deep with 2" flanges and utilizes J-style non-drainable 45 degree blades. Available in Aluminum or Galvanized Steel and comes standard with a birdscreen.

Single Panel Sizes - 12"W x 14"H to 48"W x 48"H

OUTSIDE H (IN.)	OUTSIDE W (IN.)	MIN. WALL OPENING (IN.)	GALVANIZED STEEL ITEM NO.	ALUMINUM ITEM NO.	OUTSIDE H (IN.)	OUTSIDE W (IN.)	MIN. WALL OPENING (IN.)	GALVANIZED STEEL ITEM NO.	ALUMINUM ITEM NO.
18	16 TO 22	14H X 12W	4F421	4F951	34	25 TO 40	30H X 21W	4F422	4F954
18	28 TO 46	14H X 24W	2FTV2	2FTV4	40	28 TO 40	36H X 24W	3C974	4F955
22	22 TO 28	18H X 18W	3C972	4F952	40	40 TO 52	36H X 36W	3C975	4F956
22	28 TO 46	18H X 24W	2FTV5	2FTV9	46	28 TO 46	42H X 24W	4F423	4F957
28	22 TO 34	24H X 18W	3C973	4F953	52	28 TO 40	48H X 24W	3C976	4F958
28	40 TO 52	24H X 36W	2FTY1	2FTX2	52	40 TO 52	48H X 36W	3C977	4F959

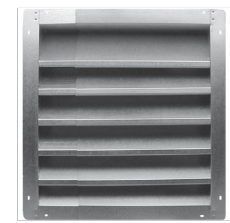

4F422

DRAINABLE BLADE FIXED INTAKE/EXHAUST LOUVERS

Drainable Blade Louvers offer excellent resistance to rain and weather. The drainable blade design channels water away from the blades and down the jambs. This eliminates water cascading from blade to blade. The channel frame is 4" deep with drainable 45 degree blades. This model is only available in extruded aluminum and comes standard with a birdscreen on the back. A 1-1/2" Flanged Frame Kit is available as an optional accessory.

Single Panel Sizes - 12"W x 12"H to 60"W x 96"H

OUTSIDE H (IN.)	OUTSIDE W (IN.)	MIN. WALL OPENING (IN.)	ALUMINUM ITEM NO.	OUTSIDE H (IN.)	OUTSIDE W (IN.)	MIN. WALL OPENING (IN.)	ALUMINUM ITEM NO.
11 1/2	11 1/2	12H X 12W	45C669	35 1/2	47 1/2	36H X 48W	5NKJ9
17 1/2	17 1/2	18H X 18W	5NKJ2	41 1/2	41 1/2	42H X 42W	45C678
23 1/2	23 1/2	24H X 24W	5NKJ3	47 1/2	35 1/2	48H X 36W	5NKJ8
23 1/2	35 1/2	24H X 36W	5NKJ6	47 1/2	47 1/2	48H X 48W	5NKK0
29 1/2	29 1/2	30H X 30W	5NKJ5	53 1/2	53 1/2	54H X 54W	45C670
35 1/2	23 1/2	36H X 24W	5NKJ4	59 1/2	59 1/2	60H X 60W	45C671
35 1/2	35 1/2	36H X 36W	5NKJ7				



5NKJ3

Call or visit your local branch or go to grainger.com/dayton for complete product line information.

LOUVER SPECIFICATIONS

SCALE: NO SCALE

PREPARED FOR:

CONSULTANT:
GENERAL DYNAMICS
Information Technology, Inc.
GENERAL DYNAMICS
101 STATION DR
WESTWOOD, MA 02090

Certification & Seal:
I hereby certify that this plan, specification, or report was prepared by me or under my direct supervision and that I am a duly Licensed Professional Engineer under the laws of the State of Connecticut.

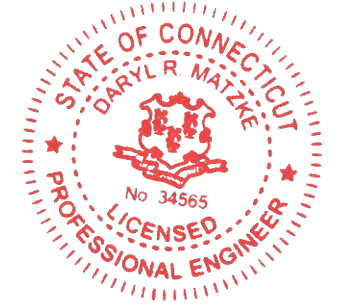

Signature: _____ Date: 4/21/2022

MARK	DATE	DESCRIPTION
4	04/21/22	REVISE GENERATOR FOOT PRINT
3	04/20/22	ADD GENERATOR SHELTER TO CDs
2	12/03/21	REVISED CDs
1	05/25/21	REVISED CDs

MARK: _____ DATE: _____ DATE ISSUED: 02/05/2021

PROJECT TITLE:
DANBURY STADLEY ROUGH ROAD
FA ID # 12676398

PROJECT INFORMATION:
52 STADLEY ROUGH ROAD
DANBURY, CT 06811

SHEET TITLE:
SHELTER SECTION DETAILS & LOUVER SPECIFICATIONS

SCALE:
AS NOTED

PROJECT NUMBER	50175
SHEET NUMBER	S-6

TECH-DATA

Ceco Door
ASSA ABLOY [Return to Index](#)

1-3/4" REGENT (RI) HONEYCOMB CORE DOORS

FLUSH AND EMBOSSED PANEL STEEL DOORS
 BEVELED LOCK EDGE, HANDED

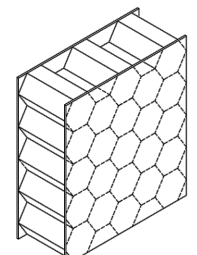

Kraft fiber honeycomb slab, bonded to the inside of both face sheets with a water resistant, contact adhesive.

Suggested Use:
 Interior or Exterior ...
 Office, Motel/Hotel, Apartment,
 Urban Renewal, Health Care,
 Institutional, Mercantile,
 Public Utility, Factory, or Warehouse.

DOOR DESIGNS

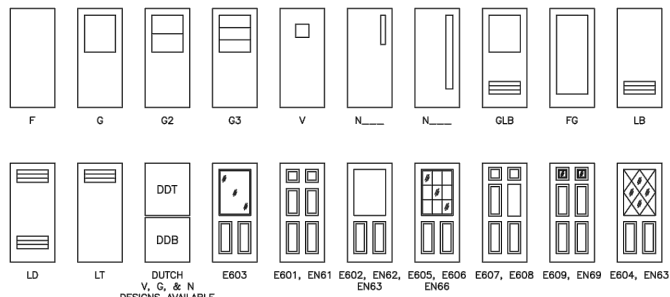

EMBOSSED 6 PANEL ORDER CODES AND DOOR WIDTHS

2'6" 2'8" NARROW 6 PANEL	2'6" 3'0" STD. 6 PANEL
EN61	E603
EN62	E601
EN63	E602
EN66	E605
E607	E606
E608	E607
EN69	E608
EN63	E609
E603	E604

6 PANEL
 MAX. SIZE 3'0"x7'0"
 MIN. SIZE 2'6"x8'8"

ALL 6 PANEL EMBOSSED DESIGNS WILL BE CENTER EDGE SEAM CONSTRUCTION.

Experience a safer and more open world

TECH-DATA

REGENT DOORS

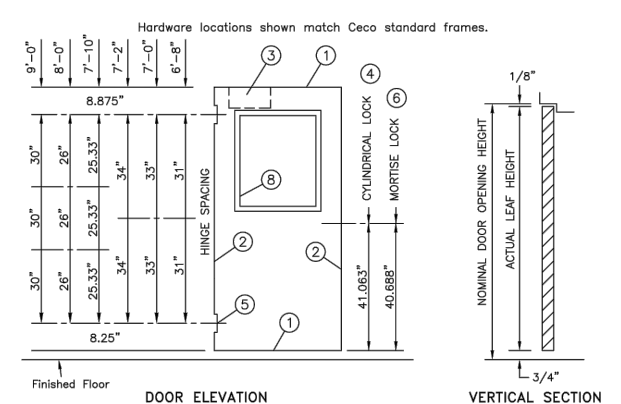

Hardware locations shown match Ceco standard frames.

Finished Floor

DOOR ELEVATION

VERTICAL SECTION

HORIZONTAL SECTIONS

(Conversion: 1" = 25.4 mm, e.g., 1-3/4" = 44.45 mm)

OVERLAPPING ASTRAGAL 4441 FOR 1-3/4" THICK DOORS

OVERLAPPING ASTRAGAL 4471 FOR 1-3/4" THICK DOORS

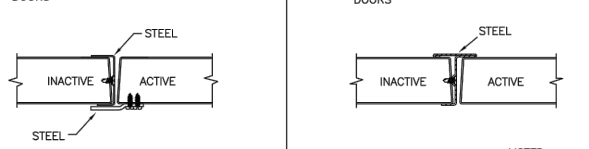

Experience a safer and more open world

[BACK TO TOP](#)

Ceco Door
ASSA ABLOY

TECH-DATA

REGENT DOORS

16 GAGE STEEL END CHANNELS

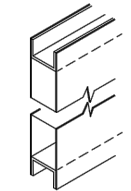

WELDED TO BOTH FACE SHEETS

INVERTED TOP AND BOTTOM

OPTIONAL TOP AND BOTTOM CAPS ARE AVAILABLE

CLOSER REINFORCEMENT (OPTIONAL)

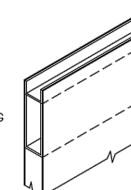

14 GAGE STEEL CHANNEL 20" LONG

VERTICAL EDGES

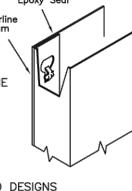

MECHANICALLY INTERLOCKED HEMMED EDGES

14 GAGE DOORS WILL BE CENTER EDGE SEAM CONSTRUCTION

OPTIONAL: SEAMLESS (WELDED OR BODY FILLER)

ALL 6 PANEL EMBOSSED DESIGNS WILL BE CENTER EDGE SEAM CONSTRUCTION.

LOCK PREPARATION GOV. 160/161 CYLINDRICAL TYPE

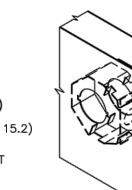

(LC1) (ANSI A115.2) 2-3/4" BACKSET

LOCK PREPARATION GOV. 86, ANSI/BHMA A115.1 MORTISE TYPE

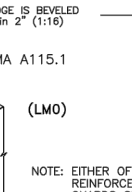

(LMO) NOTE: EITHER OF THE LOCK REINFORCEMENTS/GUARDS SHOWN MAY BE INSTALLED WITH ANY MORTISE LOCK PREPARATION.

LOCK EDGE IS BEVELED 1/8" IN 2" (1:16)

HINGE PREPARATION

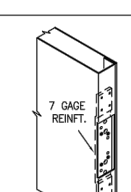

4-1/2 OR 5 IN. HIGH, STANDARD OR HEAVY WEIGHT, FULL MORTISE HINGES

HINGE EDGE IS HANDED AND NOT BEVELED.

VERTICAL EDGES

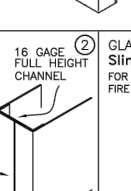

ALL 6 PANEL DESIGNS ARE CENTER EDGE SEAM CONSTRUCTION

14 GAGE WILL BE CENTER EDGE SEAM CONSTRUCTION

WELD SEAMLESS AND BODY FILLER SEAMLESS IS OPTIONAL

GLAZING TRIM SlimTrim FOR ALL FIRE DOORS

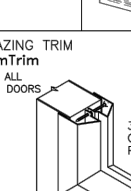

3/8" WIDE GLAZING POCKET

FIXED SLAT TYPE LOUVER 4634 FOR 1-3/4" THICK DOORS

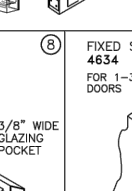

50% FREE AIR FLOW

Experience a safer and more open world

[BACK TO TOP](#)

Ceco Door
ASSA ABLOY

TECH-DATA

REGENT DOORS

PRODUCT SPECIFICATIONS

1-3/4" Thick steel doors shall be as manufactured by Ceco Door Products. Doors shall conform to the Steel Door Institute guide specification, ANSI A250.8; see chart below for performance classifications.

REGENT doors are made full-flush or (optional) seamless style. Face sheets are commercial quality cold rolled steel conforming to ASTM A1008 ... or (optional) hot-dipped galvanealed or galvanized steel conforming to ASTM A924 and A853 - see chart below.

Regent full-flush doors have mechanically interlocked, hemmed, hairline seams on vertical edges and have no visible seams on faces. Embossed 6 panel doors will have center edge seam construction. Doors specified "seamless" have no visible seams on faces or vertical edges (S.D.I. Model 2). A one piece, kraft honeycomb core is securely bonded to both face sheets under pressure with contact adhesive. The top and bottom door edges are closed with 16 gage steel channels welded to both face sheets.

Hardware Provisions: Hinge preparations are handed. Hinge edges are mortised for 4-1/2" or 5" high, standard and heavy weight hinges (specify which). 7 gage steel hinge reinforcements are welded inside the door edge and are drilled and tapped for fasteners in accordance with ANSI A156.7. The lock edge has a standard bevel (1:16) and is prepared for Gov. series 86, 160/161, or 90 locks in accordance with ANSI A115 (specify which). Optional closer reinforcement is a 14 gage steel channel.

Paint: 1-3/4" steel doors shall be provided with one coat of oven-cured neutral color primer paint. Primer coat shall conform with ANSI A250.10. The primer coat is a preparatory base for necessary finish painting. "Colorstyle" finish coat is also available from a selection of standard colors (optional). Colorstyle finish is electrostatically applied, oven-cured urethane enamel, and shall conform to ANSI A250.3. For accurate color selectors ask for a Ceco Colorstyle chart.

STANDARD SIZES

NOMINAL DOOR OPENING		HEIGHT
SINGLE	DOUBLE	
2'-0"	4'-0"	6'-8"
2'-4"	4'-8"	
2'-8"	5'-4"	7'-0"
3'-0"	5'-8"	
3'-4"	6'-2"	7'-2"
3'-8"	6'-6"	
4'-0"	7'-0"	7'-10"
4'-4"	7'-4"	
4'-8"	8'-0"	8'-0"
5'-0"	8'-4"	
5'-4"	8'-8"	9'-0"
5'-8"	9'-2"	

FIRE DOORS

LABELING AGENCIES:
 • UNDERWRITERS LABORATORY
 • WARNOCK HERSEY
 • FACTORY MUTUAL

TEST: UL10C, UL10B, UL1784, & NFPA 252
 • RATING: 20 MIN. 3/4 HR, 1 HR, 1-1/2 HR, OR 3 HR
 • MAX. SIZE: 4'0" x 9'0" SINGLE 8'0" x 9'0" PAIR
 • DESIGNS: F, FG, G, N, & V
 Not all ratings are available in all sizes, designs and materials.

MATERIAL

DOOR FACE SHEETS	LEVEL	C.R.	GALV A60/G90	RECOMMENDED DOOR FRAME MATERIAL
20 Gage Steel (4080 max.)	Standard Duty	N/A	STD N/A	16 Gage Steel
18 Gage Steel	Heavy Duty	STD	OPT OPT	16 Gage Steel
16 Gage Steel	Extra Heavy Duty	STD	OPT OPT	16 or 14 Gage Steel
14 Gage Steel	Maximum Duty	STD	OPT OPT	14 or 12 Gage Steel

PERFORMANCE

Sound Transmission Class:	STC 32 (F Design, 18 Gage Face Sheets, ASTM E90 & E413 [Fully Operable])
Physical Endurance (Level):	Meets ANSI A250.4 Performance Test, 20 GAGE: Level B (500,000 Cycles); 18 and 16 Gage: Level A (1,000,000 Cycles)

(Conversion: 1" = 25.4 mm, e.g., 1-3/4" = 44.45 mm)

Experience a safer and more open world

[BACK TO TOP](#)

Ceco Door
ASSA ABLOY

DOOR FRAME OUT DETAIL

SCALE: 1/12" = 1'-0"

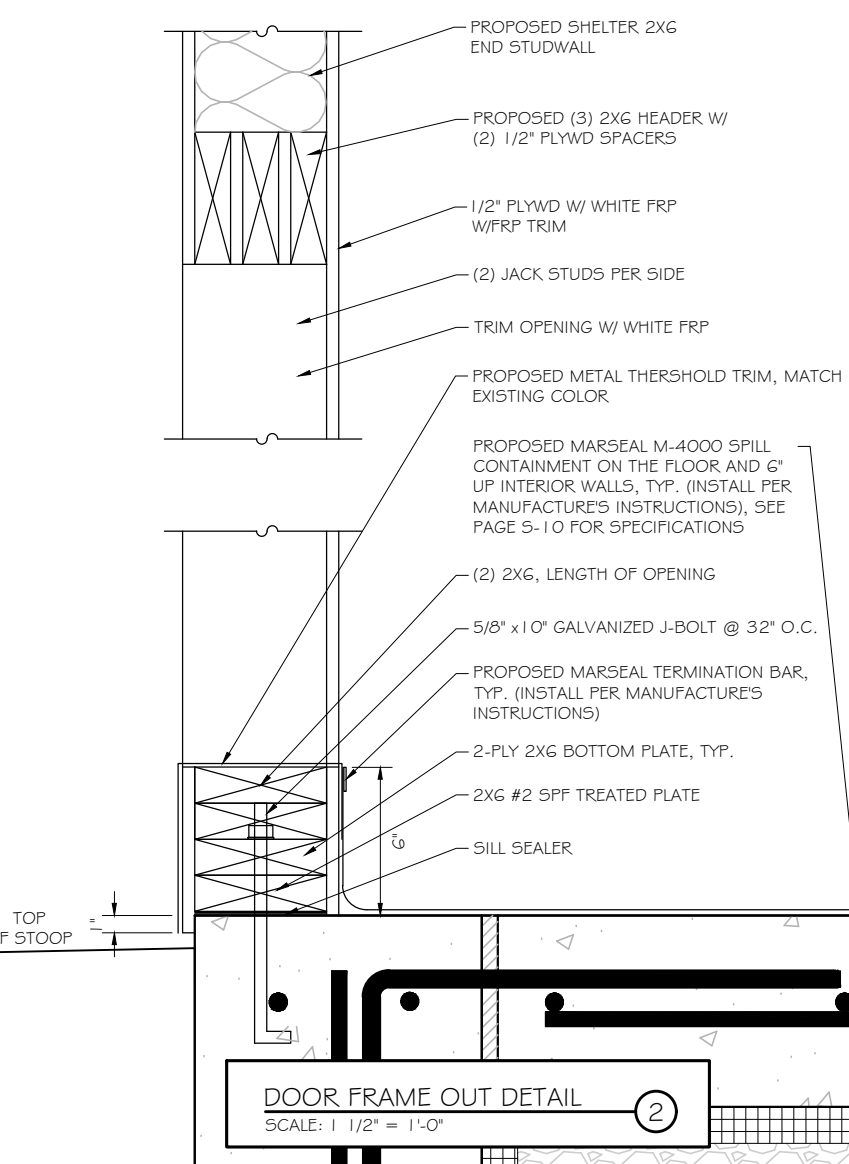

PROPOSED SHELTER 2X6 END STUDWALL

PROPOSED (3) 2X6 HEADER W/ (2) 1/2" PLYWD SPACERS

1/2" PLYWD W/ WHITE FRP W/FRP TRIM

(2) JACK STUDS PER SIDE

TRIM OPENING W/ WHITE FRP

PROPOSED METAL THRESHOLD TRIM, MATCH EXISTING COLOR

PROPOSED MARSEAL M-4000 SPILL CONTAINMENT ON THE FLOOR AND 6" UP INTERIOR WALLS, TYP. (INSTALL PER MANUFACTURE'S INSTRUCTIONS), SEE PAGE 5-10 FOR SPECIFICATIONS

(2) 2X6, LENGTH OF OPENING

5/8" x 1 0" GALVANIZED J-BOLT @ 32" O.C.

PROPOSED MARSEAL TERMINATION BAR, TYP. (INSTALL PER MANUFACTURE'S INSTRUCTIONS)

2-PLY 2X6 BOTTOM PLATE, TYP.

2X6 #2 SPF TREATED PLATE

SILL SEALER

TOP OF STOOP

PITCH STOOP AWAY FROM BUILDING FOUNDATION A TOTAL OF 1"

HEAVY BROOM FINISH WITH TOWELED EDGE

TOOLED EDGE (3) SIDES

4'-0"

1" SLOPE

EQUIPMENT SHELTER

FINISHED GRADE

8" CONCRETE STOOP WITH #4 BARS SPACED AT 12" O.C. EACH WAY, MAINTAIN 3" COVER.

1/2" EXPANSION JOINT

#4 DOWELS - 2'-0" LONG @ 1'-0" O.C.

COMPACTED SUBGRADE

6" THICK COMPACTED AGGREGATE BASE COURSE

STOOP DETAIL SCALE: NTS

DOOR SPECIFICATIONS # SHELTER SECTION DETAILS

SCALE: AS NOTED

DOOR SPECIFICATIONS SCALE: NTS



RAMAKER
 employee-owned
 (608) 643-4100 www.ramaker.com

PREPARED FOR:



CONSULTANT:
GENERAL DYNAMICS
 Information Technology, Inc.
 GENERAL DYNAMICS
 101 STATION DR
 WESTWOOD, MA 02090

Certification & Seal:
 I hereby certify that this plan, specification, or report was prepared by me or under my direct supervision and that I am a duly Licensed Professional Engineer under the laws of the State of Connecticut.

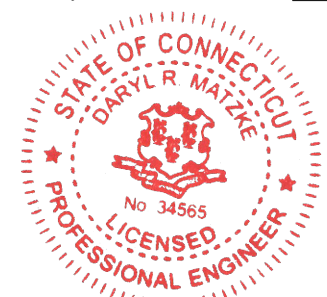

Signature: _____ Date: 4/21/2022

MARK	DATE	DESCRIPTION
4	04/21/22	REVISE GENERATOR FOOT PRINT
3	04/20/22	ADD GENERATOR SHELTER TO CDs
2	12/03/21	REVISED CDs
1	05/25/21	REVISED CDs

ISSUE PHASE: FINAL DATE ISSUED: 02/05/2021

PROJECT TITLE:
DANBURY STADLEY ROUGH ROAD
FA ID # 12676398

PROJECT INFORMATION:
 52 STADLEY ROUGH ROAD
 DANBURY, CT 06811

SHEET TITLE:
DOOR SPECIFICATIONS # SHELTER SECTION DETAILS

SCALE:
 AS NOTED

PROJECT NUMBER: 50175
 SHEET NUMBER: 5-7

Operating Instructions & Parts Manual

3C131F, 3C132F, 3C234F, 3C235F
 3C728F, 3C729F, 3C730F and 3C731F

Please read and save these instructions. Read carefully before attempting to assemble, install, operate or maintain the product described. Protect yourself and others by observing all safety information. Failure to comply with instructions could result in personal injury and/or property damage! Retain instructions for future reference.

Dayton® Motorized Dampers

Description

Dayton heavy-duty dampers are constructed of extruded aluminum or galvanized steel frame and blades. Dampers can be mounted horizontally or vertically. For intake or exhaust applications. Tie rod linkage is attached to blades on fan side.

100 to 240 VAC

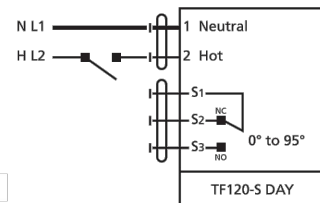

Figure 1 - Electrical Connection Diagram

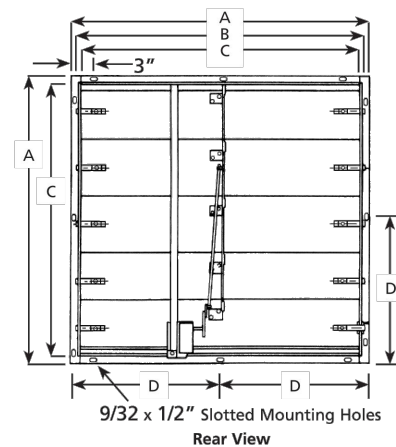
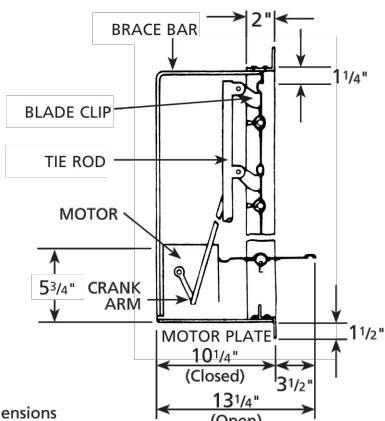

Figure 2 - Dimensions



Dimensions

Model No.		Opening Req'd Square			
Aluminum	Galvanized	A	B	C	D
3C234F	3C728F	33"	31"	30"	—
3C131F	3C729F	39	37	36	19 1/2"
3C235F	3C730F	45	43	42	22 1/2
3C132F	3C731F	51	49	48	25 1/2

Specifications

Model No.		Power Supply Req'd	Motor (*)		Motor Dimensions (In)		
Aluminum	Galvanized		Watts: Run (Hold)	Torque	H	W	D
3C234F	3C728F	100 to 240v, 50/60 Hz	2.0 (.13)	18 inch-lbs	6 1/4	3	3 1/2
3C131F	3C729F	100 to 240v, 50/60 Hz	2.0 (.13)	18 inch-lbs	6 1/4	3	3 1/2
3C235F	3C730F	100 to 240v, 50/60 Hz	2.0 (.13)	18 inch-lbs	6 1/4	3	3 1/2
3C132F	3C731F	100 to 240v, 50/60 Hz	2.0 (.13)	18 inch-lbs	6 1/4	3	3 1/2

(*) Motor is single-phase, continuous duty with a 50°C, (122°F) maximum ambient temperature. (+) 1 SPDT, 3A (0.5A) @ 250 VAC

Form 556936

Printed in U.S.A.
 01280
 Version 2

10/2013



ENGLISH

ENGLISH

ESPAÑOL

FRANÇAIS

Dayton Operating Instructions and Parts Manual

3C131F, 3C132F, 3C234F, 3C235F
 3C728F, 3C729F, 3C730F and 3C731F

Dayton® Motorized Dampers

General Safety Information

- Follow all local electrical and safety codes, as well as the National Electrical Code (NEC) and the Occupational Safety and Health Act (OSHA) in the United States.
- Motor must be securely and adequately grounded. This can be accomplished by wiring with a grounded, metal-clad raceway system, by using a separate ground wire connected to the bare metal of the motor frame, or other suitable means.

⚠ WARNING Always disconnect power source before working on or near a motor or its connected load. If the power disconnect point is out-of-sight, lock it in the open position and tag to prevent unexpected application of power.

- Protect the power cable from coming in contact with sharp objects.
- Do not kink power cable and never allow the cable to come in contact with oil, grease, hot surfaces, or chemicals.

- Make certain that the power source conforms to the requirements of your equipment.

Installation

- Cut opening required for correct damper size. Do not force damper into opening. Damper must operate freely.
- Following General Safety information and Wiring Diagram, wire damper motor as illustrated.

⚠ WARNING To avoid risk of electrical shock, more than one disconnect switch may be required to de-energize the device for servicing.

For Repair Parts, call 1-800-323-0620

24 hours a day - 365 days a year

Please provide following information:
 - Model number
 - Serial number (if any)
 - Part description and number as shown in parts list

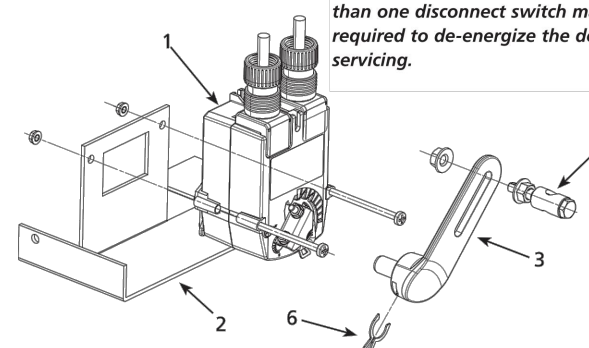

Figure 3 - Repair Parts Illustration for Motorized Dampers

Repair Parts List for Motorized Dampers

Ref. No.	Description	Part Number For Models:				Qty.
		3C234F	3C131F	3C235F	3C132F	
1	50/60Hz Motor, 100 to 240v	22YH16	22YH16	22YH16	22YH16	1
2	Motor bracket	22YH17	22YH17	22YH17	22YH17	1
3	*Motor crankarm	▲	▲	▲	▲	1
4	*Swivel ball joints	▲	▲	▲	▲	2
5	*Connecting rod (Not Shown)	▲	▲	▲	▲	1
6	*Retaining Clip	▲	▲	▲	▲	1
▲	Linkage kit	28DV58	28DV58	28DV58	28DV58	1

Ref. No.	Description	Part Number For Models:				Qty.
		3C728F	3C729F	3C730F	3C731F	
1	50/60Hz Motor, 100 to 240v	22YH16	22YH16	22YH16	22YH16	1
2	Motor bracket	22YH18	22YH18	22YH18	22YH18	1
3	*Motor crankarm	▲	▲	▲	▲	1
4	*Swivel ball joints	▲	▲	▲	▲	2
5	*Connecting rod (Not Shown)	▲	▲	▲	▲	1
6	*Retaining Clip	▲	▲	▲	▲	1
▲	Linkage kit	28DV58	28DV58	28DV58	28DV58	1
(▲)	Included in kit					

(*)Not sold separately.



PREPARED FOR:



CONSULTANT:
GENERAL DYNAMICS
 Information Technology, Inc.

GENERAL DYNAMICS
 101 STATION DR
 WESTWOOD, MA 02090

Certification & Seal:
 I hereby certify that this plan, specification, or report was prepared by me or under my direct supervision and that I am a duly Licensed Professional Engineer under the laws of the State of Connecticut.

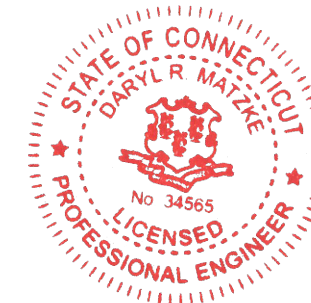

Signature: _____ Date: 4/21/2022

MARK	DATE	DESCRIPTION
4	04/21/22	REVISE GENERATOR FOOT PRINT
3	04/20/22	ADD GENERATOR SHELTER TO CDs
2	12/03/21	REVISED CDs
1	05/25/21	REVISED CDs

PROJECT TITLE:
DANBURY STADLEY ROUGH ROAD
 FA ID # 12676398

PROJECT INFORMATION:
 52 STADLEY ROUGH ROAD
 DANBURY, CT 06811

SHEET TITLE:
DAMPER SPECIFICATIONS

SCALE: NONE

PROJECT NUMBER: 50175
 SHEET NUMBER: S-8

Operating Instructions

1WBV9, 1WBW1 thru 1WBW6, 3FKF2, 16D554 thru 16D559

Please read and save these instructions. Read carefully before attempting to assemble, install, operate or maintain the product described. Protect yourself and others by observing all safety information. Failure to comply with instructions could result in personal injury and/or property damage! Retain instructions for future reference.

Dayton® Weather Hoods for Exhaust and Supply Fans

Description

Dayton weather hoods are for use in commercial and industrial applications. They provide protection for Dayton propeller fans and accessories from rain and snow. Weather hoods up to size 18" are constructed of 20 gauge galvanized steel, 18 gauge for sizes 20" and larger. Shipped unassembled with assembly hardware and birdscreen included.

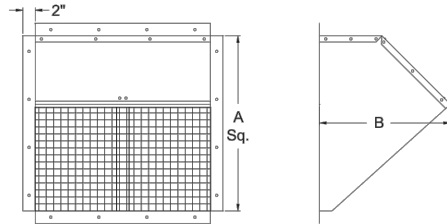

Figure 1 — Dimensions

Dimensions and Specifications (See Figure 1)

Model	For Fan Dia.	A	B	Recommended Wall Opening	
				Direct to Wall	With Wall Collar
16D554	8"	12 ¹ / ₈ "	11 ¹ / ₈ "	10 ¹ / ₂ x 10 ¹ / ₂ "	13 ³ / ₈ x 13 ³ / ₈ "
16D555	10	14 ¹ / ₈	12 ¹ / ₂	12 ¹ / ₂ x 12 ¹ / ₂	15 ⁵ / ₈ x 15 ⁵ / ₈
16D556	12	16 ¹ / ₈	14 ¹ / ₄	14 ¹ / ₂ x 14 ¹ / ₂	17 ³ / ₈ x 17 ³ / ₈
16D557	14	18 ¹ / ₈	15 ¹ / ₂	16 ¹ / ₂ x 16 ¹ / ₂	19 ³ / ₈ x 19 ³ / ₈
16D558	16	20 ¹ / ₈	17	18 ¹ / ₂ x 18 ¹ / ₂	21 ³ / ₈ x 21 ³ / ₈
16D559	18	22 ¹ / ₈	18 ¹ / ₄	20 ¹ / ₂ x 20 ¹ / ₂	23 ³ / ₈ x 23 ³ / ₈
3FKF2	20	24 ¹ / ₈	18 ³ / ₈	22 ¹ / ₂ x 22 ¹ / ₂	25 ⁵ / ₈ x 25 ⁵ / ₈
1WBV9	24	28 ¹ / ₈	21	26 ¹ / ₂ x 26 ¹ / ₂	29 ⁵ / ₈ x 29 ⁵ / ₈
1WBW1	30	34 ¹ / ₈	25	32 ¹ / ₂ x 32 ¹ / ₂	35 ⁵ / ₈ x 35 ⁵ / ₈
1WBW2	36	40 ¹ / ₈	29	38 ¹ / ₂ x 38 ¹ / ₂	41 ⁵ / ₈ x 41 ⁵ / ₈
1WBW3	42	46 ¹ / ₈	33	44 ¹ / ₂ x 44 ¹ / ₂	47 ⁵ / ₈ x 47 ⁵ / ₈
1WBW4	48	54 ¹ / ₄	38	50 ¹ / ₂ x 50 ¹ / ₂	55 ⁵ / ₈ x 55 ⁵ / ₈
1WBW5	54	60 ¹ / ₄	44 ¹ / ₂	56 ¹ / ₂ x 56 ¹ / ₂	61 ³ / ₄ x 61 ³ / ₄
1WBW6	60	66 ¹ / ₄	48 ³ / ₈	62 ¹ / ₂ x 62 ¹ / ₂	67 ³ / ₄ x 67 ³ / ₄

Form 5S5659

Printed in U.S.A.
04632
Version 1

469584
Rev. 3 August 2012



Includes	Quantity
Top Panel	1
Front Panel	1
Side Panel	2
Bottom Panel	1
Birdscreen	1 (2 on Models 1WBW5, 1WBW6)
#12 x 5/8" Screws	32 (56 on Models 1WBW5, 1WBW6)

Unpacking

1. Inspect for any damage that may have occurred during transit.
2. Shipping damage claim must be filed with carrier.

General Safety Information

⚠ DANGER Do not depend on any switch as the sole means of disconnecting power when installing or servicing a fan. Always disconnect, lock and tag power source before installing or servicing. Failure to disconnect power source can result in fire, shock or serious injury. Motor will restart without warning after thermal protector trips. Do not touch operating motor, it may be hot enough to cause injury.

Assembly

1. Identify parts for assembly, 1 top, 1 front, 2 sides, 1 bottom and 1 birdscreen. See Figure 2.

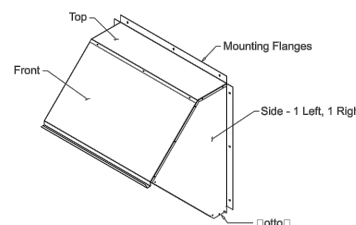

Figure 2 — Assembly Parts

ENGLISH

ENGLISH

ESPAÑOL

FRANÇAIS

Dayton Operating Instructions

1WBV9, 1WBW1 thru 1WBW6, 3FKF2, 16D554 thru 16D559

Dayton® Weather Hoods for Exhaust and Supply Fans

Assembly (Continued)

2. Assemble front to right side with 5/8" length sheet metal screws. Overlap the flange on the front, over the right side. Repeat step 2 for left side.
3. Assemble the top to the front and sides overlapping with the flanges as shown in Figure 3. Use 5/8" length supplied sheet metal screws.

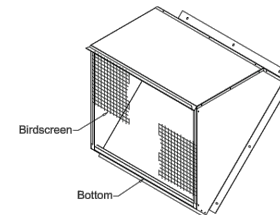

Figure 3 — Top and Front Assembly

4. Install the bottom to the sides using the 5/8" length sheet metal screws. Place the bottom inside each flanged side.
5. Slide the birdscreen into the bottom of the assembled weather hood through the openings on the underside. See Figure 4. Place birdscreen in the frame and rest on the flanges on each side. Fasten screen to each side using the 5/8" length sheet metal screws.

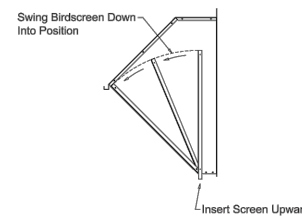

Figure 4 — Placing Birdscreen in Assembled Weather Hood

Manufactured for Dayton Electric Mfg. Co.
Lake Forest, Illinois 60045 U.S.A.



NOTE: On certain sizes, not all fasteners will be used.

Installation

1. Move weather hood to desired location.
2. Wall opening size is shown in the dimensions table on page 1. Fans mounted direct to the wall require a different wall opening (W.O.) size than those mounted in wall collars. Note the size of fan you have and mounting method to determine the wall opening size.
3. Figure 5 shows the direct to wall installation.

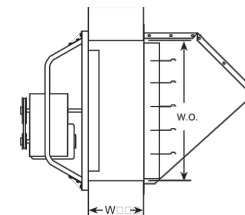

Figure 5 — Direct to Wall Installation

4. Figure 6 shows the wall collar installation.

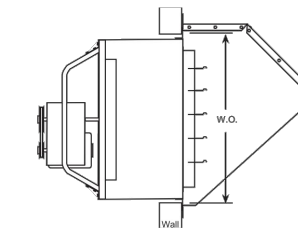

Figure 6 — Wall Collar Installation

5. Fasten weather hood directly to the wall or to the wall collar using corrosion resistant fasteners (supplied by others).

NOTE: For weather tight seal, add silicone to flange prior to mounting.

Maintenance

⚠ WARNING Disconnect and lockout power source before cleaning.

1. Clean weather hood of any accumulated dirt which would restrict air flow.
- NOTE:** No repair parts available.

RAMAKER
employee-owned
(608) 643-4100 www.ramaker.com

PREPARED FOR:

CONSULTANT:
GENERAL DYNAMICS
Information Technology, Inc.

GENERAL DYNAMICS
101 STATION DR
WESTWOOD, MA 02090

Certification & Seal:
I hereby certify that this plan, specification, or report was prepared by me or under my direct supervision and that I am a duly Licensed Professional Engineer under the laws of the State of Connecticut.

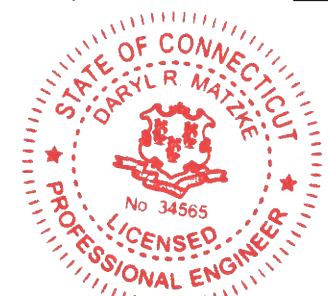

Signature: _____ Date: 4/21/2022

MARK	DATE	DESCRIPTION
4	04/21/22	REVISE GENERATOR FOOT PRINT
3	04/20/22	ADD GENERATOR SHELTER TO CDs
2	12/03/21	REVISED CDs
1	05/25/21	REVISED CDs

ISSUE PHASE: FINAL
DATE ISSUED: 02/05/2021

PROJECT TITLE:
DANBURY STADLEY ROUGH ROAD
FA ID # 12676398

PROJECT INFORMATION:
52 STADLEY ROUGH ROAD
DANBURY, CT 06811

SHEET TITLE:
WEATHER HOOD SPECIFICATIONS

SCALE: NONE

PROJECT NUMBER	50175
SHEET NUMBER	S-9



M-4000

MARSEAL® 90-mil heavy-duty system, corrosion resistant lining, surface adhered to concrete. Includes DuPont Elvaloy® resin, reinforced with dispersed polyester fibers. Ideal for the containment of mild acids, caustics and hydrocarbons.

SPECIFICATIONS

AVAILABLE SIZES:
38" wide x 50' long rolls.
Covers 158.3 square feet per roll.

MAX TEMPERATURE:
150°F (65°C)

- PROTECTS AGAINST:**
- Caustics
 - Hydrocarbon-Based Derivatives
 - Hydrochloric Acid & Mild Acids



TYPICAL PHYSICAL PROPERTIES		
Hardness	Shore A	85 A +/-5
Elongation	ASTM D412	170%
Tensile Strength at Yield	ASTM D412	1200 lbs/in ²
Tear Strength	ASTM D624	330 ppi
Low Temperature Flexibility	ASTM D2137	Pass
Water Absorption	ASTM D471	<0.1%
Water Vapor Transmission	ASTM E96	0.065 grains/h-ft ²

APPLICATOR NOTES

1. Recommended as a containment lining for protection against a wide range of chemicals such as: hydrocarbon-based derivatives (jet fuel A, kerosene, gasoline and fuel oil) organic and inorganic acids and caustics.
2. Also used as a waterproofing membrane.
3. Fully adhered to concrete with its rubberized adhesive backing.

DISCLAIMER:

The above guidelines are based on general industry practices and not applicable to all installations. Please contact Blair Rubber Company for specific application instructions. Application methods shall conform to Blair Rubber Company instructions contained in the Engineering & Applicator manual. Deviations from the specifications must be approved in writing by Blair Rubber Company. Data values are approximate and may vary based on installation techniques and atmospheric conditions. As such, data values should be used as general guidelines and are not a legally binding warranty of product characteristics. This document is copyright to and the intellectual property of Blair Rubber Company and may not be copied or distributed without prior consent.

5020 Enterprise Parkway, Seville, Ohio 44273
 Ph. 800-321-5583 • Fx. 330-769-9334
www.blairrubber.com



TERMINATION BARS

MARSEAL® used as mechanical attachment devices for anchoring MARSEAL® membranes at termination points.

MARSEAL® TERMINATION BAR - FLAT (MEMBRANE EDGE DOWN)	
Material	Extruded aluminum without sharp edges.
Dimensions	1" wide x .090" thick x 5' length.
Holes	1/4" x 3/8" slotted holes 6" centers.
Shipping Weight	.625 lbs. / bar.

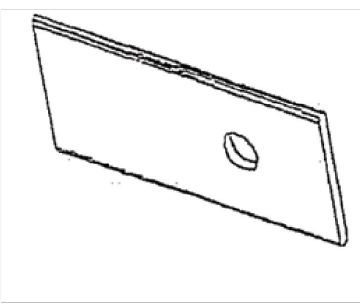

MARSEAL® TERMINATION BAR - CAULK LIP (MEMBRANE EDGE UP)	
Material	Extruded aluminum without sharp edges.
Dimensions	1" wide x .090" thick x 5' length, with 45° caulk lip on one side of bar.
Holes	1/4" x 3/8" slotted holes 6" centers.
Shipping Weight	.625 lbs. / bar.

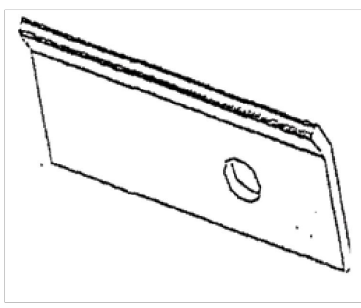

DISCLAIMER:

The above guidelines are based on general industry practices and not applicable to all installations. Please contact Blair Rubber Company for specific application instructions. Application methods shall conform to Blair Rubber Company instructions contained in the Engineering & Applicator manual. Deviations from the specifications must be approved in writing by Blair Rubber Company. Data values are approximate and may vary based on installation techniques and atmospheric conditions. As such, data values should be used as general guidelines and are not a legally binding warranty of product characteristics. This document is copyright to and the intellectual property of Blair Rubber Company and may not be copied or distributed without prior consent.

5020 Enterprise Parkway, Seville, Ohio 44273
 Ph. 800-321-5583 • Fx. 330-769-9334
www.blairrubber.com



RAMAKER
 employee-owned
 (608) 643-4100 www.ramaker.com

PREPARED FOR:

CONSULTANT:
GENERAL DYNAMICS
 Information Technology, Inc.
 GENERAL DYNAMICS
 101 STATION DR
 WESTWOOD, MA 02090

Certification & Seal:
 I hereby certify that this plan, specification, or report was prepared by me or under my direct supervision and that I am a duly Licensed Professional Engineer under the laws of the State of Connecticut.

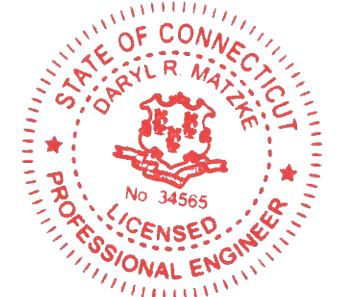

Signature: _____ Date: 4/21/2022

MARK	DATE	DESCRIPTION
4	04/21/22	REVISE GENERATOR FOOT PRINT
3	04/20/22	ADD GENERATOR SHELTER TO CD's
2	12/03/21	REVISED CD's
1	05/25/21	REVISED CD's

ISSUE PHASE: FINAL DATE ISSUED: 02/05/2021

PROJECT TITLE:
**DANBURY STADLEY
 ROUGH ROAD
 FA ID # 12676398**

PROJECT INFORMATION:
 52 STADLEY ROUGH ROAD
 DANBURY, CT 06811

SHEET TITLE:
**MARSEAL LINING
 SPECIFICATIONS**

SCALE: NONE

PROJECT NUMBER	50175
SHEET NUMBER	S-10

DIAGRAM CIRCUIT SCHEDULE

NO.	FROM	TO	WIRES	GROUND	CONDUIT SIZE	FUNCTION
1	NORMAL POWER SOURCE	AUTOMATIC TRANSFER SWITCH	(3) 3/0	(1) #4	2"	NORMAL POWER FEEDER TO ATS (CUT BACK EXISTING)
2	AUTOMATIC TRANSFER SWITCH	LOAD CENTER	(3) 3/0	(1) #4	2"	POWER FEEDER FROM ATS TO PANEL
3	GENERATOR	AUTOMATIC TRANSFER SWITCH	(3) 3/0	(1) #4	2"	EMERGENCY POWER FEEDER TO ATS
4	AUTOMATIC TRANSFER SWITCH	GENERATOR	(2) #10	(1) #10	1"	START CIRCUIT
5	LOAD CENTER (DISTRIBUTION CENTER)	GENERATOR, ATS	(2) #12 (2) #12 (2) #12	(1) #12 (1) #12 (1) #12	1" 1" 1"	CIRCUIT FOR GENERATOR BLOCK HEATER & BATTERY HEATER CIRCUIT FOR BATTERY CHARGER CIRCUIT FOR ATS
6	GENERATOR	AUTOMATIC TRANSFER SWITCH	1 2-PAIR 24 AWG OR 2EA 6-PAIR CAT5	N/A	1"	ALARM CABLES (1) 1 2 PAIR 24 AWG. PROVIDE 24" OF SLACK CABLE. FINAL PUNCH DOWN IS BY AT&T TECH. LABEL ALL WIRES
7	AUTOMATIC TRANSFER SWITCH	ALARM BLOCK	1 2-PAIR 24 AWG OR 2EA 6-PAIR CAT5	N/A	1"	ALARM CABLES (1) 1 2 PAIR 24 AWG (RUN TO PURCELL CABINET & INTO ALARM BOX). PROVIDE 24" OF SLACK CABLE. FINAL PUNCH DOWN IS BY AT&T TECH. LABEL ALL WIRES

CIRCUIT DETAIL

SCALE: NTS

1

ALARM WIRE IDENTIFICATION CHART

WIRE	ALARM
BROWN BROWN / WHITE	GENERATOR RUNNING
GREEN GREEN / WHITE	CRITICAL FAULT
BLUE BLUE / WHITE	MINOR FAULT
ORANGE	LOW FUEL
ORANGE / WHITE	FUEL LEAK
BROWN *	
BROWN / WHITE *	

*CAT5 CABLE ONLY, FROM 2ND CAT5 CABLE

ALARM WIRING IDENTIFICATION CHART

SCALE: NTS

2

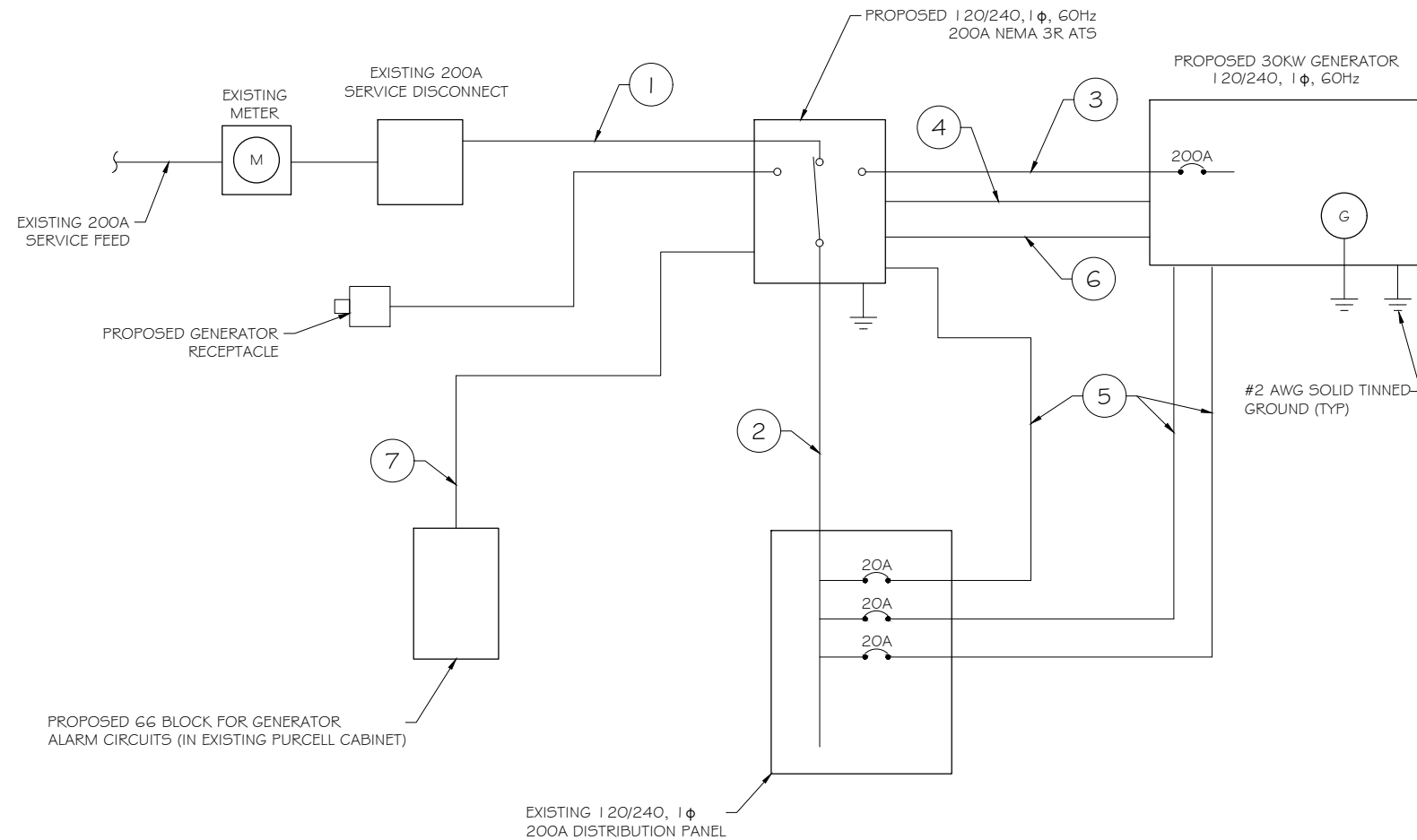

PROPOSED WIRING DIAGRAM

SCALE: NTS

3

RAMAKER
employee-owned
(608) 643-4100 www.ramaker.com

PREPARED FOR:

CONSULTANT:
GENERAL DYNAMICS
Information Technology, Inc.

GENERAL DYNAMICS
101 STATION DR
WESTWOOD, MA 02090

Certification & Seal:
I hereby certify that this plan, specification, or report was prepared by me or under my direct supervision and that I am a duly Licensed Professional Engineer under the laws of the State of Connecticut.



Signature: _____ Date: 4/21/2022

MARK	DATE	DESCRIPTION
4	04/21/22	REVISE GENERATOR FOOT PRINT
3	04/20/22	ADD GENERATOR SHELTER TO CDs
2	12/03/21	REVISED CDs
1	05/25/21	REVISED CDs

ISSUE PHASE: FINAL DATE ISSUED: 02/05/2021

PROJECT TITLE:
DANBURY STADLEY
ROUGH ROAD
FA ID # 12676398

PROJECT INFORMATION:
52 STADLEY ROUGH ROAD
DANBURY, CT 06811

SHEET TITLE:
WIRING DETAILS

SCALE: NONE

PROJECT NUMBER: 50175
SHEET NUMBER: E-1

AC Distribution Panel - Layout Diagram									
Breaker Position	Breaker Type	On/Off	Size	Circuit Label	Breaker Position	Breaker Type	On/Off	Size	Circuit Label
1	2P	ON	40	RECTIFIER #1	2	2P	ON	50	HVAC UNIT #1
3					4				
5	2P	ON	40	RECTIFIER #2	6	2P	ON	50	HVAC UNIT #2
7					8				
9	2P	ON	40	RECTIFIER #3	10	1P	ON	20	DUPLEX RECEPT. CORD REEL
11					12	1P	ON	20	EXIT EMERGENCY INT. LIGHT
13	2P	ON	40	RECTIFIER #4	14	1P	ON	20	EXTERIOR LIGHT
15					16	1P	ON	20	DUPLEX RECEPTACLE
17	2P	ON	40	RECTIFIER #5	18	1P	OFF	20	
19					20	2P	ON	100	SUBPANEL
21	2P	ON	40	RECTIFIER #6	22				
23					24	2P	OFF	40	RECTIFIER #11
25	2P	OFF	40	RECTIFIER #7	26				
27					28	2P	OFF	40	RECTIFIER #12
29	2P	OFF	40	RECTIFIER #8	30				
31					32	2P	OFF	40	
33	2P	OFF	40	RECTIFIER #9	34				
35					36	2P		40	
37	2P	OFF	40	RECTIFIER #10	38				
39					40	2P		40	
41	1P	ON	20	GFCI	42				

PROPOSED 2P BREAKER FOR PROPOSED SUBPANEL, SEE DETAIL 1a/E-2. (SQUARE D QO LOAD CENTER RECOMMENDED)

EXISTING PANEL SCHEDULE

SCALE: NTS

AC Distribution Panel - Layout Diagram									
Breaker Position	Breaker Type	On/Off	Size	Circuit Label	Breaker Position	Breaker Type	On/Off	Size	Circuit Label
1	1P	ON	20	ATS	2	1P	ON	20	GEN OUTLETS
3	1P	ON	20	BLOCK HEATER	4	1P	ON	15	GEN LIGHTS
5	1P	ON	20	BATTERY CHARGER	6				
7					8				
9					10				
11					12				

PROPOSED 20A BREAKER FOR NEW GENERATOR SHELTER OUTLETS AND 15A BREAKER FOR NEW GENERATOR SHELTER LIGHTS

PROPOSED 20A BREAKERS FOR ATS, BLOCK HEATER AND BATTERY CHARGER ON NEW AT&T GENERATOR

PROPOSED SUBPANEL SCHEDULE

SCALE: NTS

NOTE:
CONTRACTOR TO LABEL WIRES WITH P-TOUCH OR SIMILAR LABELS ONLY. ABSOLUTELY NO HANDWRITTEN LABELS.

*CONTRACTOR TO UTILIZE NEXT AVAILABLE IN SEQUENCE SINGLE BREAKER POSITION FOR GENERATOR, BATTERY CHARGER, BATTERY HEATER AND BLOCK HEATER

NOTE:
1. IF EXISTING CONSTRUCTION VARIES FROM THIS DETAIL, AN EQUAL 3-HR U.L. PENETRATION APPROPRIATE FOR THE EXISTING WALL TYPE SHALL BE CONSTRUCTED
2. GC SHALL USE NON-SHRINKING CAULK TO WEATHERSEAL ALL PENETRATIONS INTO OR THRU SHELTER WALL.

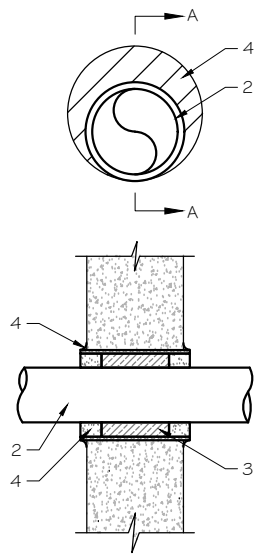

U.L. SYSTEM NO. C-AJ-1150
CONDUIT THROUGH BEARING WALL SIMILAR TO U.L. DESIGN NO. U902
F RATING = 3 HR
T RATING = 0 HR

- FLOOR OR WALL ASSEMBLY : MINIMUM 4-1/2" THICK REINFORCED LIGHTWEIGHT OR NORMAL WEIGHT (100-150 PCF) CONCRETE. WALL MAY ALSO BE CONSTRUCTED OF ANY UL CLASSIFIED CONCRETE BLOCKS*. MAX DIAMETER OF OPENING IS 4". SEE CONCRETE BLOCKS (9CATZ) CATEGORY IN THE FIRE RESISTANCE DIRECTORY FOR NAMES OF MANUFACTURERS.
- THROUGH PENETRATIONS : ONE METALLIC PIPE OR CONDUIT TO BE RIGIDLY SUPPORTED ON BOTH SIDES OF FLOOR OR WALL ASSEMBLY. THE ANNULAR SPACE SHALL BE MINIMUM 0". (POINT CONTACT) TO MAXIMUM 1-3/8". THE FOLLOWING TYPES AND SIZES OF METALLIC PIPES OR CONDUITS MAY BE USED:
A. STEEL PIPE-NOMINAL 6" DIAMETER (OR SMALLER) SCHEDULE 40 (OR HEAVIER) STEEL PIPE.
B. IRON PIPE-NOMINAL 6" DIAMETER (OR SMALLER) CAST OR DUCTILE IRON PIPE.
C. CONDUIT - NOMINAL 4" DIAMETER (OR SMALLER) STEEL ELECTRICAL METALLIC TUBING OR NOMINAL 3-1/2" DIAMETER (OR SMALLER) STEEL CONDUIT.
- PACKING MATERIAL: MINIMUM 6" THICKNESS OF MIN 4.0 PCF MINERAL WOOL BATTING INSULATION FIRMLY PACKED INTO OPENING AS A PERMANENT FORM. PACKING MATERIAL TO BE RECESSED FROM TOP SURFACE OF FLOOR OR FROM BOTH SURFACES OF WALL AS REQUIRED TO ACCOMMODATE THE REQUIRED THICKNESS OF FILL MATERIAL.
- FILL, VOID, OR CAVITY MATERIAL*: SEALANT: MINIMUM 1/4" THICKNESS OF FILL MATERIAL APPLIED WITHIN THE ANNULUS, FLUSH WITH TOP SURFACE OF FLOOR AND WITH BOTH SURFACES OF WALL. AT THE POINT CONTACT LOCATION BETWEEN PIPE AND CONCRETE, A MINIMUM 1/2" DIAMETER BEAD OF FILL MATERIAL SHALL BE APPLIED AT THE CONCRETE/PIPE INTERFACE ON THE TOP SURFACE OF FLOOR AND ON BOTH SURFACES OF WALL. W RATING APPLIES ONLY WHEN CP6015 OR CP604 SEALANT IS USED.

HILTI CONSTRUCTION CHEMICALS, DIV OF HILTI INC. : CP6015, CP604, CP606, OR F5-ONE SEALANT.

* BEARING THE UL CLASSIFICATION MARK.

OUTER WALL PENETRATION DETAIL (IF APPLICABLE)

SCALE: NTS

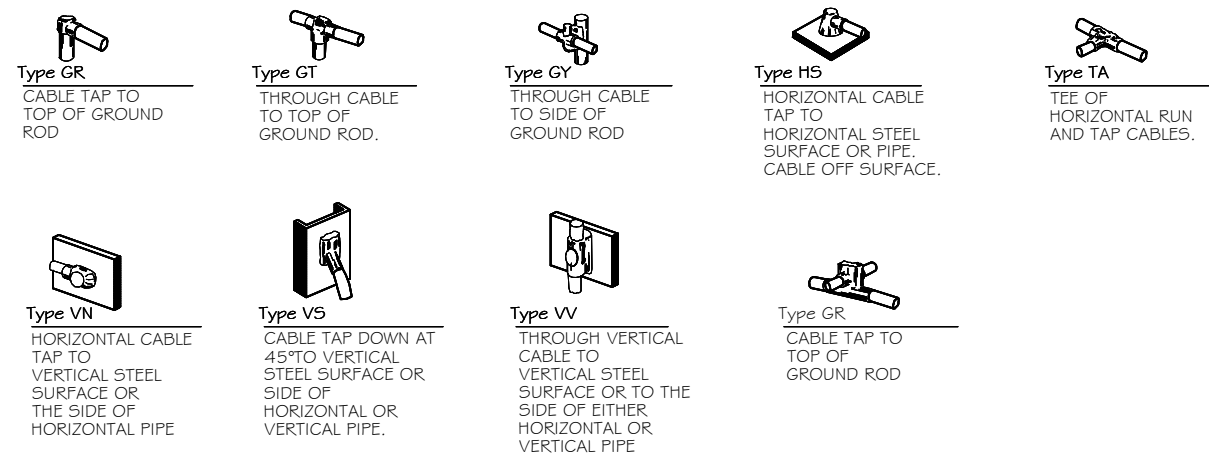

CADWELD DETAILS

SCALE: NTS

PREPARED FOR:

CONSULTANT:
GENERAL DYNAMICS
Information Technology, Inc.
GENERAL DYNAMICS
101 STATION DR
WESTWOOD, MA 02090

Certification & Seal:
I hereby certify that this plan, specification, or report was prepared by me or under my direct supervision and that I am a duly Licensed Professional Engineer under the laws of the State of Connecticut.

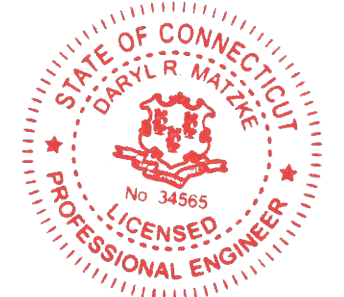

Signature: _____ Date: 4/21/2022

MARK	DATE	DESCRIPTION
4	04/21/22	REVISE GENERATOR FOOT PRINT
3	04/20/22	ADD GENERATOR SHELTER TO CDs
2	12/03/21	REVISED CDs
1	05/25/21	REVISED CDs

ISSUE PHASE: FINAL DATE ISSUED: 02/05/2021

PROJECT TITLE:
DANBURY STADLEY ROUGH ROAD
FA ID # 12676398

PROJECT INFORMATION:
52 STADLEY ROUGH ROAD
DANBURY, CT 06811

SHEET TITLE:
PANEL AND PENETRATION DETAILS

SCALE: NONE

PROJECT NUMBER: 50175
SHEET NUMBER: E-2

- ① CONDUIT (TYP)
- ② BUTTERFLY CLAMP AS REQUIRED
- ③ EXISTING WALL/CEILING
- ④ VERTICAL "UNISTRUT" P1000 T SERIES LENGTH BASED ON NUMBER OF CONDUIT TO BE MOUNTED

WALL CONSTRUCTION TYPE	USE
HOLLOW	3/8" DIA. TOGGLE BOLT
HOLLOW, AT STUD	3/8" DIA. LAG SCREW
CONCRETE BLOCK (HOLLOW)	3/8" DIA. HILTI HY-20 WITH SCREEN, MINIMUM EMBEDMENT 2-1/2"
CONCRETE (SOLID)	3/8" DIA. HILTI HY-150 WITH SCREEN, MINIMUM EMBEDMENT 2-1/2"

NOTE: USE GALVANIZED OR STAINLESS STEEL HARDWARE FOR WALL MOUNT & CONNECTIONS OF CHANNELS SPACE UNITS @ 5'-0" O.C. LENGTH OF RUN

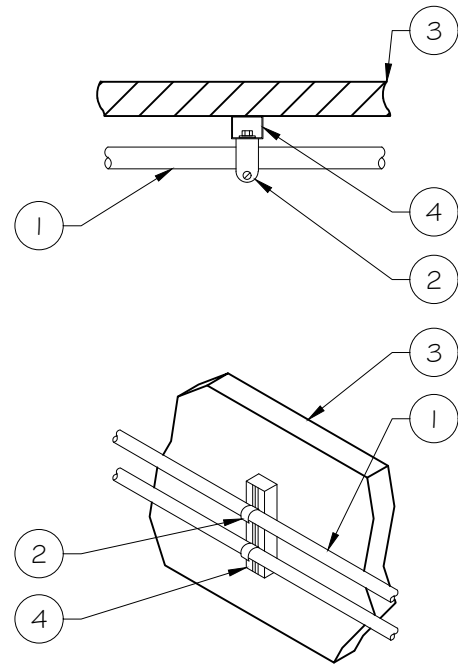

CONDUIT WALL MOUNT
SCALE: NTS ①

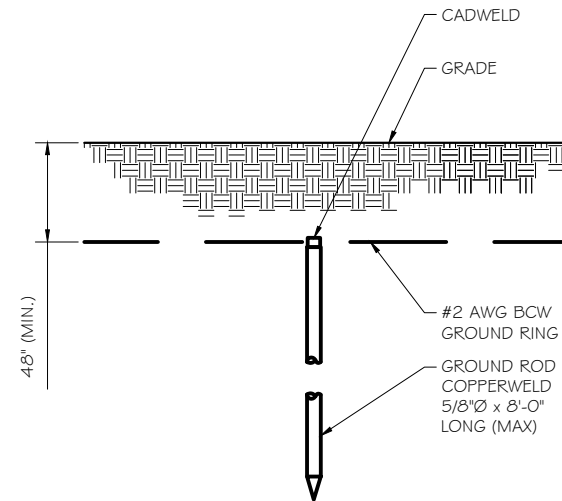

- NOTE:
- GROUND RODS MAY BE:
 - COPPER CLAD STEEL
 - SOLID COPPER
 - GROUND RODS SHALL HAVE A MAXIMUM SPACING TWICE THE LENGTH OF ROD
 - SEE RESISTIVITY REPORT FOR VERIFICATION AS AVAILABLE
 - A LARGER CONDUCTOR SHALL BE REQUIRED IN AREAS HIGHLY PRONE TO LIGHTNING AND/OR AREAS WITH HIGHLY ACIDIC SOIL
 - GROUND RODS INSTALLED WITHIN CLOSE PROXIMITY TO TOWER OR WHEN SOIL IS AT OR BELOW 2,000 OHM-CM, SHALL BE GALVANIZED TO PREVENT GALVANIC CORROSION OF TOWER, (SEE ANSI/TIA-EIA-222-G)
 - PROVIDE (1) GROUND LEAD TO EACH SIDE OF THE GENERATOR

GROUND ROD DETAIL
SCALE: NTS ②

WALL CONSTRUCTION TYPE	USE
HOLLOW	3/8" DIA. TOGGLE BOLT
HOLLOW, AT STUD	3/8" DIA. LAG SCREW
CONCRETE BLOCK (HOLLOW)	7/16" DIA. HILTI HY-20 WITH SCREEN MINIMUM EMBEDMENT 2-1/2"
CONCRETE (SOLID)	7/16" DIA. HILTI HY-150 WITH SCREEN MINIMUM EMBEDMENT 2-1/2"

- NOTE:
- USE GALVANIZED OR STAINLESS STEEL HARDWARE FOR WALL MOUNT AND CONNECTION OF CHANNELS
 - GC SHALL USE NON-SHRINKING CAULK TO WEATHER SEAL ALL PENETRATIONS INTO OR THROUGH SHELTER WALL

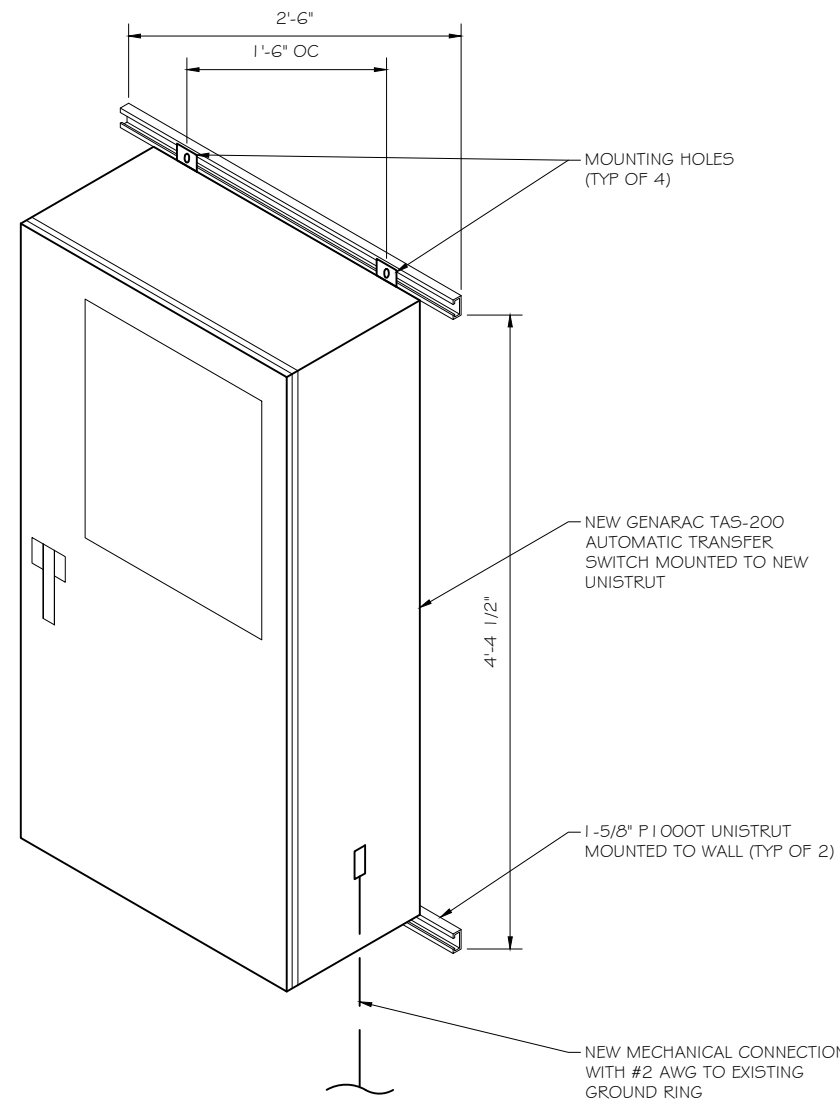

GENERAC ATS MOUNTING DETAIL
SCALE: NTS ③

RAMAKER
employee-owned
(608) 643-4100 www.ramaker.com

PREPARED FOR:

at&t
Mobility

CONSULTANT:
GENERAL DYNAMICS
Information Technology, Inc.
GENERAL DYNAMICS
101 STATION DR
WESTWOOD, MA 02090

Certification & Seal:
I hereby certify that this plan, specification, or report was prepared by me or under my direct supervision and that I am a duly Licensed Professional Engineer under the laws of the State of Connecticut.

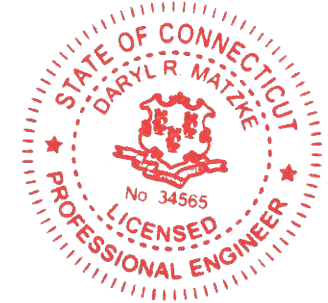

Signature: _____ Date: 4/21/2022

MARK	DATE	DESCRIPTION
4	04/21/22	REVISE GENERATOR FOOT PRINT
3	04/20/22	ADD GENERATOR SHELTER TO CDs
2	12/03/21	REVISED CDs
1	05/25/21	REVISED CDs

ISSUE PHASE: FINAL DATE ISSUED: 02/05/2021

PROJECT TITLE:
DANBURY STADLEY ROUGH ROAD
FA ID # 12676398

PROJECT INFORMATION:
52 STADLEY ROUGH ROAD
DANBURY, CT 06811

SHEET TITLE:
ATS, CONDUIT & GROUND ROD DETAILS

SCALE: NONE

PROJECT NUMBER	50175
SHEET NUMBER	E-3

SD030 | 2.2L | 30 kW
INDUSTRIAL DIESEL GENERATOR SET
 EPA Certified Stationary Emergency



Standby Power Rating
 30 kW, 38 kVA, 60 Hz

Prime Power Rating*
 27 kW, 34 kVA, 60 Hz

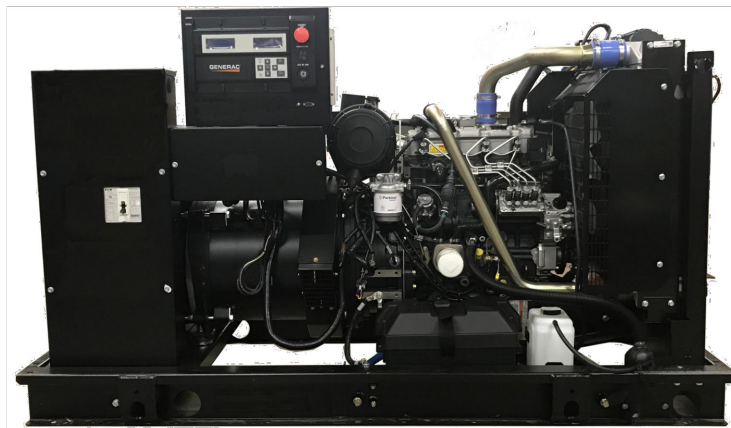

Image used for illustration purposes only



*EPA Certified Prime ratings are not available in the US or its Territories

Codes and Standards

Not all codes and standards apply to all configurations. Contact factory for details.

- UL2200, UL508, UL489, UL142
- CSA C22.2
- BS5514 and DIN 6271
- SAE J1349
- NFPA 37, 70, 99, 110
- NEC700, 701, 702, 708
- ISO 3046, 7637, 8528, 9001
- NEMA ICS10, MG1, 250, ICS6, AB1
- ANSI C62.41

Powering Ahead

For over 50 years, Generac has provided innovative design and superior manufacturing.

Generac ensures superior quality by designing and manufacturing most of its generator components, including alternators, enclosures and base tanks, control systems and communications software.

Generac gensets utilize a wide variety of options, configurations and arrangements, allowing us to meet the standby power needs of practically every application.

Generac searched globally to ensure the most reliable engines power our generators. We choose only engines that have already been proven in heavy-duty industrial applications under adverse conditions.

Generac is committed to ensuring our customers' service support continues after their generator purchase.

SPEC SHEET

1 of 6

SD030 | 2.2L | 30 kW
INDUSTRIAL DIESEL GENERATOR SET
 EPA Certified Stationary Emergency



STANDARD FEATURES

ENGINE SYSTEM

- Oil Drain Extension
- Air Cleaner
- Fan Guard
- Stainless Steel Flexible Exhaust Connection
- Factory Filled Oil and Coolant
- Radiator Duct Adapter (Open Set Only)
- Critical Silencer (Enclosed Unit Only)
- Engine Coolant Heater

Fuel System

- Fuel Lockoff Solenoid
- Primary Fuel Filter

Cooling System

- Closed Coolant Recovery System
- UV/Ozone Resistant Hoses
- Factory-Installed Radiator
- Radiator Drain Extension
- 50/50 Ethylene Glycol Antifreeze

Electrical System

- Battery Charging Alternator
- Battery Cables
- Battery Tray
- Rubber-Booted Engine Electrical Connections
- Solenoid Activated Starter Motor

ALTERNATOR SYSTEM

- UL2200 GENprotect™
- Class H Insulation Material
- 2/3 Pitch
- Skewed Stator
- Brushless Excitation
- Sealed Bearing
- Rotor Dynamically Spin Balanced
- Amortisseur Winding (3-Phase Only)
- Full Load Capacity Alternator
- Protective Thermal Switch

GENERATOR SET

- Internal Genset Vibration Isolation
- Separation of Circuits - High/Low Voltage
- Separation of Circuits - Multiple Breakers
- Wrapped Exhaust Piping
- Standard Factory Testing
- 2 Year Limited Warranty (Standby Rated Units)
- 1 Year Limited Warranty (Prime Rated Units)
- Silencer Mounted in the Discharge Hood (Enclosed Unit Only)

ENCLOSURE (If Selected)

- Rust-Proof Fasteners with Nylon Washers to Protect Finish
- High Performance Sound-Absorbing Material (Sound Attenuation Enclosures)
- Gasketed Doors
- Stamped Air-Intake Louvers
- Upward Facing Discharge Hoods (Radiator and Exhaust)
- Stainless Steel Lift Off Door Hinges
- Stainless Steel Lockable Handles
- RhinoCoat™ - Textured Polyester Powder Coat Paint

FUEL TANKS (If Selected)

- UL 142/ULC S601
- Double Wall
- Normal and Emergency Vents
- Sloped Top
- Sloped Bottom
- Factory Pressure Tested
- Rupture Basin Alarm
- Fuel Level
- Check Valve In Supply and Return Lines
- RhinoCoat™ - Textured Polyester Powder Coat Paint
- Stainless Steel Hardware

CONTROL SYSTEM



Digital H Control Panel- Dual 4x20 Display

Program Functions

- Programmable Crank Limiter
- 7-Day Programmable Exerciser
- Special Applications Programmable Logic Controller
- RS-232/485 Communications
- All Phase Sensing Digital Voltage Regulator
- 2-Wire Start Capability
- Data/Time Fault History (Event Log)
- Isochronous Governor Control
- Waterproof/Sealed Connectors

- Audible Alarms and Shutdowns
- Not in Auto (Flashing Light)
- Auto/Off/Manual Switch
- E-Stop (Red Mushroom-Type)
- NFPA110 Level I and II (Programmable)
- Customizable Alarms, Warnings, and Events
- Modbus® Protocol
- Predictive Maintenance Algorithm
- Sealed Boards
- Password Parameter Adjustment Protection
- Single Point Ground
- 16 Channel Remote Trending
- 0.2 msec High Speed Remote Trending
- Alarm Information Automatically Annunciated on the Display

Full System Status Display

- Power Output (kW)
- Power Factor
- kW Hours, Total, and Last Run
- Real/Reactive/Apparent Power
- All Phase AC Voltage
- All Phase Currents

- Oil Pressure
- Coolant Temperature
- Coolant Level
- Engine Speed
- Battery Voltage
- Frequency

Alarms and Warnings

- Oil Pressure
- Coolant Temperature
- Coolant Level
- Engine Overspeed
- Battery Voltage
- Alarms and Warnings Time and Date Stamped
- Snap Shots of Key Operation Parameters During Alarms and Warnings
- Alarms and Warnings Spelled Out (No Alarm Codes)

employee-owned
 (608) 643-4100 www.ramaker.com

PREPARED FOR:

CONSULTANT:
GENERAL DYNAMICS
 Information Technology, Inc.

GENERAL DYNAMICS
 101 STATION DR
 WESTWOOD, MA 02090

Certification & Seal:
 I hereby certify that this plan, specification, or report was prepared by me or under my direct supervision and that I am a duly Licensed Professional Engineer under the laws of the State of Connecticut.

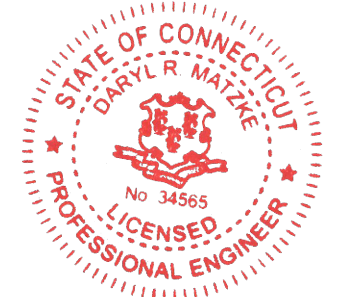

Signature: _____ Date: 4/21/2022

MARK	DATE	DESCRIPTION
4	04/21/22	REVISE GENERATOR FOOT PRINT
3	04/20/22	ADD GENERATOR SHELTER TO CDs
2	12/03/21	REVISED CDs
1	05/25/21	REVISED CDs

ISSUE PHASE: FINAL DATE ISSUED: 02/05/2021

PROJECT TITLE:
DANBURY STADLEY ROUGH ROAD
FA ID # 12676398

PROJECT INFORMATION:
 52 STADLEY ROUGH ROAD
 DANBURY, CT 06811

SHEET TITLE:
GENERAC 30KW GENERATOR SPECIFICATIONS

SCALE: NONE

PROJECT NUMBER: 50175
 SHEET NUMBER: E-4

SD030 | 2.2L | 30 kW
INDUSTRIAL DIESEL GENERATOR SET
 EPA Certified Stationary Emergency



CONFIGURABLE OPTIONS

ENGINE SYSTEM

- Oil Heater
- Critical Silencer (Open Set Only)
- Radiator Stone Guard
- Level 1 Fan and Belt Guards (Open Set Only)

FUEL SYSTEM

- NPT Flexible Fuel Line

ELECTRICAL SYSTEM

- 10A UL Listed Battery Charger
- Battery Warmer

ALTERNATOR SYSTEM

- Alternator Upsizing
- Anti-Condensation Heater
- Tropical Coating
- Permanent Magnet Excitation

GENERATOR SET

- Extended Factory Testing
- 8 Position Load Center
- Pad Vibration Isolation

ENGINEERED OPTIONS

ENGINE SYSTEM

- Coolant Heater Isolation Ball Valves
- Fluid Containment Pan

CONTROL SYSTEM

- Spare Inputs (x4) / Outputs (x4)
- Battery Disconnect Switch

CIRCUIT BREAKER OPTIONS

- Main Line Circuit Breaker
- 2nd Main Line Circuit Breaker
- Shunt Trip and Auxiliary Contact
- Electronic Trip Breakers

ENCLOSURE

- Weather Protected Enclosure
- Level 1 Sound Attenuation
- Level 2 Sound Attenuation
- Level 2 Sound Attenuation with Motorized Dampers
- Steel Enclosure
- Aluminum Enclosure
- Up to 200 MPH Wind Load Rating (Contact Factory for Availability)
- AC/DC Enclosure Lighting Kit
- Door Alarm Switch
- Enclosure Heater
- Damper Alarm Contacts

WARRANTY (Standby Gensets Only)

- 2 Year Extended Limited Warranty
- 5 Year Limited Warranty
- 5 Year Extended Limited Warranty
- 7 Year Extended Limited Warranty
- 10 Year Extended Limited Warranty

ALTERNATOR SYSTEM

- 3rd Breaker System

GENERATOR SET

- Special Testing

CONTROL SYSTEM

- NFPA 110 Compliant 21-Light Remote Annunciator
- Remote Relay Assembly (8 or 16)
- Oil Temperature Indication and Alarm
- Remote E-Stop (Break Glass-Type, Surface Mount)
- Remote E-Stop (Red Mushroom-Type, Surface Mount)
- Remote E-Stop (Red Mushroom-Type, Flush Mount)
- 100 dB Alarm Horn
- Ground Fault Annunciation
- 120V GFCI and 240V Outlets
- Remote Communication - Modem
- 10A Engine Run Relay

FUEL TANKS (Size On Last Page)

- 8 in (203.2 mm) Fill Extension
- 13 in (330.2 mm) Fill Extension
- 19 in (482.6 mm) Fill Extension
- Overfill Protection Valve
- 5 Gallon Spill Box Return Hose
- 5 Gallon Spill Box
- Tank Risers
- Fuel Level Switch and Alarm
- 12' Vent System
- Fire Rated Stainless Steel Fuel Hose

FUEL TANKS

- UL2085 Tank
- Stainless Steel Tanks
- Special Fuel Tanks
- Vent Extensions

SD030 | 2.2L | 30 kW
INDUSTRIAL DIESEL GENERATOR SET
 EPA Certified Stationary Emergency



APPLICATION AND ENGINEERING DATA

ENGINE SPECIFICATIONS

General

Make	Perkins
EPA Emissions Compliance	Stationary Emergency
EPA Emissions Reference	See Emission Data Sheet
Cylinder #	4
Type	In-Line
Displacement - in ³ (L)	135 (2.22)
Bore - in (mm)	3.3 (84)
Stroke - in (mm)	3.9 (100)
Compression Ratio	23.3:1
Intake Air Method	Turbocharged
Cylinder Head	Cast Iron
Piston Type	Aluminum
Crankshaft Type	Forged Steel

Engine Governing

Governor	Electronic Isochronous
Frequency Regulation (Steady State)	±0.5%

Lubrication System

Oil Pump Type	Gear
Oil Filter Type	Full-Flow
Crankcase Capacity - qt (L)	11.2 (10.6)

Cooling System

Cooling System Type	Closed Recovery
Water Pump Type	Pre-Lubed, Self Sealing
Fan Type	Pusher
Fan Speed - RPM	1,980
Fan Diameter - in (mm)	18 (457)

Fuel System

Fuel Type	Ultra Low Sulfur Diesel Fuel #2
Fuel Specifications	ASTM
Fuel Filtering (Microns)	5
Fuel Inject Pump	Distribution Injection Pump
Fuel Pump Type	Engine Driven Gear
Injector Type	Mechanical
Fuel Supply Line - in (mm)	0.31 (7.9) ID
Fuel Return Line - in (mm)	0.2 (4.8) ID

Engine Electrical System

System Voltage	12 VDC
Battery Charger Alternator	Standard
Battery Size	See Battery Index 0161970S8Y
Battery Voltage	12 VDC
Ground Polarity	Negative

ALTERNATOR SPECIFICATIONS

Standard Model	K0035124Y21
Poles	4
Field Type	Revolving
Insulation Class - Rotor	H
Insulation Class - Stator	H
Total Harmonic Distortion	<5% (3-Phase)
Telephone Interference Factor (TIF)	< 50

Standard Excitation	Brushless
Bearings	Single Sealed
Coupling	Direct via Flexible Disc
Load Capacity - Standby	100%
Prototype Short Circuit Test	Yes
Voltage Regulator Type	Digital
Number of Sensed Phases	All
Regulation Accuracy (Steady State)	±0.25%

SPEC SHEET



PREPARED FOR:



CONSULTANT:

GENERAL DYNAMICS
 Information Technology, Inc.
 GENERAL DYNAMICS
 101 STATION DR
 WESTWOOD, MA 02090

Certification & Seal:
 I hereby certify that this plan, specification, or report was prepared by me or under my direct supervision and that I am a duly Licensed Professional Engineer under the laws of the State of Connecticut.

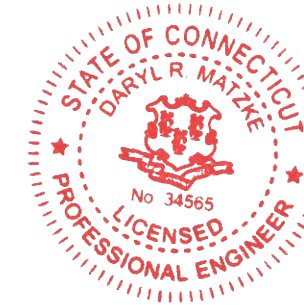

Signature: _____ Date: 4/21/2022

MARK	DATE	DESCRIPTION
4	04/21/22	REVISE GENERATOR FOOT PRINT
3	04/20/22	ADD GENERATOR SHELTER TO CDs
2	12/03/21	REVISED CDs
1	05/25/21	REVISED CDs

ISSUE PHASE	FINAL	DATE ISSUED	02/05/2021
-------------	-------	-------------	------------

PROJECT TITLE:
DANBURY STADLEY ROUGH ROAD
FA ID # 12676398

PROJECT INFORMATION:
 52 STADLEY ROUGH ROAD
 DANBURY, CT 06811

SHEET TITLE:
GENERAC 30KW GENERATOR SPECIFICATIONS

SCALE: NONE

PROJECT NUMBER	50175
SHEET NUMBER	E-4.1

SPEC SHEET

TTS Series Switches
200 Amps
600 VAC

GENERAC | INDUSTRIAL POWER

TAS200
200A Automatic Transfer Switch

TAS200
TAS200
 1 of 3 2 of 3



Image used for illustration purposes only.

The Generac TAS200 Automatic Transfer Switch

- Flexibility for multiple application installations
- Multiple generator support with 3 source panel
- Designed with a 6 inch touch screen controller for improved user interface
- Camlock functionality for mobile generator sources

Features

- STEEL CONSTRUCTION
- NEMA 3R ENCLOSURE WITH HINGED "PADLOCKING" DOORS
- STAINLESS STEEL HARDWARE
- CAMLOCK "QUICK CONNECT" CAPABILITY
- OPERATIONAL STATUS VIEW VIA 6 INCH TOUCH SCREEN
- TEST FUNCTION - FAST TEST & NORMAL TEST
- UL1008 LISTED - FOR EMERGENCY SYSTEMS

Optional Features

- EXTENDED WARRANTY
- THREE-PHASE VOLTAGE CONFIGURATIONS

Codes and Standards

Generac products are designed to the following standards:



UL1008,
UL508,
UL50,
CSA C22.2 No. 178



NEC 700, 701 and 702



NEMA 250

Application and Engineering Data

Cabinet Specifications	
Dimensions	24"W x 12"D x 48"H
Weight	210 lbs.
Construction	Single Chamber with Main Door
	Steel
	UL Type / NEMA 3R Rated
	Powder Coat Finish for Corrosion Resistance
	C-UL-US Listed - Automatic Transfer Switch
Mounting Options	Stainless Steel Hardware
	3-Point Latching System with Pad-Lockable Handles
Installed	Wall H-frame Pre-wired alarm terminal strip

Electrical Specifications	
Voltage/Phase/Amps	120/240 Single-Phase, 200A 120/208 3-Phase, 200A 120/240 3-Phase, 200A
Breaker	Eaton 200 amp Utility Breaker Eaton 200 amp Generator Breaker
Maximum RMS Symmetrical Fault Current - Amps	25k AIC Rated
Protective Device Continuous Rating (Max) Amp	200
Input to Generator	350MCM - #6 AWG
Output to Site	350MCM - #6 AWG
Generator Annunciator Connector	Deutsch DTM04-12PA-L012
Alarm Terminal Board	Generator Run Alarm
	Generator Fail – Shutdown Alarm
	Generator Fail – Non Shutdown Alarm
	Low Fuel Alarm
	Generator Theft Alarm AC Utility Fail Alarm

Camlock Component	
Camlock Component	Shipped loose for multiple installation options
Dimensions	9" W x 9.4" D x 24.25" H
200A Camlock Generator Connection	Single-Phase: Black L1, Red L2, White-Neutral, Green-Ground
	3-Phase: Black L1, Red L2, Blue L3, White-Neutral, Green-Ground
	Uses 4 CH E1016 Male Connectors
	Mating Connector – CH E1016 Female



RAMAKER
 employee-owned
 (608) 643-4100 www.ramaker.com

PREPARED FOR:

CONSULTANT:
GENERAL DYNAMICS
 Information Technology, Inc.
 GENERAL DYNAMICS
 101 STATION DR
 WESTWOOD, MA 02090

Certification & Seal:
 I hereby certify that this plan, specification, or report was prepared by me or under my direct supervision and that I am a duly Licensed Professional Engineer under the laws of the State of Connecticut.

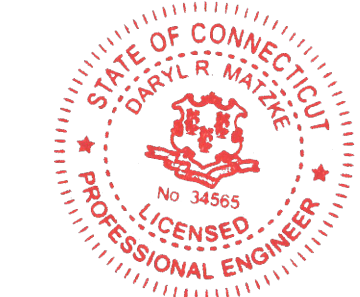

Signature: _____ Date: 4/21/2022

MARK	DATE	DESCRIPTION
4	04/21/22	REVISE GENERATOR FOOT PRINT
3	04/20/22	ADD GENERATOR SHELTER TO CDs
2	12/03/21	REVISED CDs
1	05/25/21	REVISED CDs

ISSUE PHASE: FINAL DATE ISSUED: 02/05/2021

PROJECT TITLE:
DANBURY STADLEY ROUGH ROAD
FA ID # 12676398

PROJECT INFORMATION:
 52 STADLEY ROUGH ROAD
 DANBURY, CT 06811

SHEET TITLE:
GENERAC ATS SPECIFICATIONS

SCALE: NONE

PROJECT NUMBER: 50175
 SHEET NUMBER: E-5

TTS Control Systems

TAS200

3 of 3

Touch Screen Interface

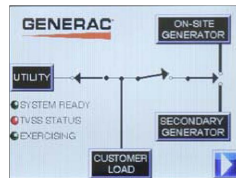

INDICATORS AND BUTTONS

<ul style="list-style-type: none"> System Ready indicator Standby Operating indicator Utility Available indicator GEN/UTIL Switch Position indicator TVSS status 	<ul style="list-style-type: none"> Normal Test button Fast Test button Return to Normal button Reset button Exercising indicator
---	---

DETAILS SCREEN

<p>System Settings:</p> <ul style="list-style-type: none"> System Voltage/Phases: <ul style="list-style-type: none"> 120/240V single phase (standard) 120/208V three phase (optional) 120/240V three phase (optional) Utility Fail Monitor: <ul style="list-style-type: none"> Under Voltage: 75-95% of nominal voltage Over Voltage: 105%-125% of nominal voltage Pickup (hysteresis): fixed at 5 volts Delay time: 0-60s Utility Interrupt Delay: 0-60s Return to Utility Timer: 1-30 minutes Transfer: <ul style="list-style-type: none"> In-phase, or Time-Delay-Neutral at 0.0-10.0s in 1 second increments 	<p>Exercise Settings:</p> <ul style="list-style-type: none"> Time of day Day of week Exercise: <ul style="list-style-type: none"> Exercise with/without load Exercise once every 1, 2, or 4 weeks. Exercise time-of-day Exercise day of week Exercise duration: 15-30 minutes
	<p>Screen Settings:</p> <ul style="list-style-type: none"> Brightness & Contrast button Screen Calibration button Startup/Clean screen
	<p>Diagnostics:</p> <ul style="list-style-type: none"> Digital I/O bits status Voltage A/D readings
<p>Engine Settings:</p> <ul style="list-style-type: none"> Engine Warm-up timer: 0-20 minutes Generator Load Accept: <ul style="list-style-type: none"> Time-Delay-Neutral at 0.0-10.0s in 1 second increments Voltage: 85-95% of nominal Frequency: 85-95% of nominal Engine Minimum Run Timer: 5-30 minutes Engine Cooldown Timer: 0-20 minutes 	<p>Mimic Diagram:</p> <ul style="list-style-type: none"> System Ready Transfer switch position Utility available Standby available Maintenance/Auto switch position Generator source TS position TVSS status

Generac Power Systems, Inc. • S45 W29290 HWY. 59, Waukesha, WI 53189 • generac.com
 ©2013 Generac Power Systems, Inc. All rights reserved. All specifications are subject to change without notice. Bulletin 0195670SBY-B / Printed in U.S.A. 03/13/13



CONSULTANT:
GENERAL DYNAMICS
 Information Technology, Inc.
 GENERAL DYNAMICS
 101 STATION DR
 WESTWOOD, MA 02090

Certification & Seal:
 I hereby certify that this plan, specification, or report was prepared by me or under my direct supervision and that I am a duly Licensed Professional Engineer under the laws of the State of Connecticut.

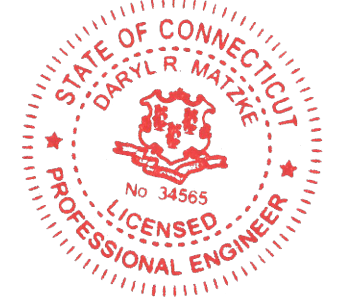

Signature: _____ Date: 4/21/2022

MARK	DATE	DESCRIPTION
4	04/21/22	REVISE GENERATOR FOOT PRINT
3	04/20/22	ADD GENERATOR SHELTER TO CDs
2	12/03/21	REVISED CDs
1	05/25/21	REVISED CDs

ISSUE PHASE	FINAL	DATE ISSUED	02/05/2021
-------------	-------	-------------	------------

PROJECT TITLE:
**DANBURY STADLEY
 ROUGH ROAD
 FA ID # 12676398**

PROJECT INFORMATION:
 52 STADLEY ROUGH ROAD
 DANBURY, CT 06811

SHEET TITLE:
GENERAC ATS SPECIFICATIONS

SCALE: NONE

PROJECT NUMBER	50175
SHEET NUMBER	E-5.1

C:\Users\steveves\AppData\Local\Temp\AcPublish\1_360A\50175_12676398_DANBURY STADLEY ROUGH ROAD_GENERATOR ATT_CDs.dwg Printed by: steves on Apr 21, 2022 - 12:46pm Copyright 2022 - Ramaker & Associates, Inc. - All Rights Reserved DRAWN BY: TRB CHECKED BY: MJR

This document contains confidential or proprietary information of Ramaker & Associates, Inc. Neither this document nor the information herein is to be reproduced, distributed, used or disclosed either in whole or in part except as authorized by Ramaker and Associates, Inc.

52 STADLEY ROUGH RD

Location 52 STADLEY ROUGH RD

Mblu K07 / 19 / 1

Acct#

Owner CHRIST THE SHEPHERD
CHURCH PCA

Assessment \$1,287,900

Appraisal \$1,839,800

PID 23658

Building Count 1

Current Value

Appraisal			
Valuation Year	Improvements	Land	Total
2017	\$1,340,100	\$499,700	\$1,839,800

Assessment			
Valuation Year	Improvements	Land	Total
2017	\$938,100	\$349,800	\$1,287,900

Owner of Record

Owner CHRIST THE SHEPHERD CHURCH PCA
Co-Owner
Address 52 STADLEY ROUGH RD
DANBURY, CT 06811

Sale Price \$450,000
Book & Page 1948/ 939
Sale Date 07/25/2007
Instrument 25

Ownership History

Ownership History				
Owner	Sale Price	Book & Page	Instrument	Sale Date
CHRIST THE SHEPHERD CHURCH PCA	\$450,000	1948/ 939	25	07/25/2007
CANDLEWOOD BAPTIST CHURCH	\$0	0510/0346		01/24/1972

Building Information

Building 1 : Section 1

Year Built: 1997
Living Area: 11,320
Replacement Cost: \$1,465,033
Building Percent Good: 90
Replacement Cost
Less Depreciation: \$1,318,500

Building Attributes

Field	Description
STYLE	Churches
MODEL	Ind/Comm
Grade	Good
Stories:	1
Occupancy	1
Exterior Wall 1	Vinyl Siding
Exterior Wall 2	
Roof Structure	Gable/Hip
Roof Cover	Asphalt Shngl.
Interior Wall 1	Drywall/Sheet
Interior Wall 2	
Interior Floor 1	Carpet
Interior Floor 2	
Heating Fuel	Oil
Heating Type	Forced Air-Duc
AC Type	Central
Bldg Use	Church
Total Rooms	
Total Bedrms	00
Total Baths	0
1st Floor Use:	200I
Heat/AC	HEAT/AC PKGS
Frame Type	WOOD FRAME
Baths/Plumbing	AVERAGE
Ceiling/Wall	SUS-CEIL & WL
Rooms/Prtns	AVERAGE
Wall Height	12
% Comn Wall	0

Building Photo



(<http://images.vgsi.com/photos2/DanburyCTPhotos//00\02\81\21.jpg>)

Building Layout

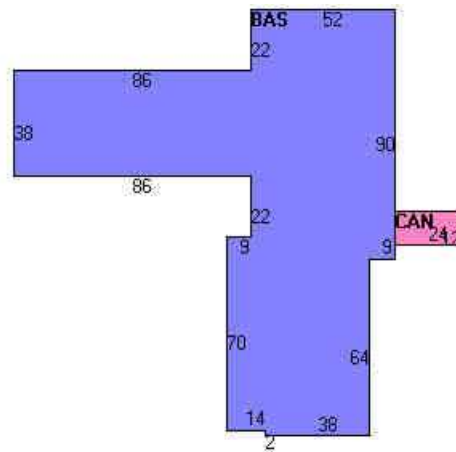

(http://images.vgsi.com/photos2/DanburyCTPhotos//Sketches/23658_2365)

Building Sub-Areas (sq ft)			Legend
Code	Description	Gross Area	Living Area
BAS	First Floor	11,320	11,320
CAN	Canopy	288	0
		11,608	11,320

Extra Features

Extra Features	Legend
No Data for Extra Features	

Land

Land Use

Use Code 918

Land Line Valuation

Size (Acres) 4.85

Description Church
Zone RA40
Neighborhood 3000
Alt Land Appr Category No

Frontage 0
Depth 0
Assessed Value \$349,800
Appraised Value \$499,700

Outbuildings

Outbuildings						Legend
Code	Description	Sub Code	Sub Description	Size	Value	Bldg #
PAV1	Paving-Asphalt			20000 S.F.	\$20,000	1
SHD1	Shed-Avg			128 S.F.	\$1,000	1
FN3	Fence 3			160 L.F.	\$600	1
CEL	Cell Tower			1 UNITS	\$0	1

Valuation History

Appraisal			
Valuation Year	Improvements	Land	Total
2016	\$1,340,100	\$499,700	\$1,839,800
2015	\$1,340,100	\$499,700	\$1,839,800
2014	\$1,340,100	\$499,700	\$1,839,800

Assessment			
Valuation Year	Improvements	Land	Total
2016	\$938,100	\$349,800	\$1,287,900
2015	\$938,100	\$349,800	\$1,287,900
2014	\$938,100	\$349,800	\$1,287,900

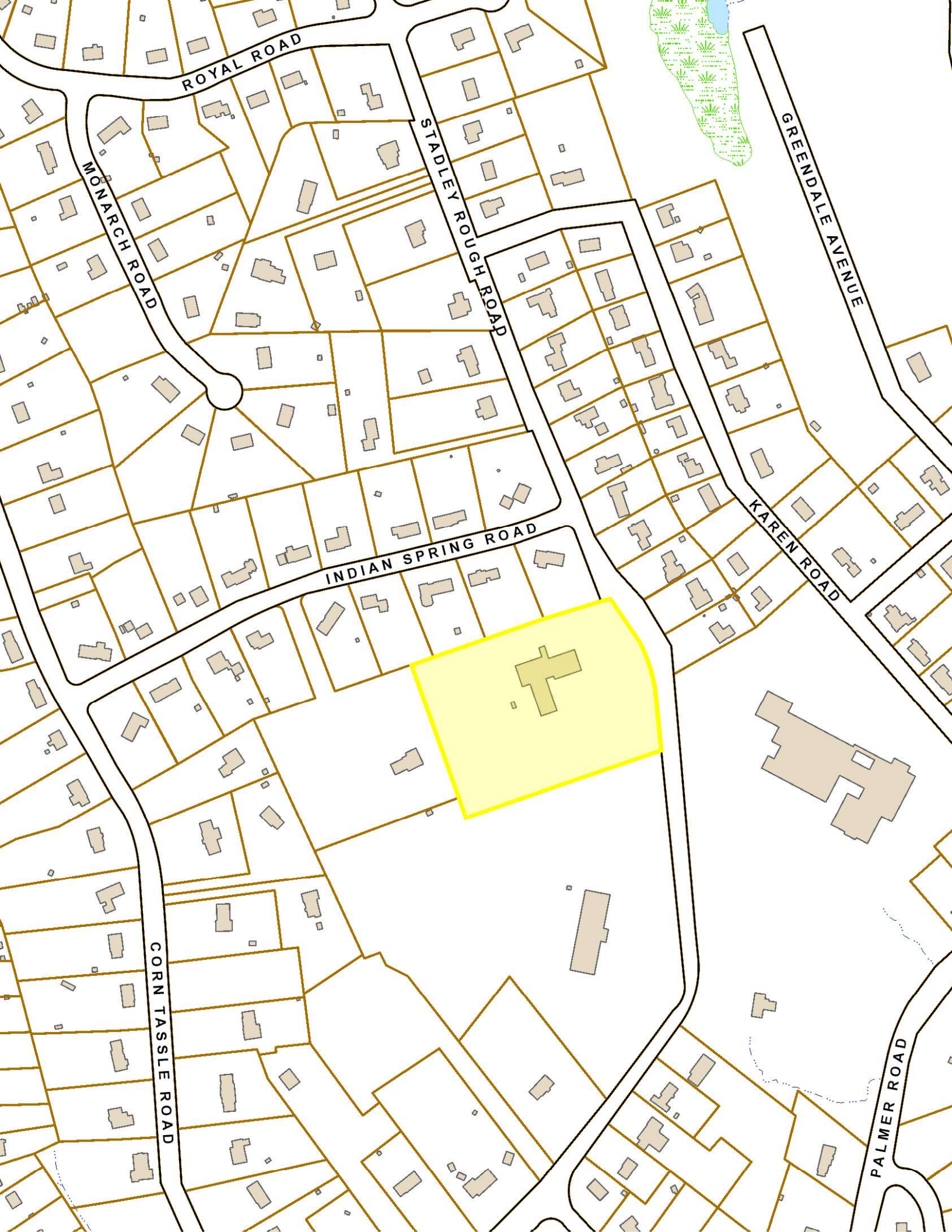

ROYAL ROAD

MONARCH ROAD

STADLEY ROUGH ROAD

INDIAN SPRING ROAD

GREENDALE AVENUE

KAREN ROAD

CORN TASSLE ROAD

PALMER ROAD

ATTACHMENT 2

DOCKET NO. 366 - Optasite Towers LLC and Omnipoint } Connecticut
Communications, Inc. application for a Certificate of }
Environmental Compatibility and Public Need for the } Siting
construction, maintenance and operation of a telecommunications }
facility located at 52 Stadley Rough Road in Danbury, } Council
Connecticut.

April 23, 2009

Decision and Order

Pursuant to the foregoing Findings of Fact and Opinion, the Connecticut Siting Council (Council) finds that the effects associated with the construction, operation, and maintenance of a telecommunications facility, including effects on the natural environment; ecological integrity and balance; public health and safety; scenic, historic, and recreational values; forests and parks; air and water purity; and fish and wildlife are not disproportionate, either alone or cumulatively with other effects, when compared to need, are not in conflict with the policies of the State concerning such effects, and are not sufficient reason to deny the application, and therefore directs that a Certificate of Environmental Compatibility and Public Need, as provided by General Statutes § 16-50k, be issued to Optasite Towers LLC, hereinafter referred to as the Certificate Holder, for a telecommunications facility at 52 Stadley Rough Road, Danbury, Connecticut.

The facility shall be constructed, operated, and maintained substantially as specified in the Council's record in this matter, and subject to the following conditions:

1. The tower shall be constructed as a monopole, no taller than necessary to provide the proposed telecommunications services, sufficient to accommodate the antennas of Omnipoint Communications, Inc. and other entities, both public and private, but such tower shall not exceed a height of 140 feet above ground level. All antennas attached to the monopole shall be flush-mounted.
2. The Certificate Holder shall shift, to the extent feasible, the compound to the north and east to help retain the existing vegetative buffer.
3. The Certificate Holder shall incorporate an architectural treatment for the fence of the facility compound and any equipment shelters therein that is consistent with and amenable to adjacent land uses.
4. The Certificate Holder shall prepare a Development and Management (D&M) Plan for this site in compliance with Sections 16-50j-75 through 16-50j-77 of the Regulations of Connecticut State Agencies. The D&M Plan shall be served on the City of Danbury for comment, and all parties and intervenors as listed in the service list, and submitted to and approved by the Council prior to the commencement of facility construction and shall include:

- a) a final site plan(s) of site development to include specifications for the tower, tower foundation, antennas, equipment compound, radio equipment, access road, utility line, and landscaping that will provide additional vegetative buffering for the adjacent properties; and
 - b) construction plans for site clearing, grading, landscaping, water drainage, and erosion and sedimentation controls consistent with the 2002 Connecticut Guidelines for Soil Erosion and Sediment Control, as amended.
5. The Certificate Holder shall, prior to the commencement of operation, provide the Council worst-case modeling of the electromagnetic radio frequency power density of all proposed entities' antennas at the closest point of uncontrolled access to the tower base, consistent with Federal Communications Commission, Office of Engineering and Technology, Bulletin No. 65, August 1997. The Certificate Holder shall ensure a recalculated report of the electromagnetic radio frequency power density be submitted to the Council if and when circumstances in operation cause a change in power density above the levels calculated and provided pursuant to this Decision and Order.
6. Upon the establishment of any new State or federal radio frequency standards applicable to frequencies of this facility, the facility granted herein shall be brought into compliance with such standards.
7. The Certificate Holder shall permit public or private entities to share space on the proposed tower for fair consideration, or shall provide any requesting entity with specific legal, technical, environmental, or economic reasons precluding such tower sharing.
8. The Certificate Holder shall provide reasonable space on the tower for no compensation for any City of Danbury public safety services (police, fire and medical services), provided such use can be accommodated and is compatible with the structural integrity of the tower.
9. Unless otherwise approved by the Council, if the facility authorized herein is not fully constructed and providing wireless services within eighteen months from the date of the mailing of the Council's Findings of Fact, Opinion, and Decision and Order (collectively called "Final Decision"), this Decision and Order shall be void, and the Certificate Holder shall dismantle the tower and remove all associated equipment or reapply for any continued or new use to the Council before any such use is made. The time between the filing and resolution of any appeals of the Council's Final Decision shall not be counted in calculating this deadline.
10. Any request for extension of the time period referred to in Condition 9 shall be filed with the Council not later than 60 days prior to the expiration date of this Certificate and shall be served on all parties and intervenors, as listed in the service list, and the City of Danbury. Any proposed modifications to this Decision and Order shall likewise be so served.
11. If the facility ceases to provide wireless services for a period of one year, this Decision and Order shall be void, and the Certificate Holder shall dismantle the tower and remove all associated equipment or reapply for any continued or new use to the Council before any such use is made.

12. The Certificate Holder shall remove any nonfunctioning antenna, and associated antenna mounting equipment, within 60 days of the date the antenna ceased to function.
13. In accordance with Section 16-50j-77 of the Regulations of Connecticut State Agencies, the Certificate Holder shall provide the Council with written notice two weeks prior to the commencement of site construction activities. In addition, the Certificate Holder shall provide the Council with written notice of the completion of site construction and the commencement of site operation.

Pursuant to General Statutes § 16-50p, the Council hereby directs that a copy of the Findings of Fact, Opinion, and Decision and Order be served on each person listed below, and notice of issuance shall be published in the Danbury News-Times.

By this Decision and Order, the Council disposes of the legal rights, duties, and privileges of each party named or admitted to the proceeding in accordance with Section 16-50j-17 of the Regulations of Connecticut State Agencies.

The parties and intervenors to this proceeding are:

APPLICANT

Optasite Towers LLC and
Omnipoint Communications, Inc.
One Research Drive, Suite 200C
Westborough, MA 01581

City of Danbury

ITS REPRESENTATIVE

Christopher B. Fisher, Esq.
Lucia Chiocchio, Esq.
Cuddy & Feder LLP
445 Hamilton Avenue, 14th Floor
White Plains, New York 10601

Laszlo L. Pinter, Esq.
Robin Edwards, Esq.
City of Danbury
155 Deer Hill Avenue
Danbury, CT 06810

ATTACHMENT 3



June 30,2022

Connecticut Siting Council
10 Franklin Square
New Britain, CT 06051

RE: New Cingular Wireless PCS, LLC -Tower Share Request/Generator Statement 52 Stadley Rough Road, Danbury, CT.

Dear Ms. Bachman:

Due to the electric load requirements associated with its radio equipment and shelter heating and cooling systems, New Cingular Wireless PCS, LLC d/b/a AT&T Mobility ("AT&T") does not intend to utilize a fuel cell for its backup power supply. Natural gas fuel cells are typically used at larger sites (like central offices) to supplement electrical power demands from the grid and are used 24/7 as opposed to as a source of backup power. Indeed, those types of large commercial units are typically 200kw plus facilities with a large footprint (similar to an entire tower site compound) with costs well in excess of those feasible for a backup power source at a wireless facility. Accordingly, a fuel cell is not a practical or feasible backup power source for AT&T at this site at this time.

As part of AT &T's continuity planning for its network service during times that CL&P commercial power supply is interrupted, AT&T is planning to provide the site with a natural gas generator. The unit is consistent with the Verizon facility approved by the Siting Council. A noise study has been prepared and mitigation measures will be employed to further reduce noise during routine cycling of the unit and during emergencies.

If you have any questions or concerns, please feel free to contact me directly.

Sincerely,

A handwritten signature in black ink that reads "John O'Connor". The signature is written in a cursive, flowing style.

John O'Connor

AT&T Project Manager

ATTACHMENT 4

CERTIFICATION

I hereby certify that on the 21st day of July, 2022, a copy of AT&T's Exempt Modification Request to the Connecticut Siting Council was sent by electronic and overnight mail to the chief elected official and planning and zoning department of the municipality in which the facility is located as well as by overnight mail to the property owner and tower owner.

Dated July 21, 2022

Mayor Dean Esposito
City of Danbury
155 Deer Hill Ave
Danbury, CT 06810

Christ the Shepherd Church PCA
52 Stadley Rough Rd
Danbury, CT 06811

Robin L. Edwards, Esq., City of Danbury Assistant Corporation Counsel
City of Danbury
155 Deer Hill Ave
Danbury, CT 06810

Jose and Christina Carvalheiro
125 Stadley Rough Rd
Danbury, CT 06811

Daniel E. Casagrande, Esq.
Cramer & Anderson, LLP
30 Main Street, Suite 204
Danbury, CT 06810

Director Sharon B. Calitro, AICP
City of Danbury
Planning and Zoning Department
155 Deer Hill Ave
Danbury, CT 06810



Cuddy & Feder LLP
445 Hamilton Avenue, Floor 14
White Plains, NY 10601
Attorneys for:
New Cingular Wireless PCS, LLC (AT&T)



Shipment Receipt

Address Information

Ship to:

Melanie A. Bachman,
Executive Dir.
Connecticut Siting Council
10 Franklin Square

NEW BRITAIN, CT
06051
US
8608272935

Ship from:

Daniel Patrick, Esq.

Cuddy & Feder LLP
445 Hamilton Avenue
Suite 1400
White Plains, NY
10601
US
9147611300

Shipment Information:

Tracking no.: 777452261201
Ship date: 07/21/2022
Estimated shipping charges: 22.97 USD

Package Information

Pricing option: FedEx Standard Rate
Service type: Priority Overnight
Package type: FedEx Pak
Number of packages: 1
Total weight: 3 LBS
Declared Value: 0.00 USD
Special Services:
Pickup/Drop-off: Use an already scheduled pickup at my location

Billing Information:

Bill transportation to: CuddyFeder-963
Your reference: 1844.3651
P.O. no.:
Invoice no.:
Department no.:

Thank you for shipping online with FedEx ShipManager at fedex.com.

Please Note

FedEx will not be responsible for any claim in excess of \$100 per package, whether the result of loss, damage, delay, non-delivery, misdelivery, or misinformation, unless you declare a higher value, pay an additional charge, document your actual loss and file a timely claim. Limitations found in the current FedEx Service Guide apply. Your right to recover from FedEx for any loss, including intrinsic value of the package, loss of sales, income interest, profit, attorney's fees, costs, and other forms of damage whether direct, incidental, consequential, or special is limited to the greater of \$100 or the authorized declared value. Recovery cannot exceed actual documented loss. Maximum for items of extraordinary value is \$1000, e.g., jewelry, precious metals, negotiable instruments and other items listed in our Service Guide. Written claims must be filed within strict time limits; Consult the applicable FedEx Service Guide for details. The estimated shipping charge may be different than the actual charges for your shipment. Differences may occur based on actual weight, dimensions, and other factors. Consult the applicable [FedEx Service Guide](#) or the FedEx Rate Sheets for details on how shipping charges are calculated.



Shipment Receipt

Address Information

Ship to:

Mayor Dean Esposito
City of Danbury
155 Deer Hill Ave

DANBURY, CT
06810
US
914-761-1300 1903

Ship from:

Daniel Patrick, Esq.
Cuddy & Feder LLP
445 Hamilton Avenue
Suite 1400

White Plains, NY
10601
US
9147611300

Shipment Information:

Tracking no.: 777452336718

Ship date: 07/21/2022

Estimated shipping charges: 17.26 USD

Package Information

Pricing option: FedEx Standard Rate

Service type: Priority Overnight

Package type: FedEx Envelope

Number of packages: 1

Total weight: 2 LBS

Declared Value: 0.00 USD

Special Services:

Pickup/Drop-off: Use an already scheduled pickup at my location

Billing Information:

Bill transportation to: CuddyFeder-963

Your reference: 1844-3651

P.O. no.:

Invoice no.:

Department no.:

Thank you for shipping online with FedEx ShipManager at fedex.com.

Please Note

FedEx will not be responsible for any claim in excess of \$100 per package, whether the result of loss, damage, delay, non-delivery, misdelivery, or misinformation, unless you declare a higher value, pay an additional charge, document your actual loss and file a timely claim. Limitations found in the current FedEx Service Guide apply. Your right to recover from FedEx for any loss, including intrinsic value of the package, loss of sales, income interest, profit, attorney's fees, costs, and other forms of damage whether direct, incidental, consequential, or special is limited to the greater of \$100 or the authorized declared value. Recovery cannot exceed actual documented loss. Maximum for items of extraordinary value is \$1000, e.g., jewelry, precious metals, negotiable instruments and other items listed in our Service Guide. Written claims must be filed within strict time limits; Consult the applicable FedEx Service Guide for details.

The estimated shipping charge may be different than the actual charges for your shipment. Differences may occur based on actual weight, dimensions, and other factors. Consult the applicable [FedEx Service Guide](#) or the FedEx Rate Sheets for details on how shipping charges are calculated.



Shipment Receipt

Address Information

Ship to:

Select or enter
Christ the Shepherd Church
PCA

52 Stadley Rough Rd

DANBURY, CT

06811

US

914-761-1300 1901

Ship from:

Daniel Patrick, Esq.
Cuddy & Feder LLP

445 Hamilton Avenue

Suite 1400

White Plains, NY

10601

US

9147611300

Shipment Information:

Tracking no.: 777452385164

Ship date: 07/21/2022

Estimated shipping charges: 17.26 USD

Package Information

Pricing option: FedEx Standard Rate

Service type: Priority Overnight

Package type: FedEx Envelope

Number of packages: 1

Total weight: 2 LBS

Declared Value: 0.00 USD

Special Services:

Pickup/Drop-off: Use an already scheduled pickup at my location

Billing Information:

Bill transportation to: CuddyFeder-963

Your reference: 1844-3651

P.O. no.:

Invoice no.:

Department no.:

Thank you for shipping online with FedEx ShipManager at fedex.com.

Please Note

FedEx will not be responsible for any claim in excess of \$100 per package, whether the result of loss, damage, delay, non-delivery, misdelivery, or misinformation, unless you declare a higher value, pay an additional charge, document your actual loss and file a timely claim. Limitations found in the current FedEx Service Guide apply. Your right to recover from FedEx for any loss, including intrinsic value of the package, loss of sales, income interest, profit, attorney's fees, costs, and other forms of damage whether direct, incidental, consequential, or special is limited to the greater of \$100 or the authorized declared value. Recovery cannot exceed actual documented loss. Maximum for items of extraordinary value is \$1000, e.g., jewelry, precious metals, negotiable instruments and other items listed in our Service Guide. Written claims must be filed within strict time limits; Consult the applicable FedEx Service Guide for details.

The estimated shipping charge may be different than the actual charges for your shipment. Differences may occur based on actual weight, dimensions, and other factors. Consult the applicable [FedEx Service Guide](#) or the FedEx Rate Sheets for details on how shipping charges are calculated.



Shipment Receipt

Address Information

Ship to:

Robin L. Edwards, Esq.
City of Danbury
155 Deer Hill Ave
City of Danbury Assistant
Corp. Co.
DANBURY, CT
06810
US
9147611300 1903

Ship from:

Daniel Patrick, Esq.
Cuddy & Feder LLP
445 Hamilton Avenue
Suite 1400

White Plains, NY
10601
US
9147611300

Shipment Information:

Tracking no.: 777452485443
Ship date: 07/21/2022
Estimated shipping charges: 17.26 USD

Package Information

Pricing option: FedEx Standard Rate
Service type: Priority Overnight
Package type: FedEx Envelope
Number of packages: 1
Total weight: 2 LBS
Declared Value: 0.00 USD
Special Services:
Pickup/Drop-off: Use an already scheduled pickup at my location

Billing Information:

Bill transportation to: CuddyFeder-963
Your reference: 1844-3651
P.O. no.:
Invoice no.:
Department no.:

Thank you for shipping online with FedEx ShipManager at fedex.com.

Please Note

FedEx will not be responsible for any claim in excess of \$100 per package, whether the result of loss, damage, delay, non-delivery, misdelivery, or misinformation, unless you declare a higher value, pay an additional charge, document your actual loss and file a timely claim. Limitations found in the current FedEx Service Guide apply. Your right to recover from FedEx for any loss, including intrinsic value of the package, loss of sales, income interest, profit, attorney's fees, costs, and other forms of damage whether direct, incidental, consequential, or special is limited to the greater of \$100 or the authorized declared value. Recovery cannot exceed actual documented loss. Maximum for items of extraordinary value is \$1000, e.g., jewelry, precious metals, negotiable instruments and other items listed in our Service Guide. Written claims must be filed within strict time limits; Consult the applicable FedEx Service Guide for details.
The estimated shipping charge may be different than the actual charges for your shipment. Differences may occur based on actual weight, dimensions, and other factors. Consult the applicable [FedEx Service Guide](#) or the FedEx Rate Sheets for details on how shipping charges are calculated.



Shipment Receipt

Address Information

Ship to:

Jose & Christina Carvalheiro
125 Stadley Rough Rd
DANBURY, CT
06811
US
914-761-1300 1901

Ship from:

Daniel Patrick, Esq.
Cuddy & Feder LLP
445 Hamilton Avenue
Suite 1400
White Plains, NY
10601
US
9147611300

Shipment Information:

Tracking no.: 777452546758
Ship date: 07/21/2022
Estimated shipping charges: 17.26 USD

Package Information

Pricing option: FedEx Standard Rate
Service type: Priority Overnight
Package type: FedEx Envelope
Number of packages: 1
Total weight: 2 LBS
Declared Value: 0.00 USD
Special Services:
Pickup/Drop-off: Use an already scheduled pickup at my location

Billing Information:

Bill transportation to: CuddyFeder-963
Your reference: 1844-3651
P.O. no.:
Invoice no.:
Department no.:

Thank you for shipping online with FedEx ShipManager at fedex.com.

Please Note

FedEx will not be responsible for any claim in excess of \$100 per package, whether the result of loss, damage, delay, non-delivery, misdelivery, or misinformation, unless you declare a higher value, pay an additional charge, document your actual loss and file a timely claim. Limitations found in the current FedEx Service Guide apply. Your right to recover from FedEx for any loss, including intrinsic value of the package, loss of sales, income interest, profit, attorney's fees, costs, and other forms of damage whether direct, incidental, consequential, or special is limited to the greater of \$100 or the authorized declared value. Recovery cannot exceed actual documented loss. Maximum for items of extraordinary value is \$1000, e.g., jewelry, precious metals, negotiable instruments and other items listed in our Service Guide. Written claims must be filed within strict time limits; Consult the applicable FedEx Service Guide for details. The estimated shipping charge may be different than the actual charges for your shipment. Differences may occur based on actual weight, dimensions, and other factors. Consult the applicable [FedEx Service Guide](#) or the FedEx Rate Sheets for details on how shipping charges are calculated.



Shipment Receipt

Address Information

Ship to:

Daniel E. Casagrande, Esq.
Cramer & Anderson, Esq.
30Main Street
Suite 204
DANBURY, CT
06810
US
914-761-1300 1901

Ship from:

Daniel Patrick, Esq.
Cuddy & Feder LLP
445 Hamilton Avenue
Suite 1400
White Plains, NY
10601
US
9147611300

Shipment Information:

Tracking no.: 777452601550
Ship date: 07/21/2022
Estimated shipping charges: 17.26 USD

Package Information

Pricing option: FedEx Standard Rate
Service type: Priority Overnight
Package type: FedEx Envelope
Number of packages: 1
Total weight: 2 LBS
Declared Value: 0.00 USD
Special Services:
Pickup/Drop-off: Use an already scheduled pickup at my location

Billing Information:

Bill transportation to: CuddyFeder-963
Your reference: 1844-3651
P.O. no.:
Invoice no.:
Department no.:

Thank you for shipping online with FedEx ShipManager at fedex.com.

Please Note

FedEx will not be responsible for any claim in excess of \$100 per package, whether the result of loss, damage, delay, non-delivery, misdelivery, or misinformation, unless you declare a higher value, pay an additional charge, document your actual loss and file a timely claim. Limitations found in the current FedEx Service Guide apply. Your right to recover from FedEx for any loss, including intrinsic value of the package, loss of sales, income interest, profit, attorney's fees, costs, and other forms of damage whether direct, incidental, consequential, or special is limited to the greater of \$100 or the authorized declared value. Recovery cannot exceed actual documented loss. Maximum for items of extraordinary value is \$1000, e.g., jewelry, precious metals, negotiable instruments and other items listed in our Service Guide. Written claims must be filed within strict time limits; Consult the applicable FedEx Service Guide for details. The estimated shipping charge may be different than the actual charges for your shipment. Differences may occur based on actual weight, dimensions, and other factors. Consult the applicable [FedEx Service Guide](#) or the FedEx Rate Sheets for details on how shipping charges are calculated.



Shipment Receipt

Address Information

Ship to:

Director Sharon B. Calitro,
AICP

City of Danbury
155 Deer Hill Ave
City of Danbury Assistant
Corp. Co.

DANBURY, CT

06810

US

9147611300 1903

Ship from:

Daniel Patrick, Esq.

Cuddy & Feder LLP
445 Hamilton Avenue
Suite 1400

White Plains, NY

10601

US

9147611300

Shipment Information:

Tracking no.: 777452654830

Ship date: 07/21/2022

Estimated shipping charges: 17.26 USD

Package Information

Pricing option: FedEx Standard Rate

Service type: Priority Overnight

Package type: FedEx Envelope

Number of packages: 1

Total weight: 2 LBS

Declared Value: 0.00 USD

Special Services:

Pickup/Drop-off: Use an already scheduled pickup at my location

Billing Information:

Bill transportation to: CuddyFeder-963

Your reference: 1844-3651

P.O. no.:

Invoice no.:

Department no.:

Thank you for shipping online with FedEx ShipManager at fedex.com.

Please Note

FedEx will not be responsible for any claim in excess of \$100 per package, whether the result of loss, damage, delay, non-delivery, misdelivery, or misinformation, unless you declare a higher value, pay an additional charge, document your actual loss and file a timely claim. Limitations found in the current FedEx Service Guide apply. Your right to recover from FedEx for any loss, including intrinsic value of the package, loss of sales, income interest, profit, attorney's fees, costs, and other forms of damage whether direct, incidental, consequential, or special is limited to the greater of \$100 or the authorized declared value. Recovery cannot exceed actual documented loss. Maximum for items of extraordinary value is \$1000, e.g., jewelry, precious metals, negotiable instruments and other items listed in our Service Guide. Written claims must be filed within strict time limits; Consult the applicable FedEx Service Guide for details. The estimated shipping charge may be different than the actual charges for your shipment. Differences may occur based on actual weight, dimensions, and other factors. Consult the applicable FedEx Service Guide or the FedEx Rate Sheets for details on how shipping charges are calculated.