



# STATE OF CONNECTICUT CONNECTICUT SITING COUNCIL

Ten Franklin Square, New Britain, CT 06051  
Phone: (860) 827-2935 Fax: (860) 827-2950  
E-Mail: [siting-council@po.state.ct.us](mailto:siting-council@po.state.ct.us)  
Web Site: [www.state.ct.us/csc/index.htm](http://www.state.ct.us/csc/index.htm)

March 28, 2002

**RECEIVED**

APR 18 2002

CONNECTICUT  
SITING COUNCIL

*Via Facsimile*

Ms. Dawn E. Holmes  
Manager  
Real Estate Administration  
Southern New England Telephone  
310 Orange Street  
New Haven, CT 06510

Re: Notice of Intent to Modify an Exempt Tower and Associated Equipment at Moses Mountain, Danbury and 310 Orange Street, New Haven.

Dear Ms. Holmes:

For the above referenced filing, I am requesting additional information needed to enable the Siting Council to act on your Notice. This information is described below:

1. For neither site do you provide a structural analysis indicating that the existing tower structure can or cannot support the proposed antennas. Please provide these analyses.
2. For each site, you have included power density calculations for the antennas you are proposing to install. However, in neither case do these calculations account for the antennas already on the Moses Mountain and 310 Orange Street towers. Please provide power density calculations that include all antennas installed and currently proposed to be installed on these two towers.
3. In addition, in previous filings there was an indication that conservative power density calculations showed that the antennas on the Moses Mountain tower may be exceeding the FCC limit for Maximum Possible Exposure (MPE). (see filing dated May, 2000 submitted by Troy Riccitelli, SNET) This concern was, in part, addressed by a field study and safety analysis for the Moses Mountain tower performed by RCC Consultants and dated November, 1997.

Please provide documentation indicating that the antennas currently being proposed for Moses Mountain will not cause this tower to exceed the FCC's MPE.

If you have any questions concerning these requests, please feel free to call me at the above number. Thank you for your assistance in this matter.

Sincerely,

David Martin  
Siting Analyst I



**BAYAR ENGINEERING, P.C.**  
**Structural Engineers**

P.O. Box 1287, Port Chester, N.Y. 10573-8287  
TEL: (914) 921-4067 FAX: (914) 987-2147

*Demirtas C. Bayar, P.E.*

April 1, 2002

Mr. Manny Litos  
The Marcus Group  
P.O.Box 8447  
275 New State Road  
Manchester, CT 06040

Re: Moses Mtn., Danbury, CT.  
BE Job No. 0210

Dear Mr. Litos,

We reviewed your proposed addition of antennas to the existing 65' tower at Moses Mtn., Danbury, CT. We understand that two Decibel DB636 antennas will be installed at about the 50' level and one TXRX antenna will be install with its top at 76' above the base of the tower. The enclosed drawing AR20689 shows our understanding of the antenna configurations.

Our analysis indicated that for the tower to be structurally adequate, four (4) grid type parabolic antennas need to be removed from the tower. These antennas are marked and defined on the enclosed drawing. The additional parabolic antenna you proposed at the 50' level will overstress the tower. For this condition we need to make additional calculations to determine the overstress, tilt and twist of the tower.

Should you have any other questions regarding this report we will be glad to discuss them with you.

Yours truly,

Demirtas C. Bayar  
President

XC: Don Wilson (RCC)

**Table #1.**

<b>Service</b> Marcus Com. LLC. Moses Mt. Danbury, CT.	<b>Power Density @</b> <b>Site Boundary</b>  mW/cm <sup>2</sup>	<b>Power Density @</b> <b>Tower Base</b>  mW/cm <sup>2</sup>	<b>Antenna</b> <b>Height</b> <b>(feet)</b>	<b>CT/ANSI</b> <b>Standard</b>  mW/cm <sup>2</sup>	<b>% of</b> <b>Standard</b>  <b>@Site</b> <b>Boundary</b>
Antenna #1	6.136%	8.344%	50'	0.3067	6.136%
Antenna #2	6.136%	8.344%	50'	0.3067	6.136%
Antenna #3 Receive Only	0%	0%	65'	0	0%
Antenna #4	0.150%	0.206%	49'	1.0	0.150%
<b>Pagenet, Inc.</b>	<b>12.275%</b>	<b>18.117%</b>	<b>58'</b>	<b>0.6269</b>	<b>12.275%</b>
<b>Bell South Wireless</b>	<b>1.656%</b>	<b>2.115%</b>	<b>76'</b>	<b>0.6253</b>	<b>1.656%</b>
<b>Verizon Wireless</b>	<b>18.56%</b>	<b>24.665%</b>	<b>69.75'</b>	<b>0.583</b>	<b>18.56%</b>
<b>Total</b>	<b>44.913%</b>	<b>61.791%</b>			<b>44.913%</b>

**Table #2.**

<b>Actual Measure.</b> Moses Mt. Danbury, Ct.	<b>All emitters from Field Study and Safety Analysis.</b> Copy of Report attached.	<b>36.8%</b>
	<b>Measurements from Table #1.</b>	<b>44.913%</b>
	<b>Total Percentage of Standard at the Site Boundary</b>	<b>81.713%</b>

<b>Service</b> Marcus com. LLC. 310 Orange St. New Haven, CT.	<b>Power Density @</b> <b>Site Boundary</b>  mW/cm <sup>2</sup>	<b>Power Density @</b> <b>Tower Base</b>  mW/cm <sup>2</sup>	<b>Antenna</b> <b>Height</b> <b>(feet)</b>	<b>CT/ANSI</b> <b>Standard</b>  mW/cm <sup>2</sup>	<b>% of</b> <b>Standard</b>  <b>@Site</b> <b>Boundary</b>
Antenna #1 Receive Only	0%	0%	117.8'	0	0
Antenna #2	2.817%	3.057%	103'	0.3067	2.817%
Antenna #3	2.817%	3.057%	103'	0.3067	2.817%
Antenna #4	0.306%	0.612%	40'	1.0	0.306%
Antenna #5	0.086%	0.173%	40'	1.0	0.086%
<b>Cingular</b> <b>(SNET Wireless)</b>	<b>3.985%</b>	<b>4.287%</b>	<b>109'</b>	<b>.6000</b>	<b>3.985%</b>
<b>Pagenet</b>	<b>7.670%</b>	<b>8.166%</b>	<b>118'</b>	<b>.6000</b>	<b>7.670%</b>
<b>Sirius Radio</b>	<b>12.765%</b>	<b>13.633%</b>	<b>115'</b>	<b>1.000</b>	<b>12.765%</b>
<b>Proposed System</b> <b>AT&amp;T Local Services</b>	<b>4.886%</b>	<b>9.7717%</b>	<b>10'</b>	<b>1.000</b>	<b>4.886%</b>
<b>Total</b>	<b>35.332%</b>	<b>42.7747%</b>			<b>35.332%</b>

The current Connecticut (and ANSI/IEEE) power density level standards, for non-ionizing radiation, are shown above. A ground reflection coefficient of 1.6 is used. The levels identified in this case are below the standards. These calculations conform to the procedures described by FCC OST Bulletin No. 65.

Conclusion

The proposed additions do not constitute a “modification” of an existing facility as defined in the Connecticut General Statutes Section 16-50i(d). There will be no change to the tower height or extension of the boundaries of the site. The tower is structurally sufficient to support the proposed antennas since existing unused two-way radio antennas will be removed. There will be no increase in noise levels at the site’s boundary by six (6) decibels or more and the total radio frequency electromagnetic radiation is not at or above the standard set forth in Section 22(a)-162 of the Connecticut General Statutes. This addition will not have a substantially adverse environment effect.

For these reasons, SNET requests that the Council acknowledge that this Notice of Modification meets the Council’s exemption criteria

POWER DENSITY CALCULATION MODEL

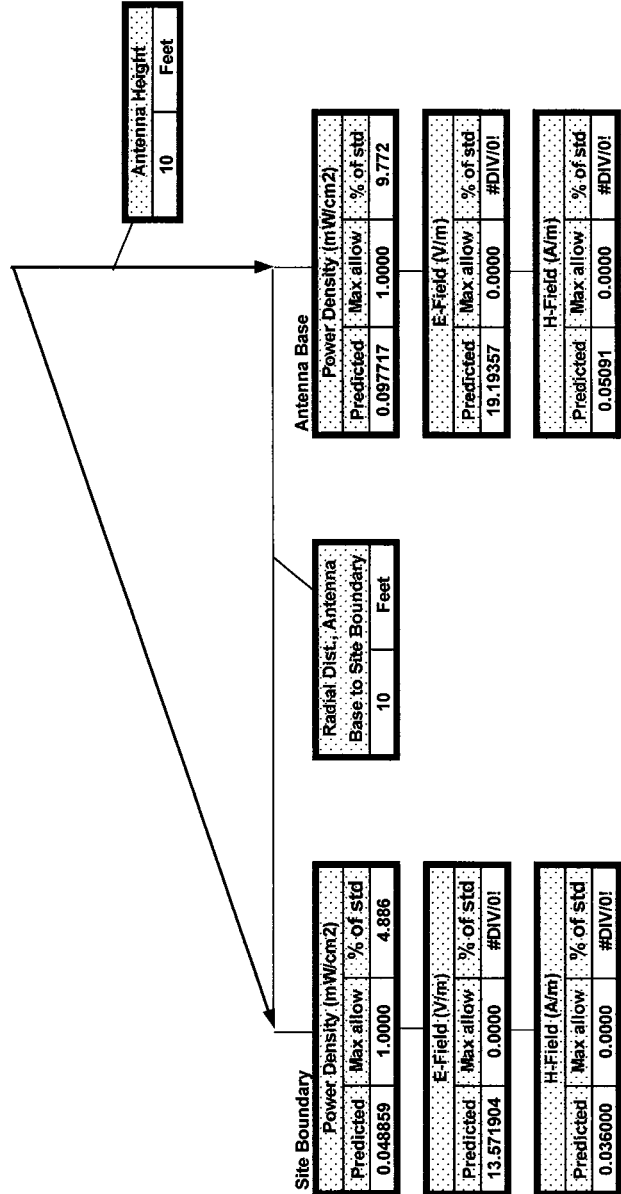
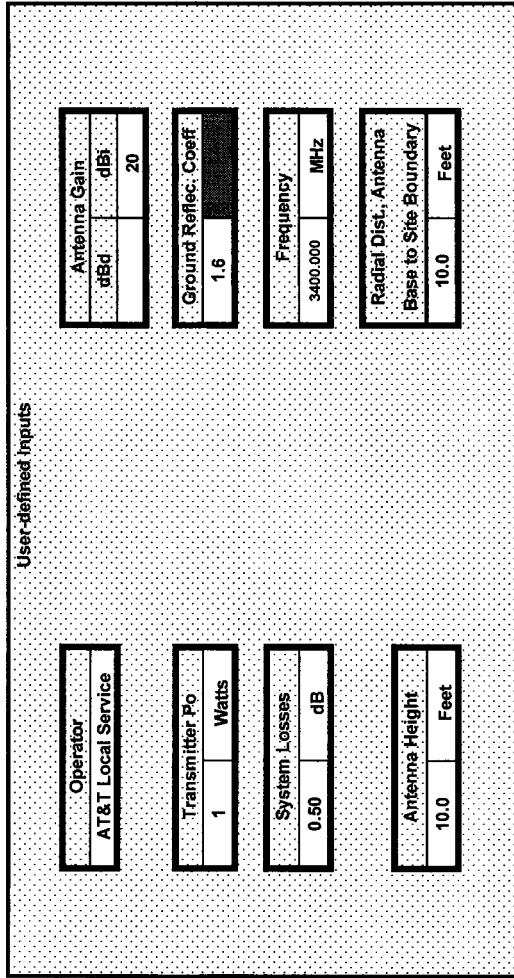

1.000

Slant  
431

Radial  
305

-1

Height  
305

E(std), f>100k	V/m	H(std), f>100k	0	A/m	S(std),>100k	0	out of f range
E(std), 1.5k<=f<100k	V/m	H(std), 1.5k<=f<100k	---	A/m	S(std),1.5k<=f<100k	1.0	mW/cm2
E(std),300<=f<1.5k	V/m	H(std),300<=f<1.5k	0	A/m	S(std),300<=f<1.5k	0	mW/cm2
E(std), 30<=f<300	V/m	H(std), 30<=f<300	0	A/m	E(std):	0	mW/cm2
					H(std):	0	mW/cm2
E(std), 1.34<=f<30	V/m	H(std), 1.34<=f<30	0	A/m	S(E)std,1.34<=f<30	0	mW/cm2
					E(std):	0	mW/cm2
E(std), 0.3<= f<1.34	V/m	H(std), 0.3<=f<1.34	0	A/m	H(std):	0	mW/cm2
					S(E)std, 0.3<= f<1.34	0	mW/cm2
E(std), <0.3	V/m	H(std), <0.3	0	A/m	E(std):	0	mW/cm2
					H(std):	0	mW/cm2
					<0.3		out of f range

Pd @ Base: (W)	Ht (cm)	Radial d (cm)	Slant d (cm)	Syst loss (dB)	Antig (dB)	Antg-loss (dB)	gnd refl	Po (mW/cm2)	Std (mW/cm2)	% of std
AT&T Local Ser 1	305	0	0	0.5	20.0	19.5	---	0.097717	0.000000	#DIV/0!

Pd @ Boundary:	Ht (cm)	Radial d (cm)	Slant d (cm)	Syst loss (dB)	Antig (dB)	Antg-loss (dB)	gnd refl	Po (mW/cm2)	Std (mW/cm2)	% of std
AT&T Local Ser 1	305	305	431	0.5	20.0	19.5	1.6	0.048859	0.000000	#DIV/0!

S("E")	E	S("H")	H	Predicted %	H %
0.2	27.459	2.261	0.245	23.6	0.017
0.2	27.459	5.163	0.370	20.4	0.015
0.2	27.459	5.284	0.374	18.2	0.013
0.2	27.459	3.016	0.283	18.2	0.013
0.2	27.459	0.200	0.073	26.8	0.019
0.301	33.686	0.301	0.089	12.2	0.011
0.577	46.640	0.577	0.124	4.7	0.006
0.577	46.640	0.577	0.124	4.7	0.006
4.517	130.496	4.517	0.346	7.5	0.026

E	H
19.19365702	0.05091133
13.5719036	0.03599974

POWER DENSITY CALCULATION MODEL

User-defined Inputs

Operator Cingular	Antenna Gain dBi 10.0	0
Transmitter P <sub>o</sub> Watts 120	Ground Reflec. Coeff. 1.6	
System Losses dB 1.50	Frequency MHz 900.000	
Antenna Height Feet 109.0	Radial Dist., Antenna Base to Site Boundary Feet 30.0	

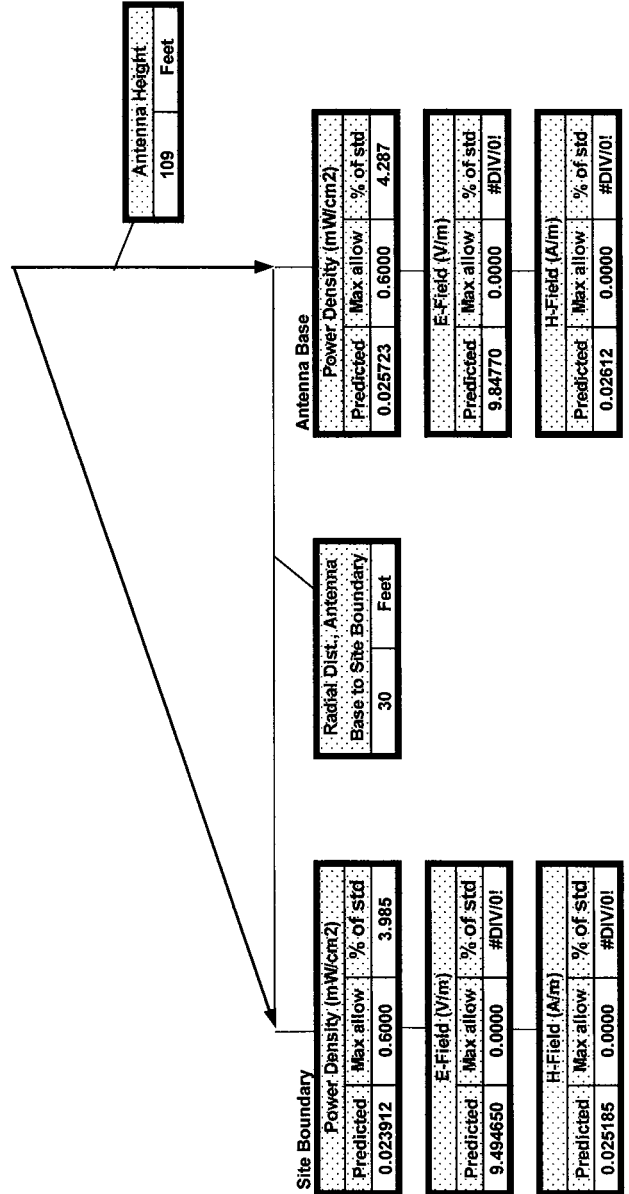

0.600

Slant  
3446

Radial  
914

0.600

Height  
3322

E(std), E(std), E(std), E(std), E(std), E(std), E(std), E(std)	P<100k 1.5k<=f<100k 300<=f<1.5k 30<=f<300 1.34<=f<30 0.3<=f<1.34 <0.3	V/m V/m V/m V/m V/m V/m V/m V/m	H(std), H(std), H(std), H(std), H(std), H(std), H(std), H(std)	P<100k 1.5k<=f<100k 300<=f<1.5k 30<=f<300 1.34<=f<30 0.3<=f<1.34 <0.3	A/m A/m A/m A/m A/m A/m A/m A/m	S(std),>100k S(std),1.5k<=f<100k S(std),300<=f<1.5k S(std),30<=f<300 S(E)std,1.34<=f<30 S(E)std,0.3<=f<1.34 S(E)std,<0.3	0 0 0 0 0 0 0 0	out of range mW/cm2 mW/cm2 mW/cm2 mW/cm2 mW/cm2 mW/cm2 mW/cm2 mW/cm2
E(std),	P<100k	V/m	H(std),	P<100k	A/m	S(std),>100k	0	out of range
E(std),	1.5k<=f<100k	V/m	H(std),	1.5k<=f<100k	A/m	S(std),1.5k<=f<100k	0	mW/cm2
E(std),	300<=f<1.5k	V/m	H(std),	300<=f<1.5k	A/m	S(std),300<=f<1.5k	0.600	mW/cm2
E(std),	30<=f<300	V/m	H(std),	30<=f<300	A/m	S(std),30<=f<300	0	mW/cm2
E(std),	1.34<=f<30	V/m	H(std),	1.34<=f<30	A/m	S(E)std,1.34<=f<30	0	mW/cm2
E(std),	0.3<=f<1.34	V/m	H(std),	0.3<=f<1.34	A/m	S(E)std,0.3<=f<1.34	0	mW/cm2
E(std),	<0.3	V/m	H(std),	<0.3	A/m	S(E)std,<0.3	0	mW/cm2

Pd @ Base:	(W)	Ht (cm)	Radial d (cm)	Slant d (cm)	Syst loss (dB)	Antg (dB)	Antg-loss (dB)	grd refi	Po (mW/cm2)	Std (mW/cm2)	% of std
Cingular	120	3322	0	0	1.5	12.2	10.7	1.6	0.025723	0.600000	4.287

Pd @ Boundary:

Cingular	120	3322	914	3446	1.5	12.2	10.7	1.6	E: 9.84770178 H: 0.02612122	0.600000	3.985
----------	-----	------	-----	------	-----	------	------	-----	--------------------------------	----------	-------

Standard

S("E")	E	H	S("H")	H	E	Predicted	%	H
0.2	27.459	0.245	2.261	0.245	6.469	23.6	23.6	0.017
0.2	27.459	0.370	5.163	0.370	5.594	20.4	20.4	0.015
0.2	27.459	0.374	5.284	0.374	4.988	18.2	18.2	0.013
0.2	27.459	0.283	3.016	0.283	4.988	18.2	18.2	0.013
0.2	27.459	0.200	0.200	0.073	7.368	26.8	26.8	0.019
0.301	33.686	0.301	0.301	0.089	4.119	12.2	12.2	0.011
0.577	46.640	0.124	0.577	0.124	2.214	4.7	4.7	0.006
0.577	46.640	0.124	0.577	0.124	2.214	4.7	4.7	0.006
0.577	46.640	0.124	0.577	0.124	2.214	4.7	4.7	0.006
4.517	130.496	0.346	4.517	0.346	9.824	7.5	7.5	0.026

# POWER DENSITY CALCULATION MODEL

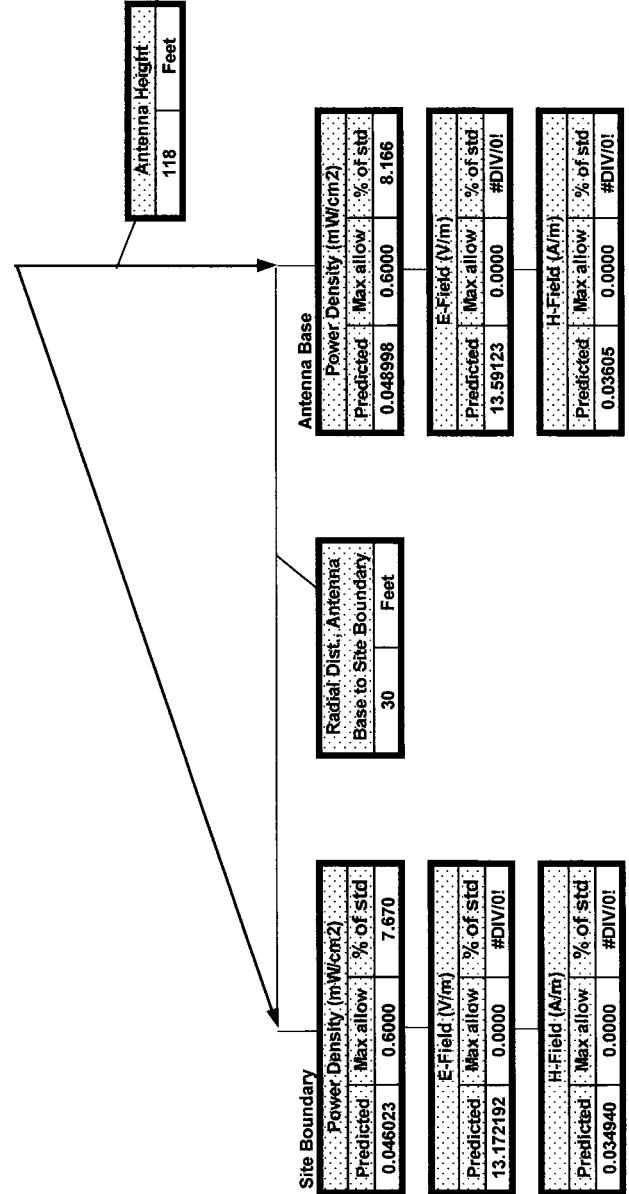
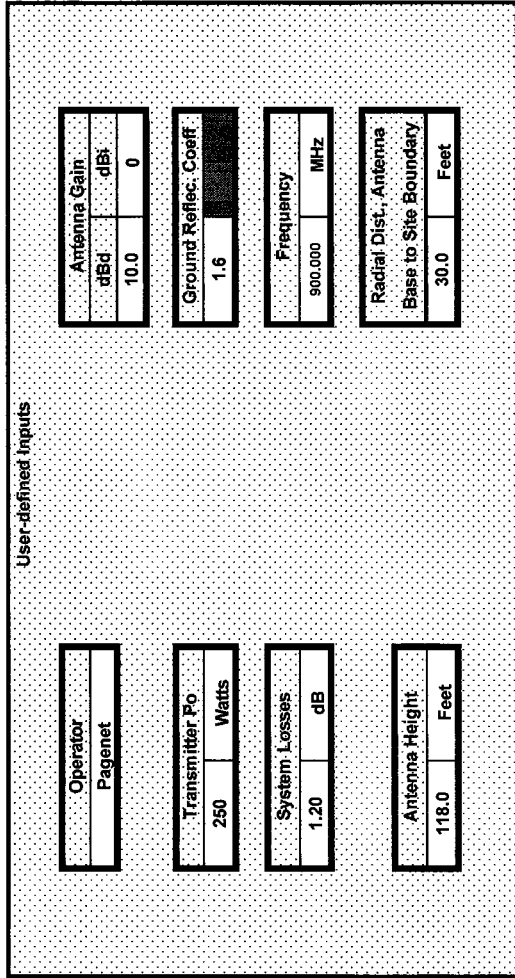



0.600

Slant  
3711

Radial  
914

0.600

Height  
3597

E(std),	P-100k	V/m	H(std),	P-100k	0	A/m	S(std), >100k	0	out of
E(std), 1.5k<=f<100k	V/m	H(std), 1.5k<=f<100k	0	A/m	S(std), 1.5k<=f<100k	0			
E(std), 300<=f<1.5k	V/m	H(std), 300<=f<1.5k	---	A/m	S(std), 300<=f<1.5k	0.600			
E(std), 30<=f<300	V/m	H(std), 30<=f<300	0	A/m	S(std), 30<=f<300	0	E(std):	0	
							H(std):	0	
E(std), 1.34<=f<30	V/m	H(std), 1.34<=f<30	0	A/m	S(E)std, 1.34<=f<30	0	E(std):	0	
							H(std):	0	
E(std), 0.3<=f<1.34	V/m	H(std), 0.3<=f<1.34	0	A/m	S(E)std, 0.3<=f<1.34	0	E(std):	0	
							H(std):	0	
E(std), <0.3	V/m	H(std), <0.3	0	A/m	S(E)std, <0.3	0	E(std):	0	
							H(std):	0	
									out of

Pd @ Base:	(W)	Ht (cm)	Radial d (cm)	Slant d (cm)	Syst loss (dB)	Antg (dB)	Antg-loss (dB)	grd refl	Po (mW/cm2)	Std (mW/cm2)
Pagenet	250	3597	0	0	1.2	12.2	11.0	1.6	0.048998	0.600000

Pd @ Boundary:	(W)	Ht (cm)	Radial d (cm)	Slant d (cm)	Syst loss (dB)	Antg (dB)	Antg-loss (dB)	grd refl	Po (mW/cm2)	Std (mW/cm2)
Pagenet	250	3597	914	3711	1.2	12.2	11.0	1.6	0.046023	0.600000

S("E")	E	S("H")	H	Predicted %	H %
0.2	27.459	2.261	0.245	23.6	0.017
0.2	27.459	5.163	0.370	20.4	0.015
0.2	27.459	5.284	0.374	18.2	0.013
0.2	27.459	3.016	0.283	18.2	0.013
0.2	27.459	0.200	0.073	26.8	0.019
0.301	33.686	0.301	0.089	12.2	0.011
0.577	46.640	0.577	0.124	4.7	0.006
0.577	46.640	0.577	0.124	4.7	0.006
0.577	46.640	0.577	0.124	4.7	0.006
4.517	130.496	4.517	0.346	7.5	0.026

E	H	Po
6.469	0.017	13.5912299
5.594	0.015	0.03605101
4.988	0.013	0.046023
4.988	0.013	13.1721924
7.368	0.019	0.0349395
4.119	0.011	
2.214	0.006	
2.214	0.006	
2.214	0.006	
9.824	0.026	

POWER DENSITY CALCULATION MODEL

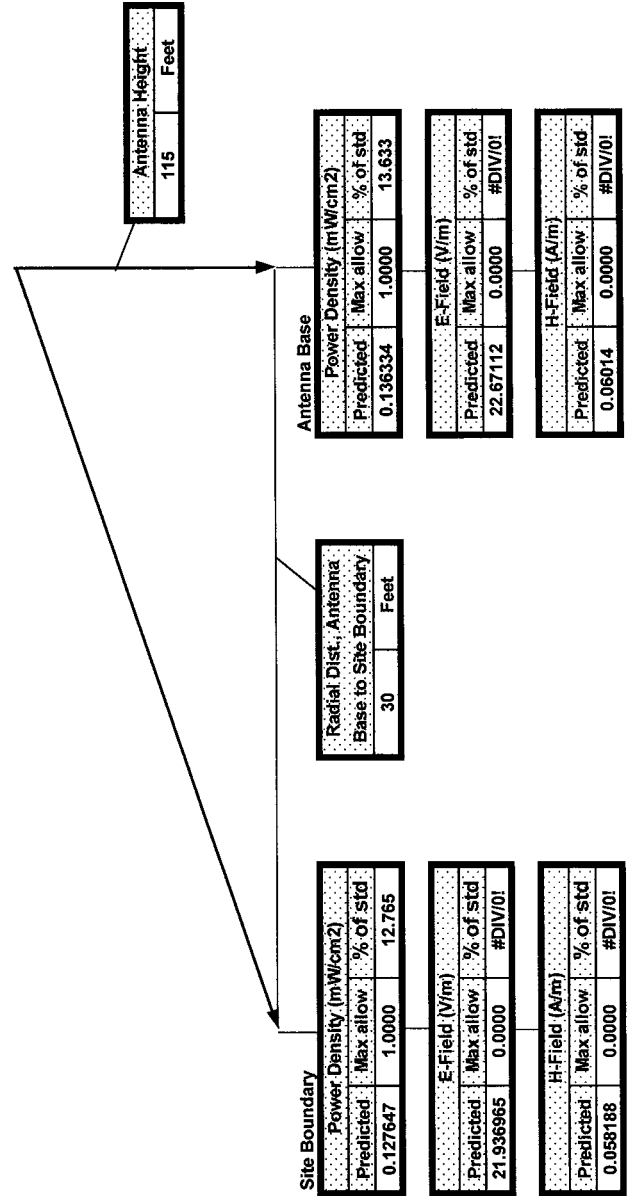
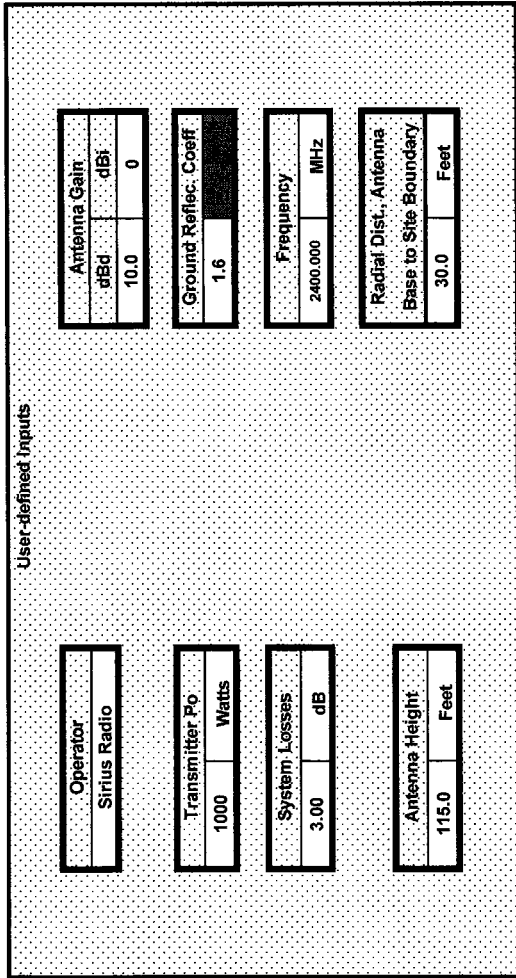

1.000

-1

Slant  
3623

Radial  
914

Height  
3505

E(std),	f>100k	V/m	H(std),	f>100k	0	A/m	S(std),>100k	0	out of
E(std),	1.5k<=f<100k	V/m	H(std),	1.5k<=f<100k	---	A/m	S(std),1.5k<=f<100k	1.0	
E(std),	300<=f<1.5k	V/m	H(std),	300<=f<1.5k	0	A/m	S(std),300<=f<1.5k	0	
E(std),	30<=f<300	V/m	H(std),	30<=f<300	0	A/m	S(std), 30<=f<300	0	
E(std),	1.34<=f<30	V/m	H(std),	1.34<=f<30	0	A/m	S(E)std,1.34<=f<30	0	
E(std),	0.3<=f<1.34	V/m	H(std),	0.3<=f<1.34	0	A/m	H(std):	0	
E(std),	<0.3	V/m	H(std),	<0.3	0	A/m	H(std):	0	

Pd @ Base:	(W)	Ht	Radial d	Slant d	Syst loss	Antg	Antg-loss	gnd refl	Po	Std
Sirius Radial	1000	(cm)	(cm)	(cm)	(dB)	(dB)	(dB)	---	(mW/cm2)	(mW/cm2)
Sirius Radial	1000	3505	0	0	3.0	12.2	9.2	1.6	0.136334	0.000000
Pd @ Boundary:	1000	3505	914	3623	3.0	12.2	9.2	1.6	0.06013559	0.000000

S("E")	E	S("H")	H	Predicted	%	H
0.2	27.459	2.261	0.245	6.469	23.6	0.017
0.2	27.459	5.163	0.370	5.594	20.4	0.015
0.2	27.459	5.284	0.374	4.988	18.2	0.013
0.2	27.459	3.016	0.283	4.988	18.2	0.013
0.2	27.459	0.200	0.073	7.368	26.8	0.019
0.301	33.886	0.301	0.089	4.119	12.2	0.011
0.577	46.640	0.577	0.124	2.214	4.7	0.006
0.577	46.640	0.577	0.124	2.214	4.7	0.006
0.577	46.640	0.577	0.124	2.214	4.7	0.006
4.517	130.496	4.517	0.346	9.824	7.5	0.026

Sirius Radial	1000	Ht	Radial d	Slant d	Syst loss	Antg	Antg-loss	gnd refl	Po	Std
Sirius Radial	1000	(cm)	(cm)	(cm)	(dB)	(dB)	(dB)	---	(mW/cm2)	(mW/cm2)
Sirius Radial	1000	3505	0	0	3.0	12.2	9.2	1.6	0.136334	0.000000
Pd @ Boundary:	1000	3505	914	3623	3.0	12.2	9.2	1.6	0.06013559	0.000000

S("E")	E	S("H")	H	Predicted	%	H
0.2	27.459	2.261	0.245	6.469	23.6	0.017
0.2	27.459	5.163	0.370	5.594	20.4	0.015
0.2	27.459	5.284	0.374	4.988	18.2	0.013
0.2	27.459	3.016	0.283	4.988	18.2	0.013
0.2	27.459	0.200	0.073	7.368	26.8	0.019
0.301	33.886	0.301	0.089	4.119	12.2	0.011
0.577	46.640	0.577	0.124	2.214	4.7	0.006
0.577	46.640	0.577	0.124	2.214	4.7	0.006
0.577	46.640	0.577	0.124	2.214	4.7	0.006
4.517	130.496	4.517	0.346	9.824	7.5	0.026



**MEASUREMENT OF  
POTENTIALLY HAZARDOUS  
RADIO FREQUENCY  
ELECTROMAGNETIC FIELDS**

**SOUTHERN NEW ENGLAND TELEPHONE**

**"MOSES MOUNTAIN"  
COMMUNICATIONS FACILITY**

**DANBURY, CONNECTICUT**

**NOVEMBER 1997**

**A Field Study and Safety Analysis  
Performed By:**

**RCC CONSULTANTS, INC.  
100 WOODBRIDGE CENTER DRIVE, STE 201  
WOODBIDGE, NEW JERSEY 07095  
(732) 404-2400**

## CERTIFICATION

I, Thomas Allen Sharp, a Professional Electrical Engineer registered in the State of Connecticut and sixteen other States of the United States of America, a Communications Engineer practicing for over 23 years, and a Senior Consultant of RCC Consultants, Inc. for over ten years, hereby certify that I have reviewed the data and conclusions attached herewith as an independent consultant retained by Southern New England Telephone.

The conclusions are based on measurements conducted by other employees of RCC Consultants, Inc. who have been properly trained in RF radiation safety and measurement techniques.

\_\_\_\_\_ on \_\_\_\_\_, 1998  
Thomas Allen Sharp, P.E.  
Senior Consultant  
RCC Consultants, Inc.

## Table of Contents

<i>Scope</i> .....	2
<b><i>Background on RF Radiation</i></b> ..... 3	
Description of Microwave Radiation.....	4
Typical Uses of Radio Frequency Radiation.....	5
Differences Between Non-Ionizing and Ionizing Radiation.....	5
Biological Effects Caused by Radiation.....	5
The Measurement of Radio Frequency Radiation.....	6
What Are Safe Levels of Exposure to RF Radiation?.....	7
FCC Guidelines for Evaluating Exposure to RF Emissions.....	7
Applicability of New Guidelines.....	13
 <b><i>Controlling Exposure to RF Fields</i></b>	
Public Exposure: Compliance with General Population/Uncontrolled MPE Limits.....	14
 <b><i>RCC NIR Measurement Methodology</i></b> ..... 18	
 <b><i>Study Conducted For SNET at Danbury, Connecticut</i></b> ..... 21	
Moses Mountain Communications Facility.....	22
Site Description and System Overview.....	23
Findings of RF Radiation Measurements.....	27
Conclusions and Recommendations.....	29
 <b><i>Summary of NIR Study for Moses Mountain Facility at Danbury, CT</i></b> ..... 29	
 <b><i>References</i></b> ..... 30	

## SCOPE

The Southern New England Telephone Company ("SNET") commissioned RCC Consultants, Inc. ("RCC") to conduct non-ionizing radiation ("NIR") measurements of potentially hazardous radio frequency ("RF") fields at the cellular base station facility in Danbury, Connecticut. This site, named Moses Mountain, is operated by SNET and contains other collocated radio transmission operators. These measurements were completed on November 7, 1997.

The purpose of the measurement was to investigate the existence of potential hazards created by the operation of radio transmission equipment used by the many communications service operators and located at the above referenced facilities. Furthermore, it is SNET's desire to ensure not only the safety of its employees and other occupational visitors who visit the facilities and might be exposed to potentially hazardous fields from time to time, but also to determine the actual energy levels of the existing RF fields through an empirical process for future reference. Moreover, the actual measurements and results thereof, along with the administration and execution of recommended safety precautions and procedures contained herein would render a state of compliance with regard to guidelines established by the Federal Communications Commission ("FCC") under Bulletin #65 drafted by the Office of Engineering & Technology ("OET") and mandated for practice as of October 15, 1997.

The primary goals were to determine the levels of NIR of the electromagnetic RF fields at Moses Mountain caused by the following equipment and antennas (or emitters) as well as the specific (physical) points of interest.

### **Moses Mountain Communications Facilities.**

This facility incorporates both two-way radio transmission equipment operating intermittently in the 450 MHz conventional radiotelephone service band, 800 MHz cellular service band, 900 MHz paging service band (929/931 MHz) and 900 MHz SMR service band. The emitters are located on a free-standing triangulated steel platform 65' tall.

## BACKGROUND

There has been an increasing interest and concern on the part of the public with respect to RF radiation issues. The expanding use of radio frequency technology has resulted in speculation concerning the alleged "electromagnetic pollution" of the environment and the potential dangers of exposure to non-ionizing radiation. Therefore, the following information has been provided to serve as an avenue of better understanding the subject matter.

Radio Frequency (RF) radiation is one of several types of electromagnetic radiation. Electromagnetic radiation consists of waves of electric and magnetic energy moving together through space. These waves are generated by the movement of electrical charges. For example, the movement of charge in a transmitting radio antenna, i.e., the alternating current, creates electromagnetic waves that radiate away from the antenna and can be intercepted by a receiving antenna.

Electromagnetic waves travel through space at the speed of light. Each electromagnetic wave has associated with it a wavelength and frequency which are inversely related by a simple mathematical formula: (frequency) times (wavelength) = the speed of light. Since the speed of light is a fixed number, electromagnetic waves with high frequencies have short wavelengths and waves with low frequencies have long wavelengths.

The electromagnetic "spectrum" includes all of the various forms of electromagnetic radiation ranging from Extremely Low Frequency (ELF) energy (with very long wavelengths) to X-rays and gamma rays which have very high frequencies and correspondingly short wavelengths. In between these extremes lie radio waves, microwaves, infrared, ultra-violet, and visible light.

The RF portion of the electromagnetic spectrum is generally defined as electromagnetic radiation with frequencies in the range from about 3 kilohertz to 300 gigahertz. One "hertz" equals one cycle per second. A kilohertz (KHz) is one thousand hertz, a megahertz (MHz) is one million hertz, and a gigahertz is one billion hertz. Figure 1 illustrates the electromagnetic spectrum and the approximate relationship between the various forms of electromagnetic energy.



MEASUREMENT OF POTENTIALLY HAZARDOUS RADIO FREQUENCY ELECTROMAGNETIC FIELDS

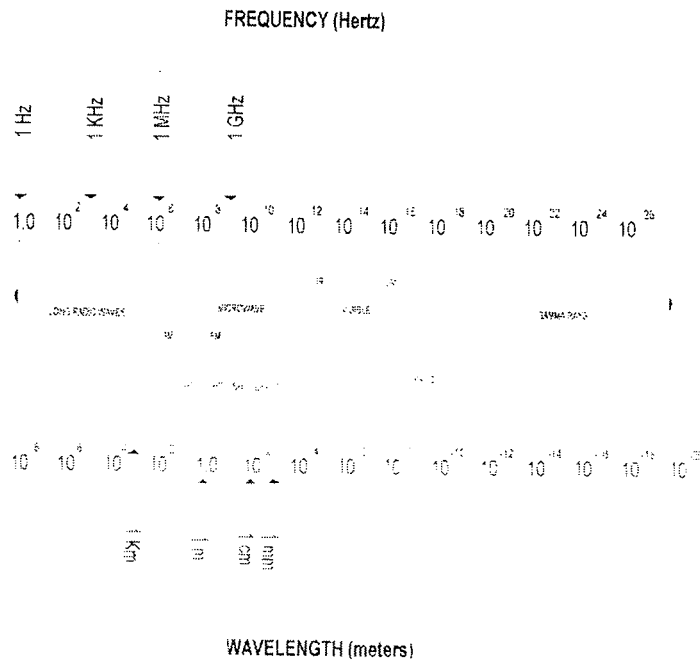

**Figure 1. The Electromagnetic Spectrum**

**Microwave Radiation**

Microwave radiation is a high frequency form of RF radiation. Microwave frequencies occupy the upper part of the RF electromagnetic spectrum, usually defined as the frequency range from about 300 MHz to 300 GHz. The most familiar use of microwave radiation is in household microwave ovens which rely on the principle that microwaves generate heat throughout an object rather than just at the surface. Therefore, microwave ovens can cook food more rapidly than conventional ovens. Other uses of microwaves are: the transmission of telephone and telegraph messages through low power microwave relay antennas, military and civilian radar systems, the transmission of signals between ground stations and satellites, and the transmission of signals in certain broadcasting operations. Certain medical devices use microwave frequencies in therapeutic applications of RF radiation.

**Typical Uses of Radio Frequency Radiation**

Many uses have been developed for RF energy. Familiar applications involving telecommunications include AM and FM radio, television, two-way radio communications, cordless telephones, and microwave point-to-point telecommunications links.

CONDUCTED BY RCC CONSULTANTS, INC. FOR SNET NOVEMBER 1997

Non-telecommunications applications include microwave ovens and radar, as previously mentioned. Also important are devices that use RF energy in industrial heating and sealing operations.

### **The Differences Between Non-Ionizing and Ionizing Radiation**

The energy associated with electromagnetic radiation depends on its frequency (or wavelength); the greater the frequency (and shorter the wavelength), the higher the energy. Therefore, x-radiation and gamma radiation, which have extremely high frequencies, have relatively large amounts of energy; while, at the other end of the electromagnetic spectrum, ELF radiation is less energetic by many orders of magnitude. In between these extremes lie ultraviolet radiation, visible light, infrared radiation, and RF radiation (including microwaves), all differing in energy content.

Of the various forms of electromagnetic radiation, x-ray and gamma ray energies represent the greatest relative hazard because of their greater energy content and corresponding greater potential for damage. In fact, X-rays and gamma rays are so energetic that they can cause ionization of atoms and molecules and thus are classified as "ionizing" radiation. Ionization is a process by which electrons are stripped from atoms and molecules, producing molecular changes that can lead to significant genetic damage in biological tissue. Less energetic forms of electromagnetic radiation, such as microwave radiation, lack the ability to ionize atoms and molecules and are classified as "non-ionizing" radiation. It is important that the terms, "*ionizing*" and "*non-ionizing*," not be confused when referring to electromagnetic radiation, since their mechanisms of interaction of the human body are quite different. Biological effects of (non-ionizing) RF radiation are discussed below.

### **Biological Effects Caused by Radiation**

There is a relatively extensive body of published literature concerning the biological effects of RF radiation. The following discussion only provides highlights of current knowledge in this area.

It has been known for some time that high intensities of RF radiation can be harmful due to the ability of RF energy to heat biological tissue rapidly. This is the principle by which microwave ovens cook food, and exposure to high RF power densities, i.e., on the order of 100 mW/cm<sup>2</sup> or more, can result in heating of the human body and an increase in body temperature. Tissue damage can result primarily because of the body's inability to cope with or dissipate the excessive heat.

Under certain conditions, exposure to RF power densities of about 10 mW/cm<sup>2</sup> or more could result in measurable heating of biological tissue. The extent of heating would depend on several factors including frequency of the radiation; size, shape, and orientation of the exposed object; duration of exposure; environmental conditions; and efficiency of heat dissipation. Biological effects that result from heating of tissue by RF energy are often referred to as "thermal" effects.

Two areas of the body, the eyes and the testes, can be particularly susceptible to heating by RF energy because of the relative lack of available blood flow to dissipate the excessive heat load. Laboratory experiments have shown that short-term exposure to high levels of RF radiation (100-200 mW/cm<sup>2</sup>) can cause cataracts in rabbits. Temporary sterility, caused by such effects as changes in sperm count and in sperm motility, is possible after exposure of the testes to high levels of RF radiation.

*It should be emphasized that environmental levels of RF radiation routinely encountered by the public are far below the levels necessary to produce significant heating and increased body temperature. In fact, the U.S. Environmental Protection Agency has estimated that 98-99% of the population in seven U.S. urban areas studied is exposed to less than 0.001 mW/cm<sup>2</sup>.*

- However, there may be situations, particularly workplace environments, where RF safety standards are exceeded and people could be exposed to potentially harmful levels of RF radiation. In addition to intensity, the electromagnetic frequency of RF radiation is important in determining the relative hazard. At a distance of several wavelengths from a source of RF radiation, whole-body absorption of RF energy by humans will occur at a maximum rate when the frequency of the radiation is between about 30 and 300 MHz. *Because of this "resonance" phenomenon, RF safety standards take this frequency dependence into account. Therefore, the most stringent standards are in this frequency range of maximum absorption.*

### **The Measurement of Radio Frequency Radiation**

Since radio frequency radiation has both an electric and a magnetic component, it is often convenient to express intensity of radiation field in terms of units specific to each component. The unit "volts per meter" (V/m) is used for the electric component, and the unit "amperes per meter" (A/m) is used for the magnetic component. We often speak of an electromagnetic "field," and these units are used to provide information about the levels of electric and magnetic "field strength" at a measurement location.

Another commonly used unit for characterizing an RF electromagnetic field is "power density." Power density is most accurately used when the point of measurement is far enough away from the RF emitter to be located in what is referred to as the "far field" zone of the radiation pattern. In proximity to the antenna, or rather "emitter", i.e., in the "near field" zone, the physical relationships between the electric and magnetic components of the field can be complex, and it is best to use the field strength units discussed above.

Power density is measured in terms of power per unit area, for example, milliwatts per square centimeter (mW/cm<sup>2</sup>). When speaking of frequencies in the microwave range and higher, power density is usually used to express intensity since exposures that might occur would likely be in the far field zone.

#### **What Are Safe Levels of Exposure to RF Radiation?**

In 1996, the FCC adopted new guidelines and procedures for evaluating environmental effects of RF emissions. The new guidelines incorporate two tiers of exposure limits based on whether exposure occurs in an occupational or "controlled" situation or whether the general population is exposed or exposure is in an "uncontrolled" situation. In addition to guidelines for evaluating fixed transmitters, the FCC adopted new limits for evaluating exposure from mobile and portable devices, such as cellular telephones and personal communications devices. The FCC also revised its policy with respect to categorically excluding certain transmitters and services from requirements for routine evaluation for compliance with the guidelines.

#### **FCC Guidelines for Evaluating Exposure to RF Emissions**

In 1985, the FCC first adopted guidelines under the Memorandum Opinion and Order (GEN Docket No. 79-144) to be used for evaluating human exposure to RF emissions. The FCC revised and updated these guidelines (*Report and Order*, ET Docket 93-62, FCC 96-326) on August 1, 1996. The new guidelines incorporate limits for Maximum Permissible Exposure (MPE) in terms of electric and magnetic field strength and power density for transmitters operating at frequencies between 300 kHz and 100 GHz. Limits are also specified for localized ("partial body") absorption that are used primarily for evaluating exposure due to transmitting devices such as hand-held portable telephones. Implementation of the new guidelines for mobile and portable devices became effective August 7, 1996. For other applicants and licensees a transition period was established before the new guidelines would apply.

MEASUREMENT OF POTENTIALLY HAZARDOUS RADIO FREQUENCY ELECTROMAGNETIC FIELDS

The FCC's MPE limits are based on exposure limits recommended by the National Council on Radiation Protection and Measurements ("NCRP") (under NCRP Report #86) and, over a wide range of frequencies, the exposure limits developed by the Institute of Electrical and Electronics Engineers, Inc., ("IEEE") and adopted by the American National Standards Institute ("ANSI") in ANSI/IEEE C95.1-1992 (previously issued as IEEE C95.1-1991)(replacing 1982 version). Limits for localized absorption are based on recommendations of both ANSI/IEEE and NCRP. The FCC's new guidelines are summarized in OET Bulletin #65. The FCC's limits, and the NCRP and ANSI/IEEE limits on which they are based, are derived from exposure criteria quantified in terms of specific absorption rate (SAR).<sup>1</sup> The basis for these limits is a whole-body averaged SAR threshold level of 4 watts per kilogram (4 W/kg), as averaged over the entire mass of the body, above which expert organizations have determined that potentially hazardous exposures may occur. The new MPE limits are derived by incorporating safety factors that lead, in some cases, to limits that are more conservative than the limits originally adopted by the FCC in 1985. Table 1 indicates the most recent MPE levels and limits published by the FCC.

Where more conservative limits exist they do not arise from a fundamental change in the RF safety criteria for whole-body averaged SAR, but from a precautionary desire to protect subgroups of the general population who, potentially, may be more at risk.

The new FCC exposure limits are also based on data showing that the human body absorbs RF energy at some frequencies more efficiently than at others. As indicated by Table 1, the most restrictive limits occur in the frequency range of 30-300 MHz where whole-body absorption of RF energy by human beings is most efficient. At other frequencies whole-body absorption is less efficient, and, consequently, the MPE limits are less restrictive.

MPE limits are defined in terms of power density: units of milliwatts per centimeter squared ( $\text{mW}/\text{cm}^2$ ); electric field strength: (units of volts per meter:  $\text{V}/\text{m}$ ); and magnetic field strength: (units of amperes per meter:  $\text{A}/\text{m}$ ). In the far-field of a transmitting antenna, where the electric field vector (E), the magnetic field vector (H), and the direction of propagation can be considered to be all mutually orthogonal ("plane-wave" conditions), these quantities are related as indicated in Equation (1). In the near-field of a transmitting antenna the term "far-field equivalent" or "plane-wave equivalent" power density is often used to indicate a quantity calculated by using the near-field values of  $E^2$  or  $H^2$  as if they were obtained in the far-field.

---

<sup>1</sup> Specific absorption rate is a measure of the rate of energy absorption by the body. SAR limits are specified for both whole-body exposure and for partial-body or localized exposure (generally specified in terms of spatial peak values).

MEASUREMENT OF POTENTIALLY HAZARDOUS RADIO FREQUENCY ELECTROMAGNETIC FIELDS

$$S = \frac{E^2}{3770} = 37.7H^2$$

where: S = power density (mW/cm<sup>2</sup>)  
E = electric field strength (V/m)  
H = magnetic field strength (A/m)

**Equation #1**

For near field exposures, the values of plane-wave equivalent power density are given in some cases for reference purposes only. These values are sometimes used as a convenient comparison with MPEs for higher frequencies and are displayed on some measuring instruments

The FCC guidelines incorporate two separate tiers of exposure limits that are dependent on the situation in which the exposure takes place and/or the status of the individuals who are subject to exposure. The decision as to which tier applies in a given situation should be based on the application of the following definitions.

Occupational/controlled exposure limits apply to situations in which persons are exposed as a consequence of their employment and in which those persons who are exposed have been made fully aware of the potential for exposure and can exercise control over their exposure. Occupational/controlled exposure limits also apply where exposure is of a transient nature as a result of incidental passage through a location where exposure levels may be above general population/uncontrolled limits (see below), as long as the exposed person has been made fully aware of the potential for exposure and can exercise control over his or her exposure by leaving the area or by some other appropriate means. As discussed later, the occupational/controlled exposure limits also apply to amateur radio operators and members of their immediate household.

General population/uncontrolled exposure limits apply to situations in which the general public may be exposed or in which persons who are exposed as a consequence of their employment may not be made fully aware of the potential for exposure or cannot exercise control over their exposure. Therefore, members of the general public would always be considered under this category when exposure is not employment-related, for example, in the case of a telecommunications tower that exposes persons in a nearby residential area.

For purposes of applying these definitions, awareness of the potential for RF exposure in a workplace or similar environment can be provided through specific training as part of an RF safety program. Warning signs and labels can also be used to establish such awareness as long as they provide information, in a prominent manner, on risk of potential exposure and instructions on methods to minimize such exposure risk.

CONDUCTED BY RCC CONSULTANTS, INC. FOR SNET NOVEMBER 1997

MEASUREMENT OF POTENTIALLY HAZARDOUS RADIO FREQUENCY ELECTROMAGNETIC FIELDS

**Table 1. Limits for Maximum Permissible Exposure (MPE)**

**(A) Limits for Occupational/Controlled Exposure**

Frequency Range (MHz)	Electric Field Strength (E) (V/m)	Magnetic Field Strength (H) (A/m)	Power Density (S) (mW/cm <sup>2</sup> )	Averaging Time (minutes)
0.3-3.0	614	1.63	(100)*	6
3.0-30	1842/f	4.89/f	(900/f <sup>2</sup> )*	6
30-300	61.4	0.163	1.0	6
300-1500	--	--	f/300	6
1500-100,000	--	--	5	6

**(B) Limits for General Population/Uncontrolled Exposure**

Frequency Range (MHz)	Electric Field Strength (E) (V/m)	Magnetic Field Strength (H) (A/m)	Power Density (S) (mW/cm <sup>2</sup> )	Averaging Time (minutes)
0.3-1.34	614	1.63	(100)*	30
1.34-30	824/f	2.19/f	(180/f <sup>2</sup> )*	30
30-300	27.5	0.073	0.2	30
300-1500	--	--	f/1500	30
1500-100,000	--	--	1.0	30

NOTE 1: *Occupational/controlled* limits apply in situations in which persons are exposed as a consequence of their employment provided those persons are fully aware of the potential for exposure and can exercise control over their exposure. Limits for occupational/controlled exposure also apply in situations when an individual is transient through a location where occupational/controlled limits apply provided he or she is made aware of the potential for exposure.

NOTE 2: *General population/uncontrolled* exposures apply in situations in which the general public may be exposed, or in which persons that are exposed as a consequence of their employment may not be fully aware of the potential for exposure or can not exercise control over their exposure.

Note: f = frequency in megahertz (MHz)  
 E<sup>2</sup> = electric field strength squared  
 H<sup>2</sup> = magnetic field strength squared  
 V<sup>2</sup>/m<sup>2</sup> = volts squared per meter squared  
 A<sup>2</sup>/m<sup>2</sup> = amperes squared per meter squared  
 mW/cm<sup>2</sup> = milliwatts per centimeter squared  
 \*Plane-wave equivalent power density

CONDUCTED BY RCC CONSULTANTS, INC. FOR SNET NOVEMBER 1997

Figure 1. FCC Limits for Maximum Permissible Exposure (MPE)  
*Plane-wave Equivalent Power Density*

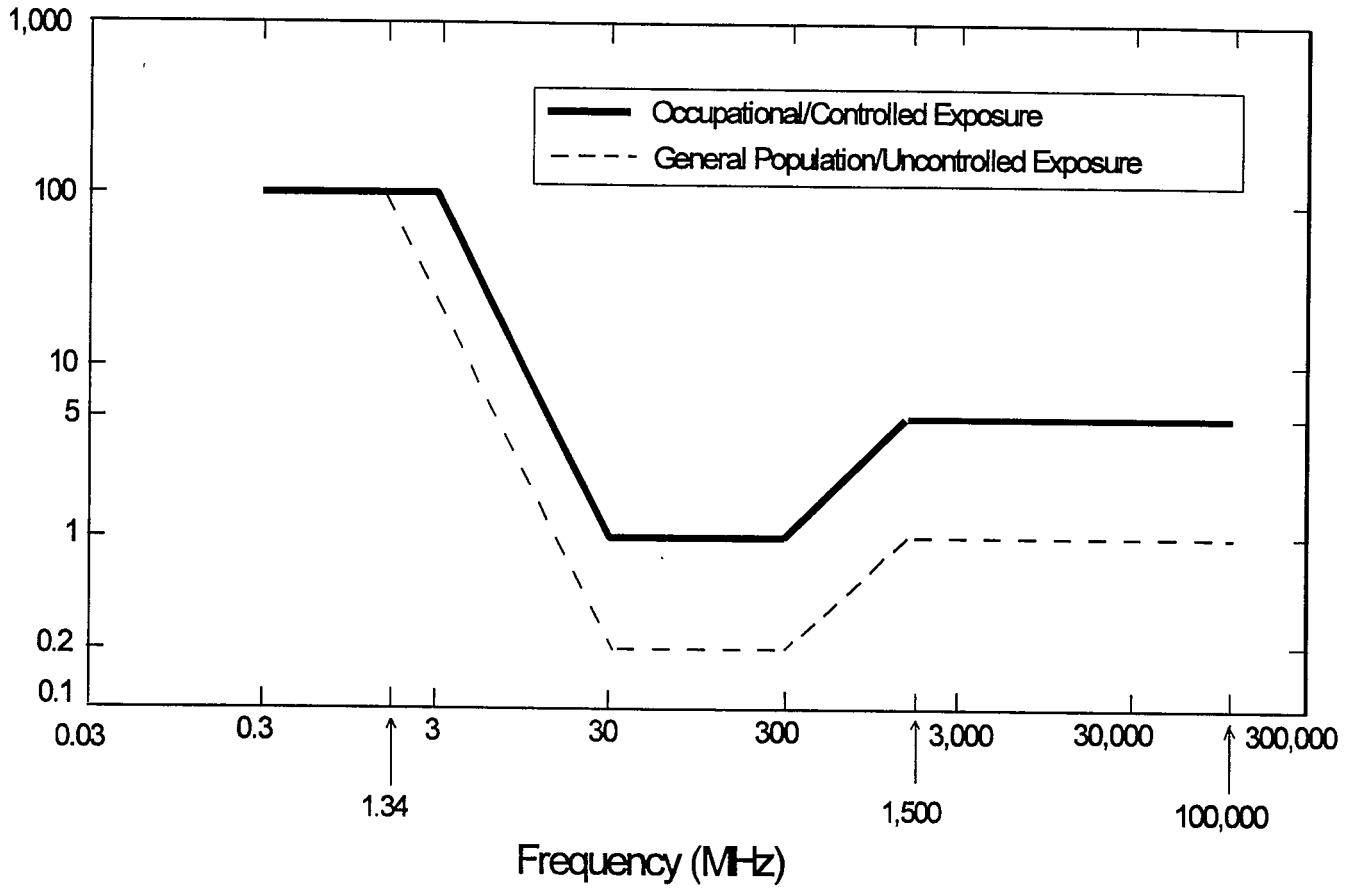



A fundamental aspect of the exposure guidelines is that they apply to power densities or the squares of the electric and magnetic field strengths that are spatially averaged over the body dimensions. Spatially averaged RF field levels most accurately relate to estimating the whole-body averaged SAR that will result from the exposure and the MPEs specified in Table 1 are based on this concept. This means that local values of exposures that exceed the stated MPEs may not be related to non-compliance if the spatial average of RF fields over the body does not exceed the MPEs. Further discussion of spatial averaging as it relates to field measurements can be found in the ANSI/IEEE and NCRP reference documents noted.

Another feature of the exposure guidelines is that exposures, in terms of power density, E<sup>2</sup> or H<sup>2</sup>, may be averaged over certain periods of time with the average not to exceed the limit for continuous exposure.<sup>2</sup> As shown in Table 1, the averaging time for occupational/controlled exposures is 6 minutes, while the averaging time for general population/uncontrolled exposures is 30 minutes. It is important to note that for general population/uncontrolled exposures it is often not possible to control exposures to the extent that averaging times can be applied. In those situations, it is often necessary to assume continuous exposure.

As an illustration of the application of time-averaging to occupational/controlled exposure consider the following. The relevant interval for time-averaging for occupational/controlled exposures is six minutes. This means, for example, that during any given six-minute period a worker could be exposed to two times the applicable power density limit for three minutes as long as he or she were not exposed at all for the preceding or following three minutes. Similarly, a worker could be exposed at three times the limit for two minutes as long as no exposure occurs during the preceding or subsequent four minutes, and so forth.

**Equation #2**

$$\sum S_{exp} t_{exp} = S_{limit} t_{avg}$$

- where:
- $S_{exp}$  = power density level of exposure (mW/cm<sup>2</sup>)
  - $S_{limit}$  = appropriate power density MPE limit (mW/cm<sup>2</sup>)
  - $t_{exp}$  = allowable time of exposure for  $S_{exp}$
  - $t_{avg}$  = appropriate MPE averaging time

---

<sup>2</sup> Note that although the FCC did not explicitly adopt limits for *peak* power density, guidance on these types of exposures can be found in Section 4.4 of the ANSI/IEEE C95.1-1992 standard.

This concept can be generalized by considering Equation #2 that allows calculation of the allowable time(s) for exposure at [a] given power density level(s) during the appropriate time-averaging interval to meet the exposure criteria of Table 1. The sum of the products of the exposure levels and the allowed times for exposure must equal the product of the appropriate MPE limit and the appropriate time-averaging interval.

For the example given in Equation #2, if the MPE limit is  $1 \text{ mW/cm}^2$ , then the right-hand side of the equation becomes  $6 \text{ mW-min/cm}^2$  ( $1 \text{ mW/cm}^2 \times 6 \text{ min}$ ). Therefore, if an exposure level is determined to be  $2 \text{ mW/cm}^2$ , the allowed time for exposure at this level during any six-minute interval would be a total of 3 minutes, since the left side of the equation must equal 6 ( $2 \text{ mW/cm}^2 \times 3 \text{ min}$ ). Of course, many other combinations of exposure levels and times may be involved during a given time-averaging interval.

However, as long as the sum of the products on the left side of the equation equals the right side, the average exposure will comply with the MPE limit. It is very important to remember that time-averaging applies to any interval of  $t_{\text{avg}}$ . Therefore, in the above example, consideration would have to be given to the exposure situation both before and after the allowed three-minute exposure. The time-averaging interval can be viewed as a "sliding" period of time, six minutes in this case.

Another important point to remember concerning the FCC's exposure guidelines is that they constitute exposure limits (not emission limits), and they are relevant only to locations that are accessible to workers or members of the public. Such access can be restricted or controlled by appropriate means such as the use of fences, warning signs, etc., as noted above. For the case of occupational/controlled exposure, procedures can be instituted for working in the vicinity of RF sources that will prevent exposures in excess of the guidelines. An example of such procedures would be restricting the time an individual could be near an RF source or requiring that work on or near such sources be performed while the transmitter is turned off or while power is appropriately reduced. In the case of broadcast antennas, the use of auxiliary antennas could prevent excessive exposures to personnel working on or near the main antenna site, depending on the separation between the main and auxiliary antennas.

#### **Applicability of New Guidelines**

The FCC's environmental rules regarding RF exposure identify particular categories of existing and proposed transmitting facilities, operations and devices for which licensees and applicants are required to conduct an initial environmental evaluation, and prepare an Environmental

## MEASUREMENT OF POTENTIALLY HAZARDOUS RADIO FREQUENCY ELECTROMAGNETIC FIELDS

Assessment if the evaluation indicates that the transmitting facility, operation or device exceeds or will exceed the FCC's RF exposure guidelines. For transmitting facilities, operations and devices not specifically identified, the FCC has determined, based on calculations, measurement data and other information, that such RF sources offer little potential for causing exposures in excess of the guidelines.

In that regard, all transmitting facilities and devices regulated by the FCC that are the subject of an FCC decision or action (e.g., grant of an application or response to a petition or inquiry) are expected to comply with the appropriate RF radiation exposure guidelines, or, if not, to file an Environmental Assessment (EA) for review under the National Environmental Protection Agency (NEPA) procedures, if such is required. It is important to emphasize that the categorical exclusions are *not* exclusions from *compliance* but, rather, exclusions from performing routine evaluations to demonstrate compliance. Normally, the exclusion from performing a routine evaluation will be a sufficient basis for assuming compliance, unless an applicant or licensee is otherwise notified by the Commission or has reason to believe that the excluded transmitter or facility encompasses exceptional characteristics that could cause non-compliance.

- It should also be stressed that even though a transmitting source or facility may not be categorically excluded from routine evaluation, no further environmental processing is required once it has been demonstrated that exposures are within the guidelines, as specified in Part 1 of the rules. These points have been the source of some confusion in the past among FCC licensees and applicants, some of whom have been under the impression that filing an EA is always required.

In adopting its new exposure guidelines, the FCC also adopted new rules indicating which transmitting facilities, operations and devices will be categorically excluded from performing routine, initial evaluations. The new exclusion criteria are based on such factors as type of service, antenna height, and operating power. The new criteria were adopted in an attempt to obtain greater consistency and scientific rigor in determining requirements for RF evaluation across the various FCC-regulated services.

## CONTROLLING EXPOSURE TO RF FIELDS

### **Public Exposure: Compliance with General Population/Uncontrolled MPE Limits**

Studies have indicated that the majority of the United States population is normally exposed to insignificant levels of RF radiation in the ambient environment.

CONDUCTED BY RCC CONSULTANTS, INC. FOR SNET NOVEMBER 1997

MEASUREMENT OF POTENTIALLY HAZARDOUS RADIO FREQUENCY ELECTROMAGNETIC FIELDS

However, there are some situations in which RF levels may be considerably higher than the median background, and in those cases preventive measures may have to be taken to control exposure levels.

As discussed in OET #65, the FCC's guidelines for exposure incorporate two tiers of limits, one for conditions under which the public may be exposed ("general population/uncontrolled" exposure) and the other for exposure situations usually involving workers ("occupational/controlled" exposure). Exposure problems involving members of the general public are generally less common than those involving persons who may be exposed at their place of employment, due to the fact that workers may be more likely to be in proximity to an RF source as part of their job.

In general, in order for a transmitting facility or operation to be out of compliance with the FCC's RF guidelines an area or areas where levels exceed the MPE limits must, first of all, be in some way *accessible* to the public or to workers. This should be obvious, but there is often confusion over an *emission* limit, e.g., a limit on field strength or power density at a specified distance from a radiator that always applies, and an *exposure* limit, that applies anywhere people may be located. The FCC guidelines specify exposure limits not emission limits, and that distinction must be emphasized. This is why the accessibility issue is key to determining compliance. The MPE limits indicate levels above which people may not be safely exposed regardless of the location where those levels occur. When accessibility to an area where an excessive level is appropriately restricted, the facility or operation can certify that it complies with the FCC requirements.

Restricting access is usually the simplest means of controlling exposure to areas where high RF levels may be present. Methods of doing this include fencing and posting such areas or locking out unauthorized persons in areas, such as rooftop locations, where this is practical.<sup>3</sup>

There may be situations where RF levels may exceed the MPE limits for the general public in remote areas, such as mountain tops, that could conceivably be accessible but are not likely to be visited by the public. In such cases, common sense should dictate how compliance is to be

3

Standard radio frequency hazard warning signs are commercially available from several vendors. They incorporate the format recommended by the American National Standards Institute (ANSI) as specified in ANSI C95.2-1982. Although the ANSI format is recommended, it is not mandatory. When signs are used, meaningful information should be placed on the sign advising of the potential for high RF fields.

CONDUCTED BY RCC CONSULTANTS, INC. FOR SNET NOVEMBER 1997

achieved. If the area of concern is properly marked by appropriate warning signs, fencing or the erection of other permanent barriers may not be necessary.

In some cases, the time-averaging aspects of the exposure limits may be used by placing appropriate restrictions on occupancy in high-field areas. However, such restrictions are often not possible where continuous exposure of the public may occur. In general, time averaging of exposures is usually more practical in controlled situations where occupational exposure is the only issue. Although restricting access may be the simplest and most cost-effective solution for reducing public exposure, other methods are also available. Such methods may be relevant for reducing exposure for both the general public and for workers.

For example, modifications to antennas, elevating antennas on roof-top installations or incorporation of appropriate shielding can reduce RF fields in locations accessible to the public or to workers.

Exposure to RF fields in the workplace or in other controlled environments usually presents different problems than does exposure of the general public. For example, with respect to a given RF transmitting facility, a worker at that facility would be more likely to be close to the radiating source than would a person who happens to live nearby. Although restricting access to high RF field areas is also a way to control exposures in such situations, this may not always be possible. In some cases a person's job may require him or her to be near an RF source for some part of the workday. Depending on the level and time of exposure this may present a problem with respect to compliance with the MPE limits.

In general, a locked rooftop or other appropriately restricted area that is only accessible to workers who are "aware of" and "exercise control over" their exposure would meet the criteria for occupational/controlled exposure, and protection would be required at the applicable occupational/controlled MPE limits for those individuals who have access to the rooftop.

As provided in OET #65, the MPE limits adopted by the FCC are *time-averaged* exposure limits. This means that the exposure duration should be taken into account when evaluating a given exposure situation, and this is especially relevant for cases of occupational/controlled exposure. For example, a person walking into an area where RF fields exceed the *absolute* MPE limit (in terms of field strength or power density) might not exceed the *time-averaged* MPE limit as long as the exposure was for an appropriately short period of time (relative to the time-averaging interval). However, if that person were to remain in the area for an extended period it is more probable that the time-averaged limit would be exceeded.

MEASUREMENT OF POTENTIALLY HAZARDOUS RADIO FREQUENCY ELECTROMAGNETIC FIELDS

Therefore, in order to comply with the FCC's guidelines, in some situations it may be necessary to limit exposure in certain areas to specific periods of time. For example, in workplace situations where extended maintenance tasks must be performed in areas where RF fields exceed MPE limits, the work may have to be divided up and carried out during several intervals of time so that the time-averaged exposure during each interval is acceptable. The actual exposure time allowed during any given interval would have to be determined by use of the appropriate averaging time specified in the guidelines (six-minutes for occupational exposure).

In addition to time-averaging, other means are available for controlling exposures in occupational or controlled environments. These include reducing or shutting off power when work is required in a high RF area, switching to an auxiliary transmitter (if available) while work on a main system is in progress or incorporating appropriate shielding techniques to reduce exposure.

In multiple transmitter environments, reducing power or RF shielding may be especially important for allowing necessary work procedures to be carried out. For example, on-tower exposures due to nearby co-located transmitting sources may be more significant when work on another station's tower is required.

In such complex environments power reduction agreements may often be necessary to ensure that all licensees are aware of the potential for their station to expose other individuals at the site and site occupants are generally jointly responsible for compliance with FCC guidelines.

CONDUCTED BY RCC CONSULTANTS, INC. FOR SNET NOVEMBER 1997

## RCC NIR MEASUREMENT METHODOLOGY

Calculations can only provide an estimate of the “field strengths” or RF energy fields produced in the near-field of radio emitters. Many factors are generally compromised when performing calculated analyses of RF radiation levels since antenna geometries, modulation, and polarization are all elements that determine RF emission levels. Since the specific characteristics are only approximated, the results determined through mathematical analyses are only a starting point. Calculations are accurate (and useful) in far-field scenarios, however, the near-field region is generally the area of predominant concern since human contact with RF emissions usually tend to occur there. When calculations alone are used to predict power densities, they are done in such a manner that ensures the actual values (of exposure) are always less than the calculated values.

RCC conducts mathematical calculations for near-field environments as well as provides on-site measurements for an empirical understanding of the RF environment. The calculated analyses are normally conducted for cases where a facility or emitter does not yet exist and data is required for safety management of the proposed entity.

RCC personnel have been trained by the Narda Division of Lockheed Martin Microwave (“NARDA”). The RCC sponsored training by NARDA covered such topics as:

- ◆ Health Effects
- ◆ Calculations and Measurements
- ◆ New Safety Standards
- ◆ Guidelines for Safety Programs
- ◆ Risk Management
- ◆ Measuring Equipment

RCC owns and maintains measuring equipment manufactured by NARDA as well. NARDA was selected for their extensive background in RF radiation protection equipment as well as knowledge of RF safety. NARDA equipment meets and exceeds instrumentation standards for basic components of an RF survey instrument in accordance with IEEE standard C95.3-1991, “IEEE Recommended Practice for the Measurement of Potentially Hazardous Electromagnetic Fields-RF and Microwave”. RCC observes this standard for all measurement equipment and procedures.

MEASUREMENT OF POTENTIALLY HAZARDOUS RADIO FREQUENCY ELECTROMAGNETIC FIELDS

The NARDA system is comprised of a Model #8718 Survey Meter combined with a wide range of electric field probes employed by RCC. The #8718 meter provides a 30 dB dynamic range, reads any unit of standards measurement, and provides automatic time and spatial averaging. For purposes of safety management, the #8710 meter employs an audible alarm that triggers at a programmable/preset level to indicate to the user that the programmed/preset RF field strength has been exceeded.

The #8700 Series probes employ mutually perpendicular sensing elements to provide isotropic response. This configuration results in accurate field measurements independent of the position of the probe or any polarization of the incident field. The sensing elements are square law devices resulting in RMS average power indications in the presence of multiple and/or pulsed signals. Each probe contains a preamplifier inside an electrically shielded handle. The main probe body is comprised of fiberglass and the actual probe element contains a cover of ABS plastic. The connecting cable is shielded from extraneous radiation (at most frequencies). A fiber optic receiver is built into the #8710 meter for low frequency measurements that could otherwise provide erroneous measurements due to induced signals on the standard probe cables.

The primary probe used in many field measurements is the #8722. This is a "shaped" probe in that it weighs the various signals in accordance with major standards. The #8722 employed by RCC is calibrated to follow the ANSI/IEEE C95.1-1992 standard for MPE levels. This minimizes the complexities when conducting measurements in multi-signal environments since the probe can differentiate between energies of varying frequencies. This probe provides a direct reading in units of percent of MPE in accordance with ANSI/IEEE C95.1-1992 standards. The probe's range of measurement is between 0.3% to 300% of standard. The probe operates in the frequency range from 300 KHz to 40 MHz.

When conducting the measurement for SNET, RCC considered the specific RF emissions present at the Moses Mountain site. The instruments used exhibited sufficient stability to permit accurate measurements of the RF fields over time consistent with applicable standards described herein. Accuracy of both the probes and meter were ensured by recent calibrations traceable to known standards as well as calibration signals provided within the meter. NARDA specifies the fields generated for calibrating probes are +/-0.5 dB. The standard for absolute field strength calibration desirability is +/-1.0 dB although +/-2.0 dB is acceptable.

RCC uses a Tektronix #2712 portable spectrum analyzer in conjunction with a broadband magnetic mount antenna to monitor RF energy of two-way radio emissions. This monitoring method ensures that communications transmitters are operating during RF radiation measurements.

CONDUCTED BY RCC CONSULTANTS, INC. FOR SNET NOVEMBER 1997



MEASUREMENT OF POTENTIALLY HAZARDOUS RADIO FREQUENCY ELECTROMAGNETIC FIELDS



**NARDA Model #8718 Meter with #8722 Shaped Probe**

CONDUCTED BY RCC CONSULTANTS, INC. FOR SNET NOVEMBER 1997

## **NON-IONIZING RF RADIATION MEASUREMENT AND FIELD STUDY CONDUCTED FOR SNET AT DANBURY, CONNECTICUT**

As indicated under the Scope in Section 1 of this document, RCC was tasked with providing emissions measurements from radio communications emitters at three locations for the SNET. Prior to conducting these measurements, RCC reviewed the basic number of RF sources, communications frequency bands in use, as well as primary antenna information. This review was conducted to ascertain both the type of probe required as well as safety characteristics to employ while undertaking the field measurement task. Upon arrival at the Danbury, CT test location, the site characteristics were observed and found to be conducive to a safe environment for personnel performing measurements.

Characteristics observed at the test location were site morphology, site layout, and antenna elevations with respect to work areas. All areas were mostly "controlled" environments in that passage to and from the interior and exterior work places were secured. Controlled Areas with unsecured access outside of the fenced perimeter were measured as well.

### **RF RADIATION MEASUREMENT AT MOSES MOUNTAIN/DANBURY, CT**

**Location:** Danbury, CT  
**Structure Type:** Tower  
**Tower Height:** 65' Self Support  
**Geodetic Coordinates:** 41-22-02.4 North 73-28-06.3 West  
**Radio Service:** Cellular/Paging/UHF Radiotelephone, Public Safety 6 GHz  
**Date of Measurement:** November 7, 1997  
**RCC Personnel:** M. Bedosky/D. Wilson

## MOSES MOUNTAIN - SITE DESCRIPTION AND SYSTEM OVERVIEW

This SNET communications facility is contained within a compound located in a densely forested area with flora being primarily heavy ground cover of bush and scrub and harboring both coniferous and deciduous trees. The compound location is accessible by an extended driveway cut through the forest. A controlled access for the driveway is located approximately 100 yards south of the compound.

The irregular-shaped compound having approximate dimensions of 90' x 90' is contained within the entire perimeter with 8' chain link fencing. The compound has two lockable access gates for controlled entry by the tenants who visit the site from time to time. The compound was unlocked upon RCC's access due to maintenance personnel working at the site. It is RCC's understanding that only SNET personnel and tenant's employees have access to these facilities.

The two single story equipment shelters are of aggregate masonry construction. All emitters were observed to be located on the 65' tower structure. RCC monitored the (RF) transmission activity of the radio traffic with a Tektronix #2712 portable spectrum analyzer and broadband antenna throughout the duration of the measurements.

Our Results and Findings section (page 27) includes an unscaled plan of the perimeter with areas of measurements indicated and locations of photographic views. The measured locations are referenced with a circled numerical indicator and are indexed and referenced as "Measurement Location" and tabulated with the appropriate measurement in accordance with the percentage of MPE levels actually measured. Photographic views are indicated with an arrow in the direction of the view along with the referenced photograph number.

MEASUREMENT OF POTENTIALLY HAZARDOUS RADIO FREQUENCY ELECTROMAGNETIC FIELDS

Moses Mountain - Site Emitter Profile

ANTENNA DESCRIPTION	FUNCTION	HEIGHT (TIP)	QTY	STATUS
Directional (dual) Panel	SNET Cellular	TOP (64')	9	3 (duplex) Antennas per face
Omnidirectional "Stick"	SNET TMRS	TOP (65')	1	UHF Station Master
Omnidirectional "Stick"	PageNet Paging	59'	1	Andrew #PG1DOF-0093
6' Microwave Dish	CT State Police	61'	1	Model PA6-65
6' Microwave Dish	CT State Police	57'	1	Model PA6-65
Grid Antenna	UHF TV	50'	1	SCALA PR-TV 57/75
Omnidirectional "Stick"	SkyTel/Destineer Paging	50'	1	SCALA OGB9-9000

CONDUCTED BY RCC CONSULTANTS, INC. FOR SNET NOVEMBER 1997



**Photo #1. Heavily Wooded Surroundings - Driveway to Site**

MEASUREMENT OF POTENTIALLY HAZARDOUS RADIO FREQUENCY ELECTROMAGNETIC FIELDS

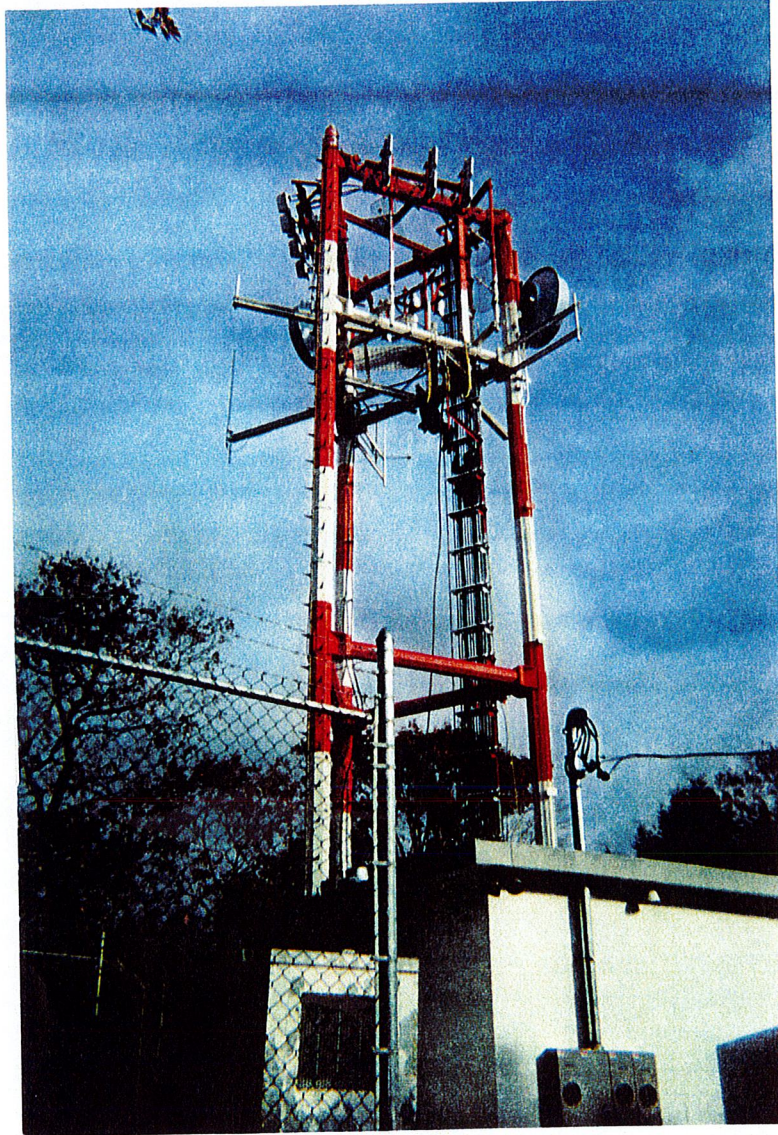

**Photo #2. 65' Steel Radio Tower**

CONDUCTED BY RCC CONSULTANTS, INC. FOR SNET NOVEMBER 1997

MEASUREMENT OF POTENTIALLY HAZARDOUS RADIO FREQUENCY ELECTROMAGNETIC FIELDS

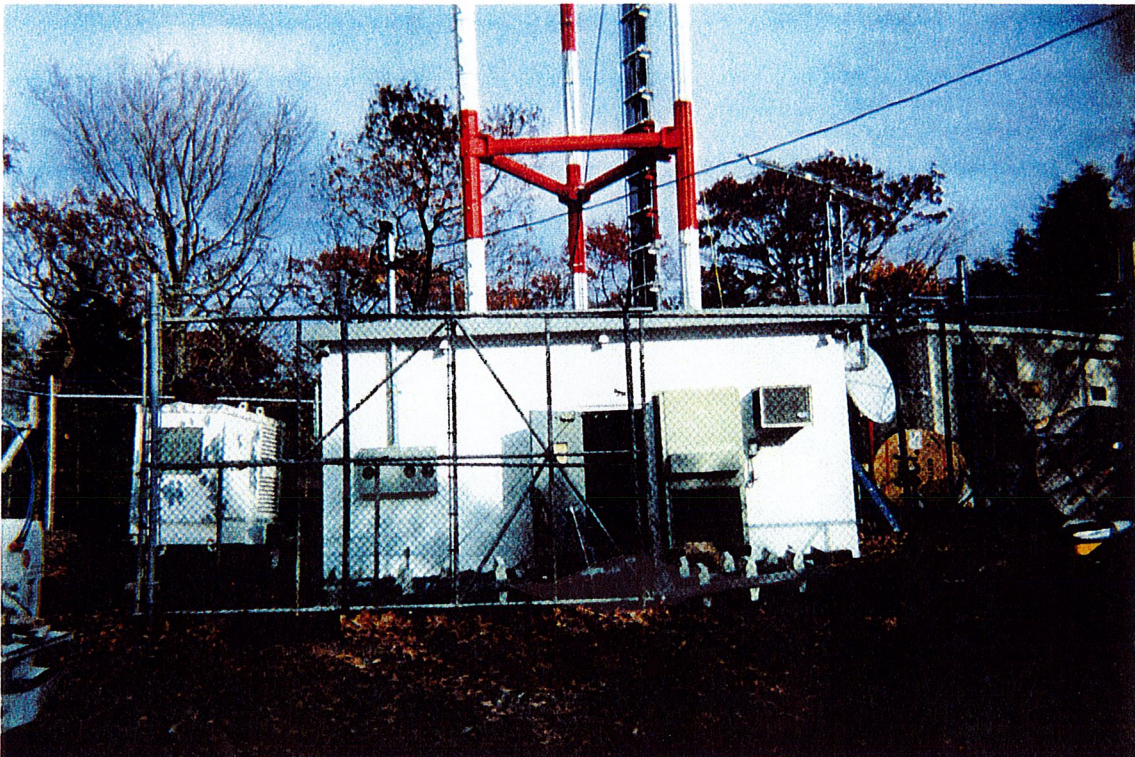

**Photo #3. Compound Perimeter is Secured with Fencing**

CONDUCTED BY RCC CONSULTANTS, INC. FOR SNET NOVEMBER 1997

MEASUREMENT OF POTENTIALLY HAZARDOUS RADIO FREQUENCY ELECTROMAGNETIC FIELDS

**RESULTS AND FINDINGS OF  
RF RADIATION MEASUREMENTS AT MOSES MOUNTAIN**

<u>MEASUREMENT LOCATION</u>	<u>PERCENTAGE OF MPE MEASURED</u>
Location#1	36.8% Max to 2% Min
Location #2	.5% Max to Undetectable
Location #3	1% Max to Undetectable
Location #4	2% Max to Undetectable
Location #5	1% Max to Undetectable
Location #6	1% Max to Undetectable
Location #7	1% Max to Undetectable
Location #8	1% Max to Undetectable
Location #9	22 % Max to Undetectable

CONDUCTED BY RCC CONSULTANTS, INC. FOR SNET NOVEMBER 1997



MEASUREMENT OF POTENTIALLY HAZARDOUS RADIO FREQUENCY ELECTROMAGNETIC FIELDS

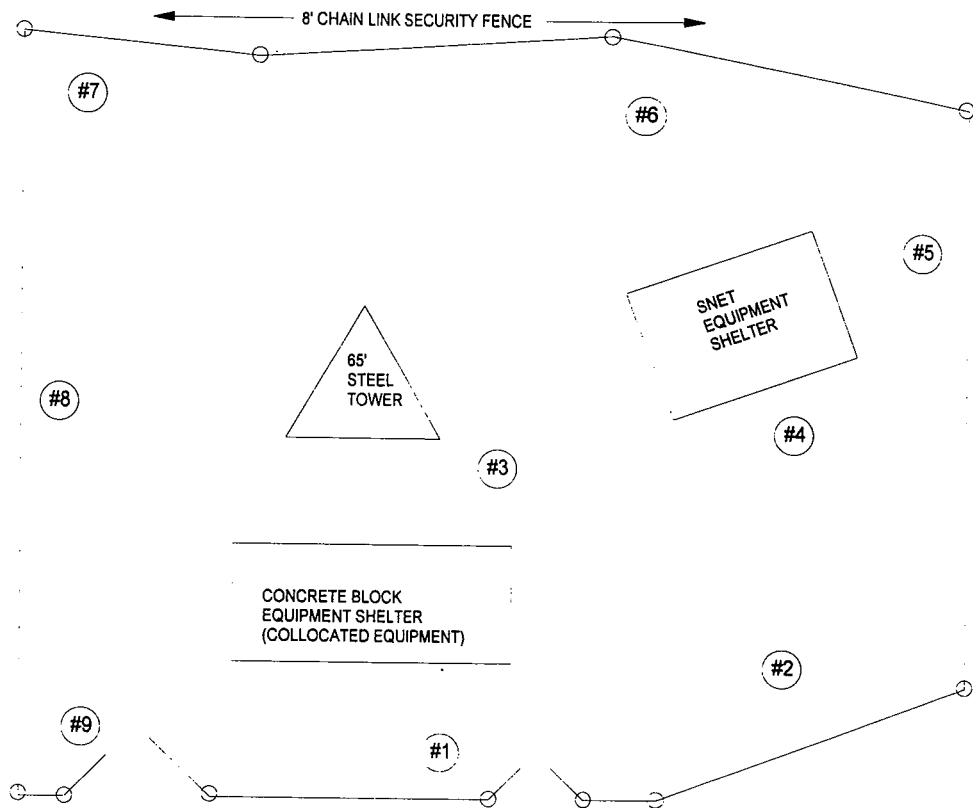

**PERIMETER LAYOUT AND MEASUREMENT LOCATIONS  
AT MOSES MOUNTAIN FACILITY  
(PLAN NOT TO SCALE)**

CONDUCTED BY RCC CONSULTANTS, INC. FOR SNET NOVEMBER 1997

## **CONCLUSIONS AND RECOMMENDATIONS FOR MOSES MOUNTAIN**

Through observation and measurements conducted with all known emitters operational, RCC found all areas in and around the Moses Mountain facility to be no greater than 36% of the MPE Levels for Uncontrolled Areas and are in accordance with emissions requirements specified in Part 47 of the Code of Federal Regulations ("CFR") §§ 1.1301 - 1.1319 along with the guidelines provided in FCC OET Bulletin #65.

The primary emissions intercepted inside the fenced perimeter were incident near the front of the building and only present when ALL cellular channels were active. These peak bursts had durations of less than one second.

## **SUMMARY**

RCC has completed field measurements to determine the RF radiation levels of non-ionizing emissions from fixed-service radio communications equipment operated at the SNET Moses Mountain Facility in Danbury, CT. RCC has provided the Results and Findings of these measurements conducted at the site. Moreover, RCC has found that the SNET will fully comply with Part 47 of the Code of Federal Regulations (CFR) §§ 1.1301 - 1.1319 along with the guidelines provided in FCC OET Bulletin #65 upon the installation of warning signs at the locations identified below.

Signs are recommended FOR TOWER CLIMBERS since the exposure levels more than likely exceed the MPE at contact surface areas of the antennas.

## REFERENCES

- [1] Federal Communications Commission, "Questions and Answers About the Biological Effects and Potential Hazards of Radiofrequency Radiation", Office of Engineering and Technology (OET) Bulletin #56, 1986.
- [2] Federal Communications Commission, "Evaluating Compliance with FCC Guidelines for Human Exposure to Radiofrequency Electromagnetic Fields", Office of Engineering and Technology (OET) Bulletin #65, August 1996.
- [3] Federal Communications Commission, "Evaluating Compliance with FCC Guidelines for Human Exposure to Radiofrequency Electromagnetic Fields", Office of Engineering and Technology Supplement A to OET Bulletin #65, August 1997.
- [4] American National Standards Institute (ANSI), "Safety Levels with Respect to Human Exposure to Radio Frequency Electromagnetic Fields, 3 kHz to 300 GHz," ANSI/IEEE C95.1-1992 (previously issued as IEEE C95.1-1991). Copyright 1992 by the Institute of Electrical and Electronics Engineers, Inc. (IEEE), New York, N.Y. 10017. For copies contact the IEEE: 1-800-678-4333 or 1-908-981-1393.
- [5] American National Standards Institute (ANSI), "Recommended Practice for the Measurement of Potentially Hazardous Electromagnetic Fields - RF and Microwave." ANSI/IEEE C95.3-1992. Copyright 1992, The Institute of Electrical and Electronics Engineers, Inc. (IEEE), New York, NY 10017. For copies contact the IEEE: 1-800-678-4333 or 1-908-981-1393.
- [6] American National Standards Institute (ANSI), "American National Standard Radio Frequency Radiation Hazard Warning Symbol," ANSIC95.2-1982. Copyright 1982, The Institute of Electrical and Electronics Engineers, Inc., (IEEE). For copies contact the IEEE: 1-800-678-4333 or 1-908-981-1393.
- [7] Federal Communications Commission (FCC), "Guidelines for Evaluating the Environmental Effects of Radio frequency Radiation," Report and Order, ET Docket 93-62, FCC 96-326, adopted August 1, 1996. 61 Federal Register 41006 (1996).
- [8] "Biological Effects and Exposure Criteria for Radio frequency Electromagnetic Fields," NCRP Report No. 86, 1986. National Council on Radiation Protection and Measurements. Purchasing information: NCRP Publications, 7910 Woodmont Ave., Suite 1016, Bethesda, MD 20814; (301) 657-2652.

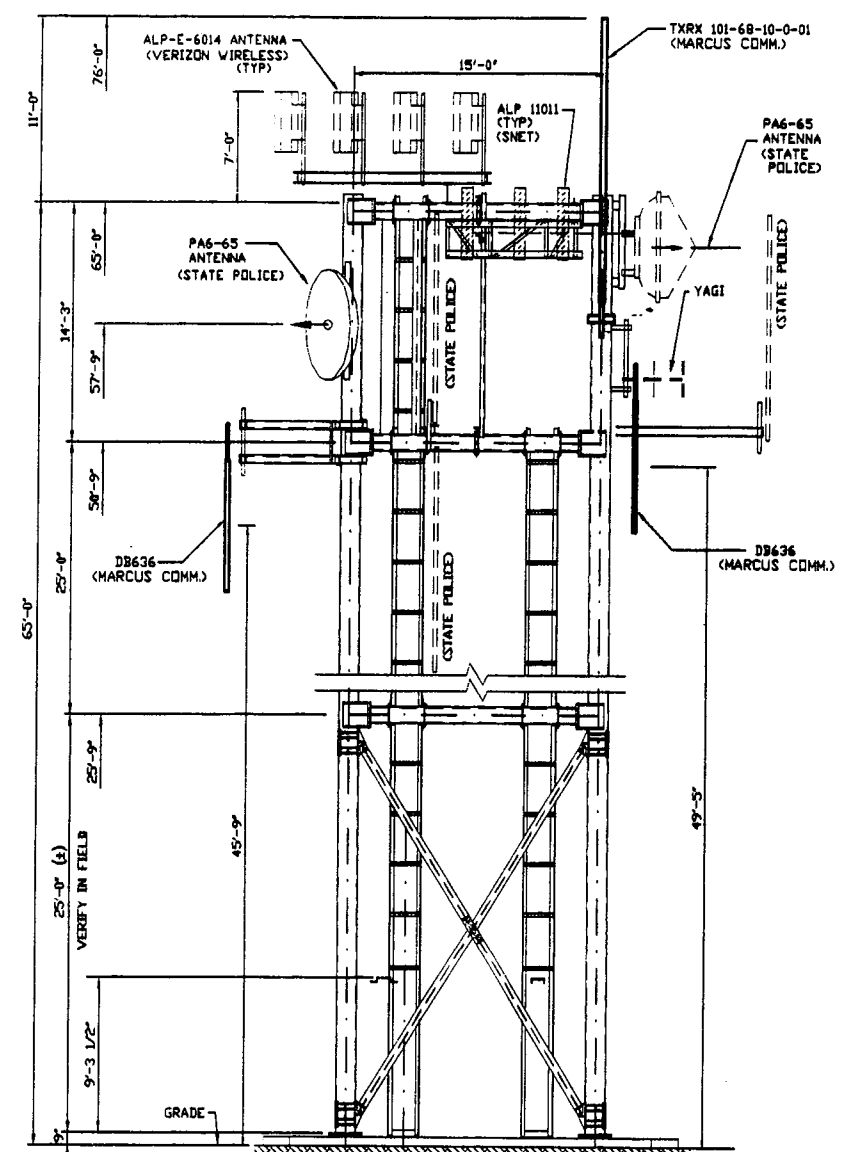

TOWER ELEVATION FACE A  
SCALE: 3/16"=1'-0"

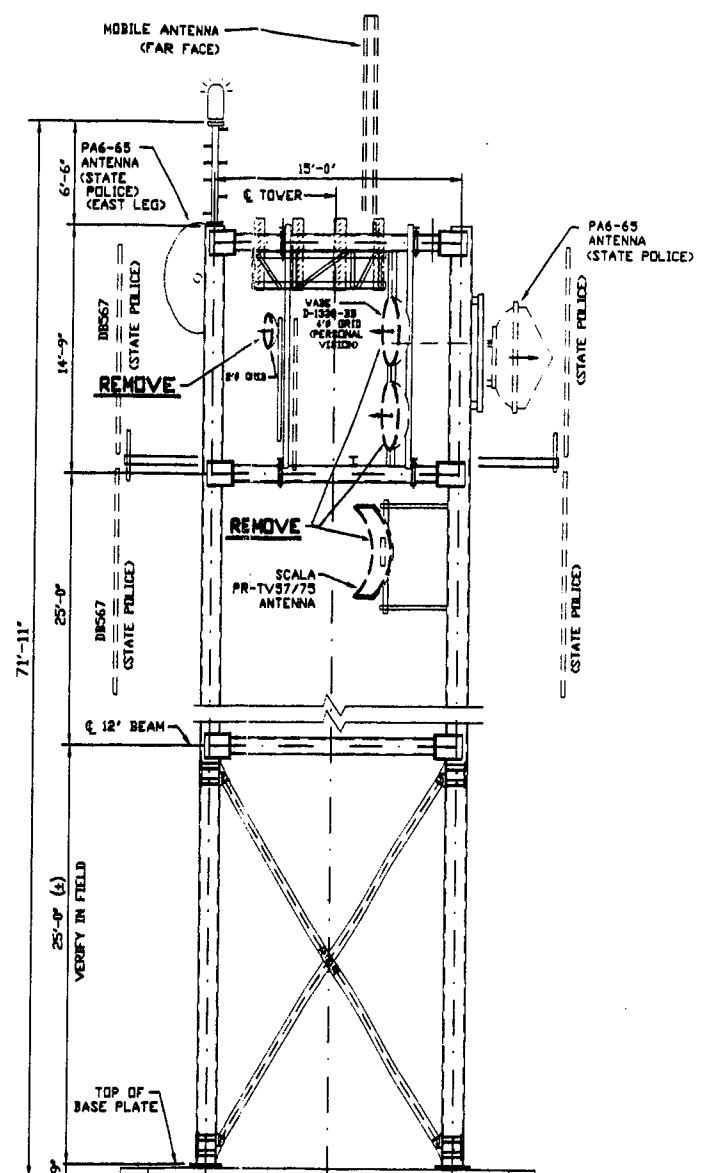

TOWER ELEVATION FACE C  
SCALE: 3/16"=1'-0"

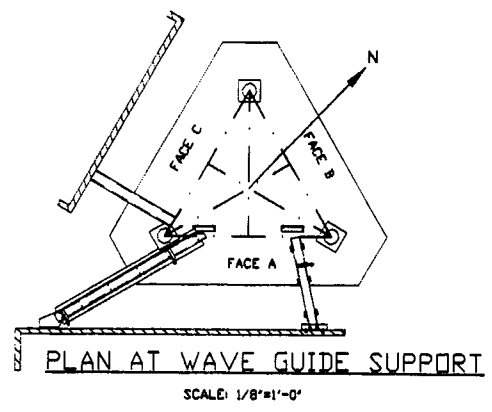

PLAN AT WAVE GUIDE SUPPORT  
SCALE: 1/8"=1'-0"

GENERAL NOTES

- ALL NEW STEEL SHALL CONFORM ASTM A36, AND ALL PIPES SHALL CONFORM TO ASTM A53.
  - ALL STEEL SHALL BE HOT-DIP GALVANIZED AFTER FABRICATION. GALVANIZING SHALL CONFORM TO ASTM A123 AND ASTM A153.
  - ALL WORK SHALL COMPLY WITH THE LATEST EDITION OF THE 'SPECIFICATION FOR THE DESIGN, FABRICATION AND ERECTION OF STRUCTURAL STEEL FOR BUILDINGS,' OF THE AMERICAN INSTITUTE OF STEEL CONSTRUCTION WITH NO INCREASE IN THE ALLOWABLE STRESSES FOR WIND LOAD COMBINATIONS.
  - ALL LOADS SHALL CONFORM TO THE LATEST EDITION OF THE 'MINIMUM DESIGN LOADS FOR BUILDING AND OTHER STRUCTURES,' ASCE 7-93 OF THE AMERICAN SOCIETY OF CIVIL ENGINEERS.
  - FIELD HOLES AND CUTS SHALL BE GIVEN TWO COATS OF ZINC COLD GALVANIZING COMPOUND CONFORMING TO THE FEDERAL SPECIFICATION DOD-P-21035A AND MIL-P-26915A AND MIL-T-26433. GALVANIZING SHALL BE PREPARED AND APPLIED IN STRICT ACCORDANCE WITH THE MANUFACTURER'S RECOMMENDATIONS.
  - ANTENNAS TO BE REMOVED FROM THE TOWER SHALL BE:
    - 1 - 2' GRID ANTENNA AT 59' ABOVE BASE.
    - 1 - WADE 4' GRID PAR. ANTENNA @ 58.5' ABOVE BASE.
    - 1 - WADE 4' GRID PAR. ANTENNA @ 53.5' ABOVE BASE.
    - 1 - SCALA PR-TV ANTENNA @ 46.25' ABOVE BASE.
  - THIS TOWER IS DESIGNED FOR A BASIC WIND SPEED OF 80 MPH, EXPOSURE B, TO CARRY THE FOLLOWING:
    - 8 - (4) ALP-E-6104 ANTENNAS TO 2 DIRECTIONS AT 70.25' ABOVE BASE.
    - 1 - 15' LONG MOBILE ANTENNA ABOVE TOP OF TOWER.
    - 1 - 15' LONG MOBILE ANTENNA ABOVE TOP OF TOWER.
    - 12 - (4) ALP11011 ANT'S TO 3 DIRECS @ 61' ABOVE BASE.
    - 2 - DB567 MOBILE ANTENNAS @ 58' ABOVE BASE.
    - 1 - PA6-65 PARABOLIC ANTENNA @ 57.75' ABOVE BASE.
    - 1 - MOBILE ANTENNAS @ 56' ABOVE BASE.
    - 1 - YAGI ANTENNA @ 53' ABOVE BASE.
    - 2 - DB567 MOBILE ANTENNAS @ 43' ABOVE BASE.
- AND THE FOLLOWING PROPOSED NEW ANTENNAS:
- 1 - TXRX ANTENNA WITH TOP AT 76' ABOVE BASE.
  - 1 - DB636 ANTENNA AT 49.42' ABOVE BASE.
  - 1 - DB636 ANTENNA AT 45.75' ABOVE BASE.

PLOT SCALE: 3/16"

MOSES MTN., CT.				
GENERAL ARRANGEMENT MOBILE ANTENNA ADDITIONS				
RADIO RELAY TOWER EXIST. 65'-0" SPECIAL TOWER				
BAYAR ENGINEERING, P.C. P.O. BOX 1287, FORT CHESTER, NY, 13073				
JOB NO. 0210	DESIGNED D.C.B.	DRAWN D.C.B.	CHECKED	DATE APR. 1, 2002
DWG. NO.			AR 20689	

Southern New England Telephone  
310 Orange ST.  
New Haven, CT. 06510  
Dawn Holmes  
(203-771-5013)

**RECEIVED**  
MAR 21 2002  
CONNECTICUT  
SITING COUNCIL

March 20, 2002

Mr. Mortimer A. Gelston, Chairman  
Connecticut Siting Council  
136 Main Street, Suite 401  
New Britain, CT 06051

Dear Chairman Gelston,

Enclosed is a Notice of Intent to Modify an Exempt Tower and Associated Equipment for facilities owned by the Southern New England Telephone Company (SNET) at Moses Mountain, in Danbury, Connecticut and 310 Orange St. New Haven, Connecticut.

The proposed modification can be generally described as the addition of five (5) antennas and associated base station equipment for Marcus communications LLC. The top of one (1) of the proposed antennas at both locations will be above the top of the existing standing tower structures. No changes will be made to either the tower structure, the fence surrounding the installation, or any of the existing structures on the site. The base station equipment will be housed inside the existing equipment room at the base of the tower.

The attached pages detail the required information for this location. As shown in the attachments, the proposed addition meets all the necessary criteria established in the Regulations of Connecticut State Agencies Section 16-50j-72 (b) (2), and is an exempt facility pursuant to Section 16-50j-73.

Please record me as Real Estate Manager for SNET in this matter and in all correspondence. Thank you in advance for your cooperation.

Sincerely,



Dawn E. Holmes  
Manager  
Real Estate Administration  
Phone 203-771-5013  
Fax 203-865-3549

Moses Mountain, Danbury, Connecticut and 310 Orange St. New Haven, Connecticut

Pursuant to Section 16-50i (a) (5) of the Connecticut General Statutes and Section 16-50j-72 (b) (2), as amended, of the Regulations of Connecticut State Agencies, the Southern New England Telephone Company (SNET) hereby notifies the Connecticut Siting Council that it intends to modify an existing communications facilities by permitting the installation of a Specialized Mobile Radio (SMR) antenna system as specified below to existing communications towers. The antennas will be owned, operated and maintained by Marcus Communications LLC. Associated communications hardware will be located in the SNET existing shelters. The one site is located on Moses Mountain in Danbury, Connecticut the other at 310 Orange St. New Haven, Connecticut.

Background

The proposed Danbury, Moses Mt. modifications are at the site of a self supporting 65 foot communications tower and one communications equipment shelter. Shelter and the tower are owned and operated by SNET. The tower was formally used as a microwave tower for the SNET telecommunications network. The proposed New Haven, 310 Orange St. modifications are at the site of a self supporting 117.8 foot communications tower located on the roof at 310 Orange St. New Haven, CT. The base of the tower at the roof level is 167.5 foot above ground level. The top of the tower is 285.3 foot above ground level.

Discussion

Danbury, CT. Moses Mt. site Marcus Communications LLC. Propose to install one (1) whip type receiver only antenna on top of the tower and two (2) transmit whip type antennas on the side of the tower with the top of the transmit antennas below the top of the tower. Five (5) UHF transmitters coupled through a transmitter combiner will feed the two (2) transmitter antennas. One (1) low power microwave transceiver will feed a three (3) foot dish antenna mounted at the forty nine (49) foot level of the tower.

New Haven, CT. 310 Orange St. site Marcus Communications LLC. Propose to install one (1) whip type receive antenna at the top of the tower and two (2) transmit whip type antennas at a lower level with the top of the transmit antennas below the top of the tower. Five (5) UHF transmitters coupled through a transmitter combiner will feed the two (2) transmitter antennas. One (1) low power microwave transceiver will feed a two (2) foot dish antenna mounted forty (40) foot above the roof level along the West wall inside of the existing penthouse. One (1) low power microwave transceiver will feed a four (4) foot dish antenna mounted forty (40) foot above the roof level along the East wall inside of the existing penthouse.

Below is a power density chart which represents calculated proposed non ionizing radiation levels. The levels shown indicate the total power density in milliwatts per square centimeter. These levels have been calculated at both the tower base, and at the site boundary.

<b>Service</b>	<b>Power Density @ Site Boundary</b>	<b>Power Density @ Tower Base</b>	<b>Antenna Height (feet)</b>	<b>CT/ANSI Standard</b>	<b>% of Standard @Site Boundary</b>
<b>Marcus Com. LLC. Moses Mt. Danbury, CT.</b>	<b>mW/cm<sup>2</sup></b>	<b>mW/cm<sup>2</sup></b>		<b>mW/cm<sup>2</sup></b>	
Antenna #1	6.136%	8.344%	50'	0.3067	6.136%
Antenna #2	6.136%	8.344%	50'	0.3067	6.136%
Antenna #3 Receive Only	0%	0%	65'	0	0%
Antenna #4	0.150%	0.206%	49'	1.0	0.150%
<b>Total</b>	<b>12.422%</b>	<b>16.894%</b>			<b>12.422%</b>

Service _Marcus com. LLC. 310 Orange St. New Haven, CT.	Power Density @	Power Density @	Antenna	CT/ANSI	% of
	Site Boundary mW/cm <sup>2</sup>	Tower Base mW/cm <sup>2</sup>	Height (feet)	Standard mW/cm <sup>2</sup>	Standard @Site Boundary
Antenna #1 Receive Only	0%	0%	117.8'	0	0
Antenna #2	2.817%	3.057%	103'	0.3067	2.817%
Antenna #3	2.817%	3.057%	103'	0.3067	2.817%
Antenna #4	0.306%	0.612%	40'	1.0	0.306%
Antenna #5	0.086%	0.173%	40'	1.0	0.086%
<b>Total</b>	<b>6.026%</b>	<b>6.899%</b>			<b>6.026%</b>

The current Connecticut (and ANSI/IEEE) power density level standards, for non-ionizing radiation, are shown above. A ground reflection coefficient of 1.6 is used. The levels identified in this case are below the standards. These calculations conform to the procedures described by FCC OST Bulletin No. 65.

#### Conclusion

The proposed additions do not constitute a “modification” of an existing facility as defined in the Connecticut General Statutes Section 16-50i(d). There will be no change to the tower height or extension of the boundaries of the site. The tower is structurally sufficient to support the proposed antennas since existing unused two-way radio antennas will be removed. There will be no increase in noise levels at the site’s boundary by six (6) decibels or more and the total radio frequency electromagnetic radiation is not at or above the standard set forth in Section 22(a)-162 of the Connecticut General Statutes. This addition will not have a substantially adverse environment effect.

For these reasons, SNET requests that the Council acknowledge that this Notice of Modification meets the Council’s exemption criteria

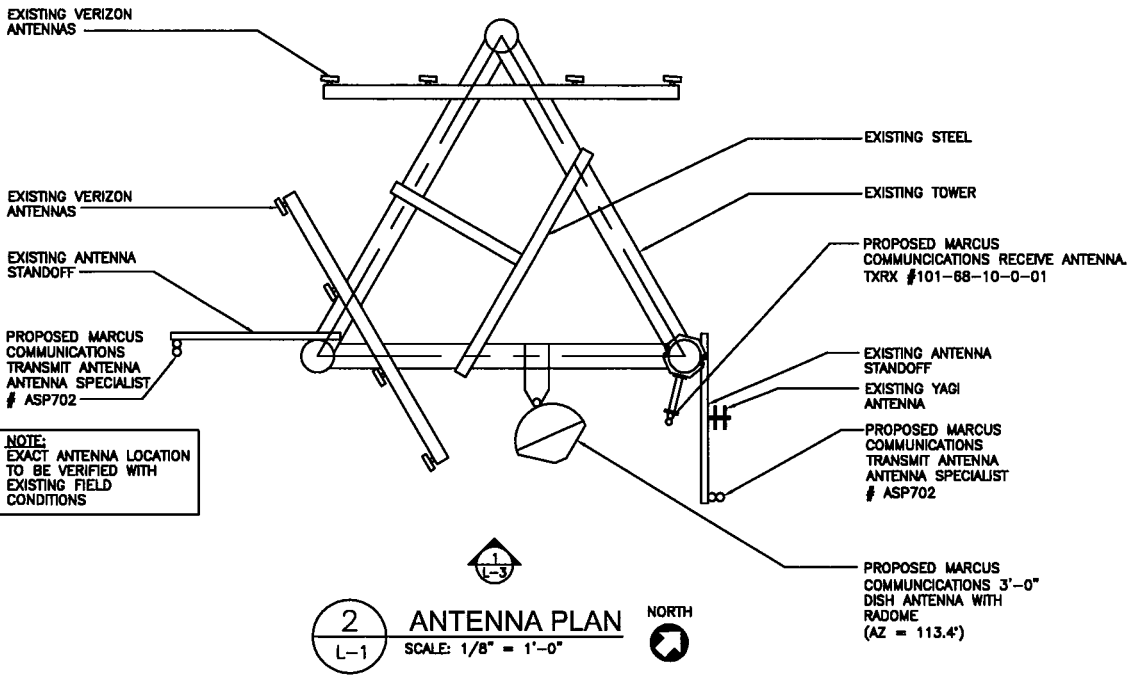

**2** ANTENNA PLAN  
 L-1 SCALE: 1/8" = 1'-0" NORTH

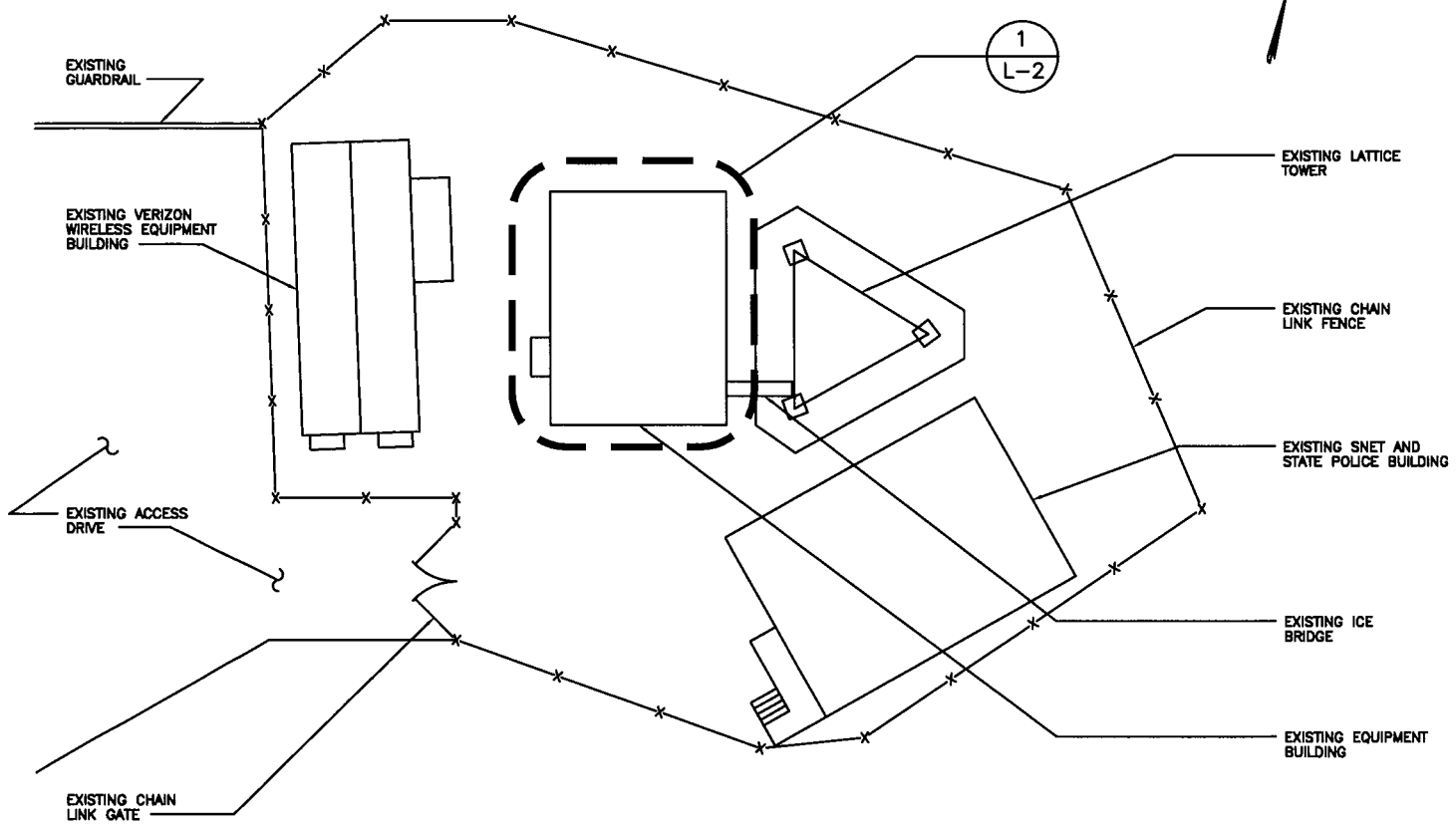

**1** SITE PLAN  
 L-1 SCALE: 1" = 20'-0"

ISSUED FOR LEASE

SITE ID NO:  
CT-910A

**URS CORPORATION AES**

795 BROOK STREET, BLDG 5  
ROCKY HILL, CONNECTICUT  
1-(860)-529-8882

Designed by:  
Drawn by: MCD  
Checked by:

**MARCUS COMMUNICATIONS LLC**  
 UNMANNED WIRELESS COMMUNICATION EQUIPMENT SITE

SITE ADDRESS:  
**DANBURY**  
 MOSES MOUNTAIN  
 DANBURY, CONNECTICUT

2	03-08-02	REVISED
1	01-25-02	ISSUED FOR LEASE
REV.	DATE:	DESCRIPTION

Scale: AS SHOWN Date: 01-10-02

Job No: F302003.18 File No. L-1 Dwg. No. L-1 Dwg. 1 of 3



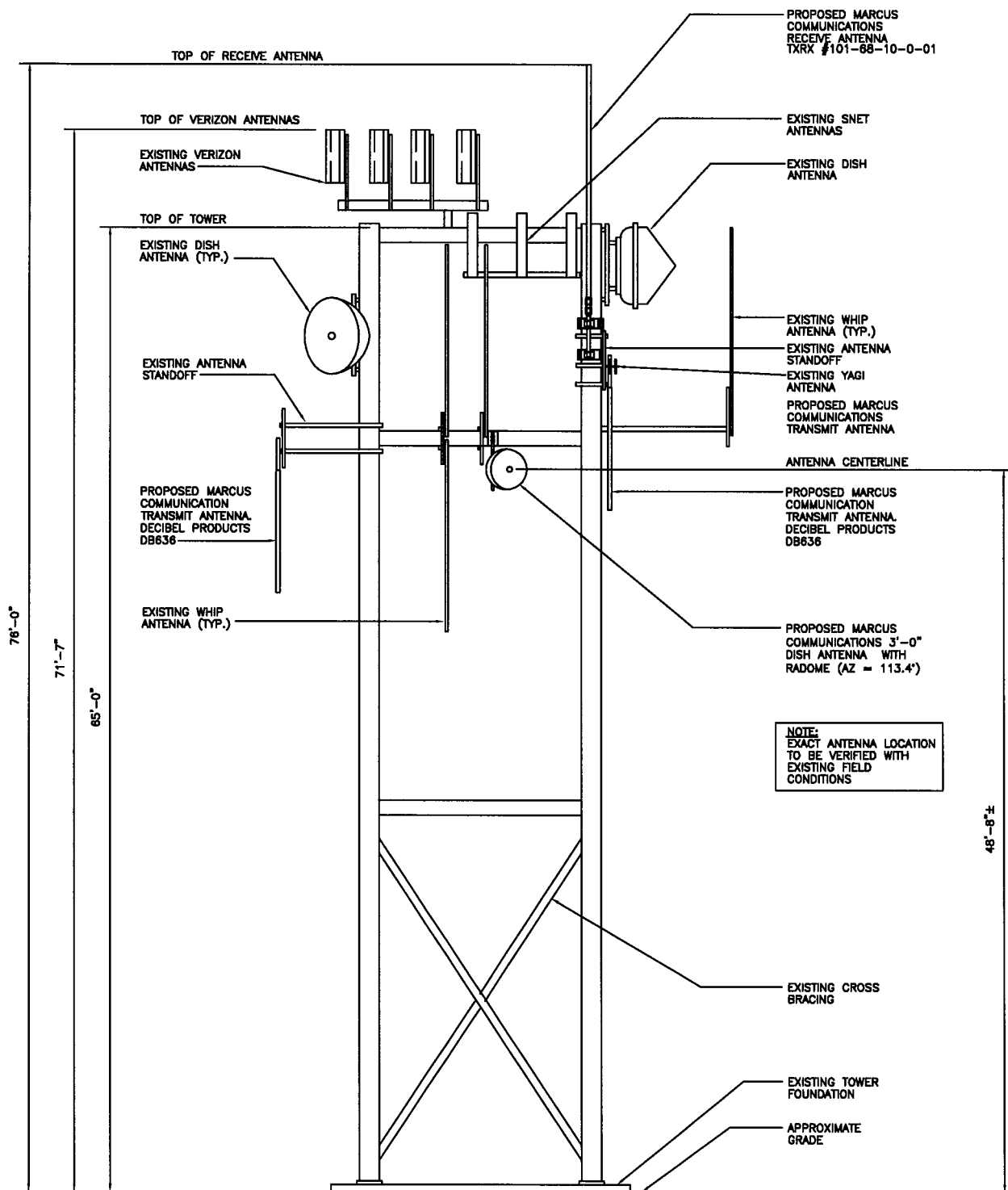

1 TOWER ELEVATION  
L-3 SCALE: 3/32" = 1'-0"

ISSUED FOR LEASE

SITE ID NO:  
CT-910A  
Designed by:  
Drawn by: JCF  
Checked by:

**URS CORPORATION AES**  
795 BROOK STREET, BLDG 5  
ROCKY HILL, CONNECTICUT  
1-(860)-529-8882

**MARCUS COMMUNICATIONS LLC**  
UNMANNED WIRELESS COMMUNICATION EQUIPMENT SITE  
SITE ADDRESS:  
**DANBURY**  
MOSES MOUNTAIN  
DANBURY, CONNECTICUT

2	03-08-02	REVISED
1	01-25-02	ISSUED FOR LEASE
REV.	DATE	DESCRIPTION
Scale: AS SHOWN		Date: 01-10-02
Job No: F302003.16		File No. L-3

Dwg. No.  
**L-3**  
Dwg. 3 of 3

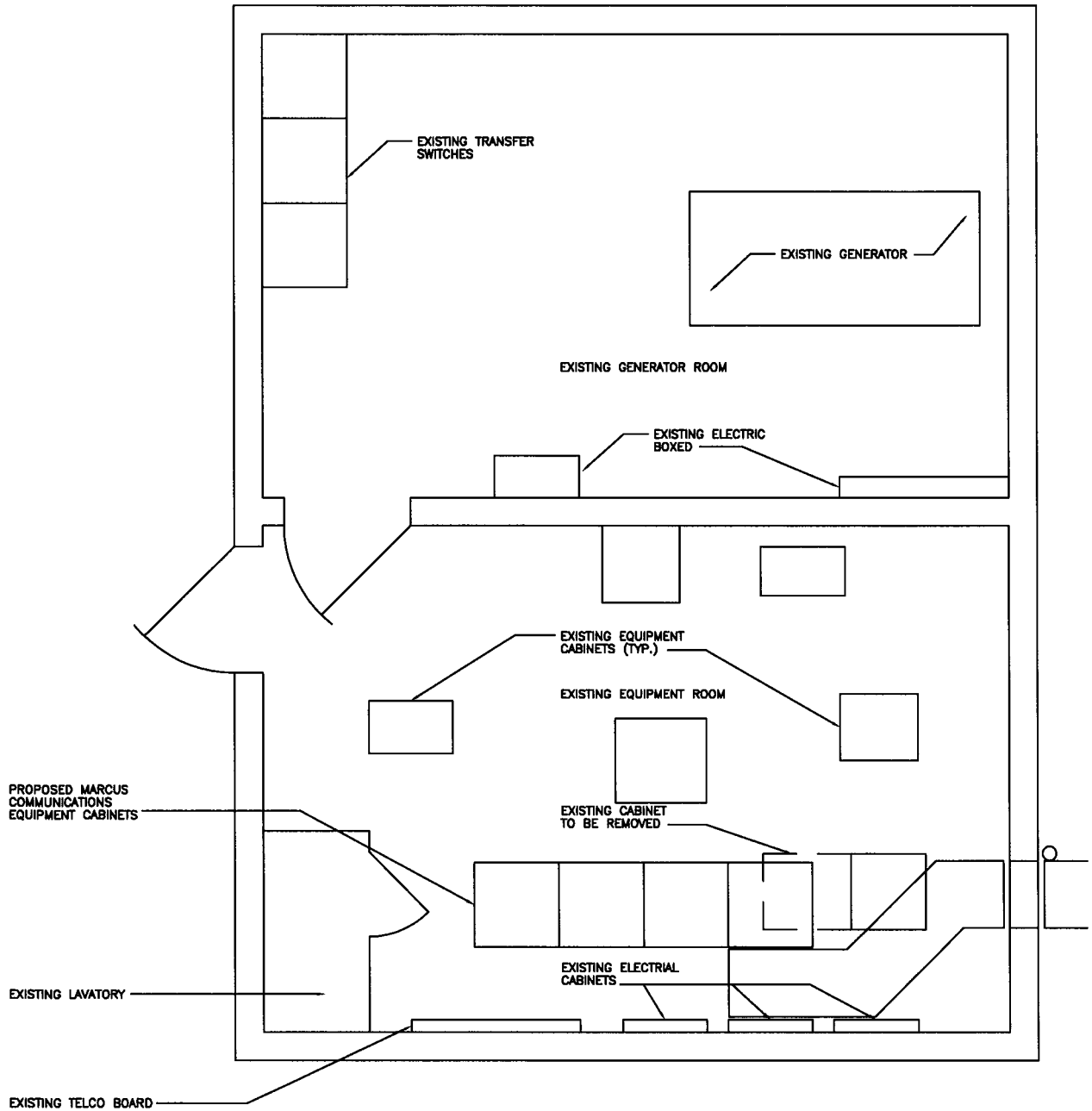

1
**EQUIPMENT ROOM PLAN**  
 L-2 SCALE: 1/4" = 1'-0"

**ISSUED FOR LEASE**

SITE ID NO: CT-910A	<b>URS CORPORATION AES</b> 795 BROOK STREET, BLDG 5 ROCKY HILL, CONNECTICUT 1-(860)-529-8882	<b>MARCUS COMMUNICATIONS LLC</b> UNMANNED WIRELESS COMMUNICATION EQUIPMENT SITE SITE ADDRESS: <b>DANBURY</b> MOSES MOUNTAIN DANBURY, CONNECTICUT	<table border="1" style="width: 100%; border-collapse: collapse;"> <tr> <td style="width: 5%;"></td> <td style="width: 15%;"></td> <td style="width: 80%;"></td> </tr> <tr> <td style="text-align: center;">2</td> <td style="text-align: center;">03-08-02</td> <td style="text-align: center;">REVISED</td> </tr> <tr> <td style="text-align: center;">1</td> <td style="text-align: center;">01-25-02</td> <td style="text-align: center;">ISSUED FOR LEASE</td> </tr> <tr> <td style="text-align: center;">REV.</td> <td style="text-align: center;">DATE:</td> <td style="text-align: center;">DESCRIPTION</td> </tr> </table>				2	03-08-02	REVISED	1	01-25-02	ISSUED FOR LEASE	REV.	DATE:	DESCRIPTION
2	03-08-02	REVISED													
1	01-25-02	ISSUED FOR LEASE													
REV.	DATE:	DESCRIPTION													
Designed by:	Drawn by: MCD	Scale: AS SHOWN Date: 01-10-02	Dwg. No. <b>L-2</b>												
Checked by:	Job No: F302003.18	File No. L-2	Dwg. 2 of 3												

POWER DENSITY CALCULATION MODEL

User-defined Inputs

Operator	Marcus Comm. LLC. Moses Mt., Danbury, CT
Transmitter Po	100 Watts
System Losses	3.50 dB
Antenna Height	50.0 Feet
Antenna Gain	6.0 dBi
Ground Reflec. Coeff.	1.6
Frequency	460.000 MHz
Radial Dist., Antenna Base to Site Boundary	30.0 Feet

Antenna Height	50 Feet
----------------	---------

Site Boundary		Antenna Base	
Power Density (mW/cm <sup>2</sup> )		Power Density (mW/cm <sup>2</sup> )	
Predicted	0.018816	Predicted	0.025589
Max allow	0.3067	Max allow	0.3067
% of std	6.136	% of std	8.344
E-Field (V/m)		E-Field (V/m)	
Predicted	8.422312	Predicted	9.82202
Max allow	0.0000	Max allow	0.0000
#DIV/0!	#DIV/0!	#DIV/0!	#DIV/0!
H-Field (A/m)		H-Field (A/m)	
Predicted	0.022340	Predicted	0.02605
Max allow	0.0000	Max allow	0.0000
#DIV/0!	#DIV/0!	#DIV/0!	#DIV/0!

Radial Dist., Antenna Base to Site Boundary	30 Feet
---	---------

0.307

0.307

0.307

Slant	1777
Radial	914
Height	1524

Slant	1777
Radial	914
Height	1524

E(std), f>100k	V/m	H(std), f>100k	0	A/m	S(std)>100k	0	out of frange
E(std), 1.5k<=f<100k	V/m	H(std), 1.5k<=f<100k	0	A/m	S(std), 1.5k<=f<100k	0	mW/cm2
E(std), 300<=f<1.5k	V/m	H(std), 300<=f<1.5k	---	A/m	S(std), 300<=f<1.5k	0.307	mW/cm2
E(std), 30<=f<300	V/m	H(std), 30<=f<300	0	A/m	E(std):	0	mW/cm2
E(std), 1.34<=f<30	V/m	H(std), 1.34<=f<30	0	A/m	H(std):	0	mW/cm2
E(std), 0.3<=f<1.34	V/m	H(std), 0.3<=f<1.34	0	A/m	E(std):	0	mW/cm2
E(std), <0.3	V/m	H(std), <0.3	0	A/m	H(std):	0	mW/cm2
					out of frange		

Pd @ Base: (W)	Ht (cm)	Radial d (cm)	Slant d (cm)	Syst loss (dB)	Antg (dB)	Antg-loss (dB)	gnd refl	Po (mW/cm2)	Std (mW/cm2)	% of std
Marcus Comm. 1	100	1524	0	0	3.5	4.7	---	0.025589	0.306667	8.344
E: 9.82201875										
H: 0.0260531										

Pd @ Boundary:	Ht (cm)	Radial d (cm)	Slant d (cm)	Syst loss (dB)	Antg (dB)	Antg-loss (dB)	gnd refl	Po (mW/cm2)	Std (mW/cm2)	% of std
Marcus Comm. 1	100	1524	914	1777	3.5	4.7	1.6	0.018816	0.306667	6.136
E: 8.42231159										
H: 0.02234035										

S("E")	E	S("H")	H	Predicted %	E	%
0.2	27.459	2.261	0.245	23.6	6.469	6.9
0.2	27.459	5.163	0.370	20.4	5.594	4.1
0.2	27.459	5.284	0.374	18.2	4.988	3.5
0.2	27.459	3.016	0.283	18.2	4.988	4.6
0.2	27.459	0.200	0.073	26.8	7.368	26.1
0.301	33.686	0.301	0.089	12.2	4.119	12.3
0.577	46.640	0.577	0.124	4.7	2.214	4.8
0.577	46.640	0.577	0.124	4.7	2.214	4.8
0.577	46.640	0.577	0.124	4.7	2.214	4.8
4.517	130.496	4.517	0.346	7.5	9.824	7.5

POWER DENSITY CALCULATION MODEL

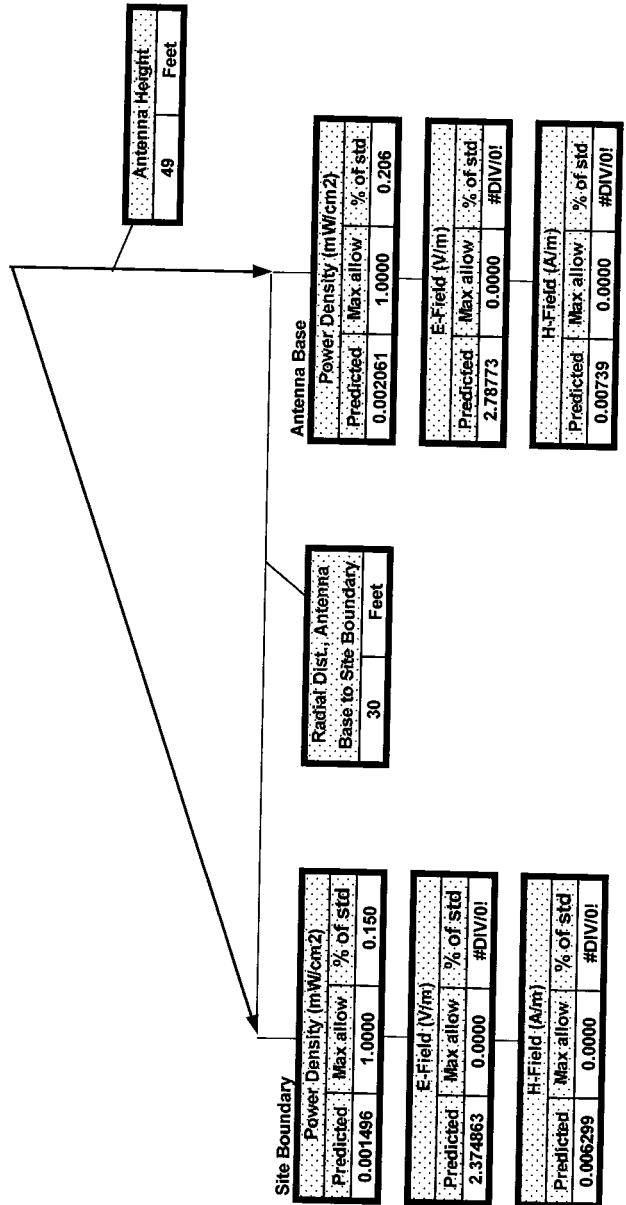
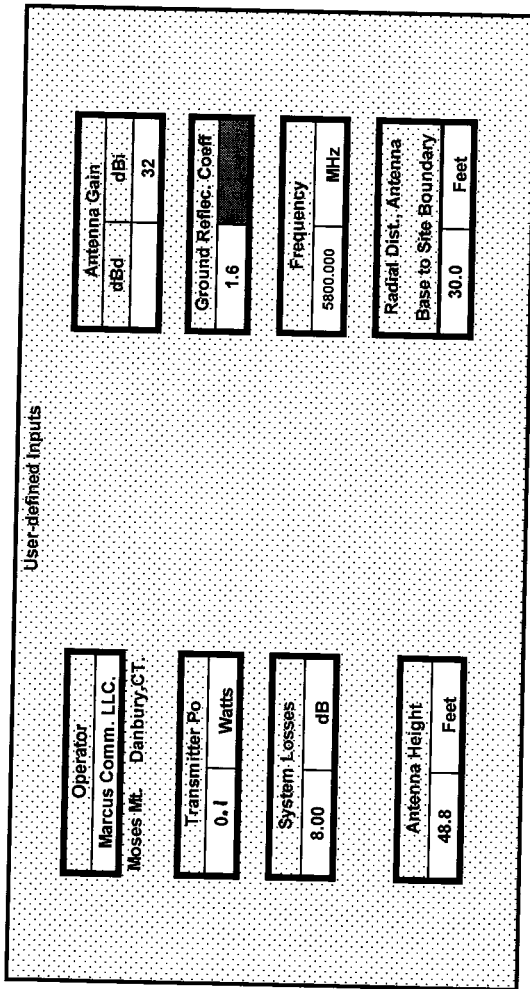

1.000

Slant  
1746

Radial  
914

-1

Height  
1487

E(std), f>100k	V/m	H(std), f>100k	0	A/m	S(std)>100k	0	out of f range
E(std), 1.5k<=f<100k	V/m	H(std), 1.5k<=f<100k	---	A/m	S(std), 1.5k<=f<100k	1.0	mW/cm2
E(std), 300<=f<1.5k	V/m	H(std), 300<=f<1.5k	0	A/m	S(std), 300<=f<1.5k	0	mW/cm2
E(std), 30<=f<300	V/m	H(std), 30<=f<300	0	A/m	S(std), 30<=f<300	0	mW/cm2
E(std), 1.34<=f<30	V/m	H(std), 1.34<=f<30	0	A/m	S(E)std, 1.34<=f<30	0	mW/cm2
E(std), 0.3<= f<1.34	V/m	H(std), 0.3<=f<1.34	0	A/m	S(E)std, 0.3<= f<1.34	0	mW/cm2
E(std), <0.3	V/m	H(std), <0.3	0	A/m	S(E)std, <0.3	0	mW/cm2

Pd @ Base: (W)	Ht (cm)	Radial d (cm)	Slant d (cm)	Syst loss (dB)	Antg (dB)	Antg-loss (dB)	gnd refl	Po (mW/cm2)	Std (mW/cm2)	#DIV/0!
Marcus Comm. I 0.1	1487	0	0	8.0	31.5	23.5	---	0.002061	0.000000	
Marcus Comm. II 0.1	1487	914	1746	8.0	31.5	23.5	1.6	2.78773149	0.000000	
Pd @ Boundary:										
Marcus Comm. I 0.1	1487	914	1746	8.0	31.5	23.5	1.6	0.00739451	0.000000	
Marcus Comm. II 0.1	1487	914	1746	8.0	31.5	23.5	1.6	2.37486282	0.000000	

S("E")	E	S("H")	H	Standard		Predicted	
0.2	27.459	2.261	0.245	E	6.469	H	6.9
0.2	27.459	5.163	0.370	E	5.594	H	4.1
0.2	27.459	5.284	0.374	E	4.988	H	3.5
0.2	27.459	3.016	0.283	E	4.988	H	4.6
0.2	27.459	0.200	0.073	E	7.368	H	26.1
0.301	33.686	0.301	0.089	E	4.119	H	12.3
0.577	46.640	0.577	0.124	E	2.214	H	4.8
0.577	46.640	0.577	0.124	E	2.214	H	4.8
4.517	130.496	4.517	0.346	E	9.824	H	7.5

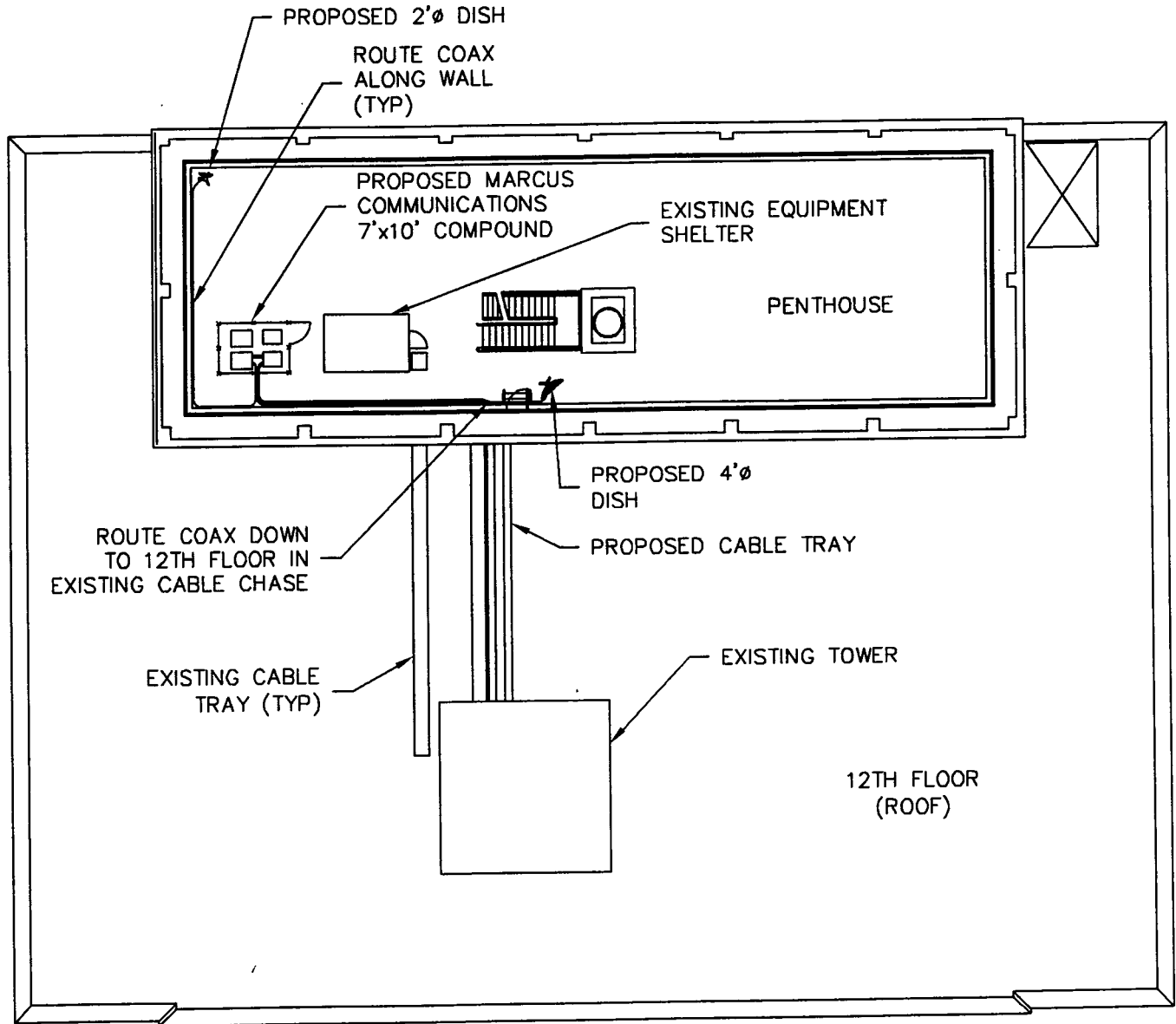

**1 SITE PLAN**  
SCALE: NOT TO SCALE

Marcus Communications LLC  
275 NEW STATE ROAD  
PHONE: (860) 643-0440  
FAX: (860) 643-0410  
CONT: STEVE HOWARD

CB JOB NUMBER: 325703.139  
DATE ISSUED: 1/17/02  
ISSUES/REVISIONS:  
ISSUE FOR REVIEW 1/17/02  
REVISED 1/24/02  
**SITE ID: CT905B**  
**310 ORANGE ST.**  
**NEW HAVEN, CT**

**Carter & Burgess**  
CARTER & BURGESS CONSULTANTS, INC.  
310 ORANGE STREET, 6TH FLOOR  
NEW HAVEN, CT 06510  
T. (203) 771-6883 F. (203) 785-8521

SHEET CONTENTS:  
**SITE PLAN**

LEASE EXHIBITS ARE A CONCEPTUAL REPRESENTATION OF THE LEASE AGREEMENT ONLY—CONSTRUCTION DOCUMENTS MAY VARY FROM THESE EXHIBITS IN ORDER TO COMPLY WITH ALL APPLICABLE CODES

THIS PLAN WAS PREPARED USING AVAILABLE SITE INFORMATION FROM SEVERAL SOURCES, SOME OF WHICH MAY BE UNCONFIRMED, AND REPRESENTS A CONCEPTUAL SITE DEVELOPMENT PLAN BASED ON DEVELOPMENT REQUIREMENTS PROVIDED BY VOICSTREAM WIRELESS

SHEET NUMBER:

**LE-1**

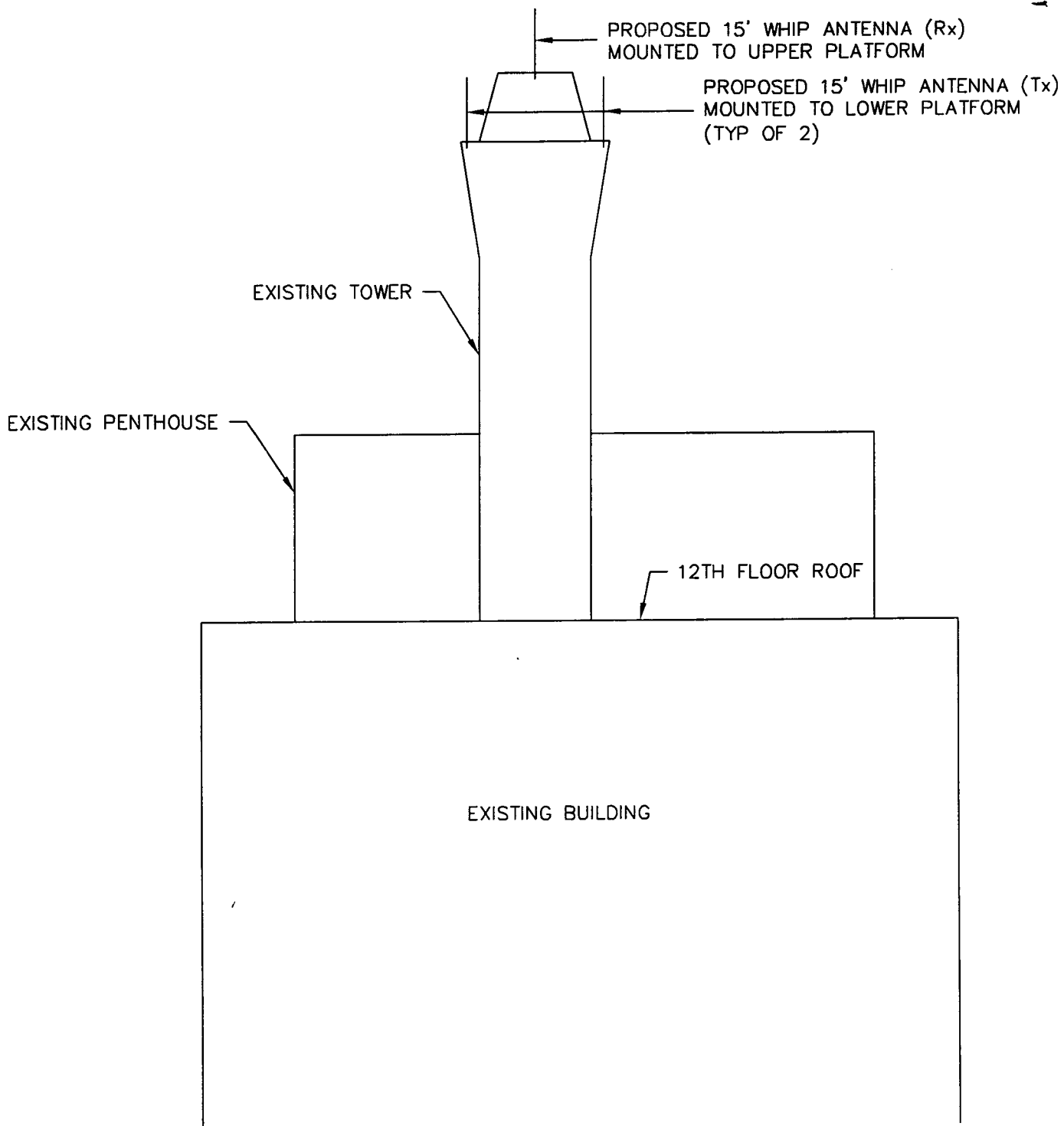

**1 SITE PLAN**  
SCALE: NOT TO SCALE

Marcus Communications LLC  
275 NEW STATE ROAD  
PHONE: (860) 643-0440  
FAX: (860) 643-0410  
CONT: STEVE HOWARD

CB JOB NUMBER: 325703.139  
DATE ISSUED: 1/17/02  
ISSUES/REVISIONS:  
ISSUE FOR REVIEW 1/17/02  
REVISED 1/24/02

**SITE ID: CT905B**  
**310 ORANGE ST.**  
**NEW HAVEN, CT**

**Carter :: Burgess**

CARTER & BURGESS CONSULTANTS, INC.  
310 ORANGE STREET, 6TH FLOOR  
NEW HAVEN, CT 06510  
T. (203) 771-6883 F. (203) 785-8521

LEASE EXHIBITS ARE A CONCEPTUAL REPRESENTATION OF THE LEASE AGREEMENT ONLY—CONSTRUCTION DOCUMENTS MAY VARY FROM THESE EXHIBITS IN ORDER TO COMPLY WITH ALL APPLICABLE CODES

THIS PLAN WAS PREPARED USING AVAILABLE SITE INFORMATION FROM SEVERAL SOURCES, SOME OF WHICH MAY BE UNCONFIRMED, AND REPRESENTS A CONCEPTUAL SITE DEVELOPMENT PLAN BASED ON DEVELOPMENT REQUIREMENTS PROVIDED BY VOICSTREAM WIRELESS

SHEET CONTENTS:  
**ELEVATION**

SHEET NUMBER:

**LE-2**



**SNET MOBILITY, INC.**

New Haven

**SITE NAME:** New Haven

**ADDRESS:** 310 Orange Street  
New Haven, Connecticut

received  
*Forney*  
10/13/99

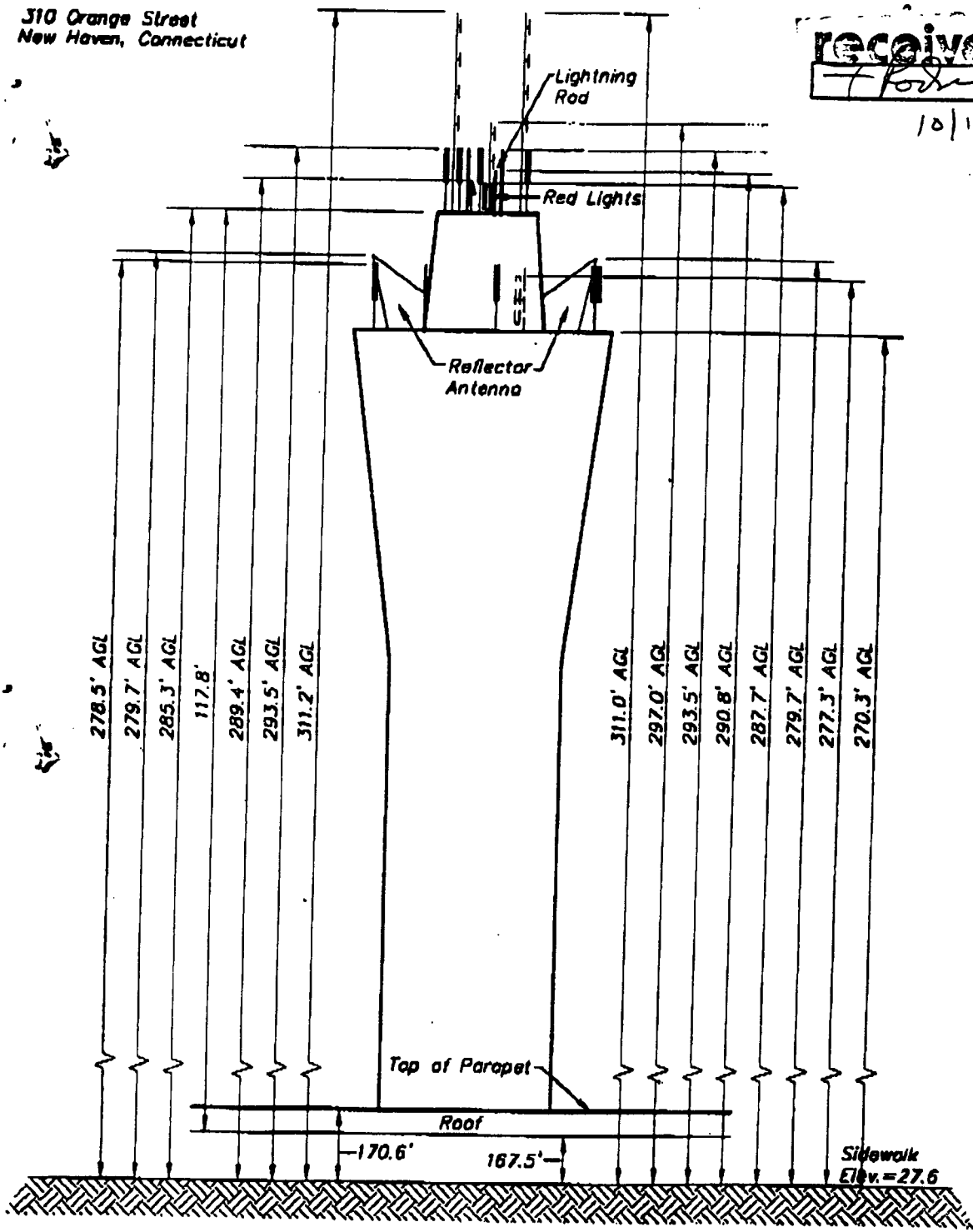

### TOWER ELEVATION

**NOTE:**

- ELEVATIONS REFER TO THE NATIONAL GEODETIC VERTICAL DATUM OF 1929.

**URS Greiner Woodward Clyde**  
 Surveying and Mapping by  
**URS Greiner Woodward-Clyde, Inc. A-E-S**  
 500 Enterprise Drive, Suite 302  
 Rocky Hill, Connecticut 06067-4002  
 Tel. (880) 329-8882

Scale: 1" = 20'  
 Date: FEBRUARY 1999

Field book # 1467-33	Crew Chief C.NEVIN	Project # F3-00001787.04	
Search # -	Drawn by E.LEWIS	Checked by <i>EL</i>	Map file # 2 of 4

POWER DENSITY CALCULATION MODEL

User-defined inputs

Operator	310OrangesINewHavenCT
Transmitter Po	100 Watts
System Losses	4.60 dB
Antenna Height	102.8 Feet
Antenna Gain	9.0 dBi
Ground Reflec. Coeff	1.6
Frequency	460.000 MHz
Radial Dist. Antenna Base to Site Boundary	30.0 Feet

Antenna Height	103 Feet
----------------	----------

Site Boundary	Power Density (mW/cm <sup>2</sup> )	Antenna Base	Power Density (mW/cm <sup>2</sup> )		
Predicted	Max allow	% of std	Predicted	Max allow	% of std
0.008640	0.3067	2.817	0.009376	0.3067	3.057
E-Field (V/m)	Max allow	% of std	E-Field (V/m)	Max allow	% of std
5.707290	0.0000	#DIV/0!	5.94535	0.0000	#DIV/0!
H-Field (A/m)	Max allow	% of std	H-Field (A/m)	Max allow	% of std
0.015139	0.0000	#DIV/0!	0.01577	0.0000	#DIV/0!

Radial Dist. Antenna Base to Site Boundary	30 Feet
--	---------

0.307	Slant 3264	0.307	Radial 914	Height 3133
-------	---------------	-------	---------------	----------------

E(std),	f>100k	V/m	H(std),	f>100k	0	A/m	S(std), >100k	0	out of f. range
E(std), 1.5k<=f<100k	V/m	H(std), 1.5k<=f<100k	0	A/m	0	A/m	S(std), 1.5k<=f<100k	0	mW/cm2
E(std), 300<=f<1.5k	V/m	H(std), 300<=f<1.5k	---	A/m	---	A/m	S(std), 300<=f<1.5k	0.307	mW/cm2
E(std), 30<=f<300	V/m	H(std), 30<=f<300	0	A/m	0	A/m	S(std), 30<=f<300	0	mW/cm2
E(std), 1.34<=f<30	V/m	H(std), 1.34<=f<30	0	A/m	0	A/m	S(E)std, 1.34<=f<30	0	mW/cm2
E(std), 0.3<=f<1.34	V/m	H(std), 0.3<=f<1.34	0	A/m	0	A/m	S(E)std, 0.3<=f<1.34	0	mW/cm2
E(std), <0.3	V/m	H(std), <0.3	0	A/m	0	A/m	S(E)std, <0.3	0	mW/cm2

Pd @ Base:	(W)	Ht	Radial d	Slant d	Syst loss	Antg	Antg-loss	gnd refl	Po	Std	% of std
310OrangeS	100	3133	0	0	4.6	11.2	6.6	---	0.009376	0.306667	3.057

Pd @ Boundary:	(W)	Ht	Radial d	Slant d	Syst loss	Antg	Antg-loss	gnd refl	Po	Std	% of std
310OrangeS	100	3133	914	3264	4.6	11.2	6.6	1.6	5.94535304	0.306667	2.817

S("E")	E	S("H")	H	Standard		Predicted	
0.2	27.459	2.261	0.245	E	%	H	%
0.2	27.459	5.163	0.370	6.469	23.6	0.017	6.9
0.2	27.459	5.284	0.374	5.594	20.4	0.015	4.1
0.2	27.459	3.016	0.283	4.988	18.2	0.013	3.5
0.2	27.459	0.200	0.073	4.988	18.2	0.013	4.6
0.301	33.686	0.301	0.089	7.368	26.8	0.019	26.1
0.577	46.640	0.577	0.124	4.119	12.2	0.011	12.3
0.577	46.640	0.577	0.124	2.214	4.7	0.006	4.8
0.577	46.640	0.577	0.124	2.214	4.7	0.006	4.8
4.517	130.496	4.517	0.346	9.824	7.5	0.026	7.5

POWER DENSITY CALCULATION MODEL

User-defined Inputs

Operator	Marcus Comm. LLC. 310OrangeStNewHavenCT
Transmitter Po	0.1 Watts
System Losses	8.00 dB
Antenna Height	40.0 Feet
Antenna Gain	35 dBd
Ground Reflec. Coeff	1.6
Frequency	5800.000 MHz
Radial Dist., Antenna Base to Site Boundary	40.0 Feet

Antenna Height	40 Feet
----------------	---------

Antenna Base

Power Density (mW/cm <sup>2</sup> )	
Predicted	Max allow % of std
0.006122	1.0000
0.612	0.612

E-Field (V/m)

Max allow % of std	
Predicted	#DIV/0!
4.80409	0.0000

H-Field (A/m)

Max allow % of std	
Predicted	#DIV/0!
0.01274	0.0000

Radial Dist., Antenna Base to Site Boundary	40 Feet
---	---------

Site Boundary

Power Density (mW/cm <sup>2</sup> )	
Predicted	Max allow % of std
0.003061	1.0000
0.306	0.306

E-Field (V/m)

Max allow % of std	
Predicted	#DIV/0!
3.397002	0.0000

H-Field (A/m)

Max allow % of std	
Predicted	#DIV/0!
0.009011	0.0000

1.000

-1

Slant	1724
-------	------

Radial	1219
--------	------

Height	1219
--------	------

E(std),	f > 100k	V/m	H(std),	f > 100k	0	A/m	S(std), > 100k	0	out of f range
E(std),	1.5k <= f < 100k	V/m	H(std),	1.5k <= f < 100k	---	A/m	S(std),	1.5k <= f < 100k	1.0
E(std),	300 <= f < 1.5k	V/m	H(std),	300 <= f < 1.5k	0	A/m	S(std),	300 <= f < 1.5k	0
E(std),	30 <= f < 300	V/m	H(std),	30 <= f < 300	0	A/m	S(std),	30 <= f < 300	0
E(std),	1.34 <= f < 30	V/m	H(std),	1.34 <= f < 30	0	A/m	S(E)std,	1.34 <= f < 30	0
E(std),	0.3 <= f < 1.34	V/m	H(std),	0.3 <= f < 1.34	0	A/m	S(E)std,	0.3 <= f < 1.34	0
E(std),	< 0.3	V/m	H(std),	< 0.3	0	A/m	S(E)std,	< 0.3	0

Pd @ Base:	(W)	Ht	Radial d	Slant d	Syst loss	Antg	Antg-loss	gnd refl	Po	Std	% of std
Marcus Comm. I	0.1	1219	0	0	8.0	34.5	26.5	---	0.006122	0.000000	#DIV/0!

Pd @ Boundary:	(W)	Ht	Radial d	Slant d	Syst loss	Antg	Antg-loss	gnd refl	Po	Std	% of std
Marcus Comm. I	0.1	1219	1219	1724	8.0	34.5	26.5	1.6	0.003061	0.000000	#DIV/0!

S("E")	E	S("H")	H	Predicted	%	H	%
0.2	27.459	2.261	0.245	E	6.469	0.017	6.9
0.2	27.459	5.163	0.370	E	5.594	0.015	4.1
0.2	27.459	5.284	0.374	E	4.988	0.013	3.5
0.2	27.459	3.016	0.283	E	4.988	0.013	4.6
0.2	27.459	0.200	0.073	E	7.368	0.019	26.1
0.301	33.686	0.301	0.089	E	4.119	0.011	12.3
0.577	46.640	0.577	0.124	E	2.214	0.006	4.8
0.577	46.640	0.577	0.124	E	2.214	0.006	4.8
0.577	46.640	0.577	0.124	E	2.214	0.006	4.8
4.517	130.496	4.517	0.346	E	9.824	0.026	7.5

**POWER DENSITY CALCULATION MODEL**

User-defined Inputs

Operator	Marcus Comm. LLC. 310OrangeStNewHavenCT
Transmitter Po	0.1 Watts
System Losses	8.00 dB
Antenna Height	40.0 Feet
Antenna Gain	29 dBd
Ground Reflec. Coeff	1.6
Frequency	5800.000 MHz
Radial Dist., Antenna Base to Site Boundary	40.0 Feet

Antenna Height	40 Feet
----------------	---------

Antenna Base

Power Density (mW/cm <sup>2</sup> )	
Predicted	0.001725
Max allow	1.0000
% of std	0.173

E-Field (V/m)	
Predicted	2.55041
Max allow	0.0000
% of std	#DIV/0!

H-Field (A/m)	
Predicted	0.00677
Max allow	0.0000
% of std	#DIV/0!

Radial Dist., Antenna Base to Site Boundary

40 Feet
---------

Site Boundary

Power Density (mW/cm <sup>2</sup> )	
Predicted	0.000863
Max allow	1.0000
% of std	0.086

E-Field (V/m)	
Predicted	1.803415
Max allow	0.0000
% of std	#DIV/0!

H-Field (A/m)	
Predicted	0.004784
Max allow	0.0000
% of std	#DIV/0!

1.000

-1

Slant  
1724

Radial  
1219

Height  
1219

E(std)	f > 100k	V/m	H(std)	f > 100k	A/m	S(std) > 100k	0	out of f range
E(std), 1.5k <= f < 100k	V/m	H(std), 1.5k <= f < 100k	A/m	S(std), 1.5k <= f < 100k	1.0	mW/cm2		
E(std), 300 <= f < 1.5k	V/m	H(std), 300 <= f < 1.5k	A/m	S(std), 300 <= f < 1.5k	0	mW/cm2		
E(std), 30 <= f < 300	V/m	H(std), 30 <= f < 300	A/m	S(std), 30 <= f < 300	0	mW/cm2		
E(std), 1.34 <= f < 30	V/m	H(std), 1.34 <= f < 30	A/m	S(E)std, 1.34 <= f < 30	0	mW/cm2		
E(std), 0.3 <= f < 1.34	V/m	H(std), 0.3 <= f < 1.34	A/m	S(E)std, 0.3 <= f < 1.34	0	mW/cm2		
E(std), < 0.3	V/m	H(std), < 0.3	A/m	S(E)std, < 0.3	0	mW/cm2		

Pd @ Base: (W)	Ht (cm)	Radial d (cm)	Slant d (cm)	Syst loss (dB)	Antg (dB)	Antg-loss (dB)	gnd refl	Po (mW/cm2)	Std (mW/cm2)	#DIV/0!
Marcus Comm. I	0.1	1219	0	8.0	29.0	21.0	---	0.001725	0.000000	
								2.55041452		
								0.00676503		
								0.000863	0.000000	
								1.8034154		
								0.0047836		

Pd @ Boundary:	Ht (cm)	Radial d (cm)	Slant d (cm)	Syst loss (dB)	Antg (dB)	Antg-loss (dB)	gnd refl	Po (mW/cm2)	Std (mW/cm2)	#DIV/0!
Marcus Comm. I	0.1	1219	1724	8.0	29.0	21.0	1.6	0.001725	0.000000	
								2.55041452		
								0.00676503		
								0.000863	0.000000	
								1.8034154		
								0.0047836		

S("E")	E	S("H")	H	Predicted	%
0.2	27.459	2.261	0.245	E	6.469
0.2	27.459	5.163	0.370	%	23.6
0.2	27.459	5.284	0.374		0.017
0.2	27.459	3.016	0.283		6.9
0.2	27.459	0.200	0.073		4.1
0.301	33.686	0.301	0.089		20.4
0.577	46.640	0.577	0.124		18.2
0.577	46.640	0.577	0.124		0.013
4.517	130.496	4.517	0.346		18.2
					0.013
					26.8
					0.019
					12.2
					0.011
					4.7
					0.006
					4.7
					0.006
					4.8
					4.8
					7.5
					0.026
					7.5



# Base Station Antenna Broadband Collinear Array

450 - 512 MHz, 8-10 dBd Gain



Put dependability on your tower with this new series of UHF antennas from TX RX Systems. Some antennas depend on the fiberglass radome for most or all of their structural integrity; their inner workings are like puppets on a string and would collapse without the radome! Not so with these new models from TX RX Systems. A unique electromechanical design introduced in our successful 800 MHz collinear line, provides unusual strength apart from the radome and superior electrical performance in the same package. A design so original that it has been awarded **two U.S. Patents**. You get an extremely rugged antenna with the broadband electrical advantages of an exposed dipole array and the superior weather resistance of a radome.

- Superior storm and lightning survivability.
- Lower deflection in high winds for consistent performance and less flutter.
- Broad bandwidth like an exposed dipole array but fully radome-protected and a truly circular pattern.
- Available in 0°, 3° and 6° downtilted models.
- Each model covers the entire band.
- Consistent main-lobe pattern across the band.
- Consistent downtilt across the band.
- Ideal for use with combined and multicoupled radio systems.

Model Numbers		
101-68-10-0-01	0° downtilt	7/16 Connector
101-68-10-0-01N	0° downtilt	N Connector
101-68-10-0INV-01	0°, inverted mtg.	7/16 Connector
101-68-10-0INV-01N	0°, inverted mtg.	N Connector

**Ordering Information:**  
Specify Model Number when ordering.  
Consult the factory for models with downtilt.

Mechanical Specifications*	
Rated Wind Velocity (RWV)	150 mph (241 kph)
RWV with 1/2 Inch ice	125 mph (200 kph)
Equivalent Flat Plate Area	2.7 ft <sup>2</sup> (.16 m <sup>2</sup> )
Lateral Thrust @ 100 mph	110 lbs. (50 kg)
Overall Length	15.8 ft. (4.8 m)
Weight	62 lbs. (27.2 kg)
Radome Diameter	3.57 in. (9.1 cm)
Support Pipe:	
Diameter	3.5 in. (8.9 cm)
Length	25 in. (63.6 cm)
Wall Thickness	.375 in. (9.5 mm)
Material	6061-T6 Aluminum
Shipping Information:	
Ship Weight	70 lbs. (22.7 kg)
Dimensions	216" x 7" x 7" 548 x 18 x 18 cm
Ship Method	Truck
Mounting Hardware	Supplied

\* Calculated in accordance with EIA RS-329

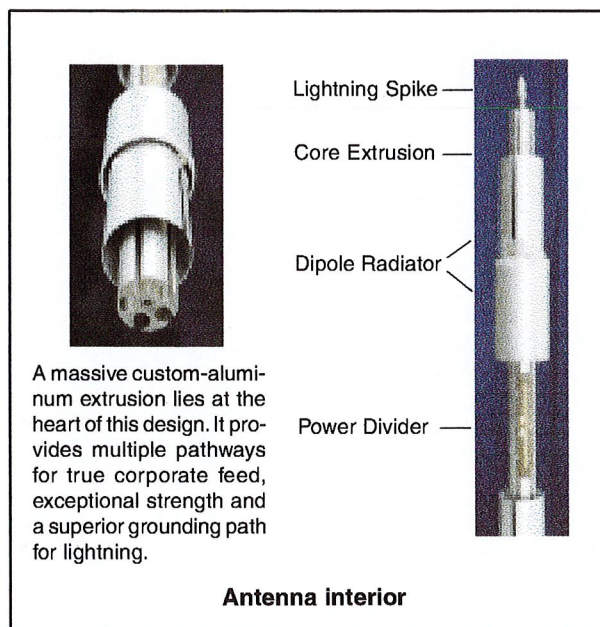

A massive custom-aluminum extrusion lies at the heart of this design. It provides multiple pathways for true corporate feed, exceptional strength and a superior grounding path for lightning.

Electrical Specifications	
Frequency Range	450 - 512 MHz
Gain	9 dBd ± 1 dB
Power Rating	1000 Watts
Bandwidth	62 MHz
VSWR, full bandwidth	1.5:1
Impedance	50 ohms
Vertical Beamwidth	10°
Pattern	Omnidirectional
Lightning Protection	Direct Ground
Termination	N female or 7/16 DIN

Antennas: 450 - 512 MHz



DUPLEXERS • CAVITY FILTERS • MULTICOUPLER SYSTEMS • SIGNAL BOOSTER SYSTEMS • ANTENNAS • RF SYSTEM PRODUCTS

TX RX SYSTEMS INC. 8625 INDUSTRIAL PARKWAY, ANGOLA, NY 14006-9696  
TELEPHONE 716-549-4700 FAX 716-549-4772 (24 HRS.) EMAIL: SALES@TXRX.COM WEB SITE: WWW.TXRX.COM  
A MEMBER OF BIRD TECHNOLOGIES GROUP



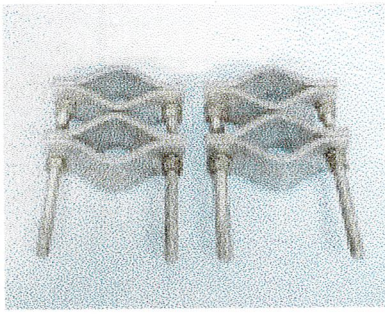

Heavy-duty mounting hardware is supplied with each antenna. These galvanized, upper and lower pipe-to-pipe clamps can accommodate pipes from 2.5" - 5" in diameter.

The three antenna radiation patterns shown below are plotted from actual measured data obtained from our own antenna range. The data was taken using the same antenna for all three plots.

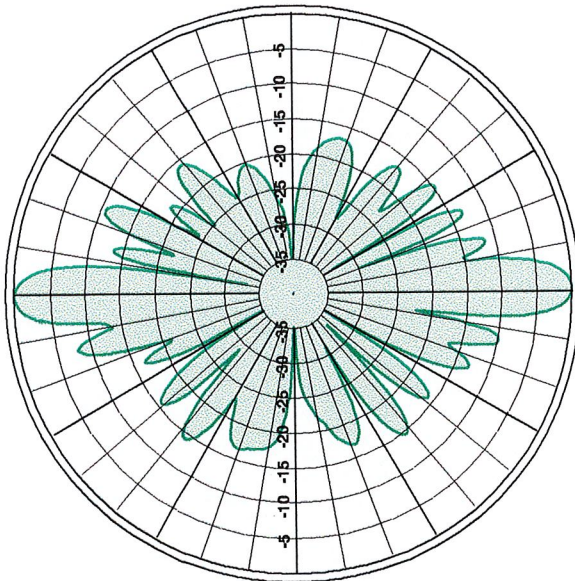

Relative E Plane pattern at 450 MHz (8 dBd gain).

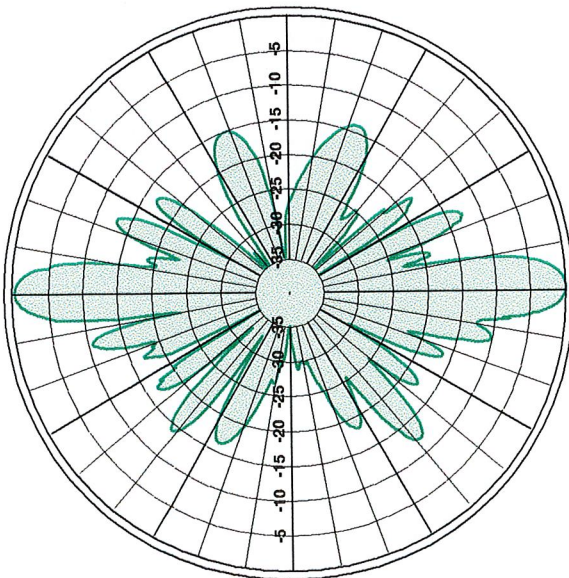

Relative E-Plane pattern at 470 MHz (9 dBd gain).

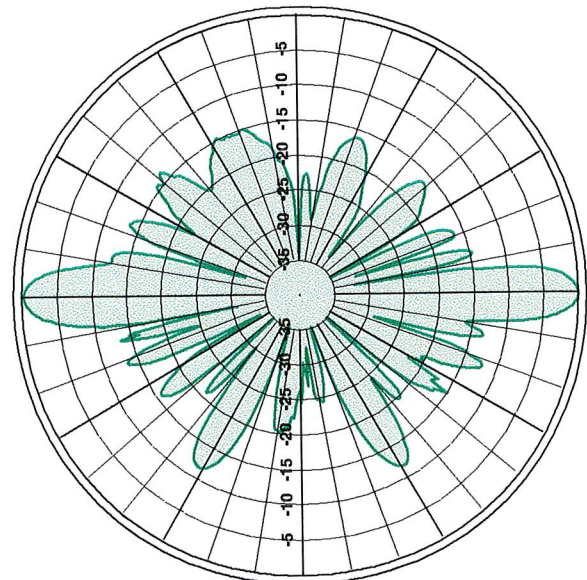

Relative E-Plane pattern at 500 MHz (10 dBd gain).

### Corporate Feed Network

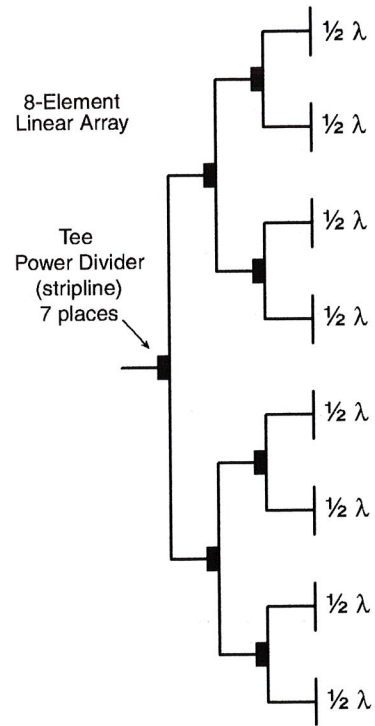

**Corporate Power Distribution** is a key reason for the superior performance of this antenna. The diagram above illustrates the interconnections that make it possible. Each antenna element receives RF power at the same amplitude and phase, a technique previously limited to exposed dipole arrays. Our patented design allows a relatively thin, radome-protected antenna to achieve the same **broadband characteristics** as the older exposed dipole design. Most competitive radome antennas of similar appearance use series-fed elements which severely limit their performance over a wide frequency range. Additionally, this new design can produce a **more circular pattern** because the support structure does not act like a reflector as it does in exposed dipole antennas.

**Decibel Products  
DB636**



Omnidirectional, dual skirt dipole fiberglass with 32 MHz of bandwidth. Drain plugs at both ends. HorizonBlue radome with minimum tip deflection.

450-512  
6  
32  
500 Watts

N/A  
20 Deg.  
N/A

Direct Ground  
N Female  
Not included  
DB365 Clamps

9.3'  
6.8'  
2.5"  
26"  
30 Lbs.

225 MPH  
1.6l  
64.4 Lbs.  
210 Ft.Lbs.  
1 Year

<b>52852</b>	406-436
<b>◆ 39638</b>	450-482
<b>78031</b>	480-512
\$1,160.00	\$870.00
45 lb.	\$852.60
20.45 kg.	\$835.20

# Filters, Combiners, Duplexers, Ferrites

## Combiners, UHF [440-52]

Product Narrative  
Combiner Type

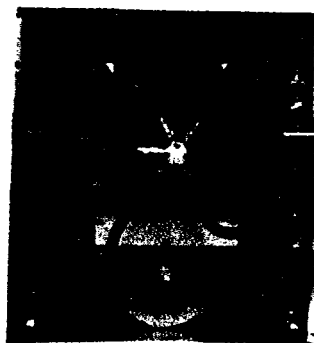

Compact low-loss combiner.  
Mounts in 19" rack.  
Cavity-Ferrite

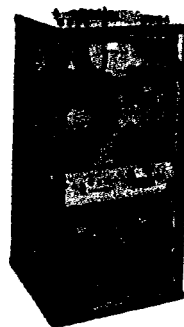

Combiner on eight position rack.  
Incl. wattmeter panel for forward/  
reflected readings on input and out-  
put, and remote Tx keying.  
Cavity-Ferrite



Combiner for close channel spac-  
ing. Housed in open frame cabinet  
with castors for mobility. Two  
frames can be stacked.  
Cavity-Ferrite

	406-512	406-512	406-512
Freq. Range (MHz)	406-512	406-512	406-512
Maximum Power Per Channel (W)	125	150	125
No. of Channels	3	3	4
Min. Separation (MHz)	200 kHz	275 kHz	100 kHz
Maximum Separation	N/A	N/A	N/A
Min. Insertion Loss	2.9	3.0	2.5
Maximum Insertion Loss	4.0 @ 200 kHz	3.5 @ 275 kHz sep.	4.4 @ 100 kHz
Isolation Tx/Tx	70	75	70
Isolation Ant/Tx	60	60	60
Second Harmonic Attenuation	90	90	90
Input VSWR	1.25:1	1.5:1	1.5:1
Tuning Method	Factory Tune	Factory Tune	Factory Tune
Expandable	Yes	Yes	Yes
Isolator Type	Dual	Dual	Dual
Cavity Size, Type	7" (1/4 wave)	10" (1/4 wave)	7" (1/2 wave)
Connectors	N Female	N Female	N Female
temp. Range deg-C	-30 to +60	-30 to +60	-30 to +60
Size (H"xW"xD")	19.25 x 19 x 15.3	48 x 24 x 24	38 x 21 x 21
Warranty	1 Year	1 Year	2 Years
<b>TESSCO Part No.</b>	<b>59393</b>	<b>73247</b>	<b>18502</b>
List Price:	T-1 Price: \$3,772.00	*Specify Frequency \$3,093.04	*Specify Frequency \$5,150.01
Ship lb.:	T-2 Price: 63 lb.	\$6,519.00	\$5,684.00
Ship kg.:	T-3 Price: 28.63 kg.	175 lb.	110 lb.
		\$2,829.00	\$4,889.25
		\$2,791.28	\$4,824.06
		79.54 kg.	50.00 kg.
			\$4,206.16



[sitemap](#) [faq](#) [site policy](#)

[search](#)



- [About TESCO](#)
- [Access Your Account](#)
- [Build Solutions](#)
- [Search/Buy Products](#)
- [Select Your Industry](#)
- [Partner With TESCO](#)
- [Invest In Our Vision](#)
- [Resources Publications](#)

[Search for Products >](#)

[Home](#) > [Buy Products](#) > [Search for Products](#)

# Antennas, Microwave Products [\(See more\)](#)

## 5.25 to 5.85 GHz Antennas [345-30] [\(See more\)](#)

<b>Manufacturer</b>	Radio Waves
<b>Table</b>	SPD2-5.8
<b>TESSCO Part No.</b>	13515 <input type="text" value="1"/> <a href="#">Add to Worksheet</a>
<b>Drawing</b>	
<b>Frequency</b>	5.725 - 5.85
<b>Diameter</b>	2 Foot
<b>Polarization</b>	Dual
<b>Pressure</b>	Unpressurized
<b>Gain at Low (dBi)</b>	28.0
<b>Gain at Mid (dBi)</b>	
<b>Gain at High (dBi)</b>	28.5
<b>Nom. Mid Band Beamwidth</b>	
<b>XPD (dB)</b>	25
<b>Front to Back Ratio (dB)</b>	35
<b>VSWR (max)</b>	1.50
<b>Return Loss (dB)</b>	
<b>Connector</b>	N/Female
<b>Mount Type</b>	1"-4.5" pipe
<b>Weight Lbs. (kg)</b>	
<b>Ship Dim. (L x W x H Inches)</b>	27 x 6 x 25
<b>Product Narrative</b>	Lightweight and rugged Spread Spectrum/ISM band parabolic antenna. Mount provides fine adjustment of azimuth and elevation.
<b>Mid Band Vert. Beamwidth (deg)</b>	
<b>Max 125mph Wind Axial Force lb</b>	
<b>Wind Load,125mph Twist Moment</b>	
<b>Warranty</b>	3 Years
<b>Qty/Uom</b>	1 EACH
<b>List (\$)</b>	890.00



# STATE OF CONNECTICUT

## CONNECTICUT SITING COUNCIL

Ten Franklin Square, New Britain, CT 06051

Phone: (860) 827-2935 Fax: (860) 827-2950

E-Mail: [siting.council@po.state.ct.us](mailto:siting.council@po.state.ct.us)

Web Site: [www.state.ct.us/csc/index.htm](http://www.state.ct.us/csc/index.htm)

April 30, 2002

Ms. Dawn E. Holmes  
Manager, Real Estate Administration  
Southern New England Telephone  
310 Orange Street  
New Haven, CT 06510

RE: **EM-SNET-073-020321** – SNET notice of intent to modify an existing telecommunications facility located at 310 Orange Street, New Haven, Connecticut.

Dear Ms. Holmes:

At a public meeting held on April 25, 2002, the Connecticut Siting Council (Council) acknowledged your notice to modify this existing telecommunications facility, pursuant to Section 16-50j-73 of the Regulations of Connecticut State Agencies with the conditions that the total equivalent flat plate area of the antennas and their mounting pipes do not exceed 9.5 square feet as per the recommendation of Demirtas Bayar, P.E. stated in a letter dated April 11, 2002.

The proposed modifications are to be implemented as specified here and in your notice[s] dated March 20, 2002. The modifications are in compliance with the exception criteria in Section 16-50j-72 (b) of the Regulations of Connecticut State Agencies as changes to an existing facility site that would not increase tower height, extend the boundaries of the tower site, increase noise levels at the tower site boundary by six decibels, and increase the total radio frequencies electromagnetic radiation power density measured at the tower site boundary to or above the standard adopted by the State Department of Environmental Protection pursuant to General Statutes § 22a-162. This facility has also been carefully modeled to ensure that radio frequency emissions are conservatively below State and federal standards applicable to the frequencies now used on this tower.

This decision is under the exclusive jurisdiction of the Council. Any additional change to this facility will require explicit notice to this agency pursuant to Regulations of Connecticut State Agencies Section 16-50j-73. Such notice shall include all relevant information regarding the proposed change with cumulative worst-case modeling of radio frequency exposure at the closest point of uncontrolled access to the tower base, consistent with Federal Communications Commission, Office of Engineering and Technology, Bulletin 65. Any deviation from this format may result in the Council implementing enforcement proceedings pursuant to General Statutes § 16-50u including, without limitation, imposition of expenses resulting from such failure and of civil penalties in an amount not less than one thousand dollars per day for each day of construction or operation in material violation.

Thank you for your attention and cooperation.

Very truly yours,

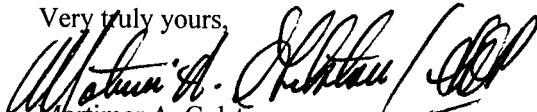
  
Mortimer A. Gelston  
Chairman

MAG/DM/laf

C: Honorable John Destefano, Jr., Mayor, City of New Haven



# STATE OF CONNECTICUT

## CONNECTICUT SITING COUNCIL

Ten Franklin Square, New Britain, CT 06051

Phone: (860) 827-2935 Fax: (860) 827-2950

E-Mail: [siting.council@po.state.ct.us](mailto:siting.council@po.state.ct.us)

Web Site: [www.state.ct.us/csc/index.htm](http://www.state.ct.us/csc/index.htm)

March 27, 2002

Honorable Mark. D. Boughton  
Mayor  
City of Danbury  
City Hall  
155 Deer Hill Avenue  
Danbury, CT 06810

RE: **EM-SNET-034-020321** - Southern New England Telephone Company notice of intent to modify an existing telecommunications facility located at Moses Mountain, Danbury, and 310 Orange Street, New Haven, Connecticut.

Dear Mayor Boughton:

The Connecticut Siting Council (Council) received this request to modify an existing telecommunications facility, pursuant to Regulations of Connecticut State Agencies Section 16-50j-72.

The Council will consider this item at the next meeting scheduled for April 3, 2002, at 1:30 p.m. in Hearing Room Two, Ten Franklin Square, New Britain, Connecticut.

Please call me or inform the Council if you have any questions or comments regarding this proposal.

Thank you for your cooperation and consideration.

Very truly yours,

S. Derek Phelps  
Executive Director

SDP/grg

Enclosure: Notice of Intent

c: Dennis Elpern, City Planner, City of Danbury



# STATE OF CONNECTICUT

## CONNECTICUT SITING COUNCIL

Ten Franklin Square, New Britain, CT 06051

Phone: (860) 827-2935 Fax: (860) 827-2950

E-Mail: [siting.council@po.state.ct.us](mailto:siting.council@po.state.ct.us)

Web Site: [www.state.ct.us/csc/index.htm](http://www.state.ct.us/csc/index.htm)

March 27, 2002

Honorable John Destefano, Jr  
Mayor  
City of New Haven  
165 Church Street  
New Haven, CT 06510

RE: **EM-SNET-034-020321** - Southern New England Telephone Company notice of intent to modify an existing telecommunications facility located at Moses Mountain, Danbury, and 310 Orange Street, New Haven, Connecticut.

Dear Mayor Destefano:

The Connecticut Siting Council (Council) received this request to modify an existing telecommunications facility, pursuant to Regulations of Connecticut State Agencies Section 16-50j-72.

The Council will consider this item at the next meeting scheduled for April 3, 2002, at 1:30 p.m. in Hearing Room Two, Ten Franklin Square, New Britain, Connecticut.

Please call me or inform the Council if you have any questions or comments regarding this proposal.

Thank you for your cooperation and consideration.

Very truly yours,

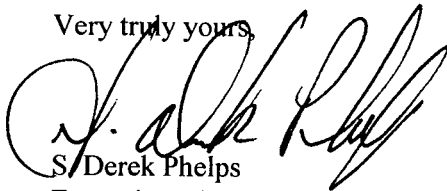

S/Derek Phelps  
Executive Director

SDP/rgg

Enclosure: Notice of Intent

c: Frank Gargiulo, Zoning Administrator, City of New Haven

Connecticut Siting Council



034

Approved by Council \_\_\_\_\_  
Date Complete: \_\_\_\_\_  
Site visit required? \_\_\_\_\_

File I.D. <sup>073</sup> EM-SNET-034-020321  
Address 034 - Moses Mountain, Danbury  
073 - 310 Orange St, New Haven

**Checklist for Exempt Modifications and Tower Sharing**

- Tower Owner SNET Tower Height 65 Type lattice Total Height \_\_\_\_\_
- Proposed Carrier Marcus Comms Number of antennas 1-whip on top Type side whips for transmit - 65' Height top whip receive only - 50' Extension \_\_\_\_\_  
2-whips on side  
Other proposed equipment on tower: dish antenna - 49'  
Proposed size/location of equipment building/cabinets: \_\_\_\_\_  
Proposed site clearing/grading: \_\_\_\_\_  
Fence line modification: none  
Other proposed items: \_\_\_\_\_
- Current carriers: Verizon Height: 71' Power density %: 24.09  
\_\_\_\_\_  
\_\_\_\_\_  
\_\_\_\_\_  
\_\_\_\_\_
- Power density calculation: Proposed carrier percentage: 16.894 Cumulative percentage: \_\_\_\_\_
- Town approval date (if necessary): \_\_\_\_\_ Town application date (if necessary): \_\_\_\_\_
- Structural analysis: not provided
- Coordinates Latitude: 41-21-34 Longitude: 73-27-58 Elevation: \_\_\_\_\_
- Town(s) CEO notified of application to Siting Council? \_\_\_\_\_

**Site Visit Information**

Date of visit: 3/28/02

9. Description of site features, surrounding land uses, and sight lines:

site on top of high mtn, wooded, visible from far but not close, access through gated community but probably not visible from here

**Issues:**

top antenna extends above ht. of tower 11'  
need structural analysis  
PD calcs unclear

**Filing Documentation for Meeting**

- 1.
- 2.
- 3.
- 4.



073

# Connecticut Siting Council



Approved by Council \_\_\_\_\_  
Date Complete: \_\_\_\_\_  
Site visit required? \_\_\_\_\_

File I.D. EM-SNET-073-020321  
Address 310-Orange Street  
New Haven

### Checklist for Exempt Modifications and Tower Sharing

- Tower Owner SNET Tower Height 118\* Type \_\_\_\_\_ Total Height \_\_\_\_\_
- Proposed Carrier Marcus Comens  
 Number of antennas \_\_\_\_\_ Type \_\_\_\_\_ Height ~~118~~ Extension \_\_\_\_\_  
 Other proposed equipment on tower: \_\_\_\_\_  
 Proposed size/location of equipment building/cabinets: \_\_\_\_\_  
 Proposed site clearing/grading: \_\_\_\_\_  
 Fence line modification: \_\_\_\_\_  
 Other proposed items: \_\_\_\_\_
- Current carriers: \_\_\_\_\_ Height: \_\_\_\_\_ Power density %: \_\_\_\_\_  
 \_\_\_\_\_  
 \_\_\_\_\_  
 \_\_\_\_\_  
 \_\_\_\_\_
- Power density calculation: Proposed carrier percentage: 6.899 Cumulative percentage: \_\_\_\_\_
- Town approval date (if necessary): \_\_\_\_\_ Town application date (if necessary): \_\_\_\_\_
- Structural analysis: \_\_\_\_\_
- Coordinates Latitude: \_\_\_\_\_ Longitude: \_\_\_\_\_ Elevation: \_\_\_\_\_
- Town(s) CEO notified of application to Siting Council? \_\_\_\_\_

**Site Visit Information** Date of visit: \_\_\_\_\_

9. Description of site features, surrounding land uses, and sight lines:  
on top of tall bldg in downtown New Haven, antennas insignificant feature on skyline

**Issues:**

### Filing Documentation for Meeting

- 1.
- 2.
- 3.
- 4.

\* tower mounted on roof top - bottom @ 167.5' AGL, top @ 285.3' AGL



# STATE OF CONNECTICUT

## CONNECTICUT SITING COUNCIL

Ten Franklin Square, New Britain, CT 06051

Phone: (860) 827-2935 Fax: (860) 827-2950

E-Mail: [siting.council@po.state.ct.us](mailto:siting.council@po.state.ct.us)

Web Site: [www.state.ct.us/csc/index.htm](http://www.state.ct.us/csc/index.htm)

March 28, 2002

### ***Via Facsimile***

Ms. Dawn E. Holmes  
Manager  
Real Estate Administration  
Southern New England Telephone  
310 Orange Street  
New Haven, CT 06510

Re: Notice of Intent to Modify an Exempt Tower and Associated Equipment at Moses Mountain, Danbury and 310 Orange Street, New Haven.

Dear Ms. Holmes:

For the above referenced filing, I am requesting additional information needed to enable the Siting Council to act on your Notice. This information is described below:

1. For neither site do you provide a structural analysis indicating that the existing tower structure can or cannot support the proposed antennas. Please provide these analyses.
2. For each site, you have included power density calculations for the antennas you are proposing to install. However, in neither case do these calculations account for the antennas already on the Moses Mountain and 310 Orange Street towers. Please provide power density calculations that include all antennas installed and currently proposed to be installed on these two towers.
3. In addition, in previous filings there was an indication that conservative power density calculations showed that the antennas on the Moses Mountain tower may be exceeding the FCC limit for Maximum Possible Exposure (MPE). (see filing dated May, 2000 submitted by Troy Riccitelli, SNET) This concern was, in part, addressed by a field study and safety analysis for the Moses Mountain tower performed by RCC Consultants and dated November, 1997.

Please provide documentation indicating that the antennas currently being proposed for Moses Mountain will not cause this tower to exceed the FCC's MPE.

If you have any questions concerning these requests, please feel free to call me at the above number. Thank you for your assistance in this matter.

Sincerely,

David Martin  
Siting Analyst I



**BAYAR ENGINEERING, P.C.**  
**Structural Engineers**

P.O. Box 1287, Port Chester, N.Y. 10573-8287  
TEL: (914) 921-4067 FAX: (914) 967-2147

*Demirtas C. Bayar, P.E.*

April 1, 2002

Mr. Manny Litos  
The Marcus Group  
P.O.Box 8447  
275 New State Road  
Manchester, CT 06040

Re: Moses Mtn., Danbury, CT.  
BE Job No. 0210

Dear Mr. Litos,

We reviewed your proposed addition of antennas to the existing 65' tower at Moses Mtn., Danbury, CT. We understand that two Decibel DB636 antennas will be installed at about the 50' level and one TXRX antenna will be install with its top at 76' above the base of the tower. The enclosed drawing AR20689 shows our understanding of the antenna configurations.

Our analysis indicated that for the tower to be structurally adequate, four (4) grid type parabolic antennas need to be removed from the tower. These antennas are marked and defined on the enclosed drawing. The additional parabolic antenna you proposed at the 50' level will overstress the tower. For this condition we need to make additional calculations to determine the overstress, tilt and twist of the tower.

Should you have any other questions regarding this report we will be glad to discuss them with you.

Yours truly,

Demirtas C. Bayar  
President

XC: Don Wilson (RCC)