

10 INDUSTRIAL AVE,
SUITE 3
MAHWAH NJ 07430
PHONE: 201.684.0055
FAX: 201.684.0066



June 17, 2021

Members of the Siting Council
Connecticut Siting Council
10 Franklin Square
New Britain, CT 06051

RE: Notice of Exempt Modification
24 Hospital Ave, Danbury, CT, 06810
Latitude: 41.40504
Longitude: -73.445988
T-Mobile Site#: CT11108A - Anchor

Dear Ms. Bachman:

T-Mobile currently maintains eleven (11) antennas at the 127-foot level and the 154-foot level of the existing 134-foot rooftop facility at 24 Hospital Ave., in Danbury, CT. The property is owned by Danbury Hospital. T-Mobile now intends to remove three (3) existing antennas and add four (4) new 2500 MHz antennas. The new antennas support 5G services and will be installed at the same 127-foot level and 154-foot level of the rooftop. Mount modifications are also required as detailed in the enclosed mount analysis.

Planned Modifications:

Tower:

Remove

(3) Ericsson AIR 21 KRC118023-1 B2A B4P

Install New:

(4) Ericsson Radio 4415 B25 RRU
(4) Ericsson AIR6449 B41
(4) 6x12 Hybrid Cables
(4) Commscope SDX1926Q Diplexers

Existing to Remain:

(4) RFS APXVAARR24 Antennas
(4) Ericsson AIR32 Antennas
(4) Ericsson Radio 4449 B71

Ground:

Install New:

(1) 6160 Cabinet and (1) B160 Battery Cabinet

The council assumed jurisdiction of this facility in Docket 79 on September 10, 1987. This approval included the conditions the facility shall be constructed in accordance with all applicable federal, state, and municipal laws and regulations, and shall comply with any future radio frequency standards promulgated by state or federal agencies. This modification complies with the aforementioned conditions.

Please accept this letter as notification pursuant to Regulations of Connecticut State Agencies § 16- SOj-73, for construction that constitutes an exempt modification pursuant to R.C.S.A. § 16-50j-72(b)(2). In accordance with R.C.S.A. § 16-SOj-73, a copy of this letter is being sent to Mayor Joseph Cavo, Elected Official, and Sharon Calitro, Director of the Planning and Zoning Department, as well as the property owner.

The planned modifications to the facility fall squarely within those activities explicitly provided for in R.C.S.A. § 16-50j-72(b)(2).

1. The proposed modifications will not result in an increase in the height of the existing structure.
2. The proposed modifications will not require the extension of the site boundary.
3. The proposed modifications will not increase noise levels at the facility by six decibels or more, or to levels that exceed state and local criteria.
4. The operation of the replacement antennas will not increase radio frequency emissions at the facility to a level at or above the Federal Communications Commission safety standard.
5. The proposed modifications will not cause a change or alteration in the physical or environmental characteristics of the site.
6. The existing structure and its foundation can support the proposed loading.

For the foregoing reasons, T-Mobile respectfully submits that the proposed modifications to the above referenced telecommunications facility constitute an exempt modification under R.C.S.A. § 16-50j-72(b)(2).

Sincerely,

Eric Breun

Transcend Wireless

Cell: 201-658-7728

Email: ebreun@transcendwireless.com

Attachments

cc: Joseph Cavo – as Mayor of the City of Danbury

Sharon Calitro - Director of Planning and Zoning Department

Danbury Hospital - Property Owner

ERIC BREUN
2016587728
10 INDUSTRIAL AVE
MAHWAH NJ 07430

1 LBS

1 OF 1

SHIP TO:
SHARON CALITRO
1ST FLOOR - ZONING DPT.
155 DEER HILL AVENUE
DANBURY CT 06810



CT 068 0-01

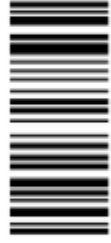

UPS GROUND

TRACKING #: 1Z V25 742 03 9495 6875

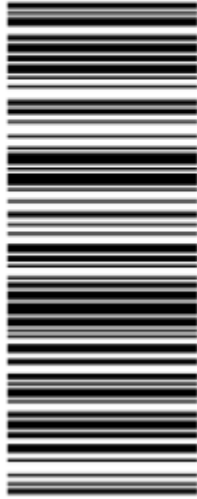

BILLING: P/P

Reference #1: CT11108A

XOL 21.05.18 NV45 25.0A 06/2021*



TM

ERIC BREUN
2016587728
10 INDUSTRIAL AVE
MAHWAH NJ 07430

1 LBS

1 OF 1

SHIP TO:
MAYOR JOSEPH CAVO
155 DEER HILL AVENUE
DANBURY CT 06810



CT 068 0-01



UPS GROUND

TRACKING #: 1Z V25 742 03 9220 6867



BILLING: P/P

Reference #1: CT11108A

XOL 21.05.18 NV45 25.0A 06/2021*



TM

ERIC BREUN
2016587728
10 INDUSTRIAL AVE
MAHWAH NJ 07430

1 LBS

1 OF 1

SHIP TO:
FACILITY MANAGEMENT DANBURY HOSP.
24 HOSPITAL AVENUE
DANBURY CT 06810



CT 068 0-01



UPS GROUND

TRACKING #: 1Z V25 742 03 9954 3927

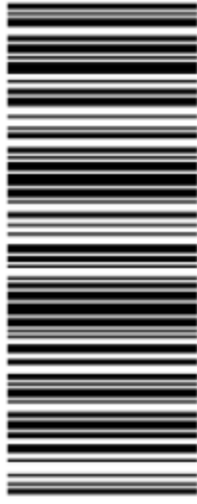

BILLING: P/P

Reference #1: CT11108A

XOL 21.05.18 NV49 25.04.06/2021*



TM

LOCUST AV

[Sales](#) [Print](#) [Map It](#)

Location LOCUST AV

Mblu I12 / 1 / 1

Acct#

Owner DANBURY HOSPITAL

Assessment \$256,676,700

Appraisal \$366,680,100

PID 24190

Building Count 16

Assessing District

Current Value

Appraisal			
Valuation Year	Improvements	Land	Total
2020	\$308,036,700	\$58,643,400	\$366,680,100

Assessment			
Valuation Year	Improvements	Land	Total
2020	\$215,626,300	\$41,050,400	\$256,676,700

Owner of Record

Owner DANBURY HOSPITAL
Co-Owner
Address 24 HOSPITAL AVE
DANBURY, CT 06810

Sale Price \$0
Book & Page 0679/0464
Sale Date 05/26/1983
Instrument

Ownership History

Ownership History				
Owner	Sale Price	Book & Page	Instrument	Sale Date
DANBURY HOSPITAL	\$0	0679/0464		05/26/1983

Building Information

Building 1 : Section 1

Year Built: 1970
 Living Area: 295,646
 Replacement Cost: \$72,929,305
 Building Percent Good: 72
 Replacement Cost
 Less Depreciation: \$52,509,100

Building Attributes	
Field	Description
STYLE	Hospital
MODEL	Commercial
Grade	Excellent
Stories:	6
Occupancy	1
Exterior Wall 1	Brick/Masonry
Exterior Wall 2	
Roof Structure	Flat
Roof Cover	Tar & Gravel
Interior Wall 1	Drywall/Sheet
Interior Wall 2	
Interior Floor 1	Vinyl/Asphalt
Interior Floor 2	
Heating Fuel	Gas
Heating Type	Forced Air-Duc
AC Type	Central
Bldg Use	Commercial MDL-94
Total Rooms	
Total Bedrms	00
Total Baths	0
1st Floor Use:	200
Heat/AC	HEAT/AC SPLIT
Frame Type	MASONRY
Baths/Plumbing	AVERAGE
Ceiling/Wall	CEIL & WALLS
Rooms/Prtns	AVERAGE
Wall Height	10
% Corn Wall	0

Building Photo

Building Photo

Building Layout

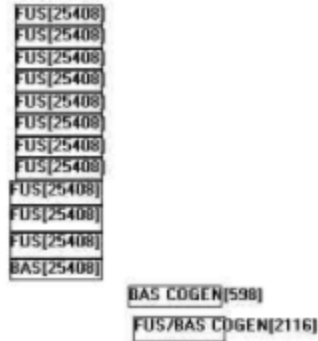

Building Sub-Areas (sq ft)			Legend
Code	Description	Gross Area	Living Area
FUS	Finished Upper Story	281,604	267,524
BAS	First Floor	28,122	28,122
		309,726	295,646

Building 1 : Section 1

Year Built: 1970
Living Area: 0
Replacement Cost: \$72,929,305
Building Percent Good: 72
Replacement Cost
Less Depreciation: \$52,509,100

Building Attributes	
Field	Description
Style	Outbuildings
Model	
Grade:	
Stories:	
Occupancy	
Exterior Wall 1	
Exterior Wall 2	
Roof Structure:	
Roof Cover	
Interior Wall 1	
Interior Wall 2	
Interior Flr 1	
Interior Flr 2	
Heat Fuel	
Heat Type:	
AC Type:	
Total Bedrooms:	
Total Bthrms:	
Total Half Baths:	
Total Xtra Fixtrs:	
Total Rooms:	
Bath Style:	
Kitchen Style:	
Fireplaces	
Whirlpool	
Addn'l Kitchen	

Building Photo



Building Layout

 Building Layout

Building Sub-Areas (sq ft)	Legend
No Data for Building Sub-Areas	

Building 2 : Section 1

Year Built: 1988
Living Area: 15,232
Replacement Cost: \$4,047,834
Building Percent Good: 86
Replacement Cost Less Depreciation: \$2,871,600

Building Attributes : Bldg 2 of 16	
Field	Description
STYLE	Hospital
MODEL	Commercial
Grade	Excellent
Stories:	3
Occupancy	1
Exterior Wall 1	Brick/Masonry
Exterior Wall 2	
Roof Structure	Flat
Roof Cover	Tar & Gravel
Interior Wall 1	Drywall/Sheet
Interior Wall 2	
Interior Floor 1	Vinyl/Asphalt
Interior Floor 2	
Heating Fuel	Gas
Heating Type	Forced Air-Duc
AC Type	Central
Bldg Use	Commercial MDL-94
Total Rooms	
Total Bedrms	00
Total Baths	0
1st Floor Use:	200
Heat/AC	HEAT/AC SPLIT
Frame Type	MASONRY
Baths/Plumbing	AVERAGE
Ceiling/Wall	CEIL & WALLS
Rooms/Prtns	AVERAGE
Wall Height	10
% Conn Wall	0

Building Photo



Building Layout

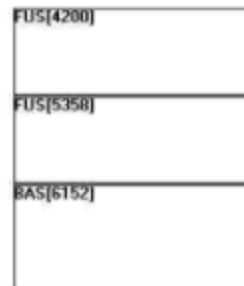

Building Sub-Areas (sq ft)			Legend
Code	Description	Gross Area	Living Area
FUS	Finished Upper Story	9,558	9,080
BAS	First Floor	6,152	6,152
		15,710	15,232

Building 3 : Section 1

Year Built: 1970
Living Area: 1,400
Replacement Cost: \$97,090
Building Percent Good: 72
Replacement Cost Less Depreciation: \$89,900

Building Attributes : Bldg 3 of 16	
Field	Description
STYLE	Warehouse
MODEL	Ind/Comm
Grade	Excellent
Stories:	1
Occupancy	1
Exterior Wall 1	Concr/Cinder
Exterior Wall 2	
Roof Structure	Flat
Roof Cover	Tar & Gravel
Interior Wall 1	Minim/Masonry
Interior Wall 2	
Interior Floor 1	Concr-Finished
Interior Floor 2	
Heating Fuel	Coal or Wood
Heating Type	None
AC Type	None
Bldg Use	Commercial MDL-96
Total Rooms	
Total Bedrms	00
Total Baths	0
1st Floor Use:	2001
Heat/AC	NONE
Frame Type	MASONRY
Baths/Plumbing	AVERAGE
Ceiling/Wall	CEIL & MIN WL
Rooms/Prtns	AVERAGE
Wall Height	14
% Conn Wall	0

Building Photo



Building Layout



Building Sub-Areas (sq ft)			Legend
Code	Description	Gross Area	Living Area
BAS	First Floor	1,400	1,400
		1,400	1,400

Building 4 : Section 1

Year Built: 1989
 Living Area: 3,000
 Replacement Cost: \$788,732
 Building Percent Good: 80
 Replacement Cost
 Less Depreciation: \$629,400

Building Attributes : Bldg 4 of 16	
Field	Description
STYLE	Hospital
MODEL	Commercial
Grade	Average+
Stories:	1
Occupancy	1
Exterior Wall 1	Brick/Masonry
Exterior Wall 2	
Roof Structure	Flat
Roof Cover	Tar & Gravel
Interior Wall 1	Drywall/Sheet
Interior Wall 2	
Interior Floor 1	Carpet
Interior Floor 2	
Heating Fuel	Gas
Heating Type	Forced Air-Duc
AC Type	Central
Bldg Use	Commercial MDL-94
Total Rooms	
Total Bedrms	00
Total Baths	0
1st Floor Use:	200
Heat/AC	HEAT/AC PKGS
Frame Type	STEEL
Baths/Plumbing	AVERAGE
Ceiling/Wall	CEIL & WALLS
Rooms/Prtns	AVERAGE
Wall Height	12
% Corn Wall	0

Building Photo



Building Layout

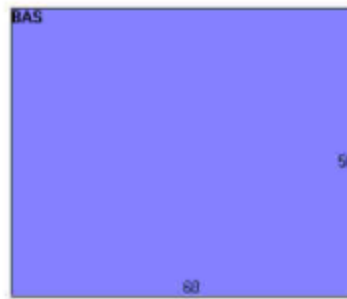

Building Sub-Areas (sq ft)			Legend
Code	Description	Gross Area	Living Area
BAS	First Floor	3,000	3,000
		3,000	3,000

Building 5 : Section 1

Year Built: 1989
Living Area: 9,810
Replacement Cost: \$2,994,187
Building Percent Good: 80
Replacement Cost Less Depreciation: \$2,395,300

Building Attributes : Bldg 5 of 16	
Field	Description
STYLE	Hospital
MODEL	Commercial
Grade	Excellent+
Stories:	2
Occupancy	1
Exterior Wall 1	Brick/Masonry
Exterior Wall 2	
Roof Structure	Flat
Roof Cover	Tar & Gravel
Interior Wall 1	Drywall/Sheet
Interior Wall 2	
Interior Floor 1	Carpet
Interior Floor 2	Ceram Clay Til
Heating Fuel	Gas
Heating Type	Forced Air-Duc
AC Type	Central
Bldg Use	Commercial MDL-94
Total Rooms	
Total Bedrms	00
Total Baths	0
1st Floor Use:	200
Heat/AC	HEAT/AC SPLIT
Frame Type	STEEL
Baths/Plumbing	AVERAGE
Ceiling/Wall	SUS-CEIL & WL
Rooms/Prtns	AVERAGE
Wall Height	10
% Conn Wall	0

Building Photo



Building Layout

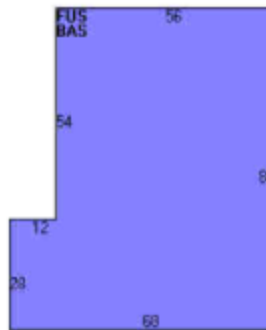

Building Sub-Areas (sq ft)			Legend
Code	Description	Gross Area	Living Area
BAS	First Floor	4,928	4,928
FUS	Finished Upper Story	4,928	4,682
		9,856	9,610

Building 6 : Section 1

Year Built: 1983
Living Area: 167,220
Replacement Cost: \$41,125,585
Building Percent Good: 80
Replacement Cost Less Depreciation: \$32,900,500

Building Attributes : Bldg 6 of 16	
Field	Description
STYLE	Hospital
MODEL	Commercial
Grade	Excellent
Stories:	3
Occupancy	1
Exterior Wall 1	Brick/Masonry
Exterior Wall 2	
Roof Structure	Flat
Roof Cover	Tar & Gravel
Interior Wall 1	Drywall/Sheet
Interior Wall 2	
Interior Floor 1	Vinyl/Asphalt
Interior Floor 2	Carpet
Heating Fuel	Gas
Heating Type	Forced Air-Duc
AC Type	None
Bldg Use	Commercial MDL-94
Total Rooms	
Total Bedrms	00
Total Baths	0
1st Floor Use:	200
Heat/AC	NONE
Frame Type	STEEL
Baths/Plumbing	AVERAGE
Ceiling/Wall	SUS-CEIL & WL
Rooms/Prtns	AVERAGE
Wall Height	12
% Conn Wall	

Building Photo



Building Layout

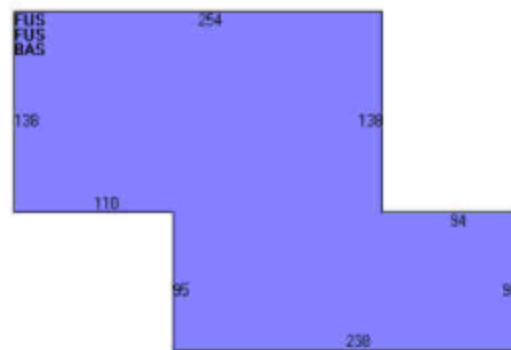

Building Sub-Areas (sq ft)			Legend
Code	Description	Gross Area	Living Area
FUS	Finished Upper Story	115,324	109,558
BAS	First Floor	57,662	57,662
		172,986	167,220

Building 7 : Section 1

Year Built: 1983
Living Area: 165,411
Replacement Cost: \$8,379,503
Building Percent Good: 88
Replacement Cost Less Depreciation: \$5,614,000

Building Attributes : Bldg 7 of 16	
Field	Description
STYLE	Parking Garage
MODEL	Ind/Comm
Grade	Good+
Stories:	2
Occupancy	1
Exterior Wall 1	Reinforc Concr
Exterior Wall 2	
Roof Structure	Reinforc Concr
Roof Cover	Concrete Tile
Interior Wall 1	Minim/Masonry
Interior Wall 2	
Interior Floor 1	Concr-Finished
Interior Floor 2	
Heating Fuel	Coal or Wood
Heating Type	None
AC Type	None
Bldg Use	Commercial MDL-96
Total Rooms	
Total Bedrms	00
Total Baths	0
1st Floor Use:	2001
Heat/AC	NONE
Frame Type	STEEL
Baths/Plumbing	NONE
Ceiling/Wall	CEILING ONLY
Rooms/Prtns	LIGHT
Wall Height	10
% Conn Wall	0

Building Photo



Building Layout

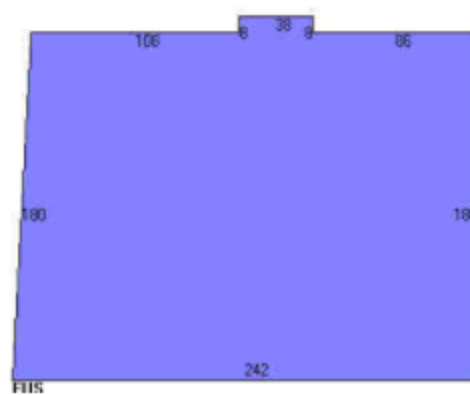

FHS

Building Sub-Areas (sq ft)			Legend
Code	Description	Gross Area	Living Area
FUS	Finished Upper Story	128,892	122,447
BAS	First Floor	42,964	42,964
BSM	Basement	42,964	0
		214,820	165,411

Building 8 : Section 1

Year Built: 1995
Living Area: 2,120
Replacement Cost: \$829,382
Building Percent Good: 81
Replacement Cost
Less Depreciation: \$871,800

Building Photo



Building Layout



Building Attributes : Bldg 8 of 16	
Field	Description
STYLE	Hospital
MODEL	Commercial
Grade	Excellent
Stories:	1
Occupancy	1
Exterior Wall 1	Brick/Masonry
Exterior Wall 2	
Roof Structure	Flat
Roof Cover	Tar & Gravel
Interior Wall 1	Drywall/Sheet
Interior Wall 2	
Interior Floor 1	Carpet
Interior Floor 2	
Heating Fuel	Gas
Heating Type	Forced Air-Duc
AC Type	Central
Bldg Use	Commercial MDL-94
Total Rooms	
Total Bedrms	00
Total Baths	0
1st Floor Use:	200
Heat/AC	HEAT/AC PKGS
Frame Type	STEEL
Baths/Plumbing	AVERAGE
Ceiling/Wall	SUS-CEIL & WL
Rooms/Prtns	AVERAGE
Wall Height	10
% Conn Wall	0

Building Sub-Areas (sq ft)			Legend
Code	Description	Gross Area	Living Area
BAS	First Floor	2,120	2,120
		2,120	2,120

Building 9 : Section 1

Year Built: 1993
Living Area: 2,766
Replacement Cost: \$1,041,765
Building Percent Good: 81
Replacement Cost
Less Depreciation: \$843,800

Building Photo



Building Attributes : Bldg 9 of 16	
Field	Description
STYLE	Hospital
MODEL	Commercial
Grade	Excellent
Stories:	1
Occupancy	1
Exterior Wall 1	Brick/Masonry
Exterior Wall 2	
Roof Structure	Flat
Roof Cover	Tar & Gravel
Interior Wall 1	Drywall/Sheet
Interior Wall 2	
Interior Floor 1	Carpet
Interior Floor 2	Vinyl/Asphalt
Heating Fuel	Gas
Heating Type	Forced Air-Duc
AC Type	Central
Bldg Use	Commercial MDL-94
Total Rooms	
Total Bedrms	00
Total Baths	0
1st Floor Use:	200
Heat/AC	HEAT/AC PKGS
Frame Type	STEEL
Baths/Plumbing	AVERAGE
Ceiling/Wall	SUS-CEIL & WL
Rooms/Prtns	AVERAGE
Wall Height	18
% Corn Wall	0

Building Layout



Building Sub-Areas (sq ft)			Legend
Code	Description	Gross Area	Living Area
BAS	First Floor	2,766	2,766
		2,766	2,766

Building 10 : Section 1

Year Built: 1976
 Living Area: 6,400
 Replacement Cost: \$257,088
 Building Percent Good: 76
 Replacement Cost
 Less Depreciation: \$195,400

Building Photo



Building Attributes : Bldg 10 of 16	
Field	Description
STYLE	Warehouse
MODEL	Ind/Comm
Grade	Average
Stories:	1
Occupancy	1
Exterior Wall 1	Concr/Cinder
Exterior Wall 2	
Roof Structure	Flat
Roof Cover	Tar & Gravel
Interior Wall 1	Minim/Masonry
Interior Wall 2	
Interior Floor 1	Concr-Finished
Interior Floor 2	
Heating Fuel	Gas
Heating Type	Forced Air-Duc
AC Type	None
Bldg Use	Commercial MDL-96
Total Rooms	
Total Bedrms	00
Total Baths	0
1st Floor Use:	200I
Heat/AC	NONE
Frame Type	MASONRY
Baths/Plumbing	AVERAGE
Ceiling/Wall	CEIL & MIN WL
Rooms/Prtns	AVERAGE
Wall Height	12
% Corn Wall	0

Building Layout



Building Sub-Areas (sq ft)			<u>Legend</u>
Code	Description	Gross Area	Living Area
BAS	First Floor	6,400	6,400
		6,400	6,400

Building 12 : Section 1

Year Built: 1991
 Living Area: 381,271
 Replacement Cost: \$15,597,492
 Building Percent Good: 81
 Replacement Cost
 Less Depreciation: \$12,634,000

Building Photo



Building Attributes : Bldg 12 of 16	
Field	Description
STYLE	Parking Garage
MODEL	Ind/Comm
Grade	Excellent
Stories:	5
Occupancy	707
Exterior Wall 1	Pre-cast Concr
Exterior Wall 2	
Roof Structure	Reinforc Concr
Roof Cover	Concrete Tile
Interior Wall 1	Minim/Masonry
Interior Wall 2	
Interior Floor 1	Concr Abv Grad
Interior Floor 2	
Heating Fuel	
Heating Type	
AC Type	None
Bldg Use	Commercial MDL-94
Total Rooms	
Total Bedrms	
Total Baths	
1st Floor Use:	
Heat/AC	NONE
Frame Type	REINF. CONCR
Baths/Plumbing	NONE
Ceiling/Wall	NONE
Rooms/Prtns	AVERAGE
Wall Height	19
% Conn Wall	

Building Layout

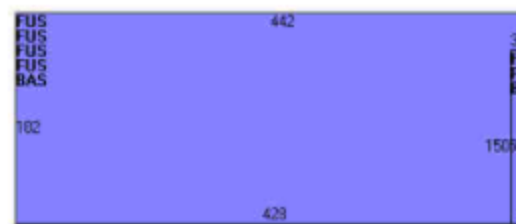

Building Sub-Areas (sq ft)			Legend
Code	Description	Gross Area	Living Area
FUS	Finished Upper Story	316,976	301,127
BAS	First Floor	80,144	80,144
		397,120	381,271

Building 13 : Section 1

Year Built: 2007
 Living Area: 155,010
 Replacement Cost: \$9,308,522
 Building Percent Good: 92
 Replacement Cost
 Less Depreciation: \$8,563,800

Building Attributes : Bldg 13 of 16	
Field	Description
STYLE	Parking Garage
MODEL	Commercial
Grade	Excellent++
Stories:	3
Occupancy	2
Exterior Wall 1	Concr/Cinder
Exterior Wall 2	Brick/Masonry
Roof Structure	Reinforc Concr
Roof Cover	Concrete Tile
Interior Wall 1	Drywall/Sheet
Interior Wall 2	
Interior Floor 1	Ceram Clay Til
Interior Floor 2	Carpet
Heating Fuel	Gas
Heating Type	Forced Air-Duc
AC Type	Central
Bldg Use	Commercial MDL-94
Total Rooms	
Total Bedrms	
Total Baths	
1st Floor Use:	
Heat/AC	HEAT/AC PKGS
Frame Type	REINF. CONCR
Baths/Plumbing	ABOVE AVERAGE
Ceiling/Wall	CEIL & WALLS
Rooms/Prtns	ABOVE AVERAGE
Wall Height	9
% Corn Wall	

Building Photo



Building Layout

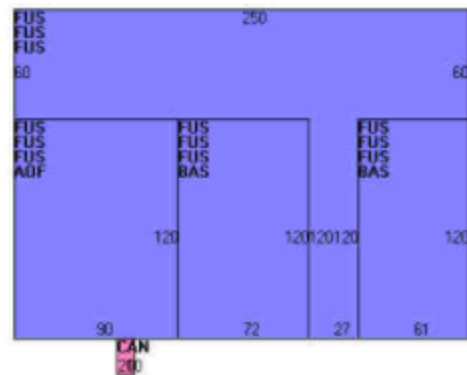

Building Sub-Areas (sq ft)			Legend	
Code	Description	Gross Area	Living Area	
FUS	Finished Upper Story	135,000	128,250	
BAS	First Floor	15,960	15,960	
AOF	Office, (Average)	10,800	10,800	
CAN	Canopy	200	0	
		161,960	155,010	

Building 14 : Section 1

Year Built: 2007
 Living Area: 35,136
 Replacement Cost: \$1,352,392
 Building Percent Good: 92
 Replacement Cost
 Less Depreciation: \$1,244,200

Building Attributes : Bldg 14 of 16	
Field	Description
STYLE	Parking Garage
MODEL	Commercial
Grade	Good+
Stories:	6
Occupancy	707
Exterior Wall 1	Reinforc Concr
Exterior Wall 2	
Roof Structure	Reinforc Concr
Roof Cover	Concrete Tile
Interior Wall 1	Minim/Masonry
Interior Wall 2	
Interior Floor 1	Concr Abv Grad
Interior Floor 2	
Heating Fuel	Coal or Wood
Heating Type	None
AC Type	None
Bldg Use	Commercial MDL-94
Total Rooms	
Total Bedrms	
Total Baths	
1st Floor Use:	
Heat/AC	NONE
Frame Type	REINF. CONCR
Baths/Plumbing	NONE
Ceiling/Wall	NONE
Rooms/Prtns	AVERAGE
Wall Height	15
% Corn Wall	

Building Photo



Building Layout

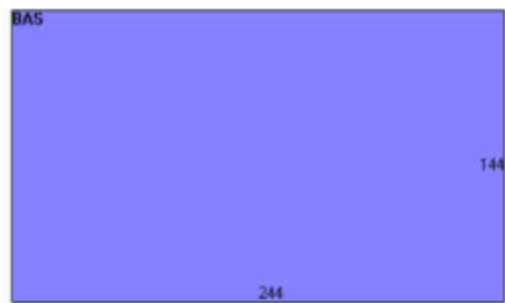

Building Sub-Areas (sq ft)			Legend
Code	Description	Gross Area	Living Area
BAS	First Floor	35,136	35,136
		35,136	35,136

Building 15 : Section 1

Year Built: 2007
Living Area: 58,869
Replacement Cost: \$11,049,292
Building Percent Good: 91
Replacement Cost
Less Depreciation: \$10,054,900

Building Attributes : Bldg 15 of 16	
Field	Description
STYLE	Profess. Bldg
MODEL	Commercial
Grade	Excellent+++
Stories:	3
Occupancy	1
Exterior Wall 1	Stucco/Masonry
Exterior Wall 2	Brick Veneer
Roof Structure	Flat
Roof Cover	Tar & Gravel
Interior Wall 1	Drywall/Sheet
Interior Wall 2	
Interior Floor 1	Ceram Clay Til
Interior Floor 2	Carpet
Heating Fuel	Gas
Heating Type	Forced Air-Duc
AC Type	Central
Bldg Use	Commercial MDL-94
Total Rooms	
Total Bedrms	
Total Baths	
1st Floor Use:	
Heat/AC	HEAT/AC PKGS
Frame Type	FIREPRF STEEL
Baths/Plumbing	ABOVE AVERAGE
Ceiling/Wall	SUS-CEIL & WL
Rooms/Prtns	ABOVE AVERAGE
Wall Height	9
% Conn Wall	

Building Photo



Building Layout

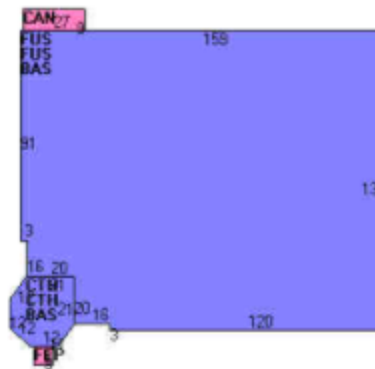

Building Sub-Areas (sq ft)			Legend	
Code	Description	Gross Area	Living Area	
FUS	Finished Upper Story	40,090	38,086	
BAS	First Floor	20,783	20,783	
CAN	Canopy	243	0	
CTH	Cathedral Ceiling	1,476	0	
FEP	Fin. Enclosed Porch	64	0	
		62,656	58,869	

Building 16 : Section 1

Year Built: 2012
Living Area: 300,000
Replacement Cost: \$101,202,000
Building Percent Good: 138
Replacement Cost Less Depreciation: \$139,658,800

Building Attributes : Bldg 16 of 16	
Field	Description
STYLE	Hospital
MODEL	Commercial
Grade	Excellent+++
Stories:	6
Occupancy	1
Exterior Wall 1	Brick/Masonry
Exterior Wall 2	
Roof Structure	Flat
Roof Cover	Tar & Gravel
Interior Wall 1	Drywall/Sheet
Interior Wall 2	
Interior Floor 1	Carpet
Interior Floor 2	Vinyl/Asphalt
Heating Fuel	Gas
Heating Type	Forced Air-Duc
AC Type	Central
Bldg Use	Hospital
Total Rooms	
Total Bedrms	
Total Baths	
1st Floor Use:	
Heat/AC	HEAT/AC PKGS
Frame Type	STEEL
Baths/Plumbing	AVERAGE
Ceiling/Wall	SUS-CEIL & WL
Rooms/Prtns	AVERAGE
Wall Height	10
% Corn Wall	

Building Photo

Building Photo

Building Layout



Building Sub-Areas (sq ft)			Legend
Code	Description	Gross Area	Living Area
BAS	First Floor	300,000	300,000
		300,000	300,000

Land Use		Land Line Valuation	
Use Code	951	Size (Acres)	23.46
Description	Hospital	Frontage	0
Zone	RH3	Depth	0
Neighborhood	7500	Assessed Value	\$41,050,400
Alt Land Appr Category	No	Appraised Value	\$58,643,400

Outbuildings

Outbuildings						Legend
Code	Description	Sub Code	Sub Description	Size	Value	Bldg #
	EXPANSION			1	\$1,720,000	14
LT2	Light 2			8 UNITS	\$5,800	12
PAV1	Paving-Asphalt			243936 S.F.	\$307,400	1
PAV1	Paving-Asphalt			56580 S.F.	\$59,400	15
CNP2	Canopy-Gd			1686 S.F.	\$30,300	6
CNP2	Canopy-Gd			2607 S.F.	\$46,900	5
CEL	Cell Tower			1 UNITS	\$300,000	1
LT1	Light 1			9 UNITS	\$1,600	2
LT2	Light 2			4 UNITS	\$1,500	7
	RENOVATE LAB		10-1-05 LIST	1	\$500,000	1
LT2	Light 2			2 UNITS	\$700	13
LT2	Light 2			9 UNITS	\$3,300	2
	FM BOOSTER FACILITY		10-1-06 LIST	1	\$235,300	1
	FM BOOSTER/REN		10-1-06 LIST	1	\$435,000	1
LT3	Lights 3			4 UNITS	\$2,100	13
	RENOVATION TO 10 BED UNIT		10-1-06 LIST	1	\$200,000	1
LT1	Light 1			18 UNITS	\$3,200	15
	4TH FLR CONV/RED LOT		10-1-06 LIST	1	\$2,000,300	1
	4TH FLR CONVERT STGE RM TO OR		10-1-06 LIST	1	\$250,000	1
LT2	Light 2			2 UNITS	\$700	15
	FIELD PRICE		RED LOT PARKING EXPANSION	1	\$1,750,000	1
	1800 SQ FT M			1	\$900,000	1
	ALTERATIONS		10-1-10 LIST	1	\$3,200,000	1
	OFFICES		10-1-10 LIST	1	\$400,000	1
	RENOVATE 1ST FLOOR SOUTH		10-1-10 LIST	1	\$750,000	1
	BLDG. EXPANSION		BLDG. EXPANSION	1	\$2,000,000	1
	TOWER ADD		TOWER ADDITION	1	\$18,000,000	1

Valuation History

Appraisal			
Valuation Year	Improvements	Land	Total
2019	\$308,036,700	\$58,643,400	\$366,680,100
2018	\$308,036,700	\$58,643,400	\$366,680,100
2017	\$308,036,700	\$58,643,400	\$366,680,100

Assessment			
Valuation Year	Improvements	Land	Total
2019	\$215,626,300	\$41,050,400	\$256,676,700
2018	\$215,626,300	\$41,050,400	\$256,676,700
2017	\$215,626,300	\$41,050,400	\$256,676,700

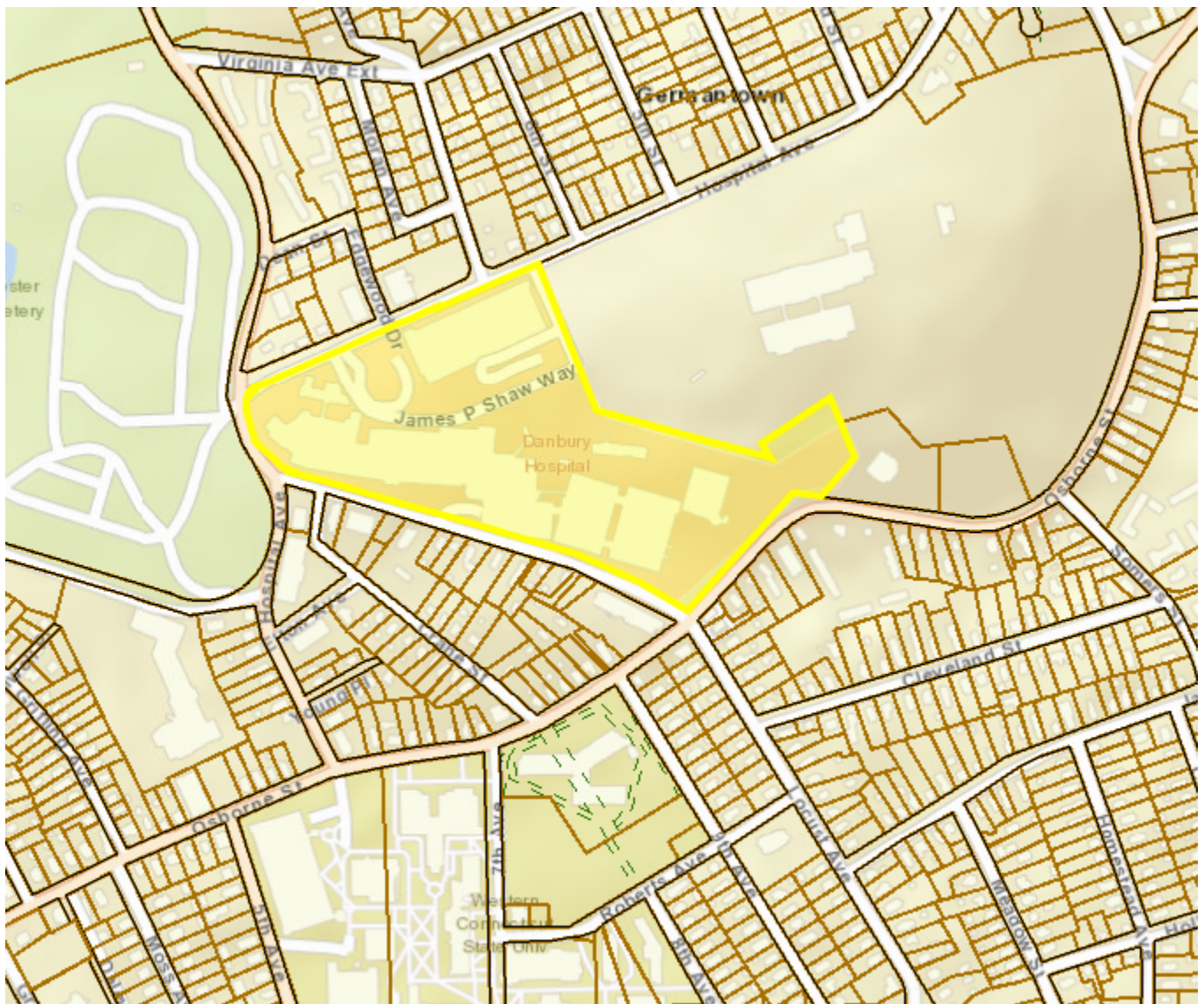

DOCKET NO. 79

AN APPLICATION OF METRO MOBILE CTS OF : CONNECTICUT SITING
FAIRFIELD COUNTY, INC., FOR A CERTIFICATE OF : COUNCIL
ENVIRONMENTAL COMPATIBILITY AND PUBLIC NEED
FOR CELLULAR TELEPHONE ANTENNAS AND ASSOCIATED :
EQUIPMENT IN THE CITY OF DANBURY, CONNECTICUT. : SEPTEMBER 10, 1987

DECISION AND ORDER

Pursuant to the foregoing opinion, the Connecticut Siting Council hereby directs that a Certificate of Environmental Compatibility and Public Need, as provided by Section 16-50k of the General Statutes of Connecticut (CGS), be issued to Metro Mobile CTS of Fairfield County, Inc., for the construction, operation, and maintenance of cellular mobile telephone antennas in the City of Danbury, Connecticut.

The facility shall be constructed, operated, and maintained substantially as specified in the Council's record on this matter, and subject to the following conditions.

1. The facility shall be constructed in accordance with all applicable federal, state, and municipal laws and regulations.
2. The Certificate holder shall notify the Federal Aviation Administration of its intention to mount antennas on the Danbury Hospital, and provide it the opportunity to comment prior to initiation of construction. A copy of the notification to the Federal Aviation Administration shall be sent to the City of Danbury's Airport Administrator.

3. The Certificate holder or its successor shall notify the Council if and when directional antennas or any equipment other than that listed in this application is added to this facility.
4. If this facility does not provide or permanently ceases to provide cellular service following completion of construction, this Decision and Order shall be void, and the antennas and all associated equipment in this application shall be dismantled and removed or reapplication for any new use shall be made to the Council before any such new use is made.
5. Unless otherwise approved by the Council, this Decision and Order shall be void if all construction authorized herein is not completed within three years of the issuance of this Decision and Order, or within three years of the completion of any appeal taken in this Decision.
6. The certificate holder shall comply with any future radio frequency (RF) standards promulgated by state or federal regulatory agencies. Upon the establishment of any new governmental RF standards, the facility granted in this Decision shall be brought into compliance with such standards.

Pursuant to CGS Section 16-50p, we hereby direct that a copy of this Decision and Order be served on each person listed below. A notice of the issuance shall be published in the Danbury News-Times.

The parties to the proceeding are:

Metro Mobile CTS of (applicant)
Fairfield County, Inc.
50 Rockland Road
South Norwalk, CT 06854
Attn: Peter Kelley, Vice President

Howard L. Slater, Esq. (its representatives)
Jennifer Young Gaudet, Esq.
Byrne, Slater, Sandler,
Shulman & Rouse, P.C.
330 Main Street
PO Box 3216
Hartford, CT 06103

Fleischman and Walsh, P.C.
1725 N Street, N.W.
Washington, DC 20036
Attn: Richard Rubin, Esq.
Jonathan Cohen, Esq.

SNET Cellular, Inc. (intervenor)
c/o Peter J. Tyrrell
Senior Attorney
227 Church Street
New Haven, CT 06506

0198E

CERTIFICATION

The undersigned members of the Connecticut Siting Council hereby certify that they have heard the case in Docket 79 or read the record thereof, and that we voted as follows:

Dated at New Britain, Connecticut the 10th day of September, 1987.

<u>Council Members</u>	<u>Vote Cast</u>
<u>Gloria Dibble Pond</u> Gloria Dibble Pond Chairperson	Yes
<u>Kathy A. Geppert</u> Commissioner Peter Boucher Designee: Kathy A. Geppert	Yes
<u>Commissioner Leslie Carothers</u> Designee: Brian Emerick	Absent
<u>Owen L. Clark</u> Owen L. Clark	Yes
<u>Fred J. Doocy</u> Fred J. Doocy	Yes
<u>Mortimer A. Gelston</u> Mortimer A. Gelston	Yes
<u>James G. Horsfall</u> James G. Horsfall	Yes
<u>William H. Smith</u> William H. Smith	Yes
<u>Colin C. Tait</u> Colin C. Tait	Yes

T-Mobile

SITE NAME: DANBURY HOSPITAL

SITE ID: CT1108A

24 HOSPITAL AVENUE DANBURY, CT 06810

T-MOBILE RAN TEMPLATE (PROVIDED BY RFDS)

4SEC-67D5A997DB OUTDOOR

T-MOBILE A+L TEMPLATE

4SEC-67D5997DB_2xAIR+1OP

GENERAL NOTES

1. ALL WORK SHALL BE IN ACCORDANCE WITH THE 2015 INTERNATIONAL BUILDING CODE AS MODIFIED BY THE 2018 CONNECTICUT SUPPLEMENT, INCLUDING THE TIA/EIA-222 REVISION "G" "STRUCTURAL STANDARDS FOR STEEL ANTENNA TOWERS AND SUPPORTING STRUCTURES." 2018 CONNECTICUT FIRE SAFETY CODE, NATIONAL ELECTRICAL CODE AND LOCAL CODES.
2. CONTRACTOR SHALL REVIEW ALL DRAWINGS AND SPECIFICATIONS IN THE CONTRACT DOCUMENT SET. CONTRACTOR SHALL COORDINATE ALL WORK SHOWN IN THE SET OF DRAWINGS. THE CONTRACTOR SHALL PROVIDE A COMPLETE SET OF DRAWINGS TO ALL SUBCONTRACTORS AND ALL RELATED PARTIES. THE SUBCONTRACTORS SHALL EXAMINE ALL THE DRAWINGS AND SPECIFICATIONS FOR THE INFORMATION THAT AFFECTS THEIR WORK.
3. CONTRACTOR SHALL PROVIDE A COMPLETE BUILD-OUT WITH ALL FINISHES, STRUCTURAL, MECHANICAL, AND ELECTRICAL COMPONENTS AND PROVIDE ALL ITEMS AS SHOWN OR INDICATED ON THE DRAWINGS OR IN THE WRITTEN SPECIFICATIONS.
4. CONTRACTOR SHALL FURNISH ALL MATERIAL, LABOR AND EQUIPMENT TO COMPLETE THE WORK AND FURNISH A COMPLETED JOB ALL IN ACCORDANCE WITH LOCAL AND STATE GOVERNING AUTHORITIES AND OTHER AUTHORITIES HAVING LAWFUL JURISDICTION OVER THE WORK.
5. CONTRACTOR SHALL SECURE AND PAY FOR ALL PERMITS AND ALL INSPECTIONS REQUIRED AND SHALL ALSO PAY FEES REQUIRED FOR THE GENERAL CONSTRUCTION, PLUMBING, ELECTRICAL AND HVAC. PERMITS SHALL BE PAID FOR BY THE RESPECTIVE SUBCONTRACTORS.
6. CONTRACTOR SHALL MAINTAIN A CURRENT SET OF DRAWINGS AND SPECIFICATIONS ON SITE AT ALL TIMES AND INSURE DISTRIBUTION OF NEW DRAWINGS TO SUBCONTRACTORS AND OTHER RELEVANT PARTIES AS SOON AS THEY ARE MADE AVAILABLE. ALL OLD DRAWINGS SHALL BE MARKED VOID AND REMOVED FROM THE CONTRACT AREA. THE CONTRACTOR SHALL FURNISH AN "AS-BUILT" SET OF DRAWINGS TO OWNER UPON COMPLETION OF PROJECT.
7. LOCATION OF EQUIPMENT, AND WORK SUPPLIED BY OTHERS THAT IS DIAGRAMMATICALLY INDICATED ON THE DRAWINGS SHALL BE DETERMINED BY THE CONTRACTOR. THE CONTRACTOR SHALL DETERMINE LOCATIONS AND DIMENSIONS SUBJECT TO STRUCTURAL CONDITIONS AND WORK OF THE SUBCONTRACTORS.
8. THE CONTRACTOR IS SOLELY RESPONSIBLE TO DETERMINE CONSTRUCTION PROCEDURE AND SEQUENCE, AND TO ENSURE THE SAFETY OF THE EXISTING STRUCTURES AND ITS COMPONENT PARTS DURING CONSTRUCTION. THIS INCLUDES THE ADDITION OF WHATEVER SHORING, BRACING, UNDERPINNING, ETC. THAT MAY BE NECESSARY.
9. DRAWINGS INDICATE THE MINIMUM STANDARDS, BUT IF ANY WORK SHOULD BE INDICATED TO BE SUBSTANDARD TO ANY ORDINANCES, LAWS, CODES, RULES, OR REGULATIONS BEARING ON THE WORK, THE CONTRACTOR SHALL INCLUDE IN HIS WORK AND SHALL EXECUTE THE WORK CORRECTLY IN ACCORDANCE WITH SUCH ORDINANCES, LAWS, CODES, RULES OR REGULATIONS WITH NO INCREASE IN COSTS.
10. ALL UTILITY WORK SHALL BE IN ACCORDANCE WITH LOCAL UTILITY COMPANY REQUIREMENTS AND SPECIFICATIONS.
11. ALL EQUIPMENT AND PRODUCTS PURCHASED ARE TO BE REVIEWED BY CONTRACTOR AND ALL APPLICABLE SUBCONTRACTORS FOR ANY CONDITION PER MFR.'S RECOMMENDATIONS. CONTRACTOR TO SUPPLY THESE ITEMS AT NO COST TO OWNER OR CONSTRUCTION MANAGER.
12. ANY AND ALL ERRORS, DISCREPANCIES, AND "MISSED" ITEMS ARE TO BE BROUGHT TO THE ATTENTION OF THE T-MOBILE CONSTRUCTION MANAGER DURING THE BIDDING PROCESS BY THE CONTRACTOR. ALL THESE ITEMS ARE TO BE INCLUDED IN THE BID. NO "EXTRA" WILL BE ALLOWED FOR MISSED ITEMS.
13. CONTRACTOR SHALL BE RESPONSIBLE FOR ALL ON-SITE SAFETY FROM THE TIME THE JOB IS AWARDED UNTIL ALL WORK IS COMPLETE AND ACCEPTED BY THE OWNER.
14. CONTRACTOR TO REVIEW ALL SHOP DRAWINGS AND SUBMIT COPY TO ENGINEER FOR APPROVAL. DRAWINGS MUST BEAR THE CHECKER'S INITIALS BEFORE SUBMITTING TO THE CONSTRUCTION MANAGER FOR REVIEW.
15. THE CONTRACTOR SHALL FIELD VERIFY ALL DIMENSIONS, ELEVATIONS, ANGLES, AND EXISTING CONDITIONS AT THE SITE, PRIOR TO FABRICATION AND/OR INSTALLATION OF ANY WORK IN THE CONTRACT AREA.
16. COORDINATION, LAYOUT, FURNISHING AND INSTALLATION OF CONDUIT AND ALL APPURTENANCES REQUIRED FOR PROPER INSTALLATION OF ELECTRICAL AND TELECOMMUNICATION SERVICE SHALL BE THE SOLE RESPONSIBILITY OF THE CONTRACTOR.
17. ALL DAMAGE CAUSED TO ANY EXISTING STRUCTURE SHALL BE THE SOLE RESPONSIBILITY OF THE CONTRACTOR. THE CONTRACTOR WILL BE HELD LIABLE FOR ALL REPAIRS REQUIRED FOR EXISTING STRUCTURES IF DAMAGED DURING CONSTRUCTION ACTIVITIES.
18. THE CONTRACTOR SHALL CONTACT "CALL BEFORE YOU DIG" AT LEAST 48 HOURS PRIOR TO ANY EXCAVATIONS AT 1-800-922-4455. ALL UTILITIES SHALL BE IDENTIFIED AND CLEARLY MARKED. CONTRACTOR SHALL MAINTAIN AND PROTECT MARKED UTILITIES THROUGHOUT PROJECT COMPLETION.
19. CONTRACTOR SHALL COMPLY WITH OWNERS ENVIRONMENTAL ENGINEER ON ALL METHODS AND PROVISIONS FOR ALL EXCAVATION ACTIVITIES INCLUDING SOIL DISPOSAL. ALL BACKFILL MATERIALS TO BE PROVIDED BY THE CONTRACTOR.

SITE DIRECTIONS

FROM: 35 GRIFFIN ROAD SOUTH BLOOMFIELD, CT 06002 **TO:** 24 HOSPITAL AVENUE DANBURY, CT 06810

1. HEAD NORTH ON GRIFFIN RD S TOWARD HARTMAN RD.
 2. TAKE THE 2ND RIGHT ONTO DAY HILL RD.
 3. TAKE 1ST RIGHT ONTO BLUE HILLS AVE EXT/CT-187. CONTINUE TO FOLLOW CT-187
 4. TURN LEFT ONTO CT-305/OLD WINDSOR RD. CONTINUE TO FOLLOW CT-305
 5. STAY STRAIGHT TO GO ONTO BLOOMFIELD AVE/CT-305
 6. MERGE ONTO I-95 S TOWARD HARTFORD
 7. MERGE ONTO I-84 W VIA EXIT 32A TOWARD WATERBURY
 8. KEEP LEFT TO TAKE I-84 W TOWARD WATERBURY
 9. TAKE EXIT 6/CT-37 TOWARD NEW FAIRFIELD
 10. TURN RIGHT ONTO NORTH ST/CT-37
 11. TAKE THE 2ND RIGHT ONTO HAYESTOWN AVE
 12. TURN RIGHT ONTO TAMARACK AVE
 13. TAKE THE 3RD LEFT ONTO HOSPITAL AVE.
- 24 HOSPITAL AVE IS ON THE RIGHT

VICINITY MAP

SCALE: 1" = 1000'

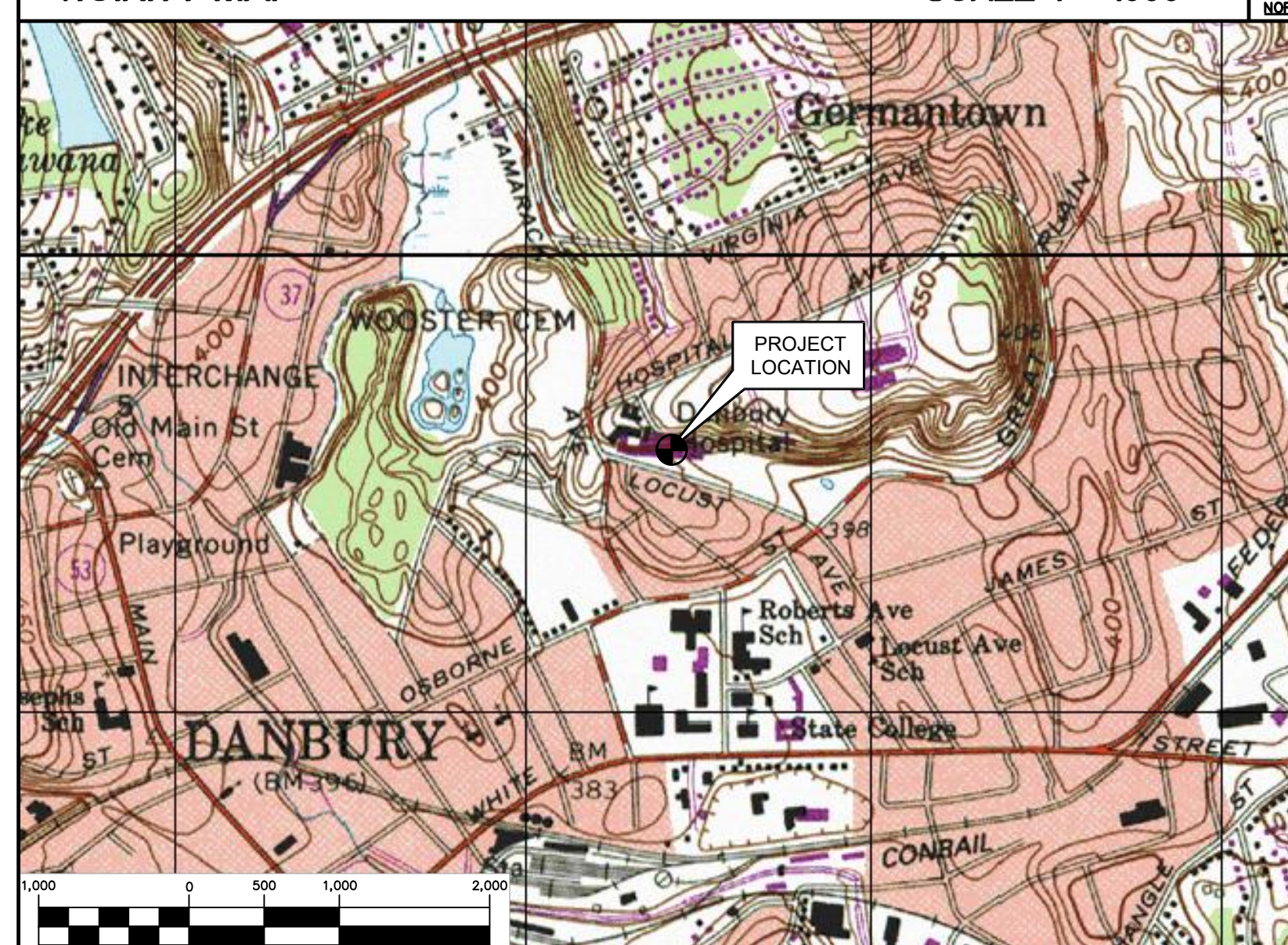

STRUCTURAL NOTE:

BETA/Delta SECTOR ANTENNA FRAME MODIFICATIONS TO BE COMPLETE PRIOR TO THE PROPOSED ANTENNA UPGRADE. SEE SHEET S-1 FOR ADDITIONAL DETAILS.

PROJECT SUMMARY

1. THE PROPOSED SCOPE OF WORK CONSISTS OF A MODIFICATION TO THE EXISTING UNMANNED TELECOMMUNICATIONS FACILITY INCLUDING THE FOLLOWING:
 - A. INSTALL (1) T-MOBILE BATTERY CABINET B160
 - B. INSTALL (1) T-MOBILE POWER ENCLOSURE 6160
 - C. INSTALL (4) 6x12 HYBRID CABLES
 - D. INSTALL (1) RADIO 4415 B25 PER SECTOR. TOTAL (4)
 - E. INSTALL 100A CIRCUIT BREAKER
 - F. REMOVE (1) ERICSSON AIR21 KRC118023-1_B2A_B4P PER SECTOR. TOTAL (3)
 - G. INSTALL (1) ERICSSON AIR6449 B41 PER SECTOR. TOTAL (4)
 - H. INSTALL FRAME MODIFICATIONS FOR BETA/Delta SECTOR.

PROJECT SUMMARY (STRUCTURAL)

FOR REQUIRED STRUCTURAL MODIFICATIONS, SEE SHEET(S) S-1 FOR ADDITIONAL DETAILS. ANTENNA FRAME MODIFICATION NEEDED FOR BETA/Delta SECTOR.

PROJECT INFORMATION

SITE NAME: DANBURY HOSPITAL
SITE ID: CT11108A
SITE ADDRESS: 24 HOSPITAL AVENUE DANBURY, CT 06810
APPLICANT: T-MOBILE NORTHEAST, LLC 35 GRIFFIN ROAD SOUTH BLOOMFIELD, CT 06002
CONTACT PERSON: DAN REID (PROJECT MANAGER) TRANSCEND WIRELESS, LLC (203) 592-8291
ENGINEER OF RECORD: CENTEK ENGINEERING, INC. 63-2 NORTH BRANFORD RD. BRANFORD, CT 06405
 CARLO F. CENTORE, PE (203) 488-0580 EXT. 122
PROJECT COORDINATES: LATITUDE: 41°-24'-18.23" N
 LONGITUDE: 73°-26'-46.50" W
 GROUND ELEVATION: 446± AMSL
 SITE COORDINATES AND GROUND ELEVATION REFERENCED FROM GOOGLE EARTH

SHEET INDEX

SHT. NO.	DESCRIPTION	REV.
T-1	TITLE SHEET	0
N-1	GENERAL NOTES AND SPECIFICATIONS	0
C-1	SITE LOCATION PLAN	0
C-2	ROOF PLAN, EQUIPMENT PLAN, AND ELEVATION	0
C-3	ANTENNA PLANS	0
C-4	ANTENNA ELEVATIONS	0
C-5	TYPICAL EQUIPMENT DETAILS	0
S-1	STRUCTURAL DETAILS	0
E-1	TYPICAL ELECTRICAL DETAILS	0

DATE: 05/14/21

SCALE: AS NOTED

JOB NO. 20074.12

TITLE SHEET

T-1

Sheet No. 1 of 9

PROFESSIONAL ENGINEER SEAL

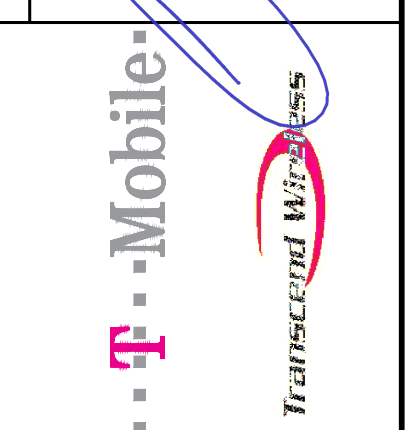
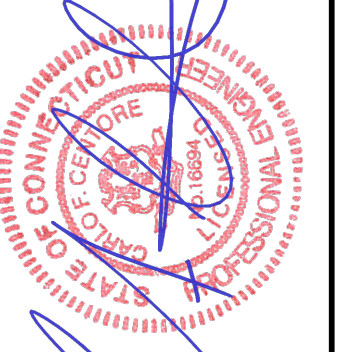

CENTEK engineering
 Centek on Solutions
 (203) 488-0380
 (203) 488-8587 Fax
 652 North Branford Road
 Branford, CT 06405
 www.CentekEng.com

T-MOBILE NORTHEAST LLC
DANBURY HOSPITAL
SITE ID: CT1108A
 24 HOSPITAL AVENUE
 DANBURY, CT 06810

CONSTRUCTION DRAWINGS - ISSUED FOR CONSTRUCTION
 DRAWN BY: CHK'D BY:
 DATE: 06/17/21
 REV. 0

NOTES AND SPECIFICATIONS

DESIGN BASIS:

GOVERNING CODE: 2015 INTERNATIONAL BUILDING (IBC) AS MODIFIED BY THE 2018 CONNECTICUT STATE BUILDING CODE.

- DESIGN CRITERIA:
 - RISK CATEGORY II (BASED ON IBC TABLE 1604.5)
 - ULTIMATE DESIGN SPEED (OTHER STRUCTURE): 125 MPH (V_{wsd}) (EXPOSURE B/ IMPORTANCE FACTOR 1.0 BASED ON ASCE 7-10).

SITE NOTES

- THE CONTRACTOR SHALL CALL UTILITIES PRIOR TO THE START OF CONSTRUCTION.
- ACTIVE EXISTING UTILITIES, WHERE ENCOUNTERED IN THE WORK, SHALL BE PROTECTED AT ALL TIMES. THE ENGINEER SHALL BE NOTIFIED IMMEDIATELY, PRIOR TO PROCEEDING, SHOULD ANY UNCOVERED EXISTING UTILITY PRECLUDE COMPLETION OF THE WORK IN ACCORDANCE WITH THE CONTRACT DOCUMENTS.
- THE AREAS OF THE COMPOUND DISTURBED BY THE WORK SHALL BE RETURNED TO THEIR ORIGINAL CONDITION.
- CONTRACTOR SHALL MINIMIZE DISTURBANCE TO EXISTING SITE DURING CONSTRUCTION. EROSION CONTROL MEASURES, SHALL BE IN CONFORMANCE WITH THE LOCAL GUIDELINES FOR EROSION AND SEDIMENT CONTROL.
- IF ANY FIELD CONDITIONS EXIST WHICH PRECLUDE COMPLIANCE WITH THE DRAWINGS, THE CONTRACTOR SHALL IMMEDIATELY NOTIFY THE ENGINEER AND SHALL PROCEED WITH AFFECTED WORK AFTER CONFLICT IS SATISFACTORILY RESOLVED.

GENERAL NOTES

- ALL WORK SHALL BE IN ACCORDANCE WITH THE 2015 INTERNATIONAL BUILDING CODE AS MODIFIED BY THE 2018 CONNECTICUT SUPPLEMENT, INCLUDING THE TIA/EIA-222 REVISION "G" "STRUCTURAL STANDARDS FOR STEEL ANTENNA TOWERS AND SUPPORTING STRUCTURES." 2017 CONNECTICUT FIRE SAFETY CODE, NATIONAL ELECTRICAL CODE AND LOCAL CODES.
- CONTRACTOR SHALL REVIEW ALL DRAWINGS AND SPECIFICATIONS IN THE CONTRACT DOCUMENT SET. CONTRACTOR SHALL COORDINATE ALL WORK SHOWN IN THE SET OF DRAWINGS. THE CONTRACTOR SHALL PROVIDE A COMPLETE SET OF DRAWINGS TO ALL SUBCONTRACTORS AND ALL RELATED PARTIES. THE SUBCONTRACTORS SHALL EXAMINE ALL THE DRAWINGS AND SPECIFICATIONS FOR THE INFORMATION THAT AFFECTS THEIR WORK.
- CONTRACTOR SHALL PROVIDE A COMPLETE BUILD-OUT WITH ALL FINISHES, STRUCTURAL, MECHANICAL, AND ELECTRICAL COMPONENTS AND PROVIDE ALL ITEMS AS SHOWN OR INDICATED ON THE DRAWINGS OR IN THE WRITTEN SPECIFICATIONS.
- CONTRACTOR SHALL FURNISH ALL MATERIAL, LABOR AND EQUIPMENT TO COMPLETE THE WORK AND FURNISH A COMPLETED JOB ALL IN ACCORDANCE WITH LOCAL AND STATE GOVERNING AUTHORITIES AND OTHER AUTHORITIES HAVING LAWFUL JURISDICTION OVER THE WORK.
- CONTRACTOR SHALL SECURE AND PAY FOR ALL PERMITS AND ALL INSPECTIONS REQUIRED AND SHALL ALSO PAY FEES REQUIRED FOR THE GENERAL CONSTRUCTION, PLUMBING, ELECTRICAL AND HVAC. PERMITS SHALL BE PAID FOR BY THE RESPECTIVE SUBCONTRACTORS.
- CONTRACTOR SHALL MAINTAIN A CURRENT SET OF DRAWINGS AND SPECIFICATIONS ON SITE AT ALL TIMES AND INSURE DISTRIBUTION OF NEW DRAWINGS TO SUBCONTRACTORS AND OTHER RELEVANT PARTIES AS SOON AS THEY ARE MADE AVAILABLE. ALL OLD DRAWINGS SHALL BE MARKED VOID AND REMOVED FROM THE CONTRACT AREA. THE CONTRACTOR SHALL FURNISH AN "AS-BUILT" SET OF DRAWINGS TO OWNER UPON COMPLETION OF PROJECT.
- LOCATION OF EQUIPMENT AND WORK SUPPLIED BY OTHERS THAT IS DIAGRAMMATICALLY INDICATED ON THE DRAWINGS, SHALL BE DETERMINED BY THE CONTRACTOR. THE CONTRACTOR SHALL DETERMINE LOCATIONS AND DIMENSIONS SUBJECT TO STRUCTURAL CONDITIONS AND WORK OF THE SUBCONTRACTORS.
- THE CONTRACTOR IS SOLELY RESPONSIBLE TO DETERMINE CONSTRUCTION PROCEDURE AND SEQUENCE, AND TO ENSURE THE SAFETY OF THE EXISTING STRUCTURES AND IT'S COMPONENT PARTS DURING CONSTRUCTION. THIS INCLUDES THE ADDITION OF WHATEVER SHORING, BRACING, UNDERPINNING, ETC. THAT MAY BE NECESSARY.
- DRAWINGS INDICATE THE MINIMUM STANDARDS, BUT IF ANY WORK SHOULD BE INDICATED TO BE SUBSTANDARD TO ANY ORDINANCES, LAWS, CODES, RULES, OR REGULATIONS BEARING ON THE WORK, THE CONTRACTOR SHALL INCLUDE IN HIS WORK AND SHALL EXECUTE THE WORK CORRECTLY IN ACCORDANCE WITH SUCH ORDINANCES, LAWS, CODES, RULES OR REGULATIONS WITH NO INCREASE IN COSTS.
- ALL UTILITY WORK SHALL BE IN ACCORDANCE WITH LOCAL UTILITY COMPANY REQUIREMENTS AND SPECIFICATIONS.
- ALL EQUIPMENT AND PRODUCTS PURCHASED ARE TO BE REVIEWED BY CONTRACTOR AND ALL APPLICABLE SUBCONTRACTORS FOR ANY CONDITION PER MFR.'S RECOMMENDATIONS. CONTRACTOR TO SUPPLY THESE ITEMS AT NO COST TO OWNER OR CONSTRUCTION MANAGER.
- ANY AND ALL ERRORS, DISCREPANCIES, AND "MISSED" ITEMS, ARE TO BE BROUGHT TO THE ATTENTION OF THE SITE OWNER'S CONSTRUCTION MANAGER DURING THE BIDDING PROCESS BY THE CONTRACTOR. ALL THESE ITEMS ARE TO BE INCLUDED IN THE BID. NO 'EXTRA' WILL BE ALLOWED FOR MISSED ITEMS.
- CONTRACTOR SHALL BE RESPONSIBLE FOR ALL ON-SITE SAFETY FROM THE TIME THE JOB IS AWARDED UNTIL ALL WORK IS COMPLETE AND ACCEPTED BY THE OWNER.
- CONTRACTOR TO REVIEW ALL SHOP DRAWINGS AND SUBMIT COPY TO ENGINEER FOR APPROVAL. DRAWINGS MUST BEAR THE CHECKER'S INITIALS BEFORE SUBMITTING TO THE CONSTRUCTION MANAGER FOR REVIEW.
- THE CONTRACTOR SHALL FIELD VERIFY ALL DIMENSIONS, ELEVATIONS, ANGLES, AND EXISTING CONDITIONS AT THE SITE, PRIOR TO FABRICATION AND/OR INSTALLATION OF ANY WORK IN THE CONTRACT AREA.
- COORDINATION, LAYOUT, FURNISHING AND INSTALLATION OF CONDUIT AND ALL APPURTENANCES REQUIRED FOR PROPER INSTALLATION OF ELECTRICAL AND TELECOMMUNICATION SERVICE SHALL BE THE SOLE RESPONSIBILITY OF THE CONTRACTOR.
- ALL DAMAGE CAUSED TO ANY EXISTING STRUCTURE SHALL BE THE SOLE RESPONSIBILITY OF THE CONTRACTOR. THE CONTRACTOR WILL BE HELD LIABLE FOR ALL REPAIRS REQUIRED FOR EXISTING STRUCTURES IF DAMAGED DURING CONSTRUCTION ACTIVITIES.
- THE CONTRACTOR SHALL CONTACT 'CALL BEFORE YOU DIG' AT LEAST 48 HOURS PRIOR TO ANY EXCAVATIONS AT 1-800-922-4455. ALL UTILITIES SHALL BE IDENTIFIED AND CLEARLY MARKED. CONTRACTOR SHALL MAINTAIN AND PROTECT MARKED UTILITIES THROUGHOUT PROJECT COMPLETION.
- CONTRACTOR SHALL COMPLY WITH OWNER'S ENVIRONMENTAL ENGINEER ON ALL METHODS AND PROVISIONS FOR ALL EXCAVATION ACTIVITIES INCLUDING SOIL DISPOSAL. ALL BACKFILL MATERIALS TO BE PROVIDED BY THE CONTRACTOR.
- THE COUNTY/CITY/TOWN WILL MAKE PERIODIC FIELD OBSERVATION AND INSPECTIONS TO MONITOR THE INSTALLATION, MATERIALS, WORKMANSHIP AND EQUIPMENT INCORPORATED INTO THE PROJECT TO ENSURE COMPLIANCE WITH THE DESIGN PLANS, SPECIFICATIONS, CONTRACT DOCUMENTS AND APPROVED SHOP DRAWINGS.
- THE COUNTY/CITY/TOWN MUST BE NOTIFIED (2) WORKING DAYS PRIOR TO CONCEALMENT/BURIAL OF ANY SYSTEM OR MATERIAL THAT WILL PREVENT THE DIRECT INSPECTION OF MATERIALS, METHODS OR WORKMANSHIP. EXAMPLES OF THESE PROCESSES ARE BACKFILLING A GROUND RING OR TOWER FOUNDATION, POURING TOWER FOUNDATIONS, BURYING GROUND RODS, PLATES OR GRIDS, ETC. THE CONTRACTOR MAY PROCEED WITH THE SCHEDULED PROCESS (2) WORKING DAYS AFTER PROVIDING NOTICE UNLESS NOTIFIED OTHERWISE BY THE COUNTY/CITY/TOWN.

STRUCTURAL STEEL

- ALL STRUCTURAL STEEL IS DESIGNED BY ALLOWABLE STRESS DESIGN (ASD)
 - STRUCTURAL STEEL (W SHAPES)---ASTM A992 (FY = 50 KSI)
 - STRUCTURAL STEEL (OTHER SHAPES)---ASTM A36 (FY = 36 KSI)
 - STRUCTURAL HSS (RECTANGULAR SHAPES)---ASTM A500 GRADE B, (FY = 46 KSI)
 - STRUCTURAL HSS (ROUND SHAPES)---ASTM A500 GRADE B, (FY = 42 KSI)
 - PIPE---ASTM A53 (FY = 35 KSI)
 - CONNECTION BOLTS---ASTM A325-N
 - U-BOLTS---ASTM A36
 - ANCHOR RODS---ASTM F 1554
 - WELDING ELECTRODE---ASTM E 70XX
- CONTRACTOR TO REVIEW ALL SHOP DRAWINGS AND SUBMIT COPY TO ENGINEER FOR APPROVAL. DRAWINGS MUST BEAR THE CHECKER'S INITIALS BEFORE SUBMITTING TO THE ENGINEER FOR REVIEW. SHOP DRAWINGS SHALL INCLUDE THE FOLLOWING: SECTION PROFILES, SIZES, CONNECTION ATTACHMENTS, REINFORCING, ANCHORAGE, SIZE AND TYPE OF FASTENERS AND ACCESSORIES. INCLUDE ERECTION DRAWINGS, ELEVATIONS AND DETAILS.
- STRUCTURAL STEEL SHALL BE DETAILED, FABRICATED AND ERECTED IN ACCORDANCE WITH THE LATEST PROVISIONS OF AISC MANUAL OF STEEL CONSTRUCTION.
- PROVIDE ALL PLATES, CLIP ANGLES, CLOSURE PIECES, STRAP ANCHORS, MISCELLANEOUS PIECES AND HOLES REQUIRED TO COMPLETE THE STRUCTURE.
- FIT AND SHOP ASSEMBLE FABRICATIONS IN THE LARGEST PRACTICAL SECTIONS FOR DELIVERY TO SITE.
- INSTALL FABRICATIONS PLUMB AND LEVEL, ACCURATELY FITTED, AND FREE FROM DISTORTIONS OR DEFECTS.
- AFTER ERECTION OF STRUCTURES, TOUCHUP ALL WELDS, ABRASIONS AND NON-GALVANIZED SURFACES WITH A 95% ORGANIC ZINC RICH PAINT IN ACCORDANCE WITH ASTM 780.
- ALL STEEL MATERIAL (EXPOSED TO WEATHER) SHALL BE GALVANIZED AFTER FABRICATION IN ACCORDANCE WITH ASTM A123 "ZINC (HOT DIPPED GALVANIZED) COATINGS" ON IRONS AND STEEL PRODUCTS.
- ALL BOLTS, ANCHORS AND MISCELLANEOUS HARDWARE SHALL BE GALVANIZED IN ACCORDANCE WITH ASTM A153 "ZINC COATING (HOT-DIP) ON IRON AND STEEL HARDWARE".
- THE ENGINEER SHALL BE NOTIFIED OF ANY INCORRECTLY FABRICATED, DAMAGED OR OTHERWISE MISFITTING OR NON CONFORMING MATERIALS OR CONDITIONS TO REMEDIAL OR CORRECTIVE ACTION. ANY SUCH ACTION SHALL REQUIRE ENGINEER REVIEW.
- CONNECTION ANGLES SHALL HAVE A MINIMUM THICKNESS OF 1/4 INCHES.
- STRUCTURAL CONNECTION BOLTS SHALL CONFORM TO ASTM A325. ALL BOLTS SHALL BE 3/4" DIAMETER MINIMUM AND SHALL HAVE A MINIMUM OF TWO BOLTS, UNLESS OTHERWISE ON THE DRAWINGS.
- LOCK WASHER ARE NOT PERMITTED FOR A325 STEEL ASSEMBLIES.
- SHOP CONNECTIONS SHALL BE WELDED OR HIGH STRENGTH BOLTED.
- MILL BEARING ENDS OF COLUMNS, STIFFENERS, AND OTHER BEARING SURFACES TO TRANSFER LOAD OVER ENTIRE CROSS SECTION.
- FABRICATE BEAMS WITH MILL CAMBER UP.
- LEVEL AND PLUMB INDIVIDUAL MEMBERS OF THE STRUCTURE TO AN ACCURACY OF 1:500, BUT NOT TO EXCEED 1/4" IN THE FULL HEIGHT OF THE COLUMN.
- COMMENCEMENT OF STRUCTURAL STEEL WORK WITHOUT NOTIFYING THE ENGINEER OF ANY DISCREPANCIES WILL BE CONSIDERED ACCEPTANCE OF PRECEDING WORK.
- INSPECTION AND TESTING OF ALL WELDING AND HIGH STRENGTH BOLTING SHALL BE PERFORMED BY AN INDEPENDENT TESTING LABORATORY.
- FOUR COPIES OF ALL INSPECTION TEST REPORTS SHALL BE SUBMITTED TO THE ENGINEER WITHIN TEN (10) WORKING DAYS OF THE DATE OF INSPECTION.

CONSTRUCTION DRAWINGS - ISSUED FOR CONSTRUCTION
J.R.
DRAWN BY
RIS
06/17/21
DATE
0
REV.

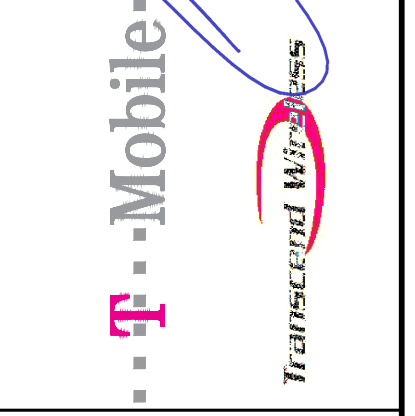
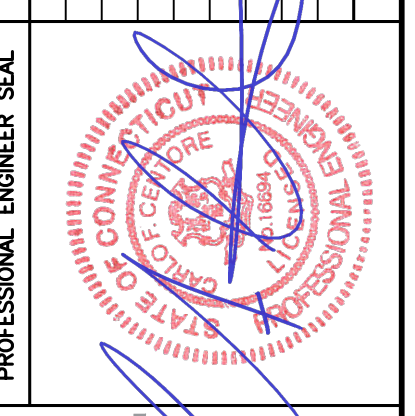

CEN TEK engineering
 Center on Solutions
 (203) 488-0380
 (203) 488-8587 Fax
 652 North Branford Road
 Branford, CT 06405
 www.CenTekEng.com

T-MOBILE NORTHEAST LLC
DANBURY HOSPITAL
SITE ID: CT1108A
24 HOSPITAL AVENUE
DANBURY, CT 06810

DATE: 05/14/21
 SCALE: AS NOTED
 JOB NO. 20074.12

GENERAL NOTES AND SPECIFICATIONS

N-1

NOTE:
ALL COAX LENGTHS TO BE MEASURED
AND VERIFIED IN FIELD BEFORE ORDERING

ANTENNA SCHEDULE								
SECTOR	EXISTING/PROPOSED	ANTENNA	SIZE (INCHES) (L x W x D)	ANTENNA Q HEIGHT	AZIMUTH	(E/P) RRU (QTY)	(E/P) TMA (QTY)	(QTY) PROPOSED COAX
A1	PROPOSED	ERICSSON (AIR6449 B41)	33.1 x 20.6 x 8.6	154'	60°			(1) 6x12 HYBRID CABLE
A2	EXISTING	ERICSSON (AIR32 KRD901146-1_B66A_B2A)	56.6 x 12.9 x 8.7	154'	60°			
A3	EXISTING	RFS (APXVAARR24_43-U_NA20)	95.9 x 24 x 8.7	154'	60°	(E) RADIO 4449 B71 (1), (P) RADIO 4415 B25 (1)	(P) COMMSCOPE-SDX1926Q-43 (1)	
B1	PROPOSED	ERICSSON (AIR6449 B41)	33.1 x 20.6 x 8.6	154'	150°			(1) 6x12 HYBRID CABLE
B2	EXISTING	RFS (APXVAARR24_43-U_NA20)	95.9 x 24 x 8.7	154'	150°	(E) RADIO 4449 B71 (1), (P) RADIO 4415 B25 (1)	(P) COMMSCOPE-SDX1926Q-43 (1)	
B3	EXISTING	ERICSSON (AIR32 KRD901146-1_B66A_B2A)	56.6 x 12.9 x 8.7	154'	150°			
C1	PROPOSED	ERICSSON (AIR6449 B41)	33.1 x 20.6 x 8.6	127'	300°			(1) 6x12 HYBRID CABLE
C2	EXISTING	RFS (APXVAARR24_43-U_NA20)	95.9 x 24 x 8.7	127'	300°	(E) RADIO 4449 B71 (1), (P) RADIO 4415 B25 (1)	(P) COMMSCOPE-SDX1926Q-43 (1)	
C3	EXISTING	ERICSSON (AIR32 KRD901146-1_B66A_B2A)	56.6 x 12.9 x 8.7	127'	300°			
D1	PROPOSED	ERICSSON (AIR6449 B41)	33.1 x 20.6 x 8.6	154'	210°			(1) 6x12 HYBRID CABLE
D2	EXISTING	RFS (APXVAARR24_43-U_NA20)	95.9 x 24 x 8.7	154'	210°	(E) RADIO 4449 B71 (1), (P) RADIO 4415 B25 (1)	(P) COMMSCOPE-SDX1926Q-43 (1)	
D3	EXISTING	ERICSSON (AIR32 KRD901146-1_B66A_B2A)	56.6 x 12.9 x 8.7	154'	210°			



1 SITE LOCATION PLAN
C-1 SCALE: NOT TO SCALE



PROFESSIONAL ENGINEER SEAL

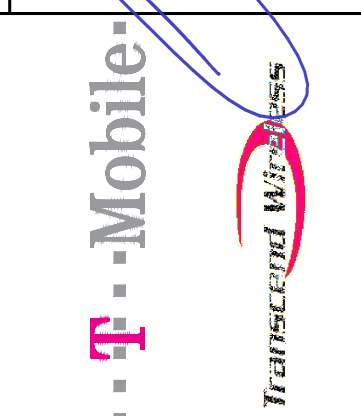
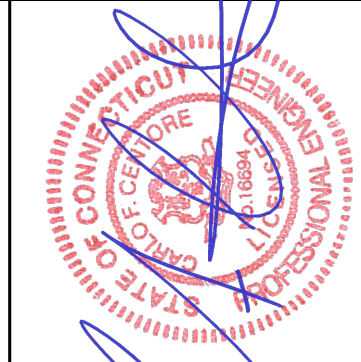

CEN TEK engineering
Centek on Solutions
(203) 488-0380
(203) 488-8587 Fax
652 North Branford Road
Branford, CT 06405
www.CentekEng.com

T-MOBILE NORTHEAST LLC
DANBURY HOSPITAL
SITE ID: CT1108A
24 HOSPITAL AVENUE
DANBURY, CT 06810

DATE: 05/14/21
SCALE: AS NOTED
JOB NO. 20074.12

SITE LOCATION PLAN

C-1

06/17/21
RIS
DATE
DRAWN BY
CHK'D BY
TJR
CONSTRUCTION DRAWINGS - ISSUED FOR CONSTRUCTION

STRUCTURAL COMPLIANCE

ANTENNA MOUNTS

A STRUCTURAL ANALYSIS OF THE ANTENNA MOUNTS WAS PERFORMED FOR THE PROPOSED EQUIPMENT INSTALLATION AND THEY WERE FOUND TO BE STRUCTURALLY DEFICIENT AND WARRANTING MODIFICATION PRIOR TO INSTALLATION OF THE PROPOSED EQUIPMENT. FOR REQUIRED STRUCTURAL MODIFICATIONS, SEE SHEET(S) S-1 FOR ADDITIONAL DETAILS.

REFER TO THE STRUCTURAL ANALYSIS REPORT PREPARED BY CENTEK ENGINEERING (PROJECT # 20074.12) DATED 05/18/21 FOR ADDITIONAL INFORMATION AND REQUIREMENTS.

EQUIPMENT PLATFORM

A STRUCTURAL ANALYSIS OF THE EQUIPMENT PLATFORM WAS PERFORMED FOR THE PROPOSED EQUIPMENT INSTALLATION AND WAS FOUND TO BE STRUCTURALLY SUFFICIENT TO ACCOMMODATE THE PROPOSED LOADING..

REFER TO THE STRUCTURAL ANALYSIS REPORT PREPARED BY CENTEK ENGINEERING (PROJECT # 20074.12) DATED 05/18/21 FOR ADDITIONAL INFORMATION AND REQUIREMENTS.

NOTE: NO EQUIPMENT SHALL BE INSTALLED ON THE HOSTING STRUCTURE WITHOUT A PASSING STRUCTURAL ANALYSIS REPORT AND CONTRACTOR PRIOR CONFIRMATION THAT ANY AND ALL REQUISITE MODIFICATIONS HAVE BEEN COMPLETED.

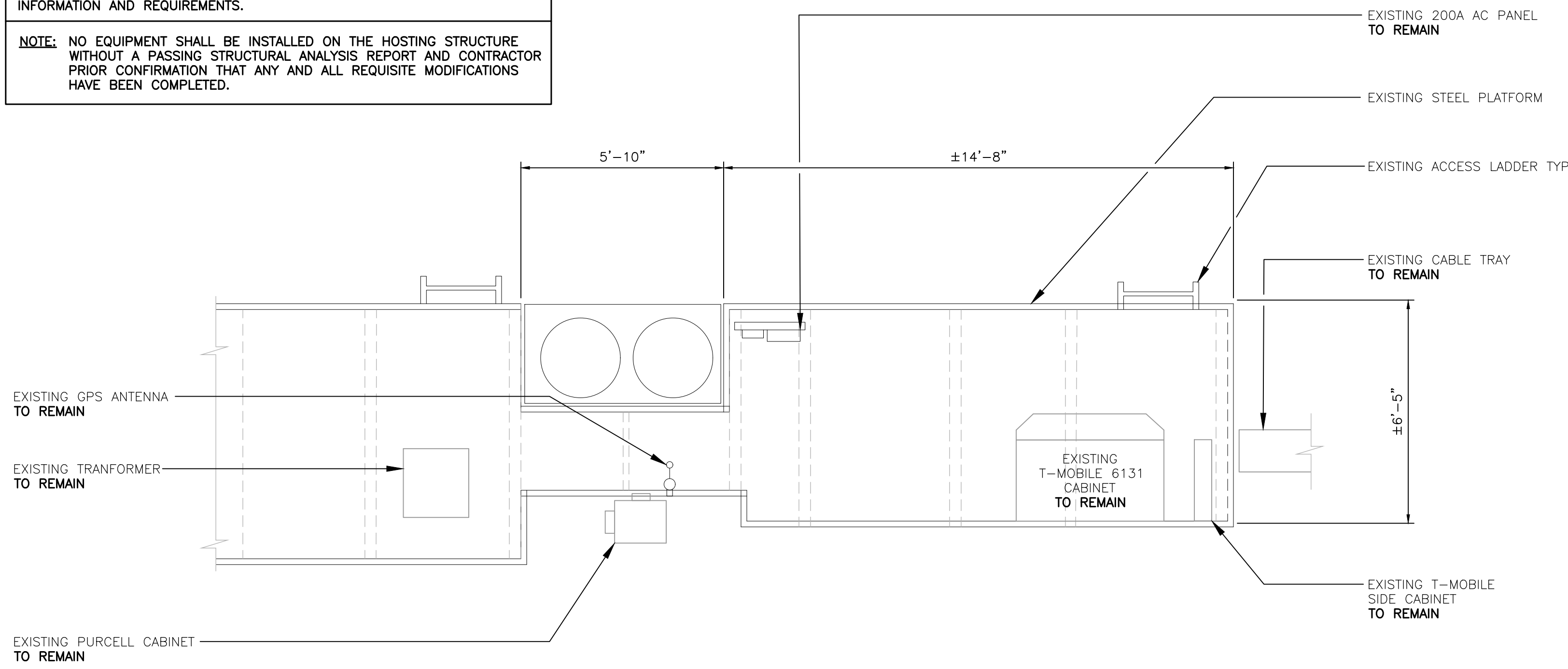

1 EXISTING EQUIPMENT PLAN
C-2 SCALE: 3/8" = 1' TRUE NORTH

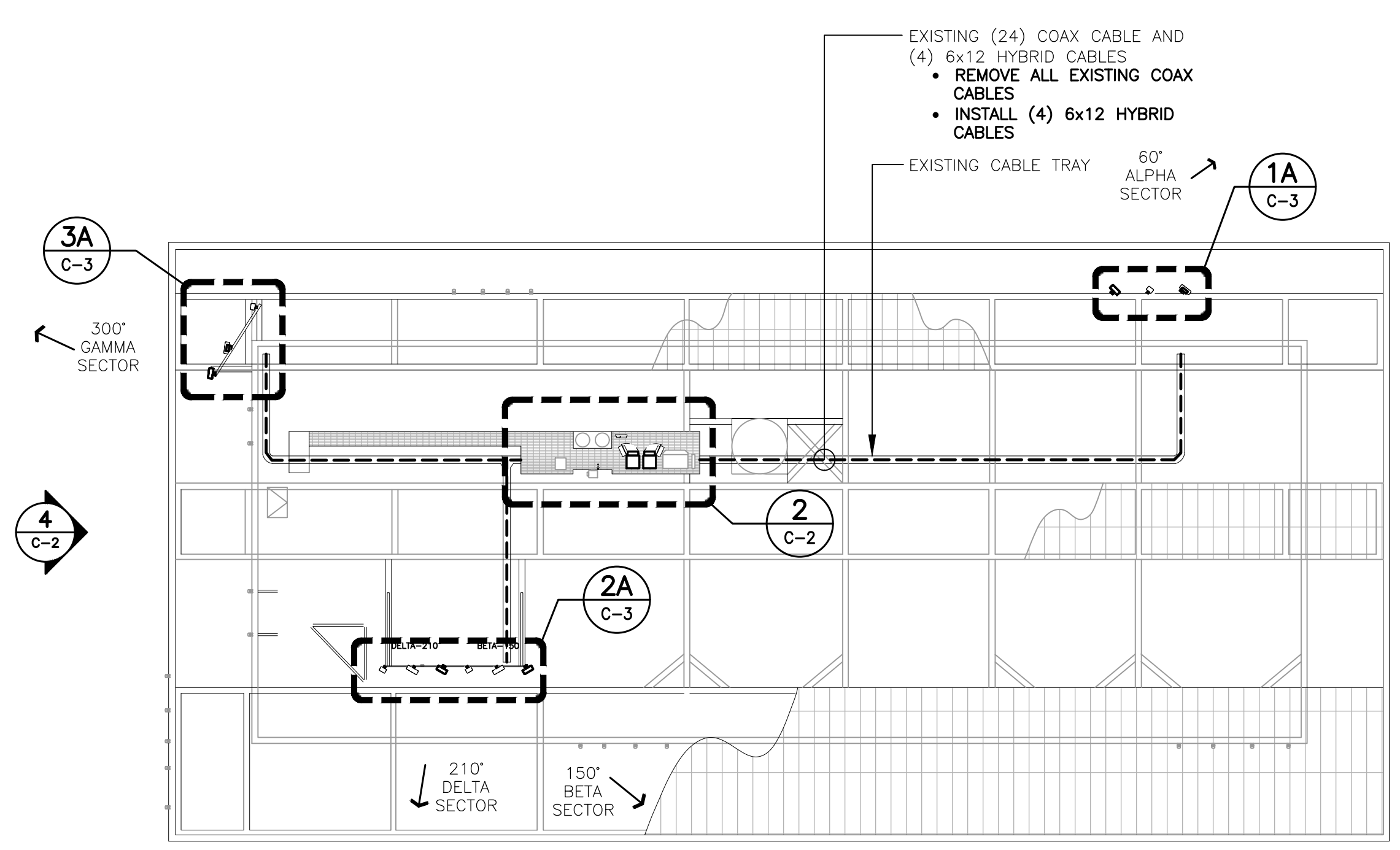

3 ROOF PLAN - PROPOSED
C-2 SCALE: 1" = 20' TRUE NORTH

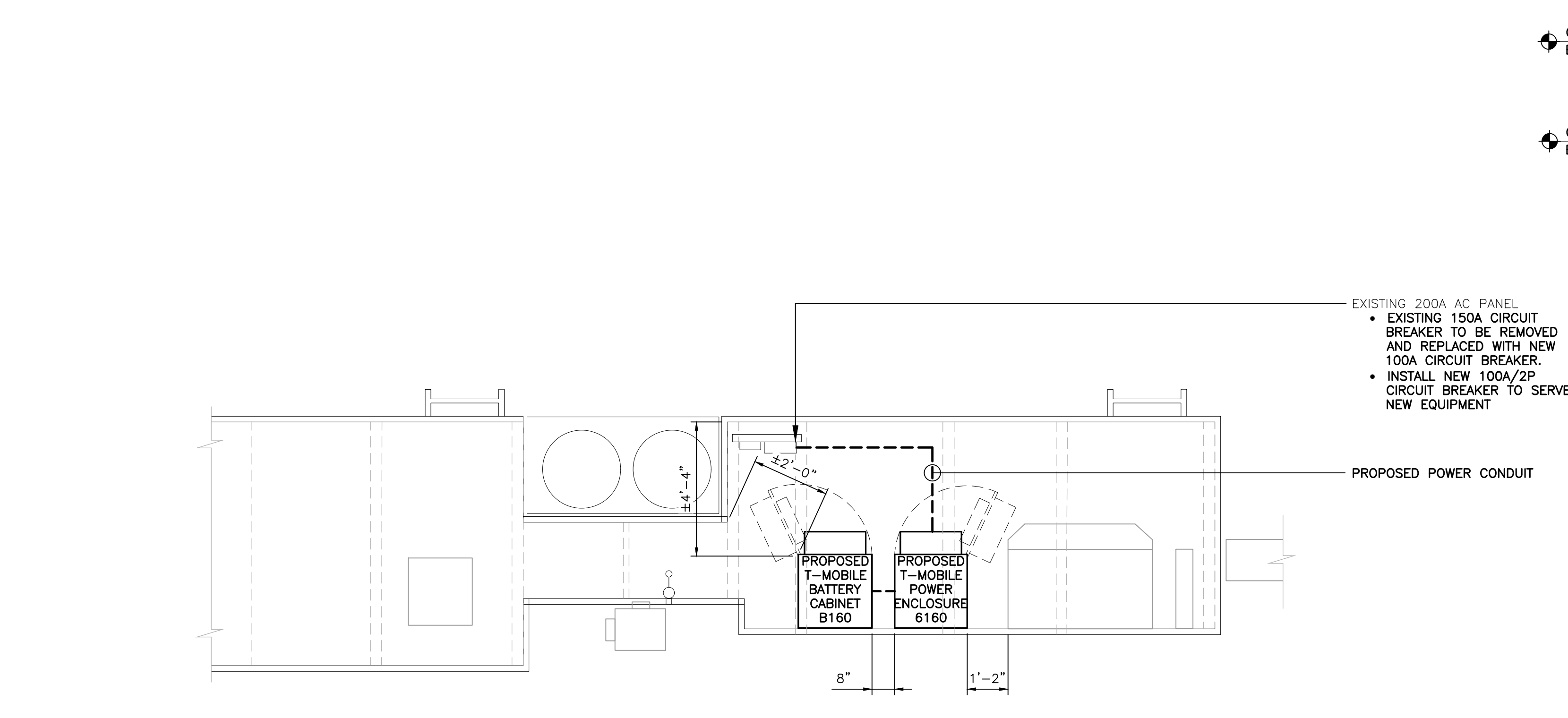

2 PROPOSED EQUIPMENT PLAN
C-2 SCALE: 3/8" = 1' TRUE NORTH

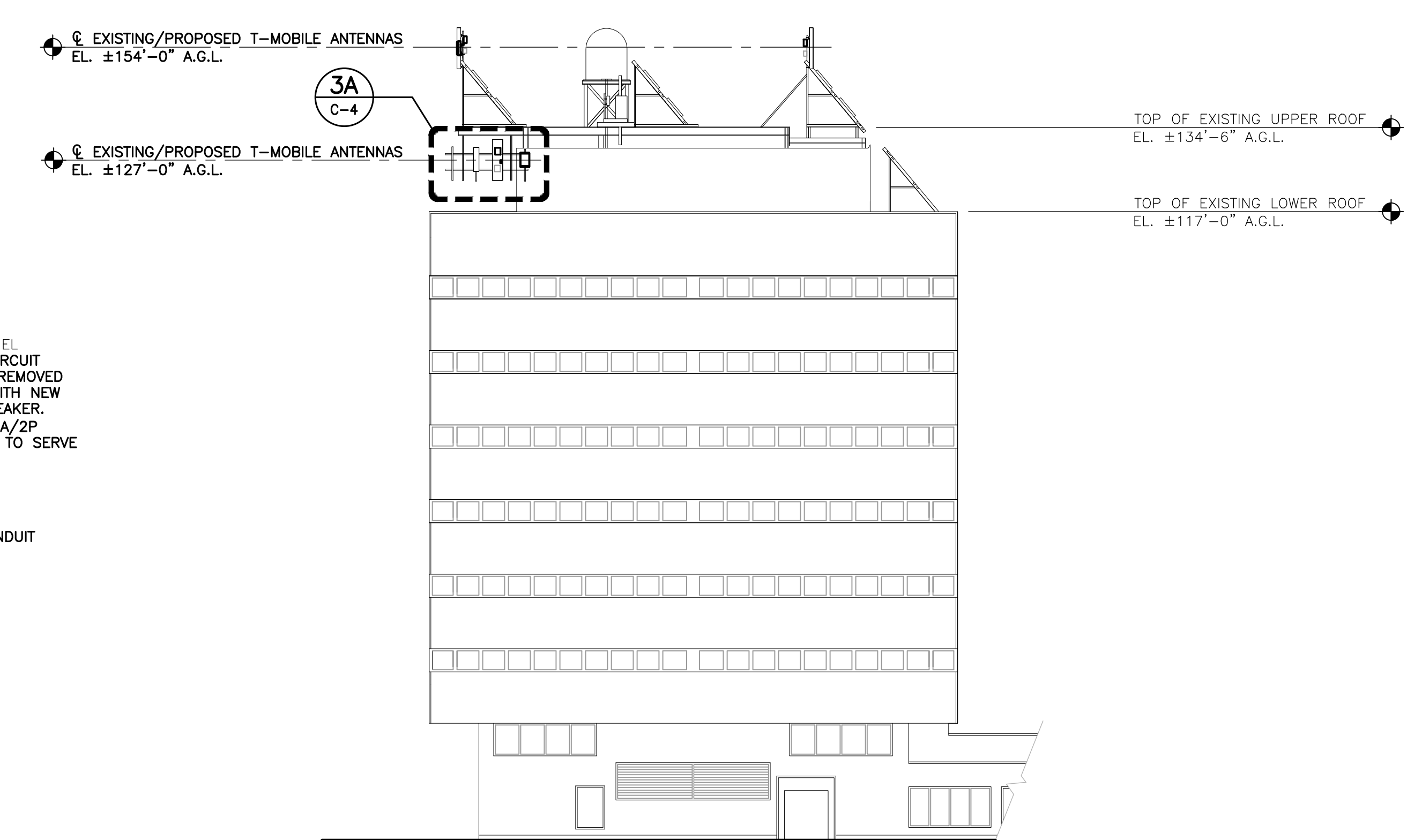

4 PARTIAL BUILDING ELEVATION - PROPOSED
C-2 SCALE: 1" = 20'

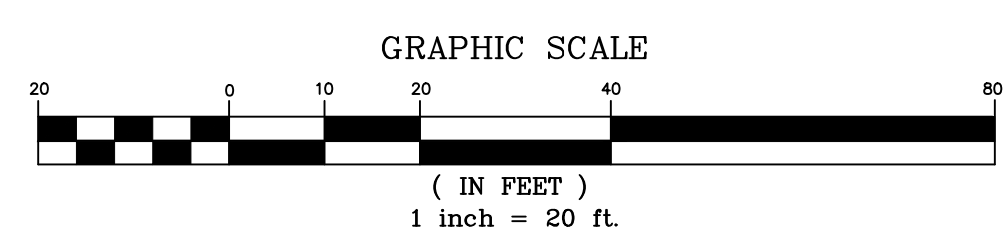

REV.	DATE	BY	CHK'D BY	DESCRIPTION
0	06/17/21	RIS	JLR	CONSTRUCTION DRAWINGS - ISSUED FOR CONSTRUCTION

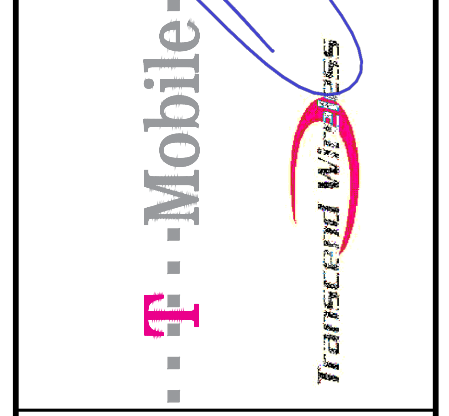

CENTEK engineering
Center on Solutions
(203) 488-0380
(203) 488-8587 Fax
652 North Branford Road
Branford, CT 06405
www.CentekEng.com

T-MOBILE NORTHEAST LLC
DANBURY HOSPITAL
SITE ID: CT1108A
24 HOSPITAL AVENUE
DANBURY, CT 06810

DATE: 05/14/21
SCALE: AS NOTED
JOB NO. 20074.12
ROOF PLAN & EQUIPMENT PLAN AND ELEVATIONS

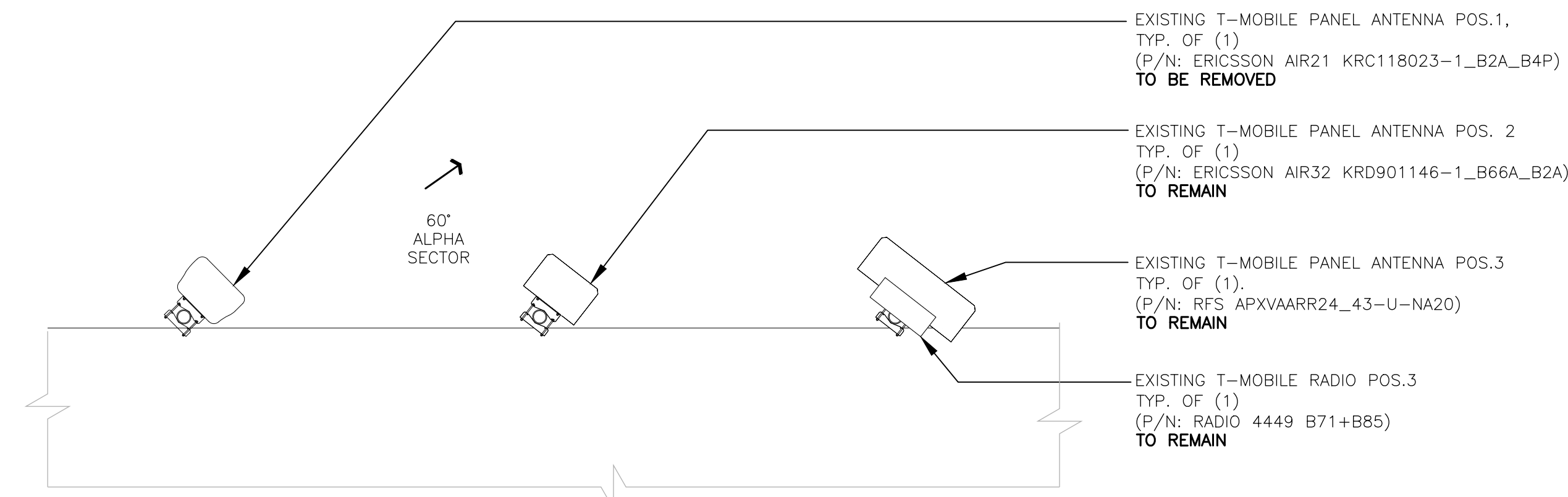

1 EXISTING ANTENNA PLAN (ALPHA)
C-3 SCALE: 1/2" = 1'
TRUE NORTH

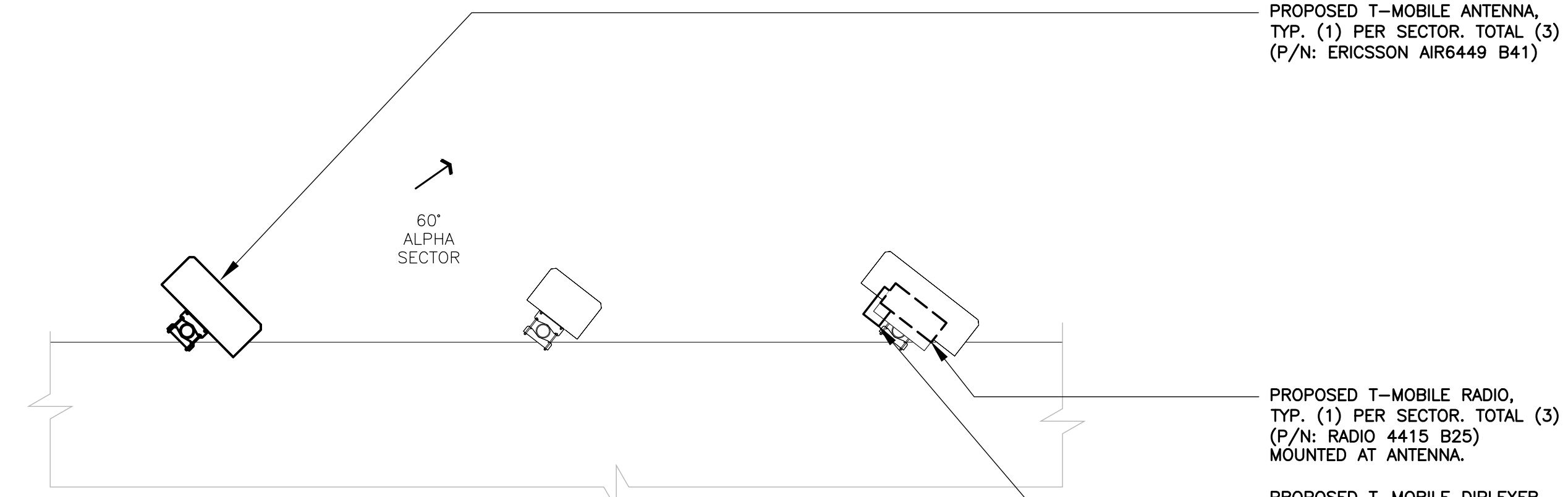

1A PROPOSED ANTENNA PLAN (ALPHA)
C-3 SCALE: 1/2" = 1'
TRUE NORTH

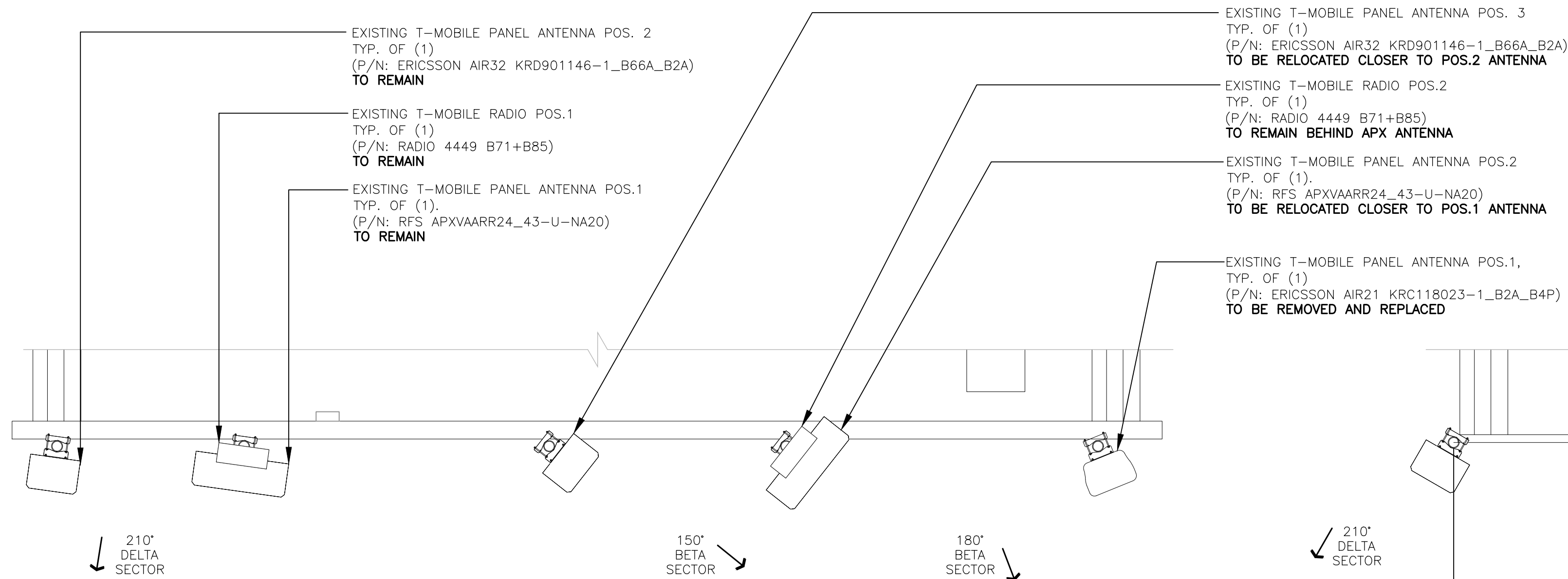

2 EXISTING ANTENNA PLAN (BETA/DELTA)
C-3 SCALE: 1/2" = 1'
TRUE NORTH

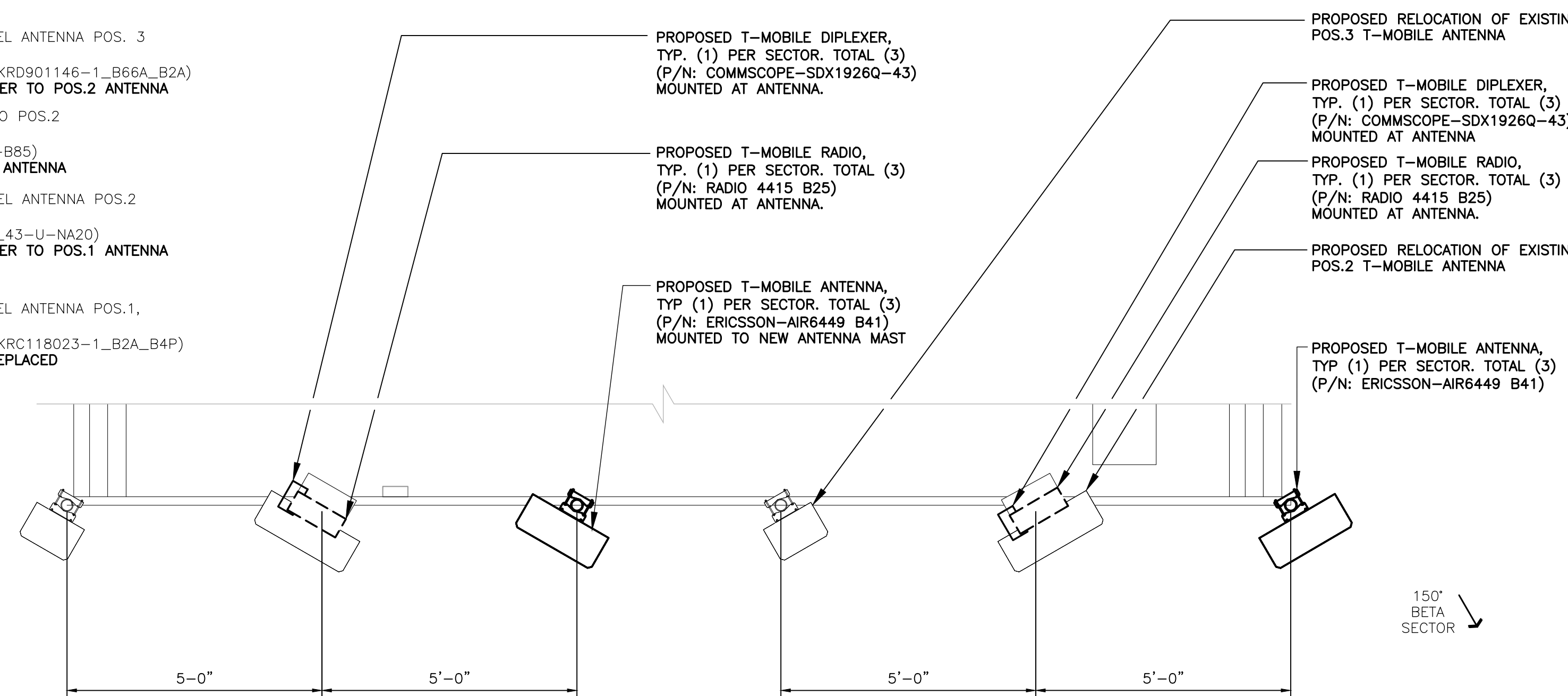

2A PROPOSED ANTENNA PLAN (BETA/DELTA)
C-3 SCALE: 1/2" = 1'
TRUE NORTH

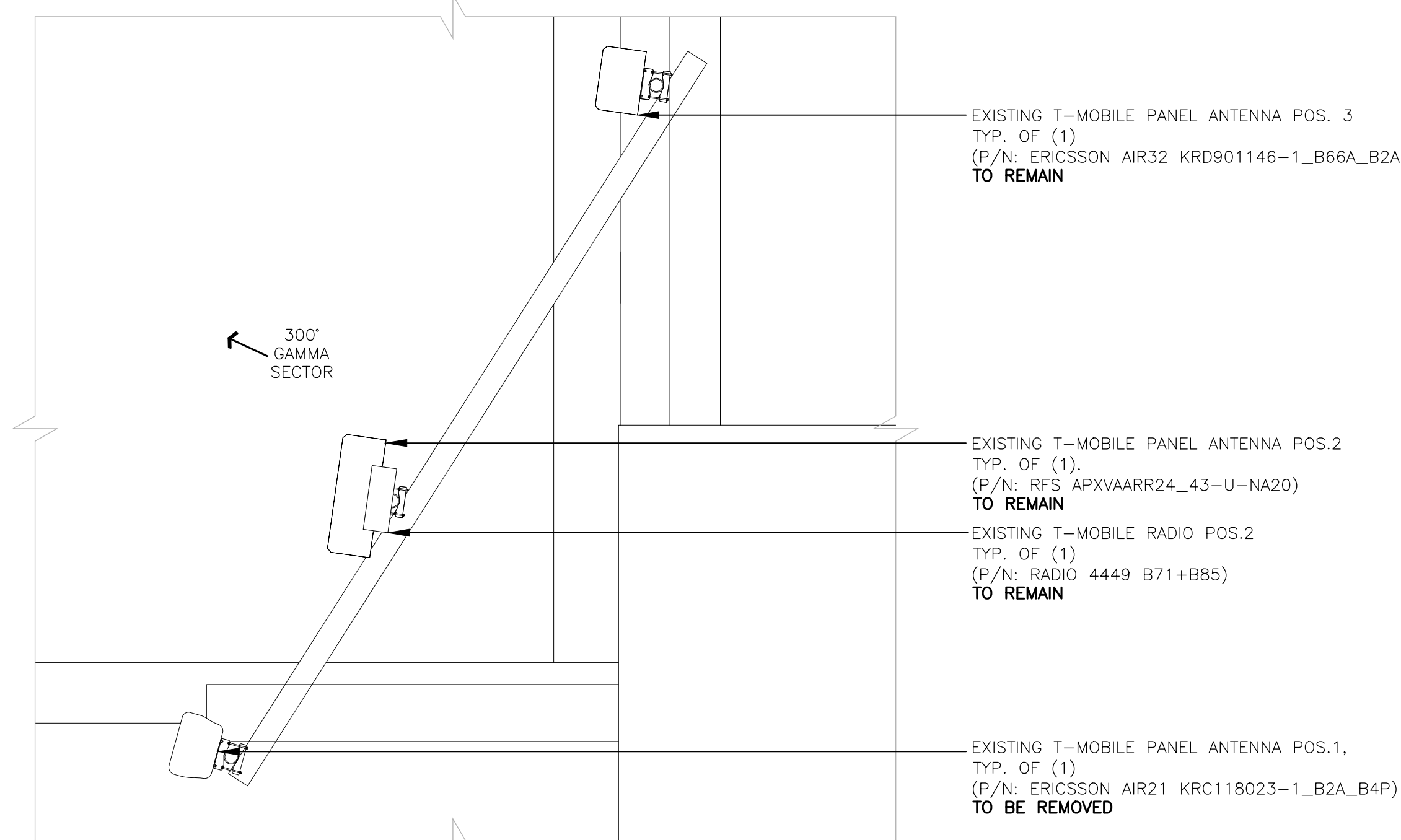

3 EXISTING ANTENNA PLAN (GAMMA)
C-3 SCALE: 1/2" = 1'
TRUE NORTH

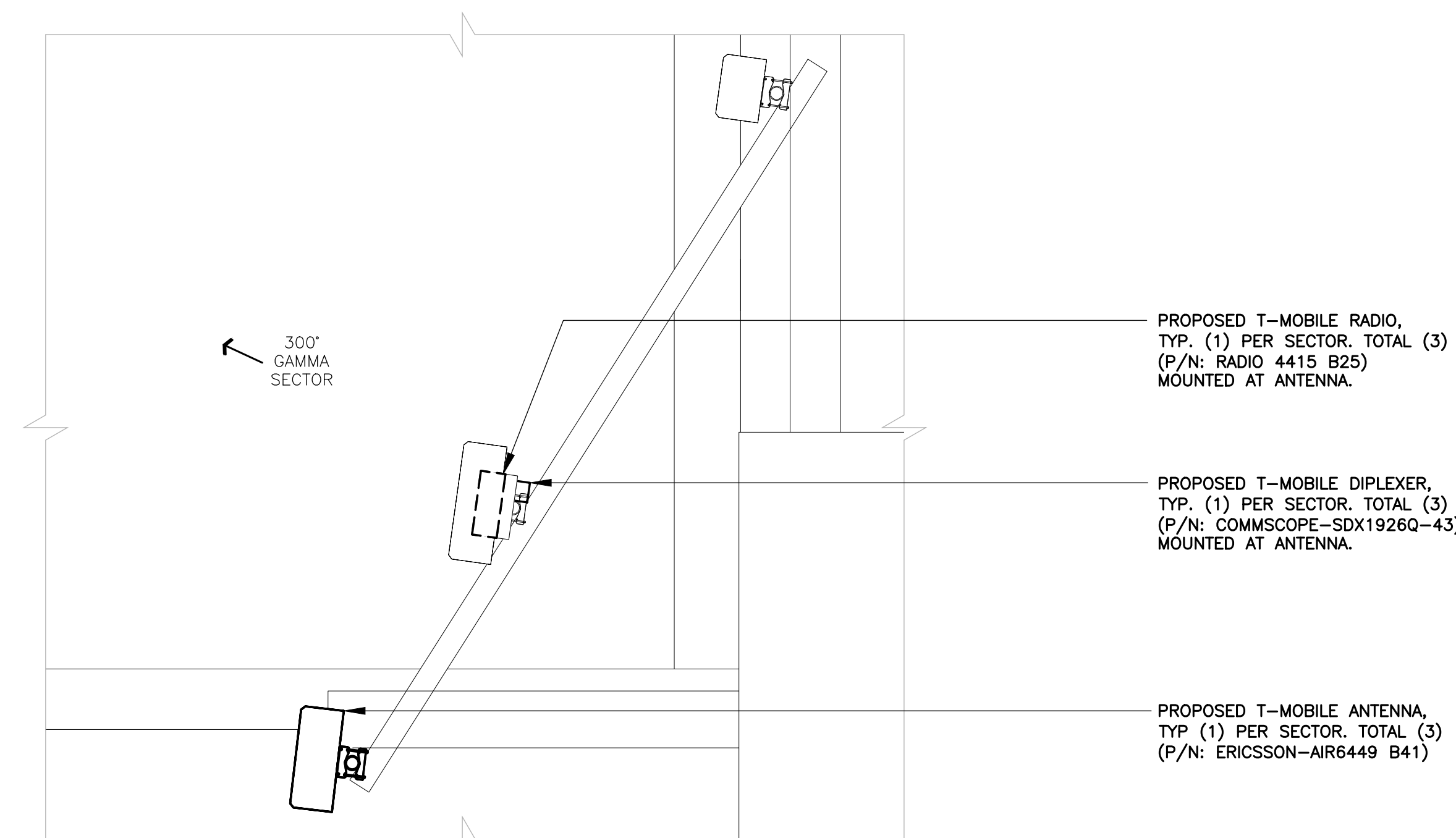

3A PROPOSED ANTENNA PLAN (GAMMA)
C-3 SCALE: 1/2" = 1'
TRUE NORTH

CONSTRUCTION DRAWINGS - ISSUED FOR CONSTRUCTION	TJR	RIS	DATE	REV.
DESCRIPTION	CHK'D BY	DRAWN BY	06/17/21	0

PROFESSIONAL ENGINEER SEAL

T-Mobile

CENTEK engineering
Centek on Solutions
(203) 488-0380
(203) 488-8587 Fax
652 North Branford Road
Branford, CT 06405
www.CentekEng.com

T-MOBILE NORTHEAST LLC
DANBURY HOSPITAL
SITE ID: CT1108A
24 HOSPITAL AVENUE
DANBURY, CT 06810

DATE: 05/14/21
SCALE: AS NOTED
JOB NO. 20074.12

ANTENNA PLANS

C-3

Sheet No. 5 of 9

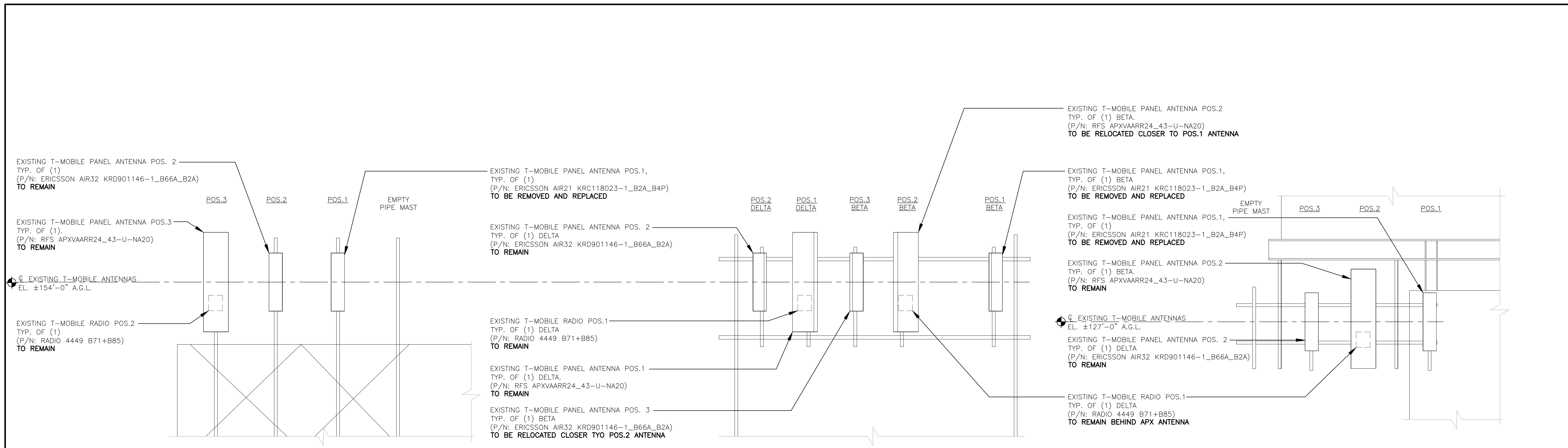

1 EXISTING ANTENNA ELEVATION - (ALPHA)
 C-4 SCALE: 1/4" = 1'

2 EXISTING ANTENNA ELEVATION - (BETA/DELTA)
 C-4 SCALE: 1/4" = 1'

3 EXISTING ANTENNA ELEVATION - (GAMMA)
 C-4 SCALE: 1/4" = 1'

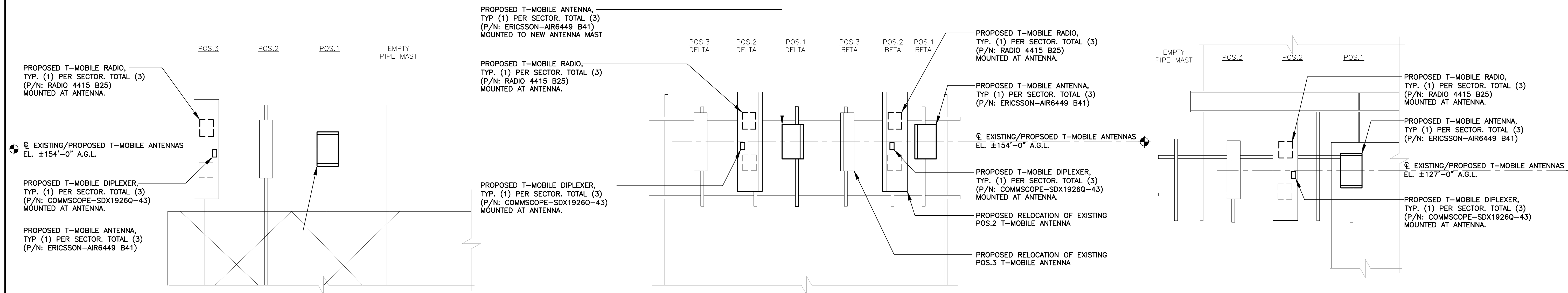

1A PROPOSED ANTENNA ELEVATION - (ALPHA)
 C-4 SCALE: 1/4" = 1'

2A PROPOSED ANTENNA ELEVATION - (BETA/DELTA)
 C-4 SCALE: 1/4" = 1'

3A PROPOSED ANTENNA ELEVATION - (GAMMA)
 C-4 SCALE: 1/4" = 1'

PROFESSIONAL ENGINEER SEAL	CONSTRUCTION DRAWINGS - ISSUED FOR CONSTRUCTION
	J.R. DRAWN BY / CHK'D BY
06/17/21	RIS DATE
0	REV.
<p>T-MOBILE NORTHEAST LLC DANBURY HOSPITAL SITE ID: CT1108A 24 HOSPITAL AVENUE DANBURY, CT 06810</p>	
DATE: 05/14/21	
SCALE: AS NOTED	
JOB NO. 20074.12	
ANTENNA ELEVATIONS	
C-4	
Sheet No. 6 of 9	

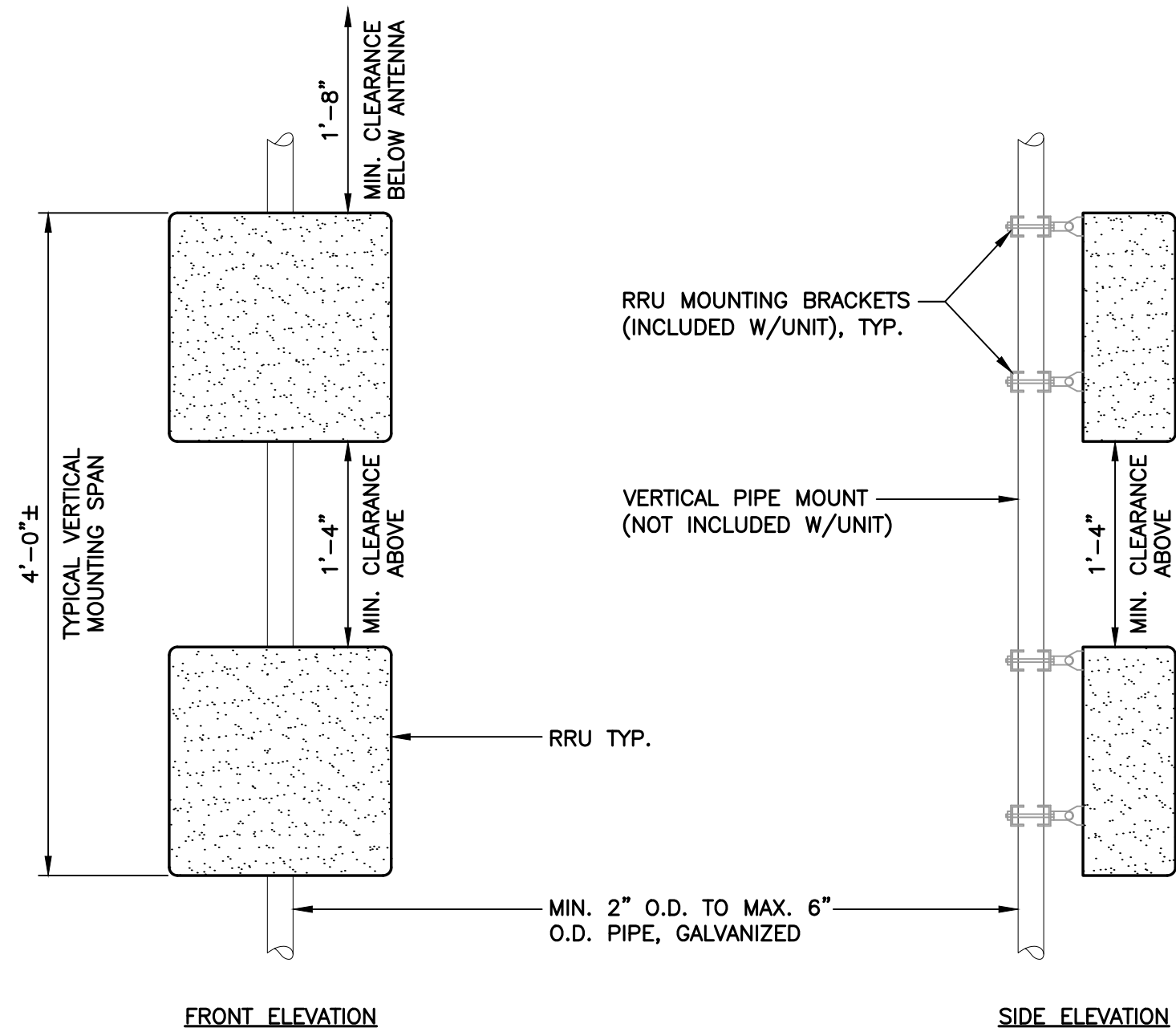

NOTES:

1. T-MOBILE SHALL SUPPLY RRU, AND RRU POLE-MOUNTING BRACKET. CONTRACTOR SHALL SUPPLY POLE/PIPE AND INSTALL ALL MOUNTING HARDWARE INCLUDING ERICSSON RRU POLE-MOUNTING BRACKET. CONTRACTOR SHALL INSTALLS RRU AND MAKES CABLE TERMINATIONS.
2. NO PAINTING OF THE RRU OR SOLAR SHIELD IS ALLOWED.

1 TYPICAL RRU MOUNTING DETAIL
C-5 SCALE: NOT TO SCALE

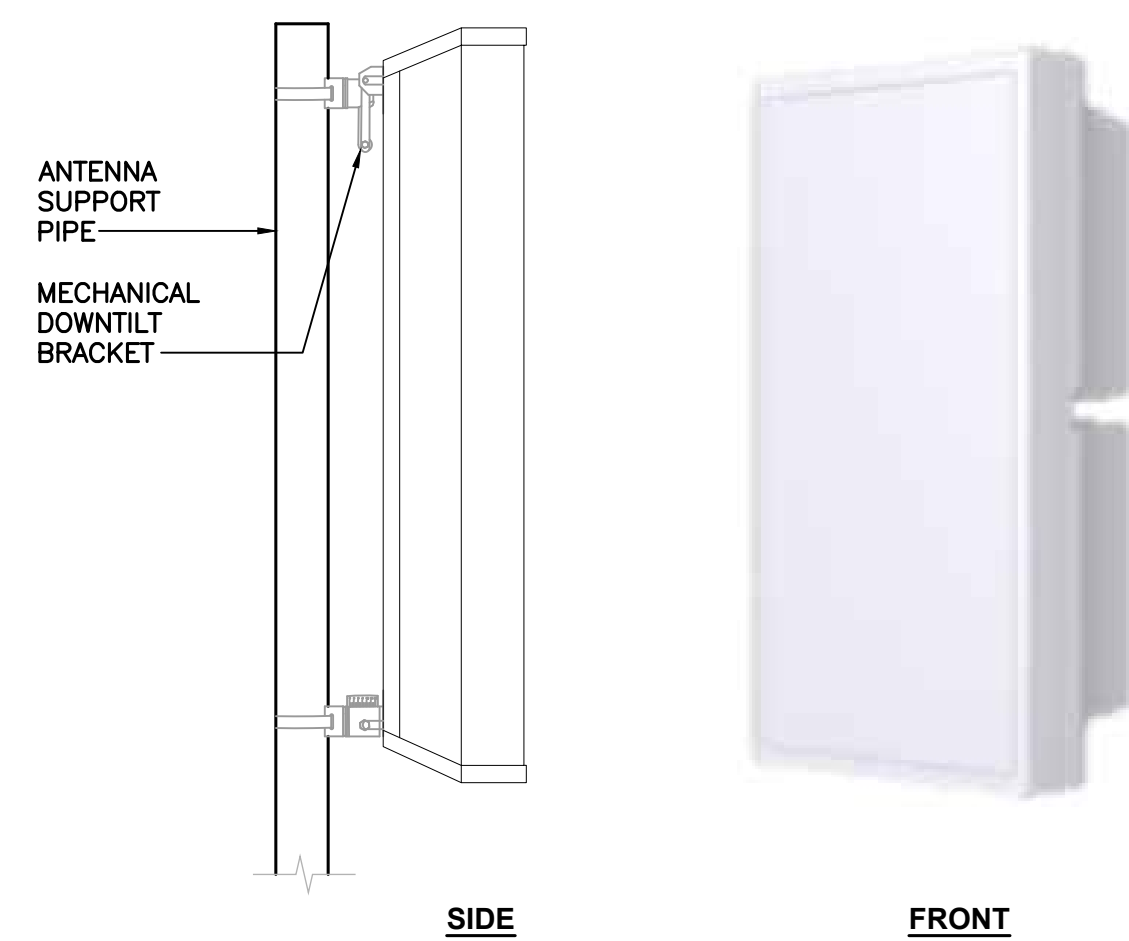

ALPHA/BETA/GAMMA ANTENNA		
EQUIPMENT	DIMENSIONS	WEIGHT
MAKE: ERICSSON MODEL: AIR6449 B41	33.1"L x 20.6"W x 8.6"D	±104 LBS.
NOTES: 1. CONTRACTOR TO COORDINATE FINAL EQUIPMENT MODEL SELECTION WITH T-MOBILE CONSTRUCTION MANAGER PRIOR TO ORDERING.		

2 PROPOSED ANTENNA DETAIL
C-5 SCALE: NOT TO SCALE



RRU (REMOTE RADIO UNIT)			
EQUIPMENT	DIMENSIONS	WEIGHT	CLEARANCES
MAKE: ERICSSON MODEL: RADIO 4415 B25	16.5"L x 13.4"W x 5.9"D	±46 LBS.	BEHIND ANT.: 8" MIN. BELOW ANT.: 20" MIN. BELOW RRU: 16" MIN.
NOTES: 1. CONTRACTOR TO COORDINATE FINAL EQUIPMENT MODEL SELECTION WITH T-MOBILE CONSTRUCTION MANAGER PRIOR TO ORDERING.			

3 PROPOSED RRU DETAIL
C-5 SCALE: NOT TO SCALE

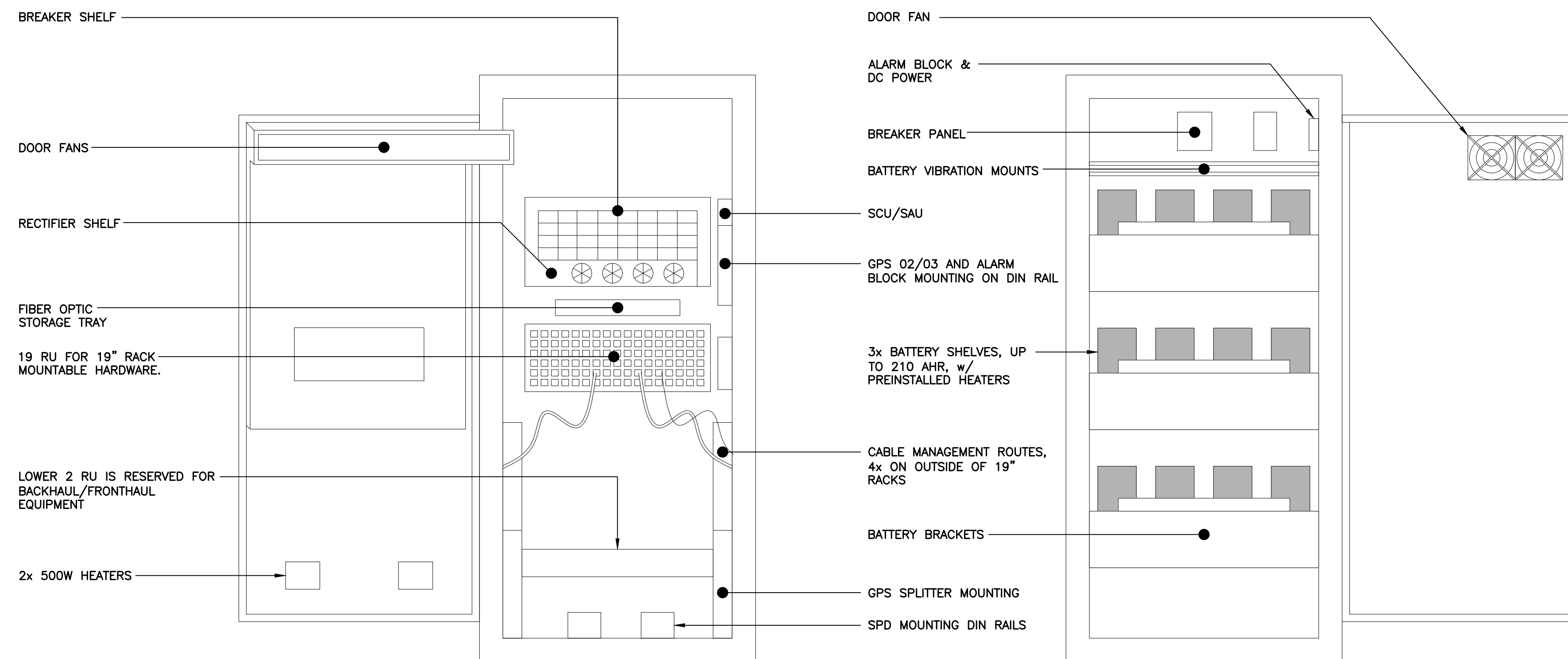

EQUIPMENT CABINET		
EQUIPMENT	DIMENSIONS	WEIGHT
MAKE: ERICSSON MODEL: ENCLOSURE 6160 CABINET	62.0"H x 26.0"W x 26.0"D	±1200 LBS

4 ENCLOSURE 6160 CABINET DETAIL
C-5 SCALE: NOT TO SCALE

EQUIPMENT CABINET		
EQUIPMENT	DIMENSIONS	WEIGHT
MAKE: ERICSSON MODEL: BATTERY B160 CABINET	62.0"H x 26.0"W x 26.0"D	±1883 LBS

5 BATTERY B160 CABINET DETAIL
C-5 SCALE: NOT TO SCALE



DIPLEXER		
EQUIPMENT	DIMENSIONS	WEIGHT
MAKE: COMMSCOPE MODEL: SDX1926Q-43(E14F05P86)	4.2"L x 7.0"W x 3.0"D	-
NOTES: 1. CONTRACTOR TO COORDINATE FINAL EQUIPMENT MODEL SELECTION WITH T-MOBILE CONSTRUCTION MANAGER PRIOR TO ORDERING.		

6 PROPOSED DIPLEXER DETAIL
C-5 SCALE: NOT TO SCALE

CONSTRUCTION DRAWINGS - ISSUED FOR CONSTRUCTION

DATE: 06/17/21
REV. 0
DRAWN BY: CHKD BY: RIS

T-MOBILE

CENTEK engineering
Center on Solutions
(203) 488-0380
(203) 488-8587 Fax
652 North Branford Road
Branford, CT 06405
www.CentekEng.com

T-MOBILE NORTHEAST LLC
DANBURY HOSPITAL
SITE ID: CT1108A
24 HOSPITAL AVENUE
DANBURY, CT 06810

DATE: 05/14/21
SCALE: AS NOTED
JOB NO. 20074.12

TYPICAL EQUIPMENT DETAILS

C-5

Sheet No. 7 of 9

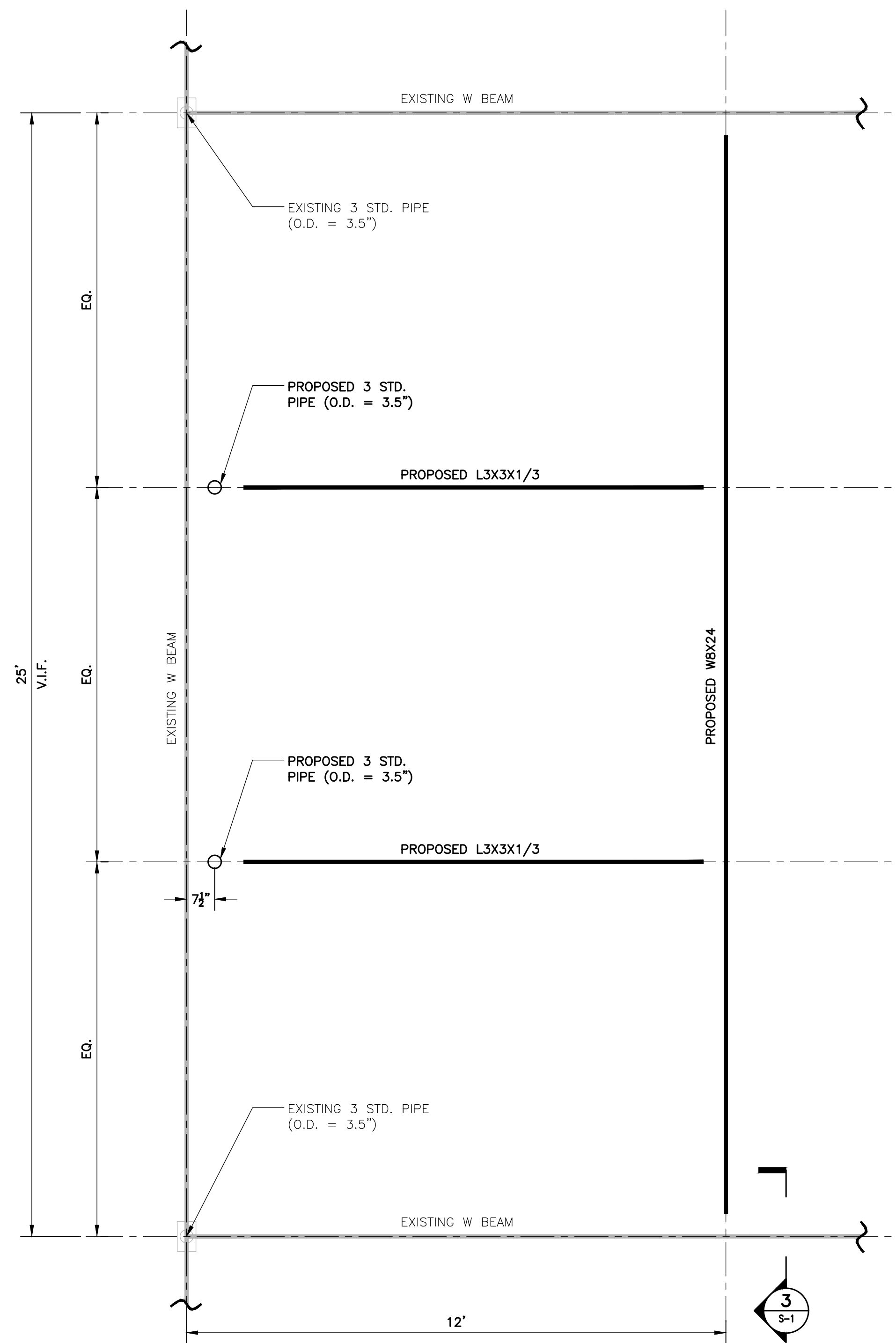

1 BETA/DELTA SECTOR ANTENNA FRAME PLAN
S-1 SCALE: 1/2" = 1'

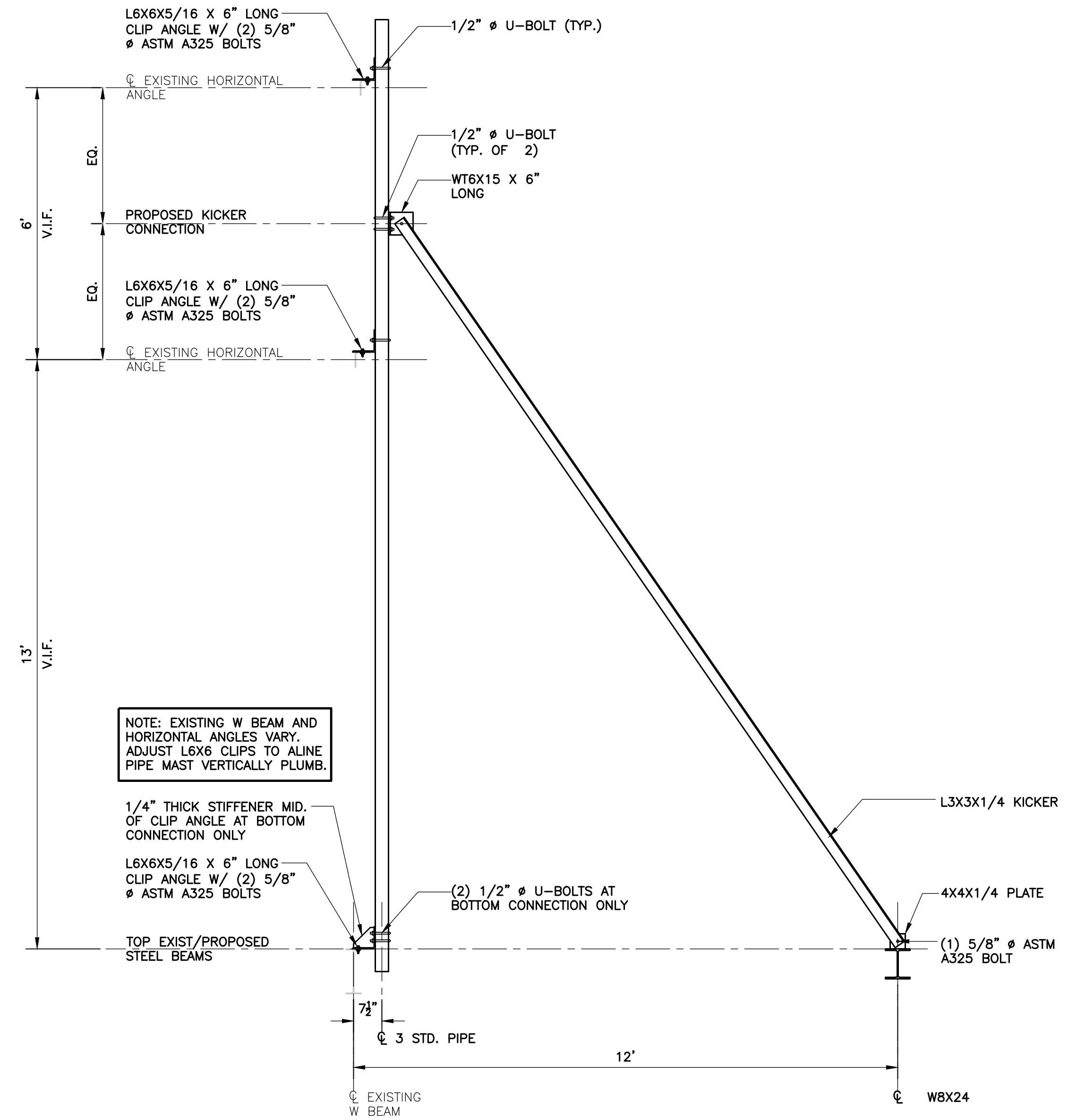

2 BETA/DELTA SECTOR ANTENNA FRAME SECTION
S-1 SCALE: 1/2" = 1'

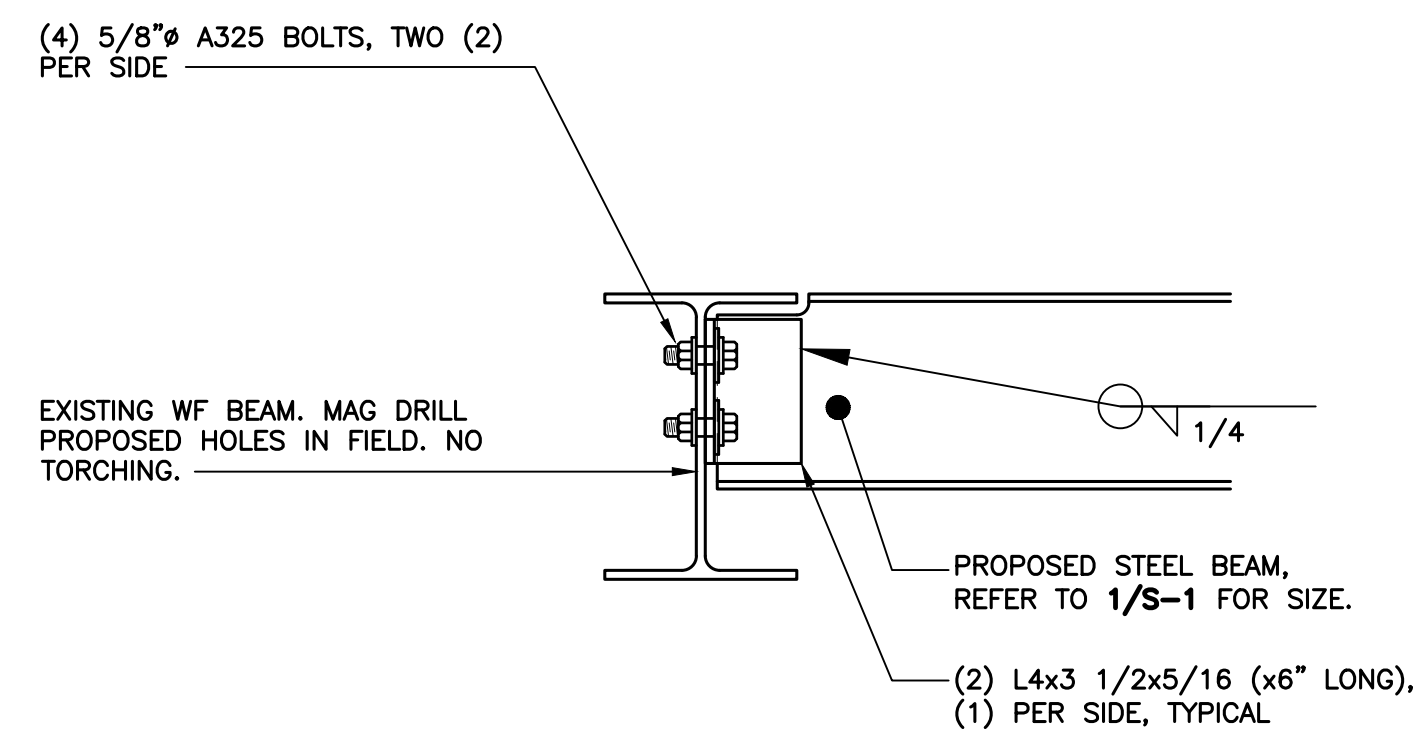

3 TYPICAL W8 TO EXIST. WF CONNECTION
S-1 SCALE: 1 1/2" = 1'-0"

REV.	DATE	BY	CHK'D BY	DESCRIPTION
0	06/17/21	RIS	JUR	CONSTRUCTION DRAWINGS - ISSUED FOR CONSTRUCTION

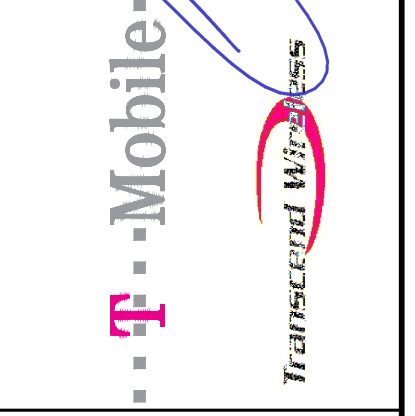
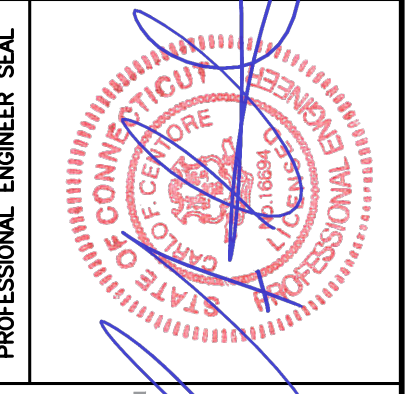

CENTEK engineering
Centek on Solutions
(203) 488-0380
(203) 488-8587 Fax
652 North Branford Road
Branford, CT 06405
www.CentekEng.com

T-MOBILE NORTHEAST LLC
DANBURY HOSPITAL
SITE ID: CT1108A
24 HOSPITAL AVENUE
DANBURY, CT 06810

DATE: 05/14/21
SCALE: AS NOTED
JOB NO. 20074.12

STRUCTURAL DETAILS

S-1
Sheet No. 8 of 9

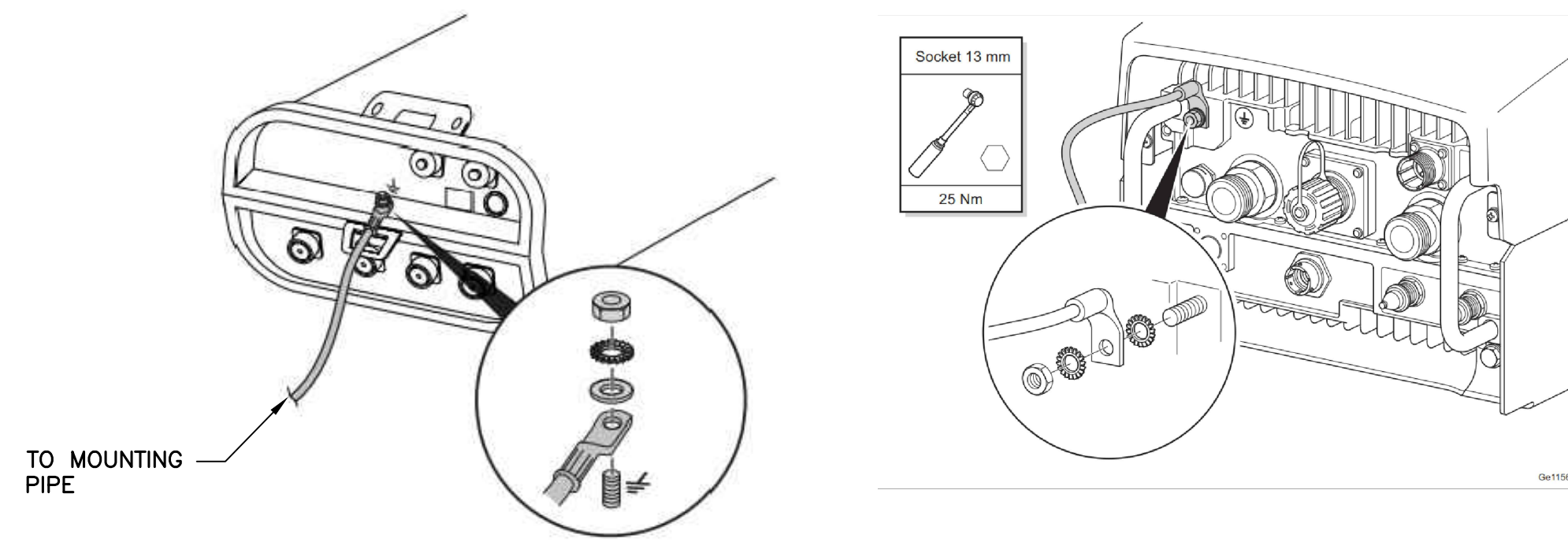

1 TYPICAL ANTENNA/RRU GROUNDING DETAILS
E-1 SCALE: NOT TO SCALE

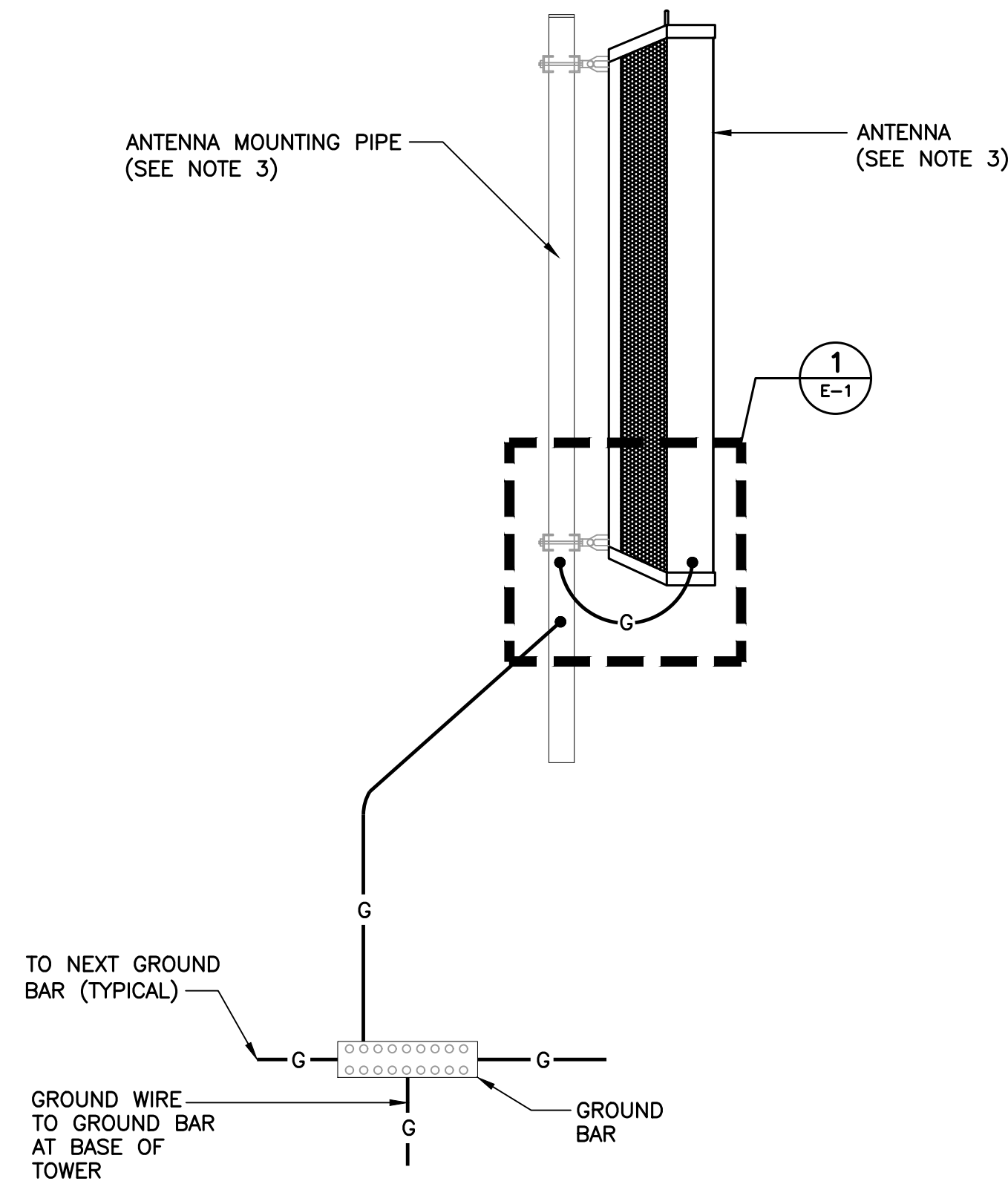

- NOTES:**
1. BOND COAXIAL CABLE GROUND KITS TO EACH OWNER'S GROUND BAR ALONG ENTIRE COAX RUN FROM ANTENNA TO SHELTER.
 2. BOND ALL EQUIPMENT TO GROUND PER NEC AND MANUFACTURERS SPECIFICATIONS.
 3. DETAIL IS TYPICAL FOR ALL ANTENNA SECTORS, INCLUDING GPS ANTENNA.

2 TYPICAL ANTENNA GROUNDING DETAIL
E-1 SCALE: NOT TO SCALE

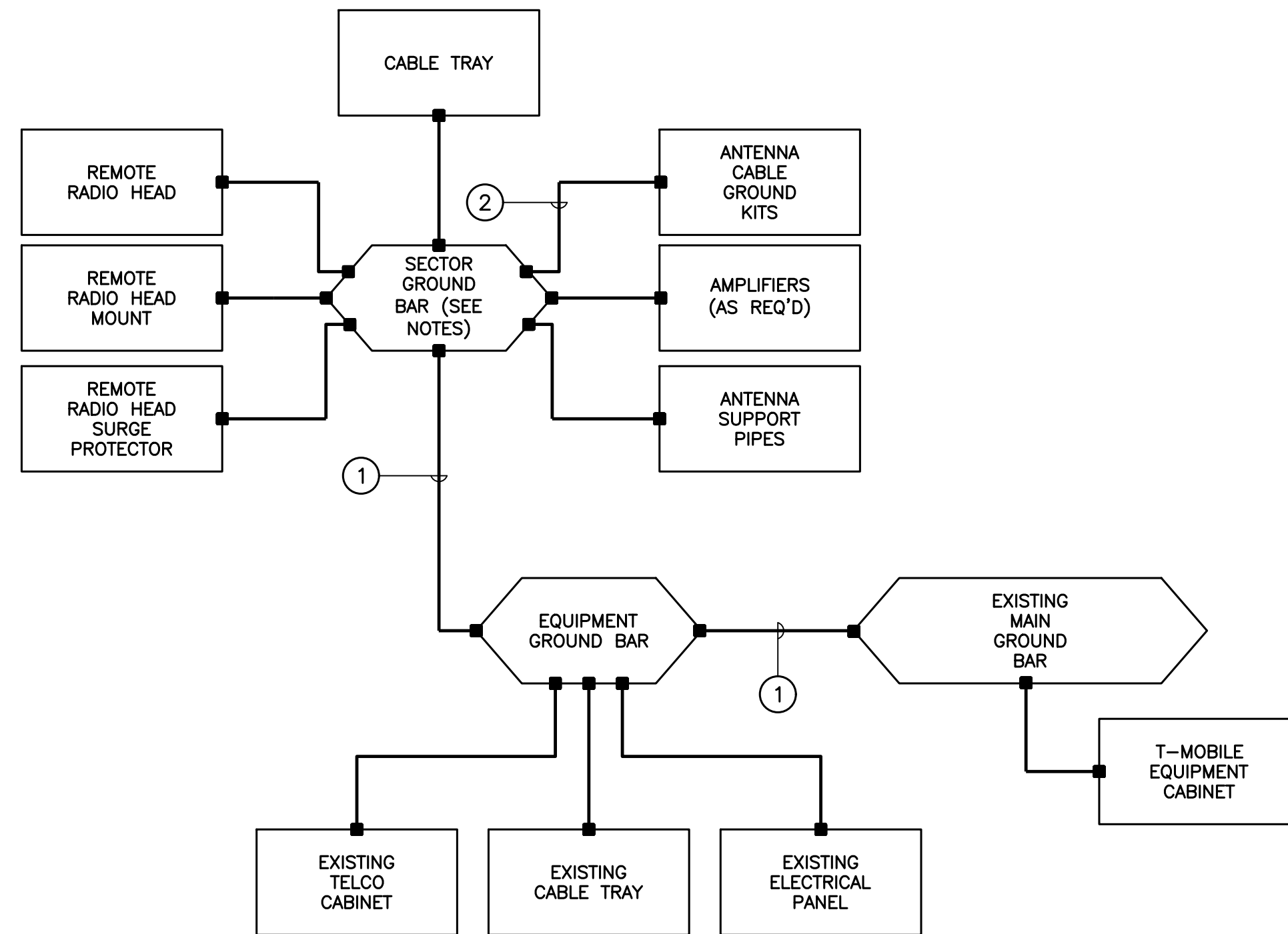

GROUNDING SCHEMATIC NOTES

- 1 #2 AWG
 - 2 #6 AWG
- GENERAL NOTES:**
1. ALL SURGE SUPPRESSION EQUIPMENT SHALL BE BONDED TO GROUND PER MANUFACTURER'S SPECIFICATIONS
 2. UNLESS OTHERWISE NOTED OR REQUIRED BY CODE, GROUND CONDUCTORS SHOWN SHALL BE #2 AWG (SOLID TINNED BCW - EXTERIOR; STRANDED GREEN INSULATED - INTERIOR).
 3. ALL SECTOR GROUND BARS SHALL BE BONDED TOGETHER WITH #2 AWG SOLID TINNED BCW.
 4. BOND ALL EQUIPMENT CABINETS AND BATTERY CABINETS TO GROUND PER MANUFACTURER'S SPECIFICATIONS.
 5. COORDINATE ALL ROOF MOUNTED EQUIPMENT WITH OWNER.
 6. ALL ROOF MOUNTED AMPLIFIERS AND ASSOCIATED EQUIPMENT SHALL BE BONDED TO THE SECTOR GROUND BAR PER MANUFACTURER'S SPECIFICATIONS.
 7. ALL GROUNDING SHALL BE IN ACCORDANCE WITH NEC AND OWNER'S REQUIREMENTS.

4 TYPICAL GROUNDING SCHEMATIC DETAIL
E-1 SCALE: NOT TO SCALE

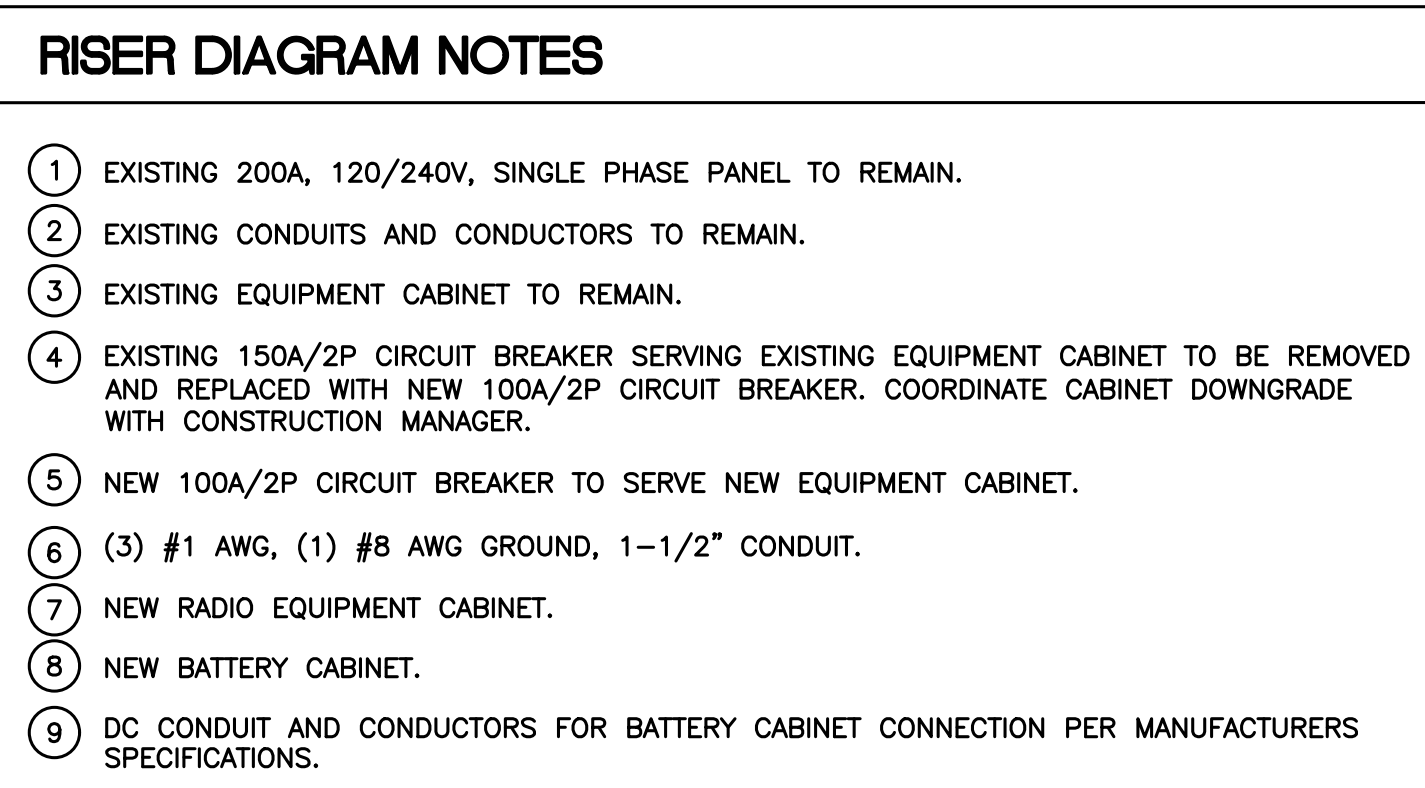

RISER DIAGRAM NOTES

- 1 EXISTING 200A, 120/240V, SINGLE PHASE PANEL TO REMAIN.
- 2 EXISTING CONDUITS AND CONDUCTORS TO REMAIN.
- 3 EXISTING EQUIPMENT CABINET TO REMAIN.
- 4 EXISTING 150A/2P CIRCUIT BREAKER SERVING EXISTING EQUIPMENT CABINET TO BE REMOVED AND REPLACED WITH NEW 100A/2P CIRCUIT BREAKER. COORDINATE CABINET DOWNGRADE WITH CONSTRUCTION MANAGER.
- 5 NEW 100A/2P CIRCUIT BREAKER TO SERVE NEW EQUIPMENT CABINET.
- 6 (3) #1 AWG, (1) #8 AWG GROUND, 1-1/2" CONDUIT.
- 7 NEW RADIO EQUIPMENT CABINET.
- 8 NEW BATTERY CABINET.
- 9 DC CONDUIT AND CONDUCTORS FOR BATTERY CABINET CONNECTION PER MANUFACTURERS SPECIFICATIONS.

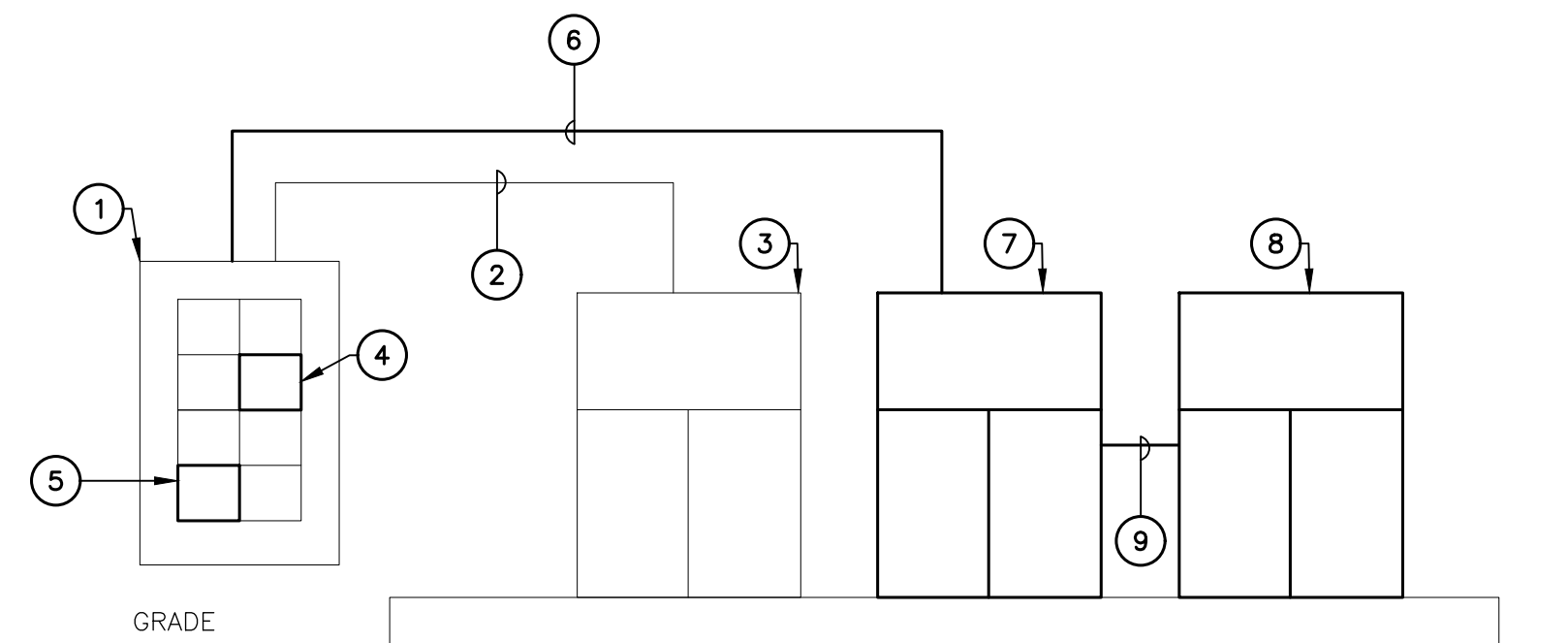

5 ELECTRICAL POWER RISER DIAGRAM
E-1 SCALE: NOT TO SCALE

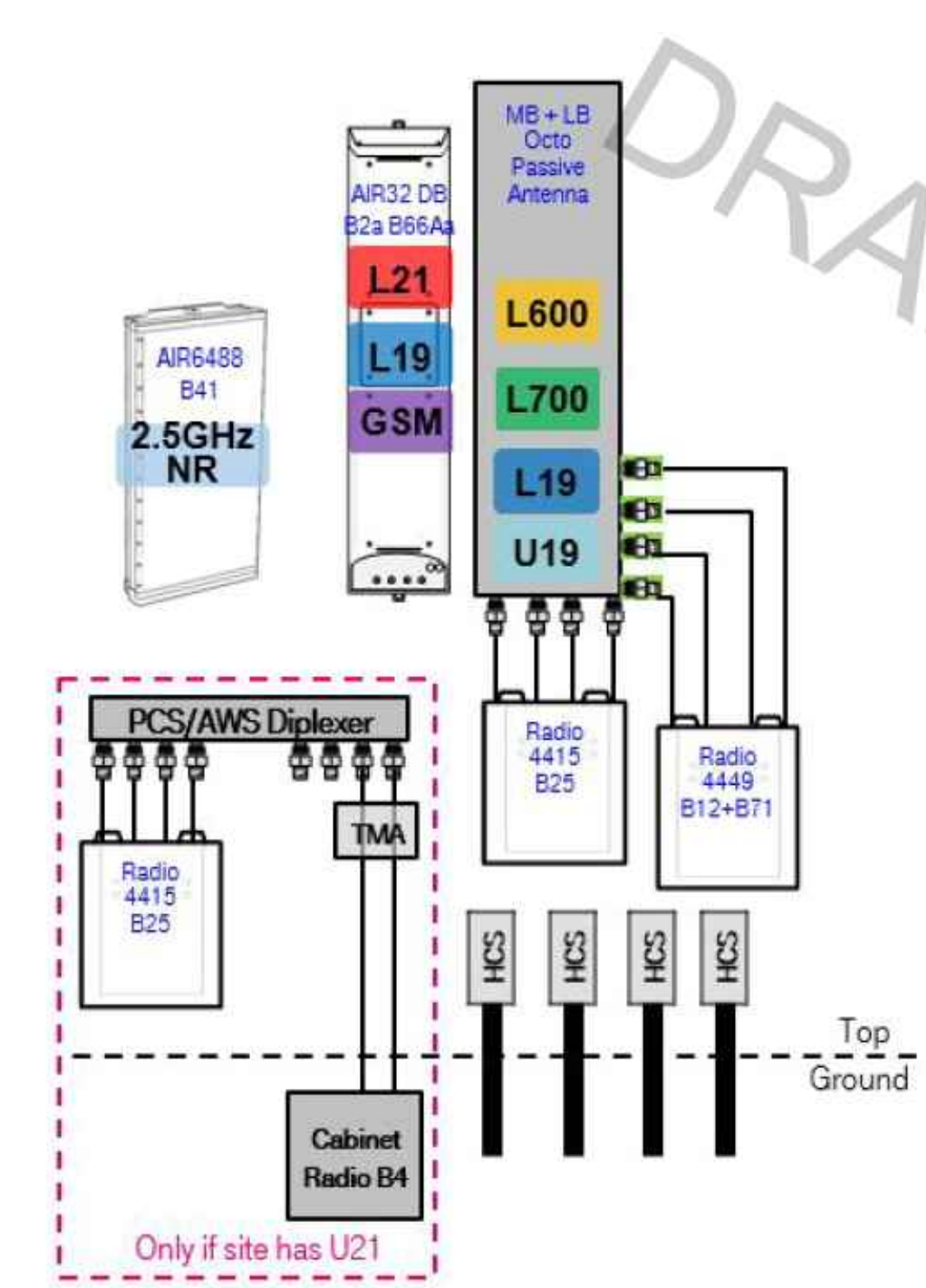

3 PROPOSED PLUMBING DIAGRAM
E-1 SCALE: NOT TO SCALE

REV.	DATE	RIS	TJR	CONSTRUCTION DRAWINGS - ISSUED FOR CONSTRUCTION
0	06/17/21	DRAWN BY	CHK'D BY	DESCRIPTION

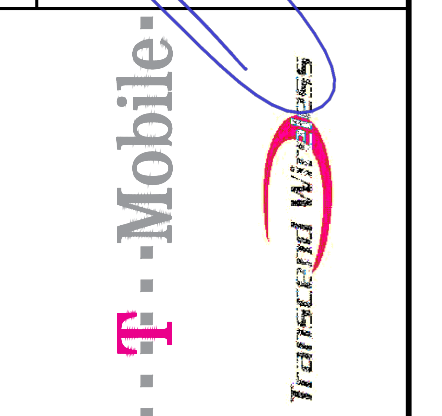
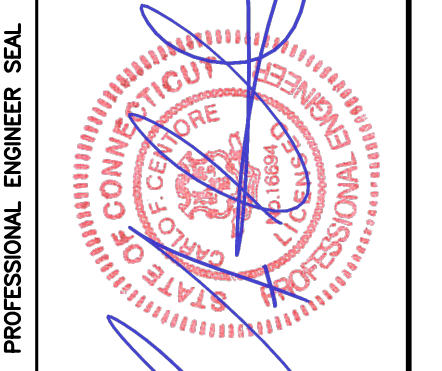

CENTEK engineering
 Center on Solutions
 (203) 488-0380
 (203) 488-8587 Fax
 652 North Branford Road
 Branford, CT 06405
 www.CentekEng.com

T-MOBILE NORTHEAST LLC
DANBURY HOSPITAL
SITE ID: CT1108A
 24 HOSPITAL AVENUE
 DANBURY, CT 06810

DATE: 05/14/21
 SCALE: AS NOTED
 JOB NO. 20074.12

TYPICAL ELECTRICAL DETAILS

E-1
 Sheet No. 9 of 9



Radio Frequency Emissions Analysis Report

T-Mobile Wireless Rooftop Facility

July 16, 2020

Analysis Format: Actual Measurements (Annual Audit)



Centerline PN: 950056-032

CT11108A

DANBURY HOSPITAL

24 Hospital Ave, Danbury, CT 06810

Additional Site Information:

Site Type: Rooftop

Site Survey Date: July 15, 2020

Statement of Compliance

T-Mobile is compliant with their signage policy based on existing and installed signage.



OVERVIEW

Centerline Communications, LLC (“Centerline”) has been contracted to provide a Radio Frequency (RF) Monitoring Analysis for the following T-Mobile wireless rooftop facility to determine whether the facility is in compliance with federal standards and regulations regarding RF emissions. This analysis includes an in-field site audit and measurements taken at the facility for all existing equipment for T-Mobile and any other wireless carriers on site.

The facility is located on a 12-story medical facility in Danbury, CT. Access to the facility is restricted to authorized personnel and facility management.

Analysis Site Data			
Site ID:		CT11108A	
Site Name:		DANBURY HOSPITAL	
Site Address:		24 Hospital Ave, Danbury, CT 06810	
Site Latitude:		41.405064	
Site Longitude:		-73.445545	
Facility Type:		Rooftop	
Compliance Summary			
Status:		Compliant with existing and installed signage	
T-Mobile Max Measured MPE% (General Public Limit):		41.45 %	
Site Survey Data			
Is Access Locked or Controlled?:		Yes	
Lock or Control Measures if Present:		Locked Door, Locked Hatch	
Access Contact:		Carlton Wallen	
Site Visit Date:	July 15, 2020	Survey Technician:	Adeyinka Adetunji
Meter Model / Serial:	NBM 520 / D-1862	Probe Model / Serial:	EA5091 / 01288
Meter Calibration Date:	2/20/2020	Probe Calibration Date:	March 22, 2018

SITE PHOTOGRAPHS

The following pages contain photographs taken from the site survey on July 15, 2020.



1. Building Overview



3. Access 2 with Existing Signage



2. Access 1 with Existing Signage



4. Access 3 with Existing Signage



5. Access 4 with Existing Signage



8. T-Mobile Sector B and D with Existing Signage



6. T-Mobile Sector A with Existing Signage



9. T-Mobile Sector B and D with Existing Signage



7. T-Mobile Sector A with Existing Signage



10. T-Mobile Sector B and D with Existing Signage



11. T-Mobile Sector C with Existing Signage



12. T-Mobile Sector C with Existing Signage



13. T-Mobile Equipment

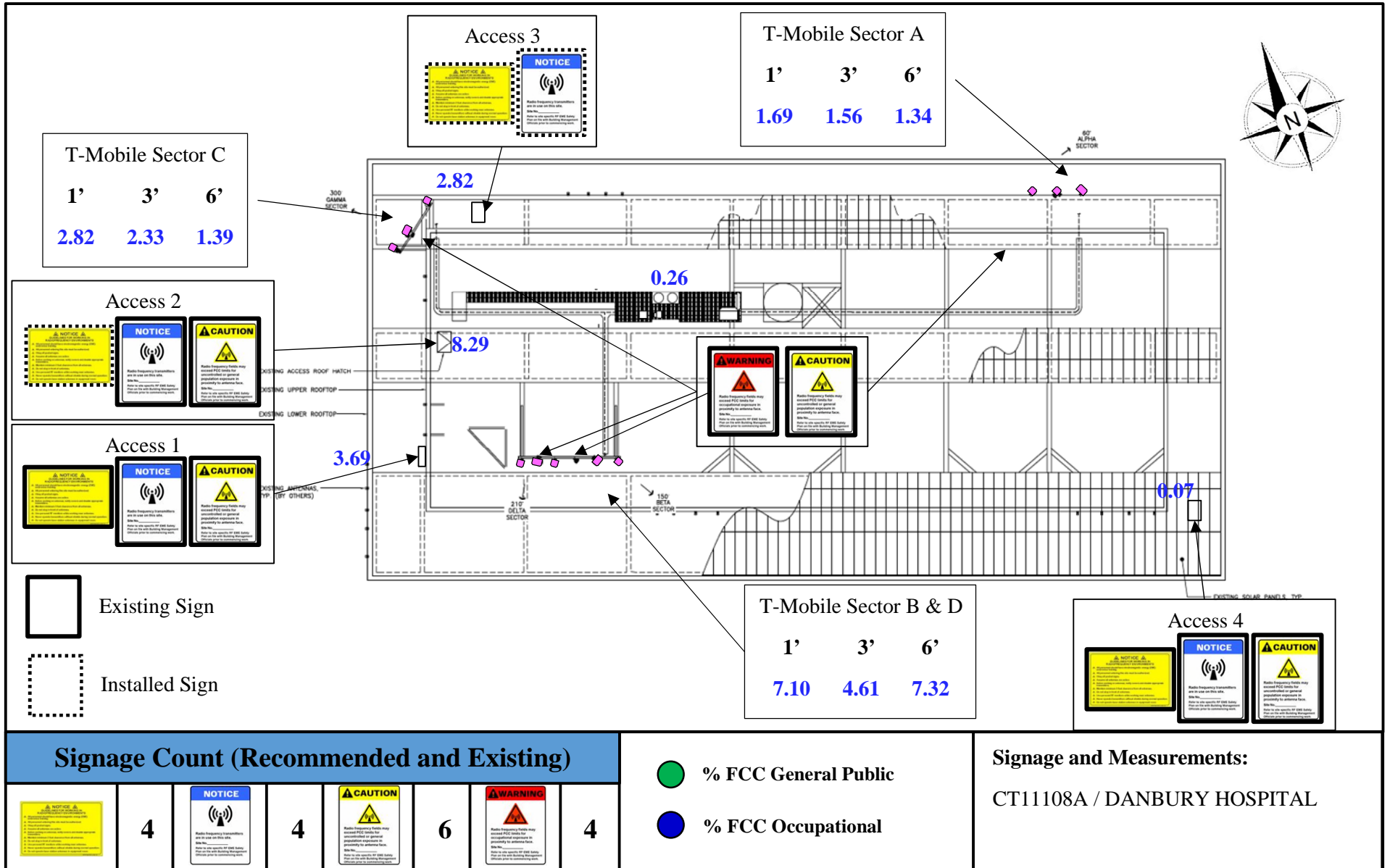

Structural Analysis Report

Equipment Platform & Antenna Mounts

*Proposed T-Mobile
Equipment Upgrade*

Site Ref: CT11108A

*24 Hospital Ave.
Danbury, CT*

CEN TEK Project No. 20074.12

Date: May 18, 2021

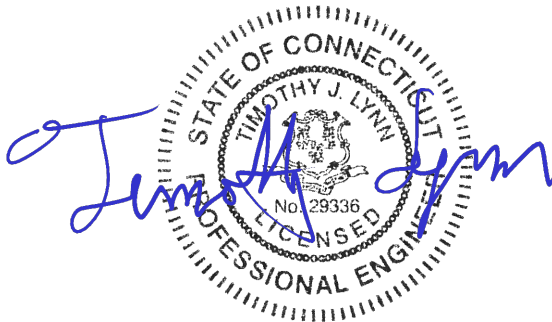

Prepared for:
T-Mobile USA
35 Griffin Road
Bloomfield, CT 06002

Table of Contents

SECTION 1 - REPORT

- INTRODUCTION
- PRIMARY ASSUMPTIONS USED IN THE ANALYSIS
- EQUIPMENT INSTALLATION SUMMARY
- ANALYSIS
- DESIGN LOADING
- RESULTS
- CONCLUSION

SECTION 2 – CONDITIONS & SOFTWARE

- STANDARD ENGINEERING CONDITIONS
- GENERAL DESCRIPTION OF STRUCTURAL ANALYSIS PROGRAM

SECTION 3 – CALCULATIONS

- WIND LOAD CALCULATION
- RISA3D – ANTENNA MOUNT MEMBER FRAMING – ALPHA SECTOR
- RISA3D – ANTENNA MOUNT REPORT – ALPHA SECTOR
- RISA3D – UNITY CHECK – ALPHA SECTOR
- RISA3D – ANTENNA MOUNT MEMBER FRAMING – BETA/DELTA SECTOR
- RISA3D – ANTENNA MOUNT REPORT – BETA/DELTA SECTOR
- RISA3D – UNITY CHECK – BETA/DELTA SECTOR
- RISA3D – ANTENNA MOUNT MEMBER FRAMING – GAMMA SECTOR
- RISA3D – ANTENNA MOUNT REPORT – GAMMA SECTOR
- RISA3D – UNITY CHECK – GAMMA SECTOR
- RISA3D OUTPUT REPORT –EQUIPMENT PLATFORM

SECTION 4 – REFERENCE MATERIAL

- RF DATA SHEET

Introduction

The purpose of this structural analysis report (SAR) is to summarize the results of the impacted structural components, by the modified equipment upgrade proposed by T-Mobile on the existing host building located in Danbury, CT.

The equipment cabinets are mounted on a structural steel dunnage platform on the roof of the building. The antennas are mounted on structural steel support frames attached to the building/solar panel support framing.

The equipment platform structure geometry and member size information were obtained from previous CDs/structural report and a site visit performed by Centek personnel on March 26, 2021.

Primary Assumptions Used in the Analysis

- The host structure's theoretical capacity not including in any assessment of the condition of the host structure.
- The existing elevated steel platform carries the horizontal and vertical loads due to the weight of equipment, and wind and transfers into host structure.
- Proposed reinforcement and support steel will be properly installed and maintained.
- Structure is in plumb condition.
- Loading for equipment and enclosure as listed in this report.
- All bolts are appropriately tightened providing the necessary connection continuity.
- All welds are fabricated with ER-70S-6 electrodes.
- All members are assumed to be as observed during roof framing mapping.
- All members are "hot dipped" galvanized in accordance with ASTM A123 and ASTM A153 Standards.
- All member protective coatings are in good condition.

Antenna and Equipment Summary

Location	Appurtenance / Equipment	Rad Center Elevation (AGL)	Mount Type
Alpha Sector	(1) Ericsson AIR21 antenna (1) Ericsson AIR32 antenna (1) RFS-APXVAARR24_43 antenna (1) Ericsson AIR6449 B41 antenna (1) Ericsson 4449 RRU (1) Ericsson 4415 RRU (1) TMA (1) Diplexer	±154-ft	Steel Frame
Beta/Delta Sectors	(1) Ericsson AIR21 antenna (2) Ericsson AIR32 antenna (2) RFS-APXVAARR24_43 antenna (2) Ericsson AIR6449 B41 antenna (2) Ericsson 4449 RRU (2) Ericsson 4415 RRU (1) TMA (1) Diplexer	±154-ft	Steel Frame
Gamma Sector	(1) Ericsson AIR21 antenna (1) Ericsson AIR32 antenna (1) RFS-APXVAARR24_43 antenna (1) Ericsson AIR6449 B41 antenna (1) Ericsson 4449 RRU (1) Ericsson 4415 RRU (1) TMA (1) Diplexer	±127-ft	Steel Frame
Equipment Dunnage	(1) Ericsson RBS 6131	±2600 lbs.	-
	(1) Ericsson B160	1883 lbs.	-
	(1) Ericsson 6160	1200 lbs.	-

Equipment – Indicates equipment to be installed.

~~Equipment~~ – Indicates equipment to be removed.

Analysis

The equipment platform and antenna mounts were analyzed using a comprehensive computer program titled Risa3D. The program analyzes the equipment platform considering the worst-case code prescribed loading condition. The structures were considered to be loaded by concentric forces, and the model assumes that the members are subjected to bending, axial, and shear forces.

Design Loading

Loading was determined per the requirements of the 2015 International Building Code amended by the 2018 CSBC and ASCE 7-10 “Minimum Design Loads for Buildings and Other Structures”.

Wind Speed:	$V_{ult} = 125$ mph	<i>Appendix N of the 2018 CT State Building Code</i>
Risk Category:	III	<i>2015 IBC; Table 1604.05</i>
Exposure Category:	Surface Roughness B	<i>ASCE 7-10; Section 26.7.2</i>
Ground Snow Load	30 psf	<i>Appendix N of the 2018 CT State Building Code</i>
Dead Load	Equipment and framing self-weight	<i>Identified within SAR design calculations</i>
Live Load	20 psf	<i>ASCE 7-10; Table 4-1 “Roofs – All Other Construction”</i>

Reference Standards

2015 International Building Code:

1. ACI 318-14, *Building Code Requirements for Structural Concrete*.
2. ACI 530-13, *Building Code Requirements for Masonry Structures*.
3. AISC 360-10, *Specification for Structural Steel Buildings*
4. AWS D1.1 – 00, *Structural Welding Code – Steel*.
5. AF&PA-12, *Span Tables for Joists and Rafters*.
6. ANSI/AWC NDS-2015, *National Design Specifications (NDS) for Wood Construction – with 2012 Supplement*.

CENTEK Engineering, Inc.

Structural Analysis – Equipment Platform & Antenna Mounts

T-Mobile Equipment Upgrade – CT11108A

Danbury, CT

May 18, 2021

Results

Member stresses and design reactions were calculated utilizing the structural analysis software RISA 3D.

The following table provides a summary of structural components impacted by the proposed upgrade along with associated member percent capacity and PASS/FAIL result:

Location	Component	Capacity (%)	Result
Equipment Platform	Frame	10%	PASS
Alpha Sector	Frame	68%	PASS
Beta/Delta Sector	Frame	80%	PASS
Gamma Sector	Frame	50%	PASS

Conclusion

This analysis shows that the subject equipment platform and antenna mounts **have sufficient capacity** to support the proposed modified antenna configuration.

The analysis is based, in part, on the information provided to this office by T-Mobile. If the existing conditions are different than the information in this report, Centek Engineering, Inc. must be contacted for resolution of any potential issues.

Please feel free to call with any questions or comments.

Respectfully Submitted by:

Timothy J. Lynn, PE
Structural Engineer

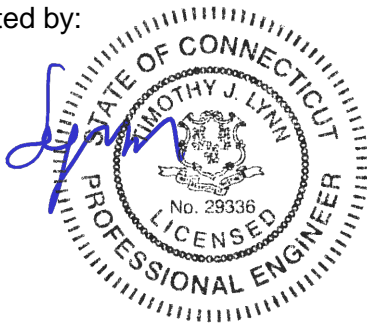

Prepared by:

Pablo Perez
Engineer

CENTEK Engineering, Inc.

Structural Analysis – Equipment Platform & Antenna Mounts

T-Mobile Equipment Upgrade – CT11108A

Danbury, CT

May 18, 2021

*Standard Conditions for Furnishing of
Professional Engineering Services on
Existing Structures*

All engineering services are performed on the basis that the information used is current and correct. This information may consist of, but is not necessarily limited to:

- Information supplied by the client regarding the structure itself, its foundations, the soil conditions, the antenna and feed line loading on the structure and its components, or other relevant information.
- Information from the field and/or drawings in the possession of Centek Engineering, Inc. or generated by field inspections or measurements of the structure.
- It is the responsibility of the client to ensure that the information provided to Centek Engineering, Inc. and used in the performance of our engineering services is correct and complete. In the absence of information to the contrary, we assume that all structures were constructed in accordance with the drawings and specifications and are in an uncorroded condition and have not deteriorated. It is therefore assumed that its capacity has not significantly changed from the “as new” condition.
- All services will be performed to the codes specified by the client, and we do not imply to meet any other codes or requirements unless explicitly agreed in writing. If wind and ice loads or other relevant parameters are to be different from the minimum values recommended by the codes, the client shall specify the exact requirement. In the absence of information to the contrary, all work will be performed in accordance with the latest revision of ANSI/ASCE10 & ANSI/EIA-222
- All services performed, results obtained, and recommendations made are in accordance with generally accepted engineering principles and practices. Centek Engineering, Inc. is not responsible for the conclusions, opinions and recommendations made by others based on the information we supply.

Design Wind Load on Other Structures:

(Based on IBC 2015, 2018 CSBC and ASCE 7-10)

Wind Speed =	V := 125	mph	(User Input)	(CSBC Appendix-N)
Risk Category =	BC := III		(User Input)	(IBC Table 1604.5)
Exposure Category =	Exp := B		(User Input)	
Height Above Grade =	Z := 154	ft	(User Input)	
Structure Type =	Structuretype := Square_Chimney		(User Input)	
Structure Height =	Height := 8	ft	(User Input)	
Horizontal Dimension of Structure =	Width := 2	ft	(User Input)	

Terrain Exposure Constants:

Nominal Height of the Atmospheric Boundary Layer =

$$z_g := \begin{cases} 1200 & \text{if Exp = B} = 1.2 \times 10^3 \\ 900 & \text{if Exp = C} \\ 700 & \text{if Exp = D} \end{cases} \quad \text{(Table 26.9-1)}$$

3-Sec Gust Speed Power Law Exponent =

$$\alpha := \begin{cases} 7 & \text{if Exp = B} = 7 \\ 9.5 & \text{if Exp = C} \\ 11.5 & \text{if Exp = D} \end{cases} \quad \text{(Table 26.9-1)}$$

Integral Length Scale Factor =

$$l := \begin{cases} 320 & \text{if Exp = B} = 320 \\ 500 & \text{if Exp = C} \\ 650 & \text{if Exp = D} \end{cases} \quad \text{(Table 26.9-1)}$$

Integral Length Scale Power Law Exponent =

$$E := \begin{cases} \frac{1}{3} & \text{if Exp = B} = 0.333 \\ \frac{1}{5} & \text{if Exp = C} \\ \frac{1}{8} & \text{if Exp = D} \end{cases} \quad \text{(Table 26.9-1)}$$

Turbulence Intensity Factor =

$$c := \begin{cases} 0.3 & \text{if Exp = B} = 0.3 \\ 0.2 & \text{if Exp = C} \\ 0.15 & \text{if Exp = D} \end{cases} \quad \text{(Table 26.9-1)}$$

Exposure Constant =

$$Z_{min} := \begin{cases} 30 & \text{if Exp = B} = 30 \\ 15 & \text{if Exp = C} \\ 7 & \text{if Exp = D} \end{cases} \quad \text{(Table 26.9-1)}$$

Exposure Coefficient =

$$K_z := \begin{cases} 2.01 \left(\frac{Z}{z_g} \right)^{\left(\frac{2}{\alpha} \right)} & \text{if } 15 \leq Z \leq z_g = 1.12 \\ 2.01 \left(\frac{15}{z_g} \right)^{\left(\frac{2}{\alpha} \right)} & \text{if } Z < 15 \end{cases} \quad \text{(Table 29.3-1)}$$

Topographic Factor =	$K_{zt} := 1$	(Eq. 26.8-2)
Wind Directionality Factor =	$K_d = 0.9$	(Table 26.6-1)
Velocity Pressure =	$q_z := 0.00256 \cdot K_z \cdot K_{zt} \cdot K_d \cdot V^2 = 40.25$	(Eq. 29.3-1)
Peak Factor for Background Response =	$g_Q := 3.4$	(Sec 26.9.4)
Peak Factor for Wind Response =	$g_V := 3.4$	(Sec 26.9.4)
Equivalent Height of Structure =	$z := \begin{cases} Z_{\min} & \text{if } Z_{\min} > 0.6 \cdot \text{Height} \\ 0.6 \cdot \text{Height} & \text{otherwise} \end{cases} = 30$	(Sec 26.9.4)
Intensity of Turbulence =	$I_z := c \cdot \left(\frac{33}{z}\right)^{\left(\frac{1}{6}\right)} = 0.305$	(Eq. 26.9-7)
Integral Length Scale of Turbulence =	$L_Z := l \cdot \left(\frac{z}{33}\right)^E = 309.993$	(Eq. 26.9-9)
Background Response Factor =	$Q := \sqrt{\frac{1}{1 + 0.63 \left(\frac{\text{Width} + \text{Height}}{L_Z}\right)^{0.63}}} = 0.966$	(Eq. 26.9-8)
Gust Response Factor =	$G := 0.925 \cdot \left[\frac{(1 + 1.7 \cdot g_Q \cdot I_z \cdot Q)}{1 + 1.7 \cdot g_V \cdot I_z} \right] = 0.905$	(Eq. 26.9-6)
Force Coefficient =	$C_f = 1.35$	(Fig 29.5-1 - 29.5-3)

Wind Force =

$F := q_z \cdot G \cdot C_f = 49$

psf

Development of Wind & Ice Load on Antennas

Antenna Data:

Antenna Model =	Ericsson AIR32	
Antenna Shape =	Flat	(User Input)
Antenna Height =	$L_{ant} := 56.6$	in (User Input)
Antenna Width =	$W_{ant} := 12.9$	in (User Input)
Antenna Thickness =	$T_{ant} := 8.7$	in (User Input)
Antenna Weight =	$WT_{ant} := 133$	lbs (User Input)
Number of Antennas =	$N_{ant} := 1$	(User Input)

Wind Load (Front)

Surface Area for One Antenna =	$SA_{ant} := \frac{L_{ant} \cdot W_{ant}}{144} = 5.1$	sf
Antenna Projected Surface Area =	$A_{ant} := SA_{ant} \cdot N_{ant} = 5.1$	sf
Total Antenna Wind Force =	$F_{ant} := F \cdot A_{ant} = 249$	lbs

Wind Load (Side)

Surface Area for One Antenna =	$SA_{ant} := \frac{L_{ant} \cdot T_{ant}}{144} = 3.4$	sf
Antenna Projected Surface Area =	$A_{ant} := SA_{ant} \cdot N_{ant} = 3.4$	sf
Total Antenna Wind Force =	$F_{ant} := F \cdot A_{ant} = 168$	lbs

Gravity Load (without ice)

Weight of All Antennas =	$WT_{ant} \cdot N_{ant} = 133$	lbs
---------------------------------	--	------------

Development of Wind & Ice Load on Antennas

Antenna Data:

Antenna Model =	RFSAPXVAALL24-43	
Antenna Shape =	Flat	(User Input)
Antenna Height =	$L_{ant} := 95.9$	in (User Input)
Antenna Width =	$W_{ant} := 24$	in (User Input)
Antenna Thickness =	$T_{ant} := 8.5$	in (User Input)
Antenna Weight =	$WT_{ant} := 150$	lbs (User Input)
Number of Antennas =	$N_{ant} := 1$	(User Input)

Wind Load (Front)

Surface Area for One Antenna =	$SA_{ant} := \frac{L_{ant} \cdot W_{ant}}{144} = 16$	sf
Antenna Projected Surface Area =	$A_{ant} := SA_{ant} \cdot N_{ant} = 16$	sf
Total Antenna Wind Force =	$F_{ant} := F \cdot A_{ant} = 786$	lbs

Wind Load (Side)

Surface Area for One Antenna =	$SA_{ant} := \frac{L_{ant} \cdot T_{ant}}{144} = 5.7$	sf
Antenna Projected Surface Area =	$A_{ant} := SA_{ant} \cdot N_{ant} = 5.7$	sf
Total Antenna Wind Force =	$F_{ant} := F \cdot A_{ant} = 278$	lbs

Gravity Load (without ice)

Weight of All Antennas =	$WT_{ant} \cdot N_{ant} = 150$	lbs
---------------------------------	--	------------

Development of Wind & Ice Load on Antennas

Antenna Model =	Ericsson AR6449	
Antenna Shape =	Flat	(User Input)
Antenna Height =	$L_{ant} := 33.1$	in (User Input)
Antenna Width =	$W_{ant} := 20.5$	in (User Input)
Antenna Thickness =	$T_{ant} := 8.3$	in (User Input)
Antenna Weight =	$WT_{ant} := 103$	lbs (User Input)
Number of Antennas =	$N_{ant} := 1$	(User Input)

Wind Load (Front)

SurfaceArea for One Antenna =	$SA_{ant} := \frac{L_{ant} \cdot W_{ant}}{144} = 4.7$	sf
Antenna Projected Surface Area =	$A_{ant} := SA_{ant} \cdot N_{ant} = 4.7$	sf
Total Antenna Wind Force =	$F_{ant} := F \cdot A_{ant} = 232$	lbs

Wind Load (Side)

SurfaceArea for One Antenna =	$SA_{ant} := \frac{L_{ant} \cdot T_{ant}}{144} = 1.9$	sf
Antenna Projected Surface Area =	$A_{ant} := SA_{ant} \cdot N_{ant} = 1.9$	sf
Total Antenna Wind Force =	$F_{ant} := F \cdot A_{ant} = 94$	lbs

Gravity Load (without ice)

Weight of All Antennas =	$WT_{ant} \cdot N_{ant} = 103$	lbs
---------------------------------	--	------------

Development of Wind & Ice Load on RRHs

RRUS Data:

RRUS Model =	Ericsson 4449	
RRUS Shape =	Flat	(User Input)
RRUS Height =	$L_{RRH} := 14.9$	in (User Input)
RRUS Width =	$W_{RRH} := 13.2$	in (User Input)
RRUS Thickness =	$T_{RRH} := 10.4$	in (User Input)
RRUS Weight =	$W_{T_{RRH}} := 74$	lbs (User Input)
Number of RRUSs =	$N_{RRH} := 1$	(User Input)

Wind Load (Front)

Surface Area for One RRH =	$SA_{RRH} := \frac{L_{RRH} \cdot W_{RRH}}{144} = 1.4$	sf
RRH Projected Surface Area =	$A_{RRH} := SA_{RRH} \cdot N_{RRH} = 1.4$	sf
Total RRH Wind Force =	$F_{RRH} := F \cdot A_{RRH} = 67$	lbs

Wind Load (Side)

Surface Area for One RRH =	$SA_{RRH} := \frac{L_{RRH} \cdot T_{RRH}}{144} = 1.1$	sf
RRH Projected Surface Area =	$A_{RRH} := SA_{RRH} \cdot N_{RRH} = 1.1$	sf
Total RRH Wind Force =	$F_{RRH} := F \cdot A_{RRH} = 53$	lbs

Gravity Load (without ice)

Weight of All RRHs =	$W_{T_{RRH}} \cdot N_{RRH} = 74$	lbs
-----------------------------	--	------------

Development of Wind & Ice Load on RRHs

RRUS Data:

RRUS Model =	Ericsson 4415	
RRUS Shape =	Flat	(User Input)
RRUS Height =	$L_{RRH} := 16.5$	in (User Input)
RRUS Width =	$W_{RRH} := 13.4$	in (User Input)
RRUS Thickness =	$T_{RRH} := 5.9$	in (User Input)
RRUS Weight =	$W_{T_{RRH}} := 46$	lbs (User Input)
Number of RRUSs =	$N_{RRH} := 1$	(User Input)

Wind Load (Front)

Surface Area for One RRH =	$SA_{RRH} := \frac{L_{RRH} \cdot W_{RRH}}{144} = 1.5$	sf
RRH Projected Surface Area =	$A_{RRH} := SA_{RRH} \cdot N_{RRH} = 1.5$	sf
Total RRH Wind Force =	$F_{RRH} := F \cdot A_{RRH} = 75$	lbs

Wind Load (Side)

Surface Area for One RRH =	$SA_{RRH} := \frac{L_{RRH} \cdot T_{RRH}}{144} = 0.7$	sf
RRH Projected Surface Area =	$A_{RRH} := SA_{RRH} \cdot N_{RRH} = 0.7$	sf
Total RRH Wind Force =	$F_{RRH} := F \cdot A_{RRH} = 33$	lbs

Gravity Load (without ice)

Weight of All RRHs =	$W_{T_{RRH}} \cdot N_{RRH} = 46$	lbs
-----------------------------	--	-----

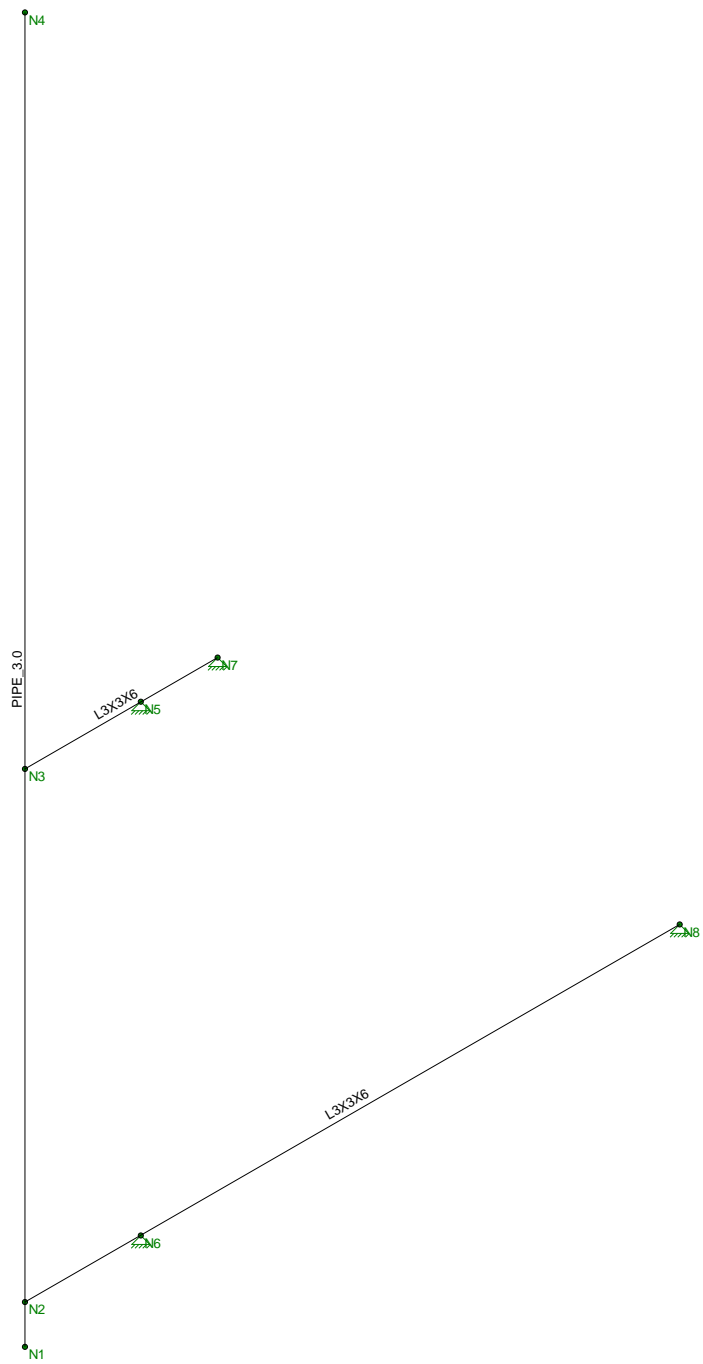

Loads: BLC 1, Self Weight
Envelope Only Solution

Centek Engineering	CT11108A - Antenna Mount Member Framing	
TJL		May 18, 2021 at 1:36 PM
20074.12		Alpha Antenna Mount.r3d

(Global) Model Settings

Display Sections for Member Calcs	5
Max Internal Sections for Member Calcs	97
Include Shear Deformation?	Yes
Increase Nailing Capacity for Wind?	Yes
Include Warping?	Yes
Trans Load Btwn Intersecting Wood Wall?	Yes
Area Load Mesh (in^2)	144
Merge Tolerance (in)	.12
P-Delta Analysis Tolerance	0.50%
Include P-Delta for Walls?	Yes
Automatically Iterate Stiffness for Walls?	Yes
Max Iterations for Wall Stiffness	3
Gravity Acceleration (ft/sec^2)	32.2
Wall Mesh Size (in)	12
Eigensolution Convergence Tol. (1.E-)	4
Vertical Axis	Y
Global Member Orientation Plane	XZ
Static Solver	Sparse Accelerated
Dynamic Solver	Accelerated Solver

Hot Rolled Steel Code	AISC 14th(360-10): ASD
Adjust Stiffness?	Yes(Iterative)
RISAConnection Code	AISC 14th(360-10): ASD
Cold Formed Steel Code	AISI S100-10: ASD
Wood Code	AWC NDS-12: ASD
Wood Temperature	< 100F
Concrete Code	ACI 318-11
Masonry Code	ACI 530-11: ASD
Aluminum Code	AA ADM1-10: ASD - Building
Stainless Steel Code	AISC 14th(360-10): ASD
Adjust Stiffness?	Yes(Iterative)

Number of Shear Regions	4
Region Spacing Increment (in)	4
Biaxial Column Method	Exact Integration
Parme Beta Factor (PCA)	.65
Concrete Stress Block	Rectangular
Use Cracked Sections?	Yes
Use Cracked Sections Slab?	Yes
Bad Framing Warnings?	No
Unused Force Warnings?	Yes
Min 1 Bar Diam. Spacing?	No
Concrete Rebar Set	REBAR_SET_ASTMA615
Min % Steel for Column	1
Max % Steel for Column	8

(Global) Model Settings, Continued

Seismic Code	ASCE 7-10
Seismic Base Elevation (ft)	Not Entered
Add Base Weight?	Yes
Ct X	.02
Ct Z	.02
T X (sec)	Not Entered
T Z (sec)	Not Entered
R X	3
R Z	3
Ct Exp. X	.75
Ct Exp. Z	.75
SD1	1
SDS	1
S1	1
TL (sec)	5
Risk Cat	I or II
Drift Cat	Other
Om Z	1
Om X	1
Cd Z	4
Cd X	4
Rho Z	1
Rho X	1
Footing Overturning Safety Factor	1
Optimize for OTM/Sliding	No
Check Concrete Bearing	No
Footing Concrete Weight (k/ft^3)	150.001
Footing Concrete f'c (ksi)	4
Footing Concrete Ec (ksi)	3644
Lambda	1
Footing Steel fy (ksi)	60
Minimum Steel	0.0018
Maximum Steel	0.0075
Footing Top Bar	#3
Footing Top Bar Cover (in)	2
Footing Bottom Bar	#3
Footing Bottom Bar Cover (in)	3.5
Pedestal Bar	#3
Pedestal Bar Cover (in)	1.5
Pedestal Ties	#3

Hot Rolled Steel Properties

	Label	E [ksi]	G [ksi]	Nu	Therm (\... Density[k/ft^3]	Yield[ksi]	Ry	Fu[ksi]	Rt	
1	A36 Gr.36	29000	11154	.3	.65	.49	36	1.5	58	1.2
2	A572 Gr.50	29000	11154	.3	.65	.49	50	1.1	58	1.2
3	A992	29000	11154	.3	.65	.49	50	1.1	58	1.2
4	A500 Gr.42	29000	11154	.3	.65	.49	42	1.3	58	1.1
5	A500 Gr.46	29000	11154	.3	.65	.49	46	1.2	58	1.1
6	A53 Grade B	29000	11154	.3	.65	.49	35	1.5	58	1.2



Hot Rolled Steel Section Sets

	Label	Shape	Type	Design List	Material	Design Rul...A [in2]	lyy [in4]	lzz [in4]	J [in4]	
1	Antenna Mast	PIPE_3.0	Beam	Pipe	A53 Grade B	Typical	2.07	2.85	2.85	5.69
2	Horz	L3X3X6	Beam	Single Angle	A36 Gr.36	Typical	2.11	1.75	1.75	.101

Hot Rolled Steel Design Parameters

	Label	Shape	Length[ft]	Lbyy[ft]	Lbzz[ft]	Lcomp top[...Lcomp bot[...L-torq...	Kyy	Kzz	Cb	Functi...
1	M4	Antenna Mast	15			Lbyy				Lateral
2	M2	Horz	8.5			Lbyy				Lateral
3	M3	Horz	2.5			Lbyy				Lateral

Member Primary Data

	Label	I Joint	J Joint	K Joint	Rotate(...	Section/Shape	Type	Design List	Material	Design R...
1	M4	N1	N4			Antenna Mast	Beam	Pipe	A53 Grade B	Typical
2	M2	N2	N8			Horz	Beam	Single Angle	A36 Gr.36	Typical
3	M3	N3	N7			Horz	Beam	Single Angle	A36 Gr.36	Typical

Joint Coordinates and Temperatures

	Label	X [ft]	Y [ft]	Z [ft]	Temp [F]	Detach From Diaphragm
1	N1	0	0	0	0	
2	N2	0	.5	0	0	
3	N3	0	6.5	0	0	
4	N4	0	15	0	0	
5	N5	0	6.5	-1.5	0	
6	N6	0	.5	-1.5	0	
7	N7	0	6.5	-2.5	0	
8	N8	0	.5	-8.5	0	

Joint Boundary Conditions

	Joint Label	X [k/in]	Y [k/in]	Z [k/in]	X Rot.[k-ft/rad]	Y Rot.[k-ft/rad]	Z Rot.[k-ft/rad]
1	N5	Reaction	Reaction	Reaction			
2	N7	Reaction	Reaction	Reaction			
3	N6	Reaction	Reaction	Reaction			
4	N8	Reaction	Reaction	Reaction			

Member Point Loads (BLC 2 : Weight of Equipment)

	Member Label	Direction	Magnitude[k,k-ft]	Location[ft,%]
1	M4	Y	-.075	14.5
2	M4	Y	-.075	7.5
3	M4	Y	-.074	9

Member Point Loads (BLC 3 : Wind X-Direction)

	Member Label	Direction	Magnitude[k,k-ft]	Location[ft,%]
1	M4	X	.139	14.5
2	M4	X	.139	7.5



Member Point Loads (BLC 3 : Wind X-Direction) (Continued)

	Member Label	Direction	Magnitude[k,k-ft]	Location[ft,%]
3	M4	X	.056	9

Member Point Loads (BLC 4 : Wind Z-Direction)

	Member Label	Direction	Magnitude[k,k-ft]	Location[ft,%]
1	M4	Z	.393	14.5
2	M4	Z	.393	7.5

Member Distributed Loads

Member Label	Direction	Start Magnitude[k/ft,F,ksf]	End Magnitude[k/f...Start Location[ft,%]	End Location[ft,%]
No Data to Print ...				

Basic Load Cases

	BLC Description	Category	X Gra...Y Gra...Z Gra...	Joint	Point	Distrib...Area(... Surfa...
1	Self Weight	DL	-1			
2	Weight of Equipment	DL			3	
3	Wind X-Direction	WLX			3	
4	Wind Z-Direction	WLZ			2	

Load Combinations

	Description	Solve	P...S...B...Fa...	BLC	Fact...BLC Fa...	BLC Fa...	BLC Fa...	B... Fa...	B... Fa...	B... Fa...	B... Fa...	B... Fa...	B... Fa...	
1	IBC 16-8	Yes	Y	DL	1									
2	IBC 16-9	Yes	Y	DL	1	LL	1	LLS	1					
3	IBC 16-10 (a)	Yes	Y	DL	1	RLL	1							
4	IBC 16-10 (b)	Yes	Y	DL	1	SL	1	SLN	1					
5	IBC 16-10 (c)	Yes	Y	DL	1	RL	1							
6	IBC 16-11 (a)	Yes	Y	DL	1	LL	.75	LLS	.75	RLL	.75			
7	IBC 16-11 (b)	Yes	Y	DL	1	LL	.75	LLS	.75	SL	.75	SLN	.75	
8	IBC 16-11 (c)	Yes	Y	DL	1	LL	.75	LLS	.75	RL	.75			
9	IBC 16-12 (a) (a)	Yes	Y	DL	1	WLX	.6							
10	IBC 16-12 (a) (b)	Yes	Y	DL	1	WLZ	.6							
11	IBC 16-12 (a) (c)	Yes	Y	DL	1	WLX	-.6							
12	IBC 16-12 (a) (d)	Yes	Y	DL	1	WLZ	-.6							
13	IBC 16-13 (a) (a)	Yes	Y	DL	1	WLX	.45	LL	.75	LLS	.75	RLL	.75	
14	IBC 16-13 (a) (b)	Yes	Y	DL	1	WLZ	.45	LL	.75	LLS	.75	RLL	.75	
15	IBC 16-13 (a) (c)	Yes	Y	DL	1	WLX	-.45	LL	.75	LLS	.75	RLL	.75	
16	IBC 16-13 (a) (d)	Yes	Y	DL	1	WLZ	-.45	LL	.75	LLS	.75	RLL	.75	
17	IBC 16-13 (b) (a)	Yes	Y	DL	1	WLX	.45	LL	.75	LLS	.75	SL	.75	S... .75
18	IBC 16-13 (b) (b)	Yes	Y	DL	1	WLZ	.45	LL	.75	LLS	.75	SL	.75	S... .75
19	IBC 16-13 (b) (c)	Yes	Y	DL	1	WLX	-.45	LL	.75	LLS	.75	SL	.75	S... .75
20	IBC 16-13 (b) (d)	Yes	Y	DL	1	WLZ	-.45	LL	.75	LLS	.75	SL	.75	S... .75
21	IBC 16-13 (c) (a)	Yes	Y	DL	1	WLX	.45	LL	.75	LLS	.75	RL	.75	
22	IBC 16-13 (c) (b)	Yes	Y	DL	1	WLZ	.45	LL	.75	LLS	.75	RL	.75	
23	IBC 16-13 (c) (c)	Yes	Y	DL	1	WLX	-.45	LL	.75	LLS	.75	RL	.75	
24	IBC 16-13 (c) (d)	Yes	Y	DL	1	WLZ	-.45	LL	.75	LLS	.75	RL	.75	
25	IBC 16-15 (a)	Yes	Y	DL	.6	WLX	.6							
26	IBC 16-15 (b)	Yes	Y	DL	.6	WLZ	.6							
27	IBC 16-15 (c)	Yes	Y	DL	.6	WLX	-.6							



Load Combinations (Continued)

	Description	Solve	P...	S...	B...	Fa...	BLC	Fact...	BLC	Fa...	BLC	Fa...	B...	Fa...	B...	Fa...	B...	Fa...	B...	Fa...
28	IBC 16-15 (d)	Yes	Y		DL	.6	WLZ	-.6												

Envelope Joint Reactions

Joint		X [k]	LC	Y [k]	LC	Z [k]	LC	MX [k-ft]	LC	MY [k-ft]	LC	MZ [k-ft]	LC
1	N5	max	.729	11	.719	12	.759	28	0	28	0	28	28
2		min	-.731	9	-.132	26	-.834	10	0	1	0	1	0
3	N7	max	.389	9	.063	27	0	28	0	28	0	28	28
4		min	-.387	11	-.307	9	0	1	0	1	0	1	0
5	N6	max	.155	9	.696	10	.362	10	0	28	0	28	28
6		min	-.154	11	-.403	28	-.287	28	0	1	0	1	0
7	N8	max	.012	11	.029	12	0	28	0	28	0	28	28
8		min	-.013	9	-.007	26	0	1	0	1	0	1	0
9	Totals:	max	.2	27	.409	24	.472	28					
10		min	-.2	9	.245	25	-.472	10					

Envelope Joint Displacements

Joint		X [in]	LC	Y [in]	LC	Z [in]	LC	X Rotation [rad]	LC	Y Rotatio...	LC	Z Rotation [rad]	LC	
1	N1	max	.028	28	.022	28	0	25	4.73e-04	11	8.935e-04	28	1.359e-03	9
2		min	-.037	10	-.038	10	-.003	11	-4.637e-05	25	-1.189e-03	10	-1.369e-03	11
3	N2	max	.026	28	.022	28	0	28	4.73e-04	11	8.935e-04	28	1.359e-03	9
4		min	-.036	10	-.038	10	0	10	-4.637e-05	25	-1.189e-03	10	-1.369e-03	11
5	N3	max	.019	25	.023	28	0	10	4.458e-03	10	1.848e-03	28	4.192e-03	11
6		min	-.027	11	-.039	10	0	28	-3.894e-03	28	-2.151e-03	10	-4.202e-03	9
7	N4	max	.893	9	.023	28	1.652	10	2.144e-02	10	1.848e-03	28	1.048e-02	11
8		min	-.903	11	-.039	10	-1.586	28	-2.075e-02	28	-2.151e-03	10	-1.049e-02	9
9	N5	max	0	28	0	28	0	28	4.97e-04	10	4.764e-04	25	4.192e-03	11
10		min	0	1	0	1	0	1	-2.333e-05	28	-7.432e-04	11	-4.202e-03	9
11	N6	max	0	28	0	28	0	28	2.397e-03	10	1.533e-03	28	1.359e-03	9
12		min	0	1	0	1	0	1	-1.622e-03	28	-2.024e-03	10	-1.369e-03	11
13	N7	max	0	28	0	28	0	28	8.174e-06	25	3.156e-04	11	4.192e-03	11
14		min	0	1	0	1	0	1	-2.088e-04	11	-1.829e-04	25	-4.202e-03	9
15	N8	max	0	28	0	28	0	28	1.e-03	12	8.467e-04	26	1.359e-03	9
16		min	0	1	0	1	0	1	-9.255e-04	26	-8.78e-04	12	-1.369e-03	11

Envelope AISC 14th(360-10): ASD Steel Code Checks

Member	Shape	Code Check	Lo...	LC	She...Lo...	Dir	...Pnc/...	Pnt/o...	Mny...	Mnz...	Cb	Eqn
1	M4 PIPE 3.0	.566	6...	10	.049,625		...	13.221	43.383	3.825	3.825	1.3...H1-...
2	M2 L3X3X6	.526	0	10	.0441...	y	...	10.29	45.485	1.535	3.541	4.2...H2-1
3	M3 L3X3X6	.684	0	12	.0481...	y	...	39.529	45.485	1.535	3.541	2.3...H2-1



Code Check (Env)	
Black	No Calc
Red	> 1.0
Magenta	.90-1.0
Green	.75-.90
Cyan	.50-.75
Blue	0-.50

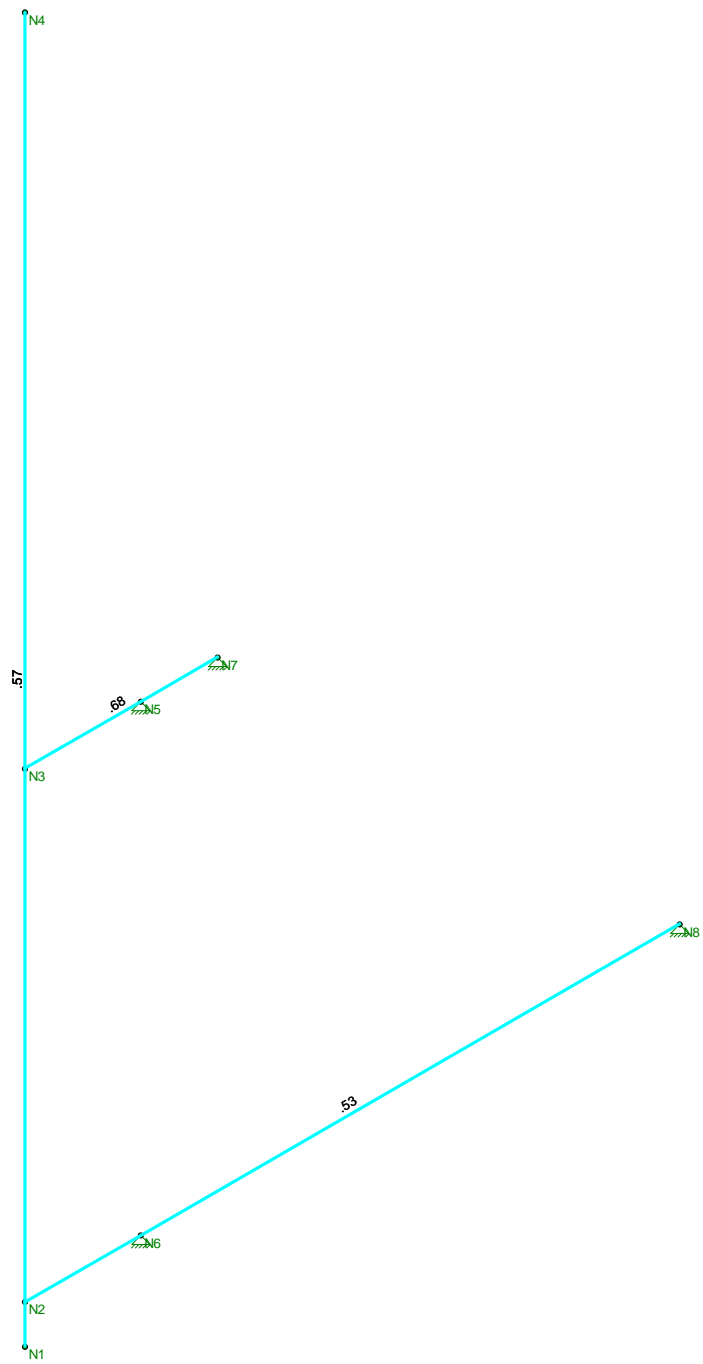

Member Code Checks Displayed (Enveloped)
 Loads: BLC 1, Self Weight
 Envelope Only Solution

Centek Engineering	CT11108A - Antenna Mount Unity Check	
TJL		May 18, 2021 at 1:36 PM
20074.12		Alpha Antenna Mount.r3d

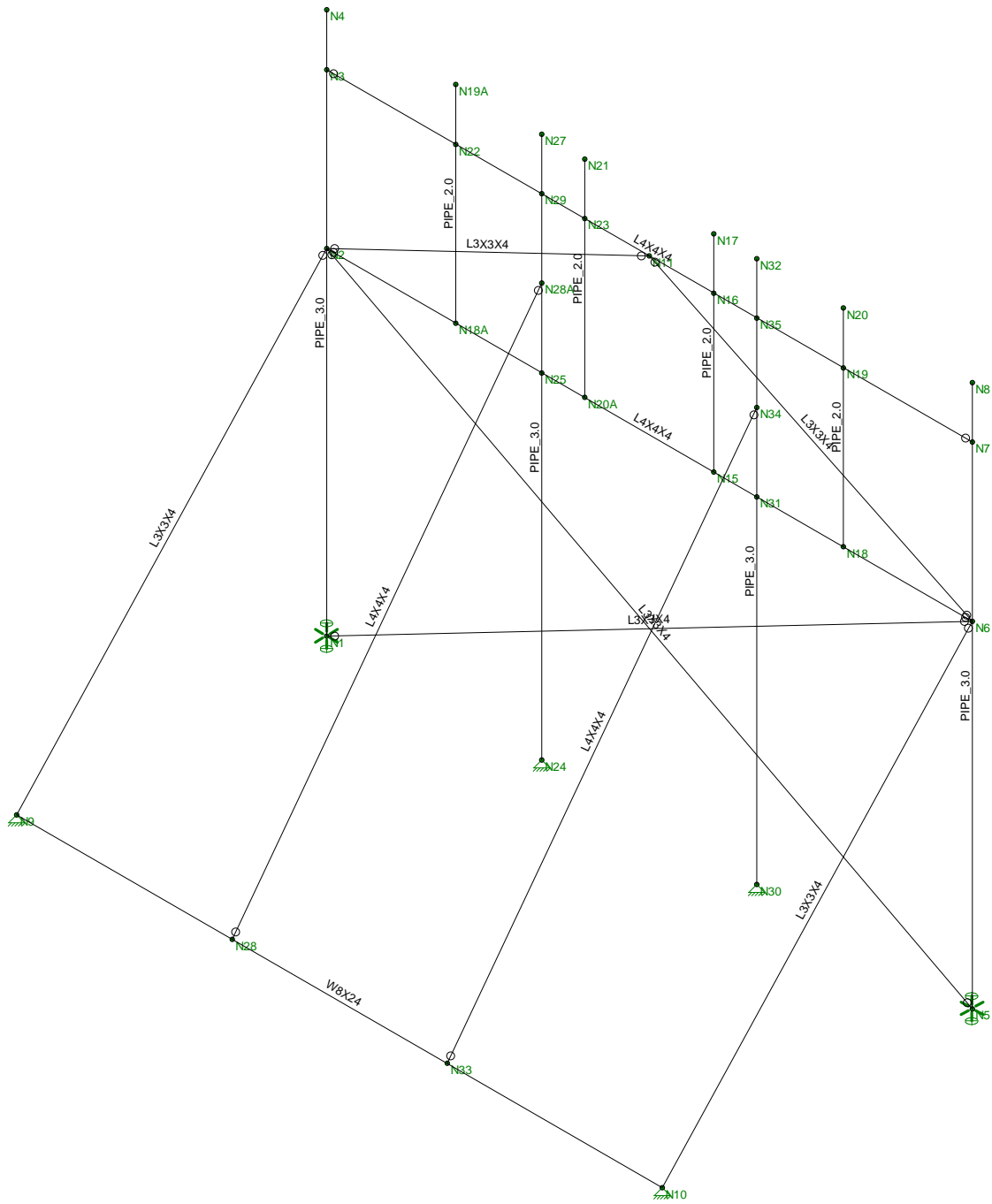

Loads: BLC 1, Self Weight
Envelope Only Solution

Centek Engineering
TJL
20074.12

CT11108A - Antenna Mount Member Framing
--

May 18, 2021 at 1:42 PM
Beta Antenna Mount - Reinforced.r3d

(Global) Model Settings

Display Sections for Member Calcs	5
Max Internal Sections for Member Calcs	97
Include Shear Deformation?	Yes
Increase Nailing Capacity for Wind?	Yes
Include Warping?	Yes
Trans Load Btwn Intersecting Wood Wall?	Yes
Area Load Mesh (in^2)	144
Merge Tolerance (in)	.12
P-Delta Analysis Tolerance	0.50%
Include P-Delta for Walls?	Yes
Automatically Iterate Stiffness for Walls?	Yes
Max Iterations for Wall Stiffness	3
Gravity Acceleration (ft/sec^2)	32.2
Wall Mesh Size (in)	12
Eigensolution Convergence Tol. (1.E-)	4
Vertical Axis	Y
Global Member Orientation Plane	XZ
Static Solver	Sparse Accelerated
Dynamic Solver	Accelerated Solver

Hot Rolled Steel Code	AISC 14th(360-10): ASD
Adjust Stiffness?	Yes(Iterative)
RISACONNECTION CODE	AISC 14th(360-10): ASD
Cold Formed Steel Code	AISI S100-10: ASD
Wood Code	AWC NDS-12: ASD
Wood Temperature	< 100F
Concrete Code	ACI 318-11
Masonry Code	ACI 530-11: ASD
Aluminum Code	AA ADM1-10: ASD - Building
Stainless Steel Code	AISC 14th(360-10): ASD
Adjust Stiffness?	Yes(Iterative)

Number of Shear Regions	4
Region Spacing Increment (in)	4
Biaxial Column Method	Exact Integration
Parame Beta Factor (PCA)	.65
Concrete Stress Block	Rectangular
Use Cracked Sections?	Yes
Use Cracked Sections Slab?	Yes
Bad Framing Warnings?	No
Unused Force Warnings?	Yes
Min 1 Bar Diam. Spacing?	No
Concrete Rebar Set	REBAR_SET_ASTMA615
Min % Steel for Column	1
Max % Steel for Column	8

(Global) Model Settings, Continued

Seismic Code	ASCE 7-10
Seismic Base Elevation (ft)	Not Entered
Add Base Weight?	Yes
Ct X	.02
Ct Z	.02
T X (sec)	Not Entered
T Z (sec)	Not Entered
R X	3
R Z	3
Ct Exp. X	.75
Ct Exp. Z	.75
SD1	1
SDS	1
S1	1
TL (sec)	5
Risk Cat	I or II
Drift Cat	Other
Om Z	1
Om X	1
Cd Z	4
Cd X	4
Rho Z	1
Rho X	1
Footing Overturning Safety Factor	1
Optimize for OTM/Sliding	No
Check Concrete Bearing	No
Footing Concrete Weight (k/ft^3)	150.001
Footing Concrete f'c (ksi)	4
Footing Concrete Ec (ksi)	3644
Lambda	1
Footing Steel fy (ksi)	60
Minimum Steel	0.0018
Maximum Steel	0.0075
Footing Top Bar	#3
Footing Top Bar Cover (in)	2
Footing Bottom Bar	#3
Footing Bottom Bar Cover (in)	3.5
Pedestal Bar	#3
Pedestal Bar Cover (in)	1.5
Pedestal Ties	#3

Hot Rolled Steel Properties

	Label	E [ksi]	G [ksi]	Nu	Therm (\... Density[k/ft^3]	Yield[ksi]	Ry	Fu[ksi]	Rt	
1	A36 Gr.36	29000	11154	.3	.65	.49	36	1.5	58	1.2
2	A572 Gr.50	29000	11154	.3	.65	.49	50	1.1	58	1.2
3	A992	29000	11154	.3	.65	.49	50	1.1	58	1.2
4	A500 Gr.42	29000	11154	.3	.65	.49	42	1.3	58	1.1
5	A500 Gr.46	29000	11154	.3	.65	.49	46	1.2	58	1.1
6	A53 Grade B	29000	11154	.3	.65	.49	35	1.5	58	1.2



Hot Rolled Steel Section Sets

	Label	Shape	Type	Design List	Material	Design Rul...A [in2]	lyy [in4]	lzz [in4]	J [in4]	
1	Pipe Mast	PIPE_2.0	Beam	Pipe	A53 Grade B	Typical	1.02	.627	.627	1.25
2	Brace	L3X3X4	Beam	Tube	A36 Gr.36	Typical	1.44	1.23	1.23	.031
3	Post	PIPE_3.0	Beam	Tube	A53 Grade B	Typical	2.07	2.85	2.85	5.69
4	Horz	L4X4X4	Beam	Single Angle	A36 Gr.36	Typical	1.93	3	3	.044
5	Brace 2	L4X4X4	Beam	Single Angle	A36 Gr.36	Typical	1.93	3	3	.044
6	W8	W8X24	Beam	Single Angle	A992	Typical	7.08	18.3	82.7	.346

Hot Rolled Steel Design Parameters

	Label	Shape	Length[ft]	Lbyy[ft]	Lbzz[ft]	Lcomp top[...Lcomp bot[...L-torq...	Kyy	Kzz	Cb	Funci...
1	M1	Horz	25	12	12	12	12	12		Lateral
2	M2	Horz	25			Lbyy				Lateral
3	M3	Post	21			Lbyy				Lateral
4	M4	Post	21			Lbyy				Lateral
5	M5	Brace	28.178	14	14	14	14	14		Lateral
6	M6	Brace	28.178	14	14	14	14	14		Lateral
7	M7	Brace	13.865			Lbyy				Lateral
8	M8	Brace	13.865			Lbyy				Lateral
9	M9	Brace	17.692			Lbyy				Lateral
10	M10	Brace	17.692			Lbyy				Lateral
11	M12	Pipe Mast	8			Lbyy				Lateral
12	M13	Pipe Mast	8			Lbyy				Lateral
13	M13A	Pipe Mast	8			Lbyy				Lateral
14	M14	Pipe Mast	8			Lbyy				Lateral
15	M15	Post	21			Lbyy				Lateral
16	M16	Brace 2	20			Lbyy				Lateral
17	M17	W8	25			Lbyy				Lateral
18	M18	Post	21			Lbyy				Lateral
19	M19	Brace 2	20			Lbyy				Lateral

Member Primary Data

	Label	I Joint	J Joint	K Joint	Rotate(...	Section/Shape	Type	Design List	Material	Design R...
1	M1	N3	N7		90	Horz	Beam	Single Angle	A36 Gr.36	Typical
2	M2	N2	N6		90	Horz	Beam	Single Angle	A36 Gr.36	Typical
3	M3	N4	N1			Post	Beam	Tube	A53 Grade B	Typical
4	M4	N8	N5			Post	Beam	Tube	A53 Grade B	Typical
5	M5	N1	N6			Brace	Beam	Tube	A36 Gr.36	Typical
6	M6	N5	N2			Brace	Beam	Tube	A36 Gr.36	Typical
7	M7	N2	N11			Brace	Beam	Tube	A36 Gr.36	Typical
8	M8	N11	N6			Brace	Beam	Tube	A36 Gr.36	Typical
9	M9	N2	N9			Brace	Beam	Tube	A36 Gr.36	Typical
10	M10	N6	N10			Brace	Beam	Tube	A36 Gr.36	Typical
11	M12	N17	N15			Pipe Mast	Beam	Pipe	A53 Grade B	Typical
12	M13	N20	N18			Pipe Mast	Beam	Pipe	A53 Grade B	Typical
13	M13A	N19A	N18A			Pipe Mast	Beam	Pipe	A53 Grade B	Typical
14	M14	N21	N20A			Pipe Mast	Beam	Pipe	A53 Grade B	Typical
15	M15	N27	N24			Post	Beam	Tube	A53 Grade B	Typical
16	M16	N28A	N28			Brace 2	Beam	Single Angle	A36 Gr.36	Typical
17	M17	N9	N10			W8	Beam	Single Angle	A992	Typical



Member Primary Data (Continued)

	Label	I Joint	J Joint	K Joint	Rotate(...)	Section/Shape	Type	Design List	Material	Design R...
18	M18	N32	N30			Post	Beam	Tube	A53 Grade B	Typical
19	M19	N34	N33			Brace 2	Beam	Single Angle	A36 Gr.36	Typical

Joint Coordinates and Temperatures

	Label	X [ft]	Y [ft]	Z [ft]	Temp [F]	Detach From Diaphragm
1	N1	0	0	0	0	
2	N2	0	13	0	0	
3	N3	0	19	0	0	
4	N4	0	21	0	0	
5	N5	25	0	0	0	
6	N6	25	13	0	0	
7	N7	25	19	0	0	
8	N8	25	21	0	0	
9	N9	0	0	12	0	
10	N10	25	0	12	0	
11	N11	12.5	19	0	0	
12	N15	15	13	0	0	
13	N16	15	19	0	0	
14	N17	15	21	0	0	
15	N18	20	13	0	0	
16	N19	20	19	0	0	
17	N20	20	21	0	0	
18	N18A	5	13	0	0	
19	N19A	5	21	0	0	
20	N20A	10	13	0	0	
21	N21	10	21	0	0	
22	N22	5	19	0	0	
23	N23	10	19	0	0	
24	N24	8.333	0	0	0	
25	N25	8.333	13	0	0	
26	N27	8.333	21	0	0	
27	N28	8.333	0	12	0	
28	N28A	8.333	16	0	0	
29	N29	8.333	19	0	0	
30	N30	16.666	0	0	0	
31	N31	16.666	13	0	0	
32	N32	16.666	21	0	0	
33	N33	16.666	0	12	0	
34	N34	16.666	16	0	0	
35	N35	16.666	19	0	0	

Joint Boundary Conditions

	Joint Label	X [k/in]	Y [k/in]	Z [k/in]	X Rot.[k-ft/rad]	Y Rot.[k-ft/rad]	Z Rot.[k-ft/rad]
1	N1	Reaction	Reaction	Reaction		Reaction	
2	N9	Reaction	Reaction	Reaction			
3	N10	Reaction	Reaction	Reaction			
4	N5	Reaction	Reaction	Reaction		Reaction	
5	N24	Reaction	Reaction	Reaction			
6	N28						

Joint Boundary Conditions (Continued)

	Joint Label	X [k/in]	Y [k/in]	Z [k/in]	X Rot.[k-ft/rad]	Y Rot.[k-ft/rad]	Z Rot.[k-ft/rad]
7	N30	Reaction	Reaction	Reaction			
8	N33						

Member Point Loads (BLC 2 : Weight of Equipment)

	Member Label	Direction	Magnitude[k,k-ft]	Location[ft,%]
1	M4	Y	-.067	0
2	M4	Y	-.067	5
3	M12	Y	-.052	1
4	M12	Y	-.052	3
5	M13	Y	-.077	1
6	M13	Y	-.077	7
7	M13	Y	-.074	%50
8	M13A	Y	-.077	1
9	M13A	Y	-.077	7
10	M13A	Y	-.074	%50
11	M14	Y	-.067	1
12	M14	Y	-.067	5
13	M3	Y	-.052	1
14	M3	Y	-.052	3

Member Point Loads (BLC 3 : Wind X-Direction)

	Member Label	Direction	Magnitude[k,k-ft]	Location[ft,%]
1	M4	X	.084	1
2	M4	X	.084	5
3	M12	X	.047	1
4	M12	X	.047	3
5	M13	X	.139	1
6	M13	X	.139	7
7	M13	X	.056	%50
8	M13A	X	.139	1
9	M13A	X	.139	7
10	M13A	X	.056	%50
11	M14	X	.084	1
12	M14	X	.084	5
13	M3	X	.047	1
14	M3	X	.047	3

Member Point Loads (BLC 4 : Wind Z-Direction)

	Member Label	Direction	Magnitude[k,k-ft]	Location[ft,%]
1	M4	Z	.125	1
2	M4	Z	.125	5
3	M12	Z	.116	1
4	M12	Z	.116	3
5	M13	Z	.393	1
6	M13	Z	.393	7
7	M13A	Z	.393	1
8	M13A	Z	.393	7
9	M14	Z	.125	1
10	M14	Z	.125	5



Member Point Loads (BLC 4 : Wind Z-Direction) (Continued)

	Member Label	Direction	Magnitude[k,k-ft]	Location[ft,%]
11	M3	Z	.116	1
12	M3	Z	.116	3

Member Distributed Loads

Member Label	Direction	Start Magnitude[k/ft,F,ksf]	End Magnitude[k/f...]	Start Location[ft,%]	End Location[ft,%]
No Data to Print ...					

Basic Load Cases

	BLC Description	Category	X Gra...	Y Gra...	Z Gra...	Joint	Point	Distrib..	Area(... Surfa...
1	Self Weight	DL		-1					
2	Weight of Equipment	DL					14		
3	Wind X-Direction	WLX					14		
4	Wind Z-Direction	WLZ					12		

Load Combinations

Description	Solve	P...	S...	B...	Fa...	BLC	Fact...	BLC	Fa...	BLC	Fa...	BLC	Fa...	B...	Fa...	B...	Fa...	B...	Fa...	B...	Fa...	
1	IBC 16-8	Yes	Y		DL 1																	
2	IBC 16-9	Yes	Y		DL 1	LL	1	LLS	1													
3	IBC 16-10 (a)	Yes	Y		DL 1	RLL	1															
4	IBC 16-10 (b)	Yes	Y		DL 1	SL	1	SLN	1													
5	IBC 16-10 (c)	Yes	Y		DL 1	RL	1															
6	IBC 16-11 (a)	Yes	Y		DL 1	LL	.75	LLS	.75	RLL	.75											
7	IBC 16-11 (b)	Yes	Y		DL 1	LL	.75	LLS	.75	SL	.75	SLN	.75									
8	IBC 16-11 (c)	Yes	Y		DL 1	LL	.75	LLS	.75	RL	.75											
9	IBC 16-12 (a) (a)	Yes	Y		DL 1	WLX	.6															
10	IBC 16-12 (a) (b)	Yes	Y		DL 1	WLZ	.6															
11	IBC 16-12 (a) (c)	Yes	Y		DL 1	WLX	-.6															
12	IBC 16-12 (a) (d)	Yes	Y		DL 1	WLZ	-.6															
13	IBC 16-13 (a) (a)	Yes	Y		DL 1	WLX	.45	LL	.75	LLS	.75	RLL	.75									
14	IBC 16-13 (a) (b)	Yes	Y		DL 1	WLZ	.45	LL	.75	LLS	.75	RLL	.75									
15	IBC 16-13 (a) (c)	Yes	Y		DL 1	WLX	-.45	LL	.75	LLS	.75	RLL	.75									
16	IBC 16-13 (a) (d)	Yes	Y		DL 1	WLZ	-.45	LL	.75	LLS	.75	RLL	.75									
17	IBC 16-13 (b) (a)	Yes	Y		DL 1	WLX	.45	LL	.75	LLS	.75	SL	.75	S...	.75							
18	IBC 16-13 (b) (b)	Yes	Y		DL 1	WLZ	.45	LL	.75	LLS	.75	SL	.75	S...	.75							
19	IBC 16-13 (b) (c)	Yes	Y		DL 1	WLX	-.45	LL	.75	LLS	.75	SL	.75	S...	.75							
20	IBC 16-13 (b) (d)	Yes	Y		DL 1	WLZ	-.45	LL	.75	LLS	.75	SL	.75	S...	.75							
21	IBC 16-13 (c) (a)	Yes	Y		DL 1	WLX	.45	LL	.75	LLS	.75	RL	.75									
22	IBC 16-13 (c) (b)	Yes	Y		DL 1	WLZ	.45	LL	.75	LLS	.75	RL	.75									
23	IBC 16-13 (c) (c)	Yes	Y		DL 1	WLX	-.45	LL	.75	LLS	.75	RL	.75									
24	IBC 16-13 (c) (d)	Yes	Y		DL 1	WLZ	-.45	LL	.75	LLS	.75	RL	.75									
25	IBC 16-15 (a)	Yes	Y		DL .6	WLX	.6															
26	IBC 16-15 (b)	Yes	Y		DL .6	WLZ	.6															
27	IBC 16-15 (c)	Yes	Y		DL .6	WLX	-.6															
28	IBC 16-15 (d)	Yes	Y		DL .6	WLZ	-.6															

Envelope Joint Reactions

	Joint		X [k]	LC	Y [k]	LC	Z [k]	LC	MX [k-ft]	LC	MY [k-ft]	LC	MZ [k-ft]	LC
1	N1	max	.395	11	1.189	12	.119	10	0	28	0	28	0	28
2		min	-.339	25	-.258	26	-.114	28	0	1	-.001	10	0	1
3	N9	max	.009	26	1.531	10	.94	12	0	28	0	28	0	28
4		min	-.015	12	-.882	28	-.928	10	0	1	0	1	0	1
5	N10	max	.008	28	1.542	10	.937	12	0	28	0	28	0	28
6		min	-.017	10	-.878	28	-.942	10	0	1	0	1	0	1
7	N5	max	.339	27	1.226	12	.116	10	0	28	.001	10	0	28
8		min	-.381	9	-.255	26	-.111	12	0	1	-.001	28	0	1
9	N24	max	.001	28	1.251	12	.057	10	0	28	0	28	0	28
10		min	-.004	10	-.089	26	-.065	12	0	1	0	1	0	1
11	N30	max	.004	10	1.191	12	.057	10	0	28	0	28	0	28
12		min	-.001	28	-.08	26	-.066	12	0	1	0	1	0	1
13	Totals:	max	.715	27	3.414	24	1.522	28						
14		min	-.715	9	2.048	25	-1.522	10						

Envelope Joint Displacements

	Joint		X [in]	LC	Y [in]	LC	Z [in]	LC	X Rotation [rad]	LC	Y Rotatio...	LC	Z Rotation [rad]	LC
1	N1	max	0	28	0	28	0	28	6.884e-03	28	0	28	3.771e-05	11
2		min	0	1	0	1	0	1	-7.235e-03	10	0	1	-2.915e-05	25
3	N2	max	.005	25	.001	26	.008	26	1.466e-02	10	1.511e-05	10	3.173e-05	27
4		min	-.006	11	-.003	12	-.01	12	-1.4e-02	28	-7.908e-06	28	-3.626e-05	9
5	N3	max	.008	25	0	26	1.55	10	2.484e-02	10	1.511e-05	10	6.116e-05	27
6		min	-.008	11	-.004	12	-1.481	28	-2.37e-02	28	-7.908e-06	28	-7.059e-05	9
7	N4	max	.01	9	0	26	2.148	10	2.492e-02	10	1.511e-05	10	9.188e-05	27
8		min	-.01	27	-.004	12	-2.052	28	-2.378e-02	28	-7.908e-06	28	-1.013e-04	9
9	N5	max	0	28	0	28	0	28	6.702e-03	28	0	28	1.188e-05	25
10		min	0	1	0	1	0	1	-7.036e-03	10	0	1	-1.915e-05	11
11	N6	max	.006	9	0	26	.008	26	1.426e-02	10	8.412e-06	28	1.312e-04	11
12		min	-.005	27	-.003	12	-.01	12	-1.365e-02	12	-1.591e-05	10	-1.275e-04	25
13	N7	max	.008	9	0	26	1.493	10	2.387e-02	10	8.412e-06	28	3.541e-05	11
14		min	-.008	27	-.004	12	-1.43	12	-2.281e-02	12	-1.591e-05	10	-2.772e-05	25
15	N8	max	.01	25	0	26	2.068	10	2.396e-02	10	8.412e-06	28	9.033e-05	11
16		min	-.01	11	-.004	12	-1.98	12	-2.29e-02	12	-1.591e-05	10	-8.262e-05	25
17	N9	max	0	28	0	28	0	28	2.316e-03	28	1.045e-02	12	2.133e-03	28
18		min	0	1	0	1	0	1	-9.209e-03	10	-9.664e-03	26	-4.41e-03	10
19	N10	max	0	28	0	28	0	28	2.79e-03	26	9.539e-03	26	4.366e-03	10
20		min	0	1	0	1	0	1	-8.499e-03	12	-1.055e-02	12	-2.139e-03	28
21	N11	max	.007	9	0	26	2.077	10	1.697e-02	10	6.24e-05	9	4.059e-05	9
22		min	-.007	11	-.006	12	-1.847	28	-1.631e-02	12	5.93e-06	27	-1.673e-05	27
23	N15	max	.005	9	.002	26	.834	10	1.663e-02	10	2.215e-03	10	1.304e-04	12
24		min	-.005	27	-.006	12	-.667	28	-1.595e-02	12	-1.532e-03	28	4.114e-05	26
25	N16	max	.007	9	.002	26	2.051	10	1.748e-02	10	1.696e-03	10	9.41e-05	10
26		min	-.007	27	-.006	12	-1.832	28	-1.681e-02	12	-1.065e-03	28	2.116e-05	28
27	N17	max	.009	25	.002	26	2.478	10	1.784e-02	10	1.696e-03	10	2.213e-04	11
28		min	-.012	11	-.006	12	-2.241	28	-1.717e-02	12	-1.065e-03	28	-1.067e-04	25
29	N18	max	.005	9	.005	28	.599	10	1.936e-02	10	6.67e-03	10	1.183e-04	28
30		min	-.005	27	-.054	10	-.47	28	-1.861e-02	12	-5.576e-03	28	-7.956e-04	10
31	N19	max	.008	9	.005	28	1.923	10	2.099e-02	10	4.064e-03	10	8.446e-05	28
32		min	-.008	27	-.055	10	-1.737	28	-2.024e-02	12	-3.088e-03	28	-7.371e-04	10

Envelope Joint Displacements (Continued)

	Joint		X [in]	LC	Y [in]	LC	Z [in]	LC	X Rotation [rad]	LC	Y Rotatio...	LC	Z Rotation [rad]	LC
33	N20	max	.028	9	.005	28	2.451	10	2.219e-02	10	4.064e-03	10	2.722e-04	27
34		min	-.013	27	-.055	10	-2.245	28	-2.144e-02	12	-3.088e-03	28	-9.256e-04	9
35	N18A	max	.005	25	.005	28	.607	10	1.955e-02	10	5.598e-03	28	8.013e-04	10
36		min	-.005	11	-.054	10	-.474	28	-1.877e-02	12	-6.727e-03	10	-1.268e-04	28
37	N19A	max	.013	25	.005	28	2.477	10	2.239e-02	10	2.621e-03	28	9.214e-04	11
38		min	-.028	11	-.054	10	-2.266	28	-2.161e-02	12	-3.596e-03	10	-2.726e-04	25
39	N20A	max	.005	25	.002	26	.84	10	1.746e-02	10	1.466e-03	28	-1.088e-05	27
40		min	-.005	11	-.007	12	-.67	28	-1.678e-02	12	-2.081e-03	10	-1.761e-04	9
41	N21	max	.015	9	.002	26	2.47	10	1.738e-02	10	9.943e-04	28	2.245e-04	27
42		min	-.012	27	-.007	12	-2.229	28	-1.672e-02	12	-1.554e-03	10	-3.514e-04	9
43	N22	max	.008	25	.005	28	1.944	10	2.12e-02	10	2.621e-03	28	7.288e-04	10
44		min	-.008	11	-.054	10	-1.753	28	-2.042e-02	12	-3.596e-03	10	-8.096e-05	28
45	N23	max	.007	25	.002	26	2.054	10	1.699e-02	10	9.943e-04	28	-2.297e-05	28
46		min	-.007	11	-.006	12	-1.832	28	-1.633e-02	12	-1.554e-03	10	-1.044e-04	10
47	N24	max	0	28	0	28	0	28	1.638e-03	10	2.469e-03	28	7.852e-05	28
48		min	0	1	0	1	0	1	-5.646e-04	28	-3.172e-03	10	-2.297e-04	10
49	N25	max	.005	25	0	26	.786	10	1.185e-02	10	2.469e-03	28	4.605e-04	10
50		min	-.005	11	-.004	12	-.63	28	-1.101e-02	28	-3.172e-03	10	-1.534e-04	28
51	N27	max	.005	25	0	26	2.517	10	2.08e-02	10	1.187e-03	28	4.023e-04	10
52		min	-.013	11	-.005	12	-2.291	28	-2.026e-02	12	-1.812e-03	10	-6.54e-05	28
53	N28	max	0	28	.184	28	.813	26	-8.104e-04	28	5.351e-03	12	1.103e-03	28
54		min	0	1	-.371	10	-.885	12	-5.663e-03	10	-4.878e-03	26	-2.189e-03	10
55	N28A	max	.006	9	0	26	1.307	10	1.748e-02	10	1.829e-03	28	4.752e-05	28
56		min	-.006	27	-.005	12	-1.123	28	-1.681e-02	12	-2.493e-03	10	-2.055e-04	10
57	N29	max	.007	25	0	26	2.018	10	2.08e-02	10	1.187e-03	28	4.023e-04	10
58		min	-.007	11	-.005	12	-1.808	28	-2.026e-02	12	-1.812e-03	10	-6.54e-05	28
59	N30	max	0	28	0	28	0	28	1.547e-03	10	3.231e-03	10	2.369e-04	10
60		min	0	1	0	1	0	1	-4.966e-04	28	-2.5e-03	28	-7.337e-05	28
61	N31	max	.005	9	0	26	.778	10	1.188e-02	10	3.231e-03	10	1.435e-04	28
62		min	-.005	27	-.004	12	-.626	28	-1.107e-02	28	-2.5e-03	28	-4.734e-04	10
63	N32	max	.013	9	0	26	2.51	10	2.079e-02	10	2.05e-03	10	6.558e-05	28
64		min	-.005	27	-.005	12	-2.288	28	-2.021e-02	12	-1.386e-03	28	-4.259e-04	10
65	N33	max	0	28	.184	28	.809	26	-6.2e-04	26	4.925e-03	26	2.205e-03	10
66		min	0	1	-.37	10	-.885	12	-5.459e-03	12	-5.329e-03	12	-1.103e-03	28
67	N34	max	.006	25	0	26	1.301	10	1.751e-02	10	2.641e-03	10	2.131e-04	10
68		min	-.006	11	-.004	12	-1.122	28	-1.684e-02	12	-1.944e-03	28	-4.626e-05	28
69	N35	max	.007	9	0	26	2.011	10	2.078e-02	10	2.05e-03	10	6.558e-05	28
70		min	-.007	27	-.005	12	-1.806	28	-2.021e-02	12	-1.386e-03	28	-4.259e-04	10

Envelope AISC 14th(360-10): ASD Steel Code Checks

Member	Shape	Code Check	Lo...	LC	Shee...Lo...	Dir	...Pnc/...	Pnt/o...	Mny...	Mnz...	Cb	Eqn		
1	M10	L3X3X4	.801	17...	10	.009	17...	y	...1.643	31.042	1.123	1.461	1.1...	H2-1
2	M5	L3X3X4	.643	13...	11	.016	0	y	...2.624	31.042	1.123	1.513	1	H2-1
3	M6	L3X3X4	.637	13...	9	.017	0	y	...2.624	31.042	1.123	1.513	1	H2-1
4	M9	L3X3X4	.606	17...	26	.009	0	y	...1.643	31.042	1.123	2.092	2.9...	H2-1
5	M3	PIPE 3.0	.455	8....	12	.020	3....		...6.746	43.383	3.825	3.825	1.5...	H1-...
6	M4	PIPE 3.0	.449	8....	12	.021	5....		...6.746	43.383	3.825	3.825	1.6...	H1-...
7	M2	L4X4X4	.433	16...	10	.061	8....	z	...1.976	41.605	2.088	2.353	1.4...	H2-1
8	M17	W8X24	.400	11...	10	.030	19...	y	...30.563	211....	21.382	29.7	1.14	H1-...
9	M16	L4X4X4	.364	10...	10	.005	0	y	...3.088	41.605	2.088	2.347	1.1...	H2-1



Company : Centek Engineering
 Designer : TJL
 Job Number : 20074.12
 Model Name : CT11108A - Antenna Mount

May 18, 2021
 1:41 PM
 Checked By: _____

Envelope AISC 14th(360-10): ASD Steel Code Checks (Continued)

Member	Shape	Code Check	Lo...	LC	She...Lo...	Dir	...Pnc/...	Pnt/o...	Mny...	Mnz...	Cb	Eqn
10	M19	L4X4X4	.357	10...	10	.005 20	y	...	3.088	41.605	2.088	2.347 1.1... H2-1
11	M15	PIPE 3.0	.353	5....	12	.056 2....		...	6.746	43.383	3.825	3.825 2.1... H1-...
12	M1	L4X4X4	.346	19...	10	.047 8....	z	...	8.577	41.605	2.088	2.962 1 H2-1
13	M18	PIPE 3.0	.343	5....	12	.052 2....		...	6.746	43.383	3.825	3.825 1.9... H1-...
14	M8	L3X3X4	.262	7....	9	.006 0	y	...	2.676	31.042	1.123	1.625 1.1... H2-1
15	M7	L3X3X4	.257	6....	11	.005 13...	y	...	2.676	31.042	1.123	1.625 1.1... H2-1
16	M13A	PIPE 2.0	.207	2	10	.083 2		...	9.924	21.377	1.245	1.245 1.6... H1-...
17	M13	PIPE 2.0	.207	2	10	.075 2		...	9.924	21.377	1.245	1.245 1.62 H1-...
18	M14	PIPE 2.0	.072	2	10	.020 2		...	9.924	21.377	1.245	1.245 1.5... H1-...
19	M12	PIPE 2.0	.066	2	10	.019 2		...	9.924	21.377	1.245	1.245 1.6... H1-...

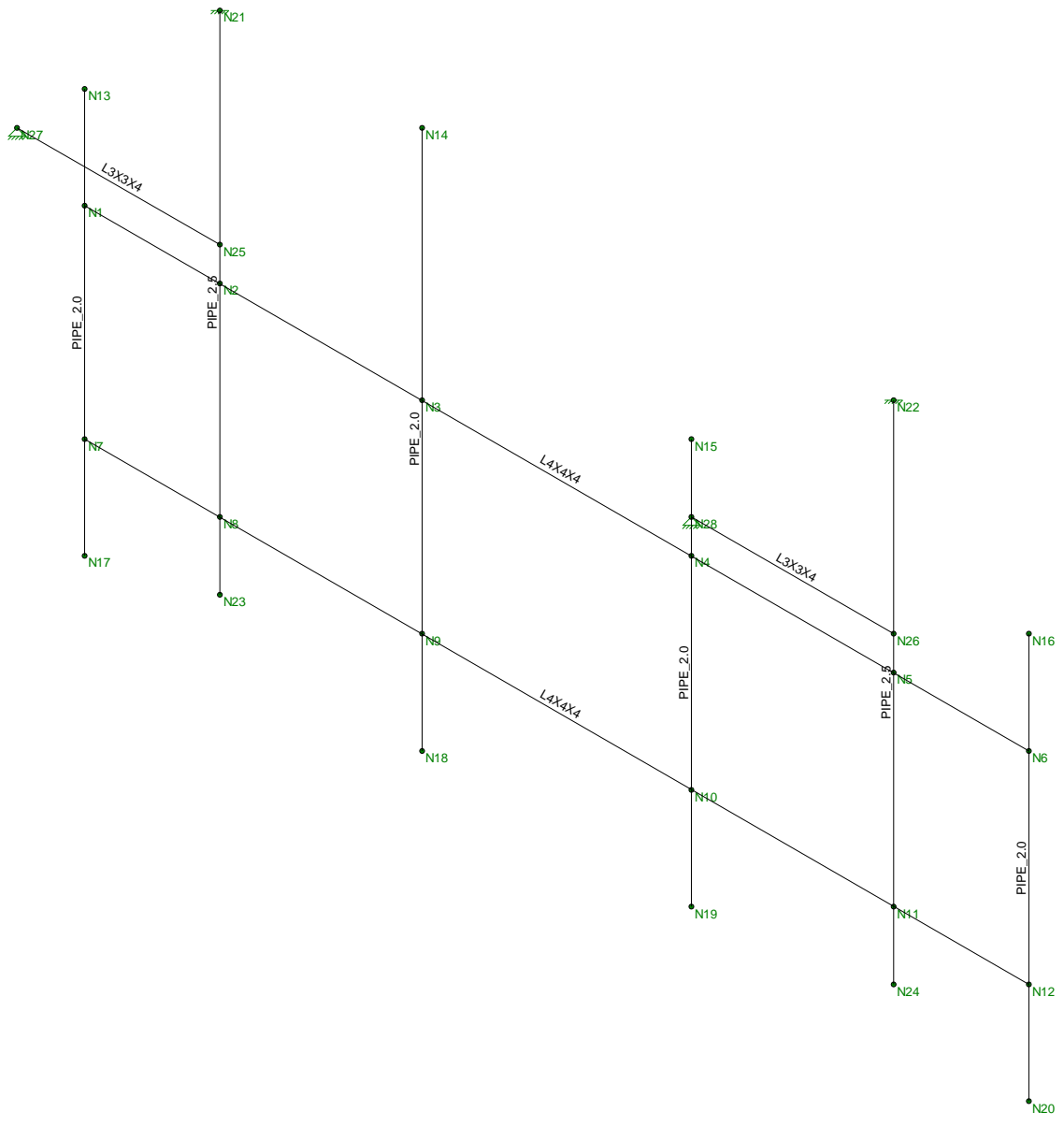

Envelope Only Solution

Centek Engineering	CT11108A - Antenna Mount Gamma Member Framing	
TJL		May 18, 2021 at 1:44 PM
20074.12		Gamma Antenna Mount.r3d

(Global) Model Settings

Display Sections for Member Calcs	5
Max Internal Sections for Member Calcs	97
Include Shear Deformation?	Yes
Increase Nailing Capacity for Wind?	Yes
Include Warping?	Yes
Trans Load Btwn Intersecting Wood Wall?	Yes
Area Load Mesh (in^2)	144
Merge Tolerance (in)	.12
P-Delta Analysis Tolerance	0.50%
Include P-Delta for Walls?	Yes
Automatically Iterate Stiffness for Walls?	Yes
Max Iterations for Wall Stiffness	3
Gravity Acceleration (ft/sec^2)	32.2
Wall Mesh Size (in)	12
Eigensolution Convergence Tol. (1.E-)	4
Vertical Axis	Y
Global Member Orientation Plane	XZ
Static Solver	Sparse Accelerated
Dynamic Solver	Accelerated Solver

Hot Rolled Steel Code	AISC 14th(360-10): ASD
Adjust Stiffness?	Yes(Iterative)
RISAConnection Code	AISC 14th(360-10): ASD
Cold Formed Steel Code	AISI S100-10: ASD
Wood Code	AWC NDS-12: ASD
Wood Temperature	< 100F
Concrete Code	ACI 318-11
Masonry Code	ACI 530-11: ASD
Aluminum Code	AA ADM1-10: ASD - Building
Stainless Steel Code	AISC 14th(360-10): ASD
Adjust Stiffness?	Yes(Iterative)

Number of Shear Regions	4
Region Spacing Increment (in)	4
Biaxial Column Method	Exact Integration
Parme Beta Factor (PCA)	.65
Concrete Stress Block	Rectangular
Use Cracked Sections?	Yes
Use Cracked Sections Slab?	Yes
Bad Framing Warnings?	No
Unused Force Warnings?	Yes
Min 1 Bar Diam. Spacing?	No
Concrete Rebar Set	REBAR_SET_ASTMA615
Min % Steel for Column	1
Max % Steel for Column	8

(Global) Model Settings, Continued

Seismic Code	ASCE 7-10
Seismic Base Elevation (ft)	Not Entered
Add Base Weight?	Yes
Ct X	.02
Ct Z	.02
T X (sec)	Not Entered
T Z (sec)	Not Entered
R X	3
R Z	3
Ct Exp. X	.75
Ct Exp. Z	.75
SD1	1
SDS	1
S1	1
TL (sec)	5
Risk Cat	I or II
Drift Cat	Other
Om Z	1
Om X	1
Cd Z	4
Cd X	4
Rho Z	1
Rho X	1
Footing Overturning Safety Factor	1
Optimize for OTM/Sliding	No
Check Concrete Bearing	No
Footing Concrete Weight (k/ft^3)	150.001
Footing Concrete f'c (ksi)	4
Footing Concrete Ec (ksi)	3644
Lambda	1
Footing Steel fy (ksi)	60
Minimum Steel	0.0018
Maximum Steel	0.0075
Footing Top Bar	#3
Footing Top Bar Cover (in)	2
Footing Bottom Bar	#3
Footing Bottom Bar Cover (in)	3.5
Pedestal Bar	#3
Pedestal Bar Cover (in)	1.5
Pedestal Ties	#3

Hot Rolled Steel Properties

	Label	E [ksi]	G [ksi]	Nu	Therm (\... Density[k/ft^3]	Yield[ksi]	Ry	Fu[ksi]	Rt	
1	A36 Gr.36	29000	11154	.3	.65	.49	36	1.5	58	1.2
2	A572 Gr.50	29000	11154	.3	.65	.49	50	1.1	58	1.2
3	A992	29000	11154	.3	.65	.49	50	1.1	58	1.2
4	A500 Gr.42	29000	11154	.3	.65	.49	42	1.3	58	1.1
5	A500 Gr.46	29000	11154	.3	.65	.49	46	1.2	58	1.1
6	A53 Grade B	29000	11154	.3	.65	.49	35	1.5	58	1.2

Hot Rolled Steel Section Sets

	Label	Shape	Type	Design List	Material	Design Rul...A [in2]	lyy [in4]	lzz [in4]	J [in4]	
1	Support Pipe Mast	PIPE_2.5	Beam	Pipe	A53 Grade B	Typical	1.61	1.45	1.45	2.89
2	Antenna Mast	PIPE_2.0	Beam	Pipe	A53 Grade B	Typical	1.02	.627	.627	1.25
3	Horz	L4X4X4	Beam	Single Angle	A36 Gr.36	Typical	1.93	3	3	.044
4	Brace	L3X3X4	Beam	Single Angle	A36 Gr.36	Typical	1.44	1.23	1.23	.031

Hot Rolled Steel Design Parameters

	Label	Shape	Length[ft]	Lbyy[ft]	Lbzz[ft]	Lcomp top[...Lcomp bot[...L-torq...	Kyy	Kzz	Cb	Functi...
1	M1	Horz	14			Lbyy				Lateral
2	M2	Horz	14			Lbyy				Lateral
3	M3	Antenna Mast	6			Lbyy				Lateral
4	M4	Antenna Mast	8			Lbyy				Lateral
5	M5	Antenna Mast	6			Lbyy				Lateral
6	M6	Antenna Mast	6			Lbyy				Lateral
7	M7	Support Pipe Mast	7.5			Lbyy				Lateral
8	M8	Support Pipe Mast	7.5			Lbyy				Lateral
9	M9	Brace	4.243			Lbyy				Lateral
10	M10	Brace	4.243			Lbyy				Lateral

Member Primary Data

	Label	I Joint	J Joint	K Joint	Rotate(...	Section/Shape	Type	Design List	Material	Design R...
1	M1	N1	N6		90	Horz	Beam	Single Angle	A36 Gr.36	Typical
2	M2	N7	N12		90	Horz	Beam	Single Angle	A36 Gr.36	Typical
3	M3	N13	N17			Antenna Mast	Beam	Pipe	A53 Grade B	Typical
4	M4	N14	N18			Antenna Mast	Beam	Pipe	A53 Grade B	Typical
5	M5	N15	N19			Antenna Mast	Beam	Pipe	A53 Grade B	Typical
6	M6	N16	N20			Antenna Mast	Beam	Pipe	A53 Grade B	Typical
7	M7	N23	N21			Support Pipe Mast	Beam	Pipe	A53 Grade B	Typical
8	M8	N24	N22			Support Pipe Mast	Beam	Pipe	A53 Grade B	Typical
9	M9	N27	N25			Brace	Beam	Single Angle	A36 Gr.36	Typical
10	M10	N28	N26			Brace	Beam	Single Angle	A36 Gr.36	Typical

Joint Coordinates and Temperatures

	Label	X [ft]	Y [ft]	Z [ft]	Temp [F]	Detach From Diaphragm
1	N1	0	0	0	0	
2	N2	2	0	0	0	
3	N3	5	0	0	0	
4	N4	9	0	0	0	
5	N5	12	0	0	0	
6	N6	14	0	0	0	
7	N7	0	-3	0	0	
8	N8	2	-3	0	0	
9	N9	5	-3	0	0	
10	N10	9	-3	0	0	
11	N11	12	-3	0	0	
12	N12	14	-3	0	0	
13	N13	0	1.5	0	0	

Joint Coordinates and Temperatures (Continued)

	Label	X [ft]	Y [ft]	Z [ft]	Temp [F]	Detach From Diaphragm
14	N14	5	3.5	0	0	
15	N15	9	1.5	0	0	
16	N16	14	1.5	0	0	
17	N17	0	-4.5	0	0	
18	N18	5	-4.5	0	0	
19	N19	9	-4.5	0	0	
20	N20	14	-4.5	0	0	
21	N21	2	3.5	0	0	
22	N22	12	3.5	0	0	
23	N23	2	-4	0	0	
24	N24	12	-4	0	0	
25	N25	2	.5	0	0	
26	N26	12	.5	0	0	
27	N27	2	3.5	3	0	
28	N28	12	3.5	3	0	

Joint Boundary Conditions

	Joint Label	X [k/in]	Y [k/in]	Z [k/in]	X Rot.[k-ft/rad]	Y Rot.[k-ft/rad]	Z Rot.[k-ft/rad]
1	N21	Reaction	Reaction	Reaction	Reaction	Reaction	Reaction
2	N22	Reaction	Reaction	Reaction	Reaction	Reaction	Reaction
3	N25						
4	N26						
5	N27	Reaction	Reaction	Reaction			
6	N28	Reaction	Reaction	Reaction			
7	N2						
8	N5						

Member Point Loads (BLC 2 : Weight of Equipment)

	Member Label	Direction	Magnitude[k,k-ft]	Location[ft,%]
1	M5	Y	-.067	1
2	M5	Y	-.067	5
3	M3	Y	-.052	1
4	M3	Y	-.052	3
5	M4	Y	-.077	1
6	M4	Y	-.077	7
7	M4	Y	-.074	%50

Member Point Loads (BLC 3 : Wind X-Direction)

	Member Label	Direction	Magnitude[k,k-ft]	Location[ft,%]
1	M5	X	.084	1
2	M5	X	.084	5
3	M3	X	.047	1
4	M3	X	.047	3
5	M4	X	.139	1
6	M4	X	.139	7
7	M4	X	.056	%50



Member Point Loads (BLC 4 : Wind Z-Direction)

	Member Label	Direction	Magnitude[k,k-ft]	Location[ft,%]
1	M5	Z	.125	1
2	M5	Z	.125	5
3	M3	Z	.116	1
4	M3	Z	.116	3
5	M4	Z	.393	1
6	M4	Z	.393	7

Member Distributed Loads (BLC 4 : Wind Z-Direction)

	Member Label	Direction	Start Magnitude[k/ft,F,ksf]	End Magnitude[k/f...]	Start Location[ft,%]	End Location[ft,%]
1	M1	Z	.017	.017	0	0
2	M2	Z	.017	.017	0	0
3	M7	Z	.017	.017	0	0
4	M8	Z	.017	.017	0	0

Basic Load Cases

	BLC Description	Category	X Gra...Y Gra...Z Gra...	Joint	Point	Distrib...	Area(... Surfa...
1	Self Weight	DL	-1				
2	Weight of Equipment	DL			7		
3	Wind X-Direction	WLX			7		
4	Wind Z-Direction	WLZ			6	4	

Load Combinations

	Description	Solve	P...S...B...Fa...	BLC Fact...BLC Fa...	BLC Fa...	BLC Fa...	B... Fa...	B... Fa...	B... Fa...	B... Fa...	B... Fa...	B... Fa...	B... Fa...	B... Fa...
1	IBC 16-8	Yes	Y	DL 1										
2	IBC 16-9	Yes	Y	DL 1	LL 1	LLS 1								
3	IBC 16-10 (a)	Yes	Y	DL 1	RLL 1									
4	IBC 16-10 (b)	Yes	Y	DL 1	SL 1	SLN 1								
5	IBC 16-10 (c)	Yes	Y	DL 1	RL 1									
6	IBC 16-11 (a)	Yes	Y	DL 1	LL .75	LLS .75	RLL .75							
7	IBC 16-11 (b)	Yes	Y	DL 1	LL .75	LLS .75	SL .75	SLN .75						
8	IBC 16-11 (c)	Yes	Y	DL 1	LL .75	LLS .75	RL .75							
9	IBC 16-12 (a) (a)	Yes	Y	DL 1	WLX .6									
10	IBC 16-12 (a) (b)	Yes	Y	DL 1	WLZ .6									
11	IBC 16-12 (a) (c)	Yes	Y	DL 1	WLX -.6									
12	IBC 16-12 (a) (d)	Yes	Y	DL 1	WLZ -.6									
13	IBC 16-13 (a) (a)	Yes	Y	DL 1	WLX .45	LL .75	LLS .75	RLL .75						
14	IBC 16-13 (a) (b)	Yes	Y	DL 1	WLZ .45	LL .75	LLS .75	RLL .75						
15	IBC 16-13 (a) (c)	Yes	Y	DL 1	WLX -.45	LL .75	LLS .75	RLL .75						
16	IBC 16-13 (a) (d)	Yes	Y	DL 1	WLZ -.45	LL .75	LLS .75	RLL .75						
17	IBC 16-13 (b) (a)	Yes	Y	DL 1	WLX .45	LL .75	LLS .75	SL .75	S... .75					
18	IBC 16-13 (b) (b)	Yes	Y	DL 1	WLZ .45	LL .75	LLS .75	SL .75	S... .75					
19	IBC 16-13 (b) (c)	Yes	Y	DL 1	WLX -.45	LL .75	LLS .75	SL .75	S... .75					
20	IBC 16-13 (b) (d)	Yes	Y	DL 1	WLZ -.45	LL .75	LLS .75	SL .75	S... .75					
21	IBC 16-13 (c) (a)	Yes	Y	DL 1	WLX .45	LL .75	LLS .75	RL .75						
22	IBC 16-13 (c) (b)	Yes	Y	DL 1	WLZ .45	LL .75	LLS .75	RL .75						
23	IBC 16-13 (c) (c)	Yes	Y	DL 1	WLX -.45	LL .75	LLS .75	RL .75						
24	IBC 16-13 (c) (d)	Yes	Y	DL 1	WLZ -.45	LL .75	LLS .75	RL .75						



Load Combinations (Continued)

	Description	Solve	P...	S...	B...	Fa...	BLC	Fact...	BLC	Fa...	BLC	Fa...	BLC	Fa...	B...	Fa...	B...	Fa...	B...	Fa...	B...	Fa...	
25	IBC 16-15 (a)	Yes	Y		DL	.6	WLX	.6															
26	IBC 16-15 (b)	Yes	Y		DL	.6	WLZ	.6															
27	IBC 16-15 (c)	Yes	Y		DL	.6	WLX	-.6															
28	IBC 16-15 (d)	Yes	Y		DL	.6	WLZ	-.6															

Envelope Joint Reactions

	Joint		X [k]	LC	Y [k]	LC	Z [k]	LC	MX [k-ft]	LC	MY [k-ft]	LC	MZ [k-ft]	LC
1	N21	max	.161	27	1.668	10	.273	26	.264	12	.106	10	.335	27
2		min	-.198	9	-.852	28	-.278	12	-.256	26	-.098	28	-.384	9
3	N22	max	.197	11	1.066	10	.252	26	.25	12	.147	28	.374	11
4		min	-.159	25	-.541	28	-.258	12	-.242	26	-.161	10	-.338	25
5	N27	max	.064	26	1.177	12	1.052	12	0	28	0	28	0	28
6		min	-.065	12	-1.158	26	-1.046	26	0	1	0	1	0	1
7	N28	max	.008	12	.741	12	.684	12	0	28	0	28	0	28
8		min	-.007	26	-.724	26	-.679	26	0	1	0	1	0	1
9	Totals:	max	.358	27	.864	24	1.199	28						
10		min	-.358	9	.518	25	-1.199	10						

Envelope Joint Displacements

	Joint		X [in]	LC	Y [in]	LC	Z [in]	LC	X Rotation [rad]	LC	Y Rotatio...	LC	Z Rotation [rad]	LC
1	N1	max	.049	9	.011	27	.017	12	6.32e-03	28	1.518e-03	12	6.142e-04	9
2		min	-.047	27	-.015	9	-.013	26	-6.315e-03	26	-1.346e-03	26	-3.773e-04	27
3	N2	max	.049	9	0	28	.024	10	3.849e-03	28	1.96e-03	28	6.04e-04	25
4		min	-.047	27	-.002	10	-.023	28	-3.848e-03	26	-2.077e-03	10	-8.322e-04	11
5	N3	max	.049	9	.01	28	.142	10	9.151e-04	10	1.905e-03	28	1.373e-04	28
6		min	-.047	27	-.051	10	-.119	28	-8.977e-04	12	-2.359e-03	10	-9.172e-04	10
7	N4	max	.049	9	.006	28	.13	10	4.668e-03	28	2.415e-03	10	9.567e-04	10
8		min	-.047	27	-.045	10	-.108	28	-4.658e-03	26	-1.946e-03	28	-1.624e-04	28
9	N5	max	.049	9	0	28	.019	10	3.274e-03	28	2.564e-03	10	9.678e-04	9
10		min	-.047	27	-.001	10	-.019	28	-3.265e-03	26	-2.347e-03	28	-5.325e-04	27
11	N6	max	.049	9	.018	9	.038	28	5.325e-03	28	2.443e-03	10	6.509e-04	9
12		min	-.047	27	-.011	27	-.041	10	-5.315e-03	26	-2.353e-03	28	-4.22e-04	27
13	N7	max	.071	9	.011	27	.214	26	6.156e-03	28	1.672e-03	12	7.234e-04	9
14		min	-.065	27	-.015	9	-.212	28	-6.151e-03	26	-1.484e-03	26	-4.749e-04	27
15	N8	max	.071	9	0	28	.253	26	7.613e-03	28	1.84e-03	28	2.589e-04	25
16		min	-.065	27	-.002	10	-.253	28	-7.604e-03	26	-1.995e-03	10	-5.779e-04	11
17	N9	max	.071	9	.01	28	.337	10	9.423e-03	28	1.112e-03	28	1.449e-04	28
18		min	-.065	27	-.051	10	-.315	28	-9.411e-03	26	-1.548e-03	10	-8.868e-04	10
19	N10	max	.071	9	.006	28	.319	10	5.92e-03	28	2.152e-03	10	9.116e-04	10
20		min	-.065	27	-.045	10	-.299	28	-5.911e-03	26	-1.713e-03	28	-1.557e-04	28
21	N11	max	.071	9	0	28	.215	26	6.491e-03	28	2.789e-03	10	7.789e-04	9
22		min	-.065	27	-.001	10	-.215	28	-6.486e-03	26	-2.511e-03	28	-2.377e-04	27
23	N12	max	.071	9	.018	9	.153	26	5.404e-03	28	2.512e-03	10	7.252e-04	9
24		min	-.065	27	-.011	27	-.156	12	-5.393e-03	26	-2.44e-03	28	-5.258e-04	27
25	N13	max	.039	25	.011	27	.128	12	6.236e-03	28	1.518e-03	12	5.796e-04	9
26		min	-.041	11	-.015	9	-.126	26	-6.231e-03	26	-1.346e-03	26	-3.425e-04	27
27	N14	max	.167	9	.01	28	.416	10	8.238e-03	10	1.905e-03	28	2.616e-03	27
28		min	-.132	27	-.051	10	-.39	28	-8.22e-03	12	-2.359e-03	10	-3.403e-03	9
29	N15	max	.044	25	.006	28	.048	10	4.577e-03	28	2.415e-03	10	9.573e-04	10



Envelope Joint Displacements (Continued)

Joint	X [in]	LC	Y [in]	LC	Z [in]	LC	X Rotation [rad]	LC	Y Rotatio...	LC	Z Rotation [rad]	LC		
30	min	-0.056	11	-0.045	10	-0.025	28	-4.567e-03	26	-1.946e-03	28	-1.624e-04	28	
31	N16	max	.038	25	.018	9	.133	28	5.326e-03	28	2.443e-03	10	6.51e-04	9
32	min	-.04	11	-.011	27	-.136	10	-5.315e-03	26	-2.353e-03	28	-4.22e-04	27	
33	N17	max	.084	9	.011	27	.325	26	6.156e-03	28	1.672e-03	12	7.234e-04	9
34	min	-.074	27	-.015	9	-.323	28	-6.151e-03	26	-1.484e-03	26	-4.749e-04	27	
35	N18	max	.067	25	.01	28	.511	10	9.71e-03	28	1.112e-03	28	1.448e-04	28
36	min	-.074	11	-.051	10	-.49	28	-9.698e-03	26	-1.548e-03	10	-8.862e-04	10	
37	N19	max	.082	9	.006	28	.427	10	6.011e-03	28	2.152e-03	10	9.111e-04	10
38	min	-.062	27	-.045	10	-.407	28	-6.001e-03	26	-1.713e-03	28	-1.557e-04	28	
39	N20	max	.084	9	.018	9	.25	26	5.404e-03	28	2.512e-03	10	7.252e-04	9
40	min	-.074	27	-.011	27	-.253	12	-5.393e-03	26	-2.44e-03	28	-5.258e-04	27	
41	N21	max	0	28	0	28	0	28	0	28	0	28	0	28
42	min	0	1	0	1	0	1	1	0	1	0	1	0	1
43	N22	max	0	28	0	28	0	28	0	28	0	28	0	28
44	min	0	1	0	1	0	1	1	0	1	0	1	0	1
45	N23	max	.073	9	0	28	.345	26	7.62e-03	28	1.84e-03	28	2.589e-04	25
46	min	-.071	27	-.002	10	-.344	28	-7.611e-03	26	-1.995e-03	10	-5.779e-04	11	
47	N24	max	.081	9	0	28	.293	26	6.498e-03	28	2.789e-03	10	7.789e-04	9
48	min	-.068	27	-.001	10	-.293	28	-6.493e-03	26	-2.511e-03	28	-2.377e-04	27	
49	N25	max	.044	9	0	28	.005	10	2.179e-03	28	1.31e-03	28	1.153e-03	25
50	min	-.041	27	-.002	10	-.004	28	-2.181e-03	26	-1.419e-03	10	-1.221e-03	11	
51	N26	max	.042	25	0	28	.003	10	1.954e-03	28	2.157e-03	10	1.333e-03	9
52	min	-.042	27	-.001	10	-.003	28	-1.943e-03	26	-1.967e-03	28	-1.086e-03	27	
53	N27	max	0	28	0	28	0	28	9.175e-04	26	5.818e-04	28	1.32e-03	25
54	min	0	1	0	1	0	1	1	-1.014e-03	12	-6.963e-04	10	-1.378e-03	11
55	N28	max	0	28	0	28	0	28	8.556e-04	26	7.565e-04	10	1.687e-03	10
56	min	0	1	0	1	0	1	1	-9.509e-04	12	-4.932e-04	28	-1.513e-03	28

Envelope AISC 14th(360-10): ASD Steel Code Checks

Member	Shape	Code Check	Lo...	LC	She...Lo...	Dir	...Pnc/...	Pnt/o...	Mny...	Mnz...	Cb	Eqn		
1	M4	PIPE 2.0	.504	3.5	10	.061	3.5	...	9.924	21.377	1.245	1.245	1.7...	H1-...
2	M7	PIPE 2.5	.397	4....	12	.213	4....	...	21.294	33.743	2.393	2.393	3.2...	H1-...
3	M1	L4X4X4	.329	2....	10	.054	2....	y	6.301	41.605	2.088	3.519	1.7...	H2-1
4	M9	L3X3X4	.306	4....	10	.009	4....	y	20.835	31.042	1.123	2.485	1.6...	H2-1
5	M8	PIPE 2.5	.296	4....	10	.126	4....	...	21.294	33.743	2.393	2.393	1.71	H1-...
6	M2	L4X4X4	.240	2....	10	.025	2....	z	6.301	41.605	2.088	3.12	1.3...	H2-1
7	M10	L3X3X4	.202	4....	10	.005	4....	y	20.835	31.042	1.123	2.499	1.7...	H2-1
8	M5	PIPE 2.0	.149	1.5	11	.025	1.5	...	13.883	21.377	1.245	1.245	1.4...	H1-...
9	M3	PIPE 2.0	.038	1.5	10	.015	1.5	...	13.883	21.377	1.245	1.245	1.4...	H1-...
10	M6	PIPE 2.0	.022	1.5	10	.005	1.5	9	13.883	21.377	1.245	1.245	1.4...	H1-...



Code Check (Env)	
Black	No Calc
Red	> 1.0
Magenta	.90-1.0
Green	.75-90
Cyan	.50-.75
Blue	0-.50

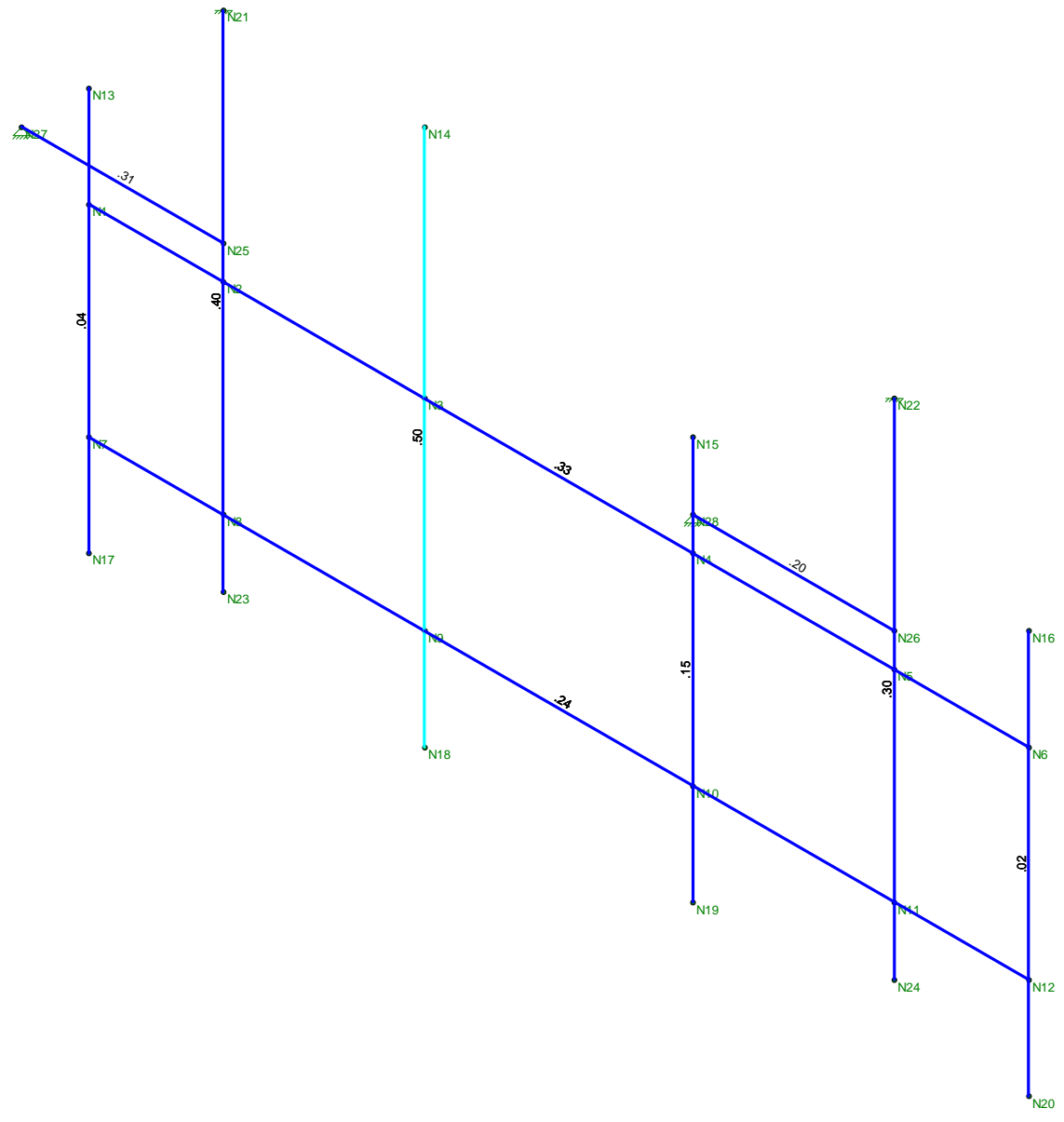

Member Code Checks Displayed (Enveloped)
Envelope Only Solution

Centek Engineering	CT11108A - Antenna Mount Gamma Unity Check	
TJL		May 18, 2021 at 1:44 PM
20074.12		Gamma Antenna Mount.r3d

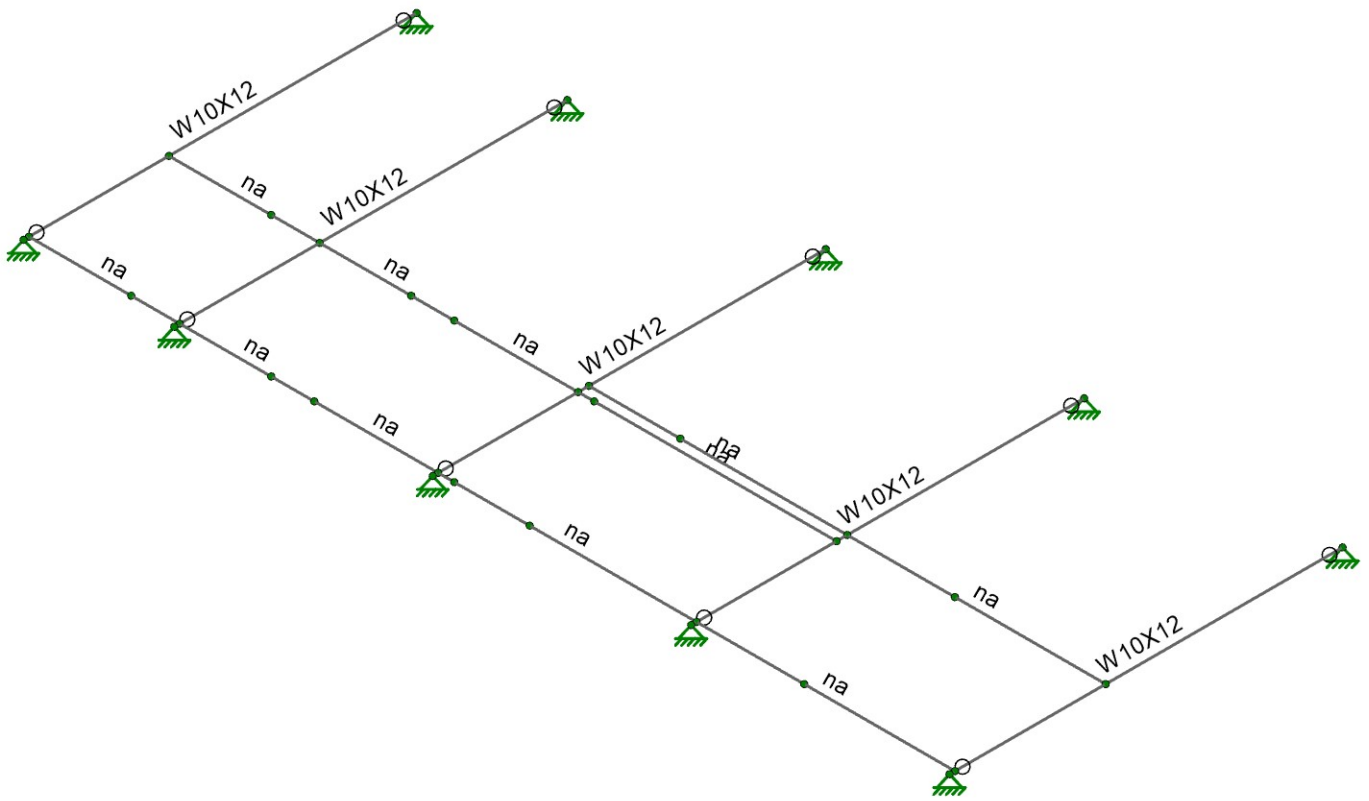

Envelope Only Solution

Centek Engineering	CT11108A - Platform Frame	SK-2
PPG		Apr 15, 2021
20074.12		Platform Frame.r3d

Nodes

	Label	X [in]	Y [in]	Z [in]	Temp [deg F]	Detach From Dia...
1	N1	0	0	0		
2	N2	172	0	0		
3	N3	0	0	-73		
4	N4	172	0	-73		
5	N5	28.003333	0	0		
6	N6	28.003333	0	-73		
7	N7	76.003333	0	0		
8	N8	76.003333	0	-73		
9	N9	124.003333	0	0		
10	N10	124.003333	0	-73		
11	N13	76.003333	0	-29		
12	N14	76.003333	0	-1		
13	N15	172	0	-29		
14	N16	172	0	-1		
15	N17	124.003333	0	-29		
16	N18	124.003333	0	-1		
17	N19	93	0	-29		
18	N20	93	0	-1		
19	N21	144	0	-29		
20	N22	144	0	-1		
21	N24	79	0	-1		
22	N23	76.003333	0	-27		
23	N25	53	0	-1		
24	N26	53	0	-27		
25	N29	28.003333	0	-1		
26	N30	28.003333	0	-27		
27	N31	0	0	-1		
28	N32	0	0	-27		
29	N33	124.003333	0	-27		
30	N34	79	0	-27		
31	N35	45	0	-1		
32	N36	45	0	-27		
33	N37	19	0	-1		
34	N38	19	0	-27		

Boundary Conditions

	Node Label	X [k/in]	Y [k/in]	Z [k/in]	X Rot [k-ft/rad]	Y Rot [k-ft/rad]	Z Rot [k-ft/rad]
1	N7	Reaction	Reaction	Reaction			
2	N9	Reaction	Reaction	Reaction			
3	N5	Reaction	Reaction	Reaction			
4	N1	Reaction	Reaction	Reaction			
5	N2	Reaction	Reaction	Reaction			
6	N4	Reaction	Reaction	Reaction			
7	N10	Reaction	Reaction	Reaction			
8	N8	Reaction	Reaction	Reaction			
9	N6	Reaction	Reaction	Reaction			
10	N3	Reaction	Reaction	Reaction			

Hot Rolled Steel Properties

	Label	E [ksj]	G [ksj]	Nu	Therm. C...	Density [k...	Yield [ksj]	Ry	Fu [ksj]	Rt
1	A36 Gr.36	29000	11154	0.3	0.65	0.49	36	1.5	58	1.2
2	A572 Gr.50	29000	11154	0.3	0.65	0.49	50	1.1	58	1.2
3	A992	29000	11154	0.3	0.65	0.49	50	1.1	58	1.2
4	A500 Gr.42	29000	11154	0.3	0.65	0.49	42	1.3	58	1.1
5	A500 Gr.46	29000	11154	0.3	0.65	0.49	46	1.2	58	1.1
6	A53 Grad...	29000	11154	0.3	0.65	0.49	35	1.5	58	1.2

General Section Sets

	Label	Shape	Type	Material	Area [in ²]	Iyy [in ⁴]	Izz [in ⁴]	J [in ⁴]
1	GEN1A	RE4X4	Beam	gen_Conc3NW	16	21.333	21.333	31.573
2	RIGID		None	RIGID	1e+06	1e+06	1e+06	1e+06

Hot Rolled Member Properties

	Label	Shape	Length [in]	Lb y-y [in]	Lb z-z [in]	Lcomp t...	Lcomp...	L-Torqu...	K y-y	K z-z	Cb	Function
1	M3	W10X12	73									Lateral
2	M4	W10X12	73									Lateral
3	M5	W10X12	73									Lateral
4	M7	W10X12	73									Lateral
5	M9	W10X12	73									Lateral

Node Loads and Enforced Displacements (BLC 2 : Weight of Equipment)

	Node Label	L, D, M	Direction	Magnitude [(k, k-ft), (... Inactive [(k, k-ft), (in,...
1	N22	L	Y	-0.648 Active
2	N21	L	Y	-0.648 Active
3	N20	L	Y	-0.648 Active
4	N19	L	Y	-0.648 Active
5	N24	L	Y	-0.3 Active
6	N34	L	Y	-0.3 Active
7	N26	L	Y	-0.3 Active
8	N25	L	Y	-0.3 Active
9	N36	L	Y	-0.471 Active
10	N38	L	Y	-0.471 Active
11	N37	L	Y	-0.471 Active
12	N35	L	Y	-0.471 Active

Node Loads and Enforced Displacements (BLC 3 : Wind X-Direction)

	Node Label	L, D, M	Direction	Magnitude [(k, k-ft), (... Inactive [(k, k-ft), (in,...
1	N22	L	X	0.169 Active
2	N21	L	X	0.169 Active
3	N20	L	X	0.169 Active
4	N19	L	X	0.169 Active
5	N20	L	Y	0.209 Active
6	N19	L	Y	0.209 Active
7	N22	L	Y	-0.209 Active
8	N21	L	Y	-0.209 Active
9	N37	L	X	0.168 Active
10	N38	L	X	0.168 Active
11	N35	L	X	0.168 Active
12	N36	L	X	0.168 Active
13	N25	L	X	0.168 Active
14	N26	L	X	0.168 Active
15	N24	L	X	0.168 Active
16	N34	L	X	0.168 Active
17	N37	L	Y	0.407 Active
18	N38	L	Y	0.407 Active
19	N25	L	Y	0.407 Active
20	N26	L	Y	0.407 Active
21	N35	L	Y	-0.407 Active
22	N36	L	Y	-0.407 Active
23	N34	L	Y	-0.407 Active
24	N24	L	Y	-0.407 Active

Node Loads and Enforced Displacements (BLC 4 : Wind Z-Direction)

	Node Label	L, D, M	Direction	Magnitude [(k, k-ft), (... Inactive [(k, k-ft), (in,...	
1	N22	L	Z	0.332	Active
2	N21	L	Z	0.332	Active
3	N20	L	Z	0.332	Active
4	N19	L	Z	0.332	Active
5	N21	L	Y	0.81	Active
6	N19	L	Y	0.81	Active
7	N22	L	Y	-0.81	Active
8	N20	L	Y	-0.81	Active
9	N34	L	Z	0.168	Active
10	N24	L	Z	0.168	Active
11	N25	L	Z	0.168	Active
12	N26	L	Z	0.168	Active
13	N36	L	Z	0.168	Active
14	N35	L	Z	0.168	Active
15	N38	L	Z	0.168	Active
16	N37	L	Z	0.168	Active
17	N34	L	Y	0.407	Active
18	N26	L	Y	0.407	Active
19	N36	L	Y	0.407	Active
20	N38	L	Y	0.407	Active
21	N37	L	Y	-0.407	Active
22	N35	L	Y	-0.407	Active
23	N25	L	Y	-0.407	Active
24	N24	L	Y	-0.407	Active

Member Distributed Loads (BLC 8 : BLC 5 Transient Area Loads)

	Member Label	Direction	Start Magnitud...	End Magnitude...	Start Location [...	End Location [(...	Inactive [(k, k-f...
1	M3	Y	-0.037	-0.041	0	14.6	Active
2	M3	Y	-0.041	-0.047	14.6	29.2	Active
3	M3	Y	-0.047	-0.042	29.2	43.8	Active
4	M3	Y	-0.042	-0.036	43.8	58.4	Active
5	M3	Y	-0.036	-0.043	58.4	73	Active
6	M4	Y	-0.023	-0.024	0	14.6	Active
7	M4	Y	-0.024	-0.025	14.6	29.2	Active
8	M4	Y	-0.025	-0.027	29.2	43.8	Active
9	M4	Y	-0.027	-0.023	43.8	58.4	Active
10	M4	Y	-0.023	-0.012	58.4	73	Active
11	M5	Y	-0.06	-0.061	0	14.6	Active
12	M5	Y	-0.061	-0.07	14.6	29.2	Active
13	M5	Y	-0.07	-0.077	29.2	43.8	Active
14	M5	Y	-0.077	-0.066	43.8	58.4	Active
15	M5	Y	-0.066	-0.043	58.4	73	Active
16	M7	Y	-0.08	-0.079	0	14.6	Active
17	M7	Y	-0.079	-0.079	14.6	29.2	Active
18	M7	Y	-0.079	-0.079	29.2	43.8	Active
19	M7	Y	-0.079	-0.078	43.8	58.4	Active
20	M7	Y	-0.078	-0.076	58.4	73	Active
21	M9	Y	-0.08	-0.078	0	14.6	Active
22	M9	Y	-0.078	-0.076	14.6	29.2	Active
23	M9	Y	-0.076	-0.078	29.2	43.8	Active
24	M9	Y	-0.078	-0.08	43.8	58.4	Active
25	M9	Y	-0.08	-0.081	58.4	73	Active

Member Distributed Loads (BLC 9 : BLC 6 Transient Area Loads)

	Member Label	Direction	Start Magnitud...	End Magnitude...	Start Location [...	End Location [(...	Inactive [(k, k-f...
1	M3	Y	-0.057	-0.063	0	14.6	Active
2	M3	Y	-0.063	-0.058	14.6	29.2	Active

Member Distributed Loads (BLC 9 : BLC 6 Transient Area Loads) (Continued)

	Member Label	Direction	Start Magnitud...	End Magnitude...	Start Location [...]	End Location [...]	Inactive [(k, k-f...
3	M3	Y	-0.058	-0.065	29.2	43.8	Active
4	M3	Y	-0.065	-0.065	43.8	58.4	Active
5	M3	Y	-0.065	-0.04	58.4	73	Active
6	M4	Y	-0.03	-0.036	0	14.6	Active
7	M4	Y	-0.036	-0.036	14.6	29.2	Active
8	M4	Y	-0.036	-0.043	29.2	43.8	Active
9	M4	Y	-0.043	-0.039	43.8	58.4	Active
10	M4	Y	-0.039	-0.015	58.4	73	Active
11	M5	Y	-0.093	-0.093	0	14.6	Active
12	M5	Y	-0.093	-0.106	14.6	29.2	Active
13	M5	Y	-0.106	-0.113	29.2	43.8	Active
14	M5	Y	-0.113	-0.094	43.8	58.4	Active
15	M5	Y	-0.094	-0.068	58.4	73	Active
16	M7	Y	-0.119	-0.118	0	14.6	Active
17	M7	Y	-0.118	-0.117	14.6	29.2	Active
18	M7	Y	-0.117	-0.116	29.2	43.8	Active
19	M7	Y	-0.116	-0.116	43.8	58.4	Active
20	M7	Y	-0.116	-0.12	58.4	73	Active
21	M9	Y	-0.123	-0.118	0	14.6	Active
22	M9	Y	-0.118	-0.122	14.6	29.2	Active
23	M9	Y	-0.122	-0.126	29.2	43.8	Active
24	M9	Y	-0.126	-0.12	43.8	58.4	Active
25	M9	Y	-0.12	-0.111	58.4	73	Active

Member Distributed Loads (BLC 10 : BLC 7 Transient Area Loads)

	Member Label	Direction	Start Magnitud...	End Magnitude...	Start Location [...]	End Location [...]	Inactive [(k, k-f...
1	M3	Y	-0.019	-0.021	0	14.6	Active
2	M3	Y	-0.021	-0.024	14.6	29.2	Active
3	M3	Y	-0.024	-0.021	29.2	43.8	Active
4	M3	Y	-0.021	-0.018	43.8	58.4	Active
5	M3	Y	-0.018	-0.021	58.4	73	Active
6	M4	Y	-0.011	-0.012	0	14.6	Active
7	M4	Y	-0.012	-0.012	14.6	29.2	Active
8	M4	Y	-0.012	-0.013	29.2	43.8	Active
9	M4	Y	-0.013	-0.012	43.8	58.4	Active
10	M4	Y	-0.012	-0.006	58.4	73	Active
11	M5	Y	-0.03	-0.031	0	14.6	Active
12	M5	Y	-0.031	-0.035	14.6	29.2	Active
13	M5	Y	-0.035	-0.038	29.2	43.8	Active
14	M5	Y	-0.038	-0.033	43.8	58.4	Active
15	M5	Y	-0.033	-0.022	58.4	73	Active
16	M7	Y	-0.04	-0.04	0	14.6	Active
17	M7	Y	-0.04	-0.039	14.6	29.2	Active
18	M7	Y	-0.039	-0.04	29.2	43.8	Active
19	M7	Y	-0.04	-0.039	43.8	58.4	Active
20	M7	Y	-0.039	-0.038	58.4	73	Active
21	M9	Y	-0.04	-0.039	0	14.6	Active
22	M9	Y	-0.039	-0.038	14.6	29.2	Active
23	M9	Y	-0.038	-0.039	29.2	43.8	Active
24	M9	Y	-0.039	-0.04	43.8	58.4	Active
25	M9	Y	-0.04	-0.041	58.4	73	Active

Member Area Loads (BLC 5 : Live Load)

	Node A	Node B	Node C	Node D	Direction	Load Direction	Magnitude [ksf]	Inactive [(k,...
1	N1	N2	N4	N3	Y	A-B	-0.02	Active

Member Area Loads (BLC 6 : Snow Load)

	Node A	Node B	Node C	Node D	Direction	Load Direction	Magnitude [ksf]	Inactive [(k,...
1	N1	N3	N4	N2	Y	B-C	-0.03	Active

Member Area Loads (BLC 7 : Grating and Rails)

	Node A	Node B	Node C	Node D	Direction	Load Direction	Magnitude [ksf]	Inactive [(k,...
1	N1	N2	N4	N3	Y	A-B	-0.01	Active

Basic Load Cases

	BLC Desc...	Category	X Gravity	Y Gravity	Z Gravity	Nodal	Point	Distributed	Area(Me...	Surface(P...
1	Self Weight	DL		-1						
2	Weight of...	DL				12				
3	Wind X-Di...	WLX				24				
4	Wind Z-Di...	WLZ				24				
5	Live Load	LL							1	
6	Snow Load	SL							1	
7	Grating a...	DL							1	
8	BLC 5 Tra...	None						25		
9	BLC 6 Tra...	None						25		
10	BLC 7 Tra...	None						25		

Load Combinations

De...	So...	PD...	SR...	BLC Fa...	BLC Fa...	BLC Fa...	BLC Fa...	BLC Fa...	BLC Fa...	BLC Fa...	BLC Fa...	BLC Fa...	BLC Fa...	BLC Fa...	
1	IB...	Yes	Y	DL	1										
2	IB...	Yes	Y	DL	1	LL	1	LLS	1						
3	IB...	Yes	Y	DL	1	RLL	1								
4	IB...	Yes	Y	DL	1	SL	1	SLN	1						
5	IB...	Yes	Y	DL	1	RL	1								
6	IB...	Yes	Y	DL	1	LL	0.75	LLS	0.75	RLL	0.75				
7	IB...	Yes	Y	DL	1	LL	0.75	LLS	0.75	SL	0.75	SLN	0.75		
8	IB...	Yes	Y	DL	1	LL	0.75	LLS	0.75	RL	0.75				
9	IB...	Yes	Y	DL	1	WLX	0.6								
10	IB...	Yes	Y	DL	1	WLZ	0.6								
11	IB...	Yes	Y	DL	1	WLX	-0.6								
12	IB...	Yes	Y	DL	1	WLX	-0.6								
13	IB...	Yes	Y	DL	1	WLX	0.45	LL	0.75	LLS	0.75	RLL	0.75		
14	IB...	Yes	Y	DL	1	WLZ	0.45	LL	0.75	LLS	0.75	RLL	0.75		
15	IB...	Yes	Y	DL	1	WLX	-0.45	LL	0.75	LLS	0.75	RLL	0.75		
16	IB...	Yes	Y	DL	1	WLZ	-0.45	LL	0.75	LLS	0.75	RLL	0.75		
17	IB...	Yes	Y	DL	1	WLX	0.45	LL	0.75	LLS	0.75	SL	0.75	SLN	0.75
18	IB...	Yes	Y	DL	1	WLZ	0.45	LL	0.75	LLS	0.75	SL	0.75	SLN	0.75
19	IB...	Yes	Y	DL	1	WLX	-0.45	LL	0.75	LLS	0.75	SL	0.75	SLN	0.75
20	IB...	Yes	Y	DL	1	WLZ	-0.45	LL	0.75	LLS	0.75	SL	0.75	SLN	0.75
21	IB...	Yes	Y	DL	1	WLX	0.45	LL	0.75	LLS	0.75	RL	0.75		
22	IB...	Yes	Y	DL	1	WLZ	0.45	LL	0.75	LLS	0.75	RL	0.75		
23	IB...	Yes	Y	DL	1	WLX	-0.45	LL	0.75	LLS	0.75	RL	0.75		
24	IB...	Yes	Y	DL	1	WLZ	-0.45	LL	0.75	LLS	0.75	RL	0.75		
25	IB...	Yes	Y	DL	0.6	WLX	0.6								
26	IB...	Yes	Y	DL	0.6	WLZ	0.6								
27	IB...	Yes	Y	DL	0.6	WLX	-0.6								
28	IB...	Yes	Y	DL	0.6	WLZ	-0.6								

Node Reactions

	Node...		X [k]	LC	Y [k]	LC	Z [k]	LC	MX [k-ft]	LC	MY [k-ft]	LC	MZ [k-ft]	LC
1	N7	max	0.236	27	1.474	18	0.257	28	0	28	0	28	0	28
2		min	-0.236	9	0.478	28	-0.257	10	0	1	0	1	0	1
3	N9	max	0.236	27	1.495	18	0.267	28	0	28	0	28	0	28
4		min	-0.236	9	0.469	28	-0.267	10	0	1	0	1	0	1

Node Reactions (Continued)

Node...	X [k]	LC	Y [k]	LC	Z [k]	LC	MX [k-ft]	LC	MY [k-ft]	LC	MZ [k-ft]	LC		
5	N5	max	0.236	27	1.45	18	0.246	28	0	28	0	28	0	28
6		min	-0.236	9	0.486	28	-0.246	10	0	1	0	1	0	1
7	N1	max	0.236	27	1.439	19	0.239	28	0	28	0	28	0	28
8		min	-0.236	9	0.481	25	-0.239	10	0	1	0	1	0	1
9	N2	max	0.236	27	1.53	17	0.276	28	0	28	0	28	0	28
10		min	-0.236	9	0.438	27	-0.276	10	0	1	0	1	0	1
11	N4	max	0.006	27	0.733	20	0.066	28	0	28	0	28	0	28
12		min	-0.006	9	0.055	26	-0.066	10	0	1	0	1	0	1
13	N10	max	0.006	27	0.867	20	0.069	28	0	28	0	28	0	28
14		min	-0.006	9	0.073	26	-0.069	10	0	1	0	1	0	1
15	N8	max	0.006	27	0.863	20	0.071	28	0	28	0	28	0	28
16		min	-0.006	9	0.074	26	-0.071	10	0	1	0	1	0	1
17	N6	max	0.006	27	0.787	20	0.057	28	0	28	0	28	0	28
18		min	-0.006	9	0.069	26	-0.057	10	0	1	0	1	0	1
19	N3	max	0.006	27	0.652	20	0.054	28	0	28	0	28	0	28
20		min	-0.006	9	0.053	26	-0.054	10	0	1	0	1	0	1
21	Totals:	max	1.212	27	10.185	20	1.603	28						
22		min	-1.212	9	4.149	26	-1.603	10						

Asd360

Member	Shape	Code...	Loc [in]	LC	Shear...	Loc [in]	Dir	LC	Pnc/o...	Pnt/o...	Mnyy/...	Mnzz/...	Cb	Eqn	
1	M3	W10X...	0.099	28.896	17	0.057	0	y	17	48.389	76.311	3.126	22.635	1.3	H1-1b
2	M4	W10X...	0.096	26.615	19	0.053	0	y	19	48.389	76.311	3.126	22.635	1.344	H1-1b
3	M5	W10X...	0.095	26.615	19	0.054	0	y	18	48.389	76.311	3.126	22.635	1.21	H1-1b
4	M7	W10X...	0.095	26.615	17	0.055	0	y	18	48.389	76.311	3.126	22.558	1.201	H1-1b
5	M9	W10X...	0.098	26.615	17	0.055	0	y	18	48.389	76.311	3.126	22.635	1.231	H1-1b

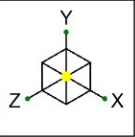

Code Check (Env)	
Black	No Calc
Red	> 1.0
Magenta	.90-1.0
Green	.75-.90
Cyan	.50-.75
Blue	.0-.50

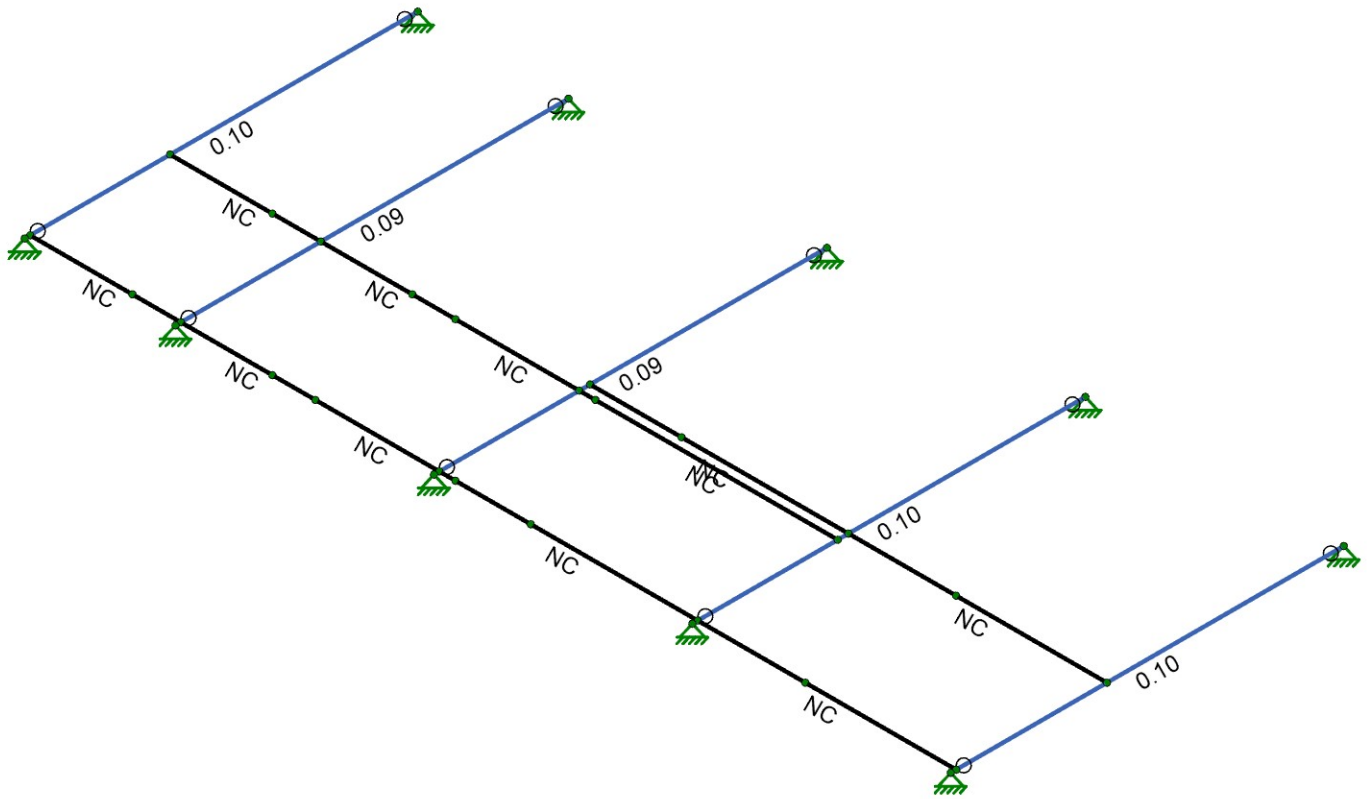

Member Code Checks Displayed (Enveloped)
Envelope Only Solution

Centek Engineering

PPG

20074.12

CT11108A - Platform Frame

SK-1

Apr 15, 2021

Platform Frame.r3d

RAN Template: 4Sec-67D5A997DB Outdoor	A&L Template: 4Sec-67D5997DB_2xAIR+1OP (U21 Market)
---	---

Section 1 - Site Information

Site ID: CT11108A
Status: Draft
Version: 6
Project Type: Anchor
Approved: Not Approved
Approved By: Not Approved
Last Modified: 5/11/2021 11:31:13 AM
Last Modified By: Dominic.Kallas2@T-Mobile.com

Site Name: Danbury Hospital
Site Class: Roof Top Mount
Site Type: Building
Plan Year: 2020
Market: CONNECTICUT CT
Vendor: Ericsson
Landlord: <undefined>

Latitude: 41.40506400
Longitude: -73.44554500
Address: 24 Hospital Ave (Danbury Hospital)
City, State: Danbury, CT
Region: NORTHEAST

RAN Template: 4Sec-67D5A997DB Outdoor		AL Template: 4Sec-67D5997DB_2xAIR+1OP (U21 Market)		
Sector Count: 4	Antenna Count: 12	Coax Line Count: 6	TMA Count: 3	RRU Count: 8

Section 2 - Existing Template Images

4Sec-67D92DB_2xAIR+1OP.JPG

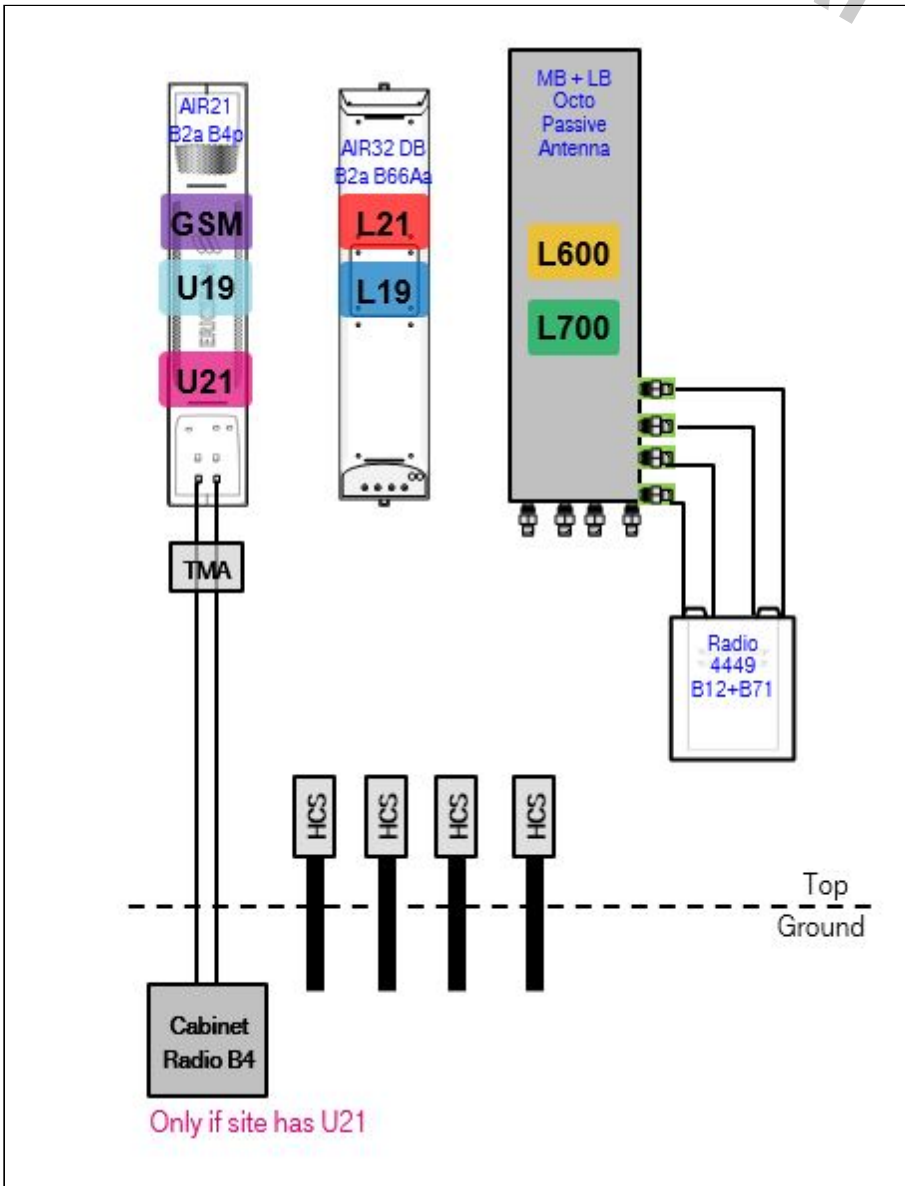

Notes:

Section 3 - Proposed Template Images

67D5997DB.jpg

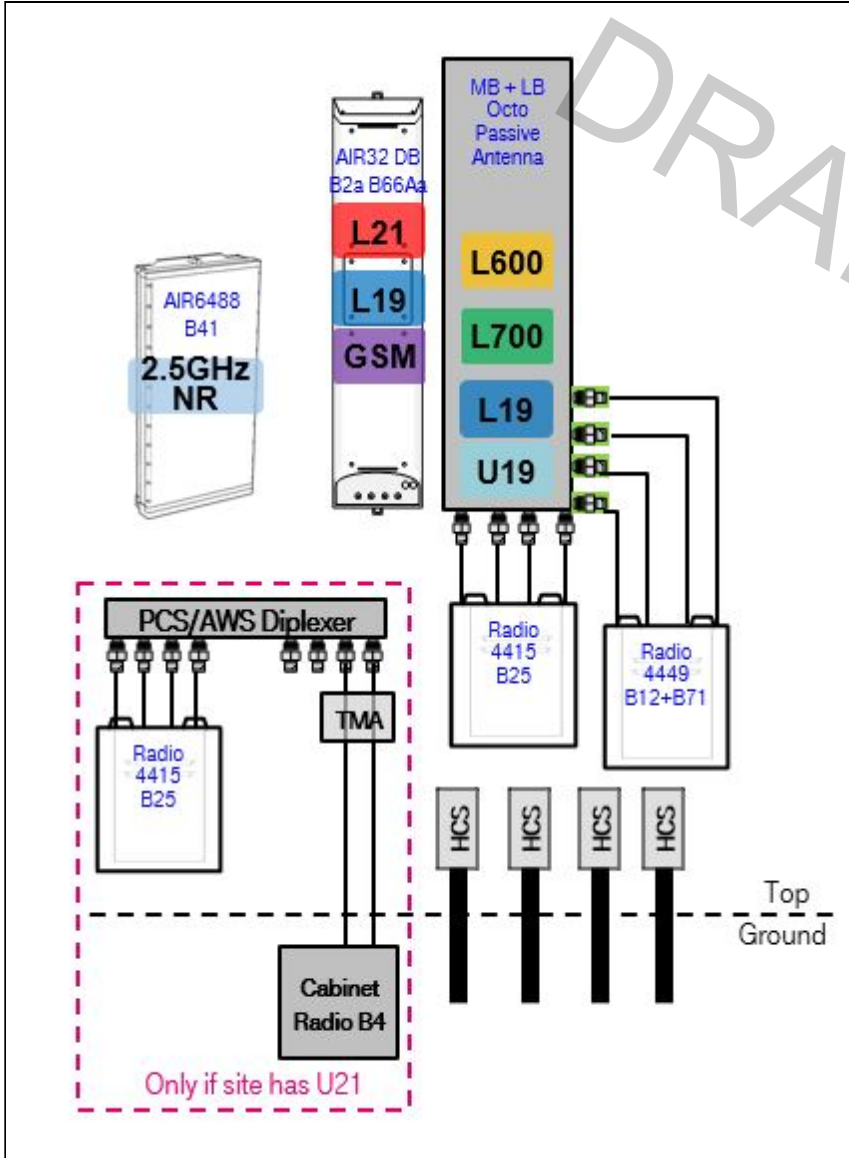

Notes:

Section 4 - Siteplan Images

----- This section is intentionally blank. -----

DRAFT

RAN Template: 4Sec-67D5A997DB Outdoor	A&L Template: 4Sec-67D5997DB_2xAIR+1OP (U21 Market)
---	---

Section 5 - RAN Equipment

Existing RAN Equipment

Template: 4Sec-67D92DB Outdoor

Enclosure	1	2
Enclosure Type	RBS 6131	Ancillary Equipment (Ericsson)
Baseband	DUW30 U1900 (DECOMMISSIONED)	DUW30 U2100
	DUG20 G1900	BB 5216 L2100 L1900
		BB 6630 L700 L600 N600
Hybrid Cable System		Ericsson 9x18 HCS *Select Length* Ericsson 6x12 HCS *Select Length & AWG* (x 2) Ericsson 6x12 HCS *Select AWG & Length*
Multiplexer	XMU	
Radio	RU22 (x 6) U2100	

Proposed RAN Equipment

Template: 4Sec-67D5A997DB Outdoor

Enclosure	1	2	3
Enclosure Type	RBS 6131	Enclosure 6160	B160
Baseband	DUW30 U2100	DUG20 G1900	
	BB 6648 L2100 L1900	BB 6630 L700 L600 N600	
		BB 6648 L2500 N2500	
Hybrid Cable System	Ericsson 6x12 HCS *Select Length & AWG* (x 4)	Ericsson 6x12 HCS *Select Length & AWG* (x 4)	
		PSU 4813 (x 2)	
Transport System		CSR IXRe V2 (Gen2)	

RAN Scope of Work:

*** Only RBS6131 at site. No Nortel cabinets. ***
 *** 200 A Service at site. ***
 Cabinet radios in existing RBS6131 base station cabinet will become unused. Remove cabinet radios.
 Replace BB5216 and XMU with (1) BB6648 for L2100 and L1900 (both carriers) in existing RBS6131 base station cabinet.
 Add (1) Enclosure 6160.
 Add (1) Battery Cabinet B160.
 Add (1) iXRe Router to new Enclosure 6160.
 Add (1) BB6648 for L2500 and N2500 (MMBB - Mixed Mode Baseband) to new Enclosure 6160.
 Add (2) PSU4813 Voltage Boosters to new Enclosure 6160.
 Existing: (24) Coaxial Lines ([6] in use); (4) 6X12 HCS.
 Add (4) 6X12 HCS ([1] per sector) terminating at the Enclosure 6160. Connect DC for the AIR6449 to the PSU4813 Voltage Booster.

RAN Template: 4Sec-67D5A997DB Outdoor	A&L Template: 4Sec-67D5997DB_2xAIR+1OP (U21 Market)
---	---

Section 6 - A&L Equipment

Existing Template: 4Sec-67D92DB_2xAIR+1OP
Proposed Template: 4Sec-67D5997DB_2xAIR+1OP (U21 Market)

Sector 1 (Existing) view from behind

Coverage Type	A - Outdoor Macro									
Antenna	1		2				3		4	
Antenna Model	Ericsson - AIR21 KRC118023-1_B2A_B4P (Quad)		Ericsson - AIR32 KRD901146-1_B66A_B2A (Octo)				RFS - APXVAARR24_43-U-NA20 (Octo)		Empty Antenna Mount (Empty mount)	
Azimuth	60		60				60			
M. Tilt	0		0				0			
Height	154		154				154			
Ports	P1	P2	P3	P4	P5	P6	P7	P8	P9	P10
Active Tech.	G1900	U2100	L2100	L2100	L1900	L1900	L700 L600 N600	L700 L600 N600		
Dark Tech.										
Restricted Tech.										
Decomm. Tech.	U1900									
E. Tilt										
Cables		1-5/8" Coax (x2) Coax Jumper (x2)					Coax Jumper (x2)	Coax Jumper (x2)		
TMA's		Generic Twin Style 1B - AWS (AtAntenna)								
Diplexers / Combiners										
Radio							Radio 4449 B71 +B85 (At Antenna)			
Sector Equipment										

Unconnected Equipment:

Scope of Work:

RAN Template: 4Sec-67D5A997DB Outdoor	A&L Template: 4Sec-67D5997DB_2xAIR+1OP (U21 Market)
---	---

Sector 1 (Proposed) view from behind

Coverage Type	A - Outdoor Macro										
Antenna	1		2				3			4	
Antenna Model	Ericsson - AIR6449 B41 (Active Antenna - Massive MIMO)		Ericsson - AIR32 KRD901146-1_B66A_B2A (Octo)				RFS - APXVAARR24_43-U-NA20 (Octo)			Empty Antenna Mount (Empty mount)	
Azimuth	60		60				60				
M. Tilt	0		0				0				
Height	154		154				154				
Ports	P1	P2	P3	P4	P5	P6	P7	P8	P9	P10	
Active Tech.	L2500 N2500	L2500 N2500	L2100	L2100	L1900 G1900	L1900 G1900	L700 L600 N600	L700 L600 N600	L1900	U2100 L1900	
Dark Tech.											
Restricted Tech.											
Decomm. Tech.											
E. Tilt											
Cables	Fiber Jumper (x2)	Fiber Jumper (x2)	Fiber Jumper	Fiber Jumper	Fiber Jumper	Fiber Jumper	Coax Jumper (x2) Fiber Jumper	Coax Jumper (x2) Fiber Jumper	Coax Jumper (x2) Fiber Jumper	Coax Jumper (x2) 1-5/8" Coax (x2) Fiber Jumper	
TMA's										Generic Twin Style 1B - AWS (AtAntenna)	
Diplexers / Combiners									Com msc ope - SDX 192 6Q-43 (E14 F05 P86) (AtAntenna)	SHAR ED Com msc ope - SDX 192 6Q-43 (E14 F05 P86) (AtAntenna)	
Radio							Radio 4449 B71 +B85 (AtAntenna)	SHAR ED Radio 4449 B71 +B85 (AtAntenna)	Radio 4415 B25 (AtAntenna)	SHAR ED Radio 4415 B25 (AtAntenna)	
Sector Equipment											

Unconnected Equipment:

Scope of Work:

Remove AIR21 B2A/B4P from Position 1.

Install (1) AIR6449 B41 for L2500 and N2500 in Position 1.

Move GSM to AIR32 Dual Band antenna in Position 2. GSM will share B2 radios with L1900 1st Carrier.

Add (1) PCS/AWS 8:4 diplexer to Position 3 at antenna, and connect its four common ports to the Mid-Band ports of the Octo Antenna.

Add (1) Radio 4415 B25 for L1900 2nd Carrier to Position 3 near antenna, and connect its ports to the four PCS ports of the diplexer.

Move coaxial lines and AWS TMA for U2100 to Position 3, and connect to two AWS ports of the diplexer.

Make sure to install metal caps on all empty ports of AWS/PCS diplexer for load balancing.

Ensure RET control is enabled for all technology layers according to the Design Documents.

*A dashed border indicates shared equipment. Any connected equipment is denoted with the SHARED keyword.

RAN Template: 4Sec-67D5A997DB Outdoor	A&L Template: 4Sec-67D5997DB_2xAIR+1OP (U21 Market)
---	---

Sector 2 (Existing) view from behind																
Coverage Type	A - Outdoor Macro															
Antenna	1			2			3			4						
Antenna Model	Ericsson - AIR21 KRC118023-1_B2A_B4P (Quad)			Empty Antenna Mount (Empty mount)			Ericsson - AIR32 KRD901146-1_B66A_B2A (Octo)			RFS - APXVAARR24_43-U-NA20 (Octo)						
Azimuth	180						150			150						
M. Tilt	0						0			0						
Height	154						154			154						
Ports	P1		P2				P3		P4	P5	P6	P7	P8	P9	P10	
Active Tech.	G1900		U2100				L2100	L2100	L1900	L1900	L700	L700	L600	L600	N600	N600
Dark Tech.																
Restricted Tech.																
Decomm. Tech.	U1900															
E. Tilt																
Cables			1-5/8" Coax (x2)										Coax Jumper (x2)	Coax Jumper (x2)		
TMA's			Generic Twin Style 1B - AWS (AtAntenna)													
Diplexers / Combiners																
Radio												Radio 4449 B71 +B85 (At Antenna)				
Sector Equipment																
Unconnected Equipment:																
Scope of Work:																

RAN Template: 4Sec-67D5A997DB Outdoor	A&L Template: 4Sec-67D5997DB_2xAIR+1OP (U21 Market)
---	---

Sector 2 (Proposed) view from behind

Coverage Type	A - Outdoor Macro												
Antenna	1			2			3			4			
Antenna Model	Empty Antenna Mount (Empty mount)			Ericsson - AIR6449 B41 (Active Antenna - Massive MIMO)			Ericsson - AIR32 KRD901146-1_B66A_B2A (Octo)			RFS - APXVAARR24_43-U-NA20 (Octo)			
Azimuth				150			150			150			
M. Tilt				0			0			0			
Height				154			154			154			
Ports				P1	P2	P3	P4	P5	P6	P7	P8	P9	P10
Active Tech.				L2500 N2500	L2500 N2500	L2100	L2100	L1900 G1900	L1900 G1900	L700 L600 N600	L700 L600 N600	L1900	U2100 L1900
Dark Tech.													
Restricted Tech.													
Decomm. Tech.													
E. Tilt													
Cables				Fiber Jumper (x2)	Fiber Jumper (x2)	Fiber Jumper	Fiber Jumper	Fiber Jumper	Fiber Jumper	Coax Jumper (x2) Fiber Jumper	Coax Jumper (x2) Fiber Jumper	Coax Jumper (x2) Fiber Jumper	Coax Jumper (x2) 1-5/8" Coax (x2) Fiber Jumper
TMA's													
Diplexers / Combiners													
Radio													
Sector Equipment													

Unconnected Equipment:

Scope of Work:

Remove AIR21 B2A/B4P from Position 1.

Install (1) AIR6449 B41 for L2500 and N2500 in Position 2.

Move GSM to AIR32 Dual Band antenna in Position 3. GSM will share B2 radios with L1900 1st Carrier.

Add (1) PCS/AWS 8:4 diplexer to Position 4 at antenna, and connect its four common ports to the Mid-Band ports of the Octo Antenna.

Add (1) Radio 4415 B25 for L1900 2nd Carrier to Position 4 near antenna, and connect its ports to the four PCS ports of the diplexer.

Move coaxial lines and AWS TMA for U2100 to Position 4, and connect to two AWS ports of the diplexer.

Make sure to install metal caps on all empty ports of AWS/PCS diplexer for load balancing.

Ensure RET control is enabled for all technology layers according to the Design Documents.

*A dashed border indicates shared equipment. Any connected equipment is denoted with the SHARED keyword.

RAN Template: 4Sec-67D5A997DB Outdoor	A&L Template: 4Sec-67D5997DB_2xAIR+1OP (U21 Market)
---	---

Sector 3 (Existing) view from behind												
Coverage Type	A - Outdoor Macro											
Antenna	1			2				3				
Antenna Model	Ericsson - AIR21 KRC118023-1_B2A_B4P (Quad)			RFS - APXVAARR24_43-U-NA20 (Octo)				Ericsson - AIR32 KRD901146-1_B66A_B2A (Octo)				
Azimuth	300			300				300				
M. Tilt	0			0				0				
Height	127			127				127				
Ports	P1		P2		P3	P4	P5	P6	P7	P8	P9	P10
Active Tech.	G1900		U2100		L700	L700			L2100	L2100	L1900	L1900
					L600	L600						
					N600	N600						
Dark Tech.												
Restricted Tech.												
Decomm. Tech.	U1900											
E. Tilt												
Cables			1-5/8" Coax (x2) Coax Jumper (x2)		Coax Jumper (x2)	Coax Jumper (x2)						
TMAS			Generic Twin Style 1B - AWS (AtAntenna)									
Diplexers / Combiners												
Radio					Radio 4449 B71+B8 5 (At Antenna)							
Sector Equipment												
Unconnected Equipment:												
Scope of Work:												

RAN Template: 4Sec-67D5A997DB Outdoor	A&L Template: 4Sec-67D5997DB_2xAIR+1OP (U21 Market)
---	---

Sector 3 (Proposed) view from behind

Coverage Type	A - Outdoor Macro										
Antenna	1		2				3			4	
Antenna Model	Ericsson - AIR6449 B41 (Active Antenna - Massive MIMO)		RFS - APXVAARR24_43-U-NA20 (Octo)				Ericsson - AIR32 KRD901146-1_B66A_B2A (Octo)			Empty Antenna Mount (Empty mount)	
Azimuth	300		300				300				
M. Tilt	0		0				0				
Height	127		127				127				
Ports	P1	P2	P3	P4	P5	P6	P7	P8	P9	P10	
Active Tech.	L2500 N2500	L2500 N2500	L700 L600 N600	L700 L600 N600	L1900	L1900 U2100	L2100	L2100	L1900 G1900	L1900 G1900	
Dark Tech.											
Restricted Tech.											
Decomm. Tech.											
E. Tilt											
Cables	Fiber Jumper (x2)	Fiber Jumper (x2)	Coax Jumper (x2) Fiber Jumper	Coax Jumper (x2) Fiber Jumper	Coax Jumper (x2) Fiber Jumper	Coax Jumper (x2) 1-5/8" Coax (x2) Fiber Jumper	Fiber Jumper	Fiber Jumper	Fiber Jumper	Fiber Jumper	
TMAs						Generic Twin Style 1B - AWS (AtAntenna)					
Diplexers / Combiners					Com msc ope SDX 192 6Q-43 (E14 F05 P86) (AtAntenna)	SHARED Com msc ope SDX 192 6Q-43 (E14 F05 P86) (AtAntenna)					
Radio			Radio 4449 B71 +B85 (AtAntenna)	SHARED Radio 4449 B71 +B85 (AtAntenna)	Radio 4415 B25 (AtAntenna)	SHARED Radio 4415 B25 (AtAntenna)					
Sector Equipment											

Unconnected Equipment:

Scope of Work:

Remove AIR21 B2A/B4P from Position 1.

Install (1) AIR6449 B41 for L2500 and N2500 in Position 1.

Move GSM to AIR32 Dual Band antenna in Position 3. GSM will share B2 radios with L1900 1st Carrier.

Add (1) PCS/AWS 8:4 diplexer to Position 2 at antenna, and connect its four common ports to the Mid-Band ports of the Octo Antenna.

Add (1) Radio 4415 B25 for L1900 2nd Carrier to Position 2 near antenna, and connect its ports to the four PCS ports of the diplexer.

Move coaxial lines and AWS TMA for U2100 to Position 2, and connect to two AWS ports of the diplexer.

Make sure to install metal caps on all empty ports of AWS/PCS diplexer for load balancing.

Ensure RET control is enabled for all technology layers according to the Design Documents.

*A dashed border indicates shared equipment. Any connected equipment is denoted with the SHARED keyword.

RAN Template: 4Sec-67D5A997DB Outdoor	A&L Template: 4Sec-67D5997DB_2xAIR+1OP (U21 Market)
---	---

Sector 4 (Existing) view from behind								
Coverage Type	A - Outdoor Macro							
Antenna	1				2			
Antenna Model	Ericsson - AIR32 KRD901146-1_B66A_B2A (Octo)				RFS - APXVAARR24_43-U-NA20 (Octo)			
Azimuth	210				210			
M. Tilt	0				0			
Height	154				154			
Ports	P1	P2	P3	P4	P5	P6	P7	P8
Active Tech.	L2100	L2100	L1900 G1900	L1900	L700 L600 N600	L700 L600 N600		
Dark Tech.								
Restricted Tech.								
Decomm. Tech.								
E. Tilt								
Cables					Coax Jumper (x2)	Coax Jumper (x2)		
TMA's								
Diplexers / Combiners								
Radio					Radio 4449 B71+B85 (At Antenna)			
Sector Equipment								
Unconnected Equipment:								
<div style="display: flex; justify-content: space-between; align-items: center;"> <div style="border: 1px solid black; border-radius: 5px; padding: 2px 5px;">Cable: Generic Feeder Coax</div> <div style="border: 1px solid black; border-radius: 5px; padding: 2px 5px;">Cable: Generic Feeder Coax</div> <div style="border: 1px solid black; border-radius: 5px; padding: 2px 5px;">Cable: Coax Jumper</div> <div style="border: 1px solid black; border-radius: 5px; padding: 2px 5px;">Cable: Coax Jumper</div> <div style="border: 1px solid black; border-radius: 5px; padding: 2px 5px;">TMA: Generic Twin Style 1B - AWS</div> </div>								
Scope of Work:								

RAN Template: 4Sec-67D5A997DB Outdoor	A&L Template: 4Sec-67D5997DB_2xAIR+1OP (U21 Market)
---	---

Sector 4 (Proposed) view from behind												
Coverage Type	A - Outdoor Macro											
Antenna	1			2				3				
Antenna Model	Ericsson - AIR6449 B41 (Active Antenna - Massive MIMO)			Ericsson - AIR32 KRD901146-1_B66A_B2A (Octo)				RFS - APXVAARR24_43-U-NA20 (Octo)				
Azimuth	210			210				210				
M. Tilt	0			0				0				
Height	154			154				154				
Ports	P1		P2		P3	P4	P5	P6	P7	P8	P9	P10
Active Tech.	L2500	N2500	L2500	N2500	L2100	L2100	L1900 G1900	L1900 G1900	L700 L600 N600	L700 L600 N600	L1900	L1900
Dark Tech.												
Restricted Tech.												
Decomm. Tech.												
E. Tilt												
Cables	Fiber Jumper (x2)		Fiber Jumper (x2)		Fiber Jumper	Fiber Jumper	Fiber Jumper	Fiber Jumper	Coax Jumper (x2) Fiber Jumper	Coax Jumper (x2) Fiber Jumper	Coax Jumper (x2) Fiber Jumper	Coax Jumper (x2) Fiber Jumper
TMA's												
Diplexers / Combiners												
Radio									Radio 4449 B71+B8 5 (At Antenna)	SHARED Radio 4449 B71+B8 5 (At Antenna)	Radio 4415 B25 (At Antenna)	SHARED Radio 4415 B25 (At Antenna)
Sector Equipment												

Unconnected Equipment:

Scope of Work:

*** No U2100 on Delta Sector. ***

Add new mount for new Position 1.

Install (1) AIR6449 B41 for L2500 and N2500 in Position 1.

Add (1) Radio 4415 B25 for L1900 2nd Carrier to New Position 3 near antenna, and connect its ports to the Mid-Band ports of the Octo Antenna.

Ensure RET control is enabled for all technology layers according to the Design Documents.

*A dashed border indicates shared equipment. Any connected equipment is denoted with the SHARED keyword.

RAN Template: 4Sec-67D5A997DB Outdoor	A&L Template: 4Sec-67D5997DB_2xAIR+1OP (U21 Market)
---	---

Section 7 - Power Systems Equipment

Existing Power Systems Equipment

----- This section is intentionally blank. -----

Proposed Power Systems Equipment

RADIO FREQUENCY EMISSIONS ANALYSIS REPORT
EVALUATION OF HUMAN EXPOSURE POTENTIAL
TO NON-IONIZING EMISSIONS

T-Mobile Existing Facility

Site ID: CT11108A

Danbury Hospital
24 Hospital Ave (Danbury Hospital)
Danbury, Connecticut 06810

June 23, 2021

EBI Project Number: 6221003241

Site Compliance Summary	
Compliance Status:	COMPLIANT
Site total MPE% of FCC general population allowable limit:	26.96%

June 23, 2021

T-Mobile

Attn: Jason Overbey, RF Manager
35 Griffin Road South
Bloomfield, Connecticut 06002

Emissions Analysis for Site: CT11108A - Danbury Hospital

EBI Consulting was directed to analyze the proposed T-Mobile facility located at **24 Hospital Ave (Danbury Hospital) in Danbury, Connecticut** for the purpose of determining whether the emissions from the Proposed T-Mobile Antenna Installation located on this property are within specified federal limits.

All information used in this report was analyzed as a percentage of current Maximum Permissible Exposure (% MPE) as listed in the FCC OET Bulletin 65 Edition 97-01 and ANSI/IEEE Std C95.1. The FCC regulates Maximum Permissible Exposure in units of microwatts per square centimeter ($\mu\text{W}/\text{cm}^2$). The number of $\mu\text{W}/\text{cm}^2$ calculated at each sample point is called the power density. The exposure limit for power density varies depending upon the frequencies being utilized. Wireless Carriers and Paging Services use different frequency bands each with different exposure limits; therefore, it is necessary to report results and limits in terms of percent MPE rather than power density.

All results were compared to the FCC (Federal Communications Commission) radio frequency exposure rules, 47 CFR 1.1307(b)(1) – (b)(3), to determine compliance with the Maximum Permissible Exposure (MPE) limits for General Population/Uncontrolled environments as defined below.

General population/uncontrolled exposure limits apply to situations in which the general population may be exposed or in which persons who are exposed as a consequence of their employment may not be made fully aware of the potential for exposure or cannot exercise control over their exposure. Therefore, members of the general population would always be considered under this category when exposure is not employment related, for example, in the case of a telecommunications tower that exposes persons in a nearby residential area.

Public exposure to radio frequencies is regulated and enforced in units of microwatts per square centimeter ($\mu\text{W}/\text{cm}^2$). The general population exposure limits for the 600 MHz and 700 MHz frequency bands are approximately $400 \mu\text{W}/\text{cm}^2$ and $467 \mu\text{W}/\text{cm}^2$, respectively. The general population exposure limit for the 1900 MHz (PCS), 2100 MHz (AWS) and 11 GHz frequency bands is $1000 \mu\text{W}/\text{cm}^2$. Because each carrier will be using different frequency bands, and each frequency band has different exposure limits, it is necessary to report percent of MPE rather than power density.

Occupational/controlled exposure limits apply to situations in which persons are exposed as a consequence of their employment and in which those persons who are exposed have been made fully aware of the potential for exposure and can exercise control over their exposure. Occupational/controlled exposure limits also apply where exposure is of a transient nature as a result of incidental passage through a location where exposure levels may be above general population/uncontrolled limits (see below), as long as the exposed person has been made fully aware of the potential for exposure and can exercise control over his or her exposure by leaving the area or by some other appropriate means.

Additional details can be found in FCC OET 65.

CALCULATIONS

Calculations were done for the proposed T-Mobile Wireless antenna facility located at 24 Hospital Ave (Danbury Hospital) in Danbury, Connecticut using the equipment information listed below. All calculations were performed per the specifications under FCC OET 65. Since T-Mobile is proposing highly focused directional panel antennas, which project most of the emitted energy out toward the horizon, all calculations were performed assuming a lobe representing the maximum gain of the antenna per the antenna manufacturer's supplied specifications, minus 10 dB for directional panel antennas and 20 dB for highly focused parabolic microwave dishes, was focused at the base of the tower. For this report, the sample point is the top of a 6-foot person standing at the base of the tower. For power density calculations, the broadcast footprint of the AIR6449 antenna has been considered. Due to the beamforming nature of this antenna, the actual beam locations vary depending on demand and are narrow in nature. Using the broadcast footprint accounts for the potential location of beams at any given time.

For all calculations, all equipment was calculated using the following assumptions:

- 1) 2 LTE channels (600 MHz Band) were considered for each sector of the proposed installation. These Channels have a transmit power of 30 Watts per Channel.
- 2) 1 NR channel (600 MHz Band) was considered for each sector of the proposed installation. This Channel has a transmit power of 80 Watts.
- 3) 2 LTE channels (700 MHz Band) were considered for each sector of the proposed installation. These Channels have a transmit power of 30 Watts per Channel.
- 4) 4 GSM channels (PCS Band - 1900 MHz) were considered for each sector of the proposed installation. These Channels have a transmit power of 30 Watts per Channel.
- 5) 4 LTE channels (PCS Band - 1900 MHz) were considered for each sector of the proposed installation. These Channels have a transmit power of 60 Watts per Channel.

- 6) 2 UMTS channels (AWS Band - 2100 MHz) were considered for each sector of the proposed installation. These Channels have a transmit power of 30 Watts per Channel.
- 7) 2 LTE channels (AWS Band – 2100 MHz) were considered for each sector of the proposed installation. These Channels have a transmit power of 60 Watts per Channel.
- 8) 1 LTE Traffic channel (LTE IC and 2C BRS Band - 2500 MHz) was considered for each sector of the proposed installation. This Channel has a transmit power of 60 Watts.
- 9) 1 LTE Broadcast channel (LTE IC and 2C BRS Band - 2500 MHz) was considered for each sector of the proposed installation. This Channel has a transmit power of 20 Watts.
- 10) 1 NR Traffic channel (BRS Band - 2500 MHz) was considered for each sector of the proposed installation. This Channel has a transmit power of 120 Watts.
- 11) 1 NR Broadcast channel (BRS Band - 2500 MHz) was considered for each sector of the proposed installation. This Channel has a transmit power of 40 Watts.
- 12) All radios at the proposed installation were considered to be running at full power and were uncombined in their RF transmissions paths per carrier prescribed configuration. Per FCC OET Bulletin No. 65 - Edition 97-01 recommendations to achieve the maximum anticipated value at each sample point, all power levels emitting from the proposed antenna installation are increased by a factor of 2.56 to account for possible in-phase reflections from the surrounding environment. This is rarely the case, and if so, is never continuous.
- 13) For the following calculations, the sample point was the top of a 6-foot person standing at the base of the tower. The maximum gain of the antenna per the antenna manufacturer's supplied specifications, minus 10 dB for directional panel antennas and 20 dB for highly focused parabolic microwave dishes, was used in this direction. This value is a very conservative estimate as gain reductions for these particular antennas are typically much higher in this direction.
- 14) The antennas used in this modeling are the Ericsson AIR 3246 for the 2100 MHz channel(s), the Ericsson AIR 32 for the 1900 MHz / 1900 MHz / 2100 MHz channel(s), the RFS APXVAARR24_43-U-NA20 for the 600 MHz / 600 MHz / 700 MHz / 1900 MHz channel(s), the Ericsson AIR 6449 for the 2500 MHz / 2500 MHz / 2500 MHz / 2500 MHz channel(s) in Sector A, the Ericsson AIR 32 for the 1900 MHz / 1900 MHz / 2100 MHz channel(s), the Ericsson AIR 6449 for the 2500 MHz / 2500 MHz / 2500 MHz / 2500 MHz channel(s), the RFS APXVAARR24_43-U-NA20 for the 600 MHz / 600 MHz / 700 MHz / 1900 MHz channel(s), the Ericsson AIR 6449 for the 2100 MHz channel(s) in Sector B, the Ericsson AIR 3246 for

the 2100 MHz channel(s), the RFS APXVAARR24_43-U-NA20 for the 600 MHz / 600 MHz / 700 MHz / 1900 MHz channel(s), the Ericsson AIR 32 for the 1900 MHz / 1900 MHz / 2100 MHz channel(s), the Ericsson AIR 6449 for the 2500 MHz / 2500 MHz / 2500 MHz / 2500 MHz channel(s) in Sector C, the Ericsson AIR 3246 for the 2100 MHz channel(s), the RFS APXVAARR24_43-U-NA20 for the 600 MHz / 600 MHz / 700 MHz / 1900 MHz channel(s), the Ericsson AIR 32 for the 1900 MHz / 1900 MHz / 2100 MHz channel(s), the Ericsson AIR 6449 for the 2500 MHz / 2500 MHz / 2500 MHz / 2500 MHz channel(s) in Sector D. This is based on feedback from the carrier with regard to anticipated antenna selection. All Antenna gain values and associated transmit power levels are shown in the Site Inventory and Power Data table below. The maximum gain of the antenna per the antenna manufacturer's supplied specifications, minus 10 dB for directional panel antennas and 20 dB for highly focused parabolic microwave dishes, was used for all calculations. This value is a very conservative estimate as gain reductions for these particular antennas are typically much higher in this direction.

- 15) The antenna mounting height centerline of the proposed antennas is 154 feet above ground level (AGL) in Sectors A, B, and D and 127 feet above ground level (AGL) in Sector C.
- 16) Emissions values for additional carriers were taken from the Connecticut Siting Council active database. Values in this database are provided by the individual carriers themselves.
- 17) All calculations were done with respect to uncontrolled / general population threshold limits.

T-Mobile Site Inventory and Power Data

Sector:	A	Sector:	B	Sector:	C	Sector:	D
Antenna #:	1	Antenna #:	1	Antenna #:	1	Antenna #:	1
Make / Model:	Ericsson AIR 3246	Make / Model:	Ericsson AIR 32	Make / Model:	Ericsson AIR 3246	Make / Model:	Ericsson AIR 3246
Frequency Bands:	2100 MHz	Frequency Bands:	1900 MHz / 1900 MHz / 2100 MHz	Frequency Bands:	2100 MHz	Frequency Bands:	2100 MHz
Gain:	15.85 dBd	Gain:	15.35 dBd / 15.35 dBd / 15.85 dBd	Gain:	15.85 dBd	Gain:	15.85 dBd
Height (AGL):	154 feet	Height (AGL):	154 feet	Height (AGL):	127 feet	Height (AGL):	154 feet
Channel Count:	4	Channel Count:	8	Channel Count:	4	Channel Count:	4
Total TX Power (W):	160 Watts	Total TX Power (W):	300 Watts	Total TX Power (W):	160 Watts	Total TX Power (W):	160 Watts
ERP (W):	6,153.47	ERP (W):	10,533.98	ERP (W):	6,153.47	ERP (W):	6,153.47
Antenna A1 MPE %:	1.01%	Antenna B1 MPE %:	1.73%	Antenna C1 MPE %:	1.51%	Antenna D1 MPE %:	1.01%
Antenna #:	2	Antenna #:	2	Antenna #:	2	Antenna #:	2
Make / Model:	Ericsson AIR 32	Make / Model:	Ericsson AIR 6449	Make / Model:	RFS APXVAARR24_43-U-NA20	Make / Model:	RFS APXVAARR24_43-U-NA20
Frequency Bands:	1900 MHz / 1900 MHz / 2100 MHz	Frequency Bands:	2500 MHz / 2500 MHz / 2500 MHz / 2500 MHz	Frequency Bands:	600 MHz / 600 MHz / 700 MHz / 1900 MHz	Frequency Bands:	600 MHz / 600 MHz / 700 MHz / 1900 MHz
Gain:	15.35 dBd / 15.35 dBd / 15.85 dBd	Gain:	22.65 dBd / 17.3 dBd / 22.65 dBd / 17.3 dBd	Gain:	12.95 dBd / 12.95 dBd / 13.35 dBd / 15.65 dBd	Gain:	12.95 dBd / 12.95 dBd / 13.35 dBd / 15.65 dBd
Height (AGL):	154 feet	Height (AGL):	154 feet	Height (AGL):	127 feet	Height (AGL):	154 feet
Channel Count:	8	Channel Count:	4	Channel Count:	7	Channel Count:	7
Total TX Power (W):	300 Watts	Total TX Power (W):	240 Watts	Total TX Power (W):	320 Watts	Total TX Power (W):	320 Watts
ERP (W):	10,533.98	ERP (W):	36,356.09	ERP (W):	8,466.41	ERP (W):	8,466.41
Antenna A2 MPE %:	1.73%	Antenna B2 MPE %:	5.97%	Antenna C2 MPE %:	3.46%	Antenna D2 MPE %:	2.31%
Antenna #:	3	Antenna #:	3	Antenna #:	3	Antenna #:	3
Make / Model:	RFS APXVAARR24_43-U-NA20	Make / Model:	RFS APXVAARR24_43-U-NA20	Make / Model:	Ericsson AIR 32	Make / Model:	Ericsson AIR 32
Frequency Bands:	600 MHz / 600 MHz / 700 MHz / 1900 MHz	Frequency Bands:	600 MHz / 600 MHz / 700 MHz / 1900 MHz	Frequency Bands:	1900 MHz / 1900 MHz / 2100 MHz	Frequency Bands:	1900 MHz / 1900 MHz / 2100 MHz
Gain:	12.95 dBd / 12.95 dBd / 13.35 dBd / 15.65 dBd	Gain:	12.95 dBd / 12.95 dBd / 13.35 dBd / 15.65 dBd	Gain:	15.35 dBd / 15.35 dBd / 15.85 dBd	Gain:	15.35 dBd / 15.35 dBd / 15.85 dBd
Height (AGL):	154 feet	Height (AGL):	154 feet	Height (AGL):	127 feet	Height (AGL):	154 feet
Channel Count:	7	Channel Count:	7	Channel Count:	8	Channel Count:	8
Total TX Power (W):	320 Watts	Total TX Power (W):	320 Watts	Total TX Power (W):	300 Watts	Total TX Power (W):	300 Watts
ERP (W):	8,466.41	ERP (W):	8,466.41	ERP (W):	10,533.98	ERP (W):	10,533.98
Antenna A3 MPE %:	2.31%	Antenna B3 MPE %:	2.31%	Antenna C3 MPE %:	2.59%	Antenna D3 MPE %:	1.73%
Antenna #:	4	Antenna #:	4	Antenna #:	4	Antenna #:	4
Make / Model:	Ericsson AIR 6449	Make / Model:	Ericsson AIR 6449	Make / Model:	Ericsson AIR 6449	Make / Model:	Ericsson AIR 6449
Frequency Bands:	2500 MHz / 2500 MHz / 2500 MHz / 2500 MHz	Frequency Bands:	2100 MHz	Frequency Bands:	2500 MHz / 2500 MHz / 2500 MHz	Frequency Bands:	2500 MHz / 2500 MHz / 2500 MHz

Gain:	22.65 dBd / 17.3 dBd / 22.65 dBd / 17.3 dBd	Gain:	15.85 dBd	Gain:	22.65 dBd / 17.3 dBd / 22.65 dBd / 17.3 dBd	Gain:	22.65 dBd / 17.3 dBd / 22.65 dBd / 17.3 dBd
Height (AGL):	154 feet	Height (AGL):	154 feet	Height (AGL):	127 feet	Height (AGL):	154 feet
Channel Count:	4	Channel Count:	4	Channel Count:	4	Channel Count:	4
Total TX Power (W):	240 Watts	Total TX Power (W):	160 Watts	Total TX Power (W):	240 Watts	Total TX Power (W):	240 Watts
ERP (W):	36,356.09	ERP (W):	6,153.47	ERP (W):	36,356.09	ERP (W):	36,356.09
Antenna A4 MPE %:	5.97%	Antenna B4 MPE %:	1.01%	Antenna C4 MPE %:	8.93%	Antenna D4 MPE %:	5.97%

Site Composite MPE %	
Carrier	MPE %
T-Mobile (Max at Sector C):	16.48%
Sprint	6.25%
Verizon	4.23%
Site Total MPE % :	26.96%

T-Mobile MPE % Per Sector	
T-Mobile Sector A Total:	11.02%
T-Mobile Sector B Total:	11.02%
T-Mobile Sector C Total:	16.48%
T-Mobile Sector D Total:	11.02%
Site Total MPE % :	
	26.96%

T-Mobile Maximum MPE Power Values (Sector C)							
T-Mobile Frequency Band / Technology (Sector C)	# Channels	Watts ERP (Per Channel)	Height (feet)	Total Power Density ($\mu\text{W}/\text{cm}^2$)	Frequency (MHz)	Allowable MPE ($\mu\text{W}/\text{cm}^2$)	Calculated % MPE
T-Mobile 2100 MHz LTE	4	1538.37	127.0	15.11	2100 MHz LTE	1000	1.51%
T-Mobile 600 MHz LTE	2	591.73	127.0	2.91	600 MHz LTE	400	0.73%
T-Mobile 600 MHz NR	1	1577.94	127.0	3.87	600 MHz NR	400	0.97%
T-Mobile 700 MHz LTE	2	648.82	127.0	3.19	700 MHz LTE	467	0.68%
T-Mobile 1900 MHz LTE	2	2203.69	127.0	10.82	1900 MHz LTE	1000	1.08%
T-Mobile 1900 MHz GSM	4	1028.30	127.0	10.10	1900 MHz GSM	1000	1.01%
T-Mobile 1900 MHz LTE	2	2056.61	127.0	10.10	1900 MHz LTE	1000	1.01%
T-Mobile 2100 MHz UMTS	2	1153.78	127.0	5.67	2100 MHz UMTS	1000	0.57%
T-Mobile 2500 MHz LTE IC & 2C Traffic	1	11044.63	127.0	27.12	2500 MHz LTE IC & 2C Traffic	1000	2.71%
T-Mobile 2500 MHz LTE IC & 2C Broadcast	1	1074.06	127.0	2.64	2500 MHz LTE IC & 2C Broadcast	1000	0.26%
T-Mobile 2500 MHz NR Traffic	1	22089.26	127.0	54.24	2500 MHz NR Traffic	1000	5.42%
T-Mobile 2500 MHz NR Broadcast	1	2148.13	127.0	5.27	2500 MHz NR Broadcast	1000	0.53%
						Total:	16.48%

• NOTE: Totals may vary by approximately 0.01% due to summation of remainders in calculations.

Summary

All calculations performed for this analysis yielded results that were **within** the allowable limits for general population exposure to RF Emissions.

The anticipated maximum composite contributions from the T-Mobile facility as well as the site composite emissions value with regards to compliance with FCC's allowable limits for general population exposure to RF Emissions are shown here:

T-Mobile Sector	Power Density Value (%)
Sector A:	11.02%
Sector B:	11.02%
Sector C:	16.48%
Sector D:	11.02%
T-Mobile Maximum MPE % (Sector C):	16.48%
Site Total:	26.96%
Site Compliance Status:	COMPLIANT

The anticipated composite MPE value for this site assuming all carriers present is **26.96%** of the allowable FCC established general population limit sampled at the ground level. This is based upon values listed in the Connecticut Siting Council database for existing carrier emissions.

FCC guidelines state that if a site is found to be out of compliance (over allowable thresholds), that carriers over a 5% contribution to the composite value will require measures to bring the site into compliance. For this facility, the composite values calculated were well within the allowable 100% threshold standard per the federal government.