

KENNETH C. BALDWIN

280 Trumbull Street
Hartford, CT 06103-3597
Main (860) 275-8200
Fax (860) 275-8299
kbaldwin@rc.com
Direct (860) 275-8345

Also admitted in Massachusetts
and New York

May 18, 2021

Via Electronic Mail

Melanie A. Bachman, Esq.
Executive Director/Staff Attorney
Connecticut Siting Council
10 Franklin Square
New Britain, CT 06051

Re: **Notice of Exempt Modification – Facility Modification
109 Federal Road, Danbury, Connecticut**

Dear Attorney Bachman:

Cellco Partnership d/b/a Verizon Wireless (“Cellco”) currently maintains an existing wireless telecommunications facility at the above-referenced address (the “Property”). The facility consists of antennas and remote radio heads attached to the roof-top tower and related equipment also located on the roof of the building. The tower and antennas are located within a faux chimney structure. Cellco’s existing facility was approved by the Council in April of 2015 (Petition No. 1149). A copy of the Council’s approval letter for Petition No. 1149 is included in Attachment 1.

Cellco now intends to modify its facility by removing two (2) antennas and installing two (2) antennas Samsung 64T64RMMU antennas, removing four (4) remote radio heads (“RRHs”) and installing two (2) RRHs on the existing roof-top tower. To meet antenna clearance requirements, the existing faux chimney enclosure will be replaced with a larger screening structure. Included in Attachment 2 is a set of project plans and new antennas and RRH specifications.

Please accept this letter as notification pursuant to R.C.S.A. § 16-50j-73, for construction that constitutes an exempt modification pursuant to R.C.S.A. § 16-50j-72(b)(2). In accordance with R.C.S.A. § 16-50j-73, a copy of this letter is being sent to Danbury’s Chief Elected Official and Land Use Officer.

Melanie A. Bachman, Esq.
May 18, 2021
Page 2

The planned modifications to the facility fall squarely within those activities explicitly provided for in R.C.S.A. § 16-50j-72(b)(2).

1. The proposed modifications will not result in an increase in the height of the existing tower or faux chimney screening structure.
2. The proposed modifications will occur on the roof of the building and will not require the extension of the site boundary.
3. The proposed modifications will not increase noise levels at the facility by six decibels or more, or to levels that exceed state and local criteria.
4. The installation of Cellco's new antennas and RRHs will not increase radio frequency (RF) emissions at the facility to a level at or above the Federal Communications Commission (FCC) safety standard. A General Power Density table for the modified facility is included in Attachment 3. The modified facility will be capable of providing Cellco's 5G wireless service.
5. The proposed modifications will not cause a change or alteration in the physical or environmental characteristics of the site.
6. According to the attached Structural Analysis (SA) and Mount (Antenna Frame) Analysis (MA) which also includes analysis of the new masts and host building, states that the existing building, faux chimney, antenna masts, and antenna mounting devices can support Cellco's proposed modifications. A copy of the SA and MA are included in Attachment 4. Also included in Attachment 4 is a separate letter prepared by the consulting engineer responsible for the preparation of the SL and MA verifying that the antenna model described in the SL and MA, as a Licensed-Sub6 Antenna or VZS01 Antenna, is the Samsung 64T64R model antenna and RRH that will be installed on the tower.

A copy of the parcel map and Property owner information is included in Attachment 5. A Certificate of Mailing verifying that this filing was sent to municipal officials is included in Attachment 6.

For the foregoing reasons, Cellco respectfully submits that the proposed modifications to the above-referenced telecommunications facility constitutes an exempt modification under R.C.S.A. § 16-50j-72(b)(2).

Melanie A. Bachman, Esq.
May 18, 2021
Page 3

Sincerely,

A handwritten signature in black ink, appearing to read "Kenneth C. Baldwin". The signature is fluid and cursive, with a long horizontal stroke at the end.

Kenneth C. Baldwin

Enclosures

Copy to:

Joseph M. Cavo, Danbury Mayor
Sharon Calitro, AICP, Danbury Director Planning and Zoning
109 Federal Road LLC
Aleksy Tyurin

ATTACHMENT 1



STATE OF CONNECTICUT

CONNECTICUT SITING COUNCIL

Ten Franklin Square, New Britain, CT 06051

Phone: (860) 827-2935 Fax: (860) 827-2950

E-Mail: siting.council@ct.gov

www.ct.gov/csc

CERTIFIED MAIL RETURN RECEIPT REQUESTED

April 20, 2015

Kenneth C. Baldwin, Esq.
Robinson & Cole LLP
280 Trumbull Street
Hartford, CT 06103-3597

RE: **PETITION NO. 1149** - Cellco Partnership d/b/a Verizon Wireless petition for a declaratory ruling that no Certificate of Environmental Compatibility and Public Need is required for the proposed installation of a small cell telecommunications facility on the roof of an existing commercial building located at 109 Federal Road, Danbury, Connecticut.

Dear Attorney Baldwin:

At a public meeting held on April 16, 2015, the Connecticut Siting Council (Council) considered and ruled that the above-referenced proposal would not have a substantial adverse environmental effect, and pursuant to Connecticut General Statutes § 16-50k, would not require a Certificate of Environmental Compatibility and Public Need with the following conditions:

- Within 45 days after completion of construction, the Council shall be notified in writing that construction has been completed;
- Any nonfunctioning antenna and associated antenna mounting equipment on this facility owned and operated by the Petitioner shall be removed within 60 days of the date the antenna ceased to function;
- If the facility ceases to provide wireless services for a period of one year the Petitioner shall dismantle the facility and remove all associated equipment or reapply for any continued or new use to the Council within 90 days from the one year period of cessation of service. The Petitioner may submit a written request to the Council for an extension of the 90 day period not later than 60 days prior to the expiration of the 90 day period; and
- This Declaratory Ruling may be transferred or partially transferred, provided both the facility owner/operator/transferor and the transferee are current with payments to the Council for their respective annual assessments and invoices under Conn. Gen. Stat. §16-50v. The Council shall be notified of such sale and/or transfer and of any change in contact information for the individual or representative responsible for management and operations of the facility within 30 days of the sale and/or transfer. Both the facility owner/operator/transferor and the transferee shall provide the Council with a written agreement as to the entity responsible for any quarterly assessment charges under Conn. Gen. Stat. §16-50v(b)(2) that may be associated with this facility.

This decision is under the exclusive jurisdiction of the Council and is not applicable to any other modification or construction. All work is to be implemented as specified in the petition dated March 18, 2015.

Enclosed for your information is a copy of the staff report on this project.

Very truly yours,

A handwritten signature in blue ink that reads "Robert Stein" followed by the initials "MAB" in a smaller, slightly larger font.

Robert Stein
Chairman

RS/RM/lm

Enclosure: Staff Report dated April 16, 2015

- c: The Honorable Mark D. Boughton, Mayor, City of Danbury
- Dennis Elpern, City Planner, City of Danbury
- The Honorable William N. Tinsley, First Selectman, Town of Brookfield
- Katherine Daniel, Community Development Director, Town of Brookfield
- Alice Dew, Zoning Enforcement Officer, Town of Brookfield
- 109 Federal Road, LLC



STATE OF CONNECTICUT

CONNECTICUT SITING COUNCIL

Ten Franklin Square, New Britain, CT 06051

Phone: (860) 827-2935 Fax: (860) 827-2950

E-Mail: siting.council@ct.gov

www.ct.gov/csc

Petition No. 1149

Cellco Partnership d/b/a Verizon Wireless

109 Federal Road, Danbury

Staff Report

April 16, 2015

On March 18, 2015, the Connecticut Siting Council (Council) received a petition from Cellco Partnership d/b/a Verizon Wireless (Cellco) for a declaratory ruling that no Certificate of Environmental Compatibility and Public Need is required for the proposed installation of a small cell telecommunications facility on a commercial building at 109 Federal Road in Danbury. Cellco seeks to improve 1900 MHz and 2100 MHz services in the surrounding area. Two adjacent Cellco sites that provide wireless service to this commercial and heavily trafficked area of Route 7 are beyond their capacity limits. The proposed site would alleviate capacity issues at these two sites as well as provide some coverage to existing service gaps in the area.

Cellco would install four small cell antennas with four remote radio heads on two pipe masts attached to the roof of the building. The masts and antennas would be concealed within a faux chimney structure extending 10.5 feet above the roof.

Two equipment cabinets would be installed on a lower roof of the building. Power and telephone service would be connected to existing service inside the building.

The maximum worst-case power density would be 69.5 percent of the applicable limit established by the Federal Communications Commission.

The visual impact of the project is expected to be negligible as the faux chimney appears similar to the building structure. The building is located in a commercial zone. The small cell would not be an aviation hazard.

Notice was provided to the City of Danbury and the Town of Brookfield (within 2,500 feet), the property owner, and abutting property owners. No comments have been received to date.



CONNECTICUT SITING COUNCIL

Affirmative Action / Equal Opportunity Employer

ATTACHMENT 2



WIRELESS COMMUNICATIONS FACILITY UPGRADE

DANBURY 10 CT
109 FEDERAL ROAD,
DANBURY, CT 06811

GENERAL NOTES

- ALL WORK SHALL BE IN ACCORDANCE WITH THE 2015 INTERNATIONAL BUILDING CODE AS MODIFIED BY THE 2018 CONNECTICUT SUPPLEMENT, INCLUDING THE IBC/EIA-222 REVISION "G" STRUCTURAL STANDARDS FOR STEEL ANTENNA TOWERS AND SUPPORTING STRUCTURES, 2017 CONNECTICUT FIRE SAFETY CODE, NATIONAL ELECTRICAL CODE, AND LOCAL CODES.
- SHOULD ANY FIELD CONDITIONS PRECLUDE COMPLIANCE WITH THE DRAWINGS, THE CONTRACTOR SHALL IMMEDIATELY NOTIFY THE ENGINEER AND SHALL NOT PROCEED WITH ANY AFFECTED WORK.
- CONTRACTOR SHALL REVIEW ALL DRAWINGS AND SPECIFICATIONS IN THE CONTRACT DOCUMENT SET. CONTRACTOR SHALL COORDINATE ALL WORK SHOWN IN THE SET OF DRAWINGS. THE CONTRACTOR SHALL PROVIDE A COMPLETE SET OF DRAWINGS TO ALL SUBCONTRACTORS AND ALL RELATED PARTIES. THE SUBCONTRACTORS SHALL EXAMINE ALL THE DRAWINGS AND SPECIFICATIONS FOR THE INFORMATION THAT AFFECTS THEIR WORK.
- CONTRACTOR SHALL PROVIDE A COMPLETE BUILD-OUT WITH ALL FINISHES, STRUCTURAL, MECHANICAL, AND ELECTRICAL COMPONENTS AND PROVIDE ALL ITEMS AS SHOWN OR INDICATED ON THE DRAWINGS OR IN THE WRITTEN SPECIFICATIONS.
- CONTRACTOR SHALL FURNISH ALL MATERIAL, LABOR AND EQUIPMENT TO COMPLETE THE WORK AND FURNISH A COMPLETED JOB ALL IN ACCORDANCE WITH LOCAL AND STATE GOVERNING AUTHORITIES AND OTHER AUTHORITIES HAVING LAWFUL JURISDICTION OVER THE WORK.
- CONTRACTOR SHALL SECURE AND PAY FOR ALL PERMITS AND ALL INSPECTIONS REQUIRED AND SHALL ALSO PAY FEES REQUIRED FOR THE GENERAL CONSTRUCTION, AND ALL TRADES APPLICABLE. PERMITS SHALL BE PAID FOR BY THE RESPECTIVE SUBCONTRACTORS.
- CONTRACTOR SHALL MAINTAIN A CURRENT SET OF DRAWINGS AND SPECIFICATIONS ON SITE AT ALL TIMES AND INSURE DISTRIBUTION OF NEW DRAWINGS TO SUBCONTRACTORS AND OTHER RELEVANT PARTIES AS SOON AS THEY ARE MADE AVAILABLE. ALL OLD DRAWINGS SHALL BE MARKED VOID AND REMOVED FROM THE CONTRACT AREA. THE CONTRACTOR SHALL FURNISH AN "AS-BUILT" SET OF DRAWINGS TO OWNER UPON COMPLETION OF PROJECT.
- LOCATION OF EQUIPMENT, AND WORK SUPPLIED BY OTHERS THAT IS DIAGRAMMATICALLY INDICATED ON THE DRAWINGS SHALL BE DETERMINED BY THE CONTRACTOR. THE CONTRACTOR SHALL DETERMINE LOCATIONS AND DIMENSIONS SUBJECT TO STRUCTURAL CONDITIONS AND WORK OF THE SUBCONTRACTORS.
- THE CONTRACTOR IS SOLELY RESPONSIBLE TO DETERMINE CONSTRUCTION PROCEDURE AND SEQUENCE, AND TO ENSURE THE SAFETY OF THE EXISTING STRUCTURES AND ITS COMPONENT PARTS DURING CONSTRUCTION. THIS INCLUDES THE ADDITION OF WHATEVER SHORING, BRACING, UNDERPINNING, ETC. THAT MAY BE NECESSARY. MAINTAIN EXISTING BUILDING'S/PROPERTY'S OPERATIONS, COORDINATE WORK WITH BUILDING/PROPERTY OWNER.
- DRAWINGS INDICATE THE MINIMUM STANDARDS, BUT IF ANY WORK SHOULD BE INDICATED TO BE SUBSTANDARD TO ANY ORDINANCES, LAWS, CODES, RULES, OR REGULATIONS BEARING ON THE WORK, THE CONTRACTOR SHALL INCLUDE IN HIS WORK AND SHALL EXECUTE THE WORK CORRECTLY IN ACCORDANCE WITH SUCH ORDINANCES, LAWS, CODES, RULES OR REGULATIONS WITH NO INCREASE IN COSTS.
- ALL UTILITY WORK SHALL BE IN ACCORDANCE WITH LOCAL UTILITY COMPANY REQUIREMENTS AND SPECIFICATIONS.
- ALL EQUIPMENT AND PRODUCTS PURCHASED ARE TO BE REVIEWED BY CONTRACTOR AND ALL APPLICABLE SUBCONTRACTORS FOR ANY CONDITION PER MFR.'S RECOMMENDATIONS. CONTRACTOR TO SUPPLY THESE ITEMS AT NO COST TO OWNER OR CONSTRUCTION MANAGER.
- ANY AND ALL ERRORS, DISCREPANCIES, AND "MISSED" ITEMS ARE TO BE BROUGHT TO THE ATTENTION OF THE VERIZON WIRELESS CONSTRUCTION MANAGER DURING THE BIDDING PROCESS BY THE CONTRACTOR. ALL THESE ITEMS ARE TO BE INCLUDED IN THE BID. NO "EXTRA" WILL BE ALLOWED FOR MISSED ITEMS.
- CONTRACTOR SHALL BE RESPONSIBLE FOR ALL ON-SITE SAFETY FROM THE TIME THE JOB IS AWARDED UNTIL ALL WORK IS COMPLETE AND ACCEPTED BY THE OWNER.
- CONTRACTOR TO REVIEW ALL SHOP DRAWINGS AND SUBMIT COPY TO ENGINEER FOR APPROVAL. DRAWINGS MUST BEAR THE CHECKER'S INITIALS BEFORE SUBMITTING TO THE CONSTRUCTION MANAGER FOR REVIEW.
- THE CONTRACTOR SHALL FIELD VERIFY ALL DIMENSIONS, ELEVATIONS, ANGLES, AND EXISTING CONDITIONS AT THE SITE, PRIOR TO FABRICATION AND/OR INSTALLATION OF ANY WORK IN THE CONTRACT AREA.
- COORDINATION, LAYOUT, FURNISHING AND INSTALLATION OF CONDUIT AND ALL APPURTENANCES REQUIRED FOR PROPER INSTALLATION OF ELECTRICAL AND TELECOMMUNICATION SERVICE SHALL BE THE SOLE RESPONSIBILITY OF THE CONTRACTOR.
- ALL EQUIPMENT AND PRODUCTS PURCHASED ARE TO BE REVIEWED BY CONTRACTOR AND ALL APPLICABLE SUB-CONTRACTORS FOR ANY CONDITION PER THE MANUFACTURER'S RECOMMENDATIONS. CONTRACTOR TO SUPPLY THESE ITEMS AT NO COST TO OWNER OR CONSTRUCTION MANAGER.
- ALL DAMAGE CAUSED TO ANY EXISTING STRUCTURE SHALL BE THE SOLE RESPONSIBILITY OF THE CONTRACTOR. THE CONTRACTOR WILL BE HELD LIABLE FOR ALL REPAIRS REQUIRED FOR EXISTING STRUCTURES IF DAMAGED DURING CONSTRUCTION ACTIVITIES.
- THE CONTRACTOR SHALL CONTACT "CALL BEFORE YOU DIG" AT LEAST 48 HOURS PRIOR TO ANY EXCAVATIONS AT 1-800-922-4455. ALL UTILITIES SHALL BE IDENTIFIED AND CLEARLY MARKED PRIOR TO ANY EXCAVATION WORK. CONTRACTOR SHALL MAINTAIN AND PROTECT MARKED UTILITIES THROUGHOUT PROJECT COMPLETION.

SITE DIRECTIONS

FROM:	TO:
20 ALEXANDER DRIVE WALLINGFORD, CONNECTICUT	109 FEDERAL RD, DANBURY, CT 06811
1. HEAD NORTH ON ALEXANDER DR. TOWARDS BARNES INDUSTRIAL RD.	0.18 MI
2. TURN RIGHT ONTO BARNES INDUSTRIAL RD.	0.11 MI
3. TAKE FIRST LEFT ONTO CT-68.	0.35 MI
4. TURN RIGHT ONTO RAMP.	0.17 MI
5. TURN RIGHT ONTO N COLONY RD/ US-5 N.	0.30 MI
6. MERGE ONTO CT-15 N TOWARD HARTFORD.	3.89 MI
7. MERGE ONTO I-81 W VIA EXIT 68W TOWARD MERIDEN/WATERBURY.	7.79 MI
8. MERGE ONTO I-84 W VIA EXIT 1 ON THE LEFT TOWARD DANBURY/WATERBURY.	33.10 MI
9. MERGE ONTO US-7 N/US-202 E VIA EXIT 7 TOWARD NEW MILFORD/BROOKFIELD.	0.91 MI
10. TAKE THE US-202 E EXIT, EXIT 11, TOWARD FEDERAL RD.	0.24 MI
11. TURN LEFT ONTO WHITE TURKEY RD/US-202 E.	0.24 MI
12. TURN LEFT ONTO FEDERAL RD.	0.37 MI
13. 109 FEDERAL RD, DANBURY, CT 06811-4019, 109 FEDERAL RD IS ON THE LEFT.	

VICINITY MAP

SCALE: 1" = 1000'

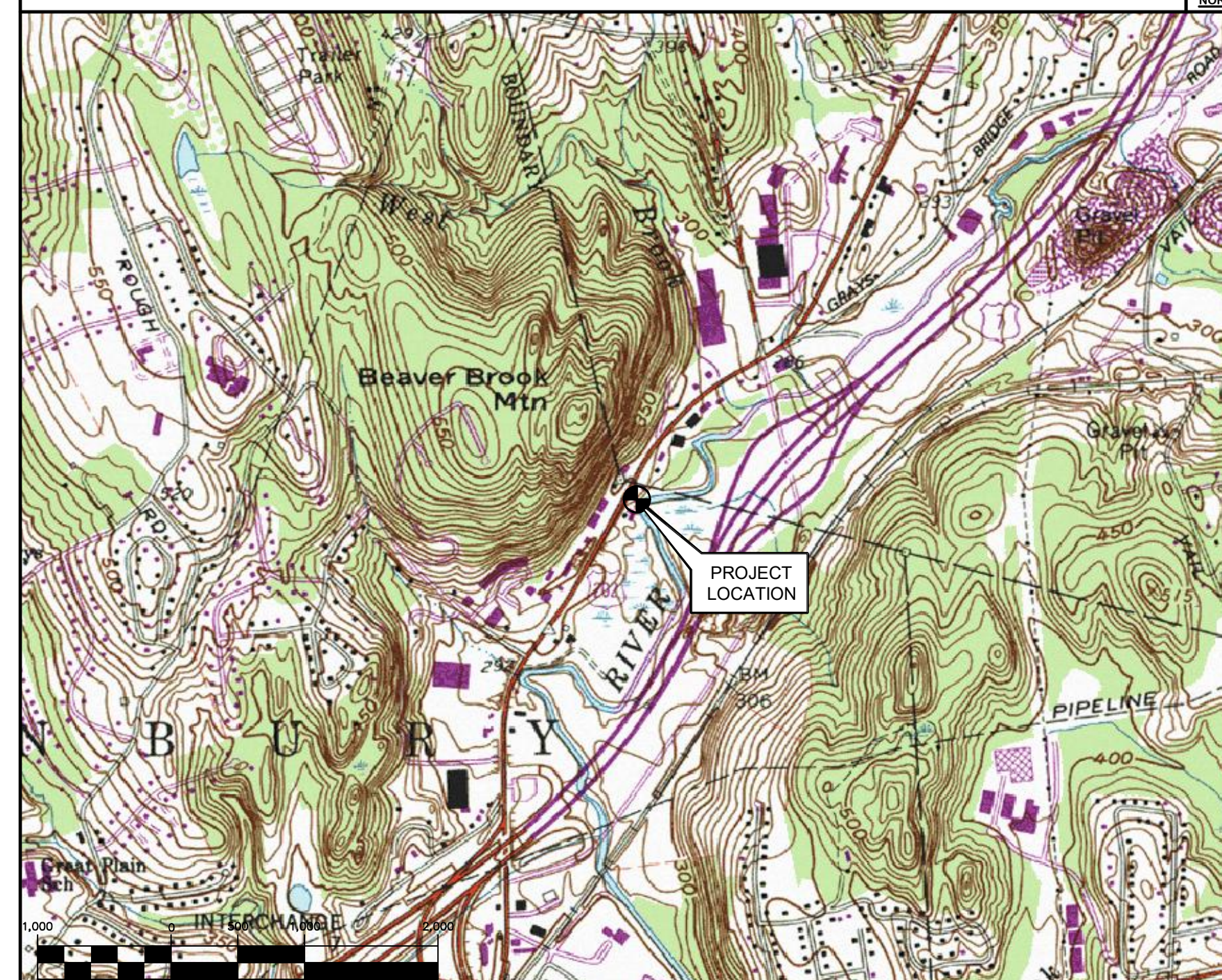

PROJECT SUMMARY

- THE PROPOSED UPGRADE SCOPE OF WORK AT THE EXISTING UNMANNED TELECOMMUNICATIONS FACILITY GENERALLY INCLUDES THE FOLLOWING:
 - AT THE EXISTING ROOFTOP ANTENNA SECTORS:
 - MODIFY THE EXISTING RF FAUX CHIMNEY SCREENING ENCLOSURE TO ACCOMMODATE PROPOSED REPLACEMENT ANTENNAS AND ASSOCIATED CLEARANCE REQUIREMENTS.
 - REMOVE (2) EXISTING ANTENNAS.
 - REMOVE (4) EXISTING REMOTE RADIO HEADS.
 - INSTALL (2) VZS01 ANTENNAS.
 - INSTALL (2) SAMSUNG B2/B66A RRH-BR049 RRUs.
 - INSTALL (2) COMMSCOPE SDX1926Q-43 DIPLEXERS.

PROJECT INFORMATION

SITE NAME:	DANBURY 10 CT
SITE ADDRESS:	109 FEDERAL RD, DANBURY, CT 06811
LESSEE/TENANT:	CELCO PARTNERSHIP d.b.c. VERIZON WIRELESS 20 ALEXANDER DRIVE WALLINGFORD, CT 06492
CONTACT PERSON:	WALTER CHARCZNSKI (CONSTRUCTION MANAGER) VERIZON WIRELESS (860) 306-1806
ENGINEER:	CEN TEK ENGINEERING, INC. 63-2 NORTH BRANFORD RD. BRANFORD, CT. 06405 (203) 488-0580
PROJECT COORDINATES:	LATITUDE: 41°-25'-47.125"N LONGITUDE: 73°-24'-56.986"W GROUND ELEVATION: 292.1'± AMSL (REFERENCED FROM FAA 2-C SURVEY CERTIFICATION AS PREPARED FOR VERIZON WIRELESS BY MARTINEZ COUCH AND ASSOCIATES LLC, DATED MARCH 11, 2015, REVISED SEPTEMBER 2, 2015)

SHEET INDEX

SHT. NO.	DESCRIPTION	REV.
T-1	TITLE SHEET	0
N-1	NOTES AND SPECIFICATIONS	0
B-1	RF BILL OF MATERIALS	0
C-1	ROOF/PARTIAL SITE PLAN AND ELEVATION	0
C-2	ANTENNA SECTOR CONFIGURATION PLANS AND SECTIONS	0
C-3	RF AND ANTENNA MOUNT ASSEMBLY DETAILS	0
S-1	RF ENCLOSURE MOD. FRAMING PLANS AND DETAILS	0
E-1	ELECTRICAL SPECIFICATIONS AND DETAILS	0

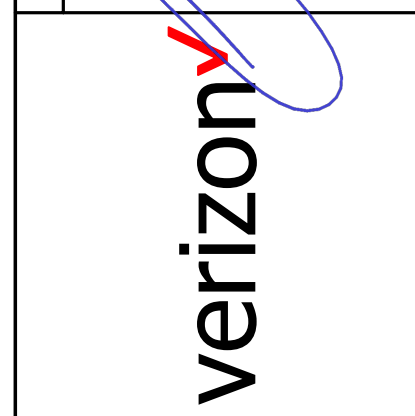

Celco Partnership d/b/a Verizon Wireless
DANBURY 10 CT
109 FEDERAL ROAD,
DANBURY, CT 06811

DATE: 01/07/21
SCALE: AS NOTED
JOB NO. 20150.07

TITLE SHEET

T-1

REV.	DATE	BY	CHK'D BY	DESCRIPTION
0	03/05/21	DMD	DMD	TUL
1	07/24/21	DMD	DMD	TUL
2	07/24/21	ASC	ASC	TUL
3	07/20/21	ASC	ASC	TUL
4				TUL
5				TUL
6				TUL
7				TUL
8				TUL
9				TUL
10				TUL
11				TUL
12				TUL
13				TUL
14				TUL
15				TUL
16				TUL
17				TUL
18				TUL
19				TUL
20				TUL

CONSTRUCTION DRAWINGS - ISSUED FOR CONSTRUCTION
PRELIMINARY CONSTRUCTION DRAWINGS - REVISED FOR ENCLOSURE MOD.
PRELIMINARY CONSTRUCTION DRAWINGS - ISSUED FOR CLIENT REVIEW

NOTES AND SPECIFICATIONS

DESIGN BASIS:

GOVERNING CODE: 2015 INTERNATIONAL BUILDING (IBC) AS MODIFIED BY THE 2018 CT STATE BUILDING CODE AND AMENDMENTS.

1. DESIGN CRITERIA:
 - RISK CATEGORY: II (BASED ON TABLE 1604.5 OF THE 2015 IBC)
 - ULTIMATE DESIGN SPEED (BUILDING): 120 MPH (V_{ult}) (EXPOSURE B/IMPORTANCE FACTOR 1.0 BASED ON ASCE 7-10) PER 2015 INTERNATIONAL BUILDING CODE (IBC) AS MODIFIED BY THE 2018 CONNECTICUT STATE BUILDING CODE.
 - SEISMIC LOAD (DOES NOT CONTROL): PER ASCE 7-10 MINIMUM DESIGN LOADS FOR BUILDING AND OTHER STRUCTURES.

GENERAL NOTES:

1. ALL CONSTRUCTION SHALL BE IN COMPLIANCE WITH THE GOVERNING BUILDING CODE.
2. DRAWINGS INDICATE THE MINIMUM STANDARDS, BUT IF ANY WORK SHOULD BE INDICATED TO BE SUBSTANDARD TO ANY ORDINANCES, LAWS, CODES, RULES, OR REGULATIONS BEARING ON THE WORK, THE CONTRACTOR SHALL INCLUDE IN HIS WORK AND SHALL EXECUTE THE WORK CORRECTLY IN ACCORDANCE WITH SUCH ORDINANCES, LAWS, CODES, RULES OR REGULATIONS WITH NO INCREASE IN COSTS.
3. BEFORE BEGINNING THE WORK, THE CONTRACTOR IS RESPONSIBLE FOR MAKING SUCH INVESTIGATIONS CONCERNING PHYSICAL CONDITIONS (SURFACE AND SUBSURFACE) AT OR CONTIGUOUS TO THE SITE WHICH MAY AFFECT PERFORMANCE AND COST OF THE WORK.
4. DIMENSIONS AND DETAILS SHALL BE CHECKED AGAINST EXISTING FIELD CONDITIONS.
5. THE CONTRACTOR SHALL VERIFY AND COORDINATE THE SIZE AND LOCATION OF ALL OPENINGS, SLEEVES AND ANCHOR BOLTS AS REQUIRED BY ALL TRADES.
6. ALL DIMENSIONS, ELEVATIONS, AND OTHER REFERENCES TO EXISTING STRUCTURES, SURFACE, AND SUBSURFACE CONDITIONS ARE APPROXIMATE. NO GUARANTEE IS MADE FOR THE ACCURACY OR COMPLETENESS OF THE INFORMATION SHOWN. THE CONTRACTOR SHALL VERIFY AND COORDINATE ALL DIMENSIONS, ELEVATIONS, ANGLES WITH EXISTING CONDITIONS AND WITH ARCHITECTURAL AND SITE DRAWINGS BEFORE PROCEEDING WITH ANY WORK.
7. AS THE WORK PROGRESSES, THE CONTRACTOR SHALL NOTIFY THE OWNER OF ANY CONDITIONS WHICH ARE IN CONFLICT OR OTHERWISE NOT CONSISTENT WITH THE CONSTRUCTION DOCUMENTS AND SHALL NOT PROCEED WITH SUCH WORK UNTIL THE CONFLICT IS SATISFACTORILY RESOLVED.
8. THE CONTRACTOR SHALL COMPLY WITH ALL APPLICABLE SAFETY CODES AND REGULATIONS DURING ALL PHASES OF CONSTRUCTION. THE CONTRACTOR IS SOLELY RESPONSIBLE FOR PROVIDING AND MAINTAINING ADEQUATE SHORING, BRACING, AND BARRICADES AS MAY BE REQUIRED FOR THE PROTECTION OF EXISTING PROPERTY, CONSTRUCTION WORKERS, AND FOR PUBLIC SAFETY.
9. THE CONTRACTOR IS SOLELY RESPONSIBLE TO DETERMINE CONSTRUCTION PROCEDURE AND SEQUENCE, AND TO ENSURE THE SAFETY OF THE EXISTING STRUCTURES AND ITS COMPONENT PARTS DURING CONSTRUCTION. THIS INCLUDES THE ADDITION OF WHATEVER SHORING, BRACING, UNDERPINNING, ETC. THAT MAY BE NECESSARY. MAINTAIN EXISTING SITE OPERATIONS, COORDINATE WORK WITH NORTHEAST UTILITIES
10. ALL DAMAGE CAUSED TO ANY EXISTING STRUCTURE SHALL BE THE SOLE RESPONSIBILITY OF THE CONTRACTOR. THE CONTRACTOR WILL BE HELD LIABLE FOR ALL REPAIRS REQUIRED FOR EXISTING STRUCTURES IF DAMAGED DURING CONSTRUCTION ACTIVITIES.
11. REFER TO DRAWING T1 FOR ADDITIONAL NOTES AND REQUIREMENTS.

ANTENNA ENCLOSURE

1. THE ANTENNA CONCEALMENT ENCLOSURE PANELS SHALL BE ENGINEERED BY A REGISTERED STATE OF CONNECTICUT LICENSED ENGINEER EXPERIENCED IN THE DESIGN OF THESE SYSTEMS.
2. THE CONTRACTOR SHALL SUBMIT DETAILED SHOP DRAWINGS AND COMPUTATIONS BEARING THE SEAL OF THE RESPONSIBLE DESIGN PROFESSIONAL FOR REVIEW BY THE ENGINEER OF RECORD PRIOR TO FABRICATION.
3. ANTENNA CONCEALMENT ENCLOSURE COMPONENTS SHALL BE DESIGNED FOR WIND LOADS BASED ON ASCE 7-02 'COMPONENTS AND CLADDING (CC)' WIND PRESSURES.
4. WIND DESIGN DATA PER 2005 CSBC SECTION 1603.1.4:
INTERNAL PRESSURE COEFFICIENT, G_{cci} = ± 0.55

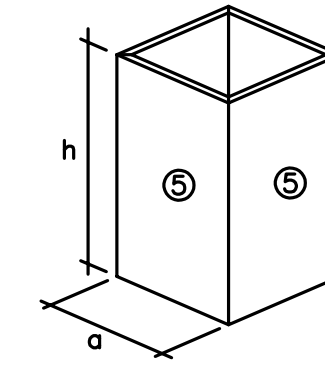

CC - ENCLOSURE SURFACE ELEVATION
N.T.S.

(ZONE NOMENCLATURE BASED ON ASCE 7-02 FIGURE 6-11A)

- a = 10 PERCENT OF LEAST HORIZONTAL DIMENSION OR 0.4h, WHICHEVER IS SMALLER, BUT NOT LESS THAN EITHER 4 PERCENT OF LEAST HORIZONTAL DIMENSION OR 3 FT.
- h = MEAN ENCLOSURE HEIGHT, IN FEET

WALL COMPONENTS AND CLADDING

EFFECTIVE WIND AREA LESS THAN OR EQUAL TO 10 SQUARE FEET:
ZONE 5; P_{cc} = +21 PSF & -26 PSF

EFFECTIVE WIND AREA MORE THAN OR EQUAL TO 500 SQUARE FEET
ZONE 5; P_{cc} = +17 PSF & -18 PSF

- i) LINEAR INTERPOLATE FOR EFFECTIVE WIND AREAS GREATER THAN 10 SQUARE FEET AND LESS THAN 500 SQUARE FEET.
 - ii) PLUS AND MINUS SIGNS SIGNIFY PRESSURES ACTING TOWARD AND AWAY FROM THE INTERNAL SURFACES, RESPECTIVELY.
 - iii) FOR A FASTENER, THE EFFECTIVE AREA EQUALS THE AREA TRIBUTARY TO AN INDIVIDUAL FASTENER.
6. EXTENT OF ANTENNA ENCLOSURE IS DENOTED WITHIN THE CONSTRUCTION DOCUMENTS.
 7. CONTRACTOR SHALL CONDUCT A DETAILED FIELD SURVEY FOR USE IN REPLICATING THE ARCHITECTURAL APPEARANCE OF THE EXISTING BUILDING.

STRUCTURAL STEEL NOTES

1. ALL STRUCTURAL STEEL IS DESIGNED BY ALLOWABLE STRESS DESIGN (ASD):
 - A. STRUCTURAL STEEL (W SHAPES)---ASTM A992, (F_y = 50 KSI)
 - B. STRUCTURAL STEEL (OTHER SHAPES)---ASTM A36, (F_y = 36 KSI)
 - C. STRUCTURAL HSS (RECTANGULAR SHAPES)---ASTM A500 GRADE B, (F_y = 46 KSI)
 - D. STRUCTURAL HSS (ROUND SHAPES)---ASTM A500 GRADE B, (F_y = 42 KSI)
 - E. STRUCTURAL PIPE (ROUND SHAPES)---ASTM A53 GRADE B, (F_y = 35 KSI)
 - F. CONNECTION BOLTS---ASTM A325-N
 - G. ANCHOR RODS---ASTM F 1554
 - H. REBAR---ASTM A-615 GRADE 60, (F_y = 60 KSI)
 - I. WELDING ELECTRODE---ASTM E 70XX
2. EXISTING DIMENSIONS OF STRUCTURE SHOWN ON THESE PLANS ARE NOT GUARANTEED. CONTRACTOR SHALL TAKE FIELD MEASUREMENTS NECESSARY TO ASSURE PROPER FIT OF ALL FINISHED WORK AND SHALL ASSUME FULL RESPONSIBILITY FOR THEIR ACCURACY WHEN SHOP DRAWINGS BASED ON FIELD MEASUREMENTS ARE SUBMITTED FOR REVIEW TO THE ENGINEER.
3. CONTRACTOR TO REVIEW ALL SHOP DRAWINGS AND SUBMIT COPY TO ENGINEER FOR APPROVAL. DRAWINGS MUST BEAR THE REVIEWER'S INITIALS BEFORE SUBMITTING TO THE ENGINEER FOR REVIEW. SHOP DRAWINGS SHALL INCLUDE THE FOLLOWING: SECTION PROFILES, SIZES, CONNECTION ATTACHMENTS, REINFORCING, ANCHORAGE, SIZE AND TYPE OF FASTENERS AND ACCESSORIES. INCLUDE ERECTION DRAWINGS, ELEVATIONS AND DETAILS.
4. STRUCTURAL STEEL SHALL BE DETAILED, FABRICATED AND ERECTED IN ACCORDANCE WITH THE LATEST PROVISIONS OF AISC MANUAL OF STEEL CONSTRUCTION.
5. PROVIDE ALL PLATES, CLIP ANGLES, CLOSURE PIECES, STRAP ANCHORS, MISCELLANEOUS PIECES AND HOLES REQUIRED TO COMPLETE THE STRUCTURE.
6. CONNECTION ANGLES SHALL HAVE A MINIMUM THICKNESS OF 1/4 INCHES.
7. MILL BEARING ENDS OF COLUMNS, STIFFENERS, AND OTHER BEARING SURFACES TO TRANSFER LOAD OVER ENTIRE CROSS SECTION.
8. FABRICATE BEAMS WITH MILL CAMBER UP.
9. THE STRUCTURE IS DESIGNED TO BE SELF SUPPORTING AND STABLE AFTER THE WORK IS FULLY COMPLETED.
10. FIT AND SHOP ASSEMBLE FABRICATIONS IN THE LARGEST PRACTICAL SECTIONS FOR DELIVERY TO SITE.
11. BOLT HOLES SHALL BE PUNCHED OR DRILLED, FLAME CUT HOLES ARE NOT ACCEPTABLE.
12. LEVEL AND PLUMB INDIVIDUAL MEMBERS OF THE STRUCTURE TO AN ACCURACY OF 1:500, BUT NOT TO EXCEED 1/4" IN THE FULL HEIGHT OF THE COLUMN.
13. INSTALL FABRICATIONS PLUMB AND LEVEL, ACCURATELY FITTED, AND FREE FROM DISTORTIONS OR DEFECTS.
14. SHOP CONNECTIONS SHALL BE WELDED OR HIGH STRENGTH BOLTED.
15. STRUCTURAL CONNECTION BOLTS SHALL CONFORM TO ASTM A325-N. ALL BOLTS SHALL BE 3/4" DIAMETER MINIMUM AND SHALL HAVE A MINIMUM OF TWO BOLTS, UNLESS NOTED OTHERWISE ON THE DRAWINGS.
16. ALL BOLTED JOINTS SHALL BE SNUG TIGHT (ST) UNLESS OTHERWISE DESIGNATED AS PRETENSIONED (PT) OR SLIP CRITICAL (SC) ON THE DRAWINGS.
17. CONTRACTOR SHALL COMPLY WITH AWS CODE FOR PROCEDURES APPEARANCE AND QUALITY OF WELDS. AND WELDING PROCESSES SHALL BE QUALIFIED IN ACCORDANCE WITH AWS "STANDARD QUALIFICATION PROCEDURES". ALL WELDING SHALL BE DONE USING E70XX ELECTRODES AND WELDING SHALL CONFORM TO AISC AND D1.1 WHERE FILLET WELD SIZES ARE NOT SHOWN, PROVIDE THE MINIMUM SIZE PER TABLE J2.4 IN THE AISC "MANUAL OF STEEL CONSTRUCTION" 9TH EDITION. AT THE COMPLETION OF WELDING, ALL DAMAGE TO GALVANIZED COATING SHALL BE REPAIRED.
18. USE PRECAUTIONS & PROCEDURES PER AWS D1.1 WHEN WELDING GALVANIZED METALS.
19. ALL WELDING SHALL BE PERFORMED BY A CERTIFIED WELDER IN ACCORDANCE WITH AWS STANDARDS. SUBMIT WELDER CERTIFICATION FOR REVIEW BY ENGINEER.
20. ALL STEEL MATERIAL (EXPOSED TO WEATHER) SHALL BE GALVANIZED AFTER FABRICATION IN ACCORDANCE WITH ASTM A123 "ZINC (HOT DIPPED GALVANIZED) COATINGS" ON IRONS AND STEEL PRODUCTS.
21. ALL BOLTS, ANCHORS AND MISCELLANEOUS HARDWARE SHALL BE GALVANIZED IN ACCORDANCE WITH ASTM A153 "ZINC COATING (HOT-DIP) ON IRON AND STEEL HARDWARE".
22. NOTIFY THE ENGINEER PRIOR TO FIELD CUTTING OR MODIFYING APPROVED FABRICATIONS.
23. THE ENGINEER SHALL BE NOTIFIED OF ANY INCORRECTLY FABRICATED, DAMAGED OR OTHERWISE MISFITTING OR NON CONFORMING MATERIALS OR CONDITIONS TO REMEDIAL OR CORRECTIVE ACTION. ANY SUCH ACTION SHALL REQUIRE ENGINEER REVIEW.
24. COMMENCEMENT OF STRUCTURAL STEEL WORK WITHOUT NOTIFYING THE ENGINEER OF ANY DISCREPANCIES WILL BE CONSIDERED ACCEPTANCE OF PRECEDING WORK.

REV.	DATE	BY	CHK'D BY	DESCRIPTION
0	03/05/21	DMD	TUL	CONSTRUCTION DRAWINGS - ISSUED FOR CONSTRUCTION
1	07/24/21	DMD	TUL	PRELIMINARY CONSTRUCTION DRAWINGS - REVISION FOR ENCLOSURE MOD.
2	07/20/21	ASC	DMD	PRELIMINARY CONSTRUCTION DRAWINGS - ISSUED FOR CLIENT REVIEW

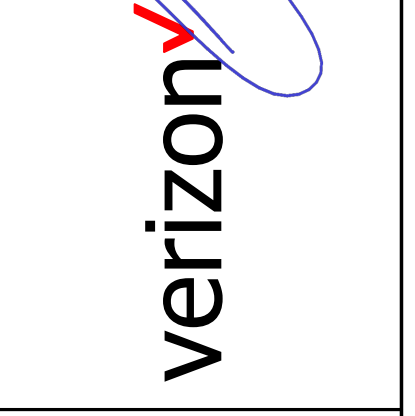
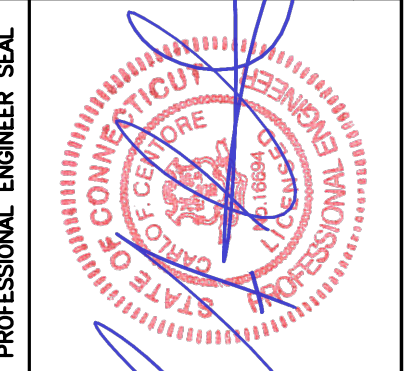

CEN TEK engineering
Centered on Solutions™
(203) 488-0580
(203) 488-8587 Fax
65-2 North Branford Road
Branford, CT 06405
www.CentekEng.com

Cellco Partnership d/b/a Verizon Wireless
DANBURY 10 CT
108 FEDERAL ROAD,
DANBURY, CT 06811

DATE: 01/07/21
SCALE: AS NOTED
JOB NO. 20150.07

NOTES AND SPECIFICATIONS

PLUMBING DIAGRAM NOTES:

1. PORTS 1 & 2 ARE FOR LOW BAND (698-896 MHz).
2. PORTS 3, 4, 5 & 5 ARE FOR HIGH BAND (1695-2360 MHz).
3. SMART BIAS TEE (SBT) IS THROUGH ANTENNA PORTS 1 & 3 (1 FOR LOW BAND AND 3 FOR HIGH BAND).
4. AISG CABLE IS ONLY NEEDED WHEN DRAWN IN THE DIAGRAMS ABOVE. IF IT IS NOT DRAWN THEN SBT IS ENOUGH TO CONTROL ALL RET MOTORS.
5. NOT ALL SBT PORTS ARE NEEDED TO CONTROL RET. ONLY GREEN PORT CONNECTION TO GREEN PORT WILL CONTROL RET.

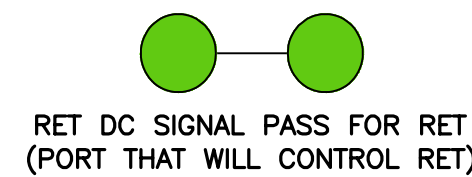

PLUMBING DIAGRAM COMMENTS:

- DIAGRAMS SHOW ANTENNA PORT CONFIGURATIONS AS VIEWED FROM BELOW ANTENNAS.
- ANTENNA POSITIONS ARE INDICATED AS VIEWED FROM IN FRONT OF ANTENNAS.
- CAP AND WEATHERPROOF UNUSED ANTENNA PORTS.
- ALL PLUMBING DIAGRAM COLORS ARE IRRELEVANT EXCEPT FOR AISG AND HYBRIFLEX CABLE. (FOR THE COAX COLORS, FOLLOW COAX COLORS GUIDE ABOVE)

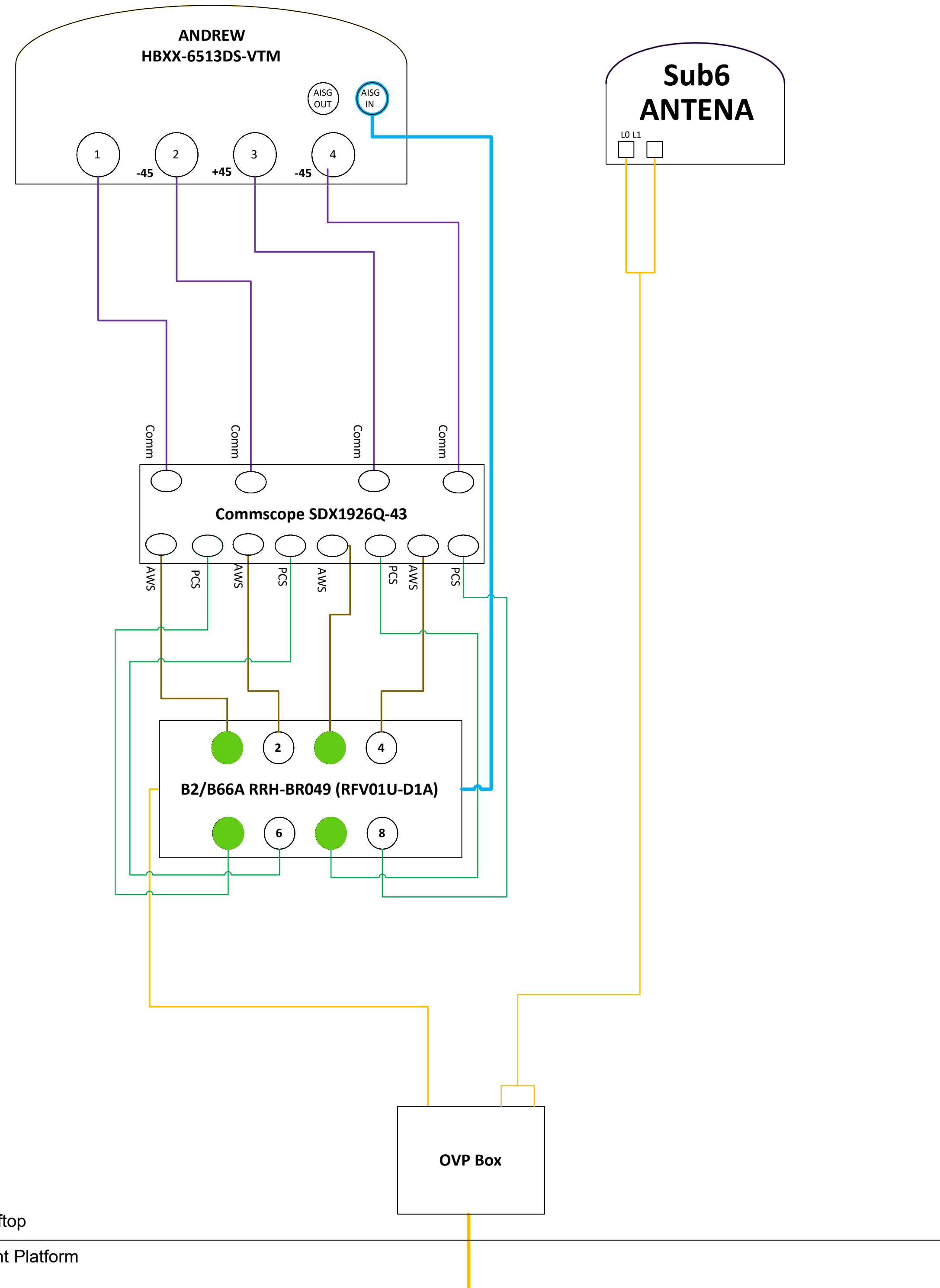

NOTES:

1. INFORMATION SHOWN HEREIN IS FOR USE BY VERIZON WIRELESS EQUIPMENT OPERATIONS.
2. THIS B.OM. DRAWING IS BASED OFF FIELD MEASUREMENTS, FACILITY UPGRADE DESIGN DRAWINGS PREPARED BY CENTEK ENGINEERING (REV.0 DATED: 03.05.21), & VERIZON WIRELESS RF ANTENNA EQUIPMENT RECOMMENDATION (DATED 11.13.20).

BILL OF MATERIALS		
TECHNOLOGY	QUANTITY	ANTENNA
5G	2	SAMSUNG ANTENNA MODEL: VZS01 ANTENNA

CABLES	QUANTITY	LENGTH	COMMENTS
-	-	-	-

RADIOS	QUANTITY	COMMENTS
LTE PCS 1900	2	SAMSUNG MODEL: B2/B66A RRH-BR049
LTE AWS 2100		
5G	2	INTEGRATED INTO VZS01 ANTENNA

DIPLEXERS	QUANTITY	COMMENTS
FOR PCS 1900 ANTENNA	2 TOTAL	MODEL: SDX1926Q-43
FOR AWS 2100 ANTENNA		

OVP BOXES	QUANTITY	COMMENTS
ROOFTOP OVP	0	-

ANTENNA MOUNT	QUANTITY	COMMENTS
SIDE-BY-SIDE MOUNTING KIT	0	-

PROFESSIONAL ENGINEER SEAL

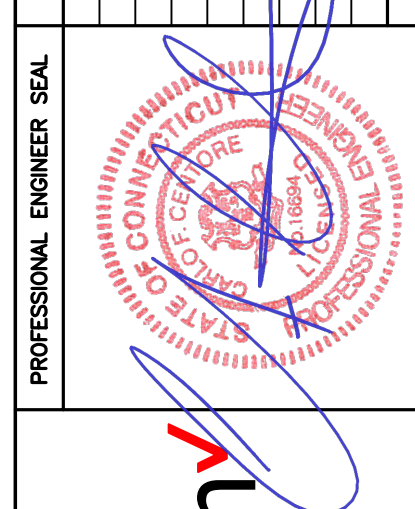

verizon

CEN TEK engineering
Centered on Solutions

(203) 488-0580
(203) 488-8587 Fax
65-2 North Branford Road
Branford, CT 06405
www.CentekEng.com

Cellco Partnership d/b/a Verizon Wireless

DANBURY 10 CT

108 FEDERAL ROAD,
DANBURY, CT 06811

DATE: 01/07/21
SCALE: AS NOTED
JOB NO. 20150.07

RF BILL OF MATERIALS

B-1

STRUCTURAL ANALYSIS REFERENCE NOTE:

REFER TO PASSING STRUCTURAL ANALYSIS REPORT (ANTENNA MOUNT AND CONNECTION TO HOST STRUCTURE) PREPARED BY CENTEK ENGINEERING DATED 01/19/2021, LAST REVISED 03/05/2021 (REV.2). CENTEK PROJECT NO. 20150.07 FOR ADDITIONAL INFORMATION.

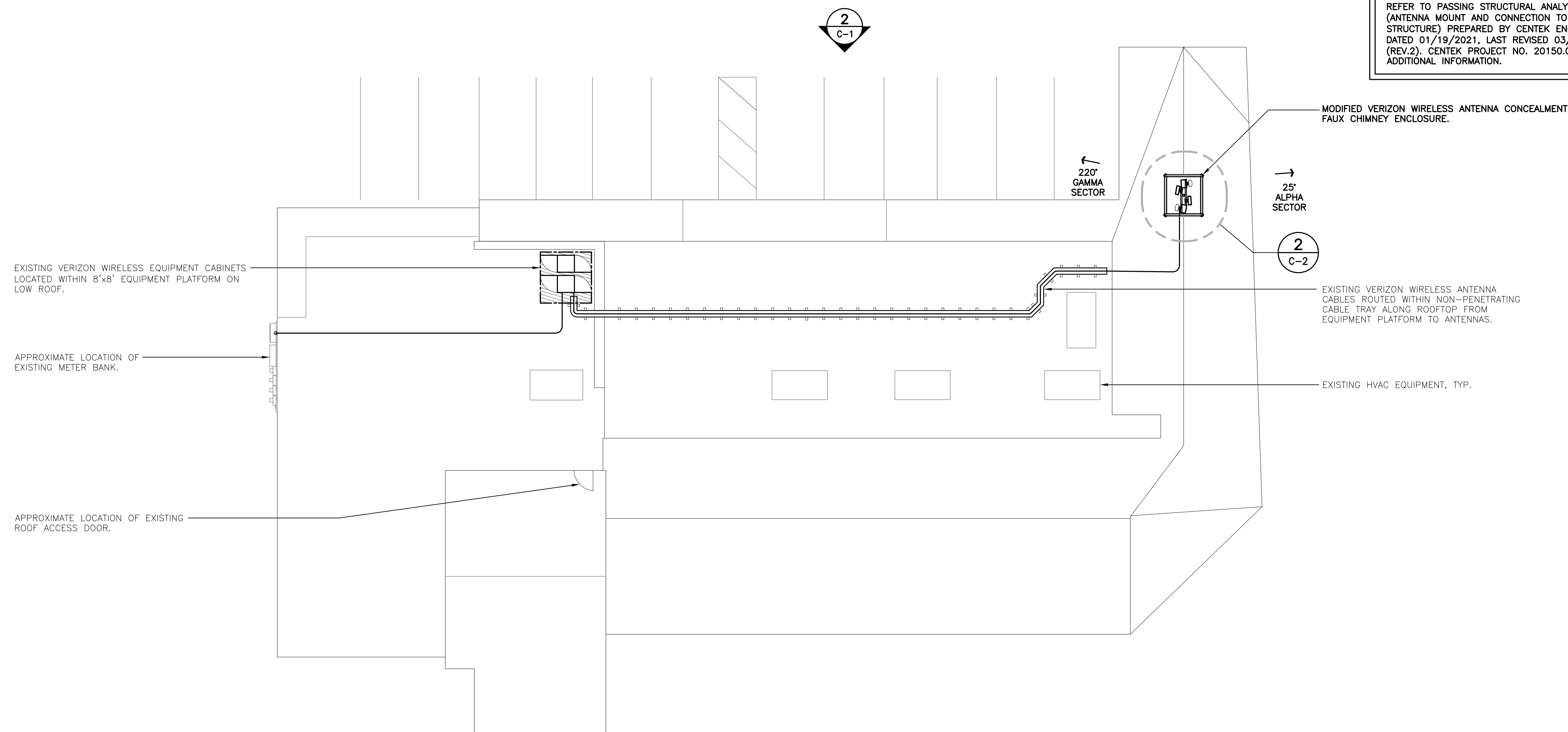

1 PARTIAL SITE/ROOF PLAN - PROPOSED CONDITIONS
 SCALE: 1" = 10'

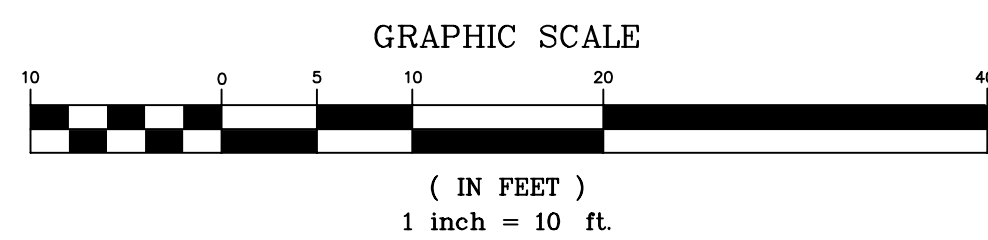

2 WEST ELEVATION - PROPOSED CONDITIONS
 SCALE: 1" = 10'

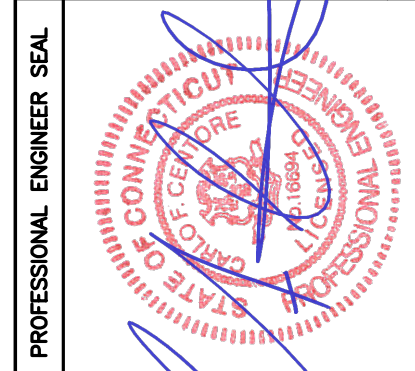
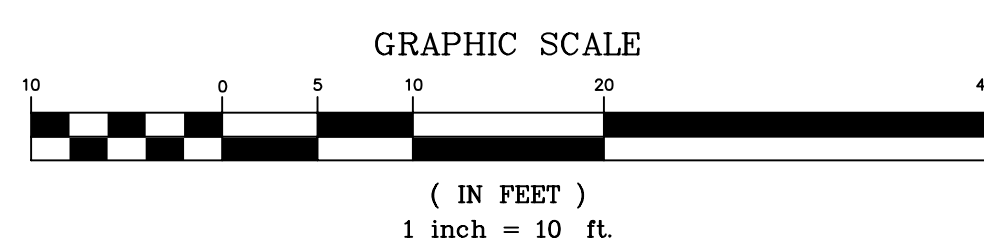

CENTEK engineering
 Centered on Solutions
 (203) 488-0580
 (203) 488-8587 Fax
 65-2 North Branford Road
 Branford, CT 06405
 www.CentekEng.com

Celco Partnership d/b/a Verizon Wireless
DANBURY 10 CT
 108 FEDERAL ROAD,
 DANBURY, CT 06811

DATE: 01/07/21
 SCALE: AS NOTED
 JOB NO. 20150.07

ROOF/ PARTIAL
 SITE PLAN AND
 ELEVATION

C-1
 Sheet No. 4 of 8

REV.	DATE	BY	DESCRIPTION
0	03/05/21	DWD	CONSTRUCTION DRAWINGS - ISSUED FOR CONSTRUCTION
1	07/24/21	TUL	PRELIMINARY CONSTRUCTION DRAWINGS - REVISED FOR ENCLOSURE MOD.
A	01/20/21	ASC	PRELIMINARY CONSTRUCTION DRAWINGS - ISSUED FOR CLIENT REVIEW

EXISTING ANTENNA CONFIGURATIONS

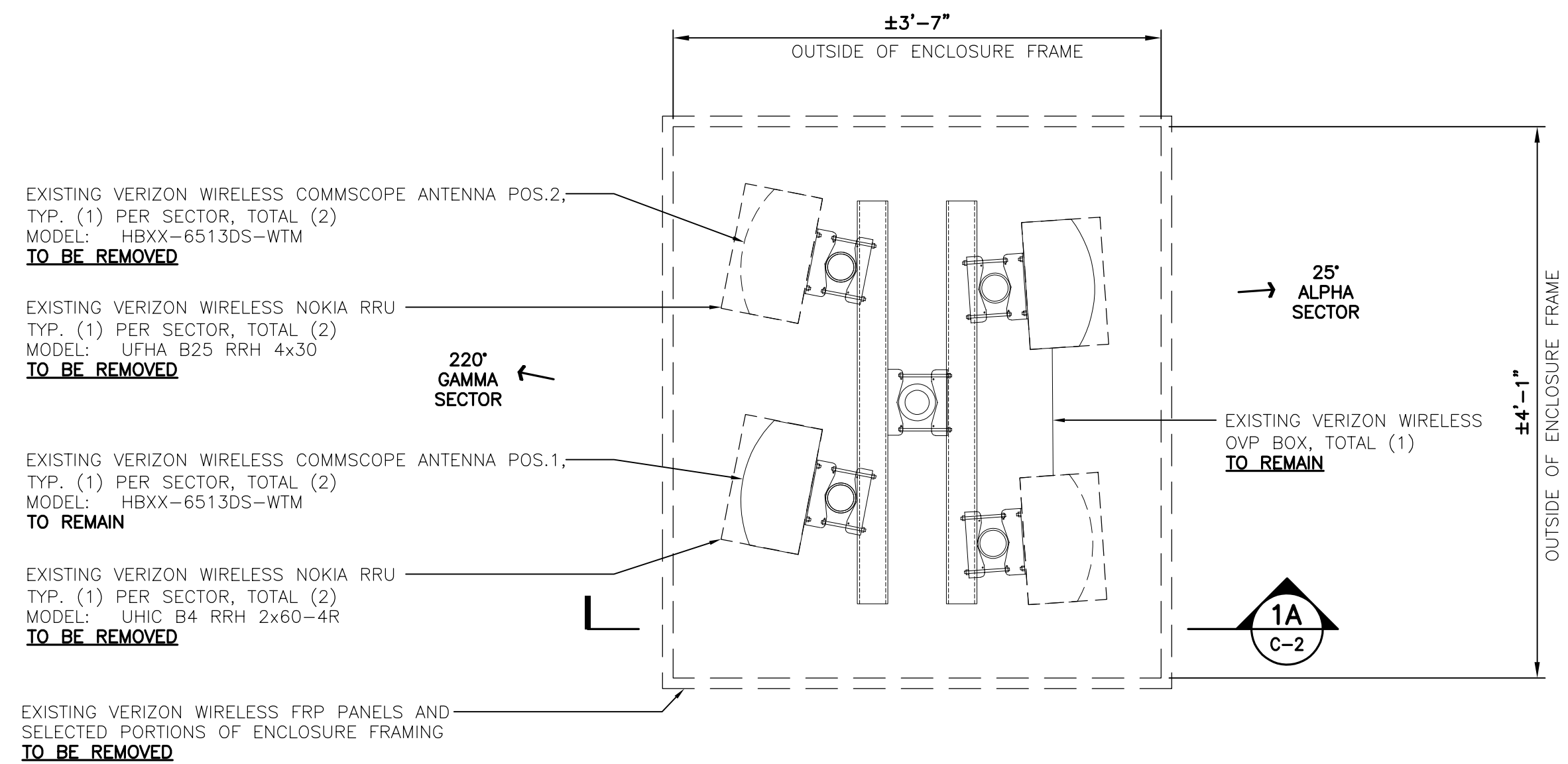

1 EXISTING ANTENNA CONFIGURATION PLAN
SCALE: 1" = 1'-0" NORTH

EXISTING VERIZON WIRELESS FRP PANELS **TO BE REMOVED**

NOTE:
EXISTING ANTENNAS, APPURTENANCES AND MOUNTS NOT SHOWN HEREIN FOR CLARITY

EXISTING VERIZON WIRELESS ENCLOSURE FRAMING **TO BE REMOVED TO EXTENT SHOWN (TYP)**

EXISTING VERIZON WIRELESS ENCLOSURE SUPPORT FRAMING **TO BE REMAIN TO EXTENT SHOWN (TYP)**

1A EXISTING ANTENNA CONFIGURATION SECTION
SCALE: 3/4" = 1'-0"

PLAN LEGEND	
---	VERIZON WIRELESS SAMSUNG SUB6 REQUIRED ANTENNA CLEARANCE LIMITS (PER DETAIL 1/C-4)
CLEARANCE STATUS	ALPHA SECTOR: COMPLIANT BETA SECTOR: COMPLIANT GAMMA SECTOR: COMPLIANT

PROPOSED VERIZON WIRELESS SAMSUNG ANTENNA POS.2, TYP. (1) PER SECTOR, TOTAL (2) MODEL: VZS01

PROPOSED VERIZON WIRELESS COMMSCOPE DIPLEXER TYP (1) PER SECTOR, TOTAL (2) (MOUNTED ON BACK SIDE OF ANTENNA MAST) MODEL: SDX1926Q-43

PROPOSED VERIZON WIRELESS SAMSUNG RRU TYP (1) PER SECTOR, TOTAL (2) (MOUNTED BELOW EXISTING ANTENNA) MODEL: B2/B66A RRH-BR049

PROPOSED VERIZON WIRELESS RF TRANSPARENT SCREENING PANELS (TYP)

2A C-2

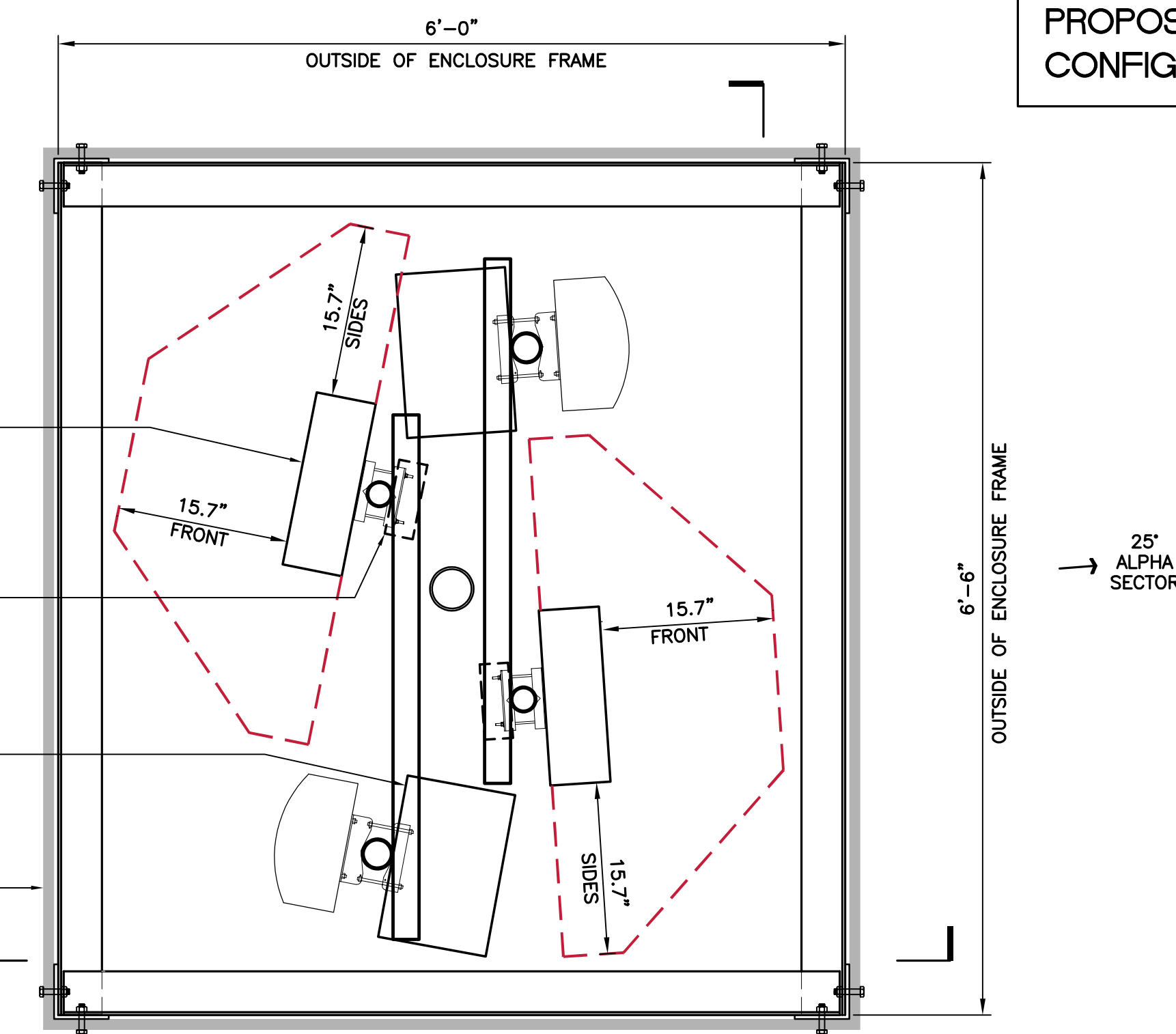

2 PROPOSED ANTENNA CONFIGURATION PLAN
SCALE: 1" = 1'-0" NORTH

TOP OF EXISTING/PROPOSED VERIZON WIRELESS ANTENNA ENCLOSURE EL. ±33.9' A.G.L.

TOP OF EXISTING/PROPOSED VERIZON WIRELESS ANTENNAS EL. ±33.4' A.G.L.

∅ OF EXISTING/PROPOSED VERIZON WIRELESS ANTENNA EL. ±31.9' A.G.L.

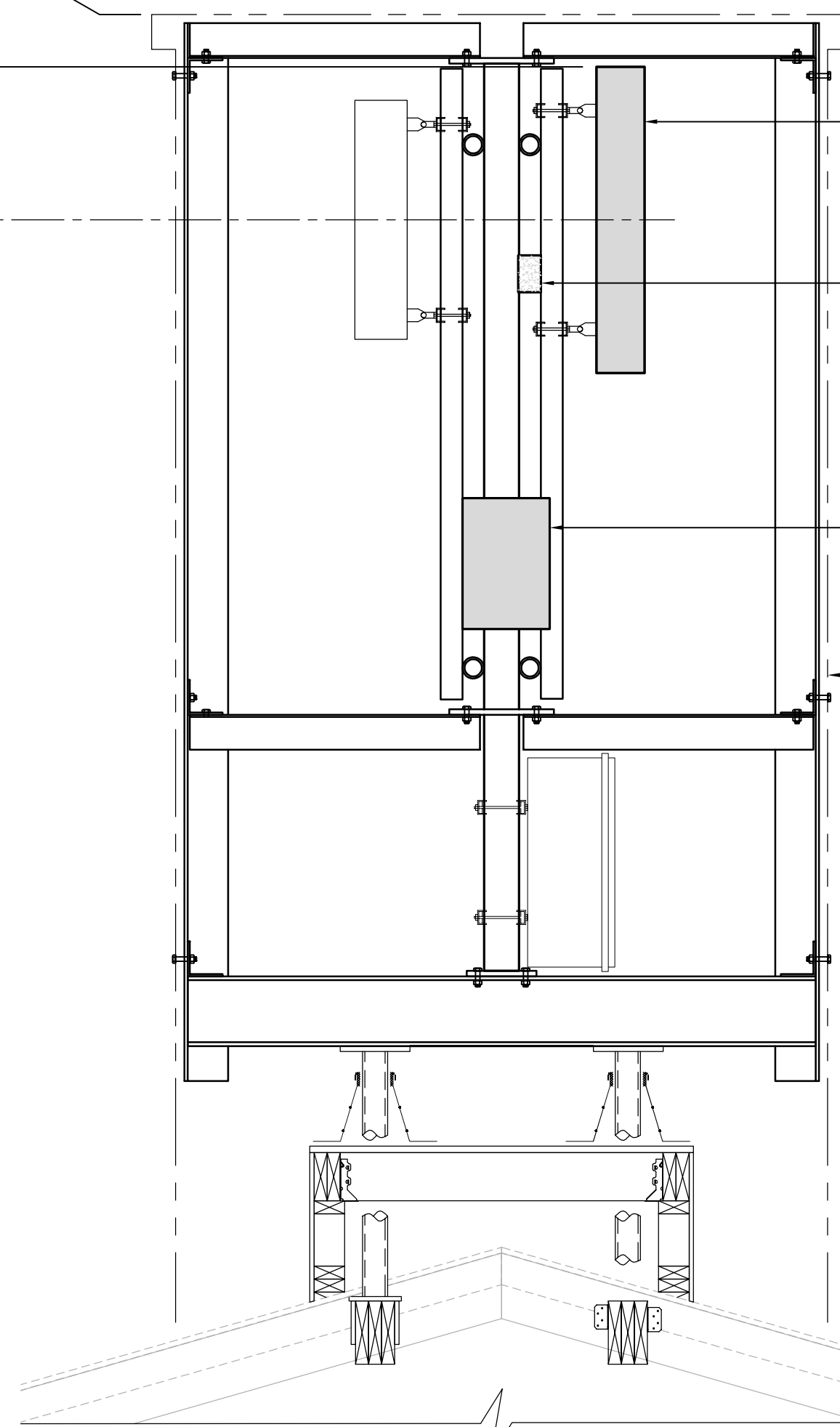

2A PROPOSED ANTENNA CONFIGURATION SECTION
SCALE: 3/4" = 1'-0"

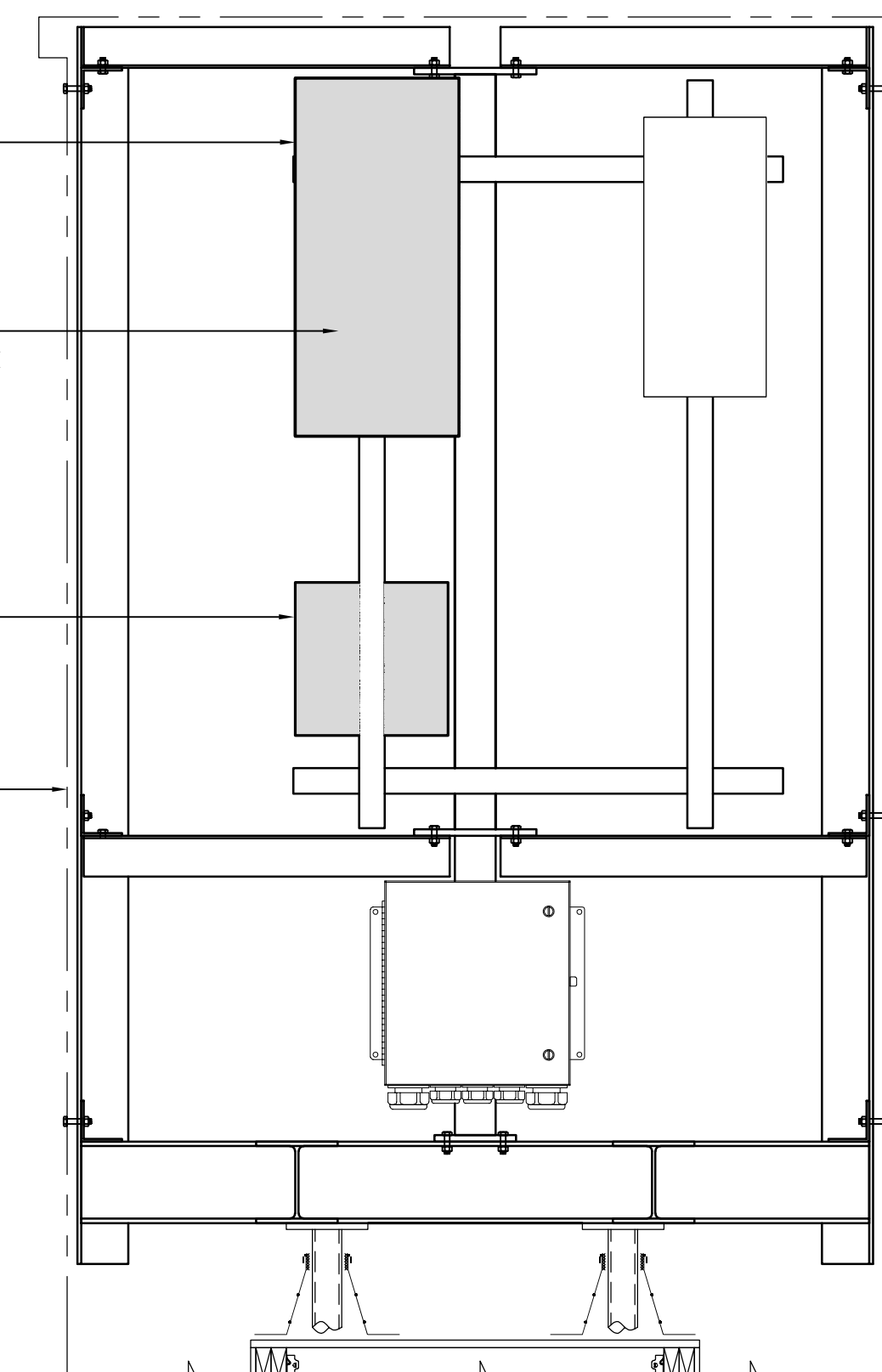

2B PROPOSED ANTENNA CONFIGURATION SECTION
SCALE: 3/4" = 1'-0"

REV.	DATE	BY	CHK'D BY	DESCRIPTION
0	03/05/21	DWD	TUL	CONSTRUCTION DRAWINGS - ISSUED FOR CONSTRUCTION
1	07/24/21	DWD	TUL	PRELIMINARY CONSTRUCTION DRAWINGS - REUSED FOR ENCLOSURE MOD.
A	01/20/21	ASC	DWD	PRELIMINARY CONSTRUCTION DRAWINGS - ISSUED FOR CLIENT REVIEW

PROFESSIONAL ENGINEER SEAL

verizon

CEN TEK engineering
Centered on Solutions
(203) 488-0580
(203) 488-8587 Fax
65-2 North Branford Road
Branford, CT 06405
www.CentekEng.com

Celco Partnership d/b/a Verizon Wireless
DANBURY 10 CT
108 FEDERAL ROAD,
DANBURY, CT 06811

DATE: 01/07/21
SCALE: AS NOTED
JOB NO. 20150.07
ANTENNA SECTOR CONFIGURATION PLANS AND SECTIONS
C-2
Sheet No. 5 of 8

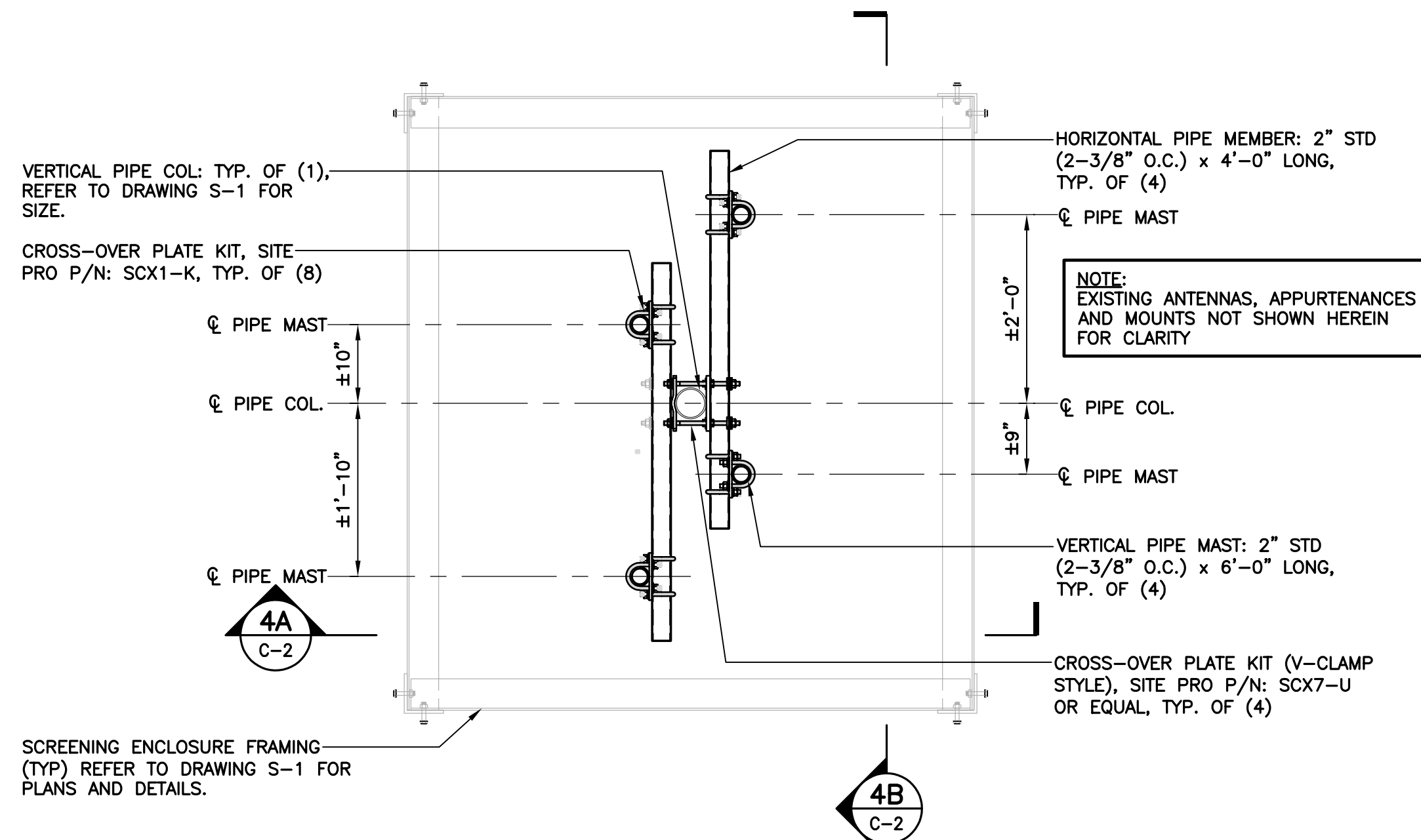

4 ANTENNA MOUNT ASSEMBLY PLAN
 SCALE: 3/4" = 1'-0"
 NORTH

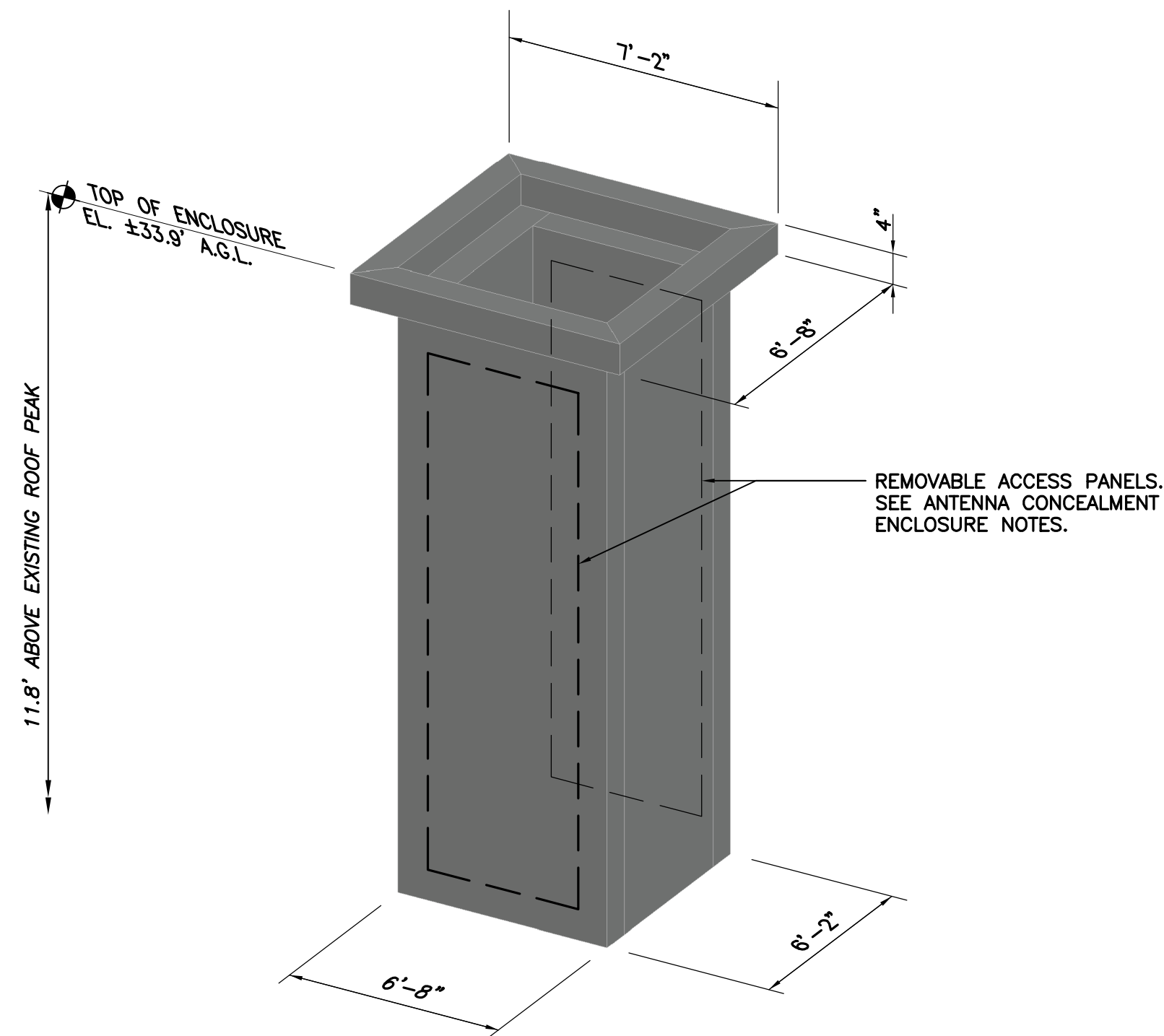

5 ANTENNA CONCEALMENT ENCLOSURE (ISOMETRIC VIEW)
 NOT TO SCALE

- ANTENNA CONCEALMENT ENCLOSURE NOTES:**
1. ANTENNA CONCEALMENT ENCLOSURE (BY ENCLOSURE MANUFACTURER) TO BE FINISHED WITH CUSTOM PANELS TO MATCH COLOR AND APPEARANCE OF THE EXISTING CHIMNEYS.
 2. FINAL PANEL DIMENSIONS TO BE COORDINATED WITH ANTENNA CONCEALMENT ENCLOSURE MANUFACTURER.
 3. TWO PANELS ON FAUX CHIMNEY ANTENNA CONCEALMENT ENCLOSURE SHALL BE DESIGNED TO HAVE REMOVABLE PANELS (ON THE WIDE SIDES OF THE ENCLOSURE FOR ACCESS TO VERIZON WIRELESS EQUIPMENT FOR MAINTENANCE AND UPGRADE PURPOSES.

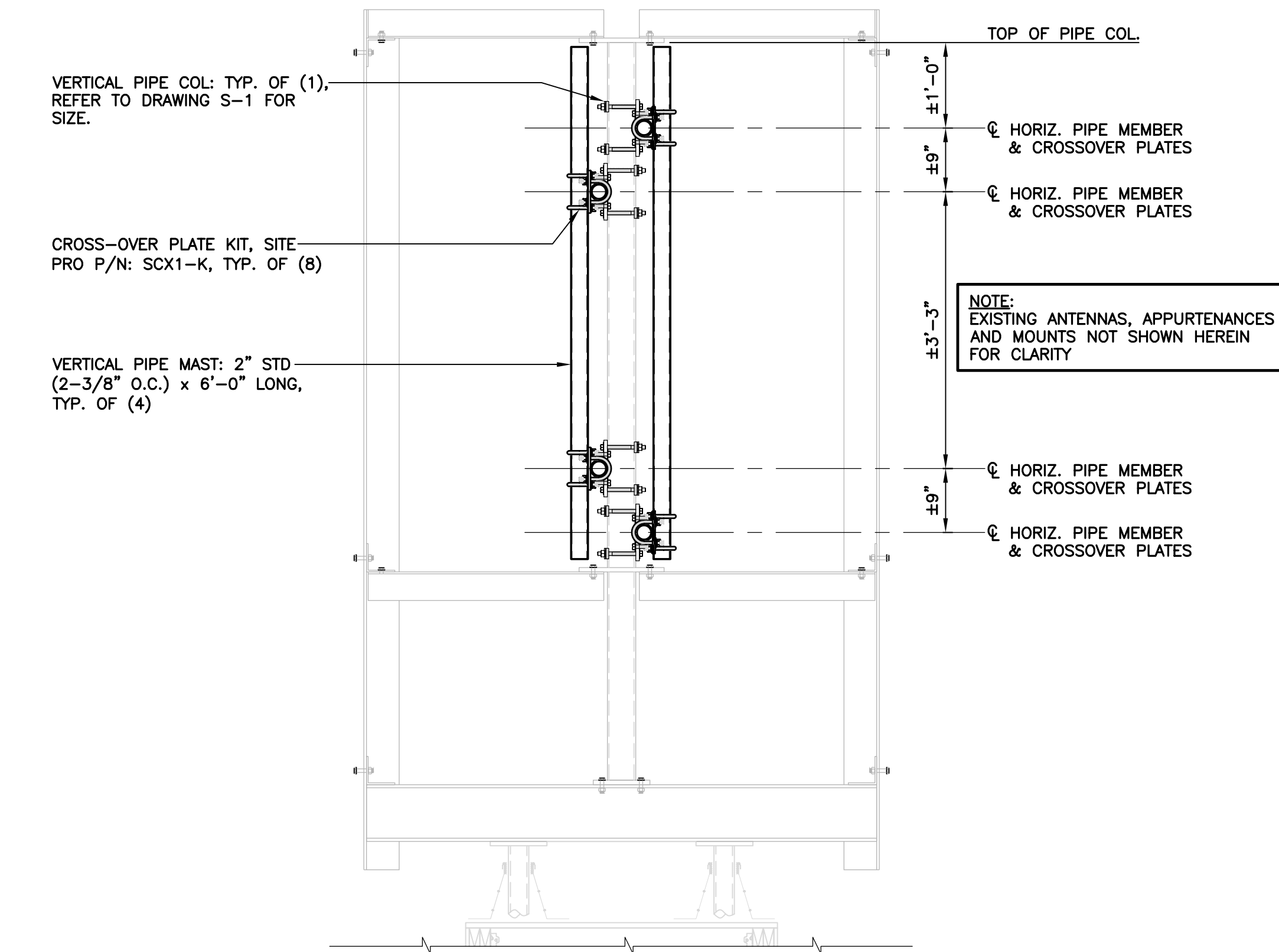

4A ANTENNA MOUNT ASSEMBLY SECTION
 SCALE: 3/4" = 1'-0"

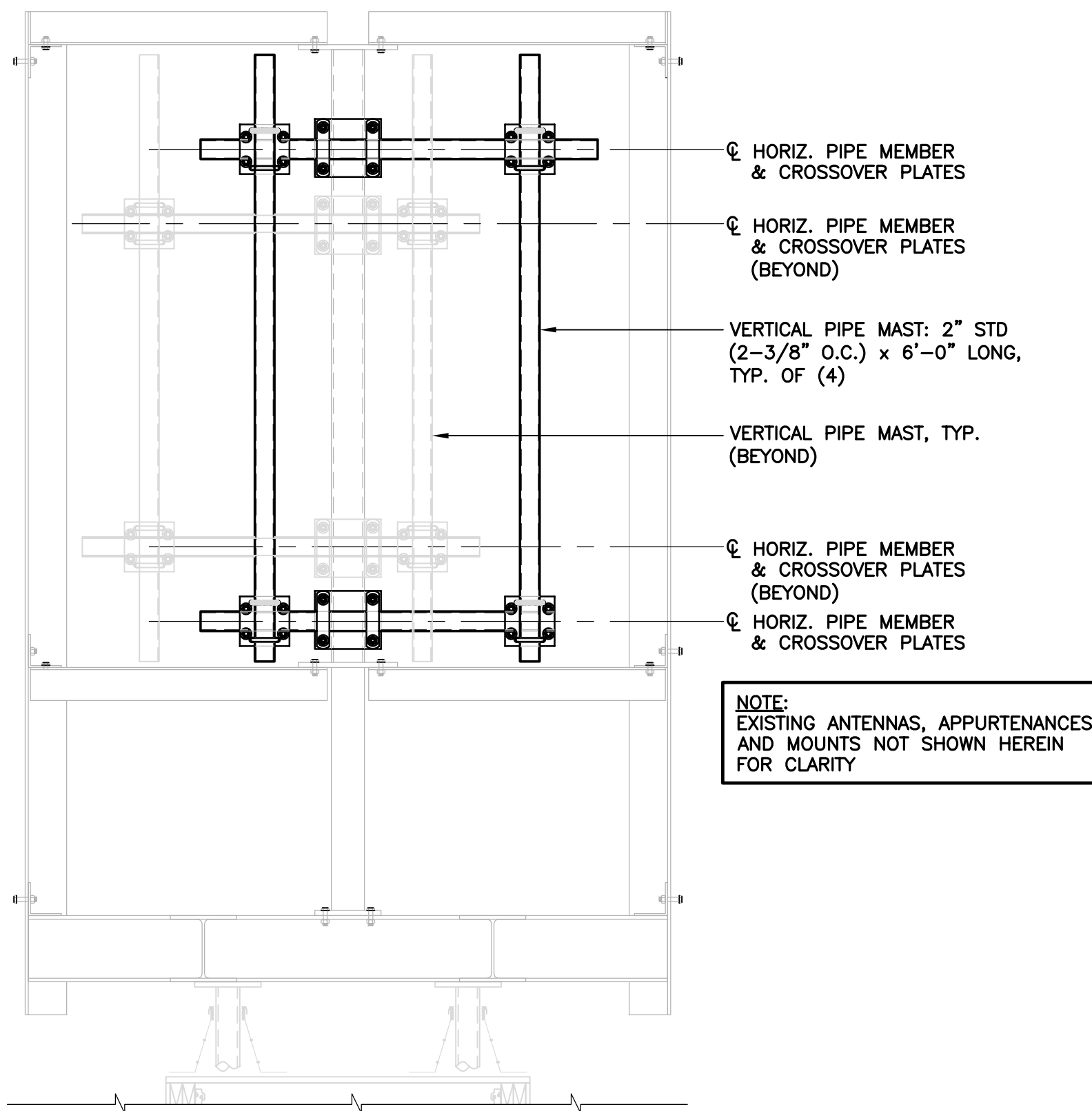

4B ANTENNA MOUNT ASSEMBLY SECTION
 SCALE: 3/4" = 1'-0"

ANTENNA FRONT

SECTOR ANTENNA		
EQUIPMENT	DIMENSIONS	WEIGHT
MAKE: TBD MODEL: VZS01	35"H x 20"W x 6"D (NOT TO EXCEED)	97 LBS. (NOT TO EXCEED)
CLEARANCES AND SERVICE AREA		
TOP:	31.5"	HORIZONTAL DISTANCE: 31.5" (ANT. TO ANT.)
FRONT, SIDES & BOTTOM:	15.7"	VERTICAL DISTANCE: 63.0" (ANT. TO ANT.)

NOTES:
 1. THIS ANTENNA HAS ITS OWN BUILT-IN RRH (VZS01).

1 SECTOR ANTENNA DETAIL
 NOT TO SCALE



DIPLEXER			
EQUIPMENT	DESCRIPTION	DIMENSIONS	WEIGHT
MAKE: COMMSCOPE MODEL: SDX1926Q-43	ULTRA COMPACT PCS/AWS	4.2"H x 6.9"W x 2.9"D	-

NOTES:
 1. CONTRACTOR TO COORDINATE FINAL EQUIPMENT MODEL SELECTION WITH VERIZON WIRELESS CONSTRUCTION MANAGER PRIOR TO ORDERING.

2 DIPLEXER DETAIL
 NOT TO SCALE

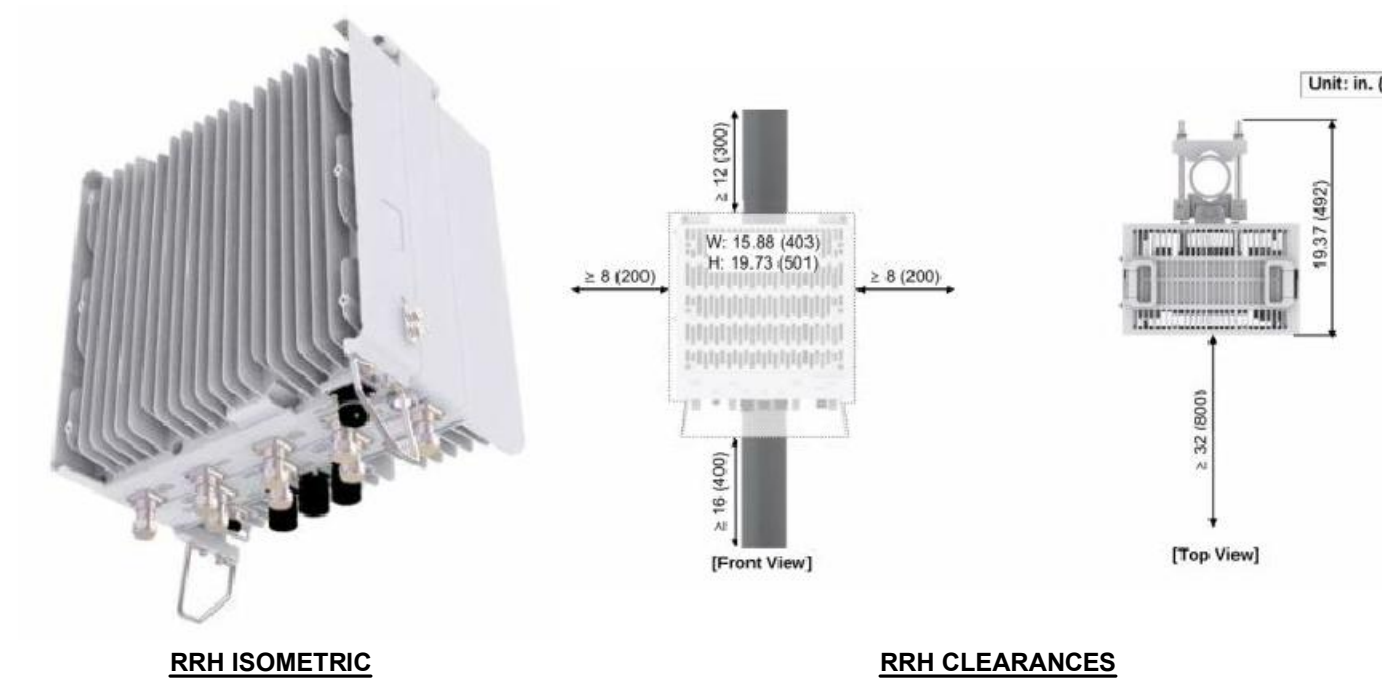

DUAL BAND RRU (REMOTE RADIO UNIT)			
EQUIPMENT	BANDS	DIMENSIONS	WEIGHT
MAKE: SAMSUNG MODEL: B2/B66A RRH-BR049 (RFV01U-D1A)	B2: PCS (1900 MHz) B66: AWS (2100 MHz)	15.0"H x 15.0"W x 10.0"D	84.4 LBS.

NOTES:
 1. CONTRACTOR TO COORDINATE FINAL EQUIPMENT MODEL SELECTION WITH VERIZON WIRELESS CONSTRUCTION MANAGER PRIOR TO ORDERING.

3 DUAL-BAND AWS/PCS RADIO UNIT DETAIL
 NOT TO SCALE

CONSTRUCTION DRAWINGS - ISSUED FOR CONSTRUCTION
 PRELIMINARY CONSTRUCTION DRAWINGS - REUSED FOR ENCLOSURE MOD.
 PRELIMINARY CONSTRUCTION DRAWINGS - ISSUED FOR CLIENT REVIEW

DATE: 01/07/21
 REV. 0
 DRAWN BY: CHK'D BY: [Signature]
 DATE: 01/20/21
 DATE: 07/24/21
 DATE: 03/05/21

PROFESSIONAL ENGINEER SEAL
 [Seal: STATE OF CONNECTICUT, PROFESSIONAL ENGINEER, CENTEK ENGINEERING]

verizon

CENTEK engineering
 Centered on Solutions
 (203) 488-0580
 (203) 488-8587 Fax
 65-2 North Branford Road
 Branford, CT 06405
 www.CentekEng.com

Cellco Partnership d/b/a Verizon Wireless
DANBURY 10 CT
 108 FEDERAL ROAD,
 DANBURY, CT 06811

DATE: 01/07/21
 SCALE: AS NOTED
 JOB NO. 20150.07

RF AND ANTENNA
 MOUNT ASSEMBLY
 DETAILS

C-3

Sheet No. 6 of 8

GENERAL NOTES

1. VERIFY ALL DIMENSIONS, ELEVATIONS, EXISTING FRAMING MEMBER SIZES AND GENERAL CONDITIONS PRIOR TO COMMENCEMENT OF WORK. NOTIFY ENGINEER OF RECORD OF ANY DISCREPANCIES BETWEEN THESE DRAWINGS AND EXISTING CONDITIONS.
2. ($\pm X'-X"$) INDICATES ELEVATION RELATIVE TO GRADE ELEVATION $\pm 0'-0"$.
3. REF. CIVIL DRAWINGS FOR ANTENNA LAYOUT AND MOUNT ASSEMBLY CONFIGURATIONS.

CONCEALMENT ENCLOSURE NOTES

1. ANTENNA CONCEALMENT ENCLOSURE PANELS TO BE DESIGN BY ANTENNA CONCEALMENT MANUFACTURER AND SUBMITTED FOR REVIEW. REFERENCE SHEET N-1 FOR DESIGN REQUIREMENTS.
2. REFERENCE 'DESIGN BASIS' ON SHEET N-1 FOR CONCEALMENT ENCLOSURE LOADING REQUIREMENTS.
3. ENGINEERED PANELS SHALL TAKE INTO CONSIDERATION ALL FRAMING AND FASTENING DENOTED WITHIN THE CONTRACT DOCUMENTS. IF ADDITIONAL FRAMING OR FASTENING IS NECESSARY, ANTENNA CONCEALMENT MANUFACTURER SHALL CONTACT THE ENGINEER OF RECORD IMMEDIATELY.

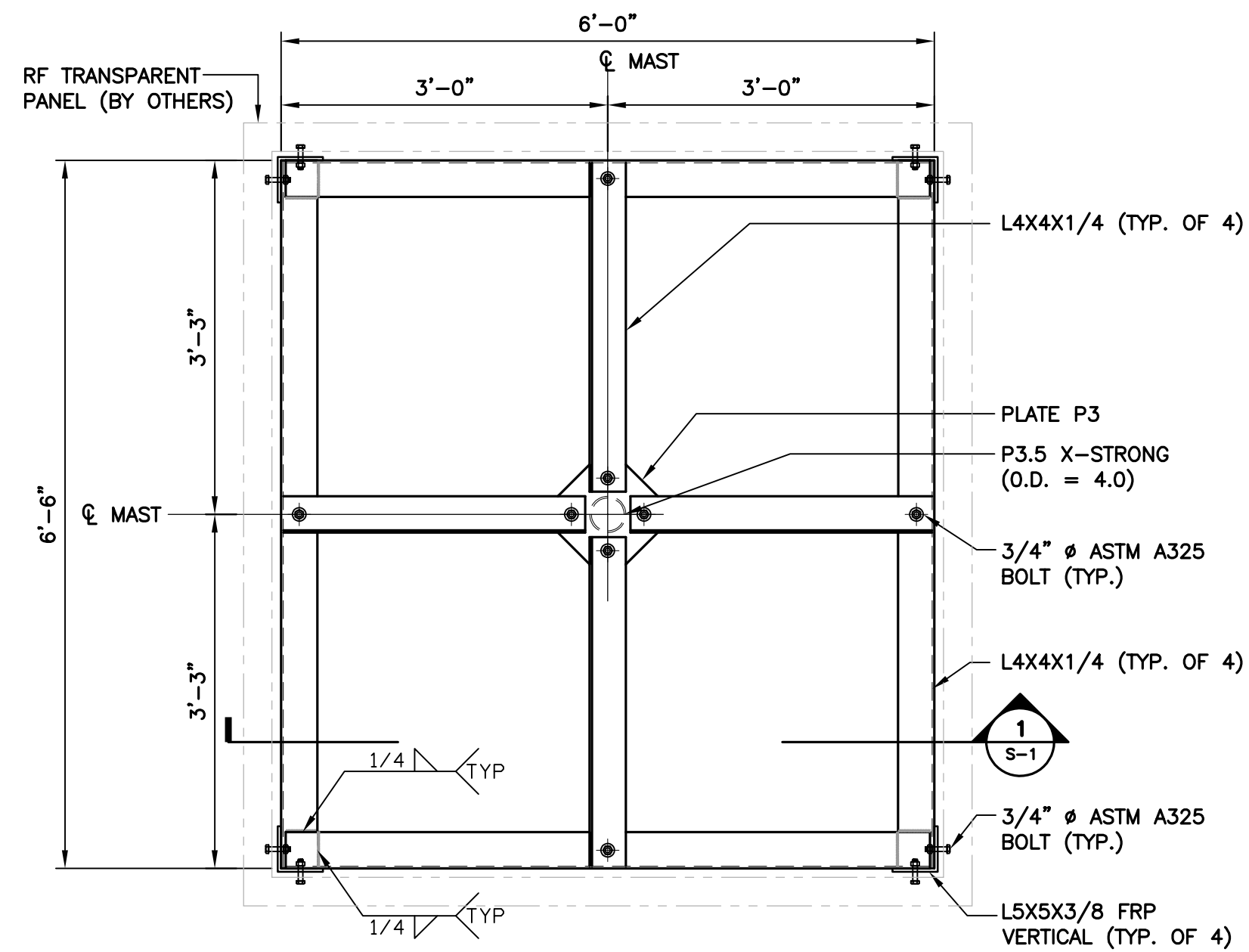

4 PLAN - HIGH FRAMING
S-1 SCALE: 3/4" = 1'-0"

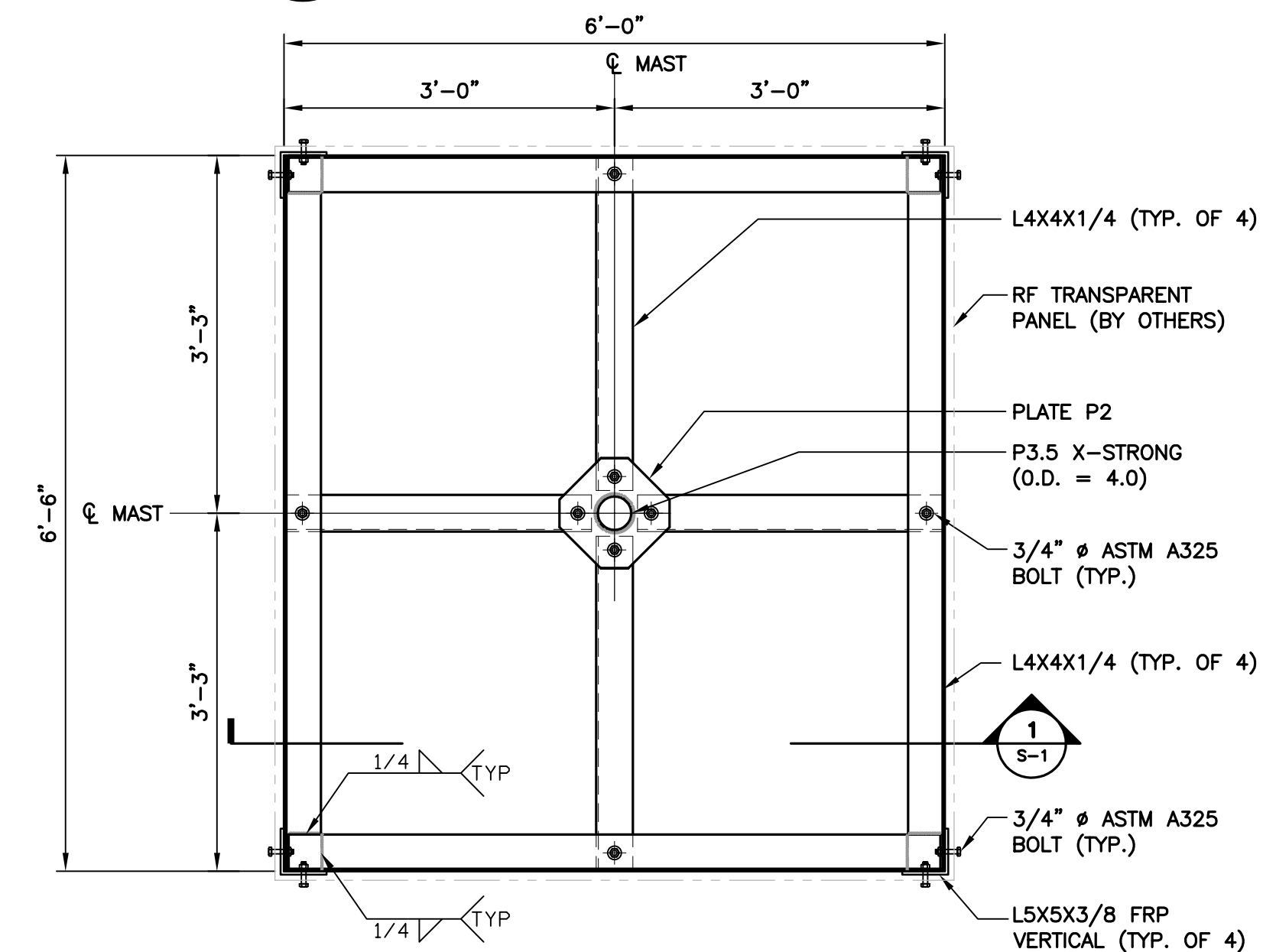

3 PLAN - MID FRAMING
S-1 SCALE: 3/4" = 1'-0"

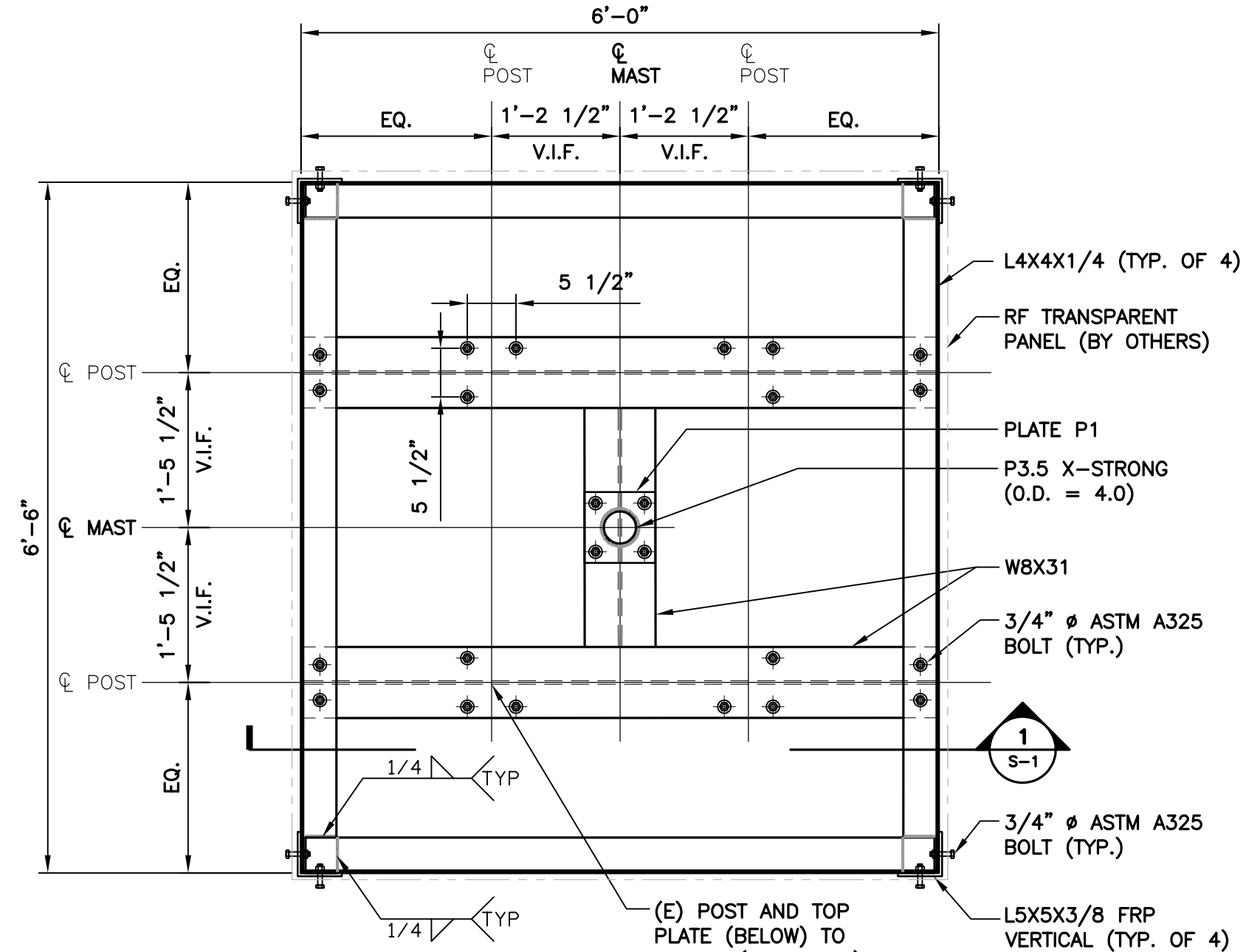

2 PLAN - LOW FRAMING
S-1 SCALE: 3/4" = 1'-0"

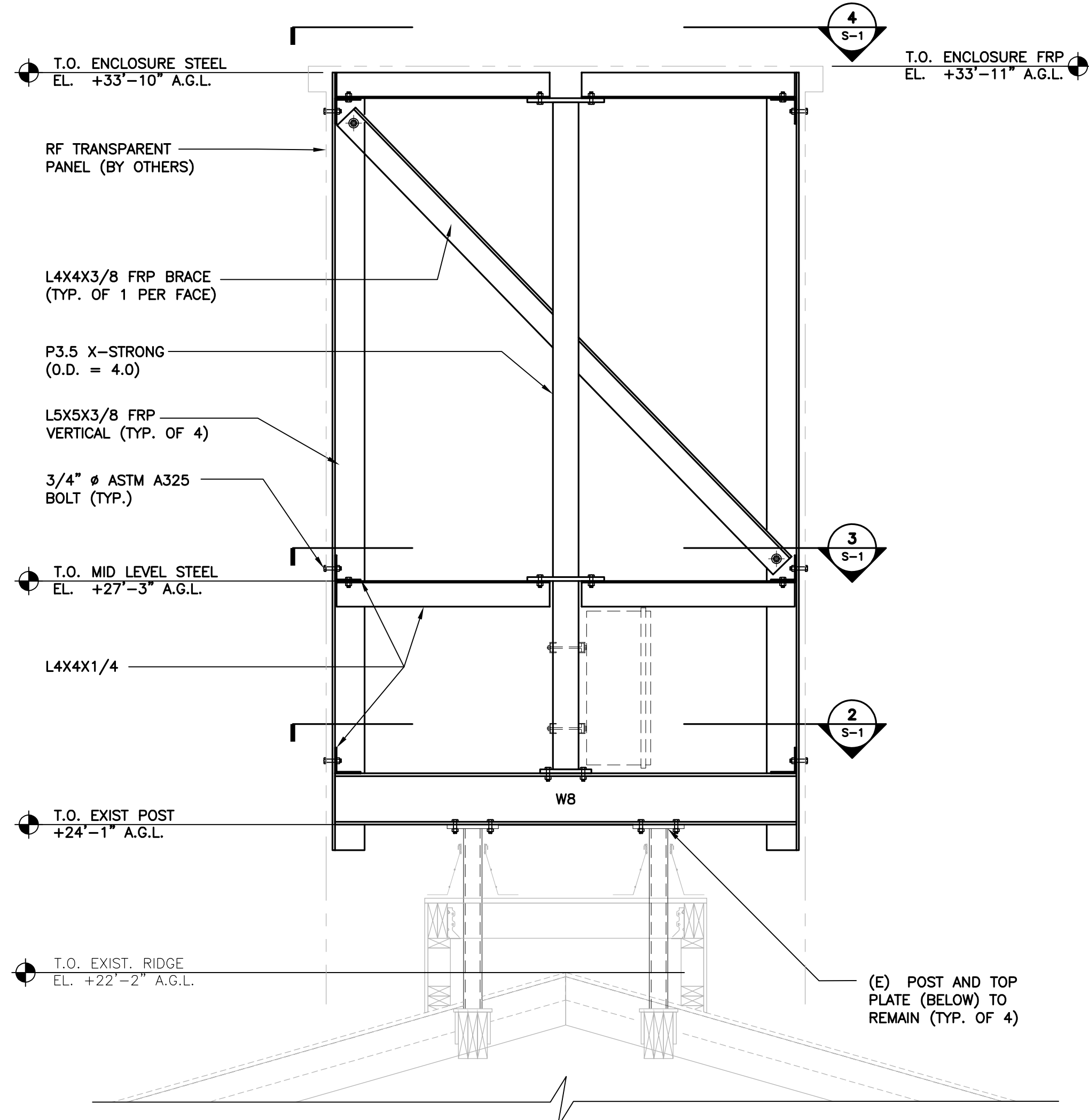

1 ENCLOSURE ELEVATION
S-1 SCALE: 3/4" = 1'-0"

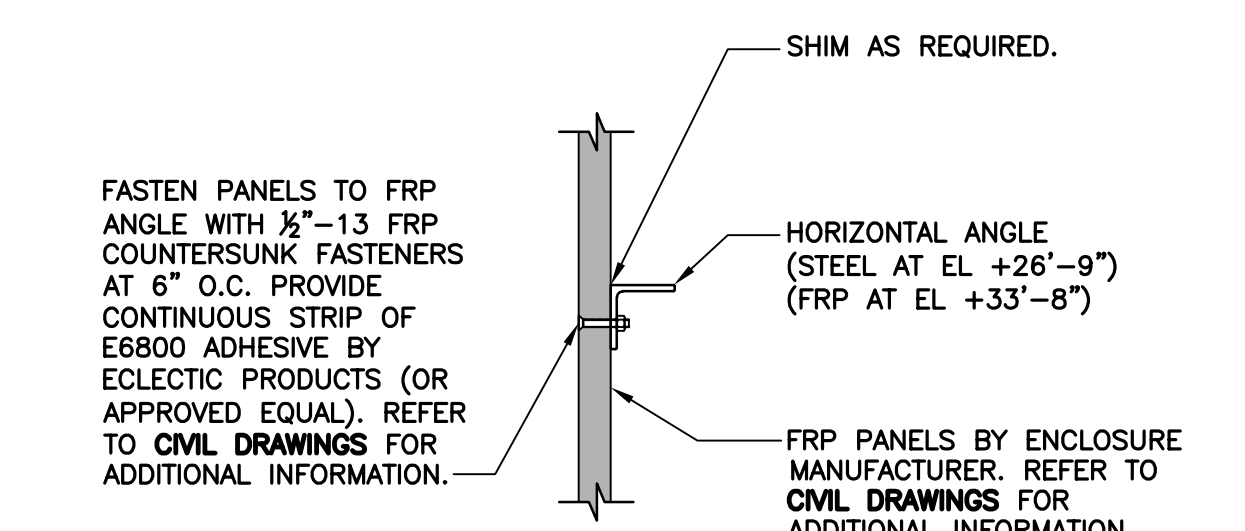

9 TYPICAL PANEL TO ANGLE CONNECTION
S-1 SCALE: 1" = 1'-0"

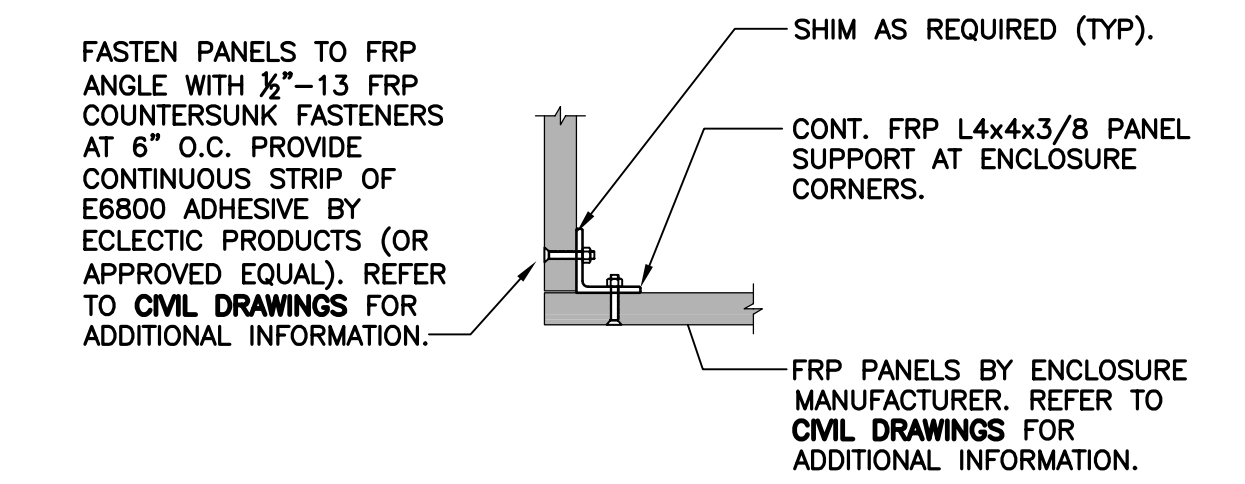

8 PLAN - TYPICAL FRP CORNER CONNECTION
S-1 SCALE: 1" = 1'-0"

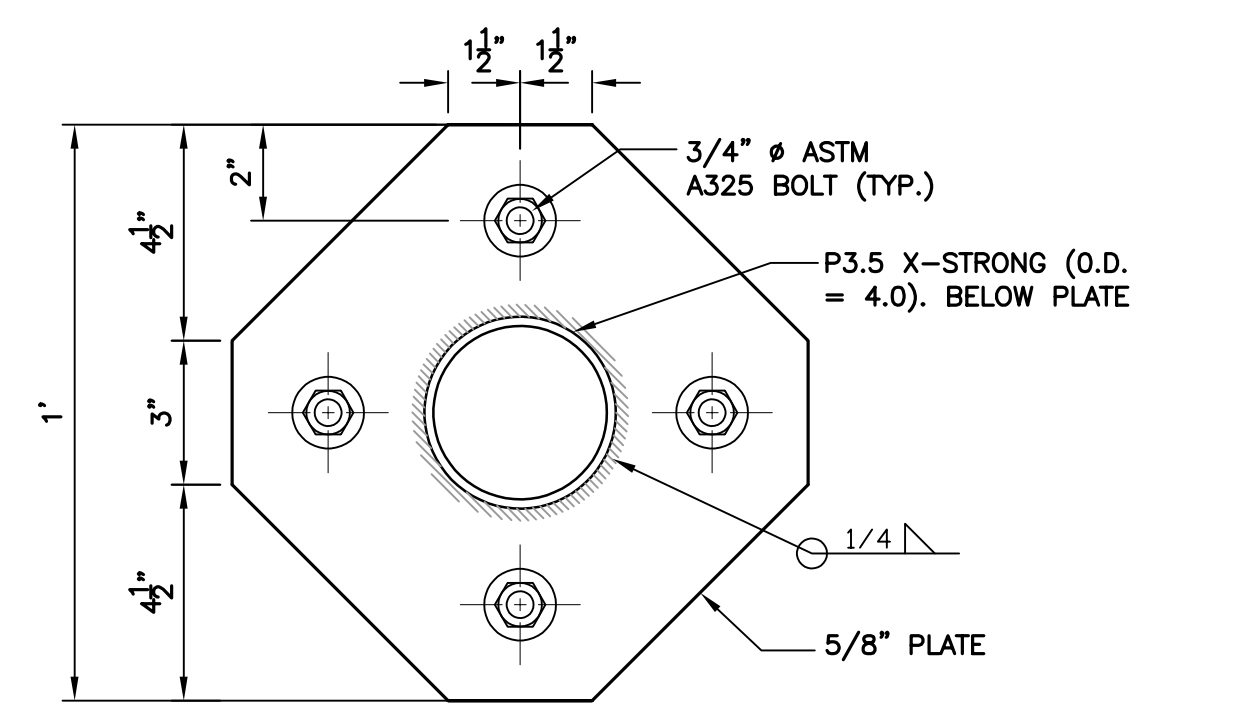

7 PLATE 'P3' DETAIL
S-1 SCALE: 3" = 1'-0"

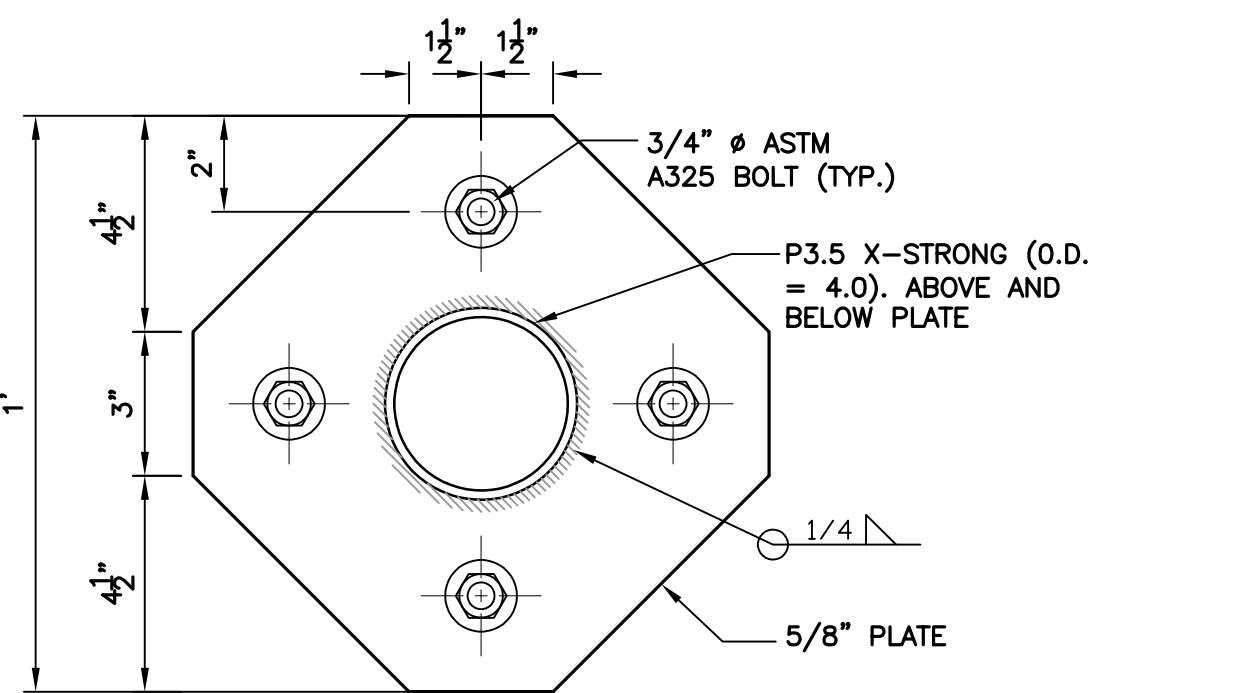

6 PLATE 'P2' DETAIL
S-1 SCALE: 3" = 1'-0"

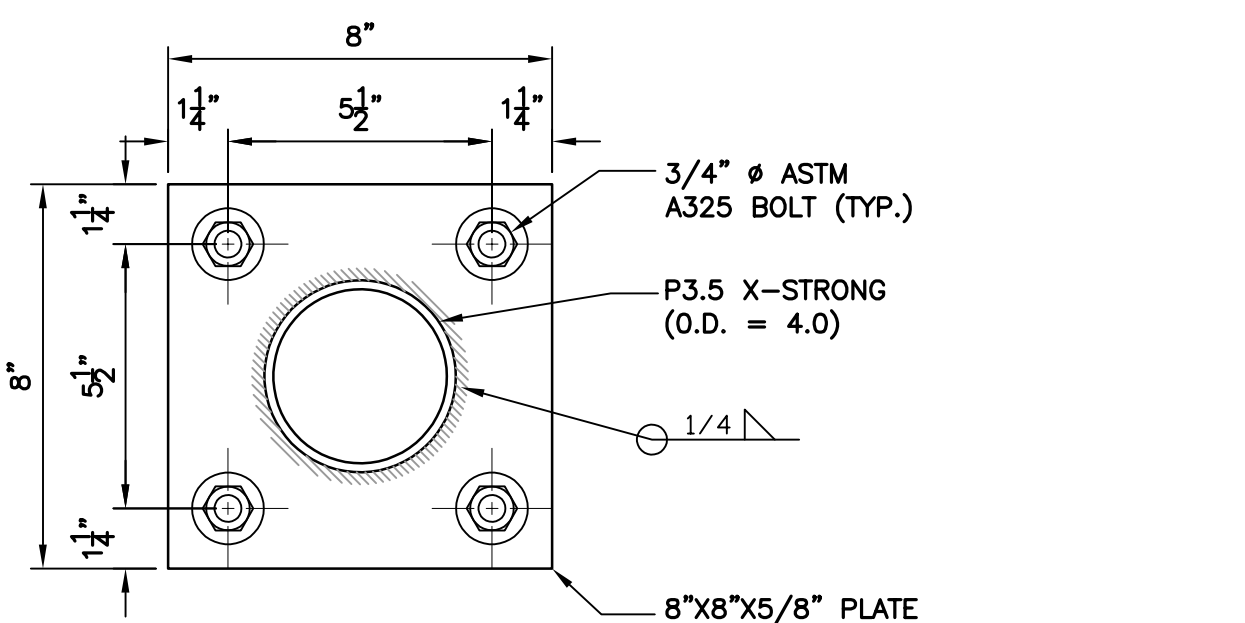

5 PLATE 'P1' DETAIL
S-1 SCALE: 3" = 1'-0"

CONSTRUCTION DRAWINGS - ISSUED FOR CONSTRUCTION
PRELIMINARY CONSTRUCTION DRAWINGS - REUSED FOR ENCLOSURE MOD.
PRELIMINARY CONSTRUCTION DRAWINGS - ISSUED FOR CLIENT REVIEW

REV.	DATE	BY	CHK'D BY	DESCRIPTION
0	03/05/21	DWD	TUL	
1	07/24/21	DWD	TUL	
2	07/20/21	ASC	DWD	
A	01/20/21	ASC	DWD	

PROFESSIONAL ENGINEER SEAL

verizon

CENTEK engineering
Centered on Solutions™
(203) 488-0580
(203) 488-8587 Fax
65-2 North Branford Road
Branford, CT 06405
www.CentekEng.com

Cellco Partnership d/b/a Verizon Wireless
DANBURY 10 CT
108 FEDERAL ROAD,
DANBURY, CT 06811

DATE: 01/07/21
SCALE: AS NOTED
JOB NO. 20150.07

RF ENCLOSURE MOD.
FRAMING PLANS AND
DETAILS

S-1

Sheet No. 1 of 8

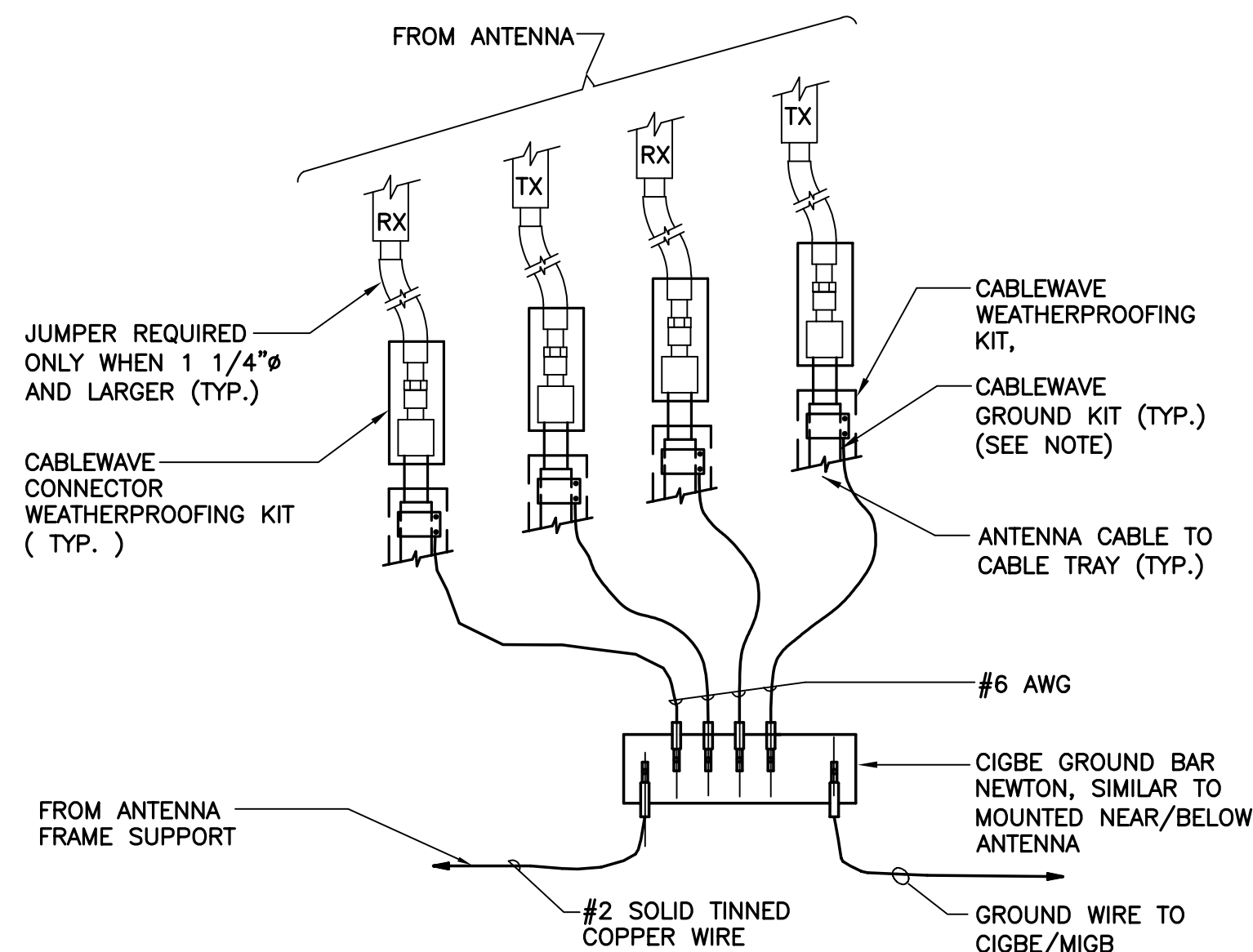

NOTES:

- DO NOT INSTALL CABLE GROUND KIT AT A BEND AND ALWAYS DIRECT GROUND WIRE DOWN TO CIGBE

1 CONNECTION OF GROUND WIRES TO GROUND BAR
E-1 NOT TO SCALE

- EACH RRH CABINET SHALL BE GROUNDED IN THE FOLLOWING MANNER:
- AT TOP OF THE CABINET
 - AT RIGHT SIDE OF THE CABINET.

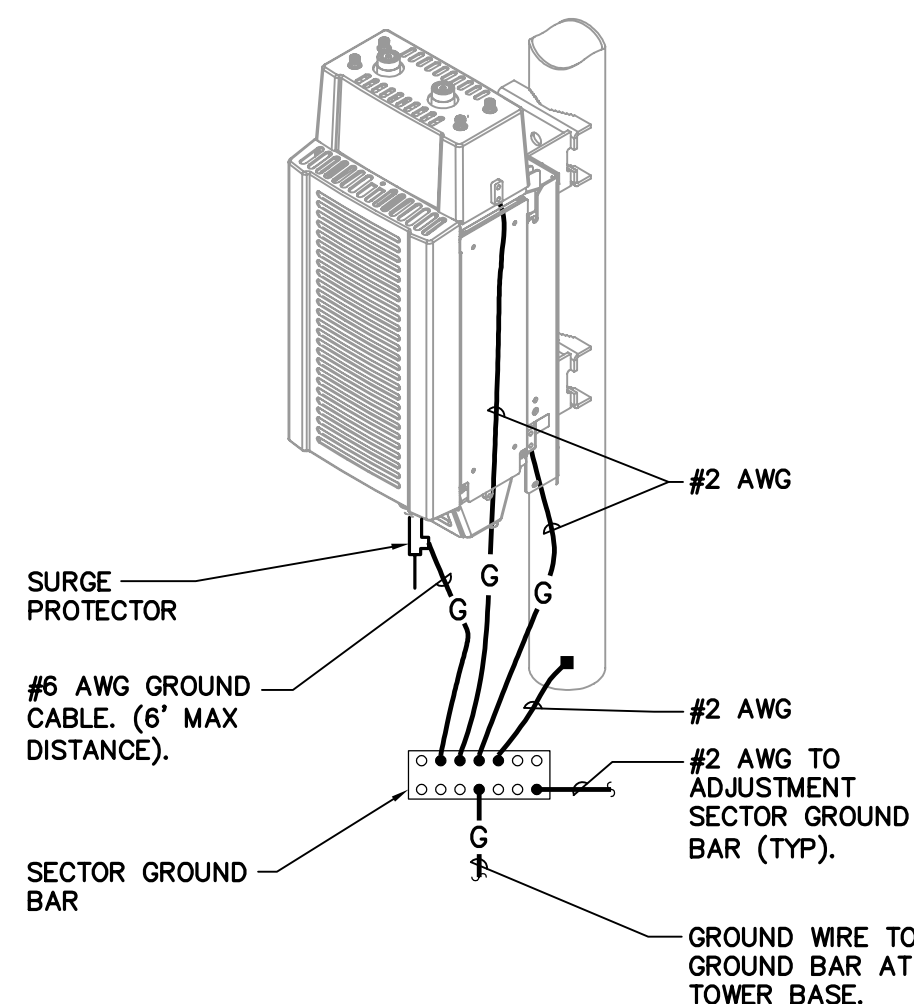

2 RRH POLE MOUNT GROUNDING
E-1 NOT TO SCALE

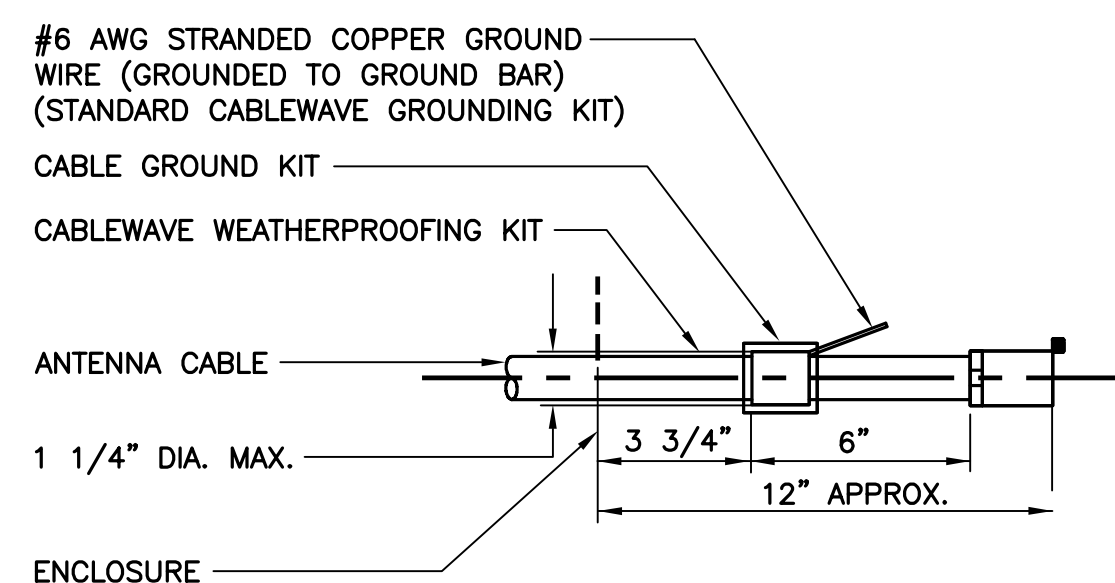

NOTES:

- DO NOT INSTALL CABLE GROUND KIT AT A BEND AND ALWAYS DIRECT GROUND WIRE DOWN TO GROUND BAR.

3 ANTENNA CABLE GROUNDING DETAIL
E-1 NOT TO SCALE

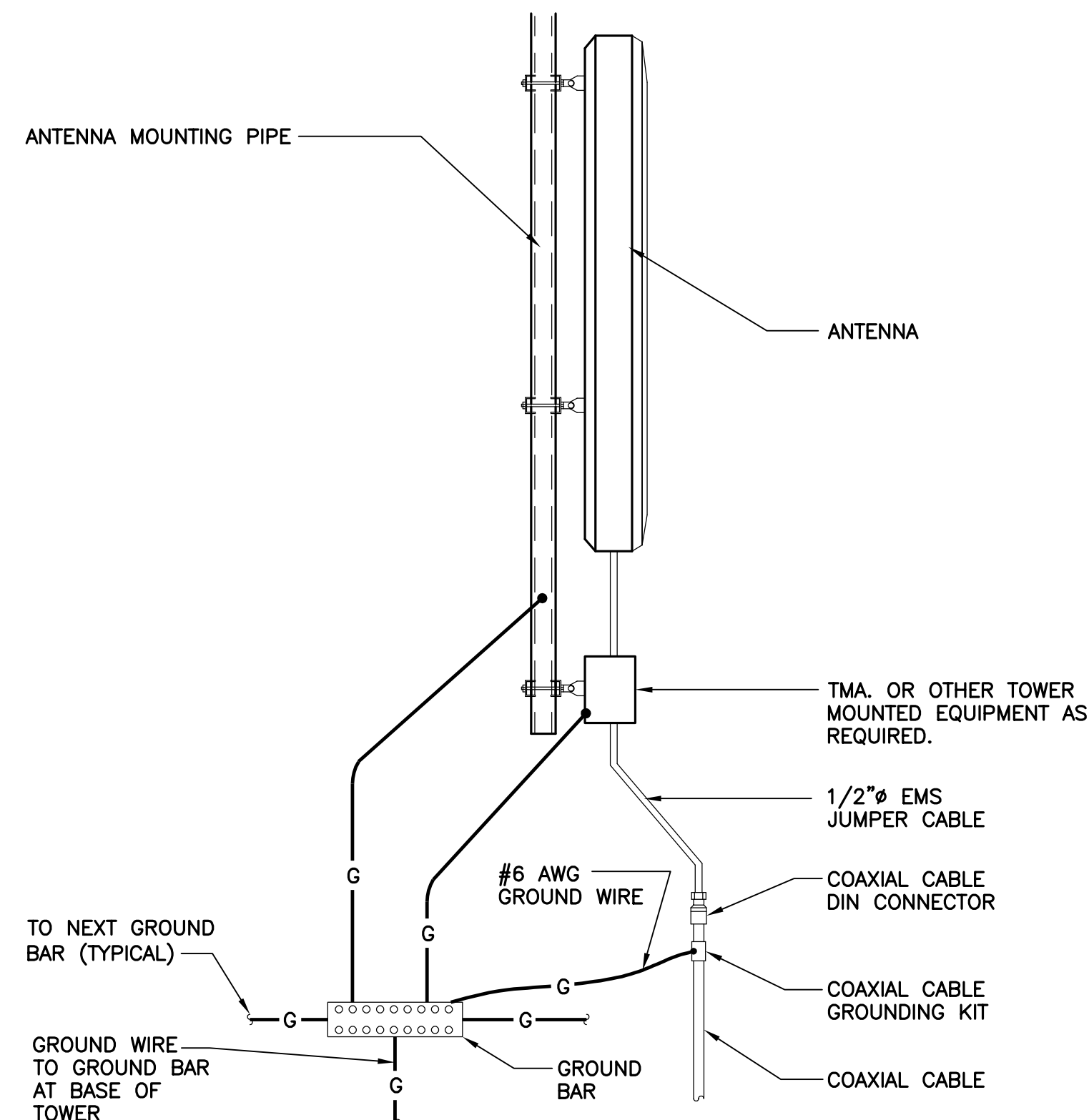

4 TYPICAL ANTENNA GROUNDING DETAIL
E-1 NOT TO SCALE

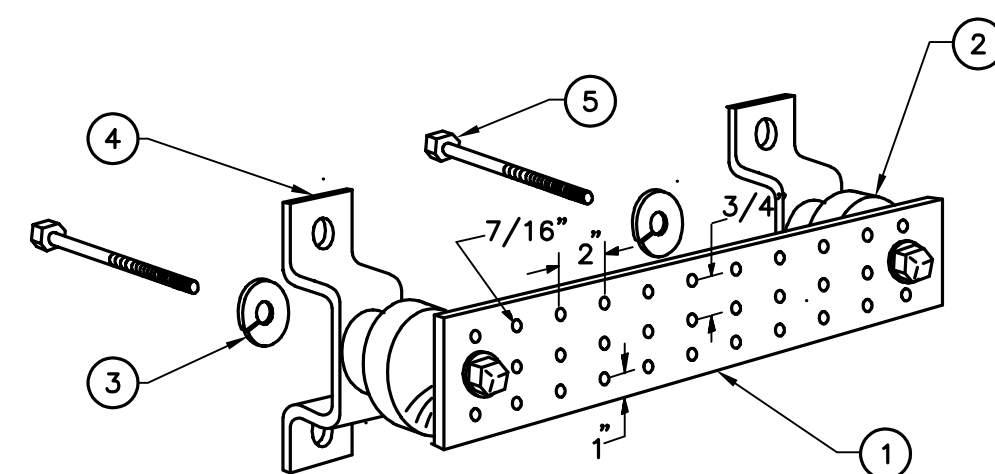

NOTES

- TINNED COPPER GROUND BAR, 1/4" x 4" x 20", NEWTON INSTRUMENT CO. HOLE CENTERS TO MATCH NEMA DOUBLE LUG CONFIGURATION.
- INSULATORS, NEWTON INSTRUMENT CAT. NO. 3061-4.
- 5/8" LOCK WASHERS, NEWTON INSTRUMENT CO. CAT. NO. 3015-8.
- WALL MOUNTING BRACKET, NEWTON INSTRUMENT CO. CAT NO. A-6056.
- 5/8-11 x 1" STAINLESS STEEL TRUSS SPANNER MACHINE SCREWS.

5 GROUND BAR DETAIL
E-1 NOT TO SCALE

ELECTRICAL SPECIFICATIONS

SECTION 16010

1.01. SCOPE OF WORK

A. WORK SHALL INCLUDE ALL LABOR, EQUIPMENT AND SERVICES REQUIRED TO COMPLETE (MAKE READY FOR OPERATION) ALL THE ELECTRICAL WORK INCLUDING, BUT NOT LIMITED TO, THE FOLLOWING:

- CELLULAR GROUNDING SYSTEMS CONSISTING OF ANTENNA GROUNDING, GROUND BARS, ETC.

1.02. GENERAL REQUIREMENTS

- THE ENTIRE ELECTRICAL INSTALLATION SHALL BE MADE IN STRICT ACCORDANCE WITH ALL LOCAL, STATE AND NATIONAL CODES AND REGULATIONS WHICH MAY APPLY AND NOTHING IN THE DRAWINGS OR SPECIFICATIONS SHALL BE INTERPRETED AS AN INFRINGEMENT OF SUCH CODES OR REGULATIONS.
- THE ELECTRICAL CONTRACTOR IS TO BE RESPONSIBLE FOR THE COMPLETE INSTALLATION AND COORDINATION OF THE ENTIRE ELECTRICAL SERVICE. ALL ACTIVITIES TO BE COORDINATED THROUGH OWNERS REPRESENTATIVE, DESIGN ENGINEER AND OTHER AUTHORITIES HAVING JURISDICTION OF TRADES.
- THE CONTRACTOR SHALL BE RESPONSIBLE FOR OBTAINING ALL PERMITS AND PAY ALL FEES THAT MAY BE REQUIRED FOR THE ELECTRICAL WORK AND FOR SCHEDULING OF ALL INSPECTIONS THAT MAY BE REQUIRED BY THE LOCAL AUTHORITY.
- THE CONTRACTOR SHALL BE RESPONSIBLE FOR COORDINATION WITH THE BUILDING OWNER FOR NEW AND/OR DEMOLITION WORK INVOLVED.
- NO MATERIAL OTHER THAN THAT CONTAINED IN THE "LATEST LIST OF ELECTRICAL FITTINGS" APPROVED BY THE UNDERWRITERS' LABORATORIES, SHALL BE USED IN ANY PART OF THE WORK. ALL MATERIAL FOR WHICH LABEL SERVICE HAS BEEN ESTABLISHED SHALL BEAR THE U.L. LABEL.
- THE CONTRACTOR SHALL GUARANTEE ALL NEW WORK FOR A PERIOD OF ONE YEAR FROM THE ACCEPTANCE DATE BY THE OWNER. THE CONTRACTOR SHALL BE RESPONSIBLE FOR OBTAINING WARRANTIES FROM ALL EQUIPMENT MANUFACTURERS FOR SUBMISSION TO THE OWNER.
- DRAWINGS INDICATE GENERAL ARRANGEMENT OF WORK INCLUDED IN CONTRACT. CONTRACTOR SHALL, WITHOUT EXTRA CHARGE, MAKE MODIFICATIONS TO THE LAYOUT OF THE WORK TO PREVENT CONFLICT WITH WORK OF OTHER TRADES AND FOR THE PROPER INSTALLATION OF WORK. CHECK ALL DRAWINGS AND VISIT JOB SITE TO VERIFY SPACE AND TYPE OF EXISTING CONDITIONS IN WHICH WORK WILL BE DONE, PRIOR TO SUBMITTAL OF BID.
- THE ELECTRICAL CONTRACTOR SHALL SUPPLY THREE (3) COMPLETE SETS OF APPROVED DRAWINGS, ENGINEERING DATA SHEETS, MAINTENANCE AND OPERATING INSTRUCTION MANUALS FOR ALL SYSTEMS AND THEIR RESPECTIVE EQUIPMENT. THESE MANUALS SHALL BE INSERTED IN VINYL COVERED 3-RING BINDERS AND TURNED OVER TO OWNER'S REPRESENTATIVE ONE (1) WEEK PRIOR TO FINAL PUNCH LIST.
- ALL WORK SHALL BE INSTALLED IN A NEAT AND WORKMAN LIKE MANNER AND WILL BE SUBJECT TO THE APPROVAL OF THE OWNER'S REPRESENTATIVE.
- ALL EQUIPMENT AND MATERIALS TO BE INSTALLED SHALL BE NEW, UNLESS OTHERWISE NOTED.
- BEFORE FINAL PAYMENT, THE CONTRACTOR SHALL PROVIDE A COMPLETE SET OF PRINTS (AS-BUILTS), LEGIBLY MARKED IN RED PENCIL TO SHOW ALL CHANGES FROM THE ORIGINAL PLANS.
- ENTIRE ELECTRICAL INSTALLATION SHALL BE IN ACCORDANCE WITH OWNER'S SPECIFICATIONS, AND REQUIREMENTS OF ALL LOCAL AUTHORITIES HAVING JURISDICTION. IT IS THE CONTRACTOR'S RESPONSIBILITY TO COORDINATE WITH APPROPRIATE INDIVIDUALS TO OBTAIN ALL SUCH SPECIFICATIONS AND REQUIREMENTS. NOTHING CONTAINED IN, OR OMITTED FROM, THESE DOCUMENTS SHALL RELIEVE CONTRACTOR FROM THIS OBLIGATION.

SECTION 16450

1.01. GROUNDING

- ALL NON-CURRENT CARRYING PARTS OF THE ELECTRICAL AND TELEPHONE CONDUIT SYSTEMS SHALL BE MECHANICALLY AND ELECTRICALLY CONNECTED TO PROVIDE AN INDEPENDENT RETURN PATH TO THE EQUIPMENT GROUNDING SOURCES.
- GROUNDING SYSTEM WILL BE IN ACCORDANCE WITH THE LATEST ACCEPTABLE EDITION OF THE NATIONAL ELECTRICAL CODE AND REQUIREMENTS PER LOCAL INSPECTOR HAVING JURISDICTION.
- EQUIPMENT GROUNDING CONDUCTOR:
 - EACH EQUIPMENT GROUND CONDUCTOR SHALL BE SIZED IN ACCORDANCE WITH THE N.E.C. ARTICLE 250-122.
 - THE MINIMUM SIZE OF EQUIPMENT GROUND CONDUCTOR SHALL BE #12 AWG COPPER.
- CELLULAR GROUNDING SYSTEM:

PROVIDE THE CELLULAR GROUNDING SYSTEM AS SPECIFIED ON DRAWINGS, INCLUDING, BUT NOT LIMITED TO:

 - GROUND BARS
 - ANTENNA GROUND CONNECTIONS AND PLATES.
- ALL EQUIPMENT SHALL BE BONDED TO GROUND AS REQUIRED BY N.E.C., MFG. SPECIFICATIONS, AND OWNER'S SPECIFICATIONS.

PROFESSIONAL ENGINEER SEAL
 STATE OF CONNECTICUT
 REGISTERED PROFESSIONAL ENGINEER
 LICENSE NO. 10400
 DATE 01/07/21
 DRAWN BY CHK'D BY
 DATE 01/07/21
 REV.

verizon
 Centek engineering
 (203) 488-0580
 (203) 488-8587 Fax
 65-2 North Branford Road
 Branford, CT 06405
 www.CentekEng.com

Cellco Partnership d/b/a Verizon Wireless
DANBURY 10 CT
 109 FEDERAL ROAD,
 DANBURY, CT 06811

DATE: 01/07/21
 SCALE: AS NOTED
 JOB NO. 20150.07
 ELECTRICAL SPECIFICATIONS AND DETAILS
E-1
 Sheet No. 8 of 8

SAMSUNG C-Band 64T64R Massive MIMO Radio

for High Capacity and Wide Coverage

Samsung C-Band 64T64R Massive MIMO Radio enables mobile operators to increase coverage range, boost data speeds and ultimately offer enriched 5G experiences to users in the U.S..

Model Code : MT6407-77A

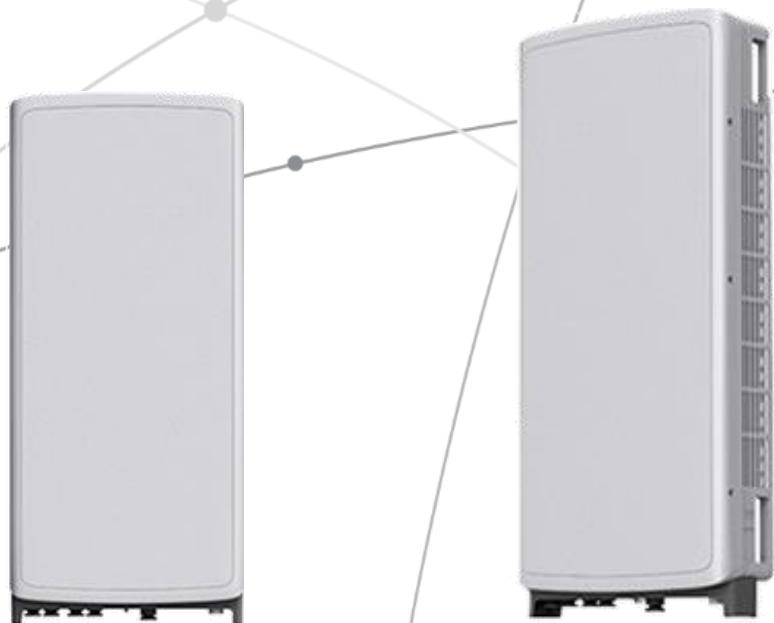

Points of Differentiation

Wide Bandwidth

With capability to support up to 2 CC carrier configuration, Samsung C-Band massive MIMO Radio supports 200 MHz bandwidth in the C-Band spectrum.

Samsung C-Band massive MIMO Radio covers the entire C-Band 280 MHz spectrum, so it can meet the operator's needs in current A block and future B/C blocks

C-Band spectrum supported by Massive MIMO Radio

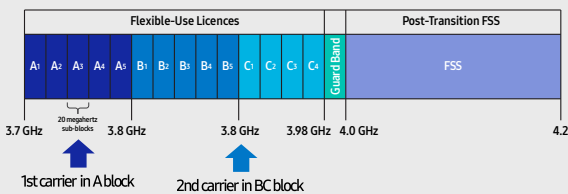

Future Proof Product

Samsung C-Band 64T64R Massive MIMO radio supports not only CPRI but also eCPRI as front-haul interface.

It enables operators can cut down on OPEX/CAPEX by reducing front-haul bandwidth through low layer split and using ethernet based higher efficient line.

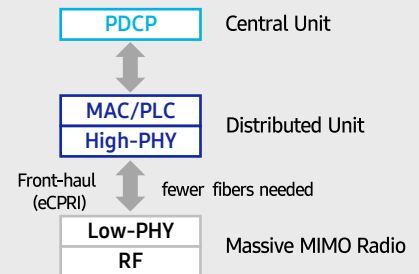

Enhanced Performance

C-Band massive MIMO Radio creates sharp beams and extends networks' coverage on the critical mid-band spectrum using a large number of antenna elements and high output power to boost data speeds.

This helps operators reduce their CAPEX as they now need less products to cover the same area than before.

Furthermore, as C-Band massive MIMO Radio supports MU-MIMO (Multi-user MIMO), it enables to increase user throughput by minimizing interference.

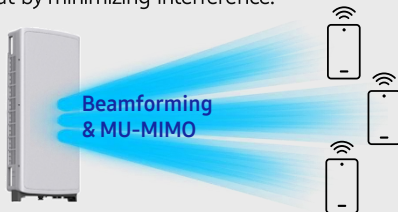

Well Matched Design

Samsung C-Band Massive MIMO radio utilizes 64 antennas, supports up to 280MHz bandwidth, and delivers a 200W output power. despite the above advanced performance, the Radio has a compact size of 50.9L and 79.4lbs. This makes it easy to install the Radio.

It is designed to look solid and compact, with a low profile appearance so that, when installed, harmonizes well with the surrounding environment.

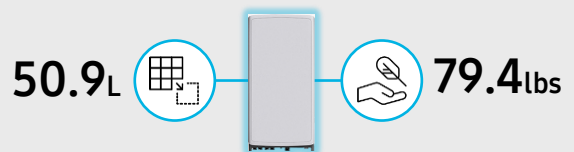

Technical Specifications

Item	Specification
Tech	NR
Band	n77
Frequency Band	3700 - 3980 MHz
EIRP	78.5dBm (53.0 dBm+25.5 dBi)
IBW/OBW	280 MHz / 200 MHz
Installation	Pole/Wall
Size/ Weight	16.06 x 35.06 x 5.51 inch (50.86L)/ 79.4 lbs



SAMSUNG



About Samsung Electronics Co., Ltd.

Samsung inspires the world and shapes the future with transformative ideas and technologies. The company is redefining the worlds of TVs, smartphones, wearable devices, tablets, digital appliances, network systems, and memory, system LSI, foundry and LED solutions.

129 Samsung-ro, Yeongtong-gu, Suwon-si Gyeonggi-do, Korea

© 2021 Samsung Electronics Co., Ltd.

All rights reserved. Information in this leaflet is proprietary to Samsung Electronics Co., Ltd. and is subject to change without notice. No information contained here may be copied, translated, transcribed or duplicated by any form without the prior written consent of Samsung Electronics.

SAMSUNG

Dual-Band Radio Unit AWS/PCS (B66/B2)

RFV01U-D1A

Samsung's RFV01U-D1A is a compact remote Radio Unit (RU) designed for deployments that require flexibility in installation and rapid onlining, without compromising on coverage, capacity or operational expenses.



The RFV01U-D1A RU targets dual-band support across Band 66 (AWS) and Band 2 (PCS), making it an ideal product for broad coverage footprints across multiple common mid-range frequencies.

The RU handles all Radio Frequency (RF) processing in a single, compact unit, and is designed to interface via CPRI with Samsung's CDU baseband offerings, in both distributed- and central-RAN configurations.

In addition to its minimal footprint and ease of installation, the RU is also designed to reduce cost of ownership through its integrated spectrum analyzer, which allows for remote RF monitoring, greatly reducing the need for on-site maintenance visits.

Features and Benefits

- Dual-band support for broad frequency coverage
- Minimal footprint reduces site costs
- Rapid, easy installation
- Flexibly deployable in any location
- Remote RF monitoring capability
- Convection cooled, silent operation
- Built-in Broadcast Auxiliary Services (BAS) filter ensures compliant AWS operation without impacting footprint

Key Technical Specifications

Duplex Type: FDD

Operating Frequencies:

B66: DL(2,110-2,180MHz)/UL(1,710-1,780MHz)

B2: DL(1,930-1,990MHz)/UL(1,850-1,910MHz)

Instantaneous Bandwidth:

70MHz(B66) + 60MHz(B2)

RF Chain: 4T4R/2T4R/2T2R

Output Power: Total 320W

DU-RU Interface: CPRI (10Gbps)

Dimensions: 380 x 380 x 255mm (36.8L)

Weight: 38.3kg

Input Power: -48V DC

Operating Temp.: -40 - 55°(w/o solar load)

Cooling: Natural convection

ATTACHMENT 3

Site Name: **DANBURY 10 CT**
 Cumulative Power Density

Operator	Operating Frequency	Number of Trans.	ERP Per Trans.	Total ERP	Distance to Target	Calculated Power Density	Maximum Permissible Exposure*	Fraction of MPE
	(MHz)		(watts)	(watts)	(feet)	(mW/cm ²)	(mW/cm ²)	(%)
VZW PCS	1980	4	685	2742	32.5	0.0934	1.0000	9.34%
VZW AWS	2120	4	735	2938	32.5	0.1000	1.0000	10.00%
VZW CBAND	3730.005	4	3427	13708	31.5	0.4968	1.0000	49.68%
Total Percentage of Maximum Permissible Exposure								69.02%

*Guidelines adopted by the FCC on August 1, 1996, 47 CFR Part 1 based on NCRP Report 86, 1986 and generally on ANSI/IEEE C95.1-1992

**Calculation includes a -10 dB Off Beam Antenna Pattern Adjustment pursuant to Attachments B and C of the Siting Council's November 10, 2015 Memorandum for Exempt Modification filings

MHz = Megahertz
 mW/cm² = milliwatts per square centimeter
 ERP = Effective Radiated Power

Absolute worst case maximum values used.

ATTACHMENT 4

Structural Analysis Report

Antenna Frame

*Proposed Verizon
Antenna Upgrade*

Site Ref: Danbury 10

*109 Federal Road
Danbury, CT*

CEN TEK Project No. 20150.07

~~Date: January 19, 2021~~

Rev 1: February 22, 2021

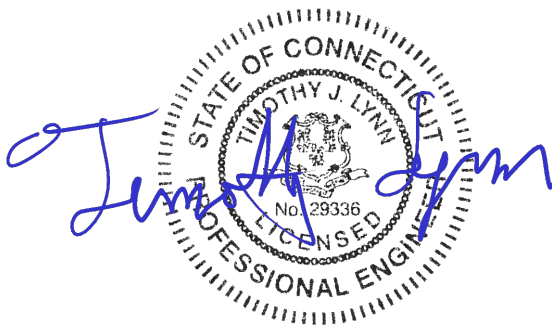

Prepared for:
*Verizon Wireless
20 Alexander Drive
Wallingford, CT 06492*

Table of Contents

SECTION 1 - REPORT

- INTRODUCTION
- PRIMARY ASSUMPTIONS USED IN THE ANALYSIS
- ANTENNA AND EQUIPMENT INSTALLATION SUMMARY
- ANALYSIS
- DESIGN LOADING
- RESULTS
- CONCLUSION

SECTION 2 – CONDITIONS & SOFTWARE

- STANDARD ENGINEERING CONDITIONS
- GENERAL DESCRIPTION OF STRUCTURAL ANALYSIS PROGRAM

SECTION 3 – CALCULATIONS

- WIND LOAD CALCULATION
- RISA 3D OUTPUT REPORT

SECTION 4 – REFERENCE MATERIAL

- RF DATA SHEET
- CONSTRUCTION DOCUMENTS PREPARED BY CENTEK
ENGINEERING REV.0 DATED JULY 10 2015 (not included)
- STEEL SHOP DRAWINGS PREPARED BY PND WELDING/GoodFAB
LLC DATED OCTOBER, 6 2016 (not included)

I n t r o d u c t i o n

The purpose of this structural analysis report (SAR) is to summarize the results, of the impacted structural components, by the equipment upgrade proposed by Verizon Wireless on the existing host building located in Danbury, CT.

The antennas are mounted on within a proposed replacement RF transparent screen enclosure attached to the roof top of the host building.

The mounts member sizes information and roof framing information were obtained from a construction documents as prepared by Centek Engineering Rev.0, dated July 10, 2015, and steel shop drawings as prepared by PND WELDING/GoodFAB LLC dated October, 6 2016. Proposed/existing antenna and appurtenance information was taken from a RF data sheet dated 11/13/2020 provided by Verizon Wireless.

P r i m a r y A s s u m p t i o n s U s e d i n t h e A n a l y s i s

- The host structure's theoretical capacity not including any assessment of the condition of the host structure.
- The existing elevated steel antenna frames carry the horizontal and vertical loads due to the weight of equipment, and wind and transfers into host structure.
- Proposed reinforcement and support steel will be properly installed and maintained.
- Structure is in plumb condition.
- Loading for equipment and enclosure as listed in this report.
- All bolts are appropriately tightened providing the necessary connection continuity.
- All welds are fabricated with ER-70S-6 electrodes.
- All members are assumed to be as observed during roof framing mapping.
- All members are "hot dipped" galvanized in accordance with ASTM A123 and ASTM A153 Standards.
- All member protective coatings are in good condition.

Antenna and Equipment Summary

Location	Appurtenance / Equipment	Rad Center Elevation (AGL)	Mount Type
Alpha Sector	(1) HBXX-6513DS Antenna (1) B25-RRH-4x30 (1) B4-RRH-2x60 (1) HBXX-6513DS Antenna (1) VZS01 Antenna (1) Samsung B2/B66A RRH – BR049 (1) SDX1926Q-43 diplexer (1) RFS RRFDC-3315-PF-48	31.9-ft	FRP enclosure attached to building rooftop
Gamma Sector	(1) HBXX-6513DS Antenna (1) B25-RRH-4x30 (1) B4-RRH-2x60 (1) HBXX-6513DS Antenna (1) VZS01 Antenna (1) Samsung B2/B66A RRH – BR049 (1) SDX1926Q-43 diplexer	31.9-ft	FRP enclosure attached to building rooftop

~~Equipment~~ – Indicates equipment to be removed.
Equipment – Indicates equipment to be installed.

Analysis

The existing antenna frames were analyzed using a comprehensive computer program titled Risa3D. The program analyzes the equipment platform and antenna mounts considering the worst case code prescribed loading condition. The structures were considered to be loaded by concentric forces, and the model assumes that the members are subjected to bending, axial, and shear forces.

Design Loading

Loading was determined per the requirements of the 2015 International Building Code amended by the 2018 CSBC and ASCE 7-10 “Minimum Design Loads for Buildings and Other Structures”.

Wind Speed:	$V_{ult} = 120$ mph	<i>Appendix N of the 2018 CT State Building Code</i>
Risk Category:	II	<i>2015 IBC; Table 1604.05</i>
Exposure Category:	Surface Roughness B	<i>ASCE 7-10; Section 26.7.2</i>
Dead Load	Equipment and framing self-weight	<i>Identified within SAR design calculations</i>

Reference Standards

2015 International Building Code:

1. ACI 318-14, *Building Code Requirements for Structural Concrete*.
2. ACI 530-13, *Building Code Requirements for Masonry Structures*.
3. AISC 360-10, *Specification for Structural Steel Buildings*
4. AWS D1.1 – 00, *Structural Welding Code – Steel*.
5. AF&PA-12, *Span Tables for Joists and Rafters*.

Results

Structure stresses were calculated utilizing the structural analysis software RISA 3D. The stresses were determined based on the AISC standard.

- Calculated stresses for the antenna frame were found to **be within allowable** limits.

Sector	Component	Stress Ratio (percentage of capacity)	Result
All Sectors	L5x5x3/8 FRP	95.4%	PASS
	Pipe 2.5 X-Strong	33.5%	PASS
	Pipe 3.5 X-Strong	34.2%	PASS

Conclusion

This analysis shows that the subject antenna frame **HAS SUFFICIENT CAPACITY** to support the proposed modified antenna configuration.

The analysis is based, in part, on the information provided to this office by Verizon. If the existing conditions are different than the information in this report, Centek Engineering, Inc. must be contacted for resolution of any potential issues.

Please feel free to call with any questions or comments.

Respectfully Submitted by:



Timothy J. Lynn, PE
Structural Engineer

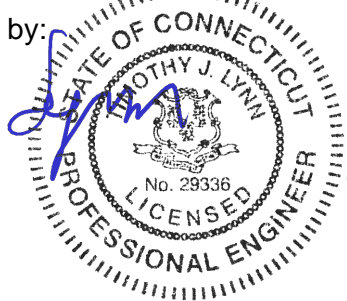

*Standard Conditions for Furnishing of
Professional Engineering Services on
Existing Structures*

All engineering services are performed on the basis that the information used is current and correct. This information may consist of, but is not necessarily limited to:

- Information supplied by the client regarding the structure itself, its foundations, the soil conditions, the antenna and feed line loading on the structure and its components, or other relevant information.
- Information from the field and/or drawings in the possession of Centek Engineering, Inc. or generated by field inspections or measurements of the structure.
- It is the responsibility of the client to ensure that the information provided to Centek Engineering, Inc. and used in the performance of our engineering services is correct and complete. In the absence of information to the contrary, we assume that all structures were constructed in accordance with the drawings and specifications and are in an un-corroded condition and have not deteriorated. It is therefore assumed that its capacity has not significantly changed from the “as new” condition.
- All services will be performed to the codes specified by the client, and we do not imply to meet any other codes or requirements unless explicitly agreed in writing. If wind and ice loads or other relevant parameters are to be different from the minimum values recommended by the codes, the client shall specify the exact requirement. In the absence of information to the contrary, all work will be performed in accordance with the latest revision of ANSI/ASCE10 & ANSI/EIA-222
- All services performed, results obtained, and recommendations made are in accordance with generally accepted engineering principles and practices. Centek Engineering, Inc. is not responsible for the conclusions, opinions and recommendations made by others based on the information we supply.

WIND LOADING ANALYSIS - Wall Components and Cladding			
Per ASCE 7-10 Code for Buildings of Any Height			
Using Part 1 & 3: Analytical Procedure (Section 30.4 & 30.6)			
Job Name:	Danbury SC 6	Subject:	Enclosure
Job Number:	20150.07	Originator:	FJP Checker: TJL

Input Data:

Wind Speed, V =	120	mph (Wind Map, Figure 26.5-1A-C)
Bldg. Classification =	II	(Table 1.5-1 Risk Category)
Exposure Category =	B	(Sect. 26.7)
Ridge Height, hr =	34.00	ft. (hr >= he)
Eave Height, he =	34.00	ft. (he <= hr)
Building Width =	38.51	ft. (Normal to Building Ridge)
Building Length =	52.75	ft. (Parallel to Building Ridge)
Roof Type =	Monoslope	(Gable or Monoslope)
Topo. Factor, Kzt =	1.00	(Sect. 26.8 & Figure 26.8-1)
Direct. Factor, Kd =	0.85	(Table 26.6)
Enclosed? (Y/N) =	n	(Sect. 28.6-1 & Figure 26.11-1)
Hurricane Region? =	Y	
Component Name =	Wall	(Girt, Siding, Wall, or Fastener)
Effective Area, Ae =	500	ft.^2 (Area Tributary to C&C)

Resulting Parameters and Coefficients:

Roof Angle, θ = deg.
Mean Roof Ht., h = ft. (h = he, for roof angle <=10 deg.)

Wall External Pressure Coefficients, GCp:

GCp Zone 4 Pos. = (Fig. 30.4-1, GCp is reduced by 10% for roof angle <=10 deg.)
GCp Zone 5 Pos. = (Fig. 30.4-1, GCp is reduced by 10% for roof angle <=10 deg.)
GCp Zone 4 Neg. = (Fig. 30.4-1, GCp is reduced by 10% for roof angle <=10 deg.)
GCp Zone 5 Neg. = (Fig. 30.4-1, GCp is reduced by 10% for roof angle <=10 deg.)

Positive & Negative Internal Pressure Coefficients, GCpi (Figure 26.11-1):

+GCpi Coef. = (positive internal pressure)
-GCpi Coef. = (negative internal pressure)

If $z \leq 15$ then: $K_z = 2.01 \cdot (15/zg)^{2/\alpha}$, If $z > 15$ then: $K_z = 2.01 \cdot (z/zg)^{2/\alpha}$ (Table 30.3-1)
 α = (Table 26.9-1) (Note: z not < 30' for Exp. B, Case 1)
zg = (Table 26.9-1)
Kh = (Kh = Kz evaluated at z = h)

Velocity Pressure: $q_z = 0.00256 \cdot K_z \cdot K_{zt} \cdot K_d \cdot V^2$ (Sect. 30.3.2, Eq. 30.3-1)
qh = psf $q_h = 0.00256 \cdot K_h \cdot K_{zt} \cdot K_d \cdot V^2$ (qz evaluated at z = h)

Design Net External Wind Pressures (Sect. 30.4 & 30.6):
For h <= 60 ft.: $p = q_h \cdot ((GC_p) - (+/-GC_{pi}))$ (psf)
For h > 60 ft.: $p = q \cdot (GC_p) - q_i \cdot (+/-GC_{pi})$ (psf)
where: q = qz for windward walls, q = qh for leeward walls and side walls
qi = qh for all walls (conservatively assumed per Sect. 30.6)

Plan

Elevation

Wall Components and Cladding:

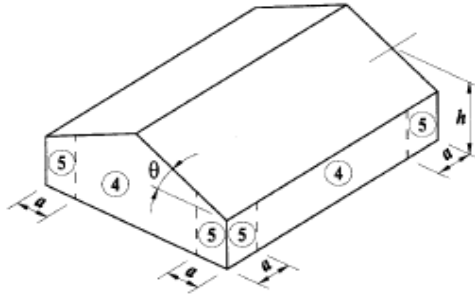

Wall Zones for Buildings with $h \leq 60$ ft.

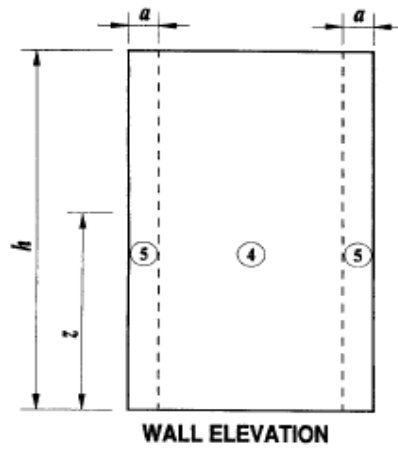

Wall Zones for Buildings with $h > 60$ ft.

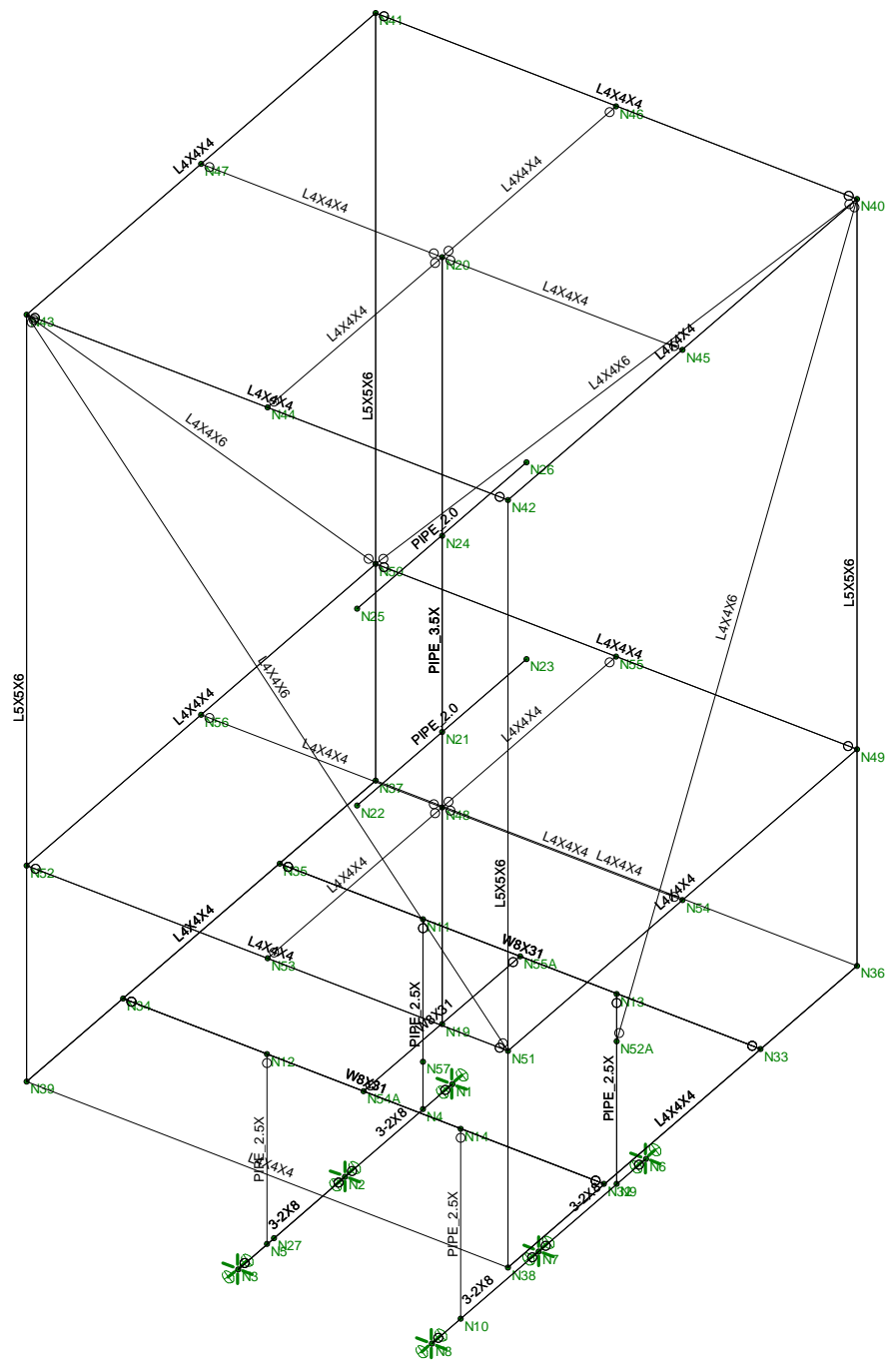

Envelope Only Solution

Centek Engineering
TJL
20150.07

Danbury 10 CT
Member Framing

Feb 22, 2021 at 4:38 PM
Antenna Frame.r3d

(Global) Model Settings

Display Sections for Member Calcs	5
Max Internal Sections for Member Calcs	97
Include Shear Deformation?	Yes
Increase Nailing Capacity for Wind?	Yes
Include Warping?	Yes
Trans Load Btwn Intersecting Wood Wall?	Yes
Area Load Mesh (in^2)	144
Merge Tolerance (in)	.12
P-Delta Analysis Tolerance	0.50%
Include P-Delta for Walls?	Yes
Automatically Iterate Stiffness for Walls?	Yes
Max Iterations for Wall Stiffness	3
Gravity Acceleration (ft/sec^2)	32.2
Wall Mesh Size (in)	12
Eigensolution Convergence Tol. (1.E-)	4
Vertical Axis	Y
Global Member Orientation Plane	XZ
Static Solver	Sparse Accelerated
Dynamic Solver	Accelerated Solver

Hot Rolled Steel Code	AISC 15th(360-16): ASD
Adjust Stiffness?	Yes(Iterative)
RISAConnection Code	AISC 14th(360-10): ASD
Cold Formed Steel Code	AISI S100-10: ASD
Wood Code	AWC NDS-12: ASD
Wood Temperature	< 100F
Concrete Code	ACI 318-11
Masonry Code	ACI 530-11: ASD
Aluminum Code	AA ADM1-10: ASD - Building
Stainless Steel Code	AISC 14th(360-10): ASD
Adjust Stiffness?	Yes(Iterative)

Number of Shear Regions	4
Region Spacing Increment (in)	4
Biaxial Column Method	Exact Integration
Parme Beta Factor (PCA)	.65
Concrete Stress Block	Rectangular
Use Cracked Sections?	Yes
Use Cracked Sections Slab?	Yes
Bad Framing Warnings?	No
Unused Force Warnings?	Yes
Min 1 Bar Diam. Spacing?	No
Concrete Rebar Set	REBAR_SET_ASTMA615
Min % Steel for Column	1
Max % Steel for Column	8

(Global) Model Settings, Continued

Seismic Code	ASCE 7-10
Seismic Base Elevation (ft)	Not Entered
Add Base Weight?	Yes
Ct X	.02
Ct Z	.02
T X (sec)	Not Entered
T Z (sec)	Not Entered
R X	3
R Z	3
Ct Exp. X	.75
Ct Exp. Z	.75
SD1	1
SDS	1
S1	1
TL (sec)	5
Risk Cat	I or II
Drift Cat	Other
Om Z	1
Om X	1
Cd Z	4
Cd X	4
Rho Z	1
Rho X	1
Footing Overturning Safety Factor	1
Optimize for OTM/Sliding	No
Check Concrete Bearing	No
Footing Concrete Weight (k/ft^3)	0
Footing Concrete f'c (ksi)	4
Footing Concrete Ec (ksi)	3644
Lambda	1
Footing Steel fy (ksi)	60
Minimum Steel	0.0018
Maximum Steel	0.0075
Footing Top Bar	#3
Footing Top Bar Cover (in)	2
Footing Bottom Bar	#3
Footing Bottom Bar Cover (in)	3.5
Pedestal Bar	#3
Pedestal Bar Cover (in)	1.5
Pedestal Ties	#3

Hot Rolled Steel Properties

	Label	E [ksi]	G [ksi]	Nu	Therm (\... Density[k/ft^3]	Yield[ksi]	Ry	Fu[ksi]	Rt	
1	A36 Gr.36	29000	11154	.3	.65	.49	36	1.5	58	1.2
2	A572 Gr.50	29000	11154	.3	.65	.49	50	1.1	58	1.2
3	A992	29000	11154	.3	.65	.49	50	1.1	58	1.2
4	A500 Gr.42	29000	11154	.3	.65	.49	42	1.3	58	1.1
5	A500 Gr.46	29000	11154	.3	.65	.49	46	1.2	58	1.1
6	FRP	2800	450	.35	.44	.12	10	1.5	58	1.2
7	A53 Grade B	29000	11154	.3	.65	.49	35	1.5	58	1.2



Company : Centek Engineering
 Designer : TJL
 Job Number : 20150.07
 Model Name : Danbury 10 CT

Feb 23, 2021
 9:39 AM
 Checked By: _____

Hot Rolled Steel Section Sets

	Label	Shape	Type	Design List	Material	Design Rul...A [in2]	Iyy [in4]	Izz [in4]	J [in4]	
1	Mount Base_Pipe_2...	PIPE_2.5X	Column	Pipe	A53 Grade B	Typical	2.1	1.83	1.83	3.66
2	Pipe_3.5 XStrong	PIPE_3.5X	Column	Pipe	A53 Grade B	Typical	3.43	5.94	5.94	11.9
3	L3X3X3/8	L4X4X6	Column	Single Angle	FRP	Typical	2.86	4.32	4.32	.141
4	L5X5X3/8_V	L5X5X6	Column	Single Angle	FRP	Typical	3.65	8.76	8.76	.183
5	Pipe 2.0 STD	PIPE_2.0	Column	Pipe	A53 Grade B	Typical	1.02	.627	.627	1.25
6	L4x4x1/4	L4X4X4	Beam	Single Angle	A36 Gr.36	Typical	1.93	3	3	.044
7	W8	W8X31	Beam	Wide Flange	A992	Typical	9.13	37.1	110	.536

Hot Rolled Steel Design Parameters

	Label	Shape	Length[ft]	Lbyy[ft]	Lbzz[ft]	Lcomp top[...Lcomp bot[...L-torq...	Kyy	Kzz	Cb	Functi...
1	M7	Mount Base_Pipe_2...	2.417							Lateral
2	M8	Mount Base_Pipe_2...	2.417							Lateral
3	M9	Mount Base_Pipe_2...	2.417							Lateral
4	M10	Mount Base_Pipe_2...	2.417							Lateral
5	M17	Pipe_3.5 XStrong	9.75							Lateral
6	M26	L5X5X3/8_V	9.75							Lateral
7	M27	L5X5X3/8_V	9.75							Lateral
8	M28	L5X5X3/8_V	9.75							Lateral
9	M29	L5X5X3/8_V	9.75							Lateral
10	M30	L4x4x1/4	6							Lateral
11	M31	L4x4x1/4	6.517							Lateral
12	M32	L4x4x1/4	6							Lateral
13	M33	L4x4x1/4	6.517							Lateral
14	M34	L4x4x1/4	3.258							Lateral
15	M35	L4x4x1/4	2.998							Lateral
16	M36	L4x4x1/4	3.258							Lateral
17	M37	L4x4x1/4	3.002							Lateral
18	M38	Pipe 2.0 STD	3.167							Lateral
19	M39	Pipe 2.0 STD	3.167							Lateral
20	M40	L4x4x1/4	6.517			Lbyy				Lateral
21	M41	L4x4x1/4	6			Lbyy				Lateral
22	M42	L4x4x1/4	6.517			Lbyy				Lateral
23	M43	L4x4x1/4	6			Lbyy				Lateral
24	M36A	L4x4x1/4	6							Lateral
25	M37A	L4x4x1/4	6.517							Lateral
26	M38B	L4x4x1/4	6							Lateral
27	M39B	L4x4x1/4	6.517							Lateral
28	M40A	L4x4x1/4	3.258							Lateral
29	M41A	L4x4x1/4	2.998							Lateral
30	M42A	L4x4x1/4	3.258							Lateral
31	M43A	L4x4x1/4	3.002							Lateral
32	M40B	W8	6			Lbyy				Lateral
33	M41B	W8	6			Lbyy				Lateral
34	M42B	W8	2.917			Lbyy				Lateral
35	M39A	L3X3X3/8	9.22							Lateral
36	M40C	L3X3X3/8	9.22							Lateral
37	M41C	L3X3X3/8	10.661							Lateral
38	M42C	L3X3X3/8	9.564							Lateral

Member Primary Data

	Label	I Joint	J Joint	K Joint	Rotate(...)	Section/Shape	Type	Design List	Material	Design R...
1	M3	N3	N2			Mount Base- (3-2x8)	Beam	Rectangular	DF	Typical
2	M4	N2	N1			Mount Base- (3-2x8)	Beam	Rectangular	DF	Typical
3	M5	N8	N7			Mount Base- (3-2x8)	Beam	Rectangular	DF	Typical
4	M6	N7	N6			Mount Base- (3-2x8)	Beam	Rectangular	DF	Typical
5	M7	N5	N12			Mount Base_Pipe_2.5 XStr...	Column	Pipe	A53 Grade B	Typical
6	M8	N10	N14			Mount Base_Pipe_2.5 XStr...	Column	Pipe	A53 Grade B	Typical
7	M9	N4	N11			Mount Base_Pipe_2.5 XStr...	Column	Pipe	A53 Grade B	Typical
8	M10	N9	N13			Mount Base_Pipe_2.5 XStr...	Column	Pipe	A53 Grade B	Typical
9	M17	N19	N20			Pipe_3.5 XStrong	Column	Pipe	A53 Grade B	Typical
10	M26	N39	N43		180	L5X5X3/8_V	Column	Single Angle	FRP	Typical
11	M27	N36	N40			L5X5X3/8_V	Column	Single Angle	FRP	Typical
12	M28	N41	N37		180	L5X5X3/8_V	Column	Single Angle	FRP	Typical
13	M29	N38	N42		270	L5X5X3/8_V	Column	Single Angle	FRP	Typical
14	M30	N43	N42		180	L4x4x1/4	Beam	Single Angle	A36 Gr.36	Typical
15	M31	N42	N40		180	L4x4x1/4	Beam	Single Angle	A36 Gr.36	Typical
16	M32	N40	N41		180	L4x4x1/4	Beam	Single Angle	A36 Gr.36	Typical
17	M33	N41	N43		180	L4x4x1/4	Beam	Single Angle	A36 Gr.36	Typical
18	M34	N44	N20		180	L4x4x1/4	Beam	Single Angle	A36 Gr.36	Typical
19	M35	N20	N45		180	L4x4x1/4	Beam	Single Angle	A36 Gr.36	Typical
20	M36	N20	N46		90	L4x4x1/4	Beam	Single Angle	A36 Gr.36	Typical
21	M37	N20	N47		180	L4x4x1/4	Beam	Single Angle	A36 Gr.36	Typical
22	M38	N22	N23			Pipe 2.0 STD	Column	Pipe	A53 Grade B	Typical
23	M39	N25	N26			Pipe 2.0 STD	Column	Pipe	A53 Grade B	Typical
24	M40	N39	N37			L4x4x1/4	Beam	Single Angle	A36 Gr.36	Typical
25	M41	N37	N36			L4x4x1/4	Beam	Single Angle	A36 Gr.36	Typical
26	M42	N36	N38			L4x4x1/4	Beam	Single Angle	A36 Gr.36	Typical
27	M43	N38	N39			L4x4x1/4	Beam	Single Angle	A36 Gr.36	Typical
28	M36A	N52	N51		270	L4x4x1/4	Beam	Single Angle	A36 Gr.36	Typical
29	M37A	N51	N49		270	L4x4x1/4	Beam	Single Angle	A36 Gr.36	Typical
30	M38B	N49	N50		270	L4x4x1/4	Beam	Single Angle	A36 Gr.36	Typical
31	M39B	N50	N52		270	L4x4x1/4	Beam	Single Angle	A36 Gr.36	Typical
32	M40A	N53	N48		180	L4x4x1/4	Beam	Single Angle	A36 Gr.36	Typical
33	M41A	N48	N54		180	L4x4x1/4	Beam	Single Angle	A36 Gr.36	Typical
34	M42A	N48	N55		90	L4x4x1/4	Beam	Single Angle	A36 Gr.36	Typical
35	M43A	N48	N56		180	L4x4x1/4	Beam	Single Angle	A36 Gr.36	Typical
36	M40B	N35	N33			W8	Beam	Wide Flange	A992	Typical
37	M41B	N34	N32			W8	Beam	Wide Flange	A992	Typical
38	M42B	N54A	N55A			W8	Beam	Wide Flange	A992	Typical
39	M39A	N50	N40			L3X3X3/8	Column	Single Angle	FRP	Typical
40	M40C	N51	N43			L3X3X3/8	Column	Single Angle	FRP	Typical
41	M41C	N40	N52A			L3X3X3/8	Column	Single Angle	FRP	Typical
42	M42C	N43	N50			L3X3X3/8	Column	Single Angle	FRP	Typical

Joint Coordinates and Temperatures

	Label	X [ft]	Y [ft]	Z [ft]	Temp [F]	Detach From Dia...
1	N1	0	0	0	0	
2	N2	0	0	2	0	
3	N3	0	0	4	0	
4	N4	0	0	0.541667	0	



Joint Coordinates and Temperatures (Continued)

	Label	X [ft]	Y [ft]	Z [ft]	Temp [F]	Detach From Dia...
5	N5	0	0	3.458333	0	
6	N6	2.416667	0	0	0	
7	N7	2.416667	0	2	0	
8	N8	2.416667	0	4	0	
9	N9	2.416667	0	0.541667	0	
10	N10	2.416667	0	3.458333	0	
11	N11	0	2.416667	0.541667	0	
12	N12	0	2.416667	3.458333	0	
13	N13	2.416667	2.416667	0.541667	0	
14	N14	2.416667	2.416667	3.458333	0	
15	N19	1.208333	2.416667	2	0	
16	N20	1.208333	12.166667	2	0	
17	N21	1.208333	6.125	2	0	
18	N22	1.208333	6.125	3.583333	0	
19	N23	1.208333	6.125	0.416667	0	
20	N24	1.208333	8.625	2	0	
21	N25	1.208333	8.625	3.583333	0	
22	N26	1.208333	8.625	0.416667	0	
23	N27	0	0	3.333333	0	
24	N32	4.206667	2.416667	3.458333	0	
25	N33	4.206667	2.416667	0.541667	0	
26	N34	-1.793333	2.416667	3.458333	0	
27	N35	-1.793333	2.416667	0.541667	0	
28	N36	4.206667	2.416667	-1.258333	0	
29	N37	-1.793333	2.416667	-1.258333	0	
30	N38	4.206667	2.416667	5.258333	0	
31	N39	-1.793333	2.416667	5.258333	0	
32	N40	4.206667	12.166667	-1.258333	0	
33	N41	-1.793333	12.166667	-1.258333	0	
34	N42	4.206667	12.166667	5.258333	0	
35	N43	-1.793333	12.166667	5.258333	0	
36	N44	1.206667	12.166667	5.258333	0	
37	N45	4.206667	12.166667	2	0	
38	N46	1.206667	12.166667	-1.258333	0	
39	N47	-1.793333	12.166667	2	0	
40	N48	1.208333	5.166667	2	0	
41	N49	4.206667	5.166667	-1.258333	0	
42	N50	-1.793333	5.166667	-1.258333	0	
43	N51	4.206667	5.166667	5.258333	0	
44	N52	-1.793333	5.166667	5.258333	0	
45	N53	1.206667	5.166667	5.258333	0	
46	N54	4.206667	5.166667	2	0	
47	N55	1.206667	5.166667	-1.258333	0	
48	N56	-1.793333	5.166667	2	0	
49	N57	0	0.604167	0.541667	0	
50	N54A	1.206667	2.416667	3.458333	0	
51	N55A	1.206667	2.416667	0.541667	0	
52	N52A	2.416667	1.8125	0.541667	0	



Joint Boundary Conditions

	Joint Label	X [k/in]	Y [k/in]	Z [k/in]	X Rot.[k-ft/rad]	Y Rot.[k-ft/rad]	Z Rot.[k-ft/rad]
1	N1	Reaction	Reaction	Reaction			Reaction
2	N2	Reaction	Reaction	Reaction			Reaction
3	N3	Reaction	Reaction	Reaction			Reaction
4	N6	Reaction	Reaction	Reaction			Reaction
5	N7	Reaction	Reaction	Reaction			Reaction
6	N8	Reaction	Reaction	Reaction			Reaction

Member Point Loads (BLC 3 : Dead: Equipment)

	Member Label	Direction	Magnitude[k,k-ft]	Location[ft,%]
1	M38	Y	-.041	.833
2	M39	Y	-.041	.833
3	M38	Y	-.006	1
4	M39	Y	-.006	1
5	M38	Y	-.043	2.333
6	M39	Y	-.043	2.333
7	M38	Y	-.02	2.333
8	M39	Y	-.02	2.333

Member Distributed Loads (BLC 6 : BLC 2 Transient Area Loads)

	Member Label	Direction	Start Magnitude[k/ft,F,ksf]	End Magnitude[k/f..	Start Location[ft,%]	End Location[ft,%]
1	M26	Y	-.026	-.067	0	1.95
2	M26	Y	-.067	-.071	1.95	3.9
3	M26	Y	-.071	-.035	3.9	5.85
4	M26	Y	-.035	-.013	5.85	7.8
5	M26	Y	-.013	-.012	7.8	9.75
6	M29	Y	-.019	-.022	0	1.95
7	M29	Y	-.022	-.015	1.95	3.9
8	M29	Y	-.015	-.01	3.9	5.85
9	M29	Y	-.01	-.022	5.85	7.8
10	M29	Y	-.022	-.04	7.8	9.75
11	M40C	Y	-.024	-.02	0	1.844
12	M40C	Y	-.02	-.023	1.844	3.688
13	M40C	Y	-.023	-.023	3.688	5.532
14	M40C	Y	-.023	-.02	5.532	7.376
15	M40C	Y	-.02	-.024	7.376	9.22
16	M27	Y	-.039	-.034	0	2.438
17	M27	Y	-.034	-.031	2.438	4.875
18	M27	Y	-.031	-.031	4.875	7.313
19	M27	Y	-.031	-.031	7.313	9.75
20	M29	Y	-.039	-.034	0	2.438
21	M29	Y	-.034	-.031	2.438	4.875
22	M29	Y	-.031	-.031	4.875	7.313
23	M29	Y	-.031	-.031	7.313	9.75
24	M27	Y	-.012	-.032	0	1.95
25	M27	Y	-.032	-.034	1.95	3.9
26	M27	Y	-.034	-.017	3.9	5.85
27	M27	Y	-.017	-.006	5.85	7.8
28	M27	Y	-.006	-.006	7.8	9.75



Member Distributed Loads (BLC 6 : BLC 2 Transient Area Loads) (Continued)

	Member Label	Direction	Start Magnitude[k/ft,F,ksf]	End Magnitude[k/f..	Start Location[ft,%]	End Location[ft,%]
29	M28	Y	-.083	-.045	0	1.95
30	M28	Y	-.045	-.021	1.95	3.9
31	M28	Y	-.021	-.032	3.9	5.85
32	M28	Y	-.032	-.045	5.85	7.8
33	M28	Y	-.045	-.04	7.8	9.75
34	M39A	Y	-.024	-.02	0	1.844
35	M39A	Y	-.02	-.023	1.844	3.688
36	M39A	Y	-.023	-.023	3.688	5.532
37	M39A	Y	-.023	-.02	5.532	7.376
38	M39A	Y	-.02	-.024	7.376	9.22
39	M42C	Y	-.025	-.021	0	1.913
40	M42C	Y	-.021	-.024	1.913	3.826
41	M42C	Y	-.024	-.024	3.826	5.738
42	M42C	Y	-.024	-.021	5.738	7.651
43	M42C	Y	-.021	-.025	7.651	9.564

Member Distributed Loads (BLC 7 : BLC 4 Transient Area Loads)

	Member Label	Direction	Start Magnitude[k/ft,F,ksf]	End Magnitude[k/f..	Start Location[ft,%]	End Location[ft,%]
1	M26	X	.041	.104	0	1.95
2	M26	X	.104	.111	1.95	3.9
3	M26	X	.111	.055	3.9	5.85
4	M26	X	.055	.021	5.85	7.8
5	M26	X	.021	.018	7.8	9.75
6	M28	X	.13	.071	0	1.95
7	M28	X	.071	.033	1.95	3.9
8	M28	X	.033	.05	3.9	5.85
9	M28	X	.05	.07	5.85	7.8
10	M28	X	.07	.062	7.8	9.75
11	M42C	X	.076	.062	0	1.913
12	M42C	X	.062	.072	1.913	3.826
13	M42C	X	.072	.072	3.826	5.738
14	M42C	X	.072	.062	5.738	7.651
15	M42C	X	.062	.076	7.651	9.564
16	M27	X	.039	.034	0	2.438
17	M27	X	.034	.031	2.438	4.875
18	M27	X	.031	.031	4.875	7.313
19	M27	X	.031	.031	7.313	9.75
20	M29	X	.039	.034	0	2.438
21	M29	X	.034	.031	2.438	4.875
22	M29	X	.031	.031	4.875	7.313
23	M29	X	.031	.031	7.313	9.75

Member Distributed Loads (BLC 8 : BLC 5 Transient Area Loads)

	Member Label	Direction	Start Magnitude[k/ft,F,ksf]	End Magnitude[k/f..	Start Location[ft,%]	End Location[ft,%]
1	M27	Z	.037	.096	0	1.95
2	M27	Z	.096	.102	1.95	3.9
3	M27	Z	.102	.05	3.9	5.85
4	M27	Z	.05	.019	5.85	7.8
5	M27	Z	.019	.017	7.8	9.75
6	M28	Z	.119	.065	0	1.95
7	M28	Z	.065	.031	1.95	3.9



Member Distributed Loads (BLC 8 : BLC 5 Transient Area Loads) (Continued)

	Member Label	Direction	Start Magnitude[k/ft,F,ksf]	End Magnitude[k/f..	Start Location[ft,%]	End Location[ft,%]
8	M28	Z	.031	.046	3.9	5.85
9	M28	Z	.046	.065	5.85	7.8
10	M28	Z	.065	.057	7.8	9.75
11	M39A	Z	.073	.059	0	1.844
12	M39A	Z	.059	.069	1.844	3.688
13	M39A	Z	.069	.069	3.688	5.532
14	M39A	Z	.069	.059	5.532	7.376
15	M39A	Z	.059	.073	7.376	9.22
16	M26	Z	.012	.032	0	1.95
17	M26	Z	.032	.034	1.95	3.9
18	M26	Z	.034	.017	3.9	5.85
19	M26	Z	.017	.006	5.85	7.8
20	M26	Z	.006	.006	7.8	9.75
21	M29	Z	.019	.022	0	1.95
22	M29	Z	.022	.015	1.95	3.9
23	M29	Z	.015	.01	3.9	5.85
24	M29	Z	.01	.022	5.85	7.8
25	M29	Z	.022	.04	7.8	9.75
26	M40C	Z	.024	.02	0	1.844
27	M40C	Z	.02	.023	1.844	3.688
28	M40C	Z	.023	.023	3.688	5.532
29	M40C	Z	.023	.02	5.532	7.376
30	M40C	Z	.02	.024	7.376	9.22

Basic Load Cases

	BLC Description	Category	X Gra...	Y Gra...	Z Gra...	Joint	Point	Distrib..	Area(...	Surfa...
1	Dead: Self	DL								
2	Dead: Enclosure	DL							4	
3	Dead: Equipment	DL					8			
4	Wind X-Dir. (29psf)	WLX							2	
5	Wind Z-Dir.(29psf)	WLZ							2	
6	BLC 2 Transient Area Loads	None						43		
7	BLC 4 Transient Area Loads	None						23		
8	BLC 5 Transient Area Loads	None						30		

Load Combinations

	Description	Solve	P...	S...	B...	Fa...	BLC	Fact...	BLC	Fa...	BLC	Fa...	B...	Fa...	B...	Fa...	B...	Fa...	B...	Fa...
1	IBC 16-8	Yes	Y		DL	1														
2	IBC 16-9	Yes	Y		DL	1	LL	1	LLS	1										
3	IBC 16-10 (b)	Yes	Y		DL	1	SL	1	SLN	1										
4	IBC 16-11 (b)	Yes	Y		DL	1	LL	.75	LLS	.75	SL	.75	SLN	.75						
5	IBC 16-12 (a) (a)	Yes	Y		DL	1	WLX	.6												
6	IBC 16-12 (a) (b)	Yes	Y		DL	1	WLZ	.6												
7	IBC 16-12 (a) (c)	Yes	Y		DL	1	WLX	-.6												
8	IBC 16-12 (a) (d)	Yes	Y		DL	1	WLZ	-.6												
9	IBC 16-13 (a) (a)	Yes	Y		DL	1	WLX	.45	LL	.75	LLS	.75								
10	IBC 16-13 (a) (b)	Yes	Y		DL	1	WLZ	.45	LL	.75	LLS	.75								
11	IBC 16-13 (a) (c)	Yes	Y		DL	1	WLX	-.45	LL	.75	LLS	.75								
12	IBC 16-13 (a) (d)	Yes	Y		DL	1	WLZ	-.45	LL	.75	LLS	.75								

Load Combinations (Continued)

Description	Solve	P...	S...	B...	Fa...	BLC	Fact...	BLC	Fa...	BLC	Fa...	BLC	Fa...	B...	Fa...	B...	Fa...	B...	Fa...	B...	Fa...
13	IBC 16-13 (b) (a)	Yes	Y		DL 1	WLX	.45	LL	.75	LLS	.75	SL	.75	S...	.75						
14	IBC 16-13 (b) (b)	Yes	Y		DL 1	WLZ	.45	LL	.75	LLS	.75	SL	.75	S...	.75						
15	IBC 16-13 (b) (c)	Yes	Y		DL 1	WLX	-.45	LL	.75	LLS	.75	SL	.75	S...	.75						
16	IBC 16-13 (b) (d)	Yes	Y		DL 1	WLZ	-.45	LL	.75	LLS	.75	SL	.75	S...	.75						
17	IBC 16-15 (a)	Yes	Y		DL .6	WLX	.6														
18	IBC 16-15 (b)	Yes	Y		DL .6	WLZ	.6														
19	IBC 16-15 (c)	Yes	Y		DL .6	WLX	-.6														
20	IBC 16-15 (d)	Yes	Y		DL .6	WLZ	-.6														

Envelope Joint Reactions

Joint		X [k]	LC	Y [k]	LC	Z [k]	LC	MX [k-ft]	LC	MY [k-ft]	LC	MZ [k-ft]	LC	
1	N1	max	.274	19	1.731	8	.257	8	0	20	0	20	.712	5
2		min	-.298	5	-1.124	18	-.251	18	0	1	0	1	-.677	19
3	N2	max	.192	19	1.178	7	.19	8	0	20	0	20	.513	5
4		min	-.206	5	-.616	17	-.186	18	0	1	0	1	-.496	19
5	N3	max	.272	19	2.072	7	.255	20	0	20	0	20	.669	5
6		min	-.289	5	-1.074	17	-.25	6	0	1	0	1	-.658	19
7	N6	max	.302	7	1.937	8	.267	20	0	20	0	20	.698	5
8		min	-.27	17	-.956	18	-.288	6	0	1	0	1	-.687	7
9	N7	max	.206	7	1.18	5	.191	20	0	20	0	20	.508	5
10		min	-.191	17	-.615	19	-.196	6	0	1	0	1	-.499	7
11	N8	max	.286	19	1.799	5	.25	8	0	20	0	20	.669	5
12		min	-.277	5	-1.232	19	-.239	18	0	1	0	1	-.658	19
13	Totals:	max	1.525	19	2.661	16	1.404	20						
14		min	-1.525	5	1.597	17	-1.404	6						

Envelope Joint Displacements

Joint		X [in]	LC	Y [in]	LC	Z [in]	LC	X Rotation [rad]	LC	Y Rotatio...	LC	Z Rotatio...	LC	
1	N1	max	0	20	0	20	0	20	0	20	0	20	0	20
2		min	0	1	0	1	0	1	0	1	0	1	0	1
3	N2	max	0	20	0	20	0	20	0	20	0	20	0	20
4		min	0	1	0	1	0	1	0	1	0	1	0	1
5	N3	max	0	20	0	20	0	20	0	20	0	20	0	20
6		min	0	1	0	1	0	1	0	1	0	1	0	1
7	N4	max	0	5	0	17	0	18	1.107e-04	7	7.579e-05	5	5.975e-04	19
8		min	0	19	-.002	7	0	8	-6.174e-05	17	-7.003e-05	19	-6.287e-04	5
9	N5	max	0	5	.001	17	0	6	9.785e-05	17	5.966e-05	19	5.81e-04	19
10		min	0	19	-.003	7	0	20	-1.944e-04	7	-6.386e-05	5	-5.901e-04	5
11	N6	max	0	20	0	20	0	20	0	20	0	20	0	20
12		min	0	1	0	1	0	1	0	1	0	1	0	1
13	N7	max	0	20	0	20	0	20	0	20	0	20	0	20
14		min	0	1	0	1	0	1	0	1	0	1	0	1
15	N8	max	0	20	0	20	0	20	0	20	0	20	0	20
16		min	0	1	0	1	0	1	0	1	0	1	0	1
17	N9	max	0	17	0	19	0	6	1.362e-04	5	6.973e-05	17	6.062e-04	7
18		min	0	7	-.002	5	0	20	-4.663e-05	19	-7.554e-05	7	-6.157e-04	5
19	N10	max	0	5	.002	19	0	18	1.118e-04	19	6.407e-05	7	5.808e-04	19
20		min	0	19	-.002	5	0	8	-1.706e-04	5	-5.983e-05	17	-5.902e-04	5
21	N11	max	.097	5	.001	17	.068	18	7.623e-04	18	1.13e-04	6	2.133e-04	7

Envelope Joint Displacements (Continued)

Joint		X [in]	LC	Y [in]	LC	Z [in]	LC	X Rotation [rad]	LC	Y Rotatio...	LC	Z Rotatio...	LC	
22		min	-.093	19	-.003	7	-.071	8	-3.691e-03	8	-1.092e-04	20	-1.7e-04	17
23	N12	max	.091	5	.002	17	.068	18	3.413e-03	7	1.114e-04	6	4.036e-04	7
24		min	-.09	19	-.004	7	-.071	8	1.515e-04	17	-1.115e-04	20	-2.362e-04	17
25	N13	max	.097	5	.001	19	.066	18	1.183e-03	18	8.851e-05	5	1.542e-04	19
26		min	-.093	19	-.003	5	-.069	8	-3.929e-03	8	-6.484e-05	19	-2.377e-04	5
27	N14	max	.091	5	.003	19	.066	18	3.138e-03	5	1.014e-04	5	2.687e-04	19
28		min	-.09	19	-.004	5	-.069	8	-1.531e-06	19	-7.168e-05	19	-3.482e-04	5
29	N19	max	.095	5	0	20	.067	18	1.055e-04	18	1.256e-04	20	5.586e-03	7
30		min	-.092	19	0	6	-.07	8	-1.236e-04	8	-2.135e-04	6	-5.682e-03	5
31	N20	max	.521	17	0	20	.501	18	4.549e-03	18	1.256e-04	20	2.295e-03	7
32		min	-.542	7	-.001	6	-.626	8	-6.133e-03	8	-2.135e-04	6	-1.917e-03	17
33	N21	max	.331	5	0	20	.187	18	3.841e-03	18	1.256e-04	20	4.288e-03	7
34		min	-.328	7	-.001	6	-.212	8	-4.805e-03	8	-2.135e-04	6	-4.139e-03	17
35	N22	max	.328	5	.088	8	.187	18	3.915e-03	18	1.256e-04	20	4.288e-03	7
36		min	-.326	7	-.075	18	-.212	8	-4.68e-03	8	-2.135e-04	6	-4.139e-03	17
37	N23	max	.335	5	.071	18	.187	18	3.735e-03	18	1.256e-04	20	4.288e-03	7
38		min	-.329	7	-.095	8	-.212	8	-4.98e-03	8	-2.135e-04	6	-4.139e-03	17
39	N24	max	.43	5	0	20	.31	18	4.309e-03	18	1.256e-04	20	2.98e-03	7
40		min	-.435	7	-.001	6	-.371	8	-5.706e-03	8	-2.135e-04	6	-2.681e-03	17
41	N25	max	.427	5	.105	8	.31	18	4.383e-03	18	1.256e-04	20	2.98e-03	7
42		min	-.434	7	-.084	18	-.371	8	-5.582e-03	8	-2.135e-04	6	-2.681e-03	17
43	N26	max	.434	5	.079	18	.31	18	4.203e-03	18	1.256e-04	20	2.98e-03	7
44		min	-.436	7	-.112	8	-.371	8	-5.882e-03	8	-2.135e-04	6	-2.681e-03	17
45	N27	max	0	5	.002	17	0	6	5.884e-05	17	3.563e-05	19	5.312e-04	19
46		min	0	19	-.003	7	0	20	-1.174e-04	7	-3.816e-05	5	-5.396e-04	5
47	N32	max	.091	5	.009	19	.065	18	4.696e-03	5	1.696e-03	5	2.91e-03	19
48		min	-.09	19	-.014	5	-.069	8	-1.868e-03	19	-1.652e-03	19	-3.777e-03	5
49	N33	max	.097	5	.006	18	.065	18	1.494e-03	18	1.618e-03	19	2.561e-03	19
50		min	-.093	19	-.011	8	-.069	8	-4.105e-03	8	-1.881e-03	5	-3.491e-03	5
51	N34	max	.092	5	.008	17	.071	18	5.372e-03	7	1.488e-03	17	4.123e-03	7
52		min	-.09	19	-.017	7	-.074	8	-1.483e-03	17	-1.963e-03	7	-2.673e-03	17
53	N35	max	.097	5	.006	17	.071	18	1.19e-03	17	1.837e-03	7	3.612e-03	7
54		min	-.093	19	-.009	7	-.074	8	-4.276e-03	7	-1.648e-03	17	-2.466e-03	17
55	N36	max	.133	5	.07	18	.065	18	3.901e-03	18	5.758e-04	7	2.345e-03	19
56		min	-.127	19	-.148	8	-.069	8	-7.043e-03	8	-1.873e-04	17	-3.315e-03	5
57	N37	max	.132	5	.037	18	.072	18	2.273e-03	18	1.628e-04	19	3.297e-03	7
58		min	-.127	19	-.123	8	-.074	8	-5.735e-03	8	-6.117e-04	5	-2.338e-03	17
59	N38	max	.127	17	.056	19	.065	18	4.434e-03	5	2.5e-04	17	3.126e-03	19
60		min	-.131	7	-.14	5	-.069	8	-1.321e-03	19	-1.003e-03	7	-3.953e-03	5
61	N39	max	.126	17	.043	17	.071	18	5.95e-03	6	7.594e-04	5	4.439e-03	7
62		min	-.131	7	-.164	7	-.074	8	-1.086e-03	20	-4.026e-04	19	-2.8e-03	17
63	N40	max	.499	5	.079	18	.629	18	2.241e-03	18	9.959e-04	17	3.2e-03	8
64		min	-.465	19	-.157	8	-.949	8	-2.871e-03	8	-1.823e-03	7	-7.323e-04	18
65	N41	max	.499	5	.036	18	.397	6	1.199e-03	6	7.59e-04	17	2.774e-03	5
66		min	-.466	19	-.128	8	-.331	20	-7.987e-04	20	-2.023e-03	7	-2.249e-03	19
67	N42	max	.542	17	.056	19	.629	18	2.517e-03	18	6.962e-04	20	2.163e-03	18
68		min	-.614	7	-.145	5	-.949	8	-3.007e-03	8	-1.626e-03	6	-3.448e-03	8
69	N43	max	.542	17	.047	17	.397	6	1.965e-03	6	5.612e-04	17	1.283e-03	5
70		min	-.614	7	-.176	7	-.33	20	-1.395e-03	20	-1.849e-03	7	-6.262e-04	19
71	N44	max	.542	17	.008	20	.5	18	2.188e-03	6	8.796e-03	8	2.928e-03	7
72		min	-.614	7	-.115	6	-.626	8	-2.133e-03	8	-3.477e-03	18	-2.355e-03	17
73	N45	max	.521	17	.05	19	.629	18	1.825e-03	6	6.178e-04	17	1.067e-03	5

Envelope Joint Displacements (Continued)

Joint	X [in]	LC	Y [in]	LC	Z [in]	LC	X Rotation [rad]	LC	Y Rotatio...	LC	Z Rotatio...	LC
74	min	7	-.542	5	-.132	8	-1.358e-03	20	-2.096e-03	7	-4.668e-04	19
75	N46	max	.499	5	.06	18	1.667e-03	18	8.795e-03	8	1.941e-03	7
76	min	19	-.465	8	-.147	8	-1.788e-03	8	-3.474e-03	18	-1.726e-03	17
77	N47	max	.521	17	.044	17	.397	6	2.041e-03	6	6.983e-04	17
78	min	7	-.542	7	-.154	20	-1.564e-03	20	-1.979e-03	7	-1.438e-03	19
79	N48	max	.28	5	0	20	.145	18	3.598e-03	18	1.256e-04	20
80	min	7	-.274	6	-.001	8	-.159	8	-4.321e-03	8	-2.135e-04	6
81	N49	max	.338	5	.073	18	.186	18	3.031e-03	18	8.433e-04	19
82	min	19	-.298	8	-.152	8	-.23	8	-3.513e-03	8	-2.261e-03	5
83	N50	max	.338	5	.037	18	.227	6	3.475e-03	6	1.224e-03	20
84	min	19	-.298	8	-.127	20	-.205	20	-2.193e-03	20	-2.36e-03	6
85	N51	max	.328	17	.057	19	.186	18	2.923e-03	18	1.528e-03	17
86	min	7	-.349	5	-.144	8	-.229	8	-4.258e-03	8	-2.756e-03	7
87	N52	max	.328	17	.044	17	.227	6	2.347e-03	18	1.862e-03	17
88	min	7	-.348	7	-.168	20	-.204	20	-2.555e-03	8	-2.301e-03	7
89	N53	max	.328	17	-.028	20	.145	18	2.635e-03	18	9.277e-04	7
90	min	7	-.348	6	-.074	8	-.159	8	-3.407e-03	8	-3.224e-05	17
91	N54	max	.28	5	.026	19	.186	18	1.402e-03	6	1.15e-03	20
92	min	7	-.275	5	-.114	8	-.23	8	-8.348e-04	20	-1.589e-03	6
93	N55	max	.338	5	.02	18	.145	18	3.2e-03	6	9.091e-04	7
94	min	19	-.298	8	-.106	8	-.159	8	-2.784e-03	20	-1.347e-05	17
95	N56	max	.28	5	.012	17	.227	6	1.346e-03	6	3.059e-04	20
96	min	7	-.275	7	-.133	20	-.205	20	-9.395e-04	20	-1.007e-03	6
97	N57	max	.012	5	.001	17	.006	6	1.559e-03	18	7.579e-05	5
98	min	19	-.012	7	-.002	8	-.006	8	-1.596e-03	8	-7.062e-05	19
99	N54A	max	.091	5	0	20	.067	18	2.728e-03	6	9.34e-05	5
100	min	19	-.09	6	-.001	8	-.07	8	6.053e-04	20	-7.911e-05	19
101	N55A	max	.097	5	0	18	.067	18	9.723e-04	18	8.287e-05	6
102	min	19	-.093	8	-.001	8	-.07	8	-3.81e-03	8	-7.25e-05	20
103	N52A	max	.064	5	.001	19	.043	18	3.07e-03	18	8.353e-05	5
104	min	19	-.061	5	-.003	8	-.044	8	-3.28e-03	8	-6.738e-05	19

Envelope AISC 15th(360-16): ASD Steel Code Checks

Member	Shape	Code Check	Lo...	LC	She...Lo...	Dir	...Pnc/...	Pnt/o...	Mny...	Mnz...	Cb	Eqn	
1	M7	PIPE 2.5X	.326	0	7	.035 0	5	41.891	44.012	3.091	3.091	1.6...H1-...	
2	M8	PIPE 2.5X	.326	0	5	.036 0	5	41.891	44.012	3.091	3.091	1.6...H1-...	
3	M9	PIPE 2.5X	.324	0	5	.032.604	8	41.891	44.012	3.091	3.091	1.6...H1-...	
4	M10	PIPE 2.5X	.335	0	5	.036 1....	5	41.891	44.012	3.091	3.091	1.6...H1-...	
5	M17	PIPE 3.5X	.342	0	8	.033 0	6	47.967	71.886	7.108	7.108	1.3...H1-...	
6	M26	L5X5X6	.911	0	7	.060.508	z	7	3.762	21.856	1.371	2.089	3.1...H2-1
7	M27	L5X5X6	.662	0	5	.055 0	y	5	3.762	21.856	1.371	2.089	2.7...H2-1
8	M28	L5X5X6	.819	9.75	7	.059.7.82	z	7	3.762	21.856	1.371	2.089	3.06H2-1
9	M29	L5X5X6	.954	0	5	.065.711	y	5	3.762	21.856	1.007	2.089	3.3...H2-1
10	M30	L4X4X4	.027	3	8	.006 3	z	8	26.599	41.605	2.088	4.007	1.3...H2-1
11	M31	L4X4X4	.167	0	8	.023 3....	y	8	24.609	41.605	2.088	4.362	2.18H2-1
12	M32	L4X4X4	.028	3	8	.007 0	z	8	26.599	41.605	2.088	4.007	1.3...H2-1
13	M33	L4X4X4	.075	0	6	.006 0	z	5	24.609	41.605	2.088	4.009	1.4...H2-1
14	M34	L4X4X4	.001	0	8	.003 0	y	7	31.579	41.605	2.088	4.295	1 H2-1
15	M35	L4X4X4	.002	0	5	.024 0	y	8	31.894	41.605	2.088	4.36	1 H2-1
16	M36	L4X4X4	.001	0	8	.002 0	y	7	31.579	41.605	2.088	4.295	1 H2-1



Company : Centek Engineering
 Designer : TJL
 Job Number : 20150.07
 Model Name : Danbury 10 CT

Feb 23, 2021
 9:40 AM
 Checked By: _____

Envelope AISC 15th(360-16): ASD Steel Code Checks (Continued)

Member	Shape	Code Check	Lo...	LC	She...Lo...	Dir	...	Pnc/...	Pnt/o...	Mny...	Mnz...	Cb	Eqn
17	M37	L4X4X4	.002	0	19	.023 0	y	8	31.89	41.605	2.088	4.359	1 H2-1
18	M38	PIPE 2.0	.038	1....	16	.010 1....			18.956	21.377	1.245	1.245	1.9...H1-...
19	M39	PIPE 2.0	.038	1....	16	.010 1....			18.956	21.377	1.245	1.245	1.9...H1-...
20	M40	L4X4X4	.723	1....	7	.104 0	y	7	24.609	41.605	2.088	3.839	1.2...H2-1
21	M41	L4X4X4	.259	6	5	.022 0	y	5	26.599	41.605	2.088	4.444	2.2...H2-1
22	M42	L4X4X4	.727	1....	8	.095 4....	y	5	24.609	41.605	2.088	4.163	1.7...H2-1
23	M43	L4X4X4	.259	0	5	.031 0	y	7	26.599	41.605	2.088	4.441	2.2...H2-1
24	M36A	L4X4X4	.259	3	6	.016 3	y	8	26.599	41.605	2.088	4.007	1.3...H2-1
25	M37A	L4X4X4	.328	0	8	.021 0	z	8	24.609	41.605	2.088	4.362	2.1...H2-1
26	M38B	L4X4X4	.265	3	6	.016 0	y	8	26.599	41.605	2.088	4.007	1.3...H2-1
27	M39B	L4X4X4	.214	3....	7	.014 3....	y	7	24.609	41.605	2.088	3.861	1.23 H2-1
28	M40A	L4X4X4	.010	0	20	.013 0	y	5	31.579	41.605	2.088	4.295	1 H2-1
29	M41A	L4X4X4	.007	0	19	.018 0	y	8	31.894	41.605	2.088	4.36	1 H2-1
30	M42A	L4X4X4	.011	0	6	.015 0	y	5	31.579	41.605	2.088	4.295	1 H2-1
31	M43A	L4X4X4	.008	0	17	.017 0	y	8	31.89	41.605	2.088	4.359	1 H2-1
32	M40B	W8X31	.049	4....	8	.039 4.25	y	8	249....	273....	35.124	75.767	1.2...H1-...
33	M41B	W8X31	.046	1....	6	.054 0	y	7	249....	273....	35.124	75.767	1.2...H1-...
34	M42B	W8X31	.019	1....	8	.087 1....	z	5	267....	273....	35.124	75.767	1.3...H1-...
35	M39A	L4X4X6	.736	4....	20	.034 0	z	8	2.058	17.126	.813	.987	1.1...H2-1
36	M40C	L4X4X6	.564	4....	5	.013 0	y	8	2.058	17.126	.772	.987	1.1...H2-1
37	M41C	L4X4X6	.788	0	6	.001 0	y	6	1.539	17.126	.813	.068	1 H2-1
38	M42C	L4X4X6	.783	4....	7	.039 0	z	5	1.912	17.126	.813	.962	1.1...H2-1



Code Check
(Env)

- No Calc
- > 1.0
- .90-1.0
- .75-.90
- .50-.75
- 0-.50

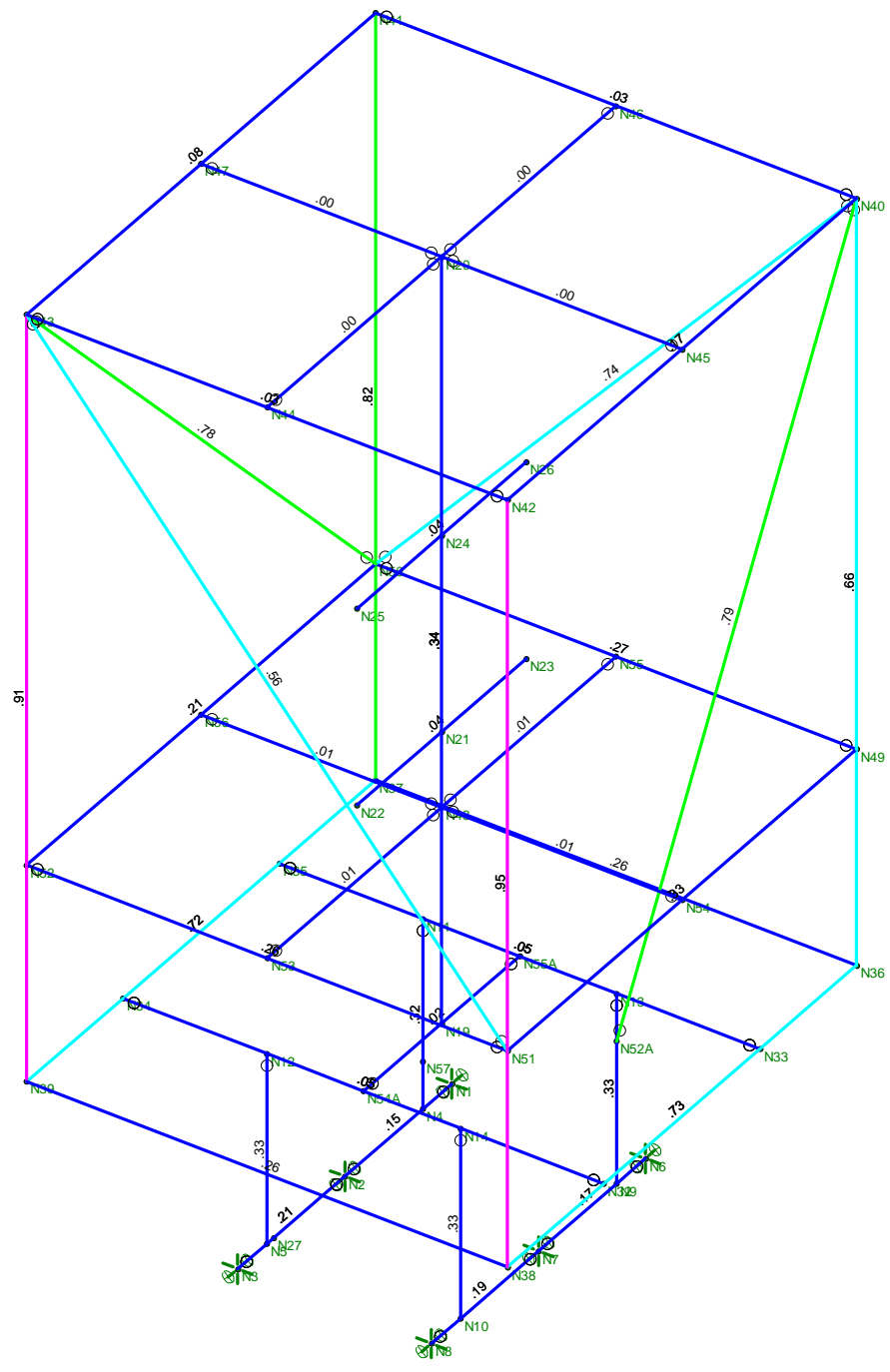

Member Code Checks Displayed (Enveloped)
Envelope Only Solution

Centek Engineering	Danbury 10 CT Unity Check	Feb 22, 2021 at 4:38 PM
TJL		Antenna Frame.r3d
20150.07		



NORTHEAST > North East > New England > New England West > DANBURY 10 CT - A

Gadasu, Shiva - shiva.gadasu@verizonwireless.com - 11/13/2020 12:1:51

Project Details

Carrier Aggregation: false
MPT Id:
eCIP-0: false
Project Name: 850 ADD
FUZE Project ID: 16244659
Designed Sector Carrier 4G: 6
Designed Sector Carrier 5G: N/A
Additional Sector Carrier 4G: N/A
Additional Sector Carrier 5G: N/A
SiteTraker Project Id:
FP Solution Type & Tech Type: MODIFICATION;4G_850,5G_L-Sub6-Prep
RFDS Project Scope: LSub6 add, RRH swap Rev0_11.13.2020 : Initial Design
Suffix: Rev0_11.13.2020

Location Information

Site ID: 5008680
E-NodeB ID: 065557,0659557
PSLC: 467984
Switch Name: Wallingford 2,Wallingford 2
Tower Owner:
Tower Type: Rooftop
Site Type: MACRO
Street Address: 109 Federal Road
City: Danbury
State: CT
Zip Code: 06811
County: Fairfield
Latitude: 41.429758 / 41° 25' 47.1288" N
Longitude: -73.415831 / 73° 24' 56.9916" W

Antenna Summary

Added																			
700	850	1900	AWS	AWS3	28 GHz	31 GHz	39 GHz	CBRS	LAA	L-Sub6	Make	Model	Centerline	Tip Height	Azimuth	RET	4xRx	Inst. Type	Quantity
											TBD	nL-Sub6 Antenna	31.5	33.6	25(0001) 220(0002)	false	false	PHYSICAL	2
Removed																			
700	850	1900	AWS	AWS3	28 GHz	31 GHz	39 GHz	CBRS	LAA	L-Sub6	Make	Model	Centerline	Tip Height	Azimuth	RET	4xRx	Inst. Type	Quantity
												ANDREW	HBXX-6513DS-VTM	32.5	25(01) 220(02)	false	false	PHYSICAL	2
Retained																			
700	850	1900	AWS	AWS3	28 GHz	31 GHz	39 GHz	CBRS	LAA	L-Sub6	Make	Model	Centerline	Tip Height	Azimuth	RET	4xRx	Inst. Type	Quantity
		LTE	LTE								ANDREW	HBXX-6513DS-VTM	32.5	33.6	25(01) 220(02)	false	false	PHYSICAL	2

Added: 2
Removed: 2
Retained: 2

Equipment Summary

Added																		
Equipment Type	Location	700	850	1900	AWS	AWS3	28 GHz	31 GHz	39 GHz	CBRS	LAA	L-Sub6	Make	Model	Cable Length	Cable Size	Install Type	Quantity
Diplexer	Tower			LTE	LTE								Commscope	SDX1926Q-43			PHYSICAL	2
RRU	Tower			LTE	LTE								Samsung	B2/B66A RRH-BR049 (RFV01U-D1A)			PHYSICAL	2
RRU	Tower												Samsung	VZS01			PHYSICAL	2
Removed																		
Equipment Type	Location	700	850	1900	AWS	AWS3	28 GHz	31 GHz	39 GHz	CBRS	LAA	L-Sub6	Make	Model	Cable Length	Cable Size	Install Type	Quantity
RRU	Tower			LTE									Nokia	UHFA B25 RRH 4x30			PHYSICAL	2
RRU	Tower				LTE								Nokia	UHIC B4 RRH 2x60-4R			PHYSICAL	2
Retained																		
Equipment Type	Location	700	850	1900	AWS	AWS3	28 GHz	31 GHz	39 GHz	CBRS	LAA	L-Sub6	Make	Model	Cable Length	Cable Size	Install Type	Quantity
OVP Box	Tower																PHYSICAL	1
Hybrid Cable	Tower																PHYSICAL	1

Service Info

1900 MHZ LTE		0000	
Sector	D1	D2	
Azimuth	25	220	
Cell / ENode B ID	065557	065557	
Antenna Model	HBXX-6513DS-VTM	HBXX-6513DS-VTM	
Antenna Make	ANDREW	ANDREW	
Antenna Centerline(Ft)	32.5	32.5	
Mechanical Down-Tilt(Deg.)	0	0	
Electrical Down-Tilt	4	4	
Tip Height	33.6	33.6	
Regulatory Power	47.39	47.39	
TMA Make			
TMA Model			
RRU Make	Nokia	Nokia	
RRU Model	UHFA B25 RRH 4x30	UHFA B25 RRH 4x30	
Number of Tx, Rx Lines	2,4	2,4	
Position			
Transmitter Id	1967909	1967911	
Source	ATOLL_API	ATOLL_API	

2100 MHZ LTE		0000	
Sector	D1	D2	
Azimuth	25	220	
Cell / ENode B ID	065557	065557	
Antenna Model	HBXX-6513DS-VTM	HBXX-6513DS-VTM	
Antenna Make	ANDREW	ANDREW	
Antenna Centerline(Ft)	32.5	32.5	
Mechanical Down-Tilt(Deg.)	0	0	
Electrical Down-Tilt	4	4	
Tip Height	33.6	33.6	
Regulatory Power	101.33	101.33	
TMA Make			
TMA Model			
RRU Make	Nokia	Nokia	
RRU Model	UHIC B4 RRH 2x60-4R	UHIC B4 RRH 2x60-4R	
Number of Tx, Rx Lines	2,4	2,4	
Position			
Transmitter Id	1967910	1967912	
Source	ATOLL_API	ATOLL_API	

nL-Sub6			
Sector			
Azimuth			
Cell / ENode B ID			
Antenna Model			
Antenna Make			
Antenna Centerline(Ft)			
Mechanical Down-Tilt(Deg.)			
Electrical Down-Tilt			
Tip Height			
Regulatory Power			
TMA Make			
TMA Model			
RRU Make			
RRU Model			
Number of Tx, Rx Lines			
Position			
Transmitter Id			
Source			

5GLS	
01	02
25	220
065557	065557
HBXX-6513DS-VTM	HBXX-6513DS-VTM
ANDREW	ANDREW
32.5	32.5
0	0
4	4
33.6	33.6
62.48	62.48
Samsung	Samsung
B2/B66A RRH-BR049 (RFV01U-D1A)	B2/B66A RRH-BR049 (RFV01U-D1A)
4,4	4,4
7842999	7843001
ATOLL_API	ATOLL_API

5GLS	
01	02
25	220
065557	065557
HBXX-6513DS-VTM	HBXX-6513DS-VTM
ANDREW	ANDREW
32.5	32.5
0	0
4	4
33.6	33.6
66.95	66.95
Samsung	Samsung
B2/B66A RRH-BR049 (RFV01U-D1A)	B2/B66A RRH-BR049 (RFV01U-D1A)
2,4	2,4
7843000	7843002
ATOLL_API	ATOLL_API

5GLS	
0001	0002
25	220
0659557	0659557
nL-Sub6 Antenna	nL-Sub6 Antenna
TBD	TBD
31.5	31.5
0	0
3	3
33.6	33.6
2711.04	2711.04
Samsung	Samsung
VZS01	VZS01
4,4	4,4
7843018	7843019
ATOLL_API	ATOLL_API

Service Comments

Callsigns Per Antenna

Sector	Antenna Make	Antenna Mode	Ant CL Height AGL	Tip Height	Azimuth (TN)	Electrical Tilt	Mechanical Tilt	Gain	Beamwidth	Regulatory Power	Callsigns					
											700	850	1900	2100	28 GHz	31 GHz
No data available.																

Callsigns

Callsign	Market	Radio Code	Market Number	Block	State	County	Licensee Name	Wholly Owned	Total MHZ	Freq Range 1	Freq Range 2	Freq Range 3	Freq Range 4	Regulatory Power	Threshold (W)	POPs/Sq Mi	Status	Action	Approved for Insvc
KNLF644	New York, NY	CW	BTA321	C	CT	Fairfield	AirTouch Cellular	Yes	20.000	1900.000-1910.000	1980.000-1990.000	.000-.000	.000-.000	62.48	1640	1467.18	Active	added	Yes
WQBT539	New York, NY	CW	BTA321	C	CT	Fairfield	Cellco Partnership	Yes	10.000	1895.000-1900.000	1975.000-1980.000	.000-.000	.000-.000	62.48	1640	1467.18	Active	added	Yes
KNLH264	New York, NY	CW	BTA321	F	CT	Fairfield	Cellco Partnership	Yes	10.000	1890.000-1895.000	1970.000-1975.000	.000-.000	.000-.000	62.48	1640	1467.18	Active	added	Yes
WQGB279	Bridgeport-Stamford-Norwalk-Danbury, CT	AW	CMA042	A	CT	Fairfield	Cellco Partnership	Yes	20.000	1710.000-1720.000	2110.000-2120.000	.000-.000	.000-.000	66.95	1640	1467.18	Active	added	Yes
WQGA906	New York-No. New Jer.-Long Island, NY-NJ-CT-PA-MA-	AW	BEA010	B	CT	Fairfield	Cellco Partnership	Yes	20.000	1720.000-1730.000	2120.000-2130.000	.000-.000	.000-.000	66.95	1640	1467.18	Active	added	Yes
WQJQ689	Northeast	WU	REA001	C	CT	Fairfield	Cellco Partnership	Yes	22.000	746.000-757.000	776.000-787.000	.000-.000	.000-.000		1000	1467.18	Active		Yes
KNKA363	Bridgeport-Stamford-Norwalk-Danbury, CT	CL	CMA042	A	CT	Fairfield	Cellco Partnership	Yes	25.000	824.000-835.000	869.000-880.000	845.000-846.500	890.000-891.500		400	1467.18	Active		Yes
WPOH942	New York, NY	LD	BTA321	A	CT	Fairfield	Cellco Partnership	Yes	300.000	29100.000-29250.000	31075.000-31225.000	.000-.000	.000-.000			1467.18	Active		No
WPLM397	New York, NY	LD	BTA321	B	CT	Fairfield	Cellco Partnership	Yes	150.000	31000.000-31075.000	31225.000-31300.000	.000-.000	.000-.000			1467.18	Active		No
WRBA702	New York, NY	UU	BTA321	L1	CT	Fairfield	Cellco Partnership	Yes	325.000	27600.000-27925.000	.000-.000	.000-.000	.000-.000			1467.18	Active		Yes
WRBA703	New York, NY	UU	BTA321	L2	CT	Fairfield	Cellco Partnership	Yes	325.000	27925.000-27950.000	28050.000-28350.000	.000-.000	.000-.000			1467.18	Active		Yes
WRHD609	New York, NY	UU	PEA001	M1	CT	Fairfield	Straight Path Spectrum, LLC	Yes	100.000	37600.000-37700.000	.000-.000	.000-.000	.000-.000			1467.18	Active		Yes
WRHD610	New York, NY	UU	PEA001	M10	CT	Fairfield	Straight Path Spectrum, LLC	Yes	100.000	38500.000-38600.000	.000-.000	.000-.000	.000-.000			1467.18	Active		Yes
WRHD611	New York, NY	UU	PEA001	M2	CT	Fairfield	Straight Path Spectrum, LLC	Yes	100.000	37700.000-37800.000	.000-.000	.000-.000	.000-.000			1467.18	Active		Yes
WRHD612	New York, NY	UU	PEA001	M3	CT	Fairfield	Straight Path Spectrum, LLC	Yes	100.000	37800.000-37900.000	.000-.000	.000-.000	.000-.000			1467.18	Active		Yes
WRHD613	New York, NY	UU	PEA001	M4	CT	Fairfield	Straight Path Spectrum, LLC	Yes	100.000	37900.000-38000.000	.000-.000	.000-.000	.000-.000			1467.18	Active		Yes
WRHD614	New York, NY	UU	PEA001	M5	CT	Fairfield	Straight Path Spectrum, LLC	Yes	100.000	38000.000-38100.000	.000-.000	.000-.000	.000-.000			1467.18	Active		Yes

WRHD615	New York, NY	UU	PEA001	M6	CT	Fairfield	Straight Path Spectrum, LLC	Yes	100.000	38100.000-38200.000	.000-.000	.000-.000	.000-.000			1467.18	Active		Yes
WRHD616	New York, NY	UU	PEA001	M7	CT	Fairfield	Straight Path Spectrum, LLC	Yes	100.000	38200.000-38300.000	.000-.000	.000-.000	.000-.000			1467.18	Active		Yes
WRHD617	New York, NY	UU	PEA001	M8	CT	Fairfield	Straight Path Spectrum, LLC	Yes	100.000	38300.000-38400.000	.000-.000	.000-.000	.000-.000			1467.18	Active		Yes
WRHD618	New York, NY	UU	PEA001	M9	CT	Fairfield	Straight Path Spectrum, LLC	Yes	100.000	38400.000-38500.000	.000-.000	.000-.000	.000-.000			1467.18	Active		Yes
WRHD619	New York, NY	UU	PEA001	N1	CT	Fairfield	Straight Path Spectrum, LLC	Yes	100.000	38600.000-38700.000	.000-.000	.000-.000	.000-.000			1467.18	Active		No
WRDG500	New York, NY	UU	PEA001	S2	CT	Fairfield	Cellco Partnership	Yes	400.000	37800.000-38200.000	.000-.000	.000-.000	.000-.000			1467.18	Active		Yes

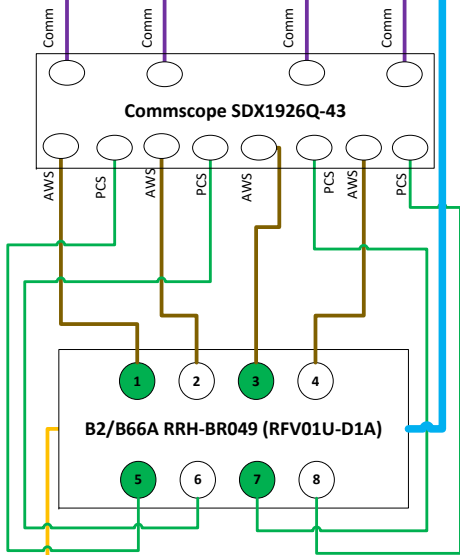
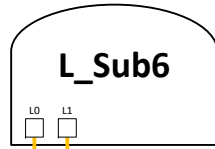
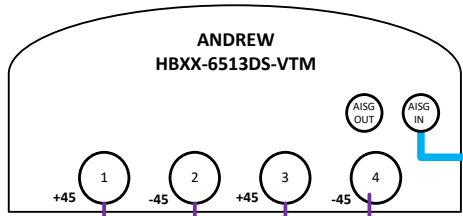

Tower/
Watertank/
Rooftop

Equipment
Pad

Structural Analysis Report

Antenna Frame & Host Building

*Proposed Verizon
Antenna Upgrade*

Site Ref: Danbury 10

*109 Federal Road
Danbury, CT*

CEN TEK Project No. 20150.07

~~*Date: January 19, 2021*~~

Rev 2: March 5, 2021

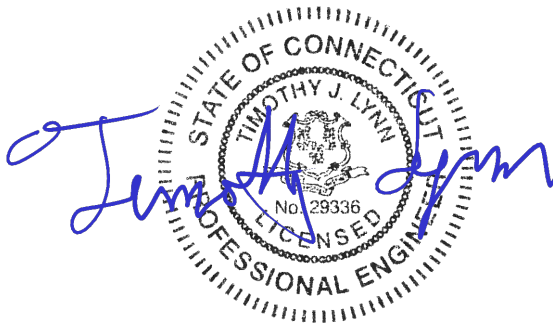

Prepared for:
*Verizon Wireless
20 Alexander Drive
Wallingford, CT 06492*

Table of Contents

SECTION 1 - REPORT

- INTRODUCTION
- PRIMARY ASSUMPTIONS USED IN THE ANALYSIS
- ANTENNA AND EQUIPMENT INSTALLATION SUMMARY
- ANALYSIS
- DESIGN LOADING
- RESULTS
- CONCLUSION

SECTION 2 – CONDITIONS & SOFTWARE

- STANDARD ENGINEERING CONDITIONS
- GENERAL DESCRIPTION OF STRUCTURAL ANALYSIS PROGRAM

SECTION 3 – CALCULATIONS

- WIND LOAD CALCULATION
- RISA 3D OUTPUT REPORT

SECTION 4 – REFERENCE MATERIAL

- RF DATA SHEET
- CONSTRUCTION DOCUMENTS PREPARED BY CENTEK
ENGINEERING REV.0 DATED JULY 10 2015 (not included)
- STEEL SHOP DRAWINGS PREPARED BY PND WELDING/GoodFAB
LLC DATED OCTOBER, 6 2016 (not included)

Introduction

The purpose of this structural analysis report (SAR) is to summarize the results, of the impacted structural components, by the equipment upgrade proposed by Verizon Wireless on the existing host building located in Danbury, CT.

The antennas are mounted on within a proposed replacement RF transparent screen enclosure attached to the roof top of the host building.

The mounts member sizes information and roof framing information were obtained from a construction documents as prepared by Centek Engineering Rev.0, dated July 10, 2015, and steel shop drawings as prepared by PND WELDING/GoodFAB LLC dated October, 6 2016. Proposed/existing antenna and appurtenance information was taken from a RF data sheet dated 11/13/2020 provided by Verizon Wireless.

Primary Assumptions Used in the Analysis

- The host structure's theoretical capacity not including any assessment of the condition of the host structure.
- The existing elevated steel antenna frames carry the horizontal and vertical loads due to the weight of equipment, and wind and transfers into host structure.
- Proposed reinforcement and support steel will be properly installed and maintained.
- Structure is in plumb condition.
- Loading for equipment and enclosure as listed in this report.
- All bolts are appropriately tightened providing the necessary connection continuity.
- All welds are fabricated with ER-70S-6 electrodes.
- All members are assumed to be as observed during roof framing mapping.
- All members are "hot dipped" galvanized in accordance with ASTM A123 and ASTM A153 Standards.
- All member protective coatings are in good condition.

Antenna and Equipment Summary

Location	Appurtenance / Equipment	Rad Center Elevation (AGL)	Mount Type
Alpha Sector	(1) HBXX-6513DS Antenna (1) B25-RRH-4x30 (1) B4-RRH-2x60 (1) HBXX-6513DS Antenna (1) VZS01 Antenna (1) Samsung B2/B66A RRH – BR049 (1) SDX1926Q-43 diplexer (1) RFS RRFDC-3315-PF-48	31.9-ft	FRP enclosure attached to building rooftop
Gamma Sector	(1) HBXX-6513DS Antenna (1) B25-RRH-4x30 (1) B4-RRH-2x60 (1) HBXX-6513DS Antenna (1) VZS01 Antenna (1) Samsung B2/B66A RRH – BR049 (1) SDX1926Q-43 diplexer	31.9-ft	FRP enclosure attached to building rooftop

~~Equipment~~ – Indicates equipment to be removed.
Equipment – Indicates equipment to be installed.

Analysis

The existing antenna frames were analyzed using a comprehensive computer program titled Risa3D. The program analyzes the equipment platform and antenna mounts considering the worst case code prescribed loading condition. The structures were considered to be loaded by concentric forces, and the model assumes that the members are subjected to bending, axial, and shear forces.

Design Loading

Loading was determined per the requirements of the 2015 International Building Code amended by the 2018 CSBC and ASCE 7-10 “Minimum Design Loads for Buildings and Other Structures”.

Wind Speed:	$V_{ult} = 120$ mph	<i>Appendix N of the 2018 CT State Building Code</i>
Risk Category:	II	<i>2015 IBC; Table 1604.05</i>
Exposure Category:	Surface Roughness B	<i>ASCE 7-10; Section 26.7.2</i>
Dead Load	Equipment and framing self-weight	<i>Identified within SAR design calculations</i>

Reference Standards

2015 International Building Code:

1. ACI 318-14, *Building Code Requirements for Structural Concrete*.
2. ACI 530-13, *Building Code Requirements for Masonry Structures*.
3. AISC 360-10, *Specification for Structural Steel Buildings*
4. AWS D1.1 – 00, *Structural Welding Code – Steel*.
5. AF&PA-12, *Span Tables for Joists and Rafters*.

Results

Structure stresses were calculated utilizing the structural analysis software RISA 3D. The stresses were determined based on the AISC standard.

- Calculated stresses for the antenna frame were found to **be within allowable** limits.

Sector	Component	Stress Ratio (percentage of capacity)	Result
All Sectors	L5x5x3/8 FRP	96.5%	PASS
	Pipe 2.5 X-Strong	28.3%	PASS
	Pipe 3.5 X-Strong	27.2%	PASS
	(3) 2x8	73.4%	PASS

Conclusion

This analysis shows that the subject antenna frame and host building **HAVE SUFFICIENT CAPACITY** to support the proposed modified antenna configuration.

The analysis is based, in part, on the information provided to this office by Verizon. If the existing conditions are different than the information in this report, Centek Engineering, Inc. must be contacted for resolution of any potential issues.

Please feel free to call with any questions or comments.

Respectfully Submitted by:

 Timothy J. Lynn, PE
 Structural Engineer

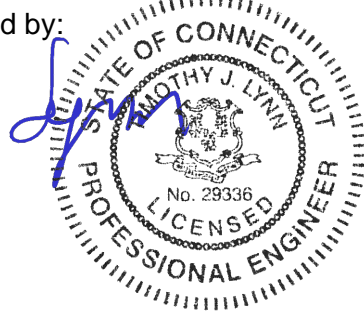

*Standard Conditions for Furnishing of
Professional Engineering Services on
Existing Structures*

All engineering services are performed on the basis that the information used is current and correct. This information may consist of, but is not necessarily limited to:

- Information supplied by the client regarding the structure itself, its foundations, the soil conditions, the antenna and feed line loading on the structure and its components, or other relevant information.
- Information from the field and/or drawings in the possession of Centek Engineering, Inc. or generated by field inspections or measurements of the structure.
- It is the responsibility of the client to ensure that the information provided to Centek Engineering, Inc. and used in the performance of our engineering services is correct and complete. In the absence of information to the contrary, we assume that all structures were constructed in accordance with the drawings and specifications and are in an un-corroded condition and have not deteriorated. It is therefore assumed that its capacity has not significantly changed from the “as new” condition.
- All services will be performed to the codes specified by the client, and we do not imply to meet any other codes or requirements unless explicitly agreed in writing. If wind and ice loads or other relevant parameters are to be different from the minimum values recommended by the codes, the client shall specify the exact requirement. In the absence of information to the contrary, all work will be performed in accordance with the latest revision of ANSI/ASCE10 & ANSI/EIA-222
- All services performed, results obtained, and recommendations made are in accordance with generally accepted engineering principles and practices. Centek Engineering, Inc. is not responsible for the conclusions, opinions and recommendations made by others based on the information we supply.

WIND LOADING ANALYSIS - Wall Components and Cladding			
Per ASCE 7-10 Code for Buildings of Any Height			
Using Part 1 & 3: Analytical Procedure (Section 30.4 & 30.6)			
Job Name:	Danbury SC 6	Subject:	Enclosure
Job Number:	20150.07	Originator:	FJP Checker: TJL

Input Data:

Wind Speed, V =	120	mph (Wind Map, Figure 26.5-1A-C)
Bldg. Classification =	II	(Table 1.5-1 Risk Category)
Exposure Category =	B	(Sect. 26.7)
Ridge Height, hr =	34.00	ft. (hr >= he)
Eave Height, he =	34.00	ft. (he <= hr)
Building Width =	38.51	ft. (Normal to Building Ridge)
Building Length =	52.75	ft. (Parallel to Building Ridge)
Roof Type =	Monoslope	(Gable or Monoslope)
Topo. Factor, Kzt =	1.00	(Sect. 26.8 & Figure 26.8-1)
Direct. Factor, Kd =	0.85	(Table 26.6)
Enclosed? (Y/N) =	n	(Sect. 28.6-1 & Figure 26.11-1)
Hurricane Region? =	Y	
Component Name =	Wall	(Girt, Siding, Wall, or Fastener)
Effective Area, Ae =	500	ft.^2 (Area Tributary to C&C)

Resulting Parameters and Coefficients:

Roof Angle, θ = deg.
Mean Roof Ht., h = ft. (h = he, for roof angle <=10 deg.)

Wall External Pressure Coefficients, GCp:

GCp Zone 4 Pos. = (Fig. 30.4-1, GCp is reduced by 10% for roof angle <=10 deg.)
GCp Zone 5 Pos. = (Fig. 30.4-1, GCp is reduced by 10% for roof angle <=10 deg.)
GCp Zone 4 Neg. = (Fig. 30.4-1, GCp is reduced by 10% for roof angle <=10 deg.)
GCp Zone 5 Neg. = (Fig. 30.4-1, GCp is reduced by 10% for roof angle <=10 deg.)

Positive & Negative Internal Pressure Coefficients, GCpi (Figure 26.11-1):

+GCpi Coef. = (positive internal pressure)
-GCpi Coef. = (negative internal pressure)

If $z \leq 15$ then: $K_z = 2.01 \cdot (15/zg)^{2/\alpha}$, If $z > 15$ then: $K_z = 2.01 \cdot (z/zg)^{2/\alpha}$ (Table 30.3-1)
 α = (Table 26.9-1) (Note: z not < 30' for Exp. B, Case 1)
zg = (Table 26.9-1)
Kh = (Kh = Kz evaluated at z = h)

Velocity Pressure: $q_z = 0.00256 \cdot K_z \cdot K_{zt} \cdot K_d \cdot V^2$ (Sect. 30.3.2, Eq. 30.3-1)
qh = psf $q_h = 0.00256 \cdot K_h \cdot K_{zt} \cdot K_d \cdot V^2$ (qz evaluated at z = h)

Design Net External Wind Pressures (Sect. 30.4 & 30.6):
For h <= 60 ft.: $p = q_h \cdot ((GC_p) - (+/-GC_{pi}))$ (psf)
For h > 60 ft.: $p = q \cdot (GC_p) - q_i \cdot (+/-GC_{pi})$ (psf)
where: q = qz for windward walls, q = qh for leeward walls and side walls
qi = qh for all walls (conservatively assumed per Sect. 30.6)

Plan

Elevation

Wall Components and Cladding:

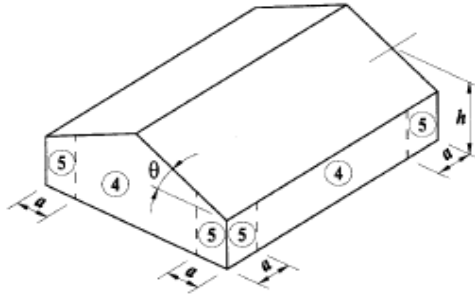

Wall Zones for Buildings with $h \leq 60$ ft.

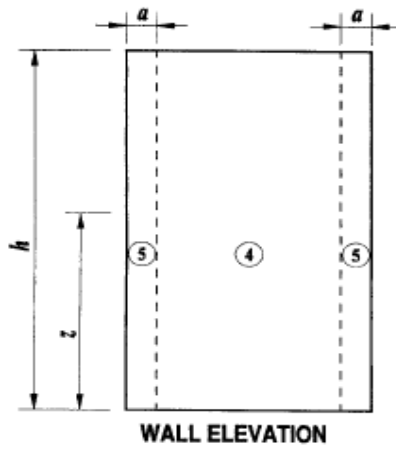

Wall Zones for Buildings with $h > 60$ ft.

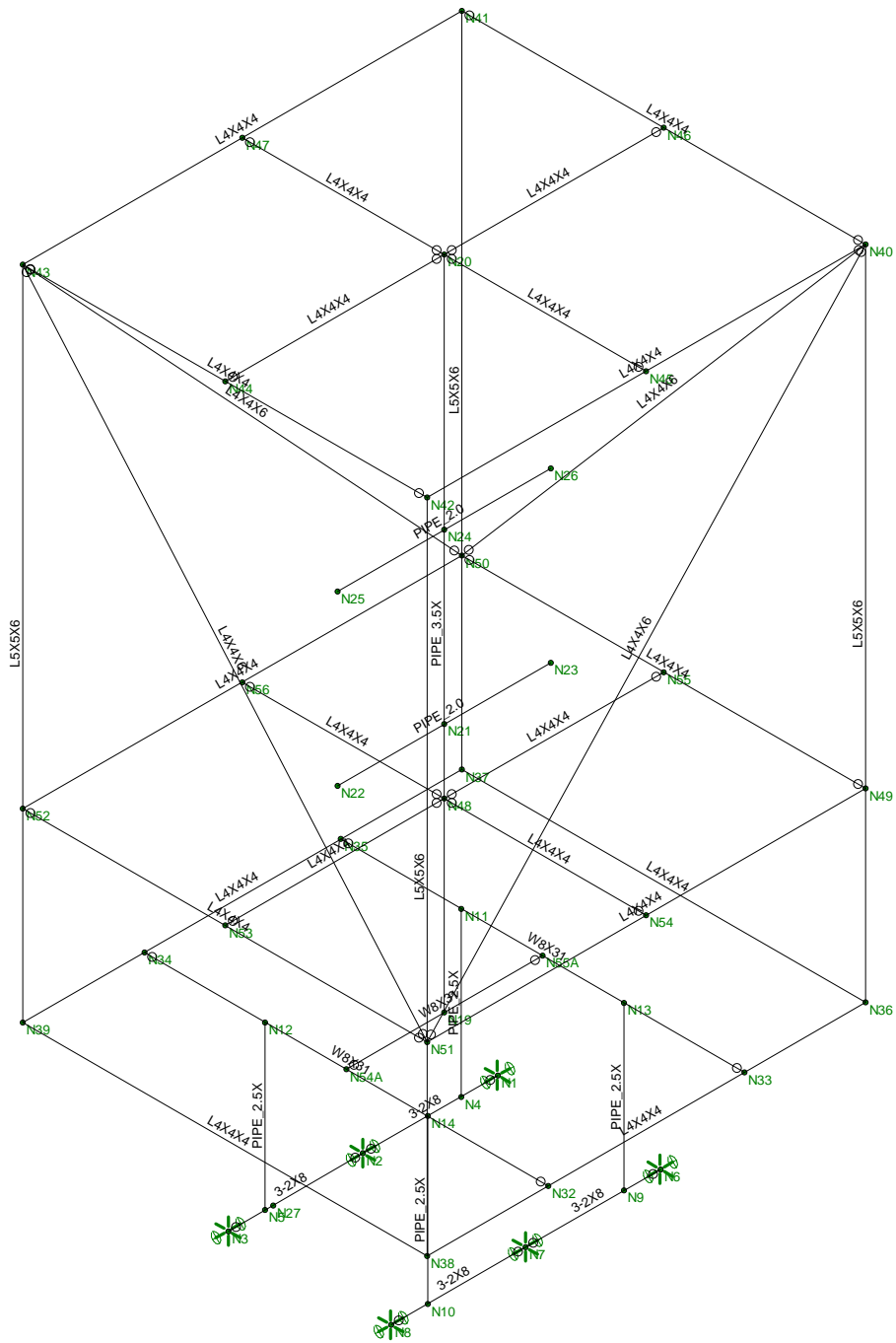

Envelope Only Solution

Centek Engineering

TJL

20150.07

Danbury 10 CT
Member Framing

Mar 5, 2021 at 7:58 AM

Antenna Frame.r3d

(Global) Model Settings

Display Sections for Member Calcs	5
Max Internal Sections for Member Calcs	97
Include Shear Deformation?	Yes
Increase Nailing Capacity for Wind?	Yes
Include Warping?	Yes
Trans Load Btwn Intersecting Wood Wall?	Yes
Area Load Mesh (in^2)	144
Merge Tolerance (in)	.12
P-Delta Analysis Tolerance	0.50%
Include P-Delta for Walls?	Yes
Automatically Iterate Stiffness for Walls?	Yes
Max Iterations for Wall Stiffness	3
Gravity Acceleration (ft/sec^2)	32.2
Wall Mesh Size (in)	12
Eigensolution Convergence Tol. (1.E-)	4
Vertical Axis	Y
Global Member Orientation Plane	XZ
Static Solver	Sparse Accelerated
Dynamic Solver	Accelerated Solver

Hot Rolled Steel Code	AISC 15th(360-16): ASD
Adjust Stiffness?	Yes(Iterative)
RISAConnection Code	AISC 14th(360-10): ASD
Cold Formed Steel Code	AISI S100-10: ASD
Wood Code	AWC NDS-12: ASD
Wood Temperature	< 100F
Concrete Code	ACI 318-11
Masonry Code	ACI 530-11: ASD
Aluminum Code	AA ADM1-10: ASD - Building
Stainless Steel Code	AISC 14th(360-10): ASD
Adjust Stiffness?	Yes(Iterative)

Number of Shear Regions	4
Region Spacing Increment (in)	4
Biaxial Column Method	Exact Integration
Parme Beta Factor (PCA)	.65
Concrete Stress Block	Rectangular
Use Cracked Sections?	Yes
Use Cracked Sections Slab?	Yes
Bad Framing Warnings?	No
Unused Force Warnings?	Yes
Min 1 Bar Diam. Spacing?	No
Concrete Rebar Set	REBAR_SET_ASTMA615
Min % Steel for Column	1
Max % Steel for Column	8

(Global) Model Settings, Continued

Seismic Code	ASCE 7-10
Seismic Base Elevation (ft)	Not Entered
Add Base Weight?	Yes
Ct X	.02
Ct Z	.02
T X (sec)	Not Entered
T Z (sec)	Not Entered
R X	3
R Z	3
Ct Exp. X	.75
Ct Exp. Z	.75
SD1	1
SDS	1
S1	1
TL (sec)	5
Risk Cat	I or II
Drift Cat	Other
Om Z	1
Om X	1
Cd Z	4
Cd X	4
Rho Z	1
Rho X	1
Footing Overturning Safety Factor	1
Optimize for OTM/Sliding	No
Check Concrete Bearing	No
Footing Concrete Weight (k/ft^3)	0
Footing Concrete f'c (ksi)	4
Footing Concrete Ec (ksi)	3644
Lambda	1
Footing Steel fy (ksi)	60
Minimum Steel	0.0018
Maximum Steel	0.0075
Footing Top Bar	#3
Footing Top Bar Cover (in)	2
Footing Bottom Bar	#3
Footing Bottom Bar Cover (in)	3.5
Pedestal Bar	#3
Pedestal Bar Cover (in)	1.5
Pedestal Ties	#3

Hot Rolled Steel Properties

	Label	E [ksi]	G [ksi]	Nu	Therm (\... Density[k/ft^3]	Yield[ksi]	Ry	Fu[ksi]	Rt
1	A36 Gr.36	29000	11154	.3	.65	.49	36	58	1.2
2	A572 Gr.50	29000	11154	.3	.65	.49	50	58	1.2
3	A992	29000	11154	.3	.65	.49	50	58	1.2
4	A500 Gr.42	29000	11154	.3	.65	.49	42	58	1.1
5	A500 Gr.46	29000	11154	.3	.65	.49	46	58	1.1
6	FRP	2800	450	.35	.44	.12	10	58	1.2
7	A53 Grade B	29000	11154	.3	.65	.49	35	58	1.2



Company : Centek Engineering
 Designer : TJL
 Job Number : 20150.07
 Model Name : Danbury 10 CT

Mar 5, 2021
 7:58 AM
 Checked By: _____

Hot Rolled Steel Section Sets

	Label	Shape	Type	Design List	Material	Design Rul...A [in2]	lyy [in4]	lzz [in4]	J [in4]	
1	Mount Base_Pipe_2...	PIPE_2.5X	Column	Pipe	A53 Grade B	Typical	2.1	1.83	1.83	3.66
2	Pipe_3.5 XStrong	PIPE_3.5X	Column	Pipe	A53 Grade B	Typical	3.43	5.94	5.94	11.9
3	L3X3X3/8	L4X4X6	Column	Single Angle	FRP	Typical	2.86	4.32	4.32	.141
4	L5X5X3/8_V	L5X5X6	Column	Single Angle	FRP	Typical	3.65	8.76	8.76	.183
5	Pipe 2.0 STD	PIPE_2.0	Column	Pipe	A53 Grade B	Typical	1.02	.627	.627	1.25
6	L4x4x1/4	L4X4X4	Beam	Single Angle	A36 Gr.36	Typical	1.93	3	3	.044
7	W8	W8X31	Beam	Wide Flange	A992	Typical	9.13	37.1	110	.536

Hot Rolled Steel Design Parameters

	Label	Shape	Length[ft]	Lbyy[ft]	Lbzz[ft]	Lcomp top[...Lcomp bot[...L-torq...	Kyy	Kzz	Cb	Functi...
1	M7	Mount Base_Pipe_2...	2.417							Lateral
2	M8	Mount Base_Pipe_2...	2.417							Lateral
3	M9	Mount Base_Pipe_2...	2.417							Lateral
4	M10	Mount Base_Pipe_2...	2.417							Lateral
5	M17	Pipe_3.5 XStrong	9.75							Lateral
6	M26	L5X5X3/8_V	9.75							Lateral
7	M27	L5X5X3/8_V	9.75							Lateral
8	M28	L5X5X3/8_V	9.75							Lateral
9	M29	L5X5X3/8_V	9.75							Lateral
10	M30	L4x4x1/4	6							Lateral
11	M31	L4x4x1/4	6.517							Lateral
12	M32	L4x4x1/4	6							Lateral
13	M33	L4x4x1/4	6.517							Lateral
14	M34	L4x4x1/4	3.258							Lateral
15	M35	L4x4x1/4	2.998							Lateral
16	M36	L4x4x1/4	3.258							Lateral
17	M37	L4x4x1/4	3.002							Lateral
18	M38	Pipe 2.0 STD	3.167							Lateral
19	M39	Pipe 2.0 STD	3.167							Lateral
20	M40	L4x4x1/4	6.517			Lbyy				Lateral
21	M41	L4x4x1/4	6			Lbyy				Lateral
22	M42	L4x4x1/4	6.517			Lbyy				Lateral
23	M43	L4x4x1/4	6			Lbyy				Lateral
24	M36A	L4x4x1/4	6							Lateral
25	M37A	L4x4x1/4	6.517							Lateral
26	M38B	L4x4x1/4	6							Lateral
27	M39B	L4x4x1/4	6.517							Lateral
28	M40A	L4x4x1/4	3.258							Lateral
29	M41A	L4x4x1/4	2.998							Lateral
30	M42A	L4x4x1/4	3.258							Lateral
31	M43A	L4x4x1/4	3.002							Lateral
32	M40B	W8	6			Lbyy				Lateral
33	M41B	W8	6			Lbyy				Lateral
34	M42B	W8	2.917			Lbyy				Lateral
35	M39A	L3X3X3/8	9.22							Lateral
36	M40C	L3X3X3/8	9.22							Lateral
37	M41C	L3X3X3/8	9.564							Lateral
38	M42C	L3X3X3/8	9.564							Lateral



Company : Centek Engineering
 Designer : TJJ
 Job Number : 20150.07
 Model Name : Danbury 10 CT

Mar 5, 2021
 7:58 AM
 Checked By: _____

Member Primary Data

	Label	I Joint	J Joint	K Joint	Rotate(...)	Section/Shape	Type	Design List	Material	Design R...
1	M3	N3	N2			Mount Base- (3-2x8)	Beam	Rectangular	DF	Typical
2	M4	N2	N1			Mount Base- (3-2x8)	Beam	Rectangular	DF	Typical
3	M5	N8	N7			Mount Base- (3-2x8)	Beam	Rectangular	DF	Typical
4	M6	N7	N6			Mount Base- (3-2x8)	Beam	Rectangular	DF	Typical
5	M7	N5	N12			Mount Base_Pipe_2.5 XStr...	Column	Pipe	A53 Grade B	Typical
6	M8	N10	N14			Mount Base_Pipe_2.5 XStr...	Column	Pipe	A53 Grade B	Typical
7	M9	N4	N11			Mount Base_Pipe_2.5 XStr...	Column	Pipe	A53 Grade B	Typical
8	M10	N9	N13			Mount Base_Pipe_2.5 XStr...	Column	Pipe	A53 Grade B	Typical
9	M17	N19	N20			Pipe_3.5 XStrong	Column	Pipe	A53 Grade B	Typical
10	M26	N39	N43		180	L5X5X3/8_V	Column	Single Angle	FRP	Typical
11	M27	N36	N40			L5X5X3/8_V	Column	Single Angle	FRP	Typical
12	M28	N41	N37		180	L5X5X3/8_V	Column	Single Angle	FRP	Typical
13	M29	N38	N42		270	L5X5X3/8_V	Column	Single Angle	FRP	Typical
14	M30	N43	N42		180	L4x4x1/4	Beam	Single Angle	A36 Gr.36	Typical
15	M31	N42	N40		180	L4x4x1/4	Beam	Single Angle	A36 Gr.36	Typical
16	M32	N40	N41		180	L4x4x1/4	Beam	Single Angle	A36 Gr.36	Typical
17	M33	N41	N43		180	L4x4x1/4	Beam	Single Angle	A36 Gr.36	Typical
18	M34	N44	N20		180	L4x4x1/4	Beam	Single Angle	A36 Gr.36	Typical
19	M35	N20	N45		180	L4x4x1/4	Beam	Single Angle	A36 Gr.36	Typical
20	M36	N20	N46		90	L4x4x1/4	Beam	Single Angle	A36 Gr.36	Typical
21	M37	N20	N47		180	L4x4x1/4	Beam	Single Angle	A36 Gr.36	Typical
22	M38	N22	N23			Pipe 2.0 STD	Column	Pipe	A53 Grade B	Typical
23	M39	N25	N26			Pipe 2.0 STD	Column	Pipe	A53 Grade B	Typical
24	M40	N39	N37			L4x4x1/4	Beam	Single Angle	A36 Gr.36	Typical
25	M41	N37	N36			L4x4x1/4	Beam	Single Angle	A36 Gr.36	Typical
26	M42	N36	N38			L4x4x1/4	Beam	Single Angle	A36 Gr.36	Typical
27	M43	N38	N39			L4x4x1/4	Beam	Single Angle	A36 Gr.36	Typical
28	M36A	N52	N51		270	L4x4x1/4	Beam	Single Angle	A36 Gr.36	Typical
29	M37A	N51	N49		270	L4x4x1/4	Beam	Single Angle	A36 Gr.36	Typical
30	M38B	N49	N50		270	L4x4x1/4	Beam	Single Angle	A36 Gr.36	Typical
31	M39B	N50	N52		270	L4x4x1/4	Beam	Single Angle	A36 Gr.36	Typical
32	M40A	N53	N48		180	L4x4x1/4	Beam	Single Angle	A36 Gr.36	Typical
33	M41A	N48	N54		180	L4x4x1/4	Beam	Single Angle	A36 Gr.36	Typical
34	M42A	N48	N55		90	L4x4x1/4	Beam	Single Angle	A36 Gr.36	Typical
35	M43A	N48	N56		180	L4x4x1/4	Beam	Single Angle	A36 Gr.36	Typical
36	M40B	N35	N33			W8	Beam	Wide Flange	A992	Typical
37	M41B	N34	N32			W8	Beam	Wide Flange	A992	Typical
38	M42B	N54A	N55A			W8	Beam	Wide Flange	A992	Typical
39	M39A	N50	N40			L3X3X3/8	Column	Single Angle	FRP	Typical
40	M40C	N51	N43			L3X3X3/8	Column	Single Angle	FRP	Typical
41	M41C	N40	N51			L3X3X3/8	Column	Single Angle	FRP	Typical
42	M42C	N43	N50			L3X3X3/8	Column	Single Angle	FRP	Typical

Joint Coordinates and Temperatures

	Label	X [ft]	Y [ft]	Z [ft]	Temp [F]	Detach From Dia...
1	N1	0	0	0	0	
2	N2	0	0	2	0	
3	N3	0	0	4	0	
4	N4	0	0	0.541667	0	



Joint Coordinates and Temperatures (Continued)

	Label	X [ft]	Y [ft]	Z [ft]	Temp [F]	Detach From Dia...
5	N5	0	0	3.458333	0	
6	N6	2.416667	0	0	0	
7	N7	2.416667	0	2	0	
8	N8	2.416667	0	4	0	
9	N9	2.416667	0	0.541667	0	
10	N10	2.416667	0	3.458333	0	
11	N11	0	2.416667	0.541667	0	
12	N12	0	2.416667	3.458333	0	
13	N13	2.416667	2.416667	0.541667	0	
14	N14	2.416667	2.416667	3.458333	0	
15	N19	1.208333	2.416667	2	0	
16	N20	1.208333	12.166667	2	0	
17	N21	1.208333	6.125	2	0	
18	N22	1.208333	6.125	3.583333	0	
19	N23	1.208333	6.125	0.416667	0	
20	N24	1.208333	8.625	2	0	
21	N25	1.208333	8.625	3.583333	0	
22	N26	1.208333	8.625	0.416667	0	
23	N27	0	0	3.333333	0	
24	N32	4.206667	2.416667	3.458333	0	
25	N33	4.206667	2.416667	0.541667	0	
26	N34	-1.793333	2.416667	3.458333	0	
27	N35	-1.793333	2.416667	0.541667	0	
28	N36	4.206667	2.416667	-1.258333	0	
29	N37	-1.793333	2.416667	-1.258333	0	
30	N38	4.206667	2.416667	5.258333	0	
31	N39	-1.793333	2.416667	5.258333	0	
32	N40	4.206667	12.166667	-1.258333	0	
33	N41	-1.793333	12.166667	-1.258333	0	
34	N42	4.206667	12.166667	5.258333	0	
35	N43	-1.793333	12.166667	5.258333	0	
36	N44	1.206667	12.166667	5.258333	0	
37	N45	4.206667	12.166667	2	0	
38	N46	1.206667	12.166667	-1.258333	0	
39	N47	-1.793333	12.166667	2	0	
40	N48	1.208333	5.166667	2	0	
41	N49	4.206667	5.166667	-1.258333	0	
42	N50	-1.793333	5.166667	-1.258333	0	
43	N51	4.206667	5.166667	5.258333	0	
44	N52	-1.793333	5.166667	5.258333	0	
45	N53	1.206667	5.166667	5.258333	0	
46	N54	4.206667	5.166667	2	0	
47	N55	1.206667	5.166667	-1.258333	0	
48	N56	-1.793333	5.166667	2	0	
49	N54A	1.206667	2.416667	3.458333	0	
50	N55A	1.206667	2.416667	0.541667	0	



Joint Boundary Conditions

	Joint Label	X [k/in]	Y [k/in]	Z [k/in]	X Rot.[k-ft/rad]	Y Rot.[k-ft/rad]	Z Rot.[k-ft/rad]
1	N1	Reaction	Reaction	Reaction			Reaction
2	N2	Reaction	Reaction	Reaction			Reaction
3	N3	Reaction	Reaction	Reaction			Reaction
4	N6	Reaction	Reaction	Reaction			Reaction
5	N7	Reaction	Reaction	Reaction			Reaction
6	N8	Reaction	Reaction	Reaction			Reaction

Member Point Loads (BLC 3 : Dead: Equipment)

	Member Label	Direction	Magnitude[k,k-ft]	Location[ft,%]
1	M38	Y	-.041	.833
2	M39	Y	-.041	.833
3	M38	Y	-.006	1
4	M39	Y	-.006	1
5	M38	Y	-.043	2.333
6	M39	Y	-.043	2.333
7	M38	Y	-.02	2.333
8	M39	Y	-.02	2.333

Member Distributed Loads (BLC 6 : BLC 2 Transient Area Loads)

	Member Label	Direction	Start Magnitude[k/ft,F,ksf]	End Magnitude[k/f...]	Start Location[ft,%]	End Location[ft,%]
1	M26	Y	-.026	-.067	0	1.95
2	M26	Y	-.067	-.071	1.95	3.9
3	M26	Y	-.071	-.035	3.9	5.85
4	M26	Y	-.035	-.013	5.85	7.8
5	M26	Y	-.013	-.012	7.8	9.75
6	M29	Y	-.04	-.045	0	1.95
7	M29	Y	-.045	-.032	1.95	3.9
8	M29	Y	-.032	-.021	3.9	5.85
9	M29	Y	-.021	-.045	5.85	7.8
10	M29	Y	-.045	-.083	7.8	9.75
11	M40C	Y	-.024	-.02	0	1.844
12	M40C	Y	-.02	-.023	1.844	3.688
13	M40C	Y	-.023	-.023	3.688	5.532
14	M40C	Y	-.023	-.02	5.532	7.376
15	M40C	Y	-.02	-.024	7.376	9.22
16	M27	Y	-.026	-.067	0	1.95
17	M27	Y	-.067	-.071	1.95	3.9
18	M27	Y	-.071	-.035	3.9	5.85
19	M27	Y	-.035	-.013	5.85	7.8
20	M27	Y	-.013	-.012	7.8	9.75
21	M41C	Y	-.025	-.021	0	1.913
22	M41C	Y	-.021	-.024	1.913	3.826
23	M41C	Y	-.024	-.024	3.826	5.738
24	M41C	Y	-.024	-.021	5.738	7.651
25	M41C	Y	-.021	-.025	7.651	9.564
26	M28	Y	-.083	-.045	0	1.95
27	M28	Y	-.045	-.021	1.95	3.9
28	M28	Y	-.021	-.032	3.9	5.85
29	M28	Y	-.032	-.045	5.85	7.8



Company : Centek Engineering
 Designer : TJJ
 Job Number : 20150.07
 Model Name : Danbury 10 CT

Mar 5, 2021
 7:58 AM
 Checked By: _____

Member Distributed Loads (BLC 6 : BLC 2 Transient Area Loads) (Continued)

	Member Label	Direction	Start Magnitude[k/ft,F,ksf]	End Magnitude[k/f..	Start Location[ft,%]	End Location[ft,%]
30	M28	Y	-.045	-.04	7.8	9.75
31	M39A	Y	-.024	-.02	0	1.844
32	M39A	Y	-.02	-.023	1.844	3.688
33	M39A	Y	-.023	-.023	3.688	5.532
34	M39A	Y	-.023	-.02	5.532	7.376
35	M39A	Y	-.02	-.024	7.376	9.22
36	M42C	Y	-.025	-.021	0	1.913
37	M42C	Y	-.021	-.024	1.913	3.826
38	M42C	Y	-.024	-.024	3.826	5.738
39	M42C	Y	-.024	-.021	5.738	7.651
40	M42C	Y	-.021	-.025	7.651	9.564

Member Distributed Loads (BLC 7 : BLC 4 Transient Area Loads)

	Member Label	Direction	Start Magnitude[k/ft,F,ksf]	End Magnitude[k/f..	Start Location[ft,%]	End Location[ft,%]
1	M26	X	.041	.104	0	1.95
2	M26	X	.104	.111	1.95	3.9
3	M26	X	.111	.055	3.9	5.85
4	M26	X	.055	.021	5.85	7.8
5	M26	X	.021	.018	7.8	9.75
6	M28	X	.13	.071	0	1.95
7	M28	X	.071	.033	1.95	3.9
8	M28	X	.033	.05	3.9	5.85
9	M28	X	.05	.07	5.85	7.8
10	M28	X	.07	.062	7.8	9.75
11	M42C	X	.076	.062	0	1.913
12	M42C	X	.062	.072	1.913	3.826
13	M42C	X	.072	.072	3.826	5.738
14	M42C	X	.072	.062	5.738	7.651
15	M42C	X	.062	.076	7.651	9.564
16	M27	X	.014	.035	0	1.95
17	M27	X	.035	.037	1.95	3.9
18	M27	X	.037	.018	3.9	5.85
19	M27	X	.018	.007	5.85	7.8
20	M27	X	.007	.006	7.8	9.75
21	M29	X	.021	.023	0	1.95
22	M29	X	.023	.017	1.95	3.9
23	M29	X	.017	.011	3.9	5.85
24	M29	X	.011	.024	5.85	7.8
25	M29	X	.024	.043	7.8	9.75
26	M41C	X	.025	.021	0	1.913
27	M41C	X	.021	.024	1.913	3.826
28	M41C	X	.024	.024	3.826	5.738
29	M41C	X	.024	.021	5.738	7.651
30	M41C	X	.021	.025	7.651	9.564

Member Distributed Loads (BLC 8 : BLC 5 Transient Area Loads)

	Member Label	Direction	Start Magnitude[k/ft,F,ksf]	End Magnitude[k/f..	Start Location[ft,%]	End Location[ft,%]
1	M27	Z	.037	.096	0	1.95
2	M27	Z	.096	.102	1.95	3.9
3	M27	Z	.102	.05	3.9	5.85
4	M27	Z	.05	.019	5.85	7.8



Member Distributed Loads (BLC 8 : BLC 5 Transient Area Loads) (Continued)

	Member Label	Direction	Start Magnitude[k/f,F,ksf]	End Magnitude[k/f..	Start Location[ft,%]	End Location[ft,%]
5	M27	Z	.019	.017	7.8	9.75
6	M28	Z	.119	.065	0	1.95
7	M28	Z	.065	.031	1.95	3.9
8	M28	Z	.031	.046	3.9	5.85
9	M28	Z	.046	.065	5.85	7.8
10	M28	Z	.065	.057	7.8	9.75
11	M39A	Z	.073	.059	0	1.844
12	M39A	Z	.059	.069	1.844	3.688
13	M39A	Z	.069	.069	3.688	5.532
14	M39A	Z	.069	.059	5.532	7.376
15	M39A	Z	.059	.073	7.376	9.22
16	M26	Z	.012	.032	0	1.95
17	M26	Z	.032	.034	1.95	3.9
18	M26	Z	.034	.017	3.9	5.85
19	M26	Z	.017	.006	5.85	7.8
20	M26	Z	.006	.006	7.8	9.75
21	M29	Z	.019	.022	0	1.95
22	M29	Z	.022	.015	1.95	3.9
23	M29	Z	.015	.01	3.9	5.85
24	M29	Z	.01	.022	5.85	7.8
25	M29	Z	.022	.04	7.8	9.75
26	M40C	Z	.024	.02	0	1.844
27	M40C	Z	.02	.023	1.844	3.688
28	M40C	Z	.023	.023	3.688	5.532
29	M40C	Z	.023	.02	5.532	7.376
30	M40C	Z	.02	.024	7.376	9.22

Basic Load Cases

	BLC Description	Category	X Gra...	Y Gra...	Z Gra...	Joint	Point	Distrib...	Area(...	Surfa...
1	Dead: Self	DL								
2	Dead: Enclosure	DL							4	
3	Dead: Equipment	DL					8			
4	Wind X-Dir. (29psf)	WLX							2	
5	Wind Z-Dir.(29psf)	WLZ							2	
6	BLC 2 Transient Area Loads	None						40		
7	BLC 4 Transient Area Loads	None						30		
8	BLC 5 Transient Area Loads	None						30		

Load Combinations

	Description	Solve	P...	S...	B...	Fa...	BLC Fact...	BLC Fa...	BLC Fa...	BLC Fa...	B...	Fa...	B...	Fa...	B...	Fa...	B...	Fa...
1	IBC 16-8	Yes	Y		DL	1												
2	IBC 16-9	Yes	Y		DL	1	LL	1	LLS	1								
3	IBC 16-10 (b)	Yes	Y		DL	1	SL	1	SLN	1								
4	IBC 16-11 (b)	Yes	Y		DL	1	LL	.75	LLS	.75	SL	.75	SLN	.75				
5	IBC 16-12 (a) (a)	Yes	Y		DL	1	WLX	.6										
6	IBC 16-12 (a) (b)	Yes	Y		DL	1	WLZ	.6										
7	IBC 16-12 (a) (c)	Yes	Y		DL	1	WLX	-.6										
8	IBC 16-12 (a) (d)	Yes	Y		DL	1	WLZ	-.6										
9	IBC 16-13 (a) (a)	Yes	Y		DL	1	WLX	.45	LL	.75	LLS	.75						



Load Combinations (Continued)

Description	Solve	P...	S...	B...	Fa...	BLC	Fact...	BLC	Fa...	BLC	Fa...	BLC	Fa...	B...	Fa...	B...	Fa...	B...	Fa...	B...	Fa...	
10	IBC 16-13 (a) (b)	Yes	Y		DL 1	WLZ	.45	LL	.75	LLS	.75											
11	IBC 16-13 (a) (c)	Yes	Y		DL 1	WLX	-.45	LL	.75	LLS	.75											
12	IBC 16-13 (a) (d)	Yes	Y		DL 1	WLZ	-.45	LL	.75	LLS	.75											
13	IBC 16-13 (b) (a)	Yes	Y		DL 1	WLX	.45	LL	.75	LLS	.75	SL	.75	S...	.75							
14	IBC 16-13 (b) (b)	Yes	Y		DL 1	WLZ	.45	LL	.75	LLS	.75	SL	.75	S...	.75							
15	IBC 16-13 (b) (c)	Yes	Y		DL 1	WLX	-.45	LL	.75	LLS	.75	SL	.75	S...	.75							
16	IBC 16-13 (b) (d)	Yes	Y		DL 1	WLZ	-.45	LL	.75	LLS	.75	SL	.75	S...	.75							
17	IBC 16-15 (a)	Yes	Y		DL .6	WLX	.6															
18	IBC 16-15 (b)	Yes	Y		DL .6	WLZ	.6															
19	IBC 16-15 (c)	Yes	Y		DL .6	WLX	-.6															
20	IBC 16-15 (d)	Yes	Y		DL .6	WLZ	-.6															

Envelope Joint Reactions

Joint		X [k]	LC	Y [k]	LC	Z [k]	LC	MX [k-ft]	LC	MY [k-ft]	LC	MZ [k-ft]	LC
1	N1	max	.275	19	1.802	7	.247	20	0	20	0	.352	5
2		min	-.301	5	-1.02	17	-.279	6	0	1	0	-.337	19
3	N2	max	.191	19	1.432	7	.193	8	0	20	0	.258	5
4		min	-.209	5	-.843	17	-.193	6	0	1	0	-.247	19
5	N3	max	.269	19	2.125	7	.279	8	0	20	0	.342	5
6		min	-.294	5	-1.356	17	-.247	18	0	1	0	-.329	19
7	N6	max	.3	7	1.955	8	.239	20	0	20	0	.338	17
8		min	-.276	17	-1.179	18	-.273	6	0	1	0	-.352	7
9	N7	max	.209	7	1.433	5	.188	20	0	20	0	.247	17
10		min	-.191	17	-.842	19	-.187	18	0	1	0	-.258	7
11	N8	max	.294	7	2.128	5	.273	8	0	20	0	.328	17
12		min	-.268	17	-1.352	19	-.239	18	0	1	0	-.342	7
13	Totals:	max	1.525	19	2.661	16	1.404	20					
14		min	-1.525	5	1.597	17	-1.404	6					

Envelope Joint Displacements

Joint		X [in]	LC	Y [in]	LC	Z [in]	LC	X Rotation [rad]	LC	Y Rotatio...	LC	Z Rotatio...	LC	
1	N1	max	0	20	0	20	0	20	0	20	0	20	0	20
2		min	0	1	0	1	0	1	0	1	0	1	0	1
3	N2	max	0	20	0	20	0	20	0	20	0	20	0	20
4		min	0	1	0	1	0	1	0	1	0	1	0	1
5	N3	max	0	20	0	20	0	20	0	20	0	20	0	20
6		min	0	1	0	1	0	1	0	1	0	1	0	1
7	N4	max	0	5	.001	17	0	6	1.703e-04	7	7.542e-05	5	2.978e-04	19
8		min	0	19	-.002	7	0	20	-9.158e-05	17	-6.942e-05	19	-3.106e-04	5
9	N5	max	0	5	.002	17	0	18	1.279e-04	17	5.988e-05	19	2.901e-04	19
10		min	0	19	-.003	7	0	8	-2.058e-04	7	-6.612e-05	5	-3.02e-04	5
11	N6	max	0	20	0	20	0	20	0	20	0	20	0	20
12		min	0	1	0	1	0	1	0	1	0	1	0	1
13	N7	max	0	20	0	20	0	20	0	20	0	20	0	20
14		min	0	1	0	1	0	1	0	1	0	1	0	1
15	N8	max	0	20	0	20	0	20	0	20	0	20	0	20
16		min	0	1	0	1	0	1	0	1	0	1	0	1
17	N9	max	0	17	.001	19	0	6	1.703e-04	5	6.94e-05	17	3.104e-04	7
18		min	0	7	-.002	5	0	20	-9.158e-05	19	-7.551e-05	7	-2.981e-04	17

Envelope Joint Displacements (Continued)

	Joint		X [in]	LC	Y [in]	LC	Z [in]	LC	X Rotation [rad]	LC	Y Rotatio...	LC	Z Rotatio...	LC
19	N10	max	0	17	.002	19	0	18	1.276e-04	19	6.603e-05	7	3.022e-04	7
20		min	0	7	-.003	5	0	8	-2.06e-04	5	-5.99e-05	17	-2.898e-04	17
21	N11	max	.029	5	.002	17	.066	6	3.133e-03	18	9.541e-05	6	3.538e-04	7
22		min	-.029	7	-.004	7	-.066	8	-3.345e-03	8	-9.209e-05	20	-2.399e-04	17
23	N12	max	.029	5	.003	17	.066	6	3.344e-03	6	9.348e-05	18	4.238e-04	7
24		min	-.029	7	-.005	7	-.066	8	-3.131e-03	20	-9.39e-05	8	-3.117e-04	17
25	N13	max	.029	5	.002	19	.064	6	3.086e-03	18	5.649e-05	17	2.395e-04	19
26		min	-.029	7	-.004	5	-.064	8	-3.3e-03	8	-6.091e-05	7	-3.53e-04	5
27	N14	max	.029	5	.003	19	.064	6	3.298e-03	6	6.651e-05	5	3.111e-04	19
28		min	-.029	7	-.005	5	-.064	8	-3.087e-03	20	-6.642e-05	7	-4.245e-04	5
29	N19	max	.029	5	0	17	.065	6	1.056e-04	6	2.354e-06	8	5.712e-03	7
30		min	-.029	7	0	7	-.065	8	-1.061e-04	8	-2.913e-06	5	-5.716e-03	5
31	N20	max	.478	5	0	17	.339	6	2.403e-03	6	2.354e-06	8	2.161e-03	7
32		min	-.477	7	0	7	-.341	8	-2.4e-03	8	-2.913e-06	5	-2.166e-03	5
33	N21	max	.27	5	0	17	.159	6	2.627e-03	6	2.354e-06	8	4.296e-03	7
34		min	-.269	7	0	7	-.16	8	-2.666e-03	8	-2.913e-06	5	-4.301e-03	5
35	N22	max	.269	5	.049	20	.159	6	2.751e-03	6	2.354e-06	8	4.296e-03	7
36		min	-.269	7	-.053	6	-.16	8	-2.574e-03	20	-2.913e-06	5	-4.301e-03	5
37	N23	max	.27	5	.048	18	.159	6	2.521e-03	18	2.354e-06	8	4.296e-03	7
38		min	-.269	7	-.054	8	-.16	8	-2.841e-03	8	-2.913e-06	5	-4.301e-03	5
39	N24	max	.376	5	0	17	.235	6	2.471e-03	6	2.354e-06	8	2.895e-03	7
40		min	-.375	7	0	7	-.237	8	-2.506e-03	8	-2.913e-06	5	-2.9e-03	5
41	N25	max	.376	5	.046	20	.235	6	2.596e-03	6	2.354e-06	8	2.895e-03	7
42		min	-.375	7	-.05	6	-.237	8	-2.416e-03	20	-2.913e-06	5	-2.9e-03	5
43	N26	max	.376	5	.045	18	.235	6	2.366e-03	18	2.354e-06	8	2.895e-03	7
44		min	-.375	7	-.051	8	-.237	8	-2.681e-03	8	-2.913e-06	5	-2.9e-03	5
45	N27	max	0	5	.002	17	0	18	7.733e-05	17	3.583e-05	19	2.652e-04	19
46		min	0	19	-.003	7	0	8	-1.25e-04	7	-3.961e-05	5	-2.761e-04	5
47	N32	max	.029	5	.01	19	.064	6	5.079e-03	5	1.873e-03	5	2.776e-03	19
48		min	-.029	7	-.017	5	-.065	8	-1.47e-03	19	-1.644e-03	19	-4.097e-03	5
49	N33	max	.029	5	.008	19	.064	6	1.087e-03	19	1.549e-03	19	2.578e-03	19
50		min	-.029	7	-.014	5	-.064	8	-4.704e-03	5	-1.778e-03	5	-3.898e-03	5
51	N34	max	.029	5	.01	17	.068	6	5.069e-03	7	1.643e-03	17	4.046e-03	7
52		min	-.029	7	-.017	7	-.069	8	-1.476e-03	17	-1.868e-03	7	-2.734e-03	17
53	N35	max	.029	5	.008	17	.069	6	1.093e-03	17	1.774e-03	7	3.853e-03	7
54		min	-.029	7	-.014	7	-.068	8	-4.703e-03	7	-1.55e-03	17	-2.542e-03	17
55	N36	max	.063	5	.028	19	.065	6	1.897e-03	18	6.861e-04	7	2.457e-03	19
56		min	-.063	19	-.139	5	-.064	8	-6.284e-03	8	-1.265e-04	17	-3.775e-03	5
57	N37	max	.063	17	.028	17	.069	6	1.292e-03	18	1.299e-04	19	3.734e-03	7
58		min	-.063	7	-.139	7	-.068	8	-5.691e-03	8	-6.912e-04	5	-2.424e-03	17
59	N38	max	.068	5	.045	19	.064	6	6.274e-03	6	3.211e-04	17	2.898e-03	19
60		min	-.067	7	-.155	5	-.065	8	-1.903e-03	20	-8.817e-04	7	-4.22e-03	5
61	N39	max	.067	5	.045	17	.068	6	5.631e-03	6	8.922e-04	5	4.165e-03	7
62		min	-.067	7	-.155	7	-.069	8	-1.271e-03	20	-3.281e-04	19	-2.852e-03	17
63	N40	max	.443	5	.031	19	.359	18	1.33e-03	18	9.58e-04	17	3.412e-04	18
64		min	-.436	7	-.149	5	-.366	8	-1.466e-03	8	-1.087e-03	7	-3.929e-04	8
65	N41	max	.444	5	.028	17	.317	6	7.169e-04	18	8.306e-04	17	2.149e-03	17
66		min	-.436	7	-.144	7	-.313	20	-7.888e-04	8	-1.e-03	7	-2.22e-03	7
67	N42	max	.499	5	.044	19	.359	18	1.686e-03	6	7.361e-04	18	4.833e-04	8
68		min	-.506	7	-.161	5	-.366	8	-1.627e-03	20	-8.966e-04	8	-4.13e-04	18
69	N43	max	.499	5	.049	17	.317	6	1.502e-03	6	5.972e-04	17	9.409e-04	5
70		min	-.506	7	-.167	7	-.312	20	-1.381e-03	20	-7.214e-04	7	-9.011e-04	19

Envelope Joint Displacements (Continued)

	Joint		X [in]	LC	Y [in]	LC	Z [in]	LC	X Rotation [rad]	LC	Y Rotatio...	LC	Z Rotatio...	LC
71	N44	max	.499	5	.017	20	.339	6	1.594e-03	6	8.122e-04	7	2.538e-03	7
72		min	-.506	7	-.133	6	-.341	8	-1.504e-03	20	-6.84e-04	17	-2.512e-03	5
73	N45	max	.478	5	.038	19	.359	18	1.865e-03	18	7.387e-04	17	4.523e-05	8
74		min	-.477	7	-.154	5	-.366	8	-1.897e-03	8	-8.929e-04	7	-3.613e-05	17
75	N46	max	.444	5	.017	18	.339	6	1.023e-03	18	8.121e-04	7	2.021e-03	7
76		min	-.436	7	-.134	8	-.341	8	-1.128e-03	8	-6.839e-04	17	-2.059e-03	5
77	N47	max	.478	5	.044	17	.317	6	1.53e-03	6	7.519e-04	17	1.539e-03	17
78		min	-.477	7	-.16	7	-.312	20	-1.515e-03	20	-9.059e-04	7	-1.553e-03	7
79	N48	max	.216	5	0	17	.128	6	2.715e-03	6	2.354e-06	8	5.026e-03	7
80		min	-.216	7	0	7	-.129	8	-2.74e-03	8	-2.913e-06	5	-5.031e-03	5
81	N49	max	.254	5	.028	19	.201	6	3.207e-03	6	1.486e-03	7	6.424e-03	7
82		min	-.254	7	-.142	5	-.202	8	-2.515e-03	20	-1.342e-03	17	-6.15e-03	17
83	N50	max	.255	5	.029	17	.188	6	2.726e-03	6	1.357e-03	19	6.746e-03	19
84		min	-.254	7	-.142	7	-.189	8	-2.025e-03	20	-1.526e-03	5	-7.069e-03	5
85	N51	max	.273	5	.046	19	.202	6	2.169e-03	18	1.822e-03	17	6.88e-03	7
86		min	-.274	7	-.159	5	-.202	8	-2.891e-03	8	-2.002e-03	7	-6.561e-03	17
87	N52	max	.273	5	.046	17	.188	6	1.806e-03	18	2.041e-03	5	7.253e-03	19
88		min	-.273	7	-.159	7	-.188	8	-2.515e-03	8	-1.891e-03	19	-7.533e-03	5
89	N53	max	.273	5	-.022	20	.129	6	1.988e-03	18	2.199e-04	7	2.457e-03	7
90		min	-.273	7	-.09	6	-.129	8	-2.703e-03	8	-2.246e-04	5	-2.466e-03	5
91	N54	max	.216	5	.016	19	.201	6	1.292e-03	6	2.442e-04	5	6.652e-03	7
92		min	-.216	7	-.142	5	-.202	8	-1.291e-03	8	-2.519e-04	7	-6.355e-03	17
93	N55	max	.254	5	-.022	18	.129	6	2.966e-03	6	2.008e-04	7	1.99e-03	7
94		min	-.254	7	-.091	8	-.129	8	-2.27e-03	20	-2.056e-04	5	-1.991e-03	5
95	N56	max	.216	5	.014	17	.188	6	9.407e-04	18	4.455e-04	6	7.e-03	19
96		min	-.216	7	-.139	7	-.189	8	-9.557e-04	8	-4.491e-04	8	-7.301e-03	5
97	N54A	max	.029	5	0	20	.065	6	3.321e-03	6	6.45e-05	5	2.971e-04	7
98		min	-.029	7	-.001	6	-.065	8	-3.109e-03	20	-6.7e-05	7	-2.975e-04	5
99	N55A	max	.029	5	0	18	.065	6	3.109e-03	18	5.771e-05	5	2.369e-04	7
100		min	-.029	7	-.001	8	-.065	8	-3.322e-03	8	-6.02e-05	7	-2.366e-04	5

Envelope AISC 15th(360-16): ASD Steel Code Checks

Member	Shape	Code Check	Lo...	LC	She...Lo...	Dir	...Pnc/...	Pnt/o...	Mny...	Mnz...	Cb	Eqn	
1	M29	L5X5X6	.965	0	5	.0641...	y	5	3.762	21.856	1.007	2.089	3.2...H2-1
2	M26	L5X5X6	.927	0	7	.063 0	z	7	3.762	21.856	1.371	2.089	3.1...H2-1
3	M28	L5X5X6	.896	9.75	7	.0639...	z	7	3.762	21.856	1.371	2.089	3.0...H2-1
4	M27	L5X5X6	.895	0	5	.064.102	z	5	3.762	21.856	1.371	2.089	3.1...H2-1
5	M42C	L4X4X6	.790	4....	7	.039 0	z	5	1.912	17.126	.813	.962	1.1...H2-1
6	M42	L4X4X4	.700	4....	5	.1014....	y	5	24.609	41.605	2.088	3.749	1.1...H2-1
7	M40	L4X4X4	.698	1....	7	.101 0	y	7	24.609	41.605	2.088	3.748	1.1...H2-1
8	M39A	L4X4X6	.691	4....	8	.034 0	z	8	2.058	17.126	.813	.987	1.1...H2-1
9	M40C	L4X4X6	.557	4....	5	.0139.22	y	5	2.058	17.126	.772	.987	1.1...H2-1
10	M41C	L4X4X6	.541	5....	6	.016 0	y	7	1.912	17.126	.772	.962	1.1...H2-1
11	M36A	L4X4X4	.290	3	8	.015 3	y	8	26.599	41.605	2.088	4.006	1.3...H2-1
12	M38B	L4X4X4	.289	3	6	.016 0	y	8	26.599	41.605	2.088	4.006	1.3...H2-1
13	M10	PIPE 2.5X	.283	0	8	.032 0		7	41.891	44.012	3.091	3.091	2.1...H1-...
14	M8	PIPE 2.5X	.283	0	6	.035 0		7	41.891	44.012	3.091	3.091	2.1...H1-...
15	M9	PIPE 2.5X	.283	0	8	.033 0		6	41.891	44.012	3.091	3.091	2.1...H1-...
16	M7	PIPE 2.5X	.283	0	6	.035 0		5	41.891	44.012	3.091	3.091	2.1...H1-...
17	M17	PIPE 3.5X	.272	0	8	.034 0		6	47.967	71.886	7.108	7.108	1.38H1-...



Company : Centek Engineering
 Designer : TJL
 Job Number : 20150.07
 Model Name : Danbury 10 CT

Mar 5, 2021
 7:58 AM
 Checked By: _____

Envelope AISC 15th(360-16): ASD Steel Code Checks (Continued)

Member	Shape	Code Check	Lo...	LC	She...Lo...	Dir	...Pnc/...	Pnt/o...	Mny...	Mnz...	Cb	Eqn			
18	M41	L4X4X4	.258	6	5	.023	0	y	5	26.599	41.605	2.088	4.439	2.23	H2-1
19	M43	L4X4X4	.257	0	5	.027	0	y	5	26.599	41.605	2.088	4.44	2.2...	H2-1
20	M37A	L4X4X4	.234	3....	5	.012	0	y	5	24.609	41.605	2.088	3.855	1.2...	H2-1
21	M39B	L4X4X4	.228	3....	7	.012	0	y	7	24.609	41.605	2.088	3.861	1.23	H2-1
22	M33	L4X4X4	.072	0	6	.005	0	z	7	24.609	41.605	2.088	4.064	1.5...	H2-1
23	M31	L4X4X4	.051	6....	6	.004	0	y	8	24.609	41.605	2.088	4.11	1.6...	H2-1
24	M40B	W8X31	.047	4.25	8	.075	4.25	y	5	249....	273....	35.124	75.767	1.1...	H1-...
25	M41B	W8X31	.047	4.25	6	.084	4.25	y	5	249....	273....	35.124	75.767	1.1...	H1-...
26	M38	PIPE 2.0	.038	1....	16	.010	1....			18.956	21.377	1.245	1.245	1.9...	H1-...
27	M39	PIPE 2.0	.038	1....	16	.010	1....			18.956	21.377	1.245	1.245	1.9...	H1-...
28	M42B	W8X31	.016	1....	8	.086	1....	z	5	267....	273....	35.124	75.767	1.3...	H1-...
29	M40A	L4X4X4	.012	0	8	.012	0	y	7	31.579	41.605	2.088	4.295	1	H2-1
30	M42A	L4X4X4	.012	0	6	.014	0	y	5	31.579	41.605	2.088	4.295	1	H2-1
31	M32	L4X4X4	.008	3	5	.003	0	z	7	26.599	41.605	2.088	4.019	1.3...	H2-1
32	M41A	L4X4X4	.007	0	19	.007	0	y	8	31.894	41.605	2.088	4.36	1	H2-1
33	M43A	L4X4X4	.007	0	17	.009	0	y	8	31.89	41.605	2.088	4.359	1	H2-1
34	M30	L4X4X4	.006	3	8	.001	3	z	8	26.599	41.605	2.088	4.01	1.32	H2-1
35	M37	L4X4X4	.002	0	19	.004	0	y	8	31.89	41.605	2.088	4.359	1	H2-1
36	M35	L4X4X4	.001	0	17	.003	0	y	6	31.894	41.605	2.088	4.36	1	H2-1
37	M36	L4X4X4	.000	0	8	.001	0	y	8	31.579	41.605	2.088	4.295	1	H2-1
38	M34	L4X4X4	.000	0	8	.002	0	y	7	31.579	41.605	2.088	4.295	1	H2-1



Code Check
(Env)

- No Calc
- > 1.0
- .90-1.0
- .75-.90
- .50-.75
- 0-.50

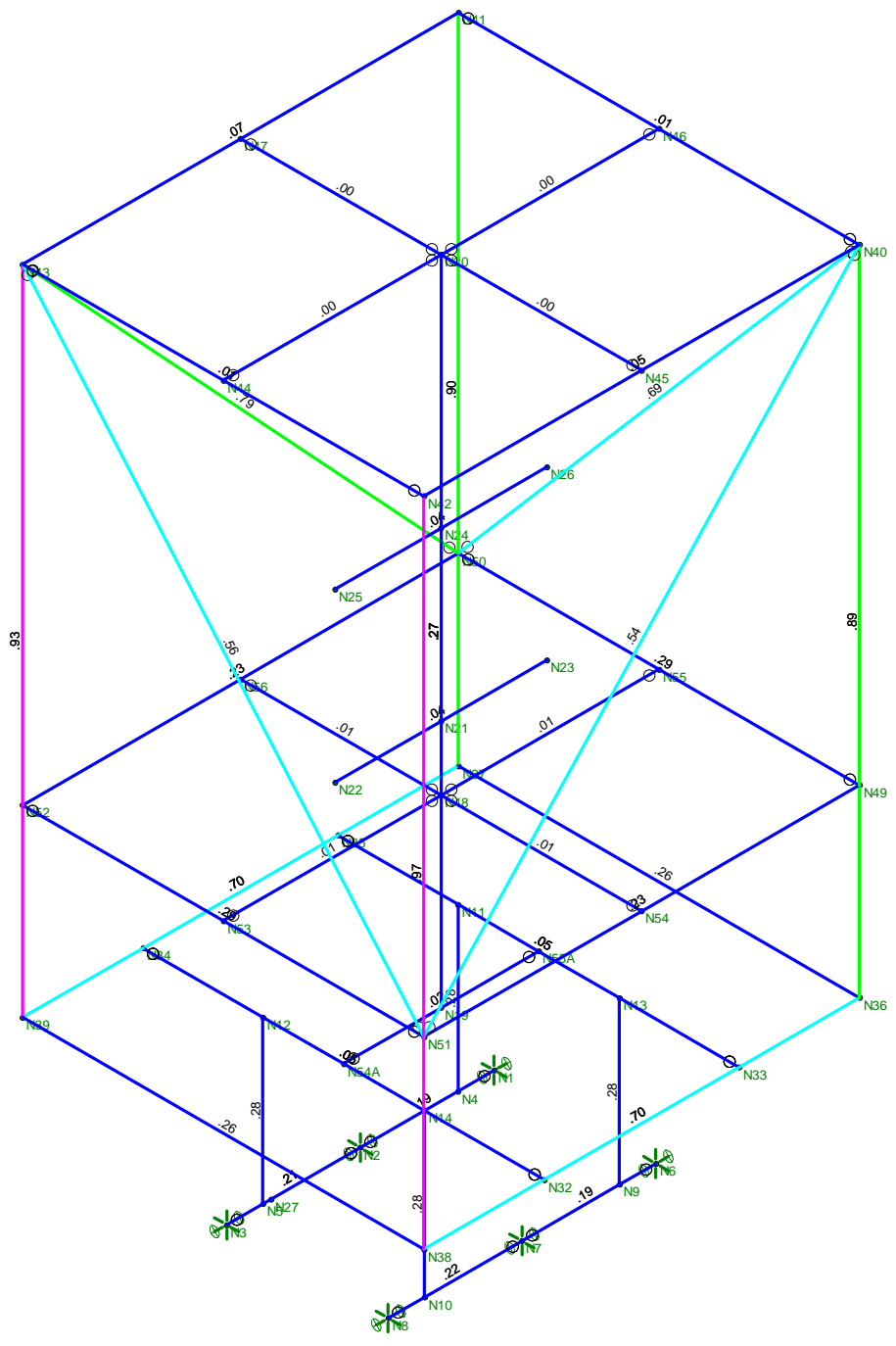

Member Code Checks Displayed (Enveloped)
Envelope Only Solution

Centek Engineering	Danbury 10 CT Unity Check	Mar 5, 2021 at 7:57 AM
TJL		Antenna Frame.r3d
20150.07		



NORTHEAST > North East > New England > New England West > DANBURY 10 CT - A

Gadasu, Shiva - shiva.gadasu@verizonwireless.com - 11/13/2020 12:1:51

Project Details

Carrier Aggregation: false
MPT Id:
eCIP-0: false
Project Name: 850 ADD
FUZE Project ID: 16244659
Designed Sector Carrier 4G: 6
Designed Sector Carrier 5G: N/A
Additional Sector Carrier 4G: N/A
Additional Sector Carrier 5G: N/A
SiteTraker Project Id:
FP Solution Type & Tech Type: MODIFICATION;4G_850,5G_L-Sub6-Prep
RFDS Project Scope: LSub6 add, RRH swap Rev0_11.13.2020 : Initial Design
Suffix: Rev0_11.13.2020

Location Information

Site ID: 5008680
E-NodeB ID: 065557,0659557
PSLC: 467984
Switch Name: Wallingford 2,Wallingford 2
Tower Owner:
Tower Type: Rooftop
Site Type: MACRO
Street Address: 109 Federal Road
City: Danbury
State: CT
Zip Code: 06811
County: Fairfield
Latitude: 41.429758 / 41° 25' 47.1288" N
Longitude: -73.415831 / 73° 24' 56.9916" W

Antenna Summary

Added																			
700	850	1900	AWS	AWS3	28 GHz	31 GHz	39 GHz	CBRS	LAA	L-Sub6	Make	Model	Centerline	Tip Height	Azimuth	RET	4xRx	Inst. Type	Quantity
											TBD	nL-Sub6 Antenna	31.5	33.6	25(0001) 220(0002)	false	false	PHYSICAL	2
Removed																			
700	850	1900	AWS	AWS3	28 GHz	31 GHz	39 GHz	CBRS	LAA	L-Sub6	Make	Model	Centerline	Tip Height	Azimuth	RET	4xRx	Inst. Type	Quantity
												ANDREW	HBXX-6513DS-VTM	32.5	25(01) 220(02)	false	false	PHYSICAL	2
Retained																			
700	850	1900	AWS	AWS3	28 GHz	31 GHz	39 GHz	CBRS	LAA	L-Sub6	Make	Model	Centerline	Tip Height	Azimuth	RET	4xRx	Inst. Type	Quantity
		LTE	LTE								ANDREW	HBXX-6513DS-VTM	32.5	33.6	25(01) 220(02)	false	false	PHYSICAL	2

Added: 2
Removed: 2
Retained: 2

Equipment Summary

Added																		
Equipment Type	Location	700	850	1900	AWS	AWS3	28 GHz	31 GHz	39 GHz	CBRS	LAA	L-Sub6	Make	Model	Cable Length	Cable Size	Install Type	Quantity
Diplexer	Tower			LTE	LTE								Commscope	SDX1926Q-43			PHYSICAL	2
RRU	Tower			LTE	LTE								Samsung	B2/B66A RRH-BR049 (RFV01U-D1A)			PHYSICAL	2
RRU	Tower												Samsung	VZS01			PHYSICAL	2
Removed																		
Equipment Type	Location	700	850	1900	AWS	AWS3	28 GHz	31 GHz	39 GHz	CBRS	LAA	L-Sub6	Make	Model	Cable Length	Cable Size	Install Type	Quantity
RRU	Tower			LTE									Nokia	UHFA B25 RRH 4x30			PHYSICAL	2
RRU	Tower				LTE								Nokia	UHIC B4 RRH 2x60-4R			PHYSICAL	2
Retained																		
Equipment Type	Location	700	850	1900	AWS	AWS3	28 GHz	31 GHz	39 GHz	CBRS	LAA	L-Sub6	Make	Model	Cable Length	Cable Size	Install Type	Quantity
OVP Box	Tower																PHYSICAL	1
Hybrid Cable	Tower																PHYSICAL	1

Service Info

1900 MHZ LTE		0000	
Sector	D1	D2	
Azimuth	25	220	
Cell / ENode B ID	065557	065557	
Antenna Model	HBXX-6513DS-VTM	HBXX-6513DS-VTM	
Antenna Make	ANDREW	ANDREW	
Antenna Centerline(Ft)	32.5	32.5	
Mechanical Down-Tilt(Deg.)	0	0	
Electrical Down-Tilt	4	4	
Tip Height	33.6	33.6	
Regulatory Power	47.39	47.39	
TMA Make			
TMA Model			
RRU Make	Nokia	Nokia	
RRU Model	UHFA B25 RRH 4x30	UHFA B25 RRH 4x30	
Number of Tx, Rx Lines	2,4	2,4	
Position			
Transmitter Id	1967909	1967911	
Source	ATOLL_API	ATOLL_API	

2100 MHZ LTE		0000	
Sector	D1	D2	
Azimuth	25	220	
Cell / ENode B ID	065557	065557	
Antenna Model	HBXX-6513DS-VTM	HBXX-6513DS-VTM	
Antenna Make	ANDREW	ANDREW	
Antenna Centerline(Ft)	32.5	32.5	
Mechanical Down-Tilt(Deg.)	0	0	
Electrical Down-Tilt	4	4	
Tip Height	33.6	33.6	
Regulatory Power	101.33	101.33	
TMA Make			
TMA Model			
RRU Make	Nokia	Nokia	
RRU Model	UHIC B4 RRH 2x60-4R	UHIC B4 RRH 2x60-4R	
Number of Tx, Rx Lines	2,4	2,4	
Position			
Transmitter Id	1967910	1967912	
Source	ATOLL_API	ATOLL_API	

nL-Sub6	
Sector	
Azimuth	
Cell / ENode B ID	
Antenna Model	
Antenna Make	
Antenna Centerline(Ft)	
Mechanical Down-Tilt(Deg.)	
Electrical Down-Tilt	
Tip Height	
Regulatory Power	
TMA Make	
TMA Model	
RRU Make	
RRU Model	
Number of Tx, Rx Lines	
Position	
Transmitter Id	
Source	

5GLS	
01	02
25	220
065557	065557
HBXX-6513DS-VTM	HBXX-6513DS-VTM
ANDREW	ANDREW
32.5	32.5
0	0
4	4
33.6	33.6
62.48	62.48
Samsung	Samsung
B2/B66A RRH-BR049 (RFV01U-D1A)	B2/B66A RRH-BR049 (RFV01U-D1A)
4,4	4,4
7842999	7843001
ATOLL_API	ATOLL_API

5GLS	
01	02
25	220
065557	065557
HBXX-6513DS-VTM	HBXX-6513DS-VTM
ANDREW	ANDREW
32.5	32.5
0	0
4	4
33.6	33.6
66.95	66.95
Samsung	Samsung
B2/B66A RRH-BR049 (RFV01U-D1A)	B2/B66A RRH-BR049 (RFV01U-D1A)
2,4	2,4
7843000	7843002
ATOLL_API	ATOLL_API

5GLS	
0001	0002
25	220
0659557	0659557
nL-Sub6 Antenna	nL-Sub6 Antenna
TBD	TBD
31.5	31.5
0	0
3	3
33.6	33.6
2711.04	2711.04
Samsung	Samsung
VZS01	VZS01
4,4	4,4
7843018	7843019
ATOLL_API	ATOLL_API

Service Comments

Callsigns Per Antenna

Sector	Antenna Make	Antenna Mode	Ant CL Height AGL	Tip Height	Azimuth (TN)	Electrical Tilt	Mechanical Tilt	Gain	Beamwidth	Regulatory Power	Callsigns				
											700	850	1900	2100	28 GHz
No data available.															

Callsigns

Callsign	Market	Radio Code	Market Number	Block	State	County	Licensee Name	Wholly Owned	Total MHZ	Freq Range 1	Freq Range 2	Freq Range 3	Freq Range 4	Regulatory Power	Threshold (W)	POPs/Sq Mi	Status	Action	Approved for Insvc
KNLF644	New York, NY	CW	BTA321	C	CT	Fairfield	AirTouch Cellular	Yes	20.000	1900.000-1910.000	1980.000-1990.000	.000-.000	.000-.000	62.48	1640	1467.18	Active	added	Yes
WQBT539	New York, NY	CW	BTA321	C	CT	Fairfield	Cellco Partnership	Yes	10.000	1895.000-1900.000	1975.000-1980.000	.000-.000	.000-.000	62.48	1640	1467.18	Active	added	Yes
KNLH264	New York, NY	CW	BTA321	F	CT	Fairfield	Cellco Partnership	Yes	10.000	1890.000-1895.000	1970.000-1975.000	.000-.000	.000-.000	62.48	1640	1467.18	Active	added	Yes
WQGB279	Bridgeport-Stamford-Norwalk-Danbury, CT	AW	CMA042	A	CT	Fairfield	Cellco Partnership	Yes	20.000	1710.000-1720.000	2110.000-2120.000	.000-.000	.000-.000	66.95	1640	1467.18	Active	added	Yes
WQGA906	New York-No. New Jer.-Long Island, NY-NJ-CT-PA-MA-	AW	BEA010	B	CT	Fairfield	Cellco Partnership	Yes	20.000	1720.000-1730.000	2120.000-2130.000	.000-.000	.000-.000	66.95	1640	1467.18	Active	added	Yes
WQJQ689	Northeast	WU	REA001	C	CT	Fairfield	Cellco Partnership	Yes	22.000	746.000-757.000	776.000-787.000	.000-.000	.000-.000		1000	1467.18	Active		Yes
KNKA363	Bridgeport-Stamford-Norwalk-Danbury, CT	CL	CMA042	A	CT	Fairfield	Cellco Partnership	Yes	25.000	824.000-835.000	869.000-880.000	845.000-846.500	890.000-891.500		400	1467.18	Active		Yes
WPOH942	New York, NY	LD	BTA321	A	CT	Fairfield	Cellco Partnership	Yes	300.000	29100.000-29250.000	31075.000-31225.000	.000-.000	.000-.000			1467.18	Active		No
WPLM397	New York, NY	LD	BTA321	B	CT	Fairfield	Cellco Partnership	Yes	150.000	31000.000-31075.000	31225.000-31300.000	.000-.000	.000-.000			1467.18	Active		No
WRBA702	New York, NY	UU	BTA321	L1	CT	Fairfield	Cellco Partnership	Yes	325.000	27600.000-27925.000	.000-.000	.000-.000	.000-.000			1467.18	Active		Yes
WRBA703	New York, NY	UU	BTA321	L2	CT	Fairfield	Cellco Partnership	Yes	325.000	27925.000-27950.000	28050.000-28350.000	.000-.000	.000-.000			1467.18	Active		Yes
WRHD609	New York, NY	UU	PEA001	M1	CT	Fairfield	Straight Path Spectrum, LLC	Yes	100.000	37600.000-37700.000	.000-.000	.000-.000	.000-.000			1467.18	Active		Yes
WRHD610	New York, NY	UU	PEA001	M10	CT	Fairfield	Straight Path Spectrum, LLC	Yes	100.000	38500.000-38600.000	.000-.000	.000-.000	.000-.000			1467.18	Active		Yes
WRHD611	New York, NY	UU	PEA001	M2	CT	Fairfield	Straight Path Spectrum, LLC	Yes	100.000	37700.000-37800.000	.000-.000	.000-.000	.000-.000			1467.18	Active		Yes
WRHD612	New York, NY	UU	PEA001	M3	CT	Fairfield	Straight Path Spectrum, LLC	Yes	100.000	37800.000-37900.000	.000-.000	.000-.000	.000-.000			1467.18	Active		Yes
WRHD613	New York, NY	UU	PEA001	M4	CT	Fairfield	Straight Path Spectrum, LLC	Yes	100.000	37900.000-38000.000	.000-.000	.000-.000	.000-.000			1467.18	Active		Yes
WRHD614	New York, NY	UU	PEA001	M5	CT	Fairfield	Straight Path Spectrum, LLC	Yes	100.000	38000.000-38100.000	.000-.000	.000-.000	.000-.000			1467.18	Active		Yes

WRHD615	New York, NY	UU	PEA001	M6	CT	Fairfield	Straight Path Spectrum, LLC	Yes	100.000	38100.000-38200.000	.000-.000	.000-.000	.000-.000			1467.18	Active		Yes
WRHD616	New York, NY	UU	PEA001	M7	CT	Fairfield	Straight Path Spectrum, LLC	Yes	100.000	38200.000-38300.000	.000-.000	.000-.000	.000-.000			1467.18	Active		Yes
WRHD617	New York, NY	UU	PEA001	M8	CT	Fairfield	Straight Path Spectrum, LLC	Yes	100.000	38300.000-38400.000	.000-.000	.000-.000	.000-.000			1467.18	Active		Yes
WRHD618	New York, NY	UU	PEA001	M9	CT	Fairfield	Straight Path Spectrum, LLC	Yes	100.000	38400.000-38500.000	.000-.000	.000-.000	.000-.000			1467.18	Active		Yes
WRHD619	New York, NY	UU	PEA001	N1	CT	Fairfield	Straight Path Spectrum, LLC	Yes	100.000	38600.000-38700.000	.000-.000	.000-.000	.000-.000			1467.18	Active		No
WRDG500	New York, NY	UU	PEA001	S2	CT	Fairfield	Cellco Partnership	Yes	400.000	37800.000-38200.000	.000-.000	.000-.000	.000-.000			1467.18	Active		Yes

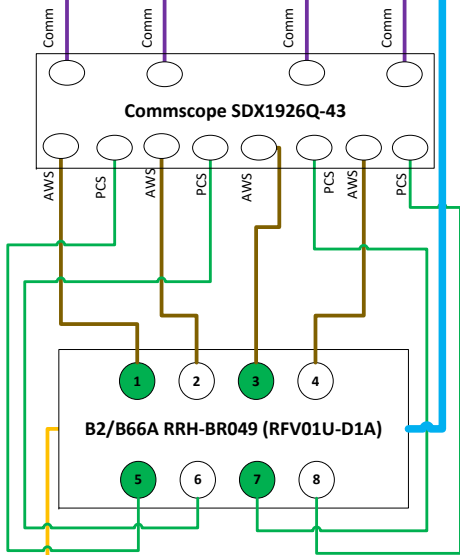
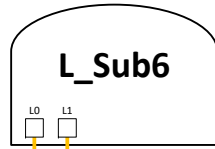
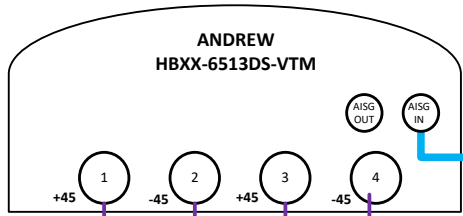

Tower/
Watertank/
Rooftop

Equipment
Pad

April 28, 2021

Mr. Andrew Leone
Verizon Wireless
20 Alexander Drive
Wallingford, CT 06492

Re: *Letter ~ Antenna Model Clarification*
Site Ref: Danbury 10
109 Federal Road
Danbury, CT 06811

Centek Project No. 20150.07

Dear Mr. Leone,

This letter is intended to clarify the equipment depicted in the Centek structural analysis and CDs for the proposed Verizon Wireless equipment upgrade at the above referenced site. One of the proposed antennas is referenced by multiple interchangeable names "Licensed Sub-6", "L-Sub6", "VZS01" and "MT6407-77A" per RF information provided by Verizon, and refers to the 64T64RMMU antenna as manufactured by Samsung Electronics.

For the purpose of the analysis a worst case design loading was used based on the following dimensions and weight per direction from Verizon.

Dimensions: 35.1" x 16.1" x 5.5"

Weight: ± 87 lbs

If the dimensions or weight of the final antenna exceed the above the analysis will need to be re-run.

Respectfully Submitted by:

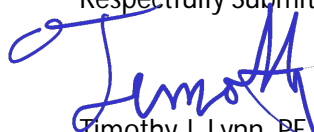
Timothy J. Lynn, PE
Structural Engineer

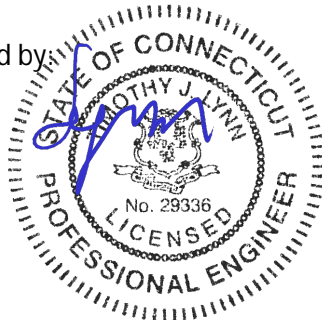

ATTACHMENT 5

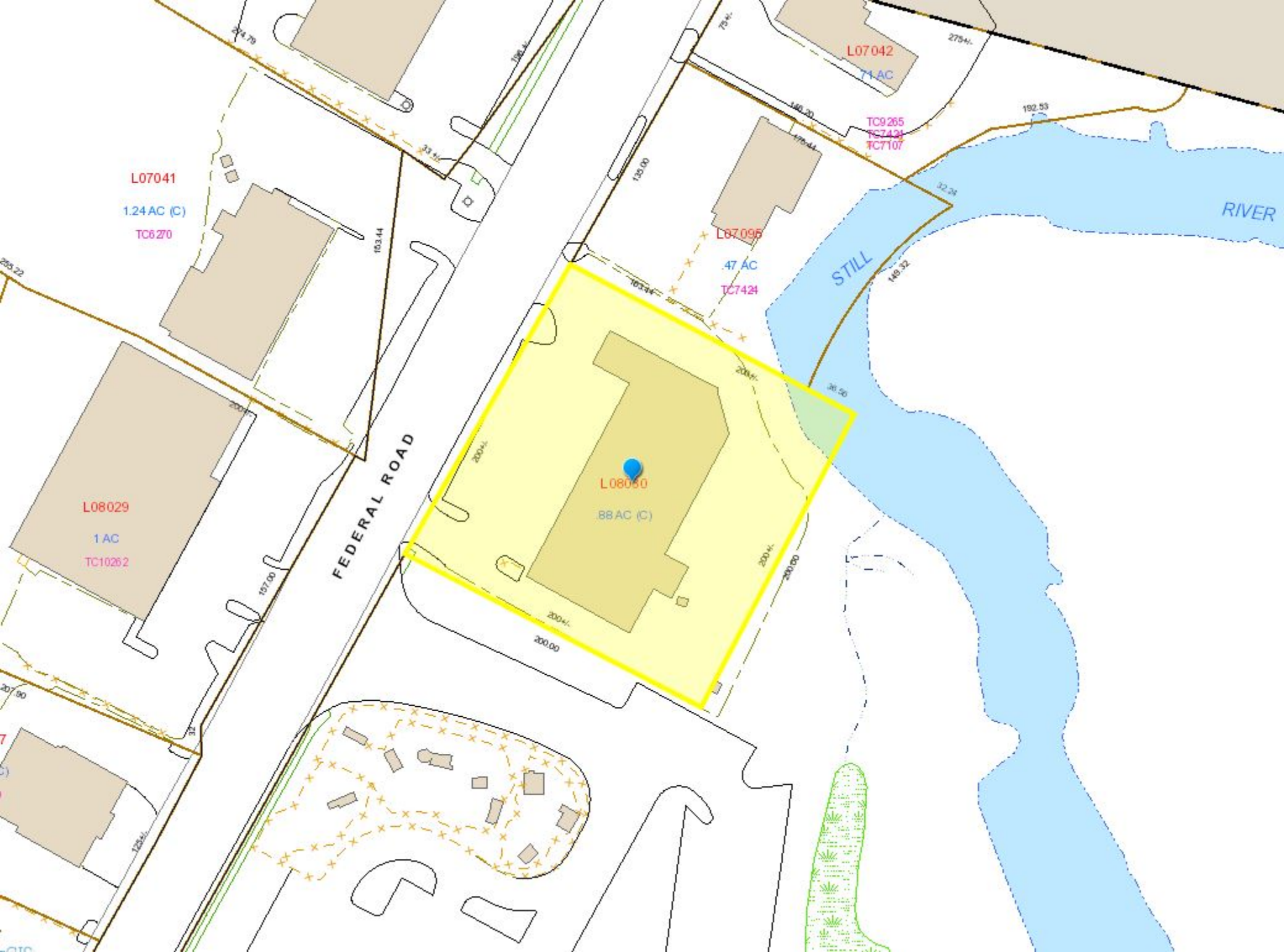

L07041

1.24 AC (C)

TC6270

L07042

71 AC

TC9265

TC7431

TC7107

L07095

47 AC

TC7424

L08050

88 AC (C)

L08029

1 AC

TC10262

FEDERAL ROAD

STILL

RIVER

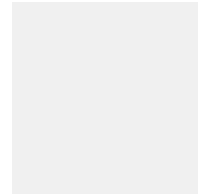

Danbury,CT

109 FEDERAL RD

Location

109 FEDERAL RD

Mblu

L08/ / 30/ /

Acct#

Owner

109 FEDERAL ROAD LLC

Assessment

\$1,254,800

Appraisal

\$1,792,500

PID

5697

Building Count

1

Current Value

Appraisal

Valuation Year	Improvements	Land	Total
2020	\$811,200	\$981,300	\$1,792,500

Assessment

Valuation Year	Improvements	Land	Total
2020	\$567,900	\$686,900	\$1,254,800

Owner of Record

Owner 109 FEDERAL ROAD LLC

Co-Owner

Address 2 STONY HILL RD SUITE 201
BETHEL, CT 06801

Sale Price \$1,375,000

Book & Page 1425/ 348

Sale Date 03/22/2002

Instrument 00

Ownership History

Ownership History

Owner	Sale Price	Book & Page	Instrument	Sale Date
109 FEDERAL ROAD LLC	\$1,375,000	1425/ 348	00	03/22/2002
DIMASI PETER ESTATE	\$0	1405/ 937	01	12/28/2001
DIMASI PETER	\$0	0341/0337		04/03/1959

Building Information

Building 1 : Section 1

Year Built: 1966

Living Area: 10,455

Replacement Cost: \$1,104,654

Building Percent Good: 72

Replacement Cost

Less Depreciation: \$795,400

Building Attributes

Field	Description
STYLE	Strip Stores
MODEL	Commercial
Grade	Good+
Stories:	2
Occupancy	5
Exterior Wall 1	Stucco on Wood
Exterior Wall 2	
Roof Structure	Flat
Roof Cover	Tar & Gravel
Interior Wall 1	Drywall/Sheet
Interior Wall 2	
Interior Floor 1	Carpet
Interior Floor 2	Concr-Finished
Heating Fuel	Oil
Heating Type	Forced Air-Duc
AC Type	Central
Bldg Use	Commercial MDL-94
Total Rooms	
Total Bedrms	00
Total Baths	0
1st Floor Use:	200
Heat/AC	HEAT/AC SPLIT
Frame Type	WOOD FRAME
Baths/Plumbing	AVERAGE
Ceiling/Wall	SUS-CEIL & WL
Rooms/Prtns	AVERAGE

Wall Height	12
% Comn Wall	0

Building Photo 

Building Layout

FGR
2012

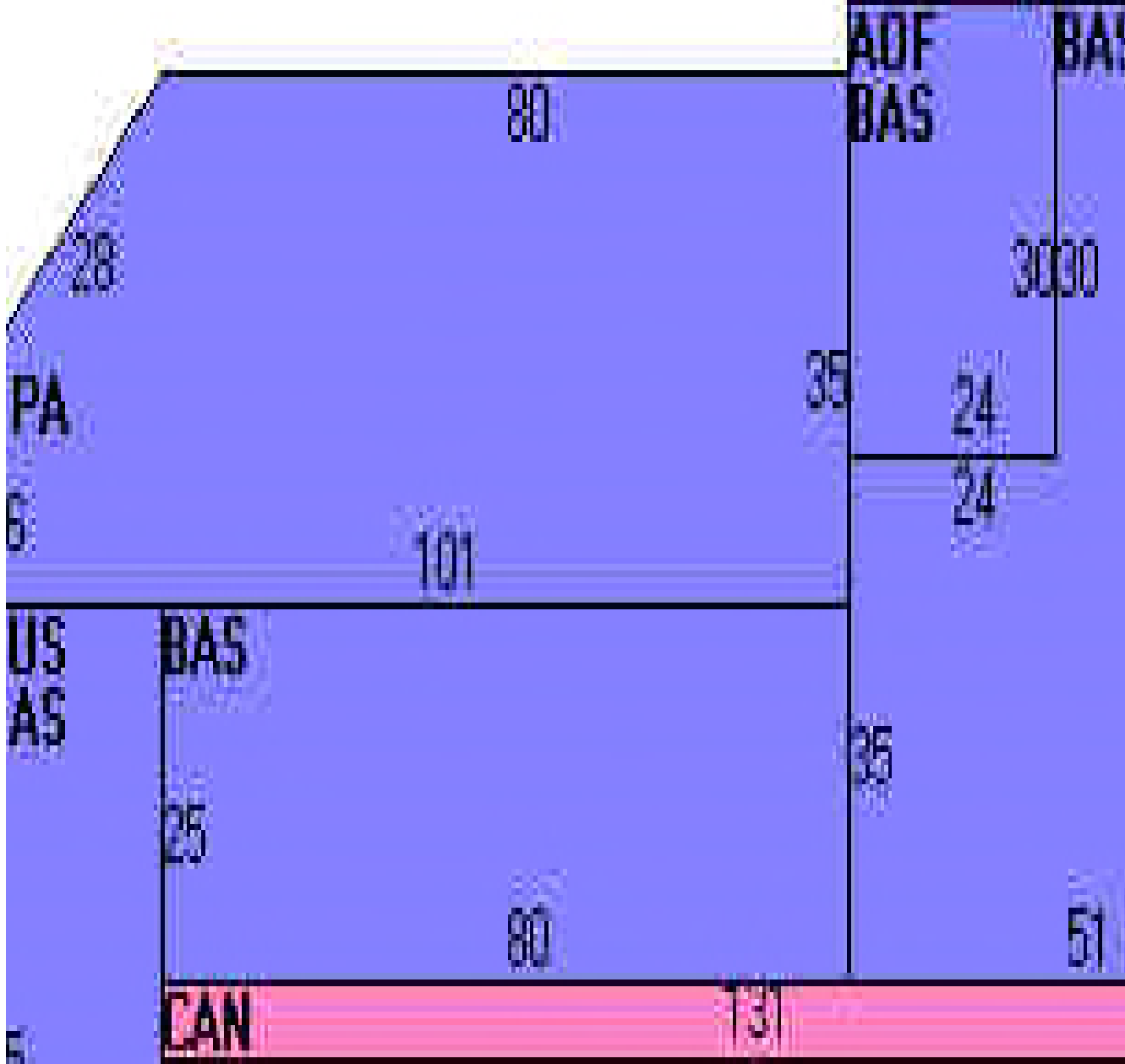

Building Sub-Areas (sq ft) Legend

Code	Description	Gross Area	Living Area
BAS	First Floor	6,470	6,470
SPA	Service Production Area	3,336	2,168
FUS	Finished Upper Story	1,155	1,097
AOF	Office, (Average)	720	720
CAN	Canopy	655	0
FGR	Garage	240	0
		12,576	10,455

Extra Features

Extra Features Legend

No Data for Extra Features

Land

Land Use

Use Code 200

Description Commercial MDL-94

Zone CG20

Neighborhood 8000

Alt Land Appr No

Category

Land Line Valuation

Size (Acres) 0.93

Frontage 0

Depth 0

Assessed Value \$686,900

Appraised Value \$981,300

Outbuildings

Outbuildings Legend

Code	Description	Sub Code	Sub Description	Size	Value	Bldg #
PAV1	Paving-Asphalt			25000 S.F.	\$15,800	1

Valuation History

Appraisal

Valuation Year	Improvements	Land	Total
2019	\$811,200	\$981,300	\$1,792,500
2018	\$811,200	\$981,300	\$1,792,500
2017	\$811,200	\$981,300	\$1,792,500

Assessment

Valuation Year	Improvements	Land	Total
2019	\$567,900	\$686,900	\$1,254,800
2018	\$567,900	\$686,900	\$1,254,800
2017	\$567,900	\$686,900	\$1,254,800

(c) 2021 Vision Government Solutions, Inc. All rights reserved.

closecloseclose

ATTACHMENT 6



DANBURY 10

Certificate of Mailing — Firm

Name and Address of Sender Kenneth C. Baldwin, Esq. Robinson & Cole LLP 280 Trumbull Street Hartford, CT 06103	TOTAL NO. of Pieces Listed by Sender <div style="text-align: center; font-size: 2em;">3</div>	TOTAL NO. of Pieces Received at Post Office™ <div style="text-align: center; font-size: 2em;">3</div>	Affix Stamp Here <i>Postmark with Date of Receipt.</i> <div style="text-align: right; color: magenta;"> neopostSM 05/18/2021 US POSTAGE \$002.89⁰ ZIP 06103 041L12203937 </div>
	Postmaster, per (name of receiving employee) <div style="text-align: center; font-size: 2em;">V.P.</div>		

USPS® Tracking Number Firm-specific Identifier	Address (Name, Street, City, State, and ZIP Code™)	Postage	Fee	Special Handling	Parcel Airlift
1.	Joseph M. Cavo, Mayor City of Danbury 155 Deer Hill Avenue Danbury, CT 06810				
2.	Sharon Calitro, AICP, Director Planning and Zoning City of Danbury 155 Deer Hill Avenue Danbury, CT 06810				
3.	109 Federal Road LLC 2 Stony Hill Road, Suite 201 Bethel, CT 06801				
4.					
5.					
6.					

