



**NSS** **NORTHEAST**  
SITE SOLUTIONS  
*Turnkey Wireless Development*

Northeast Site Solutions  
Victoria Masse  
420 Main Street #2, Sturbridge, MA 01566  
860-306-2326  
victoria@northeastsitesolutions.com

December 14, 2020

Members of the Siting Council  
Connecticut Siting Council  
Ten Franklin Square  
New Britain, CT 06051

RE: Notice of Exempt Modification  
207 West Street, Cromwell CT 06416  
Latitude: 41.602208  
Longitude: -72.67934  
T-Mobile Site#: CTHA241C\_Anchor\_L600

Dear Ms. Bachman:

T-Mobile currently maintains six (6) antennas at the 50 and 41-foot levels of the existing 53-foot monopole tower at 207 West Street, Cromwell CT. The 53-foot tower and property are owned by The Stop & Shop Supermarket Company LLC. T-Mobile now intends to replace six (6) of its existing antennas with three (3) new 2500 MHz 5G antenna and three (3) new 1900/2100 MHz antenna. T-Mobile also intends to add and three (3) new 600/700/1900/2100 MHz 5G antenna. Some of the antenna being installed are 5G technology. The new antennas would be installed at the 50 and 41-foot level of the tower.

**Planned Modifications:**

Remove:

- (3) TMA
- (6) Coax

Remove and Replace:

- (3)AIR21 Antenna (REMOVE) - (3) AIR6449 B41 Antenna 2500 MHz 5G Antenna (REPLACE)
- (3)AIR21 Antenna (REMOVE) – (3) APXVAALL18- 600/700/1900/2100 MHz 5G Antenna (REPLACE)

Install New:

- (3) AIR32 - 1900/2100 MHz 5G Antenna
- (3) RRU 4415 B25
- (3) RRU 4449 B12
- (3) Hybrid Lines
- (3) Diplexers
- Valmont Site Pro 1

Existing to Remain:



- (6) Coax
- (1) Hybrid
- (3) TMA

This facility was approved by the CT Siting Council –on January 18, 2006- Petition No. 799. Please see attached approval.

Please accept this letter as notification pursuant to Regulations of Connecticut State Agencies § 16- SOj-73, for construction that constitutes an exempt modification pursuant to R.C.S.A. § 16-50j-72(b)(2). In accordance with R.C.S.A. § 16-SOj-73, a copy of this letter is being sent to Mayor Enzo Faienza, and Stuart B. Popper, Director of Planning and Development for the Town of Cromwell, as well as the property owner and the tower owner.

The planned modifications to the facility fall squarely within those activities explicitly provided for in R.C.S.A. § 16-50j-72(b)(2).

1. The proposed modifications will not result in an increase in the height of the existing structure.
2. The proposed modifications will not require the extension of the site boundary.
3. The proposed modifications will not increase noise levels at the facility by six decibels or more, or to levels that exceed state and local criteria.
4. The operation of the replacement antennas will not increase radio frequency emissions at the facility to a level at or above the Federal Communications Commission safety standard.
5. The proposed modifications will not cause a change or alteration in the physical or environmental characteristics of the site.
6. The existing structure and its foundation can support the proposed loading.

For the foregoing reasons, T-Mobile respectfully submits that the proposed modifications to the above referenced telecommunications facility constitute an exempt modification under R.C.S.A. § 16-50j-72(b)(2).

Sincerely,  
Victoria Masse  
Mobile: 860-306-2326  
Fax: 413-521-0558  
Office: 420 Main Street, Unit 2, Sturbridge MA 01566  
Email: [victoria@northeastsitesolutions.com](mailto:victoria@northeastsitesolutions.com)



**NSS** **NORTHEAST**  
SITE SOLUTIONS  
*Turnkey Wireless Development*

Attachments

cc: Mayor Enzo Faienza

Town Manager- Anthony J Salvatore

Stuart B. Popper, Director of Planning and Development

The Stop & Shop Supermarket Company LLC. - as property and tower owner

# Exhibit A



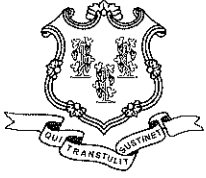

Daniel F. Caruso  
Chairman

STATE OF CONNECTICUT  
CONNECTICUT SITING COUNCIL

Ten Franklin Square, New Britain, CT 06051  
Phone: (860) 827-2935 Fax: (860) 827-2950  
E-Mail: [siting.council@ct.gov](mailto:siting.council@ct.gov)  
Internet: [ct.gov/csc](http://ct.gov/csc)

**CERTIFIED MAIL  
RETURN RECEIPT REQUESTED**

January 22, 2007

H. Karina Fournier  
Zoning Department  
T-Mobile  
30 Cold Spring Road  
Rocky Hill, CT 06067

RE: **PETITION NO. 799** - Omnipoint Communications, Inc. (T-Mobile) petition for a declaratory ruling that no Certificate of Environmental Compatibility and Public Need is required for the replacement of an existing gas station sign with a monopole at 207 West Street, Cromwell, Connecticut.

Dear Ms. Fournier:

At a public meeting held on January 18, 2007, the Connecticut Siting Council (Council) considered and ruled that this proposal would not have a substantial adverse environmental effect, and pursuant to General Statutes § 16-50k would not require a Certificate of Environmental Compatibility and Public Need with the following conditions:

1. The applicant shall prepare an erosion and sediment control checklist for use in the field.
2. The applicant shall notify the Development Compliance Officer and the Town Engineer prior to commencement of work.

This decision is under the exclusive jurisdiction of the Council and is not applicable to any other modification or construction. All work is to be implemented as specified in the petition, dated December 21, 2006.

Enclosed for your information is a copy of the staff report on this project.

Very truly yours,

Daniel F. Caruso  
Chairman

DFC/MP/laf

c: The Honorable Paul C. Beaulieu, First Selectman, Town of Cromwell  
Frederic Curtin, Zoning Enforcement Officer, Town of Cromwell



Daniel F. Caruso  
Chairman

# STATE OF CONNECTICUT

## CONNECTICUT SITING COUNCIL

Ten Franklin Square, New Britain, CT 06051

Phone: (860) 827-2935 Fax: (860) 827-2950

E-Mail: [siting.council@ct.gov](mailto:siting.council@ct.gov)

Internet: [ct.gov/csc](http://ct.gov/csc)

### **Petition No. 799**

### **Staff Report**

### **T-Mobile**

**207 West Street, Cromwell**

**January 18, 2006**

On December 21, 2006, the Connecticut Siting Council (Council) received a petition (Petition) from Omnipoint Communications, Inc. (T-Mobile) for a declaratory ruling that no Certificate of Environmental Compatibility and Public Need is required for the proposed replacement of a gas station sign with a monopole at 207 West Street, Cromwell. Specifically, T-Mobile seeks to remove an existing 54-foot high sign structure (that is not currently being used for any purpose) and replace it with a 54-foot monopole on the property of an Exxon Station on Route 372 (West Street). The existing sign structure does not meet the current wind load requirements for T-Mobile's proposed antennas.

The Petition was field reviewed by Council member Phil Ashton and Mike Perrone of the Council staff on January 8, 2007. Two representatives from T-Mobile: H. Karina Fournier, Zoning Department and Brian Paul, Construction Manager also attended the field review.

The monopole would have three flush-mounted panel antennas centered at the 51-foot level, so that the top of the antennas would be flush with the top of the tower. The proposed antennas would fill an existing coverage gap T-Mobile has in parts of Cromwell in the vicinity of Route 372.

T-Mobile would also install a 15-foot x 15-foot fenced compound which would contain equipment including three BTS cabinets on two 5-foot x 10-foot concrete pads. The proposed tower would be located in the same location as the existing sign. The compound would be separate from the tower.

To the south of the site, the surrounding area is wooded. To the north of the site is Route 372 with a commercial property across the street and one residential/commercial property diagonally across the street. To the east of the site is Stop and Shop Plaza. To the west of the site is commercial.

The nearest wetlands are approximately 55 feet to the south of the proposed compound. T-Mobile would install proper erosion and sedimentation controls. T-Mobile has received a permit from the Town of Cromwell Inland Wetlands and Watercourses Agency (Town IWWA). The Town IWWA granted the petition with the following general conditions:



CONNECTICUT SITING COUNCIL  
Affirmative Action / Equal Opportunity Employer

1. The applicant shall prepare an erosion and sediment control checklist for use in the field.
2. The permit shall expire five years after the date of the issuance (if the project is not constructed).
3. All development shall be conducted as shown on plans submitted in connection with the application as amended to reflect any conditions of approval.
4. The Permittee shall notify the Development Compliance Officer and the Town Engineer prior to commencement of any work.

The tower would not be located in a flood zone. The equipment compound would be technically located in a 500-year flood zone; however, the chances of such a flood occurring are very remote (approximately 0.2 percent in a given year).

The proposed monopole would be the same height as the existing sign structure, but considerably narrower and more compact. As such, the visual impact is expected to decrease with T-Mobile's proposal. In addition, the equipment compound would be located behind an existing wood stockade fence, thus significantly blocking the view of the compound from Route 372. Utilities would run underground and would connect to an existing wood pole on Route 372.

The height of the proposed monopole is also not significantly higher than the existing 40 to 45 feet tall electric distribution poles on Route 372. The tower is well under 200 feet tall and there are no airports within 5 miles of the site, so FAA registration is not required. Also, the worst-case power density at the base of the tower would be 24.9% of the applicable limit.

The structural analysis takes into account the three antennas and also indicates that the tower would be capable of supporting a 9-foot by 9-foot sign on the top. However, there are no plans to install a sign as part of T-Mobile's proposal. Should the property owner decide to install a sign in the future, it would require a separate municipal review and approval. But if a sign is contemplated, Council staff notes that this could increase the visibility of the structure.

All abutters (including the properties across the street) and the property owner were notified by T-Mobile by letters and all were asked to contact S. Derek Phelps with any questions or concerns by January 16, 2006. No comments were received.

Staff suggests adopting the following conditions:

1. The applicant shall prepare an erosion and sediment control checklist for use in the field.
2. The applicant shall notify the Development Compliance Officer and the Town Engineer prior to commencement of any work.

# Exhibit B



**Patriot Properties Inc.**

Parcel ID: **00422500** Location: **207 WEST STREET** Map-Lot **21-6A** Last Revaluation - **October 1, 2017**

**Current Owner**  
 TA CROMWELL LLC  
 TA NEW MILFORD LLC  
 0 PO BOX 6500  
 CARLISLE PA 17013

**Current Value Information**

Use Code	Land Value	PA 490 Value	Building Value	Outbuildings	Total Value	Total Assessed
201	652,600	0	284,543	100,000	1,037,143	726,000
<b>TOTAL</b>	<b>652,600</b>	<b>0</b>	<b>284,543</b>	<b>100,000</b>	<b>1,037,143</b>	<b>726,000</b>

**Previous Owner(s)**

TA CROMWELL LLC  
 CPI CROMWELL LLC

**Previous Value Information**

Tax Yr	Land Value	Bldg Value	Outbuildings	Total Value	Total Assesmen
2018	652,600	252,800	464,300	1,369,700	958,790
2017	652,600	252,800	464,300	1,369,700	958,790
2016	537,650	317,140	87,480	942,270	659,600
2015	537,650	317,140	87,480	942,270	659,600
2014	537,650	317,140	87,480	942,270	659,600
2013	537,650	317,140	87,480	942,270	659,600

**General Notes**

STOP + SHOP GAS MART

**Sales Information**

Grantee	Vol-Page	Type	SaleDate	SalePrice	Sale Verif	GeneralNotes
TA CROMWELL LLC	1474-120		09/11/2013	1,282,105	Other	1,282,105 PURCHASE WAS FOR 36.8
TA CROMWELL LLC	1432-218		10/17/2012	0	Other	
COLUMBIA PROPERTY INVE\$	1338-242		06/25/2010	2,896,897		
GAS DEVELOPMENT CROMW	1335-029		05/26/2010	1,820,000		
CHOUDHRY TAHIR	989-131		12/08/2003	610,000		

**Property Factors**

Census 5701  
 Flood: YES  
 Topo:  
 Street: Paved  
 Dev. Map ZZ-18  
 Dev. Map

**Zoning Data**

Desc. %  
 HB 100.00

**Utilities**

2 Public Water  
 3 Public Sewer

**BAA**

17G;07K

**Activity Information**

Date	Results	Visited By
12/27/2017	Informal Review No Change	John Valente
09/11/2017	Change - Value Change Company	John Valente
05/19/2017	No Change - Field Review	Dave Stannard
09/20/2011	Permit- Miscellaneous	AO
01/28/2011	Permit- Miscellaneous	AO
11/18/2010	Permit- Miscellaneous	AO
11/16/2010	Permit- Miscellaneous	AO
10/25/2010	Permit- Miscellaneous	AO
10/19/2010	Permit- Miscellaneous	AO
10/19/2010	Permit- Miscellaneous	AO

**Building Permit Information**

Date	Permit #	Description	Amount	% Comp	Visit Date	CO Date	GeneralNotes
09/13/2011	20141	Other	5,400	100	09/20/2011	09/20/2011	Rplc tank monitor, consul
11/29/2010	19525	Sign	25,000	100	01/28/2011	01/01/2011	
11/18/2010	19514	Other	0	100	11/18/2010		Inst dry chem fire suppre
11/16/2010	19498	Electric	0	100	11/16/2010		Install CCTV close circui
10/25/2010	19445	Electric	0	100	10/25/2010		
10/19/2010	19427	Other	565,000	100	10/19/2010	12/01/2010	Retrofit existng fuel fa
10/19/2010	19428	Other	0	100	10/19/2010		Install burglar alarm
06/01/2009	18378	Other	26,000	100	01/27/2010	01/27/2010	swap antennas on cell tow

**Land Data**

Use	Description	Units	Type	Neiah	Land Adjustments	Special Land Calc	Appraised Value	PA 490 Asmt	Neigh Order	Notes
201	Commercial	51,836	SF	CL			652,600	0	1400	USE

Total Area: 1.19 PA 490 Use Asmt: 0 Total Appraised: 652,600 Assessed Value: 456,820

ParcelID: 00422500  
 Bldg Seq 1 Of 1

Location: 207 WEST STREET

Printed By: Shawna 04/06/2018 9:01:10PM

**Exterior Information**

Building Type: Gas Mart  
 Story Ht: 1 Story  
 Living Units: 0  
 Foundation:  
 Prim. Ext. Wall: Concrete 50%  
 Sec. Ext. Wall: Pre-finish Me 50%  
 Roof Type: Flat  
 Roof Cover: T&G/Rubber  
 Avg. Wall Ht: 14.00  
 Color:

**Condo Information**

Name:  
 Style:  
 Location:  
 Tot Units:

**General Information**

Year Blt: 1973  
 Grade: B-  
 Remodeled Yr: 2010  
 Rem. Kitchen Yr:  
 Rem. Bath Yr:

**Interior Information**

Prime Wall: Drywall  
 Sec. Wall:  
 Floor Type: Ceram Clay T  
 Sec. Floor:  
 Heat Fuel: Gas  
 Heat Type: Forced Air  
 Sec. Ht Type:  
 % A/C: 100  
 % Sprinkled: 0  
 Bsmt. Gar: 0  
 Kitchens: 0 Add. Kit: 0  
 Fireplaces: 0 Gas: 0  
 Int. Condition: Typical

**Depreciation**

	%
Phys Cond	Very Good 13.20
Func	0.00
Econ	0.00
Spec	0.00
OV	0.00
<b>Total %Dep:</b>	<b>13.20</b>

**Calculation**

Basic \$/SQ	117.00
Replacement Cost	296,863
Depreciation	39,186
Depreciated Value	257,677
<b>Final Total (Rounded)</b>	<b>257,700</b>

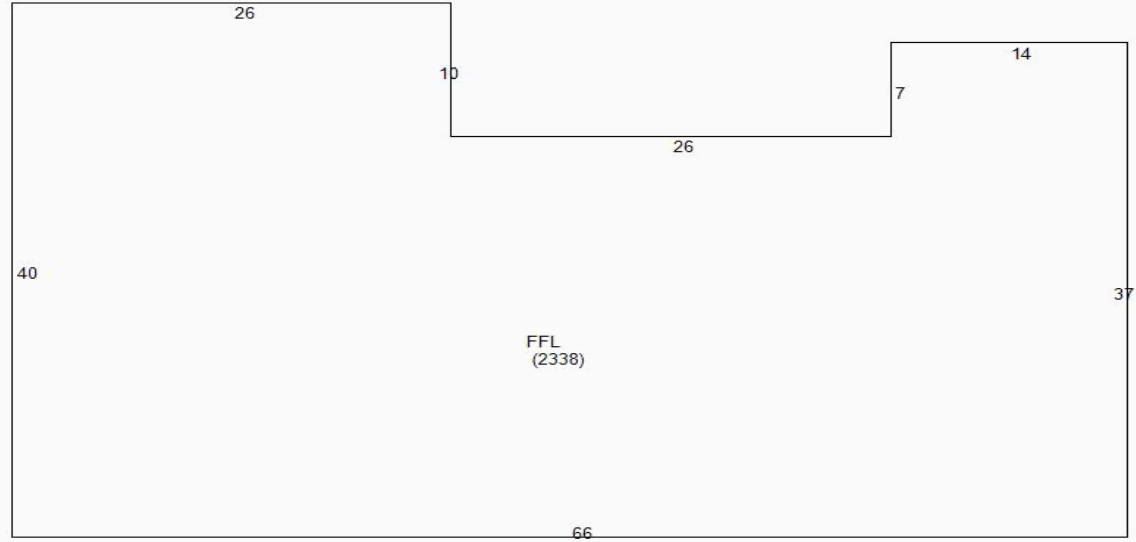

**Room Count**

Total Rooms:  
 Bedrooms:

**Bath Features**

Full Baths: 0  
 Addl. Full Baths: 0  
 Half Baths: 0  
 Addl. Half Baths: 0  
 Full Bths Below: 0  
 Half Bths Below: 0  
 Other Fixtures: 0  
 Total Baths: 0



**Extra Features / Yard Items (1st 10 Lines Displayed)**

Code	Description	Qty	Size	Cond.	Year	Unit Price	Dep%	UndepValue	Appraised Value	Assessment
LT1	Light 1	1	3	AV	2002	1,000.00	13	3,600	3,100	2,170
LT2	Light 2	1	1	AV	2002	1,500.00	13	1,800	1,600	1,120
PAV1	Paving Asph.	1	12,900	AV	1973	3.00	35	46,440	30,200	21,140
PAV2	Paving Concr	1	4,370	AV	2002	5.00	13	26,220	22,800	15,960
TNK2	Tank 3K-10K	1	10,000	PR	2002	20.00	23	240,000	184,800	129,360
TNK3	Tank >10K	1	12,000	PR	2002	20.00	23	288,000	221,800	155,260
<b>Total Sp. Features:</b>			<b>Total Yard Items</b>			<b>464,300</b>	<b>Total Appraised:</b>	<b>464,300</b>	<b>Total Assessed Value</b>	<b>325,010</b>

**Sub Area Detail**

Code	Desc.	Living	Gross Area
FFL	First Floor	2,338	2,338
<b>Total</b>		<b>2,338</b>	<b>2,338</b>



- Parcel on Current Map
- Parcel Not on Current Map
- Easements
- Historic Lines
- 0088200 Parcel Identifier
- 9.02 AC Parcel Size (in acres)
- 100 Parcel Address
- 234.5 Parcel Dimension

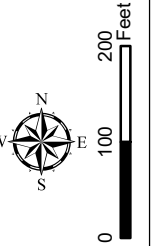

# Town of Cromwell Connecticut



15	22	32
14	21	31
13	20	30

This tax map is for assessment purpose only.  
It is not valid to use this map as a survey or for  
property conveyance.

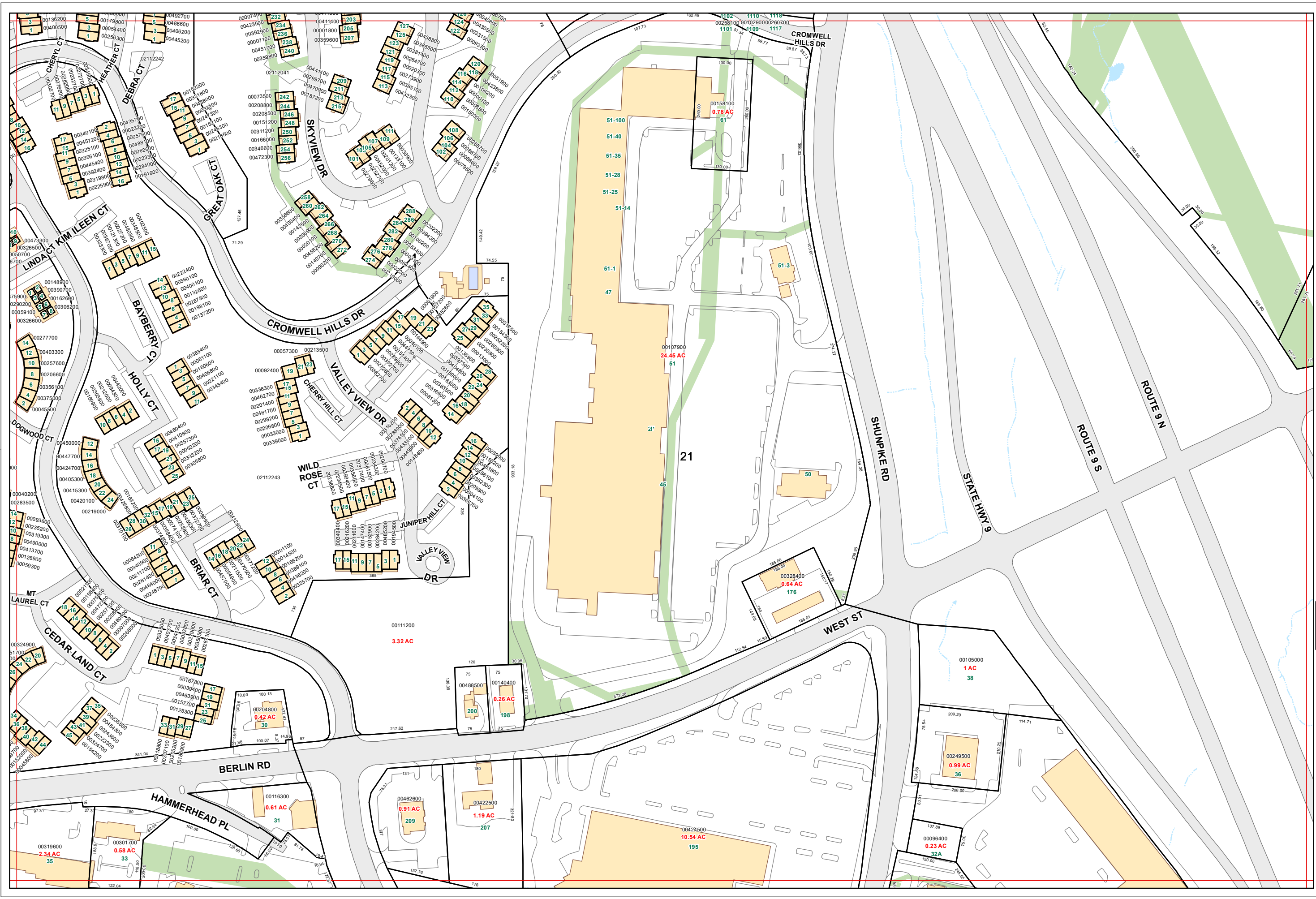

# Exhibit C



Copyright © 2020 Foresite LLC all rights reserved. The details, templates, drawing formats or any portion of this document generated by Foresite LLC may not be duplicated, traced or used otherwise for any profit-driven enterprise.

MODIFICATION OF EXISTING WIRELESS FACILITY BY



**T-MOBILE NORTHEAST LLC**

PROJECT TITLE: ANCHOR-L600

SITE NUMBER: CTHA241C

SITE NAME: HA241 / EXXON SIGN

SITE ADDRESS: 207 WEST STREET

CROMWELL, CT 06416

(RF CONFIGURATION: 67D5997DB\_2xAIR+1OP (U21 Market))

**APPLICANT:**  
  
**T-MOBILE NORTHEAST LLC**  
 35 GRIFFIN ROAD SOUTH  
 BLOOMFIELD, CT 06002  
 860-692-7100

**PROJECT MANAGER**  
  
**NORTHEAST SITE SOLUTIONS**  
*Tuesday Wireless Development*  
 420 MAIN STREET, BLDG 4  
 STURBRIDGE, MA 01566  
 203-275-6669

**CONSULTANT:**  
  
**FORESITE LLC**  
 Architects . Engineers . Surveyors  
 462 WALNUT STREET  
 NEWTON, MA 02460  
 617-212-3123

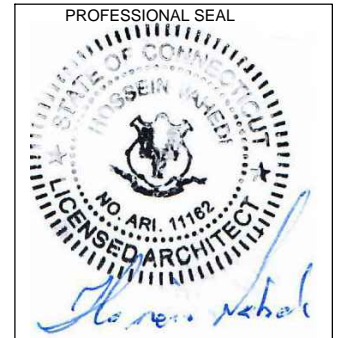

THIS DOCUMENT IS THE DESIGN PROPERTY AND COPYRIGHT OF FORESITE, LLC. AND FOR THE EXCLUSIVE USE BY THE TITLE CLIENT. DUPLICATION OR USE WITHOUT THE EXPRESS WRITTEN CONSENT OF THE CREATOR IS STRICTLY PROHIBITED. DRAWING SCALES ARE INTENDED FOR 11"x17" SIZE PRINTED MEDIA ONLY. ALL OTHER PRINTED SIZES ARE DEEMED "NOT TO SCALE".

**PROJECT NOTES:**

1. THIS IS AN UNMANNED TELECOMMUNICATION FACILITY AND NOT FOR HUMAN HABITATION: HANDICAPPED ACCESS IS NOT REQUIRED. POTABLE WATER OR SANITARY SERVICE IS NOT REQUIRED. NO OUTDOOR STORAGE OR ANY SOLID WASTE RECEPTACLES REQUIRED.
2. CONTRACTOR SHALL VERIFY ALL PLANS, EXISTING DIMENSIONS, AND CONDITIONS ON THE JOB SITE. CONTRACTOR SHALL IMMEDIATELY NOTIFY THE ARCHITECT/ENGINEER IN WRITING OF ANY DISCREPANCIES BEFORE PROCEEDING WITH THE WORK. FAILURE TO NOTIFY THE ARCHITECT/ENGINEER PLACES THE RESPONSIBILITY ON THE CONTRACTOR TO CORRECT THE DISCREPANCIES AT THE CONTRACTOR'S EXPENSE.
3. DEVELOPMENT AND USE OF THE SITE WILL CONFORM TO ALL APPLICABLE CODES, ORDINANCES AND SPECIFICATIONS.

REFER TO STRUCTURAL ANALYSIS REPORT TITLED " STRUCTURAL ANALYSIS REPORT - MONOPOLE TOWER " SITE ID: CTHA241C, DATED DECEMBER 03, 2020 AND -MOUNT STRUCTURAL ANALYSIS REPORT- REPLACEMENT, DATED DECEMBER 03, 2020 BOTH PREPARED BY EFI GLOBAL, INC.

**CODE COMPLIANCE:**

- ALL WORK SHALL COMPLY WITH THE CURRENT NATIONAL AND CONNECTICUT STATE BUILDING AND LIFE SAFETY CODES. SUPPLEMENTS AND AMENDMENTS INCLUDING BUT NOT LIMITED TO THE LATEST EDITION OF:
- CONNECTICUT STATE BUILDING CODE (CSBC).
  - ANSI/TIA-222-G STRUCTURAL STANDARD FOR ANTENNA SUPPORTING STRUCTURES AND ANTENNAS.
  - NATIONAL ELECTRICAL CODE (NEC) FOR POWER AND GROUNDING REQUIREMENTS.
  - OCCUPATIONAL SAFETY AND HEALTH ACT (OSHA).
  - NFPA - NATIONAL FIRE PROTECTION ASSOCIATION.
- Connecticut - Call Before You Dig** **Advance Notice:**  
 811 or 1-800-922-4455 Minimum of 2 working days in advance, no more than 30 days in advance

**APPROVALS:**

FSA CM	DATE
RF ENGINEER	DATE
FOPS	DATE
T-MOBILE ENGINEERING AND DEVELOPMENT	DATE
	DATE
	DATE

**SITE IMAGE:**



**SITE MAP :**

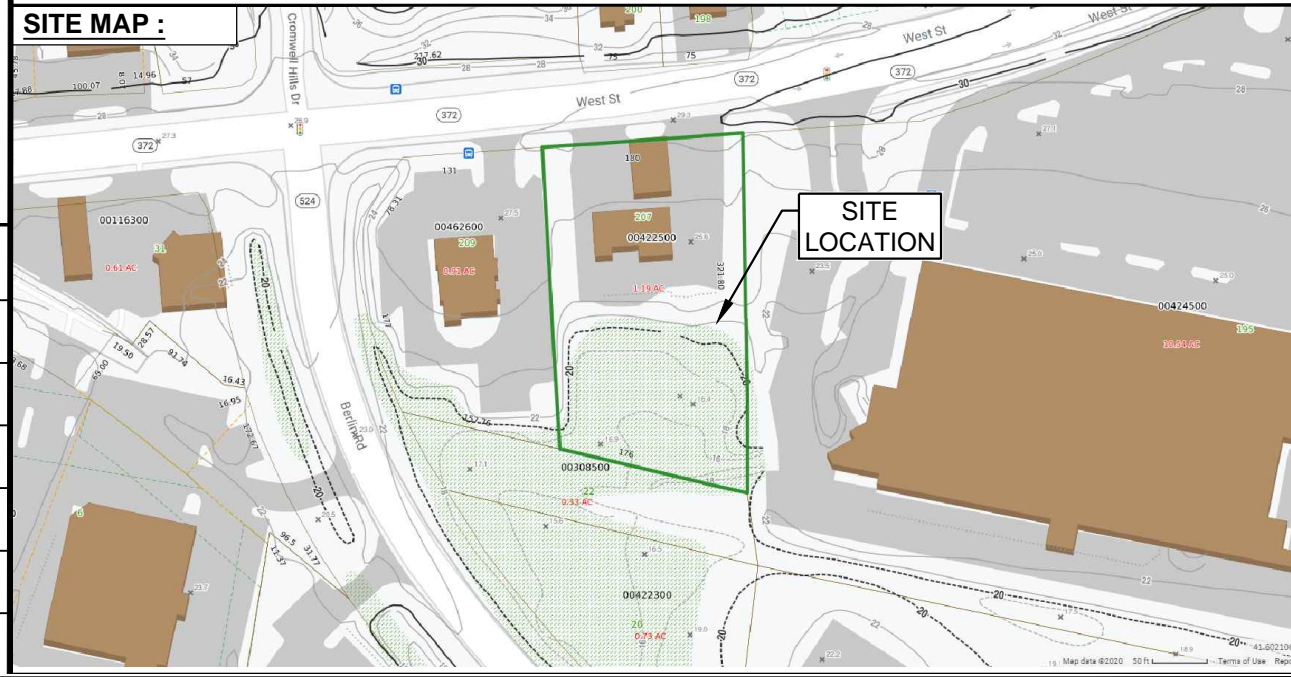

**PROJECT SCOPE:**

UPGRADE OF EXISTING WIRELESS FACILITY AS FOLLOWS:  
 UPGRADE EXISTING RBS 6131 CABINET INTERNALLY.  
 ADD (1) ENCLOSURE 6160 SITE SUPPORT CABINET.  
 ADD (1) BATTERY CABINET B160.  
 REPLACE (6) OF (6) EXISTING ANTENNAS AND ADD (3) NEW ANTENNAS FOR A TOTAL OF (9) ANTENNAS ON THE TOWER.  
 ADD (6) RADIO REMOTE UNITS AND (3) DIPLEXERS AND (3) TMAS AT ANTENNA.  
 REMOVE (6) OF (12) EXISTING 1-5/8" COAX AND ADD (3) 6X12 HCS, FOR FINAL COUNT OF (6) 1-5/8" COAX, (1) 9X18 HCS AND (3) 6X12 HCS LINES.

**PROJECT INFORMATION:**

ADDRESS: 207 WEST STREET  
 CROMWELL, CT 06416  
 PARCEL ID: 00422500  
 ZONING DISTRICT: HB  
 COORDINATES: 41° 36' 07.94" N, 72° 40' 45.61" W  
 AVERAGE GROUND ELEV.: 23± (AMSL)

**PROJECT TEAM:**

APPLICANT: T-MOBILE NORTHEAST, LLC.  
 35 GRIFFIN ROAD SOUTH  
 BLOOMFIELD, CT 06002  
 860-692-7100

PROPERTY OWNER: TA CROMWELL LLC  
 TA NEW MILFORD LLC  
 PO BOX 6500  
 CARLISLE, PA 17013

PROJECT MANAGER: NORTHEAST SITE SOLUTIONS  
 420 MAIN STREET, BLDG 4  
 STURBRIDGE, MA 01566  
 SHELDON FREINCLE  
 SHELDON@NORTHEASTSITESOLUTIONS.COM  
 201-776-8521

CONSULTANTS: FORESITE LLC  
 462 WALNUT ST  
 NEWTON, MA 02460  
 SAEED MOSSAVAT  
 SMOSSAVAT@FORESITELLC.COM  
 617-212-3123

**SHEET INDEX:**

- T-1: TITLE SHEET
- N-1: GENERAL NOTES
- A-1: SITE PLAN AND ELEVATION
- A-2: EQUIPMENT LAYOUT AND ANTENNA PLANS
- A-3: ANTENNAS AND EQUIPMENT SPECIFICATIONS
- A-4: ANTENNA MOUNT SPECIFICATIONS
- E-1: ELECTRICAL DETAILS

REV	DESCRIPTION	DATE
A	PRELIMINARY	12/03/20

SITE NUMBER: CTHA241C  
 SITE NAME: HA241 / EXXON SIGN  
 SITE ADDRESS: 207 WEST STREET  
 CROMWELL, CT 06416

SHEET TITLE:  
 T-1: TITLE SHEET



Copyright © 2020 Foresite LLC all rights reserved. The details, templates, drawing formats or any portion of this document generated by Foresite LLC may not be duplicated, traced or used otherwise for any profit-driven enterprise.

1. THE CONTRACTOR SHALL GIVE ALL NOTICES AND COMPLY WITH ALL LAWS, ORDINANCES, RULES, REGULATIONS AND LAWFUL ORDERS OF ANY PUBLIC AUTHORITY, MUNICIPAL AND UTILITY COMPANY SPECIFICATIONS, AND LOCAL AND STATE JURISDICTIONAL CODES BEARING ON THE PERFORMANCE OF THE WORK. THE WORK PERFORMED ON THE PROJECT AND THE MATERIALS INSTALLED SHALL BE IN STRICT ACCORDANCE WITH ALL APPLICABLE CODES, REGULATIONS, AND ORDINANCES.
2. THE ARCHITECT/ENGINEER HAS MADE EVERY EFFORT TO SET FORTH IN THE CONSTRUCTION AND CONTRACT DOCUMENTS THE COMPLETE SCOPE OF WORK. THE CONTRACTOR BIDDING THE JOB IS NEVERTHELESS CAUTIONED THAT MINOR OMISSIONS OR ERRORS IN THE DRAWINGS AND OR SPECIFICATIONS SHALL NOT EXCUSE SAID CONTRACTOR FROM COMPLETING THE PROJECT AND IMPROVEMENTS IN ACCORDANCE WITH THE INTENT OF THESE DOCUMENTS.
3. THE CONTRACTOR OR BIDDER SHALL BEAR THE RESPONSIBILITY OF NOTIFYING (IN WRITING) THE CLIENT'S REPRESENTATIVE OF ANY CONFLICTS, ERRORS, OR OMISSIONS PRIOR TO THE SUBMISSION OF CONTRACTOR'S PROPOSAL OR PERFORMANCE OF WORK.
5. THE CONTRACTOR SHALL VISIT THE JOB SITE PRIOR TO THE SUBMISSION OF BIDS OR PERFORMING WORK TO FAMILIARIZE HIMSELF WITH THE FIELD CONDITIONS AND TO VERIFY THAT THE PROJECT CAN BE CONSTRUCTED IN ACCORDANCE WITH THE CONSTRUCTION DOCUMENTS.
6. THE CONTRACTOR SHALL INSTALL ALL EQUIPMENT AND MATERIALS ACCORDING TO THE MANUFACTURER'S / VENDOR'S SPECIFICATIONS UNLESS NOTED OTHERWISE OR WHERE LOCAL CODES OR ORDINANCES TAKE PRECEDENCE.
7. THE CONTRACTOR SHALL MAKE NECESSARY PROVISIONS TO PROTECT EXISTING IMPROVEMENTS DURING CONSTRUCTION.
8. THE CONTRACTOR SHALL COMPLY WITH ALL PERTINENT SECTIONS OF THE BASIC STATE BUILDING CODE, LATEST EDITION, AND ALL OSHA REQUIREMENTS AS THEY APPLY TO THIS PROJEC
9. THE CONTRACTOR SHALL NOTIFY THE CLIENT'S REPRESENTATIVE IN WRITING WHERE A CONFLICT OCCURS ON ANY OF THE CONTRACT DOCUMENTS. THE CONTRACTOR IS NOT TO ORDER MATERIAL OR CONSTRUCT ANY PORTION OF THE WORK THAT IS IN CONFLICT UNTIL CONFLICT IS RESOLVED BY THE CLIENT'S REPRESENTATIVE.
10. THE WORK SHALL CONFORM TO THE CODES AND STANDARDS OF THE FOLLOWING AGENCIES AS FURTHER CITED HEREIN:
  - A. ASTM: AMERICAN SOCIETY FOR TESTING AND MATERIALS, AS PUBLISHED IN "COMPILATION OF ASTM STANDARDS BUILDING CODES" OR LATEST EDITION.
  - B. AWS: AMERICAN WELDING SOCIETY INC. AS PUBLISHED IN "STANDARD D1.1-08, STRUCTURAL WELDING CODE" OR LATEST EDITION.
  - C. AISC: AMERICAN INSTITUTE FOR STEEL CONSTRUCTION AS PUBLISHED IN "CODE FOR STANDARD PRACTICE FOR STEEL BUILDINGS AND BRIDGES"; "SPECIFICATIONS FOR THE DESIGN, FABRICATION AND ERECTION OF STRUCTURAL STEEL FOR BUILDINGS" (LATEST EDITION).
11. BOLTING:
  - A. BOLTS SHALL BE CONFORMING TO ASTM A325 HIGH STRENGTH, HOT DIP GALVANIZED WITH ASTM A153 HEAVY HEX TYPE NUTS.
  - B. BOLTS SHALL BE 3/4"Ø MINIMUM (UNLESS OTHERWISE NOTED)
  - C. ALL CONNECTIONS SHALL BE 2 BOLTS MINIMUM.
12. FABRICATION:
  - A. FABRICATION OF STEEL SHALL CONFORM TO THE AISC AND AWS STANDARDS AND CODES (LATEST EDITION).
  - B. ALL STRUCTURAL STEEL SHALL BE HOT-DIP GALVANIZED AFTER FABRICATION IN ACCORDANCE WITH ASTM A123 (LATEST EDITION), UNLESS OTHERWISE NOTED.
13. ERECTION OF STEEL:
  - A. PROVIDE ALL ERECTION EQUIPMENT, BRACING, PLANKING, FIELD BOLTS, NUTS, WASHERS, DRIFT PINS, AND SIMILAR MATERIALS WHICH DO NOT FORM A PART OF THE COMPLETED CONSTRUCTION BUT ARE NECESSARY FOR ITS PROPER ERECTION.
  - B. ERECT AND ANCHOR ALL STRUCTURAL STEEL IN ACCORDANCE WITH AISC REFERENCE STANDARDS. ALL WORK SHALL BE ACCURATELY SET TO ESTABLISHED LINES AND ELEVATIONS AND RIGIDLY FASTENED IN PLACE WITH SUITABLE ATTACHMENTS TO THE CONSTRUCTION OF THE BUILDING.
  - C. TEMPORARY BRACING, GUYING AND SUPPORT SHALL BE PROVIDED TO KEEP THE STRUCTURE SAFE AND ALIGNED AT ALL TIMES DURING CONSTRUCTION, AND TO PREVENT DANGER TO PERSONS AND PROPERTY. CHECK ALL TEMPORARY LOADS AND STAY WITHIN SAFE CAPACITY OF ALL BUILDING COMPONENTS.
14. ANTENNA INSTALLATION:
  - A. INSTALL ANTENNAS AS INDICATED ON DRAWINGS AND CLIENT'S REPRESENTATIVE SPECIFICATIONS.
  - B. INSTALL GALVANIZED STEEL ANTENNA MOUNTS AS INDICATED ON DRAWINGS.

- C. INSTALL COAXIAL / FIBER CABLES AND TERMINATIONS BETWEEN ANTENNAS AND EQUIPMENT PER MANUFACTURER'S RECOMMENDATIONS. WEATHERPROOF ALL CONNECTORS BETWEEN THE ANTENNA AND EQUIPMENT PER MANUFACTURER'S REQUIREMENTS.
15. ANTENNA AND COAXIAL / FIBER CABLE GROUNDING:
  - A. ALL EXTERIOR #6 GREEN GROUND WIRE "DAISY CHAIN" CONNECTIONS ARE TO BE WEATHER SEALED WITH ANDREWS CONNECTOR/SPLICE WEATHERPROOFING KIT TYPE #221213 OR EQUAL.
  - B. ALL COAXIAL / FIBER CABLE GROUNDING KITS ARE TO BE INSTALLED ON STRAIGHT RUNS OF COAXIAL / FIBER CABLE (NOT WITHIN BENDS).
16. RELATED WORK, FURNISH THE FOLLOWING WORK AS SPECIFIED UNDER CONSTRUCTION DOCUMENTS, BUT COORDINATE WITH OTHER TRADES PRIOR TO BID:
  - A. FLASHING OF OPENING INTO OUTSIDE WALLS
  - B. SEALING AND CAULKING ALL OPENINGS
  - C. PAINTING
  - D. CUTTING AND PATCHING
17. REQUIREMENTS OF REGULATORY AGENCIES:
  - A. FURNISH U.L. LISTED EQUIPMENT WHERE SUCH LABEL IS AVAILABLE. INSTALL IN CONFORMANCE WITH U.L. STANDARDS WHERE APPLICABLE.
  - B. INSTALL ANTENNA, ANTENNA CABLES, GROUNDING SYSTEM IN ACCORDANCE WITH DRAWINGS AND SPECIFICATION IN EFFECT AT PROJECT LOCATION AND RECOMMENDATIONS OF STATE AND LOCAL BUILDING CODES, AND SPECIAL CODES HAVING JURISDICTION OVER SPECIFIC PORTIONS OF WORK. THIS WORK INCLUDES BUT IS NOT LIMITED TO THE FOLLOWING:
    - C. TIA-EIA - 222 (LATEST EDITION). STRUCTURAL STANDARDS FOR STEEL ANTENNA TOWERS AND ANTENNA SUPPORTING STRUCTURES.
    - D. FAA - FEDERAL AVIATION ADMINISTRATION ADVISORY CIRCULAR AC 70/7460-IH, OBSTRUCTION MARKING AND LIGHTING.
    - E. FCC - FEDERAL COMMUNICATIONS COMMISSION RULES AND REGULATIONS FORM 715, OBSTRUCTION MARKING AND LIGHTING SPECIFICATION FOR ANTENNA STRUCTURES AND FORM 715A, HIGH INTENSITY OBSTRUCTION LIGHTING SPECIFICATIONS FOR ANTENNA STRUCTURES.
    - F. AISC - AMERICAN INSTITUTE OF STEEL CONSTRUCTION SPECIFICATION FOR STRUCTURAL JOINTS USING ASTM A325 BOLTS (LATEST EDITION).
    - G. NEC - NATIONAL ELECTRICAL CODE - ON TOWER LIGHTING KITS.
    - H. UL - UNDERWRITER'S LABORATORIES APPROVED ELECTRICAL PRODUCTS.
  - I. IN ALL CASES, PART 77 OF THE FAA RULES AND PARTS 17 AND 22 OF THE FCC RULES ARE APPLICABLE AND IN THE EVENT OF CONFLICT, SUPERSEDE ANY OTHER STANDARDS OR SPECIFICATIONS.
  - J. 2018 LIFE SAFETY CODE NFPA - 101.

**APPLICANT:**  
  
**T-MOBILE NORTHEAST LLC**  
 35 GRIFFIN ROAD SOUTH  
 BLOOMFIELD, CT 06002  
 860-692-7100

**PROJECT MANAGER**  
  
 420 MAIN STREET, BLDG 4  
 STURBRIDGE, MA 01566  
 203-275-6669

**CONSULTANT:**  
  
 Architects . Engineers . Surveyors  
 462 WALNUT STREET  
 NEWTON, MA 02460  
 617-212-3123

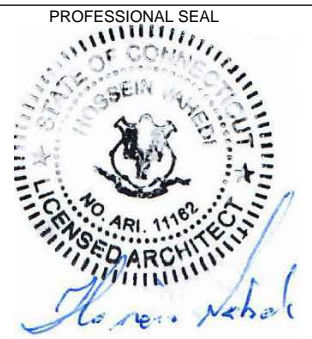
PROFESSIONAL SEAL  

THIS DOCUMENT IS THE DESIGN PROPERTY AND COPYRIGHT OF FORESITE, LLC. AND FOR THE EXCLUSIVE USE BY THE TITLE CLIENT. DUPLICATION OR USE WITHOUT THE EXPRESS WRITTEN CONSENT OF THE CREATOR IS STRICTLY PROHIBITED. DRAWING SCALES ARE INTENDED FOR 11"x17" SIZE PRINTED MEDIA ONLY. ALL OTHER PRINTED SIZES ARE DEEMED "NOT TO SCALE".

REV	DESCRIPTION	DATE
A	PRELIMINARY	12/03/20

SITE NUMBER: CTHA241C  
 SITE NAME: HA241 / EXXON SIGN  
 SITE ADDRESS: 207 WEST STREET  
 CROMWELL, CT 06416

SHEET TITLE:  
 N-1: GENERAL NOTES

Copyright © 2020 Foresite LLC all rights reserved. The details, templates, drawing formats or any portion of this document generated by Foresite LLC may not be duplicated, traced or used otherwise for any profit-driven enterprise.

**KEY PLAN**  
N.T.S. 1  
A-1

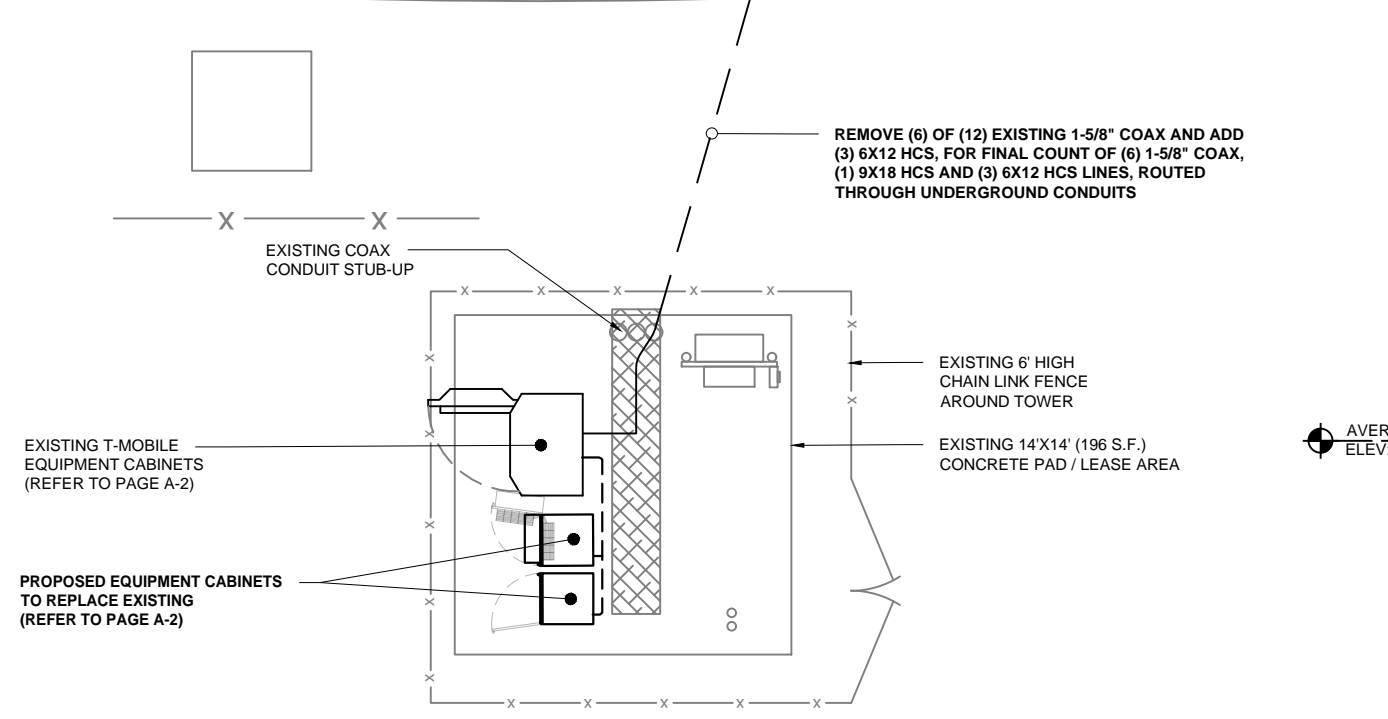
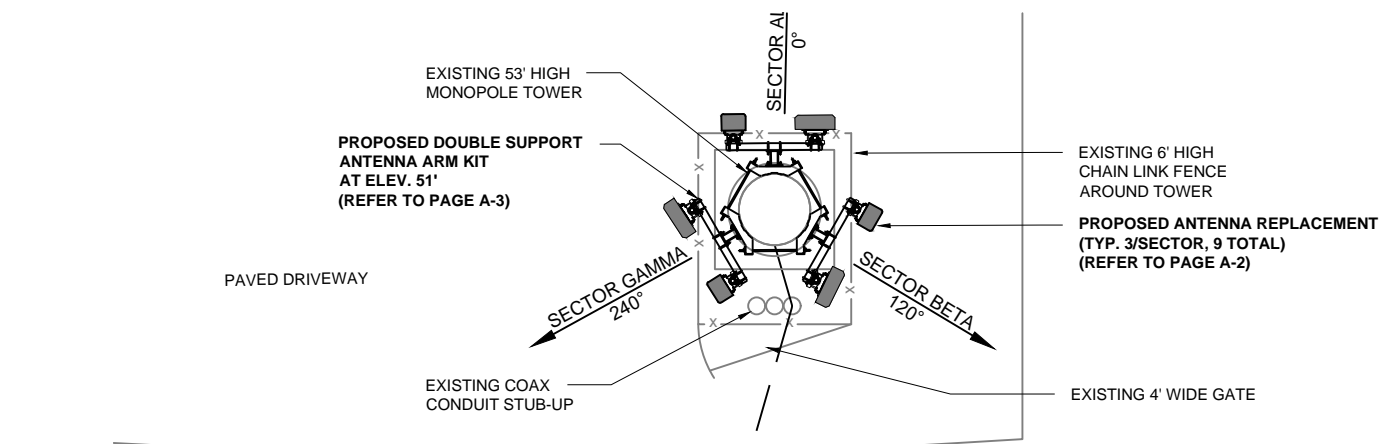
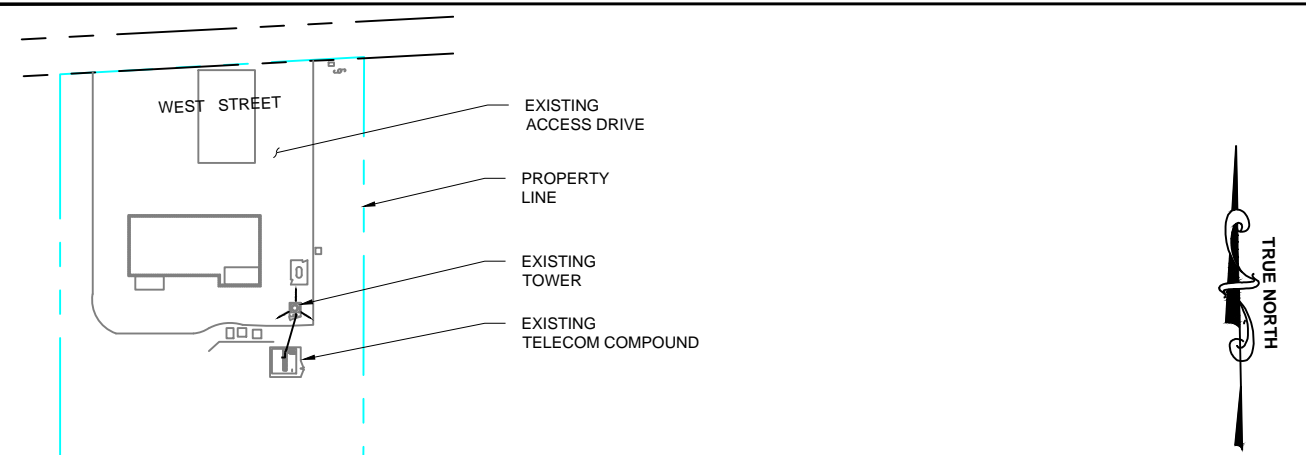

**PARTIAL SITE PLAN**  
SCALE: 1/8" = 1'-0" 2  
A-1

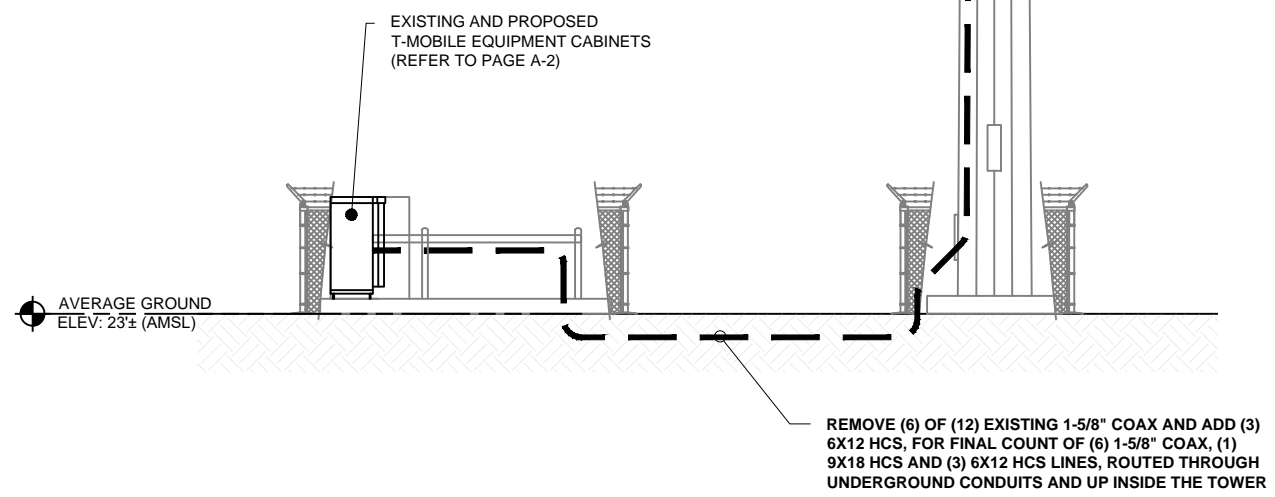
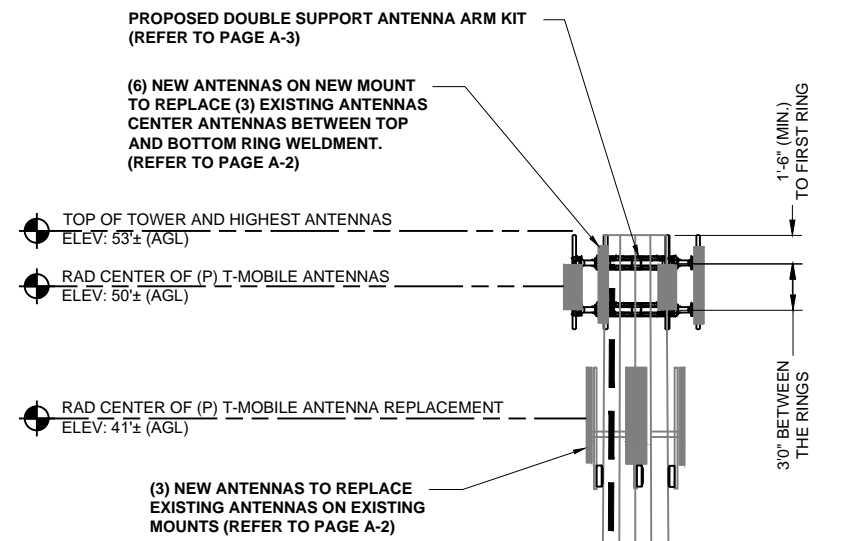

**ELEVATION**  
SCALE: 3/32" = 1'-0" 3  
A-1

**APPLICANT:**  
**T-Mobile**  
**T-MOBILE NORTHEAST LLC**  
35 GRIFFIN ROAD SOUTH  
BLOOMFIELD, CT 06002  
860-692-7100

**PROJECT MANAGER**  
**NORTHEAST SITE SOLUTIONS**  
Turning Vision Development  
420 MAIN STREET, BLDG 4  
STURBRIDGE, MA 01566  
203-275-6669

**CONSULTANT:**  
**FORESITE** LLC  
Architects . Engineers . Surveyors  
462 WALNUT STREET  
NEWTON, MA 02460  
617-212-3123

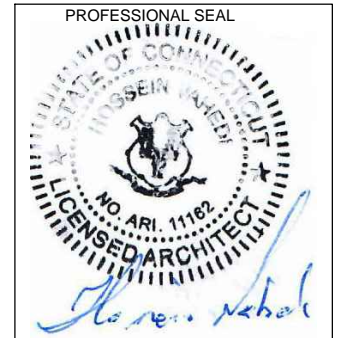

THIS DOCUMENT IS THE DESIGN PROPERTY AND COPYRIGHT OF FORESITE, LLC. AND FOR THE EXCLUSIVE USE BY THE TITLE CLIENT. DUPLICATION OR USE WITHOUT THE EXPRESS WRITTEN CONSENT OF THE CREATOR IS STRICTLY PROHIBITED. DRAWING SCALES ARE INTENDED FOR 11"x17" SIZE PRINTED MEDIA ONLY. ALL OTHER PRINTED SIZES ARE DEEMED "NOT TO SCALE".

REV	DESCRIPTION	DATE
A	PRELIMINARY	12/03/20

SITE NUMBER: CTHA241C  
SITE NAME: HA241 / EXXON SIGN  
SITE ADDRESS: 207 WEST STREET  
CROMWELL, CT 06416

SHEET TITLE:  
A-1: SITE PLAN AND ELEVATION

Copyright © 2020 Foresite LLC all rights reserved. The details, templates, drawing formats or any portion of this document generated by Foresite LLC may not be duplicated, traced or used otherwise for any profit-driven enterprise.

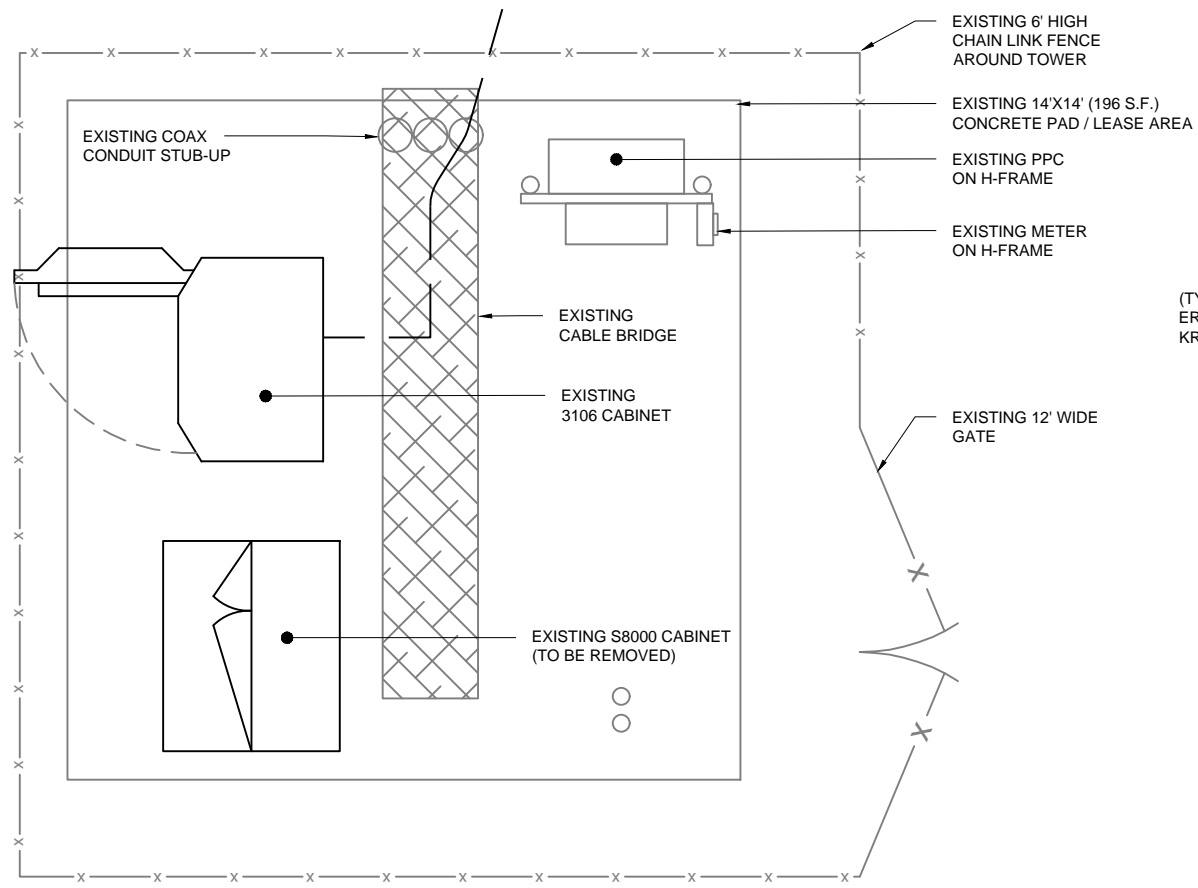

**EXISTING CABINET LAYOUT** 1  
SCALE: 1/4"=1'-0" A-2

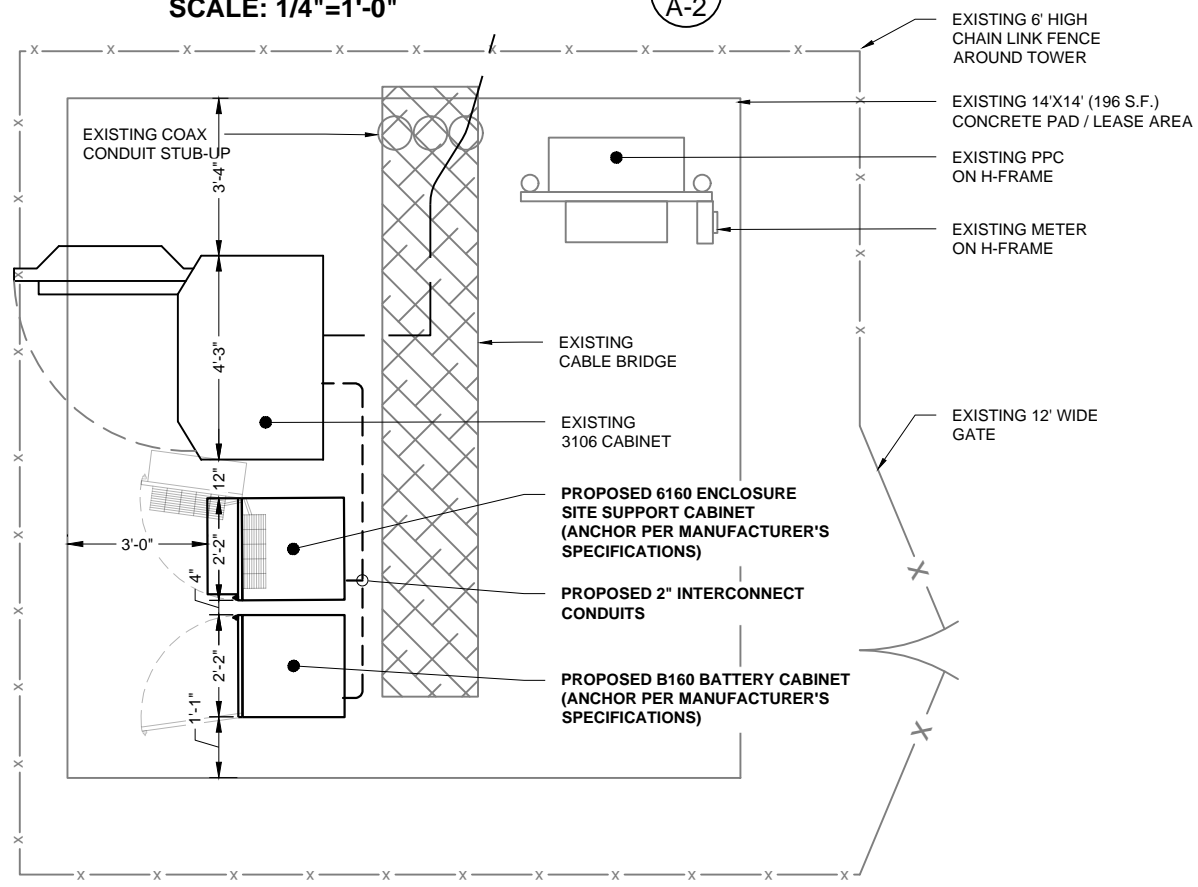

**FINAL CABINET LAYOUT** 2  
SCALE: 1/4"=1'-0" A-2

**EXISTING ANTENNA PLAN**

**RAD CENTER 50'**

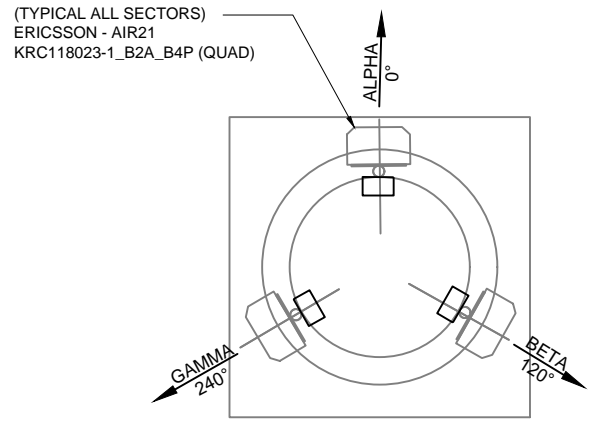

**EXISTING ANTENNA LAYOUT** 3  
N.T.S. A-2

**FINAL ANTENNA PLAN**

**RAD CENTER 50'**

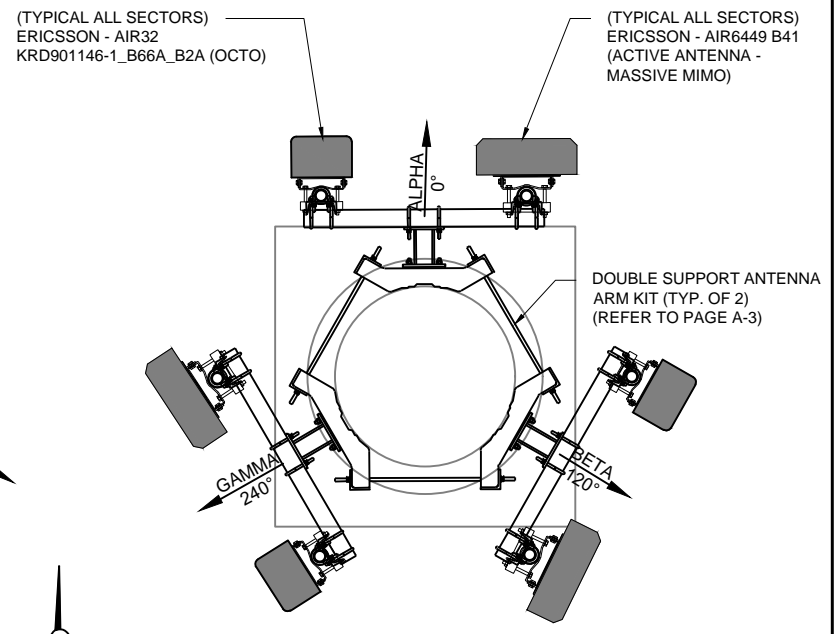

**FINAL ANTENNA LAYOUT** 4  
N.T.S. A-2

**RAD CENTER 41'**

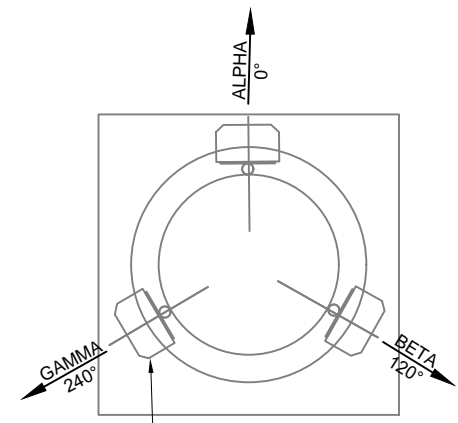

**RAD CENTER 41'**

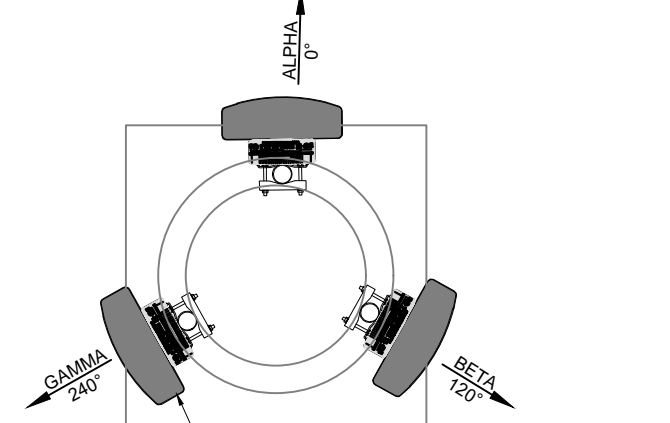

**APPLICANT:**  
**T-Mobile**  
**T-MOBILE NORTHEAST LLC**  
 35 GRIFFIN ROAD SOUTH  
 BLOOMFIELD, CT 06002  
 860-692-7100

**PROJECT MANAGER**  
**NORtheast SITE SOLUTIONS**  
*Turning Vision Development*  
 420 MAIN STREET, BLDG 4  
 STURBRIDGE, MA 01566  
 203-275-6669

**CONSULTANT:**  
**FORESITE** LLC  
 Architects . Engineers . Surveyors  
 462 WALNUT STREET  
 NEWTON, MA 02460  
 617-212-3123

PROFESSIONAL SEAL  

 FORESITE LLC  
 NO. ARI. 11162  
 LICENSED ARCHITECT  
*Foresite LLC*

THIS DOCUMENT IS THE DESIGN PROPERTY AND COPYRIGHT OF FORESITE, LLC. AND FOR THE EXCLUSIVE USE BY THE TITLE CLIENT. DUPLICATION OR USE WITHOUT THE EXPRESS WRITTEN CONSENT OF THE CREATOR IS STRICTLY PROHIBITED. DRAWING SCALES ARE INTENDED FOR 11"x17" SIZE PRINTED MEDIA ONLY. ALL OTHER PRINTED SIZES ARE DEEMED "NOT TO SCALE".

REV	DESCRIPTION	DATE
A	PRELIMINARY	12/03/20

SITE NUMBER: CTHA241C  
 SITE NAME: HA241 / EXXON SIGN  
 SITE ADDRESS: 207 WEST STREET  
 CROMWELL, CT 06416

SHEET TITLE:  
 A-2: EQUIPMENT AND ANTENNA PLANS



Copyright © 2020 Foresite LLC all rights reserved. The details, templates, drawing formats or any portion of this document generated by Foresite LLC may not be duplicated, traced or used otherwise for any profit-driven enterprise.

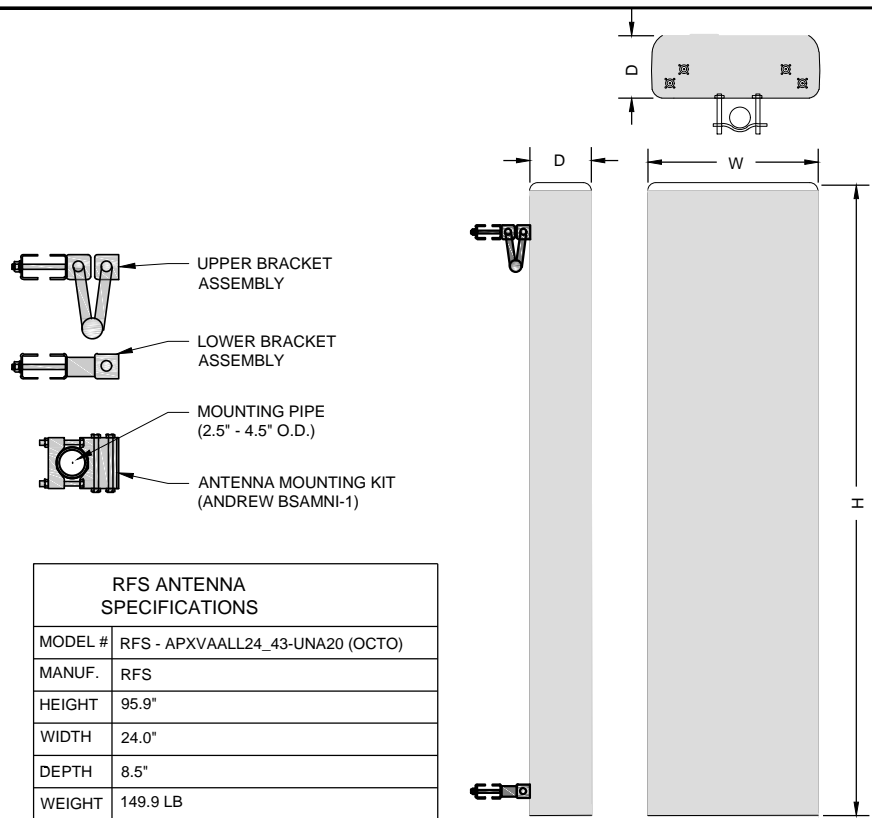

RFS ANTENNA SPECIFICATIONS	
MODEL #	RFS - APXVAALL24_43-UNA20 (OCTO)
MANUF.	RFS
HEIGHT	95.9"
WIDTH	24.0"
DEPTH	8.5"
WEIGHT	149.9 LB

RFS ANTENNA  
N.T.S. 1  
A-3

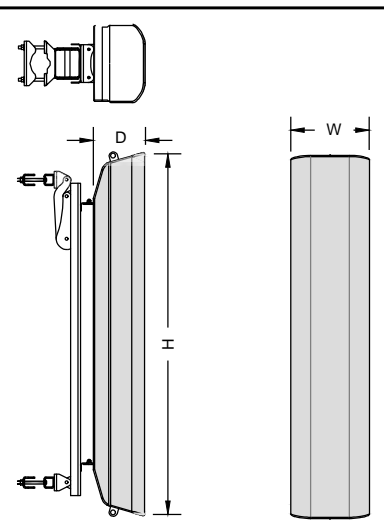

ERICSSON ANTENNA SPECIFICATIONS	
MODEL #	AIR32 KRD901146-1 B66A_B2A
MANUF.	ERICSSON
HEIGHT	56.6"
WIDTH	12.9"
DEPTH	8.7"
WEIGHT	132.2 LB

ERICSSON ANTENNA  
N.T.S. 2  
A-3

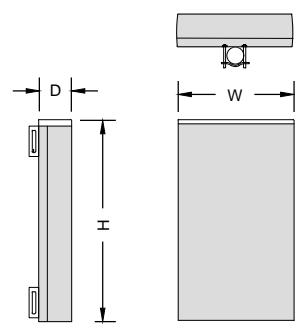

ERICSSON ANTENNA SPECIFICATIONS	
MODEL #	AIR6449 B41
MANUF.	ERICSSON
HEIGHT	33.1"
WIDTH	20.5"
DEPTH	8.3"
WEIGHT	103 LB

ERICSSON ANTENNA  
N.T.S. 3  
A-3

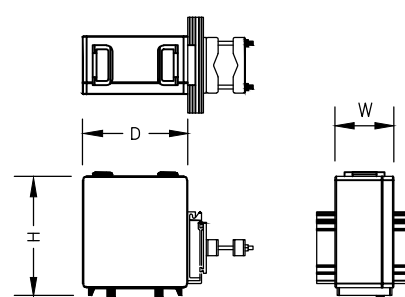

REMOTE RADIO UNIT SPECIFICATIONS	
MODEL #	RADIO 4415 B25
MANUF.	ERICSSON
HEIGHT	14.9"
WIDTH	13.2"
DEPTH	5.4"
WEIGHT	46.3 LB

REMOTE RADIO UNIT  
N.T.S. 4  
A-3

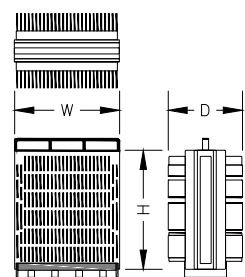

REMOTE RADIO UNIT SPECIFICATIONS	
MODEL #	RADIO 4449 B71+B85
MANUF.	ERICSSON
HEIGHT	14.9"
WIDTH	13.2"
DEPTH	10.4"
WEIGHT	74 LB

REMOTE RADIO UNIT  
N.T.S. 5  
A-3

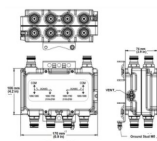

DIPLEXER	
MODEL #	SDX1926Q-43
MANUF.	COMMSCOPE
HEIGHT	4.173"
WIDTH	6.929"
DEPTH	2.913"
WEIGHT	0.441 LB

DIPLEXER  
N.T.S. 6  
A-3

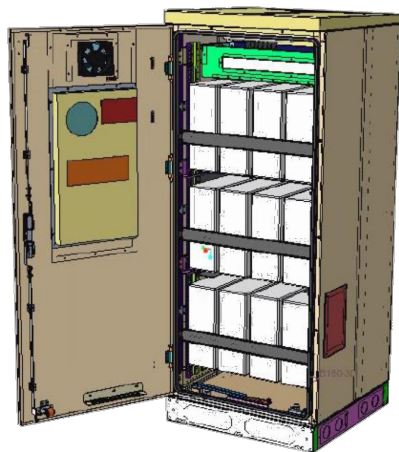

BATTERY CABINET SPECIFICATIONS	
MODEL #	B160
MANUF.	ERICSSON
HEIGHT	63"
WIDTH	26"
DEPTH	26"
WEIGHT	1883 lbs

BATTERY CABINET  
N.T.S. 7  
A-3

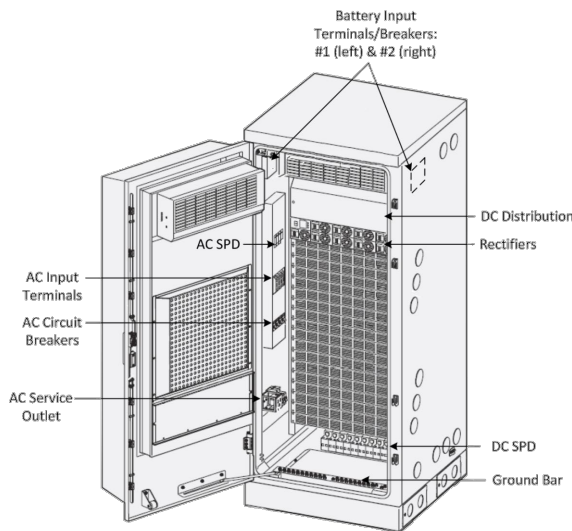

SITE SUPPORT CABINET SPECIFICATIONS	
MODEL #	6160
MANUF.	ERICSSON
HEIGHT	63"
WIDTH	25.6"
DEPTH	33.5"
WEIGHT	605 lbs

SITE SUPPORT CABINET  
N.T.S. 8  
A-3

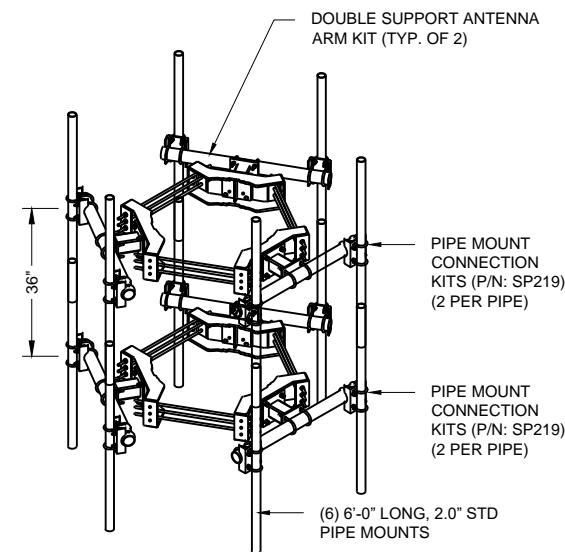

SITE SUPPORT CABINET SPECIFICATIONS	
MODEL #	RDS-NP
MANUF.	SITEPRO 1
HEIGHT	72"
WIDTH	48"

ANTENNA SUPPORT ARM KIT (TYP. OF 2)  
N.T.S. 9  
A-3

APPLICANT:  
**T-Mobile**  
**T-MOBILE NORTHEAST LLC**  
35 GRIFFIN ROAD SOUTH  
BLOOMFIELD, CT 06002  
860-692-7100

PROJECT MANAGER  
**NORTHEAST SITE SOLUTIONS**  
Turning Vision Development  
420 MAIN STREET, BLDG 4  
STURBRIDGE, MA 01566  
203-275-6669

CONSULTANT:  
**FORESITE** LLC  
Architects . Engineers . Surveyors  
462 WALNUT STREET  
NEWTON, MA 02460  
617-212-3123

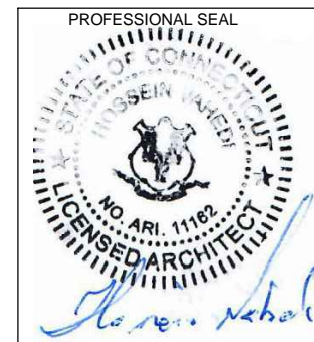

THIS DOCUMENT IS THE DESIGN PROPERTY AND COPYRIGHT OF FORESITE, LLC. AND FOR THE EXCLUSIVE USE BY THE TITLE CLIENT. DUPLICATION OR USE WITHOUT THE EXPRESS WRITTEN CONSENT OF THE CREATOR IS STRICTLY PROHIBITED. DRAWING SCALES ARE INTENDED FOR 11"x17" SIZE PRINTED MEDIA ONLY. ALL OTHER PRINTED SIZES ARE DEEMED "NOT TO SCALE".

REV	DESCRIPTION	DATE
A	PRELIMINARY	12/03/20

SITE NUMBER: CTHA241C  
SITE NAME: HA241 / EXXON SIGN  
SITE ADDRESS: 207 WEST STREET  
CROMWELL, CT 06416

SHEET TITLE:  
A-3: ANTENNA AND EQUIPMENT SPECS

Copyright © 2020 Foresite LLC all rights reserved. The details, templates, drawing formats or any portion of this document generated by Foresite LLC may not be duplicated, traced or used otherwise for any profit-driven enterprise.

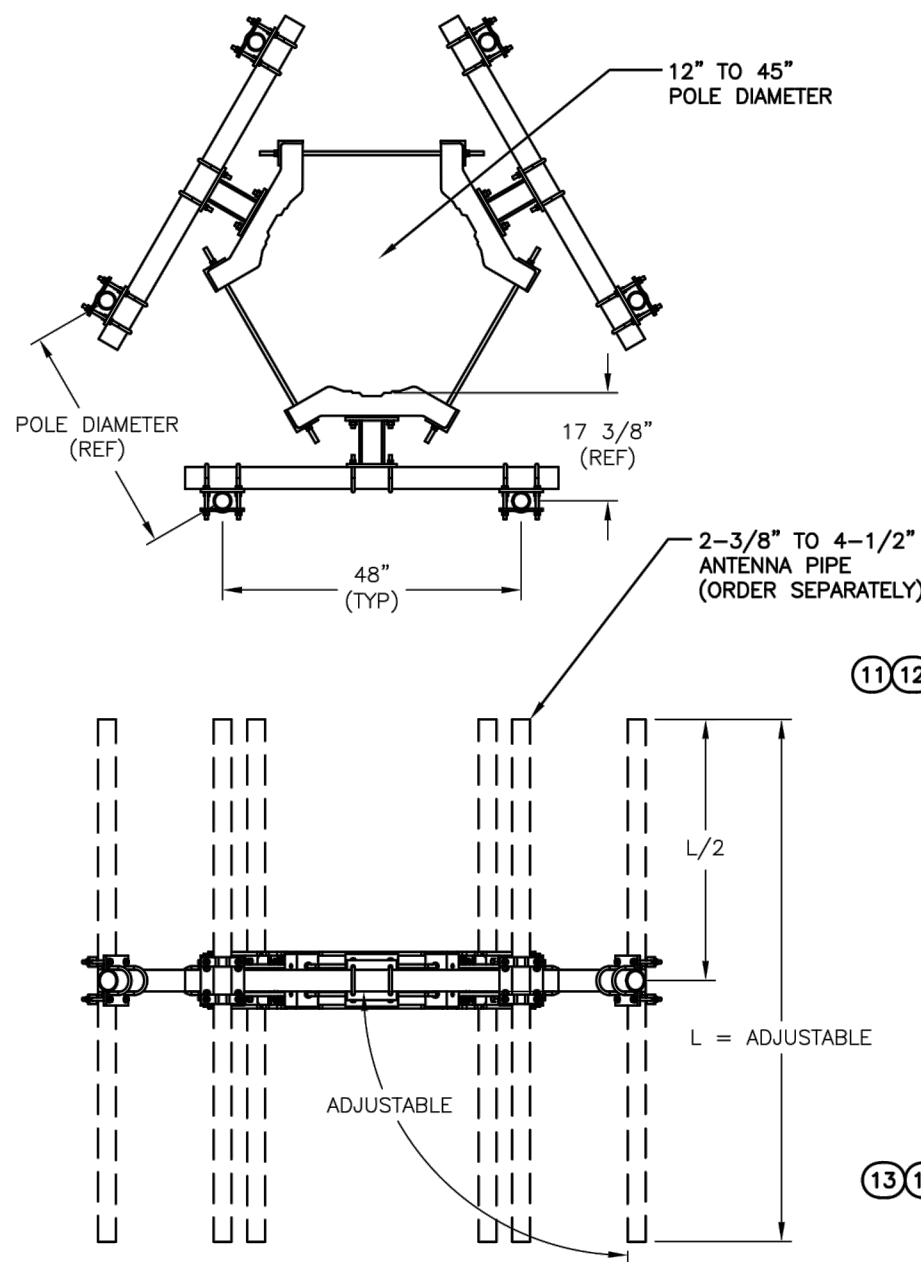

ITEM	QTY	PART NO.	PART DESCRIPTION	LENGTH	UNIT WT.	NET WT.
1	3	X-LWRM	RING MOUNT WELDMENT		65.47#	196.41#
2	3	X-WWM01	8" STANDOFF ARM		20.43#	61.29#
3	3	P360	3" SCH. 40 PIPE (3 1/2" O.D.)	60"	37.97#	113.91#
4	6	SCX7	CROSSOVER PLATE		7.55#	45.30#
5	12	X-115765	5" V-CLAMP		1.02#	12.24#
6	9	G58R-24	5/8" THREADED ROD	24"	1.69#	15.21#
6	9	G58R-48	5/8" THREADED ROD	48"	3.38#	30.42#
7	12	A582112	5/8" (A325) HEX BOLT (HDG)	2 1/2"	0.22#	2.64#
8	30	G58LW	5/8" LOCK WASHER		0.02#	0.60#
9	30	A58NUT	5/8" HEX NUT (HDG)		0.12#	3.60#
10	18	X-UB1358	1/2" X 3-5/8" U-BOLT	5 1/2"	0.77#	13.86#
11	84	G12FW	1/2" FLAT WASHER		0.01#	0.84#
12	60	G12LW	1/2" LOCK WASHER		0.01#	0.60#
13	60	G12NUT	1/2" HEX NUT (HDG)		0.05#	3.00#
14	24	G12045	1/2" (GRADE 5) HEX BOLT (HDG)	4 1/2"	0.37#	8.88#
14	24	G12065	1/2" (GRADE 5) HEX BOLT (HDG)	6 1/2"	0.53#	12.72#
					TOTAL WT.	548#

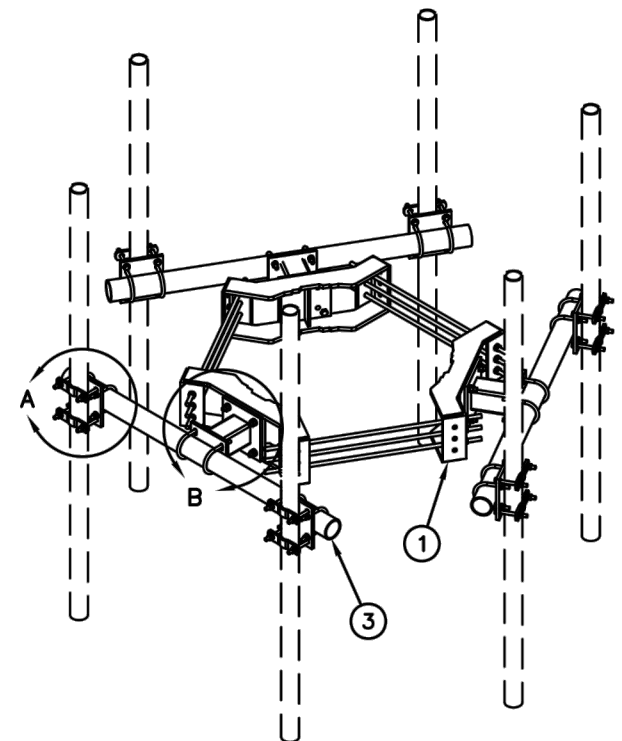
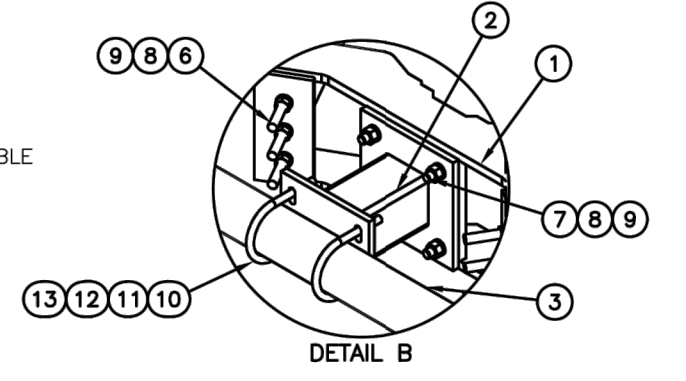
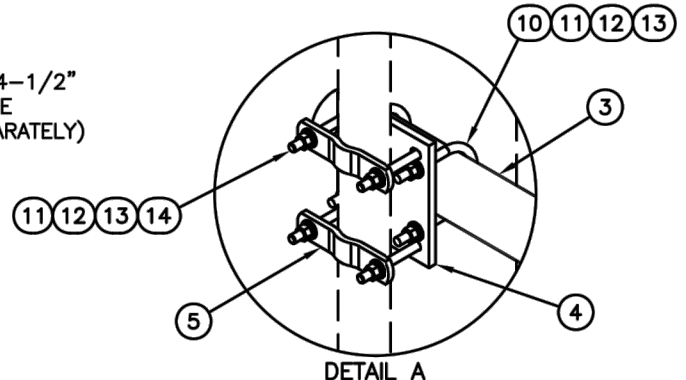

**PROPRIETARY NOTE:**  
THE DATA AND TECHNIQUES CONTAINED IN THIS DRAWING ARE PROPRIETARY INFORMATION OF VALMONT INDUSTRIES AND CONSIDERED A TRADE SECRET. ANY USE OR DISCLOSURE WITHOUT THE CONSENT OF VALMONT INDUSTRIES IS STRICTLY PROHIBITED.

**TOLERANCE NOTE:**  
TOLERANCES ON DIMENSIONS UNLESS OTHERWISE NOTED ARE (PLUS OR MINUS) MACHINING 0.030" AND STRUCTURAL 0.060". BENDS ARE (+ OR -) 1/2 DEGREE.

**DESCRIPTION**  
DUAL ANTENNA POLE MOUNT ASSEMBLY  
17 3/8" STANDOFF  
12" TO 45" MONOPOLE DIAMETER

**valmont** STRUCTURES  
1-877-467-4763 Plymouth, IN  
1-888-880-9191 Salem, OR

REV.	DESCRIPTION OF REVISIONS	CPD	BY	DATE

DR BY BMC 1/25/2010	CPD NO.	DRAWING USAGE CUSTOMER	PART NO. RDS-NP
ENG. APPROVAL	CHECKED BY MVC 01/25/2010	DWG. NO. RDS-NP	

1 OF 1  
PAGE

**APPLICANT:**  
**T-Mobile**  
**T-MOBILE NORTHEAST LLC**  
35 GRIFFIN ROAD SOUTH  
BLOOMFIELD, CT 06002  
860-692-7100

**PROJECT MANAGER**  
**NORTHEAST SITE SOLUTIONS**  
Turning Vision Development  
420 MAIN STREET, BLDG 4  
STURBRIDGE, MA 01566  
203-275-6669

**CONSULTANT:**  
**FORESITE** LLC  
Architects . Engineers . Surveyors  
462 WALNUT STREET  
NEWTON, MA 02460  
617-212-3123

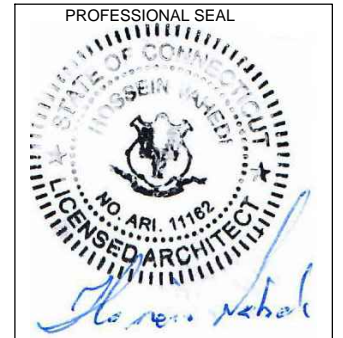

THIS DOCUMENT IS THE DESIGN PROPERTY AND COPYRIGHT OF FORESITE, LLC. AND FOR THE EXCLUSIVE USE BY THE TITLE CLIENT. DUPLICATION OR USE WITHOUT THE EXPRESS WRITTEN CONSENT OF THE CREATOR IS STRICTLY PROHIBITED. DRAWING SCALES ARE INTENDED FOR 11"x17" SIZE PRINTED MEDIA ONLY. ALL OTHER PRINTED SIZES ARE DEEMED "NOT TO SCALE".

REV	DESCRIPTION	DATE
A	PRELIMINARY	12/03/20

SITE NUMBER: CTHA241C  
SITE NAME: HA241 / EXXON SIGN  
SITE ADDRESS: 207 WEST STREET  
CROMWELL, CT 06416

SHEET TITLE:  
A-4: ANTENNA MOUNT SPECS



Copyright © 2020 Foresite LLC all rights reserved. The details, templates, drawing formats or any portion of this document generated by Foresite LLC may not be duplicated, traced or used otherwise for any profit-driven enterprise.

**ELECTRICAL & GROUNDING NOTES**

1. ALL ELECTRICAL WORK SHALL CONFORM TO THE REQUIREMENTS OF THE NATIONAL ELECTRICAL CODE (NEC) AS WELL AS APPLICABLE STATE AND LOCAL CODES.
2. ALL ELECTRICAL ITEMS SHALL BE U.L. APPROVED OR LISTED AND PRODUCED PER SPECIFICATION REQUIREMENTS.
3. THE ELECTRICAL WORK INCLUDES ALL LABOR AND MATERIAL DESCRIBED BY DRAWINGS AND SPECIFICATION INCLUDING INCIDENTAL WORK TO PROVIDE COMPLETE OPERATING AND APPROVED ELECTRICAL SYSTEM.
4. GENERAL CONTRACTOR SHALL PAY FEES FOR PERMITS, AND RESPONSIBLE FOR OBTAINING SAID PERMITS AND COORDINATION OF INSPECTIONS.
5. ELECTRICAL AND TELCO WIRING OUTSIDE A BUILDING AND EXPOSED TO WEATHER SHALL BE IN WATER TIGHT GALVANIZED RIGID STEEL CONDUITS OR SCHEDULE 80 PVC (AS PERMITTED BY CODE) AND WHERE REQUIRED IN LIQUID TIGHT FLEXIBLE METAL OR NONMETALLIC CONDUITS.
6. RIGID STEEL CONDUITS SHALL BE GROUNDED AT BOTH ENDS.
7. ELECTRICAL WIRING SHALL BE COPPER WITH TYPE XHHW, THWN, OR THIN INSULATION.
8. RUN ELECTRICAL CONDUIT OR CABLING BETWEEN ELECTRICAL ROOM AND PROPOSED CELL SITE ARE PEDESTAL AS INDICATED ON THIS DRAWING. PROVIDE FULL LENGTH PULL ROPE. COORDINATE INSTALLATION WITH UTILITY COMPANY.
9. RUN TELCO CONDUIT OR CABLE BETWEEN TELEPHONE UTILITY DEMARCATION POINT AND PROPOSED CELL SITE TELECOM CABINET AND RBS CABINET AS INDICATED ON DRAWING A-1. PROVIDE FULL LENGTH PULL ROPE INSTALLED TELCO CONDUIT. PROVIDE GREENLEE CONDUIT MEASURING TAPE AT EACH END.
10. ALL EQUIPMENT LOCATED OUTSIDE SHALL HAVE NAME 3R ENCLOSURE.
11. GROUNDING SHALL COMPLY WITH NEC ART. 250.
12. GROUNDING COAX CABLE SHIELDS MINIMUM AT BOTH ENDS USING MANUFACTURERS COAX CABLE GROUNDING KITS SUPPLIED BY PROJECT OWNER.
13. USE #6 COPPER STRANDED WIRE WITH GREEN COLOR INSTALLATION FOR ABOVE GRADE GROUNDING (UNLESS OTHERWISE SPECIFIED) AND #2 SOLID TINNED BARE COPPER WIRE FOR BELOW GRADE GROUNDING AS INDICATED ON THE GROUND.
14. ALL GROUND CONNECTION TO BE BURNDY HYGROUND COMPRESSION TYPE CONNECTORS OR CADWELD EXOTHERMIC WELD. DO NOT ALLOW BARE COPPER WIRE TO BE IN CONTACT WITH GALVANIZED STEEL.
15. ROUTE GROUNDING CONDUCTORS ALONG THE SHORTEST AND STRAIGHTEST PATH POSSIBLE, EXCEPT AS OTHERWISE INDICATED. GROUNDING LEADS SHOULD NEVER BE BENT AS RIGHT ANGLE. ALWAYS MAKE AT LEAST 12" RADIUS BENDS. #6 WIRE CAN BE BENT AT 6" RADIUS WHEN NECESSARY BOND ANY METER OBJECTS WITHIN 7 FEET OF PROPOSED EQUIPMENT OR CABINET TO MASTER GROUND BAR.
16. CONNECTIONS TO MGB SHALL BE ARRANGED IN THREE MAIN GROUPS: SURGE PROCEDURES (COAXIAL CABLE GROUND KITS, TELCO AND POWER PANEL GROUND); (GROUNDING ELECTRODE RING OR BUILDING STEEL); NON-SURGING OBJECTS (EGB GROUND IN RBS UNIT).
17. CONNECTIONS TO GROUND BARS SHALL BE MADE WITH TWO HOLE COMPRESSION TYPE COPPER LUGS. APPLY OXIDE INHIBITING COMPOUND TO ALL LOCATIONS.
18. APPLY OXIDE INHIBITING COMPOUND TO ALL COMPRESSION TYPE GROUND CONNECTION.
19. BOND ANTENNA MOUNTING BRACKETS, COAXIAL CABLE GROUND KITS, AND ALNA TO EGB PLACED NEAR THE ANTENNA LOCATION.
20. BOND ANTENNA EGB'S AND MGB TO WATER MAIN.
21. TEST COMPLETED GROUND SYSTEM AND RECORD RESULTS FOR PROJECT CLOSE-OUT DOCUMENTATION.
22. BOND ANY METAL OBJECTS WITHIN 7 FEET OF PROPOSED EQUIPMENT OR CABINET TO MASTER GROUND BAR.
23. VERIFY PROPOSED SERVICE UPGRADE WITH LOCAL UTILITY COMPANY PRIOR TO CONSTRUCTION.

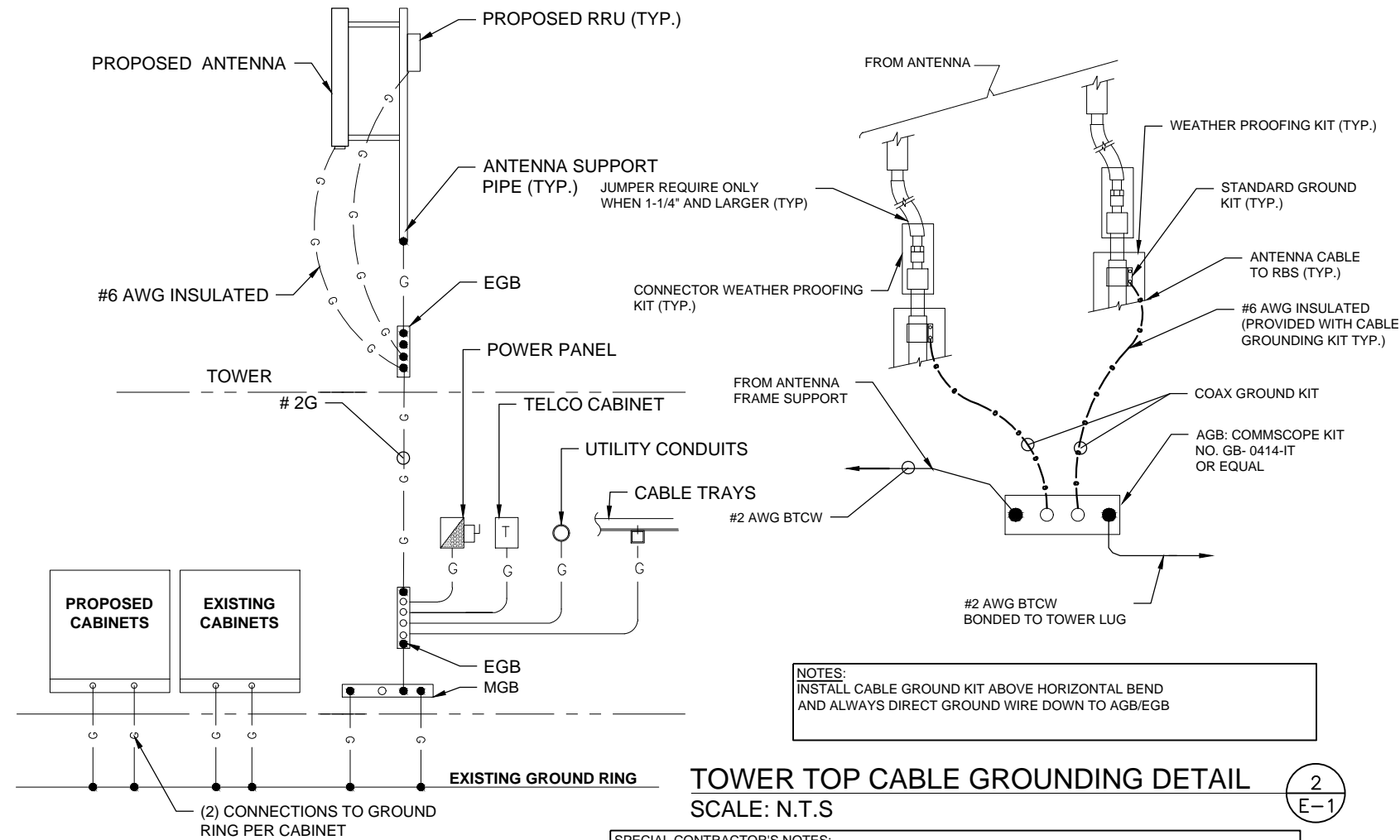

**GROUNDING RISER DIAGRAM**  
SCALE: N.T.S

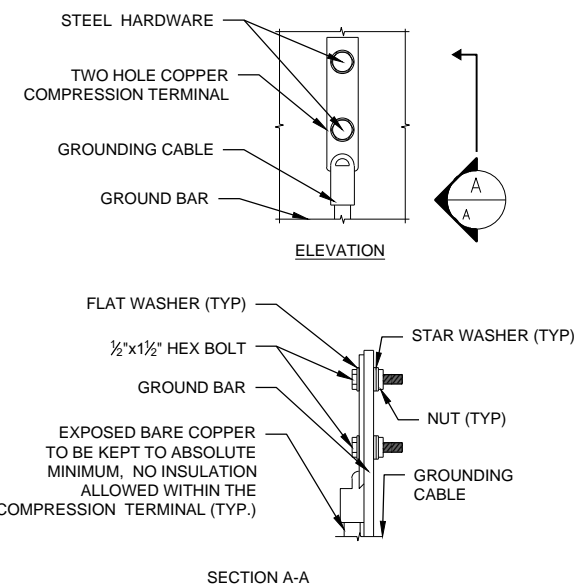

- NOTES:  
1. "DOUBLING UP" OR "STACKING" OF CONNECTION IS NOT PERMITTED.  
2. OXIDE INHIBITING COMPOUND TO BE USED AT ALL LOCATIONS.

**TYPICAL GROUND BAR CONNECTIONS DETAIL**  
SCALE: N.T.S

- SPECIAL CONTRACTOR'S NOTES:**  
CONTRACTOR TO VERIFY THE POWER FEED & PHASE OF METER BANK AND THAT THE EXISTING AND PROPOSED CONDUITS AND WIRE SIZES ARE ADEQUATE FOR THE PROPOSED LOADING IN ACCORDANCE WITH NEC AND INCLUDE ELECTRICAL UPGRADES IN THE SCOPE OF WORK AS REQUIRED.

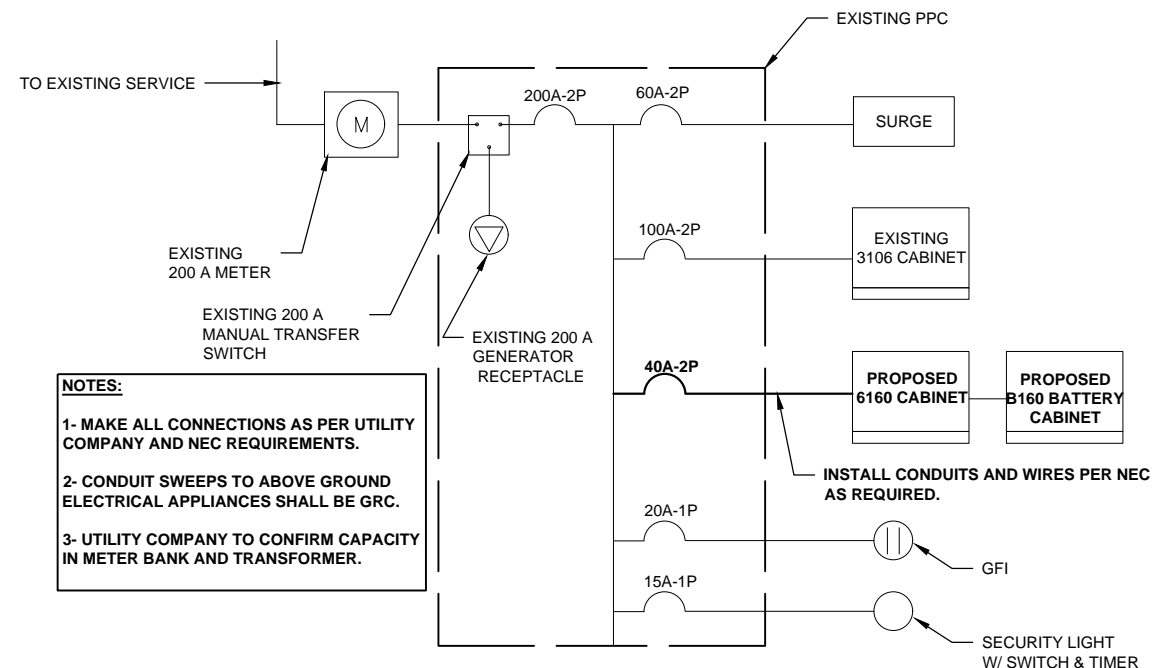

**TYPICAL ONE LINE DIAGRAM**  
SCALE: N.T.S

**APPLICANT:**  
**T-Mobile**  
**T-MOBILE NORTHEAST LLC**  
35 GRIFFIN ROAD SOUTH  
BLOOMFIELD, CT 06002  
860-692-7100

**PROJECT MANAGER**  
**NORTHEAST SITE SOLUTIONS**  
Turning Vision Development  
420 MAIN STREET, BLDG 4  
STURBRIDGE, MA 01566  
203-275-6669

**CONSULTANT:**  
**FORESITE** LLC  
Architects . Engineers . Surveyors  
462 WALNUT STREET  
NEWTON, MA 02460  
617-212-3123

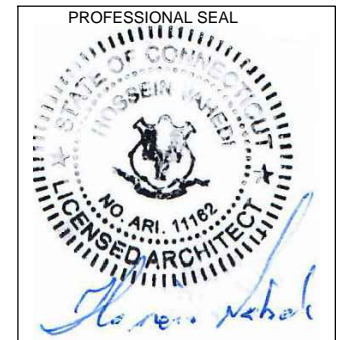

THIS DOCUMENT IS THE DESIGN PROPERTY AND COPYRIGHT OF FORESITE, LLC. AND FOR THE EXCLUSIVE USE BY THE TITLE CLIENT. DUPLICATION OR USE WITHOUT THE EXPRESS WRITTEN CONSENT OF THE CREATOR IS STRICTLY PROHIBITED. DRAWING SCALES ARE INTENDED FOR 11"x17" SIZE PRINTED MEDIA ONLY. ALL OTHER PRINTED SIZES ARE DEEMED "NOT TO SCALE".

REV	DESCRIPTION	DATE
A	PRELIMINARY	12/03/20

SITE NUMBER: CTHA241C  
SITE NAME: HA241 / EXXON SIGN  
SITE ADDRESS: 207 WEST STREET  
CROMWELL, CT 06416

SHEET TITLE:  
E-1: ELECTRICAL & GROUNDING DETAIL

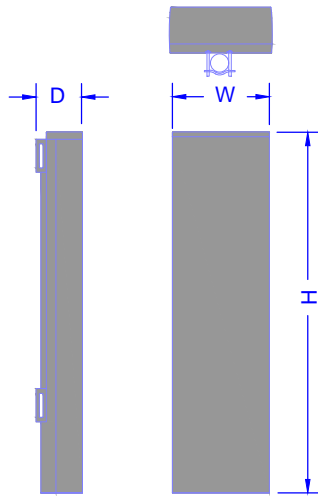

ERICSSON ANTENNA SPECIFICATIONS	
MODEL #	AIR3246 B66
MANUF.	ERICSSON
HEIGHT	58.1"
WIDTH	15.7"
DEPTH	9.4"
WEIGHT	180 LB

MANUFACTURER: ERICSSON  
 MODEL: AIR-21 KRC118023-1\_B4A\_B2P  
 FOOTPRINT: 55"HX12"WX7.9"D  
 WEIGHT: 83 LBS  
 FREQUENCY BAND: 1700-2100 MHZ

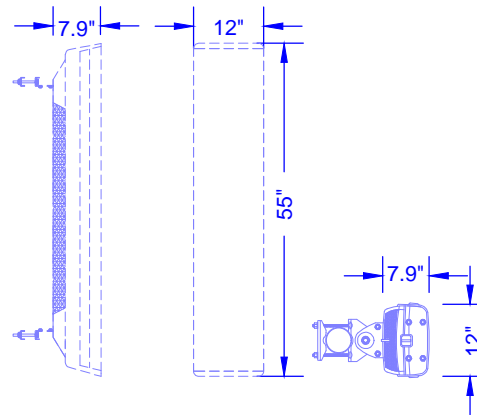

MANUFACTURER: ERICSSON  
 MODEL: AIR32 KRD901146-1\_  
 FOOTPRINT: 56.6"HX12.9"WX8.7"D  
 WEIGHT: 132.2 LBS  
 FREQUENCY BAND: 1710-1755  
 ANTENNA TYPE: SINGLE BAND  
 WIND LOADING LATERAL: 300N  
 WIND LOADING REAR: 660N  
 WIND LOADING MAXIMUM: 640N

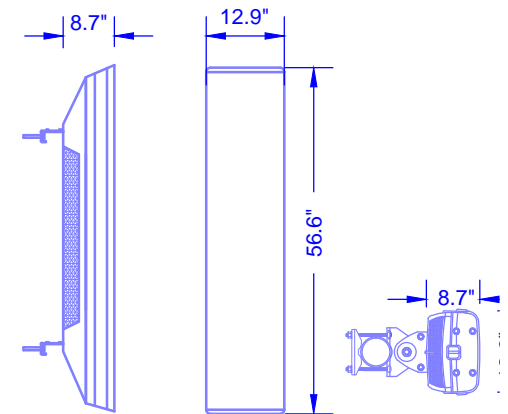



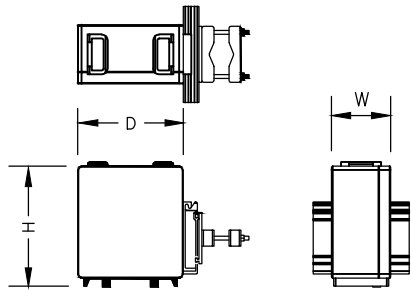

REMOTE RADIO UNIT SPECIFICATIONS	
MODEL #	RADIO 4415 B25
MANUF.	ERICSSON
HEIGHT	14.9"
WIDTH	13.2"
DEPTH	5.4"
WEIGHT	46.3 LB

REMOTE RADIO UNIT  
N.T.S.

3  
A-3

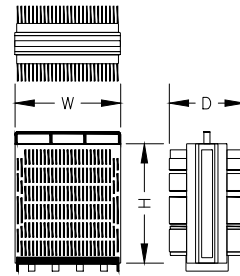

REMOTE RADIO UNIT SPECIFICATIONS	
MODEL #	RADIO 4449 B71+B85
MANUF.	ERICSSON
HEIGHT	14.9"
WIDTH	13.2"
DEPTH	9.3"
WEIGHT	74 LB

REMOTE RADIO UNIT  
N.T.S.

3  
A-3

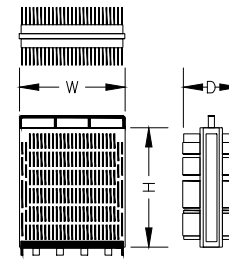

REMOTE RADIO UNIT SPECIFICATIONS	
MODEL #	RADIO 4415 B25
MANUF.	ERICSSON
HEIGHT	14.9"
WIDTH	13.2"
DEPTH	5.4"
WEIGHT	46.3 LB

REMOTE RADIO UNIT  
N.T.S.

4  
A-3

# Exhibit D

Prepared For:



**T-Mobile Northeast, LLC  
35 Griffin Road South  
Bloomfield, CT 06002**



**Structure Rating**

<b>Monopole Tower:</b>	<b>Pass (33.5%)</b>
<b>Base Plate:</b>	<b>Pass (19.6%)</b>
<b>Foundation:</b>	<b>Pass (54.0%)</b>

Sincerely,  
EFI Global, Inc.  
License No: PEC0001245

12/2/2020



Ahmet Colakoglu, PE  
Connecticut Professional Engineer  
License No: 27057

**Site ID: CTHA241C  
Site Name: HA241/Exxon\_Sign  
207 West Street  
Cromwell, CT 06416**

**CONTENTS**

1.0 - SUBJECT AND REFERENCES

1.1 - STRUCTURE

2.0 - EXISTING AND PROPOSED APPURTENANCES

3.0 - CODES AND LOADING

4.0 - STANDARD CONDITIONS FOR ENGINEERING SERVICES ON EXISTING  
STRUCTURES

5.0 – ANALYSIS AND ASSUMPTIONS

6.0 – CONCLUSION AND RESULTS

APPENDICES

A – SOFTWARE OUTPUT

## 1.0 SUBJECT AND REFERENCES

The purpose of this analysis is to evaluate the structural capacity of the existing 53' tall monopole tower located at 207 West Street, Cromwell, CT 06320, for the alteration and addition of wireless telecommunication appurtenances proposed by T-Mobile.

The structural analysis is based on the following documentation provided to EFI Global, Inc. (EFI):

- RFDS provided by T-Mobil, dated 10/14/2020.
- Structural Analysis Report prepared by Armor Tower, Inc. dated 04/08/2009.
- Structural Analysis Report prepared by Atlantis Group, dated 09/04/2014.
- Mount Analysis Report - Rev. 1 prepared by EFI Global, Inc., dated 12/2/2020.

## 1.1 STRUCTURE

The structure is a 53' high, 18-sided monopole, which is attached to the foundation with a base plate and anchor bolts. Please refer to the software output in Appendix A, for details about the tower geometry and calculations.

The monopole is formed by the following sections:

Section Length (ft)	Lap Spice (in)	Shaft Thickness (in)	Top Dia / Bottom Dia (in / in)	Steel Yield Strength (ksi)
53	-	0.1875	18.00/30.00	65

## 2.0 EXISTING AND PROPOSED APPURTENANCES

Existing Configuration of T-Mobile Appurtenances:

Rad Center (ft.)	Antennas & Equipment	Coax*	Mount
50	(3) AIR21 B2A/B4P (3) Generic Twin Style 1B - AWS	(12) 7/8" (1) 9x18 HCS	(3) Pipe Mounts
41	(3) AIR21 B4A/B12P		(3) Pipe Mounts

\*: Feedlines are located inside the monopole

**Proposed and Final Configuration of T-Mobile Appurtenances:**

Rad Center (ft.)	Antennas & Equipment	Coax*	Mount
50	(3) AIR32 B66A/B2A (3) AIR6449 B41	(6) 7/8" (1) 9x18 HCS (3) 6x12 HCS	(2) Valmont/Site Pro 1 T-Arm Mounts (P/N: RDS)
41	(3) APXVAALL24_43-U-NA20 (3) Radio 4449 B71+B85 (3) Radio 4415 B25 (3) Generic Twin Style 1B – AWS (3) SDX1926Q-43		(3) Pipe Mounts

\*: Feedlines are located inside the monopole

**3.0 CODES AND LOADING**

This analysis has been performed in accordance with the 2018 Connecticut State Building Code (2015 IBC) based upon an ultimate 3-second gust wind speed of 125 mph (Risk category II) converted to a nominal 3-second gust wind speed of 97 mph per section 1609.3.1 and Appendix N as required for use in the TIA-222-G Standard per Exception #5 of Section 1609.1.1. The following loading criteria were used in compliance with the standard for New London, CT:

- Ultimate wind speed 125 mph converted to a Basic wind speed 97 mph without ice (V)
- Nominal wind speed 50 mph with 1.00" escalating ice (V<sub>i</sub>)
- Exposure Category C, Risk Category II
- Topographic Category 1

The following load combinations were used with wind blowing at 0°, 30°, 45°, 60°, and 90°, measured from a line normal to the face of the tower:

- 1.2 D + 1.0 D<sub>g</sub> + 1.6 W<sub>o</sub>
- 0.9 D + 1.0 D<sub>g</sub> + 1.6 W<sub>o</sub>
- 1.2 D + 1.0 D<sub>g</sub> + 1.0 D<sub>i</sub> + 1.0 W<sub>i</sub> + 1.0 T<sub>i</sub>

D: Dead load of structures and appurtenances, except guy wires

D<sub>g</sub>: Dead load of guy assemblies

D<sub>i</sub>: Weight of ice due to factored ice thickness (based upon t<sub>i</sub>)

T<sub>i</sub>: Load effects due to temperature

W<sub>o</sub>: Wind load without ice (based upon V)

W<sub>i</sub>: Wind load with ice (based upon V<sub>i</sub>)

#### **4.0 STANDARD CONDITIONS FOR ENGINEERING SERVICES ON EXISTING STRUCTURES**

The analysis is based on the information provided and is assumed to be current and correct. Unless otherwise noted, the structure is assumed to be in good condition, free of defects and can achieve theoretical strength.

It is assumed that the structure has been maintained and shall be maintained during its service. The superstructure and the foundation system are assumed to be designed with proper engineering practice and fabricated, constructed and erected in accordance with the design documents. EFI will accept no liability which may arise due to any existing deficiency in design, material, fabrication, erection, construction, etc. or lack of maintenance.

The analysis does not include a qualification of the mounts attached on the structure or their connections. The analysis is performed to verify the capacity of the main structural members, which is the current practice in the tower industry.

The analysis results presented in this report are only applicable for the previously mentioned existing and proposed appurtenances. Any deviation of the appurtenances and placement, etc., will require EFI to generate an additional structural analysis.

#### **5.0 ANALYSIS AND ASSUMPTIONS**

The tower was analyzed by utilizing tnxTower, a non-linear, three-dimensional, finite element-analysis software package, a product of Tower Numerics, Inc. Software output for this analysis is provided in Appendix A of this report.

## 6.0 CONCLUSION AND RESULTS

Based on a structural analysis per ANSI/TIA-222-G, the existing tower is found to have **adequate** structural capacity for the proposed changes by T-Mobile. For the code specified load combinations and as a maximum, the monopole shaft is stressed to **33.5%** of its structural capacity. The anchor rods and base plate are stressed to **20.0% and 19.6%** of their structural capacities, respectively. Monopole foundation (pier and pad) is found to have **adequate** capacity at **54.0%** with a reaction comparison.

Reactions	EI Design Reactions	EFI Reactions	Comparison (%)
Base Shear (kips)	11.3	6.1	54.0%
Base Moment (kip-ft)	547.3	227	41.5%

Therefore, the proposed changes by T-Mobile **can** be implemented with the conditions outlined in this report.

Should you have any questions about this report, please contact EFI at [telecom@efiglobal.com](mailto:telecom@efiglobal.com).



**APPENDIX A**  
**SOFTWARE OUTPUT**

53.0 ft

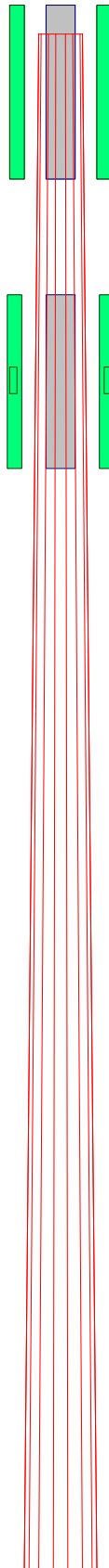

**DESIGNED APPURTENANCE LOADING**

TYPE	ELEVATION	TYPE	ELEVATION
4' Long, 3.0" STD Pipe	51.5	APXVAALL24_43-U-NA20 w/ Mount Pipe	41
4' Long, 3.0" STD Pipe	51.5	RADIO 4449 B71/B85	41
4' Long, 3.0" STD Pipe	51.5	RADIO 4449 B71/B85	41
AIR6449 B41 w/ Mount Pipe	50	RADIO 4415 B25	41
AIR6449 B41 w/ Mount Pipe	50	RADIO 4415 B25	41
AIR6449 B41 w/ Mount Pipe	50	RADIO 4415 B25	41
AIR32 DB B66Aa B2a w/ Mount Pipe	50	RADIO 4415 B25	41
AIR32 DB B66Aa B2a w/ Mount Pipe	50	RADIO 4415 B25	41
AIR32 DB B66Aa B2a w/ Mount Pipe	50	KRY 112 489/2	41
4' Long, 3.0" STD Pipe	49.5	KRY 112 489/2	41
4' Long, 3.0" STD Pipe	49.5	KRY 112 489/2	41
4' Long, 3.0" STD Pipe	49.5	SDX1926Q-43	41
APXVAALL24_43-U-NA20 w/ Mount Pipe	41	SDX1926Q-43	41
APXVAALL24_43-U-NA20 w/ Mount Pipe	41	SDX1926Q-43	41

**MATERIAL STRENGTH**

GRADE	Fy	Fu	GRADE	Fy	Fu
A572-65	65 ksi	80 ksi			

**TOWER DESIGN NOTES**

1. Tower is located in Middlesex County, Connecticut.
2. Tower designed for Exposure C to the TIA-222-G Standard.
3. Tower designed for a 97 mph basic wind in accordance with the TIA-222-G Standard.
4. Tower is also designed for a 50 mph basic wind with 1.00 in ice. Ice is considered to increase in thickness with height.
5. Deflections are based upon a 60 mph wind.
6. Tower Structure Class II.
7. Topographic Category 1 with Crest Height of 0.00 ft
8. TOWER RATING: 33.5%

Section	1
Length (ft)	53.00
Number of Sides	18
Thickness (in)	0.1875
Top Dia (in)	18.0000
Bot Dia (in)	30.0000
Grade	A572-65
Weight (lb)	2555.8

ALL REACTIONS ARE FACTORED

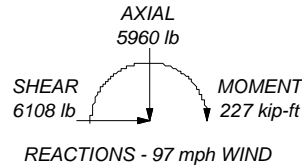
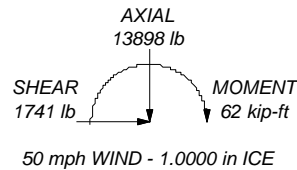

0.0 ft

<b>EFI Global, Inc.</b> 1117 Perimeter Center West, Suite E500 Atlanta, GA 30338 Phone: (770) 693-0835 FAX:			Job: <b>CTHA241C</b> Project: <b>049.00939 - 2075087</b>
Client: T-Mobile	Drawn by: Evan.Martin	App'd:	
Code: TIA-222-G	Date: 12/02/20	Scale: NTS	
Path:		Dwg No. E-1	

<b>tnxTower</b>  <b>EFI Global, Inc.</b> 1117 Perimeter Center West, Suite E500 Atlanta, GA 30338 Phone: (770) 693-0835 FAX:	<b>Job</b> CTHA241C	<b>Page</b> 1 of 11
	<b>Project</b> 049.00939 - 2075087	<b>Date</b> 16:59:55 12/02/20
	<b>Client</b> T-Mobile	<b>Designed by</b> Evan.Martin

## Tower Input Data

The tower is a monopole.

This tower is designed using the TIA-222-G standard.

The following design criteria apply:

- Tower is located in Middlesex County, Connecticut.
- Basic wind speed of 97 mph.
- Structure Class II.
- Exposure Category C.
- Topographic Category 1.
- Crest Height 0.00 ft.
- Nominal ice thickness of 1.0000 in.
- Ice thickness is considered to increase with height.
- Ice density of 56 pcf.
- A wind speed of 50 mph is used in combination with ice.
- Temperature drop of 50 °F.
- Deflections calculated using a wind speed of 60 mph.
- A non-linear (P-delta) analysis was used.
- Pressures are calculated at each section.
- Stress ratio used in pole design is 1.
- Local bending stresses due to climbing loads, feed line supports, and appurtenance mounts are not considered.

## Options

- |  |   |   |
|--|---|---|
| <ul style="list-style-type: none"> <li>Consider Moments - Legs</li> <li>Consider Moments - Horizontals</li> <li>Consider Moments - Diagonals</li> <li>Use Moment Magnification</li> <li>√ Use Code Stress Ratios</li> <li>√ Use Code Safety Factors - Guys</li> <li>Escalate Ice</li> <li>Always Use Max Kz</li> <li>Use Special Wind Profile</li> <li>Include Bolts In Member Capacity</li> <li>Leg Bolts Are At Top Of Section</li> <li>Secondary Horizontal Braces Leg</li> <li>Use Diamond Inner Bracing (4 Sided)</li> <li>SR Members Have Cut Ends</li> <li>SR Members Are Concentric</li> </ul> | <ul style="list-style-type: none"> <li>Distribute Leg Loads As Uniform</li> <li>Assume Legs Pinned</li> <li>√ Assume Rigid Index Plate</li> <li>√ Use Clear Spans For Wind Area</li> <li>Use Clear Spans For KL/r</li> <li>Retention Guys To Initial Tension</li> <li>√ Bypass Mast Stability Checks</li> <li>√ Use Azimuth Dish Coefficients</li> <li>√ Project Wind Area of Appurt.</li> <li>Autocalc Torque Arm Areas</li> <li>Add IBC .6D+W Combination</li> <li>√ Sort Capacity Reports By Component</li> <li>Triangulate Diamond Inner Bracing</li> <li>Treat Feed Line Bundles As Cylinder</li> <li>Ignore KL/ry For 60 Deg. Angle Legs</li> </ul> | <ul style="list-style-type: none"> <li>Use ASCE 10 X-Brace Ly Rules</li> <li>Calculate Redundant Bracing Forces</li> <li>Ignore Redundant Members in FEA</li> <li>SR Leg Bolts Resist Compression</li> <li>All Leg Panels Have Same Allowable</li> <li>Offset Girt At Foundation</li> <li>√ Consider Feed Line Torque</li> <li>Include Angle Block Shear Check</li> <li>Use TIA-222-G Bracing Resist. Exemption</li> <li>Use TIA-222-G Tension Splice Exemption</li> <li style="text-align: center;">Poles</li> <li>√ Include Shear-Torsion Interaction</li> <li>Always Use Sub-Critical Flow</li> <li>Use Top Mounted Sockets</li> <li>Pole Without Linear Attachments</li> <li>Pole With Shroud Or No Appurtenances</li> <li>Outside and Inside Corner Radii Are Known</li> </ul> |
|--|---|---|

## Tapered Pole Section Geometry

Section	Elevation	Section Length	Splice Length	Number of Sides	Top Diameter	Bottom Diameter	Wall Thickness	Bend Radius	Pole Grade
	ft	ft	ft		in	in	in	in	
L1	53.00-0.00	53.00		18	18.0000	30.0000	0.1875	0.7500	A572-65

<b>tnxTower</b>  <b>EFI Global, Inc.</b> 1117 Perimeter Center West, Suite E500 Atlanta, GA 30338 Phone: (770) 693-0835 FAX:	<b>Job</b> CTHA241C	<b>Page</b> 2 of 11
	<b>Project</b> 049.00939 - 2075087	<b>Date</b> 16:59:55 12/02/20
	<b>Client</b> T-Mobile	<b>Designed by</b> Evan.Martin

Section	Elevation	Section Length	Splice Length	Number of Sides	Top Diameter	Bottom Diameter	Wall Thickness	Bend Radius	Pole Grade
	ft	ft	ft		in	in	in	in	(65 ksi)

### Tapered Pole Properties

Section	Tip Dia.	Area	I	r	C	I/C	J	It/Q	w	w/t
	in	in <sup>2</sup>	in <sup>4</sup>	in	in	in <sup>3</sup>	in <sup>4</sup>	in <sup>2</sup>	in	
L1	18.2488 30.4339	10.6007 17.7422	424.9328 1992.2362	6.3234 10.5834	9.1440 15.2400	46.4712 130.7242	850.4248 3987.0939	5.3013 8.8728	2.8380 4.9500	15.136 26.4

Tower Elevation	Gusset Area	Gusset Thickness	Gusset Grade	Adjust. Factor	Adjust. Factor	Weight Mult.	Double Angle	Double Angle	Double Angle
ft	ft <sup>2</sup>	in		A <sub>f</sub>	A <sub>r</sub>		Stitch Bolt Spacing Diagonals	Stitch Bolt Spacing Horizontals	Stitch Bolt Spacing Redundants
							in	in	in
L1 53.00-0.00				1	1	1			

### Feed Line/Linear Appurtenances - Entered As Area

Description	Face or Leg	Allow Shield	Exclude From Torque Calculation	Component Type	Placement	Total Number	C <sub>A</sub> A <sub>A</sub>	Weight	
					ft		ft <sup>2</sup> /ft	plf	
AL5-50(7/8)	A	No	No	Inside Pole	51.00 - 0.00	6	No Ice 1/2" Ice 1" Ice	0.00 0.00 0.00	0.26 0.26 0.26
MLE Hybrid 9Power/18Fiber RL 2(1 5/8)	C	No	No	Inside Pole	41.00 - 0.00	1	No Ice 1/2" Ice 1" Ice	0.00 0.00 0.00	1.07 1.07 1.07
HCS 6X12 4AWG(1-5/8)	C	No	No	Inside Pole	51.00 - 0.00	3	No Ice 1/2" Ice 1" Ice	0.00 0.00 0.00	2.40 2.40 2.40

### Feed Line/Linear Appurtenances Section Areas

Tower Section	Tower Elevation	Face	A <sub>R</sub>	A <sub>F</sub>	C <sub>A</sub> A <sub>A</sub> In Face	C <sub>A</sub> A <sub>A</sub> Out Face	Weight
	ft		ft <sup>2</sup>	ft <sup>2</sup>	ft <sup>2</sup>	ft <sup>2</sup>	lb
L1	53.00-0.00	A	0.000	0.000	0.000	0.000	79.56
		B	0.000	0.000	0.000	0.000	0.00
		C	0.000	0.000	0.000	0.000	411.07

### Feed Line/Linear Appurtenances Section Areas - With Ice

<b>tnxTower</b>  <b>EFI Global, Inc.</b> 1117 Perimeter Center West, Suite E500 Atlanta, GA 30338 Phone: (770) 693-0835 FAX:	<b>Job</b>	CTHA241C	<b>Page</b>	3 of 11
	<b>Project</b>	049.00939 - 2075087	<b>Date</b>	16:59:55 12/02/20
	<b>Client</b>	T-Mobile	<b>Designed by</b>	Evan.Martin

Tower Section	Tower Elevation ft	Face or Leg	Ice Thickness in	A <sub>R</sub> ft <sup>2</sup>	A <sub>F</sub> ft <sup>2</sup>	C <sub>AA</sub> In Face ft <sup>2</sup>	C <sub>AA</sub> Out Face ft <sup>2</sup>	Weight lb
L1	53.00-0.00	A	1.950	0.000	0.000	0.000	0.000	79.56
		B		0.000	0.000	0.000	0.000	0.00
		C		0.000	0.000	0.000	0.000	411.07

### Feed Line Center of Pressure

Section	Elevation ft	CP <sub>X</sub> in	CP <sub>Z</sub> in	CP <sub>X</sub> Ice in	CP <sub>Z</sub> Ice in
L1	53.00-0.00	0.0000	0.0000	0.0000	0.0000

Note: For pole sections, center of pressure calculations do not consider feed line shielding.

### Shielding Factor Ka

Tower Section	Feed Line Record No.	Description	Feed Line Segment Elev.	K <sub>a</sub> No Ice	K <sub>a</sub> Ice
---------------	----------------------	-------------	-------------------------	--------------------------	-----------------------

### Discrete Tower Loads

Description	Face or Leg	Offset Type	Offsets: Horz Lateral Vert ft ft ft	Azimuth Adjustment °	Placement ft	C <sub>AA</sub> Front ft <sup>2</sup>	C <sub>AA</sub> Side ft <sup>2</sup>	Weight lb
*51*								
AIR32 DB B66Aa B2a w/ Mount Pipe	A	From Leg	1.00 0.00 0.00	0.0000	51.00	No Ice 6.75 1/2" Ice 7.20 1" Ice 7.65	6.07 6.87 7.58	126.67 187.64 255.49
AIR32 DB B66Aa B2a w/ Mount Pipe	B	From Leg	1.00 0.00 0.00	0.0000	51.00	No Ice 6.75 1/2" Ice 7.20 1" Ice 7.65	6.07 6.87 7.58	126.67 187.64 255.49
AIR32 DB B66Aa B2a w/ Mount Pipe	C	From Leg	1.00 0.00 0.00	0.0000	51.00	No Ice 6.75 1/2" Ice 7.20 1" Ice 7.65	6.07 6.87 7.58	126.67 187.64 255.49
AIR6449 B41 w/ Mount Pipe	A	From Leg	1.00 0.00 0.00	0.0000	51.00	No Ice 6.19 1/2" Ice 6.63 1" Ice 7.08	3.66 4.20 4.74	132.88 185.05 242.91
AIR6449 B41 w/ Mount Pipe	B	From Leg	1.00 0.00 0.00	0.0000	51.00	No Ice 6.19 1/2" Ice 6.63 1" Ice 7.08	3.66 4.20 4.74	132.88 185.05 242.91
AIR6449 B41 w/ Mount Pipe	C	From Leg	1.00 0.00 0.00	0.0000	51.00	No Ice 6.19 1/2" Ice 6.63 1" Ice 7.08	3.66 4.20 4.74	132.88 185.05 242.91
4' Long, 3.0" STD Pipe	A	From Leg	1.00 0.00	0.0000	52.50	No Ice 1.11 1/2" Ice 1.36	1.11 1.36	30.32 40.61

<b>tnxTower</b>  <b>EFI Global, Inc.</b> 1117 Perimeter Center West, Suite E500 Atlanta, GA 30338 Phone: (770) 693-0835 FAX:	<b>Job</b>	CTHA241C	<b>Page</b>	4 of 11
	<b>Project</b>	049.00939 - 2075087	<b>Date</b>	16:59:55 12/02/20
	<b>Client</b>	T-Mobile	<b>Designed by</b>	Evan.Martin

Description	Face or Leg	Offset Type	Offsets:		Azimuth Adjustment	Placement	CAAA Front	CAAA Side	Weight	
			Horz	Lateral						
			Vert		°	ft	ft <sup>2</sup>	ft <sup>2</sup>	lb	
			ft	ft						
4' Long, 3.0" STD Pipe	B	From Leg	0.00		0.0000	52.50	1" Ice	1.62	1.62	53.85
			1.00				No Ice	1.11	1.11	30.32
			0.00				1/2" Ice	1.36	1.36	40.61
4' Long, 3.0" STD Pipe	C	From Leg	0.00		0.0000	52.50	1" Ice	1.62	1.62	53.85
			1.00				No Ice	1.11	1.11	30.32
			0.00				1/2" Ice	1.36	1.36	40.61
4' Long, 3.0" STD Pipe	A	From Leg	0.00		0.0000	49.50	1" Ice	1.62	1.62	53.85
			1.00				No Ice	1.11	1.11	30.32
			0.00				1/2" Ice	1.36	1.36	40.61
4' Long, 3.0" STD Pipe	B	From Leg	0.00		0.0000	49.50	1" Ice	1.62	1.62	53.85
			1.00				No Ice	1.11	1.11	30.32
			0.00				1/2" Ice	1.36	1.36	40.61
4' Long, 3.0" STD Pipe	C	From Leg	0.00		0.0000	49.50	1" Ice	1.62	1.62	53.85
			1.00				No Ice	1.11	1.11	30.32
			0.00				1/2" Ice	1.36	1.36	40.61
*41*	A	From Leg	0.00		0.0000	41.00	1" Ice	1.62	1.62	53.85
			1.00				No Ice	20.24	10.63	179.10
			0.00				1/2" Ice	20.89	12.06	312.01
APXVAALL24_43-U-NA20 w/ Mount Pipe	B	From Leg	0.00		0.0000	41.00	1" Ice	21.55	13.34	455.52
			1.00				No Ice	20.24	10.63	179.10
			0.00				1/2" Ice	20.89	12.06	312.01
APXVAALL24_43-U-NA20 w/ Mount Pipe	C	From Leg	0.00		0.0000	41.00	1" Ice	21.55	13.34	455.52
			1.00				No Ice	20.24	10.63	179.10
			0.00				1/2" Ice	20.89	12.06	312.01
RADIO 4449 B71/B85	A	From Leg	0.00		0.0000	41.00	1" Ice	21.55	13.34	455.52
			1.00				No Ice	1.97	1.59	73.21
			0.00				1/2" Ice	2.15	1.75	92.97
RADIO 4449 B71/B85	B	From Leg	0.00		0.0000	41.00	1" Ice	2.33	1.92	115.64
			1.00				No Ice	1.97	1.59	73.21
			0.00				1/2" Ice	2.15	1.75	92.97
RADIO 4449 B71/B85	C	From Leg	0.00		0.0000	41.00	1" Ice	2.33	1.92	115.64
			1.00				No Ice	1.97	1.59	73.21
			0.00				1/2" Ice	2.15	1.75	92.97
RADIO 4415 B25	A	From Leg	0.00		0.0000	41.00	1" Ice	2.33	1.92	115.64
			1.00				No Ice	1.84	0.82	46.00
			0.00				1/2" Ice	2.01	0.94	60.07
RADIO 4415 B25	B	From Leg	0.00		0.0000	41.00	1" Ice	2.19	1.07	76.66
			1.00				No Ice	1.84	0.82	46.00
			0.00				1/2" Ice	2.01	0.94	60.07
RADIO 4415 B25	C	From Leg	0.00		0.0000	41.00	1" Ice	2.19	1.07	76.66
			1.00				No Ice	1.84	0.82	46.00
			0.00				1/2" Ice	2.01	0.94	60.07
KRY 112 489/2	A	From Leg	0.00		0.0000	41.00	1" Ice	2.19	1.07	76.66
			1.00				No Ice	0.56	0.37	15.40
			0.00				1/2" Ice	0.66	0.45	20.47
KRY 112 489/2	B	From Leg	0.00		0.0000	41.00	1" Ice	0.76	0.54	27.10
			1.00				No Ice	0.56	0.37	15.40
			0.00				1/2" Ice	0.66	0.45	20.47
KRY 112 489/2	C	From Leg	0.00		0.0000	41.00	1" Ice	0.76	0.54	27.10
			1.00				No Ice	0.56	0.37	15.40
			0.00				1/2" Ice	0.66	0.45	20.47
SDX1926Q-43	A	From Leg	0.00		0.0000	41.00	1" Ice	0.76	0.54	27.10
			1.00				No Ice	0.24	0.10	6.17
			0.00				1/2" Ice	0.31	0.14	8.64
SDX1926Q-43	B	From Leg	0.00		0.0000	41.00	1" Ice	0.38	0.19	12.22
			1.00				No Ice	0.24	0.10	6.17
			0.00				1/2" Ice	0.31	0.14	8.64

<b>tnxTower</b>  <b>EFI Global, Inc.</b> 1117 Perimeter Center West, Suite E500 Atlanta, GA 30338 Phone: (770) 693-0835 FAX:	<b>Job</b>	CTHA241C	<b>Page</b>	5 of 11
	<b>Project</b>	049.00939 - 2075087	<b>Date</b>	16:59:55 12/02/20
	<b>Client</b>	T-Mobile	<b>Designed by</b>	Evan.Martin

Description	Face or Leg	Offset Type	Offsets:		Azimuth Adjustment	Placement	C <sub>AA</sub> Front	C <sub>AA</sub> Side	Weight	
			Horz Lateral	Vert						
			ft	ft	°	ft	ft <sup>2</sup>	ft <sup>2</sup>	lb	
SDX1926Q-43	C	From Leg	0.00				1/2" Ice	0.31	0.14	8.64
			0.00				1" Ice	0.38	0.19	12.22
			1.00	0.0000	41.00	No Ice	0.24	0.10	6.17	
			0.00			1/2" Ice	0.31	0.14	8.64	
			0.00			1" Ice	0.38	0.19	12.22	

## Load Combinations

Comb. No.	Description
1	Dead Only
2	1.2 Dead+1.6 Wind 0 deg - No Ice
3	0.9 Dead+1.6 Wind 0 deg - No Ice
4	1.2 Dead+1.6 Wind 30 deg - No Ice
5	0.9 Dead+1.6 Wind 30 deg - No Ice
6	1.2 Dead+1.6 Wind 60 deg - No Ice
7	0.9 Dead+1.6 Wind 60 deg - No Ice
8	1.2 Dead+1.6 Wind 90 deg - No Ice
9	0.9 Dead+1.6 Wind 90 deg - No Ice
10	1.2 Dead+1.6 Wind 120 deg - No Ice
11	0.9 Dead+1.6 Wind 120 deg - No Ice
12	1.2 Dead+1.6 Wind 150 deg - No Ice
13	0.9 Dead+1.6 Wind 150 deg - No Ice
14	1.2 Dead+1.6 Wind 180 deg - No Ice
15	0.9 Dead+1.6 Wind 180 deg - No Ice
16	1.2 Dead+1.6 Wind 210 deg - No Ice
17	0.9 Dead+1.6 Wind 210 deg - No Ice
18	1.2 Dead+1.6 Wind 240 deg - No Ice
19	0.9 Dead+1.6 Wind 240 deg - No Ice
20	1.2 Dead+1.6 Wind 270 deg - No Ice
21	0.9 Dead+1.6 Wind 270 deg - No Ice
22	1.2 Dead+1.6 Wind 300 deg - No Ice
23	0.9 Dead+1.6 Wind 300 deg - No Ice
24	1.2 Dead+1.6 Wind 330 deg - No Ice
25	0.9 Dead+1.6 Wind 330 deg - No Ice
26	1.2 Dead+1.0 Ice+1.0 Temp
27	1.2 Dead+1.0 Wind 0 deg+1.0 Ice+1.0 Temp
28	1.2 Dead+1.0 Wind 30 deg+1.0 Ice+1.0 Temp
29	1.2 Dead+1.0 Wind 60 deg+1.0 Ice+1.0 Temp
30	1.2 Dead+1.0 Wind 90 deg+1.0 Ice+1.0 Temp
31	1.2 Dead+1.0 Wind 120 deg+1.0 Ice+1.0 Temp
32	1.2 Dead+1.0 Wind 150 deg+1.0 Ice+1.0 Temp
33	1.2 Dead+1.0 Wind 180 deg+1.0 Ice+1.0 Temp
34	1.2 Dead+1.0 Wind 210 deg+1.0 Ice+1.0 Temp
35	1.2 Dead+1.0 Wind 240 deg+1.0 Ice+1.0 Temp
36	1.2 Dead+1.0 Wind 270 deg+1.0 Ice+1.0 Temp
37	1.2 Dead+1.0 Wind 300 deg+1.0 Ice+1.0 Temp
38	1.2 Dead+1.0 Wind 330 deg+1.0 Ice+1.0 Temp
39	Dead+Wind 0 deg - Service
40	Dead+Wind 30 deg - Service
41	Dead+Wind 60 deg - Service

<b>tnxTower</b>  <b>EFI Global, Inc.</b> 1117 Perimeter Center West, Suite E500 Atlanta, GA 30338 Phone: (770) 693-0835 FAX:	<b>Job</b>	CTHA241C	<b>Page</b>	6 of 11
	<b>Project</b>	049.00939 - 2075087	<b>Date</b>	16:59:55 12/02/20
	<b>Client</b>	T-Mobile	<b>Designed by</b>	Evan.Martin

Comb. No.	Description
42	Dead+Wind 90 deg - Service
43	Dead+Wind 120 deg - Service
44	Dead+Wind 150 deg - Service
45	Dead+Wind 180 deg - Service
46	Dead+Wind 210 deg - Service
47	Dead+Wind 240 deg - Service
48	Dead+Wind 270 deg - Service
49	Dead+Wind 300 deg - Service
50	Dead+Wind 330 deg - Service

### Maximum Member Forces

Section No.	Elevation ft	Component Type	Condition	Gov. Load Comb.	Axial lb	Major Axis Moment kip-ft	Minor Axis Moment kip-ft
L1	53 - 0	Pole	Max Tension	30	0.00	0.00	0.00
			Max. Compression	26	-13898.17	0.00	0.00
			Max. Mx	8	-5955.34	-227.33	0.00
			Max. My	2	-5955.34	0.00	227.33
			Max. Vy	8	6112.13	-227.33	0.00
			Max. Vx	14	6112.13	0.00	-227.33
			Max. Torque	24			0.00

### Maximum Reactions

Location	Condition	Gov. Load Comb.	Vertical lb	Horizontal, X lb	Horizontal, Z lb
Pole	Max. Vert	26	13898.17	0.00	0.00
	Max. H <sub>x</sub>	21	4469.96	6107.65	0.00
	Max. H <sub>z</sub>	3	4469.96	0.00	6107.65
	Max. M <sub>x</sub>	2	227.33	0.00	6107.63
	Max. M <sub>z</sub>	8	227.33	-6107.63	0.00
	Max. Torsion	24	0.00	3053.82	5289.37
	Min. Vert	9	4469.96	-6107.65	0.00
	Min. H <sub>x</sub>	9	4469.96	-6107.65	0.00
	Min. H <sub>z</sub>	15	4469.96	0.00	-6107.65
	Min. M <sub>x</sub>	14	-227.33	0.00	-6107.63
	Min. M <sub>z</sub>	20	-227.33	6107.63	0.00
	Min. Torsion	4	-0.00	-3053.82	5289.37

### Tower Mast Reaction Summary

Load Combination	Vertical lb	Shear <sub>x</sub> lb	Shear <sub>z</sub> lb	Overturning Moment, M <sub>x</sub> kip-ft	Overturning Moment, M <sub>z</sub> kip-ft	Torque kip-ft
Dead Only	4966.63	0.00	0.00	0.00	0.00	0.00
1.2 Dead+1.6 Wind 0 deg - No Ice	5959.95	0.00	-6107.63	-227.33	0.00	0.00
0.9 Dead+1.6 Wind 0 deg - No Ice	4469.96	0.00	-6107.65	-226.84	0.00	0.00



<b>tnxTower</b>  <b>EFI Global, Inc.</b> 1117 Perimeter Center West, Suite E500 Atlanta, GA 30338 Phone: (770) 693-0835 FAX:	<b>Job</b>	CTHA241C	<b>Page</b>	7 of 11
	<b>Project</b>	049.00939 - 2075087	<b>Date</b>	16:59:55 12/02/20
	<b>Client</b>	T-Mobile	<b>Designed by</b>	Evan.Martin

Load Combination	Vertical lb	Shear <sub>x</sub> lb	Shear <sub>z</sub> lb	Overturning Moment, M <sub>x</sub> kip-ft	Overturning Moment, M <sub>z</sub> kip-ft	Torque kip-ft
1.2 Dead+1.6 Wind 30 deg - No Ice	5959.95	3053.82	-5289.37	-196.87	-113.66	0.00
0.9 Dead+1.6 Wind 30 deg - No Ice	4469.96	3053.82	-5289.38	-196.45	-113.42	0.00
1.2 Dead+1.6 Wind 60 deg - No Ice	5959.95	5289.37	-3053.82	-113.66	-196.87	-0.00
0.9 Dead+1.6 Wind 60 deg - No Ice	4469.96	5289.38	-3053.82	-113.42	-196.45	-0.00
1.2 Dead+1.6 Wind 90 deg - No Ice	5959.95	6107.63	0.00	0.00	-227.33	0.00
0.9 Dead+1.6 Wind 90 deg - No Ice	4469.96	6107.65	0.00	0.00	-226.84	0.00
1.2 Dead+1.6 Wind 120 deg - No Ice	5959.95	5289.37	3053.82	113.66	-196.87	0.00
0.9 Dead+1.6 Wind 120 deg - No Ice	4469.96	5289.38	3053.82	113.42	-196.45	0.00
1.2 Dead+1.6 Wind 150 deg - No Ice	5959.95	3053.82	5289.37	196.87	-113.66	-0.00
0.9 Dead+1.6 Wind 150 deg - No Ice	4469.96	3053.82	5289.38	196.45	-113.42	-0.00
1.2 Dead+1.6 Wind 180 deg - No Ice	5959.95	0.00	6107.63	227.33	0.00	0.00
0.9 Dead+1.6 Wind 180 deg - No Ice	4469.96	0.00	6107.65	226.84	0.00	0.00
1.2 Dead+1.6 Wind 210 deg - No Ice	5959.95	-3053.82	5289.37	196.87	113.66	0.00
0.9 Dead+1.6 Wind 210 deg - No Ice	4469.96	-3053.82	5289.38	196.45	113.42	0.00
1.2 Dead+1.6 Wind 240 deg - No Ice	5959.95	-5289.37	3053.82	113.66	196.87	-0.00
0.9 Dead+1.6 Wind 240 deg - No Ice	4469.96	-5289.38	3053.82	113.42	196.45	-0.00
1.2 Dead+1.6 Wind 270 deg - No Ice	5959.95	-6107.63	0.00	0.00	227.33	0.00
0.9 Dead+1.6 Wind 270 deg - No Ice	4469.96	-6107.65	0.00	0.00	226.84	0.00
1.2 Dead+1.6 Wind 300 deg - No Ice	5959.95	-5289.37	-3053.82	-113.66	196.87	0.00
0.9 Dead+1.6 Wind 300 deg - No Ice	4469.96	-5289.38	-3053.82	-113.42	196.45	0.00
1.2 Dead+1.6 Wind 330 deg - No Ice	5959.95	-3053.82	-5289.37	-196.87	113.66	-0.00
0.9 Dead+1.6 Wind 330 deg - No Ice	4469.96	-3053.82	-5289.38	-196.45	113.42	-0.00
1.2 Dead+1.0 Ice+1.0 Temp	13898.17	0.00	0.00	0.00	0.00	0.00
1.2 Dead+1.0 Wind 0 deg+1.0 Ice+1.0 Temp	13898.17	0.00	-1740.79	-62.20	0.00	0.00
1.2 Dead+1.0 Wind 30 deg+1.0 Ice+1.0 Temp	13898.17	870.39	-1507.57	-53.87	-31.10	0.00
1.2 Dead+1.0 Wind 60 deg+1.0 Ice+1.0 Temp	13898.17	1507.57	-870.39	-31.10	-53.87	0.00
1.2 Dead+1.0 Wind 90 deg+1.0 Ice+1.0 Temp	13898.17	1740.79	0.00	0.00	-62.20	0.00
1.2 Dead+1.0 Wind 120 deg+1.0 Ice+1.0 Temp	13898.17	1507.57	870.39	31.10	-53.87	0.00
1.2 Dead+1.0 Wind 150 deg+1.0 Ice+1.0 Temp	13898.17	870.39	1507.57	53.87	-31.10	0.00
1.2 Dead+1.0 Wind 180 deg+1.0 Ice+1.0 Temp	13898.17	0.00	1740.79	62.20	0.00	0.00
1.2 Dead+1.0 Wind 210 deg+1.0 Ice+1.0 Temp	13898.17	-870.39	1507.57	53.87	31.10	0.00

<b>tnxTower</b>  <b>EFI Global, Inc.</b> 1117 Perimeter Center West, Suite E500 Atlanta, GA 30338 Phone: (770) 693-0835 FAX:	<b>Job</b> CTHA241C	<b>Page</b> 8 of 11
	<b>Project</b> 049.00939 - 2075087	<b>Date</b> 16:59:55 12/02/20
	<b>Client</b> T-Mobile	<b>Designed by</b> Evan.Martin

Load Combination	Vertical lb	Shear <sub>x</sub> lb	Shear <sub>z</sub> lb	Overturning Moment, M <sub>x</sub> kip-ft	Overturning Moment, M <sub>z</sub> kip-ft	Torque kip-ft
1.2 Dead+1.0 Wind 240 deg+1.0 Ice+1.0 Temp	13898.17	-1507.57	870.39	31.10	53.87	0.00
1.2 Dead+1.0 Wind 270 deg+1.0 Ice+1.0 Temp	13898.17	-1740.79	0.00	0.00	62.20	0.00
1.2 Dead+1.0 Wind 300 deg+1.0 Ice+1.0 Temp	13898.17	-1507.57	-870.39	-31.10	53.87	0.00
1.2 Dead+1.0 Wind 330 deg+1.0 Ice+1.0 Temp	13898.17	-870.39	-1507.57	-53.87	31.10	0.00
Dead+Wind 0 deg - Service	4966.63	0.00	-1306.74	-48.57	0.00	0.00
Dead+Wind 30 deg - Service	4966.63	653.37	-1131.67	-42.06	-24.29	0.00
Dead+Wind 60 deg - Service	4966.63	1131.67	-653.37	-24.29	-42.06	0.00
Dead+Wind 90 deg - Service	4966.63	1306.74	0.00	0.00	-48.57	0.00
Dead+Wind 120 deg - Service	4966.63	1131.67	653.37	24.29	-42.06	0.00
Dead+Wind 150 deg - Service	4966.63	653.37	1131.67	42.06	-24.29	0.00
Dead+Wind 180 deg - Service	4966.63	0.00	1306.74	48.57	0.00	0.00
Dead+Wind 210 deg - Service	4966.63	-653.37	1131.67	42.06	24.29	0.00
Dead+Wind 240 deg - Service	4966.63	-1131.67	653.37	24.29	42.06	0.00
Dead+Wind 270 deg - Service	4966.63	-1306.74	0.00	0.00	48.57	0.00
Dead+Wind 300 deg - Service	4966.63	-1131.67	-653.37	-24.29	42.06	0.00
Dead+Wind 330 deg - Service	4966.63	-653.37	-1131.67	-42.06	24.29	0.00

## Solution Summary

Load Comb.	Sum of Applied Forces			Sum of Reactions			% Error
	PX lb	PY lb	PZ lb	PX lb	PY lb	PZ lb	
1	0.00	-4966.63	0.00	0.00	4966.63	0.00	0.000%
2	0.00	-5959.95	-6107.68	0.00	5959.95	6107.63	0.001%
3	0.00	-4469.96	-6107.68	0.00	4469.96	6107.65	0.000%
4	3053.84	-5959.95	-5289.41	-3053.82	5959.95	5289.37	0.001%
5	3053.84	-4469.96	-5289.41	-3053.82	4469.96	5289.38	0.000%
6	5289.41	-5959.95	-3053.84	-5289.37	5959.95	3053.82	0.001%
7	5289.41	-4469.96	-3053.84	-5289.38	4469.96	3053.82	0.000%
8	6107.68	-5959.95	0.00	-6107.63	5959.95	0.00	0.001%
9	6107.68	-4469.96	0.00	-6107.65	4469.96	0.00	0.000%
10	5289.41	-5959.95	3053.84	-5289.37	5959.95	-3053.82	0.001%
11	5289.41	-4469.96	3053.84	-5289.38	4469.96	-3053.82	0.000%
12	3053.84	-5959.95	5289.41	-3053.82	5959.95	-5289.37	0.001%
13	3053.84	-4469.96	5289.41	-3053.82	4469.96	-5289.38	0.000%
14	0.00	-5959.95	6107.68	0.00	5959.95	-6107.63	0.001%
15	0.00	-4469.96	6107.68	0.00	4469.96	-6107.65	0.000%
16	-3053.84	-5959.95	5289.41	3053.82	5959.95	-5289.37	0.001%
17	-3053.84	-4469.96	5289.41	3053.82	4469.96	-5289.38	0.000%
18	-5289.41	-5959.95	3053.84	5289.37	5959.95	-3053.82	0.001%
19	-5289.41	-4469.96	3053.84	5289.38	4469.96	-3053.82	0.000%
20	-6107.68	-5959.95	0.00	6107.63	5959.95	0.00	0.001%
21	-6107.68	-4469.96	0.00	6107.65	4469.96	0.00	0.000%
22	-5289.41	-5959.95	-3053.84	5289.37	5959.95	3053.82	0.001%
23	-5289.41	-4469.96	-3053.84	5289.38	4469.96	3053.82	0.000%
24	-3053.84	-5959.95	-5289.41	3053.82	5959.95	5289.37	0.001%
25	-3053.84	-4469.96	-5289.41	3053.82	4469.96	5289.38	0.000%
26	0.00	-13898.17	0.00	0.00	13898.17	0.00	0.000%
27	0.00	-13898.17	-1741.04	0.00	13898.17	1740.79	0.002%
28	870.52	-13898.17	-1507.78	-870.39	13898.17	1507.57	0.002%
29	1507.78	-13898.17	-870.52	-1507.57	13898.17	870.39	0.002%
30	1741.04	-13898.17	0.00	-1740.79	13898.17	0.00	0.002%
31	1507.78	-13898.17	870.52	-1507.57	13898.17	-870.39	0.002%
32	870.52	-13898.17	1507.78	-870.39	13898.17	-1507.57	0.002%

<b>tnxTower</b>  <b>EFI Global, Inc.</b> 1117 Perimeter Center West, Suite E500 Atlanta, GA 30338 Phone: (770) 693-0835 FAX:	<b>Job</b>	CTHA241C	<b>Page</b>	9 of 11
	<b>Project</b>	049.00939 - 2075087	<b>Date</b>	16:59:55 12/02/20
	<b>Client</b>	T-Mobile	<b>Designed by</b>	Evan.Martin

Load Comb.	Sum of Applied Forces			Sum of Reactions			% Error
	PX lb	PY lb	PZ lb	PX lb	PY lb	PZ lb	
33	0.00	-13898.17	1741.04	0.00	13898.17	-1740.79	0.002%
34	-870.52	-13898.17	1507.78	870.39	13898.17	-1507.57	0.002%
35	-1507.78	-13898.17	870.52	1507.57	13898.17	-870.39	0.002%
36	-1741.04	-13898.17	0.00	1740.79	13898.17	0.00	0.002%
37	-1507.78	-13898.17	-870.52	1507.57	13898.17	870.39	0.002%
38	-870.52	-13898.17	-1507.78	870.39	13898.17	1507.57	0.002%
39	0.00	-4966.63	-1306.81	0.00	4966.63	1306.74	0.001%
40	653.40	-4966.63	-1131.73	-653.37	4966.63	1131.67	0.001%
41	1131.73	-4966.63	-653.40	-1131.67	4966.63	653.37	0.001%
42	1306.81	-4966.63	0.00	-1306.74	4966.63	0.00	0.001%
43	1131.73	-4966.63	653.40	-1131.67	4966.63	-653.37	0.001%
44	653.40	-4966.63	1131.73	-653.37	4966.63	-1131.67	0.001%
45	0.00	-4966.63	1306.81	0.00	4966.63	-1306.74	0.001%
46	-653.40	-4966.63	1131.73	653.37	4966.63	-1131.67	0.001%
47	-1131.73	-4966.63	653.40	1131.67	4966.63	-653.37	0.001%
48	-1306.81	-4966.63	0.00	1306.74	4966.63	0.00	0.001%
49	-1131.73	-4966.63	-653.40	1131.67	4966.63	653.37	0.001%
50	-653.40	-4966.63	-1131.73	653.37	4966.63	1131.67	0.001%

## Non-Linear Convergence Results

Load Combination	Converged?	Number of Cycles	Displacement Tolerance	Force Tolerance
1	Yes	6	0.0000001	0.0000001
2	Yes	8	0.0000001	0.00004421
3	Yes	8	0.0000001	0.00003619
4	Yes	8	0.0000001	0.00003738
5	Yes	8	0.0000001	0.00003062
6	Yes	8	0.0000001	0.00003738
7	Yes	8	0.0000001	0.00003062
8	Yes	8	0.0000001	0.00004421
9	Yes	8	0.0000001	0.00003619
10	Yes	8	0.0000001	0.00003738
11	Yes	8	0.0000001	0.00003062
12	Yes	8	0.0000001	0.00003738
13	Yes	8	0.0000001	0.00003062
14	Yes	8	0.0000001	0.00004421
15	Yes	8	0.0000001	0.00003619
16	Yes	8	0.0000001	0.00003738
17	Yes	8	0.0000001	0.00003062
18	Yes	8	0.0000001	0.00003738
19	Yes	8	0.0000001	0.00003062
20	Yes	8	0.0000001	0.00004421
21	Yes	8	0.0000001	0.00003619
22	Yes	8	0.0000001	0.00003738
23	Yes	8	0.0000001	0.00003062
24	Yes	8	0.0000001	0.00003738
25	Yes	8	0.0000001	0.00003062
26	Yes	6	0.0000001	0.0000001
27	Yes	7	0.0000001	0.00004971
28	Yes	7	0.0000001	0.00004976
29	Yes	7	0.0000001	0.00004976
30	Yes	7	0.0000001	0.00004971
31	Yes	7	0.0000001	0.00004976
32	Yes	7	0.0000001	0.00004976
33	Yes	7	0.0000001	0.00004971

<b>tnxTower</b>  <b>EFI Global, Inc.</b> 1117 Perimeter Center West, Suite E500 Atlanta, GA 30338 Phone: (770) 693-0835 FAX:	<b>Job</b>	CTHA241C	<b>Page</b>	10 of 11
	<b>Project</b>	049.00939 - 2075087	<b>Date</b>	16:59:55 12/02/20
	<b>Client</b>	T-Mobile	<b>Designed by</b>	Evan.Martin

34	Yes	7	0.00000001	0.00004976
35	Yes	7	0.00000001	0.00004976
36	Yes	7	0.00000001	0.00004971
37	Yes	7	0.00000001	0.00004976
38	Yes	7	0.00000001	0.00004976
39	Yes	7	0.00000001	0.00007591
40	Yes	7	0.00000001	0.00007546
41	Yes	7	0.00000001	0.00007546
42	Yes	7	0.00000001	0.00007591
43	Yes	7	0.00000001	0.00007546
44	Yes	7	0.00000001	0.00007546
45	Yes	7	0.00000001	0.00007591
46	Yes	7	0.00000001	0.00007546
47	Yes	7	0.00000001	0.00007546
48	Yes	7	0.00000001	0.00007591
49	Yes	7	0.00000001	0.00007546
50	Yes	7	0.00000001	0.00007546

### Compression Checks

### Pole Design Data

Section No.	Elevation ft	Size	L ft	L <sub>u</sub> ft	Kl/r	A in <sup>2</sup>	P <sub>u</sub> lb	φP <sub>n</sub> lb	Ratio $\frac{P_u}{\phi P_n}$
L1	53 - 0 (1)	TP30x18x0.1875	53.00	0.00	0.0	17.7422	-5955.34	1123340.00	0.005

### Pole Bending Design Data

Section No.	Elevation ft	Size	M <sub>ux</sub> kip-ft	φM <sub>ux</sub> kip-ft	Ratio $\frac{M_{ux}}{\phi M_{ux}}$	M <sub>uy</sub> kip-ft	φM <sub>uy</sub> kip-ft	Ratio $\frac{M_{uy}}{\phi M_{uy}}$
L1	53 - 0 (1)	TP30x18x0.1875	227.33	689.73	0.330	0.00	689.73	0.000

### Pole Shear Design Data

Section No.	Elevation ft	Size	Actual V <sub>u</sub> lb	φV <sub>n</sub> lb	Ratio $\frac{V_u}{\phi V_n}$	Actual T <sub>u</sub> kip-ft	φT <sub>n</sub> kip-ft	Ratio $\frac{T_u}{\phi T_n}$
L1	53 - 0 (1)	TP30x18x0.1875	6112.13	561670.00	0.011	0.00	1382.46	0.000

### Pole Interaction Design Data

<b>tnxTower</b>  <b>EFI Global, Inc.</b> 1117 Perimeter Center West, Suite E500 Atlanta, GA 30338 Phone: (770) 693-0835 FAX:	<b>Job</b>	CTHA241C	<b>Page</b>	11 of 11
	<b>Project</b>	049.00939 - 2075087	<b>Date</b>	16:59:55 12/02/20
	<b>Client</b>	T-Mobile	<b>Designed by</b>	Evan.Martin

Section No.	Elevation ft	Ratio $P_u$	Ratio $M_{ux}$	Ratio $M_{uy}$	Ratio $V_u$	Ratio $T_u$	Comb. Stress Ratio	Allow. Stress Ratio	Criteria
L1	53 - 0 (1)	0.005	0.330	0.000	0.011	0.000	0.335	1.000	4.8.2

### Section Capacity Table

Section No.	Elevation ft	Component Type	Size	Critical Element	P lb	$\phi P_{allow}$ lb	% Capacity	Pass Fail	
L1	53 - 0	Pole	TP30x18x0.1875	1	-5955.34	1123340.00	33.5	Pass	
							Summary		
							Pole (L1)	33.5	Pass
							<b>RATING =</b>	<b>33.5</b>	<b>Pass</b>

# Monopole Base Plate Connection

Site Info	
BU #	
Site Name	
Order #	

Analysis Considerations	
TIA-222 Revision	G
Grout Considered:	No
$I_{ar}$ (in)	0
Eta Factor, $\eta$	0.5

Applied Loads	
Moment (kip-ft)	227.33
Axial Force (kips)	5.96
Shear Force (kips)	6.11

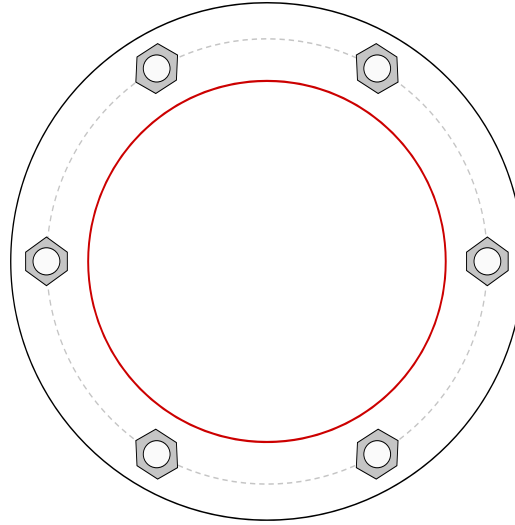

Connection Properties	Analysis Results
-----------------------	------------------

Anchor Rod Data	
(6) 2-1/4" $\phi$ bolts (A615-75 N; $F_y=75$ ksi, $F_u=100$ ksi) on 37" BC	
Base Plate Data	
43" OD x 1.75" Plate (A572-60; $F_y=60$ ksi, $F_u=75$ ksi)	
Stiffener Data	
N/A	
Pole Data	
30" x 0.1875" 18-sided pole (A572-65; $F_y=65$ ksi, $F_u=80$ ksi)	

Anchor Rod Summary		
$Pu_c = 50.07$	$\phi Pn_t = 260$	<b>Stress Rating</b>
$Vu = 1.02$	$\phi Vn = n/a$	<b>20.0%</b>
$Mu = n/a$	$\phi Mn = n/a$	<b>Pass</b>
Base Plate Summary		
Max Stress (ksi):	10.57	(Flexural)
Allowable Stress (ksi):	54	
Stress Rating:	<b>19.6%</b>	<b>Pass</b>

# Exhibit E

Date: 12/2/2020

To: T-Mobile Northeast, LLC  
35 Griffin Road South  
Bloomfield, CT 06002

**Subject: Mount Structural Analysis Report – Replacement - Rev. 1**

**T-Mobile Designation:**                      **Site Name:**                      HA241/Exxon\_Sign  
**Site Number:**                      CTHA241C

**EFI Designation:**                              **Project Number:** 049.00939 - 2075087

**Site Data:**                                      **207 West Street, Cromwell, CT 06416**  
**Latitude 41.602208°, Longitude -72.67934°**

EFI Global, Inc. is pleased to submit this **“Mount Structural Analysis Report - Replacement - Rev. 1”** to determine the structural capacity of the antenna mounts utilized by T-Mobile at the above referenced site.

The purpose of the analysis is to determine acceptability of the mount stress level for the changes proposed by T-Mobile. Under the following load case we have determined the mounts to have:

**Adequate Capacity w/Replacement @ 50’Antenna RAD (33.0%)**  
Existing + Proposed Equipment                                      **Adequate Capacity @ 41’ Antenna RAD (84.9%)**  
Note: See Analysis Criteria for loading configuration

The analysis has been performed in accordance with the TIA-222-G Standard and 2018 Connecticut State Building Code (2015 IBC).

We at *EFI Global, Inc.* appreciate the opportunity of providing our continuing professional services to you. If you have any questions or need further assistance on this or any other projects, please give us a call.

Sincerely,  
EFI Global, Inc.  
License No: PEC0001245

Ahmet Colakoglu, PE  
Connecticut Professional Engineer  
License No: 27057





## 1) ANALYSIS CRITERIA

The analysis was performed for the existing and proposed appurtenances as specified in the loading information referenced below, and per the following loading criteria of Table 1.

**Table 1 – Loading and Analysis Criteria**

<b>Rad Center</b>	50' & 41'
<b>Structure Type</b>	Monopole Tower
<b>Exposure Category</b>	C
<b>Basic Wind Speed (3-Second Gust)</b>	$125 * \sqrt{0.6} = 97$ mph (Nominal)
<b>Ice Loading</b>	1.00" with 50 mph Wind
<b>Risk Category</b>	II
<b>Topographic Factor</b>	Kzt = 1.0

**Table 1.1 – Existing Appurtenance Configuration**

Qty	Model
3	Ericsson AIR21 B2A/B4P – Antennas
3	Ericsson AIR21 B4A/B12P – Antennas
3	Generic Twin Style 1B - AWS – TMAs

**Table 1.2 – Proposed and Final Appurtenance Configuration**

Qty	Model
3	Ericsson AIR32 B66A B2A – Antennas
3	Ericsson AIR6449 B41 – Antennas
3	RFS APXVAALL24_43-U-NA20 – Antennas
3	Radio 4449 B71 + B85 – RRUs*
3	Radio 4415 B25 – RRUs*
3	Generic Twin Style 1B - AWS – TMAs
3	SDX1926Q-43 – Diplexers
-	(2) Valmont/Site Pro 1 Double Support Arm Kits (P/N: RDS-NP) with (6) 6'-0" long, 2.0" STD pipe mounts at 51' antenna RAD

\*To be mounted below the antenna

**Table 1.3 – Assumed Material Properties**

Member Type	ASTM Material Designation	Fy (ksi)	Fu (ksi)
Pipes	A53 Gr. B	35	60
Angles/Channels	A36	36	58
Rectangular HSS	A500 Gr. B - 46	46	58
Round HSS	A500 Gr. B - 42	42	58
Others (UNO)	A572 Gr. 50	50	65

## 2) ANALYSIS PROCEDURE

The analysis is based on the following information:

**Table 2 – Documents**

Document	Provided By	Date
RFDS	T-Mobile	10/14/2020
Structural Analysis Report	Atlantis Group	09/04/2014

## 2.1) Analysis Method

Risa-3D, a commercially available analysis software package, was used to create a three-dimensional model of the mount and calculate member stresses for various loading cases. Selected output from the analysis is included in the Appendix.

## 2.2) Analysis Conditions and Assumptions

- 1) The mount was built and installed in accordance with the manufacturer's specifications.
- 2) The mount has been maintained and will be maintained in accordance with the manufacturer's specifications. All structural members and connections of the mount are in good condition and can achieve theoretical strength.
- 3) The configuration of antennas is as specified in "1) Analysis Criteria".
- 4) The analysis was performed for the subject mount only. It does not include an evaluation of the other mounts or the tower, which should be analyzed by others.
- 5) The evaluation does not include any antenna rigging loads. The equipment should not be rigged using the subject antenna mount as the support.
- 6) The analysis includes a minimum 250 lbf maintenance point load at the worst-case location on the mount, as well as a minimum 500 lbf maintenance point load at each antenna location in conjunction with a 30 mph wind load.
- 7) Any steel grating represented in this model is for loading purposes only and it is not considered to provide any structural restraint or support.
- 8) Member sizes per the available mount specifications and assumed based on our experience with similar structures. Please refer to calculation output in the appendix of this report for sizes and lengths assumed.
- 9) All member connections are assumed to have been designed to meet or exceed the load carrying capacity of the connected member unless otherwise specified in this report.

EFI Global, Inc. (EFI), must be notified immediately if any of these assumptions are discovered to be incorrect. The results of this analysis may be affected if any of the assumptions are not valid or have been made in error.

### 3) ANALYSIS RESULTS AND CONCLUSION

The analysis results are shown on the table below.

**Table 3.1 – Mount Component Stresses vs. Capacity – @ 50' Antenna RAD**

Component	% Capacity	Pass / Fail
Antenna Mount Pipe	33.0	Pass
Standoff Arm Tube	<20.0	Pass
Horizontal Face Pipe	<20.0	Pass

**T-Arm Mount @ 51' Antenna Rad:** The new t-arm mounts **will have adequate** capacity for the proposed changes by T-Mobile, **once the proposed modifications are completed. The existing pipe mounts at 51' level should be replaced with (2) Valmont/Site Pro 1 Double Support Arm Kits for 6 Antennas with No Pipes (P/N: RDS-NP), specs as attached on appendix, and (6) 6'-0" long, 2.0" STD pipe mounts. The pipe mounts should be attached to both support arm kits using pipe mount connection kits (P/N: SP219).** For the code specified load combinations and as a maximum, the mount members are stressed to **33.0%** of their structural capacity.

This analysis also assumes the following:

- The antenna RAD centerline should be at equidistant between top & bottom ring weldment.
- The top ring mount weldment should be attached at 51'-6" AGL (above grade level), at least 1.5' below the top of monopole.
- The ring mount weldments (top & bottom) should be spaced 36", vertically.

**Table 3.2 – Mount Component Stresses vs. Capacity – @ 41' Antenna RAD**

Component	% Capacity	Pass / Fail
Antenna Mount Pipe	84.9	Pass

**Chain Mount @ 41' Antenna Rad:** The existing pipe mounts have **adequate** capacity for the proposed changes by T-Mobile. For the code specified load combinations and as a maximum, the mount members are stressed to **84.9%** of their structural capacity.

**APPENDIX**

**INPUT LOADS**  
**ANALYSIS OUTPUT**  
**MOUNT SPECIFICATIONS**

CLIENT: Foresite LLC / T-Mobile  
 PROJECT: CTHA241C  
 SUBJECT: Antenna Loads - G Code with Sections 16 Revisions

Tower Height	53.00	ft	Type of Mount	Sector
Basic Wind Speed, V	97	mph (=Ultimate Speed* $\sqrt{0.6}$ )		
Basic Wind Speed with Ice, $V_i$	50	mph		
Maintenance Load Factor, $L_{FM}$	0.0957	Load Factor for Maint. Load Cases (Basic Wind Speed=30 mph)		
Design Ice Thickness, $t_i$	1	inches		

Table 2-3 Importance Factors

Structure Classification	Wind Load Without Ice	Wind Load With Ice	Ice Thickness	Earthquake
II	1	1	1	1

Table 2-4 Exposure Category Coefficients

Exposure Category	$Z_g$	$\alpha$	$K_{zmin}$	$K_e$	$m$
C	900	9.5	0.85	1	0.6

Table 2-5 Topographic Categories

$K_{zt}$  1.000

Table 2-2 Wind Directionality Factor,  $K_d$

Structure Type	$K_d$	
Monopole	0.95	DOES NOT CHANGE
<b>Gust Effect Factor <math>G_h</math></b>		
Structure Type	$G_h$	
Monopole	1.00	DOES NOT CHANGE
<b>Shielding Factor, <math>K_a</math></b>		
Structure Type	$K_a$	
Monopole	0.90	DOES NOT CHANGE

CLIENT: **Foresite LLC / T-Mobile**  
 PROJECT: **CTHA241C**  
 SUBJECT: **Antenna Loads - G Code with Sections 16 Revisions**

Rad Center **51.00** ft

**Antenna AND Mount Without Ice**

Mounting Pole	Height (ft)	Model Number	#	Weight (lbs)	H (in)	*W (in)	D (in)	Ka	**A <sub>N</sub> (ft2)	***A <sub>T</sub> (ft2)	Aspect (FRONT)	Aspect (SIDE)	Ca (FRONT)	Ca (SIDE)	K <sub>z</sub>	q <sub>z</sub> (psf)	Pounds			Total Wind Load (Front)	Total Wind Load (Side)	Total Dead Load	
																	Wind Load (Front)	Wind Load (Side)	Dead Load				
Pos. 1	51.00	Ericsson AIR32 B66A_B2A	1	172.0	59.3	12.9	8.7	0.90	5.30	3.58	4.60	6.81	1.29	1.39	1.098	25.1	154.9	112.7	171.96	155	113	172	
		Empty		0.0	-	-	-	0.90	-	-	-	-	-	-	-	-	-	0.0	0.0	0			
		Empty		0.0	-	-	-	0.90	-	-	-	-	-	-	-	-	-	0.0	0.0	0			
		Empty		0.0	-	-	-	0.90	-	-	-	-	-	-	-	-	-	0.0	0.0	0			
		Empty		0.0	-	-	-	0.90	-	-	-	-	-	-	-	-	-	0.0	0.0	0			
Pos. 2	51.00	Ericsson AIR6449 B41	1	114.6	33.1	20.5	8.5	0.90	4.72	1.96	1.61	3.88	1.20	1.26	1.098	25.1	128.0	56.0	114.63	128	56	115	
		Empty		0.0	-	-	-	0.90	-	-	-	-	-	-	-	-	-	0.0	0.0	0			
		Empty		0.0	-	-	-	0.90	-	-	-	-	-	-	-	-	-	0.0	0.0	0			
		Empty		0.0	-	-	-	0.90	-	-	-	-	-	-	-	-	-	0.0	0.0	0			
		Empty		0.0	-	-	-	0.90	-	-	-	-	-	-	-	-	-	0.0	0.0	0			
		Empty		0.0	-	-	-	0.90	-	-	-	-	-	-	-	-	0.0	0.0	0	0	0	0	
		Empty		0.0	-	-	-	0.90	-	-	-	-	-	-	-	-	-	0.0	0.0	0			
		Empty		0.0	-	-	-	0.90	-	-	-	-	-	-	-	-	-	0.0	0.0	0			
		Empty		0.0	-	-	-	0.90	-	-	-	-	-	-	-	-	-	0.0	0.0	0			
		Empty		0.0	-	-	-	0.90	-	-	-	-	-	-	-	-	-	0.0	0.0	0			
		Empty		0.0	-	-	-	0.90	-	-	-	-	-	-	-	-	0.0	0.0	0	0	0	0	
		Empty		0.0	-	-	-	0.90	-	-	-	-	-	-	-	-	-	0.0	0.0	0			
		Empty		0.0	-	-	-	0.90	-	-	-	-	-	-	-	-	-	0.0	0.0	0			
		Empty		0.0	-	-	-	0.90	-	-	-	-	-	-	-	-	-	0.0	0.0	0			
		Empty		0.0	-	-	-	0.90	-	-	-	-	-	-	-	-	-	0.0	0.0	0			

\* Enter N/A in the W column for front shielded apertures.

\*\* A<sub>N</sub> is the product of H and W

\*\*\* A<sub>T</sub> is the product of H and D

DL #REF!

Mount	Height (ft)	Member	*L (in)	**W (in)	D (in)	*** Ca	K <sub>z</sub>	q <sub>z</sub> (psf)	Wind Load (PLF)
	51.00	2.5 STD Pipe	0.00	2.88	0.00	-	-	-	-
	51.00	2.0 STD Pipe	12.00	2.38	0.00	1.20	1.098	22.6	5
	51.00	3.0 STD Pipe	12.00	3.50	0.00	1.20	1.098	22.6	8
	51.00	3/4" SR	0.00	0.75	0.00	-	-	-	-
	51.00	L3x3x4	0.00	3.00	3.00	-	-	-	-
	51.00	L3x1.75x3	0.00	3.00	1.75	-	-	-	-
	51.00	Angle Diagonal	0.00	0.00	0.00	-	-	-	-
	51.00	Plate Horizontal (PL0.625x3.5)	0.00	0.63	3.50	-	-	-	-
	51.00	Plate Horizontal (PL2x0.625)	0.00	2.00	0.63	-	-	-	-
	51.00	HSS4x4x4	12.00	4.00	4.00	2.00	1.098	22.6	15
	51.00	Double Angle (LL2x2x3x0)	0.00	2.00	2.00	-	-	-	-
	51.00	Double Angle (LL3x3x4x0)	0.00	3.00	3.00	-	-	-	-
	51.00	Channel (Weak Axis Bending)	0.00	0.00	0.00	-	-	-	-
	51.00	Invert U 5.375x3.625x.375	0.00	3.63	5.38	-	-	-	-

\* The dimension L is the longest dimension of the member

\*\* The dimension W is the height or width of the member that resists wind load

\*\*\* Ca will equal 1.2 for round members and 2.0 for flat members

CLIENT: **Foresite LLC / T-Mobile**  
 PROJECT: **CTHA241C**  
 SUBJECT: **Antenna Loads - G Code with Sections 16 Revisions**

ti (in) 2.088986 Kiz 1.0444932 reduction 0.2657

Antenna AND Mount With Ice																Pounds							
Mounting Pole	Height (ft)	Model Number	#	H (in)	W (in)	D (in)	Ka	*A <sub>N</sub> (ft <sup>2</sup> )	*A <sub>T</sub> (ft <sup>2</sup> )	*Volume Ice (ft <sup>3</sup> )	*Weight Ice (lbs)	**Ca (FRONT)	**Ca (SIDE)	Kz	q <sub>z</sub> (psf)	Ice Wind Load (Front)	Ice Wind Load (Side)	Combined Wind Load (Front)	Combined Wind Load (Side)	Ice Dead Load	**Total Wind Load (Front)	**Total Wind Load (Side)	Total Ice Load
Pos. 1	51.00	Ericsson AIR32 B66A_B2A	1	59.3	12.9	8.7	0.90	2.21	2.09	4.22	236.28	0.73	0.75	1.098	6.7	9.7	9.5	50.8	39.4	236	51	39	236
		Empty		-	-	-	0.90	-	-	-	0.00	-	-	-	-	0.0	0.0	0.0	0.0	0			
		Empty		-	-	-	0.90	-	-	-	0.00	-	-	-	-	0.0	0.0	0.0	0.0	0			
		Empty		-	-	-	0.90	-	-	-	0.00	-	-	-	-	0.0	0.0	0.0	0.0	0			
		Empty		-	-	-	0.90	-	-	-	0.00	-	-	-	-	0.0	0.0	0.0	0.0	0			
Pos.2	51.00	Ericsson AIR6449 B41	1	33.1	20.5	8.5	0.90	1.68	1.33	3.42	191.47	0.70	0.71	1.098	6.7	7.1	5.7	41.1	20.6	191	26	20	119
		Empty		-	-	-	0.90	-	-	-	0.00	-	-	-	-	0.0	0.0	0.0	0.0	0	41	21	191
		Empty		-	-	-	0.90	-	-	-	0.00	-	-	-	-	0.0	0.0	0.0	0.0	0			
		Empty		-	-	-	0.90	-	-	-	0.00	-	-	-	-	0.0	0.0	0.0	0.0	0			
		Empty		-	-	-	0.90	-	-	-	0.00	-	-	-	-	0.0	0.0	0.0	0.0	0			
		Empty		-	-	-	0.90	-	-	-	0.00	-	-	-	-	0.0	0.0	0.0	0.0	0			
		Empty		-	-	-	0.90	-	-	-	0.00	-	-	-	-	0.0	0.0	0.0	0.0	0			
		Empty		-	-	-	0.90	-	-	-	0.00	-	-	-	-	0.0	0.0	0.0	0.0	0			
		Empty		-	-	-	0.90	-	-	-	0.00	-	-	-	-	0.0	0.0	0.0	0.0	0			
		Empty		-	-	-	0.90	-	-	-	0.00	-	-	-	-	0.0	0.0	0.0	0.0	0			
		Empty		-	-	-	0.90	-	-	-	0.00	-	-	-	-	0.0	0.0	0.0	0.0	0			
		Empty		-	-	-	0.90	-	-	-	0.00	-	-	-	-	0.0	0.0	0.0	0.0	0			
		Empty		-	-	-	0.90	-	-	-	0.00	-	-	-	-	0.0	0.0	0.0	0.0	0			
		Empty		-	-	-	0.90	-	-	-	0.00	-	-	-	-	0.0	0.0	0.0	0.0	0			
		Empty		-	-	-	0.90	-	-	-	0.00	-	-	-	-	0.0	0.0	0.0	0.0	0			
		Empty		-	-	-	0.90	-	-	-	0.00	-	-	-	-	0.0	0.0	0.0	0.0	0			
		Empty		-	-	-	0.90	-	-	-	0.00	-	-	-	-	0.0	0.0	0.0	0.0	0			
		Empty		-	-	-	0.90	-	-	-	0.00	-	-	-	-	0.0	0.0	0.0	0.0	0			
		Empty		-	-	-	0.90	-	-	-	0.00	-	-	-	-	0.0	0.0	0.0	0.0	0			
		Empty		-	-	-	0.90	-	-	-	0.00	-	-	-	-	0.0	0.0	0.0	0.0	0			
		Empty		-	-	-	0.90	-	-	-	0.00	-	-	-	-	0.0	0.0	0.0	0.0	0			
		Empty		-	-	-	0.90	-	-	-	0.00	-	-	-	-	0.0	0.0	0.0	0.0	0			
		Empty		-	-	-	0.90	-	-	-	0.00	-	-	-	-	0.0	0.0	0.0	0.0	0			
		Empty		-	-	-	0.90	-	-	-	0.00	-	-	-	-	0.0	0.0	0.0	0.0	0			
		Empty		-	-	-	0.90	-	-	-	0.00	-	-	-	-	0.0	0.0	0.0	0.0	0			
		Empty		-	-	-	0.90	-	-	-	0.00	-	-	-	-	0.0	0.0	0.0	0.0	0			
		Empty		-	-	-	0.90	-	-	-	0.00	-	-	-	-	0.0	0.0	0.0	0.0	0			
		Empty		-	-	-	0.90	-	-	-	0.00	-	-	-	-	0.0	0.0	0.0	0.0	0			
		Empty		-	-	-	0.90	-	-	-	0.00	-	-	-	-	0.0	0.0	0.0	0.0	0			
		Empty		-	-	-	0.90	-	-	-	0.00	-	-	-	-	0.0	0.0	0.0	0.0	0			
		Empty		-	-	-	0.90	-	-	-	0.00	-	-	-	-	0.0	0.0	0.0	0.0	0			
		Empty		-	-	-	0.90	-	-	-	0.00	-	-	-	-	0.0	0.0	0.0	0.0	0			
		Empty		-	-	-	0.90	-	-	-	0.00	-	-	-	-	0.0	0.0	0.0	0.0	0			
		Empty		-	-	-	0.90	-	-	-	0.00	-	-	-	-	0.0	0.0	0.0	0.0	0			
		Empty		-	-	-	0.90	-	-	-	0.00	-	-	-	-	0.0	0.0	0.0	0.0	0			
		Empty		-	-	-	0.90	-	-	-	0.00	-	-	-	-	0.0	0.0	0.0	0.0	0			
		Empty		-	-	-	0.90	-	-	-	0.00	-	-	-	-	0.0	0.0	0.0	0.0	0			
		Empty		-	-	-	0.90	-	-	-	0.00	-	-	-	-	0.0	0.0	0.0	0.0	0			
		Empty		-	-	-	0.90	-	-	-	0.00	-	-	-	-	0.0	0.0	0.0	0.0	0			
		Empty		-	-	-	0.90	-	-	-	0.00	-	-	-	-	0.0	0.0	0.0	0.0	0			
		Empty		-	-	-	0.90	-	-	-	0.00	-	-	-	-	0.0	0.0	0.0	0.0	0			
		Empty		-	-	-	0.90	-	-	-	0.00	-	-	-	-	0.0	0.0	0.0	0.0	0			
		Empty		-	-	-	0.90	-	-	-	0.00	-	-	-	-	0.0	0.0	0.0	0.0	0			
		Empty		-	-	-	0.90	-	-	-	0.00	-	-	-	-	0.0	0.0	0.0	0.0	0			
		Empty		-	-	-	0.90	-	-	-	0.00	-	-	-	-	0.0	0.0	0.0	0.0	0			
		Empty		-	-	-	0.90	-	-	-	0.00	-	-	-	-	0.0	0.0	0.0	0.0	0			
		Empty		-	-	-	0.90	-	-	-	0.00	-	-	-	-	0.0	0.0	0.0	0.0	0			
		Empty		-	-	-	0.90	-	-	-	0.00	-	-	-	-	0.0	0.0	0.0	0.0	0			
		Empty		-	-	-	0.90	-	-	-	0.00	-	-	-	-	0.0	0.0	0.0	0.0	0			
		Empty		-	-	-	0.90	-	-	-	0.00	-	-	-	-	0.0	0.0	0.0	0.0	0			
		Empty		-	-	-	0.90	-	-	-	0.00	-	-	-	-	0.0	0.0	0.0	0.0	0			
		Empty		-	-	-	0.90	-	-	-	0.00	-	-	-	-	0.0	0.0	0.0	0.0	0			
		Empty		-	-	-	0.90	-	-	-	0.00	-	-	-	-	0.0	0.0	0.0	0.0	0			
		Empty		-	-	-	0.90	-	-	-	0.00	-	-	-	-	0.0	0.0	0.0	0.0	0			
		Empty		-	-	-	0.90	-	-	-	0.00	-	-	-	-	0.0	0.0	0.0	0.0	0			
		Empty		-	-	-	0.90	-	-	-	0.00	-	-	-	-	0.0	0.0	0.0	0.0	0			
		Empty		-	-	-	0.90	-	-	-	0.00	-	-	-	-	0.0	0.0	0.0	0.0	0			
		Empty		-	-	-	0.90	-	-	-	0.00	-	-	-	-	0.0	0.0	0.0	0.0	0			
		Empty		-	-	-	0.90	-	-	-	0.00	-	-	-	-	0.0	0.0	0.0	0.0	0			
		Empty		-	-	-	0.90	-	-	-	0.00	-	-	-	-	0.0	0.0	0.0	0.0	0			
		Empty		-	-	-	0.90	-	-	-	0.00	-	-	-	-	0.0	0.0	0.0	0.0	0			
		Empty		-	-	-	0.90	-	-	-	0.00	-	-	-	-	0.0	0.0	0.0	0.0	0			
		Empty		-	-	-	0.90	-	-	-	0.00	-	-	-	-	0.0	0.0	0.0	0.0	0			
		Empty		-	-	-	0.90	-	-	-	0.00	-	-	-	-	0.0	0.0	0.0	0.0	0			
		Empty		-	-	-	0.90	-	-	-	0.00	-	-	-	-	0.0	0.0	0.0	0.0	0			
		Empty																					



CLIENT: Foresite LLC / T-Mobile  
 PROJECT: CTHA241C  
 SUBJECT: Antenna Loads - G Code with Sections 16 Revisions

Tower Height 53.00 ft Type of Mount Sector  
 Basic Wind Speed, V 97 mph (=Ultimate Speed\* $\sqrt{0.6}$ )  
 Basic Wind Speed with Ice,  $V_i$  50 mph  
 Maintenance Load Factor,  $L_{FM}$  0.0957 Load Factor for Maint. Load Cases (Basic Wind Speed=30 mph)  
 Design Ice Thickness,  $t_i$  1 inches

Table 2-3 Importance Factors

Structure Classification	Wind Load Without Ice	Wind Load With Ice	Ice Thickness	Earthquake
II	1	1	1	1

Table 2-4 Exposure Category Coefficients

Exposure Category	Zg	$\alpha$	Kzmin	Ke	m
C	900	9.5	0.85	1	0.6

Table 2-5 Topographic Categories

Kzt 1.000

Table 2-2 Wind Directionality Factor, Kd

Structure Type	Kd
Monopole	0.95

DOES NOT CHANGE

Gust Effect Factor Gh

Structure Type	Gh
Monopole	1.00

DOES NOT CHANGE

Shielding Factor, Ka

Structure Type	Ka
Monopole	0.90

DOES NOT CHANGE

CLIENT: Foresite LLC / T-Mobile  
 PROJECT: CTHA241C  
 SUBJECT: Antenna Loads - G Code with Sections 16 Revisions

Rad Center 41.00 ft

**Antenna AND Mount Without Ice**

Mounting Pole	Height (ft)	Model Number	#	Weight (lbs)	H (in)	*W (in)	D (in)	Ka	**A <sub>w</sub> (ft2)	***A <sub>r</sub> (ft2)	Aspect (FRONT)	Aspect (SIDE)	Ca (FRONT)	Ca (SIDE)	K <sub>z</sub>	q <sub>z</sub> (psf)	Pounds			Total Wind Load (Front)	Total Wind Load (Side)	Total Dead Load	
																	Wind Load (Front)	Wind Load (Side)	Dead Load				
Pos.3	41.00	RFS APXVAALL24_43-U-NA20	1	149.9	95.9	24.0	8.5	0.90	15.98	5.66	4.00	11.28	1.27	1.54	1.049	24.0	437.3	188.7	149.9	437	195	167	
	41.00	SDX1926Q-43	1	6.2	4.2	N/A	2.9	0.90	-	0.08	-	1.43	-	1.20	1.049	24.0	0.0	2.2	6.17				
	41.00	Generic Twin Style 1B - AWS	1	11.0	7.0	N/A	3.0	0.90	-	0.15	-	2.33	-	1.20	1.049	24.0	0.0	3.8	11				
		Empty		0.0	-	-	-	-	0.90	-	-	-	-	-	-	-	-	0.0	0.0	0			
		Empty		0.0	-	-	-	-	0.90	-	-	-	-	-	-	-	-	0.0	0.0	0	219	98	84
below Antenna	41.00	Empty		0.0	-	-	-	0.90	-	-	-	-	-	-	-	-	-	0.0	0.0	0	78	49	117
	41.00	Radio 4449 B71+B85	1	73.2	17.9	13.2	10.6	0.90	1.64	1.32	1.36	1.68	1.20	1.20	1.049	24.0	42.6	34.3	73.21				
	41.00	Radio 4415 B25	1	44.0	15.0	13.2	5.4	0.90	1.37	0.56	1.13	2.78	1.20	1.21	1.049	24.0	35.5	14.7	44				
		Empty		0.0	-	-	-	-	0.90	-	-	-	-	-	-	-	-	0.0	0.0	0			
		Empty		0.0	-	-	-	0.90	-	-	-	-	-	-	-	-	-	0.0	0.0	0	40	25	59
		Empty		0.0	-	-	-	0.90	-	-	-	-	-	-	-	-	-	0.0	0.0	0	0	0	0
		Empty		0.0	-	-	-	0.90	-	-	-	-	-	-	-	-	-	0.0	0.0	0	0	0	0
		Empty		0.0	-	-	-	0.90	-	-	-	-	-	-	-	-	-	0.0	0.0	0	0	0	0
		Empty		0.0	-	-	-	0.90	-	-	-	-	-	-	-	-	-	0.0	0.0	0	0	0	0
		Empty		0.0	-	-	-	0.90	-	-	-	-	-	-	-	-	-	0.0	0.0	0	0	0	0

\* Enter N/A in the W column for front shielded apertures.

\*\* A<sub>w</sub> is the product of H and W

\*\*\* A<sub>r</sub> is the product of H and D

DL #REF!

Mount	Height (ft)	Member	*L (in)	**W (in)	D (in)	*** Ca	K <sub>z</sub>	q <sub>z</sub> (psf)	Wind Load (PLF)
	41.00	2.5 STD Pipe	0.00	2.88	0.00	-	-	-	-
	41.00	2.0 STD Pipe	12.00	2.38	0.00	1.20	1.049	21.6	5
	41.00	5/8" SR	0.00	0.63	0.00	-	-	-	-
	41.00	3/4" SR	0.00	0.75	0.00	-	-	-	-
	41.00	L3x3x4	0.00	3.00	3.00	-	-	-	-
	41.00	L3x1.75x3	0.00	3.00	1.75	-	-	-	-
	41.00	Angle Diagonal	0.00	0.00	0.00	-	-	-	-
	41.00	Plate Horizontal (PL0.625x3.5)	0.00	0.63	3.50	-	-	-	-
	41.00	Plate Horizontal (PL2x0.625)	0.00	2.00	0.63	-	-	-	-
	41.00	Tube Radial (4x4)	0.00	4.00	4.00	-	-	-	-
	41.00	Double Angle (LL2x2x3x0)	0.00	2.00	2.00	-	-	-	-
	41.00	Double Angle (LL3x3x4x0)	0.00	3.00	3.00	-	-	-	-
	41.00	Channel (Weak Axis Bending)	0.00	0.00	0.00	-	-	-	-
	41.00	Invert U 5.375x3.625x.375	0.00	3.63	5.38	-	-	-	-

\* The dimension L is the longest dimension of the member

\*\* The dimension W is the height or width of the member that resists wind load

\*\*\* Ca will equal 1.2 for round members and 2.0 for flat members

CLIENT: Foresite LLC / T-Mobile  
 PROJECT: CTHA241C  
 SUBJECT: Antenna Loads - G Code with Sections 16 Revisions

ti (in) 2.043887 Kiz 1.0219437 reduction 0.2657

**Antenna AND Mount With Ice**

Mounting Pole	Height (ft)	Model Number	#	H (in)	W (in)	D (in)	Ka	*A <sub>N</sub> (ft2)	*A <sub>T</sub> (ft2)	*Volume Ice (ft3)	*Weight Ice (lbs)	**Ca (FRONT)	**Ca (SIDE)	Kz	q <sub>z</sub> (psf)	Pounds							
																Ice Wind Load (Front)	Ice Wind Load (Side)	Combined Wind Load (Front)	Combined Wind Load (Side)	Ice Dead Load	**Total Wind Load (Front)	**Total Wind Load (Side)	Total Ice Load
Pos.3	41.00	RFS APXVAALL24_43-U-NA20	1	95.9	24.0	8.5	0.90	3.52	3.08	9.14	511.66	0.72	0.82	1.049	6.4	14.6	14.5	130.8	64.6	512	131	69	551
	41.00	SDX1926Q-43	1	4.2	6.9	2.9	0.90	-	0.32	0.32	17.92	0.70	0.70	1.049	6.4	0.0	1.3	0.0	1.9	18			
	41.00	Generic Twin Style 1B - AWS	1	7.0	6.0	3.0	0.90	-	0.40	0.39	21.61	0.70	0.70	1.049	6.4	0.0	1.6	0.0	2.6	22			
		Empty			-	-	-	0.90	-	-	-	0.00	-	-	-	-	0.0	0.0	0.0	0.0	0		
		Empty		-	-	-	0.90	-	-	-	0.00	-	-	-	-	0.0	0.0	0.0	0.0	0			
below Antenna	41.00	Empty		-	-	-	0.90	-	-	-	0.00	-	-	-	-	0.0	0.0	0.0	0.0	0	66	35	276
	41.00	Radio 4449 B71+B85	1	17.9	13.2	10.6	0.90	1.00	0.93	1.78	99.94	0.70	0.70	1.049	6.4	4.0	3.7	15.3	12.8	100	28	20	167
	41.00	Radio 4415 B25	1	15.0	13.2	5.4	0.90	0.92	0.69	1.19	66.62	0.70	0.70	1.049	6.4	3.7	2.8	13.1	6.7	67			
		Empty			-	-	-	0.90	-	-	-	0.00	-	-	-	-	0.0	0.0	0.0	0.0	0		
		Empty		-	-	-	0.90	-	-	-	0.00	-	-	-	-	0.0	0.0	0.0	0.0	0			
		Empty		-	-	-	0.90	-	-	-	0.00	-	-	-	-	0.0	0.0	0.0	0.0	0			
		Empty		-	-	-	0.90	-	-	-	0.00	-	-	-	-	0.0	0.0	0.0	0.0	0			
		Empty		-	-	-	0.90	-	-	-	0.00	-	-	-	-	0.0	0.0	0.0	0.0	0			
		Empty		-	-	-	0.90	-	-	-	0.00	-	-	-	-	0.0	0.0	0.0	0.0	0	0	0	0
		Empty		-	-	-	0.90	-	-	-	0.00	-	-	-	-	0.0	0.0	0.0	0.0	0	0	0	0
		Empty		-	-	-	0.90	-	-	-	0.00	-	-	-	-	0.0	0.0	0.0	0.0	0	0	0	0
		Empty		-	-	-	0.90	-	-	-	0.00	-	-	-	-	0.0	0.0	0.0	0.0	0	0	0	0
		Empty		-	-	-	0.90	-	-	-	0.00	-	-	-	-	0.0	0.0	0.0	0.0	0	0	0	0

\* A<sub>N</sub>, A<sub>T</sub>, Volume Ice and Weight Ice are calculated per unit  
 \*\* Ca will equal 1.2 for all ice load calculations

Mount	Height (ft)	Member	*L (in)	**W (in)	D (in)	***A <sub>N</sub> (ft2)	Volume Ice (ft3)	Weight Ice (lbs)	****Ca (FRONT)	Kz	q <sub>z</sub> (psf)	PLF		
												Ice Wind Load (Front)	Combined Wind Load (Front)	Ice Dead Load
	41.00	2.5 STD Pipe	0.00	2.88	0.00	-	-	-	-	-	-	-	-	-
	41.00	2.0 STD Pipe	12.00	2.38	0.00	0.52	0.20	11.03	1.20	1.049	5.7	3.6	5.0	11
	41.00	5/8" SR	0.00	0.63	0.00	-	-	-	-	-	-	-	-	-
	41.00	3/4" SR	0.00	0.75	0.00	-	-	-	-	-	-	-	-	-
	41.00	L3x3x4	0.00	3.00	3.00	-	-	-	-	-	-	-	-	-
	41.00	L3x1.75x3	0.00	3.00	1.75	-	-	-	-	-	-	-	-	-
	41.00	Angle Diagonal	0.00	0.00	0.00	-	-	-	-	-	-	-	-	-
	41.00	Plate Horizontal (PL0.625x3.5)	0.00	0.63	3.50	-	-	-	-	-	-	-	-	-
	41.00	Plate Horizontal (PL2x0.625)	0.00	2.00	0.63	-	-	-	-	-	-	-	-	-
	41.00	Tube Radial (4x4)	0.00	4.00	4.00	-	-	-	-	-	-	-	-	-
	41.00	Double Angle (LL2x2x3x0)	0.00	2.00	2.00	-	-	-	-	-	-	-	-	-
	41.00	Double Angle (LL3x3x4x0)	0.00	3.00	3.00	-	-	-	-	-	-	-	-	-
	41.00	Channel (Weak Axis Bending)	0.00	0.00	0.00	-	-	-	-	-	-	-	-	-
	41.00	Invert U 5.375x3.625x.375	0.00	3.63	5.38	-	-	-	-	-	-	-	-	-

\* The dimension L is the longest dimension of the member  
 \*\* The dimension W is the height or width of the member that resists wind load  
 \*\*\* A<sub>N</sub> is the area of ice built up on the LW plane  
 \*\*\*\* Ca will equal 1.2 for all ice load calculations

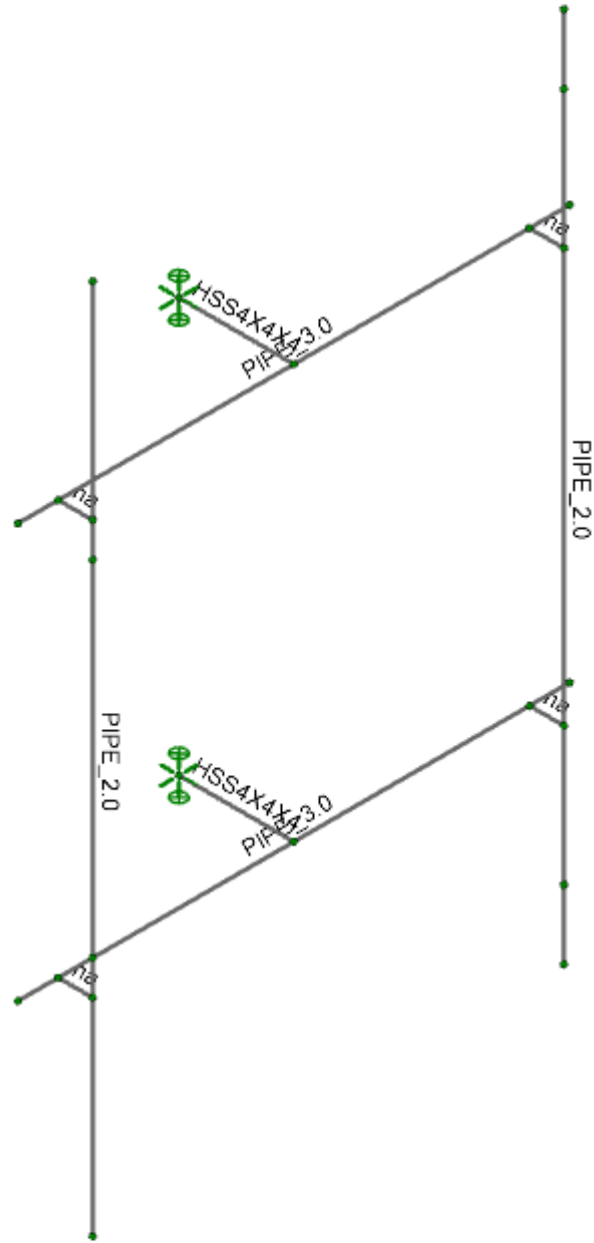

Envelope Only Solution

Foresite LLC / EFI Global Inc.	CTHA241C - 51'	1
GHK		Dec 02, 2020
049.00939 - 2075087		CTHA241C - Replacement - 51' - ...

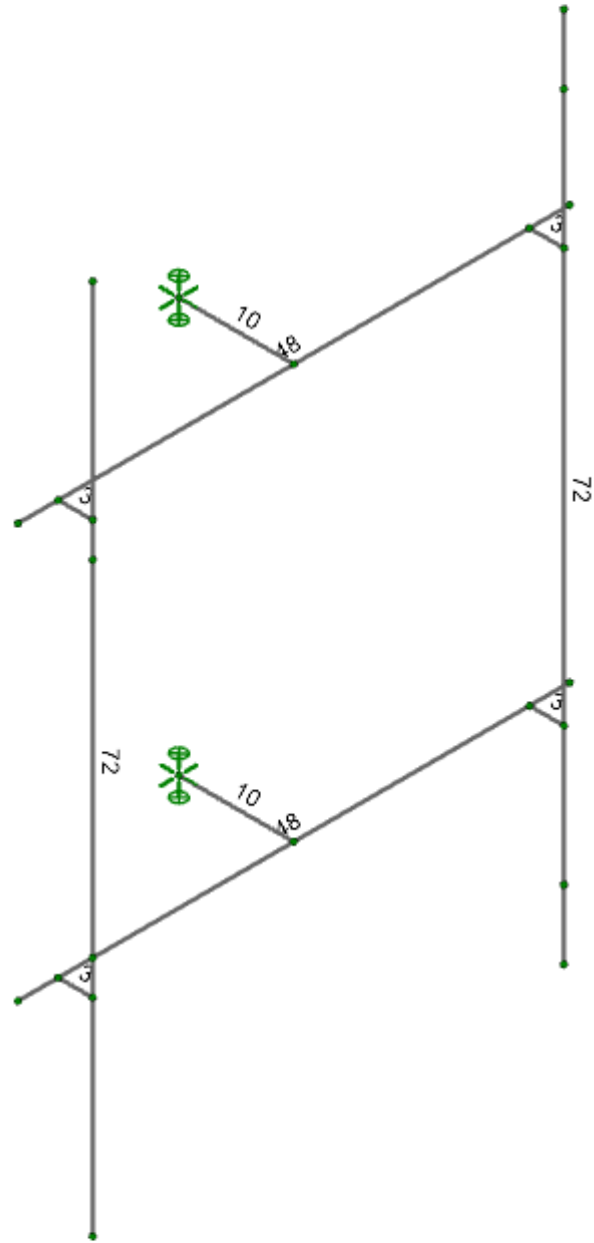
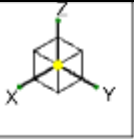

Member Length (in) Displayed  
Envelope Only Solution

Foresite LLC / EFI Global Inc.	CTHA241C - 51'	2
GHK		Dec 02, 2020
049.00939 - 2075087		CTHA241C - Replacement - 51' - ...

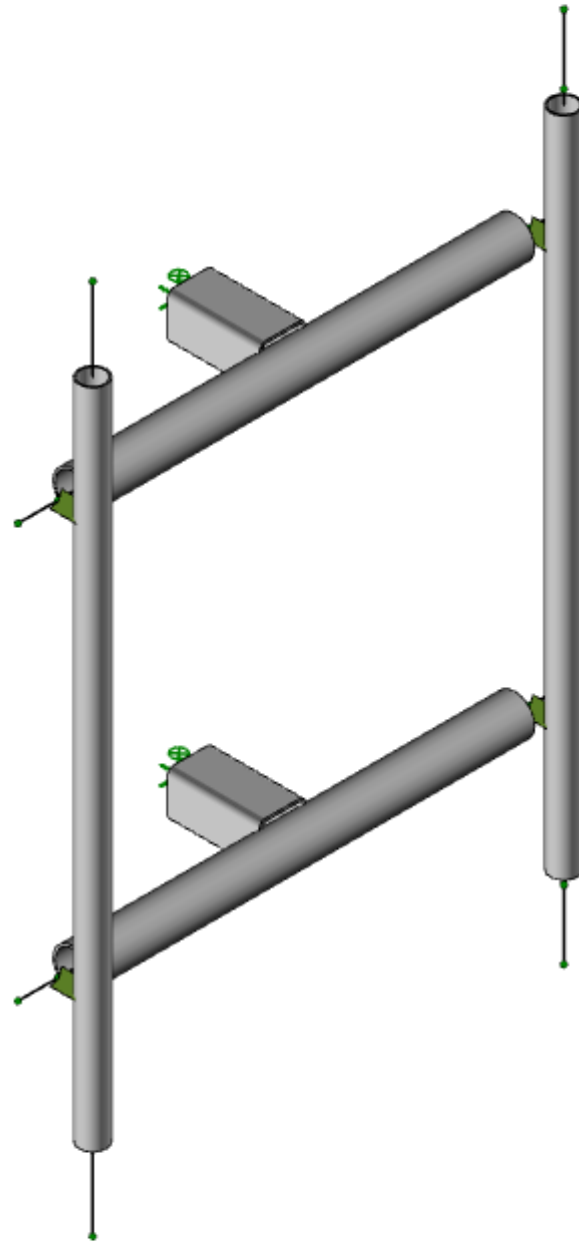

Member Length (in) Displayed  
Envelope Only Solution

Foresite LLC / EFI Global Inc.	CTHA241C - 51'	3
GHK		Dec 02, 2020
049.00939 - 2075087		CTHA241C - Replacement - 51' - ...

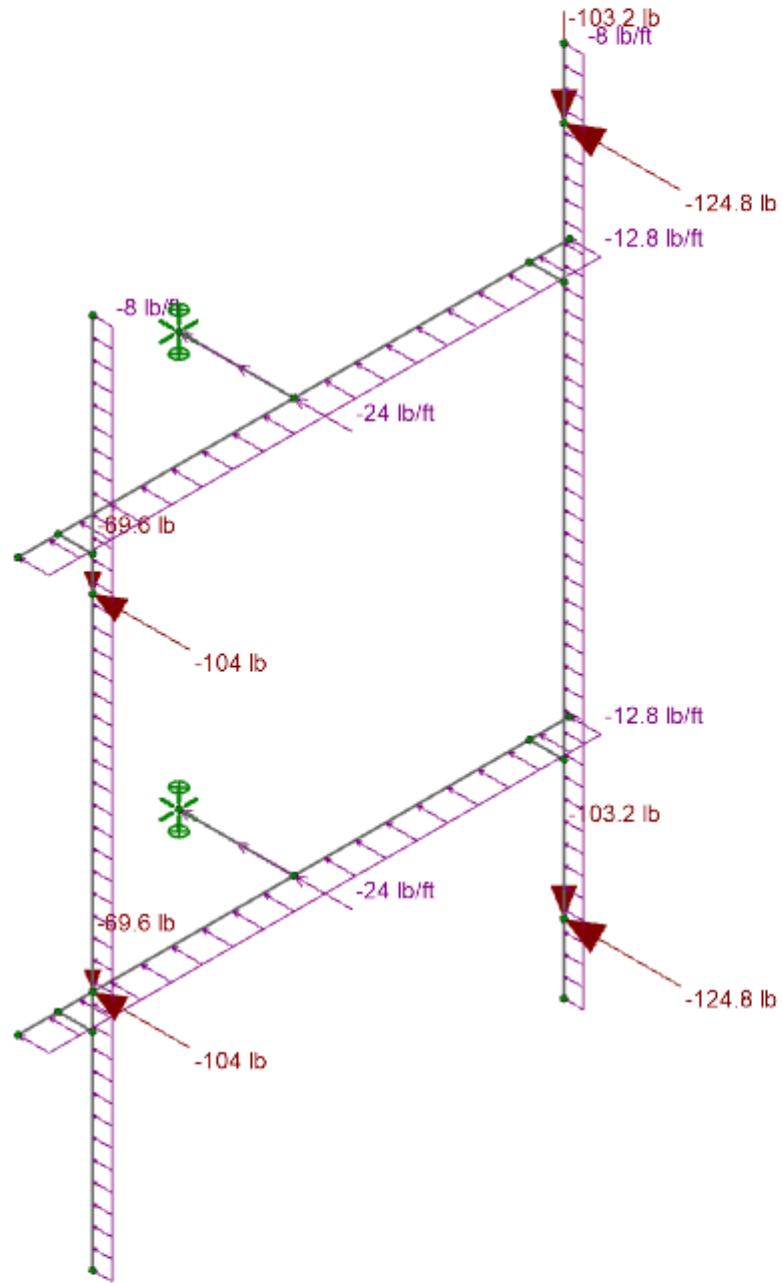

Loads: LC 1, DL + WL (NO ICE) 0 Degree  
Envelope Only Solution

Foresite LLC / EFI Global Inc.

CTHA241C - 51'

4

GHK

Dec 02, 2020

049.00939 - 2075087

CTHA241C - Replacement - 51' - ...



Code Check (Env)	
Black	No Calc
Red	> 1.0
Magenta	90-1.0
Green	.75-.90
Cyan	.50-.75
Blue	.0-.50

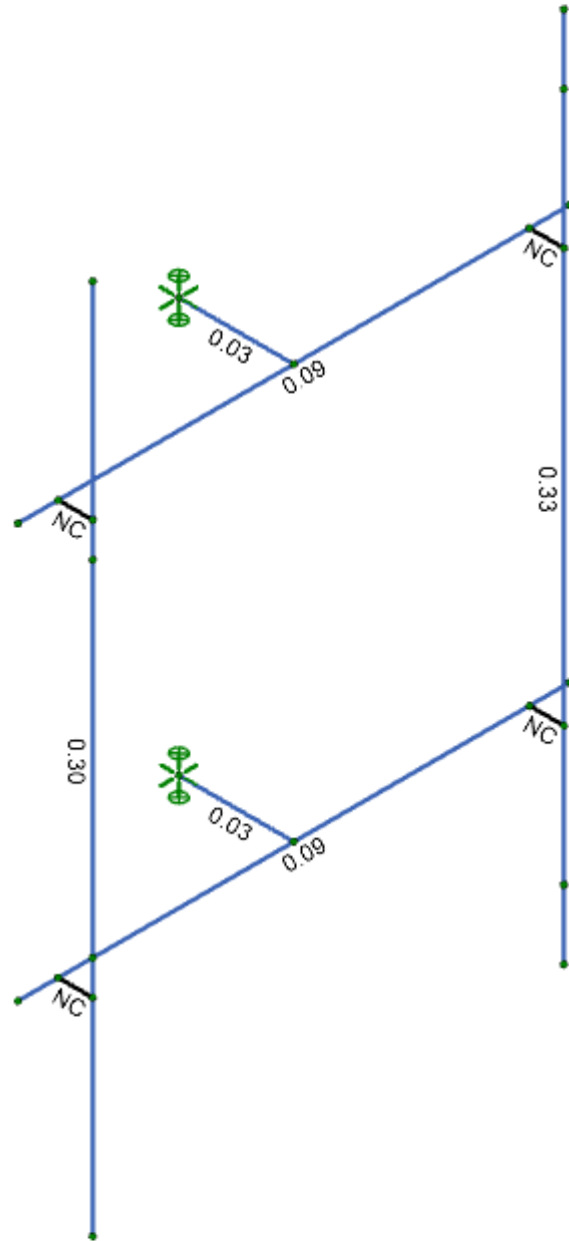

Member Code Checks Displayed (Enveloped)  
Envelope Only Solution

Foresite LLC / EFI Global Inc.	CTHA241C - 51'	5
GHK		Dec 02, 2020
049.00939 - 2075087		CTHA241C - Replacement - 51' - ...



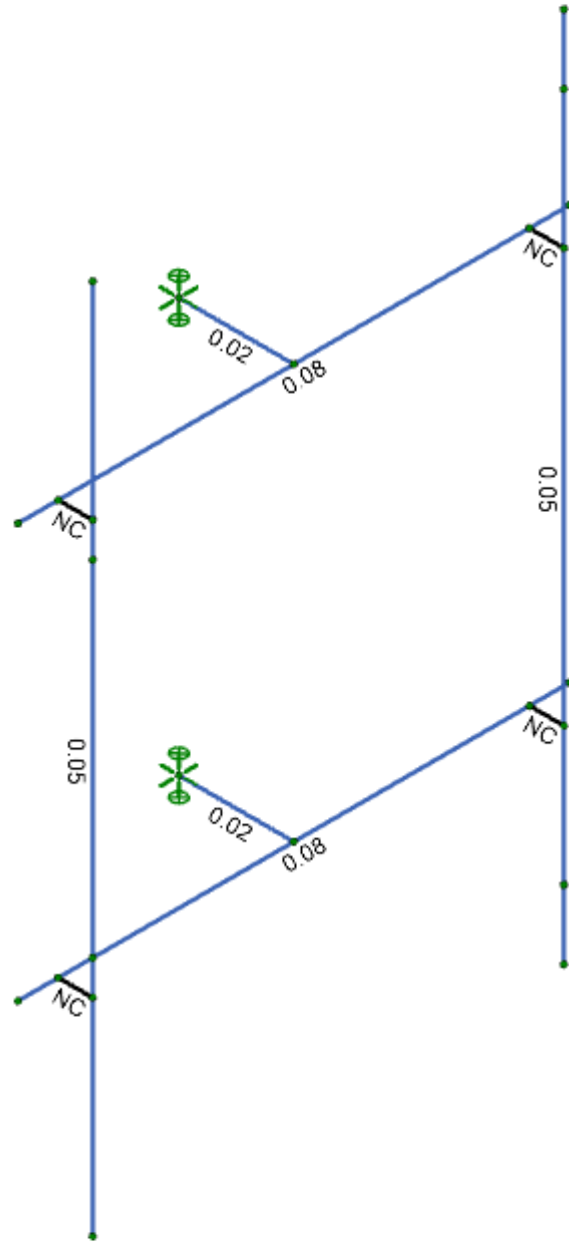
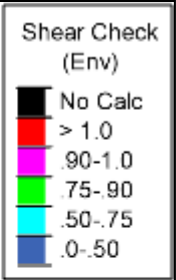
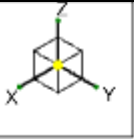

Member Shear Checks Displayed (Enveloped)  
Envelope Only Solution

Foresite LLC / EFI Global Inc.	CTHA241C - 51'	6
GHK		Dec 02, 2020
049.00939 - 2075087		CTHA241C - Replacement - 51' - ...

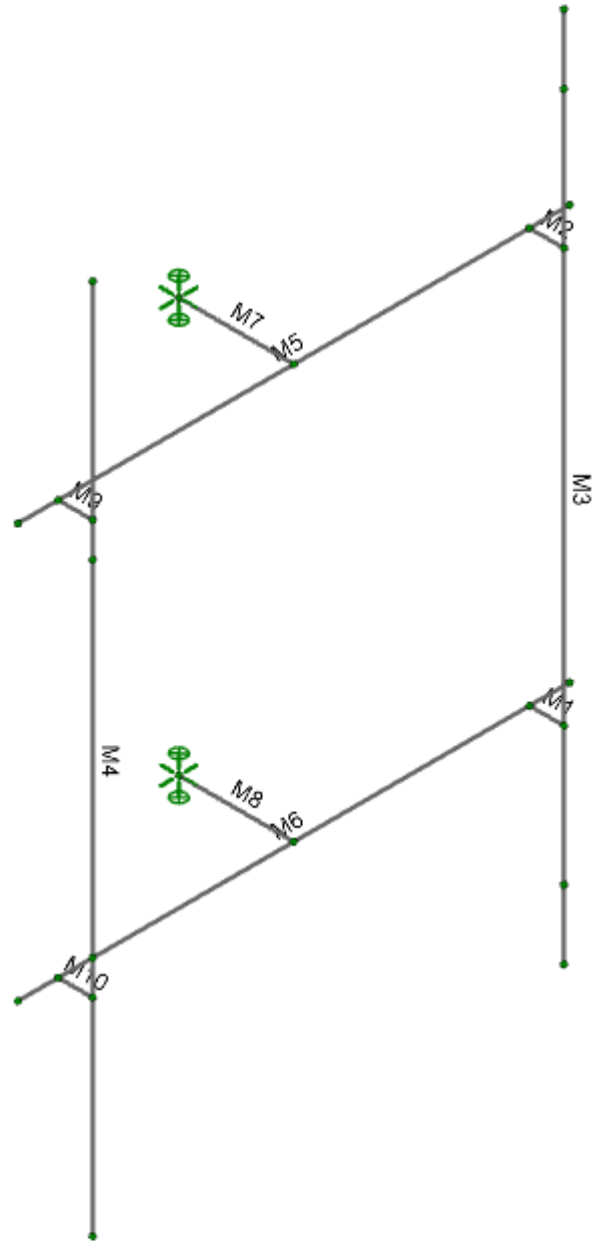

Envelope Only Solution

Foresite LLC / EFI Global Inc.  
GHK  
049.00939 - 2075087

CTHA241C - 51'

7

Dec 02, 2020

CTHA241C - Replacement - 51' - ...

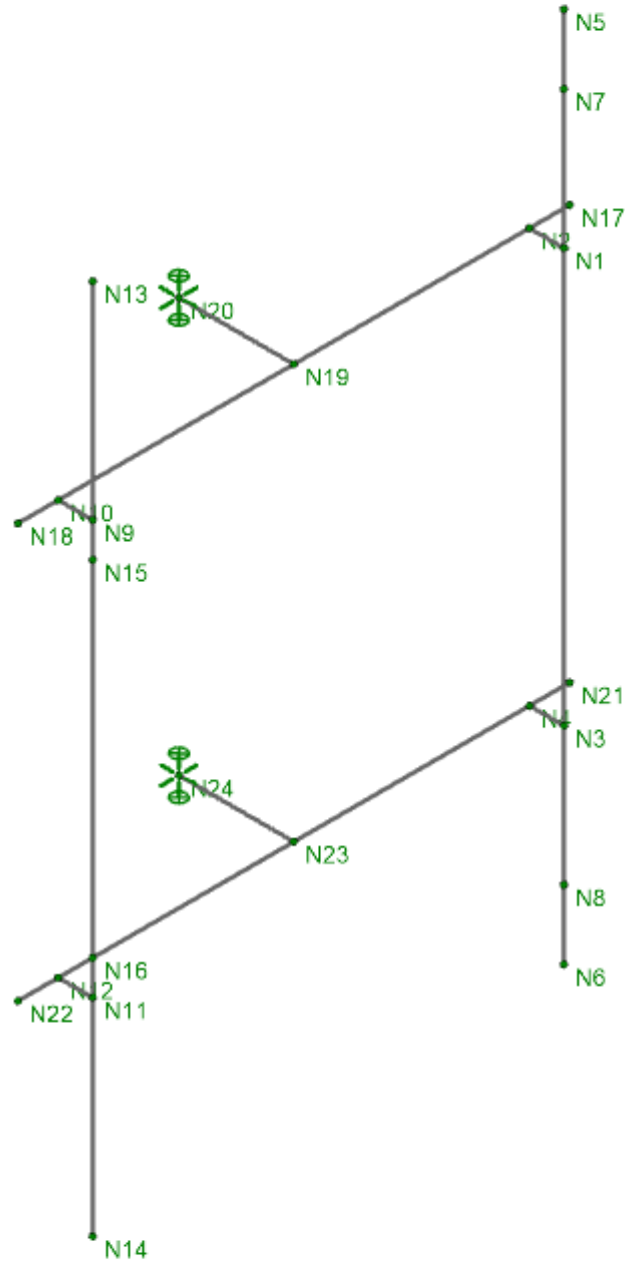
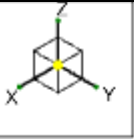

Envelope Only Solution

Foresite LLC / EFI Global Inc.

CTHA241C - 51'

8

GHK

Dec 02, 2020

049.00939 - 2075087

CTHA241C - Replacement - 51' - ...

**Model Settings**

Number of Reported Sections	5
Number of Internal Sections	97
Member Area Load Mesh Size (in <sup>2</sup> )	144
Consider Shear Deformation	Yes
Consider Torsional Warping	Yes

Approximate Mesh Size (in)	12
Transfer Forces Between Intersecting Wood Walls	No
Increase Wood Wall Nailing Capacity for Wind Loads	Yes
Include P-Delta for Walls	Yes
Optimize Masonry and Wood Walls	Yes
Maximum Number of Iterations	3

Single	No
Multiple (Optimum)	Yes
Maximum	No

Global Axis corresponding to vertical direction	Z
Convert Existing Data	Yes

Default Global Plane for z-axis	XZ
---------------------------------	----

Plate Local Axis Orientation	Nodal
------------------------------	-------

Hot Rolled Steel	AISC 14th (360-10): LRFD
Stiffness Adjustment	Yes (Iterative)
Notional Annex	None
Connections	AISC 14th (360-10): LRFD
Cold Formed Steel	AISI NAS-01: ASD
Stiffness Adjustment	Yes (Iterative)
Wood	AF&PA NDS-05/08: ASD
Temperature	< 100F
Concrete	ACI 318-05
Masonry	ACI 530-05: ASD
Aluminum	AA ADM1-05: ASD
Structure Type	Building
Stiffness Adjustment	Yes (Iterative)
Stainless	AISC 14th (360-10): ASD
Stiffness Adjustment	Yes (Iterative)

Analysis Methodology	Exact Integration Method
Parme Beta Factor	0.65
Compression Stress Block	Rectangular Stress Block
Analyze using Cracked Sections	Yes
Leave room for horizontal rebar splices (2*d bar spacing)	No
List forces which were ignored for design in the Detail Report	Yes

Column Min Steel	1
Column Max Steel	8
Rebar Material Spec	ASTM A615
Warn if beam-column framing arrangement is not understood	No
Number of Shear Regions	4
Region 2 & 3 Spacing Increase Increment (in)	4

Code	ASCE 7-05
------	-----------



Company : Foresite LLC / EFI Global Inc.  
 Designer : GHK  
 Job Number : 049.00939 - 2075087  
 Model Name : CTHA241C - 51'

12/2/2020  
 11:46:49 AM  
 Checked By : \_\_\_\_\_

**Model Settings (Continued)**

Risk Category	I
Drift Cat	Other
Base Elevation (ft)	-999999
Include the weight of the structure in base shear calcs	Yes

$S_x(g)$	1
$SD_x(g)$	1
$SD_y(g)$	1
$T_x(sec)$	-1

$T(sec)$	
$T(sec)$	
$C_r$	0.035
$C_r$	0.035
$C_{Exp}$	0.75
$C_{Exp}$	0.75
R	8.5
R	8.5
$\Omega_x$	1
$\Omega_y$	1
$C_w$	4
$C_w$	4
$\rho$	1
$\rho$	1

**Line Project Grid**

No Data to Print...

**Hot Rolled Steel Properties**

	Label	E [ksi]	G [ksi]	Nu	Therm. C...	Density [k...	Yield [ksi]	Ry	Fu [ksi]	Rt
1	A36 Gr.36	29000	11154	0.3	0.65	0.49	36	1.5	58	1.2
2	A572 Gr.50	29000	11154	0.3	0.65	0.49	50	1.1	65	1.2
3	A992	29000	11154	0.3	0.65	0.49	50	1.1	65	1.2
4	A500 Gr.42	29000	11154	0.3	0.65	0.49	42	1.3	58	1.1
5	A500 Gr.46	29000	11154	0.3	0.65	0.49	46	1.2	58	1.1
6	A53 Gr.B	29000	11154	0.3	0.65	0.49	35	1.5	60	1.2
7	A529 Gr.50	29000	11154	0.3	0.65	0.49	50	1.1	65	1.2

**Cold Formed Steel Properties**

	Label	E [ksi]	G [ksi]	Nu	Therm. Coeff...	Density [k/ft³]	Yield [ksi]	Fu [ksi]
1	A570_33	29500	11346	0.3	0.65	0.49	33	52
2	A607_C1_55	29500	11346	0.3	0.65	0.49	55	70

**Hot Rolled Steel Section Sets**

	Label	Shape	Type	Design List	Material	Design Rule	Area [in²]	Iyy [in⁴]	Izz [in⁴]	J [in⁴]
1	HR1A	C15X50	Beam	None	A36 Gr.36	Typical	14.7	11	404	2.65

**Cold Formed Steel Section Sets**

	Label	Shape	Type	Design List	Material	Design Rule	Area [in²]	Iyy [in⁴]	Izz [in⁴]	J [in⁴]
1	CF1A	1.5CU1.2...	Beam	None	A570_33	Typical	0.131	0.022	0.052	5.4e-05

**Primary Member Properties**

	Label	I Node	J Node	K Node	Rotate(deg)	Section/S...	Type	Design List	Material	Design Rule
1	M1	N3	N4			RIGID	None	None	LINK	Typical
2	M2	N1	N2			RIGID	None	None	LINK	Typical
3	M3	N5	N6			PIPE_2.0	Beam	None	A53 Gr.B	Typical
4	M4	N13	N14			PIPE_2.0	Beam	None	A53 Gr.B	Typical
5	M5	N17	N18			PIPE_3.0	Beam	None	A53 Gr.B	Typical
6	M6	N21	N22			PIPE_3.0	Beam	None	A53 Gr.B	Typical
7	M7	N19	N20			HSS4X4X4	Beam	None	A500 Gr.46	Typical
8	M8	N23	N24			HSS4X4X4	Beam	None	A500 Gr.46	Typical
9	M9	N9	N10			RIGID	None	None	LINK	Typical
10	M10	N11	N12			RIGID	None	None	LINK	Typical

**Advanced Member Properties**

	Label	I Release	J Release	I Offset [in]	J Offset [in]	T/C Only	Physical	Deflectio...	Analysis...	Activation	Seismic...
1	M1						Yes	** NA **			None
2	M2						Yes	** NA **			None
3	M3						Yes				None
4	M4						Yes				None
5	M5						Yes				None
6	M6						Yes				None
7	M7						Yes				None
8	M8						Yes				None
9	M9						Yes	** NA **			None
10	M10						Yes	** NA **			None

**Hot Rolled Member Properties**

	Label	Shape	Length [in]	Lb y-y [in]	Lb z-z [in]	Lcomp t...	Lcomp...	L-Torqu...	K y-y	K z-z	Cb	Function
1	M3	PIPE_2.0	72									Lateral
2	M4	PIPE_2.0	72									Lateral
3	M5	PIPE_3.0	48									Lateral



**Hot Rolled Member Properties (Continued)**

	Label	Shape	Length [in]	Lb y-y [in]	Lb z-z [in]	Lcomp t...	Lcomp...	L-Torqu...	K y-y	K z-z	Cb	Function
4	M6	PIPE_3.0	48									Lateral
5	M7	HSS4X...	10									Lateral
6	M8	HSS4X...	10									Lateral

**Cold Formed Member Properties**

No Data to Print...												
---------------------	--	--	--	--	--	--	--	--	--	--	--	--

**Nodes**

	Label	X [in]	Y [in]	Z [in]	Temp [deg F]	Detach From Dia...
1	N1	-20.5	3	36		
2	N2	-20.5	0	36		
3	N3	-20.5	3	0		
4	N4	-20.5	0	0		
5	N5	-20.5	3	54		
6	N6	-20.5	3	-18		
7	N7	-20.5	3	48		
8	N8	-20.5	3	-12		
9	N9	20.5	3	36		
10	N10	20.5	0	36		
11	N11	20.5	3	0		
12	N12	20.5	0	0		
13	N13	20.5	3	54		
14	N14	20.5	3	-18		
15	N15	20.5	3	33		
16	N16	20.5	3	3		
17	N17	-24	0	36		
18	N18	24	0	36		
19	N19	0	0	36		
20	N20	0	-10	36		
21	N21	-24	0	0		
22	N22	24	0	0		
23	N23	0	0	0		
24	N24	0	-10	0		

**Boundary Conditions**

	Node Label	X [k/in]	Y [k/in]	Z [k/in]	X Rot [k-ft/rad]	Y Rot [k-ft/rad]	Z Rot [k-ft/rad]
1	N20	Reaction	Reaction	Reaction			Reaction
2	N24	Reaction	Reaction	Reaction			Reaction

**Basic Load Cases**

	BLC Desc...	Category	X Gravity	Y Gravity	Z Gravity	Nodal	Point	Distributed	Area(Me...	Surface(P...
1	DEAD LO...	None			-1	4				
2	DEAD LO...	None				4		6		
3	WIND LO...	None				4		6		
4	WIND LO...	None				4		6		
5	WIND LO...	None				4		6		
6	WIND LO...	None				4		6		
7	LIVE LOA...	None				1				
8	LIVE LOA...	None				1				
9	LIVE LOA...	None				1				
10	MAINTEN...	None				1				
11	MAINTEN...	None				1				
12	MAINTEN...	None								
13	MAINTEN...	None								

**Node Loads and Enforced Displacements (BLC 1 : DEAD LOAD)**

	Node Label	L, D, M	Direction	Magnitude [(lb, k-ft),...]	Inactive [(lb, k-ft), (in,...)]
1	N8	L	Z	-86	Active
2	N7	L	Z	-86	Active
3	N15	L	Z	-58	Active
4	N16	L	Z	-58	Active

**Node Loads and Enforced Displacements (BLC 2 : DEAD LOAD ICE)**

	Node Label	L, D, M	Direction	Magnitude [(lb, k-ft),...]	Inactive [(lb, k-ft), (in,...)]
1	N8	L	Z	-119	Active
2	N7	L	Z	-119	Active
3	N15	L	Z	-96	Active
4	N16	L	Z	-96	Active

**Node Loads and Enforced Displacements (BLC 3 : WIND LOAD (NO ICE) FRONT)**

	Node Label	L, D, M	Direction	Magnitude [(lb, k-ft),...]	Inactive [(lb, k-ft), (in,...)]
1	N8	L	Y	-78	Active
2	N7	L	Y	-78	Active
3	N15	L	Y	-65	Active
4	N16	L	Y	-65	Active

**Node Loads and Enforced Displacements (BLC 4 : WIND LOAD (NO ICE) SIDE)**

	Node Label	L, D, M	Direction	Magnitude [(lb, k-ft),...]	Inactive [(lb, k-ft), (in,...)]
1	N8	L	X	-57	Active
2	N7	L	X	-57	Active
3	N15	L	X	-29	Active
4	N16	L	X	-29	Active

**Node Loads and Enforced Displacements (BLC 5 : WIND LOAD (ICE) FRONT)**

	Node Label	L, D, M	Direction	Magnitude [(lb, k-ft),...]	Inactive [(lb, k-ft), (in,...)]
1	N8	L	Y	-26	Active
2	N7	L	Y	-26	Active
3	N15	L	Y	-21	Active
4	N16	L	Y	-21	Active

**Node Loads and Enforced Displacements (BLC 6 : WIND LOAD (ICE) SIDE)**

	Node Label	L, D, M	Direction	Magnitude [(lb, k-ft),...]	Inactive [(lb, k-ft), (in,...)]
1	N8	L	X	-20	Active
2	N7	L	X	-20	Active
3	N15	L	X	-11	Active
4	N16	L	X	-11	Active

**Node Loads and Enforced Displacements (BLC 7 : LIVE LOAD1)**

	Node Label	L, D, M	Direction	Magnitude [(lb, k-ft),...]	Inactive [(lb, k-ft), (in,...)]
1	N17	L	Z	-250	Active

**Node Loads and Enforced Displacements (BLC 8 : LIVE LOAD2)**

	Node Label	L, D, M	Direction	Magnitude [(lb, k-ft),...]	Inactive [(lb, k-ft), (in,...)]
1	N18	L	Z	-250	Active

**Node Loads and Enforced Displacements (BLC 9 : LIVE LOAD3)**

	Node Label	L, D, M	Direction	Magnitude [(lb, k-ft),...]	Inactive [(lb, k-ft), (in,...)]
1	N21	L	Z	-250	Active



**Node Loads and Enforced Displacements (BLC 10 : MAINTENANCE LOAD 1)**

1	Node Label	L, D, M	Direction	Magnitude [(lb, k-ft),...]	Inactive [(lb, k-ft), (in,...)]
1	N6	L	Z	-500	Active

**Node Loads and Enforced Displacements (BLC 11 : MAINTENANCE LOAD 2)**

1	Node Label	L, D, M	Direction	Magnitude [(lb, k-ft),...]	Inactive [(lb, k-ft), (in,...)]
1	N14	L	Z	-500	Active

**Member Distributed Loads (BLC 2 : DEAD LOAD ICE)**

1	Member Label	Direction	Start Magnitud...	End Magnitude...	Start Location [...]	End Location [(...]	Inactive [(lb, k-...]
1	M3	Z	-11	-11	0	%100	Active
2	M4	Z	-11	-11	0	%100	Active
3	M5	Z	-14	-14	0	%100	Active
4	M6	Z	-14	-14	0	%100	Active
5	M7	Z	-29	-29	0	%100	Active
6	M8	Z	-29	-29	0	%100	Active

**Member Distributed Loads (BLC 3 : WIND LOAD (NO ICE) FRONT)**

1	Member Label	Direction	Start Magnitud...	End Magnitude...	Start Location [...]	End Location [(...]	Inactive [(lb, k-...]
1	M3	PY	-5	-5	0	%100	Active
2	M4	PY	-5	-5	0	%100	Active
3	M5	PY	-8	-8	0	%100	Active
4	M6	PY	-8	-8	0	%100	Active
5	M7	PY	-15	-15	0	%100	Active
6	M8	PY	-15	-15	0	%100	Active

**Member Distributed Loads (BLC 4 : WIND LOAD (NO ICE) SIDE)**

1	Member Label	Direction	Start Magnitud...	End Magnitude...	Start Location [...]	End Location [(...]	Inactive [(lb, k-...]
1	M3	PX	-5	-5	0	%100	Active
2	M4	PX	-5	-5	0	%100	Active
3	M5	PX	-8	-8	0	%100	Active
4	M6	PX	-8	-8	0	%100	Active
5	M7	PX	-15	-15	0	%100	Active
6	M8	PX	-15	-15	0	%100	Active

**Member Distributed Loads (BLC 5 : WIND LOAD (ICE) FRONT)**

1	Member Label	Direction	Start Magnitud...	End Magnitude...	Start Location [...]	End Location [(...]	Inactive [(lb, k-...]
1	M3	PY	-5.3	-5.3	0	%100	Active
2	M4	PY	-5.3	-5.3	0	%100	Active
3	M5	PY	-6.2	-6.2	0	%100	Active
4	M6	PY	-6.2	-6.2	0	%100	Active
5	M7	PY	-8.2	-8.2	0	%100	Active
6	M8	PY	-8.2	-8.2	0	%100	Active

**Member Distributed Loads (BLC 6 : WIND LOAD (ICE) SIDE)**

1	Member Label	Direction	Start Magnitud...	End Magnitude...	Start Location [...]	End Location [(...]	Inactive [(lb, k-...]
1	M3	PX	-5.3	-5.3	0	%100	Active
2	M4	PX	-5.3	-5.3	0	%100	Active
3	M5	PX	-6.2	-6.2	0	%100	Active
4	M6	PX	-6.2	-6.2	0	%100	Active
5	M7	PX	-8.2	-8.2	0	%100	Active
6	M8	PX	-8.2	-8.2	0	%100	Active

**Load Combinations**

De...	So...	PD...	SR...	BLC Fa...	BLC Fa...	BLC Fa...	BLC Fa...	BLC Fa...	BLC Fa...	BLC Fa...	BLC Fa...	BLC Fa...	BLC Fa...	BLC Fa...
1	DL...	Yes	Y	1	1.2		3	1.6						
2	DL...	Yes	Y	1	1.2		3	1.3...	4	0.8				

**Load Combinations (Continued)**

De...	So...	PD...	SR...	BLC Fa...	BLC Fa...	BLC Fa...	BLC Fa...	BLC Fa...	BLC Fa...	BLC Fa...	BLC Fa...	BLC Fa...	BLC Fa...	BLC Fa...
3	DL...	Yes	Y	1	1.2			3	0.8	4	1.3...			
4	DL...	Yes	Y	1	1.2					4	1.6			
5	DL...	Yes	Y	1	1.2			3	-0.8	4	1.3...			
6	DL...	Yes	Y	1	1.2			3	-1....	4	0.8			
7	DL...	Yes	Y	1	1.2			3	-1.6					
8	DL...	Yes	Y	1	1.2			3	-1....	4	-0.8			
9	DL...	Yes	Y	1	1.2			3	-0.8	4	-1....			
10	DL...	Yes	Y	1	1.2					4	-1.6			
11	DL...	Yes	Y	1	1.2			3	0.8	4	-1....			
12	DL...	Yes	Y	1	1.2			3	1.3...	4	-0.8			
13	DL...	Yes	Y	1	1.2	2	1	5	1					
14	DL...	Yes	Y	1	1.2	2	1	5	0.8...	6	0.5			
15	DL...	Yes	Y	1	1.2	2	1	5	0.5	6	0.8...			
16	DL...	Yes	Y	1	1.2	2	1			6	1			
17	DL...	Yes	Y	1	1.2	2	1	5	-0.5	6	0.8...			
18	DL...	Yes	Y	1	1.2	2	1	5	-0....	6	0.5			
19	DL...	Yes	Y	1	1.2	2	1	5	-1					
20	DL...	Yes	Y	1	1.2	2	1	5	-0....	6	-0.5			
21	DL...	Yes	Y	1	1.2	2	1	5	-0.5	6	-0....			
22	DL...	Yes	Y	1	1.2	2	1			6	-1			
23	DL...	Yes	Y	1	1.2	2	1	5	0.5	6	-0....			
24	DL...	Yes	Y	1	1.2	2	1	5	0.8...	6	-0.5			
25	DE...	Yes	Y	1	1.2					7	1.5			
26	DE...	Yes	Y	1	1.2					8	1.5			
27	DE...	Yes	Y	1	1.2					9	1.5			
28	DL...	Yes	Y	1	1.2	10	1.5	3	0.0...					
29	DL...	Yes	Y	1	1.2	11	1.5	3	0.0...					
30	DL...	Yes	Y	1	1.2	12	1.5	3	0.0...					
31	DL...	Yes	Y	1	1.2	13	1.5	3	0.0...					
32	DL...	Yes	Y	1	1.2	10	1.5	4	0.0...					
33	DL...	Yes	Y	1	1.2	11	1.5	4	0.0...					
34	DL...	Yes	Y	1	1.2	12	1.5	4	0.0...					
35	DL...	Yes	Y	1	1.2	13	1.5	4	0.0...					
36	DL...	Yes	Y	1	1.2	10	1.5	3	-0....					
37	DL...	Yes	Y	1	1.2	11	1.5	3	-0....					
38	DL...	Yes	Y	1	1.2	12	1.5	3	-0....					
39	DL...	Yes	Y	1	1.2	13	1.5	3	-0....					
40	DL...	Yes	Y	1	1.2	10	1.5	4	-0....					
41	DL...	Yes	Y	1	1.2	11	1.5	4	-0....					
42	DL...	Yes	Y	1	1.2	12	1.5	4	-0....					
43	DL...	Yes	Y	1	1.2	13	1.5	4	-0....					

**Node Reactions**

Node...		X [lbs]	LC	Y [lbs]	LC	Z [lbs]	LC	MX [k-ft]	LC	MY [k-ft]	LC	MZ [k-ft]	LC	
1	N20	max	476.758	32	162.987	1	621.932	13	0	43	0	43	0.333	41
2		min	-400.344	41	-509.018	19	170.896	7	0	1	0	1	-0.396	32
3	N24	max	400.337	33	509.353	13	623.206	36	0	43	0	43	0.396	40
4		min	-476.757	40	-163.38	7	170.621	1	0	1	0	1	-0.333	33
5	Totals:	max	411.2	4	656	1	1236.1...	28						
6		min	-411.2	10	-656.001	7	486.134	7						

**Node Displacements**

Node...		X [in]	LC	Y [in]	LC	Z [in]	LC	X Rota...	LC	Y Rota...	LC	Z Rota...	LC	
1	N1	max	0.003	37	0.011	37	-0.008	37	-3.562...	1	1.06e-03	41	3.842e...	2
2		min	-0.002	2	-0.005	2	-0.095	32	-2.147...	36	-2.372...	32	-7.306...	8
3	N2	max	0.001	41	0.011	37	-0.001	37	-3.562...	1	1.06e-03	41	3.842e...	2
4		min	-0.001	32	-0.005	2	-0.088	28	-2.147...	36	-2.372...	32	-7.306...	8



**Node Displacements (Continued)**

Node...		X [in]	LC	Y [in]	LC	Z [in]	LC	X Rota...	LC	Y Rota...	LC	Z Rota...	LC	
5	N3	max	0.002	8	0.005	8	-0.008	37	-3.543...	7	1.071e...	33	7.311e...	2
6		min	-0.003	29	-0.011	2	-0.095	28	-2.157...	28	-2.384...	40	-3.847...	8
7	N4	max	0.001	40	0.005	8	-0.001	29	-3.543...	7	1.071e...	33	7.311e...	2
8		min	-0.001	33	-0.011	2	-0.089	36	-2.157...	28	-2.384...	40	-3.847...	8
9	N5	max	0.023	41	0.049	37	-0.008	37	3.061e...	1	1.091e...	41	3.842e...	2
10		min	-0.044	32	-0.008	1	-0.095	32	-2.212...	19	-2.403...	32	-7.306...	8
11	N6	max	0.043	40	0.008	7	-0.008	37	3.079e...	7	1.1e-03	33	7.311e...	2
12		min	-0.023	33	-0.049	29	-0.096	28	-2.208...	13	-2.392...	40	-3.847...	8
13	N7	max	0.016	41	0.036	37	-0.008	37	3.045e...	1	1.09e-03	41	3.842e...	2
14		min	-0.029	32	-0.006	1	-0.095	32	-2.211...	19	-2.403...	32	-7.306...	8
15	N8	max	0.029	40	0.006	7	-0.008	37	3.063e...	7	1.1e-03	33	7.311e...	2
16		min	-0.016	33	-0.036	29	-0.096	28	-2.207...	13	-2.394...	40	-3.847...	8
17	N9	max	0	12	0.011	36	0	36	-7.192...	4	2.058e...	33	7.307e...	36
18		min	-0.003	36	-0.003	12	-0.087	29	-2.118...	41	-1.36e...	40	-2.314...	12
19	N10	max	0.001	41	0.011	36	0.006	40	-7.192...	4	2.058e...	33	7.307e...	36
20		min	-0.001	32	-0.003	12	-0.08	33	-2.118...	41	-1.36e...	40	-2.314...	12
21	N11	max	0.003	28	0.003	6	0	36	-7.195...	10	2.071e...	41	2.32e-04	6
22		min	0	6	-0.011	28	-0.087	29	-2.129...	33	-1.372...	32	-7.302...	28
23	N12	max	0.001	40	0.003	6	0.006	32	-7.195...	10	2.071e...	41	2.32e-04	6
24		min	-0.001	33	-0.011	28	-0.081	41	-2.129...	33	-1.372...	32	-7.302...	28
25	N13	max	0.037	29	0.048	36	0	36	-7.143...	3	2.057e...	29	7.307e...	36
26		min	-0.028	36	0.011	1	-0.087	29	-2.118...	41	-1.359...	36	-2.314...	12
27	N14	max	0.028	28	-0.011	7	0	36	-7.134...	9	2.052e...	37	2.32e-04	6
28		min	-0.037	37	-0.048	28	-0.088	29	-2.111...	33	-1.37e...	28	-7.302...	28
29	N15	max	0	11	0.008	6	0	36	-4.402...	5	1.138e...	33	6.131e...	36
30		min	-0.005	33	-0.005	12	-0.087	29	-1.401...	40	-8.335...	40	-2.66e...	12
31	N16	max	0.005	41	0.005	6	0	36	-4.412...	11	1.148e...	41	2.664e...	6
32		min	0	5	-0.008	12	-0.087	29	-1.415...	32	-8.428...	32	-6.126...	28
33	N17	max	0.001	41	0.013	8	0.002	37	-3.562...	1	1.06e-03	41	3.843e...	2
34		min	-0.001	32	-0.007	2	-0.097	28	-2.147...	36	-2.372...	32	-7.307...	8
35	N18	max	0.001	41	0.014	36	0.011	40	-7.192...	4	2.058e...	33	7.307e...	36
36		min	-0.001	32	-0.004	12	-0.088	33	-2.118...	41	-1.36e...	40	-2.315...	12
37	N19	max	0	41	0	19	-0.011	3	-1.037...	3	2.094e...	37	1.312e...	32
38		min	-0.001	32	0	1	-0.032	40	-3.074...	40	-2.507...	28	-1.104...	41
39	N20	max	0	41	0	19	0	7	-1.111...	3	2.094e...	37	0	32
40		min	0	32	0	1	0	13	-3.243...	40	-2.507...	28	0	41
41	N21	max	0.001	40	0.007	8	0.002	29	-3.543...	7	1.071e...	33	7.312e...	2
42		min	-0.001	33	-0.013	2	-0.097	36	-2.157...	28	-2.384...	40	-3.848...	8
43	N22	max	0.001	40	0.004	6	0.011	32	-7.195...	10	2.071e...	41	2.321e...	6
44		min	-0.001	33	-0.014	28	-0.088	41	-2.129...	33	-1.371...	32	-7.302...	28
45	N23	max	0.001	40	0	7	-0.011	9	-1.036...	9	2.109e...	29	1.102e...	33
46		min	0	33	0	13	-0.032	32	-3.094...	32	-2.523...	36	-1.309...	40
47	N24	max	0	40	0	7	0	1	-1.109...	9	2.109e...	29	0	33
48		min	0	33	0	13	0	36	-3.265...	32	-2.523...	36	0	40

**LRFD**

Member	Shape	Code...	Loc [in]	LC	Shear...	Loc [in]	Dir	LC	phi*P...	phi*P...	phi*M...	phi*M...	Cb	Eqn
1	M3	PIPE...	0.330	54	28	0.052	18	32	20866...	32130	1.872	1.872	1.474	H1-1b
2	M4	PIPE...	0.303	54	29	0.053	18	36	20866...	32130	1.872	1.872	1.477	H1-1b
3	M5	PIPE...	0.092	24	36	0.081	24	36	59852...	65205	5.749	5.749	1.483	H1-1b
4	M6	PIPE...	0.092	24	28	0.081	24	28	59852...	65205	5.749	5.749	1.483	H1-1b
5	M7	HSS4...	0.033	0	29	0.016	10	z	13911...	139518	16.181	16.181	1.684	H1-1b
6	M8	HSS4...	0.034	0	37	0.016	10	z	13911...	139518	16.181	16.181	1.685	H1-1b



Company : Foresite LLC / EFI Global Inc.  
Designer : GHK  
Job Number : 049.00939 - 2075087  
Model Name : CTHA241C - 51'

12/2/2020  
11:46:49 AM  
Checked By : \_\_\_\_\_

---

---

***Cold Formed Steel Code Checks***

---

---

No Data to Print...

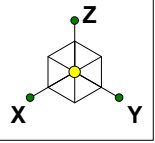

Envelope Only Solution

Foresite LLC / EFI Global ...	CTHA241C - 41'	SK - 1
GHK		Oct 26, 2020 at 4:23 PM
049.00939 - 2075087		CTHA241C - 41'.r3d

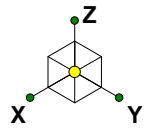

Member Length (in) Displayed  
Envelope Only Solution

Foresite LLC / EFI Global ...
GHK
049.00939 - 2075087

CTHA241C - 41'

SK - 2
Oct 26, 2020 at 4:23 PM
CTHA241C - 41'.r3d

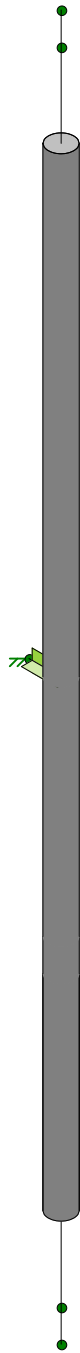
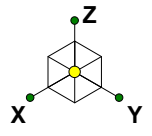

Envelope Only Solution

Foresite LLC / EFI Global ...  
GHK  
049.00939 - 2075087

CTHA241C - 41'

SK - 3

Oct 26, 2020 at 4:23 PM

CTHA241C - 41'.r3d

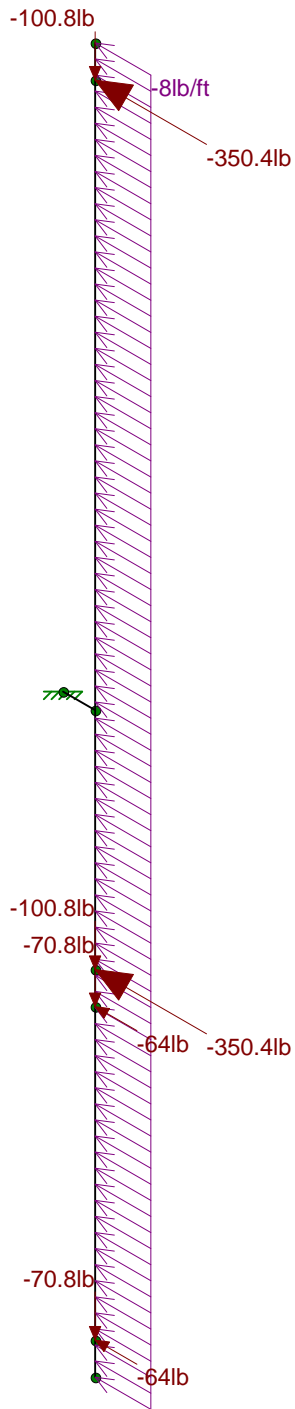
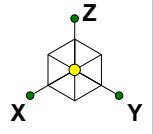

Loads: LC 1, DL + WL (NO ICE) 0 Degree  
Envelope Only Solution

Foresite LLC / EFI Global ...	CTHA241C - 41'	SK - 4
GHK		Oct 26, 2020 at 4:24 PM
049.00939 - 2075087		CTHA241C - 41'.r3d



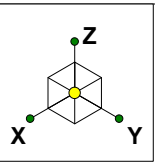

Code Check ( Env )	
Black	No Calc
Red	> 1.0
Magenta	.90-1.0
Green	.75-.90
Cyan	.50-.75
Blue	0-.50



Member Code Checks Displayed (Enveloped)  
Envelope Only Solution

Foresite LLC / EFI Global ...	CTHA241C - 41'	SK - 5
GHK		Oct 26, 2020 at 4:24 PM
049.00939 - 2075087		CTHA241C - 41'.r3d

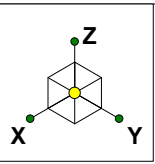

Shear Check ( Env )	
Black	No Calc
Red	> 1.0
Magenta	.90-1.0
Green	.75-.90
Cyan	.50-.75
Blue	0-.50



Member Shear Checks Displayed (Enveloped)  
Envelope Only Solution

Foresite LLC / EFI Global ...	CTHA241C - 41'	SK - 6
GHK		Oct 26, 2020 at 4:24 PM
049.00939 - 2075087		CTHA241C - 41'.r3d

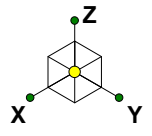

Envelope Only Solution

Foresite LLC / EFI Global ...

GHK

049.00939 - 2075087

CTHA241C - 41'

SK - 7

Oct 26, 2020 at 4:25 PM

CTHA241C - 41'.r3d

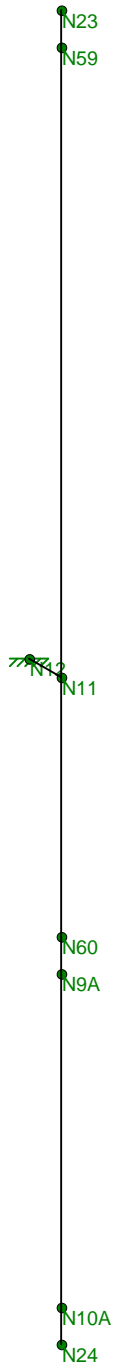
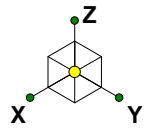

Envelope Only Solution

Foresite LLC / EFI Global ...	CTHA241C - 41'	SK - 8
GHK		Oct 26, 2020 at 4:25 PM
049.00939 - 2075087		CTHA241C - 41'.r3d



Company : Foresite LLC / EFI Global Inc.  
 Designer : GHK  
 Job Number : 049.00939 - 2075087  
 Model Name : CTHA241C - 41'

Oct 26, 2020  
 4:25 PM  
 Checked By: \_\_\_\_\_

**(Global) Model Settings**

Display Sections for Member Calcs	5
Max Internal Sections for Member Calcs	97
Include Shear Deformation?	Yes
Increase Nailing Capacity for Wind?	Yes
Include Warping?	Yes
Trans Load Btwn Intersecting Wood Wall?	Yes
Area Load Mesh (in^2)	144
Merge Tolerance (in)	.12
P-Delta Analysis Tolerance	0.50%
Include P-Delta for Walls?	Yes
Automatically Iterate Stiffness for Walls?	No
Max Iterations for Wall Stiffness	3
Gravity Acceleration (in/sec^2)	386.4
Wall Mesh Size (in)	12
Eigensolution Convergence Tol. (1.E-)	4
Vertical Axis	Z
Global Member Orientation Plane	XZ
Static Solver	Sparse Accelerated
Dynamic Solver	Accelerated Solver

Hot Rolled Steel Code	AISC 14th(360-10): LRFD
Adjust Stiffness?	Yes(Iterative)
RISACONNECTION CODE	AISC 14th(360-10): LRFD
Cold Formed Steel Code	AISI NAS-01: ASD
Wood Code	AF&PA NDS-05/08: ASD
Wood Temperature	< 100F
Concrete Code	ACI 318-05
Masonry Code	ACI 530-05: ASD
Aluminum Code	AA ADM1-05: ASD - Building AISC 14th(360-10): ASD

Number of Shear Regions	4
Region Spacing Increment (in)	4
Biaxial Column Method	Exact Integration
Parame Beta Factor (PCA)	.65
Concrete Stress Block	Rectangular
Use Cracked Sections?	Yes
Use Cracked Sections Slab?	No
Bad Framing Warnings?	No
Unused Force Warnings?	Yes
Min 1 Bar Diam. Spacing?	No
Concrete Rebar Set	REBAR_SET_ASTMA615
Min % Steel for Column	1
Max % Steel for Column	8



**(Global) Model Settings, Continued**

Seismic Code	ASCE 7-05
Seismic Base Elevation (in)	Not Entered
Add Base Weight?	Yes
Ct X	.035
Ct Z	.035
T X (sec)	Not Entered
T Z (sec)	Not Entered
R X	8.5
R Z	8.5
Ct Exp. X	.75
Ct Exp. Z	.75
SD1	1
SDS	1
S1	1
TL (sec)	Not Entered
Occupancy Cat	I or II
Drift Cat	Other
Om Z	1
Om X	1
Cd Z	4
Cd X	4
Rho Z	1
Rho X	1

**Project Grid Lines**

Label	Start X [in]	End X [in]	Start Y [in]	End Y [in]	Start Bubble	End Bubble
No Data to Print ...						

**Hot Rolled Steel Properties**

	Label	E [ksi]	G [ksi]	Nu	Therm (1E...	Density[k/ft...	Yield[ksi]	Ry	Fu[ksi]	Rt
1	A36 Gr.36	29000	11154	.3	.65	.49	36	1.5	58	1.2
2	A572 Gr.50	29000	11154	.3	.65	.49	50	1.1	65	1.2
3	A992	29000	11154	.3	.65	.49	50	1.1	65	1.2
4	A500 Gr.42	29000	11154	.3	.65	.49	42	1.3	58	1.1
5	A500 Gr.46	29000	11154	.3	.65	.49	46	1.2	58	1.1
6	A53 Gr.B	29000	11154	.3	.65	.49	35	1.5	60	1.2
7	A529 Gr.50	29000	11154	.3	.65	.49	50	1.1	65	1.2

**Hot Rolled Steel Section Sets**

	Label	Shape	Type	Design List	Material	Design Rules	A [in2]	Iyy [in4]	Izz [in4]	J [in4]
1	HR1A	C15x50	Beam	Wide Flange	A36 Gr.36	Typical	14.7	11	404	2.65

**Member Primary Data**

	Label	I Joint	J Joint	K Joint	Rotat...	Section/Shape	Type	Design List	Material	Design...
1	M4	N11	N12			RIGID	None	None	LINK	Typical
2	M14	N23	N24			PIPE 2.0	Beam	Pipe	A53 Gr.B	Typical



Company : Foresite LLC / EFI Global Inc.  
 Designer : GHK  
 Job Number : 049.00939 - 2075087  
 Model Name : CTHA241C - 41'

Oct 26, 2020  
 4:25 PM  
 Checked By: \_\_\_\_\_

**Member Advanced Data**

	Label	I Release	J Release	I Offset[in]	J Offset[in]	T/C Only	Physical Analysis ...	Inactive	Seismic Design ...
1	M4						Yes		None
2	M14						Yes		None

**Hot Rolled Steel Design Parameters**

	Label	Shape	Length[in]	Lbyy[in]	Lbzz[in]	Lcomp top[in]	Lcomp bot[in]	L-torq...	Kyy	Kzz	Cb	Function
1	M14	PIPE 2.0	108									Lateral

**Joint Coordinates and Temperatures**

	Label	X [in]	Y [in]	Z [in]	Temp [F]	Detach From Diaphragm
1	N11	-24	3	18	0	
2	N12	-24	0	18	0	
3	N23	-24	3	72	0	
4	N24	-24	3	-36	0	
5	N59	-24	3	69	0	
6	N60	-24	3	-3	0	
7	N9A	-24	3	-6	0	
8	N10A	-24	3	-33	0	

**Joint Boundary Conditions**

	Joint Label	X [k/in]	Y [k/in]	Z [k/in]	X Rot.[k-ft/rad]	Y Rot.[k-ft/rad]	Z Rot.[k-ft/rad]
1	N12	Reaction	Reaction	Reaction	Reaction	Reaction	Reaction

**Basic Load Cases**

	BLC Description	Category	X Gravi...	Y Gravi...	Z Gravity	Joint	Point	Distrib...	Area(M...	Surfac...
1	DEAD LOAD	None			-1	4				
2	DEAD LOAD ICE	None				4		1		
3	WIND LOAD (NO ICE) FRONT	None				4		1		
4	WIND LOAD (NO ICE) SIDE	None				4		1		
5	WIND LOAD (ICE) FRONT	None				4		1		
6	WIND LOAD (ICE) SIDE	None				4		1		
7	LIVE LOAD1	None								
8	LIVE LOAD2	None								
9	LIVE LOAD3	None								
10	MAINTENANCE LOAD 1	None				1				
11	MAINTENANCE LOAD 2	None								
12	MAINTENANCE LOAD 3	None								
13	MAINTENANCE LOAD 4	None								

**Joint Loads and Enforced Displacements (BLC 1 : DEAD LOAD)**

	Joint Label	L,D,M	Direction	Magnitude[(lb,k-ft), (in,rad), (lb*s^2/in, lb*s^2*in)]
1	N60	L	Z	-84
2	N59	L	Z	-84
3	N9A	L	Z	-59
4	N10A	L	Z	-59

**Joint Loads and Enforced Displacements (BLC 2 : DEAD LOAD ICE)**

	Joint Label	L,D,M	Direction	Magnitude[(lb,k-ft), (in,rad), (lb*s^2/in, lb*s^2*in)]
1	N60	L	Z	-276
2	N59	L	Z	-276



Company : Foresite LLC / EFI Global Inc.  
 Designer : GHK  
 Job Number : 049.00939 - 2075087  
 Model Name : CTHA241C - 41'

Oct 26, 2020  
 4:25 PM  
 Checked By: \_\_\_\_\_

**Joint Loads and Enforced Displacements (BLC 2 : DEAD LOAD ICE) (Continued)**

	Joint Label	L,D,M	Direction	Magnitude[(lb,k-ft), (in,rad), (lb*s^2/in, lb*s^2*in)]
3	N9A	L	Z	-84
4	N10A	L	Z	-84

**Joint Loads and Enforced Displacements (BLC 3 : WIND LOAD (NO ICE) FRONT)**

	Joint Label	L,D,M	Direction	Magnitude[(lb,k-ft), (in,rad), (lb*s^2/in, lb*s^2*in)]
1	N60	L	Y	-219
2	N59	L	Y	-219
3	N9A	L	Y	-40
4	N10A	L	Y	-40

**Joint Loads and Enforced Displacements (BLC 4 : WIND LOAD (NO ICE) SIDE)**

	Joint Label	L,D,M	Direction	Magnitude[(lb,k-ft), (in,rad), (lb*s^2/in, lb*s^2*in)]
1	N60	L	X	-98
2	N59	L	X	-98
3	N9A	L	X	-25
4	N10A	L	X	-25

**Joint Loads and Enforced Displacements (BLC 5 : WIND LOAD (ICE) FRONT)**

	Joint Label	L,D,M	Direction	Magnitude[(lb,k-ft), (in,rad), (lb*s^2/in, lb*s^2*in)]
1	N60	L	Y	-66
2	N59	L	Y	-66
3	N9A	L	Y	-15
4	N10A	L	Y	-15

**Joint Loads and Enforced Displacements (BLC 6 : WIND LOAD (ICE) SIDE)**

	Joint Label	L,D,M	Direction	Magnitude[(lb,k-ft), (in,rad), (lb*s^2/in, lb*s^2*in)]
1	N60	L	X	-35
2	N59	L	X	-35
3	N9A	L	X	-10
4	N10A	L	X	-10

**Joint Loads and Enforced Displacements (BLC 10 : MAINTENANCE LOAD 1)**

	Joint Label	L,D,M	Direction	Magnitude[(lb,k-ft), (in,rad), (lb*s^2/in, lb*s^2*in)]
1	N24	L	Z	-500

**Member Point Loads**

Member Label	Direction	Magnitude[lb,k-ft]	Location[in,%]
No Data to Print ...			

**Member Distributed Loads (BLC 2 : DEAD LOAD ICE)**

Member Label	Direction	Start Magnitude[lb/ft,F,ksf]	End Magnitude[lb/ft,F,k...]	Start Location[in,%]	End Location[in,%]
1	M14	Z	-11	-11	0 0

**Member Distributed Loads (BLC 3 : WIND LOAD (NO ICE) FRONT)**

Member Label	Direction	Start Magnitude[lb/ft,F,ksf]	End Magnitude[lb/ft,F,k...]	Start Location[in,%]	End Location[in,%]
1	M14	PY	-5	-5	0 0

**Member Distributed Loads (BLC 4 : WIND LOAD (NO ICE) SIDE)**

Member Label	Direction	Start Magnitude[lb/ft,F,ksf]	End Magnitude[lb/ft,F,k...]	Start Location[in,%]	End Location[in,%]
1	M14	PX	-5	-5	0 0







**Load Combinations (Continued)**

	Description	Solve	PD	S	B	Fa	B	Fa	B	Factor	B	Fa	B	Fa	B	Fa	B	Fa	B
42	DL + MAIN L3+30MPH WL SI...	Yes	Y		1	1.2	12	1.5	4	-0.096									
43	DL + MAIN L4+30MPH WL SI...	Yes	Y		1	1.2	13	1.5	4	-0.096									

**Envelope Joint Reactions**

	Joint		X [lb]	LC	Y [lb]	LC	Z [lb]	LC	MX [k-ft]	LC	MY [k-ft]	LC	MZ [k-ft]	LC
1	N12	max	465.6	4	900.8	1	1199.685	17	.587	7	.15	4	.116	10
2		min	-465.6	10	-900.8	7	380.685	2	-.397	1	-.15	10	-.116	4
3	Totals:	max	465.6	4	900.8	1	1199.685	17						
4		min	-465.6	10	-900.8	7	380.685	2						

**Envelope Joint Displacements**

	Joint		X [in]	LC	Y [in]	LC	Z [in]	LC	X Rotation ...	LC	Y Rotation ...	LC	Z Rotation [...]	LC
1	N11	max	0	10	0	7	0	1	0	1	0	10	0	4
2		min	0	4	0	1	0	7	0	7	0	4	0	10
3	N12	max	0	10	0	7	0	2	0	1	0	10	0	4
4		min	0	4	0	1	0	17	0	7	0	4	0	10
5	N23	max	.573	10	1.219	7	0	1	3.275e-02	1	1.532e-02	10	0	4
6		min	-.573	4	-1.219	1	0	19	-3.275e-02	7	-1.532e-02	4	0	10
7	N24	max	.328	10	.567	7	0	1	1.34e-02	7	7.888e-03	4	0	4
8		min	-.328	4	-.567	1	-.002	36	-1.34e-02	1	-7.888e-03	10	0	10
9	N59	max	.527	10	1.121	7	0	1	3.275e-02	1	1.532e-02	10	0	4
10		min	-.527	4	-1.121	1	0	19	-3.275e-02	7	-1.532e-02	4	0	10
11	N60	max	.082	10	.146	7	0	1	1.116e-02	7	6.381e-03	4	0	4
12		min	-.082	4	-.146	1	0	36	-1.116e-02	1	-6.381e-03	10	0	10
13	N9A	max	.102	10	.18	7	0	1	1.161e-02	7	6.694e-03	4	0	4
14		min	-.102	4	-.18	1	-.001	36	-1.161e-02	1	-6.694e-03	10	0	10
15	N10A	max	.304	10	.526	7	0	1	1.34e-02	7	7.888e-03	4	0	4
16		min	-.304	4	-.526	1	-.002	36	-1.34e-02	1	-7.888e-03	10	0	10

**Envelope AISC 14th(360-10): LRFD Steel Code Checks**

	Memb...	Shape	Code	Ch...	Loc[in]	LC	Shear Check	Loc[in]	Dir	LC	phi*Pnc [lb]	phi*Pnt...	phi*Mn ...	phi*Mn...	Cb	Eqn
1	M14	PIPE...		.849	54	7	.053	54		7	12143.947	32130	1.872	1.872	1.533	H1-1b

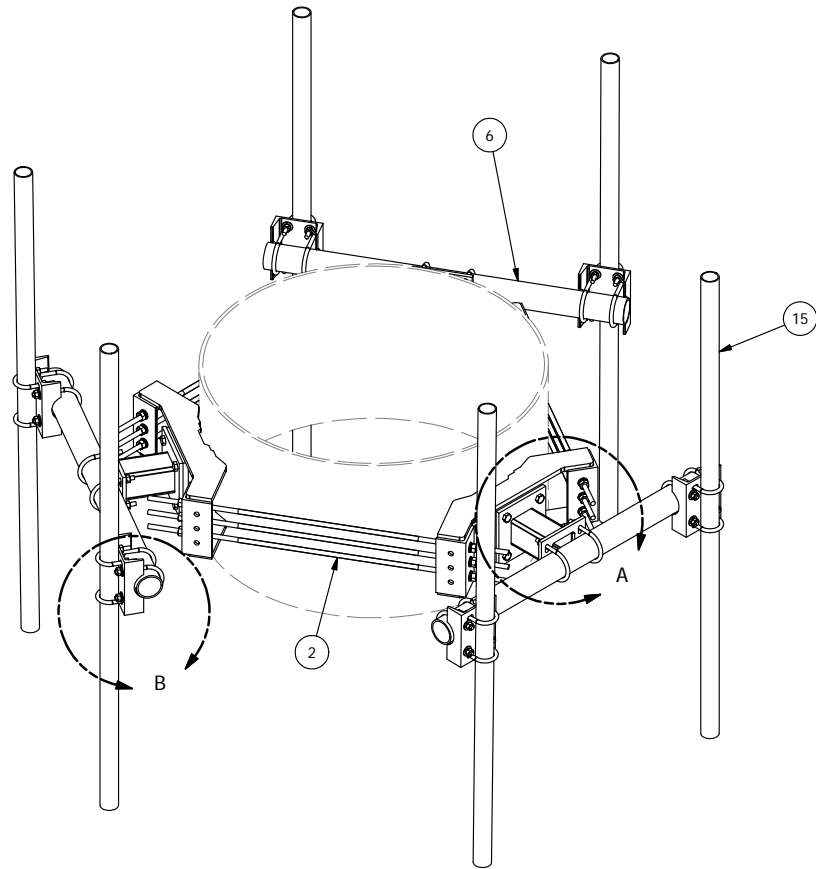

PARTS LIST						
ITEM	QTY	PART NO.	PART DESCRIPTION	LENGTH	UNIT WT.	NET WT.
1	3	X-LWRM	RING MOUNT WELDMENT		68.81	206.42
2	9	G58R-48	5/8" x 48" THREADED ROD (HDG.)		0.40	3.59
2	9	G58R-24	5/8" x 24" THREADED ROD (HDG.)		0.40	3.59
3	30	A58FW	5/8" HDG A325 FLATWASHER		0.03	1.02
4	30	G58LW	5/8" HDG LOCKWASHER		0.03	0.78
5	30	A58NUT	5/8" HDG A325 HEX NUT		0.13	3.90
6	3	P348	3-1/2" X 48" SCH 40 GALVANIZED PIPE	48	31.89	95.68
7	3	X-WWM01	8" STAND-OFF ARM / WALL MOUNT		18.12	54.37
8	12	A582112	5/8" x 2-1/2" HDG A325 HEX BOLT	2.5	0.33	4.01
9	12	X-UB1212	1/2" X 2-1/2" X 4-1/2" X 2" GALV. U-BOLT		0.66	7.88
10	12	X-UB1306	1/2" X 3-5/8" X 6" X 3" GALV U-BOLT		0.83	9.94
11	6	X-UB1358	1/2" X 3-5/8" X 5-1/2" X 3" GALV U-BOLT		0.77	4.63
12	60	G12FW	1/2" HDG USS FLATWASHER		0.03	2.04
13	60	G12LW	1/2" HDG LOCKWASHER		0.01	0.83
14	60	G12NUT	1/2" HDG HEAVY 2H HEX NUT		0.07	4.30
15	6	B	C	D	E	F
16	6	X-SP219	SMALL SUPPORT CROSS PLATE	8.250 in	8.61	51.66

2-3/8" MOUNTING PIPES						
ASSEMBLY "A"	PART NO "B"	PART DESCRIPTION "C"	LENGTH "D"	UNIT WEIGHT "	NET WEIGHT "F"	TOTAL WEIGHT
RDS-263	P263	2 3/8" O.D. VERTICAL MOUNTING PIPE	63"	19.22	115.32	578.11
RDS-272	P272	2 3/8" O.D. VERTICAL MOUNTING PIPE	72"	21.97	131.82	594.61
RDS-284	P284	2 3/8" O.D. VERTICAL MOUNTING PIPE	84"	25.63	153.78	616.57
RDS-296	P296	2 3/8" O.D. VERTICAL MOUNTING PIPE	96"	29.29	175.74	638.53
RDS-2126	P2126	2 3/8" O.D. VERTICAL MOUNTING PIPE	126"	40.75	122.25	585.04

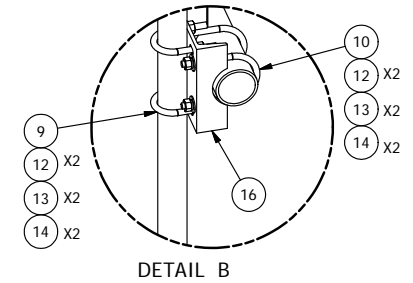
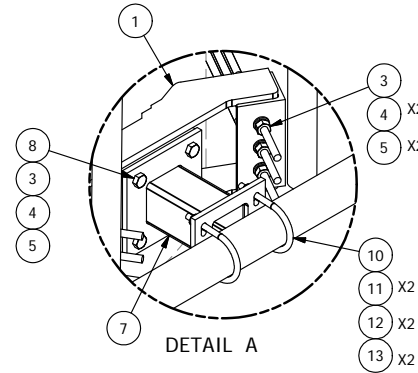

REV	DESCRIPTION OF REVISIONS	CPD	BY	DATE
B	ADDED 126" 2-3/8" ANTENNA MOUNTING PIPES		CEK	6/29/2015
A	REDRAWN IN MDT		KC8	5/22/2012
REV	DESCRIPTION OF REVISIONS	CPD	BY	DATE
REVISION HISTORY				

**TOLERANCE NOTES**

**TOLERANCES ON DIMENSIONS, UNLESS OTHERWISE NOTED ARE:  
SAWED, SHEARED AND GAS CUT EDGES ( $\pm 0.030"$ )  
DRILLED AND GAS CUT HOLES ( $\pm 0.030"$ ) - NO CONING OF HOLES  
LASER CUT EDGES AND HOLES ( $\pm 0.010"$ ) - NO CONING OF HOLES  
BENDS ARE  $\pm 1/2$  DEGREE  
ALL OTHER MACHINING ( $\pm 0.030"$ )  
ALL OTHER ASSEMBLY ( $\pm 0.060"$ )**

PROPRIETARY NOTE:  
THE DATA AND TECHNIQUES CONTAINED IN THIS DRAWING ARE PROPRIETARY INFORMATION OF VALMONT INDUSTRIES AND CONSIDERED A TRADE SECRET. ANY USE OR DISCLOSURE WITHOUT THE CONSENT OF VALMONT INDUSTRIES IS STRICTLY PROHIBITED.

DESCRIPTION			
<b>MONOPOLE DOUBLE SUPPORT ARM KIT</b>			
CPD NO.	DRAWN BY	ENG. APPROVAL	
4546	CEK 7/13/2009		
CLASS	SUB	DRAWING USAGE	CHECKED BY
81	01	CUSTOMER	CEK 8/20/2012

 <b>A valmont COMPANY</b>	Locations: New York, NY Atlanta, GA Los Angeles, CA Plymouth, IN Salem, OR Dallas, TX
	Engineering Support Team: 1-888-753-7446
PART NO.	<b>SEE ASSEMBLY "A"</b>
DWG. NO.	<b>RDS-2XX</b>

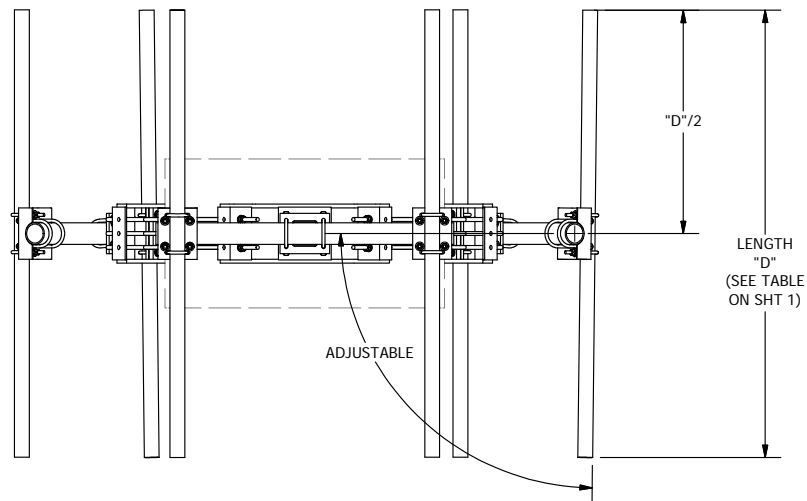
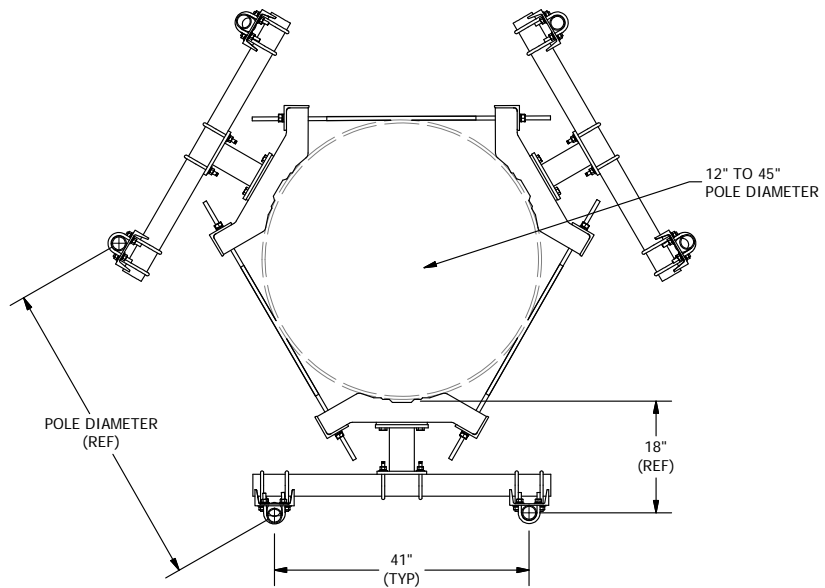

**TOLERANCE NOTES**

**TOLERANCES ON DIMENSIONS, UNLESS OTHERWISE NOTED ARE:  
 SAWED, SHEARED AND GAS CUT EDGES ( $\pm 0.030$ )  
 DRILLED AND GAS CUT HOLES ( $\pm 0.030$ ) - NO CONING OF HOLES  
 LASER CUT EDGES AND HOLES ( $\pm 0.010$ ) - NO CONING OF HOLES  
 BENDS ARE  $\pm 1/2$  DEGREE  
 ALL OTHER MACHINING ( $\pm 0.030$ )  
 ALL OTHER ASSEMBLY ( $\pm 0.060$ )**

**PROPRIETARY NOTE:  
 THE DATA AND TECHNIQUES CONTAINED IN THIS DRAWING ARE PROPRIETARY INFORMATION OF VALMONT  
 INDUSTRIES AND CONSIDERED A TRADE SECRET. ANY USE OR DISCLOSURE WITHOUT THE CONSENT OF  
 VALMONT INDUSTRIES IS STRICTLY PROHIBITED.**

DESCRIPTION  
**MONOPOLE  
 DOUBLE SUPPORT  
 ARM KIT**

CPD NO. <b>4546</b>	DRAWN BY <b>CEK 7/13/2009</b>	ENG. APPROVAL
CLASS <b>81</b>	SUB <b>01</b>	DRAWING USAGE <b>CUSTOMER</b>
CHECKED BY <b>CEK 8/20/2012</b>		



Locations:  
 New York, NY  
 Atlanta, GA  
 Los Angeles, CA  
 Plymouth, IN  
 Salem, OR  
 Dallas, TX

Engineering  
 Support Team:  
 1-888-753-7446

PART NO. <b>SEE ASSEMBLY "A"</b>	PAGE <b>2 OF 2</b>
DWG. NO. <b>RDS-2XX</b>	

<b>A</b>	<b>REDRAWN IN INV</b>		<b>KC8</b>	<b>5/22/2012</b>
REV	DESCRIPTION OF REVISIONS	CPD	BY	DATE
REVISION HISTORY				

# Exhibit F

RADIO FREQUENCY EMISSIONS ANALYSIS REPORT  
EVALUATION OF HUMAN EXPOSURE POTENTIAL  
TO NON-IONIZING EMISSIONS

T-Mobile Existing Facility

Site ID: CTHA241C

HA241/Exxon\_Sign  
207 West Street  
Cromwell, Connecticut 06416

**November 3, 2020**

**EBI Project Number: 6220005712**

Site Compliance Summary	
Compliance Status:	<b>COMPLIANT</b>
Site total MPE% of FCC general population allowable limit:	<b>89.01%</b>

November 3, 2020

T-Mobile

Attn: Jason Overbey, RF Manager  
35 Griffin Road South  
Bloomfield, Connecticut 06002

Emissions Analysis for Site: CTHA241C - HA241/Exxon\_Sign

EBI Consulting was directed to analyze the proposed T-Mobile facility located at **207 West Street in Cromwell, Connecticut** for the purpose of determining whether the emissions from the Proposed T-Mobile Antenna Installation located on this property are within specified federal limits.

All information used in this report was analyzed as a percentage of current Maximum Permissible Exposure (% MPE) as listed in the FCC OET Bulletin 65 Edition 97-01 and ANSI/IEEE Std C95.1. The FCC regulates Maximum Permissible Exposure in units of microwatts per square centimeter ( $\mu\text{W}/\text{cm}^2$ ). The number of  $\mu\text{W}/\text{cm}^2$  calculated at each sample point is called the power density. The exposure limit for power density varies depending upon the frequencies being utilized. Wireless Carriers and Paging Services use different frequency bands each with different exposure limits; therefore, it is necessary to report results and limits in terms of percent MPE rather than power density.

All results were compared to the FCC (Federal Communications Commission) radio frequency exposure rules, 47 CFR 1.1307(b)(1) – (b)(3), to determine compliance with the Maximum Permissible Exposure (MPE) limits for General Population/Uncontrolled environments as defined below.

General population/uncontrolled exposure limits apply to situations in which the general population may be exposed or in which persons who are exposed as a consequence of their employment may not be made fully aware of the potential for exposure or cannot exercise control over their exposure. Therefore, members of the general population would always be considered under this category when exposure is not employment related, for example, in the case of a telecommunications tower that exposes persons in a nearby residential area.

Public exposure to radio frequencies is regulated and enforced in units of microwatts per square centimeter ( $\mu\text{W}/\text{cm}^2$ ). The general population exposure limits for the 600 MHz and 700 MHz frequency bands are approximately  $400 \mu\text{W}/\text{cm}^2$  and  $467 \mu\text{W}/\text{cm}^2$ , respectively. The general population exposure limit for the 1900 MHz (PCS), 2100 MHz (AWS) and 11 GHz frequency bands is  $1000 \mu\text{W}/\text{cm}^2$ . Because each carrier will be using different frequency bands, and each frequency band has different exposure limits, it is necessary to report percent of MPE rather than power density.

Occupational/controlled exposure limits apply to situations in which persons are exposed as a consequence of their employment and in which those persons who are exposed have been made fully aware of the potential for exposure and can exercise control over their exposure. Occupational/controlled exposure limits also apply where exposure is of a transient nature as a result of incidental passage through a location where exposure levels may be above general population/uncontrolled limits (see below), as long as the exposed person has been made fully aware of the potential for exposure and can exercise control over his or her exposure by leaving the area or by some other appropriate means.

Additional details can be found in FCC OET 65.

## **CALCULATIONS**

Calculations were done for the proposed T-Mobile Wireless antenna facility located at 207 West Street in Cromwell, Connecticut using the equipment information listed below. All calculations were performed per the specifications under FCC OET 65. Since T-Mobile is proposing highly focused directional panel antennas, which project most of the emitted energy out toward the horizon, all calculations were performed assuming a lobe representing the maximum gain of the antenna per the antenna manufacturer's supplied specifications, minus 10 dB for directional panel antennas and 20 dB for highly focused parabolic microwave dishes, was focused at the base of the tower. For this report, the sample point is the top of a 6-foot person standing at the base of the tower.

For all calculations, all equipment was calculated using the following assumptions:

- 1) 2 LTE channels (600 MHz Band) were considered for each sector of the proposed installation. These Channels have a transmit power of 30 Watts per Channel.
- 2) 1 NR channel (600 MHz Band) was considered for each sector of the proposed installation. This Channel has a transmit power of 80 Watts.
- 3) 2 LTE channels (700 MHz Band) were considered for each sector of the proposed installation. These Channels have a transmit power of 30 Watts per Channel.
- 4) 4 GSM channels (PCS Band - 1900 MHz) were considered for each sector of the proposed installation. These Channels have a transmit power of 30 Watts per Channel.
- 5) 4 LTE channels (PCS Band - 1900 MHz) were considered for each sector of the proposed installation. These Channels have a transmit power of 60 Watts per Channel.



- 6) 2 UMTS channels (AWS Band - 2100 MHz) were considered for each sector of the proposed installation. These Channels have a transmit power of 30 Watts per Channel.
- 7) 2 LTE channels (AWS Band – 2100 MHz) were considered for each sector of the proposed installation. These Channels have a transmit power of 60 Watts per Channel.
- 8) 2 LTE channels (BRS Band - 2500 MHz) were considered for each sector of the proposed installation. These Channels have a transmit power of 40 Watts per Channel.
- 9) 2 NR channels (BRS Band - 2500 MHz) were considered for each sector of the proposed installation. These Channels have a transmit power of 40 Watts per Channel.
- 10) All radios at the proposed installation were considered to be running at full power and were uncombined in their RF transmissions paths per carrier prescribed configuration. Per FCC OET Bulletin No. 65 - Edition 97-01 recommendations to achieve the maximum anticipated value at each sample point, all power levels emitting from the proposed antenna installation are increased by a factor of 2.56 to account for possible in-phase reflections from the surrounding environment. This is rarely the case, and if so, is never continuous.
- 11) For the following calculations, the sample point was the top of a 6-foot person standing at the base of the tower. The maximum gain of the antenna per the antenna manufacturer's supplied specifications, minus 10 dB for directional panel antennas and 20 dB for highly focused parabolic microwave dishes, was used in this direction. This value is a very conservative estimate as gain reductions for these particular antennas are typically much higher in this direction.
- 12) The antennas used in this modeling are the Ericsson AIR 32 for the 1900 MHz / 1900 MHz / 2100 MHz channel(s), the Ericsson AIR 6449 for the 2500 MHz / 2500 MHz channel(s), the RFS APXVAALL24\_43-U-NA20 for the 600 MHz / 600 MHz / 700 MHz / 1900 MHz / 2100 MHz channel(s) in Sector A, the Ericsson AIR 32 for the 1900 MHz / 1900 MHz / 2100 MHz channel(s), the Ericsson AIR 6449 for the 2500 MHz / 2500 MHz channel(s), the RFS APXVAALL24\_43-U-NA20 for the 600 MHz / 600 MHz / 700 MHz / 1900 MHz / 2100 MHz channel(s) in Sector B, the Ericsson AIR 32 for the 1900 MHz / 1900 MHz / 2100 MHz channel(s), the Ericsson AIR 6449 for the 2500 MHz / 2500 MHz channel(s), the RFS APXVAALL24\_43-U-NA20 for the 600 MHz / 600 MHz / 700 MHz / 1900 MHz / 2100 MHz channel(s) in Sector C. This is based on feedback from the carrier with regard to anticipated antenna selection. All Antenna gain values and associated transmit power levels are shown in the Site Inventory and Power Data table below. The maximum gain of the antenna per the antenna manufacturer's supplied specifications, minus 10 dB for directional panel antennas and 20 dB for highly focused parabolic microwave dishes, was used for all calculations. This value

is a very conservative estimate as gain reductions for these particular antennas are typically much higher in this direction.

- 13) The antenna mounting height centerlines of the proposed antennas are 41 and 51 feet above ground level (AGL).
- 14) Emissions values for additional carriers were taken from the Connecticut Siting Council active database. Values in this database are provided by the individual carriers themselves.
- 15) Emissions from additional carriers were not included because emissions data for the site location are not available.
- 16) All calculations were done with respect to uncontrolled / general population threshold limits.

## T-Mobile Site Inventory and Power Data

Sector:	A	Sector:	B	Sector:	C
Antenna #:	1	Antenna #:	1	Antenna #:	1
Make / Model:	Ericsson AIR 32	Make / Model:	Ericsson AIR 32	Make / Model:	Ericsson AIR 32
Frequency Bands:	1900 MHz / 1900 MHz / 2100 MHz	Frequency Bands:	1900 MHz / 1900 MHz / 2100 MHz	Frequency Bands:	1900 MHz / 1900 MHz / 2100 MHz
Gain:	15.35 dBd / 15.35 dBd / 15.85 dBd	Gain:	15.35 dBd / 15.35 dBd / 15.85 dBd	Gain:	15.35 dBd / 15.35 dBd / 15.85 dBd
Height (AGL):	51 feet	Height (AGL):	51 feet	Height (AGL):	51 feet
Channel Count:	8	Channel Count:	8	Channel Count:	8
Total TX Power (W):	360 Watts	Total TX Power (W):	360 Watts	Total TX Power (W):	360 Watts
ERP (W):	12,841.53	ERP (W):	12,841.53	ERP (W):	12,841.53
Antenna A1 MPE %:	<b>17.75%</b>	Antenna B1 MPE %:	<b>17.75%</b>	Antenna C1 MPE %:	<b>17.75%</b>
Antenna #:	2	Antenna #:	2	Antenna #:	2
Make / Model:	Ericsson AIR 6449	Make / Model:	Ericsson AIR 6449	Make / Model:	Ericsson AIR 6449
Frequency Bands:	2500 MHz / 2500 MHz	Frequency Bands:	2500 MHz / 2500 MHz	Frequency Bands:	2500 MHz / 2500 MHz
Gain:	22.05 dBd / 22.05 dBd	Gain:	22.05 dBd / 22.05 dBd	Gain:	22.05 dBd / 22.05 dBd
Height (AGL):	51 feet	Height (AGL):	51 feet	Height (AGL):	51 feet
Channel Count:	4	Channel Count:	4	Channel Count:	4
Total TX Power (W):	160 Watts	Total TX Power (W):	160 Watts	Total TX Power (W):	160 Watts
ERP (W):	25,651.93	ERP (W):	25,651.93	ERP (W):	25,651.93
Antenna A2 MPE %:	<b>35.46%</b>	Antenna B2 MPE %:	<b>35.46%</b>	Antenna C2 MPE %:	<b>35.46%</b>
Antenna #:	3	Antenna #:	3	Antenna #:	3
Make / Model:	RFS APXVAALL24_43-U-NA20	Make / Model:	RFS APXVAALL24_43-U-NA20	Make / Model:	RFS APXVAALL24_43-U-NA20
Frequency Bands:	600 MHz / 600 MHz / 700 MHz / 1900 MHz / 2100 MHz	Frequency Bands:	600 MHz / 600 MHz / 700 MHz / 1900 MHz / 2100 MHz	Frequency Bands:	600 MHz / 600 MHz / 700 MHz / 1900 MHz / 2100 MHz
Gain:	12.95 dBd / 12.95 dBd / 13.65 dBd / 15.45 dBd / 16.45 dBd	Gain:	12.95 dBd / 12.95 dBd / 13.65 dBd / 15.45 dBd / 16.45 dBd	Gain:	12.95 dBd / 12.95 dBd / 13.65 dBd / 15.45 dBd / 16.45 dBd
Height (AGL):	41 feet	Height (AGL):	41 feet	Height (AGL):	41 feet
Channel Count:	9	Channel Count:	9	Channel Count:	9
Total TX Power (W):	380 Watts	Total TX Power (W):	380 Watts	Total TX Power (W):	380 Watts
ERP (W):	11,010.27	ERP (W):	11,010.27	ERP (W):	11,010.27
Antenna A3 MPE %:	<b>35.80%</b>	Antenna B3 MPE %:	<b>35.80%</b>	Antenna C3 MPE %:	<b>35.80%</b>

Site Composite MPE %	
Carrier	MPE %
T-Mobile (Max at Sector A):	89.01%
no additional carriers	N/A
<b>Site Total MPE % :</b>	<b>89.01%</b>

T-Mobile MPE % Per Sector	
T-Mobile Sector A Total:	89.01%
T-Mobile Sector B Total:	89.01%
T-Mobile Sector C Total:	89.01%
<b>Site Total MPE % :</b>	<b>89.01%</b>

## T-Mobile Maximum MPE Power Values (Sector A)

T-Mobile Frequency Band / Technology (Sector A)	# Channels	Watts ERP (Per Channel)	Height (feet)	Total Power Density ( $\mu\text{W}/\text{cm}^2$ )	Frequency (MHz)	Allowable MPE ( $\mu\text{W}/\text{cm}^2$ )	Calculated % MPE
T-Mobile 1900 MHz GSM	4	1028.30	51.0	56.85	1900 MHz GSM	1000	5.69%
T-Mobile 1900 MHz LTE	2	2056.61	51.0	56.85	1900 MHz LTE	1000	5.69%
T-Mobile 2100 MHz LTE	2	2307.55	51.0	63.79	2100 MHz LTE	1000	6.38%
T-Mobile 2500 MHz LTE	2	6412.98	51.0	177.28	2500 MHz LTE	1000	17.73%
T-Mobile 2500 MHz NR	2	6412.98	51.0	177.28	2500 MHz NR	1000	17.73%
T-Mobile 600 MHz LTE	2	591.73	41.0	25.31	600 MHz LTE	400	6.33%
T-Mobile 600 MHz NR	1	1577.94	41.0	33.75	600 MHz NR	400	8.44%
T-Mobile 700 MHz LTE	2	695.22	41.0	29.74	700 MHz LTE	467	6.37%
T-Mobile 1900 MHz LTE	2	2104.51	41.0	90.02	1900 MHz LTE	1000	9.00%
T-Mobile 2100 MHz UMTS	2	1324.71	41.0	56.66	2100 MHz UMTS	1000	5.67%
						<b>Total:</b>	<b>89.01%</b>

• NOTE: Totals may vary by approximately 0.01% due to summation of remainders in calculations.

## Summary

All calculations performed for this analysis yielded results that were **within** the allowable limits for general population exposure to RF Emissions.

The anticipated maximum composite contributions from the T-Mobile facility as well as the site composite emissions value with regards to compliance with FCC's allowable limits for general population exposure to RF Emissions are shown here:

T-Mobile Sector	Power Density Value (%)
Sector A:	89.01%
Sector B:	89.01%
Sector C:	89.01%
T-Mobile Maximum MPE % (Sector A):	89.01%
Site Total:	89.01%
Site Compliance Status:	<b>COMPLIANT</b>

The anticipated composite MPE value for this site assuming all carriers present is **89.01%** of the allowable FCC established general population limit sampled at the ground level. This is based upon values listed in the Connecticut Siting Council database for existing carrier emissions.

FCC guidelines state that if a site is found to be out of compliance (over allowable thresholds), that carriers over a 5% contribution to the composite value will require measures to bring the site into compliance. For this facility, the composite values calculated were well within the allowable 100% threshold standard per the federal government.

# Exhibit G



**UNITED STATES  
POSTAL SERVICE®**

**Click-N-Ship®**

**P**

usps.com  
**US POSTAGE**  
 Flat Rate Env  
 \$7.75



12/23/2020

Mailed from 01566 062S0000001309

**PRIORITY MAIL 2-DAY™**

Expected Delivery Date: 12/29/20  
 Ref#: HA241-ZAP  
**0006**

DEBORAH CHASE  
 NORTHEAST SITE SOLUTIONS, LLC  
 420 MAIN ST STE 2  
 STURBRIDGE MA 01566-1359

**C006**

SHIP TO: LISA MATTHEWS  
 CT SITING COUNCIL  
 10 FRANKLIN SQ  
 NEW BRITAIN CT 06051-2655

**USPS TRACKING #**

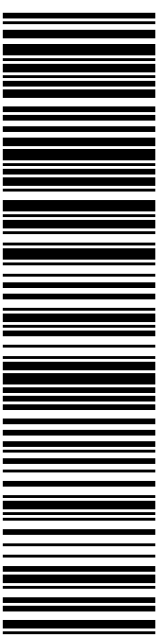

**9405 5036 9930 0206 5033 35**

Electronic Rate Approved #038555749



Cut on dotted line.

### Instructions

1. Each Click-N-Ship® label is unique. Labels are to be used as printed and used only once. DO NOT PHOTO COPY OR ALTER LABEL.
2. Place your label so it does not wrap around the edge of the package.
3. Adhere your label to the package. A self-adhesive label is recommended. If tape or glue is used, DO NOT TAPE OVER BARCODE. Be sure all edges are secure.
4. To mail your package with PC Postage®, you may schedule a Package Pickup online, hand to your letter carrier, take to a Post Office™, or drop in a USPS collection box.
5. Mail your package on the "Ship Date" you selected when creating this label.

### Click-N-Ship® Label Record

**USPS TRACKING # :**  
**9405 5036 9930 0206 5033 35**

Trans. #: 519332745	Priority Mail® Postage: <b>\$7.75</b>
Print Date: 12/21/2020	Total: <b>\$7.75</b>
Ship Date: 12/23/2020	
Expected Delivery Date: 12/29/2020	

**From:** DEBORAH CHASE      Ref#: HA241-ZAP  
 NORTHEAST SITE SOLUTIONS, LLC  
 420 MAIN ST STE 2  
 STURBRIDGE MA 01566-1359

**To:** LISA MATTHEWS  
 CT SITING COUNCIL  
 10 FRANKLIN SQ  
 NEW BRITAIN CT 06051-2655

\* Retail Pricing Priority Mail rates apply. There is no fee for USPS Tracking® service on Priority Mail service with use of this electronic rate shipping label. Refunds for unused postage paid labels can be requested online 30 days from the print date.



Thank you for shipping with the United States Postal Service!  
 Check the status of your shipment on the USPS Tracking® page at usps.com



**UNITED STATES  
POSTAL SERVICE®**

**Click-N-Ship®**

**P**

usps.com  
**US POSTAGE** \$7.75  
 Flat Rate Env  
 9405 5036 9930 0206 5033 73 0077 5000 0010 6416



Mailed from 01566 062S0000001309

**PRIORITY MAIL 2-DAY™**

Expected Delivery Date: 12/29/20  
 Ref#: HA241-ZAP  
**0006**

SHIP TO:

MAYOR ENZO FAIENZA  
 41 WEST ST  
 CROMWELL CT 06416-2180

**USPS TRACKING #**



**9405 5036 9930 0206 5033 73**

Electronic Rate Approved #038555749



Cut on dotted line.

### Instructions

1. Each Click-N-Ship® label is unique. Labels are to be used as printed and used only once. DO NOT PHOTO COPY OR ALTER LABEL.
2. Place your label so it does not wrap around the edge of the package.
3. Adhere your label to the package. A self-adhesive label is recommended. If tape or glue is used, DO NOT TAPE OVER BARCODE. Be sure all edges are secure.
4. To mail your package with PC Postage®, you may schedule a Package Pickup online, hand to your letter carrier, take to a Post Office™, or drop in a USPS collection box.
5. Mail your package on the "Ship Date" you selected when creating this label.

### Click-N-Ship® Label Record

**USPS TRACKING # :**  
**9405 5036 9930 0206 5033 73**

Trans. #: 519332745	Priority Mail® Postage: <b>\$7.75</b>
Print Date: 12/21/2020	Total: <b>\$7.75</b>
Ship Date: 12/23/2020	
Expected Delivery Date: 12/29/2020	

**From:** DEBORAH CHASE Ref#: HA241-ZAP  
 NORTHEAST SITE SOLUTIONS, LLC  
 420 MAIN ST STE 2  
 STURBRIDGE MA 01566-1359

**To:** MAYOR ENZO FAIENZA  
 41 WEST ST  
 CROMWELL CT 06416-2180

\* Retail Pricing Priority Mail rates apply. There is no fee for USPS Tracking® service on Priority Mail service with use of this electronic rate shipping label. Refunds for unused postage paid labels can be requested online 30 days from the print date.



Thank you for shipping with the United States Postal Service!  
 Check the status of your shipment on the USPS Tracking® page at usps.com





**UNITED STATES  
POSTAL SERVICE®**

**Click-N-Ship®**

**P**

usps.com  
**US POSTAGE** \$7.75  
 Flat Rate Env  
 9405 5036 9930 0206 5034 03 0077 5000 0010 6416



Mailed from 01566 062S0000001311

**PRIORITY MAIL 2-DAY™**

Expected Delivery Date: 12/29/20  
 Ref#: HA241-ZAP  
**0006**

SHIP TO:  
 ANTHONY J SALVATORE  
 41 WEST ST  
 CROMWELL CT 06416-2180

**USPS TRACKING #**



**9405 5036 9930 0206 5034 03**

Electronic Rate Approved #038555749



Cut on dotted line.

### Instructions

1. Each Click-N-Ship® label is unique. Labels are to be used as printed and used only once. DO NOT PHOTO COPY OR ALTER LABEL.
2. Place your label so it does not wrap around the edge of the package.
3. Adhere your label to the package. A self-adhesive label is recommended. If tape or glue is used, DO NOT TAPE OVER BARCODE. Be sure all edges are secure.
4. To mail your package with PC Postage®, you may schedule a Package Pickup online, hand to your letter carrier, take to a Post Office™, or drop in a USPS collection box.
5. Mail your package on the "Ship Date" you selected when creating this label.

### Click-N-Ship® Label Record

**USPS TRACKING # :**  
**9405 5036 9930 0206 5034 03**

Trans. #: 519332745	Priority Mail® Postage: <b>\$7.75</b>
Print Date: 12/21/2020	Total: <b>\$7.75</b>
Ship Date: 12/23/2020	
Expected Delivery Date: 12/29/2020	

**From:** DEBORAH CHASE      Ref#: HA241-ZAP  
 NORTHEAST SITE SOLUTIONS, LLC  
 420 MAIN ST STE 2  
 STURBRIDGE MA 01566-1359

**To:** ANTHONY J SALVATORE  
 41 WEST ST  
 CROMWELL CT 06416-2180

\* Retail Pricing Priority Mail rates apply. There is no fee for USPS Tracking® service on Priority Mail service with use of this electronic rate shipping label. Refunds for unused postage paid labels can be requested online 30 days from the print date.



Thank you for shipping with the United States Postal Service!  
 Check the status of your shipment on the USPS Tracking® page at usps.com



**UNITED STATES POSTAL SERVICE®**

**Click-N-Ship®**

**P**

usps.com  
**US POSTAGE** \$7.75  
 Flat Rate Enviv



12/23/2020 Mailed from 01566 062S0000000313

**PRIORITY MAIL 2-DAY™**

Expected Delivery Date: 12/29/20  
 Ref#: HA241-ZAP  
**0006**

SHIP TO:

DEBORAH CHASE  
 NORTHEAST SITE SOLUTIONS, LLC  
 420 MAIN ST STE 2  
 STURBRIDGE MA 01566-1359

C003

STUART POPPER  
 41 WEST ST  
 CROMWELL CT 06416-2180

**USPS TRACKING #**

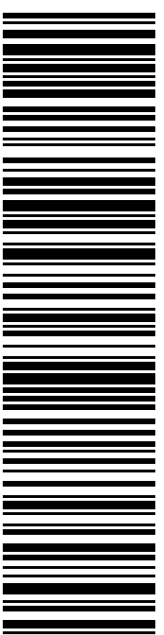

**9405 5036 9930 0206 5034 27**

Electronic Rate Approved #038555749



Cut on dotted line.

### Instructions

1. Each Click-N-Ship® label is unique. Labels are to be used as printed and used only once. DO NOT PHOTO COPY OR ALTER LABEL.
2. Place your label so it does not wrap around the edge of the package.
3. Adhere your label to the package. A self-adhesive label is recommended. If tape or glue is used, DO NOT TAPE OVER BARCODE. Be sure all edges are secure.
4. To mail your package with PC Postage®, you may schedule a Package Pickup online, hand to your letter carrier, take to a Post Office™, or drop in a USPS collection box.
5. Mail your package on the "Ship Date" you selected when creating this label.

### Click-N-Ship® Label Record

**USPS TRACKING # :**  
**9405 5036 9930 0206 5034 27**

Trans. #: 519332745	Priority Mail® Postage: <b>\$7.75</b>
Print Date: 12/21/2020	Total: <b>\$7.75</b>
Ship Date: 12/23/2020	
Expected Delivery Date: 12/29/2020	

**From:** DEBORAH CHASE      Ref#: HA241-ZAP  
 NORTHEAST SITE SOLUTIONS, LLC  
 420 MAIN ST STE 2  
 STURBRIDGE MA 01566-1359

**To:** STUART POPPER  
 41 WEST ST  
 CROMWELL CT 06416-2180

\* Retail Pricing Priority Mail rates apply. There is no fee for USPS Tracking® service on Priority Mail service with use of this electronic rate shipping label. Refunds for unused postage paid labels can be requested online 30 days from the print date.



Thank you for shipping with the United States Postal Service!  
 Check the status of your shipment on the USPS Tracking® page at usps.com



**UNITED STATES  
POSTAL SERVICE®**

**Click-N-Ship®**

**P**

usps.com  
**US POSTAGE** \$7.75  
 Flat Rate Env  
 9405 5036 9930 0206 5034 41 0077 5000 0010 2169



12/23/2020 Mailed from 01566 062S0000001310

**PRIORITY MAIL 1-DAY™**

Expected Delivery Date: 12/24/20  
 Ref#: HA241-ZAP  
**0006**

SHIP TO:  
 STOP-N-SHOP CORPORATE- REAL ESTATE DEPT.  
 1385 HANCOCK ST  
 QUINCY MA 02169-5103

**USPS TRACKING #**

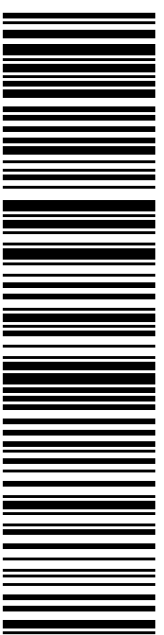

**9405 5036 9930 0206 5034 41**

Electronic Rate Approved #038555749



Cut on dotted line.

### Instructions

1. Each Click-N-Ship® label is unique. Labels are to be used as printed and used only once. DO NOT PHOTO COPY OR ALTER LABEL.
2. Place your label so it does not wrap around the edge of the package.
3. Adhere your label to the package. A self-adhesive label is recommended. If tape or glue is used, DO NOT TAPE OVER BARCODE. Be sure all edges are secure.
4. To mail your package with PC Postage®, you may schedule a Package Pickup online, hand to your letter carrier, take to a Post Office™, or drop in a USPS collection box.
5. Mail your package on the "Ship Date" you selected when creating this label.

### Click-N-Ship® Label Record

**USPS TRACKING # :**  
**9405 5036 9930 0206 5034 41**

Trans. #: 519332745	Priority Mail® Postage: <b>\$7.75</b>
Print Date: 12/21/2020	Total: <b>\$7.75</b>
Ship Date: 12/23/2020	
Expected Delivery Date: 12/24/2020	

**From:** DEBORAH CHASE Ref#: HA241-ZAP  
 NORTHEAST SITE SOLUTIONS, LLC  
 420 MAIN ST STE 2  
 STURBRIDGE MA 01566-1359

**To:** STOP-N-SHOP CORPORATE- REAL ESTATE DEPT.  
 1385 HANCOCK ST  
 QUINCY MA 02169-5103

\* Retail Pricing Priority Mail rates apply. There is no fee for USPS Tracking® service on Priority Mail service with use of this electronic rate shipping label. Refunds for unused postage paid labels can be requested online 30 days from the print date.



Thank you for shipping with the United States Postal Service!  
 Check the status of your shipment on the USPS Tracking® page at usps.com

# Exhibit H

## Deborah Chase

---

**From:** Deborah Chase  
**Sent:** Monday, December 21, 2020 2:45 PM  
**To:** 'spopper@cromwellct.com'; 'asalvatore@cromwellct.com'; 'Mayor@cromwellct.com'  
**Cc:** 'service@peapod.com'  
**Subject:** 207 WEST STREETCROMWELL CT 06416 T-MOBILE EM APPLICATION (CTHA241C-ANCHOR)  
**Attachments:** 207 WEST STREET CROMWELL CT 06416 T-MOBILE EM APPLICATION (CTHA241C Anchor).pdf

Good afternoon,

On behalf of our client, (T-Mobile), I am forwarding copies of T-Mobile's Exempt Modification Request to collocate on a wireless telecommunications facility located at 207 West Street, Cromwell, CT

Hard copies will be sent as well for your records.

Feel free to contact me with any questions regarding T-Mobile's Exempt Modification Request.

Thank you very much

### Deborah Chase

Senior Project Coordinator & Analyst

Mobile: 860-490-8839



🌱 Save a tree. Refuse. Reduce. Reuse. Recycle.