



T-Mobile Northeast LLC, a subsidiary of T-Mobile USA, Inc.

Connecticut Market

March 8, 2024

Honorable Robert Stein, Chairman,
and members of the Council
Connecticut Siting Council
10 Franklin Square
New Britain, CT 06051

Re: T-MOBILE Northeast LLC notice of intent to install a temporary cellular telephone facility located at 1 Golf Club Rd Cromwell, Connecticut

Dear Chairman Stein and Members of the Council:

Centerline is pleased to submit this Notice of Exempt Modification on behalf of T-MOBILE Northeast LLC

T-MOBILE Northeast LLC hereby notifies the Connecticut Siting Council of its intent for the temporary use of telecommunications equipment by placing a Cell On Light Truck (COLT) on the grounds of TPC River Highlands located at 1 Golf Club Rd Cromwell, Connecticut for the Travelers Championship Golf Tournament. Please accept this Notice to the Connecticut Siting Council, Pursuant to RCSA Section 16-50j-73, of construction that constitutes an exempt modification under RCSA Section 16-50j-72 (d). In compliance with RCSA Section 16-50j-73, copies of this Notice of Exempt Modification are being sent to the Mayor of Cromwell and TPC River Highlands, where the event takes place.

The proposed temporary cell site meets the criteria set forth in RCSA 16-50j-72(d) for temporary cellular service for events of statewide significance. The site is necessary to provide additional system capacity to accommodate the increased communication needs during the Travelers Championship.

The Traveler's Championship is June 17-23, 2024 but T-Mobile will need to do testing beforehand to make sure the site is up and running before the event.

Proposed Temporary Facility

The temporary site will be located at 1 Golf Club Rd. in Cromwell, Connecticut on the property known as TPC River Highlands. (See attached location map) Coordinates for the location are N 41.624589, W 72.640581. A 15 kw diesel generator will be used for power and the proposed temporary cell site will not increase the noise level by six decibels or more.

Equipment installation will start on June 8, 2024 and the site will be on-air until June 28, 2024. The COLT will be removed on June 28, 2024.

T-Mobile's temporary cell site will consist of a "Cell On Light Truck" ("COLT") (See attached photo) which needs a 25' x 25' footprint, contains three indoor RBS6201's and PBC6200 with battery backup, a backup generator, dual masts and can support 5 sector multibeam antennas.

Power Density Calculations

T-Mobile's temporary cell site will not result in a total radio frequency electromagnetic radiation power density, measured at ground level at the COLT location, at or above State or Federal standards. The following table shows the power density at the site from the proposed temporary cellular transmissions form the COLT:

Site Compliance Summary	
Compliance Status:	COMPLIANT
Site total MPE% of FCC general population allowable limit:	8.92%

See attached full report

Conclusion

For the reasons above, we respectfully request the Council acknowledge T-Mobile's Notice of Exempt Modification for the temporary cell site to be operated during the Travelers Championship pursuant to RCSA Section 16-50j-72(d).

Please call me with any questions concerning this Notice at 203-417-4446. Thank you.

Respectfully,

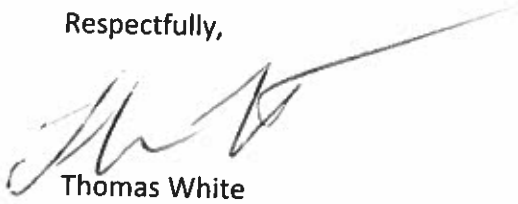
A handwritten signature in black ink, appearing to read 'Thomas White', with a long horizontal line extending to the right.

Thomas White
Agent of T-Mobile

Cc: Mayor James Demetriades

TPC River Highlands



T-Mobile Northeast LLC, a subsidiary of T-Mobile USA, Inc.

New England Market

Nathan Grube
Executive Director
Travelers Championship
90 State House Square
11th Floor
Hartford, CT 06103

February 6, 2024

Re: STANDARD AGREEMENT by and between The Greater Hartford Community Foundation, Inc. dba Travelers Championship ("Lessor") and T-Mobile Northeast LLC as successor-in interest to Omnipoint Communications, Inc. ("Lessee").

Site Number: CTCLT08A
Site Address: 1 Golf Club Rd Cromwell, CT("Property")

To Whom It May Concern,

Tenant has the right to place a Cell On Light Truck ("COLT") at 1 Golf Club Rd Cromwell, CT from 6/10/24 to 6/25/24. The COW will be removed by 6/25/24. (See exhibit A for placement)

Please signify your approval by signing and dating one (1) original of this Consent Letter in the space provided below. Kindly return the Consent Letter to Thomas White via email at twhite@clinellc.com.

Should you have any questions, please contact Thomas White at 203-417-4446. Thank you in advance for your cooperation in this matter.

Very truly yours,

Thomas White
Agent for T-Mobile

Acknowledged, Accepted and Agreed:

By: 

Date: 14/02/2024

Exhibit A

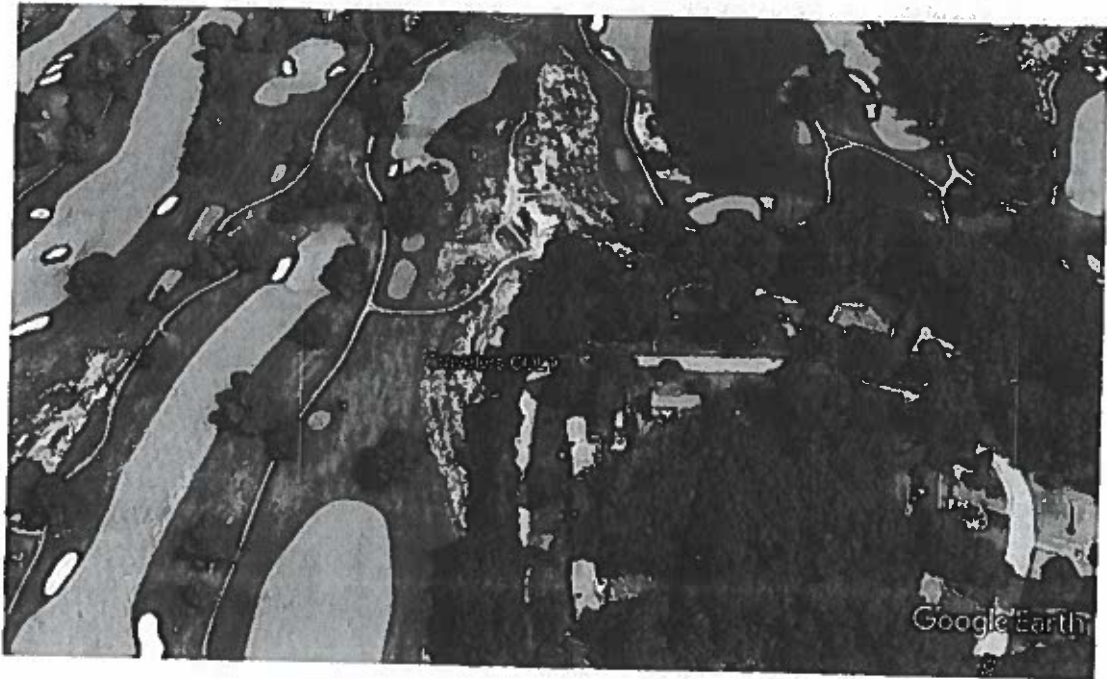



Empowering Real People

Magnum Mobile Lite Generator – MLG15 Specifications

ENGINE

- Mitsubishi® S4L2-Y461ML - naturally aspirated, diesel engine ◦ Prime - 22.3 hp @ 1800 rpm ◦ 4 cylinder ◦ 1.8 L displacement ◦ Interim Tier IV approved
- Polyethylene fuel tank ◦ 56 gal. capacity ◦ 43 hr. run time – full load ◦ 3 ½" fill port
- Fuel consumption at prime:
 - 100% - 1.30 gph (4.92 Lph) ◦ 75% - 0.98 gph (3.71 Lph) ◦ 50% - 0.65 gph (2.46 Lph)
- Cooling system capable of operating at 120°F ambient
- Rubber vibration dampers isolate engine/generator from frame
- Full flow oil filter, spin on type
- Fuel filter with replaceable element
- Dry type cartridge air filter
- 60 Hz engine/generator

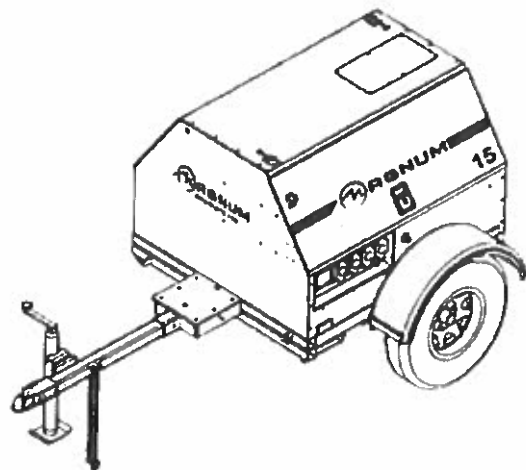

ENGINE CONTROLS

- Engraved aluminum punched and anodized control panel
- Four position keyed switch – glow plugs (preheat, off, run, start)
- Hour meter
- Automatic low oil/high temperature shutdown system

GENERATOR

- Marathon Electric® ◦ Brushless ◦ 4 pole ◦ Class H insulation
- Single phase output ◦ Prime - 13 kW / 13 kVA (54A @ 240V) ◦ Standby - 14 kW / 14 kVA (58A @ 240V)
- Voltage regulation +/- 1% with Marathon SE350 Voltage Regulator



ELECTRICAL SYSTEM AND CONTROLS

- 70A start limit breaker (assures no load condition exists before starting)
- Convenience receptacles with individual breakers ○ (2) 120V 20 Amp GFCI duplex outlets (Nema 5-20R type) ○ (2) 240V 30 Amp twistlock outlets (Nema L6-30R type) ○ (2) 240V 50 Amp twistlock outlets (Non-Nema 6369)
- 440 CCA wet cell battery

ENCLOSURE

- Steel, 14-gauge, sound attenuated enclosure ○ UV & fade resistant, high temperature cured, white polyester powder paint ○ Insulated and baffled ○ 70 dB(A) at 23 feet – prime power
- Fully lockable enclosure
- Stainless steel hinges, door latches and exterior hardware
- Emergency stop switch located on front panel
- License plate holder with light
- Multi-lingual operating/safety decals
- Document holder with operating/parts manuals including AC/DC wiring diagrams

TRAILER

- DOT approved tail, side, brake, and directional lights ○ Recessed rear lights
- Transportation tie downs
- Safety chains with spring loaded safety hooks
- Single wall polyethylene fenders
- 2" ball hitch
- 2200 lb. leaf spring axle
- 2000 lb. tongue jack with footplate
- ST205/75R15 tubeless tires – 6 ply
- 48" track width

WEIGHTS & DIMENSIONS

- Dry weight: 1425 lbs (646 kg)
- Operating weight: 1823 lbs (827 kg)
- 105 x 68 x 56 in
(2.67 x 1.73 x 1.42 m)

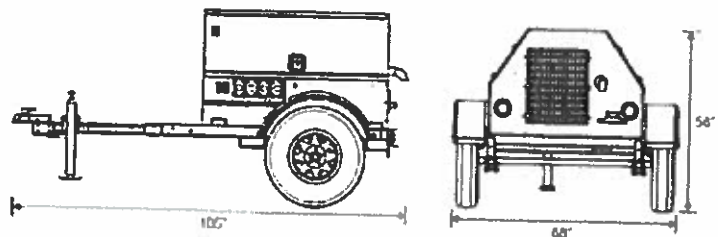

WARRANTY

- • Engine and generator covered under OEM warranty – consult factory for details

CERTIFICATIONS

- CSA certified



MLG15 Options

ENGINE OPTIONS

- ◆ Heated fuel filter
- ◆ Lower radiator hose – engine heater
- ◆ Oil drain valve kit

ELECTRICAL CONTROLS OPTIONS

- ◆ 720 CCA gel cell battery
- ◆ 720 CCA wet cell battery
- ◆ 685 CCA gel cell battery
- ◆ Battery disconnect
- ◆ Battery charger – 2A trickle

VOLTAGE OUTPUT OPTIONS

- ◆ Alternative receptacle panel – consult factory for configurations

COOLANT OPTIONS

- ◆ 60/40 Coolant – cold weather applications

ENCLOSURE OPTIONS

- ◆ Interior cabinet light
- ◆ Level indicator
- ◆ Tamper pack
- ◆ Liquid containment / Quiet pack
- ◆ Lift structure



FUEL TANK OPTIONS

- ◆ 56 gal. fuel tank
- ◆ Tethered fuel tank cap

TRAILER OPTIONS

- ◆ 6 pin or 7 spade electrical connectors
- ◆ Outrigger package
- ◆ Tube and sleeve jack
- ◆ Spare tire/wheel kit

HITCH OPTIONS

- ◆ 2.5" lunette ring
- ◆  3" lunette ring
- ◆  3" HD lunette ring

- ◆ 2 5/16" ball
- ◆ Combination hitch – 2.5" lunette ring / 2" ball

05/09



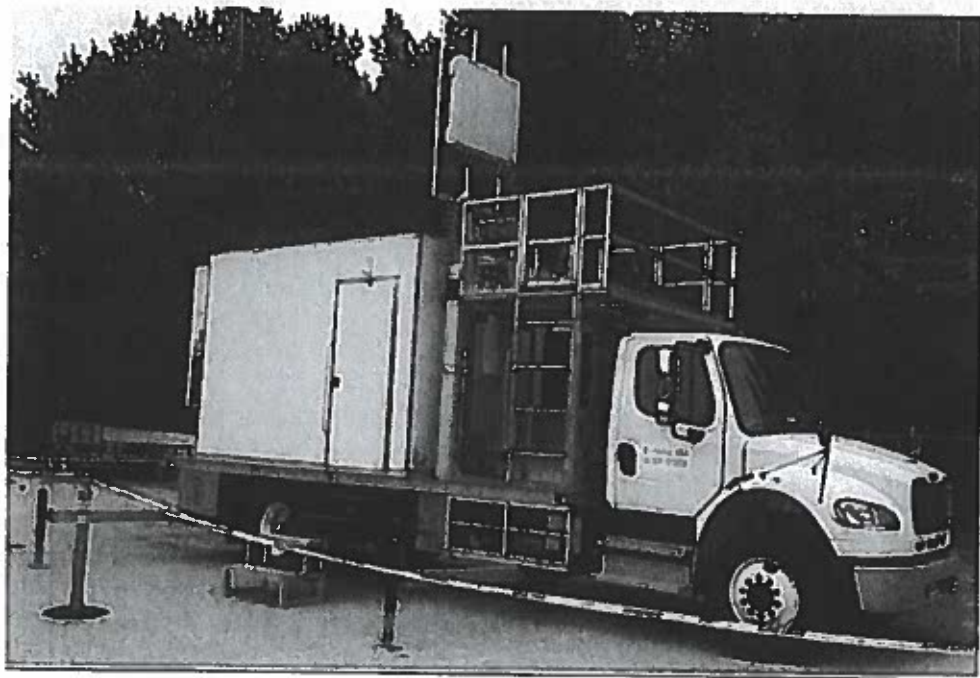

NOTE:
 ALL EQUIPMENT LOCATIONS ARE APPROXIMATE AND ARE SUBJECT TO APPROVAL BY T-MOBILE NORTHEAST, LLC. STRUCTURAL & RF ENGINEERS. ALL PHONE FACILITIES ARE SUBJECT TO APPROVAL BY OTHER UTILITY COMPANIES.

NOTES:
 1. CALL THE FOLLOWING FOR ALL PRE CONSTRUCTION NOTIFICATION 72 HOURS PRIOR TO ANY EXCAVATION ACTIVITY:
 DIG SAFE SYSTEM (MA, NH, NJ, RI, VT):
 1-800-932-4455
 CALL BEFORE YOU DIG (CT):
 1-800-932-4455
 2. CONTRACTOR TO FIELD VERIFY DESIGN AND NOTIFY THE CONSTRUCTION MANAGER AND ENGINEER OF ANY DISCREPANCIES.
 APPROXIMATE COORDINATES OF SITE LOCATION:
 LATITUDE: 41.62489
 LONGITUDE: 72.64281

T-MOBILE NORTHEAST LLC
 30 OWEN ROAD SUITE 100
 BURLINGTON, CT 06702
 PHONE: 860-381-1714

CENTERLINE
 760 WEST CENTER ST. SUITE 301
 WEST BROMFIELD, MA 01976
 PHONE: 781.713.0725

REVISIONS	
NO.	DESCRIPTION
0	4/29/20 ISSUED FOR REVIEW

DESIGNED BY:	TC	APPROVED BY:	DC
--------------	----	--------------	----



SHEET INFO:
 CTCLTSTA
 STAFFORD MOTOR SPEEDWAY
 55 WEST ST.
 STAFFORD SPRINGS, CT 06076

SHEET TITLE:
 COLT LOCATION MAP & EQUIPMENT PLAN
 DRAWING # LE-1
 REVISION 0

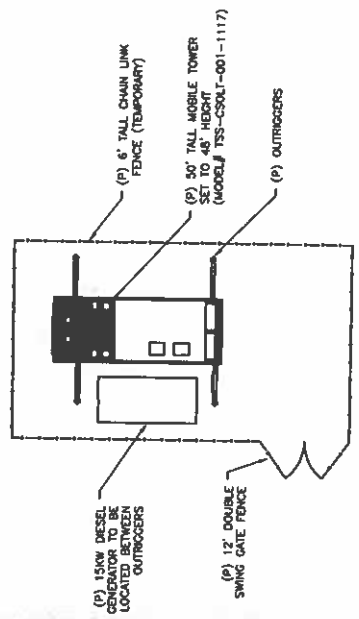

COLT LOCATION MAP
 SCALE: 1"=1000' (22"x34")
 1"=2000' (11"x17")
 GRAPHIC SCALE
 (IN FEET)

EQUIPMENT PLAN
 SCALE: 1/8" = 1'-0" (22"x34")
 1/16" = 1'-0" (11"x17")
 GRAPHIC SCALE
 (IN FEET)

NOTE:
 ALL EQUIPMENT LOCATIONS ARE APPROXIMATE AND ARE SUBJECT TO CHANGE. ALL EQUIPMENT LOCATIONS ARE SUBJECT TO APPROVAL BY OTHER UTILITY COMPANIES.

**T-MOBILE
 NORTHEAST LLC**

14 GARDEN ROAD, SUITE 200
 BOSTON, MA 02114
 PHONE: 617 552 1114

CENTERLINE
 CONSULTING ENGINEERS

750 WEST CENTER ST. SUITE 301
 WEST BRIDGEWATER, MA 02779
 PHONE: 781 713 8725

REVISIONS

NO.	DATE	ISSUED FOR REVIEW	DESCRIPTION
0	4/29/20		

DESIGNED BY: IC
 APPROVED BY: DC

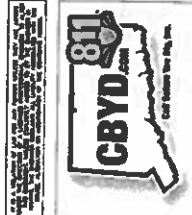

SITE INFO:
 CTCLTSTA
 STAFFORD MOTOR
 SPEEDWAY
 55 WEST ST.
 STAFFORD SPRINGS, CT
 06076

SHEET TITLE: NORTHEAST ELEVATION
 DRAWING # LE-2
 REVISION: 0

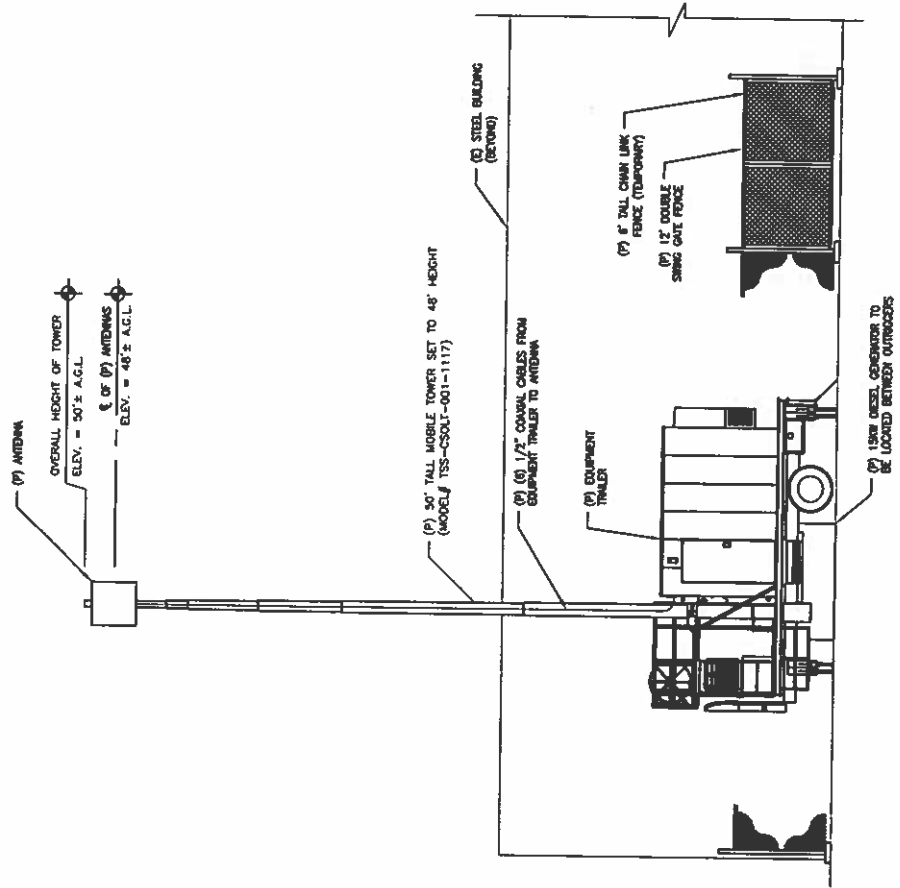

ELEVATION
 SCALE: 1/4" = 1'-0" (22"x34")
 1/8" = 1'-0" (11"x17")
 GRAPHIC SCALE
 (IN FEET)

**RADIO FREQUENCY EMISSIONS ANALYSIS REPORT
EVALUATION OF HUMAN EXPOSURE POTENTIAL
TO NON-IONIZING EMISSIONS**

T-Mobile Existing Facility

Site ID: Travelers

**Glenwood Terrace
Cromwell, Connecticut 06416**

May 3, 2023

EBI Project Number: 6223001578

Site Compliance Summary	
Compliance Status:	COMPLIANT
Site total MPE% of FCC general population allowable limit:	8.92%

May 3, 2023

T-Mobile
Attn: Jason Overbey, RF Manager
35 Griffin Road South
Bloomfield, Connecticut 06002

Emissions Analysis for Site: Travelers

EBI Consulting was directed to analyze the proposed T-Mobile facility located at **Glenwood Terrace in Cromwell, Connecticut** for the purpose of determining whether the emissions from the Proposed T-Mobile Antenna Installation located on this property are within specified federal limits.

All information used in this report was analyzed as a percentage of current Maximum Permissible Exposure (% MPE) as listed in the FCC OET Bulletin 65 Edition 97-01 and ANSI/IEEE Std C95.1. The FCC regulates Maximum Permissible Exposure in units of microwatts per square centimeter ($\mu\text{W}/\text{cm}^2$). The number of $\mu\text{W}/\text{cm}^2$ calculated at each sample point is called the power density. The exposure limit for power density varies depending upon the frequencies being utilized. Wireless Carriers and Paging Services use different frequency bands each with different exposure limits; therefore, it is necessary to report results and limits in terms of percent MPE rather than power density.

All results were compared to the FCC (Federal Communications Commission) radio frequency exposure rules, 47 CFR 1.1307(b)(1) – (b)(3), to determine compliance with the Maximum Permissible Exposure (MPE) limits for General Population/Uncontrolled environments as defined below.

General population/uncontrolled exposure limits apply to situations in which the general population may be exposed or in which persons who are exposed as a consequence of their employment may not be made fully aware of the potential for exposure or cannot exercise control over their exposure. Therefore, members of the general population would always be considered under this category when exposure is not employment related, for example, in the case of a telecommunications tower that exposes persons in a nearby residential area.

Public exposure to radio frequencies is regulated and enforced in units of microwatts per square centimeter ($\mu\text{W}/\text{cm}^2$). The general population exposure limits for the 600 MHz and 700 MHz frequency bands are approximately $400 \mu\text{W}/\text{cm}^2$ and $467 \mu\text{W}/\text{cm}^2$, respectively. The general population exposure limit for the 1900 MHz (PCS), 2100 MHz (AWS) and 11 GHz frequency bands is $1000 \mu\text{W}/\text{cm}^2$. Because each carrier will be using different frequency bands, and each frequency band has different exposure limits, it is necessary to report percent of MPE rather than power density.

Occupational/controlled exposure limits apply to situations in which persons are exposed as a consequence of their employment and in which those persons who are exposed have been made fully aware of the potential for exposure and can exercise control over their exposure. Occupational/controlled exposure limits also apply where exposure is of a transient nature as a result of incidental passage through a location where exposure levels may be above general population/uncontrolled limits (see below), as long as the exposed person has been made fully aware of the potential for exposure and can exercise control over his or her exposure by leaving the area or by some other appropriate means.

Additional details can be found in FCC OET 65.

CALCULATIONS

Calculations were done for the proposed T-Mobile Wireless antenna facility located at Glenwood Terrace in Cromwell, Connecticut using the equipment information listed below. All calculations were performed per the specifications under FCC OET 65. Since T-Mobile is proposing highly focused directional panel antennas, which project most of the emitted energy out toward the horizon, all calculations were performed assuming a lobe representing the maximum gain of the antenna per the antenna manufacturer's supplied specifications at the base of the tower. For this report, the sample point is the top of a 6-foot person standing at the base of the tower. **All calculations were performed using Far Field Analysis.**

For all calculations, all equipment was calculated using the following assumptions:

- 1) 2 LTE channels (PCS Band - 1900 MHz) were considered for each sector of the proposed installation. These Channels have a total transmit power of 120 Watts per Channel.
- 2) 2 LTE channels (AWS Band - 2100 MHz) were considered for each sector of the proposed installation. These Channels have a total transmit power of 120 Watts per Channel.
- 3) 1 LTE Traffic channel (LTE IC and 2C BRS Band - 2500 MHz) was considered for each sector of the proposed installation. This Channel has a transmit power of 45 Watts.
- 4) 1 LTE Broadcast channel (LTE IC and 2C BRS Band - 2500 MHz) was considered for each sector of the proposed installation. This Channel has a transmit power of 15 Watts.
- 5) 1 NR Traffic channel (BRS Band - 2500 MHz) was considered for each sector of the proposed installation. This Channel has a transmit power of 90 Watts.
- 6) 1 NR Broadcast channel (BRS Band - 2500 MHz) was considered for each sector of the proposed installation. This Channel has a transmit power of 30 Watts.



environmental | engineering | due diligence

- 7) All radios at the proposed installation were considered to be running at full power and were uncombined in their RF transmissions paths per carrier prescribed configuration. Per FCC OET Bulletin No. 65 - Edition 97-01 recommendations to achieve the maximum anticipated value at each sample point, all power levels emitting from the proposed antenna installation are increased by a factor of 2.56 to account for possible in-phase reflections from the surrounding environment. This is rarely the case, and if so, is never continuous.
- 8) For the following far field calculations, the sample point was the top of a 6-foot person standing at the base of the tower. The maximum gain of the antenna per the antenna manufacturer's supplied specifications was used in this direction. This value is a very conservative estimate as gain reductions for these particular antennas are typically much higher in this direction.
- 9) The antennas used in this modeling are the COMMSCOPE SON_5NPX1006F Beam 1 06DT 1900 for the 1900 MHz / 2100 MHz channel(s), the ERICSSON SON_AIR6449 2500 LTE TB for the 2500 MHz / 2500 MHz / 2500 MHz / 2500 MHz channel(s) in Sector A. This is based on feedback from the carrier with regard to anticipated antenna selection. All Antenna gain values and associated transmit power levels are shown in the Site Inventory and Power Data table below. The maximum gain of the antenna per the antenna manufacturer's supplied specifications was used for all calculations. This value is a very conservative estimate as gain reductions for these particular antennas are typically much higher in this direction.
- 10) The antenna mounting height centerline of the proposed antennas is 48 feet above ground level (AGL).
- 11) Emissions from additional carriers were not included because there are no other carriers on this site.
- 12) All calculations were done with respect to uncontrolled / general population threshold limits.



EBI Consulting

environmental | engineering | due diligence

T-Mobile Site Inventory and Power Data

Sector:	A
Antenna #:	1
Make / Model:	COMMSCOPE SON_5NPX1006F Beam 1 06DT 1900
Frequency Bands:	1900 MHz / 1900 MHz / 1900 MHz / 1900 MHz / 1900 MHz / 1900 MHz / 2100 MHz / 2100 MHz / 2100 MHz / 2100 MHz
Gain:	18.45 dBd / 19.94 dBd / 20.4 dBd / 19.93 dBd / 18.51 dBd / 18.73 dBd / 20.33 dBd / 20.43 dBd / 20.19 dBd / 19.02 dBd
Height (AGL):	48 feet
Channel Count:	20
Total TX Power (W):	480.00 Watts
ERP (W):	26,212.40
Antenna A1 MPE %:	53.42%
Antenna #:	2
Make / Model:	ERICSSON SON_AIR6449 2500 LTE TB
Frequency Bands:	2500 MHz / 2500 MHz / 2500 MHz / 2500 MHz
Gain:	22.35 dBd / 22.35 dBd / 17.3 dBd / 17.3 dBd
Height (AGL):	48 feet
Channel Count:	4
Total TX Power (W):	180.00 Watts
ERP (W):	25,608.41
Antenna A2 MPE %:	52.19%



environmental | engineering | due diligence

Site Composite MPE %	
Carrier	MPE %
T-Mobile (Max at Sector A):	8.92%
no additional carriers	N/A
Site Total MPE % :	8.92%

T-Mobile Sector A Total:	8.92%
Site Total MPE % :	8.92%

T-Mobile Maximum MPE Power Values (Sector A)

T-Mobile Frequency Band / Technology (Sector A)	# Channels	Watts ERP (Per Channel)	Height (feet)	Total Power Density ($\mu\text{W}/\text{cm}^2$)	Frequency (MHz)	Allowable MPE ($\mu\text{W}/\text{cm}^2$)	Calculated % MPE
T-Mobile 1900 MHz LTE	2	991.7706269	48	40.42585352	1900 MHz LTE	1000.0	4.04%
T-Mobile 1900 MHz LTE	2	1397.691235	48	56.97170254	1900 MHz LTE	1000.0	5.70%
T-Mobile 1900 MHz LTE	2	1553.857691	48	63.33724927	1900 MHz LTE	1000.0	6.33%
T-Mobile 1900 MHz LTE	2	1394.476634	48	56.84067126	1900 MHz LTE	1000.0	5.68%
T-Mobile 1900 MHz LTE	2	1005.567531	48	40.98823316	1900 MHz LTE	1000.0	4.10%
T-Mobile 2100 MHz LTE	2	1057.818704	48	43.11805856	2100 MHz LTE	1000.0	4.31%
T-Mobile 2100 MHz LTE	2	1529.013225	48	62.32455669	2100 MHz LTE	1000.0	6.23%
T-Mobile 2100 MHz LTE	2	1564.628518	48	63.7762821	2100 MHz LTE	1000.0	6.38%
T-Mobile 2100 MHz LTE	2	1480.509647	48	60.34748814	2100 MHz LTE	1000.0	6.03%
T-Mobile 2100 MHz LTE	2	1130.866247	48	46.09557089	2100 MHz LTE	1000.0	4.61%
T-Mobile 2500 MHz LTE	1	7730.587742	48	157.5543776	2500 MHz LTE	1000.0	15.76%
T-Mobile 2500 MHz NR	1	15461.17548	48	315.1087552	2500 MHz NR	1000.0	31.51%
T-Mobile 2500 MHz LTE	1	805.5476946	48	16.41758297	2500 MHz LTE	1000.0	1.64%
T-Mobile 2500 MHz NR	1	1611.095389	48	32.83516594	2500 MHz NR	1000.0	3.28%
Total:							8.92%

* NOTE: Totals may vary by approximately 0.01% due to summation of remainders in calculations.

Summary

All calculations performed for this analysis yielded results that were **within** the allowable limits for general population exposure to RF Emissions.

The anticipated maximum composite contributions from the T-Mobile facility as well as the site composite emissions value with regards to compliance with FCC's allowable limits for general population exposure to RF Emissions are shown here:

T-Mobile Sector	Power Density Value (%)
Sector A:	8.92%
T-Mobile Maximum MPE % (Sector A):	8.92%
Site Total:	8.92%
Site Compliance Status:	COMPLIANT

The anticipated composite MPE value for this site assuming all carriers present is **8.92%** of the allowable FCC established general population limit sampled at the ground level. This is based upon values listed in the Connecticut Siting Council database for existing carrier emissions.

FCC guidelines state that if a site is found to be out of compliance (over allowable thresholds), that carriers over a 5% contribution to the composite value will require measures to bring the site into compliance. For this facility, the composite values calculated were well within the allowable 100% threshold standard per the federal government.



Patriot
Properties Inc.

Map-Lot 60-17
Last Revaluation - October 1, 2017

Current Value Information		Mkt Adj Cost		Total Assessed		
Use Code	Land Value	PA 490 Value	Building Value	Outbuildings	Total Value	Total Assessed
201	6,198,700	0	302,100	452,600	6,953,400	4,867,380
TOTAL	6,198,700	0	302,100	452,600	6,953,400	4,867,380

PERCENT 100
100 GOLF CLUB ROAD
CROMWELL CT 06416

Previous Value Information		Bldg Value		Outbuildings		Total Assessment	
Tax Yr	Land Value	Bldg Value	Outbuildings	Total Value	Total Assessment	Flood:	Census
2019	6,198,700	302,100	452,600	6,953,400	4,867,380		5703
2018	6,198,700	302,100	452,600	6,953,400	4,867,380	Topo:	
2017	6,198,700	1,176,600	615,100	7,990,400	5,593,280	Street: Paved	
2016	5,929,490	1,204,210	359,400	7,493,100	5,222,500	Dev. Map	
2015	5,929,490	1,204,210	359,400	7,493,100	5,222,500	Dev. Map	
2014	5,929,490	1,171,810	359,400	7,460,700	5,222,500		

Property Factors

Desc. %
R-25 100.00

Utilities
2 Public Water
3 Public Sewer
BAA
09K,07K

Sales Information		Vol-Page		Sale Price		Sale Verif		GeneralNotes	
Grantee	Type	SaleDate	SalePrice	Sale Verif	GeneralNotes				
TOURNAMENT PLAYERS CLU	242-84	04/25/1984	0						

General Notes	
TPC Golf Course	

Activity Information

Date	Results	Visited By
09/27/2018	Permit- Drive By	Karen Vaiculis
08/31/2018	Permit- Drive By	Assessor Office
09/12/2017	Change - Value Change Company	John Valente
05/17/2017	No Change - Field Review	Dave Stannard
07/22/2016	Permit- Miscellaneous	Assessor Office
07/22/2016	Permit- Miscellaneous	Assessor Office
07/18/2016	Permit- Miscellaneous	Assessor Office
06/28/2016	Permit- Miscellaneous	Assessor Office
06/28/2016	Permit- Miscellaneous	Assessor Office
03/29/2016	Permit- Miscellaneous	Assessor Office

Building Permit Information

Date	Permit #	Description	Amount	% Comp	Visit Date	CO Date	GeneralNotes
03/21/2019	25929	Other	15,000	100			TEMP TENT 50' X 70'
07/09/2018	25494	Demolish		100	31-Aug-2018	16-Jul-2018	
06/08/2018	25431	Propane Tank	3,000	100			
05/17/2018	25392	Other	35,000	100			
05/11/2018	25386	Electric	30,000	100			
04/30/2018	25361	New Construction	8,000,000	5	27-Sep-2018		
04/30/2018	25356	Other	15,000	100			
04/30/2018	25363	Other	748,000	100			

Land Data

Use	Description	Units	Type	Neigh	Special Land Calc	Appraised Value	PA 490 Asmt	Neigh Order	Notes
201	Commercial	217,800	SF	CJ		457,400	0	4300	
201	Commercial	153,100	AC	CJ		5,741,300	0	4300	
Total Area: 158.10					PA 490 Use Asmt: 0	Total Appraised: 6,198,700	Assessed Value: 4,339,090		

Disclaimer: This information is believed to be correct but is subject to change and is not warranted.

ParcelID: 00457800
 Bldg Seq 1 Of 5

Location: 100 GOLF CLUB ROAD

Printed By: Shawna 04/05/2019 10:10:14AM

Exterior Information

Building Type: Pre-Eng Gara
 Story Ht: 1 Story
 Living Units: Concrete
 Foundation: Concrete
 Prim. Ext. Wall: Pre-Finish Me
 Sec. Ext. Wall:
 Roof Type: Flat
 Roof Cover: 16.00
 Avg. Wall Ht:
 Color:

Interior Information

Prime Wall: Minimum
 Sec. Wall: Concrete
 Floor Type: Concrete
 Sec. Floor:
 Heat Fuel: Gas
 Heat Type: Hot Air-No D
 Sec. Ht Type:
 % A/C: 0
 % Sprinkled:
 Bsmt. Gar:
 Kitchens: Add. Kit:
 Fireplaces: Gas:
 Int. Condition:

Room Count

Total Rooms:
 Bedrooms:

Bath Features

Full Baths:
 Addl. Full Baths:
 Half Baths:
 Addl. Half Baths:
 Full Bths Below:
 Half Bths Below:
 Other Fixtures:
 Total Baths:

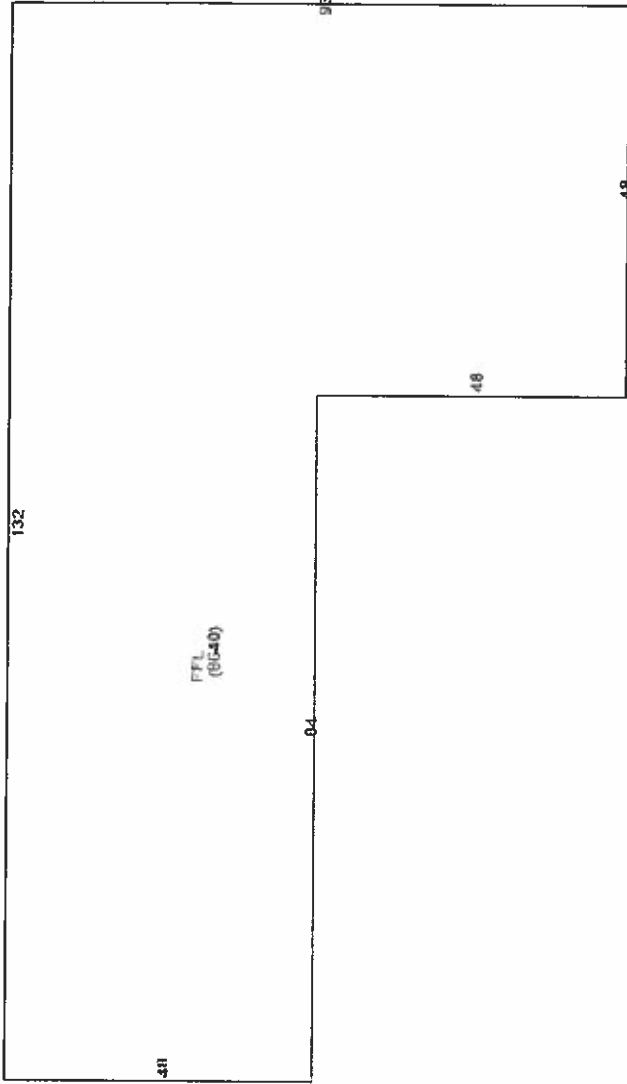

Condo Information

Name:
 Style:
 Location:
 Tot Units:

General Information

Year Bt: 1990
 Grade: C
 Remodeled Yr:
 Rem. Kitchen Yr:
 Rem. Bath Yr:

Depreciation

Phys Cond Average 20.25
 Func
 Econ
 Spec
 OV

Total %Dep: 20.25

Calculation

Basic \$SQ 57.00
 Replacement Cost 378,778
 Depreciation 76,703
 Depreciated Value 302,075
 Final Total (Rounded) 302,100



Extra Features / Yard Items (1st 10 Lines Displayed)

Code	Description	Qty	Size	Cond.	Year	Unit Price	Dep%	UndepValue	Appraised Value	Assessment	
TEN	Tennis Court	1	2	AV	1997	20,000.00	18	48,000	39,400	27,580	
GAR1	Garage Frame	1	6,875	AV	1978	25.00	30	206,250	144,400	101,060	
GAR1	Garage Frame	1	7,500	AV	1983	25.00	25	225,000	168,800	118,160	
FDC	Foundation C	1	1	AV		100,000.00	0	100,000	100,000	70,000	
Total Yard Items:									452,600	452,600	316,820
Total Sp. Features:									452,600	452,600	316,820

Code	Desc.	Living	Gross Area
FFL	First Floor	8,640	8,640

Disclaimer: This information is believed to be correct but is subject to change and is not warranted.

Map: 60
June 2021

Parcel Map
Assessor's Office
0082000 Parcel Number
000 AC Parcel Area
100' Parcel Width
200' Parcel Depth

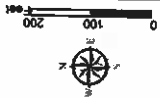

Town of Cromwell Connecticut



49	61	70
48	60	69
47	59	68

This tax map is for assessment purpose only. It is not valid to use this map as a survey or for property conveyance.

AppGeo

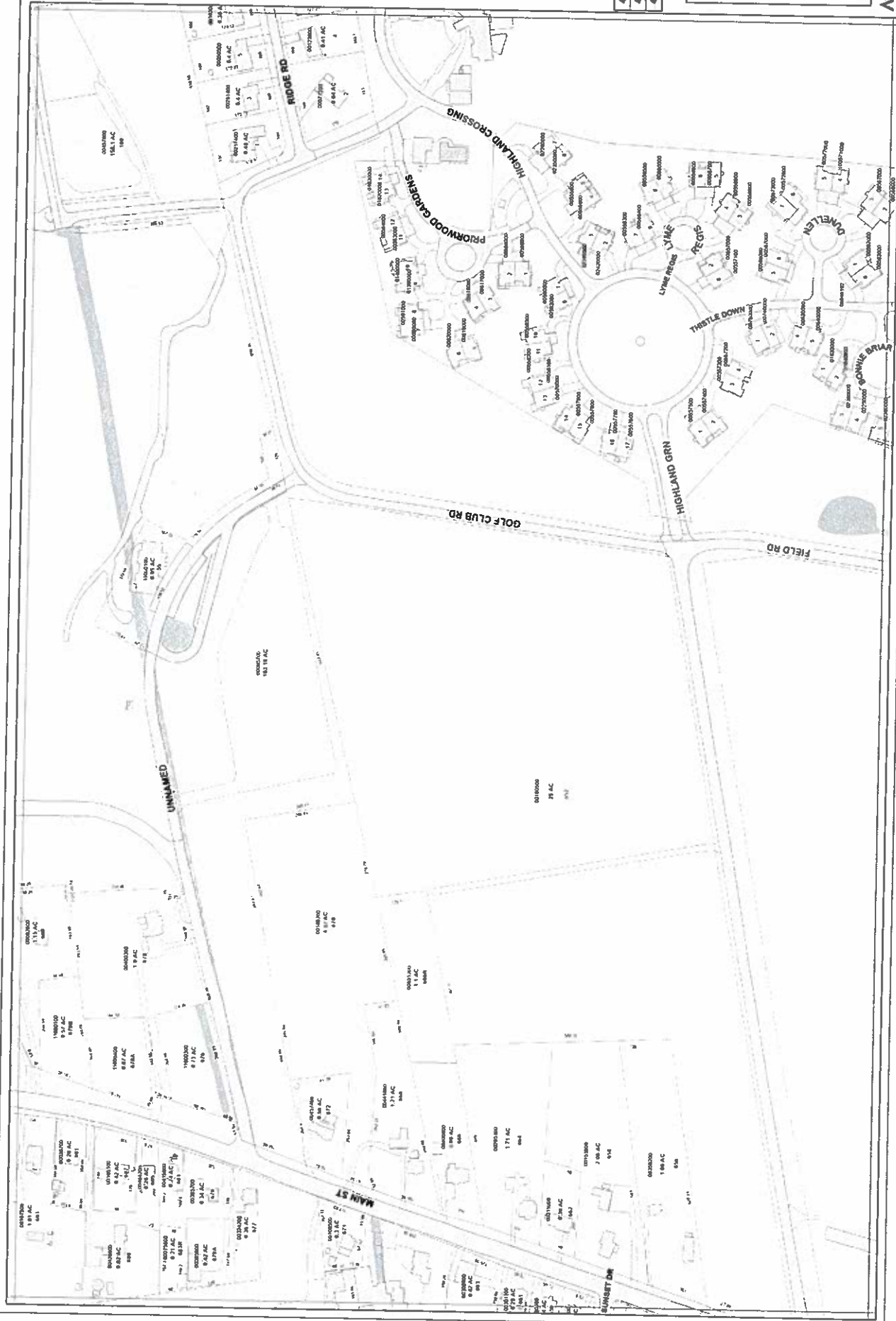



SWANSEA
1278 GAR HWY
SWANSEA, MA 02777-9998
(800)275-8777

03/11/2024

02:24 PM

Product	Qty	Unit Price	Price
Priority Mail® Flat Rate Env Groton, CT 06340 Flat Rate Expected Delivery Date Wed 03/13/2024 Tracking #: 9505 5102 6317 4071 9214 80 Insurance Up to \$100.00 included	1		\$9.85 \$0.00
Total			\$9.85
Priority Mail® Flat Rate Env Groton, CT 06340 Flat Rate Expected Delivery Date Wed 03/13/2024 Tracking #: 9505 5102 6317 4071 9215 03 Insurance Up to \$100.00 included	1		\$9.85 \$0.00
Total			\$9.85
Priority Mail® Flat Rate Env Cromwell, CT 06416 Flat Rate Expected Delivery Date Wed 03/13/2024 Tracking #: 9505 5102 6317 4071 9215 27 Insurance Up to \$100.00 included	1		\$9.85 \$0.00
Total			\$9.85
Priority Mail® Flat Rate Env Hartford, CT 06103 Flat Rate Expected Delivery Date Wed 03/13/2024 Tracking #: 9505 5102 6317 4071 9215 41 Insurance Up to \$100.00 included	1		\$9.85 \$0.00
Total			\$9.85
Grand Total:			\$39.40
Credit Card Remit Card Name: VISA Account #: XXXXXXXXXXXX8795 Approval #: 032446 Transaction #: 063 AID: A0000000980840 AL: US DEBIT			\$39.40 Contactless

Text your tracking number to 28777 (2USPS) to get the latest status. Standard Message and Data rates may apply. You may also