

January 7, 2015

Melanie A. Bachman  
Acting Executive Director  
Connecticut Siting Council  
10 Franklin Square  
New Britain, CT 06051

Re: **Notice of Exempt Modification – Facility Modification  
1712 Main Street in Coventry, Connecticut**

Dear Ms. Bachman:

Cellco Partnership d/b/a Verizon Wireless (“Cellco”) currently maintains twelve (12) antennas at the 150-foot level of the existing 190-foot lattice tower at 1712 Main Street in Coventry, Connecticut (the “Property”). The tower and the Property are owned by the Town of Coventry. Cellco’s shared use of this tower was approved by the Council in 2004. Cellco now intends to modify its facility by replacing all of its existing antennas with three (3) model LNX-6514DS-VTM, 700 MHz antennas; three (3) model LNX-6514DS-VTM, 850 MHz antennas; three (3) model HBXX-6517DS-VTM, 1900 MHz antennas; and three (3) model HBXX-6517DS-VTM, 2100 MHz antennas, all at the same level on the tower. Cellco also intends to install six (6) remote radio heads (“RRHs”) behind its 1900 MHz and 2100 MHz antennas and two (2) HYBRIFLEX™ antenna cable. Included in Attachment 1 are specifications for the replacement antennas, RRHs and HYBRIFLEX™ cables.

Please accept this letter as notification pursuant to R.C.S.A. § 16-50j-73, for construction that constitutes an exempt modification pursuant to R.C.S.A. § 16-50j-72(b)(2). In accordance with R.C.S.A. § 16-50j-73, a copy of this letter is being sent to John Elsesser, Town Manager for the Town of Coventry.

The planned modifications to the facility fall squarely within those activities explicitly provided for in R.C.S.A. § 16-50j-72(b)(2).

# Robinson+Cole

Melanie A. Bachman

January 7, 2015

Page 2

1. The proposed modifications will not result in an increase in the height of the existing tower. Cellco's replacement antennas and RRHs will be installed on its existing antenna platform at the 150-foot level of the 190-foot tower.
2. The proposed modifications will not involve any change to ground-mounted equipment and, therefore, will not require the extension of the site boundary.
3. The proposed modifications will not increase noise levels at the facility by six decibels or more, or to levels that exceed state and local criteria.
4. The operation of the replacement antennas will not increase radio frequency (RF) emissions at the facility to a level at or above the Federal Communications Commission (FCC) safety standard. A cumulative General Power Density table for Cellco's modified facility is included in Attachment 2.
5. The proposed modifications will not cause a change or alteration in the physical or environmental characteristics of the site.
6. The tower and its foundation can support Cellco's proposed modifications. (*See Structural Analysis Report included in Attachment 3*).

For the foregoing reasons, Cellco respectfully submits that the proposed modifications to the above-referenced telecommunications facility constitutes an exempt modification under R.C.S.A. § 16-50j-72(b)(2).

Sincerely,

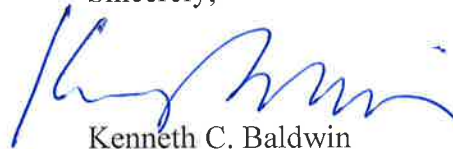

Kenneth C. Baldwin

Enclosures

Copy to:

John Elsesser, Coventry Town Manager  
Sandy M. Carter

# **ATTACHMENT 1**

# Product Specifications

COMMSCOPE®

LNX-6514DS-VTM

Andrew® Antenna, 698–896 MHz, 65° horizontal beamwidth, RET compatible



## Electrical Specifications

Frequency Band, MHz	698–806	806–896
Gain, dBi	15.7	16.3
Beamwidth, Horizontal, degrees	65	65
Beamwidth, Horizontal Tolerance, degrees	±3	±3
Beamwidth, Vertical, degrees	12.5	11.2
Beam Tilt, degrees	0–10	0–10
USLS, typical, dB	17	18
Front-to-Back Ratio at 180°, dB	32	30
CPR at Boresight, dB	20	20
CPR at Sector, dB	10	10
Isolation, dB	30	30
VSWR   Return Loss, dB	1.4   15.6	1.4   15.6
PIM, 3rd Order, 2 x 20 W, dBc	-153	-153
Input Power per Port, maximum, watts	400	400
Polarization	±45°	±45°

## Mechanical Specifications

Color   Radome Material	Light gray   Fiberglass, UV resistant
Connector Interface   Location   Quantity	7-16 DIN Female   Bottom   2
Wind Loading, maximum	617.7 N @ 150 km/h 138.9 lbf @ 150 km/h
Wind Speed, maximum	241.0 km/h   149.8 mph
Antenna Dimensions, L x W x D	1847.0 mm x 301.0 mm x 181.0 mm   72.7 in x 11.9 in x 7.1 in
Net Weight	17.6 kg   38.8 lb
Model with factory installed AISG 2.0 RET	LNX-6514DS-A1M



# Product Specifications

COMMScope®

HBXX-6517DS-VTM

Andrew® Quad Port Teletilt® Antenna, 1710–2180 MHz, 65° horizontal beamwidth, RET compatible

POWERED BY



## Electrical Specifications

Frequency Band, MHz	1710–1880	1850–1990	1920–2180
Gain by all Beam Tilts, average, dBi	18.5	18.6	18.8
Gain by all Beam Tilts Tolerance, dB	±0.4	±0.3	±0.4
Gain by Beam Tilt, average, dBi	0 °   18.4 3 °   18.7 6 °   18.4	0 °   18.4 3 °   18.7 6 °   18.5	0 °   18.7 3 °   18.9 6 °   18.6
Beamwidth, Horizontal, degrees	67	66	65
Beamwidth, Horizontal Tolerance, degrees	±2.4	±1.7	±2.9
Beamwidth, Vertical, degrees	5.0	4.7	4.4
Beamwidth, Vertical Tolerance, degrees	±0.3	±0.3	±0.3
Beam Tilt, degrees	0–6	0–6	0–6
USLS, dB	18	19	19
Front-to-Back Total Power at 180° ± 30°, dB	25	26	26
CPR at Boresight, dB	22	23	22
CPR at Sector, dB	10	10	9
Isolation, dB	30	30	30
VSWR   Return Loss, dB	1.4   15.6	1.4   15.6	1.4   15.6
PIM, 3rd Order, 2 x 20 W, dBc	-153	-153	-153
Input Power per Port, maximum, watts	350	350	350
Polarization	±45°	±45°	±45°

\*Values calculated using NGMN Alliance N-P-BASTA v9.6

## Mechanical Specifications

Color   Radome Material	Light gray   PVC, UV resistant
Connector Interface   Location   Quantity	7-16 DIN Female   Bottom   4
Wind Loading, maximum	668.0 N @ 150 km/h 150.2 lbf @ 150 km/h
Wind Speed, maximum	241.0 km/h   149.8 mph
Antenna Dimensions, L x W x D	1903.0 mm x 305.0 mm x 166.0 mm   74.9 in x 12.0 in x 6.5 in
Net Weight	19.5 kg   43.0 lb
Model with factory installed AISG 2.0 RET	HBXX-6517DS-A2M



# PCS RF MODULES

## RRH1900 2X60 - HW CHARACTERISTICS

LA6.0.1/13.3

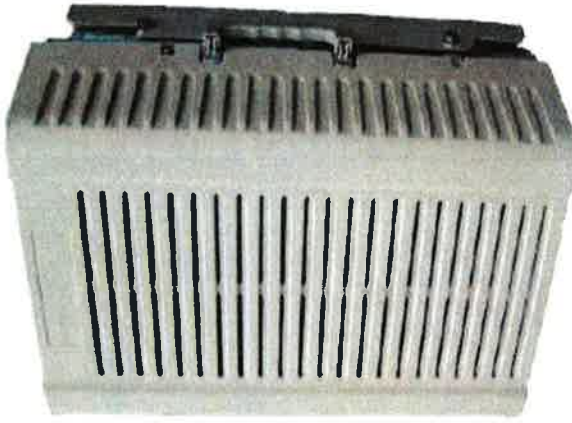

<b>RRH2x60</b>	
RF Output Power	2x60W
Instantaneous Bandwidth	20MHz
Transmitter	2 TX
Receiver	1900 HW version 1900A HW version
Features	2 Branch RX – LA6.0.1 4 Branch RX – LR13.3 AISG 2.0 for RET/TMA Internal Smart Bias-T
Power	-48VDC
CPRI Ports	2 CPRI Rate 3 Ports
External Alarms	4 External User Alarms
Monitor Ports	TX
Environmental	GR487 Compliance
RF Connectors	7/16 DIN (top mounted)

\*\* Not a Verizon Wireless deployed product

ALCATEL-LUCENT – CONFIDENTIAL – SOLELY FOR AUTHORIZED PERSONS HAVING A NEED TO KNOW – PROPRIETARY – USE PURSUANT TO COMPANY INSTRUCTION

# NEW PCS RF MODULES FOR VZW

## RRH2X60 - HW CHARACTERISTICS

LR14.3

	RRH2X60
RF Output Power	2x60W (4x30W HW Ready)
Instantaneous Bandwidth	60MHz
Target Reliability (Annual Return Rate)	<2%
Receiver	4 Branch Rx
Features	AISG 2.0 for RET/TMA
Power	-48VDC Internal Smart Bias-T
CPRI Ports	2 CPRI Rate 5 Ports
External Alarms	4 External User Alarms
Monitor Ports	TX, RX
Environmental	GR487 Compliance
RF Connectors	7/16 DIN (downward facing)
Dimensions	22"(h) x 12"(w) x 9.4" (d)**
Weight	55lb**

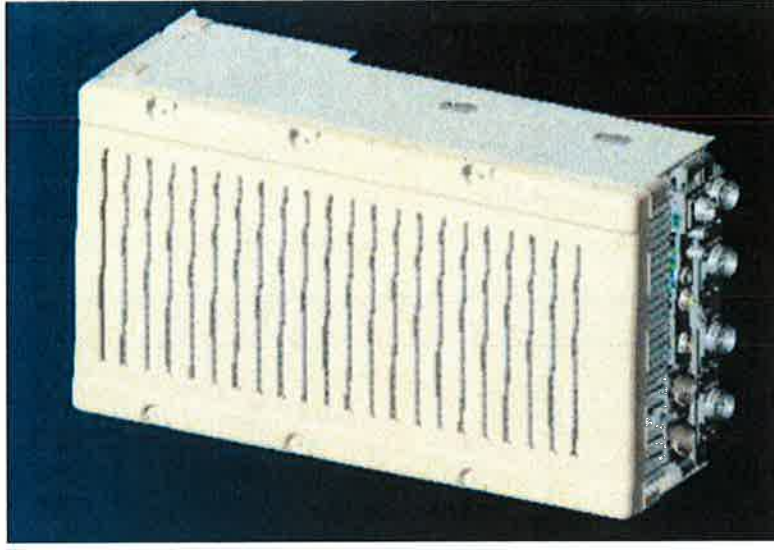

\*\* - Includes solar shield but not mounting brackets (8 lbs.)

# ALCATEL-LUCENT WIRELESS PRODUCT DATASHEET RRH2X60-AWS FOR BAND 4 APPLICATIONS

The Alcatel-Lucent RRH2x60-AWS is a high power, small form factor Remote Radio Head operating in the AWS frequency band (3GPP Band 4) for LTE technology. It is designed with an eco-efficient approach, providing operators with the means to achieve high quality and high capacity coverage with minimum site requirements and efficient operation.

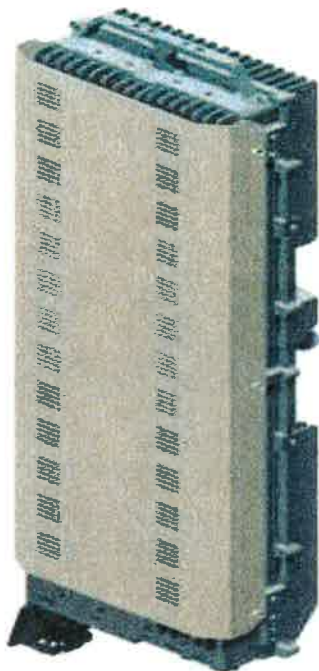

A distributed Node B expands the deployment options by using two components, a Base Band Unit (BBU) containing the digital assets and a separate RRH containing the radio-frequency (RF) elements. This modular design optimizes available space and allows the main components of a Node B to be installed separately, within the same site or several kilometers apart.

The Alcatel-Lucent RRH2x60-AWS is linked to the BBU by an optical-fiber connection carrying downlink and uplink digital radio signals

along with operations, administration and maintenance (OA&M) information.

## SUPERIOR RF PERFORMANCE

The Alcatel-Lucent RRH2x60-AWS integrates all the latest technologies. This allows to offer best-in-class characteristics.

It delivers an outstanding 120 watts of total RF power thanks to its two transmit RF paths of 60 W each.

It is ideally suited to support multiple-input multiple-output (MIMO) 2x2 operation.

It includes four RF receivers to natively support 4-way uplink reception diversity. This improves the radio uplink coverage and this can be used to extend the cell radius commensurate with 2x2MIMO 2x60 W for the downlink.

It supports multiple discontinuous LTE carriers within an instantaneous bandwidth of 45 MHz corresponding to the entire AWS B4 spectrum.

The latest generation power amplifiers (PA) used in this product achieve high efficiency (>40%), resulting in improved power consumption figures.

## OPTIMIZED TCO

The Alcatel-Lucent RRH2x60-AWS is designed to make available all the benefits of a distributed Node B, with excellent RF characteristics, with low capital expenditures (CAPEX) and low operating expenditures (OPEX).

The Alcatel-Lucent RRH2x60-AWS is a very cost-effective solution to deploy LTE MIMO.

## EASY INSTALLATION

The RRH2x60-AWS includes a reversible mounting bracket which allows for ease of installation behind an antenna, or on a rooftop knee wall while providing easy access to the mid body RF connectors.

The limited space available in some sites may prevent the installation of traditional single-cabinet BTS equipment. However, many of these sites can host an Alcatel-Lucent RRH2x60-AWS installation, providing more flexible site selection and improved network quality along with greatly reduced installation time and costs.

The Alcatel-Lucent RRH2x60-AWS is a zero-footprint solution and is convection cooled without fans for silent operation, simplifying negotiations with site property owners and minimizing environmental impacts.

Installation can easily be done by a single person as the Alcatel-Lucent RRH2x60-AWS is compact and weighs about 20 kg, eliminating the need for a crane to hoist the BTS cabinet to the rooftop. A site can be in operation in less than one day.



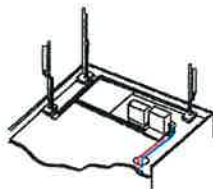

Macro

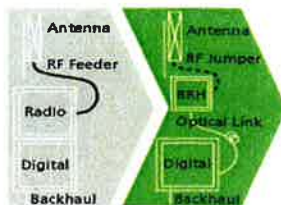

RRH for space-constrained cell sites

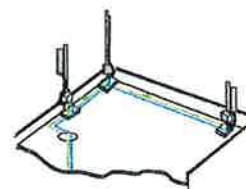

Distributed

## FEATURES

- RRH2x60-AWS integrates two power amplifiers of 60W rating (at each antenna connector)
- Support multiple carriers over the entire 3GPP band 4
- RRH2x60-AWS is optimized for LTE operation
- RRH2x60-AWS is a very compact and lightweight product
- Advanced power management techniques are embedded to provide power savings, such as PA bias control

## BENEFITS

- MIMO LTE operation with only one single unit per sector
- Improved uplink coverage with built-in 4-way receive diversity capability
- RRH can be mounted close to the antenna, eliminating nearly all losses in RF cables and thus reducing power consumption by 50% compared to conventional solutions
- Distributed configurations provide easily deployable and cost-effective solutions, near zero footprint and

silent solutions, with minimum impact on the neighborhood, which ease the deployment

- RETA and TMA support without additional hardware thanks to the AISG v2.0 port and the integrated Bias-Tees. Bias-Tees support AISG DC supply and signaling.

## TECHNICAL SPECIFICATIONS

Specifications listed are hardware capabilities. Some capabilities depend on support in a specific software release or future release.

### Dimensions and weights

- HxWxD : 510x285x186mm (27 l with solar shield)
- Weight : 20 kg (44 lbs)

### Electrical Data

- Power Supply : -48V DC (-40.5 to -57V)
- Power Consumption (ETSI average traffic load reference) : 250W @2x60W

### RF Characteristics

- Frequency band: 1710-1755, UL / 2110-2155 MHz, DL (3GPP band 4)
- Output power: 2x60W at antenna connectors
- Technology supported: LTE
- Instantaneous bandwidth: 45 MHz
- Rx diversity: 2-way and 4-way uplink reception
- Typical sensitivity without Rx diversity: -105 dBm for LTE

### Connectivity

- Two CPRI optical ports for daisy chaining and up to six RRHs per fiber
- Type of optical fiber: Single-Mode (SM) and Multi-Mode (MM) SFPs
- Optical fiber length: up to 500m using MM fiber, up to 20km using SM fiber
- TMA/RETA : AISG 2.0 (RS485 connector and internal Bias-Tee)
- Six external alarms
- Surge protection for all external ports (DC and RF)

### Safety and Regulatory Data

- EMC : 3GPP 25113, EN 301 489-1, EN 301 489-23, GR 1089, GR 3108, OET-65
- Safety : IEC60950-1, EN 60825-1, UL, ANSI/NFPA 70, CAN/CSA-C22.2
- Regulatory : FCC Part 15 Class B, CE Mark – European Directive : 2002/95/EC (ROHS); 2002/96/EC (WEEE); 1999/5/EC (R&TTE)
- Health : EN 50385

### Environmental specifications

- Operating temperature: -40°C to 55°C including solar load
- Operating relative humidity: 8% to 100%
- Environmental Conditions : ETS 300 019-1-4 class 4.1E
- Ingress Protection : IEC 60529 IP65
- Acoustic Noise : Noiseless (natural convection cooling)

www.alcatel-lucent.com Alcatel, Lucent, Alcatel-Lucent and the Alcatel-Lucent logo are trademarks of Alcatel-Lucent. All other trademarks are the property of their respective owners. The Information presented is subject to change without notice. Alcatel-Lucent assumes no responsibility for inaccuracies contained herein.

Copyright © 2012 Alcatel-Lucent. All rights reserved. M2012XXXXXX (March)



**HYBRIFLEX™ RRH Hybrid Feeder Cabling Solution, 1-5/8", Single-Mode Fiber**

**Product Description**

RFS' HYBRIFLEX Remote Radio Head (RRH) hybrid feeder cabling solution combines optical fiber and DC power for RRHs in a single lightweight aluminum corrugated cable, making it the world's most innovative solution for RRH deployments.

It was developed to reduce installation complexity and costs at Cellular sites, HYBRIFLEX allows mobile operators deploying an RRH architecture to standardize the RRH installation process and eliminate the need for and cost of cable grounding. HYBRIFLEX combines optical fiber (multi-mode or single-mode) and power in a single corrugated cable. It eliminates the need for junction boxes and can connect multiple RRHs with a single feeder. Standard RFS CELLFLEX® accessories can be used with HYBRIFLEX cable. Both pre-connectorized and on-site options are available.

**Features/Benefits**

- Aluminum corrugated armor with outstanding bending characteristics - minimizes installation time and enables mechanical protection and shielding
- Same accessories as 1 5/8" coaxial cable
- Outer conductor grounding - Eliminates typical grounding requirements and saves on installation costs
- Lightweight solution and compact design - Decreases tower loading
- Robust cabling - Eliminates need for expensive cable trays and ducts
- Installation of tight bundled fiber optic cable pairs directly to the RRH - Reduces CAPEX and wind load by eliminating need for interconnection
- Optical fiber and power cables housed in single corrugated cable - Saves CAPEX by standardizing RRH cable installation and reducing installation requirements
- Outdoor polyethylene jacket - Ensures long-lasting cable protection

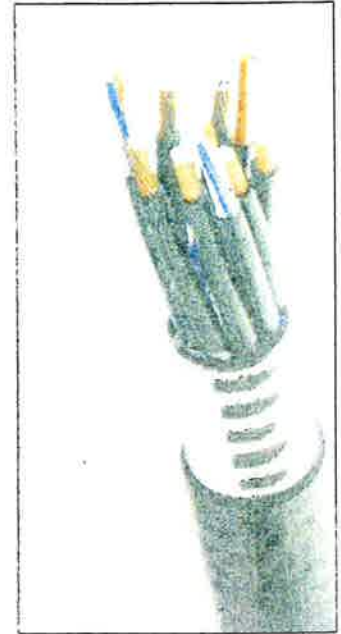

Figure 1: HYBRIFLEX Series

**Technical Specifications**

Outer Conductor Armor	Corrugated Aluminum	(mm (in.))	46.5 (1.83)
Jacket	Polyethylene, PE	(mm (in.))	50.3 (1.98)
UV-Protection	Individual and External Jacket		Yes
Weight, Approximate		(kg/m (lb/ft))	1.9 (1.30)
Minimum Bending Radius, Single Bending		(mm (in.))	200 (8)
Minimum Bending Radius, Repeated Bending		(mm (in.))	500 (20)
Recommended/Maximum Clamp Spacing		(m (ft))	1.0 / 1.2 (3.25 / 4.0)
DC-Resistance Outer Conductor Armor		(Ω/km (Ω/1000ft))	0.68 (0.205)
DC-Resistance Power Cable 3 4mm <sup>2</sup> (8AWG)		(Ω/km (Ω/1000ft))	2.1 (0.307)
Version:			Single-mode OM3
Quantity, Fiber Count			16 (8 pairs)
Core/Clad		(μm)	50/125
Primary Coating (Acrylate)		(μm)	245
Buffer Diameter, Nominal		(μm)	900
Secondary Protection, Jacket, Nominal		(mm (in.))	2.0 (0.08)
Minimum Bending Radius		(mm (in.))	104 (4.1)
Insertion Loss @ wavelength 850nm		dB/km	3.0
Insertion Loss @ wavelength 1310nm		dB/km	1.0
Standards (Meets or exceeds)			UL34-V0 UL1666 Ro-S Compliant
Size (Power)		(mm (AWG))	8.4 (8)
Quantity, Wire Count (Power)			16 (8 pairs)
Size (Alarm)		(mm (AWG))	0.8 (18)
Quantity, Wire Count (Alarm)			4 (2 pairs)
Type			UV protected
Strands			19
Primary Jacket Diameter, Nominal		(mm (in.))	6.8 (0.27)
Standards (Meets or exceeds)			NFPA 130, ICEA S-95-658 UL Type XHHW-2, UL 44 UL-LS Limited Smoke, UL VW-1 IEEE-383 (1974), IEEE1202/FT4 RoHS Compliant
Installation Temperature		(°C (°F))	-40 to +65 (-40 to 149)
Operation Temperature		(°C (°F))	-40 to +65 (-40 to 149)

\* This data is provisional and subject to change

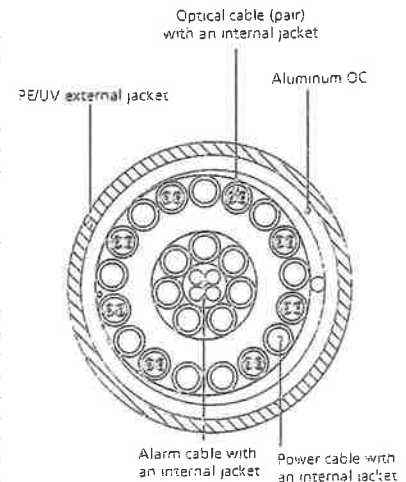

Figure 2: Construction Detail

All information contained in the present datasheet is subject to confirmation at time of ordering

# **ATTACHMENT 2**

Site Name: Coventry E Tower Height: 190Ft.		General		Power		Density							
CARRIER	# OF CHAN.	WATTS ERP	HEIGHT	CALC. POWER DENS	FREQ.	MAX. PERMISS. EXP.	FRACTION MPE	Total					
*Sprint	11	200	180	0.0244	1900	1.0000	2.44%						
*Nextel	12	100	130	0.0255	851	0.5673	4.50%						
*Unknown	1	80	190	0.0008	75.98	0.2000	0.40%						
*Unknown	1	1000	190	0.0100	449.875	0.2999	3.32%						
*Unknown	1	200	190	0.0020	33.8	0.2000	1.00%						
*Unknown	1	750	160	0.0105	450	0.3000	3.51%						
*Unknown	1	600	160	0.0084	450	0.3000	2.81%						
*Unknown	1	100	160	0.0014	450	0.3000	0.47%						
*Unknown	1	30	140	0.0006	145.63	0.2000	0.28%						
*Unknown	1	15	140	0.0003	440.925	0.2940	0.09%						
*Unknown	1	8	140	0.0001	173.20375	0.2000	0.07%						
*Unknown	1	30	190	0.0003	50.4	0.2000	0.15%						
*Unknown	1	2	120	0.0000	420.5	0.2803	0.02%						
*Unknown	1	250	190	0.0025	152.0075	0.2000	1.25%						
*Unknown	1	4	188	0.0000	903	0.6020	0.01%						
*Unknown	1	40	95	0.0016	33.44	0.2000	0.80%						
*Unknown	1	80	75	0.0051	45.4	0.2000	2.56%						
*Unknown	1	80	95	0.0032	45.14	0.2000	1.59%						
*Unknown	1	200	75	0.0128	33.8	0.2000	6.39%						
*Unknown	1	100	120	0.0025	153.955	0.2000	1.25%						
*Unknown	1	4	188	0.0000	903	0.6020	0.01%						
*Unknown	1	80	110	0.0024	45.14	0.2000	1.19%						
*Unknown	1	50	115	0.0014	47.54	0.2000	0.68%						
*Pocket	3	631	95	0.0754	2130	1.0000	7.54%						
<b>Verizon PCS</b>	<b>11</b>	<b>408</b>	<b>150</b>	<b>0.0717</b>	<b>1970</b>	<b>1.0000</b>	<b>7.17%</b>						
<b>Verizon Cellular</b>	<b>9</b>	<b>386</b>	<b>150</b>	<b>0.0555</b>	<b>869</b>	<b>0.5793</b>	<b>9.58%</b>						
<b>Verizon AWS</b>	<b>1</b>	<b>1750</b>	<b>150</b>	<b>0.0280</b>	<b>2145</b>	<b>1.0000</b>	<b>2.80%</b>						
<b>Verizon 700</b>	<b>1</b>	<b>1050</b>	<b>150</b>	<b>0.0168</b>	<b>746</b>	<b>0.4973</b>	<b>3.37%</b>						<b>65.24%</b>
* Source: Siting Council													

# **ATTACHMENT 3**

**Structural Analysis Report**

*190' Existing Rohn Lattice Tower*

*Proposed Verizon Wireless  
Antenna Upgrade*

*Verizon Site Ref: Coventry East*

*1712 Main Street  
Coventry, CT*

*CEN TEK Project No. 14001.057*

*Date: December 3, 2014*



**Prepared for:**  
**Verizon Wireless**  
**99 East River Road, 9<sup>th</sup> Floor**  
**East Hartford, CT 06108**

## **Table of Contents**

### **SECTION 1 - REPORT**

- INTRODUCTION
- ANTENNA AND APPURTENANCE SUMMARY
- PRIMARY ASSUMPTIONS USED IN THE ANALYSIS
- ANALYSIS
- TOWER LOADING
- TOWER CAPACITY
- FOUNDATION AND ANCHORS
- CONCLUSION

### **SECTION 2 – CONDITIONS & SOFTWARE**

- STANDARD ENGINEERING CONDITIONS
- GENERAL DESCRIPTION OF STRUCTURAL ANALYSIS PROGRAM

### **SECTION 3 – CALCULATIONS**

- tnxTower INPUT/OUTPUT SUMMARY
- tnxTower FEED LINE PLAN
- tnxTower FEED LINE DISTRIBUTION
- tnxTower DETAILED OUTPUT
- FOUNDATION ANALYSIS

### **SECTION 4 – REFERENCE MATERIALS**

- RF DATA SHEET
- EQUIPMENT CUT SHEETS

## Introduction

The purpose of this report is to summarize the results of the non-linear, P- $\Delta$  structural analysis of the antenna upgrade proposed by Verizon Wireless on the existing lattice tower located in Coventry, Connecticut.

The host tower is a 190-ft, three legged, lattice tower originally manufactured by ROHN eng. file no. 33814PH dated 7/24/96. The tower geometry, structure member sizes and foundation information were taken from a previous structural report prepared by Centek Engineering job no; 12001.CO64 dated May 21, 2012.

Antenna and appurtenance inventory were taken from the aforementioned Centek structural report and a Verizon RF data sheet.

The tower consists of ten (10) vertical sections consisting of steel pipe legs conforming to ASTM A572 Gr. 50 and lateral bracing conforming to ASTM A572 Gr. 50 and ASTM A36. The vertical tower sections are connected by bolted flange plates with the diagonal and horizontal bracing to pipe legs consisting of bolted connections. The width of the tower face is 4-ft 8-in at the top and 19-ft 0-in at the bottom.

Verizon Wireless proposes the removal of twelve (12) panel antennas and the installation of twelve (12) panel antennas, six (6) remote radio heads and two (2) main distribution boxes mounted on the existing T-frames. Refer to the Antenna and Appurtenance Summary below for a detailed description of the proposed antenna and appurtenance configuration.

## Antenna and Appurtenance Summary

The existing tower supports several communication antennas. The existing and proposed loads considered in the analysis consist of the following:

- UNKNOWN (Existing):  
Antenna: Two (2) obstruction lights, one (1) PD1142-3 Omni-directional whip antenna, one (1) ASP705 Omni-directional whip antenna, one (1) DB420 dipole antenna and one (1) 3' yagi pipe mounted to the top of the tower.  
Coax Cable: Two (2) 1-1/4"  $\varnothing$  and two (2) 7/8"  $\varnothing$  coax cables running on a leg/face of the existing tower as specified in Section 3 of this report.
- UNKNOWN (Existing):  
Antenna: One (1) PD1142-2A Omni-directional whip antenna, one (1) ASP705 Omni-directional whip antenna, one (1) 4' Omni-directional whip antenna, one (1) 3' yagi, one (1) halo and one (1) paraflector grid mounted on three (3) 4-ft side arms with an elevation of  $\pm 188$ -ft above grade level.  
Coax Cable: Three (3) 7/8"  $\varnothing$  and three (3) 1/2"  $\varnothing$  coax cables running on a leg/face of the existing tower as specified in Section 3 of this report.
- SPRINT (Existing):  
Antenna: Six (6) Andrew DB980H90E-M panel antennas mounted on three (3) 14-ft boom gates with a RAD center elevation of  $\pm 180$ -ft above grade level.  
Coax Cable: Six (6) 1-5/8"  $\varnothing$  coax cables running on a leg/face of the existing tower as specified in Section 3 of this report.



- UNKNOWN (Existing):  
Antenna: Two (2) ASP705 Omni-directional whip antennas and one (1) 3-ft dish mounted on two (2) 4-ft side arms with an elevation of ±156-ft above grade level.  
Coax Cable: Three (3) 7/8" Ø coax cables running on a leg/face of the existing tower as specified in Section 3 of this report.
- UNKNOWN (Existing):  
Antenna: Two (2) paraflector grid antennas, one (1) DB264 dipole antenna and one (1) DB436 yagi mounted on two (2) 4-ft side arms with an elevation of ±142-ft above grade level.  
Coax Cable: Two (2) 7/8" Ø and one (1) 1/2" Ø coax cables running on a leg/face of the existing tower as specified in Section 3 of this report.
- UNKNOWN (Existing):  
Antenna: One (1) DB230 yagi leg mounted with an elevation of ±142-ft above grade level.  
Coax Cable: One (1) 1/2" Ø coax cable running on a leg/face of the existing tower as specified in Section 3 of this report.
- UNKNOWN (Existing):  
Antenna: One (1) single dipole antenna leg mounted with an elevation of ±136-ft above grade level.  
Coax Cable: One (1) 1/2" Ø coax cable running on a leg/face of the existing tower as specified in Section 3 of this report.
- UNKNOWN (Existing):  
Antenna: One (1) Dipole antenna mounted on one (1) 4-ft side arm with an elevation of ±113-ft above grade level.  
Coax Cable: One (1) 1/2" Ø coax cable running on a leg/face of the existing tower as specified in Section 3 of this report.
- UNKNOWN (Existing):  
Antenna: One (1) PD320 dipole antenna leg mounted with an elevation of ±110-ft above grade level.  
Coax Cable: One (1) 7/8" Ø coax cable running on a leg/face of the existing tower as specified in Section 3 of this report.
- UNKNOWN (Existing):  
Antenna: One (1) 14-ft Omni-directional whip antenna mounted on one (1) 4-ft side arm with an elevation of ±109-ft above grade level.  
Coax Cable: One (1) 7/8" Ø coax cable running on a leg/face of the existing tower as specified in Section 3 of this report.
- UNKNOWN (Existing):  
Antenna: One (1) 14-ft Omni-directional whip antenna mounted on one (1) 4-ft side arm with an elevation of ±103-ft above grade level.  
Coax Cable: One (1) 7/8" Ø coax cable running on a leg/face of the existing tower as specified in Section 3 of this report.

- UNKNOWN (Existing):  
Antenna: One (1) GPS antenna mounted on a 1-ft standoff pipe with an elevation of  $\pm 102$ -ft above grade level.  
Coax Cable: One (1) 1/2"  $\varnothing$  coax cable running on a leg/face of the existing tower as specified in Section 3 of this report.
- UNKNOWN (Existing):  
Antenna: One (1) DB212 single dipole antenna leg mounted with an elevation of  $\pm 94$ -ft above grade level.  
Coax Cable: One (1) 1/2"  $\varnothing$  coax cable running on a leg/face of the existing tower as specified in Section 3 of this report.
- UNKNOWN (Existing):  
Antenna: One (1) single dipole antenna leg mounted with an elevation of  $\pm 92$ -ft above grade level.  
Coax Cable: One (1) 7/8"  $\varnothing$  coax cable running on a leg/face of the existing tower as specified in Section 3 of this report.
- UNKNOWN (Existing):  
Antenna: One (1) PD320 dipole antenna leg mounted with an elevation of  $\pm 74$ -ft above grade level.  
Coax Cable: One (1) 7/8"  $\varnothing$  coax cable running on a leg/face of the existing tower as specified in Section 3 of this report.
- UNKNOWN (Existing):  
Antenna: One (1) single dipole antenna leg mounted with an elevation of  $\pm 70$ -ft above grade level.  
Coax Cable: One (1) 1/2"  $\varnothing$  coax cable running on a leg/face of the existing tower as specified in Section 3 of this report.
- UNKNOWN (Existing):  
Antenna: One (1) single dipole antenna leg mounted with an elevation of  $\pm 50$ -ft above grade level.  
Coax Cable: One (1) 1/2"  $\varnothing$  coax cable running on a leg/face of the existing tower as specified in Section 3 of this report.
- UNKNOWN (Existing):  
Antenna: One (1) DB212 single dipole antenna leg mounted with an elevation of  $\pm 50$ -ft above grade level.  
Coax Cable: One (1) 1/2"  $\varnothing$  coax cable running on a leg/face of the existing tower as specified in Section 3 of this report.
- UNKNOWN (Existing):  
Antenna: One (1) DB212 single dipole antenna leg mounted with an elevation of  $\pm 32$ -ft above grade level.  
Coax Cable: One (1) 1/2"  $\varnothing$  coax cable running on a leg/face of the existing tower as specified in Section 3 of this report.

- UNKNOWN (Existing):  
Antenna: One (1) single dipole antenna leg mounted with an elevation of  $\pm 31$ -ft above grade level.  
Coax Cable: One (1) 1/2"  $\varnothing$  coax cable running on a leg/face of the existing tower as specified in Section 3 of this report.
- UNKNOWN (Existing):  
Antenna: One (1) PD 400 Omni-directional whip antenna and one (1) 3-ft yagi mounted on one (1) 4-ft side arm with an elevation of  $\pm 17$ -ft above grade level.  
Coax Cable: One (1) 1/2"  $\varnothing$  coax cable running on a leg/face of the existing tower as specified in Section 3 of this report.
- **Nextel (Existing to be Removed):**  
**Antenna: Twelve (12) Andrew DB844H90E-XY panel antennas mounted on three (3) 10-ft T-Frames with a RAD center elevation of  $\pm 130$ -ft above grade level.**  
**Coax Cable: Twelve (12) 1-1/4"  $\varnothing$  coax cables running on a leg/face of the existing tower as specified in Section 3 of this report.**
- VERIZON (Existing to Remain):  
Coax Cables: Eighteen (18) 1-5/8"  $\varnothing$  coax cables running on a leg/face of the existing tower as specified in Section 3 of this report.
- VERIZON (Existing to Remove):  
Antennas: Three (3) Antel BXA-70063-6CF, two (2) Antel LPA-80080-4CF, four (4) Antel LPA-80063-4CF and three (3) Antel BXA-171085-8CF panel antennas mounted on (3) 12-ft T-Frames with a RAD center elevation of  $\pm 150$ -ft above grade level.
- **VERIZON (Proposed):**  
**Antennas: Six (6) Andrew HBXX-6517DS panel antennas, six (6) Andrew LNX-6514DS panel antennas, three (3) Alcatel-Lucent RRH-2x60-PCS remote radio heads, three (3) Alcatel-Lucent RRH-2x60-AWS remote radio heads and two (2) RFD DB-T1-6Z-8AB-0Z main distribution boxes mounted on (3) 12-ft T-Frames with a RAD center elevation of  $\pm 150$ -ft above grade level.**  
**Coax Cables: Two (2) 1-5/8"  $\varnothing$  fiber cables mounted to the exterior of the existing tower.**

### Primary Assumptions Used in the Analysis

- The tower structure's theoretical capacity not including any assessment of the condition of the tower.
- The tower carries the horizontal and vertical loads due to the weight of antennas, ice load and wind.
- Tower is properly installed and maintained.
- Tower is in plumb condition.
- Tower loading for antennas and mounts as listed in this report.
- All bolts are appropriately tightened providing the necessary connection continuity.
- All welds are fabricated with ER-70S-6 electrodes.
- All members are assumed to be as specified in the original tower design documents.
- All members are "hot dipped" galvanized in accordance with ASTM A123 and ASTM A153 Standards.
- All member protective coatings are in good condition.
- All tower members were properly designed, detailed, fabricated, installed and have been properly maintained since erection.
- Any deviation from the analyzed antenna loading will require a new analysis for verification of structural adequacy.
- All coax cables should be routed as specified in section 3 of this report.
- **All Nextel equipment to be removed prior to Verizon upgrade**

## Analysis

The existing tower was analyzed using a comprehensive computer program entitled *tnxTower*. The program analyzes the tower, considering the worst case loading condition. The tower is considered as loaded by concentric forces along the tower shaft, and the model assumes that the shaft members are subjected to bending, axial, and shear forces.

The existing tower was analyzed for the controlling basic wind speed (fastest mile) with no ice and a 75% reduction of wind force with ½ inch accumulative ice to determine stresses in members as per guidelines of TIA/EIA-222-F-96 entitled “Structural Standards for Steel Antenna Towers and Antenna Supporting Structures”, the American Institute of Steel Construction (AISC) and the Manual of Steel Construction; Allowable Stress Design (ASD).

The controlling wind speed is determined by evaluating the local available wind speed data as provided in Appendix K of the CSBC<sup>1</sup> and the wind speed data available in the TIA/EIA-222-F-96 Standard. The higher of the two wind speeds is utilized in preparation of the tower analysis.

## Tower Loading

Tower loading was determined by the basic wind speed as applied to projected surface areas with modification factors per TIA/EIA-222-F, gravity loads of the tower structure and its components, and the application of ½” radial ice on the tower structure and its components.

Basic Wind Speed:	Tolland; v = 85 mph (fastest mile) Coventry; v = 100 mph (3 second gust) equivalent to v = 80 mph (fastest mile) <i>TIA/EIA-222-F wind speed controls.</i>	<i>[Section 16 of TIA/EIA-222-F-96]</i> <i>[Appendix K of the 2005 CT Building Code Supplement]</i>
Load Cases:	<u>Load Case 1</u> ; 85 mph wind speed w/ no ice plus gravity load – used in calculation of tower stresses and rotation.  <u>Load Case 2</u> ; 74 mph wind speed w/ ½” radial ice plus gravity load – used in calculation of tower stresses. The 74 mph wind speed velocity represents 75% of the wind pressure generated by the 85 mph wind speed.  <u>Load Case 3</u> ; Seismic – not checked	<i>[Section 2.3.16 of TIA/EIA-222-F-96]</i> <i>[Section 2.3.16 of TIA/EIA-222-F-96]</i> <i>[Section 1614.5 of State Bldg. Code 2005] does not control in the design of this structure type</i>

<sup>1</sup> The 2005 Connecticut State Building Code as amended by the 2009 CT State Supplement. (CSBC)

## Tower Capacity

Tower stresses were calculated utilizing the structural analysis software tnxTower. Allowable stresses were determined based on Table 5 of the TIA/EIA code with a 1/3 increase per Section 3.1.1.1 of the same code.

- Calculated stresses were found to be within allowable limits. In Load Case 2, per tnxTower "Section Capacity Table", this tower was found to be at **92.8%** of its total capacity.

Tower Section	Elevation	Stress Ratio (percentage of capacity)	Result
Diagonal (T9)	20'-0"-40'-0"	92.5%	<b>PASS</b>
Leg (T8)	40'-0"-60'-0"	92.8%	<b>PASS</b>
Secondary Horizontal (T7)	60'-0"-80'-0"	79.0%	<b>PASS</b>

## Foundation and Anchors

The existing foundation consists of a 32-ft square x 4.5-ft thick reinforced concrete mat. The base of the tower is connected to the foundation by means of (24) 1.00"Ø, ASTM A354 Gr. BC anchor bolts embedded approximately 5.5-ft into the concrete foundation structure.

- The tower reactions developed from the governing Load Case 2 were used in the verification of the foundation:

Reactions	Vector	Proposed Base Reactions
Base	Shear	<b>43 kips</b>
	Compression	<b>54 kips</b>
	Moment	<b>4519 kip-ft</b>
Leg	Shear	<b>28 kips</b>
	Uplift	<b>253 kips</b>
	Compression	<b>293 kips</b>

- The anchor bolts were found to be within allowable limits.

Tower Component	Design Limit	Stress Ratio (percentage of capacity)	Result
Anchor Bolts	Tension	71.3%	<b>PASS</b>

**CENTEK** Engineering, Inc.  
 Structural Analysis - 190-ft Rohn Lattice Tower  
 Verizon Wireless Antenna Upgrade – Coventry East  
 Coventry, CT  
 December 3, 2014

- The foundation was found to be within allowable limits.

Foundation	Design Limit	IBC 2003/2005 CT State Building Code Section 3108.4.2 (FS) <sup>(1)</sup>	Proposed Loading (FS) <sup>(1)</sup>	Result
Reinforced Concrete Mat	OM <sup>(2)</sup>	2.0	2.56	<b>PASS</b>

Note 1: FS denotes Factor of Safety  
 Note 2: OM denotes Overturning Moment.

### Conclusion

This analysis shows that the subject tower **is adequate** to support the proposed modified antenna configuration.

The analysis is based, in part, on the information provided to this office by Verizon Wireless. If the existing conditions are different than the information in this report, Centek Engineering, Inc. must be contacted for resolution of any potential issues.

Please feel free to call with any questions or comments.

Respectfully Submitted by:

Timothy J. Lynn, PE  
 Structural Engineer



CENTEK Engineering, Inc.  
Structural Analysis - 190-ft Rohn Lattice Tower  
Verizon Wireless Antenna Upgrade – Coventry East  
Coventry, CT  
December 3, 2014

Standard Conditions for Furnishing of  
Professional Engineering Services on  
Existing Structures

All engineering services are performed on the basis that the information used is current and correct. This information may consist of, but is not necessarily limited to:

- Information supplied by the client regarding the structure itself, its foundations, the soil conditions, the antenna and feed line loading on the structure and its components, or other relevant information.
- Information from the field and/or drawings in the possession of Centek Engineering, Inc. or generated by field inspections or measurements of the structure.
- It is the responsibility of the client to ensure that the information provided to Centek Engineering, Inc. and used in the performance of our engineering services is correct and complete. In the absence of information to the contrary, we assume that all structures were constructed in accordance with the drawings and specifications and are in an un-corroded condition and have not deteriorated. It is therefore assumed that its capacity has not significantly changed from the “as new” condition.
- All services will be performed to the codes specified by the client, and we do not imply to meet any other codes or requirements unless explicitly agreed in writing. If wind and ice loads or other relevant parameters are to be different from the minimum values recommended by the codes, the client shall specify the exact requirement. In the absence of information to the contrary, all work will be performed in accordance with the latest revision of ANSI/ASCE10 & ANSI/EIA-222
- All services performed, results obtained, and recommendations made are in accordance with generally accepted engineering principles and practices. Centek Engineering, Inc. is not responsible for the conclusions, opinions and recommendations made by others based on the information we supply.



CENTEK Engineering, Inc.  
Structural Analysis - 190-ft Rohn Lattice Tower  
Verizon Wireless Antenna Upgrade – Coventry East  
Coventry, CT  
December 3, 2014

## GENERAL DESCRIPTION OF STRUCTURAL ANALYSIS PROGRAM

tnxTower, is an integrated structural analysis and design software package for Designed specifically for the telecommunications industry, tnxTower, formerly RISATower, automates much of the tower analysis and design required by the TIA/EIA 222 Standard.

### tnxTower Features:

- tnxTower can analyze and design 3- and 4-sided guyed towers, 3- and 4-sided self-supporting towers and either round or tapered ground mounted poles with or without guys.
- The program analyzes towers using the TIA-222-G (2005) standard or any of the previous TIA/EIA standards back to RS-222 (1959). Steel design is checked using the AISC ASD 9th Edition or the AISC LRFD specifications.
- Linear and non-linear (P-delta) analyses can be used in determining displacements and forces in the structure. Wind pressures and forces are automatically calculated.
- Extensive graphics plots include material take-off, shear-moment, leg compression, displacement, twist, feed line, guy anchor and stress plots.
- tnxTower contains unique features such as True Cable behavior, hog rod take-up, foundation stiffness and much more.

Section	T1	T2	T3	T4	T5	T6	T7	T8	T9	T10
Legs	ROHN 2.5 STD	ROHN 3 EH	ROHN 3.5 EH	ROHN 4 EH	ROHN 4 EH	ROHN 5 EH	ROHN 5 EH	ROHN 6 EHS	ROHN 6 EH	ROHN 8 EHS
Leg Grade	A572-50									
Diagonals	L1 3/4x1 3/4x3/16									
Diagonal Grade	A36									
Top Chords	L1 3/4x1 3/4x3/16									
Sec. Horizontals	N.A.									
Face Width (ft)	4.65	4.65	4.72	6.75	8.83	10.83	12.92	14.85	16.95	19.9
# Panels @ (ft)	2 @ 5	15 @ 4	1.0	1.2	1.7	1.9	2.7	3.4	3.4	3.4
Weight (K)	0.3	0.7	1.0	1.7	1.9	2.7	3.5	3.4	3.4	3.4

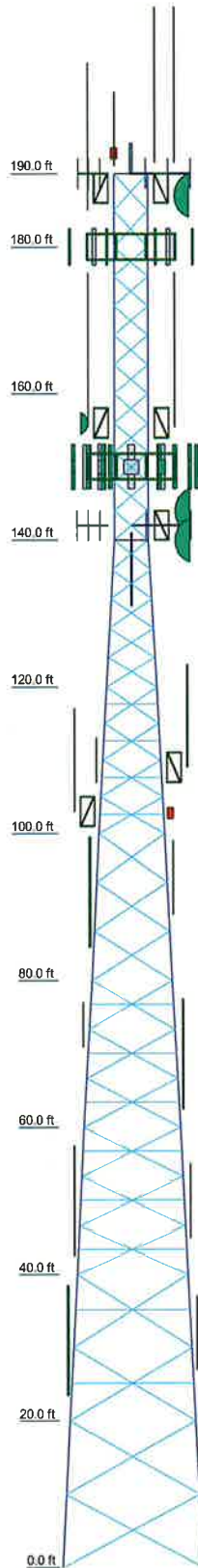

### DESIGNED APPURTENANCE LOADING

TYPE	ELEVATION	TYPE	ELEVATION
(2) Obstruction Lights	192	HBXX-6517DS (Verizon Proposed)	150
PD1142-3	192	LNX-6514DS-T4M (Verizon Proposed)	150
ASP-705	192	HBXX-6517DS (Verizon Proposed)	150
ASP-705	192	RRH2x60-AWS (Verizon Proposed)	150
DB420	192	RRH2x60-AWS (Verizon Proposed)	150
Halo	192	RRH2x60-AWS (Verizon Proposed)	150
4' x 3" DIA Omni	190	RRH2x60-PCS (Verizon Proposed)	150
3' Yagi	190	RRH2x60-PCS (Verizon Proposed)	150
3' Yagi	190	RRH2x60-PCS (Verizon Proposed)	150
Pirod 4' Side Mount Standoff (1)	188	DB-T1-6Z-8AB-0Z (Verizon Proposed)	150
Pirod 4' Side Mount Standoff (1)	188	DB-T1-6Z-8AB-0Z (Verizon Proposed)	150
Pirod 4' Side Mount Standoff (1)	188	Paraflector	144
Paraflector	187	DB230-2A	142
PD1142-2A	187	Pirod 4' Side Mount Standoff (1)	142
Rohn 6'x14' Boom Gate (3) (Sprint Existing)	180	Pirod 4' Side Mount Standoff (1)	142
(2) DB980H90E-M (Sprint Existing)	180	DB264-A	142
(2) DB980H90E-M (Sprint Existing)	180	DB436-C	142
(2) DB980H90E-M (Sprint Existing)	180	Paraflector	140
Pirod 4' Side Mount Standoff (1)	156	Single Dipole	136
ASP-705	156	Pirod 4' Side Mount Standoff (1)	113
Pirod 4' Side Mount Standoff (1)	156	Dipole	113
ASP-705	156	PD320	110
3-ft dish	156	Pirod 4' Side Mount Standoff (1)	109
Pirod 12' T-Frame Sector Mount (1) (Verizon Existing)	150	14' x 3" Dia Omni	109
Pirod 12' T-Frame Sector Mount (1) (Verizon Existing)	150	Pirod 4' Side Mount Standoff (1)	103
Pirod 12' T-Frame Sector Mount (1) (Verizon Existing)	150	14' x 3" Dia Omni	103
LNX-6514DS-T4M (Verizon Proposed)	150	GPS	102
HBXX-6517DS (Verizon Proposed)	150	1' Standoff Pipe	102
LNX-6514DS-T4M (Verizon Proposed)	150	DB212 Single Dipole	94
HBXX-6517DS (Verizon Proposed)	150	15-ft Single Dipole	92
LNX-6514DS-T4M (Verizon Proposed)	150	PD320	74
HBXX-6517DS (Verizon Proposed)	150	15-ft Single Dipole	70
LNX-6514DS-T4M (Verizon Proposed)	150	15-ft Single Dipole	50
HBXX-6517DS (Verizon Proposed)	150	DB212 Single Dipole	50
LNX-6514DS-T4M (Verizon Proposed)	150	DB212 Single Dipole	32
HBXX-6517DS (Verizon Proposed)	150	15-ft Single Dipole	31
LNX-6514DS-T4M (Verizon Proposed)	150	PD400	17
HBXX-6517DS (Verizon Proposed)	150	3' Yagi	17
LNX-6514DS-T4M (Verizon Proposed)	150	Pirod 4' Side Mount Standoff (1)	17

### SYMBOL LIST

MARK	SIZE	MARK	SIZE
A	ROHN 2 STD	B	L1 3/4x1 3/4x3/16

### MATERIAL STRENGTH

GRADE	Fy	Fu	GRADE	Fy	Fu
A572-50	50 ksi	65 ksi	A36	36 ksi	58 ksi

### TOWER DESIGN NOTES

1. Tower designed for a 85 mph basic wind in accordance with the TIA/EIA-222-F Standard.
2. Tower is also designed for a 74 mph basic wind with 0.50 in ice.

MAX. CORNER F3:  
 DOWN: 293 K, TOWER RATING: 92.8%  
 UPLIFT: -253 K  
 SHEAR: 28 K

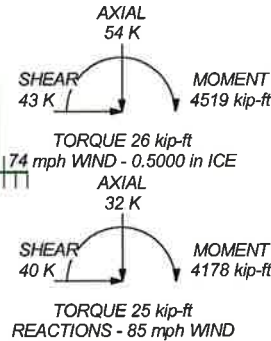

### Centek Engineering Inc.

63-2 North Branford Rd.  
 Branford, CT 06405  
 Phone: (203) 488-0580  
 FAX: (203) 488-8587

Job: 14001.057 - Coventry East

Project: 190' Rohn Lattice Tower - 1712 Main St., Coventry, CT	Client: Verizon Wireless	Drawn by: T.JL	App'd:
Code: TIA/EIA-222-F	Date: 12/03/14	Scale: NTS	Dwg No. E-1
Path: \\194450020\W097_Centek_East\Office\Projects\14001.057\190' Rohn Lattice Tower			

# Feedline Plan

— Round   
 — Flat   
 — App In Face   
 — App Out Face

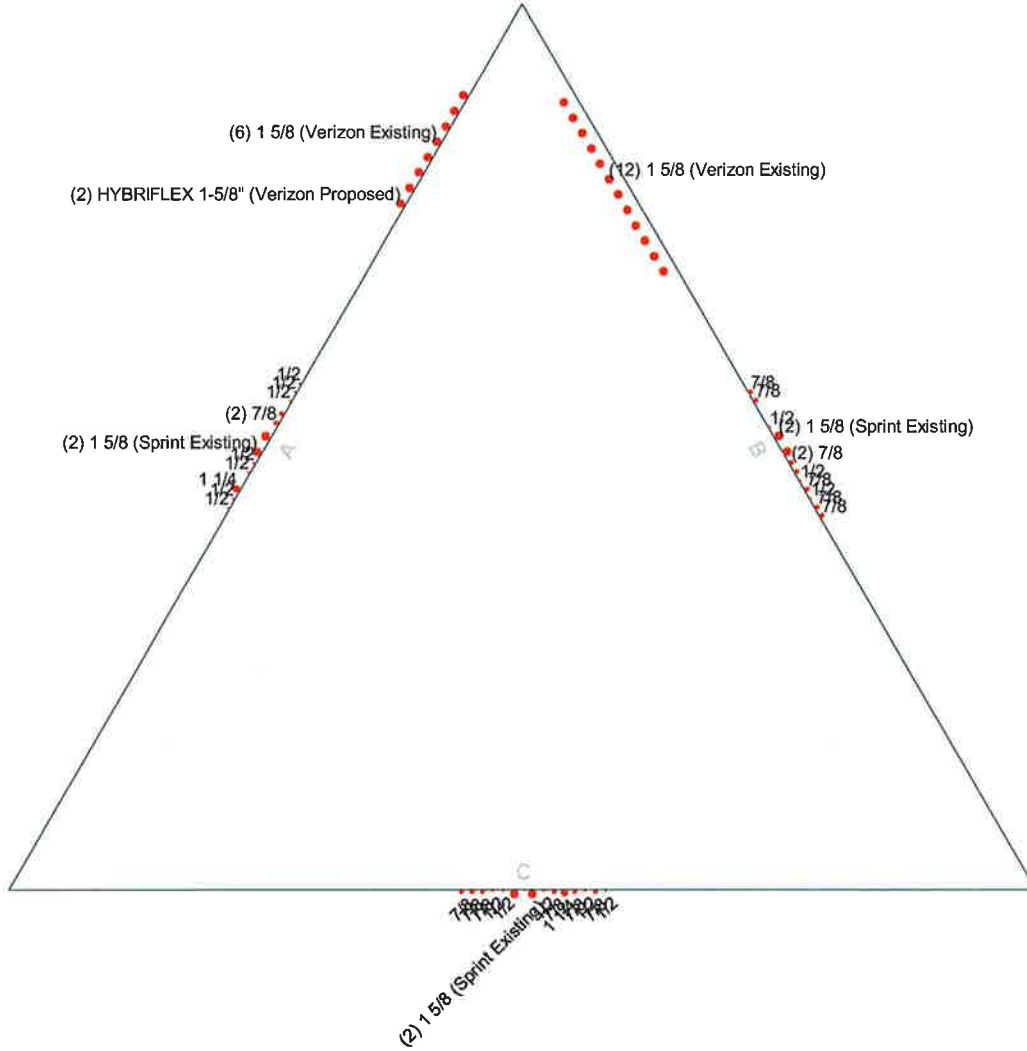

<b>Centek Engineering Inc.</b> 63-2 North Branford Rd. Branford, CT 06405 Phone: (203) 488-0580 FAX: (203) 488-8587	<b>Job: 14001.057 - Coventry East</b>		
	<b>Project: 190' Rohn Lattice Tower - 1712 Main St., Coventry, CT</b>		
	Client: Verizon Wireless	Drawn by: T.JL	App'd:
	Code: TIA/EIA-222-F	Date: 12/03/14	Scale: NTS
	Path:	Dwg No. E-7	

# Feedline Distribution Chart

## 0' - 190'

— Round   
 — Flat   
 — App In Face   
 — App Out Face   
 — Truss Leg

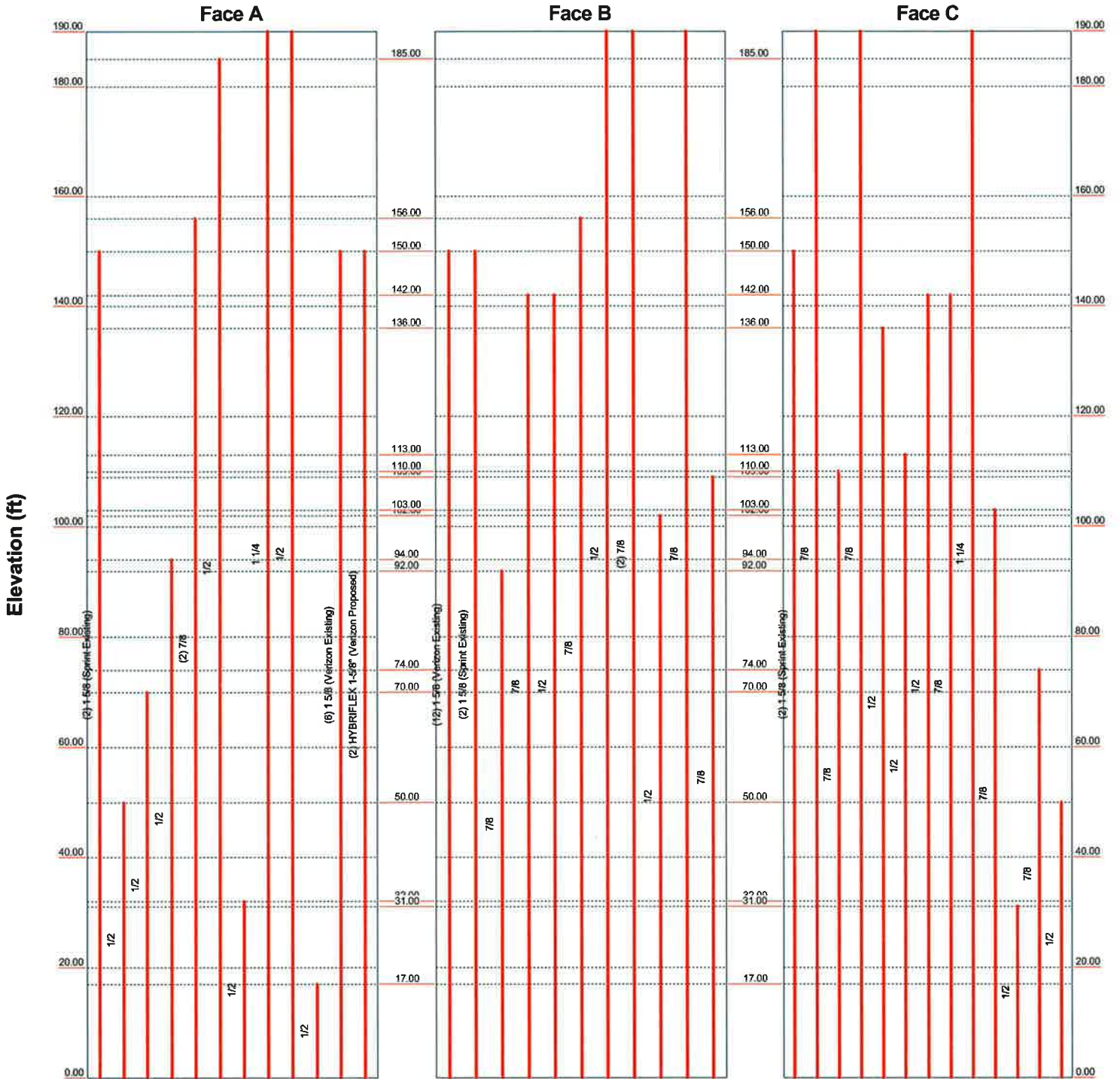

<b>Centek Engineering Inc.</b> 63-2 North Branford Rd. Branford, CT 06405 Phone: (203) 488-0580 FAX: (203) 488-8587	Job: <b>14001.057 - Coventry East</b>
	Project: <b>190' Rohn Lattice Tower - 1712 Main St., Coventry, CT</b>
	Client: Verizon Wireless      Drawn by: T.JL      App'd:
	Code: TIA/EIA-222-F      Date: 12/03/14      Scale: NTS
	Path: <small>J:\2014\1000\WVF - Coventry East CellSite\Drawings\CA0103 Feed 190' Rohn Lattice Tower.dwg</small> Dwg No. E-7

<b>tnxTower</b>  <b>Centek Engineering Inc.</b> 63-2 North Branford Rd. Branford, CT 06405 Phone: (203) 488-0580 FAX: (203) 488-8587	<b>Job</b> 14001.057 - Coventry East	<b>Page</b> 1 of 39
	<b>Project</b> 190' Rohn Lattice Tower - 1712 Main St., Coventry, CT	<b>Date</b> 09:25:07 12/03/14
	<b>Client</b> Verizon Wireless	<b>Designed by</b> TJL

## Tower Input Data

The main tower is a 3x free standing tower with an overall height of 190.00 ft above the ground line.  
 The base of the tower is set at an elevation of 0.00 ft above the ground line.  
 The face width of the tower is 4.65 ft at the top and 19.00 ft at the base.  
 This tower is designed using the TIA/EIA-222-F standard.

The following design criteria apply:

- Basic wind speed of 85 mph.
- Nominal ice thickness of 0.5000 in.
- Ice density of 56 pcf.
- A wind speed of 74 mph is used in combination with ice.
- Temperature drop of 50 °F.
- Deflections calculated using a wind speed of 50 mph.
- A non-linear (P-delta) analysis was used.
- Pressures are calculated at each section.
- Stress ratio used in tower member design is 1.333.
- Local bending stresses due to climbing loads, feedline supports, and appurtenance mounts are not considered.

## Options

- |  |  |   |
|--|--|---|
| <ul style="list-style-type: none"> <li>Consider Moments - Legs</li> <li>Consider Moments - Horizontals</li> <li>Consider Moments - Diagonals</li> <li>Use Moment Magnification</li> <li>√ Use Code Stress Ratios</li> <li>√ Use Code Safety Factors - Guys</li> <li>Escalate Ice</li> <li>Always Use Max Kz</li> <li>Use Special Wind Profile</li> <li>√ Include Bolts In Member Capacity</li> <li>Leg Bolts Are At Top Of Section</li> <li>√ Secondary Horizontal Braces Leg</li> <li>Use Diamond Inner Bracing (4 Sided)</li> <li>Add IBC .6D+W Combination</li> </ul> | <ul style="list-style-type: none"> <li>Distribute Leg Loads As Uniform</li> <li>Assume Legs Pinned</li> <li>√ Assume Rigid Index Plate</li> <li>√ Use Clear Spans For Wind Area</li> <li>√ Use Clear Spans For KL/r</li> <li>Retention Guys To Initial Tension</li> <li>Bypass Mast Stability Checks</li> <li>√ Use Azimuth Dish Coefficients</li> <li>√ Project Wind Area of Appurt.</li> <li>Autocalc Torque Arm Areas</li> <li>√ SR Members Have Cut Ends</li> <li>√ Sort Capacity Reports By Component</li> <li>Triangulate Diamond Inner Bracing</li> </ul> | <ul style="list-style-type: none"> <li>Treat Feedline Bundles As Cylinder</li> <li>Use ASCE 10 X-Brace Ly Rules</li> <li>√ Calculate Redundant Bracing Forces</li> <li>Ignore Redundant Members in FEA</li> <li>√ SR Leg Bolts Resist Compression</li> <li>√ All Leg Panels Have Same Allowable</li> <li>Offset Girt At Foundation</li> <li>√ Consider Feedline Torque</li> <li>Include Angle Block Shear Check</li> <li style="padding-left: 20px;">Poles</li> <li>Include Shear-Torsion Interaction</li> <li>Always Use Sub-Critical Flow</li> <li>Use Top Mounted Sockets</li> </ul> |
|--|--|---|

<b>tnxTower</b>  <b>Centek Engineering Inc.</b> 63-2 North Branford Rd. Branford, CT 06405 Phone: (203) 488-0580 FAX: (203) 488-8587	<b>Job</b> 14001.057 - Coventry East	<b>Page</b> 2 of 39
	<b>Project</b> 190' Rohn Lattice Tower - 1712 Main St., Coventry, CT	<b>Date</b> 09:25:07 12/03/14
	<b>Client</b> Verizon Wireless	<b>Designed by</b> T.J.L.

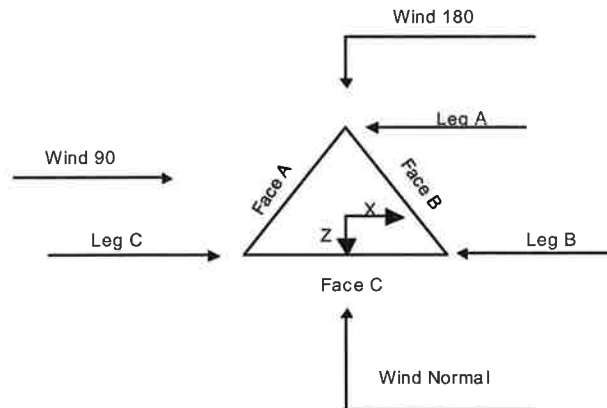

**Triangular Tower**

**Tower Section Geometry**

Tower Section	Tower Elevation	Assembly Database	Description	Section Width	Number of Sections	Section Length
	ft			ft		ft
T1	190.00-180.00			4.65	1	10.00
T2	180.00-160.00			4.65	1	20.00
T3	160.00-140.00			4.69	1	20.00
T4	140.00-120.00			4.72	1	20.00
T5	120.00-100.00			6.76	1	20.00
T6	100.00-80.00			8.83	1	20.00
T7	80.00-60.00			10.83	1	20.00
T8	60.00-40.00			12.92	1	20.00
T9	40.00-20.00			14.85	1	20.00
T10	20.00-0.00			16.99	1	20.00

**Tower Section Geometry (cont'd)**

Tower Section	Tower Elevation	Diagonal Spacing	Bracing Type	Has K Brace End Panels	Has Horizontals	Top Girt Offset	Bottom Girt Offset
	ft	ft				in	in
T1	190.00-180.00	5.00	X Brace	No	Yes	0.0000	0.0000
T2	180.00-160.00	4.00	X Brace	No	No	0.0000	0.0000
T3	160.00-140.00	4.00	X Brace	No	Yes	0.0000	0.0000
T4	140.00-120.00	4.00	X Brace	No	Yes	0.0000	0.0000
T5	120.00-100.00	5.00	X Brace	No	Yes	0.0000	0.0000

<b>tnxTower</b>  <b>Centek Engineering Inc.</b> 63-2 North Branford Rd. Branford, CT 06405 Phone: (203) 488-0580 FAX: (203) 488-8587	<b>Job</b> 14001.057 - Coventry East	<b>Page</b> 3 of 39
	<b>Project</b> 190' Rohn Lattice Tower - 1712 Main St., Coventry, CT	<b>Date</b> 09:25:07 12/03/14
	<b>Client</b> Verizon Wireless	<b>Designed by</b> T.J.L

Tower Section	Tower Elevation	Diagonal Spacing	Bracing Type	Has K Brace End Panels	Has Horizontals	Top Girt Offset	Bottom Girt Offset
	ft	ft				in	in
T6	100.00-80.00	6.67	X Brace	No	Yes	0.0000	0.0000
T7	80.00-60.00	6.67	X Brace	No	Yes	0.0000	0.0000
T8	60.00-40.00	6.67	X Brace	No	Yes	0.0000	0.0000
T9	40.00-20.00	10.00	X Brace	No	Yes	0.0000	0.0000
T10	20.00-0.00	10.00	X Brace	No	Yes	0.0000	0.0000

### Tower Section Geometry (cont'd)

Tower Elevation	Leg Type	Leg Size	Leg Grade	Diagonal Type	Diagonal Size	Diagonal Grade
ft						
T1 190.00-180.00	Pipe	ROHN 2 STD	A572-50 (50 ksi)	Single Angle	L1 3/4x1 3/4x3/16	A36 (36 ksi)
T2 180.00-160.00	Pipe	ROHN 2.5 STD	A572-50 (50 ksi)	Single Angle	L1 3/4x1 3/4x3/16	A36 (36 ksi)
T3 160.00-140.00	Pipe	ROHN 3 EH	A572-50 (50 ksi)	Single Angle	L1 3/4x1 3/4x3/16	A36 (36 ksi)
T4 140.00-120.00	Pipe	ROHN 3.5 EH	A572-50 (50 ksi)	Single Angle	L1 3/4x1 3/4x3/16	A36 (36 ksi)
T5 120.00-100.00	Pipe	ROHN 4 EH	A572-50 (50 ksi)	Single Angle	L2x2x3/16	A36 (36 ksi)
T6 100.00-80.00	Pipe	ROHN 5 EH	A572-50 (50 ksi)	Single Angle	L2 1/2x2 1/2x3/16	A36 (36 ksi)
T7 80.00-60.00	Pipe	ROHN 5 EH	A572-50 (50 ksi)	Single Angle	L2 1/2x2 1/2x1/4	A36 (36 ksi)
T8 60.00-40.00	Pipe	ROHN 6 EHS	A572-50 (50 ksi)	Single Angle	L3x3x1/4	A572-50 (50 ksi)
T9 40.00-20.00	Pipe	ROHN 6 EH	A572-50 (50 ksi)	Single Angle	L3x3x1/4	A572-50 (50 ksi)
T10 20.00-0.00	Pipe	ROHN 8 EHS	A572-50 (50 ksi)	Single Angle	L3 1/2x3 1/2x1/4	A572-50 (50 ksi)

### Tower Section Geometry (cont'd)

Tower Elevation	Top Girt Type	Top Girt Size	Top Girt Grade	Bottom Girt Type	Bottom Girt Size	Bottom Girt Grade
ft						
T1 190.00-180.00	Single Angle	L1 3/4x1 3/4x3/16	A36 (36 ksi)	Single Angle		A36 (36 ksi)
T4 140.00-120.00	Single Angle	L1 3/4x1 3/4x3/16	A36 (36 ksi)	Single Angle		A36 (36 ksi)

### Tower Section Geometry (cont'd)





<b>tnxTower</b>  <b>Centek Engineering Inc.</b> 63-2 North Branford Rd. Branford, CT 06405 Phone: (203) 488-0580 FAX: (203) 488-8587	<b>Job</b> 14001.057 - Coventry East	<b>Page</b> 5 of 39
	<b>Project</b> 190' Rohn Lattice Tower - 1712 Main St., Coventry, CT	<b>Date</b> 09:25:07 12/03/14
	<b>Client</b> Verizon Wireless	<b>Designed by</b> TJJ

Tower Elevation ft	Calc K Single Angles	Calc K Solid Rounds	K Factors <sup>1</sup>								
			Legs	X Brace Diags	K Brace Diags	Single Diags	Girts	Horiz.	Sec. Horiz.	Inner Brace	
			X Y	X Y	X Y	X Y	X Y	X Y	X Y	X Y	
140.00-120.00											
T5	Yes	Yes	1	1	1	1	1	1	1	1	1
120.00-100.00											
T6	Yes	Yes	1	1	1	1	1	1	1	1	
100.00-80.00											
T7	Yes	Yes	1	1	1	1	1	1	1	1	
80.00-60.00											
T8	Yes	Yes	1	1	1	1	1	1	1	1	
60.00-40.00											
T9	Yes	Yes	1	1	1	1	1	1	1	1	
40.00-20.00											
T10	Yes	Yes	1	1	1	1	1	1	1	1	
20.00-0.00											

<sup>1</sup>Note: K factors are applied to member segment lengths. K-braces without inner supporting members will have the K factor in the out-of-plane direction applied to the overall length.

### Tower Section Geometry (cont'd)

Tower Elevation ft	Leg		Diagonal		Top Girt		Bottom Girt		Mid Girt		Long Horizontal		Short Horizontal	
	Net Width Deduct in	U	Net Width Deduct in	U	Net Width Deduct in	U	Net Width Deduct in	U	Net Width Deduct in	U	Net Width Deduct in	U	Net Width Deduct in	U
T1	0.0000	1	0.0000	1	0.0000	1	0.0000	1	0.0000	0.75	0.0000	1	0.0000	0.75
190.00-180.00														
T2	0.0000	1	0.0000	1	0.0000	1	0.0000	1	0.0000	1	0.0000	1	0.0000	1
180.00-160.00														
T3	0.0000	1	0.0000	1	0.0000	1	0.0000	1	0.0000	1	0.0000	1	0.0000	1
160.00-140.00														
T4	0.0000	1	0.0000	1	0.0000	1	0.0000	1	0.0000	1	0.0000	1	0.0000	1
140.00-120.00														
T5	0.0000	1	0.0000	1	0.0000	1	0.0000	1	0.0000	1	0.0000	1	0.0000	1
120.00-100.00														
T6	0.0000	1	0.0000	1	0.0000	1	0.0000	1	0.0000	1	0.0000	1	0.0000	1
100.00-80.00														
T7	0.0000	1	0.0000	1	0.0000	1	0.0000	1	0.0000	1	0.0000	1	0.0000	1
80.00-60.00														
T8	0.0000	1	0.0000	1	0.0000	1	0.0000	1	0.0000	1	0.0000	1	0.0000	1
60.00-40.00														
T9	0.0000	1	0.0000	1	0.0000	1	0.0000	1	0.0000	1	0.0000	1	0.0000	1
40.00-20.00														
T10	0.0000	1	0.0000	1	0.0000	1	0.0000	1	0.0000	1	0.0000	1	0.0000	1
20.00-0.00														

### Tower Section Geometry (cont'd)

<b>tnxTower</b>  <b>Centek Engineering Inc.</b> 63-2 North Branford Rd. Branford, CT 06405 Phone: (203) 488-0580 FAX: (203) 488-8587	<b>Job</b> 14001.057 - Coventry East	<b>Page</b> 6 of 39
	<b>Project</b> 190' Rohn Lattice Tower - 1712 Main St., Coventry, CT	<b>Date</b> 09:25:07 12/03/14
	<b>Client</b> Verizon Wireless	<b>Designed by</b> TJL

Tower Elevation ft	Leg Connection Type	Leg Bolt Size in	Leg No.	Diagonal		Top Girt		Bottom Girt		Mid Girt		Long Horizontal		Short Horizontal	
				Bolt Size in	No.	Bolt Size in	No.	Bolt Size in	No.	Bolt Size in	No.	Bolt Size in	No.	Bolt Size in	No.
T1 190.00-180.00	Flange	0.6250	4	0.6250	1	0.6250	1	0.6250	0	0.6250	0	0.6250	0	0.6250	0
T2 180.00-160.00	Flange	0.7500	4	0.6250	1	0.6250	0	0.6250	0	0.6250	0	0.6250	0	0.6250	0
T3 160.00-140.00	Flange	0.8750	4	0.6250	1	0.6250	0	0.6250	0	0.6250	0	0.6250	0	0.6250	0
T4 140.00-120.00	Flange	0.8750	4	0.6250	1	0.6250	1	0.6250	0	0.6250	0	0.6250	0	0.6250	0
T5 120.00-100.00	Flange	1.0000	4	0.6250	1	0.6250	0	0.6250	0	0.6250	0	0.6250	0	0.6250	2
T6 100.00-80.00	Flange	1.0000	4	0.6250	1	0.6250	0	0.6250	0	0.6250	0	0.6250	0	0.6250	0
T7 80.00-60.00	Flange	1.0000	6	0.6250	1	0.6250	0	0.6250	0	0.6250	0	0.6250	0	0.6250	2
T8 60.00-40.00	Flange	1.0000	6	0.6250	1	0.6250	0	0.6250	0	0.6250	0	0.6250	0	0.6250	2
T9 40.00-20.00	Flange	1.0000	8	0.6250	1	0.6250	0	0.6250	0	0.6250	0	0.6250	0	0.6250	2
T10 20.00-0.00	Flange	1.0000	8	0.7500	1	0.6250	0	0.6250	0	0.6250	0	0.6250	0	0.6250	0
		A354-BC		A325N		A325N		A325N		A325X		A325N		A325N	

### Feed Line/Linear Appurtenances - Entered As Round Or Flat

Description	Face or Leg	Allow Shield	Component Type	Placement ft	Face Offset in	Lateral Offset (Frac FW)	#	# Per Row	Clear Spacing in	Width or Diameter in	Perimeter in	Weight plf
1 5/8 (Verizon Existing)	B	Yes	Ar (CfAe)	150.00 - 0.00	-2.0000	-0.3	12	12	1.9800	1.9800		1.04
1 5/8 (Sprint Existing)	A	Yes	Ar (CfAe)	150.00 - 0.00	0.0000	0	2	2	1.9800	1.9800		1.04
1 5/8 (Sprint Existing)	B	Yes	Ar (CfAe)	150.00 - 0.00	0.0000	0	2	2	1.9800	1.9800		1.04
1 5/8 (Sprint Existing)	C	Yes	Ar (CfAe)	150.00 - 0.00	0.0000	0	2	2	1.9800	1.9800		1.04
1/2	A	Yes	Ar (CfAe)	50.00 - 0.00	0.0000	0.07	1	1	0.5800	0.5800		0.25
1/2	A	Yes	Ar (CfAe)	70.00 - 0.00	0.0000	0.06	1	1	0.5800	0.5800		0.25
1/2	A	Yes	Ar (CfAe)	94.00 - 0.00	0.0000	0.05	1	1	0.5800	0.5800		0.25
7/8	A	Yes	Ar (CfAe)	156.00 - 0.00	0.0000	0.03	2	2	1.1100	1.1100		0.54
1/2	A	Yes	Ar (CfAe)	185.00 - 0.00	0.0000	-0.02	1	1	0.5800	0.5800		0.25
1/2	A	Yes	Ar (CfAe)	32.00 - 0.00	0.0000	-0.03	1	1	0.5800	0.5800		0.25
1 1/4	A	Yes	Ar (CfAe)	190.00 - 0.00	0.0000	-0.05	1	1	1.5500	1.5500		0.66
1/2	A	Yes	Ar (CfAe)	190.00 - 0.00	0.0000	-0.06	1	1	0.5800	0.5800		0.25
1/2	A	Yes	Ar (CfAe)	17.00 - 0.00	0.0000	-0.07	1	1	0.5800	0.5800		0.25
7/8	B	Yes	Ar (CfAe)	92.00 - 0.00	0.0000	0.08	1	1	1.1100	1.1100		0.54
7/8	B	Yes	Ar (CfAe)	142.00 - 0.00	0.0000	0.07	1	1	1.1100	1.1100		0.54
1/2	B	Yes	Ar (CfAe)	142.00 - 0.00	0.0000	0.06	1	1	0.5800	0.5800		0.25
7/8	B	Yes	Ar (CfAe)	156.00 - 0.00	0.0000	0.05	1	1	1.1100	1.1100		0.54
1/2	B	Yes	Ar (CfAe)	190.00 - 0.00	0.0000	0.04	1	1	0.5800	0.5800		0.25
7/8	B	Yes	Ar (CfAe)	190.00 - 0.00	0.0000	0.025	2	2	1.1100	1.1100		0.54
1/2	B	Yes	Ar (CfAe)	102.00 - 0.00	0.0000	-0.02	1	1	0.5800	0.5800		0.25

<b>tnxTower</b>  <b>Centek Engineering Inc.</b> 63-2 North Branford Rd. Branford, CT 06405 Phone: (203) 488-0580 FAX: (203) 488-8587	<b>Job</b> 14001.057 - Coventry East	<b>Page</b> 7 of 39
	<b>Project</b> 190' Rohn Lattice Tower - 1712 Main St., Coventry, CT	<b>Date</b> 09:25:07 12/03/14
	<b>Client</b> Verizon Wireless	<b>Designed by</b> TJL

Description	Face or Leg	Allow Shield	Component Type	Placement ft	Face Offset in	Lateral Offset (Frac FW)	#	# Per Row	Clear Spacing in	Width or Diameter in	Perimeter in	Weight plf
7/8	B	Yes	Ar (CfAe)	190.00 - 0.00	0.0000	-0.05	1	1	1.1100	1.1100		0.54
7/8	B	Yes	Ar (CfAe)	109.00 - 0.00	0.0000	-0.06	1	1	1.1100	1.1100		0.54
7/8	C	Yes	Ar (CfAe)	190.00 - 0.00	0.0000	0.06	1	1	1.1100	1.1100		0.54
7/8	C	Yes	Ar (CfAe)	110.00 - 0.00	0.0000	0.05	1	1	1.1100	1.1100		0.54
7/8	C	Yes	Ar (CfAe)	190.00 - 0.00	0.0000	0.04	1	1	1.1100	1.1100		0.54
1/2	C	Yes	Ar (CfAe)	136.00 - 0.00	0.0000	0.03	1	1	0.5800	0.5800		0.25
1/2	C	Yes	Ar (CfAe)	113.00 - 0.00	0.0000	0.02	1	1	0.5800	0.5800		0.25
1/2	C	Yes	Ar (CfAe)	142.00 - 0.00	0.0000	-0.02	1	1	0.5800	0.5800		0.25
7/8	C	Yes	Ar (CfAe)	142.00 - 0.00	0.0000	-0.03	1	1	1.1100	1.1100		0.54
1 1/4	C	Yes	Ar (CfAe)	190.00 - 0.00	0.0000	-0.04	1	1	1.5500	1.5500		0.66
7/8	C	Yes	Ar (CfAe)	103.00 - 0.00	0.0000	-0.05	1	1	1.1100	1.1100		0.54
1/2	C	Yes	Ar (CfAe)	31.00 - 0.00	0.0000	-0.06	1	1	0.5800	0.5800		0.25
7/8	C	Yes	Ar (CfAe)	74.00 - 0.00	0.0000	-0.07	1	1	1.1100	1.1100		0.54
1/2	C	Yes	Ar (CfAe)	50.00 - 0.00	0.0000	-0.08	1	1	0.5800	0.5800		0.25
1 5/8	A	Yes	Ar (CfAe)	150.00 - 0.00	0.0000	0.35	6	6	1.9800	1.9800		1.04
(Verizon Existing)												
HYBRIFLEX 1-5/8"	A	Yes	Ar (CfAe)	150.00 - 0.00	0.0000	0.28	2	2	1.9800	1.9800		1.90
(Verizon Proposed)												

### Feed Line/Linear Appurtenances Section Areas

Tower Section	Tower Elevation ft	Face	A <sub>R</sub> ft <sup>2</sup>	A <sub>F</sub> ft <sup>2</sup>	C <sub>AA</sub> In Face ft <sup>2</sup>	C <sub>AA</sub> Out Face ft <sup>2</sup>	Weight K
T1	190.00-180.00	A	2.017	0.000	0.000	0.000	0.01
		B	3.258	0.000	0.000	0.000	0.02
		C	3.142	0.000	0.000	0.000	0.02
T2	180.00-160.00	A	4.517	0.000	0.000	0.000	0.02
		B	6.517	0.000	0.000	0.000	0.04
		C	6.283	0.000	0.000	0.000	0.03
T3	160.00-140.00	A	23.977	0.000	0.000	0.000	0.16
		B	31.378	0.000	0.000	0.000	0.19
		C	9.865	0.000	0.000	0.000	0.06
T4	140.00-120.00	A	41.217	0.000	0.000	0.000	0.29
		B	57.383	0.000	0.000	0.000	0.36
		C	16.473	0.000	0.000	0.000	0.10
T5	120.00-100.00	A	41.217	0.000	0.000	0.000	0.29
		B	58.313	0.000	0.000	0.000	0.36
		C	18.497	0.000	0.000	0.000	0.11
T6	100.00-80.00	A	41.893	0.000	0.000	0.000	0.29
		B	61.310	0.000	0.000	0.000	0.38
		C	21.333	0.000	0.000	0.000	0.12
T7	80.00-60.00	A	42.667	0.000	0.000	0.000	0.29
		B	62.050	0.000	0.000	0.000	0.38
		C	22.628	0.000	0.000	0.000	0.13
T8	60.00-40.00	A	43.633	0.000	0.000	0.000	0.30
		B	62.050	0.000	0.000	0.000	0.38
		C	23.667	0.000	0.000	0.000	0.14
T9	40.00-20.00	A	44.697	0.000	0.000	0.000	0.31
		B	62.050	0.000	0.000	0.000	0.38
		C	24.682	0.000	0.000	0.000	0.14
T10	20.00-0.00	A	45.905	0.000	0.000	0.000	0.31
		B	62.050	0.000	0.000	0.000	0.38

<b>tnxTower</b>  <b>Centek Engineering Inc.</b> 63-2 North Branford Rd. Branford, CT 06405 Phone: (203) 488-0580 FAX: (203) 488-8587	<b>Job</b> 14001.057 - Coventry East	<b>Page</b> 8 of 39
	<b>Project</b> 190' Rohn Lattice Tower - 1712 Main St., Coventry, CT	<b>Date</b> 09:25:07 12/03/14
	<b>Client</b> Verizon Wireless	<b>Designed by</b> TJL

Tower Section	Tower Elevation ft	Face	$A_R$ ft <sup>2</sup>	$A_F$ ft <sup>2</sup>	$C_{AA}$ In Face ft <sup>2</sup>	$C_{AA}$ Out Face ft <sup>2</sup>	Weight K
		C	25.117	0.000	0.000	0.000	0.14

### Feed Line/Linear Appurtenances Section Areas - With Ice

Tower Section	Tower Elevation ft	Face or Leg	Ice Thickness in	$A_R$ ft <sup>2</sup>	$A_F$ ft <sup>2</sup>	$C_{AA}$ In Face ft <sup>2</sup>	$C_{AA}$ Out Face ft <sup>2</sup>	Weight K
T1	190.00-180.00	A	0.500	4.100	0.000	0.000	0.000	0.03
		B		6.592	0.000	0.000	0.000	0.05
		C		5.642	0.000	0.000	0.000	0.05
T2	180.00-160.00	A	0.500	9.517	0.000	0.000	0.000	0.07
		B		13.183	0.000	0.000	0.000	0.11
		C		11.283	0.000	0.000	0.000	0.10
T3	160.00-140.00	A	0.500	39.977	0.000	0.000	0.000	0.40
		B		51.378	0.000	0.000	0.000	0.50
		C		16.865	0.000	0.000	0.000	0.16
T4	140.00-120.00	A	0.500	66.217	0.000	0.000	0.000	0.68
		B		92.383	0.000	0.000	0.000	0.90
		C		29.473	0.000	0.000	0.000	0.26
T5	120.00-100.00	A	0.500	66.217	0.000	0.000	0.000	0.68
		B		94.229	0.000	0.000	0.000	0.92
		C		33.998	0.000	0.000	0.000	0.30
T6	100.00-80.00	A	0.500	68.060	0.000	0.000	0.000	0.69
		B		100.643	0.000	0.000	0.000	0.97
		C		39.667	0.000	0.000	0.000	0.35
T7	80.00-60.00	A	0.500	70.167	0.000	0.000	0.000	0.71
		B		102.050	0.000	0.000	0.000	0.98
		C		42.128	0.000	0.000	0.000	0.37
T8	60.00-40.00	A	0.500	72.800	0.000	0.000	0.000	0.73
		B		102.050	0.000	0.000	0.000	0.98
		C		44.500	0.000	0.000	0.000	0.39
T9	40.00-20.00	A	0.500	75.697	0.000	0.000	0.000	0.75
		B		102.050	0.000	0.000	0.000	0.98
		C		47.265	0.000	0.000	0.000	0.41
T10	20.00-0.00	A	0.500	78.988	0.000	0.000	0.000	0.77
		B		102.050	0.000	0.000	0.000	0.98
		C		48.450	0.000	0.000	0.000	0.41

### Feed Line Shielding

Section	Elevation ft	Face	$A_R$ ft <sup>2</sup>	$A_R$ Ice ft <sup>2</sup>	$A_F$ ft <sup>2</sup>	$A_F$ Ice ft <sup>2</sup>
T1	190.00-180.00	A	0.000	0.235	0.202	0.411
		B	0.000	0.378	0.327	0.661
		C	0.000	0.323	0.315	0.566
T2	180.00-160.00	A	0.000	0.522	0.434	0.914
		B	0.000	0.723	0.626	1.266
		C	0.000	0.619	0.603	1.083
T3	160.00-140.00	A	0.000	2.186	2.295	3.826
		B	0.000	2.810	3.003	4.917
		C	0.000	0.922	0.944	1.614
T4	140.00-120.00	A	0.000	3.654	3.980	6.394
		B	0.000	5.098	5.541	8.921

<b>tnxTower</b>  <b>Centek Engineering Inc.</b> 63-2 North Branford Rd. Branford, CT 06405 Phone: (203) 488-0580 FAX: (203) 488-8587	<b>Job</b> 14001.057 - Coventry East	<b>Page</b> 9 of 39
	<b>Project</b> 190' Rohn Lattice Tower - 1712 Main St., Coventry, CT	<b>Date</b> 09:25:07 12/03/14
	<b>Client</b> Verizon Wireless	<b>Designed by</b> TJL

Section	Elevation	Face	$A_R$	$A_{R\ Ice}$	$A_F$	$A_{F\ Ice}$
	ft		ft <sup>2</sup>	ft <sup>2</sup>	ft <sup>2</sup>	ft <sup>2</sup>
T5	120.00-100.00	C	0.000	1.626	1.591	2.846
		A	0.000	3.732	4.645	7.463
		B	0.000	5.310	6.572	10.620
T6	100.00-80.00	C	0.000	1.916	2.085	3.832
		A	0.000	2.058	3.168	5.146
		B	0.000	3.044	4.636	7.610
T7	80.00-60.00	C	0.000	1.200	1.613	2.999
		A	0.000	2.890	4.394	7.226
		B	0.000	4.204	6.390	10.509
T8	60.00-40.00	C	0.000	1.735	2.330	4.338
		A	0.000	2.930	5.268	8.789
		B	0.000	4.107	7.491	12.320
T9	40.00-20.00	C	0.000	1.791	2.857	5.372
		A	0.000	2.121	3.758	6.364
		B	0.000	2.860	5.216	8.579
T10	20.00-0.00	C	0.000	1.324	2.075	3.973
		A	0.000	1.506	3.064	5.272
		B	0.000	1.946	4.142	6.812
		C	0.000	0.924	1.677	3.234

### Feed Line Center of Pressure

Section	Elevation	$CP_X$	$CP_Z$	$CP_X\ Ice$	$CP_Z\ Ice$
	ft	in	in	in	in
T1	190.00-180.00	0.3629	0.3944	0.4331	0.2891
T2	180.00-160.00	0.2511	0.3282	0.2667	0.2053
T3	160.00-140.00	-0.0419	-5.7692	-0.0339	-5.6275
T4	140.00-120.00	0.2732	-9.3685	0.3741	-8.9423
T5	120.00-100.00	0.5887	-10.8248	0.7201	-10.3248
T6	100.00-80.00	1.1875	-13.2544	1.4725	-13.0702
T7	80.00-60.00	1.3966	-13.7279	1.6517	-13.4948
T8	60.00-40.00	1.3857	-13.6422	1.6168	-13.7948
T9	40.00-20.00	1.6702	-17.0031	1.8446	-17.0379
T10	20.00-0.00	1.6454	-18.5002	1.6934	-19.0442

### Discrete Tower Loads

Description	Face or Leg	Offset Type	Offsets: Horz Lateral	Azimuth Adjustment	Placement	$C_{AA}\ Front$	$C_{AA}\ Side$	Weight	
			ft	°	ft	ft <sup>2</sup>	ft <sup>2</sup>	K	
Pirod 4' Side Mount Standoff (1)	A	From Leg	2.00	0.0000	188.00	No Ice	2.72	2.72	0.05
			0.00			1/2" Ice	4.91	4.91	0.09
			0.00						
Pirod 4' Side Mount Standoff (1)	B	From Leg	2.00	0.0000	188.00	No Ice	2.72	2.72	0.05
			0.00			1/2" Ice	4.91	4.91	0.09
			0.00						
Pirod 4' Side Mount Standoff	C	From Leg	2.00	0.0000	188.00	No Ice	2.72	2.72	0.05

<b>tnxTower</b>  <b>Centek Engineering Inc.</b> 63-2 North Branford Rd. Branford, CT 06405 Phone: (203) 488-0580 FAX: (203) 488-8587	<b>Job</b> 14001.057 - Coventry East	<b>Page</b> 10 of 39
	<b>Project</b> 190' Rohn Lattice Tower - 1712 Main St., Coventry, CT	<b>Date</b> 09:25:07 12/03/14
	<b>Client</b> Verizon Wireless	<b>Designed by</b> TJL

Description	Face or Leg	Offset Type	Offsets: Horz Lateral Vert ft ft ft	Azimuth Adjustment °	Placement ft	C <sub>AA</sub> Front ft <sup>2</sup>	C <sub>AA</sub> Side ft <sup>2</sup>	Weight K	
(1)			0.00			1/2" Ice	4.91	4.91	0.09
(2) Obstruction Lights	C	From Leg	0.00	0.0000	192.00	No Ice	0.18	0.18	0.01
			0.00			1/2" Ice	0.25	0.25	0.01
PD1142-3	C	From Leg	0.00	0.0000	192.00	No Ice	0.48	0.48	0.01
			0.00			1/2" Ice	0.55	0.55	0.01
			4.00						
3' Yagi	C	From Leg	1.00	0.0000	190.00	No Ice	2.08	2.08	0.03
			0.00			1/2" Ice	3.79	3.79	0.05
			0.00						
PD1142-2A	C	From Leg	4.00	0.0000	187.00	No Ice	0.79	0.79	0.01
			0.00			1/2" Ice	0.91	0.91	0.01
			8.00						
Pirod 4' Side Mount Standoff (1)	C	From Leg	2.00	0.0000	156.00	No Ice	2.72	2.72	0.05
			0.00			1/2" Ice	4.91	4.91	0.09
			0.00						
ASP-705	C	From Leg	4.00	0.0000	156.00	No Ice	5.88	5.88	0.03
			0.00			1/2" Ice	8.01	8.01	0.07
			10.00						
DB230-2A	C	From Leg	1.00	0.0000	142.00	No Ice	3.00	3.00	0.11
			0.00			1/2" Ice	5.40	5.40	0.15
			0.00						
PD320	C	From Leg	1.00	0.0000	110.00	No Ice	2.03	2.03	0.01
			0.00			1/2" Ice	4.58	4.58	0.03
			0.00						
Pirod 4' Side Mount Standoff (1)	C	From Leg	2.00	0.0000	103.00	No Ice	2.72	2.72	0.05
			0.00			1/2" Ice	4.91	4.91	0.09
			0.00						
14' x 3" Dia Omni	C	From Leg	4.00	0.0000	103.00	No Ice	4.20	4.20	0.04
			0.00			1/2" Ice	5.63	5.63	0.07
			7.00						
15-ft Single Dipole	C	From Leg	1.00	0.0000	92.00	No Ice	3.00	3.00	0.04
			0.00			1/2" Ice	6.00	6.00	0.06
			0.00						
PD320	C	From Leg	1.00	0.0000	74.00	No Ice	2.03	2.03	0.01
			0.00			1/2" Ice	4.58	4.58	0.03
			0.00						
15-ft Single Dipole	C	From Leg	1.00	0.0000	50.00	No Ice	3.00	3.00	0.04
			0.00			1/2" Ice	6.00	6.00	0.06
			0.00						
15-ft Single Dipole	C	From Leg	1.00	0.0000	31.00	No Ice	3.00	3.00	0.04
			0.00			1/2" Ice	6.00	6.00	0.06
			0.00						
ASP-705	B	From Leg	1.00	0.0000	192.00	No Ice	5.88	5.88	0.03
			0.00			1/2" Ice	8.01	8.01	0.07
			10.00						
ASP-705	B	From Leg	4.00	0.0000	192.00	No Ice	5.88	5.88	0.03
			0.00			1/2" Ice	8.01	8.01	0.07
			10.00						
Paraflector	B	From Leg	4.00	0.0000	187.00	No Ice	8.90	8.90	0.04
			0.00			1/2" Ice	10.70	10.70	0.60
			0.00						
Pirod 4' Side Mount Standoff (1)	B	From Leg	2.00	0.0000	156.00	No Ice	2.72	2.72	0.05
			0.00			1/2" Ice	4.91	4.91	0.09
			0.00						
ASP-705	B	From Leg	4.00	0.0000	156.00	No Ice	5.88	5.88	0.03

<b>tnxTower</b>  <b>Centek Engineering Inc.</b> 63-2 North Branford Rd. Branford, CT 06405 Phone: (203) 488-0580 FAX: (203) 488-8587	<b>Job</b> 14001.057 - Coventry East	<b>Page</b> 11 of 39
	<b>Project</b> 190' Rohn Lattice Tower - 1712 Main St., Coventry, CT	<b>Date</b> 09:25:07 12/03/14
	<b>Client</b> Verizon Wireless	<b>Designed by</b> TJL

Description	Face or Leg	Offset Type	Offsets:		Azimuth Adjustment	Placement	C <sub>AA</sub> Front	C <sub>AA</sub> Side	Weight	
			Horz	Lateral						
			Vert							
			ft	ft	°	ft	ft <sup>2</sup>	ft <sup>2</sup>	K	
			ft							
			0.00			1/2" Ice	8.01	8.01	0.07	
			10.00							
Paraflector	B	From Leg	4.00		0.0000	144.00	No Ice	8.90	8.90	0.04
			0.00				1/2" Ice	10.70	10.70	0.60
			0.00							
Paraflector	B	From Leg	4.00		0.0000	140.00	No Ice	8.90	8.90	0.04
			0.00				1/2" Ice	10.70	10.70	0.60
			0.00							
Pirod 4' Side Mount Standoff (1)	B	From Leg	2.00		0.0000	142.00	No Ice	2.72	2.72	0.05
			0.00				1/2" Ice	4.91	4.91	0.09
			0.00							
Pirod 4' Side Mount Standoff (1)	B	From Leg	2.00		0.0000	109.00	No Ice	2.72	2.72	0.05
			0.00				1/2" Ice	4.91	4.91	0.09
			0.00							
14' x 3" Dia Omni	B	From Leg	4.00		0.0000	109.00	No Ice	4.20	4.20	0.04
			0.00				1/2" Ice	5.63	5.63	0.07
			7.00							
GPS	B	From Leg	1.00		0.0000	102.00	No Ice	1.00	1.00	0.01
			0.00				1/2" Ice	1.50	1.50	0.01
			0.00							
1' Standoff Pipe	B	From Leg	0.50		0.0000	102.00	No Ice	0.16	0.16	0.01
			0.00				1/2" Ice	0.23	0.23	0.01
			0.00							
DB212 Single Dipole	B	From Leg	1.00		0.0000	94.00	No Ice	1.60	1.60	0.03
			0.00				1/2" Ice	3.20	3.20	0.04
			0.00							
15-ft Single Dipole	B	From Leg	1.00		0.0000	70.00	No Ice	3.00	3.00	0.04
			0.00				1/2" Ice	6.00	6.00	0.06
			0.00							
DB212 Single Dipole	B	From Leg	1.00		0.0000	50.00	No Ice	1.60	1.60	0.03
			0.00				1/2" Ice	3.20	3.20	0.04
			0.00							
DB212 Single Dipole	B	From Leg	1.00		0.0000	32.00	No Ice	1.60	1.60	0.03
			0.00				1/2" Ice	3.20	3.20	0.04
			0.00							
Pirod 4' Side Mount Standoff (1)	B	From Leg	2.00		0.0000	17.00	No Ice	2.72	2.72	0.05
			0.00				1/2" Ice	4.91	4.91	0.09
			0.00							
PD400	B	From Leg	4.00		0.0000	17.00	No Ice	3.14	3.14	0.02
			0.00				1/2" Ice	4.48	4.48	0.04
			6.00							
3' Yagi	B	From Leg	4.00		0.0000	17.00	No Ice	2.08	2.08	0.03
			0.00				1/2" Ice	3.79	3.79	0.05
			0.00							
DB420	A	From Leg	1.00		0.0000	192.00	No Ice	3.33	3.33	0.03
			0.00				1/2" Ice	5.99	5.99	0.04
			10.00							
4' x 3" DIA Omni	A	From Leg	4.00		0.0000	190.00	No Ice	1.00	1.00	0.02
			0.00				1/2" Ice	1.25	1.25	0.02
			2.00							
Halo	A	From Leg	4.00		0.0000	192.00	No Ice	4.00	4.00	0.01
			0.00				1/2" Ice	5.60	5.60	0.03
			0.00							
3' Yagi	A	From Leg	4.00		0.0000	190.00	No Ice	2.08	2.08	0.03
			0.00				1/2" Ice	3.79	3.79	0.05
			0.00							
Pirod 4' Side Mount Standoff	A	From Leg	2.00		0.0000	142.00	No Ice	2.72	2.72	0.05

<b>tnxTower</b>  <b>Centek Engineering Inc.</b> 63-2 North Branford Rd. Branford, CT 06405 Phone: (203) 488-0580 FAX: (203) 488-8587	<b>Job</b>		14001.057 - Coventry East		<b>Page</b>		12 of 39	
	<b>Project</b>		190' Rohn Lattice Tower - 1712 Main St., Coventry, CT		<b>Date</b>		09:25:07 12/03/14	
	<b>Client</b>		Verizon Wireless		<b>Designed by</b>		TJL	

Description	Face or Leg	Offset Type	Offsets:		Azimuth Adjustment	Placement	C <sub>AA</sub> Front	C <sub>AA</sub> Side	Weight	
			Horz	Vert						
			ft	ft	°	ft	ft <sup>2</sup>	ft <sup>2</sup>	K	
(1)			0.00			1/2" Ice	4.91	4.91	0.09	
DB264-A	A	From Leg	0.00							
			4.00		0.0000	142.00	No Ice	3.16	3.16	0.04
			0.00				1/2" Ice	5.69	5.69	0.05
DB436-C	A	From Leg	0.00							
			4.00		0.0000	142.00	No Ice	0.45	0.45	0.01
			0.00				1/2" Ice	0.81	0.81	0.01
Single Dipole	A	From Leg	0.00							
			1.00		0.0000	136.00	No Ice	1.60	1.60	0.03
			0.00				1/2" Ice	3.20	3.20	0.04
Pirod 4' Side Mount Standoff (1)	A	From Leg	0.00							
			2.00		0.0000	113.00	No Ice	2.72	2.72	0.05
			0.00				1/2" Ice	4.91	4.91	0.09
Dipole	A	From Leg	0.00							
			4.00		0.0000	113.00	No Ice	3.16	3.16	0.04
			0.00				1/2" Ice	5.69	5.69	0.05
Rohn 6'x14' Boom Gate (3) (Sprint Existing)	C	None	0.00							
			0.00		0.0000	180.00	No Ice	52.00	52.00	1.75
			0.00				1/2" Ice	61.90	61.90	2.19
(2) DB980H90E-M (Sprint Existing)	A	From Leg	4.00							
			0.00		0.0000	180.00	No Ice	3.80	2.19	0.01
			0.00				1/2" Ice	4.18	2.56	0.03
(2) DB980H90E-M (Sprint Existing)	B	From Leg	4.00							
			0.00		0.0000	180.00	No Ice	3.80	2.19	0.01
			0.00				1/2" Ice	4.18	2.56	0.03
(2) DB980H90E-M (Sprint Existing)	C	From Leg	4.00							
			0.00		0.0000	180.00	No Ice	3.80	2.19	0.01
			0.00				1/2" Ice	4.18	2.56	0.03
Pirod 12' T-Frame Sector Mount (1) (Verizon Existing)	A	None	0.00							
			0.00		0.0000	150.00	No Ice	13.60	13.60	0.47
			0.00				1/2" Ice	18.40	18.40	0.60
Pirod 12' T-Frame Sector Mount (1) (Verizon Existing)	B	None	0.00							
			0.00		0.0000	150.00	No Ice	13.60	13.60	0.47
			0.00				1/2" Ice	18.40	18.40	0.60
Pirod 12' T-Frame Sector Mount (1) (Verizon Existing)	C	None	0.00							
			0.00		0.0000	150.00	No Ice	13.60	13.60	0.47
			0.00				1/2" Ice	18.40	18.40	0.60
LNX-6514DS-T4M (Verizon Proposed)	A	From Leg	4.00							
			0.00		0.0000	150.00	No Ice	8.41	5.41	0.04
			-6.00				1/2" Ice	8.96	5.86	0.09
HBXX-6517DS (Verizon Proposed)	A	From Leg	0.00							
			4.00		0.0000	150.00	No Ice	8.74	5.24	0.05
			-4.00				1/2" Ice	9.31	5.71	0.10
LNX-6514DS-T4M (Verizon Proposed)	A	From Leg	0.00							
			4.00		0.0000	150.00	No Ice	8.41	5.41	0.04
			0.00				1/2" Ice	8.96	5.86	0.09
HBXX-6517DS (Verizon Proposed)	A	From Leg	0.00							
			4.00		0.0000	150.00	No Ice	8.74	5.24	0.05
			4.00				1/2" Ice	9.31	5.71	0.10
LNX-6514DS-T4M (Verizon Proposed)	B	From Leg	0.00							
			4.00		0.0000	150.00	No Ice	8.41	5.41	0.04
			-6.00				1/2" Ice	8.96	5.86	0.09
HBXX-6517DS (Verizon Proposed)	B	From Leg	0.00							
			4.00		0.0000	150.00	No Ice	8.74	5.24	0.05
			-4.00				1/2" Ice	9.31	5.71	0.10
LNX-6514DS-T4M (Verizon Proposed)	B	From Leg	0.00							
			4.00		0.0000	150.00	No Ice	8.41	5.41	0.04
			0.00				1/2" Ice	8.96	5.86	0.09



<b>tnxTower</b>  <b>Centek Engineering Inc.</b> 63-2 North Branford Rd. Branford, CT 06405 Phone: (203) 488-0580 FAX: (203) 488-8587	<b>Job</b>	14001.057 - Coventry East	<b>Page</b>	13 of 39
	<b>Project</b>	190' Rohn Lattice Tower - 1712 Main St., Coventry, CT	<b>Date</b>	09:25:07 12/03/14
	<b>Client</b>	Verizon Wireless	<b>Designed by</b>	TJL

Description	Face or Leg	Offset Type	Offsets:		Azimuth Adjustment	Placement	C <sub>AA</sub> Front	C <sub>AA</sub> Side	Weight	
			Horz	Vert						
			ft	ft	°	ft	ft <sup>2</sup>	ft <sup>2</sup>	K	
HBXX-6517DS (Verizon Proposed)	B	From Leg	4.00	0.00	0.0000	150.00	No Ice	8.74	5.24	0.05
			4.00	0.00			1/2" Ice	9.31	5.71	0.10
			0.00	0.00						
LNX-6514DS-T4M (Verizon Proposed)	C	From Leg	4.00	0.00	0.0000	150.00	No Ice	8.41	5.41	0.04
			-6.00	0.00			1/2" Ice	8.96	5.86	0.09
			0.00	0.00						
HBXX-6517DS (Verizon Proposed)	C	From Leg	4.00	0.00	0.0000	150.00	No Ice	8.74	5.24	0.05
			-4.00	0.00			1/2" Ice	9.31	5.71	0.10
			0.00	0.00						
LNX-6514DS-T4M (Verizon Proposed)	C	From Leg	4.00	0.00	0.0000	150.00	No Ice	8.41	5.41	0.04
			0.00	0.00			1/2" Ice	8.96	5.86	0.09
			0.00	0.00						
HBXX-6517DS (Verizon Proposed)	C	From Leg	4.00	0.00	0.0000	150.00	No Ice	8.74	5.24	0.05
			4.00	0.00			1/2" Ice	9.31	5.71	0.10
			0.00	0.00						
RRH2x60-AWS (Verizon Proposed)	A	From Leg	4.00	0.00	0.0000	150.00	No Ice	2.19	1.43	0.05
			4.00	0.00			1/2" Ice	2.40	1.61	0.07
			0.00	0.00						
RRH2x60-AWS (Verizon Proposed)	B	From Leg	4.00	0.00	0.0000	150.00	No Ice	2.19	1.43	0.05
			4.00	0.00			1/2" Ice	2.40	1.61	0.07
			0.00	0.00						
RRH2x60-AWS (Verizon Proposed)	C	From Leg	4.00	0.00	0.0000	150.00	No Ice	2.19	1.43	0.05
			4.00	0.00			1/2" Ice	2.40	1.61	0.07
			0.00	0.00						
RRH2x60-PCS (Verizon Proposed)	A	From Leg	4.00	0.00	0.0000	150.00	No Ice	2.58	2.03	0.06
			-4.00	0.00			1/2" Ice	2.80	2.24	0.08
			0.00	0.00						
RRH2x60-PCS (Verizon Proposed)	B	From Leg	4.00	0.00	0.0000	150.00	No Ice	2.58	2.03	0.06
			-4.00	0.00			1/2" Ice	2.80	2.24	0.08
			0.00	0.00						
RRH2x60-PCS (Verizon Proposed)	C	From Leg	4.00	0.00	0.0000	150.00	No Ice	2.58	2.03	0.06
			-4.00	0.00			1/2" Ice	2.80	2.24	0.08
			0.00	0.00						
DB-T1-6Z-8AB-0Z (Verizon Proposed)	A	From Leg	2.00	0.00	0.0000	150.00	No Ice	5.60	2.33	0.04
			0.00	0.00			1/2" Ice	5.92	2.56	0.08
			0.00	0.00						
DB-T1-6Z-8AB-0Z (Verizon Proposed)	B	From Leg	2.00	0.00	0.0000	150.00	No Ice	5.60	2.33	0.04
			0.00	0.00			1/2" Ice	5.92	2.56	0.08
			0.00	0.00						

### Dishes

Description	Face or Leg	Dish Type	Offset Type	Offsets:		Azimuth Adjustment	3 dB Beam Width	Elevation	Outside Diameter	Aperture Area	Weight	
				Horz	Vert							
			ft	ft	°	°	ft	ft	ft <sup>2</sup>	K		
3-ft dish	C	Paraboloid w/o Radome	From Leg	4.00	0.00	0.0000		156.00	3.00	No Ice	3.14	0.08
				0.00	0.00					1/2" Ice	3.41	0.10
				0.00	0.00							

<b>tnxTower</b>  <b>Centek Engineering Inc.</b> 63-2 North Branford Rd. Branford, CT 06405 Phone: (203) 488-0580 FAX: (203) 488-8587	<b>Job</b> 14001.057 - Coventry East	<b>Page</b> 14 of 39
	<b>Project</b> 190' Rohn Lattice Tower - 1712 Main St., Coventry, CT	<b>Date</b> 09:25:07 12/03/14
	<b>Client</b> Verizon Wireless	<b>Designed by</b> TJL

**Tower Pressures - No Ice**

$G_H = 1.117$

Section Elevation	z	K <sub>Z</sub>	q <sub>z</sub>	A <sub>G</sub>	F a c e	A <sub>F</sub>	A <sub>R</sub>	A <sub>leg</sub>	Leg %	C <sub>A A A</sub> In Face	C <sub>A A A</sub> Out Face
ft	ft		psf	ft <sup>2</sup>		ft <sup>2</sup>	ft <sup>2</sup>	ft <sup>2</sup>		ft <sup>2</sup>	ft <sup>2</sup>
T1 190.00-180.00	185.00	1.636	30	48.479	A	4.261	5.975	3.958	38.67	0.000	0.000
					B	4.136	7.217		34.87	0.000	0.000
					C	4.148	7.100		35.19	0.000	0.000
T2 180.00-160.00	170.00	1.597	30	98.192	A	8.081	14.100	9.583	43.20	0.000	0.000
					B	7.889	16.100		39.95	0.000	0.000
					C	7.912	15.867		40.30	0.000	0.000
T3 160.00-140.00	150.00	1.541	29	99.933	A	6.163	35.643	11.667	27.91	0.000	0.000
					B	5.455	43.045		24.06	0.000	0.000
					C	7.514	21.532		40.17	0.000	0.000
T4 140.00-120.00	130.00	1.48	27	121.475	A	6.294	54.573	13.356	21.94	0.000	0.000
					B	4.733	70.740		17.70	0.000	0.000
					C	8.684	29.830		34.68	0.000	0.000
T5 120.00-100.00	110.00	1.411	26	163.410	A	12.065	56.243	15.027	22.00	0.000	0.000
					B	10.138	73.339		18.00	0.000	0.000
					C	14.626	33.524		31.21	0.000	0.000
T6 100.00-80.00	90.00	1.332	25	205.883	A	11.008	60.468	18.574	25.99	0.000	0.000
					B	9.540	79.884		20.77	0.000	0.000
					C	12.562	39.908		35.40	0.000	0.000
T7 80.00-60.00	70.00	1.24	23	246.784	A	19.095	61.244	18.577	23.12	0.000	0.000
					B	17.099	80.627		19.01	0.000	0.000
					C	21.159	41.205		29.79	0.000	0.000
T8 60.00-40.00	50.00	1.126	21	288.755	A	26.940	65.751	22.118	23.86	0.000	0.000
					B	24.717	84.168		20.31	0.000	0.000
					C	29.351	45.784		29.44	0.000	0.000
T9 40.00-20.00	30.00	1	18	329.457	A	22.070	66.822	22.125	24.89	0.000	0.000
					B	20.611	84.175		21.11	0.000	0.000
					C	23.753	46.807		31.36	0.000	0.000
T10 20.00-0.00	10.00	1	18	374.293	A	20.054	74.703	28.798	30.39	0.000	0.000
					B	18.977	90.848		26.22	0.000	0.000
					C	21.442	53.915		38.22	0.000	0.000

**Tower Pressure - With Ice**

$G_H = 1.117$

Section Elevation	z	K <sub>Z</sub>	q <sub>z</sub>	t <sub>z</sub>	A <sub>G</sub>	F a c e	A <sub>F</sub>	A <sub>R</sub>	A <sub>leg</sub>	Leg %	C <sub>A A A</sub> In Face	C <sub>A A A</sub> Out Face
ft	ft		psf	in	ft <sup>2</sup>		ft <sup>2</sup>	ft <sup>2</sup>	ft <sup>2</sup>		ft <sup>2</sup>	ft <sup>2</sup>
T1 190.00-180.00	185.00	1.636	23	0.5000	49.313	A	4.052	12.040	5.625	34.96	0.000	0.000
						B	3.802	14.389		30.92	0.000	0.000
						C	3.897	13.494		32.34	0.000	0.000
T2 180.00-160.00	170.00	1.597	22	0.5000	99.858	A	7.601	26.777	12.917	37.57	0.000	0.000
						B	7.249	30.243		34.45	0.000	0.000
						C	7.432	28.447		36.00	0.000	0.000
T3 160.00-140.00	150.00	1.541	21	0.5000	101.600	A	4.632	57.623	15.000	24.09	0.000	0.000
						B	3.540	68.401		20.85	0.000	0.000
						C	6.844	35.776		35.20	0.000	0.000

<b>tnxTower</b>  <b>Centek Engineering Inc.</b> 63-2 North Branford Rd. Branford, CT 06405 Phone: (203) 488-0580 FAX: (203) 488-8587	<b>Job</b> 14001.057 - Coventry East	<b>Page</b> 15 of 39
	<b>Project</b> 190' Rohn Lattice Tower - 1712 Main St., Coventry, CT	<b>Date</b> 09:25:07 12/03/14
	<b>Client</b> Verizon Wireless	<b>Designed by</b> TJL

Section Elevation ft	z ft	K <sub>Z</sub>	q <sub>z</sub> psf	t <sub>z</sub> in	A <sub>G</sub> ft <sup>2</sup>	F a c e	A <sub>F</sub> ft <sup>2</sup>	A <sub>R</sub> ft <sup>2</sup>	A <sub>leg</sub> ft <sup>2</sup>	Leg %	C <sub>A</sub> A <sub>A</sub> In Face ft <sup>2</sup>	C <sub>A</sub> A <sub>A</sub> Out Face ft <sup>2</sup>
T4 140.00-120.00	130.00	1.48	21	0.5000	123.144	A	3.880	85.130	16.696	18.76	0.000	0.000
						B	1.354	109.852		15.01	0.000	0.000
						C	7.428	50.414		28.86	0.000	0.000
T5 120.00-100.00	110.00	1.411	20	0.5000	165.079	A	9.247	89.206	18.366	18.65	0.000	0.000
						B	6.090	115.640		15.09	0.000	0.000
						C	12.879	58.803		25.62	0.000	0.000
T6 100.00-80.00	90.00	1.332	18	0.5000	207.552	A	9.029	93.585	21.913	21.35	0.000	0.000
						B	6.566	125.183		16.63	0.000	0.000
						C	11.176	66.050		28.38	0.000	0.000
T7 80.00-60.00	70.00	1.24	17	0.5000	248.453	A	16.263	98.589	21.916	19.08	0.000	0.000
						B	12.980	129.159		15.42	0.000	0.000
						C	19.151	71.705		24.12	0.000	0.000
T8 60.00-40.00	50.00	1.126	16	0.5000	290.423	A	23.419	106.062	25.456	19.66	0.000	0.000
						B	19.888	134.135		16.53	0.000	0.000
						C	26.836	78.901		24.07	0.000	0.000
T9 40.00-20.00	30.00	1	14	0.5000	331.127	A	19.464	107.650	25.465	20.03	0.000	0.000
						B	17.248	133.265		16.92	0.000	0.000
						C	21.854	80.015		25.00	0.000	0.000
T10 20.00-0.00	10.00	1	14	0.5000	375.962	A	17.846	116.225	32.137	23.97	0.000	0.000
						B	16.307	138.846		20.71	0.000	0.000
						C	19.885	86.269		30.27	0.000	0.000

### Tower Pressure - Service

$$G_H = 1.117$$

Section Elevation ft	z ft	K <sub>Z</sub>	q <sub>z</sub> psf	A <sub>G</sub> ft <sup>2</sup>	F a c e	A <sub>F</sub> ft <sup>2</sup>	A <sub>R</sub> ft <sup>2</sup>	A <sub>leg</sub> ft <sup>2</sup>	Leg %	C <sub>A</sub> A <sub>A</sub> In Face ft <sup>2</sup>	C <sub>A</sub> A <sub>A</sub> Out Face ft <sup>2</sup>
T1 190.00-180.00	185.00	1.636	10	48.479	A	4.261	5.975	3.958	38.67	0.000	0.000
					B	4.136	7.217		34.87	0.000	0.000
					C	4.148	7.100		35.19	0.000	0.000
T2 180.00-160.00	170.00	1.597	10	98.192	A	8.081	14.100	9.583	43.20	0.000	0.000
					B	7.889	16.100		39.95	0.000	0.000
					C	7.912	15.867		40.30	0.000	0.000
T3 160.00-140.00	150.00	1.541	10	99.933	A	6.163	35.643	11.667	27.91	0.000	0.000
					B	5.455	43.045		24.06	0.000	0.000
					C	7.514	21.532		40.17	0.000	0.000
T4 140.00-120.00	130.00	1.48	9	121.475	A	6.294	54.573	13.356	21.94	0.000	0.000
					B	4.733	70.740		17.70	0.000	0.000
					C	8.684	29.830		34.68	0.000	0.000
T5 120.00-100.00	110.00	1.411	9	163.410	A	12.065	56.243	15.027	22.00	0.000	0.000
					B	10.138	73.339		18.00	0.000	0.000
					C	14.626	33.524		31.21	0.000	0.000
T6 100.00-80.00	90.00	1.332	9	205.883	A	11.008	60.468	18.574	25.99	0.000	0.000
					B	9.540	79.884		20.77	0.000	0.000
					C	12.562	39.908		35.40	0.000	0.000
T7 80.00-60.00	70.00	1.24	8	246.784	A	19.095	61.244	18.577	23.12	0.000	0.000
					B	17.099	80.627		19.01	0.000	0.000
					C	21.159	41.205		29.79	0.000	0.000
T8 60.00-40.00	50.00	1.126	7	288.755	A	26.940	65.751	22.118	23.86	0.000	0.000
					B	24.717	84.168		20.31	0.000	0.000
					C	29.351	45.784		29.44	0.000	0.000
T9 40.00-20.00	30.00	1	6	329.457	A	22.070	66.822	22.125	24.89	0.000	0.000

<b>tnxTower</b>  <b>Centek Engineering Inc.</b> 63-2 North Branford Rd. Branford, CT 06405 Phone: (203) 488-0580 FAX: (203) 488-8587	<b>Job</b> 14001.057 - Coventry East	<b>Page</b> 16 of 39
	<b>Project</b> 190' Rohn Lattice Tower - 1712 Main St., Coventry, CT	<b>Date</b> 09:25:07 12/03/14
	<b>Client</b> Verizon Wireless	<b>Designed by</b> T.J.L.

Section Elevation	z	Kz	qz	AG	F a c e	AF	AR	Alog	Leg %	CAAA In Face	CAAA Out Face
ft	ft		psf	ft <sup>2</sup>		ft <sup>2</sup>	ft <sup>2</sup>	ft <sup>2</sup>		ft <sup>2</sup>	ft <sup>2</sup>
T10 20.00-0.00	10.00	1	6	374.293	B	20.611	84.175	28.798	21.11	0.000	0.000
					C	23.753	46.807		31.36	0.000	0.000
					A	20.054	74.703		30.39	0.000	0.000
					B	18.977	90.848		26.22	0.000	0.000
					C	21.442	53.915	38.22	0.000	0.000	

### Tower Forces - No Ice - Wind Normal To Face

Section Elevation	Add Weight	Self Weight	F a c e	e	CF	RR	DF	DR	AE	F	w	Ctrl. Face
ft	K	K							ft <sup>2</sup>	K	plf	
T1 190.00-180.00	0.05	0.31	A	0.211	2.559	0.593	1	1	7.802	0.71	71.04	B
			B	0.234	2.486	0.598	1	1	8.451			
			C	0.232	2.493	0.597	1	1	8.390			
T2 180.00-160.00	0.10	0.74	A	0.226	2.512	0.596	1	1	16.485	1.42	71.13	B
			B	0.244	2.455	0.6	1	1	17.557			
			C	0.242	2.461	0.6	1	1	17.430			
T3 160.00-140.00	0.41	1.01	A	0.418	2.029	0.659	1	1	29.661	2.15	107.50	B
			B	0.485	1.92	0.69	1	1	35.161			
			C	0.291	2.321	0.613	1	1	20.714			
T4 140.00-120.00	0.74	1.23	A	0.501	1.899	0.698	1	1	44.389	3.23	161.60	B
			B	0.621	1.792	0.767	1	1	58.981			
			C	0.317	2.252	0.621	1	1	27.216			
T5 120.00-100.00	0.76	1.74	A	0.418	2.029	0.659	1	1	49.136	3.39	169.63	B
			B	0.511	1.886	0.703	1	1	61.703			
			C	0.295	2.31	0.614	1	1	35.219			
T6 100.00-80.00	0.79	1.91	A	0.347	2.178	0.631	1	1	49.191	3.45	172.74	B
			B	0.434	2	0.666	1	1	62.760			
			C	0.255	2.423	0.603	1	1	36.632			
T7 80.00-60.00	0.81	2.68	A	0.326	2.23	0.624	1	1	57.314	3.69	184.46	B
			B	0.396	2.072	0.65	1	1	69.505			
			C	0.253	2.429	0.603	1	1	45.988			
T8 60.00-40.00	0.82	3.49	A	0.321	2.242	0.623	1	1	67.874	3.87	193.54	B
			B	0.377	2.111	0.643	1	1	78.796			
			C	0.26	2.407	0.605	1	1	57.029			
T9 40.00-20.00	0.83	3.40	A	0.27	2.379	0.607	1	1	62.640	3.39	169.48	B
			B	0.318	2.249	0.622	1	1	72.934			
			C	0.214	2.549	0.593	1	1	51.528			
T10 20.00-0.00	0.84	3.41	A	0.253	2.428	0.603	1	1	65.077	3.57	178.69	B
			B	0.293	2.314	0.614	1	1	74.749			
			C	0.201	2.592	0.591	1	1	53.288			
Sum Weight:	6.13	19.91						OTM	2389.28 kip-ft	28.89		

### Tower Forces - No Ice - Wind 45 To Face

Section Elevation	Add Weight	Self Weight	F a c e	e	CF	RR	DF	DR	AE	F	w	Ctrl. Face
ft	K	K							ft <sup>2</sup>	K	plf	
T1 190.00-180.00	0.05	0.31	A	0.211	2.559	0.593	0.825	1	7.057	0.65	64.96	B
			B	0.234	2.486	0.598	0.825	1	7.728			

<b>tnxTower</b>  <b>Centek Engineering Inc.</b> 63-2 North Branford Rd. Branford, CT 06405 Phone: (203) 488-0580 FAX: (203) 488-8587	<b>Job</b>	14001.057 - Coventry East	<b>Page</b>	17 of 39
	<b>Project</b>	190' Rohn Lattice Tower - 1712 Main St., Coventry, CT	<b>Date</b>	09:25:07 12/03/14
	<b>Client</b>	Verizon Wireless	<b>Designed by</b>	TJL

Section Elevation	Add Weight	Self Weight	F a c e	e	C <sub>F</sub>	R <sub>R</sub>	D <sub>F</sub>	D <sub>R</sub>	A <sub>E</sub>	F	w	Ctrl. Face
ft	K	K							ft <sup>2</sup>	K	plf	
T2	0.10	0.74	C	0.232	2.493	0.597	0.825	1	7.664			
180.00-160.00			A	0.226	2.512	0.596	0.825	1	15.071	1.31	65.53	B
			B	0.244	2.455	0.6	0.825	1	16.176			
			C	0.242	2.461	0.6	0.825	1	16.046			
T3	0.41	1.01	A	0.418	2.029	0.659	0.825	1	28.582	2.09	104.58	B
160.00-140.00			B	0.485	1.92	0.69	0.825	1	34.206			
			C	0.291	2.321	0.613	0.825	1	19.399			
			A	0.501	1.899	0.698	0.825	1	43.287	3.19	159.33	B
T4	0.74	1.23	B	0.621	1.792	0.767	0.825	1	58.153			
140.00-120.00			C	0.317	2.252	0.621	0.825	1	25.696			
			A	0.418	2.029	0.659	0.825	1	47.025	3.30	164.75	B
			B	0.511	1.886	0.703	0.825	1	59.928			
T5	0.76	1.74	C	0.295	2.31	0.614	0.825	1	32.659			
120.00-100.00			A	0.347	2.178	0.631	0.825	1	47.265	3.36	168.15	B
			B	0.434	2	0.666	0.825	1	61.090			
			C	0.255	2.423	0.603	0.825	1	34.433			
T6	0.79	1.91	A	0.326	2.23	0.624	0.825	1	53.973	3.53	176.52	B
100.00-80.00			B	0.396	2.072	0.65	0.825	1	66.513			
			C	0.253	2.429	0.603	0.825	1	42.285			
			A	0.321	2.242	0.623	0.825	1	63.159	3.66	182.92	B
T7	0.81	2.68	B	0.377	2.111	0.643	0.825	1	74.470			
80.00-60.00			C	0.26	2.407	0.605	0.825	1	51.892			
			A	0.27	2.379	0.607	0.825	1	58.777	3.22	161.10	B
			B	0.318	2.249	0.622	0.825	1	69.327			
T8	0.82	3.49	C	0.214	2.549	0.593	0.825	1	47.371			
60.00-40.00			A	0.253	2.428	0.603	0.825	1	61.568	3.42	170.75	B
			B	0.293	2.314	0.614	0.825	1	71.428			
			C	0.201	2.592	0.591	0.825	1	49.536			
Sum Weight:	6.13	19.91						OTM	2296.98	27.72		
									kip-ft			

### Tower Forces - No Ice - Wind 60 To Face

Section Elevation	Add Weight	Self Weight	F a c e	e	C <sub>F</sub>	R <sub>R</sub>	D <sub>F</sub>	D <sub>R</sub>	A <sub>E</sub>	F	w	Ctrl. Face
ft	K	K							ft <sup>2</sup>	K	plf	
T1	0.05	0.31	A	0.211	2.559	0.593	0.8	1	6.950	0.64	64.09	B
190.00-180.00			B	0.234	2.486	0.598	0.8	1	7.624			
			C	0.232	2.493	0.597	0.8	1	7.560			
			A	0.226	2.512	0.596	0.8	1	14.869	1.29	64.74	B
T2	0.10	0.74	B	0.244	2.455	0.6	0.8	1	15.979			
180.00-160.00			C	0.242	2.461	0.6	0.8	1	15.848			
			A	0.418	2.029	0.659	0.8	1	28.428	2.08	104.16	B
			B	0.485	1.92	0.69	0.8	1	34.070			
T3	0.41	1.01	C	0.291	2.321	0.613	0.8	1	19.211			
160.00-140.00			A	0.501	1.899	0.698	0.8	1	43.130	3.18	159.01	B
			B	0.621	1.792	0.767	0.8	1	58.035			
			C	0.317	2.252	0.621	0.8	1	25.479			
T4	0.74	1.23	A	0.418	2.029	0.659	0.8	1	46.723	3.28	164.06	B
140.00-120.00			B	0.511	1.886	0.703	0.8	1	59.675			
			C	0.295	2.31	0.614	0.8	1	32.294			
			A	0.347	2.178	0.631	0.8	1	46.990	3.35	167.49	B
T5	0.76	1.74	B	0.434	2	0.666	0.8	1	60.852			
120.00-100.00			C	0.255	2.423	0.603	0.8	1	34.119			
			A	0.326	2.23	0.624	0.8	1	53.495	3.51	175.39	B
			T6	0.79	1.91	A	0.326	2.23	0.624	0.8	1	53.495
100.00-80.00			B	0.434	2	0.666	0.8	1	60.852			
			C	0.255	2.423	0.603	0.8	1	34.119			
			A	0.326	2.23	0.624	0.8	1	53.495	3.51	175.39	B
T7	0.81	2.68	A	0.326	2.23	0.624	0.8	1	53.495	3.51	175.39	B

<b>tnxTower</b>  <b>Centek Engineering Inc.</b> 63-2 North Branford Rd. Branford, CT 06405 Phone: (203) 488-0580 FAX: (203) 488-8587	<b>Job</b>	14001.057 - Coventry East	<b>Page</b>	18 of 39
	<b>Project</b>	190' Rohn Lattice Tower - 1712 Main St., Coventry, CT	<b>Date</b>	09:25:07 12/03/14
	<b>Client</b>	Verizon Wireless	<b>Designed by</b>	TJL

Section Elevation	Add Weight	Self Weight	F a c e	e	C <sub>F</sub>	R <sub>R</sub>	D <sub>F</sub>	D <sub>R</sub>	A <sub>E</sub>	F	w	Ctrl. Face
ft	K	K							ft <sup>2</sup>	K	plf	
80.00-60.00			B	0.396	2.072	0.65	0.8	1	66.085			
			C	0.253	2.429	0.603	0.8	1	41.756			
T8	0.82	3.49	A	0.321	2.242	0.623	0.8	1	62.485	3.63	181.40	B
60.00-40.00			B	0.377	2.111	0.643	0.8	1	73.853			
			C	0.26	2.407	0.605	0.8	1	51.158			
T9	0.83	3.40	A	0.27	2.379	0.607	0.8	1	58.226	3.20	159.91	B
40.00-20.00			B	0.318	2.249	0.622	0.8	1	68.812			
			C	0.214	2.549	0.593	0.8	1	46.777			
T10	0.84	3.41	A	0.253	2.428	0.603	0.8	1	61.066	3.39	169.62	B
20.00-0.00			B	0.293	2.314	0.614	0.8	1	70.954			
			C	0.201	2.592	0.591	0.8	1	49.000			
Sum Weight:	6.13	19.91						OTM	2283.80 kip-ft	27.56		

### Tower Forces - No Ice - Wind 90 To Face

Section Elevation	Add Weight	Self Weight	F a c e	e	C <sub>F</sub>	R <sub>R</sub>	D <sub>F</sub>	D <sub>R</sub>	A <sub>E</sub>	F	w	Ctrl. Face
ft	K	K							ft <sup>2</sup>	K	plf	
T1	0.05	0.31	A	0.211	2.559	0.593	0.85	1	7.163	0.66	65.83	B
190.00-180.00			B	0.234	2.486	0.598	0.85	1	7.831			
			C	0.232	2.493	0.597	0.85	1	7.768			
T2	0.10	0.74	A	0.226	2.512	0.596	0.85	1	15.273	1.33	66.33	B
180.00-160.00			B	0.244	2.455	0.6	0.85	1	16.373			
			C	0.242	2.461	0.6	0.85	1	16.244			
T3	0.41	1.01	A	0.418	2.029	0.659	0.85	1	28.737	2.10	105.00	B
160.00-140.00			B	0.485	1.92	0.69	0.85	1	34.343			
			C	0.291	2.321	0.613	0.85	1	19.587			
T4	0.74	1.23	A	0.501	1.899	0.698	0.85	1	43.445	3.19	159.66	B
140.00-120.00			B	0.621	1.792	0.767	0.85	1	58.271			
			C	0.317	2.252	0.621	0.85	1	25.913			
T5	0.76	1.74	A	0.418	2.029	0.659	0.85	1	47.326	3.31	165.45	B
120.00-100.00			B	0.511	1.886	0.703	0.85	1	60.182			
			C	0.295	2.31	0.614	0.85	1	33.025			
T6	0.79	1.91	A	0.347	2.178	0.631	0.85	1	47.540	3.38	168.81	B
100.00-80.00			B	0.434	2	0.666	0.85	1	61.329			
			C	0.255	2.423	0.603	0.85	1	34.747			
T7	0.81	2.68	A	0.326	2.23	0.624	0.85	1	54.450	3.55	177.65	B
80.00-60.00			B	0.396	2.072	0.65	0.85	1	66.940			
			C	0.253	2.429	0.603	0.85	1	42.814			
T8	0.82	3.49	A	0.321	2.242	0.623	0.85	1	63.832	3.69	184.44	B
60.00-40.00			B	0.377	2.111	0.643	0.85	1	75.088			
			C	0.26	2.407	0.605	0.85	1	52.626			
T9	0.83	3.40	A	0.27	2.379	0.607	0.85	1	59.329	3.25	162.30	B
40.00-20.00			B	0.318	2.249	0.622	0.85	1	69.842			
			C	0.214	2.549	0.593	0.85	1	47.965			
T10	0.84	3.41	A	0.253	2.428	0.603	0.85	1	62.069	3.44	171.89	B
20.00-0.00			B	0.293	2.314	0.614	0.85	1	71.903			
			C	0.201	2.592	0.591	0.85	1	50.072			
Sum Weight:	6.13	19.91						OTM	2310.17 kip-ft	27.89		

<b>tnxTower</b>  <b>Centek Engineering Inc.</b> 63-2 North Branford Rd. Branford, CT 06405 Phone: (203) 488-0580 FAX: (203) 488-8587	<b>Job</b> 14001.057 - Coventry East	<b>Page</b> 19 of 39
	<b>Project</b> 190' Rohn Lattice Tower - 1712 Main St., Coventry, CT	<b>Date</b> 09:25:07 12/03/14
	<b>Client</b> Verizon Wireless	<b>Designed by</b> TJL

**Tower Forces - With Ice - Wind Normal To Face**

Section Elevation	Add Weight	Self Weight	F a c e	e	C <sub>F</sub>	R <sub>R</sub>	D <sub>F</sub>	D <sub>R</sub>	A <sub>E</sub>	F	w	Ctrl. Face
ft	K	K	e						ft <sup>2</sup>	K	plf	
190.00-180.00	0.14	0.53	A	0.326	2.228	0.624	1	1	11.569	0.70	70.21	B
			B	0.369	2.129	0.639	1	1	13.003			
			C	0.353	2.165	0.633	1	1	12.445			
180.00-160.00	0.28	1.18	A	0.344	2.185	0.63	1	1	24.483	1.40	69.79	B
			B	0.375	2.115	0.642	1	1	26.662			
			C	0.359	2.15	0.636	1	1	25.519			
160.00-140.00	1.05	1.48	A	0.613	1.797	0.761	1	1	48.511	2.55	127.37	B
			B	0.708	1.777	0.826	1	1	60.020			
			C	0.419	2.027	0.66	1	1	30.446			
140.00-120.00	1.85	1.78	A	0.723	1.779	0.836	1	1	75.087	4.85	242.44	B
			B	0.903	1.928	0.986	1	1	109.658			
			C	0.47	1.942	0.683	1	1	41.837			
120.00-100.00	1.90	2.54	A	0.596	1.806	0.751	1	1	76.278	4.06	202.84	B
			B	0.737	1.783	0.847	1	1	104.075			
			C	0.434	2	0.666	1	1	52.051			
100.00-80.00	2.01	2.63	A	0.494	1.907	0.695	1	1	74.039	3.82	191.12	B
			B	0.635	1.787	0.775	1	1	103.644			
			C	0.372	2.122	0.641	1	1	53.488			
80.00-60.00	2.06	3.72	A	0.462	1.954	0.679	1	1	83.203	3.79	189.52	B
			B	0.572	1.824	0.737	1	1	108.160			
			C	0.366	2.136	0.638	1	1	64.913			
60.00-40.00	2.10	4.84	A	0.446	1.98	0.671	1	1	94.626	3.76	187.97	B
			B	0.53	1.864	0.713	1	1	115.586			
			C	0.364	2.14	0.638	1	1	77.143			
40.00-20.00	2.14	4.54	A	0.384	2.097	0.645	1	1	88.915	3.27	163.41	B
			B	0.455	1.966	0.675	1	1	107.252			
			C	0.308	2.276	0.618	1	1	71.325			
20.00-0.00	2.17	4.51	A	0.357	2.156	0.635	1	1	91.632	3.40	169.91	B
			B	0.413	2.039	0.657	1	1	107.509			
			C	0.282	2.344	0.611	1	1	72.565			
Sum Weight:	15.69	27.74						OTM	2755.21 kip-ft	31.59		

**Tower Forces - With Ice - Wind 45 To Face**

Section Elevation	Add Weight	Self Weight	F a c e	e	C <sub>F</sub>	R <sub>R</sub>	D <sub>F</sub>	D <sub>R</sub>	A <sub>E</sub>	F	w	Ctrl. Face
ft	K	K	e						ft <sup>2</sup>	K	plf	
190.00-180.00	0.14	0.53	A	0.326	2.228	0.624	0.825	1	10.860	0.67	66.61	B
			B	0.369	2.129	0.639	0.825	1	12.337			
			C	0.353	2.165	0.633	0.825	1	11.763			
180.00-160.00	0.28	1.18	A	0.344	2.185	0.63	0.825	1	23.153	1.33	66.47	B
			B	0.375	2.115	0.642	0.825	1	25.393			
			C	0.359	2.15	0.636	0.825	1	24.219			
160.00-140.00	1.05	1.48	A	0.613	1.797	0.761	0.825	1	47.700	2.52	126.05	B
			B	0.708	1.777	0.826	0.825	1	59.401			
			C	0.419	2.027	0.66	0.825	1	29.249			
140.00-120.00	1.85	1.78	A	0.723	1.779	0.836	0.825	1	74.408	4.84	241.92	B
			B	0.903	1.928	0.986	0.825	1	109.421			
			C	0.47	1.942	0.683	0.825	1	40.537			
120.00-100.00	1.90	2.54	A	0.596	1.806	0.751	0.825	1	74.660	4.02	200.76	B
			B	0.737	1.783	0.847	0.825	1	103.009			

<b>tnxTower</b>  <b>Centek Engineering Inc.</b> 63-2 North Branford Rd. Branford, CT 06405 Phone: (203) 488-0580 FAX: (203) 488-8587	<b>Job</b> 14001.057 - Coventry East	<b>Page</b> 20 of 39
	<b>Project</b> 190' Rohn Lattice Tower - 1712 Main St., Coventry, CT	<b>Date</b> 09:25:07 12/03/14
	<b>Client</b> Verizon Wireless	<b>Designed by</b> TJL

Section Elevation	Add Weight	Self Weight	F a c e	e	C <sub>F</sub>	R <sub>R</sub>	D <sub>F</sub>	D <sub>R</sub>	A <sub>E</sub>	F	w	Ctrl. Face
ft	K	K							ft <sup>2</sup>	K	plf	
T6 100.00-80.00	2.01	2.63	C	0.434	2	0.666	0.825	1	49.797	3.78	189.00	B
			A	0.494	1.907	0.695	0.825	1	72.459			
			B	0.635	1.787	0.775	0.825	1	102.496			
T7 80.00-60.00	2.06	3.72	C	0.372	2.122	0.641	0.825	1	51.533	3.71	185.54	B
			A	0.462	1.954	0.679	0.825	1	80.357			
			B	0.572	1.824	0.737	0.825	1	105.888			
T8 60.00-40.00	2.10	4.84	C	0.366	2.136	0.638	0.825	1	61.562	3.65	182.31	B
			A	0.446	1.98	0.671	0.825	1	90.528			
			B	0.53	1.864	0.713	0.825	1	112.105			
T9 40.00-20.00	2.14	4.54	C	0.364	2.14	0.638	0.825	1	72.447	3.18	158.81	B
			A	0.384	2.097	0.645	0.825	1	85.509			
			B	0.455	1.966	0.675	0.825	1	104.233			
T10 20.00-0.00	2.17	4.51	C	0.308	2.276	0.618	0.825	1	67.500	3.31	165.40	B
			A	0.357	2.156	0.635	0.825	1	88.509			
			B	0.413	2.039	0.657	0.825	1	104.655			
Sum Weight:	15.69	27.74						OTM	2708.69 kip-ft	30.99		

### Tower Forces - With Ice - Wind 60 To Face

Section Elevation	Add Weight	Self Weight	F a c e	e	C <sub>F</sub>	R <sub>R</sub>	D <sub>F</sub>	D <sub>R</sub>	A <sub>E</sub>	F	w	Ctrl. Face
ft	K	K							ft <sup>2</sup>	K	plf	
T1 190.00-180.00	0.14	0.53	A	0.326	2.228	0.624	0.8	1	10.758	0.66	66.10	B
			B	0.369	2.129	0.639	0.8	1	12.242			
			C	0.353	2.165	0.633	0.8	1	11.665			
T2 180.00-160.00	0.28	1.18	A	0.344	2.185	0.63	0.8	1	22.963	1.32	66.00	B
			B	0.375	2.115	0.642	0.8	1	25.212			
			C	0.359	2.15	0.636	0.8	1	24.033			
T3 160.00-140.00	1.05	1.48	A	0.613	1.797	0.761	0.8	1	47.584	2.52	125.86	B
			B	0.708	1.777	0.826	0.8	1	59.312			
			C	0.419	2.027	0.66	0.8	1	29.078			
T4 140.00-120.00	1.85	1.78	A	0.723	1.779	0.836	0.8	1	74.311	4.84	241.85	B
			B	0.903	1.928	0.986	0.8	1	109.387			
			C	0.47	1.942	0.683	0.8	1	40.351			
T5 120.00-100.00	1.90	2.54	A	0.596	1.806	0.751	0.8	1	74.428	4.01	200.46	B
			B	0.737	1.783	0.847	0.8	1	102.857			
			C	0.434	2	0.666	0.8	1	49.475			
T6 100.00-80.00	2.01	2.63	A	0.494	1.907	0.695	0.8	1	72.233	3.77	188.70	B
			B	0.635	1.787	0.775	0.8	1	102.331			
			C	0.372	2.122	0.641	0.8	1	51.253			
T7 80.00-60.00	2.06	3.72	A	0.462	1.954	0.679	0.8	1	79.951	3.70	184.97	B
			B	0.572	1.824	0.737	0.8	1	105.564			
			C	0.366	2.136	0.638	0.8	1	61.083			
T8 60.00-40.00	2.10	4.84	A	0.446	1.98	0.671	0.8	1	89.943	3.63	181.50	B
			B	0.53	1.864	0.713	0.8	1	111.608			
			C	0.364	2.14	0.638	0.8	1	71.776			
T9 40.00-20.00	2.14	4.54	A	0.384	2.097	0.645	0.8	1	85.022	3.16	158.15	B
			B	0.455	1.966	0.675	0.8	1	103.802			
			C	0.308	2.276	0.618	0.8	1	66.954			
T10 20.00-0.00	2.17	4.51	A	0.357	2.156	0.635	0.8	1	88.063	3.30	164.75	B
			B	0.413	2.039	0.657	0.8	1	104.248			
			C	0.282	2.344	0.611	0.8	1	68.588			



<b>tnxTower</b>  <b>Centek Engineering Inc.</b> 63-2 North Branford Rd. Branford, CT 06405 Phone: (203) 488-0580 FAX: (203) 488-8587	<b>Job</b> 14001.057 - Coventry East	<b>Page</b> 21 of 39
	<b>Project</b> 190' Rohn Lattice Tower - 1712 Main St., Coventry, CT	<b>Date</b> 09:25:07 12/03/14
	<b>Client</b> Verizon Wireless	<b>Designed by</b> T.J.L.

Section Elevation	Add Weight	Self Weight	F a c e	e	C <sub>F</sub>	R <sub>R</sub>	D <sub>F</sub>	D <sub>R</sub>	A <sub>E</sub>	F	w	Ctrl. Face
ft	K	K							ft <sup>2</sup>	K	plf	
Sum Weight:	15.69	27.74						OTM	2702.04 kip-ft	30.91		

**Tower Forces - With Ice - Wind 90 To Face**

Section Elevation	Add Weight	Self Weight	F a c e	e	C <sub>F</sub>	R <sub>R</sub>	D <sub>F</sub>	D <sub>R</sub>	A <sub>E</sub>	F	w	Ctrl. Face
ft	K	K							ft <sup>2</sup>	K	plf	
T1	0.14	0.53	A	0.326	2.228	0.624	0.85	1	10.961	0.67	67.13	B
190.00-180.00			B	0.369	2.129	0.639	0.85	1	12.432			
			C	0.353	2.165	0.633	0.85	1	11.860			
T2	0.28	1.18	A	0.344	2.185	0.63	0.85	1	23.343	1.34	66.94	B
180.00-160.00			B	0.375	2.115	0.642	0.85	1	25.574			
			C	0.359	2.15	0.636	0.85	1	24.405			
T3	1.05	1.48	A	0.613	1.797	0.761	0.85	1	47.816	2.52	126.24	B
160.00-140.00			B	0.708	1.777	0.826	0.85	1	59.489			
			C	0.419	2.027	0.66	0.85	1	29.420			
T4	1.85	1.78	A	0.723	1.779	0.836	0.85	1	74.505	4.84	242.00	B
140.00-120.00			B	0.903	1.928	0.986	0.85	1	109.455			
			C	0.47	1.942	0.683	0.85	1	40.722			
T5	1.90	2.54	A	0.596	1.806	0.751	0.85	1	74.891	4.02	201.06	B
120.00-100.00			B	0.737	1.783	0.847	0.85	1	103.162			
			C	0.434	2	0.666	0.85	1	50.119			
T6	2.01	2.63	A	0.494	1.907	0.695	0.85	1	72.685	3.79	189.31	B
100.00-80.00			B	0.635	1.787	0.775	0.85	1	102.660			
			C	0.372	2.122	0.641	0.85	1	51.812			
T7	2.06	3.72	A	0.462	1.954	0.679	0.85	1	80.764	3.72	186.10	B
80.00-60.00			B	0.572	1.824	0.737	0.85	1	106.213			
			C	0.366	2.136	0.638	0.85	1	62.040			
T8	2.10	4.84	A	0.446	1.98	0.671	0.85	1	91.114	3.66	183.12	B
60.00-40.00			B	0.53	1.864	0.713	0.85	1	112.602			
			C	0.364	2.14	0.638	0.85	1	73.118			
T9	2.14	4.54	A	0.384	2.097	0.645	0.85	1	85.995	3.19	159.47	B
40.00-20.00			B	0.455	1.966	0.675	0.85	1	104.665			
			C	0.308	2.276	0.618	0.85	1	68.047			
T10	2.17	4.51	A	0.357	2.156	0.635	0.85	1	88.955	3.32	166.04	B
20.00-0.00			B	0.413	2.039	0.657	0.85	1	105.063			
			C	0.282	2.344	0.611	0.85	1	69.582			
Sum Weight:	15.69	27.74						OTM	2715.33 kip-ft	31.08		

**Tower Forces - Service - Wind Normal To Face**

Section Elevation	Add Weight	Self Weight	F a c e	e	C <sub>F</sub>	R <sub>R</sub>	D <sub>F</sub>	D <sub>R</sub>	A <sub>E</sub>	F	w	Ctrl. Face
ft	K	K							ft <sup>2</sup>	K	plf	
T1	0.05	0.31	A	0.211	2.559	0.593	1	1	7.802	0.25	24.58	B
190.00-180.00			B	0.234	2.486	0.598	1	1	8.451			
			C	0.232	2.493	0.597	1	1	8.390			

<b>tnxTower</b>  <b>Centek Engineering Inc.</b> 63-2 North Branford Rd. Branford, CT 06405 Phone: (203) 488-0580 FAX: (203) 488-8587	<b>Job</b> 14001.057 - Coventry East	<b>Page</b> 22 of 39
	<b>Project</b> 190' Rohn Lattice Tower - 1712 Main St., Coventry, CT	<b>Date</b> 09:25:07 12/03/14
	<b>Client</b> Verizon Wireless	<b>Designed by</b> TJJ

Section Elevation	Add Weight	Self Weight	F a c e	e	C <sub>F</sub>	R <sub>R</sub>	D <sub>F</sub>	D <sub>R</sub>	A <sub>E</sub>	F	w	Ctrl. Face
ft	K	K	e						ft <sup>2</sup>	K	plf	
T2 180.00-160.00	0.10	0.74	A	0.226	2.512	0.596	1	1	16.485	0.49	24.61	B
			B	0.244	2.455	0.6	1	1	17.557			
			C	0.242	2.461	0.6	1	1	17.430			
T3 160.00-140.00	0.41	1.01	A	0.418	2.029	0.659	1	1	29.661	0.74	37.20	B
			B	0.485	1.92	0.69	1	1	35.161			
			C	0.291	2.321	0.613	1	1	20.714			
T4 140.00-120.00	0.74	1.23	A	0.501	1.899	0.698	1	1	44.389	1.12	55.92	B
			B	0.621	1.792	0.767	1	1	58.981			
			C	0.317	2.252	0.621	1	1	27.216			
T5 120.00-100.00	0.76	1.74	A	0.418	2.029	0.659	1	1	49.136	1.17	58.70	B
			B	0.511	1.886	0.703	1	1	61.703			
			C	0.295	2.31	0.614	1	1	35.219			
T6 100.00-80.00	0.79	1.91	A	0.347	2.178	0.631	1	1	49.191	1.20	59.77	B
			B	0.434	2	0.666	1	1	62.760			
			C	0.255	2.423	0.603	1	1	36.632			
T7 80.00-60.00	0.81	2.68	A	0.326	2.23	0.624	1	1	57.314	1.28	63.83	B
			B	0.396	2.072	0.65	1	1	69.505			
			C	0.253	2.429	0.603	1	1	45.988			
T8 60.00-40.00	0.82	3.49	A	0.321	2.242	0.623	1	1	67.874	1.34	66.97	B
			B	0.377	2.111	0.643	1	1	78.796			
			C	0.26	2.407	0.605	1	1	57.029			
T9 40.00-20.00	0.83	3.40	A	0.27	2.379	0.607	1	1	62.640	1.17	58.65	B
			B	0.318	2.249	0.622	1	1	72.934			
			C	0.214	2.549	0.593	1	1	51.528			
T10 20.00-0.00	0.84	3.41	A	0.253	2.428	0.603	1	1	65.077	1.24	61.83	B
			B	0.293	2.314	0.614	1	1	74.749			
			C	0.201	2.592	0.591	1	1	53.288			
Sum Weight:	6.13	19.91						OTM	826.74 kip-ft	10.00		

### Tower Forces - Service - Wind 45 To Face

Section Elevation	Add Weight	Self Weight	F a c e	e	C <sub>F</sub>	R <sub>R</sub>	D <sub>F</sub>	D <sub>R</sub>	A <sub>E</sub>	F	w	Ctrl. Face
ft	K	K	e						ft <sup>2</sup>	K	plf	
T1 190.00-180.00	0.05	0.31	A	0.211	2.559	0.593	0.825	1	7.057	0.22	22.48	B
			B	0.234	2.486	0.598	0.825	1	7.728			
			C	0.232	2.493	0.597	0.825	1	7.664			
T2 180.00-160.00	0.10	0.74	A	0.226	2.512	0.596	0.825	1	15.071	0.45	22.68	B
			B	0.244	2.455	0.6	0.825	1	16.176			
			C	0.242	2.461	0.6	0.825	1	16.046			
T3 160.00-140.00	0.41	1.01	A	0.418	2.029	0.659	0.825	1	28.582	0.72	36.19	B
			B	0.485	1.92	0.69	0.825	1	34.206			
			C	0.291	2.321	0.613	0.825	1	19.399			
T4 140.00-120.00	0.74	1.23	A	0.501	1.899	0.698	0.825	1	43.287	1.10	55.13	B
			B	0.621	1.792	0.767	0.825	1	58.153			
			C	0.317	2.252	0.621	0.825	1	25.696			
T5 120.00-100.00	0.76	1.74	A	0.418	2.029	0.659	0.825	1	47.025	1.14	57.01	B
			B	0.511	1.886	0.703	0.825	1	59.928			
			C	0.295	2.31	0.614	0.825	1	32.659			
T6 100.00-80.00	0.79	1.91	A	0.347	2.178	0.631	0.825	1	47.265	1.16	58.18	B
			B	0.434	2	0.666	0.825	1	61.090			
			C	0.255	2.423	0.603	0.825	1	34.433			
T7 80.00-60.00	0.81	2.68	A	0.326	2.23	0.624	0.825	1	53.973	1.22	61.08	B
			B	0.396	2.072	0.65	0.825	1	66.513			

<b>tnxTower</b>  <b>Centek Engineering Inc.</b> 63-2 North Branford Rd. Branford, CT 06405 Phone: (203) 488-0580 FAX: (203) 488-8587	<b>Job</b>	14001.057 - Coventry East	<b>Page</b>	23 of 39
	<b>Project</b>	190' Rohn Lattice Tower - 1712 Main St., Coventry, CT	<b>Date</b>	09:25:07 12/03/14
	<b>Client</b>	Verizon Wireless	<b>Designed by</b>	TJL

Section Elevation	Add Weight	Self Weight	F a c e	e	C <sub>F</sub>	R <sub>R</sub>	D <sub>F</sub>	D <sub>R</sub>	A <sub>E</sub>	F	w	Ctrl. Face
ft	K	K							ft <sup>2</sup>	K	plf	
T8 60.00-40.00	0.82	3.49	C	0.253	2.429	0.603	0.825	1	42.285	1.27	63.29	B
			A	0.321	2.242	0.623	0.825	1	63.159			
			B	0.377	2.111	0.643	0.825	1	74.470			
T9 40.00-20.00	0.83	3.40	C	0.26	2.407	0.605	0.825	1	51.892	1.11	55.74	B
			A	0.27	2.379	0.607	0.825	1	58.777			
			B	0.318	2.249	0.622	0.825	1	69.327			
T10 20.00-0.00	0.84	3.41	C	0.214	2.549	0.593	0.825	1	47.371	1.18	59.08	B
			A	0.253	2.428	0.603	0.825	1	61.568			
			B	0.293	2.314	0.614	0.825	1	71.428			
Sum Weight:	6.13	19.91	C	0.201	2.592	0.591	0.825	1	49.536	9.59		
								OTM	794.80			
									kip-ft			

### Tower Forces - Service - Wind 60 To Face

Section Elevation	Add Weight	Self Weight	F a c e	e	C <sub>F</sub>	R <sub>R</sub>	D <sub>F</sub>	D <sub>R</sub>	A <sub>E</sub>	F	w	Ctrl. Face
ft	K	K							ft <sup>2</sup>	K	plf	
T1 190.00-180.00	0.05	0.31	A	0.211	2.559	0.593	0.8	1	6.950	0.22	22.18	B
			B	0.234	2.486	0.598	0.8	1	7.624			
			C	0.232	2.493	0.597	0.8	1	7.560			
T2 180.00-160.00	0.10	0.74	A	0.226	2.512	0.596	0.8	1	14.869	0.45	22.40	B
			B	0.244	2.455	0.6	0.8	1	15.979			
			C	0.242	2.461	0.6	0.8	1	15.848			
T3 160.00-140.00	0.41	1.01	A	0.418	2.029	0.659	0.8	1	28.428	0.72	36.04	B
			B	0.485	1.92	0.69	0.8	1	34.070			
			C	0.291	2.321	0.613	0.8	1	19.211			
T4 140.00-120.00	0.74	1.23	A	0.501	1.899	0.698	0.8	1	43.130	1.10	55.02	B
			B	0.621	1.792	0.767	0.8	1	58.035			
			C	0.317	2.252	0.621	0.8	1	25.479			
T5 120.00-100.00	0.76	1.74	A	0.418	2.029	0.659	0.8	1	46.723	1.14	56.77	B
			B	0.511	1.886	0.703	0.8	1	59.675			
			C	0.295	2.31	0.614	0.8	1	32.294			
T6 100.00-80.00	0.79	1.91	A	0.347	2.178	0.631	0.8	1	46.990	1.16	57.96	B
			B	0.434	2	0.666	0.8	1	60.852			
			C	0.255	2.423	0.603	0.8	1	34.119			
T7 80.00-60.00	0.81	2.68	A	0.326	2.23	0.624	0.8	1	53.495	1.21	60.69	B
			B	0.396	2.072	0.65	0.8	1	66.085			
			C	0.253	2.429	0.603	0.8	1	41.756			
T8 60.00-40.00	0.82	3.49	A	0.321	2.242	0.623	0.8	1	62.485	1.26	62.77	B
			B	0.377	2.111	0.643	0.8	1	73.853			
			C	0.26	2.407	0.605	0.8	1	51.158			
T9 40.00-20.00	0.83	3.40	A	0.27	2.379	0.607	0.8	1	58.226	1.11	55.33	B
			B	0.318	2.249	0.622	0.8	1	68.812			
			C	0.214	2.549	0.593	0.8	1	46.777			
T10 20.00-0.00	0.84	3.41	A	0.253	2.428	0.603	0.8	1	61.066	1.17	58.69	B
			B	0.293	2.314	0.614	0.8	1	70.954			
			C	0.201	2.592	0.591	0.8	1	49.000			
Sum Weight:	6.13	19.91						OTM	790.24	9.54		
									kip-ft			

<b>tnxTower</b>  <b>Centek Engineering Inc.</b> 63-2 North Branford Rd. Branford, CT 06405 Phone: (203) 488-0580 FAX: (203) 488-8587	<b>Job</b> 14001.057 - Coventry East	<b>Page</b> 24 of 39
	<b>Project</b> 190' Rohn Lattice Tower - 1712 Main St., Coventry, CT	<b>Date</b> 09:25:07 12/03/14
	<b>Client</b> Verizon Wireless	<b>Designed by</b> TJL

**Tower Forces - Service - Wind 90 To Face**

Section Elevation	Add Weight	Self Weight	F a c e	e	C <sub>F</sub>	R <sub>R</sub>	D <sub>F</sub>	D <sub>R</sub>	A <sub>E</sub>	F	w	Ctrl. Face
ft	K	K							ft <sup>2</sup>	K	plf	
190.00-180.00	0.05	0.31	A	0.211	2.559	0.593	0.85	1	7.163	0.23	22.78	B
			B	0.234	2.486	0.598	0.85	1	7.831			
			C	0.232	2.493	0.597	0.85	1	7.768			
180.00-160.00	0.10	0.74	A	0.226	2.512	0.596	0.85	1	15.273	0.46	22.95	B
			B	0.244	2.455	0.6	0.85	1	16.373			
			C	0.242	2.461	0.6	0.85	1	16.244			
160.00-140.00	0.41	1.01	A	0.418	2.029	0.659	0.85	1	28.737	0.73	36.33	B
			B	0.485	1.92	0.69	0.85	1	34.343			
			C	0.291	2.321	0.613	0.85	1	19.587			
140.00-120.00	0.74	1.23	A	0.501	1.899	0.698	0.85	1	43.445	1.10	55.25	B
			B	0.621	1.792	0.767	0.85	1	58.271			
			C	0.317	2.252	0.621	0.85	1	25.913			
120.00-100.00	0.76	1.74	A	0.418	2.029	0.659	0.85	1	47.326	1.14	57.25	B
			B	0.511	1.886	0.703	0.85	1	60.182			
			C	0.295	2.31	0.614	0.85	1	33.025			
100.00-80.00	0.79	1.91	A	0.347	2.178	0.631	0.85	1	47.540	1.17	58.41	B
			B	0.434	2	0.666	0.85	1	61.329			
			C	0.255	2.423	0.603	0.85	1	34.747			
80.00-60.00	0.81	2.68	A	0.326	2.23	0.624	0.85	1	54.450	1.23	61.47	B
			B	0.396	2.072	0.65	0.85	1	66.940			
			C	0.253	2.429	0.603	0.85	1	42.814			
60.00-40.00	0.82	3.49	A	0.321	2.242	0.623	0.85	1	63.832	1.28	63.82	B
			B	0.377	2.111	0.643	0.85	1	75.088			
			C	0.26	2.407	0.605	0.85	1	52.626			
40.00-20.00	0.83	3.40	A	0.27	2.379	0.607	0.85	1	59.329	1.12	56.16	B
			B	0.318	2.249	0.622	0.85	1	69.842			
			C	0.214	2.549	0.593	0.85	1	47.965			
20.00-0.00	0.84	3.41	A	0.253	2.428	0.603	0.85	1	62.069	1.19	59.48	B
			B	0.293	2.314	0.614	0.85	1	71.903			
			C	0.201	2.592	0.591	0.85	1	50.072			
Sum Weight:	6.13	19.91						OTM	799.37 kip-ft	9.65		

**Force Totals**

Load Case	Vertical Forces	Sum of Forces X	Sum of Forces Z	Sum of Overturning Moments, M <sub>x</sub>	Sum of Overturning Moments, M <sub>z</sub>	Sum of Torques
	K	K	K	kip-ft	kip-ft	kip-ft
Leg Weight	10.31					
Bracing Weight	9.60					
Total Member Self-Weight	19.91					
Total Weight	31.87					
Wind 0 deg - No Ice		0.09	-40.28	-4157.97	-16.05	10.23
Wind 30 deg - No Ice		19.66	-33.98	-3528.45	-2038.81	-2.09
Wind 45 deg - No Ice		27.65	-27.62	-2873.81	-2867.65	-8.18
Wind 60 deg - No Ice		33.71	-19.46	-2030.87	-3497.60	-13.69
Wind 90 deg - No Ice		39.26	-0.04	-18.73	-4065.14	-22.09
Wind 120 deg - No Ice		34.92	20.06	2047.80	-3598.95	-25.00
Wind 135 deg - No Ice		27.69	27.60	2843.59	-2873.58	-22.43
Wind 150 deg - No Ice		19.62	33.98	3502.57	-2031.57	-19.65
Wind 180 deg - No Ice		0.03	38.91	4020.45	-6.31	-9.89
Wind 210 deg - No Ice		-19.57	33.98	3502.46	2020.42	2.42

<b>tnxTower</b>  <b>Centek Engineering Inc.</b> 63-2 North Branford Rd. Branford, CT 06405 Phone: (203) 488-0580 FAX: (203) 488-8587	<b>Job</b> 14001.057 - Coventry East	<b>Page</b> 25 of 39
	<b>Project</b> 190' Rohn Lattice Tower - 1712 Main St., Coventry, CT	<b>Date</b> 09:25:07 12/03/14
	<b>Client</b> Verizon Wireless	<b>Designed by</b> TJL

Load Case	Vertical Forces K	Sum of Forces X K	Sum of Forces Z K	Sum of Overturning Moments, $M_x$ kip-ft	Sum of Overturning Moments, $M_z$ kip-ft	Sum of Torques kip-ft
Wind 225 deg - No Ice		-27.58	27.62	2846.85	2852.46	8.39
Wind 240 deg - No Ice		-34.81	20.10	2054.11	3577.79	14.77
Wind 270 deg - No Ice		-39.21	-0.04	-18.79	4053.41	21.75
Wind 300 deg - No Ice		-33.68	-19.48	-2032.98	3488.64	23.58
Wind 315 deg - No Ice		-27.64	-27.63	-2873.90	2860.40	22.42
Wind 330 deg - No Ice		-19.62	-33.98	-3527.97	2027.51	19.65
Member Ice	7.84					
Total Weight Ice	53.74			-25.69	-14.87	
Wind 0 deg - Ice		0.07	-42.84	-4481.65	-26.45	10.10
Wind 30 deg - Ice		21.18	-36.63	-3845.67	-2226.25	-3.13
Wind 45 deg - Ice		29.87	-29.84	-3139.93	-3132.97	-9.64
Wind 60 deg - Ice		36.49	-21.07	-2225.90	-3825.44	-15.49
Wind 90 deg - Ice		42.31	-0.03	-30.82	-4428.75	-23.93
Wind 120 deg - Ice		37.14	21.36	2192.26	-3879.63	-26.14
Wind 135 deg - Ice		29.90	29.82	3084.35	-3137.38	-23.77
Wind 150 deg - Ice		21.14	36.62	3793.75	-2219.85	-20.52
Wind 180 deg - Ice		0.02	42.12	4371.83	-17.93	-9.85
Wind 210 deg - Ice		-21.11	36.62	3793.95	2185.11	3.40
Wind 225 deg - Ice		-29.81	29.84	3087.43	3094.42	9.81
Wind 240 deg - Ice		-37.05	21.39	2197.91	3836.52	16.04
Wind 270 deg - Ice		-42.27	-0.03	-30.28	4393.03	23.66
Wind 300 deg - Ice		-36.47	-21.08	-2227.11	3791.97	25.34
Wind 315 deg - Ice		-29.85	-29.84	-3139.59	3100.47	23.76
Wind 330 deg - Ice		-21.15	-36.62	-3844.98	2190.37	20.52
Total Weight	31.87			-12.79	-2.19	
Wind 0 deg - Service		0.03	-13.94	-1431.98	-6.13	3.54
Wind 30 deg - Service		6.80	-11.76	-1214.15	-706.04	-0.72
Wind 45 deg - Service		9.57	-9.56	-987.63	-992.84	-2.83
Wind 60 deg - Service		11.66	-6.73	-695.96	-1210.82	-4.74
Wind 90 deg - Service		13.58	-0.01	0.28	-1407.20	-7.64
Wind 120 deg - Service		12.08	6.94	715.34	-1245.89	-8.65
Wind 135 deg - Service		9.58	9.55	990.70	-994.89	-7.76
Wind 150 deg - Service		6.79	11.76	1218.73	-703.54	-6.80
Wind 180 deg - Service		0.01	13.46	1397.92	-2.76	-3.42
Wind 210 deg - Service		-6.77	11.76	1218.69	698.53	0.84
Wind 225 deg - Service		-9.54	9.56	991.83	986.44	2.90
Wind 240 deg - Service		-12.05	6.96	717.53	1237.41	5.11
Wind 270 deg - Service		-13.57	-0.01	0.26	1401.99	7.53
Wind 300 deg - Service		-11.65	-6.74	-696.69	1206.57	8.16
Wind 315 deg - Service		-9.56	-9.56	-987.67	989.18	7.76
Wind 330 deg - Service		-6.79	-11.76	-1213.99	700.99	6.80

## Load Combinations

Comb. No.	Description
1	Dead Only
2	Dead+Wind 0 deg - No Ice
3	Dead+Wind 30 deg - No Ice
4	Dead+Wind 45 deg - No Ice
5	Dead+Wind 60 deg - No Ice
6	Dead+Wind 90 deg - No Ice
7	Dead+Wind 120 deg - No Ice
8	Dead+Wind 135 deg - No Ice
9	Dead+Wind 150 deg - No Ice
10	Dead+Wind 180 deg - No Ice

<b>tnxTower</b>  <b>Centek Engineering Inc.</b> 63-2 North Branford Rd. Branford, CT 06405 Phone: (203) 488-0580 FAX: (203) 488-8587	<b>Job</b> 14001.057 - Coventry East	<b>Page</b> 26 of 39
	<b>Project</b> 190' Rohn Lattice Tower - 1712 Main St., Coventry, CT	<b>Date</b> 09:25:07 12/03/14
	<b>Client</b> Verizon Wireless	<b>Designed by</b> TJL

Comb. No.	Description
11	Dead+Wind 210 deg - No Ice
12	Dead+Wind 225 deg - No Ice
13	Dead+Wind 240 deg - No Ice
14	Dead+Wind 270 deg - No Ice
15	Dead+Wind 300 deg - No Ice
16	Dead+Wind 315 deg - No Ice
17	Dead+Wind 330 deg - No Ice
18	Dead+Ice+Temp
19	Dead+Wind 0 deg+Ice+Temp
20	Dead+Wind 30 deg+Ice+Temp
21	Dead+Wind 45 deg+Ice+Temp
22	Dead+Wind 60 deg+Ice+Temp
23	Dead+Wind 90 deg+Ice+Temp
24	Dead+Wind 120 deg+Ice+Temp
25	Dead+Wind 135 deg+Ice+Temp
26	Dead+Wind 150 deg+Ice+Temp
27	Dead+Wind 180 deg+Ice+Temp
28	Dead+Wind 210 deg+Ice+Temp
29	Dead+Wind 225 deg+Ice+Temp
30	Dead+Wind 240 deg+Ice+Temp
31	Dead+Wind 270 deg+Ice+Temp
32	Dead+Wind 300 deg+Ice+Temp
33	Dead+Wind 315 deg+Ice+Temp
34	Dead+Wind 330 deg+Ice+Temp
35	Dead+Wind 0 deg - Service
36	Dead+Wind 30 deg - Service
37	Dead+Wind 45 deg - Service
38	Dead+Wind 60 deg - Service
39	Dead+Wind 90 deg - Service
40	Dead+Wind 120 deg - Service
41	Dead+Wind 135 deg - Service
42	Dead+Wind 150 deg - Service
43	Dead+Wind 180 deg - Service
44	Dead+Wind 210 deg - Service
45	Dead+Wind 225 deg - Service
46	Dead+Wind 240 deg - Service
47	Dead+Wind 270 deg - Service
48	Dead+Wind 300 deg - Service
49	Dead+Wind 315 deg - Service
50	Dead+Wind 330 deg - Service

### Maximum Member Forces

Section No.	Elevation ft	Component Type	Condition	Gov. Load Comb.	Force K	Major Axis Moment kip-ft	Minor Axis Moment kip-ft
T1	190 - 180	Leg	Max Tension	22	4.83	-0.16	-0.02
			Max. Compression	24	-6.43	0.01	0.00
			Max. Mx	23	-3.95	0.27	0.07
			Max. My	27	-2.91	0.06	0.34
			Max. Vy	32	0.60	-0.00	0.00
			Max. Vx	27	-0.68	-0.00	0.00
		Diagonal	Max Tension	27	1.75	0.00	0.00
			Max. Compression	19	-1.78	0.00	0.00
			Max. Mx	24	0.21	0.02	0.00
			Max. My	3	-0.44	-0.00	-0.01
			Max. Vy	24	0.01	0.02	0.00
			Max. Vx	2	-0.00	0.00	0.00
		Top Girt	Max Tension	24	0.31	0.00	0.00

<b>tnxTower</b>  <b>Centek Engineering Inc.</b> 63-2 North Branford Rd. Branford, CT 06405 Phone: (203) 488-0580 FAX: (203) 488-8587	<b>Job</b>	14001.057 - Coventry East	<b>Page</b>	27 of 39
	<b>Project</b>	190' Rohn Lattice Tower - 1712 Main St., Coventry, CT	<b>Date</b>	09:25:07 12/03/14
	<b>Client</b>	Verizon Wireless	<b>Designed by</b>	TJL

Section No.	Elevation ft	Component Type	Condition	Gov. Load Comb.	Force K	Major Axis Moment kip-ft	Minor Axis Moment kip-ft
T2	180 - 160	Leg	Max. Compression	22	-0.35	0.00	0.00
			Max. Mx	18	0.00	-0.01	0.00
			Max. My	26	0.04	0.00	-0.00
			Max. Vy	18	-0.01	0.00	0.00
			Max. Vx	26	-0.00	0.00	0.00
			Max Tension	22	27.69	-0.06	-0.00
			Max. Compression	24	-32.08	0.11	-0.00
		Diagonal	Max. Mx	7	-30.08	0.11	-0.01
			Max. My	3	-0.91	0.00	0.10
			Max. Vy	7	-0.03	0.11	-0.01
			Max. Vx	3	0.07	-0.00	-0.10
			Max Tension	34	2.91	0.00	0.00
			Max. Compression	26	-2.96	0.00	0.00
			Max. Mx	23	1.11	0.02	-0.00
T3	160 - 140	Leg	Max. My	10	-2.12	0.00	0.01
			Max. Vy	25	-0.01	0.02	0.00
			Max. Vx	10	0.00	0.00	0.00
			Max Tension	5	70.80	0.03	0.04
			Max. Compression	24	-80.46	0.79	0.10
			Max. Mx	10	46.92	0.93	0.02
			Max. My	14	-1.29	-0.01	1.04
		Diagonal	Max. Vy	2	-0.84	0.75	-0.02
			Max. Vx	6	0.89	-0.02	0.70
			Max Tension	17	6.28	0.00	0.00
			Max. Compression	34	-6.51	0.00	0.00
			Max. Mx	24	4.39	0.03	0.00
			Max. My	3	-5.10	-0.02	-0.01
			Max. Vy	24	-0.02	0.03	0.00
T4	140 - 120	Leg	Max. Vx	3	0.00	-0.02	-0.01
			Max Tension	22	106.15	-0.38	0.01
			Max. Compression	24	-119.12	0.11	0.01
			Max. Mx	24	-90.56	0.79	0.10
			Max. My	23	-5.55	-0.04	0.73
			Max. Vy	32	-0.32	-0.66	-0.10
			Max. Vx	10	0.25	0.37	-0.00
		Diagonal	Max Tension	34	4.16	0.00	0.00
			Max. Compression	19	-4.44	0.00	0.00
			Max. Mx	21	3.50	0.03	-0.00
			Max. My	27	-3.24	-0.01	0.01
			Max. Vy	24	-0.01	0.03	0.00
			Max. Vx	27	-0.00	0.00	0.00
			Max Tension	5	0.13	0.00	0.00
T5	120 - 100	Leg	Max. Compression	24	-0.21	0.00	0.00
			Max. Mx	18	-0.02	-0.01	0.00
			Max. My	32	-0.11	0.00	0.00
			Max. Vy	18	-0.01	0.00	0.00
			Max. Vx	32	-0.00	0.00	0.00
			Max Tension	22	133.68	0.13	-0.02
			Max. Compression	24	-149.36	0.13	-0.00
		Diagonal	Max. Mx	24	-133.29	1.29	-0.10
			Max. My	23	-6.68	-0.12	1.38
			Max. Vy	24	-0.79	1.29	-0.10
			Max. Vx	20	-0.84	-0.12	-1.32
			Max Tension	33	4.95	0.00	0.00
			Max. Compression	25	-5.12	0.00	0.00
			Max. Mx	24	2.05	0.03	0.00
Secondary Horizontal	Max. My	34	-4.89	-0.01	-0.01		
	Max. Vy	22	0.02	0.03	0.00		
	Max. Vx	33	0.00	0.00	0.00		
	Max Tension	24	2.59	0.00	0.00		

<b>tnxTower</b>  <b>Centek Engineering Inc.</b> 63-2 North Branford Rd. Branford, CT 06405 Phone: (203) 488-0580 FAX: (203) 488-8587	<b>Job</b>	14001.057 - Coventry East	<b>Page</b>	28 of 39
	<b>Project</b>	190' Rohn Lattice Tower - 1712 Main St., Coventry, CT	<b>Date</b>	09:25:07 12/03/14
	<b>Client</b>	Verizon Wireless	<b>Designed by</b>	TJL

Section No.	Elevation ft	Component Type	Condition	Gov. Load Comb.	Force K	Major Axis Moment kip-ft	Minor Axis Moment kip-ft
T6	100 - 80	Leg	Max. Compression	24	-2.59	0.00	0.00
			Max. Mx	30	-1.08	-0.05	0.00
			Max. My	32	1.31	0.00	0.00
			Max. Vy	30	0.02	0.00	0.00
			Max. Vx	32	-0.00	0.00	0.00
			Max Tension	22	160.07	-0.71	0.02
			Max. Compression	24	-178.77	0.23	0.05
			Max. Mx	24	-158.43	0.79	0.02
			Max. My	23	-9.65	-0.08	1.30
			Max. Vy	30	-0.15	0.78	-0.03
			Max. Vx	23	-0.18	-0.08	1.30
			Max Tension	34	5.64	0.00	0.00
			Max. Compression	34	-5.82	0.00	0.00
			Max. Mx	24	3.53	0.05	0.00
T7	80 - 60	Leg	Max. My	33	-5.43	-0.01	-0.01
			Max. Vy	24	-0.02	0.05	0.00
			Max. Vx	33	0.00	0.00	0.00
			Max Tension	22	184.16	0.27	0.01
			Max. Compression	19	-206.58	-0.71	0.01
			Max. Mx	19	-206.42	2.06	-0.02
			Max. My	23	-11.81	-0.06	2.21
			Max. Vy	24	-0.90	2.06	-0.01
			Max. Vx	23	-0.84	-0.06	2.21
			Max Tension	33	5.81	0.00	0.00
			Max. Compression	25	-6.18	0.00	0.00
			Max. Mx	24	3.12	0.07	0.01
			Max. My	33	-5.65	0.01	-0.01
			Max. Vy	22	0.03	0.07	0.01
T8	60 - 40	Leg	Max. Vx	33	0.00	0.00	0.00
			Max Tension	19	3.58	0.00	0.00
			Max. Compression	19	-3.58	0.00	0.00
			Max. Mx	18	0.20	-0.13	0.00
			Max. My	24	3.58	0.00	0.00
			Max. Vy	18	0.04	0.00	0.00
			Max. Vx	24	0.00	0.00	0.00
			Max Tension	22	207.98	0.70	0.01
			Max. Compression	19	-236.32	-1.45	0.00
			Max. Mx	19	-236.13	2.86	-0.00
			Max. My	23	-14.77	-0.82	2.52
			Max. Vy	19	1.27	2.86	-0.00
			Max. Vx	23	-0.95	-0.82	2.52
			Max Tension	33	7.12	0.00	0.00
T9	40 - 20	Leg	Max. Compression	25	-7.27	0.00	0.00
			Max. Mx	19	3.88	0.11	-0.01
			Max. My	33	-6.11	0.01	-0.01
			Max. Vy	22	0.04	0.11	0.01
			Max. Vx	33	0.00	0.00	0.00
			Max Tension	19	4.10	0.00	0.00
			Max. Compression	19	-4.10	0.00	0.00
			Max. Mx	18	0.25	-0.23	0.00
			Max. My	23	3.54	0.00	0.01
			Max. Vy	18	0.06	0.00	0.00
			Max. Vx	23	-0.00	0.00	0.00
			Max Tension	22	226.77	1.68	0.05
			Max. Compression	19	-260.79	-2.19	-0.04
			Max. Mx	19	-260.49	3.70	-0.02
Max. My	23	-16.98	0.44	3.42			
Max. Vy	24	1.15	3.68	-0.03			
Max. Vx	23	0.96	0.44	3.42			



<b>tnxTower</b>  <b>Centek Engineering Inc.</b> 63-2 North Branford Rd. Branford, CT 06405 Phone: (203) 488-0580 FAX: (203) 488-8587	<b>Job</b> 14001.057 - Coventry East	<b>Page</b> 29 of 39
	<b>Project</b> 190' Rohn Lattice Tower - 1712 Main St., Coventry, CT	<b>Date</b> 09:25:07 12/03/14
	<b>Client</b> Verizon Wireless	<b>Designed by</b> TJJ

Section No.	Elevation ft	Component Type	Condition	Gov. Load Comb.	Force K	Major Axis Moment kip-ft	Minor Axis Moment kip-ft	
T10	20 - 0	Diagonal	Max Tension	33	7.54	0.00	0.00	
			Max. Compression	25	-7.91	0.00	0.00	
			Max. Mx	22	4.74	0.13	0.01	
			Max. My	25	-7.87	0.03	0.03	
			Max. Vy	22	0.04	0.13	0.01	
			Max. Vx	25	-0.00	0.00	0.00	
			Secondary Horizontal	Max Tension	19	4.52	0.00	0.00
				Max. Compression	19	-4.52	0.00	0.00
				Max. Mx	18	0.42	-0.30	0.00
				Max. My	23	3.90	0.00	0.01
		Max. Vy		18	-0.07	0.00	0.00	
		Leg	Max. Vx	23	-0.00	0.00	0.00	
			Max Tension	22	246.34	1.12	0.02	
			Max. Compression	19	-287.57	-0.00	0.00	
			Max. Mx	24	-270.94	4.71	0.02	
			Max. My	23	-20.58	2.85	3.21	
			Max. Vy	30	-0.76	4.70	-0.00	
			Max. Vx	23	0.42	2.85	3.21	
			Diagonal	Max Tension	33	9.81	0.00	0.00
				Max. Compression	26	-9.03	0.00	0.00
Max. Mx	22			3.52	0.20	0.01		
Max. My	33	-8.92		0.10	-0.03			
Max. Vy	22	0.06		0.20	0.01			
Max. Vx	33	0.00	0.00	0.00				

### Maximum Reactions

Location	Condition	Gov. Load Comb.	Vertical K	Horizontal, X K	Horizontal, Z K
Leg C	Max. Vert	30	288.84	21.05	-12.72
	Max. H <sub>x</sub>	13	262.58	21.76	-13.09
	Max. H <sub>z</sub>	22	-253.32	-23.86	14.31
	Min. Vert	22	-253.32	-23.86	14.31
	Min. H <sub>x</sub>	22	-253.32	-23.86	14.31
	Min. H <sub>z</sub>	13	262.58	21.76	-13.09
Leg B	Max. Vert	24	290.97	-20.95	-13.04
	Max. H <sub>x</sub>	32	-251.55	23.67	14.54
	Max. H <sub>z</sub>	33	-242.81	22.71	14.55
	Min. Vert	32	-251.55	23.67	14.54
	Min. H <sub>x</sub>	7	263.51	-21.65	-13.38
	Min. H <sub>z</sub>	7	263.51	-21.65	-13.38
Leg A	Max. Vert	19	292.53	0.32	24.69
	Max. H <sub>x</sub>	31	19.77	2.83	-1.74
	Max. H <sub>z</sub>	2	264.56	0.31	25.46
	Min. Vert	27	-249.99	-0.30	-27.74
	Min. H <sub>x</sub>	23	19.80	-2.80	-1.74
	Min. H <sub>z</sub>	27	-249.99	-0.30	-27.74

### Tower Mast Reaction Summary

<b>tnxTower</b>  <b>Centek Engineering Inc.</b> 63-2 North Branford Rd. Branford, CT 06405 Phone: (203) 488-0580 FAX: (203) 488-8587	<b>Job</b> 14001.057 - Coventry East	<b>Page</b> 30 of 39
	<b>Project</b> 190' Rohn Lattice Tower - 1712 Main St., Coventry, CT	<b>Date</b> 09:25:07 12/03/14
	<b>Client</b> Verizon Wireless	<b>Designed by</b> TJL

Load Combination	Vertical	Shear <sub>x</sub>	Shear <sub>y</sub>	Overturning Moment, M <sub>x</sub>	Overturning Moment, M <sub>y</sub>	Torque
	K	K	K	kip-ft	kip-ft	kip-ft
Dead Only	31.87	0.00	0.00	-12.80	-2.19	0.00
Dead+Wind 0 deg - No Ice	31.87	0.09	-40.28	-4178.41	-16.18	10.24
Dead+Wind 30 deg - No Ice	31.87	19.66	-33.98	-3545.84	-2048.89	-2.12
Dead+Wind 45 deg - No Ice	31.87	27.65	-27.62	-2887.99	-2881.82	-8.22
Dead+Wind 60 deg - No Ice	31.87	33.71	-19.46	-2040.91	-3514.88	-13.76
Dead+Wind 90 deg - No Ice	31.87	39.26	-0.04	-18.87	-4085.21	-22.18
Dead+Wind 120 deg - No Ice	31.87	34.92	20.06	2057.81	-3616.69	-25.08
Dead+Wind 135 deg - No Ice	31.87	27.69	27.60	2857.58	-2887.82	-22.49
Dead+Wind 150 deg - No Ice	31.87	19.62	33.98	3519.84	-2041.65	-19.69
Dead+Wind 180 deg - No Ice	31.87	0.03	38.91	4040.34	-6.39	-9.90
Dead+Wind 210 deg - No Ice	31.87	-19.57	33.98	3519.78	2030.37	2.45
Dead+Wind 225 deg - No Ice	31.87	-27.58	27.62	2860.92	2866.53	8.44
Dead+Wind 240 deg - No Ice	31.87	-34.81	20.10	2064.20	3595.39	14.84
Dead+Wind 270 deg - No Ice	31.87	-39.21	-0.04	-18.93	4073.43	21.84
Dead+Wind 300 deg - No Ice	31.87	-33.68	-19.48	-2043.07	3505.86	23.66
Dead+Wind 315 deg - No Ice	31.87	-27.64	-27.63	-2888.12	2874.50	22.48
Dead+Wind 330 deg - No Ice	31.87	-19.62	-33.98	-3545.39	2037.48	19.69
Dead+Ice+Temp	53.74	-0.00	0.00	-25.71	-15.06	-0.00
Dead+Wind 0 deg+Ice+Temp	53.74	0.07	-42.84	-4518.65	-26.88	10.36
Dead+Wind 30 deg+Ice+Temp	53.74	21.18	-36.63	-3877.42	-2244.88	-2.92
Dead+Wind 45 deg+Ice+Temp	53.74	29.87	-29.84	-3165.85	-3159.10	-9.48
Dead+Wind 60 deg+Ice+Temp	53.74	36.49	-21.07	-2244.27	-3857.61	-15.42
Dead+Wind 90 deg+Ice+Temp	53.74	42.31	-0.03	-31.02	-4465.61	-24.02
Dead+Wind 120 deg+Ice+Temp	53.74	37.14	21.36	2210.48	-3911.94	-26.33
Dead+Wind 135 deg+Ice+Temp	53.74	29.90	29.82	3110.03	-3163.58	-24.00
Dead+Wind 150 deg+Ice+Temp	53.74	21.14	36.62	3825.34	-2238.43	-20.78
Dead+Wind 180 deg+Ice+Temp	53.74	0.02	42.12	4408.28	-18.26	-10.12
Dead+Wind 210 deg+Ice+Temp	53.74	-21.11	36.62	3825.58	2203.07	3.19
Dead+Wind 225 deg+Ice+Temp	53.74	-29.81	29.84	3113.17	3119.94	9.66
Dead+Wind 240 deg+Ice+Temp	53.74	-37.05	21.39	2216.21	3868.17	15.97
Dead+Wind 270 deg+Ice+Temp	53.74	-42.27	-0.03	-30.50	4429.32	23.75
Dead+Wind 300 deg+Ice+Temp	53.74	-36.47	-21.08	-2245.56	3823.27	25.53
Dead+Wind 315 deg+Ice+Temp	53.74	-29.85	-29.84	-3165.58	3126.01	23.99
Dead+Wind 330 deg+Ice+Temp	53.74	-21.15	-36.62	-3876.79	2208.35	20.78
Dead+Wind 0 deg - Service	31.87	0.03	-13.94	-1454.30	-7.03	3.54
Dead+Wind 30 deg - Service	31.87	6.80	-11.76	-1235.40	-710.43	-0.74
Dead+Wind 45 deg - Service	31.87	9.57	-9.56	-1007.76	-998.66	-2.85
Dead+Wind 60 deg - Service	31.87	11.66	-6.73	-714.63	-1217.72	-4.76
Dead+Wind 90 deg - Service	31.87	13.58	-0.01	-14.92	-1415.08	-7.67
Dead+Wind 120 deg - Service	31.87	12.08	6.94	703.70	-1252.96	-8.68
Dead+Wind 135 deg - Service	31.87	9.58	9.55	980.45	-1000.73	-7.79
Dead+Wind 150 deg - Service	31.87	6.79	11.76	1209.61	-707.92	-6.82
Dead+Wind 180 deg - Service	31.87	0.01	13.46	1389.71	-3.64	-3.43
Dead+Wind 210 deg - Service	31.87	-6.77	11.76	1209.58	701.15	0.85
Dead+Wind 225 deg - Service	31.87	-9.54	9.56	981.59	990.50	2.92
Dead+Wind 240 deg - Service	31.87	-12.05	6.96	705.90	1242.71	5.13
Dead+Wind 270 deg - Service	31.87	-13.57	-0.01	-14.94	1408.13	7.55
Dead+Wind 300 deg - Service	31.87	-11.65	-6.74	-715.37	1211.73	8.19
Dead+Wind 315 deg - Service	31.87	-9.56	-9.56	-1007.79	993.26	7.78
Dead+Wind 330 deg - Service	31.87	-6.79	-11.76	-1235.24	703.62	6.82

## Solution Summary

Load Comb.	Sum of Applied Forces			Sum of Reactions			% Error
	PX K	PY K	PZ K	PX K	PY K	PZ K	
1	0.00	-31.87	0.00	0.00	31.87	0.00	0.000%
2	0.09	-31.87	-40.28	-0.09	31.87	40.28	0.000%

<b>tnxTower</b>  <b>Centek Engineering Inc.</b> 63-2 North Branford Rd. Branford, CT 06405 Phone: (203) 488-0580 FAX: (203) 488-8587	<b>Job</b> 14001.057 - Coventry East	<b>Page</b> 31 of 39
	<b>Project</b> 190' Rohn Lattice Tower - 1712 Main St., Coventry, CT	<b>Date</b> 09:25:07 12/03/14
	<b>Client</b> Verizon Wireless	<b>Designed by</b> TJL

Load Comb.	Sum of Applied Forces			Sum of Reactions			% Error
	PX K	PY K	PZ K	PX K	PY K	PZ K	
3	19.66	-31.87	-33.98	-19.66	31.87	33.98	0.000%
4	27.65	-31.87	-27.62	-27.65	31.87	27.62	0.000%
5	33.71	-31.87	-19.46	-33.71	31.87	19.46	0.000%
6	39.26	-31.87	-0.04	-39.26	31.87	0.04	0.000%
7	34.92	-31.87	20.06	-34.92	31.87	-20.06	0.000%
8	27.69	-31.87	27.60	-27.69	31.87	-27.60	0.000%
9	19.62	-31.87	33.98	-19.62	31.87	-33.98	0.000%
10	0.03	-31.87	38.91	-0.03	31.87	-38.91	0.000%
11	-19.57	-31.87	33.98	19.57	31.87	-33.98	0.000%
12	-27.58	-31.87	27.62	27.58	31.87	-27.62	0.000%
13	-34.81	-31.87	20.10	34.81	31.87	-20.10	0.000%
14	-39.21	-31.87	-0.04	39.21	31.87	0.04	0.000%
15	-33.68	-31.87	-19.48	33.68	31.87	19.48	0.000%
16	-27.64	-31.87	-27.63	27.64	31.87	27.63	0.000%
17	-19.62	-31.87	-33.98	19.62	31.87	33.98	0.000%
18	0.00	-53.74	0.00	0.00	53.74	-0.00	0.000%
19	0.07	-53.74	-42.84	-0.07	53.74	42.84	0.000%
20	21.18	-53.74	-36.63	-21.18	53.74	36.63	0.000%
21	29.87	-53.74	-29.84	-29.87	53.74	29.84	0.000%
22	36.49	-53.74	-21.07	-36.49	53.74	21.07	0.000%
23	42.31	-53.74	-0.03	-42.31	53.74	0.03	0.000%
24	37.14	-53.74	21.36	-37.14	53.74	-21.36	0.000%
25	29.90	-53.74	29.82	-29.90	53.74	-29.82	0.000%
26	21.14	-53.74	36.62	-21.14	53.74	-36.62	0.000%
27	0.02	-53.74	42.12	-0.02	53.74	-42.12	0.000%
28	-21.11	-53.74	36.62	21.11	53.74	-36.62	0.000%
29	-29.81	-53.74	29.84	29.81	53.74	-29.84	0.000%
30	-37.05	-53.74	21.39	37.05	53.74	-21.39	0.000%
31	-42.27	-53.74	-0.03	42.27	53.74	0.03	0.000%
32	-36.47	-53.74	-21.08	36.47	53.74	21.08	0.000%
33	-29.85	-53.74	-29.84	29.85	53.74	29.84	0.000%
34	-21.15	-53.74	-36.62	21.15	53.74	36.62	0.000%
35	0.03	-31.87	-13.94	-0.03	31.87	13.94	0.000%
36	6.80	-31.87	-11.76	-6.80	31.87	11.76	0.000%
37	9.57	-31.87	-9.56	-9.57	31.87	9.56	0.000%
38	11.66	-31.87	-6.73	-11.66	31.87	6.73	0.000%
39	13.58	-31.87	-0.01	-13.58	31.87	0.01	0.000%
40	12.08	-31.87	6.94	-12.08	31.87	-6.94	0.000%
41	9.58	-31.87	9.55	-9.58	31.87	-9.55	0.000%
42	6.79	-31.87	11.76	-6.79	31.87	-11.76	0.000%
43	0.01	-31.87	13.46	-0.01	31.87	-13.46	0.000%
44	-6.77	-31.87	11.76	6.77	31.87	-11.76	0.000%
45	-9.54	-31.87	9.56	9.54	31.87	-9.56	0.000%
46	-12.05	-31.87	6.96	12.05	31.87	-6.96	0.000%
47	-13.57	-31.87	-0.01	13.57	31.87	0.01	0.000%
48	-11.65	-31.87	-6.74	11.65	31.87	6.74	0.000%
49	-9.56	-31.87	-9.56	9.56	31.87	9.56	0.000%
50	-6.79	-31.87	-11.76	6.79	31.87	11.76	0.000%

### Non-Linear Convergence Results

Load Combination	Converged?	Number of Cycles	Displacement Tolerance	Force Tolerance
1	Yes	4	0.00000001	0.00000001
2	Yes	4	0.00000001	0.00000001
3	Yes	4	0.00000001	0.00000106

<b>tnxTower</b>  <b>Centek Engineering Inc.</b> 63-2 North Branford Rd. Branford, CT 06405 Phone: (203) 488-0580 FAX: (203) 488-8587	<b>Job</b> 14001.057 - Coventry East	<b>Page</b> 32 of 39
	<b>Project</b> 190' Rohn Lattice Tower - 1712 Main St., Coventry, CT	<b>Date</b> 09:25:07 12/03/14
	<b>Client</b> Verizon Wireless	<b>Designed by</b> T.J.L.

4	Yes	4	0.00000001	0.00000081
5	Yes	4	0.00000001	0.00000001
6	Yes	4	0.00000001	0.00000118
7	Yes	4	0.00000001	0.00000001
8	Yes	4	0.00000001	0.00000066
9	Yes	4	0.00000001	0.00000098
10	Yes	4	0.00000001	0.00000001
11	Yes	4	0.00000001	0.00000106
12	Yes	4	0.00000001	0.00000073
13	Yes	4	0.00000001	0.00000001
14	Yes	4	0.00000001	0.00000118
15	Yes	4	0.00000001	0.00000001
16	Yes	4	0.00000001	0.00000074
17	Yes	4	0.00000001	0.00000099
18	Yes	4	0.00000001	0.00000001
19	Yes	4	0.00000001	0.00000238
20	Yes	4	0.00000001	0.00000302
21	Yes	4	0.00000001	0.00000291
22	Yes	4	0.00000001	0.00000250
23	Yes	4	0.00000001	0.00000255
24	Yes	4	0.00000001	0.00000211
25	Yes	4	0.00000001	0.00000219
26	Yes	4	0.00000001	0.00000237
27	Yes	4	0.00000001	0.00000265
28	Yes	4	0.00000001	0.00000305
29	Yes	4	0.00000001	0.00000268
30	Yes	4	0.00000001	0.00000220
31	Yes	4	0.00000001	0.00000265
32	Yes	4	0.00000001	0.00000259
33	Yes	4	0.00000001	0.00000252
34	Yes	4	0.00000001	0.00000242
35	Yes	4	0.00000001	0.00000001
36	Yes	4	0.00000001	0.00000001
37	Yes	4	0.00000001	0.00000001
38	Yes	4	0.00000001	0.00000001
39	Yes	4	0.00000001	0.00000001
40	Yes	4	0.00000001	0.00000001
41	Yes	4	0.00000001	0.00000001
42	Yes	4	0.00000001	0.00000001
43	Yes	4	0.00000001	0.00000001
44	Yes	4	0.00000001	0.00000001
45	Yes	4	0.00000001	0.00000001
46	Yes	4	0.00000001	0.00000001
47	Yes	4	0.00000001	0.00000001
48	Yes	4	0.00000001	0.00000001
49	Yes	4	0.00000001	0.00000001
50	Yes	4	0.00000001	0.00000001

### Maximum Tower Deflections - Service Wind

Section No.	Elevation ft	Horz. Deflection in	Gov. Load Comb.	Tilt °	Twist °
T1	190 - 180	10.688	35	0.5809	0.0932
T2	180 - 160	9.476	35	0.5723	0.0852
T3	160 - 140	7.145	35	0.5175	0.0682
T4	140 - 120	5.095	35	0.4294	0.0506
T5	120 - 100	3.494	35	0.3211	0.0317
T6	100 - 80	2.300	35	0.2358	0.0215
T7	80 - 60	1.407	35	0.1772	0.0154

<b>tnxTower</b>  <b>Centek Engineering Inc.</b> 63-2 North Branford Rd. Branford, CT 06405 Phone: (203) 488-0580 FAX: (203) 488-8587	<b>Job</b> 14001.057 - Coventry East	<b>Page</b> 33 of 39
	<b>Project</b> 190' Rohn Lattice Tower - 1712 Main St., Coventry, CT	<b>Date</b> 09:25:07 12/03/14
	<b>Client</b> Verizon Wireless	<b>Designed by</b> TJL

Section No.	Elevation ft	Horz. Deflection in	Gov. Load Comb.	Tilt °	Twist °
T8	60 - 40	0.760	35	0.1209	0.0106
T9	40 - 20	0.332	35	0.0711	0.0066
T10	20 - 0	0.091	35	0.0324	0.0031

### Critical Deflections and Radius of Curvature - Service Wind

Elevation ft	Appurtenance	Gov. Load Comb.	Deflection in	Tilt °	Twist °	Radius of Curvature ft
192.00	(2) Obstruction Lights	35	10.688	0.5809	0.0932	98142
190.00	3' Yagi	35	10.688	0.5809	0.0932	98142
188.00	Pirod 4' Side Mount Standoff (1)	35	10.445	0.5797	0.0916	98142
187.00	PD1142-2A	35	10.324	0.5791	0.0908	98142
180.00	Rohn 6'x14' Boom Gate (3)	35	9.476	0.5723	0.0852	49653
156.00	3-ft dish	35	6.706	0.5021	0.0649	15061
150.00	Pirod 12' T-Frame Sector Mount (1)	35	6.071	0.4770	0.0597	12357
144.00	Paraflector	35	5.472	0.4494	0.0540	10478
142.00	DB230-2A	35	5.281	0.4395	0.0522	10031
140.00	Paraflector	35	5.095	0.4294	0.0506	9775
136.00	Single Dipole	35	4.737	0.4082	0.0471	9886
113.00	Pirod 4' Side Mount Standoff (1)	35	3.035	0.2874	0.0272	12997
110.00	PD320	35	2.853	0.2743	0.0258	13687
109.00	Pirod 4' Side Mount Standoff (1)	35	2.794	0.2701	0.0253	13933
103.00	Pirod 4' Side Mount Standoff (1)	35	2.458	0.2465	0.0227	15612
102.00	GPS	35	2.404	0.2429	0.0223	15908
94.00	DB212 Single Dipole	35	2.004	0.2166	0.0194	17510
92.00	15-ft Single Dipole	35	1.911	0.2107	0.0187	17825
74.00	PD320	35	1.189	0.1604	0.0139	20425
70.00	15-ft Single Dipole	35	1.055	0.1490	0.0129	20735
50.00	15-ft Single Dipole	35	0.521	0.0946	0.0085	23780
32.00	DB212 Single Dipole	35	0.214	0.0544	0.0051	26638
31.00	15-ft Single Dipole	35	0.201	0.0525	0.0049	26653
17.00	Pirod 4' Side Mount Standoff (1)	35	0.071	0.0273	0.0026	31642

### Maximum Tower Deflections - Design Wind

Section No.	Elevation ft	Horz. Deflection in	Gov. Load Comb.	Tilt °	Twist °
T1	190 - 180	32.619	24	1.7664	0.2694
T2	180 - 160	28.937	24	1.7354	0.2461
T3	160 - 140	21.889	24	1.5655	0.1990
T4	140 - 120	15.688	24	1.3040	0.1625
T5	120 - 100	10.826	19	0.9833	0.1090
T6	100 - 80	7.152	19	0.7278	0.0729
T7	80 - 60	4.383	19	0.5498	0.0501
T8	60 - 40	2.368	19	0.3760	0.0338
T9	40 - 20	1.032	19	0.2213	0.0205
T10	20 - 0	0.282	19	0.1009	0.0094

<b>tnxTower</b>  <b>Centek Engineering Inc.</b> 63-2 North Branford Rd. Branford, CT 06405 Phone: (203) 488-0580 FAX: (203) 488-8587	<b>Job</b> 14001.057 - Coventry East	<b>Page</b> 34 of 39
	<b>Project</b> 190' Rohn Lattice Tower - 1712 Main St., Coventry, CT	<b>Date</b> 09:25:07 12/03/14
	<b>Client</b> Verizon Wireless	<b>Designed by</b> T.J.L.

### Critical Deflections and Radius of Curvature - Design Wind

Elevation	Appurtenance	Gov. Load Comb.	Deflection in	Tilt °	Twist °	Radius of Curvature ft
192.00	(2) Obstruction Lights	24	32.619	1.7664	0.2694	26565
190.00	3' Yagi	24	32.619	1.7664	0.2694	26565
188.00	Pirod 4' Side Mount Standoff (1)	24	31.880	1.7618	0.2648	26565
187.00	PD1142-2A	24	31.510	1.7593	0.2625	26565
180.00	Rohn 6'x14' Boom Gate (3)	24	28.937	1.7354	0.2461	13717
156.00	3-ft dish	24	20.562	1.5194	0.1923	5089
150.00	Pirod 12' T-Frame Sector Mount (1)	24	18.645	1.4449	0.1825	4197
144.00	Paraflector	24	16.831	1.3631	0.1715	3572
142.00	DB230-2A	24	16.252	1.3340	0.1672	3423
140.00	Paraflector	24	15.688	1.3040	0.1625	3336
136.00	Single Dipole	24	14.602	1.2414	0.1517	3370
113.00	Pirod 4' Side Mount Standoff (1)	19	9.421	0.8827	0.0949	4382
110.00	PD320	19	8.860	0.8432	0.0893	4592
109.00	Pirod 4' Side Mount Standoff (1)	19	8.678	0.8305	0.0875	4666
103.00	Pirod 4' Side Mount Standoff (1)	19	7.640	0.7598	0.0774	5167
102.00	GPS	19	7.475	0.7489	0.0758	5254
94.00	DB212 Single Dipole	19	6.236	0.6697	0.0648	5733
92.00	15-ft Single Dipole	19	5.947	0.6518	0.0625	5829
74.00	PD320	19	3.703	0.4980	0.0448	6609
70.00	15-ft Single Dipole	19	3.286	0.4629	0.0415	6699
50.00	15-ft Single Dipole	19	1.621	0.2945	0.0268	7629
32.00	DB212 Single Dipole	19	0.664	0.1695	0.0158	8521
31.00	15-ft Single Dipole	19	0.625	0.1634	0.0153	8525
17.00	Pirod 4' Side Mount Standoff (1)	19	0.218	0.0850	0.0079	10111

### Bolt Design Data

Section No.	Elevation ft	Component Type	Bolt Grade	Bolt Size in	Number Of Bolts	Maximum Load per Bolt K	Allowable Load K	Ratio Load Allowable	Allowable Ratio	Criteria
T1	190	Leg	A325N	0.6250	4	1.21	13.50	0.089 ✓	1.333	Bolt Tension
		Diagonal	A325N	0.6250	1	1.75	6.12	0.286 ✓	1.333	Member Bearing
		Top Girt	A325N	0.6250	1	0.35	6.44	0.054 ✓	1.333	Bolt Shear
T2	180	Leg	A325N	0.7500	4	6.92	19.44	0.356 ✓	1.333	Bolt Tension
		Diagonal	A325N	0.6250	1	2.91	6.12	0.475 ✓	1.333	Member Bearing
T3	160	Leg	A325N	0.8750	4	17.70	26.46	0.669 ✓	1.333	Bolt Tension
		Diagonal	A325N	0.6250	1	6.28	6.12	1.027 ✓	1.333	Member Bearing
T4	140	Leg	A325N	0.8750	4	26.54	26.46	1.003 ✓	1.333	Bolt Tension
		Diagonal	A325N	0.6250	1	4.44	6.44	0.688 ✓	1.333	Bolt Shear
		Top Girt	A325N	0.6250	1	0.21	6.44	0.033 ✓	1.333	Bolt Shear
T5	120	Leg	A325N	1.0000	4	33.37	34.56	0.966 ✓	1.333	Bolt Tension
		Diagonal	A325N	0.6250	1	4.95	6.12	0.809 ✓	1.333	Member Bearing
		Secondary Horizontal	A325N	0.6250	2	1.30	6.44	0.201 ✓	1.333	Bolt Shear
T6	100	Leg	A325N	1.0000	4	40.02	34.56	1.158 ✓	1.333	Bolt Tension

<b>tnxTower</b>  <b>Centek Engineering Inc.</b> 63-2 North Branford Rd. Branford, CT 06405 Phone: (203) 488-0580 FAX: (203) 488-8587	<b>Job</b> 14001.057 - Coventry East	<b>Page</b> 35 of 39
	<b>Project</b> 190' Rohn Lattice Tower - 1712 Main St., Coventry, CT	<b>Date</b> 09:25:07 12/03/14
	<b>Client</b> Verizon Wireless	<b>Designed by</b> T.J.L

Section No.	Elevation ft	Component Type	Bolt Grade	Bolt Size in	Number Of Bolts	Maximum Load per Bolt K	Allowable Load K	Ratio Load Allowable	Allowable Ratio	Criteria
T7	80	Diagonal	A325N	0.6250	1	5.64	6.12	0.921 ✓	1.333	Member Bearing
		Leg	A325N	1.0000	6	30.66	34.56	0.887 ✓	1.333	Bolt Tension
T8	60	Diagonal	A325N	0.6250	1	6.18	6.44	0.960 ✓	1.333	Bolt Shear
		Secondary Horizontal	A325N	0.6250	2	1.79	6.44	0.278 ✓	1.333	Bolt Shear
		Leg	A325N	1.0000	6	34.62	34.56	1.002 ✓	1.333	Bolt Tension
		Diagonal	A325N	0.6250	1	7.27	6.44	1.129 ✓	1.333	Bolt Shear
T9	40	Secondary Horizontal	A325N	0.6250	2	2.05	6.44	0.318 ✓	1.333	Bolt Shear
		Leg	A325N	1.0000	8	28.31	34.56	0.819 ✓	1.333	Bolt Tension
		Diagonal	A325N	0.6250	1	7.91	6.44	1.227 ✓	1.333	Bolt Shear
T10	20	Secondary Horizontal	A325N	0.6250	2	2.26	6.44	0.351 ✓	1.333	Bolt Shear
		Leg	A354-BC	1.0000	8	30.79	32.40	0.950 ✓	1.333	Bolt Tension
		Diagonal	A325N	0.7500	1	9.81	9.28	1.057 ✓	1.333	Bolt Shear

### Compression Checks

### Leg Design Data (Compression)

Section No.	Elevation ft	Size	L ft	L <sub>u</sub> ft	Kl/r	F <sub>a</sub> ksi	A in <sup>2</sup>	Actual P K	Allow. P <sub>a</sub> K	Ratio P P <sub>a</sub>
T1	190 - 180	ROHN 2 STD	10.00	5.00	76.2 K=1.00	19.756	1.0745	-6.43	21.23	0.303 ✓
T2	180 - 160	ROHN 2.5 STD	20.00	4.00	50.7 K=1.00	24.247	1.7040	-32.08	41.32	0.777 ✓
T3	160 - 140	ROHN 3 EH	20.00	4.00	42.2 K=1.00	25.514	3.0159	-80.46	76.95	1.046 ✓
T4	140 - 120	ROHN 3.5 EH	20.03	4.01	36.8 K=1.00	26.273	3.6784	-119.13	96.64	1.233 ✓
T5	120 - 100	ROHN 4 EH	20.04	2.60	21.1 K=1.00	28.182	4.4074	-149.35	124.21	1.202 ✓
T6	100 - 80	ROHN 5 EH	20.03	6.68	43.6 K=1.00	25.320	6.1120	-178.77	154.76	1.155 ✓
T7	80 - 60	ROHN 5 EH	20.04	3.44	22.5 K=1.00	28.033	6.1120	-206.58	171.34	1.206 ✓
T8	60 - 40	ROHN 6 EHS	20.03	3.42	18.4 K=1.00	28.462	6.7133	-236.32	191.07	1.237 ✓
T9	40 - 20	ROHN 6 EH	20.04	5.18	28.3 K=1.00	27.355	8.4049	-260.79	229.92	1.134 ✓
T10	20 - 0	ROHN 8 EHS	20.03	10.02	41.2 K=1.00	25.667	9.7193	-287.57	249.47	1.153 ✓

<b>tnxTower</b>  <b>Centek Engineering Inc.</b> 63-2 North Branford Rd. Branford, CT 06405 Phone: (203) 488-0580 FAX: (203) 488-8587	<b>Job</b> 14001.057 - Coventry East	<b>Page</b> 36 of 39
	<b>Project</b> 190' Rohn Lattice Tower - 1712 Main St., Coventry, CT	<b>Date</b> 09:25:07 12/03/14
	<b>Client</b> Verizon Wireless	<b>Designed by</b> TJL

### Diagonal Design Data (Compression)

Section No.	Elevation ft	Size	L ft	L <sub>u</sub> ft	Kl/r	F <sub>a</sub> ksi	A in <sup>2</sup>	Actual P K	Allow. P <sub>a</sub> K	Ratio P P <sub>a</sub>
T1	190 - 180	L1 3/4x1 3/4x3/16	6.83	3.13	112.1 K=1.02	11.386	0.6211	-1.78	7.07	0.252 ✓
T2	180 - 160	L1 3/4x1 3/4x3/16	6.16	2.79	103.1 K=1.06	12.579	0.6211	-2.96	7.81	0.379 ✓
T3	160 - 140	L1 3/4x1 3/4x3/16	6.18	2.77	102.5 K=1.06	12.656	0.6211	-6.51	7.86	0.828 ✓
T4	140 - 120	L1 3/4x1 3/4x3/16	7.68	3.63	126.8 K=1.00	9.287	0.6211	-4.27	5.77	0.740 ✓
T5	120 - 100	L2x2x3/16	9.92	4.76	145.0 K=1.00	7.107	0.7150	-4.96	5.08	0.975 ✓
T6	100 - 80	L2 1/2x2 1/2x3/16	12.44	6.01	145.6 K=1.00	7.045	0.9020	-5.82	6.35	0.916 ✓
T7	80 - 60	L2 1/2x2 1/2x1/4	14.23	6.92	169.0 K=1.00	5.228	1.1900	-6.18	6.22	0.994 ✓
T8	60 - 40	L3x3x1/4	15.40	7.44	150.8 K=1.00	6.564	1.4400	-7.27	9.45	0.769 ✓
T9	40 - 20	L3x3x1/4	18.35	9.04	183.2 K=1.00	4.451	1.4400	-7.91	6.41	1.234 ✓
T10	20 - 0	L3 1/2x3 1/2x1/4	20.15	9.81	169.6 K=1.00	5.189	1.6900	-9.03	8.77	1.030 ✓

### Secondary Horizontal Design Data (Compression)

Section No.	Elevation ft	Size	L ft	L <sub>u</sub> ft	Kl/r	F <sub>a</sub> ksi	A in <sup>2</sup>	Actual P K	Allow. P <sub>a</sub> K	Ratio P P <sub>a</sub>
T5	120 - 100	L2x2x1/4	8.56	7.76	196.9 K=0.83	3.853	0.9380	-2.59	3.61	0.717 ✓
T7	80 - 60	L2 1/2x2 1/2x1/4	12.56	11.67	228.6 K=0.80	2.857	1.1900	-3.58	3.40	1.054 ✓
T8	60 - 40	L3x3x5/16	14.52	13.54	222.4 K=0.81	3.020	1.7800	-4.10	5.38	0.762 ✓
T9	40 - 20	L3x3x5/16	16.44	15.46	248.4 K=0.79	2.420	1.7800	-4.52	4.31	1.050 ✓

### Top Girt Design Data (Compression)

Section No.	Elevation ft	Size	L ft	L <sub>u</sub> ft	Kl/r	F <sub>a</sub> ksi	A in <sup>2</sup>	Actual P K	Allow. P <sub>a</sub> K	Ratio P P <sub>a</sub>
T1	190 - 180	L1 3/4x1 3/4x3/16	4.65	4.18	146.1 K=1.00	6.997	0.6211	-0.35	4.35	0.080 ✓



<b>tnxTower</b>  <b>Centek Engineering Inc.</b> 63-2 North Branford Rd. Branford, CT 06405 Phone: (203) 488-0580 FAX: (203) 488-8587	<b>Job</b> 14001.057 - Coventry East	<b>Page</b> 37 of 39
	<b>Project</b> 190' Rohn Lattice Tower - 1712 Main St., Coventry, CT	<b>Date</b> 09:25:07 12/03/14
	<b>Client</b> Verizon Wireless	<b>Designed by</b> TJL

Section No.	Elevation ft	Size	L ft	L <sub>u</sub> ft	Kl/r	F <sub>a</sub> ksi	A in <sup>2</sup>	Actual P K	Allow. P <sub>a</sub> K	Ratio P P <sub>a</sub>
T4	140 - 120	L1 3/4x1 3/4x3/16	4.72	4.16	145.3 K=1.00	7.077	0.6211	-0.21	4.40	0.048 ✓

### Tension Checks

### Leg Design Data (Tension)

Section No.	Elevation ft	Size	L ft	L <sub>u</sub> ft	Kl/r	F <sub>a</sub> ksi	A in <sup>2</sup>	Actual P K	Allow. P <sub>a</sub> K	Ratio P P <sub>a</sub>
T1	190 - 180	ROHN 2 STD	10.00	5.00	76.2	30.000	1.0745	4.83	32.24	0.150 ✓
T2	180 - 160	ROHN 2.5 STD	20.00	4.00	50.7	30.000	1.7040	27.69	51.12	0.542 ✓
T3	160 - 140	ROHN 3 EH	20.00	4.00	42.2	30.000	3.0159	70.82	90.48	0.783 ✓
T4	140 - 120	ROHN 3.5 EH	20.03	4.01	36.8	30.000	3.6784	106.15	110.35	0.962 ✓
T5	120 - 100	ROHN 4 EH	20.04	2.60	21.1	30.000	4.4074	133.68	132.22	1.011 ✓
T6	100 - 80	ROHN 5 EH	20.03	6.68	43.6	30.000	6.1120	160.07	183.36	0.873 ✓
T7	80 - 60	ROHN 5 EH	20.04	3.44	22.5	30.000	6.1120	184.16	183.36	1.004 ✓
T8	60 - 40	ROHN 6 EHS	20.03	3.42	18.4	30.000	6.7133	207.98	201.40	1.033 ✓
T9	40 - 20	ROHN 6 EH	20.04	5.18	28.3	30.000	8.4049	226.77	252.15	0.899 ✓
T10	20 - 0	ROHN 8 EHS	20.03	10.02	41.2	30.000	9.7193	246.34	291.58	0.845 ✓

### Diagonal Design Data (Tension)

Section No.	Elevation ft	Size	L ft	L <sub>u</sub> ft	Kl/r	F <sub>a</sub> ksi	A in <sup>2</sup>	Actual P K	Allow. P <sub>a</sub> K	Ratio P P <sub>a</sub>
T1	190 - 180	L1 3/4x1 3/4x3/16	6.83	3.13	73.1	21.600	0.6211	1.75	13.42	0.130 ✓
T2	180 - 160	L1 3/4x1 3/4x3/16	6.16	2.79	65.4	21.600	0.6211	2.91	13.42	0.217 ✓
T3	160 - 140	L1 3/4x1 3/4x3/16	6.18	2.77	64.9	21.600	0.6211	6.28	13.42	0.468 ✓
T4	140 - 120	L1 3/4x1 3/4x3/16	7.68	3.63	84.1	21.600	0.6211	4.16	13.42	0.310 ✓
T5	120 - 100	L2x2x3/16	9.48	4.54	90.9	21.600	0.7150	4.95	15.44	0.320 ✓

<b>tnxTower</b>  <b>Centek Engineering Inc.</b> 63-2 North Branford Rd. Branford, CT 06405 Phone: (203) 488-0580 FAX: (203) 488-8587	<b>Job</b> 14001.057 - Coventry East	<b>Page</b> 38 of 39
	<b>Project</b> 190' Rohn Lattice Tower - 1712 Main St., Coventry, CT	<b>Date</b> 09:25:07 12/03/14
	<b>Client</b> Verizon Wireless	<b>Designed by</b> TJL

Section No.	Elevation ft	Size	L ft	L <sub>u</sub> ft	Kl/r	F <sub>a</sub> ksi	A in <sup>2</sup>	Actual P K	Allow. P <sub>a</sub> K	Ratio P P <sub>a</sub>
T6	100 - 80	L2 1/2x2 1/2x3/16	12.44	6.01	94.7	21.600	0.9020	5.64	19.48	0.289 ✓
T7	80 - 60	L2 1/2x2 1/2x1/4	13.62	6.61	105.3	21.600	1.1900	5.81	25.70	0.226 ✓
T8	60 - 40	L3x3x1/4	15.99	7.73	101.5	32.500	1.2525	7.12	40.71	0.175 ✓
T9	40 - 20	L3x3x1/4	19.26	9.48	124.1	32.500	1.2525	7.54	40.71	0.185 ✓
T10	20 - 0	L3 1/2x3 1/2x1/4	21.03	10.25	114.4	32.500	1.4713	9.81	47.82	0.205 ✓

### Secondary Horizontal Design Data (Tension)

Section No.	Elevation ft	Size	L ft	L <sub>u</sub> ft	Kl/r	F <sub>a</sub> ksi	A in <sup>2</sup>	Actual P K	Allow. P <sub>a</sub> K	Ratio P P <sub>a</sub>
T5	120 - 100	L2x2x1/4	8.56	7.76	161.3	21.600	0.9380	2.59	20.26	0.128 ✓
T7	80 - 60	L2 1/2x2 1/2x1/4	12.56	11.67	188.8	21.600	1.1900	3.58	25.70	0.139 ✓
T8	60 - 40	L3x3x5/16	14.52	13.54	181.8	21.600	1.7800	4.10	38.45	0.107 ✓
T9	40 - 20	L3x3x5/16	16.44	15.46	206.8	21.600	1.7800	4.52	38.45	0.118 ✓

### Top Girt Design Data (Tension)

Section No.	Elevation ft	Size	L ft	L <sub>u</sub> ft	Kl/r	F <sub>a</sub> ksi	A in <sup>2</sup>	Actual P K	Allow. P <sub>a</sub> K	Ratio P P <sub>a</sub>
T1	190 - 180	L1 3/4x1 3/4x3/16	4.65	4.18	99.5	21.600	0.6211	0.31	13.42	0.023 ✓
T4	140 - 120	L1 3/4x1 3/4x3/16	4.72	4.16	99.0	21.600	0.6211	0.13	13.42	0.010 ✓

### Section Capacity Table

Section No.	Elevation ft	Component Type	Size	Critical Element	P K	SF*P <sub>allow</sub> K	% Capacity	Pass Fail
T1	190 - 180	Leg	ROHN 2 STD	2	-6.43	28.30	22.7	Pass
T2	180 - 160	Leg	ROHN 2.5 STD	20	-32.08	55.08	58.3	Pass
T3	160 - 140	Leg	ROHN 3 EH	53	-80.46	102.57	78.4	Pass
T4	140 - 120	Leg	ROHN 3.5 EH	86	-119.13	128.82	92.5	Pass
T5	120 - 100	Leg	ROHN 4 EH	122	-149.35	165.57	90.2	Pass

<b>tnxTower</b>  <b>Centek Engineering Inc.</b> 63-2 North Branford Rd. Branford, CT 06405 Phone: (203) 488-0580 FAX: (203) 488-8587	<b>Job</b> 14001.057 - Coventry East	<b>Page</b> 39 of 39
	<b>Project</b> 190' Rohn Lattice Tower - 1712 Main St., Coventry, CT	<b>Date</b> 09:25:07 12/03/14
	<b>Client</b> Verizon Wireless	<b>Designed by</b> TJL

Section No.	Elevation ft	Component Type	Size	Critical Element	P K	SF*P <sub>allow</sub> K	% Capacity	Pass Fail	
T6	100 - 80	Leg	ROHN 5 EH	161	-178.77	206.29	86.7 86.9 (b)	Pass	
T7	80 - 60	Leg	ROHN 5 EH	183	-206.58	228.40	90.4	Pass	
T8	60 - 40	Leg	ROHN 6 EHS	213	-236.32	254.70	92.8	Pass	
T9	40 - 20	Leg	ROHN 6 EH	243	-260.79	306.48	85.1	Pass	
T10	20 - 0	Leg	ROHN 8 EHS	264	-287.57	332.54	86.5	Pass	
T1	190 - 180	Diagonal	L1 3/4x1 3/4x3/16	10	-1.78	9.43	18.9 21.5 (b)	Pass	
T2	180 - 160	Diagonal	L1 3/4x1 3/4x3/16	24	-2.96	10.41	28.5 35.6 (b)	Pass	
T3	160 - 140	Diagonal	L1 3/4x1 3/4x3/16	58	-6.51	10.48	62.1 77.0 (b)	Pass	
T4	140 - 120	Diagonal	L1 3/4x1 3/4x3/16	94	-4.27	7.69	55.5	Pass	
T5	120 - 100	Diagonal	L2x2x3/16	127	-4.96	6.77	73.2	Pass	
T6	100 - 80	Diagonal	L2 1/2x2 1/2x3/16	166	-5.82	8.47	68.7 69.1 (b)	Pass	
T7	80 - 60	Diagonal	L2 1/2x2 1/2x1/4	186	-6.18	8.29	74.6	Pass	
T8	60 - 40	Diagonal	L3x3x1/4	225	-7.27	12.60	57.7 84.7 (b)	Pass	
T9	40 - 20	Diagonal	L3x3x1/4	255	-7.91	8.54	92.5	Pass	
T10	20 - 0	Diagonal	L3 1/2x3 1/2x1/4	273	-9.03	11.69	77.3 79.3 (b)	Pass	
T5	120 - 100	Secondary Horizontal	L2x2x1/4	130	-2.59	4.82	53.8	Pass	
T7	80 - 60	Secondary Horizontal	L2 1/2x2 1/2x1/4	192	-3.58	4.53	79.0	Pass	
T8	60 - 40	Secondary Horizontal	L3x3x5/16	221	-4.10	7.17	57.2	Pass	
T9	40 - 20	Secondary Horizontal	L3x3x5/16	251	-4.52	5.74	78.8	Pass	
T1	190 - 180	Top Girt	L1 3/4x1 3/4x3/16	5	-0.35	5.79	6.0	Pass	
T4	140 - 120	Top Girt	L1 3/4x1 3/4x3/16	90	-0.21	5.86	3.6	Pass	
							Summary		
							Leg (T8)	92.8	Pass
							Diagonal (T9)	92.5	Pass
							Secondary Horizontal (T7)	79.0	Pass
							Top Girt (T1)	6.0	Pass
							Bolt Checks	92.1	Pass
							<b>RATING =</b>	<b>92.8</b>	<b>Pass</b>

**Mat Foundation Analysis:**

**Input Data:**

Tower Data

Overturning Moment =	OM := 4519-ft-kips	(User Input from trnTower)
Shear Force =	S <sub>t</sub> := 43-kip	(User Input from trnTower)
Axial Force =	WT <sub>t</sub> := 54-kip	(User Input from trnTower)
Max Compression Force =	C <sub>t</sub> := 293-kip	(User Input from trnTower)
Max Uplift Force =	U <sub>t</sub> := 253-kip	(User Input from trnTower)
Tower Height =	H <sub>t</sub> := 190-ft	(User Input)
Tower Width =	W <sub>t</sub> := 19-ft	(User Input)
Tower Position on Foundation (1=offset, 2=centered) =	Pos <sub>t</sub> := 2	(User Input)

Footing Data:

Overall Depth of Footing =	D <sub>f</sub> := 4-ft	(User Input)
Thickness of Footing =	T <sub>f</sub> := 4.5-ft	(User Input)
Width of Footing =	W <sub>f</sub> := 32.0-ft	(User Input)

Material Properties:

Concrete Compressive Strength =	f <sub>c</sub> := 3000-psi	(User Input)
Steel Reinforcement Yield Strength =	f <sub>y</sub> := 60000-psi	(User Input)
Internal Friction Angle of Soil =	φ <sub>s</sub> := 30-deg	(User Input)
Allowable Soil Bearing Capacity =	q <sub>s</sub> := 4000-psf	(User Input)
Unit Weight of Soil =	γ <sub>soil</sub> := 120-pcf	(User Input)
Unit Weight of Concrete =	γ <sub>conc</sub> := 150-pcf	(User Input)
Foundation Bouyancy =	Bouyancy := 0	(User Input) (Yes=1 / No=0)
Depth to Neglect =	n := 0-ft	(User Input)
Cohesion of Clay Type Soil =	c := 0-ksf	(User Input) (Use 0 for Sandy Soil)
Seismic Zone Factor =	Z := 2	(User Input) (UBC-1997 Fig 23-2)
Coefficient of Friction Between Concrete =	μ := 0.45	(User Input)

Pad Reinforcement:

Bar Size =	BS <sub>top</sub> := 7	(User Input)	(Top of Pad)
Bar Diameter =	d <sub>btop</sub> := 0.875-in	(User Input)	(Top of Pad)
Number of Bars =	NB <sub>top</sub> := 33	(User Input)	(Top of Pad)
Bar Size =	BS <sub>bot</sub> := 7	(User Input)	(Bottom of Pad)
Bar Diameter =	d <sub>bbot</sub> := 0.875-in	(User Input)	(Bottom of Pad)
Number of Bars =	NB <sub>bot</sub> := 33	(User Input)	(Bottom of Pad)
Clear Cover of Reinforcement =	Cvr <sub>pad</sub> := 3.0-in	(User Input)	
Reinforcement Location Factor =	α <sub>pad</sub> := 1.0	(User Input)	(ACI-2008 12.2.4)
Coating Factor =	β <sub>pad</sub> := 1.0	(User Input)	(ACI-2008 12.2.4)
Concrete Strength Factor =	λ <sub>pad</sub> := 1.0	(User Input)	(ACI-2008 12.2.4)
Reinforcement Size Factor =	γ <sub>pad</sub> := 1.0	(User Input)	(ACI-2008 12.2.4)

**Calculated Factors:**

Pad Top Reinforcement Bar Area =	$A_{btop} := \frac{\pi \cdot d_{btop}^2}{4} = 0.601 \cdot \text{in}^2$	
Pad Bottom Reinforcement Bar Area =	$A_{bbot} := \frac{\pi \cdot d_{bbot}^2}{4} = 0.601 \cdot \text{in}^2$	
Coefficient of Lateral Soil Pressure =	$K_p := \frac{1 + \sin(\Phi_s)}{1 - \sin(\Phi_s)} = 3$	
Load Factor =	$LF := \begin{cases} 1.333 & \text{if } H_t \leq 700\text{-ft} \\ 1.7 & \text{if } H_t \geq 1200\text{-ft} \\ 1.333 + \left( \frac{H_t - 700\text{ft}}{1200\text{ft} - 700\text{ft}} \right) \cdot 0.4 & \text{otherwise} \end{cases}$	= 1.333

**Bearing Pressure Caused by Footing:**

Total Load =	$Load_{tot} := WT_c + WT_f = 745 \text{ kip}$	
Area of the Mat =	$A_{mat} := W_f^2 = 1.024 \times 10^3$	
Section Modulus of Mat =	$S := \frac{W_f^3}{6} = 5461.33 \text{ ft}^3$	
Maximum Pressure in Mat =	$P_{max} := \frac{Load_{tot}}{A_{mat}} + \frac{M_{ot}}{S} = 1.591 \text{ ksf}$	
	$Max\_Pressure\_Check := \text{if}(P_{max} < q_s, \text{"Okay"}, \text{"No Good"})$	
	<b>Max_Pressure_Check = "Okay"</b>	
Minimum Pressure in Mat =	$P_{min} := \frac{Load_{tot}}{A_{mat}} - \frac{M_{ot}}{S} = -0.135 \text{ ksf}$	
	$Min\_Pressure\_Check := \text{if}[(P_{min} \geq 0) \cdot (P_{min} < q_s), \text{"Okay"}, \text{"No Good"}]$	
	<b>Min_Pressure_Check = "No Good"</b>	
Distance to Resultant of Pressure Distribution =	$X_p := \frac{P_{max}}{P_{max} - P_{min}} \cdot \frac{1}{3} = 9.831$	
Distance to Kern =	$X_k := \frac{W_f}{6} = 5.333$	Since Resultant Force is Not in Kern, Area to which Pressure is Applied Must be Reduced.
Eccentricity =	$e := \frac{M_{ot}}{WT_{tot}} = 6.324$	
Adjusted Soil Pressure =	$P_a := \frac{2 \cdot WT_{tot}}{3 \cdot W_f \left( \frac{W_f}{2} - e \right)} = 1.604 \text{ ksf}$	
	$q_{adj} := \text{if}(P_{min} < 0, P_a, P_{max}) = 1.604 \text{ ksf}$	
	$Pressure\_Check := \text{if}(q_{adj} < q_s, \text{"Okay"}, \text{"No Good"})$	
	<b>Pressure_Check = "Okay"</b>	

**Steel Reinforcement in Pad:**

Required Reinforcement for Bending:

Strength Reduction Factor =  $\phi_m := .90$  (ACI-2008 9.3.2.1)

Maximum Moment in Pad =  $M_{max} := 1188 \text{ kip-ft}$  (User Input)

Design Moment =  $M_n := \frac{LF \cdot M_{max}}{\phi_m} = 1.76 \times 10^3 \text{ kips-ft}$

$$\beta := \begin{cases} 0.85 & \text{if } 2500 \text{ psi} \leq f_c \leq 4000 \text{ psi} \\ 0.65 & \text{if } f_c > 8000 \text{ psi} \\ \left[ 0.85 - \left[ \frac{\left( \frac{f_c}{\text{psi}} - 4000 \right)}{1000} \right] \cdot 0.5 \right] & \text{otherwise} \end{cases} = 0.85$$

(ACI-2008 10.2.7.3)

$b_{eff} := W_f \cdot \cos(30 \text{ deg}) + d_p = 197.454 \text{ in}$

$d := T_f - C_{vr_{pad}} - d_{bot} = 50.125 \text{ in}$

$A_s := \frac{M_n}{(f_y \cdot d)} = 7.021 \text{ in}^2$

$a := \frac{A_s \cdot f_y}{\beta \cdot f_c \cdot b_{eff}} = 0.837 \text{ in}$

$A_s := \frac{M_n}{f_y \cdot \left( d - \frac{a}{2} \right)} = 7.08 \text{ in}^2$

$\rho := \frac{A_s}{b_{eff} \cdot d} = 0.00072$

Required Reinforcement for Temperature and Shrinkage:

$$\rho_{sh} := \begin{cases} .0018 & \text{if } f_y \geq 60000 \text{ psi} = 0.0018 \\ .0020 & \text{otherwise} \end{cases} \quad (\text{ACI -2008 7.12.2.1})$$

Check Bottom Bars:

$$A_s := \begin{cases} (\rho \cdot b_{eff} \cdot d) & \text{if } (\rho \cdot b_{eff} \cdot d) > \rho_{sh} \cdot \frac{b_{eff}}{2} \cdot d = 8.908 \cdot \text{in}^2 \\ \rho_{sh} \cdot \frac{b_{eff}}{2} \cdot d & \text{otherwise} \end{cases}$$

$$A_{s_{prov}} := A_{b_{bot}} \cdot N_{B_{bot}} = 19.8 \cdot \text{in}^2$$

$$\text{Pad\_Reinforcement\_Bot} := \text{if}(A_{s_{prov}} > A_s, \text{"Okay"}, \text{"No Good"})$$

$$\text{Pad\_Reinforcement\_Bot} = \text{"Okay"}$$

Check top Bars:

$$A_s := \text{if}\left(\rho \geq \rho_{sh}, A_s, \rho_{sh} \cdot \frac{b_{eff}}{2} \cdot d\right) = 8.9 \cdot \text{in}^2$$

$$A_{s_{prov}} := A_{b_{top}} \cdot N_{B_{top}} = 19.8 \cdot \text{in}^2$$

$$\text{Pad\_Reinforcement\_Top} := \text{if}(A_{s_{prov}} > A_s, \text{"Okay"}, \text{"No Good"})$$

$$\text{Pad\_Reinforcement\_Top} = \text{"Okay"}$$

**Development Length Pad Reinforcement:**

Bar Spacing =

$$B_{sPad} := \frac{W_f - 2 \cdot C_{vr_{pad}} - N_{B_{bot}} \cdot d_{b_{bot}}}{N_{B_{bot}} - 1} = 10.91 \cdot \text{in}$$

Spacing or Cover Dimension =

$$c := \text{if}\left(C_{vr_{pad}} < \frac{B_{sPad}}{2}, C_{vr_{pad}}, \frac{B_{sPad}}{2}\right) = 3 \cdot \text{in}$$

Transverse Reinforcement Index =

$$k_{tr} := 0 \quad (\text{ACI-2008 12.2.3})$$

$$L_{dbt} := \frac{3 \cdot f_y \cdot \alpha_{pad} \cdot \beta_{pad} \cdot \gamma_{pad} \cdot \lambda_{pad}}{40 \cdot \sqrt{f_c \cdot \text{psi}} \cdot \frac{c + k_{tr}}{d_{b_{bot}}}} \cdot d_{b_{bot}} = 21 \cdot \text{in}$$

Minimum Development Length =

$$L_{dbmin} := 12 \cdot \text{in} \quad (\text{ACI-2008 12.2.1})$$

$$L_{dbtCheck} := \text{if}(L_{dbt} \geq L_{dbmin}, \text{"Use L.dbt"}, \text{"Use L.dbmin"}) = \text{"Use L.dbt"}$$

Available Length in Pad =

$$L_{Pad} := \frac{W_f}{2} - \frac{W_t}{2} - C_{vr_{pad}} = 75 \cdot \text{in}$$

$$L_{pad\_Check} := \text{if}(L_{Pad} > L_{dbt}, \text{"Okay"}, \text{"No Good"})$$

$$L_{pad\_Check} = \text{"Okay"}$$



SITE NAME	COVENTRY EAST CT		ECP - CELL #	2	119
LATITUDE	41-29-35.75 N		LONGITUDE	72-00-11.17 W	
Additional Comments: 2015 AWS ADD.			SAVE BUTTON		
			STRUCTURE TYPE	Monopole	
AWS - LTE ANTENNA ADD	ALPHA		BETA		GAMMA
EQUIPMENT TYPE	2100 MHz BBU		2100 MHz BBU		2100 MHz BBU
ANTENNA TYPE	HBXX-6517DS-A2M		HBXX-6517DS-A2M		HBXX-6517DS-A2M
QTY OF ANTENNAS PER FACE	1		1		1
ORIENTATION (DEG)	40		150		270
DOWN TILT ( MECH/ELEC)	0M/3E		0M/2E		0M/2E
RAD CTR (FT AGL)	150		150		150
TMA - QTY / MODEL					
DIPLEXER - QTY / MODEL					
RRH - QTY/MODEL	1	ALU RH_2X60-AWS	1	ALU RH_2X60-AWS	1 ALU RH_2X60-AWS
SECTOR DISTRIBUTION BOX					
MAIN DISTRIBUTION BOX	2				DB-T1-6Z-8AB-0Z
700 Mhz - LTE Current Config	ALPHA		BETA		GAMMA
EQUIPMENT TYPE	eNodeB		eNodeB		eNodeB
ANTENNA TYPE	BXA-70063-6CF_2		BXA-70063-6CF_2		BXA-70063-6CF_2
QTY OF ANTENNAS PER FACE	1		1		1
ORIENTATION (DEG)	40		150		270
DOWN TILT ( MECH/DEG )	0		0		0
RAD CTR (FT AGL)	150		150		150
TMA - QTY / MODEL					
DIPLEXER - QTY / MODEL					
700 Mhz - LTE Future Config	ALPHA		BETA		GAMMA
EQUIPMENT TYPE	eNodeB		eNodeB		eNodeB
ANTENNA TYPE	LNX-6514DS-A1M		LNX-6514DS-A1M		LNX-6514DS-A1M
QTY OF ANTENNAS PER FACE	1		1		1
ORIENTATION (DEG)	40		150		270
DOWN TILT ( MECH/DEG )	0M/6E		0M/6E		0M/0E
RAD CTR (FT AGL)	150		150		150
TMA - QTY / MODEL					
DIPLEXER - QTY / MODEL					
850 Cellular - Current Config	ALPHA		BETA		GAMMA
EQUIPMENT TYPE	Cellular Modcell 4.0B		Cellular Modcell 4.0B		Cellular Modcell 4.0B
ANTENNA TYPE	LPA-80080/4CF		LPA-80063/4CF		LPA-80063/4CF
QTY OF ANTENNAS PER FACE	2		2		2
ORIENTATION (DEG)	40		150		270
DOWN TILT ( MECH/DEG )	4		0		0
RAD CTR (FT AGL)	150		150		150
TMA - QTY / MODEL					
DIPLEXER - QTY / MODEL					
850 Cellular - Future Config	ALPHA		BETA		GAMMA
EQUIPMENT TYPE	Cellular Modcell 4.0B		Cellular Modcell 4.0B		Cellular Modcell 4.0B
ANTENNA TYPE	LNX-6514DS-A1M		LNX-6514DS-A1M		LNX-6514DS-A1M
QTY OF ANTENNAS PER FACE	1		1		1
ORIENTATION (DEG)	40		150		270
DOWN TILT ( MECH/ELEC )	0M/4E		0M/0E		0M/0E
RAD CTR (FT AGL)	150		150		150
TMA - QTY / MODEL					
DIPLEXER - QTY / MODEL					
DIPLEX WITH LTE CABLE					
1900 PCS - Current Config	ALPHA		BETA		GAMMA
EQUIPMENT TYPE	PCS Modcell 4.0B		PCS Modcell 4.0B		PCS Modcell 4.0B
ANTENNA TYPE	BXA-171085-8BF_2		BXA-171085-8BF_2		BXA-171085-8BF_2
QTY OF ANTENNAS PER FACE	1		1		1
ORIENTATION (DEG)	40		150		270
DOWN TILT ( MECH/DEG )	0		0		0
RAD CTR (FT AGL)	150		150		150
TMA - QTY / MODEL					
DIPLEXER - QTY / MODEL					
1900 PCS - Future Config	ALPHA		BETA		GAMMA
EQUIPMENT TYPE	PCS Modcell 4.0B		PCS Modcell 4.0B		PCS Modcell 4.0B
ANTENNA TYPE	HBXX-6517DS-A2M		HBXX-6517DS-A2M		HBXX-6517DS-A2M
QTY OF ANTENNAS PER FACE	1		1		1
ORIENTATION (DEG)	40		150		270
DOWN TILT ( MECH/DEG )	0M/2E		0M/2E		0M/2E
RAD CTR (FT AGL)	150		150		150
RRH - QTY/MODEL	1	ALU RRH_2X60-PCS	1	ALU RRH_2X60-PCS	1 ALU RRH_2X60-PCS
TMA - QTY / MODEL					
DIPLEX WITH CELLULAR CABLE					

NUMBER OF CABLE'S NEEDED						ESTIMATED CABLE LENGTH					
MAINLINE SIZE	1 5/8"		TOTAL # OF MAINLINES	18		MAINLINE (FT)					
JUMPER SIZE	1/2 "		TOTAL # OF TOP JUMPERS	18		TOP JUMPER (FT)	12				
Equipment Cable Ordering			MAIN CABLE	18	+	0	TOP JUMPER #	18	+	0	
FIBER LINE SIZE	1 5/8"		TOTAL # OF FIBER LINES	2		FIBER LINE MODEL #	HB158-1-08U8-S8J18				
JUMPER SIZE	5/8"		TOTAL # OF TOP JUMPERS	3		TOP JUMPER MODEL #	HB058-1-08U1-S1J18				
Fiber Cable Ordering			FIBER CABLE	0	+	2	TOP JUMPER #	0	+	3	
TX / RX FREQUENCIES						TX POWER OUTPUT					
Cellular A-Band			PCS F / AWS-Band	700 Mhz C - B		Cellular (Watts)		20			
TX - 869-880,890-891.5 MHz			TX - 1970-1975 / 2145-21	TX - 746-757		PCS (Watts)		16			
RX - 824-835,845-846.5 MHz			RX - 1890-1895 / 1745-17	RX - 776-787		LTE (Watts)		60			
ALPHA				BETA				GAMMA			
Ant.	Freq.	Func.	Color Code	Ant.	Freq.	Func.	Color Code	Ant.	Freq.	Func.	Color Code
A1	800	Tx1/Rx0	RED	A7	800	Tx2/Rx0	BLUE	A13	800	Tx3/Rx0	GREEN
A2	1900	Tx1/Rx0	RED/ WHITE	A8	1900	Tx2/Rx0	BLUE/ WHITE	A14	1900	Tx3/Rx0	GREEN/WHITE
A3	700	Tx1/Rx0	RED/ ORANGE	A9	700	Tx2/Rx0	BLUE/ ORANGE	A15	700	Tx3/Rx0	GREEN/ORANGE
A4	700	Tx4/Rx1	RED/RED/ ORANGE	A10	700	Tx5/Rx1	BLUE/BLUE/ ORANGE	A16	700	Tx6/Rx1	GREEN/GREEN/ ORANGE
A5	1900	Tx4/Rx1	RED/RED/ WHITE	A11	1900	Tx5/Rx1	BLUE/BLUE/ WHITE	A17	1900	Tx6/Rx1	GREEN/GREEN/ WHITE
A6	800	Tx4/Rx1	RED/RED	A12	800	Tx5/Rx1	BLUE/BLUE	A18	800	Tx6/Rx1	GREEN/GREEN
RF ENGINEER				RF MANAGER				INITIALS		DATE	
Prepared By: Mark Brauer				Rob Hesselbach				MB		3/13/2014	

## Site Configuration

# Product Specifications

COMMScope®

POWERED BY



## HBXX-6517DS-VTM

**Andrew® Quad Port Teletilt® Antenna, 1710–2180 MHz, 65° horizontal beamwidth, RET compatible**

- Superior azimuth tracking and pattern symmetry with excellent passive intermodulation suppression
- The values presented on this datasheet have been calculated based on N-P-BASTA White Paper version 9.6 by the NGMN Alliance

### Electrical Specifications

Frequency Band, MHz	1710–1880	1850–1990	1920–2180
Gain by all Beam Tilts, average, dBi	18.5	18.6	18.8
Gain by all Beam Tilts Tolerance, dB	±0.4	±0.3	±0.4
	0 °   18.4	0 °   18.4	0 °   18.7
Gain by Beam Tilt, average, dBi	3 °   18.7	3 °   18.7	3 °   18.9
	6 °   18.4	6 °   18.5	6 °   18.6
Beamwidth, Horizontal, degrees	67	66	65
Beamwidth, Horizontal Tolerance, degrees	±2.4	±1.7	±2.9
Beamwidth, Vertical, degrees	5.0	4.7	4.4
Beamwidth, Vertical Tolerance, degrees	±0.3	±0.3	±0.3
Beam Tilt, degrees	0–6	0–6	0–6
USLS, dB	18	19	19
Front-to-Back Total Power at 180° ± 30°, dB	25	26	26
CPR at Boresight, dB	22	23	22
CPR at Sector, dB	10	10	9
Isolation, dB	30	30	30
VSWR   Return Loss, dB	1.4   15.6	1.4   15.6	1.4   15.6
PIM, 3rd Order, 2 x 20 W, dBc	-153	-153	-153
Input Power per Port, maximum, watts	350	350	350
Polarization	±45°	±45°	±45°
Impedance	50 ohm	50 ohm	50 ohm

### General Specifications

Antenna Brand	Andrew®
Antenna Type	DualPol® single band, quad
Band	Single band
Brand	DualPol®   Teletilt®
Operating Frequency Band	1710 – 2180 MHz
Number of Ports, all types	4

### Mechanical Specifications

Color	Light gray
Lightning Protection	dc Ground
Radiator Material	Low loss circuit board
Radome Material	PVC, UV resistant
RF Connector Interface	7-16 DIN Female
RF Connector Location	Bottom

# Product Specifications

COMMSCOPE®

HBXX-6517DS-VTM

POWERED BY



RF Connector Quantity, total	4
Wind Loading, maximum	668.0 N @ 150 km/h 150.2 lbf @ 150 km/h
Wind Speed, maximum	241.0 km/h   149.8 mph

## Dimensions

Depth	166.0 mm   6.5 in
Length	1903.0 mm   74.9 in
Width	305.0 mm   12.0 in
Net Weight	19.5 kg   43.0 lb

## Remote Electrical Tilt (RET) Information

Model with Factory Installed AISG 1.1 Actuator HBXX-6517DS-R2M

Model with Factory Installed AISG 2.0 Actuator HBXX-6517DS-A2M

RET System Teletilt®

## Regulatory Compliance/Certifications

### Agency

RoHS 2011/65/EU

China RoHS SJ/T 11364-2006

ISO 9001:2008

### Classification

Compliant by Exemption

Above Maximum Concentration Value (MCV)

Designed, manufactured and/or distributed under this quality management system



## Included Products

600899A-2 — Downtilt Mounting Kit for 2.4 - 4.5 in (60 - 115 mm) OD round members. Kit contains one scissor top bracket set and one bottom bracket set.

# Product Specifications

COMMScope®

POWERED BY



## LNX-6514DS-VTM

Andrew® Antenna, 698–896 MHz, 65° horizontal beamwidth, RET compatible

- Great solution to maximize network coverage and capacity
- Excellent gain, VSWR, front-to-back ratio, and PIM specifications for robust network performance
- Ideal choice for site collocations and tough zoning restrictions
- Excellent solution for site sharing and maximizing capacity
- Fully compatible with Andrew remote electrical tilt system for greater OpEx savings
- The RF connectors are designed for IP67 rating and the radome for IP56 rating

### Electrical Specifications

Frequency Band, MHz	698–806	806–896
Gain, dBi	15.7	16.3
Beamwidth, Horizontal, degrees	65	65
Beamwidth, Horizontal Tolerance, degrees	±3	±3
Beamwidth, Vertical, degrees	12.5	11.2
Beam Tilt, degrees	0–10	0–10
USLS, typical, dB	17	18
Front-to-Back Ratio at 180°, dB	32	30
CPR at Boresight, dB	20	20
CPR at Sector, dB	10	10
Isolation, dB	30	30
VSWR   Return Loss, dB	1.4   15.6	1.4   15.6
PIM, 3rd Order, 2 x 20 W, dBc	-153	-153
Input Power per Port, maximum, watts	400	400
Polarization	±45°	±45°
Impedance	50 ohm	50 ohm

### General Specifications

Antenna Brand	Andrew®
Antenna Type	DualPol®
Band	Single band
Brand	DualPol®   Teletilt®
Operating Frequency Band	698 – 896 MHz

### Mechanical Specifications

Color	Light gray
Connector Interface	7-16 DIN Female
Connector Location	Bottom
Connector Quantity, total	2
Lightning Protection	dc Ground
Radiator Material	Aluminum
Radome Material	Fiberglass, UV resistant
Wind Loading, maximum	617.7 N @ 150 km/h 138.9 lbf @ 150 km/h
Wind Speed, maximum	241.0 km/h   149.8 mph

# Product Specifications

COMMSCOPE®

LNX-6514DS-VTM

POWERED BY



## Dimensions

Depth	181.0 mm   7.1 in
Length	1847.0 mm   72.7 in
Width	301.0 mm   11.9 in
Net Weight	17.6 kg   38.8 lb

## Remote Electrical Tilt (RET) Information

Model with Factory Installed AISG 1.1 Actuator LNX-6514DS-R2M

Model with Factory Installed AISG 2.0 Actuator LNX-6514DS-A1M

RET System Teletilt®

## Regulatory Compliance/Certifications

### Agency

RoHS 2011/65/EU

China RoHS SJ/T 11364-2006

ISO 9001:2008

### Classification

Compliant by Exemption

Above Maximum Concentration Value (MCV)

Designed, manufactured and/or distributed under this quality management system



## Included Products

DB380 — Pipe Mounting Kit for 2.4"-4.5" (60-115mm) OD round members on wide panel antennas. Includes 2 clamp sets and double nuts.

DB5083 — Downtilt Mounting Kit for 2.4"-4.5" (60 - 115 mm) OD round members. Includes a heavy-duty, galvanized steel downtilt mounting bracket assembly and associated hardware. This kit is compatible with the DB380 pipe mount kit for panel antennas that are equipped with two mounting brackets.

# ALCATEL-LUCENT WIRELESS PRODUCT DATASHEET RRH2X60-AWS FOR BAND 4 APPLICATIONS

The Alcatel-Lucent RRH2x60-AWS is a high power, small form factor Remote Radio Head operating in the AWS frequency band (3GPP Band 4) for LTE technology. It is designed with an eco-efficient approach, providing operators with the means to achieve high quality and high capacity coverage with minimum site requirements and efficient operation.



A distributed Node B expands the deployment options by using two components, a Base Band Unit (BBU) containing the digital assets and a separate RRH containing the radio-frequency (RF) elements. This modular design optimizes available space and allows the main components of a Node B to be installed separately, within the same site or several kilometers apart.

The Alcatel-Lucent RRH2x60-AWS is linked to the BBU by an optical-fiber connection carrying downlink and uplink digital radio signals

along with operations, administration and maintenance (OA&M) information.

## SUPERIOR RF PERFORMANCE

The Alcatel-Lucent RRH2x60-AWS integrates all the latest technologies. This allows to offer best-in-class characteristics.

It delivers an outstanding 120 watts of total RF power thanks to its two transmit RF paths of 60 W each.

It is ideally suited to support multiple-input multiple-output (MIMO) 2x2 operation.

It includes four RF receivers to natively support 4-way uplink reception diversity. This improves the radio uplink coverage and this can be used to extend the cell radius commensurate with 2x2MIMO 2x60 W for the downlink.

It supports multiple discontinuous LTE carriers within an instantaneous bandwidth of 45 MHz corresponding to the entire AWS B4 spectrum.

The latest generation power amplifiers (PA) used in this product achieve high efficiency (>40%), resulting in improved power consumption figures.

## OPTIMIZED TCO

The Alcatel-Lucent RRH2x60-AWS is designed to make available all the benefits of a distributed Node B, with excellent RF characteristics, with low capital expenditures (CAPEX) and low operating expenditures (OPEX).

The Alcatel-Lucent RRH2x60-AWS is a very cost-effective solution to deploy LTE MIMO.

## EASY INSTALLATION

The RRH2x60-AWS includes a reversible mounting bracket which allows for ease of installation behind an antenna, or on a rooftop knee wall while providing easy access to the mid body RF connectors.

The limited space available in some sites may prevent the installation of traditional single-cabinet BTS equipment. However, many of these sites can host an Alcatel-Lucent RRH2x60-AWS installation, providing more flexible site selection and improved network quality along with greatly reduced installation time and costs.

The Alcatel-Lucent RRH2x60-AWS is a zero-footprint solution and is convection cooled without fans for silent operation, simplifying negotiations with site property owners and minimizing environmental impacts.

Installation can easily be done by a single person as the Alcatel-Lucent RRH2x60-AWS is compact and weighs about 20 kg, eliminating the need for a crane to hoist the BTS cabinet to the rooftop. A site can be in operation in less than one day.

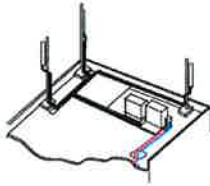

Macro

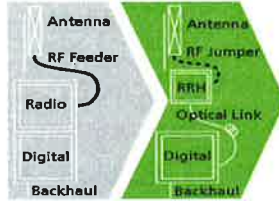

RRH for space-constrained cell sites

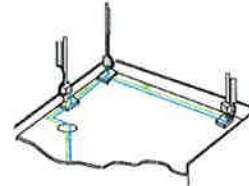

Distributed

## FEATURES

- RRH2x60-AWS integrates two power amplifiers of 60W rating (at each antenna connector)
- Support multiple carriers over the entire 3GPP band 4
- RRH2x60-AWS is optimized for LTE operation
- RRH2x60-AWS is a very compact and lightweight product
- Advanced power management techniques are embedded to provide power savings, such as PA bias control

## BENEFITS

- MIMO LTE operation with only one single unit per sector
- Improved uplink coverage with built-in 4-way receive diversity capability
- RRH can be mounted close to the antenna, eliminating nearly all losses in RF cables and thus reducing power consumption by 50% compared to conventional solutions
- Distributed configurations provide easily deployable and cost-effective solutions, near zero footprint and

- silent solutions, with minimum impact on the neighborhood, which ease the deployment
- RETA and TMA support without additional hardware thanks to the AISG v2.0 port and the integrated Bias-Tees. Bias-Tees support AISG DC supply and signaling.

## TECHNICAL SPECIFICATIONS

Specifications listed are hardware capabilities. Some capabilities depend on support in a specific software release or future release.

### Dimensions and weights

- HxWxD : 510x285x186mm (27 l with solar shield)
- Weight : 20 kg (44 lbs)

### Electrical Data

- Power Supply : -48V DC (-40.5 to -57V)
- Power Consumption (ETSI average traffic load reference) : 250W @2x60W

### RF Characteristics

- Frequency band: 1710-1755, UL / 2110-2155 MHz, DL (3GPP band 4)
- Output power: 2x60W at antenna connectors
- Technology supported: LTE
- Instantaneous bandwidth: 45 MHz
- Rx diversity: 2-way and 4-way uplink reception
- Typical sensitivity without Rx diversity: -105 dBm for LTE

### Connectivity

- Two CPRI optical ports for daisy chaining and up to six RRHs per fiber
- Type of optical fiber: Single-Mode (SM) and Multi-Mode (MM) SFPs
- Optical fiber length: up to 500m using MM fiber, up to 20km using SM fiber
- TMA/RETA : AISG 2.0 (RS485 connector and internal Bias-Tee)
- Six external alarms
- Surge protection for all external ports (DC and RF)

### Environmental specifications

- Operating temperature: -40°C to 55°C including solar load
- Operating relative humidity: 8% to 100%
- Environmental Conditions : ETS 300 019-1-4 class 4.1E
- Ingress Protection : IEC 60529 IP65
- Acoustic Noise : Noiseless (natural convection cooling)

### Safety and Regulatory Data

- EMC : 3GPP 25113, EN 301 489-1, EN 301 489-23, GR 1089, GR 3108, OET-65
- Safety : IEC60950-1, EN 60825-1, UL, ANSI/NFPA 70, CAN/CSA-C22.2
- Regulatory : FCC Part 15 Class B, CE Mark – European Directive : 2002/95/EC (ROHS); 2002/96/EC (WEEE); 1999/5/EC (R&TTE)
- Health : EN 50385

www.alcatel-lucent.com Alcatel, Lucent, Alcatel-Lucent and the Alcatel-Lucent logo are trademarks of Alcatel-Lucent. All other trademarks are the property of their respective owners. The information presented is subject to change without notice. Alcatel-Lucent assumes no responsibility for inaccuracies contained herein.

Copyright © 2012 Alcatel-Lucent. All rights reserved. M2012XXXXXX (March)



**DC and Fiber Management Distribution Boxes for HYBRIFLEX™ Cable**

**Product Description**

The RFS Distribution Box design comes with the option for pluggable over voltage protection (OVP) for up to 6 remote radios and the connection for 6 pairs of optical fiber with LC optical fiber cable management. There is a hybrid cable input with a jumper configuration for power and optical fiber to the remote radio heads (RRHs). A custom wall, a 2-inch pole, and an H-Frame mounting bracket are included. Both the compact and standard design are available with lightening protection.



**Features/Benefits**

- Designed to accommodate varying diameters of HYBRIFLEX™ (combined power and fiber optic) cables – up to 2 inches
- Supports Single- and Multi-Mode Optical fiber
- NEMA 4x rated enclosure – allows **flexibility for indoor or outdoor installation** on a roof or tower top
- Weatherproof enclosure and ports – **improves system reliability**
- Modular design – makes replacement or addition of OVP easy without removal of other components within the box
- Strikesorb OVP technology – protects equipment from damaging surges up to 60 kA on an 8/20 waveform and up to 5 kA on a 10/350 waveform (certain models only)
- Low residual voltage and high impedance – **ideally suited for RRH technology** – won't shut down the RRH the way spark gap technology does (certain models only)

**Technical Specifications**

**Mechanical Specifications**

Model Number	DB-B1-6C-8AB-0Z	DB-T1-6Z-8AB-0Z
Enclosure Design	Standard, 6 OVP's	Standard without OVP
Dimensions - H x W x D, mm (in)	610 x 610 x 254 (24 x 24 x 10)	610 x 610 x 254 (24 x 24 x 10)
Weight, kg (lb)	20 (44)	20 (44)
Suppression Connection Method	Compression lug, #2-#14 AWG Copper, #2-#12 Aluminum	
Fiber Connection Method	LC-LC Single- or Multi-mode duplex	
Environmental Rating	NEMA 4x	
Operating Temperature, °C (°F)	-40 to +80 (-40 to +176)	
UV Protection	ISO 4892-2 Method A Xenon-Arc 2160 hrs	

**Electrical Specifications**

Nominal Operating Voltage	48 VDC	
Nominal Discharge Current (I <sub>n</sub> ) per UL 1449 3rd Ed	20 kA 8/20 μs	N/A
Maximum Discharge Current (I <sub>max</sub> ) per NEMA LS-1	60 kA 8/20 μs	N/A
Maximum Impulse (Lightning) Current (I <sub>imp</sub> ) per IEC 61643-1	5 kA 10/350 μs	N/A
Maximum Continuous Operating Voltage (U <sub>c</sub> )	75 VDC	N/A
Voltage Protection Rating per UL1449 3rd Ed	400 V	N/A
Protection Class as per IEC 61643-1	Class 1	N/A
Strikesorb OVP Compliance	ANSI/UL 1449-3rd Ed	N/A
	IEEE C62.41	N/A
	NEMA LS-1	N/A
	IEC 61643-1	N/A
	IEC 61643-12	N/A
	EN 61643-11	N/A

\* This data is provisional and subject to change.

All information contained in the present datasheet is subject to confirmation at time of ordering.