



Crown Castle
7 Corporate Park Drive, Suite 101
Clifton Park, NY 12065

August 1, 2023

Melanie A. Bachman
Executive Director
Connecticut Siting Council
10 Franklin Square
New Britain, CT 06051

RE: **Notice of Exempt Modification for Verizon
Crown #801367_Crown_VZW
1121 Summit Road, Cheshire, CT 06410
Latitude: 41.536444 / Longitude: -72.957306**

Dear Ms. Bachman:

Verizon Wireless is requesting to file an exempt modification for an existing tower located at 1121 Summit Road, Cheshire, CT 06410. The property is owned by Timothy DiDomizio and the tower is owned by Crown Castle. Verizon now intends to add two (2) interference mitigation filters to be installed at the 167-foot level of the tower of the 167-foot monopole. This modification may include B2, B5, B17, B14, B29, B30, B66 & n77 hardware that is 4G(LTE) and/or 5GNR capable through remote software configuration and either or both services may be turned on or off at various times.

Panned Modification:

Tower:

Installed New:

(2) Kaelus BSF0020F3V1-1 Twin Bandstop 900MHZ Interference Mitigation Filters

The facility was approved by the Connecticut Siting Council, Docket #199, on April 12, 2001. Please see attached.

Please accept this letter as notification pursuant to Regulations of Connecticut State Agencies §16-50j-73, for construction that constitutes an exempt modification pursuant to R.C.S.A. § 16-50j-72(b)(2). In accordance with R.C.S.A. § 16-50j-73, a copy of this letter is being sent to Chairman Tim Slocum and Town Planner Michael Glidden for the municipality. A copy is also being sent to Timothy DiDomizio as the property owner and Crown Castle is the tower owner. The proposed modifications will not result in an increase in the height of the existing tower.

1. The proposed modifications will not require the extension of the site boundary.
2. The proposed modification will not increase noise levels at the facility by six decibels or more, or to levels that exceed state and local criteria.
3. The operation of the replacement antennas will not increase radio frequency emissions at the facility to a level at or above the Federal Communication Commission safety standard.

The Foundation for a Wireless World.
CrownCastle.com

Melanie A. Bachman

Page 2

4. The proposed modifications will not cause a change or alteration in the physical or environmental characteristics of the site.
5. The existing structure and its foundation can support the proposed loading.

For the foregoing reasons, Verizon respectfully submits that the proposed modifications to the above-reference telecommunications facility constitutes an exempt modification under R.C.S.A. § 16-50j-72(b)(2). Please send approval/rejection letter to Attn: Domenica Tatasciore.

Sincerely,



Domenica Tatasciore
Site Acquisition Specialist
1800 W. Park Drive
Westborough, MA 01581
(508) 621-9161/ Domenica.Tatasciore@crowncastle.com

Attachments

cc:

Chairman Tim Slocum
Town of Cheshire
84 South Main Street
Cheshire, CT 06410
203-271-6670

Town Planner Michael Glidden
Town of Cheshire
84 South Main Street
Cheshire, CT 06410
203-271-6670

Timothy DiDomizio, Property Owner
1119 Summit Road
Cheshire, CT 06410
203-667-5981

Crown Castle, Tower Owner

From: TrackingUpdates@fedex.com
To: [Tatasciore, Domenica](#)
Subject: FedEx Shipment 772866441862: Your package has been delivered
Date: Tuesday, August 1, 2023 10:12:34 AM

CAUTION: This email originated from outside of the organization. Do not click links or open attachments unless you recognize the sender and know the content is safe.

FedEx



Hi. Your package was
delivered Tue, 08/01/2023 at
10:03am.



Delivered to 84 S MAIN ST, CHESHIRE, CT 06410
Received by J.OTLOWSKI

[OBTAIN PROOF OF DELIVERY](#)

How was your delivery ?



TRACKING NUMBER	772866441862
FROM	Crown Castle 1800 West Park Drive Suite 200 WESTBOROUGH, MA, US, 01581
TO	Town of Cheshire Chairman Tim Slocum 84 South Main Street CHESHIRE, CT, US, 06410
REFERENCE	799001.7680
SHIPPER REFERENCE	799001.7680
SHIP DATE	Mon 7/31/2023 05:28 PM
DELIVERED TO	Receptionist/Front Desk
PACKAGING TYPE	FedEx Envelope
ORIGIN	WESTBOROUGH, MA, US, 01581
DESTINATION	CHESHIRE, CT, US, 06410
NUMBER OF PIECES	1
TOTAL SHIPMENT WEIGHT	0.50 LB
SERVICE TYPE	FedEx Priority Overnight

Press pause while you're away

Enroll in FedEx Delivery Manager®
to place a [free vacation hold](#) on
deliveries. We'll hold on to your
packages for up to 14 days.

From: TrackingUpdates@fedex.com
To: [Tatasciore, Domenica](#)
Subject: FedEx Shipment 772866457563: Your package has been delivered
Date: Tuesday, August 1, 2023 10:11:53 AM

CAUTION: This email originated from outside of the organization. Do not click links or open attachments unless you recognize the sender and know the content is safe.

FedEx



Hi. Your package was
delivered Tue, 08/01/2023 at
10:03am.



Delivered to 84 S MAIN ST, CHESHIRE, CT 06410
Received by J.OTLOWSKI

[OBTAIN PROOF OF DELIVERY](#)

How was your delivery ?



TRACKING NUMBER [772866457563](#)

FROM Crown Castle
1800 West Park Drive
Suite 200
WESTBOROUGH, MA, US, 01581

TO Town of Cheshire
Town Planner Michael Glidden
84 South Main Street
CHESHIRE, CT, US, 06410

REFERENCE 799001.7680

SHIPPER REFERENCE 799001.7680

SHIP DATE Mon 7/31/2023 05:28 PM

DELIVERED TO Receptionist/Front Desk

PACKAGING TYPE FedEx Envelope

ORIGIN WESTBOROUGH, MA, US, 01581

DESTINATION CHESHIRE, CT, US, 06410

NUMBER OF PIECES 1

TOTAL SHIPMENT WEIGHT 0.50 LB

SERVICE TYPE FedEx Priority Overnight

Press pause while
you're away

Enroll in FedEx Delivery Manager®
to place a [free vacation hold](#) on
deliveries. We'll hold on to your
packages for up to 14 days.

From: TrackingUpdates@fedex.com
To: [Tatasciore, Domenica](#)
Subject: FedEx Shipment 772866475481: Your package has been delivered
Date: Tuesday, August 1, 2023 11:42:26 AM

CAUTION: This email originated from outside of the organization. Do not click links or open attachments unless you recognize the sender and know the content is safe.

FedEx



Hi. Your package was
delivered Tue, 08/01/2023 at
11:36am.



Delivered to 1119 SUMMIT RD, CHESHIRE, CT 06410

OBTAIN PROOF OF DELIVERY



Delivery picture not showing? [View](#) in browser.

How was your delivery ?



TRACKING NUMBER	772866475481
FROM	Crown Castle 1800 West Park Drive Suite 200 WESTBOROUGH, MA, US, 01581
TO	Timothy DiDomizio 1119 Summit Road CHESHIRE, CT, US, 06410
REFERENCE	799001.7680
SHIPPER REFERENCE	799001.7680
SHIP DATE	Mon 7/31/2023 05:28 PM
DELIVERED TO	Residence
PACKAGING TYPE	FedEx Envelope
ORIGIN	WESTBOROUGH, MA, US, 01581
DESTINATION	CHESHIRE, CT, US, 06410

Connecticut Siting Council ^(/CSC)

[CT.gov Home](#) (/) [Connecticut Siting Council](#) (/CSC) Cheshire Docket No. 199 Decision

<p>DOCKET NO. 199 - Crown Atlantic Company LLC and Cellco Partnership d/b/a Verizon Wireless application for a Certificate of Environmental Compatibility and Public Need for the construction, maintenance and operation of a cellular telecommunications facility at 1119 Summit Road, Cheshire, Connecticut.</p>	<p>Connecticut Siting Council April 12, 2001</p>
--	--

Decision and Order

Pursuant to the foregoing Findings of Fact and Opinion, the Connecticut Siting Council (Council) finds that the effects associated with the construction, operation, and maintenance of a telecommunications facility at the proposed alternate site in Cheshire, Connecticut, including effects on the natural environment; ecological integrity and balance; public health and safety; scenic, historic, and recreational values; forests and parks; air and water purity; and fish and wildlife are not disproportionate either alone or cumulatively with other effects when compared to need, are not in conflict with the policies of the State concerning such effects, and are not sufficient reason to deny the application and therefore directs that a Certificate of Environmental Compatibility and Public Need, as provided by General Statutes § 16-50k, be issued to Crown Atlantic Company LLC and Cellco Partnership d/b/a Verizon Wireless for the construction, maintenance and operation of a cellular telecommunications facility at the proposed alternate site located at 1119 Summit Road, Cheshire, Connecticut. We deny certification of the proposed prime site located at 1119 Summit Road, Cheshire, Connecticut.

The facility shall be constructed, operated, and maintained substantially as specified in the Council’s record in this matter, and subject to the following conditions:

1. The tower shall be constructed as a monopole, no taller than necessary to provide the proposed telecommunications services, sufficient to accommodate the antennas of AT&T, Voicestream, Sprint, the Town of Cheshire and other entities, both public and private, but such tower shall not exceed a height of 170 feet above ground level.
2. The Certificate Holder shall prepare a Development and Management (D&M) Plan for this site in compliance with Sections 16-50j-75 through 16-50j-77 of the Regulations of Connecticut State Agencies. The D&M Plan shall be submitted to and approved by the Council prior to the commencement of facility construction and shall include: a final site plan(s) for site development to include the location and specifications for the tower, tower foundation, antennas, a single equipment building capable to house all proposed users including the Town of Cheshire, security fence, access road, utility line, and landscaping plan. The D&M Plan shall also include construction plans to be submitted prior to construction for site clearing, water drainage, and erosion and sedimentation control consistent with the Connecticut Guidelines for Soil Erosion and Sediment Control, as amended.
3. The Certificate Holder shall, prior to the commencement of operation, provide the Council worst-case modeling of electromagnetic radio frequency power density of all proposed entities’ antennas at the closest point of uncontrolled access to the tower base, consistent with Federal Communications Commission, Office of Engineering and Technology, Bulletin No. 65, August 1997. The Certificate Holder shall provide a recalculated report of electromagnetic radio frequency power density if and when circumstances in operation cause a change in power density above the levels calculated and provided pursuant to this Decision and Order.
4. Upon the establishment of any new State or federal radio frequency standards applicable to frequencies of this facility, the facility granted herein shall be brought into compliance with such standards.
5. The Certificate Holder shall permit public or private entities to share space on the proposed tower for fair consideration, or shall provide any requesting entity with specific legal, technical, environmental, or economic reasons precluding such tower sharing.
6. If the facility does not initially provide, or permanently ceases to provide cellular services following completion of construction, this Decision and Order shall be void, and the Certificate Holder shall dismantle the tower and remove all associated equipment or reapply for any continued or new use to the Council before any such use is made.
7. Any antenna that becomes obsolete and ceases to function shall be removed within 60 days after such antennas become obsolete and ceases to function.
8. Unless otherwise approved by the Council, this Decision and Order shall be void if all construction authorized herein is not completed within three years of the effective date of this Decision and Order or within three years after all appeals to this Decision and Order have been resolved.

Pursuant to General Statutes § 16-50p, we hereby direct that a copy of the Findings of Fact, Opinion, and Decision and Order be served on each person listed below, and notice of issuance shall be published in The Hartford Courant, The Cheshire Herald, The Waterbury Republican-American and The Record Journal.

By this Decision and Order, the Council disposes of the legal rights, duties, and privileges of each party named or admitted to the proceeding in accordance with Section 16-50j-17 of the Regulations of Connecticut State Agencies.

The parties and intervenors to this proceeding are:

Crown Atlantic Company LLC
And Cellco Partnership d/b/a
Verizon Wireless

Robert Stanford, Project Manager
Crown Atlantic Company LLC
703 Hebron Avenue
Glastonbury, CT 06033
Kenneth C. Baldwin, Esq.
Robinson & Cole LLP
280 Trumbull Street
Hartford, CT 06103-3597

AT&T Wireless Services, Inc.

Anthony B. Gioffre III, Esq.
Cuddy & Feder & Worby
90 Maple Avenue
White Plains, NY 10601



Property Information

Property Location	1119 SUMMIT RD
Mailing Address	1119 SUMMIT ROAD CHESHIRE CT 06410
Land Use	Residential
Zoning Code	R-80
Neighborhood	2B

Owner	DIDOMIZIO TIMOTHY
Co-Owner	
Book / Page	2850/ 331
Land Class	Residential
Census Tract	3432
Acreage	22.52

Valuation Summary

(Assessed value = 70% of Appraised Value)

Item	Appraised	Assessed
Buildings	543472	380430
Outbuildings	5880	4120
Land	572860	252980
Total	1122212	637530

Utility Information

Electric	No
Gas	No
Sewer	No
Public Water	No
Well	Yes

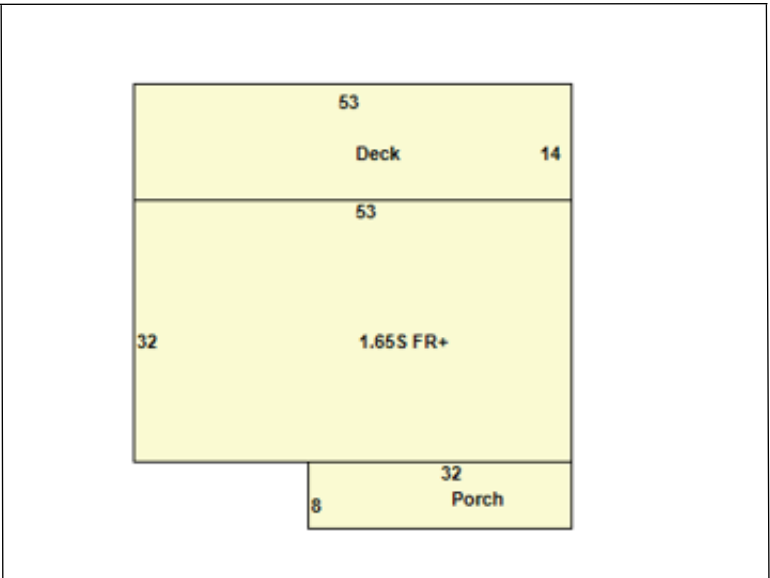

Primary Construction Details

Year Built	2018
Building Desc.	Residential
Building Style	Cape
Stories	1.65
Exterior Walls	Vinyl
Exterior Walls 2	
Interior Walls	Drywall
Interior Walls 2	
Interior Floors 1	Hardwood
Interior Floors 2	

Heating Fuel	Propane
Heating Type	FHA
AC Type	Central
Bedrooms	4
Full Bathrooms	2
Half Bathrooms	1
Extra Fixtures	0
Total Rooms	8
Bath Style	NA
Kitchen Style	Modern
Occupancy	1

Building Use	Single Family
Building Condition	Average
Frame Type	Wood Frame
Fireplaces	1
Bsmt Gar	2
Fin Bsmt Area	
Fin Bsmt Quality	
Building Grade	-10
Roof Style	Gable
Roof Cover	Arch Shingles



Town of Cheshire, CT

Property Listing Report

Map Block Lot **24 2**

Building # **1**

Unique Identifier

00087800

Detached Outbuildings

Type	Description	Area (sq ft)	Condition	Year Built
Fencing	Fencing	1600	Average	2002

Attached Extra Features

Type	Description	Area (sq ft)	Condition	Year Built
Porch	Open	256	Average	2018
Deck	Wood	742	Average	2019

Sales History

Owner of Record	Book/ Page	Sale Date	Sale Price
DIDOMIZIO TIMOTHY	2850_ 331	5/21/2018	0
DIDOMIZIO M JOANNE	798_ 74	4/3/2017	0

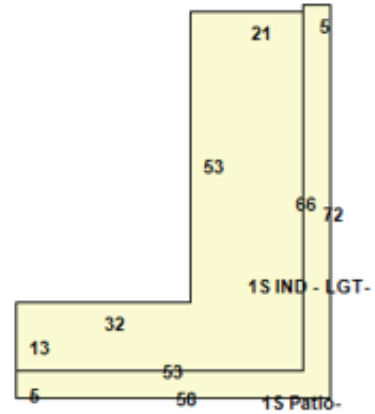

Primary Construction Details

Table with 2 columns: Field (Year Built, Building Desc, etc.) and Value (2002, Light Industrial, etc.)

Table with 2 columns: Field (Heating Fuel, Bedrooms, etc.) and Value (Blank, 0, NA, etc.)

Table with 2 columns: Field (Building Use, Building Condition, etc.) and Value (Commercial, Average, Good, etc.)

Attached Extra Features

Table with 5 columns: Type, Description, Area (sq ft), Condition, Year Built. Contains one row for a concrete patio.

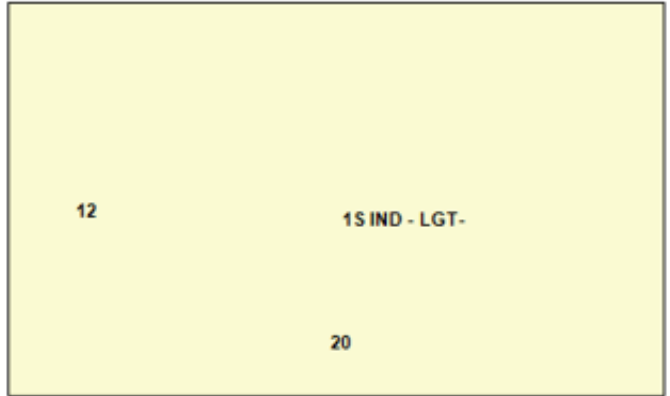

Primary Construction Details

Year Built	2004
Building Desc.	Light Industrial
Building Style	
Stories	1.00
Exterior Walls	Concrete Block
Exterior Walls 2	
Interior Walls	
Interior Walls 2	
Interior Floors 1	
Interior Floors 2	

Heating Fuel	
Heating Type	
AC Type	
Bedrooms	0
Full Bathrooms	0
Half Bathrooms	0
Extra Fixtures	0
Total Rooms	0
Bath Style	NA
Kitchen Style	
Occupancy	0

Building Use	Commercial
Building Condition	Average
Frame Type	Good
Fireplaces	0
Bsmt Gar	0
Fin Bsmt Area	
Fin Bsmt Quality	
Building Grade	0
Roof Style	Flat
Roof Cover	

Attached Extra Features

Type	Description	Area (sq ft)	Condition	Year Built

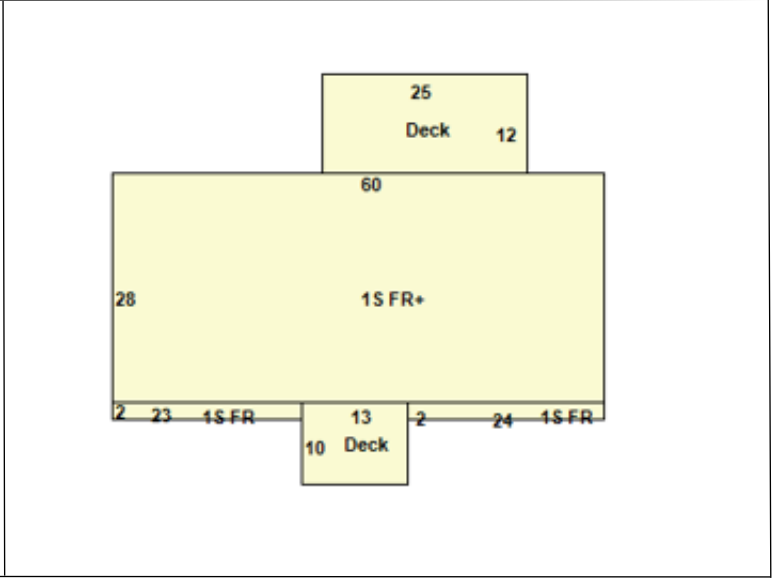

Primary Construction Details

Year Built	1990
Building Desc.	Single Family
Building Style	Ranch
Stories	1.00
Exterior Walls	Clapboards
Exterior Walls 2	
Interior Walls	
Interior Walls 2	
Interior Floors 1	Hardwood
Interior Floors 2	

Heating Fuel	Oil
Heating Type	FHA
AC Type	
Bedrooms	2
Full Bathrooms	3
Half Bathrooms	1
Extra Fixtures	0
Total Rooms	7
Bath Style	NA
Kitchen Style	
Occupancy	1

Building Use	Residential
Building Condition	Average
Frame Type	Wood Frame
Fireplaces	0
Bsmt Gar	2
Fin Bsmt Area	
Fin Bsmt Quality	
Building Grade	-5
Roof Style	Gable
Roof Cover	Asphalt

Attached Extra Features

Type	Description	Area (sq ft)	Condition	Year Built
Deck	Wood	130	Average	1990
Deck	Wood	300	Average	1990

Town of Cheshire, Connecticut - Assessment Parcel Map



Parcel: 00087800

Location: 1119 SUMMIT RD

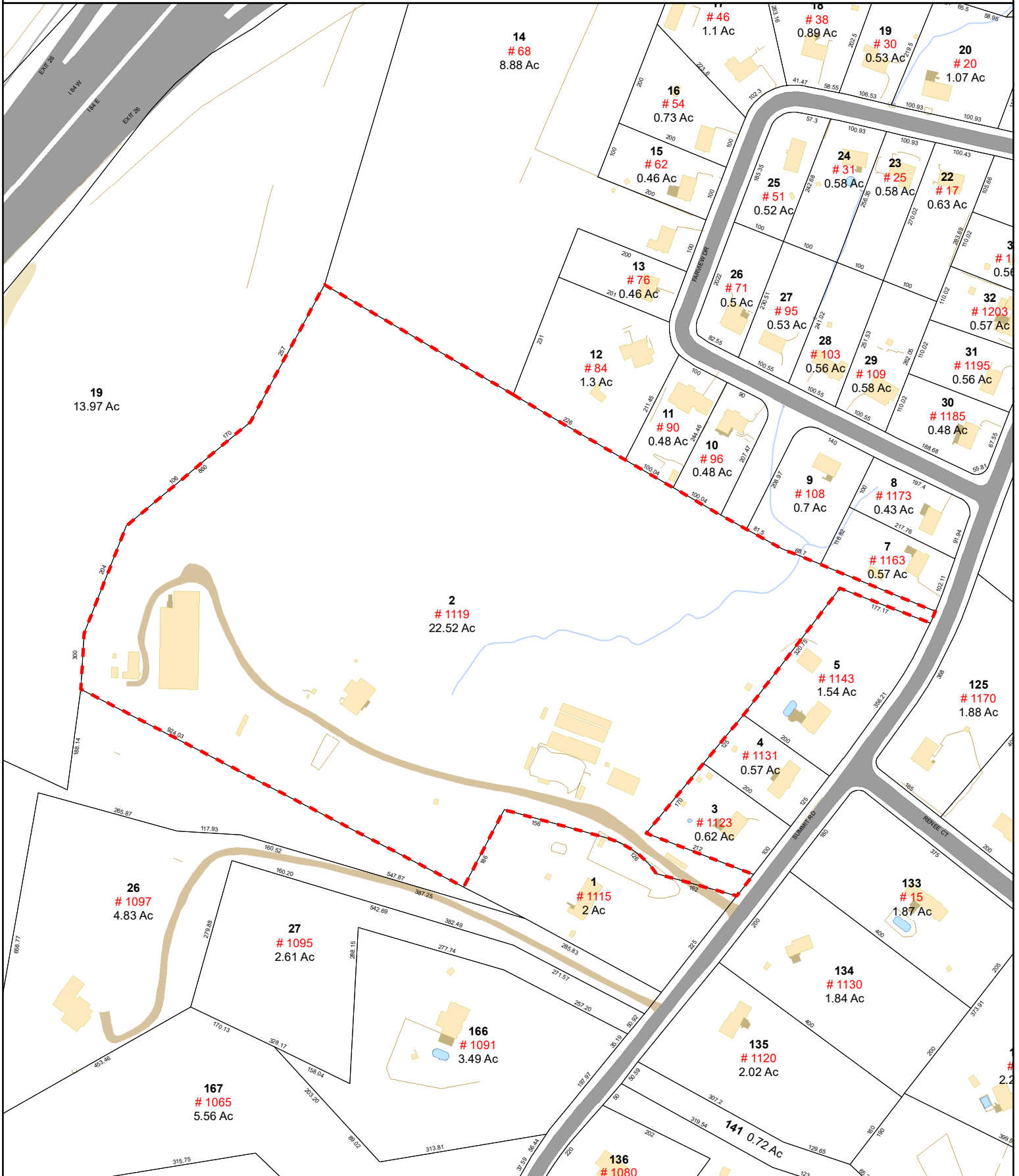

Approximate Scale: 1 inch = 233 feet

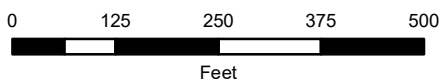

Map Produced: December 2022

Disclaimer: This map is for informational purposes only. All information is subject to verification by any user. The Town of Cheshire and its mapping contractors assume no legal responsibility for the information contained herein.

BSF0020F3V1-1

TWIN BANDSTOP 900MHZ INTERFERENCE MITIGATION FILTER

The BSF0020 is ideal for co-located 700, 850 and 900 networks. Utilising a 2.6MHz guardband the BSF0020 provides rejection of the 900 UL band while passing 700/850 UL and DL bands. Capable of being used in an outdoor environment the BSF0020 contains two identical bandstop filters, suitable for 2x2 MIMO configuration, offering excellent insertion loss, group delay and rejection.

FEATURES

- Passes full 700 and 850 bands
- Low insertion loss
- Rejection of 900MHz uplink
- DC/AISG pass
- Twin unit
- Dual twin mounting available

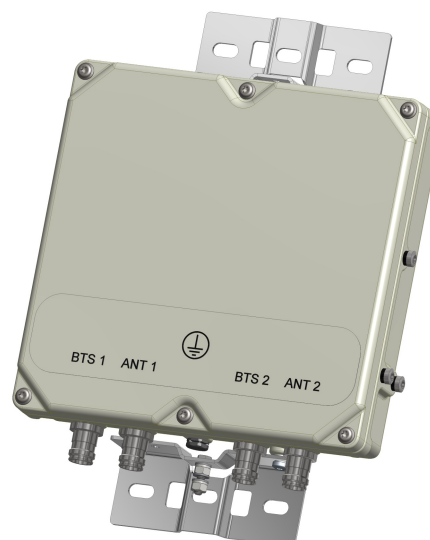

TECHNICAL SPECIFICATIONS

BAND NAME	700 PATH / 850 UPLINK PATH	850 DOWNLINK PATH
Passband	698 - 849MHz	869 - 891.5MHz
Insertion loss	0.1dB typical / 0.3dB maximum	0.5dB typical, 1.45dB maximum
Return loss	24dB typical, 18dB minimum	
Maximum input power (Per Port)	100W average	200W average and 66W per 5MHz
Rejection	53dB minimum @ 894.1 - 896.5MHz	
ELECTRICAL		
Impedance	50Ohms	
Intermodulation products	-160dBc maximum in UL Band (assuming 20MHz Signal), with 2 x 43dBm carriers -153dBc maximum with 2 x 43dBm	
DC / AISG		
Passband	0 - 13MHz	
Insertion loss	0.3dB maximum	
Return loss	15dB minimum	
Input voltage range	± 33V	
DC current rating	2A continuous, 4A peak	
Compliance	3GPP TS 25.461	
ENVIRONMENTAL		
For further details of environmental compliance, please contact Kaelus.		
Temperature range	-20°C to +60°C -4°F to +140°F	
Ingress protection	IP67	
Altitude	2600m 8530ft	
Lightning protection	RF port: ±5kA maximum (8/20us), IEC 61000-4-5 – Unit must be terminated with some lightning protection circuits.	
MTBF	>1,000,000 hours	
Compliance	ETSI EN 300 019 class 4.1H, RoHS, NEBS GR-487-CORE	
MECHANICAL		
Dimensions H x D x W	269 x 277 x 80mm 10.60 x 10.90 x 3.15in (Excluding brackets and connectors)	
Weight	8.0 kg 17.6 lbs (no bracket)	
Finish	Powder coated, light grey (RAL7035)	
Connectors	RF: 4.3-10 (F) x 4	
Mounting	Optional pole/wall bracket supplied with two metal clamps 45-178mm diameter poles or custom bracket. See ordering information.	

ORDERING INFORMATION

PART NUMBER	CONFIGURATION	OPTIONAL FEATURES	CONNECTORS
BSF0020F3V1	TWIN, 2 in / 2 out	DC/AISG PASS NO BRACKET	4.3-10 (F)
BSF0020F3V1-1	TWIN, 2 in / 2 out	DC/AISG PASS	4.3-10 (F)
BSF0020F3V1-2	QUAD, 4 in / 4 out	DC/AISG PASS	4.3-10 (F)

ELECTRICAL BLOCK DIAGRAM

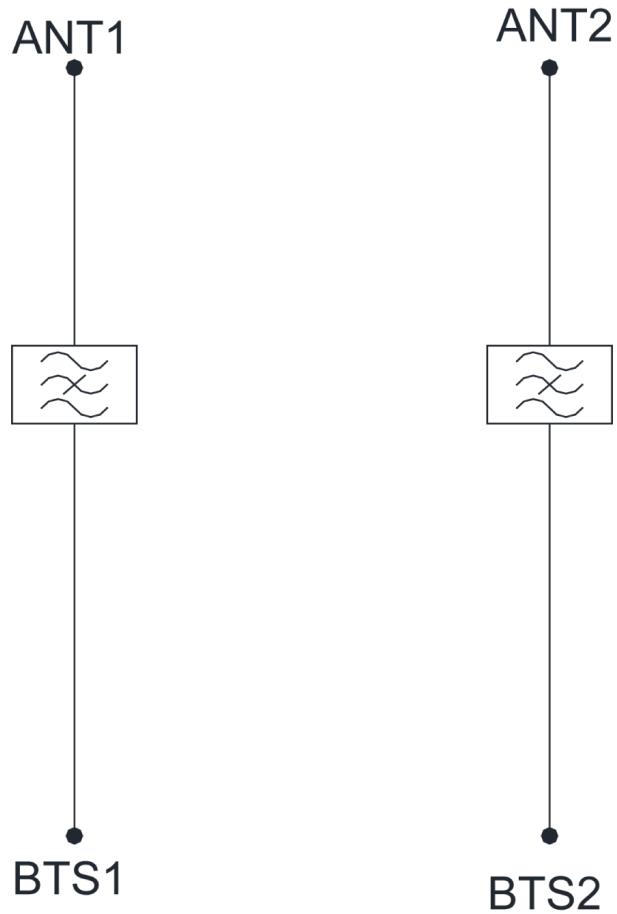

MECHANICAL BLOCK DIAGRAM

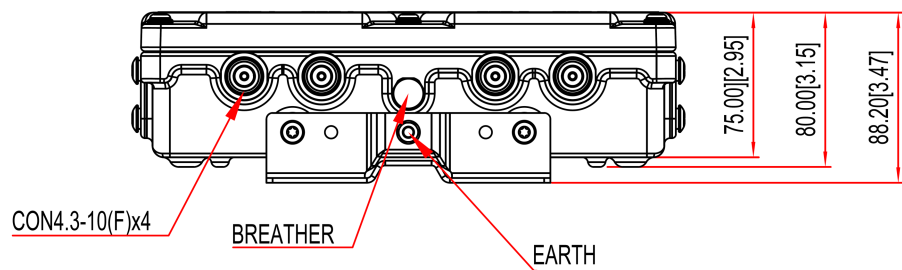
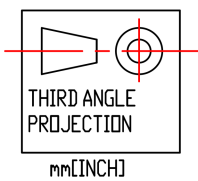
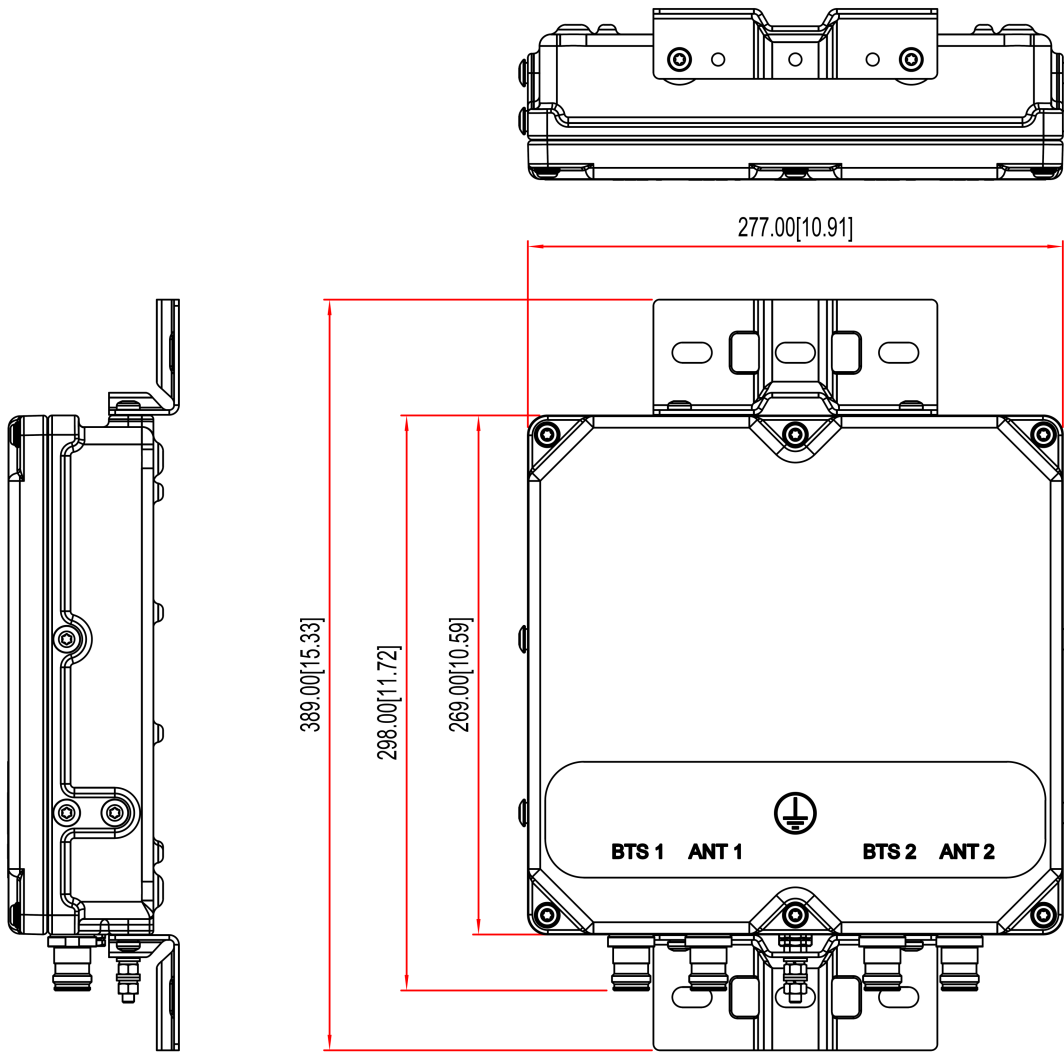

Colliers Engineering & Design CT, P.C.
1055 Washington Boulevard
Stamford, CT 06901
203.324.0800
peter.albano@collierseng.com

Antenna Mount Analysis Report and PMI Requirements

Mount ReAnalysis

SMART Tool Project #: 10206414
Colliers Engineering & Design Project #: 23777061 (Rev. 1)

July 10, 2023

Site Information

Site ID: 5000381811-VZW / CHESHIRE 2 CT
Site Name: CHESHIRE 2 CT
Carrier Name: Verizon Wireless
Address: 1119 Summit Rd
Cheshire, Connecticut 06410
New Haven County
Latitude: 41.536389°
Longitude: -72.957278°

Structure Information

Tower Type: 170-Ft Monopole
Mount Type: 14.00-Ft Platform

FUZE ID # 17123721

Analysis Results

Platform: 69.4% Pass*

***Antennas and equipment to be installed in compliance with PMI Requirements of this mount analysis.**

***Contractor PMI Requirements:

Included at the end of this MA report

Available & Submitted via portal at <https://pmi.vzwsmart.com>

For additional questions and support, please reach out to:

pmisupport@colliersengineering.com

Report Prepared By: Frank Centone



Executive Summary:

The objective of this report is to determine the capacity of the antenna support mount at the subject facility for the final wireless telecommunications configuration, per the applicable codes and standards. Any modification listed under Sources of Information was assumed completed and was included in this analysis.

This analysis is inclusive of the mount structure only and does not address the structural capacity of the supporting structure. This mounting frame was not analyzed as an anchor attachment point for fall protection. All climbing activities are required to have a fall protection plan completed by a competent person.

Sources of Information:

Document Type	Remarks
Radio Frequency Data Sheet (RFDS)	Verizon RFDS, Site ID: 323579, dated February 4, 2021
Mount Mapping Report	Structural Components, Project # 16244585, dated February 24, 2021
Post Modification Inspection Report	Colliers Engineering & Design Project #: 21777111, dated April 10, 2023
Final Loading Guidance	Filter Add Scope Provided by Verizon Wireless

Analysis Criteria:

Codes and Standards:	ANSI/TIA-222-H 2022 Connecticut State Building Code (CSBC), Effective October 1, 2022
Wind Parameters:	Basic Wind Speed (Ultimate 3-sec. Gust), V_{ULT} : 120 mph Ice Wind Speed (3-sec. Gust): 50 mph Design Ice Thickness: 1.00 in Risk Category: II Exposure Category: C Topographic Category: 1 Topographic Feature Considered: N/A Topographic Method: N/A Ground Elevation Factor, K_e : 0.978
Seismic Parameters:	S_s : 0.200 g S_1 : 0.055 g
Maintenance Parameters:	Wind Speed (3-sec. Gust): 30 mph Maintenance Load, L_v : 250 lbs. Maintenance Load, L_m : 500 lbs.
Analysis Software:	RISA-3D (V17)

Final Loading Configuration:

The following equipment has been considered for the analysis of the mount:

Mount Elevation (ft)	Equipment Elevation (ft)	Quantity	Manufacturer	Model	Status
165.00	167.00	6	JMA Wireless	MX06FRO660-03	Retained
		3	Samsung	MT6407-77A	
		3	Samsung	B2/B66A RRH-BR049	
		3	Samsung	B5/B13 RRH-BR04C	
		6	Amphenol Antel	LPA-80063/6CF	
		1	-	4.0'x3.0' Grid Dish	
		1	-	2.5'x1.5' Grid Dish	
		1	Raycap	OVP-12*	
		4	KAelus	BSF0020F3V1-1	Added

* Equipment to be flush mounted directly to the Monopole. They are not mounted on the platform mounts and are not included in this mount analysis.

The provided closeout photos reported existing OVP units. It is acceptable to install up to any three (3) of the OVP model numbers listed below as required at any location other than the mount face without affecting the structural capacity of the mount. If OVP units are installed on the mount face, a mount re-analysis may be required unless replacing an existing OVP.

Model Number	Ports	AKA
RVZDC-6627-PF-48	12	OVP-12
DB-B1-6C-12AB-0Z	6	OVP-6

Standard Conditions:

1. All engineering services are performed on the basis that the information provided to Colliers Engineering & Design and used in this analysis is current and correct. The existing equipment loading has been applied at locations determined from the supplied documentation. Any deviation from the loading locations specified in this report shall be communicated to Colliers Engineering & Design to verify deviation will not adversely impact the analysis.
2. Mounts are assumed to have been properly fabricated, installed and maintained in good condition, twist free and plumb in accordance with its original design and manufacturer’s specifications.

Obvious safety and structural issues/deficiencies noticed at the time of the mount mapping and reported in the Mount Mapping Report are assumed to be corrected and documented as part of the PMI process and are not considered in the mount analysis.

The mount analysis and the mount mapping are not a condition assessment of the mount. Proper maintenance and condition assessments are still required post analysis.

3. For mount analyses completed from other data sources (including new replacement mounts) and not specifically mapped in accordance with the NSTD-446 Standard, the mounts are assumed to have been properly fabricated, installed and maintained in good condition, twist free and plumb in accordance with its original design and manufacturer’s specifications.
4. All member connections are assumed to have been designed to meet or exceed the load carrying capacity of the connected member unless otherwise specified in this report.

5. The mount was checked up to, and including, the bolts that fasten it to the mount collar/attachment and threaded rod connections in collar members if applicable. Local deformation and interaction between the mount collar/attachment and the supporting tower structure are outside the scope of this analysis.
6. All services are performed, results obtained, and recommendations made in accordance with generally accepted engineering principles and practices. Colliers Engineering & Design is not responsible for the conclusion, opinions, and recommendations made by others based on the information supplied.
7. Structural Steel Grades have been assumed as follows, if applicable, unless otherwise noted in this analysis:
 - o Channel, Solid Round, Angle, Plate ASTM A36 (Gr. 36)
 - o HSS (Rectangular) ASTM 500 (Gr. B-46)
 - o Pipe ASTM A53 (Gr. B-35)
 - o Threaded Rod F1554 (Gr. 36)
 - o Bolts ASTM A325

Discrepancies between in-field conditions and the assumptions listed above may render this analysis invalid unless explicitly approved by Colliers Engineering & Design.

Analysis Results:

Component	Utilization %	Pass/Fail
Face Horizontal	50.5%	Pass
Standoff Angle	31.6%	Pass
Standoff Horizontal	69.4%	Pass
Antenna Pipe	42.0%	Pass
Dual Antenna Pipe	24.3%	Pass
Solid Rod	59.6%	Pass
Support Rail	14.7%	Pass
V-Bracing	38.3%	Pass
Support Rail Angle	28.5%	Pass
Mount Connection	50.2%	Pass

Structure Rating – (Controlling Utilization of all Components)	69.4%
---	--------------

Mount Steel (EPA)a per ANSI/TIA-222-H Section 2.6.11.2:

Ice Thickness (In)	Mount Pipes Excluded		Mount Pipes Included	
	Front (EPA)a (Sq. Ft.)	Side (EPA)a (Sq. Ft.)	Front (EPA)a (Sq. Ft.)	Side (EPA)a (Sq. Ft.)
0	48.4	48.3	68.0	68.0
0.5	61.2	61.1	88.8	88.6
1	73.4	73.2	108.9	108.7

Notes:

- (EPA)a values listed above may be used in the absence of more precise information
- (EPA)a values in the table above include 3 sector(s).
- Ka factors included in (EPA)a calculations

Requirements:

The existing mount is **SUFFICIENT** for the final loading configuration shown in attachment 2 and do not require modifications. Additional requirements are noted below.

Contractor shall inspect climbing facilities and safety climb and ensure they are in good condition. Contractor shall install safety climb wire rope guides in locations where wire rope is rubbing against the mount or mount-to-tower connection steel. Wire brush clean any observed corrosion and protect with two (2) coats of cold galvanization (Zinga or Zinc Kote). Contractor shall provide photos of wire rope guide installation as part of PMI documents. Contact EOR if additional guidance is required.

If required, ANSI/ASSP rigging plan review services compliant with the requirements of ANSI/TIA 322 are available for a Construction Class IV site or other. Separate review fees will apply.

Attachments:

1. **Contractor Required Post Installation Inspection (PMI) Report Deliverables**
2. Antenna Placement Diagrams
3. Mount Photos
4. Mount Mapping Report (for reference only)
5. Analysis Calculations

Mount Desktop – Post Modification Inspection (PMI) Report Requirements

Documents & Photos Required from Contractor – **Passing Mount Analysis**

Passing Mount Analysis requires a PMI due to a modification in loading.

Electronic pdf version of this can be downloaded at <https://pmi.vzwsmart.com>.

For additional questions and support, please reach out to pmisupport@colliersengineering.com

MDG #: 5000381811

SMART Project #: 10206414

Fuze Project ID: 17123721

Purpose – to provide SMART Tool structural vendor the proper documentation in order to complete the required Mount Desktop review of the Post Modification Inspection Report.

- Contractor is responsible for making certain the photos provided as noted below provide confirmation that the installation was completed in accordance with this Passing Mount Analysis.
- Contractor shall relay any data that can impact the performance of the mount, this includes safety issues.

Base Requirements:

- If installation will cause damage to the structure, the climbing facility, or safety climb if present or any installed system, SMART Tool vendor to be notified prior to install. Any special photos outside of the standard requirements will be indicated on the drawings.
- Provide “as built mount drawings” showing contractor’s name, contact information, preparer’s signature, and date. Any deviations from the drawings (Proposed modification) shall be shown. NOTE: If loading is different than what is conveyed in the passing mount analysis (MA) contact the SMART Tool vendor immediately.
- Each photo should be time and date stamped
- Photos should be high resolution.
- Contractor shall ensure that the safety climb wire rope is supported and not adversely impacted by the install of the modification components. This may involve the install of wire rope guides, or other items to protect the wire rope. If there is conflict, contact the SMART Tool engineer for recommendations.
- The PMI can be accessed at the following portal: <https://pmi.vzwsmart.com>

Photo Requirements:

- Photos taken at ground level
 - Photo of Gate Signs showing the tower owner, site name, and number.
 - Overall tower structure after installation.
 - Photos of the mount after installation; if the mounts are at different rad elevations, pictures must be provided for all elevations that equipment was installed.
- Photos taken at Mount Elevation
 - Photos showing the safety climb wire rope above and below the mount prior to installation.
 - Photos showing the climbing facility and safety climb if present.

- Photos showing each individual sector after installation. Each entire sector shall be in one photo to show the interconnection of members.
 - These photos shall also certify that the placement and geometry of the equipment on the mount is as depicted in the antenna placement diagram in this form.
- Photos that show the model number of each antenna and piece of equipment installed per sector.

Antenna & equipment placement and Geometry Confirmation:

- The contractor shall certify that the antenna & equipment placement and geometry is in accordance with the sketch and table as included in the mount analysis and noted below.
 - The contractor certifies that the photos support and the equipment on the mount is as depicted on the sketch and table included in this form and with the mount analysis provided.

OR

- The contractor notes that the equipment on the mount is not in accordance with the sketch and has noted the differences below and provided photo documentation of any alterations.

Special Instructions / Validation as required from the MA or any other information the contractor deems necessary to share that was identified:

Issue:

Contractor shall inspect climbing facilities and safety climb and ensure they are in good condition. Contractor shall install safety climb wire rope guides in locations where wire rope is rubbing against the mount or mount-to-tower connection steel. Wire brush clean any observed corrosion and protect with two (2) coats of cold galvanization (Zinga or Zinc Kote). Contractor shall provide photos of wire rope guide installation as part of PMI documents. Contact EOR if additional guidance is required.

Response:

Special Instruction Confirmation:

- The contractor has read and acknowledges the above special instructions.
- All hardware listed in the Special Instructions above (if applicable) has been properly installed, and the existing hardware was inspected.
- The material utilized was as specified in the SMART Tool engineering vendor Special Instructions above (if applicable) and included in the material certification folder is a packing list or invoice for these materials.

OR

The material utilized was approved by a SMART Tool engineering vendor as an “equivalent” and this approval is included as part of the contractor submission.

Comments:

--

Contractor certifies that the climbing facility / safety climb was not damaged prior to starting work:

Yes No

Contractor certifies no new damage created during the current installation:

Yes No

Contractor to certify the condition of the safety climb and verify no damage when leaving the site:

Safety Climb in Good Condition Safety Climb Damaged

Certifying Individual:

Company:	
Employee Name:	
Contact Phone:	
Email:	
Date:	

Plan View

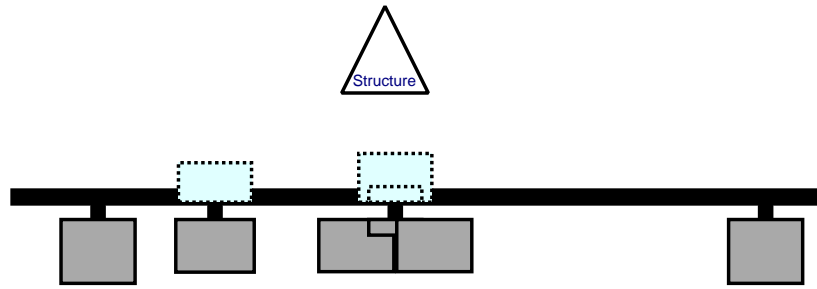

Front View - Looking at Structure

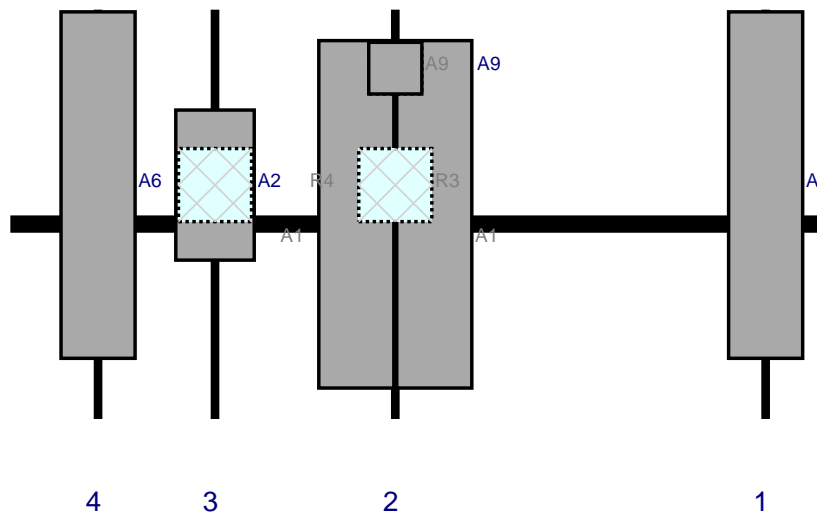

Ref#	Model	Height (in)	Width (in)	H Dist Frm L.	Pipe #	Pipe Pos V	Ant Pos	C. Ant Frm T.	Ant H Off	Status	Validation
A6	LPA-80063/6CF	71.1	15.2	155	1	a	Front	36	0	Retained	03/24/2023
A1	MX06FRO660-03	71.3	15.4	79	2	a	Front	42	8	Retained	03/24/2023
A1	MX06FRO660-03	71.3	15.4	79	2	b	Front	42	-8	Retained	03/24/2023
R3	B2/B66A RRH-BR049	15	15	79	2	a	Behind	36	0	Retained	03/24/2023
A9	BSF0020F3V1-1	10.6	10.9	79	2	a	Behind	12	0	Added	
A9	BSF0020F3V1-1	10.6	10.9	79	2	b	Front	12	0	Added	
A2	MT6407-77A	30.8	16.1	42	3	a	Front	36	0	Retained	03/24/2023
R4	B5/B13 RRH-BR04C	15	15	42	3	a	Behind	36	0	Retained	03/24/2023
A6	LPA-80063/6CF	71.1	15.2	18	4	a	Front	36	0	Retained	03/24/2023
M76	4.0'x3.0' Grid Dish	10	10			Member				Retained	03/24/2023
M76	2.5'x1.5' Grid Dish	8	8			Member				Retained	03/24/2023

Sector: **B**
 Structure Type: Self Support
 Mount Elev: 165.00

7/10/2023

10206414



Page: 2

Plan View

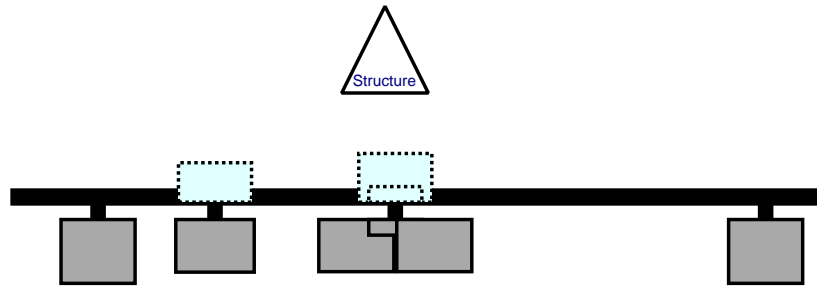

Front View - Looking at Structure

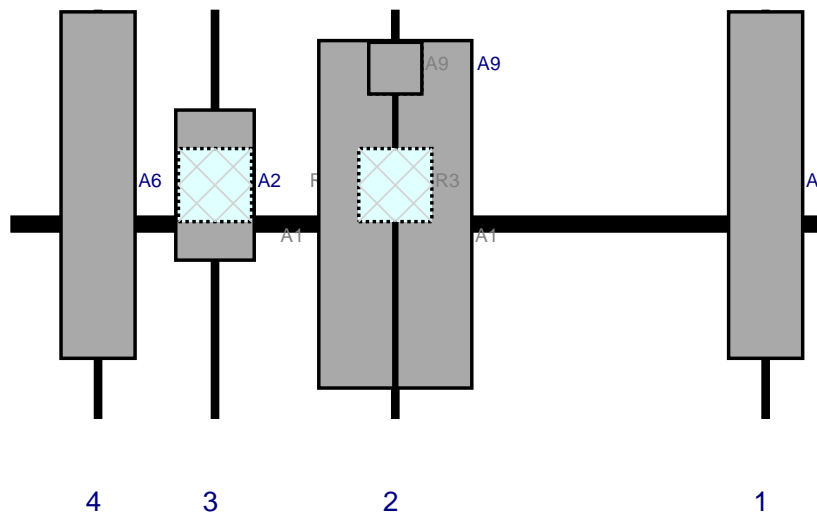

Ref#	Model	Height (in)	Width (in)	H Dist Frm L.	Pipe #	Pipe Pos V	Ant Pos	C. Ant Frm T.	Ant H Off	Status	Validation
A6	LPA-80063/6CF	71.1	15.2	155	1	a	Front	36	0	Retained	03/24/2023
A1	MX06FRO660-03	71.3	15.4	79	2	a	Front	42	8	Retained	03/24/2023
A1	MX06FRO660-03	71.3	15.4	79	2	b	Front	42	-8	Retained	03/24/2023
R3	B2/B66A RRH-BR049	15	15	79	2	a	Behind	36	0	Retained	03/24/2023
A9	BSF0020F3V1-1	10.6	10.9	79	2	a	Behind	12	0	Added	
A9	BSF0020F3V1-1	10.6	10.9	79	2	b	Front	12	0	Added	
A2	MT6407-77A	30.8	16.1	42	3	a	Front	36	0	Retained	03/24/2023
R4	B5/B13 RRH-BR04C	15	15	42	3	a	Behind	36	0	Retained	03/24/2023
A6	LPA-80063/6CF	71.1	15.2	18	4	a	Front	36	0	Retained	03/24/2023

Plan View

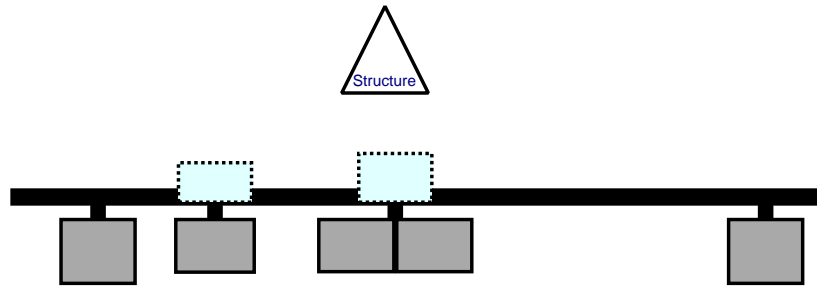

Front View - Looking at Structure

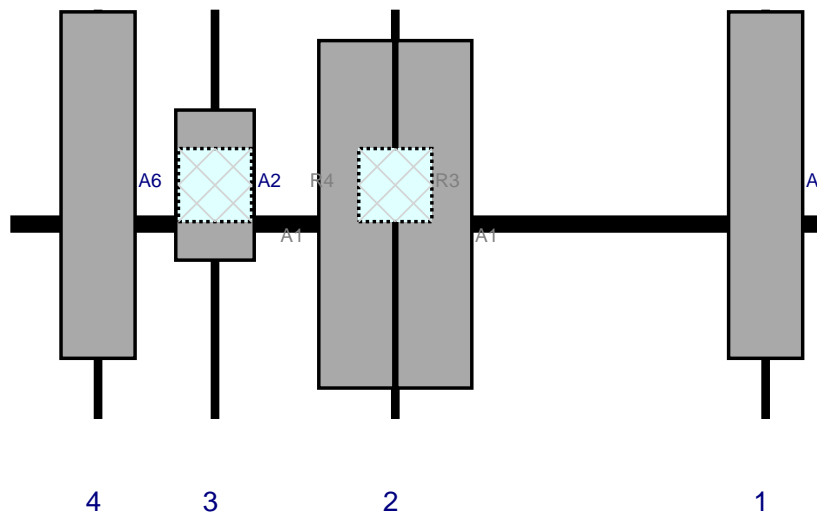

Ref#	Model	Height (in)	Width (in)	H Dist Frm L.	Pipe #	Pipe Pos V	Ant Pos	C. Ant Frm T.	Ant H Off	Status	Validation
A6	LPA-80063/6CF	71.1	15.2	155	1	a	Front	36	0	Retained	03/24/2023
A1	MX06FRO660-03	71.3	15.4	79	2	a	Front	42	8	Retained	03/24/2023
A1	MX06FRO660-03	71.3	15.4	79	2	b	Front	42	-8	Retained	03/24/2023
R3	B2/B66A RRH-BR049	15	15	79	2	a	Behind	36	0	Retained	03/24/2023
A2	MT6407-77A	30.8	16.1	42	3	a	Front	36	0	Retained	03/24/2023
R4	B5/B13 RRH-BR04C	15	15	42	3	a	Behind	36	0	Retained	03/24/2023
A6	LPA-80063/6CF	71.1	15.2	18	4	a	Front	36	0	Retained	03/24/2023



Mount Azimuth (Degree) for Each Sector				Tower Leg Azimuth (Degree) for Each Sector				Sector B													
Sector A:	60.00	Deg	Leg A:		Deg	Ant _{1a}															
Sector B:	180.00	Deg	Leg B:		Deg	Ant _{1b}	Amphonal LPA 80063	15.00	12.00	71.00	1) 1-5/8 T	166.25	29.00	17.00	180.00	17.25					
Sector C:	300.00	Deg	Leg C:		Deg	Ant _{1c}															
Sector D:		Deg	Leg D:		Deg	Ant _{2a}	9442 RRH 2x40 AWS	12.00	8.00	21.00		167.25	17.00	-7.00		17					
Climbing Facility Information						Ant _{2b}	Amphonal BXA 17106	6.00	4.00	48.00	Jumpers	166.167	30.00	10.00	180.00	17.25					
Location:	300.00	Deg	N/A			Ant _{2c}															
Climbing Facility	Corrosion Type:	N/A				Ant _{3a}															
	Access:	Climbing path was obstructed.				Ant _{3b}	Amphonal BXA 70063	11.00	4.00	71.00	2) 1-5/8 T	165.5	35.00	8.50	180.00	17.25					
	Condition:	Missing safety cable.				Ant _{3c}															
						Ant _{4a}															
						Ant _{4b}	Amphonal BXA 17106	6.00	4.00	48.00	2) 1-5/8 T	165.917	21.00	8.00	180.00	17					
						Ant _{4c}															
						Ant _{5a}															
						Ant _{5b}	Amphonal LPA 80063	15.00	12.00	71.00	1) 1-5/8 T	165.583	36.00	18.00	180.00	17.25					
						Ant _{5c}															
						Ant on Standoff															
						Ant on Standoff															
						Ant on Tower															
						Ant on Tower															
Sector C																					
						Ant _{1a}	GPS	3.00			1/2 tx	169.75	-14.00			247					
						Ant _{1b}	Amphonal LPA 80063	15.00	12.00	71.00	1) 1-5/8 T	166.083	30.00	17.00	300.00	23.25					
						Ant _{1c}															
						Ant _{2a}	9442 RRH 2x40 AWS	12.00	8.00	21.00		167	17.00	-7.00		23					
						Ant _{2b}	Amphonal BXA 17106	6.00	4.00	48.00	Jumpers	166.083	28.00	9.00	300.00	23.25					
						Ant _{2c}															
						Ant _{3a}															
						Ant _{3b}	Amphonal BXA 70063	11.00	4.00	71.00	2) 1-5/8 T	165.167	33.00	15.00	300.00	23.25					
						Ant _{3c}															
						Ant _{4a}															
						Ant _{4b}	Amphonal BXA 17106	6.00	4.00	48.00	2) 1-5/8 T	166	30.00	8.00	300.00	23.25					
						Ant _{4c}															
						Ant _{5a}															
						Ant _{5b}	Amphonal LPA 80063	15.00	12.00	71.00	1) 1-5/8 T	165.417	36.00	17.00	300.00	10,23.25					
						Ant _{5c}															
						Ant on Standoff															
						Ant on Standoff															
						Ant on Tower															
						Ant on Tower															
Sector D																					
Ant _{1a}																					
Ant _{1b}																					
Ant _{1c}																					
Ant _{2a}																					
Ant _{2b}																					
Ant _{2c}																					
Ant _{3a}																					
Ant _{3b}																					
Ant _{3c}																					
Ant _{4a}																					
Ant _{4b}																					
Ant _{4c}																					
Ant _{5a}																					
Ant _{5b}																					
Ant _{5c}																					
Ant on Standoff																					
Ant on Standoff																					
Ant on Tower																					
Ant on Tower																					

Observed Safety and Structural Issues During the Mount Mapping		
Issue #	Description of Issue	Photo #

1		
2		
3		
4		
5		
6		
7		
8		

Mapping Notes

1. Please report any visible structural or safety issues observed on the antenna mounts (Damaged members, loose connections, tilting mounts, safety climb issues, etc.)
2. If the thickness of the existing pipes or tubing can't be obtained from a general tool (such as Caliper), please use an ultrasonic measurement tool (thickness gauge) to measure the thickness.
3. Please create all required detail sketches of the mounts and insert them into the "Sketches" tab.
4. Please measure and enter the bolt sizes and types under the Members Box in the spreadsheet of the mount type.
5. Take and label the photos of the tower, mounts, connections, antennas and all measurements. Minimum 50 photos are required.
6. Please measure and report the size and length of all existing antenna mounting pipes.
7. Please measure and report the antenna information for all sectors.
8. Don't delete or rearrange any sheet or contents of any sheet from this mapping form.

Standard Conditions

1. Obvious safety and structural issues/deficiencies noticed at the time of the mount mapping are to be reported in this mapping. However, this mount mapping is not a condition assessment of the mount.



Antenna Mount Mapping Form (PATENT PENDING)

FCC #

Tower Owner:	Crown Castle	Mapping Date:	2/24/2021
Site Name:	Cheshire 2 CT	Tower Type:	Monopole
Site Number or ID:	16244585	Tower Height (Ft.):	165
Mapping Contractor:	Structural Components	Mount Elevation (Ft.):	165

This antenna mapping form is the property of TES and under PATENT PENDING. The formation contained herein is considered confidential in nature and is to be used only for the specific customer it was intended for. Reproduction, transmission, publication, modification or disclosure by any method is prohibited except by express written permission of TES. All means and methods are the responsibility of the contractor and the work shall be compliant with ANSI/ASSE A 10.48, OSHA, FCC, FAA and other safety requirements that may apply. TES is not warranting the usability of the safety climb as it must be assessed prior to each use in compliance with OSHA requirements.

Please Insert Sketches of the Antenna Mount

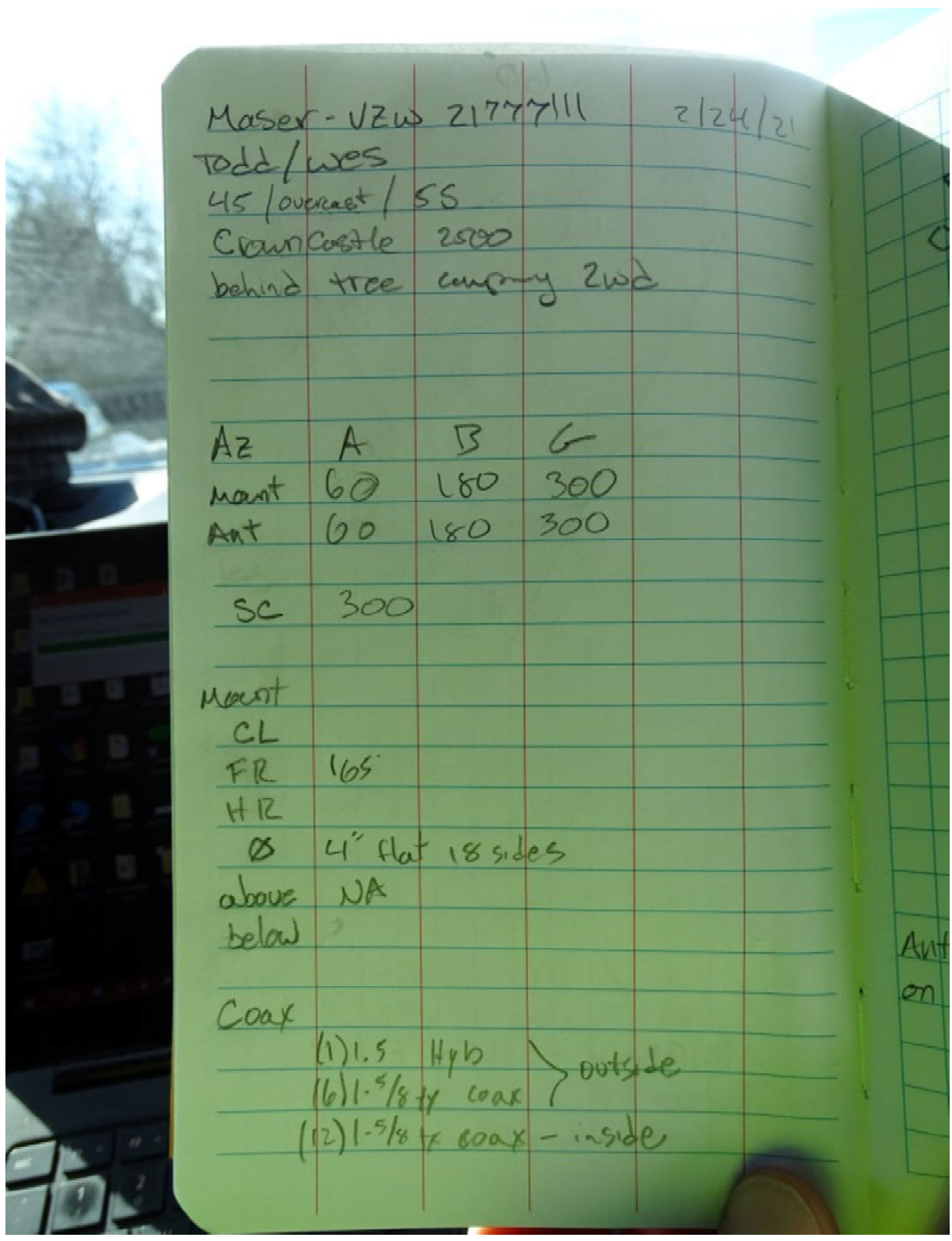

21777111 Chesire Ct
 Maser/Vet MM
 2wo Access through private
 450F, PC, 5-10 W
 Crown Size

2/23/21
 Nest/Todd
 property

Mount attached to top flange

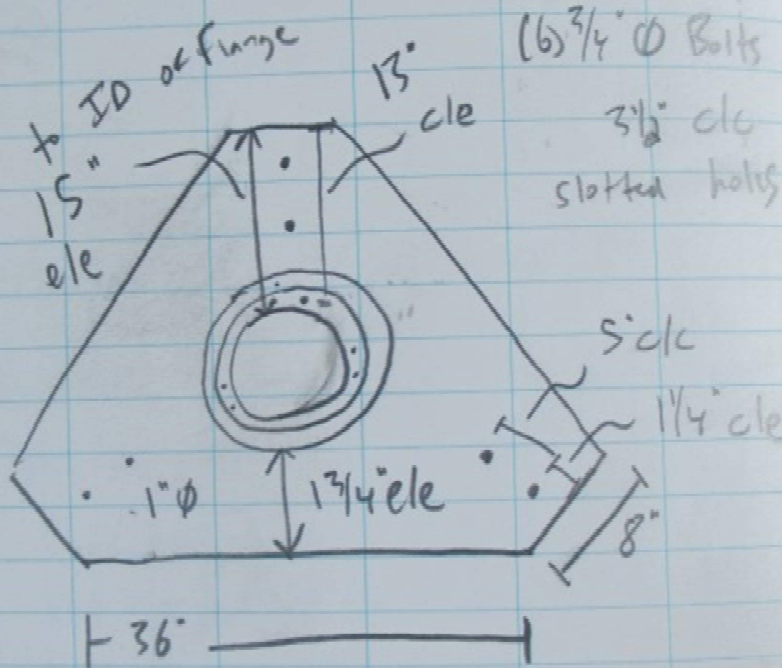

Pole = 18 sides, 4" E/E, 2 1/2" less than
 flange Ø
 Top flange = 3/4" thick

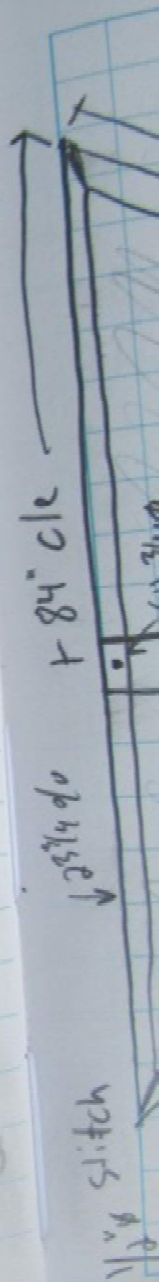

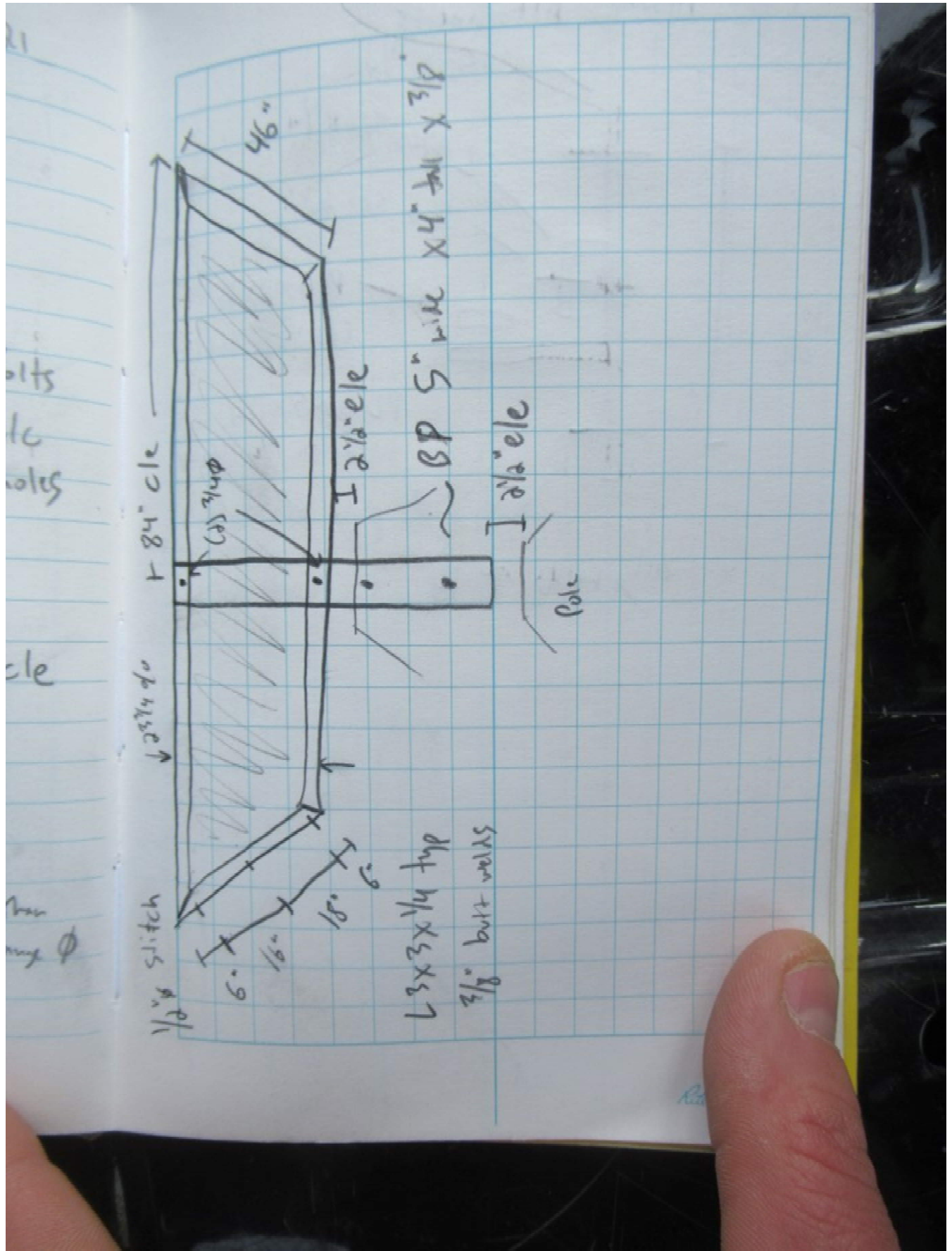

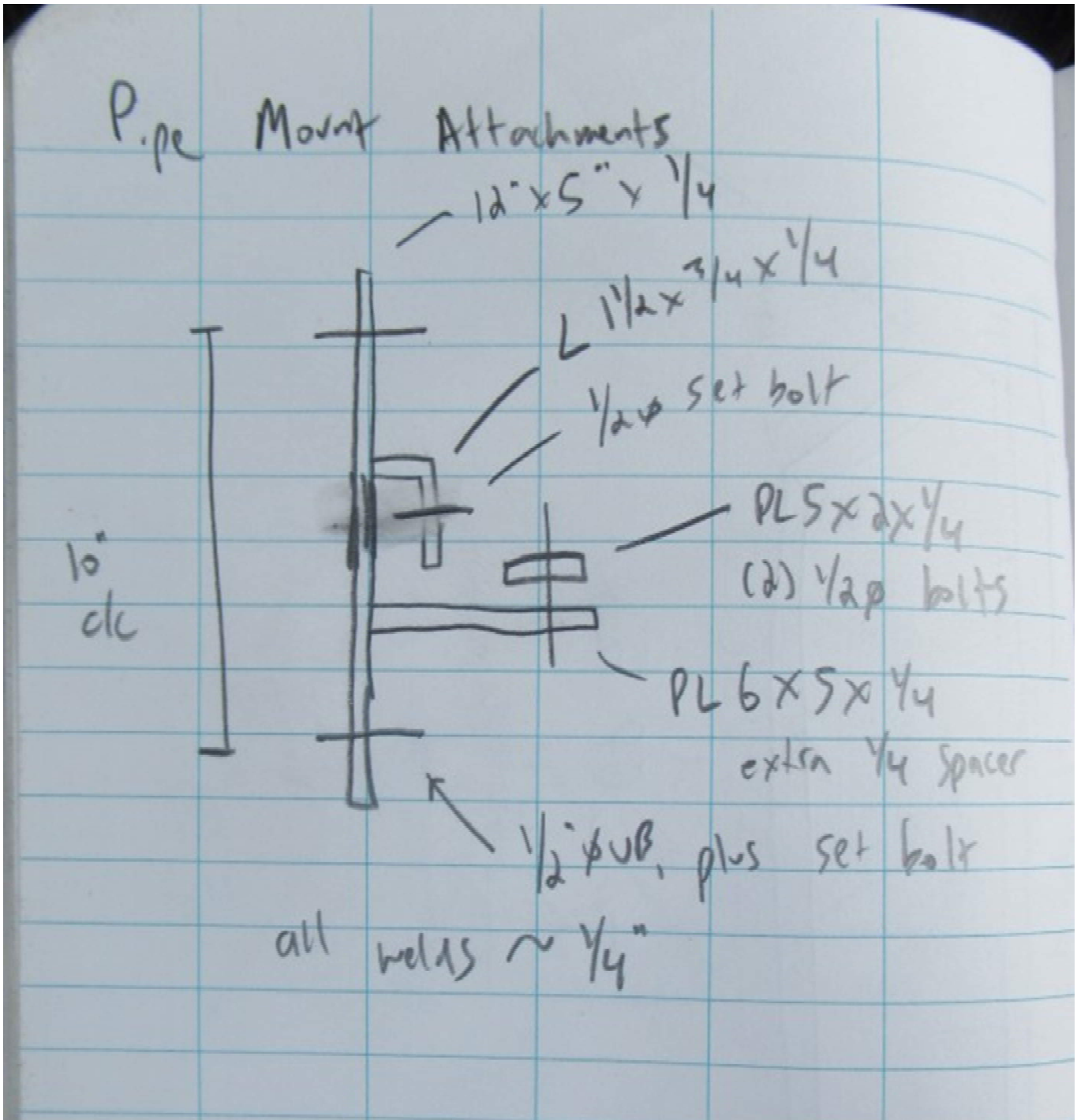

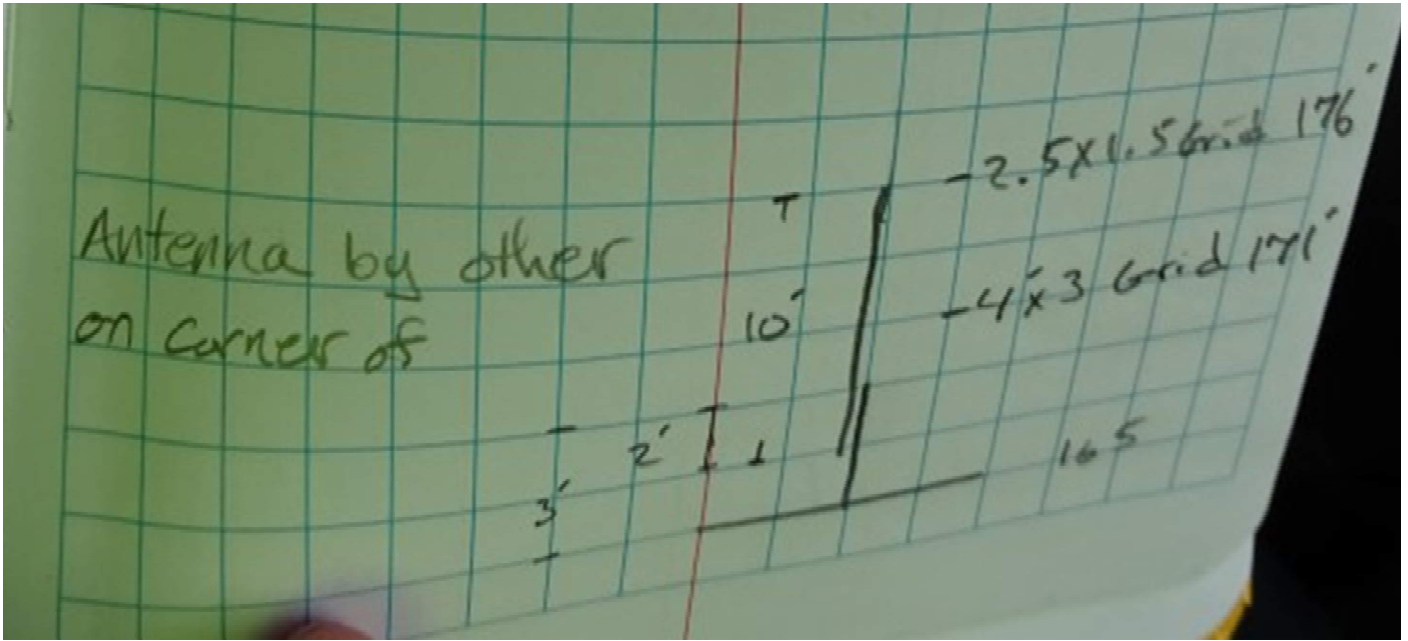

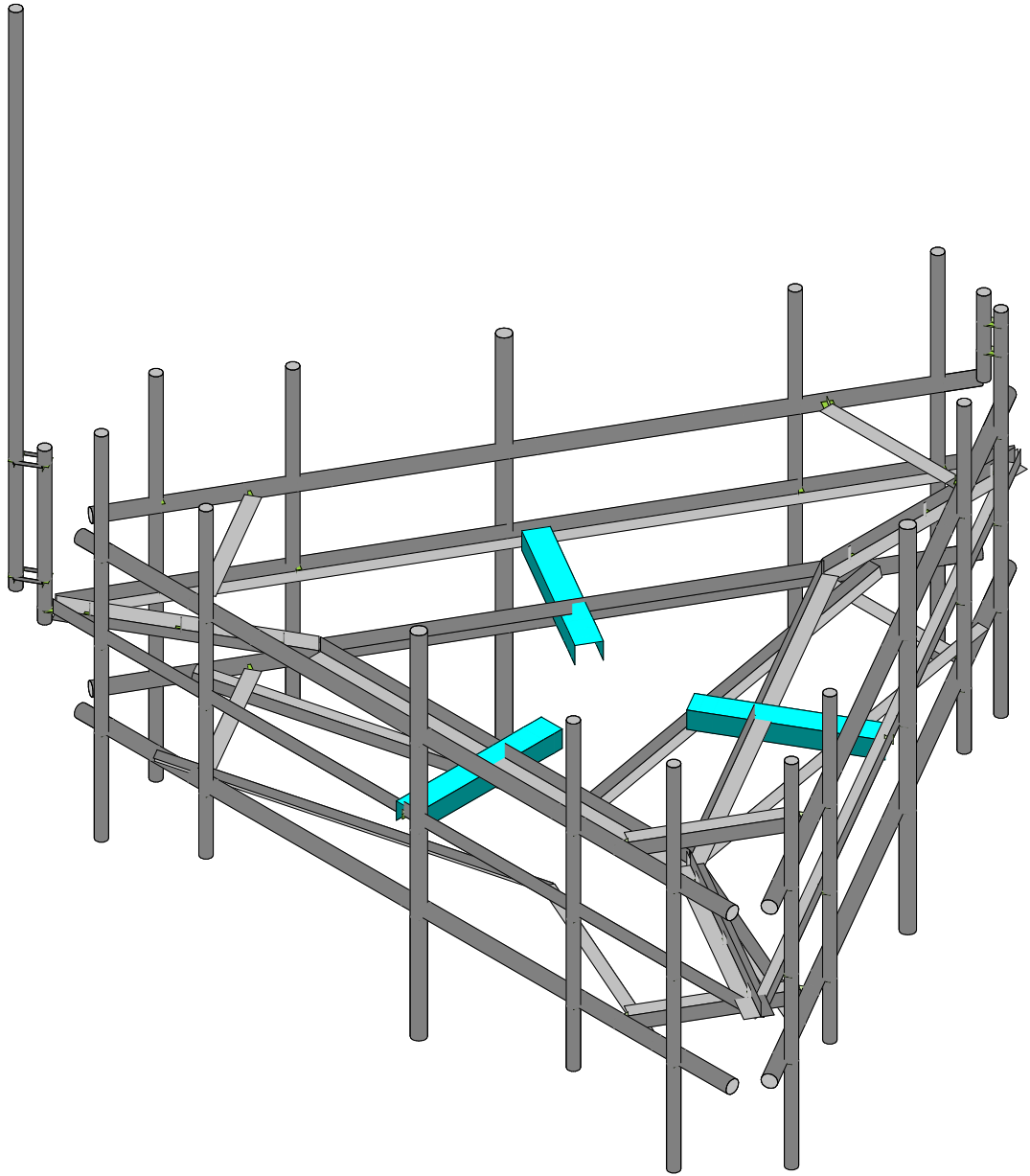
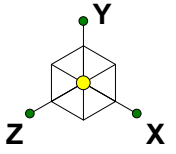

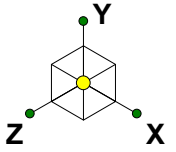

Code Check (Env)

Black	No Calc
Red	> 1.0
Magenta	.90-1.0
Green	.75-.90
Cyan	.50-.75
Blue	0-.50

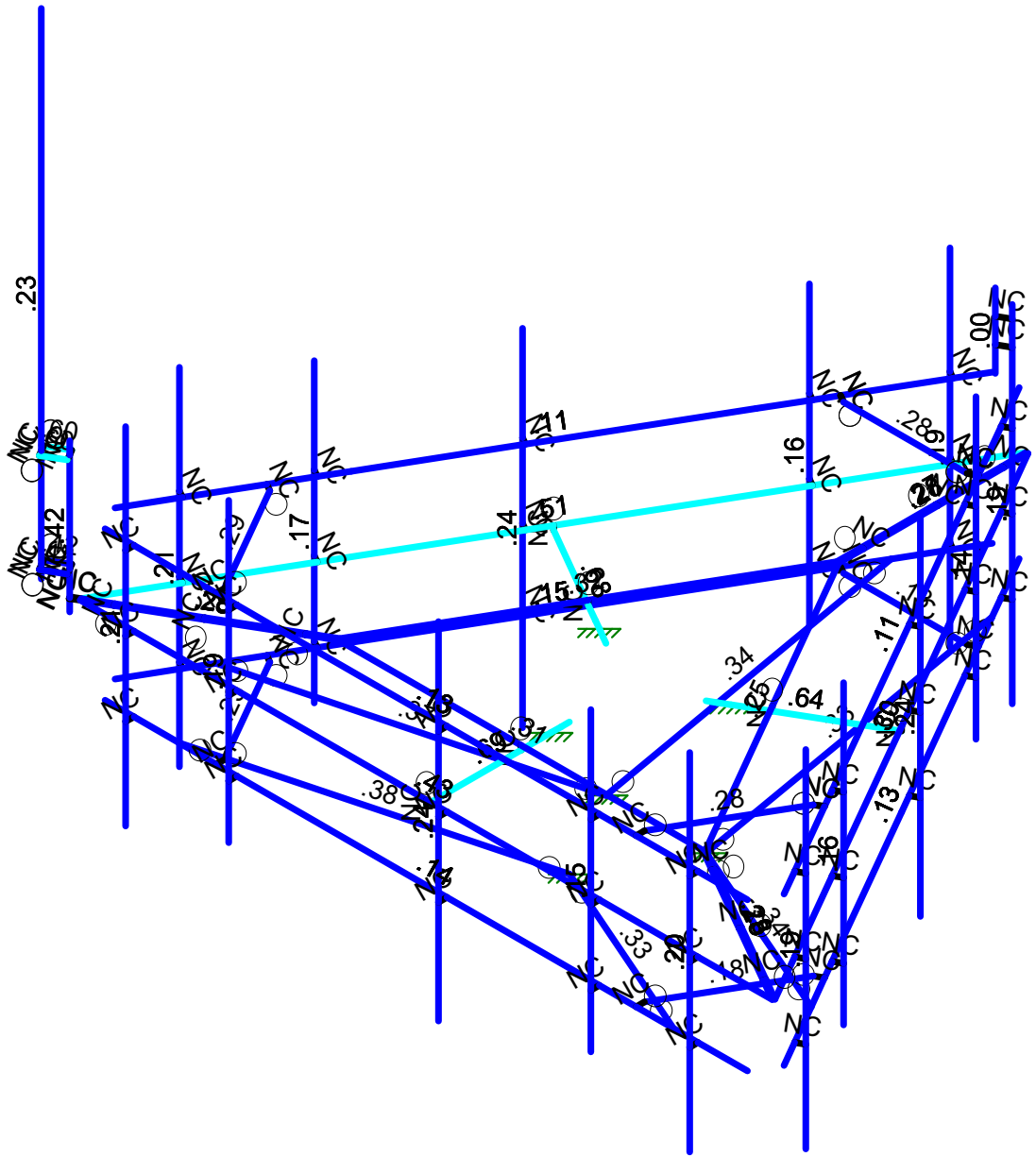

Member Code Checks Displayed (Enveloped)
Results for LC 1, 1.2D+1.0Wo (0 Deg)

Colliers Engineering & De...

Mount Analysis

SK - 5

July 5, 2023 at 5:19 PM

5000381811-VZW_MT_LO_H.r3d

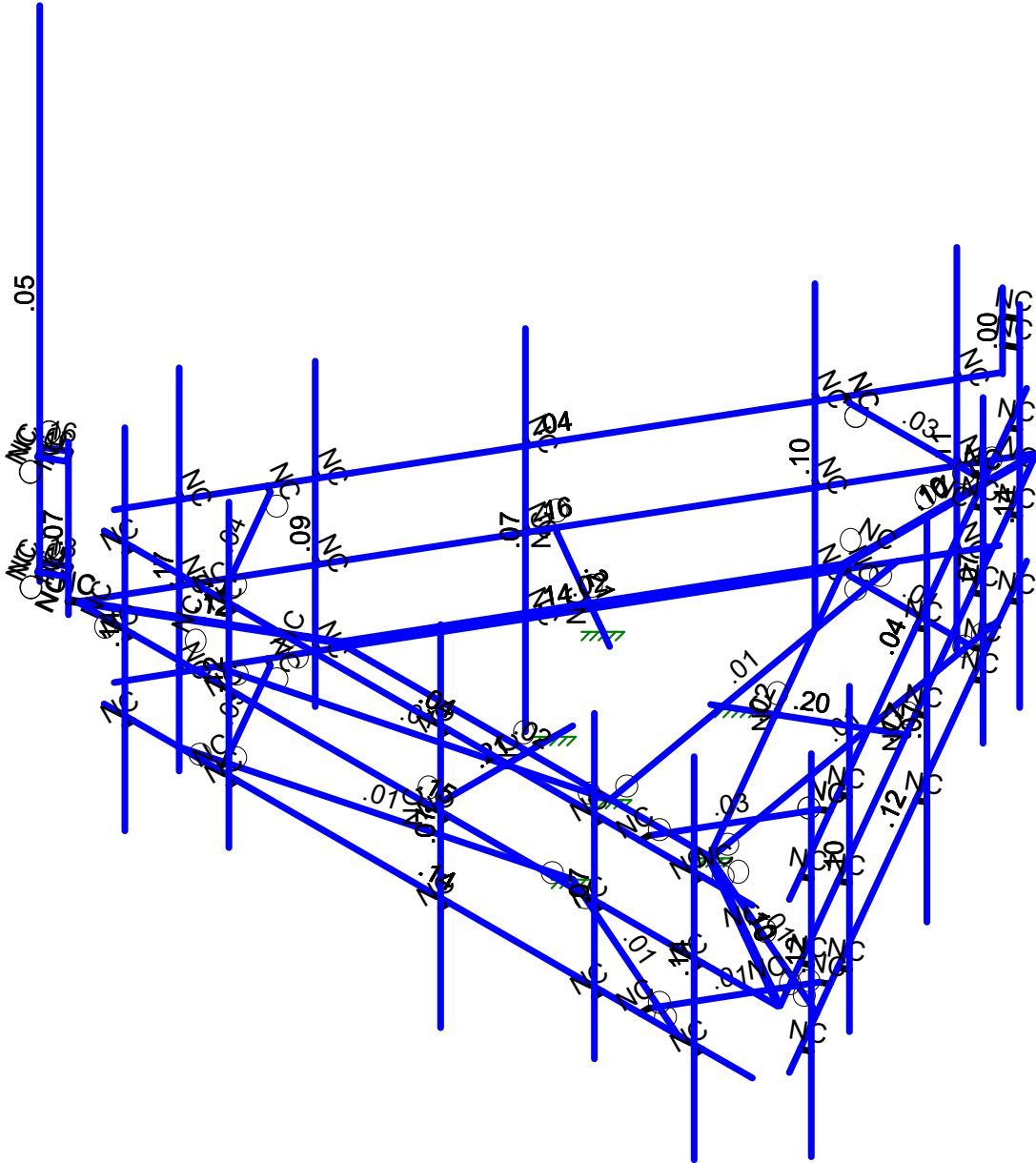
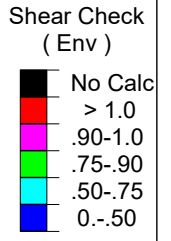
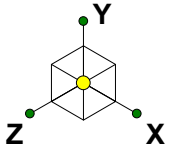

Member Shear Checks Displayed (Enveloped)
Results for LC 1, 1.2D+1.0Wo (0 Deg)

Colliers Engineering & De...

Mount Analysis

SK - 6

July 5, 2023 at 5:19 PM

5000381811-VZW_MT_LO_H.r3d

Basic Load Cases

	BLC Description	Category	X Grav...	Y Grav...	Z Grav...	Joint	Point	Distrib...	Area(Member)	Surface(Plate/Wall)
1	Antenna D	None					120			
2	Antenna Di	None					120			
3	Antenna Wo (0...	None					120			
4	Antenna Wo (3...	None					120			
5	Antenna Wo (6...	None					120			
6	Antenna Wo (9...	None					120			
7	Antenna Wo (1...	None					120			
8	Antenna Wo (1...	None					120			
9	Antenna Wo (1...	None					120			
10	Antenna Wo (2...	None					120			
11	Antenna Wo (2...	None					120			
12	Antenna Wo (2...	None					120			
13	Antenna Wo (3...	None					120			
14	Antenna Wo (3...	None					120			
15	Antenna Wi (0 ...	None					120			
16	Antenna Wi (30...	None					120			
17	Antenna Wi (60...	None					120			
18	Antenna Wi (90...	None					120			
19	Antenna Wi (12...	None					120			
20	Antenna Wi (15...	None					120			
21	Antenna Wi (18...	None					120			
22	Antenna Wi (21...	None					120			
23	Antenna Wi (24...	None					120			
24	Antenna Wi (27...	None					120			
25	Antenna Wi (30...	None					120			
26	Antenna Wi (33...	None					120			
27	Antenna Wm (...	None					120			
28	Antenna Wm (...	None					120			
29	Antenna Wm (...	None					120			
30	Antenna Wm (...	None					120			
31	Antenna Wm (...	None					120			
32	Antenna Wm (...	None					120			
33	Antenna Wm (...	None					120			
34	Antenna Wm (...	None					120			
35	Antenna Wm (...	None					120			
36	Antenna Wm (...	None					120			
37	Antenna Wm (...	None					120			
38	Antenna Wm (...	None					120			
39	Structure D	None		-1					3	
40	Structure Di	None						55	3	
41	Structure Wo (...	None						110		
42	Structure Wo (...	None						110		
43	Structure Wo (...	None						110		
44	Structure Wo (...	None						110		
45	Structure Wo (...	None						110		
46	Structure Wo (...	None						110		
47	Structure Wo (...	None						110		
48	Structure Wo (...	None						110		
49	Structure Wo (...	None						110		
50	Structure Wo (...	None						110		
51	Structure Wo (...	None						110		
52	Structure Wo (...	None						110		
53	Structure Wi (...	None						110		
54	Structure Wi (...	None						110		
55	Structure Wi (...	None						110		
56	Structure Wi (...	None						110		
57	Structure Wi (...	None						110		
58	Structure Wi (...	None						110		

Basic Load Cases (Continued)

	BLC Description	Category	X Grav...	Y Grav...	Z Grav...	Joint	Point	Distrib...	Area(Member)	Surface(Plate/Wall)
59	Structure Wi (...)	None						110		
60	Structure Wi (...)	None						110		
61	Structure Wi (...)	None						110		
62	Structure Wi (...)	None						110		
63	Structure Wi (...)	None						110		
64	Structure Wi (...)	None						110		
65	Structure Wm ...	None						110		
66	Structure Wm ...	None						110		
67	Structure Wm ...	None						110		
68	Structure Wm ...	None						110		
69	Structure Wm ...	None						110		
70	Structure Wm ...	None						110		
71	Structure Wm ...	None						110		
72	Structure Wm ...	None						110		
73	Structure Wm ...	None						110		
74	Structure Wm ...	None						110		
75	Structure Wm ...	None						110		
76	Structure Wm ...	None						110		
77	Lm1	None					1			
78	Lm2	None					1			
79	Lv1	None					1			
80	Lv2	None					1			
81	Antenna Ev	None					120			
82	Antenna Eh (0 ...	None					80			
83	Antenna Eh (90...	None					80			
84	Structure Ev	ELY		-.042					3	
85	Structure Eh (0...	ELZ			-.105				3	
86	Structure Eh (9...	ELX	.105						3	
87	BLC 39 Transie...	None						54		
88	BLC 40 Transie...	None						54		
89	BLC 84 Transie...	None						54		
90	BLC 85 Transie...	None						54		
91	BLC 86 Transie...	None						54		

Load Combinations

	Description	So..P...	S...	BLCFac..	BLCFac..	BLCFac..	BLCFac..	BLCFac..	BLCFac..	BLCFac..	BLCFac..	BLCFac..	BLCFac..	BLCFac..	BLCFac..
1	1.2D+1.0Wo (0 Deg)	Yes	Y	1	1.2	39	1.2	3	1	41	1				
2	1.2D+1.0Wo (30 Deg)	Yes	Y	1	1.2	39	1.2	4	1	42	1				
3	1.2D+1.0Wo (60 Deg)	Yes	Y	1	1.2	39	1.2	5	1	43	1				
4	1.2D+1.0Wo (90 Deg)	Yes	Y	1	1.2	39	1.2	6	1	44	1				
5	1.2D+1.0Wo (120 Deg)	Yes	Y	1	1.2	39	1.2	7	1	45	1				
6	1.2D+1.0Wo (150 Deg)	Yes	Y	1	1.2	39	1.2	8	1	46	1				
7	1.2D+1.0Wo (180 Deg)	Yes	Y	1	1.2	39	1.2	9	1	47	1				
8	1.2D+1.0Wo (210 Deg)	Yes	Y	1	1.2	39	1.2	10	1	48	1				
9	1.2D+1.0Wo (240 Deg)	Yes	Y	1	1.2	39	1.2	11	1	49	1				
10	1.2D+1.0Wo (270 Deg)	Yes	Y	1	1.2	39	1.2	12	1	50	1				
11	1.2D+1.0Wo (300 Deg)	Yes	Y	1	1.2	39	1.2	13	1	51	1				
12	1.2D+1.0Wo (330 Deg)	Yes	Y	1	1.2	39	1.2	14	1	52	1				
13	1.2D + 1.0Di + 1.0Wi (...)	Yes	Y	1	1.2	39	1.2	2	1	40	1	15	1	53	1
14	1.2D + 1.0Di + 1.0Wi (...)	Yes	Y	1	1.2	39	1.2	2	1	40	1	16	1	54	1
15	1.2D + 1.0Di + 1.0Wi (...)	Yes	Y	1	1.2	39	1.2	2	1	40	1	17	1	55	1
16	1.2D + 1.0Di + 1.0Wi (...)	Yes	Y	1	1.2	39	1.2	2	1	40	1	18	1	56	1
17	1.2D + 1.0Di + 1.0Wi (...)	Yes	Y	1	1.2	39	1.2	2	1	40	1	19	1	57	1
18	1.2D + 1.0Di + 1.0Wi (...)	Yes	Y	1	1.2	39	1.2	2	1	40	1	20	1	58	1
19	1.2D + 1.0Di + 1.0Wi (...)	Yes	Y	1	1.2	39	1.2	2	1	40	1	21	1	59	1
20	1.2D + 1.0Di + 1.0Wi (...)	Yes	Y	1	1.2	39	1.2	2	1	40	1	22	1	60	1
21	1.2D + 1.0Di + 1.0Wi (...)	Yes	Y	1	1.2	39	1.2	2	1	40	1	23	1	61	1

Load Combinations (Continued)

	Description	So.	P...	S...	BLCFac..	BLCFac..	BLCFac..	BLCFac..	BLCFac..	BLCFac..	BLCFac..	BLCFac..	BLCFac..	BLCFac..	BLCFac..	BLCFac..
22	1.2D + 1.0Di + 1.0Wi (...)	Yes	Y		1	1.2	39	1.2	2	1	40	1	24	1	62	1
23	1.2D + 1.0Di + 1.0Wi (...)	Yes	Y		1	1.2	39	1.2	2	1	40	1	25	1	63	1
24	1.2D + 1.0Di + 1.0Wi (...)	Yes	Y		1	1.2	39	1.2	2	1	40	1	26	1	64	1
25	1.2D + 1.5Lm1 + 1.0W...	Yes	Y		1	1.2	39	1.2	77	1.5	27	1	65	1		
26	1.2D + 1.5Lm1 + 1.0W...	Yes	Y		1	1.2	39	1.2	77	1.5	28	1	66	1		
27	1.2D + 1.5Lm1 + 1.0W...	Yes	Y		1	1.2	39	1.2	77	1.5	29	1	67	1		
28	1.2D + 1.5Lm1 + 1.0W...	Yes	Y		1	1.2	39	1.2	77	1.5	30	1	68	1		
29	1.2D + 1.5Lm1 + 1.0W...	Yes	Y		1	1.2	39	1.2	77	1.5	31	1	69	1		
30	1.2D + 1.5Lm1 + 1.0W...	Yes	Y		1	1.2	39	1.2	77	1.5	32	1	70	1		
31	1.2D + 1.5Lm1 + 1.0W...	Yes	Y		1	1.2	39	1.2	77	1.5	33	1	71	1		
32	1.2D + 1.5Lm1 + 1.0W...	Yes	Y		1	1.2	39	1.2	77	1.5	34	1	72	1		
33	1.2D + 1.5Lm1 + 1.0W...	Yes	Y		1	1.2	39	1.2	77	1.5	35	1	73	1		
34	1.2D + 1.5Lm1 + 1.0W...	Yes	Y		1	1.2	39	1.2	77	1.5	36	1	74	1		
35	1.2D + 1.5Lm1 + 1.0W...	Yes	Y		1	1.2	39	1.2	77	1.5	37	1	75	1		
36	1.2D + 1.5Lm1 + 1.0W...	Yes	Y		1	1.2	39	1.2	77	1.5	38	1	76	1		
37	1.2D + 1.5Lm2 + 1.0W...	Yes	Y		1	1.2	39	1.2	78	1.5	27	1	65	1		
38	1.2D + 1.5Lm2 + 1.0W...	Yes	Y		1	1.2	39	1.2	78	1.5	28	1	66	1		
39	1.2D + 1.5Lm2 + 1.0W...	Yes	Y		1	1.2	39	1.2	78	1.5	29	1	67	1		
40	1.2D + 1.5Lm2 + 1.0W...	Yes	Y		1	1.2	39	1.2	78	1.5	30	1	68	1		
41	1.2D + 1.5Lm2 + 1.0W...	Yes	Y		1	1.2	39	1.2	78	1.5	31	1	69	1		
42	1.2D + 1.5Lm2 + 1.0W...	Yes	Y		1	1.2	39	1.2	78	1.5	32	1	70	1		
43	1.2D + 1.5Lm2 + 1.0W...	Yes	Y		1	1.2	39	1.2	78	1.5	33	1	71	1		
44	1.2D + 1.5Lm2 + 1.0W...	Yes	Y		1	1.2	39	1.2	78	1.5	34	1	72	1		
45	1.2D + 1.5Lm2 + 1.0W...	Yes	Y		1	1.2	39	1.2	78	1.5	35	1	73	1		
46	1.2D + 1.5Lm2 + 1.0W...	Yes	Y		1	1.2	39	1.2	78	1.5	36	1	74	1		
47	1.2D + 1.5Lm2 + 1.0W...	Yes	Y		1	1.2	39	1.2	78	1.5	37	1	75	1		
48	1.2D + 1.5Lm2 + 1.0W...	Yes	Y		1	1.2	39	1.2	78	1.5	38	1	76	1		
49	1.2D + 1.5Lv1	Yes	Y		1	1.2	39	1.2	79	1.5						
50	1.2D + 1.5Lv2	Yes	Y		1	1.2	39	1.2	80	1.5						
51	1.4D	Yes	Y		1	1.4	39	1.4								
52	1.2D + 1.0Ev + 1.0Eh ...	Yes	Y		1	1.2	39	1.2	81	1	ELY	1	82	1	83	ELZ 1 ELX
53	1.2D + 1.0Ev + 1.0Eh ...	Yes	Y		1	1.2	39	1.2	81	1	ELY	1	82	.866	83	.5 ELZ .866 ELX .5
54	1.2D + 1.0Ev + 1.0Eh ...	Yes	Y		1	1.2	39	1.2	81	1	ELY	1	82	.5	83	.866 ELZ .5 ELX .866
55	1.2D + 1.0Ev + 1.0Eh ...	Yes	Y		1	1.2	39	1.2	81	1	ELY	1	82		83	1 ELZ ELX 1
56	1.2D + 1.0Ev + 1.0Eh ...	Yes	Y		1	1.2	39	1.2	81	1	ELY	1	82	-.5	83	.866 ELZ -.5 ELX .866
57	1.2D + 1.0Ev + 1.0Eh ...	Yes	Y		1	1.2	39	1.2	81	1	ELY	1	82	-.866	83	.5 ELZ -.866 ELX .5
58	1.2D + 1.0Ev + 1.0Eh ...	Yes	Y		1	1.2	39	1.2	81	1	ELY	1	82	-1	83	ELZ -1 ELX
59	1.2D + 1.0Ev + 1.0Eh ...	Yes	Y		1	1.2	39	1.2	81	1	ELY	1	82	-.866	83	-.5 ELZ -.866 ELX -.5
60	1.2D + 1.0Ev + 1.0Eh ...	Yes	Y		1	1.2	39	1.2	81	1	ELY	1	82	-.5	83	-.866 ELZ -.5 ELX -.866
61	1.2D + 1.0Ev + 1.0Eh ...	Yes	Y		1	1.2	39	1.2	81	1	ELY	1	82		83	-1 ELZ ELX -1
62	1.2D + 1.0Ev + 1.0Eh ...	Yes	Y		1	1.2	39	1.2	81	1	ELY	1	82	.5	83	-.866 ELZ .5 ELX -.866
63	1.2D + 1.0Ev + 1.0Eh ...	Yes	Y		1	1.2	39	1.2	81	1	ELY	1	82	.866	83	-.5 ELZ .866 ELX -.5
64	0.9D - 1.0Ev + 1.0Eh (...)	Yes	Y		1	.9	39	.9	81	-1	ELY	-1	82	1	83	ELZ 1 ELX
65	0.9D - 1.0Ev + 1.0Eh (...)	Yes	Y		1	.9	39	.9	81	-1	ELY	-1	82	.866	83	.5 ELZ .866 ELX .5
66	0.9D - 1.0Ev + 1.0Eh (...)	Yes	Y		1	.9	39	.9	81	-1	ELY	-1	82	.5	83	.866 ELZ .5 ELX .866
67	0.9D - 1.0Ev + 1.0Eh (...)	Yes	Y		1	.9	39	.9	81	-1	ELY	-1	82		83	1 ELZ ELX 1
68	0.9D - 1.0Ev + 1.0Eh (...)	Yes	Y		1	.9	39	.9	81	-1	ELY	-1	82	-.5	83	.866 ELZ -.5 ELX .866
69	0.9D - 1.0Ev + 1.0Eh (...)	Yes	Y		1	.9	39	.9	81	-1	ELY	-1	82	-.866	83	.5 ELZ -.866 ELX .5
70	0.9D - 1.0Ev + 1.0Eh (...)	Yes	Y		1	.9	39	.9	81	-1	ELY	-1	82	-1	83	ELZ -1 ELX
71	0.9D - 1.0Ev + 1.0Eh (...)	Yes	Y		1	.9	39	.9	81	-1	ELY	-1	82	-.866	83	-.5 ELZ -.866 ELX -.5
72	0.9D - 1.0Ev + 1.0Eh (...)	Yes	Y		1	.9	39	.9	81	-1	ELY	-1	82	-.5	83	-.866 ELZ -.5 ELX -.866
73	0.9D - 1.0Ev + 1.0Eh (...)	Yes	Y		1	.9	39	.9	81	-1	ELY	-1	82		83	-1 ELZ ELX -1
74	0.9D - 1.0Ev + 1.0Eh (...)	Yes	Y		1	.9	39	.9	81	-1	ELY	-1	82	.5	83	-.866 ELZ .5 ELX -.866
75	0.9D - 1.0Ev + 1.0Eh (...)	Yes	Y		1	.9	39	.9	81	-1	ELY	-1	82	.866	83	-.5 ELZ .866 ELX -.5

Joint Coordinates and Temperatures

	Label	X [ft]	Y [ft]	Z [ft]	Temp [F]	Detach From Diap...
1	N1	0.	0	4.065508	0	
2	N2	7	0	4.065508	0	
3	N3	-7	0	4.065508	0	
4	N5	0.020833	0	-8.094932	0	
5	N6	7.020833	0	4.029424	0	
6	N7	-7.020833	0	4.029424	0	
7	N8	-0.020833	0	-8.094932	0	
8	N10A	3.520833	0	-2.032754	0	
9	N11	-3.520833	0	-2.032754	0	
10	N13	0	0	0	0	
11	N14	0.020833	0	-4.261599	0	
12	N15	-0.020833	0	-4.261599	0	
13	N16	0.020833	0	-7.594932	0	
14	N17	-0.020833	0	-7.594932	0	
15	N18	0.020833	0	-6.261599	0	
16	N19	-0.020833	0	-6.261599	0	
17	N20	0.020833	0	-4.761599	0	
18	N21	-0.020833	0	-4.761599	0	
19	N25	-3.701069	0	2.112757	0	
20	N26	-3.680236	0	2.148841	0	
21	N27	-6.587821	0	3.779424	0	
22	N28	-6.566987	0	3.815508	0	
23	N29	-5.43312	0	3.112757	0	
24	N30	-5.412287	0	3.148841	0	
25	N31	-4.134082	0	2.362757	0	
26	N32	-4.113249	0	2.398841	0	
27	N36	3.680236	0	2.148841	0	
28	N37	3.701069	0	2.112757	0	
29	N38	6.566987	0	3.815508	0	
30	N39	6.587821	0	3.779424	0	
31	N40	5.412287	0	3.148841	0	
32	N41	5.43312	0	3.112757	0	
33	N42	4.113249	0	2.398841	0	
34	N43	4.134082	0	2.362757	0	
35	N38A	0.	-0.083333	1.166667	0	
36	N39A	-0.	0	2.148841	0	
37	N40A	0.	-0.083333	4.065508	0	
38	N41A	-0.	-0.083333	2.148841	0	
39	N43A	1.010363	-0.083333	-0.583333	0	
40	N44	1.860951	0	-1.074421	0	
41	N45	3.520833	-0.083333	-2.032754	0	
42	N46	1.860951	-0.083333	-1.074421	0	
43	N48	-1.010363	-0.083333	-0.583333	0	
44	N49	-1.860951	0	-1.074421	0	
45	N50	-3.520833	-0.083333	-2.032754	0	
46	N51	-1.860951	-0.083333	-1.074421	0	
47	N50A	0.	-0.083333	1.333333	0	
48	N51A	0.	-0.083333	1.75	0	
49	N52	1.154701	-0.083333	-0.666667	0	
50	N53	1.515544	-0.083333	-.875	0	
51	N54	-1.154701	-0.083333	-0.666667	0	
52	N55	-1.515544	-0.083333	-.875	0	
53	N53A	5.5	0	4.065508	0	
54	N54A	3.5	0	4.065508	0	
55	N55A	0.416667	0	4.065508	0	
56	N56	-3.833333	0	4.065508	0	
57	N57	-5.916667	0	4.065508	0	
58	N58	5.5	0	4.232175	0	



Joint Coordinates and Temperatures (Continued)

	Label	X [ft]	Y [ft]	Z [ft]	Temp [F]	Detach From Diap...
59	N59	3.5	0	4.232175	0	
60	N60	0.416667	0	4.232175	0	
61	N61	-3.833333	0	4.232175	0	
62	N62	-5.916667	0	4.232175	0	
63	N63	5.5	3.666667	4.232175	0	
64	N64	3.5	3.416667	4.232175	0	
65	N65	0.416667	3.416667	4.232175	0	
66	N66	-3.833333	3.416667	4.232175	0	
67	N67	-5.916667	3.666667	4.232175	0	
68	N68	5.5	-3.333333	4.232175	0	
69	N69	0.416667	-3.583333	4.232175	0	
70	N70	-5.916667	-3.333333	4.232175	0	
71	N71	3.5	-2.583333	4.232175	0	
72	N72	-3.833333	-2.583333	4.232175	0	
73	N73	0.770833	0	-6.795894	0	
74	N74	1.770833	0	-5.063843	0	
75	N75	3.3125	0	-2.393598	0	
76	N76	5.4375	0	1.28701	0	
77	N77	6.479167	0	3.09123	0	
78	N78	0.915171	0	-6.879227	0	
79	N79	1.915171	0	-5.147176	0	
80	N80	3.456838	0	-2.476931	0	
81	N81	5.581838	0	1.203677	0	
82	N82	6.623504	0	3.007896	0	
83	N83	0.915171	3.666667	-6.879227	0	
84	N84	1.915171	3.416667	-5.147176	0	
85	N85	3.456838	3.416667	-2.476931	0	
86	N86	5.581838	3.416667	1.203677	0	
87	N87	6.623504	3.666667	3.007896	0	
88	N88	0.915171	-3.333333	-6.879227	0	
89	N89	3.456838	-3.583333	-2.476931	0	
90	N90	6.623504	-3.333333	3.007896	0	
91	N91	1.915171	-2.583333	-5.147176	0	
92	N92	5.581838	-2.583333	1.203677	0	
93	N93	-6.270833	0	2.730386	0	
94	N94	-5.270833	0	0.998335	0	
95	N95	-3.729167	0	-1.67191	0	
96	N96	-1.604167	0	-5.352518	0	
97	N97	-0.5625	0	-7.156738	0	
98	N98	-6.415171	0	2.647052	0	
99	N99	-5.415171	0	0.915001	0	
100	N100	-3.873504	0	-1.755243	0	
101	N101	-1.748504	0	-5.435851	0	
102	N102	-0.706838	0	-7.240071	0	
103	N103	-6.415171	3.666667	2.647052	0	
104	N104	-5.415171	3.416667	0.915001	0	
105	N105	-3.873504	3.416667	-1.755243	0	
106	N106	-1.748504	3.416667	-5.435851	0	
107	N107	-0.706838	3.666667	-7.240071	0	
108	N108	-6.415171	-3.333333	2.647052	0	
109	N109	-3.873504	-3.583333	-1.755243	0	
110	N110	-0.706838	-3.333333	-7.240071	0	
111	N111	-5.415171	-2.583333	0.915001	0	
112	N112	-1.748504	-2.583333	-5.435851	0	
113	N113	-7.165171	0	4.112757	0	
114	N114	-7.144338	0	4.148841	0	
115	N115	-7.154754	0	4.130799	0	
116	N116	-7.154754	-0.25	4.130799	0	
117	N117	-7.154754	2.75	4.130799	0	



Joint Coordinates and Temperatures (Continued)

	Label	X [ft]	Y [ft]	Z [ft]	Temp [F]	Detach From Diap...
118	N119	-7.154754	2.5	4.130799	0	
119	N120	-7.217254	2.5	4.022546	0	
120	N121	-7.092254	2.5	4.239052	0	
121	N122	-7.515598	2.5	4.339133	0	
122	N123	-7.578098	2.5	4.230879	0	
123	N124	-7.453098	2.5	4.447386	0	
124	N130A	-7.515598	.25	4.339133	0	
125	N131	-7.515598	10.25	4.339133	0	
126	N126	0.915171	3.416667	-6.879227	0	
127	N127	0.915171	2.916667	-6.879227	0	
128	N128	0.698665	3.416667	-6.754227	0	
129	N129	0.698665	2.916667	-6.754227	0	
130	N130	0.698665	2.416667	-6.754227	0	
131	N131A	0.698665	3.916667	-6.754227	0	
132	N132	-7.154754	.5	4.130799	0	
133	N133	-7.217254	.5	4.022546	0	
134	N134	-7.092254	.5	4.239052	0	
135	N135	-7.515598	.5	4.339133	0	
136	N136	-7.578098	.5	4.230879	0	
137	N137	-7.453098	.5	4.447386	0	
138	N138	6.5	-1.5	4.065508	0	
139	N139	-6.5	-1.5	4.065508	0	
140	N140	5.5	-1.5	4.065508	0	
141	N141	3.5	-1.5	4.065508	0	
142	N142	0.416667	-1.5	4.065508	0	
143	N143	-3.833333	-1.5	4.065508	0	
144	N144	-5.916667	-1.5	4.065508	0	
145	N145	5.5	-1.5	4.232175	0	
146	N146	3.5	-1.5	4.232175	0	
147	N147	0.416667	-1.5	4.232175	0	
148	N148	-3.833333	-1.5	4.232175	0	
149	N149	-5.916667	-1.5	4.232175	0	
150	N150	0.270833	-1.5	-7.661919	0	
151	N151	6.770833	-1.5	3.596411	0	
152	N152	0.770833	-1.5	-6.795894	0	
153	N153	1.770833	-1.5	-5.063843	0	
154	N154	3.3125	-1.5	-2.393598	0	
155	N155	5.4375	-1.5	1.28701	0	
156	N156	6.479167	-1.5	3.09123	0	
157	N157	0.915171	-1.5	-6.879227	0	
158	N158	1.915171	-1.5	-5.147176	0	
159	N159	3.456838	-1.5	-2.476931	0	
160	N160	5.581838	-1.5	1.203677	0	
161	N161	6.623504	-1.5	3.007896	0	
162	N162	-6.770833	-1.5	3.596411	0	
163	N163	-0.270833	-1.5	-7.661919	0	
164	N164	-6.270833	-1.5	2.730386	0	
165	N165	-5.270833	-1.5	0.998335	0	
166	N166	-3.729167	-1.5	-1.67191	0	
167	N167	-1.604167	-1.5	-5.352518	0	
168	N168	-0.5625	-1.5	-7.156738	0	
169	N169	-6.415171	-1.5	2.647052	0	
170	N170	-5.415171	-1.5	0.915001	0	
171	N171	-3.873504	-1.5	-1.755243	0	
172	N172	-1.748504	-1.5	-5.435851	0	
173	N173	-0.706838	-1.5	-7.240071	0	
174	N186	0.	-2.75	1.166667	0	
175	N187	5	-1.5	4.065508	0	
176	N188	0.	-1.5	4.065508	0	



Joint Coordinates and Temperatures (Continued)

	Label	X [ft]	Y [ft]	Z [ft]	Temp [F]	Detach From Diap...
177	N189	-5	-1.5	4.065508	0	
178	N192	3.520833	-1.5	-2.032754	0	
179	N196	-3.520833	-1.5	-2.032754	0	
180	N198	6.5	1.5	4.065508	0	
181	N199	-6.5	1.5	4.065508	0	
182	N200	5.5	1.5	4.065508	0	
183	N201	3.5	1.5	4.065508	0	
184	N202	0.416667	1.5	4.065508	0	
185	N203	-3.833333	1.5	4.065508	0	
186	N204	-5.916667	1.5	4.065508	0	
187	N205	5.5	1.5	4.232175	0	
188	N206	3.5	1.5	4.232175	0	
189	N207	0.416667	1.5	4.232175	0	
190	N208	-3.833333	1.5	4.232175	0	
191	N209	-5.916667	1.5	4.232175	0	
192	N210	0.270833	1.5	-7.661919	0	
193	N211	6.770833	1.5	3.596411	0	
194	N212	0.770833	1.5	-6.795894	0	
195	N213	1.770833	1.5	-5.063843	0	
196	N214	3.3125	1.5	-2.393598	0	
197	N215	5.4375	1.5	1.28701	0	
198	N216	6.479167	1.5	3.09123	0	
199	N217	0.915171	1.5	-6.879227	0	
200	N218	1.915171	1.5	-5.147176	0	
201	N219	3.456838	1.5	-2.476931	0	
202	N220	5.581838	1.5	1.203677	0	
203	N221	6.623504	1.5	3.007896	0	
204	N222	-6.770833	1.5	3.596411	0	
205	N223	-0.270833	1.5	-7.661919	0	
206	N224	-6.270833	1.5	2.730386	0	
207	N225	-5.270833	1.5	0.998335	0	
208	N226	-3.729167	1.5	-1.67191	0	
209	N227	-1.604167	1.5	-5.352518	0	
210	N228	-0.5625	1.5	-7.156738	0	
211	N229	-6.415171	1.5	2.647052	0	
212	N230	-5.415171	1.5	0.915001	0	
213	N231	-3.873504	1.5	-1.755243	0	
214	N232	-1.748504	1.5	-5.435851	0	
215	N233	-0.706838	1.5	-7.240071	0	
216	N234	-4.25	1.5	4.065508	0	
217	N236	-4.25	1.5	3.898842	0	
218	N246	3	1.5	4.065508	0	
219	N247	0.	1.5	4.065508	0	
220	N248	-3	1.5	4.065508	0	
221	N249	2.020833	1.5	-4.63083	0	
222	N250	3.520833	1.5	-2.032754	0	
223	N251	5.020833	1.5	0.565322	0	
224	N252	-5.020833	1.5	0.565322	0	
225	N253	-3.520833	1.5	-2.032754	0	
226	N254	-2.020833	1.5	-4.63083	0	
227	N255	0.	-0.083333	1.541667	0	
228	N257	1.335122	-0.083333	-0.770833	0	
229	N259	-1.335122	-0.083333	-0.770833	0	
230	N270	5.645833	1.5	1.647854	0	
231	N271	1.395833	1.5	-5.713362	0	
232	N272	5.501496	1.5	1.731187	0	
233	N273	1.251496	1.5	-5.630029	0	
234	N274	-1.395833	1.5	-5.713362	0	
235	N275	-5.645833	1.5	1.647854	0	

Joint Coordinates and Temperatures (Continued)

	Label	X [ft]	Y [ft]	Z [ft]	Temp [F]	Detach From Diap...
236	N276	-1.251496	1.5	-5.630029	0	
237	N277	-5.501496	1.5	1.731187	0	
238	N258A	4.25	1.5	4.065508	0	
239	N259B	4.25	1.5	3.898842	0	
240	N258B	-4.25	-1.5	4.065508	0	
241	N259C	-4.25	-1.5	3.898842	0	
242	N260A	5.645833	-1.5	1.647854	0	
243	N261A	1.395833	-1.5	-5.713362	0	
244	N262A	5.501496	-1.5	1.731187	0	
245	N263A	1.251496	-1.5	-5.630029	0	
246	N264A	-1.395833	-1.5	-5.713362	0	
247	N265A	-5.645833	-1.5	1.647854	0	
248	N266A	-1.251496	-1.5	-5.630029	0	
249	N267A	-5.501496	-1.5	1.731187	0	
250	N268A	4.25	-1.5	4.065508	0	
251	N269A	4.25	-1.5	3.898842	0	
252	N264B	1.010363	-2.75	-0.583333	0	
253	N265B	1.020833	-1.5	-6.362881	0	
254	N266B	6.020833	-1.5	2.297373	0	
255	N267B	-1.010363	-2.75	-0.583333	0	
256	N268B	-6.020833	-1.5	2.297373	0	
257	N269B	-1.020833	-1.5	-6.362881	0	

Hot Rolled Steel Section Sets

	Label	Shape	Type	Design List	Material	Design R...	A [in2]	Iyy [in4]	Izz [in4]	J [in4]
1	Antenna Pipe	PIPE 2.0	Column	None	A53 Gr. B	Typical	1.02	.627	.627	1.25
2	Mod Support Rail	PIPE 2.5	Column	None	A53 Gr. B	Typical	1.61	1.45	1.45	2.89
3	Face Horizontal	L3X3X4	Beam	None	A36 Gr.36	Typical	1.44	1.23	1.23	.031
4	Mod Support Rail ...	L3X3X4	Beam	None	A36 Gr.36	Typical	1.44	1.23	1.23	.031
5	Standoff Angle	L3X3X4	Beam	None	A36 Gr.36	Typical	1.44	1.23	1.23	.031
6	Mod V Kit	L2.5x2.5x3	Beam	None	A36 Gr.36	Typical	.901	.535	.535	.011
7	SR	SR 0.5	Beam	None	A36 Gr.36	Typical	.196	.003	.003	.006
8	TES Channel	L5X5X5	Beam	None	A36 Gr.36	Typical	3.07	7.44	7.44	.108
9	MOD Threaded R...	SR 0.625_HRA	Beam	None	A36 Gr.36	Typical	.307	.007	.007	.015

Hot Rolled Steel Design Parameters

	Label	Shape	Length[ft]	Lbyy[ft]	Lbzz[ft]	Lcomp top[ft]	Lcomp bot[ft]	L-torqu...	Kyy	Kzz	Cb	Function
1	FACE	Face Horizo...	14	7	7	Lbyy						Lateral
2	M2	Face Horizo...	14	7	7	Lbyy						Lateral
3	M3	Face Horizo...	14	7	7	Lbyy						Lateral
4	M4	Standoff An...	3.833			Lbyy						Lateral
5	M5	Standoff An...	3.833			Lbyy						Lateral
6	M9	Standoff An...	3.833			Lbyy						Lateral
7	M10	Standoff An...	3.833			Lbyy						Lateral
8	M14	Standoff An...	3.833			Lbyy						Lateral
9	M15	Standoff An...	3.833			Lbyy						Lateral
10	M19	Standoff An...	7.36			Lbyy						Lateral
11	M20	Standoff An...	7.36			Lbyy						Lateral
12	M21	Standoff An...	7.36			Lbyy						Lateral
13	MP1A	Antenna Pipe	7									Lateral
14	MP2A	Antenna Pipe	6									Lateral
15	MP3A	PIPE 2.5	7									Lateral
16	MP4A	Antenna Pipe	6									Lateral
17	MP5A	Antenna Pipe	7									Lateral
18	MP1C	Antenna Pipe	7									Lateral
19	MP2C	Antenna Pipe	6									Lateral

Hot Rolled Steel Design Parameters (Continued)

	Label	Shape	Length[ft]	Lbv[ft]	Lbzz[ft]	Lcomp top[ft]	Lcomp bot[ft]	L-torqu...	Kyy	Kzz	Cb	Function
20	MP3C	PIPE 2.5	7									Lateral
21	MP4C	Antenna Pipe	6									Lateral
22	MP5C	Antenna Pipe	7									Lateral
23	MP1B	Antenna Pipe	7									Lateral
24	MP2B	Antenna Pipe	6									Lateral
25	MP3B	PIPE 2.5	7									Lateral
26	MP4B	Antenna Pipe	6									Lateral
27	MP5B	Antenna Pipe	7									Lateral
28	M76	Antenna Pipe	10									Lateral
29	M77	Antenna Pipe	3									Lateral
30	M72	SR	.417				Lbyy					Lateral
31	M73	SR	.417				Lbyy					Lateral
32	M76A	Antenna Pipe	1.5									Lateral
33	M81A	SR	.417				Lbyy					Lateral
34	M82	SR	.417				Lbyy					Lateral
35	M82A	Mod Suppor...	13				Lbyy					Lateral
36	M88	Mod Suppor...	13				Lbyy					Lateral
37	M94	Mod Suppor...	13				Lbyy					Lateral
38	M109	Mod V Kit	5.913				Lbyy					Lateral
39	M110	Mod V Kit	5.913				Lbyy					Lateral
40	M115	Mod Suppor...	13				Lbyy					Lateral
41	M121	Mod Suppor...	13				Lbyy					Lateral
42	M127	Mod Suppor...	13				Lbyy					Lateral
43	M139	Mod Suppor...	2.503				Lbyy					Lateral
44	M143A	Mod Suppor...	2.503				Lbyy					Lateral
45	M146A	Mod Suppor...	2.503				Lbyy					Lateral
46	M149A	Mod Suppor...	2.503				Lbyy					Lateral
47	M152A	Mod Suppor...	2.503				Lbyy					Lateral
48	M155A	Mod Suppor...	2.503				Lbyy					Lateral
49	M153B	Mod V Kit	5.913				Lbyy					Lateral
50	M154B	Mod V Kit	5.913				Lbyy					Lateral
51	M155B	Mod V Kit	5.913				Lbyy					Lateral
52	M156B	Mod V Kit	5.913				Lbyy					Lateral

Member Primary Data

	Label	I Joint	J Joint	K Joint	Rotate(deg)	Section/Shape	Type	Design List	Material	Design Rules
1	FACE	N3	N2		270	Face Horizontal	Beam	None	A36 Gr.36	Typical
2	M2	N6	N5		270	Face Horizontal	Beam	None	A36 Gr.36	Typical
3	M3	N8	N7		270	Face Horizontal	Beam	None	A36 Gr.36	Typical
4	M4	N8	N15			Standoff Angle	Beam	None	A36 Gr.36	Typical
5	M5	N5	N14		270	Standoff Angle	Beam	None	A36 Gr.36	Typical
6	M6	N16	N17			RIGID	None	None	RIGID	Typical
7	M7	N18	N19			RIGID	None	None	RIGID	Typical
8	M8	N20	N21			RIGID	None	None	RIGID	Typical
9	M9	N3	N26			Standoff Angle	Beam	None	A36 Gr.36	Typical
10	M10	N7	N25		270	Standoff Angle	Beam	None	A36 Gr.36	Typical
11	M11	N27	N28			RIGID	None	None	RIGID	Typical
12	M12	N29	N30			RIGID	None	None	RIGID	Typical
13	M13	N31	N32			RIGID	None	None	RIGID	Typical
14	M14	N6	N37			Standoff Angle	Beam	None	A36 Gr.36	Typical
15	M15	N2	N36		270	Standoff Angle	Beam	None	A36 Gr.36	Typical
16	M16	N38	N39			RIGID	None	None	RIGID	Typical
17	M17	N40	N41			RIGID	None	None	RIGID	Typical
18	M18	N42	N43			RIGID	None	None	RIGID	Typical
19	M19	N25	N15		270	Standoff Angle	Beam	None	A36 Gr.36	Typical
20	M20	N36	N26		270	Standoff Angle	Beam	None	A36 Gr.36	Typical
21	M21	N14	N37		270	Standoff Angle	Beam	None	A36 Gr.36	Typical

Member Primary Data (Continued)

	Label	I Joint	J Joint	K Joint	Rotate(deg)	Section/Shape	Type	Design List	Material	Design Rules
22	M23	N40A	N1			RIGID	None	None	RIGID	Typical
23	M24	N41A	N39A			RIGID	None	None	RIGID	Typical
24	M25	N38A	N40A		90	Cold Formed ...	Beam	CU	A570 Gr.33	Typical
25	M26	N45	N10A			RIGID	None	None	RIGID	Typical
26	M27	N46	N44			RIGID	None	None	RIGID	Typical
27	M28	N43A	N45		90	Cold Formed ...	Beam	CU	A570 Gr.33	Typical
28	M29	N50	N11			RIGID	None	None	RIGID	Typical
29	M30	N51	N49			RIGID	None	None	RIGID	Typical
30	M31	N48	N50		90	Cold Formed ...	Beam	CU	A570 Gr.33	Typical
31	M32	N57	N62			RIGID	None	None	RIGID	Typical
32	LIVE2	N56	N61			RIGID	None	None	RIGID	Typical
33	LIVE1	N55A	N60			RIGID	None	None	RIGID	Typical
34	M35	N54A	N59			RIGID	None	None	RIGID	Typical
35	M36	N53A	N58			RIGID	None	None	RIGID	Typical
36	MP1A	N63	N68			Antenna Pipe	Column	None	A53 Gr. B	Typical
37	MP2A	N64	N71			Antenna Pipe	Column	None	A53 Gr. B	Typical
38	MP3A	N65	N69			PIPE 2.5	Beam	Pipe	A53 Gr. B	Typical
39	MP4A	N66	N72			Antenna Pipe	Column	None	A53 Gr. B	Typical
40	MP5A	N67	N70			Antenna Pipe	Column	None	A53 Gr. B	Typical
41	M42	N77	N82			RIGID	None	None	RIGID	Typical
42	M43	N76	N81			RIGID	None	None	RIGID	Typical
43	M44	N75	N80			RIGID	None	None	RIGID	Typical
44	M45	N74	N79			RIGID	None	None	RIGID	Typical
45	M46	N73	N78			RIGID	None	None	RIGID	Typical
46	MP1C	N83	N88			Antenna Pipe	Column	None	A53 Gr. B	Typical
47	MP2C	N84	N91			Antenna Pipe	Column	None	A53 Gr. B	Typical
48	MP3C	N85	N89			PIPE 2.5	Beam	Pipe	A53 Gr. B	Typical
49	MP4C	N86	N92			Antenna Pipe	Column	None	A53 Gr. B	Typical
50	MP5C	N87	N90			Antenna Pipe	Column	None	A53 Gr. B	Typical
51	M52	N97	N102			RIGID	None	None	RIGID	Typical
52	M53	N96	N101			RIGID	None	None	RIGID	Typical
53	M54	N95	N100			RIGID	None	None	RIGID	Typical
54	M55	N94	N99			RIGID	None	None	RIGID	Typical
55	M56	N93	N98			RIGID	None	None	RIGID	Typical
56	MP1B	N103	N108			Antenna Pipe	Column	None	A53 Gr. B	Typical
57	MP2B	N104	N111			Antenna Pipe	Column	None	A53 Gr. B	Typical
58	MP3B	N105	N109			PIPE 2.5	Beam	Pipe	A53 Gr. B	Typical
59	MP4B	N106	N112			Antenna Pipe	Column	None	A53 Gr. B	Typical
60	MP5B	N107	N110			Antenna Pipe	Column	None	A53 Gr. B	Typical
61	M64	N113	N115			RIGID	None	None	RIGID	Typical
62	M81	N115	N114			RIGID	None	None	RIGID	Typical
63	M76	N131	N130A			Antenna Pipe	Column	None	A53 Gr. B	Typical
64	M77	N117	N116			Antenna Pipe	Column	None	A53 Gr. B	Typical
65	M68	N119	N121			RIGID	None	None	RIGID	Typical
66	M69	N119	N120			RIGID	None	None	RIGID	Typical
67	M70	N124	N122			RIGID	None	None	RIGID	Typical
68	M71	N123	N122			RIGID	None	None	RIGID	Typical
69	M72	N121	N124			SR	Beam	None	A36 Gr.36	Typical
70	M73	N120	N123			SR	Beam	None	A36 Gr.36	Typical
71	M72A	N7	N113			RIGID	None	None	RIGID	Typical
72	M73A	N3	N114			RIGID	None	None	RIGID	Typical
73	M74	N127	N129			RIGID	None	None	RIGID	Typical
74	M75	N126	N128			RIGID	None	None	RIGID	Typical
75	M76A	N131A	N130			Antenna Pipe	Column	None	A53 Gr. B	Typical
76	M77A	N132	N134			RIGID	None	None	RIGID	Typical
77	M78	N132	N133			RIGID	None	None	RIGID	Typical
78	M79	N137	N135			RIGID	None	None	RIGID	Typical
79	M80	N136	N135			RIGID	None	None	RIGID	Typical
80	M81A	N134	N137			SR	Beam	None	A36 Gr.36	Typical

Member Primary Data (Continued)

	Label	I Joint	J Joint	K Joint	Rotate(deg)	Section/Shape	Type	Design List	Material	Design Rules
81	M82	N133	N136			SR	Beam	None	A36 Gr.36	Typical
82	M82A	N139	N138		270	Mod Support ...	Column	None	A53 Gr. B	Typical
83	M83	N144	N149			RIGID	None	None	RIGID	Typical
84	M84	N143	N148			RIGID	None	None	RIGID	Typical
85	M85	N142	N147			RIGID	None	None	RIGID	Typical
86	M86	N141	N146			RIGID	None	None	RIGID	Typical
87	M87	N140	N145			RIGID	None	None	RIGID	Typical
88	M88	N151	N150		270	Mod Support ...	Column	None	A53 Gr. B	Typical
89	M89	N156	N161			RIGID	None	None	RIGID	Typical
90	M90	N155	N160			RIGID	None	None	RIGID	Typical
91	M91	N154	N159			RIGID	None	None	RIGID	Typical
92	M92	N153	N158			RIGID	None	None	RIGID	Typical
93	M93	N152	N157			RIGID	None	None	RIGID	Typical
94	M94	N163	N162		270	Mod Support ...	Column	None	A53 Gr. B	Typical
95	M95	N168	N173			RIGID	None	None	RIGID	Typical
96	M96	N167	N172			RIGID	None	None	RIGID	Typical
97	M97	N166	N171			RIGID	None	None	RIGID	Typical
98	M98	N165	N170			RIGID	None	None	RIGID	Typical
99	M99	N164	N169			RIGID	None	None	RIGID	Typical
100	M109	N186	N189		180	Mod V Kit	Beam	None	A36 Gr.36	Typical
101	M110	N186	N187		90	Mod V Kit	Beam	None	A36 Gr.36	Typical
102	M115	N199	N198		270	Mod Support ...	Column	None	A53 Gr. B	Typical
103	M116	N204	N209			RIGID	None	None	RIGID	Typical
104	M117	N203	N208			RIGID	None	None	RIGID	Typical
105	M118	N202	N207			RIGID	None	None	RIGID	Typical
106	M119	N201	N206			RIGID	None	None	RIGID	Typical
107	M120	N200	N205			RIGID	None	None	RIGID	Typical
108	M121	N211	N210		270	Mod Support ...	Column	None	A53 Gr. B	Typical
109	M122	N216	N221			RIGID	None	None	RIGID	Typical
110	M123	N215	N220			RIGID	None	None	RIGID	Typical
111	M124	N214	N219			RIGID	None	None	RIGID	Typical
112	M125	N213	N218			RIGID	None	None	RIGID	Typical
113	M126	N212	N217			RIGID	None	None	RIGID	Typical
114	M127	N223	N222		270	Mod Support ...	Column	None	A53 Gr. B	Typical
115	M128	N228	N233			RIGID	None	None	RIGID	Typical
116	M129	N227	N232			RIGID	None	None	RIGID	Typical
117	M130	N226	N231			RIGID	None	None	RIGID	Typical
118	M131	N225	N230			RIGID	None	None	RIGID	Typical
119	M132	N224	N229			RIGID	None	None	RIGID	Typical
120	M133	N236	N234			RIGID	None	None	RIGID	Typical
121	M139	N236	N277		90	Mod Support ...	Beam	None	A36 Gr.36	Typical
122	M154	N272	N270			RIGID	None	None	RIGID	Typical
123	M155	N273	N271			RIGID	None	None	RIGID	Typical
124	M156	N276	N274			RIGID	None	None	RIGID	Typical
125	M157	N277	N275			RIGID	None	None	RIGID	Typical
126	M142A	N272	N270			RIGID	None	None	RIGID	Typical
127	M143A	N272	N259B		90	Mod Support ...	Beam	None	A36 Gr.36	Typical
128	M144A	N259B	N258A			RIGID	None	None	RIGID	Typical
129	M145A	N276	N274			RIGID	None	None	RIGID	Typical
130	M146A	N276	N273		90	Mod Support ...	Beam	None	A36 Gr.36	Typical
131	M147A	N273	N271			RIGID	None	None	RIGID	Typical
132	M148A	N259C	N258B			RIGID	None	None	RIGID	Typical
133	M149A	N259C	N267A		90	Mod Support ...	Beam	None	A36 Gr.36	Typical
134	M150A	N267A	N265A			RIGID	None	None	RIGID	Typical
135	M151A	N262A	N260A			RIGID	None	None	RIGID	Typical
136	M152A	N262A	N269A		90	Mod Support ...	Beam	None	A36 Gr.36	Typical
137	M153A	N269A	N268A			RIGID	None	None	RIGID	Typical
138	M154A	N266A	N264A			RIGID	None	None	RIGID	Typical
139	M155A	N266A	N263A		90	Mod Support ...	Beam	None	A36 Gr.36	Typical

Member Primary Data (Continued)

	Label	I Joint	J Joint	K Joint	Rotate(deg)	Section/Shape	Type	Design List	Material	Design Rules
140	M156A	N263A	N261A			RIGID	None	None	RIGID	Typical
141	M153B	N264B	N266B		180	Mod V Kit	Beam	None	A36 Gr.36	Typical
142	M154B	N264B	N265B		90	Mod V Kit	Beam	None	A36 Gr.36	Typical
143	M155B	N267B	N269B		180	Mod V Kit	Beam	None	A36 Gr.36	Typical
144	M156B	N267B	N268B		90	Mod V Kit	Beam	None	A36 Gr.36	Typical

Member Advanced Data

	Label	I Release	J Release	I Offset[in]	J Offset[in]	T/C Only	Physical	Defl Rat...	Analysis ...	Inactive	Seismic...
1	FACE						Yes				None
2	M2						Yes				None
3	M3						Yes				None
4	M4						Yes				None
5	M5						Yes				None
6	M6	OOOXOO					Yes	** NA **			None
7	M7	OOOXOO					Yes	** NA **			None
8	M8	OOOXOO					Yes	** NA **			None
9	M9						Yes				None
10	M10						Yes				None
11	M11	OOOXOO					Yes	** NA **			None
12	M12	OOOXOO					Yes	** NA **			None
13	M13	OOOXOO					Yes	** NA **			None
14	M14						Yes				None
15	M15						Yes				None
16	M16	OOOXOO					Yes	** NA **			None
17	M17	OOOXOO					Yes	** NA **			None
18	M18	OOOXOO					Yes	** NA **			None
19	M19						Yes				None
20	M20						Yes				None
21	M21						Yes				None
22	M23	OOOXOO					Yes	** NA **			None
23	M24	OOOXOO					Yes	** NA **			None
24	M25						Yes				None
25	M26	OOOXOO					Yes	** NA **			None
26	M27	OOOXOO					Yes	** NA **			None
27	M28						Yes				None
28	M29	OOOXOO					Yes	** NA **			None
29	M30	OOOXOO					Yes	** NA **			None
30	M31						Yes				None
31	M32						Yes	** NA **			None
32	LIVE2						Yes	** NA **			None
33	LIVE1						Yes	** NA **			None
34	M35						Yes	** NA **			None
35	M36						Yes	** NA **			None
36	MP1A						Yes	** NA **			None
37	MP2A						Yes	** NA **			None
38	MP3A						Yes				None
39	MP4A						Yes	** NA **			None
40	MP5A						Yes	** NA **			None
41	M42						Yes	** NA **			None
42	M43						Yes	** NA **			None
43	M44						Yes	** NA **			None
44	M45						Yes	** NA **			None
45	M46						Yes	** NA **			None
46	MP1C						Yes	** NA **			None
47	MP2C						Yes	** NA **			None
48	MP3C						Yes				None
49	MP4C						Yes	** NA **			None

Member Advanced Data (Continued)

	Label	I Release	J Release	I Offset[in]	J Offset[in]	T/C Only	Physical	Defl Rat...	Analysis ...	Inactive	Seismic...
50	MP5C						Yes	** NA **			None
51	M52						Yes	** NA **			None
52	M53						Yes	** NA **			None
53	M54						Yes	** NA **			None
54	M55						Yes	** NA **			None
55	M56						Yes	** NA **			None
56	MP1B						Yes	** NA **			None
57	MP2B						Yes	** NA **			None
58	MP3B						Yes	** NA **			None
59	MP4B						Yes	** NA **			None
60	MP5B						Yes	** NA **			None
61	M64						Yes	** NA **			None
62	M81						Yes	** NA **			None
63	M76						Yes	** NA **			None
64	M77						Yes	** NA **			None
65	M68						Yes	** NA **			None
66	M69						Yes	** NA **			None
67	M70		OOOXOO				Yes	** NA **			None
68	M71		OOOXOO				Yes	** NA **			None
69	M72						Yes	** NA **			None
70	M73						Yes	** NA **			None
71	M72A						Yes	** NA **			None
72	M73A						Yes	** NA **			None
73	M74						Yes	** NA **			None
74	M75						Yes	** NA **			None
75	M76A						Yes	** NA **			None
76	M77A						Yes	** NA **			None
77	M78						Yes	** NA **			None
78	M79		OOOXOO				Yes	** NA **			None
79	M80		OOOXOO				Yes	** NA **			None
80	M81A						Yes	** NA **			None
81	M82						Yes	** NA **			None
82	M82A						Yes	** NA **			None
83	M83						Yes	** NA **			None
84	M84						Yes	** NA **			None
85	M85						Yes	** NA **			None
86	M86						Yes	** NA **			None
87	M87						Yes	** NA **			None
88	M88						Yes	** NA **			None
89	M89						Yes	** NA **			None
90	M90						Yes	** NA **			None
91	M91						Yes	** NA **			None
92	M92						Yes	** NA **			None
93	M93						Yes	** NA **			None
94	M94						Yes	** NA **			None
95	M95						Yes	** NA **			None
96	M96						Yes	** NA **			None
97	M97						Yes	** NA **			None
98	M98						Yes	** NA **			None
99	M99						Yes	** NA **			None
100	M109	BenPIN	BenPIN				Yes	** NA **			None
101	M110	BenPIN	BenPIN				Yes	** NA **			None
102	M115						Yes	** NA **			None
103	M116						Yes	** NA **			None
104	M117						Yes	** NA **			None
105	M118						Yes	** NA **			None
106	M119						Yes	** NA **			None
107	M120						Yes	** NA **			None
108	M121						Yes	** NA **			None

Member Advanced Data (Continued)

	Label	I Release	J Release	I Offset[in]	J Offset[in]	T/C Only	Physical	Defl Rat...	Analysis ...	Inactive	Seismic...
109	M122						Yes	** NA **			None
110	M123						Yes	** NA **			None
111	M124						Yes	** NA **			None
112	M125						Yes	** NA **			None
113	M126						Yes	** NA **			None
114	M127						Yes	** NA **			None
115	M128						Yes	** NA **			None
116	M129						Yes	** NA **			None
117	M130						Yes	** NA **			None
118	M131						Yes	** NA **			None
119	M132						Yes	** NA **			None
120	M133		000000				Yes	** NA **			None
121	M139						Yes				None
122	M154		000000				Yes	** NA **			None
123	M155		000000				Yes	** NA **			None
124	M156		000000				Yes	** NA **			None
125	M157		000000				Yes	** NA **			None
126	M142A		000000				Yes	** NA **			None
127	M143A						Yes				None
128	M144A		000000				Yes	** NA **			None
129	M145A		000000				Yes	** NA **			None
130	M146A						Yes				None
131	M147A		000000				Yes	** NA **			None
132	M148A		000000				Yes	** NA **			None
133	M149A						Yes				None
134	M150A		000000				Yes	** NA **			None
135	M151A		000000				Yes	** NA **			None
136	M152A						Yes				None
137	M153A		000000				Yes	** NA **			None
138	M154A		000000				Yes	** NA **			None
139	M155A						Yes				None
140	M156A		000000				Yes	** NA **			None
141	M153B	BenPIN	BenPIN				Yes				None
142	M154B	BenPIN	BenPIN				Yes				None
143	M155B	BenPIN	BenPIN				Yes				None
144	M156B	BenPIN	BenPIN				Yes				None

Member Point Loads (BLC 1 : Antenna D)

	Member Label	Direction	Magnitude[lb.k-ft]	Location[ft,%]
1	MP3A	Y	-23	1
2	MP3A	My	-.011	1
3	MP3A	Mz	.015	1
4	MP3A	Y	-23	6
5	MP3A	My	-.011	6
6	MP3A	Mz	.015	6
7	MP3B	Y	-23	1
8	MP3B	My	-.008	1
9	MP3B	Mz	-.018	1
10	MP3B	Y	-23	6
11	MP3B	My	-.008	6
12	MP3B	Mz	-.018	6
13	MP3C	Y	-23	1
14	MP3C	My	.019	1
15	MP3C	Mz	.002	1
16	MP3C	Y	-23	6
17	MP3C	My	.019	6
18	MP3C	Mz	.002	6

Member Point Loads (BLC 1 : Antenna D) (Continued)

	Member Label	Direction	Magnitude[lb.k-ft]	Location[ft. %]
19	MP3A	Y	-23	1
20	MP3A	My	-.011	1
21	MP3A	Mz	-.015	1
22	MP3A	Y	-23	6
23	MP3A	My	-.011	6
24	MP3A	Mz	-.015	6
25	MP3B	Y	-23	1
26	MP3B	My	.019	1
27	MP3B	Mz	-.002	1
28	MP3B	Y	-23	6
29	MP3B	My	.019	6
30	MP3B	Mz	-.002	6
31	MP3C	Y	-23	1
32	MP3C	My	-.008	1
33	MP3C	Mz	.018	1
34	MP3C	Y	-23	6
35	MP3C	My	-.008	6
36	MP3C	Mz	.018	6
37	MP4A	Y	-44	2
38	MP4A	My	-.022	2
39	MP4A	Mz	0	2
40	MP4A	Y	-44	4
41	MP4A	My	-.022	4
42	MP4A	Mz	0	4
43	MP4B	Y	-44	2
44	MP4B	My	.011	2
45	MP4B	Mz	-.019	2
46	MP4B	Y	-44	4
47	MP4B	My	.011	4
48	MP4B	Mz	-.019	4
49	MP4C	Y	-44	2
50	MP4C	My	.011	2
51	MP4C	Mz	.019	2
52	MP4C	Y	-44	4
53	MP4C	My	.011	4
54	MP4C	Mz	.019	4
55	MP3A	Y	-84.4	2
56	MP3A	My	.042	2
57	MP3A	Mz	0	2
58	MP3B	Y	-84.4	2
59	MP3B	My	-.021	2
60	MP3B	Mz	.037	2
61	MP3C	Y	-84.4	2
62	MP3C	My	-.021	2
63	MP3C	Mz	-.037	2
64	MP4A	Y	-70.3	1.5
65	MP4A	My	.035	1.5
66	MP4A	Mz	0	1.5
67	MP4B	Y	-70.3	1.5
68	MP4B	My	-.018	1.5
69	MP4B	Mz	.03	1.5
70	MP4C	Y	-70.3	1.5
71	MP4C	My	-.018	1.5
72	MP4C	Mz	-.03	1.5
73	MP1A	Y	-13.5	1
74	MP1A	My	-.007	1
75	MP1A	Mz	0	1
76	MP1A	Y	-13.5	5
77	MP1A	My	-.007	5

Member Point Loads (BLC 1 : Antenna D) (Continued)

	Member Label	Direction	Magnitude[lb.k-ft]	Location[ft.%]
78	MP1A	Mz	0	5
79	MP1B	Y	-13.5	1
80	MP1B	My	.003	1
81	MP1B	Mz	-.006	1
82	MP1B	Y	-13.5	5
83	MP1B	My	.003	5
84	MP1B	Mz	-.006	5
85	MP1C	Y	-13.5	1
86	MP1C	My	.003	1
87	MP1C	Mz	.006	1
88	MP1C	Y	-13.5	5
89	MP1C	My	.003	5
90	MP1C	Mz	.006	5
91	MP5A	Y	-13.5	1
92	MP5A	My	-.007	1
93	MP5A	Mz	0	1
94	MP5A	Y	-13.5	5
95	MP5A	My	-.007	5
96	MP5A	Mz	0	5
97	MP5B	Y	-13.5	1
98	MP5B	My	.003	1
99	MP5B	Mz	-.006	1
100	MP5B	Y	-13.5	5
101	MP5B	My	.003	5
102	MP5B	Mz	-.006	5
103	MP5C	Y	-13.5	1
104	MP5C	My	.003	1
105	MP5C	Mz	.006	1
106	MP5C	Y	-13.5	5
107	MP5C	My	.003	5
108	MP5C	Mz	.006	5
109	M76	Y	-20	5
110	M76	My	0	5
111	M76	Mz	0	5
112	M76	Y	-15	2
113	M76	My	0	2
114	M76	Mz	0	2
115	MP1A	Y	-17.6	2
116	MP1A	My	.004	2
117	MP1A	Mz	-.008	2
118	MP1B	Y	-17.6	2
119	MP1B	My	.004	2
120	MP1B	Mz	-.008	2

Member Point Loads (BLC 2 : Antenna Di)

	Member Label	Direction	Magnitude[lb.k-ft]	Location[ft.%]
1	MP3A	Y	-84.062	1
2	MP3A	My	-.042	1
3	MP3A	Mz	.056	1
4	MP3A	Y	-84.062	6
5	MP3A	My	-.042	6
6	MP3A	Mz	.056	6
7	MP3B	Y	-84.062	1
8	MP3B	My	-.028	1
9	MP3B	Mz	-.064	1
10	MP3B	Y	-84.062	6
11	MP3B	My	-.028	6
12	MP3B	Mz	-.064	6

Member Point Loads (BLC 2 : Antenna Di) (Continued)

	Member Label	Direction	Magnitude[lb.k-ft]	Location[ft. %]
13	MP3C	Y	-84.062	1
14	MP3C	My	.07	1
15	MP3C	Mz	.008	1
16	MP3C	Y	-84.062	6
17	MP3C	My	.07	6
18	MP3C	Mz	.008	6
19	MP3A	Y	-84.062	1
20	MP3A	My	-.042	1
21	MP3A	Mz	-.056	1
22	MP3A	Y	-84.062	6
23	MP3A	My	-.042	6
24	MP3A	Mz	-.056	6
25	MP3B	Y	-84.062	1
26	MP3B	My	.07	1
27	MP3B	Mz	-.008	1
28	MP3B	Y	-84.062	6
29	MP3B	My	.07	6
30	MP3B	Mz	-.008	6
31	MP3C	Y	-84.062	1
32	MP3C	My	-.028	1
33	MP3C	Mz	.064	1
34	MP3C	Y	-84.062	6
35	MP3C	My	-.028	6
36	MP3C	Mz	.064	6
37	MP4A	Y	-42.32	2
38	MP4A	My	-.021	2
39	MP4A	Mz	0	2
40	MP4A	Y	-42.32	4
41	MP4A	My	-.021	4
42	MP4A	Mz	0	4
43	MP4B	Y	-42.32	2
44	MP4B	My	.011	2
45	MP4B	Mz	-.018	2
46	MP4B	Y	-42.32	4
47	MP4B	My	.011	4
48	MP4B	Mz	-.018	4
49	MP4C	Y	-42.32	2
50	MP4C	My	.011	2
51	MP4C	Mz	.018	2
52	MP4C	Y	-42.32	4
53	MP4C	My	.011	4
54	MP4C	Mz	.018	4
55	MP3A	Y	-45.809	2
56	MP3A	My	.023	2
57	MP3A	Mz	0	2
58	MP3B	Y	-45.809	2
59	MP3B	My	-.011	2
60	MP3B	Mz	.02	2
61	MP3C	Y	-45.809	2
62	MP3C	My	-.011	2
63	MP3C	Mz	-.02	2
64	MP4A	Y	-41.202	1.5
65	MP4A	My	.021	1.5
66	MP4A	Mz	0	1.5
67	MP4B	Y	-41.202	1.5
68	MP4B	My	-.01	1.5
69	MP4B	Mz	.018	1.5
70	MP4C	Y	-41.202	1.5
71	MP4C	My	-.01	1.5

Member Point Loads (BLC 2 : Antenna Di) (Continued)

	Member Label	Direction	Magnitude[lb.k-ft]	Location[ft.%]
72	MP4C	Mz	-.018	1.5
73	MP1A	Y	-91.266	1
74	MP1A	My	-.046	1
75	MP1A	Mz	0	1
76	MP1A	Y	-91.266	5
77	MP1A	My	-.046	5
78	MP1A	Mz	0	5
79	MP1B	Y	-91.266	1
80	MP1B	My	.023	1
81	MP1B	Mz	-.04	1
82	MP1B	Y	-91.266	5
83	MP1B	My	.023	5
84	MP1B	Mz	-.04	5
85	MP1C	Y	-91.266	1
86	MP1C	My	.023	1
87	MP1C	Mz	.04	1
88	MP1C	Y	-91.266	5
89	MP1C	My	.023	5
90	MP1C	Mz	.04	5
91	MP5A	Y	-91.266	1
92	MP5A	My	-.046	1
93	MP5A	Mz	0	1
94	MP5A	Y	-91.266	5
95	MP5A	My	-.046	5
96	MP5A	Mz	0	5
97	MP5B	Y	-91.266	1
98	MP5B	My	.023	1
99	MP5B	Mz	-.04	1
100	MP5B	Y	-91.266	5
101	MP5B	My	.023	5
102	MP5B	Mz	-.04	5
103	MP5C	Y	-91.266	1
104	MP5C	My	.023	1
105	MP5C	Mz	.04	1
106	MP5C	Y	-91.266	5
107	MP5C	My	.023	5
108	MP5C	Mz	.04	5
109	M76	Y	-17.295	5
110	M76	My	0	5
111	M76	Mz	0	5
112	M76	Y	-12.639	2
113	M76	My	0	2
114	M76	Mz	0	2
115	MP1A	Y	-17.724	2
116	MP1A	My	.004	2
117	MP1A	Mz	-.008	2
118	MP1B	Y	-17.724	2
119	MP1B	My	.004	2
120	MP1B	Mz	-.008	2

Member Point Loads (BLC 3 : Antenna Wo (0 Deg))

	Member Label	Direction	Magnitude[lb.k-ft]	Location[ft.%]
1	MP3A	X	0	1
2	MP3A	Z	-102.519	1
3	MP3A	Mx	-.068	1
4	MP3A	X	0	6
5	MP3A	Z	-102.519	6
6	MP3A	Mx	-.068	6

Member Point Loads (BLC 3 : Antenna Wo (0 Deg)) (Continued)

	Member Label	Direction	Magnitude[lb.k-ft]	Location[ft.%]
7	MP3B	X	0	1
8	MP3B	Z	-83.175	1
9	MP3B	Mx	.064	1
10	MP3B	X	0	6
11	MP3B	Z	-83.175	6
12	MP3B	Mx	.064	6
13	MP3C	X	0	1
14	MP3C	Z	-83.175	1
15	MP3C	Mx	-.008	1
16	MP3C	X	0	6
17	MP3C	Z	-83.175	6
18	MP3C	Mx	-.008	6
19	MP3A	X	0	1
20	MP3A	Z	-102.519	1
21	MP3A	Mx	.068	1
22	MP3A	X	0	6
23	MP3A	Z	-102.519	6
24	MP3A	Mx	.068	6
25	MP3B	X	0	1
26	MP3B	Z	-83.175	1
27	MP3B	Mx	.008	1
28	MP3B	X	0	6
29	MP3B	Z	-83.175	6
30	MP3B	Mx	.008	6
31	MP3C	X	0	1
32	MP3C	Z	-83.175	1
33	MP3C	Mx	-.064	1
34	MP3C	X	0	6
35	MP3C	Z	-83.175	6
36	MP3C	Mx	-.064	6
37	MP4A	X	0	2
38	MP4A	Z	-89.515	2
39	MP4A	Mx	0	2
40	MP4A	X	0	4
41	MP4A	Z	-89.515	4
42	MP4A	Mx	0	4
43	MP4B	X	0	2
44	MP4B	Z	-68.027	2
45	MP4B	Mx	.029	2
46	MP4B	X	0	4
47	MP4B	Z	-68.027	4
48	MP4B	Mx	.029	4
49	MP4C	X	0	2
50	MP4C	Z	-68.027	2
51	MP4C	Mx	-.029	2
52	MP4C	X	0	4
53	MP4C	Z	-68.027	4
54	MP4C	Mx	-.029	4
55	MP3A	X	0	2
56	MP3A	Z	-67.19	2
57	MP3A	Mx	0	2
58	MP3B	X	0	2
59	MP3B	Z	-50.609	2
60	MP3B	Mx	-.022	2
61	MP3C	X	0	2
62	MP3C	Z	-50.609	2
63	MP3C	Mx	.022	2
64	MP4A	X	0	1.5
65	MP4A	Z	-67.19	1.5

Member Point Loads (BLC 3 : Antenna Wo (0 Deg)) (Continued)

	Member Label	Direction	Magnitude[lb.k-ft]	Location[ft.%]
66	MP4A	Mx	0	1.5
67	MP4B	X	0	1.5
68	MP4B	Z	-44.432	1.5
69	MP4B	Mx	-.019	1.5
70	MP4C	X	0	1.5
71	MP4C	Z	-44.432	1.5
72	MP4C	Mx	.019	1.5
73	MP1A	X	0	1
74	MP1A	Z	-211.541	1
75	MP1A	Mx	0	1
76	MP1A	X	0	5
77	MP1A	Z	-211.541	5
78	MP1A	Mx	0	5
79	MP1B	X	0	1
80	MP1B	Z	-192.738	1
81	MP1B	Mx	.083	1
82	MP1B	X	0	5
83	MP1B	Z	-192.738	5
84	MP1B	Mx	.083	5
85	MP1C	X	0	1
86	MP1C	Z	-192.738	1
87	MP1C	Mx	-.083	1
88	MP1C	X	0	5
89	MP1C	Z	-192.738	5
90	MP1C	Mx	-.083	5
91	MP5A	X	0	1
92	MP5A	Z	-211.541	1
93	MP5A	Mx	0	1
94	MP5A	X	0	5
95	MP5A	Z	-211.541	5
96	MP5A	Mx	0	5
97	MP5B	X	0	1
98	MP5B	Z	-192.738	1
99	MP5B	Mx	.083	1
100	MP5B	X	0	5
101	MP5B	Z	-192.738	5
102	MP5B	Mx	.083	5
103	MP5C	X	0	1
104	MP5C	Z	-192.738	1
105	MP5C	Mx	-.083	1
106	MP5C	X	0	5
107	MP5C	Z	-192.738	5
108	MP5C	Mx	-.083	5
109	M76	X	0	5
110	M76	Z	-10.837	5
111	M76	Mx	0	5
112	M76	X	0	2
113	M76	Z	-8.453	2
114	M76	Mx	0	2
115	MP1A	X	0	2
116	MP1A	Z	-19.87	2
117	MP1A	Mx	.009	2
118	MP1B	X	0	2
119	MP1B	Z	-19.87	2
120	MP1B	Mx	.009	2

Member Point Loads (BLC 4 : Antenna Wo (30 Deg))

	Member Label	Direction	Magnitude[lb,k-ft]	Location[ft.%]
--	--------------	-----------	--------------------	----------------

Member Point Loads (BLC 4 : Antenna Wo (30 Deg)) (Continued)

	Member Label	Direction	Magnitude[lb.k-ft]	Location[ft.%]
1	MP3A	X	48.036	1
2	MP3A	Z	-83.2	1
3	MP3A	Mx	-.079	1
4	MP3A	X	48.036	6
5	MP3A	Z	-83.2	6
6	MP3A	Mx	-.079	6
7	MP3B	X	38.363	1
8	MP3B	Z	-66.447	1
9	MP3B	Mx	.038	1
10	MP3B	X	38.363	6
11	MP3B	Z	-66.447	6
12	MP3B	Mx	.038	6
13	MP3C	X	48.036	1
14	MP3C	Z	-83.2	1
15	MP3C	Mx	.031	1
16	MP3C	X	48.036	6
17	MP3C	Z	-83.2	6
18	MP3C	Mx	.031	6
19	MP3A	X	48.036	1
20	MP3A	Z	-83.2	1
21	MP3A	Mx	.031	1
22	MP3A	X	48.036	6
23	MP3A	Z	-83.2	6
24	MP3A	Mx	.031	6
25	MP3B	X	38.363	1
26	MP3B	Z	-66.447	1
27	MP3B	Mx	.038	1
28	MP3B	X	38.363	6
29	MP3B	Z	-66.447	6
30	MP3B	Mx	.038	6
31	MP3C	X	48.036	1
32	MP3C	Z	-83.2	1
33	MP3C	Mx	-.079	1
34	MP3C	X	48.036	6
35	MP3C	Z	-83.2	6
36	MP3C	Mx	-.079	6
37	MP4A	X	41.176	2
38	MP4A	Z	-71.319	2
39	MP4A	Mx	-.021	2
40	MP4A	X	41.176	4
41	MP4A	Z	-71.319	4
42	MP4A	Mx	-.021	4
43	MP4B	X	30.432	2
44	MP4B	Z	-52.71	2
45	MP4B	Mx	.03	2
46	MP4B	X	30.432	4
47	MP4B	Z	-52.71	4
48	MP4B	Mx	.03	4
49	MP4C	X	41.176	2
50	MP4C	Z	-71.319	2
51	MP4C	Mx	-.021	2
52	MP4C	X	41.176	4
53	MP4C	Z	-71.319	4
54	MP4C	Mx	-.021	4
55	MP3A	X	30.832	2
56	MP3A	Z	-53.402	2
57	MP3A	Mx	.015	2
58	MP3B	X	22.541	2
59	MP3B	Z	-39.043	2



Member Point Loads (BLC 4 : Antenna Wo (30 Deg)) (Continued)

	Member Label	Direction	Magnitude[lb.k-ft]	Location[ft.%]
60	MP3B	Mx	-.023	2
61	MP3C	X	30.832	2
62	MP3C	Z	-53.402	2
63	MP3C	Mx	.015	2
64	MP4A	X	29.802	1.5
65	MP4A	Z	-51.619	1.5
66	MP4A	Mx	.015	1.5
67	MP4B	X	18.423	1.5
68	MP4B	Z	-31.91	1.5
69	MP4B	Mx	-.018	1.5
70	MP4C	X	29.802	1.5
71	MP4C	Z	-51.619	1.5
72	MP4C	Mx	.015	1.5
73	MP1A	X	102.637	1
74	MP1A	Z	-177.772	1
75	MP1A	Mx	-.051	1
76	MP1A	X	102.637	5
77	MP1A	Z	-177.772	5
78	MP1A	Mx	-.051	5
79	MP1B	X	93.235	1
80	MP1B	Z	-161.488	1
81	MP1B	Mx	.093	1
82	MP1B	X	93.235	5
83	MP1B	Z	-161.488	5
84	MP1B	Mx	.093	5
85	MP1C	X	102.637	1
86	MP1C	Z	-177.772	1
87	MP1C	Mx	-.051	1
88	MP1C	X	102.637	5
89	MP1C	Z	-177.772	5
90	MP1C	Mx	-.051	5
91	MP5A	X	102.637	1
92	MP5A	Z	-177.772	1
93	MP5A	Mx	-.051	1
94	MP5A	X	102.637	5
95	MP5A	Z	-177.772	5
96	MP5A	Mx	-.051	5
97	MP5B	X	93.235	1
98	MP5B	Z	-161.488	1
99	MP5B	Mx	.093	1
100	MP5B	X	93.235	5
101	MP5B	Z	-161.488	5
102	MP5B	Mx	.093	5
103	MP5C	X	102.637	1
104	MP5C	Z	-177.772	1
105	MP5C	Mx	-.051	1
106	MP5C	X	102.637	5
107	MP5C	Z	-177.772	5
108	MP5C	Mx	-.051	5
109	M76	X	7.225	5
110	M76	Z	-12.514	5
111	M76	Mx	0	5
112	M76	X	5.635	2
113	M76	Z	-9.761	2
114	M76	Mx	0	2
115	MP1A	X	6.311	2
116	MP1A	Z	-10.931	2
117	MP1A	Mx	.006	2
118	MP1B	X	6.311	2



Member Point Loads (BLC 4 : Antenna Wo (30 Deg)) (Continued)

	Member Label	Direction	Magnitude[lb.k-ft]	Location[ft. %]
119	MP1B	Z	-10.931	2
120	MP1B	Mx	.006	2

Member Point Loads (BLC 5 : Antenna Wo (60 Deg))

	Member Label	Direction	Magnitude[lb.k-ft]	Location[ft. %]
1	MP3A	X	72.032	1
2	MP3A	Z	-41.587	1
3	MP3A	Mx	-.064	1
4	MP3A	X	72.032	6
5	MP3A	Z	-41.587	6
6	MP3A	Mx	-.064	6
7	MP3B	X	72.032	1
8	MP3B	Z	-41.587	1
9	MP3B	Mx	.008	1
10	MP3B	X	72.032	6
11	MP3B	Z	-41.587	6
12	MP3B	Mx	.008	6
13	MP3C	X	88.784	1
14	MP3C	Z	-51.26	1
15	MP3C	Mx	.068	1
16	MP3C	X	88.784	6
17	MP3C	Z	-51.26	6
18	MP3C	Mx	.068	6
19	MP3A	X	72.032	1
20	MP3A	Z	-41.587	1
21	MP3A	Mx	-.008	1
22	MP3A	X	72.032	6
23	MP3A	Z	-41.587	6
24	MP3A	Mx	-.008	6
25	MP3B	X	72.032	1
26	MP3B	Z	-41.587	1
27	MP3B	Mx	.064	1
28	MP3B	X	72.032	6
29	MP3B	Z	-41.587	6
30	MP3B	Mx	.064	6
31	MP3C	X	88.784	1
32	MP3C	Z	-51.26	1
33	MP3C	Mx	-.068	1
34	MP3C	X	88.784	6
35	MP3C	Z	-51.26	6
36	MP3C	Mx	-.068	6
37	MP4A	X	58.913	2
38	MP4A	Z	-34.013	2
39	MP4A	Mx	-.029	2
40	MP4A	X	58.913	4
41	MP4A	Z	-34.013	4
42	MP4A	Mx	-.029	4
43	MP4B	X	58.913	2
44	MP4B	Z	-34.013	2
45	MP4B	Mx	.029	2
46	MP4B	X	58.913	4
47	MP4B	Z	-34.013	4
48	MP4B	Mx	.029	4
49	MP4C	X	77.522	2
50	MP4C	Z	-44.757	2
51	MP4C	Mx	0	2
52	MP4C	X	77.522	4
53	MP4C	Z	-44.757	4



Member Point Loads (BLC 5 : Antenna Wo (60 Deg)) (Continued)

	Member Label	Direction	Magnitude[lb.k-ft]	Location[ft.%]
54	MP4C	Mx	0	4
55	MP3A	X	43.829	2
56	MP3A	Z	-25.305	2
57	MP3A	Mx	.022	2
58	MP3B	X	43.829	2
59	MP3B	Z	-25.305	2
60	MP3B	Mx	-.022	2
61	MP3C	X	58.188	2
62	MP3C	Z	-33.595	2
63	MP3C	Mx	0	2
64	MP4A	X	38.479	1.5
65	MP4A	Z	-22.216	1.5
66	MP4A	Mx	.019	1.5
67	MP4B	X	38.479	1.5
68	MP4B	Z	-22.216	1.5
69	MP4B	Mx	-.019	1.5
70	MP4C	X	58.188	1.5
71	MP4C	Z	-33.595	1.5
72	MP4C	Mx	0	1.5
73	MP1A	X	166.916	1
74	MP1A	Z	-96.369	1
75	MP1A	Mx	-.083	1
76	MP1A	X	166.916	5
77	MP1A	Z	-96.369	5
78	MP1A	Mx	-.083	5
79	MP1B	X	166.916	1
80	MP1B	Z	-96.369	1
81	MP1B	Mx	.083	1
82	MP1B	X	166.916	5
83	MP1B	Z	-96.369	5
84	MP1B	Mx	.083	5
85	MP1C	X	183.2	1
86	MP1C	Z	-105.77	1
87	MP1C	Mx	0	1
88	MP1C	X	183.2	5
89	MP1C	Z	-105.77	5
90	MP1C	Mx	0	5
91	MP5A	X	166.916	1
92	MP5A	Z	-96.369	1
93	MP5A	Mx	-.083	1
94	MP5A	X	166.916	5
95	MP5A	Z	-96.369	5
96	MP5A	Mx	-.083	5
97	MP5B	X	166.916	1
98	MP5B	Z	-96.369	1
99	MP5B	Mx	.083	1
100	MP5B	X	166.916	5
101	MP5B	Z	-96.369	5
102	MP5B	Mx	.083	5
103	MP5C	X	183.2	1
104	MP5C	Z	-105.77	1
105	MP5C	Mx	0	1
106	MP5C	X	183.2	5
107	MP5C	Z	-105.77	5
108	MP5C	Mx	0	5
109	M76	X	9.385	5
110	M76	Z	-5.419	5
111	M76	Mx	0	5
112	M76	X	7.32	2



Member Point Loads (BLC 5 : Antenna Wo (60 Deg)) (Continued)

	Member Label	Direction	Magnitude[lb.k-ft]	Location[ft.%]
113	M76	Z	-4.226	2
114	M76	Mx	0	2
115	MP1A	X	17.208	2
116	MP1A	Z	-9.935	2
117	MP1A	Mx	.009	2
118	MP1B	X	17.208	2
119	MP1B	Z	-9.935	2
120	MP1B	Mx	.009	2

Member Point Loads (BLC 6 : Antenna Wo (90 Deg))

	Member Label	Direction	Magnitude[lb.k-ft]	Location[ft.%]
1	MP3A	X	76.727	1
2	MP3A	Z	0	1
3	MP3A	Mx	-.038	1
4	MP3A	X	76.727	6
5	MP3A	Z	0	6
6	MP3A	Mx	-.038	6
7	MP3B	X	96.071	1
8	MP3B	Z	0	1
9	MP3B	Mx	-.031	1
10	MP3B	X	96.071	6
11	MP3B	Z	0	6
12	MP3B	Mx	-.031	6
13	MP3C	X	96.071	1
14	MP3C	Z	0	1
15	MP3C	Mx	.079	1
16	MP3C	X	96.071	6
17	MP3C	Z	0	6
18	MP3C	Mx	.079	6
19	MP3A	X	76.727	1
20	MP3A	Z	0	1
21	MP3A	Mx	-.038	1
22	MP3A	X	76.727	6
23	MP3A	Z	0	6
24	MP3A	Mx	-.038	6
25	MP3B	X	96.071	1
26	MP3B	Z	0	1
27	MP3B	Mx	.079	1
28	MP3B	X	96.071	6
29	MP3B	Z	0	6
30	MP3B	Mx	.079	6
31	MP3C	X	96.071	1
32	MP3C	Z	0	1
33	MP3C	Mx	-.031	1
34	MP3C	X	96.071	6
35	MP3C	Z	0	6
36	MP3C	Mx	-.031	6
37	MP4A	X	60.864	2
38	MP4A	Z	0	2
39	MP4A	Mx	-.03	2
40	MP4A	X	60.864	4
41	MP4A	Z	0	4
42	MP4A	Mx	-.03	4
43	MP4B	X	82.352	2
44	MP4B	Z	0	2
45	MP4B	Mx	.021	2
46	MP4B	X	82.352	4
47	MP4B	Z	0	4



Member Point Loads (BLC 6 : Antenna Wo (90 Deg)) (Continued)

	Member Label	Direction	Magnitude[lb.k-ft]	Location[ft.%]
48	MP4B	Mx	.021	4
49	MP4C	X	82.352	2
50	MP4C	Z	0	2
51	MP4C	Mx	.021	2
52	MP4C	X	82.352	4
53	MP4C	Z	0	4
54	MP4C	Mx	.021	4
55	MP3A	X	45.082	2
56	MP3A	Z	0	2
57	MP3A	Mx	.023	2
58	MP3B	X	61.663	2
59	MP3B	Z	0	2
60	MP3B	Mx	-.015	2
61	MP3C	X	61.663	2
62	MP3C	Z	0	2
63	MP3C	Mx	-.015	2
64	MP4A	X	36.846	1.5
65	MP4A	Z	0	1.5
66	MP4A	Mx	.018	1.5
67	MP4B	X	59.604	1.5
68	MP4B	Z	0	1.5
69	MP4B	Mx	-.015	1.5
70	MP4C	X	59.604	1.5
71	MP4C	Z	0	1.5
72	MP4C	Mx	-.015	1.5
73	MP1A	X	186.471	1
74	MP1A	Z	0	1
75	MP1A	Mx	-.093	1
76	MP1A	X	186.471	5
77	MP1A	Z	0	5
78	MP1A	Mx	-.093	5
79	MP1B	X	205.273	1
80	MP1B	Z	0	1
81	MP1B	Mx	.051	1
82	MP1B	X	205.273	5
83	MP1B	Z	0	5
84	MP1B	Mx	.051	5
85	MP1C	X	205.273	1
86	MP1C	Z	0	1
87	MP1C	Mx	.051	1
88	MP1C	X	205.273	5
89	MP1C	Z	0	5
90	MP1C	Mx	.051	5
91	MP5A	X	186.471	1
92	MP5A	Z	0	1
93	MP5A	Mx	-.093	1
94	MP5A	X	186.471	5
95	MP5A	Z	0	5
96	MP5A	Mx	-.093	5
97	MP5B	X	205.273	1
98	MP5B	Z	0	1
99	MP5B	Mx	.051	1
100	MP5B	X	205.273	5
101	MP5B	Z	0	5
102	MP5B	Mx	.051	5
103	MP5C	X	205.273	1
104	MP5C	Z	0	1
105	MP5C	Mx	.051	1
106	MP5C	X	205.273	5



Member Point Loads (BLC 6 : Antenna Wo (90 Deg)) (Continued)

	Member Label	Direction	Magnitude[lb.k-ft]	Location[ft.%]
107	MP5C	Z	0	5
108	MP5C	Mx	.051	5
109	M76	X	3.612	5
110	M76	Z	0	5
111	M76	Mx	0	5
112	M76	X	2.818	2
113	M76	Z	0	2
114	M76	Mx	0	2
115	MP1A	X	34.366	2
116	MP1A	Z	0	2
117	MP1A	Mx	.009	2
118	MP1B	X	34.366	2
119	MP1B	Z	0	2
120	MP1B	Mx	.009	2

Member Point Loads (BLC 7 : Antenna Wo (120 Deg))

	Member Label	Direction	Magnitude[lb.k-ft]	Location[ft.%]
1	MP3A	X	72.032	1
2	MP3A	Z	41.587	1
3	MP3A	Mx	-.008	1
4	MP3A	X	72.032	6
5	MP3A	Z	41.587	6
6	MP3A	Mx	-.008	6
7	MP3B	X	88.784	1
8	MP3B	Z	51.26	1
9	MP3B	Mx	-.068	1
10	MP3B	X	88.784	6
11	MP3B	Z	51.26	6
12	MP3B	Mx	-.068	6
13	MP3C	X	72.032	1
14	MP3C	Z	41.587	1
15	MP3C	Mx	.064	1
16	MP3C	X	72.032	6
17	MP3C	Z	41.587	6
18	MP3C	Mx	.064	6
19	MP3A	X	72.032	1
20	MP3A	Z	41.587	1
21	MP3A	Mx	-.064	1
22	MP3A	X	72.032	6
23	MP3A	Z	41.587	6
24	MP3A	Mx	-.064	6
25	MP3B	X	88.784	1
26	MP3B	Z	51.26	1
27	MP3B	Mx	.068	1
28	MP3B	X	88.784	6
29	MP3B	Z	51.26	6
30	MP3B	Mx	.068	6
31	MP3C	X	72.032	1
32	MP3C	Z	41.587	1
33	MP3C	Mx	.008	1
34	MP3C	X	72.032	6
35	MP3C	Z	41.587	6
36	MP3C	Mx	.008	6
37	MP4A	X	58.913	2
38	MP4A	Z	34.013	2
39	MP4A	Mx	-.029	2
40	MP4A	X	58.913	4
41	MP4A	Z	34.013	4



Member Point Loads (BLC 7 : Antenna Wo (120 Deg)) (Continued)

	Member Label	Direction	Magnitude[lb.k-ft]	Location[ft.%]
42	MP4A	Mx	-.029	4
43	MP4B	X	77.522	2
44	MP4B	Z	44.757	2
45	MP4B	Mx	0	2
46	MP4B	X	77.522	4
47	MP4B	Z	44.757	4
48	MP4B	Mx	0	4
49	MP4C	X	58.913	2
50	MP4C	Z	34.013	2
51	MP4C	Mx	.029	2
52	MP4C	X	58.913	4
53	MP4C	Z	34.013	4
54	MP4C	Mx	.029	4
55	MP3A	X	43.829	2
56	MP3A	Z	25.305	2
57	MP3A	Mx	.022	2
58	MP3B	X	58.188	2
59	MP3B	Z	33.595	2
60	MP3B	Mx	0	2
61	MP3C	X	43.829	2
62	MP3C	Z	25.305	2
63	MP3C	Mx	-.022	2
64	MP4A	X	38.479	1.5
65	MP4A	Z	22.216	1.5
66	MP4A	Mx	.019	1.5
67	MP4B	X	58.188	1.5
68	MP4B	Z	33.595	1.5
69	MP4B	Mx	0	1.5
70	MP4C	X	38.479	1.5
71	MP4C	Z	22.216	1.5
72	MP4C	Mx	-.019	1.5
73	MP1A	X	166.916	1
74	MP1A	Z	96.369	1
75	MP1A	Mx	-.083	1
76	MP1A	X	166.916	5
77	MP1A	Z	96.369	5
78	MP1A	Mx	-.083	5
79	MP1B	X	183.2	1
80	MP1B	Z	105.77	1
81	MP1B	Mx	0	1
82	MP1B	X	183.2	5
83	MP1B	Z	105.77	5
84	MP1B	Mx	0	5
85	MP1C	X	166.916	1
86	MP1C	Z	96.369	1
87	MP1C	Mx	.083	1
88	MP1C	X	166.916	5
89	MP1C	Z	96.369	5
90	MP1C	Mx	.083	5
91	MP5A	X	166.916	1
92	MP5A	Z	96.369	1
93	MP5A	Mx	-.083	1
94	MP5A	X	166.916	5
95	MP5A	Z	96.369	5
96	MP5A	Mx	-.083	5
97	MP5B	X	183.2	1
98	MP5B	Z	105.77	1
99	MP5B	Mx	0	1
100	MP5B	X	183.2	5

Member Point Loads (BLC 7 : Antenna Wo (120 Deg)) (Continued)

	Member Label	Direction	Magnitude[lb.k-ft]	Location[ft. %]
101	MP5B	Z	105.77	5
102	MP5B	Mx	0	5
103	MP5C	X	166.916	1
104	MP5C	Z	96.369	1
105	MP5C	Mx	.083	1
106	MP5C	X	166.916	5
107	MP5C	Z	96.369	5
108	MP5C	Mx	.083	5
109	M76	X	0	5
110	M76	Z	0	5
111	M76	Mx	0	5
112	M76	X	0	2
113	M76	Z	0	2
114	M76	Mx	0	2
115	MP1A	X	36.039	2
116	MP1A	Z	20.807	2
117	MP1A	Mx	0	2
118	MP1B	X	36.039	2
119	MP1B	Z	20.807	2
120	MP1B	Mx	0	2

Member Point Loads (BLC 8 : Antenna Wo (150 Deg))

	Member Label	Direction	Magnitude[lb.k-ft]	Location[ft. %]
1	MP3A	X	48.036	1
2	MP3A	Z	83.2	1
3	MP3A	Mx	.031	1
4	MP3A	X	48.036	6
5	MP3A	Z	83.2	6
6	MP3A	Mx	.031	6
7	MP3B	X	48.036	1
8	MP3B	Z	83.2	1
9	MP3B	Mx	-.079	1
10	MP3B	X	48.036	6
11	MP3B	Z	83.2	6
12	MP3B	Mx	-.079	6
13	MP3C	X	38.363	1
14	MP3C	Z	66.447	1
15	MP3C	Mx	.038	1
16	MP3C	X	38.363	6
17	MP3C	Z	66.447	6
18	MP3C	Mx	.038	6
19	MP3A	X	48.036	1
20	MP3A	Z	83.2	1
21	MP3A	Mx	-.079	1
22	MP3A	X	48.036	6
23	MP3A	Z	83.2	6
24	MP3A	Mx	-.079	6
25	MP3B	X	48.036	1
26	MP3B	Z	83.2	1
27	MP3B	Mx	.031	1
28	MP3B	X	48.036	6
29	MP3B	Z	83.2	6
30	MP3B	Mx	.031	6
31	MP3C	X	38.363	1
32	MP3C	Z	66.447	1
33	MP3C	Mx	.038	1
34	MP3C	X	38.363	6
35	MP3C	Z	66.447	6



Member Point Loads (BLC 8 : Antenna Wo (150 Deg)) (Continued)

	Member Label	Direction	Magnitude[lb.k-ft]	Location[ft.%]
36	MP3C	Mx	.038	6
37	MP4A	X	41.176	2
38	MP4A	Z	71.319	2
39	MP4A	Mx	-.021	2
40	MP4A	X	41.176	4
41	MP4A	Z	71.319	4
42	MP4A	Mx	-.021	4
43	MP4B	X	41.176	2
44	MP4B	Z	71.319	2
45	MP4B	Mx	-.021	2
46	MP4B	X	41.176	4
47	MP4B	Z	71.319	4
48	MP4B	Mx	-.021	4
49	MP4C	X	30.432	2
50	MP4C	Z	52.71	2
51	MP4C	Mx	.03	2
52	MP4C	X	30.432	4
53	MP4C	Z	52.71	4
54	MP4C	Mx	.03	4
55	MP3A	X	30.832	2
56	MP3A	Z	53.402	2
57	MP3A	Mx	.015	2
58	MP3B	X	30.832	2
59	MP3B	Z	53.402	2
60	MP3B	Mx	.015	2
61	MP3C	X	22.541	2
62	MP3C	Z	39.043	2
63	MP3C	Mx	-.023	2
64	MP4A	X	29.802	1.5
65	MP4A	Z	51.619	1.5
66	MP4A	Mx	.015	1.5
67	MP4B	X	29.802	1.5
68	MP4B	Z	51.619	1.5
69	MP4B	Mx	.015	1.5
70	MP4C	X	18.423	1.5
71	MP4C	Z	31.91	1.5
72	MP4C	Mx	-.018	1.5
73	MP1A	X	102.637	1
74	MP1A	Z	177.772	1
75	MP1A	Mx	-.051	1
76	MP1A	X	102.637	5
77	MP1A	Z	177.772	5
78	MP1A	Mx	-.051	5
79	MP1B	X	102.637	1
80	MP1B	Z	177.772	1
81	MP1B	Mx	-.051	1
82	MP1B	X	102.637	5
83	MP1B	Z	177.772	5
84	MP1B	Mx	-.051	5
85	MP1C	X	93.235	1
86	MP1C	Z	161.488	1
87	MP1C	Mx	.093	1
88	MP1C	X	93.235	5
89	MP1C	Z	161.488	5
90	MP1C	Mx	.093	5
91	MP5A	X	102.637	1
92	MP5A	Z	177.772	1
93	MP5A	Mx	-.051	1
94	MP5A	X	102.637	5

Member Point Loads (BLC 8 : Antenna Wo (150 Deg)) (Continued)

	Member Label	Direction	Magnitude[lb.k-ft]	Location[ft. %]
95	MP5A	Z	177.772	5
96	MP5A	Mx	-.051	5
97	MP5B	X	102.637	1
98	MP5B	Z	177.772	1
99	MP5B	Mx	-.051	1
100	MP5B	X	102.637	5
101	MP5B	Z	177.772	5
102	MP5B	Mx	-.051	5
103	MP5C	X	93.235	1
104	MP5C	Z	161.488	1
105	MP5C	Mx	.093	1
106	MP5C	X	93.235	5
107	MP5C	Z	161.488	5
108	MP5C	Mx	.093	5
109	M76	X	1.806	5
110	M76	Z	3.128	5
111	M76	Mx	0	5
112	M76	X	1.409	2
113	M76	Z	2.44	2
114	M76	Mx	0	2
115	MP1A	X	17.183	2
116	MP1A	Z	29.762	2
117	MP1A	Mx	-.009	2
118	MP1B	X	17.183	2
119	MP1B	Z	29.762	2
120	MP1B	Mx	-.009	2

Member Point Loads (BLC 9 : Antenna Wo (180 Deg))

	Member Label	Direction	Magnitude[lb.k-ft]	Location[ft. %]
1	MP3A	X	0	1
2	MP3A	Z	102.519	1
3	MP3A	Mx	.068	1
4	MP3A	X	0	6
5	MP3A	Z	102.519	6
6	MP3A	Mx	.068	6
7	MP3B	X	0	1
8	MP3B	Z	83.175	1
9	MP3B	Mx	-.064	1
10	MP3B	X	0	6
11	MP3B	Z	83.175	6
12	MP3B	Mx	-.064	6
13	MP3C	X	0	1
14	MP3C	Z	83.175	1
15	MP3C	Mx	.008	1
16	MP3C	X	0	6
17	MP3C	Z	83.175	6
18	MP3C	Mx	.008	6
19	MP3A	X	0	1
20	MP3A	Z	102.519	1
21	MP3A	Mx	-.068	1
22	MP3A	X	0	6
23	MP3A	Z	102.519	6
24	MP3A	Mx	-.068	6
25	MP3B	X	0	1
26	MP3B	Z	83.175	1
27	MP3B	Mx	-.008	1
28	MP3B	X	0	6
29	MP3B	Z	83.175	6

Member Point Loads (BLC 9 : Antenna Wo (180 Deg)) (Continued)

	Member Label	Direction	Magnitude[lb.k-ft]	Location[ft.%]
30	MP3B	Mx	-.008	6
31	MP3C	X	0	1
32	MP3C	Z	83.175	1
33	MP3C	Mx	.064	1
34	MP3C	X	0	6
35	MP3C	Z	83.175	6
36	MP3C	Mx	.064	6
37	MP4A	X	0	2
38	MP4A	Z	89.515	2
39	MP4A	Mx	0	2
40	MP4A	X	0	4
41	MP4A	Z	89.515	4
42	MP4A	Mx	0	4
43	MP4B	X	0	2
44	MP4B	Z	68.027	2
45	MP4B	Mx	-.029	2
46	MP4B	X	0	4
47	MP4B	Z	68.027	4
48	MP4B	Mx	-.029	4
49	MP4C	X	0	2
50	MP4C	Z	68.027	2
51	MP4C	Mx	.029	2
52	MP4C	X	0	4
53	MP4C	Z	68.027	4
54	MP4C	Mx	.029	4
55	MP3A	X	0	2
56	MP3A	Z	67.19	2
57	MP3A	Mx	0	2
58	MP3B	X	0	2
59	MP3B	Z	50.609	2
60	MP3B	Mx	.022	2
61	MP3C	X	0	2
62	MP3C	Z	50.609	2
63	MP3C	Mx	-.022	2
64	MP4A	X	0	1.5
65	MP4A	Z	67.19	1.5
66	MP4A	Mx	0	1.5
67	MP4B	X	0	1.5
68	MP4B	Z	44.432	1.5
69	MP4B	Mx	.019	1.5
70	MP4C	X	0	1.5
71	MP4C	Z	44.432	1.5
72	MP4C	Mx	-.019	1.5
73	MP1A	X	0	1
74	MP1A	Z	211.541	1
75	MP1A	Mx	0	1
76	MP1A	X	0	5
77	MP1A	Z	211.541	5
78	MP1A	Mx	0	5
79	MP1B	X	0	1
80	MP1B	Z	192.738	1
81	MP1B	Mx	-.083	1
82	MP1B	X	0	5
83	MP1B	Z	192.738	5
84	MP1B	Mx	-.083	5
85	MP1C	X	0	1
86	MP1C	Z	192.738	1
87	MP1C	Mx	.083	1
88	MP1C	X	0	5

Member Point Loads (BLC 9 : Antenna Wo (180 Deg)) (Continued)

	Member Label	Direction	Magnitude[lb.k-ft]	Location[ft. %]
89	MP1C	Z	192.738	5
90	MP1C	Mx	.083	5
91	MP5A	X	0	1
92	MP5A	Z	211.541	1
93	MP5A	Mx	0	1
94	MP5A	X	0	5
95	MP5A	Z	211.541	5
96	MP5A	Mx	0	5
97	MP5B	X	0	1
98	MP5B	Z	192.738	1
99	MP5B	Mx	-.083	1
100	MP5B	X	0	5
101	MP5B	Z	192.738	5
102	MP5B	Mx	-.083	5
103	MP5C	X	0	1
104	MP5C	Z	192.738	1
105	MP5C	Mx	.083	1
106	MP5C	X	0	5
107	MP5C	Z	192.738	5
108	MP5C	Mx	.083	5
109	M76	X	0	5
110	M76	Z	10.837	5
111	M76	Mx	0	5
112	M76	X	0	2
113	M76	Z	8.453	2
114	M76	Mx	0	2
115	MP1A	X	0	2
116	MP1A	Z	19.87	2
117	MP1A	Mx	-.009	2
118	MP1B	X	0	2
119	MP1B	Z	19.87	2
120	MP1B	Mx	-.009	2

Member Point Loads (BLC 10 : Antenna Wo (210 Deg))

	Member Label	Direction	Magnitude[lb.k-ft]	Location[ft. %]
1	MP3A	X	-48.036	1
2	MP3A	Z	83.2	1
3	MP3A	Mx	.079	1
4	MP3A	X	-48.036	6
5	MP3A	Z	83.2	6
6	MP3A	Mx	.079	6
7	MP3B	X	-38.363	1
8	MP3B	Z	66.447	1
9	MP3B	Mx	-.038	1
10	MP3B	X	-38.363	6
11	MP3B	Z	66.447	6
12	MP3B	Mx	-.038	6
13	MP3C	X	-48.036	1
14	MP3C	Z	83.2	1
15	MP3C	Mx	-.031	1
16	MP3C	X	-48.036	6
17	MP3C	Z	83.2	6
18	MP3C	Mx	-.031	6
19	MP3A	X	-48.036	1
20	MP3A	Z	83.2	1
21	MP3A	Mx	-.031	1
22	MP3A	X	-48.036	6
23	MP3A	Z	83.2	6

Member Point Loads (BLC 10 : Antenna Wo (210 Deg)) (Continued)

	Member Label	Direction	Magnitude[lb.k-ft]	Location[ft.%]
24	MP3A	Mx	-.031	6
25	MP3B	X	-38.363	1
26	MP3B	Z	66.447	1
27	MP3B	Mx	-.038	1
28	MP3B	X	-38.363	6
29	MP3B	Z	66.447	6
30	MP3B	Mx	-.038	6
31	MP3C	X	-48.036	1
32	MP3C	Z	83.2	1
33	MP3C	Mx	.079	1
34	MP3C	X	-48.036	6
35	MP3C	Z	83.2	6
36	MP3C	Mx	.079	6
37	MP4A	X	-41.176	2
38	MP4A	Z	71.319	2
39	MP4A	Mx	.021	2
40	MP4A	X	-41.176	4
41	MP4A	Z	71.319	4
42	MP4A	Mx	.021	4
43	MP4B	X	-30.432	2
44	MP4B	Z	52.71	2
45	MP4B	Mx	-.03	2
46	MP4B	X	-30.432	4
47	MP4B	Z	52.71	4
48	MP4B	Mx	-.03	4
49	MP4C	X	-41.176	2
50	MP4C	Z	71.319	2
51	MP4C	Mx	.021	2
52	MP4C	X	-41.176	4
53	MP4C	Z	71.319	4
54	MP4C	Mx	.021	4
55	MP3A	X	-30.832	2
56	MP3A	Z	53.402	2
57	MP3A	Mx	-.015	2
58	MP3B	X	-22.541	2
59	MP3B	Z	39.043	2
60	MP3B	Mx	.023	2
61	MP3C	X	-30.832	2
62	MP3C	Z	53.402	2
63	MP3C	Mx	-.015	2
64	MP4A	X	-29.802	1.5
65	MP4A	Z	51.619	1.5
66	MP4A	Mx	-.015	1.5
67	MP4B	X	-18.423	1.5
68	MP4B	Z	31.91	1.5
69	MP4B	Mx	.018	1.5
70	MP4C	X	-29.802	1.5
71	MP4C	Z	51.619	1.5
72	MP4C	Mx	-.015	1.5
73	MP1A	X	-102.637	1
74	MP1A	Z	177.772	1
75	MP1A	Mx	.051	1
76	MP1A	X	-102.637	5
77	MP1A	Z	177.772	5
78	MP1A	Mx	.051	5
79	MP1B	X	-93.235	1
80	MP1B	Z	161.488	1
81	MP1B	Mx	-.093	1
82	MP1B	X	-93.235	5



Member Point Loads (BLC 10 : Antenna Wo (210 Deg)) (Continued)

	Member Label	Direction	Magnitude[lb.k-ft]	Location[ft.%]
83	MP1B	Z	161.488	5
84	MP1B	Mx	-.093	5
85	MP1C	X	-102.637	1
86	MP1C	Z	177.772	1
87	MP1C	Mx	.051	1
88	MP1C	X	-102.637	5
89	MP1C	Z	177.772	5
90	MP1C	Mx	.051	5
91	MP5A	X	-102.637	1
92	MP5A	Z	177.772	1
93	MP5A	Mx	.051	1
94	MP5A	X	-102.637	5
95	MP5A	Z	177.772	5
96	MP5A	Mx	.051	5
97	MP5B	X	-93.235	1
98	MP5B	Z	161.488	1
99	MP5B	Mx	-.093	1
100	MP5B	X	-93.235	5
101	MP5B	Z	161.488	5
102	MP5B	Mx	-.093	5
103	MP5C	X	-102.637	1
104	MP5C	Z	177.772	1
105	MP5C	Mx	.051	1
106	MP5C	X	-102.637	5
107	MP5C	Z	177.772	5
108	MP5C	Mx	.051	5
109	M76	X	-7.225	5
110	M76	Z	12.514	5
111	M76	Mx	0	5
112	M76	X	-5.635	2
113	M76	Z	9.761	2
114	M76	Mx	0	2
115	MP1A	X	-6.311	2
116	MP1A	Z	10.931	2
117	MP1A	Mx	-.006	2
118	MP1B	X	-6.311	2
119	MP1B	Z	10.931	2
120	MP1B	Mx	-.006	2

Member Point Loads (BLC 11 : Antenna Wo (240 Deg))

	Member Label	Direction	Magnitude[lb.k-ft]	Location[ft.%]
1	MP3A	X	-72.032	1
2	MP3A	Z	41.587	1
3	MP3A	Mx	.064	1
4	MP3A	X	-72.032	6
5	MP3A	Z	41.587	6
6	MP3A	Mx	.064	6
7	MP3B	X	-72.032	1
8	MP3B	Z	41.587	1
9	MP3B	Mx	-.008	1
10	MP3B	X	-72.032	6
11	MP3B	Z	41.587	6
12	MP3B	Mx	-.008	6
13	MP3C	X	-88.784	1
14	MP3C	Z	51.26	1
15	MP3C	Mx	-.068	1
16	MP3C	X	-88.784	6
17	MP3C	Z	51.26	6



Member Point Loads (BLC 11 : Antenna Wo (240 Deg)) (Continued)

	Member Label	Direction	Magnitude[lb.k-ft]	Location[ft.%]
18	MP3C	Mx	-.068	6
19	MP3A	X	-72.032	1
20	MP3A	Z	41.587	1
21	MP3A	Mx	.008	1
22	MP3A	X	-72.032	6
23	MP3A	Z	41.587	6
24	MP3A	Mx	.008	6
25	MP3B	X	-72.032	1
26	MP3B	Z	41.587	1
27	MP3B	Mx	-.064	1
28	MP3B	X	-72.032	6
29	MP3B	Z	41.587	6
30	MP3B	Mx	-.064	6
31	MP3C	X	-88.784	1
32	MP3C	Z	51.26	1
33	MP3C	Mx	.068	1
34	MP3C	X	-88.784	6
35	MP3C	Z	51.26	6
36	MP3C	Mx	.068	6
37	MP4A	X	-58.913	2
38	MP4A	Z	34.013	2
39	MP4A	Mx	.029	2
40	MP4A	X	-58.913	4
41	MP4A	Z	34.013	4
42	MP4A	Mx	.029	4
43	MP4B	X	-58.913	2
44	MP4B	Z	34.013	2
45	MP4B	Mx	-.029	2
46	MP4B	X	-58.913	4
47	MP4B	Z	34.013	4
48	MP4B	Mx	-.029	4
49	MP4C	X	-77.522	2
50	MP4C	Z	44.757	2
51	MP4C	Mx	0	2
52	MP4C	X	-77.522	4
53	MP4C	Z	44.757	4
54	MP4C	Mx	0	4
55	MP3A	X	-43.829	2
56	MP3A	Z	25.305	2
57	MP3A	Mx	-.022	2
58	MP3B	X	-43.829	2
59	MP3B	Z	25.305	2
60	MP3B	Mx	.022	2
61	MP3C	X	-58.188	2
62	MP3C	Z	33.595	2
63	MP3C	Mx	0	2
64	MP4A	X	-38.479	1.5
65	MP4A	Z	22.216	1.5
66	MP4A	Mx	-.019	1.5
67	MP4B	X	-38.479	1.5
68	MP4B	Z	22.216	1.5
69	MP4B	Mx	.019	1.5
70	MP4C	X	-58.188	1.5
71	MP4C	Z	33.595	1.5
72	MP4C	Mx	0	1.5
73	MP1A	X	-166.916	1
74	MP1A	Z	96.369	1
75	MP1A	Mx	.083	1
76	MP1A	X	-166.916	5

Member Point Loads (BLC 11 : Antenna Wo (240 Deg)) (Continued)

	Member Label	Direction	Magnitude[lb.k-ft]	Location[ft. %]
77	MP1A	Z	96.369	5
78	MP1A	Mx	.083	5
79	MP1B	X	-166.916	1
80	MP1B	Z	96.369	1
81	MP1B	Mx	-.083	1
82	MP1B	X	-166.916	5
83	MP1B	Z	96.369	5
84	MP1B	Mx	-.083	5
85	MP1C	X	-183.2	1
86	MP1C	Z	105.77	1
87	MP1C	Mx	0	1
88	MP1C	X	-183.2	5
89	MP1C	Z	105.77	5
90	MP1C	Mx	0	5
91	MP5A	X	-166.916	1
92	MP5A	Z	96.369	1
93	MP5A	Mx	.083	1
94	MP5A	X	-166.916	5
95	MP5A	Z	96.369	5
96	MP5A	Mx	.083	5
97	MP5B	X	-166.916	1
98	MP5B	Z	96.369	1
99	MP5B	Mx	-.083	1
100	MP5B	X	-166.916	5
101	MP5B	Z	96.369	5
102	MP5B	Mx	-.083	5
103	MP5C	X	-183.2	1
104	MP5C	Z	105.77	1
105	MP5C	Mx	0	1
106	MP5C	X	-183.2	5
107	MP5C	Z	105.77	5
108	MP5C	Mx	0	5
109	M76	X	-9.385	5
110	M76	Z	5.419	5
111	M76	Mx	0	5
112	M76	X	-7.32	2
113	M76	Z	4.226	2
114	M76	Mx	0	2
115	MP1A	X	-17.208	2
116	MP1A	Z	9.935	2
117	MP1A	Mx	-.009	2
118	MP1B	X	-17.208	2
119	MP1B	Z	9.935	2
120	MP1B	Mx	-.009	2

Member Point Loads (BLC 12 : Antenna Wo (270 Deg))

	Member Label	Direction	Magnitude[lb.k-ft]	Location[ft. %]
1	MP3A	X	-76.727	1
2	MP3A	Z	0	1
3	MP3A	Mx	.038	1
4	MP3A	X	-76.727	6
5	MP3A	Z	0	6
6	MP3A	Mx	.038	6
7	MP3B	X	-96.071	1
8	MP3B	Z	0	1
9	MP3B	Mx	.031	1
10	MP3B	X	-96.071	6
11	MP3B	Z	0	6



Member Point Loads (BLC 12 : Antenna Wo (270 Deg)) (Continued)

	Member Label	Direction	Magnitude[lb.k-ft]	Location[ft.%]
12	MP3B	Mx	.031	6
13	MP3C	X	-96.071	1
14	MP3C	Z	0	1
15	MP3C	Mx	-.079	1
16	MP3C	X	-96.071	6
17	MP3C	Z	0	6
18	MP3C	Mx	-.079	6
19	MP3A	X	-76.727	1
20	MP3A	Z	0	1
21	MP3A	Mx	.038	1
22	MP3A	X	-76.727	6
23	MP3A	Z	0	6
24	MP3A	Mx	.038	6
25	MP3B	X	-96.071	1
26	MP3B	Z	0	1
27	MP3B	Mx	-.079	1
28	MP3B	X	-96.071	6
29	MP3B	Z	0	6
30	MP3B	Mx	-.079	6
31	MP3C	X	-96.071	1
32	MP3C	Z	0	1
33	MP3C	Mx	.031	1
34	MP3C	X	-96.071	6
35	MP3C	Z	0	6
36	MP3C	Mx	.031	6
37	MP4A	X	-60.864	2
38	MP4A	Z	0	2
39	MP4A	Mx	.03	2
40	MP4A	X	-60.864	4
41	MP4A	Z	0	4
42	MP4A	Mx	.03	4
43	MP4B	X	-82.352	2
44	MP4B	Z	0	2
45	MP4B	Mx	-.021	2
46	MP4B	X	-82.352	4
47	MP4B	Z	0	4
48	MP4B	Mx	-.021	4
49	MP4C	X	-82.352	2
50	MP4C	Z	0	2
51	MP4C	Mx	-.021	2
52	MP4C	X	-82.352	4
53	MP4C	Z	0	4
54	MP4C	Mx	-.021	4
55	MP3A	X	-45.082	2
56	MP3A	Z	0	2
57	MP3A	Mx	-.023	2
58	MP3B	X	-61.663	2
59	MP3B	Z	0	2
60	MP3B	Mx	.015	2
61	MP3C	X	-61.663	2
62	MP3C	Z	0	2
63	MP3C	Mx	.015	2
64	MP4A	X	-36.846	1.5
65	MP4A	Z	0	1.5
66	MP4A	Mx	-.018	1.5
67	MP4B	X	-59.604	1.5
68	MP4B	Z	0	1.5
69	MP4B	Mx	.015	1.5
70	MP4C	X	-59.604	1.5



Member Point Loads (BLC 12 : Antenna Wo (270 Deg)) (Continued)

	Member Label	Direction	Magnitude[lb.k-ft]	Location[ft. %]
71	MP4C	Z	0	1.5
72	MP4C	Mx	.015	1.5
73	MP1A	X	-186.471	1
74	MP1A	Z	0	1
75	MP1A	Mx	.093	1
76	MP1A	X	-186.471	5
77	MP1A	Z	0	5
78	MP1A	Mx	.093	5
79	MP1B	X	-205.273	1
80	MP1B	Z	0	1
81	MP1B	Mx	-.051	1
82	MP1B	X	-205.273	5
83	MP1B	Z	0	5
84	MP1B	Mx	-.051	5
85	MP1C	X	-205.273	1
86	MP1C	Z	0	1
87	MP1C	Mx	-.051	1
88	MP1C	X	-205.273	5
89	MP1C	Z	0	5
90	MP1C	Mx	-.051	5
91	MP5A	X	-186.471	1
92	MP5A	Z	0	1
93	MP5A	Mx	.093	1
94	MP5A	X	-186.471	5
95	MP5A	Z	0	5
96	MP5A	Mx	.093	5
97	MP5B	X	-205.273	1
98	MP5B	Z	0	1
99	MP5B	Mx	-.051	1
100	MP5B	X	-205.273	5
101	MP5B	Z	0	5
102	MP5B	Mx	-.051	5
103	MP5C	X	-205.273	1
104	MP5C	Z	0	1
105	MP5C	Mx	-.051	1
106	MP5C	X	-205.273	5
107	MP5C	Z	0	5
108	MP5C	Mx	-.051	5
109	M76	X	-3.612	5
110	M76	Z	0	5
111	M76	Mx	0	5
112	M76	X	-2.818	2
113	M76	Z	0	2
114	M76	Mx	0	2
115	MP1A	X	-34.366	2
116	MP1A	Z	0	2
117	MP1A	Mx	-.009	2
118	MP1B	X	-34.366	2
119	MP1B	Z	0	2
120	MP1B	Mx	-.009	2

Member Point Loads (BLC 13 : Antenna Wo (300 Deg))

	Member Label	Direction	Magnitude[lb.k-ft]	Location[ft. %]
1	MP3A	X	-72.032	1
2	MP3A	Z	-41.587	1
3	MP3A	Mx	.008	1
4	MP3A	X	-72.032	6
5	MP3A	Z	-41.587	6



Member Point Loads (BLC 13 : Antenna Wo (300 Deg)) (Continued)

	Member Label	Direction	Magnitude[lb.k-ft]	Location[ft.%]
6	MP3A	Mx	.008	6
7	MP3B	X	-88.784	1
8	MP3B	Z	-51.26	1
9	MP3B	Mx	.068	1
10	MP3B	X	-88.784	6
11	MP3B	Z	-51.26	6
12	MP3B	Mx	.068	6
13	MP3C	X	-72.032	1
14	MP3C	Z	-41.587	1
15	MP3C	Mx	-.064	1
16	MP3C	X	-72.032	6
17	MP3C	Z	-41.587	6
18	MP3C	Mx	-.064	6
19	MP3A	X	-72.032	1
20	MP3A	Z	-41.587	1
21	MP3A	Mx	.064	1
22	MP3A	X	-72.032	6
23	MP3A	Z	-41.587	6
24	MP3A	Mx	.064	6
25	MP3B	X	-88.784	1
26	MP3B	Z	-51.26	1
27	MP3B	Mx	-.068	1
28	MP3B	X	-88.784	6
29	MP3B	Z	-51.26	6
30	MP3B	Mx	-.068	6
31	MP3C	X	-72.032	1
32	MP3C	Z	-41.587	1
33	MP3C	Mx	-.008	1
34	MP3C	X	-72.032	6
35	MP3C	Z	-41.587	6
36	MP3C	Mx	-.008	6
37	MP4A	X	-58.913	2
38	MP4A	Z	-34.013	2
39	MP4A	Mx	.029	2
40	MP4A	X	-58.913	4
41	MP4A	Z	-34.013	4
42	MP4A	Mx	.029	4
43	MP4B	X	-77.522	2
44	MP4B	Z	-44.757	2
45	MP4B	Mx	0	2
46	MP4B	X	-77.522	4
47	MP4B	Z	-44.757	4
48	MP4B	Mx	0	4
49	MP4C	X	-58.913	2
50	MP4C	Z	-34.013	2
51	MP4C	Mx	-.029	2
52	MP4C	X	-58.913	4
53	MP4C	Z	-34.013	4
54	MP4C	Mx	-.029	4
55	MP3A	X	-43.829	2
56	MP3A	Z	-25.305	2
57	MP3A	Mx	-.022	2
58	MP3B	X	-58.188	2
59	MP3B	Z	-33.595	2
60	MP3B	Mx	0	2
61	MP3C	X	-43.829	2
62	MP3C	Z	-25.305	2
63	MP3C	Mx	.022	2
64	MP4A	X	-38.479	1.5



Member Point Loads (BLC 13 : Antenna Wo (300 Deg)) (Continued)

	Member Label	Direction	Magnitude[lb.k-ft]	Location[ft.%]
65	MP4A	Z	-22.216	1.5
66	MP4A	Mx	-.019	1.5
67	MP4B	X	-58.188	1.5
68	MP4B	Z	-33.595	1.5
69	MP4B	Mx	0	1.5
70	MP4C	X	-38.479	1.5
71	MP4C	Z	-22.216	1.5
72	MP4C	Mx	.019	1.5
73	MP1A	X	-166.916	1
74	MP1A	Z	-96.369	1
75	MP1A	Mx	.083	1
76	MP1A	X	-166.916	5
77	MP1A	Z	-96.369	5
78	MP1A	Mx	.083	5
79	MP1B	X	-183.2	1
80	MP1B	Z	-105.77	1
81	MP1B	Mx	0	1
82	MP1B	X	-183.2	5
83	MP1B	Z	-105.77	5
84	MP1B	Mx	0	5
85	MP1C	X	-166.916	1
86	MP1C	Z	-96.369	1
87	MP1C	Mx	-.083	1
88	MP1C	X	-166.916	5
89	MP1C	Z	-96.369	5
90	MP1C	Mx	-.083	5
91	MP5A	X	-166.916	1
92	MP5A	Z	-96.369	1
93	MP5A	Mx	.083	1
94	MP5A	X	-166.916	5
95	MP5A	Z	-96.369	5
96	MP5A	Mx	.083	5
97	MP5B	X	-183.2	1
98	MP5B	Z	-105.77	1
99	MP5B	Mx	0	1
100	MP5B	X	-183.2	5
101	MP5B	Z	-105.77	5
102	MP5B	Mx	0	5
103	MP5C	X	-166.916	1
104	MP5C	Z	-96.369	1
105	MP5C	Mx	-.083	1
106	MP5C	X	-166.916	5
107	MP5C	Z	-96.369	5
108	MP5C	Mx	-.083	5
109	M76	X	0	5
110	M76	Z	0	5
111	M76	Mx	0	5
112	M76	X	0	2
113	M76	Z	0	2
114	M76	Mx	0	2
115	MP1A	X	-36.039	2
116	MP1A	Z	-20.807	2
117	MP1A	Mx	0	2
118	MP1B	X	-36.039	2
119	MP1B	Z	-20.807	2
120	MP1B	Mx	0	2

Member Point Loads (BLC 14 : Antenna Wo (330 Deg))

Member Point Loads (BLC 14 : Antenna Wo (330 Deg)) (Continued)

	Member Label	Direction	Magnitude[lb.k-ft]	Location[ft. %]
1	MP3A	X	-48.036	1
2	MP3A	Z	-83.2	1
3	MP3A	Mx	-.031	1
4	MP3A	X	-48.036	6
5	MP3A	Z	-83.2	6
6	MP3A	Mx	-.031	6
7	MP3B	X	-48.036	1
8	MP3B	Z	-83.2	1
9	MP3B	Mx	.079	1
10	MP3B	X	-48.036	6
11	MP3B	Z	-83.2	6
12	MP3B	Mx	.079	6
13	MP3C	X	-38.363	1
14	MP3C	Z	-66.447	1
15	MP3C	Mx	-.038	1
16	MP3C	X	-38.363	6
17	MP3C	Z	-66.447	6
18	MP3C	Mx	-.038	6
19	MP3A	X	-48.036	1
20	MP3A	Z	-83.2	1
21	MP3A	Mx	.079	1
22	MP3A	X	-48.036	6
23	MP3A	Z	-83.2	6
24	MP3A	Mx	.079	6
25	MP3B	X	-48.036	1
26	MP3B	Z	-83.2	1
27	MP3B	Mx	-.031	1
28	MP3B	X	-48.036	6
29	MP3B	Z	-83.2	6
30	MP3B	Mx	-.031	6
31	MP3C	X	-38.363	1
32	MP3C	Z	-66.447	1
33	MP3C	Mx	-.038	1
34	MP3C	X	-38.363	6
35	MP3C	Z	-66.447	6
36	MP3C	Mx	-.038	6
37	MP4A	X	-41.176	2
38	MP4A	Z	-71.319	2
39	MP4A	Mx	.021	2
40	MP4A	X	-41.176	4
41	MP4A	Z	-71.319	4
42	MP4A	Mx	.021	4
43	MP4B	X	-41.176	2
44	MP4B	Z	-71.319	2
45	MP4B	Mx	.021	2
46	MP4B	X	-41.176	4
47	MP4B	Z	-71.319	4
48	MP4B	Mx	.021	4
49	MP4C	X	-30.432	2
50	MP4C	Z	-52.71	2
51	MP4C	Mx	-.03	2
52	MP4C	X	-30.432	4
53	MP4C	Z	-52.71	4
54	MP4C	Mx	-.03	4
55	MP3A	X	-30.832	2
56	MP3A	Z	-53.402	2
57	MP3A	Mx	-.015	2
58	MP3B	X	-30.832	2
59	MP3B	Z	-53.402	2



Member Point Loads (BLC 14 : Antenna Wo (330 Deg)) (Continued)

	Member Label	Direction	Magnitude[lb.k-ft]	Location[ft.%]
60	MP3B	Mx	-.015	2
61	MP3C	X	-22.541	2
62	MP3C	Z	-39.043	2
63	MP3C	Mx	.023	2
64	MP4A	X	-29.802	1.5
65	MP4A	Z	-51.619	1.5
66	MP4A	Mx	-.015	1.5
67	MP4B	X	-29.802	1.5
68	MP4B	Z	-51.619	1.5
69	MP4B	Mx	-.015	1.5
70	MP4C	X	-18.423	1.5
71	MP4C	Z	-31.91	1.5
72	MP4C	Mx	.018	1.5
73	MP1A	X	-102.637	1
74	MP1A	Z	-177.772	1
75	MP1A	Mx	.051	1
76	MP1A	X	-102.637	5
77	MP1A	Z	-177.772	5
78	MP1A	Mx	.051	5
79	MP1B	X	-102.637	1
80	MP1B	Z	-177.772	1
81	MP1B	Mx	.051	1
82	MP1B	X	-102.637	5
83	MP1B	Z	-177.772	5
84	MP1B	Mx	.051	5
85	MP1C	X	-93.235	1
86	MP1C	Z	-161.488	1
87	MP1C	Mx	-.093	1
88	MP1C	X	-93.235	5
89	MP1C	Z	-161.488	5
90	MP1C	Mx	-.093	5
91	MP5A	X	-102.637	1
92	MP5A	Z	-177.772	1
93	MP5A	Mx	.051	1
94	MP5A	X	-102.637	5
95	MP5A	Z	-177.772	5
96	MP5A	Mx	.051	5
97	MP5B	X	-102.637	1
98	MP5B	Z	-177.772	1
99	MP5B	Mx	.051	1
100	MP5B	X	-102.637	5
101	MP5B	Z	-177.772	5
102	MP5B	Mx	.051	5
103	MP5C	X	-93.235	1
104	MP5C	Z	-161.488	1
105	MP5C	Mx	-.093	1
106	MP5C	X	-93.235	5
107	MP5C	Z	-161.488	5
108	MP5C	Mx	-.093	5
109	M76	X	-1.806	5
110	M76	Z	-3.128	5
111	M76	Mx	0	5
112	M76	X	-1.409	2
113	M76	Z	-2.44	2
114	M76	Mx	0	2
115	MP1A	X	-17.183	2
116	MP1A	Z	-29.762	2
117	MP1A	Mx	.009	2
118	MP1B	X	-17.183	2



Member Point Loads (BLC 14 : Antenna Wo (330 Deg)) (Continued)

	Member Label	Direction	Magnitude[lb.k-ft]	Location[ft. %]
119	MP1B	Z	-29.762	2
120	MP1B	Mx	.009	2

Member Point Loads (BLC 15 : Antenna Wi (0 Deg))

	Member Label	Direction	Magnitude[lb.k-ft]	Location[ft. %]
1	MP3A	X	0	1
2	MP3A	Z	-40.561	1
3	MP3A	Mx	-.027	1
4	MP3A	X	0	6
5	MP3A	Z	-40.561	6
6	MP3A	Mx	-.027	6
7	MP3B	X	0	1
8	MP3B	Z	-33.162	1
9	MP3B	Mx	.025	1
10	MP3B	X	0	6
11	MP3B	Z	-33.162	6
12	MP3B	Mx	.025	6
13	MP3C	X	0	1
14	MP3C	Z	-33.162	1
15	MP3C	Mx	-.003	1
16	MP3C	X	0	6
17	MP3C	Z	-33.162	6
18	MP3C	Mx	-.003	6
19	MP3A	X	0	1
20	MP3A	Z	-40.561	1
21	MP3A	Mx	.027	1
22	MP3A	X	0	6
23	MP3A	Z	-40.561	6
24	MP3A	Mx	.027	6
25	MP3B	X	0	1
26	MP3B	Z	-33.162	1
27	MP3B	Mx	.003	1
28	MP3B	X	0	6
29	MP3B	Z	-33.162	6
30	MP3B	Mx	.003	6
31	MP3C	X	0	1
32	MP3C	Z	-33.162	1
33	MP3C	Mx	-.025	1
34	MP3C	X	0	6
35	MP3C	Z	-33.162	6
36	MP3C	Mx	-.025	6
37	MP4A	X	0	2
38	MP4A	Z	-17.666	2
39	MP4A	Mx	0	2
40	MP4A	X	0	4
41	MP4A	Z	-17.666	4
42	MP4A	Mx	0	4
43	MP4B	X	0	2
44	MP4B	Z	-13.663	2
45	MP4B	Mx	.006	2
46	MP4B	X	0	4
47	MP4B	Z	-13.663	4
48	MP4B	Mx	.006	4
49	MP4C	X	0	2
50	MP4C	Z	-13.663	2
51	MP4C	Mx	-.006	2
52	MP4C	X	0	4
53	MP4C	Z	-13.663	4



Member Point Loads (BLC 15 : Antenna Wi (0 Deg)) (Continued)

	Member Label	Direction	Magnitude[lb.k-ft]	Location[ft.%]
54	MP4C	Mx	-.006	4
55	MP3A	X	0	2
56	MP3A	Z	-16.891	2
57	MP3A	Mx	0	2
58	MP3B	X	0	2
59	MP3B	Z	-13.041	2
60	MP3B	Mx	-.006	2
61	MP3C	X	0	2
62	MP3C	Z	-13.041	2
63	MP3C	Mx	.006	2
64	MP4A	X	0	1.5
65	MP4A	Z	-16.891	1.5
66	MP4A	Mx	0	1.5
67	MP4B	X	0	1.5
68	MP4B	Z	-11.578	1.5
69	MP4B	Mx	-.005	1.5
70	MP4C	X	0	1.5
71	MP4C	Z	-11.578	1.5
72	MP4C	Mx	.005	1.5
73	MP1A	X	0	1
74	MP1A	Z	-40.017	1
75	MP1A	Mx	0	1
76	MP1A	X	0	5
77	MP1A	Z	-40.017	5
78	MP1A	Mx	0	5
79	MP1B	X	0	1
80	MP1B	Z	-36.727	1
81	MP1B	Mx	.016	1
82	MP1B	X	0	5
83	MP1B	Z	-36.727	5
84	MP1B	Mx	.016	5
85	MP1C	X	0	1
86	MP1C	Z	-36.727	1
87	MP1C	Mx	-.016	1
88	MP1C	X	0	5
89	MP1C	Z	-36.727	5
90	MP1C	Mx	-.016	5
91	MP5A	X	0	1
92	MP5A	Z	-40.017	1
93	MP5A	Mx	0	1
94	MP5A	X	0	5
95	MP5A	Z	-40.017	5
96	MP5A	Mx	0	5
97	MP5B	X	0	1
98	MP5B	Z	-36.727	1
99	MP5B	Mx	.016	1
100	MP5B	X	0	5
101	MP5B	Z	-36.727	5
102	MP5B	Mx	.016	5
103	MP5C	X	0	1
104	MP5C	Z	-36.727	1
105	MP5C	Mx	-.016	1
106	MP5C	X	0	5
107	MP5C	Z	-36.727	5
108	MP5C	Mx	-.016	5
109	M76	X	0	5
110	M76	Z	-4.983	5
111	M76	Mx	0	5
112	M76	X	0	2



Member Point Loads (BLC 15 : Antenna Wi (0 Deg)) (Continued)

	Member Label	Direction	Magnitude[lb.k-ft]	Location[ft. %]
113	M76	Z	-3.784	2
114	M76	Mx	0	2
115	MP1A	X	0	2
116	MP1A	Z	-4.96	2
117	MP1A	Mx	.002	2
118	MP1B	X	0	2
119	MP1B	Z	-4.96	2
120	MP1B	Mx	.002	2

Member Point Loads (BLC 16 : Antenna Wi (30 Deg))

	Member Label	Direction	Magnitude[lb.k-ft]	Location[ft. %]
1	MP3A	X	19.047	1
2	MP3A	Z	-32.991	1
3	MP3A	Mx	-.032	1
4	MP3A	X	19.047	6
5	MP3A	Z	-32.991	6
6	MP3A	Mx	-.032	6
7	MP3B	X	15.347	1
8	MP3B	Z	-26.583	1
9	MP3B	Mx	.015	1
10	MP3B	X	15.347	6
11	MP3B	Z	-26.583	6
12	MP3B	Mx	.015	6
13	MP3C	X	19.047	1
14	MP3C	Z	-32.991	1
15	MP3C	Mx	.012	1
16	MP3C	X	19.047	6
17	MP3C	Z	-32.991	6
18	MP3C	Mx	.012	6
19	MP3A	X	19.047	1
20	MP3A	Z	-32.991	1
21	MP3A	Mx	.012	1
22	MP3A	X	19.047	6
23	MP3A	Z	-32.991	6
24	MP3A	Mx	.012	6
25	MP3B	X	15.347	1
26	MP3B	Z	-26.583	1
27	MP3B	Mx	.015	1
28	MP3B	X	15.347	6
29	MP3B	Z	-26.583	6
30	MP3B	Mx	.015	6
31	MP3C	X	19.047	1
32	MP3C	Z	-32.991	1
33	MP3C	Mx	-.032	1
34	MP3C	X	19.047	6
35	MP3C	Z	-32.991	6
36	MP3C	Mx	-.032	6
37	MP4A	X	8.166	2
38	MP4A	Z	-14.144	2
39	MP4A	Mx	-.004	2
40	MP4A	X	8.166	4
41	MP4A	Z	-14.144	4
42	MP4A	Mx	-.004	4
43	MP4B	X	6.164	2
44	MP4B	Z	-10.677	2
45	MP4B	Mx	.006	2
46	MP4B	X	6.164	4
47	MP4B	Z	-10.677	4

Member Point Loads (BLC 16 : Antenna Wi (30 Deg)) (Continued)

	Member Label	Direction	Magnitude[lb.k-ft]	Location[ft.%]
48	MP4B	Mx	.006	4
49	MP4C	X	8.166	2
50	MP4C	Z	-14.144	2
51	MP4C	Mx	-.004	2
52	MP4C	X	8.166	4
53	MP4C	Z	-14.144	4
54	MP4C	Mx	-.004	4
55	MP3A	X	7.804	2
56	MP3A	Z	-13.517	2
57	MP3A	Mx	.004	2
58	MP3B	X	5.879	2
59	MP3B	Z	-10.182	2
60	MP3B	Mx	-.006	2
61	MP3C	X	7.804	2
62	MP3C	Z	-13.517	2
63	MP3C	Mx	.004	2
64	MP4A	X	7.56	1.5
65	MP4A	Z	-13.094	1.5
66	MP4A	Mx	.004	1.5
67	MP4B	X	4.904	1.5
68	MP4B	Z	-8.493	1.5
69	MP4B	Mx	-.005	1.5
70	MP4C	X	7.56	1.5
71	MP4C	Z	-13.094	1.5
72	MP4C	Mx	.004	1.5
73	MP1A	X	19.46	1
74	MP1A	Z	-33.706	1
75	MP1A	Mx	-.01	1
76	MP1A	X	19.46	5
77	MP1A	Z	-33.706	5
78	MP1A	Mx	-.01	5
79	MP1B	X	17.815	1
80	MP1B	Z	-30.857	1
81	MP1B	Mx	.018	1
82	MP1B	X	17.815	5
83	MP1B	Z	-30.857	5
84	MP1B	Mx	.018	5
85	MP1C	X	19.46	1
86	MP1C	Z	-33.706	1
87	MP1C	Mx	-.01	1
88	MP1C	X	19.46	5
89	MP1C	Z	-33.706	5
90	MP1C	Mx	-.01	5
91	MP5A	X	19.46	1
92	MP5A	Z	-33.706	1
93	MP5A	Mx	-.01	1
94	MP5A	X	19.46	5
95	MP5A	Z	-33.706	5
96	MP5A	Mx	-.01	5
97	MP5B	X	17.815	1
98	MP5B	Z	-30.857	1
99	MP5B	Mx	.018	1
100	MP5B	X	17.815	5
101	MP5B	Z	-30.857	5
102	MP5B	Mx	.018	5
103	MP5C	X	19.46	1
104	MP5C	Z	-33.706	1
105	MP5C	Mx	-.01	1
106	MP5C	X	19.46	5

Member Point Loads (BLC 16 : Antenna Wi (30 Deg)) (Continued)

	Member Label	Direction	Magnitude[lb.k-ft]	Location[ft.%]
107	MP5C	Z	-33.706	5
108	MP5C	Mx	-.01	5
109	M76	X	1.957	5
110	M76	Z	-3.389	5
111	M76	Mx	0	5
112	M76	X	1.591	2
113	M76	Z	-2.755	2
114	M76	Mx	0	2
115	MP1A	X	1.758	2
116	MP1A	Z	-3.044	2
117	MP1A	Mx	.002	2
118	MP1B	X	1.758	2
119	MP1B	Z	-3.044	2
120	MP1B	Mx	.002	2

Member Point Loads (BLC 17 : Antenna Wi (60 Deg))

	Member Label	Direction	Magnitude[lb.k-ft]	Location[ft.%]
1	MP3A	X	28.719	1
2	MP3A	Z	-16.581	1
3	MP3A	Mx	-.025	1
4	MP3A	X	28.719	6
5	MP3A	Z	-16.581	6
6	MP3A	Mx	-.025	6
7	MP3B	X	28.719	1
8	MP3B	Z	-16.581	1
9	MP3B	Mx	.003	1
10	MP3B	X	28.719	6
11	MP3B	Z	-16.581	6
12	MP3B	Mx	.003	6
13	MP3C	X	35.127	1
14	MP3C	Z	-20.281	1
15	MP3C	Mx	.027	1
16	MP3C	X	35.127	6
17	MP3C	Z	-20.281	6
18	MP3C	Mx	.027	6
19	MP3A	X	28.719	1
20	MP3A	Z	-16.581	1
21	MP3A	Mx	-.003	1
22	MP3A	X	28.719	6
23	MP3A	Z	-16.581	6
24	MP3A	Mx	-.003	6
25	MP3B	X	28.719	1
26	MP3B	Z	-16.581	1
27	MP3B	Mx	.025	1
28	MP3B	X	28.719	6
29	MP3B	Z	-16.581	6
30	MP3B	Mx	.025	6
31	MP3C	X	35.127	1
32	MP3C	Z	-20.281	1
33	MP3C	Mx	-.027	1
34	MP3C	X	35.127	6
35	MP3C	Z	-20.281	6
36	MP3C	Mx	-.027	6
37	MP4A	X	11.832	2
38	MP4A	Z	-6.831	2
39	MP4A	Mx	-.006	2
40	MP4A	X	11.832	4
41	MP4A	Z	-6.831	4



Member Point Loads (BLC 17 : Antenna Wi (60 Deg)) (Continued)

	Member Label	Direction	Magnitude[lb.k-ft]	Location[ft.%]
42	MP4A	Mx	-.006	4
43	MP4B	X	11.832	2
44	MP4B	Z	-6.831	2
45	MP4B	Mx	.006	2
46	MP4B	X	11.832	4
47	MP4B	Z	-6.831	4
48	MP4B	Mx	.006	4
49	MP4C	X	15.299	2
50	MP4C	Z	-8.833	2
51	MP4C	Mx	0	2
52	MP4C	X	15.299	4
53	MP4C	Z	-8.833	4
54	MP4C	Mx	0	4
55	MP3A	X	11.294	2
56	MP3A	Z	-6.521	2
57	MP3A	Mx	.006	2
58	MP3B	X	11.294	2
59	MP3B	Z	-6.521	2
60	MP3B	Mx	-.006	2
61	MP3C	X	14.628	2
62	MP3C	Z	-8.446	2
63	MP3C	Mx	0	2
64	MP4A	X	10.027	1.5
65	MP4A	Z	-5.789	1.5
66	MP4A	Mx	.005	1.5
67	MP4B	X	10.027	1.5
68	MP4B	Z	-5.789	1.5
69	MP4B	Mx	-.005	1.5
70	MP4C	X	14.628	1.5
71	MP4C	Z	-8.446	1.5
72	MP4C	Mx	0	1.5
73	MP1A	X	31.807	1
74	MP1A	Z	-18.364	1
75	MP1A	Mx	-.016	1
76	MP1A	X	31.807	5
77	MP1A	Z	-18.364	5
78	MP1A	Mx	-.016	5
79	MP1B	X	31.807	1
80	MP1B	Z	-18.364	1
81	MP1B	Mx	.016	1
82	MP1B	X	31.807	5
83	MP1B	Z	-18.364	5
84	MP1B	Mx	.016	5
85	MP1C	X	34.656	1
86	MP1C	Z	-20.009	1
87	MP1C	Mx	0	1
88	MP1C	X	34.656	5
89	MP1C	Z	-20.009	5
90	MP1C	Mx	0	5
91	MP5A	X	31.807	1
92	MP5A	Z	-18.364	1
93	MP5A	Mx	-.016	1
94	MP5A	X	31.807	5
95	MP5A	Z	-18.364	5
96	MP5A	Mx	-.016	5
97	MP5B	X	31.807	1
98	MP5B	Z	-18.364	1
99	MP5B	Mx	.016	1
100	MP5B	X	31.807	5

Member Point Loads (BLC 17 : Antenna Wi (60 Deg)) (Continued)

	Member Label	Direction	Magnitude[lb.k-ft]	Location[ft. %]
101	MP5B	Z	-18.364	5
102	MP5B	Mx	.016	5
103	MP5C	X	34.656	1
104	MP5C	Z	-20.009	1
105	MP5C	Mx	0	1
106	MP5C	X	34.656	5
107	MP5C	Z	-20.009	5
108	MP5C	Mx	0	5
109	M76	X	4.316	5
110	M76	Z	-2.492	5
111	M76	Mx	0	5
112	M76	X	3.277	2
113	M76	Z	-1.892	2
114	M76	Mx	0	2
115	MP1A	X	4.296	2
116	MP1A	Z	-2.48	2
117	MP1A	Mx	.002	2
118	MP1B	X	4.296	2
119	MP1B	Z	-2.48	2
120	MP1B	Mx	.002	2

Member Point Loads (BLC 18 : Antenna Wi (90 Deg))

	Member Label	Direction	Magnitude[lb.k-ft]	Location[ft. %]
1	MP3A	X	30.695	1
2	MP3A	Z	0	1
3	MP3A	Mx	-.015	1
4	MP3A	X	30.695	6
5	MP3A	Z	0	6
6	MP3A	Mx	-.015	6
7	MP3B	X	38.095	1
8	MP3B	Z	0	1
9	MP3B	Mx	-.012	1
10	MP3B	X	38.095	6
11	MP3B	Z	0	6
12	MP3B	Mx	-.012	6
13	MP3C	X	38.095	1
14	MP3C	Z	0	1
15	MP3C	Mx	.032	1
16	MP3C	X	38.095	6
17	MP3C	Z	0	6
18	MP3C	Mx	.032	6
19	MP3A	X	30.695	1
20	MP3A	Z	0	1
21	MP3A	Mx	-.015	1
22	MP3A	X	30.695	6
23	MP3A	Z	0	6
24	MP3A	Mx	-.015	6
25	MP3B	X	38.095	1
26	MP3B	Z	0	1
27	MP3B	Mx	.032	1
28	MP3B	X	38.095	6
29	MP3B	Z	0	6
30	MP3B	Mx	.032	6
31	MP3C	X	38.095	1
32	MP3C	Z	0	1
33	MP3C	Mx	-.012	1
34	MP3C	X	38.095	6
35	MP3C	Z	0	6



Member Point Loads (BLC 18 : Antenna Wi (90 Deg)) (Continued)

	Member Label	Direction	Magnitude[lb.k-ft]	Location[ft.%]
36	MP3C	Mx	-.012	6
37	MP4A	X	12.329	2
38	MP4A	Z	0	2
39	MP4A	Mx	-.006	2
40	MP4A	X	12.329	4
41	MP4A	Z	0	4
42	MP4A	Mx	-.006	4
43	MP4B	X	16.332	2
44	MP4B	Z	0	2
45	MP4B	Mx	.004	2
46	MP4B	X	16.332	4
47	MP4B	Z	0	4
48	MP4B	Mx	.004	4
49	MP4C	X	16.332	2
50	MP4C	Z	0	2
51	MP4C	Mx	.004	2
52	MP4C	X	16.332	4
53	MP4C	Z	0	4
54	MP4C	Mx	.004	4
55	MP3A	X	11.758	2
56	MP3A	Z	0	2
57	MP3A	Mx	.006	2
58	MP3B	X	15.608	2
59	MP3B	Z	0	2
60	MP3B	Mx	-.004	2
61	MP3C	X	15.608	2
62	MP3C	Z	0	2
63	MP3C	Mx	-.004	2
64	MP4A	X	9.807	1.5
65	MP4A	Z	0	1.5
66	MP4A	Mx	.005	1.5
67	MP4B	X	15.12	1.5
68	MP4B	Z	0	1.5
69	MP4B	Mx	-.004	1.5
70	MP4C	X	15.12	1.5
71	MP4C	Z	0	1.5
72	MP4C	Mx	-.004	1.5
73	MP1A	X	35.63	1
74	MP1A	Z	0	1
75	MP1A	Mx	-.018	1
76	MP1A	X	35.63	5
77	MP1A	Z	0	5
78	MP1A	Mx	-.018	5
79	MP1B	X	38.92	1
80	MP1B	Z	0	1
81	MP1B	Mx	.01	1
82	MP1B	X	38.92	5
83	MP1B	Z	0	5
84	MP1B	Mx	.01	5
85	MP1C	X	38.92	1
86	MP1C	Z	0	1
87	MP1C	Mx	.01	1
88	MP1C	X	38.92	5
89	MP1C	Z	0	5
90	MP1C	Mx	.01	5
91	MP5A	X	35.63	1
92	MP5A	Z	0	1
93	MP5A	Mx	-.018	1
94	MP5A	X	35.63	5

Member Point Loads (BLC 18 : Antenna Wi (90 Deg)) (Continued)

	Member Label	Direction	Magnitude[lb.k-ft]	Location[ft. %]
95	MP5A	Z	0	5
96	MP5A	Mx	-.018	5
97	MP5B	X	38.92	1
98	MP5B	Z	0	1
99	MP5B	Mx	.01	1
100	MP5B	X	38.92	5
101	MP5B	Z	0	5
102	MP5B	Mx	.01	5
103	MP5C	X	38.92	1
104	MP5C	Z	0	1
105	MP5C	Mx	.01	1
106	MP5C	X	38.92	5
107	MP5C	Z	0	5
108	MP5C	Mx	.01	5
109	M76	X	7.123	5
110	M76	Z	0	5
111	M76	Mx	0	5
112	M76	X	4.988	2
113	M76	Z	0	2
114	M76	Mx	0	2
115	MP1A	X	7.851	2
116	MP1A	Z	0	2
117	MP1A	Mx	.002	2
118	MP1B	X	7.851	2
119	MP1B	Z	0	2
120	MP1B	Mx	.002	2

Member Point Loads (BLC 19 : Antenna Wi (120 Deg))

	Member Label	Direction	Magnitude[lb.k-ft]	Location[ft. %]
1	MP3A	X	28.719	1
2	MP3A	Z	16.581	1
3	MP3A	Mx	-.003	1
4	MP3A	X	28.719	6
5	MP3A	Z	16.581	6
6	MP3A	Mx	-.003	6
7	MP3B	X	35.127	1
8	MP3B	Z	20.281	1
9	MP3B	Mx	-.027	1
10	MP3B	X	35.127	6
11	MP3B	Z	20.281	6
12	MP3B	Mx	-.027	6
13	MP3C	X	28.719	1
14	MP3C	Z	16.581	1
15	MP3C	Mx	.025	1
16	MP3C	X	28.719	6
17	MP3C	Z	16.581	6
18	MP3C	Mx	.025	6
19	MP3A	X	28.719	1
20	MP3A	Z	16.581	1
21	MP3A	Mx	-.025	1
22	MP3A	X	28.719	6
23	MP3A	Z	16.581	6
24	MP3A	Mx	-.025	6
25	MP3B	X	35.127	1
26	MP3B	Z	20.281	1
27	MP3B	Mx	.027	1
28	MP3B	X	35.127	6
29	MP3B	Z	20.281	6

Member Point Loads (BLC 19 : Antenna Wi (120 Deg)) (Continued)

	Member Label	Direction	Magnitude[lb.k-ft]	Location[ft.%]
30	MP3B	Mx	.027	6
31	MP3C	X	28.719	1
32	MP3C	Z	16.581	1
33	MP3C	Mx	.003	1
34	MP3C	X	28.719	6
35	MP3C	Z	16.581	6
36	MP3C	Mx	.003	6
37	MP4A	X	11.832	2
38	MP4A	Z	6.831	2
39	MP4A	Mx	-.006	2
40	MP4A	X	11.832	4
41	MP4A	Z	6.831	4
42	MP4A	Mx	-.006	4
43	MP4B	X	15.299	2
44	MP4B	Z	8.833	2
45	MP4B	Mx	0	2
46	MP4B	X	15.299	4
47	MP4B	Z	8.833	4
48	MP4B	Mx	0	4
49	MP4C	X	11.832	2
50	MP4C	Z	6.831	2
51	MP4C	Mx	.006	2
52	MP4C	X	11.832	4
53	MP4C	Z	6.831	4
54	MP4C	Mx	.006	4
55	MP3A	X	11.294	2
56	MP3A	Z	6.521	2
57	MP3A	Mx	.006	2
58	MP3B	X	14.628	2
59	MP3B	Z	8.446	2
60	MP3B	Mx	0	2
61	MP3C	X	11.294	2
62	MP3C	Z	6.521	2
63	MP3C	Mx	-.006	2
64	MP4A	X	10.027	1.5
65	MP4A	Z	5.789	1.5
66	MP4A	Mx	.005	1.5
67	MP4B	X	14.628	1.5
68	MP4B	Z	8.446	1.5
69	MP4B	Mx	0	1.5
70	MP4C	X	10.027	1.5
71	MP4C	Z	5.789	1.5
72	MP4C	Mx	-.005	1.5
73	MP1A	X	31.807	1
74	MP1A	Z	18.364	1
75	MP1A	Mx	-.016	1
76	MP1A	X	31.807	5
77	MP1A	Z	18.364	5
78	MP1A	Mx	-.016	5
79	MP1B	X	34.656	1
80	MP1B	Z	20.009	1
81	MP1B	Mx	0	1
82	MP1B	X	34.656	5
83	MP1B	Z	20.009	5
84	MP1B	Mx	0	5
85	MP1C	X	31.807	1
86	MP1C	Z	18.364	1
87	MP1C	Mx	.016	1
88	MP1C	X	31.807	5

Member Point Loads (BLC 19 : Antenna Wi (120 Deg)) (Continued)

	Member Label	Direction	Magnitude[lb.k-ft]	Location[ft. %]
89	MP1C	Z	18.364	5
90	MP1C	Mx	.016	5
91	MP5A	X	31.807	1
92	MP5A	Z	18.364	1
93	MP5A	Mx	-.016	1
94	MP5A	X	31.807	5
95	MP5A	Z	18.364	5
96	MP5A	Mx	-.016	5
97	MP5B	X	34.656	1
98	MP5B	Z	20.009	1
99	MP5B	Mx	0	1
100	MP5B	X	34.656	5
101	MP5B	Z	20.009	5
102	MP5B	Mx	0	5
103	MP5C	X	31.807	1
104	MP5C	Z	18.364	1
105	MP5C	Mx	.016	1
106	MP5C	X	31.807	5
107	MP5C	Z	18.364	5
108	MP5C	Mx	.016	5
109	M76	X	7.095	5
110	M76	Z	4.096	5
111	M76	Mx	0	5
112	M76	X	4.842	2
113	M76	Z	2.795	2
114	M76	Mx	0	2
115	MP1A	X	8.05	2
116	MP1A	Z	4.648	2
117	MP1A	Mx	0	2
118	MP1B	X	8.05	2
119	MP1B	Z	4.648	2
120	MP1B	Mx	0	2

Member Point Loads (BLC 20 : Antenna Wi (150 Deg))

	Member Label	Direction	Magnitude[lb.k-ft]	Location[ft. %]
1	MP3A	X	19.047	1
2	MP3A	Z	32.991	1
3	MP3A	Mx	.012	1
4	MP3A	X	19.047	6
5	MP3A	Z	32.991	6
6	MP3A	Mx	.012	6
7	MP3B	X	19.047	1
8	MP3B	Z	32.991	1
9	MP3B	Mx	-.032	1
10	MP3B	X	19.047	6
11	MP3B	Z	32.991	6
12	MP3B	Mx	-.032	6
13	MP3C	X	15.347	1
14	MP3C	Z	26.583	1
15	MP3C	Mx	.015	1
16	MP3C	X	15.347	6
17	MP3C	Z	26.583	6
18	MP3C	Mx	.015	6
19	MP3A	X	19.047	1
20	MP3A	Z	32.991	1
21	MP3A	Mx	-.032	1
22	MP3A	X	19.047	6
23	MP3A	Z	32.991	6



Member Point Loads (BLC 20 : Antenna Wi (150 Deg)) (Continued)

	Member Label	Direction	Magnitude[lb.k-ft]	Location[ft.%]
24	MP3A	Mx	-.032	6
25	MP3B	X	19.047	1
26	MP3B	Z	32.991	1
27	MP3B	Mx	.012	1
28	MP3B	X	19.047	6
29	MP3B	Z	32.991	6
30	MP3B	Mx	.012	6
31	MP3C	X	15.347	1
32	MP3C	Z	26.583	1
33	MP3C	Mx	.015	1
34	MP3C	X	15.347	6
35	MP3C	Z	26.583	6
36	MP3C	Mx	.015	6
37	MP4A	X	8.166	2
38	MP4A	Z	14.144	2
39	MP4A	Mx	-.004	2
40	MP4A	X	8.166	4
41	MP4A	Z	14.144	4
42	MP4A	Mx	-.004	4
43	MP4B	X	8.166	2
44	MP4B	Z	14.144	2
45	MP4B	Mx	-.004	2
46	MP4B	X	8.166	4
47	MP4B	Z	14.144	4
48	MP4B	Mx	-.004	4
49	MP4C	X	6.164	2
50	MP4C	Z	10.677	2
51	MP4C	Mx	.006	2
52	MP4C	X	6.164	4
53	MP4C	Z	10.677	4
54	MP4C	Mx	.006	4
55	MP3A	X	7.804	2
56	MP3A	Z	13.517	2
57	MP3A	Mx	.004	2
58	MP3B	X	7.804	2
59	MP3B	Z	13.517	2
60	MP3B	Mx	.004	2
61	MP3C	X	5.879	2
62	MP3C	Z	10.182	2
63	MP3C	Mx	-.006	2
64	MP4A	X	7.56	1.5
65	MP4A	Z	13.094	1.5
66	MP4A	Mx	.004	1.5
67	MP4B	X	7.56	1.5
68	MP4B	Z	13.094	1.5
69	MP4B	Mx	.004	1.5
70	MP4C	X	4.904	1.5
71	MP4C	Z	8.493	1.5
72	MP4C	Mx	-.005	1.5
73	MP1A	X	19.46	1
74	MP1A	Z	33.706	1
75	MP1A	Mx	-.01	1
76	MP1A	X	19.46	5
77	MP1A	Z	33.706	5
78	MP1A	Mx	-.01	5
79	MP1B	X	19.46	1
80	MP1B	Z	33.706	1
81	MP1B	Mx	-.01	1
82	MP1B	X	19.46	5



Member Point Loads (BLC 20 : Antenna Wi (150 Deg)) (Continued)

	Member Label	Direction	Magnitude[lb.k-ft]	Location[ft. %]
83	MP1B	Z	33.706	5
84	MP1B	Mx	-.01	5
85	MP1C	X	17.815	1
86	MP1C	Z	30.857	1
87	MP1C	Mx	.018	1
88	MP1C	X	17.815	5
89	MP1C	Z	30.857	5
90	MP1C	Mx	.018	5
91	MP5A	X	19.46	1
92	MP5A	Z	33.706	1
93	MP5A	Mx	-.01	1
94	MP5A	X	19.46	5
95	MP5A	Z	33.706	5
96	MP5A	Mx	-.01	5
97	MP5B	X	19.46	1
98	MP5B	Z	33.706	1
99	MP5B	Mx	-.01	1
100	MP5B	X	19.46	5
101	MP5B	Z	33.706	5
102	MP5B	Mx	-.01	5
103	MP5C	X	17.815	1
104	MP5C	Z	30.857	1
105	MP5C	Mx	.018	1
106	MP5C	X	17.815	5
107	MP5C	Z	30.857	5
108	MP5C	Mx	.018	5
109	M76	X	3.561	5
110	M76	Z	6.168	5
111	M76	Mx	0	5
112	M76	X	2.494	2
113	M76	Z	4.32	2
114	M76	Mx	0	2
115	MP1A	X	3.925	2
116	MP1A	Z	6.799	2
117	MP1A	Mx	-.002	2
118	MP1B	X	3.925	2
119	MP1B	Z	6.799	2
120	MP1B	Mx	-.002	2

Member Point Loads (BLC 21 : Antenna Wi (180 Deg))

	Member Label	Direction	Magnitude[lb.k-ft]	Location[ft. %]
1	MP3A	X	0	1
2	MP3A	Z	40.561	1
3	MP3A	Mx	.027	1
4	MP3A	X	0	6
5	MP3A	Z	40.561	6
6	MP3A	Mx	.027	6
7	MP3B	X	0	1
8	MP3B	Z	33.162	1
9	MP3B	Mx	-.025	1
10	MP3B	X	0	6
11	MP3B	Z	33.162	6
12	MP3B	Mx	-.025	6
13	MP3C	X	0	1
14	MP3C	Z	33.162	1
15	MP3C	Mx	.003	1
16	MP3C	X	0	6
17	MP3C	Z	33.162	6



Member Point Loads (BLC 21 : Antenna Wi (180 Deg)) (Continued)

	Member Label	Direction	Magnitude[lb.k-ft]	Location[ft.%]
18	MP3C	Mx	.003	6
19	MP3A	X	0	1
20	MP3A	Z	40.561	1
21	MP3A	Mx	-.027	1
22	MP3A	X	0	6
23	MP3A	Z	40.561	6
24	MP3A	Mx	-.027	6
25	MP3B	X	0	1
26	MP3B	Z	33.162	1
27	MP3B	Mx	-.003	1
28	MP3B	X	0	6
29	MP3B	Z	33.162	6
30	MP3B	Mx	-.003	6
31	MP3C	X	0	1
32	MP3C	Z	33.162	1
33	MP3C	Mx	.025	1
34	MP3C	X	0	6
35	MP3C	Z	33.162	6
36	MP3C	Mx	.025	6
37	MP4A	X	0	2
38	MP4A	Z	17.666	2
39	MP4A	Mx	0	2
40	MP4A	X	0	4
41	MP4A	Z	17.666	4
42	MP4A	Mx	0	4
43	MP4B	X	0	2
44	MP4B	Z	13.663	2
45	MP4B	Mx	-.006	2
46	MP4B	X	0	4
47	MP4B	Z	13.663	4
48	MP4B	Mx	-.006	4
49	MP4C	X	0	2
50	MP4C	Z	13.663	2
51	MP4C	Mx	.006	2
52	MP4C	X	0	4
53	MP4C	Z	13.663	4
54	MP4C	Mx	.006	4
55	MP3A	X	0	2
56	MP3A	Z	16.891	2
57	MP3A	Mx	0	2
58	MP3B	X	0	2
59	MP3B	Z	13.041	2
60	MP3B	Mx	.006	2
61	MP3C	X	0	2
62	MP3C	Z	13.041	2
63	MP3C	Mx	-.006	2
64	MP4A	X	0	1.5
65	MP4A	Z	16.891	1.5
66	MP4A	Mx	0	1.5
67	MP4B	X	0	1.5
68	MP4B	Z	11.578	1.5
69	MP4B	Mx	.005	1.5
70	MP4C	X	0	1.5
71	MP4C	Z	11.578	1.5
72	MP4C	Mx	-.005	1.5
73	MP1A	X	0	1
74	MP1A	Z	40.017	1
75	MP1A	Mx	0	1
76	MP1A	X	0	5

Member Point Loads (BLC 21 : Antenna Wi (180 Deg)) (Continued)

	Member Label	Direction	Magnitude[lb.k-ft]	Location[ft.%]
77	MP1A	Z	40.017	5
78	MP1A	Mx	0	5
79	MP1B	X	0	1
80	MP1B	Z	36.727	1
81	MP1B	Mx	-.016	1
82	MP1B	X	0	5
83	MP1B	Z	36.727	5
84	MP1B	Mx	-.016	5
85	MP1C	X	0	1
86	MP1C	Z	36.727	1
87	MP1C	Mx	.016	1
88	MP1C	X	0	5
89	MP1C	Z	36.727	5
90	MP1C	Mx	.016	5
91	MP5A	X	0	1
92	MP5A	Z	40.017	1
93	MP5A	Mx	0	1
94	MP5A	X	0	5
95	MP5A	Z	40.017	5
96	MP5A	Mx	0	5
97	MP5B	X	0	1
98	MP5B	Z	36.727	1
99	MP5B	Mx	-.016	1
100	MP5B	X	0	5
101	MP5B	Z	36.727	5
102	MP5B	Mx	-.016	5
103	MP5C	X	0	1
104	MP5C	Z	36.727	1
105	MP5C	Mx	.016	1
106	MP5C	X	0	5
107	MP5C	Z	36.727	5
108	MP5C	Mx	.016	5
109	M76	X	0	5
110	M76	Z	4.983	5
111	M76	Mx	0	5
112	M76	X	0	2
113	M76	Z	3.784	2
114	M76	Mx	0	2
115	MP1A	X	0	2
116	MP1A	Z	4.96	2
117	MP1A	Mx	-.002	2
118	MP1B	X	0	2
119	MP1B	Z	4.96	2
120	MP1B	Mx	-.002	2

Member Point Loads (BLC 22 : Antenna Wi (210 Deg))

	Member Label	Direction	Magnitude[lb.k-ft]	Location[ft.%]
1	MP3A	X	-19.047	1
2	MP3A	Z	32.991	1
3	MP3A	Mx	.032	1
4	MP3A	X	-19.047	6
5	MP3A	Z	32.991	6
6	MP3A	Mx	.032	6
7	MP3B	X	-15.347	1
8	MP3B	Z	26.583	1
9	MP3B	Mx	-.015	1
10	MP3B	X	-15.347	6
11	MP3B	Z	26.583	6



Member Point Loads (BLC 22 : Antenna Wi (210 Deg)) (Continued)

	Member Label	Direction	Magnitude[lb.k-ft]	Location[ft.%]
12	MP3B	Mx	-.015	6
13	MP3C	X	-19.047	1
14	MP3C	Z	32.991	1
15	MP3C	Mx	-.012	1
16	MP3C	X	-19.047	6
17	MP3C	Z	32.991	6
18	MP3C	Mx	-.012	6
19	MP3A	X	-19.047	1
20	MP3A	Z	32.991	1
21	MP3A	Mx	-.012	1
22	MP3A	X	-19.047	6
23	MP3A	Z	32.991	6
24	MP3A	Mx	-.012	6
25	MP3B	X	-15.347	1
26	MP3B	Z	26.583	1
27	MP3B	Mx	-.015	1
28	MP3B	X	-15.347	6
29	MP3B	Z	26.583	6
30	MP3B	Mx	-.015	6
31	MP3C	X	-19.047	1
32	MP3C	Z	32.991	1
33	MP3C	Mx	.032	1
34	MP3C	X	-19.047	6
35	MP3C	Z	32.991	6
36	MP3C	Mx	.032	6
37	MP4A	X	-8.166	2
38	MP4A	Z	14.144	2
39	MP4A	Mx	.004	2
40	MP4A	X	-8.166	4
41	MP4A	Z	14.144	4
42	MP4A	Mx	.004	4
43	MP4B	X	-6.164	2
44	MP4B	Z	10.677	2
45	MP4B	Mx	-.006	2
46	MP4B	X	-6.164	4
47	MP4B	Z	10.677	4
48	MP4B	Mx	-.006	4
49	MP4C	X	-8.166	2
50	MP4C	Z	14.144	2
51	MP4C	Mx	.004	2
52	MP4C	X	-8.166	4
53	MP4C	Z	14.144	4
54	MP4C	Mx	.004	4
55	MP3A	X	-7.804	2
56	MP3A	Z	13.517	2
57	MP3A	Mx	-.004	2
58	MP3B	X	-5.879	2
59	MP3B	Z	10.182	2
60	MP3B	Mx	.006	2
61	MP3C	X	-7.804	2
62	MP3C	Z	13.517	2
63	MP3C	Mx	-.004	2
64	MP4A	X	-7.56	1.5
65	MP4A	Z	13.094	1.5
66	MP4A	Mx	-.004	1.5
67	MP4B	X	-4.904	1.5
68	MP4B	Z	8.493	1.5
69	MP4B	Mx	.005	1.5
70	MP4C	X	-7.56	1.5



Member Point Loads (BLC 22 : Antenna Wi (210 Deg)) (Continued)

	Member Label	Direction	Magnitude[lb.k-ft]	Location[ft.%]
71	MP4C	Z	13.094	1.5
72	MP4C	Mx	-.004	1.5
73	MP1A	X	-19.46	1
74	MP1A	Z	33.706	1
75	MP1A	Mx	.01	1
76	MP1A	X	-19.46	5
77	MP1A	Z	33.706	5
78	MP1A	Mx	.01	5
79	MP1B	X	-17.815	1
80	MP1B	Z	30.857	1
81	MP1B	Mx	-.018	1
82	MP1B	X	-17.815	5
83	MP1B	Z	30.857	5
84	MP1B	Mx	-.018	5
85	MP1C	X	-19.46	1
86	MP1C	Z	33.706	1
87	MP1C	Mx	.01	1
88	MP1C	X	-19.46	5
89	MP1C	Z	33.706	5
90	MP1C	Mx	.01	5
91	MP5A	X	-19.46	1
92	MP5A	Z	33.706	1
93	MP5A	Mx	.01	1
94	MP5A	X	-19.46	5
95	MP5A	Z	33.706	5
96	MP5A	Mx	.01	5
97	MP5B	X	-17.815	1
98	MP5B	Z	30.857	1
99	MP5B	Mx	-.018	1
100	MP5B	X	-17.815	5
101	MP5B	Z	30.857	5
102	MP5B	Mx	-.018	5
103	MP5C	X	-19.46	1
104	MP5C	Z	33.706	1
105	MP5C	Mx	.01	1
106	MP5C	X	-19.46	5
107	MP5C	Z	33.706	5
108	MP5C	Mx	.01	5
109	M76	X	-1.957	5
110	M76	Z	3.389	5
111	M76	Mx	0	5
112	M76	X	-1.591	2
113	M76	Z	2.755	2
114	M76	Mx	0	2
115	MP1A	X	-1.758	2
116	MP1A	Z	3.044	2
117	MP1A	Mx	-.002	2
118	MP1B	X	-1.758	2
119	MP1B	Z	3.044	2
120	MP1B	Mx	-.002	2

Member Point Loads (BLC 23 : Antenna Wi (240 Deg))

	Member Label	Direction	Magnitude[lb.k-ft]	Location[ft.%]
1	MP3A	X	-28.719	1
2	MP3A	Z	16.581	1
3	MP3A	Mx	.025	1
4	MP3A	X	-28.719	6
5	MP3A	Z	16.581	6



Member Point Loads (BLC 23 : Antenna Wi (240 Deg)) (Continued)

	Member Label	Direction	Magnitude[lb.k-ft]	Location[ft.%]
6	MP3A	Mx	.025	6
7	MP3B	X	-28.719	1
8	MP3B	Z	16.581	1
9	MP3B	Mx	-.003	1
10	MP3B	X	-28.719	6
11	MP3B	Z	16.581	6
12	MP3B	Mx	-.003	6
13	MP3C	X	-35.127	1
14	MP3C	Z	20.281	1
15	MP3C	Mx	-.027	1
16	MP3C	X	-35.127	6
17	MP3C	Z	20.281	6
18	MP3C	Mx	-.027	6
19	MP3A	X	-28.719	1
20	MP3A	Z	16.581	1
21	MP3A	Mx	.003	1
22	MP3A	X	-28.719	6
23	MP3A	Z	16.581	6
24	MP3A	Mx	.003	6
25	MP3B	X	-28.719	1
26	MP3B	Z	16.581	1
27	MP3B	Mx	-.025	1
28	MP3B	X	-28.719	6
29	MP3B	Z	16.581	6
30	MP3B	Mx	-.025	6
31	MP3C	X	-35.127	1
32	MP3C	Z	20.281	1
33	MP3C	Mx	.027	1
34	MP3C	X	-35.127	6
35	MP3C	Z	20.281	6
36	MP3C	Mx	.027	6
37	MP4A	X	-11.832	2
38	MP4A	Z	6.831	2
39	MP4A	Mx	.006	2
40	MP4A	X	-11.832	4
41	MP4A	Z	6.831	4
42	MP4A	Mx	.006	4
43	MP4B	X	-11.832	2
44	MP4B	Z	6.831	2
45	MP4B	Mx	-.006	2
46	MP4B	X	-11.832	4
47	MP4B	Z	6.831	4
48	MP4B	Mx	-.006	4
49	MP4C	X	-15.299	2
50	MP4C	Z	8.833	2
51	MP4C	Mx	0	2
52	MP4C	X	-15.299	4
53	MP4C	Z	8.833	4
54	MP4C	Mx	0	4
55	MP3A	X	-11.294	2
56	MP3A	Z	6.521	2
57	MP3A	Mx	-.006	2
58	MP3B	X	-11.294	2
59	MP3B	Z	6.521	2
60	MP3B	Mx	.006	2
61	MP3C	X	-14.628	2
62	MP3C	Z	8.446	2
63	MP3C	Mx	0	2
64	MP4A	X	-10.027	1.5

Member Point Loads (BLC 23 : Antenna Wi (240 Deg)) (Continued)

	Member Label	Direction	Magnitude[lb.k-ft]	Location[ft.%]
65	MP4A	Z	5.789	1.5
66	MP4A	Mx	-.005	1.5
67	MP4B	X	-10.027	1.5
68	MP4B	Z	5.789	1.5
69	MP4B	Mx	.005	1.5
70	MP4C	X	-14.628	1.5
71	MP4C	Z	8.446	1.5
72	MP4C	Mx	0	1.5
73	MP1A	X	-31.807	1
74	MP1A	Z	18.364	1
75	MP1A	Mx	.016	1
76	MP1A	X	-31.807	5
77	MP1A	Z	18.364	5
78	MP1A	Mx	.016	5
79	MP1B	X	-31.807	1
80	MP1B	Z	18.364	1
81	MP1B	Mx	-.016	1
82	MP1B	X	-31.807	5
83	MP1B	Z	18.364	5
84	MP1B	Mx	-.016	5
85	MP1C	X	-34.656	1
86	MP1C	Z	20.009	1
87	MP1C	Mx	0	1
88	MP1C	X	-34.656	5
89	MP1C	Z	20.009	5
90	MP1C	Mx	0	5
91	MP5A	X	-31.807	1
92	MP5A	Z	18.364	1
93	MP5A	Mx	.016	1
94	MP5A	X	-31.807	5
95	MP5A	Z	18.364	5
96	MP5A	Mx	.016	5
97	MP5B	X	-31.807	1
98	MP5B	Z	18.364	1
99	MP5B	Mx	-.016	1
100	MP5B	X	-31.807	5
101	MP5B	Z	18.364	5
102	MP5B	Mx	-.016	5
103	MP5C	X	-34.656	1
104	MP5C	Z	20.009	1
105	MP5C	Mx	0	1
106	MP5C	X	-34.656	5
107	MP5C	Z	20.009	5
108	MP5C	Mx	0	5
109	M76	X	-4.316	5
110	M76	Z	2.492	5
111	M76	Mx	0	5
112	M76	X	-3.277	2
113	M76	Z	1.892	2
114	M76	Mx	0	2
115	MP1A	X	-4.296	2
116	MP1A	Z	2.48	2
117	MP1A	Mx	-.002	2
118	MP1B	X	-4.296	2
119	MP1B	Z	2.48	2
120	MP1B	Mx	-.002	2

Member Point Loads (BLC 24 : Antenna Wi (270 Deg))



Member Point Loads (BLC 24 : Antenna Wi (270 Deg)) (Continued)

	Member Label	Direction	Magnitude[lb.k-ft]	Location[ft.%]
1	MP3A	X	-30.695	1
2	MP3A	Z	0	1
3	MP3A	Mx	.015	1
4	MP3A	X	-30.695	6
5	MP3A	Z	0	6
6	MP3A	Mx	.015	6
7	MP3B	X	-38.095	1
8	MP3B	Z	0	1
9	MP3B	Mx	.012	1
10	MP3B	X	-38.095	6
11	MP3B	Z	0	6
12	MP3B	Mx	.012	6
13	MP3C	X	-38.095	1
14	MP3C	Z	0	1
15	MP3C	Mx	-.032	1
16	MP3C	X	-38.095	6
17	MP3C	Z	0	6
18	MP3C	Mx	-.032	6
19	MP3A	X	-30.695	1
20	MP3A	Z	0	1
21	MP3A	Mx	.015	1
22	MP3A	X	-30.695	6
23	MP3A	Z	0	6
24	MP3A	Mx	.015	6
25	MP3B	X	-38.095	1
26	MP3B	Z	0	1
27	MP3B	Mx	-.032	1
28	MP3B	X	-38.095	6
29	MP3B	Z	0	6
30	MP3B	Mx	-.032	6
31	MP3C	X	-38.095	1
32	MP3C	Z	0	1
33	MP3C	Mx	.012	1
34	MP3C	X	-38.095	6
35	MP3C	Z	0	6
36	MP3C	Mx	.012	6
37	MP4A	X	-12.329	2
38	MP4A	Z	0	2
39	MP4A	Mx	.006	2
40	MP4A	X	-12.329	4
41	MP4A	Z	0	4
42	MP4A	Mx	.006	4
43	MP4B	X	-16.332	2
44	MP4B	Z	0	2
45	MP4B	Mx	-.004	2
46	MP4B	X	-16.332	4
47	MP4B	Z	0	4
48	MP4B	Mx	-.004	4
49	MP4C	X	-16.332	2
50	MP4C	Z	0	2
51	MP4C	Mx	-.004	2
52	MP4C	X	-16.332	4
53	MP4C	Z	0	4
54	MP4C	Mx	-.004	4
55	MP3A	X	-11.758	2
56	MP3A	Z	0	2
57	MP3A	Mx	-.006	2
58	MP3B	X	-15.608	2
59	MP3B	Z	0	2



Member Point Loads (BLC 24 : Antenna Wi (270 Deg)) (Continued)

	Member Label	Direction	Magnitude[lb.k-ft]	Location[ft.%]
60	MP3B	Mx	.004	2
61	MP3C	X	-15.608	2
62	MP3C	Z	0	2
63	MP3C	Mx	.004	2
64	MP4A	X	-9.807	1.5
65	MP4A	Z	0	1.5
66	MP4A	Mx	-.005	1.5
67	MP4B	X	-15.12	1.5
68	MP4B	Z	0	1.5
69	MP4B	Mx	.004	1.5
70	MP4C	X	-15.12	1.5
71	MP4C	Z	0	1.5
72	MP4C	Mx	.004	1.5
73	MP1A	X	-35.63	1
74	MP1A	Z	0	1
75	MP1A	Mx	.018	1
76	MP1A	X	-35.63	5
77	MP1A	Z	0	5
78	MP1A	Mx	.018	5
79	MP1B	X	-38.92	1
80	MP1B	Z	0	1
81	MP1B	Mx	-.01	1
82	MP1B	X	-38.92	5
83	MP1B	Z	0	5
84	MP1B	Mx	-.01	5
85	MP1C	X	-38.92	1
86	MP1C	Z	0	1
87	MP1C	Mx	-.01	1
88	MP1C	X	-38.92	5
89	MP1C	Z	0	5
90	MP1C	Mx	-.01	5
91	MP5A	X	-35.63	1
92	MP5A	Z	0	1
93	MP5A	Mx	.018	1
94	MP5A	X	-35.63	5
95	MP5A	Z	0	5
96	MP5A	Mx	.018	5
97	MP5B	X	-38.92	1
98	MP5B	Z	0	1
99	MP5B	Mx	-.01	1
100	MP5B	X	-38.92	5
101	MP5B	Z	0	5
102	MP5B	Mx	-.01	5
103	MP5C	X	-38.92	1
104	MP5C	Z	0	1
105	MP5C	Mx	-.01	1
106	MP5C	X	-38.92	5
107	MP5C	Z	0	5
108	MP5C	Mx	-.01	5
109	M76	X	-7.123	5
110	M76	Z	0	5
111	M76	Mx	0	5
112	M76	X	-4.988	2
113	M76	Z	0	2
114	M76	Mx	0	2
115	MP1A	X	-7.851	2
116	MP1A	Z	0	2
117	MP1A	Mx	-.002	2
118	MP1B	X	-7.851	2



Member Point Loads (BLC 24 : Antenna Wi (270 Deg)) (Continued)

	Member Label	Direction	Magnitude[lb.k-ft]	Location[ft. %]
119	MP1B	Z	0	2
120	MP1B	Mx	-.002	2

Member Point Loads (BLC 25 : Antenna Wi (300 Deg))

	Member Label	Direction	Magnitude[lb.k-ft]	Location[ft. %]
1	MP3A	X	-28.719	1
2	MP3A	Z	-16.581	1
3	MP3A	Mx	.003	1
4	MP3A	X	-28.719	6
5	MP3A	Z	-16.581	6
6	MP3A	Mx	.003	6
7	MP3B	X	-35.127	1
8	MP3B	Z	-20.281	1
9	MP3B	Mx	.027	1
10	MP3B	X	-35.127	6
11	MP3B	Z	-20.281	6
12	MP3B	Mx	.027	6
13	MP3C	X	-28.719	1
14	MP3C	Z	-16.581	1
15	MP3C	Mx	-.025	1
16	MP3C	X	-28.719	6
17	MP3C	Z	-16.581	6
18	MP3C	Mx	-.025	6
19	MP3A	X	-28.719	1
20	MP3A	Z	-16.581	1
21	MP3A	Mx	.025	1
22	MP3A	X	-28.719	6
23	MP3A	Z	-16.581	6
24	MP3A	Mx	.025	6
25	MP3B	X	-35.127	1
26	MP3B	Z	-20.281	1
27	MP3B	Mx	-.027	1
28	MP3B	X	-35.127	6
29	MP3B	Z	-20.281	6
30	MP3B	Mx	-.027	6
31	MP3C	X	-28.719	1
32	MP3C	Z	-16.581	1
33	MP3C	Mx	-.003	1
34	MP3C	X	-28.719	6
35	MP3C	Z	-16.581	6
36	MP3C	Mx	-.003	6
37	MP4A	X	-11.832	2
38	MP4A	Z	-6.831	2
39	MP4A	Mx	.006	2
40	MP4A	X	-11.832	4
41	MP4A	Z	-6.831	4
42	MP4A	Mx	.006	4
43	MP4B	X	-15.299	2
44	MP4B	Z	-8.833	2
45	MP4B	Mx	0	2
46	MP4B	X	-15.299	4
47	MP4B	Z	-8.833	4
48	MP4B	Mx	0	4
49	MP4C	X	-11.832	2
50	MP4C	Z	-6.831	2
51	MP4C	Mx	-.006	2
52	MP4C	X	-11.832	4
53	MP4C	Z	-6.831	4



Member Point Loads (BLC 25 : Antenna Wi (300 Deg)) (Continued)

	Member Label	Direction	Magnitude[lb.k-ft]	Location[ft.%]
54	MP4C	Mx	-.006	4
55	MP3A	X	-11.294	2
56	MP3A	Z	-6.521	2
57	MP3A	Mx	-.006	2
58	MP3B	X	-14.628	2
59	MP3B	Z	-8.446	2
60	MP3B	Mx	0	2
61	MP3C	X	-11.294	2
62	MP3C	Z	-6.521	2
63	MP3C	Mx	.006	2
64	MP4A	X	-10.027	1.5
65	MP4A	Z	-5.789	1.5
66	MP4A	Mx	-.005	1.5
67	MP4B	X	-14.628	1.5
68	MP4B	Z	-8.446	1.5
69	MP4B	Mx	0	1.5
70	MP4C	X	-10.027	1.5
71	MP4C	Z	-5.789	1.5
72	MP4C	Mx	.005	1.5
73	MP1A	X	-31.807	1
74	MP1A	Z	-18.364	1
75	MP1A	Mx	.016	1
76	MP1A	X	-31.807	5
77	MP1A	Z	-18.364	5
78	MP1A	Mx	.016	5
79	MP1B	X	-34.656	1
80	MP1B	Z	-20.009	1
81	MP1B	Mx	0	1
82	MP1B	X	-34.656	5
83	MP1B	Z	-20.009	5
84	MP1B	Mx	0	5
85	MP1C	X	-31.807	1
86	MP1C	Z	-18.364	1
87	MP1C	Mx	-.016	1
88	MP1C	X	-31.807	5
89	MP1C	Z	-18.364	5
90	MP1C	Mx	-.016	5
91	MP5A	X	-31.807	1
92	MP5A	Z	-18.364	1
93	MP5A	Mx	.016	1
94	MP5A	X	-31.807	5
95	MP5A	Z	-18.364	5
96	MP5A	Mx	.016	5
97	MP5B	X	-34.656	1
98	MP5B	Z	-20.009	1
99	MP5B	Mx	0	1
100	MP5B	X	-34.656	5
101	MP5B	Z	-20.009	5
102	MP5B	Mx	0	5
103	MP5C	X	-31.807	1
104	MP5C	Z	-18.364	1
105	MP5C	Mx	-.016	1
106	MP5C	X	-31.807	5
107	MP5C	Z	-18.364	5
108	MP5C	Mx	-.016	5
109	M76	X	-7.095	5
110	M76	Z	-4.096	5
111	M76	Mx	0	5
112	M76	X	-4.842	2

Member Point Loads (BLC 25 : Antenna Wi (300 Deg)) (Continued)

	Member Label	Direction	Magnitude[lb.k-ft]	Location[ft.%]
113	M76	Z	-2.795	2
114	M76	Mx	0	2
115	MP1A	X	-8.05	2
116	MP1A	Z	-4.648	2
117	MP1A	Mx	0	2
118	MP1B	X	-8.05	2
119	MP1B	Z	-4.648	2
120	MP1B	Mx	0	2

Member Point Loads (BLC 26 : Antenna Wi (330 Deg))

	Member Label	Direction	Magnitude[lb.k-ft]	Location[ft.%]
1	MP3A	X	-19.047	1
2	MP3A	Z	-32.991	1
3	MP3A	Mx	-.012	1
4	MP3A	X	-19.047	6
5	MP3A	Z	-32.991	6
6	MP3A	Mx	-.012	6
7	MP3B	X	-19.047	1
8	MP3B	Z	-32.991	1
9	MP3B	Mx	.032	1
10	MP3B	X	-19.047	6
11	MP3B	Z	-32.991	6
12	MP3B	Mx	.032	6
13	MP3C	X	-15.347	1
14	MP3C	Z	-26.583	1
15	MP3C	Mx	-.015	1
16	MP3C	X	-15.347	6
17	MP3C	Z	-26.583	6
18	MP3C	Mx	-.015	6
19	MP3A	X	-19.047	1
20	MP3A	Z	-32.991	1
21	MP3A	Mx	.032	1
22	MP3A	X	-19.047	6
23	MP3A	Z	-32.991	6
24	MP3A	Mx	.032	6
25	MP3B	X	-19.047	1
26	MP3B	Z	-32.991	1
27	MP3B	Mx	-.012	1
28	MP3B	X	-19.047	6
29	MP3B	Z	-32.991	6
30	MP3B	Mx	-.012	6
31	MP3C	X	-15.347	1
32	MP3C	Z	-26.583	1
33	MP3C	Mx	-.015	1
34	MP3C	X	-15.347	6
35	MP3C	Z	-26.583	6
36	MP3C	Mx	-.015	6
37	MP4A	X	-8.166	2
38	MP4A	Z	-14.144	2
39	MP4A	Mx	.004	2
40	MP4A	X	-8.166	4
41	MP4A	Z	-14.144	4
42	MP4A	Mx	.004	4
43	MP4B	X	-8.166	2
44	MP4B	Z	-14.144	2
45	MP4B	Mx	.004	2
46	MP4B	X	-8.166	4
47	MP4B	Z	-14.144	4



Member Point Loads (BLC 26 : Antenna Wi (330 Deg)) (Continued)

	Member Label	Direction	Magnitude[lb.k-ft]	Location[ft.%]
48	MP4B	Mx	.004	4
49	MP4C	X	-6.164	2
50	MP4C	Z	-10.677	2
51	MP4C	Mx	-.006	2
52	MP4C	X	-6.164	4
53	MP4C	Z	-10.677	4
54	MP4C	Mx	-.006	4
55	MP3A	X	-7.804	2
56	MP3A	Z	-13.517	2
57	MP3A	Mx	-.004	2
58	MP3B	X	-7.804	2
59	MP3B	Z	-13.517	2
60	MP3B	Mx	-.004	2
61	MP3C	X	-5.879	2
62	MP3C	Z	-10.182	2
63	MP3C	Mx	.006	2
64	MP4A	X	-7.56	1.5
65	MP4A	Z	-13.094	1.5
66	MP4A	Mx	-.004	1.5
67	MP4B	X	-7.56	1.5
68	MP4B	Z	-13.094	1.5
69	MP4B	Mx	-.004	1.5
70	MP4C	X	-4.904	1.5
71	MP4C	Z	-8.493	1.5
72	MP4C	Mx	.005	1.5
73	MP1A	X	-19.46	1
74	MP1A	Z	-33.706	1
75	MP1A	Mx	.01	1
76	MP1A	X	-19.46	5
77	MP1A	Z	-33.706	5
78	MP1A	Mx	.01	5
79	MP1B	X	-19.46	1
80	MP1B	Z	-33.706	1
81	MP1B	Mx	.01	1
82	MP1B	X	-19.46	5
83	MP1B	Z	-33.706	5
84	MP1B	Mx	.01	5
85	MP1C	X	-17.815	1
86	MP1C	Z	-30.857	1
87	MP1C	Mx	-.018	1
88	MP1C	X	-17.815	5
89	MP1C	Z	-30.857	5
90	MP1C	Mx	-.018	5
91	MP5A	X	-19.46	1
92	MP5A	Z	-33.706	1
93	MP5A	Mx	.01	1
94	MP5A	X	-19.46	5
95	MP5A	Z	-33.706	5
96	MP5A	Mx	.01	5
97	MP5B	X	-19.46	1
98	MP5B	Z	-33.706	1
99	MP5B	Mx	.01	1
100	MP5B	X	-19.46	5
101	MP5B	Z	-33.706	5
102	MP5B	Mx	.01	5
103	MP5C	X	-17.815	1
104	MP5C	Z	-30.857	1
105	MP5C	Mx	-.018	1
106	MP5C	X	-17.815	5

Member Point Loads (BLC 26 : Antenna Wi (330 Deg)) (Continued)

	Member Label	Direction	Magnitude[lb.k-ft]	Location[ft.%]
107	MP5C	Z	-30.857	5
108	MP5C	Mx	-.018	5
109	M76	X	-3.561	5
110	M76	Z	-6.168	5
111	M76	Mx	0	5
112	M76	X	-2.494	2
113	M76	Z	-4.32	2
114	M76	Mx	0	2
115	MP1A	X	-3.925	2
116	MP1A	Z	-6.799	2
117	MP1A	Mx	.002	2
118	MP1B	X	-3.925	2
119	MP1B	Z	-6.799	2
120	MP1B	Mx	.002	2

Member Point Loads (BLC 27 : Antenna Wm (0 Deg))

	Member Label	Direction	Magnitude[lb.k-ft]	Location[ft.%]
1	MP3A	X	0	1
2	MP3A	Z	-6.407	1
3	MP3A	Mx	-.004	1
4	MP3A	X	0	6
5	MP3A	Z	-6.407	6
6	MP3A	Mx	-.004	6
7	MP3B	X	0	1
8	MP3B	Z	-5.198	1
9	MP3B	Mx	.004	1
10	MP3B	X	0	6
11	MP3B	Z	-5.198	6
12	MP3B	Mx	.004	6
13	MP3C	X	0	1
14	MP3C	Z	-5.198	1
15	MP3C	Mx	-.000518	1
16	MP3C	X	0	6
17	MP3C	Z	-5.198	6
18	MP3C	Mx	-.000518	6
19	MP3A	X	0	1
20	MP3A	Z	-6.407	1
21	MP3A	Mx	.004	1
22	MP3A	X	0	6
23	MP3A	Z	-6.407	6
24	MP3A	Mx	.004	6
25	MP3B	X	0	1
26	MP3B	Z	-5.198	1
27	MP3B	Mx	.000518	1
28	MP3B	X	0	6
29	MP3B	Z	-5.198	6
30	MP3B	Mx	.000518	6
31	MP3C	X	0	1
32	MP3C	Z	-5.198	1
33	MP3C	Mx	-.004	1
34	MP3C	X	0	6
35	MP3C	Z	-5.198	6
36	MP3C	Mx	-.004	6
37	MP4A	X	0	2
38	MP4A	Z	-5.595	2
39	MP4A	Mx	0	2
40	MP4A	X	0	4
41	MP4A	Z	-5.595	4

Member Point Loads (BLC 27 : Antenna Wm (0 Deg)) (Continued)

	Member Label	Direction	Magnitude[lb.k-ft]	Location[ft.%]
42	MP4A	Mx	0	4
43	MP4B	X	0	2
44	MP4B	Z	-4.252	2
45	MP4B	Mx	.002	2
46	MP4B	X	0	4
47	MP4B	Z	-4.252	4
48	MP4B	Mx	.002	4
49	MP4C	X	0	2
50	MP4C	Z	-4.252	2
51	MP4C	Mx	-.002	2
52	MP4C	X	0	4
53	MP4C	Z	-4.252	4
54	MP4C	Mx	-.002	4
55	MP3A	X	0	2
56	MP3A	Z	-4.199	2
57	MP3A	Mx	0	2
58	MP3B	X	0	2
59	MP3B	Z	-3.163	2
60	MP3B	Mx	-.001	2
61	MP3C	X	0	2
62	MP3C	Z	-3.163	2
63	MP3C	Mx	.001	2
64	MP4A	X	0	1.5
65	MP4A	Z	-4.199	1.5
66	MP4A	Mx	0	1.5
67	MP4B	X	0	1.5
68	MP4B	Z	-2.777	1.5
69	MP4B	Mx	-.001	1.5
70	MP4C	X	0	1.5
71	MP4C	Z	-2.777	1.5
72	MP4C	Mx	.001	1.5
73	MP1A	X	0	1
74	MP1A	Z	-13.221	1
75	MP1A	Mx	0	1
76	MP1A	X	0	5
77	MP1A	Z	-13.221	5
78	MP1A	Mx	0	5
79	MP1B	X	0	1
80	MP1B	Z	-12.046	1
81	MP1B	Mx	.005	1
82	MP1B	X	0	5
83	MP1B	Z	-12.046	5
84	MP1B	Mx	.005	5
85	MP1C	X	0	1
86	MP1C	Z	-12.046	1
87	MP1C	Mx	-.005	1
88	MP1C	X	0	5
89	MP1C	Z	-12.046	5
90	MP1C	Mx	-.005	5
91	MP5A	X	0	1
92	MP5A	Z	-13.221	1
93	MP5A	Mx	0	1
94	MP5A	X	0	5
95	MP5A	Z	-13.221	5
96	MP5A	Mx	0	5
97	MP5B	X	0	1
98	MP5B	Z	-12.046	1
99	MP5B	Mx	.005	1
100	MP5B	X	0	5

Member Point Loads (BLC 27 : Antenna Wm (0 Deg)) (Continued)

	Member Label	Direction	Magnitude[lb.k-ft]	Location[ft. %]
101	MP5B	Z	-12.046	5
102	MP5B	Mx	.005	5
103	MP5C	X	0	1
104	MP5C	Z	-12.046	1
105	MP5C	Mx	-.005	1
106	MP5C	X	0	5
107	MP5C	Z	-12.046	5
108	MP5C	Mx	-.005	5
109	M76	X	0	5
110	M76	Z	-.677	5
111	M76	Mx	0	5
112	M76	X	0	2
113	M76	Z	-.528	2
114	M76	Mx	0	2
115	MP1A	X	0	2
116	MP1A	Z	-1.242	2
117	MP1A	Mx	.000538	2
118	MP1B	X	0	2
119	MP1B	Z	-1.242	2
120	MP1B	Mx	.000538	2

Member Point Loads (BLC 28 : Antenna Wm (30 Deg))

	Member Label	Direction	Magnitude[lb.k-ft]	Location[ft. %]
1	MP3A	X	3.002	1
2	MP3A	Z	-5.2	1
3	MP3A	Mx	-.005	1
4	MP3A	X	3.002	6
5	MP3A	Z	-5.2	6
6	MP3A	Mx	-.005	6
7	MP3B	X	2.398	1
8	MP3B	Z	-4.153	1
9	MP3B	Mx	.002	1
10	MP3B	X	2.398	6
11	MP3B	Z	-4.153	6
12	MP3B	Mx	.002	6
13	MP3C	X	3.002	1
14	MP3C	Z	-5.2	1
15	MP3C	Mx	.002	1
16	MP3C	X	3.002	6
17	MP3C	Z	-5.2	6
18	MP3C	Mx	.002	6
19	MP3A	X	3.002	1
20	MP3A	Z	-5.2	1
21	MP3A	Mx	.002	1
22	MP3A	X	3.002	6
23	MP3A	Z	-5.2	6
24	MP3A	Mx	.002	6
25	MP3B	X	2.398	1
26	MP3B	Z	-4.153	1
27	MP3B	Mx	.002	1
28	MP3B	X	2.398	6
29	MP3B	Z	-4.153	6
30	MP3B	Mx	.002	6
31	MP3C	X	3.002	1
32	MP3C	Z	-5.2	1
33	MP3C	Mx	-.005	1
34	MP3C	X	3.002	6
35	MP3C	Z	-5.2	6



Member Point Loads (BLC 28 : Antenna Wm (30 Deg)) (Continued)

	Member Label	Direction	Magnitude[lb.k-ft]	Location[ft.%]
36	MP3C	Mx	-.005	6
37	MP4A	X	2.574	2
38	MP4A	Z	-4.457	2
39	MP4A	Mx	-.001	2
40	MP4A	X	2.574	4
41	MP4A	Z	-4.457	4
42	MP4A	Mx	-.001	4
43	MP4B	X	1.902	2
44	MP4B	Z	-3.294	2
45	MP4B	Mx	.002	2
46	MP4B	X	1.902	4
47	MP4B	Z	-3.294	4
48	MP4B	Mx	.002	4
49	MP4C	X	2.574	2
50	MP4C	Z	-4.457	2
51	MP4C	Mx	-.001	2
52	MP4C	X	2.574	4
53	MP4C	Z	-4.457	4
54	MP4C	Mx	-.001	4
55	MP3A	X	1.927	2
56	MP3A	Z	-3.338	2
57	MP3A	Mx	.000964	2
58	MP3B	X	1.409	2
59	MP3B	Z	-2.44	2
60	MP3B	Mx	-.001	2
61	MP3C	X	1.927	2
62	MP3C	Z	-3.338	2
63	MP3C	Mx	.000964	2
64	MP4A	X	1.863	1.5
65	MP4A	Z	-3.226	1.5
66	MP4A	Mx	.000932	1.5
67	MP4B	X	1.151	1.5
68	MP4B	Z	-1.994	1.5
69	MP4B	Mx	-.001	1.5
70	MP4C	X	1.863	1.5
71	MP4C	Z	-3.226	1.5
72	MP4C	Mx	.000931	1.5
73	MP1A	X	6.415	1
74	MP1A	Z	-11.111	1
75	MP1A	Mx	-.003	1
76	MP1A	X	6.415	5
77	MP1A	Z	-11.111	5
78	MP1A	Mx	-.003	5
79	MP1B	X	5.827	1
80	MP1B	Z	-10.093	1
81	MP1B	Mx	.006	1
82	MP1B	X	5.827	5
83	MP1B	Z	-10.093	5
84	MP1B	Mx	.006	5
85	MP1C	X	6.415	1
86	MP1C	Z	-11.111	1
87	MP1C	Mx	-.003	1
88	MP1C	X	6.415	5
89	MP1C	Z	-11.111	5
90	MP1C	Mx	-.003	5
91	MP5A	X	6.415	1
92	MP5A	Z	-11.111	1
93	MP5A	Mx	-.003	1
94	MP5A	X	6.415	5

Member Point Loads (BLC 28 : Antenna Wm (30 Deg)) (Continued)

	Member Label	Direction	Magnitude[lb.k-ft]	Location[ft. %]
95	MP5A	Z	-11.111	5
96	MP5A	Mx	-.003	5
97	MP5B	X	5.827	1
98	MP5B	Z	-10.093	1
99	MP5B	Mx	.006	1
100	MP5B	X	5.827	5
101	MP5B	Z	-10.093	5
102	MP5B	Mx	.006	5
103	MP5C	X	6.415	1
104	MP5C	Z	-11.111	1
105	MP5C	Mx	-.003	1
106	MP5C	X	6.415	5
107	MP5C	Z	-11.111	5
108	MP5C	Mx	-.003	5
109	M76	X	.452	5
110	M76	Z	-.782	5
111	M76	Mx	0	5
112	M76	X	.352	2
113	M76	Z	-.61	2
114	M76	Mx	0	2
115	MP1A	X	.394	2
116	MP1A	Z	-.683	2
117	MP1A	Mx	.000394	2
118	MP1B	X	.394	2
119	MP1B	Z	-.683	2
120	MP1B	Mx	.000394	2

Member Point Loads (BLC 29 : Antenna Wm (60 Deg))

	Member Label	Direction	Magnitude[lb.k-ft]	Location[ft. %]
1	MP3A	X	4.502	1
2	MP3A	Z	-2.599	1
3	MP3A	Mx	-.004	1
4	MP3A	X	4.502	6
5	MP3A	Z	-2.599	6
6	MP3A	Mx	-.004	6
7	MP3B	X	4.502	1
8	MP3B	Z	-2.599	1
9	MP3B	Mx	.000518	1
10	MP3B	X	4.502	6
11	MP3B	Z	-2.599	6
12	MP3B	Mx	.000518	6
13	MP3C	X	5.549	1
14	MP3C	Z	-3.204	1
15	MP3C	Mx	.004	1
16	MP3C	X	5.549	6
17	MP3C	Z	-3.204	6
18	MP3C	Mx	.004	6
19	MP3A	X	4.502	1
20	MP3A	Z	-2.599	1
21	MP3A	Mx	-.000518	1
22	MP3A	X	4.502	6
23	MP3A	Z	-2.599	6
24	MP3A	Mx	-.000518	6
25	MP3B	X	4.502	1
26	MP3B	Z	-2.599	1
27	MP3B	Mx	.004	1
28	MP3B	X	4.502	6
29	MP3B	Z	-2.599	6



Member Point Loads (BLC 29 : Antenna Wm (60 Deg)) (Continued)

	Member Label	Direction	Magnitude[lb.k-ft]	Location[ft.%]
30	MP3B	Mx	.004	6
31	MP3C	X	5.549	1
32	MP3C	Z	-3.204	1
33	MP3C	Mx	-.004	1
34	MP3C	X	5.549	6
35	MP3C	Z	-3.204	6
36	MP3C	Mx	-.004	6
37	MP4A	X	3.682	2
38	MP4A	Z	-2.126	2
39	MP4A	Mx	-.002	2
40	MP4A	X	3.682	4
41	MP4A	Z	-2.126	4
42	MP4A	Mx	-.002	4
43	MP4B	X	3.682	2
44	MP4B	Z	-2.126	2
45	MP4B	Mx	.002	2
46	MP4B	X	3.682	4
47	MP4B	Z	-2.126	4
48	MP4B	Mx	.002	4
49	MP4C	X	4.845	2
50	MP4C	Z	-2.797	2
51	MP4C	Mx	0	2
52	MP4C	X	4.845	4
53	MP4C	Z	-2.797	4
54	MP4C	Mx	0	4
55	MP3A	X	2.739	2
56	MP3A	Z	-1.582	2
57	MP3A	Mx	.001	2
58	MP3B	X	2.739	2
59	MP3B	Z	-1.582	2
60	MP3B	Mx	-.001	2
61	MP3C	X	3.637	2
62	MP3C	Z	-2.1	2
63	MP3C	Mx	0	2
64	MP4A	X	2.405	1.5
65	MP4A	Z	-1.389	1.5
66	MP4A	Mx	.001	1.5
67	MP4B	X	2.405	1.5
68	MP4B	Z	-1.389	1.5
69	MP4B	Mx	-.001	1.5
70	MP4C	X	3.637	1.5
71	MP4C	Z	-2.1	1.5
72	MP4C	Mx	0	1.5
73	MP1A	X	10.432	1
74	MP1A	Z	-6.023	1
75	MP1A	Mx	-.005	1
76	MP1A	X	10.432	5
77	MP1A	Z	-6.023	5
78	MP1A	Mx	-.005	5
79	MP1B	X	10.432	1
80	MP1B	Z	-6.023	1
81	MP1B	Mx	.005	1
82	MP1B	X	10.432	5
83	MP1B	Z	-6.023	5
84	MP1B	Mx	.005	5
85	MP1C	X	11.45	1
86	MP1C	Z	-6.611	1
87	MP1C	Mx	0	1
88	MP1C	X	11.45	5

Member Point Loads (BLC 29 : Antenna Wm (60 Deg)) (Continued)

	Member Label	Direction	Magnitude[lb.k-ft]	Location[ft. %]
89	MP1C	Z	-6.611	5
90	MP1C	Mx	0	5
91	MP5A	X	10.432	1
92	MP5A	Z	-6.023	1
93	MP5A	Mx	-.005	1
94	MP5A	X	10.432	5
95	MP5A	Z	-6.023	5
96	MP5A	Mx	-.005	5
97	MP5B	X	10.432	1
98	MP5B	Z	-6.023	1
99	MP5B	Mx	.005	1
100	MP5B	X	10.432	5
101	MP5B	Z	-6.023	5
102	MP5B	Mx	.005	5
103	MP5C	X	11.45	1
104	MP5C	Z	-6.611	1
105	MP5C	Mx	0	1
106	MP5C	X	11.45	5
107	MP5C	Z	-6.611	5
108	MP5C	Mx	0	5
109	M76	X	.587	5
110	M76	Z	-.339	5
111	M76	Mx	0	5
112	M76	X	.458	2
113	M76	Z	-.264	2
114	M76	Mx	0	2
115	MP1A	X	1.075	2
116	MP1A	Z	-.621	2
117	MP1A	Mx	.000538	2
118	MP1B	X	1.075	2
119	MP1B	Z	-.621	2
120	MP1B	Mx	.000538	2

Member Point Loads (BLC 30 : Antenna Wm (90 Deg))

	Member Label	Direction	Magnitude[lb.k-ft]	Location[ft. %]
1	MP3A	X	4.795	1
2	MP3A	Z	0	1
3	MP3A	Mx	-.002	1
4	MP3A	X	4.795	6
5	MP3A	Z	0	6
6	MP3A	Mx	-.002	6
7	MP3B	X	6.004	1
8	MP3B	Z	0	1
9	MP3B	Mx	-.002	1
10	MP3B	X	6.004	6
11	MP3B	Z	0	6
12	MP3B	Mx	-.002	6
13	MP3C	X	6.004	1
14	MP3C	Z	0	1
15	MP3C	Mx	.005	1
16	MP3C	X	6.004	6
17	MP3C	Z	0	6
18	MP3C	Mx	.005	6
19	MP3A	X	4.795	1
20	MP3A	Z	0	1
21	MP3A	Mx	-.002	1
22	MP3A	X	4.795	6
23	MP3A	Z	0	6



Member Point Loads (BLC 30 : Antenna Wm (90 Deg)) (Continued)

	Member Label	Direction	Magnitude[lb.k-ft]	Location[ft.%]
24	MP3A	Mx	-.002	6
25	MP3B	X	6.004	1
26	MP3B	Z	0	1
27	MP3B	Mx	.005	1
28	MP3B	X	6.004	6
29	MP3B	Z	0	6
30	MP3B	Mx	.005	6
31	MP3C	X	6.004	1
32	MP3C	Z	0	1
33	MP3C	Mx	-.002	1
34	MP3C	X	6.004	6
35	MP3C	Z	0	6
36	MP3C	Mx	-.002	6
37	MP4A	X	3.804	2
38	MP4A	Z	0	2
39	MP4A	Mx	-.002	2
40	MP4A	X	3.804	4
41	MP4A	Z	0	4
42	MP4A	Mx	-.002	4
43	MP4B	X	5.147	2
44	MP4B	Z	0	2
45	MP4B	Mx	.001	2
46	MP4B	X	5.147	4
47	MP4B	Z	0	4
48	MP4B	Mx	.001	4
49	MP4C	X	5.147	2
50	MP4C	Z	0	2
51	MP4C	Mx	.001	2
52	MP4C	X	5.147	4
53	MP4C	Z	0	4
54	MP4C	Mx	.001	4
55	MP3A	X	2.818	2
56	MP3A	Z	0	2
57	MP3A	Mx	.001	2
58	MP3B	X	3.854	2
59	MP3B	Z	0	2
60	MP3B	Mx	-.000964	2
61	MP3C	X	3.854	2
62	MP3C	Z	0	2
63	MP3C	Mx	-.000964	2
64	MP4A	X	2.303	1.5
65	MP4A	Z	0	1.5
66	MP4A	Mx	.001	1.5
67	MP4B	X	3.725	1.5
68	MP4B	Z	0	1.5
69	MP4B	Mx	-.000931	1.5
70	MP4C	X	3.725	1.5
71	MP4C	Z	0	1.5
72	MP4C	Mx	-.000931	1.5
73	MP1A	X	11.654	1
74	MP1A	Z	0	1
75	MP1A	Mx	-.006	1
76	MP1A	X	11.654	5
77	MP1A	Z	0	5
78	MP1A	Mx	-.006	5
79	MP1B	X	12.83	1
80	MP1B	Z	0	1
81	MP1B	Mx	.003	1
82	MP1B	X	12.83	5

Member Point Loads (BLC 30 : Antenna Wm (90 Deg)) (Continued)

	Member Label	Direction	Magnitude[lb.k-ft]	Location[ft. %]
83	MP1B	Z	0	5
84	MP1B	Mx	.003	5
85	MP1C	X	12.83	1
86	MP1C	Z	0	1
87	MP1C	Mx	.003	1
88	MP1C	X	12.83	5
89	MP1C	Z	0	5
90	MP1C	Mx	.003	5
91	MP5A	X	11.654	1
92	MP5A	Z	0	1
93	MP5A	Mx	-.006	1
94	MP5A	X	11.654	5
95	MP5A	Z	0	5
96	MP5A	Mx	-.006	5
97	MP5B	X	12.83	1
98	MP5B	Z	0	1
99	MP5B	Mx	.003	1
100	MP5B	X	12.83	5
101	MP5B	Z	0	5
102	MP5B	Mx	.003	5
103	MP5C	X	12.83	1
104	MP5C	Z	0	1
105	MP5C	Mx	.003	1
106	MP5C	X	12.83	5
107	MP5C	Z	0	5
108	MP5C	Mx	.003	5
109	M76	X	.226	5
110	M76	Z	0	5
111	M76	Mx	0	5
112	M76	X	.176	2
113	M76	Z	0	2
114	M76	Mx	0	2
115	MP1A	X	2.148	2
116	MP1A	Z	0	2
117	MP1A	Mx	.000537	2
118	MP1B	X	2.148	2
119	MP1B	Z	0	2
120	MP1B	Mx	.000537	2

Member Point Loads (BLC 31 : Antenna Wm (120 Deg))

	Member Label	Direction	Magnitude[lb.k-ft]	Location[ft. %]
1	MP3A	X	4.502	1
2	MP3A	Z	2.599	1
3	MP3A	Mx	-.000518	1
4	MP3A	X	4.502	6
5	MP3A	Z	2.599	6
6	MP3A	Mx	-.000518	6
7	MP3B	X	5.549	1
8	MP3B	Z	3.204	1
9	MP3B	Mx	-.004	1
10	MP3B	X	5.549	6
11	MP3B	Z	3.204	6
12	MP3B	Mx	-.004	6
13	MP3C	X	4.502	1
14	MP3C	Z	2.599	1
15	MP3C	Mx	.004	1
16	MP3C	X	4.502	6
17	MP3C	Z	2.599	6



Member Point Loads (BLC 31 : Antenna Wm (120 Deg)) (Continued)

	Member Label	Direction	Magnitude[lb.k-ft]	Location[ft.%]
18	MP3C	Mx	.004	6
19	MP3A	X	4.502	1
20	MP3A	Z	2.599	1
21	MP3A	Mx	-.004	1
22	MP3A	X	4.502	6
23	MP3A	Z	2.599	6
24	MP3A	Mx	-.004	6
25	MP3B	X	5.549	1
26	MP3B	Z	3.204	1
27	MP3B	Mx	.004	1
28	MP3B	X	5.549	6
29	MP3B	Z	3.204	6
30	MP3B	Mx	.004	6
31	MP3C	X	4.502	1
32	MP3C	Z	2.599	1
33	MP3C	Mx	.000518	1
34	MP3C	X	4.502	6
35	MP3C	Z	2.599	6
36	MP3C	Mx	.000518	6
37	MP4A	X	3.682	2
38	MP4A	Z	2.126	2
39	MP4A	Mx	-.002	2
40	MP4A	X	3.682	4
41	MP4A	Z	2.126	4
42	MP4A	Mx	-.002	4
43	MP4B	X	4.845	2
44	MP4B	Z	2.797	2
45	MP4B	Mx	0	2
46	MP4B	X	4.845	4
47	MP4B	Z	2.797	4
48	MP4B	Mx	0	4
49	MP4C	X	3.682	2
50	MP4C	Z	2.126	2
51	MP4C	Mx	.002	2
52	MP4C	X	3.682	4
53	MP4C	Z	2.126	4
54	MP4C	Mx	.002	4
55	MP3A	X	2.739	2
56	MP3A	Z	1.582	2
57	MP3A	Mx	.001	2
58	MP3B	X	3.637	2
59	MP3B	Z	2.1	2
60	MP3B	Mx	0	2
61	MP3C	X	2.739	2
62	MP3C	Z	1.582	2
63	MP3C	Mx	-.001	2
64	MP4A	X	2.405	1.5
65	MP4A	Z	1.389	1.5
66	MP4A	Mx	.001	1.5
67	MP4B	X	3.637	1.5
68	MP4B	Z	2.1	1.5
69	MP4B	Mx	0	1.5
70	MP4C	X	2.405	1.5
71	MP4C	Z	1.389	1.5
72	MP4C	Mx	-.001	1.5
73	MP1A	X	10.432	1
74	MP1A	Z	6.023	1
75	MP1A	Mx	-.005	1
76	MP1A	X	10.432	5

Member Point Loads (BLC 31 : Antenna Wm (120 Deg)) (Continued)

	Member Label	Direction	Magnitude[lb.k-ft]	Location[ft. %]
77	MP1A	Z	6.023	5
78	MP1A	Mx	-.005	5
79	MP1B	X	11.45	1
80	MP1B	Z	6.611	1
81	MP1B	Mx	0	1
82	MP1B	X	11.45	5
83	MP1B	Z	6.611	5
84	MP1B	Mx	0	5
85	MP1C	X	10.432	1
86	MP1C	Z	6.023	1
87	MP1C	Mx	.005	1
88	MP1C	X	10.432	5
89	MP1C	Z	6.023	5
90	MP1C	Mx	.005	5
91	MP5A	X	10.432	1
92	MP5A	Z	6.023	1
93	MP5A	Mx	-.005	1
94	MP5A	X	10.432	5
95	MP5A	Z	6.023	5
96	MP5A	Mx	-.005	5
97	MP5B	X	11.45	1
98	MP5B	Z	6.611	1
99	MP5B	Mx	0	1
100	MP5B	X	11.45	5
101	MP5B	Z	6.611	5
102	MP5B	Mx	0	5
103	MP5C	X	10.432	1
104	MP5C	Z	6.023	1
105	MP5C	Mx	.005	1
106	MP5C	X	10.432	5
107	MP5C	Z	6.023	5
108	MP5C	Mx	.005	5
109	M76	X	0	5
110	M76	Z	0	5
111	M76	Mx	0	5
112	M76	X	0	2
113	M76	Z	0	2
114	M76	Mx	0	2
115	MP1A	X	2.252	2
116	MP1A	Z	1.3	2
117	MP1A	Mx	0	2
118	MP1B	X	2.252	2
119	MP1B	Z	1.3	2
120	MP1B	Mx	0	2

Member Point Loads (BLC 32 : Antenna Wm (150 Deg))

	Member Label	Direction	Magnitude[lb.k-ft]	Location[ft. %]
1	MP3A	X	3.002	1
2	MP3A	Z	5.2	1
3	MP3A	Mx	.002	1
4	MP3A	X	3.002	6
5	MP3A	Z	5.2	6
6	MP3A	Mx	.002	6
7	MP3B	X	3.002	1
8	MP3B	Z	5.2	1
9	MP3B	Mx	-.005	1
10	MP3B	X	3.002	6
11	MP3B	Z	5.2	6



Member Point Loads (BLC 32 : Antenna Wm (150 Deg)) (Continued)

	Member Label	Direction	Magnitude[lb.k-ft]	Location[ft.%]
12	MP3B	Mx	-.005	6
13	MP3C	X	2.398	1
14	MP3C	Z	4.153	1
15	MP3C	Mx	.002	1
16	MP3C	X	2.398	6
17	MP3C	Z	4.153	6
18	MP3C	Mx	.002	6
19	MP3A	X	3.002	1
20	MP3A	Z	5.2	1
21	MP3A	Mx	-.005	1
22	MP3A	X	3.002	6
23	MP3A	Z	5.2	6
24	MP3A	Mx	-.005	6
25	MP3B	X	3.002	1
26	MP3B	Z	5.2	1
27	MP3B	Mx	.002	1
28	MP3B	X	3.002	6
29	MP3B	Z	5.2	6
30	MP3B	Mx	.002	6
31	MP3C	X	2.398	1
32	MP3C	Z	4.153	1
33	MP3C	Mx	.002	1
34	MP3C	X	2.398	6
35	MP3C	Z	4.153	6
36	MP3C	Mx	.002	6
37	MP4A	X	2.574	2
38	MP4A	Z	4.457	2
39	MP4A	Mx	-.001	2
40	MP4A	X	2.574	4
41	MP4A	Z	4.457	4
42	MP4A	Mx	-.001	4
43	MP4B	X	2.574	2
44	MP4B	Z	4.457	2
45	MP4B	Mx	-.001	2
46	MP4B	X	2.574	4
47	MP4B	Z	4.457	4
48	MP4B	Mx	-.001	4
49	MP4C	X	1.902	2
50	MP4C	Z	3.294	2
51	MP4C	Mx	.002	2
52	MP4C	X	1.902	4
53	MP4C	Z	3.294	4
54	MP4C	Mx	.002	4
55	MP3A	X	1.927	2
56	MP3A	Z	3.338	2
57	MP3A	Mx	.000964	2
58	MP3B	X	1.927	2
59	MP3B	Z	3.338	2
60	MP3B	Mx	.000964	2
61	MP3C	X	1.409	2
62	MP3C	Z	2.44	2
63	MP3C	Mx	-.001	2
64	MP4A	X	1.863	1.5
65	MP4A	Z	3.226	1.5
66	MP4A	Mx	.000932	1.5
67	MP4B	X	1.863	1.5
68	MP4B	Z	3.226	1.5
69	MP4B	Mx	.000931	1.5
70	MP4C	X	1.151	1.5



Member Point Loads (BLC 32 : Antenna Wm (150 Deg)) (Continued)

	Member Label	Direction	Magnitude[lb.k-ft]	Location[ft.%]
71	MP4C	Z	1.994	1.5
72	MP4C	Mx	-.001	1.5
73	MP1A	X	6.415	1
74	MP1A	Z	11.111	1
75	MP1A	Mx	-.003	1
76	MP1A	X	6.415	5
77	MP1A	Z	11.111	5
78	MP1A	Mx	-.003	5
79	MP1B	X	6.415	1
80	MP1B	Z	11.111	1
81	MP1B	Mx	-.003	1
82	MP1B	X	6.415	5
83	MP1B	Z	11.111	5
84	MP1B	Mx	-.003	5
85	MP1C	X	5.827	1
86	MP1C	Z	10.093	1
87	MP1C	Mx	.006	1
88	MP1C	X	5.827	5
89	MP1C	Z	10.093	5
90	MP1C	Mx	.006	5
91	MP5A	X	6.415	1
92	MP5A	Z	11.111	1
93	MP5A	Mx	-.003	1
94	MP5A	X	6.415	5
95	MP5A	Z	11.111	5
96	MP5A	Mx	-.003	5
97	MP5B	X	6.415	1
98	MP5B	Z	11.111	1
99	MP5B	Mx	-.003	1
100	MP5B	X	6.415	5
101	MP5B	Z	11.111	5
102	MP5B	Mx	-.003	5
103	MP5C	X	5.827	1
104	MP5C	Z	10.093	1
105	MP5C	Mx	.006	1
106	MP5C	X	5.827	5
107	MP5C	Z	10.093	5
108	MP5C	Mx	.006	5
109	M76	X	.113	5
110	M76	Z	.196	5
111	M76	Mx	0	5
112	M76	X	.088	2
113	M76	Z	.153	2
114	M76	Mx	0	2
115	MP1A	X	1.074	2
116	MP1A	Z	1.86	2
117	MP1A	Mx	-.000537	2
118	MP1B	X	1.074	2
119	MP1B	Z	1.86	2
120	MP1B	Mx	-.000537	2

Member Point Loads (BLC 33 : Antenna Wm (180 Deg))

	Member Label	Direction	Magnitude[lb.k-ft]	Location[ft.%]
1	MP3A	X	0	1
2	MP3A	Z	6.407	1
3	MP3A	Mx	.004	1
4	MP3A	X	0	6
5	MP3A	Z	6.407	6



Member Point Loads (BLC 33 : Antenna Wm (180 Deg)) (Continued)

	Member Label	Direction	Magnitude[lb.k-ft]	Location[ft.%]
6	MP3A	Mx	.004	6
7	MP3B	X	0	1
8	MP3B	Z	5.198	1
9	MP3B	Mx	-.004	1
10	MP3B	X	0	6
11	MP3B	Z	5.198	6
12	MP3B	Mx	-.004	6
13	MP3C	X	0	1
14	MP3C	Z	5.198	1
15	MP3C	Mx	.000518	1
16	MP3C	X	0	6
17	MP3C	Z	5.198	6
18	MP3C	Mx	.000518	6
19	MP3A	X	0	1
20	MP3A	Z	6.407	1
21	MP3A	Mx	-.004	1
22	MP3A	X	0	6
23	MP3A	Z	6.407	6
24	MP3A	Mx	-.004	6
25	MP3B	X	0	1
26	MP3B	Z	5.198	1
27	MP3B	Mx	-.000518	1
28	MP3B	X	0	6
29	MP3B	Z	5.198	6
30	MP3B	Mx	-.000518	6
31	MP3C	X	0	1
32	MP3C	Z	5.198	1
33	MP3C	Mx	.004	1
34	MP3C	X	0	6
35	MP3C	Z	5.198	6
36	MP3C	Mx	.004	6
37	MP4A	X	0	2
38	MP4A	Z	5.595	2
39	MP4A	Mx	0	2
40	MP4A	X	0	4
41	MP4A	Z	5.595	4
42	MP4A	Mx	0	4
43	MP4B	X	0	2
44	MP4B	Z	4.252	2
45	MP4B	Mx	-.002	2
46	MP4B	X	0	4
47	MP4B	Z	4.252	4
48	MP4B	Mx	-.002	4
49	MP4C	X	0	2
50	MP4C	Z	4.252	2
51	MP4C	Mx	.002	2
52	MP4C	X	0	4
53	MP4C	Z	4.252	4
54	MP4C	Mx	.002	4
55	MP3A	X	0	2
56	MP3A	Z	4.199	2
57	MP3A	Mx	0	2
58	MP3B	X	0	2
59	MP3B	Z	3.163	2
60	MP3B	Mx	.001	2
61	MP3C	X	0	2
62	MP3C	Z	3.163	2
63	MP3C	Mx	-.001	2
64	MP4A	X	0	1.5



Member Point Loads (BLC 33 : Antenna Wm (180 Deg)) (Continued)

	Member Label	Direction	Magnitude[lb.k-ft]	Location[ft.%]
65	MP4A	Z	4.199	1.5
66	MP4A	Mx	0	1.5
67	MP4B	X	0	1.5
68	MP4B	Z	2.777	1.5
69	MP4B	Mx	.001	1.5
70	MP4C	X	0	1.5
71	MP4C	Z	2.777	1.5
72	MP4C	Mx	-.001	1.5
73	MP1A	X	0	1
74	MP1A	Z	13.221	1
75	MP1A	Mx	0	1
76	MP1A	X	0	5
77	MP1A	Z	13.221	5
78	MP1A	Mx	0	5
79	MP1B	X	0	1
80	MP1B	Z	12.046	1
81	MP1B	Mx	-.005	1
82	MP1B	X	0	5
83	MP1B	Z	12.046	5
84	MP1B	Mx	-.005	5
85	MP1C	X	0	1
86	MP1C	Z	12.046	1
87	MP1C	Mx	.005	1
88	MP1C	X	0	5
89	MP1C	Z	12.046	5
90	MP1C	Mx	.005	5
91	MP5A	X	0	1
92	MP5A	Z	13.221	1
93	MP5A	Mx	0	1
94	MP5A	X	0	5
95	MP5A	Z	13.221	5
96	MP5A	Mx	0	5
97	MP5B	X	0	1
98	MP5B	Z	12.046	1
99	MP5B	Mx	-.005	1
100	MP5B	X	0	5
101	MP5B	Z	12.046	5
102	MP5B	Mx	-.005	5
103	MP5C	X	0	1
104	MP5C	Z	12.046	1
105	MP5C	Mx	.005	1
106	MP5C	X	0	5
107	MP5C	Z	12.046	5
108	MP5C	Mx	.005	5
109	M76	X	0	5
110	M76	Z	.677	5
111	M76	Mx	0	5
112	M76	X	0	2
113	M76	Z	.528	2
114	M76	Mx	0	2
115	MP1A	X	0	2
116	MP1A	Z	1.242	2
117	MP1A	Mx	-.000538	2
118	MP1B	X	0	2
119	MP1B	Z	1.242	2
120	MP1B	Mx	-.000538	2

Member Point Loads (BLC 34 : Antenna Wm (210 Deg))



Member Point Loads (BLC 34 : Antenna Wm (210 Deg)) (Continued)

	Member Label	Direction	Magnitude[lb.k-ft]	Location[ft.%]
1	MP3A	X	-3.002	1
2	MP3A	Z	5.2	1
3	MP3A	Mx	.005	1
4	MP3A	X	-3.002	6
5	MP3A	Z	5.2	6
6	MP3A	Mx	.005	6
7	MP3B	X	-2.398	1
8	MP3B	Z	4.153	1
9	MP3B	Mx	-.002	1
10	MP3B	X	-2.398	6
11	MP3B	Z	4.153	6
12	MP3B	Mx	-.002	6
13	MP3C	X	-3.002	1
14	MP3C	Z	5.2	1
15	MP3C	Mx	-.002	1
16	MP3C	X	-3.002	6
17	MP3C	Z	5.2	6
18	MP3C	Mx	-.002	6
19	MP3A	X	-3.002	1
20	MP3A	Z	5.2	1
21	MP3A	Mx	-.002	1
22	MP3A	X	-3.002	6
23	MP3A	Z	5.2	6
24	MP3A	Mx	-.002	6
25	MP3B	X	-2.398	1
26	MP3B	Z	4.153	1
27	MP3B	Mx	-.002	1
28	MP3B	X	-2.398	6
29	MP3B	Z	4.153	6
30	MP3B	Mx	-.002	6
31	MP3C	X	-3.002	1
32	MP3C	Z	5.2	1
33	MP3C	Mx	.005	1
34	MP3C	X	-3.002	6
35	MP3C	Z	5.2	6
36	MP3C	Mx	.005	6
37	MP4A	X	-2.574	2
38	MP4A	Z	4.457	2
39	MP4A	Mx	.001	2
40	MP4A	X	-2.574	4
41	MP4A	Z	4.457	4
42	MP4A	Mx	.001	4
43	MP4B	X	-1.902	2
44	MP4B	Z	3.294	2
45	MP4B	Mx	-.002	2
46	MP4B	X	-1.902	4
47	MP4B	Z	3.294	4
48	MP4B	Mx	-.002	4
49	MP4C	X	-2.574	2
50	MP4C	Z	4.457	2
51	MP4C	Mx	.001	2
52	MP4C	X	-2.574	4
53	MP4C	Z	4.457	4
54	MP4C	Mx	.001	4
55	MP3A	X	-1.927	2
56	MP3A	Z	3.338	2
57	MP3A	Mx	-.000964	2
58	MP3B	X	-1.409	2
59	MP3B	Z	2.44	2

Member Point Loads (BLC 34 : Antenna Wm (210 Deg)) (Continued)

	Member Label	Direction	Magnitude[lb.k-ft]	Location[ft.%]
60	MP3B	Mx	.001	2
61	MP3C	X	-1.927	2
62	MP3C	Z	3.338	2
63	MP3C	Mx	-.000964	2
64	MP4A	X	-1.863	1.5
65	MP4A	Z	3.226	1.5
66	MP4A	Mx	-.000932	1.5
67	MP4B	X	-1.151	1.5
68	MP4B	Z	1.994	1.5
69	MP4B	Mx	.001	1.5
70	MP4C	X	-1.863	1.5
71	MP4C	Z	3.226	1.5
72	MP4C	Mx	-.000931	1.5
73	MP1A	X	-6.415	1
74	MP1A	Z	11.111	1
75	MP1A	Mx	.003	1
76	MP1A	X	-6.415	5
77	MP1A	Z	11.111	5
78	MP1A	Mx	.003	5
79	MP1B	X	-5.827	1
80	MP1B	Z	10.093	1
81	MP1B	Mx	-.006	1
82	MP1B	X	-5.827	5
83	MP1B	Z	10.093	5
84	MP1B	Mx	-.006	5
85	MP1C	X	-6.415	1
86	MP1C	Z	11.111	1
87	MP1C	Mx	.003	1
88	MP1C	X	-6.415	5
89	MP1C	Z	11.111	5
90	MP1C	Mx	.003	5
91	MP5A	X	-6.415	1
92	MP5A	Z	11.111	1
93	MP5A	Mx	.003	1
94	MP5A	X	-6.415	5
95	MP5A	Z	11.111	5
96	MP5A	Mx	.003	5
97	MP5B	X	-5.827	1
98	MP5B	Z	10.093	1
99	MP5B	Mx	-.006	1
100	MP5B	X	-5.827	5
101	MP5B	Z	10.093	5
102	MP5B	Mx	-.006	5
103	MP5C	X	-6.415	1
104	MP5C	Z	11.111	1
105	MP5C	Mx	.003	1
106	MP5C	X	-6.415	5
107	MP5C	Z	11.111	5
108	MP5C	Mx	.003	5
109	M76	X	-.452	5
110	M76	Z	.782	5
111	M76	Mx	0	5
112	M76	X	-.352	2
113	M76	Z	.61	2
114	M76	Mx	0	2
115	MP1A	X	-.394	2
116	MP1A	Z	.683	2
117	MP1A	Mx	-.000394	2
118	MP1B	X	-.394	2



Member Point Loads (BLC 34 : Antenna Wm (210 Deg)) (Continued)

	Member Label	Direction	Magnitude[lb.k-ft]	Location[ft. %]
119	MP1B	Z	.683	2
120	MP1B	Mx	-.000394	2

Member Point Loads (BLC 35 : Antenna Wm (240 Deg))

	Member Label	Direction	Magnitude[lb.k-ft]	Location[ft. %]
1	MP3A	X	-4.502	1
2	MP3A	Z	2.599	1
3	MP3A	Mx	.004	1
4	MP3A	X	-4.502	6
5	MP3A	Z	2.599	6
6	MP3A	Mx	.004	6
7	MP3B	X	-4.502	1
8	MP3B	Z	2.599	1
9	MP3B	Mx	-.000518	1
10	MP3B	X	-4.502	6
11	MP3B	Z	2.599	6
12	MP3B	Mx	-.000518	6
13	MP3C	X	-5.549	1
14	MP3C	Z	3.204	1
15	MP3C	Mx	-.004	1
16	MP3C	X	-5.549	6
17	MP3C	Z	3.204	6
18	MP3C	Mx	-.004	6
19	MP3A	X	-4.502	1
20	MP3A	Z	2.599	1
21	MP3A	Mx	.000518	1
22	MP3A	X	-4.502	6
23	MP3A	Z	2.599	6
24	MP3A	Mx	.000518	6
25	MP3B	X	-4.502	1
26	MP3B	Z	2.599	1
27	MP3B	Mx	-.004	1
28	MP3B	X	-4.502	6
29	MP3B	Z	2.599	6
30	MP3B	Mx	-.004	6
31	MP3C	X	-5.549	1
32	MP3C	Z	3.204	1
33	MP3C	Mx	.004	1
34	MP3C	X	-5.549	6
35	MP3C	Z	3.204	6
36	MP3C	Mx	.004	6
37	MP4A	X	-3.682	2
38	MP4A	Z	2.126	2
39	MP4A	Mx	.002	2
40	MP4A	X	-3.682	4
41	MP4A	Z	2.126	4
42	MP4A	Mx	.002	4
43	MP4B	X	-3.682	2
44	MP4B	Z	2.126	2
45	MP4B	Mx	-.002	2
46	MP4B	X	-3.682	4
47	MP4B	Z	2.126	4
48	MP4B	Mx	-.002	4
49	MP4C	X	-4.845	2
50	MP4C	Z	2.797	2
51	MP4C	Mx	0	2
52	MP4C	X	-4.845	4
53	MP4C	Z	2.797	4



Member Point Loads (BLC 35 : Antenna Wm (240 Deg)) (Continued)

	Member Label	Direction	Magnitude[lb.k-ft]	Location[ft.%]
54	MP4C	Mx	0	4
55	MP3A	X	-2.739	2
56	MP3A	Z	1.582	2
57	MP3A	Mx	-.001	2
58	MP3B	X	-2.739	2
59	MP3B	Z	1.582	2
60	MP3B	Mx	.001	2
61	MP3C	X	-3.637	2
62	MP3C	Z	2.1	2
63	MP3C	Mx	0	2
64	MP4A	X	-2.405	1.5
65	MP4A	Z	1.389	1.5
66	MP4A	Mx	-.001	1.5
67	MP4B	X	-2.405	1.5
68	MP4B	Z	1.389	1.5
69	MP4B	Mx	.001	1.5
70	MP4C	X	-3.637	1.5
71	MP4C	Z	2.1	1.5
72	MP4C	Mx	0	1.5
73	MP1A	X	-10.432	1
74	MP1A	Z	6.023	1
75	MP1A	Mx	.005	1
76	MP1A	X	-10.432	5
77	MP1A	Z	6.023	5
78	MP1A	Mx	.005	5
79	MP1B	X	-10.432	1
80	MP1B	Z	6.023	1
81	MP1B	Mx	-.005	1
82	MP1B	X	-10.432	5
83	MP1B	Z	6.023	5
84	MP1B	Mx	-.005	5
85	MP1C	X	-11.45	1
86	MP1C	Z	6.611	1
87	MP1C	Mx	0	1
88	MP1C	X	-11.45	5
89	MP1C	Z	6.611	5
90	MP1C	Mx	0	5
91	MP5A	X	-10.432	1
92	MP5A	Z	6.023	1
93	MP5A	Mx	.005	1
94	MP5A	X	-10.432	5
95	MP5A	Z	6.023	5
96	MP5A	Mx	.005	5
97	MP5B	X	-10.432	1
98	MP5B	Z	6.023	1
99	MP5B	Mx	-.005	1
100	MP5B	X	-10.432	5
101	MP5B	Z	6.023	5
102	MP5B	Mx	-.005	5
103	MP5C	X	-11.45	1
104	MP5C	Z	6.611	1
105	MP5C	Mx	0	1
106	MP5C	X	-11.45	5
107	MP5C	Z	6.611	5
108	MP5C	Mx	0	5
109	M76	X	-.587	5
110	M76	Z	.339	5
111	M76	Mx	0	5
112	M76	X	-.458	2



Member Point Loads (BLC 35 : Antenna Wm (240 Deg)) (Continued)

	Member Label	Direction	Magnitude[lb.k-ft]	Location[ft.%]
113	M76	Z	.264	2
114	M76	Mx	0	2
115	MP1A	X	-1.075	2
116	MP1A	Z	.621	2
117	MP1A	Mx	-.000538	2
118	MP1B	X	-1.075	2
119	MP1B	Z	.621	2
120	MP1B	Mx	-.000538	2

Member Point Loads (BLC 36 : Antenna Wm (270 Deg))

	Member Label	Direction	Magnitude[lb.k-ft]	Location[ft.%]
1	MP3A	X	-4.795	1
2	MP3A	Z	0	1
3	MP3A	Mx	.002	1
4	MP3A	X	-4.795	6
5	MP3A	Z	0	6
6	MP3A	Mx	.002	6
7	MP3B	X	-6.004	1
8	MP3B	Z	0	1
9	MP3B	Mx	.002	1
10	MP3B	X	-6.004	6
11	MP3B	Z	0	6
12	MP3B	Mx	.002	6
13	MP3C	X	-6.004	1
14	MP3C	Z	0	1
15	MP3C	Mx	-.005	1
16	MP3C	X	-6.004	6
17	MP3C	Z	0	6
18	MP3C	Mx	-.005	6
19	MP3A	X	-4.795	1
20	MP3A	Z	0	1
21	MP3A	Mx	.002	1
22	MP3A	X	-4.795	6
23	MP3A	Z	0	6
24	MP3A	Mx	.002	6
25	MP3B	X	-6.004	1
26	MP3B	Z	0	1
27	MP3B	Mx	-.005	1
28	MP3B	X	-6.004	6
29	MP3B	Z	0	6
30	MP3B	Mx	-.005	6
31	MP3C	X	-6.004	1
32	MP3C	Z	0	1
33	MP3C	Mx	.002	1
34	MP3C	X	-6.004	6
35	MP3C	Z	0	6
36	MP3C	Mx	.002	6
37	MP4A	X	-3.804	2
38	MP4A	Z	0	2
39	MP4A	Mx	.002	2
40	MP4A	X	-3.804	4
41	MP4A	Z	0	4
42	MP4A	Mx	.002	4
43	MP4B	X	-5.147	2
44	MP4B	Z	0	2
45	MP4B	Mx	-.001	2
46	MP4B	X	-5.147	4
47	MP4B	Z	0	4

Member Point Loads (BLC 36 : Antenna Wm (270 Deg)) (Continued)

	Member Label	Direction	Magnitude[lb.k-ft]	Location[ft.%]
48	MP4B	Mx	-.001	4
49	MP4C	X	-5.147	2
50	MP4C	Z	0	2
51	MP4C	Mx	-.001	2
52	MP4C	X	-5.147	4
53	MP4C	Z	0	4
54	MP4C	Mx	-.001	4
55	MP3A	X	-2.818	2
56	MP3A	Z	0	2
57	MP3A	Mx	-.001	2
58	MP3B	X	-3.854	2
59	MP3B	Z	0	2
60	MP3B	Mx	.000964	2
61	MP3C	X	-3.854	2
62	MP3C	Z	0	2
63	MP3C	Mx	.000964	2
64	MP4A	X	-2.303	1.5
65	MP4A	Z	0	1.5
66	MP4A	Mx	-.001	1.5
67	MP4B	X	-3.725	1.5
68	MP4B	Z	0	1.5
69	MP4B	Mx	.000931	1.5
70	MP4C	X	-3.725	1.5
71	MP4C	Z	0	1.5
72	MP4C	Mx	.000931	1.5
73	MP1A	X	-11.654	1
74	MP1A	Z	0	1
75	MP1A	Mx	.006	1
76	MP1A	X	-11.654	5
77	MP1A	Z	0	5
78	MP1A	Mx	.006	5
79	MP1B	X	-12.83	1
80	MP1B	Z	0	1
81	MP1B	Mx	-.003	1
82	MP1B	X	-12.83	5
83	MP1B	Z	0	5
84	MP1B	Mx	-.003	5
85	MP1C	X	-12.83	1
86	MP1C	Z	0	1
87	MP1C	Mx	-.003	1
88	MP1C	X	-12.83	5
89	MP1C	Z	0	5
90	MP1C	Mx	-.003	5
91	MP5A	X	-11.654	1
92	MP5A	Z	0	1
93	MP5A	Mx	.006	1
94	MP5A	X	-11.654	5
95	MP5A	Z	0	5
96	MP5A	Mx	.006	5
97	MP5B	X	-12.83	1
98	MP5B	Z	0	1
99	MP5B	Mx	-.003	1
100	MP5B	X	-12.83	5
101	MP5B	Z	0	5
102	MP5B	Mx	-.003	5
103	MP5C	X	-12.83	1
104	MP5C	Z	0	1
105	MP5C	Mx	-.003	1
106	MP5C	X	-12.83	5



Member Point Loads (BLC 36 : Antenna Wm (270 Deg)) (Continued)

	Member Label	Direction	Magnitude[lb.k-ft]	Location[ft.%]
107	MP5C	Z	0	5
108	MP5C	Mx	-.003	5
109	M76	X	-.226	5
110	M76	Z	0	5
111	M76	Mx	0	5
112	M76	X	-.176	2
113	M76	Z	0	2
114	M76	Mx	0	2
115	MP1A	X	-2.148	2
116	MP1A	Z	0	2
117	MP1A	Mx	-.000537	2
118	MP1B	X	-2.148	2
119	MP1B	Z	0	2
120	MP1B	Mx	-.000537	2

Member Point Loads (BLC 37 : Antenna Wm (300 Deg))

	Member Label	Direction	Magnitude[lb.k-ft]	Location[ft.%]
1	MP3A	X	-4.502	1
2	MP3A	Z	-2.599	1
3	MP3A	Mx	.000518	1
4	MP3A	X	-4.502	6
5	MP3A	Z	-2.599	6
6	MP3A	Mx	.000518	6
7	MP3B	X	-5.549	1
8	MP3B	Z	-3.204	1
9	MP3B	Mx	.004	1
10	MP3B	X	-5.549	6
11	MP3B	Z	-3.204	6
12	MP3B	Mx	.004	6
13	MP3C	X	-4.502	1
14	MP3C	Z	-2.599	1
15	MP3C	Mx	-.004	1
16	MP3C	X	-4.502	6
17	MP3C	Z	-2.599	6
18	MP3C	Mx	-.004	6
19	MP3A	X	-4.502	1
20	MP3A	Z	-2.599	1
21	MP3A	Mx	.004	1
22	MP3A	X	-4.502	6
23	MP3A	Z	-2.599	6
24	MP3A	Mx	.004	6
25	MP3B	X	-5.549	1
26	MP3B	Z	-3.204	1
27	MP3B	Mx	-.004	1
28	MP3B	X	-5.549	6
29	MP3B	Z	-3.204	6
30	MP3B	Mx	-.004	6
31	MP3C	X	-4.502	1
32	MP3C	Z	-2.599	1
33	MP3C	Mx	-.000518	1
34	MP3C	X	-4.502	6
35	MP3C	Z	-2.599	6
36	MP3C	Mx	-.000518	6
37	MP4A	X	-3.682	2
38	MP4A	Z	-2.126	2
39	MP4A	Mx	.002	2
40	MP4A	X	-3.682	4
41	MP4A	Z	-2.126	4



Member Point Loads (BLC 37 : Antenna Wm (300 Deg)) (Continued)

	Member Label	Direction	Magnitude[lb.k-ft]	Location[ft.%]
42	MP4A	Mx	.002	4
43	MP4B	X	-4.845	2
44	MP4B	Z	-2.797	2
45	MP4B	Mx	0	2
46	MP4B	X	-4.845	4
47	MP4B	Z	-2.797	4
48	MP4B	Mx	0	4
49	MP4C	X	-3.682	2
50	MP4C	Z	-2.126	2
51	MP4C	Mx	-.002	2
52	MP4C	X	-3.682	4
53	MP4C	Z	-2.126	4
54	MP4C	Mx	-.002	4
55	MP3A	X	-2.739	2
56	MP3A	Z	-1.582	2
57	MP3A	Mx	-.001	2
58	MP3B	X	-3.637	2
59	MP3B	Z	-2.1	2
60	MP3B	Mx	0	2
61	MP3C	X	-2.739	2
62	MP3C	Z	-1.582	2
63	MP3C	Mx	.001	2
64	MP4A	X	-2.405	1.5
65	MP4A	Z	-1.389	1.5
66	MP4A	Mx	-.001	1.5
67	MP4B	X	-3.637	1.5
68	MP4B	Z	-2.1	1.5
69	MP4B	Mx	0	1.5
70	MP4C	X	-2.405	1.5
71	MP4C	Z	-1.389	1.5
72	MP4C	Mx	.001	1.5
73	MP1A	X	-10.432	1
74	MP1A	Z	-6.023	1
75	MP1A	Mx	.005	1
76	MP1A	X	-10.432	5
77	MP1A	Z	-6.023	5
78	MP1A	Mx	.005	5
79	MP1B	X	-11.45	1
80	MP1B	Z	-6.611	1
81	MP1B	Mx	0	1
82	MP1B	X	-11.45	5
83	MP1B	Z	-6.611	5
84	MP1B	Mx	0	5
85	MP1C	X	-10.432	1
86	MP1C	Z	-6.023	1
87	MP1C	Mx	-.005	1
88	MP1C	X	-10.432	5
89	MP1C	Z	-6.023	5
90	MP1C	Mx	-.005	5
91	MP5A	X	-10.432	1
92	MP5A	Z	-6.023	1
93	MP5A	Mx	.005	1
94	MP5A	X	-10.432	5
95	MP5A	Z	-6.023	5
96	MP5A	Mx	.005	5
97	MP5B	X	-11.45	1
98	MP5B	Z	-6.611	1
99	MP5B	Mx	0	1
100	MP5B	X	-11.45	5

Member Point Loads (BLC 37 : Antenna Wm (300 Deg)) (Continued)

	Member Label	Direction	Magnitude[lb.k-ft]	Location[ft. %]
101	MP5B	Z	-6.611	5
102	MP5B	Mx	0	5
103	MP5C	X	-10.432	1
104	MP5C	Z	-6.023	1
105	MP5C	Mx	-.005	1
106	MP5C	X	-10.432	5
107	MP5C	Z	-6.023	5
108	MP5C	Mx	-.005	5
109	M76	X	0	5
110	M76	Z	0	5
111	M76	Mx	0	5
112	M76	X	0	2
113	M76	Z	0	2
114	M76	Mx	0	2
115	MP1A	X	-2.252	2
116	MP1A	Z	-1.3	2
117	MP1A	Mx	0	2
118	MP1B	X	-2.252	2
119	MP1B	Z	-1.3	2
120	MP1B	Mx	0	2

Member Point Loads (BLC 38 : Antenna Wm (330 Deg))

	Member Label	Direction	Magnitude[lb.k-ft]	Location[ft. %]
1	MP3A	X	-3.002	1
2	MP3A	Z	-5.2	1
3	MP3A	Mx	-.002	1
4	MP3A	X	-3.002	6
5	MP3A	Z	-5.2	6
6	MP3A	Mx	-.002	6
7	MP3B	X	-3.002	1
8	MP3B	Z	-5.2	1
9	MP3B	Mx	.005	1
10	MP3B	X	-3.002	6
11	MP3B	Z	-5.2	6
12	MP3B	Mx	.005	6
13	MP3C	X	-2.398	1
14	MP3C	Z	-4.153	1
15	MP3C	Mx	-.002	1
16	MP3C	X	-2.398	6
17	MP3C	Z	-4.153	6
18	MP3C	Mx	-.002	6
19	MP3A	X	-3.002	1
20	MP3A	Z	-5.2	1
21	MP3A	Mx	.005	1
22	MP3A	X	-3.002	6
23	MP3A	Z	-5.2	6
24	MP3A	Mx	.005	6
25	MP3B	X	-3.002	1
26	MP3B	Z	-5.2	1
27	MP3B	Mx	-.002	1
28	MP3B	X	-3.002	6
29	MP3B	Z	-5.2	6
30	MP3B	Mx	-.002	6
31	MP3C	X	-2.398	1
32	MP3C	Z	-4.153	1
33	MP3C	Mx	-.002	1
34	MP3C	X	-2.398	6
35	MP3C	Z	-4.153	6



Member Point Loads (BLC 38 : Antenna Wm (330 Deg)) (Continued)

	Member Label	Direction	Magnitude[lb.k-ft]	Location[ft.%]
36	MP3C	Mx	-.002	6
37	MP4A	X	-2.574	2
38	MP4A	Z	-4.457	2
39	MP4A	Mx	.001	2
40	MP4A	X	-2.574	4
41	MP4A	Z	-4.457	4
42	MP4A	Mx	.001	4
43	MP4B	X	-2.574	2
44	MP4B	Z	-4.457	2
45	MP4B	Mx	.001	2
46	MP4B	X	-2.574	4
47	MP4B	Z	-4.457	4
48	MP4B	Mx	.001	4
49	MP4C	X	-1.902	2
50	MP4C	Z	-3.294	2
51	MP4C	Mx	-.002	2
52	MP4C	X	-1.902	4
53	MP4C	Z	-3.294	4
54	MP4C	Mx	-.002	4
55	MP3A	X	-1.927	2
56	MP3A	Z	-3.338	2
57	MP3A	Mx	-.000964	2
58	MP3B	X	-1.927	2
59	MP3B	Z	-3.338	2
60	MP3B	Mx	-.000964	2
61	MP3C	X	-1.409	2
62	MP3C	Z	-2.44	2
63	MP3C	Mx	.001	2
64	MP4A	X	-1.863	1.5
65	MP4A	Z	-3.226	1.5
66	MP4A	Mx	-.000932	1.5
67	MP4B	X	-1.863	1.5
68	MP4B	Z	-3.226	1.5
69	MP4B	Mx	-.000931	1.5
70	MP4C	X	-1.151	1.5
71	MP4C	Z	-1.994	1.5
72	MP4C	Mx	.001	1.5
73	MP1A	X	-6.415	1
74	MP1A	Z	-11.111	1
75	MP1A	Mx	.003	1
76	MP1A	X	-6.415	5
77	MP1A	Z	-11.111	5
78	MP1A	Mx	.003	5
79	MP1B	X	-6.415	1
80	MP1B	Z	-11.111	1
81	MP1B	Mx	.003	1
82	MP1B	X	-6.415	5
83	MP1B	Z	-11.111	5
84	MP1B	Mx	.003	5
85	MP1C	X	-5.827	1
86	MP1C	Z	-10.093	1
87	MP1C	Mx	-.006	1
88	MP1C	X	-5.827	5
89	MP1C	Z	-10.093	5
90	MP1C	Mx	-.006	5
91	MP5A	X	-6.415	1
92	MP5A	Z	-11.111	1
93	MP5A	Mx	.003	1
94	MP5A	X	-6.415	5

Member Point Loads (BLC 38 : Antenna Wm (330 Deg)) (Continued)

	Member Label	Direction	Magnitude[lb.k-ft]	Location[ft. %]
95	MP5A	Z	-11.111	5
96	MP5A	Mx	.003	5
97	MP5B	X	-6.415	1
98	MP5B	Z	-11.111	1
99	MP5B	Mx	.003	1
100	MP5B	X	-6.415	5
101	MP5B	Z	-11.111	5
102	MP5B	Mx	.003	5
103	MP5C	X	-5.827	1
104	MP5C	Z	-10.093	1
105	MP5C	Mx	-.006	1
106	MP5C	X	-5.827	5
107	MP5C	Z	-10.093	5
108	MP5C	Mx	-.006	5
109	M76	X	-.113	5
110	M76	Z	-.196	5
111	M76	Mx	0	5
112	M76	X	-.088	2
113	M76	Z	-.153	2
114	M76	Mx	0	2
115	MP1A	X	-1.074	2
116	MP1A	Z	-1.86	2
117	MP1A	Mx	.000537	2
118	MP1B	X	-1.074	2
119	MP1B	Z	-1.86	2
120	MP1B	Mx	.000537	2

Member Point Loads (BLC 77 : Lm1)

	Member Label	Direction	Magnitude[lb.k-ft]	Location[ft. %]
1	LIVE2	Y	-500	%100

Member Point Loads (BLC 78 : Lm2)

	Member Label	Direction	Magnitude[lb.k-ft]	Location[ft. %]
1	LIVE1	Y	-500	%100

Member Point Loads (BLC 79 : Lv1)

	Member Label	Direction	Magnitude[lb.k-ft]	Location[ft. %]
1	FACE	Y	-250	0

Member Point Loads (BLC 80 : Lv2)

	Member Label	Direction	Magnitude[lb.k-ft]	Location[ft. %]
1	FACE	Y	-250	%50

Member Point Loads (BLC 81 : Antenna Ev)

	Member Label	Direction	Magnitude[lb.k-ft]	Location[ft. %]
1	MP3A	Y	-.962	1
2	MP3A	My	-.000481	1
3	MP3A	Mz	.000641	1
4	MP3A	Y	-.962	6
5	MP3A	My	-.000481	6
6	MP3A	Mz	.000641	6
7	MP3B	Y	-.962	1
8	MP3B	My	-.000315	1
9	MP3B	Mz	-.000737	1
10	MP3B	Y	-.962	6
11	MP3B	My	-.000315	6

Member Point Loads (BLC 81 : Antenna Ev) (Continued)

	Member Label	Direction	Magnitude[lb.k-ft]	Location[ft.%]
12	MP3B	Mz	-.000737	6
13	MP3C	Y	-.962	1
14	MP3C	My	.000796	1
15	MP3C	Mz	9.6e-5	1
16	MP3C	Y	-.962	6
17	MP3C	My	.000796	6
18	MP3C	Mz	9.6e-5	6
19	MP3A	Y	-.962	1
20	MP3A	My	-.000481	1
21	MP3A	Mz	-.000641	1
22	MP3A	Y	-.962	6
23	MP3A	My	-.000481	6
24	MP3A	Mz	-.000641	6
25	MP3B	Y	-.962	1
26	MP3B	My	.000796	1
27	MP3B	Mz	-9.6e-5	1
28	MP3B	Y	-.962	6
29	MP3B	My	.000796	6
30	MP3B	Mz	-9.6e-5	6
31	MP3C	Y	-.962	1
32	MP3C	My	-.000315	1
33	MP3C	Mz	.000737	1
34	MP3C	Y	-.962	6
35	MP3C	My	-.000315	6
36	MP3C	Mz	.000737	6
37	MP4A	Y	-1.84	2
38	MP4A	My	-.00092	2
39	MP4A	Mz	0	2
40	MP4A	Y	-1.84	4
41	MP4A	My	-.00092	4
42	MP4A	Mz	0	4
43	MP4B	Y	-1.84	2
44	MP4B	My	.00046	2
45	MP4B	Mz	-.000797	2
46	MP4B	Y	-1.84	4
47	MP4B	My	.00046	4
48	MP4B	Mz	-.000797	4
49	MP4C	Y	-1.84	2
50	MP4C	My	.00046	2
51	MP4C	Mz	.000797	2
52	MP4C	Y	-1.84	4
53	MP4C	My	.00046	4
54	MP4C	Mz	.000797	4
55	MP3A	Y	-3.529	2
56	MP3A	My	.002	2
57	MP3A	Mz	0	2
58	MP3B	Y	-3.529	2
59	MP3B	My	-.000882	2
60	MP3B	Mz	.002	2
61	MP3C	Y	-3.529	2
62	MP3C	My	-.000882	2
63	MP3C	Mz	-.002	2
64	MP4A	Y	-2.939	1.5
65	MP4A	My	.001	1.5
66	MP4A	Mz	0	1.5
67	MP4B	Y	-2.939	1.5
68	MP4B	My	-.000735	1.5
69	MP4B	Mz	.001	1.5
70	MP4C	Y	-2.939	1.5



Member Point Loads (BLC 81 : Antenna Ev) (Continued)

	Member Label	Direction	Magnitude[lb.k-ft]	Location[ft. %]
71	MP4C	My	-.000735	1.5
72	MP4C	Mz	-.001	1.5
73	MP1A	Y	-.564	1
74	MP1A	My	-.000282	1
75	MP1A	Mz	0	1
76	MP1A	Y	-.564	5
77	MP1A	My	-.000282	5
78	MP1A	Mz	0	5
79	MP1B	Y	-.564	1
80	MP1B	My	.000141	1
81	MP1B	Mz	-.000244	1
82	MP1B	Y	-.564	5
83	MP1B	My	.000141	5
84	MP1B	Mz	-.000244	5
85	MP1C	Y	-.564	1
86	MP1C	My	.000141	1
87	MP1C	Mz	.000244	1
88	MP1C	Y	-.564	5
89	MP1C	My	.000141	5
90	MP1C	Mz	.000244	5
91	MP5A	Y	-.564	1
92	MP5A	My	-.000282	1
93	MP5A	Mz	0	1
94	MP5A	Y	-.564	5
95	MP5A	My	-.000282	5
96	MP5A	Mz	0	5
97	MP5B	Y	-.564	1
98	MP5B	My	.000141	1
99	MP5B	Mz	-.000244	1
100	MP5B	Y	-.564	5
101	MP5B	My	.000141	5
102	MP5B	Mz	-.000244	5
103	MP5C	Y	-.564	1
104	MP5C	My	.000141	1
105	MP5C	Mz	.000244	1
106	MP5C	Y	-.564	5
107	MP5C	My	.000141	5
108	MP5C	Mz	.000244	5
109	M76	Y	-.836	5
110	M76	My	0	5
111	M76	Mz	0	5
112	M76	Y	-.627	2
113	M76	My	0	2
114	M76	Mz	0	2
115	MP1A	Y	-.736	2
116	MP1A	My	.000184	2
117	MP1A	Mz	-.000319	2
118	MP1B	Y	-.736	2
119	MP1B	My	.000184	2
120	MP1B	Mz	-.000319	2

Member Point Loads (BLC 82 : Antenna Eh (0 Deg))

	Member Label	Direction	Magnitude[lb.k-ft]	Location[ft. %]
1	MP3A	Z	-2.404	1
2	MP3A	Mx	-.002	1
3	MP3A	Z	-2.404	6
4	MP3A	Mx	-.002	6
5	MP3B	Z	-2.404	1



Member Point Loads (BLC 82 : Antenna Eh (0 Deg)) (Continued)

	Member Label	Direction	Magnitude[lb.k-ft]	Location[ft.%]
6	MP3B	Mx	.002	1
7	MP3B	Z	-2.404	6
8	MP3B	Mx	.002	6
9	MP3C	Z	-2.404	1
10	MP3C	Mx	-.00024	1
11	MP3C	Z	-2.404	6
12	MP3C	Mx	-.00024	6
13	MP3A	Z	-2.404	1
14	MP3A	Mx	.002	1
15	MP3A	Z	-2.404	6
16	MP3A	Mx	.002	6
17	MP3B	Z	-2.404	1
18	MP3B	Mx	.00024	1
19	MP3B	Z	-2.404	6
20	MP3B	Mx	.00024	6
21	MP3C	Z	-2.404	1
22	MP3C	Mx	-.002	1
23	MP3C	Z	-2.404	6
24	MP3C	Mx	-.002	6
25	MP4A	Z	-4.599	2
26	MP4A	Mx	0	2
27	MP4A	Z	-4.599	4
28	MP4A	Mx	0	4
29	MP4B	Z	-4.599	2
30	MP4B	Mx	.002	2
31	MP4B	Z	-4.599	4
32	MP4B	Mx	.002	4
33	MP4C	Z	-4.599	2
34	MP4C	Mx	-.002	2
35	MP4C	Z	-4.599	4
36	MP4C	Mx	-.002	4
37	MP3A	Z	-8.823	2
38	MP3A	Mx	0	2
39	MP3B	Z	-8.823	2
40	MP3B	Mx	-.004	2
41	MP3C	Z	-8.823	2
42	MP3C	Mx	.004	2
43	MP4A	Z	-7.349	1.5
44	MP4A	Mx	0	1.5
45	MP4B	Z	-7.349	1.5
46	MP4B	Mx	-.003	1.5
47	MP4C	Z	-7.349	1.5
48	MP4C	Mx	.003	1.5
49	MP1A	Z	-1.411	1
50	MP1A	Mx	0	1
51	MP1A	Z	-1.411	5
52	MP1A	Mx	0	5
53	MP1B	Z	-1.411	1
54	MP1B	Mx	.000611	1
55	MP1B	Z	-1.411	5
56	MP1B	Mx	.000611	5
57	MP1C	Z	-1.411	1
58	MP1C	Mx	-.000611	1
59	MP1C	Z	-1.411	5
60	MP1C	Mx	-.000611	5
61	MP5A	Z	-1.411	1
62	MP5A	Mx	0	1
63	MP5A	Z	-1.411	5
64	MP5A	Mx	0	5

Member Point Loads (BLC 82 : Antenna Eh (0 Deg)) (Continued)

	Member Label	Direction	Magnitude[lb.k-ft]	Location[ft.%]
65	MP5B	Z	-1.411	1
66	MP5B	Mx	.000611	1
67	MP5B	Z	-1.411	5
68	MP5B	Mx	.000611	5
69	MP5C	Z	-1.411	1
70	MP5C	Mx	-.000611	1
71	MP5C	Z	-1.411	5
72	MP5C	Mx	-.000611	5
73	M76	Z	-2.091	5
74	M76	Mx	0	5
75	M76	Z	-1.568	2
76	M76	Mx	0	2
77	MP1A	Z	-1.84	2
78	MP1A	Mx	.000797	2
79	MP1B	Z	-1.84	2
80	MP1B	Mx	.000797	2

Member Point Loads (BLC 83 : Antenna Eh (90 Deg))

	Member Label	Direction	Magnitude[lb.k-ft]	Location[ft.%]
1	MP3A	X	2.404	1
2	MP3A	Mx	-.001	1
3	MP3A	X	2.404	6
4	MP3A	Mx	-.001	6
5	MP3B	X	2.404	1
6	MP3B	Mx	-.000787	1
7	MP3B	X	2.404	6
8	MP3B	Mx	-.000787	6
9	MP3C	X	2.404	1
10	MP3C	Mx	.002	1
11	MP3C	X	2.404	6
12	MP3C	Mx	.002	6
13	MP3A	X	2.404	1
14	MP3A	Mx	-.001	1
15	MP3A	X	2.404	6
16	MP3A	Mx	-.001	6
17	MP3B	X	2.404	1
18	MP3B	Mx	.002	1
19	MP3B	X	2.404	6
20	MP3B	Mx	.002	6
21	MP3C	X	2.404	1
22	MP3C	Mx	-.000787	1
23	MP3C	X	2.404	6
24	MP3C	Mx	-.000787	6
25	MP4A	X	4.599	2
26	MP4A	Mx	-.002	2
27	MP4A	X	4.599	4
28	MP4A	Mx	-.002	4
29	MP4B	X	4.599	2
30	MP4B	Mx	.001	2
31	MP4B	X	4.599	4
32	MP4B	Mx	.001	4
33	MP4C	X	4.599	2
34	MP4C	Mx	.001	2
35	MP4C	X	4.599	4
36	MP4C	Mx	.001	4
37	MP3A	X	8.823	2
38	MP3A	Mx	.004	2
39	MP3B	X	8.823	2

Member Point Loads (BLC 83 : Antenna Eh (90 Deg)) (Continued)

	Member Label	Direction	Magnitude[lb.k-ft]	Location[ft.%]
40	MP3B	Mx	-.002	2
41	MP3C	X	8.823	2
42	MP3C	Mx	-.002	2
43	MP4A	X	7.349	1.5
44	MP4A	Mx	.004	1.5
45	MP4B	X	7.349	1.5
46	MP4B	Mx	-.002	1.5
47	MP4C	X	7.349	1.5
48	MP4C	Mx	-.002	1.5
49	MP1A	X	1.411	1
50	MP1A	Mx	-.000706	1
51	MP1A	X	1.411	5
52	MP1A	Mx	-.000706	5
53	MP1B	X	1.411	1
54	MP1B	Mx	.000353	1
55	MP1B	X	1.411	5
56	MP1B	Mx	.000353	5
57	MP1C	X	1.411	1
58	MP1C	Mx	.000353	1
59	MP1C	X	1.411	5
60	MP1C	Mx	.000353	5
61	MP5A	X	1.411	1
62	MP5A	Mx	-.000706	1
63	MP5A	X	1.411	5
64	MP5A	Mx	-.000706	5
65	MP5B	X	1.411	1
66	MP5B	Mx	.000353	1
67	MP5B	X	1.411	5
68	MP5B	Mx	.000353	5
69	MP5C	X	1.411	1
70	MP5C	Mx	.000353	1
71	MP5C	X	1.411	5
72	MP5C	Mx	.000353	5
73	M76	X	2.091	5
74	M76	Mx	0	5
75	M76	X	1.568	2
76	M76	Mx	0	2
77	MP1A	X	1.84	2
78	MP1A	Mx	.00046	2
79	MP1B	X	1.84	2
80	MP1B	Mx	.00046	2

Member Distributed Loads (BLC 40 : Structure Di)

	Member Label	Direction	Start Magnitude[lb/ft,...	End Magnitude[lb/ft,...	Start Location[ft, %]	End Location[ft, %]
1	FACE	Y	-7.774	-7.774	0	%100
2	M2	Y	-7.774	-7.774	0	%100
3	M3	Y	-7.774	-7.774	0	%100
4	M4	Y	-7.774	-7.774	0	%100
5	M5	Y	-7.774	-7.774	0	%100
6	M9	Y	-7.774	-7.774	0	%100
7	M10	Y	-7.774	-7.774	0	%100
8	M14	Y	-7.774	-7.774	0	%100
9	M15	Y	-7.774	-7.774	0	%100
10	M19	Y	-7.774	-7.774	0	%100
11	M20	Y	-7.774	-7.774	0	%100
12	M21	Y	-7.774	-7.774	0	%100
13	M25	Y	-11.833	-11.833	0	%100

Member Distributed Loads (BLC 40 : Structure Di) (Continued)

Member Label	Direction	Start Magnitude[lb/ft....	End Magnitude[lb/ft....	Start Location[ft.%]	End Location[ft.%]
14	M28	Y	-11.833	-11.833	0 %100
15	M31	Y	-11.833	-11.833	0 %100
16	MP1A	Y	-5.094	-5.094	0 %100
17	MP2A	Y	-5.094	-5.094	0 %100
18	MP3A	Y	-5.811	-5.811	0 %100
19	MP4A	Y	-5.094	-5.094	0 %100
20	MP5A	Y	-5.094	-5.094	0 %100
21	MP1C	Y	-5.094	-5.094	0 %100
22	MP2C	Y	-5.094	-5.094	0 %100
23	MP3C	Y	-5.811	-5.811	0 %100
24	MP4C	Y	-5.094	-5.094	0 %100
25	MP5C	Y	-5.094	-5.094	0 %100
26	MP1B	Y	-5.094	-5.094	0 %100
27	MP2B	Y	-5.094	-5.094	0 %100
28	MP3B	Y	-5.811	-5.811	0 %100
29	MP4B	Y	-5.094	-5.094	0 %100
30	MP5B	Y	-5.094	-5.094	0 %100
31	M76	Y	-5.094	-5.094	0 %100
32	M77	Y	-5.094	-5.094	0 %100
33	M72	Y	-2.403	-2.403	0 %100
34	M73	Y	-2.403	-2.403	0 %100
35	M76A	Y	-5.094	-5.094	0 %100
36	M81A	Y	-2.403	-2.403	0 %100
37	M82	Y	-2.403	-2.403	0 %100
38	M82A	Y	-5.811	-5.811	0 %100
39	M88	Y	-5.811	-5.811	0 %100
40	M94	Y	-5.811	-5.811	0 %100
41	M109	Y	-6.759	-6.759	0 %100
42	M110	Y	-6.759	-6.759	0 %100
43	M115	Y	-5.811	-5.811	0 %100
44	M121	Y	-5.811	-5.811	0 %100
45	M127	Y	-5.811	-5.811	0 %100
46	M139	Y	-7.774	-7.774	0 %100
47	M143A	Y	-7.774	-7.774	0 %100
48	M146A	Y	-7.774	-7.774	0 %100
49	M149A	Y	-7.774	-7.774	0 %100
50	M152A	Y	-7.774	-7.774	0 %100
51	M155A	Y	-7.774	-7.774	0 %100
52	M153B	Y	-6.759	-6.759	0 %100
53	M154B	Y	-6.759	-6.759	0 %100
54	M155B	Y	-6.759	-6.759	0 %100
55	M156B	Y	-6.759	-6.759	0 %100

Member Distributed Loads (BLC 41 : Structure Wo (0 Deg))

Member Label	Direction	Start Magnitude[lb/ft....	End Magnitude[lb/ft....	Start Location[ft.%]	End Location[ft.%]
1	FACE	X	0	0	0 %100
2	FACE	Z	-21.674	-21.674	0 %100
3	M2	X	0	0	0 %100
4	M2	Z	-5.419	-5.419	0 %100
5	M3	X	0	0	0 %100
6	M3	Z	-5.419	-5.419	0 %100
7	M4	X	0	0	0 %100
8	M4	Z	0	0	0 %100
9	M5	X	0	0	0 %100
10	M5	Z	0	0	0 %100
11	M9	X	0	0	0 %100
12	M9	Z	-13.637	-13.637	0 %100
13	M10	X	0	0	0 %100

Member Distributed Loads (BLC 41 : Structure Wo (0 Deg)) (Continued)

Member Label	Direction	Start Magnitude[lb/ft....]	End Magnitude[lb/ft....]	Start Location[ft.%]	End Location[ft.%]
14	M10	Z	-13.637	-13.637	0 %100
15	M14	X	0	0	0 %100
16	M14	Z	-13.637	-13.637	0 %100
17	M15	X	0	0	0 %100
18	M15	Z	-13.637	-13.637	0 %100
19	M19	X	0	0	0 %100
20	M19	Z	-5.419	-5.419	0 %100
21	M20	X	0	0	0 %100
22	M20	Z	-21.674	-21.674	0 %100
23	M21	X	0	0	0 %100
24	M21	Z	-5.419	-5.419	0 %100
25	M25	X	0	0	0 %100
26	M25	Z	0	0	0 %100
27	M28	X	0	0	0 %100
28	M28	Z	-18.939	-18.939	0 %100
29	M31	X	0	0	0 %100
30	M31	Z	-18.939	-18.939	0 %100
31	MP1A	X	0	0	0 %100
32	MP1A	Z	-10.295	-10.295	0 %100
33	MP2A	X	0	0	0 %100
34	MP2A	Z	-10.295	-10.295	0 %100
35	MP3A	X	0	0	0 %100
36	MP3A	Z	-12.463	-12.463	0 %100
37	MP4A	X	0	0	0 %100
38	MP4A	Z	-10.295	-10.295	0 %100
39	MP5A	X	0	0	0 %100
40	MP5A	Z	-10.295	-10.295	0 %100
41	MP1C	X	0	0	0 %100
42	MP1C	Z	-10.295	-10.295	0 %100
43	MP2C	X	0	0	0 %100
44	MP2C	Z	-10.295	-10.295	0 %100
45	MP3C	X	0	0	0 %100
46	MP3C	Z	-12.463	-12.463	0 %100
47	MP4C	X	0	0	0 %100
48	MP4C	Z	-10.295	-10.295	0 %100
49	MP5C	X	0	0	0 %100
50	MP5C	Z	-10.295	-10.295	0 %100
51	MP1B	X	0	0	0 %100
52	MP1B	Z	-10.295	-10.295	0 %100
53	MP2B	X	0	0	0 %100
54	MP2B	Z	-10.295	-10.295	0 %100
55	MP3B	X	0	0	0 %100
56	MP3B	Z	-12.463	-12.463	0 %100
57	MP4B	X	0	0	0 %100
58	MP4B	Z	-10.295	-10.295	0 %100
59	MP5B	X	0	0	0 %100
60	MP5B	Z	-10.295	-10.295	0 %100
61	M76	X	0	0	0 %100
62	M76	Z	-10.295	-10.295	0 %100
63	M77	X	0	0	0 %100
64	M77	Z	-8.419	-8.419	0 %100
65	M72	X	0	0	0 %100
66	M72	Z	-1.174	-1.174	0 %100
67	M73	X	0	0	0 %100
68	M73	Z	-1.174	-1.174	0 %100
69	M76A	X	0	0	0 %100
70	M76A	Z	-6.974	-6.974	0 %100
71	M81A	X	0	0	0 %100
72	M81A	Z	-1.174	-1.174	0 %100

Member Distributed Loads (BLC 41 : Structure Wo (0 Deg)) (Continued)

	Member Label	Direction	Start Magnitude[lb/ft....	End Magnitude[lb/ft....	Start Location[ft, %]	End Location[ft, %]
73	M82	X	0	0	0	%100
74	M82	Z	-1.174	-1.174	0	%100
75	M82A	X	0	0	0	%100
76	M82A	Z	-12.463	-12.463	0	%100
77	M88	X	0	0	0	%100
78	M88	Z	-3.116	-3.116	0	%100
79	M94	X	0	0	0	%100
80	M94	Z	-3.116	-3.116	0	%100
81	M109	X	0	0	0	%100
82	M109	Z	-13.721	-13.721	0	%100
83	M110	X	0	0	0	%100
84	M110	Z	-13.721	-13.721	0	%100
85	M115	X	0	0	0	%100
86	M115	Z	-12.463	-12.463	0	%100
87	M121	X	0	0	0	%100
88	M121	Z	-3.116	-3.116	0	%100
89	M127	X	0	0	0	%100
90	M127	Z	-3.116	-3.116	0	%100
91	M139	X	0	0	0	%100
92	M139	Z	-4.065	-4.065	0	%100
93	M143A	X	0	0	0	%100
94	M143A	Z	-4.065	-4.065	0	%100
95	M146A	X	0	0	0	%100
96	M146A	Z	-16.26	-16.26	0	%100
97	M149A	X	0	0	0	%100
98	M149A	Z	-4.065	-4.065	0	%100
99	M152A	X	0	0	0	%100
100	M152A	Z	-4.065	-4.065	0	%100
101	M155A	X	0	0	0	%100
102	M155A	Z	-16.26	-16.26	0	%100
103	M153B	X	0	0	0	%100
104	M153B	Z	-13.775	-13.775	0	%100
105	M154B	X	0	0	0	%100
106	M154B	Z	-.807	-.807	0	%100
107	M155B	X	0	0	0	%100
108	M155B	Z	-.807	-.807	0	%100
109	M156B	X	0	0	0	%100
110	M156B	Z	-13.775	-13.775	0	%100

Member Distributed Loads (BLC 42 : Structure Wo (30 Deg))

	Member Label	Direction	Start Magnitude[lb/ft....	End Magnitude[lb/ft....	Start Location[ft, %]	End Location[ft, %]
1	FACE	X	8.128	8.128	0	%100
2	FACE	Z	-14.078	-14.078	0	%100
3	M2	X	8.128	8.128	0	%100
4	M2	Z	-14.078	-14.078	0	%100
5	M3	X	0	0	0	%100
6	M3	Z	0	0	0	%100
7	M4	X	2.273	2.273	0	%100
8	M4	Z	-3.937	-3.937	0	%100
9	M5	X	2.273	2.273	0	%100
10	M5	Z	-3.937	-3.937	0	%100
11	M9	X	2.273	2.273	0	%100
12	M9	Z	-3.937	-3.937	0	%100
13	M10	X	2.273	2.273	0	%100
14	M10	Z	-3.937	-3.937	0	%100
15	M14	X	9.091	9.091	0	%100
16	M14	Z	-15.746	-15.746	0	%100
17	M15	X	9.091	9.091	0	%100



Member Distributed Loads (BLC 42 : Structure Wo (30 Deg)) (Continued)

Member Label	Direction	Start Magnitude[lb/ft....]	End Magnitude[lb/ft....]	Start Location[ft.%]	End Location[ft.%]
18	M15	Z	-15.746	-15.746	0 %100
19	M19	X	0	0	0 %100
20	M19	Z	0	0	0 %100
21	M20	X	8.128	8.128	0 %100
22	M20	Z	-14.078	-14.078	0 %100
23	M21	X	8.128	8.128	0 %100
24	M21	Z	-14.078	-14.078	0 %100
25	M25	X	3.157	3.157	0 %100
26	M25	Z	-5.467	-5.467	0 %100
27	M28	X	3.157	3.157	0 %100
28	M28	Z	-5.467	-5.467	0 %100
29	M31	X	12.626	12.626	0 %100
30	M31	Z	-21.869	-21.869	0 %100
31	MP1A	X	5.148	5.148	0 %100
32	MP1A	Z	-8.916	-8.916	0 %100
33	MP2A	X	5.148	5.148	0 %100
34	MP2A	Z	-8.916	-8.916	0 %100
35	MP3A	X	6.231	6.231	0 %100
36	MP3A	Z	-10.793	-10.793	0 %100
37	MP4A	X	5.148	5.148	0 %100
38	MP4A	Z	-8.916	-8.916	0 %100
39	MP5A	X	5.148	5.148	0 %100
40	MP5A	Z	-8.916	-8.916	0 %100
41	MP1C	X	5.148	5.148	0 %100
42	MP1C	Z	-8.916	-8.916	0 %100
43	MP2C	X	5.148	5.148	0 %100
44	MP2C	Z	-8.916	-8.916	0 %100
45	MP3C	X	6.231	6.231	0 %100
46	MP3C	Z	-10.793	-10.793	0 %100
47	MP4C	X	5.148	5.148	0 %100
48	MP4C	Z	-8.916	-8.916	0 %100
49	MP5C	X	5.148	5.148	0 %100
50	MP5C	Z	-8.916	-8.916	0 %100
51	MP1B	X	5.148	5.148	0 %100
52	MP1B	Z	-8.916	-8.916	0 %100
53	MP2B	X	5.148	5.148	0 %100
54	MP2B	Z	-8.916	-8.916	0 %100
55	MP3B	X	6.231	6.231	0 %100
56	MP3B	Z	-10.793	-10.793	0 %100
57	MP4B	X	5.148	5.148	0 %100
58	MP4B	Z	-8.916	-8.916	0 %100
59	MP5B	X	5.148	5.148	0 %100
60	MP5B	Z	-8.916	-8.916	0 %100
61	M76	X	5.148	5.148	0 %100
62	M76	Z	-8.916	-8.916	0 %100
63	M77	X	4.209	4.209	0 %100
64	M77	Z	-7.291	-7.291	0 %100
65	M72	X	.196	.196	0 %100
66	M72	Z	-.339	-.339	0 %100
67	M73	X	.196	.196	0 %100
68	M73	Z	-.339	-.339	0 %100
69	M76A	X	3.487	3.487	0 %100
70	M76A	Z	-6.04	-6.04	0 %100
71	M81A	X	.196	.196	0 %100
72	M81A	Z	-.339	-.339	0 %100
73	M82	X	.196	.196	0 %100
74	M82	Z	-.339	-.339	0 %100
75	M82A	X	4.674	4.674	0 %100
76	M82A	Z	-8.095	-8.095	0 %100

Member Distributed Loads (BLC 42 : Structure Wo (30 Deg)) (Continued)

Member Label	Direction	Start Magnitude[lb/ft....	End Magnitude[lb/ft....	Start Location[ft.%]	End Location[ft.%]
77	M88	X	4.674	4.674	0 %100
78	M88	Z	-8.095	-8.095	0 %100
79	M94	X	0	0	0 %100
80	M94	Z	0	0	0 %100
81	M109	X	2.547	2.547	0 %100
82	M109	Z	-4.411	-4.411	0 %100
83	M110	X	9.031	9.031	0 %100
84	M110	Z	-15.642	-15.642	0 %100
85	M115	X	4.674	4.674	0 %100
86	M115	Z	-8.095	-8.095	0 %100
87	M121	X	4.674	4.674	0 %100
88	M121	Z	-8.095	-8.095	0 %100
89	M127	X	0	0	0 %100
90	M127	Z	0	0	0 %100
91	M139	X	6.098	6.098	0 %100
92	M139	Z	-10.561	-10.561	0 %100
93	M143A	X	0	0	0 %100
94	M143A	Z	0	0	0 %100
95	M146A	X	6.098	6.098	0 %100
96	M146A	Z	-10.561	-10.561	0 %100
97	M149A	X	6.098	6.098	0 %100
98	M149A	Z	-10.561	-10.561	0 %100
99	M152A	X	0	0	0 %100
100	M152A	Z	0	0	0 %100
101	M155A	X	6.098	6.098	0 %100
102	M155A	Z	-10.561	-10.561	0 %100
103	M153B	X	9.031	9.031	0 %100
104	M153B	Z	-15.642	-15.642	0 %100
105	M154B	X	2.547	2.547	0 %100
106	M154B	Z	-4.411	-4.411	0 %100
107	M155B	X	2.574	2.574	0 %100
108	M155B	Z	-4.458	-4.458	0 %100
109	M156B	X	2.574	2.574	0 %100
110	M156B	Z	-4.458	-4.458	0 %100

Member Distributed Loads (BLC 43 : Structure Wo (60 Deg))

Member Label	Direction	Start Magnitude[lb/ft....	End Magnitude[lb/ft....	Start Location[ft.%]	End Location[ft.%]
1	FACE	X	4.693	4.693	0 %100
2	FACE	Z	-2.709	-2.709	0 %100
3	M2	X	18.77	18.77	0 %100
4	M2	Z	-10.837	-10.837	0 %100
5	M3	X	4.693	4.693	0 %100
6	M3	Z	-2.709	-2.709	0 %100
7	M4	X	11.81	11.81	0 %100
8	M4	Z	-6.818	-6.818	0 %100
9	M5	X	11.81	11.81	0 %100
10	M5	Z	-6.818	-6.818	0 %100
11	M9	X	0	0	0 %100
12	M9	Z	0	0	0 %100
13	M10	X	0	0	0 %100
14	M10	Z	0	0	0 %100
15	M14	X	11.81	11.81	0 %100
16	M14	Z	-6.818	-6.818	0 %100
17	M15	X	11.81	11.81	0 %100
18	M15	Z	-6.818	-6.818	0 %100
19	M19	X	4.693	4.693	0 %100
20	M19	Z	-2.709	-2.709	0 %100
21	M20	X	4.693	4.693	0 %100

Member Distributed Loads (BLC 43 : Structure Wo (60 Deg)) (Continued)

Member Label	Direction	Start Magnitude[lb/ft....]	End Magnitude[lb/ft....]	Start Location[ft.%]	End Location[ft.%]
22	M20	Z	-2.709	-2.709	0 %100
23	M21	X	18.77	18.77	0 %100
24	M21	Z	-10.837	-10.837	0 %100
25	M25	X	16.402	16.402	0 %100
26	M25	Z	-9.47	-9.47	0 %100
27	M28	X	0	0	0 %100
28	M28	Z	0	0	0 %100
29	M31	X	16.402	16.402	0 %100
30	M31	Z	-9.47	-9.47	0 %100
31	MP1A	X	8.916	8.916	0 %100
32	MP1A	Z	-5.148	-5.148	0 %100
33	MP2A	X	8.916	8.916	0 %100
34	MP2A	Z	-5.148	-5.148	0 %100
35	MP3A	X	10.793	10.793	0 %100
36	MP3A	Z	-6.231	-6.231	0 %100
37	MP4A	X	8.916	8.916	0 %100
38	MP4A	Z	-5.148	-5.148	0 %100
39	MP5A	X	8.916	8.916	0 %100
40	MP5A	Z	-5.148	-5.148	0 %100
41	MP1C	X	8.916	8.916	0 %100
42	MP1C	Z	-5.148	-5.148	0 %100
43	MP2C	X	8.916	8.916	0 %100
44	MP2C	Z	-5.148	-5.148	0 %100
45	MP3C	X	10.793	10.793	0 %100
46	MP3C	Z	-6.231	-6.231	0 %100
47	MP4C	X	8.916	8.916	0 %100
48	MP4C	Z	-5.148	-5.148	0 %100
49	MP5C	X	8.916	8.916	0 %100
50	MP5C	Z	-5.148	-5.148	0 %100
51	MP1B	X	8.916	8.916	0 %100
52	MP1B	Z	-5.148	-5.148	0 %100
53	MP2B	X	8.916	8.916	0 %100
54	MP2B	Z	-5.148	-5.148	0 %100
55	MP3B	X	10.793	10.793	0 %100
56	MP3B	Z	-6.231	-6.231	0 %100
57	MP4B	X	8.916	8.916	0 %100
58	MP4B	Z	-5.148	-5.148	0 %100
59	MP5B	X	8.916	8.916	0 %100
60	MP5B	Z	-5.148	-5.148	0 %100
61	M76	X	8.916	8.916	0 %100
62	M76	Z	-5.148	-5.148	0 %100
63	M77	X	7.291	7.291	0 %100
64	M77	Z	-4.209	-4.209	0 %100
65	M72	X	0	0	0 %100
66	M72	Z	0	0	0 %100
67	M73	X	0	0	0 %100
68	M73	Z	0	0	0 %100
69	M76A	X	6.04	6.04	0 %100
70	M76A	Z	-3.487	-3.487	0 %100
71	M81A	X	0	0	0 %100
72	M81A	Z	0	0	0 %100
73	M82	X	0	0	0 %100
74	M82	Z	0	0	0 %100
75	M82A	X	2.698	2.698	0 %100
76	M82A	Z	-1.558	-1.558	0 %100
77	M88	X	10.793	10.793	0 %100
78	M88	Z	-6.231	-6.231	0 %100
79	M94	X	2.698	2.698	0 %100
80	M94	Z	-1.558	-1.558	0 %100

Member Distributed Loads (BLC 43 : Structure Wo (60 Deg)) (Continued)

Member Label	Direction	Start Magnitude[lb/ft....	End Magnitude[lb/ft....	Start Location[ft.%]	End Location[ft.%]
81	M109	X	.699	.699	0 %100
82	M109	Z	-.404	-.404	0 %100
83	M110	X	11.93	11.93	0 %100
84	M110	Z	-6.888	-6.888	0 %100
85	M115	X	2.698	2.698	0 %100
86	M115	Z	-1.558	-1.558	0 %100
87	M121	X	10.793	10.793	0 %100
88	M121	Z	-6.231	-6.231	0 %100
89	M127	X	2.698	2.698	0 %100
90	M127	Z	-1.558	-1.558	0 %100
91	M139	X	14.082	14.082	0 %100
92	M139	Z	-8.13	-8.13	0 %100
93	M143A	X	3.52	3.52	0 %100
94	M143A	Z	-2.033	-2.033	0 %100
95	M146A	X	3.52	3.52	0 %100
96	M146A	Z	-2.033	-2.033	0 %100
97	M149A	X	14.082	14.082	0 %100
98	M149A	Z	-8.13	-8.13	0 %100
99	M152A	X	3.52	3.52	0 %100
100	M152A	Z	-2.033	-2.033	0 %100
101	M155A	X	3.52	3.52	0 %100
102	M155A	Z	-2.033	-2.033	0 %100
103	M153B	X	11.883	11.883	0 %100
104	M153B	Z	-6.861	-6.861	0 %100
105	M154B	X	11.883	11.883	0 %100
106	M154B	Z	-6.861	-6.861	0 %100
107	M155B	X	11.93	11.93	0 %100
108	M155B	Z	-6.888	-6.888	0 %100
109	M156B	X	.699	.699	0 %100
110	M156B	Z	-.404	-.404	0 %100

Member Distributed Loads (BLC 44 : Structure Wo (90 Deg))

Member Label	Direction	Start Magnitude[lb/ft....	End Magnitude[lb/ft....	Start Location[ft.%]	End Location[ft.%]
1	FACE	X	0	0	0 %100
2	FACE	Z	0	0	0 %100
3	M2	X	16.256	16.256	0 %100
4	M2	Z	0	0	0 %100
5	M3	X	16.256	16.256	0 %100
6	M3	Z	0	0	0 %100
7	M4	X	18.182	18.182	0 %100
8	M4	Z	0	0	0 %100
9	M5	X	18.182	18.182	0 %100
10	M5	Z	0	0	0 %100
11	M9	X	4.546	4.546	0 %100
12	M9	Z	0	0	0 %100
13	M10	X	4.546	4.546	0 %100
14	M10	Z	0	0	0 %100
15	M14	X	4.546	4.546	0 %100
16	M14	Z	0	0	0 %100
17	M15	X	4.546	4.546	0 %100
18	M15	Z	0	0	0 %100
19	M19	X	16.256	16.256	0 %100
20	M19	Z	0	0	0 %100
21	M20	X	0	0	0 %100
22	M20	Z	0	0	0 %100
23	M21	X	16.256	16.256	0 %100
24	M21	Z	0	0	0 %100
25	M25	X	25.252	25.252	0 %100

Member Distributed Loads (BLC 44 : Structure Wo (90 Deg)) (Continued)

Member Label	Direction	Start Magnitude[lb/ft....]	End Magnitude[lb/ft....]	Start Location[ft.%]	End Location[ft.%]
26	M25	Z	0	0	%100
27	M28	X	6.313	6.313	0
28	M28	Z	0	0	%100
29	M31	X	6.313	6.313	0
30	M31	Z	0	0	%100
31	MP1A	X	10.295	10.295	0
32	MP1A	Z	0	0	%100
33	MP2A	X	10.295	10.295	0
34	MP2A	Z	0	0	%100
35	MP3A	X	12.463	12.463	0
36	MP3A	Z	0	0	%100
37	MP4A	X	10.295	10.295	0
38	MP4A	Z	0	0	%100
39	MP5A	X	10.295	10.295	0
40	MP5A	Z	0	0	%100
41	MP1C	X	10.295	10.295	0
42	MP1C	Z	0	0	%100
43	MP2C	X	10.295	10.295	0
44	MP2C	Z	0	0	%100
45	MP3C	X	12.463	12.463	0
46	MP3C	Z	0	0	%100
47	MP4C	X	10.295	10.295	0
48	MP4C	Z	0	0	%100
49	MP5C	X	10.295	10.295	0
50	MP5C	Z	0	0	%100
51	MP1B	X	10.295	10.295	0
52	MP1B	Z	0	0	%100
53	MP2B	X	10.295	10.295	0
54	MP2B	Z	0	0	%100
55	MP3B	X	12.463	12.463	0
56	MP3B	Z	0	0	%100
57	MP4B	X	10.295	10.295	0
58	MP4B	Z	0	0	%100
59	MP5B	X	10.295	10.295	0
60	MP5B	Z	0	0	%100
61	M76	X	10.295	10.295	0
62	M76	Z	0	0	%100
63	M77	X	8.419	8.419	0
64	M77	Z	0	0	%100
65	M72	X	.391	.391	0
66	M72	Z	0	0	%100
67	M73	X	.391	.391	0
68	M73	Z	0	0	%100
69	M76A	X	6.974	6.974	0
70	M76A	Z	0	0	%100
71	M81A	X	.391	.391	0
72	M81A	Z	0	0	%100
73	M82	X	.391	.391	0
74	M82	Z	0	0	%100
75	M82A	X	0	0	%100
76	M82A	Z	0	0	%100
77	M88	X	9.347	9.347	0
78	M88	Z	0	0	%100
79	M94	X	9.347	9.347	0
80	M94	Z	0	0	%100
81	M109	X	5.148	5.148	0
82	M109	Z	0	0	%100
83	M110	X	5.148	5.148	0
84	M110	Z	0	0	%100

Member Distributed Loads (BLC 44 : Structure Wo (90 Deg)) (Continued)

	Member Label	Direction	Start Magnitude[lb/ft,...]	End Magnitude[lb/ft,...]	Start Location[ft,%]	End Location[ft,%]
85	M115	X	0	0	0	%100
86	M115	Z	0	0	0	%100
87	M121	X	9.347	9.347	0	%100
88	M121	Z	0	0	0	%100
89	M127	X	9.347	9.347	0	%100
90	M127	Z	0	0	0	%100
91	M139	X	12.195	12.195	0	%100
92	M139	Z	0	0	0	%100
93	M143A	X	12.195	12.195	0	%100
94	M143A	Z	0	0	0	%100
95	M146A	X	0	0	0	%100
96	M146A	Z	0	0	0	%100
97	M149A	X	12.195	12.195	0	%100
98	M149A	Z	0	0	0	%100
99	M152A	X	12.195	12.195	0	%100
100	M152A	Z	0	0	0	%100
101	M155A	X	0	0	0	%100
102	M155A	Z	0	0	0	%100
103	M153B	X	5.094	5.094	0	%100
104	M153B	Z	0	0	0	%100
105	M154B	X	18.062	18.062	0	%100
106	M154B	Z	0	0	0	%100
107	M155B	X	18.062	18.062	0	%100
108	M155B	Z	0	0	0	%100
109	M156B	X	5.094	5.094	0	%100
110	M156B	Z	0	0	0	%100

Member Distributed Loads (BLC 45 : Structure Wo (120 Deg))

	Member Label	Direction	Start Magnitude[lb/ft,...]	End Magnitude[lb/ft,...]	Start Location[ft,%]	End Location[ft,%]
1	FACE	X	4.693	4.693	0	%100
2	FACE	Z	2.709	2.709	0	%100
3	M2	X	4.693	4.693	0	%100
4	M2	Z	2.709	2.709	0	%100
5	M3	X	18.77	18.77	0	%100
6	M3	Z	10.837	10.837	0	%100
7	M4	X	11.81	11.81	0	%100
8	M4	Z	6.818	6.818	0	%100
9	M5	X	11.81	11.81	0	%100
10	M5	Z	6.818	6.818	0	%100
11	M9	X	11.81	11.81	0	%100
12	M9	Z	6.818	6.818	0	%100
13	M10	X	11.81	11.81	0	%100
14	M10	Z	6.818	6.818	0	%100
15	M14	X	0	0	0	%100
16	M14	Z	0	0	0	%100
17	M15	X	0	0	0	%100
18	M15	Z	0	0	0	%100
19	M19	X	18.77	18.77	0	%100
20	M19	Z	10.837	10.837	0	%100
21	M20	X	4.693	4.693	0	%100
22	M20	Z	2.709	2.709	0	%100
23	M21	X	4.693	4.693	0	%100
24	M21	Z	2.709	2.709	0	%100
25	M25	X	16.402	16.402	0	%100
26	M25	Z	9.47	9.47	0	%100
27	M28	X	16.402	16.402	0	%100
28	M28	Z	9.47	9.47	0	%100
29	M31	X	0	0	0	%100



Member Distributed Loads (BLC 45 : Structure Wo (120 Deg)) (Continued)

Member Label	Direction	Start Magnitude[lb/ft....]	End Magnitude[lb/ft....]	Start Location[ft.%]	End Location[ft.%]
30	M31	Z	0	0	%100
31	MP1A	X	8.916	8.916	0
32	MP1A	Z	5.148	5.148	0
33	MP2A	X	8.916	8.916	0
34	MP2A	Z	5.148	5.148	0
35	MP3A	X	10.793	10.793	0
36	MP3A	Z	6.231	6.231	0
37	MP4A	X	8.916	8.916	0
38	MP4A	Z	5.148	5.148	0
39	MP5A	X	8.916	8.916	0
40	MP5A	Z	5.148	5.148	0
41	MP1C	X	8.916	8.916	0
42	MP1C	Z	5.148	5.148	0
43	MP2C	X	8.916	8.916	0
44	MP2C	Z	5.148	5.148	0
45	MP3C	X	10.793	10.793	0
46	MP3C	Z	6.231	6.231	0
47	MP4C	X	8.916	8.916	0
48	MP4C	Z	5.148	5.148	0
49	MP5C	X	8.916	8.916	0
50	MP5C	Z	5.148	5.148	0
51	MP1B	X	8.916	8.916	0
52	MP1B	Z	5.148	5.148	0
53	MP2B	X	8.916	8.916	0
54	MP2B	Z	5.148	5.148	0
55	MP3B	X	10.793	10.793	0
56	MP3B	Z	6.231	6.231	0
57	MP4B	X	8.916	8.916	0
58	MP4B	Z	5.148	5.148	0
59	MP5B	X	8.916	8.916	0
60	MP5B	Z	5.148	5.148	0
61	M76	X	8.916	8.916	0
62	M76	Z	5.148	5.148	0
63	M77	X	7.291	7.291	0
64	M77	Z	4.209	4.209	0
65	M72	X	1.017	1.017	0
66	M72	Z	.587	.587	0
67	M73	X	1.017	1.017	0
68	M73	Z	.587	.587	0
69	M76A	X	6.04	6.04	0
70	M76A	Z	3.487	3.487	0
71	M81A	X	1.017	1.017	0
72	M81A	Z	.587	.587	0
73	M82	X	1.017	1.017	0
74	M82	Z	.587	.587	0
75	M82A	X	2.698	2.698	0
76	M82A	Z	1.558	1.558	0
77	M88	X	2.698	2.698	0
78	M88	Z	1.558	1.558	0
79	M94	X	10.793	10.793	0
80	M94	Z	6.231	6.231	0
81	M109	X	11.93	11.93	0
82	M109	Z	6.888	6.888	0
83	M110	X	.699	.699	0
84	M110	Z	.404	.404	0
85	M115	X	2.698	2.698	0
86	M115	Z	1.558	1.558	0
87	M121	X	2.698	2.698	0
88	M121	Z	1.558	1.558	0

Member Distributed Loads (BLC 45 : Structure Wo (120 Deg)) (Continued)

	Member Label	Direction	Start Magnitude[lb/ft....	End Magnitude[lb/ft....	Start Location[ft, %]	End Location[ft, %]
89	M127	X	10.793	10.793	0	%100
90	M127	Z	6.231	6.231	0	%100
91	M139	X	3.52	3.52	0	%100
92	M139	Z	2.033	2.033	0	%100
93	M143A	X	14.082	14.082	0	%100
94	M143A	Z	8.13	8.13	0	%100
95	M146A	X	3.52	3.52	0	%100
96	M146A	Z	2.033	2.033	0	%100
97	M149A	X	3.52	3.52	0	%100
98	M149A	Z	2.033	2.033	0	%100
99	M152A	X	14.082	14.082	0	%100
100	M152A	Z	8.13	8.13	0	%100
101	M155A	X	3.52	3.52	0	%100
102	M155A	Z	2.033	2.033	0	%100
103	M153B	X	.699	.699	0	%100
104	M153B	Z	.404	.404	0	%100
105	M154B	X	11.93	11.93	0	%100
106	M154B	Z	6.888	6.888	0	%100
107	M155B	X	11.883	11.883	0	%100
108	M155B	Z	6.861	6.861	0	%100
109	M156B	X	11.883	11.883	0	%100
110	M156B	Z	6.861	6.861	0	%100

Member Distributed Loads (BLC 46 : Structure Wo (150 Deg))

	Member Label	Direction	Start Magnitude[lb/ft....	End Magnitude[lb/ft....	Start Location[ft, %]	End Location[ft, %]
1	FACE	X	8.128	8.128	0	%100
2	FACE	Z	14.078	14.078	0	%100
3	M2	X	0	0	0	%100
4	M2	Z	0	0	0	%100
5	M3	X	8.128	8.128	0	%100
6	M3	Z	14.078	14.078	0	%100
7	M4	X	2.273	2.273	0	%100
8	M4	Z	3.937	3.937	0	%100
9	M5	X	2.273	2.273	0	%100
10	M5	Z	3.937	3.937	0	%100
11	M9	X	9.091	9.091	0	%100
12	M9	Z	15.746	15.746	0	%100
13	M10	X	9.091	9.091	0	%100
14	M10	Z	15.746	15.746	0	%100
15	M14	X	2.273	2.273	0	%100
16	M14	Z	3.937	3.937	0	%100
17	M15	X	2.273	2.273	0	%100
18	M15	Z	3.937	3.937	0	%100
19	M19	X	8.128	8.128	0	%100
20	M19	Z	14.078	14.078	0	%100
21	M20	X	8.128	8.128	0	%100
22	M20	Z	14.078	14.078	0	%100
23	M21	X	0	0	0	%100
24	M21	Z	0	0	0	%100
25	M25	X	3.157	3.157	0	%100
26	M25	Z	5.467	5.467	0	%100
27	M28	X	12.626	12.626	0	%100
28	M28	Z	21.869	21.869	0	%100
29	M31	X	3.157	3.157	0	%100
30	M31	Z	5.467	5.467	0	%100
31	MP1A	X	5.148	5.148	0	%100
32	MP1A	Z	8.916	8.916	0	%100
33	MP2A	X	5.148	5.148	0	%100

Member Distributed Loads (BLC 46 : Structure Wo (150 Deg)) (Continued)

Member Label	Direction	Start Magnitude[lb/ft....]	End Magnitude[lb/ft....]	Start Location[ft.%]	End Location[ft.%]
34	MP2A	Z	8.916	8.916	0 %100
35	MP3A	X	6.231	6.231	0 %100
36	MP3A	Z	10.793	10.793	0 %100
37	MP4A	X	5.148	5.148	0 %100
38	MP4A	Z	8.916	8.916	0 %100
39	MP5A	X	5.148	5.148	0 %100
40	MP5A	Z	8.916	8.916	0 %100
41	MP1C	X	5.148	5.148	0 %100
42	MP1C	Z	8.916	8.916	0 %100
43	MP2C	X	5.148	5.148	0 %100
44	MP2C	Z	8.916	8.916	0 %100
45	MP3C	X	6.231	6.231	0 %100
46	MP3C	Z	10.793	10.793	0 %100
47	MP4C	X	5.148	5.148	0 %100
48	MP4C	Z	8.916	8.916	0 %100
49	MP5C	X	5.148	5.148	0 %100
50	MP5C	Z	8.916	8.916	0 %100
51	MP1B	X	5.148	5.148	0 %100
52	MP1B	Z	8.916	8.916	0 %100
53	MP2B	X	5.148	5.148	0 %100
54	MP2B	Z	8.916	8.916	0 %100
55	MP3B	X	6.231	6.231	0 %100
56	MP3B	Z	10.793	10.793	0 %100
57	MP4B	X	5.148	5.148	0 %100
58	MP4B	Z	8.916	8.916	0 %100
59	MP5B	X	5.148	5.148	0 %100
60	MP5B	Z	8.916	8.916	0 %100
61	M76	X	5.148	5.148	0 %100
62	M76	Z	8.916	8.916	0 %100
63	M77	X	4.209	4.209	0 %100
64	M77	Z	7.291	7.291	0 %100
65	M72	X	.783	.783	0 %100
66	M72	Z	1.356	1.356	0 %100
67	M73	X	.783	.783	0 %100
68	M73	Z	1.356	1.356	0 %100
69	M76A	X	3.487	3.487	0 %100
70	M76A	Z	6.04	6.04	0 %100
71	M81A	X	.783	.783	0 %100
72	M81A	Z	1.356	1.356	0 %100
73	M82	X	.783	.783	0 %100
74	M82	Z	1.356	1.356	0 %100
75	M82A	X	4.674	4.674	0 %100
76	M82A	Z	8.095	8.095	0 %100
77	M88	X	0	0	0 %100
78	M88	Z	0	0	0 %100
79	M94	X	4.674	4.674	0 %100
80	M94	Z	8.095	8.095	0 %100
81	M109	X	9.031	9.031	0 %100
82	M109	Z	15.642	15.642	0 %100
83	M110	X	2.547	2.547	0 %100
84	M110	Z	4.411	4.411	0 %100
85	M115	X	4.674	4.674	0 %100
86	M115	Z	8.095	8.095	0 %100
87	M121	X	0	0	0 %100
88	M121	Z	0	0	0 %100
89	M127	X	4.674	4.674	0 %100
90	M127	Z	8.095	8.095	0 %100
91	M139	X	0	0	0 %100
92	M139	Z	0	0	0 %100

Member Distributed Loads (BLC 46 : Structure Wo (150 Deg)) (Continued)

	Member Label	Direction	Start Magnitude[lb/ft....	End Magnitude[lb/ft....	Start Location[ft.%]	End Location[ft.%]
93	M143A	X	6.098	6.098	0	%100
94	M143A	Z	10.561	10.561	0	%100
95	M146A	X	6.098	6.098	0	%100
96	M146A	Z	10.561	10.561	0	%100
97	M149A	X	0	0	0	%100
98	M149A	Z	0	0	0	%100
99	M152A	X	6.098	6.098	0	%100
100	M152A	Z	10.561	10.561	0	%100
101	M155A	X	6.098	6.098	0	%100
102	M155A	Z	10.561	10.561	0	%100
103	M153B	X	2.574	2.574	0	%100
104	M153B	Z	4.458	4.458	0	%100
105	M154B	X	2.574	2.574	0	%100
106	M154B	Z	4.458	4.458	0	%100
107	M155B	X	2.547	2.547	0	%100
108	M155B	Z	4.411	4.411	0	%100
109	M156B	X	9.031	9.031	0	%100
110	M156B	Z	15.642	15.642	0	%100

Member Distributed Loads (BLC 47 : Structure Wo (180 Deg))

	Member Label	Direction	Start Magnitude[lb/ft....	End Magnitude[lb/ft....	Start Location[ft.%]	End Location[ft.%]
1	FACE	X	0	0	0	%100
2	FACE	Z	21.674	21.674	0	%100
3	M2	X	0	0	0	%100
4	M2	Z	5.419	5.419	0	%100
5	M3	X	0	0	0	%100
6	M3	Z	5.419	5.419	0	%100
7	M4	X	0	0	0	%100
8	M4	Z	0	0	0	%100
9	M5	X	0	0	0	%100
10	M5	Z	0	0	0	%100
11	M9	X	0	0	0	%100
12	M9	Z	13.637	13.637	0	%100
13	M10	X	0	0	0	%100
14	M10	Z	13.637	13.637	0	%100
15	M14	X	0	0	0	%100
16	M14	Z	13.637	13.637	0	%100
17	M15	X	0	0	0	%100
18	M15	Z	13.637	13.637	0	%100
19	M19	X	0	0	0	%100
20	M19	Z	5.419	5.419	0	%100
21	M20	X	0	0	0	%100
22	M20	Z	21.674	21.674	0	%100
23	M21	X	0	0	0	%100
24	M21	Z	5.419	5.419	0	%100
25	M25	X	0	0	0	%100
26	M25	Z	0	0	0	%100
27	M28	X	0	0	0	%100
28	M28	Z	18.939	18.939	0	%100
29	M31	X	0	0	0	%100
30	M31	Z	18.939	18.939	0	%100
31	MP1A	X	0	0	0	%100
32	MP1A	Z	10.295	10.295	0	%100
33	MP2A	X	0	0	0	%100
34	MP2A	Z	10.295	10.295	0	%100
35	MP3A	X	0	0	0	%100
36	MP3A	Z	12.463	12.463	0	%100
37	MP4A	X	0	0	0	%100

Member Distributed Loads (BLC 47 : Structure Wo (180 Deg)) (Continued)

Member Label	Direction	Start Magnitude[lb/ft....]	End Magnitude[lb/ft....]	Start Location[ft.%]	End Location[ft.%]
38	MP4A	Z	10.295	10.295	0 %100
39	MP5A	X	0	0	0 %100
40	MP5A	Z	10.295	10.295	0 %100
41	MP1C	X	0	0	0 %100
42	MP1C	Z	10.295	10.295	0 %100
43	MP2C	X	0	0	0 %100
44	MP2C	Z	10.295	10.295	0 %100
45	MP3C	X	0	0	0 %100
46	MP3C	Z	12.463	12.463	0 %100
47	MP4C	X	0	0	0 %100
48	MP4C	Z	10.295	10.295	0 %100
49	MP5C	X	0	0	0 %100
50	MP5C	Z	10.295	10.295	0 %100
51	MP1B	X	0	0	0 %100
52	MP1B	Z	10.295	10.295	0 %100
53	MP2B	X	0	0	0 %100
54	MP2B	Z	10.295	10.295	0 %100
55	MP3B	X	0	0	0 %100
56	MP3B	Z	12.463	12.463	0 %100
57	MP4B	X	0	0	0 %100
58	MP4B	Z	10.295	10.295	0 %100
59	MP5B	X	0	0	0 %100
60	MP5B	Z	10.295	10.295	0 %100
61	M76	X	0	0	0 %100
62	M76	Z	10.295	10.295	0 %100
63	M77	X	0	0	0 %100
64	M77	Z	8.419	8.419	0 %100
65	M72	X	0	0	0 %100
66	M72	Z	1.174	1.174	0 %100
67	M73	X	0	0	0 %100
68	M73	Z	1.174	1.174	0 %100
69	M76A	X	0	0	0 %100
70	M76A	Z	6.974	6.974	0 %100
71	M81A	X	0	0	0 %100
72	M81A	Z	1.174	1.174	0 %100
73	M82	X	0	0	0 %100
74	M82	Z	1.174	1.174	0 %100
75	M82A	X	0	0	0 %100
76	M82A	Z	12.463	12.463	0 %100
77	M88	X	0	0	0 %100
78	M88	Z	3.116	3.116	0 %100
79	M94	X	0	0	0 %100
80	M94	Z	3.116	3.116	0 %100
81	M109	X	0	0	0 %100
82	M109	Z	13.721	13.721	0 %100
83	M110	X	0	0	0 %100
84	M110	Z	13.721	13.721	0 %100
85	M115	X	0	0	0 %100
86	M115	Z	12.463	12.463	0 %100
87	M121	X	0	0	0 %100
88	M121	Z	3.116	3.116	0 %100
89	M127	X	0	0	0 %100
90	M127	Z	3.116	3.116	0 %100
91	M139	X	0	0	0 %100
92	M139	Z	4.065	4.065	0 %100
93	M143A	X	0	0	0 %100
94	M143A	Z	4.065	4.065	0 %100
95	M146A	X	0	0	0 %100
96	M146A	Z	16.26	16.26	0 %100

Member Distributed Loads (BLC 47 : Structure Wo (180 Deg)) (Continued)

	Member Label	Direction	Start Magnitude[lb/ft....	End Magnitude[lb/ft....	Start Location[ft.%]	End Location[ft.%]
97	M149A	X	0	0	0	%100
98	M149A	Z	4.065	4.065	0	%100
99	M152A	X	0	0	0	%100
100	M152A	Z	4.065	4.065	0	%100
101	M155A	X	0	0	0	%100
102	M155A	Z	16.26	16.26	0	%100
103	M153B	X	0	0	0	%100
104	M153B	Z	13.775	13.775	0	%100
105	M154B	X	0	0	0	%100
106	M154B	Z	.807	.807	0	%100
107	M155B	X	0	0	0	%100
108	M155B	Z	.807	.807	0	%100
109	M156B	X	0	0	0	%100
110	M156B	Z	13.775	13.775	0	%100

Member Distributed Loads (BLC 48 : Structure Wo (210 Deg))

	Member Label	Direction	Start Magnitude[lb/ft....	End Magnitude[lb/ft....	Start Location[ft.%]	End Location[ft.%]
1	FACE	X	-8.128	-8.128	0	%100
2	FACE	Z	14.078	14.078	0	%100
3	M2	X	-8.128	-8.128	0	%100
4	M2	Z	14.078	14.078	0	%100
5	M3	X	0	0	0	%100
6	M3	Z	0	0	0	%100
7	M4	X	-2.273	-2.273	0	%100
8	M4	Z	3.937	3.937	0	%100
9	M5	X	-2.273	-2.273	0	%100
10	M5	Z	3.937	3.937	0	%100
11	M9	X	-2.273	-2.273	0	%100
12	M9	Z	3.937	3.937	0	%100
13	M10	X	-2.273	-2.273	0	%100
14	M10	Z	3.937	3.937	0	%100
15	M14	X	-9.091	-9.091	0	%100
16	M14	Z	15.746	15.746	0	%100
17	M15	X	-9.091	-9.091	0	%100
18	M15	Z	15.746	15.746	0	%100
19	M19	X	0	0	0	%100
20	M19	Z	0	0	0	%100
21	M20	X	-8.128	-8.128	0	%100
22	M20	Z	14.078	14.078	0	%100
23	M21	X	-8.128	-8.128	0	%100
24	M21	Z	14.078	14.078	0	%100
25	M25	X	-3.157	-3.157	0	%100
26	M25	Z	5.467	5.467	0	%100
27	M28	X	-3.157	-3.157	0	%100
28	M28	Z	5.467	5.467	0	%100
29	M31	X	-12.626	-12.626	0	%100
30	M31	Z	21.869	21.869	0	%100
31	MP1A	X	-5.148	-5.148	0	%100
32	MP1A	Z	8.916	8.916	0	%100
33	MP2A	X	-5.148	-5.148	0	%100
34	MP2A	Z	8.916	8.916	0	%100
35	MP3A	X	-6.231	-6.231	0	%100
36	MP3A	Z	10.793	10.793	0	%100
37	MP4A	X	-5.148	-5.148	0	%100
38	MP4A	Z	8.916	8.916	0	%100
39	MP5A	X	-5.148	-5.148	0	%100
40	MP5A	Z	8.916	8.916	0	%100
41	MP1C	X	-5.148	-5.148	0	%100



Member Distributed Loads (BLC 48 : Structure Wo (210 Deg)) (Continued)

Member Label	Direction	Start Magnitude[lb/ft....]	End Magnitude[lb/ft....]	Start Location[ft.%]	End Location[ft.%]
42	MP1C	Z	8.916	8.916	0 %100
43	MP2C	X	-5.148	-5.148	0 %100
44	MP2C	Z	8.916	8.916	0 %100
45	MP3C	X	-6.231	-6.231	0 %100
46	MP3C	Z	10.793	10.793	0 %100
47	MP4C	X	-5.148	-5.148	0 %100
48	MP4C	Z	8.916	8.916	0 %100
49	MP5C	X	-5.148	-5.148	0 %100
50	MP5C	Z	8.916	8.916	0 %100
51	MP1B	X	-5.148	-5.148	0 %100
52	MP1B	Z	8.916	8.916	0 %100
53	MP2B	X	-5.148	-5.148	0 %100
54	MP2B	Z	8.916	8.916	0 %100
55	MP3B	X	-6.231	-6.231	0 %100
56	MP3B	Z	10.793	10.793	0 %100
57	MP4B	X	-5.148	-5.148	0 %100
58	MP4B	Z	8.916	8.916	0 %100
59	MP5B	X	-5.148	-5.148	0 %100
60	MP5B	Z	8.916	8.916	0 %100
61	M76	X	-5.148	-5.148	0 %100
62	M76	Z	8.916	8.916	0 %100
63	M77	X	-4.209	-4.209	0 %100
64	M77	Z	7.291	7.291	0 %100
65	M72	X	-.196	-.196	0 %100
66	M72	Z	.339	.339	0 %100
67	M73	X	-.196	-.196	0 %100
68	M73	Z	.339	.339	0 %100
69	M76A	X	-3.487	-3.487	0 %100
70	M76A	Z	6.04	6.04	0 %100
71	M81A	X	-.196	-.196	0 %100
72	M81A	Z	.339	.339	0 %100
73	M82	X	-.196	-.196	0 %100
74	M82	Z	.339	.339	0 %100
75	M82A	X	-4.674	-4.674	0 %100
76	M82A	Z	8.095	8.095	0 %100
77	M88	X	-4.674	-4.674	0 %100
78	M88	Z	8.095	8.095	0 %100
79	M94	X	0	0	0 %100
80	M94	Z	0	0	0 %100
81	M109	X	-2.547	-2.547	0 %100
82	M109	Z	4.411	4.411	0 %100
83	M110	X	-9.031	-9.031	0 %100
84	M110	Z	15.642	15.642	0 %100
85	M115	X	-4.674	-4.674	0 %100
86	M115	Z	8.095	8.095	0 %100
87	M121	X	-4.674	-4.674	0 %100
88	M121	Z	8.095	8.095	0 %100
89	M127	X	0	0	0 %100
90	M127	Z	0	0	0 %100
91	M139	X	-6.098	-6.098	0 %100
92	M139	Z	10.561	10.561	0 %100
93	M143A	X	0	0	0 %100
94	M143A	Z	0	0	0 %100
95	M146A	X	-6.098	-6.098	0 %100
96	M146A	Z	10.561	10.561	0 %100
97	M149A	X	-6.098	-6.098	0 %100
98	M149A	Z	10.561	10.561	0 %100
99	M152A	X	0	0	0 %100
100	M152A	Z	0	0	0 %100

Member Distributed Loads (BLC 48 : Structure Wo (210 Deg)) (Continued)

Member Label	Direction	Start Magnitude[lb/ft,...	End Magnitude[lb/ft,...	Start Location[ft, %]	End Location[ft, %]
101	M155A	X	-6.098	-6.098	0 %100
102	M155A	Z	10.561	10.561	0 %100
103	M153B	X	-9.031	-9.031	0 %100
104	M153B	Z	15.642	15.642	0 %100
105	M154B	X	-2.547	-2.547	0 %100
106	M154B	Z	4.411	4.411	0 %100
107	M155B	X	-2.574	-2.574	0 %100
108	M155B	Z	4.458	4.458	0 %100
109	M156B	X	-2.574	-2.574	0 %100
110	M156B	Z	4.458	4.458	0 %100

Member Distributed Loads (BLC 49 : Structure Wo (240 Deg))

Member Label	Direction	Start Magnitude[lb/ft,...	End Magnitude[lb/ft,...	Start Location[ft, %]	End Location[ft, %]
1	FACE	X	-4.693	-4.693	0 %100
2	FACE	Z	2.709	2.709	0 %100
3	M2	X	-18.77	-18.77	0 %100
4	M2	Z	10.837	10.837	0 %100
5	M3	X	-4.693	-4.693	0 %100
6	M3	Z	2.709	2.709	0 %100
7	M4	X	-11.81	-11.81	0 %100
8	M4	Z	6.818	6.818	0 %100
9	M5	X	-11.81	-11.81	0 %100
10	M5	Z	6.818	6.818	0 %100
11	M9	X	0	0	0 %100
12	M9	Z	0	0	0 %100
13	M10	X	0	0	0 %100
14	M10	Z	0	0	0 %100
15	M14	X	-11.81	-11.81	0 %100
16	M14	Z	6.818	6.818	0 %100
17	M15	X	-11.81	-11.81	0 %100
18	M15	Z	6.818	6.818	0 %100
19	M19	X	-4.693	-4.693	0 %100
20	M19	Z	2.709	2.709	0 %100
21	M20	X	-4.693	-4.693	0 %100
22	M20	Z	2.709	2.709	0 %100
23	M21	X	-18.77	-18.77	0 %100
24	M21	Z	10.837	10.837	0 %100
25	M25	X	-16.402	-16.402	0 %100
26	M25	Z	9.47	9.47	0 %100
27	M28	X	0	0	0 %100
28	M28	Z	0	0	0 %100
29	M31	X	-16.402	-16.402	0 %100
30	M31	Z	9.47	9.47	0 %100
31	MP1A	X	-8.916	-8.916	0 %100
32	MP1A	Z	5.148	5.148	0 %100
33	MP2A	X	-8.916	-8.916	0 %100
34	MP2A	Z	5.148	5.148	0 %100
35	MP3A	X	-10.793	-10.793	0 %100
36	MP3A	Z	6.231	6.231	0 %100
37	MP4A	X	-8.916	-8.916	0 %100
38	MP4A	Z	5.148	5.148	0 %100
39	MP5A	X	-8.916	-8.916	0 %100
40	MP5A	Z	5.148	5.148	0 %100
41	MP1C	X	-8.916	-8.916	0 %100
42	MP1C	Z	5.148	5.148	0 %100
43	MP2C	X	-8.916	-8.916	0 %100
44	MP2C	Z	5.148	5.148	0 %100
45	MP3C	X	-10.793	-10.793	0 %100



Member Distributed Loads (BLC 49 : Structure Wo (240 Deg)) (Continued)

Member Label	Direction	Start Magnitude[lb/ft....]	End Magnitude[lb/ft....]	Start Location[ft.%]	End Location[ft.%]
46	MP3C	Z	6.231	6.231	0 %100
47	MP4C	X	-8.916	-8.916	0 %100
48	MP4C	Z	5.148	5.148	0 %100
49	MP5C	X	-8.916	-8.916	0 %100
50	MP5C	Z	5.148	5.148	0 %100
51	MP1B	X	-8.916	-8.916	0 %100
52	MP1B	Z	5.148	5.148	0 %100
53	MP2B	X	-8.916	-8.916	0 %100
54	MP2B	Z	5.148	5.148	0 %100
55	MP3B	X	-10.793	-10.793	0 %100
56	MP3B	Z	6.231	6.231	0 %100
57	MP4B	X	-8.916	-8.916	0 %100
58	MP4B	Z	5.148	5.148	0 %100
59	MP5B	X	-8.916	-8.916	0 %100
60	MP5B	Z	5.148	5.148	0 %100
61	M76	X	-8.916	-8.916	0 %100
62	M76	Z	5.148	5.148	0 %100
63	M77	X	-7.291	-7.291	0 %100
64	M77	Z	4.209	4.209	0 %100
65	M72	X	0	0	0 %100
66	M72	Z	0	0	0 %100
67	M73	X	0	0	0 %100
68	M73	Z	0	0	0 %100
69	M76A	X	-6.04	-6.04	0 %100
70	M76A	Z	3.487	3.487	0 %100
71	M81A	X	0	0	0 %100
72	M81A	Z	0	0	0 %100
73	M82	X	0	0	0 %100
74	M82	Z	0	0	0 %100
75	M82A	X	-2.698	-2.698	0 %100
76	M82A	Z	1.558	1.558	0 %100
77	M88	X	-10.793	-10.793	0 %100
78	M88	Z	6.231	6.231	0 %100
79	M94	X	-2.698	-2.698	0 %100
80	M94	Z	1.558	1.558	0 %100
81	M109	X	-.699	-.699	0 %100
82	M109	Z	.404	.404	0 %100
83	M110	X	-11.93	-11.93	0 %100
84	M110	Z	6.888	6.888	0 %100
85	M115	X	-2.698	-2.698	0 %100
86	M115	Z	1.558	1.558	0 %100
87	M121	X	-10.793	-10.793	0 %100
88	M121	Z	6.231	6.231	0 %100
89	M127	X	-2.698	-2.698	0 %100
90	M127	Z	1.558	1.558	0 %100
91	M139	X	-14.082	-14.082	0 %100
92	M139	Z	8.13	8.13	0 %100
93	M143A	X	-3.52	-3.52	0 %100
94	M143A	Z	2.033	2.033	0 %100
95	M146A	X	-3.52	-3.52	0 %100
96	M146A	Z	2.033	2.033	0 %100
97	M149A	X	-14.082	-14.082	0 %100
98	M149A	Z	8.13	8.13	0 %100
99	M152A	X	-3.52	-3.52	0 %100
100	M152A	Z	2.033	2.033	0 %100
101	M155A	X	-3.52	-3.52	0 %100
102	M155A	Z	2.033	2.033	0 %100
103	M153B	X	-11.883	-11.883	0 %100
104	M153B	Z	6.861	6.861	0 %100

Member Distributed Loads (BLC 49 : Structure Wo (240 Deg)) (Continued)

	Member Label	Direction	Start Magnitude[lb/ft....	End Magnitude[lb/ft....	Start Location[ft.%]	End Location[ft.%]
105	M154B	X	-11.883	-11.883	0	%100
106	M154B	Z	6.861	6.861	0	%100
107	M155B	X	-11.93	-11.93	0	%100
108	M155B	Z	6.888	6.888	0	%100
109	M156B	X	-.699	-.699	0	%100
110	M156B	Z	.404	.404	0	%100

Member Distributed Loads (BLC 50 : Structure Wo (270 Deg))

	Member Label	Direction	Start Magnitude[lb/ft....	End Magnitude[lb/ft....	Start Location[ft.%]	End Location[ft.%]
1	FACE	X	0	0	0	%100
2	FACE	Z	0	0	0	%100
3	M2	X	-16.256	-16.256	0	%100
4	M2	Z	0	0	0	%100
5	M3	X	-16.256	-16.256	0	%100
6	M3	Z	0	0	0	%100
7	M4	X	-18.182	-18.182	0	%100
8	M4	Z	0	0	0	%100
9	M5	X	-18.182	-18.182	0	%100
10	M5	Z	0	0	0	%100
11	M9	X	-4.546	-4.546	0	%100
12	M9	Z	0	0	0	%100
13	M10	X	-4.546	-4.546	0	%100
14	M10	Z	0	0	0	%100
15	M14	X	-4.546	-4.546	0	%100
16	M14	Z	0	0	0	%100
17	M15	X	-4.546	-4.546	0	%100
18	M15	Z	0	0	0	%100
19	M19	X	-16.256	-16.256	0	%100
20	M19	Z	0	0	0	%100
21	M20	X	0	0	0	%100
22	M20	Z	0	0	0	%100
23	M21	X	-16.256	-16.256	0	%100
24	M21	Z	0	0	0	%100
25	M25	X	-25.252	-25.252	0	%100
26	M25	Z	0	0	0	%100
27	M28	X	-6.313	-6.313	0	%100
28	M28	Z	0	0	0	%100
29	M31	X	-6.313	-6.313	0	%100
30	M31	Z	0	0	0	%100
31	MP1A	X	-10.295	-10.295	0	%100
32	MP1A	Z	0	0	0	%100
33	MP2A	X	-10.295	-10.295	0	%100
34	MP2A	Z	0	0	0	%100
35	MP3A	X	-12.463	-12.463	0	%100
36	MP3A	Z	0	0	0	%100
37	MP4A	X	-10.295	-10.295	0	%100
38	MP4A	Z	0	0	0	%100
39	MP5A	X	-10.295	-10.295	0	%100
40	MP5A	Z	0	0	0	%100
41	MP1C	X	-10.295	-10.295	0	%100
42	MP1C	Z	0	0	0	%100
43	MP2C	X	-10.295	-10.295	0	%100
44	MP2C	Z	0	0	0	%100
45	MP3C	X	-12.463	-12.463	0	%100
46	MP3C	Z	0	0	0	%100
47	MP4C	X	-10.295	-10.295	0	%100
48	MP4C	Z	0	0	0	%100
49	MP5C	X	-10.295	-10.295	0	%100

Member Distributed Loads (BLC 50 : Structure Wo (270 Deg)) (Continued)

Member Label	Direction	Start Magnitude[lb/ft....]	End Magnitude[lb/ft....]	Start Location[ft.%]	End Location[ft.%]
50	MP5C	Z	0	0	%100
51	MP1B	X	-10.295	-10.295	0
52	MP1B	Z	0	0	%100
53	MP2B	X	-10.295	-10.295	0
54	MP2B	Z	0	0	%100
55	MP3B	X	-12.463	-12.463	0
56	MP3B	Z	0	0	%100
57	MP4B	X	-10.295	-10.295	0
58	MP4B	Z	0	0	%100
59	MP5B	X	-10.295	-10.295	0
60	MP5B	Z	0	0	%100
61	M76	X	-10.295	-10.295	0
62	M76	Z	0	0	%100
63	M77	X	-8.419	-8.419	0
64	M77	Z	0	0	%100
65	M72	X	-.391	-.391	0
66	M72	Z	0	0	%100
67	M73	X	-.391	-.391	0
68	M73	Z	0	0	%100
69	M76A	X	-6.974	-6.974	0
70	M76A	Z	0	0	%100
71	M81A	X	-.391	-.391	0
72	M81A	Z	0	0	%100
73	M82	X	-.391	-.391	0
74	M82	Z	0	0	%100
75	M82A	X	0	0	%100
76	M82A	Z	0	0	%100
77	M88	X	-9.347	-9.347	0
78	M88	Z	0	0	%100
79	M94	X	-9.347	-9.347	0
80	M94	Z	0	0	%100
81	M109	X	-5.148	-5.148	0
82	M109	Z	0	0	%100
83	M110	X	-5.148	-5.148	0
84	M110	Z	0	0	%100
85	M115	X	0	0	%100
86	M115	Z	0	0	%100
87	M121	X	-9.347	-9.347	0
88	M121	Z	0	0	%100
89	M127	X	-9.347	-9.347	0
90	M127	Z	0	0	%100
91	M139	X	-12.195	-12.195	0
92	M139	Z	0	0	%100
93	M143A	X	-12.195	-12.195	0
94	M143A	Z	0	0	%100
95	M146A	X	0	0	%100
96	M146A	Z	0	0	%100
97	M149A	X	-12.195	-12.195	0
98	M149A	Z	0	0	%100
99	M152A	X	-12.195	-12.195	0
100	M152A	Z	0	0	%100
101	M155A	X	0	0	%100
102	M155A	Z	0	0	%100
103	M153B	X	-5.094	-5.094	0
104	M153B	Z	0	0	%100
105	M154B	X	-18.062	-18.062	0
106	M154B	Z	0	0	%100
107	M155B	X	-18.062	-18.062	0
108	M155B	Z	0	0	%100

Member Distributed Loads (BLC 50 : Structure Wo (270 Deg)) (Continued)

	Member Label	Direction	Start Magnitude[lb/ft....]	End Magnitude[lb/ft....]	Start Location[ft.%]	End Location[ft.%]
109	M156B	X	-5.094	-5.094	0	%100
110	M156B	Z	0	0	0	%100

Member Distributed Loads (BLC 51 : Structure Wo (300 Deg))

	Member Label	Direction	Start Magnitude[lb/ft....]	End Magnitude[lb/ft....]	Start Location[ft.%]	End Location[ft.%]
1	FACE	X	-4.693	-4.693	0	%100
2	FACE	Z	-2.709	-2.709	0	%100
3	M2	X	-4.693	-4.693	0	%100
4	M2	Z	-2.709	-2.709	0	%100
5	M3	X	-18.77	-18.77	0	%100
6	M3	Z	-10.837	-10.837	0	%100
7	M4	X	-11.81	-11.81	0	%100
8	M4	Z	-6.818	-6.818	0	%100
9	M5	X	-11.81	-11.81	0	%100
10	M5	Z	-6.818	-6.818	0	%100
11	M9	X	-11.81	-11.81	0	%100
12	M9	Z	-6.818	-6.818	0	%100
13	M10	X	-11.81	-11.81	0	%100
14	M10	Z	-6.818	-6.818	0	%100
15	M14	X	0	0	0	%100
16	M14	Z	0	0	0	%100
17	M15	X	0	0	0	%100
18	M15	Z	0	0	0	%100
19	M19	X	-18.77	-18.77	0	%100
20	M19	Z	-10.837	-10.837	0	%100
21	M20	X	-4.693	-4.693	0	%100
22	M20	Z	-2.709	-2.709	0	%100
23	M21	X	-4.693	-4.693	0	%100
24	M21	Z	-2.709	-2.709	0	%100
25	M25	X	-16.402	-16.402	0	%100
26	M25	Z	-9.47	-9.47	0	%100
27	M28	X	-16.402	-16.402	0	%100
28	M28	Z	-9.47	-9.47	0	%100
29	M31	X	0	0	0	%100
30	M31	Z	0	0	0	%100
31	MP1A	X	-8.916	-8.916	0	%100
32	MP1A	Z	-5.148	-5.148	0	%100
33	MP2A	X	-8.916	-8.916	0	%100
34	MP2A	Z	-5.148	-5.148	0	%100
35	MP3A	X	-10.793	-10.793	0	%100
36	MP3A	Z	-6.231	-6.231	0	%100
37	MP4A	X	-8.916	-8.916	0	%100
38	MP4A	Z	-5.148	-5.148	0	%100
39	MP5A	X	-8.916	-8.916	0	%100
40	MP5A	Z	-5.148	-5.148	0	%100
41	MP1C	X	-8.916	-8.916	0	%100
42	MP1C	Z	-5.148	-5.148	0	%100
43	MP2C	X	-8.916	-8.916	0	%100
44	MP2C	Z	-5.148	-5.148	0	%100
45	MP3C	X	-10.793	-10.793	0	%100
46	MP3C	Z	-6.231	-6.231	0	%100
47	MP4C	X	-8.916	-8.916	0	%100
48	MP4C	Z	-5.148	-5.148	0	%100
49	MP5C	X	-8.916	-8.916	0	%100
50	MP5C	Z	-5.148	-5.148	0	%100
51	MP1B	X	-8.916	-8.916	0	%100
52	MP1B	Z	-5.148	-5.148	0	%100
53	MP2B	X	-8.916	-8.916	0	%100

Member Distributed Loads (BLC 51 : Structure Wo (300 Deg)) (Continued)

Member Label	Direction	Start Magnitude[lb/ft....]	End Magnitude[lb/ft....]	Start Location[ft.%]	End Location[ft.%]
54	MP2B	Z	-5.148	-5.148	0 %100
55	MP3B	X	-10.793	-10.793	0 %100
56	MP3B	Z	-6.231	-6.231	0 %100
57	MP4B	X	-8.916	-8.916	0 %100
58	MP4B	Z	-5.148	-5.148	0 %100
59	MP5B	X	-8.916	-8.916	0 %100
60	MP5B	Z	-5.148	-5.148	0 %100
61	M76	X	-8.916	-8.916	0 %100
62	M76	Z	-5.148	-5.148	0 %100
63	M77	X	-7.291	-7.291	0 %100
64	M77	Z	-4.209	-4.209	0 %100
65	M72	X	-1.017	-1.017	0 %100
66	M72	Z	-.587	-.587	0 %100
67	M73	X	-1.017	-1.017	0 %100
68	M73	Z	-.587	-.587	0 %100
69	M76A	X	-6.04	-6.04	0 %100
70	M76A	Z	-3.487	-3.487	0 %100
71	M81A	X	-1.017	-1.017	0 %100
72	M81A	Z	-.587	-.587	0 %100
73	M82	X	-1.017	-1.017	0 %100
74	M82	Z	-.587	-.587	0 %100
75	M82A	X	-2.698	-2.698	0 %100
76	M82A	Z	-1.558	-1.558	0 %100
77	M88	X	-2.698	-2.698	0 %100
78	M88	Z	-1.558	-1.558	0 %100
79	M94	X	-10.793	-10.793	0 %100
80	M94	Z	-6.231	-6.231	0 %100
81	M109	X	-11.93	-11.93	0 %100
82	M109	Z	-6.888	-6.888	0 %100
83	M110	X	-.699	-.699	0 %100
84	M110	Z	-.404	-.404	0 %100
85	M115	X	-2.698	-2.698	0 %100
86	M115	Z	-1.558	-1.558	0 %100
87	M121	X	-2.698	-2.698	0 %100
88	M121	Z	-1.558	-1.558	0 %100
89	M127	X	-10.793	-10.793	0 %100
90	M127	Z	-6.231	-6.231	0 %100
91	M139	X	-3.52	-3.52	0 %100
92	M139	Z	-2.033	-2.033	0 %100
93	M143A	X	-14.082	-14.082	0 %100
94	M143A	Z	-8.13	-8.13	0 %100
95	M146A	X	-3.52	-3.52	0 %100
96	M146A	Z	-2.033	-2.033	0 %100
97	M149A	X	-3.52	-3.52	0 %100
98	M149A	Z	-2.033	-2.033	0 %100
99	M152A	X	-14.082	-14.082	0 %100
100	M152A	Z	-8.13	-8.13	0 %100
101	M155A	X	-3.52	-3.52	0 %100
102	M155A	Z	-2.033	-2.033	0 %100
103	M153B	X	-.699	-.699	0 %100
104	M153B	Z	-.404	-.404	0 %100
105	M154B	X	-11.93	-11.93	0 %100
106	M154B	Z	-6.888	-6.888	0 %100
107	M155B	X	-11.883	-11.883	0 %100
108	M155B	Z	-6.861	-6.861	0 %100
109	M156B	X	-11.883	-11.883	0 %100
110	M156B	Z	-6.861	-6.861	0 %100

Member Distributed Loads (BLC 52 : Structure Wo (330 Deg))

Member Label	Direction	Start Magnitude[lb/ft....	End Magnitude[lb/ft....	Start Location[ft.%]	End Location[ft.%]
1	FACE	X	-8.128	-8.128	0 %100
2	FACE	Z	-14.078	-14.078	0 %100
3	M2	X	0	0	0 %100
4	M2	Z	0	0	0 %100
5	M3	X	-8.128	-8.128	0 %100
6	M3	Z	-14.078	-14.078	0 %100
7	M4	X	-2.273	-2.273	0 %100
8	M4	Z	-3.937	-3.937	0 %100
9	M5	X	-2.273	-2.273	0 %100
10	M5	Z	-3.937	-3.937	0 %100
11	M9	X	-9.091	-9.091	0 %100
12	M9	Z	-15.746	-15.746	0 %100
13	M10	X	-9.091	-9.091	0 %100
14	M10	Z	-15.746	-15.746	0 %100
15	M14	X	-2.273	-2.273	0 %100
16	M14	Z	-3.937	-3.937	0 %100
17	M15	X	-2.273	-2.273	0 %100
18	M15	Z	-3.937	-3.937	0 %100
19	M19	X	-8.128	-8.128	0 %100
20	M19	Z	-14.078	-14.078	0 %100
21	M20	X	-8.128	-8.128	0 %100
22	M20	Z	-14.078	-14.078	0 %100
23	M21	X	0	0	0 %100
24	M21	Z	0	0	0 %100
25	M25	X	-3.157	-3.157	0 %100
26	M25	Z	-5.467	-5.467	0 %100
27	M28	X	-12.626	-12.626	0 %100
28	M28	Z	-21.869	-21.869	0 %100
29	M31	X	-3.157	-3.157	0 %100
30	M31	Z	-5.467	-5.467	0 %100
31	MP1A	X	-5.148	-5.148	0 %100
32	MP1A	Z	-8.916	-8.916	0 %100
33	MP2A	X	-5.148	-5.148	0 %100
34	MP2A	Z	-8.916	-8.916	0 %100
35	MP3A	X	-6.231	-6.231	0 %100
36	MP3A	Z	-10.793	-10.793	0 %100
37	MP4A	X	-5.148	-5.148	0 %100
38	MP4A	Z	-8.916	-8.916	0 %100
39	MP5A	X	-5.148	-5.148	0 %100
40	MP5A	Z	-8.916	-8.916	0 %100
41	MP1C	X	-5.148	-5.148	0 %100
42	MP1C	Z	-8.916	-8.916	0 %100
43	MP2C	X	-5.148	-5.148	0 %100
44	MP2C	Z	-8.916	-8.916	0 %100
45	MP3C	X	-6.231	-6.231	0 %100
46	MP3C	Z	-10.793	-10.793	0 %100
47	MP4C	X	-5.148	-5.148	0 %100
48	MP4C	Z	-8.916	-8.916	0 %100
49	MP5C	X	-5.148	-5.148	0 %100
50	MP5C	Z	-8.916	-8.916	0 %100
51	MP1B	X	-5.148	-5.148	0 %100
52	MP1B	Z	-8.916	-8.916	0 %100
53	MP2B	X	-5.148	-5.148	0 %100
54	MP2B	Z	-8.916	-8.916	0 %100
55	MP3B	X	-6.231	-6.231	0 %100
56	MP3B	Z	-10.793	-10.793	0 %100
57	MP4B	X	-5.148	-5.148	0 %100
58	MP4B	Z	-8.916	-8.916	0 %100
59	MP5B	X	-5.148	-5.148	0 %100

Member Distributed Loads (BLC 52 : Structure Wo (330 Deg)) (Continued)

Member Label	Direction	Start Magnitude[lb/ft....]	End Magnitude[lb/ft....]	Start Location[ft.%]	End Location[ft.%]
60	MP5B	Z	-8.916	-8.916	0 %100
61	M76	X	-5.148	-5.148	0 %100
62	M76	Z	-8.916	-8.916	0 %100
63	M77	X	-4.209	-4.209	0 %100
64	M77	Z	-7.291	-7.291	0 %100
65	M72	X	-.783	-.783	0 %100
66	M72	Z	-1.356	-1.356	0 %100
67	M73	X	-.783	-.783	0 %100
68	M73	Z	-1.356	-1.356	0 %100
69	M76A	X	-3.487	-3.487	0 %100
70	M76A	Z	-6.04	-6.04	0 %100
71	M81A	X	-.783	-.783	0 %100
72	M81A	Z	-1.356	-1.356	0 %100
73	M82	X	-.783	-.783	0 %100
74	M82	Z	-1.356	-1.356	0 %100
75	M82A	X	-4.674	-4.674	0 %100
76	M82A	Z	-8.095	-8.095	0 %100
77	M88	X	0	0	0 %100
78	M88	Z	0	0	0 %100
79	M94	X	-4.674	-4.674	0 %100
80	M94	Z	-8.095	-8.095	0 %100
81	M109	X	-9.031	-9.031	0 %100
82	M109	Z	-15.642	-15.642	0 %100
83	M110	X	-2.547	-2.547	0 %100
84	M110	Z	-4.411	-4.411	0 %100
85	M115	X	-4.674	-4.674	0 %100
86	M115	Z	-8.095	-8.095	0 %100
87	M121	X	0	0	0 %100
88	M121	Z	0	0	0 %100
89	M127	X	-4.674	-4.674	0 %100
90	M127	Z	-8.095	-8.095	0 %100
91	M139	X	0	0	0 %100
92	M139	Z	0	0	0 %100
93	M143A	X	-6.098	-6.098	0 %100
94	M143A	Z	-10.561	-10.561	0 %100
95	M146A	X	-6.098	-6.098	0 %100
96	M146A	Z	-10.561	-10.561	0 %100
97	M149A	X	0	0	0 %100
98	M149A	Z	0	0	0 %100
99	M152A	X	-6.098	-6.098	0 %100
100	M152A	Z	-10.561	-10.561	0 %100
101	M155A	X	-6.098	-6.098	0 %100
102	M155A	Z	-10.561	-10.561	0 %100
103	M153B	X	-2.574	-2.574	0 %100
104	M153B	Z	-4.458	-4.458	0 %100
105	M154B	X	-2.574	-2.574	0 %100
106	M154B	Z	-4.458	-4.458	0 %100
107	M155B	X	-2.547	-2.547	0 %100
108	M155B	Z	-4.411	-4.411	0 %100
109	M156B	X	-9.031	-9.031	0 %100
110	M156B	Z	-15.642	-15.642	0 %100

Member Distributed Loads (BLC 53 : Structure Wi (0 Deg))

Member Label	Direction	Start Magnitude[lb/ft....]	End Magnitude[lb/ft....]	Start Location[ft.%]	End Location[ft.%]
1	FACE	X	0	0	0 %100
2	FACE	Z	-5.531	-5.531	0 %100
3	M2	X	0	0	0 %100
4	M2	Z	-1.383	-1.383	0 %100

Member Distributed Loads (BLC 53 : Structure Wi (0 Deg)) (Continued)

Member Label	Direction	Start Magnitude[lb/ft....	End Magnitude[lb/ft....	Start Location[ft.%]	End Location[ft.%]
5	M3	X	0	0	%100
6	M3	Z	-1.383	-1.383	%100
7	M4	X	0	0	%100
8	M4	Z	0	0	%100
9	M5	X	0	0	%100
10	M5	Z	0	0	%100
11	M9	X	0	0	%100
12	M9	Z	-3.56	-3.56	%100
13	M10	X	0	0	%100
14	M10	Z	-3.56	-3.56	%100
15	M14	X	0	0	%100
16	M14	Z	-3.56	-3.56	%100
17	M15	X	0	0	%100
18	M15	Z	-3.56	-3.56	%100
19	M19	X	0	0	%100
20	M19	Z	-1.383	-1.383	%100
21	M20	X	0	0	%100
22	M20	Z	-5.531	-5.531	%100
23	M21	X	0	0	%100
24	M21	Z	-1.383	-1.383	%100
25	M25	X	0	0	%100
26	M25	Z	0	0	%100
27	M28	X	0	0	%100
28	M28	Z	-4.364	-4.364	%100
29	M31	X	0	0	%100
30	M31	Z	-4.364	-4.364	%100
31	MP1A	X	0	0	%100
32	MP1A	Z	-3.555	-3.555	%100
33	MP2A	X	0	0	%100
34	MP2A	Z	-3.555	-3.555	%100
35	MP3A	X	0	0	%100
36	MP3A	Z	-3.932	-3.932	%100
37	MP4A	X	0	0	%100
38	MP4A	Z	-3.555	-3.555	%100
39	MP5A	X	0	0	%100
40	MP5A	Z	-3.555	-3.555	%100
41	MP1C	X	0	0	%100
42	MP1C	Z	-3.555	-3.555	%100
43	MP2C	X	0	0	%100
44	MP2C	Z	-3.555	-3.555	%100
45	MP3C	X	0	0	%100
46	MP3C	Z	-3.932	-3.932	%100
47	MP4C	X	0	0	%100
48	MP4C	Z	-3.555	-3.555	%100
49	MP5C	X	0	0	%100
50	MP5C	Z	-3.555	-3.555	%100
51	MP1B	X	0	0	%100
52	MP1B	Z	-3.555	-3.555	%100
53	MP2B	X	0	0	%100
54	MP2B	Z	-3.555	-3.555	%100
55	MP3B	X	0	0	%100
56	MP3B	Z	-3.932	-3.932	%100
57	MP4B	X	0	0	%100
58	MP4B	Z	-3.555	-3.555	%100
59	MP5B	X	0	0	%100
60	MP5B	Z	-3.555	-3.555	%100
61	M76	X	0	0	%100
62	M76	Z	-3.555	-3.555	%100
63	M77	X	0	0	%100

Member Distributed Loads (BLC 53 : Structure Wi (0 Deg)) (Continued)

Member Label	Direction	Start Magnitude[lb/ft....]	End Magnitude[lb/ft....]	Start Location[ft.%]	End Location[ft.%]
64	M77	Z	-2.913	-2.913	0 %100
65	M72	X	0	0	0 %100
66	M72	Z	-.977	-.977	0 %100
67	M73	X	0	0	0 %100
68	M73	Z	-.977	-.977	0 %100
69	M76A	X	0	0	0 %100
70	M76A	Z	-2.411	-2.411	0 %100
71	M81A	X	0	0	0 %100
72	M81A	Z	-.977	-.977	0 %100
73	M82	X	0	0	0 %100
74	M82	Z	-.977	-.977	0 %100
75	M82A	X	0	0	0 %100
76	M82A	Z	-3.932	-3.932	0 %100
77	M88	X	0	0	0 %100
78	M88	Z	-.983	-.983	0 %100
79	M94	X	0	0	0 %100
80	M94	Z	-.983	-.983	0 %100
81	M109	X	0	0	0 %100
82	M109	Z	-3.725	-3.725	0 %100
83	M110	X	0	0	0 %100
84	M110	Z	-3.725	-3.725	0 %100
85	M115	X	0	0	0 %100
86	M115	Z	-3.932	-3.932	0 %100
87	M121	X	0	0	0 %100
88	M121	Z	-.983	-.983	0 %100
89	M127	X	0	0	0 %100
90	M127	Z	-.983	-.983	0 %100
91	M139	X	0	0	0 %100
92	M139	Z	-1.048	-1.048	0 %100
93	M143A	X	0	0	0 %100
94	M143A	Z	-1.048	-1.048	0 %100
95	M146A	X	0	0	0 %100
96	M146A	Z	-4.191	-4.191	0 %100
97	M149A	X	0	0	0 %100
98	M149A	Z	-1.048	-1.048	0 %100
99	M152A	X	0	0	0 %100
100	M152A	Z	-1.048	-1.048	0 %100
101	M155A	X	0	0	0 %100
102	M155A	Z	-4.191	-4.191	0 %100
103	M153B	X	0	0	0 %100
104	M153B	Z	-3.74	-3.74	0 %100
105	M154B	X	0	0	0 %100
106	M154B	Z	-.219	-.219	0 %100
107	M155B	X	0	0	0 %100
108	M155B	Z	-.219	-.219	0 %100
109	M156B	X	0	0	0 %100
110	M156B	Z	-3.74	-3.74	0 %100

Member Distributed Loads (BLC 54 : Structure Wi (30 Deg))

Member Label	Direction	Start Magnitude[lb/ft....]	End Magnitude[lb/ft....]	Start Location[ft.%]	End Location[ft.%]
1	FACE	X	2.074	2.074	0 %100
2	FACE	Z	-3.592	-3.592	0 %100
3	M2	X	2.074	2.074	0 %100
4	M2	Z	-3.592	-3.592	0 %100
5	M3	X	0	0	0 %100
6	M3	Z	0	0	0 %100
7	M4	X	.593	.593	0 %100
8	M4	Z	-1.028	-1.028	0 %100

Member Distributed Loads (BLC 54 : Structure Wi (30 Deg)) (Continued)

	Member Label	Direction	Start Magnitude[lb/ft....	End Magnitude[lb/ft....	Start Location[ft.%]	End Location[ft.%]
9	M5	X	.593	.593	0	%100
10	M5	Z	-1.028	-1.028	0	%100
11	M9	X	.593	.593	0	%100
12	M9	Z	-1.028	-1.028	0	%100
13	M10	X	.593	.593	0	%100
14	M10	Z	-1.028	-1.028	0	%100
15	M14	X	2.374	2.374	0	%100
16	M14	Z	-4.111	-4.111	0	%100
17	M15	X	2.374	2.374	0	%100
18	M15	Z	-4.111	-4.111	0	%100
19	M19	X	0	0	0	%100
20	M19	Z	0	0	0	%100
21	M20	X	2.074	2.074	0	%100
22	M20	Z	-3.592	-3.592	0	%100
23	M21	X	2.074	2.074	0	%100
24	M21	Z	-3.592	-3.592	0	%100
25	M25	X	.727	.727	0	%100
26	M25	Z	-1.26	-1.26	0	%100
27	M28	X	.727	.727	0	%100
28	M28	Z	-1.26	-1.26	0	%100
29	M31	X	2.909	2.909	0	%100
30	M31	Z	-5.039	-5.039	0	%100
31	MP1A	X	1.778	1.778	0	%100
32	MP1A	Z	-3.079	-3.079	0	%100
33	MP2A	X	1.778	1.778	0	%100
34	MP2A	Z	-3.079	-3.079	0	%100
35	MP3A	X	1.966	1.966	0	%100
36	MP3A	Z	-3.405	-3.405	0	%100
37	MP4A	X	1.778	1.778	0	%100
38	MP4A	Z	-3.079	-3.079	0	%100
39	MP5A	X	1.778	1.778	0	%100
40	MP5A	Z	-3.079	-3.079	0	%100
41	MP1C	X	1.778	1.778	0	%100
42	MP1C	Z	-3.079	-3.079	0	%100
43	MP2C	X	1.778	1.778	0	%100
44	MP2C	Z	-3.079	-3.079	0	%100
45	MP3C	X	1.966	1.966	0	%100
46	MP3C	Z	-3.405	-3.405	0	%100
47	MP4C	X	1.778	1.778	0	%100
48	MP4C	Z	-3.079	-3.079	0	%100
49	MP5C	X	1.778	1.778	0	%100
50	MP5C	Z	-3.079	-3.079	0	%100
51	MP1B	X	1.778	1.778	0	%100
52	MP1B	Z	-3.079	-3.079	0	%100
53	MP2B	X	1.778	1.778	0	%100
54	MP2B	Z	-3.079	-3.079	0	%100
55	MP3B	X	1.966	1.966	0	%100
56	MP3B	Z	-3.405	-3.405	0	%100
57	MP4B	X	1.778	1.778	0	%100
58	MP4B	Z	-3.079	-3.079	0	%100
59	MP5B	X	1.778	1.778	0	%100
60	MP5B	Z	-3.079	-3.079	0	%100
61	M76	X	1.778	1.778	0	%100
62	M76	Z	-3.079	-3.079	0	%100
63	M77	X	1.456	1.456	0	%100
64	M77	Z	-2.523	-2.523	0	%100
65	M72	X	.163	.163	0	%100
66	M72	Z	-.282	-.282	0	%100
67	M73	X	.163	.163	0	%100

Member Distributed Loads (BLC 54 : Structure Wi (30 Deg)) (Continued)

Member Label	Direction	Start Magnitude[lb/ft....]	End Magnitude[lb/ft....]	Start Location[ft.%]	End Location[ft.%]
68	M73	Z	-.282	0	%100
69	M76A	X	1.206	0	%100
70	M76A	Z	-2.088	0	%100
71	M81A	X	.163	0	%100
72	M81A	Z	-.282	0	%100
73	M82	X	.163	0	%100
74	M82	Z	-.282	0	%100
75	M82A	X	1.474	0	%100
76	M82A	Z	-2.554	0	%100
77	M88	X	1.474	0	%100
78	M88	Z	-2.554	0	%100
79	M94	X	0	0	%100
80	M94	Z	0	0	%100
81	M109	X	.691	0	%100
82	M109	Z	-1.198	0	%100
83	M110	X	2.452	0	%100
84	M110	Z	-4.247	0	%100
85	M115	X	1.474	0	%100
86	M115	Z	-2.554	0	%100
87	M121	X	1.474	0	%100
88	M121	Z	-2.554	0	%100
89	M127	X	0	0	%100
90	M127	Z	0	0	%100
91	M139	X	1.572	0	%100
92	M139	Z	-2.722	0	%100
93	M143A	X	0	0	%100
94	M143A	Z	0	0	%100
95	M146A	X	1.572	0	%100
96	M146A	Z	-2.722	0	%100
97	M149A	X	1.572	0	%100
98	M149A	Z	-2.722	0	%100
99	M152A	X	0	0	%100
100	M152A	Z	0	0	%100
101	M155A	X	1.572	0	%100
102	M155A	Z	-2.722	0	%100
103	M153B	X	2.452	0	%100
104	M153B	Z	-4.247	0	%100
105	M154B	X	.691	0	%100
106	M154B	Z	-1.198	0	%100
107	M155B	X	.699	0	%100
108	M155B	Z	-1.21	0	%100
109	M156B	X	.699	0	%100
110	M156B	Z	-1.21	0	%100

Member Distributed Loads (BLC 55 : Structure Wi (60 Deg))

Member Label	Direction	Start Magnitude[lb/ft....]	End Magnitude[lb/ft....]	Start Location[ft.%]	End Location[ft.%]
1	FACE	X	1.197	0	%100
2	FACE	Z	-.691	0	%100
3	M2	X	4.79	0	%100
4	M2	Z	-2.765	0	%100
5	M3	X	1.197	0	%100
6	M3	Z	-.691	0	%100
7	M4	X	3.083	0	%100
8	M4	Z	-1.78	0	%100
9	M5	X	3.083	0	%100
10	M5	Z	-1.78	0	%100
11	M9	X	0	0	%100
12	M9	Z	0	0	%100



Member Distributed Loads (BLC 55 : Structure Wi (60 Deg)) (Continued)

	Member Label	Direction	Start Magnitude[lb/ft....	End Magnitude[lb/ft....	Start Location[ft.%]	End Location[ft.%]
13	M10	X	0	0	0	%100
14	M10	Z	0	0	0	%100
15	M14	X	3.083	3.083	0	%100
16	M14	Z	-1.78	-1.78	0	%100
17	M15	X	3.083	3.083	0	%100
18	M15	Z	-1.78	-1.78	0	%100
19	M19	X	1.197	1.197	0	%100
20	M19	Z	-.691	-.691	0	%100
21	M20	X	1.197	1.197	0	%100
22	M20	Z	-.691	-.691	0	%100
23	M21	X	4.79	4.79	0	%100
24	M21	Z	-2.765	-2.765	0	%100
25	M25	X	3.779	3.779	0	%100
26	M25	Z	-2.182	-2.182	0	%100
27	M28	X	0	0	0	%100
28	M28	Z	0	0	0	%100
29	M31	X	3.779	3.779	0	%100
30	M31	Z	-2.182	-2.182	0	%100
31	MP1A	X	3.079	3.079	0	%100
32	MP1A	Z	-1.778	-1.778	0	%100
33	MP2A	X	3.079	3.079	0	%100
34	MP2A	Z	-1.778	-1.778	0	%100
35	MP3A	X	3.405	3.405	0	%100
36	MP3A	Z	-1.966	-1.966	0	%100
37	MP4A	X	3.079	3.079	0	%100
38	MP4A	Z	-1.778	-1.778	0	%100
39	MP5A	X	3.079	3.079	0	%100
40	MP5A	Z	-1.778	-1.778	0	%100
41	MP1C	X	3.079	3.079	0	%100
42	MP1C	Z	-1.778	-1.778	0	%100
43	MP2C	X	3.079	3.079	0	%100
44	MP2C	Z	-1.778	-1.778	0	%100
45	MP3C	X	3.405	3.405	0	%100
46	MP3C	Z	-1.966	-1.966	0	%100
47	MP4C	X	3.079	3.079	0	%100
48	MP4C	Z	-1.778	-1.778	0	%100
49	MP5C	X	3.079	3.079	0	%100
50	MP5C	Z	-1.778	-1.778	0	%100
51	MP1B	X	3.079	3.079	0	%100
52	MP1B	Z	-1.778	-1.778	0	%100
53	MP2B	X	3.079	3.079	0	%100
54	MP2B	Z	-1.778	-1.778	0	%100
55	MP3B	X	3.405	3.405	0	%100
56	MP3B	Z	-1.966	-1.966	0	%100
57	MP4B	X	3.079	3.079	0	%100
58	MP4B	Z	-1.778	-1.778	0	%100
59	MP5B	X	3.079	3.079	0	%100
60	MP5B	Z	-1.778	-1.778	0	%100
61	M76	X	3.079	3.079	0	%100
62	M76	Z	-1.778	-1.778	0	%100
63	M77	X	2.523	2.523	0	%100
64	M77	Z	-1.456	-1.456	0	%100
65	M72	X	0	0	0	%100
66	M72	Z	0	0	0	%100
67	M73	X	0	0	0	%100
68	M73	Z	0	0	0	%100
69	M76A	X	2.088	2.088	0	%100
70	M76A	Z	-1.206	-1.206	0	%100
71	M81A	X	0	0	0	%100

Member Distributed Loads (BLC 55 : Structure Wi (60 Deg)) (Continued)

	Member Label	Direction	Start Magnitude[lb/ft....]	End Magnitude[lb/ft....]	Start Location[ft.%]	End Location[ft.%]
72	M81A	Z	0	0	0	%100
73	M82	X	0	0	0	%100
74	M82	Z	0	0	0	%100
75	M82A	X	.851	.851	0	%100
76	M82A	Z	-.491	-.491	0	%100
77	M88	X	3.405	3.405	0	%100
78	M88	Z	-1.966	-1.966	0	%100
79	M94	X	.851	.851	0	%100
80	M94	Z	-.491	-.491	0	%100
81	M109	X	.19	.19	0	%100
82	M109	Z	-.11	-.11	0	%100
83	M110	X	3.239	3.239	0	%100
84	M110	Z	-1.87	-1.87	0	%100
85	M115	X	.851	.851	0	%100
86	M115	Z	-.491	-.491	0	%100
87	M121	X	3.405	3.405	0	%100
88	M121	Z	-1.966	-1.966	0	%100
89	M127	X	.851	.851	0	%100
90	M127	Z	-.491	-.491	0	%100
91	M139	X	3.63	3.63	0	%100
92	M139	Z	-2.095	-2.095	0	%100
93	M143A	X	.907	.907	0	%100
94	M143A	Z	-.524	-.524	0	%100
95	M146A	X	.907	.907	0	%100
96	M146A	Z	-.524	-.524	0	%100
97	M149A	X	3.63	3.63	0	%100
98	M149A	Z	-2.095	-2.095	0	%100
99	M152A	X	.907	.907	0	%100
100	M152A	Z	-.524	-.524	0	%100
101	M155A	X	.907	.907	0	%100
102	M155A	Z	-.524	-.524	0	%100
103	M153B	X	3.226	3.226	0	%100
104	M153B	Z	-1.863	-1.863	0	%100
105	M154B	X	3.226	3.226	0	%100
106	M154B	Z	-1.863	-1.863	0	%100
107	M155B	X	3.239	3.239	0	%100
108	M155B	Z	-1.87	-1.87	0	%100
109	M156B	X	.19	.19	0	%100
110	M156B	Z	-.11	-.11	0	%100

Member Distributed Loads (BLC 56 : Structure Wi (90 Deg))

	Member Label	Direction	Start Magnitude[lb/ft....]	End Magnitude[lb/ft....]	Start Location[ft.%]	End Location[ft.%]
1	FACE	X	0	0	0	%100
2	FACE	Z	0	0	0	%100
3	M2	X	4.148	4.148	0	%100
4	M2	Z	0	0	0	%100
5	M3	X	4.148	4.148	0	%100
6	M3	Z	0	0	0	%100
7	M4	X	4.747	4.747	0	%100
8	M4	Z	0	0	0	%100
9	M5	X	4.747	4.747	0	%100
10	M5	Z	0	0	0	%100
11	M9	X	1.187	1.187	0	%100
12	M9	Z	0	0	0	%100
13	M10	X	1.187	1.187	0	%100
14	M10	Z	0	0	0	%100
15	M14	X	1.187	1.187	0	%100
16	M14	Z	0	0	0	%100



Member Distributed Loads (BLC 56 : Structure Wi (90 Deg)) (Continued)

Member Label	Direction	Start Magnitude[lb/ft....	End Magnitude[lb/ft....	Start Location[ft.%]	End Location[ft.%]
17	M15	X	1.187	1.187	0 %100
18	M15	Z	0	0	0 %100
19	M19	X	4.148	4.148	0 %100
20	M19	Z	0	0	0 %100
21	M20	X	0	0	0 %100
22	M20	Z	0	0	0 %100
23	M21	X	4.148	4.148	0 %100
24	M21	Z	0	0	0 %100
25	M25	X	5.818	5.818	0 %100
26	M25	Z	0	0	0 %100
27	M28	X	1.455	1.455	0 %100
28	M28	Z	0	0	0 %100
29	M31	X	1.455	1.455	0 %100
30	M31	Z	0	0	0 %100
31	MP1A	X	3.555	3.555	0 %100
32	MP1A	Z	0	0	0 %100
33	MP2A	X	3.555	3.555	0 %100
34	MP2A	Z	0	0	0 %100
35	MP3A	X	3.932	3.932	0 %100
36	MP3A	Z	0	0	0 %100
37	MP4A	X	3.555	3.555	0 %100
38	MP4A	Z	0	0	0 %100
39	MP5A	X	3.555	3.555	0 %100
40	MP5A	Z	0	0	0 %100
41	MP1C	X	3.555	3.555	0 %100
42	MP1C	Z	0	0	0 %100
43	MP2C	X	3.555	3.555	0 %100
44	MP2C	Z	0	0	0 %100
45	MP3C	X	3.932	3.932	0 %100
46	MP3C	Z	0	0	0 %100
47	MP4C	X	3.555	3.555	0 %100
48	MP4C	Z	0	0	0 %100
49	MP5C	X	3.555	3.555	0 %100
50	MP5C	Z	0	0	0 %100
51	MP1B	X	3.555	3.555	0 %100
52	MP1B	Z	0	0	0 %100
53	MP2B	X	3.555	3.555	0 %100
54	MP2B	Z	0	0	0 %100
55	MP3B	X	3.932	3.932	0 %100
56	MP3B	Z	0	0	0 %100
57	MP4B	X	3.555	3.555	0 %100
58	MP4B	Z	0	0	0 %100
59	MP5B	X	3.555	3.555	0 %100
60	MP5B	Z	0	0	0 %100
61	M76	X	3.555	3.555	0 %100
62	M76	Z	0	0	0 %100
63	M77	X	2.913	2.913	0 %100
64	M77	Z	0	0	0 %100
65	M72	X	.326	.326	0 %100
66	M72	Z	0	0	0 %100
67	M73	X	.326	.326	0 %100
68	M73	Z	0	0	0 %100
69	M76A	X	2.411	2.411	0 %100
70	M76A	Z	0	0	0 %100
71	M81A	X	.326	.326	0 %100
72	M81A	Z	0	0	0 %100
73	M82	X	.326	.326	0 %100
74	M82	Z	0	0	0 %100
75	M82A	X	0	0	0 %100

Member Distributed Loads (BLC 56 : Structure Wi (90 Deg)) (Continued)

	Member Label	Direction	Start Magnitude[lb/ft....]	End Magnitude[lb/ft....]	Start Location[ft.%]	End Location[ft.%]
76	M82A	Z	0	0	0	%100
77	M88	X	2.949	2.949	0	%100
78	M88	Z	0	0	0	%100
79	M94	X	2.949	2.949	0	%100
80	M94	Z	0	0	0	%100
81	M109	X	1.398	1.398	0	%100
82	M109	Z	0	0	0	%100
83	M110	X	1.398	1.398	0	%100
84	M110	Z	0	0	0	%100
85	M115	X	0	0	0	%100
86	M115	Z	0	0	0	%100
87	M121	X	2.949	2.949	0	%100
88	M121	Z	0	0	0	%100
89	M127	X	2.949	2.949	0	%100
90	M127	Z	0	0	0	%100
91	M139	X	3.143	3.143	0	%100
92	M139	Z	0	0	0	%100
93	M143A	X	3.143	3.143	0	%100
94	M143A	Z	0	0	0	%100
95	M146A	X	0	0	0	%100
96	M146A	Z	0	0	0	%100
97	M149A	X	3.143	3.143	0	%100
98	M149A	Z	0	0	0	%100
99	M152A	X	3.143	3.143	0	%100
100	M152A	Z	0	0	0	%100
101	M155A	X	0	0	0	%100
102	M155A	Z	0	0	0	%100
103	M153B	X	1.383	1.383	0	%100
104	M153B	Z	0	0	0	%100
105	M154B	X	4.904	4.904	0	%100
106	M154B	Z	0	0	0	%100
107	M155B	X	4.904	4.904	0	%100
108	M155B	Z	0	0	0	%100
109	M156B	X	1.383	1.383	0	%100
110	M156B	Z	0	0	0	%100

Member Distributed Loads (BLC 57 : Structure Wi (120 Deg))

	Member Label	Direction	Start Magnitude[lb/ft....]	End Magnitude[lb/ft....]	Start Location[ft.%]	End Location[ft.%]
1	FACE	X	1.197	1.197	0	%100
2	FACE	Z	.691	.691	0	%100
3	M2	X	1.197	1.197	0	%100
4	M2	Z	.691	.691	0	%100
5	M3	X	4.79	4.79	0	%100
6	M3	Z	2.765	2.765	0	%100
7	M4	X	3.083	3.083	0	%100
8	M4	Z	1.78	1.78	0	%100
9	M5	X	3.083	3.083	0	%100
10	M5	Z	1.78	1.78	0	%100
11	M9	X	3.083	3.083	0	%100
12	M9	Z	1.78	1.78	0	%100
13	M10	X	3.083	3.083	0	%100
14	M10	Z	1.78	1.78	0	%100
15	M14	X	0	0	0	%100
16	M14	Z	0	0	0	%100
17	M15	X	0	0	0	%100
18	M15	Z	0	0	0	%100
19	M19	X	4.79	4.79	0	%100
20	M19	Z	2.765	2.765	0	%100



Member Distributed Loads (BLC 57 : Structure Wi (120 Deg)) (Continued)

Member Label	Direction	Start Magnitude[lb/ft....	End Magnitude[lb/ft....	Start Location[ft.%]	End Location[ft.%]
21	M20	X	1.197	1.197	0 %100
22	M20	Z	.691	.691	0 %100
23	M21	X	1.197	1.197	0 %100
24	M21	Z	.691	.691	0 %100
25	M25	X	3.779	3.779	0 %100
26	M25	Z	2.182	2.182	0 %100
27	M28	X	3.779	3.779	0 %100
28	M28	Z	2.182	2.182	0 %100
29	M31	X	0	0	0 %100
30	M31	Z	0	0	0 %100
31	MP1A	X	3.079	3.079	0 %100
32	MP1A	Z	1.778	1.778	0 %100
33	MP2A	X	3.079	3.079	0 %100
34	MP2A	Z	1.778	1.778	0 %100
35	MP3A	X	3.405	3.405	0 %100
36	MP3A	Z	1.966	1.966	0 %100
37	MP4A	X	3.079	3.079	0 %100
38	MP4A	Z	1.778	1.778	0 %100
39	MP5A	X	3.079	3.079	0 %100
40	MP5A	Z	1.778	1.778	0 %100
41	MP1C	X	3.079	3.079	0 %100
42	MP1C	Z	1.778	1.778	0 %100
43	MP2C	X	3.079	3.079	0 %100
44	MP2C	Z	1.778	1.778	0 %100
45	MP3C	X	3.405	3.405	0 %100
46	MP3C	Z	1.966	1.966	0 %100
47	MP4C	X	3.079	3.079	0 %100
48	MP4C	Z	1.778	1.778	0 %100
49	MP5C	X	3.079	3.079	0 %100
50	MP5C	Z	1.778	1.778	0 %100
51	MP1B	X	3.079	3.079	0 %100
52	MP1B	Z	1.778	1.778	0 %100
53	MP2B	X	3.079	3.079	0 %100
54	MP2B	Z	1.778	1.778	0 %100
55	MP3B	X	3.405	3.405	0 %100
56	MP3B	Z	1.966	1.966	0 %100
57	MP4B	X	3.079	3.079	0 %100
58	MP4B	Z	1.778	1.778	0 %100
59	MP5B	X	3.079	3.079	0 %100
60	MP5B	Z	1.778	1.778	0 %100
61	M76	X	3.079	3.079	0 %100
62	M76	Z	1.778	1.778	0 %100
63	M77	X	2.523	2.523	0 %100
64	M77	Z	1.456	1.456	0 %100
65	M72	X	.846	.846	0 %100
66	M72	Z	.489	.489	0 %100
67	M73	X	.846	.846	0 %100
68	M73	Z	.489	.489	0 %100
69	M76A	X	2.088	2.088	0 %100
70	M76A	Z	1.206	1.206	0 %100
71	M81A	X	.846	.846	0 %100
72	M81A	Z	.489	.489	0 %100
73	M82	X	.846	.846	0 %100
74	M82	Z	.489	.489	0 %100
75	M82A	X	.851	.851	0 %100
76	M82A	Z	.491	.491	0 %100
77	M88	X	.851	.851	0 %100
78	M88	Z	.491	.491	0 %100
79	M94	X	3.405	3.405	0 %100

Member Distributed Loads (BLC 57 : Structure Wi (120 Deg)) (Continued)

Member Label	Direction	Start Magnitude[lb/ft....]	End Magnitude[lb/ft....]	Start Location[ft.%]	End Location[ft.%]
80	M94	Z	1.966	1.966	0 %100
81	M109	X	3.239	3.239	0 %100
82	M109	Z	1.87	1.87	0 %100
83	M110	X	.19	.19	0 %100
84	M110	Z	.11	.11	0 %100
85	M115	X	.851	.851	0 %100
86	M115	Z	.491	.491	0 %100
87	M121	X	.851	.851	0 %100
88	M121	Z	.491	.491	0 %100
89	M127	X	3.405	3.405	0 %100
90	M127	Z	1.966	1.966	0 %100
91	M139	X	.907	.907	0 %100
92	M139	Z	.524	.524	0 %100
93	M143A	X	3.63	3.63	0 %100
94	M143A	Z	2.095	2.095	0 %100
95	M146A	X	.907	.907	0 %100
96	M146A	Z	.524	.524	0 %100
97	M149A	X	.907	.907	0 %100
98	M149A	Z	.524	.524	0 %100
99	M152A	X	3.63	3.63	0 %100
100	M152A	Z	2.095	2.095	0 %100
101	M155A	X	.907	.907	0 %100
102	M155A	Z	.524	.524	0 %100
103	M153B	X	.19	.19	0 %100
104	M153B	Z	.11	.11	0 %100
105	M154B	X	3.239	3.239	0 %100
106	M154B	Z	1.87	1.87	0 %100
107	M155B	X	3.226	3.226	0 %100
108	M155B	Z	1.863	1.863	0 %100
109	M156B	X	3.226	3.226	0 %100
110	M156B	Z	1.863	1.863	0 %100

Member Distributed Loads (BLC 58 : Structure Wi (150 Deg))

Member Label	Direction	Start Magnitude[lb/ft....]	End Magnitude[lb/ft....]	Start Location[ft.%]	End Location[ft.%]
1	FACE	X	2.074	2.074	0 %100
2	FACE	Z	3.592	3.592	0 %100
3	M2	X	0	0	0 %100
4	M2	Z	0	0	0 %100
5	M3	X	2.074	2.074	0 %100
6	M3	Z	3.592	3.592	0 %100
7	M4	X	.593	.593	0 %100
8	M4	Z	1.028	1.028	0 %100
9	M5	X	.593	.593	0 %100
10	M5	Z	1.028	1.028	0 %100
11	M9	X	2.374	2.374	0 %100
12	M9	Z	4.111	4.111	0 %100
13	M10	X	2.374	2.374	0 %100
14	M10	Z	4.111	4.111	0 %100
15	M14	X	.593	.593	0 %100
16	M14	Z	1.028	1.028	0 %100
17	M15	X	.593	.593	0 %100
18	M15	Z	1.028	1.028	0 %100
19	M19	X	2.074	2.074	0 %100
20	M19	Z	3.592	3.592	0 %100
21	M20	X	2.074	2.074	0 %100
22	M20	Z	3.592	3.592	0 %100
23	M21	X	0	0	0 %100
24	M21	Z	0	0	0 %100

Member Distributed Loads (BLC 58 : Structure Wi (150 Deg)) (Continued)

Member Label	Direction	Start Magnitude[lb/ft....	End Magnitude[lb/ft....	Start Location[ft.%]	End Location[ft.%]
25	M25	X	.727	.727	0 %100
26	M25	Z	1.26	1.26	0 %100
27	M28	X	2.909	2.909	0 %100
28	M28	Z	5.039	5.039	0 %100
29	M31	X	.727	.727	0 %100
30	M31	Z	1.26	1.26	0 %100
31	MP1A	X	1.778	1.778	0 %100
32	MP1A	Z	3.079	3.079	0 %100
33	MP2A	X	1.778	1.778	0 %100
34	MP2A	Z	3.079	3.079	0 %100
35	MP3A	X	1.966	1.966	0 %100
36	MP3A	Z	3.405	3.405	0 %100
37	MP4A	X	1.778	1.778	0 %100
38	MP4A	Z	3.079	3.079	0 %100
39	MP5A	X	1.778	1.778	0 %100
40	MP5A	Z	3.079	3.079	0 %100
41	MP1C	X	1.778	1.778	0 %100
42	MP1C	Z	3.079	3.079	0 %100
43	MP2C	X	1.778	1.778	0 %100
44	MP2C	Z	3.079	3.079	0 %100
45	MP3C	X	1.966	1.966	0 %100
46	MP3C	Z	3.405	3.405	0 %100
47	MP4C	X	1.778	1.778	0 %100
48	MP4C	Z	3.079	3.079	0 %100
49	MP5C	X	1.778	1.778	0 %100
50	MP5C	Z	3.079	3.079	0 %100
51	MP1B	X	1.778	1.778	0 %100
52	MP1B	Z	3.079	3.079	0 %100
53	MP2B	X	1.778	1.778	0 %100
54	MP2B	Z	3.079	3.079	0 %100
55	MP3B	X	1.966	1.966	0 %100
56	MP3B	Z	3.405	3.405	0 %100
57	MP4B	X	1.778	1.778	0 %100
58	MP4B	Z	3.079	3.079	0 %100
59	MP5B	X	1.778	1.778	0 %100
60	MP5B	Z	3.079	3.079	0 %100
61	M76	X	1.778	1.778	0 %100
62	M76	Z	3.079	3.079	0 %100
63	M77	X	1.456	1.456	0 %100
64	M77	Z	2.523	2.523	0 %100
65	M72	X	.652	.652	0 %100
66	M72	Z	1.129	1.129	0 %100
67	M73	X	.652	.652	0 %100
68	M73	Z	1.129	1.129	0 %100
69	M76A	X	1.206	1.206	0 %100
70	M76A	Z	2.088	2.088	0 %100
71	M81A	X	.652	.652	0 %100
72	M81A	Z	1.129	1.129	0 %100
73	M82	X	.652	.652	0 %100
74	M82	Z	1.129	1.129	0 %100
75	M82A	X	1.474	1.474	0 %100
76	M82A	Z	2.554	2.554	0 %100
77	M88	X	0	0	0 %100
78	M88	Z	0	0	0 %100
79	M94	X	1.474	1.474	0 %100
80	M94	Z	2.554	2.554	0 %100
81	M109	X	2.452	2.452	0 %100
82	M109	Z	4.247	4.247	0 %100
83	M110	X	.691	.691	0 %100

Member Distributed Loads (BLC 58 : Structure Wi (150 Deg)) (Continued)

	Member Label	Direction	Start Magnitude[lb/ft....]	End Magnitude[lb/ft....]	Start Location[ft.%]	End Location[ft.%]
84	M110	Z	1.198	1.198	0	%100
85	M115	X	1.474	1.474	0	%100
86	M115	Z	2.554	2.554	0	%100
87	M121	X	0	0	0	%100
88	M121	Z	0	0	0	%100
89	M127	X	1.474	1.474	0	%100
90	M127	Z	2.554	2.554	0	%100
91	M139	X	0	0	0	%100
92	M139	Z	0	0	0	%100
93	M143A	X	1.572	1.572	0	%100
94	M143A	Z	2.722	2.722	0	%100
95	M146A	X	1.572	1.572	0	%100
96	M146A	Z	2.722	2.722	0	%100
97	M149A	X	0	0	0	%100
98	M149A	Z	0	0	0	%100
99	M152A	X	1.572	1.572	0	%100
100	M152A	Z	2.722	2.722	0	%100
101	M155A	X	1.572	1.572	0	%100
102	M155A	Z	2.722	2.722	0	%100
103	M153B	X	.699	.699	0	%100
104	M153B	Z	1.21	1.21	0	%100
105	M154B	X	.699	.699	0	%100
106	M154B	Z	1.21	1.21	0	%100
107	M155B	X	.691	.691	0	%100
108	M155B	Z	1.198	1.198	0	%100
109	M156B	X	2.452	2.452	0	%100
110	M156B	Z	4.247	4.247	0	%100

Member Distributed Loads (BLC 59 : Structure Wi (180 Deg))

	Member Label	Direction	Start Magnitude[lb/ft....]	End Magnitude[lb/ft....]	Start Location[ft.%]	End Location[ft.%]
1	FACE	X	0	0	0	%100
2	FACE	Z	5.531	5.531	0	%100
3	M2	X	0	0	0	%100
4	M2	Z	1.383	1.383	0	%100
5	M3	X	0	0	0	%100
6	M3	Z	1.383	1.383	0	%100
7	M4	X	0	0	0	%100
8	M4	Z	0	0	0	%100
9	M5	X	0	0	0	%100
10	M5	Z	0	0	0	%100
11	M9	X	0	0	0	%100
12	M9	Z	3.56	3.56	0	%100
13	M10	X	0	0	0	%100
14	M10	Z	3.56	3.56	0	%100
15	M14	X	0	0	0	%100
16	M14	Z	3.56	3.56	0	%100
17	M15	X	0	0	0	%100
18	M15	Z	3.56	3.56	0	%100
19	M19	X	0	0	0	%100
20	M19	Z	1.383	1.383	0	%100
21	M20	X	0	0	0	%100
22	M20	Z	5.531	5.531	0	%100
23	M21	X	0	0	0	%100
24	M21	Z	1.383	1.383	0	%100
25	M25	X	0	0	0	%100
26	M25	Z	0	0	0	%100
27	M28	X	0	0	0	%100
28	M28	Z	4.364	4.364	0	%100

Member Distributed Loads (BLC 59 : Structure Wi (180 Deg)) (Continued)

Member Label	Direction	Start Magnitude[lb/ft....	End Magnitude[lb/ft....	Start Location[ft.%]	End Location[ft.%]
29	M31	X	0	0	%100
30	M31	Z	4.364	4.364	%100
31	MP1A	X	0	0	%100
32	MP1A	Z	3.555	3.555	%100
33	MP2A	X	0	0	%100
34	MP2A	Z	3.555	3.555	%100
35	MP3A	X	0	0	%100
36	MP3A	Z	3.932	3.932	%100
37	MP4A	X	0	0	%100
38	MP4A	Z	3.555	3.555	%100
39	MP5A	X	0	0	%100
40	MP5A	Z	3.555	3.555	%100
41	MP1C	X	0	0	%100
42	MP1C	Z	3.555	3.555	%100
43	MP2C	X	0	0	%100
44	MP2C	Z	3.555	3.555	%100
45	MP3C	X	0	0	%100
46	MP3C	Z	3.932	3.932	%100
47	MP4C	X	0	0	%100
48	MP4C	Z	3.555	3.555	%100
49	MP5C	X	0	0	%100
50	MP5C	Z	3.555	3.555	%100
51	MP1B	X	0	0	%100
52	MP1B	Z	3.555	3.555	%100
53	MP2B	X	0	0	%100
54	MP2B	Z	3.555	3.555	%100
55	MP3B	X	0	0	%100
56	MP3B	Z	3.932	3.932	%100
57	MP4B	X	0	0	%100
58	MP4B	Z	3.555	3.555	%100
59	MP5B	X	0	0	%100
60	MP5B	Z	3.555	3.555	%100
61	M76	X	0	0	%100
62	M76	Z	3.555	3.555	%100
63	M77	X	0	0	%100
64	M77	Z	2.913	2.913	%100
65	M72	X	0	0	%100
66	M72	Z	.977	.977	%100
67	M73	X	0	0	%100
68	M73	Z	.977	.977	%100
69	M76A	X	0	0	%100
70	M76A	Z	2.411	2.411	%100
71	M81A	X	0	0	%100
72	M81A	Z	.977	.977	%100
73	M82	X	0	0	%100
74	M82	Z	.977	.977	%100
75	M82A	X	0	0	%100
76	M82A	Z	3.932	3.932	%100
77	M88	X	0	0	%100
78	M88	Z	.983	.983	%100
79	M94	X	0	0	%100
80	M94	Z	.983	.983	%100
81	M109	X	0	0	%100
82	M109	Z	3.725	3.725	%100
83	M110	X	0	0	%100
84	M110	Z	3.725	3.725	%100
85	M115	X	0	0	%100
86	M115	Z	3.932	3.932	%100
87	M121	X	0	0	%100

Member Distributed Loads (BLC 59 : Structure Wi (180 Deg)) (Continued)

	Member Label	Direction	Start Magnitude[lb/ft....]	End Magnitude[lb/ft....]	Start Location[ft.%]	End Location[ft.%]
88	M121	Z	.983	.983	0	%100
89	M127	X	0	0	0	%100
90	M127	Z	.983	.983	0	%100
91	M139	X	0	0	0	%100
92	M139	Z	1.048	1.048	0	%100
93	M143A	X	0	0	0	%100
94	M143A	Z	1.048	1.048	0	%100
95	M146A	X	0	0	0	%100
96	M146A	Z	4.191	4.191	0	%100
97	M149A	X	0	0	0	%100
98	M149A	Z	1.048	1.048	0	%100
99	M152A	X	0	0	0	%100
100	M152A	Z	1.048	1.048	0	%100
101	M155A	X	0	0	0	%100
102	M155A	Z	4.191	4.191	0	%100
103	M153B	X	0	0	0	%100
104	M153B	Z	3.74	3.74	0	%100
105	M154B	X	0	0	0	%100
106	M154B	Z	.219	.219	0	%100
107	M155B	X	0	0	0	%100
108	M155B	Z	.219	.219	0	%100
109	M156B	X	0	0	0	%100
110	M156B	Z	3.74	3.74	0	%100

Member Distributed Loads (BLC 60 : Structure Wi (210 Deg))

	Member Label	Direction	Start Magnitude[lb/ft....]	End Magnitude[lb/ft....]	Start Location[ft.%]	End Location[ft.%]
1	FACE	X	-2.074	-2.074	0	%100
2	FACE	Z	3.592	3.592	0	%100
3	M2	X	-2.074	-2.074	0	%100
4	M2	Z	3.592	3.592	0	%100
5	M3	X	0	0	0	%100
6	M3	Z	0	0	0	%100
7	M4	X	-.593	-.593	0	%100
8	M4	Z	1.028	1.028	0	%100
9	M5	X	-.593	-.593	0	%100
10	M5	Z	1.028	1.028	0	%100
11	M9	X	-.593	-.593	0	%100
12	M9	Z	1.028	1.028	0	%100
13	M10	X	-.593	-.593	0	%100
14	M10	Z	1.028	1.028	0	%100
15	M14	X	-2.374	-2.374	0	%100
16	M14	Z	4.111	4.111	0	%100
17	M15	X	-2.374	-2.374	0	%100
18	M15	Z	4.111	4.111	0	%100
19	M19	X	0	0	0	%100
20	M19	Z	0	0	0	%100
21	M20	X	-2.074	-2.074	0	%100
22	M20	Z	3.592	3.592	0	%100
23	M21	X	-2.074	-2.074	0	%100
24	M21	Z	3.592	3.592	0	%100
25	M25	X	-.727	-.727	0	%100
26	M25	Z	1.26	1.26	0	%100
27	M28	X	-.727	-.727	0	%100
28	M28	Z	1.26	1.26	0	%100
29	M31	X	-2.909	-2.909	0	%100
30	M31	Z	5.039	5.039	0	%100
31	MP1A	X	-1.778	-1.778	0	%100
32	MP1A	Z	3.079	3.079	0	%100

Member Distributed Loads (BLC 60 : Structure Wi (210 Deg)) (Continued)

Member Label	Direction	Start Magnitude[lb/ft....	End Magnitude[lb/ft....	Start Location[ft.%]	End Location[ft.%]
33	MP2A	X	-1.778	-1.778	0 %100
34	MP2A	Z	3.079	3.079	0 %100
35	MP3A	X	-1.966	-1.966	0 %100
36	MP3A	Z	3.405	3.405	0 %100
37	MP4A	X	-1.778	-1.778	0 %100
38	MP4A	Z	3.079	3.079	0 %100
39	MP5A	X	-1.778	-1.778	0 %100
40	MP5A	Z	3.079	3.079	0 %100
41	MP1C	X	-1.778	-1.778	0 %100
42	MP1C	Z	3.079	3.079	0 %100
43	MP2C	X	-1.778	-1.778	0 %100
44	MP2C	Z	3.079	3.079	0 %100
45	MP3C	X	-1.966	-1.966	0 %100
46	MP3C	Z	3.405	3.405	0 %100
47	MP4C	X	-1.778	-1.778	0 %100
48	MP4C	Z	3.079	3.079	0 %100
49	MP5C	X	-1.778	-1.778	0 %100
50	MP5C	Z	3.079	3.079	0 %100
51	MP1B	X	-1.778	-1.778	0 %100
52	MP1B	Z	3.079	3.079	0 %100
53	MP2B	X	-1.778	-1.778	0 %100
54	MP2B	Z	3.079	3.079	0 %100
55	MP3B	X	-1.966	-1.966	0 %100
56	MP3B	Z	3.405	3.405	0 %100
57	MP4B	X	-1.778	-1.778	0 %100
58	MP4B	Z	3.079	3.079	0 %100
59	MP5B	X	-1.778	-1.778	0 %100
60	MP5B	Z	3.079	3.079	0 %100
61	M76	X	-1.778	-1.778	0 %100
62	M76	Z	3.079	3.079	0 %100
63	M77	X	-1.456	-1.456	0 %100
64	M77	Z	2.523	2.523	0 %100
65	M72	X	-.163	-.163	0 %100
66	M72	Z	.282	.282	0 %100
67	M73	X	-.163	-.163	0 %100
68	M73	Z	.282	.282	0 %100
69	M76A	X	-1.206	-1.206	0 %100
70	M76A	Z	2.088	2.088	0 %100
71	M81A	X	-.163	-.163	0 %100
72	M81A	Z	.282	.282	0 %100
73	M82	X	-.163	-.163	0 %100
74	M82	Z	.282	.282	0 %100
75	M82A	X	-1.474	-1.474	0 %100
76	M82A	Z	2.554	2.554	0 %100
77	M88	X	-1.474	-1.474	0 %100
78	M88	Z	2.554	2.554	0 %100
79	M94	X	0	0	0 %100
80	M94	Z	0	0	0 %100
81	M109	X	-.691	-.691	0 %100
82	M109	Z	1.198	1.198	0 %100
83	M110	X	-2.452	-2.452	0 %100
84	M110	Z	4.247	4.247	0 %100
85	M115	X	-1.474	-1.474	0 %100
86	M115	Z	2.554	2.554	0 %100
87	M121	X	-1.474	-1.474	0 %100
88	M121	Z	2.554	2.554	0 %100
89	M127	X	0	0	0 %100
90	M127	Z	0	0	0 %100
91	M139	X	-1.572	-1.572	0 %100

Member Distributed Loads (BLC 60 : Structure Wi (210 Deg)) (Continued)

	Member Label	Direction	Start Magnitude[lb/ft....]	End Magnitude[lb/ft....]	Start Location[ft.%]	End Location[ft.%]
92	M139	Z	2.722	2.722	0	%100
93	M143A	X	0	0	0	%100
94	M143A	Z	0	0	0	%100
95	M146A	X	-1.572	-1.572	0	%100
96	M146A	Z	2.722	2.722	0	%100
97	M149A	X	-1.572	-1.572	0	%100
98	M149A	Z	2.722	2.722	0	%100
99	M152A	X	0	0	0	%100
100	M152A	Z	0	0	0	%100
101	M155A	X	-1.572	-1.572	0	%100
102	M155A	Z	2.722	2.722	0	%100
103	M153B	X	-2.452	-2.452	0	%100
104	M153B	Z	4.247	4.247	0	%100
105	M154B	X	-.691	-.691	0	%100
106	M154B	Z	1.198	1.198	0	%100
107	M155B	X	-.699	-.699	0	%100
108	M155B	Z	1.21	1.21	0	%100
109	M156B	X	-.699	-.699	0	%100
110	M156B	Z	1.21	1.21	0	%100

Member Distributed Loads (BLC 61 : Structure Wi (240 Deg))

	Member Label	Direction	Start Magnitude[lb/ft....]	End Magnitude[lb/ft....]	Start Location[ft.%]	End Location[ft.%]
1	FACE	X	-1.197	-1.197	0	%100
2	FACE	Z	.691	.691	0	%100
3	M2	X	-4.79	-4.79	0	%100
4	M2	Z	2.765	2.765	0	%100
5	M3	X	-1.197	-1.197	0	%100
6	M3	Z	.691	.691	0	%100
7	M4	X	-3.083	-3.083	0	%100
8	M4	Z	1.78	1.78	0	%100
9	M5	X	-3.083	-3.083	0	%100
10	M5	Z	1.78	1.78	0	%100
11	M9	X	0	0	0	%100
12	M9	Z	0	0	0	%100
13	M10	X	0	0	0	%100
14	M10	Z	0	0	0	%100
15	M14	X	-3.083	-3.083	0	%100
16	M14	Z	1.78	1.78	0	%100
17	M15	X	-3.083	-3.083	0	%100
18	M15	Z	1.78	1.78	0	%100
19	M19	X	-1.197	-1.197	0	%100
20	M19	Z	.691	.691	0	%100
21	M20	X	-1.197	-1.197	0	%100
22	M20	Z	.691	.691	0	%100
23	M21	X	-4.79	-4.79	0	%100
24	M21	Z	2.765	2.765	0	%100
25	M25	X	-3.779	-3.779	0	%100
26	M25	Z	2.182	2.182	0	%100
27	M28	X	0	0	0	%100
28	M28	Z	0	0	0	%100
29	M31	X	-3.779	-3.779	0	%100
30	M31	Z	2.182	2.182	0	%100
31	MP1A	X	-3.079	-3.079	0	%100
32	MP1A	Z	1.778	1.778	0	%100
33	MP2A	X	-3.079	-3.079	0	%100
34	MP2A	Z	1.778	1.778	0	%100
35	MP3A	X	-3.405	-3.405	0	%100
36	MP3A	Z	1.966	1.966	0	%100

Member Distributed Loads (BLC 61 : Structure Wi (240 Deg)) (Continued)

Member Label	Direction	Start Magnitude[lb/ft....	End Magnitude[lb/ft....	Start Location[ft.%]	End Location[ft.%]
37	MP4A	X	-3.079	-3.079	0 %100
38	MP4A	Z	1.778	1.778	0 %100
39	MP5A	X	-3.079	-3.079	0 %100
40	MP5A	Z	1.778	1.778	0 %100
41	MP1C	X	-3.079	-3.079	0 %100
42	MP1C	Z	1.778	1.778	0 %100
43	MP2C	X	-3.079	-3.079	0 %100
44	MP2C	Z	1.778	1.778	0 %100
45	MP3C	X	-3.405	-3.405	0 %100
46	MP3C	Z	1.966	1.966	0 %100
47	MP4C	X	-3.079	-3.079	0 %100
48	MP4C	Z	1.778	1.778	0 %100
49	MP5C	X	-3.079	-3.079	0 %100
50	MP5C	Z	1.778	1.778	0 %100
51	MP1B	X	-3.079	-3.079	0 %100
52	MP1B	Z	1.778	1.778	0 %100
53	MP2B	X	-3.079	-3.079	0 %100
54	MP2B	Z	1.778	1.778	0 %100
55	MP3B	X	-3.405	-3.405	0 %100
56	MP3B	Z	1.966	1.966	0 %100
57	MP4B	X	-3.079	-3.079	0 %100
58	MP4B	Z	1.778	1.778	0 %100
59	MP5B	X	-3.079	-3.079	0 %100
60	MP5B	Z	1.778	1.778	0 %100
61	M76	X	-3.079	-3.079	0 %100
62	M76	Z	1.778	1.778	0 %100
63	M77	X	-2.523	-2.523	0 %100
64	M77	Z	1.456	1.456	0 %100
65	M72	X	0	0	0 %100
66	M72	Z	0	0	0 %100
67	M73	X	0	0	0 %100
68	M73	Z	0	0	0 %100
69	M76A	X	-2.088	-2.088	0 %100
70	M76A	Z	1.206	1.206	0 %100
71	M81A	X	0	0	0 %100
72	M81A	Z	0	0	0 %100
73	M82	X	0	0	0 %100
74	M82	Z	0	0	0 %100
75	M82A	X	-.851	-.851	0 %100
76	M82A	Z	.491	.491	0 %100
77	M88	X	-3.405	-3.405	0 %100
78	M88	Z	1.966	1.966	0 %100
79	M94	X	-.851	-.851	0 %100
80	M94	Z	.491	.491	0 %100
81	M109	X	-.19	-.19	0 %100
82	M109	Z	.11	.11	0 %100
83	M110	X	-3.239	-3.239	0 %100
84	M110	Z	1.87	1.87	0 %100
85	M115	X	-.851	-.851	0 %100
86	M115	Z	.491	.491	0 %100
87	M121	X	-3.405	-3.405	0 %100
88	M121	Z	1.966	1.966	0 %100
89	M127	X	-.851	-.851	0 %100
90	M127	Z	.491	.491	0 %100
91	M139	X	-3.63	-3.63	0 %100
92	M139	Z	2.095	2.095	0 %100
93	M143A	X	-.907	-.907	0 %100
94	M143A	Z	.524	.524	0 %100
95	M146A	X	-.907	-.907	0 %100

Member Distributed Loads (BLC 61 : Structure Wi (240 Deg)) (Continued)

	Member Label	Direction	Start Magnitude[lb/ft....]	End Magnitude[lb/ft....]	Start Location[ft.%]	End Location[ft.%]
96	M146A	Z	.524	.524	0	%100
97	M149A	X	-3.63	-3.63	0	%100
98	M149A	Z	2.095	2.095	0	%100
99	M152A	X	-.907	-.907	0	%100
100	M152A	Z	.524	.524	0	%100
101	M155A	X	-.907	-.907	0	%100
102	M155A	Z	.524	.524	0	%100
103	M153B	X	-3.226	-3.226	0	%100
104	M153B	Z	1.863	1.863	0	%100
105	M154B	X	-3.226	-3.226	0	%100
106	M154B	Z	1.863	1.863	0	%100
107	M155B	X	-3.239	-3.239	0	%100
108	M155B	Z	1.87	1.87	0	%100
109	M156B	X	-.19	-.19	0	%100
110	M156B	Z	.11	.11	0	%100

Member Distributed Loads (BLC 62 : Structure Wi (270 Deg))

	Member Label	Direction	Start Magnitude[lb/ft....]	End Magnitude[lb/ft....]	Start Location[ft.%]	End Location[ft.%]
1	FACE	X	0	0	0	%100
2	FACE	Z	0	0	0	%100
3	M2	X	-4.148	-4.148	0	%100
4	M2	Z	0	0	0	%100
5	M3	X	-4.148	-4.148	0	%100
6	M3	Z	0	0	0	%100
7	M4	X	-4.747	-4.747	0	%100
8	M4	Z	0	0	0	%100
9	M5	X	-4.747	-4.747	0	%100
10	M5	Z	0	0	0	%100
11	M9	X	-1.187	-1.187	0	%100
12	M9	Z	0	0	0	%100
13	M10	X	-1.187	-1.187	0	%100
14	M10	Z	0	0	0	%100
15	M14	X	-1.187	-1.187	0	%100
16	M14	Z	0	0	0	%100
17	M15	X	-1.187	-1.187	0	%100
18	M15	Z	0	0	0	%100
19	M19	X	-4.148	-4.148	0	%100
20	M19	Z	0	0	0	%100
21	M20	X	0	0	0	%100
22	M20	Z	0	0	0	%100
23	M21	X	-4.148	-4.148	0	%100
24	M21	Z	0	0	0	%100
25	M25	X	-5.818	-5.818	0	%100
26	M25	Z	0	0	0	%100
27	M28	X	-1.455	-1.455	0	%100
28	M28	Z	0	0	0	%100
29	M31	X	-1.455	-1.455	0	%100
30	M31	Z	0	0	0	%100
31	MP1A	X	-3.555	-3.555	0	%100
32	MP1A	Z	0	0	0	%100
33	MP2A	X	-3.555	-3.555	0	%100
34	MP2A	Z	0	0	0	%100
35	MP3A	X	-3.932	-3.932	0	%100
36	MP3A	Z	0	0	0	%100
37	MP4A	X	-3.555	-3.555	0	%100
38	MP4A	Z	0	0	0	%100
39	MP5A	X	-3.555	-3.555	0	%100
40	MP5A	Z	0	0	0	%100



Member Distributed Loads (BLC 62 : Structure Wi (270 Deg)) (Continued)

Member Label	Direction	Start Magnitude[lb/ft....	End Magnitude[lb/ft....	Start Location[ft.%]	End Location[ft.%]
41	MP1C	X	-3.555	-3.555	0 %100
42	MP1C	Z	0	0	0 %100
43	MP2C	X	-3.555	-3.555	0 %100
44	MP2C	Z	0	0	0 %100
45	MP3C	X	-3.932	-3.932	0 %100
46	MP3C	Z	0	0	0 %100
47	MP4C	X	-3.555	-3.555	0 %100
48	MP4C	Z	0	0	0 %100
49	MP5C	X	-3.555	-3.555	0 %100
50	MP5C	Z	0	0	0 %100
51	MP1B	X	-3.555	-3.555	0 %100
52	MP1B	Z	0	0	0 %100
53	MP2B	X	-3.555	-3.555	0 %100
54	MP2B	Z	0	0	0 %100
55	MP3B	X	-3.932	-3.932	0 %100
56	MP3B	Z	0	0	0 %100
57	MP4B	X	-3.555	-3.555	0 %100
58	MP4B	Z	0	0	0 %100
59	MP5B	X	-3.555	-3.555	0 %100
60	MP5B	Z	0	0	0 %100
61	M76	X	-3.555	-3.555	0 %100
62	M76	Z	0	0	0 %100
63	M77	X	-2.913	-2.913	0 %100
64	M77	Z	0	0	0 %100
65	M72	X	-.326	-.326	0 %100
66	M72	Z	0	0	0 %100
67	M73	X	-.326	-.326	0 %100
68	M73	Z	0	0	0 %100
69	M76A	X	-2.411	-2.411	0 %100
70	M76A	Z	0	0	0 %100
71	M81A	X	-.326	-.326	0 %100
72	M81A	Z	0	0	0 %100
73	M82	X	-.326	-.326	0 %100
74	M82	Z	0	0	0 %100
75	M82A	X	0	0	0 %100
76	M82A	Z	0	0	0 %100
77	M88	X	-2.949	-2.949	0 %100
78	M88	Z	0	0	0 %100
79	M94	X	-2.949	-2.949	0 %100
80	M94	Z	0	0	0 %100
81	M109	X	-1.398	-1.398	0 %100
82	M109	Z	0	0	0 %100
83	M110	X	-1.398	-1.398	0 %100
84	M110	Z	0	0	0 %100
85	M115	X	0	0	0 %100
86	M115	Z	0	0	0 %100
87	M121	X	-2.949	-2.949	0 %100
88	M121	Z	0	0	0 %100
89	M127	X	-2.949	-2.949	0 %100
90	M127	Z	0	0	0 %100
91	M139	X	-3.143	-3.143	0 %100
92	M139	Z	0	0	0 %100
93	M143A	X	-3.143	-3.143	0 %100
94	M143A	Z	0	0	0 %100
95	M146A	X	0	0	0 %100
96	M146A	Z	0	0	0 %100
97	M149A	X	-3.143	-3.143	0 %100
98	M149A	Z	0	0	0 %100
99	M152A	X	-3.143	-3.143	0 %100

Member Distributed Loads (BLC 62 : Structure Wi (270 Deg)) (Continued)

Member Label	Direction	Start Magnitude[lb/ft....]	End Magnitude[lb/ft....]	Start Location[ft,%]	End Location[ft,%]
100	M152A	Z	0	0	%100
101	M155A	X	0	0	%100
102	M155A	Z	0	0	%100
103	M153B	X	-1.383	-1.383	0
104	M153B	Z	0	0	%100
105	M154B	X	-4.904	-4.904	0
106	M154B	Z	0	0	%100
107	M155B	X	-4.904	-4.904	0
108	M155B	Z	0	0	%100
109	M156B	X	-1.383	-1.383	0
110	M156B	Z	0	0	%100

Member Distributed Loads (BLC 63 : Structure Wi (300 Deg))

Member Label	Direction	Start Magnitude[lb/ft....]	End Magnitude[lb/ft....]	Start Location[ft,%]	End Location[ft,%]
1	FACE	X	-1.197	-1.197	0
2	FACE	Z	-.691	-.691	0
3	M2	X	-1.197	-1.197	0
4	M2	Z	-.691	-.691	0
5	M3	X	-4.79	-4.79	0
6	M3	Z	-2.765	-2.765	0
7	M4	X	-3.083	-3.083	0
8	M4	Z	-1.78	-1.78	0
9	M5	X	-3.083	-3.083	0
10	M5	Z	-1.78	-1.78	0
11	M9	X	-3.083	-3.083	0
12	M9	Z	-1.78	-1.78	0
13	M10	X	-3.083	-3.083	0
14	M10	Z	-1.78	-1.78	0
15	M14	X	0	0	0
16	M14	Z	0	0	0
17	M15	X	0	0	0
18	M15	Z	0	0	0
19	M19	X	-4.79	-4.79	0
20	M19	Z	-2.765	-2.765	0
21	M20	X	-1.197	-1.197	0
22	M20	Z	-.691	-.691	0
23	M21	X	-1.197	-1.197	0
24	M21	Z	-.691	-.691	0
25	M25	X	-3.779	-3.779	0
26	M25	Z	-2.182	-2.182	0
27	M28	X	-3.779	-3.779	0
28	M28	Z	-2.182	-2.182	0
29	M31	X	0	0	0
30	M31	Z	0	0	0
31	MP1A	X	-3.079	-3.079	0
32	MP1A	Z	-1.778	-1.778	0
33	MP2A	X	-3.079	-3.079	0
34	MP2A	Z	-1.778	-1.778	0
35	MP3A	X	-3.405	-3.405	0
36	MP3A	Z	-1.966	-1.966	0
37	MP4A	X	-3.079	-3.079	0
38	MP4A	Z	-1.778	-1.778	0
39	MP5A	X	-3.079	-3.079	0
40	MP5A	Z	-1.778	-1.778	0
41	MP1C	X	-3.079	-3.079	0
42	MP1C	Z	-1.778	-1.778	0
43	MP2C	X	-3.079	-3.079	0
44	MP2C	Z	-1.778	-1.778	0

Member Distributed Loads (BLC 63 : Structure Wi (300 Deg)) (Continued)

Member Label	Direction	Start Magnitude[lb/ft....	End Magnitude[lb/ft....	Start Location[ft.%]	End Location[ft.%]
45	MP3C	X	-3.405	-3.405	0 %100
46	MP3C	Z	-1.966	-1.966	0 %100
47	MP4C	X	-3.079	-3.079	0 %100
48	MP4C	Z	-1.778	-1.778	0 %100
49	MP5C	X	-3.079	-3.079	0 %100
50	MP5C	Z	-1.778	-1.778	0 %100
51	MP1B	X	-3.079	-3.079	0 %100
52	MP1B	Z	-1.778	-1.778	0 %100
53	MP2B	X	-3.079	-3.079	0 %100
54	MP2B	Z	-1.778	-1.778	0 %100
55	MP3B	X	-3.405	-3.405	0 %100
56	MP3B	Z	-1.966	-1.966	0 %100
57	MP4B	X	-3.079	-3.079	0 %100
58	MP4B	Z	-1.778	-1.778	0 %100
59	MP5B	X	-3.079	-3.079	0 %100
60	MP5B	Z	-1.778	-1.778	0 %100
61	M76	X	-3.079	-3.079	0 %100
62	M76	Z	-1.778	-1.778	0 %100
63	M77	X	-2.523	-2.523	0 %100
64	M77	Z	-1.456	-1.456	0 %100
65	M72	X	-.846	-.846	0 %100
66	M72	Z	-.489	-.489	0 %100
67	M73	X	-.846	-.846	0 %100
68	M73	Z	-.489	-.489	0 %100
69	M76A	X	-2.088	-2.088	0 %100
70	M76A	Z	-1.206	-1.206	0 %100
71	M81A	X	-.846	-.846	0 %100
72	M81A	Z	-.489	-.489	0 %100
73	M82	X	-.846	-.846	0 %100
74	M82	Z	-.489	-.489	0 %100
75	M82A	X	-.851	-.851	0 %100
76	M82A	Z	-.491	-.491	0 %100
77	M88	X	-.851	-.851	0 %100
78	M88	Z	-.491	-.491	0 %100
79	M94	X	-3.405	-3.405	0 %100
80	M94	Z	-1.966	-1.966	0 %100
81	M109	X	-3.239	-3.239	0 %100
82	M109	Z	-1.87	-1.87	0 %100
83	M110	X	-.19	-.19	0 %100
84	M110	Z	-.11	-.11	0 %100
85	M115	X	-.851	-.851	0 %100
86	M115	Z	-.491	-.491	0 %100
87	M121	X	-.851	-.851	0 %100
88	M121	Z	-.491	-.491	0 %100
89	M127	X	-3.405	-3.405	0 %100
90	M127	Z	-1.966	-1.966	0 %100
91	M139	X	-.907	-.907	0 %100
92	M139	Z	-.524	-.524	0 %100
93	M143A	X	-3.63	-3.63	0 %100
94	M143A	Z	-2.095	-2.095	0 %100
95	M146A	X	-.907	-.907	0 %100
96	M146A	Z	-.524	-.524	0 %100
97	M149A	X	-.907	-.907	0 %100
98	M149A	Z	-.524	-.524	0 %100
99	M152A	X	-3.63	-3.63	0 %100
100	M152A	Z	-2.095	-2.095	0 %100
101	M155A	X	-.907	-.907	0 %100
102	M155A	Z	-.524	-.524	0 %100
103	M153B	X	-.19	-.19	0 %100

Member Distributed Loads (BLC 63 : Structure Wi (300 Deg)) (Continued)

	Member Label	Direction	Start Magnitude[lb/ft....]	End Magnitude[lb/ft....]	Start Location[ft.%]	End Location[ft.%]
104	M153B	Z	-.11	-.11	0	%100
105	M154B	X	-3.239	-3.239	0	%100
106	M154B	Z	-1.87	-1.87	0	%100
107	M155B	X	-3.226	-3.226	0	%100
108	M155B	Z	-1.863	-1.863	0	%100
109	M156B	X	-3.226	-3.226	0	%100
110	M156B	Z	-1.863	-1.863	0	%100

Member Distributed Loads (BLC 64 : Structure Wi (330 Deg))

	Member Label	Direction	Start Magnitude[lb/ft....]	End Magnitude[lb/ft....]	Start Location[ft.%]	End Location[ft.%]
1	FACE	X	-2.074	-2.074	0	%100
2	FACE	Z	-3.592	-3.592	0	%100
3	M2	X	0	0	0	%100
4	M2	Z	0	0	0	%100
5	M3	X	-2.074	-2.074	0	%100
6	M3	Z	-3.592	-3.592	0	%100
7	M4	X	-.593	-.593	0	%100
8	M4	Z	-1.028	-1.028	0	%100
9	M5	X	-.593	-.593	0	%100
10	M5	Z	-1.028	-1.028	0	%100
11	M9	X	-2.374	-2.374	0	%100
12	M9	Z	-4.111	-4.111	0	%100
13	M10	X	-2.374	-2.374	0	%100
14	M10	Z	-4.111	-4.111	0	%100
15	M14	X	-.593	-.593	0	%100
16	M14	Z	-1.028	-1.028	0	%100
17	M15	X	-.593	-.593	0	%100
18	M15	Z	-1.028	-1.028	0	%100
19	M19	X	-2.074	-2.074	0	%100
20	M19	Z	-3.592	-3.592	0	%100
21	M20	X	-2.074	-2.074	0	%100
22	M20	Z	-3.592	-3.592	0	%100
23	M21	X	0	0	0	%100
24	M21	Z	0	0	0	%100
25	M25	X	-.727	-.727	0	%100
26	M25	Z	-1.26	-1.26	0	%100
27	M28	X	-2.909	-2.909	0	%100
28	M28	Z	-5.039	-5.039	0	%100
29	M31	X	-.727	-.727	0	%100
30	M31	Z	-1.26	-1.26	0	%100
31	MP1A	X	-1.778	-1.778	0	%100
32	MP1A	Z	-3.079	-3.079	0	%100
33	MP2A	X	-1.778	-1.778	0	%100
34	MP2A	Z	-3.079	-3.079	0	%100
35	MP3A	X	-1.966	-1.966	0	%100
36	MP3A	Z	-3.405	-3.405	0	%100
37	MP4A	X	-1.778	-1.778	0	%100
38	MP4A	Z	-3.079	-3.079	0	%100
39	MP5A	X	-1.778	-1.778	0	%100
40	MP5A	Z	-3.079	-3.079	0	%100
41	MP1C	X	-1.778	-1.778	0	%100
42	MP1C	Z	-3.079	-3.079	0	%100
43	MP2C	X	-1.778	-1.778	0	%100
44	MP2C	Z	-3.079	-3.079	0	%100
45	MP3C	X	-1.966	-1.966	0	%100
46	MP3C	Z	-3.405	-3.405	0	%100
47	MP4C	X	-1.778	-1.778	0	%100
48	MP4C	Z	-3.079	-3.079	0	%100

Member Distributed Loads (BLC 64 : Structure Wi (330 Deg)) (Continued)

Member Label	Direction	Start Magnitude[lb/ft....	End Magnitude[lb/ft....	Start Location[ft.%]	End Location[ft.%]
49	MP5C	X	-1.778	-1.778	0 %100
50	MP5C	Z	-3.079	-3.079	0 %100
51	MP1B	X	-1.778	-1.778	0 %100
52	MP1B	Z	-3.079	-3.079	0 %100
53	MP2B	X	-1.778	-1.778	0 %100
54	MP2B	Z	-3.079	-3.079	0 %100
55	MP3B	X	-1.966	-1.966	0 %100
56	MP3B	Z	-3.405	-3.405	0 %100
57	MP4B	X	-1.778	-1.778	0 %100
58	MP4B	Z	-3.079	-3.079	0 %100
59	MP5B	X	-1.778	-1.778	0 %100
60	MP5B	Z	-3.079	-3.079	0 %100
61	M76	X	-1.778	-1.778	0 %100
62	M76	Z	-3.079	-3.079	0 %100
63	M77	X	-1.456	-1.456	0 %100
64	M77	Z	-2.523	-2.523	0 %100
65	M72	X	-.652	-.652	0 %100
66	M72	Z	-1.129	-1.129	0 %100
67	M73	X	-.652	-.652	0 %100
68	M73	Z	-1.129	-1.129	0 %100
69	M76A	X	-1.206	-1.206	0 %100
70	M76A	Z	-2.088	-2.088	0 %100
71	M81A	X	-.652	-.652	0 %100
72	M81A	Z	-1.129	-1.129	0 %100
73	M82	X	-.652	-.652	0 %100
74	M82	Z	-1.129	-1.129	0 %100
75	M82A	X	-1.474	-1.474	0 %100
76	M82A	Z	-2.554	-2.554	0 %100
77	M88	X	0	0	0 %100
78	M88	Z	0	0	0 %100
79	M94	X	-1.474	-1.474	0 %100
80	M94	Z	-2.554	-2.554	0 %100
81	M109	X	-2.452	-2.452	0 %100
82	M109	Z	-4.247	-4.247	0 %100
83	M110	X	-.691	-.691	0 %100
84	M110	Z	-1.198	-1.198	0 %100
85	M115	X	-1.474	-1.474	0 %100
86	M115	Z	-2.554	-2.554	0 %100
87	M121	X	0	0	0 %100
88	M121	Z	0	0	0 %100
89	M127	X	-1.474	-1.474	0 %100
90	M127	Z	-2.554	-2.554	0 %100
91	M139	X	0	0	0 %100
92	M139	Z	0	0	0 %100
93	M143A	X	-1.572	-1.572	0 %100
94	M143A	Z	-2.722	-2.722	0 %100
95	M146A	X	-1.572	-1.572	0 %100
96	M146A	Z	-2.722	-2.722	0 %100
97	M149A	X	0	0	0 %100
98	M149A	Z	0	0	0 %100
99	M152A	X	-1.572	-1.572	0 %100
100	M152A	Z	-2.722	-2.722	0 %100
101	M155A	X	-1.572	-1.572	0 %100
102	M155A	Z	-2.722	-2.722	0 %100
103	M153B	X	-.699	-.699	0 %100
104	M153B	Z	-1.21	-1.21	0 %100
105	M154B	X	-.699	-.699	0 %100
106	M154B	Z	-1.21	-1.21	0 %100
107	M155B	X	-.691	-.691	0 %100

Member Distributed Loads (BLC 64 : Structure Wi (330 Deg)) (Continued)

	Member Label	Direction	Start Magnitude[lb/ft....]	End Magnitude[lb/ft....]	Start Location[ft.%]	End Location[ft.%]
108	M155B	Z	-1.198	-1.198	0	%100
109	M156B	X	-2.452	-2.452	0	%100
110	M156B	Z	-4.247	-4.247	0	%100

Member Distributed Loads (BLC 65 : Structure Wm (0 Deg))

	Member Label	Direction	Start Magnitude[lb/ft....]	End Magnitude[lb/ft....]	Start Location[ft.%]	End Location[ft.%]
1	FACE	X	0	0	0	%100
2	FACE	Z	-1.355	-1.355	0	%100
3	M2	X	0	0	0	%100
4	M2	Z	-.339	-.339	0	%100
5	M3	X	0	0	0	%100
6	M3	Z	-.339	-.339	0	%100
7	M4	X	0	0	0	%100
8	M4	Z	0	0	0	%100
9	M5	X	0	0	0	%100
10	M5	Z	0	0	0	%100
11	M9	X	0	0	0	%100
12	M9	Z	-.852	-.852	0	%100
13	M10	X	0	0	0	%100
14	M10	Z	-.852	-.852	0	%100
15	M14	X	0	0	0	%100
16	M14	Z	-.852	-.852	0	%100
17	M15	X	0	0	0	%100
18	M15	Z	-.852	-.852	0	%100
19	M19	X	0	0	0	%100
20	M19	Z	-.339	-.339	0	%100
21	M20	X	0	0	0	%100
22	M20	Z	-1.355	-1.355	0	%100
23	M21	X	0	0	0	%100
24	M21	Z	-.339	-.339	0	%100
25	M25	X	0	0	0	%100
26	M25	Z	0	0	0	%100
27	M28	X	0	0	0	%100
28	M28	Z	-1.184	-1.184	0	%100
29	M31	X	0	0	0	%100
30	M31	Z	-1.184	-1.184	0	%100
31	MP1A	X	0	0	0	%100
32	MP1A	Z	-.643	-.643	0	%100
33	MP2A	X	0	0	0	%100
34	MP2A	Z	-.643	-.643	0	%100
35	MP3A	X	0	0	0	%100
36	MP3A	Z	-.779	-.779	0	%100
37	MP4A	X	0	0	0	%100
38	MP4A	Z	-.643	-.643	0	%100
39	MP5A	X	0	0	0	%100
40	MP5A	Z	-.643	-.643	0	%100
41	MP1C	X	0	0	0	%100
42	MP1C	Z	-.643	-.643	0	%100
43	MP2C	X	0	0	0	%100
44	MP2C	Z	-.643	-.643	0	%100
45	MP3C	X	0	0	0	%100
46	MP3C	Z	-.779	-.779	0	%100
47	MP4C	X	0	0	0	%100
48	MP4C	Z	-.643	-.643	0	%100
49	MP5C	X	0	0	0	%100
50	MP5C	Z	-.643	-.643	0	%100
51	MP1B	X	0	0	0	%100
52	MP1B	Z	-.643	-.643	0	%100

Member Distributed Loads (BLC 65 : Structure Wm (0 Deg)) (Continued)

Member Label	Direction	Start Magnitude[lb/ft....]	End Magnitude[lb/ft....]	Start Location[ft.%]	End Location[ft.%]
53	MP2B	X	0	0	%100
54	MP2B	Z	-.643	-.643	0
55	MP3B	X	0	0	%100
56	MP3B	Z	-.779	-.779	0
57	MP4B	X	0	0	%100
58	MP4B	Z	-.643	-.643	0
59	MP5B	X	0	0	%100
60	MP5B	Z	-.643	-.643	0
61	M76	X	0	0	%100
62	M76	Z	-.643	-.643	0
63	M77	X	0	0	%100
64	M77	Z	-.526	-.526	0
65	M72	X	0	0	%100
66	M72	Z	-.073	-.073	0
67	M73	X	0	0	%100
68	M73	Z	-.073	-.073	0
69	M76A	X	0	0	%100
70	M76A	Z	-.436	-.436	0
71	M81A	X	0	0	%100
72	M81A	Z	-.073	-.073	0
73	M82	X	0	0	%100
74	M82	Z	-.073	-.073	0
75	M82A	X	0	0	%100
76	M82A	Z	-.779	-.779	0
77	M88	X	0	0	%100
78	M88	Z	-.195	-.195	0
79	M94	X	0	0	%100
80	M94	Z	-.195	-.195	0
81	M109	X	0	0	%100
82	M109	Z	-.858	-.858	0
83	M110	X	0	0	%100
84	M110	Z	-.858	-.858	0
85	M115	X	0	0	%100
86	M115	Z	-.779	-.779	0
87	M121	X	0	0	%100
88	M121	Z	-.195	-.195	0
89	M127	X	0	0	%100
90	M127	Z	-.195	-.195	0
91	M139	X	0	0	%100
92	M139	Z	-.254	-.254	0
93	M143A	X	0	0	%100
94	M143A	Z	-.254	-.254	0
95	M146A	X	0	0	%100
96	M146A	Z	-1.016	-1.016	0
97	M149A	X	0	0	%100
98	M149A	Z	-.254	-.254	0
99	M152A	X	0	0	%100
100	M152A	Z	-.254	-.254	0
101	M155A	X	0	0	%100
102	M155A	Z	-1.016	-1.016	0
103	M153B	X	0	0	%100
104	M153B	Z	-.861	-.861	0
105	M154B	X	0	0	%100
106	M154B	Z	-.05	-.05	0
107	M155B	X	0	0	%100
108	M155B	Z	-.05	-.05	0
109	M156B	X	0	0	%100
110	M156B	Z	-.861	-.861	0

Member Distributed Loads (BLC 66 : Structure Wm (30 Deg))

Member Label	Direction	Start Magnitude[lb/ft....	End Magnitude[lb/ft....	Start Location[ft.%]	End Location[ft.%]
1	FACE	X	.508	.508	0 %100
2	FACE	Z	-.88	-.88	0 %100
3	M2	X	.508	.508	0 %100
4	M2	Z	-.88	-.88	0 %100
5	M3	X	0	0	0 %100
6	M3	Z	0	0	0 %100
7	M4	X	.142	.142	0 %100
8	M4	Z	-.246	-.246	0 %100
9	M5	X	.142	.142	0 %100
10	M5	Z	-.246	-.246	0 %100
11	M9	X	.142	.142	0 %100
12	M9	Z	-.246	-.246	0 %100
13	M10	X	.142	.142	0 %100
14	M10	Z	-.246	-.246	0 %100
15	M14	X	.568	.568	0 %100
16	M14	Z	-.984	-.984	0 %100
17	M15	X	.568	.568	0 %100
18	M15	Z	-.984	-.984	0 %100
19	M19	X	0	0	0 %100
20	M19	Z	0	0	0 %100
21	M20	X	.508	.508	0 %100
22	M20	Z	-.88	-.88	0 %100
23	M21	X	.508	.508	0 %100
24	M21	Z	-.88	-.88	0 %100
25	M25	X	.197	.197	0 %100
26	M25	Z	-.342	-.342	0 %100
27	M28	X	.197	.197	0 %100
28	M28	Z	-.342	-.342	0 %100
29	M31	X	.789	.789	0 %100
30	M31	Z	-1.367	-1.367	0 %100
31	MP1A	X	.322	.322	0 %100
32	MP1A	Z	-.557	-.557	0 %100
33	MP2A	X	.322	.322	0 %100
34	MP2A	Z	-.557	-.557	0 %100
35	MP3A	X	.389	.389	0 %100
36	MP3A	Z	-.675	-.675	0 %100
37	MP4A	X	.322	.322	0 %100
38	MP4A	Z	-.557	-.557	0 %100
39	MP5A	X	.322	.322	0 %100
40	MP5A	Z	-.557	-.557	0 %100
41	MP1C	X	.322	.322	0 %100
42	MP1C	Z	-.557	-.557	0 %100
43	MP2C	X	.322	.322	0 %100
44	MP2C	Z	-.557	-.557	0 %100
45	MP3C	X	.389	.389	0 %100
46	MP3C	Z	-.675	-.675	0 %100
47	MP4C	X	.322	.322	0 %100
48	MP4C	Z	-.557	-.557	0 %100
49	MP5C	X	.322	.322	0 %100
50	MP5C	Z	-.557	-.557	0 %100
51	MP1B	X	.322	.322	0 %100
52	MP1B	Z	-.557	-.557	0 %100
53	MP2B	X	.322	.322	0 %100
54	MP2B	Z	-.557	-.557	0 %100
55	MP3B	X	.389	.389	0 %100
56	MP3B	Z	-.675	-.675	0 %100
57	MP4B	X	.322	.322	0 %100
58	MP4B	Z	-.557	-.557	0 %100
59	MP5B	X	.322	.322	0 %100

Member Distributed Loads (BLC 66 : Structure Wm (30 Deg)) (Continued)

Member Label	Direction	Start Magnitude[lb/ft....]	End Magnitude[lb/ft....]	Start Location[ft.%]	End Location[ft.%]
60	MP5B	Z	-.557	0	%100
61	M76	X	.322	0	%100
62	M76	Z	-.557	0	%100
63	M77	X	.263	0	%100
64	M77	Z	-.456	0	%100
65	M72	X	.012	0	%100
66	M72	Z	-.021	0	%100
67	M73	X	.012	0	%100
68	M73	Z	-.021	0	%100
69	M76A	X	.218	0	%100
70	M76A	Z	-.377	0	%100
71	M81A	X	.012	0	%100
72	M81A	Z	-.021	0	%100
73	M82	X	.012	0	%100
74	M82	Z	-.021	0	%100
75	M82A	X	.292	0	%100
76	M82A	Z	-.506	0	%100
77	M88	X	.292	0	%100
78	M88	Z	-.506	0	%100
79	M94	X	0	0	%100
80	M94	Z	0	0	%100
81	M109	X	.159	0	%100
82	M109	Z	-.276	0	%100
83	M110	X	.564	0	%100
84	M110	Z	-.978	0	%100
85	M115	X	.292	0	%100
86	M115	Z	-.506	0	%100
87	M121	X	.292	0	%100
88	M121	Z	-.506	0	%100
89	M127	X	0	0	%100
90	M127	Z	0	0	%100
91	M139	X	.381	0	%100
92	M139	Z	-.66	0	%100
93	M143A	X	0	0	%100
94	M143A	Z	0	0	%100
95	M146A	X	.381	0	%100
96	M146A	Z	-.66	0	%100
97	M149A	X	.381	0	%100
98	M149A	Z	-.66	0	%100
99	M152A	X	0	0	%100
100	M152A	Z	0	0	%100
101	M155A	X	.381	0	%100
102	M155A	Z	-.66	0	%100
103	M153B	X	.564	0	%100
104	M153B	Z	-.978	0	%100
105	M154B	X	.159	0	%100
106	M154B	Z	-.276	0	%100
107	M155B	X	.161	0	%100
108	M155B	Z	-.279	0	%100
109	M156B	X	.161	0	%100
110	M156B	Z	-.279	0	%100

Member Distributed Loads (BLC 67 : Structure Wm (60 Deg))

Member Label	Direction	Start Magnitude[lb/ft....]	End Magnitude[lb/ft....]	Start Location[ft.%]	End Location[ft.%]
1	FACE	X	.293	0	%100
2	FACE	Z	-.169	0	%100
3	M2	X	1.173	0	%100
4	M2	Z	-.677	0	%100

Member Distributed Loads (BLC 67 : Structure Wm (60 Deg)) (Continued)

Member Label	Direction	Start Magnitude[lb/ft....	End Magnitude[lb/ft....	Start Location[ft.%]	End Location[ft.%]
5	M3	X	.293	.293	0 %100
6	M3	Z	-.169	-.169	0 %100
7	M4	X	.738	.738	0 %100
8	M4	Z	-.426	-.426	0 %100
9	M5	X	.738	.738	0 %100
10	M5	Z	-.426	-.426	0 %100
11	M9	X	0	0	0 %100
12	M9	Z	0	0	0 %100
13	M10	X	0	0	0 %100
14	M10	Z	0	0	0 %100
15	M14	X	.738	.738	0 %100
16	M14	Z	-.426	-.426	0 %100
17	M15	X	.738	.738	0 %100
18	M15	Z	-.426	-.426	0 %100
19	M19	X	.293	.293	0 %100
20	M19	Z	-.169	-.169	0 %100
21	M20	X	.293	.293	0 %100
22	M20	Z	-.169	-.169	0 %100
23	M21	X	1.173	1.173	0 %100
24	M21	Z	-.677	-.677	0 %100
25	M25	X	1.025	1.025	0 %100
26	M25	Z	-.592	-.592	0 %100
27	M28	X	0	0	0 %100
28	M28	Z	0	0	0 %100
29	M31	X	1.025	1.025	0 %100
30	M31	Z	-.592	-.592	0 %100
31	MP1A	X	.557	.557	0 %100
32	MP1A	Z	-.322	-.322	0 %100
33	MP2A	X	.557	.557	0 %100
34	MP2A	Z	-.322	-.322	0 %100
35	MP3A	X	.675	.675	0 %100
36	MP3A	Z	-.389	-.389	0 %100
37	MP4A	X	.557	.557	0 %100
38	MP4A	Z	-.322	-.322	0 %100
39	MP5A	X	.557	.557	0 %100
40	MP5A	Z	-.322	-.322	0 %100
41	MP1C	X	.557	.557	0 %100
42	MP1C	Z	-.322	-.322	0 %100
43	MP2C	X	.557	.557	0 %100
44	MP2C	Z	-.322	-.322	0 %100
45	MP3C	X	.675	.675	0 %100
46	MP3C	Z	-.389	-.389	0 %100
47	MP4C	X	.557	.557	0 %100
48	MP4C	Z	-.322	-.322	0 %100
49	MP5C	X	.557	.557	0 %100
50	MP5C	Z	-.322	-.322	0 %100
51	MP1B	X	.557	.557	0 %100
52	MP1B	Z	-.322	-.322	0 %100
53	MP2B	X	.557	.557	0 %100
54	MP2B	Z	-.322	-.322	0 %100
55	MP3B	X	.675	.675	0 %100
56	MP3B	Z	-.389	-.389	0 %100
57	MP4B	X	.557	.557	0 %100
58	MP4B	Z	-.322	-.322	0 %100
59	MP5B	X	.557	.557	0 %100
60	MP5B	Z	-.322	-.322	0 %100
61	M76	X	.557	.557	0 %100
62	M76	Z	-.322	-.322	0 %100
63	M77	X	.456	.456	0 %100

Member Distributed Loads (BLC 67 : Structure Wm (60 Deg)) (Continued)

Member Label	Direction	Start Magnitude[lb/ft....]	End Magnitude[lb/ft....]	Start Location[ft.%]	End Location[ft.%]
64	M77	Z	-.263	-.263	0 %100
65	M72	X	0	0	0 %100
66	M72	Z	0	0	0 %100
67	M73	X	0	0	0 %100
68	M73	Z	0	0	0 %100
69	M76A	X	.377	.377	0 %100
70	M76A	Z	-.218	-.218	0 %100
71	M81A	X	0	0	0 %100
72	M81A	Z	0	0	0 %100
73	M82	X	0	0	0 %100
74	M82	Z	0	0	0 %100
75	M82A	X	.169	.169	0 %100
76	M82A	Z	-.097	-.097	0 %100
77	M88	X	.675	.675	0 %100
78	M88	Z	-.389	-.389	0 %100
79	M94	X	.169	.169	0 %100
80	M94	Z	-.097	-.097	0 %100
81	M109	X	.044	.044	0 %100
82	M109	Z	-.025	-.025	0 %100
83	M110	X	.746	.746	0 %100
84	M110	Z	-.43	-.43	0 %100
85	M115	X	.169	.169	0 %100
86	M115	Z	-.097	-.097	0 %100
87	M121	X	.675	.675	0 %100
88	M121	Z	-.389	-.389	0 %100
89	M127	X	.169	.169	0 %100
90	M127	Z	-.097	-.097	0 %100
91	M139	X	.88	.88	0 %100
92	M139	Z	-.508	-.508	0 %100
93	M143A	X	.22	.22	0 %100
94	M143A	Z	-.127	-.127	0 %100
95	M146A	X	.22	.22	0 %100
96	M146A	Z	-.127	-.127	0 %100
97	M149A	X	.88	.88	0 %100
98	M149A	Z	-.508	-.508	0 %100
99	M152A	X	.22	.22	0 %100
100	M152A	Z	-.127	-.127	0 %100
101	M155A	X	.22	.22	0 %100
102	M155A	Z	-.127	-.127	0 %100
103	M153B	X	.743	.743	0 %100
104	M153B	Z	-.429	-.429	0 %100
105	M154B	X	.743	.743	0 %100
106	M154B	Z	-.429	-.429	0 %100
107	M155B	X	.746	.746	0 %100
108	M155B	Z	-.43	-.43	0 %100
109	M156B	X	.044	.044	0 %100
110	M156B	Z	-.025	-.025	0 %100

Member Distributed Loads (BLC 68 : Structure Wm (90 Deg))

Member Label	Direction	Start Magnitude[lb/ft....]	End Magnitude[lb/ft....]	Start Location[ft.%]	End Location[ft.%]
1	FACE	X	0	0	0 %100
2	FACE	Z	0	0	0 %100
3	M2	X	1.016	1.016	0 %100
4	M2	Z	0	0	0 %100
5	M3	X	1.016	1.016	0 %100
6	M3	Z	0	0	0 %100
7	M4	X	1.136	1.136	0 %100
8	M4	Z	0	0	0 %100

Member Distributed Loads (BLC 68 : Structure Wm (90 Deg)) (Continued)

	Member Label	Direction	Start Magnitude[lb/ft....	End Magnitude[lb/ft....	Start Location[ft.%]	End Location[ft.%]
9	M5	X	1.136	1.136	0	%100
10	M5	Z	0	0	0	%100
11	M9	X	.284	.284	0	%100
12	M9	Z	0	0	0	%100
13	M10	X	.284	.284	0	%100
14	M10	Z	0	0	0	%100
15	M14	X	.284	.284	0	%100
16	M14	Z	0	0	0	%100
17	M15	X	.284	.284	0	%100
18	M15	Z	0	0	0	%100
19	M19	X	1.016	1.016	0	%100
20	M19	Z	0	0	0	%100
21	M20	X	0	0	0	%100
22	M20	Z	0	0	0	%100
23	M21	X	1.016	1.016	0	%100
24	M21	Z	0	0	0	%100
25	M25	X	1.578	1.578	0	%100
26	M25	Z	0	0	0	%100
27	M28	X	.395	.395	0	%100
28	M28	Z	0	0	0	%100
29	M31	X	.395	.395	0	%100
30	M31	Z	0	0	0	%100
31	MP1A	X	.643	.643	0	%100
32	MP1A	Z	0	0	0	%100
33	MP2A	X	.643	.643	0	%100
34	MP2A	Z	0	0	0	%100
35	MP3A	X	.779	.779	0	%100
36	MP3A	Z	0	0	0	%100
37	MP4A	X	.643	.643	0	%100
38	MP4A	Z	0	0	0	%100
39	MP5A	X	.643	.643	0	%100
40	MP5A	Z	0	0	0	%100
41	MP1C	X	.643	.643	0	%100
42	MP1C	Z	0	0	0	%100
43	MP2C	X	.643	.643	0	%100
44	MP2C	Z	0	0	0	%100
45	MP3C	X	.779	.779	0	%100
46	MP3C	Z	0	0	0	%100
47	MP4C	X	.643	.643	0	%100
48	MP4C	Z	0	0	0	%100
49	MP5C	X	.643	.643	0	%100
50	MP5C	Z	0	0	0	%100
51	MP1B	X	.643	.643	0	%100
52	MP1B	Z	0	0	0	%100
53	MP2B	X	.643	.643	0	%100
54	MP2B	Z	0	0	0	%100
55	MP3B	X	.779	.779	0	%100
56	MP3B	Z	0	0	0	%100
57	MP4B	X	.643	.643	0	%100
58	MP4B	Z	0	0	0	%100
59	MP5B	X	.643	.643	0	%100
60	MP5B	Z	0	0	0	%100
61	M76	X	.643	.643	0	%100
62	M76	Z	0	0	0	%100
63	M77	X	.526	.526	0	%100
64	M77	Z	0	0	0	%100
65	M72	X	.024	.024	0	%100
66	M72	Z	0	0	0	%100
67	M73	X	.024	.024	0	%100

Member Distributed Loads (BLC 68 : Structure Wm (90 Deg)) (Continued)

Member Label	Direction	Start Magnitude[lb/ft....]	End Magnitude[lb/ft....]	Start Location[ft.%]	End Location[ft.%]
68	M73	Z	0	0	%100
69	M76A	X	.436	.436	%100
70	M76A	Z	0	0	%100
71	M81A	X	.024	.024	%100
72	M81A	Z	0	0	%100
73	M82	X	.024	.024	%100
74	M82	Z	0	0	%100
75	M82A	X	0	0	%100
76	M82A	Z	0	0	%100
77	M88	X	.584	.584	%100
78	M88	Z	0	0	%100
79	M94	X	.584	.584	%100
80	M94	Z	0	0	%100
81	M109	X	.322	.322	%100
82	M109	Z	0	0	%100
83	M110	X	.322	.322	%100
84	M110	Z	0	0	%100
85	M115	X	0	0	%100
86	M115	Z	0	0	%100
87	M121	X	.584	.584	%100
88	M121	Z	0	0	%100
89	M127	X	.584	.584	%100
90	M127	Z	0	0	%100
91	M139	X	.762	.762	%100
92	M139	Z	0	0	%100
93	M143A	X	.762	.762	%100
94	M143A	Z	0	0	%100
95	M146A	X	0	0	%100
96	M146A	Z	0	0	%100
97	M149A	X	.762	.762	%100
98	M149A	Z	0	0	%100
99	M152A	X	.762	.762	%100
100	M152A	Z	0	0	%100
101	M155A	X	0	0	%100
102	M155A	Z	0	0	%100
103	M153B	X	.318	.318	%100
104	M153B	Z	0	0	%100
105	M154B	X	1.129	1.129	%100
106	M154B	Z	0	0	%100
107	M155B	X	1.129	1.129	%100
108	M155B	Z	0	0	%100
109	M156B	X	.318	.318	%100
110	M156B	Z	0	0	%100

Member Distributed Loads (BLC 69 : Structure Wm (120 Deg))

Member Label	Direction	Start Magnitude[lb/ft....]	End Magnitude[lb/ft....]	Start Location[ft.%]	End Location[ft.%]
1	FACE	X	.293	.293	%100
2	FACE	Z	.169	.169	%100
3	M2	X	.293	.293	%100
4	M2	Z	.169	.169	%100
5	M3	X	1.173	1.173	%100
6	M3	Z	.677	.677	%100
7	M4	X	.738	.738	%100
8	M4	Z	.426	.426	%100
9	M5	X	.738	.738	%100
10	M5	Z	.426	.426	%100
11	M9	X	.738	.738	%100
12	M9	Z	.426	.426	%100

Member Distributed Loads (BLC 69 : Structure Wm (120 Deg)) (Continued)

Member Label	Direction	Start Magnitude[lb/ft....	End Magnitude[lb/ft....	Start Location[ft.%]	End Location[ft.%]
13	M10	X	.738	.738	0 %100
14	M10	Z	.426	.426	0 %100
15	M14	X	0	0	0 %100
16	M14	Z	0	0	0 %100
17	M15	X	0	0	0 %100
18	M15	Z	0	0	0 %100
19	M19	X	1.173	1.173	0 %100
20	M19	Z	.677	.677	0 %100
21	M20	X	.293	.293	0 %100
22	M20	Z	.169	.169	0 %100
23	M21	X	.293	.293	0 %100
24	M21	Z	.169	.169	0 %100
25	M25	X	1.025	1.025	0 %100
26	M25	Z	.592	.592	0 %100
27	M28	X	1.025	1.025	0 %100
28	M28	Z	.592	.592	0 %100
29	M31	X	0	0	0 %100
30	M31	Z	0	0	0 %100
31	MP1A	X	.557	.557	0 %100
32	MP1A	Z	.322	.322	0 %100
33	MP2A	X	.557	.557	0 %100
34	MP2A	Z	.322	.322	0 %100
35	MP3A	X	.675	.675	0 %100
36	MP3A	Z	.389	.389	0 %100
37	MP4A	X	.557	.557	0 %100
38	MP4A	Z	.322	.322	0 %100
39	MP5A	X	.557	.557	0 %100
40	MP5A	Z	.322	.322	0 %100
41	MP1C	X	.557	.557	0 %100
42	MP1C	Z	.322	.322	0 %100
43	MP2C	X	.557	.557	0 %100
44	MP2C	Z	.322	.322	0 %100
45	MP3C	X	.675	.675	0 %100
46	MP3C	Z	.389	.389	0 %100
47	MP4C	X	.557	.557	0 %100
48	MP4C	Z	.322	.322	0 %100
49	MP5C	X	.557	.557	0 %100
50	MP5C	Z	.322	.322	0 %100
51	MP1B	X	.557	.557	0 %100
52	MP1B	Z	.322	.322	0 %100
53	MP2B	X	.557	.557	0 %100
54	MP2B	Z	.322	.322	0 %100
55	MP3B	X	.675	.675	0 %100
56	MP3B	Z	.389	.389	0 %100
57	MP4B	X	.557	.557	0 %100
58	MP4B	Z	.322	.322	0 %100
59	MP5B	X	.557	.557	0 %100
60	MP5B	Z	.322	.322	0 %100
61	M76	X	.557	.557	0 %100
62	M76	Z	.322	.322	0 %100
63	M77	X	.456	.456	0 %100
64	M77	Z	.263	.263	0 %100
65	M72	X	.064	.064	0 %100
66	M72	Z	.037	.037	0 %100
67	M73	X	.064	.064	0 %100
68	M73	Z	.037	.037	0 %100
69	M76A	X	.377	.377	0 %100
70	M76A	Z	.218	.218	0 %100
71	M81A	X	.064	.064	0 %100

Member Distributed Loads (BLC 69 : Structure Wm (120 Deg)) (Continued)

	Member Label	Direction	Start Magnitude[lb/ft....	End Magnitude[lb/ft....	Start Location[ft.%]	End Location[ft.%]
72	M81A	Z	.037	.037	0	%100
73	M82	X	.064	.064	0	%100
74	M82	Z	.037	.037	0	%100
75	M82A	X	.169	.169	0	%100
76	M82A	Z	.097	.097	0	%100
77	M88	X	.169	.169	0	%100
78	M88	Z	.097	.097	0	%100
79	M94	X	.675	.675	0	%100
80	M94	Z	.389	.389	0	%100
81	M109	X	.746	.746	0	%100
82	M109	Z	.43	.43	0	%100
83	M110	X	.044	.044	0	%100
84	M110	Z	.025	.025	0	%100
85	M115	X	.169	.169	0	%100
86	M115	Z	.097	.097	0	%100
87	M121	X	.169	.169	0	%100
88	M121	Z	.097	.097	0	%100
89	M127	X	.675	.675	0	%100
90	M127	Z	.389	.389	0	%100
91	M139	X	.22	.22	0	%100
92	M139	Z	.127	.127	0	%100
93	M143A	X	.88	.88	0	%100
94	M143A	Z	.508	.508	0	%100
95	M146A	X	.22	.22	0	%100
96	M146A	Z	.127	.127	0	%100
97	M149A	X	.22	.22	0	%100
98	M149A	Z	.127	.127	0	%100
99	M152A	X	.88	.88	0	%100
100	M152A	Z	.508	.508	0	%100
101	M155A	X	.22	.22	0	%100
102	M155A	Z	.127	.127	0	%100
103	M153B	X	.044	.044	0	%100
104	M153B	Z	.025	.025	0	%100
105	M154B	X	.746	.746	0	%100
106	M154B	Z	.43	.43	0	%100
107	M155B	X	.743	.743	0	%100
108	M155B	Z	.429	.429	0	%100
109	M156B	X	.743	.743	0	%100
110	M156B	Z	.429	.429	0	%100

Member Distributed Loads (BLC 70 : Structure Wm (150 Deg))

	Member Label	Direction	Start Magnitude[lb/ft....	End Magnitude[lb/ft....	Start Location[ft.%]	End Location[ft.%]
1	FACE	X	.508	.508	0	%100
2	FACE	Z	.88	.88	0	%100
3	M2	X	0	0	0	%100
4	M2	Z	0	0	0	%100
5	M3	X	.508	.508	0	%100
6	M3	Z	.88	.88	0	%100
7	M4	X	.142	.142	0	%100
8	M4	Z	.246	.246	0	%100
9	M5	X	.142	.142	0	%100
10	M5	Z	.246	.246	0	%100
11	M9	X	.568	.568	0	%100
12	M9	Z	.984	.984	0	%100
13	M10	X	.568	.568	0	%100
14	M10	Z	.984	.984	0	%100
15	M14	X	.142	.142	0	%100
16	M14	Z	.246	.246	0	%100



Member Distributed Loads (BLC 70 : Structure Wm (150 Deg)) (Continued)

Member Label	Direction	Start Magnitude[lb/ft....	End Magnitude[lb/ft....	Start Location[ft,%]	End Location[ft,%]
17	M15	X	.142	.142	0 %100
18	M15	Z	.246	.246	0 %100
19	M19	X	.508	.508	0 %100
20	M19	Z	.88	.88	0 %100
21	M20	X	.508	.508	0 %100
22	M20	Z	.88	.88	0 %100
23	M21	X	0	0	0 %100
24	M21	Z	0	0	0 %100
25	M25	X	.197	.197	0 %100
26	M25	Z	.342	.342	0 %100
27	M28	X	.789	.789	0 %100
28	M28	Z	1.367	1.367	0 %100
29	M31	X	.197	.197	0 %100
30	M31	Z	.342	.342	0 %100
31	MP1A	X	.322	.322	0 %100
32	MP1A	Z	.557	.557	0 %100
33	MP2A	X	.322	.322	0 %100
34	MP2A	Z	.557	.557	0 %100
35	MP3A	X	.389	.389	0 %100
36	MP3A	Z	.675	.675	0 %100
37	MP4A	X	.322	.322	0 %100
38	MP4A	Z	.557	.557	0 %100
39	MP5A	X	.322	.322	0 %100
40	MP5A	Z	.557	.557	0 %100
41	MP1C	X	.322	.322	0 %100
42	MP1C	Z	.557	.557	0 %100
43	MP2C	X	.322	.322	0 %100
44	MP2C	Z	.557	.557	0 %100
45	MP3C	X	.389	.389	0 %100
46	MP3C	Z	.675	.675	0 %100
47	MP4C	X	.322	.322	0 %100
48	MP4C	Z	.557	.557	0 %100
49	MP5C	X	.322	.322	0 %100
50	MP5C	Z	.557	.557	0 %100
51	MP1B	X	.322	.322	0 %100
52	MP1B	Z	.557	.557	0 %100
53	MP2B	X	.322	.322	0 %100
54	MP2B	Z	.557	.557	0 %100
55	MP3B	X	.389	.389	0 %100
56	MP3B	Z	.675	.675	0 %100
57	MP4B	X	.322	.322	0 %100
58	MP4B	Z	.557	.557	0 %100
59	MP5B	X	.322	.322	0 %100
60	MP5B	Z	.557	.557	0 %100
61	M76	X	.322	.322	0 %100
62	M76	Z	.557	.557	0 %100
63	M77	X	.263	.263	0 %100
64	M77	Z	.456	.456	0 %100
65	M72	X	.049	.049	0 %100
66	M72	Z	.085	.085	0 %100
67	M73	X	.049	.049	0 %100
68	M73	Z	.085	.085	0 %100
69	M76A	X	.218	.218	0 %100
70	M76A	Z	.377	.377	0 %100
71	M81A	X	.049	.049	0 %100
72	M81A	Z	.085	.085	0 %100
73	M82	X	.049	.049	0 %100
74	M82	Z	.085	.085	0 %100
75	M82A	X	.292	.292	0 %100

Member Distributed Loads (BLC 70 : Structure Wm (150 Deg)) (Continued)

Member Label	Direction	Start Magnitude[lb/ft....]	End Magnitude[lb/ft....]	Start Location[ft.%]	End Location[ft.%]
76	M82A	Z	.506	.506	0 %100
77	M88	X	0	0	0 %100
78	M88	Z	0	0	0 %100
79	M94	X	.292	.292	0 %100
80	M94	Z	.506	.506	0 %100
81	M109	X	.564	.564	0 %100
82	M109	Z	.978	.978	0 %100
83	M110	X	.159	.159	0 %100
84	M110	Z	.276	.276	0 %100
85	M115	X	.292	.292	0 %100
86	M115	Z	.506	.506	0 %100
87	M121	X	0	0	0 %100
88	M121	Z	0	0	0 %100
89	M127	X	.292	.292	0 %100
90	M127	Z	.506	.506	0 %100
91	M139	X	0	0	0 %100
92	M139	Z	0	0	0 %100
93	M143A	X	.381	.381	0 %100
94	M143A	Z	.66	.66	0 %100
95	M146A	X	.381	.381	0 %100
96	M146A	Z	.66	.66	0 %100
97	M149A	X	0	0	0 %100
98	M149A	Z	0	0	0 %100
99	M152A	X	.381	.381	0 %100
100	M152A	Z	.66	.66	0 %100
101	M155A	X	.381	.381	0 %100
102	M155A	Z	.66	.66	0 %100
103	M153B	X	.161	.161	0 %100
104	M153B	Z	.279	.279	0 %100
105	M154B	X	.161	.161	0 %100
106	M154B	Z	.279	.279	0 %100
107	M155B	X	.159	.159	0 %100
108	M155B	Z	.276	.276	0 %100
109	M156B	X	.564	.564	0 %100
110	M156B	Z	.978	.978	0 %100

Member Distributed Loads (BLC 71 : Structure Wm (180 Deg))

Member Label	Direction	Start Magnitude[lb/ft....]	End Magnitude[lb/ft....]	Start Location[ft.%]	End Location[ft.%]
1	FACE	X	0	0	0 %100
2	FACE	Z	1.355	1.355	0 %100
3	M2	X	0	0	0 %100
4	M2	Z	.339	.339	0 %100
5	M3	X	0	0	0 %100
6	M3	Z	.339	.339	0 %100
7	M4	X	0	0	0 %100
8	M4	Z	0	0	0 %100
9	M5	X	0	0	0 %100
10	M5	Z	0	0	0 %100
11	M9	X	0	0	0 %100
12	M9	Z	.852	.852	0 %100
13	M10	X	0	0	0 %100
14	M10	Z	.852	.852	0 %100
15	M14	X	0	0	0 %100
16	M14	Z	.852	.852	0 %100
17	M15	X	0	0	0 %100
18	M15	Z	.852	.852	0 %100
19	M19	X	0	0	0 %100
20	M19	Z	.339	.339	0 %100



Member Distributed Loads (BLC 71 : Structure Wm (180 Deg)) (Continued)

Member Label	Direction	Start Magnitude[lb/ft....	End Magnitude[lb/ft....	Start Location[ft,%]	End Location[ft,%]
21	M20	X	0	0	%100
22	M20	Z	1.355	1.355	%100
23	M21	X	0	0	%100
24	M21	Z	.339	.339	%100
25	M25	X	0	0	%100
26	M25	Z	0	0	%100
27	M28	X	0	0	%100
28	M28	Z	1.184	1.184	%100
29	M31	X	0	0	%100
30	M31	Z	1.184	1.184	%100
31	MP1A	X	0	0	%100
32	MP1A	Z	.643	.643	%100
33	MP2A	X	0	0	%100
34	MP2A	Z	.643	.643	%100
35	MP3A	X	0	0	%100
36	MP3A	Z	.779	.779	%100
37	MP4A	X	0	0	%100
38	MP4A	Z	.643	.643	%100
39	MP5A	X	0	0	%100
40	MP5A	Z	.643	.643	%100
41	MP1C	X	0	0	%100
42	MP1C	Z	.643	.643	%100
43	MP2C	X	0	0	%100
44	MP2C	Z	.643	.643	%100
45	MP3C	X	0	0	%100
46	MP3C	Z	.779	.779	%100
47	MP4C	X	0	0	%100
48	MP4C	Z	.643	.643	%100
49	MP5C	X	0	0	%100
50	MP5C	Z	.643	.643	%100
51	MP1B	X	0	0	%100
52	MP1B	Z	.643	.643	%100
53	MP2B	X	0	0	%100
54	MP2B	Z	.643	.643	%100
55	MP3B	X	0	0	%100
56	MP3B	Z	.779	.779	%100
57	MP4B	X	0	0	%100
58	MP4B	Z	.643	.643	%100
59	MP5B	X	0	0	%100
60	MP5B	Z	.643	.643	%100
61	M76	X	0	0	%100
62	M76	Z	.643	.643	%100
63	M77	X	0	0	%100
64	M77	Z	.526	.526	%100
65	M72	X	0	0	%100
66	M72	Z	.073	.073	%100
67	M73	X	0	0	%100
68	M73	Z	.073	.073	%100
69	M76A	X	0	0	%100
70	M76A	Z	.436	.436	%100
71	M81A	X	0	0	%100
72	M81A	Z	.073	.073	%100
73	M82	X	0	0	%100
74	M82	Z	.073	.073	%100
75	M82A	X	0	0	%100
76	M82A	Z	.779	.779	%100
77	M88	X	0	0	%100
78	M88	Z	.195	.195	%100
79	M94	X	0	0	%100

Member Distributed Loads (BLC 71 : Structure Wm (180 Deg)) (Continued)

Member Label	Direction	Start Magnitude[lb/ft....]	End Magnitude[lb/ft....]	Start Location[ft.%]	End Location[ft.%]
80	M94	Z	.195	.195	0 %100
81	M109	X	0	0	0 %100
82	M109	Z	.858	.858	0 %100
83	M110	X	0	0	0 %100
84	M110	Z	.858	.858	0 %100
85	M115	X	0	0	0 %100
86	M115	Z	.779	.779	0 %100
87	M121	X	0	0	0 %100
88	M121	Z	.195	.195	0 %100
89	M127	X	0	0	0 %100
90	M127	Z	.195	.195	0 %100
91	M139	X	0	0	0 %100
92	M139	Z	.254	.254	0 %100
93	M143A	X	0	0	0 %100
94	M143A	Z	.254	.254	0 %100
95	M146A	X	0	0	0 %100
96	M146A	Z	1.016	1.016	0 %100
97	M149A	X	0	0	0 %100
98	M149A	Z	.254	.254	0 %100
99	M152A	X	0	0	0 %100
100	M152A	Z	.254	.254	0 %100
101	M155A	X	0	0	0 %100
102	M155A	Z	1.016	1.016	0 %100
103	M153B	X	0	0	0 %100
104	M153B	Z	.861	.861	0 %100
105	M154B	X	0	0	0 %100
106	M154B	Z	.05	.05	0 %100
107	M155B	X	0	0	0 %100
108	M155B	Z	.05	.05	0 %100
109	M156B	X	0	0	0 %100
110	M156B	Z	.861	.861	0 %100

Member Distributed Loads (BLC 72 : Structure Wm (210 Deg))

Member Label	Direction	Start Magnitude[lb/ft....]	End Magnitude[lb/ft....]	Start Location[ft.%]	End Location[ft.%]
1	FACE	X	-.508	-.508	0 %100
2	FACE	Z	.88	.88	0 %100
3	M2	X	-.508	-.508	0 %100
4	M2	Z	.88	.88	0 %100
5	M3	X	0	0	0 %100
6	M3	Z	0	0	0 %100
7	M4	X	-.142	-.142	0 %100
8	M4	Z	.246	.246	0 %100
9	M5	X	-.142	-.142	0 %100
10	M5	Z	.246	.246	0 %100
11	M9	X	-.142	-.142	0 %100
12	M9	Z	.246	.246	0 %100
13	M10	X	-.142	-.142	0 %100
14	M10	Z	.246	.246	0 %100
15	M14	X	-.568	-.568	0 %100
16	M14	Z	.984	.984	0 %100
17	M15	X	-.568	-.568	0 %100
18	M15	Z	.984	.984	0 %100
19	M19	X	0	0	0 %100
20	M19	Z	0	0	0 %100
21	M20	X	-.508	-.508	0 %100
22	M20	Z	.88	.88	0 %100
23	M21	X	-.508	-.508	0 %100
24	M21	Z	.88	.88	0 %100



Member Distributed Loads (BLC 72 : Structure Wm (210 Deg)) (Continued)

Member Label	Direction	Start Magnitude[lb/ft....	End Magnitude[lb/ft....	Start Location[ft.%]	End Location[ft.%]
25	M25	X	-.197	-.197	0 %100
26	M25	Z	.342	.342	0 %100
27	M28	X	-.197	-.197	0 %100
28	M28	Z	.342	.342	0 %100
29	M31	X	-.789	-.789	0 %100
30	M31	Z	1.367	1.367	0 %100
31	MP1A	X	-.322	-.322	0 %100
32	MP1A	Z	.557	.557	0 %100
33	MP2A	X	-.322	-.322	0 %100
34	MP2A	Z	.557	.557	0 %100
35	MP3A	X	-.389	-.389	0 %100
36	MP3A	Z	.675	.675	0 %100
37	MP4A	X	-.322	-.322	0 %100
38	MP4A	Z	.557	.557	0 %100
39	MP5A	X	-.322	-.322	0 %100
40	MP5A	Z	.557	.557	0 %100
41	MP1C	X	-.322	-.322	0 %100
42	MP1C	Z	.557	.557	0 %100
43	MP2C	X	-.322	-.322	0 %100
44	MP2C	Z	.557	.557	0 %100
45	MP3C	X	-.389	-.389	0 %100
46	MP3C	Z	.675	.675	0 %100
47	MP4C	X	-.322	-.322	0 %100
48	MP4C	Z	.557	.557	0 %100
49	MP5C	X	-.322	-.322	0 %100
50	MP5C	Z	.557	.557	0 %100
51	MP1B	X	-.322	-.322	0 %100
52	MP1B	Z	.557	.557	0 %100
53	MP2B	X	-.322	-.322	0 %100
54	MP2B	Z	.557	.557	0 %100
55	MP3B	X	-.389	-.389	0 %100
56	MP3B	Z	.675	.675	0 %100
57	MP4B	X	-.322	-.322	0 %100
58	MP4B	Z	.557	.557	0 %100
59	MP5B	X	-.322	-.322	0 %100
60	MP5B	Z	.557	.557	0 %100
61	M76	X	-.322	-.322	0 %100
62	M76	Z	.557	.557	0 %100
63	M77	X	-.263	-.263	0 %100
64	M77	Z	.456	.456	0 %100
65	M72	X	-.012	-.012	0 %100
66	M72	Z	.021	.021	0 %100
67	M73	X	-.012	-.012	0 %100
68	M73	Z	.021	.021	0 %100
69	M76A	X	-.218	-.218	0 %100
70	M76A	Z	.377	.377	0 %100
71	M81A	X	-.012	-.012	0 %100
72	M81A	Z	.021	.021	0 %100
73	M82	X	-.012	-.012	0 %100
74	M82	Z	.021	.021	0 %100
75	M82A	X	-.292	-.292	0 %100
76	M82A	Z	.506	.506	0 %100
77	M88	X	-.292	-.292	0 %100
78	M88	Z	.506	.506	0 %100
79	M94	X	0	0	0 %100
80	M94	Z	0	0	0 %100
81	M109	X	-.159	-.159	0 %100
82	M109	Z	.276	.276	0 %100
83	M110	X	-.564	-.564	0 %100

Member Distributed Loads (BLC 72 : Structure Wm (210 Deg)) (Continued)

	Member Label	Direction	Start Magnitude[lb/ft....]	End Magnitude[lb/ft....]	Start Location[ft.%]	End Location[ft.%]
84	M110	Z	.978	.978	0	%100
85	M115	X	-.292	-.292	0	%100
86	M115	Z	.506	.506	0	%100
87	M121	X	-.292	-.292	0	%100
88	M121	Z	.506	.506	0	%100
89	M127	X	0	0	0	%100
90	M127	Z	0	0	0	%100
91	M139	X	-.381	-.381	0	%100
92	M139	Z	.66	.66	0	%100
93	M143A	X	0	0	0	%100
94	M143A	Z	0	0	0	%100
95	M146A	X	-.381	-.381	0	%100
96	M146A	Z	.66	.66	0	%100
97	M149A	X	-.381	-.381	0	%100
98	M149A	Z	.66	.66	0	%100
99	M152A	X	0	0	0	%100
100	M152A	Z	0	0	0	%100
101	M155A	X	-.381	-.381	0	%100
102	M155A	Z	.66	.66	0	%100
103	M153B	X	-.564	-.564	0	%100
104	M153B	Z	.978	.978	0	%100
105	M154B	X	-.159	-.159	0	%100
106	M154B	Z	.276	.276	0	%100
107	M155B	X	-.161	-.161	0	%100
108	M155B	Z	.279	.279	0	%100
109	M156B	X	-.161	-.161	0	%100
110	M156B	Z	.279	.279	0	%100

Member Distributed Loads (BLC 73 : Structure Wm (240 Deg))

	Member Label	Direction	Start Magnitude[lb/ft....]	End Magnitude[lb/ft....]	Start Location[ft.%]	End Location[ft.%]
1	FACE	X	-.293	-.293	0	%100
2	FACE	Z	.169	.169	0	%100
3	M2	X	-1.173	-1.173	0	%100
4	M2	Z	.677	.677	0	%100
5	M3	X	-.293	-.293	0	%100
6	M3	Z	.169	.169	0	%100
7	M4	X	-.738	-.738	0	%100
8	M4	Z	.426	.426	0	%100
9	M5	X	-.738	-.738	0	%100
10	M5	Z	.426	.426	0	%100
11	M9	X	0	0	0	%100
12	M9	Z	0	0	0	%100
13	M10	X	0	0	0	%100
14	M10	Z	0	0	0	%100
15	M14	X	-.738	-.738	0	%100
16	M14	Z	.426	.426	0	%100
17	M15	X	-.738	-.738	0	%100
18	M15	Z	.426	.426	0	%100
19	M19	X	-.293	-.293	0	%100
20	M19	Z	.169	.169	0	%100
21	M20	X	-.293	-.293	0	%100
22	M20	Z	.169	.169	0	%100
23	M21	X	-1.173	-1.173	0	%100
24	M21	Z	.677	.677	0	%100
25	M25	X	-1.025	-1.025	0	%100
26	M25	Z	.592	.592	0	%100
27	M28	X	0	0	0	%100
28	M28	Z	0	0	0	%100

Member Distributed Loads (BLC 73 : Structure Wm (240 Deg)) (Continued)

Member Label	Direction	Start Magnitude[lb/ft....	End Magnitude[lb/ft....	Start Location[ft.%]	End Location[ft.%]
29	M31	X	-1.025	-1.025	0 %100
30	M31	Z	.592	.592	0 %100
31	MP1A	X	-.557	-.557	0 %100
32	MP1A	Z	.322	.322	0 %100
33	MP2A	X	-.557	-.557	0 %100
34	MP2A	Z	.322	.322	0 %100
35	MP3A	X	-.675	-.675	0 %100
36	MP3A	Z	.389	.389	0 %100
37	MP4A	X	-.557	-.557	0 %100
38	MP4A	Z	.322	.322	0 %100
39	MP5A	X	-.557	-.557	0 %100
40	MP5A	Z	.322	.322	0 %100
41	MP1C	X	-.557	-.557	0 %100
42	MP1C	Z	.322	.322	0 %100
43	MP2C	X	-.557	-.557	0 %100
44	MP2C	Z	.322	.322	0 %100
45	MP3C	X	-.675	-.675	0 %100
46	MP3C	Z	.389	.389	0 %100
47	MP4C	X	-.557	-.557	0 %100
48	MP4C	Z	.322	.322	0 %100
49	MP5C	X	-.557	-.557	0 %100
50	MP5C	Z	.322	.322	0 %100
51	MP1B	X	-.557	-.557	0 %100
52	MP1B	Z	.322	.322	0 %100
53	MP2B	X	-.557	-.557	0 %100
54	MP2B	Z	.322	.322	0 %100
55	MP3B	X	-.675	-.675	0 %100
56	MP3B	Z	.389	.389	0 %100
57	MP4B	X	-.557	-.557	0 %100
58	MP4B	Z	.322	.322	0 %100
59	MP5B	X	-.557	-.557	0 %100
60	MP5B	Z	.322	.322	0 %100
61	M76	X	-.557	-.557	0 %100
62	M76	Z	.322	.322	0 %100
63	M77	X	-.456	-.456	0 %100
64	M77	Z	.263	.263	0 %100
65	M72	X	0	0	0 %100
66	M72	Z	0	0	0 %100
67	M73	X	0	0	0 %100
68	M73	Z	0	0	0 %100
69	M76A	X	-.377	-.377	0 %100
70	M76A	Z	.218	.218	0 %100
71	M81A	X	0	0	0 %100
72	M81A	Z	0	0	0 %100
73	M82	X	0	0	0 %100
74	M82	Z	0	0	0 %100
75	M82A	X	-.169	-.169	0 %100
76	M82A	Z	.097	.097	0 %100
77	M88	X	-.675	-.675	0 %100
78	M88	Z	.389	.389	0 %100
79	M94	X	-.169	-.169	0 %100
80	M94	Z	.097	.097	0 %100
81	M109	X	-.044	-.044	0 %100
82	M109	Z	.025	.025	0 %100
83	M110	X	-.746	-.746	0 %100
84	M110	Z	.43	.43	0 %100
85	M115	X	-.169	-.169	0 %100
86	M115	Z	.097	.097	0 %100
87	M121	X	-.675	-.675	0 %100

Member Distributed Loads (BLC 73 : Structure Wm (240 Deg)) (Continued)

Member Label	Direction	Start Magnitude[lb/ft....	End Magnitude[lb/ft....	Start Location[ft.%]	End Location[ft.%]
88	M121	Z	.389	.389	0 %100
89	M127	X	-.169	-.169	0 %100
90	M127	Z	.097	.097	0 %100
91	M139	X	-.88	-.88	0 %100
92	M139	Z	.508	.508	0 %100
93	M143A	X	-.22	-.22	0 %100
94	M143A	Z	.127	.127	0 %100
95	M146A	X	-.22	-.22	0 %100
96	M146A	Z	.127	.127	0 %100
97	M149A	X	-.88	-.88	0 %100
98	M149A	Z	.508	.508	0 %100
99	M152A	X	-.22	-.22	0 %100
100	M152A	Z	.127	.127	0 %100
101	M155A	X	-.22	-.22	0 %100
102	M155A	Z	.127	.127	0 %100
103	M153B	X	-.743	-.743	0 %100
104	M153B	Z	.429	.429	0 %100
105	M154B	X	-.743	-.743	0 %100
106	M154B	Z	.429	.429	0 %100
107	M155B	X	-.746	-.746	0 %100
108	M155B	Z	.43	.43	0 %100
109	M156B	X	-.044	-.044	0 %100
110	M156B	Z	.025	.025	0 %100

Member Distributed Loads (BLC 74 : Structure Wm (270 Deg))

Member Label	Direction	Start Magnitude[lb/ft....	End Magnitude[lb/ft....	Start Location[ft.%]	End Location[ft.%]
1	FACE	X	0	0	0 %100
2	FACE	Z	0	0	0 %100
3	M2	X	-1.016	-1.016	0 %100
4	M2	Z	0	0	0 %100
5	M3	X	-1.016	-1.016	0 %100
6	M3	Z	0	0	0 %100
7	M4	X	-1.136	-1.136	0 %100
8	M4	Z	0	0	0 %100
9	M5	X	-1.136	-1.136	0 %100
10	M5	Z	0	0	0 %100
11	M9	X	-.284	-.284	0 %100
12	M9	Z	0	0	0 %100
13	M10	X	-.284	-.284	0 %100
14	M10	Z	0	0	0 %100
15	M14	X	-.284	-.284	0 %100
16	M14	Z	0	0	0 %100
17	M15	X	-.284	-.284	0 %100
18	M15	Z	0	0	0 %100
19	M19	X	-1.016	-1.016	0 %100
20	M19	Z	0	0	0 %100
21	M20	X	0	0	0 %100
22	M20	Z	0	0	0 %100
23	M21	X	-1.016	-1.016	0 %100
24	M21	Z	0	0	0 %100
25	M25	X	-1.578	-1.578	0 %100
26	M25	Z	0	0	0 %100
27	M28	X	-.395	-.395	0 %100
28	M28	Z	0	0	0 %100
29	M31	X	-.395	-.395	0 %100
30	M31	Z	0	0	0 %100
31	MP1A	X	-.643	-.643	0 %100
32	MP1A	Z	0	0	0 %100



Member Distributed Loads (BLC 74 : Structure Wm (270 Deg)) (Continued)

Member Label	Direction	Start Magnitude[lb/ft....	End Magnitude[lb/ft....	Start Location[ft.%]	End Location[ft.%]
33	MP2A	X	-.643	-.643	0 %100
34	MP2A	Z	0	0	0 %100
35	MP3A	X	-.779	-.779	0 %100
36	MP3A	Z	0	0	0 %100
37	MP4A	X	-.643	-.643	0 %100
38	MP4A	Z	0	0	0 %100
39	MP5A	X	-.643	-.643	0 %100
40	MP5A	Z	0	0	0 %100
41	MP1C	X	-.643	-.643	0 %100
42	MP1C	Z	0	0	0 %100
43	MP2C	X	-.643	-.643	0 %100
44	MP2C	Z	0	0	0 %100
45	MP3C	X	-.779	-.779	0 %100
46	MP3C	Z	0	0	0 %100
47	MP4C	X	-.643	-.643	0 %100
48	MP4C	Z	0	0	0 %100
49	MP5C	X	-.643	-.643	0 %100
50	MP5C	Z	0	0	0 %100
51	MP1B	X	-.643	-.643	0 %100
52	MP1B	Z	0	0	0 %100
53	MP2B	X	-.643	-.643	0 %100
54	MP2B	Z	0	0	0 %100
55	MP3B	X	-.779	-.779	0 %100
56	MP3B	Z	0	0	0 %100
57	MP4B	X	-.643	-.643	0 %100
58	MP4B	Z	0	0	0 %100
59	MP5B	X	-.643	-.643	0 %100
60	MP5B	Z	0	0	0 %100
61	M76	X	-.643	-.643	0 %100
62	M76	Z	0	0	0 %100
63	M77	X	-.526	-.526	0 %100
64	M77	Z	0	0	0 %100
65	M72	X	-.024	-.024	0 %100
66	M72	Z	0	0	0 %100
67	M73	X	-.024	-.024	0 %100
68	M73	Z	0	0	0 %100
69	M76A	X	-.436	-.436	0 %100
70	M76A	Z	0	0	0 %100
71	M81A	X	-.024	-.024	0 %100
72	M81A	Z	0	0	0 %100
73	M82	X	-.024	-.024	0 %100
74	M82	Z	0	0	0 %100
75	M82A	X	0	0	0 %100
76	M82A	Z	0	0	0 %100
77	M88	X	-.584	-.584	0 %100
78	M88	Z	0	0	0 %100
79	M94	X	-.584	-.584	0 %100
80	M94	Z	0	0	0 %100
81	M109	X	-.322	-.322	0 %100
82	M109	Z	0	0	0 %100
83	M110	X	-.322	-.322	0 %100
84	M110	Z	0	0	0 %100
85	M115	X	0	0	0 %100
86	M115	Z	0	0	0 %100
87	M121	X	-.584	-.584	0 %100
88	M121	Z	0	0	0 %100
89	M127	X	-.584	-.584	0 %100
90	M127	Z	0	0	0 %100
91	M139	X	-.762	-.762	0 %100

Member Distributed Loads (BLC 74 : Structure Wm (270 Deg)) (Continued)

	Member Label	Direction	Start Magnitude[lb/ft....]	End Magnitude[lb/ft....]	Start Location[ft.%]	End Location[ft.%]
92	M139	Z	0	0	0	%100
93	M143A	X	-0.762	-0.762	0	%100
94	M143A	Z	0	0	0	%100
95	M146A	X	0	0	0	%100
96	M146A	Z	0	0	0	%100
97	M149A	X	-0.762	-0.762	0	%100
98	M149A	Z	0	0	0	%100
99	M152A	X	-0.762	-0.762	0	%100
100	M152A	Z	0	0	0	%100
101	M155A	X	0	0	0	%100
102	M155A	Z	0	0	0	%100
103	M153B	X	-0.318	-0.318	0	%100
104	M153B	Z	0	0	0	%100
105	M154B	X	-1.129	-1.129	0	%100
106	M154B	Z	0	0	0	%100
107	M155B	X	-1.129	-1.129	0	%100
108	M155B	Z	0	0	0	%100
109	M156B	X	-0.318	-0.318	0	%100
110	M156B	Z	0	0	0	%100

Member Distributed Loads (BLC 75 : Structure Wm (300 Deg))

	Member Label	Direction	Start Magnitude[lb/ft....]	End Magnitude[lb/ft....]	Start Location[ft.%]	End Location[ft.%]
1	FACE	X	-0.293	-0.293	0	%100
2	FACE	Z	-0.169	-0.169	0	%100
3	M2	X	-0.293	-0.293	0	%100
4	M2	Z	-0.169	-0.169	0	%100
5	M3	X	-1.173	-1.173	0	%100
6	M3	Z	-0.677	-0.677	0	%100
7	M4	X	-0.738	-0.738	0	%100
8	M4	Z	-0.426	-0.426	0	%100
9	M5	X	-0.738	-0.738	0	%100
10	M5	Z	-0.426	-0.426	0	%100
11	M9	X	-0.738	-0.738	0	%100
12	M9	Z	-0.426	-0.426	0	%100
13	M10	X	-0.738	-0.738	0	%100
14	M10	Z	-0.426	-0.426	0	%100
15	M14	X	0	0	0	%100
16	M14	Z	0	0	0	%100
17	M15	X	0	0	0	%100
18	M15	Z	0	0	0	%100
19	M19	X	-1.173	-1.173	0	%100
20	M19	Z	-0.677	-0.677	0	%100
21	M20	X	-0.293	-0.293	0	%100
22	M20	Z	-0.169	-0.169	0	%100
23	M21	X	-0.293	-0.293	0	%100
24	M21	Z	-0.169	-0.169	0	%100
25	M25	X	-1.025	-1.025	0	%100
26	M25	Z	-0.592	-0.592	0	%100
27	M28	X	-1.025	-1.025	0	%100
28	M28	Z	-0.592	-0.592	0	%100
29	M31	X	0	0	0	%100
30	M31	Z	0	0	0	%100
31	MP1A	X	-0.557	-0.557	0	%100
32	MP1A	Z	-0.322	-0.322	0	%100
33	MP2A	X	-0.557	-0.557	0	%100
34	MP2A	Z	-0.322	-0.322	0	%100
35	MP3A	X	-0.675	-0.675	0	%100
36	MP3A	Z	-0.389	-0.389	0	%100

Member Distributed Loads (BLC 75 : Structure Wm (300 Deg)) (Continued)

Member Label	Direction	Start Magnitude[lb/ft....	End Magnitude[lb/ft....	Start Location[ft.%]	End Location[ft.%]
37	MP4A	X	-.557	-.557	0 %100
38	MP4A	Z	-.322	-.322	0 %100
39	MP5A	X	-.557	-.557	0 %100
40	MP5A	Z	-.322	-.322	0 %100
41	MP1C	X	-.557	-.557	0 %100
42	MP1C	Z	-.322	-.322	0 %100
43	MP2C	X	-.557	-.557	0 %100
44	MP2C	Z	-.322	-.322	0 %100
45	MP3C	X	-.675	-.675	0 %100
46	MP3C	Z	-.389	-.389	0 %100
47	MP4C	X	-.557	-.557	0 %100
48	MP4C	Z	-.322	-.322	0 %100
49	MP5C	X	-.557	-.557	0 %100
50	MP5C	Z	-.322	-.322	0 %100
51	MP1B	X	-.557	-.557	0 %100
52	MP1B	Z	-.322	-.322	0 %100
53	MP2B	X	-.557	-.557	0 %100
54	MP2B	Z	-.322	-.322	0 %100
55	MP3B	X	-.675	-.675	0 %100
56	MP3B	Z	-.389	-.389	0 %100
57	MP4B	X	-.557	-.557	0 %100
58	MP4B	Z	-.322	-.322	0 %100
59	MP5B	X	-.557	-.557	0 %100
60	MP5B	Z	-.322	-.322	0 %100
61	M76	X	-.557	-.557	0 %100
62	M76	Z	-.322	-.322	0 %100
63	M77	X	-.456	-.456	0 %100
64	M77	Z	-.263	-.263	0 %100
65	M72	X	-.064	-.064	0 %100
66	M72	Z	-.037	-.037	0 %100
67	M73	X	-.064	-.064	0 %100
68	M73	Z	-.037	-.037	0 %100
69	M76A	X	-.377	-.377	0 %100
70	M76A	Z	-.218	-.218	0 %100
71	M81A	X	-.064	-.064	0 %100
72	M81A	Z	-.037	-.037	0 %100
73	M82	X	-.064	-.064	0 %100
74	M82	Z	-.037	-.037	0 %100
75	M82A	X	-.169	-.169	0 %100
76	M82A	Z	-.097	-.097	0 %100
77	M88	X	-.169	-.169	0 %100
78	M88	Z	-.097	-.097	0 %100
79	M94	X	-.675	-.675	0 %100
80	M94	Z	-.389	-.389	0 %100
81	M109	X	-.746	-.746	0 %100
82	M109	Z	-.43	-.43	0 %100
83	M110	X	-.044	-.044	0 %100
84	M110	Z	-.025	-.025	0 %100
85	M115	X	-.169	-.169	0 %100
86	M115	Z	-.097	-.097	0 %100
87	M121	X	-.169	-.169	0 %100
88	M121	Z	-.097	-.097	0 %100
89	M127	X	-.675	-.675	0 %100
90	M127	Z	-.389	-.389	0 %100
91	M139	X	-.22	-.22	0 %100
92	M139	Z	-.127	-.127	0 %100
93	M143A	X	-.88	-.88	0 %100
94	M143A	Z	-.508	-.508	0 %100
95	M146A	X	-.22	-.22	0 %100

Member Distributed Loads (BLC 75 : Structure Wm (300 Deg)) (Continued)

	Member Label	Direction	Start Magnitude[lb/ft....]	End Magnitude[lb/ft....]	Start Location[ft.%]	End Location[ft.%]
96	M146A	Z	-.127	-.127	0	%100
97	M149A	X	-.22	-.22	0	%100
98	M149A	Z	-.127	-.127	0	%100
99	M152A	X	-.88	-.88	0	%100
100	M152A	Z	-.508	-.508	0	%100
101	M155A	X	-.22	-.22	0	%100
102	M155A	Z	-.127	-.127	0	%100
103	M153B	X	-.044	-.044	0	%100
104	M153B	Z	-.025	-.025	0	%100
105	M154B	X	-.746	-.746	0	%100
106	M154B	Z	-.43	-.43	0	%100
107	M155B	X	-.743	-.743	0	%100
108	M155B	Z	-.429	-.429	0	%100
109	M156B	X	-.743	-.743	0	%100
110	M156B	Z	-.429	-.429	0	%100

Member Distributed Loads (BLC 76 : Structure Wm (330 Deg))

	Member Label	Direction	Start Magnitude[lb/ft....]	End Magnitude[lb/ft....]	Start Location[ft.%]	End Location[ft.%]
1	FACE	X	-.508	-.508	0	%100
2	FACE	Z	-.88	-.88	0	%100
3	M2	X	0	0	0	%100
4	M2	Z	0	0	0	%100
5	M3	X	-.508	-.508	0	%100
6	M3	Z	-.88	-.88	0	%100
7	M4	X	-.142	-.142	0	%100
8	M4	Z	-.246	-.246	0	%100
9	M5	X	-.142	-.142	0	%100
10	M5	Z	-.246	-.246	0	%100
11	M9	X	-.568	-.568	0	%100
12	M9	Z	-.984	-.984	0	%100
13	M10	X	-.568	-.568	0	%100
14	M10	Z	-.984	-.984	0	%100
15	M14	X	-.142	-.142	0	%100
16	M14	Z	-.246	-.246	0	%100
17	M15	X	-.142	-.142	0	%100
18	M15	Z	-.246	-.246	0	%100
19	M19	X	-.508	-.508	0	%100
20	M19	Z	-.88	-.88	0	%100
21	M20	X	-.508	-.508	0	%100
22	M20	Z	-.88	-.88	0	%100
23	M21	X	0	0	0	%100
24	M21	Z	0	0	0	%100
25	M25	X	-.197	-.197	0	%100
26	M25	Z	-.342	-.342	0	%100
27	M28	X	-.789	-.789	0	%100
28	M28	Z	-1.367	-1.367	0	%100
29	M31	X	-.197	-.197	0	%100
30	M31	Z	-.342	-.342	0	%100
31	MP1A	X	-.322	-.322	0	%100
32	MP1A	Z	-.557	-.557	0	%100
33	MP2A	X	-.322	-.322	0	%100
34	MP2A	Z	-.557	-.557	0	%100
35	MP3A	X	-.389	-.389	0	%100
36	MP3A	Z	-.675	-.675	0	%100
37	MP4A	X	-.322	-.322	0	%100
38	MP4A	Z	-.557	-.557	0	%100
39	MP5A	X	-.322	-.322	0	%100
40	MP5A	Z	-.557	-.557	0	%100

Member Distributed Loads (BLC 76 : Structure Wm (330 Deg)) (Continued)

Member Label	Direction	Start Magnitude[lb/ft....	End Magnitude[lb/ft....	Start Location[ft.%]	End Location[ft.%]
41	MP1C	X	-0.322	-0.322	0 %100
42	MP1C	Z	-0.557	-0.557	0 %100
43	MP2C	X	-0.322	-0.322	0 %100
44	MP2C	Z	-0.557	-0.557	0 %100
45	MP3C	X	-0.389	-0.389	0 %100
46	MP3C	Z	-0.675	-0.675	0 %100
47	MP4C	X	-0.322	-0.322	0 %100
48	MP4C	Z	-0.557	-0.557	0 %100
49	MP5C	X	-0.322	-0.322	0 %100
50	MP5C	Z	-0.557	-0.557	0 %100
51	MP1B	X	-0.322	-0.322	0 %100
52	MP1B	Z	-0.557	-0.557	0 %100
53	MP2B	X	-0.322	-0.322	0 %100
54	MP2B	Z	-0.557	-0.557	0 %100
55	MP3B	X	-0.389	-0.389	0 %100
56	MP3B	Z	-0.675	-0.675	0 %100
57	MP4B	X	-0.322	-0.322	0 %100
58	MP4B	Z	-0.557	-0.557	0 %100
59	MP5B	X	-0.322	-0.322	0 %100
60	MP5B	Z	-0.557	-0.557	0 %100
61	M76	X	-0.322	-0.322	0 %100
62	M76	Z	-0.557	-0.557	0 %100
63	M77	X	-0.263	-0.263	0 %100
64	M77	Z	-0.456	-0.456	0 %100
65	M72	X	-0.049	-0.049	0 %100
66	M72	Z	-0.085	-0.085	0 %100
67	M73	X	-0.049	-0.049	0 %100
68	M73	Z	-0.085	-0.085	0 %100
69	M76A	X	-0.218	-0.218	0 %100
70	M76A	Z	-0.377	-0.377	0 %100
71	M81A	X	-0.049	-0.049	0 %100
72	M81A	Z	-0.085	-0.085	0 %100
73	M82	X	-0.049	-0.049	0 %100
74	M82	Z	-0.085	-0.085	0 %100
75	M82A	X	-0.292	-0.292	0 %100
76	M82A	Z	-0.506	-0.506	0 %100
77	M88	X	0	0	0 %100
78	M88	Z	0	0	0 %100
79	M94	X	-0.292	-0.292	0 %100
80	M94	Z	-0.506	-0.506	0 %100
81	M109	X	-0.564	-0.564	0 %100
82	M109	Z	-0.978	-0.978	0 %100
83	M110	X	-0.159	-0.159	0 %100
84	M110	Z	-0.276	-0.276	0 %100
85	M115	X	-0.292	-0.292	0 %100
86	M115	Z	-0.506	-0.506	0 %100
87	M121	X	0	0	0 %100
88	M121	Z	0	0	0 %100
89	M127	X	-0.292	-0.292	0 %100
90	M127	Z	-0.506	-0.506	0 %100
91	M139	X	0	0	0 %100
92	M139	Z	0	0	0 %100
93	M143A	X	-0.381	-0.381	0 %100
94	M143A	Z	-0.66	-0.66	0 %100
95	M146A	X	-0.381	-0.381	0 %100
96	M146A	Z	-0.66	-0.66	0 %100
97	M149A	X	0	0	0 %100
98	M149A	Z	0	0	0 %100
99	M152A	X	-0.381	-0.381	0 %100

Member Distributed Loads (BLC 76 : Structure Wm (330 Deg)) (Continued)

Member Label	Direction	Start Magnitude[lb/ft....]	End Magnitude[lb/ft....]	Start Location[ft,%]	End Location[ft,%]
100	M152A	Z	-.66	0	%100
101	M155A	X	-.381	0	%100
102	M155A	Z	-.66	0	%100
103	M153B	X	-.161	0	%100
104	M153B	Z	-.279	0	%100
105	M154B	X	-.161	0	%100
106	M154B	Z	-.279	0	%100
107	M155B	X	-.159	0	%100
108	M155B	Z	-.276	0	%100
109	M156B	X	-.564	0	%100
110	M156B	Z	-.978	0	%100

Member Distributed Loads (BLC 87 : BLC 39 Transient Area Loads)

Member Label	Direction	Start Magnitude[lb/ft....]	End Magnitude[lb/ft....]	Start Location[ft,%]	End Location[ft,%]
1	M3	Y	-1.019	0	2.333
2	M3	Y	-2.63	2.333	4.667
3	M3	Y	-4.723	4.667	7
4	M3	Y	-6.01	7	9.333
5	M3	Y	-4.723	9.333	11.667
6	M3	Y	-2.63	11.667	14
7	M4	Y	-.497	0	1.917
8	M4	Y	-2.435	1.917	3.833
9	M10	Y	-.497	0	1.917
10	M10	Y	-2.435	1.917	3.833
11	M19	Y	-5.056	.014	7.346
12	FACE	Y	-.492	0	2
13	FACE	Y	-2.793	2	4
14	FACE	Y	-4.5	4	6
15	FACE	Y	-5.143	6	8
16	FACE	Y	-5.292	8	10
17	FACE	Y	-4.772	10	12
18	FACE	Y	-3.025	12	14
19	M9	Y	-.067	0	.767
20	M9	Y	-1.007	.767	1.533
21	M9	Y	-2.131	1.533	2.3
22	M9	Y	-3.327	2.3	3.067
23	M9	Y	-4.08	3.067	3.833
24	M10	Y	.002	1.533	1.993
25	M10	Y	-.005	1.993	2.453
26	M10	Y	-.024	2.453	2.913
27	M10	Y	-.05	2.913	3.373
28	M10	Y	-.084	3.373	3.833
29	M12	Y	-.743	.019	.042
30	M13	Y	-2.18	0	.042
31	M15	Y	-.393	.383	1.073
32	M15	Y	-1.105	1.073	1.763
33	M15	Y	-2.436	1.763	2.453
34	M15	Y	-3.408	2.453	3.143
35	M15	Y	-3.365	3.143	3.833
36	M18	Y	-5.464	0	.042
37	M20	Y	-4.202	0	1.472
38	M20	Y	-4.697	1.472	2.944
39	M20	Y	-5.052	2.944	4.416
40	M20	Y	-5.254	4.416	5.888
41	M20	Y	-5.049	5.888	7.36
42	LIVE2	Y	-2.056	0	.167
43	M35	Y	-2.739	0	.167
44	M2	Y	-1.019	0	2.333

Member Distributed Loads (BLC 87 : BLC 39 Transient Area Loads) (Continued)

	Member Label	Direction	Start Magnitude[lb/ft,...	End Magnitude[lb/ft,...	Start Location[ft, %]	End Location[ft, %]
45	M2	Y	-2.63	-4.723	2.333	4.667
46	M2	Y	-4.723	-6.01	4.667	7
47	M2	Y	-6.01	-4.723	7	9.333
48	M2	Y	-4.723	-2.63	9.333	11.667
49	M2	Y	-2.63	-1.019	11.667	14
50	M5	Y	-.497	-2.435	0	1.917
51	M5	Y	-2.435	-4.372	1.917	3.833
52	M14	Y	-.497	-2.435	0	1.917
53	M14	Y	-2.435	-4.372	1.917	3.833
54	M21	Y	-5.056	-5.056	.014	7.346

Member Distributed Loads (BLC 88 : BLC 40 Transient Area Loads)

	Member Label	Direction	Start Magnitude[lb/ft,...	End Magnitude[lb/ft,...	Start Location[ft, %]	End Location[ft, %]
1	M3	Y	-1.989	-5.133	0	2.333
2	M3	Y	-5.133	-9.217	2.333	4.667
3	M3	Y	-9.217	-11.729	4.667	7
4	M3	Y	-11.729	-9.217	7	9.333
5	M3	Y	-9.217	-5.133	9.333	11.667
6	M3	Y	-5.133	-1.989	11.667	14
7	M4	Y	-.969	-4.751	0	1.917
8	M4	Y	-4.751	-8.533	1.917	3.833
9	M10	Y	-.969	-4.751	0	1.917
10	M10	Y	-4.751	-8.533	1.917	3.833
11	M19	Y	-9.866	-9.866	.014	7.346
12	FACE	Y	-.961	-5.451	0	2
13	FACE	Y	-5.451	-8.781	2	4
14	FACE	Y	-8.781	-10.036	4	6
15	FACE	Y	-10.036	-10.328	6	8
16	FACE	Y	-10.328	-9.314	8	10
17	FACE	Y	-9.314	-5.903	10	12
18	FACE	Y	-5.903	-1.354	12	14
19	M9	Y	-.131	-1.966	0	.767
20	M9	Y	-1.966	-4.158	.767	1.533
21	M9	Y	-4.158	-6.492	1.533	2.3
22	M9	Y	-6.492	-7.963	2.3	3.067
23	M9	Y	-7.963	-8.788	3.067	3.833
24	M10	Y	.004	-.01	1.533	1.993
25	M10	Y	-.01	-.048	1.993	2.453
26	M10	Y	-.048	-.098	2.453	2.913
27	M10	Y	-.098	-.164	2.913	3.373
28	M10	Y	-.164	-.242	3.373	3.833
29	M12	Y	-1.45	-1.45	.019	.042
30	M13	Y	-4.254	-1.45	0	.042
31	M15	Y	-.767	-2.156	.383	1.073
32	M15	Y	-2.156	-4.754	1.073	1.763
33	M15	Y	-4.754	-6.651	1.763	2.453
34	M15	Y	-6.651	-6.568	2.453	3.143
35	M15	Y	-6.568	-6.418	3.143	3.833
36	M18	Y	-10.663	-10.663	0	.042
37	M20	Y	-8.2	-9.165	0	1.472
38	M20	Y	-9.165	-9.859	1.472	2.944
39	M20	Y	-9.859	-10.254	2.944	4.416
40	M20	Y	-10.254	-9.853	4.416	5.888
41	M20	Y	-9.853	-8.682	5.888	7.36
42	LIVE2	Y	-4.012	-4.012	0	.167
43	M35	Y	-5.345	-5.345	0	.167
44	M2	Y	-1.989	-5.133	0	2.333
45	M2	Y	-5.133	-9.217	2.333	4.667

Member Distributed Loads (BLC 88 : BLC 40 Transient Area Loads) (Continued)

	Member Label	Direction	Start Magnitude[lb/ft....]	End Magnitude[lb/ft....]	Start Location[ft.%]	End Location[ft.%]
46	M2	Y	-9.217	-11.729	4.667	7
47	M2	Y	-11.729	-9.217	7	9.333
48	M2	Y	-9.217	-5.133	9.333	11.667
49	M2	Y	-5.133	-1.989	11.667	14
50	M5	Y	-.969	-4.751	0	1.917
51	M5	Y	-4.751	-8.533	1.917	3.833
52	M14	Y	-.969	-4.751	0	1.917
53	M14	Y	-4.751	-8.533	1.917	3.833
54	M21	Y	-9.866	-9.866	.014	7.346

Member Distributed Loads (BLC 89 : BLC 84 Transient Area Loads)

	Member Label	Direction	Start Magnitude[lb/ft....]	End Magnitude[lb/ft....]	Start Location[ft.%]	End Location[ft.%]
1	M3	Y	-.043	-.11	0	2.333
2	M3	Y	-.11	-.197	2.333	4.667
3	M3	Y	-.197	-.251	4.667	7
4	M3	Y	-.251	-.197	7	9.333
5	M3	Y	-.197	-.11	9.333	11.667
6	M3	Y	-.11	-.043	11.667	14
7	M4	Y	-.021	-.102	0	1.917
8	M4	Y	-.102	-.182	1.917	3.833
9	M10	Y	-.021	-.102	0	1.917
10	M10	Y	-.102	-.182	1.917	3.833
11	M19	Y	-.211	-.211	.014	7.346
12	FACE	Y	-.021	-.117	0	2
13	FACE	Y	-.117	-.188	2	4
14	FACE	Y	-.188	-.215	4	6
15	FACE	Y	-.215	-.221	6	8
16	FACE	Y	-.221	-.199	8	10
17	FACE	Y	-.199	-.126	10	12
18	FACE	Y	-.126	-.029	12	14
19	M9	Y	-.003	-.042	0	.767
20	M9	Y	-.042	-.089	.767	1.533
21	M9	Y	-.089	-.139	1.533	2.3
22	M9	Y	-.139	-.17	2.3	3.067
23	M9	Y	-.17	-.188	3.067	3.833
24	M10	Y	8.309e-5	-.000224	1.533	1.993
25	M10	Y	-.000224	-.001	1.993	2.453
26	M10	Y	-.001	-.002	2.453	2.913
27	M10	Y	-.002	-.004	2.913	3.373
28	M10	Y	-.004	-.005	3.373	3.833
29	M12	Y	-.031	-.031	.019	.042
30	M13	Y	-.091	-.031	0	.042
31	M15	Y	-.016	-.046	.383	1.073
32	M15	Y	-.046	-.102	1.073	1.763
33	M15	Y	-.102	-.142	1.763	2.453
34	M15	Y	-.142	-.14	2.453	3.143
35	M15	Y	-.14	-.137	3.143	3.833
36	M18	Y	-.228	-.228	0	.042
37	M20	Y	-.175	-.196	0	1.472
38	M20	Y	-.196	-.211	1.472	2.944
39	M20	Y	-.211	-.219	2.944	4.416
40	M20	Y	-.219	-.211	4.416	5.888
41	M20	Y	-.211	-.186	5.888	7.36
42	LIVE2	Y	-.086	-.086	0	.167
43	M35	Y	-.114	-.114	0	.167
44	M2	Y	-.043	-.11	0	2.333
45	M2	Y	-.11	-.197	2.333	4.667
46	M2	Y	-.197	-.251	4.667	7

Member Distributed Loads (BLC 89 : BLC 84 Transient Area Loads) (Continued)

	Member Label	Direction	Start Magnitude[lb/ft....	End Magnitude[lb/ft....	Start Location[ft.%]	End Location[ft.%]
47	M2	Y	-.251	-.197	7	9.333
48	M2	Y	-.197	-.11	9.333	11.667
49	M2	Y	-.11	-.043	11.667	14
50	M5	Y	-.021	-.102	0	1.917
51	M5	Y	-.102	-.182	1.917	3.833
52	M14	Y	-.021	-.102	0	1.917
53	M14	Y	-.102	-.182	1.917	3.833
54	M21	Y	-.211	-.211	.014	7.346

Member Distributed Loads (BLC 90 : BLC 85 Transient Area Loads)

	Member Label	Direction	Start Magnitude[lb/ft....	End Magnitude[lb/ft....	Start Location[ft.%]	End Location[ft.%]
1	M3	Z	-.107	-.275	0	2.333
2	M3	Z	-.275	-.494	2.333	4.667
3	M3	Z	-.494	-.629	4.667	7
4	M3	Z	-.629	-.494	7	9.333
5	M3	Z	-.494	-.275	9.333	11.667
6	M3	Z	-.275	-.107	11.667	14
7	M4	Z	-.052	-.255	0	1.917
8	M4	Z	-.255	-.457	1.917	3.833
9	M10	Z	-.052	-.255	0	1.917
10	M10	Z	-.255	-.457	1.917	3.833
11	M19	Z	-.529	-.529	.014	7.346
12	FACE	Z	-.052	-.292	0	2
13	FACE	Z	-.292	-.471	2	4
14	FACE	Z	-.471	-.538	4	6
15	FACE	Z	-.538	-.554	6	8
16	FACE	Z	-.554	-.499	8	10
17	FACE	Z	-.499	-.316	10	12
18	FACE	Z	-.316	-.073	12	14
19	M9	Z	-.007	-.105	0	.767
20	M9	Z	-.105	-.223	.767	1.533
21	M9	Z	-.223	-.348	1.533	2.3
22	M9	Z	-.348	-.427	2.3	3.067
23	M9	Z	-.427	-.471	3.067	3.833
24	M10	Z	.0002083	-.0005616	1.533	1.993
25	M10	Z	-.0005616	-.003	1.993	2.453
26	M10	Z	-.003	-.005	2.453	2.913
27	M10	Z	-.005	-.009	2.913	3.373
28	M10	Z	-.009	-.013	3.373	3.833
29	M12	Z	-.078	-.078	.019	.042
30	M13	Z	-.228	-.078	0	.042
31	M15	Z	-.041	-.116	.383	1.073
32	M15	Z	-.116	-.255	1.073	1.763
33	M15	Z	-.255	-.357	1.763	2.453
34	M15	Z	-.357	-.352	2.453	3.143
35	M15	Z	-.352	-.344	3.143	3.833
36	M18	Z	-.572	-.572	0	.042
37	M20	Z	-.44	-.491	0	1.472
38	M20	Z	-.491	-.528	1.472	2.944
39	M20	Z	-.528	-.55	2.944	4.416
40	M20	Z	-.55	-.528	4.416	5.888
41	M20	Z	-.528	-.465	5.888	7.36
42	LIVE2	Z	-.215	-.215	0	.167
43	M35	Z	-.287	-.287	0	.167
44	M2	Z	-.107	-.275	0	2.333
45	M2	Z	-.275	-.494	2.333	4.667
46	M2	Z	-.494	-.629	4.667	7
47	M2	Z	-.629	-.494	7	9.333

Member Distributed Loads (BLC 90 : BLC 85 Transient Area Loads) (Continued)

	Member Label	Direction	Start Magnitude[lb/ft....]	End Magnitude[lb/ft....]	Start Location[ft.%]	End Location[ft.%]
48	M2	Z	-.494	-.275	9.333	11.667
49	M2	Z	-.275	-.107	11.667	14
50	M5	Z	-.052	-.255	0	1.917
51	M5	Z	-.255	-.457	1.917	3.833
52	M14	Z	-.052	-.255	0	1.917
53	M14	Z	-.255	-.457	1.917	3.833
54	M21	Z	-.529	-.529	.014	7.346

Member Distributed Loads (BLC 91 : BLC 86 Transient Area Loads)

	Member Label	Direction	Start Magnitude[lb/ft....]	End Magnitude[lb/ft....]	Start Location[ft.%]	End Location[ft.%]
1	M3	X	.107	.275	0	2.333
2	M3	X	.275	.494	2.333	4.667
3	M3	X	.494	.629	4.667	7
4	M3	X	.629	.494	7	9.333
5	M3	X	.494	.275	9.333	11.667
6	M3	X	.275	.107	11.667	14
7	M4	X	.052	.255	0	1.917
8	M4	X	.255	.457	1.917	3.833
9	M10	X	.052	.255	0	1.917
10	M10	X	.255	.457	1.917	3.833
11	M19	X	.529	.529	.014	7.346
12	FACE	X	.052	.292	0	2
13	FACE	X	.292	.471	2	4
14	FACE	X	.471	.538	4	6
15	FACE	X	.538	.554	6	8
16	FACE	X	.554	.499	8	10
17	FACE	X	.499	.316	10	12
18	FACE	X	.316	.073	12	14
19	M9	X	.007	.105	0	.767
20	M9	X	.105	.223	.767	1.533
21	M9	X	.223	.348	1.533	2.3
22	M9	X	.348	.427	2.3	3.067
23	M9	X	.427	.471	3.067	3.833
24	M10	X	-.0002083	.0005616	1.533	1.993
25	M10	X	.0005616	.003	1.993	2.453
26	M10	X	.003	.005	2.453	2.913
27	M10	X	.005	.009	2.913	3.373
28	M10	X	.009	.013	3.373	3.833
29	M12	X	.078	.078	.019	.042
30	M13	X	.228	.078	0	.042
31	M15	X	.041	.116	.383	1.073
32	M15	X	.116	.255	1.073	1.763
33	M15	X	.255	.357	1.763	2.453
34	M15	X	.357	.352	2.453	3.143
35	M15	X	.352	.344	3.143	3.833
36	M18	X	.572	.572	0	.042
37	M20	X	.44	.491	0	1.472
38	M20	X	.491	.528	1.472	2.944
39	M20	X	.528	.55	2.944	4.416
40	M20	X	.55	.528	4.416	5.888
41	M20	X	.528	.465	5.888	7.36
42	LIVE2	X	.215	.215	0	.167
43	M35	X	.287	.287	0	.167
44	M2	X	.107	.275	0	2.333
45	M2	X	.275	.494	2.333	4.667
46	M2	X	.494	.629	4.667	7
47	M2	X	.629	.494	7	9.333
48	M2	X	.494	.275	9.333	11.667

Member Distributed Loads (BLC 91 : BLC 86 Transient Area Loads) (Continued)

	Member Label	Direction	Start Magnitude[lb/ft....]	End Magnitude[lb/ft....]	Start Location[ft.%]	End Location[ft.%]
49	M2	X	.275	.107	11.667	14
50	M5	X	.052	.255	0	1.917
51	M5	X	.255	.457	1.917	3.833
52	M14	X	.052	.255	0	1.917
53	M14	X	.255	.457	1.917	3.833
54	M21	X	.529	.529	.014	7.346

Member Area Loads (BLC 39 : Structure D)

	Joint A	Joint B	Joint C	Joint D	Direction	Distribution	Magnitude[ksf]
1	N8	N15	N25	N7	Y	Two Way	-.005
2	N3	N25	N36	N2	Y	Two Way	-.005
3	N5	N14	N37	N6	Y	Two Way	-.005

Member Area Loads (BLC 40 : Structure Di)

	Joint A	Joint B	Joint C	Joint D	Direction	Distribution	Magnitude[ksf]
1	N8	N15	N25	N7	Y	Two Way	-.01
2	N3	N25	N36	N2	Y	Two Way	-.01
3	N5	N14	N37	N6	Y	Two Way	-.01

Member Area Loads (BLC 84 : Structure Ev)

	Joint A	Joint B	Joint C	Joint D	Direction	Distribution	Magnitude[ksf]
1	N8	N15	N25	N7	Y	Two Way	-.000217
2	N3	N25	N36	N2	Y	Two Way	-.000217
3	N5	N14	N37	N6	Y	Two Way	-.000217

Member Area Loads (BLC 85 : Structure Eh (0 Deg))

	Joint A	Joint B	Joint C	Joint D	Direction	Distribution	Magnitude[ksf]
1	N8	N15	N25	N7	Z	Two Way	-.000544
2	N3	N25	N36	N2	Z	Two Way	-.000544
3	N5	N14	N37	N6	Z	Two Way	-.000544

Member Area Loads (BLC 86 : Structure Eh (90 Deg))

	Joint A	Joint B	Joint C	Joint D	Direction	Distribution	Magnitude[ksf]
1	N8	N15	N25	N7	X	Two Way	.000544
2	N3	N25	N36	N2	X	Two Way	.000544
3	N5	N14	N37	N6	X	Two Way	.000544

Envelope AISC 15th(360-16): LRFD Steel Code Checks

	Member	Shape	Code Ch...	Lo...	LC	She...Lo.....	LC	phi*...	phi*...	phi*...	phi*Mn z-...	Cb	Eqn
1	FACE	L3X3X4	.430	0	11	.155 7 y	1	1577..	46656	1.688	2.161	1	H2-1
2	M2	L3X3X4	.298	7	10	.170 7 y	9	1577..	46656	1.688	2.161	1	H2-1
3	M3	L3X3X4	.505	14	7	.156 7 y	5	1577..	46656	1.688	2.161	1	H2-1
4	M4	L3X3X4	.274	.479	6	.102 3... z	1	3369..	46656	1.688	3.756	3.786	H2-1
5	M5	L3X3X4	.283	.479	7	.099 3... y	1	3369..	46656	1.688	3.756	4.18	H2-1
6	M9	L3X3X4	.282	3...	9	.117 3... z	3	3369..	46656	1.688	3.756	2.232	H2-1
7	M10	L3X3X4	.283	3...	9	.124 3... y	2	3369..	46656	1.688	3.756	1.986	H2-1
8	M14	L3X3X4	.279	.479	11	.104 3... z	5	3369..	46656	1.688	3.756	4.334	H2-1
9	M15	L3X3X4	.281	.479	12	.100 3... y	5	3369..	46656	1.688	3.756	3.896	H2-1
10	M19	L3X3X4	.316	3.68	2	.019 3.68 z	24	1427..	46656	1.688	3.256	1.53	H2-1
11	M20	L3X3X4	.310	3.68	4	.019 3.68 z	17	1427..	46656	1.688	3.257	1.532	H2-1
12	M21	L3X3X4	.248	3.68	6	.019 3.68 z	13	1427..	46656	1.688	3.197	1.421	H2-1
13	MP1A	PIPE_2...	.197	3...	8	.137 3...	19	1785..	32130	1.872	1.872	1.74	H1-1b
14	MP2A	PIPE_2...	.153	1...	10	.072 3...	17	2086..	32130	1.872	1.872	2.452	H1-1b
15	MP3A	PIPE_2...	.240	3...	1	.072 3...	6	3396..	50715	3.596	3.596	1.976	H1-1b

Envelope AISC 15th(360-16): LRFD Steel Code Checks (Continued)

Member	Shape	Code	Ch...	Lo...	LC	She...	Lo.....	LC	phi*...	phi*...	phi*...	phi*Mn z-...	Cb	Eqn
16	MP4A	PIPE_2...	.186	3...	5	.120	4....	20	2086..	32130	1.872	1.872	2.767	H1-1b
17	MP5A	PIPE_2...	.210	3...	9	.140	5....	21	1785..	32130	1.872	1.872	2.569	H1-1b
18	MP1C	PIPE_2...	.191	3...	4	.137	3....	15	1785..	32130	1.872	1.872	1.563	H1-1b
19	MP2C	PIPE_2...	.142	1...	6	.073	3....	13	2086..	32130	1.872	1.872	3.298	H1-1b
20	MP3C	PIPE_2...	.243	3...	9	.072	3....	2	3396..	50715	3.596	3.596	1.719	H1-1b
21	MP4C	PIPE_2...	.158	1...	12	.098	4....	17	2086..	32130	1.872	1.872	1.95	H1-1b
22	MP5C	PIPE_2...	.190	3...	2	.116	3....	3	1785..	32130	1.872	1.872	1.751	H1-1b
23	MP1B	PIPE_2...	.206	3...	9	.169	5....	21	1785..	32130	1.872	1.872	1.931	H1-1b
24	MP2B	PIPE_2...	.170	1...	1	.093	3....	22	2086..	32130	1.872	1.872	3.298	H1-1b
25	MP3B	PIPE_2...	.240	3...	5	.071	3....	11	3396..	50715	3.596	3.596	1.664	H1-1b
26	MP4B	PIPE_2...	.162	3...	9	.095	4....	13	2086..	32130	1.872	1.872	2.139	H1-1b
27	MP5B	PIPE_2...	.194	3...	10	.112	3....	23	1785..	32130	1.872	1.872	1.594	H1-1b
28	M76	PIPE_2...	.226	7...	8	.054	7....	7	9836..	32130	1.872	1.872	1.729	H1-1b
29	M77	PIPE_2...	.420	2.75	8	.068	2.25	7	2884..	32130	1.872	1.872	1.578	H1-1b
30	M72	SR_0.5	.595	0	1	.163	0	16	5827..	6350.4	.052	.052	1.669	H1-1b
31	M73	SR_0.5	.596	0	1	.162	0	16	5827..	6350.4	.052	.052	1.669	H1-1b
32	M76A	PIPE_2...	.002	1	12	.001	1	11	3127..	32130	1.872	1.872	2.265	H1-1b
33	M81A	SR_0.5	.421	0	7	.176	0	22	5827..	6350.4	.052	.052	1.669	H1-1b
34	M82	SR_0.5	.419	0	22	.175	0	21	5827..	6350.4	.052	.052	1.673	H1-1b
35	M82A	PIPE_2...	.140	6...	32	.140	2....	19	1346..	50715	3.596	3.596	2.631	H1-1b
36	M88	PIPE_2...	.126	10...	15	.124	2....	15	1346..	50715	3.596	3.596	2.296	H1-1b
37	M94	PIPE_2...	.147	10...	23	.135	10...	23	1346..	50715	3.596	3.596	2.404	H1-1b
38	M109	L2.5x2...	.383	2....	19	.007	5.... z	12	9391..	2919..	.873	1.538	1.136	H2-1
39	M110	L2.5x2...	.333	2....	20	.008	0 y	2	9391..	2919..	.873	1.538	1.136	H2-1
40	M115	PIPE_2...	.129	6...	6	.044	10...	1	1346..	50715	3.596	3.596	1.842	H1-1b
41	M121	PIPE_2...	.105	6...	1	.043	10...	10	1346..	50715	3.596	3.596	1.878	H1-1b
42	M127	PIPE_2...	.109	6...	10	.044	7....	11	1346..	50715	3.596	3.596	1.926	H1-1b
43	M139	L3X3X4	.285	2....	6	.037	.052 y	6	4061..	46656	1.688	3.756	2.254	H2-1
44	M143A	L3X3X4	.278	2....	2	.027	.365 y	2	4061..	46656	1.688	3.756	2.263	H2-1
45	M146A	L3X3X4	.278	2....	10	.027	.078 y	10	4061..	46656	1.688	3.756	2.263	H2-1
46	M149A	L3X3X4	.231	0	18	.026	0 y	6	4061..	46656	1.688	3.756	1.222	H2-1
47	M152A	L3X3X4	.180	0	14	.009	0 y	2	4061..	46656	1.688	3.716	1.052	H2-1
48	M155A	L3X3X4	.184	0	22	.009	0 y	10	4061..	46656	1.688	3.737	1.092	H2-1
49	M153B	L2.5x2...	.342	2....	15	.007	0 z	8	9391..	2919..	.873	1.538	1.136	H2-1
50	M154B	L2.5x2...	.330	2....	16	.008	0 y	10	9391..	2919..	.873	1.538	1.136	H2-1
51	M155B	L2.5x2...	.341	2....	22	.007	0 z	4	9391..	2919..	.873	1.538	1.136	H2-1
52	M156B	L2.5x2...	.372	2....	23	.007	5.... y	6	9391..	2919..	.873	1.538	1.136	H2-1

Envelope Joint Reactions

Joint		X [lb]	LC	Y [lb]	LC	Z [lb]	LC	MX [k-ft]	LC	MY [k-ft]	LC	MZ [k-ft]	LC	
1	N186	max	176.586	3	1217.349	20	2696.366	21	0	16	0	4	0	4
2		min	-654.937	33	338.618	64	753.088	64	0	9	0	10	0	10
3	N255	max	3927.422	10	2057.552	18	1390.977	1	-0.823	1	2.953	9	.041	4
4		min	-3622.988	4	462.146	1	-1249.249	7	-4.469	18	-2.664	3	-.044	10
5	N257	max	2206.818	11	1923.809	15	2976.753	1	2.069	15	2.716	5	3.584	15
6		min	-2100.553	5	544.447	72	-3097.376	7	.536	9	-2.613	11	.927	9
7	N259	max	2246.004	9	2059.385	24	3220.97	1	2.239	24	2.761	1	-.753	5
8		min	-2209.552	3	457.631	6	-3550.507	7	.407	6	-2.918	7	-3.87	23
9	N264B	max	2248.762	18	1136.595	17	-246.864	6	0	1	0	12	0	5
10		min	623.017	73	315.009	72	-1216.4	24	0	7	0	6	0	23
11	N267B	max	-668.175	68	1210.328	22	-293.256	8	0	2	0	8	0	15
12		min	-2439.748	23	337.975	68	-1271.696	17	0	20	0	2	0	10
13	Totals:	max	7474.564	10	9288.104	14	7459.877	1						
14		min	-7474.569	4	2711.601	71	-7459.914	7						

I. Mount-to-Tower Connection Check

<u>Custom Orientation Required</u>	No
<u>Tower Connection Bolt Checks</u>	Yes
<u>Bolt Orientation</u>	Vertical (top)
Bolt Quantity per Reaction:	2 (Vertical)
d_x (in) (Delta X of typ. bolt config. sketch):	4
d_y (in) (Delta Y of typ. bolt config. sketch):	5
Bolt Type:	A325N
Bolt Diameter (in):	0.75
Required Tensile Strength / bolt (kips):	5.4
Required Shear Strength / bolt (kips):	9.0
Tensile Capacity / bolt (kips):	29.8
Shear Capacity / bolt (kips):	17.9
Bolt Overall Utilization:	50.2%
<u>Tower Connection Baseplate Checks</u>	No

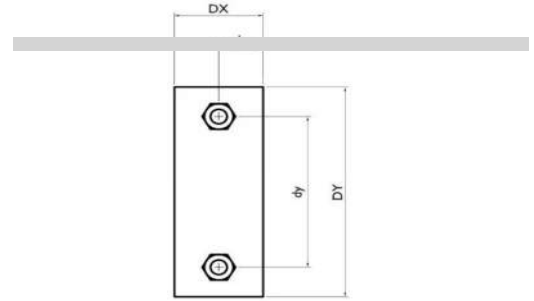



MORRISON HERSHFIELD

Date: July 24, 2023

Morrison Hershfield
1455 Lincoln Parkway, Suite 500
Atlanta, GA 30346
(770) 379-8500

Subject: Structural Analysis Report
Carrier Designation: Verizon Wireless Co-Locate
Site Number: 5000381811
Site Name: Cheshire 2 CT
Crown Castle Designation: BU Number: 801367
Site Name: CT NHV-2075 CAC 801367
JDE Job Number: 751320
Work Order Number: 2246055
Order Number: 654634 Rev. 0
Engineering Firm Designation: Morrison Hershfield Project Number: CN12-592 / 2300001
Site Data: 1121 Summit Road, Cheshire, New Haven County, CT 06410
Latitude 41° 32' 11.20", Longitude -72° 57' 26.30"
167 Foot – Summit Monopole Tower

Morrison Hershfield is pleased to submit this "Structural Analysis Report" to determine the structural integrity of the above-mentioned tower.

The purpose of the analysis is to determine acceptability of the tower stress level. Based on our analysis we have determined the tower stress level for the structure and foundation, under the following load case, to be:

LC7: Proposed Equipment Configuration Sufficient Capacity – 71.6%

This analysis utilizes an ultimate 3-second gust wind speed of 118 mph as required by the 2022 Connecticut State Building Code. Applicable Standard references and design criteria are listed in Section 2 - Analysis Criteria.

Respectfully submitted by:

G. Lance Cooke, P.E. (CT License No. PEN.0028133)
Senior Engineer

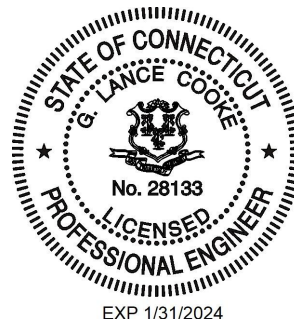

TABLE OF CONTENTS

1) INTRODUCTION

2) ANALYSIS CRITERIA

Table 1 - Proposed Equipment Configuration

Table 2 - Other Considered Equipment

3) ANALYSIS PROCEDURE

Table 3 - Documents Provided

3.1) Analysis Method

3.2) Assumptions

4) ANALYSIS RESULTS

Table 4 - Section Capacity (Summary)

Table 5 - Tower Component Stresses vs. Capacity – LC7

4.1) Recommendations

5) APPENDIX A

tnxTower Output

6) APPENDIX B

Base Level Drawing

7) APPENDIX C

Additional Calculations

1) INTRODUCTION

This tower is a 167 ft monopole tower designed by Summit Manufacturing, LLC.,.

The tower was modified multiple times in the past to accommodate additional loading. However, the modifications were ineffective and are not considered in this analysis.

2) ANALYSIS CRITERIA

TIA-222 Revision:	TIA-222-H
Risk Category:	II
Wind Speed:	118 mph
Exposure Category:	B
Topographic Factor:	1
Ice Thickness:	1 in
Wind Speed with Ice:	50 mph
Service Wind Speed:	60 mph

Table 1 - Proposed Equipment Configuration

Mounting Level (ft)	Center Line Elevation (ft)	Number of Antennas	Antenna Manufacturer	Antenna Model	Number of Feed Lines	Feed Line Size (in)	
167.0	171.0	1	gps	GPS_A	6 2 1	1-5/8 1-1/2 1/2	
	168.0	3	samsung telecommunications	RFV01U-D1A			
	167.0	167.0	6	antel			LPA-80063-6CF-EDIN w/ Mount Pipe
			3	samsung telecommunications			MT6407-77A w/ Mount Pipe
			6	jma wireless			MX06FRO660-03
			2	kaelus			BSF0020F3V1
			3	samsung telecommunications			RFV01U-D2A
			1	raycap			RVZDC-6627-PF-48_CCIV2
			3	-			Dual Antenna Mounting Kit
			1	-			Miscellaneous [NA 510-1]
			1	-			Platform Mount [LP 1201-1_KCKR-HR-1]

Table 2 - Other Considered Equipment

Mounting Level (ft)	Center Line Elevation (ft)	Number of Antennas	Antenna Manufacturer	Antenna Model	Number of Feed Lines	Feed Line Size (in)
167.0	176.0	1	rfi antennas	FSA10-67-DIN	2	7/8
	172.0	1	rfi antennas	FSA10-41-DIN		
159.0	163.0	3	ericsson	RRUS 32 B2	6	1-5/8
	160.0	3	ericsson	AIR 6419 B77G w/ Mount Pipe	5	7/8
		3	cci antennas	DMP65R-BU8D w/ Mount Pipe	4	13/16
		3	quintel technology	QD8616-7 w/ Mount Pipe	3	3/8
		3	ericsson	RRUS 32 B30	1	1C

Mounting Level (ft)	Center Line Elevation (ft)	Number of Antennas	Antenna Manufacturer	Antenna Model	Number of Feed Lines	Feed Line Size (in)
159.0	160.0	3	ericsson	RRUS 4426 B66	-	-
		3	ericsson	RRUS 4449 B5/B12		
		3	ericsson	RRUS 4478 B14_CCIV2		
		3	raycap	DC9-48-60-24-8C-EV_CCIV2		
	159.0	1	-	Platform Mount [LP 1201-1_KCKR-HR-1]		
158.0	3	ericsson	AIR 6449 B77D w/ Mount Pipe			
151.0	153.0	3	alcatel lucent	800MHz 2X50W RRH W/FILTER	-	-
	151.0	3	alcatel lucent	PCS 1900MHz 4x45W-65MHz		
147.0	150.0	3	alcatel lucent	TD-RRH8X20-25	4	1-1/4
	148.0	2	rfs/celwave	APXVSP18-C-A20 w/ Mount Pipe		
		3	rfs/celwave	APXVTM14-ALU-I20 w/ Mount Pipe		
	147.0	1	rfs/celwave	APXVSP18-C-A20 w/ Mount Pipe		
		1	-	Platform Mount [LP 1201-1]		
138.0	138.0	3	ericsson	AIR6449 B41_T-MOBILE w/ Mount Pipe	2 2	1-5/8 1-3/8
		3	rfs/celwave	APXVAARR24_43-U-NA20 w/ Mount Pipe		
		3	ericsson	RADIO 4460 B2/B25 B66_TMO		
		3	ericsson	Radio 4480_TMOV2		
		1	-	Platform Mount [LP 1201-1_KCKR-HR-1]		
130.0	130.0	1	-	Pipe Mount [PM 601-1]	1	EW90
		1	-	Side Arm Mount [SO 701-1]		
	129.0	1	rfs/celwave	SC3-W100AC		
119.0	119.0	3	jma wireless	MX08FRO665-21 w/ Mount Pipe	1	1-3/8
		3	fujitsu	TA08025-B604		
		3	fujitsu	TA08025-B605		
		1	raycap	RDIDC-9181-PF-48		
		1	tower mounts	Valmont SNP8HR-396		

3) ANALYSIS PROCEDURE

Table 3 - Documents Provided

Document	Reference	Source
4-GEOTECHNICAL REPORTS	445076	CCISITES
4-TOWER FOUNDATION DRAWINGS/DESIGN/SPECS	842573	CCISITES
4-TOWER MANUFACTURER DRAWINGS	799210	CCISITES
4-TOWER REINFORCEMENT DESIGN/DRAWINGS/DATA	3245562	CCISITES
4-POST-MODIFICATION INSPECTION	3379750	CCISITES
4-TOWER REINFORCEMENT DESIGN/DRAWINGS/DATA	3461318	CCISITES
4-POST-MODIFICATION INSPECTION	3847627	CCISITES

3.1) Analysis Method

tnxTower (version 8.1.1.0), a commercially available analysis software package, was used to create a three-dimensional model of the tower and calculate member stresses for various loading cases. Selected output from the analysis is included in Appendix A. When applicable, Crown Castle has calculated and provided the effective area for panel antennas using approved methods following the intent of the TIA-222 standard.

3.2) Assumptions

- 1) Tower and structures were maintained in accordance with the TIA-222 Standard.
- 2) The configuration of antennas, transmission cables, mounts and other appurtenances are as specified in Tables 1 and 2 and the referenced drawings.

This analysis may be affected if any assumptions are not valid or have been made in error. Morrison Hershfield should be notified to determine the effect on the structural integrity of the tower.

4) ANALYSIS RESULTS

Table 4 - Section Capacity (Summary)

Section No.	Elevation (ft)	Component Type	Size	Critical Element	P (K)	SF*P_allow (K)	% Capacity	Pass / Fail
L1	167 - 118.25	Pole	TP35.36x24x0.25	1	-25.70	1660.18	58.3	Pass
L2	118.25 - 77.75	Pole	TP44.297x33.8114x0.3125	2	-37.56	2601.71	71.6	Pass
L3	77.75 - 38.25	Pole	TP52.877x42.3904x0.375	3	-49.70	3723.48	68.2	Pass
L4	38.25 - 0	Pole	TP61.04x50.554x0.4375	4	-68.19	5169.17	62.2	Pass
							Summary	
						Pole (L2)	71.6	Pass
						Rating =	71.6	Pass

Table 5 - Tower Component Stresses vs. Capacity – LC7

Notes	Component	Elevation (ft)	% Capacity	Pass / Fail
1	Anchor Rods	0	59.8	Pass
1	Base Plate		48.2	Pass
1	Base Foundation (Structure)	0	39.5	Pass
1	Base Foundation (Soil Interaction)		55.9	Pass

Structure Rating (max from all components) =	71.6%*
---	---------------

Notes:

- 1) See additional documentation in "Appendix C – Additional Calculations" for calculations supporting the % capacity consumed.
- 2) *Rating per TIA-222-H, Section 15.5.

4.1) Recommendations

The tower and its foundation have sufficient capacity to carry the proposed load configuration. No modifications are required at this time.

APPENDIX A
TNXTOWER OUTPUT

Section	Length (ft)	Number of Sides	Thickness (in)	Socket Length (ft)	Top Dia (in)	Bot Dia (in)	Grade	Weight (K)
1	48.75	18	0.2500	4.50	24.0000	35.3600	A607-65	3.9
2	45.00	18	0.3125	5.50	33.8114	44.2970	A607-65	5.9
3	45.00	18	0.3750	6.75	42.3904	52.8770	A607-65	8.6
4	45.00	18	0.4375	50.5540	61.0400		A607-65	11.8
								30.1

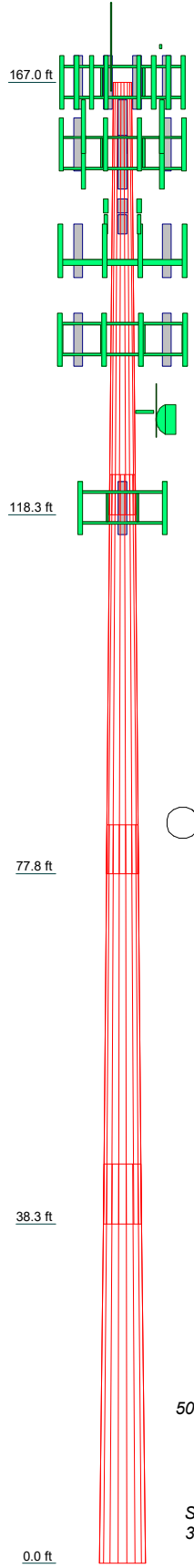

MATERIAL STRENGTH

GRADE	Fy	Fu	GRADE	Fy	Fu
A607-65	65 ksi	80 ksi			

TOWER DESIGN NOTES

1. Tower is located in New Haven County, Connecticut.
2. Tower designed for Exposure B to the TIA-222-H Standard.
3. Tower designed for a 118 mph basic wind in accordance with the TIA-222-H Standard.
4. Tower is also designed for a 50 mph basic wind with 1.00 in ice. Ice is considered to increase in thickness with height.
5. Deflections are based upon a 60 mph wind.
6. Tower Risk Category II.
7. Topographic Category 1 with Crest Height of 0.00 ft
8. TOWER RATING: 71.6%

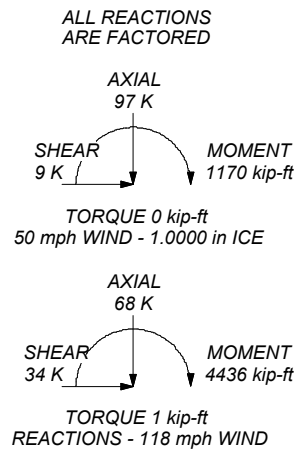

Morrison Hershfield
 1455 Lincoln Parkway, Suite 500
 Atlanta, GA 30346
 Phone: (770) 379-8500
 FAX: (770) 379-8501
 Consulting Engineers

Job: CN12-592 / 2300001	Project: 801367 / CT NHV-2075 CAC 801367	
Client: Crown Castle USA	Drawn by: RP	App'd:
Code: TIA-222-H	Date: 07/24/23	Scale: NTS
Path:		Dwg No. E-1

Tower Input Data

The tower is a monopole.

This tower is designed using the TIA-222-H standard.

The following design criteria apply:

Tower is located in New Haven County, Connecticut.

Tower base elevation above sea level: 628.00 ft.

Basic wind speed of 118 mph.

Risk Category II.

Exposure Category B.

Simplified Topographic Factor Procedure for wind speed-up calculations is used.

Topographic Category: 1.

Crest Height: 0.00 ft.

Nominal ice thickness of 1.0000 in.

Ice thickness is considered to increase with height.

Ice density of 56 pcf.

A wind speed of 50 mph is used in combination with ice.

Temperature drop of 50 °F.

Deflections calculated using a wind speed of 60 mph.

A non-linear (P-delta) analysis was used.

Pressures are calculated at each section.

Stress ratio used in pole design is 1.

Tower analysis based on target reliabilities in accordance with Annex S.

Load Modification Factors used: $K_{es}(F_w) = 0.95$, $K_{es}(t_i) = 0.85$.

Maximum demand-capacity ratio is: 1.05.

Local bending stresses due to climbing loads, feed line supports, and appurtenance mounts are not considered.

Options

Consider Moments - Legs Consider Moments - Horizontals Consider Moments - Diagonals Use Moment Magnification ✓ Use Code Stress Ratios ✓ Use Code Safety Factors - Guys Escalate Ice Always Use Max Kz Use Special Wind Profile Include Bolts In Member Capacity Leg Bolts Are At Top Of Section Secondary Horizontal Braces Leg Use Diamond Inner Bracing (4 Sided) SR Members Have Cut Ends SR Members Are Concentric	Distribute Leg Loads As Uniform Assume Legs Pinned ✓ Assume Rigid Index Plate ✓ Use Clear Spans For Wind Area Use Clear Spans For KL/r Retension Guys To Initial Tension ✓ Bypass Mast Stability Checks ✓ Use Azimuth Dish Coefficients ✓ Project Wind Area of Appurt. Autocalc Torque Arm Areas Add IBC .6D+W Combination Sort Capacity Reports By Component Triangulate Diamond Inner Bracing Treat Feed Line Bundles As Cylinder Ignore KL/ry For 60 Deg. Angle Legs	Use ASCE 10 X-Brace Ly Rules Calculate Redundant Bracing Forces Ignore Redundant Members in FEA SR Leg Bolts Resist Compression All Leg Panels Have Same Allowable Offset Girt At Foundation ✓ Consider Feed Line Torque Include Angle Block Shear Check Use TIA-222-H Bracing Resist. Exemption Use TIA-222-H Tension Splice Exemption <div style="text-align: center; background-color: #e0e0e0; padding: 2px;">Poles</div> ✓ Include Shear-Torsion Interaction Always Use Sub-Critical Flow Use Top Mounted Sockets Pole Without Linear Attachments Pole With Shroud Or No Appurtenances Outside and Inside Corner Radii Are Known
--	---	---

Tapered Pole Section Geometry

Section	Elevation	Section Length	Splice Length	Number of Sides	Top Diameter	Bottom Diameter	Wall Thickness	Bend Radius	Pole Grade
	ft	ft	ft		in	in	in	in	
L1	167.00-118.25	48.75	4.50	18	24.0000	35.3600	0.2500	1.0000	A607-65 (65 ksi)
L2	118.25-77.75	45.00	5.50	18	33.8114	44.2970	0.3125	1.2500	A607-65 (65 ksi)

Section	Elevation ft	Section Length ft	Splice Length ft	Number of Sides	Top Diameter in	Bottom Diameter in	Wall Thickness in	Bend Radius in	Pole Grade
L3	77.75-38.25	45.00	6.75	18	42.3904	52.8770	0.3750	1.5000	A607-65 (65 ksi)
L4	38.25-0.00	45.00		18	50.5540	61.0400	0.4375	1.7500	A607-65 (65 ksi)

Tapered Pole Properties

Section	Tip Dia. in	Area in ²	I in ⁴	r in	C in	I/C in ³	J in ⁴	It/Q in ²	w in	w/t
L1	24.3317	18.8456	1342.9976	8.4313	12.1920	110.1540	2687.7623	9.4246	3.7840	15.136
	35.8669	27.8598	4338.8723	12.4641	17.9629	241.5466	8683.4538	13.9325	5.7834	23.133
L2	35.3495	33.2267	4710.7000	11.8921	17.1762	274.2577	9427.5985	16.6165	5.4008	17.283
	44.9321	43.6271	10663.3428	15.6145	22.5029	473.8658	21340.7168	21.8177	7.2463	23.188
L3	44.2880	50.0089	11153.2625	14.9155	21.5343	517.9293	22321.2007	25.0092	6.8007	18.135
	53.6349	62.4905	21762.2193	18.6382	26.8615	810.1635	43553.0740	31.2512	8.6464	23.057
L4	52.8636	69.5930	22083.3520	17.7914	25.6814	859.8954	44195.7618	34.8031	8.1275	18.577
	61.9141	84.1541	39047.5735	21.5139	31.0083	1259.2612	78146.5267	42.0851	9.9730	22.796

Tower Elevation ft	Gusset Area (per face) ft ²	Gusset Thickness in	Gusset Grade	Adjust. Factor A _r	Adjust. Factor A _r	Weight Mult.	Double Angle Stitch Bolt Spacing Diagonals in	Double Angle Stitch Bolt Spacing Horizontal in	Double Angle Stitch Bolt Spacing Redundants in
L1 167.00- 118.25				1	1	1			
L2 118.25- 77.75				1	1	1			
L3 77.75- 38.25				1	1	1			
L4 38.25-0.00				1	1	1			

Feed Line/Linear Appurtenances - Entered As Round Or Flat

Description	Sector	Exclude From Torque Calculation	Componen t Type	Placement ft	Total Number	Number Per Row	Start/En d Position	Width or Diamete r in	Perimete r in	Weight plf
***** Climbing Pegs	A	No	Surface Ar (CaAa)	167.00 - 0.00	1	1	0.200 0.300	0.7050		1.80
***** HCS 6X12 6AWG(1- 3/8)	C	No	Surface Ar (CaAa)	138.00 - 6.00	2	2	0.050 0.109	1.3800		1.70
HB158-21U6S24- xxM_TMO(1-5/8) *****	C	No	Surface Ar (CaAa)	138.00 - 6.00	2	2	-0.078 0.000	1.9960		2.50
MP303	A	No	Surface Af (CaAa)	91.50 - 81.50	1	1	0.000 0.000	4.0600	11.2600	0.01
MP303	B	No	Surface Af (CaAa)	91.50 - 81.50	1	1	0.000 0.000	4.0600	11.2600	0.01
MP303	C	No	Surface Af (CaAa)	91.50 - 81.50	1	1	0.000 0.000	4.0600	11.2600	0.01
MP304	A	No	Surface Af (CaAa)	53.00 - 43.00	1	1	0.000 0.000	4.7800	12.7800	0.01
MP304	B	No	Surface Af (CaAa)	53.00 - 43.00	1	1	0.000 0.000	4.7800	12.7800	0.01
MP304	C	No	Surface Af	53.00 -	1	1	0.000	4.7800	12.7800	0.01

Description	Sector	Exclude From Torque Calculation	Component Type	Placement ft	Total Number	Number Per Row	Start/End Position	Width or Diameter in	Perimeter in	Weight plf
*****			(CaAa)	43.00			0.000			
MP304	A	No	Surface Af (CaAa)	65.50 - 50.50	1	1	0.100 0.100	4.7800	12.7800	0.01
MP304	B	No	Surface Af (CaAa)	65.50 - 50.50	1	1	0.100 0.100	4.7800	12.7800	0.01
MP304	C	No	Surface Af (CaAa)	65.50 - 50.50	1	1	0.100 0.100	4.7800	12.7800	0.01

Feed Line/Linear Appurtenances - Entered As Area

Description	Face or Leg	Allow Shield	Exclude From Torque Calculation	Component Type	Placement ft	Total Number		C _A A _A ft ² /ft	Weight plf

HRC-24SM-1206RC-1818-APVI(1-1/2)561(1-5/8)	C	No	No	Inside Pole	167.00 - 6.00	2	No Ice 1/2" Ice 1" Ice	0.00 0.00 0.00	1.80 1.80 1.80
	C	No	No	Inside Pole	167.00 - 6.00	6	No Ice 1/2" Ice 1" Ice	0.00 0.00 0.00	1.35 1.35 1.35
LDF4-50A(1/2)	C	No	No	Inside Pole	167.00 - 6.00	1	No Ice 1/2" Ice 1" Ice	0.00 0.00 0.00	0.15 0.15 0.15
**									
LDF5-50A(7/8)	A	No	No	Inside Pole	167.00 - 6.00	2	No Ice 1/2" Ice 1" Ice	0.00 0.00 0.00	0.33 0.33 0.33

LDF7-50A(1-5/8)	B	No	No	Inside Pole	159.00 - 6.00	6	No Ice 1/2" Ice 1" Ice	0.00 0.00 0.00	0.82 0.82 0.82
FB-L98B-034-XXX(3/8)	B	No	No	Inside Pole	159.00 - 6.00	1	No Ice 1/2" Ice 1" Ice	0.00 0.00 0.00	0.06 0.06 0.06
Conduit (1")	B	No	No	Inside Pole	159.00 - 6.00	1	No Ice 1/2" Ice 1" Ice	0.00 0.00 0.00	0.50 0.50 0.50

FB-L98B-034-XXX(3/8)	B	No	No	Inside Pole	159.00 - 6.00	1	No Ice 1/2" Ice 1" Ice	0.00 0.00 0.00	0.06 0.06 0.06
PWRT-606-S(7/8)	B	No	No	Inside Pole	159.00 - 6.00	5	No Ice 1/2" Ice 1" Ice	0.00 0.00 0.00	0.89 0.89 0.89
PWRT-608-S(13/16)	B	No	No	Inside Pole	159.00 - 6.00	4	No Ice 1/2" Ice 1" Ice	0.00 0.00 0.00	0.62 0.62 0.62
FB-L98B-235-XXX(3/8)	B	No	No	Inside Pole	159.00 - 6.00	1	No Ice 1/2" Ice 1" Ice	0.00 0.00 0.00	0.06 0.06 0.06

MLE HYBRID 3POWER/6FIBER RL 2(1-1/4)	C	No	No	Inside Pole	147.00 - 6.00	4	No Ice 1/2" Ice 1" Ice	0.00 0.00 0.00	0.68 0.68 0.68

EW90(ELLIPTICAL)	A	No	No	Inside Pole	130.00 - 6.00	1	No Ice 1/2" Ice 1" Ice	0.00 0.00 0.00	0.32 0.32 0.32

CU12PSM9P8XXX (1-3/8)	C	No	No	Inside Pole	119.00 - 6.00	1	No Ice 1/2" Ice 1" Ice	0.00 0.00 0.00	1.66 1.66 1.66

Description	Face or Leg	Allow Shield	Exclude From Torque Calculation	Component Type	Placement ft	Total Number	C _A A _A ft ² /ft	Weight plf

Feed Line/Linear Appurtenances Section Areas

Tower Section n	Tower Elevation ft	Face	A _R ft ²	A _F ft ²	C _A A _A In Face ft ²	C _A A _A Out Face ft ²	Weight K
L1	167.00-118.25	A	0.000	0.000	3.437	0.000	0.12
		B	0.000	0.000	0.000	0.000	0.51
		C	0.000	0.000	13.335	0.000	0.82
L2	118.25-77.75	A	0.000	0.000	9.622	0.000	0.11
		B	0.000	0.000	6.767	0.000	0.51
		C	0.000	0.000	34.112	0.000	1.00
L3	77.75-38.25	A	0.000	0.000	22.541	0.000	0.11
		B	0.000	0.000	19.756	0.000	0.50
		C	0.000	0.000	46.427	0.000	0.97
L4	38.25-0.00	A	0.000	0.000	2.697	0.000	0.10
		B	0.000	0.000	0.000	0.000	0.40
		C	0.000	0.000	21.775	0.000	0.79

Feed Line/Linear Appurtenances Section Areas - With Ice

Tower Section n	Tower Elevation ft	Face or Leg	Ice Thickness in	A _R ft ²	A _F ft ²	C _A A _A In Face ft ²	C _A A _A Out Face ft ²	Weight K
L1	167.00-118.25	A	0.983	0.000	0.000	13.022	0.000	0.22
		B		0.000	0.000	0.000	0.000	0.51
		C		0.000	0.000	26.377	0.000	1.01
L2	118.25-77.75	A	0.947	0.000	0.000	18.967	0.000	0.25
		B		0.000	0.000	8.149	0.000	0.56
		C		0.000	0.000	62.239	0.000	1.44
L3	77.75-38.25	A	0.899	0.000	0.000	33.927	0.000	0.34
		B		0.000	0.000	23.659	0.000	0.65
		C		0.000	0.000	75.705	0.000	1.48
L4	38.25-0.00	A	0.803	0.000	0.000	9.575	0.000	0.17
		B		0.000	0.000	0.000	0.000	0.40
		C		0.000	0.000	41.717	0.000	1.07

Feed Line Center of Pressure

Section	Elevation ft	CP _x in	CP _z in	CP _x Ice in	CP _z Ice in
L1	167.00-118.25	-0.2864	1.7454	-0.5199	1.3275
L2	118.25-77.75	-0.2626	3.4198	-0.4683	3.1000
L3	77.75-38.25	-0.2256	2.9214	-0.4350	2.9066
L4	38.25-0.00	-0.3190	3.5174	-0.5543	3.1293

Note: For pole sections, center of pressure calculations do not consider feed line shielding.

Shielding Factor Ka

Tower Section	Feed Line Record No.	Description	Feed Line Segment Elev.	K _a No Ice	K _a Ice
L1	2	Climbing Pegs	118.25 - 167.00	1.0000	1.0000
L1	24	HCS 6X12 6AWG(1-3/8)	118.25 - 138.00	1.0000	1.0000
L1	25	HB158-21U6S24-xxM_TMO(1-5/8)	118.25 - 138.00	1.0000	1.0000
L2	2	Climbing Pegs	77.75 - 118.25	1.0000	1.0000
L2	24	HCS 6X12 6AWG(1-3/8)	77.75 - 118.25	1.0000	1.0000
L2	25	HB158-21U6S24-xxM_TMO(1-5/8)	77.75 - 118.25	1.0000	1.0000
L2	31	MP303	81.50 - 91.50	1.0000	1.0000
L2	32	MP303	81.50 - 91.50	1.0000	1.0000
L2	33	MP303	81.50 - 91.50	1.0000	1.0000
L3	2	Climbing Pegs	38.25 - 77.75	1.0000	1.0000
L3	24	HCS 6X12 6AWG(1-3/8)	38.25 - 77.75	1.0000	1.0000
L3	25	HB158-21U6S24-xxM_TMO(1-5/8)	38.25 - 77.75	1.0000	1.0000
L3	34	MP304	43.00 - 53.00	1.0000	1.0000
L3	35	MP304	43.00 - 53.00	1.0000	1.0000
L3	36	MP304	43.00 - 53.00	1.0000	1.0000
L3	38	MP304	50.50 - 65.50	1.0000	1.0000
L3	39	MP304	50.50 - 65.50	1.0000	1.0000
L3	40	MP304	50.50 - 65.50	1.0000	1.0000
L4	2	Climbing Pegs	0.00 - 38.25	1.0000	1.0000
L4	24	HCS 6X12 6AWG(1-3/8)	6.00 - 38.25	1.0000	1.0000
L4	25	HB158-21U6S24-xxM_TMO(1-5/8)	6.00 - 38.25	1.0000	1.0000

Effective Width of Flat Linear Attachments / Feed Lines

Tower Section	Attachment Record No.	Description	Attachment Segment Elev.	Ratio Calculation Method	Effective Width Ratio
L2	31	MP303	81.50 - 91.50	Auto	0.0000
L2	32	MP303	81.50 - 91.50	Auto	0.0000
L2	33	MP303	81.50 - 91.50	Auto	0.0000
L3	34	MP304	43.00 - 53.00	Auto	0.0000
L3	35	MP304	43.00 - 53.00	Auto	0.0000
L3	36	MP304	43.00 - 53.00	Auto	0.0000
L3	38	MP304	50.50 - 65.50	Auto	0.0000
L3	39	MP304	50.50 - 65.50	Auto	0.0000

Tower Section	Attachment Record No.	Description	Attachment Segment Elev.	Ratio Calculation Method	Effective Width Ratio
L3	40	MP304	50.50 - 65.50	Auto	0.0000

Discrete Tower Loads

Description	Face or Leg	Offset Type	Offsets: Horz Lateral Vert ft ft ft	Azimuth Adjustment t °	Placement ft	C _A A _A Front ft ²	C _A A _A Side ft ²	Weight K

Top Hat (5')	C	None		0.0000	168.00	No Ice 2.92 1/2" Ice 4.33 1" Ice 4.69	2.92 4.33 4.69	0.33 0.37 0.42
Lightning Rod 3/4" x 6'	C	From Leg	0.50 0.00 3.00	0.0000	168.00	No Ice 0.45 1/2" Ice 1.06 1" Ice 1.70	0.45 1.06 1.70	0.03 0.03 0.04

(2) LPA-80063-6CF-EDIN w/ Mount Pipe	A	From Leg	4.00 0.00 0.00	0.0000	167.00	No Ice 7.29 1/2" Ice 7.86 1" Ice 8.45	7.26 7.83 8.42	0.08 0.16 0.26
(2) LPA-80063-6CF-EDIN w/ Mount Pipe	B	From Leg	4.00 0.00 0.00	0.0000	167.00	No Ice 7.29 1/2" Ice 7.86 1" Ice 8.45	7.26 7.83 8.42	0.08 0.16 0.26
(2) LPA-80063-6CF-EDIN w/ Mount Pipe	C	From Leg	4.00 0.00 0.00	0.0000	167.00	No Ice 7.29 1/2" Ice 7.86 1" Ice 8.45	7.26 7.83 8.42	0.08 0.16 0.26
(2) MX06FRO660-03	A	From Leg	4.00 0.00 0.00	0.0000	167.00	No Ice 6.81 1/2" Ice 7.37 1" Ice 7.93	4.67 5.19 5.73	0.08 0.15 0.22
(2) MX06FRO660-03	B	From Leg	4.00 0.00 0.00	0.0000	167.00	No Ice 6.81 1/2" Ice 7.37 1" Ice 7.93	4.67 5.19 5.73	0.08 0.15 0.22
(2) MX06FRO660-03	C	From Leg	4.00 0.00 0.00	0.0000	167.00	No Ice 6.81 1/2" Ice 7.37 1" Ice 7.93	4.67 5.19 5.73	0.08 0.15 0.22
MT6407-77A w/ Mount Pipe	A	From Leg	4.00 0.00 0.00	0.0000	167.00	No Ice 5.94 1/2" Ice 6.47 1" Ice 7.02	3.10 3.55 4.02	0.10 0.13 0.18
MT6407-77A w/ Mount Pipe	B	From Leg	4.00 0.00 0.00	0.0000	167.00	No Ice 5.94 1/2" Ice 6.47 1" Ice 7.02	3.10 3.55 4.02	0.10 0.13 0.18
MT6407-77A w/ Mount Pipe	C	From Leg	4.00 0.00 0.00	0.0000	167.00	No Ice 5.94 1/2" Ice 6.47 1" Ice 7.02	3.10 3.55 4.02	0.10 0.13 0.18
GPS_A	B	From Leg	4.00 0.00 4.00	0.0000	167.00	No Ice 0.26 1/2" Ice 0.32 1" Ice 0.39	0.26 0.32 0.39	0.00 0.00 0.01
RFV01U-D2A	A	From Leg	4.00 0.00 0.00	0.0000	167.00	No Ice 1.88 1/2" Ice 2.05 1" Ice 2.22	1.01 1.14 1.28	0.07 0.09 0.11
RFV01U-D2A	B	From Leg	4.00 0.00 0.00	0.0000	167.00	No Ice 1.88 1/2" Ice 2.05 1" Ice 2.22	1.01 1.14 1.28	0.07 0.09 0.11
RFV01U-D2A	C	From Leg	4.00 0.00 0.00	0.0000	167.00	No Ice 1.88 1/2" Ice 2.05 1" Ice 2.22	1.01 1.14 1.28	0.07 0.09 0.11
RFV01U-D1A	A	From Leg	4.00 0.00 1.00	0.0000	167.00	No Ice 1.88 1/2" Ice 2.05 1" Ice 2.22	1.25 1.39 1.54	0.08 0.10 0.12
RFV01U-D1A	B	From Leg	4.00 0.00 1.00	0.0000	167.00	No Ice 1.88 1/2" Ice 2.05 1" Ice 2.22	1.25 1.39 1.54	0.08 0.10 0.12

Description	Face or Leg	Offset Type	Offsets:		Azimuth Adjustment	Placement	C _A A _A Front	C _A A _A Side	Weight
			Horz	Lateral					
			ft	ft	°	ft	ft ²	ft ²	K
RFV01U-D1A	C	From Leg	4.00	0.0000	167.00	No Ice	1.88	1.25	0.08
			0.00			1/2" Ice	2.05	1.39	0.10
			1.00			1" Ice	2.22	1.54	0.12
RVZDC-6627-PF-48_CCIV2	C	From Leg	4.00	0.0000	167.00	No Ice	4.06	3.10	0.03
			0.00			1/2" Ice	4.32	3.34	0.07
			0.00			1" Ice	4.58	3.58	0.11
Dual Antenna Mounting Kit	A	From Leg	4.00	0.0000	167.00	No Ice	1.66	1.66	0.03
			0.00			1/2" Ice	2.39	2.39	0.04
			0.00			1" Ice	2.83	2.83	0.06
Dual Antenna Mounting Kit	B	From Leg	4.00	0.0000	167.00	No Ice	1.66	1.66	0.03
			0.00			1/2" Ice	2.39	2.39	0.04
			0.00			1" Ice	2.83	2.83	0.06
Dual Antenna Mounting Kit	C	From Leg	4.00	0.0000	167.00	No Ice	1.66	1.66	0.03
			0.00			1/2" Ice	2.39	2.39	0.04
			0.00			1" Ice	2.83	2.83	0.06
6' x 2" Mount Pipe	A	From Leg	4.00	0.0000	167.00	No Ice	1.43	1.43	0.02
			0.00			1/2" Ice	1.92	1.92	0.03
			0.00			1" Ice	2.29	2.29	0.05
6' x 2" Mount Pipe	B	From Leg	4.00	0.0000	167.00	No Ice	1.43	1.43	0.02
			0.00			1/2" Ice	1.92	1.92	0.03
			0.00			1" Ice	2.29	2.29	0.05
6' x 2" Mount Pipe	C	From Leg	4.00	0.0000	167.00	No Ice	1.43	1.43	0.02
			0.00			1/2" Ice	1.92	1.92	0.03
			0.00			1" Ice	2.29	2.29	0.05
2' x 2" Pipe Mount	C	From Leg	4.00	0.0000	167.00	No Ice	0.02	0.02	0.01
			0.00			1/2" Ice	0.05	0.05	0.01
			0.00			1" Ice	0.09	0.09	0.01
4' x 2" Pipe Mount	A	From Leg	4.00	0.0000	167.00	No Ice	0.79	0.79	0.03
			0.00			1/2" Ice	1.03	1.03	0.04
			0.00			1" Ice	1.28	1.28	0.04
10' x 2" Mount Pipe	A	From Leg	4.00	0.0000	167.00	No Ice	2.38	2.38	0.04
			0.00			1/2" Ice	3.40	3.40	0.05
			0.00			1" Ice	4.45	4.45	0.08
Miscellaneous [NA 510-1]	C	None		0.0000	167.00	No Ice	6.36	6.36	0.26
						1/2" Ice	8.52	8.52	0.34
						1" Ice	10.62	10.62	0.46
Platform Mount [LP 1201-1_KCKR-HR-1]	C	None		0.0000	167.00	No Ice	37.61	37.61	2.63
						1/2" Ice	45.62	45.62	3.48
						1" Ice	53.59	53.59	4.46
**									
FSA10-41-DIN	A	From Leg	4.00	0.0000	167.00	No Ice	6.10	6.10	0.03
			0.00			1/2" Ice	8.47	8.47	0.11
			5.00			1" Ice	10.87	10.87	0.22
FSA10-67-DIN	A	From Leg	4.00	0.0000	167.00	No Ice	1.40	1.40	0.01
			0.00			1/2" Ice	2.26	2.26	0.03
			9.00			1" Ice	3.15	3.15	0.06

BSF0020F3V1	A	From Leg	4.00	0.0000	167.00	No Ice	0.96	0.29	0.02
			0.00			1/2" Ice	1.09	0.36	0.02
			0.00			1" Ice	1.22	0.45	0.03
BSF0020F3V1	B	From Leg	4.00	0.0000	167.00	No Ice	0.96	0.29	0.02
			0.00			1/2" Ice	1.09	0.36	0.02
			0.00			1" Ice	1.22	0.45	0.03

RRUS 32 B2	A	From Leg	4.00	0.0000	159.00	No Ice	2.73	1.67	0.05
			0.00			1/2" Ice	2.95	1.86	0.07
			4.00			1" Ice	3.18	2.05	0.10
RRUS 32 B2	B	From Leg	4.00	0.0000	159.00	No Ice	2.73	1.67	0.05
			0.00			1/2" Ice	2.95	1.86	0.07
			4.00			1" Ice	3.18	2.05	0.10
RRUS 32 B2	C	From Leg	4.00	0.0000	159.00	No Ice	2.73	1.67	0.05
			0.00			1/2" Ice	2.95	1.86	0.07
			4.00			1" Ice	3.18	2.05	0.10
RRUS 32 B30	A	From Leg	4.00	0.0000	159.00	No Ice	2.73	1.67	0.05
			0.00			1/2" Ice	2.95	1.86	0.07

Description	Face or Leg	Offset Type	Offsets: Horz Lateral Vert ft ft ft	Azimuth Adjustment t °	Placement ft		C _A A _A Front ft ²	C _A A _A Side ft ²	Weight K
RRUS 32 B30	B	From Leg	1.00	0.0000	159.00	1" Ice	3.18	2.05	0.10
			4.00			No Ice	2.73	1.67	0.05
			0.00			1/2" Ice	2.95	1.86	0.07
RRUS 32 B30	C	From Leg	1.00	0.0000	159.00	1" Ice	3.18	2.05	0.10
			4.00			No Ice	2.73	1.67	0.05
			0.00			1/2" Ice	2.95	1.86	0.07
Platform Mount [LP 1201-1_KCKR-HR-1]	C	None	1.00	0.0000	159.00	1" Ice	3.18	2.05	0.10
						No Ice	37.61	37.61	2.63
						1/2" Ice	45.62	45.62	3.48

AIR 6419 B77G w/ Mount Pipe	A	From Leg	4.00	0.0000	159.00	No Ice	4.32	2.49	0.08
			0.00			1/2" Ice	4.74	2.84	0.11
			3.00			1" Ice	5.17	3.21	0.15
AIR 6419 B77G w/ Mount Pipe	B	From Leg	4.00	0.0000	159.00	No Ice	4.32	2.49	0.08
			0.00			1/2" Ice	4.74	2.84	0.11
			3.00			1" Ice	5.17	3.21	0.15
AIR 6419 B77G w/ Mount Pipe	C	From Leg	4.00	0.0000	159.00	No Ice	4.32	2.49	0.08
			0.00			1/2" Ice	4.74	2.84	0.11
			3.00			1" Ice	5.17	3.21	0.15
DMP65R-BU8D w/ Mount Pipe	A	From Leg	4.00	0.0000	159.00	No Ice	15.89	7.89	0.14
			0.00			1/2" Ice	16.81	8.74	0.25
			1.00			1" Ice	17.76	9.60	0.38
DMP65R-BU8D w/ Mount Pipe	B	From Leg	4.00	0.0000	159.00	No Ice	15.89	7.89	0.14
			0.00			1/2" Ice	16.81	8.74	0.25
			1.00			1" Ice	17.76	9.60	0.38
DMP65R-BU8D w/ Mount Pipe	C	From Leg	4.00	0.0000	159.00	No Ice	15.89	7.89	0.14
			0.00			1/2" Ice	16.81	8.74	0.25
			1.00			1" Ice	17.76	9.60	0.38
QD8616-7 w/ Mount Pipe	A	From Leg	4.00	0.0000	159.00	No Ice	16.93	9.31	0.18
			0.00			1/2" Ice	17.87	10.17	0.31
			1.00			1" Ice	18.83	11.05	0.45
QD8616-7 w/ Mount Pipe	B	From Leg	4.00	0.0000	159.00	No Ice	16.93	9.31	0.18
			0.00			1/2" Ice	17.87	10.17	0.31
			1.00			1" Ice	18.83	11.05	0.45
QD8616-7 w/ Mount Pipe	C	From Leg	4.00	0.0000	159.00	No Ice	16.93	9.31	0.18
			0.00			1/2" Ice	17.87	10.17	0.31
			1.00			1" Ice	18.83	11.05	0.45
AIR 6449 B77D w/ Mount Pipe	A	From Leg	4.00	0.0000	159.00	No Ice	3.58	2.31	0.09
			0.00			1/2" Ice	3.92	2.60	0.13
			-1.00			1" Ice	4.27	2.91	0.17
AIR 6449 B77D w/ Mount Pipe	B	From Leg	4.00	0.0000	159.00	No Ice	3.58	2.31	0.09
			0.00			1/2" Ice	3.92	2.60	0.13
			-1.00			1" Ice	4.27	2.91	0.17
AIR 6449 B77D w/ Mount Pipe	C	From Leg	4.00	0.0000	159.00	No Ice	3.58	2.31	0.09
			0.00			1/2" Ice	3.92	2.60	0.13
			-1.00			1" Ice	4.27	2.91	0.17
RRUS 4449 B5/B12	A	From Leg	4.00	0.0000	159.00	No Ice	1.97	1.41	0.07
			0.00			1/2" Ice	2.14	1.56	0.09
			1.00			1" Ice	2.33	1.73	0.11
RRUS 4449 B5/B12	B	From Leg	4.00	0.0000	159.00	No Ice	1.97	1.41	0.07
			0.00			1/2" Ice	2.14	1.56	0.09
			1.00			1" Ice	2.33	1.73	0.11
RRUS 4449 B5/B12	C	From Leg	4.00	0.0000	159.00	No Ice	1.97	1.41	0.07
			0.00			1/2" Ice	2.14	1.56	0.09
			1.00			1" Ice	2.33	1.73	0.11
RRUS 4478 B14_CCIV2	A	From Leg	4.00	0.0000	159.00	No Ice	2.02	1.25	0.06
			0.00			1/2" Ice	2.20	1.40	0.08
			1.00			1" Ice	2.39	1.55	0.10
RRUS 4478 B14_CCIV2	B	From Leg	4.00	0.0000	159.00	No Ice	2.02	1.25	0.06
			0.00			1/2" Ice	2.20	1.40	0.08
			1.00			1" Ice	2.39	1.55	0.10
RRUS 4478 B14_CCIV2	C	From Leg	4.00	0.0000	159.00	No Ice	2.02	1.25	0.06
			0.00			1/2" Ice	2.20	1.40	0.08
			1.00			1" Ice	2.39	1.55	0.10

Description	Face or Leg	Offset Type	Offsets:		Azimuth Adjustment	Placement	C _A A _A Front	C _A A _A Side	Weight	
			Horz	Lateral						Vert
			ft	ft	°	ft	ft ²	ft ²	K	
RRUS 4426 B66	A	From Leg	4.00		0.0000	159.00	No Ice	1.64	0.73	0.05
			0.00				1/2" Ice	1.80	0.84	0.06
			1.00				1" Ice	1.97	0.97	0.08
RRUS 4426 B66	B	From Leg	4.00		0.0000	159.00	No Ice	1.64	0.73	0.05
			0.00				1/2" Ice	1.80	0.84	0.06
			1.00				1" Ice	1.97	0.97	0.08
RRUS 4426 B66	C	From Leg	4.00		0.0000	159.00	No Ice	1.64	0.73	0.05
			0.00				1/2" Ice	1.80	0.84	0.06
			1.00				1" Ice	1.97	0.97	0.08
DC9-48-60-24-8C-EV_CCIV2	A	From Leg	4.00		0.0000	159.00	No Ice	2.74	2.74	0.02
			0.00				1/2" Ice	2.96	2.96	0.04
			1.00				1" Ice	3.20	3.20	0.07
DC9-48-60-24-8C-EV_CCIV2	B	From Leg	4.00		0.0000	159.00	No Ice	2.74	2.74	0.02
			0.00				1/2" Ice	2.96	2.96	0.04
			1.00				1" Ice	3.20	3.20	0.07
DC9-48-60-24-8C-EV_CCIV2	C	From Leg	4.00		0.0000	159.00	No Ice	2.74	2.74	0.02
			0.00				1/2" Ice	2.96	2.96	0.04
			1.00				1" Ice	3.20	3.20	0.07

PCS 1900MHz 4x45W-65MHz	A	From Leg	1.00		0.0000	151.00	No Ice	2.32	2.24	0.06
			0.00				1/2" Ice	2.53	2.44	0.08
			0.00				1" Ice	2.74	2.65	0.11
PCS 1900MHz 4x45W-65MHz	B	From Leg	1.00		0.0000	151.00	No Ice	2.32	2.24	0.06
			0.00				1/2" Ice	2.53	2.44	0.08
			0.00				1" Ice	2.74	2.65	0.11
PCS 1900MHz 4x45W-65MHz	C	From Leg	1.00		0.0000	151.00	No Ice	2.32	2.24	0.06
			0.00				1/2" Ice	2.53	2.44	0.08
			0.00				1" Ice	2.74	2.65	0.11
800MHz 2X50W RRH W/FILTER	A	From Leg	1.00		0.0000	151.00	No Ice	2.06	1.93	0.06
			0.00				1/2" Ice	2.24	2.11	0.09
			2.00				1" Ice	2.43	2.29	0.11
800MHz 2X50W RRH W/FILTER	B	From Leg	1.00		0.0000	151.00	No Ice	2.06	1.93	0.06
			0.00				1/2" Ice	2.24	2.11	0.09
			2.00				1" Ice	2.43	2.29	0.11
800MHz 2X50W RRH W/FILTER	C	From Leg	1.00		0.0000	151.00	No Ice	2.06	1.93	0.06
			0.00				1/2" Ice	2.24	2.11	0.09
			2.00				1" Ice	2.43	2.29	0.11
Side Arm Mount [SO 102-3]	C	None			0.0000	151.00	No Ice	3.60	3.60	0.07
							1/2" Ice	4.18	4.18	0.11
							1" Ice	4.75	4.75	0.14
Pipe Mount [PM 601-3]	C	None			0.0000	151.00	No Ice	3.17	3.17	0.20
							1/2" Ice	3.79	3.79	0.23
							1" Ice	4.42	4.42	0.28

APXVTM14-ALU-I20 w/ Mount Pipe	A	From Leg	4.00		0.0000	147.00	No Ice	4.09	2.86	0.08
			0.00				1/2" Ice	4.48	3.23	0.13
			1.00				1" Ice	4.88	3.61	0.19
APXVTM14-ALU-I20 w/ Mount Pipe	B	From Leg	4.00		0.0000	147.00	No Ice	4.09	2.86	0.08
			0.00				1/2" Ice	4.48	3.23	0.13
			1.00				1" Ice	4.88	3.61	0.19
APXVTM14-ALU-I20 w/ Mount Pipe	C	From Leg	4.00		0.0000	147.00	No Ice	4.09	2.86	0.08
			0.00				1/2" Ice	4.48	3.23	0.13
			1.00				1" Ice	4.88	3.61	0.19
APX/SPP18-C-A20 w/ Mount Pipe	A	From Leg	4.00		0.0000	147.00	No Ice	4.60	4.01	0.10
			0.00				1/2" Ice	5.05	4.45	0.16
			0.00				1" Ice	5.50	4.89	0.23
APX/SPP18-C-A20 w/ Mount Pipe	B	From Leg	4.00		0.0000	147.00	No Ice	4.60	4.01	0.10
			0.00				1/2" Ice	5.05	4.45	0.16
			1.00				1" Ice	5.50	4.89	0.23
APX/SPP18-C-A20 w/ Mount Pipe	C	From Leg	4.00		0.0000	147.00	No Ice	4.60	4.01	0.10
			0.00				1/2" Ice	5.05	4.45	0.16
			1.00				1" Ice	5.50	4.89	0.23
TD-RRH8X20-25	A	From Leg	4.00		0.0000	147.00	No Ice	3.70	1.29	0.07
			0.00				1/2" Ice	3.95	1.46	0.09
			3.00				1" Ice	4.20	1.64	0.12

Description	Face or Leg	Offset Type	Offsets:		Azimuth Adjustment	Placement	C _A A _A Front	C _A A _A Side	Weight	
			Horz	Lateral						Vert
			ft	ft	°	ft	ft ²	ft ²	K	
TD-RRH8X20-25	B	From Leg	4.00		0.0000	147.00	No Ice	3.70	1.29	0.07
			0.00				1/2" Ice	3.95	1.46	0.09
			3.00				1" Ice	4.20	1.64	0.12
TD-RRH8X20-25	C	From Leg	4.00		0.0000	147.00	No Ice	3.70	1.29	0.07
			0.00				1/2" Ice	3.95	1.46	0.09
			3.00				1" Ice	4.20	1.64	0.12
6' x 2" Mount Pipe	A	From Leg	4.00		0.0000	147.00	No Ice	1.43	1.43	0.02
			0.00				1/2" Ice	1.92	1.92	0.03
			0.00				1" Ice	2.29	2.29	0.05
6' x 2" Mount Pipe	B	From Leg	4.00		0.0000	147.00	No Ice	1.43	1.43	0.02
			0.00				1/2" Ice	1.92	1.92	0.03
			0.00				1" Ice	2.29	2.29	0.05
6' x 2" Mount Pipe	C	From Leg	4.00		0.0000	147.00	No Ice	1.43	1.43	0.02
			0.00				1/2" Ice	1.92	1.92	0.03
			0.00				1" Ice	2.29	2.29	0.05
Platform Mount [LP 1201-1]	C	None			0.0000	147.00	No Ice	18.38	18.38	2.10
							1/2" Ice	22.11	22.11	2.65
							1" Ice	25.87	25.87	3.26

APXVAARR24_43-U-NA20 w/ Mount Pipe	A	From Leg	4.00		0.0000	138.00	No Ice	14.69	6.87	0.19
			0.00				1/2" Ice	15.46	7.55	0.31
			0.00				1" Ice	16.23	8.25	0.46
APXVAARR24_43-U-NA20 w/ Mount Pipe	B	From Leg	4.00		0.0000	138.00	No Ice	14.69	6.87	0.19
			0.00				1/2" Ice	15.46	7.55	0.31
			0.00				1" Ice	16.23	8.25	0.46
APXVAARR24_43-U-NA20 w/ Mount Pipe	C	From Leg	4.00		0.0000	138.00	No Ice	14.69	6.87	0.19
			0.00				1/2" Ice	15.46	7.55	0.31
			0.00				1" Ice	16.23	8.25	0.46
AIR6449 B41_T-MOBILE w/ Mount Pipe	A	From Leg	4.00		0.0000	138.00	No Ice	5.19	2.71	0.13
			0.00				1/2" Ice	5.59	3.04	0.17
			0.00				1" Ice	6.02	3.38	0.23
AIR6449 B41_T-MOBILE w/ Mount Pipe	B	From Leg	4.00		0.0000	138.00	No Ice	5.19	2.71	0.13
			0.00				1/2" Ice	5.59	3.04	0.17
			0.00				1" Ice	6.02	3.38	0.23
AIR6449 B41_T-MOBILE w/ Mount Pipe	C	From Leg	4.00		0.0000	138.00	No Ice	5.19	2.71	0.13
			0.00				1/2" Ice	5.59	3.04	0.17
			0.00				1" Ice	6.02	3.38	0.23
Radio 4480_TMOV2	A	From Leg	4.00		0.0000	138.00	No Ice	2.88	1.40	0.08
			0.00				1/2" Ice	3.09	1.56	0.10
			0.00				1" Ice	3.31	1.73	0.13
Radio 4480_TMOV2	B	From Leg	4.00		0.0000	138.00	No Ice	2.88	1.40	0.08
			0.00				1/2" Ice	3.09	1.56	0.10
			0.00				1" Ice	3.31	1.73	0.13
Radio 4480_TMOV2	C	From Leg	4.00		0.0000	138.00	No Ice	2.88	1.40	0.08
			0.00				1/2" Ice	3.09	1.56	0.10
			0.00				1" Ice	3.31	1.73	0.13
RADIO 4460 B2/B25 B66_TMO	A	From Leg	4.00		0.0000	138.00	No Ice	2.14	1.69	0.11
			0.00				1/2" Ice	2.32	1.85	0.13
			0.00				1" Ice	2.51	2.02	0.16
RADIO 4460 B2/B25 B66_TMO	B	From Leg	4.00		0.0000	138.00	No Ice	2.14	1.69	0.11
			0.00				1/2" Ice	2.32	1.85	0.13
			0.00				1" Ice	2.51	2.02	0.16
RADIO 4460 B2/B25 B66_TMO	C	From Leg	4.00		0.0000	138.00	No Ice	2.14	1.69	0.11
			0.00				1/2" Ice	2.32	1.85	0.13
			0.00				1" Ice	2.51	2.02	0.16
4' x 2" Pipe Mount	A	From Leg	4.00		0.0000	138.00	No Ice	0.79	0.79	0.03
			0.00				1/2" Ice	1.03	1.03	0.04
			0.00				1" Ice	1.28	1.28	0.04
4' x 2" Pipe Mount	B	From Leg	4.00		0.0000	138.00	No Ice	0.79	0.79	0.03
			0.00				1/2" Ice	1.03	1.03	0.04
			0.00				1" Ice	1.28	1.28	0.04
4' x 2" Pipe Mount	C	From Leg	4.00		0.0000	138.00	No Ice	0.79	0.79	0.03
			0.00				1/2" Ice	1.03	1.03	0.04
			0.00				1" Ice	1.28	1.28	0.04
6' x 2" Mount Pipe	A	From Leg	4.00		0.0000	138.00	No Ice	1.43	1.43	0.02

Description	Face or Leg	Offset Type	Offsets:		Azimuth Adjustment	Placement	C _A A _A Front	C _A A _A Side	Weight
			Horz	Lateral					
			ft	ft	°	ft	ft ²	ft ²	K
6' x 2" Mount Pipe	B	From Leg	0.00			1/2" Ice	1.92	1.92	0.03
			0.00			1" Ice	2.29	2.29	0.05
			4.00	0.0000	138.00	No Ice	1.43	1.43	0.02
6' x 2" Mount Pipe	C	From Leg	0.00			1/2" Ice	1.92	1.92	0.03
			0.00			1" Ice	2.29	2.29	0.05
			4.00	0.0000	138.00	No Ice	1.43	1.43	0.02
Platform Mount [LP 1201-1_KCKR-HR-1]	C	None	0.00			1/2" Ice	1.92	1.92	0.03
			0.00			1" Ice	2.29	2.29	0.05
			0.00	0.0000	138.00	No Ice	37.61	37.61	2.63

Side Arm Mount [SO 701-1]	B	From Leg	1.50			No Ice	0.85	1.67	0.07
			0.00			1/2" Ice	1.14	2.34	0.08
			0.00			1" Ice	1.43	3.01	0.09
6' x 2" Horizontal Mount Pipe	B	From Leg	1.50			No Ice	1.14	0.01	0.02
			0.00			1/2" Ice	1.76	0.04	0.03
			0.00			1" Ice	2.14	0.09	0.04
Pipe Mount [PM 601-1]	B	From Leg	3.00			No Ice	1.32	1.32	0.07
			0.00			1/2" Ice	1.58	1.58	0.08
			0.00			1" Ice	1.84	1.84	0.09

MX08FRO665-21 w/ Mount Pipe	A	From Leg	4.00			No Ice	8.01	4.23	0.11
			0.00			1/2" Ice	8.52	4.69	0.19
			0.00			1" Ice	9.04	5.16	0.29
MX08FRO665-21 w/ Mount Pipe	B	From Leg	4.00			No Ice	8.01	4.23	0.11
			0.00			1/2" Ice	8.52	4.69	0.19
			0.00			1" Ice	9.04	5.16	0.29
MX08FRO665-21 w/ Mount Pipe	C	From Leg	4.00			No Ice	8.01	4.23	0.11
			0.00			1/2" Ice	8.52	4.69	0.19
			0.00			1" Ice	9.04	5.16	0.29
TA08025-B604	A	From Leg	4.00			No Ice	1.96	0.98	0.06
			0.00			1/2" Ice	2.14	1.11	0.08
			0.00			1" Ice	2.32	1.25	0.10
TA08025-B604	B	From Leg	4.00			No Ice	1.96	0.98	0.06
			0.00			1/2" Ice	2.14	1.11	0.08
			0.00			1" Ice	2.32	1.25	0.10
TA08025-B604	C	From Leg	4.00			No Ice	1.96	0.98	0.06
			0.00			1/2" Ice	2.14	1.11	0.08
			0.00			1" Ice	2.32	1.25	0.10
TA08025-B605	A	From Leg	4.00			No Ice	1.96	1.13	0.08
			0.00			1/2" Ice	2.14	1.27	0.09
			0.00			1" Ice	2.32	1.41	0.11
TA08025-B605	B	From Leg	4.00			No Ice	1.96	1.13	0.08
			0.00			1/2" Ice	2.14	1.27	0.09
			0.00			1" Ice	2.32	1.41	0.11
TA08025-B605	C	From Leg	4.00			No Ice	1.96	1.13	0.08
			0.00			1/2" Ice	2.14	1.27	0.09
			0.00			1" Ice	2.32	1.41	0.11
RDIDC-9181-PF-48	C	From Leg	2.00			No Ice	2.01	1.17	0.02
			0.00			1/2" Ice	2.19	1.31	0.04
			0.00			1" Ice	2.37	1.46	0.06
6' x 2" Mount Pipe	C	From Leg	2.00			No Ice	1.43	1.43	0.02
			0.00			1/2" Ice	1.92	1.92	0.03
			0.00			1" Ice	2.29	2.29	0.05
(2) 8' x 2" Mount Pipe	A	From Leg	4.00			No Ice	1.90	1.90	0.03
			0.00			1/2" Ice	2.73	2.73	0.04
			0.00			1" Ice	3.40	3.40	0.06
(2) 8' x 2" Mount Pipe	B	From Leg	4.00			No Ice	1.90	1.90	0.03
			0.00			1/2" Ice	2.73	2.73	0.04
			0.00			1" Ice	3.40	3.40	0.06
(2) 8' x 2" Mount Pipe	C	From Leg	4.00			No Ice	1.90	1.90	0.03
			0.00			1/2" Ice	2.73	2.73	0.04
			0.00			1" Ice	3.40	3.40	0.06
Valmont SNP8HR-396	C	None	0.00			No Ice	26.80	26.80	1.51

Description	Face or Leg	Offset Type	Offsets: Horz Lateral Vert ft ft ft	Azimuth Adjustment °	Placement ft	C _A A _A Front ft ²	C _A A _A Side ft ²	Weight K	
						1/2" Ice	32.20	32.20	1.81
						1" Ice	37.60	37.60	2.11

Dishes

Description	Face or Leg	Dish Type	Offset Type	Offsets: Horz Lateral Vert ft ft ft	Azimuth Adjustment °	3 dB Beam Width °	Elevation ft	Outside Diameter ft	Aperture Area ft ²	Weight K	

SC3-W100AC	B	Paraboloid w/Shroud (HP)	From Leg	3.00 0.00 -1.00	-27.0000		130.00	3.29	No Ice 1/2" Ice 1" Ice	8.51 8.95 9.38	0.05 0.09 0.14

Load Combinations

Comb. No.	Description
1	Dead Only
2	1.2 Dead+1.0 Wind 0 deg - No Ice
3	0.9 Dead+1.0 Wind 0 deg - No Ice
4	1.2 Dead+1.0 Wind 30 deg - No Ice
5	0.9 Dead+1.0 Wind 30 deg - No Ice
6	1.2 Dead+1.0 Wind 60 deg - No Ice
7	0.9 Dead+1.0 Wind 60 deg - No Ice
8	1.2 Dead+1.0 Wind 90 deg - No Ice
9	0.9 Dead+1.0 Wind 90 deg - No Ice
10	1.2 Dead+1.0 Wind 120 deg - No Ice
11	0.9 Dead+1.0 Wind 120 deg - No Ice
12	1.2 Dead+1.0 Wind 150 deg - No Ice
13	0.9 Dead+1.0 Wind 150 deg - No Ice
14	1.2 Dead+1.0 Wind 180 deg - No Ice
15	0.9 Dead+1.0 Wind 180 deg - No Ice
16	1.2 Dead+1.0 Wind 210 deg - No Ice
17	0.9 Dead+1.0 Wind 210 deg - No Ice
18	1.2 Dead+1.0 Wind 240 deg - No Ice
19	0.9 Dead+1.0 Wind 240 deg - No Ice
20	1.2 Dead+1.0 Wind 270 deg - No Ice
21	0.9 Dead+1.0 Wind 270 deg - No Ice
22	1.2 Dead+1.0 Wind 300 deg - No Ice
23	0.9 Dead+1.0 Wind 300 deg - No Ice
24	1.2 Dead+1.0 Wind 330 deg - No Ice
25	0.9 Dead+1.0 Wind 330 deg - No Ice
26	1.2 Dead+1.0 Ice+1.0 Temp
27	1.2 Dead+1.0 Wind 0 deg+1.0 Ice+1.0 Temp
28	1.2 Dead+1.0 Wind 30 deg+1.0 Ice+1.0 Temp
29	1.2 Dead+1.0 Wind 60 deg+1.0 Ice+1.0 Temp
30	1.2 Dead+1.0 Wind 90 deg+1.0 Ice+1.0 Temp
31	1.2 Dead+1.0 Wind 120 deg+1.0 Ice+1.0 Temp
32	1.2 Dead+1.0 Wind 150 deg+1.0 Ice+1.0 Temp
33	1.2 Dead+1.0 Wind 180 deg+1.0 Ice+1.0 Temp
34	1.2 Dead+1.0 Wind 210 deg+1.0 Ice+1.0 Temp
35	1.2 Dead+1.0 Wind 240 deg+1.0 Ice+1.0 Temp
36	1.2 Dead+1.0 Wind 270 deg+1.0 Ice+1.0 Temp
37	1.2 Dead+1.0 Wind 300 deg+1.0 Ice+1.0 Temp
38	1.2 Dead+1.0 Wind 330 deg+1.0 Ice+1.0 Temp

Comb. No.	Description
39	Dead+Wind 0 deg - Service
40	Dead+Wind 30 deg - Service
41	Dead+Wind 60 deg - Service
42	Dead+Wind 90 deg - Service
43	Dead+Wind 120 deg - Service
44	Dead+Wind 150 deg - Service
45	Dead+Wind 180 deg - Service
46	Dead+Wind 210 deg - Service
47	Dead+Wind 240 deg - Service
48	Dead+Wind 270 deg - Service
49	Dead+Wind 300 deg - Service
50	Dead+Wind 330 deg - Service

Maximum Member Forces

Section No.	Elevation ft	Component Type	Condition	Gov. Load Comb.	Axial K	Major Axis Moment kip-ft	Minor Axis Moment kip-ft
L1	167 - 118.25	Pole	Max Tension	30	0.00	0.00	-0.00
			Max. Compression	26	-45.24	-0.70	0.71
			Max. Mx	8	-25.70	-749.01	-0.00
			Max. My	14	-25.71	-0.67	-747.28
			Max. Vy	20	-23.58	748.61	-0.20
			Max. Vx	14	23.36	-0.67	-747.28
			Max. Torque	20			-1.82
L2	118.25 - 77.75	Pole	Max Tension	1	0.00	0.00	0.00
			Max. Compression	26	-60.85	-0.13	-0.58
			Max. Mx	20	-37.56	1821.16	-0.76
			Max. My	14	-37.58	-2.00	-1810.98
			Max. Vy	20	-28.70	1821.16	-0.76
			Max. Vx	14	28.47	-2.00	-1810.98
			Max. Torque	8			0.82
L3	77.75 - 38.25	Pole	Max Tension	1	0.00	0.00	0.00
			Max. Compression	26	-75.46	0.14	-1.92
			Max. Mx	20	-49.70	2969.94	-1.43
			Max. My	14	-49.71	-3.32	-2951.44
			Max. Vy	20	-31.24	2969.94	-1.43
			Max. Vx	14	31.02	-3.32	-2951.44
			Max. Torque	8			0.82
L4	38.25 - 0	Pole	Max Tension	1	0.00	0.00	0.00
			Max. Compression	26	-96.58	0.50	-3.42
			Max. Mx	20	-68.19	4435.91	-2.18
			Max. My	14	-68.19	-4.79	-4407.84
			Max. Vy	20	-33.80	4435.91	-2.18
			Max. Vx	14	33.57	-4.79	-4407.84
			Max. Torque	8			0.82

Maximum Reactions

Location	Condition	Gov. Load Comb.	Vertical K	Horizontal, X K	Horizontal, Z K
Pole	Max. Vert	36	96.58	8.88	0.00
	Max. H _x	21	51.16	33.76	0.00
	Max. H _z	3	51.16	-0.02	33.53
	Max. M _x	2	4402.58	-0.02	33.53
	Max. M _z	8	4425.03	-33.68	0.00
	Max. Torsion	8	0.82	-33.68	0.00
	Min. Vert	5	51.16	-16.90	29.01
	Min. H _x	8	68.21	-33.68	0.00
	Min. H _z	15	51.16	-0.04	-33.54

Location	Condition	Gov. Load Comb.	Vertical K	Horizontal, X K	Horizontal, Z K
	Min. M _x	14	-4407.84	-0.04	-33.54
	Min. M _z	20	-4435.91	33.76	0.00
	Min. Torsion	20	-0.68	33.76	0.00

Tower Mast Reaction Summary

Load Combination	Vertical K	Shear _x K	Shear _z K	Overturning Moment, M _x kip-ft	Overturning Moment, M _z kip-ft	Torque kip-ft
Dead Only	56.84	0.00	0.00	1.84	0.08	0.00
1.2 Dead+1.0 Wind 0 deg - No Ice	68.21	0.02	-33.53	-4402.58	-2.47	0.52
0.9 Dead+1.0 Wind 0 deg - No Ice	51.16	0.02	-33.53	-4329.58	-2.45	0.52
1.2 Dead+1.0 Wind 30 deg - No Ice	68.21	16.90	-29.01	-3808.89	-2221.34	0.07
0.9 Dead+1.0 Wind 30 deg - No Ice	51.16	16.90	-29.01	-3745.84	-2184.28	0.08
1.2 Dead+1.0 Wind 60 deg - No Ice	68.21	29.20	-16.72	-2194.33	-3836.51	-0.55
0.9 Dead+1.0 Wind 60 deg - No Ice	51.16	29.20	-16.72	-2158.24	-3772.48	-0.54
1.2 Dead+1.0 Wind 90 deg - No Ice	68.21	33.68	-0.00	1.93	-4425.03	-0.82
0.9 Dead+1.0 Wind 90 deg - No Ice	51.16	33.68	-0.00	1.32	-4351.17	-0.80
1.2 Dead+1.0 Wind 120 deg - No Ice	68.21	29.19	16.73	2199.76	-3834.77	-0.80
0.9 Dead+1.0 Wind 120 deg - No Ice	51.16	29.19	16.73	2162.45	-3770.77	-0.78
1.2 Dead+1.0 Wind 150 deg - No Ice	68.21	16.90	29.00	3812.48	-2221.03	-0.60
0.9 Dead+1.0 Wind 150 deg - No Ice	51.16	16.90	29.00	3748.23	-2183.98	-0.59
1.2 Dead+1.0 Wind 180 deg - No Ice	68.21	0.04	33.54	4407.84	-4.79	-0.44
0.9 Dead+1.0 Wind 180 deg - No Ice	51.16	0.04	33.54	4333.63	-4.73	-0.44
1.2 Dead+1.0 Wind 210 deg - No Ice	68.21	-16.97	28.99	3810.26	2230.05	-0.02
0.9 Dead+1.0 Wind 210 deg - No Ice	51.16	-16.97	28.99	3746.05	2192.83	-0.02
1.2 Dead+1.0 Wind 240 deg - No Ice	68.21	-29.27	16.74	2200.83	3847.20	0.45
0.9 Dead+1.0 Wind 240 deg - No Ice	51.16	-29.27	16.74	2163.50	3782.98	0.43
1.2 Dead+1.0 Wind 270 deg - No Ice	68.21	-33.76	-0.00	2.18	4435.91	0.68
0.9 Dead+1.0 Wind 270 deg - No Ice	51.16	-33.76	-0.00	1.58	4361.83	0.66
1.2 Dead+1.0 Wind 300 deg - No Ice	68.21	-29.27	-16.75	-2197.77	3845.95	0.59
0.9 Dead+1.0 Wind 300 deg - No Ice	51.16	-29.27	-16.75	-2161.63	3781.75	0.58
1.2 Dead+1.0 Wind 330 deg - No Ice	68.21	-16.98	-28.99	-3806.15	2231.23	0.28
0.9 Dead+1.0 Wind 330 deg - No Ice	51.16	-16.98	-28.99	-3743.13	2193.99	0.27
1.2 Dead+1.0 Ice+1.0 Temp	96.58	0.00	0.00	3.42	0.50	0.00
1.2 Dead+1.0 Wind 0 deg+1.0 Ice+1.0 Temp	96.58	0.00	-8.83	-1159.30	0.08	0.10
1.2 Dead+1.0 Wind 30 deg+1.0 Ice+1.0 Temp	96.58	4.44	-7.64	-1002.73	-584.77	-0.13
1.2 Dead+1.0 Wind 60 deg+1.0 Ice+1.0 Temp	96.58	7.68	-4.41	-576.57	-1011.06	-0.36

Load Combination	Vertical	Shear _x	Shear _z	Overturning Moment, M _x	Overturning Moment, M _z	Torque
	K	K	K	kip-ft	kip-ft	kip-ft
1.2 Dead+1.0 Wind 90 deg+1.0 Ice+1.0 Temp	96.58	8.86	0.00	3.63	-1166.58	-0.45
1.2 Dead+1.0 Wind 120 deg+1.0 Ice+1.0 Temp	96.58	7.68	4.41	584.14	-1010.80	-0.41
1.2 Dead+1.0 Wind 150 deg+1.0 Ice+1.0 Temp	96.58	4.44	7.64	1009.84	-584.87	-0.26
1.2 Dead+1.0 Wind 180 deg+1.0 Ice+1.0 Temp	96.58	0.01	8.83	1166.67	-0.59	-0.08
1.2 Dead+1.0 Wind 210 deg+1.0 Ice+1.0 Temp	96.58	-4.45	7.64	1009.29	587.54	0.14
1.2 Dead+1.0 Wind 240 deg+1.0 Ice+1.0 Temp	96.58	-7.69	4.41	584.19	1014.25	0.34
1.2 Dead+1.0 Wind 270 deg+1.0 Ice+1.0 Temp	96.58	-8.88	-0.00	3.49	1169.81	0.42
1.2 Dead+1.0 Wind 300 deg+1.0 Ice+1.0 Temp	96.58	-7.69	-4.41	-577.45	1014.09	0.36
1.2 Dead+1.0 Wind 330 deg+1.0 Ice+1.0 Temp	96.58	-4.46	-7.64	-1002.26	587.96	0.20
Dead+Wind 0 deg - Service	56.84	0.00	-8.17	-1060.70	-0.55	0.13
Dead+Wind 30 deg - Service	56.84	4.12	-7.07	-917.48	-535.82	0.02
Dead+Wind 60 deg - Service	56.84	7.11	-4.07	-528.00	-925.46	-0.13
Dead+Wind 90 deg - Service	56.84	8.20	-0.00	1.82	-1067.44	-0.20
Dead+Wind 120 deg - Service	56.84	7.11	4.07	532.02	-925.04	-0.20
Dead+Wind 150 deg - Service	56.84	4.12	7.06	921.06	-535.75	-0.15
Dead+Wind 180 deg - Service	56.84	0.01	8.17	1064.69	-1.11	-0.11
Dead+Wind 210 deg - Service	56.84	-4.13	7.06	920.53	538.02	-0.00
Dead+Wind 240 deg - Service	56.84	-7.13	4.08	532.28	928.15	0.11
Dead+Wind 270 deg - Service	56.84	-8.22	-0.00	1.88	1070.17	0.17
Dead+Wind 300 deg - Service	56.84	-7.13	-4.08	-528.83	927.84	0.14
Dead+Wind 330 deg - Service	56.84	-4.13	-7.06	-916.82	538.30	0.07

Solution Summary

Load Comb.	Sum of Applied Forces			Sum of Reactions			% Error
	PX K	PY K	PZ K	PX K	PY K	PZ K	
1	0.00	-56.84	0.00	0.00	56.84	0.00	0.000%
2	0.02	-68.21	-33.53	-0.02	68.21	33.53	0.000%
3	0.02	-51.16	-33.53	-0.02	51.16	33.53	0.000%
4	16.90	-68.21	-29.01	-16.90	68.21	29.01	0.000%
5	16.90	-51.16	-29.01	-16.90	51.16	29.01	0.000%
6	29.20	-68.21	-16.72	-29.20	68.21	16.72	0.000%
7	29.20	-51.16	-16.72	-29.20	51.16	16.72	0.000%
8	33.68	-68.21	-0.00	-33.68	68.21	0.00	0.000%
9	33.68	-51.16	-0.00	-33.68	51.16	0.00	0.000%
10	29.19	-68.21	16.73	-29.19	68.21	-16.73	0.000%
11	29.19	-51.16	16.73	-29.19	51.16	-16.73	0.000%
12	16.90	-68.21	29.00	-16.90	68.21	-29.00	0.000%
13	16.90	-51.16	29.00	-16.90	51.16	-29.00	0.000%
14	0.04	-68.21	33.54	-0.04	68.21	-33.54	0.000%
15	0.04	-51.16	33.54	-0.04	51.16	-33.54	0.000%
16	-16.97	-68.21	28.99	16.97	68.21	-28.99	0.000%
17	-16.97	-51.16	28.99	16.97	51.16	-28.99	0.000%
18	-29.27	-68.21	16.74	29.27	68.21	-16.74	0.000%
19	-29.27	-51.16	16.74	29.27	51.16	-16.74	0.000%
20	-33.76	-68.21	-0.00	33.76	68.21	0.00	0.000%
21	-33.76	-51.16	-0.00	33.76	51.16	0.00	0.000%
22	-29.27	-68.21	-16.75	29.27	68.21	16.75	0.000%

Load Comb.	Sum of Applied Forces			Sum of Reactions			% Error
	PX K	PY K	PZ K	PX K	PY K	PZ K	
23	-29.27	-51.16	-16.75	29.27	51.16	16.75	0.000%
24	-16.98	-68.21	-28.99	16.98	68.21	28.99	0.000%
25	-16.98	-51.16	-28.99	16.98	51.16	28.99	0.000%
26	0.00	-96.58	0.00	0.00	96.58	0.00	0.000%
27	0.00	-96.58	-8.83	-0.00	96.58	8.83	0.000%
28	4.44	-96.58	-7.64	-4.44	96.58	7.64	0.000%
29	7.68	-96.58	-4.41	-7.68	96.58	4.41	0.000%
30	8.86	-96.58	0.00	-8.86	96.58	-0.00	0.000%
31	7.68	-96.58	4.41	-7.68	96.58	-4.41	0.000%
32	4.44	-96.58	7.64	-4.44	96.58	-7.64	0.000%
33	0.01	-96.58	8.83	-0.01	96.58	-8.83	0.000%
34	-4.45	-96.58	7.64	4.45	96.58	-7.64	0.000%
35	-7.69	-96.58	4.41	7.69	96.58	-4.41	0.000%
36	-8.88	-96.58	-0.00	8.88	96.58	0.00	0.000%
37	-7.69	-96.58	-4.41	7.69	96.58	4.41	0.000%
38	-4.46	-96.58	-7.64	4.46	96.58	7.64	0.000%
39	0.00	-56.84	-8.17	-0.00	56.84	8.17	0.000%
40	4.12	-56.84	-7.07	-4.12	56.84	7.07	0.000%
41	7.11	-56.84	-4.07	-7.11	56.84	4.07	0.000%
42	8.20	-56.84	-0.00	-8.20	56.84	0.00	0.000%
43	7.11	-56.84	4.07	-7.11	56.84	-4.07	0.000%
44	4.12	-56.84	7.06	-4.12	56.84	-7.06	0.000%
45	0.01	-56.84	8.17	-0.01	56.84	-8.17	0.000%
46	-4.13	-56.84	7.06	4.13	56.84	-7.06	0.000%
47	-7.13	-56.84	4.08	7.13	56.84	-4.08	0.000%
48	-8.22	-56.84	-0.00	8.22	56.84	0.00	0.000%
49	-7.13	-56.84	-4.08	7.13	56.84	4.08	0.000%
50	-4.13	-56.84	-7.06	4.13	56.84	7.06	0.000%

Non-Linear Convergence Results

Load Combination	Converged?	Number of Cycles	Displacement Tolerance	Force Tolerance
1	Yes	4	0.00000001	0.00000001
2	Yes	5	0.00000001	0.00006995
3	Yes	4	0.00000001	0.00080636
4	Yes	6	0.00000001	0.00031529
5	Yes	6	0.00000001	0.00010737
6	Yes	6	0.00000001	0.00031729
7	Yes	6	0.00000001	0.00010814
8	Yes	5	0.00000001	0.00010014
9	Yes	5	0.00000001	0.00004683
10	Yes	6	0.00000001	0.00031172
11	Yes	6	0.00000001	0.00010598
12	Yes	6	0.00000001	0.00031808
13	Yes	6	0.00000001	0.00010838
14	Yes	5	0.00000001	0.00006880
15	Yes	4	0.00000001	0.00079898
16	Yes	6	0.00000001	0.00031720
17	Yes	6	0.00000001	0.00010798
18	Yes	6	0.00000001	0.00031378
19	Yes	6	0.00000001	0.00010667
20	Yes	5	0.00000001	0.00009223
21	Yes	4	0.00000001	0.00095465
22	Yes	6	0.00000001	0.00031834
23	Yes	6	0.00000001	0.00010845
24	Yes	6	0.00000001	0.00031529
25	Yes	6	0.00000001	0.00010731
26	Yes	4	0.00000001	0.00000001
27	Yes	5	0.00000001	0.00076561
28	Yes	5	0.00000001	0.00095401
29	Yes	5	0.00000001	0.00095963
30	Yes	5	0.00000001	0.00076954
31	Yes	5	0.00000001	0.00095410
32	Yes	5	0.00000001	0.00096036
33	Yes	5	0.00000001	0.00076711

34	Yes	5	0.0000001	0.00096048
35	Yes	5	0.0000001	0.00095642
36	Yes	5	0.0000001	0.00077080
37	Yes	5	0.0000001	0.00096180
38	Yes	5	0.0000001	0.00095510
39	Yes	4	0.0000001	0.00017005
40	Yes	4	0.0000001	0.00084421
41	Yes	4	0.0000001	0.00086467
42	Yes	4	0.0000001	0.00018023
43	Yes	4	0.0000001	0.00082497
44	Yes	4	0.0000001	0.00086753
45	Yes	4	0.0000001	0.00016996
46	Yes	4	0.0000001	0.00085593
47	Yes	4	0.0000001	0.00083502
48	Yes	4	0.0000001	0.00017818
49	Yes	4	0.0000001	0.00086732
50	Yes	4	0.0000001	0.00083954

Maximum Tower Deflections - Service Wind

Section No.	Elevation ft	Horz. Deflection in	Gov. Load Comb.	Tilt °	Twist °
L1	167 - 118.25	27.355	48	1.5220	0.0035
L2	122.75 - 77.75	14.303	48	1.1972	0.0006
L3	83.25 - 38.25	6.171	48	0.7364	0.0002
L4	45 - 0	1.732	48	0.3533	0.0001

Critical Deflections and Radius of Curvature - Service Wind

Elevation ft	Appurtenance	Gov. Load Comb.	Deflection in	Tilt °	Twist °	Radius of Curvature ft
168.00	Top Hat (5')	48	27.355	1.5220	0.0037	39842
167.00	(2) LPA-80063-6CF-EDIN w/ Mount Pipe	48	27.355	1.5220	0.0037	39842
159.00	RRUS 32 B2	48	24.843	1.4734	0.0030	24901
151.00	PCS 1900MHz 4x45W-65MHz	48	22.362	1.4227	0.0024	12450
147.00	APXVTM14-ALU-I20 w/ Mount Pipe	48	21.143	1.3960	0.0021	9960
138.00	APXVAARR24_43-U-NA20 w/ Mount Pipe	48	18.475	1.3308	0.0014	6868
130.00	Side Arm Mount [SO 701-1]	48	16.222	1.2650	0.0010	5383
129.00	SC3-W100AC	48	15.950	1.2561	0.0009	5241
119.00	MX08FRO665-21 w/ Mount Pipe	48	13.363	1.1587	0.0006	4575

Maximum Tower Deflections - Design Wind

Section No.	Elevation ft	Horz. Deflection in	Gov. Load Comb.	Tilt °	Twist °
L1	167 - 118.25	113.631	20	6.3312	0.0145
L2	122.75 - 77.75	59.412	20	4.9813	0.0023
L3	83.25 - 38.25	25.621	20	3.0607	0.0009
L4	45 - 0	7.186	20	1.4664	0.0003

Critical Deflections and Radius of Curvature - Design Wind

Elevation ft	Appurtenance	Gov. Load Comb.	Deflection in	Tilt °	Twist °	Radius of Curvature ft
168.00	Top Hat (5')	20	113.631	6.3312	0.0150	9772
167.00	(2) LPA-80063-6CF-EDIN w/ Mount Pipe	20	113.631	6.3312	0.0150	9772
159.00	RRUS 32 B2	20	103.197	6.1296	0.0123	6107
151.00	PCS 1900MHz 4x45W-65MHz	20	92.892	5.9193	0.0097	3051
147.00	APXVTM14-ALU-I20 w/ Mount Pipe	20	87.827	5.8083	0.0084	2440
138.00	APXVAARR24_43-U-NA20 w/ Mount Pipe	20	76.748	5.5372	0.0059	1680
130.00	Side Arm Mount [SO 701-1]	20	67.387	5.2635	0.0040	1315
129.00	SC3-W100AC	20	66.256	5.2266	0.0038	1280
119.00	MX08FRO665-21 w/ Mount Pipe	20	55.507	4.8208	0.0024	1114

Compression Checks

Pole Design Data

Section No.	Elevation ft	Size	L ft	L _u ft	KI/r	A in ²	P _u K	φP _n K	Ratio P _u / φP _n
L1	167 - 118.25 (1)	TP35.36x24x0.25	48.75	0.00	0.0	27.027 7	-25.70	1581.12	0.016
L2	118.25 - 77.75 (2)	TP44.297x33.8114x0.312 5	45.00	0.00	0.0	42.356 0	-37.56	2477.82	0.015
L3	77.75 - 38.25 (3)	TP52.877x42.3904x0.375	45.00	0.00	0.0	60.618 3	-49.70	3546.17	0.014
L4	38.25 - 0 (4)	TP61.04x50.554x0.4375	45.00	0.00	0.0	84.154 1	-68.19	4923.02	0.014

Pole Bending Design Data

Section No.	Elevation ft	Size	M _{ux} kip-ft	φM _{nx} kip-ft	Ratio M _{ux} / φM _{nx}	M _{uy} kip-ft	φM _{ny} kip-ft	Ratio M _{uy} / φM _{ny}
L1	167 - 118.25 (1)	TP35.36x24x0.25	749.01	1261.85	0.594	0.00	1261.85	0.000
L2	118.25 - 77.75 (2)	TP44.297x33.8114x0.312 5	1821.16	2476.44	0.735	0.00	2476.44	0.000
L3	77.75 - 38.25 (3)	TP52.877x42.3904x0.375	2969.94	4236.66	0.701	0.00	4236.66	0.000
L4	38.25 - 0 (4)	TP61.04x50.554x0.4375	4435.92	6946.78	0.639	0.00	6946.78	0.000

Pole Shear Design Data

Section No.	Elevation ft	Size	Actual V _u K	φV _n K	Ratio V _u / φV _n	Actual T _u kip-ft	φT _n kip-ft	Ratio T _u / φT _n
L1	167 - 118.25 (1)	TP35.36x24x0.25	23.49	474.34	0.050	0.95	1414.91	0.001
L2	118.25 - 77.75 (2)	TP44.297x33.8114x0.312 5	28.70	743.35	0.039	0.68	2779.90	0.000
L3	77.75 - 38.25	TP52.877x42.3904x0.375	31.24	1063.85	0.029	0.68	4744.88	0.000

Section No.	Elevation ft	Size	Actual V_u K	ϕV_n K	Ratio $\frac{V_u}{\phi V_n}$	Actual T_u kip-ft	ϕT_n kip-ft	Ratio $\frac{T_u}{\phi T_n}$
L4	38.25 - 0 (4) (3)	TP61.04x50.554x0.4375	33.80	1476.91	0.023	0.68	7838.32	0.000

Pole Interaction Design Data

Section No.	Elevation ft	Ratio P_u ϕP_n	Ratio M_{ux} ϕM_{nx}	Ratio M_{uy} ϕM_{ny}	Ratio V_u ϕV_n	Ratio T_u ϕT_n	Comb. Stress Ratio	Allow. Stress Ratio	Criteria
L1	167 - 118.25 (1)	0.016	0.594	0.000	0.050	0.001	0.612	1.050	4.8.2
L2	118.25 - 77.75 (2)	0.015	0.735	0.000	0.039	0.000	0.752	1.050	4.8.2
L3	77.75 - 38.25 (3)	0.014	0.701	0.000	0.029	0.000	0.716	1.050	4.8.2
L4	38.25 - 0 (4)	0.014	0.639	0.000	0.023	0.000	0.653	1.050	4.8.2

Section Capacity Table

Section No.	Elevation ft	Component Type	Size	Critical Element	P K	ϕP_{allow} K	% Capacity	Pass Fail	
L1	167 - 118.25	Pole	TP35.36x24x0.25	1	-25.70	1660.18	58.3	Pass	
L2	118.25 - 77.75	Pole	TP44.297x33.8114x0.3125	2	-37.56	2601.71	71.6	Pass	
L3	77.75 - 38.25	Pole	TP52.877x42.3904x0.375	3	-49.70	3723.48	68.2	Pass	
L4	38.25 - 0	Pole	TP61.04x50.554x0.4375	4	-68.19	5169.17	62.2	Pass	
							Summary		
							Pole (L2)	71.6	Pass
							RATING =	71.6	Pass

APPENDIX B
BASE LEVEL DRAWING

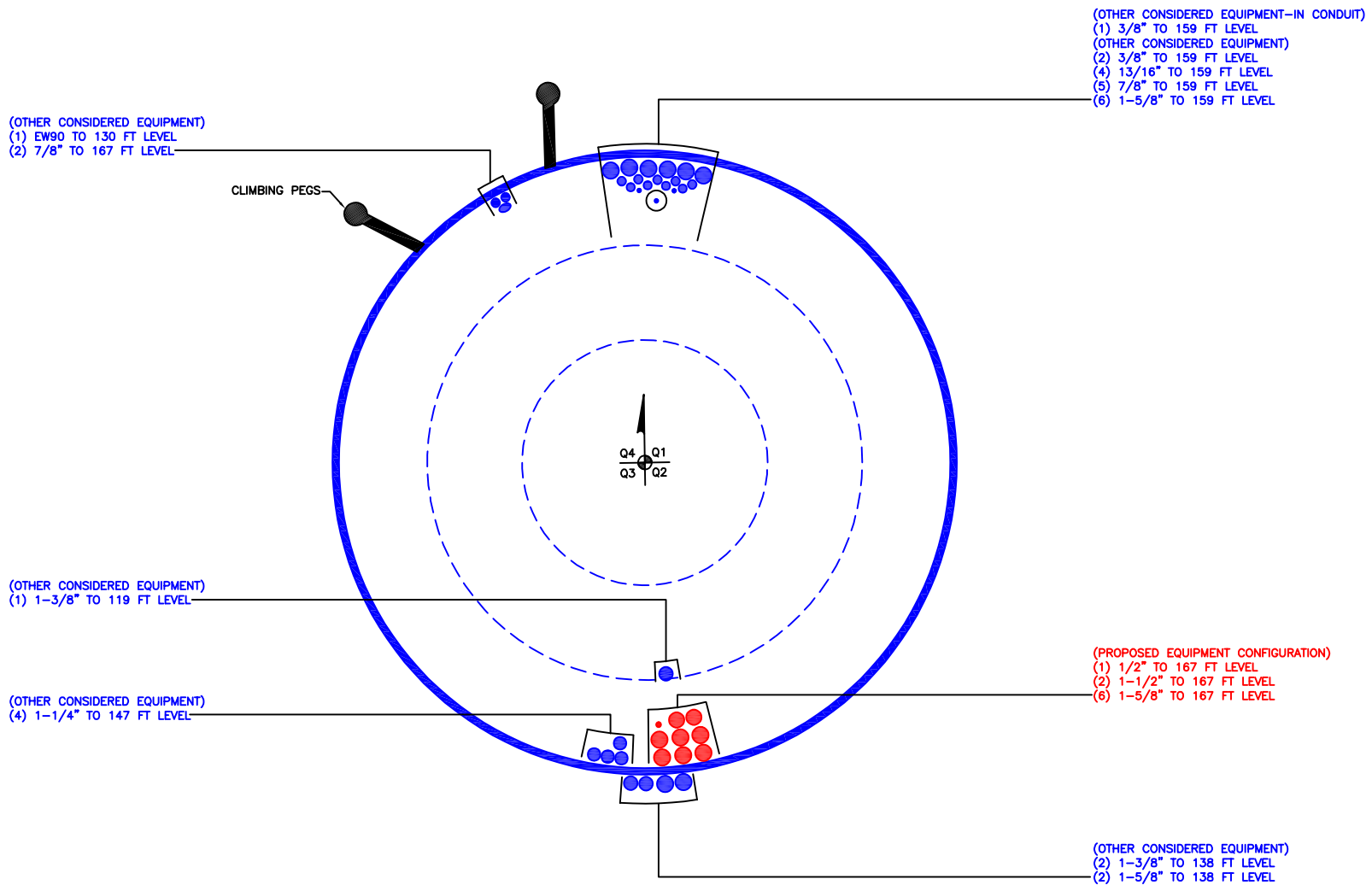

APPENDIX C
ADDITIONAL CALCULATIONS

Monopole Base Plate Connection



Site Info	
BU #	801367
Site Name	NHV-2075 CAC 801367
Order #	654634 Rev. 0

Analysis Considerations	
TIA-222 Revision	H
Grout Considered:	No
l_{ar} (in)	1

Applied Loads	
Moment (kip-ft)	4435.91
Axial Force (kips)	68.19
Shear Force (kips)	33.80

*TIA-222-H Section 15.5 Applied

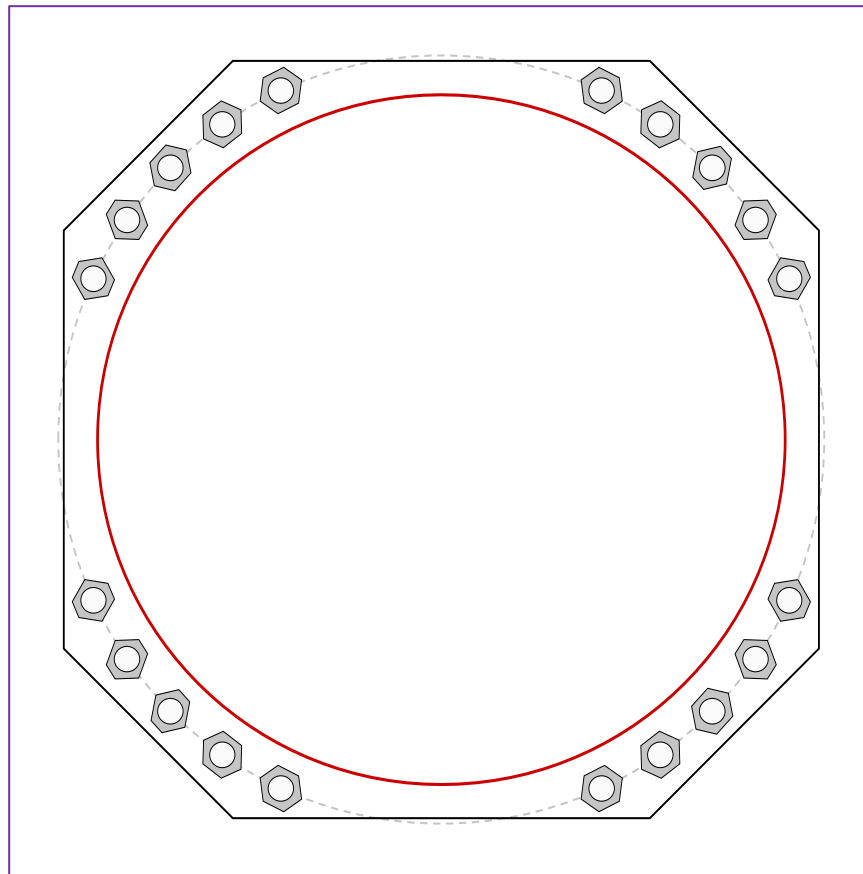

Connection Properties	Analysis Results
-----------------------	------------------

Anchor Rod Data
(20) 2-1/4" ϕ bolts (A615-75 N; $F_y=75$ ksi, $F_u=100$ ksi) on 68" BC <i>Anchor Spacing: 6 in</i>
Base Plate Data
67" W x 3" Plate (A572-55; $F_y=55$ ksi, $F_u=70$ ksi); Clip: 15 in
Stiffener Data
N/A
Pole Data
61.04" x 0.4375" 18-sided pole (A607-65; $F_y=65$ ksi, $F_u=80$ ksi)

Anchor Rod Summary			<i>(units of kips, kip-in)</i>
$P_{u_t} = 153.08$	$\phi P_{n_t} = 243.75$	Stress Rating	
$V_u = 1.69$	$\phi V_n = 149.1$	59.8%	
$M_u = n/a$	$\phi M_n = n/a$	Pass	
Base Plate Summary			
Max Stress (ksi):	25.05	(Flexural)	
Allowable Stress (ksi):	49.5		
Stress Rating:	48.2%	Pass	

Pier and Pad Foundation



BU #: 801367
Site Name: CT NHV-2075 CAC
App. Number: 654634 Rev. 0

TIA-222 Revision: H
Tower Type: Monopole

Top & Bot. Pad Rein. Different?:
Block Foundation?:
Rectangular Pad?:

Superstructure Analysis Reactions		
Compression, P_{comp} :	68.21	kips
Base Shear, Vu_{comp} :	33.76	kips
Moment, M_u :	4435.91	ft-kips
Tower Height, H :	167	ft
BP Dist. Above Fdn, bp_{dist} :	3.25	in

Foundation Analysis Checks				
	Capacity	Demand	Rating*	Check
<i>Lateral (Sliding) (kips)</i>	417.88	33.76	7.7%	Pass
<i>Bearing Pressure (ksf)</i>	12.00	2.50	20.8%	Pass
<i>Overturning (kip*ft)</i>	8402.94	4698.25	55.9%	Pass
<i>Pier Flexure (Comp.) (kip*ft)</i>	10982.87	4554.07	39.5%	Pass
<i>Pier Compression (kip)</i>	23994.73	99.88	0.4%	Pass
<i>Pad Flexure (kip*ft)</i>	8284.82	1563.74	18.0%	Pass
<i>Pad Shear - 1-way (kips)</i>	1104.67	215.50	18.6%	Pass
<i>Pad Shear - 2-way (Comp) (ksi)</i>	0.164	0.024	13.9%	Pass
<i>Flexural 2-way (Comp) (kip*ft)</i>	12679.86	2732.44	20.5%	Pass

Pier Properties		
Pier Shape:	Circular	
Pier Diameter, $dpier$:	8	ft
Ext. Above Grade, E :	0.5	ft
Pier Rebar Size, Sc :	11	
Pier Rebar Quantity, mc :	40	
Pier Tie/Spiral Size, St :	4	
Pier Tie/Spiral Quantity, mt :	12	
Pier Reinforcement Type:	Tie	
Pier Clear Cover, cc_{pier} :	3	in

*Rating per TIA-222-H Section 15.5

Structural Rating*:	39.5%
Soil Rating*:	55.9%

Pad Properties		
Depth, D :	7	ft
Pad Width, W_1 :	26	ft
Pad Thickness, T :	4	ft
Pad Rebar Size (Bottom dir. 2), Sp_2 :	10	
Pad Rebar Quantity (Bottom dir. 2), mp_2 :	35	
Pad Clear Cover, cc_{pad} :	3	in

Material Properties		
Rebar Grade, F_y :	60	ksi
Concrete Compressive Strength, F'_c :	3	ksi
Dry Concrete Density, δ_c :	150	pcf

Soil Properties		
Total Soil Unit Weight, γ :	135	pcf
Ultimate Gross Bearing, Q_{ult} :	16.000	ksf
Cohesion, C_u :	0.000	ksf
Friction Angle, ϕ :	35	degrees
SPT Blow Count, N_{blows} :	100	
Base Friction, μ :		
Neglected Depth, N :	2.00	ft
Foundation Bearing on Rock?	No	
Groundwater Depth, gw :	N/A	ft

--Toggle between Gross and Net

ASCE 7 Hazards Report

Address:
No Address at This Location

Standard: ASCE/SEI 7-16
Risk Category: II
Soil Class: D - Default (see Section 11.4.3)

Latitude: 41.536444
Longitude: -72.957306
Elevation: 627.8517315741943 ft (NAVD 88)

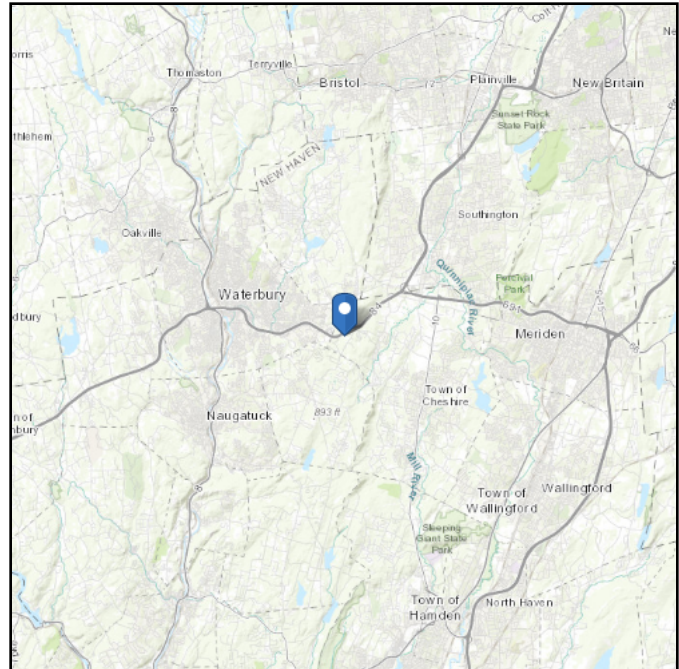
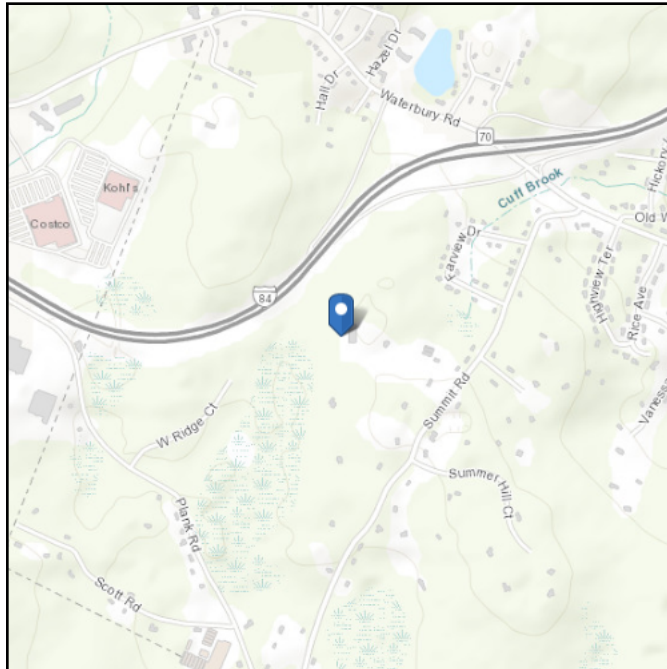

Wind

Results:

Wind Speed	118 Vmph
10-year MRI	75 Vmph
25-year MRI	84 Vmph
50-year MRI	90 Vmph
100-year MRI	97 Vmph

Data Source: ASCE/SEI 7-16, Fig. 26.5-1B and Figs. CC.2-1–CC.2-4, and Section 26.5.2
Date Accessed: Mon Jul 24 2023

Value provided is 3-second gust wind speeds at 33 ft above ground for Exposure C Category, based on linear interpolation between contours. Wind speeds are interpolated in accordance with the 7-16 Standard. Wind speeds correspond to approximately a 7% probability of exceedance in 50 years (annual exceedance probability = 0.00143, MRI = 700 years).

Site is in a hurricane-prone region as defined in ASCE/SEI 7-16 Section 26.2. Glazed openings need not be protected against wind-borne debris.

Site Soil Class:

Results:

S_s :	0.196	S_{D1} :	0.087
S_1 :	0.054	T_L :	6
F_a :	1.6	PGA :	0.108
F_v :	2.4	PGA _M :	0.172
S_{MS} :	0.314	F_{PGA} :	1.583
S_{M1} :	0.131	I_e :	1
S_{DS} :	0.209	C_v :	0.7

Seismic Design Category: B

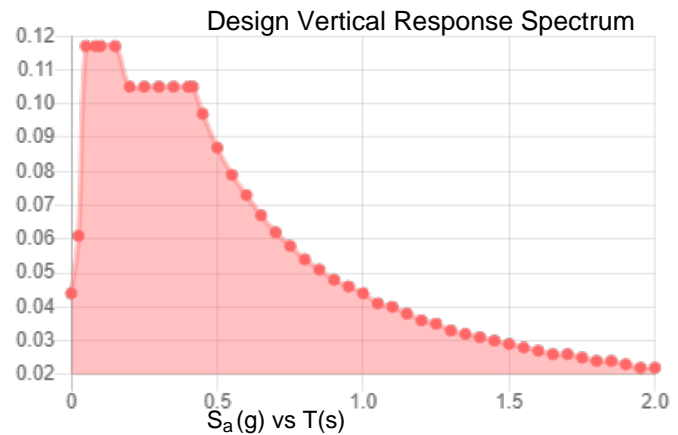
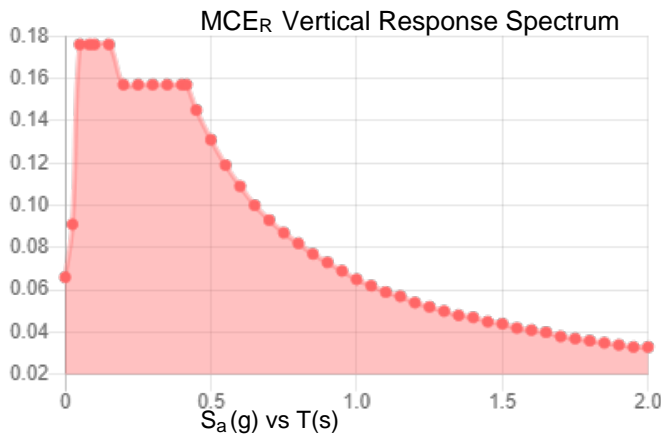
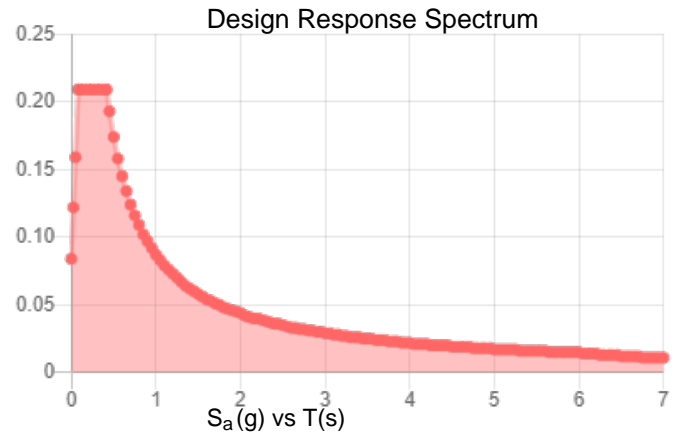
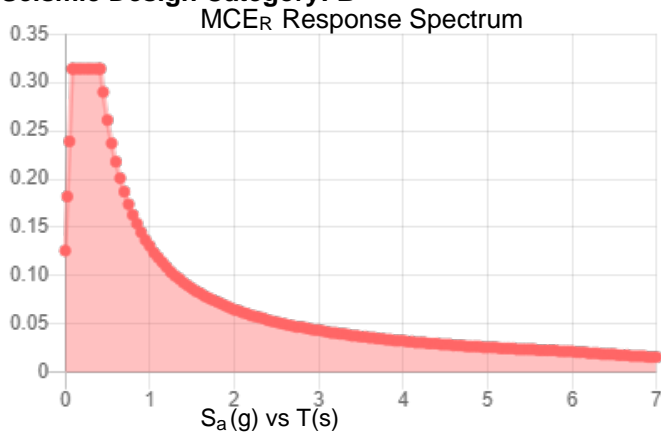

Data Accessed:

Mon Jul 24 2023

Date Source:

USGS Seismic Design Maps based on ASCE/SEI 7-16 and ASCE/SEI 7-16 Table 1.5-2. Additional data for site-specific ground motion procedures in accordance with ASCE/SEI 7-16 Ch. 21 are available from USGS.

Ice

Results:

Ice Thickness: 1.00 in.
Concurrent Temperature: 15 F
Gust Speed 50 mph

Data Source: Standard ASCE/SEI 7-16, Figs. 10-2 through 10-8

Date Accessed: Mon Jul 24 2023

Ice thicknesses on structures in exposed locations at elevations higher than the surrounding terrain and in valleys and gorges may exceed the mapped values.

Values provided are equivalent radial ice thicknesses due to freezing rain with concurrent 3-second gust speeds, for a 500-year mean recurrence interval, and temperatures concurrent with ice thicknesses due to freezing rain. Thicknesses for ice accretions caused by other sources shall be obtained from local meteorological studies. Ice thicknesses in exposed locations at elevations higher than the surrounding terrain and in valleys and gorges may exceed the mapped values.

The ASCE 7 Hazard Tool is provided for your convenience, for informational purposes only, and is provided “as is” and without warranties of any kind. The location data included herein has been obtained from information developed, produced, and maintained by third party providers; or has been extrapolated from maps incorporated in the ASCE 7 standard. While ASCE has made every effort to use data obtained from reliable sources or methodologies, ASCE does not make any representations or warranties as to the accuracy, completeness, reliability, currency, or quality of any data provided herein. Any third-party links provided by this Tool should not be construed as an endorsement, affiliation, relationship, or sponsorship of such third-party content by or from ASCE.

ASCE does not intend, nor should anyone interpret, the results provided by this Tool to replace the sound judgment of a competent professional, having knowledge and experience in the appropriate field(s) of practice, nor to substitute for the standard of care required of such professionals in interpreting and applying the contents of this Tool or the ASCE 7 standard.

In using this Tool, you expressly assume all risks associated with your use. Under no circumstances shall ASCE or its officers, directors, employees, members, affiliates, or agents be liable to you or any other person for any direct, indirect, special, incidental, or consequential damages arising from or related to your use of, or reliance on, the Tool or any information obtained therein. To the fullest extent permitted by law, you agree to release and hold harmless ASCE from any and all liability of any nature arising out of or resulting from any use of data provided by the ASCE 7 Hazard Tool.