

PROJECT NARRATIVE

October 28, 2021

Melanie A. Bachman
Executive Director
Connecticut Siting Council
10 Franklin Square
New Britain, CT 06051

Re: Request of DISH Wireless LLC for an Order to Approve the Shared Use of an Existing Tower
87 Monce Road, Burlington, CT 06013
Latitude: 41°44'20.89" /Longitude: -72°54'28.06"

Dear Ms. Bachman:

Pursuant to Connecticut General Statutes ("C.G.S.") §16-50aa, as amended, DISH Wireless LLC ("DISH") hereby requests an order from the Connecticut Siting Council ("Council") to approve the shared use by DISH of an existing telecommunication tower at 87 Monce Road in Burlington (the "Property"). The existing 119-foot monopole tower is owned by American Tower Corporation ("ATC"). The underlying property is owned by Insite Towers Devt LLC. DISH requests that the Council find that the proposed shared use of the ATC tower satisfies the criteria of C.G.S. §16-50aa and issue an order approving the proposed shared use. A copy of this filing is being sent to Theodore Shafer, First Selectman for the Town of Burlington, Larry Farrell, Town of Burlington Building Official, and Insite Towers Devt LLC as the property owner.

Background

The existing ATC facility consists of a 119-foot monopole tower located within an existing leased area. Public Safety currently maintains antennas at the 129-foot and 123.7-foot levels. AT&T Mobility currently maintains antennas at the 110-foot and 3-foot level. T-Mobile currently maintains antennas at the 100-foot level. Verizon Wireless currently maintains antennas at the 91.2-foot level. Equipment associated with these antennas are located at various positions within the tower and compound.

DISH is licensed by the Federal Communications Commission ("FCC") to provide wireless services throughout the State of Connecticut. DISH and ATC have agreed to the proposed shared use of the 87 Monce Road tower pursuant to mutually acceptable terms and conditions. Likewise, DISH and ATC have agreed to the proposed installation of equipment cabinets within the existing compound. ATC has authorized DISH to apply for all necessary permits and approvals that may be required to share the existing tower.
(See attached Letter of Authorization)

DISH proposes to install three (3) antennas, (1) Tower platform mount, (6) Remote radio units at the 70-foot level along with (1) over voltage protection device (OVP) and (1) Hybrid cable. DISH will install an equipment cabinet on a 5'x7' equipment platform. DISH's Construction Drawings provide project specifications for all proposed site improvement locations.

The construction drawings also include specifications for DISH's proposed antenna and groundwork.

C.G.S. § 16-50aa(c)(1) provides that, upon written request for approval of a proposed shared use, "if the Council finds that the proposed shared use of the facility is technically, legally, environmentally and economically feasible and meets public safety concerns, the council shall issue an order approving such a shared use." DISH respectfully submits that the shared use of the tower satisfies these criteria.

A. Technical Feasibility. The existing ATC tower is structurally capable of supporting DISH's proposed improvements. The proposed shared use of this tower is, therefore, technically feasible. A Feasibility Structural Analysis Report ("Structural Report") prepared for this project confirms that this tower can support DISH's proposed loading. A copy of the Structural Report has been included in this application.

B. Legal Feasibility. Under C.G.S. § 16-50aa, the Council has been authorized to issue order approving the shared use of an existing tower such as the ATC tower. This authority complements the Council's prior-existing authority under C.G.S. § 16-50p to issue orders approving the construction of new towers that are subject to the Council's jurisdiction. In addition, § 16-50x(a) directs the Council to "give such consideration to the other state laws and municipal regulations as it shall deem appropriate" in ruling on requests for the shared use of existing tower facilities. Under the statutory authority vested in the Council, an order by the Council approving the requested shared use would permit the Applicant to obtain a building permit for the proposed installations.

C. Environmental Feasibility. The proposed shared use of the ATC tower would have a minimal environmental effect for the following reasons:

1. The proposed installation will have no visual impact on the area of the tower. DISH's equipment cabinet would be installed within the existing facility compound. DISH's shared use of this tower therefore will not cause any significant change or alteration in the physical or environmental characteristics of the existing site.
2. Operation of DISH's antennas at this site would not exceed the RF emissions standard adopted by the Federal Communications Commission ("FCC"). Included in the EME report of this filing are the approximation tables that demonstrate that DISH's proposed facility will operate well within the FCC RF emissions safety standards.
3. Under ordinary operating conditions, the proposed installation would not require the use of any water or sanitary facilities and would not generate air emissions or discharges to water bodies or sanitary facilities. After construction is complete the proposed installations would not generate any increased traffic to the ATC facility other than periodic maintenance. The proposed shared use of the ATC tower, would, therefore, have a minimal environmental effect, and is environmentally feasible.

D. **Economic Feasibility.** As previously mentioned, DISH has entered into an agreement with ATC for the shared use of the existing facility subject to mutually agreeable terms. The proposed tower sharing is, therefore, economically feasible.

E. **Public Safety Concerns.** As discussed above, the tower is structurally capable of supporting DISH's full array of three (3) antennas, (1) Tower platform mount, (6) Remote radio units, (1) over voltage protection device (OVP) and (1) Hybrid cable and all related equipment. DISH is not aware of any public safety concerns relative to the proposed sharing of the existing ATC tower.

Conclusion

For the reasons discussed above, the proposed shared use of the existing ATC tower at 87 Monce Road satisfies the criteria stated in C.G.S. §16-50aa and advances the Council's goal of preventing the unnecessary proliferation of towers in Connecticut. The Applicant, therefore, respectfully requests that the Council issue an order approving the proposed shared use.

Sincerely,

David Hoogasian

David Hoogasian
Project Manager

LETTER OF AUTHORIZATION



AMERICAN TOWER®
CORPORATION

LETTER OF AUTHORIZATION
LICENSEE: DISH WIRELESS L.L.C.

I, Margaret Robinson, Senior Counsel for American Tower*, owner/operator of the tower facility located at the address identified above (the "Tower Facility"), do hereby authorize DISH WIRELESS L.L.C., its successors and assigns, and/or its agent, (collectively, the "Licensee") to act as American Tower's non-exclusive agent for the sole purpose of filing and consummating any land-use or building permit application(s) as may be required by the applicable permitting authorities for Licensee's telecommunications' installation.

We understand that this application may be denied, modified or approved with conditions. The above authorization is limited to the acceptance by Licensee only of conditions related to Licensee's installation and any such conditions of approval or modifications will be Licensee's sole responsibility.

*American Tower includes all affiliates and subsidiaries of American Tower Corporation.

Project #	ATC Site #	ATC Site Name	ATC Site Address
13688133	208450	Enfield	1A Ecology Drive, Enfield CT
13700322	209115	Ridgefield 2	320 Old Stagecoach Road, Ridgefield, CT
13688136	209185	Burlington 2	87 Monce Road, Burlington CT
13700320	209271	Brookfield 2	100 Pocono Road, Brookfield CT
13693702	243036	WEST HAVEN & RT 162 CT	668 Jones Hill Road, West Haven CT
13693677	280501	ROXBURY CT	377 Southbury Road, Roxbury CT
13685406	281416	WILLINGTON CT	196 Tolland Turnpike, Willington CT
13709418	281862	BRIDGEWATER CT	111 SECOND HILL RD, Bridgewater CT
13693659	283418	NORTH HAVEN CT	50 Devine Street, North Haven CT
13694329	283419	PINE ORCHARD BRANFORD CT	123 Pine Orchard Road, Branford CT
13694332	283422	SHORT BEACH BRANFORD CT	171 Short Beach Road, Branford CT
13698427	283423	NAUGATUCK CT	880 Andrew Mountain Road, Naugatuck CT
13685464	283563	MANSFIELD CT	343 Daleville Road, Willington CT
13692735	284983	OLD LYME CT	61-1 Buttonball Road, Old Lyme CT
13693120	284984	PAWCATUCK CT	166 Pawcatuck Ave, Pawcatuck CT
13693144	284988	GUILFORD CT	Moose Hill Road, Guilford CT
13694582	302465	Colchester CT 6	355 Route 85, Colchester CT
13683501	302468	Petro Lock	99 Meadow St, Hartford CT
13685427	302469	Bridgeport CT 2	1069 Connecticut Avenue, Bridgeport CT
13683503	302472	Andover-bunker Hill Road	104 Bunker Hill Road, Andover CT
13683507	302473	E H F R - Prestige Park	310 Prestige Park Road, East Hartford CT



AMERICAN TOWER®
CORPORATION

Project #	ATC Site #	ATC Site Name	ATC Site Address
13683510	302474	South Windsor	391 Niederwerfer Road, South Windsor CT
13683513	302483	Brln - Berlin	286 Beckley Road, Berlin CT
13692185	302488	Cntn - Canton	4 Hoffmann Road, Canton CT
13692173	302495	Tolland CT	56 Ruops Road, Tolland CT
13694579	302496	Clch - Colchester	Chestnut Hill Road, Colchester CT
13701212	302501	Plymouth CT 3	297 North Street, Plymouth CT
13685414	302515	SMFR - North	5 High Ridge Park Road, Stamford CT
13702496	302516	Mlfd - Milford	438 Bridgeport Ave, Milford CT
13688395	302518	Newtown CT 3	25 Meridian Ridge Drive, Newton CT
13692174	302529	Vernon CT 6	777 Talcotville Road, Vernon Rockville CT
13693124	311014	NORWICH CT	202 N Wawecus Hill Rd, Norwich CT
13702522	311305	GLFD-GUILFORD REBUILD CT	10 Tanner Marsh Road, Guilford CT
13693127	370623	MONTVILLE CT	139 Sharp Hill Road, Uncasville CT
13681964	370625	Old Saybrook	77 Springbrook Road, Old Saybrook CT
13702535	383660	North Madison Volunteer FD	864 Opening Hill Road, Madison CT
13702538	411180	Good Hill CT	481 GOOD HILL ROAD, Woodbury CT
13693709	411182	Nepaug CT	20 Antolini Road, New Hartford CT
13693131	411183	WATERFORD CT	53 Dayton Rd., Waterford CT
13693135	411184	SALEM CT SQA	399 West Road, Salem CT
13692177	411186	West Granby, CT CT	207 West Granby Road, Granby CT
13692178	411187	Hartford North 2 CT	811 Blue Hills Avenue, Bloomfield CT
13693705	411188	Southbury CT	111 Upper Fishrock Road, Southbury CT
13692179	411256	CANTON CT	14 CANTON SPRINGS ROAD, Canton CT
13681988	411257	Middle Haddam Road-CROWN CT	191 Middle Haddam Rd, Portland CT
13692180	411258	Farmington North 2 CT	199 Town Farm Road, Farmington CT
13692182	411259	CT Collinsville CAC 802816 CT	650 Albany Turnpike, Collinsville CT
13692184	416862	SUFFIELD SW CT CT	106 South Grand St., West Suffield CT
13694578	6260	NORTH STONINGTON CT	118C Wintechog Hill Rd., off of Rt. 2, North Stonington CT
13681397	88013	Killingworth	131 Little City Road, Killingworth CT

Signature:

Print Name: Margaret Robinson
Senior Counsel
American Tower*



AMERICAN TOWER®
CORPORATION

**LETTER OF AUTHORIZATION
LICENSEE: DISH WIRELESS L.L.C.**

NOTARY BLOCK

Commonwealth of MASSACHUSETTS
County of Middlesex

This instrument was acknowledged before me by Margaret Robinson, Senior Counsel for American Tower*, personally known to me (or proved to me on the basis of satisfactory evidence) to be the person whose name is subscribed to the within instrument and acknowledged to me that he executed the same.

WITNESS my hand and official seal, this 10th day of September 2021.

NOTARY SEAL

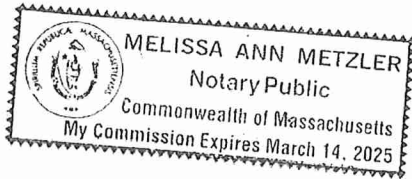

Notary Public 
My Commission Expires: March 14, 2025

ENGINEERING DRAWINGS



DISH Wireless L.L.C. SITE ID:

BOBDL00109A

DISH Wireless L.L.C. SITE ADDRESS:

**87 MONCE RD.
BURLINGTON, CT 06013**

SCOPE OF WORK	
THIS IS NOT AN ALL INCLUSIVE LIST. CONTRACTOR SHALL UTILIZE SPECIFIED EQUIPMENT PART OR ENGINEER APPROVED EQUIVALENT. CONTRACTOR SHALL VERIFY ALL NEEDED EQUIPMENT TO PROVIDE A FUNCTIONAL SITE. THE PROJECT GENERALLY CONSISTS OF THE FOLLOWING:	
TOWER SCOPE OF WORK:	
<ul style="list-style-type: none"> • INSTALL (3) PROPOSED PANEL ANTENNAS (1 PER SECTOR) • INSTALL (1) PROPOSED TOWER PLATFORM MOUNT • INSTALL PROPOSED JUMPERS • INSTALL (6) PROPOSED RRUs (2 PER SECTOR) • INSTALL (1) PROPOSED OVER VOLTAGE PROTECTION DEVICE (OVP) • INSTALL (1) PROPOSED HYBRID CABLE 	
GROUND SCOPE OF WORK:	
<ul style="list-style-type: none"> • INSTALL (1) PROPOSED METAL PLATFORM • INSTALL (1) PROPOSED ICE BRIDGE • INSTALL (1) PROPOSED PPC CABINET • INSTALL (1) PROPOSED EQUIPMENT CABINET • INSTALL (1) PROPOSED POWER CONDUIT • INSTALL (1) PROPOSED TELCO CONDUIT • INSTALL (1) PROPOSED TELCO-FIBER BOX • INSTALL (1) PROPOSED GPS UNIT • INSTALL (1) PROPOSED FIBER NID (IF REQUIRED) 	

SITE INFORMATION	PROJECT DIRECTORY
PROPERTY OWNER: INSITE TOWERS DEVT LLC ADDRESS: CO RYAN PTS DEPT 607 HOUSTON, TX 77056	APPLICANT: DISH Wireless L.L.C. 5701 SOUTH SANTA FE DRIVE LITTLETON, CO 80120
TOWER TYPE: MONOPOLE	TOWER OWNER: AMERICAN TOWER CORPORATION 10 PRESIDENTIAL WAY WOBURN, MA 01801 (781) 926-4500
TOWER CO SITE ID: 209185	SITE DESIGNER: B+T GROUP 1717 S. BOULDER AVE, SUITE 300 TULSA, OK 74119 (918) 587-4630
TOWER APP NUMBER: 13688136	SITE ACQUISITION: APRIL PARROTT APRIL.PARROTT@DISH.COM
COUNTY: HARTFORD	CONSTRUCTION MANAGER: JAVIER SOTO JAVIER.SOTO@DISH.COM
LATITUDE (NAD 83): 41° 44' 20.89" N 41.73913611 N	RF ENGINEER: BOSSENER CHARLES BOSSENER.CHARLES@DISH.COM
LONGITUDE (NAD 83): 72° 54' 28.06" W 72.90779444 W	
ZONING JURISDICTION: TOWN OF BURLINGTON	
ZONING DISTRICT: R44	
PARCEL NUMBER: 11-06-33	
OCCUPANCY GROUP: U	
CONSTRUCTION TYPE: V-B	
POWER COMPANY: CONNECTICUT LIGHT & POWER CO	
TELEPHONE COMPANY: XFINITY	



5701 SOUTH SANTA FE DRIVE
LITTLETON, CO 80120



B&T ENGINEERING, INC.
PEC.0001564
Expires 2/10/22

IT IS A VIOLATION OF LAW FOR ANY PERSON, UNLESS THEY ARE ACTING UNDER THE DIRECTION OF A LICENSED PROFESSIONAL ENGINEER, TO ALTER THIS DOCUMENT.

DRAWN BY: BLJ
CHECKED BY: BLJ
APPROVED BY: MP

RFDS REV #: ---

CONSTRUCTION DOCUMENTS

SUBMITTALS		
REV	DATE	DESCRIPTION
A	7/16/21	ISSUED FOR REVIEW
0	8/2/21	ISSUED FOR CONSTRUCTION

A&E PROJECT NUMBER
152988.001.01

DISH Wireless L.L.C.
PROJECT INFORMATION
BOBDL00109A
87 MONCE RD.
BURLINGTON, CT 06013

SHEET TITLE
TITLE SHEET

SHEET NUMBER
T-1

CONNECTICUT CODE COMPLIANCE

ALL WORK SHALL BE PERFORMED AND MATERIALS INSTALLED IN ACCORDANCE WITH THE CURRENT EDITIONS OF THE FOLLOWING CODES AS ADOPTED BY THE LOCAL GOVERNING AUTHORITIES. NOTHING IN THESE PLANS IS TO BE CONSTRUED TO PERMIT WORK NOT CONFORMING TO THESE CODES:

CODE TYPE	CODE
BUILDING	2018 CT STATE BUILDING CODE/2015 IBC W/ CT AMENDMENTS
MECHANICAL	2018 CT STATE BUILDING CODE/2015 IMC W/ CT AMENDMENTS
ELECTRICAL	2018 CT STATE BUILDING CODE/2017 NEC W/ CT AMENDMENTS

SITE PHOTO

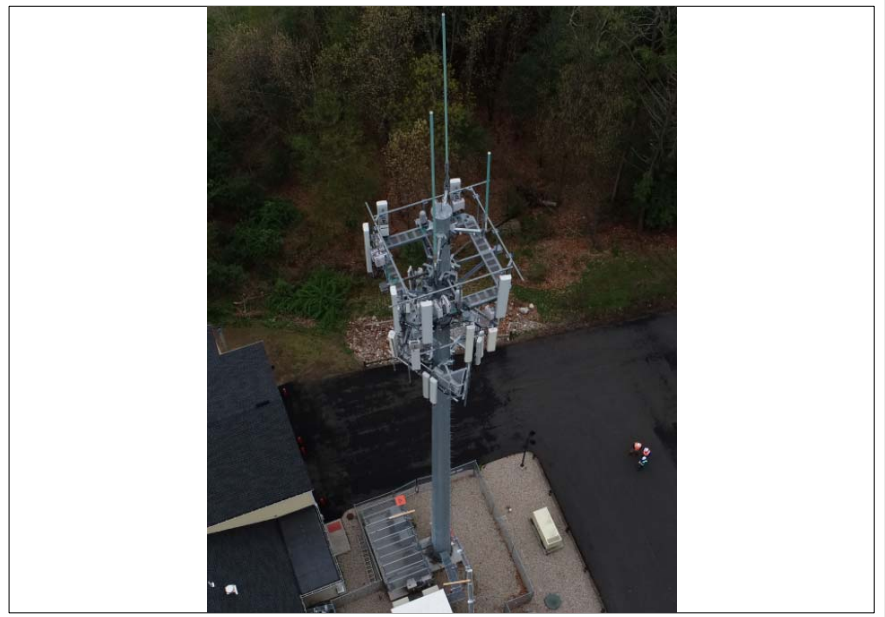

DIRECTIONS

DIRECTIONS FROM BRADLEY INTERNATIONAL AIRPORT:
DEPART BRADLEY INTERNATIONAL AIRPORT ON TERMINAL RD. ROAD NAME CHANGES TO BRADLEY FIELD CONNECTOR. TAKE RAMP (RIGHT) ONTO I-91 [RICHARD P HORAN MEMORIAL HWY]. AT EXIT 32A-32B, TURN RIGHT ONTO RAMP. TAKE RAMP (LEFT) ONTO I-84 [US-6]. AT EXIT 38, TURN RIGHT ONTO RAMP. ROAD NAME CHANGES TO US-6 [COLT HWY]. TURN RIGHT ONTO CT-177 [PLAINVILLE AVE]. TURN LEFT ONTO COPPER MINE RD [COPPERMINE RD]. ROAD NAME CHANGES TO STAFFORD RD. TURN RIGHT ONTO MONCE RD. TURN LEFT ONTO ACCESS ROAD. ARRIVE AT BOBDL00109A.

VICINITY MAP



UNDERGROUND SERVICE ALERT CBYD 811
UTILITY NOTIFICATION CENTER OF CONNECTICUT
(800) 922-4455
WWW.CBYD.COM
CALL 2 WORKING DAYS UTILITY NOTIFICATION PRIOR TO CONSTRUCTION

GENERAL NOTES

THE FACILITY IS UNMANNED AND NOT FOR HUMAN HABITATION. A TECHNICIAN WILL VISIT THE SITE AS REQUIRED FOR ROUTINE MAINTENANCE. THE PROJECT WILL NOT RESULT IN ANY SIGNIFICANT DISTURBANCE OR EFFECT ON DRAINAGE, NO SANITARY SEWER SERVICE, POTABLE WATER, OR TRASH DISPOSAL IS REQUIRED AND NO COMMERCIAL SIGNAGE IS PROPOSED.

11"x17" PLOT WILL BE HALF SCALE UNLESS OTHERWISE NOTED

CONTRACTOR SHALL VERIFY ALL PLANS, EXISTING DIMENSIONS, AND CONDITIONS ON THE JOB SITE, AND SHALL IMMEDIATELY NOTIFY THE ENGINEER IN WRITING OF ANY DISCREPANCIES BEFORE PROCEEDING WITH THE WORK.

NOTES

1. CONTRACTOR SHALL FIELD VERIFY ALL DIMENSIONS.
2. ANTENNA AND MW DISH SPECIFICATIONS REFER TO ANTENNA SCHEDULE AND TO FINAL CONSTRUCTION RFDS FOR ALL RF DETAILS
3. EXISTING EQUIPMENT AND FENCE OMITTED FOR CLARITY.

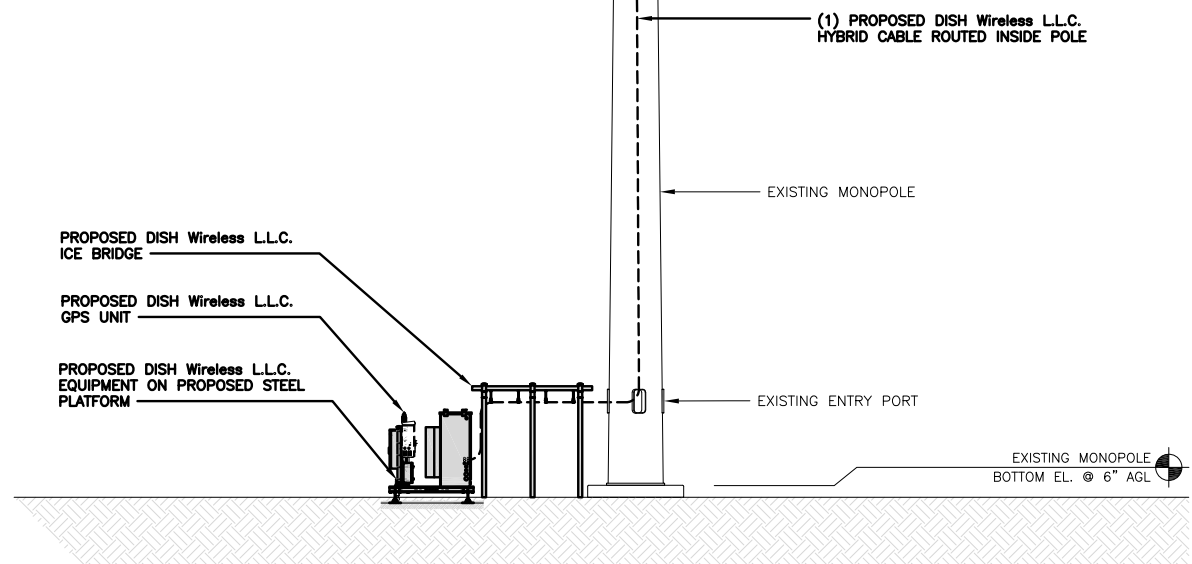
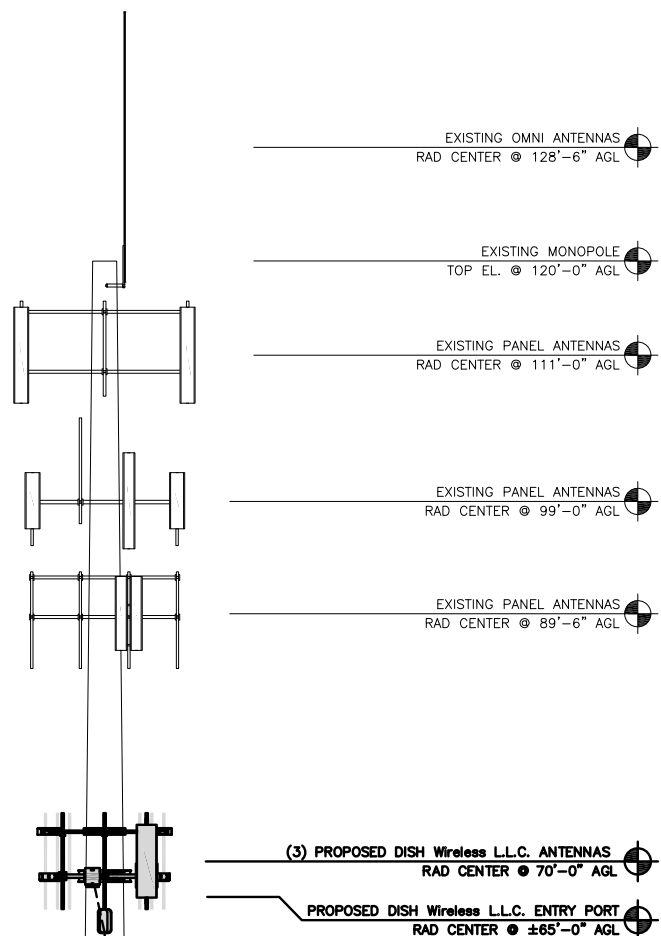

PROPOSED WEST ELEVATION

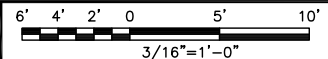

1

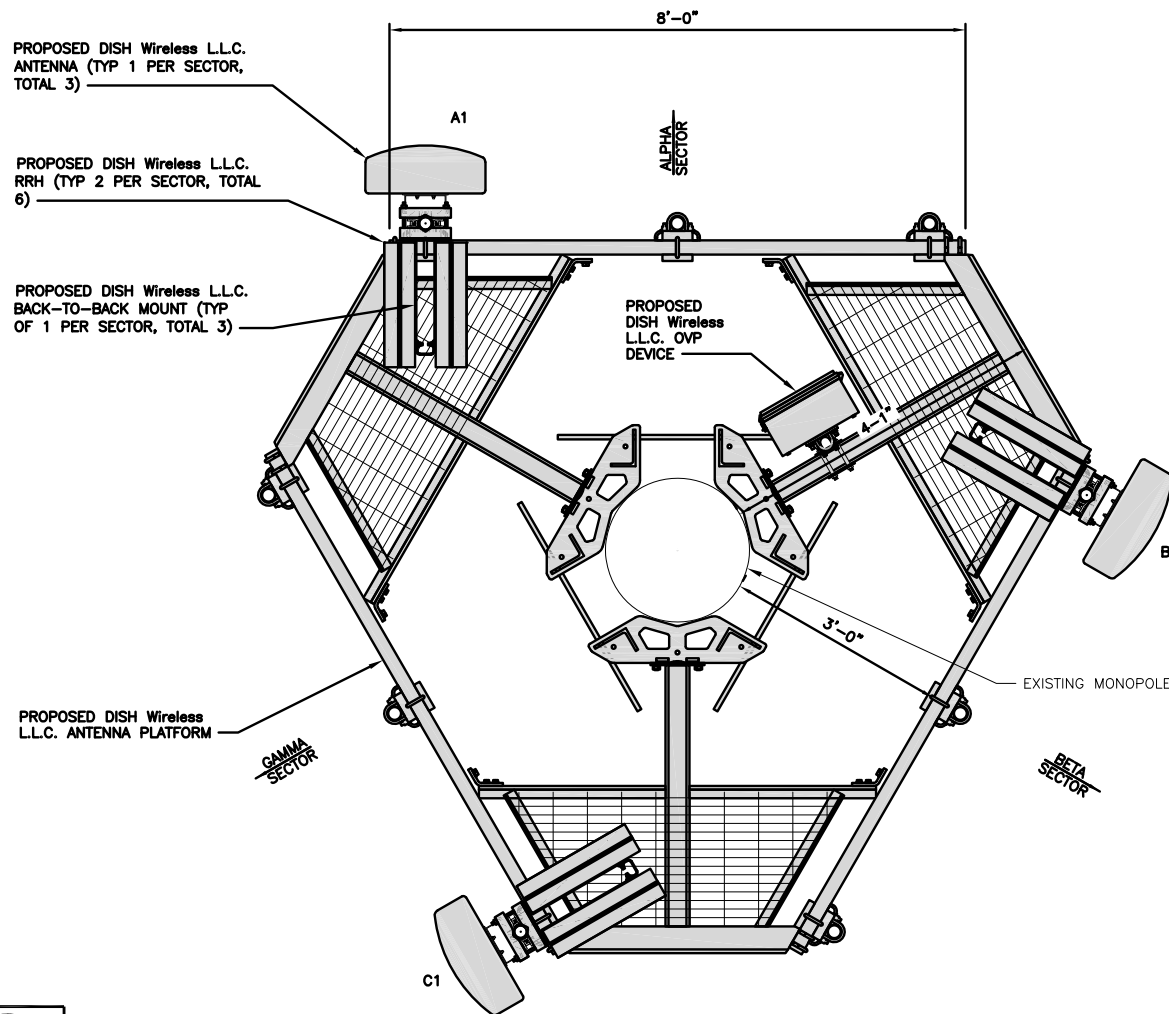

ANTENNA LAYOUT

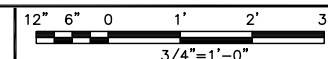

2

SECTOR	POSITION	ANTENNA						TRANSMISSION CABLE
		EXISTING OR PROPOSED	MANUFACTURER - MODEL NUMBER	TECHNOLOGY	SIZE (HxW)	AZIMUTH	RAD CENTER	FEED LINE TYPE AND LENGTH
ALPHA	A1	PROPOSED	JMA WIRELESS-MX08FRO665-21	5G	72.0" x 20.0"	0°	70'-0"	(1) HIGH-CAPACITY HYBRID CABLE (105' LONG)
BETA	B1	PROPOSED	JMA WIRELESS-MX08FRO665-21	5G	72.0" x 20.0"	120°	70'-0"	
GAMMA	C1	PROPOSED	JMA WIRELESS-MX08FRO665-21	5G	72.0" x 20.0"	240°	70'-0"	

SECTOR	POSITION	RRH		NOTES
		MANUFACTURER - MODEL NUMBER	TECHNOLOGY	
ALPHA	A1	FUJITSU-TA08025-B604	5G	1. CONTRACTOR TO REFER TO FINAL CONSTRUCTION RFDS FOR ALL RF DETAILS. 2. ANTENNA AND RRH MODELS MAY CHANGE DUE TO EQUIPMENT AVAILABILITY. ALL EQUIPMENT CHANGES MUST BE APPROVED AND REMAIN IN COMPLIANCE WITH THE PROPOSED DESIGN AND STRUCTURAL ANALYSES.
	A1	FUJITSU-TA08025-B605	5G	
BETA	B1	FUJITSU-TA08025-B604	5G	
	B1	FUJITSU-TA08025-B605	5G	
GAMMA	C1	FUJITSU-TA08025-B604	5G	
	C1	FUJITSU-TA08025-B605	5G	

ANTENNA SCHEDULE

NO SCALE

3



5701 SOUTH SANTA FE DRIVE
LITTLETON, CO 80120



B&T ENGINEERING, INC.
PEC.0001564
Expires 2/10/22

IT IS A VIOLATION OF LAW FOR ANY PERSON, UNLESS THEY ARE ACTING UNDER THE DIRECTION OF A LICENSED PROFESSIONAL ENGINEER, TO ALTER THIS DOCUMENT.

DRAWN BY: BLJ
CHECKED BY: BLJ
APPROVED BY: MP

RFDS REV #: ---

CONSTRUCTION DOCUMENTS

SUBMITTALS		
REV	DATE	DESCRIPTION
A	7/16/21	ISSUED FOR REVIEW
0	8/2/21	ISSUED FOR CONSTRUCTION

A&E PROJECT NUMBER
152988.001.01

DISH Wireless L.L.C. PROJECT INFORMATION
BOBDL00109A
87 MONCE RD.
BURLINGTON, CT 06013

SHEET TITLE
ELEVATION, ANTENNA LAYOUT AND SCHEDULE

SHEET NUMBER
A-2



5701 SOUTH SANTA FE DRIVE
LITTLETON, CO 80120



B&T ENGINEERING, INC.
PEC.0001564
Expires 2/10/22

IT IS A VIOLATION OF LAW FOR ANY PERSON, UNLESS THEY ARE ACTING UNDER THE DIRECTION OF A LICENSED PROFESSIONAL ENGINEER, TO ALTER THIS DOCUMENT.

DRAWN BY: BLJ CHECKED BY: BLJ APPROVED BY: MP

RFDS REV #: ---

CONSTRUCTION DOCUMENTS

SUBMITTALS		
REV	DATE	DESCRIPTION
A	7/16/21	ISSUED FOR REVIEW
0	8/2/21	ISSUED FOR CONSTRUCTION

A&E PROJECT NUMBER
152988.001.01

DISH Wireless L.L.C.
PROJECT INFORMATION
BOBDL00109A
87 MONCE RD.
BURLINGTON, CT 06013

SHEET TITLE
EQUIPMENT PLATFORM AND
H-FRAME DETAILS

SHEET NUMBER
A-3

NOTES

- CONTRACTOR TO BURY PLATFORM FEET WITH A MINIMUM OF 2" OF FILL PER EXISTING SITE SURFACE
- WEED BARRIER FABRIC TO BE ADDED AT DISCRETION OF DISH Wireless L.L.C. CONSTRUCTION MANAGER AT TIME OF CONSTRUCTION. ONE SHEET 8'x8' INSTALLED UNDER ALL FOUR FEET OF THE PLATFORM (4 MIL BLACK PLASTIC)
- EQUIPMENT CABINET OMITTED FOR CLARITY

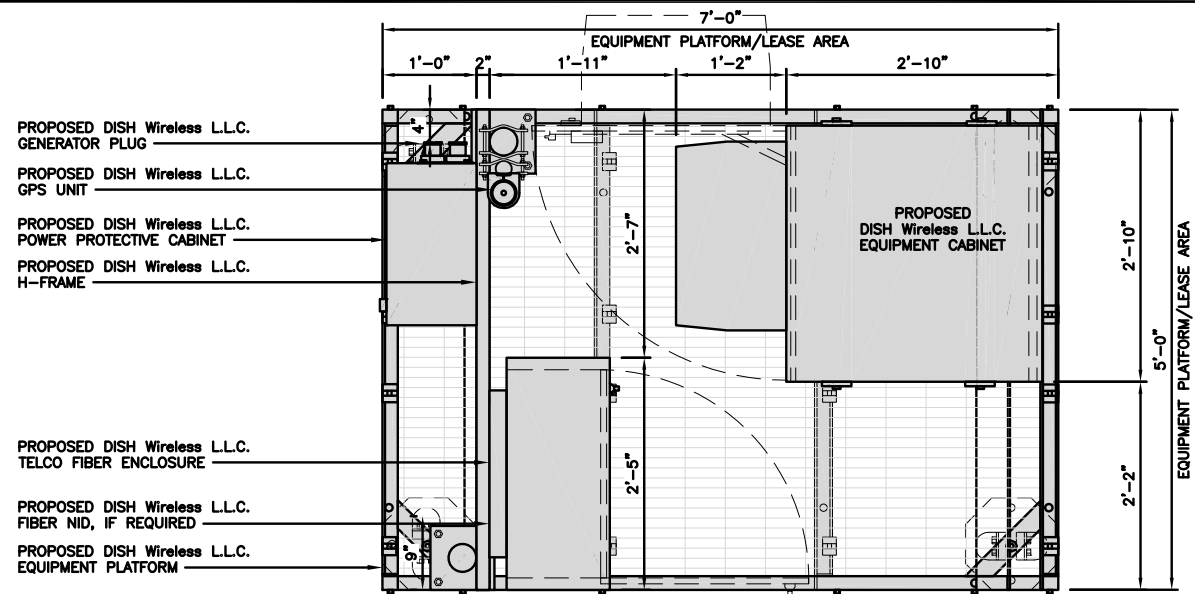

PLATFORM EQUIPMENT PLAN

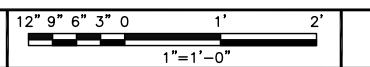

**COMMSCOPE MTC4045LP
5X7 PLATFORM**

DIMENSIONS (HxWxD)	16"x84"x60"
TOTAL WEIGHT	423 LBS

NOTE:
GC TO PROVIDE EXTENDED
THREAD FOR PLATFORM IF
REQUIRED HEIGHT EXCEEDS 17"

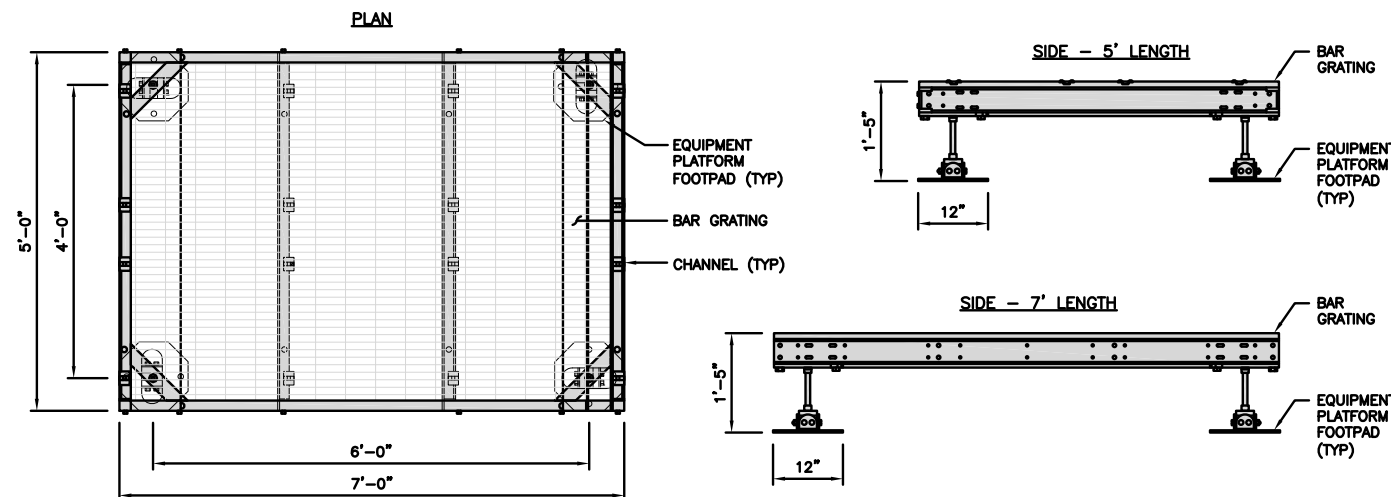

PLATFORM DETAIL

NO SCALE 2

**COMMSCOPE MTC4045HFLD
H-FRAME**

UNISTRUT/SUPPORT RAILS QTY	5
WEIGHT	59.74 lbs

NOTE:
OR DISH Wireless L.L.C.
APPROVED EQUIVALENT

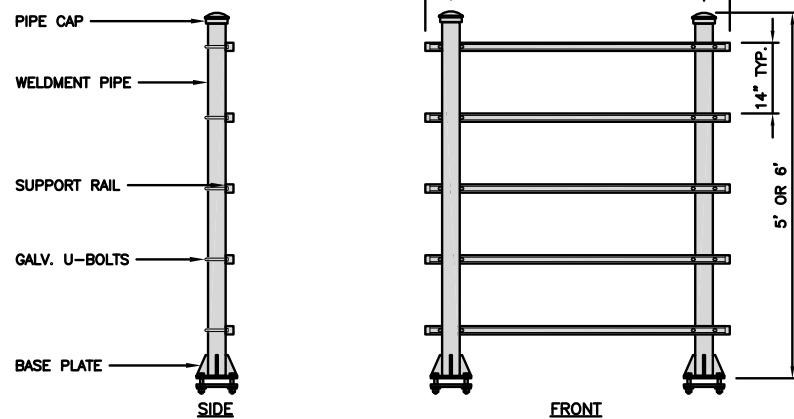

H-FRAME DETAIL

NO SCALE 3

NOT USED

NO SCALE 4

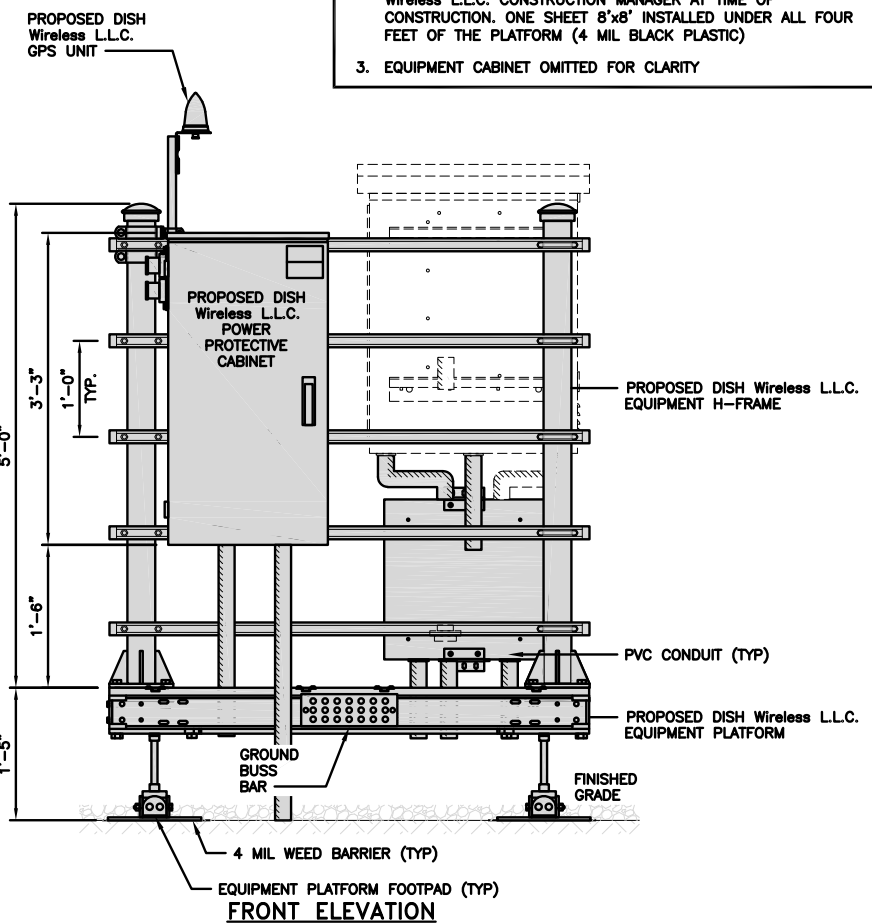

FRONT ELEVATION

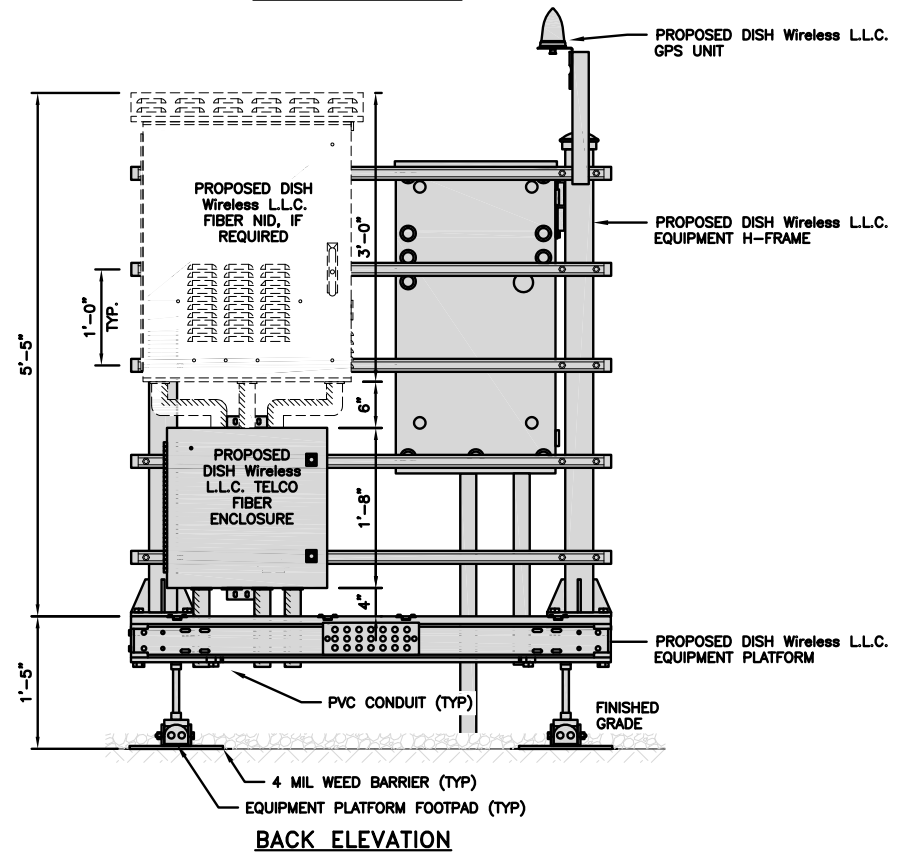

BACK ELEVATION

H-FRAME EQUIPMENT ELEVATION

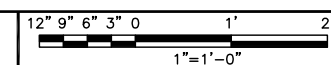

5

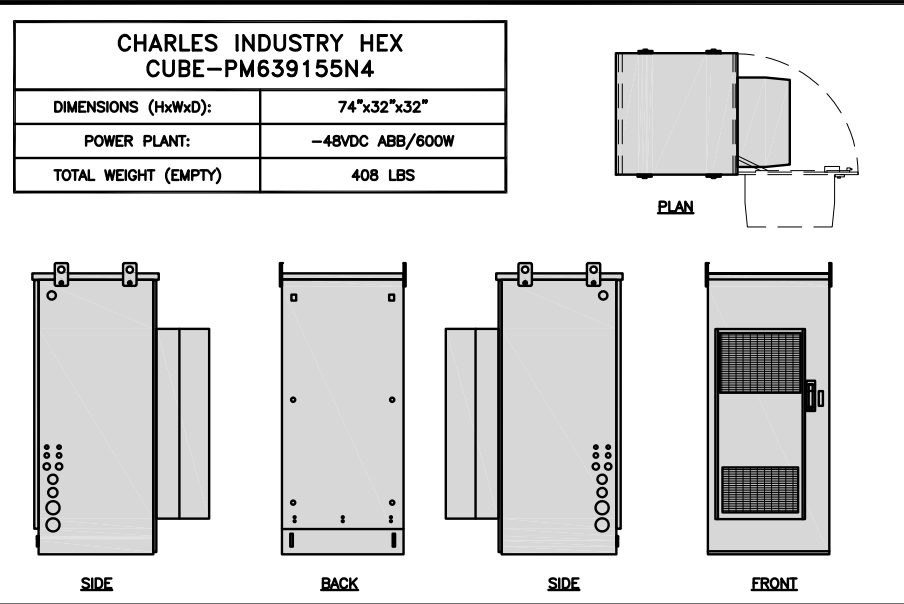

CABINET DETAIL NO SCALE 1

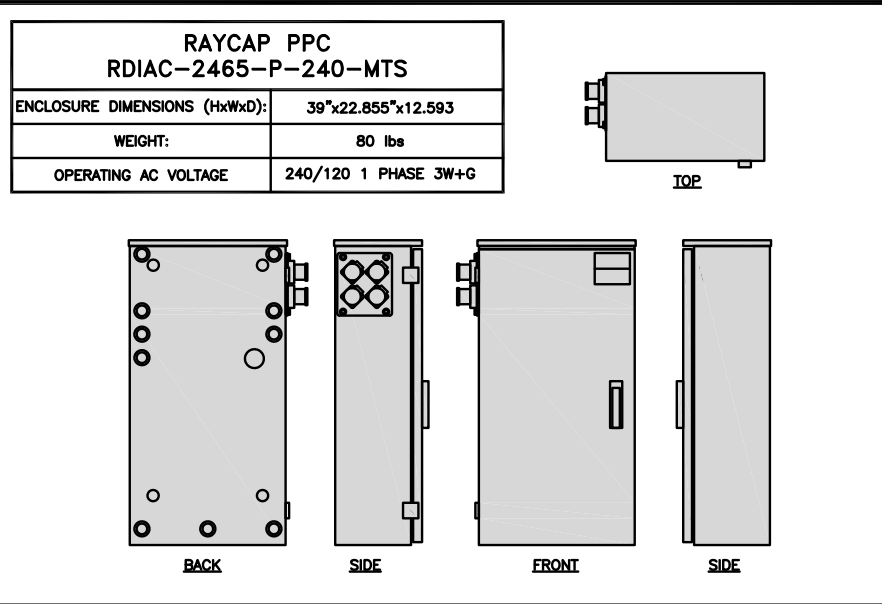

POWER PROTECTION CABINET (PPC) DETAIL NO SCALE 2

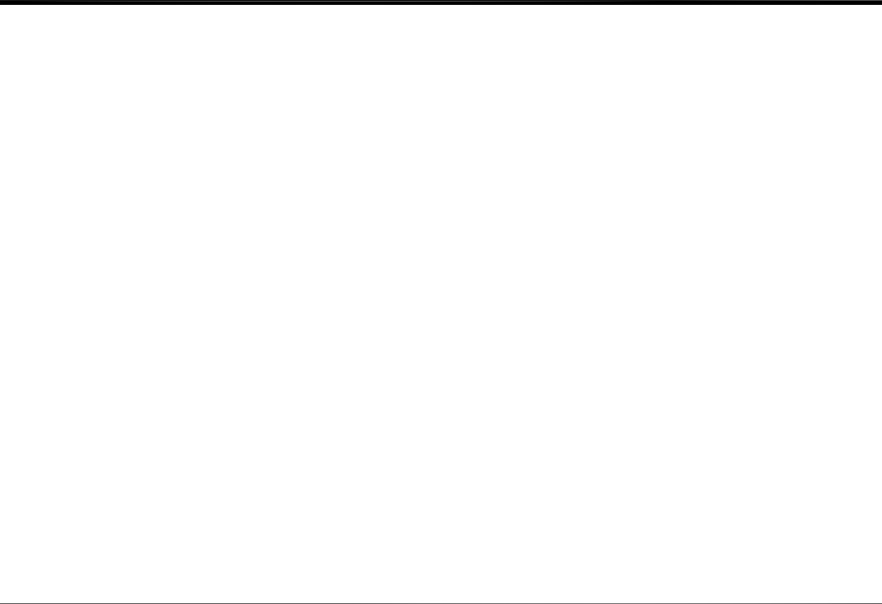

NO SCALE 3



NO SCALE 4

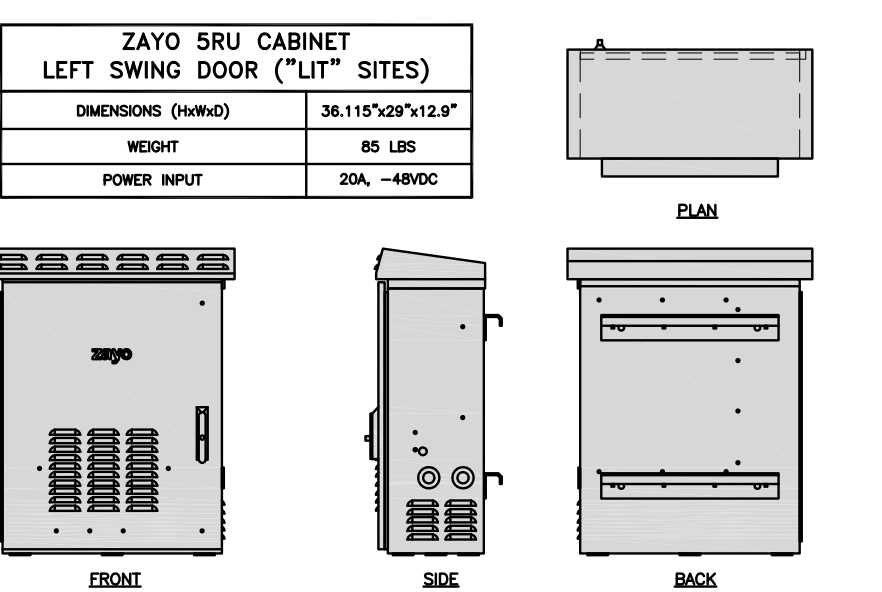

NETWORK INTERFACE UNIT DETAIL NO SCALE 5

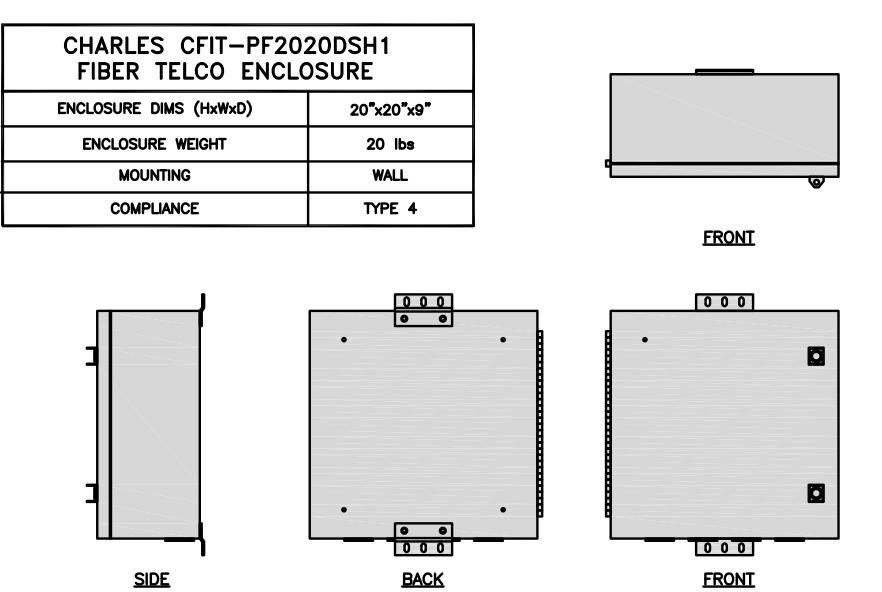

FIBER TELCO ENCLOSURE DETAIL NO SCALE 6

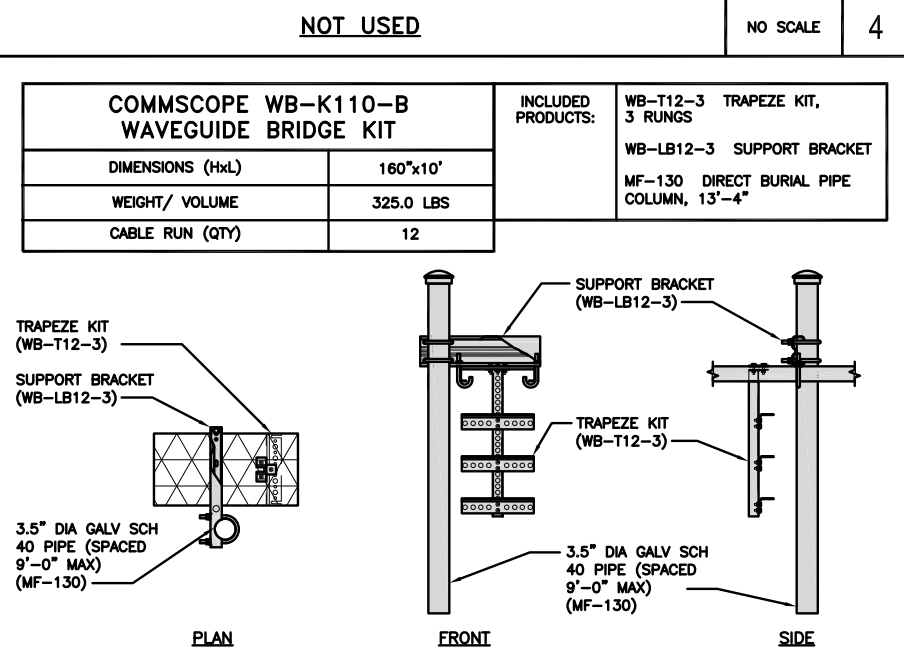

ICE BRIDGE DETAIL NO SCALE 7

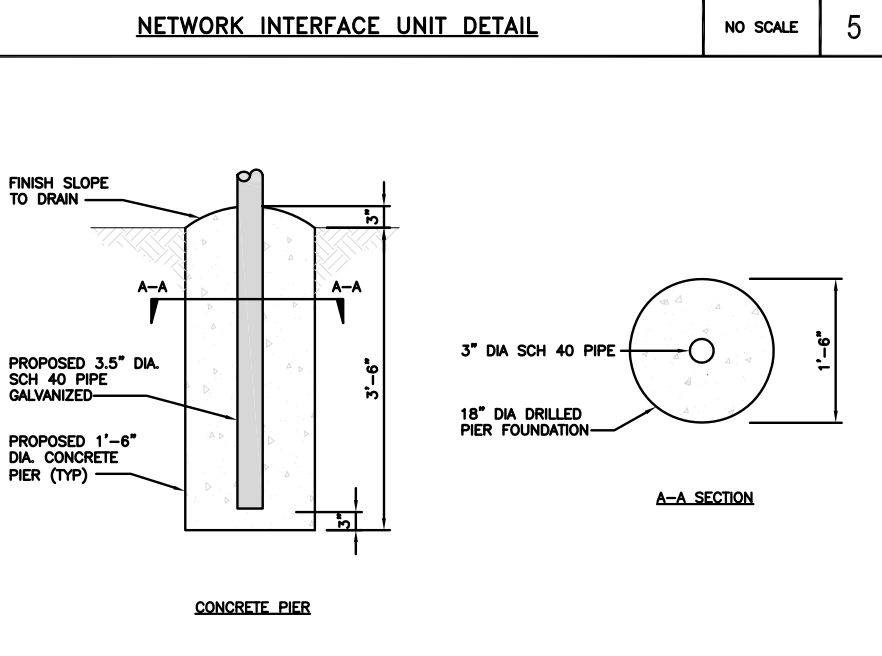

TYPICAL ICE BRIDGE CONCRETE PIER DETAIL NO SCALE 8

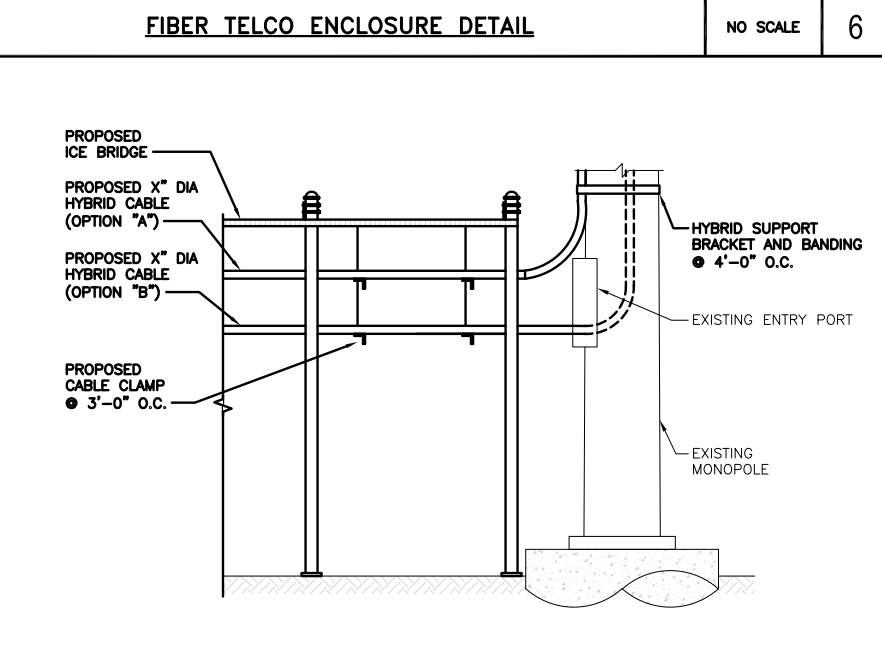

HYBRID CABLE RUN NO SCALE 9

5701 SOUTH SANTA FE DRIVE
LITTLETON, CO 80120

10 PRESIDENTIAL WAY
WOBURN, MA 01801

1717 S. BOULDER
SUITE 300
TULSA, OK 74119
PH: (918) 587-4630
www.btgrp.com

B&T ENGINEERING, INC.
PEC.0001564
Expires 2/10/22

IT IS A VIOLATION OF LAW FOR ANY PERSON, UNLESS THEY ARE ACTING UNDER THE DIRECTION OF A LICENSED PROFESSIONAL ENGINEER, TO ALTER THIS DOCUMENT.

DRAWN BY:	CHECKED BY:	APPROVED BY:
BLJ	BLJ	MP

RFDS REV #: ---

CONSTRUCTION DOCUMENTS

SUBMITTALS		
REV	DATE	DESCRIPTION
A	7/16/21	ISSUED FOR REVIEW
0	8/2/21	ISSUED FOR CONSTRUCTION

A&E PROJECT NUMBER
152988.001.01

DISH Wireless L.L.C.
PROJECT INFORMATION
BOBDL00109A
87 MONCE RD.
BURLINGTON, CT 06013

SHEET TITLE
EQUIPMENT DETAILS

SHEET NUMBER
A-4

PCTEL GPSGL-TMG-SPI-40NCB	
DIMENSIONS (DIAxH) MM/INCH	81x184mm 3.2"x7.25"
WEIGHT W/ACCESSORIES	075 lbs
CONNECTOR	N-FEMALE
FREQUENCY RANGE	1590 ± 30MHz

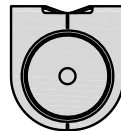

TOP

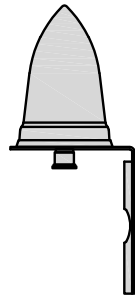

BACK

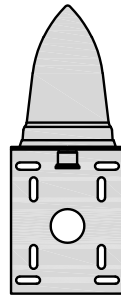

SIDE

GPS DETAIL

NO SCALE

1

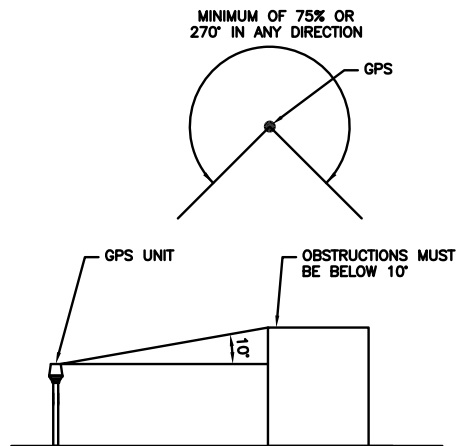

GPS MINIMUM SKY VIEW REQUIREMENTS

NO SCALE

2

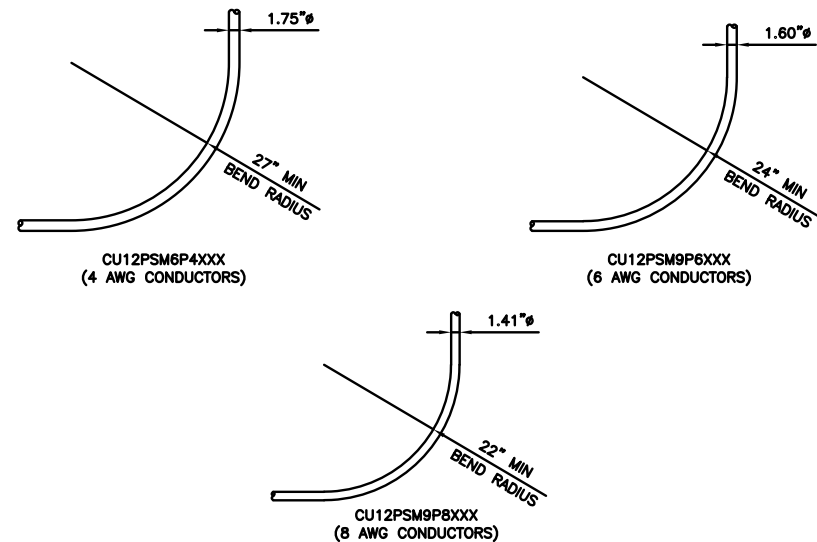

CABLES UNLIMITED HYBRID CABLE
MINIMUM BEND RADIUS

NO SCALE

3

NOT USED

NO SCALE

4

NOT USED

NO SCALE

5

NOT USED

NO SCALE

6

NOT USED

NO SCALE

7

NOT USED

NO SCALE

8

NOT USED

NO SCALE

9

dish
wireless.

5701 SOUTH SANTA FE DRIVE
LITTLETON, CO 80120

AMERICAN TOWER
10 PRESIDENTIAL WAY
WOBURN, MA 01801

B+T GRP
1717 S. BOULDER
SUITE 300
TULSA, OK 74119
PH: (918) 587-4630
www.btgrp.com



B&T ENGINEERING, INC.
PEC.0001564
Expires 2/10/22

IT IS A VIOLATION OF LAW FOR ANY PERSON,
UNLESS THEY ARE ACTING UNDER THE DIRECTION
OF A LICENSED PROFESSIONAL ENGINEER,
TO ALTER THIS DOCUMENT.

DRAWN BY:	CHECKED BY:	APPROVED BY:
BLJ	BLJ	MP

RFDS REV #: ---

**CONSTRUCTION
DOCUMENTS**

SUBMITTALS		
REV	DATE	DESCRIPTION
A	7/16/21	ISSUED FOR REVIEW
0	8/2/21	ISSUED FOR CONSTRUCTION

A&E PROJECT NUMBER
152988.001.01

DISH Wireless L.L.C.
PROJECT INFORMATION

BOBDL00109A
87 MONCE RD.
BURLINGTON, CT 06013

SHEET TITLE
EQUIPMENT DETAILS

SHEET NUMBER

A-5

FUJITSU TRIPLE BAND TA08025-B605	
DIMENSIONS (HxWxD)	14.9"x15.7"x9"
WEIGHT	74.95 lbs
CONNECTOR TYPE	4.3-10 RF CONNECTOR
POWER SUPPLY	DC -58~-36V

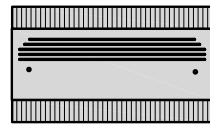

PLAN

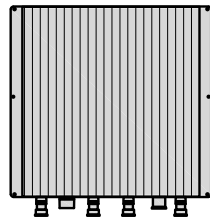

BACK

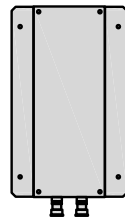

SIDE

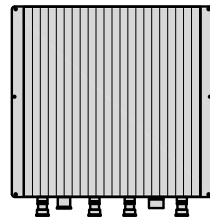

FRONT

RRH DETAIL

NO SCALE

1

FUJITSU DUAL BAND TA08025-B604	
DIMENSIONS (HxWxD)	14.9"x15.7"x7.8"
WEIGHT	63.9 lbs
CONNECTOR TYPE	4.3-10 RF CONNECTOR
POWER SUPPLY	DC -58~-36V

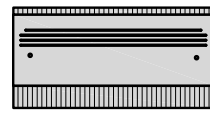

PLAN

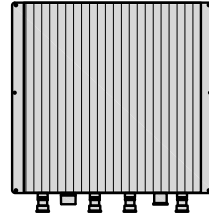

BACK

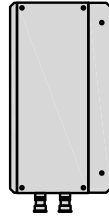

SIDE

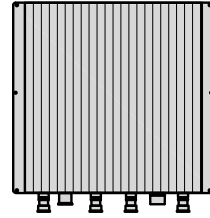

FRONT

RRH DETAIL

NO SCALE

2

SABRE DOUBLE Z-BRACKET C10123155	
DIMENSIONS (HxWxD) (1 BRACKET)	5"x20"x1-13/16"
WEIGHT (FULL ASSEMBLY)	35.79 lbs
PACKAGE QUANTITY	4

#	DESCRIPTION
1	PLATE, CHANNEL BRACKET
2	RRH Z BRACKET, 3/16"
3	THREADED ROD ASSEMBLY 1/2"x12"

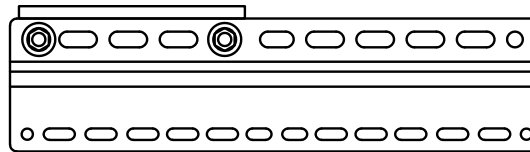

NOTE:
OR DISH Wireless L.L.C.
APPROVED EQUIVALENT

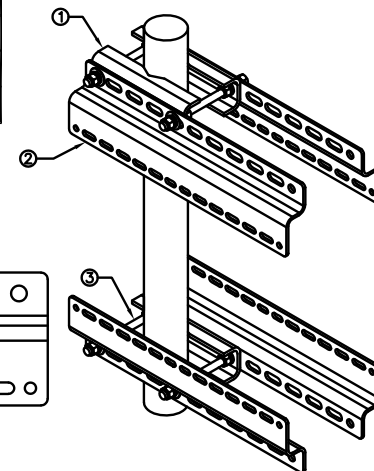

RRH MOUNT DETAIL

NO SCALE

3

JMA WIRELESS MX08FRO665-21 ANTENNA	
DIMENSIONS (HxWxD)	72.0"x20.0"x8.0"
TOTAL WEIGHT	64.5 LB
RF PORTS, CONNECTOR TYPE	8 x 4.3-10 FEMALE

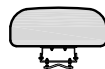

PLAN

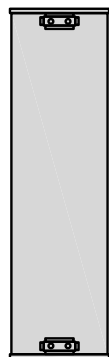

BACK



SIDE



FRONT

ANTENNA DETAIL

NO SCALE

4

RAYCAP RDIC-9181-PF-48 DC SURGE PROTECTION (OVP)	
DIMENSIONS (HxWxD)	18.98"x14.39"x8.15"
WEIGHT	21.82 LBS

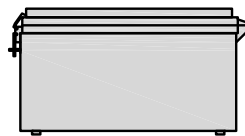

PLAN

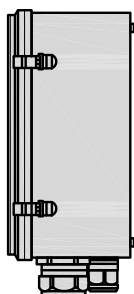

SIDE

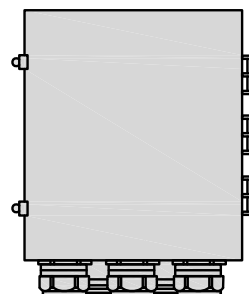

BACK

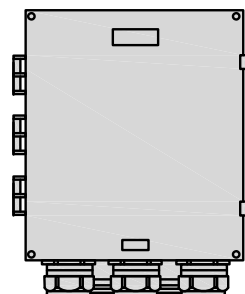

FRONT

SURGE SUPPRESSION DETAIL (OVP)

NO SCALE

7

COMMSCOPE XP-2040 CROSSOVER PLATE	
DIMENSIONS (HxW)	10"x12"
WEIGHT	11 lbs

NOTE:
OR DISH Wireless L.L.C.
APPROVED EQUIVALENT

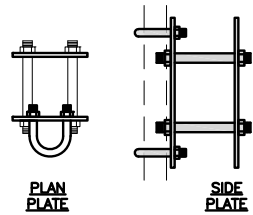

PLAN
U-BOLT

SIDE
U-BOLT

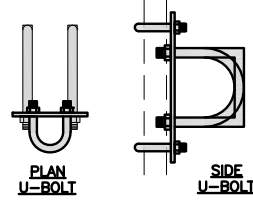

PLAN
U-BOLT

SIDE
U-BOLT

RRH/OVP MOUNT DETAIL

NO SCALE

8

COMMSCOPE MC-PK8-DSH	
FACE WIDTH	96"
WEIGHT	1373.08 lbs
NOTE: 15" TO 38" O.D.	

NOTE:
OR DISH Wireless L.L.C.
APPROVED EQUIVALENT

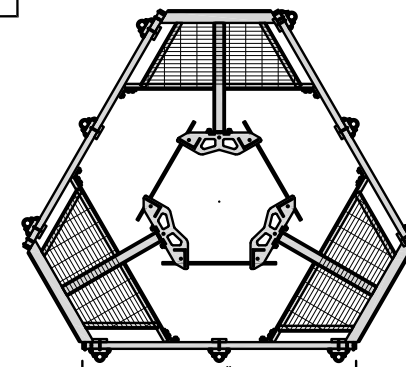
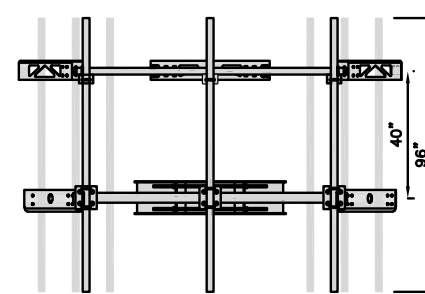

ANTENNA PLATFORM DETAIL

NO SCALE

9

dish
wireless.

5701 SOUTH SANTA FE DRIVE
LITTLETON, CO 80120

AMERICAN TOWER
10 PRESIDENTIAL WAY
WOBUEN, MA 01801

B+T GRP
1717 S. BOULDER
SUITE 300
TULSA, OK 74119
PH: (918) 587-4630
www.btgrp.com



B&T ENGINEERING, INC.
PEC.0001564
Expires 2/10/22

IT IS A VIOLATION OF LAW FOR ANY PERSON,
UNLESS THEY ARE ACTING UNDER THE DIRECTION
OF A LICENSED PROFESSIONAL ENGINEER,
TO ALTER THIS DOCUMENT.

DRAWN BY: CHECKED BY: APPROVED BY:

BLJ BLJ MP

RFDS REV #: ---

**CONSTRUCTION
DOCUMENTS**

SUBMITTALS		
REV	DATE	DESCRIPTION
A	7/16/21	ISSUED FOR REVIEW
0	8/2/21	ISSUED FOR CONSTRUCTION

A&E PROJECT NUMBER
152988.001.01

DISH Wireless L.L.C.
PROJECT INFORMATION

BOBDL00109A
87 MONCE RD.
BURLINGTON, CT 06013

SHEET TITLE
EQUIPMENT DETAILS

SHEET NUMBER

A-6

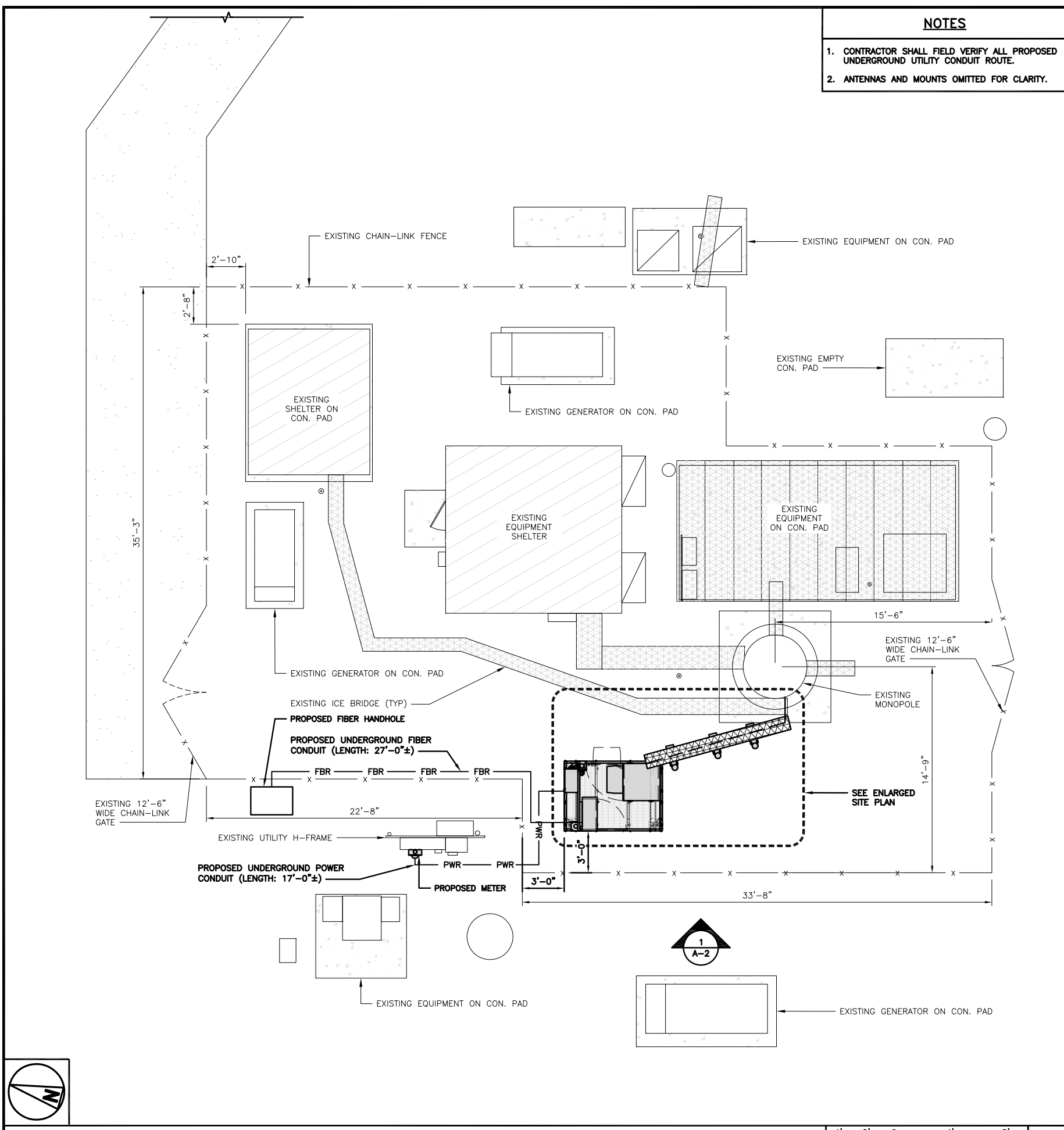

UTILITY ROUTE PLAN

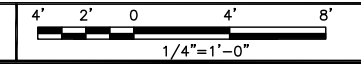

- DC POWER WIRING SHALL BE COLOR CODED AT EACH END FOR IDENTIFYING +24V AND -48V CONDUCTORS. RED MARKINGS SHALL IDENTIFY +24V AND BLUE MARKINGS SHALL IDENTIFY -48V.
- CONTRACTOR SHALL INSPECT THE EXISTING CONDITIONS PRIOR TO SUBMITTING A BID. ANY QUESTIONS ARISING DURING THE BID PERIOD IN REGARDS TO THE CONTRACTOR'S FUNCTIONS, THE SCOPE OF WORK, OR ANY OTHER ISSUE RELATED TO THIS PROJECT SHALL BE BROUGHT UP DURING THE BID PERIOD WITH THE PROJECT MANAGER FOR CLARIFICATION, NOT AFTER THE CONTRACT HAS BEEN AWARDED.
 - ALL ELECTRICAL WORK SHALL BE DONE IN ACCORDANCE WITH CURRENT NATIONAL ELECTRICAL CODES AND ALL STATE AND LOCAL CODES, LAWS, AND ORDINANCES. PROVIDE ALL COMPONENTS AND WIRING SIZES AS REQUIRED TO MEET NEC STANDARDS.
 - LOCATION OF EQUIPMENT, CONDUIT AND DEVICES SHOWN ON THE DRAWINGS ARE APPROXIMATE AND SHALL BE COORDINATED WITH FIELD CONDITIONS PRIOR TO CONSTRUCTION.
 - CONDUIT ROUGH-IN SHALL BE COORDINATED WITH THE MECHANICAL EQUIPMENT TO AVOID LOCATION CONFLICTS. VERIFY WITH THE MECHANICAL EQUIPMENT CONTRACTOR AND COMPLY AS REQUIRED.
 - CONTRACTOR SHALL PROVIDE ALL BREAKERS, CONDUITS AND CIRCUITS AS REQUIRED FOR A COMPLETE SYSTEM.
 - CONTRACTOR SHALL PROVIDE PULL BOXES AND JUNCTION BOXES AS REQUIRED BY THE NEC ARTICLE 314.
 - CONTRACTOR SHALL PROVIDE ALL STRAIN RELIEF AND CABLE SUPPORTS FOR ALL CABLE ASSEMBLIES. INSTALLATION SHALL BE IN ACCORDANCE WITH MANUFACTURER'S SPECIFICATIONS AND RECOMMENDATIONS.
 - ALL DISCONNECTS AND CONTROLLING DEVICES SHALL BE PROVIDED WITH ENGRAVED PHENOLIC NAMEPLATES INDICATING EQUIPMENT CONTROLLED, BRANCH CIRCUITS INSTALLED ON, AND PANEL FIELD LOCATIONS FED FROM.
 - INSTALL AN EQUIPMENT GROUNDING CONDUCTOR IN ALL CONDUITS PER THE SPECIFICATIONS AND NEC 250. THE EQUIPMENT GROUNDING CONDUCTORS SHALL BE BONDED AT ALL JUNCTION BOXES, PULL BOXES, AND ALL DISCONNECT SWITCHES, AND EQUIPMENT CABINETS.
 - ALL NEW MATERIAL SHALL HAVE A U.L. LABEL.
 - PANEL SCHEDULE LOADING AND CIRCUIT ARRANGEMENTS REFLECT POST-CONSTRUCTION EQUIPMENT.
 - CONTRACTOR SHALL BE RESPONSIBLE FOR AS-BUILT PANEL SCHEDULE AND SITE DRAWINGS.
 - ALL TRENCHES IN COMPOUND TO BE HAND DUG

ELECTRICAL NOTES



5701 SOUTH SANTA FE DRIVE
LITTLETON, CO 80120



10 PRESIDENTIAL WAY
WOBURN, MA 01801



1717 S. BOULDER
SUITE 300
TULSA, OK 74119
PH: (918) 587-4630
www.btgrp.com



B&T ENGINEERING, INC.
PEC.0001564
Expires 2/10/22

IT IS A VIOLATION OF LAW FOR ANY PERSON, UNLESS THEY ARE ACTING UNDER THE DIRECTION OF A LICENSED PROFESSIONAL ENGINEER, TO ALTER THIS DOCUMENT.

DRAWN BY:	CHECKED BY:	APPROVED BY:
BLJ	BLJ	MP

RFDS REV #: ---

CONSTRUCTION DOCUMENTS

SUBMITTALS		
REV	DATE	DESCRIPTION
A	7/16/21	ISSUED FOR REVIEW
0	8/2/21	ISSUED FOR CONSTRUCTION

A&E PROJECT NUMBER
152988.001.01

DISH Wireless L.L.C.
PROJECT INFORMATION

BOBDL00109A
87 MONCE RD.
BURLINGTON, CT 06013

SHEET TITLE
ELECTRICAL/FIBER ROUTE
PLAN AND NOTES

SHEET NUMBER
E-1



AN EXISTING CONDITIONS SURVEY WAS NOT AVAILABLE AT THE TIME THIS DRAWING'S CREATION

CARLON EXPANSION FITTINGS				
COUPLING END PART#	MALE TERMINAL ADAPTER END PART#	SIZE	STD CTN QTY.	TRAVEL LENGTH
E945D	E945DX	1/2"	20	4"
E945E	E945EX	3/4"	15	4"
E945F	E945FX	1"	10	4"
E945G	E945GX	1 1/4"	5	4"
E945H	E945HX	1 1/2"	5	4"
E945J	E945JX	2"	15	8"
E945K	E945KX	2 1/2"	10	8"
E945L	E945LX	3"	10	8"
E945M	E945MX	3 1/2"	5	8"
E945N	E945NX	4"	5	8"
E945P	E945PX	5"	1	8"
E945R	E945RX	6"	1	8"

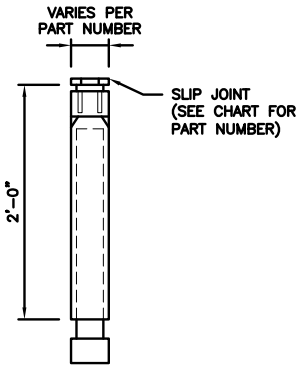

NOTE: CONTRACTOR TO INSTALL EXPANSION FITTING SLIP JOINT AT METER CENTER CONDUIT TERMINATION, AS PER LOCAL UTILITY POLICY, ORDINANCE AND/OR SPECIFIED REQUIREMENT.

TRENCHING NOTES

- CONTRACTOR SHALL RESTORE THE TRENCH TO ITS ORIGINAL CONDITIONS BY EITHER SEEDING OR SODDING GRASS AREAS, OR REPLACING ASPHALT OR CONCRETE AREAS TO ITS ORIGINAL CROSS SECTION.
- TRENCHING SAFETY; INCLUDING, BUT NOT LIMITED TO SOIL CLASSIFICATION, SLOPING, AND SHORING, SHALL BE GOVERNED BY THE CURRENT OSHA TRENCHING AND EXCAVATION SAFETY STANDARDS.
- ALL CONDUITS SHALL BE INSTALLED IN COMPLIANCE WITH THE CURRENT NATIONAL ELECTRIC CODE (NEC) OR AS REQUIRED BY THE LOCAL JURISDICTION, WHICHEVER IS THE MOST STRINGENT.

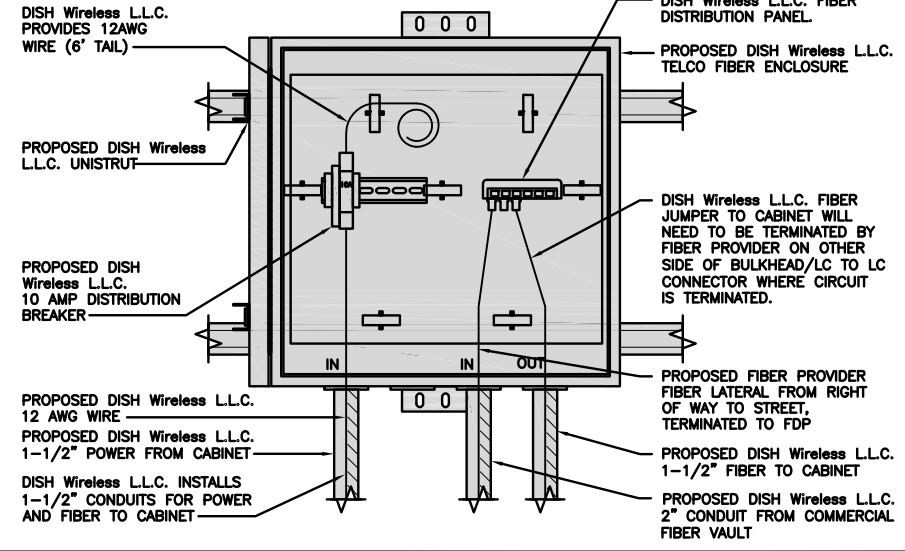
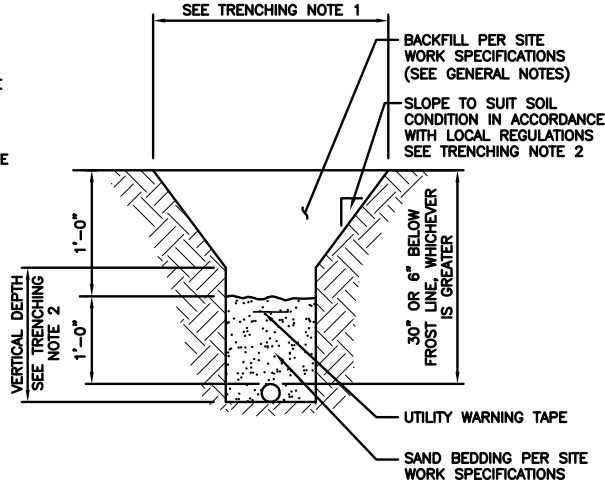

EXPANSION JOINT DETAIL

NO SCALE 1

TYPICAL UNDERGROUND TRENCH DETAIL

NO SCALE 2

DARK TELCO BOX – INTERIOR WIRING LAYOUT

NO SCALE 3

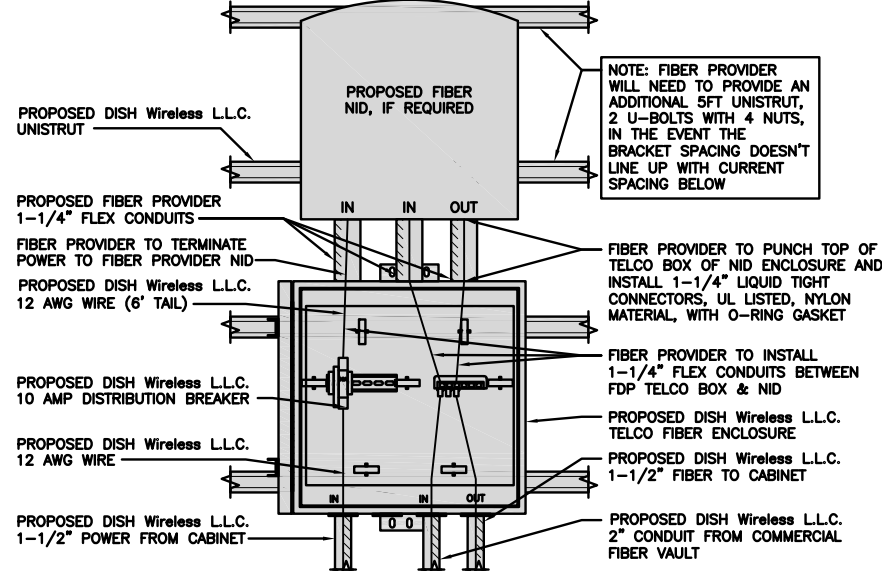

LIT TELCO BOX – INTERIOR WIRING LAYOUT (OPTIONAL)

NO SCALE 4

NOT USED

NO SCALE 5

NOT USED

NO SCALE 6

NOT USED

NO SCALE 8

NOT USED

NO SCALE 9



5701 SOUTH SANTA FE DRIVE
LITTLETON, CO 80120



B&T ENGINEERING, INC.
PEC.0001564
Expires 2/10/22

IT IS A VIOLATION OF LAW FOR ANY PERSON, UNLESS THEY ARE ACTING UNDER THE DIRECTION OF A LICENSED PROFESSIONAL ENGINEER, TO ALTER THIS DOCUMENT.

DRAWN BY: BLJ CHECKED BY: BLJ APPROVED BY: MP

RFDS REV #: ---

CONSTRUCTION DOCUMENTS

SUBMITTALS		
REV	DATE	DESCRIPTION
A	7/16/21	ISSUED FOR REVIEW
0	8/2/21	ISSUED FOR CONSTRUCTION

A&E PROJECT NUMBER
152988.001.01

DISH Wireless L.L.C.
PROJECT INFORMATION
BOBDL00109A
87 MONCE RD.
BURLINGTON, CT 06013

SHEET TITLE
ELECTRICAL
DETAILS

SHEET NUMBER
E-2

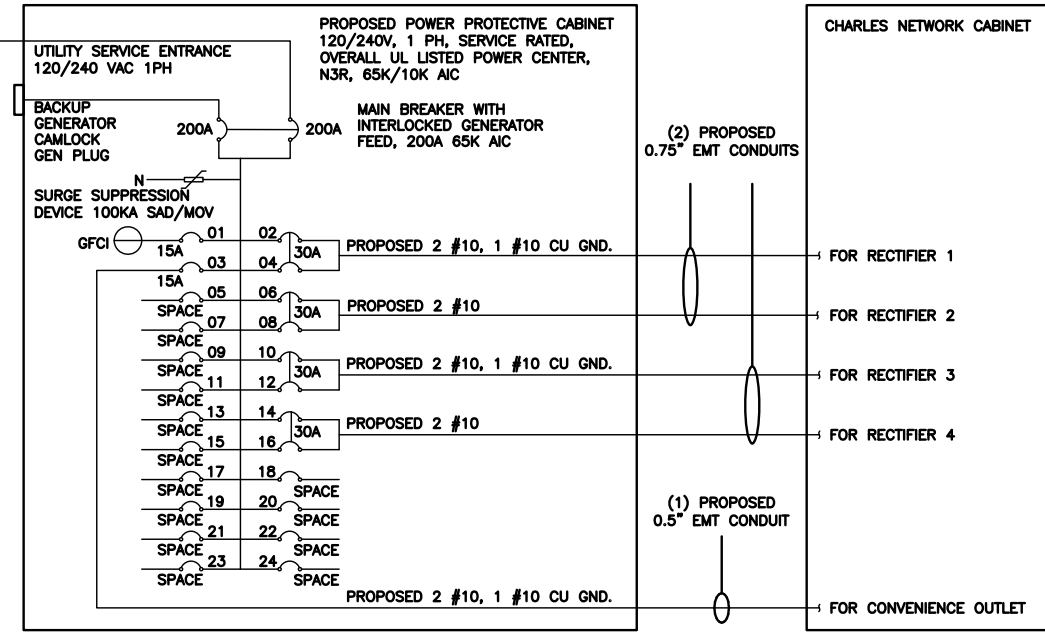
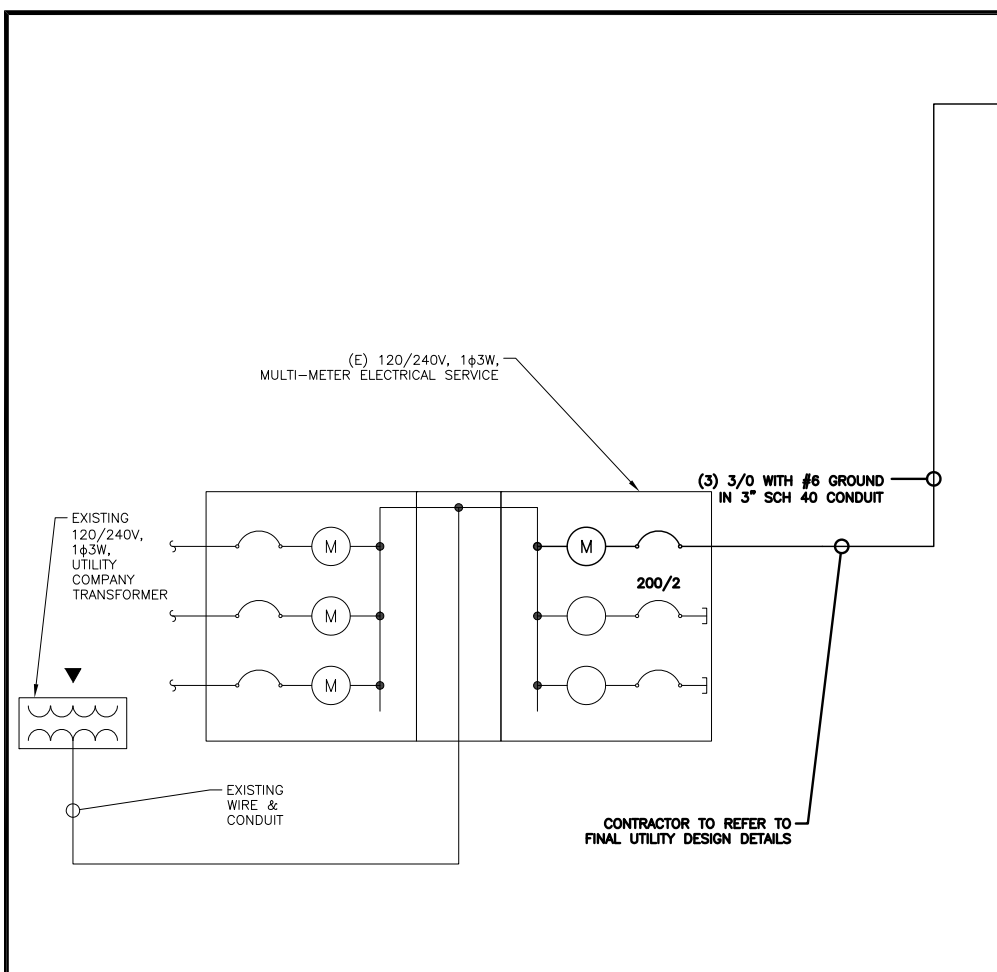

NOTE:
BRANCH CIRCUIT WIRING SUPPLYING RECTIFIERS ARE TO BE RATED UL1015, 105°C, 600V, AND PVC INSULATED, IN THE SIZES SHOWN IN THE ONE-LINE DIAGRAM. CONTRACTOR MAY SUBSTITUTE UL1015 WIRE FOR THWN-2 FOR CONVENIENCE OUTLET BRANCH CIRCUIT.

BREAKERS REQUIRED:
(4) 30A, 2P BREAKER - SQUARE D P/N:Q0230
(1) 15A, 1P BREAKER - SQUARE D P/N:Q0115

NOTES

THE (2) CONDUITS WITH (4) CURRENT CARRYING CONDUCTORS EACH, SHALL APPLY THE ADJUSTMENT FACTOR OF 80% PER 2014/17 NEC TABLE 310.15(B)(3)(g) OR 2020 NEC TABLE 310.15(C)(1) FOR UL1015 WIRE.

#12 FOR 15A-20A/1P BREAKER: 0.8 x 30A = 24.0A
#10 FOR 25A-30A/2P BREAKER: 0.8 x 40A = 32.0A
#8 FOR 35A-40A/2P BREAKER: 0.8 x 55A = 44.0A
#6 FOR 45A-60A/2P BREAKER: 0.8 x 75A = 60.0A

CONDUIT SIZING: AT 40% FILL PER NEC CHAPTER 9, TABLE 4, ARTICLE 358.
0.5" CONDUIT - 0.122 SQ. IN AREA
0.75" CONDUIT - 0.213 SQ. IN AREA
2.0" CONDUIT - 1.316 SQ. IN AREA
3.0" CONDUIT - 2.907 SQ. IN AREA

CABINET CONVENIENCE OUTLET CONDUCTORS (1 CONDUIT): USING THWN-2, CU.
#10 - 0.0211 SQ. IN X 2 = 0.0422 SQ. IN
#10 - 0.0211 SQ. IN X 1 = 0.0211 SQ. IN <GROUND
TOTAL = 0.0633 SQ. IN

0.5" EMT CONDUIT IS ADEQUATE TO HANDLE THE TOTAL OF (3) WIRES, INCLUDING GROUND WIRE, AS INDICATED ABOVE.

RECTIFIER CONDUCTORS (2 CONDUITS): USING UL1015, CU.
#10 - 0.0266 SQ. IN X 4 = 0.1064 SQ. IN
#10 - 0.0082 SQ. IN X 1 = 0.0082 SQ. IN <BARE GROUND
TOTAL = 0.1146 SQ. IN

0.75" EMT CONDUIT IS ADEQUATE TO HANDLE THE TOTAL OF (5) WIRES, INCLUDING GROUND WIRE, AS INDICATED ABOVE.

PPC FEED CONDUCTORS (1 CONDUIT): USING THWN, CU.
3/0 - 0.2679 SQ. IN X 3 = 0.8037 SQ. IN
#6 - 0.0507 SQ. IN X 1 = 0.0507 SQ. IN <GROUND
TOTAL = 0.8544 SQ. IN

3.0" SCH 40 PVC CONDUIT IS ADEQUATE TO HANDLE THE TOTAL OF (4) WIRES, INCLUDING GROUND WIRE, AS INDICATED ABOVE.

PPC ONE-LINE DIAGRAM

NO SCALE 1

PROPOSED CHARLES PANEL SCHEDULE										
LOAD SERVED	VOLT AMPS (WATTS)		TRIP	CKT #	PHASE	CKT #	TRIP	VOLT AMPS (WATTS)		LOAD SERVED
	L1	L2						L1	L2	
PPC GFCI OUTLET	180	180	15A	1	A	2	30A	2880	2880	ABB/GE INFINITY RECTIFIER 1
CHARLES GFCI OUTLET			15A	3	B	4	30A	2880	2880	ABB/GE INFINITY RECTIFIER 2
-SPACE-				5	A	6	30A	2880	2880	ABB/GE INFINITY RECTIFIER 3
-SPACE-				7	B	8	30A	2880	2880	ABB/GE INFINITY RECTIFIER 4
-SPACE-				9	A	10				-SPACE-
-SPACE-				11	B	12				-SPACE-
-SPACE-				13	A	14				-SPACE-
-SPACE-				15	B	16				-SPACE-
-SPACE-				17	A	18				-SPACE-
-SPACE-				19	B	20				-SPACE-
-SPACE-				21	A	22				-SPACE-
-SPACE-				23	B	24				-SPACE-
VOLTAGE AMPS								11520	11520	
200A MCB, 1φ, 24 SPACE, 120/240V				L1	L2					
MB RATING: 65,000 AIC				11700	11700					
				98	98					
				98						
				123						

PANEL SCHEDULE

NO SCALE 2

NOT USED

NO SCALE 3



5701 SOUTH SANTA FE DRIVE
LITTLETON, CO 80120



B&T ENGINEERING, INC.
PEC.0001564
Expires 2/10/22

IT IS A VIOLATION OF LAW FOR ANY PERSON, UNLESS THEY ARE ACTING UNDER THE DIRECTION OF A LICENSED PROFESSIONAL ENGINEER, TO ALTER THIS DOCUMENT.

DRAWN BY: BLJ
CHECKED BY: BLJ
APPROVED BY: MP

RFDS REV #: ---

CONSTRUCTION DOCUMENTS

SUBMITTALS		
REV	DATE	DESCRIPTION
A	7/16/21	ISSUED FOR REVIEW
0	8/2/21	ISSUED FOR CONSTRUCTION

A&E PROJECT NUMBER
152988.001.01

DISH Wireless L.L.C.
PROJECT INFORMATION
BOBDL00109A
87 MONCE RD.
BURLINGTON, CT 06013

SHEET TITLE
ELECTRICAL ONE-LINE, FAULT
CALCS & PANEL SCHEDULE

SHEET NUMBER
E-3

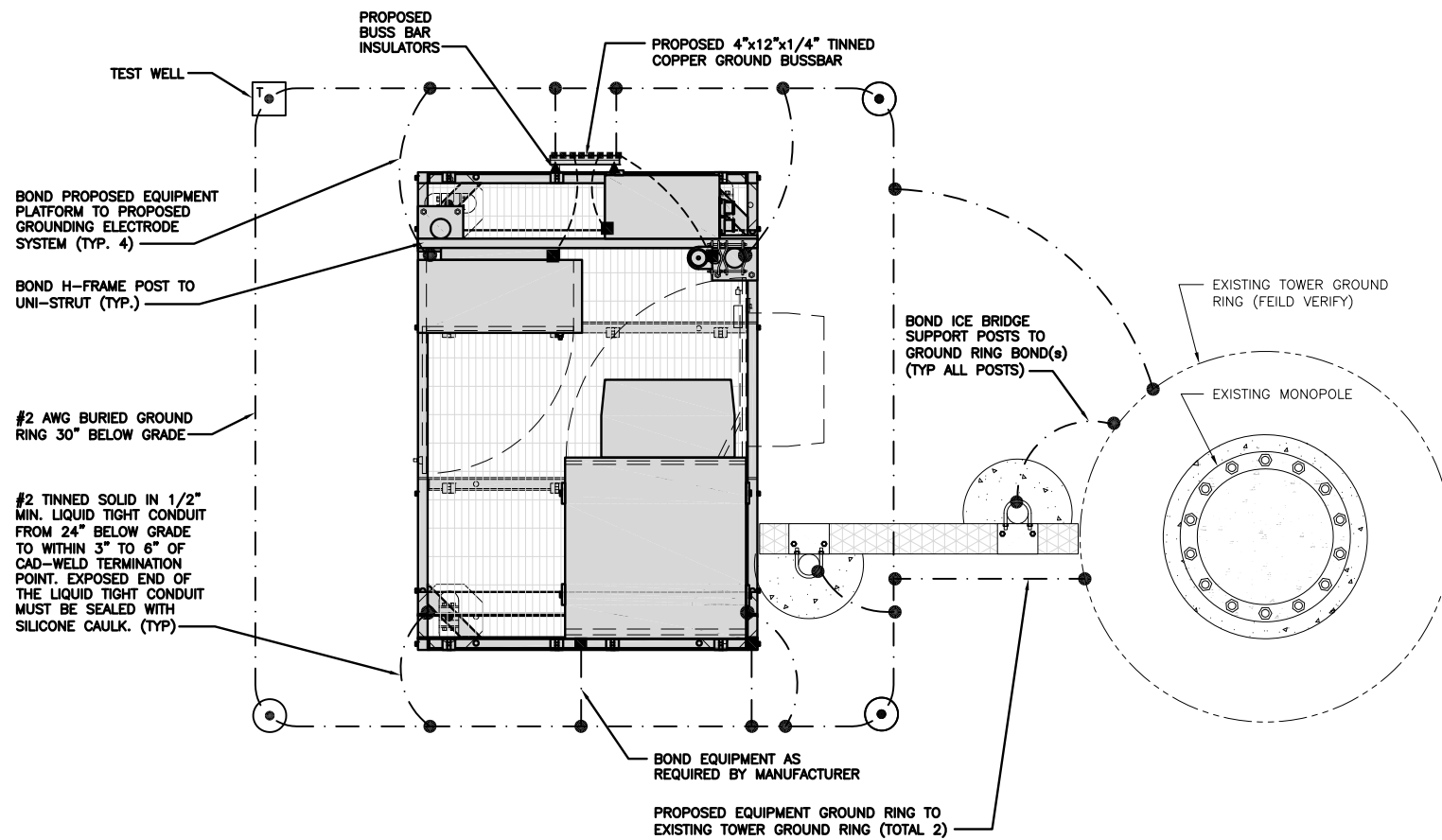

TYPICAL EQUIPMENT GROUNDING PLAN

NO SCALE 1

NOTES

1. ANTENNAS AND OVP SHOWN ARE GENERIC AND NOT REFERENCING TO A SPECIFIC MANUFACTURER. THIS LAYOUT IS FOR REFERENCE ONLY

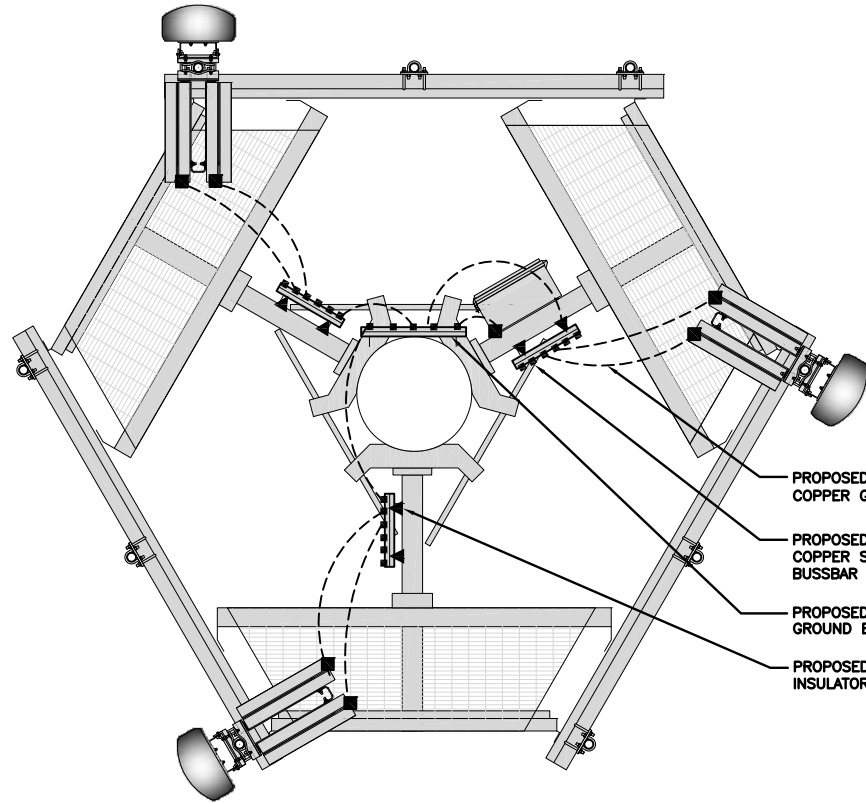

TYPICAL ANTENNA GROUNDING PLAN

NO SCALE 2

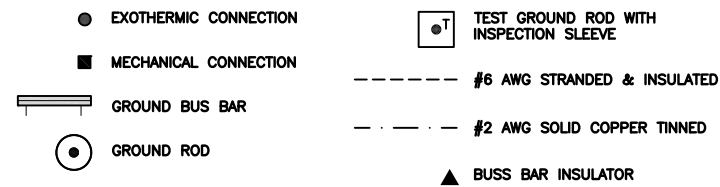

GROUNDING LEGEND

1. GROUNDING IS SHOWN DIAGRAMMATICALLY ONLY.
2. CONTRACTOR SHALL GROUND ALL EQUIPMENT AS A COMPLETE SYSTEM. GROUNDING SHALL BE IN COMPLIANCE WITH NEC SECTION 250 AND DISH Wireless L.L.C. GROUNDING AND BONDING REQUIREMENTS AND MANUFACTURER'S SPECIFICATIONS.
3. ALL GROUND CONDUCTORS SHALL BE COPPER; NO ALUMINUM CONDUCTORS SHALL BE USED.

GROUNDING KEY NOTES

- (A) EXTERIOR GROUND RING: #2 AWG SOLID COPPER, BURIED AT A DEPTH OF AT LEAST 30 INCHES BELOW GRADE, OR 6 INCHES BELOW THE FROST LINE AND APPROXIMATELY 24 INCHES FROM THE EXTERIOR WALL OR FOOTING.
- (B) TOWER GROUND RING: THE GROUND RING SYSTEM SHALL BE INSTALLED AROUND AN ANTENNA TOWER'S LEGS, AND/OR GUY ANCHORS. WHERE SEPARATE SYSTEMS HAVE BEEN PROVIDED FOR THE TOWER AND THE BUILDING, AT LEAST TWO BONDS SHALL BE MADE BETWEEN THE TOWER RING GROUND SYSTEM AND THE BUILDING RING GROUND SYSTEM USING MINIMUM #2 AWG SOLID COPPER CONDUCTORS.
- (C) INTERIOR GROUND RING: #2 AWG STRANDED GREEN INSULATED COPPER CONDUCTOR EXTENDED AROUND THE PERIMETER OF THE EQUIPMENT AREA. ALL NON-TELECOMMUNICATIONS RELATED METALLIC OBJECTS FOUND WITHIN A SITE SHALL BE GROUNDED TO THE INTERIOR GROUND RING WITH #6 AWG STRANDED GREEN INSULATED CONDUCTOR.
- (D) BOND TO INTERIOR GROUND RING: #2 AWG SOLID TINNED COPPER WIRE PRIMARY BONDS SHALL BE PROVIDED AT LEAST AT FOUR POINTS ON THE INTERIOR GROUND RING, LOCATED AT THE CORNERS OF THE BUILDING.
- (E) GROUND ROD: UL LISTED COPPER CLAD STEEL MINIMUM 1/2" DIAMETER BY EIGHT FEET LONG. GROUND RODS SHALL BE INSTALLED WITH INSPECTION SLEEVES. GROUND RODS SHALL BE DRIVEN TO THE DEPTH OF GROUND RING CONDUCTOR.
- (F) CELL REFERENCE GROUND BAR: POINT OF GROUND REFERENCE FOR ALL COMMUNICATIONS EQUIPMENT FRAMES. ALL BONDS ARE MADE WITH #2 AWG UNLESS NOTED OTHERWISE STRANDED GREEN INSULATED COPPER CONDUCTORS. BOND TO GROUND RING WITH (2) #2 SOLID TINNED COPPER CONDUCTORS.
- (G) HATCH PLATE GROUND BAR: BOND TO THE INTERIOR GROUND RING WITH TWO #2 AWG STRANDED GREEN INSULATED COPPER CONDUCTORS. WHEN A HATCH-PLATE AND A CELL REFERENCE GROUND BAR ARE BOTH PRESENT, THE CRGB MUST BE CONNECTED TO THE HATCH-PLATE AND TO THE INTERIOR GROUND RING USING (2) TWO #2 AWG STRANDED GREEN INSULATED COPPER CONDUCTORS EACH.
- (H) EXTERIOR CABLE ENTRY PORT GROUND BARS: LOCATED AT THE ENTRANCE TO THE CELL SITE BUILDING. BOND TO GROUND RING WITH A #2 AWG SOLID TINNED COPPER CONDUCTORS WITH AN EXOTHERMIC WELD AND INSPECTION SLEEVE.
- (I) TELCO GROUND BAR: BOND TO BOTH CELL REFERENCE GROUND BAR OR EXTERIOR GROUND RING.
- (J) FRAME BONDING: THE BONDING POINT FOR TELECOM EQUIPMENT FRAMES SHALL BE THE GROUND BUS THAT IS NOT ISOLATED FROM THE EQUIPMENTS METAL FRAMEWORK.
- (K) INTERIOR UNIT BONDS: METAL FRAMES, CABINETS AND INDIVIDUAL METALLIC UNITS LOCATED WITH THE AREA OF THE INTERIOR GROUND RING REQUIRE A #6 AWG STRANDED GREEN INSULATED COPPER BOND TO THE INTERIOR GROUND RING.
- (L) FENCE AND GATE GROUNDING: METAL FENCES WITHIN 7 FEET OF THE EXTERIOR GROUND RING OR OBJECTS BONDED TO THE EXTERIOR GROUND RING SHALL BE BONDED TO THE GROUND RING WITH A #2 AWG SOLID TINNED COPPER CONDUCTOR AT AN INTERVAL NOT EXCEEDING 25 FEET. BONDS SHALL BE MADE AT EACH GATE POST AND ACROSS GATE OPENINGS.
- (M) EXTERIOR UNIT BONDS: METALLIC OBJECTS, EXTERNAL TO OR MOUNTED TO THE BUILDING, SHALL BE BONDED TO THE EXTERIOR GROUND RING. USING #2 TINNED SOLID COPPER WIRE
- (N) ICE BRIDGE SUPPORTS: EACH ICE BRIDGE LEG SHALL BE BONDED TO THE GROUND RING WITH #2 AWG BARE TINNED COPPER CONDUCTOR. PROVIDE EXOTHERMIC WELDS AT BOTH THE ICE BRIDGE LEG AND BURIED GROUND RING.
- (O) DURING ALL DC POWER SYSTEM CHANGES INCLUDING DC SYSTEM CHANGE OUTS, RECTIFIER REPLACEMENTS OR ADDITIONS, BREAKER DISTRIBUTION CHANGES, BATTERY ADDITIONS, BATTERY REPLACEMENTS AND INSTALLATIONS OR CHANGES TO DC CONVERTER SYSTEMS IT SHALL BE REQUIRED THAT SERVICE CONTRACTORS VERIFY ALL DC POWER SYSTEMS ARE EQUIPPED WITH A MASTER DC SYSTEM RETURN GROUND CONDUCTOR FROM THE DC POWER SYSTEM COMMON RETURN BUS DIRECTLY CONNECTED TO THE CELL SITE REFERENCE GROUND BAR
- (P) TOWER TOP COLLECTOR BUSS BAR IS TO BE MECHANICALLY BONDED TO PROPOSED ANTENNA MOUNT COLLAR. REFER TO DISH Wireless L.L.C. GROUNDING NOTES.

GROUNDING KEY NOTES

NO SCALE 3



5701 SOUTH SANTA FE DRIVE
LITTLETON, CO 80120



B&T ENGINEERING, INC.
PEC.0001564
Expires 2/10/22

IT IS A VIOLATION OF LAW FOR ANY PERSON, UNLESS THEY ARE ACTING UNDER THE DIRECTION OF A LICENSED PROFESSIONAL ENGINEER, TO ALTER THIS DOCUMENT.

DRAWN BY:	CHECKED BY:	APPROVED BY:
BLJ	BLJ	MP

RFDS REV #: ---

CONSTRUCTION DOCUMENTS

SUBMITTALS		
REV	DATE	DESCRIPTION
A	7/16/21	ISSUED FOR REVIEW
0	8/2/21	ISSUED FOR CONSTRUCTION

A&E PROJECT NUMBER
152988.001.01

DISH Wireless L.L.C.
PROJECT INFORMATION

BOBDL00109A
87 MONCE RD.
BURLINGTON, CT 06013

SHEET TITLE
GROUNDING PLANS
AND NOTES

SHEET NUMBER
G-1

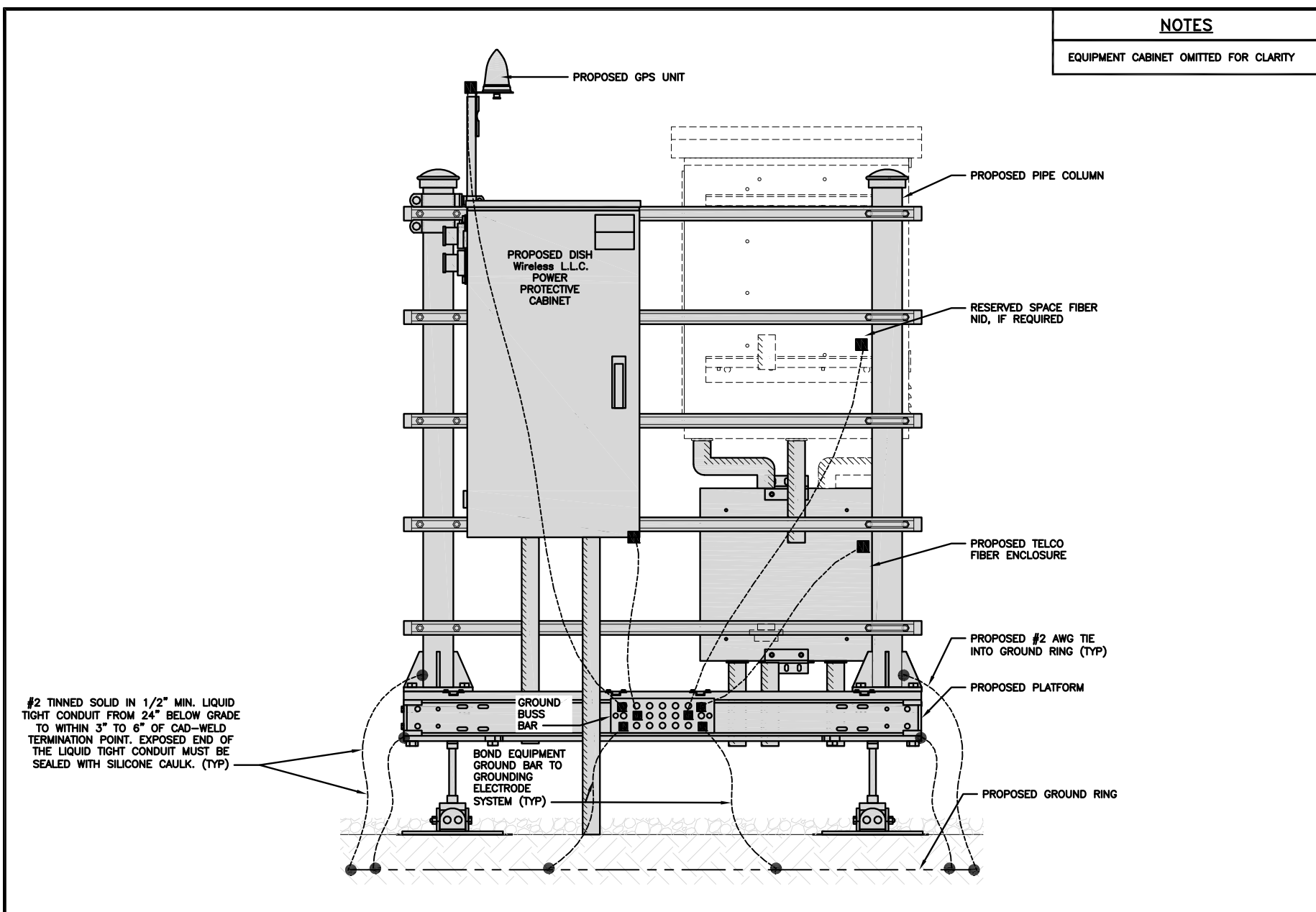

H-FRAME GROUNDING DETAIL

NO SCALE 1

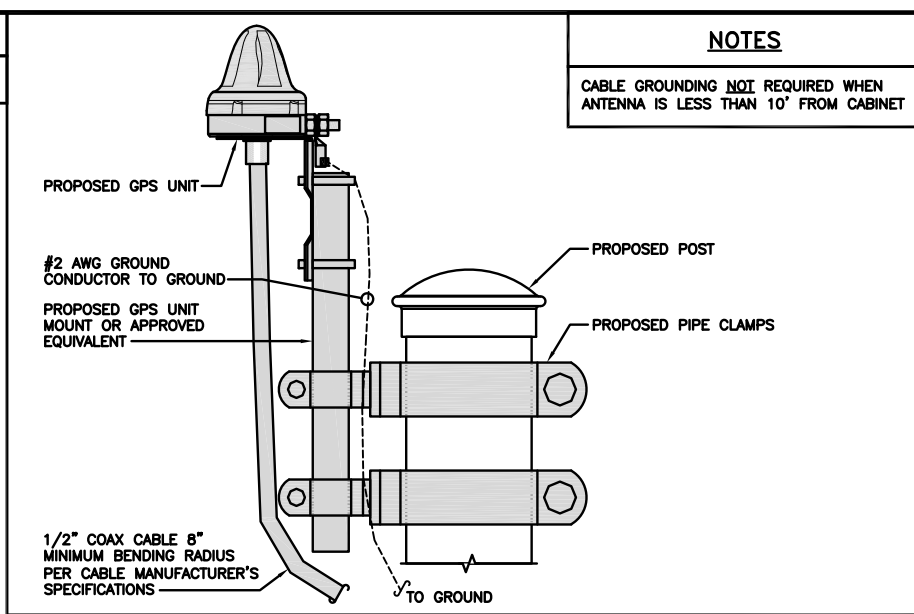

TYPICAL GPS UNIT GROUNDING

NO SCALE 2

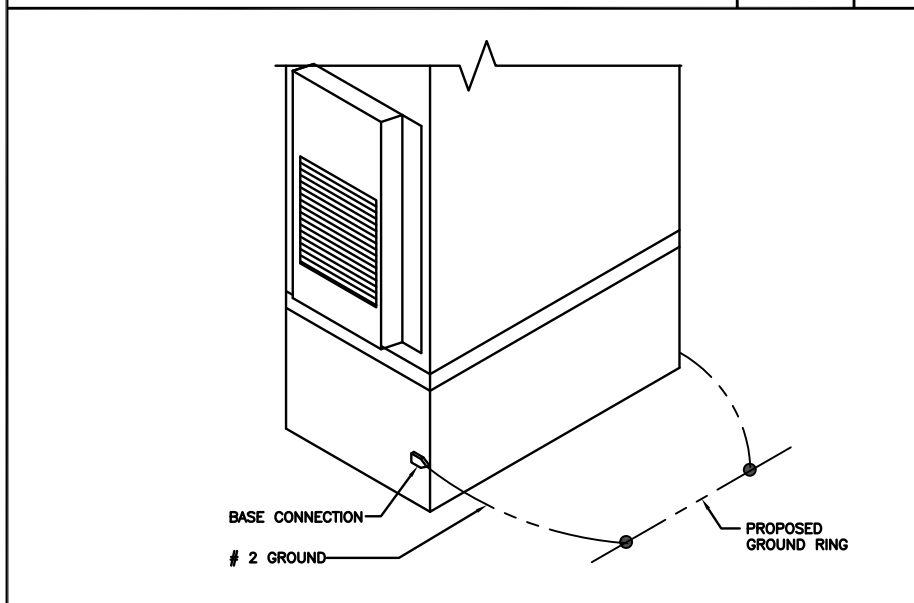

OUTDOOR CABINET GROUNDING

NO SCALE 3

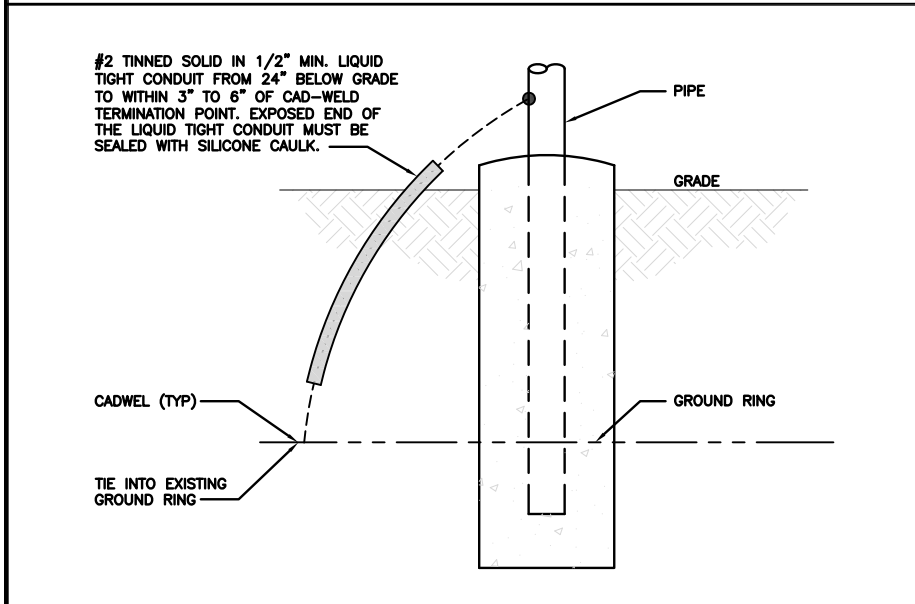

TRANSITIONING GROUND DETAIL

NO SCALE 4

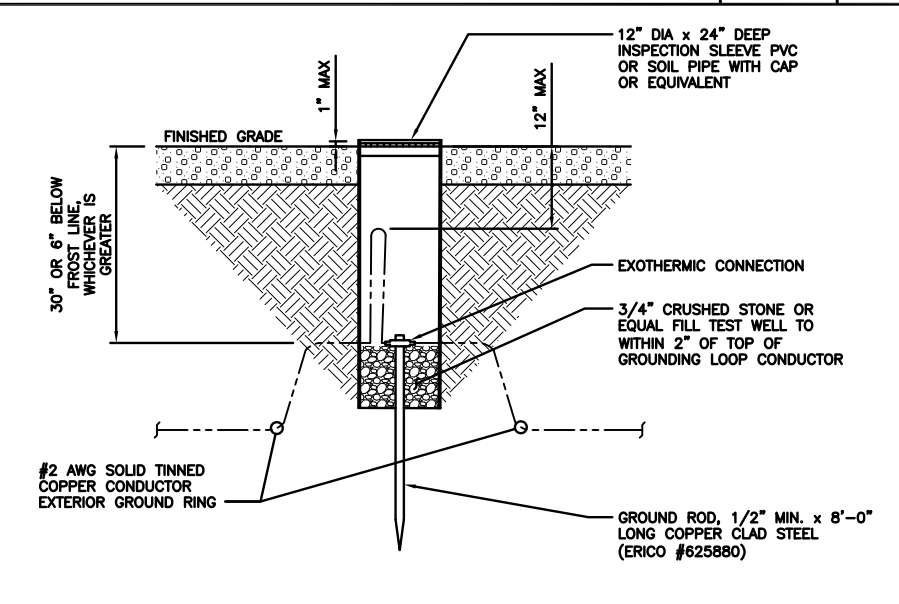

TYPICAL TEST GROUND ROD WITH INSPECTION SLEEVE

NO SCALE 5

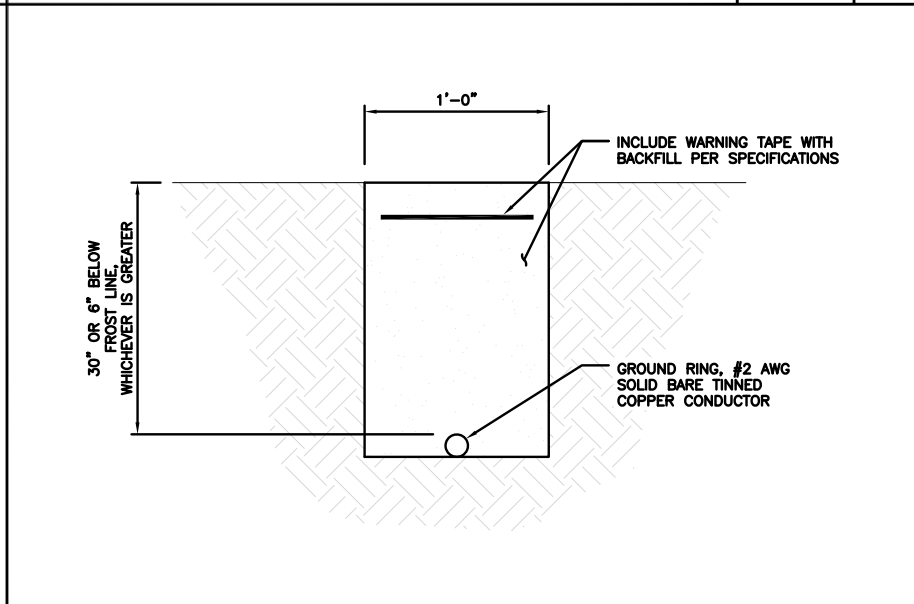

TYPICAL GROUND RING TRENCH

NO SCALE 6



5701 SOUTH SANTA FE DRIVE
LITTLETON, CO 80120



B&T ENGINEERING, INC.
PEC.0001564
Expires 2/10/22

IT IS A VIOLATION OF LAW FOR ANY PERSON, UNLESS THEY ARE ACTING UNDER THE DIRECTION OF A LICENSED PROFESSIONAL ENGINEER, TO ALTER THIS DOCUMENT.

DRAWN BY: CHECKED BY: APPROVED BY:
BLJ BLJ MP

RFDS REV #: ---

CONSTRUCTION DOCUMENTS

SUBMITTALS		
REV	DATE	DESCRIPTION
A	7/16/21	ISSUED FOR REVIEW
0	8/2/21	ISSUED FOR CONSTRUCTION

A&E PROJECT NUMBER
152988.001.01

DISH Wireless L.L.C.
PROJECT INFORMATION

BOBDL00109A
87 MONCE RD.
BURLINGTON, CT 06013

SHEET TITLE
GROUNDING DETAILS

SHEET NUMBER

G-2

1. EXOTHERMIC WELD (2) TWO, #2 AWG BARE TINNED SOLID COPPER CONDUCTORS TO GROUND BAR. ROUTE CONDUCTORS TO BURIED GROUND RING AND PROVIDE PARALLEL EXOTHERMIC WELD.
2. ALL EXTERIOR GROUNDING HARDWARE SHALL BE STAINLESS STEEL 3/8" DIAMETER OR LARGER. ALL HARDWARE 18-8 STAINLESS STEEL INCLUDING LOCK WASHERS, COAT ALL SURFACES WITH AN ANTI-OXIDANT COMPOUND BEFORE MATING.
3. FOR GROUND BOND TO STEEL ONLY: COAT ALL SURFACES WITH AN ANTI-OXIDANT COMPOUND BEFORE MATING.
4. DO NOT INSTALL CABLE GROUNDING KIT AT A BEND AND ALWAYS DIRECT GROUND CONDUCTOR DOWN TO GROUNDING BUS.
5. NUT & WASHER SHALL BE PLACED ON THE FRONT SIDE OF THE GROUND BAR AND BOLTED ON THE BACK SIDE.
6. ALL GROUNDING PARTS AND EQUIPMENT TO BE SUPPLIED AND INSTALLED BY CONTRACTOR.
7. THE CONTRACTOR SHALL BE RESPONSIBLE FOR INSTALLING ADDITIONAL GROUND BAR AS REQUIRED.
8. ENSURE THE WIRE INSULATION TERMINATION IS WITHIN 1/8" OF THE BARREL (NO SHINERS).

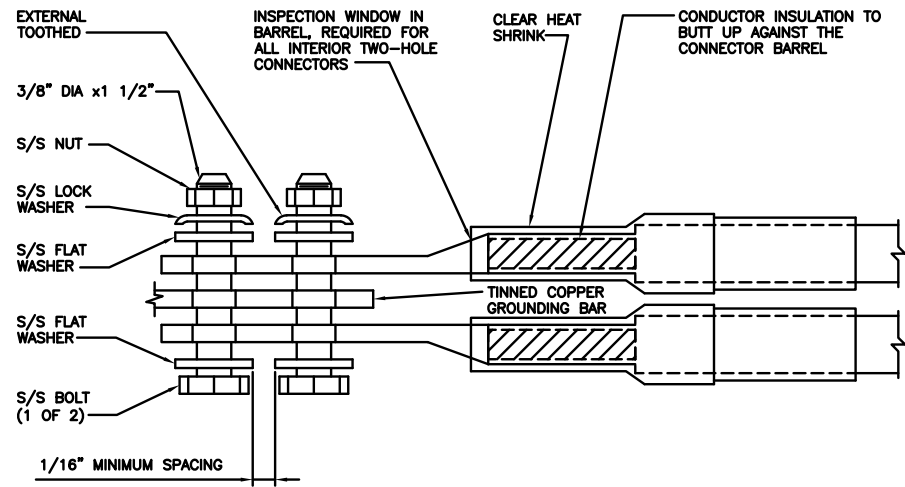
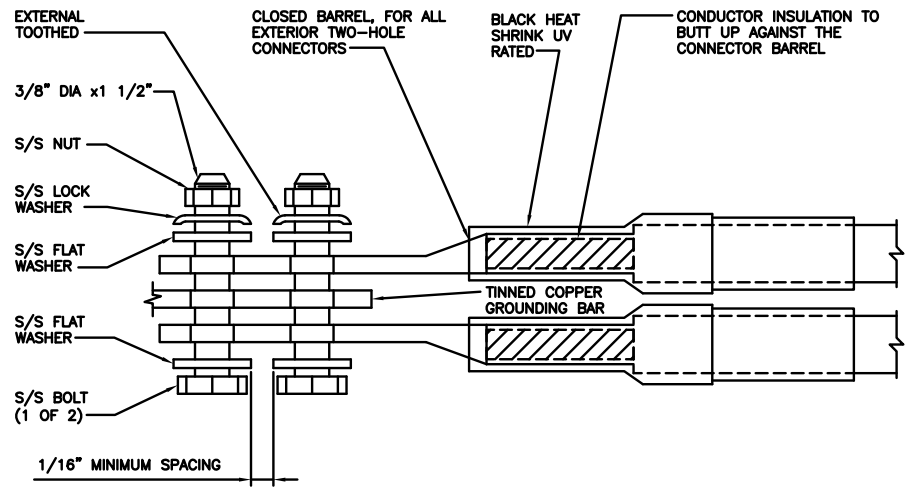

TYPICAL GROUNDING NOTES

NO SCALE 1

TYPICAL EXTERIOR TWO HOLE LUG

NO SCALE 2

TYPICAL INTERIOR TWO HOLE LUG

NO SCALE 3

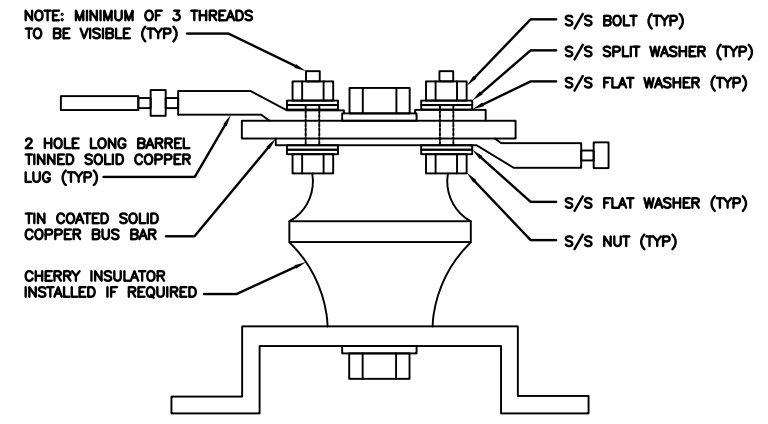

LUG DETAIL

NO SCALE 4

NOT USED

NO SCALE 5

NOT USED

NO SCALE 6

NOT USED

NO SCALE 7

NOT USED

NO SCALE 8

NOT USED

NO SCALE 9



5701 SOUTH SANTA FE DRIVE
LITTLETON, CO 80120



B&T ENGINEERING, INC.
PEC.0001564
Expires 2/10/22

IT IS A VIOLATION OF LAW FOR ANY PERSON, UNLESS THEY ARE ACTING UNDER THE DIRECTION OF A LICENSED PROFESSIONAL ENGINEER, TO ALTER THIS DOCUMENT.

DRAWN BY: BLJ
CHECKED BY: BLJ
APPROVED BY: MP

RFDS REV #: ---

CONSTRUCTION DOCUMENTS

SUBMITTALS		
REV	DATE	DESCRIPTION
A	7/16/21	ISSUED FOR REVIEW
0	8/2/21	ISSUED FOR CONSTRUCTION

A&E PROJECT NUMBER
152988.001.01

DISH Wireless L.L.C.
PROJECT INFORMATION
BOBDL00109A
87 MONCE RD.
BURLINGTON, CT 06013

SHEET TITLE
GROUNDING DETAILS

SHEET NUMBER
G-3

RF JUMPER COLOR CODING

3/4" TAPE WIDTHS WITH 3/4" SPACING

LOW-BAND RRH -
(600MHz N71 BASEBAND) +
(850MHz N26 BAND) +
(700MHz N29 BAND) - OPTIONAL PER MARKET

ADD FREQUENCY COLOR TO SECTOR BAND
(CBRS WILL USE YELLOW BANDS)

ALPHA RRH				BETA RRH				GAMMA RRH			
PORT 1 + SLANT	PORT 2 - SLANT	PORT 3 + SLANT	PORT 4 - SLANT	PORT 1 + SLANT	PORT 2 - SLANT	PORT 3 + SLANT	PORT 4 - SLANT	PORT 1 + SLANT	PORT 2 - SLANT	PORT 3 + SLANT	PORT 4 - SLANT
RED	RED	RED	RED	BLUE	BLUE	BLUE	BLUE	GREEN	GREEN	GREEN	GREEN
ORANGE	ORANGE	RED	RED	ORANGE	ORANGE	BLUE	BLUE	ORANGE	ORANGE	GREEN	GREEN
	WHITE (-) PORT	ORANGE	ORANGE		WHITE (-) PORT	ORANGE	ORANGE		WHITE (-) PORT	ORANGE	ORANGE
			WHITE (-) PORT				WHITE (-) PORT				WHITE (-) PORT

MID-BAND RRH -
(AWS BANDS N66+N70)

ADD FREQUENCY COLOR TO SECTOR BAND
(CBRS WILL USE YELLOW BANDS)

RED	RED	RED	RED	BLUE	BLUE	BLUE	BLUE	GREEN	GREEN	GREEN	GREEN
PURPLE	PURPLE	RED	RED	PURPLE	PURPLE	BLUE	BLUE	PURPLE	PURPLE	GREEN	GREEN
	WHITE (-) PORT	PURPLE	PURPLE		WHITE (-) PORT	PURPLE	PURPLE		WHITE (-) PORT	PURPLE	PURPLE
			WHITE (-) PORT				WHITE (-) PORT				WHITE (-) PORT

HYBRID/DISCREET CABLES

INCLUDE SECTOR BANDS BEING SUPPORTED
ALONG WITH FREQUENCY BANDS

EXAMPLE 1 - HYBRID, OR DISCREET, SUPPORTS
ALL SECTORS, BOTH LOW-BANDS AND MID-BANDS

EXAMPLE 2 - HYBRID, OR DISCREET, SUPPORTS
CBRS ONLY, ALL SECTORS

EXAMPLE 1	EXAMPLE 2	EXAMPLE 3
RED	RED	RED
BLUE	BLUE	
GREEN	GREEN	ORANGE
ORANGE	YELLOW	PURPLE
PURPLE		

NOTES

- CONTRACTOR TO REFER TO FINAL CONSTRUCTION RFDS FOR ALL RF DETAILS. FINAL RFDS IS IN NEXYSONE.

FIBER JUMPERS TO RRHs

LOW-BAND RRH FIBER CABLES HAVE SECTOR
STRIPE ONLY

LOW BAND RRH	HIGH BAND RRH	LOW BAND RRH	HIGH BAND RRH	LOW BAND RRH	HIGH BAND RRH
RED	RED	BLUE	BLUE	GREEN	GREEN
	PURPLE		PURPLE		PURPLE

POWER CABLES TO RRHs

LOW-BAND RRH POWER CABLES HAVE SECTOR
STRIPE ONLY

LOW BAND RRH	HIGH BAND RRH	LOW BAND RRH	HIGH BAND RRH	LOW BAND RRH	HIGH BAND RRH
RED	RED	BLUE	BLUE	GREEN	GREEN
	PURPLE		PURPLE		PURPLE

RET MOTORS AT ANTENNAS

ANTENNA 1 LOW BAND/ "IN"	ANTENNA 1 HIGH BAND/ "IN"	ANTENNA 1 LOW BAND/ "IN"	ANTENNA 1 HIGH BAND/ "IN"	ANTENNA 1 LOW BAND/ "IN"	ANTENNA 1 HIGH BAND/ "IN"
RED	RED	BLUE	BLUE	GREEN	GREEN
	PURPLE		PURPLE		PURPLE

MICROWAVE RADIO LINKS

LINKS WILL HAVE A 1.5-2 INCH WHITE WRAP WITH
THE AZIMUTH COLOR OVERLAPPING IN THE MIDDLE.
ADD ADDITIONAL SECTOR COLOR BANDS FOR EACH
ADDITIONAL MW RADIO.

MICROWAVE CABLES WILL REQUIRE P-TOUCH
LABELS INSIDE THE CABINET TO IDENTIFY THE
LOCAL AND REMOTE SITE ID'S

FORWARD AZIMUTH OF 0-120 DEGREES		FORWARD AZIMUTH OF 120-240 DEGREES		FORWARD AZIMUTH OF 240-360 DEGREES	
PRIMARY	SECONDARY	PRIMARY	SECONDARY	PRIMARY	SECONDARY
WHITE	WHITE	WHITE	WHITE	WHITE	WHITE
RED	RED	BLUE	BLUE	GREEN	GREEN
WHITE	WHITE	WHITE	WHITE	WHITE	WHITE
	RED		BLUE		GREEN
	WHITE		WHITE		WHITE

RF CABLE COLOR CODES

NO SCALE

1

NOT USED

NO SCALE

4

LOW BANDS (N71+N26)
OPTIONAL - (N29)
ORANGE

AWS
(N66+N70+H-BLOCK)
PURPLE

CBRS TECH
(3 GHz)
YELLOW

NEGATIVE SLANT PORT
ON ANT/RRH
WHITE

ALPHA SECTOR

RED

BETA SECTOR

BLUE

GAMMA SECTOR

GREEN

COLOR IDENTIFIER

NO SCALE

2

NOT USED

NO SCALE

3

NOT USED

NO SCALE

4



5701 SOUTH SANTA FE DRIVE
LITTLETON, CO 80120



1717 S. BOULDER
SUITE 300
TULSA, OK 74119
PH: (918) 587-4630
www.blgrp.com



B&T ENGINEERING, INC.
PEC.0001564
Expires 2/10/22

IT IS A VIOLATION OF LAW FOR ANY PERSON,
UNLESS THEY ARE ACTING UNDER THE DIRECTION
OF A LICENSED PROFESSIONAL ENGINEER,
TO ALTER THIS DOCUMENT.

DRAWN BY: BLJ
CHECKED BY: BLJ
APPROVED BY: MP

RFDS REV #: ---

CONSTRUCTION DOCUMENTS

SUBMITTALS		
REV	DATE	DESCRIPTION
A	7/16/21	ISSUED FOR REVIEW
0	8/2/21	ISSUED FOR CONSTRUCTION

A&E PROJECT NUMBER
152988.001.01

DISH Wireless L.L.C.
PROJECT INFORMATION

BOBDL00109A
87 MONCE RD.
BURLINGTON, CT 06013

SHEET TITLE
RF
CABLE COLOR CODES

SHEET NUMBER

RF-1

EXOTHERMIC CONNECTION
 MECHANICAL CONNECTION
 BUSS BAR INSULATOR
 CHEMICAL ELECTROLYTIC GROUNDING SYSTEM
 TEST CHEMICAL ELECTROLYTIC GROUNDING SYSTEM
 EXOTHERMIC WITH INSPECTION SLEEVE
 GROUNDING BAR
 GROUND ROD
 TEST GROUND ROD WITH INSPECTION SLEEVE
 SINGLE POLE SWITCH
 DUPLEX RECEPTACLE
 DUPLEX GFCI RECEPTACLE
 FLUORESCENT LIGHTING FIXTURE (2) TWO LAMPS 48-T8
 SMOKE DETECTION (DC)
 EMERGENCY LIGHTING (DC)
 SECURITY LIGHT W/PHOTOCELL LITHONIA ALXW
 LED-1-25A400/51K-SR4-120-PE-DOBTXD
 CHAIN LINK FENCE
 WOOD/WROUGHT IRON FENCE
 WALL STRUCTURE
 LEASE AREA
 PROPERTY LINE (PL)
 SETBACKS
 ICE BRIDGE
 CABLE TRAY
 WATER LINE
 UNDERGROUND POWER
 UNDERGROUND TELCO
 OVERHEAD POWER
 OVERHEAD TELCO
 UNDERGROUND TELCO/POWER
 ABOVE GROUND POWER
 ABOVE GROUND TELCO
 ABOVE GROUND TELCO/POWER
 WORKPOINT

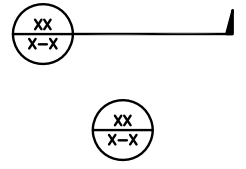
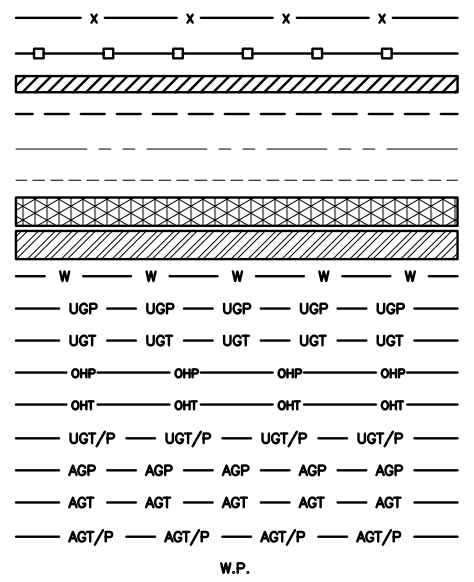
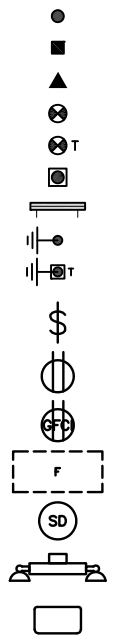

AB ANCHOR BOLT
 ABV ABOVE
 AC ALTERNATING CURRENT
 ADDL ADDITIONAL
 AFF ABOVE FINISHED FLOOR
 AFG ABOVE FINISHED GRADE
 AGL ABOVE GROUND LEVEL
 AIC AMPERAGE INTERRUPTION CAPACITY
 ALUM ALUMINUM
 ALT ALTERNATE
 ANT ANTENNA
 APPROX APPROXIMATE
 ARCH ARCHITECTURAL
 ATS AUTOMATIC TRANSFER SWITCH
 AWG AMERICAN WIRE GAUGE
 BATT BATTERY
 BLDG BUILDING
 BLK BLOCK
 BLKG BLOCKING
 BM BEAM
 BTC BARE TINNED COPPER CONDUCTOR
 BOF BOTTOM OF FOOTING
 CAB CABINET
 CANT CANTILEVERED
 CHG CHARGING
 CLG CEILING
 CLR CLEAR
 COL COLUMN
 COMM COMMON
 CONC CONCRETE
 CONSTR CONSTRUCTION
 DBL DOUBLE
 DC DIRECT CURRENT
 DEPT DEPARTMENT
 DF DOUGLAS FIR
 DIA DIAMETER
 DIAG DIAGONAL
 DIM DIMENSION
 DWG DRAWING
 DWL DOWEL
 EA EACH
 EC ELECTRICAL CONDUCTOR
 EL ELEVATION
 ELEC ELECTRICAL
 EMT ELECTRICAL METALLIC TUBING
 ENG ENGINEER
 EQ EQUAL
 EXP EXPANSION
 EXT EXTERIOR
 EW EACH WAY
 FAB FABRICATION
 FF FINISH FLOOR
 FG FINISH GRADE
 FIF FACILITY INTERFACE FRAME
 FIN FINISH(ED)
 FLR FLOOR
 FDN FOUNDATION
 FOC FACE OF CONCRETE
 FOM FACE OF MASONRY
 FOS FACE OF STUD
 FOW FACE OF WALL
 FS FINISH SURFACE
 FT FOOT
 FTG FOOTING
 GA GAUGE
 GEN GENERATOR
 GFCI GROUND FAULT CIRCUIT INTERRUPTER
 GLB GLUE LAMINATED BEAM
 GLV GALVANIZED
 GPS GLOBAL POSITIONING SYSTEM
 GND GROUND
 GSM GLOBAL SYSTEM FOR MOBILE
 HDG HOT DIPPED GALVANIZED
 HDR HEADER
 HGR HANGER
 HVAC HEAT/VENTILATION/AIR CONDITIONING
 HT HEIGHT
 IGR INTERIOR GROUND RING
 IN INCH
 INT INTERIOR
 LB(S) POUND(S)
 LF LINEAR FEET
 LTE LONG TERM EVOLUTION
 MAS MASONRY
 MAX MAXIMUM
 MB MACHINE BOLT
 MECH MECHANICAL
 MFR MANUFACTURER
 MGB MASTER GROUND BAR
 MIN MINIMUM
 MISC MISCELLANEOUS
 MTL METAL
 MTS MANUAL TRANSFER SWITCH
 MW MICROWAVE
 NEC NATIONAL ELECTRIC CODE
 NM NEWTON METERS
 NO. NUMBER
 # NUMBER
 NTS NOT TO SCALE
 OC ON-CENTER
 OSHA OCCUPATIONAL SAFETY AND HEALTH ADMINISTRATION
 OPNG OPENING
 P/C PRECAST CONCRETE
 PCS PERSONAL COMMUNICATION SERVICES
 PCU PRIMARY CONTROL UNIT
 PRC PRIMARY RADIO CABINET
 PP POLARIZING PRESERVING
 PSF POUNDS PER SQUARE FOOT
 PSI POUNDS PER SQUARE INCH
 PT PRESSURE TREATED
 PWR POWER CABINET
 QTY QUANTITY
 RAD RADIUS
 RECT RECTIFIER
 REF REFERENCE
 REINF REINFORCEMENT
 REQ'D REQUIRED
 RET REMOTE ELECTRIC TILT
 RF RADIO FREQUENCY
 RMC RIGID METALLIC CONDUIT
 RRH REMOTE RADIO HEAD
 RRU REMOTE RADIO UNIT
 RWY RACEWAY
 SCH SCHEDULE
 SHT SHEET
 SIAD SMART INTEGRATED ACCESS DEVICE
 SIM SIMILAR
 SPEC SPECIFICATION
 SQ SQUARE
 SS STAINLESS STEEL
 STD STANDARD
 STL STEEL
 TEMP TEMPORARY
 THK THICKNESS
 TMA TOWER MOUNTED AMPLIFIER
 TN TOE NAIL
 TOA TOP OF ANTENNA
 TOC TOP OF CURB
 TOF TOP OF FOUNDATION
 TOP TOP OF PLATE (PARAPET)
 TOS TOP OF STEEL
 TOW TOP OF WALL
 TVSS TRANSIENT VOLTAGE SURGE SUPPRESSION
 TYP TYPICAL
 UG UNDERGROUND
 UL UNDERWRITERS LABORATORY
 UNO UNLESS NOTED OTHERWISE
 UMTS UNIVERSAL MOBILE TELECOMMUNICATIONS SYSTEM
 UPS UNINTERRUPTIBLE POWER SYSTEM (DC POWER PLANT)
 VIF VERIFIED IN FIELD
 W WIDE
 W/ WITH
 WD WOOD
 WP WEATHERPROOF
 WT WEIGHT

LEGEND

ABBREVIATIONS



5701 SOUTH SANTA FE DRIVE
 LITTLETON, CO 80120



B&T ENGINEERING, INC.
 PEC.0001564
 Expires 2/10/22

IT IS A VIOLATION OF LAW FOR ANY PERSON,
 UNLESS THEY ARE ACTING UNDER THE DIRECTION
 OF A LICENSED PROFESSIONAL ENGINEER,
 TO ALTER THIS DOCUMENT.

DRAWN BY:	CHECKED BY:	APPROVED BY:
BLJ	BLJ	MP

RFDS REV #: ---

CONSTRUCTION DOCUMENTS

SUBMITTALS		
REV	DATE	DESCRIPTION
A	7/16/21	ISSUED FOR REVIEW
0	8/2/21	ISSUED FOR CONSTRUCTION

A&E PROJECT NUMBER
 152988.001.01

DISH Wireless L.L.C.
 PROJECT INFORMATION
 BOBDL00109A
 87 MONCE RD.
 BURLINGTON, CT 06013

SHEET TITLE
 LEGEND AND ABBREVIATIONS

SHEET NUMBER
GN-1

SITE ACTIVITY REQUIREMENTS:

- NOTICE TO PROCEED – NO WORK SHALL COMMENCE PRIOR TO CONTRACTOR RECEIVING A WRITTEN NOTICE TO PROCEED (NTP) AND THE ISSUANCE OF A PURCHASE ORDER. PRIOR TO ACCESSING/ENTERING THE SITE YOU MUST CONTACT THE DISH Wireless L.L.C. AND TOWER OWNER NOC & THE DISH Wireless L.L.C. AND TOWER OWNER CONSTRUCTION MANAGER.
- "LOOK UP" – DISH Wireless L.L.C. AND TOWER OWNER SAFETY CLIMB REQUIREMENT:
THE INTEGRITY OF THE SAFETY CLIMB AND ALL COMPONENTS OF THE CLIMBING FACILITY SHALL BE CONSIDERED DURING ALL STAGES OF DESIGN, INSTALLATION, AND INSPECTION. TOWER MODIFICATION, MOUNT REINFORCEMENTS, AND/OR EQUIPMENT INSTALLATIONS SHALL NOT COMPROMISE THE INTEGRITY OR FUNCTIONAL USE OF THE SAFETY CLIMB OR ANY COMPONENTS OF THE CLIMBING FACILITY ON THE STRUCTURE. THIS SHALL INCLUDE, BUT NOT BE LIMITED TO: PINCHING OF THE WIRE ROPE, BENDING OF THE WIRE ROPE FROM ITS SUPPORTS, DIRECT CONTACT OR CLOSE PROXIMITY TO THE WIRE ROPE WHICH MAY CAUSE FRICTIONAL WEAR, IMPACT TO THE ANCHORAGE POINTS IN ANY WAY, OR TO IMPEDE/BLOCK ITS INTENDED USE. ANY COMPROMISED SAFETY CLIMB, INCLUDING EXISTING CONDITIONS MUST BE TAGGED OUT AND REPORTED TO YOUR DISH Wireless L.L.C. AND DISH Wireless L.L.C. AND TOWER OWNER POC OR CALL THE NOC TO GENERATE A SAFETY CLIMB MAINTENANCE AND CONTRACTOR NOTICE TICKET.
- PRIOR TO THE START OF CONSTRUCTION, ALL REQUIRED JURISDICTIONAL PERMITS SHALL BE OBTAINED. THIS INCLUDES, BUT IS NOT LIMITED TO, BUILDING, ELECTRICAL, MECHANICAL, FIRE, FLOOD ZONE, ENVIRONMENTAL, AND ZONING. AFTER ONSITE ACTIVITIES AND CONSTRUCTION ARE COMPLETED, ALL REQUIRED PERMITS SHALL BE SATISFIED AND CLOSED OUT ACCORDING TO LOCAL JURISDICTIONAL REQUIREMENTS.
- ALL CONSTRUCTION MEANS AND METHODS; INCLUDING BUT NOT LIMITED TO, ERECTION PLANS, RIGGING PLANS, CLIMBING PLANS, AND RESCUE PLANS SHALL BE THE RESPONSIBILITY OF THE GENERAL CONTRACTOR RESPONSIBLE FOR THE EXECUTION OF THE WORK CONTAINED HEREIN, AND SHALL MEET ANSI/ASSE A10.48 (LATEST EDITION); FEDERAL, STATE, AND LOCAL REGULATIONS; AND ANY APPLICABLE INDUSTRY CONSENSUS STANDARDS RELATED TO THE CONSTRUCTION ACTIVITIES BEING PERFORMED. ALL RIGGING PLANS SHALL ADHERE TO ANSI/ASSE A10.48 (LATEST EDITION) AND DISH Wireless L.L.C. AND TOWER OWNER STANDARDS, INCLUDING THE REQUIRED INVOLVEMENT OF A QUALIFIED ENGINEER FOR CLASS IV CONSTRUCTION, TO CERTIFY THE SUPPORTING STRUCTURE(S) IN ACCORDANCE WITH ANSI/TIA-322 (LATEST EDITION).
- ALL SITE WORK TO COMPLY WITH DISH Wireless L.L.C. AND TOWER OWNER INSTALLATION STANDARDS FOR CONSTRUCTION ACTIVITIES ON DISH Wireless L.L.C. AND TOWER OWNER TOWER SITE AND LATEST VERSION OF ANSI/TIA-1019-A-2012 "STANDARD FOR INSTALLATION, ALTERATION, AND MAINTENANCE OF ANTENNA SUPPORTING STRUCTURES AND ANTENNAS."
- IF THE SPECIFIED EQUIPMENT CAN NOT BE INSTALLED AS SHOWN ON THESE DRAWINGS, THE CONTRACTOR SHALL PROPOSE AN ALTERNATIVE INSTALLATION FOR APPROVAL BY DISH Wireless L.L.C. AND TOWER OWNER PRIOR TO PROCEEDING WITH ANY SUCH CHANGE OF INSTALLATION.
- ALL MATERIALS FURNISHED AND INSTALLED SHALL BE IN STRICT ACCORDANCE WITH ALL APPLICABLE CODES, REGULATIONS AND ORDINANCES. CONTRACTOR SHALL ISSUE ALL APPROPRIATE NOTICES AND COMPLY WITH ALL LAWS, ORDINANCES, RULES, REGULATIONS AND LAWFUL ORDERS OF ANY PUBLIC AUTHORITY REGARDING THE PERFORMANCE OF THE WORK. ALL WORK CARRIED OUT SHALL COMPLY WITH ALL APPLICABLE MUNICIPAL AND UTILITY COMPANY SPECIFICATIONS AND LOCAL JURISDICTIONAL CODES, ORDINANCES AND APPLICABLE REGULATIONS.
- THE CONTRACTOR SHALL INSTALL ALL EQUIPMENT AND MATERIALS IN ACCORDANCE WITH MANUFACTURER'S RECOMMENDATIONS UNLESS SPECIFICALLY STATED OTHERWISE.
- THE CONTRACTOR SHALL CONTACT UTILITY LOCATING SERVICES INCLUDING PRIVATE LOCATES SERVICES PRIOR TO THE START OF CONSTRUCTION.
- ALL EXISTING ACTIVE SEWER, WATER, GAS, ELECTRIC AND OTHER UTILITIES WHERE ENCOUNTERED IN THE WORK, SHALL BE PROTECTED AT ALL TIMES AND WHERE REQUIRED FOR THE PROPER EXECUTION OF THE WORK, SHALL BE RELOCATED AS DIRECTED BY CONTRACTOR. EXTREME CAUTION SHOULD BE USED BY THE CONTRACTOR WHEN EXCAVATING OR DRILLING PIERS AROUND OR NEAR UTILITIES. CONTRACTOR SHALL PROVIDE SAFETY TRAINING FOR THE WORKING CREW. THIS WILL INCLUDE BUT NOT BE LIMITED TO A) FALL PROTECTION B) CONFINED SPACE C) ELECTRICAL SAFETY D) TRENCHING AND EXCAVATION E) CONSTRUCTION SAFETY PROCEDURES.
- ALL SITE WORK SHALL BE AS INDICATED ON THE STAMPED CONSTRUCTION DRAWINGS AND DISH PROJECT SPECIFICATIONS, LATEST APPROVED REVISION.
- CONTRACTOR SHALL KEEP THE SITE FREE FROM ACCUMULATING WASTE MATERIAL, DEBRIS, AND TRASH AT THE COMPLETION OF THE WORK. IF NECESSARY, RUBBISH, STUMPS, DEBRIS, STICKS, STONES AND OTHER REFUSE SHALL BE REMOVED FROM THE SITE AND DISPOSED OF LEGALLY.
- ALL EXISTING INACTIVE SEWER, WATER, GAS, ELECTRIC AND OTHER UTILITIES, WHICH INTERFERE WITH THE EXECUTION OF THE WORK, SHALL BE REMOVED AND/OR CAPPED, PLUGGED OR OTHERWISE DISCONTINUED AT POINTS WHICH WILL NOT INTERFERE WITH THE EXECUTION OF THE WORK, SUBJECT TO THE APPROVAL OF DISH Wireless L.L.C. AND TOWER OWNER, AND/OR LOCAL UTILITIES.
- THE CONTRACTOR SHALL PROVIDE SITE SIGNAGE IN ACCORDANCE WITH THE TECHNICAL SPECIFICATION FOR SITE SIGNAGE REQUIRED BY LOCAL JURISDICTION AND SIGNAGE REQUIRED ON INDIVIDUAL PIECES OF EQUIPMENT, ROOMS, AND SHELTERS.
- THE SITE SHALL BE GRADED TO CAUSE SURFACE WATER TO FLOW AWAY FROM THE CARRIER'S EQUIPMENT AND TOWER AREAS.
- THE SUB GRADE SHALL BE COMPACTED AND BROUGHT TO A SMOOTH UNIFORM GRADE PRIOR TO FINISHED SURFACE APPLICATION.
- THE AREAS OF THE OWNERS PROPERTY DISTURBED BY THE WORK AND NOT COVERED BY THE TOWER, EQUIPMENT OR DRIVEWAY, SHALL BE GRADED TO A UNIFORM SLOPE, AND STABILIZED TO PREVENT EROSION AS SPECIFIED ON THE CONSTRUCTION DRAWINGS AND/OR PROJECT SPECIFICATIONS.
- CONTRACTOR SHALL MINIMIZE DISTURBANCE TO EXISTING SITE DURING CONSTRUCTION. EROSION CONTROL MEASURES, IF REQUIRED DURING CONSTRUCTION, SHALL BE IN CONFORMANCE WITH THE LOCAL GUIDELINES FOR EROSION AND SEDIMENT CONTROL.
- THE CONTRACTOR SHALL PROTECT EXISTING IMPROVEMENTS, PAVEMENTS, CURBS, LANDSCAPING AND STRUCTURES. ANY DAMAGED PART SHALL BE REPAIRED AT CONTRACTOR'S EXPENSE TO THE SATISFACTION OF OWNER.
- CONTRACTOR SHALL LEGALLY AND PROPERLY DISPOSE OF ALL SCRAP MATERIALS SUCH AS COAXIAL CABLES AND OTHER ITEMS REMOVED FROM THE EXISTING FACILITY. ANTENNAS AND RADIOS REMOVED SHALL BE RETURNED TO THE OWNER'S DESIGNATED LOCATION.
- CONTRACTOR SHALL LEAVE PREMISES IN CLEAN CONDITION. TRASH AND DEBRIS SHOULD BE REMOVED FROM SITE ON A DAILY BASIS.
- NO FILL OR EMBANKMENT MATERIAL SHALL BE PLACED ON FROZEN GROUND. FROZEN MATERIALS, SNOW OR ICE SHALL NOT BE PLACED IN ANY FILL OR EMBANKMENT.

GENERAL NOTES:

- FOR THE PURPOSE OF CONSTRUCTION DRAWING, THE FOLLOWING DEFINITIONS SHALL APPLY:
CONTRACTOR:GENERAL CONTRACTOR RESPONSIBLE FOR CONSTRUCTION
CARRIER:DISH Wireless L.L.C.
TOWER OWNER:TOWER OWNER
- THESE DRAWINGS HAVE BEEN PREPARED USING STANDARDS OF PROFESSIONAL CARE AND COMPLETENESS NORMALLY EXERCISED UNDER SIMILAR CIRCUMSTANCES BY REPUTABLE ENGINEERS IN THIS OR SIMILAR LOCALITIES. IT IS ASSUMED THAT THE WORK DEPICTED WILL BE PERFORMED BY AN EXPERIENCED CONTRACTOR AND/OR WORKPEOPLE WHO HAVE A WORKING KNOWLEDGE OF THE APPLICABLE CODE STANDARDS AND REQUIREMENTS AND OF INDUSTRY ACCEPTED STANDARD GOOD PRACTICE. AS NOT EVERY CONDITION OR ELEMENT IS (OR CAN BE) EXPLICITLY SHOWN ON THESE DRAWINGS, THE CONTRACTOR SHALL USE INDUSTRY ACCEPTED STANDARD GOOD PRACTICE FOR MISCELLANEOUS WORK NOT EXPLICITLY SHOWN.
- THESE DRAWINGS REPRESENT THE FINISHED STRUCTURE. THEY DO NOT INDICATE THE MEANS OR METHODS OF CONSTRUCTION. THE CONTRACTOR SHALL BE SOLELY RESPONSIBLE FOR THE CONSTRUCTION MEANS, METHODS, TECHNIQUES, SEQUENCES, AND PROCEDURES. THE CONTRACTOR SHALL PROVIDE ALL MEASURES NECESSARY FOR PROTECTION OF LIFE AND PROPERTY DURING CONSTRUCTION. SUCH MEASURES SHALL INCLUDE, BUT NOT BE LIMITED TO, BRACING, FORMWORK, SHORING, ETC. SITE VISITS BY THE ENGINEER OR HIS REPRESENTATIVE WILL NOT INCLUDE INSPECTION OF THESE ITEMS AND IS FOR STRUCTURAL OBSERVATION OF THE FINISHED STRUCTURE ONLY.
- NOTES AND DETAILS IN THE CONSTRUCTION DRAWINGS SHALL TAKE PRECEDENCE OVER GENERAL NOTES AND TYPICAL DETAILS. WHERE NO DETAILS ARE SHOWN, CONSTRUCTION SHALL CONFORM TO SIMILAR WORK ON THE PROJECT, AND/OR AS PROVIDED FOR IN THE CONTRACT DOCUMENTS. WHERE DISCREPANCIES OCCUR BETWEEN PLANS, DETAILS, GENERAL NOTES, AND SPECIFICATIONS, THE GREATER, MORE STRICT REQUIREMENTS, SHALL GOVERN. IF FURTHER CLARIFICATION IS REQUIRED CONTACT THE ENGINEER OF RECORD.
- SUBSTANTIAL EFFORT HAS BEEN MADE TO PROVIDE ACCURATE DIMENSIONS AND MEASUREMENTS ON THE DRAWINGS TO ASSIST IN THE FABRICATION AND/OR PLACEMENT OF CONSTRUCTION ELEMENTS BUT IT IS THE SOLE RESPONSIBILITY OF THE CONTRACTOR TO FIELD VERIFY THE DIMENSIONS, MEASUREMENTS, AND/OR CLEARANCES SHOWN IN THE CONSTRUCTION DRAWINGS PRIOR TO FABRICATION OR CUTTING OF ANY NEW OR EXISTING CONSTRUCTION ELEMENTS. IF IT IS DETERMINED THAT THERE ARE DISCREPANCIES AND/OR CONFLICTS WITH THE CONSTRUCTION DRAWINGS THE ENGINEER OF RECORD IS TO BE NOTIFIED AS SOON AS POSSIBLE.
- PRIOR TO THE SUBMISSION OF BIDS, THE BIDDING CONTRACTOR SHALL VISIT THE CELL SITE TO FAMILIARIZE WITH THE EXISTING CONDITIONS AND TO CONFIRM THAT THE WORK CAN BE ACCOMPLISHED AS SHOWN ON THE CONSTRUCTION DRAWINGS. ANY DISCREPANCY FOUND SHALL BE BROUGHT TO THE ATTENTION OF CARRIER POC AND TOWER OWNER.
- ALL MATERIALS FURNISHED AND INSTALLED SHALL BE IN STRICT ACCORDANCE WITH ALL APPLICABLE CODES, REGULATIONS AND ORDINANCES. CONTRACTOR SHALL ISSUE ALL APPROPRIATE NOTICES AND COMPLY WITH ALL LAWS, ORDINANCES, RULES, REGULATIONS AND LAWFUL ORDERS OF ANY PUBLIC AUTHORITY REGARDING THE PERFORMANCE OF THE WORK. ALL WORK CARRIED OUT SHALL COMPLY WITH ALL APPLICABLE MUNICIPAL AND UTILITY COMPANY SPECIFICATIONS AND LOCAL JURISDICTIONAL CODES, ORDINANCES AND APPLICABLE REGULATIONS.
- UNLESS NOTED OTHERWISE, THE WORK SHALL INCLUDE FURNISHING MATERIALS, EQUIPMENT, APPURTENANCES AND LABOR NECESSARY TO COMPLETE ALL INSTALLATIONS AS INDICATED ON THE DRAWINGS.
- THE CONTRACTOR SHALL INSTALL ALL EQUIPMENT AND MATERIALS IN ACCORDANCE WITH MANUFACTURER'S RECOMMENDATIONS UNLESS SPECIFICALLY STATED OTHERWISE.
- IF THE SPECIFIED EQUIPMENT CAN NOT BE INSTALLED AS SHOWN ON THESE DRAWINGS, THE CONTRACTOR SHALL PROPOSE AN ALTERNATIVE INSTALLATION FOR APPROVAL BY THE CARRIER AND TOWER OWNER PRIOR TO PROCEEDING WITH ANY SUCH CHANGE OF INSTALLATION.
- CONTRACTOR IS TO PERFORM A SITE INVESTIGATION, BEFORE SUBMITTING BIDS, TO DETERMINE THE BEST ROUTING OF ALL CONDUITS FOR POWER, AND TELCO AND FOR GROUNDING CABLES AS SHOWN IN THE POWER, TELCO, AND GROUNDING PLAN DRAWINGS.
- THE CONTRACTOR SHALL PROTECT EXISTING IMPROVEMENTS, PAVEMENTS, CURBS, LANDSCAPING AND STRUCTURES. ANY DAMAGED PART SHALL BE REPAIRED AT CONTRACTOR'S EXPENSE TO THE SATISFACTION OF DISH Wireless L.L.C. AND TOWER OWNER
- CONTRACTOR SHALL LEGALLY AND PROPERLY DISPOSE OF ALL SCRAP MATERIALS SUCH AS COAXIAL CABLES AND OTHER ITEMS REMOVED FROM THE EXISTING FACILITY. ANTENNAS REMOVED SHALL BE RETURNED TO THE OWNER'S DESIGNATED LOCATION.
- CONTRACTOR SHALL LEAVE PREMISES IN CLEAN CONDITION. TRASH AND DEBRIS SHOULD BE REMOVED FROM SITE ON A DAILY BASIS.



5701 SOUTH SANTA FE DRIVE
LITTLETON, CO 80120



10 PRESIDENTIAL WAY
WOBURN, MA 01801



1717 S. BOULDER
SUITE 300
TULSA, OK 74119
PH: (918) 587-4630
www.blgrp.com



B&T ENGINEERING, INC.
PEC.0001564
Expires 2/10/22

IT IS A VIOLATION OF LAW FOR ANY PERSON, UNLESS THEY ARE ACTING UNDER THE DIRECTION OF A LICENSED PROFESSIONAL ENGINEER, TO ALTER THIS DOCUMENT.

DRAWN BY:	CHECKED BY:	APPROVED BY:
BLJ	BLJ	MP

RFDS REV #: ---

CONSTRUCTION DOCUMENTS

SUBMITTALS		
REV	DATE	DESCRIPTION
A	7/16/21	ISSUED FOR REVIEW
0	8/2/21	ISSUED FOR CONSTRUCTION

A&E PROJECT NUMBER
152988.001.01

DISH Wireless L.L.C.
PROJECT INFORMATION

BOBDL00109A
87 MONCE RD.
BURLINGTON, CT 06013

SHEET TITLE
GENERAL NOTES

SHEET NUMBER
GN-2

CONCRETE, FOUNDATIONS, AND REINFORCING STEEL:

1. ALL CONCRETE WORK SHALL BE IN ACCORDANCE WITH THE ACI 301, ACI 318, ACI 336, ASTM A184, ASTM A185 AND THE DESIGN AND CONSTRUCTION SPECIFICATION FOR CAST-IN-PLACE CONCRETE.
2. UNLESS NOTED OTHERWISE, SOIL BEARING PRESSURE USED FOR DESIGN OF SLABS AND FOUNDATIONS IS ASSUMED TO BE 1000 psf.
3. ALL CONCRETE SHALL HAVE A MINIMUM COMPRESSIVE STRENGTH (f'c) OF 3000 psi AT 28 DAYS, UNLESS NOTED OTHERWISE. NO MORE THAN 90 MINUTES SHALL ELAPSE FROM BATCH TIME TO TIME OF PLACEMENT UNLESS APPROVED BY THE ENGINEER OF RECORD. TEMPERATURE OF CONCRETE SHALL NOT EXCEED 90°f AT TIME OF PLACEMENT.
4. CONCRETE EXPOSED TO FREEZE-THAW CYCLES SHALL CONTAIN AIR ENTRAINING ADMIXTURES. AMOUNT OF AIR ENTRAINMENT TO BE BASED ON SIZE OF AGGREGATE AND F3 CLASS EXPOSURE (VERY SEVERE). CEMENT USED TO BE TYPE II PORTLAND CEMENT WITH A MAXIMUM WATER-TO-CEMENT RATIO (W/C) OF 0.45.
5. ALL STEEL REINFORCING SHALL CONFORM TO ASTM A615. ALL WELDED WIRE FABRIC (WWF) SHALL CONFORM TO ASTM A185. ALL SPLICES SHALL BE CLASS "B" TENSION SPLICES, UNLESS NOTED OTHERWISE. ALL HOOKS SHALL BE STANDARD 90 DEGREE HOOKS, UNLESS NOTED OTHERWISE. YIELD STRENGTH (Fy) OF STANDARD DEFORMED BARS ARE AS FOLLOWS:
 #4 BARS AND SMALLER 40 ksi
 #5 BARS AND LARGER 60 ksi
6. THE FOLLOWING MINIMUM CONCRETE COVER SHALL BE PROVIDED FOR REINFORCING STEEL UNLESS SHOWN OTHERWISE ON DRAWINGS:
 - CONCRETE CAST AGAINST AND PERMANENTLY EXPOSED TO EARTH 3"
 - CONCRETE EXPOSED TO EARTH OR WEATHER:
 - #6 BARS AND LARGER 2"
 - #5 BARS AND SMALLER 1-1/2"
 - CONCRETE NOT EXPOSED TO EARTH OR WEATHER:
 - SLAB AND WALLS 3/4"
 - BEAMS AND COLUMNS 1-1/2"
7. A TOOLED EDGE OR A 3/4" CHAMFER SHALL BE PROVIDED AT ALL EXPOSED EDGES OF CONCRETE, UNLESS NOTED OTHERWISE, IN ACCORDANCE WITH ACI 301 SECTION 4.2.4.

ELECTRICAL INSTALLATION NOTES:

1. ALL ELECTRICAL WORK SHALL BE PERFORMED IN ACCORDANCE WITH THE PROJECT SPECIFICATIONS, NEC AND ALL APPLICABLE FEDERAL, STATE, AND LOCAL CODES/ORDINANCES.
2. CONDUIT ROUTINGS ARE SCHEMATIC. CONTRACTOR SHALL INSTALL CONDUITS SO THAT ACCESS TO EQUIPMENT IS NOT BLOCKED AND TRIP HAZARDS ARE ELIMINATED.
3. WIRING, RACEWAY AND SUPPORT METHODS AND MATERIALS SHALL COMPLY WITH THE REQUIREMENTS OF THE NEC.
4. ALL CIRCUITS SHALL BE SEGREGATED AND MAINTAIN MINIMUM CABLE SEPARATION AS REQUIRED BY THE NEC.
- 4.1. ALL EQUIPMENT SHALL BEAR THE UNDERWRITERS LABORATORIES LABEL OF APPROVAL, AND SHALL CONFORM TO REQUIREMENT OF THE NATIONAL ELECTRICAL CODE.
- 4.2. ALL OVERCURRENT DEVICES SHALL HAVE AN INTERRUPTING CURRENT RATING THAT SHALL BE GREATER THAN THE SHORT CIRCUIT CURRENT TO WHICH THEY ARE SUBJECTED, 22,000 AIC MINIMUM. VERIFY AVAILABLE SHORT CIRCUIT CURRENT DOES NOT EXCEED THE RATING OF ELECTRICAL EQUIPMENT IN ACCORDANCE WITH ARTICLE 110.24 NEC OR THE MOST CURRENT ADOPTED CODE PRE THE GOVERNING JURISDICTION.
5. EACH END OF EVERY POWER PHASE CONDUCTOR, GROUNDING CONDUCTOR, AND TELCO CONDUCTOR OR CABLE SHALL BE LABELED WITH COLOR-CODED INSULATION OR ELECTRICAL TAPE (3M BRAND, 1/2" PLASTIC ELECTRICAL TAPE WITH UV PROTECTION, OR EQUAL). THE IDENTIFICATION METHOD SHALL CONFORM WITH NEC AND OSHA.
6. ALL ELECTRICAL COMPONENTS SHALL BE CLEARLY LABELED WITH LAMICOID TAGS SHOWING THEIR RATED VOLTAGE, PHASE CONFIGURATION, WIRE CONFIGURATION, POWER OR AMPACITY RATING AND BRANCH CIRCUIT ID NUMBERS (i.e. PANEL BOARD AND CIRCUIT ID'S).
7. PANEL BOARDS (ID NUMBERS) SHALL BE CLEARLY LABELED WITH PLASTIC LABELS.
8. TIE WRAPS ARE NOT ALLOWED.
9. ALL POWER AND EQUIPMENT GROUND WIRING IN TUBING OR CONDUIT SHALL BE SINGLE COPPER CONDUCTOR (#14 OR LARGER) WITH TYPE THHW, THWN, THWN-2, XHHW, XHHW-2, THW, THW-2, RHW, OR RHW-2 INSULATION UNLESS OTHERWISE SPECIFIED.
10. SUPPLEMENTAL EQUIPMENT GROUND WIRING LOCATED INDOORS SHALL BE SINGLE COPPER CONDUCTOR (#6 OR LARGER) WITH TYPE THHW, THWN, THWN-2, XHHW, XHHW-2, THW, THW-2, RHW, OR RHW-2 INSULATION UNLESS OTHERWISE SPECIFIED.
11. POWER AND CONTROL WIRING IN FLEXIBLE CORD SHALL BE MULTI-CONDUCTOR, TYPE SOOW CORD (#14 OR LARGER) UNLESS OTHERWISE SPECIFIED.
12. POWER AND CONTROL WIRING FOR USE IN CABLE TRAY SHALL BE MULTI-CONDUCTOR, TYPE TC CABLE (#14 OR LARGER), WITH TYPE THHW, THWN, THWN-2, XHHW, XHHW-2, THW, THW-2, RHW, OR RHW-2 INSULATION UNLESS OTHERWISE SPECIFIED.
13. ALL POWER AND GROUNDING CONNECTIONS SHALL BE CRIMP-STYLE, COMPRESSION WIRE LUGS AND WIRE NUTS BY THOMAS AND BETTS (OR EQUAL). LUGS AND WIRE NUTS SHALL BE RATED FOR OPERATION NOT LESS THAN 75° C (90° C IF AVAILABLE).
14. RACEWAY AND CABLE TRAY SHALL BE LISTED OR LABELED FOR ELECTRICAL USE IN ACCORDANCE WITH NEMA, UL, ANSI/IEEE AND NEC.
15. ELECTRICAL METALLIC TUBING (EMT), INTERMEDIATE METAL CONDUIT (IMC), OR RIGID METAL CONDUIT (RMC) SHALL BE USED FOR EXPOSED INDOOR LOCATIONS.

16. ELECTRICAL METALLIC TUBING (EMT) OR METAL-CLAD CABLE (MC) SHALL BE USED FOR CONCEALED INDOOR LOCATIONS.
17. SCHEDULE 40 PVC UNDERGROUND ON STRAIGHTS AND SCHEDULE 80 PVC FOR ALL ELBOWS/90s AND ALL APPROVED ABOVE GRADE PVC CONDUIT.
18. LIQUID-TIGHT FLEXIBLE METALLIC CONDUIT (LIQUID-TITE FLEX) SHALL BE USED INDOORS AND OUTDOORS, WHERE VIBRATION OCCURS OR FLEXIBILITY IS NEEDED.
19. CONDUIT AND TUBING FITTINGS SHALL BE THREADED OR COMPRESSION-TYPE AND APPROVED FOR THE LOCATION USED. SET SCREW FITTINGS ARE NOT ACCEPTABLE.
20. CABINETS, BOXES AND WIRE WAYS SHALL BE LABELED FOR ELECTRICAL USE IN ACCORDANCE WITH NEMA, UL, ANSI/IEEE AND THE NEC.
21. WIREWAYS SHALL BE METAL WITH AN ENAMEL FINISH AND INCLUDE A HINGED COVER, DESIGNED TO SWING OPEN DOWNWARDS (WIREMOLD SPECMATE WIREWAY).
22. SLOTTED WIRING DUCT SHALL BE PVC AND INCLUDE COVER (PANDUIT TYPE E OR EQUAL).
23. CONDUITS SHALL BE FASTENED SECURELY IN PLACE WITH APPROVED NON-PERFORATED STRAPS AND HANGERS. EXPLOSIVE DEVICES (i.e. POWDER-ACTUATED) FOR ATTACHING HANGERS TO STRUCTURE WILL NOT BE PERMITTED. CLOSELY FOLLOW THE LINES OF THE STRUCTURE, MAINTAIN CLOSE PROXIMITY TO THE STRUCTURE AND KEEP CONDUITS IN TIGHT ENVELOPES. CHANGES IN DIRECTION TO ROUTE AROUND OBSTACLES SHALL BE MADE WITH CONDUIT OUTLET BODIES. CONDUIT SHALL BE INSTALLED IN A NEAT AND WORKMANLIKE MANNER. PARALLEL AND PERPENDICULAR TO STRUCTURE WALL AND CEILING LINES. ALL CONDUIT SHALL BE FISHED TO CLEAR OBSTRUCTIONS. ENDS OF CONDUITS SHALL BE TEMPORARILY CAPPED FLUSH TO FINISH GRADE TO PREVENT CONCRETE, PLASTER OR DIRT FROM ENTERING. CONDUITS SHALL BE RIGIDLY CLAMPED TO BOXES BY GALVANIZED MALLEABLE IRON BUSHING ON INSIDE AND GALVANIZED MALLEABLE IRON LOCKNUT ON OUTSIDE AND INSIDE.
24. EQUIPMENT CABINETS, TERMINAL BOXES, JUNCTION BOXES AND PULL BOXES SHALL BE GALVANIZED OR EPOXY-COATED SHEET STEEL. SHALL MEET OR EXCEED UL 50 AND BE RATED NEMA 1 (OR BETTER) FOR INTERIOR LOCATIONS AND NEMA 3 (OR BETTER) FOR EXTERIOR LOCATIONS.
25. METAL RECEPTACLE, SWITCH AND DEVICE BOXES SHALL BE GALVANIZED, EPOXY-COATED OR NON-CORRODING; SHALL MEET OR EXCEED UL 514A AND NEMA OS 1 AND BE RATED NEMA 1 (OR BETTER) FOR INTERIOR LOCATIONS AND WEATHER PROTECTED (WP OR BETTER) FOR EXTERIOR LOCATIONS.
26. NONMETALLIC RECEPTACLE, SWITCH AND DEVICE BOXES SHALL MEET OR EXCEED NEMA OS 2 (NEWEST REVISION) AND BE RATED NEMA 1 (OR BETTER) FOR INTERIOR LOCATIONS AND WEATHER PROTECTED (WP OR BETTER) FOR EXTERIOR LOCATIONS.
27. THE CONTRACTOR SHALL NOTIFY AND OBTAIN NECESSARY AUTHORIZATION FROM THE CARRIER AND/OR DISH Wireless L.L.C. AND TOWER OWNER BEFORE COMMENCING WORK ON THE AC POWER DISTRIBUTION PANELS.
28. THE CONTRACTOR SHALL PROVIDE NECESSARY TAGGING ON THE BREAKERS, CABLES AND DISTRIBUTION PANELS IN ACCORDANCE WITH THE APPLICABLE CODES AND STANDARDS TO SAFEGUARD LIFE AND PROPERTY.
29. INSTALL LAMICOID LABEL ON THE METER CENTER TO SHOW "DISH Wireless L.L.C.".
30. ALL EMPTY/SPARE CONDUITS THAT ARE INSTALLED ARE TO HAVE A METERED MULE TAPE PULL CORD INSTALLED.



5701 SOUTH SANTA FE DRIVE
LITTLETON, CO 80120



B&T ENGINEERING, INC.
PEC.0001564
Expires 2/10/22

IT IS A VIOLATION OF LAW FOR ANY PERSON, UNLESS THEY ARE ACTING UNDER THE DIRECTION OF A LICENSED PROFESSIONAL ENGINEER, TO ALTER THIS DOCUMENT.

DRAWN BY:	CHECKED BY:	APPROVED BY:
BLJ	BLJ	MP

RFDS REV #: ---

CONSTRUCTION DOCUMENTS

SUBMITTALS		
REV	DATE	DESCRIPTION
A	7/16/21	ISSUED FOR REVIEW
0	8/2/21	ISSUED FOR CONSTRUCTION

A&E PROJECT NUMBER
152988.001.01

DISH Wireless L.L.C.
PROJECT INFORMATION

BOBDL00109A
87 MONCE RD.
BURLINGTON, CT 06013

SHEET TITLE
GENERAL NOTES

SHEET NUMBER
GN-3

GROUNDING NOTES:

1. ALL GROUND ELECTRODE SYSTEMS (INCLUDING TELECOMMUNICATION, RADIO, LIGHTNING PROTECTION AND AC POWER GES'S) SHALL BE BONDED TOGETHER AT OR BELOW GRADE, BY TWO OR MORE COPPER BONDING CONDUCTORS IN ACCORDANCE WITH THE NEC.
2. THE CONTRACTOR SHALL PERFORM IEEE FALL-OF-POTENTIAL RESISTANCE TO EARTH TESTING (PER IEEE 1100 AND 81) FOR GROUND ELECTRODE SYSTEMS, THE CONTRACTOR SHALL FURNISH AND INSTALL SUPPLEMENTAL GROUND ELECTRODES AS NEEDED TO ACHIEVE A TEST RESULT OF 5 OHMS OR LESS.
3. THE CONTRACTOR IS RESPONSIBLE FOR PROPERLY SEQUENCING GROUNDING AND UNDERGROUND CONDUIT INSTALLATION AS TO PREVENT ANY LOSS OF CONTINUITY IN THE GROUNDING SYSTEM OR DAMAGE TO THE CONDUIT AND PROVIDE TESTING RESULTS.
4. METAL CONDUIT AND TRAY SHALL BE GROUNDED AND MADE ELECTRICALLY CONTINUOUS WITH LISTED BONDING FITTINGS OR BY BONDING ACROSS THE DISCONTINUITY WITH #6 COPPER WIRE UL APPROVED GROUNDING TYPE CONDUIT CLAMPS.
5. METAL RACEWAY SHALL NOT BE USED AS THE NEC REQUIRED EQUIPMENT GROUND CONDUCTOR. STRANDED COPPER CONDUCTORS WITH GREEN INSULATION, SIZED IN ACCORDANCE WITH THE NEC, SHALL BE FURNISHED AND INSTALLED WITH THE POWER CIRCUITS TO BTS EQUIPMENT.
6. EACH CABINET FRAME SHALL BE DIRECTLY CONNECTED TO THE MASTER GROUND BAR WITH GREEN INSULATED SUPPLEMENTAL EQUIPMENT GROUND WIRES, #6 STRANDED COPPER OR LARGER FOR INDOOR BTS; #2 BARE SOLID TINNED COPPER FOR OUTDOOR BTS.
7. CONNECTIONS TO THE GROUND BUS SHALL NOT BE DOUBLED UP OR STACKED BACK TO BACK CONNECTIONS ON OPPOSITE SIDE OF THE GROUND BUS ARE PERMITTED.
8. ALL EXTERIOR GROUND CONDUCTORS BETWEEN EQUIPMENT/GROUND BARS AND THE GROUND RING SHALL BE #2 SOLID TINNED COPPER UNLESS OTHERWISE INDICATED.
9. ALUMINUM CONDUCTOR OR COPPER CLAD STEEL CONDUCTOR SHALL NOT BE USED FOR GROUNDING CONNECTIONS.
10. USE OF 90° BENDS IN THE PROTECTION GROUNDING CONDUCTORS SHALL BE AVOIDED WHEN 45° BENDS CAN BE ADEQUATELY SUPPORTED.
11. EXOTHERMIC WELDS SHALL BE USED FOR ALL GROUNDING CONNECTIONS BELOW GRADE.
12. ALL GROUND CONNECTIONS ABOVE GRADE (INTERIOR AND EXTERIOR) SHALL BE FORMED USING HIGH PRESS CRIMPS.
13. COMPRESSION GROUND CONNECTIONS MAY BE REPLACED BY EXOTHERMIC WELD CONNECTIONS.
14. ICE BRIDGE BONDING CONDUCTORS SHALL BE EXOTHERMICALLY BONDED OR BOLTED TO THE BRIDGE AND THE TOWER GROUND BAR.
15. APPROVED ANTIOXIDANT COATINGS (i.e. CONDUCTIVE GEL OR PASTE) SHALL BE USED ON ALL COMPRESSION AND BOLTED GROUND CONNECTIONS.
16. ALL EXTERIOR GROUND CONNECTIONS SHALL BE COATED WITH A CORROSION RESISTANT MATERIAL.
17. MISCELLANEOUS ELECTRICAL AND NON-ELECTRICAL METAL BOXES, FRAMES AND SUPPORTS SHALL BE BONDED TO THE GROUND RING, IN ACCORDANCE WITH THE NEC.
18. BOND ALL METALLIC OBJECTS WITHIN 6 ft OF MAIN GROUND RING WITH (1) #2 BARE SOLID TINNED COPPER GROUND CONDUCTOR.
19. GROUND CONDUCTORS USED FOR THE FACILITY GROUNDING AND LIGHTNING PROTECTION SYSTEMS SHALL NOT BE ROUTED THROUGH METALLIC OBJECTS THAT FORM A RING AROUND THE CONDUCTOR, SUCH AS METALLIC CONDUITS, METAL SUPPORT CLIPS OR SLEEVES THROUGH WALLS OR FLOORS. WHEN IT IS REQUIRED TO BE HOUSED IN CONDUIT TO MEET CODE REQUIREMENTS OR LOCAL CONDITIONS, NON-METALLIC MATERIAL SUCH AS PVC CONDUIT SHALL BE USED. WHERE USE OF METAL CONDUIT IS UNAVOIDABLE (i.e., NONMETALLIC CONDUIT PROHIBITED BY LOCAL CODE) THE GROUND CONDUCTOR SHALL BE BONDED TO EACH END OF THE METAL CONDUIT.
20. ALL GROUNDS THAT TRANSITION FROM BELOW GRADE TO ABOVE GRADE MUST BE #2 BARE SOLID TINNED COPPER IN 3/4" NON-METALLIC, FLEXIBLE CONDUIT FROM 24" BELOW GRADE TO WITHIN 3" TO 6" OF CAD-WELD TERMINATION POINT. THE EXPOSED END OF THE CONDUIT MUST BE SEALED WITH SILICONE CAULK. (ADD TRANSITIONING GROUND STANDARD DETAIL AS WELL).
21. BUILDINGS WHERE THE MAIN GROUNDING CONDUCTORS ARE REQUIRED TO BE ROUTED TO GRADE, THE CONTRACTOR SHALL ROUTE TWO GROUNDING CONDUCTORS FROM THE ROOFTOP, TOWERS, AND WATER TOWERS GROUNDING RING, TO THE EXISTING GROUNDING SYSTEM, THE GROUNDING CONDUCTORS SHALL NOT BE SMALLER THAN 2/0 COPPER. ROOFTOP GROUNDING RING SHALL BE BONDED TO THE EXISTING GROUNDING SYSTEM, THE BUILDING STEEL COLUMNS, LIGHTNING PROTECTION SYSTEM, AND BUILDING MAIN WATER LINE (FERROUS OR NONFERROUS METAL PIPING ONLY). DO NOT ATTACH GROUNDING TO FIRE SPRINKLER SYSTEM PIPES.



5701 SOUTH SANTA FE DRIVE
LITTLETON, CO 80120



B&T ENGINEERING, INC.
PEC.0001564
Expires 2/10/22

IT IS A VIOLATION OF LAW FOR ANY PERSON, UNLESS THEY ARE ACTING UNDER THE DIRECTION OF A LICENSED PROFESSIONAL ENGINEER, TO ALTER THIS DOCUMENT.

DRAWN BY:	CHECKED BY:	APPROVED BY:
BLJ	BLJ	MP

RFDS REV #: ---

CONSTRUCTION DOCUMENTS

SUBMITTALS		
REV	DATE	DESCRIPTION
A	7/16/21	ISSUED FOR REVIEW
0	8/2/21	ISSUED FOR CONSTRUCTION

A&E PROJECT NUMBER
152988.001.01

DISH Wireless L.L.C.
PROJECT INFORMATION

BOBDL00109A
87 MONCE RD.
BURLINGTON, CT 06013

SHEET TITLE
GENERAL NOTES

SHEET NUMBER
GN-4

ENGINEERING:
STRUCTURAL ANALYSIS
MOUNT ANALYSIS



AMERICAN TOWER®
CORPORATION

Structural Analysis Report

Structure : 119 ft Monopole
ATC Site Name : Burlington 2, CT
ATC Asset Number : 209185
Engineering Number : 13688136_C3_03
Proposed Carrier : DISH WIRELESS L.L.C.
Carrier Site Name : BOBDL00109A
Carrier Site Number : BOBDL00109A
Site Location : 87 Monce Road
Burlington, CT 6013-2542
41.739100,-72.907800
County : Hartford
Date : July 14, 2021
Max Usage : 57%
Result : Pass



Prepared By:
Kennedy Smith
Engineer Intern

Reviewed By:

Kennedy Smith

COA: PEC.0001553



Table of Contents

Introduction	1
Supporting Documents	1
Analysis	1
Conclusion.....	1
Existing and Reserved Equipment.....	2
Equipment to be Removed.....	2
Proposed Equipment	2
Structure Usages	3
Foundations	3
Deflection and Sway	3
Standard Conditions	4
Calculations	Attached



Introduction

The purpose of this report is to summarize results of a structural analysis performed on the 119 ft monopole to reflect the change in loading by DISH WIRELESS L.L.C..

Supporting Documents

Tower Drawings	Sabre Job #160579, dated April 5, 2017
Foundation Drawing	Sabre Job #160579, dated April 5, 2017
Geotechnical Report	Geotechnical Report by Dr. Clarence Welti, P.E., dated March 17, 2014

Analysis

The tower was analyzed using American Tower Corporation's tower analysis software. This program considers an elastic three-dimensional model and second-order effects per ANSI/TIA-222.

Basic Wind Speed:	116 mph (3-Second Gust)
Basic Wind Speed w/ Ice:	50 mph (3-Second Gust) w/ 1"1/2 radial ice concurrent
Code:	ANSI/TIA-222-H / 2015 IBC / 2018 Connecticut State Building Code
Exposure Category:	C
Risk Category:	II
Topographic Factor Procedure:	Method 1
Topographic Category:	1
Crest Height (H):	0 ft
Spectral Response:	$S_s = 0.18, S_1 = 0.06$
Site Class:	D - Stiff Soil

Conclusion

Based on the analysis results, the structure meets the requirements per the applicable codes listed above. The tower and foundation can support the equipment as described in this report.

If you have any questions or require additional information, please contact American Tower via email at Engineering@americantower.com. Please include the American Tower site name, site number, and engineering number in the subject line for any questions.



Existing and Reserved Equipment

Elev. ¹ (ft)	Qty	Equipment	Mount Type	Lines	Carrier
129.0	2	Generic 22' Omni	Stand Off	(3) 7/8" Coax	OTHER
123.7	1	Generic 12' Omni			
110.0	3	Ericsson RRUS-32 (77 lbs)	Square Platform with Handrails		
	4	Raycap DC6-48-60-18-8F (31.25" Height)			
	6	Ericsson RRUS-12 B2			
	12	CCI HPA-65R-BUU-H8			
	3	Ericsson RRUS 32 B66A			
100.0	6	Ericsson RRUS-11 (19.7")	Triangular Low Profile Platform	(1) 0.78" (19.7mm) 8 AWG 6 (3) 1.4" (35.6mm) Hybrid (1) 1/2" Coax	T-MOBILE
	1	Generic GPS			
	3	Andrew LNX-6515DS-A1M (43.7lbs)			
	3	Generic 96" x 12" x 7" Panel			
	3	RFS APX16DWV-16DWVS-E-A20			
	6	Ericsson RRUS 11 B12			
91.2	3	Ericsson RRUS 11 B4	Triangular Platform with Handrails	(1) 2.02 (51.2mm) Hybrid	VERIZON WIRELESS
	3	Raycap RVZDC-6627-PF-48			
	3	Samsung B5/B13 RRH-BR04C			
	3	Samsung B2/B66A RRH-BR049			
	6	Commscope NHH-65B-R2B			
3.0	3	Ericsson RRUS E2	Flush	-	AT&T MOBILITY

Equipment to be Removed

Elev. ¹ (ft)	Qty	Equipment	Mount Type	Lines	Carrier
No loading was considered as removed as part of this analysis.					

Proposed Equipment

Elev. ¹ (ft)	Qty	Equipment	Mount Type	Lines	Carrier
70.0	3	Fujitsu TA08025-B604	Triangular Platform with Handrails	(1) 1.60" (40.6mm) Hybrid	DISH WIRELESS L.L.C.
	1	Commscope RDIDC-9181-PF-48			
	3	Fujitsu TA08025-B605			
	3	JMA Wireless MX08FRO665-21			

¹ Contracted elevations are shown for appurtenances within contracted installation tolerances. Appurtenances outside of contract limits are shown at installed elevations.

Install proposed lines inside the pole shaft.



Structure Usages

Structural Component	Controlling Usage	Pass/Fail
Anchor Bolts	55%	Pass
Shaft	55%	Pass
Base Plate	32%	Pass

Foundations

Reaction Component	Analysis Reactions	% of Usage
Moment (Kips-Ft)	2,472.5	50%
Axial (Kips)	44.4	49%
Shear (Kips)	28.6	57%

The structure base reactions resulting from this analysis were found to be acceptable through analysis based on geotechnical and foundation information, therefore no modification or reinforcement of the foundation will be required.

Deflection and Sway*

Antenna Elevation (ft)	Antenna	Carrier	Deflection (ft)	Sway (Rotation) (°)
70.0	Commscope RDIDC-9181-PF-48	DISH WIRELESS L.L.C.	0.332	0.545
	Fujitsu TA08025-B605			
	Fujitsu TA08025-B604			
	JMA Wireless MX08FRO665-21			

*Deflection and Sway was evaluated considering a design wind speed of 60 mph (3-Second Gust) per ANSI/TIA-222-H



Standard Conditions

All engineering services performed by A.T. Engineering Service, PLLC are prepared on the basis that the information used is current and correct. This information may consist of, but is not limited to the following:

- Information supplied by the client regarding antenna, mounts and feed line loading
- Information from drawings, design and analysis documents, and field notes in the possession of A.T. Engineering Service, PLLC

It is the responsibility of the client to ensure that the information provided to A.T. Engineering Service, PLLC and used in the performance of our engineering services is correct and complete.

All assets of American Tower Corporation, its affiliates and subsidiaries (collectively "American Tower") are inspected at regular intervals. Based upon these inspections and in the absence of information to the contrary, American Tower assumes that all structures were constructed in accordance with the drawings and specifications.

Unless explicitly agreed by both the client and A.T. Engineering Service, PLLC, all services will be performed in accordance with the current revision of ANSI/TIA-222.

All services are performed, results obtained, and recommendations made in accordance with generally accepted engineering principles and practices. A.T. Engineering Service, PLLC is not responsible for the conclusions, opinions and recommendations made by others based on the information supplied herein.

© 2007 - 2021 by ATC IP LLC. All rights reserved.

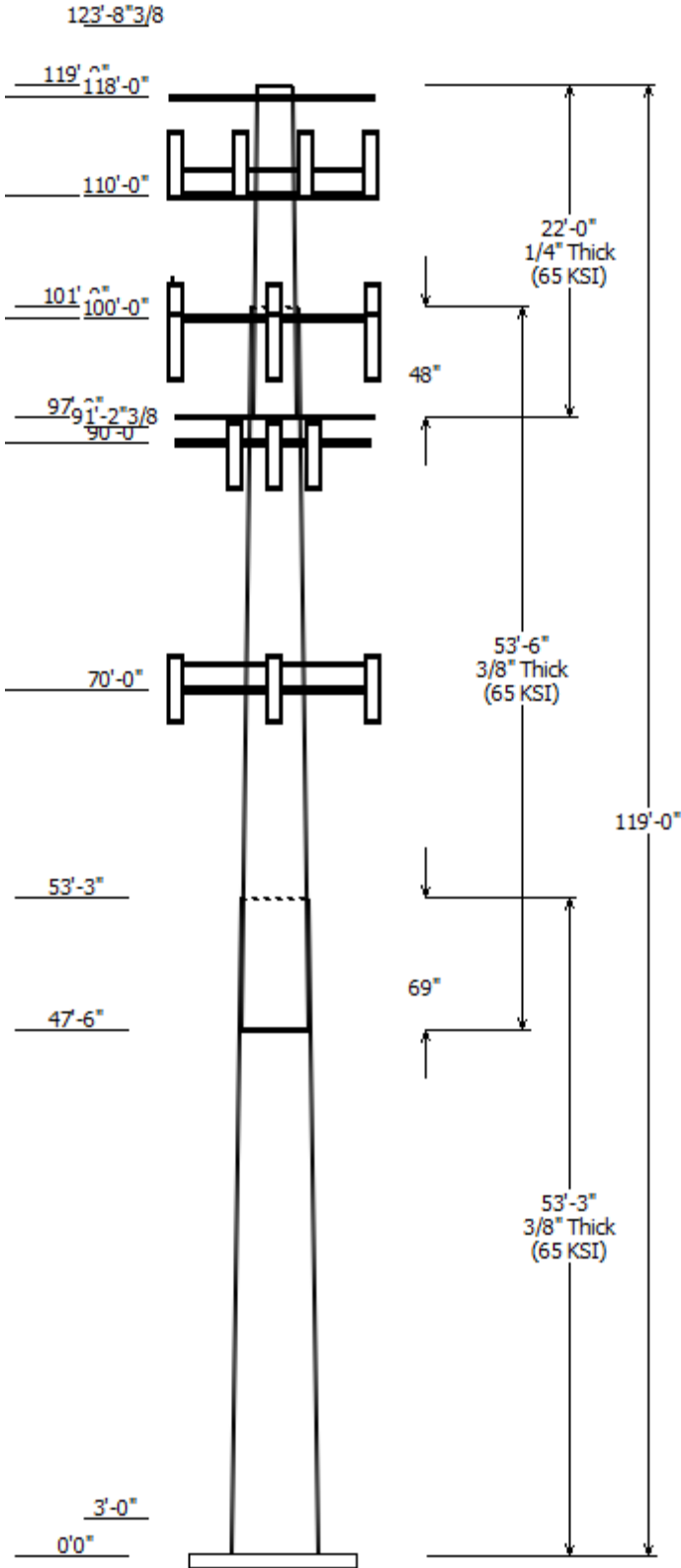

Job Information	
Client : DISH WIRELESS L.L.C.	
Pole : 209185	Code: ANSI/TIA-222-H
Location : Burlington 2, CT	
Description :	Risk Category : II
Shape : 18 Sides	Exposure : C
Height : 119.00 (ft)	Topo Method : Method 1
Base Elev (ft): 0.00	Topographic Category : 1
Taper: 0.277647(in/ft)	

Sections Properties						
Shaft Section	Length (ft)	Diameter (in)		Thick Joint (in)	Overlap Length (in)	Steel Grade
		Across Top	Flats Bottom			
1	53.250	38.55	53.34	0.375	0.000	18 Sides 65
2	53.500	26.04	40.90	0.375 Slip Joint	69.000	18 Sides 65
3	22.000	21.55	27.65	0.250 Slip Joint	48.000	18 Sides 65

Discrete Appurtenance			
Attach Elev (ft)	Force Elev (ft)	Qty	Description
129.000	129.000	2	Generic 22' Omni
123.700	123.700	1	Generic 12' Omni
118.000	118.000	3	Generic Flat Stand-Off
110.000	110.000	1	Generic Square Platform with
110.000	111.600	12	CCI HPA-65R-BUU-H8
110.000	110.000	4	Raycap DC6-48-60-18-8F (31.25"
110.000	110.000	3	Ericsson RRUS-32 (77 lbs)
110.000	110.000	6	Ericsson RRUS-12 B2
110.000	110.000	6	Ericsson RRUS-11 (19.7")
110.000	110.000	3	Ericsson RRUS 32 B66A
100.000	100.000	1	Generic Round Low Profile
100.000	99.500	3	Andrew LNX-6515DS-A1M
100.000	100.000	3	Generic 96" x 12" x 7" Panel
100.000	99.500	3	RFS APX16DWV-16DWVS-E-A20
100.000	100.000	6	Ericsson RRUS 11 B12
100.000	100.000	3	Ericsson RRUS 11 B4
100.000	100.000	1	Generic GPS
91.200	90.200	6	Commscope NHH-65B-R2B
91.200	91.200	3	Raycap RVZDC-6627-PF-48
91.200	91.200	3	Samsung B5/B13 RRH-BR04C
91.200	91.200	3	Samsung B2/B66A RRH-BR049
90.000	90.000	1	Generic Round Platform with
70.000	70.000	1	Generic Flat Platform with Han
70.000	70.000	3	JMA Wireless MX08FRO665-21
70.000	70.000	3	Fujitsu TA08025-B605
70.000	70.000	1	Commscope RDIDC-9181-PF-48
70.000	70.000	3	Fujitsu TA08025-B604
3.000	3.000	3	Ericsson RRUS E2

Linear Appurtenance			
From Elev (ft)	To Elev (ft)	Description	Exposed To Wind
0.000	70.000	1.60" (40.6mm)	No
0.000	91.200	2.02 (51.2mm)	No
0.000	100.0	0.78" (19.7mm) 8	No
0.000	100.0	1.4" (35.6mm)	No
0.000	100.0	1/2" Coax	No
0.000	110.0	0.39" (10mm)	No
0.000	110.0	0.76" (19.2mm) 8	No
0.000	111.0	2" conduit	No
0.000	129.0	7/8" Coax	No

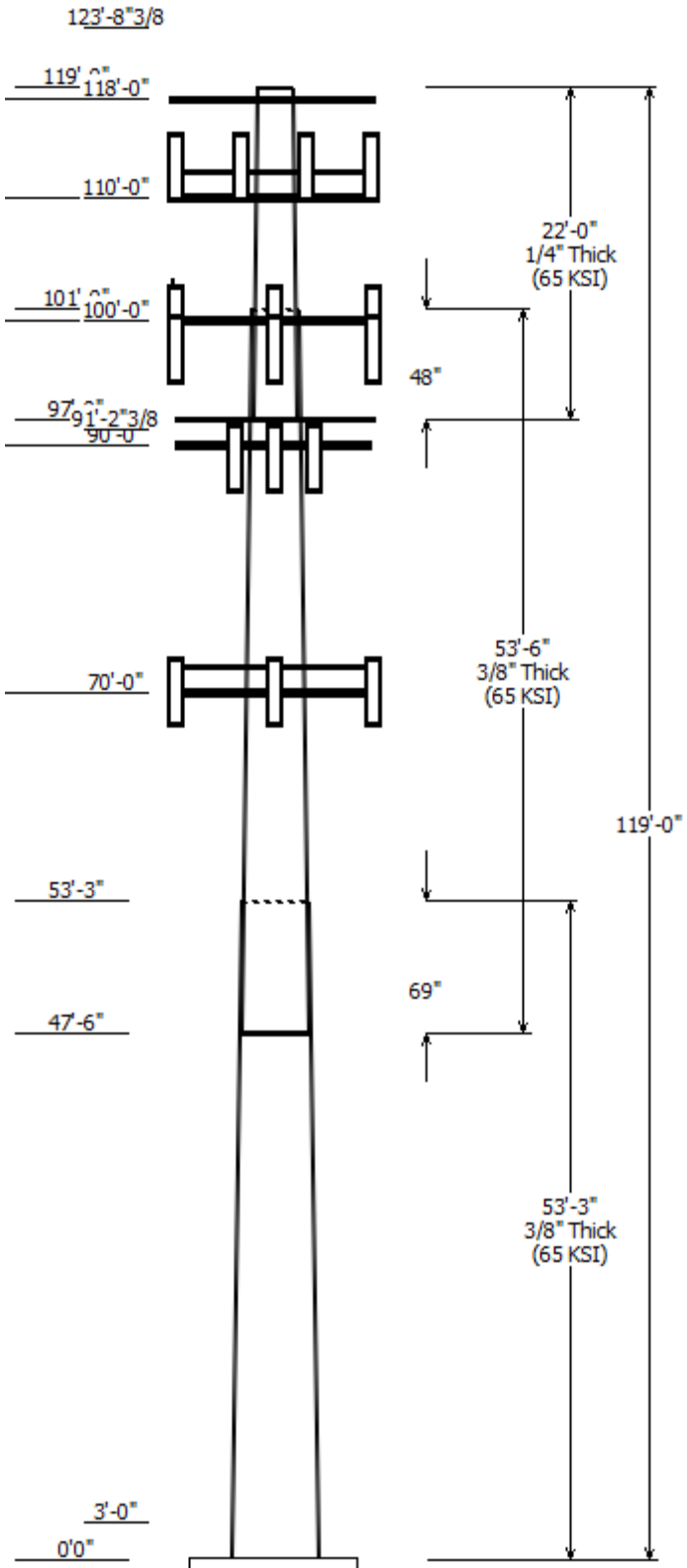

Load Cases	
1.2D + 1.0W	116 mph with No Ice
0.9D + 1.0W	116 mph with No Ice (Reduced DL)
1.2D + 1.0Di + 1.0Wi	50 mph with 1.50 in Radial Ice
1.2D + 1.0Ev + 1.0Eh	Seismic
0.9D - 1.0Ev + 1.0Eh	Seismic (Reduced DL)
1.0D + 1.0W	Serviceability 60 mph

Reactions			
Load Case	Moment (kip-ft)	Shear (kip)	Axial (kip)
1.2D + 1.0W	2472.54	28.58	44.42
0.9D + 1.0W	2452.79	28.57	33.31
1.2D + 1.0Di + 1.0Wi	785.17	8.85	69.30
1.2D + 1.0Ev + 1.0Eh	115.61	1.23	45.01
0.9D - 1.0Ev + 1.0Eh	114.48	1.23	31.26
1.0D + 1.0W	588.93	6.84	37.04

Dish Deflections			
Load Case	Attach Elev (ft)	Deflection (in)	Rotation (deg)
	0.00	0.000	0.000

Load Case : 1.2D + 1.0W
Max Ratio 55.14% at 0.0 ft

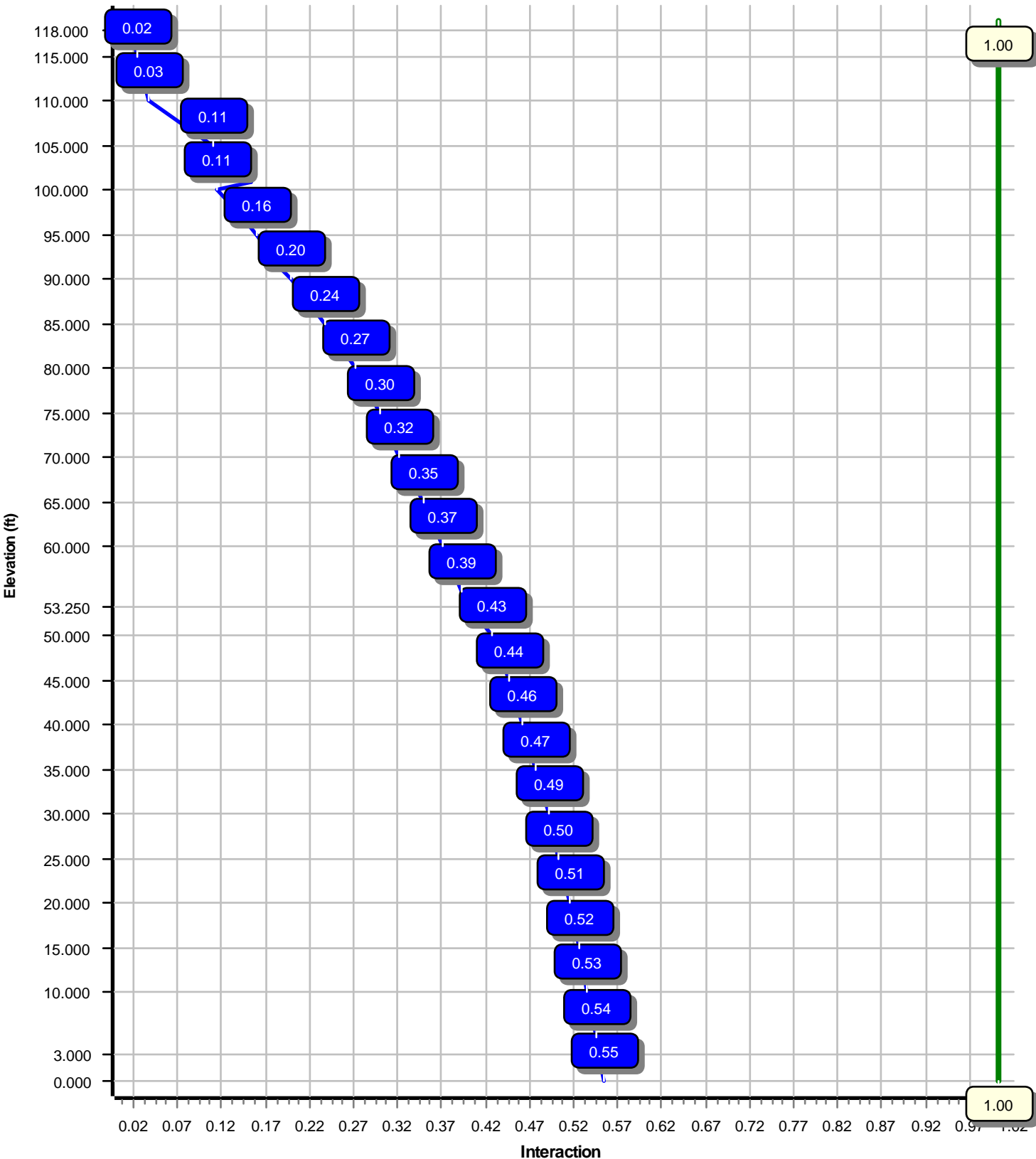

Site Number: 209185

Code: ANSI/TIA-222-H

© 2007 - 2021 by ATC IP LLC. All rights reserved.

Site Name: Burlington 2, CT

Engineering Number: 13688136_C3_03

7/14/2021 12:27:05 PM

Customer: DISH WIRELESS L.L.C.

Analysis Parameters

Location :	Hartford County, CT	Height (ft) :	119
Code :	ANSI/TIA-222-H	Base Diameter (in) :	53.34
Shape :	18 Sides	Top Diameter (in) :	21.55
Pole Type :	Taper	Taper (in/ft) :	0.278
Pole Manufacturer :	Sabre	Rotation (deg) :	0.00
Kd (non-service) :	0.95	Ke :	0.99

Ice & Wind Parameters

Exposure Category:	C	Design Wind Speed Without Ice:	116 mph
Risk Category:	II	Design Wind Speed With Ice:	50 mph
Topographic Factor Procedure:	Method 1	Operational Wind Speed:	60 mph
Topographic Category:	1	Design Ice Thickness:	1.50 in
Crest Height:	0 ft	HMSL:	287.00 ft

Seismic Parameters

Analysis Method:	Equivalent Lateral Force Method		
Site Class:	D - Stiff Soil		
Period Based on Rayleigh Method (sec):	1.74		
T _L (sec):	6	p:	1
S _s :	0.184	S ₁ :	0.054
F _a :	1.600	F _v :	2.400
S _{ds} :	0.196	S _{d1} :	0.086
		C _s :	0.033
		C _s Max:	0.033
		C _s Min:	0.030

Load Cases

1.2D + 1.0W	116 mph with No Ice
0.9D + 1.0W	116 mph with No Ice (Reduced DL)
1.2D + 1.0Di + 1.0Wi	50 mph with 1.50 in Radial Ice
1.2D + 1.0Ev + 1.0Eh	Seismic
0.9D - 1.0Ev + 1.0Eh	Seismic (Reduced DL)
1.0D + 1.0W	Serviceability 60 mph

Site Number: 209185

Code: ANSI/TIA-222-H

© 2007 - 2021 by ATC IP LLC. All rights reserved.

Site Name: Burlington 2, CT

Engineering Number: 13688136_C3_03

7/14/2021 12:27:05 PM

Customer: DISH WIRELESS L.L.C.

Shaft Section Properties

Sect Info	Length (ft)	Thick (in)	Fy (ksi)	Joint Type	Slip Joint Len (in)	Weight (lb)	Bottom						Top						
							Dia (in)	Elev (ft)	Area (in ²)	Ix (in ⁴)	W/t Ratio	D/t Ratio	Dia (in)	Elev (ft)	Area (in ²)	Ix (in ⁴)	W/t Ratio	D/t Ratio	Taper (in/ft)
1-18	53.250	0.3750	65		0.00	9,828	53.34	0.00	63.04	22343.1	23.32	142.24	38.55	53.25	45.44	8369.4	16.37	102.81	0.277647
2-18	53.500	0.3750	65	Slip	69.00	7,172	40.90	47.50	48.24	10009.2	17.47	109.07	26.04	101.00	30.56	2544.4	10.48	69.46	0.277647
3-18	22.000	0.2500	65	Slip	48.00	1,447	27.65	97.00	21.75	2064.1	17.74	110.63	21.55	119.00	16.90	968.8	13.44	86.20	0.277647
Shaft Weight						18,447													

Discrete Appurtenance Properties

Attach Elev (ft)	Description	Qty	Ka	Vert Ecc (ft)	Weight (lb)	No Ice EPAa (sf)	Orientation Factor	Weight (lb)	Ice EPAa (sf)	Orientation Factor
129.00	Generic 22' Omni	2	1.00	0.000	70.00	6.600	1.00	231.75	14.214	1.00
123.70	Generic 12' Omni	1	1.00	0.000	40.00	3.600	1.00	128.86	7.805	1.00
118.00	Generic Flat Stand-Off	3	1.00	0.000	187.50	6.300	0.67	317.68	9.345	0.67
110.00	Ericsson RRUS 32 B66A	3	0.75	0.000	50.70	2.720	0.67	121.73	3.848	0.67
110.00	Ericsson RRUS-11 (19.7")	6	0.75	0.000	51.00	2.791	0.67	124.76	3.852	0.67
110.00	Ericsson RRUS-12 B2	6	0.75	0.000	58.00	3.145	0.62	136.40	4.268	0.62
110.00	Ericsson RRUS-32 (77 lbs)	3	0.75	0.000	77.00	3.314	0.71	171.26	4.558	0.71
110.00	Raycap DC6-48-60-18-8F (31.25")	4	0.75	0.000	32.80	3.340	0.67	127.19	4.759	0.67
110.00	CCI HPA-65R-BUU-H8	12	0.75	1.600	68.00	12.976	0.67	317.04	16.446	0.67
110.00	Generic Square Platform with	1	1.00	0.000	3,790.00	49.300	1.00	8,089.22	131.854	1.00
100.00	Generic GPS	1	1.00	0.000	10.00	0.900	1.00	38.11	1.514	1.00
100.00	Ericsson RRUS 11 B4	3	0.80	0.000	50.70	2.791	0.67	120.27	3.845	0.67
100.00	Ericsson RRUS 11 B12	6	0.80	0.000	50.70	2.791	0.67	120.27	3.845	0.67
100.00	RFS APX16DWV-16DWVS-E-A20	3	0.80	-0.500	40.70	6.586	0.60	152.94	8.667	0.60
100.00	Generic 96" x 12" x 7" Panel	3	0.80	0.000	50.00	11.467	0.69	269.51	14.575	0.69
100.00	Andrew LNX-6515DS-A1M	3	0.80	-0.500	43.70	11.470	0.70	264.57	14.587	0.70
100.00	Generic Round Low Profile	1	1.00	0.000	1,875.00	21.700	1.00	2,653.10	40.146	1.00
91.20	Samsung B2/B66A RRH-BR049	3	0.75	0.000	84.40	1.875	0.50	145.18	2.735	0.50
91.20	Samsung B5/B13 RRH-BR04C	3	0.75	0.000	70.30	1.875	0.50	124.80	2.735	0.50
91.20	Raycap RVZDC-6627-PF-48	3	0.75	0.000	32.00	3.781	0.69	136.48	5.041	0.69
91.20	Commscope NHH-65B-R2B	6	0.75	-1.000	43.70	8.079	0.69	209.82	10.733	0.69
90.00	Generic Round Platform with	1	1.00	0.000	2,500.00	27.200	1.00	4,037.88	50.409	1.00
70.00	Commscope RDIDC-9181-PF-48	1	0.75	0.000	21.90	1.867	1.00	74.55	2.700	1.00
70.00	Fujitsu TA08025-B605	3	0.75	0.000	75.00	1.962	0.50	132.96	2.813	0.50
70.00	Fujitsu TA08025-B604	3	0.75	0.000	63.90	1.962	0.50	117.85	2.813	0.50
70.00	JMA Wireless MX08FRO665-21	3	0.75	0.000	64.50	12.489	0.64	302.29	15.089	0.64
70.00	Generic Flat Platform with	1	1.00	0.000	2,500.00	42.400	1.00	4,143.50	61.802	1.00
3.00	Ericsson RRUS E2	3	1.00	0.000	52.90	2.475	0.67	92.46	3.127	0.67
Totals	Num Loadings:28	91			15,874.40			34,899.40		

Linear Appurtenance Properties

Load Case Azimuth (deg) : 0

Elev From (ft)	Elev To (ft)	Qty	Coax Dia (in)	Coax Wt (lb/ft)	Max Coax / Flat Row	Dist Between Rows (in)	Dist Between Cols (in)	Dist Azimuth (deg)	Dist From Face (in)	Exposed To Wind Carrier
0.00	129.00	3	7/8"	0.33	N	0	0.00	0.00	0	N Other
0.00	111.00	3	2"	3.65	N	0	0.00	0.00	0	N AT&T MOBILITY
0.00	110.00	2	0.39"	0.06	N	0	0.00	0.00	0	N AT&T MOBILITY
0.00	110.00	8	0.76"	0.53	N	0	0.00	0.00	0	N AT&T MOBILITY
0.00	100.00	1	0.78"	0.59	N	0	0.00	0.00	0	N T-MOBILE
0.00	100.00	3	1.4"	1.30	N	0	0.00	0.00	0	N T-MOBILE
0.00	100.00	1	1/2"	0.15	N	0	0.00	0.00	0	N T-MOBILE
0.00	91.20	1	2.02"	3.04	N	0	0.00	0.00	0	N VERIZON WIRELESS

Site Number: 209185

Code: ANSI/TIA-222-H

© 2007 - 2021 by ATC IP LLC. All rights reserved.

Site Name: Burlington 2, CT

Engineering Number: 13688136_C3_03

7/14/2021 12:27:05 PM

Customer: DISH WIRELESS L.L.C.

0.00 70.00 1 1.60" (40.6mm) Hybrid 1.60 2.34 N 0 0.00 0.00 0 0.00 N DISH WIRELESS

Segment Properties (Max Len : 5. ft)

Seg Top Elev (ft)	Description	Thick (in)	Flat Dia (in)	Area (in ²)	Ix (in ⁴)	W/t Ratio	D/t Ratio	F'y (ksi)	S (in ³)	Z (in ³)	Weight (lb)
0.00		0.3750	53.340	63.039	22,343.1	23.32	142.24	74.0	825.0	0.0	0.0
3.00		0.3750	52.507	62.048	21,305.4	22.93	140.02	74.4	799.2	0.0	638.5
5.00		0.3750	51.952	61.387	20,631.8	22.66	138.54	74.7	782.2	0.0	420.0
10.00		0.3750	50.564	59.735	19,010.3	22.01	134.84	75.5	740.5	0.0	1,030.4
15.00		0.3750	49.175	58.082	17,476.0	21.36	131.13	76.3	700.0	0.0	1,002.3
20.00		0.3750	47.787	56.430	16,026.6	20.71	127.43	77.0	660.6	0.0	974.2
25.00		0.3750	46.399	54.778	14,659.7	20.05	123.73	77.8	622.3	0.0	946.0
30.00		0.3750	45.011	53.126	13,372.7	19.40	120.03	78.6	585.2	0.0	917.9
35.00		0.3750	43.622	51.473	12,163.4	18.75	116.33	79.3	549.2	0.0	889.8
40.00		0.3750	42.234	49.821	11,029.2	18.10	112.62	80.1	514.4	0.0	861.7
45.00		0.3750	40.846	48.169	9,967.9	17.44	108.92	80.9	480.7	0.0	833.6
47.50	Bot - Section 2	0.3750	40.152	47.343	9,463.8	17.12	107.07	81.3	464.2	0.0	406.3
50.00		0.3750	39.458	46.516	8,976.9	16.79	105.22	81.7	448.1	0.0	806.0
53.25	Top - Section 1	0.3750	39.305	46.335	8,872.4	16.72	104.81	81.7	444.6	0.0	1,026.8
55.00		0.3750	38.819	45.757	8,544.3	16.49	103.52	82.0	433.5	0.0	274.2
60.00		0.3750	37.431	44.105	7,651.7	15.84	99.82	82.6	402.6	0.0	764.4
65.00		0.3750	36.043	42.452	6,823.5	15.18	96.11	82.6	372.9	0.0	736.3
70.00		0.3750	34.655	40.800	6,057.4	14.53	92.41	82.6	344.3	0.0	708.2
75.00		0.3750	33.266	39.148	5,350.9	13.88	88.71	82.6	316.8	0.0	680.1
80.00		0.3750	31.878	37.495	4,701.5	13.23	85.01	82.6	290.5	0.0	652.0
85.00		0.3750	30.490	35.843	4,107.0	12.57	81.31	82.6	265.3	0.0	623.9
90.00		0.3750	29.102	34.191	3,564.8	11.92	77.60	82.6	241.3	0.0	595.8
91.20		0.3750	28.769	33.794	3,442.2	11.76	76.72	82.6	235.7	0.0	138.8
95.00		0.3750	27.714	32.539	3,072.6	11.27	73.90	82.6	218.4	0.0	428.9
97.00	Bot - Section 3	0.3750	27.158	31.878	2,889.1	11.01	72.42	82.6	209.5	0.0	219.2
100.0		0.3750	26.325	30.886	2,627.9	10.62	70.20	82.6	196.6	0.0	539.0
101.0	Top - Section 2	0.2500	26.548	20.866	1,823.2	16.96	106.19	81.5	135.3	0.0	175.9
105.0		0.2500	25.437	19.985	1,601.8	16.18	101.75	82.4	124.0	0.0	278.0
110.0		0.2500	24.049	18.884	1,351.3	15.20	96.20	82.6	110.7	0.0	330.7
115.0		0.2500	22.661	17.782	1,128.4	14.22	90.64	82.6	98.1	0.0	311.9
118.0		0.2500	21.828	17.121	1,007.2	13.63	87.31	82.6	90.9	0.0	178.2
119.0		0.2500	21.550	16.901	968.8	13.44	86.20	82.6	88.5	0.0	57.9
18,446.9											

Load Case: 1.2D + 1.0W	116 mph with No Ice	20 Iterations
Gust Response Factor :1.10		
Dead Load Factor :1.20		
Wind Load Factor :1.00		

Applied Segment Forces Summary

Seg Elev (ft)	Description	Shaft Forces		Discrete Forces			Linear Forces		Sum of Forces				
		Wind FX (lb)	Dead Load (lb)	Wind FX (lb)	Torsion MY (lb-ft)	Moment MZ (lb-ft)	Dead Load (lb)	Wind FX (lb)	Dead Load (lb)	Wind FX (lb)	Dead Load (lb)	Torsion MY (lb-ft)	Moment MZ (lb)
0.00		148.5	0.0					0.0	0.0	148.5	0.0	0.0	0.0
3.00	Appurtenance(s)	246.2	766.2	150.6	0.0	0.0	190.4	0.0	94.8	396.8	1,051.4	0.0	0.0
5.00		337.4	504.0					0.0	63.2	337.4	567.2	0.0	0.0
10.00		472.9	1,236.5					0.0	157.9	472.9	1,394.4	0.0	0.0
15.00		467.1	1,202.7					0.0	157.9	467.1	1,360.6	0.0	0.0
20.00		473.4	1,169.0					0.0	157.9	473.4	1,326.9	0.0	0.0
25.00		482.0	1,135.2					0.0	157.9	482.0	1,293.2	0.0	0.0
30.00		486.1	1,101.5					0.0	157.9	486.1	1,259.4	0.0	0.0
35.00		486.7	1,067.8					0.0	157.9	486.7	1,225.7	0.0	0.0
40.00		484.7	1,034.0					0.0	157.9	484.7	1,192.0	0.0	0.0
45.00		361.4	1,000.3					0.0	157.9	361.4	1,158.2	0.0	0.0
47.50	Bot - Section 2	241.2	487.5					0.0	79.0	241.2	566.5	0.0	0.0
50.00		277.9	967.3					0.0	79.0	277.9	1,046.2	0.0	0.0
53.25	Top - Section 1	240.2	1,232.2					0.0	102.6	240.2	1,334.9	0.0	0.0
55.00		319.9	329.0					0.0	55.3	319.9	384.3	0.0	0.0
60.00		468.0	917.3					0.0	157.9	468.0	1,075.3	0.0	0.0
65.00		458.3	883.6					0.0	157.9	458.3	1,041.5	0.0	0.0
70.00	Appurtenance(s)	447.6	849.9	2,768.9	0.0	0.0	3,758.5	0.0	157.9	3,216.4	4,766.3	0.0	0.0
75.00		435.9	816.1					0.0	143.9	435.9	960.0	0.0	0.0
80.00		423.5	782.4					0.0	143.9	423.5	926.3	0.0	0.0
85.00		410.2	748.7					0.0	143.9	410.2	892.5	0.0	0.0
90.00	Appurtenance(s)	249.1	714.9	1,199.5	0.0	0.0	3,000.0	0.0	143.9	1,448.6	3,858.8	0.0	0.0
91.20		194.6	166.6					0.0	34.5	194.6	201.1	0.0	0.0
95.00		223.0	514.6					0.0	95.5	223.0	610.1	0.0	0.0
97.00	Bot - Section 3	189.2	263.0					0.0	50.3	189.2	313.3	0.0	0.0
100.00	Appurtenance(s)	150.7	646.8	3,777.3	0.0	-647.5	3,293.4	0.0	75.4	3,928.0	4,015.6	0.0	0.0
101.00	Top - Section 2	182.9	211.1					0.0	19.6	182.9	230.7	0.0	0.0
105.00		320.6	333.6					0.0	78.2	320.6	411.9	0.0	0.0
110.00	Appurtenance(s)	341.6	396.8	7,410.1	0.0	5,776.6	6,929.2	0.0	97.8	7,751.7	7,423.7	0.0	0.0
115.00		262.7	374.3					0.0	19.1	262.7	393.4	0.0	0.0
118.00	Appurtenance(s)	127.3	213.8	591.2	0.0	0.0	675.0	0.0	3.6	718.5	892.3	0.0	0.0
119.00		31.3	69.5					0.0	1.2	31.3	70.6	0.0	0.0
Totals:										26,339.6	43,244.2	0.00	0.00

Load Case: 1.2D + 1.0W

116 mph with No Ice

20 Iterations

Gust Response Factor :1.10

Dead Load Factor :1.20

Wind Load Factor :1.00

Calculated Forces

Seg Elev (ft)	Pu FY (-) (kips)	Vu FX (-) (kips)	Tu MY (ft-kips)	Mu MZ (ft-kips)	Mu MX (ft-kips)	Resultant Moment (ft-kips)	phi Pn (kips)	phi Vn (kips)	phi Tn (ft-kips)	phi Mn (ft-kips)	Total Deflect (in)	Rotation (deg)	Ratio
0.00	-44.42	-28.58	0.00	-2,472.54	0.00	2,472.54	4,197.01	1,106.34	5,292.54	4,577.40	0.00	0.00	0.551
3.00	-43.33	-28.24	0.00	-2,386.80	0.00	2,386.80	4,156.73	1,088.94	5,127.40	4,461.67	0.03	-0.09	0.546
5.00	-42.71	-27.98	0.00	-2,330.32	0.00	2,330.32	4,129.42	1,077.34	5,018.76	4,384.81	0.08	-0.16	0.542
10.00	-41.25	-27.62	0.00	-2,190.41	0.00	2,190.41	4,059.55	1,048.34	4,752.26	4,193.75	0.33	-0.31	0.533
15.00	-39.81	-27.25	0.00	-2,052.32	0.00	2,052.32	3,987.39	1,019.35	4,493.02	4,004.43	0.74	-0.47	0.523
20.00	-38.41	-26.88	0.00	-1,916.06	0.00	1,916.06	3,912.96	990.35	4,241.06	3,817.03	1.32	-0.63	0.513
25.00	-37.05	-26.49	0.00	-1,781.69	0.00	1,781.69	3,836.23	961.35	3,996.37	3,631.76	2.07	-0.80	0.501
30.00	-35.72	-26.08	0.00	-1,649.26	0.00	1,649.26	3,757.23	932.35	3,758.94	3,448.80	3.00	-0.96	0.489
35.00	-34.43	-25.68	0.00	-1,518.85	0.00	1,518.85	3,675.94	903.36	3,528.79	3,268.37	4.10	-1.13	0.475
40.00	-33.17	-25.27	0.00	-1,390.46	0.00	1,390.46	3,592.36	874.36	3,305.91	3,090.65	5.37	-1.30	0.460
45.00	-31.97	-24.95	0.00	-1,264.14	0.00	1,264.14	3,506.51	845.36	3,090.30	2,915.85	6.83	-1.47	0.444
47.50	-31.37	-24.74	0.00	-1,201.77	0.00	1,201.77	3,462.72	830.86	2,985.22	2,829.60	7.62	-1.56	0.435
50.00	-30.29	-24.49	0.00	-1,139.92	0.00	1,139.92	3,418.37	816.36	2,881.95	2,744.16	8.47	-1.65	0.425
53.25	-28.93	-24.25	0.00	-1,060.34	0.00	1,060.34	3,408.56	813.18	2,859.53	2,725.51	9.63	-1.76	0.398
55.00	-28.50	-23.98	0.00	-1,017.90	0.00	1,017.90	3,377.08	803.03	2,788.61	2,666.32	10.29	-1.82	0.391
60.00	-27.38	-23.55	0.00	-898.02	0.00	898.02	3,276.75	774.03	2,590.88	2,492.78	12.28	-1.98	0.370
65.00	-26.29	-23.12	0.00	-780.29	0.00	780.29	3,153.99	745.04	2,400.42	2,308.60	14.44	-2.14	0.347
70.00	-21.61	-19.78	0.00	-664.68	0.00	664.68	3,031.23	716.04	2,217.23	2,131.50	16.77	-2.29	0.320
75.00	-20.62	-19.35	0.00	-565.79	0.00	565.79	2,908.48	687.04	2,041.31	1,961.46	19.24	-2.43	0.296
80.00	-19.67	-18.94	0.00	-469.02	0.00	469.02	2,785.72	658.04	1,872.66	1,798.48	21.87	-2.57	0.269
85.00	-18.75	-18.53	0.00	-374.33	0.00	374.33	2,662.96	629.05	1,711.29	1,642.58	24.63	-2.70	0.236
90.00	-14.95	-16.91	0.00	-281.70	0.00	281.70	2,540.21	600.05	1,557.18	1,493.74	27.52	-2.81	0.195
91.20	-13.84	-15.12	0.00	-261.41	0.00	261.41	2,510.74	593.09	1,521.27	1,459.08	28.23	-2.84	0.185
95.00	-13.22	-14.88	0.00	-203.96	0.00	203.96	2,417.45	571.05	1,410.34	1,351.98	30.52	-2.91	0.157
97.00	-12.91	-14.68	0.00	-174.21	0.00	174.21	2,368.35	559.45	1,353.64	1,297.25	31.75	-2.95	0.140
100.00	-9.10	-10.56	0.00	-130.16	0.00	130.16	2,294.69	542.05	1,270.77	1,217.28	33.61	-2.99	0.111
101.00	-8.87	-10.37	0.00	-119.60	0.00	119.60	1,529.64	366.21	869.88	826.32	34.24	-3.01	0.151
105.00	-8.47	-10.03	0.00	-78.14	0.00	78.14	1,481.61	350.74	797.97	766.26	36.78	-3.05	0.109
110.00	-1.47	-1.89	0.00	-22.21	0.00	22.21	1,402.96	331.41	712.44	685.20	40.00	-3.10	0.033
115.00	-1.09	-1.61	0.00	-12.75	0.00	12.75	1,321.13	312.08	631.76	607.20	43.25	-3.12	0.022
118.00	-0.24	-0.84	0.00	-7.92	0.00	7.92	1,272.02	300.48	585.68	562.66	45.21	-3.12	0.014
119.00	0.00	-0.83	0.00	-7.08	0.00	7.08	1,255.66	296.61	570.71	548.20	45.87	-3.12	0.013

Load Case: 0.9D + 1.0W	116 mph with No Ice (Reduced DL)	20 Iterations
Gust Response Factor :1.10		
Dead Load Factor :0.90		
Wind Load Factor :1.00		

Applied Segment Forces Summary

Seg Elev (ft)	Description	Shaft Forces		Discrete Forces			Linear Forces		Sum of Forces				
		Wind FX (lb)	Dead Load (lb)	Wind FX (lb)	Torsion MY (lb-ft)	Moment MZ (lb-ft)	Dead Load (lb)	Wind FX (lb)	Dead Load (lb)	Wind FX (lb)	Dead Load (lb)	Torsion MY (lb-ft)	Moment MZ (lb)
0.00		148.5	0.0					0.0	0.0	148.5	0.0	0.0	0.0
3.00	Appurtenance(s)	246.2	574.6	150.6	0.0	0.0	142.8	0.0	71.1	396.8	788.5	0.0	0.0
5.00		337.4	378.0					0.0	47.4	337.4	425.4	0.0	0.0
10.00		472.9	927.3					0.0	118.4	472.9	1,045.8	0.0	0.0
15.00		467.1	902.0					0.0	118.4	467.1	1,020.5	0.0	0.0
20.00		473.4	876.7					0.0	118.4	473.4	995.2	0.0	0.0
25.00		482.0	851.4					0.0	118.4	482.0	969.9	0.0	0.0
30.00		486.1	826.1					0.0	118.4	486.1	944.6	0.0	0.0
35.00		486.7	800.8					0.0	118.4	486.7	919.3	0.0	0.0
40.00		484.7	775.5					0.0	118.4	484.7	894.0	0.0	0.0
45.00		361.4	750.2					0.0	118.4	361.4	868.7	0.0	0.0
47.50	Bot - Section 2	241.2	365.6					0.0	59.2	241.2	424.8	0.0	0.0
50.00		277.9	725.4					0.0	59.2	277.9	784.7	0.0	0.0
53.25	Top - Section 1	240.2	924.2					0.0	77.0	240.2	1,001.1	0.0	0.0
55.00		319.9	246.8					0.0	41.5	319.9	288.2	0.0	0.0
60.00		468.0	688.0					0.0	118.4	468.0	806.4	0.0	0.0
65.00		458.3	662.7					0.0	118.4	458.3	781.1	0.0	0.0
70.00	Appurtenance(s)	447.6	637.4	2,768.9	0.0	0.0	2,818.9	0.0	118.4	3,216.4	3,574.7	0.0	0.0
75.00		435.9	612.1					0.0	107.9	435.9	720.0	0.0	0.0
80.00		423.5	586.8					0.0	107.9	423.5	694.7	0.0	0.0
85.00		410.2	561.5					0.0	107.9	410.2	669.4	0.0	0.0
90.00	Appurtenance(s)	249.1	536.2	1,199.5	0.0	0.0	2,250.0	0.0	107.9	1,448.6	2,894.1	0.0	0.0
91.20		194.6	124.9					0.0	25.9	194.6	150.8	0.0	0.0
95.00		223.0	386.0					0.0	71.6	223.0	457.6	0.0	0.0
97.00	Bot - Section 3	189.2	197.3					0.0	37.7	189.2	235.0	0.0	0.0
100.00	Appurtenance(s)	150.7	485.1	3,777.3	0.0	-647.5	2,470.0	0.0	56.5	3,928.0	3,011.7	0.0	0.0
101.00	Top - Section 2	182.9	158.3					0.0	14.7	182.9	173.0	0.0	0.0
105.00		320.6	250.2					0.0	58.7	320.6	308.9	0.0	0.0
110.00	Appurtenance(s)	341.6	297.6	7,410.1	0.0	5,776.6	5,196.9	0.0	73.3	7,751.7	5,567.8	0.0	0.0
115.00		262.7	280.7					0.0	14.3	262.7	295.0	0.0	0.0
118.00	Appurtenance(s)	127.3	160.3	591.2	0.0	0.0	506.3	0.0	2.7	718.5	669.3	0.0	0.0
119.00		31.3	52.1					0.0	0.9	31.3	53.0	0.0	0.0
Totals:										26,339.6	32,433.1	0.00	0.00

Load Case: 0.9D + 1.0W

116 mph with No Ice (Reduced DL)

20 Iterations

Gust Response Factor :1.10

Dead Load Factor :0.90

Wind Load Factor :1.00

Calculated Forces

Seg Elev (ft)	Pu FY (-) (kips)	Vu FX (-) (kips)	Tu MY (ft-kips)	Mu MZ (ft-kips)	Mu MX (ft-kips)	Resultant Moment (ft-kips)	phi Pn (kips)	phi Vn (kips)	phi Tn (ft-kips)	phi Mn (ft-kips)	Total Deflect (in)	Rotation (deg)	Ratio
0.00	-33.31	-28.57	0.00	-2,452.79	0.00	2,452.79	4,197.01	1,106.34	5,292.54	4,577.40	0.00	0.00	0.544
3.00	-32.49	-28.22	0.00	-2,367.08	0.00	2,367.08	4,156.73	1,088.94	5,127.40	4,461.67	0.03	-0.09	0.539
5.00	-32.01	-27.94	0.00	-2,310.65	0.00	2,310.65	4,129.42	1,077.34	5,018.76	4,384.81	0.08	-0.15	0.535
10.00	-30.89	-27.55	0.00	-2,170.97	0.00	2,170.97	4,059.55	1,048.34	4,752.26	4,193.75	0.33	-0.31	0.526
15.00	-29.80	-27.15	0.00	-2,033.24	0.00	2,033.24	3,987.39	1,019.35	4,493.02	4,004.43	0.74	-0.47	0.516
20.00	-28.73	-26.75	0.00	-1,897.48	0.00	1,897.48	3,912.96	990.35	4,241.06	3,817.03	1.31	-0.63	0.505
25.00	-27.69	-26.34	0.00	-1,763.72	0.00	1,763.72	3,836.23	961.35	3,996.37	3,631.76	2.06	-0.79	0.494
30.00	-26.68	-25.91	0.00	-1,632.04	0.00	1,632.04	3,757.23	932.35	3,758.94	3,448.80	2.97	-0.95	0.481
35.00	-25.69	-25.49	0.00	-1,502.47	0.00	1,502.47	3,675.94	903.36	3,528.79	3,268.37	4.06	-1.12	0.467
40.00	-24.74	-25.06	0.00	-1,375.04	0.00	1,375.04	3,592.36	874.36	3,305.91	3,090.65	5.32	-1.29	0.453
45.00	-23.82	-24.73	0.00	-1,249.77	0.00	1,249.77	3,506.51	845.36	3,090.30	2,915.85	6.77	-1.46	0.436
47.50	-23.37	-24.51	0.00	-1,187.95	0.00	1,187.95	3,462.72	830.86	2,985.22	2,829.60	7.55	-1.54	0.427
50.00	-22.55	-24.25	0.00	-1,126.68	0.00	1,126.68	3,418.37	816.36	2,881.95	2,744.16	8.39	-1.63	0.418
53.25	-21.52	-24.01	0.00	-1,047.87	0.00	1,047.87	3,408.56	813.18	2,859.53	2,725.51	9.54	-1.74	0.392
55.00	-21.19	-23.72	0.00	-1,005.85	0.00	1,005.85	3,377.08	803.03	2,788.61	2,666.32	10.19	-1.80	0.384
60.00	-20.34	-23.29	0.00	-887.23	0.00	887.23	3,276.75	774.03	2,590.88	2,492.78	12.16	-1.96	0.363
65.00	-19.52	-22.85	0.00	-770.81	0.00	770.81	3,153.99	745.04	2,400.42	2,308.60	14.30	-2.12	0.341
70.00	-16.02	-19.54	0.00	-656.55	0.00	656.55	3,031.23	716.04	2,217.23	2,131.50	16.60	-2.27	0.314
75.00	-15.27	-19.11	0.00	-558.85	0.00	558.85	2,908.48	687.04	2,041.31	1,961.46	19.05	-2.41	0.291
80.00	-14.55	-18.69	0.00	-463.28	0.00	463.28	2,785.72	658.04	1,872.66	1,798.48	21.65	-2.54	0.264
85.00	-13.86	-18.28	0.00	-369.82	0.00	369.82	2,662.96	629.05	1,711.29	1,642.58	24.38	-2.67	0.231
90.00	-11.02	-16.71	0.00	-278.41	0.00	278.41	2,540.21	600.05	1,557.18	1,493.74	27.24	-2.78	0.191
91.20	-10.20	-14.93	0.00	-258.35	0.00	258.35	2,510.74	593.09	1,521.27	1,459.08	27.94	-2.81	0.182
95.00	-9.74	-14.69	0.00	-201.62	0.00	201.62	2,417.45	571.05	1,410.34	1,351.98	30.21	-2.88	0.154
97.00	-9.51	-14.50	0.00	-172.23	0.00	172.23	2,368.35	559.45	1,353.64	1,297.25	31.42	-2.91	0.137
100.00	-6.70	-10.43	0.00	-128.73	0.00	128.73	2,294.69	542.05	1,270.77	1,217.28	33.27	-2.96	0.109
101.00	-6.53	-10.24	0.00	-118.31	0.00	118.31	1,529.64	366.21	869.88	826.32	33.89	-2.97	0.148
105.00	-6.23	-9.91	0.00	-77.36	0.00	77.36	1,481.61	350.74	797.97	766.26	36.40	-3.02	0.106
110.00	-1.08	-1.87	0.00	-22.05	0.00	22.05	1,402.96	331.41	712.44	685.20	39.59	-3.06	0.033
115.00	-0.80	-1.59	0.00	-12.69	0.00	12.69	1,321.13	312.08	631.76	607.20	42.80	-3.08	0.022
118.00	-0.17	-0.84	0.00	-7.92	0.00	7.92	1,272.02	300.48	585.68	562.66	44.74	-3.09	0.014
119.00	0.00	-0.83	0.00	-7.08	0.00	7.08	1,255.66	296.61	570.71	548.20	45.39	-3.09	0.013

Load Case: 1.2D + 1.0Di + 1.0Wi	50 mph with 1.50 in Radial Ice	19 Iterations
Gust Response Factor :1.10	Ice Dead Load Factor :1.00	
Dead Load Factor :1.20		Ice Importance Factor :1.00
Wind Load Factor :1.00		

Applied Segment Forces Summary

Seg Elev (ft)	Description	Shaft Forces		Discrete Forces			Linear Forces		Sum of Forces				
		Wind FX (lb)	Dead Load (lb)	Wind FX (lb)	Torsion MY (lb-ft)	Moment MZ (lb-ft)	Dead Load (lb)	Wind FX (lb)	Dead Load (lb)	Wind FX (lb)	Dead Load (lb)	Torsion MY (lb-ft)	Moment MZ (lb)
0.00		47.2	0.0					0.0	0.0	47.2	0.0	0.0	0.0
3.00	Appurtenance(s)	78.4	988.0	35.4	0.0	0.0	282.2	0.0	94.8	113.8	1,365.0	0.0	0.0
5.00		108.0	665.8					0.0	63.2	108.0	729.0	0.0	0.0
10.00		151.9	1,656.6					0.0	157.9	151.9	1,814.5	0.0	0.0
15.00		150.6	1,633.6					0.0	157.9	150.6	1,791.6	0.0	0.0
20.00		153.1	1,602.8					0.0	157.9	153.1	1,760.7	0.0	0.0
25.00		156.3	1,567.9					0.0	157.9	156.3	1,725.8	0.0	0.0
30.00		158.1	1,530.4					0.0	157.9	158.1	1,688.3	0.0	0.0
35.00		158.8	1,491.0					0.0	157.9	158.8	1,649.0	0.0	0.0
40.00		158.6	1,450.4					0.0	157.9	158.6	1,608.3	0.0	0.0
45.00		118.5	1,408.7					0.0	157.9	118.5	1,566.6	0.0	0.0
47.50	Bot - Section 2	79.2	690.1					0.0	79.0	79.2	769.1	0.0	0.0
50.00		91.4	1,171.3					0.0	79.0	91.4	1,250.2	0.0	0.0
53.25	Top - Section 1	79.1	1,493.2					0.0	102.6	79.1	1,595.9	0.0	0.0
55.00		105.6	468.6					0.0	55.3	105.6	523.9	0.0	0.0
60.00		154.9	1,304.8					0.0	157.9	154.9	1,462.7	0.0	0.0
65.00		152.2	1,260.5					0.0	157.9	152.2	1,418.4	0.0	0.0
70.00	Appurtenance(s)	149.3	1,215.8	714.0	0.0	0.0	6,077.8	0.0	157.9	863.3	7,451.5	0.0	0.0
75.00		146.0	1,170.7					0.0	143.9	146.0	1,314.6	0.0	0.0
80.00		142.4	1,125.2					0.0	143.9	142.4	1,269.1	0.0	0.0
85.00		138.6	1,079.4					0.0	143.9	138.6	1,223.3	0.0	0.0
90.00	Appurtenance(s)	84.4	1,033.4	413.0	0.0	0.0	4,305.4	0.0	143.9	497.5	5,482.6	0.0	0.0
91.20		66.3	242.4					0.0	34.5	66.3	277.0	0.0	0.0
95.00		76.1	747.2					0.0	95.5	76.1	842.7	0.0	0.0
97.00	Bot - Section 3	64.8	383.5					0.0	50.3	64.8	433.8	0.0	0.0
100.00	Appurtenance(s)	51.6	825.9	1,016.1	0.0	-154.8	5,921.9	0.0	75.4	1,067.7	6,823.2	0.0	0.0
101.00	Top - Section 2	62.9	270.4					0.0	19.6	62.9	289.9	0.0	0.0
105.00		110.8	561.9					0.0	78.2	110.8	640.2	0.0	0.0
110.00	Appurtenance(s)	118.8	668.8	2,371.7	0.0	1,360.2	14,659.4	0.0	97.8	2,490.5	15,426.0	0.0	0.0
115.00		91.9	632.8					0.0	19.1	91.9	651.9	0.0	0.0
118.00	Appurtenance(s)	44.8	364.2	162.9	0.0	0.0	1,008.2	0.0	3.6	207.7	1,375.9	0.0	0.0
119.00		11.0	119.1					0.0	1.2	11.0	120.3	0.0	0.0
Totals:										8,174.82	66,341.0	0.00	0.00

Site Number: 209185

Code: ANSI/TIA-222-H

© 2007 - 2021 by ATC IP LLC. All rights reserved.

Site Name: Burlington 2, CT

Engineering Number: 13688136_C3_03

7/14/2021 12:27:10 PM

Customer: DISH WIRELESS L.L.C.

Load Case: 1.2D + 1.0Di + 1.0Wi

50 mph with 1.50 in Radial Ice

19 Iterations

Gust Response Factor :1.10

Ice Dead Load Factor :1.00

Dead Load Factor :1.20

Ice Importance Factor :1.00

Wind Load Factor :1.00

Calculated Forces

Seg Elev (ft)	Pu FY (-) (kips)	Vu FX (-) (kips)	Tu MY (ft-kips)	Mu MZ (ft-kips)	Mu MX (ft-kips)	Resultant Moment (ft-kips)	phi Pn (kips)	phi Vn (kips)	phi Tn (ft-kips)	phi Mn (ft-kips)	Total Deflect (in)	Rotation (deg)	Ratio
0.00	-69.30	-8.85	0.00	-785.17	0.00	785.17	4,197.01	1,106.34	5,292.54	4,577.40	0.00	0.00	0.188
3.00	-67.93	-8.77	0.00	-758.62	0.00	758.62	4,156.73	1,088.94	5,127.40	4,461.67	0.01	-0.03	0.186
5.00	-67.20	-8.70	0.00	-741.08	0.00	741.08	4,129.42	1,077.34	5,018.76	4,384.81	0.03	-0.05	0.185
10.00	-65.37	-8.60	0.00	-697.58	0.00	697.58	4,059.55	1,048.34	4,752.26	4,193.75	0.11	-0.10	0.183
15.00	-63.58	-8.51	0.00	-654.57	0.00	654.57	3,987.39	1,019.35	4,493.02	4,004.43	0.24	-0.15	0.179
20.00	-61.81	-8.40	0.00	-612.04	0.00	612.04	3,912.96	990.35	4,241.06	3,817.03	0.42	-0.20	0.176
25.00	-60.08	-8.30	0.00	-570.02	0.00	570.02	3,836.23	961.35	3,996.37	3,631.76	0.66	-0.25	0.173
30.00	-58.38	-8.18	0.00	-528.55	0.00	528.55	3,757.23	932.35	3,758.94	3,448.80	0.95	-0.31	0.169
35.00	-56.72	-8.07	0.00	-487.63	0.00	487.63	3,675.94	903.36	3,528.79	3,268.37	1.31	-0.36	0.165
40.00	-55.11	-7.95	0.00	-447.28	0.00	447.28	3,592.36	874.36	3,305.91	3,090.65	1.71	-0.42	0.160
45.00	-53.54	-7.86	0.00	-407.52	0.00	407.52	3,506.51	845.36	3,090.30	2,915.85	2.18	-0.47	0.155
47.50	-52.77	-7.80	0.00	-387.87	0.00	387.87	3,462.72	830.86	2,985.22	2,829.60	2.43	-0.50	0.152
50.00	-51.51	-7.73	0.00	-368.37	0.00	368.37	3,418.37	816.36	2,881.95	2,744.16	2.70	-0.53	0.149
53.25	-49.91	-7.66	0.00	-343.25	0.00	343.25	3,408.56	813.18	2,859.53	2,725.51	3.07	-0.56	0.141
55.00	-49.39	-7.58	0.00	-329.85	0.00	329.85	3,377.08	803.03	2,788.61	2,666.32	3.29	-0.58	0.138
60.00	-47.92	-7.45	0.00	-291.96	0.00	291.96	3,276.75	774.03	2,590.88	2,492.78	3.93	-0.64	0.132
65.00	-46.50	-7.32	0.00	-254.71	0.00	254.71	3,153.99	745.04	2,400.42	2,308.60	4.62	-0.69	0.125
70.00	-39.05	-6.40	0.00	-218.09	0.00	218.09	3,031.23	716.04	2,217.23	2,131.50	5.37	-0.74	0.115
75.00	-37.73	-6.27	0.00	-186.09	0.00	186.09	2,908.48	687.04	2,041.31	1,961.46	6.16	-0.78	0.108
80.00	-36.46	-6.14	0.00	-154.76	0.00	154.76	2,785.72	658.04	1,872.66	1,798.48	7.01	-0.83	0.099
85.00	-35.24	-6.00	0.00	-124.08	0.00	124.08	2,662.96	629.05	1,711.29	1,642.58	7.90	-0.87	0.089
90.00	-29.76	-5.43	0.00	-94.07	0.00	94.07	2,540.21	600.05	1,557.18	1,493.74	8.83	-0.91	0.075
91.20	-27.09	-4.94	0.00	-87.55	0.00	87.55	2,510.74	593.09	1,521.27	1,459.08	9.06	-0.92	0.071
95.00	-26.25	-4.86	0.00	-68.77	0.00	68.77	2,417.45	571.05	1,410.34	1,351.98	9.80	-0.94	0.062
97.00	-25.82	-4.80	0.00	-59.05	0.00	59.05	2,368.35	559.45	1,353.64	1,297.25	10.20	-0.95	0.056
100.00	-19.01	-3.62	0.00	-44.66	0.00	44.66	2,294.69	542.05	1,270.77	1,217.28	10.81	-0.97	0.045
101.00	-18.72	-3.55	0.00	-41.04	0.00	41.04	1,529.64	366.21	869.88	826.32	11.01	-0.97	0.062
105.00	-18.08	-3.44	0.00	-26.83	0.00	26.83	1,481.61	350.74	797.97	766.26	11.83	-0.99	0.047
110.00	-2.70	-0.68	0.00	-8.29	0.00	8.29	1,402.96	331.41	712.44	685.20	12.88	-1.01	0.014
115.00	-2.05	-0.57	0.00	-4.90	0.00	4.90	1,321.13	312.08	631.76	607.20	13.94	-1.01	0.010
118.00	-0.68	-0.34	0.00	-3.18	0.00	3.18	1,272.02	300.48	585.68	562.66	14.57	-1.02	0.006
119.00	0.00	-0.33	0.00	-2.83	0.00	2.83	1,255.66	296.61	570.71	548.20	14.79	-1.02	0.005

Load Case: 1.0D + 1.0W	Serviceability 60 mph	19 Iterations
Gust Response Factor :1.10		
Dead Load Factor :1.00		
Wind Load Factor :1.00		

Applied Segment Forces Summary

Seg Elev (ft)	Description	Shaft Forces		Discrete Forces			Linear Forces		Sum of Forces				
		Wind FX (lb)	Dead Load (lb)	Wind FX (lb)	Torsion MY (lb-ft)	Moment MZ (lb-ft)	Dead Load (lb)	Wind FX (lb)	Dead Load (lb)	Wind FX (lb)	Dead Load (lb)	Torsion MY (lb-ft)	Moment MZ (lb)
0.00		35.5	0.0					0.0	0.0	35.5	0.0	0.0	0.0
3.00	Appurtenance(s)	58.9	638.5	36.1	0.0	0.0	158.7	0.0	79.0	95.0	876.1	0.0	0.0
5.00		80.8	420.0					0.0	52.6	80.8	472.7	0.0	0.0
10.00		113.2	1,030.4					0.0	131.6	113.2	1,162.0	0.0	0.0
15.00		111.8	1,002.3					0.0	131.6	111.8	1,133.9	0.0	0.0
20.00		113.3	974.2					0.0	131.6	113.3	1,105.8	0.0	0.0
25.00		115.4	946.0					0.0	131.6	115.4	1,077.6	0.0	0.0
30.00		116.4	917.9					0.0	131.6	116.4	1,049.5	0.0	0.0
35.00		116.5	889.8					0.0	131.6	116.5	1,021.4	0.0	0.0
40.00		116.0	861.7					0.0	131.6	116.0	993.3	0.0	0.0
45.00		86.5	833.6					0.0	131.6	86.5	965.2	0.0	0.0
47.50	Bot - Section 2	57.7	406.3					0.0	65.8	57.7	472.1	0.0	0.0
50.00		66.5	806.0					0.0	65.8	66.5	871.8	0.0	0.0
53.25	Top - Section 1	57.5	1,026.8					0.0	85.5	57.5	1,112.4	0.0	0.0
55.00		76.6	274.2					0.0	46.1	76.6	320.3	0.0	0.0
60.00		112.0	764.4					0.0	131.6	112.0	896.0	0.0	0.0
65.00		109.7	736.3					0.0	131.6	109.7	867.9	0.0	0.0
70.00	Appurtenance(s)	107.1	708.2	662.8	0.0	0.0	3,132.1	0.0	131.6	769.9	3,971.9	0.0	0.0
75.00		104.4	680.1					0.0	119.9	104.4	800.0	0.0	0.0
80.00		101.4	652.0					0.0	119.9	101.4	771.9	0.0	0.0
85.00		98.2	623.9					0.0	119.9	98.2	743.8	0.0	0.0
90.00	Appurtenance(s)	59.6	595.8	287.1	0.0	0.0	2,500.0	0.0	119.9	346.8	3,215.7	0.0	0.0
91.20		46.6	138.8					0.0	28.8	46.6	167.6	0.0	0.0
95.00		53.4	428.9					0.0	79.6	53.4	508.4	0.0	0.0
97.00	Bot - Section 3	45.3	219.2					0.0	41.9	45.3	261.1	0.0	0.0
100.00	Appurtenance(s)	36.1	539.0	904.2	0.0	-155.0	2,744.5	0.0	62.8	940.3	3,346.3	0.0	0.0
101.00	Top - Section 2	43.8	175.9					0.0	16.3	43.8	192.2	0.0	0.0
105.00		76.7	278.0					0.0	65.2	76.7	343.2	0.0	0.0
110.00	Appurtenance(s)	81.8	330.7	1,773.8	0.0	1,382.8	5,774.3	0.0	81.5	1,855.6	6,186.5	0.0	0.0
115.00		62.9	311.9					0.0	15.9	62.9	327.8	0.0	0.0
118.00	Appurtenance(s)	30.5	178.2	141.5	0.0	0.0	562.5	0.0	3.0	172.0	743.6	0.0	0.0
119.00		7.5	57.9					0.0	1.0	7.5	58.9	0.0	0.0
Totals:										6,305.09	36,036.8	0.00	0.00

Load Case: 1.0D + 1.0W

Serviceability 60 mph

19 Iterations

Gust Response Factor :1.10

Dead Load Factor :1.00

Wind Load Factor :1.00

Calculated Forces

Seg Elev (ft)	Pu FY (-) (kips)	Vu FX (-) (kips)	Tu MY (ft-kips)	Mu MZ (ft-kips)	Mu MX (ft-kips)	Resultant Moment (ft-kips)	phi Pn (kips)	phi Vn (kips)	phi Tn (ft-kips)	phi Mn (ft-kips)	Total Deflect (in)	Rotation (deg)	Ratio
0.00	-37.04	-6.84	0.00	-588.93	0.00	588.93	4,197.01	1,106.34	5,292.54	4,577.40	0.00	0.00	0.138
3.00	-36.16	-6.76	0.00	-568.41	0.00	568.41	4,156.73	1,088.94	5,127.40	4,461.67	0.01	-0.02	0.136
5.00	-35.68	-6.69	0.00	-554.90	0.00	554.90	4,129.42	1,077.34	5,018.76	4,384.81	0.02	-0.04	0.135
10.00	-34.52	-6.60	0.00	-521.44	0.00	521.44	4,059.55	1,048.34	4,752.26	4,193.75	0.08	-0.07	0.133
15.00	-33.38	-6.51	0.00	-488.45	0.00	488.45	3,987.39	1,019.35	4,493.02	4,004.43	0.18	-0.11	0.130
20.00	-32.27	-6.41	0.00	-455.91	0.00	455.91	3,912.96	990.35	4,241.06	3,817.03	0.32	-0.15	0.128
25.00	-31.19	-6.32	0.00	-423.85	0.00	423.85	3,836.23	961.35	3,996.37	3,631.76	0.49	-0.19	0.125
30.00	-30.13	-6.22	0.00	-392.26	0.00	392.26	3,757.23	932.35	3,758.94	3,448.80	0.71	-0.23	0.122
35.00	-29.11	-6.12	0.00	-361.18	0.00	361.18	3,675.94	903.36	3,528.79	3,268.37	0.98	-0.27	0.118
40.00	-28.11	-6.02	0.00	-330.60	0.00	330.60	3,592.36	874.36	3,305.91	3,090.65	1.28	-0.31	0.115
45.00	-27.14	-5.94	0.00	-300.52	0.00	300.52	3,506.51	845.36	3,090.30	2,915.85	1.63	-0.35	0.111
47.50	-26.67	-5.89	0.00	-285.67	0.00	285.67	3,462.72	830.86	2,985.22	2,829.60	1.81	-0.37	0.109
50.00	-25.80	-5.83	0.00	-270.96	0.00	270.96	3,418.37	816.36	2,881.95	2,744.16	2.01	-0.39	0.106
53.25	-24.68	-5.77	0.00	-252.02	0.00	252.02	3,408.56	813.18	2,859.53	2,725.51	2.29	-0.42	0.100
55.00	-24.36	-5.70	0.00	-241.93	0.00	241.93	3,377.08	803.03	2,788.61	2,666.32	2.45	-0.43	0.098
60.00	-23.46	-5.60	0.00	-213.42	0.00	213.42	3,276.75	774.03	2,590.88	2,492.78	2.92	-0.47	0.093
65.00	-22.59	-5.49	0.00	-185.43	0.00	185.43	3,153.99	745.04	2,400.42	2,308.60	3.44	-0.51	0.088
70.00	-18.62	-4.70	0.00	-157.96	0.00	157.96	3,031.23	716.04	2,217.23	2,131.50	3.99	-0.54	0.080
75.00	-17.82	-4.60	0.00	-134.46	0.00	134.46	2,908.48	687.04	2,041.31	1,961.46	4.58	-0.58	0.075
80.00	-17.05	-4.50	0.00	-111.47	0.00	111.47	2,785.72	658.04	1,872.66	1,798.48	5.20	-0.61	0.068
85.00	-16.30	-4.40	0.00	-88.98	0.00	88.98	2,662.96	629.05	1,711.29	1,642.58	5.86	-0.64	0.060
90.00	-13.09	-4.02	0.00	-66.98	0.00	66.98	2,540.21	600.05	1,557.18	1,493.74	6.55	-0.67	0.050
91.20	-12.11	-3.59	0.00	-62.16	0.00	62.16	2,510.74	593.09	1,521.27	1,459.08	6.72	-0.68	0.047
95.00	-11.60	-3.54	0.00	-48.50	0.00	48.50	2,417.45	571.05	1,410.34	1,351.98	7.26	-0.69	0.041
97.00	-11.34	-3.49	0.00	-41.43	0.00	41.43	2,368.35	559.45	1,353.64	1,297.25	7.55	-0.70	0.037
100.00	-8.00	-2.51	0.00	-30.96	0.00	30.96	2,294.69	542.05	1,270.77	1,217.28	8.00	-0.71	0.029
101.00	-7.81	-2.46	0.00	-28.45	0.00	28.45	1,529.64	366.21	869.88	826.32	8.15	-0.71	0.040
105.00	-7.47	-2.38	0.00	-18.60	0.00	18.60	1,481.61	350.74	797.97	766.26	8.75	-0.73	0.029
110.00	-1.30	-0.45	0.00	-5.29	0.00	5.29	1,402.96	331.41	712.44	685.20	9.52	-0.74	0.009
115.00	-0.98	-0.38	0.00	-3.04	0.00	3.04	1,321.13	312.08	631.76	607.20	10.29	-0.74	0.006
118.00	-0.24	-0.20	0.00	-1.90	0.00	1.90	1,272.02	300.48	585.68	562.66	10.76	-0.74	0.004
119.00	0.00	-0.20	0.00	-1.69	0.00	1.69	1,255.66	296.61	570.71	548.20	10.91	-0.74	0.003

Equivalent Lateral Forces Method Analysis

Spectral Response Acceleration for Short Period (S_s):	0.18
Spectral Response Acceleration at 1.0 Second Period (S_{d1}):	0.05
Long-Period Transition Period (T_L):	6
Importance Factor (I_E):	1.00
Site Coefficient F_a :	1.60
Site Coefficient F_v :	2.40
Response Modification Coefficient (R):	1.50
Design Spectral Response Acceleration at Short Period (S_{ds}):	0.20
Design Spectral Response Acceleration at 1.0 Second Period (S_{d1}):	0.09
Seismic Response Coefficient (C_s):	0.03
Upper Limit C_s	0.03
Lower Limit C_s	0.03
Period based on Rayleigh Method (sec):	1.74
Redundancy Factor (ρ):	1.00
Seismic Force Distribution Exponent (k):	1.62
Total Unfactored Dead Load:	37.04 k
Seismic Base Shear (E):	1.23 k

Load Case 1.2D + 1.0Ev + 1.0Eh

Seismic

Segment	Height Above Base (ft)	Weight (lb)	W_z (lb-ft)	C_{vx}	Horizontal Force (lb)	Vertical Force (lb)
31	118.50	59	135	0.003	4	73
30	116.50	181	404	0.010	12	224
29	112.50	328	690	0.017	21	406
28	107.50	412	806	0.020	24	511
27	103.00	343	626	0.015	19	425
26	100.50	192	337	0.008	10	238
25	98.50	602	1,022	0.025	31	746
24	96.00	261	425	0.010	13	324
23	93.10	508	788	0.019	24	630
22	90.60	168	248	0.006	7	208
21	87.50	716	1,003	0.025	30	887
20	82.50	744	947	0.023	29	922
19	77.50	772	888	0.022	27	957
18	72.50	800	826	0.020	25	991
17	67.50	840	773	0.019	23	1,041
16	62.50	868	705	0.017	21	1,076
15	57.50	896	636	0.016	19	1,110
14	54.13	320	206	0.005	6	397
13	51.63	1,112	663	0.016	20	1,379
12	48.75	872	473	0.012	14	1,080
11	46.25	472	235	0.006	7	585
10	42.50	965	420	0.010	13	1,196
9	37.50	993	353	0.009	11	1,231
8	32.50	1,021	288	0.007	9	1,266
7	27.50	1,050	225	0.006	7	1,301

6	22.50	1,078	167	0.004	5	1,335
5	17.50	1,106	114	0.003	3	1,370
4	12.50	1,134	68	0.002	2	1,405
3	7.50	1,162	30	0.001	1	1,440
2	4.00	473	4	0.000	0	586
1	1.50	717	1	0.000	0	889
Generic 22' Omni	119.00	140	323	0.008	10	173
Generic 12' Omni	119.00	40	92	0.002	3	50
Generic Flat Stand-O	118.00	563	1,279	0.031	39	697
Ericsson RRUS 32 B66	110.00	152	309	0.008	9	188
Ericsson RRUS-11 (19	110.00	306	621	0.015	19	379
Ericsson RRUS-12 B2	110.00	348	706	0.017	21	431
Ericsson RRUS-32 (77	110.00	231	469	0.012	14	286
Raycap DC6-48-60-18-	110.00	131	266	0.007	8	163
CCI HPA-65R-BUU-H8	110.00	816	1,656	0.041	50	1,011
Generic Square Platf	110.00	3,790	7,693	0.189	232	4,697
Generic GPS	100.00	10	17	0.000	1	12
Ericsson RRUS 11 B4	100.00	152	265	0.007	8	188
Ericsson RRUS 11 B12	100.00	304	529	0.013	16	377
RFS APX16DWV-16DWVS-	100.00	122	212	0.005	6	151
Generic 96" x 12" x	100.00	150	261	0.006	8	186
Andrew LNX-6515DS-A1	100.00	131	228	0.006	7	162
Generic Round Low Pr	100.00	1,875	3,261	0.080	98	2,324
Samsung B2/B66A RRH-	91.20	253	379	0.009	11	314
Samsung B5/B13 RRH-B	91.20	211	316	0.008	10	261
Raycap RVZDC-6627-PF	91.20	96	144	0.004	4	119
Commscope NHH-65B-R2	91.20	262	393	0.010	12	325
Generic Round Platfo	90.00	2,500	3,666	0.090	111	3,098
Commscope RDIDC-9181	70.00	22	21	0.001	1	27
Fujitsu TA08025-B605	70.00	225	220	0.005	7	279
Fujitsu TA08025-B604	70.00	192	187	0.005	6	238
JMA Wireless MX08FRO	70.00	193	189	0.005	6	240
Generic Flat Platfor	70.00	2,500	2,440	0.060	74	3,098
Ericsson RRUS E2	3.00	159	1	0.000	0	197
		37,039	40,654	1.000	1,226	45,901

Load Case 0.9D - 1.0Ev + 1.0Eh

Seismic (Reduced DL)

Segment	Height Above Base (ft)	Weight (lb)	W _z (lb-ft)	C _{vx}	Horizontal Force (lb)	Vertical Force (lb)
31	118.50	59	135	0.003	4	51
30	116.50	181	404	0.010	12	156
29	112.50	328	690	0.017	21	282
28	107.50	412	806	0.020	24	355
27	103.00	343	626	0.015	19	295
26	100.50	192	337	0.008	10	165
25	98.50	602	1,022	0.025	31	518
24	96.00	261	425	0.010	13	225
23	93.10	508	788	0.019	24	438
22	90.60	168	248	0.006	7	144
21	87.50	716	1,003	0.025	30	616
20	82.50	744	947	0.023	29	640
19	77.50	772	888	0.022	27	664
18	72.50	800	826	0.020	25	689
17	67.50	840	773	0.019	23	723
16	62.50	868	705	0.017	21	747
15	57.50	896	636	0.016	19	771
14	54.13	320	206	0.005	6	276
13	51.63	1,112	663	0.016	20	957
12	48.75	872	473	0.012	14	750
11	46.25	472	235	0.006	7	406

Site Number: 209185

Code: ANSI/TIA-222-H

© 2007 - 2021 by ATC IP LLC. All rights reserved.

Site Name: Burlington 2, CT

Engineering Number: 13688136_C3_03

7/14/2021 12:27:12 PM

Customer: DISH WIRELESS L.L.C.

10	42.50	965	420	0.010	13	831
9	37.50	993	353	0.009	11	855
8	32.50	1,021	288	0.007	9	879
7	27.50	1,050	225	0.006	7	903
6	22.50	1,078	167	0.004	5	928
5	17.50	1,106	114	0.003	3	952
4	12.50	1,134	68	0.002	2	976
3	7.50	1,162	30	0.001	1	1,000
2	4.00	473	4	0.000	0	407
1	1.50	717	1	0.000	0	618
Generic 22' Omni	119.00	140	323	0.008	10	121
Generic 12' Omni	119.00	40	92	0.002	3	34
Generic Flat Stand-O	118.00	563	1,279	0.031	39	484
Ericsson RRUS 32 B66	110.00	152	309	0.008	9	131
Ericsson RRUS-11 (19	110.00	306	621	0.015	19	263
Ericsson RRUS-12 B2	110.00	348	706	0.017	21	300
Ericsson RRUS-32 (77	110.00	231	469	0.012	14	199
Raycap DC6-48-60-18-	110.00	131	266	0.007	8	113
CCI HPA-65R-BUU-H8	110.00	816	1,656	0.041	50	702
Generic Square Platf	110.00	3,790	7,693	0.189	232	3,262
Generic GPS	100.00	10	17	0.000	1	9
Ericsson RRUS 11 B4	100.00	152	265	0.007	8	131
Ericsson RRUS 11 B12	100.00	304	529	0.013	16	262
RFS APX16DWV-16DWVS-	100.00	122	212	0.005	6	105
Generic 96" x 12" x	100.00	150	261	0.006	8	129
Andrew LNX-6515DS-A1	100.00	131	228	0.006	7	113
Generic Round Low Pr	100.00	1,875	3,261	0.080	98	1,614
Samsung B2/B66A RRH-	91.20	253	379	0.009	11	218
Samsung B5/B13 RRH-B	91.20	211	316	0.008	10	182
Raycap RVZDC-6627-PF	91.20	96	144	0.004	4	83
Commscope NHH-65B-R2	91.20	262	393	0.010	12	226
Generic Round Platfo	90.00	2,500	3,666	0.090	111	2,152
Commscope RDIDC-9181	70.00	22	21	0.001	1	19
Fujitsu TA08025-B605	70.00	225	220	0.005	7	194
Fujitsu TA08025-B604	70.00	192	187	0.005	6	165
JMA Wireless MX08FRO	70.00	193	189	0.005	6	167
Generic Flat Platfor	70.00	2,500	2,440	0.060	74	2,152
Ericsson RRUS E2	3.00	159	1	0.000	0	137
		37,039	40,654	1.000	1,226	31,881

Load Case 1.2D + 1.0Ev + 1.0Eh

Seismic

Calculated Forces

Seg Elev (ft)	Pu FY (-) (kips)	Vu FX (-) (kips)	Tu MY (ft-kips)	Mu MZ (ft-kips)	Mu MX (ft-kips)	Resultant Moment (ft-kips)	phi Pn (kips)	phi Vn (kips)	phi Tn (ft-kips)	phi Mn (ft-kips)	Total Deflect (in)	Rotation (deg)	Ratio
0.00	-45.01	-1.23	0.00	-115.61	0.00	115.61	4,197.01	1,106.34	5,292.54	4,577.40	0.00	0.00	0.036
3.00	-44.23	-1.23	0.00	-111.93	0.00	111.93	4,156.73	1,088.94	5,127.40	4,461.67	0.00	0.00	0.036
5.00	-42.79	-1.23	0.00	-109.47	0.00	109.47	4,129.42	1,077.34	5,018.76	4,384.81	0.00	-0.01	0.035
10.00	-41.38	-1.24	0.00	-103.31	0.00	103.31	4,059.55	1,048.34	4,752.26	4,193.75	0.02	-0.01	0.035
15.00	-40.01	-1.24	0.00	-97.13	0.00	97.13	3,987.39	1,019.35	4,493.02	4,004.43	0.03	-0.02	0.034
20.00	-38.68	-1.24	0.00	-90.95	0.00	90.95	3,912.96	990.35	4,241.06	3,817.03	0.06	-0.03	0.034
25.00	-37.38	-1.23	0.00	-84.77	0.00	84.77	3,836.23	961.35	3,996.37	3,631.76	0.10	-0.04	0.033
30.00	-36.11	-1.23	0.00	-78.60	0.00	78.60	3,757.23	932.35	3,758.94	3,448.80	0.14	-0.05	0.032
35.00	-34.88	-1.22	0.00	-72.45	0.00	72.45	3,675.94	903.36	3,528.79	3,268.37	0.19	-0.05	0.032
40.00	-33.68	-1.21	0.00	-66.33	0.00	66.33	3,592.36	874.36	3,305.91	3,090.65	0.25	-0.06	0.031
45.00	-33.10	-1.21	0.00	-60.27	0.00	60.27	3,506.51	845.36	3,090.30	2,915.85	0.32	-0.07	0.030
47.50	-32.02	-1.20	0.00	-57.24	0.00	57.24	3,462.72	830.86	2,985.22	2,829.60	0.36	-0.07	0.029
50.00	-30.64	-1.18	0.00	-54.25	0.00	54.25	3,418.37	816.36	2,881.95	2,744.16	0.40	-0.08	0.029
53.25	-30.24	-1.17	0.00	-50.43	0.00	50.43	3,408.56	813.18	2,859.53	2,725.51	0.46	-0.08	0.027
55.00	-29.13	-1.15	0.00	-48.38	0.00	48.38	3,377.08	803.03	2,788.61	2,666.32	0.49	-0.09	0.027
60.00	-28.06	-1.13	0.00	-42.61	0.00	42.61	3,276.75	774.03	2,590.88	2,492.78	0.58	-0.09	0.026
65.00	-27.02	-1.11	0.00	-36.93	0.00	36.93	3,153.99	745.04	2,400.42	2,308.60	0.68	-0.10	0.025
70.00	-22.14	-0.99	0.00	-31.37	0.00	31.37	3,031.23	716.04	2,217.23	2,131.50	0.79	-0.11	0.022
75.00	-21.19	-0.96	0.00	-26.42	0.00	26.42	2,908.48	687.04	2,041.31	1,961.46	0.91	-0.12	0.021
80.00	-20.26	-0.94	0.00	-21.60	0.00	21.60	2,785.72	658.04	1,872.66	1,798.48	1.04	-0.12	0.019
85.00	-19.38	-0.91	0.00	-16.92	0.00	16.92	2,662.96	629.05	1,711.29	1,642.58	1.17	-0.13	0.018
90.00	-16.07	-0.78	0.00	-12.40	0.00	12.40	2,540.21	600.05	1,557.18	1,493.74	1.30	-0.13	0.015
91.20	-14.42	-0.72	0.00	-11.46	0.00	11.46	2,510.74	593.09	1,521.27	1,459.08	1.34	-0.13	0.014
95.00	-14.10	-0.70	0.00	-8.74	0.00	8.74	2,417.45	571.05	1,410.34	1,351.98	1.45	-0.14	0.012
97.00	-13.35	-0.67	0.00	-7.33	0.00	7.33	2,368.35	559.45	1,353.64	1,297.25	1.50	-0.14	0.011
100.00	-9.71	-0.51	0.00	-5.32	0.00	5.32	2,294.69	542.05	1,270.77	1,217.28	1.59	-0.14	0.009
101.00	-9.29	-0.49	0.00	-4.81	0.00	4.81	1,529.64	366.21	869.88	826.32	1.62	-0.14	0.012
105.00	-8.78	-0.46	0.00	-2.85	0.00	2.85	1,481.61	350.74	797.97	766.26	1.74	-0.14	0.010
110.00	-1.22	-0.07	0.00	-0.54	0.00	0.54	1,402.96	331.41	712.44	685.20	1.89	-0.14	0.002
115.00	-0.99	-0.06	0.00	-0.19	0.00	0.19	1,321.13	312.08	631.76	607.20	2.04	-0.14	0.001
118.00	-0.22	-0.01	0.00	-0.01	0.00	0.01	1,272.02	300.48	585.68	562.66	2.13	-0.14	0.000
119.00	0.00	-0.01	0.00	0.00	0.00	0.00	1,255.66	296.61	570.71	548.20	2.16	-0.14	0.000

Load Case 0.9D - 1.0Ev + 1.0Eh

Seismic (Reduced DL)

Calculated Forces

Seg Elev (ft)	Pu FY (-) (kips)	Vu FX (-) (kips)	Tu MY (ft-kips)	Mu MZ (ft-kips)	Mu MX (ft-kips)	Resultant Moment (ft-kips)	phi Pn (kips)	phi Vn (kips)	phi Tn (ft-kips)	phi Mn (ft-kips)	Total Deflect (in)	Rotation (deg)	Ratio
0.00	-31.26	-1.23	0.00	-114.48	0.00	114.48	4,197.01	1,106.34	5,292.54	4,577.40	0.00	0.00	0.032
3.00	-30.72	-1.23	0.00	-110.80	0.00	110.80	4,156.73	1,088.94	5,127.40	4,461.67	0.00	0.00	0.032
5.00	-29.72	-1.23	0.00	-108.35	0.00	108.35	4,129.42	1,077.34	5,018.76	4,384.81	0.00	-0.01	0.032
10.00	-28.74	-1.23	0.00	-102.20	0.00	102.20	4,059.55	1,048.34	4,752.26	4,193.75	0.02	-0.01	0.031
15.00	-27.79	-1.23	0.00	-96.04	0.00	96.04	3,987.39	1,019.35	4,493.02	4,004.43	0.03	-0.02	0.031
20.00	-26.86	-1.23	0.00	-89.89	0.00	89.89	3,912.96	990.35	4,241.06	3,817.03	0.06	-0.03	0.030
25.00	-25.96	-1.23	0.00	-83.74	0.00	83.74	3,836.23	961.35	3,996.37	3,631.76	0.10	-0.04	0.030
30.00	-25.08	-1.22	0.00	-77.61	0.00	77.61	3,757.23	932.35	3,758.94	3,448.80	0.14	-0.05	0.029
35.00	-24.23	-1.21	0.00	-71.51	0.00	71.51	3,675.94	903.36	3,528.79	3,268.37	0.19	-0.05	0.028
40.00	-23.40	-1.20	0.00	-65.45	0.00	65.45	3,592.36	874.36	3,305.91	3,090.65	0.25	-0.06	0.028
45.00	-22.99	-1.20	0.00	-59.45	0.00	59.45	3,506.51	845.36	3,090.30	2,915.85	0.32	-0.07	0.027
47.50	-22.24	-1.18	0.00	-56.46	0.00	56.46	3,462.72	830.86	2,985.22	2,829.60	0.36	-0.07	0.026
50.00	-21.28	-1.16	0.00	-53.50	0.00	53.50	3,418.37	816.36	2,881.95	2,744.16	0.40	-0.08	0.026
53.25	-21.00	-1.16	0.00	-49.72	0.00	49.72	3,408.56	813.18	2,859.53	2,725.51	0.45	-0.08	0.024
55.00	-20.23	-1.14	0.00	-47.69	0.00	47.69	3,377.08	803.03	2,788.61	2,666.32	0.48	-0.09	0.024
60.00	-19.49	-1.12	0.00	-41.99	0.00	41.99	3,276.75	774.03	2,590.88	2,492.78	0.57	-0.09	0.023
65.00	-18.76	-1.10	0.00	-36.39	0.00	36.39	3,153.99	745.04	2,400.42	2,308.60	0.68	-0.10	0.022
70.00	-15.38	-0.98	0.00	-30.91	0.00	30.91	3,031.23	716.04	2,217.23	2,131.50	0.79	-0.11	0.020
75.00	-14.71	-0.95	0.00	-26.02	0.00	26.02	2,908.48	687.04	2,041.31	1,961.46	0.90	-0.11	0.018
80.00	-14.07	-0.92	0.00	-21.27	0.00	21.27	2,785.72	658.04	1,872.66	1,798.48	1.02	-0.12	0.017
85.00	-13.46	-0.89	0.00	-16.67	0.00	16.67	2,662.96	629.05	1,711.29	1,642.58	1.15	-0.13	0.015
90.00	-11.16	-0.77	0.00	-12.21	0.00	12.21	2,540.21	600.05	1,557.18	1,493.74	1.29	-0.13	0.013
91.20	-10.02	-0.71	0.00	-11.29	0.00	11.29	2,510.74	593.09	1,521.27	1,459.08	1.32	-0.13	0.012
95.00	-9.79	-0.69	0.00	-8.61	0.00	8.61	2,417.45	571.05	1,410.34	1,351.98	1.43	-0.14	0.010
97.00	-9.27	-0.66	0.00	-7.22	0.00	7.22	2,368.35	559.45	1,353.64	1,297.25	1.48	-0.14	0.009
100.00	-6.75	-0.50	0.00	-5.24	0.00	5.24	2,294.69	542.05	1,270.77	1,217.28	1.57	-0.14	0.007
101.00	-6.45	-0.48	0.00	-4.74	0.00	4.74	1,529.64	366.21	869.88	826.32	1.60	-0.14	0.010
105.00	-6.10	-0.46	0.00	-2.81	0.00	2.81	1,481.61	350.74	797.97	766.26	1.72	-0.14	0.008
110.00	-0.85	-0.07	0.00	-0.53	0.00	0.53	1,402.96	331.41	712.44	685.20	1.87	-0.14	0.001
115.00	-0.69	-0.06	0.00	-0.18	0.00	0.18	1,321.13	312.08	631.76	607.20	2.01	-0.14	0.001
118.00	-0.15	-0.01	0.00	-0.01	0.00	0.01	1,272.02	300.48	585.68	562.66	2.10	-0.14	0.000
119.00	0.00	-0.01	0.00	0.00	0.00	0.00	1,255.66	296.61	570.71	548.20	2.13	-0.14	0.000

Site Number: 209185

Code: ANSI/TIA-222-H

© 2007 - 2021 by ATC IP LLC. All rights reserved.

Site Name: Burlington 2, CT

Engineering Number: 13688136_C3_03

7/14/2021 12:27:12 PM

Customer: DISH WIRELESS L.L.C.

Analysis Summary

Load Case	Reactions						Max Usage	
	Shear FX (kips)	Shear FZ (kips)	Axial FY (kips)	Moment MX (ft-kips)	Moment MY (ft-kips)	Moment MZ (ft-kips)	Elev (ft)	Interaction Ratio
1.2D + 1.0W	28.58	0.00	44.42	0.00	0.00	2472.54	0.00	0.55
0.9D + 1.0W	28.57	0.00	33.31	0.00	0.00	2452.79	0.00	0.54
1.2D + 1.0Di + 1.0Wi	8.85	0.00	69.30	0.00	0.00	785.17	0.00	0.19
1.2D + 1.0Ev + 1.0Eh	1.23	0.00	45.01	0.00	0.00	115.61	0.00	0.04
0.9D - 1.0Ev + 1.0Eh	1.23	0.00	31.26	0.00	0.00	114.48	0.00	0.03
1.0D + 1.0W	6.84	0.00	37.04	0.00	0.00	588.93	0.00	0.14

Site Name: Burlington 2, CT
Site Number: 209185
Tower Type: MP
Design Loads (Factored) - Analysis per TIA-222-H Standards

Monolithic Mat & Pier Foundation Analysis

Foundation Analysis Parameters		
Design / Analysis / Mapping:	Analysis	-
Compression/Leg:	44.4	k
Uplift/Leg:	0.0	k
Total Shear:	28.6	k
Moment:	2,472.5	k-ft
Tower + Appurtenance Weight:	44.4	k
Depth to Base of Foundation (l + t - h):	6	ft
Diameter of Pier (d):	8	ft
Length of Pier (l):	4.5	ft
Height of Pier above Ground (h):	0.5	ft
Width of Pad (W):	24	ft
Length of Pad (L):	24	ft
Thickness of Pad (t):	1.5	ft
Tower Leg Center to Center:	0	ft
Number of Tower Legs:	1	-
Tower Center from Mat Center:	0	ft
Depth Below Ground Surface to Water Table:	99	ft
Unit Weight of Concrete:	150	pcf
Unit Weight of Soil Above Water Table:	125	pcf
Unit Weight of Water:	62.4	pcf
Unit Weight of Soil Below Water Table:	62.6	pcf
Friction Angle of Uplift:	34	°
Coefficient of Shear Friction:	0.2	-
Ultimate Compressive Bearing Pressure:	8,000	psf
Ultimate Passive Pressure on Pad Face:	8,000	psf
$f_{\text{Soil and Concrete Weight}}$:	0.9	-
f_{Soil} :	0.75	-

Foundation Steel Parameters		
Shear/Leg (Compression):	19.1	k
Shear/Leg (Uplift):	15.7	k
Concrete Strength (f'_c):	4,500	psi
Pad Tension Steel Depth:	14.50	in
Dead Load Factor:	0.9	-
f_{Shear} :	0.75	-
$f_{\text{Flexure / Tension}}$:	0.9	-
$f_{\text{Compression}}$:	0.65	-
b:	0.83	-
Bottom Pad Rebar Size #:	8	-
# of Bottom Pad Rebar:	52	-
Pad Bottom Steel Area:	41.08	in ²
Pad Steel F_y :	60,000	psi
Top Pad Rebar Size #:	8	-
# of Top Pad Rebar:	52	-
Pad Top Steel Area:	41.08	in ²
Pier Rebar Size #:	8	-
Pier Steel Area (Single Bar):	0.79	in ²
# of Pier Rebar:	48	-
Pier Steel F_y :	60,000	psi
Pier Cage Diameter:	87.8	in
Rebar Strain Limit:	0.008	-
Steel Elastic Modulus:	29,000	ksi
Tie Rebar Size #:	5	-
Tie Steel Area (Single Bar):	0.31	in ²
Tie Spacing:	12	in
Tie Steel F_y :	60,000	psi
Clear Cover:	3	in

Overturning Moment Usage		
Design OTM:	2644.0	k-ft
OTM Resistance:	5309.7	k-ft
Design OTM / OTM Resistance:	50%	Pass

Soil Bearing Pressure Usage		
Net Bearing Pressure:	2914	psf
Factored Nominal Bearing Pressure:	6000	psf
Factored Nominal (Net) Bearing Pressure:	49%	Pass
Load Direction Controlling Design Bearing Pressure:	Diagonal to Pad Edge	

Sliding Factor of Safety		
Ultimate Friction Resistance:	92.7	k
Ultimate Passive Pressure Resistance:	216.0	k
Total Factored Sliding Resistance:	231.5	k
Sliding Design / Sliding Resistance:	12%	Pass

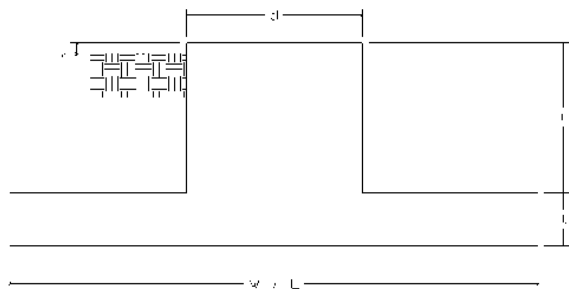

Pad Strength Capacity

Factored One Way Shear (V_u):	239.9	k	
One Way Shear Capacity (fV_c):	420.2	k	ACI 318-14 25.5.5.1
V_u / fV_c :	57%	Pass	
Load Direction Controlling Shear Capacity:	<i>Parallel to Pad Edge</i>		
Lower Steel Pad Factored Moment (M_u):	1338.5	k-ft	
Lower Steel Pad Moment Capacity (fM_n):	2671.1	k-ft	ACI 318-14 22.3.1.1
M_u / fM_n :	50%	Pass	
Load Direction Controlling Flexural Capacity:	<i>Diagonal to Pad Edge</i>		
Upper Steel Pad Factored Moment (M_u):	555.6	k-ft	
Upper Steel Pad Moment Capacity (fM_n):	2504.7	k-ft	
M_u / fM_n :	22%	Pass	
Lower Pad Flexural Reinforcement Ratio:	0.0098		OK - ACI 318-14 7.6.1.1 & 8.6.1.1
Upper Pad Flexural Reinforcement Ratio:	0.0098		OK - ACI 318-14 7.6.1.1 & 8.6.1.1
Pad Shrinkage Reinforcement Ratio:	0.0197		OK - ACI 318-14 24.4.3.2
Lower Pad Reinforcement Spacing:	5.5	in	OK - ACI 318-14 7.7.2.3, 8.7.2.2, & 24.4.3.3
Upper Pad Reinforcement Spacing:	5.5	in	OK - ACI 318-14 7.7.2.3, 8.7.2.2, & 24.4.3.3
Ultimate Punching Shear Stress, v_u :	72.34	psi	ACI 318-14 R8.4.4.2.3
Nominal Punching Shear Capacity ($f_c v_c$):	184.7	psi	ACI 318-14 22.6.5.2
$v_u / f_c v_c$:	39%	Pass	
Pier Moment Pad Flexure Transfer Ratio, γ_f :	0.60		TIA-222-H 9.4.2
Moment Transfer Effective Flexural Width, B_{eff} :	12.50	ft	TIA-222-H 9.4.2
Moment Transfer Through Pad Flexure:	18727.99	k-in	TIA-222-H 9.4.2
Moment Transfer Flexural Capacity ($fM_{sc,f}$):	16239.63	k-in	
$g_f M_{sc} / fM_{sc,f}$:	0%	Pass	

Pier Strength Capacity

Factored Moment in Pier (M_u):	2601.1	k-ft	
Pier Moment Capacity (fM_n):	7322.0	k-ft	
M_u / fM_n :	36%	Pass	
Factored Shear in Pier (V_u):	28.6	k	
Pier Shear Capacity (fV_n):	909.1	k	ACI 318-14 22.5.1.1
V_u / fV_c :	3%	Pass	
Pier Shear Reinforcement Ratio:	0.0005		OK - No Ties Necessary for Shear - ACI11.5.6.1
Factored Tension in Pier (T_u):	0.0	k	
Pier Tension Capacity (fT_n):	2047.7	k	
T_u / fT_n :	0%	Pass	
Factored Compression in Pier (P_u):	44.4	k	
Pier Compression Capacity (fP_n):	14346.1	k	ACI 318-14 22.4.2.1
P_u / fP_n :	0%	Pass	
Pier Compression Reinforcement Ratio:	0.005		OK - TIA-222-H 9.4.1
Minimum Depth to Develop Vertical Rebar:	27	in	ACI 318-14 25.4.2.3
Minimum Hook Development Length:	18	in	ACI 318-14 25.4.3.1
Minimum Mat Thickness / Edge Distance from Pier:	21.0	in	
Minimum Foundation Depth:	4.27	ft	
$M_u / f_B M_n + T_u / f_T T_n$:	36%	Pass	

Base Plate & Anchor Rod Analysis

Pole Dimensions		
Number of Sides	18	-
Diameter	53.34	in
Thickness	3/8	in
Orientation Offset	0	°

Base Reactions		
Moment, Mu	2,472.5	k-ft
Axial, Pu	44.4	k
Shear, Vu	28.6	k
Neutral Axis	315	°

Report Capacities		
Component	Capacity	Result
Base Plate	32%	Pass
Anchor Rods	55%	Pass
Dwyidag	-	-

Base Plate		
Shape	Round	-
Diameter, ϕ	65.75	in
Thickness	2	in
Grade	A572-50	
Yield Strength, Fy	50	ksi
Tensile Strength, Fu	65	ksi
Clip		in
Orientation Offset	0	°
Anchor Rod Detail	d	$\eta=0.5$
Clear Distance	3 1/4	in
Applied Moment, Mu	273.4	k
Bending Stress, ϕMn	861.4	k

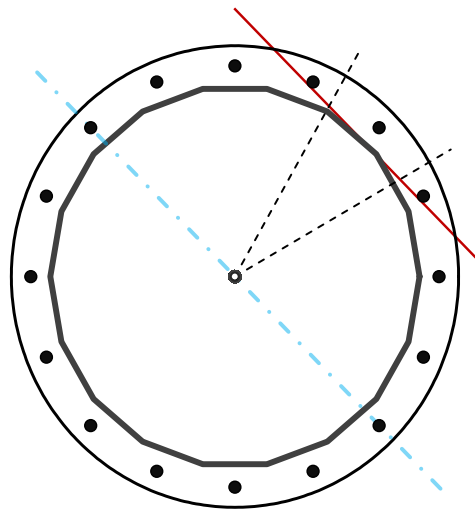

Original Anchor Rods		
Arrangement	Radial	-
Quantity	16	-
Diameter, ϕ	2 1/4	in
Bolt Circle	60	in
Grade	A615-75	
Yield Strength, Fy	75	ksi
Tensile Strength, Fu	100	ksi
Spacing	11.8	in
Orientation Offset	0	°
Applied Force, Pu	131.4	k
Anchor Rods, ϕPn	243.6	k

Calculations for Monopole Base Plate & Anchor Rod Analysis

Reaction Distribution

Reaction	Shear Vu	Moment Mu	Factor
-	k	k-ft	-
Base Forces	28.6	2472.5	1.00
Anchor Rod Forces	28.6	2472.5	1.00
Additional Bolt (Grp1) Forces	0.0	0.0	0.00
Additional Bolt (Grp2) Forces	0.0	0.0	0.00
Dywidag Forces	0.0	0.0	0.00
Stiffener Forces	0.0	0.0	0.00

Geometric Properties

Section	Gross Area	Net Area	Individual Inertia	Threads per Inch	Moment of Inertia
-	in ²	in ²	in ⁴	#	in ⁴
Pole	62.0816	3.4490	0.1622		21772.55
Bolt	3.9761	3.2477	0.8393	4.5	21582.25
Bolt1	0.0000	0.0000	0.0000	0	0.00
Bolt2	0.0000	0.0000	0.0000	0	0.00
Dywidag	0.0000	0.0000	0.0000		0.00
Stiffener	0.0000	0.0000	0.0000		0.00

Base Plate

Shape	Round	-
Diameter, D	65.75	in
Thickness, t	2	in
Yield Strength, Fy	50	ksi
Tensile Strength, Fu	65	ksi
Base Plate Chord	38.444	in
Detail Type	d	-
Detail Factor	0.50	-
Clear Distance	3.25	-

Anchor Rods

Anchor Rod Quantity, N	16	-
Rod Diameter, d	2.25	in
Bolt Circle, BC	60	in
Yield Strength, Fy	75	ksi
Tensile Strength, Fu	100	ksi
Applied Axial, Pu	131.4	k
Applied Shear, Vu	1.1	k
Compressive Capacity, ϕP_n	243.6	k
Tensile Capacity, ϕR_n	0.540	OK
Interaction Capacity	0.548	OK

External Base Plate

Chord Length AA	32.369	in
Additional AA	4.000	in
Section Modulus, Z	36.369	in ³
Applied Moment, Mu	273.4	k-ft
Bending Capacity, ϕM_n	1636.6	k-ft
Capacity, Mu/ ϕM_n	0.167	OK

Chord Length AB	30.966	in
Additional AB	4.000	in
Section Modulus, Z	34.966	in ³
Applied Moment, Mu	219.2	k-ft
Bending Capacity, ϕM_n	1573.5	k-ft
Capacity, Mu/ ϕM_n	0.139	OK

Bend Line Length	19.142	in
Additional Bend Line	0.000	in
Section Modulus, Z	19.142	in ³
Applied Moment, Mu	273.4	k-ft
Bending Capacity, ϕM_n	861.4	k-ft
Capacity, Mu/ ϕM_n	0.317	OK

Internal Base Plate

Arc Length	0.000	in
Section Modulus, Z	0.000	in ³
Moment Arm	0.000	in
Applied Moment, Mu	0.0	k-ft
Bending Capacity, ϕM_n	0.0	k-ft
Capacity, Mu/ ϕM_n		

INFINIGY

MOUNT ANALYSIS REPORT

August 27, 2021

Dish Wireless Site Name	BOBDL00109A
Dish Wireless Site Number	BOBDL00109A
ATC Site Name	Burlington 2, CT
ATC Site Number	209185
Infinigy Job Number	1197-F0001-C
Client	ATC
Carrier	Dish Wireless
Site Location	87 Monce Road Burlington, CT 06013 Hartford County 41.739136 N NAD83 72.907794 W NAD83
Mount Type	8.0 ft Platform
Mount Elevation	70.0 ft AGL
Structural Usage Ratio	42.1
Overall Result	Pass

The enclosed mount structural analysis has been performed in accordance with the 2018 Connecticut State Building Code (2015 IBC) based on an ultimate 3-second gust wind speed of 120 mph. The evaluation criteria and applicable codes are presented in the next section of this report.

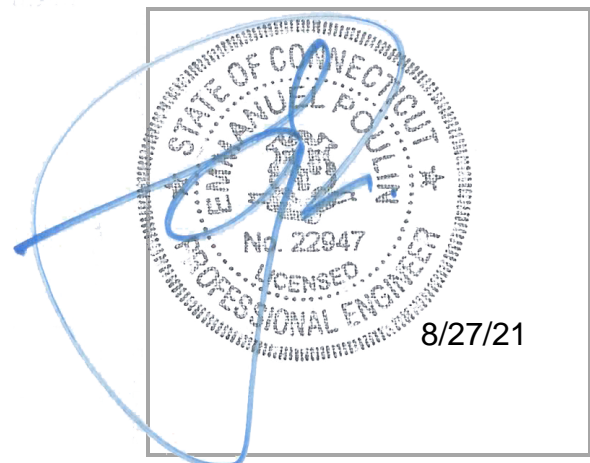

CONTENTS

1. Introduction
2. Design/Analysis Parameters
3. Proposed Loading Configuration
4. Supporting Documentation
5. Results
6. Recommendations
7. Assumptions
8. Liability Waiver and Limitations
9. Calculations

1. INTRODUCTION

Infinigy performed a structural analysis on the Dish Wireless proposed telecommunication equipment supporting Platform mounted to the existing structure located at the aforementioned address. All referenced supporting documents have been obtained from the client and are assumed to be accurate and applicable to this site. The mount was analyzed using Risa-3D version 17.0.4 analysis software.

2. DESIGN/ANALYSIS PARAMETERS

Wind Speed	120 mph (3-Second Gust)
Wind Speed w/ ice	50 mph (3-Second Gust) w/ 2.0" ice
Code / Standard	TIA-222-H
Adopted Code	2018 Connecticut State Building Code (2015 IBC)
Risk Category	II
Exposure Category	C
Topographic Category	1
Calculated Crest Height	0 ft.
Seismic Spectral Response	$S_s = 0.183 \text{ g} / S_1 = 0.064 \text{ g}$
Live Load Wind Speed	60 mph
Man Live Load at Mid/End Points	250 lbs
Man Live Load at Mount Pipes	500 lbs

3. PROPOSED LOADING CONFIGURATION - 70.0 ft. AGL Platform

Antenna Centerline (ft)	Qty.	Appurtenance Manufacturers	Appurtenance Models
70.0	3	JMA WIRELESS	MX08FRO665-21
	3	FUJITSU	TA08025-B605
	3	FUJITSU	TA08025-B604
	1	RAYCAP	RDIDC-9181-PF-48

4. SUPPORTING DOCUMENTATION

Proposed Loading	Dish Wireless Asset ID CT-ATC-T-CT011 Rev 1, Site #BOBDL00109A, dated July 09, 2021
Mount Manufacturer Drawings	Commscope Document # MC-PK8-DSH, dated March 08, 2021
Structural Analysis Report	ATC, Asset #209185, dated July 14, 2021

5. RESULTS

Components	Capacity	Pass/Fail
Mount Pipes	20.1%	Pass
Horizontals	12.1%	Pass
Standoffs	32.7%	Pass
Handrails	24.1%	Pass
Connections	42.1%	Pass
MOUNT RATING =	42.1 %	Pass

Notes:

1. See additional documentation in Appendix for calculations supporting the capacity consumed and detailed mount connection calculations.

6. RECOMMENDATIONS

Infinigy recommends installing Dish Wireless's proposed equipment loading configuration on the mount at 70.0 ft. The installation shall be performed in accordance with the construction documents issued for this site.

Pradin Suinyal Magar
Project Engineer II | **INFINIGY**

7. ASSUMPTIONS

The antenna mounting system was properly fabricated, installed and maintained in accordance with its original design and manufacturer's specifications.	
The configuration of antennas, mounts, and other appurtenances are as specified in the proposed loading configuration table.	
All member connections are assumed to have been designed to meet or exceed the load carrying capacity of the connected member unless otherwise specified in this report.	
The analysis will require revisions if the existing conditions in the field differ from those shown in the above-referenced documents or assumed in this analysis. No allowance was made for any damaged, missing, or rusted members.	
Steel grades have been assumed as follows, unless noted otherwise:	
Channel, Solid Round, Plate, Built-up Angle	ASTM A1011 36 KSI
Structural Angle	ASTM A529 Gr. 50
HSS (Rectangular)	ASTM A500-B GR 46
HSS (Circular)	ASTM A500-B GR 42
Pipe	ASTM A500 Gr C
Connection Bolts	ASTM A325
U-Bolts	ASTM A307
All bolted connections are pretensioned in accordance with Table 8.2 of the RCSC 2014 Standard	

8. LIABILITY WAIVER AND LIMITATIONS

Our structural calculations are completed assuming all information provided to Infinigy is accurate and applicable to this site. For the purposes of calculations, we assume an overall structure condition as erected and all members and connections to be free of corrosion and/or structural defects. The structure owner and/or contractor shall verify the structure's condition prior to installation of any proposed equipment. If actual conditions differ from those described in this report, Infinigy should be notified immediately to assess the impact on the results of this report.

Our evaluation is completed using industry standard methods and procedures. The structural results, conclusions and recommendations contained in this report are proprietary and should not be used by others as their own. Infinigy is not responsible for decisions made by others that are or are not based on the stated assumptions and conclusions in this report.

This report is an evaluation of the mount structure only and does not determine the adequacy of the supporting structure, other carrier mounts or cable mounting attachments. The analysis of these elements is outside the scope of this analysis, are assumed to be adequate for the purpose of this report and to have been installed per their manufacturer requirements. This document is not for construction purposes.

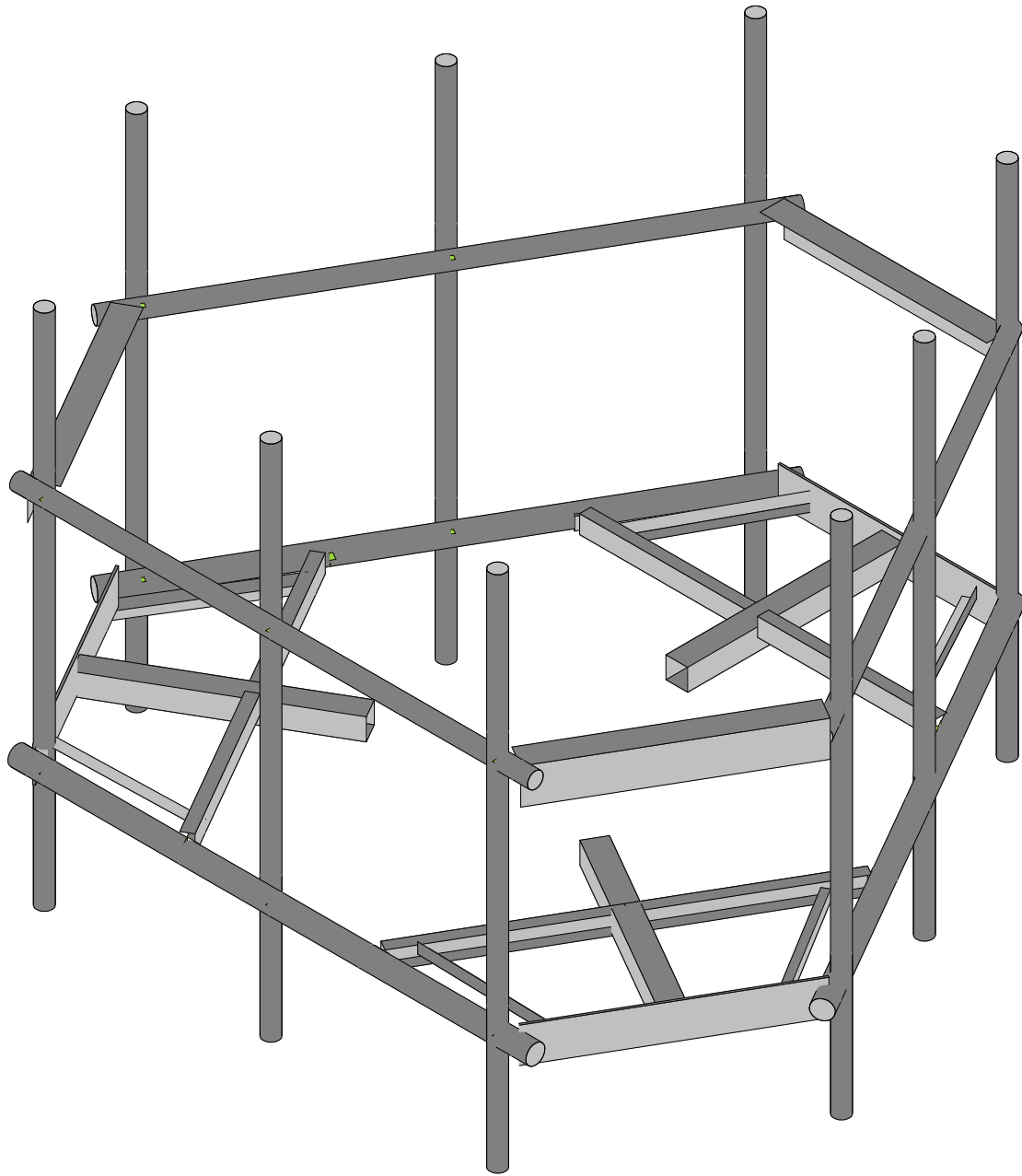
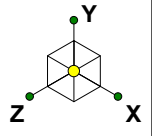

Envelope Only Solution

Infinigy Engineering, PLLC

PSM

1197-F0001-C

BOBDL00109A

Rendered

Aug 27, 2021 at 11:23 AM

BOBDL000109A_loaded.r3d

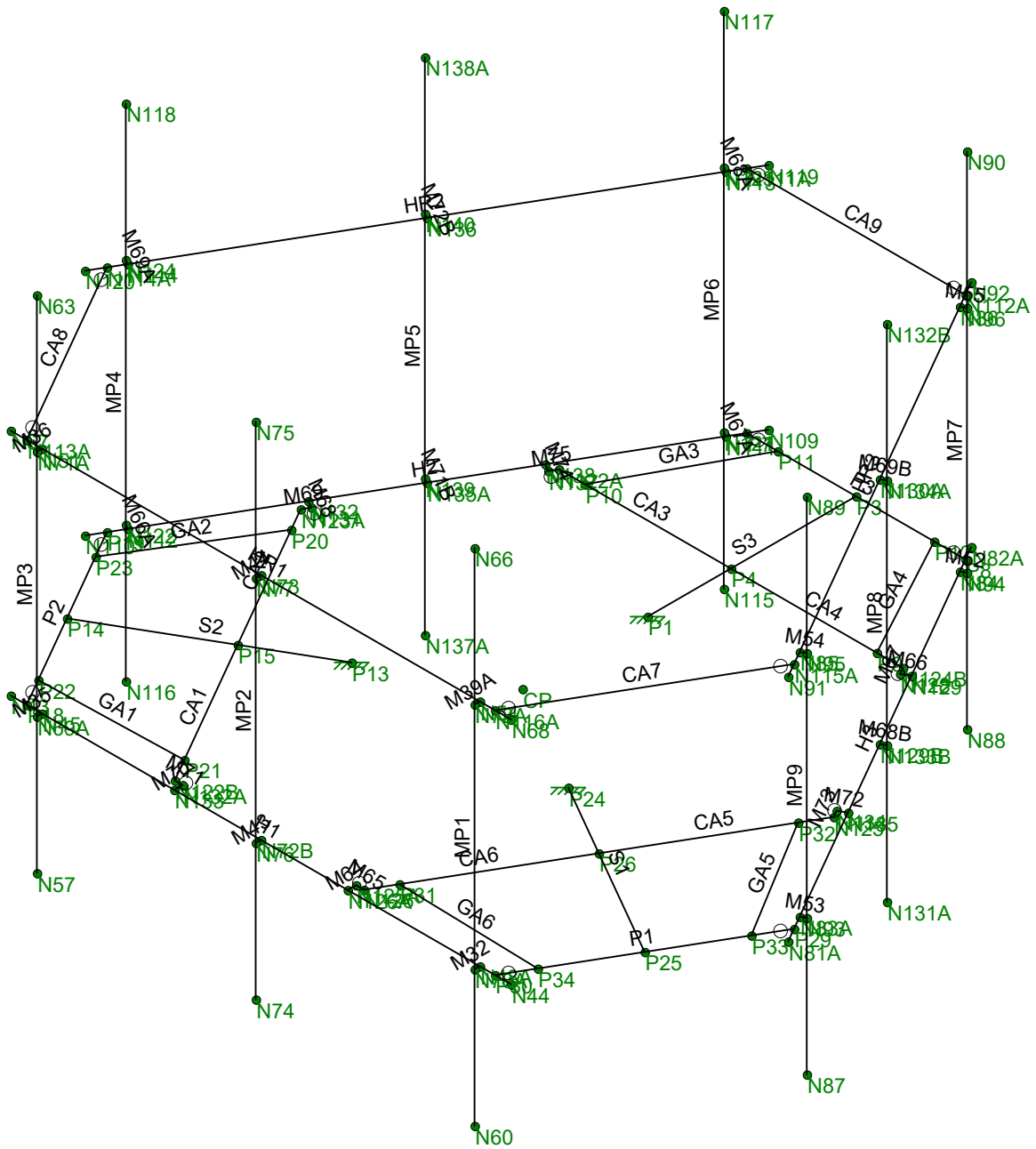
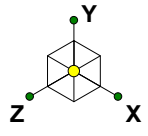

Envelope Only Solution

Infinigy Engineering, PLLC

PSM

1197-F0001-C

BOBDL00109A

WireFrame

Aug 27, 2021 at 11:23 AM

BOBDL000109A_loaded.r3d

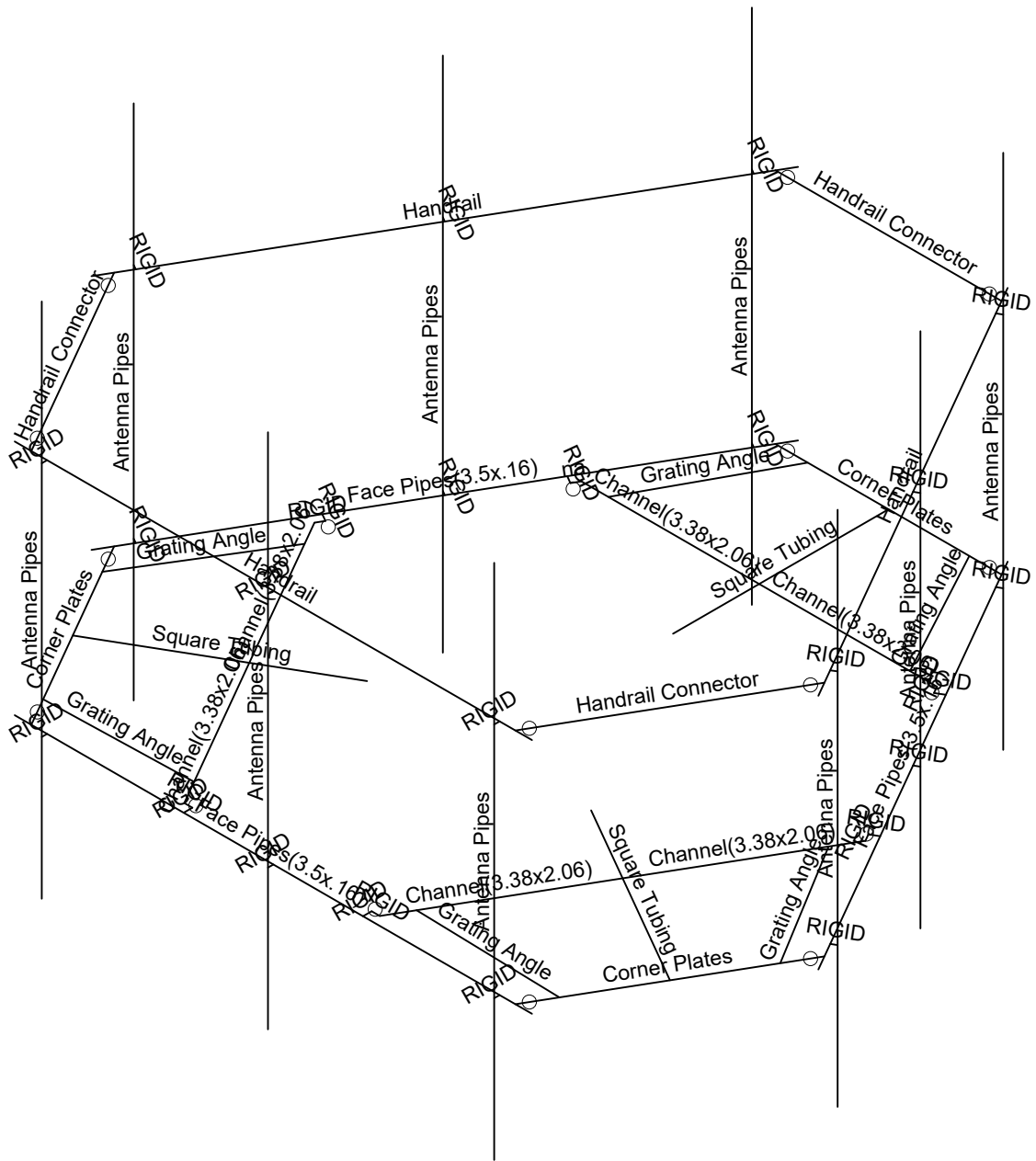
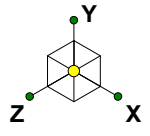

Envelope Only Solution

Infinigy Engineering, PLLC

PSM

1197-F0001-C

BOBDL00109A

Section Sets

Aug 27, 2021 at 11:24 AM

BOBDL000109A_loaded.r3d

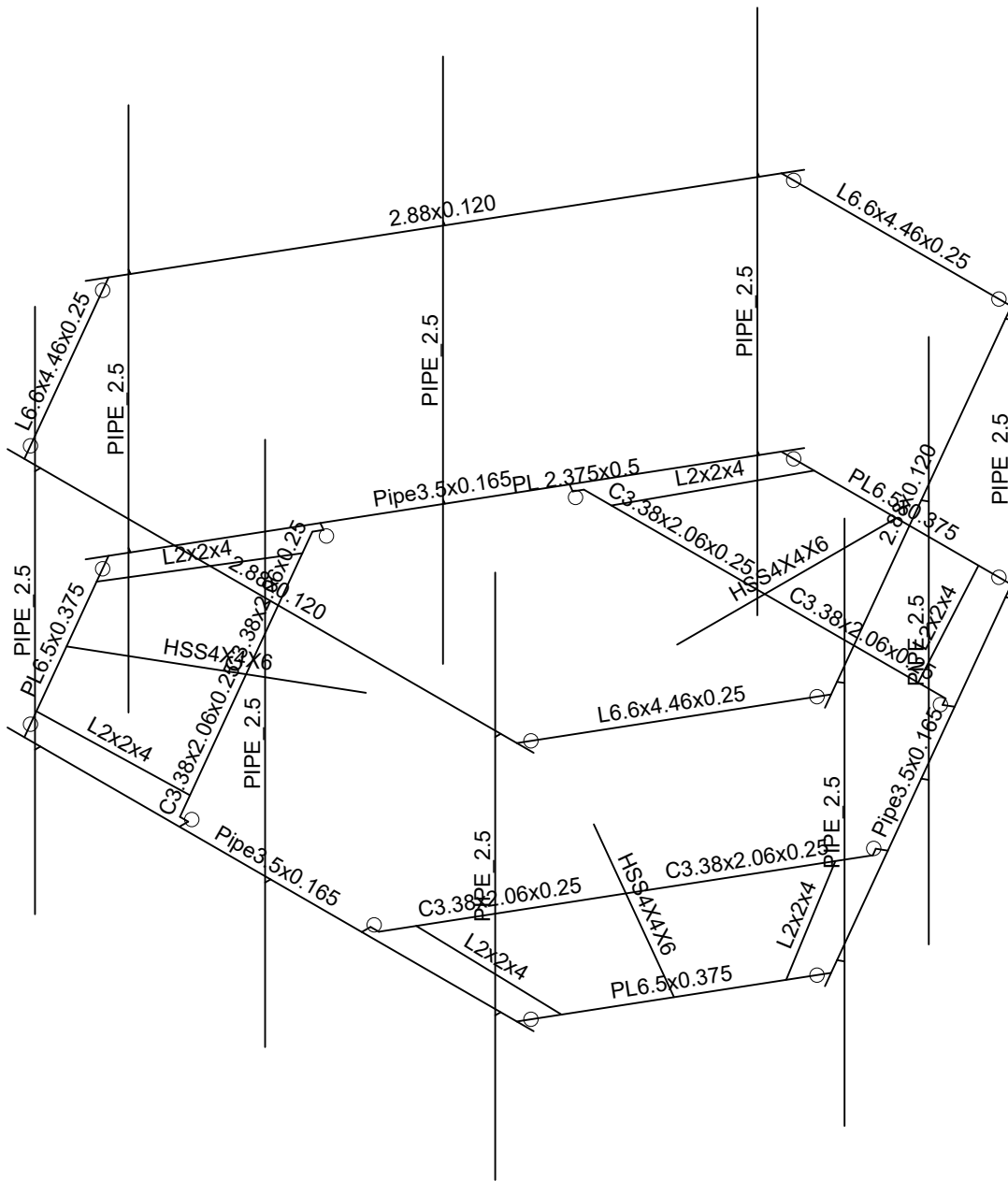
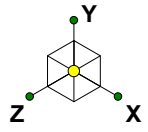

Envelope Only Solution

Infinigy Engineering, PLLC

PSM

1197-F0001-C

BOBDL00109A

Member Shapes

Aug 27, 2021 at 11:24 AM

BOBDL000109A_loaded.r3d

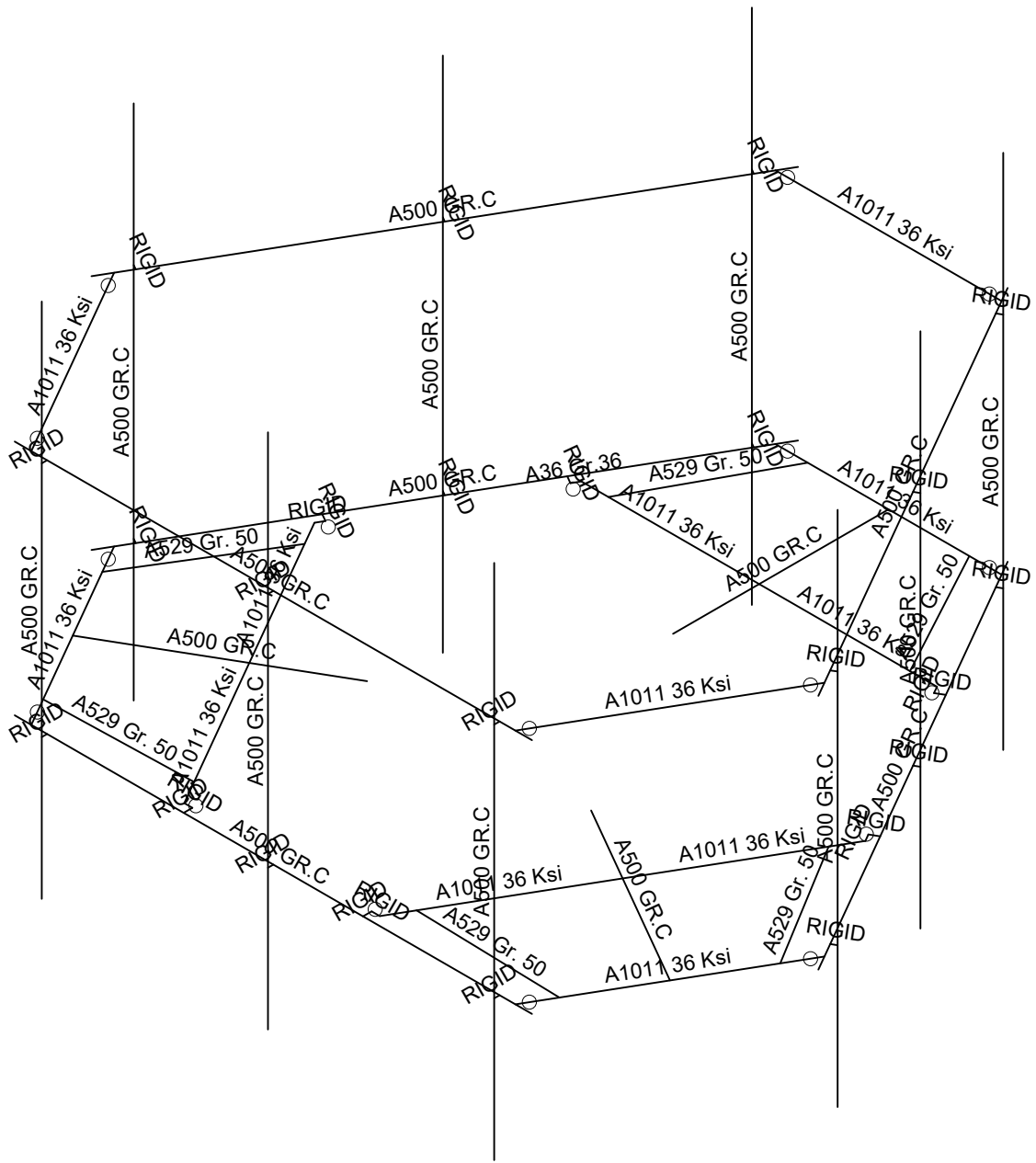
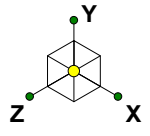

Envelope Only Solution

Infinigy Engineering, PLLC

PSM

1197-F0001-C

BOBDL00109A

Material Sets

Aug 27, 2021 at 11:24 AM

BOBDL000109A_loaded.r3d

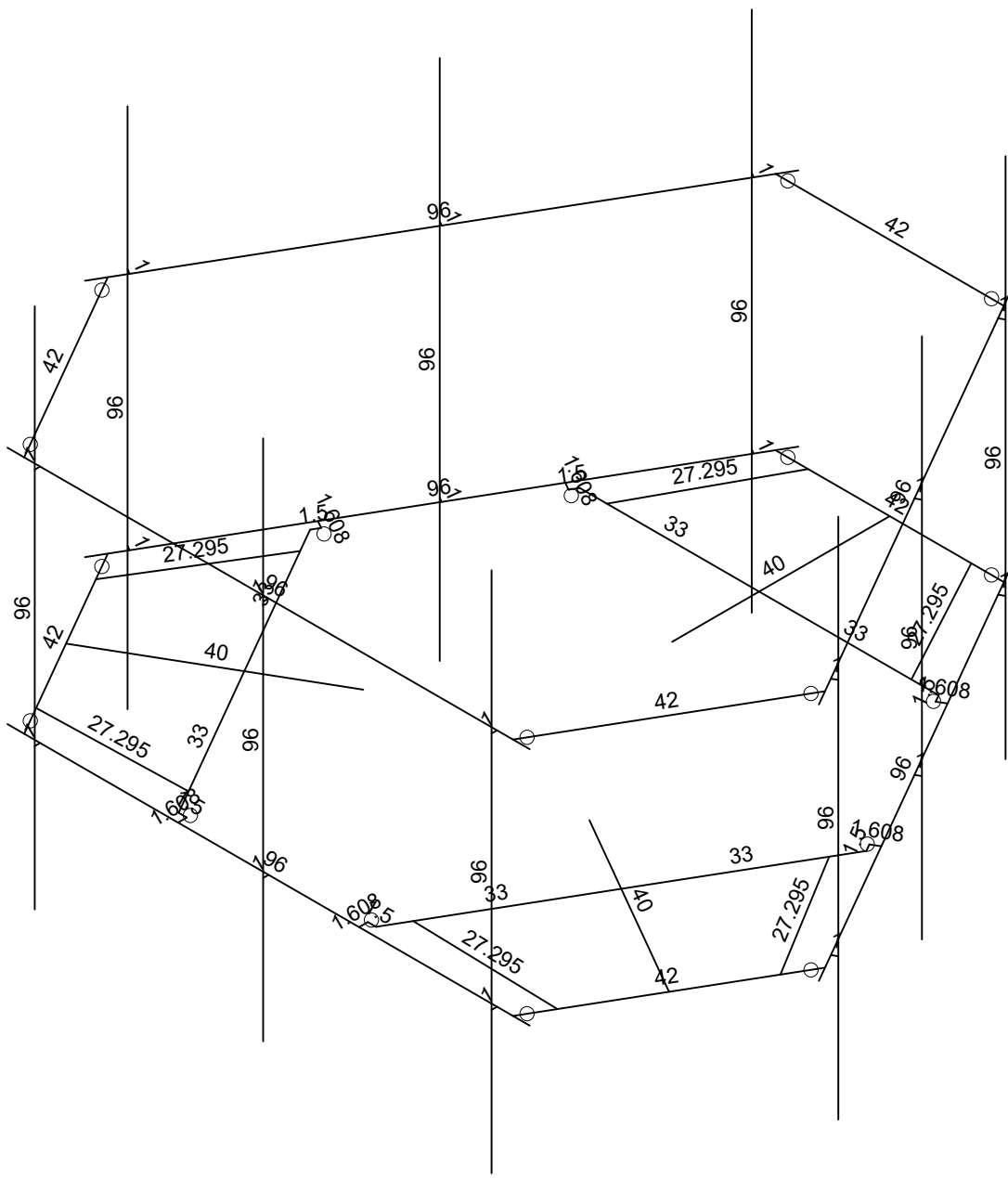
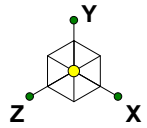

Member Length (in) Displayed
Envelope Only Solution

Infinigy Engineering, PLLC
PSM
1197-F0001-C

BOBDL00109A

Member Lengths
Aug 27, 2021 at 11:24 AM
BOBDL000109A_loaded.r3d

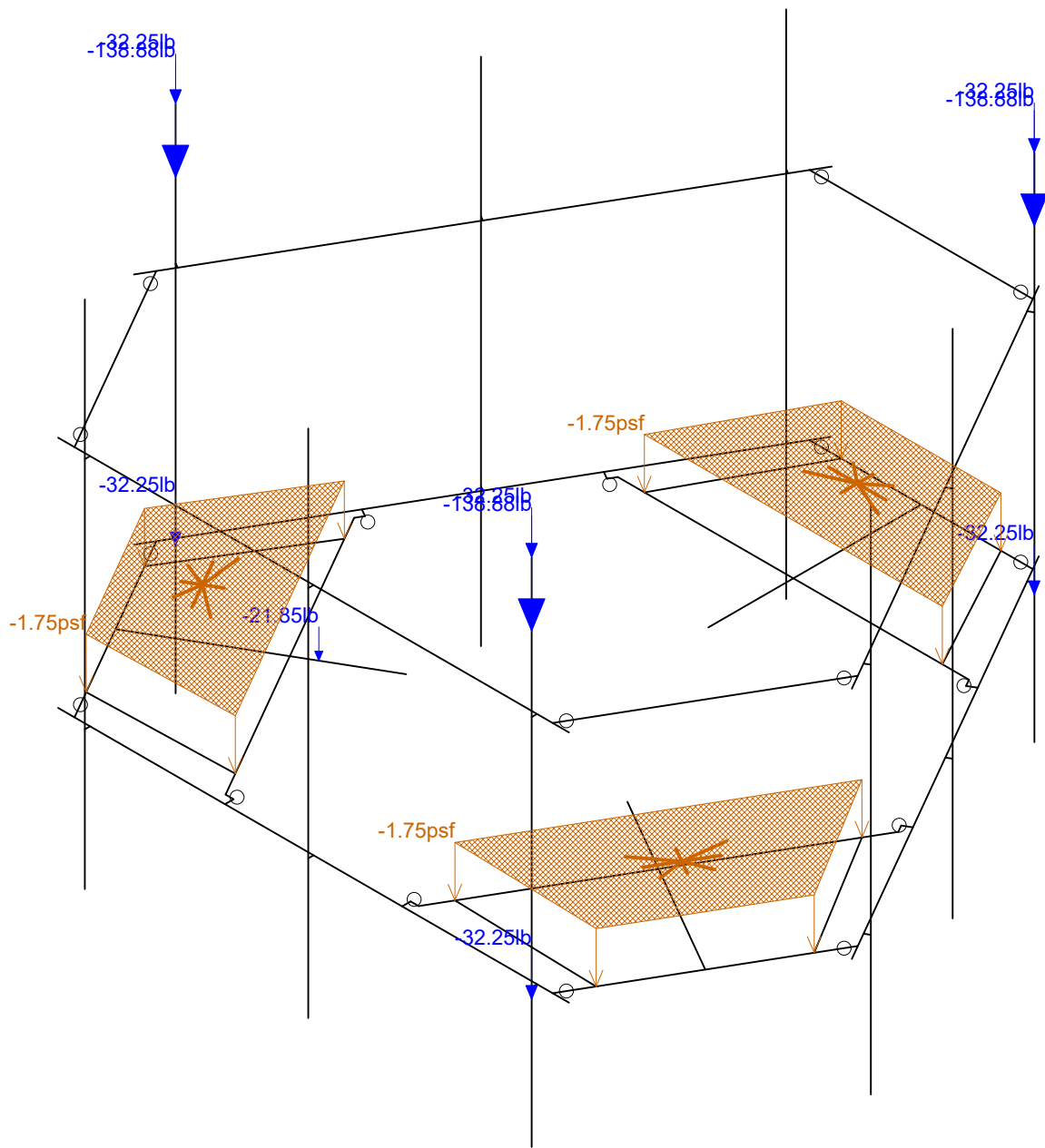
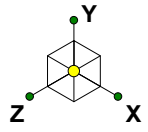

Loads: BLC 1, Self Weight
Envelope Only Solution

Infinigy Engineering, PLLC
PSM
1197-F0001-C

BOBDL00109A

Self Weight
Aug 27, 2021 at 11:25 AM
BOBDL000109A_loaded.r3d

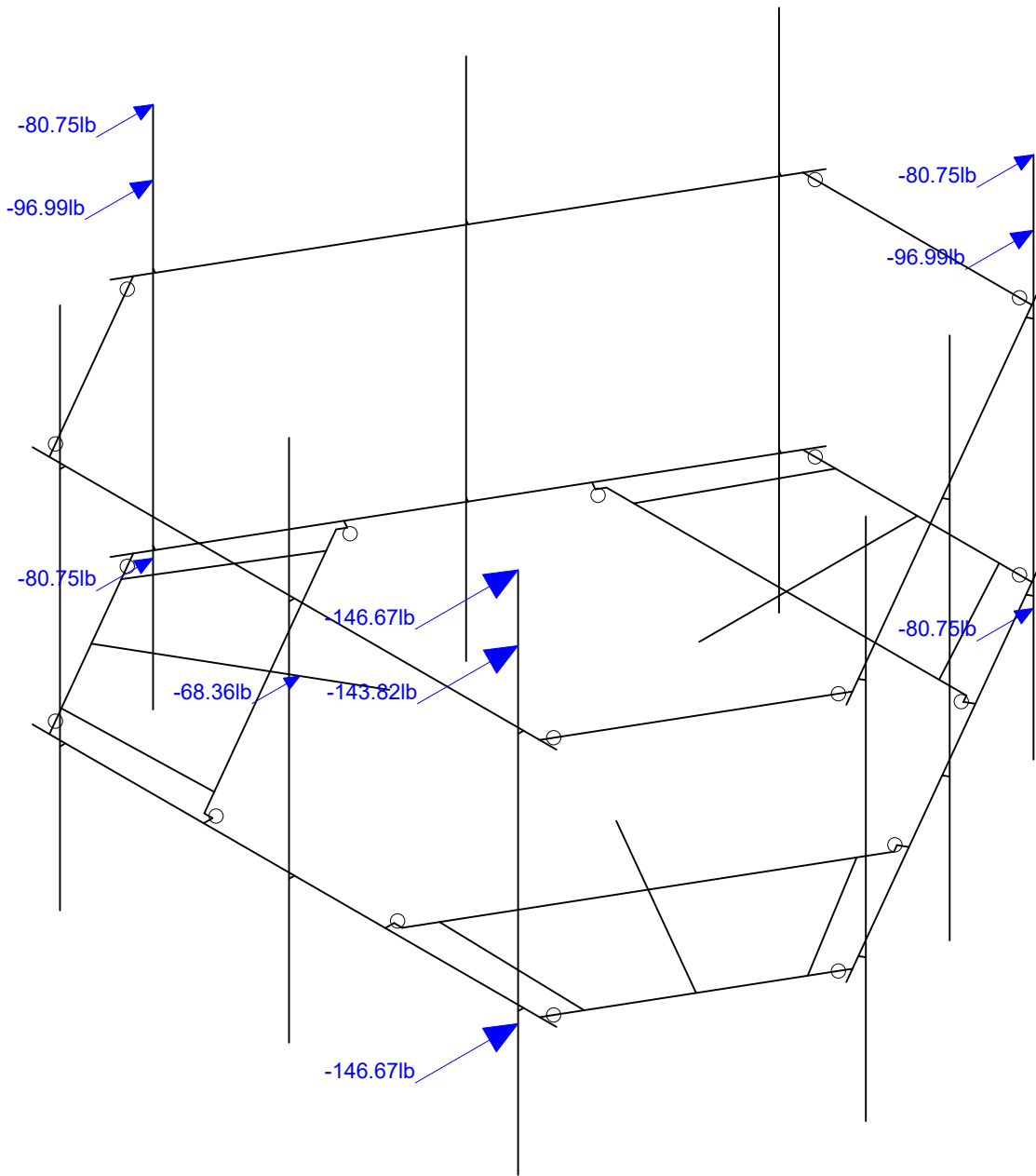
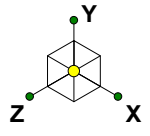

Loads: BLC 2, Wind Load AZI 0
Envelope Only Solution

Infinigy Engineering, PLLC
PSM
1197-F0001-C

BOBDL00109A

Wind Load AZI 000

Aug 27, 2021 at 11:25 AM

BOBDL000109A_loaded.r3d

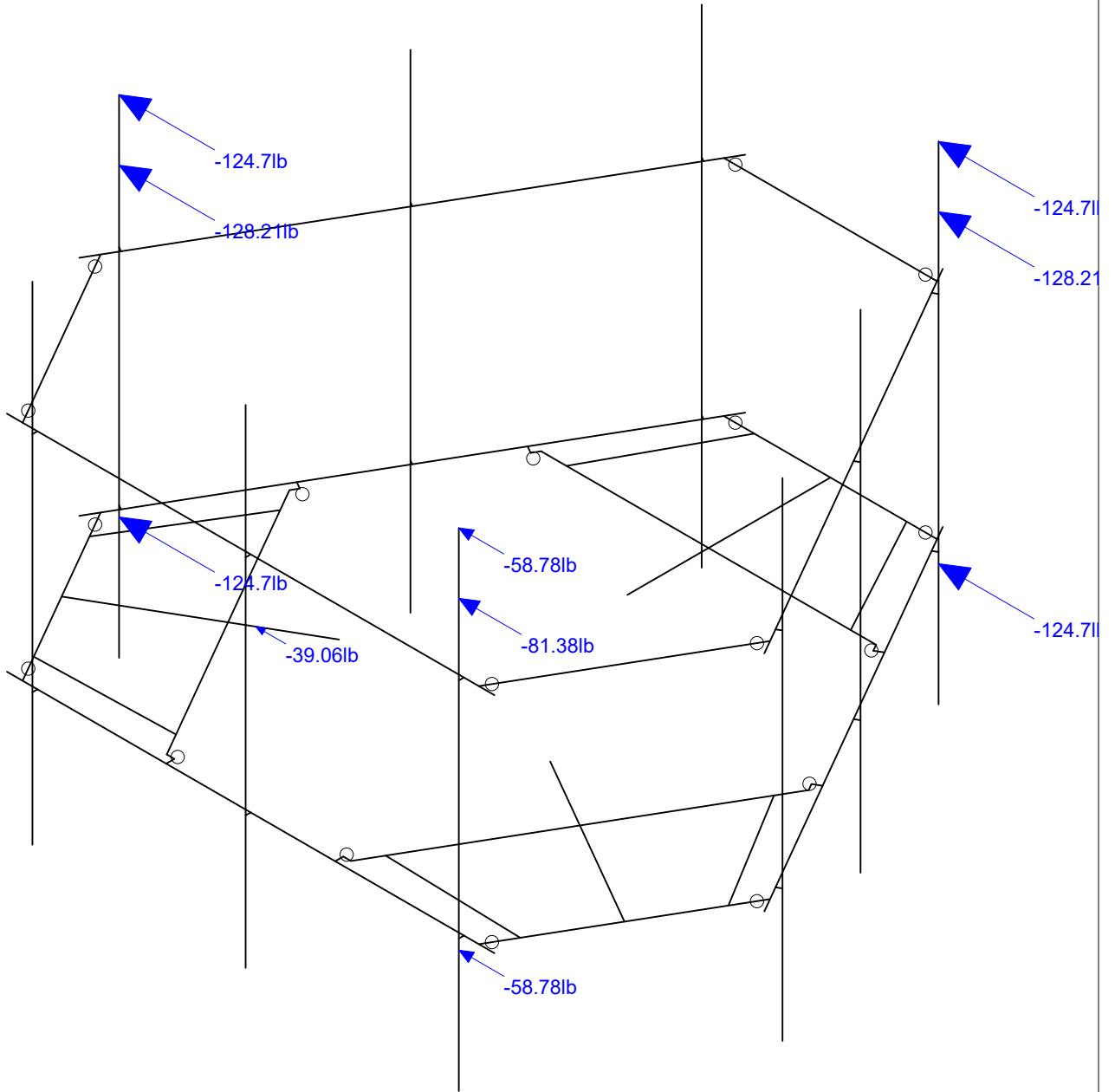
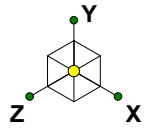

Loads: BLC 5, Wind Load AZI 90
Envelope Only Solution

Infinigy Engineering, PLLC	BOBDL00109A	Wind Load AZI 090
PSM		Aug 27, 2021 at 11:25 AM
1197-F0001-C		BOBDL000109A_loaded.r3d

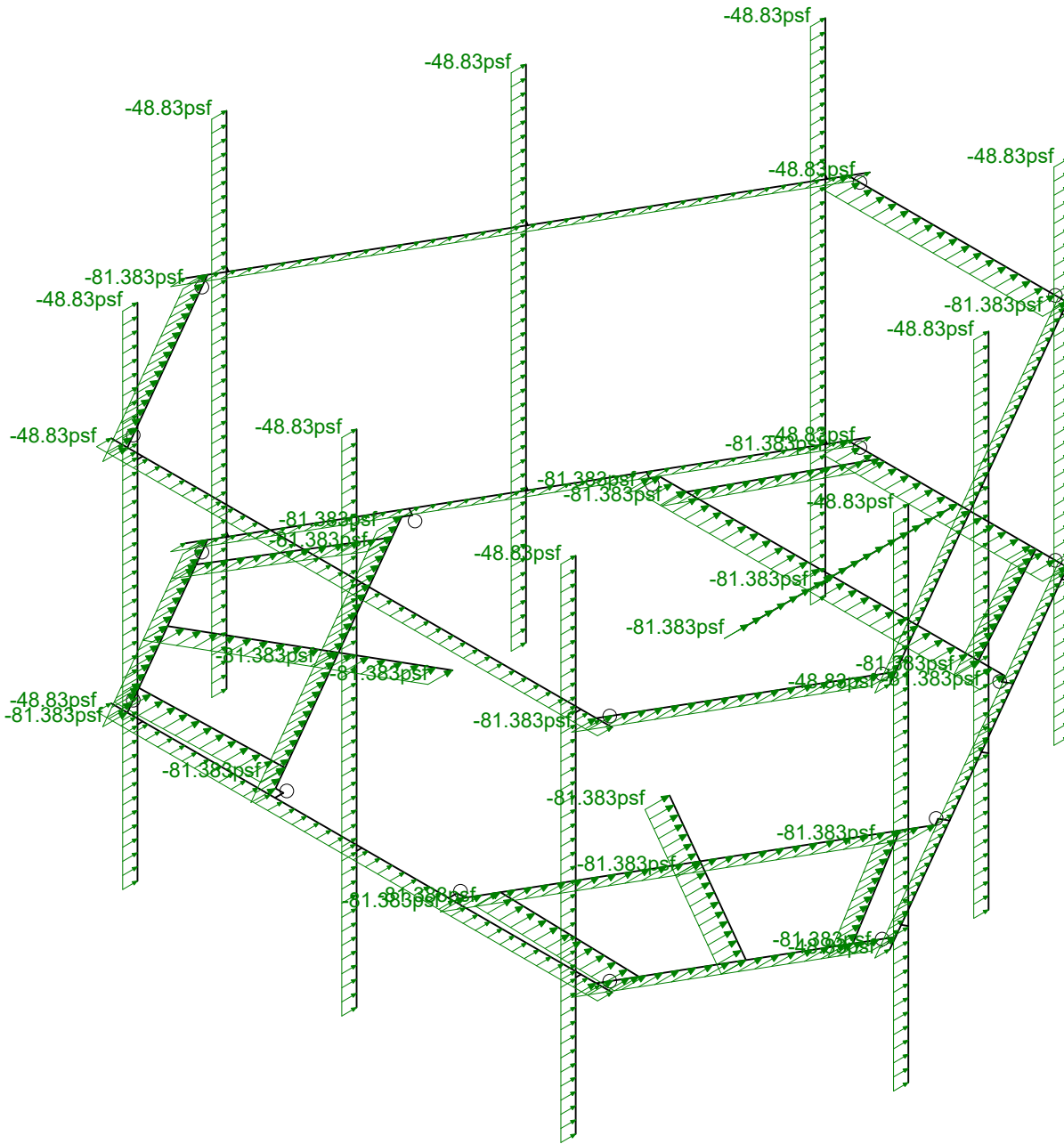
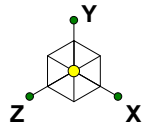

Loads: BLC 14, Distr. Wind Load Z
Envelope Only Solution

Infinigy Engineering, PLLC
PSM
1197-F0001-C

BOBDL00109A

Distr Wind Load AZI 000
Aug 27, 2021 at 11:25 AM
BOBDL000109A_loaded.r3d

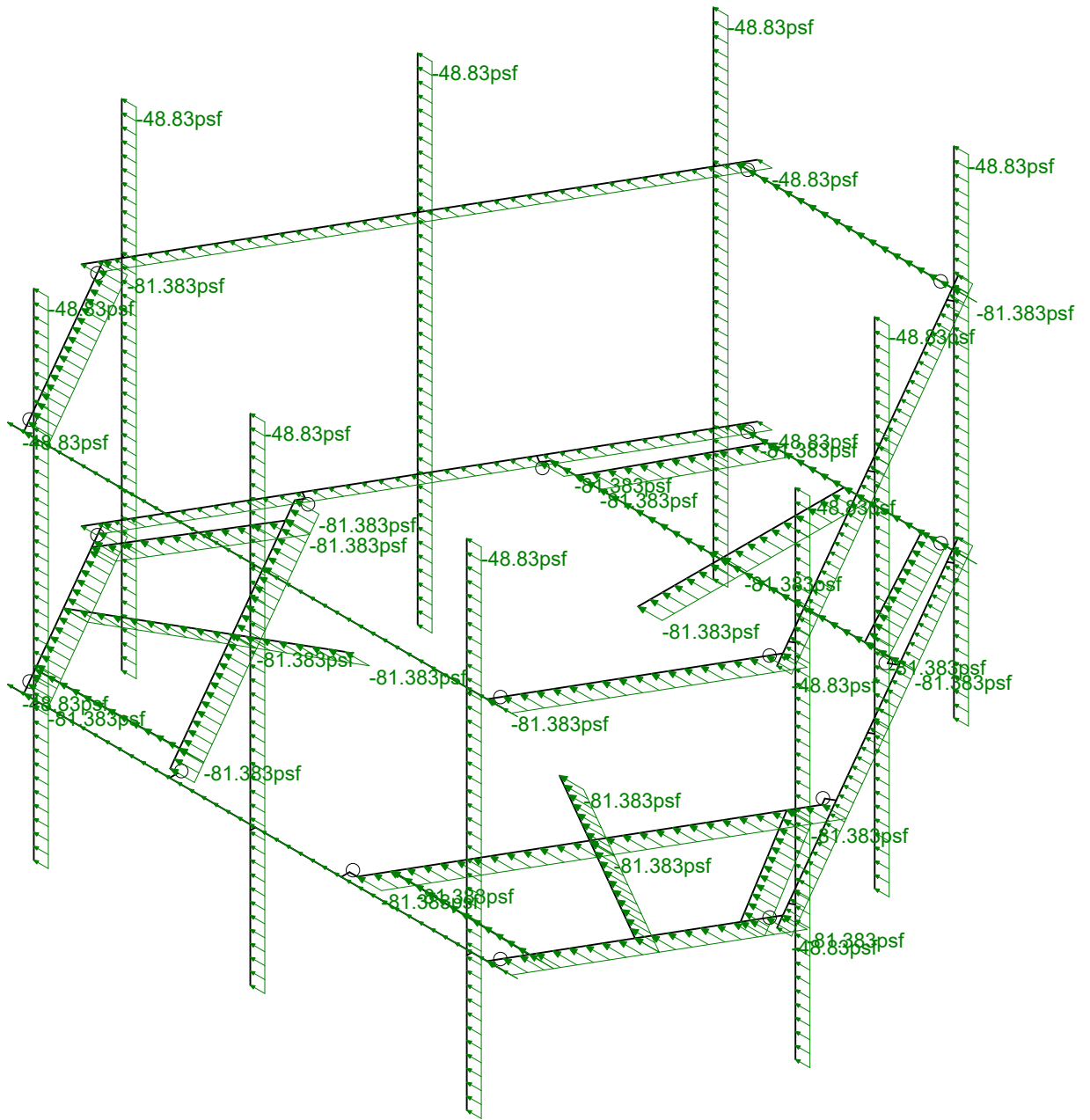
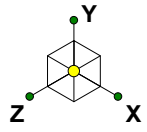

Loads: BLC 15, Distr. Wind Load X
Envelope Only Solution

Infinigy Engineering, PLLC
PSM
1197-F0001-C

BOBDL00109A

Distr Wind Load AZI 090
Aug 27, 2021 at 11:26 AM
BOBDL000109A_loaded.r3d

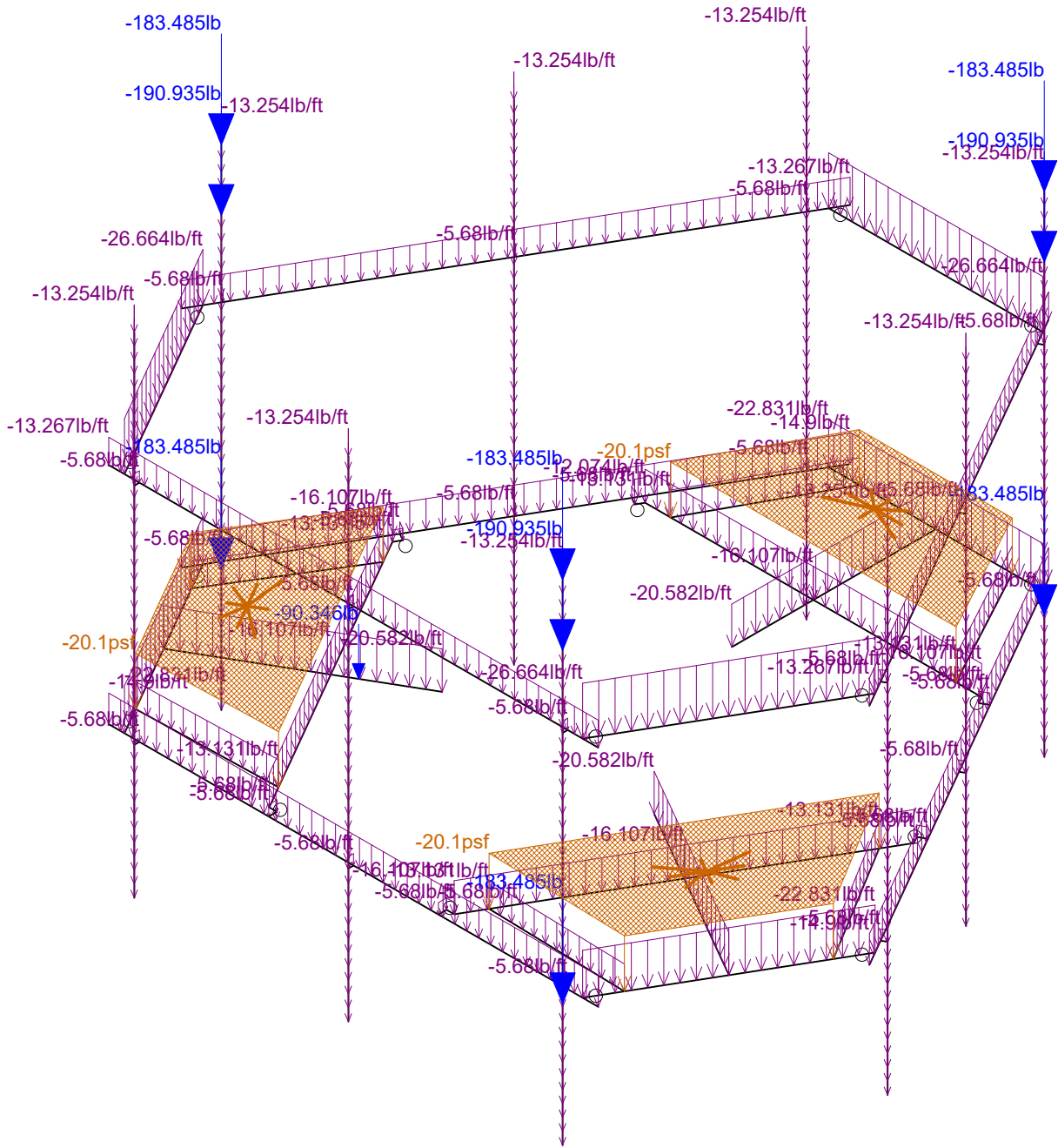
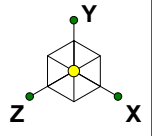

Loads: BLC 16, Ice Weight
Envelope Only Solution

Infinigy Engineering, PLLC	BOBDL00109A	Ice Weight
PSM		Aug 27, 2021 at 11:26 AM
1197-F0001-C		BOBDL000109A_loaded.r3d

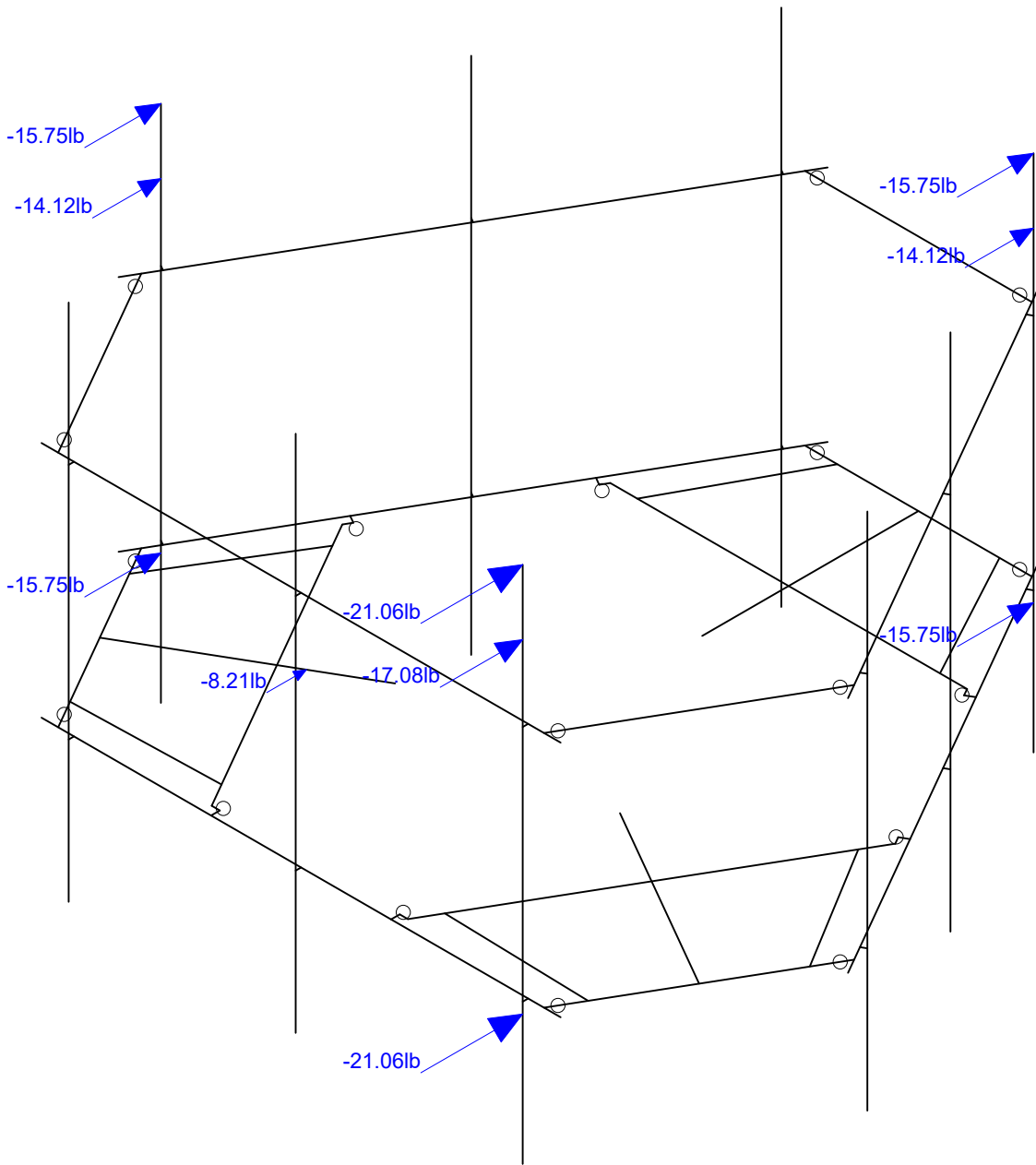
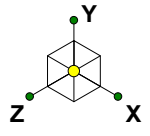

Loads: BLC 17, Ice Wind Load AZI 0
Envelope Only Solution

Infinigy Engineering, PLLC

PSM

1197-F0001-C

BOBDL00109A

Ice + Wind Load AZI 000

Aug 27, 2021 at 11:26 AM

BOBDL000109A_loaded.r3d

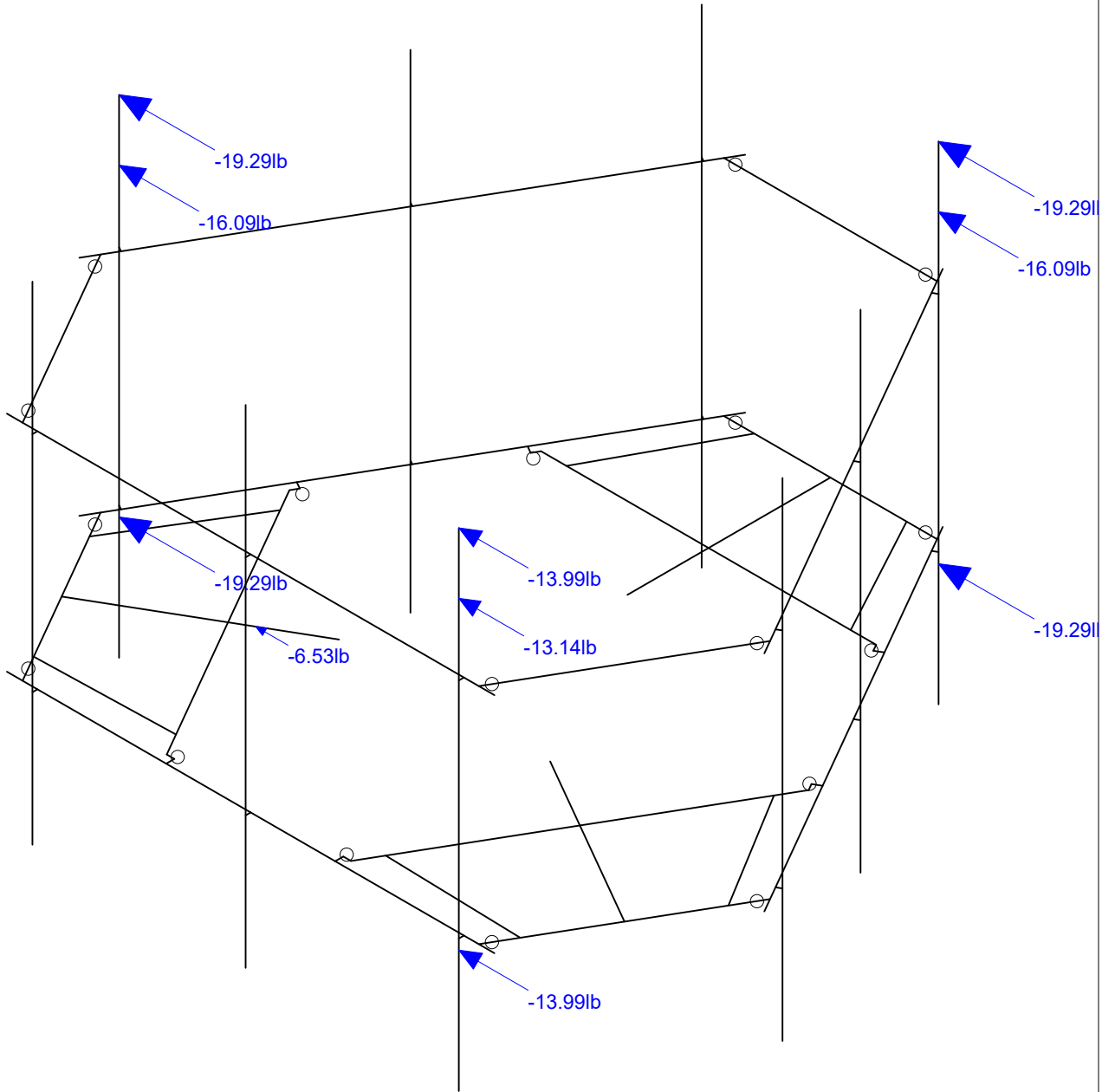
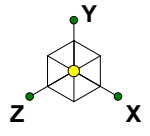

Loads: BLC 20, Ice Wind Load AZI 90
Envelope Only Solution

Infinigy Engineering, PLLC	BOBDL00109A	Ice + Wind Load AZI 090
PSM		Aug 27, 2021 at 11:26 AM
1197-F0001-C		BOBDL000109A_loaded.r3d

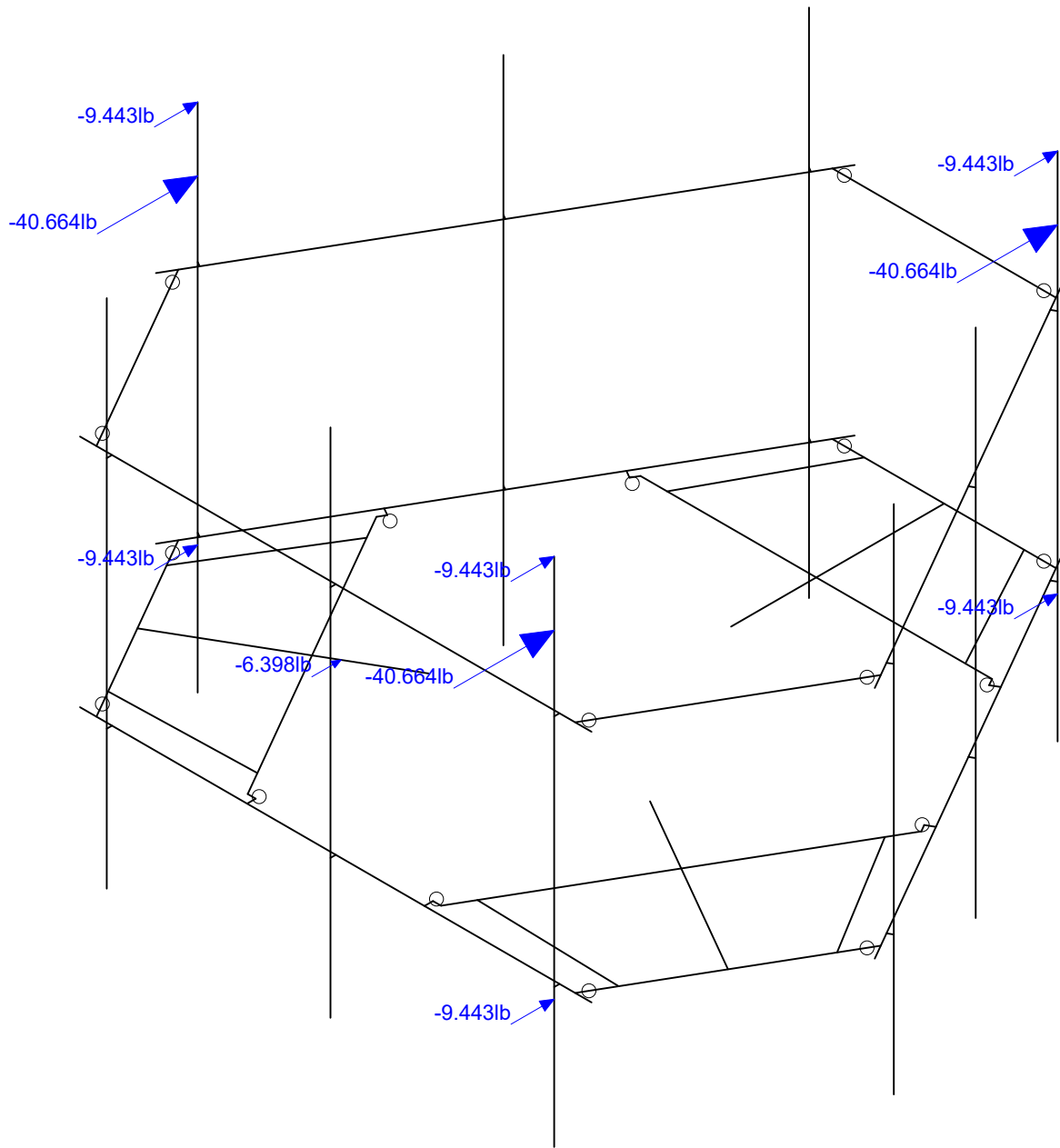
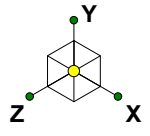

Loads: BLC 31, Seismic Load Z
Envelope Only Solution

Infinigy Engineering, PLLC	BOBDL00109A	Seismic Load AZI 000
PSM		Aug 27, 2021 at 11:27 AM
1197-F0001-C		BOBDL000109A_loaded.r3d

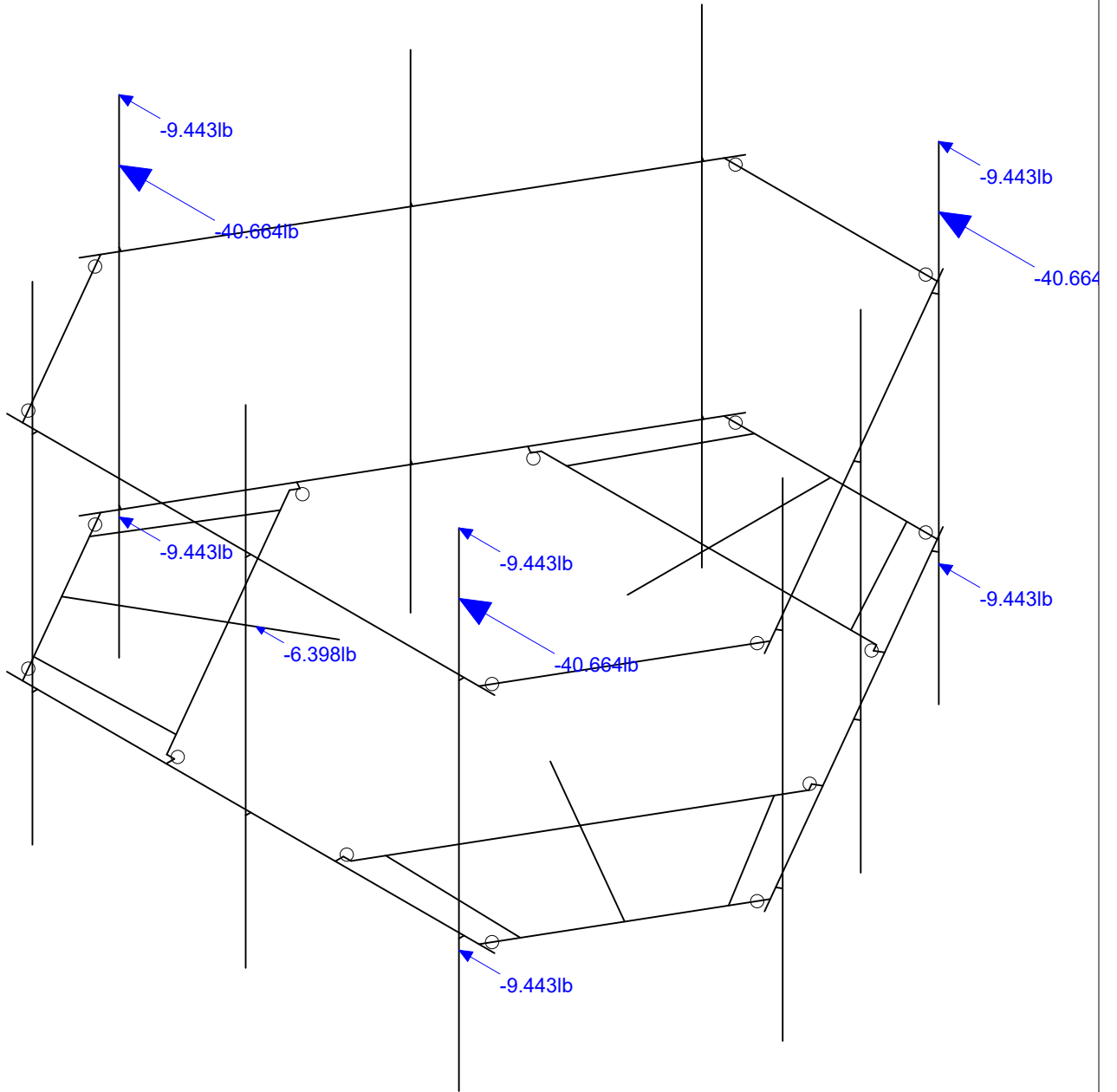
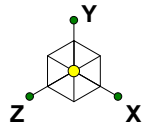

Loads: BLC 32, Seismic Load X
Envelope Only Solution

Infinigy Engineering, PLLC
PSM
1197-F0001-C

BOBDL00109A

Seismic Load AZI 090
Aug 27, 2021 at 11:27 AM
BOBDL000109A_loaded.r3d

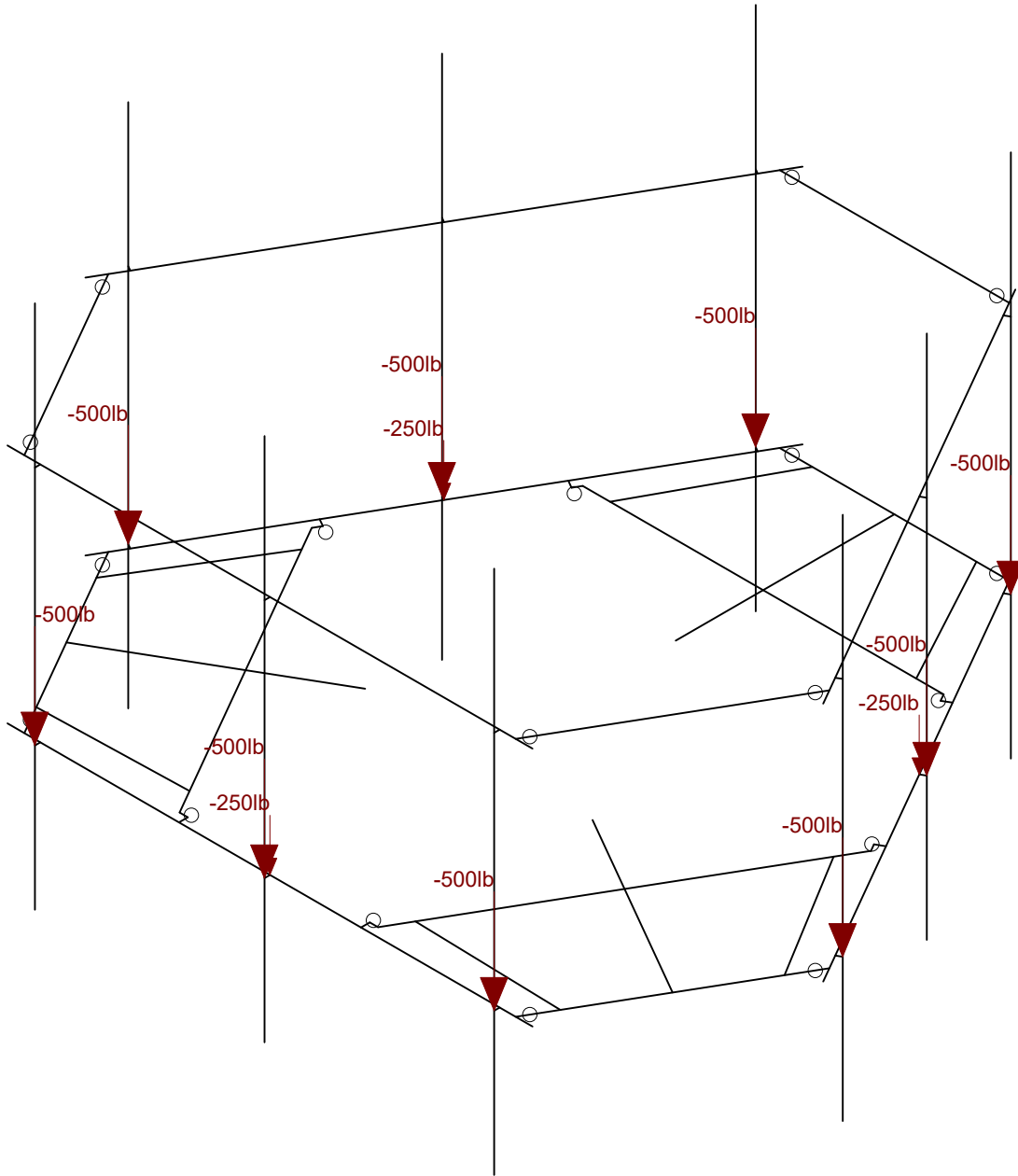
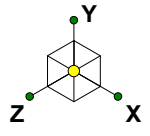

Loads: LL - Live Load
Envelope Only Solution

Infinigy Engineering, PLLC

PSM

1197-F0001-C

BOBDL00109A

Non-concurrent Live Loads

Aug 27, 2021 at 11:28 AM

BOBDL000109A_loaded.r3d

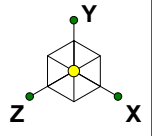

Code Check (Env)	
Black	No Calc
Red	> 1.0
Magenta	.90-1.0
Green	.75-.90
Cyan	.50-.75
Blue	0-.50

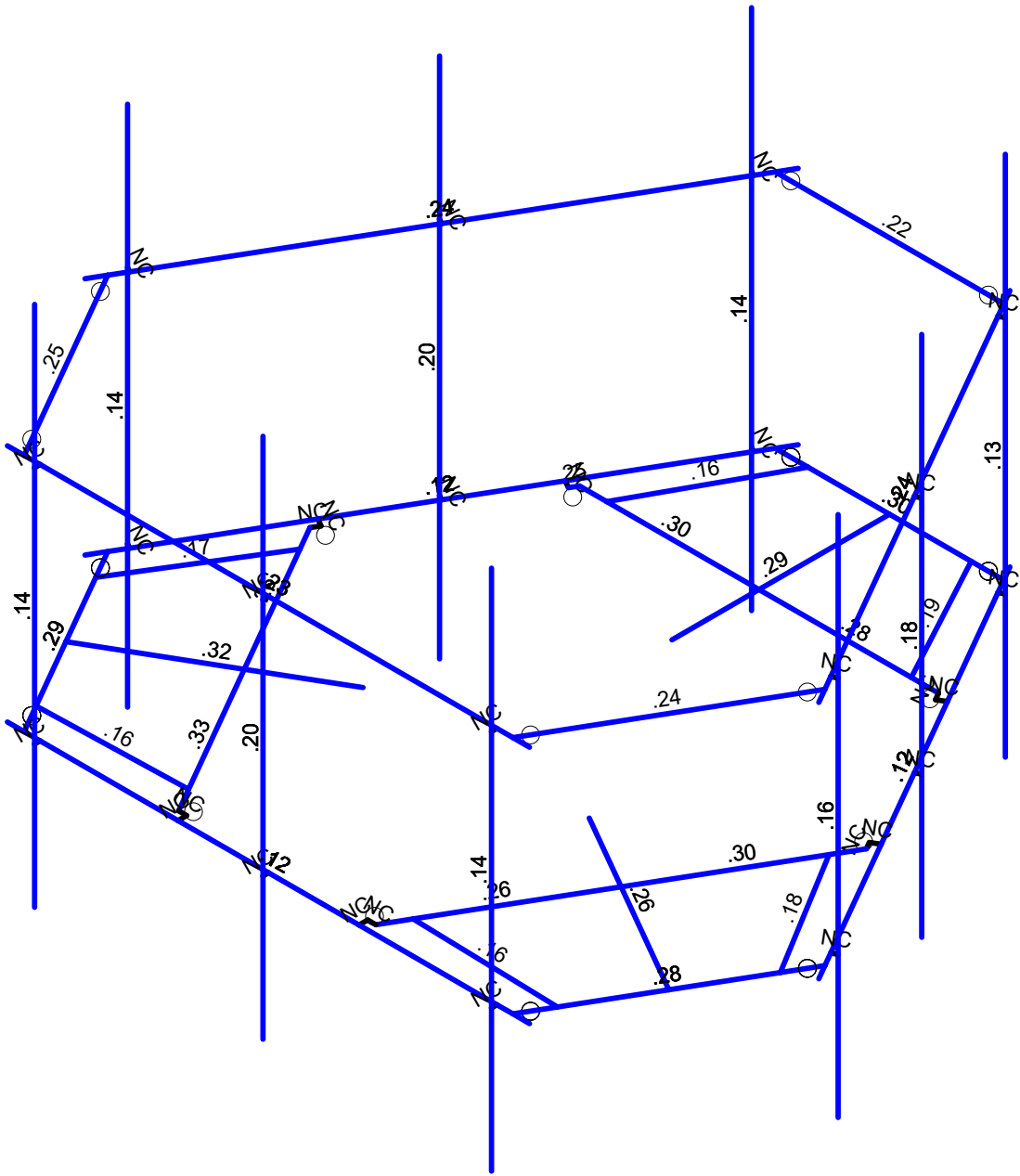

Member Code Checks Displayed (Enveloped)
Envelope Only Solution

Infinigy Engineering, PLLC	BOBDL00109A	Bending Check
PSM		Aug 27, 2021 at 11:28 AM
1197-F0001-C		BOBDL000109A_loaded.r3d

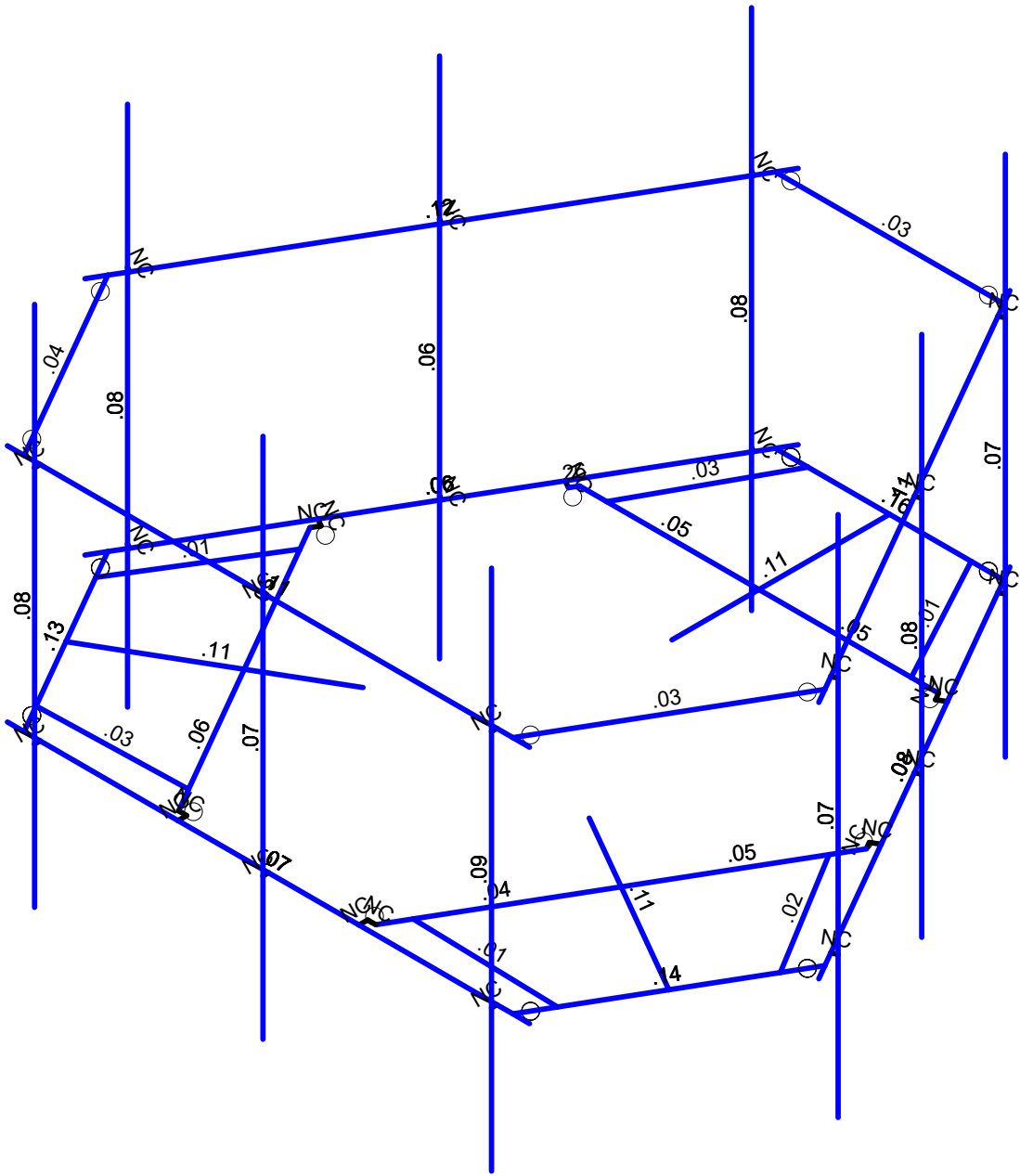
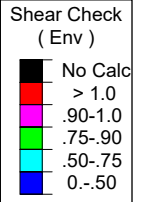
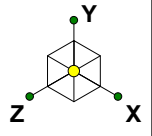

Member Shear Checks Displayed (Enveloped)
Envelope Only Solution

Infinigy Engineering, PLLC	BOBDL00109A	Shear Check
PSM		Aug 27, 2021 at 11:28 AM
1197-F0001-C		BOBDL000109A_loaded.r3d

Program Inputs

PROJECT INFORMATION		
Client:	ATC	
Carrier:	Dish Wireless	
Engineer:	Pradin Suinyal Magar, M.S	

SITE INFORMATION		
Risk Category:	II	
Exposure Category:	C	
Topo Factor Procedure:	Method 1, Category 1	
Site Class:	D - Stiff Soil (Assumed)	
Ground Elevation:	287.12	ft *Rev H

MOUNT INFORMATION		
Mount Type:	Platform	
Num Sectors:	3	
Centerline AGL:	70.00	ft
Tower Height AGL:	119.00	ft

TOPOGRAPHIC DATA		
Topo Feature:	N/A	
Slope Distance:	N/A	ft
Crest Distance:	N/A	ft
Crest Height:	N/A	ft

FACTORS		
Directionality Fact. (K_d):	0.950	
Ground Ele. Factor (K_e):	0.990	*Rev H Only
Rooftop Speed-Up (K_s):	1.000	*Rev H Only
Topographic Factor (K_{zt}):	1.000	
Gust Effect Factor (G_h):	1.000	

CODE STANDARDS		
Building Code:	2015 IBC	
TIA Standard:	TIA-222-H	
ASCE Standard:	ASCE 7-10	

WIND AND ICE DATA		
Ultimate Wind (V_{ult}):	120	mph
Design Wind (V):	N/A	mph
Ice Wind (V_{ice}):	50	mph
Base Ice Thickness (t_i):	2	in
Flat Pressure:	81.383	psf
Round Pressure:	48.830	psf
Ice Wind Pressure:	8.477	psf

SEISMIC DATA		
Short-Period Accel. (S_s):	0.183	g
1-Second Accel. (S_1):	0.064	g
Short-Period Design (S_{DS}):	0.195	
1-Second Design (S_{D1}):	0.102	
Short-Period Coeff. (F_a):	1.600	
1-Second Coeff. (F_v):	2.400	
Amplification Factor (A_s):	3.000	
Response Mod. Coeff. (R):	2.000	



Infinigy Load Calculator V2.1.7

ASCE 7 Hazards Report

Address:
No Address at This
Location

Standard: ASCE/SEI 7-10
Risk Category: II
Soil Class: D - Stiff Soil

Elevation: 287.12 ft (NAVD 88)
Latitude: 41.739136
Longitude: -72.907794

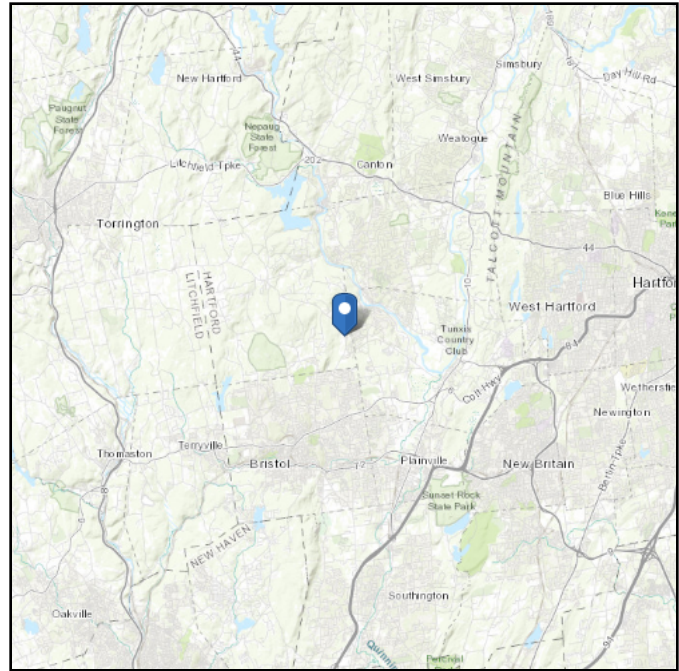

Wind

Results:

Wind Speed:	120 mph per Burlington City Requirements in WSEL
10-year MRI	76 Vmph
25-year MRI	86 Vmph
50-year MRI	91 Vmph
100-year MRI	98 Vmph

Data Source: ASCE/SEI 7-10, Fig. 26.5-1A and Figs. CC-1–CC-4, and Section 26.5.2, incorporating errata of March 12, 2014

Value provided is 3-second gust wind speeds at 33 ft above ground for Exposure C Category, based on linear interpolation between contours. Wind speeds are interpolated in accordance with the 7-10 Standard. Wind speeds correspond to approximately a 7% probability of exceedance in 50 years (annual exceedance probability = 0.00143, MRI = 700 years).

Site is in a hurricane-prone region as defined in ASCE/SEI 7-10 Section 26.2. Glazed openings need not be protected against wind-borne debris.

Site Soil Class: D - Stiff Soil

Results:

S_s :	0.183	S_{DS} :	0.195
S_1 :	0.064	S_{D1} :	0.103
F_a :	1.6	T_L :	6
F_v :	2.4	PGA :	0.092
S_{MS} :	0.292	PGA _M :	0.148
S_{M1} :	0.154	F _{PGA} :	1.6
		I_e :	1

Seismic Design Category B

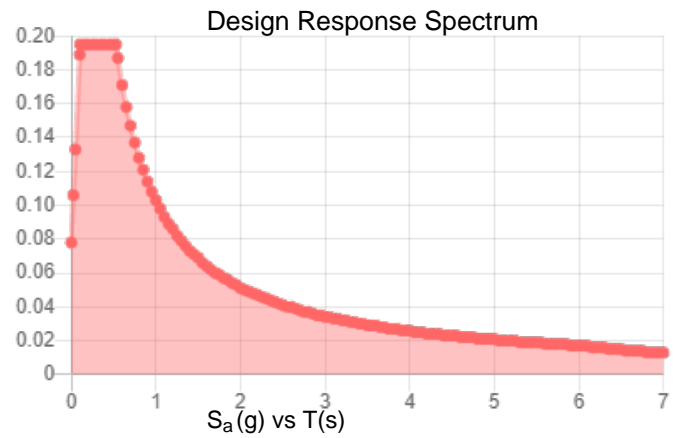
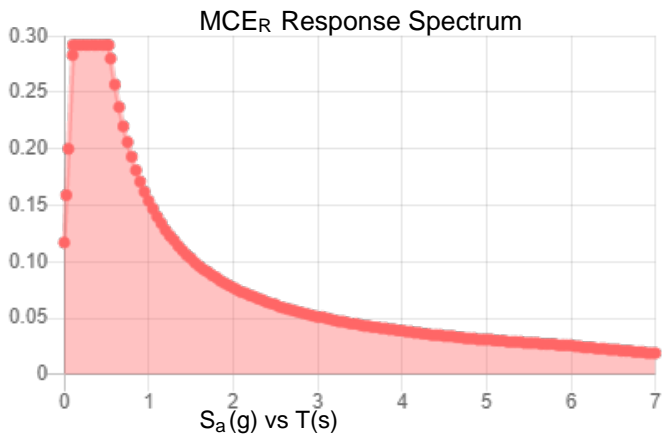

Data Accessed:

Fri Aug 27 2021

Date Source:

USGS Seismic Design Maps based on ASCE/SEI 7-10, incorporating Supplement 1 and errata of March 31, 2013, and ASCE/SEI 7-10 Table 1.5-2. Additional data for site-specific ground motion procedures in accordance with ASCE/SEI 7-10 Ch. 21 are available from USGS.

Ice

Results:

Ice Thickness: 1.00 in.

Concurrent Temperature: 5 F

Gust Speed: 50 mph

Data Source: Standard ASCE/SEI 7-10, Figs. 10-2 through 10-8

Date Accessed: Fri Aug 27 2021

Ice thicknesses on structures in exposed locations at elevations higher than the surrounding terrain and in valleys and gorges may exceed the mapped values.

Values provided are equivalent radial ice thicknesses due to freezing rain with concurrent 3-second gust speeds, for a 50-year mean recurrence interval, and temperatures concurrent with ice thicknesses due to freezing rain. Thicknesses for ice accretions caused by other sources shall be obtained from local meteorological studies. Ice thicknesses in exposed locations at elevations higher than the surrounding terrain and in valleys and gorges may exceed the mapped values.

The ASCE 7 Hazard Tool is provided for your convenience, for informational purposes only, and is provided “as is” and without warranties of any kind. The location data included herein has been obtained from information developed, produced, and maintained by third party providers; or has been extrapolated from maps incorporated in the ASCE 7 standard. While ASCE has made every effort to use data obtained from reliable sources or methodologies, ASCE does not make any representations or warranties as to the accuracy, completeness, reliability, currency, or quality of any data provided herein. Any third-party links provided by this Tool should not be construed as an endorsement, affiliation, relationship, or sponsorship of such third-party content by or from ASCE.

ASCE does not intend, nor should anyone interpret, the results provided by this Tool to replace the sound judgment of a competent professional, having knowledge and experience in the appropriate field(s) of practice, nor to substitute for the standard of care required of such professionals in interpreting and applying the contents of this Tool or the ASCE 7 standard.

In using this Tool, you expressly assume all risks associated with your use. Under no circumstances shall ASCE or its officers, directors, employees, members, affiliates, or agents be liable to you or any other person for any direct, indirect, special, incidental, or consequential damages arising from or related to your use of, or reliance on, the Tool or any information obtained therein. To the fullest extent permitted by law, you agree to release and hold harmless ASCE from any and all liability of any nature arising out of or resulting from any use of data provided by the ASCE 7 Hazard Tool.



Member Primary Data

	Label	I Joint	J Joint	K Joint	Rotate(...)	Section/Shape	Type	Design List	Material	Design Rules
1	S3	P1	P3			Square Tubing	Beam	None	A500 GR.C	Typical
2	GA4	P9	P12		270	Grating Angle	Beam	None	A529 Gr. 50	Typical
3	GA3	P10	P11			Grating Angle	Beam	None	A529 Gr. 50	Typical
4	P3	P7	P8			Corner Plates	Beam	None	A1011 36 Ksi	Typical
5	S2	P13	P14			Square Tubing	Beam	None	A500 GR.C	Typical
6	GA2	P20	P23		270	Grating Angle	Beam	None	A529 Gr. 50	Typical
7	GA1	P21	P22			Grating Angle	Beam	None	A529 Gr. 50	Typical
8	P2	P18	P19			Corner Plates	Beam	None	A1011 36 Ksi	Typical
9	S1	P24	P25			Square Tubing	Beam	None	A500 GR.C	Typical
10	GA6	P31	P34		270	Grating Angle	Beam	None	A529 Gr. 50	Typical
11	GA5	P32	P33			Grating Angle	Beam	None	A529 Gr. 50	Typical
12	P1	P29	P30			Corner Plates	Beam	None	A1011 36 Ksi	Typical
13	H1	N43	N44			Face Pipes(3.5x.16)	Beam	None	A500 GR.C	Typical
14	MP1	N66	N60			Antenna Pipes	Beam	None	A500 GR.C	Typical
15	MP3	N63	N57			Antenna Pipes	Beam	None	A500 GR.C	Typical
16	HR1	N67	N68			Handrail	Beam	None	A500 GR.C	Typical
17	CA8	N114A	N113A		180	Handrail Connector	Beam	None	A1011 36 Ksi	Typical
18	CA9	N112A	N111A		180	Handrail Connector	Beam	None	A1011 36 Ksi	Typical
19	CA7	N116A	N115A		180	Handrail Connector	Beam	None	A1011 36 Ksi	Typical
20	M32	N48A	N70A			RIGID	None	None	RIGID	Typical
21	M35	N45	N69A			RIGID	None	None	RIGID	Typical
22	M36	N51	N71A			RIGID	None	None	RIGID	Typical
23	M39A	N54	N72A			RIGID	None	None	RIGID	Typical
24	CA3	P4	N122A			Channel(3.38x2.06)	Beam	None	A1011 36 Ksi	Typical
25	CA4	N124B	P4			Channel(3.38x2.06)	Beam	None	A1011 36 Ksi	Typical
26	CA1	P15	N122B			Channel(3.38x2.06)	Beam	None	A1011 36 Ksi	Typical
27	CA2	N123A	P15			Channel(3.38x2.06)	Beam	None	A1011 36 Ksi	Typical
28	CA5	P26	N125			Channel(3.38x2.06)	Beam	None	A1011 36 Ksi	Typical
29	CA6	N126	P26			Channel(3.38x2.06)	Beam	None	A1011 36 Ksi	Typical
30	M64	N126A	N125A			RIGID	None	None	RIGID	Typical
31	M65	N126	N125A			RIGID	None	None	RIGID	Typical
32	M66	N129	N128			RIGID	None	None	RIGID	Typical
33	M67	N124B	N128			RIGID	None	None	RIGID	Typical
34	M68	N132	N131			RIGID	None	None	RIGID	Typical
35	M69	N123A	N131			RIGID	None	None	RIGID	Typical
36	M70	N133	N132A			RIGID	None	None	RIGID	Typical
37	M71	N122B	N132A			RIGID	None	None	RIGID	Typical
38	M72	N135	N134			RIGID	None	None	RIGID	Typical
39	M73	N125	N134			RIGID	None	None	RIGID	Typical
40	M74	N138	N137			RIGID	None	None	RIGID	Typical
41	M75	N122A	N137			PL 2.375x0.5	None	None	A36 Gr.36	Typical



Member Primary Data (Continued)

	Label	I Joint	J Joint	K Joint	Rotate(...)	Section/Shape	Type	Design List	Material	Design Rules
42	MP2	N75	N74			Antenna Pipes	Beam	None	A500 GR.C	Typical
43	M43	N72B	N76			RIGID	None	None	RIGID	Typical
44	M44	N73	N77			RIGID	None	None	RIGID	Typical
45	H3	N81A	N82A			Face Pipes(3.5x.16)	Beam	None	A500 GR.C	Typical
46	MP7	N90	N88			Antenna Pipes	Beam	None	A500 GR.C	Typical
47	MP9	N89	N87			Antenna Pipes	Beam	None	A500 GR.C	Typical
48	HR3	N91	N92			Handrail	Beam	None	A500 GR.C	Typical
49	M52	N84	N94			RIGID	None	None	RIGID	Typical
50	M53	N83A	N93			RIGID	None	None	RIGID	Typical
51	M54	N85	N95			RIGID	None	None	RIGID	Typical
52	M55	N86	N96			RIGID	None	None	RIGID	Typical
53	H2	N109	N110			Face Pipes(3.5x.16)	Beam	None	A500 GR.C	Typical
54	MP4	N118	N116			Antenna Pipes	Beam	None	A500 GR.C	Typical
55	MP6	N117	N115			Antenna Pipes	Beam	None	A500 GR.C	Typical
56	HR2	N119	N120			Handrail	Beam	None	A500 GR.C	Typical
57	M66A	N112	N122			RIGID	None	None	RIGID	Typical
58	M67A	N111	N121			RIGID	None	None	RIGID	Typical
59	M68A	N113	N123			RIGID	None	None	RIGID	Typical
60	M69A	N114	N124			RIGID	None	None	RIGID	Typical
61	MP8	N132B	N131A			Antenna Pipes	Beam	None	A500 GR.C	Typical
62	M68B	N129B	N133B			RIGID	None	None	RIGID	Typical
63	M69B	N130A	N134A			RIGID	None	None	RIGID	Typical
64	MP5	N138A	N137A			Antenna Pipes	Beam	None	A500 GR.C	Typical
65	M71B	N135A	N139			RIGID	None	None	RIGID	Typical
66	M72B	N136	N140			RIGID	None	None	RIGID	Typical

Hot Rolled Steel Design Parameters

	Label	Shape	Lengt...	Lbyy[in]	Lbzz[in]	Lcomp t...	Lcomp b...	L-tor...	Kyy	Kzz	Cb	Func...
1	S3	Square Tubing	40			Lbyy						Late...
2	GA4	Grating Angle	27.295			Lbyy						Late...
3	GA3	Grating Angle	27.295			Lbyy						Late...
4	P3	Corner Plates	42			Lbyy						Late...
5	S2	Square Tubing	40			Lbyy						Late...
6	GA2	Grating Angle	27.295			Lbyy						Late...
7	GA1	Grating Angle	27.295			Lbyy						Late...
8	P2	Corner Plates	42			Lbyy						Late...
9	S1	Square Tubing	40			Lbyy						Late...
10	GA6	Grating Angle	27.295			Lbyy						Late...
11	GA5	Grating Angle	27.295			Lbyy						Late...
12	P1	Corner Plates	42			Lbyy						Late...
13	H1	Face Pipes(3.5x.16)	96			Lbyy						Late...

Hot Rolled Steel Design Parameters (Continued)

	Label	Shape	Lengt...	Lbyy[in]	Lbzz[in]	Lcomp t...	Lcomp b...	L-tor...	Kyy	Kzz	Cb	Func...
14	MP1	Antenna Pipes	96			Lbyy						Late...
15	MP3	Antenna Pipes	96			Lbyy						Late...
16	HR1	Handrail	96			Lbyy						Late...
17	CA8	Handrail Connector	42			Lbyy						Late...
18	CA9	Handrail Connector	42			Lbyy						Late...
19	CA7	Handrail Connector	42			Lbyy						Late...
20	CA3	Channel(3.38x2.06)	33			Lbyy						Late...
21	CA4	Channel(3.38x2.06)	33			Lbyy						Late...
22	CA1	Channel(3.38x2.06)	33			Lbyy						Late...
23	CA2	Channel(3.38x2.06)	33			Lbyy						Late...
24	CA5	Channel(3.38x2.06)	33			Lbyy						Late...
25	CA6	Channel(3.38x2.06)	33			Lbyy						Late...
26	M75	PL 2.375x0.5	1.5			Lbyy						Late...
27	MP2	Antenna Pipes	96			Lbyy						Late...
28	H3	Face Pipes(3.5x.16)	96			Lbyy						Late...
29	MP7	Antenna Pipes	96			Lbyy						Late...
30	MP9	Antenna Pipes	96			Lbyy						Late...
31	HR3	Handrail	96			Lbyy						Late...
32	H2	Face Pipes(3.5x.16)	96			Lbyy						Late...
33	MP4	Antenna Pipes	96			Lbyy						Late...
34	MP6	Antenna Pipes	96			Lbyy						Late...
35	HR2	Handrail	96			Lbyy						Late...
36	MP8	Antenna Pipes	96			Lbyy						Late...
37	MP5	Antenna Pipes	96			Lbyy						Late...

Member Advanced Data

	Label	I Release	J Release	I Offset[in]	J Offset[in]	T/C Only	Physical Defl Ra..	Analysis ...	Inactive	Seismi...
1	S3						Yes			None
2	GA4						Yes			None
3	GA3						Yes			None
4	P3	BenPIN	BenPIN				Yes	Default		None
5	S2						Yes			None
6	GA2						Yes			None
7	GA1						Yes			None
8	P2	BenPIN	BenPIN				Yes	Default		None
9	S1						Yes	Default		None
10	GA6						Yes			None
11	GA5						Yes			None
12	P1	BenPIN	BenPIN				Yes	Default		None
13	H1						Yes			None
14	MP1						Yes	+y+3		None



Member Advanced Data (Continued)

	Label	I Release	J Release	I Offset[in]	J Offset[in]	T/C Only	Physical	Defl Ra..	Analysis ...	Inactive	Seismi...
15	MP3						Yes		+y+3		None
16	HR1						Yes				None
17	CA8	00000X	00000X				Yes				None
18	CA9	00000X	00000X				Yes				None
19	CA7	00000X	00000X				Yes	Default			None
20	M32						Yes	** NA **			None
21	M35						Yes	** NA **			None
22	M36						Yes	** NA **			None
23	M39A						Yes	** NA **			None
24	CA3						Yes	Default			None
25	CA4						Yes	Default			None
26	CA1						Yes	Default			None
27	CA2						Yes	Default			None
28	CA5						Yes	Default			None
29	CA6						Yes	Default			None
30	M64	BenPIN					Yes	** NA **			None
31	M65						Yes	** NA **			None
32	M66	BenPIN					Yes	** NA **			None
33	M67						Yes	** NA **			None
34	M68	BenPIN					Yes	** NA **			None
35	M69						Yes	** NA **			None
36	M70	BenPIN					Yes	** NA **			None
37	M71						Yes	** NA **			None
38	M72	BenPIN					Yes	** NA **			None
39	M73						Yes	** NA **			None
40	M74	BenPIN					Yes	** NA **			None
41	M75						Yes	** NA **			None
42	MP2						Yes		+y+3		None
43	M43						Yes	** NA **			None
44	M44						Yes	** NA **			None
45	H3						Yes				None
46	MP7						Yes		+y+3		None
47	MP9						Yes		+y+3		None
48	HR3						Yes				None
49	M52						Yes	** NA **			None
50	M53						Yes	** NA **			None
51	M54						Yes	** NA **			None
52	M55						Yes	** NA **			None
53	H2						Yes				None
54	MP4						Yes		+y+3		None
55	MP6						Yes		+y+3		None
56	HR2						Yes				None

Member Advanced Data (Continued)

	Label	I Release	J Release	I Offset[in]	J Offset[in]	T/C Only	Physical Defl Ra..	Analysis ...	Inactive	Seismi...
57	M66A						Yes ** NA **			None
58	M67A						Yes ** NA **			None
59	M68A						Yes ** NA **			None
60	M69A						Yes ** NA **			None
61	MP8						Yes	+y+3		None
62	M68B						Yes ** NA **			None
63	M69B						Yes ** NA **			None
64	MP5						Yes	+y+3		None
65	M71B						Yes ** NA **			None
66	M72B						Yes ** NA **			None

Material Takeoff

	Material	Size	Pieces	Length[in]	Weight[LB]
1	General				
2	RIGID		29	35.1	0
3	Total General		29	35.1	0
4					
5	Hot Rolled Steel				
6	A1011 36 Ksi	C3.38x2.06x0.25	6	198	98.255
7	A1011 36 Ksi	PL6.5x0.375	3	126	87.09
8	A1011 36 Ksi	L6.6x4.46x0.25	3	126	96.558
9	A36 Gr.36	PL 2.375x0.5	1	1.5	.505
10	A500 GR.C	2.88x0.120	3	288	84.974
11	A500 GR.C	HSS4X4X6	3	120	162.653
12	A500 GR.C	Pipe3.5x0.165	3	288	141.202
13	A500 GR.C	PIPE 2.5	9	864	394.45
14	A529 Gr. 50	L2x2x4	6	163.8	43.838
15	Total HR Steel		37	2175.3	1109.525

Hot Rolled Steel Section Sets

	Label	Shape	Type	Design List	Material	Design... A [in2]	Iyy [in...lzz [in... J [in4]
1	Corner Plates	PL6.5x0.375	Beam	None	A1011 ...	Typical 2.438	.029 8.582 .11
2	6"x0.37" Plate	Plate 6x.37	Beam	None	A1011 ...	Typical 2.22	.025 6.66 .097
3	Grating Angle	L2x2x4	Beam	None	A529 G...	Typical .944	.346 .346 .021
4	Face Pipes(3.5x.1...	Pipe3.5x0.165	Beam	None	A500 G...	Typical 1.729	2.409 2.409 4.819
5	Antenna Pipes	PIPE 2.5	Beam	None	A500 G...	Typical 1.61	1.45 1.45 2.89
6	Channel(3.38x2.06)	C3.38x2.06x0.25	Beam	None	A1011 ...	Typical 1.75	.715 3.026 .034
7	Square Tubing	HSS4X4X6	Beam	None	A500 G...	Typical 4.78	10.3 10.3 17.5
8	Handrail Connector	L6.6x4.46x0.25	Beam	None	A1011 ...	Typical 2.703	4.759 12.473 .055



Hot Rolled Steel Section Sets (Continued)

Label	Shape	Type	Design List	Material	Design... A [in2]	lyy [in...lzz [in... J [in4]
9 Handrail	2.88x0.120	Beam	None	A500 G...	Typical 1.04	.993 .993 1.985

Basic Load Cases

BLC Description	Category	X Gr...	Y Gr...	Z Gr...	Joint	Point	Distributed	Area(Memb...	Surface(Plate/Wall)
1 Self Weight	DL		-1			13		3	
2 Wind Load AZI 0	WLZ					26			
3 Wind Load AZI 30	None					26			
4 Wind Load AZI 60	None					26			
5 Wind Load AZI 90	WLX					26			
6 Wind Load AZI 1...	None					26			
7 Wind Load AZI 1...	None					26			
8 Wind Load AZI 1...	None					26			
9 Wind Load AZI 2...	None					26			
10 Wind Load AZI 2...	None					26			
11 Wind Load AZI 2...	None					26			
12 Wind Load AZI 3...	None					26			
13 Wind Load AZI 3...	None					26			
14 Distr. Wind Load Z	WLZ						66		
15 Distr. Wind Load X	WLX						66		
16 Ice Weight	OL1					13	66	3	
17 Ice Wind Load A...	OL2					26			
18 Ice Wind Load A...	None					26			
19 Ice Wind Load A...	None					26			
20 Ice Wind Load A...	OL3					26			
21 Ice Wind Load A...	None					26			
22 Ice Wind Load A...	None					26			
23 Ice Wind Load A...	None					26			
24 Ice Wind Load A...	None					26			
25 Ice Wind Load A...	None					26			
26 Ice Wind Load A...	None					26			
27 Ice Wind Load A...	None					26			
28 Ice Wind Load A...	None					26			
29 Distr. Ice Wind L...	OL2						66		
30 Distr. Ice Wind L...	OL3						66		
31 Seismic Load Z	ELZ			-.293		13			
32 Seismic Load X	ELX	-.293				13			
33 Service Live Loa...	LL					3			
34 Maintenance Loa...	LL					1			
35 Maintenance Loa...	LL					1			
36 Maintenance Loa...	LL					1			
37 Maintenance Loa...	LL					1			



Load Combinations (Continued)

	Description	S...	P...	S...B...	Fa...B...	Fa...B...	Fa...B...	Fa...B...	Fa...B...	Fa...B...	Fa...B...	Fa...B...	Fa...B...	Fa...B...	Fa...B...	Fa...B...	Fa...B...	Fa...B...	Fa...B...
32	1.2D + 1.0Di + 1.0Wi AZI 150	Y...	Y	1	1.2	16	1	22	1	29	-8...	30	.5						
33	1.2D + 1.0Di + 1.0Wi AZI 180	Y...	Y	1	1.2	16	1	23	1	29	-1	30							
34	1.2D + 1.0Di + 1.0Wi AZI 210	Y...	Y	1	1.2	16	1	24	1	29	-8...	30	-.5						
35	1.2D + 1.0Di + 1.0Wi AZI 240	Y...	Y	1	1.2	16	1	25	1	29	-.5	30	-8...						
36	1.2D + 1.0Di + 1.0Wi AZI 270	Y...	Y	1	1.2	16	1	26	1	29		30	-1						
37	1.2D + 1.0Di + 1.0Wi AZI 300	Y...	Y	1	1.2	16	1	27	1	29	.5	30	-8...						
38	1.2D + 1.0Di + 1.0Wi AZI 330	Y...	Y	1	1.2	16	1	28	1	29	.866	30	-.5						
39	(1.2 + 0.2Sds)DL + 1.0E AZI 0	Y...	Y	1	1.2	.31	1	32											
40	(1.2 + 0.2Sds)DL + 1.0E AZI 30	Y...	Y	1	1.2	.31	.866	32	.5										
41	(1.2 + 0.2Sds)DL + 1.0E AZI 60	Y...	Y	1	1.2	.31	.5	32	.866										
42	(1.2 + 0.2Sds)DL + 1.0E AZI 90	Y...	Y	1	1.2	.31		32	1										
43	(1.2 + 0.2Sds)DL + 1.0E AZI 1..	Y...	Y	1	1.2	.31	-.5	32	.866										
44	(1.2 + 0.2Sds)DL + 1.0E AZI 1..	Y...	Y	1	1.2	.31	-8...	32	.5										
45	(1.2 + 0.2Sds)DL + 1.0E AZI 1..	Y...	Y	1	1.2	.31	-1	32											
46	(1.2 + 0.2Sds)DL + 1.0E AZI 2..	Y...	Y	1	1.2	.31	-8...	32	-.5										
47	(1.2 + 0.2Sds)DL + 1.0E AZI 2..	Y...	Y	1	1.2	.31	-.5	32	-8...										
48	(1.2 + 0.2Sds)DL + 1.0E AZI 2..	Y...	Y	1	1.2	.31		32	-1										
49	(1.2 + 0.2Sds)DL + 1.0E AZI 3..	Y...	Y	1	1.2	.31	.5	32	-8...										
50	(1.2 + 0.2Sds)DL + 1.0E AZI 3..	Y...	Y	1	1.2	.31	.866	32	-.5										
51	(0.9 - 0.2Sds)DL + 1.0E AZI 0	Y...	Y	1	.861	31	1	32											
52	(0.9 - 0.2Sds)DL + 1.0E AZI 30	Y...	Y	1	.861	31	.866	32	.5										
53	(0.9 - 0.2Sds)DL + 1.0E AZI 60	Y...	Y	1	.861	31	.5	32	.866										
54	(0.9 - 0.2Sds)DL + 1.0E AZI 90	Y...	Y	1	.861	31		32	1										
55	(0.9 - 0.2Sds)DL + 1.0E AZI 1..	Y...	Y	1	.861	31	-.5	32	.866										
56	(0.9 - 0.2Sds)DL + 1.0E AZI 1..	Y...	Y	1	.861	31	-8...	32	.5										
57	(0.9 - 0.2Sds)DL + 1.0E AZI 1..	Y...	Y	1	.861	31	-1	32											
58	(0.9 - 0.2Sds)DL + 1.0E AZI 2..	Y...	Y	1	.861	31	-8...	32	-.5										
59	(0.9 - 0.2Sds)DL + 1.0E AZI 2..	Y...	Y	1	.861	31	-.5	32	-8...										
60	(0.9 - 0.2Sds)DL + 1.0E AZI 2..	Y...	Y	1	.861	31		32	-1										
61	(0.9 - 0.2Sds)DL + 1.0E AZI 3..	Y...	Y	1	.861	31	.5	32	-8...										
62	(0.9 - 0.2Sds)DL + 1.0E AZI 3..	Y...	Y	1	.861	31	.866	32	-.5										
63	1.0DL + 1.5LL + 1.0SWL (60 ...	Y...	Y	1	1	2	.25	14	.25	15		33	1.5						
64	1.0DL + 1.5LL + 1.0SWL (60 ...	Y...	Y	1	1	3	.25	14	.216	15	.125	33	1.5						
65	1.0DL + 1.5LL + 1.0SWL (60 ...	Y...	Y	1	1	4	.25	14	.125	15	.216	33	1.5						
66	1.0DL + 1.5LL + 1.0SWL (60 ...	Y...	Y	1	1	5	.25	14		15	.25	33	1.5						
67	1.0DL + 1.5LL + 1.0SWL (60 ...	Y...	Y	1	1	6	.25	14	-.1...	15	.216	33	1.5						
68	1.0DL + 1.5LL + 1.0SWL (60 ...	Y...	Y	1	1	7	.25	14	-.2...	15	.125	33	1.5						
69	1.0DL + 1.5LL + 1.0SWL (60 ...	Y...	Y	1	1	8	.25	14	-.25	15		33	1.5						
70	1.0DL + 1.5LL + 1.0SWL (60 ...	Y...	Y	1	1	9	.25	14	-.2...	15	-.1...	33	1.5						
71	1.0DL + 1.5LL + 1.0SWL (60 ...	Y...	Y	1	1	10	.25	14	-.1...	15	-.2...	33	1.5						
72	1.0DL + 1.5LL + 1.0SWL (60 ...	Y...	Y	1	1	11	.25	14		15	-.25	33	1.5						
73	1.0DL + 1.5LL + 1.0SWL (60 ...	Y...	Y	1	1	12	.25	14	.125	15	-.2...	33	1.5						



Load Combinations (Continued)

Description	S...	P...	S...B...	Fa...B...	Fa...B...	Fa...B...	Fa...B...	Fa...B...	Fa...B...	Fa...B...	Fa...B...	Fa...B...	Fa...B...	Fa...B...	Fa...B...	Fa...B...	Fa...B...	Fa...B...
74	1.0DL + 1.5LL + 1.0SWL (60 ...	Y...	Y	1	1	13	.25	14	.216	15	-1...	33	1.5					
75	1.2DL + 1.5LL	Y...	Y	1	1.2	33	1.5											
76	1.2DL + 1.5LM-MP1 + 1SWL (...)	Y...	Y	1	1.2	34	1.5	2	.063	14	.063	15						
77	1.2DL + 1.5LM-MP1 + 1SWL (...)	Y...	Y	1	1.2	34	1.5	3	.063	14	.054	15	.031					
78	1.2DL + 1.5LM-MP1 + 1SWL (...)	Y...	Y	1	1.2	34	1.5	4	.063	14	.031	15	.054					
79	1.2DL + 1.5LM-MP1 + 1SWL (...)	Y...	Y	1	1.2	34	1.5	5	.063	14		15	.063					
80	1.2DL + 1.5LM-MP1 + 1SWL (...)	Y...	Y	1	1.2	34	1.5	6	.063	14	-0...	15	.054					
81	1.2DL + 1.5LM-MP1 + 1SWL (...)	Y...	Y	1	1.2	34	1.5	7	.063	14	-0...	15	.031					
82	1.2DL + 1.5LM-MP1 + 1SWL (...)	Y...	Y	1	1.2	34	1.5	8	.063	14	-0...	15						
83	1.2DL + 1.5LM-MP1 + 1SWL (...)	Y...	Y	1	1.2	34	1.5	9	.063	14	-0...	15	-0...					
84	1.2DL + 1.5LM-MP1 + 1SWL (...)	Y...	Y	1	1.2	34	1.5	10	.063	14	-0...	15	-0...					
85	1.2DL + 1.5LM-MP1 + 1SWL (...)	Y...	Y	1	1.2	34	1.5	11	.063	14		15	-0...					
86	1.2DL + 1.5LM-MP1 + 1SWL (...)	Y...	Y	1	1.2	34	1.5	12	.063	14	.031	15	-0...					
87	1.2DL + 1.5LM-MP1 + 1SWL (...)	Y...	Y	1	1.2	34	1.5	13	.063	14	.054	15	-0...					
88	1.2DL + 1.5LM-MP2 + 1SWL (...)	Y...	Y	1	1.2	35	1.5	2	.063	14	.063	15						
89	1.2DL + 1.5LM-MP2 + 1SWL (...)	Y...	Y	1	1.2	35	1.5	3	.063	14	.054	15	.031					
90	1.2DL + 1.5LM-MP2 + 1SWL (...)	Y...	Y	1	1.2	35	1.5	4	.063	14	.031	15	.054					
91	1.2DL + 1.5LM-MP2 + 1SWL (...)	Y...	Y	1	1.2	35	1.5	5	.063	14		15	.063					
92	1.2DL + 1.5LM-MP2 + 1SWL (...)	Y...	Y	1	1.2	35	1.5	6	.063	14	-0...	15	.054					
93	1.2DL + 1.5LM-MP2 + 1SWL (...)	Y...	Y	1	1.2	35	1.5	7	.063	14	-0...	15	.031					
94	1.2DL + 1.5LM-MP2 + 1SWL (...)	Y...	Y	1	1.2	35	1.5	8	.063	14	-0...	15						
95	1.2DL + 1.5LM-MP2 + 1SWL (...)	Y...	Y	1	1.2	35	1.5	9	.063	14	-0...	15	-0...					
96	1.2DL + 1.5LM-MP2 + 1SWL (...)	Y...	Y	1	1.2	35	1.5	10	.063	14	-0...	15	-0...					
97	1.2DL + 1.5LM-MP2 + 1SWL (...)	Y...	Y	1	1.2	35	1.5	11	.063	14		15	-0...					
98	1.2DL + 1.5LM-MP2 + 1SWL (...)	Y...	Y	1	1.2	35	1.5	12	.063	14	.031	15	-0...					
99	1.2DL + 1.5LM-MP2 + 1SWL (...)	Y...	Y	1	1.2	35	1.5	13	.063	14	.054	15	-0...					
100	1.2DL + 1.5LM-MP3 + 1SWL (...)	Y...	Y	1	1.2	36	1.5	2	.063	14	.063	15						
101	1.2DL + 1.5LM-MP3 + 1SWL (...)	Y...	Y	1	1.2	36	1.5	3	.063	14	.054	15	.031					
102	1.2DL + 1.5LM-MP3 + 1SWL (...)	Y...	Y	1	1.2	36	1.5	4	.063	14	.031	15	.054					
103	1.2DL + 1.5LM-MP3 + 1SWL (...)	Y...	Y	1	1.2	36	1.5	5	.063	14		15	.063					
104	1.2DL + 1.5LM-MP3 + 1SWL (...)	Y...	Y	1	1.2	36	1.5	6	.063	14	-0...	15	.054					
105	1.2DL + 1.5LM-MP3 + 1SWL (...)	Y...	Y	1	1.2	36	1.5	7	.063	14	-0...	15	.031					
106	1.2DL + 1.5LM-MP3 + 1SWL (...)	Y...	Y	1	1.2	36	1.5	8	.063	14	-0...	15						
107	1.2DL + 1.5LM-MP3 + 1SWL (...)	Y...	Y	1	1.2	36	1.5	9	.063	14	-0...	15	-0...					
108	1.2DL + 1.5LM-MP3 + 1SWL (...)	Y...	Y	1	1.2	36	1.5	10	.063	14	-0...	15	-0...					
109	1.2DL + 1.5LM-MP3 + 1SWL (...)	Y...	Y	1	1.2	36	1.5	11	.063	14		15	-0...					
110	1.2DL + 1.5LM-MP3 + 1SWL (...)	Y...	Y	1	1.2	36	1.5	12	.063	14	.031	15	-0...					
111	1.2DL + 1.5LM-MP3 + 1SWL (...)	Y...	Y	1	1.2	36	1.5	13	.063	14	.054	15	-0...					
112	1.2DL + 1.5LM-MP4 + 1SWL (...)	Y...	Y	1	1.2	37	1.5	2	.063	14	.063	15						
113	1.2DL + 1.5LM-MP4 + 1SWL (...)	Y...	Y	1	1.2	37	1.5	3	.063	14	.054	15	.031					
114	1.2DL + 1.5LM-MP4 + 1SWL (...)	Y...	Y	1	1.2	37	1.5	4	.063	14	.031	15	.054					
115	1.2DL + 1.5LM-MP4 + 1SWL (...)	Y...	Y	1	1.2	37	1.5	5	.063	14		15	.063					



Load Combinations (Continued)

	Description	S...	P...	S...B...	Fa...B...	Fa...B...	Fa...B...	Fa...B...	Fa...B...	Fa...B...	Fa...B...	Fa...B...	Fa...B...	Fa...B...	Fa...B...	Fa...B...	Fa...B...	Fa...B...	Fa...B...
116	1.2DL + 1.5LM-MP4 + 1SWL (...Y...)	Y		1	1.2	37	1.5	6	.063	14	-0...	15	.054						
117	1.2DL + 1.5LM-MP4 + 1SWL (...Y...)	Y		1	1.2	37	1.5	7	.063	14	-0...	15	.031						
118	1.2DL + 1.5LM-MP4 + 1SWL (...Y...)	Y		1	1.2	37	1.5	8	.063	14	-0...	15							
119	1.2DL + 1.5LM-MP4 + 1SWL (...Y...)	Y		1	1.2	37	1.5	9	.063	14	-0...	15	-0...						
120	1.2DL + 1.5LM-MP4 + 1SWL (...Y...)	Y		1	1.2	37	1.5	10	.063	14	-0...	15	-0...						
121	1.2DL + 1.5LM-MP4 + 1SWL (...Y...)	Y		1	1.2	37	1.5	11	.063	14		15	-0...						
122	1.2DL + 1.5LM-MP4 + 1SWL (...Y...)	Y		1	1.2	37	1.5	12	.063	14	.031	15	-0...						
123	1.2DL + 1.5LM-MP4 + 1SWL (...Y...)	Y		1	1.2	37	1.5	13	.063	14	.054	15	-0...						
124	1.2DL + 1.5LM-MP5 + 1SWL (...Y...)	Y		1	1.2	38	1.5	2	.063	14	.063	15							
125	1.2DL + 1.5LM-MP5 + 1SWL (...Y...)	Y		1	1.2	38	1.5	3	.063	14	.054	15	.031						
126	1.2DL + 1.5LM-MP5 + 1SWL (...Y...)	Y		1	1.2	38	1.5	4	.063	14	.031	15	.054						
127	1.2DL + 1.5LM-MP5 + 1SWL (...Y...)	Y		1	1.2	38	1.5	5	.063	14		15	.063						
128	1.2DL + 1.5LM-MP5 + 1SWL (...Y...)	Y		1	1.2	38	1.5	6	.063	14	-0...	15	.054						
129	1.2DL + 1.5LM-MP5 + 1SWL (...Y...)	Y		1	1.2	38	1.5	7	.063	14	-0...	15	.031						
130	1.2DL + 1.5LM-MP5 + 1SWL (...Y...)	Y		1	1.2	38	1.5	8	.063	14	-0...	15							
131	1.2DL + 1.5LM-MP5 + 1SWL (...Y...)	Y		1	1.2	38	1.5	9	.063	14	-0...	15	-0...						
132	1.2DL + 1.5LM-MP5 + 1SWL (...Y...)	Y		1	1.2	38	1.5	10	.063	14	-0...	15	-0...						
133	1.2DL + 1.5LM-MP5 + 1SWL (...Y...)	Y		1	1.2	38	1.5	11	.063	14		15	-0...						
134	1.2DL + 1.5LM-MP5 + 1SWL (...Y...)	Y		1	1.2	38	1.5	12	.063	14	.031	15	-0...						
135	1.2DL + 1.5LM-MP5 + 1SWL (...Y...)	Y		1	1.2	38	1.5	13	.063	14	.054	15	-0...						
136	1.2DL + 1.5LM-MP6 + 1SWL (...Y...)	Y		1	1.2	39	1.5	2	.063	14	.063	15							
137	1.2DL + 1.5LM-MP6 + 1SWL (...Y...)	Y		1	1.2	39	1.5	3	.063	14	.054	15	.031						
138	1.2DL + 1.5LM-MP6 + 1SWL (...Y...)	Y		1	1.2	39	1.5	4	.063	14	.031	15	.054						
139	1.2DL + 1.5LM-MP6 + 1SWL (...Y...)	Y		1	1.2	39	1.5	5	.063	14		15	.063						
140	1.2DL + 1.5LM-MP6 + 1SWL (...Y...)	Y		1	1.2	39	1.5	6	.063	14	-0...	15	.054						
141	1.2DL + 1.5LM-MP6 + 1SWL (...Y...)	Y		1	1.2	39	1.5	7	.063	14	-0...	15	.031						
142	1.2DL + 1.5LM-MP6 + 1SWL (...Y...)	Y		1	1.2	39	1.5	8	.063	14	-0...	15							
143	1.2DL + 1.5LM-MP6 + 1SWL (...Y...)	Y		1	1.2	39	1.5	9	.063	14	-0...	15	-0...						
144	1.2DL + 1.5LM-MP6 + 1SWL (...Y...)	Y		1	1.2	39	1.5	10	.063	14	-0...	15	-0...						
145	1.2DL + 1.5LM-MP6 + 1SWL (...Y...)	Y		1	1.2	39	1.5	11	.063	14		15	-0...						
146	1.2DL + 1.5LM-MP6 + 1SWL (...Y...)	Y		1	1.2	39	1.5	12	.063	14	.031	15	-0...						
147	1.2DL + 1.5LM-MP6 + 1SWL (...Y...)	Y		1	1.2	39	1.5	13	.063	14	.054	15	-0...						
148	1.2DL + 1.5LM-MP7 + 1SWL (...Y...)	Y		1	1.2	40	1.5	2	.063	14	.063	15							
149	1.2DL + 1.5LM-MP7 + 1SWL (...Y...)	Y		1	1.2	40	1.5	3	.063	14	.054	15	.031						
150	1.2DL + 1.5LM-MP7 + 1SWL (...Y...)	Y		1	1.2	40	1.5	4	.063	14	.031	15	.054						
151	1.2DL + 1.5LM-MP7 + 1SWL (...Y...)	Y		1	1.2	40	1.5	5	.063	14		15	.063						
152	1.2DL + 1.5LM-MP7 + 1SWL (...Y...)	Y		1	1.2	40	1.5	6	.063	14	-0...	15	.054						
153	1.2DL + 1.5LM-MP7 + 1SWL (...Y...)	Y		1	1.2	40	1.5	7	.063	14	-0...	15	.031						
154	1.2DL + 1.5LM-MP7 + 1SWL (...Y...)	Y		1	1.2	40	1.5	8	.063	14	-0...	15							
155	1.2DL + 1.5LM-MP7 + 1SWL (...Y...)	Y		1	1.2	40	1.5	9	.063	14	-0...	15	-0...						
156	1.2DL + 1.5LM-MP7 + 1SWL (...Y...)	Y		1	1.2	40	1.5	10	.063	14	-0...	15	-0...						
157	1.2DL + 1.5LM-MP7 + 1SWL (...Y...)	Y		1	1.2	40	1.5	11	.063	14		15	-0...						

Load Combinations (Continued)

	Description	S...	P...	S...B...	Fa...B...	Fa...B...	Fa...B...	Fa...B...	Fa...B...	Fa...B...	Fa...B...	Fa...B...	Fa...B...	Fa...B...	Fa...B...	Fa...B...	Fa...B...	Fa...B...	Fa...B...
158	1.2DL + 1.5LM-MP7 + 1SWL (...Y...)	Y		1	1.2	40	1.5	12	.063	14	.031	15	-0...						
159	1.2DL + 1.5LM-MP7 + 1SWL (...Y...)	Y		1	1.2	40	1.5	13	.063	14	.054	15	-0...						
160	1.2DL + 1.5LM-MP8 + 1SWL (...Y...)	Y		1	1.2	41	1.5	2	.063	14	.063	15							
161	1.2DL + 1.5LM-MP8 + 1SWL (...Y...)	Y		1	1.2	41	1.5	3	.063	14	.054	15	.031						
162	1.2DL + 1.5LM-MP8 + 1SWL (...Y...)	Y		1	1.2	41	1.5	4	.063	14	.031	15	.054						
163	1.2DL + 1.5LM-MP8 + 1SWL (...Y...)	Y		1	1.2	41	1.5	5	.063	14		15	.063						
164	1.2DL + 1.5LM-MP8 + 1SWL (...Y...)	Y		1	1.2	41	1.5	6	.063	14	-0...	15	.054						
165	1.2DL + 1.5LM-MP8 + 1SWL (...Y...)	Y		1	1.2	41	1.5	7	.063	14	-0...	15	.031						
166	1.2DL + 1.5LM-MP8 + 1SWL (...Y...)	Y		1	1.2	41	1.5	8	.063	14	-0...	15							
167	1.2DL + 1.5LM-MP8 + 1SWL (...Y...)	Y		1	1.2	41	1.5	9	.063	14	-0...	15	-0...						
168	1.2DL + 1.5LM-MP8 + 1SWL (...Y...)	Y		1	1.2	41	1.5	10	.063	14	-0...	15	-0...						
169	1.2DL + 1.5LM-MP8 + 1SWL (...Y...)	Y		1	1.2	41	1.5	11	.063	14		15	-0...						
170	1.2DL + 1.5LM-MP8 + 1SWL (...Y...)	Y		1	1.2	41	1.5	12	.063	14	.031	15	-0...						
171	1.2DL + 1.5LM-MP8 + 1SWL (...Y...)	Y		1	1.2	41	1.5	13	.063	14	.054	15	-0...						
172	1.2DL + 1.5LM-MP9 + 1SWL (...Y...)	Y		1	1.2	42	1.5	2	.063	14	.063	15							
173	1.2DL + 1.5LM-MP9 + 1SWL (...Y...)	Y		1	1.2	42	1.5	3	.063	14	.054	15	.031						
174	1.2DL + 1.5LM-MP9 + 1SWL (...Y...)	Y		1	1.2	42	1.5	4	.063	14	.031	15	.054						
175	1.2DL + 1.5LM-MP9 + 1SWL (...Y...)	Y		1	1.2	42	1.5	5	.063	14		15	.063						
176	1.2DL + 1.5LM-MP9 + 1SWL (...Y...)	Y		1	1.2	42	1.5	6	.063	14	-0...	15	.054						
177	1.2DL + 1.5LM-MP9 + 1SWL (...Y...)	Y		1	1.2	42	1.5	7	.063	14	-0...	15	.031						
178	1.2DL + 1.5LM-MP9 + 1SWL (...Y...)	Y		1	1.2	42	1.5	8	.063	14	-0...	15							
179	1.2DL + 1.5LM-MP9 + 1SWL (...Y...)	Y		1	1.2	42	1.5	9	.063	14	-0...	15	-0...						
180	1.2DL + 1.5LM-MP9 + 1SWL (...Y...)	Y		1	1.2	42	1.5	10	.063	14	-0...	15	-0...						
181	1.2DL + 1.5LM-MP9 + 1SWL (...Y...)	Y		1	1.2	42	1.5	11	.063	14		15	-0...						
182	1.2DL + 1.5LM-MP9 + 1SWL (...Y...)	Y		1	1.2	42	1.5	12	.063	14	.031	15	-0...						

Joint Boundary Conditions

	Joint Label	X [k/in]	Y [k/in]	Z [k/in]	X Rot.[k-ft/rad]	Y Rot.[k-ft/rad]	Z Rot.[k-ft/rad]
1	P24	Reaction	Reaction	Reaction	Reaction	Reaction	Reaction
2	P13	Reaction	Reaction	Reaction	Reaction	Reaction	Reaction
3	P1	Reaction	Reaction	Reaction	Reaction	Reaction	Reaction

Envelope Joint Reactions

Joint	X [lb]	LC	Y [lb]	LC	Z [lb]	LC	MX [lb-ft]	LC	MY [lb-ft]	LC	MZ [lb-ft]	LC		
1	P24	...	898.225	6	2409.6...	35	1367.6...	13	858.706	16	1728.5	19	4321.755	35
2		...	-881.663	24	-460.56	16	-1359.5...	19	-3705.3...	35	-1745.982	13	-1543.942	16
3	P13	...	1097.093	4	2878.5...	31	1448.0...	15	826.224	24	1944.657	15	1331.581	24
4		...	-1095.165	22	-366.4...	24	-1455.7...	9	-2818.2...	92	-1991.244	9	-6465.666	31
5	P1	...	1410.852	17	2579.1...	27	729.444	2	6200.3...	27	1606.258	11	1582.281	115



Envelope Joint Reactions (Continued)

Joint	X [lb]	LC	Y [lb]	LC	Z [lb]	LC	MX [lb-ft]	LC	MY [lb-ft]	LC	MZ [lb-ft]	LC
6	-1429.471	11	-450.4...	20	-734.258	8	-1746.6...	20	-1554.562	17	-861.012	157
7	Totals: ... 3243.404	5	7149.8...	34	3435.2...	14						
8	-3243.396	23	1531.7...	53	-3435.2...	8						

Member Point Loads (BLC 1 : Self Weight)

	Member Label	Direction	Magnitude[lb,lb-ft]	Location[in, %]
1	MP1	Y	-32.25	0
2	MP1	Y	-32.25	72
3	MP1	Y	-74.95	12
4	MP1	Y	-63.93	12
5	S2	Y	-21.85	12
6	MP4	Y	-32.25	0
7	MP4	Y	-32.25	72
8	MP4	Y	-74.95	12
9	MP4	Y	-63.93	12
10	MP7	Y	-32.25	0
11	MP7	Y	-32.25	72
12	MP7	Y	-74.95	12
13	MP7	Y	-63.93	12

Member Point Loads (BLC 2 : Wind Load AZI 0)

	Member Label	Direction	Magnitude[lb,lb-ft]	Location[in, %]
1	MP1	X	0	0
2	MP1	Z	-146.67	0
3	MP1	X	0	72
4	MP1	Z	-146.67	72
5	MP1	X	0	12
6	MP1	Z	-71.91	12
7	MP1	X	0	12
8	MP1	Z	-71.91	12
9	S2	X	0	12
10	S2	Z	-68.36	12
11	MP4	X	0	0
12	MP4	Z	-80.75	0
13	MP4	X	0	72
14	MP4	Z	-80.75	72
15	MP4	X	0	12
16	MP4	Z	-50.64	12
17	MP4	X	0	12
18	MP4	Z	-46.35	12



Member Point Loads (BLC 2 : Wind Load AZI 0) (Continued)

	Member Label	Direction	Magnitude[lb,lb-ft]	Location[in,%]
19	MP7	X	0	0
20	MP7	Z	-80.75	0
21	MP7	X	0	72
22	MP7	Z	-80.75	72
23	MP7	X	0	12
24	MP7	Z	-50.64	12
25	MP7	X	0	12
26	MP7	Z	-46.35	12

Member Point Loads (BLC 3 : Wind Load AZI 30)

	Member Label	Direction	Magnitude[lb,lb-ft]	Location[in,%]
1	MP1	X	-62.35	0
2	MP1	Z	-107.99	0
3	MP1	X	-62.35	72
4	MP1	Z	-107.99	72
5	MP1	X	-32.41	12
6	MP1	Z	-56.13	12
7	MP1	X	-31.69	12
8	MP1	Z	-54.9	12
9	S2	X	-30.52	12
10	S2	Z	-52.86	12
11	MP4	X	-62.35	0
12	MP4	Z	-107.99	0
13	MP4	X	-62.35	72
14	MP4	Z	-107.99	72
15	MP4	X	-32.41	12
16	MP4	Z	-56.13	12
17	MP4	X	-31.69	12
18	MP4	Z	-54.9	12
19	MP7	X	-29.39	0
20	MP7	Z	-50.9	0
21	MP7	X	-29.39	72
22	MP7	Z	-50.9	72
23	MP7	X	-21.77	12
24	MP7	Z	-37.71	12
25	MP7	X	-18.91	12
26	MP7	Z	-32.76	12

Member Point Loads (BLC 4 : Wind Load AZI 60)

	Member Label	Direction	Magnitude[lb,lb-ft]	Location[in,%]
1	MP1	X	-69.93	0

Member Point Loads (BLC 4 : Wind Load AZI 60) (Continued)

	Member Label	Direction	Magnitude[lb,lb-ft]	Location[in,%]
2	MP1	Z	-40.38	0
3	MP1	X	-69.93	72
4	MP1	Z	-40.38	72
5	MP1	X	-43.85	12
6	MP1	Z	-25.32	12
7	MP1	X	-40.14	12
8	MP1	Z	-23.17	12
9	S2	X	-40.17	12
10	S2	Z	-23.19	12
11	MP4	X	-127.02	0
12	MP4	Z	-73.34	0
13	MP4	X	-127.02	72
14	MP4	Z	-73.34	72
15	MP4	X	-62.27	12
16	MP4	Z	-35.95	12
17	MP4	X	-62.27	12
18	MP4	Z	-35.95	12
19	MP7	X	-69.93	0
20	MP7	Z	-40.38	0
21	MP7	X	-69.93	72
22	MP7	Z	-40.38	72
23	MP7	X	-43.85	12
24	MP7	Z	-25.32	12
25	MP7	X	-40.14	12
26	MP7	Z	-23.17	12

Member Point Loads (BLC 5 : Wind Load AZI 90)

	Member Label	Direction	Magnitude[lb,lb-ft]	Location[in,%]
1	MP1	X	-58.78	0
2	MP1	Z	0	0
3	MP1	X	-58.78	72
4	MP1	Z	0	72
5	MP1	X	-43.55	12
6	MP1	Z	0	12
7	MP1	X	-37.83	12
8	MP1	Z	0	12
9	S2	X	-39.06	12
10	S2	Z	0	12
11	MP4	X	-124.7	0
12	MP4	Z	0	0
13	MP4	X	-124.7	72
14	MP4	Z	0	72



Member Point Loads (BLC 5 : Wind Load AZI 90) (Continued)

	Member Label	Direction	Magnitude[lb,lb-ft]	Location[in,%]
15	MP4	X	-64.82	12
16	MP4	Z	0	12
17	MP4	X	-63.39	12
18	MP4	Z	0	12
19	MP7	X	-124.7	0
20	MP7	Z	0	0
21	MP7	X	-124.7	72
22	MP7	Z	0	72
23	MP7	X	-64.82	12
24	MP7	Z	0	12
25	MP7	X	-63.39	12
26	MP7	Z	0	12

Member Point Loads (BLC 6 : Wind Load AZI 120)

	Member Label	Direction	Magnitude[lb,lb-ft]	Location[in,%]
1	MP1	X	-69.93	0
2	MP1	Z	40.38	0
3	MP1	X	-69.93	72
4	MP1	Z	40.38	72
5	MP1	X	-43.85	12
6	MP1	Z	25.32	12
7	MP1	X	-40.14	12
8	MP1	Z	23.17	12
9	S2	X	-40.17	12
10	S2	Z	23.19	12
11	MP4	X	-69.93	0
12	MP4	Z	40.38	0
13	MP4	X	-69.93	72
14	MP4	Z	40.38	72
15	MP4	X	-43.85	12
16	MP4	Z	25.32	12
17	MP4	X	-40.14	12
18	MP4	Z	23.17	12
19	MP7	X	-127.02	0
20	MP7	Z	73.34	0
21	MP7	X	-127.02	72
22	MP7	Z	73.34	72
23	MP7	X	-62.27	12
24	MP7	Z	35.95	12
25	MP7	X	-62.27	12
26	MP7	Z	35.95	12



Member Point Loads (BLC 7 : Wind Load AZI 150)

	Member Label	Direction	Magnitude[lb,lb-ft]	Location[in,%]
1	MP1	X	-62.35	0
2	MP1	Z	107.99	0
3	MP1	X	-62.35	72
4	MP1	Z	107.99	72
5	MP1	X	-32.41	12
6	MP1	Z	56.13	12
7	MP1	X	-31.69	12
8	MP1	Z	54.9	12
9	S2	X	-30.52	12
10	S2	Z	52.86	12
11	MP4	X	-29.39	0
12	MP4	Z	50.9	0
13	MP4	X	-29.39	72
14	MP4	Z	50.9	72
15	MP4	X	-21.77	12
16	MP4	Z	37.71	12
17	MP4	X	-18.91	12
18	MP4	Z	32.76	12
19	MP7	X	-62.35	0
20	MP7	Z	107.99	0
21	MP7	X	-62.35	72
22	MP7	Z	107.99	72
23	MP7	X	-32.41	12
24	MP7	Z	56.13	12
25	MP7	X	-31.69	12
26	MP7	Z	54.9	12

Member Point Loads (BLC 8 : Wind Load AZI 180)

	Member Label	Direction	Magnitude[lb,lb-ft]	Location[in,%]
1	MP1	X	0	0
2	MP1	Z	146.67	0
3	MP1	X	0	72
4	MP1	Z	146.67	72
5	MP1	X	0	12
6	MP1	Z	71.91	12
7	MP1	X	0	12
8	MP1	Z	71.91	12
9	S2	X	0	12
10	S2	Z	68.36	12
11	MP4	X	0	0
12	MP4	Z	80.75	0
13	MP4	X	0	72



Member Point Loads (BLC 8 : Wind Load AZI 180) (Continued)

	Member Label	Direction	Magnitude[lb,lb-ft]	Location[in, %]
14	MP4	Z	80.75	72
15	MP4	X	0	12
16	MP4	Z	50.64	12
17	MP4	X	0	12
18	MP4	Z	46.35	12
19	MP7	X	0	0
20	MP7	Z	80.75	0
21	MP7	X	0	72
22	MP7	Z	80.75	72
23	MP7	X	0	12
24	MP7	Z	50.64	12
25	MP7	X	0	12
26	MP7	Z	46.35	12

Member Point Loads (BLC 9 : Wind Load AZI 210)

	Member Label	Direction	Magnitude[lb,lb-ft]	Location[in, %]
1	MP1	X	62.35	0
2	MP1	Z	107.99	0
3	MP1	X	62.35	72
4	MP1	Z	107.99	72
5	MP1	X	32.41	12
6	MP1	Z	56.13	12
7	MP1	X	31.69	12
8	MP1	Z	54.9	12
9	S2	X	30.52	12
10	S2	Z	52.86	12
11	MP4	X	62.35	0
12	MP4	Z	107.99	0
13	MP4	X	62.35	72
14	MP4	Z	107.99	72
15	MP4	X	32.41	12
16	MP4	Z	56.13	12
17	MP4	X	31.69	12
18	MP4	Z	54.9	12
19	MP7	X	29.39	0
20	MP7	Z	50.9	0
21	MP7	X	29.39	72
22	MP7	Z	50.9	72
23	MP7	X	21.77	12
24	MP7	Z	37.71	12
25	MP7	X	18.91	12
26	MP7	Z	32.76	12



Member Point Loads (BLC 10 : Wind Load AZI 240)

	Member Label	Direction	Magnitude[lb,lb-ft]	Location[in,%]
1	MP1	X	69.93	0
2	MP1	Z	40.38	0
3	MP1	X	69.93	72
4	MP1	Z	40.38	72
5	MP1	X	43.85	12
6	MP1	Z	25.32	12
7	MP1	X	40.14	12
8	MP1	Z	23.17	12
9	S2	X	40.17	12
10	S2	Z	23.19	12
11	MP4	X	127.02	0
12	MP4	Z	73.34	0
13	MP4	X	127.02	72
14	MP4	Z	73.34	72
15	MP4	X	62.27	12
16	MP4	Z	35.95	12
17	MP4	X	62.27	12
18	MP4	Z	35.95	12
19	MP7	X	69.93	0
20	MP7	Z	40.38	0
21	MP7	X	69.93	72
22	MP7	Z	40.38	72
23	MP7	X	43.85	12
24	MP7	Z	25.32	12
25	MP7	X	40.14	12
26	MP7	Z	23.17	12

Member Point Loads (BLC 11 : Wind Load AZI 270)

	Member Label	Direction	Magnitude[lb,lb-ft]	Location[in,%]
1	MP1	X	58.78	0
2	MP1	Z	0	0
3	MP1	X	58.78	72
4	MP1	Z	0	72
5	MP1	X	43.55	12
6	MP1	Z	0	12
7	MP1	X	37.83	12
8	MP1	Z	0	12
9	S2	X	39.06	12
10	S2	Z	0	12
11	MP4	X	124.7	0
12	MP4	Z	0	0
13	MP4	X	124.7	72



Member Point Loads (BLC 11 : Wind Load AZI 270) (Continued)

	Member Label	Direction	Magnitude[lb,lb-ft]	Location[in,%]
14	MP4	Z	0	72
15	MP4	X	64.82	12
16	MP4	Z	0	12
17	MP4	X	63.39	12
18	MP4	Z	0	12
19	MP7	X	124.7	0
20	MP7	Z	0	0
21	MP7	X	124.7	72
22	MP7	Z	0	72
23	MP7	X	64.82	12
24	MP7	Z	0	12
25	MP7	X	63.39	12
26	MP7	Z	0	12

Member Point Loads (BLC 12 : Wind Load AZI 300)

	Member Label	Direction	Magnitude[lb,lb-ft]	Location[in,%]
1	MP1	X	69.93	0
2	MP1	Z	-40.38	0
3	MP1	X	69.93	72
4	MP1	Z	-40.38	72
5	MP1	X	43.85	12
6	MP1	Z	-25.32	12
7	MP1	X	40.14	12
8	MP1	Z	-23.17	12
9	S2	X	40.17	12
10	S2	Z	-23.19	12
11	MP4	X	69.93	0
12	MP4	Z	-40.38	0
13	MP4	X	69.93	72
14	MP4	Z	-40.38	72
15	MP4	X	43.85	12
16	MP4	Z	-25.32	12
17	MP4	X	40.14	12
18	MP4	Z	-23.17	12
19	MP7	X	127.02	0
20	MP7	Z	-73.34	0
21	MP7	X	127.02	72
22	MP7	Z	-73.34	72
23	MP7	X	62.27	12
24	MP7	Z	-35.95	12
25	MP7	X	62.27	12
26	MP7	Z	-35.95	12



Member Point Loads (BLC 13 : Wind Load AZI 330)

	Member Label	Direction	Magnitude[lb,lb-ft]	Location[in,%]
1	MP1	X	62.35	0
2	MP1	Z	-107.99	0
3	MP1	X	62.35	72
4	MP1	Z	-107.99	72
5	MP1	X	32.41	12
6	MP1	Z	-56.13	12
7	MP1	X	31.69	12
8	MP1	Z	-54.9	12
9	S2	X	30.52	12
10	S2	Z	-52.86	12
11	MP4	X	29.39	0
12	MP4	Z	-50.9	0
13	MP4	X	29.39	72
14	MP4	Z	-50.9	72
15	MP4	X	21.77	12
16	MP4	Z	-37.71	12
17	MP4	X	18.91	12
18	MP4	Z	-32.76	12
19	MP7	X	62.35	0
20	MP7	Z	-107.99	0
21	MP7	X	62.35	72
22	MP7	Z	-107.99	72
23	MP7	X	32.41	12
24	MP7	Z	-56.13	12
25	MP7	X	31.69	12
26	MP7	Z	-54.9	12

Member Point Loads (BLC 16 : Ice Weight)

	Member Label	Direction	Magnitude[lb,lb-ft]	Location[in,%]
1	MP1	Y	-183.485	0
2	MP1	Y	-183.485	72
3	MP1	Y	-98.38	12
4	MP1	Y	-92.555	12
5	S2	Y	-90.346	12
6	MP4	Y	-183.485	0
7	MP4	Y	-183.485	72
8	MP4	Y	-98.38	12
9	MP4	Y	-92.555	12
10	MP7	Y	-183.485	0
11	MP7	Y	-183.485	72
12	MP7	Y	-98.38	12
13	MP7	Y	-92.555	12



Member Point Loads (BLC 17 : Ice Wind Load AZI 0)

	Member Label	Direction	Magnitude[lb,lb-ft]	Location[in,%]
1	MP1	X	0	0
2	MP1	Z	-21.06	0
3	MP1	X	0	72
4	MP1	Z	-21.06	72
5	MP1	X	0	12
6	MP1	Z	-8.54	12
7	MP1	X	0	12
8	MP1	Z	-8.54	12
9	S2	X	0	12
10	S2	Z	-8.21	12
11	MP4	X	0	0
12	MP4	Z	-15.75	0
13	MP4	X	0	72
14	MP4	Z	-15.75	72
15	MP4	X	0	12
16	MP4	Z	-7.18	12
17	MP4	X	0	12
18	MP4	Z	-6.94	12
19	MP7	X	0	0
20	MP7	Z	-15.75	0
21	MP7	X	0	72
22	MP7	Z	-15.75	72
23	MP7	X	0	12
24	MP7	Z	-7.18	12
25	MP7	X	0	12
26	MP7	Z	-6.94	12

Member Point Loads (BLC 18 : Ice Wind Load AZI 30)

	Member Label	Direction	Magnitude[lb,lb-ft]	Location[in,%]
1	MP1	X	-9.65	0
2	MP1	Z	-16.71	0
3	MP1	X	-9.65	72
4	MP1	Z	-16.71	72
5	MP1	X	-4.04	12
6	MP1	Z	-7	12
7	MP1	X	-4	12
8	MP1	Z	-6.93	12
9	S2	X	-3.9	12
10	S2	Z	-6.75	12
11	MP4	X	-9.65	0
12	MP4	Z	-16.71	0
13	MP4	X	-9.65	72



Member Point Loads (BLC 18 : Ice Wind Load AZI 30) (Continued)

	Member Label	Direction	Magnitude[lb,lb-ft]	Location[in,%]
14	MP4	Z	-16.71	72
15	MP4	X	-4.04	12
16	MP4	Z	-7	12
17	MP4	X	-4	12
18	MP4	Z	-6.93	12
19	MP7	X	-6.99	0
20	MP7	Z	-12.11	0
21	MP7	X	-6.99	72
22	MP7	Z	-12.11	72
23	MP7	X	-3.36	12
24	MP7	Z	-5.83	12
25	MP7	X	-3.21	12
26	MP7	Z	-5.55	12

Member Point Loads (BLC 19 : Ice Wind Load AZI 60)

	Member Label	Direction	Magnitude[lb,lb-ft]	Location[in,%]
1	MP1	X	-13.64	0
2	MP1	Z	-7.88	0
3	MP1	X	-13.64	72
4	MP1	Z	-7.88	72
5	MP1	X	-6.22	12
6	MP1	Z	-3.59	12
7	MP1	X	-6.01	12
8	MP1	Z	-3.47	12
9	S2	X	-6.02	12
10	S2	Z	-3.47	12
11	MP4	X	-18.24	0
12	MP4	Z	-10.53	0
13	MP4	X	-18.24	72
14	MP4	Z	-10.53	72
15	MP4	X	-7.39	12
16	MP4	Z	-4.27	12
17	MP4	X	-7.39	12
18	MP4	Z	-4.27	12
19	MP7	X	-13.64	0
20	MP7	Z	-7.88	0
21	MP7	X	-13.64	72
22	MP7	Z	-7.88	72
23	MP7	X	-6.22	12
24	MP7	Z	-3.59	12
25	MP7	X	-6.01	12
26	MP7	Z	-3.47	12

Member Point Loads (BLC 20 : Ice Wind Load AZI 90)

	Member Label	Direction	Magnitude[lb,lb-ft]	Location[in,%]
1	MP1	X	-13.99	0
2	MP1	Z	0	0
3	MP1	X	-13.99	72
4	MP1	Z	0	72
5	MP1	X	-6.73	12
6	MP1	Z	0	12
7	MP1	X	-6.41	12
8	MP1	Z	0	12
9	S2	X	-6.53	12
10	S2	Z	0	12
11	MP4	X	-19.29	0
12	MP4	Z	0	0
13	MP4	X	-19.29	72
14	MP4	Z	0	72
15	MP4	X	-8.08	12
16	MP4	Z	0	12
17	MP4	X	-8.01	12
18	MP4	Z	0	12
19	MP7	X	-19.29	0
20	MP7	Z	0	0
21	MP7	X	-19.29	72
22	MP7	Z	0	72
23	MP7	X	-8.08	12
24	MP7	Z	0	12
25	MP7	X	-8.01	12
26	MP7	Z	0	12

Member Point Loads (BLC 21 : Ice Wind Load AZI 120)

	Member Label	Direction	Magnitude[lb,lb-ft]	Location[in,%]
1	MP1	X	-13.64	0
2	MP1	Z	7.88	0
3	MP1	X	-13.64	72
4	MP1	Z	7.88	72
5	MP1	X	-6.22	12
6	MP1	Z	3.59	12
7	MP1	X	-6.01	12
8	MP1	Z	3.47	12
9	S2	X	-6.02	12
10	S2	Z	3.47	12
11	MP4	X	-13.64	0
12	MP4	Z	7.88	0
13	MP4	X	-13.64	72



Member Point Loads (BLC 21 : Ice Wind Load AZI 120) (Continued)

	Member Label	Direction	Magnitude[lb,lb-ft]	Location[in, %]
14	MP4	Z	7.88	72
15	MP4	X	-6.22	12
16	MP4	Z	3.59	12
17	MP4	X	-6.01	12
18	MP4	Z	3.47	12
19	MP7	X	-18.24	0
20	MP7	Z	10.53	0
21	MP7	X	-18.24	72
22	MP7	Z	10.53	72
23	MP7	X	-7.39	12
24	MP7	Z	4.27	12
25	MP7	X	-7.39	12
26	MP7	Z	4.27	12

Member Point Loads (BLC 22 : Ice Wind Load AZI 150)

	Member Label	Direction	Magnitude[lb,lb-ft]	Location[in, %]
1	MP1	X	-9.65	0
2	MP1	Z	16.71	0
3	MP1	X	-9.65	72
4	MP1	Z	16.71	72
5	MP1	X	-4.04	12
6	MP1	Z	7	12
7	MP1	X	-4	12
8	MP1	Z	6.93	12
9	S2	X	-3.9	12
10	S2	Z	6.75	12
11	MP4	X	-6.99	0
12	MP4	Z	12.11	0
13	MP4	X	-6.99	72
14	MP4	Z	12.11	72
15	MP4	X	-3.36	12
16	MP4	Z	5.83	12
17	MP4	X	-3.21	12
18	MP4	Z	5.55	12
19	MP7	X	-9.65	0
20	MP7	Z	16.71	0
21	MP7	X	-9.65	72
22	MP7	Z	16.71	72
23	MP7	X	-4.04	12
24	MP7	Z	7	12
25	MP7	X	-4	12
26	MP7	Z	6.93	12



Member Point Loads (BLC 23 : Ice Wind Load AZI 180)

	Member Label	Direction	Magnitude[lb,lb-ft]	Location[in,%]
1	MP1	X	0	0
2	MP1	Z	21.06	0
3	MP1	X	0	72
4	MP1	Z	21.06	72
5	MP1	X	0	12
6	MP1	Z	8.54	12
7	MP1	X	0	12
8	MP1	Z	8.54	12
9	S2	X	0	12
10	S2	Z	8.21	12
11	MP4	X	0	0
12	MP4	Z	15.75	0
13	MP4	X	0	72
14	MP4	Z	15.75	72
15	MP4	X	0	12
16	MP4	Z	7.18	12
17	MP4	X	0	12
18	MP4	Z	6.94	12
19	MP7	X	0	0
20	MP7	Z	15.75	0
21	MP7	X	0	72
22	MP7	Z	15.75	72
23	MP7	X	0	12
24	MP7	Z	7.18	12
25	MP7	X	0	12
26	MP7	Z	6.94	12

Member Point Loads (BLC 24 : Ice Wind Load AZI 210)

	Member Label	Direction	Magnitude[lb,lb-ft]	Location[in,%]
1	MP1	X	9.65	0
2	MP1	Z	16.71	0
3	MP1	X	9.65	72
4	MP1	Z	16.71	72
5	MP1	X	4.04	12
6	MP1	Z	7	12
7	MP1	X	4	12
8	MP1	Z	6.93	12
9	S2	X	3.9	12
10	S2	Z	6.75	12
11	MP4	X	9.65	0
12	MP4	Z	16.71	0
13	MP4	X	9.65	72



Member Point Loads (BLC 24 : Ice Wind Load AZI 210) (Continued)

	Member Label	Direction	Magnitude[lb,lb-ft]	Location[in,%]
14	MP4	Z	16.71	72
15	MP4	X	4.04	12
16	MP4	Z	7	12
17	MP4	X	4	12
18	MP4	Z	6.93	12
19	MP7	X	6.99	0
20	MP7	Z	12.11	0
21	MP7	X	6.99	72
22	MP7	Z	12.11	72
23	MP7	X	3.36	12
24	MP7	Z	5.83	12
25	MP7	X	3.21	12
26	MP7	Z	5.55	12

Member Point Loads (BLC 25 : Ice Wind Load AZI 240)

	Member Label	Direction	Magnitude[lb,lb-ft]	Location[in,%]
1	MP1	X	13.64	0
2	MP1	Z	7.88	0
3	MP1	X	13.64	72
4	MP1	Z	7.88	72
5	MP1	X	6.22	12
6	MP1	Z	3.59	12
7	MP1	X	6.01	12
8	MP1	Z	3.47	12
9	S2	X	6.02	12
10	S2	Z	3.47	12
11	MP4	X	18.24	0
12	MP4	Z	10.53	0
13	MP4	X	18.24	72
14	MP4	Z	10.53	72
15	MP4	X	7.39	12
16	MP4	Z	4.27	12
17	MP4	X	7.39	12
18	MP4	Z	4.27	12
19	MP7	X	13.64	0
20	MP7	Z	7.88	0
21	MP7	X	13.64	72
22	MP7	Z	7.88	72
23	MP7	X	6.22	12
24	MP7	Z	3.59	12
25	MP7	X	6.01	12
26	MP7	Z	3.47	12



Member Point Loads (BLC 26 : Ice Wind Load AZI 270)

	Member Label	Direction	Magnitude[lb,lb-ft]	Location[in,%]
1	MP1	X	13.99	0
2	MP1	Z	0	0
3	MP1	X	13.99	72
4	MP1	Z	0	72
5	MP1	X	6.73	12
6	MP1	Z	0	12
7	MP1	X	6.41	12
8	MP1	Z	0	12
9	S2	X	6.53	12
10	S2	Z	0	12
11	MP4	X	19.29	0
12	MP4	Z	0	0
13	MP4	X	19.29	72
14	MP4	Z	0	72
15	MP4	X	8.08	12
16	MP4	Z	0	12
17	MP4	X	8.01	12
18	MP4	Z	0	12
19	MP7	X	19.29	0
20	MP7	Z	0	0
21	MP7	X	19.29	72
22	MP7	Z	0	72
23	MP7	X	8.08	12
24	MP7	Z	0	12
25	MP7	X	8.01	12
26	MP7	Z	0	12

Member Point Loads (BLC 27 : Ice Wind Load AZI 300)

	Member Label	Direction	Magnitude[lb,lb-ft]	Location[in,%]
1	MP1	X	13.64	0
2	MP1	Z	-7.88	0
3	MP1	X	13.64	72
4	MP1	Z	-7.88	72
5	MP1	X	6.22	12
6	MP1	Z	-3.59	12
7	MP1	X	6.01	12
8	MP1	Z	-3.47	12
9	S2	X	6.02	12
10	S2	Z	-3.47	12
11	MP4	X	13.64	0
12	MP4	Z	-7.88	0
13	MP4	X	13.64	72



Member Point Loads (BLC 27 : Ice Wind Load AZI 300) (Continued)

	Member Label	Direction	Magnitude[lb,lb-ft]	Location[in,%]
14	MP4	Z	-7.88	72
15	MP4	X	6.22	12
16	MP4	Z	-3.59	12
17	MP4	X	6.01	12
18	MP4	Z	-3.47	12
19	MP7	X	18.24	0
20	MP7	Z	-10.53	0
21	MP7	X	18.24	72
22	MP7	Z	-10.53	72
23	MP7	X	7.39	12
24	MP7	Z	-4.27	12
25	MP7	X	7.39	12
26	MP7	Z	-4.27	12

Member Point Loads (BLC 28 : Ice Wind Load AZI 330)

	Member Label	Direction	Magnitude[lb,lb-ft]	Location[in,%]
1	MP1	X	9.65	0
2	MP1	Z	-16.71	0
3	MP1	X	9.65	72
4	MP1	Z	-16.71	72
5	MP1	X	4.04	12
6	MP1	Z	-7	12
7	MP1	X	4	12
8	MP1	Z	-6.93	12
9	S2	X	3.9	12
10	S2	Z	-6.75	12
11	MP4	X	6.99	0
12	MP4	Z	-12.11	0
13	MP4	X	6.99	72
14	MP4	Z	-12.11	72
15	MP4	X	3.36	12
16	MP4	Z	-5.83	12
17	MP4	X	3.21	12
18	MP4	Z	-5.55	12
19	MP7	X	9.65	0
20	MP7	Z	-16.71	0
21	MP7	X	9.65	72
22	MP7	Z	-16.71	72
23	MP7	X	4.04	12
24	MP7	Z	-7	12
25	MP7	X	4	12
26	MP7	Z	-6.93	12

Member Point Loads (BLC 31 : Seismic Load Z)

	Member Label	Direction	Magnitude[lb,lb-ft]	Location[in,%]
1	MP1	Z	-9.443	0
2	MP1	Z	-9.443	72
3	MP1	Z	-21.945	12
4	MP1	Z	-18.719	12
5	S2	Z	-6.398	12
6	MP4	Z	-9.443	0
7	MP4	Z	-9.443	72
8	MP4	Z	-21.945	12
9	MP4	Z	-18.719	12
10	MP7	Z	-9.443	0
11	MP7	Z	-9.443	72
12	MP7	Z	-21.945	12
13	MP7	Z	-18.719	12

Member Point Loads (BLC 32 : Seismic Load X)

	Member Label	Direction	Magnitude[lb,lb-ft]	Location[in,%]
1	MP1	X	-9.443	0
2	MP1	X	-9.443	72
3	MP1	X	-21.945	12
4	MP1	X	-18.719	12
5	S2	X	-6.398	12
6	MP4	X	-9.443	0
7	MP4	X	-9.443	72
8	MP4	X	-21.945	12
9	MP4	X	-18.719	12
10	MP7	X	-9.443	0
11	MP7	X	-9.443	72
12	MP7	X	-21.945	12
13	MP7	X	-18.719	12

Joint Loads and Enforced Displacements (BLC 33 : Service Live Loads)

	Joint Label	L,D,M	Direction	Magnitude[(lb,lb-ft), (in,rad), (lb*s^2/in, lb*s^2*in)]
1	N72B	L	Y	-250
2	N135A	L	Y	-250
3	N129B	L	Y	-250

Joint Loads and Enforced Displacements (BLC 34 : Maintenance Load 1)

	Joint Label	L,D,M	Direction	Magnitude[(lb,lb-ft), (in,rad), (lb*s^2/in, lb*s^2*in)]
1	N70A	L	Y	-500



Joint Loads and Enforced Displacements (BLC 35 : Maintenance Load 2)

	Joint Label	L,D,M	Direction	Magnitude[(lb,lb-ft), (in,rad), (lb*s^2/in, lb*s^2*in)]
1	N69A	L	Y	-500

Joint Loads and Enforced Displacements (BLC 36 : Maintenance Load 3)

	Joint Label	L,D,M	Direction	Magnitude[(lb,lb-ft), (in,rad), (lb*s^2/in, lb*s^2*in)]
1	N76	L	Y	-500

Joint Loads and Enforced Displacements (BLC 37 : Maintenance Load 4)

	Joint Label	L,D,M	Direction	Magnitude[(lb,lb-ft), (in,rad), (lb*s^2/in, lb*s^2*in)]
1	N94	L	Y	-500

Joint Loads and Enforced Displacements (BLC 38 : Maintenance Load 5)

	Joint Label	L,D,M	Direction	Magnitude[(lb,lb-ft), (in,rad), (lb*s^2/in, lb*s^2*in)]
1	N93	L	Y	-500

Joint Loads and Enforced Displacements (BLC 39 : Maintenance Load 6)

	Joint Label	L,D,M	Direction	Magnitude[(lb,lb-ft), (in,rad), (lb*s^2/in, lb*s^2*in)]
1	N122	L	Y	-500

Joint Loads and Enforced Displacements (BLC 40 : Maintenance Load 7)

	Joint Label	L,D,M	Direction	Magnitude[(lb,lb-ft), (in,rad), (lb*s^2/in, lb*s^2*in)]
1	N121	L	Y	-500

Joint Loads and Enforced Displacements (BLC 41 : Maintenance Load 8)

	Joint Label	L,D,M	Direction	Magnitude[(lb,lb-ft), (in,rad), (lb*s^2/in, lb*s^2*in)]
1	N133B	L	Y	-500

Joint Loads and Enforced Displacements (BLC 42 : Maintenance Load 9)

	Joint Label	L,D,M	Direction	Magnitude[(lb,lb-ft), (in,rad), (lb*s^2/in, lb*s^2*in)]
1	N139	L	Y	-500

Member Distributed Loads (BLC 14 : Distr. Wind Load Z)

	Member Label	Direction	Start Magnitude[lb/ft,...	End Magn...	Start Location..	End Location[in,%]
1	S3	SZ	-81.383	-81.383	0	%100
2	GA4	SZ	-81.383	-81.383	0	%100
3	GA3	SZ	-81.383	-81.383	0	%100
4	P3	SZ	-81.383	-81.383	0	%100
5	S2	SZ	-81.383	-81.383	0	%100
6	GA2	SZ	-81.383	-81.383	0	%100



Member Distributed Loads (BLC 14 : Distr. Wind Load Z) (Continued)

	Member Label	Direction	Start Magnitude[lb/ft,...	End Magn...	Start Location...	End Location[in,%]
7	GA1	SZ	-81.383	-81.383	0	%100
8	P2	SZ	-81.383	-81.383	0	%100
9	S1	SZ	-81.383	-81.383	0	%100
10	GA6	SZ	-81.383	-81.383	0	%100
11	GA5	SZ	-81.383	-81.383	0	%100
12	P1	SZ	-81.383	-81.383	0	%100
13	H1	SZ	-48.83	-48.83	0	%100
14	MP1	SZ	-48.83	-48.83	0	%100
15	MP3	SZ	-48.83	-48.83	0	%100
16	HR1	SZ	-48.83	-48.83	0	%100
17	CA8	SZ	-81.383	-81.383	0	%100
18	CA9	SZ	-81.383	-81.383	0	%100
19	CA7	SZ	-81.383	-81.383	0	%100
20	M32	SZ	0	0	0	%100
21	M35	SZ	0	0	0	%100
22	M36	SZ	0	0	0	%100
23	M39A	SZ	0	0	0	%100
24	CA3	SZ	-81.383	-81.383	0	%100
25	CA4	SZ	-81.383	-81.383	0	%100
26	CA1	SZ	-81.383	-81.383	0	%100
27	CA2	SZ	-81.383	-81.383	0	%100
28	CA5	SZ	-81.383	-81.383	0	%100
29	CA6	SZ	-81.383	-81.383	0	%100
30	M64	SZ	0	0	0	%100
31	M65	SZ	0	0	0	%100
32	M66	SZ	0	0	0	%100
33	M67	SZ	0	0	0	%100
34	M68	SZ	0	0	0	%100
35	M69	SZ	0	0	0	%100
36	M70	SZ	0	0	0	%100
37	M71	SZ	0	0	0	%100
38	M72	SZ	0	0	0	%100
39	M73	SZ	0	0	0	%100
40	M74	SZ	0	0	0	%100
41	M75	SZ	-81.383	-81.383	0	%100
42	MP2	SZ	-48.83	-48.83	0	%100
43	M43	SZ	0	0	0	%100
44	M44	SZ	0	0	0	%100
45	H3	SZ	-48.83	-48.83	0	%100
46	MP7	SZ	-48.83	-48.83	0	%100
47	MP9	SZ	-48.83	-48.83	0	%100
48	HR3	SZ	-48.83	-48.83	0	%100



Member Distributed Loads (BLC 14 : Distr. Wind Load Z) (Continued)

	Member Label	Direction	Start Magnitude[lb/ft,...	End Magn...	Start Location...	End Location[in, %]
49	M52	SZ	0	0	0	%100
50	M53	SZ	0	0	0	%100
51	M54	SZ	0	0	0	%100
52	M55	SZ	0	0	0	%100
53	H2	SZ	-48.83	-48.83	0	%100
54	MP4	SZ	-48.83	-48.83	0	%100
55	MP6	SZ	-48.83	-48.83	0	%100
56	HR2	SZ	-48.83	-48.83	0	%100
57	M66A	SZ	0	0	0	%100
58	M67A	SZ	0	0	0	%100
59	M68A	SZ	0	0	0	%100
60	M69A	SZ	0	0	0	%100
61	MP8	SZ	-48.83	-48.83	0	%100
62	M68B	SZ	0	0	0	%100
63	M69B	SZ	0	0	0	%100
64	MP5	SZ	-48.83	-48.83	0	%100
65	M71B	SZ	0	0	0	%100
66	M72B	SZ	0	0	0	%100

Member Distributed Loads (BLC 15 : Distr. Wind Load X)

	Member Label	Direction	Start Magnitude[lb/ft,...	End Magn...	Start Location...	End Location[in, %]
1	S3	SX	-81.383	-81.383	0	%100
2	GA4	SX	-81.383	-81.383	0	%100
3	GA3	SX	-81.383	-81.383	0	%100
4	P3	SX	-81.383	-81.383	0	%100
5	S2	SX	-81.383	-81.383	0	%100
6	GA2	SX	-81.383	-81.383	0	%100
7	GA1	SX	-81.383	-81.383	0	%100
8	P2	SX	-81.383	-81.383	0	%100
9	S1	SX	-81.383	-81.383	0	%100
10	GA6	SX	-81.383	-81.383	0	%100
11	GA5	SX	-81.383	-81.383	0	%100
12	P1	SX	-81.383	-81.383	0	%100
13	H1	SX	-48.83	-48.83	0	%100
14	MP1	SX	-48.83	-48.83	0	%100
15	MP3	SX	-48.83	-48.83	0	%100
16	HR1	SX	-48.83	-48.83	0	%100
17	CA8	SX	-81.383	-81.383	0	%100
18	CA9	SX	-81.383	-81.383	0	%100
19	CA7	SX	-81.383	-81.383	0	%100
20	M32	SX	0	0	0	%100
21	M35	SX	0	0	0	%100



Member Distributed Loads (BLC 15 : Distr. Wind Load X) (Continued)

	Member Label	Direction	Start Magnitude[lb/ft,...	End Magn...	Start Location...	End Location[in,%]
22	M36	SX	0	0	0	%100
23	M39A	SX	0	0	0	%100
24	CA3	SX	-81.383	-81.383	0	%100
25	CA4	SX	-81.383	-81.383	0	%100
26	CA1	SX	-81.383	-81.383	0	%100
27	CA2	SX	-81.383	-81.383	0	%100
28	CA5	SX	-81.383	-81.383	0	%100
29	CA6	SX	-81.383	-81.383	0	%100
30	M64	SX	0	0	0	%100
31	M65	SX	0	0	0	%100
32	M66	SX	0	0	0	%100
33	M67	SX	0	0	0	%100
34	M68	SX	0	0	0	%100
35	M69	SX	0	0	0	%100
36	M70	SX	0	0	0	%100
37	M71	SX	0	0	0	%100
38	M72	SX	0	0	0	%100
39	M73	SX	0	0	0	%100
40	M74	SX	0	0	0	%100
41	M75	SX	-81.383	-81.383	0	%100
42	MP2	SX	-48.83	-48.83	0	%100
43	M43	SX	0	0	0	%100
44	M44	SX	0	0	0	%100
45	H3	SX	-48.83	-48.83	0	%100
46	MP7	SX	-48.83	-48.83	0	%100
47	MP9	SX	-48.83	-48.83	0	%100
48	HR3	SX	-48.83	-48.83	0	%100
49	M52	SX	0	0	0	%100
50	M53	SX	0	0	0	%100
51	M54	SX	0	0	0	%100
52	M55	SX	0	0	0	%100
53	H2	SX	-48.83	-48.83	0	%100
54	MP4	SX	-48.83	-48.83	0	%100
55	MP6	SX	-48.83	-48.83	0	%100
56	HR2	SX	-48.83	-48.83	0	%100
57	M66A	SX	0	0	0	%100
58	M67A	SX	0	0	0	%100
59	M68A	SX	0	0	0	%100
60	M69A	SX	0	0	0	%100
61	MP8	SX	-48.83	-48.83	0	%100
62	M68B	SX	0	0	0	%100
63	M69B	SX	0	0	0	%100



Member Distributed Loads (BLC 15 : Distr. Wind Load X) (Continued)

	Member Label	Direction	Start Magnitude[lb/ft,...	End Magn...	Start Location...	End Location[in,%]
64	MP5	SX	-48.83	-48.83	0	%100
65	M71B	SX	0	0	0	%100
66	M72B	SX	0	0	0	%100

Member Distributed Loads (BLC 16 : Ice Weight)

	Member Label	Direction	Start Magnitude[lb/ft,...	End Magn...	Start Location...	End Location[in,%]
1	S3	Y	-20.582	-20.582	0	%100
2	GA4	Y	-13.131	-13.131	0	%100
3	GA3	Y	-13.131	-13.131	0	%100
4	P3	Y	-22.831	-22.831	0	%100
5	S2	Y	-20.582	-20.582	0	%100
6	GA2	Y	-13.131	-13.131	0	%100
7	GA1	Y	-13.131	-13.131	0	%100
8	P2	Y	-22.831	-22.831	0	%100
9	S1	Y	-20.582	-20.582	0	%100
10	GA6	Y	-13.131	-13.131	0	%100
11	GA5	Y	-13.131	-13.131	0	%100
12	P1	Y	-22.831	-22.831	0	%100
13	H1	Y	-14.9	-14.9	0	%100
14	MP1	Y	-13.254	-13.254	0	%100
15	MP3	Y	-13.254	-13.254	0	%100
16	HR1	Y	-13.267	-13.267	0	%100
17	CA8	Y	-26.664	-26.664	0	%100
18	CA9	Y	-26.664	-26.664	0	%100
19	CA7	Y	-26.664	-26.664	0	%100
20	M32	Y	-5.68	-5.68	0	%100
21	M35	Y	-5.68	-5.68	0	%100
22	M36	Y	-5.68	-5.68	0	%100
23	M39A	Y	-5.68	-5.68	0	%100
24	CA3	Y	-16.107	-16.107	0	%100
25	CA4	Y	-16.107	-16.107	0	%100
26	CA1	Y	-16.107	-16.107	0	%100
27	CA2	Y	-16.107	-16.107	0	%100
28	CA5	Y	-16.107	-16.107	0	%100
29	CA6	Y	-16.107	-16.107	0	%100
30	M64	Y	-5.68	-5.68	0	%100
31	M65	Y	-5.68	-5.68	0	%100
32	M66	Y	-5.68	-5.68	0	%100
33	M67	Y	-5.68	-5.68	0	%100
34	M68	Y	-5.68	-5.68	0	%100
35	M69	Y	-5.68	-5.68	0	%100
36	M70	Y	-5.68	-5.68	0	%100



Member Distributed Loads (BLC 16 : Ice Weight) (Continued)

	Member Label	Direction	Start Magnitude[lb/ft,...	End Magn...	Start Location...	End Location[in,%]
37	M71	Y	-5.68	-5.68	0	%100
38	M72	Y	-5.68	-5.68	0	%100
39	M73	Y	-5.68	-5.68	0	%100
40	M74	Y	-5.68	-5.68	0	%100
41	M75	Y	-12.074	-12.074	0	%100
42	MP2	Y	-13.254	-13.254	0	%100
43	M43	Y	-5.68	-5.68	0	%100
44	M44	Y	-5.68	-5.68	0	%100
45	H3	Y	-14.9	-14.9	0	%100
46	MP7	Y	-13.254	-13.254	0	%100
47	MP9	Y	-13.254	-13.254	0	%100
48	HR3	Y	-13.267	-13.267	0	%100
49	M52	Y	-5.68	-5.68	0	%100
50	M53	Y	-5.68	-5.68	0	%100
51	M54	Y	-5.68	-5.68	0	%100
52	M55	Y	-5.68	-5.68	0	%100
53	H2	Y	-14.9	-14.9	0	%100
54	MP4	Y	-13.254	-13.254	0	%100
55	MP6	Y	-13.254	-13.254	0	%100
56	HR2	Y	-13.267	-13.267	0	%100
57	M66A	Y	-5.68	-5.68	0	%100
58	M67A	Y	-5.68	-5.68	0	%100
59	M68A	Y	-5.68	-5.68	0	%100
60	M69A	Y	-5.68	-5.68	0	%100
61	MP8	Y	-13.254	-13.254	0	%100
62	M68B	Y	-5.68	-5.68	0	%100
63	M69B	Y	-5.68	-5.68	0	%100
64	MP5	Y	-13.254	-13.254	0	%100
65	M71B	Y	-5.68	-5.68	0	%100
66	M72B	Y	-5.68	-5.68	0	%100

Member Distributed Loads (BLC 29 : Distr. Ice Wind Load Z)

	Member Label	Direction	Start Magnitude[lb/ft,...	End Magn...	Start Location...	End Location[in,%]
1	S3	SZ	-14.94	-14.94	0	%100
2	GA4	SZ	-21.403	-21.403	0	%100
3	GA3	SZ	-21.403	-21.403	0	%100
4	P3	SZ	-14.092	-14.092	0	%100
5	S2	SZ	-14.94	-14.94	0	%100
6	GA2	SZ	-21.403	-21.403	0	%100
7	GA1	SZ	-21.403	-21.403	0	%100
8	P2	SZ	-14.092	-14.092	0	%100
9	S1	SZ	-14.94	-14.94	0	%100

Member Distributed Loads (BLC 29 : Distr. Ice Wind Load Z) (Continued)

Member Label	Direction	Start Magnitude[lb/ft,...	End Magn...	Start Location...	End Location[in,%]
10	GA6	SZ	-21.403	-21.403	0 %100
11	GA5	SZ	-21.403	-21.403	0 %100
12	P1	SZ	-14.092	-14.092	0 %100
13	H1	SZ	-18.923	-18.923	0 %100
14	MP1	SZ	-21.193	-21.193	0 %100
15	MP3	SZ	-21.193	-21.193	0 %100
16	HR1	SZ	-21.171	-21.171	0 %100
17	CA8	SZ	-13.067	-13.067	0 %100
18	CA9	SZ	-13.067	-13.067	0 %100
19	CA7	SZ	-13.067	-13.067	0 %100
20	M32	SZ	0	0	0 %100
21	M35	SZ	0	0	0 %100
22	M36	SZ	0	0	0 %100
23	M39A	SZ	0	0	0 %100
24	CA3	SZ	-17.713	-17.713	0 %100
25	CA4	SZ	-17.713	-17.713	0 %100
26	CA1	SZ	-17.713	-17.713	0 %100
27	CA2	SZ	-17.713	-17.713	0 %100
28	CA5	SZ	-17.713	-17.713	0 %100
29	CA6	SZ	-17.713	-17.713	0 %100
30	M64	SZ	0	0	0 %100
31	M65	SZ	0	0	0 %100
32	M66	SZ	0	0	0 %100
33	M67	SZ	0	0	0 %100
34	M68	SZ	0	0	0 %100
35	M69	SZ	0	0	0 %100
36	M70	SZ	0	0	0 %100
37	M71	SZ	0	0	0 %100
38	M72	SZ	0	0	0 %100
39	M73	SZ	0	0	0 %100
40	M74	SZ	0	0	0 %100
41	M75	SZ	-23.54	-23.54	0 %100
42	MP2	SZ	-21.193	-21.193	0 %100
43	M43	SZ	0	0	0 %100
44	M44	SZ	0	0	0 %100
45	H3	SZ	-18.923	-18.923	0 %100
46	MP7	SZ	-21.193	-21.193	0 %100
47	MP9	SZ	-21.193	-21.193	0 %100
48	HR3	SZ	-21.171	-21.171	0 %100
49	M52	SZ	0	0	0 %100
50	M53	SZ	0	0	0 %100
51	M54	SZ	0	0	0 %100



Member Distributed Loads (BLC 29 : Distr. Ice Wind Load Z) (Continued)

	Member Label	Direction	Start Magnitude[lb/ft,...	End Magn...	Start Location...	End Location[in,%]
52	M55	SZ	0	0	0	%100
53	H2	SZ	-18.923	-18.923	0	%100
54	MP4	SZ	-21.193	-21.193	0	%100
55	MP6	SZ	-21.193	-21.193	0	%100
56	HR2	SZ	-21.171	-21.171	0	%100
57	M66A	SZ	0	0	0	%100
58	M67A	SZ	0	0	0	%100
59	M68A	SZ	0	0	0	%100
60	M69A	SZ	0	0	0	%100
61	MP8	SZ	-21.193	-21.193	0	%100
62	M68B	SZ	0	0	0	%100
63	M69B	SZ	0	0	0	%100
64	MP5	SZ	-21.193	-21.193	0	%100
65	M71B	SZ	0	0	0	%100
66	M72B	SZ	0	0	0	%100

Member Distributed Loads (BLC 30 : Distr. Ice Wind Load X)

	Member Label	Direction	Start Magnitude[lb/ft,...	End Magn...	Start Location...	End Location[in,%]
1	S3	SX	-14.94	-14.94	0	%100
2	GA4	SX	-21.403	-21.403	0	%100
3	GA3	SX	-21.403	-21.403	0	%100
4	P3	SX	-14.092	-14.092	0	%100
5	S2	SX	-14.94	-14.94	0	%100
6	GA2	SX	-21.403	-21.403	0	%100
7	GA1	SX	-21.403	-21.403	0	%100
8	P2	SX	-14.092	-14.092	0	%100
9	S1	SX	-14.94	-14.94	0	%100
10	GA6	SX	-21.403	-21.403	0	%100
11	GA5	SX	-21.403	-21.403	0	%100
12	P1	SX	-14.092	-14.092	0	%100
13	H1	SX	-18.923	-18.923	0	%100
14	MP1	SX	-21.193	-21.193	0	%100
15	MP3	SX	-21.193	-21.193	0	%100
16	HR1	SX	-21.171	-21.171	0	%100
17	CA8	SX	-13.067	-13.067	0	%100
18	CA9	SX	-13.067	-13.067	0	%100
19	CA7	SX	-13.067	-13.067	0	%100
20	M32	SX	0	0	0	%100
21	M35	SX	0	0	0	%100
22	M36	SX	0	0	0	%100
23	M39A	SX	0	0	0	%100
24	CA3	SX	-17.713	-17.713	0	%100



Member Distributed Loads (BLC 30 : Distr. Ice Wind Load X) (Continued)

	Member Label	Direction	Start Magnitude[lb/ft,...	End Magn...	Start Location...	End Location[in, %]
25	CA4	SX	-17.713	-17.713	0	%100
26	CA1	SX	-17.713	-17.713	0	%100
27	CA2	SX	-17.713	-17.713	0	%100
28	CA5	SX	-17.713	-17.713	0	%100
29	CA6	SX	-17.713	-17.713	0	%100
30	M64	SX	0	0	0	%100
31	M65	SX	0	0	0	%100
32	M66	SX	0	0	0	%100
33	M67	SX	0	0	0	%100
34	M68	SX	0	0	0	%100
35	M69	SX	0	0	0	%100
36	M70	SX	0	0	0	%100
37	M71	SX	0	0	0	%100
38	M72	SX	0	0	0	%100
39	M73	SX	0	0	0	%100
40	M74	SX	0	0	0	%100
41	M75	SX	-23.54	-23.54	0	%100
42	MP2	SX	-21.193	-21.193	0	%100
43	M43	SX	0	0	0	%100
44	M44	SX	0	0	0	%100
45	H3	SX	-18.923	-18.923	0	%100
46	MP7	SX	-21.193	-21.193	0	%100
47	MP9	SX	-21.193	-21.193	0	%100
48	HR3	SX	-21.171	-21.171	0	%100
49	M52	SX	0	0	0	%100
50	M53	SX	0	0	0	%100
51	M54	SX	0	0	0	%100
52	M55	SX	0	0	0	%100
53	H2	SX	-18.923	-18.923	0	%100
54	MP4	SX	-21.193	-21.193	0	%100
55	MP6	SX	-21.193	-21.193	0	%100
56	HR2	SX	-21.171	-21.171	0	%100
57	M66A	SX	0	0	0	%100
58	M67A	SX	0	0	0	%100
59	M68A	SX	0	0	0	%100
60	M69A	SX	0	0	0	%100
61	MP8	SX	-21.193	-21.193	0	%100
62	M68B	SX	0	0	0	%100
63	M69B	SX	0	0	0	%100
64	MP5	SX	-21.193	-21.193	0	%100
65	M71B	SX	0	0	0	%100
66	M72B	SX	0	0	0	%100

Member Distributed Loads (BLC 43 : BLC 1 Transient Area Loads)

	Member Label	Direction	Start Magnitude[lb/ft,...	End Magn...	Start Location...	End Location[in, %]
1	S2	Y	-3.185	-3.185	16.404	40
2	GA2	Y	-1.605	-1.605	3.828	27.295
3	GA1	Y	-1.605	-1.605	3.828	27.295
4	S3	Y	-3.185	-3.185	16.404	40
5	GA4	Y	-1.605	-1.605	3.828	27.295
6	GA3	Y	-1.605	-1.605	3.828	27.295
7	S1	Y	-3.185	-3.185	16.404	40
8	GA6	Y	-1.605	-1.605	3.828	27.295
9	GA5	Y	-1.605	-1.605	3.828	27.295

Member Distributed Loads (BLC 44 : BLC 16 Transient Area Loads)

	Member Label	Direction	Start Magnitude[lb/ft,...	End Magn...	Start Location...	End Location[in, %]
1	S2	Y	-36.585	-36.585	16.404	40
2	GA2	Y	-18.437	-18.437	3.828	27.295
3	GA1	Y	-18.437	-18.437	3.828	27.295
4	S3	Y	-36.585	-36.585	16.404	40
5	GA4	Y	-18.437	-18.437	3.828	27.295
6	GA3	Y	-18.437	-18.437	3.828	27.295
7	S1	Y	-36.585	-36.585	16.404	40
8	GA6	Y	-18.437	-18.437	3.828	27.295
9	GA5	Y	-18.437	-18.437	3.828	27.295

Member Area Loads (BLC 1 : Self Weight)

	Joint A	Joint B	Joint C	Joint D	Direction	Distribution	Magnitude[psf]
1	P22	P21	P20	P23	Y	Two Way	-1.75
2	P10	P11	P12	P9	Y	Two Way	-1.75
3	P31	P34	P33	P32	Y	Two Way	-1.75

Member Area Loads (BLC 16 : Ice Weight)

	Joint A	Joint B	Joint C	Joint D	Direction	Distribution	Magnitude[psf]
1	P22	P21	P20	P23	Y	Two Way	-20.1
2	P10	P11	P12	P9	Y	Two Way	-20.1
3	P31	P34	P33	P32	Y	Two Way	-20.1

Envelope AISC 15th(360-16): LRFD Steel Code Checks

	Member	Shape	Code Check	Loc[in]	LC	She...Loc[in]	Dir	LC	phi*P...	phi*P...	phi*M...	phi*Mn z-z [lb...Cb	Eqn
1	CA1	C3.38x2.06...	.327	0	31	.055 28.188	y	36	4776...	56700	2202...	5751.945	1.... H1-1b
2	S2	HSS4X4X6	.323	0	32	.114 0	y	32	1882...	1978...	2204...	22045.5	1.... H1-1b
3	P3	PL6.5x0.375	.300	21	2	.165 36.312	y	30	3658...	78975	616.9...	7968.007	1.... H1-1b

Envelope AISC 15th(360-16): LRFD Steel Code Checks (Continued)

Member	Shape	Code Check	Loc[in]	LC	She...	Loc[in]	Dir	LC	phi*P...	phi*P...	phi*M...	phi*Mn z-z	lb...	Cb	Eqn
4	CA3	C3.38x2.06...	.299	0	27	.055	28.188	y	32	4776...	56700	2202...	5751.945	1....	H1-1b
5	CA5	C3.38x2.06...	.298	0	35	.053	28.187	y	28	4776...	56700	2202...	5751.945	1....	H1-1b
6	P2	PL6.5x0.375	.294	21	6	.128	36.312	y	10	3658...	78975	616.9...	7951.017	1....	H1-1b
7	S3	HSS4X4X6	.293	0	38	.114	0	y	29	1882...	1978...	2204...	22045.5	1....	H1-1b
8	CA4	C3.38x2.06...	.276	33	2	.045	33	y	31	4776...	56700	2202...	5751.945	1....	H1-1b
9	P1	PL6.5x0.375	.275	21	10	.138	36.312	y	2	3658...	78975	616.9...	7970.495	1....	H1-1b
10	CA2	C3.38x2.06...	.264	33	31	.046	33	y	34	4776...	56700	2202...	5751.945	1....	H1-1b
11	CA6	C3.38x2.06...	.264	33	30	.045	33	y	38	4776...	56700	2202...	5751.945	1....	H1-1b
12	S1	HSS4X4X6	.260	0	36	.108	0	y	86	1882...	1978...	2204...	22045.5	1....	H1-1b
13	CA8	L6.6x4.46x0...	.249	41.562	22	.035	42	z	4	5117...	87561	2464...	7125.374	1....	H2-1
14	M75	PL 2.375x0.5	.246	1.5	12	.261	0	y	28	3825...	38475	400.7...	1903.711	2....	H1-1b
15	HR2	2.88x0.120	.241	90	3	.120	92		4	2249...	4307...	3155...	3155.674	1....	H1-1b
16	CA7	L6.6x4.46x0...	.241	41.562	3	.033	42	z	8	5117...	87561	2464...	7125.374	1....	H2-1
17	HR3	2.88x0.120	.238	6	2	.112	92		6	2249...	4307...	3155...	3155.674	1....	H1-1b
18	HR1	2.88x0.120	.231	6	4	.105	6		4	2249...	4307...	3155...	3155.674	1.92	H1-1b
19	CA9	L6.6x4.46x0...	.221	41.562	6	.031	42	z	12	5117...	87561	2464...	7125.374	1....	H2-1
20	MP2	PIPE 2.5	.201	70	5	.072	70		5	3348...	66654	4726.5	4726.5	4....	H1-1b
21	MP5	PIPE 2.5	.196	70	7	.061	70		7	3348...	66654	4726.5	4726.5	4....	H1-1b
22	GA4	L2x2x4	.186	0	2	.013	27.295	y	9	2952...	42480	959.63	2190.068	2....	H2-1
23	MP8	PIPE 2.5	.176	70	9	.076	70		3	3348...	66654	4726.5	4726.5	4....	H1-1b
24	GA5	L2x2x4	.176	0	9	.024	27.295	y	38	2952...	42480	959.63	2190.068	2....	H2-1
25	GA2	L2x2x4	.170	0	12	.014	0	y	12	2952...	42480	959.63	2190.068	2....	H2-1
26	GA1	L2x2x4	.159	0	6	.025	27.295	y	34	2952...	42480	959.63	2190.068	2.29	H2-1
27	GA3	L2x2x4	.158	0	7	.026	27.295	y	30	2952...	42480	959.63	2190.068	2....	H2-1
28	GA6	L2x2x4	.158	0	4	.013	0	y	4	2952...	42480	959.63	2190.068	2....	H2-1
29	MP9	PIPE 2.5	.157	70	2	.071	70		7	3348...	66654	4726.5	4726.5	3....	H1-1b
30	MP6	PIPE 2.5	.143	70	7	.077	70		6	3348...	66654	4726.5	4726.5	4....	H1-1b
31	MP1	PIPE 2.5	.140	70	11	.086	26		8	3348...	66654	4726.5	4726.5	2....	H1-1b
32	MP3	PIPE 2.5	.138	70	5	.078	70		3	3348...	66654	4726.5	4726.5	4....	H1-1b
33	MP4	PIPE 2.5	.135	70	7	.078	26		4	3348...	66654	4726.5	4726.5	1....	H1-1b
34	MP7	PIPE 2.5	.132	70	9	.070	26		6	3348...	66654	4726.5	4726.5	3....	H1-1b
35	H3	Pipe3.5x0.1...	.121	31	2	.075	90		2	4587...	7158...	6337...	6337.65	1....	H1-1b
36	H1	Pipe3.5x0.1...	.116	31	10	.067	48		4	4587...	7158...	6337...	6337.65	2.06	H1-1b
37	H2	Pipe3.5x0.1...	.115	31	6	.055	90		34	4587...	7158...	6337...	6337.65	1.76	H1-1b

Bolt Calculation Tool, V1.5.1

PROJECT DATA	
Site Name:	BOBDL00109A
Site Number:	BOBDL00109A
Connection Description:	Platform to Monopole

MAXIMUM BOLT LOADS		
Bolt Tension:	8568.96	lbs
Bolt Shear:	1634.12	lbs

WORST CASE BOLT LOADS ¹		
Bolt Tension:	8568.96	lbs
Bolt Shear:	1510.97	lbs

BOLT PROPERTIES		
Bolt Type:	Bolt	-
Bolt Diameter:	0.625	in
Bolt Grade:	A325	-
# of Bolts:	4	-
Threads Excluded?	No	-

¹ Worst case bolt loads correspond to Load combination #32 on member S2 in RISA-3D, which causes the maximum demand on the bolts.

Member Information
I nodes of S3, S2, S1

BOLT CHECK		
Tensile Strength	20340.15	
Shear Strength	13805.83	
Max Tensile Usage	42.1%	
Max Shear Usage	11.8%	
Interaction Check (Worst Case)	0.19	≤1.05
Result	Pass	

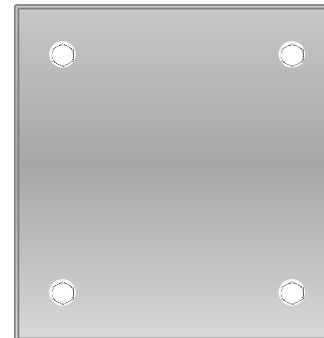

POWER DENSITY STUDY

**RADIO FREQUENCY EMISSIONS ANALYSIS REPORT
EVALUATION OF HUMAN EXPOSURE POTENTIAL
TO NON-IONIZING EMISSIONS**

Dish Wireless Existing Facility

Site ID: BOBDL00109A

**87 Monce Road
Burlington, Connecticut 06013**

August 16, 2021

EBI Project Number: 6221004019

Site Compliance Summary	
Compliance Status:	COMPLIANT
Site total MPE% of FCC general population allowable limit:	26.24%

August 16, 2021

Dish Wireless

Emissions Analysis for Site: BOBDL00109A -

EBI Consulting was directed to analyze the proposed Dish Wireless facility located at **87 Monce Road in Burlington, Connecticut** for the purpose of determining whether the emissions from the Proposed Dish Wireless Antenna Installation located on this property are within specified federal limits.

All information used in this report was analyzed as a percentage of current Maximum Permissible Exposure (% MPE) as listed in the FCC OET Bulletin 65 Edition 97-01 and ANSI/IEEE Std C95.1. The FCC regulates Maximum Permissible Exposure in units of microwatts per square centimeter ($\mu\text{W}/\text{cm}^2$). The number of $\mu\text{W}/\text{cm}^2$ calculated at each sample point is called the power density. The exposure limit for power density varies depending upon the frequencies being utilized. Wireless Carriers and Paging Services use different frequency bands each with different exposure limits; therefore, it is necessary to report results and limits in terms of percent MPE rather than power density.

All results were compared to the FCC (Federal Communications Commission) radio frequency exposure rules, 47 CFR 1.1307(b)(1) – (b)(3), to determine compliance with the Maximum Permissible Exposure (MPE) limits for General Population/Uncontrolled environments as defined below.

General population/uncontrolled exposure limits apply to situations in which the general population may be exposed or in which persons who are exposed as a consequence of their employment may not be made fully aware of the potential for exposure or cannot exercise control over their exposure. Therefore, members of the general population would always be considered under this category when exposure is not employment related, for example, in the case of a telecommunications tower that exposes persons in a nearby residential area.

Public exposure to radio frequencies is regulated and enforced in units of microwatts per square centimeter ($\mu\text{W}/\text{cm}^2$). The general population exposure limits for the 600 MHz and 700 MHz frequency bands are approximately $400 \mu\text{W}/\text{cm}^2$ and $467 \mu\text{W}/\text{cm}^2$, respectively. The general population exposure limit for the 1900 MHz (PCS), 2100 MHz (AWS) and 11 GHz frequency bands is $1000 \mu\text{W}/\text{cm}^2$. Because each carrier will be using different frequency bands, and each frequency band has different exposure limits, it is necessary to report percent of MPE rather than power density.

Occupational/controlled exposure limits apply to situations in which persons are exposed as a consequence of their employment and in which those persons who are exposed have been made fully aware of the potential for exposure and can exercise control over their exposure.

Occupational/controlled exposure limits also apply where exposure is of a transient nature as a result of incidental passage through a location where exposure levels may be above general population/uncontrolled limits (see below), as long as the exposed person has been made fully aware of the potential for exposure and can exercise control over his or her exposure by leaving the area or by some other appropriate means.

Additional details can be found in FCC OET 65.

CALCULATIONS

Calculations were done for the proposed Dish Wireless Wireless antenna facility located at 87 Monce Road in Burlington, Connecticut using the equipment information listed below. All calculations were performed per the specifications under FCC OET 65. Since Dish Wireless is proposing highly focused directional panel antennas, which project most of the emitted energy out toward the horizon, all calculations were performed assuming a lobe representing the maximum gain of the antenna per the antenna manufacturer's supplied specifications, minus 20 dB for directional panel antennas and 20 dB for highly focused parabolic microwave dishes, was focused at the base of the tower. For this report, the sample point is the top of a 6-foot person standing at the base of the tower.

For all calculations, all equipment was calculated using the following assumptions:

- 1) 4 n71 channels (600 MHz Band) were considered for each sector of the proposed installation. These Channels have a transmit power of 30 Watts per Channel.
- 2) 4 n70 channels (PCS Band - 1900 MHz) were considered for each sector of the proposed installation. These Channels have a transmit power of 40 Watts per Channel.
- 3) 4 n66 channels (AWS Band - 2190 MHz) were considered for each sector of the proposed installation. These Channels have a transmit power of 40 Watts per Channel.
- 4) All radios at the proposed installation were considered to be running at full power and were uncombined in their RF transmissions paths per carrier prescribed configuration. Per FCC OET Bulletin No. 65 - Edition 97-01 recommendations to achieve the maximum anticipated value at each sample point, all power levels emitting from the proposed antenna installation are increased by a factor of 2.56 to account for possible in-phase reflections from the surrounding environment. This is rarely the case, and if so, is never continuous.
- 5) For the following calculations, the sample point was the top of a 6-foot person standing at the base of the tower. The maximum gain of the antenna per the antenna manufacturer's supplied specifications, minus 20 dB for directional panel antennas and 20 dB for highly focused parabolic microwave dishes, was used in this direction. This value is a very conservative

estimate as gain reductions for these particular antennas are typically much higher in this direction.

- 6) The antennas used in this modeling are the JMA MX08FRO665-21 for the 600 MHz / 1900 MHz / 2190 MHz channel(s) in Sector A, the JMA MX08FRO665-21 for the 600 MHz / 1900 MHz / 2190 MHz channel(s) in Sector B, the JMA MX08FRO665-21 for the 600 MHz / 1900 MHz / 2190 MHz channel(s) in Sector C. This is based on feedback from the carrier with regard to anticipated antenna selection. All Antenna gain values and associated transmit power levels are shown in the Site Inventory and Power Data table below. The maximum gain of the antenna per the antenna manufacturer's supplied specifications, minus 20 dB for directional panel antennas and 20 dB for highly focused parabolic microwave dishes, was used for all calculations. This value is a very conservative estimate as gain reductions for these particular antennas are typically much higher in this direction.
- 7) The antenna mounting height centerline of the proposed antennas is 70 feet above ground level (AGL).
- 8) Emissions values for additional carriers were taken from the Connecticut Siting Council active database. Values in this database are provided by the individual carriers themselves.
- 9) All calculations were done with respect to uncontrolled / general population threshold limits.

Dish Wireless Site Inventory and Power Data

Sector:	A	Sector:	B	Sector:	C
Antenna #:	1	Antenna #:	1	Antenna #:	1
Make / Model:	JMA MX08FRO665-21	Make / Model:	JMA MX08FRO665-21	Make / Model:	JMA MX08FRO665-21
Frequency Bands:	600 MHz / 1900 MHz / 2190 MHz	Frequency Bands:	600 MHz / 1900 MHz / 2190 MHz	Frequency Bands:	600 MHz / 1900 MHz / 2190 MHz
Gain:	17.45 dBd / 22.65 dBd / 22.65 dBd	Gain:	17.45 dBd / 22.65 dBd / 22.65 dBd	Gain:	17.45 dBd / 22.65 dBd / 22.65 dBd
Height (AGL):	70 feet	Height (AGL):	70 feet	Height (AGL):	70 feet
Channel Count:	12	Channel Count:	12	Channel Count:	12
Total TX Power (W):	440 Watts	Total TX Power (W):	440 Watts	Total TX Power (W):	440 Watts
ERP (W):	5,236.31	ERP (W):	5,236.31	ERP (W):	5,236.31
Antenna AI MPE %:	5.77%	Antenna BI MPE %:	5.77%	Antenna CI MPE %:	5.77%

Site Composite MPE %	
Carrier	MPE %
Dish Wireless (Max at Sector A):	5.77%
Verizon	11.58%
T-Mobile	5.6%
AT&T	2.42%
Public Safety	0.87%
Site Total MPE % :	26.24%

Dish Wireless MPE % Per Sector	
Dish Wireless Sector A Total:	5.77%
Dish Wireless Sector B Total:	5.77%
Dish Wireless Sector C Total:	5.77%
Site Total MPE % :	26.24%

Dish Wireless Maximum MPE Power Values (Sector A)							
Dish Wireless Frequency Band / Technology (Sector A)	# Channels	Watts ERP (Per Channel)	Height (feet)	Total Power Density ($\mu\text{W}/\text{cm}^2$)	Frequency (MHz)	Allowable MPE ($\mu\text{W}/\text{cm}^2$)	Calculated % MPE
Dish Wireless 600 MHz n71	4	223.68	70.0	7.85	600 MHz n71	400	1.96%
Dish Wireless 1900 MHz n70	4	542.70	70.0	19.05	1900 MHz n70	1000	1.91%
Dish Wireless 2190 MHz n66	4	542.70	70.0	19.05	2190 MHz n66	1000	1.91%
						Total:	5.77%

• NOTE: Totals may vary by approximately 0.01% due to summation of remainders in calculations.

Summary

All calculations performed for this analysis yielded results that were **within** the allowable limits for general population exposure to RF Emissions.

The anticipated maximum composite contributions from the Dish Wireless facility as well as the site composite emissions value with regards to compliance with FCC's allowable limits for general population exposure to RF Emissions are shown here:

Dish Wireless Sector	Power Density Value (%)
Sector A:	5.77%
Sector B:	5.77%
Sector C:	5.77%
Dish Wireless Maximum MPE % (Sector A):	5.77%
Site Total:	26.24%
Site Compliance Status:	COMPLIANT

The anticipated composite MPE value for this site assuming all carriers present is **26.24%** of the allowable FCC established general population limit sampled at the ground level. This is based upon values listed in the Connecticut Siting Council database for existing carrier emissions.

FCC guidelines state that if a site is found to be out of compliance (over allowable thresholds), that carriers over a 5% contribution to the composite value will require measures to bring the site into compliance. For this facility, the composite values calculated were well within the allowable 100% threshold standard per the federal government.



November 09, 2021

Dear Customer,

The following is the proof-of-delivery for tracking number: 775107488530

Delivery Information:

Status:	Delivered	Delivered To:	
Signed for by:	Signature release on file	Delivery Location:	200 SPIELMAN HWY
Service type:	FedEx 2Day		
Special Handling:	Deliver Weekday		BURLINGTON, CT, 06013
		Delivery date:	Nov 9, 2021 11:16

Shipping Information:

Tracking number:	775107488530	Ship Date:	Nov 5, 2021
		Weight:	1.0 LB/0.45 KG

Recipient:
Larry Farrell,
200 Spielman Hwy
BURLINGTON, CT, US, 06013

Shipper:
Corey Milan, NB+C
100 Apollo Dr.
Suite 303
CHELMSFORD, MA, US, 01824

Reference 100814

Thank you for choosing FedEx



November 09, 2021

Dear Customer,

The following is the proof-of-delivery for tracking number: 775107463607

Delivery Information:

Status:	Delivered	Delivered To:	
Signed for by:	Signature release on file	Delivery Location:	200 SPIELMAN HWY
Service type:	FedEx 2Day		
Special Handling:	Deliver Weekday		BURLINGTON, CT, 06013
		Delivery date:	Nov 9, 2021 11:16

Shipping Information:

Tracking number:	775107463607	Ship Date:	Nov 5, 2021
		Weight:	1.0 LB/0.45 KG

Recipient:
Theodore Shafer,
200 Spielman Hwy
BURLINGTON, CT, US, 06013

Shipper:
Corey Milan, NB+C
100 Apollo Dr.
Suite 303
CHELMSFORD, MA, US, 01824

Reference 100814

Thank you for choosing FedEx

Track Another Package +

Tracking Number: 9505511588611319441353

Remove X

Your item has been delivered and is available at a PO Box at 6:47 am on November 19, 2021 in BALTIMORE, MD 21275.

USPS Tracking Plus™ Available ∨

 **Delivered, PO Box**

November 19, 2021 at 6:47 am
BALTIMORE, MD 21275

Get Updates ∨

Text & Email Updates



Tracking History



USPS Tracking Plus™



Product Information



Feedback

See Less ^

Can't find what you're looking for?

Go to our FAQs section to find answers to your tracking questions.

FAQs