

280 Trumbull Street  
 Hartford, CT 06103-3597  
 Main (860) 275-8200  
 Fax (860) 275-8299  
 kbaldwin@rc.com  
 Direct (860) 275-8345

Also admitted in Massachusetts

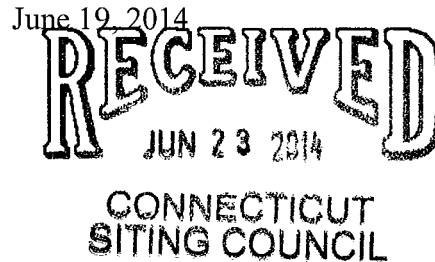

Melanie A. Bachman  
 Acting Executive Director  
 Connecticut Siting Council  
 10 Franklin Square  
 New Britain, CT 06051

Re: **Notice of Exempt Modification – Facility Modification  
 146 Brown Road, Brooklyn, Connecticut**

Dear Ms. Bachman:

Cellco Partnership d/b/a Verizon Wireless (“Cellco”) currently maintains twelve (12) wireless telecommunications antennas at the 127-foot level on an existing 150-foot tower at 146 Brown Road in Brooklyn, Connecticut (the “Property”). The tower is owned by SBA. Cellco’s use of the tower was approved by the Council in 2007. Cellco now intends to modify its facility by removing six (6) 850 MHz antennas and replacing them with three (3) model BXA-70080-6CF, 850 MHz antennas and three (3) model WBX065X19R050, 2100 MHz antenna. Cellco also intends to install three (3) remote radio heads (“RRHs”) behind its new 2100 MHz antennas and one (1) HYBRIFLEX™ antenna cable attached to the inside of the monopole. Included in Attachment 1 are specifications for Cellco’s replacement antennas, RRHs and HYBRIFLEX™ cable.

Please accept this letter as notification pursuant to R.C.S.A. § 16-50j-73, for construction that constitutes an exempt modification pursuant to R.C.S.A. § 16-50j-72(b)(2). In accordance with R.C.S.A. § 16-50j-73, a copy of this notice is being sent to Rick Ives, First Selectman of the Town of Brooklyn. A copy of this letter is also being sent to Ralph G. Ingalls Family Trust, the owner of the Property.

The planned modifications to the facility fall squarely within those activities explicitly provided for in R.C.S.A. § 16-50j-72(b)(2).



*Law Offices*

BOSTON

HARTFORD

NEW YORK

PROVIDENCE

STAMFORD

ALBANY

LOS ANGELES

NEW LONDON

SARASOTA

*www.rc.com*

12979373-v1

# ROBINSON & COLE<sup>LLP</sup>

Melanie A. Bachman  
June 19, 2014  
Page 2

1. The proposed modifications will not result in an increase in the height of the existing tower. Cellco's new and replacement antennas and RRHs will be installed at the 127-foot level on the existing 150-foot tower.
2. The proposed modifications will not involve any change to ground-mounted equipment and, therefore, will not require the extension of the site boundary.
3. The proposed modifications will not increase noise levels at the facility by six decibels or more, or to levels that exceed state and local criteria.
4. The operation of the replacement antennas will not increase radio frequency (RF) emissions at the facility to a level at or above the Federal Communications Commission (FCC) safety standard. A cumulative General Power Density table for Cellco's modified facility is included in Attachment 2.
5. The proposed modifications will not cause a change or alteration in the physical or environmental characteristics of the site.
6. The tower and its foundation can support Cellco's proposed modifications. (See Structural Analysis included in Attachment 3).

For the foregoing reasons, Cellco respectfully submits that the proposed modifications to the above-referenced telecommunications facility constitutes an exempt modification under R.C.S.A. § 16-50j-72(b)(2).

Sincerely,



Kenneth C. Baldwin

Enclosures  
Copy to:

Rick Ives, Brooklyn First Selectman  
Ralph G. Ingalls Family Trust  
Sandy M. Carter



# **ATTACHMENT 1**

## BXA-70080-6CF-EDIN-X

X-Pol | FET Panel | 80° | 13.5 dBd

Replace "X" with desired electrical downtilt.

Antenna is also available with NE connector(s)  
Replace "EDIN" with "NE" in the model number  
when ordering.

Electrical Characteristics	696-900 MHz		
Frequency bands	696-806 MHz	806-900 MHz	
Polarization	±45°		
Horizontal beamwidth	82°	80°	
Vertical beamwidth	12°	10°	
Gain	13.0 dBd (15.1 dBi)	13.5 dBd (15.6 dBi)	
Electrical downtilt (X)	0, 2, 4, 6, 8, 10		
Impedance	50Ω		
VSWR	≤1.35:1		
Upper sidelobe suppression (0°)	-18.3 dB	-18.6 dB	
Front-to-back ratio (+/-30°)	-26.9 dB	-25.6 dB	
Null fill	5% (-26.02 dB)		
Isolation between ports	< -30 dB		
Input power with EDIN connectors	500 W		
Input power with NE connectors	300 W		
Lightning protection	Direct Ground		
Connector(s)	2 Ports / EDIN or NE / Female / Center (Back)		
Mechanical Characteristics			
Dimensions Length x Width x Depth	1804 x 204 x 151 mm	71.0 x 8.0 x 5.9 in	
Depth with z-brackets	191 mm	7.5 in	
Weight without mounting brackets	8.2 kg	18 lbs	
Survival wind speed	> 201 km/hr	> 125 mph	
Wind area	Front: 0.37 m <sup>2</sup> Side: 0.27 m <sup>2</sup>	Front: 3.9 ft <sup>2</sup> Side: 2.9 ft <sup>2</sup>	
Wind load @ 161 km/hr (100 mph)	Front: 531 N Side: 475 N	Front: 119 lbf Side: 104 lbf	
Mounting Options	Part Number	Fits Pipe Diameter	Weight
3-Point Mounting & Downtilt Bracket Kit	36210008	40-115 mm 1.57-4.5 in	6.9 kg 15.2 lbs
Concealment Configurations	For concealment configurations, order BXA-70080-6CF-EDIN-X-FP		



**BXA-70080-6CF-EDIN-X**

**BXA-70080-6CF-EDIN-0**

**BXA-70080-6CF-EDIN-2**

**BXA-70080-6CF-EDIN-4**

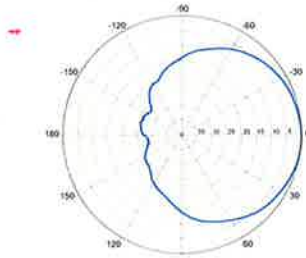

Horizontal | 750 MHz

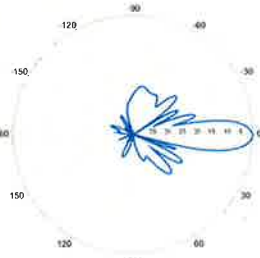

0° | Vertical | 750 MHz

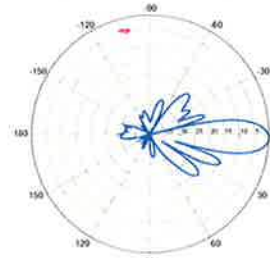

2° | Vertical | 750 MHz

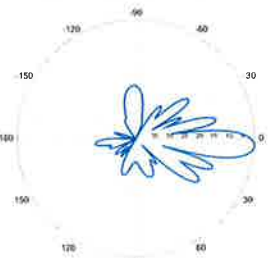

4° | Vertical | 750 MHz

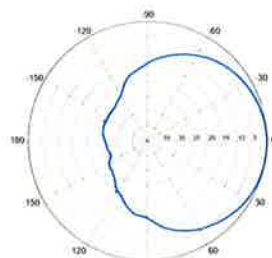

Horizontal | 850 MHz

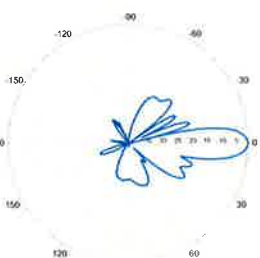

0° | Vertical | 850 MHz

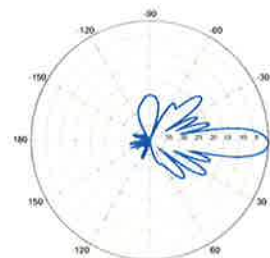

2° | Vertical | 850 MHz

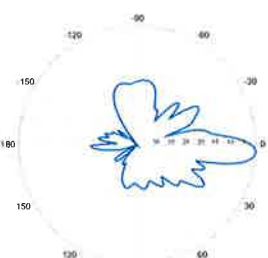

4° | Vertical | 850 MHz

Quoted performance parameters are provided to offer typical or range values only and may vary as a result of normal manufacturing and operational conditions. Extreme operational conditions and/or stress on structural supports is beyond our control. Such conditions may result in damage to this product. Improvements to product may be made without notice.

**BXA-70080-6CF-EDIN-X**

X-Pol | FET Panel | 80° | 13.5 dBd

**BXA-70080-6CF-EDIN-6**

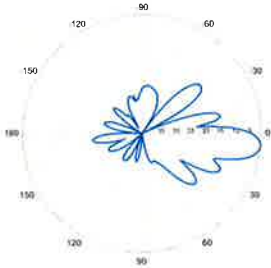

6° | Vertical | 750 MHz

**BXA-70080-6CF-EDIN-8**

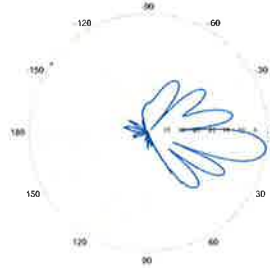

8° | Vertical | 750 MHz

**BXA-70080-6CF-EDIN-10**

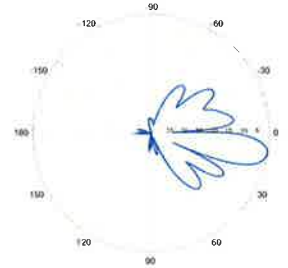

10° | Vertical | 750 MHz

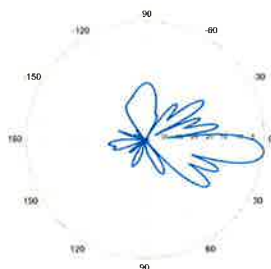

6° | Vertical | 850 MHz

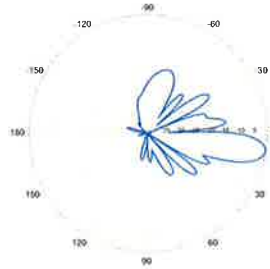

8° | Vertical | 850 MHz

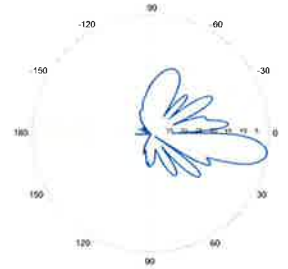

10° | Vertical | 850 MHz

Quoted performance parameters are provided to offer typical or range values only and may vary as a result of normal manufacturing and operational conditions. Extreme operational conditions and/or stress on structural supports is beyond our control. Such conditions may result in damage to this product. Improvements to product may be made without notice.

## WBX065X19x050

X-Pol | VET Panel | 65° | 19.0 dBi



Model Number Options  
 WBX065X19M150 - Manual Electrical Tilt Antenna (aka 5142100)  
 WBX065X19R150 - Remote Electrical Tilt Antenna (aka 5142000)

Electrical Characteristics	1710-2170 MHz		
Frequency bands	1710-1880 MHz	1850-1990 MHz	1900-2170 MHz
Polarization	± 45°	± 45°	± 45°
Horizontal beamwidth	69°	66°	63°
Vertical beamwidth	4.9°	4.6°	4.3°
Gain	15.9 dBd / 18.0 dBi	16.4 dBd / 18.5 dBi	16.9 dBd / 19.0 dBi
Electrical downtilt	2°-10° Variable Electrical Tilt		
Impedance	50Ω		
VSWR	< 1.4:1		
Upper sidelobe suppression	< -18 dB		
Front-to-Back ratio	> 25 dB		
First null	> -20 dB typical		
Inter-port isolation	> 30 dB		
IM3 (2x20W carrier)	< -153 dBc		
Input power	2 x 160 W		
Connector(s)	2 Ports / 7/16 DIN / Female / Bottom		
Operating temperature	-40° to +60° C (-40° to +140° F)		
Mechanical Characteristics			
Dimensions HxWxD	1950 x 157 x 69 mm		76.8 x 6.2 x 2.7 in
Weight without brackets	9.5 kg		20.9 lbs
Survival wind speed	241 km/hr		150 mph
Wind load @ 161 km/hr (100 mph)	Front: 405 N	Side: 176 N	Front: 91 lbf Side: 40 lbf
RET type / Part number	Internal / RETU-CA01		
Mounting Options	Part Number	Fits Pipe Diameter	Weight
Pole mounting bracket kit	MKS05P01	40-115 mm 1.6-4.5 in	2.9 kg 6.5 lbs
Scissor tilt bracket kit	MKS05T03	40-115 mm 1.6-4.5 in	4.1 kg 9.1 lbs
Bar tilt bracket kit	MKS05T04	40-115 mm 1.6-4.5 in	4.0 kg 8.8 lbs
Concealment Options			
UNICELL module	UNX14-19	UNX20-19	
Azimuth swivel	± 30°	± 30°	
Elevation tilt	Fixed	Fixed	
Required mounting kit	UNX14-WBX-AZ	UNX20-WBX-AZ	
FP mounting configuration	None		

1710-1880 MHz

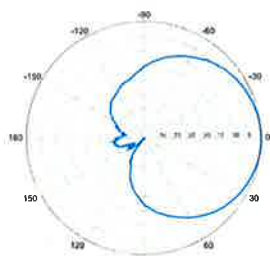

Horizontal

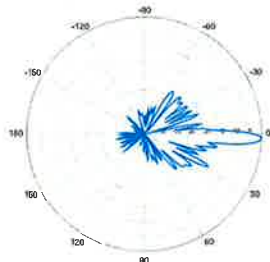

2° | Vertical

1850-1990 MHz

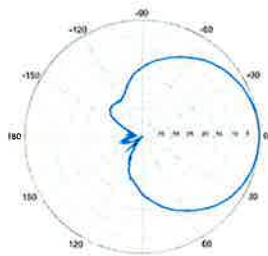

Horizontal

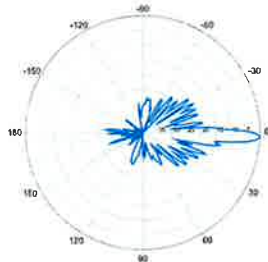

2° | Vertical

1900-2170 MHz

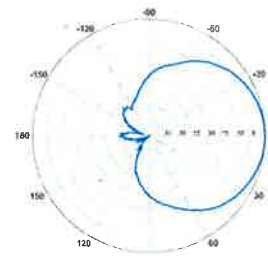

Horizontal

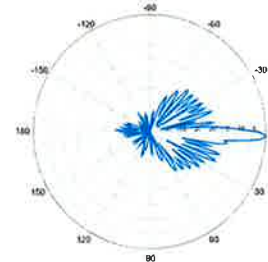

2° | Vertical

Quoted performance parameters are provided to offer typical or range values only and may vary as a result of normal manufacturing and operational conditions. Extreme operational conditions and/or stress on structural supports is beyond our control. Such conditions may result in damage to this product. Improvements to product may be made without notice.

## WBX065X19x050

X-Pol | VET Panel | 65° | 19.0 dBi

1710-1880 MHz

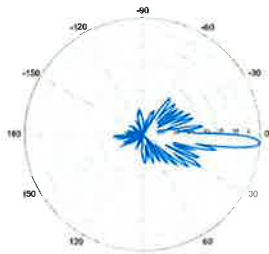

4° | Vertical

1850-1990 MHz

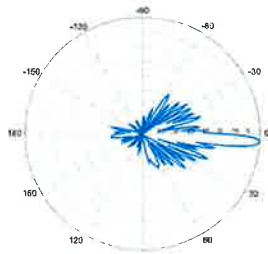

4° | Vertical

1900-2170 MHz

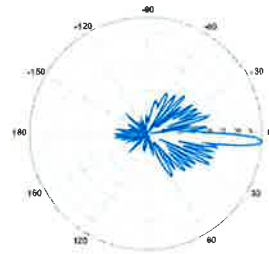

4° | Vertical

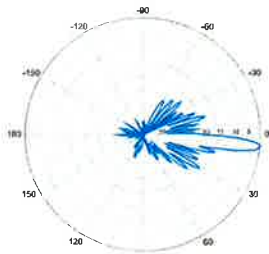

6° | Vertical

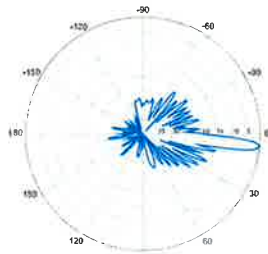

6° | Vertical

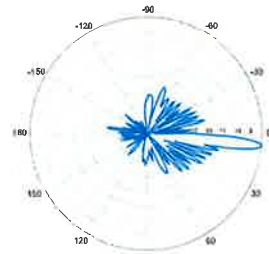

6° | Vertical

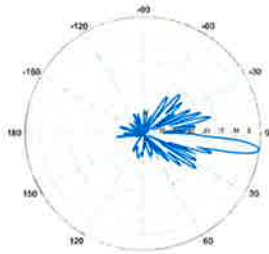

8° | Vertical

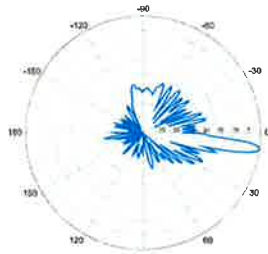

8° | Vertical

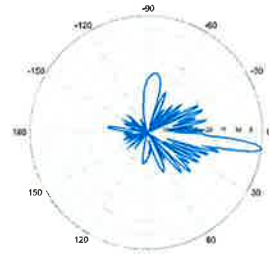

8° | Vertical

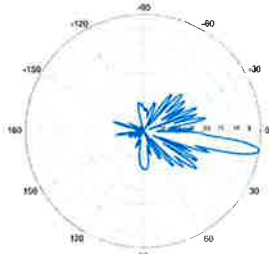

10° | Vertical

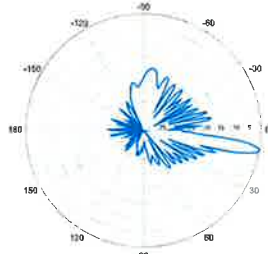

10° | Vertical

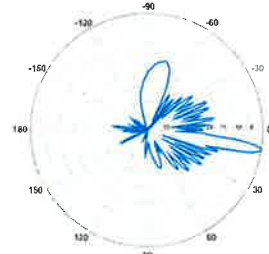

10° | Vertical

Quoted performance parameters are provided to offer typical or range values only and may vary as a result of normal manufacturing and operational conditions. Extreme operational conditions and/or stress on structural supports is beyond our control. Such conditions may result in damage to this product. Improvements to product may be made without notice.

## Alcatel-Lucent RRH2x40-AWS

### REMOTE RADIO HEAD

The Alcatel-Lucent RRH2x40-AWS is a high-power, small form-factor Remote Radio Head (RRH) operating in the AWS frequency band (1700/2100MHz - 3GPP Band 4). The Alcatel-Lucent RRH2x40-AWS is designed with an eco-efficient approach, providing operators with the means to achieve high quality and capacity coverage with minimum site requirements.

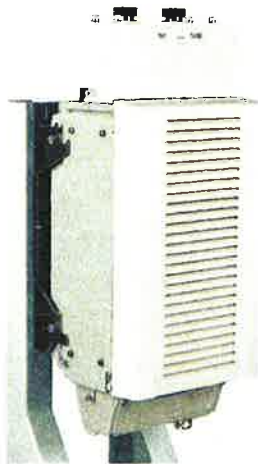

A distributed eNodeB expands deployment options by using two components, a Base Band Unit (BBU) containing the digital assets and a separate RRH containing the radio-frequency (RF) elements. This modular design optimizes available space and allows the main components of an eNodeB to be installed separately, within the same site or several kilometres apart.

The Alcatel-Lucent RRH2x40-AWS is linked to the BBU by an optical-fiber connection carrying downlink and uplink digital radio signals along with operations, administration and maintenance (OA&M) information. The Alcatel-Lucent RRH2x40-AWS has two transmit RF paths, 40 W RF output power per transmit path, and is designed to manage up to four-way receive diversity. The device is ideally suited to support macro coverage, with multiple-input multiple-output (MIMO) 2x2 operation in up to 20 MHz of bandwidth.

The Alcatel-Lucent RRH2x40-AWS is designed to make available all the benefits of a distributed eNodeB, with excellent RF characteristics, with low

capital expenditures (CAPEX) and low operating expenditures (OPEX). The limited space available in some sites may prevent the installation of traditional single-cabinet BTS equipment or require costly cranes to be employed, leaving coverage holes. However, many of these sites can host an Alcatel-Lucent RRH2x40-AWS installation, providing more flexible site selection and improved network quality along with greatly reduced installation time and costs.

#### Fast, low-cost installation and deployment

The Alcatel-Lucent RRH2x40-AWS is a zero-footprint solution and operates noise-free, simplifying negotiations with site property owners and minimizing environmental impacts. Installation can easily be done by a single person because the Alcatel-Lucent RRH2x40-AWS is compact and weighs less than 20 kg (44 lb), eliminating the need for a crane to hoist the BTS cabinet to the rooftop. A site can be in operation in less than one day — a fraction of the time required for a traditional BTS.



## Excellent RF performance

Because of its small size and weight, the Alcatel-Lucent RRH2x40-AWS can be installed close to the antenna. Operators can therefore locate the Alcatel-Lucent RRH2x40-AWS where RF engineering is deemed ideal, minimizing trade-offs between available sites and RF optimum sites. The RF feeder cost and installation costs are reduced or eliminated, and there is no need for a Tower Mounted Amplifier (TMA) because losses introduced by the RF feeder are greatly reduced. The Alcatel-Lucent RRH2x40-AWS provides more RF power while at the same time consuming less electricity.

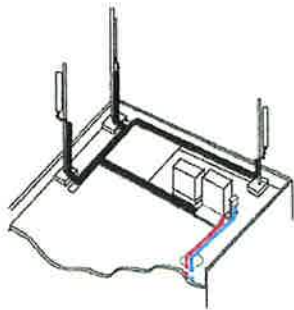

Macro

## Features

- Zero-footprint deployment
- Easy installation, with a lightweight unit can be carried and set up by one person
- Optimized RF power, with flexible site selection and elimination of a TMA
- Convection-cooled (fanless)
- Noise-free
- Best-in-class power efficiency, with significantly reduced energy consumption

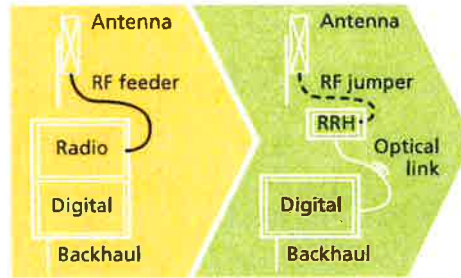

RRH for space-constrained cell sites

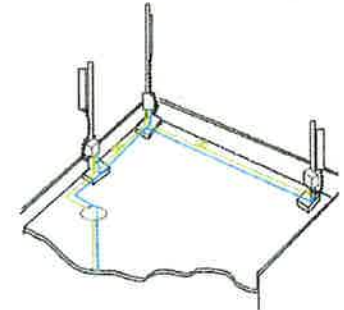

Distributed

## Benefits

- Leverages existing real estate with lower site costs
- Reduces installation costs, with fewer installation materials and simplified logistics
- Decreases power costs and minimizes environmental impacts, with the potential for eco-sustainable power options
- Improves RF performance and adds flexibility to network planning

## Technical specifications

### Physical dimensions

- Height: 620 mm (24.4 in.)
- Width: 270 mm (10.63 in.)
- Depth: 170mm (6.7 in.)
- Weight (without mounting kit): less than 20 kg (44 lb)

### Power

- Power supply: -48VDC

### Operating environment

- Outdoor temperature range:
  - With solar load: -40°C to +50°C (-40°F to +122°F)
  - Without solar load: -40°C to +55°C (-40°F to +131°F)

- Passive convection cooling (no fans)
- Enclosure protection
  - IP65 (International Protection rating)

### RF characteristics

- Frequency band: 1700/2100 MHz (AWS); 3GPP Band 4
- Bandwidth: up to 20 MHz
- RF output power at antenna port: 40 W nominal RF power for each Tx port
- Rx diversity: 2-way or 4-way with optional Rx Diversity module
- Noise figure: below 2.0 dB typical
- Antenna Line Device features
  - TMA and Remote electrical tilt (RET) support via AISG v2.0

### Optical characteristics

#### Type/number of fibers

- Single-mode variant
  - One Single Mode Single Fiber per RRH2x, carrying UL and DL using CWDM
  - Single mode dual fiber (SM/DF)
- Multi-mode variant
  - Two Multi-mode fibers per RRH2x: one carrying UL, the other carrying DL

### Optical fiber length

- Up to 500 m (0.31 mi), using MM fiber
- Up to 20 km (12.43 mi), using SM fiber

### Digital Ports and Alarms

- Two optical ports to support daisy-chaining
- Six external alarms

[www.alcatel-lucent.com](http://www.alcatel-lucent.com) Alcatel, Lucent, Alcatel-Lucent and the Alcatel-Lucent logo are trademarks of Alcatel-Lucent. All other trademarks are the property of their respective owners. The information presented is subject to change without notice. Alcatel-Lucent assumes no responsibility for inaccuracies contained herein. Copyright © 2010 Alcatel-Lucent. All rights reserved. CPG2809100912 (09)



**HYBRIFLEX™ RRH Hybrid Feeder Cabling Solution, 1-5/8", Single-Mode Fiber**

**Product Description**

RFS' HYBRIFLEX Remote Radio Head (RRH) hybrid feeder cabling solution combines optical fiber and DC power for RRHs in a single lightweight aluminum corrugated cable, making it the world's most innovative solution for RRH deployments.

It was developed to reduce installation complexity and costs at Cellular sites. HYBRIFLEX allows mobile operators deploying an RRH architecture to standardize the RRH installation process and eliminate the need for and cost of cable grounding. HYBRIFLEX combines optical fiber (multi-mode or single-mode) and power in a single corrugated cable. It eliminates the need for junction boxes and can connect multiple RRHs with a single feeder. Standard RFS CELLFLEX® accessories can be used with HYBRIFLEX cable. Both pre-connectorized and on-site options are available.

**Features/Benefits**

- Aluminum corrugated armor with outstanding bending characteristics - minimizes installation time and enables mechanical protection and shielding
- Same accessories as 1 5/8" coaxial cable
- Outer conductor grounding - Eliminates typical grounding requirements and saves on installation costs
- Lightweight solution and compact design - Decreases tower loading
- Robust cabling - Eliminates need for expensive cable trays and ducts
- Installation of tight bundled fiber optic cable pairs directly to the RRH - Reduces CAPEX and wind load by eliminating need for interconnection
- Optical fiber and power cables housed in single corrugated cable - Saves CAPEX by standardizing RRH cable installation and reducing installation requirements
- Outdoor polyethylene jacket - Ensures long-lasting cable protection



Figure 1: HYBRIFLEX Series

**Technical Specifications**

<b>Structure</b>			
Outer Conductor Armor	Corrugated Aluminum	(mm (in))	46.5 (1.83)
Jacket	Polyethylene, PE	(mm (in))	50.3 (1.98)
UV-Protection	Individual and External Jacket		Yes
<b>Mechanical Properties</b>			
Weight, Approximate		(kg/m (lb/ft))	1.9 (1.30)
Minimum Bending Radius, Single Bending		(mm (in))	200 (8)
Minimum Bending Radius, Repeated Bending		(mm (in))	500 (20)
Recommended/Maximum Clamp Spacing		(m (ft))	1.0 / 1.2 (3.25 / 4.0)
<b>Electrical Properties</b>			
DC-Resistance Outer Conductor Armor		(Ω/km (Ω/1000ft))	068 (0.265)
DC-Resistance Power Cable, 8.4mm²(8AWG)		(Ω/km (Ω/1000ft))	2.1 (0.307)
<b>Optical Properties</b>			
Version			Single-mode OM3
Quantity, Fiber Count			16 (8 pairs)
Core/Clad		(μm)	50/125
Primary Coating (Acrylate)		(μm)	245
Buffer Diameter, Nominal		(μm)	900
Secondary Protection, Jacket, Nominal		(mm (in))	2.0 (0.08)
Minimum Bending Radius		(mm (in))	104 (4.1)
Insertion Loss @ wavelength 850nm		dB/km	3.0
Insertion Loss @ wavelength 1310nm		dB/km	1.0
Standards (Meets or exceeds)			UL34-V0, UL1666 RoHS Compliant
<b>Power Cable Properties</b>			
Size (Power)		(mm (AWG))	8.4 (8)
Quantity, Wire Count (Power)			16 (8 pairs)
Size (Alarm)		(mm (AWG))	0.8 (18)
Quantity, Wire Count (Alarm)			4 (2 pairs)
Type			UV protected
Strands			19
Primary Jacket Diameter, Nominal		(mm (in))	6.8 (0.27)
Standards (Meets or exceeds)			NFPA 130, ICEA S-95-658 UL Type XHHW-2, UL 44 UL-LS Limited Smoke, UL VW-1 IEEE-383 (1974), IEEE1202/FT4 RoHS Compliant
<b>Operating Range</b>			
Installation Temperature		(°C (°F))	-40 to +65 (-40 to 149)
Operation Temperature		(°C (°F))	-40 to +65 (-40 to 149)

\* This data is provisional and subject to change

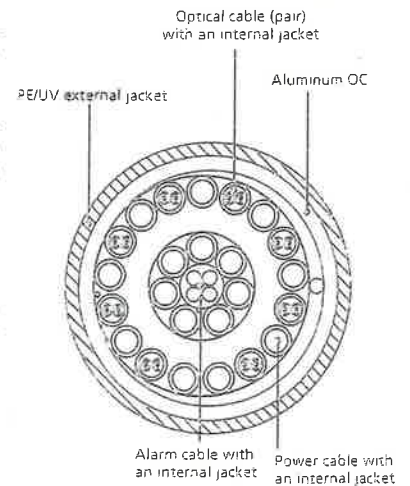

Figure 2: Construction Detail

All information contained in the present datasheet is subject to confirmation at time of ordering

# **ATTACHMENT 2**



# **ATTACHMENT 3**



FDH Engineering, Inc., 2730 Rowland Rd. Raleigh, NC 27615, Ph. 919.755.1012, Fax 919.755.1031

**Structural Analysis for  
SBA Network Services, Inc.**

**150' Monopole Tower**

**SBA Site Name: Ingalls  
SBA Site ID: CT13612-A  
Verizon Site Name: Danielson West CT  
Verizon Site ID: 176421**

FDH Project Number 1422VO1400

**Analysis Results**

Tower Components	50.3%	Sufficient
Foundation	54.8%	Sufficient

Prepared By:

Jeffrey B. Ray, EI  
Project Engineer

Reviewed By:

Dennis D. Abel, PE  
Director – Structural Engineering  
CT PE License No. 23247

**FDH Engineering, Inc.**  
2730 Rowland Rd.  
Raleigh, NC 27615  
(919) 755-1012  
info@fdh-inc.com



02-21-2014

February 21, 2014

*Prepared pursuant to TIA/EIA-222-F Structural Standards for Steel Antenna Towers and Antenna Supporting Structures and the 2005 Connecticut State Building Code*

**TABLE OF CONTENTS**

EXECUTIVE SUMMARY ..... 3

    Conclusions..... 3

    Recommendation ..... 3

APPURTENANCE LISTING ..... 4

RESULTS ..... 5

GENERAL COMMENTS ..... 6

LIMITATIONS..... 6

APPENDIX ..... 7

## EXECUTIVE SUMMARY

At the request of SBA Network Services, Inc., FDH Engineering, Inc. performed a structural analysis of the monopole located in Brooklyn, CT to determine whether the tower is structurally adequate to support both the existing and proposed loads pursuant to the *Structural Standards for Steel Antenna Towers and Antenna Supporting Structures, TIA/EIA-222-F and the 2005 Connecticut State Building Code*. Information pertaining to the existing/proposed antenna loading, current tower geometry, geotechnical data, and member sizes was obtained from:

- Engineering Endeavors, Inc. (Project No. 12401) Structure and Foundation Design dated March 18, 2004
- FDH, Inc. (Project No. 08-07604T) TIA Inspection Report dated September 19, 2008
- Jaworski Geotech, Inc. (Project No. 04196G) Geotechnical Evaluation dated April 19, 2004
- SBA Network Services, Inc.

The *basic design wind speed* per the *TIA/EIA-222-F standards and the 2005 Connecticut State Building Code* is 85 mph without ice and 38 mph with 1 " radial ice. Ice is considered to increase in thickness with height.

## Conclusions

With the existing and proposed antennas from Verizon in place at 128.8 ft, the tower meets the requirements of the *TIA/EIA-222-F standards and the 2005 Connecticut State Building Code* provided the **Recommendations** listed below are satisfied. Furthermore, provided the foundations were designed and constructed to support the original design reactions (see Engineering Endeavors, Inc. Project No. 12401), the foundations should have the necessary capacity to support the existing and proposed loading. For a more detailed description of the analysis of the tower, see the **Results** section of this report.

Our structural analysis has been performed assuming all information provided to FDH Engineering, Inc. is accurate (i.e., the steel data, tower layout, existing antenna loading, and proposed antenna loading) and that the tower has been properly erected and maintained per the original design drawings.

## Recommendations

To ensure the requirements of the *TIA/EIA-222-F standards and the 2005 Connecticut State Building Code* are met with the existing and proposed loading in place, we have the following recommendations:

1. The proposed coax should be installed inside the pole's shaft.
2. RRU/RRH Stipulation: The proposed equipment may be installed in any arrangement as determined by the client.



**APPURTENANCE LISTING**

The proposed and existing antennas with their corresponding cables/coax lines are shown in **Table 1**. *If the actual layout determined in the field deviates from the layout, FDH Engineering, Inc. should be contacted to perform a revised analysis.*

**Table 1 - Appurtenance Loading**

**Existing Loading:**

Antenna Elevation (ft)	Description	Coax and Lines	Carrier	Mount Elevation (ft)	Mount Type
139	(3) RFS APX16PV-16PVL w/ Mount Pipe (6) Remec S20057A1 TMAs	(12) 1-5/8" (1) 1/4"	Cingular	139	(3) 7"x2.39" Pipe Mounts
128.8	(3) Antel BXA-70063-6CF w/Mount Pipe (6) Antel LPA-80080-6CF W/Mount Pipe (3) Antel BXA-171085-12BF w/Mount Pipe (6) RFS FD9R6004/2C-3L Diplexers	(12) 1-5/8"	Verizon	128.8	(1) 12.5' LP Platform Mount

1.Coax installed inside the pole shaft unless otherwise noted.

**Proposed Loading:**

Antenna Elevation (ft)	Description	Coax and Lines	Carrier	Mount Elevation (ft)	Mount Type
128.8	(3) Antel BXA-70063-6CF (3) Antel BXA-70080-6CF (3) Antel BXA-171085-12BF (3) Antel WBX065X19R050 (3) ALU RRRH-2x40-AWS RRRHs (6) RFS FD9R6004/2C-3L Diplexers (1) RFS DB-T1-6Z-8AB-0Z Distribution Box	(12) 1-5/8" (1) 1-5/8" Fiber	Verizon	128.8	(1) 12.5' LP Platform Mount

## RESULTS

The following yield strength of steel for individual members was used for analysis:

**Table 2 - Material Strength**

Member Type	Yield Strength
Tower Shaft Sections	65 ksi
Base Plate	60 ksi
Anchor Bolts	75 ksi

**Table 3** displays the summary of the ratio (as a percentage) of force in the member to their capacities. Values greater than 100% indicate locations where the maximum force in the member exceeds its capacity. *Note: Capacities up to 100% are considered acceptable.* **Table 4** displays the maximum foundation reactions.

If the assumptions outlined in this report differ from actual field conditions, FDH Engineering, Inc. should be contacted to perform a revised analysis. Furthermore, as no information pertaining to the allowable twist and sway requirements for the existing or proposed appurtenances was provided, deflection and rotation were not taken into consideration when performing this analysis.

See the **Appendix** for detailed modeling information

**Table 3 - Summary of Working Percentage of Structural Components**

Section No.	Elevation ft	Component Type	Size	% Capacity*	Pass Fail
L1	150 - 120.625	Pole	TP26.0938x20.5x0.1875	9.4	Pass
L2	120.625 - 75.455	Pole	TP37.5625x24.8791x0.25	41.6	Pass
L3	75.455 - 41.448	Pole	TP45.25x33.7314x0.3125	44.5	Pass
L4	41.448 - 0	Pole	TP55x43.1787x0.375	44.2	Pass
		Anchor Bolts	(16) 2.25"Ø x 64"Ø BC	38.9	Pass
		Base Plate	70" Ø x 2" tk. PL	50.3	Pass

\*Capacities include a 1/3 allowable stress increase for wind per TIA/EIA-222-F Standards.

**Table 4 - Maximum Base Reactions**

Base Reactions	Current Analysis (TIA/EIA-222-F)	Original Design (TIA/EIA-222-F)
Axial	27 k*	31 k
Shear	18 k*	28 k
Moment	1,652 k-ft	3,015 k-ft

\*Per experience with foundations of similar type, the axial and shear loading should not control the foundation analysis.

## **GENERAL COMMENTS**

This engineering analysis is based upon the theoretical capacity of the structure. It is not a condition assessment of the tower and its foundation. It is the responsibility of SBA Network Services, Inc. to verify that the tower modeled and analyzed is the correct structure (with accurate antenna loading information) modeled. If there are substantial modifications to be made or the assumptions made in this analysis are not accurate, FDH Engineering, Inc. should be notified immediately to perform a revised analysis.

## **LIMITATIONS**

All opinions and conclusions are considered accurate to a reasonable degree of engineering certainty based upon the evidence available at the time of this report. All opinions and conclusions are subject to revision based upon receipt of new or additional/updated information. All services are provided exercising a level of care and diligence equivalent to the standard and care of our profession. No other warranty or guarantee, expressed or implied, is offered. Our services are confidential in nature and we will not release this report to any other party without the client's consent. The use of this engineering work is limited to the express purpose for which it was commissioned and it may not be reused, copied, or distributed for any other purpose without the written consent of FDH Engineering, Inc.

## **APPENDIX**

Section	1	2	3	4
Length (ft)	28.38	48.41	40.53	48.91
Number of Stiles	18	18	18	18
Thickness (in)	0.1875	0.2500	0.3125	0.3750
Socket Length (ft)	3.87	5.19	6.16	43.1787
Top Dia (in)	20.5000	24.8976	35.7314	55.0000
Bot Dia (in)	26.0638	37.5625	45.2500	9.6
Grade			A572-85	
Weight (K)	1.2	4.1	5.5	9.6

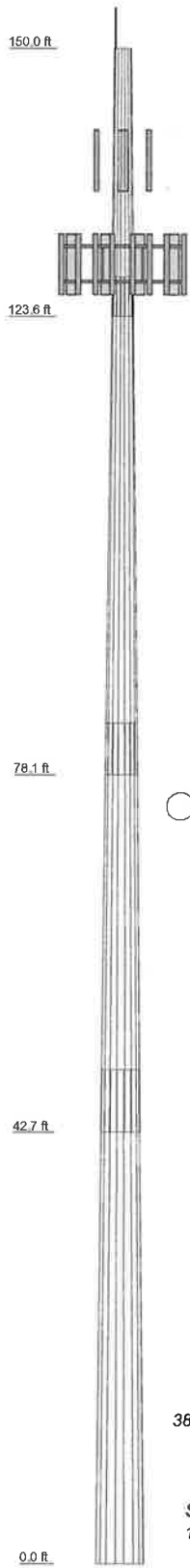

### DESIGNED APPURTENANCE LOADING

TYPE	ELEVATION	TYPE	ELEVATION
Lightning Rod 1"x10'	150	WBX065X19R050 w/ Mount Pipe	128.79
APX16PV-16PVL w/ Mount Pipe	139	WBX065X19R050 w/ Mount Pipe	128.79
APX16PV-16PVL w/ Mount Pipe	139	BXA-70080/6CF w/ Mount Pipe	128.79
(2) Remec S20057A1 TMAs	139	BXA-70080/6CF w/ Mount Pipe	128.79
(2) Remec S20057A1 TMAs	139	BXA-70080/6CF w/ Mount Pipe	128.79
(2) Remec S20057A1 TMAs	139	9442 RRH2x40-AWS	128.79
APX16PV-16PVL w/ Mount Pipe	139	9442 RRH2x40-AWS	128.79
BXA-70063/6CF w/ Mount Pipe	128.79	9442 RRH2x40-AWS	128.79
BXA-70063/6CF w/ Mount Pipe	128.79	(2) FD9R6004/2C-3L Diplexer	128.79
BXA-70063/6CF w/ Mount Pipe	128.79	(2) FD9R6004/2C-3L Diplexer	128.79
BXA-171085-12BF w/ Mount Pipe	128.79	(2) FD9R6004/2C-3L Diplexer	128.79
BXA-171085-12BF w/ Mount Pipe	128.79	DB-T1-6Z-8AB-0Z	128.79
BXA-171085-12BF w/ Mount Pipe	128.79	(1) 12.5' LP Platform Mount	128.79
WBX065X19R050 w/ Mount Pipe	128.79		

### MATERIAL STRENGTH

GRADE	Fy	Fu	GRADE	Fy	Fu
A572-85	65 ksi	80 ksi			

### TOWER DESIGN NOTES

1. Tower is located in Windham County, Connecticut.
2. Tower designed for a 85 mph basic wind in accordance with the TIA/EIA-222-F Standard.
3. Tower is also designed for a 38 mph basic wind with 1.00 in ice. Ice is considered to increase in thickness with height.
4. Deflections are based upon a 50 mph wind.
5. TOWER RATING: 44.5%

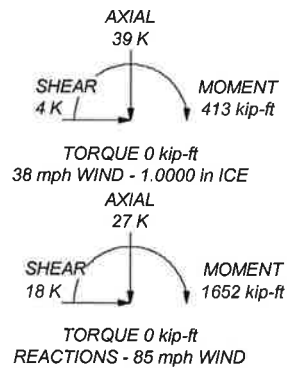

 Tower Analysis	<b>FDH Engineering, Inc.</b> 6521 Meridian Drive, Suite 107 Raleigh, North Carolina Phone: 9197551012 FAX: 9197551031		Job: <b>Ingalls CT13612-A</b> Project: <b>1422VO1400</b>	
	Client: SBA	Drawn by: Jeffrey B. Ray	App'd:	
	Code: TIA/EIA-222-F	Date: 02/21/14	Scale: NTS	
	Path:		Dwg No. E-1	