



Crown Castle
3 Corporate Park Drive, Suite 101
Clifton Park, NY 12065

November 13, 2018

Melanie A. Bachman
Acting Executive Director
Connecticut Siting Council
10 Franklin Square
New Britain, CT 06051

RE: Notice of Exempt Modification for Verizon DO Macro: 842859
Verizon Site ID: Bristol W 2 CT
371 Terryville Ave. Bristol, CT 06010
Latitude: 41° 40' 47.89"/ Longitude: 72° 57' 44.79"

Dear Ms. Bachman:

Verizon currently maintains four (4) antennas at the 140-foot level of the existing 169-foot monopole tower at 371 Terryville Ave. Bristol, CT 06010. The tower is owned by Crown Castle. Bristol Hospital owns the property. Verizon now intends to replace six (6) RRH's with six (6) new RRH's. These RRH's would be installed at the 140-foot level of the tower. Verizon also intends to install a junction box, and three (3) side-by-side mount brackets.

This facility was approved by the City of Bristol Zoning Commission on 12/09/2003, this approval was given without conditions.

Please accept this letter as notification pursuant to Regulations of Connecticut State Agencies § 16-50j-73, for construction that constitutes an exempt modification pursuant to R.C.S.A. § 16-50j-72(b)(2). In accordance with R.S.C.A. § 16-50j-73, a copy of this letter is being sent to Town mayor Ellen zoppo-sassu, Town of Bristol, Guy Morin, Building Official, Town of Bristol, the property owner and Crown Castle is the tower owner.

1. The proposed modifications will not result in an increase in the height of the existing tower.
2. The proposed modifications will not require the extension of the site boundary.
3. The proposed modification will not increase noise levels at the facility by six decibels or more, or to levels that exceed state and local criteria.
4. The operation of the replacement antennas will not increase radio frequency emissions at the facility to a level at or above the Federal Communication Commission safety standard.

The Foundation for a Wireless World.

CrownCastle.com

Melanie A. Bachman

November 13, 2018

Page 2

5. The proposed modifications will not cause a change or alteration in the physical or environmental characteristics of the site.
6. The existing structure and its foundation can support the proposed loading.

For the foregoing reasons, Verizon respectfully submits that the proposed modifications to the above-reference telecommunications facility constitutes an exempt modification under R.C.S.A. § 16-50j-72(b)(2). Please send approval/rejection letter to Attn: Jeffrey Barbadora.

Sincerely,

Jeffrey Barbadora
Real Estate Specialist
12 Gill Street, Suite 5800, Woburn, MA 01801
781-729-0053
Jeff.Barbadora@crowncastle.com

Attachments:

Tab 1: Exhibit-1: Compound plan and elevation depicting the planned changes

Tab 2: Exhibit-2: Structural Modification Report

Tab 3: Exhibit-3: General Power Density Table Report (RF Emissions Analysis Report)

cc: Ellen zoppo-sassu, Mayor
City Hall
111 N. Main St.
Second Floor
Bristol, CT 06010

Guy Morin, Building Official
City Hall
111 N. Main St.
Second Floor
Bristol, CT 06010

Bristol Hospital Administration
Brewster Rd.
Bristol, CT 06010

Melanie A. Bachman

November 13, 2018

Page 3

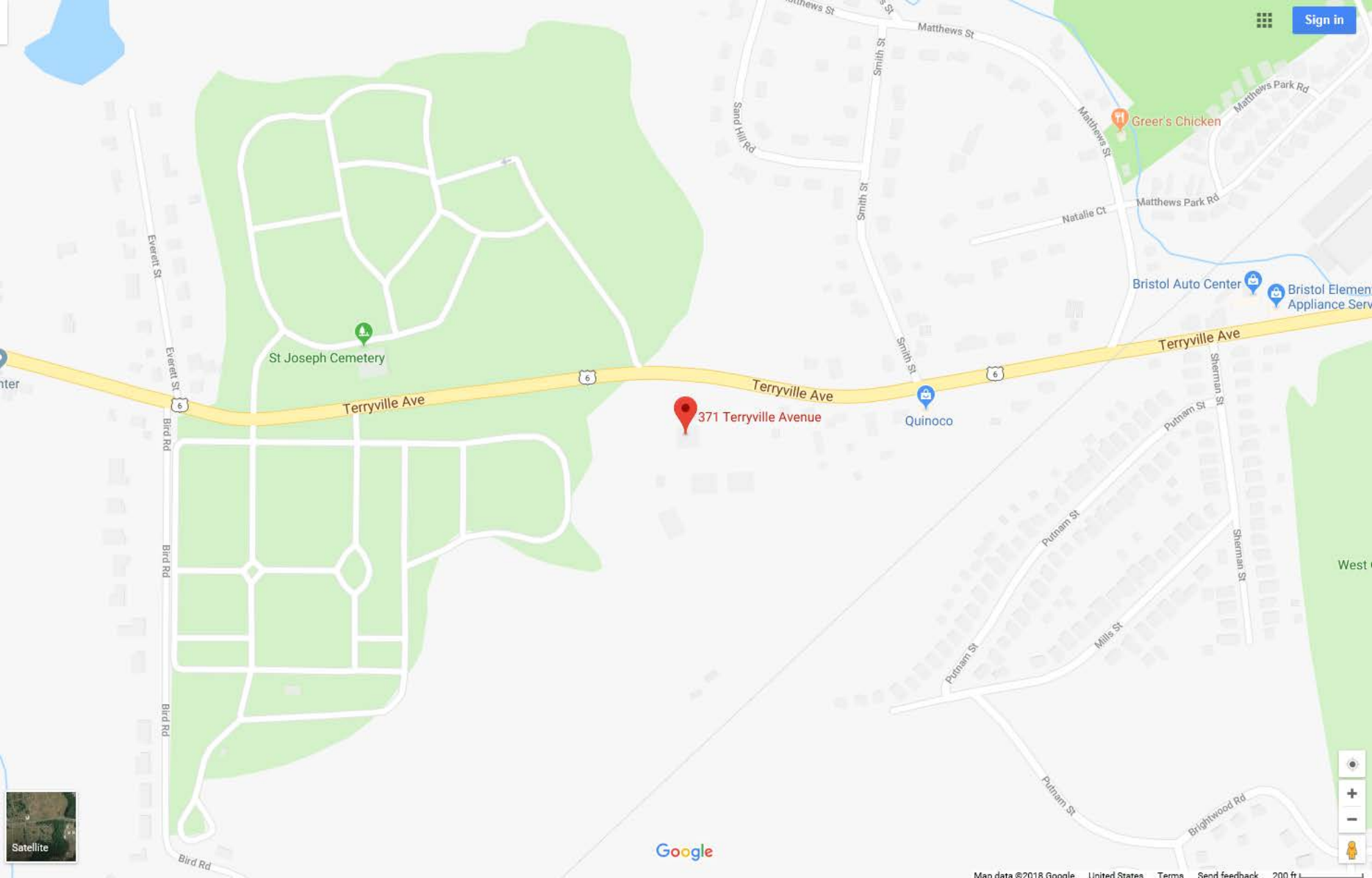

St Joseph Cemetery

371 Terryville Avenue

Quinoco

Greer's Chicken

Bristol Auto Center

Bristol Element Appliance Service

Terryville Ave

371 TERRYVILLE AVE

Location 371 TERRYVILLE AVE

Mblu 61/ / 67-1/ /

Acct# 0136999

Owner BRISTOL HOSPITAL INC

Assessment \$363,370

Appraisal \$519,100

PID 2194

Building Count 2

Current Value

Appraisal			
Valuation Year	Improvements	Land	Total
2017	\$280,000	\$239,100	\$519,100

Assessment			
Valuation Year	Improvements	Land	Total
2017	\$196,000	\$167,370	\$363,370

Owner of Record

Owner BRISTOL HOSPITAL INC
Co-Owner
Address BREWSTER RD
 BRISTOL, CT 06010

Sale Price \$400,000
Certificate 1
Book & Page 1564/ 795
Sale Date 06/08/2004
Instrument 00

Ownership History

Ownership History					
Owner	Sale Price	Certificate	Book & Page	Instrument	Sale Date
BRISTOL HOSPITAL INC	\$400,000	1	1564/ 795	00	06/08/2004
LAVIERO REALTY LLC	\$0		1564/ 792		06/08/2004
LAVIERO REALTY LLC	\$0		1352/ 30		02/08/2001
LAVIERO MORRIS + RICHARD	\$0		1139/ 447		09/23/1994
GTT CORP TRUSTEE OF OREGON	\$0		1103/ 330		09/30/1993

Building Information

Building 1 : Section 1

Year Built: 1996
Living Area: 960
Replacement Cost: \$117,937
Building Percent 91
Good:
Replacement Cost
Less Depreciation: \$107,300

Building Photo

Building Attributes	
Field	Description
STYLE	Office Bldg
MODEL	Comm/Ind
Stories:	1
Occupancy	1
Exterior Wall 1	Vinyl Siding
Exterior Wall 2	
Roof Structure	Gable
Roof Cover	Asphalt Shingl
Interior Wall 1	Drywall/Sheetr
Interior Wall 2	
Interior Floor 1	Carpet
Interior Floor 2	
Heating Fuel	Electric
Heating Type	Electr Basebrd
AC Type	Central
Bldg Use	Hospital 94
Bedrooms	
Full Baths	
Half Baths	
1st Floor Use:	
Heat/AC	Heat/AC Split
Frame Type	Wood Frame
Baths/Plumbing	Average
Ceiling/Wall	Ceil & Walls
Rooms/Prtns	Average
Wall Height	10
% Comn Wall	



0136999 03/20/2016

(<http://images.vgsi.com/photos2/BristolCTPhotos/\00\03\34\29.JPG>)

Building Layout

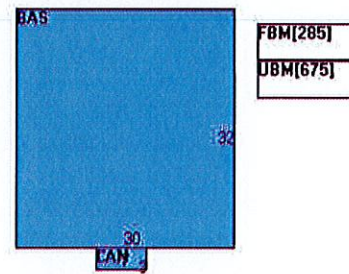

Building Sub-Areas (sq ft)			Legend
Code	Description	Gross Area	Living Area
BAS	First Floor	960	960
CAN	Canopy	21	0
FBM	Basement, Finished	285	0
UBM	Basement, Unfinished	675	0
		1,941	960

Building 2 : Section 1

Year Built: 1996
Living Area: 3,900
Replacement Cost: \$185,406
Building Percent 78
Good:
Replacement Cost
Less Depreciation: \$144,600

Building Attributes : Bldg 2 of 2	
Field	Description
STYLE	Pre-Eng Garage
MODEL	Ind/Comm
Stories:	1
Occupancy	1

Building Photo

Exterior Wall 1	Pre-finish Metl
Exterior Wall 2	
Roof Structure	Gable
Roof Cover	Metal/Tin
Interior Wall 1	Minim/Masonry
Interior Wall 2	
Interior Floor 1	Concr-Finished
Interior Floor 2	
Heating Fuel	Oil
Heating Type	Hot Air-no Duc
AC Type	None
Bldg Use	Hospital 96
Bedrooms	
Full Baths	
Half Baths	
1st Floor Use:	
Heat/AC	None
Frame Type	Steel
Baths/Plumbing	Average
Ceiling/Wall	None
Rooms/Prtns	Average
Wall Height	18
% Comn Wall	

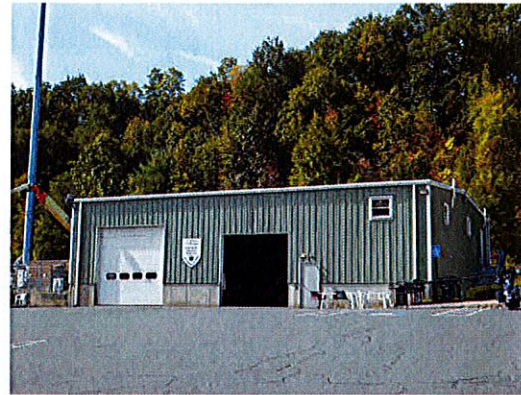

(http://images.vgsi.com/photos2/BristolCTPhotos//\00\02\98\62.jpg)

Building Layout

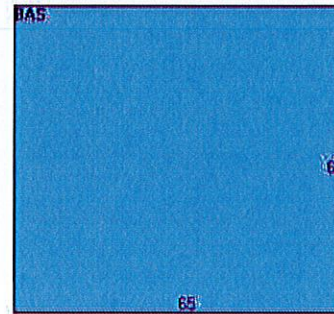

Building Sub-Areas (sq ft)			Legend
Code	Description	Gross Area	Living Area
BAS	First Floor	3,900	3,900
		3,900	3,900

Extra Features

Extra Features				Legend
Code	Description	Size	Value	Bldg #
OHD	Overhead Door	2 Units	\$0	2
MEZ2	Mezzanine Fin.	600 S.F.	\$12,900	2

Land

Land Use

Use Code 928
Description Hospital 94
Zone I
Neighborhood
Alt Land Appr No
Category

Land Line Valuation

Size (Acres) 1.8
Frontage 412
Depth
Assessed Value \$167,370
Appraised Value \$239,100

Outbuildings

Outbuildings						Legend
Code	Description	Sub Code	Sub Description	Size	Value	Bldg #
PAV1	Paving Asph.			8285 S.F.	\$8,700	1
LT1	Light (1fixt)			2 UNITS	\$1,900	1
FN3	Fence 6'			470 L.F.	\$3,600	1
SHD1	Shed	MT	Metal	160 S.F.	\$1,000	1

Valuation History

Appraisal			
Valuation Year	Improvements	Land	Total
2017	\$280,000	\$239,100	\$519,100
2016	\$283,100	\$227,400	\$510,500
2015	\$283,100	\$227,400	\$510,500

Assessment			
Valuation Year	Improvements	Land	Total
2017	\$196,000	\$167,370	\$363,370
2016	\$198,170	\$159,180	\$357,350
2015	\$198,170	\$159,180	\$357,350

(c) 2016 Vision Government Solutions, Inc. All rights reserved.

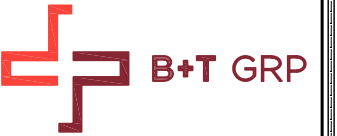

verizon

400 FRIBERG PARKWAY
WESTBOROUGH, MA 01581
PH: (508) 330-3300

BRISTOL W 2 CT

371 TERRYVILLE AVE
BRISTOL, CT 06010
EXISTING MONOPOLE

verizon

**BRISTOL W 2 CT
371 TERRYVILLE AVE
BRISTOL, CT 06010**

PROJECT SUMMARY

SITE NAME: BRISTOL W 2 CT
 SITE ADDRESS: 371 TERRYVILLE AVE
 BRISTOL, CT 06010
 TOWER OWNER: CROWN CASTLE
 2000 CORPORATE DR
 CANONSBURG, PA 15317
 842859
 BU NUMBER: 61-67
 MAP NUMBER: 3
 LOT NUMBER: 3
 CUSTOMER/APPLICANT: VERIZON WIRELESS
 400 FRIEBERG PARKWAY
 WESTBOROUGH, MA 01581
 DAN MYZYRI
 (617) 945-7288
 CONTACT:
 NAD83
 LATITUDE: 41° 40' 47.89" N
 LONGITUDE: 72° 57' 44.79" W
 ELEVATION: 527'
 CURRENT ZONING: I: INDUSTRIAL
 A&E FIRM: B+T GROUP
 1717 S. BOULDER, SUITE 300
 TULSA, OK 74119
 STEVE THORNHILL
 (918) 587-4630
 OCCUPANCY TYPE: UNMANNED
 A.D.A. COMPLIANCE: FACILITY IS UNMANNED AND NOT
 FOR HUMAN HABITATION.

LOCATION MAP

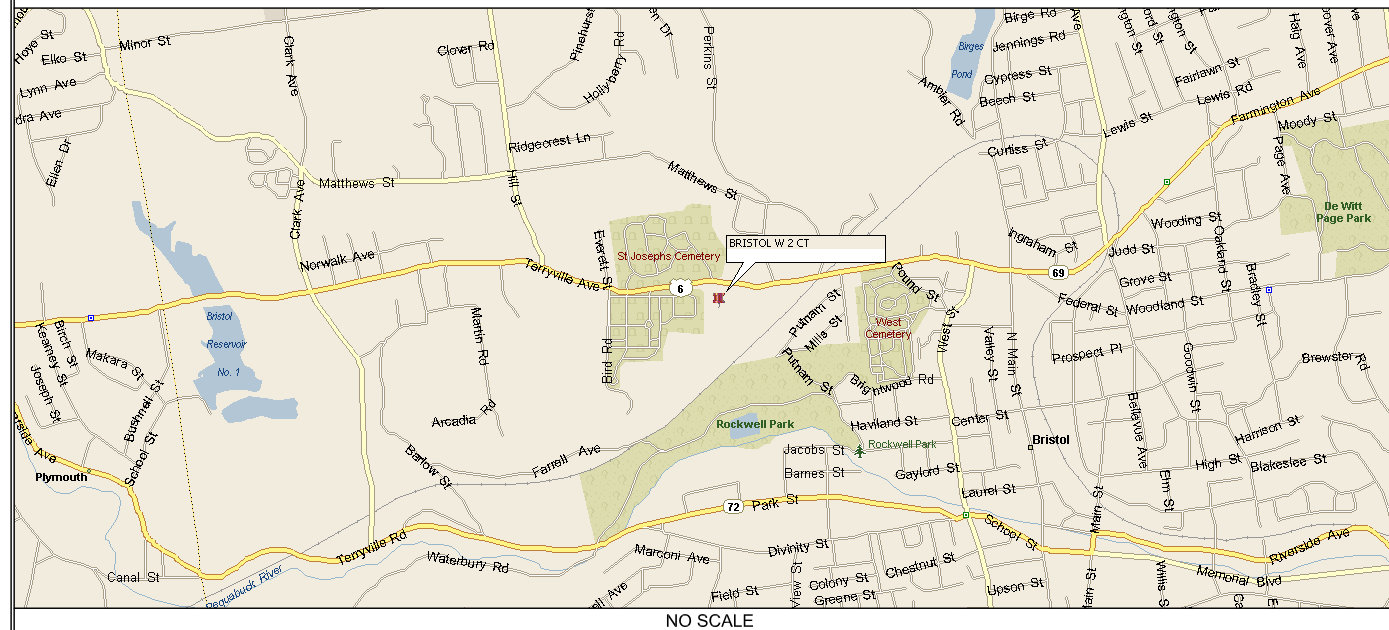

DRIVING DIRECTIONS

DEPART FROM BRADLEY INTERNATIONAL AIRPORT: HEAD NORTHWEST ON SCHOEPHOESTER RD TOWARD AIRPORT SRV RD. CONTINUE ONTO BRADLEY INTERNATIONAL AIRPORT CON. CONTINUE ONTO CT-20 E/BRADLEY INTERNATIONAL AIRPORT CON. TAKE THE EXIT ONTO I-91 S TOWARD HARTFORD. TAKE EXIT 32A-32B FOR I-84 W TOWARD WATERBURY. MERGE ONTO I-84. KEEP LEFT TO STAY ON I-84. TAKE EXIT 33 FOR CT-72 W TOWARD BRISTOL. CONTINUE ONTO CT-72 W. TURN RIGHT ONTO CT-72. CONTINUE STRAIGHT ONTO MEMORIAL BLVD. CONTINUE ONTO SCHOOL ST. TURN RIGHT ONTO WEST ST. TURN LEFT ONTO POUND ST. TURN LEFT ONTO TERRYVILLE AVE DESTINATION WILL BE ON THE LEFT. ARRIVE AT BRISTOL CENTER.

DRAWING INDEX

SHEET #	SHEET DESCRIPTION	REV. #
T-1	TITLE SHEET	0
A-1	COMPOUND PLAN AND TOWER ELEVATION	0
A-2	EQUIPMENT DETAILS	0

A/E DOCUMENT REVIEW STATUS

TITLE	SIGNATURE	DATE
OWNER:		
R.F. ENGINEER:		
CONSTRUCTION MGR.:		
LEASING & ZONING:		
VERIZON WIRELESS:		

THE FOLLOWING PARTIES HEREBY APPROVE AND ACCEPT THESE DOCUMENTS AND AUTHORIZE THE CONTRACTOR TO PROCEED WITH THE CONSTRUCTION DESCRIBED HEREIN. ALL DOCUMENTS ARE SUBJECT TO REVIEW BY THE LOCAL BUILDING DEPARTMENT AND MAY IMPOSE CHANGES OR MODIFICATIONS.

DO NOT SCALE DRAWINGS

ALL DRAWINGS CONTAINED HEREIN ARE FORMATTED FOR 11x17. CONTRACTOR SHALL VERIFY ALL PLANS AND EXISTING DIMENSIONS AND CONDITIONS ON THE JOB SITE AND SHALL IMMEDIATELY NOTIFY THE ENGINEER IN WRITING OF ANY DISCREPANCIES BEFORE PROCEEDING WITH THE WORK OR BE RESPONSIBLE FOR SAME.



CALL CONNECTICUT ONE CALL
(800) 922-4455
CALL 3 WORKING DAYS
BEFORE YOU DIG!



PROJECT NO: 096712.002.01
CHECKED BY: RPS

ISSUED FOR:

REV	DATE	DRWN	DESCRIPTION
A	8/20/18	RMC	PRELIMINARY REVIEW
0	10/15/18	RMC	CONSTRUCTION

B&T ENGINEERING, INC.
PEC.0001564
Expires 2/10/19



IT IS A VIOLATION OF LAW FOR ANY PERSON, UNLESS THEY ARE ACTING UNDER THE DIRECTION OF A LICENSED PROFESSIONAL ENGINEER, TO ALTER THIS DOCUMENT.

SHEET NUMBER: **T-1** REVISION: **0**

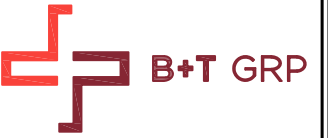

verizon

400 FRIBERG PARKWAY
WESTBOROUGH, MA 01581
PH: (508) 330-3300

BRISTOL W 2 CT

371 TERRYVILLE AVE
BRISTOL, CT 06010
EXISTING MONOPOLE

PROJECT NO: 096712.002.01
CHECKED BY: RPS

ISSUED FOR:

REV	DATE	DRWN	DESCRIPTION
A	8/20/18	RMC	PRELIMINARY REVIEW
0	10/15/18	RMC	CONSTRUCTION

B&T ENGINEERING, INC.
PEC.0001564
Expires 2/10/19



IT IS A VIOLATION OF LAW FOR ANY PERSON, UNLESS THEY ARE ACTING UNDER THE DIRECTION OF A LICENSED PROFESSIONAL ENGINEER, TO ALTER THIS DOCUMENT.

SHEET NUMBER: **A-1** REVISION: **0**

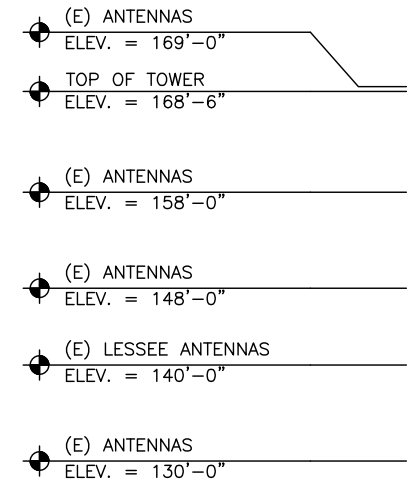

REMOVE:
(3) 30W 700U RRH
(3) 60W AWS RRH
PROPOSED:
(1) 120VP JUNCTION BOX WITH HYBRID CABLE
(3) B5/B13 RRH
(3) B2/B66A RRH
(3) SIDE-BY-SIDE MOUNT BRACKETS

NOTES:
1. CONTRACTOR TO VERIFY EXACT COAX AND ANTENNA INSTALLATION AND ANTENNA HEIGHT WITH LATEST RF DATA SHEETS PRIOR TO INSTALLATION.
2. STRUCTURAL ANALYSIS DONE BY OTHERS.
3. VERIZON SHALL PROVIDE A STRUCTURAL ANALYSIS OF THE TOWER PREPARED BY A LICENSED STATE STRUCTURAL ENGINEER CERTIFYING THAT THE EXISTING TOWER AND PROPOSED IMPROVEMENTS HAVE SUFFICIENT CAPACITY TO SUPPORT ALL NEW WORK THAT WILL BE DONE IN COMPLIANCE WITH THE CURRENT EDITION OF BUILDING CODES AND EIA/TIA CRITERIA. THE CONTRACTOR IS RESPONSIBLE TO CONFIRM THAT ANY AND ALL IMPROVEMENTS REQUIRED BY THE STRUCTURAL ANALYSIS CERTIFICATION ARE PROPERLY INSTALLED PRIOR TO THE ADDITION OF ANTENNAS, SUPPORTS AND APPURTENANCES PROPOSED ON THESE DRAWING OTHERWISE NOTED IN THE STRUCTURAL ANALYSIS.CAP AND WEATHERPROFF UNUSED ANTENNA PORTS.
4. ESTIMATED HYBRIFLEX CABLE LENGTH: 190' (EACH RUN)

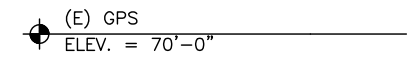

EXISTING 168'-6" MONOPOLE

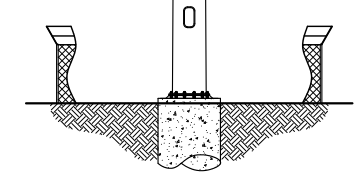

2 FINAL TOWER ELEVATION
SCALE: 1"=20'

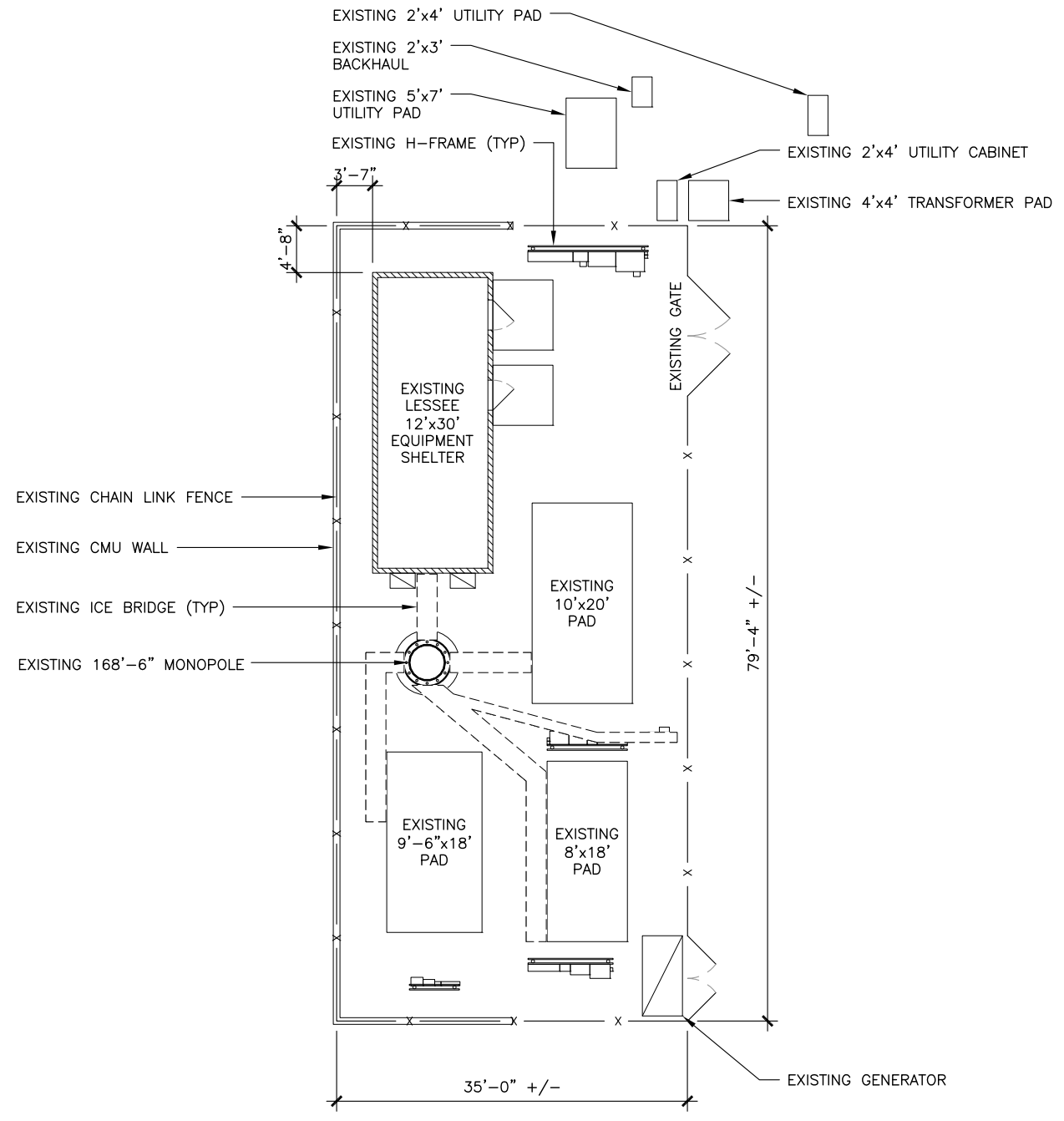

1 COMPOUND PLAN
SCALE: 1"=20'



96712_842859_Bristol Center.dwg - Sheet A-1 - User: rsmith - Oct 15, 2018 - 4:06pm

NOT
AVAILABLE
AT TIME
OF ISSUE

- NOTE:
1. INSTALL ALL EQUIPMENT, MOUNTING BRACKETS AND HARDWARE ACCORDING WITH MANUFACTURE'S RECOMMENDATIONS.
 2. GROUND DISTRIBUTION BOXES, MOUNTING PIPES AND RRHs IN ACCORDANCE WITH MANUFACTURE'S RECOMMENDATIONS.
 3. INSTALLED EQUIPMENT AND MOUNTING BRACKETS SHALL NOT INTERFERE WITH CLIMBING ACCESS NOR ANT INSTALLED SAFETY DEVICES.
 4. EQUIPMENT TO BE INSTALLED AT VERIZON'S RAD. CENTER IN ACCORDANCE WITH TOWER STRUCTURAL ANALYSIS (ANALYSIS BY OTHERS).

REMOTE RADIO HEAD DIMENSIONS (INCHES)				
MODEL	HEIGHT	WIDTH	DEPTH	WEIGHT
RFV01U-D1A	15"	15"	10"	84.40 LBS
RFV01U-D2A	15"	15"	8.10"	70.30 LBS

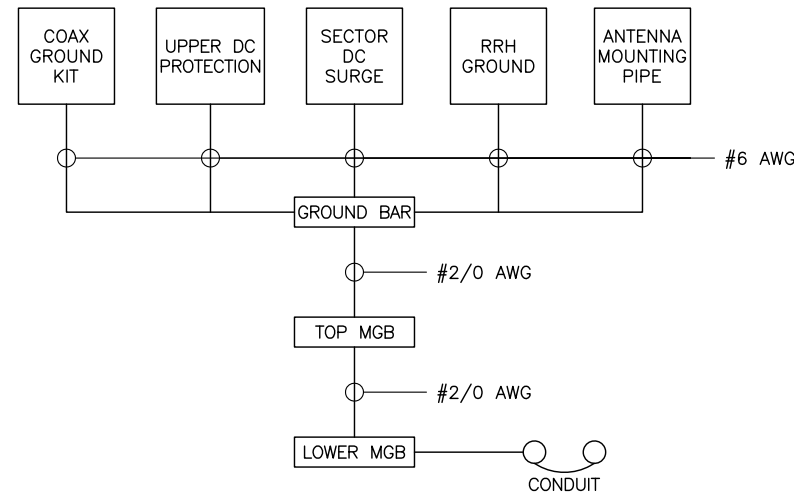

- NOTE:
1. BOND ANTENNA GROUNDING KIT CABLES TO TOP CIBE.
 2. BOND ANTENNA GROUNDING KIT CABLE TO BOTTOM CIBE.
 3. TYPICAL FOR ALL SECTORS.

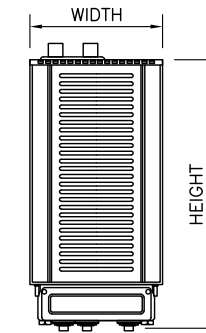

1 ANTENNA SYSTEM LAYOUT
SCALE: N.T.S.

2 GROUNDING SCHEMATIC DIAGRAM
SCALE: N.T.S.

3 RRH SPECIFICATIONS
SCALE: N.T.S.

DC SURGE SUPPRESSION DIMENSIONS (INCHES)				
MODEL	HEIGHT	WIDTH	DEPTH	WEIGHT
RVZDC-6627-PF-48	28.93"	15.73"	10.31"	32 LBS

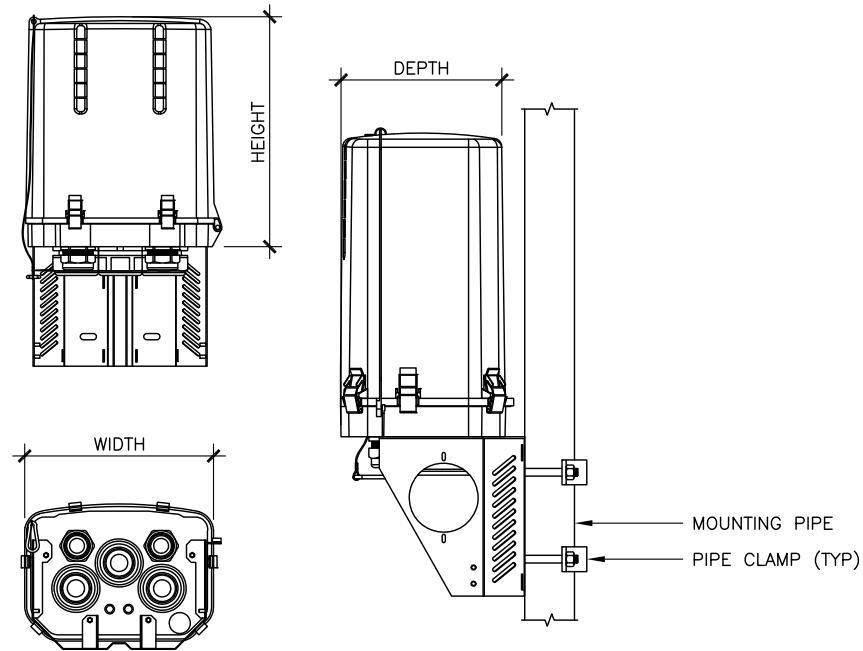

4 RAYCAP SPECIFICATIONS
SCALE: N.T.S.

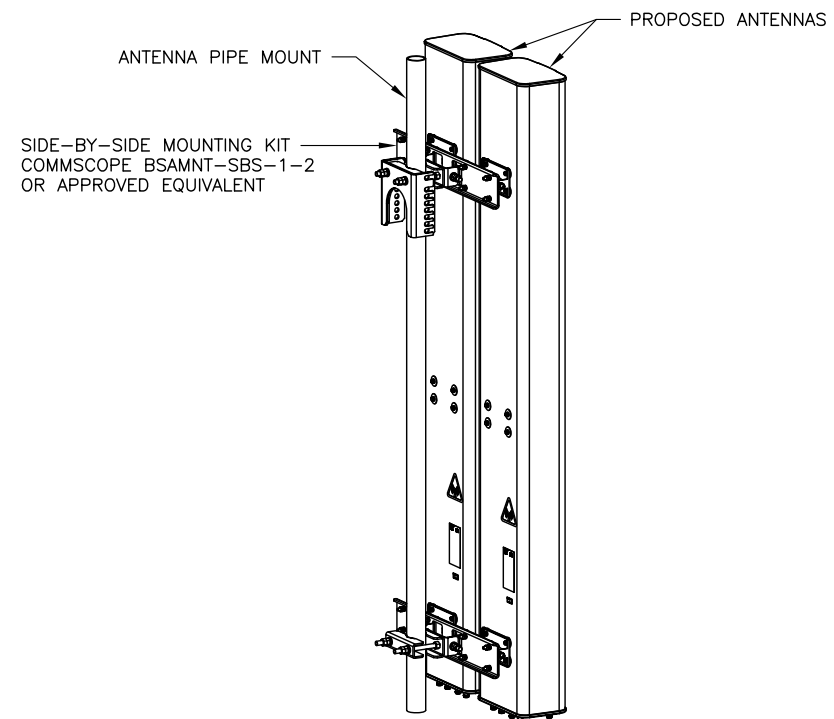

5 ANTENNA MOUNTING DETAIL
SCALE: N.T.S.

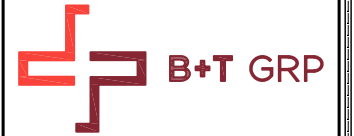

400 FRIBERG PARKWAY
WESTBOROUGH, MA 01581
PH: (508) 330-3300

BRISTOL W 2 CT

371 TERRYVILLE AVE
BRISTOL, CT 06010
EXISTING MONOPOLE

PROJECT NO: 096712.002.01
CHECKED BY: RPS

ISSUED FOR:			
REV	DATE	DRWN	DESCRIPTION
A	8/20/18	RMC	PRELIMINARY REVIEW
0	10/15/18	RMC	CONSTRUCTION

B&T ENGINEERING, INC.
PEC.0001564
Expires 2/10/19



IT IS A VIOLATION OF LAW FOR ANY PERSON, UNLESS THEY ARE ACTING UNDER THE DIRECTION OF A LICENSED PROFESSIONAL ENGINEER, TO ALTER THIS DOCUMENT.

SHEET NUMBER: **A-2** REVISION: **0**



ZONING PERMIT
CITY OF BRISTOL ZONING COMMISSION

THIS IS TO CERTIFY that in accordance with Section XII.D of the Zoning Regulations, This Permit is hereby granted.

PROPERTY INFORMATION

Location: 371 Terryville Avenue
Zoning District: I, Property Use: Telecommunications

TYPE OF PERMIT

- New Construction
- Addition
- Accessory Structure
- Fence
- Deck
- Swimming Pool
- Home Business/Office
- Change of Use
- Other: see Below

SIGNS

- Classification: Permanent Temporary (30-day) Portable (1-Year)
- Type: Wall Freestanding A-Frame Sandwich Other: _____

DESCRIPTION OF ACTIVITY

Construct telecommunications facility, 171' high tower retaining walls & associated equipment per submitted plans

OTHER APPROVALS

Description: CT. Selective Council approval 4/3/02

APPLICANT INFORMATION

Applicant Name(s): Peter Maxwell
Business Name: URS Corp.

This permit is based upon the plan submitted. Falsification, by misrepresentation or omission, or failure to comply with the conditions of approval of this permit shall constitute a violation of the City of Bristol Zoning Regulations.

Approved by: [Signature] 12/9/03
Zoning Enforcement Officer Date Issued

Date: **August 06, 2018**



Amanda Brown
Crown Castle
3530 Toringdon Way Suite 300
Charlotte, NC 28277

Black & Veatch Corp.
6800 W. 115th St., Suite 2292
Overland Park, KS 66211
(913) 458-8145

Subject: **Structural Analysis Report**

Carrier Designation: **Verizon Wireless Co-Locate**

Carrier Site Number: 65617
Carrier Site Name: Bristol W 2 CT

Crown Castle Designation: **Crown Castle BU Number:** 842859
Crown Castle Site Name: BRISTOL CENTER
Crown Castle JDE Job Number: 518915
Crown Castle Work Order Number: 1609286
Crown Castle Order Number: 450296 Rev. 0

Engineering Firm Designation: **Black & Veatch Corp. Project Number:** 194393

Site Data: **371 Terryville Avenue, Bristol, Hartford County, CT**
Latitude 41° 40' 47.71", Longitude -72° 57' 45.18"
168.333 Foot - Monopole Tower

Dear Amanda Brown,

Black & Veatch Corp. is pleased to submit this “**Structural Analysis Report**” to determine the structural integrity of the above mentioned tower. This analysis has been performed in accordance with the Crown Castle Structural ‘Statement of Work’ and the terms of Crown Castle Purchase Order Number 1229112, in accordance with order 450296, revision 0.

The purpose of the analysis is to determine acceptability of the tower stress level. Based on our analysis we have determined the tower stress level for the structure and foundation, under the following load case, to be:

LC7: Proposed Equipment Configuration

Sufficient Capacity

***The structure has sufficient capacity once the loading changes described in the Recommendations section of this report are completed.**

This analysis utilizes an ultimate 3-second gust wind speed of 120 mph (converted an equivalent 93 mph nominal 3-second gust wind speed per Section 1609.3.1 for use with TIA-222-G) as required by the 2016 Connecticut State Building Code. Applicable Standard references and design criteria are listed in Section 2 - Analysis Criteria.

We at *Black & Veatch Corp.* appreciate the opportunity of providing our continuing professional services to you and Crown Castle. If you have any questions or need further assistance on this or any other projects please give us a call.

Structural analysis prepared by: Saranphat Klurvudthikul

Respectfully submitted by:



Ping Jiang, P.E.
Professional Engineer

TABLE OF CONTENTS

1) INTRODUCTION

2) ANALYSIS CRITERIA

Table 1 - Proposed Antenna and Cable Information

Table 2 - Existing and Reserved Antenna and Cable Information

3) ANALYSIS PROCEDURE

Table 3 - Documents Provided

3.1) Analysis Method

3.2) Assumptions

4) ANALYSIS RESULTS

4.1) Wind Results

Table 4 - Section Capacity (Summary)

Table 5 – Tower Components vs. Capacity

4.2) Seismic Results

4.3) Recommendations

5) APPENDIX A

tnxTower Output

6) APPENDIX B

Base Level Drawing

7) APPENDIX C

Additional Calculations

1) INTRODUCTION

This tower is a 168.333 ft Monopole tower designed by Engineered Endeavors, Inc.

The tower has been modified multiple times in the past to accommodate additional loading.

The tower has been modified per reinforcement drawings prepared by Black & Veatch Corp., in May of 2012. Reinforcement consists of addition of reinforcement plates at 0' – 120', stiffener plates at baseplate, and new anchor rods at baseplate. Refer to post modification inspection report by Black & Veatch Corp., in October of 2012. All reinforcement plates are considered ineffective in this analysis.

The tower was later modified per reinforcement drawings prepared by GPD Group, in February of 2013. Reinforcement consists of removal of all stiffener plates. And addition of reinforcement plates at 0.75' – 115.83', stiffener plates at baseplate, and transition stiffeners at baseplate. Refer to legacy modification inspection report by B+T Group in March of 2015.

The tower was later modified per reinforcement drawings prepared by GPD Group, in August of 2013. Reinforcement consists of addition of new rebar into the existing foundation. Refer to post modification observation report by GPD Group in December of 2013.

The tower was later modified per reinforcement drawings prepared by Black & Veatch Corp., in September of 2015. Reinforcement consists of removal of some reinforcement plates at 0' – 84.67' and all stiffener plates. And addition of reinforcement plates at 1.25' – 84.33' and 87.92' – 127.33', stiffener plates at baseplate, transition stiffeners at baseplate, and new rebar into the existing foundation. Refer to modification inspection report by Engineered Tower Solutions, PLLC., in February of 2016.

2) ANALYSIS CRITERIA

TIA-222 Revision:	TIA-222-G
Risk Category:	II
Wind Speed:	120 mph
Exposure Category:	C
Topographic Factor:	1
Ice Thickness:	1 in
Wind Speed with Ice:	50 mph
Seismic Ss:	0.185
Seismic S1:	0.064
Service Wind Speed:	60 mph

Table 1 - Proposed Antenna and Cable Information

Mounting Level (ft)	Center Line Elevation (ft)	Number of Antennas	Antenna Manufacturer	Antenna Model	Number of Feed Lines	Feed Line Size (in)
138.0	140.0	2	antel	BXA-70063/4CF w/ Mount Pipe	1 7	1-1/4 1-5/8
		1	raycap	RVZDC-6627-PF-48		
		3	samsung telecommunications	RFV01U-D1A		
		3	samsung telecommunications	RFV01U-D2A		
		4	antel	BXA-70063/4CF w/ Mount Pipe		
		6	commscope	SBNHH-1D65B w/ Mount Pipe		
		1	rfs celwave	DB-T1-6Z-8AB-0Z		

Mounting Level (ft)	Center Line Elevation (ft)	Number of Antennas	Antenna Manufacturer	Antenna Model	Number of Feed Lines	Feed Line Size (in)
	138.0	1	cci tower mounts	Platform Mount [LP 303-1]		

Table 2 - Existing and Reserved Antenna and Cable Information

Mounting Level (ft)	Center Line Elevation (ft)	Number of Antennas	Antenna Manufacturer	Antenna Model	Number of Feed Lines	Feed Line Size (in)	
168.0	169.0	1	andrew	SBNH-1D6565C w/ Mount Pipe	1 1 2 6 1	3/8 1/2 7/8 1-5/8 2" Conduit	
		3	ericsson	RRUS-11			
		3	kathrein	800 10121 w/ Mount Pipe			
		1	kmw communications	AM-X-CD-16-65-00T-RET w/ Mount Pipe			
		1	kmw communications	AM-X-CD-17-65-00T-RET w/ Mount Pipe			
		6	powerwave technologies	LGP21401			
	168.0	168.0	2	cci antennas	TPA-65R-LCUUUU-H8 w/ Mount Pipe	2 4	3/8 7/8
			3	ericsson	RRUS 32		
			3	ericsson	RRUS 32 B2		
			3	ericsson	RRUS E2 B29		
			1	kathrein	80010798 w/ Mount Pipe		
			1	cci tower mounts	Platform Mount [LP 303-1]		
	167.0	167.0	6	kathrein	860 10025	-	-
			1	raycap	DC6-48-60-18-8F		
158.0	158.0	3	alcatel lucent	1900MHz RRH (65MHz)	3	1-1/4	
		3	alcatel lucent	800 EXTERNAL NOTCH FILTER			
		3	alcatel lucent	800MHZ RRH			
		1	cci tower mounts	T-Arm Mount [TA 602-3]			
		2	powerwave technologies	P40-16-XLPP-RR-A w/ Mount Pipe			
		1	rfs celwave	APXVSPP18-C-A20 w/ Mount Pipe			
		3	alcatel lucent	TD-RRH8x20-25			
	3	rfs celwave	APXVTM14-C-120 w/ Mount Pipe	1	1-1/4		
155.5	155.5	1		PQ-1245L [NA 509-3]			
148.0	148.0	3	rfs celwave	APXV18-206517S-C w/ Mount Pipe	6	1-5/8	
128.0	130.0	3	andrew	ONEBASE TWIN DUAL DUPLEX TMA	1	1-1/4	
		3	ericsson	ERICSSON AIR 21 B2A	12	1-5/8	

Mounting Level (ft)	Center Line Elevation (ft)	Number of Antennas	Antenna Manufacturer	Antenna Model	Number of Feed Lines	Feed Line Size (in)
				B4P w/ Mount Pipe		
		3	ericsson	ERICSSON AIR 21 B4A B2P w/ Mount Pipe		
	128.0	1	cci tower mounts	Platform Mount [LP 303-1]		
70.0	70.0	1	cci tower mounts	Side Arm Mount [SO 701-1]	1	1/2
		1	gps	GPS_A		

3) ANALYSIS PROCEDURE

Table 3 - Documents Provided

Document	Remarks	Reference	Source
4-GEOTECHNICAL REPORTS	FDH Engineering, Inc.	5452600	CCISITES
4-POST-MODIFICATION INSPECTION	Black & Veatch Corp.	5111172	CCISITES
4-POST-MODIFICATION INSPECTION	GPD Group	5114340	CCISITES
4-POST-MODIFICATION INSPECTION	B+T Group	5595874	CCISITES
4-POST-MODIFICATION INSPECTION	Engineered Tower Solutions, PLLC	6121087	CCISITES
4-TOWER FOUNDATION DRAWINGS/DESIGN/SPECS	Engineered Endeavors, Inc.	4529295	CCISITES
4-TOWER MANUFACTURER DRAWINGS	Engineered Endeavors, Inc.	5135435	CCISITES
4-TOWER REINFORCEMENT DESIGN/DRAWINGS/DATA	GPD Group	4964264	CCISITES
4-TOWER REINFORCEMENT DESIGN/DRAWINGS/DATA	GPD Group	5111173	CCISITES
4-TOWER REINFORCEMENT DESIGN/DRAWINGS/DATA	Black & Veatch Corp.	5907572	CCISITES
4-TOWER STRUCTURAL ANALYSIS REPORTS	Black & Veatch Corp. (Mod Design)	5111174	CCISITES

3.1) Analysis Method

tnxTower (version 8.0.2.1), a commercially available analysis software package, was used to create a three-dimensional model of the tower and calculate member stresses for various loading cases. Selected output from the analysis is included in Appendix A.

tnxTower was used to determine the loads on the modified structure. Additional calculations were performed to determine the stresses in the pole and in the reinforcing elements. These calculations are presented in Appendix C.

3.2) Assumptions

- 1) Tower and structures were built and maintained in accordance with the manufacturer's specifications.
- 2) The configuration of antennas, transmission cables, mounts and other appurtenances are as specified in Tables 1 and 2 and the referenced drawings.
- 3) The existing base plate grout was not considered in this analysis.
- 4) This analysis was performed under the assumption that all information provided to Black & Veatch is current and correct. This is to include site data, existing/proposed appurtenance loading, tower/foundation details, and geotechnical data. The existing/proposed loading on the structure is based on CAD level drawings and carrier applications provided by the owner. If any of this information is not current and correct, this report should be considered obsolete and further analysis will be required.

This analysis may be affected if any assumptions are not valid or have been made in error. Black & Veatch Corp. should be notified to determine the effect on the structural integrity of the tower.

4) ANALYSIS RESULTS

4.1) Wind Results

Table 4 - Section Capacity (Summary) (Monopole Tower)

Elevation (ft)	Component Type	Size	Critical Element	% Capacity	Pass / Fail
168.33 - 163.33	Pole	TP19.834x19x0.1875	Pole	10.0%	Pass
163.33 - 158.33	Pole	TP20.669x19.834x0.1875	Pole	18.6%	Pass
158.33 - 153.33	Pole	TP21.503x20.669x0.1875	Pole	32.3%	Pass
153.33 - 148.33	Pole	TP22.337x21.503x0.1875	Pole	44.7%	Pass
148.33 - 143.33	Pole	TP23.171x22.337x0.1875	Pole	56.6%	Pass
143.33 - 138.33	Pole	TP24.006x23.171x0.1875	Pole	67.5%	Pass
138.33 - 134.16	Pole	TP25.313x24.006x0.1875	Pole	81.2%	Pass
134.16 - 129.16	Pole	TP25.149x24.326x0.25	Pole	67.1%	Pass
129.16 - 125.5	Pole	TP25.752x25.149x0.25	Pole	74.7%	Pass
125.5 - 125.25	Pole	TP25.794x25.752x0.25	Pole	75.2%	Pass
125.25 - 120.25	Pole	TP26.617x25.794x0.25	Pole	84.4%	Pass
120.25 - 115.25	Pole	TP27.44x26.617x0.25	Pole	92.9%	Pass
115.25 - 113.83	Pole	TP27.674x27.44x0.25	Pole	95.2%	Pass
113.83 - 113.58	Pole + Reinf.	TP27.715x27.674x0.65	Reinf. 10 Tension Rupture	62.7%	Pass
113.58 - 108.58	Pole + Reinf.	TP28.538x27.715x0.6375	Reinf. 10 Tension Rupture	68.4%	Pass
108.58 - 103.58	Pole + Reinf.	TP29.361x28.538x0.625	Reinf. 10 Tension Rupture	73.8%	Pass
103.58 - 98.58	Pole + Reinf.	TP30.184x29.361x0.6125	Reinf. 10 Tension Rupture	78.8%	Pass
98.58 - 93.58	Pole + Reinf.	TP31.007x30.184x0.6	Reinf. 10 Tension Rupture	83.6%	Pass
93.58 - 89.11	Pole + Reinf.	TP32.493x31.007x0.6	Reinf. 10 Tension Rupture	87.6%	Pass
89.11 - 83.55	Pole + Reinf.	TP32.155x31.242x0.575	Reinf. 2 Tension Rupture	97.3%	Pass
83.55 - 82.83	Pole + Reinf.	TP32.274x32.155x0.575	Reinf. 2 Tension Rupture	97.8%	Pass
82.83 - 82.58	Pole + Reinf.	TP32.315x32.274x0.6875	Reinf. 2 Tension Rupture	82.3%	Pass
82.58 - 77.58	Pole + Reinf.	TP33.135x32.315x0.675	Reinf. 2 Tension Rupture	85.7%	Pass
77.58 - 73.42	Pole + Reinf.	TP33.818x33.135x0.6625	Reinf. 2 Tension Rupture	88.4%	Pass
73.42 - 73.17	Pole + Reinf.	TP33.859x33.818x1.0125	Reinf. 2 Tension Rupture	60.5%	Pass
73.17 - 72.75	Pole + Reinf.	TP33.928x33.859x1.0125	Reinf. 2 Tension Rupture	60.7%	Pass

Elevation (ft)	Component Type	Size	Critical Element	% Capacity	Pass / Fail
72.75 - 72.5	Pole + Reinf.	TP33.969x33.928x0.925	Reinf. 9 Tension Rupture	67.5%	Pass
72.5 - 67.5	Pole + Reinf.	TP34.79x33.969x0.9125	Reinf. 9 Tension Rupture	70.1%	Pass
67.5 - 64.25	Pole + Reinf.	TP35.323x34.79x0.8875	Reinf. 9 Tension Rupture	71.7%	Pass
64.25 - 64	Pole + Reinf.	TP35.364x35.323x0.7375	Reinf. 3 Tension Rupture	82.4%	Pass
64 - 59	Pole + Reinf.	TP36.185x35.364x0.7375	Reinf. 3 Tension Rupture	85.0%	Pass
59 - 54	Pole + Reinf.	TP37.006x36.185x0.7125	Reinf. 3 Tension Rupture	87.5%	Pass
54 - 49	Pole + Reinf.	TP38.702x37.006x0.7125	Reinf. 3 Tension Rupture	89.8%	Pass
49 - 42.66	Pole + Reinf.	TP37.854x37.201x0.7625	Reinf. 4 Tension Rupture	85.0%	Pass
42.66 - 37.66	Pole + Reinf.	TP38.369x37.854x0.7625	Reinf. 4 Tension Rupture	87.8%	Pass
37.66 - 32.66	Pole + Reinf.	TP38.884x38.369x0.75	Reinf. 4 Tension Rupture	90.5%	Pass
32.66 - 28.25	Pole + Reinf.	TP39.339x38.884x0.75	Reinf. 4 Tension Rupture	92.9%	Pass
28.25 - 28	Pole + Reinf.	TP39.365x39.339x1.1	Reinf. 4 Tension Rupture	65.5%	Pass
28 - 27.75	Pole + Reinf.	TP39.391x39.365x1.1	Reinf. 4 Tension Rupture	65.6%	Pass
27.75 - 27.5	Pole + Reinf.	TP39.416x39.391x0.975	Reinf. 8 Tension Rupture	78.8%	Pass
27.5 - 22.5	Pole + Reinf.	TP39.932x39.416x0.975	Reinf. 8 Tension Rupture	81.1%	Pass
22.5 - 19.25	Pole + Reinf.	TP40.267x39.932x0.975	Reinf. 8 Tension Rupture	82.6%	Pass
19.25 - 19	Pole + Reinf.	TP40.292x40.267x0.85	Reinf. 5 Tension Rupture	85.8%	Pass
19 - 14	Pole + Reinf.	TP40.807x40.292x0.8375	Reinf. 5 Tension Rupture	88.0%	Pass
14 - 9	Pole + Reinf.	TP41.323x40.807x0.825	Reinf. 5 Tension Rupture	90.2%	Pass
9 - 4	Pole + Reinf.	TP41.838x41.323x0.825	Reinf. 5 Tension Rupture	92.4%	Pass
4 - 0	Pole + Reinf.	TP42.25x41.838x0.825	Reinf. 5 Tension Rupture	94.0%	Pass
				Summary	
			Pole	95.2%	Pass
			Reinforcement	97.8%	Pass
			Overall	97.8%	Pass

Table 5 - Tower Component Stresses vs. Capacity (Monopole Tower) – LC7

Notes	Component	Elevation (ft)	% Capacity	Pass / Fail
1	Anchor Rods	0	58.4	Pass
	Base Plate		41.7	Pass
1	Base Foundation	0	76.5	Pass
	Base Foundation Soil Interaction		53.4	Pass

4.2) Seismic Results

Tower and foundation have been analyzed based on the seismic criteria outlined in section 2 of this report. Based on the analysis, seismic loading is not governing the tower and foundation stress. Wind loading is governing the tower and foundation stress.

Structure Rating (max from all components) =	97.8%
---	--------------

Notes:

- 1) See additional documentation in "Appendix C – Additional Calculations" for calculations supporting the % capacity consumed.

4.3) Recommendations

The tower and its foundation have sufficient capacity to carry the proposed load configuration. In order for the results of this analysis to be considered valid, the list as follows, must be completed.

1. Shield the front area of the proposed (3) RRUS 32 at 168' level
2. Shield the front area of the proposed (3) RRUS 32 B2 at 168' level
3. Remove the empty mount pipes from the platform at 168' level

No structural modifications are required at this time, provided that the above listed changes are implemented.

Date: July 26, 2018

William Gates
Crown Castle
3 Corporate Dr., St 101
Clifton Park, NY 12065

INFINIGY

FROM ZERO TO INFINIGY
the solutions are endless
Infinigy Engineering, PLLC
1033 Watervliet Shaker Road
Albany, NY 12205
518-690-0790
structural@infinigy.com

Subject: Mount Structural Analysis

Carrier Designation: Verizon Wireless Change-Out
Carrier Site Number: 65617
Carrier Site Name: Bristol W 2 CT

Crown Castle Designation: Crown Castle BU Number: 842859
Crown Castle Site Name: Bristol Center
Crown Castle JDE Job Number: 518915
Crown Castle Application Number: 450296, Rev.0

Engineering Firm Designation: Infinigy Report Designation: 600-004

Site Data: 371 Terryville Avenue, Bristol, Hartford County, CT 06010
Latitude 41° 40' 47.71" Longitude -72° 57' 45.18"

Structure Information: Tower Height & Type: 168.5 Foot Monopole Tower
Mount Elevation: 138 ft
Mount Type: 12.5 ft Platform

Dear William Gates,

Infinigy Engineering, PLLC is pleased to submit this "Mount Structural Analysis Report" to determine the structural integrity of Verizon Wireless's antenna existing mounting system with the proposed appurtenance on the abovementioned supporting tower structure. Analysis of the existing supporting tower structure is to be completed by others and therefore is not part of this analysis. Analysis of the antenna mounting system as a tie-off point for fall protection or rigging is not part of this document.

Based upon our analysis, we have determined the adequacy of the antenna mounting system that will support the proposed loading to be:

Platform

Sufficient Capacity

This analysis has been performed in accordance with the 2012 International Building Code and 2016 Connecticut State Building Code and the Infinigy Engineering, PLLC wind speed requirement of a 93 mph nominal 3-second gust wind speed as required for use in the ANSI/TIA-222-G Standard per Exception #5 of Section 1609.1. Exposure Category C and Risk Category II were used in this analysis.

We at Infinigy Engineering, PLLC appreciate the opportunity of providing our continuing professional services to you and Crown Castle. If you have any questions or need further assistance on this or any other projects, please give us a call.

Mount structural analysis prepared by: Dmitriy Albul, P.E.

Respectfully Submitted by:

Joe Johnston, P.E.
VP Structural Engineering / Principal

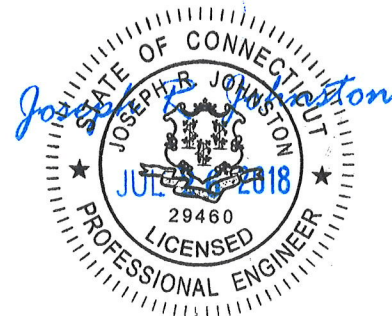

TABLE OF CONTENTS

1) INTRODUCTION

2) ANALYSIS CRITERIA

Table 1 - Proposed Equipment Loading Information

Table 2 - Existing Equipment Loading Information

3) ANALYSIS PROCEDURE

Table 3 - Documents Provided

3.1) Analysis Method

3.2) Assumptions

4) ANALYSIS RESULTS

Table 4 - Mount Component Stresses vs. Capacity

4.1) Recommendations

5) APPENDIX A

Wire Frame and Rendered Models

6) APPENDIX B

Software Input Calculations

7) APPENDIX C

Software Analysis Output

8) APPENDIX D

Reference Documents

1) INTRODUCTION

The existing mount installation will consist of 12.5 ft wide Platform at the 138 ft elevation. The proposed antenna loading was obtained from the Application provided by CCI, Application Number 450296, Revision 0 and the Mount Photos, dated 10/25/2017.

2) ANALYSIS CRITERIA

The structural analysis was performed in accordance with the requirements of TIA 222-G Structural Standards for Steel Antenna Towers and Antenna Supporting Structures using a 3-second gust wind speed of 93 mph with no ice, 50 mph with 1.0 inch escalated ice thickness, Exposure Category C and Topographic Category 1. In addition, the Platform has been analyzed for a load combination consisting of a 250-pound man live load using a 3-second wind gustwind speed of 30 mph.

Table 1 - Proposed Equipment Loading Information

Mount Centerline (ft)	Antenna Centerline (ft)	Number of Antennas	Antenna Manufacturer	Antenna Model	Proposed Mount Type	Note
138.0	140.0	2	Antel	BXA-70063/4CF	-	1
		1	Raycap	RVZDC-6627-PF-48		
		3	Samsung	RFV01U-D1A		
		3	Samsung	RFV01U-D2A		

Notes:

- 1) Proposed equipment

Table 2 - Existing Antenna and Cable Information

Mount Centerline (ft)	Antenna Centerline (ft)	Number of Antennas	Antenna Manufacturer	Antenna Model	Existing Mount Type	Note
138.0	140.0	4	Antel	BXA-70063/4CF	12.5ft Platform	1
		6	Commscope	SBNHH-1D65B		
		1	RFS	DB-T1-6Z-8AB-0Z		
		2	Antel	BXA-70080-6CF-4	-	2
		6	RFS	FD9R6004/2C-3L		
		3	Ericsson	AIR 21 B2A B4P		
		3	Alcatel-Lucent	RRH2x60-PCS		
		3	Alcatel-Lucent	RRH2x60-700		
		3	Alcatel-Lucent	RRH2x60-AWS		

Notes:

- 1) Existing Equipment to Remain
- 2) Existing Equipment to be Removed

3) ANALYSIS PROCEDURE

Table 3 - Documents Provided

Document	Remarks	Reference	Source
Crown Application	Verizon Wireless Application	450296, Rev.0	CCI Sites
Mount Photos	Verizon Wireless	842859	CCI Sites
Design Drawings	Mount	Part # MT-196	Andrew

3.1) Analysis Method

RISA-3D (Version 16.0.5), a commercially available analysis software package, was used to create a three-dimensional model of the antenna mounting system and calculate member stresses for various loading cases.

Infinigy Mount Analysis Tool 3.0.2, a tool internally developed by Infinigy, was used to calculate member loading for various load cases. Selected output from the analysis is included in Appendix B.

3.2) Assumptions

- 1) The antenna mounting system was properly fabricated, installed and maintained in good condition in accordance with its original design and manufacturer's specifications.
- 2) The configuration of antennas, mounts, and other appurtenances are as specified in Tables 1 and 2 and the referenced drawings.
- 3) All member connections are assumed to have been designed to meet or exceed the load carrying capacity of the connected member unless otherwise specified in this report.
- 4) Steel grades have been assumed as follows:

Channel, Solid Round, Angle, Plate	ASTM A36 (GR 36)
HSS (Rectangular)	ASTM A500 (GR B-46)
Pipe	ASTM A53 (GR 35)
Connection Bolts	ASTM A325

This analysis may be affected if any assumptions are not valid or have been made in error. Crown Castle should be notified to determine the effect on the structural integrity of the antenna mounting system.

4) ANALYSIS RESULTS

Table 4 - Mount Component Stresses vs. Capacity (Platform)

Notes	Component	Mount Centerline (ft)	% Capacity	Pass / Fail
1,2	Face Horizontal	138.0	38.2%	Pass
	Mount Pipe		39.0%	Pass
	Arm		72.2%	Pass
	Angle		26.1%	Pass
	Bolts		15.1%	Pass

Structure Rating (max from all components) =	72.2%
---	--------------

Notes:

- 1) See additional documentation in "Appendix C - Analysis Output" for calculations supporting the % capacity consumed.
- 2) All sectors are typical

4.1) Recommendations

The mount has sufficient capacity to carry the proposed loading configuration. No modifications are required at this time.

General Power Density

Site Name: Bristol West 2, CT

Cumulative Power Density

Operator	Operating Frequency	Number of Trans.	ERP Per Trans.	Total ERP	Distance to Target	Calculated Power Density	Maximum Permissible Exposure*	Fraction of MPE
	(MHz)		(watts)	(watts)	(feet)	(mW/cm ²)	(mW/cm ²)	(%)
VZW PCS	1970	1	6399	6399	140	0.1174	1.0	11.74%
VZW Cellular LTE	869	1	3476	3476	140	0.0638	0.579333333	11.01%
VZW Cellular	869	3	386	1158	140	0.0212	0.579333333	3.67%
VZW AWS LTE	2145	1	6578	6578	140	0.1207	1.0	12.07%
VZW 700 LTE	746	1	2931	2931	140	0.0538	0.497333333	10.81%

Total Percentage of Maximum Permissible Exposure

49.30%

*Guidelines adopted by the FCC on August 1, 1996, 47 CFR Section 1.13101 based on NCRP Report 86, 1986 and generally on ANSI/IEEE C95.1-

MHz = Megahertz

mW/cm² = milliwatts per square centimeter

ERP = Effective Radiated Power

Absolute worst case maximum values used, including the following assumptions:

1. closest accessible point is distance from antenna to base of pole;
2. continuous transmission from all available channels at full power for indefinite time period; and,
3. all RF energy is assumed to be directed solely to the base of the pole.

General Power Density

-1992



November 15, 2018

Dear Customer:

The following is the proof-of-delivery for tracking number **773714228443**.

Delivery Information:

Status:	Delivered	Delivered to:	Shipping/Receiving
Signed for by:	K.PERRY	Delivery location:	41 BREWSTER RD BRISTOL, CT 06010
Service type:	FedEx Priority Overnight	Delivery date:	Nov 14, 2018 10:13
Special Handling:	Deliver Weekday		



Shipping Information:

Tracking number:	773714228443	Ship date:	Nov 13, 2018
		Weight:	1.0 lbs/0.5 kg

Recipient:
Admin.
Bristol Hospital
Brewster Rd.
BRISTOL, CT 06010 US

Shipper:
Kristian McKay
3530 Toringdon Way
STE 300
CHARLOTTE, NC 28277 US

Reference 1766.6680

Thank you for choosing FedEx.



November 15, 2018

Dear Customer:

The following is the proof-of-delivery for tracking number **773714029580**.

Delivery Information:

Status:	Delivered	Delivered to:	Receptionist/Front Desk
Signed for by:	O.SOAKI	Delivery location:	111 N MAIN ST 2ND FLOOR BRISTOL, CT 06010
Service type:	FedEx Priority Overnight	Delivery date:	Nov 14, 2018 10:49
Special Handling:	Deliver Weekday		



Shipping Information:

Tracking number:	773714029580	Ship date:	Nov 13, 2018
		Weight:	1.0 lbs/0.5 kg

Recipient:
Guy Morin
Town of Bristol Building Dept.
111 N. Main St. 2nd floor
BRISTOL, CT 06010 US

Shipper:
Kristian McKay
3530 Toringdon Way
STE 300
CHARLOTTE, NC 28277 US

Reference 1766.6680

Thank you for choosing FedEx.



November 15, 2018

Dear Customer:

The following is the proof-of-delivery for tracking number **773714017429**.

Delivery Information:

Status:	Delivered	Delivered to:	Receptionist/Front Desk
Signed for by:	A.SAVINO	Delivery location:	111 N MAIN ST 2ND FLOOR BRISTOL, CT 06010
Service type:	FedEx Priority Overnight	Delivery date:	Nov 14, 2018 10:50
Special Handling:	Deliver Weekday		

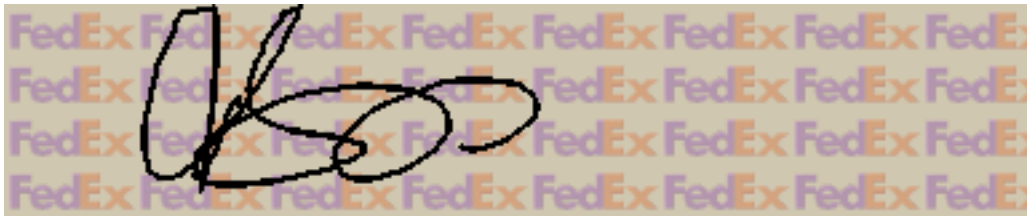

Shipping Information:

Tracking number:	773714017429	Ship date:	Nov 13, 2018
		Weight:	1.0 lbs/0.5 kg

Recipient:
Ellen Zoppo-sassu
Town of Bristol
111 N. Main St. 2nd floor
BRISTOL, CT 06010 US

Shipper:
Kristian McKay
3530 Toringdon Way
STE 300
CHARLOTTE, NC 28277 US

Reference 1766.6680

Thank you for choosing FedEx.