

John Coleman, Project Manager  
c/o Cellco Partnership d/b/a Verizon Wireless  
Centerline Communications, LLC  
750 West Center Street, Floor 3  
West Bridgewater, MA 02379  
Mobile: (240) 615 -7389  
[JColeman@clinellc.com](mailto:JColeman@clinellc.com)

July 18, 2022

Melanie A. Bachman  
Acting Executive Director  
Connecticut Siting Council  
10 Franklin Square  
New Britain, CT 06051

**RE: Notice of Exempt Modification // Site: BRIDGEPORT NORTH (ATC: 383598)  
655 Bassett Road, Watertown, CT 06795  
N 42.2196 // W 73.2013**

Dear Ms. Bachman:

Cellco Partnership d/b/a Verizon Wireless currently maintains 12 antennas at the 155 foot mount on the existing 240 foot monopole tower, located at 1000 Trumbull Ave, Bridgeport, CT. The tower is owned by American Tower. The property is owned by Global Tower Assets, LLC which is a subsidiary of American Tower. The tower was originally approved by the Council in 1990. Verizon Wireless now intends to install 3 new antenna and three (3) RRH's for its 5G (3700 MHz) upgrade; altogether updating leased equipment rights, as reflected by the final configuration outlined in the structural analysis and proposed hereby.

Please accept this letter as notification pursuant to Regulations of Connecticut State Agencies §16-50j-73, for construction that constitutes an exempt modification pursuant to R.C.S.A. § 16-50j-72(b)(2). In accordance with R.C.S.A. § 16-50j-73, a copy of this letter is being sent to Joseph Peter Ganim, Mayor of Bridgeport, Dennis Buckley Zoning Enforcement Officer, American Tower, the tower owner and property owner.

The planned modifications to the facility fall squarely within those activities explicitly provided for in R.C.S.A. § 16-50j-72(b)(2). Enclosed to accommodate this filing are construction drawings dated June 30, 2021 by Dewberry Engineers, Inc., a structural analysis dated July 6, 2021 by A.T. Engineering Services PLLC., a structural mount analysis by Maser Consulting Connecticut dated June 11, 2021, and radio frequency (RF) analysis table showing worst-case RF emission calculation by Verizon Wireless RF Design Engineering.

1. The proposed modifications will not result in an increase in the height of the existing structure.

2. The proposed modifications will not require the extension of the site boundary.
3. The proposed modifications will not increase noise levels at the facility by six decibels or more, or to levels that exceed state and local criteria.
4. The operation of the new antennas will not increase radio frequency emissions at the facility to a level at or above the Federal Communications Commission safety standard.
5. The proposed modifications will not cause a change or alteration in the physical or environmental characteristics of the site.
6. The existing structure and its foundation can support the proposed loading, as shown in the attached structural analysis by A.T. Engineering Service, PLLC, dated July 6, 2021, structural mount analysis by Maser Consulting Connecticut dated June 11, 2021, pursuant to certain conditions defined therein. Design and engineering is fully illustrated within final construction drawings, signed and stamped dated June 30, 2021.

For the foregoing reasons, Verizon Wireless respectfully submits that the proposed modifications to the above referenced telecommunications facility constitute an exempt modification under R.C.S.A. § 16-50j-72(b)(2).

Sincerely,

*John Coleman*

---

John Coleman, Project Manager  
c/o Cellco Partnership d/b/a Verizon Wireless  
Centerline Communications, LLC  
750 West Center Street, Floor 3  
West Bridgewater, MA 02379  
Mobile: (240) 615 -7389  
[JColeman@clinellc.com](mailto:JColeman@clinellc.com)

Attachments

cc: Joseph Peter Ganim - as chief elected official  
Dennis Buckley, Zoning Enforcement Officer - as P&Z official  
American Tower Corporation - as tower owner & Property Owner

UPS CampusShip: View/Print Label

- 1. **Ensure there are no other shipping or tracking labels attached to your package.** Select the Print button on the print dialog box that appears. Note: If your browser does not support this function select Print from the File menu to print the label.
- 2. **Fold the printed label at the solid line below.** Place the label in a UPS Shipping Pouch. If you do not have a pouch, affix the folded label using clear plastic shipping tape over the entire label.
- 3. **GETTING YOUR SHIPMENT TO UPS**  
**Customers with a Daily Pickup**  
 Your driver will pickup your shipment(s) as usual.

**Customers without a Daily Pickup**



Take your package to any location of The UPS Store®, UPS Access Point(TM) location, UPS Drop Box, UPS Customer Center, Staples® or Authorized Shipping Outlet near you. Items sent via UPS Return Services(SM) (including via Ground) are also accepted at Drop Boxes. To find the location nearest you, please visit the Resources area of CampusShip and select UPS Locations.  
 Schedule a same day or future day Pickup to have a UPS driver pickup all your CampusShip packages.  
 Hand the package to any UPS driver in your area.

UPS Access Point™  
 CVS STORE # 972  
 555 WASHINGTON ST  
 SOUTH EASTON ,MA 02375

UPS Access Point™  
 CVS STORE # 7232  
 689 DEPOT ST  
 NORTH EASTON ,MA 02356

UPS Access Point™  
 TOWN LINE GENERAL STORE  
 450 E CENTER ST  
 WEST BRIDGEWATER ,MA 02379

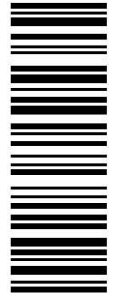
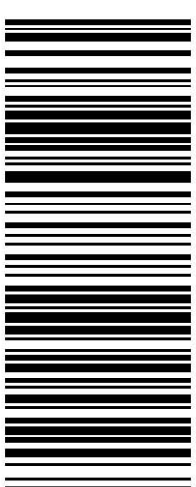
FOLD HERE

<p style="text-align: right;"><b>1 OF 1</b></p> <p style="text-align: center;"><b>1 LBS</b></p> <p>MJUMALI        9785687906        CENTERLINE COMMUNICATIONS, LLC        750 WEST CENTER STREET        WEST BRIDGEWATER, MA 02379</p> <p><b>SHIP TO:</b>        JOSEPH P. GANIM        MAYOR OR BRIDGEPORT CT        999 BROAD STREET        MARGARET E. MORTON GVT CENTER        BRIDGEPORT CT 06604-4320</p>	<p style="font-size: 2em;"><b>CT 066 9-04</b></p> 	<p style="font-size: 1.5em;"><b>UPS GROUND</b></p> <p>TRACKING #: 1Z 9Y4 503 03 0387 8954</p> 	<p style="text-align: center;"><b>BILLING: P/P</b></p> <p style="text-align: center;">Reference # 1: 383598        Reference # 2: Tartaglia  <small>CG 22.0.18. WNTNIN50 31.DA 07/2021*</small></p> 
---	---	--	---

# Proof of Delivery

Dear Customer,

This notice serves as proof of delivery for the shipment listed below.

**Tracking Number**

1Z9Y45030303878954

**Weight**

1.00 LBS

**Service**

UPS Ground

**Shipped / Billed On**

08/05/2021

**Delivered On**

09/16/2021 11:39 A.M.

**Delivered To**

BRIDGEPORT, CT, US

**Received By**

ELLA

**Left At**

Office

Thank you for giving us this opportunity to serve you. Details are only available for shipments delivered within the last 120 days. Please print for your records if you require this information after 120 days.

Sincerely,

UPS

Tracking results provided by UPS: 10/25/2021 12:09 P.M. EST

UPS CampusShip: View/Print Label

- 1. **Ensure there are no other shipping or tracking labels attached to your package.** Select the Print button on the print dialog box that appears. Note: If your browser does not support this function select Print from the File menu to print the label.
- 2. **Fold the printed label at the solid line below.** Place the label in a UPS Shipping Pouch. If you do not have a pouch, affix the folded label using clear plastic shipping tape over the entire label.
- 3. **GETTING YOUR SHIPMENT TO UPS**  
**Customers with a Daily Pickup**  
 Your driver will pickup your shipment(s) as usual.

**Customers without a Daily Pickup**



Take your package to any location of The UPS Store®, UPS Access Point(TM) location, UPS Drop Box, UPS Customer Center, Staples® or Authorized Shipping Outlet near you. Items sent via UPS Return Services(SM) (including via Ground) are also accepted at Drop Boxes. To find the location nearest you, please visit the Resources area of CampusShip and select UPS Locations.  
 Schedule a same day or future day Pickup to have a UPS driver pickup all your CampusShip packages.  
 Hand the package to any UPS driver in your area.

UPS Access Point™  
 CVS STORE # 972  
 555 WASHINGTON ST  
 SOUTH EASTON ,MA 02375

UPS Access Point™  
 CVS STORE # 7232  
 689 DEPOT ST  
 NORTH EASTON ,MA 02356

UPS Access Point™  
 TOWN LINE GENERAL STORE  
 450 E CENTER ST  
 WEST BRIDGEWATER ,MA 02379

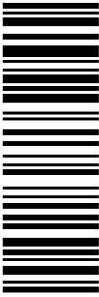
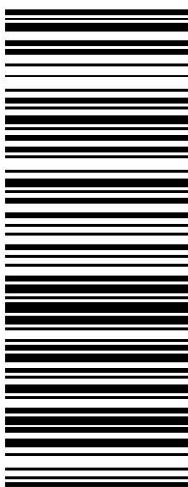
FOLD HERE

<p style="text-align: right;"><b>1 OF 1</b></p> <p style="text-align: center;"><b>1 LBS</b></p> <p>MJUMALT        9785687906        CENTERLINE COMMUNICATIONS, LLC        750 WEST CENTER STREET        WEST BRIDGEWATER, MA 02379</p> <p><b>SHIP TO:</b>        DENNIS BUCKLEY        ZONING ADMINISTRATOR        45 LYON TERRACE ROOM 210        CITY HALL        ZONING DEPARTMENT  <b>BRIDGEPORT CT 06604-4023</b></p>	<p style="font-size: 2em;"><b>CT 066 9-04</b></p> 	<p style="font-size: 1.5em;"><b>UPS GROUND</b></p> <p>TRACKING #: 1Z 9Y4 503 03 1967 1969</p> 	<p style="text-align: right;"><b>BILLING: P/P</b></p> <p style="text-align: right;">Reference # 1: 383598        Reference # 2: Tartaglia  <small>CG 22.0.18. WNTNIN50 31.0A 07/2021*</small></p> 
--	---	---	---

383598

# Proof of Delivery

Dear Customer,

This notice serves as proof of delivery for the shipment listed below.

**Tracking Number**

1Z9Y45030319671969

**Weight**

1.00 LBS

**Service**

UPS Ground

**Shipped / Billed On**

08/05/2021

**Delivered On**

11/02/2021 3:10 P.M.

**Delivered To**

BRIDGEPORT, CT, US

**Received By**

DENNI

**Left At**

Office

Thank you for giving us this opportunity to serve you. Details are only available for shipments delivered within the last 120 days. Please print for your records if you require this information after 120 days.

Sincerely,

UPS

Tracking results provided by UPS: 01/18/2022 1:46 P.M. EST

UPS CampusShip: View/Print Label

- 1. **Ensure there are no other shipping or tracking labels attached to your package.** Select the Print button on the print dialog box that appears. Note: If your browser does not support this function select Print from the File menu to print the label.
- 2. **Fold the printed label at the solid line below.** Place the label in a UPS Shipping Pouch. If you do not have a pouch, affix the folded label using clear plastic shipping tape over the entire label.
- 3. **GETTING YOUR SHIPMENT TO UPS**  
**Customers with a Daily Pickup**  
 Your driver will pickup your shipment(s) as usual.

**Customers without a Daily Pickup**



Take your package to any location of The UPS Store®, UPS Access Point(TM) location, UPS Drop Box, UPS Customer Center, Staples® or Authorized Shipping Outlet near you. Items sent via UPS Return Services(SM) (including via Ground) are also accepted at Drop Boxes. To find the location nearest you, please visit the Resources area of CampusShip and select UPS Locations.  
 Schedule a same day or future day Pickup to have a UPS driver pickup all your CampusShip packages.  
 Hand the package to any UPS driver in your area.

UPS Access Point™  
 CVS STORE # 972  
 555 WASHINGTON ST  
 SOUTH EASTON ,MA 02375

UPS Access Point™  
 CVS STORE # 7232  
 689 DEPOT ST  
 NORTH EASTON ,MA 02356

UPS Access Point™  
 TOWN LINE GENERAL STORE  
 450 E CENTER ST  
 WEST BRIDGEWATER ,MA 02379

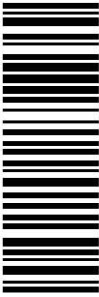
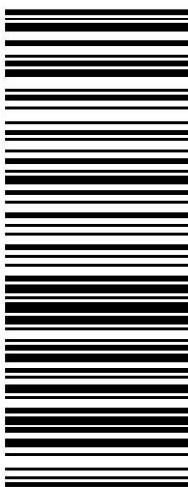
FOLD HERE

<p style="text-align: right;"><b>1 OF 1</b></p> <p style="text-align: right;"><b>1 LBS</b></p> <p>MJUMALT        9785687906        CENTERLINE COMMUNICATIONS, LLC        750 WEST CENTER STREET        WEST BRIDGEWATER, MA 02379</p> <p><b>SHIP TO:</b>        LAND MANAGEMENT        7814287250        AMERICAN TOWER CORPORATION        10 PRESIDENTIAL WAY        WOBURN MA 01801-1053</p>	<p style="font-size: 2em; font-weight: bold;">MA 018 9-04</p> 	<p style="font-size: 1.5em; font-weight: bold;">UPS GROUND</p> <p>TRACKING #: 1Z 9Y4 503 03 1406 6971</p> 	 <p>Reference # 1: 383598        Reference # 2: Tartaglia  <small>CG 22.0.18. WNTNIN50 31.0A 07/2021*</small></p>
<b>BILLING: P/P</b>			

# Proof of Delivery

Dear Customer,

This notice serves as proof of delivery for the shipment listed below.

**Tracking Number**

1Z9Y45030314066971

**Weight**

1.00 LBS

**Service**

UPS Ground

**Shipped / Billed On**

08/05/2021

**Delivered On**

11/02/2021 11:07 A.M.

**Delivered To**

WOBURN, MA, US

**Received By**

ANCRI

**Left At**

Front Desk

Thank you for giving us this opportunity to serve you. Details are only available for shipments delivered within the last 120 days. Please print for your records if you require this information after 120 days.

Sincerely,

UPS

Tracking results provided by UPS: 01/18/2022 1:47 P.M. EST



018651

NOTICE OF GRANTING OF VARIANCE,  
SPECIAL EXCEPTION, SPECIAL PERMIT

Pursuant to Chapter 1 (C.G.S. § 8-75-317) of the General Statutes of the State of Connecticut, notice is hereby given that August 17, 1987, the Zoning Board of Appeals of the City of Bridgeport, Connecticut, granted or granted conditionally a variance, special exception, special permit for property located 1330 Chopsey Hill Road and 800 Trumbull Avenue.

DESCRIPTION OF PROPERTY (lot size) about 6 acres (for description see Schedule A attached)

Property owned by The [redacted] Development Co., Inc.

NATURE OF VARIANCE, SPECIAL EXCEPTION, SPECIAL PERMIT

Chapter      Section   2   Chapter   4   Section     

Chapter      Section      Chapter      Section     

Chapter      Section      Chapter      Section     

ZONING REGULATIONS - CITY OF BRIDGEPORT, CONNECTICUT

IS PERMITTED erection of a 250' high radio station tower and accessory transmission equipment building

Dated and published by the Zoning Board of Appeals, Bridgeport, Connecticut, this 3 day of September, 1987.

BY [Signature]  
Chmn \_\_\_\_\_ Secr'y \_\_\_\_\_ Clerk

2011 Mar 140

SCHEDULE A

All that certain parcel of land situated in the City of Bridgeport, County of Fairfield and the State of Connecticut and more particularly bounded and described as follows:

WESTERLY: by the east street line of Chopsey Hill Road, 140 feet

NORTHERLY: by land N/F of City of Bridgeport (Samuel Johnson Elementary School), 711 feet

EASTERLY: by land N/F of State of Connecticut (Beardsley Terrace Apts.), 9 feet M/L;

SOUTHERLY: by the north street line of Trumbull Avenue., 45 feet M/L

Recorded for record September 16, 1987 at 12:47 P.M.

A. EST

*Hector Diaz*  
Hector Diaz, Town Clerk

018070

NO. 2750-11

NOTICE OF GRANT OF VARIANCE,  
SPECIAL EXCEPTION, OR SPECIAL PERMIT

Pursuant to Chapter 124 (PA-75-317) of the General Statutes  
of the State of Connecticut, notice is hereby given that on  
November 1989, the Zoning Board of Appeals of the City  
of Bridgeport, Connecticut, granted or granted conditionally  
variance, special exception, special permit for property located  
at 1330 Chosey Hill Road, Bridgeport.

DESCRIPTION OF PROPERTY (lot size Three (3) ± ac.

Property owned by Chase Hill Associates

NATURE OF VARIANCE, SPECIAL EXCEPTION, SPECIAL PERMIT

Chapter Section 3 Chapter Section  
Chapter Section Chapter Section  
Chapter Section Chapter Section

ZONING REGULATIONS - CITY OF BRIDGEPORT, CONNECTICUT

USE PERMITTED To construct a 4' x 6' addition to the existing  
nonconforming transmission building extension + enlargement  
of a non conforming use in an A-Residence zone.

Dated and approved by the Zoning Board of Appeals, Bridgeport,  
Connecticut this 9<sup>th</sup> day of Dec, 1989.

BY Dennis Buckley  
Chmn. Sec'y Clerk  
Enforcement Officers

RECEIVED FOR RECORD Dec. 19, 1989 at 9:37 A.M.

David A. Trefl

ATTEST:

TOWN CLERK



**AMERICAN TOWER®**  
CORPORATION

---

## Structural Analysis Report

**Structure** : 240 ft Self Supported Tower  
**ATC Site Name** : Tartaglia, CT  
**ATC Asset Number** : 383598  
**Engineering Number** : 13668689\_C3\_03  
**Proposed Carrier** : VERIZON WIRELESS  
**Carrier Site Name** : BRIDGEPORT NORTH  
**Carrier Site Number** : 467325  
**Site Location** : 1000 Trumbull Avenue  
Bridgeport, CT 06606  
41.219600,-73.201300  
**County** : Fairfield  
**Date** : July 6, 2021  
**Max Usage** : 98%  
**Result** : Pass

Prepared By:  
Hussam Al Tahan  
Structural Engineer II

*Hussam Al Tahan*

Reviewed By:



**COA: PEC.0001553**



**Table of Contents**

Introduction .....	1
Supporting Documents .....	1
Analysis .....	1
Conclusion.....	1
Existing and Reserved Equipment.....	2
Equipment to be Removed.....	3
Proposed Equipment .....	3
Structure Usages .....	4
Foundations .....	4
Deflection, Twist, and Sway.....	4
Standard Conditions .....	5
Calculations .....	Attached



## Introduction

The purpose of this report is to summarize results of a structural analysis performed on the 240 ft self supported tower to reflect the change in loading by VERIZON WIRELESS.

## Supporting Documents

<b>Tower Drawings</b>	Rohn Drawing #C880400RI, dated March 3, 1988
<b>Foundation Drawing</b>	Mapping by FDH Project #10-12269E N1, dated January 17, 2011
<b>Geotechnical Report</b>	Soiltesting Job #G96-1987-87, dated January 6, 1988
<b>Modifications</b>	Centek Job #10001.CO78, dated December 6, 2010 GlenMartin Drawing #GM-07602, dated February 21, 2013
<b>Mount Analysis</b>	Maser Consulting Project #21777438A, dated June 11, 2021

## Analysis

The tower was analyzed using American Tower Corporation's tower analysis software. This program considers an elastic three-dimensional model and second-order effects per ANSI/TIA-222.

<b>Basic Wind Speed:</b>	119 mph (3-Second Gust)
<b>Basic Wind Speed w/ Ice:</b>	50 mph (3-Second Gust) w/ 1" radial ice concurrent
<b>Code:</b>	ANSI/TIA-222-H / 2015 IBC / 2018 Connecticut State Building Code
<b>Exposure Category:</b>	C
<b>Risk Category:</b>	II
<b>Topographic Factor Procedure:</b>	Method 1
<b>Topographic Category:</b>	1
<b>Spectral Response:</b>	$S_s = 0.21, S_1 = 0.05$
<b>Site Class:</b>	D - Stiff Soil

## Conclusion

Based on the analysis results, the structure meets the requirements per the applicable codes listed above. The tower and foundation can support the equipment as described in this report.

If you have any questions or require additional information, please contact American Tower via email at [Engineering@americantower.com](mailto:Engineering@americantower.com). Please include the American Tower site name, site number, and engineering number in the subject line for any questions.



**Existing and Reserved Equipment**

Elev. <sup>1</sup> (ft)	Qty	Equipment	Mount Type	Lines	Carrier
256.0	1	Generic 8' Yagi	Leg	-	OTHER
245.0	1	Generic 10' Omni		(1) 1 1/4" Coax	
243.0	1	Dielectric DCR-L1	Leg	(1) 1 5/8" Coax	RED WOLF BROADCASTING
240.0	1	Dielectric DCR-L1 w/ Radome			
234.0	2	Generic 8' Omni	Side Arm	(2) 7/8" Coax	OTHER
229.0	1	Generic 12' Omni	Side Arm	(1) 1 1/4" Coax	
202.0	3	Ericsson Radio 4449 B71 B85A	Sector Frame	(2) 1 1/4" Hybriflex Cable (3) 1 5/8" Hybriflex	T-MOBILE
	3	Ericsson RRUS 4415 B25			
	3	Ericsson Air6449 B41			
	3	Ericsson AIR 32 B66AA B2P			
	3	RFS APXVAARR24_43-U-NA20			
181.0	3	Nokia 2.5G MAA - AAHC(64T64R)	Sector Frame	(1) 1.7" (43.2mm) Hybrid (3) 1 1/4" (1.25"-31.8mm) Fiber (1) 1 1/4" Hybriflex Cable (3) 1/2" Coax (2) 2" conduit (6) 5/16" (0.31"-7.9mm) Coax	SPRINT NEXTEL
180.0	1	RFS APXV9ERR18-C-A20			
	3	Motorola DAP Vx			
	3	Alcatel-Lucent 800 MHz RRH			
	6	Alcatel-Lucent 1900MHz RRH			
	3	Argus LLPX310R			
	1	Generic 24" x 24" Junction Box			
	2	RFS APXVSPP18-C-A20			
3	Generic 2' Std. Dish				
165.0	3	Kathrein Scala 80010965	Sector Frame	(6) 0.39" (10mm) Fiber Trunk (8) 0.78" (19.7mm) 8 AWG 6 (12) 1 5/8" Coax (2) 2" conduit	AT&T MOBILITY
	3	Quintel QS66512-3 (112 lbs.)			
	3	Andrew SBNHH-1D65A			
	3	Powerwave Allgon 7770.00			
	3	Ericsson Radio 4449			
	3	Ericsson RRUS 32 B2			
	3	Ericsson RRUS 32 (50.8 lbs)			
	3	Ericsson RRUS 4478 B14			
	3	Raycap DC6-48-60-18-8F (23.5" Height)			
	9	Powerwave Allgon LGP21401			
	1	Commscope WCS-IMFQ-AMT			
	3	CCI DTMAPB7819VG12A			
	6	Powerwave Allgon 7020.00 Dual Band RET			
	12	Powerwave Allgon LGP21901			
3	Ericsson RRUS 4426 B66				
155.0	3	Samsung Outdoor CBRS 20W RRH –Clip-on Antenna	Sector Frame	(6) 1 5/8" Coax (2) 1 5/8" Hybriflex	VERIZON WIRELESS
	3	Samsung B5/B13 RRH-BR04C			
	3	Samsung B2/B66A RRH-BR049			
	2	Raycap RxxDC-3315-PF-48			
	3	Commscope CBC78T-DS-43-2X			
	6	Commscope JAHH-65B-R3B			
	3	Samsung Outdoor CBRS 20W RRH			
3	Amphenol Antel BXA-80063-6BF-EDIN-X				



**Existing and Reserved Equipment**

Elev. <sup>1</sup> (ft)	Qty	Equipment	Mount Type	Lines	Carrier
132.0	1	Generic 4' Yagi	Side Arm	(1) 1 1/4" Coax	OTHER
123.0	1	Generic 10' Omni	Side Arm	(1) 7/8" Coax	
98.0	1	Generic 4' Yagi	Side Arm	(1) 1 1/4" Coax	

**Equipment to be Removed**

Elev. <sup>1</sup> (ft)	Qty	Equipment	Mount Type	Lines	Carrier
No loading was considered as removed as part of this analysis.					

**Proposed Equipment**

Elev. <sup>1</sup> (ft)	Qty	Equipment	Mount Type	Lines	Carrier
155.0	3	Samsung MT6407-77A	Sector Frame w/ Reinforcement	-	VERIZON WIRELESS

<sup>1</sup> Contracted elevations are shown for appurtenances within contracted installation tolerances. Appurtenances outside of contract limits are shown at installed elevations.





**Structure Usages**

Structural Component	Controlling Usage	Pass/Fail
Legs	43%	Pass
Diagonals	98%	Pass
Horizontals	87%	Pass
Anchor Bolts	49%	Pass
Leg Bolts	36%	Pass

**Foundations**

Reaction Component	Analysis Reactions	% of Usage
Uplift (Kips)	276.7	90%
Axial (Kips)	340.9	1%

The structure base reactions resulting from this analysis were found to be acceptable through analysis based on geotechnical and foundation information, therefore no modification or reinforcement of the foundation will be required.

**Deflection, Twist and Sway\***

Antenna Elevation (ft)	Antenna	Carrier	Deflection (ft)	Twist (°)	Sway (Rotation) (°)
180.0	Generic 2' Std. Dish	SPRINT NEXTEL	0.119	0.004	0.051
155.0	Samsung MT6407-77A	VERIZON WIRELESS	0.102		

\*Deflection, Twist and Sway was evaluated considering a design wind speed of 60 mph (3-Second Gust) per ANSI/TIA-222-H



## Standard Conditions

All engineering services performed by A.T. Engineering Service, PLLC are prepared on the basis that the information used is current and correct. This information may consist of, but is not limited to the following:

- Information supplied by the client regarding antenna, mounts and feed line loading
- Information from drawings, design and analysis documents, and field notes in the possession of A.T. Engineering Service, PLLC

It is the responsibility of the client to ensure that the information provided to A.T. Engineering Service, PLLC and used in the performance of our engineering services is correct and complete.

All assets of American Tower Corporation, its affiliates and subsidiaries (collectively "American Tower") are inspected at regular intervals. Based upon these inspections and in the absence of information to the contrary, American Tower assumes that all structures were constructed in accordance with the drawings and specifications.

Unless explicitly agreed by both the client and A.T. Engineering Service, PLLC, all services will be performed in accordance with the current revision of ANSI/TIA-222.

All services are performed, results obtained, and recommendations made in accordance with generally accepted engineering principles and practices. A.T. Engineering Service, PLLC is not responsible for the conclusions, opinions and recommendations made by others based on the information supplied herein.

Quadrant 1

240.00

Sect 11

220.00

Sect 10

200.00

Sect 9

180.00

Sect 8

160.00

Sect 7

140.00

Sect 6

120.00

Sect 5

100.00

Sect 4

80.00

Sect 3

60.00

Sect 2

30.00

Sect 1

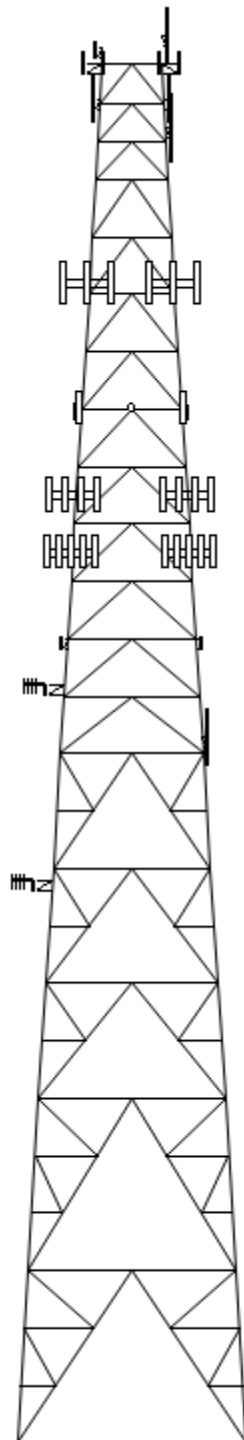

© 2007 - 2021 by ATC IP LLC. All rights reserved.

Loads: 119 mph no ice  
50 mph w/ 1" radial ice  
Site Class: D Ss: 0.21 S1: 0.05  
60 mph Serviceability

### Job Information

Client : VERIZON WIRELESS

Tower : 383598

Location : Tartaglia, CT

Base Width : 40.33 ft

Code : ANSI/TIA-222-H

Topo Method: Method 1

Top Width : 10.93 ft

Risk Cat : II

Topo: 1

Tower Ht : 240.00 ft

Exposure : C

Shape : Triangle

### Sections Properties

Section	Leg Members	Diagonal Members	Horizontal Members
1	PX 50 ksi 10" DIA PIPE	PST 50 ksi 3" DIA PIPE	PST 50 ksi 3-1/2" DIA PIPE
2 - 3	PX 50 ksi 10" DIA PIPE	PST 50 ksi 3" DIA PIPE	PST 50 ksi 3" DIA PIPE
4	PX 50 ksi 8" DIA PIPE	PST 50 ksi 3" DIA PIPE	PST 50 ksi 3" DIA PIPE
5	PX 50 ksi 8" DIA PIPE	PST 50 ksi 2-1/2" DIA PIPE	PST 50 ksi 2-1/2" DIA PIPE
6	PX 50 ksi 8" DIA PIPE	PST 50 ksi 3" DIA PIPE	PST 50 ksi 2-1/2" DIA PIPE
7 - 8	PX 50 ksi 8" DIA PIPE	PST 50 ksi 2-1/2" DIA PIPE	PST 50 ksi 2-1/2" DIA PIPE
9 - 10	PX 50 ksi 8" DIA PIPE	PST 50 ksi 2-1/2" DIA PIPE	PST 50 ksi 2" DIA PIPE
11	PX 50 ksi 8" DIA PIPE	PST 50 ksi 2" DIA PIPE	PST 50 ksi 2" DIA PIPE

### Redundant Secondary Bracing

Section	Sub Diag 1	Sub Horiz 1	Sub Diag 2	Sub Horiz 2	Sub Diag 3	Sub Horiz 3
1	P1-1/2" DIA PIPE	P1-1/2" DIA PIPE	P2-1/2" DIA PIPE	P2" DIA PIPE	-	-
2	P1-1/2" DIA PIPE	P1-1/2" DIA PIPE	P2" DIA PIPE	P2" DIA PIPE	-	-
3 - 4	P2" DIA PIPE	P1-1/2" DIA PIPE	-	-	-	-
5	P1-1/2" DIA PIPE	P1-1/2" DIA PIPE	-	-	-	-
6 - 11	-	-	-	-	-	-

### Discrete Appurtenance

Elev (ft)	Type	Qty	Description
256.00	Yagi	1	Generic 8' Yagi
245.00	Whip	1	Generic 10' Omni
243.00	Whip	1	Dielectric DCR-L1
240.00	Straight Arm	1	Round Side Arm
240.00	Mounting Frame	1	Round Sector Frame
240.00	Other	1	Dielectric DCR-L1 w/ Radome
240.00	Whip	1	Beacon
240.00	Whip	1	Lightning Rod
234.00	Whip	2	Generic 8' Omni
230.00	Straight Arm	1	Round Side Arm
229.00	Whip	1	Generic 12' Omni
223.00	Straight Arm	1	Round Side Arm
223.00	Straight Arm	1	Empty Flat Side Arm
202.00	Mounting Frame	3	Round Sector Frame
202.00	Panel	3	RFS APXVAARR24_43-U-NA20
202.00	Panel	3	Ericsson AIR 32 B66AA B2P
202.00	Panel	3	Ericsson Air6449 B41
202.00	Panel	3	Ericsson RRUS 4415 B25
202.00	Panel	3	Ericsson Radio 4449 B71 B85A
183.00	Straight Arm	3	Side Arms
183.00	Mounting Frame	3	Flat Light Sector Frame
181.00	Panel	3	Nokia 2.5G MAA - AAHC(64T64R)
180.00	Panel	1	RFS APXV9ERR18-C-A20
180.00	Panel	2	RFS APXVSP18-C-A20
180.00	Dish	3	Generic 2' Std. Dish
180.00	Panel	3	Argus LLPX310R
180.00	Panel	1	Generic 24" x 24" Junction Box
180.00	Panel	6	Alcatel-Lucent 1900MHz RRH
180.00	Panel	3	Alcatel-Lucent 800 MHz RRH
180.00	Panel	3	Motorola DAP Vx
165.00	Mounting Frame	3	Round Sector Frame
165.00	Panel	3	Kathrein Scala 80010965
165.00	Panel	3	Quintel QS66512-3 (112 lbs.)
165.00	Panel	3	Andrew SBNHH-1D65A
165.00	Panel	3	Powerwave Allgon 7770.00

© 2007 - 2021 by ATC IP LLC. All rights reserved.

Job Information		
Client : VERIZON WIRELESS		
Tower : 383598	Location : Tartaglia, CT	Base Width : 40.33 ft
Code : ANSI/TIA-222-H	Topo Method: Method 1	Top Width : 10.93 ft
Risk Cat : II	Topo: 1	Tower Ht : 240.00 ft
	Exposure : C	Shape : Triangle

165.00	3	Ericsson Radio 4449
165.00	3	Ericsson RRUS 32 B2
165.00	3	Ericsson RRUS 32 (50.8 lbs)
165.00	3	Ericsson RRUS 4478 B14
165.00	3	Ericsson RRUS 4426 B66
165.00	3	Raycap DC6-48-60-18-8F (23.5"
165.00	9	Powerwave Allgon LGP21401
165.00	1	Commscope WCS-IMFQ-AMT
165.00	3	CCI DTMAP7819VG12A
165.00	6	Powerwave Allgon 7020.00 Dual
165.00	12	Powerwave Allgon LGP21901
155.00	1	Generic Mount Reinforcement
155.00	3	Panel Samsung MT6407-77A
155.00	3	Mounting Frame Flat Light Sector Frame
155.00	6	Panel Commscope JAHH-65B-R3B
155.00	3	Panel Amphenol Antel BXA-80063-6BF-E
155.00	2	Raycap RxxDC-3315-PF-48
155.00	3	Samsung B2/B66A RRH-BR049
155.00	3	Panel Samsung Outdoor CBRS 20W
155.00	3	Panel Samsung Outdoor CBRS 20W
155.00	3	Panel Commscope CBC78T-DS-43-2X
155.00	3	Panel Samsung B5/B13 RRH-BR04C
140.00	3	Whip Small Side Lights
132.00	1	Straight Arm Flat Side Arm
132.00	1	Yagi Generic 4' Yagi
123.00	1	Whip Generic 10' Omni
118.00	1	Straight Arm Round Side Arm
108.00	1	Straight Arm Round Side Arm
98.00	1	Straight Arm Flat Side Arm
98.00	1	Yagi Generic 4' Yagi
80.00	1	Straight Arm Empty Round Side Arm
8.00	1	Straight Arm Round Side Arm

### Linear Appurtenance

Elev (ft)		Qty	Description
From	To		
0.00	245.00	1	1 1/4" Coax
0.00	243.00	1	1 5/8" Coax
0.00	240.00	1	Waveguide
0.00	234.00	2	7/8" Coax
0.00	229.00	1	1 1/4" Coax
0.00	202.00	1	Waveguide
0.00	202.00	3	1 5/8" Hybriflex
0.00	202.00	2	1 1/4" Hybriflex Cab
0.00	183.00	1	Waveguide
0.00	181.00	1	1.7" (43.2mm) Hybrid
0.00	180.00	6	5/16" (0.31"-7.9mm)
0.00	180.00	2	2" conduit
0.00	180.00	3	1/2" Coax
0.00	180.00	1	1 1/4" Hybriflex Cab
0.00	180.00	3	1 1/4" (1.25"- 31.8m
0.00	174.00	1	Waveguide
0.00	165.00	1	Waveguide
0.00	165.00	2	2" conduit
0.00	165.00	12	1 5/8" Coax
0.00	165.00	6	0.78" (19.7mm) 8 AWG
0.00	165.00	4	0.39" (10mm) Fiber T
0.00	165.00	2	0.39" (10mm) Fiber T
0.00	164.00	2	0.78" (19.7mm) 8 AWG
0.00	155.00	1	Waveguide
0.00	155.00	2	1 5/8" Hybriflex

© 2007 - 2021 by ATC IP LLC. All rights reserved.

Job Information		
Client : VERIZON WIRELESS		
Tower : 383598	Location : Tartaglia, CT	Base Width : 40.33 ft
Code : ANSI/TIA-222-H	Topo Method: Method 1	Top Width : 10.93 ft
Risk Cat : II	Topo: 1	Tower Ht : 240.00 ft
	Exposure : C	Shape : Triangle

0.00	155.00	6	1 5/8" Coax
0.00	132.00	1	1 1/4" Coax
0.00	123.00	1	7/8" Coax
0.00	98.00	1	1 1/4" Coax

Global Base Foundation Design Loads			
Load Case	Moment (k-ft)	Vertical (kip)	Horizontal (kip)
DL + WL	10,629.10	109.74	82.06
DL + WL + IL	3,711.06	194.38	29.52

Individual Base Foundation Design Loads		
Vertical (kip)	Uplift (kip)	Horizontal (kip)
340.86	276.65	49.08

Site Number: 383598

Code: ANSI/TIA-222-H

© 2007 - 2021 by ATC IP LLC. All rights reserved.

Site Name: Tartaglia, CT

Engineering Number: 13668689\_C3\_03

7/6/2021 6:21:58 PM

Customer: VERIZON WIRELESS

### Analysis Parameters

Location:	Fairfield County, CT	Height (ft):	240
Code:	ANSI/TIA-222-H	Base Elevation (ft):	0.00
Shape:	Triangle	Bottom Face Width (ft):	40.33
Tower Manufacturer:	Rohn	Top Face Width (ft):	10.93
Tower Type:	Self Support	Anchor Bolt Detail Type	c
Kd:	0.85		
Ke:	0.99		

### Ice & Wind Parameters

Exposure Category:	C	Design Windspeed Without Ice:	119 mph
Risk Category:	II	Design Windspeed With Ice:	50 mph
Topographic Factor Procedure:	Method 1	Operational Windspeed:	60 mph
Topographic Category:	1	Design Ice Thickness:	1.00 in
Crest Height:	0 ft	HMSL:	212.00 ft

### Seismic Parameters

Analysis Method:	Equivalent Lateral Force Method		
Site Class:	D - Stiff Soil		
Period Based on Rayleigh Method (sec):	0.71		
$T_L$ (sec):	6	p:	1.3
$S_S$ :	0.211	$S_1$ :	0.054
$F_a$ :	1.600	$F_v$ :	2.400
$S_{ds}$ :	0.225	$S_{d1}$ :	0.086
		$C_S$ :	0.040
		$C_S, Max$ :	0.040
		$C_S, Min$ :	0.030

### Load Cases

1.2D + 1.0W Normal	119 mph Normal with No Ice
1.2D + 1.0W 60 deg	119 mph 60 degree with No Ice
1.2D + 1.0W 90 deg	119 mph 90 degree with No Ice
0.9D + 1.0W Normal	119 mph Normal with No Ice (Reduced DL)
0.9D + 1.0W 60 deg	119 mph 60 deg with No Ice (Reduced DL)
0.9D + 1.0W 90 deg	119 mph 90 deg with No Ice (Reduced DL)
1.2D + 1.0Di + 1.0Wi Normal	50 mph Normal with 1.00 in Radial Ice
1.2D + 1.0Di + 1.0Wi 60 deg	50 mph 60 deg with 1.00 in Radial Ice
1.2D + 1.0Di + 1.0Wi 90 deg	50 mph 90 deg with 1.00 in Radial Ice
1.2D + 1.0Ev + 1.0Eh Normal	Seismic Normal
1.2D + 1.0Ev + 1.0Eh 60 deg	Seismic 60 deg
1.2D + 1.0Ev + 1.0Eh 90 deg	Seismic 90 deg
0.9D - 1.0Ev + 1.0Eh Normal	Seismic (Reduced DL) Normal
0.9D - 1.0Ev + 1.0Eh 60 deg	Seismic (Reduced DL) 60 deg
0.9D - 1.0Ev + 1.0Eh 90 deg	Seismic (Reduced DL) 90 deg
1.0D + 1.0W Service Normal	Serviceability - 60 mph Wind Normal
1.0D + 1.0W Service 60 deg	Serviceability - 60 mph Wind 60 deg
1.0D + 1.0W Service 90 deg	Serviceability - 60 mph Wind 90 deg

### Tower Loading

**Discrete Appurtenance Properties** 1.2D + 1.0W

Elevation (ft)	Description	Qty	Wt. (lb)	EPA (sf)	Length (ft)	Width (in)	Depth (in)	K <sub>a</sub>	Orient. Factor	Vert. Ecc.(ft)	M <sub>u</sub> (lb-ft)	Q <sub>z</sub> (psf)	F <sub>a</sub> (WL) (lb)	P <sub>a</sub> (DL) (lb)
256.0	Generic 8' Yagi	1	30	12.0	8.0	60.0	3.0	1.00	1.00	0.0	0.0	47.17	481	36
245.0	Generic 10' Omni	1	25	3.0	10.0	3.0	3.0	1.00	1.00	0.0	0.0	46.74	119	30
243.0	Dielectric DCR-L1	1	8	1.2	2.0	14.0	36.0	1.00	1.00	0.0	0.0	46.66	48	10
240.0	Lightning Rod	1	10	1.0	4.0	3.0	3.0	1.00	1.00	0.0	0.0	46.53	40	12
240.0	Dielectric DCR-L1 w/	1	18	1.8	0.0	0.0	0.0	1.00	1.00	3.0	214.1	46.66	71	22
240.0	Beacon	1	70	4.5	3.0	18.0	18.0	1.00	1.00	0.0	0.0	46.53	178	84
240.0	Round Side Arm	1	150	5.2	0.0	0.0	0.0	1.00	1.00	0.0	0.0	46.53	206	180
240.0	Round Sector Frame	1	300	14.4	0.0	0.0	0.0	1.00	1.00	0.0	0.0	46.53	570	360
234.0	Generic 8' Omni	2	25	2.4	8.0	3.0	3.0	1.00	1.00	0.0	0.0	46.29	189	60
230.0	Round Side Arm	1	150	5.2	0.0	0.0	0.0	1.00	0.67	0.0	0.0	46.12	137	180
229.0	Generic 12' Omni	1	40	3.6	12.0	3.0	3.0	1.00	1.00	0.0	0.0	46.08	141	48
223.0	Round Side Arm	1	150	5.2	0.0	0.0	0.0	1.00	1.00	0.0	0.0	45.82	203	180
223.0	Empty Flat Side Arm	1	150	6.3	0.0	0.0	0.0	1.00	1.00	0.0	0.0	45.82	245	180
202.0	Ericsson Radio 4449	3	75	1.6	1.3	13.2	10.5	0.80	0.50	0.0	0.0	44.88	76	270
202.0	Ericsson RRUS 4415	3	46	1.8	1.4	13.4	5.9	0.80	0.50	0.0	0.0	44.88	84	166
202.0	Ericsson Air6449	3	104	5.7	2.8	20.6	8.6	0.80	0.63	0.0	0.0	44.88	328	374
202.0	Ericsson AIR 32	3	109	6.9	4.9	12.9	8.7	0.80	0.71	0.0	0.0	44.88	447	392
202.0	Round Sector Frame	3	300	14.4	0.0	0.0	0.0	0.75	0.67	0.0	0.0	44.88	828	1080
202.0	RFS	3	128	20.2	8.0	24.0	8.7	0.80	0.63	0.0	0.0	44.88	1167	460
183.0	Side Arms	3	560	8.5	0.0	0.0	0.0	1.00	0.67	0.0	0.0	43.95	638	2016
183.0	Flat Light Sector	3	400	17.9	0.0	0.0	0.0	0.75	0.67	0.0	0.0	43.95	1008	1440
181.0	Nokia 2.5G MAA -	3	104	4.2	2.1	19.7	9.6	0.80	0.64	0.0	0.0	43.85	241	373
180.0	Motorola DAP Vx	3	27	1.6	2.1	7.6	5.5	0.80	0.50	0.0	0.0	43.80	73	95
180.0	Alcatel-Lucent 800	3	53	2.1	1.6	13.0	10.8	0.80	0.50	0.0	0.0	43.80	95	191
180.0	Alcatel-Lucent	6	44	3.3	1.9	13.0	17.0	0.80	0.50	0.0	0.0	43.80	291	317
180.0	Argus LLPX310R	3	29	4.3	3.5	11.8	4.5	0.80	0.63	0.0	0.0	43.80	242	103
180.0	Generic 24" x 24"	1	20	4.8	2.0	24.0	8.0	0.80	1.00	0.0	0.0	43.80	143	24
180.0	Generic 2' Std. Dish	3	14	5.2	2.0	24.0	0.0	1.00	1.00	0.0	0.0	43.80	584	50
180.0	RFS APXVSP18-C-	2	57	8.0	6.0	11.8	7.0	0.80	0.77	0.0	0.0	43.80	368	137
180.0	RFS APXV9ERR18-C-	1	62	8.0	6.0	11.8	7.9	0.80	1.00	0.0	0.0	43.80	239	74
165.0	Powerwave Allgon	12	6	0.2	0.3	6.0	3.0	0.80	0.50	0.0	0.0	43.00	35	79
165.0	Powerwave Allgon	6	2	0.3	0.4	8.3	2.4	0.80	0.50	0.0	0.0	43.00	30	16
165.0	CCI	3	19	1.0	0.9	11.0	3.8	0.80	0.50	0.0	0.0	43.00	43	69
165.0	Commscope WCS-	1	30	1.0	0.9	10.6	6.9	0.80	0.50	0.0	0.0	43.00	14	35
165.0	Powerwave Allgon	9	14	1.1	1.2	9.2	2.6	0.80	0.50	0.0	0.0	43.00	145	152
165.0	Raycap DC6-48-60-	3	20	1.3	2.0	9.7	9.7	0.80	0.50	0.0	0.0	43.00	55	72
165.0	Ericsson RRUS 4426	3	48	1.6	1.3	13.2	5.8	0.80	0.50	0.0	0.0	43.00	72	174
165.0	Ericsson RRUS 4478	3	60	1.8	1.4	13.4	7.7	0.80	0.50	0.0	0.0	43.00	81	216
165.0	Ericsson RRUS 32	3	51	2.7	2.2	12.1	6.7	0.80	0.50	0.0	0.0	43.00	118	183
165.0	Ericsson RRUS 32 B2	3	53	2.7	2.3	12.1	7.0	0.80	0.50	0.0	0.0	43.00	120	191
165.0	Ericsson Radio 4449	3	85	3.5	2.3	15.0	10.0	0.80	0.50	0.0	0.0	43.00	154	306
165.0	Powerwave Allgon	3	35	5.5	4.6	11.0	5.0	0.80	0.65	0.0	0.0	43.00	314	126
165.0	Andrew SBNHH-	3	41	5.9	4.6	11.9	7.1	0.80	0.69	0.0	0.0	43.00	356	147
165.0	Quintel QS66512-3	3	112	8.1	6.0	12.0	9.6	0.80	0.74	0.0	0.0	43.00	528	403
165.0	Kathrein Scala	3	98	13.8	6.6	20.0	6.9	0.80	0.62	0.0	0.0	43.00	751	351
165.0	Round Sector Frame	3	300	14.4	0.0	0.0	0.0	0.75	0.67	0.0	0.0	43.00	794	1080
155.0	Commscope	3	21	0.6	0.8	6.9	6.4	0.80	0.50	0.0	0.0	42.44	24	75
155.0	Samsung Outdoor	3	19	0.9	1.0	8.5	4.1	0.80	0.50	0.0	0.0	42.44	37	67
155.0	Samsung Outdoor	3	4	0.9	1.0	8.7	1.4	0.80	0.50	0.0	0.0	42.44	39	16
155.0	Samsung B2/B66A	3	84	1.9	1.3	15.0	10.0	0.80	0.50	0.0	0.0	42.44	81	304
155.0	Samsung B5/B13	3	70	1.9	1.3	15.0	8.1	0.80	0.50	0.0	0.0	42.44	81	253
155.0	Raycap RxxDC-3315-	2	21	2.5	1.6	15.7	10.3	0.80	0.67	0.0	0.0	42.44	97	51
155.0	Samsung MT6407-	3	82	4.7	2.9	16.1	5.5	0.80	0.61	0.0	0.0	42.44	249	294
155.0	Amphenol Antel BXA-	3	19	7.3	5.7	11.2	5.3	0.80	0.66	0.0	0.0	42.44	415	69

Site Number: 383598

Code: ANSI/TIA-222-H

© 2007 - 2021 by ATC IP LLC. All rights reserved.

Site Name: Tartaglia, CT

Engineering Number: 13668689\_C3\_03

7/6/2021 6:21:58 PM

Customer: VERIZON WIRELESS

### Tower Loading

155.0	Generic Mount	1	200	7.5	0.0	0.0	0.0	1.00	1.00	0.0	0.0	42.44	271	240
155.0	Commscope JAHH-	6	61	9.1	6.0	13.8	8.2	0.80	0.69	0.0	0.0	42.44	1089	436
155.0	Flat Light Sector	3	400	17.9	0.0	0.0	0.0	0.75	0.67	0.0	0.0	42.44	973	1440
140.0	Small Side Lights	3	45	2.0	1.0	8.0	8.0	1.00	1.00	0.0	0.0	41.54	212	162
132.0	Generic 4' Yagi	1	15	4.9	4.0	48.0	3.0	1.00	1.00	0.0	0.0	41.03	171	18
132.0	Flat Side Arm	1	150	6.3	0.0	0.0	0.0	1.00	1.00	0.0	0.0	41.03	220	180
123.0	Generic 10' Omni	1	25	3.0	10.0	3.0	3.0	1.00	1.00	0.0	0.0	40.43	103	30
118.0	Round Side Arm	1	150	5.2	0.0	0.0	0.0	1.00	1.00	0.0	0.0	40.07	177	180
108.0	Round Side Arm	1	150	5.2	0.0	0.0	0.0	1.00	1.00	0.0	0.0	39.33	174	180
98.00	Generic 4' Yagi	1	15	4.9	4.0	48.0	3.0	1.00	1.00	0.0	0.0	38.54	161	18
98.00	Flat Side Arm	1	150	6.3	0.0	0.0	0.0	1.00	1.00	0.0	0.0	38.54	206	180
80.00	Empty Round Side	1	150	5.2	0.0	0.0	0.0	1.00	1.00	0.0	0.0	36.93	163	180
8.00	Round Side Arm	1	150	5.2	0.0	0.0	0.0	1.00	1.00	0.0	0.0	25.99	115	180
<b>Totals</b>		<b>172</b>	<b>14249</b>	<b>830.1</b>									<b>18146</b>	<b>17099</b>

### Discrete Appurtenance Properties 0.9D + 1.0W

Elevation (ft)	Description	Qty	Wt. (lb)	EPA (sf)	Length (ft)	Width (in)	Depth (in)	K <sub>a</sub>	Orient. Factor	Vert. Ecc.(ft)	M <sub>u</sub> (lb-ft)	Q <sub>z</sub> (psf)	F <sub>a</sub> (WL) (lb)	P <sub>a</sub> (DL) (lb)
256.0	Generic 8' Yagi	1	30	12.0	8.0	60.0	3.0	1.00	1.00	0.0	0.0	47.17	481	27
245.0	Generic 10' Omni	1	25	3.0	10.0	3.0	3.0	1.00	1.00	0.0	0.0	46.74	119	23
243.0	Dielectric DCR-L1	1	8	1.2	2.0	14.0	36.0	1.00	1.00	0.0	0.0	46.66	48	7
240.0	Lightning Rod	1	10	1.0	4.0	3.0	3.0	1.00	1.00	0.0	0.0	46.53	40	9
240.0	Dielectric DCR-L1 w/ Beacon	1	18	1.8	0.0	0.0	0.0	1.00	1.00	3.0	214.1	46.66	71	16
240.0	Round Side Arm	1	70	4.5	3.0	18.0	18.0	1.00	1.00	0.0	0.0	46.53	178	63
240.0	Round Side Arm	1	150	5.2	0.0	0.0	0.0	1.00	1.00	0.0	0.0	46.53	206	135
240.0	Round Sector Frame	1	300	14.4	0.0	0.0	0.0	1.00	1.00	0.0	0.0	46.53	570	270
234.0	Generic 8' Omni	2	25	2.4	8.0	3.0	3.0	1.00	1.00	0.0	0.0	46.29	189	45
230.0	Round Side Arm	1	150	5.2	0.0	0.0	0.0	1.00	0.67	0.0	0.0	46.12	137	135
229.0	Generic 12' Omni	1	40	3.6	12.0	3.0	3.0	1.00	1.00	0.0	0.0	46.08	141	36
223.0	Round Side Arm	1	150	5.2	0.0	0.0	0.0	1.00	1.00	0.0	0.0	45.82	203	135
223.0	Empty Flat Side Arm	1	150	6.3	0.0	0.0	0.0	1.00	1.00	0.0	0.0	45.82	245	135
202.0	Ericsson Radio 4449	3	75	1.6	1.3	13.2	10.5	0.80	0.50	0.0	0.0	44.88	76	203
202.0	Ericsson RRUS 4415	3	46	1.8	1.4	13.4	5.9	0.80	0.50	0.0	0.0	44.88	84	124
202.0	Ericsson Air6449	3	104	5.7	2.8	20.6	8.6	0.80	0.63	0.0	0.0	44.88	328	281
202.0	Ericsson AIR 32	3	109	6.9	4.9	12.9	8.7	0.80	0.71	0.0	0.0	44.88	447	294
202.0	Round Sector Frame	3	300	14.4	0.0	0.0	0.0	0.75	0.67	0.0	0.0	44.88	828	810
202.0	RFS	3	128	20.2	8.0	24.0	8.7	0.80	0.63	0.0	0.0	44.88	1167	345
183.0	Side Arms	3	560	8.5	0.0	0.0	0.0	1.00	0.67	0.0	0.0	43.95	638	1512
183.0	Flat Light Sector	3	400	17.9	0.0	0.0	0.0	0.75	0.67	0.0	0.0	43.95	1008	1080
181.0	Nokia 2.5G MAA -	3	104	4.2	2.1	19.7	9.6	0.80	0.64	0.0	0.0	43.85	241	280
180.0	Motorola DAP Vx	3	27	1.6	2.1	7.6	5.5	0.80	0.50	0.0	0.0	43.80	73	72
180.0	Alcatel-Lucent 800	3	53	2.1	1.6	13.0	10.8	0.80	0.50	0.0	0.0	43.80	95	143
180.0	Alcatel-Lucent	6	44	3.3	1.9	13.0	17.0	0.80	0.50	0.0	0.0	43.80	291	238
180.0	Argus LLPX310R	3	29	4.3	3.5	11.8	4.5	0.80	0.63	0.0	0.0	43.80	242	77
180.0	Generic 24" x 24"	1	20	4.8	2.0	24.0	8.0	0.80	1.00	0.0	0.0	43.80	143	18
180.0	Generic 2' Std. Dish	3	14	5.2	2.0	24.0	0.0	1.00	1.00	0.0	0.0	43.80	584	38
180.0	RFS APXVSP18-C-	2	57	8.0	6.0	11.8	7.0	0.80	0.77	0.0	0.0	43.80	368	103
180.0	RFS APXV9ERR18-C-	1	62	8.0	6.0	11.8	7.9	0.80	1.00	0.0	0.0	43.80	239	56
165.0	Powerwave Allgon	12	6	0.2	0.3	6.0	3.0	0.80	0.50	0.0	0.0	43.00	35	59
165.0	Powerwave Allgon	6	2	0.3	0.4	8.3	2.4	0.80	0.50	0.0	0.0	43.00	30	12
165.0	CCI	3	19	1.0	0.9	11.0	3.8	0.80	0.50	0.0	0.0	43.00	43	52
165.0	Commscope WCS-	1	30	1.0	0.9	10.6	6.9	0.80	0.50	0.0	0.0	43.00	14	27
165.0	Powerwave Allgon	9	14	1.1	1.2	9.2	2.6	0.80	0.50	0.0	0.0	43.00	145	114
165.0	Raycap DC6-48-60-	3	20	1.3	2.0	9.7	9.7	0.80	0.50	0.0	0.0	43.00	55	54
165.0	Ericsson RRUS 4426	3	48	1.6	1.3	13.2	5.8	0.80	0.50	0.0	0.0	43.00	72	131



Tower Loading

165.0	Ericsson RRUS 4478	3	60	1.8	1.4	13.4	7.7	0.80	0.50	0.0	0.0	43.00	81	162
165.0	Ericsson RRUS 32	3	51	2.7	2.2	12.1	6.7	0.80	0.50	0.0	0.0	43.00	118	137
165.0	Ericsson RRUS 32 B2	3	53	2.7	2.3	12.1	7.0	0.80	0.50	0.0	0.0	43.00	120	143
165.0	Ericsson Radio 4449	3	85	3.5	2.3	15.0	10.0	0.80	0.50	0.0	0.0	43.00	154	230
165.0	Powerwave Allgon	3	35	5.5	4.6	11.0	5.0	0.80	0.65	0.0	0.0	43.00	314	95
165.0	Andrew SBNHH-	3	41	5.9	4.6	11.9	7.1	0.80	0.69	0.0	0.0	43.00	356	110
165.0	Quintel QS66512-3	3	112	8.1	6.0	12.0	9.6	0.80	0.74	0.0	0.0	43.00	528	302
165.0	Kathrein Scala	3	98	13.8	6.6	20.0	6.9	0.80	0.62	0.0	0.0	43.00	751	264
165.0	Round Sector Frame	3	300	14.4	0.0	0.0	0.0	0.75	0.67	0.0	0.0	43.00	794	810
155.0	Commscope	3	21	0.6	0.8	6.9	6.4	0.80	0.50	0.0	0.0	42.44	24	56
155.0	Samsung Outdoor	3	19	0.9	1.0	8.5	4.1	0.80	0.50	0.0	0.0	42.44	37	50
155.0	Samsung Outdoor	3	4	0.9	1.0	8.7	1.4	0.80	0.50	0.0	0.0	42.44	39	12
155.0	Samsung B2/B66A	3	84	1.9	1.3	15.0	10.0	0.80	0.50	0.0	0.0	42.44	81	228
155.0	Samsung B5/B13	3	70	1.9	1.3	15.0	8.1	0.80	0.50	0.0	0.0	42.44	81	190
155.0	Raycap RxxDC-3315-	2	21	2.5	1.6	15.7	10.3	0.80	0.67	0.0	0.0	42.44	97	39
155.0	Samsung MT6407-	3	82	4.7	2.9	16.1	5.5	0.80	0.61	0.0	0.0	42.44	249	220
155.0	Amphenol Antel BXA-	3	19	7.3	5.7	11.2	5.3	0.80	0.66	0.0	0.0	42.44	415	52
155.0	Generic Mount	1	200	7.5	0.0	0.0	0.0	1.00	1.00	0.0	0.0	42.44	271	180
155.0	Commscope JAHH-	6	61	9.1	6.0	13.8	8.2	0.80	0.69	0.0	0.0	42.44	1089	327
155.0	Flat Light Sector	3	400	17.9	0.0	0.0	0.0	0.75	0.67	0.0	0.0	42.44	973	1080
140.0	Small Side Lights	3	45	2.0	1.0	8.0	8.0	1.00	1.00	0.0	0.0	41.54	212	122
132.0	Generic 4' Yagi	1	15	4.9	4.0	48.0	3.0	1.00	1.00	0.0	0.0	41.03	171	14
132.0	Flat Side Arm	1	150	6.3	0.0	0.0	0.0	1.00	1.00	0.0	0.0	41.03	220	135
123.0	Generic 10' Omni	1	25	3.0	10.0	3.0	3.0	1.00	1.00	0.0	0.0	40.43	103	23
118.0	Round Side Arm	1	150	5.2	0.0	0.0	0.0	1.00	1.00	0.0	0.0	40.07	177	135
108.0	Round Side Arm	1	150	5.2	0.0	0.0	0.0	1.00	1.00	0.0	0.0	39.33	174	135
98.00	Generic 4' Yagi	1	15	4.9	4.0	48.0	3.0	1.00	1.00	0.0	0.0	38.54	161	14
98.00	Flat Side Arm	1	150	6.3	0.0	0.0	0.0	1.00	1.00	0.0	0.0	38.54	206	135
80.00	Empty Round Side	1	150	5.2	0.0	0.0	0.0	1.00	1.00	0.0	0.0	36.93	163	135
8.00	Round Side Arm	1	150	5.2	0.0	0.0	0.0	1.00	1.00	0.0	0.0	25.99	115	135
Totals		172	14249	830.1									18146	12824

Discrete Appurtenance Properties 1.2D + 1.0Di + 1.0Wi

Elevation (ft)	Description	Qty	Ice Wt (lb)	Ice EPA (sf)	Length (ft)	Width (in)	Depth (in)	K <sub>a</sub>	Orient. Factor	Vert. Ecc.(ft)	M <sub>u</sub> (lb-ft)	Q <sub>z</sub> (psf)	F <sub>a</sub> (WL) (lb)	P <sub>a</sub> (DL) (lb)
256.0	Generic 8' Yagi	1	266	35.3	8.0	60.0	3.0	1.00	1.00	0.0	0.0	8.33	250	272
245.0	Generic 10' Omni	1	78	5.5	10.0	3.0	3.0	1.00	1.00	0.0	0.0	8.25	39	83
243.0	Dielectric DCR-L1	1	31	2.7	2.0	14.0	36.0	1.00	1.00	0.0	0.0	8.24	19	32
240.0	Lightning Rod	1	44	1.6	4.0	3.0	3.0	1.00	1.00	0.0	0.0	8.22	11	46
240.0	Dielectric DCR-L1 w/	1	69	4.0	0.0	0.0	0.0	1.00	1.00	3.0	83.9	8.24	28	73
240.0	Beacon	1	212	3.8	3.0	18.0	18.0	1.00	1.00	0.0	0.0	8.22	27	226
240.0	Round Side Arm	1	201	7.1	0.0	0.0	0.0	1.00	1.00	0.0	0.0	8.22	50	231
240.0	Round Sector Frame	1	556	25.9	0.0	0.0	0.0	1.00	1.00	0.0	0.0	8.22	181	616
234.0	Generic 8' Omni	2	68	4.3	8.0	3.0	3.0	1.00	1.00	0.0	0.0	8.17	60	145
230.0	Round Side Arm	1	201	7.1	0.0	0.0	0.0	1.00	0.67	0.0	0.0	8.14	33	231
229.0	Generic 12' Omni	1	103	6.6	12.0	3.0	3.0	1.00	1.00	0.0	0.0	8.13	46	111
223.0	Round Side Arm	1	201	7.1	0.0	0.0	0.0	1.00	1.00	0.0	0.0	8.09	49	231
223.0	Empty Flat Side Arm	1	201	8.0	0.0	0.0	0.0	1.00	1.00	0.0	0.0	8.09	55	231
202.0	Ericsson Radio 4449	3	116	2.2	1.3	13.2	10.5	0.80	0.50	0.0	0.0	7.92	18	393
202.0	Ericsson RRUS 4415	3	80	2.5	1.4	13.4	5.9	0.80	0.50	0.0	0.0	7.92	20	266
202.0	Ericsson Air6449	3	197	6.8	2.8	20.6	8.6	0.80	0.63	0.0	0.0	7.92	69	654
202.0	Ericsson AIR 32	3	223	8.4	4.9	12.9	8.7	0.80	0.71	0.0	0.0	7.92	97	734
202.0	Round Sector Frame	3	552	25.7	0.0	0.0	0.0	0.75	0.67	0.0	0.0	7.92	261	1835
202.0	RFS	3	396	22.8	8.0	24.0	8.7	0.80	0.63	0.0	0.0	7.92	232	1266
183.0	Side Arms	3	877	13.3	0.0	0.0	0.0	1.00	0.67	0.0	0.0	7.76	176	2966

Site Number: 383598

Code:

ANSI/TIA-222-H

© 2007 - 2021 by ATC IP LLC. All rights reserved.

Site Name: Tartaglia, CT

Engineering Number: 13668689\_C3\_03

7/6/2021 6:21:58 PM

Customer: VERIZON WIRELESS

### Tower Loading

183.0	Flat Light Sector	3	604	28.1	0.0	0.0	0.0	0.75	0.67	0.0	0.0	7.76	279	2051
181.0	Nokia 2.5G MAA -	3	180	5.1	2.1	19.7	9.6	0.80	0.64	0.0	0.0	7.74	52	602
180.0	Motorola DAP Vx	3	58	2.3	2.1	7.6	5.5	0.80	0.50	0.0	0.0	7.73	18	190
180.0	Alcatel-Lucent 800	3	103	2.8	1.6	13.0	10.8	0.80	0.50	0.0	0.0	7.73	22	341
180.0	Alcatel-Lucent	6	118	4.1	1.9	13.0	17.0	0.80	0.50	0.0	0.0	7.73	64	759
180.0	Argus LLPX310R	3	90	5.4	3.5	11.8	4.5	0.80	0.63	0.0	0.0	7.73	54	286
180.0	Generic 24" x 24"	1	98	5.8	2.0	24.0	8.0	0.80	1.00	0.0	0.0	7.73	30	102
180.0	Generic 2' Std. Dish	3	51	6.3	2.0	24.0	0.0	1.00	1.00	0.0	0.0	7.73	124	163
180.0	RFS APXVSPP18-C-	2	174	9.9	6.0	11.8	7.0	0.80	0.77	0.0	0.0	7.73	80	370
180.0	RFS APXV9ERR18-C-	1	185	9.9	6.0	11.8	7.9	0.80	1.00	0.0	0.0	7.73	52	197
165.0	Powerwave Allgon	12	11	0.4	0.3	6.0	3.0	0.80	0.50	0.0	0.0	7.59	13	141
165.0	Powerwave Allgon	6	9	0.6	0.4	8.3	2.4	0.80	0.50	0.0	0.0	7.59	9	57
165.0	CCI	3	36	1.4	0.9	11.0	3.8	0.80	0.50	0.0	0.0	7.59	11	120
165.0	Commscope WCS-	1	52	1.4	0.9	10.6	6.9	0.80	0.50	0.0	0.0	7.59	4	58
165.0	Powerwave Allgon	9	31	1.6	1.2	9.2	2.6	0.80	0.50	0.0	0.0	7.59	37	302
165.0	Raycap DC6-48-60-	3	55	1.7	2.0	9.7	9.7	0.80	0.50	0.0	0.0	7.59	13	178
165.0	Ericsson RRUS 4426	3	78	2.2	1.3	13.2	5.8	0.80	0.50	0.0	0.0	7.59	17	264
165.0	Ericsson RRUS 4478	3	97	2.4	1.4	13.4	7.7	0.80	0.50	0.0	0.0	7.59	19	326
165.0	Ericsson RRUS 32	3	99	3.5	2.2	12.1	6.7	0.80	0.50	0.0	0.0	7.59	27	326
165.0	Ericsson RRUS 32 B2	3	102	3.5	2.3	12.1	7.0	0.80	0.50	0.0	0.0	7.59	27	338
165.0	Ericsson Radio 4449	3	153	4.4	2.3	15.0	10.0	0.80	0.50	0.0	0.0	7.59	34	510
165.0	Powerwave Allgon	3	118	6.2	4.6	11.0	5.0	0.80	0.65	0.0	0.0	7.59	62	376
165.0	Andrew SBNHH-	3	131	7.3	4.6	11.9	7.1	0.80	0.69	0.0	0.0	7.59	78	419
165.0	Quintel QS66512-3	3	245	10.0	6.0	12.0	9.6	0.80	0.74	0.0	0.0	7.59	115	803
165.0	Kathrein Scala	3	276	15.9	6.6	20.0	6.9	0.80	0.62	0.0	0.0	7.59	152	886
165.0	Round Sector Frame	3	546	25.5	0.0	0.0	0.0	0.75	0.67	0.0	0.0	7.59	248	1817
155.0	Commscope	3	35	0.9	0.8	6.9	6.4	0.80	0.50	0.0	0.0	7.49	7	119
155.0	Samsung Outdoor	3	35	1.3	1.0	8.5	4.1	0.80	0.50	0.0	0.0	7.49	10	115
155.0	Samsung Outdoor	3	16	1.3	1.0	8.7	1.4	0.80	0.50	0.0	0.0	7.49	10	52
155.0	Samsung B2/B66A	3	127	2.5	1.3	15.0	10.0	0.80	0.50	0.0	0.0	7.49	19	432
155.0	Samsung B5/B13	3	109	2.5	1.3	15.0	8.1	0.80	0.50	0.0	0.0	7.49	19	368
155.0	Raycap RxxDC-3315-	2	75	3.2	1.6	15.7	10.3	0.80	0.67	0.0	0.0	7.49	22	158
155.0	Samsung MT6407-	3	150	5.7	2.9	16.1	5.5	0.80	0.61	0.0	0.0	7.49	53	498
155.0	Amphenol Antel BXA-	3	116	9.0	5.7	11.2	5.3	0.80	0.66	0.0	0.0	7.49	91	358
155.0	Generic Mount	1	293	11.0	0.0	0.0	0.0	1.00	1.00	0.0	0.0	7.49	70	333
155.0	Commscope JAHH-	6	196	11.0	6.0	13.8	8.2	0.80	0.69	0.0	0.0	7.49	231	1247
155.0	Flat Light Sector	3	601	28.0	0.0	0.0	0.0	0.75	0.67	0.0	0.0	7.49	269	2043
140.0	Small Side Lights	3	69	0.7	1.0	8.0	8.0	1.00	1.00	0.0	0.0	7.33	13	235
132.0	Generic 4' Yagi	1	110	13.4	4.0	48.0	3.0	1.00	1.00	0.0	0.0	7.24	83	113
132.0	Flat Side Arm	1	198	7.9	0.0	0.0	0.0	1.00	1.00	0.0	0.0	7.24	49	228
123.0	Generic 10' Omni	1	74	5.3	10.0	3.0	3.0	1.00	1.00	0.0	0.0	7.14	32	79
118.0	Round Side Arm	1	197	7.0	0.0	0.0	0.0	1.00	1.00	0.0	0.0	7.07	42	227
108.0	Round Side Arm	1	196	6.9	0.0	0.0	0.0	1.00	1.00	0.0	0.0	6.94	41	226
98.00	Generic 4' Yagi	1	107	13.1	4.0	48.0	3.0	1.00	1.00	0.0	0.0	6.80	76	110
98.00	Flat Side Arm	1	196	7.9	0.0	0.0	0.0	1.00	1.00	0.0	0.0	6.80	45	226
80.00	Empty Round Side	1	195	6.9	0.0	0.0	0.0	1.00	1.00	0.0	0.0	6.52	38	225
8.00	Round Side Arm	1	189	6.6	0.0	0.0	0.0	1.00	1.00	0.0	0.0	4.59	26	219
Totals		172	27385	1168.4									4606	30235

### Discrete Appurtenance Properties 1.0D + 1.0W Service

Elevation (ft)	Description	Qty	Wt. (lb)	EPA (sf)	Length (ft)	Width (in)	Depth (in)	K <sub>a</sub>	Orient. Factor	Vert. Ecc.(ft)	M <sub>u</sub> (lb-ft)	Q <sub>z</sub> (psf)	F <sub>a</sub> (WL) (lb)	P <sub>a</sub> (DL) (lb)
256.0	Generic 8' Yagi	1	30	12.0	8.0	60.0	3.0	1.00	1.00	0.0	0.0	11.99	122	30
245.0	Generic 10' Omni	1	25	3.0	10.0	3.0	3.0	1.00	1.00	0.0	0.0	11.88	30	25
243.0	Dielectric DCR-L1	1	8	1.2	2.0	14.0	36.0	1.00	1.00	0.0	0.0	11.86	12	8

### Tower Loading

240.0	Lightning Rod	1	10	1.0	4.0	3.0	3.0	1.00	1.00	0.0	0.0	11.83	10	10
240.0	Dielectric DCR-L1 w/	1	18	1.8	0.0	0.0	0.0	1.00	1.00	3.0	54.4	11.86	18	18
240.0	Beacon	1	70	4.5	3.0	18.0	18.0	1.00	1.00	0.0	0.0	11.83	45	70
240.0	Round Side Arm	1	150	5.2	0.0	0.0	0.0	1.00	1.00	0.0	0.0	11.83	52	150
240.0	Round Sector Frame	1	300	14.4	0.0	0.0	0.0	1.00	1.00	0.0	0.0	11.83	145	300
234.0	Generic 8' Omni	2	25	2.4	8.0	3.0	3.0	1.00	1.00	0.0	0.0	11.77	48	50
230.0	Round Side Arm	1	150	5.2	0.0	0.0	0.0	1.00	0.67	0.0	0.0	11.72	35	150
229.0	Generic 12' Omni	1	40	3.6	12.0	3.0	3.0	1.00	1.00	0.0	0.0	11.71	36	40
223.0	Round Side Arm	1	150	5.2	0.0	0.0	0.0	1.00	1.00	0.0	0.0	11.65	51	150
223.0	Empty Flat Side Arm	1	150	6.3	0.0	0.0	0.0	1.00	1.00	0.0	0.0	11.65	62	150
202.0	Ericsson Radio 4449	3	75	1.6	1.3	13.2	10.5	0.80	0.50	0.0	0.0	11.41	19	225
202.0	Ericsson RRUS 4415	3	46	1.8	1.4	13.4	5.9	0.80	0.50	0.0	0.0	11.41	21	138
202.0	Ericsson Air6449	3	104	5.7	2.8	20.6	8.6	0.80	0.63	0.0	0.0	11.41	83	312
202.0	Ericsson AIR 32	3	109	6.9	4.9	12.9	8.7	0.80	0.71	0.0	0.0	11.41	114	327
202.0	Round Sector Frame	3	300	14.4	0.0	0.0	0.0	0.75	0.67	0.0	0.0	11.41	211	900
202.0	RFS	3	128	20.2	8.0	24.0	8.7	0.80	0.63	0.0	0.0	11.41	297	384
183.0	Side Arms	3	560	8.5	0.0	0.0	0.0	1.00	0.67	0.0	0.0	11.17	162	1680
183.0	Flat Light Sector	3	400	17.9	0.0	0.0	0.0	0.75	0.67	0.0	0.0	11.17	256	1200
181.0	Nokia 2.5G MAA -	3	104	4.2	2.1	19.7	9.6	0.80	0.64	0.0	0.0	11.15	61	311
180.0	Motorola DAP Vx	3	27	1.6	2.1	7.6	5.5	0.80	0.50	0.0	0.0	11.13	19	80
180.0	Alcatel-Lucent 800	3	53	2.1	1.6	13.0	10.8	0.80	0.50	0.0	0.0	11.13	24	159
180.0	Alcatel-Lucent	6	44	3.3	1.9	13.0	17.0	0.80	0.50	0.0	0.0	11.13	74	264
180.0	Argus LLPX310R	3	29	4.3	3.5	11.8	4.5	0.80	0.63	0.0	0.0	11.13	61	86
180.0	Generic 24" x 24"	1	20	4.8	2.0	24.0	8.0	0.80	1.00	0.0	0.0	11.13	36	20
180.0	Generic 2' Std. Dish	3	14	5.2	2.0	24.0	0.0	1.00	1.00	0.0	0.0	11.13	148	42
180.0	RFS APXVSPP18-C-	2	57	8.0	6.0	11.8	7.0	0.80	0.77	0.0	0.0	11.13	94	114
180.0	RFS APXV9ERR18-C-	1	62	8.0	6.0	11.8	7.9	0.80	1.00	0.0	0.0	11.13	61	62
165.0	Powerwave Allgon	12	6	0.2	0.3	6.0	3.0	0.80	0.50	0.0	0.0	10.93	9	66
165.0	Powerwave Allgon	6	2	0.3	0.4	8.3	2.4	0.80	0.50	0.0	0.0	10.93	8	13
165.0	CCI	3	19	1.0	0.9	11.0	3.8	0.80	0.50	0.0	0.0	10.93	11	58
165.0	Commscope WCS-	1	30	1.0	0.9	10.6	6.9	0.80	0.50	0.0	0.0	10.93	4	30
165.0	Powerwave Allgon	9	14	1.1	1.2	9.2	2.6	0.80	0.50	0.0	0.0	10.93	37	127
165.0	Raycap DC6-48-60-	3	20	1.3	2.0	9.7	9.7	0.80	0.50	0.0	0.0	10.93	14	60
165.0	Ericsson RRUS 4426	3	48	1.6	1.3	13.2	5.8	0.80	0.50	0.0	0.0	10.93	18	145
165.0	Ericsson RRUS 4478	3	60	1.8	1.4	13.4	7.7	0.80	0.50	0.0	0.0	10.93	21	180
165.0	Ericsson RRUS 32	3	51	2.7	2.2	12.1	6.7	0.80	0.50	0.0	0.0	10.93	30	152
165.0	Ericsson RRUS 32 B2	3	53	2.7	2.3	12.1	7.0	0.80	0.50	0.0	0.0	10.93	31	159
165.0	Ericsson Radio 4449	3	85	3.5	2.3	15.0	10.0	0.80	0.50	0.0	0.0	10.93	39	255
165.0	Powerwave Allgon	3	35	5.5	4.6	11.0	5.0	0.80	0.65	0.0	0.0	10.93	80	105
165.0	Andrew SBNHH-	3	41	5.9	4.6	11.9	7.1	0.80	0.69	0.0	0.0	10.93	91	123
165.0	Quintel QS66512-3	3	112	8.1	6.0	12.0	9.6	0.80	0.74	0.0	0.0	10.93	134	336
165.0	Kathrein Scala	3	98	13.8	6.6	20.0	6.9	0.80	0.62	0.0	0.0	10.93	191	293
165.0	Round Sector Frame	3	300	14.4	0.0	0.0	0.0	0.75	0.67	0.0	0.0	10.93	202	900
155.0	Commscope	3	21	0.6	0.8	6.9	6.4	0.80	0.50	0.0	0.0	10.79	6	62
155.0	Samsung Outdoor	3	19	0.9	1.0	8.5	4.1	0.80	0.50	0.0	0.0	10.79	9	56
155.0	Samsung Outdoor	3	4	0.9	1.0	8.7	1.4	0.80	0.50	0.0	0.0	10.79	10	13
155.0	Samsung B2/B66A	3	84	1.9	1.3	15.0	10.0	0.80	0.50	0.0	0.0	10.79	21	253
155.0	Samsung B5/B13	3	70	1.9	1.3	15.0	8.1	0.80	0.50	0.0	0.0	10.79	21	211
155.0	Raycap RxxDC-3315-	2	21	2.5	1.6	15.7	10.3	0.80	0.67	0.0	0.0	10.79	25	43
155.0	Samsung MT6407-	3	82	4.7	2.9	16.1	5.5	0.80	0.61	0.0	0.0	10.79	63	245
155.0	Amphenol Antel BXA-	3	19	7.3	5.7	11.2	5.3	0.80	0.66	0.0	0.0	10.79	105	58
155.0	Generic Mount	1	200	7.5	0.0	0.0	0.0	1.00	1.00	0.0	0.0	10.79	69	200
155.0	Commscope JAHH-	6	61	9.1	6.0	13.8	8.2	0.80	0.69	0.0	0.0	10.79	277	364
155.0	Flat Light Sector	3	400	17.9	0.0	0.0	0.0	0.75	0.67	0.0	0.0	10.79	247	1200
140.0	Small Side Lights	3	45	2.0	1.0	8.0	8.0	1.00	1.00	0.0	0.0	10.56	54	135
132.0	Generic 4' Yagi	1	15	4.9	4.0	48.0	3.0	1.00	1.00	0.0	0.0	10.43	43	15
132.0	Flat Side Arm	1	150	6.3	0.0	0.0	0.0	1.00	1.00	0.0	0.0	10.43	56	150
123.0	Generic 10' Omni	1	25	3.0	10.0	3.0	3.0	1.00	1.00	0.0	0.0	10.28	26	25
118.0	Round Side Arm	1	150	5.2	0.0	0.0	0.0	1.00	1.00	0.0	0.0	10.19	45	150

Site Number: 383598

Code: ANSI/TIA-222-H

© 2007 - 2021 by ATC IP LLC. All rights reserved.

Site Name: Tartaglia, CT

Engineering Number: 13668689\_C3\_03

7/6/2021 6:21:58 PM

Customer: VERIZON WIRELESS

### Tower Loading

108.0 Round Side Arm	1	150	5.2	0.0	0.0	0.0	1.00	1.00	0.0	0.0	10.00	44	150
98.00 Generic 4' Yagi	1	15	4.9	4.0	48.0	3.0	1.00	1.00	0.0	0.0	9.80	41	15
98.00 Flat Side Arm	1	150	6.3	0.0	0.0	0.0	1.00	1.00	0.0	0.0	9.80	52	150
80.00 Empty Round Side	1	150	5.2	0.0	0.0	0.0	1.00	1.00	0.0	0.0	9.39	41	150
8.00 Round Side Arm	1	150	5.2	0.0	0.0	0.0	1.00	1.00	0.0	0.0	6.61	29	150
Totals	172	14249	830.1									4613	14249

### Tower Loading

#### Linear Appurtenance Properties

Elev From (ft)	Elev To (ft)	Description	Qty	Width (in)	Weight (lb/ft)	Pct In Block	Spread On Faces	Bundling Arrangement	Cluster Dia (in)	Out Of Zone	Spacing (in)	Orientation Factor	Ka Override
0.00	245.0	1 1/4" Coax	1	1.55	0.63	100	1	Individual	0.00	N	1.00	1.00	0.00
0.00	243.0	1 5/8" Coax	1	1.98	0.82	100	1	Individual	0.00	N	1.00	1.00	0.00
0.00	240.0	Waveguide	1	1.50	6.00	100	1	Individual	0.00	N	1.00	1.00	0.00
0.00	234.0	7/8" Coax	2	1.09	0.33	100	1	Individual	0.00	N	1.00	1.00	0.00
0.00	229.0	1 1/4" Coax	1	1.55	0.63	100	1	Individual	0.00	N	1.00	1.00	0.00
0.00	202.0	1 1/4" Hybriflex	2	1.54	1.00	100	2	Individual	0.00	N	1.00	1.00	0.00
0.00	202.0	1 5/8" Hybriflex	3	1.98	1.30	100	2	Individual	0.00	N	1.00	1.00	0.00
0.00	202.0	Waveguide	1	1.50	6.00	100	2	Individual	0.00	N	1.00	1.00	0.00
0.00	183.0	Waveguide	1	1.50	6.00	100	2	Individual	0.00	N	1.00	1.00	0.00
0.00	181.0	1.7" (43.2mm)	1	1.70	1.78	100	2	Individual	0.00	N	1.00	1.00	0.00
0.00	180.0	1 1/4" (1.25"-	3	1.25	1.05	100	2	Individual	0.00	N	1.00	1.00	0.00
0.00	180.0	1 1/4" Hybriflex	1	1.54	1.00	100	None	Individual	0.00	N	1.00	1.00	0.00
0.00	180.0	1/2" Coax	3	0.63	0.15	67	2	Block	0.00	N	1.00	1.00	0.00
0.00	180.0	2" conduit	2	2.38	3.65	100	None	Individual	0.00	N	1.00	1.00	0.00
0.00	180.0	5/16" (0.31"-	6	0.31	0.05	50	2	Block	0.00	N	1.00	1.00	0.00
0.00	174.0	Waveguide	1	1.50	6.00	100	1	Individual	0.00	N	1.00	1.00	0.00
0.00	165.0	0.39" (10mm) Fiber	2	0.39	0.06	100	1	Individual	0.00	N	1.00	1.00	0.00
0.00	165.0	0.39" (10mm) Fiber	4	0.39	0.06	100	None	Individual	0.00	N	1.00	1.00	0.00
0.00	165.0	0.78" (19.7mm) 8	6	0.78	0.59	50	1	Block	0.00	N	1.00	1.00	0.00
0.00	165.0	1 5/8" Coax	12	1.98	0.82	50	1	Block	0.00	N	1.00	1.00	0.00
0.00	165.0	2" conduit	2	2.38	3.65	100	1	Individual	0.00	N	1.00	1.00	0.00
0.00	165.0	Waveguide	1	1.50	6.00	100	1	Individual	0.00	N	1.00	1.00	0.00
0.00	164.0	0.78" (19.7mm) 8	2	0.78	0.59	100	None	Individual	0.00	N	1.00	1.00	0.00
0.00	155.0	1 5/8" Coax	6	1.98	0.82	100	1	Individual	0.00	N	1.00	1.00	0.00
0.00	155.0	1 5/8" Hybriflex	2	1.98	1.30	100	None	Individual	0.00	N	1.00	1.00	0.00
0.00	155.0	Waveguide	1	1.50	6.00	100	1	Individual	0.00	N	1.00	1.00	0.00
0.00	132.0	1 1/4" Coax	1	1.55	0.63	100	3	Individual	0.00	N	1.00	1.00	0.00
0.00	123.0	7/8" Coax	1	1.09	0.33	100	1	Individual	0.00	N	1.00	1.00	0.00
0.00	98.00	1 1/4" Coax	1	1.55	0.63	100	3	Individual	0.00	N	1.00	1.00	0.00

### Section Forces

LoadCase 1.2D + 1.0W Normal

119 mph Normal with No Ice

Gust Response Factor (Gh): 0.85

Wind Importance Factor (Iw) : 1.00

Section Elev. (ft)	Q <sub>z</sub> (psf)	A <sub>f</sub> (sf)	A <sub>r</sub> (sf)	Ice A <sub>r</sub> (sf)	e	C <sub>f</sub>	D <sub>f</sub>	D <sub>r</sub>	T <sub>iz</sub> (in)	A <sub>e</sub> (sf)	EPA <sub>a</sub> (sf)	EPA <sub>bi</sub> (sf)	Wt. (lb)	Ice Wt. (lb)	F <sub>st</sub> (lb)	F <sub>a</sub> (lb)	Force (lb)	
11	230.00	46.12	0.000	45.353	0.000	0.179	2.67	1.00	1.00	0.0	22.58	60.21	0.00	4730	0	2360	388	2749
10	210.00	45.24	0.000	45.187	0.000	0.153	2.76	1.00	1.00	0.0	21.88	60.41	0.00	4935	0	2323	504	2827
9	190.00	44.30	0.000	46.842	0.000	0.137	2.82	1.00	1.00	0.0	22.55	63.63	0.00	5372	0	2396	982	3379
8	170.00	43.28	0.000	50.084	0.000	0.127	2.86	1.00	1.00	0.0	24.29	69.39	0.00	6687	0	2552	2215	4768
7	150.00	42.15	0.000	57.359	0.000	0.130	2.85	1.00	1.00	0.0	28.04	79.87	0.00	8282	0	2861	3976	6837
6	130.00	40.90	0.000	57.395	0.000	0.116	2.90	1.00	1.00	0.0	28.31	82.08	0.00	8449	0	2853	4095	6948
5	110.00	39.49	0.000	56.861	0.000	0.105	2.95	1.00	1.00	0.0	27.07	79.74	0.00	7954	0	2676	4015	6692
4	90.00	37.85	0.000	57.777	0.000	0.097	2.98	1.00	1.00	0.0	28.05	83.46	0.00	8240	0	2685	3903	6588
3	70.00	35.90	0.000	66.406	0.000	0.102	2.96	1.00	1.00	0.0	31.82	94.04	0.00	9234	0	2870	3708	6577
2	45.00	32.71	0.000	98.555	0.000	0.092	3.00	1.00	1.00	0.0	46.70	139.88	0.00	13420	0	3890	5068	8957
1	15.00	25.99	0.000	114.52	0.000	0.097	2.98	1.00	1.00	0.0	54.02	160.77	0.00	15341	0	3552	4026	7578
														92644	0			63899

LoadCase 1.2D + 1.0W 60 deg

119 mph 60 degree with No Ice

Gust Response Factor (Gh): 0.85

Wind Importance Factor (Iw) : 1.00

Section Elev. (ft)	Q <sub>z</sub> (psf)	A <sub>f</sub> (sf)	A <sub>r</sub> (sf)	Ice A <sub>r</sub> (sf)	e	C <sub>f</sub>	D <sub>f</sub>	D <sub>r</sub>	T <sub>iz</sub> (in)	A <sub>e</sub> (sf)	EPA <sub>a</sub> (sf)	EPA <sub>bi</sub> (sf)	Wt. (lb)	Ice Wt. (lb)	F <sub>st</sub> (lb)	F <sub>a</sub> (lb)	Force (lb)	
11	230.00	46.12	0.000	45.353	0.000	0.179	2.67	0.80	1.00	0.0	22.58	60.21	0.00	4730	0	2360	388	2749
10	210.00	45.24	0.000	45.187	0.000	0.153	2.76	0.80	1.00	0.0	21.88	60.41	0.00	4935	0	2323	504	2827
9	190.00	44.30	0.000	46.842	0.000	0.137	2.82	0.80	1.00	0.0	22.55	63.63	0.00	5372	0	2396	982	3379
8	170.00	43.28	0.000	50.084	0.000	0.127	2.86	0.80	1.00	0.0	24.29	69.39	0.00	6687	0	2552	2215	4768
7	150.00	42.15	0.000	57.359	0.000	0.130	2.85	0.80	1.00	0.0	28.04	79.87	0.00	8282	0	2861	3976	6837
6	130.00	40.90	0.000	57.395	0.000	0.116	2.90	0.80	1.00	0.0	28.31	82.08	0.00	8449	0	2853	4095	6948
5	110.00	39.49	0.000	56.861	0.000	0.105	2.95	0.80	1.00	0.0	27.07	79.74	0.00	7954	0	2676	4015	6692
4	90.00	37.85	0.000	57.777	0.000	0.097	2.98	0.80	1.00	0.0	28.05	83.46	0.00	8240	0	2685	3903	6588
3	70.00	35.90	0.000	66.406	0.000	0.102	2.96	0.80	1.00	0.0	31.82	94.04	0.00	9234	0	2870	3708	6577
2	45.00	32.71	0.000	98.555	0.000	0.092	3.00	0.80	1.00	0.0	46.70	139.88	0.00	13420	0	3890	5068	8957
1	15.00	25.99	0.000	114.52	0.000	0.097	2.98	0.80	1.00	0.0	54.99	163.66	0.00	15341	0	3616	4026	7642
														92644	0			63963

LoadCase 1.2D + 1.0W 90 deg

119 mph 90 degree with No Ice

Gust Response Factor (Gh): 0.85

Wind Importance Factor (Iw) : 1.00

Section Elev. (ft)	Q <sub>z</sub> (psf)	A <sub>f</sub> (sf)	A <sub>r</sub> (sf)	Ice A <sub>r</sub> (sf)	e	C <sub>f</sub>	D <sub>f</sub>	D <sub>r</sub>	T <sub>iz</sub> (in)	A <sub>e</sub> (sf)	EPA <sub>a</sub> (sf)	EPA <sub>bi</sub> (sf)	Wt. (lb)	Ice Wt. (lb)	F <sub>st</sub> (lb)	F <sub>a</sub> (lb)	Force (lb)	
11	230.00	46.12	0.000	45.353	0.000	0.179	2.67	0.85	1.00	0.0	22.58	60.21	0.00	4730	0	2360	388	2749
10	210.00	45.24	0.000	45.187	0.000	0.153	2.76	0.85	1.00	0.0	21.88	60.41	0.00	4935	0	2323	504	2827
9	190.00	44.30	0.000	46.842	0.000	0.137	2.82	0.85	1.00	0.0	22.55	63.63	0.00	5372	0	2396	982	3379
8	170.00	43.28	0.000	50.084	0.000	0.127	2.86	0.85	1.00	0.0	24.29	69.39	0.00	6687	0	2552	2215	4768
7	150.00	42.15	0.000	57.359	0.000	0.130	2.85	0.85	1.00	0.0	28.04	79.87	0.00	8282	0	2861	3976	6837
6	130.00	40.90	0.000	57.395	0.000	0.116	2.90	0.85	1.00	0.0	28.31	82.08	0.00	8449	0	2853	4095	6948
5	110.00	39.49	0.000	56.861	0.000	0.105	2.95	0.85	1.00	0.0	27.07	79.74	0.00	7954	0	2676	4015	6692
4	90.00	37.85	0.000	57.777	0.000	0.097	2.98	0.85	1.00	0.0	28.05	83.46	0.00	8240	0	2685	3903	6588
3	70.00	35.90	0.000	66.406	0.000	0.102	2.96	0.85	1.00	0.0	31.82	94.04	0.00	9234	0	2870	3708	6577

Site Number: 383598

Code:

ANSI/TIA-222-H

© 2007 - 2021 by ATC IP LLC. All rights reserved.

Site Name: Tartaglia, CT

Engineering Number: 13668689\_C3\_03

7/6/2021 6:21:58 PM

Customer: VERIZON WIRELESS

### Section Forces

2	45.00	32.71	0.000	98.555	0.000	0.092	3.00	0.85	1.00	0.0	46.70	139.88	0.00	13420	0	3890	5068	8957
1	15.00	25.99	0.000	114.52	0.000	0.097	2.98	0.85	1.00	0.0	54.99	163.66	0.00	15341	0	3616	4026	7642
														92644	0			63963

#### LoadCase 0.9D + 1.0W Normal

#### 119 mph Normal with No Ice (Reduced DL)

Gust Response Factor (Gh): 0.85

Wind Importance Factor (Iw) : 1.00

Section	Elev. (ft)	Q <sub>z</sub> (psf)	A <sub>f</sub> (sf)	A <sub>r</sub> (sf)	Ice A <sub>r</sub> (sf)	e	C <sub>f</sub>	D <sub>f</sub>	D <sub>r</sub>	T <sub>iz</sub> (in)	A <sub>e</sub> (sf)	EPA <sub>a</sub> (sf)	EPA <sub>ai</sub> (sf)	Wt. (lb)	Ice Wt. (lb)	F <sub>st</sub> (lb)	F <sub>a</sub> (lb)	Force (lb)
11	230.00	46.12	0.000	45.353	0.000	0.179	2.67	1.00	1.00	0.0	22.58	60.21	0.00	3547	0	2360	388	2749
10	210.00	45.24	0.000	45.187	0.000	0.153	2.76	1.00	1.00	0.0	21.88	60.41	0.00	3702	0	2323	504	2827
9	190.00	44.30	0.000	46.842	0.000	0.137	2.82	1.00	1.00	0.0	22.55	63.63	0.00	4029	0	2396	982	3379
8	170.00	43.28	0.000	50.084	0.000	0.127	2.86	1.00	1.00	0.0	24.29	69.39	0.00	5015	0	2552	2215	4768
7	150.00	42.15	0.000	57.359	0.000	0.130	2.85	1.00	1.00	0.0	28.04	79.87	0.00	6211	0	2861	3976	6837
6	130.00	40.90	0.000	57.395	0.000	0.116	2.90	1.00	1.00	0.0	28.31	82.08	0.00	6337	0	2853	4095	6948
5	110.00	39.49	0.000	56.861	0.000	0.105	2.95	1.00	1.00	0.0	27.07	79.74	0.00	5966	0	2676	4015	6692
4	90.00	37.85	0.000	57.777	0.000	0.097	2.98	1.00	1.00	0.0	28.05	83.46	0.00	6180	0	2685	3903	6588
3	70.00	35.90	0.000	66.406	0.000	0.102	2.96	1.00	1.00	0.0	31.82	94.04	0.00	6926	0	2870	3708	6577
2	45.00	32.71	0.000	98.555	0.000	0.092	3.00	1.00	1.00	0.0	46.70	139.88	0.00	10065	0	3890	5068	8957
1	15.00	25.99	0.000	114.52	0.000	0.097	2.98	1.00	1.00	0.0	54.99	163.66	0.00	11506	0	3616	4026	7642
														69483	0			63963

#### LoadCase 0.9D + 1.0W 60 deg

#### 119 mph 60 deg with No Ice (Reduced DL)

Gust Response Factor (Gh): 0.85

Wind Importance Factor (Iw) : 1.00

Section	Elev. (ft)	Q <sub>z</sub> (psf)	A <sub>f</sub> (sf)	A <sub>r</sub> (sf)	Ice A <sub>r</sub> (sf)	e	C <sub>f</sub>	D <sub>f</sub>	D <sub>r</sub>	T <sub>iz</sub> (in)	A <sub>e</sub> (sf)	EPA <sub>a</sub> (sf)	EPA <sub>ai</sub> (sf)	Wt. (lb)	Ice Wt. (lb)	F <sub>st</sub> (lb)	F <sub>a</sub> (lb)	Force (lb)
11	230.00	46.12	0.000	45.353	0.000	0.179	2.67	0.80	1.00	0.0	22.58	60.21	0.00	3547	0	2360	388	2749
10	210.00	45.24	0.000	45.187	0.000	0.153	2.76	0.80	1.00	0.0	21.88	60.41	0.00	3702	0	2323	504	2827
9	190.00	44.30	0.000	46.842	0.000	0.137	2.82	0.80	1.00	0.0	22.55	63.63	0.00	4029	0	2396	982	3379
8	170.00	43.28	0.000	50.084	0.000	0.127	2.86	0.80	1.00	0.0	24.29	69.39	0.00	5015	0	2552	2215	4768
7	150.00	42.15	0.000	57.359	0.000	0.130	2.85	0.80	1.00	0.0	28.04	79.87	0.00	6211	0	2861	3976	6837
6	130.00	40.90	0.000	57.395	0.000	0.116	2.90	0.80	1.00	0.0	28.31	82.08	0.00	6337	0	2853	4095	6948
5	110.00	39.49	0.000	56.861	0.000	0.105	2.95	0.80	1.00	0.0	27.07	79.74	0.00	5966	0	2676	4015	6692
4	90.00	37.85	0.000	57.777	0.000	0.097	2.98	0.80	1.00	0.0	28.05	83.46	0.00	6180	0	2685	3903	6588
3	70.00	35.90	0.000	66.406	0.000	0.102	2.96	0.80	1.00	0.0	31.82	94.04	0.00	6926	0	2870	3708	6577
2	45.00	32.71	0.000	98.555	0.000	0.092	3.00	0.80	1.00	0.0	46.70	139.88	0.00	10065	0	3890	5068	8957
1	15.00	25.99	0.000	114.52	0.000	0.097	2.98	0.80	1.00	0.0	54.99	163.66	0.00	11506	0	3616	4026	7642
														69483	0			63963

#### LoadCase 0.9D + 1.0W 90 deg

#### 119 mph 90 deg with No Ice (Reduced DL)

Gust Response Factor (Gh): 0.85

Wind Importance Factor (Iw) : 1.00

Section	Elev. (ft)	Q <sub>z</sub> (psf)	A <sub>f</sub> (sf)	A <sub>r</sub> (sf)	Ice A <sub>r</sub> (sf)	e	C <sub>f</sub>	D <sub>f</sub>	D <sub>r</sub>	T <sub>iz</sub> (in)	A <sub>e</sub> (sf)	EPA <sub>a</sub> (sf)	EPA <sub>ai</sub> (sf)	Wt. (lb)	Ice Wt. (lb)	F <sub>st</sub> (lb)	F <sub>a</sub> (lb)	Force (lb)
11	230.00	46.12	0.000	45.353	0.000	0.179	2.67	0.85	1.00	0.0	22.58	60.21	0.00	3547	0	2360	388	2749
10	210.00	45.24	0.000	45.187	0.000	0.153	2.76	0.85	1.00	0.0	21.88	60.41	0.00	3702	0	2323	504	2827
9	190.00	44.30	0.000	46.842	0.000	0.137	2.82	0.85	1.00	0.0	22.55	63.63	0.00	4029	0	2396	982	3379
8	170.00	43.28	0.000	50.084	0.000	0.127	2.86	0.85	1.00	0.0	24.29	69.39	0.00	5015	0	2552	2215	4768

Site Number: 383598

Code:

ANSI/TIA-222-H

© 2007 - 2021 by ATC IP LLC. All rights reserved.

Site Name: Tartaglia, CT

Engineering Number: 13668689\_C3\_03

7/6/2021 6:21:58 PM

Customer: VERIZON WIRELESS

### Section Forces

7	150.00	42.15	0.000	57.359	0.000	0.130	2.85	0.85	1.00	0.0	28.04	79.87	0.00	6211	0	2861	3976	6837
6	130.00	40.90	0.000	57.395	0.000	0.116	2.90	0.85	1.00	0.0	28.31	82.08	0.00	6337	0	2853	4095	6948
5	110.00	39.49	0.000	56.861	0.000	0.105	2.95	0.85	1.00	0.0	27.07	79.74	0.00	5966	0	2676	4015	6692
4	90.00	37.85	0.000	57.777	0.000	0.097	2.98	0.85	1.00	0.0	28.05	83.46	0.00	6180	0	2685	3903	6588
3	70.00	35.90	0.000	66.406	0.000	0.102	2.96	0.85	1.00	0.0	31.82	94.04	0.00	6926	0	2870	3708	6577
2	45.00	32.71	0.000	98.555	0.000	0.092	3.00	0.85	1.00	0.0	46.70	139.88	0.00	10065	0	3890	5068	8957
1	15.00	25.99	0.000	114.52	0.000	0.097	2.98	0.85	1.00	0.0	54.99	163.66	0.00	11506	0	3616	4026	7642
														69483	0			63963

#### LoadCase 1.2D + 1.0Di + 1.0Wi Normal

#### 50 mph Normal with 1.00 in Radial Ice

Gust Response Factor (Gh): 0.85

Ice Dead Load Factor :1.00

Ice Importance Factor :1.00

Wind Importance Factor (Iw) : 1.00

Section	Elev. (ft)	Q <sub>z</sub> (psf)	A <sub>f</sub> (sf)	A <sub>r</sub> (sf)	Ice A <sub>r</sub> (sf)	e	C <sub>f</sub>	D <sub>f</sub>	D <sub>r</sub>	T <sub>iz</sub> (in)	A <sub>e</sub> (sf)	EPA <sub>a</sub> (sf)	EPA <sub>ai</sub> (sf)	Wt. (lb)	Ice Wt. (lb)	F <sub>st</sub> (lb)	F <sub>a</sub> (lb)	Force (lb)
11	230.00	8.14	0.000	71.503	26.15	0.278	2.36	1.00	1.00	1.2	43.01	101.30	26.15	7699	2969	701	205	906
10	210.00	7.99	0.000	68.577	23.39	0.229	2.50	1.00	1.00	1.2	40.27	100.76	23.39	7856	2921	684	282	966
9	190.00	7.82	0.000	71.522	24.68	0.206	2.58	1.00	1.00	1.2	41.65	107.27	24.68	8897	3525	713	536	1250
8	170.00	7.64	0.000	76.135	26.05	0.192	2.62	1.00	1.00	1.2	44.16	115.85	26.05	11772	5085	752	1169	1922
7	150.00	7.44	0.000	82.279	30.13	0.184	2.65	1.00	1.00	1.2	50.61	134.12	30.13	15903	7622	848	1926	2775
6	130.00	7.22	0.000	86.081	28.68	0.173	2.69	1.00	1.00	1.1	49.71	133.59	28.69	15859	7410	820	1998	2818
5	110.00	6.97	0.000	75.818	23.56	0.139	2.81	1.00	1.00	1.1	45.84	128.98	23.56	15483	7528	764	2012	2776
4	90.00	6.68	0.000	79.522	21.74	0.133	2.84	1.00	1.00	1.1	45.37	128.65	21.75	15363	7122	731	1950	2681
3	70.00	6.34	0.000	88.365	21.95	0.135	2.83	1.00	1.00	1.1	50.42	142.52	21.96	16437	7202	768	1825	2592
2	45.00	5.78	0.000	126.62	28.07	0.118	2.89	1.00	1.00	1.0	71.94	208.12	28.07	23493	10073	1022	2471	3492
1	15.00	4.59	0.000	134.52	28.64	0.114	2.91	1.00	1.00	0.9	81.34	236.73	28.65	25385	10044	923	1863	2786
														164147	71503			24964

#### LoadCase 1.2D + 1.0Di + 1.0Wi 60 deg

#### 50 mph 60 deg with 1.00 in Radial Ice

Gust Response Factor (Gh): 0.85

Ice Dead Load Factor :1.00

Ice Importance Factor :1.00

Wind Importance Factor (Iw) : 1.00

Section	Elev. (ft)	Q <sub>z</sub> (psf)	A <sub>f</sub> (sf)	A <sub>r</sub> (sf)	Ice A <sub>r</sub> (sf)	e	C <sub>f</sub>	D <sub>f</sub>	D <sub>r</sub>	T <sub>iz</sub> (in)	A <sub>e</sub> (sf)	EPA <sub>a</sub> (sf)	EPA <sub>ai</sub> (sf)	Wt. (lb)	Ice Wt. (lb)	F <sub>st</sub> (lb)	F <sub>a</sub> (lb)	Force (lb)
11	230.00	8.14	0.000	71.503	26.15	0.278	2.36	0.80	1.00	1.2	43.01	101.30	26.15	7699	2969	701	205	906
10	210.00	7.99	0.000	68.577	23.39	0.229	2.50	0.80	1.00	1.2	40.27	100.76	23.39	7856	2921	684	282	966
9	190.00	7.82	0.000	71.522	24.68	0.206	2.58	0.80	1.00	1.2	41.65	107.27	24.68	8897	3525	713	536	1250
8	170.00	7.64	0.000	76.135	26.05	0.192	2.62	0.80	1.00	1.2	44.16	115.85	26.05	11772	5085	752	1169	1922
7	150.00	7.44	0.000	82.279	30.13	0.184	2.65	0.80	1.00	1.2	50.61	134.12	30.13	15903	7622	848	1926	2775
6	130.00	7.22	0.000	86.081	28.68	0.173	2.69	0.80	1.00	1.1	49.71	133.59	28.69	15859	7410	820	1998	2818
5	110.00	6.97	0.000	75.818	23.56	0.139	2.81	0.80	1.00	1.1	45.84	128.98	23.56	15483	7528	764	2012	2776
4	90.00	6.68	0.000	79.522	21.74	0.133	2.84	0.80	1.00	1.1	45.37	128.65	21.75	15363	7122	731	1950	2681
3	70.00	6.34	0.000	88.365	21.95	0.135	2.83	0.80	1.00	1.1	50.42	142.52	21.96	16437	7202	768	1825	2592
2	45.00	5.78	0.000	126.62	28.07	0.118	2.89	0.80	1.00	1.0	71.94	208.12	28.07	23493	10073	1022	2471	3492
1	15.00	4.59	0.000	134.52	28.64	0.114	2.91	0.80	1.00	0.9	81.34	236.73	28.65	25385	10044	923	1863	2786
														164147	71503			24964



### Section Forces

LoadCase 1.2D + 1.0Di + 1.0Wi 90 deg

50 mph 90 deg with 1.00 in Radial Ice

Gust Response Factor (Gh): 0.85

Ice Dead Load Factor :1.00

Ice Importance Factor :1.00

Wind Importance Factor (Iw) : 1.00

Section Elev. (ft)	Q <sub>z</sub> (psf)	A <sub>f</sub> (sf)	A <sub>r</sub> (sf)	Ice A <sub>r</sub> (sf)	e	C <sub>f</sub>	D <sub>f</sub>	D <sub>r</sub>	T <sub>iz</sub> (in)	A <sub>e</sub> (sf)	EPA <sub>a</sub> (sf)	EPA <sub>bi</sub> (sf)	Wt. (lb)	Ice Wt. (lb)	F <sub>st</sub> (lb)	F <sub>a</sub> (lb)	Force (lb)
11 230.00	8.14	0.000	71.503	26.15	0.278	2.36	0.85	1.00	1.2	43.01	101.30	26.15	7699	2969	701	205	906
10 210.00	7.99	0.000	68.577	23.39	0.229	2.50	0.85	1.00	1.2	40.27	100.76	23.39	7856	2921	684	282	966
9 190.00	7.82	0.000	71.522	24.68	0.206	2.58	0.85	1.00	1.2	41.65	107.27	24.68	8897	3525	713	536	1250
8 170.00	7.64	0.000	76.135	26.05	0.192	2.62	0.85	1.00	1.2	44.16	115.85	26.05	11772	5085	752	1169	1922
7 150.00	7.44	0.000	82.279	30.13	0.184	2.65	0.85	1.00	1.2	50.61	134.12	30.13	15903	7622	848	1926	2775
6 130.00	7.22	0.000	86.081	28.68	0.173	2.69	0.85	1.00	1.1	49.71	133.59	28.69	15859	7410	820	1998	2818
5 110.00	6.97	0.000	75.818	23.56	0.139	2.81	0.85	1.00	1.1	45.84	128.98	23.56	15483	7528	764	2012	2776
4 90.00	6.68	0.000	79.522	21.74	0.133	2.84	0.85	1.00	1.1	45.37	128.65	21.75	15363	7122	731	1950	2681
3 70.00	6.34	0.000	88.365	21.95	0.135	2.83	0.85	1.00	1.1	50.42	142.52	21.96	16437	7202	768	1825	2592
2 45.00	5.78	0.000	126.62	28.07	0.118	2.89	0.85	1.00	1.0	71.94	208.12	28.07	23493	10073	1022	2471	3492
1 15.00	4.59	0.000	134.52	28.64	0.114	2.91	0.85	1.00	0.9	81.34	236.73	28.65	25385	10044	923	1863	2786
													164147	71503			24964

LoadCase 1.0D + 1.0W Service Normal

Serviceability - 60 mph Wind Normal

Gust Response Factor (Gh): 0.85

Wind Importance Factor (Iw) : 1.00

Section Elev. (ft)	Q <sub>z</sub> (psf)	A <sub>f</sub> (sf)	A <sub>r</sub> (sf)	Ice A <sub>r</sub> (sf)	e	C <sub>f</sub>	D <sub>f</sub>	D <sub>r</sub>	T <sub>iz</sub> (in)	A <sub>e</sub> (sf)	EPA <sub>a</sub> (sf)	EPA <sub>bi</sub> (sf)	Wt. (lb)	Ice Wt. (lb)	F <sub>st</sub> (lb)	F <sub>a</sub> (lb)	Force (lb)
11 230.00	11.72	0.000	45.353	0.000	0.179	2.67	1.00	1.00	0.0	25.16	67.10	0.00	3941	0	669	99	767
10 210.00	11.50	0.000	45.187	0.000	0.153	2.76	1.00	1.00	0.0	24.73	68.26	0.00	4113	0	667	128	795
9 190.00	11.26	0.000	46.842	0.000	0.137	2.82	1.00	1.00	0.0	25.60	72.23	0.00	4477	0	691	250	941
8 170.00	11.00	0.000	50.084	0.000	0.127	2.86	1.00	1.00	0.0	27.49	78.52	0.00	5572	0	734	563	1297
7 150.00	10.72	0.000	57.359	0.000	0.130	2.85	1.00	1.00	0.0	31.63	90.10	0.00	6901	0	821	1011	1831
6 130.00	10.40	0.000	57.395	0.000	0.116	2.90	1.00	1.00	0.0	31.83	92.27	0.00	7041	0	815	1041	1856
5 110.00	10.04	0.000	56.861	0.000	0.105	2.95	1.00	1.00	0.0	31.16	91.77	0.00	6628	0	783	1021	1804
4 90.00	9.62	0.000	57.777	0.000	0.097	2.98	1.00	1.00	0.0	31.99	95.18	0.00	6867	0	779	992	1771
3 70.00	9.13	0.000	66.406	0.000	0.102	2.96	1.00	1.00	0.0	35.30	104.31	0.00	7695	0	809	943	1752
2 45.00	8.32	0.000	98.555	0.000	0.092	3.00	1.00	1.00	0.0	53.48	160.19	0.00	11183	0	1132	1288	2421
1 15.00	6.61	0.000	114.52	0.000	0.097	2.98	1.00	1.00	0.0	62.36	185.60	0.00	12784	0	1042	1024	2066
													77204	0			17302

LoadCase 1.0D + 1.0W Service 60 deg

Serviceability - 60 mph Wind 60 deg

Gust Response Factor (Gh): 0.85

Wind Importance Factor (Iw) : 1.00

Section Elev. (ft)	Q <sub>z</sub> (psf)	A <sub>f</sub> (sf)	A <sub>r</sub> (sf)	Ice A <sub>r</sub> (sf)	e	C <sub>f</sub>	D <sub>f</sub>	D <sub>r</sub>	T <sub>iz</sub> (in)	A <sub>e</sub> (sf)	EPA <sub>a</sub> (sf)	EPA <sub>bi</sub> (sf)	Wt. (lb)	Ice Wt. (lb)	F <sub>st</sub> (lb)	F <sub>a</sub> (lb)	Force (lb)
11 230.00	11.72	0.000	45.353	0.000	0.179	2.67	0.80	1.00	0.0	25.16	67.10	0.00	3941	0	669	99	767
10 210.00	11.50	0.000	45.187	0.000	0.153	2.76	0.80	1.00	0.0	24.73	68.26	0.00	4113	0	667	128	795
9 190.00	11.26	0.000	46.842	0.000	0.137	2.82	0.80	1.00	0.0	25.60	72.23	0.00	4477	0	691	250	941
8 170.00	11.00	0.000	50.084	0.000	0.127	2.86	0.80	1.00	0.0	27.49	78.52	0.00	5572	0	734	563	1297
7 150.00	10.72	0.000	57.359	0.000	0.130	2.85	0.80	1.00	0.0	31.63	90.10	0.00	6901	0	821	1011	1831
6 130.00	10.40	0.000	57.395	0.000	0.116	2.90	0.80	1.00	0.0	31.83	92.27	0.00	7041	0	815	1041	1856
5 110.00	10.04	0.000	56.861	0.000	0.105	2.95	0.80	1.00	0.0	31.16	91.77	0.00	6628	0	783	1021	1804
4 90.00	9.62	0.000	57.777	0.000	0.097	2.98	0.80	1.00	0.0	31.99	95.18	0.00	6867	0	779	992	1771

Site Number: 383598

Code: ANSI/TIA-222-H

© 2007 - 2021 by ATC IP LLC. All rights reserved.

Site Name: Tartaglia, CT

Engineering Number: 13668689\_C3\_03

7/6/2021 6:21:58 PM

Customer: VERIZON WIRELESS

### Section Forces

3	70.00	9.13	0.000	66.406	0.000	0.102	2.96	0.80	1.00	0.0	35.30	104.31	0.00	7695	0	809	943	1752
2	45.00	8.32	0.000	98.555	0.000	0.092	3.00	0.80	1.00	0.0	53.48	160.19	0.00	11183	0	1132	1288	2421
1	15.00	6.61	0.000	114.52	0.000	0.097	2.98	0.80	1.00	0.0	62.36	185.60	0.00	12784	0	1042	1024	2066
														77204	0			17302

LoadCase 1.0D + 1.0W Service 90 deg

Serviceability - 60 mph Wind 90 deg

Gust Response Factor (Gh): 0.85

Wind Importance Factor (Iw) : 1.00

Section	Elev. (ft)	Q <sub>z</sub> (psf)	A <sub>f</sub> (sf)	A <sub>r</sub> (sf)	Ice A <sub>r</sub> (sf)	e	C <sub>f</sub>	D <sub>f</sub>	D <sub>r</sub>	T <sub>iz</sub> (in)	A <sub>e</sub> (sf)	EPA <sub>a</sub> (sf)	EPA <sub>bi</sub> (sf)	Wt. (lb)	Ice Wt. (lb)	F <sub>st</sub> (lb)	F <sub>a</sub> (lb)	Force (lb)
11	230.00	11.72	0.000	45.353	0.000	0.179	2.67	0.85	1.00	0.0	25.16	67.10	0.00	3941	0	669	99	767
10	210.00	11.50	0.000	45.187	0.000	0.153	2.76	0.85	1.00	0.0	24.73	68.26	0.00	4113	0	667	128	795
9	190.00	11.26	0.000	46.842	0.000	0.137	2.82	0.85	1.00	0.0	25.60	72.23	0.00	4477	0	691	250	941
8	170.00	11.00	0.000	50.084	0.000	0.127	2.86	0.85	1.00	0.0	27.49	78.52	0.00	5572	0	734	563	1297
7	150.00	10.72	0.000	57.359	0.000	0.130	2.85	0.85	1.00	0.0	31.63	90.10	0.00	6901	0	821	1011	1831
6	130.00	10.40	0.000	57.395	0.000	0.116	2.90	0.85	1.00	0.0	31.83	92.27	0.00	7041	0	815	1041	1856
5	110.00	10.04	0.000	56.861	0.000	0.105	2.95	0.85	1.00	0.0	31.16	91.77	0.00	6628	0	783	1021	1804
4	90.00	9.62	0.000	57.777	0.000	0.097	2.98	0.85	1.00	0.0	31.99	95.18	0.00	6867	0	779	992	1771
3	70.00	9.13	0.000	66.406	0.000	0.102	2.96	0.85	1.00	0.0	35.30	104.31	0.00	7695	0	809	943	1752
2	45.00	8.32	0.000	98.555	0.000	0.092	3.00	0.85	1.00	0.0	53.48	160.19	0.00	11183	0	1132	1288	2421
1	15.00	6.61	0.000	114.52	0.000	0.097	2.98	0.85	1.00	0.0	62.36	185.60	0.00	12784	0	1042	1024	2066
														77204	0			17302

Site Number: 383598

Code: ANSI/TIA-222-H

© 2007 - 2021 by ATC IP LLC. All rights reserved.

Site Name: Tartaglia, CT

Engineering Number: 13668689\_C3\_03

7/6/2021 6:21:58 PM

Customer: VERIZON WIRELESS

### Equivalent Lateral Force Method

Spectral Response Acceleration for Short Period ( $S_s$ ):	0.21
Spectral Response Acceleration at 1.0 Second Period ( $S_{d1}$ ):	0.05
Long-Period Transition Period ( $T_L$ - Seconds):	6
Importance Factor ( $I_p$ ):	1.00
Site Coefficient $F_a$ :	1.60
Site Coefficient $F_v$ :	2.40
Response Modification Coefficient (R):	3.00
Design Spectral Response Acceleration at Short Period ( $S_{ds}$ ):	0.23
Design Spectral Response Acceleration at 1.0 Second Period ( $S_{d1}$ ):	0.09
Seismic Response Coefficient ( $C_s$ ):	0.04
Upper Limit $C_s$ :	0.04
Lower Limit $C_s$ :	0.03
Period based on Rayleigh Method (sec):	0.71
Redundancy Factor (p):	1.30
Seismic Force Distribution Exponent (k):	1.11
Total Unfactored Dead Load:	91.45 k
Seismic Base Shear (E):	4.80 k

#### LoadCase 1.2D + 1.0Ev + 1.0Eh

#### Seismic

Section	Height Above Base (ft)	Weight (lb)	$W_z$ (lb-ft)	$C_{vx}$	Horizontal Force (lb)	Vertical Force (lb)
11	230.00	3,941	1,617,78	0.090	433	4,907
10	210.00	4,113	1,526,46	0.085	409	5,120
9	190.00	4,477	1,487,38	0.083	398	5,574
8	170.00	5,572	1,636,97	0.091	438	6,938
7	150.00	6,901	1,765,17	0.098	472	8,592
6	130.00	7,041	1,537,15	0.086	411	8,766
5	110.00	6,628	1,202,88	0.067	322	8,252
4	90.00	6,867	998,043	0.056	267	8,550
3	70.00	7,695	846,905	0.047	227	9,581
2	45.00	11,183	754,854	0.042	202	13,923
1	15.00	12,784	255,871	0.014	68	15,916
Generic 8' Yagi	240.00	30	12,907	0.001	3	37
Generic 10' Omni	240.00	25	10,756	0.001	3	31
Dielectric DCR-L1	240.00	8	3,442	0.000	1	10
Lightning Rod	240.00	10	4,302	0.000	1	12
Dielectric DCR-L1 w/ Radome	240.00	18	7,744	0.000	2	22
Beacon	240.00	70	30,117	0.002	8	87
Round Side Arm	240.00	150	64,537	0.004	17	187
Round Sector Frame	240.00	300	129,074	0.007	35	374
Generic 8' Omni	234.00	50	20,918	0.001	6	62
Round Side Arm	230.00	150	61,568	0.003	16	187
Generic 12' Omni	229.00	40	16,339	0.001	4	50
Round Side Arm	223.00	150	59,498	0.003	16	187
Empty Flat Side Arm	223.00	150	59,498	0.003	16	187
Ericsson Radio 4449 B71 B85A	202.00	225	79,996	0.004	21	280

Site Number: 383598

Code:

ANSI/TIA-222-H

© 2007 - 2021 by ATC IP LLC. All rights reserved.

Site Name: Tartaglia, CT

Engineering Number: 13668689\_C3\_03

7/6/2021 6:21:58 PM

Customer: VERIZON WIRELESS

### Equivalent Lateral Force Method

Ericsson RRUS 4415 B25	202.00	138	49,064	0.003	13	172
Ericsson Air6449 B41	202.00	312	110,928	0.006	30	388
Ericsson AIR 32 B66AA B2P	202.00	327	116,261	0.006	31	407
Round Sector Frame	202.00	900	319,984	0.018	86	1,121
RFS APXVAARR24_43-U-NA20	202.00	384	136,420	0.008	37	478
Side Arms	183.00	1,680	535,458	0.030	143	2,092
Flat Light Sector Frame	183.00	1,200	382,470	0.021	102	1,494
Nokia 2.5G MAA - AAHC(64T64R)	181.00	311	97,862	0.005	26	387
Motorola DAP Vx	180.00	79	24,879	0.001	7	99
Alcatel-Lucent 800 MHz RRH	180.00	159	49,759	0.003	13	198
Alcatel-Lucent 1900MHz RRH	180.00	264	82,618	0.005	22	329
Argus LLPX310R	180.00	86	26,851	0.001	7	107
Generic 24" x 24" Junction Box	180.00	20	6,259	0.000	2	25
Generic 2' Std. Dish	180.00	42	13,144	0.001	4	52
RFS APXVSP18-C-A20	180.00	114	35,676	0.002	10	142
RFS APXV9ERR18-C-A20	180.00	62	19,403	0.001	5	77
Powerwave Allgon LGP21901	165.00	66	18,759	0.001	5	82
Powerwave Allgon 7020.00 Dual Band	165.00	13	3,752	0.000	1	16
CCI DTMAPB7819VG12A	165.00	58	16,371	0.001	4	72
Commscope WCS-IMFQ-AMT	165.00	30	8,385	0.000	2	37
Powerwave Allgon LGP21401	165.00	127	36,068	0.002	10	158
Raycap DC6-48-60-18-8F (23.5" Height)	165.00	60	17,053	0.001	5	75
Ericsson RRUS 4426 B66	165.00	145	41,269	0.002	11	181
Ericsson RRUS 4478 B14	165.00	180	51,075	0.003	14	224
Ericsson RRUS 32 (50.8 lbs)	165.00	152	43,316	0.002	12	190
Ericsson RRUS 32 B2	165.00	159	45,191	0.003	12	198
Ericsson Radio 4449	165.00	255	72,477	0.004	19	317
Powerwave Allgon 7770.00	165.00	105	29,843	0.002	8	131
Andrew SBNHH-1D65A	165.00	123	34,874	0.002	9	153
Quintel QS66512-3 (112 lbs.)	165.00	336	95,499	0.005	26	418
Kathrein Scala 80010965	165.00	293	83,221	0.005	22	365
Round Sector Frame	165.00	900	255,801	0.014	68	1,121
Commscope CBC78T-DS-43-2X	155.00	62	16,471	0.001	4	77
Samsung Outdoor CBRS 20W RRH	155.00	56	14,800	0.001	4	69
Samsung Outdoor CBRS 20W RRH -Clip-	155.00	13	3,501	0.000	1	16
Samsung B2/B66A RRH-BR049	155.00	253	67,155	0.004	18	315
Samsung B5/B13 RRH-BR04C	155.00	211	55,936	0.003	15	263
Raycap RxxDC-3315-PF-48	155.00	43	11,352	0.001	3	53
Samsung MT6407-77A	155.00	245	64,927	0.004	17	305
Amphenol Antel BXA-80063-6BF-EDIN-X	155.00	58	15,277	0.001	4	72
Generic Mount Reinforcement	155.00	200	53,045	0.003	14	249
Commscope JAHH-65B-R3B	155.00	364	96,436	0.005	26	453
Flat Light Sector Frame	155.00	1,200	318,271	0.018	85	1,494
Small Side Lights	140.00	135	31,992	0.002	9	168
Generic 4' Yagi	132.00	15	3,331	0.000	1	19
Flat Side Arm	132.00	150	33,306	0.002	9	187
Generic 10' Omni	123.00	25	5,134	0.000	1	31
Round Side Arm	118.00	150	29,420	0.002	8	187
Round Side Arm	108.00	150	26,674	0.001	7	187
Generic 4' Yagi	98.00	15	2,395	0.000	1	19
Flat Side Arm	98.00	150	23,955	0.001	6	187
Empty Round Side Arm	80.00	150	19,137	0.001	5	187
Round Side Arm	8.00	150	1,497	0.000	0	187
		91,452	17,944,201	1.000	4,802	113,860

### Equivalent Lateral Force Method

LoadCase 0.9D - 1.0Ev + 1.0Eh

Seismic (Reduced DL)

Section	Height Above Base (ft)	Weight (lb)	$W_z$ (lb-ft)	$C_{vx}$	Horizontal Force (lb)	Vertical Force (lb)
11	230.00	3,941	1,617,78	0.090	433	3,370
10	210.00	4,113	1,526,46	0.085	409	3,516
9	190.00	4,477	1,487,38	0.083	398	3,828
8	170.00	5,572	1,636,97	0.091	438	4,764
7	150.00	6,901	1,765,17	0.098	472	5,901
6	130.00	7,041	1,537,15	0.086	411	6,020
5	110.00	6,628	1,202,88	0.067	322	5,667
4	90.00	6,867	998,044	0.056	267	5,871
3	70.00	7,695	846,905	0.047	227	6,579
2	45.00	11,183	754,854	0.042	202	9,562
1	15.00	12,784	255,871	0.014	68	10,930
Generic 8' Yagi	240.00	30	12,907	0.001	3	26
Generic 10' Omni	240.00	25	10,756	0.001	3	21
Dielectric DCR-L1	240.00	8	3,442	0.000	1	7
Lightning Rod	240.00	10	4,302	0.000	1	9
Dielectric DCR-L1 w/ Radome	240.00	18	7,744	0.000	2	15
Beacon	240.00	70	30,117	0.002	8	60
Round Side Arm	240.00	150	64,537	0.004	17	128
Round Sector Frame	240.00	300	129,074	0.007	35	256
Generic 8' Omni	234.00	50	20,918	0.001	6	43
Round Side Arm	230.00	150	61,568	0.003	16	128
Generic 12' Omni	229.00	40	16,339	0.001	4	34
Round Side Arm	223.00	150	59,498	0.003	16	128
Empty Flat Side Arm	223.00	150	59,498	0.003	16	128
Ericsson Radio 4449 B71 B85A	202.00	225	79,996	0.004	21	192
Ericsson RRUS 4415 B25	202.00	138	49,064	0.003	13	118
Ericsson Air6449 B41	202.00	312	110,928	0.006	30	267
Ericsson AIR 32 B66AA B2P	202.00	327	116,261	0.006	31	280
Round Sector Frame	202.00	900	319,984	0.018	86	769
RFS APXVAARR24_43-U-NA20	202.00	384	136,420	0.008	37	328
Side Arms	183.00	1,680	535,458	0.030	143	1,436
Flat Light Sector Frame	183.00	1,200	382,470	0.021	102	1,026
Nokia 2.5G MAA - AAHC(64T64R)	181.00	311	97,862	0.005	26	266
Motorola DAP Vx	180.00	79	24,879	0.001	7	68
Alcatel-Lucent 800 MHz RRH	180.00	159	49,759	0.003	13	136
Alcatel-Lucent 1900MHz RRH	180.00	264	82,618	0.005	22	226
Argus LLPX310R	180.00	86	26,851	0.001	7	73
Generic 24" x 24" Junction Box	180.00	20	6,259	0.000	2	17
Generic 2' Std. Dish	180.00	42	13,144	0.001	4	36
RFS APXVSP18-C-A20	180.00	114	35,676	0.002	10	97
RFS APXV9ERR18-C-A20	180.00	62	19,403	0.001	5	53
Powerwave Allgon LGP21901	165.00	66	18,759	0.001	5	56
Powerwave Allgon 7020.00 Dual Band	165.00	13	3,752	0.000	1	11
CCI DTMABP7819VG12A	165.00	58	16,371	0.001	4	49
Commscope WCS-IMFQ-AMT	165.00	30	8,385	0.000	2	25
Powerwave Allgon LGP21401	165.00	127	36,068	0.002	10	108
Raycap DC6-48-60-18-8F (23.5" Height)	165.00	60	17,053	0.001	5	51
Ericsson RRUS 4426 B66	165.00	145	41,269	0.002	11	124
Ericsson RRUS 4478 B14	165.00	180	51,075	0.003	14	154
Ericsson RRUS 32 (50.8 lbs)	165.00	152	43,316	0.002	12	130

Site Number: 383598

Code: ANSI/TIA-222-H

© 2007 - 2021 by ATC IP LLC. All rights reserved.

Site Name: Tartaglia, CT

Engineering Number: 13668689\_C3\_03

7/6/2021 6:21:59 PM

Customer: VERIZON WIRELESS

Equivalent Lateral Force Method

Ericsson RRUS 32 B2	165.00	159	45,191	0.003	12	136
Ericsson Radio 4449	165.00	255	72,477	0.004	19	218
Powerwave Allgon 7770.00	165.00	105	29,843	0.002	8	90
Andrew SBNHH-1D65A	165.00	123	34,874	0.002	9	105
Quintel QS66512-3 (112 lbs.)	165.00	336	95,499	0.005	26	287
Kathrein Scala 80010965	165.00	293	83,221	0.005	22	250
Round Sector Frame	165.00	900	255,801	0.014	68	769
Commscope CBC78T-DS-43-2X	155.00	62	16,471	0.001	4	53
Samsung Outdoor CBRS 20W RRH	155.00	56	14,800	0.001	4	48
Samsung Outdoor CBRS 20W RRH -Clip-	155.00	13	3,501	0.000	1	11
Samsung B2/B66A RRH-BR049	155.00	253	67,155	0.004	18	216
Samsung B5/B13 RRH-BR04C	155.00	211	55,936	0.003	15	180
Raycap RxxDC-3315-PF-48	155.00	43	11,352	0.001	3	37
Samsung MT6407-77A	155.00	245	64,927	0.004	17	209
Amphenol Antel BXA-80063-6BF-EDIN-X	155.00	58	15,277	0.001	4	49
Generic Mount Reinforcement	155.00	200	53,045	0.003	14	171
Commscope JAHH-65B-R3B	155.00	364	96,436	0.005	26	311
Flat Light Sector Frame	155.00	1,200	318,271	0.018	85	1,026
Small Side Lights	140.00	135	31,992	0.002	9	115
Generic 4' Yagi	132.00	15	3,331	0.000	1	13
Flat Side Arm	132.00	150	33,306	0.002	9	128
Generic 10' Omni	123.00	25	5,134	0.000	1	21
Round Side Arm	118.00	150	29,420	0.002	8	128
Round Side Arm	108.00	150	26,674	0.001	7	128
Generic 4' Yagi	98.00	15	2,395	0.000	1	13
Flat Side Arm	98.00	150	23,955	0.001	6	128
Empty Round Side Arm	80.00	150	19,137	0.001	5	128
Round Side Arm	8.00	150	1,497	0.000	0	128
		91,452	17,944,201	1.000	4,802	78,191

Site Number: 383598

Code: ANSI/TIA-222-H

© 2007 - 2021 by ATC IP LLC. All rights reserved.

Site Name: Tartaglia, CT

Engineering Number: 13668689\_C3\_03

7/6/2021 6:21:59 PM

Customer: VERIZON WIRELESS

### Force/Stress Summary

Section: 1		1		Bot Elev (ft): 0.00				Height (ft): 30.000							
		Pu (kip)	Load Case	Len (ft)	Bracing %			F'y (ksi)	Phic (kip)	Pn Num Bolts	Num Holes	Shear phiRnv (kip)	Bear phiRn (kip)	Use %	Controls
<b>Max Compression Member</b>															
LEG	PX - 10" DIA PIPE	-294.44	1.2D + 1.0W Normal	30.08	33	33	33	32.8	50.0	669.65	0	0	0.00	0.00	43 Member X
HORIZ	PST - 3-1/2" DIA PIP	-15.89	0.9D + 1.0W 90 deg	18.29	100	100	100	163.8	50.0	22.56	2	0	0.00	42.31	70 Member X
DIAG	PST - 3" DIA PIPE	-31.46	1.2D + 1.0W 90 deg	36.16	33	33	33	0.0	0.0	41.40	3	0	0.00	60.65	75 User Input
<b>Max Tension Member</b>															
LEG	PX - 10" DIA PIPE	236.19	0.9D + 1.0W 60 deg	50	65	724.50	0	0	0.00	0.00	0	0	0.00	0.00	32 Member
HORIZ	PST - 3-1/2" DIA PIP	16.48	1.2D + 1.0W 90 deg	50	65	120.60	2	0	0.00	33.93	0	0	0.00	0.00	48 Bolt Bear
DIAG	PST - 3" DIA PIPE	29.66	0.9D + 1.0W 90 deg	50	65	100.35	3	0	0.00	52.65	0	0	0.00	0.00	56 Bolt Bear
<b>Max Splice Forces</b>															
		Pu (kip)	Load Case		phiRnt (kip)	Use %	Num Bolts	Bolt Type							
	Top Tension	234.51	0.9D + 1.0W 60 deg		0.00	0	0								
	Top Compression	292.67	1.2D + 1.0W Normal		0.00	0									
	Bot Tension	280.36	0.9D + 1.0W 60 deg		681.46	17	12	1" A193-B7							
	Bot Compression	341.67	1.2D + 1.0W Normal		763.24	49									

Section: 2		2		Bot Elev (ft): 30.00				Height (ft): 30.000							
		Pu (kip)	Load Case	Len (ft)	Bracing %			F'y (ksi)	Phic (kip)	Pn Num Bolts	Num Holes	Shear phiRnv (kip)	Bear phiRn (kip)	Use %	Controls
<b>Max Compression Member</b>															
LEG	PX - 10" DIA PIPE	-241.54	1.2D + 1.0W Normal	30.08	33	33	33	32.8	50.0	669.65	0	0	0.00	0.00	36 Member X
HORIZ	PST - 3" DIA PIPE	-15.23	1.2D + 1.0W 90 deg	16.41	100	100	100	169.8	50.0	17.47	2	0	0.00	40.44	87 Member X
DIAG	PST - 3" DIA PIPE	-34.32	1.2D + 1.0W 90 deg	35.15	33	33	33	120.0	50.0	34.98	3	0	0.00	60.65	98 Member X
<b>Max Tension Member</b>															
LEG	PX - 10" DIA PIPE	190.25	0.9D + 1.0W 60 deg	50	65	724.50	0	0	0.00	0.00	0	0	0.00	0.00	26 Member
HORIZ	PST - 3" DIA PIPE	16.14	1.2D + 1.0W 90 deg	50	65	100.35	2	0	0.00	32.43	0	0	0.00	0.00	49 Bolt Bear
DIAG	PST - 3" DIA PIPE	31.71	1.2D + 1.0W 90 deg	50	65	100.35	3	0	0.00	52.65	0	0	0.00	0.00	60 Bolt Bear
<b>Max Splice Forces</b>															
		Pu (kip)	Load Case		phiRnt (kip)	Use %	Num Bolts	Bolt Type							
	Top Tension	188.65	0.9D + 1.0W 60 deg		0.00	0	0								
	Top Compression	239.84	1.2D + 1.0W Normal		0.00	0									
	Bot Tension	234.51	0.9D + 1.0W 60 deg		654.20	36	12	1 A325							
	Bot Compression	0.00			0.00	0									

### Force/Stress Summary

Section: 3		3	Bot Elev (ft): 60.00				Height (ft): 20.000									
		Pu (kip)	Load Case	Len (ft)	Bracing %			F'y (ksi)	Phic Pn (kip)	Num Bolts	Num Holes	Shear phiRnv (kip)	Bear phiRn (kip)	Blk Shear phiT Pn (kip)	Use %	Controls
<b>Max Compression Member</b>																
LEG	PX - 10" DIA PIPE	-205.26	1.2D + 1.0W Normal	20.05	50	50	50	33.1	50.0	668.58	0	0	0.00	0.00	30	Member X
HORIZ	PST - 3" DIA PIPE	-13.95	0.9D + 1.0W 90 deg	15.16	100	100	100	156.9	50.0	20.47	2	0	0.00	40.44	68	Member X
DIAG	PST - 3" DIA PIPE	-25.21	1.2D + 1.0W 90 deg	25.88	50	50	50	133.9	50.0	28.10	3	0	0.00	50.54	89	Member X
<b>Max Tension Member</b>																
LEG	PX - 10" DIA PIPE	160.61	0.9D + 1.0W 60 deg	50	65	724.50	0	0	0.00	0.00				22	Member	
HORIZ	PST - 3" DIA PIPE	14.69	1.2D + 1.0W 90 deg	50	65	100.35	2	0	0.00	32.43			0.00	45	Bolt Bear	
DIAG	PST - 3" DIA PIPE	23.23	1.2D + 1.0W 90 deg	50	65	100.35	3	0	0.00	43.80			0.00	53	Bolt Bear	
<b>Max Splice Forces</b>																
		Pu (kip)	Load Case		phiRnt (kip)	Use %	Num Bolts	Bolt Type								
	Top Tension	159.13	0.9D + 1.0W 60 deg		0.00	0	0									
	Top Compression	203.69	1.2D + 1.0W Normal		0.00	0										
	Bot Tension	188.65	0.9D + 1.0W 60 deg		654.20	29	12	1 A325								
	Bot Compression	0.00			0.00	0										

Section: 4		4	Bot Elev (ft): 80.00				Height (ft): 20.000									
		Pu (kip)	Load Case	Len (ft)	Bracing %			F'y (ksi)	Phic Pn (kip)	Num Bolts	Num Holes	Shear phiRnv (kip)	Bear phiRn (kip)	Blk Shear phiT Pn (kip)	Use %	Controls
<b>Max Compression Member</b>																
LEG	PX - 8" DIA PIPE	-170.29	1.2D + 1.0W Normal	20.06	50	50	50	41.8	50.0	506.95	0	0	0.00	0.00	33	Member X
HORIZ	PST - 3" DIA PIPE	-12.67	1.2D + 1.0W 90 deg	13.83	100	100	100	143.2	50.0	24.58	2	0	0.00	40.44	51	Member X
DIAG	PST - 3" DIA PIPE	-24.02	1.2D + 1.0W 90 deg	25.11	50	50	50	129.9	50.0	29.86	3	0	0.00	50.54	80	Member X
<b>Max Tension Member</b>																
LEG	PX - 8" DIA PIPE	130.87	0.9D + 1.0W 60 deg	50	65	576.00	0	0	0.00	0.00				22	Member	
HORIZ	PST - 3" DIA PIPE	13.11	1.2D + 1.0W 90 deg	50	65	100.35	2	0	0.00	32.43			0.00	40	Bolt Bear	
DIAG	PST - 3" DIA PIPE	22.51	0.9D + 1.0W 90 deg	50	65	100.35	3	0	0.00	43.80			0.00	51	Bolt Bear	
<b>Max Splice Forces</b>																
		Pu (kip)	Load Case		phiRnt (kip)	Use %	Num Bolts	Bolt Type								
	Top Tension	129.48	0.9D + 1.0W 60 deg		0.00	0	0									
	Top Compression	168.85	1.2D + 1.0W Normal		0.00	0										
	Bot Tension	159.13	0.9D + 1.0W 60 deg		654.20	24	12	1 A325								
	Bot Compression	0.00			0.00	0										



### Force/Stress Summary

Section: 5		5		Bot Elev (ft): 100.0				Height (ft): 20.000							
		Pu (kip)	Load Case	Len (ft)	Bracing %			F'y (ksi)	Phic Pn (kip)	Num Bolts	Num Holes	Shear phiRnv (kip)	Bear phiRn (kip)	Use %	Controls
<b>Max Compression Member</b>															
LEG	PX - 8" DIA PIPE	-134.82	1.2D + 1.0W Normal	20.05	50	50	50	41.8	50.0	507.00	0	0	0.00	0.00	26 Member X
HORIZ	PST - 2-1/2" DIA PIP	-11.57	0.9D + 1.0W 90 deg	12.58	100	100	100	159.5	50.0	15.13	2	0	0.00	38.00	76 Member X
DIAG	PST - 2-1/2" DIA PIP	-23.63	1.2D + 1.0W 90 deg	24.33	50	50	50	0.0	0.0	28.20	3	0	0.00	47.50	83 User Input
<b>Max Tension Member</b>															
LEG	PX - 8" DIA PIPE	100.40	0.9D + 1.0W 60 deg	50	65	576.00	0	0	0.00	0.00				17 Member	
HORIZ	PST - 2-1/2" DIA PIP	12.24	1.2D + 1.0W 90 deg	50	65	76.68	2	0	0.00	30.48			0.00	40 Bolt Bear	
DIAG	PST - 2-1/2" DIA PIP	22.04	1.2D + 1.0W 90 deg	50	65	76.68	3	0	0.00	41.17			0.00	53 Bolt Bear	
<b>Max Splice Forces</b>															
		Pu (kip)	Load Case		phiRnt (kip)	Use %	Num Bolts	Bolt Type							
	Top Tension	99.19	0.9D + 1.0W 60 deg		0.00	0	0								
	Top Compression	133.53	1.2D + 1.0W Normal		0.00	0									
	Bot Tension	129.48	0.9D + 1.0W 60 deg		436.14	30	8	1 A325							
	Bot Compression	0.00			0.00	0									

Section: 6		6		Bot Elev (ft): 120.0				Height (ft): 20.000							
		Pu (kip)	Load Case	Len (ft)	Bracing %			F'y (ksi)	Phic Pn (kip)	Num Bolts	Num Holes	Shear phiRnv (kip)	Bear phiRn (kip)	Use %	Controls
<b>Max Compression Member</b>															
LEG	PX - 8" DIA PIPE	-116.97	1.2D + 1.0W Normal	10.03	100	100	100	41.8	50.0	507.00	0	0	0.00	0.00	23 Member X
HORIZ	PST - 2-1/2" DIA PIP	-10.47	1.2D + 1.0W 90 deg	11.96	100	100	100	151.6	50.0	16.75	2	0	0.00	31.67	62 Member X
DIAG	PST - 3" DIA PIPE	-15.14	1.2D + 1.0W 90 deg	16.08	100	100	100	166.4	50.0	18.20	3	0	0.00	50.54	83 Member X
<b>Max Tension Member</b>															
LEG	PX - 8" DIA PIPE	81.95	1.2D + 1.0W 60 deg	50	65	576.00	0	0	0.00	0.00				14 Member	
HORIZ	PST - 2-1/2" DIA PIP	11.19	1.2D + 1.0W 90 deg	50	65	76.68	2	0	0.00	25.33			0.00	44 Bolt Bear	
DIAG	PST - 3" DIA PIPE	14.14	0.9D + 1.0W 90 deg	50	65	100.35	3	0	0.00	43.80			0.00	32 Bolt Bear	
<b>Max Splice Forces</b>															
		Pu (kip)	Load Case		phiRnt (kip)	Use %	Num Bolts	Bolt Type							
	Top Tension	70.95	0.9D + 1.0W 60 deg		0.00	0	0								
	Top Compression	99.02	1.2D + 1.0W Normal		0.00	0									
	Bot Tension	99.19	0.9D + 1.0W 60 deg		436.14	23	8	1 A325							
	Bot Compression	0.00			0.00	0									

### Force/Stress Summary

Section: 7		7		Bot Elev (ft): 140.0				Height (ft): 20.000								
		Pu (kip)	Load Case	Len (ft)	Bracing %			F'y (ksi)	Phic Pn (kip)	Num Bolts	Num Holes	Shear phiRnv (kip)	Bear phiRn (kip)	Blk Shear phiT Pn (kip)	Use %	Controls
<b>Max Compression Member</b>																
LEG	PX - 8" DIA PIPE	-83.58	1.2D + 1.0W Normal	10.03	100	100	100	41.8	50.0	507.00	0	0	0.00	0.00	16	Member X
HORIZ	PST - 2-1/2" DIA PIP	-9.05	0.9D + 1.0W 90 deg	10.71	100	100	100	135.8	50.0	20.89	2	0	0.00	31.67	43	Member X
DIAG	PST - 2-1/2" DIA PIP	-13.67	1.2D + 1.0W 90 deg	15.12	100	100	100	0.0	0.0	23.40	3	0	0.00	47.50	58	User Input
<b>Max Tension Member</b>																
LEG	PX - 8" DIA PIPE	57.98	0.9D + 1.0W 60 deg	50	65	576.00	0	0	0.00	0.00				10	Member	
HORIZ	PST - 2-1/2" DIA PIP	9.60	1.2D + 1.0W 90 deg	50	65	76.68	2	0	0.00	25.33			0.00	37	Bolt Bear	
DIAG	PST - 2-1/2" DIA PIP	12.63	1.2D + 1.0W 90 deg	50	65	76.68	3	0	0.00	41.17			0.00	30	Bolt Bear	
<b>Max Splice Forces</b>																
		Pu (kip)	Load Case		phiRnt (kip)	Use %	Num Bolts	Bolt Type								
	Top Tension	43.31	0.9D + 1.0W 60 deg		0.00	0	0									
	Top Compression	66.44	1.2D + 1.0W Normal		0.00	0										
	Bot Tension	70.95	0.9D + 1.0W 60 deg		436.14	16	8	1 A325								
	Bot Compression	0.00			0.00	0										

Section: 8		8		Bot Elev (ft): 160.0				Height (ft): 20.000								
		Pu (kip)	Load Case	Len (ft)	Bracing %			F'y (ksi)	Phic Pn (kip)	Num Bolts	Num Holes	Shear phiRnv (kip)	Bear phiRn (kip)	Blk Shear phiT Pn (kip)	Use %	Controls
<b>Max Compression Member</b>																
LEG	PX - 8" DIA PIPE	-52.91	1.2D + 1.0W Normal	10.03	100	100	100	41.8	50.0	507.00	0	0	0.00	0.00	10	Member X
HORIZ	PST - 2-1/2" DIA PIP	-5.69	1.2D + 1.0W 90 deg	9.464	100	100	100	119.9	50.0	26.77	2	0	0.00	31.67	21	Member X
DIAG	PST - 2-1/2" DIA PIP	-9.27	1.2D + 1.0W 90 deg	14.20	100	100	100	180.1	50.0	11.87	3	0	0.00	47.50	78	Member X
<b>Max Tension Member</b>																
LEG	PX - 8" DIA PIPE	35.93	0.9D + 1.0W 60 deg	50	65	576.00	0	0	0.00	0.00				6	Member	
HORIZ	PST - 2-1/2" DIA PIP	6.12	1.2D + 1.0W 90 deg	50	65	76.68	2	0	0.00	25.33			0.00	24	Bolt Bear	
DIAG	PST - 2-1/2" DIA PIP	8.48	1.2D + 1.0W 90 deg	50	65	76.68	3	0	0.00	41.17			0.00	20	Bolt Bear	
<b>Max Splice Forces</b>																
		Pu (kip)	Load Case		phiRnt (kip)	Use %	Num Bolts	Bolt Type								
	Top Tension	25.80	0.9D + 1.0W 60 deg		0.00	0	0									
	Top Compression	40.79	1.2D + 1.0W Normal		0.00	0										
	Bot Tension	43.31	0.9D + 1.0W 60 deg		436.14	10	8	1 A325								
	Bot Compression	0.00			0.00	0										

Site Number: 383598

Code: ANSI/TIA-222-H

© 2007 - 2021 by ATC IP LLC. All rights reserved.

Site Name: Tartaglia, CT

Engineering Number: 13668689\_C3\_03

7/6/2021 6:21:59 PM

Customer: VERIZON WIRELESS

### Force/Stress Summary

Section: 9		9		Bot Elev (ft): 180.0				Height (ft): 20.000							
Max Compression Member		Pu (kip)	Load Case	Len (ft)	Bracing %			F'y (ksi)	Phic Pn (kip)	Num Bolts	Num Holes	Shear phiRnv (kip)	Bear phiRn (kip)	Use %	Controls
LEG	PX - 8" DIA PIPE	-30.84	1.2D + 1.0W Normal	10.03	100	100	100	41.8	50.0	507.00	0	0	0.00	0.00	6 Member X
HORIZ	PST - 2" DIA PIPE	-3.58	1.2D + 1.0W 90 deg	8.214	100	100	100	125.2	50.0	15.41	2	0	0.00	24.02	23 Member X
DIAG	PST - 2-1/2" DIA PIP	-6.34	1.2D + 1.0W 90 deg	13.35	100	100	100	169.2	50.0	13.45	3	0	0.00	47.50	47 Member X
Max Tension Member		Pu (kip)	Load Case	Fy (ksi)	Fu (ksi)	Phit Pn (kip)	Num Bolts	Num Holes	Shear phiRnv (kip)	Bear phiRn (kip)	Blk Shear phit Pn (kip)	Use %	Controls		
LEG	PX - 8" DIA PIPE	18.94	1.2D + 1.0W 60 deg	50	65	576.00	0	0	0.00	0.00			3 Member		
HORIZ	PST - 2" DIA PIPE	3.87	1.2D + 1.0W 90 deg	50	65	48.15	2	0	0.00	19.22	0.00		20 Bolt Bear		
DIAG	PST - 2-1/2" DIA PIP	5.82	0.9D + 1.0W 90 deg	50	65	76.68	3	0	0.00	41.17	0.00		14 Bolt Bear		
Max Splice Forces		Pu (kip)	Load Case	phiRnt (kip)	Use %	Num Bolts	Bolt Type								
Top Tension		13.16	0.9D + 1.0W 60 deg	0.00	0	0									
Top Compression		22.01	1.2D + 1.0W Normal	0.00	0										
Bot Tension		25.80	0.9D + 1.0W 60 deg	436.14	6	8	1 A325								
Bot Compression		0.00		0.00	0										

Section: 10		10		Bot Elev (ft): 200.0				Height (ft): 20.000							
Max Compression Member		Pu (kip)	Load Case	Len (ft)	Bracing %			F'y (ksi)	Phic Pn (kip)	Num Bolts	Num Holes	Shear phiRnv (kip)	Bear phiRn (kip)	Use %	Controls
LEG	PX - 8" DIA PIPE	-15.06	1.2D + 1.0W Normal	10.02	100	100	100	41.8	50.0	507.06	0	0	0.00	0.00	2 Member X
HORIZ	PST - 2" DIA PIPE	-2.05	1.2D + 1.0W 90 deg	7.026	100	100	100	107.1	50.0	20.80	2	0	0.00	24.02	9 Member X
DIAG	PST - 2-1/2" DIA PIP	-4.23	1.2D + 1.0W 90 deg	12.55	100	100	100	159.1	50.0	15.20	3	0	0.00	47.50	27 Member X
Max Tension Member		Pu (kip)	Load Case	Fy (ksi)	Fu (ksi)	Phit Pn (kip)	Num Bolts	Num Holes	Shear phiRnv (kip)	Bear phiRn (kip)	Blk Shear phit Pn (kip)	Use %	Controls		
LEG	PX - 8" DIA PIPE	8.49	1.2D + 1.0W 60 deg	50	65	576.00	0	0	0.00	0.00			1 Member		
HORIZ	PST - 2" DIA PIPE	2.28	1.2D + 1.0W 90 deg	50	65	48.15	2	0	0.00	19.22	0.00		11 Bolt Bear		
DIAG	PST - 2-1/2" DIA PIP	3.72	1.2D + 1.0W 90 deg	50	65	76.68	3	0	0.00	41.17	0.00		9 Bolt Bear		
Max Splice Forces		Pu (kip)	Load Case	phiRnt (kip)	Use %	Num Bolts	Bolt Type								
Top Tension		4.74	0.9D + 1.0W 60 deg	0.00	0	0									
Top Compression		9.04	1.2D + 1.0W Normal	0.00	0										
Bot Tension		13.16	0.9D + 1.0W 60 deg	436.14	3	8	1 A325								
Bot Compression		0.00		0.00	0										

Site Number: 383598

Code: ANSI/TIA-222-H

© 2007 - 2021 by ATC IP LLC. All rights reserved.

Site Name: Tartaglia, CT

Engineering Number: 13668689\_C3\_03

7/6/2021 6:21:59 PM

Customer: VERIZON WIRELESS

### Force/Stress Summary

Section: 11		11		Bot Elev (ft): 220.0				Height (ft): 20.000									
Max Compression Member		Pu (kip)	Load Case	Len (ft)	Bracing %			F'y (ksi)	Phic (kip)	Pn Num Bolts	Num Holes	Shear phiRnv (kip)	Bear phiRn (kip)	Use %	Controls		
LEG	PX - 8" DIA PIPE	-5.71	1.2D + 1.0W Normal	6.68	100	100	100	27.8	50.0	544.30	0	0	0.00	0.00	1	Member	X
HORIZ	PST - 2" DIA PIPE	-1.28	0.9D + 1.0W 90 deg	6.130	100	100	100	93.5	50.0	25.42	2	0	0.00	24.02	5	Member	X
DIAG	PST - 2" DIA PIPE	-2.35	1.2D + 1.0W 90 deg	9.288	100	100	100	141.6	50.0	12.05	3	0	0.00	36.04	19	Member	X

Max Tension Member		Pu (kip)	Load Case	Fy (ksi)	Fu (ksi)	Phit (kip)	Pn Num Bolts	Num Holes	Shear phiRnv (kip)	Bear phiRn (kip)	Blk Shear phit Pn (kip)	Use %	Controls
LEG	PX - 8" DIA PIPE	0.38	1.2D + 1.0W Normal	50	65	576.00	0	0	0.00	0.00		0	Member
HORIZ	PST - 2" DIA PIPE	1.35	1.2D + 1.0W 60 deg	50	65	48.15	2	0	0.00	19.22	0.00	7	Bolt Bear
DIAG	PST - 2" DIA PIPE	1.99	1.2D + 1.0W 90 deg	50	65	48.15	3	0	0.00	31.23	0.00	6	Bolt Bear

Max Splice Forces		Pu (kip)	Load Case	phiRnt (kip)	Use %	Num Bolts	Bolt Type
Top Tension		0.00		0.00	0	0	
Top Compression		0.97	1.2D + 1.0Di + 1.0Wi	0.00	0		
Bot Tension		4.74	0.9D + 1.0W 60 deg	436.14	1	8	1 A325
Bot Compression		0.00		0.00	0		

### Detailed Reactions

Load Case	Radius (ft)	Elevation (ft)	Azimuth (deg)	Node	FX (kip)	FY (kip)	FZ (kip)	(-) = Uplift (+) = Down
<b>1.2D + 1.0W Normal</b>	23.29	00.00	0	1	0.00	340.86	-49.08	
	23.29	00.00	120	1a	13.20	-115.56	-16.46	
	23.29	00.00	240	1b	-13.20	-115.56	-16.46	
<b>1.2D + 1.0W 60 deg</b>	23.29	00.00	0	1	-7.37	188.74	-26.35	
	23.29	00.00	120	1a	-26.51	188.73	6.79	
	23.29	00.00	240	1b	-37.19	-267.72	-21.47	
<b>1.2D + 1.0W 90 deg</b>	23.29	00.00	0	1	-8.68	36.58	-3.42	
	23.29	00.00	120	1a	-39.36	300.11	17.88	
	23.29	00.00	240	1b	-34.02	-226.95	-14.46	
<b>0.9D + 1.0W Normal</b>	23.29	00.00	0	1	0.00	331.53	-48.25	
	23.29	00.00	120	1a	13.94	-124.61	-16.91	
	23.29	00.00	240	1b	-13.94	-124.61	-16.91	
<b>0.9D + 1.0W 60 deg</b>	23.29	00.00	0	1	-7.38	179.48	-25.49	
	23.29	00.00	120	1a	-25.77	179.48	6.35	
	23.29	00.00	240	1b	-37.92	-276.65	-21.89	
<b>0.9D + 1.0W 90 deg</b>	23.29	00.00	0	1	-8.69	27.44	-2.57	
	23.29	00.00	120	1a	-38.62	290.78	17.45	
	23.29	00.00	240	1b	-34.75	-235.91	-14.88	
<b>1.2D + 1.0Di + 1.0Wi Normal</b>	23.29	00.00	0	1	0.00	171.04	-22.39	
	23.29	00.00	120	1a	0.65	11.67	-3.57	
	23.29	00.00	240	1b	-0.65	11.67	-3.57	
<b>1.2D + 1.0Di + 1.0Wi 60 deg</b>	23.29	00.00	0	1	-2.73	117.92	-14.16	
	23.29	00.00	120	1a	-13.63	117.91	4.72	
	23.29	00.00	240	1b	-9.21	-41.45	-5.32	
<b>1.2D + 1.0Di + 1.0Wi 90 deg</b>	23.29	00.00	0	1	-3.17	64.79	-5.92	
	23.29	00.00	120	1a	-18.26	156.80	8.74	
	23.29	00.00	240	1b	-8.09	-27.21	-2.82	
<b>1.2D + 1.0Ev + 1.0Eh Normal M1</b>	23.29	00.00	0	1	0.00	58.56	-6.33	
	23.29	00.00	120	1a	-2.04	24.96	0.79	
	23.29	00.00	240	1b	2.04	24.96	0.79	
<b>1.2D + 1.0Ev + 1.0Eh 60 deg M1</b>	23.29	00.00	0	1	-0.34	47.36	-4.94	
	23.29	00.00	120	1a	-4.45	47.36	2.18	
	23.29	00.00	240	1b	0.67	13.77	0.39	
<b>1.2D + 1.0Ev + 1.0Eh 90 deg M1</b>	23.29	00.00	0	1	-0.39	36.16	-3.56	
	23.29	00.00	120	1a	-5.26	55.56	2.81	
	23.29	00.00	240	1b	0.90	16.77	0.74	
<b>0.9D - 1.0Ev + 1.0Eh Normal M1</b>	23.29	00.00	0	1	0.00	47.21	-5.22	
	23.29	00.00	120	1a	-1.08	13.65	0.23	
	23.29	00.00	240	1b	1.08	13.65	0.23	
<b>0.9D - 1.0Ev + 1.0Eh 60 deg M1</b>	23.29	00.00	0	1	-0.34	36.02	-3.83	
	23.29	00.00	120	1a	-3.49	36.02	1.62	
	23.29	00.00	240	1b	-0.29	2.46	-0.17	
<b>0.9D - 1.0Ev + 1.0Eh 90 deg M1</b>	23.29	00.00	0	1	-0.39	24.83	-2.44	
	23.29	00.00	120	1a	-4.29	44.21	2.25	

Site Number: 383598

Code:

ANSI/TIA-222-H

© 2007 - 2021 by ATC IP LLC. All rights reserved.

Site Name: Tartaglia, CT

Engineering Number: 13668689\_C3\_03

7/6/2021 6:21:59 PM

Customer: VERIZON WIRELESS

	<b>23.29</b>	<b>00.00</b>	<b>240</b>	<b>1b</b>	<b>-0.07</b>	<b>5.46</b>	<b>0.19</b>
<b>1.0D + 1.0W Service Normal</b>	<b>23.29</b>	<b>00.00</b>	<b>0</b>	<b>1</b>	<b>0.00</b>	<b>111.39</b>	<b>-15.09</b>
	<b>23.29</b>	<b>00.00</b>	<b>120</b>	<b>1a</b>	<b>1.84</b>	<b>-9.97</b>	<b>-3.40</b>
	<b>23.29</b>	<b>00.00</b>	<b>240</b>	<b>1b</b>	<b>-1.84</b>	<b>-9.97</b>	<b>-3.40</b>
<b>1.0D + 1.0W Service 60 deg</b>	<b>23.29</b>	<b>00.00</b>	<b>0</b>	<b>1</b>	<b>-2.00</b>	<b>70.94</b>	<b>-8.97</b>
	<b>23.29</b>	<b>00.00</b>	<b>120</b>	<b>1a</b>	<b>-8.77</b>	<b>70.93</b>	<b>2.75</b>
	<b>23.29</b>	<b>00.00</b>	<b>240</b>	<b>1b</b>	<b>-8.18</b>	<b>-50.42</b>	<b>-4.72</b>
<b>1.0D + 1.0W Service 90 deg</b>	<b>23.29</b>	<b>00.00</b>	<b>0</b>	<b>1</b>	<b>-2.32</b>	<b>30.48</b>	<b>-2.84</b>
	<b>23.29</b>	<b>00.00</b>	<b>120</b>	<b>1a</b>	<b>-12.22</b>	<b>100.55</b>	<b>5.73</b>
	<b>23.29</b>	<b>00.00</b>	<b>240</b>	<b>1b</b>	<b>-7.34</b>	<b>-39.58</b>	<b>-2.88</b>

Max Uplift:	276.65 (kip)	Moment Ice:	3,711.06 (kip-ft)	Moment:	10,629.10 (kip-ft)	1.2D + 1.0W 60 deg
Max Down:	340.86 (kip)	Total Down Ice:	194.38 (kip)	Total Down:	109.74 (kip)	
Max Shear:	49.08 (kip)	Total Shear Ice:	29.52 (kip)	Total Shear:	82.06 (kip)	

### Deflections and Rotations

Load Case	Elevation (ft)	Deflection (ft)	Twist (deg)	Sway (deg)	Resultant (deg)
119 mph Normal with No Ice	80.00	0.137	0.0075	0.1283	0.1285
119 mph Normal with No Ice	100.00	0.187	0.0097	0.1662	0.1665
119 mph Normal with No Ice	120.00	0.251	0.0105	0.1800	0.1801
119 mph Normal with No Ice	130.00	0.282	0.0102	0.1758	0.1761
119 mph Normal with No Ice	140.00	0.313	0.0109	0.1877	0.1877
119 mph Normal with No Ice	160.00	0.382	0.0112	0.1928	0.1929
119 mph Normal with No Ice	180.00	0.449	0.0111	0.1909	0.1912
119 mph Normal with No Ice	200.00	0.515	0.0109	0.1891	0.1891
119 mph Normal with No Ice	220.00	0.580	0.0106	0.1870	0.1870
119 mph Normal with No Ice	226.67	0.602	0.0104	0.1860	0.1860
119 mph Normal with No Ice	233.33	0.623	0.0103	0.1831	0.1833
119 mph Normal with No Ice	240.00	0.645	0.0102	0.1827	0.1830
119 mph 60 degree with No Ice	80.00	0.137	-0.0085	0.1279	0.1281
119 mph 60 degree with No Ice	100.00	0.187	-0.0111	0.1660	0.1663
119 mph 60 degree with No Ice	120.00	0.251	-0.0124	0.1802	0.1802
119 mph 60 degree with No Ice	130.00	0.282	-0.0124	0.1760	0.1760
119 mph 60 degree with No Ice	140.00	0.313	-0.0133	0.1880	0.1880
119 mph 60 degree with No Ice	160.00	0.382	-0.0141	0.1932	0.1932
119 mph 60 degree with No Ice	180.00	0.449	-0.0145	0.1911	0.1911
119 mph 60 degree with No Ice	200.00	0.515	-0.0148	0.1893	0.1893
119 mph 60 degree with No Ice	220.00	0.580	-0.0149	0.1870	0.1870
119 mph 60 degree with No Ice	226.67	0.602	-0.0149	0.1859	0.1859
119 mph 60 degree with No Ice	233.33	0.623	-0.0149	0.1833	0.1833
119 mph 60 degree with No Ice	240.00	0.645	-0.0149	0.1816	0.1820
119 mph 90 degree with No Ice	80.00	0.137	-0.0098	0.1282	0.1285
119 mph 90 degree with No Ice	100.00	0.188	-0.0129	0.1663	0.1668
119 mph 90 degree with No Ice	120.00	0.251	-0.0144	0.1800	0.1802
119 mph 90 degree with No Ice	130.00	0.282	-0.0144	0.1759	0.1761
119 mph 90 degree with No Ice	140.00	0.313	-0.0155	0.1878	0.1879
119 mph 90 degree with No Ice	160.00	0.382	-0.0164	0.1929	0.1931
119 mph 90 degree with No Ice	180.00	0.449	-0.0168	0.1909	0.1912
119 mph 90 degree with No Ice	200.00	0.515	-0.0172	0.1890	0.1892
119 mph 90 degree with No Ice	220.00	0.580	-0.0174	0.1868	0.1870
119 mph 90 degree with No Ice	226.67	0.602	-0.0174	0.1855	0.1857
119 mph 90 degree with No Ice	233.33	0.623	-0.0174	0.1832	0.1835
119 mph 90 degree with No Ice	240.00	0.645	-0.0174	0.1814	0.1821
119 mph Normal with No Ice (Reduced DL)	80.00	0.137	0.0075	0.1281	0.1283
119 mph Normal with No Ice (Reduced DL)	100.00	0.187	0.0097	0.1660	0.1663
119 mph Normal with No Ice (Reduced DL)	120.00	0.251	0.0105	0.1798	0.1799
119 mph Normal with No Ice (Reduced DL)	130.00	0.281	0.0102	0.1756	0.1759
119 mph Normal with No Ice (Reduced DL)	140.00	0.313	0.0109	0.1875	0.1875
119 mph Normal with No Ice (Reduced DL)	160.00	0.382	0.0112	0.1927	0.1927
119 mph Normal with No Ice (Reduced DL)	180.00	0.448	0.0111	0.1908	0.1910
119 mph Normal with No Ice (Reduced DL)	200.00	0.515	0.0109	0.1889	0.1889
119 mph Normal with No Ice (Reduced DL)	220.00	0.580	0.0106	0.1868	0.1868
119 mph Normal with No Ice (Reduced DL)	226.67	0.601	0.0104	0.1858	0.1858
119 mph Normal with No Ice (Reduced DL)	233.33	0.623	0.0102	0.1829	0.1831
119 mph Normal with No Ice (Reduced DL)	240.00	0.644	0.0102	0.1825	0.1828
119 mph 60 deg with No Ice (Reduced DL)	80.00	0.137	-0.0085	0.1278	0.1280
119 mph 60 deg with No Ice (Reduced DL)	100.00	0.187	-0.0111	0.1658	0.1662
119 mph 60 deg with No Ice (Reduced DL)	120.00	0.251	-0.0124	0.1800	0.1800
119 mph 60 deg with No Ice (Reduced DL)	130.00	0.282	-0.0124	0.1758	0.1758
119 mph 60 deg with No Ice (Reduced DL)	140.00	0.313	-0.0133	0.1878	0.1878
119 mph 60 deg with No Ice (Reduced DL)	160.00	0.382	-0.0141	0.1930	0.1930
119 mph 60 deg with No Ice (Reduced DL)	180.00	0.448	-0.0145	0.1909	0.1909

Site Number: 383598

Code:

ANSI/TIA-222-H

© 2007 - 2021 by ATC IP LLC. All rights reserved.

Site Name: Tartaglia, CT

Engineering Number: 13668689\_C3\_03

7/6/2021 6:21:59 PM

Customer: VERIZON WIRELESS

119 mph 60 deg with No Ice (Reduced DL)	200.00	0.515	-0.0148	0.1891	0.1891
119 mph 60 deg with No Ice (Reduced DL)	220.00	0.580	-0.0149	0.1868	0.1868
119 mph 60 deg with No Ice (Reduced DL)	226.67	0.601	-0.0149	0.1857	0.1857
119 mph 60 deg with No Ice (Reduced DL)	233.33	0.623	-0.0149	0.1831	0.1832
119 mph 60 deg with No Ice (Reduced DL)	240.00	0.644	-0.0149	0.1814	0.1819
119 mph 90 deg with No Ice (Reduced DL)	80.00	0.137	-0.0098	0.1281	0.1284
119 mph 90 deg with No Ice (Reduced DL)	100.00	0.187	-0.0129	0.1661	0.1666
119 mph 90 deg with No Ice (Reduced DL)	120.00	0.251	-0.0144	0.1798	0.1800
119 mph 90 deg with No Ice (Reduced DL)	130.00	0.282	-0.0144	0.1757	0.1759
119 mph 90 deg with No Ice (Reduced DL)	140.00	0.313	-0.0155	0.1875	0.1877
119 mph 90 deg with No Ice (Reduced DL)	160.00	0.382	-0.0164	0.1927	0.1929
119 mph 90 deg with No Ice (Reduced DL)	180.00	0.448	-0.0168	0.1907	0.1910
119 mph 90 deg with No Ice (Reduced DL)	200.00	0.515	-0.0172	0.1888	0.1890
119 mph 90 deg with No Ice (Reduced DL)	220.00	0.580	-0.0174	0.1866	0.1868
119 mph 90 deg with No Ice (Reduced DL)	226.67	0.601	-0.0174	0.1854	0.1856
119 mph 90 deg with No Ice (Reduced DL)	233.33	0.623	-0.0174	0.1830	0.1833
119 mph 90 deg with No Ice (Reduced DL)	240.00	0.644	-0.0174	0.1812	0.1820
50 mph Normal with 1.00 in Radial Ice	80.00	0.051	0.0025	0.0450	0.0451
50 mph Normal with 1.00 in Radial Ice	100.00	0.068	0.0032	0.0572	0.0573
50 mph Normal with 1.00 in Radial Ice	120.00	0.089	0.0034	0.0606	0.0607
50 mph Normal with 1.00 in Radial Ice	130.00	0.100	0.0032	0.0585	0.0586
50 mph Normal with 1.00 in Radial Ice	140.00	0.110	0.0034	0.0621	0.0621
50 mph Normal with 1.00 in Radial Ice	160.00	0.132	0.0035	0.0633	0.0634
50 mph Normal with 1.00 in Radial Ice	180.00	0.154	0.0034	0.0627	0.0628
50 mph Normal with 1.00 in Radial Ice	200.00	0.176	0.0033	0.0622	0.0623
50 mph Normal with 1.00 in Radial Ice	220.00	0.197	0.0032	0.0617	0.0617
50 mph Normal with 1.00 in Radial Ice	226.67	0.204	0.0031	0.0615	0.0615
50 mph Normal with 1.00 in Radial Ice	233.33	0.211	0.0031	0.0606	0.0607
50 mph Normal with 1.00 in Radial Ice	240.00	0.218	0.0030	0.0607	0.0608
50 mph 60 deg with 1.00 in Radial Ice	80.00	0.052	-0.0029	0.0453	0.0453
50 mph 60 deg with 1.00 in Radial Ice	100.00	0.069	-0.0038	0.0571	0.0571
50 mph 60 deg with 1.00 in Radial Ice	120.00	0.090	-0.0042	0.0609	0.0609
50 mph 60 deg with 1.00 in Radial Ice	130.00	0.101	-0.0041	0.0588	0.0588
50 mph 60 deg with 1.00 in Radial Ice	140.00	0.111	-0.0044	0.0624	0.0624
50 mph 60 deg with 1.00 in Radial Ice	160.00	0.133	-0.0046	0.0637	0.0637
50 mph 60 deg with 1.00 in Radial Ice	180.00	0.155	-0.0047	0.0629	0.0629
50 mph 60 deg with 1.00 in Radial Ice	200.00	0.177	-0.0048	0.0624	0.0624
50 mph 60 deg with 1.00 in Radial Ice	220.00	0.198	-0.0049	0.0618	0.0618
50 mph 60 deg with 1.00 in Radial Ice	226.67	0.205	-0.0049	0.0614	0.0614
50 mph 60 deg with 1.00 in Radial Ice	233.33	0.212	-0.0049	0.0608	0.0608
50 mph 60 deg with 1.00 in Radial Ice	240.00	0.219	-0.0049	0.0604	0.0604
50 mph 90 deg with 1.00 in Radial Ice	80.00	0.052	-0.0034	0.0453	0.0453
50 mph 90 deg with 1.00 in Radial Ice	100.00	0.069	-0.0044	0.0571	0.0573
50 mph 90 deg with 1.00 in Radial Ice	120.00	0.090	-0.0048	0.0607	0.0608
50 mph 90 deg with 1.00 in Radial Ice	130.00	0.100	-0.0047	0.0587	0.0587
50 mph 90 deg with 1.00 in Radial Ice	140.00	0.111	-0.0051	0.0623	0.0623
50 mph 90 deg with 1.00 in Radial Ice	160.00	0.133	-0.0053	0.0635	0.0636
50 mph 90 deg with 1.00 in Radial Ice	180.00	0.155	-0.0055	0.0628	0.0628
50 mph 90 deg with 1.00 in Radial Ice	200.00	0.176	-0.0056	0.0623	0.0624
50 mph 90 deg with 1.00 in Radial Ice	220.00	0.198	-0.0057	0.0617	0.0618
50 mph 90 deg with 1.00 in Radial Ice	226.67	0.205	-0.0057	0.0613	0.0614
50 mph 90 deg with 1.00 in Radial Ice	233.33	0.212	-0.0057	0.0607	0.0608
50 mph 90 deg with 1.00 in Radial Ice	240.00	0.219	-0.0057	0.0603	0.0603
Seismic Normal M1	80.00	0.009	0.0006	0.0101	0.0102
Seismic Normal M1	100.00	0.013	0.0008	0.0136	0.0136
Seismic Normal M1	120.00	0.018	0.0009	0.0156	0.0156
Seismic Normal M1	130.00	0.021	0.0010	0.0157	0.0157
Seismic Normal M1	140.00	0.024	0.0010	0.0170	0.0170
Seismic Normal M1	160.00	0.030	0.0011	0.0182	0.0183
Seismic Normal M1	180.00	0.036	0.0012	0.0188	0.0188
Seismic Normal M1	200.00	0.043	0.0012	0.0189	0.0189
Seismic Normal M1	220.00	0.049	0.0012	0.0183	0.0184



Site Number: 383598

Code:

ANSI/TIA-222-H

© 2007 - 2021 by ATC IP LLC. All rights reserved.

Site Name: Tartaglia, CT

Engineering Number: 13668689\_C3\_03

7/6/2021 6:21:59 PM

Customer: VERIZON WIRELESS

Seismic Normal M1	226.67	0.052	0.0011	0.0181	0.0181
Seismic Normal M1	233.33	0.054	0.0011	0.0177	0.0177
Seismic Normal M1	240.00	0.056	0.0011	0.0175	0.0176
Seismic 60 deg M1	80.00	0.009	-0.0006	0.0102	0.0102
Seismic 60 deg M1	100.00	0.013	-0.0008	0.0136	0.0136
Seismic 60 deg M1	120.00	0.018	-0.0009	0.0157	0.0157
Seismic 60 deg M1	130.00	0.021	-0.0010	0.0158	0.0158
Seismic 60 deg M1	140.00	0.024	-0.0010	0.0171	0.0171
Seismic 60 deg M1	160.00	0.030	-0.0011	0.0184	0.0184
Seismic 60 deg M1	180.00	0.036	-0.0012	0.0188	0.0188
Seismic 60 deg M1	200.00	0.043	-0.0012	0.0190	0.0190
Seismic 60 deg M1	220.00	0.049	-0.0012	0.0185	0.0185
Seismic 60 deg M1	226.67	0.052	-0.0011	0.0181	0.0181
Seismic 60 deg M1	233.33	0.054	-0.0011	0.0178	0.0178
Seismic 60 deg M1	240.00	0.056	-0.0011	0.0177	0.0177
Seismic 90 deg M1	80.00	0.009	-0.0007	0.0102	0.0102
Seismic 90 deg M1	100.00	0.013	-0.0009	0.0136	0.0136
Seismic 90 deg M1	120.00	0.018	-0.0011	0.0156	0.0156
Seismic 90 deg M1	130.00	0.021	-0.0011	0.0157	0.0158
Seismic 90 deg M1	140.00	0.024	-0.0012	0.0171	0.0171
Seismic 90 deg M1	160.00	0.030	-0.0013	0.0183	0.0183
Seismic 90 deg M1	180.00	0.036	-0.0013	0.0188	0.0188
Seismic 90 deg M1	200.00	0.043	-0.0014	0.0190	0.0190
Seismic 90 deg M1	220.00	0.049	-0.0013	0.0184	0.0184
Seismic 90 deg M1	226.67	0.052	-0.0013	0.0181	0.0181
Seismic 90 deg M1	233.33	0.054	-0.0013	0.0178	0.0178
Seismic 90 deg M1	240.00	0.056	-0.0013	0.0177	0.0177
Seismic (Reduced DL) Normal M1	80.00	0.009	0.0006	0.0101	0.0101
Seismic (Reduced DL) Normal M1	100.00	0.013	0.0008	0.0135	0.0135
Seismic (Reduced DL) Normal M1	120.00	0.018	0.0009	0.0155	0.0155
Seismic (Reduced DL) Normal M1	130.00	0.021	0.0010	0.0157	0.0157
Seismic (Reduced DL) Normal M1	140.00	0.024	0.0010	0.0170	0.0170
Seismic (Reduced DL) Normal M1	160.00	0.030	0.0011	0.0182	0.0182
Seismic (Reduced DL) Normal M1	180.00	0.036	0.0012	0.0187	0.0188
Seismic (Reduced DL) Normal M1	200.00	0.043	0.0012	0.0188	0.0188
Seismic (Reduced DL) Normal M1	220.00	0.049	0.0012	0.0183	0.0183
Seismic (Reduced DL) Normal M1	226.67	0.052	0.0011	0.0181	0.0181
Seismic (Reduced DL) Normal M1	233.33	0.054	0.0011	0.0176	0.0177
Seismic (Reduced DL) Normal M1	240.00	0.056	0.0011	0.0175	0.0175
Seismic (Reduced DL) 60 deg M1	80.00	0.009	-0.0006	0.0101	0.0101
Seismic (Reduced DL) 60 deg M1	100.00	0.013	-0.0008	0.0135	0.0135
Seismic (Reduced DL) 60 deg M1	120.00	0.018	-0.0009	0.0156	0.0156
Seismic (Reduced DL) 60 deg M1	130.00	0.021	-0.0010	0.0157	0.0157
Seismic (Reduced DL) 60 deg M1	140.00	0.024	-0.0010	0.0170	0.0170
Seismic (Reduced DL) 60 deg M1	160.00	0.030	-0.0011	0.0183	0.0183
Seismic (Reduced DL) 60 deg M1	180.00	0.036	-0.0012	0.0188	0.0188
Seismic (Reduced DL) 60 deg M1	200.00	0.043	-0.0012	0.0189	0.0189
Seismic (Reduced DL) 60 deg M1	220.00	0.049	-0.0012	0.0184	0.0184
Seismic (Reduced DL) 60 deg M1	226.67	0.052	-0.0011	0.0181	0.0181
Seismic (Reduced DL) 60 deg M1	233.33	0.054	-0.0011	0.0178	0.0178
Seismic (Reduced DL) 60 deg M1	240.00	0.056	-0.0011	0.0176	0.0176
Seismic (Reduced DL) 90 deg M1	80.00	0.009	-0.0007	0.0101	0.0101
Seismic (Reduced DL) 90 deg M1	100.00	0.013	-0.0009	0.0135	0.0135
Seismic (Reduced DL) 90 deg M1	120.00	0.018	-0.0011	0.0156	0.0156
Seismic (Reduced DL) 90 deg M1	130.00	0.021	-0.0011	0.0157	0.0157
Seismic (Reduced DL) 90 deg M1	140.00	0.024	-0.0012	0.0170	0.0170
Seismic (Reduced DL) 90 deg M1	160.00	0.030	-0.0013	0.0183	0.0183
Seismic (Reduced DL) 90 deg M1	180.00	0.036	-0.0013	0.0188	0.0188
Seismic (Reduced DL) 90 deg M1	200.00	0.043	-0.0014	0.0189	0.0189
Seismic (Reduced DL) 90 deg M1	220.00	0.049	-0.0013	0.0184	0.0184
Seismic (Reduced DL) 90 deg M1	226.67	0.052	-0.0013	0.0181	0.0181
Seismic (Reduced DL) 90 deg M1	233.33	0.054	-0.0013	0.0177	0.0177

Site Number: 383598

Code:

ANSI/TIA-222-H

© 2007 - 2021 by ATC IP LLC. All rights reserved.

Site Name: Tartaglia, CT

Engineering Number: 13668689\_C3\_03

7/6/2021 6:21:59 PM

Customer: VERIZON WIRELESS

Seismic (Reduced DL) 90 deg M1	240.00	0.056	-0.0013	0.0176	0.0176
Serviceability - 60 mph Wind Normal	80.00	0.037	0.0020	0.0341	0.0342
Serviceability - 60 mph Wind Normal	100.00	0.050	0.0026	0.0442	0.0443
Serviceability - 60 mph Wind Normal	120.00	0.067	0.0028	0.0477	0.0478
Serviceability - 60 mph Wind Normal	130.00	0.075	0.0027	0.0467	0.0468
Serviceability - 60 mph Wind Normal	140.00	0.083	0.0029	0.0498	0.0498
Serviceability - 60 mph Wind Normal	160.00	0.101	0.0030	0.0512	0.0513
Serviceability - 60 mph Wind Normal	180.00	0.119	0.0030	0.0508	0.0509
Serviceability - 60 mph Wind Normal	200.00	0.137	0.0029	0.0503	0.0503
Serviceability - 60 mph Wind Normal	220.00	0.154	0.0028	0.0497	0.0497
Serviceability - 60 mph Wind Normal	226.67	0.160	0.0028	0.0495	0.0495
Serviceability - 60 mph Wind Normal	233.33	0.166	0.0027	0.0487	0.0488
Serviceability - 60 mph Wind Normal	240.00	0.171	0.0027	0.0486	0.0487
Serviceability - 60 mph Wind 60 deg	80.00	0.037	-0.0022	0.0341	0.0341
Serviceability - 60 mph Wind 60 deg	100.00	0.050	-0.0029	0.0441	0.0441
Serviceability - 60 mph Wind 60 deg	120.00	0.067	-0.0033	0.0479	0.0479
Serviceability - 60 mph Wind 60 deg	130.00	0.075	-0.0033	0.0468	0.0468
Serviceability - 60 mph Wind 60 deg	140.00	0.083	-0.0035	0.0500	0.0500
Serviceability - 60 mph Wind 60 deg	160.00	0.101	-0.0037	0.0514	0.0514
Serviceability - 60 mph Wind 60 deg	180.00	0.119	-0.0038	0.0509	0.0509
Serviceability - 60 mph Wind 60 deg	200.00	0.137	-0.0039	0.0504	0.0504
Serviceability - 60 mph Wind 60 deg	220.00	0.154	-0.0039	0.0498	0.0498
Serviceability - 60 mph Wind 60 deg	226.67	0.160	-0.0039	0.0494	0.0494
Serviceability - 60 mph Wind 60 deg	233.33	0.166	-0.0039	0.0488	0.0488
Serviceability - 60 mph Wind 60 deg	240.00	0.171	-0.0039	0.0484	0.0484
Serviceability - 60 mph Wind 90 deg	80.00	0.037	-0.0026	0.0341	0.0342
Serviceability - 60 mph Wind 90 deg	100.00	0.050	-0.0034	0.0441	0.0443
Serviceability - 60 mph Wind 90 deg	120.00	0.067	-0.0038	0.0478	0.0479
Serviceability - 60 mph Wind 90 deg	130.00	0.075	-0.0038	0.0468	0.0468
Serviceability - 60 mph Wind 90 deg	140.00	0.083	-0.0041	0.0499	0.0499
Serviceability - 60 mph Wind 90 deg	160.00	0.102	-0.0043	0.0513	0.0514
Serviceability - 60 mph Wind 90 deg	180.00	0.119	-0.0044	0.0508	0.0509
Serviceability - 60 mph Wind 90 deg	200.00	0.137	-0.0045	0.0504	0.0504
Serviceability - 60 mph Wind 90 deg	220.00	0.154	-0.0046	0.0497	0.0498
Serviceability - 60 mph Wind 90 deg	226.67	0.160	-0.0046	0.0493	0.0494
Serviceability - 60 mph Wind 90 deg	233.33	0.166	-0.0046	0.0487	0.0488
Serviceability - 60 mph Wind 90 deg	240.00	0.171	-0.0046	0.0483	0.0484

### Maximum Reactions Summary

Anchor Group	Vertical (kip)				Horizontal (kip)		Moment (kip-ft)	
	DL+WL	DL+WL+IL	UpLift	Shear	DL+WL	DL+WL+IL	DL+WL	DL+WL+IL
Base	109.74	194.38	340.86	49.08	82.06	29.52	10629.10	3711.06

## Pad & Pier Foundation Analysis (ANSI/TIA-222-H)

### Foundation & Soil Parameters

Ignore Rebar?		Y	
Pier Diameter	<i>D</i>	1.00	ft
Pier Height Above Ground	<i>h</i>	0.5	ft
Pad Base Depth	<i>l+T-h</i>	5.6	ft
Pad Width	<i>W</i>	22.0	ft
Pad Thickness	<i>T</i>	6.1	ft
Water Table Depth [BGL]	<i>GW</i>	99	ft
Unit Weight of Concrete		150	pcf
Unit Weight of Soil Above Water Table		140.0	pcf
Unit Weight of Water		62.4	pcf
Unit Weight of Soil [Submerged]		77.6	pcf
Cohesion		13,979	psf
Friction Angle		0	°
Ultimate Skin Friction		0	psf
Ultimate Bearing Pressure		95,574	psf
Conical Failure Angle		30	°
Soil Uplift at _____ of Pad		Top	
Capacity Increase (Transient Loads)		1.00	
Bearing Strength Reduction Factor, $\phi_s$		0.75	
Uplift Strength Reduction Factor, $\phi_s$		0.75	

### Reactions

Moment, $M_u$	0.0	k-ft
Shear, $V_u$	49.1	k
Compression, $P_u$	340.9	k
Uplift, $T_u$	276.7	k

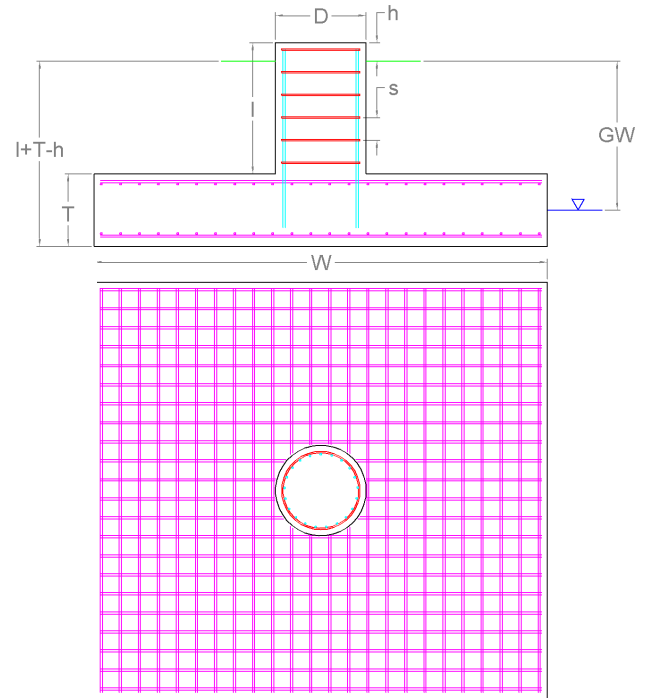

### Soil Axial Capacities and Design Moment

Weight of Concrete [Buoyancy Considered]	442.9	k
Weight of Soil [Buoyancy Considered]	0.0	k
Skin Friction Resistance	0.0	k
Controlling Failure Mode	Top	
Nominal Uplift Capacity per Leg, $\phi_s T_n$	307.4	k
$T_u / \phi_s T_n$	90.0%	
Compressive Force, $P_u$	376.4	k
Nominal Compressive Capacity per Leg, $\phi_s P_n$	34,693.4	k
$P_u / \phi_s P_n$	1.1%	
Inflection Point [BGL]	1.3	ft
Design Moment at Inflection Point, $M_u$	49.1	k-ft





**AMERICAN TOWER®**  
CORPORATION

---

## Structural Analysis Report

**Structure** : 240 ft Self Support Tower  
**ATC Site Name** : Tartaglia,CT  
**ATC Site Number** : 383598  
**Engineering Number** : 13682699\_C3\_05  
**Proposed Carrier** : AT&T MOBILITY  
**Carrier Site Name** : MRCTB051560  
**Carrier Site Number** : N/A  
**Site Location** : 1000 Trumbull Avenue  
Bridgeport, CT 06606  
41.2196, -73.2013  
**County** : Fairfield  
**Date** : December 2, 2021  
**Max Usage** : 97%  
**Result** : Pass

Prepared By:

Tanner Putman  
Structural Engineer

Reviewed By:

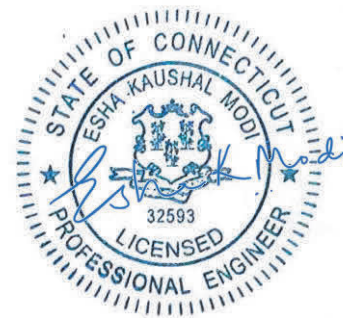

Authorized by "EOR"  
03 Dec 2021 09:08:22

**COA : PEC.0001553**



## Table of Contents

Introduction .....	3
Supporting Documents.....	3
Analysis.....	3
Conclusion .....	3
Existing and Reserved Equipment .....	4
Equipment to be Removed.....	5
Proposed Equipment.....	5
Structure Usages .....	6
Foundations.....	6
Deflection, Twist and Sway* .....	6
Standard Conditions.....	7
Calculations .....	Attached

## Introduction

The purpose of this report is to summarize results of a structural analysis performed on the 240 ft Self Support tower to reflect the change in loading by AT&T MOBILITY.

## Supporting Documents

<b>Tower Drawings</b>	Rohn Drawing #C880400RI, dated March 3, 1988
<b>Foundation Drawing</b>	Mapping by FDH Project #10-12269E N1, dated January 17, 2011
<b>Geotechnical Report</b>	Soiltesting Job #G96-1987-87, dated January 6, 1988
<b>Modifications</b>	Centek Job #10001.CO78, dated December 6, 2010 GlenMartin Drawing #GM-07602, dated February 21, 2013

## Analysis

The tower was analyzed using American Tower Corporation's tower analysis software. This program considers an elastic three-dimensional model and second-order effects per ANSI/TIA-222.

<b>Basic Wind Speed:</b>	119 mph (3-second gust)
<b>Basic Wind Speed w/ Ice:</b>	50 mph (3-second gust) w/ 1.00" radial ice concurrent
<b>Code:</b>	ANSI/TIA-222-H / 2015 IBC / 2018 Connecticut State Building Code
<b>Exposure Category:</b>	C
<b>Risk Category:</b>	II
<b>Topographic Factor Procedure:</b>	Method 1
<b>Topographic Category:</b>	1
<b>Crest Height (H):</b>	0 ft
<b>Crest Length (L):</b>	0 ft
<b>Spectral Response:</b>	$S_s = 0.21, S_i = 0.05$
<b>Site Class:</b>	D - Stiff Soil - Default

\*\*Wind load and Ice thickness have been reduced by applicable existing structure load modification factors in accordance with TIA-222-H, Annex S.

## Conclusion

Based on the analysis results, the structure meets the requirements per the applicable codes listed above. The tower and foundation can support the equipment as described in this report.

If you have any questions or require additional information, please contact American Tower via email at [Engineering@americantower.com](mailto:Engineering@americantower.com). Please include the American Tower site name, site number, and engineering number in the subject line for any questions.

**Existing and Reserved Equipment**

Elev. <sup>1</sup> (ft)	Qty	Equipment	Mount Type	Lines	Carrier
256.0	1	Generic 8' Yagi	Side Arm	-	OTHER
245.0	1	Generic 10' Omni	Side Arm	(1) 1 1/4" Coax	
240.0	1	Dielectric DCR-L1 w/ Radome	Leg	(1) 1 5/8" Coax	RED WOLF BROADCASTING
234.0	2	Generic 8' Omni	Side Arm	(2) 7/8" Coax	OTHER
229.0	1	Generic 12' Omni	Side Arm	(1) 1 1/4" Coax	
223.0	-	-	Empty Side Arm	-	
202.0	3	Ericsson AIR 32 B66AA B2P	Sector Frame	(2) 1 1/4" Hybriflex Cable (3) 1 5/8" Hybriflex	T-MOBILE
	3	Ericsson Air6449 B41			
	3	Ericsson RRUS 4415 B25			
	3	RFS APXVAARR24_43-U-NA20			
	3	Ericsson Radio 4449 B71 B85A			
181.0	3	Nokia 2.5G MAA - AAHC(64T64R)	Sector Frame	(1) 1.7" (43.2mm) Hybrid (3) 1 1/4" (1.25"-31.8mm) Fiber (1) 1 1/4" Hybriflex Cable (3) 1/2" Coax (2) 2" conduit (6) 5/16" (0.31"-7.9mm) Coax	SPRINT NEXTEL
180.0	3	Alcatel-Lucent 800 MHz RRH			
	6	Alcatel-Lucent 1900MHz RRH			
	3	Argus LLPX310R			
	1	Generic 24" x 24" Junction Box			
	3	Generic 2' Std. Dish			
	2	RFS APXVSP18-C-A20			
	1	RFS APXV9ERR18-C-A20			
3	Motorola DAP Vx				
165.0	3	Andrew SBNHH-1D65A	Sector Frame	(6) 1 5/8" Coax (1) 2" conduit	AT&T MOBILITY
	3	Powerwave Allgon 7770.00			
	3	Ericsson RRUS 4478 B14			
	2	Raycap DC6-48-60-18-8F (23.5" Height)			
155.0	3	Commscope CBC78T-DS-43-2X	Sector Frame with Reinforcement	(6) 1 5/8" Coax (3) 1 5/8" Hybriflex	VERIZON WIRELESS
	3	Samsung Outdoor CBRS 20W RRH –Clip-on Antenna			
	3	Samsung Outdoor CBRS 20W RRH			
	6	Commscope JAHH-65B-R3B			
	3	Samsung B5/B13 RRH-BR04C			
	3	Samsung MT6407-77A			
	2	Raycap RxxDC-3315-PF-48			
	3	Samsung B2/B66A RRH-BR049			
3	Amphenol Antel BXA-80063-6BF-EDIN-X				
145.0	1	Commscope RDIDC-9181-PF-48	Sector Frame	(1) 1.75" (44.5mm) Hybrid	DISH WIRELESS L.L.C.
	3	Fujitsu TA08025-B604			
	3	Fujitsu TA08025-B605			
	3	JMA Wireless MX08FRO665-21			
132.0	1	Generic 4' Yagi	Side Arm	(1) 1 1/4" Coax	OTHER
123.0	1	Generic 10' Omni	Side Arm	(1) 7/8" Coax	
98.0	1	Generic 4' Yagi	Side Arm	(1) 1 1/4" Coax	
80.0	-	-	Empty Side Arm	-	

**Equipment to be Removed**

Elev. <sup>1</sup> (ft)	Qty	Equipment	Mount Type	Lines	Carrier
165.0	3	Kathrein Scala 80010965	-	(2) 0.39" (10mm) Fiber Trunk (6) 0.78" (19.7mm) 8 AWG 6 (6) 1 5/8" Coax (1) 2" conduit	AT&T MOBILITY
	12	Powerwave Allgon LGP21901			
	1	Commscope WCS-IMFQ-AMT			
	6	Powerwave Allgon 7020.00 Dual Band RET			
	3	CCI DTMAPB7819VG12A			
	3	Quintel QS66512-3 (112 lbs.)			
	1	Raycap DC6-48-60-18-8F (23.5" Height)			
	3	Ericsson RRUS 4426 B66			
	3	Ericsson RRUS 32 (50.8 lbs)			
	3	Ericsson RRUS 32 B2			
	3	Ericsson Radio 4449			
	9	Powerwave Allgon LGP21401			

**Proposed Equipment**

Elev. <sup>1</sup> (ft)	Qty	Equipment	Mount Type	Lines	Carrier
167.0	3	Ericsson AIR 6449 n77D	Sector Frame	(3) 0.40" (10.3mm) Fiber (4) 0.82" (20.8mm) 8 AWG 6 (3) 0.92" (23.4mm) Cable	AT&T MOBILITY
165.0	3	CCI DMP65R-BU6DA			
	3	Quintel QD6616-7			
	3	Ericsson RRUS 4415 B25			
	3	Ericsson RRUS 4449 B5, B12			
	3	Ericsson RRUS 32 B66A			
	3	Ericsson RRUS 32 B30			
	1	Raycap DC9-48-60-24-8C-EV			
163.0	3	Ericsson AIR 6419 N77G			

<sup>1</sup> Contracted elevations are shown for appurtenances within contracted installation tolerances. Appurtenances outside of contract limits are shown at installed elevations.

Install proposed lines alongside existing AT&T MOBILITY lines.



## Structure Usages

Structural Component	Controlling Usage	Pass/Fail
Legs	43%	Pass
Diagonals	97%	Pass
Horizontals	87%	Pass
Anchor Bolts	49%	Pass
Leg Bolts	36%	Pass

## Foundations

Reaction Component	Analysis Reactions	% of Usage
Uplift (Kips)	274.0	89%
Axial (Kips)	340.6	1%

The structure base reactions resulting from this analysis were found to be acceptable through analysis based on geotechnical and foundation information, therefore no modification or reinforcement of the foundation will be required.

## Deflection, Twist and Sway\*

Antenna Elevation (ft)	Antenna	Carrier	Deflection (ft)	Twist (°)	Sway (Rotation) (°)
180.0	Generic 2' Std. Dish	SPRINT NEXTEL	0.124	0.004	0.052
167.0	Ericsson AIR 6449 n77D	AT&T MOBILITY	0.115	0.004	0.052
165.0	CCI DMP65R-BU6DA		0.106	0.004	0.053
	Ericsson RRUS 32 B30				
	Ericsson RRUS 32 B66A				
	Ericsson RRUS 4415 B25				
	Ericsson RRUS 4449 B5, B12				
	Quintel QD6616-7				
	Raycap DC9-48-60-24-8C-EV				
	CCI DMP65R-BU6DA				
	Ericsson RRUS 32 B30				
	Ericsson RRUS 32 B66A				
Ericsson RRUS 4415 B25					
Ericsson RRUS 4449 B5, B12					
Quintel QD6616-7					
Raycap DC9-48-60-24-8C-EV					
163.0	Ericsson AIR 6419 N77G	0.106	0.004	0.053	
145.0	Commscope RDIDC-9181-PF-48	DISH WIRELESS L.L.C.	0.087	0.004	0.052
	Fujitsu TA08025-B604				
	Fujitsu TA08025-B605				
	JMA Wireless MX08FRO665-21				

\*Deflection, Twist and Sway was evaluated considering a design wind speed of 60 mph (3-Second Gust) per ANSI/TIA-222-H

## **Standard Conditions**

All engineering services performed by A.T. Engineering Service, PLLC are prepared on the basis that the information used is current and correct. This information may consist of, but is not limited to the following:

- Information supplied by the client regarding antenna, mounts and feed line loading
- Information from drawings, design and analysis documents, and field notes in the possession of A.T. Engineering Service, PLLC

It is the responsibility of the client to ensure that the information provided to A.T. Engineering Service, PLLC and used in the performance of our engineering services is correct and complete.

All assets of American Tower Corporation, its affiliates, and subsidiaries (collectively “American Tower”) are inspected at regular intervals. Based upon these inspections and in the absence of information to the contrary, American Tower assumes that all structures were constructed in accordance with the drawings and specifications.

Unless explicitly agreed by both the client and A.T. Engineering Service, PLLC, all services will be performed in accordance with the current revision of ANSI/TIA-222.

All services are performed, results obtained, and recommendations made in accordance with generally accepted engineering principles and practices. A.T. Engineering Service, PLLC is not responsible for the conclusions, opinions and recommendations made by others based on the information supplied herein.

Asset: 383598, Tartaglia  
 Client: AT&T MOBILITY  
 Code: ANS/TIA-222-H

Height: 240 ft  
 Base Width: 40.33 ft  
 Shape: Triangle

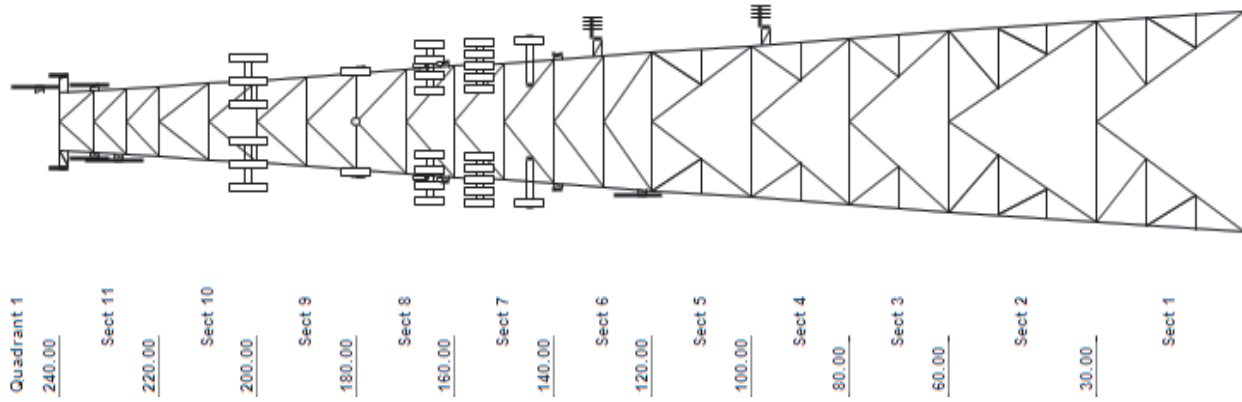

SITE PARAMETERS		
Nominal Wind : 115.99 mph wind with no ic	Exposure : C	Site Class : D
Ice Wind: 48.73 mph wind with 0.850"	Topo Method: Method 1	Risk Cat : II
Service Wind : 60 mph Serviceability	Topo Feature :	S <sub>s</sub> : 0.211 S <sub>1</sub> : 0.054

SECTION PROPERTIES			
Section	Leg Members	Diagonal Members	Horizontal Members
1	PX 50 ksi 10" DIA PIP	PST 50 ksi 3" DIA PIPE	PST 50 ksi 3-1/2" DIA PIPE
2 - 3	PX 50 ksi 10" DIA PIP	PST 50 ksi 3" DIA PIPE	PST 50 ksi 3" DIA PIPE
4	PX 50 ksi 8" DIA PIPE	PST 50 ksi 3" DIA PIPE	PST 50 ksi 3" DIA PIPE
5	PX 50 ksi 8" DIA PIPE	PST 50 ksi 2-1/2" DIA PIPE	PST 50 ksi 2-1/2" DIA PIPE
6	PX 50 ksi 8" DIA PIPE	PST 50 ksi 3" DIA PIPE	PST 50 ksi 2-1/2" DIA PIPE
7 - 8	PX 50 ksi 8" DIA PIPE	PST 50 ksi 2-1/2" DIA PIPE	PST 50 ksi 2-1/2" DIA PIPE
9 - 10	PX 50 ksi 8" DIA PIPE	PST 50 ksi 2-1/2" DIA PIPE	PST 50 ksi 2" DIA PIPE
11	PX 50 ksi 8" DIA PIPE	PST 50 ksi 2" DIA PIPE	PST 50 ksi 2" DIA PIPE

REDUNDANT SECONDARY BRACING					
Section	Sub Diag 1	Sub Horiz 1	Sub Horiz 2	Sub Diag 3	Sub Horiz 3
1	P1-1/2" DIA PIPE	P1-1/2" DIA PI	P2-1/2" DIA PIPE	P2" DIA PIPE	-
2	P1-1/2" DIA PIPE	P1-1/2" DIA PI	P2" DIA PIPE	P2" DIA PIPE	-
3-4	P2" DIA PIPE	P1-1/2" DIA PI	-	-	-
5	P1-1/2" DIA PIPE	P1-1/2" DIA PI	-	-	-
6-11	-	-	-	-	-

DISCRETE APPURTENANCE		
Elev (ft)	Type	Qty Description
256.00	YAGI	1 Generic 8' Yagi
245.00	OMNI	1 Generic 10' Omni
240.00	OMNI	1 Lightning Rod
240.00	OMNI	1 Beacon
240.00	Other	1 Dielectric DCR-L1 w/ Radome
240.00	Side Arm	2 Generic Round Side Arm
234.00	OMNI	2 Generic 8' Omni
230.00	T-Arm	1 Round Side Arm
229.00	OMNI	1 Generic 12' Omni
223.00	T-Arm	1 Round Side Arm
223.00	T-Arm	1 Empty Flat Side Arm
202.00	PANEL	3 Ericsson Air6449 B41
202.00	PANEL	3 RFS APXVAARR24_43-U-NA20
202.00	PANEL	3 Ericsson AIR 32 B66AA B2P
202.00	RRU/RRH	3 Ericsson Radio 4449 B71 B85A
202.00	RRU/RRH	3 Ericsson RRU 4415 B25
202.00	Sector Frame	3 Generic Round Sector Frame
183.00	Sector Frame	3 Flat Light Sector Frame
183.00	T-Arm	3 Side Arms
181.00	PANEL	3 Nokia 2.5G MAA - AAHC(64T64R)
180.00	BOB/SSB	1 Generic 24" x 24" Junction Box
180.00	DISH-STANDARD	3 Generic 2' Std. Dish
180.00	PANEL	1 RFS APXV9ERR18-C-A20
180.00	PANEL	2 RFS APXVSP18-C-A20
180.00	PANEL	3 Argus LLPX310R
180.00	RRU/RRH	3 Alcatel-Lucent 800 MHz RRH
180.00	RRU/RRH	3 Motorola DAP Vx

Asset: 383598, Tartaglia  
 Client: AT&T MOBILITY  
 Code: ANS/TIA-222-H

Height : 240 ft  
 Base Width : 40.33 ft  
 Shape : Triangle

DISCRETE APPURTENANCE

Elev (ft)	Type	Qty	Description
180.00	RRU/RRH	6	Alcatel-Lucent 1900MHz RRH
167.00	PANEL	3	Ericsson AIR 6449 n77D
165.00	BOB/SSB	1	Raycap DC9-48-60-24-8C-EV
165.00	BOB/SSB	2	Raycap DC6-48-60-18-8F (23.5"
165.00	PANEL	3	CCI DMP65R-BU6DA
165.00	PANEL	3	Quintel QD6616-7
165.00	PANEL	3	Powerwave Allgon 7770.00
165.00	PANEL	3	Andrew SBNHH-1D65A
165.00	RRU/RRH	3	Ericsson RRUS 32 B66A
165.00	RRU/RRH	3	Ericsson RRUS 32 B30
165.00	RRU/RRH	3	Ericsson RRUS 4449 B5, B12
165.00	RRU/RRH	3	Ericsson RRUS 4478 B14
165.00	RRU/RRH	3	Ericsson RRUS 4415 B25
165.00	Sector Frame	3	Generic Round Sector Frame
163.00	PANEL	3	Ericsson AIR 6419 N77G
155.00	BOB/SSB	2	Raycap RxxDC-3315-PF-48
155.00	DIPLEXER/DUAL COUPLER	3	Commscope CBC78T-DS-43-2X
155.00	Mount Reinforcement	1	Generic Mount Reinforcement
155.00	PANEL	3	Samsung MT6407-77A
155.00	PANEL	3	Amphenol Antel BXA-80063-6BF-E
155.00	PANEL	3	Samsung Outdoor CBRS 20W RRH --
155.00	PANEL	6	Commscope JAHH-65B-R3B
155.00	RRU/RRH	3	Samsung Outdoor CBRS 20W RRH
155.00	RRU/RRH	3	Samsung B5/B13 RRH-BR04C
155.00	RRU/RRH	3	Samsung B2/B66A RRH-BR049
155.00	Sector Frame	3	Flat Light Sector Frame
145.00	BOB/SSB	1	Commscope RDIDC-9181-PF-48
145.00	PANEL	3	JMA Wireless MX08FRO665-21
145.00	RRU/RRH	3	Fujitsu TA08025-B605
145.00	RRU/RRH	3	Fujitsu TA08025-B604
145.00	Sector Frame	3	Generic Flat Light Sector Fram
140.00	OMNI	3	Small Side Lights
132.00	T-Arm	1	Flat Side Arm
132.00	YAGI	1	Generic 4' Yagi
123.00	OMNI	1	Generic 10' Omni
118.00	T-Arm	1	Round Side Arm
108.00	T-Arm	1	Round Side Arm
98.00	T-Arm	1	Flat Side Arm
98.00	YAGI	1	Generic 4' Yagi
80.00	T-Arm	1	Empty Round Side Arm
8.00	T-Arm	1	Round Side Arm

LINEAR APPURTENANCE

Elev (ft)	From	To	Qty	Description
0.00	245.00		1	1 1/4" Coax
0.00	243.00		1	1 5/8" Coax
0.00	240.00		1	Waveguide
0.00	234.00		2	7/8" Coax
0.00	229.00		1	1 1/4" Coax
0.00	202.00		1	Waveguide
0.00	202.00		3	1 5/8" Hybriflex
0.00	202.00		2	1 1/4" Hybriflex Cable

Asset: 383598, Tartaglia  
 Client: AT&T MOBILITY  
 Code: ANS/TIA-222-H

Height : 240 ft  
 Base Width : 40.33 ft  
 Shape : Triangle

LINEAR APPURTENANCE

Elev (ft)		Qty	Description
From	To		
0.00	183.00	1	Waveguide
0.00	181.00	1	1.7" (43.2mm) Hybrid
0.00	180.00	6	5/16" (0.31"-7.9mm) Coax
0.00	180.00	2	2" conduit
0.00	180.00	3	1/2" Coax
0.00	180.00	1	1 1/4" Hybriflex Cable
0.00	180.00	3	1 1/4" (1.25"-31.8mm) Fiber
0.00	174.00	1	Waveguide
0.00	165.00	1	Waveguide
0.00	165.00	1	2" conduit
0.00	165.00	6	1 5/8" Coax
0.00	165.00	3	0.92" (23.4mm) Cable
0.00	165.00	4	0.82" (20.8mm) 8 AWG 6
0.00	165.00	3	0.40" (10.3mm) Fiber
0.00	155.00	1	Waveguide
0.00	155.00	3	1 5/8" Hybriflex
0.00	155.00	6	1 5/8" Coax
0.00	145.00	1	Waveguide
0.00	145.00	1	1.75" (44.5mm) Hybrid
0.00	132.00	1	1 1/4" Coax
0.00	123.00	1	7/8" Coax
0.00	98.00	1	1 1/4" Coax

GLOBAL BASE FOUNDATION DESIGN LOADS

Load Case	Moment (k-ft)	Vertical (kip)	Horizontal (kip)
DL+WL	10570.86	113.88	81.3
DL+WL+IL	3540.49	185.41	28.39

INDIVIDUAL BASE FOUNDATION DESIGN LOADS

Vertical (kip)	Uplift (kip)	Horizontal (kip)
340.58	273.95	48.83

Asset: 383598, Tartaglia  
Client: AT&T MOBILITY  
Code: ANS/TIA-222-H

Height: 240 ft  
Base Width: 40.33 ft  
Shape: Triangle



Maser Consulting Connecticut  
2000 Midlantic Drive, Suite 100  
Mt. Laurel, NJ 08054  
856.797.0412  
Peter.Albano@ColliersEngineering.com

---

## Post-Mod Antenna Mount Analysis Report and PMI Requirements

Mount Fix

SMART Tool Project #: 10069536  
Maser Consulting Connecticut Project #: 21777438A

June 11, 2021

### Site Information

Site ID: 467325-VZW / N BRIDGEPORT CT  
Site Name: N BRIDGEPORT CT  
Carrier Name: Verizon Wireless  
Address: 1330 Chopsey Hill Rd.  
Bridgeport, Connecticut 06606,  
Fairfield County  
Latitude: 41.219528°  
Longitude: -73.201779°

### Structure Information

Tower Type: Self-Support  
Mount Type: 13.00-Ft Sector Frame

FUZE ID # 16231899

### Analysis Results

Sector Frame: 81.2% Pass

### \*\*\*Contractor PMI Requirements:

**Included at the end of this MA report**

**Available & Submitted via portal at <https://pmi.vzwsmart.com>**

**Contractor - Please Review Specific Site PMI Requirements Upon Award**

**Requirements also Noted on Mount Modification Drawings**

**Requirements may also be Noted on A & E drawings**

Report Prepared By: Abigail Enriquez

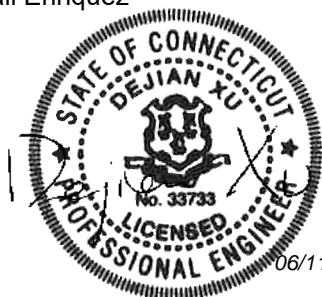

06/11/2021

**Executive Summary:**

The objective of this report is to summarize the analysis results of the antenna support mount including the proposed modifications at the subject facility for the final wireless telecommunications configuration, per the applicable codes and standards.

This analysis is inclusive of the mount structure only and does not address the structural capacity of the supporting structure. This mounting frame was not analyzed as an anchor attachment point for fall protection. All climbing activities are required to have a fall protection plan completed by a competent person.

**Sources of Information:**

Document Type	Remarks
<i>Radio Frequency Data Sheet (RFDS)</i>	<i>Verizon RFDS Site ID: 324428, dated March 17, 2021</i>
<i>Mount Mapping Report</i>	<i>RKS Design &amp; Engineering LLC., Site ID: VZW:467325, dated April 02, 2021</i>
<i>Previous Mount Analysis Report</i>	<i>Maser Consulting Connecticut, Project # 21777438A, dated May 7, 2021</i>
<i>Mount Modification Drawings</i>	<i>Maser Consulting Connecticut, Project # 21777438A, dated June 11, 2021</i>

**Analysis Criteria:**

Codes and Standards:	ANSI/TIA-222-H
Wind Parameters:	Basic Wind Speed (Ultimate 3-sec. Gust), $V_{ULT}$ : 119 mph
	Ice Wind Speed (3-sec. Gust): 50 mph
	Design Ice Thickness: 1.00 in
	Risk Category: II
	Exposure Category: C
	Topographic Category: 1
	Topographic Feature Considered: N/A
	Topographic Method: N/A
	Ground Elevation Factor, $K_e$ : 0.993
Seismic Parameters:	$S_s$ : 0.211
	$S_1$ : 0.054
Maintenance Parameters:	Wind Speed (3-sec. Gust): 30 mph
	Maintenance Live Load, $L_v$ : 250 lbs.
	Maintenance Live Load, $L_m$ : 500 lbs.
Analysis Software:	RISA-3D (V17)



**Final Loading Configuration:**

The following equipment has been considered for the analysis of the mount:

Mount Elevation (ft)	Equipment Elevation (ft)	Quantity	Manufacturer	Model	Status
153.90	155.00	3	Samsung	MT6407-77A	Retained
		1	Raycap	RC3DC-3315-PF-48	
		3	Samsung	B5/B13 RRH-BR04C	
		2	Amphenol	BXA-80063-6BF-EDIN-4	
		1	Amphenol	BXA-80063-6BF-EDIN-6	
		6	Commscope	JAHH-65B-R3B	
		3	Samsung	XXDWMM-12.5-65-8T-CBRS	
		3	Commscope	CBC78T-DS-43-2X	
		3	Samsung	B2/B66 RRH-BR049	

The recent mount mapping reported existing OVP units. It is acceptable to install up to any three (3) of the OVP model numbers listed below as required at any location other than the mount face without affecting the structural capacity of the mount. If OVP units are installed on the mount face, a mount re-analysis may be required unless replacing an existing OVP.

Model Number	Ports	AKA
DB-B1-6C-12AB-0Z	6	OVP-6
RVZDC-6627-PF-48	12	OVP-12

**Standard Conditions:**

1. All engineering services are performed on the basis that the information provided to Maser Consulting Connecticut and used in this analysis is current and correct. The existing equipment loading has been applied at locations determined from the supplied documentation. Any deviation from the loading locations specified in this report shall be communicated to Maser Consulting Connecticut to verify deviation will not adversely impact the analysis.
2. Mounts are assumed to have been properly fabricated, installed and maintained in good condition, twist free and plumb in accordance with its original design and manufacturer’s specifications.

Obvious safety and structural issues/deficiencies noticed at the time of the mount mapping and reported in the Mount Mapping Report are assumed to be corrected and documented as part of the PMI process and are not considered in the mount analysis.

The mount analysis and the mount mapping are not a condition assessment of the mount. Proper maintenance and condition assessments are still required post analysis.

3. For mount analyses completed from other data sources (including new replacement mounts) and not specifically mapped by Maser Consulting Connecticut, the mounts are assumed to have been properly fabricated, installed and maintained in good condition, twist free and plumb in accordance with its original design and manufacturer’s specifications.
4. All member connections are assumed to have been designed to meet or exceed the load carrying capacity of the connected member unless otherwise specified in this report.

5. The mount was checked up to, and including, the bolts that fasten it to the mount collar/attachment and threaded rod connections in collar members if applicable. Local deformation and interaction between the mount collar/attachment and the supporting tower structure are outside the scope of this analysis.
6. All services are performed, results obtained, and recommendations made in accordance with generally accepted engineering principles and practices. Maser Consulting Connecticut is not responsible for the conclusion, opinions, and recommendations made by others based on the information supplied.
7. Structural Steel Grades have been assumed as follows, if applicable, unless otherwise noted in this analysis:
  - o Channel, Solid Round, Angle, Plate      ASTM A36 (Gr. 36)
  - o HSS (Rectangular)                              ASTM 500 (Gr. B-46)
  - o Pipe    ASTM A53 (Gr. B-35)
  - o Threaded Rod                                      F1554 (Gr. 36)
  - o Bolts    ASTM A325
8. Any mount modifications listed under Sources of Information are assumed to have been installed per the design specifications.

**Discrepancies between in-field conditions and the assumptions listed above may render this analysis invalid unless explicitly approved by Maser Consulting Connecticut.**

**Analysis Results:**

Component	Utilization %	Pass/Fail
Pipe Standoff Horizontal	11.2 %	Pass
Face Horizontal	45.8 %	Pass
Face Diagonal	6.6 %	Pass
Mount Pipe	69.1 %	Pass
Pipe Face Horizontal	81.2 %	Pass
Standoff Horizontal	26.8 %	Pass
Standoff Vertical	12.4 %	Pass
Standoff Diagonal	6.3 %	Pass
Dual Mount Pipe	19.4 %	Pass
Tieback	11.3 %	Pass
V-Brace	27.0 %	Pass
Mount Connection Check	8.5 %	Pass
Kicker Connection Check	26.6 %	Pass
<b>Structure Rating – (Controlling Utilization of all Components)</b>		<b>81.2%</b>

**Recommendation:**

The existing mounts will be **SUFFICIENT** for the final loading after the proposed modifications are successfully completed.

ANSI/ASSP rigging plan review services compliant with the requirements of ANSI/TIA 322 are available for a Construction Class IV site or other, if required. Separate review fees will apply.

**Attachments:**

1. Mount Photos
2. Mount Mapping Report (for reference only)
3. Analysis Calculations
- 4. Contractor Required PMI Report Deliverables**
5. Antenna Placement Diagrams
6. TIA Adoption and Wind Speed Usage Letter





### Antenna Mount Mapping Form (PATENT PENDING)

FCC #  
1203184

Tower Owner:	ATC	Mapping Date:	4/2/2021
Site Name:	ATC: Tartaglia VZW: N Bridgeport CT	Tower Type:	Self Support
Site Number or ID:	ATC:383598, VZW:467325	Tower Height (Ft.):	UNKNOWN
Mapping Contractor:	RKS Design & Engineering LLC.	Mount Elevation (Ft.):	150.9

This antenna mapping form is the property of TES and under **PATENT PENDING**. The formation contained herein is considered confidential in nature and is to be used only for the specific customer it was intended for. Reproduction, transmission, publication, modification or disclosure by any method is prohibited except by express written permission of TES. All means and methods are the responsibility of the contractor and the work shall be compliant with ANSI/ASSE A 10.48, OSHA, FCC, FAA and other safety requirements that may apply. TES is not warranting the usability of the safety climb as it must be assessed prior to each use in compliance with OSHA requirements.

Please insert the sketches of the antenna mount from the "Sketches" tab with dimensions and members here.

Mount Pipe Configuration and Geometries [Unit = Inches]							
Sector / Position	Mount Pipe Size & Length	Vertical Offset Dimension "u"	Horizontal Offset "C1, C2, C3, etc."	Sector / Position	Mount Pipe Size & Length	Vertical Offset Dimension "u"	Horizontal Offset "C1, C2, C3, etc."
A1	PIPE 2.375"Ø X 0.15" X 72" LONG	64.50	11.50	C1	PIPE 2.375"Ø X 0.15" X 72" LONG	64.50	11.50
A2	PIPE 2.375"Ø X 0.15" X 72" LONG	65.75	84.00	C2	PIPE 2.375"Ø X 0.15" X 72" LONG	65.75	84.00
A3	PIPE 2.375"Ø X 0.15" X 72" LONG	63.50	132.00	C3	PIPE 2.375"Ø X 0.15" X 72" LONG	63.50	132.00
A4	PIPE 2.375"Ø X 0.15" X 72" LONG	64.50	157.50	C4	PIPE 2.375"Ø X 0.15" X 72" LONG	64.50	157.50
A5				C5			
A6				C6			
B1	PIPE 2.375"Ø X 0.15" X 72" LONG	64.50	11.50	D1			
B2	PIPE 2.375"Ø X 0.15" X 72" LONG	65.75	84.00	D2			
B3	PIPE 2.375"Ø X 0.15" X 72" LONG	63.50	132.00	D3			
B4	PIPE 2.375"Ø X 0.15" X 72" LONG	64.50	157.50	D4			
B5				D5			
B6				D6			
Distance between bottom rail and mount CL elevation (dim d). Unit is inches. See 'Mount Elev Ref' tab for details. :							18.00
Distance from top of bottom support rail to lowest tip of ant./eqpt. of Carrier above. (N/A if > 10 ft.) :							
Distance from top of bottom support rail to highest tip of ant./eqpt. of Carrier below. (N/A if > 10 ft.) :							
Please enter additional information or comments below.							
Tower Face Width at Mount Elev. (ft.):		15	Tower Leg Size or Pole Shaft Diameter at Mount Elev. (in.):		9		

Ants. Items	Enter antenna model. If not labeled, enter "Unknown".						Mounting Locations [Units are inches and degrees]			Photos of antennas
	Antenna Models if Known	Width (in.)	Depth (in.)	Height (in.)	Coax Size and Qty	Antenna Center-line (Ft.)	Vertical Distances "b <sub>1a</sub> , b <sub>2a</sub> , b <sub>3a</sub> , b <sub>1b</sub> ..." (Inches)	Horiz. Offset "h" (Use "-" if Ant. is behind)	Antenna Azimuth (Degrees)	
<b>Sector A</b>										
Ant <sub>1a</sub>	RT4401-48A	12.00	8.25	12.00		152.942	22.00	-8.25		11, 295
Ant <sub>1b</sub>										
Ant <sub>1c</sub>										
Ant <sub>2a</sub>	CBC78T-DS-43-2X	9.50	6.25	6.75		152.879	24.00	-6.50		11
Ant <sub>2b</sub>	(2) JAHH-65B-R3B	13.75	8.25	72.00		152.108	33.25	12.00	50.00	11
Ant <sub>2c</sub>	RFV01U-D1A	15.00	10.00	15.00		152.025	34.25	-8.50		11
Ant <sub>3a</sub>	RFV01U-D2A	15.00	8.00	15.00		152.088	31.25	-7.75		11
Ant <sub>3b</sub>										
Ant <sub>3c</sub>										
Ant <sub>4a</sub>										
Ant <sub>4b</sub>	BXA-80063-6BF-EDIN	11.25	5.25	68.00		152.025	33.00	10.25	50.00	11
Ant <sub>4c</sub>										
Ant <sub>5a</sub>										
Ant <sub>5b</sub>										
Ant <sub>5c</sub>										
Ant on Standoff										
Ant on Standoff										
Ant on Tower										
Ant on Tower										

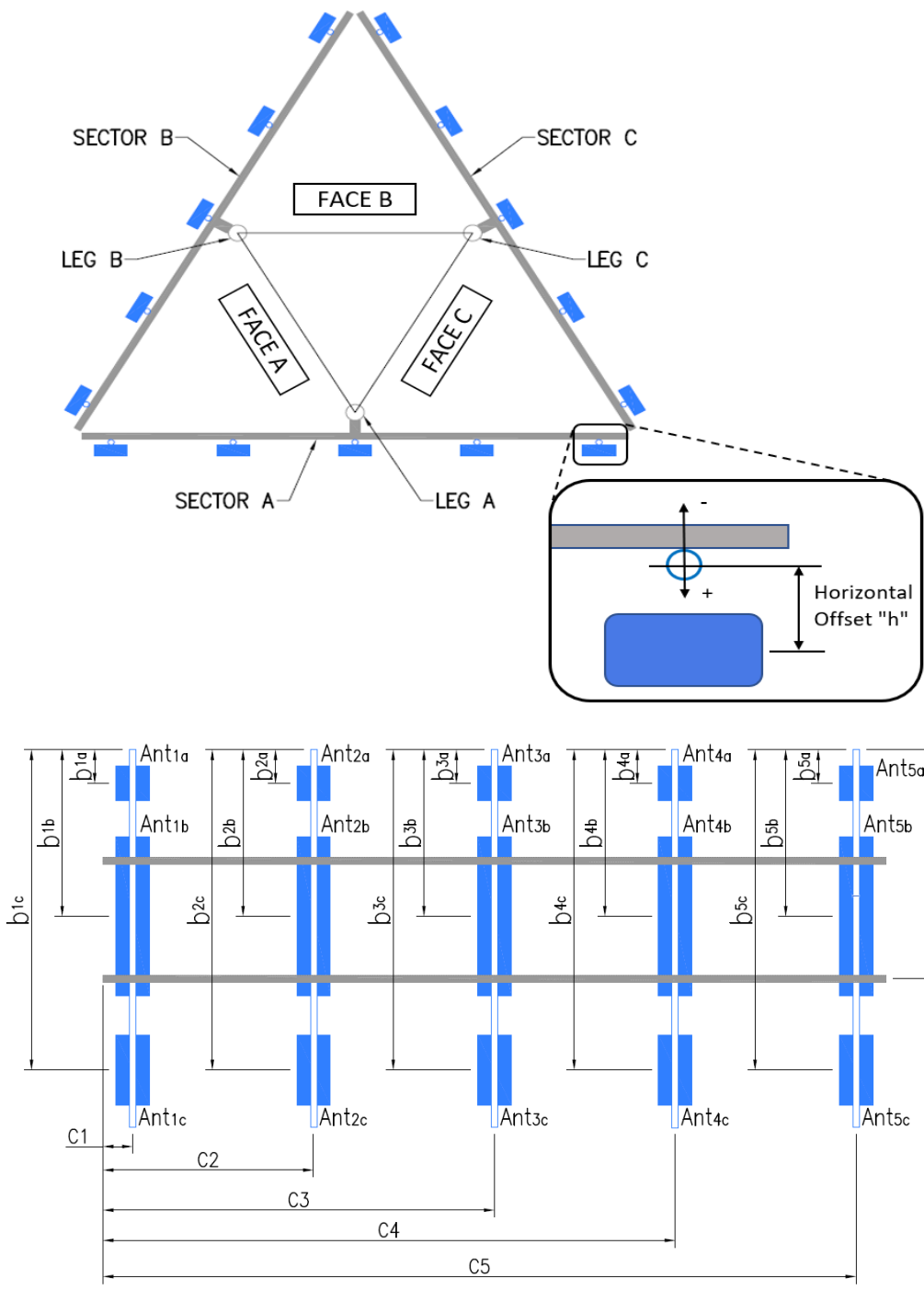

**Antenna Layout (Looking Out From Tower)**

Mount Azimuth (Degree) for Each Sector			Tower Leg Azimuth (Degree) for Each Sector			Sector B										
Sector A:	50.00	Deg	Leg A:	50.00	Deg	Ant <sub>1a</sub>	RT4401-48A	12.00	8.25	12.00		152.942	22.00	-8.25		19,416
Sector B:	170.00	Deg	Leg B:	170.00	Deg	Ant <sub>1b</sub>										
Sector C:	290.00	Deg	Leg C:	290.00	Deg	Ant <sub>1c</sub>										
Sector D:		Deg	Leg D:		Deg	Ant <sub>2a</sub>	CBC78T-DS-43-2X	9.50	6.25	6.75		152.879	24.00	-6.50		19,416
<b>Climbing Facility Information</b>						Ant <sub>2b</sub>	(2) JAHH-65B-R3B	13.75	8.25	72.00		152.108	33.25	12.00	170.00	19,416
Location:	50.00	Deg	Sector A			Ant <sub>2c</sub>	RFV01U-D1A	15.00	10.00	15.00		152.025	34.25	-8.50		19,416
Climbing Facility	Corrosion Type:		N/A			Ant <sub>3a</sub>	RFV01U-D2A	15.00	8.00	15.00		152.088	31.25	-7.75		19,416
	Access:		Climbing path was unobstructed.			Ant <sub>3b</sub>										
	Condition:		Good condition.			Ant <sub>3c</sub>										

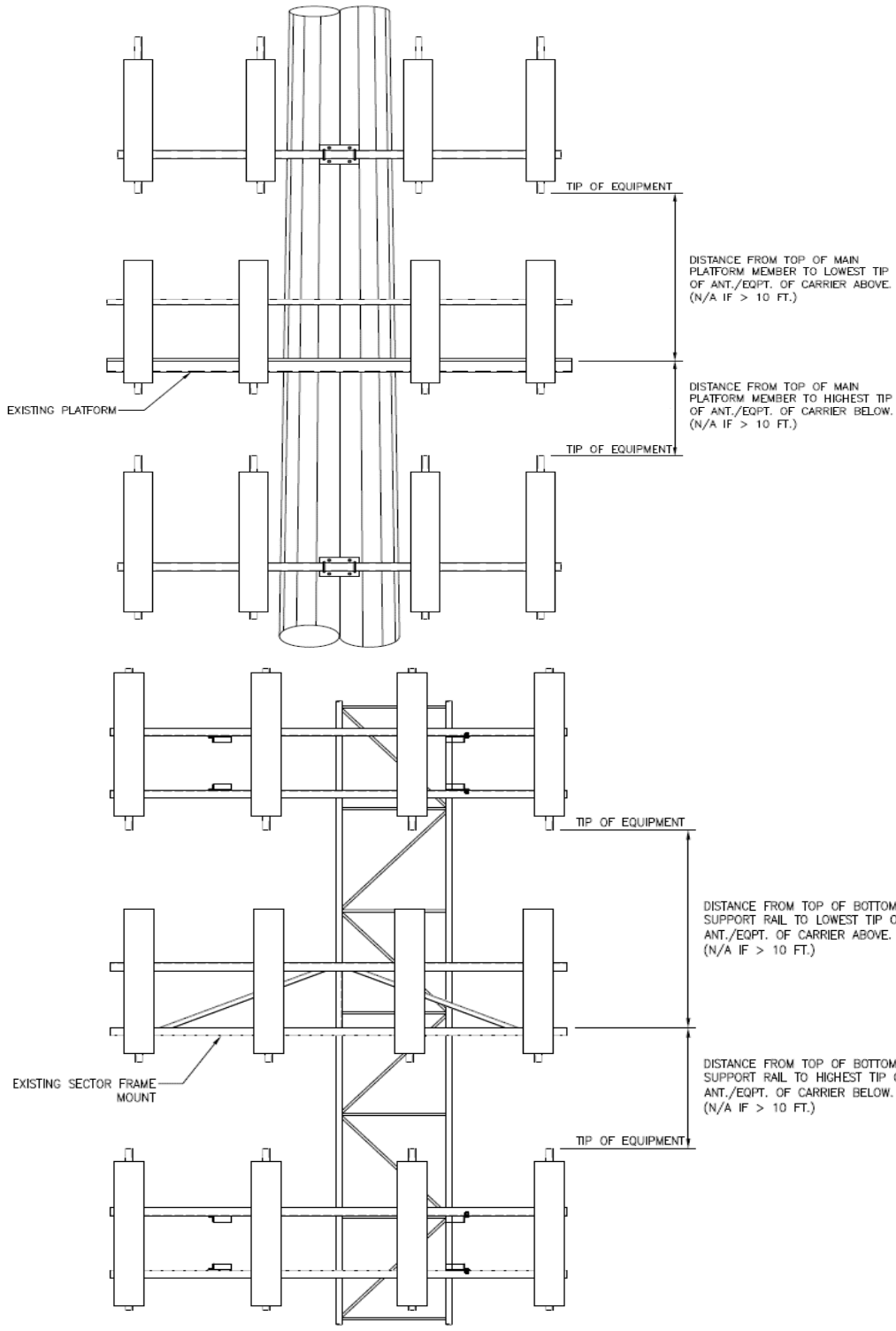

Ant <sub>4a</sub>																
Ant <sub>4b</sub>	BXA-80063-6BF-EDIN	11.25	5.25	68.00		152.025	33.00	10.25	170.00		19,416					
Ant <sub>4c</sub>																
Ant <sub>5a</sub>																
Ant <sub>5b</sub>																
Ant <sub>5c</sub>																
Ant on Standoff	RC3DC-3315-PF-48	15.00	10.00	28.00			30.00	8.00			422					
Ant on Standoff																
Ant on Tower																
Ant on Tower																

Sector C																
Ant <sub>1a</sub>	RT4401-48A	12.00	8.25	12.00		152.942	22.00	-8.25			25					
Ant <sub>1b</sub>																
Ant <sub>1c</sub>																
Ant <sub>2a</sub>	CBC78T-DS-43-2X	9.50	6.25	6.75		152.879	24.00	-6.50			25					
Ant <sub>2b</sub>	(2) JAHH-65B-R3B	13.75	8.25	72.00		152.108	33.25	12.00	290.00		25					
Ant <sub>2c</sub>	RFV01U-D1A	15.00	10.00	15.00		152.025	34.25	-8.50			25					
Ant <sub>3a</sub>	RFV01U-D2A	15.00	8.00	15.00		152.088	31.25	-7.75			25					
Ant <sub>3b</sub>																
Ant <sub>3c</sub>																
Ant <sub>4a</sub>																
Ant <sub>4b</sub>	BXA-80063-6BF-EDIN	11.25	5.25	68.00		152.025	33.00	10.25	290.00		25					
Ant <sub>4c</sub>																
Ant <sub>5a</sub>																
Ant <sub>5b</sub>																
Ant <sub>5c</sub>																
Ant on Standoff																
Ant on Standoff																
Ant on Tower																
Ant on Tower																

Sector D																
Ant <sub>1a</sub>																
Ant <sub>1b</sub>																
Ant <sub>1c</sub>																
Ant <sub>2a</sub>																
Ant <sub>2b</sub>																
Ant <sub>2c</sub>																
Ant <sub>3a</sub>																
Ant <sub>3b</sub>																
Ant <sub>3c</sub>																
Ant <sub>4a</sub>																
Ant <sub>4b</sub>																
Ant <sub>4c</sub>																
Ant <sub>5a</sub>																
Ant <sub>5b</sub>																
Ant <sub>5c</sub>																
Ant on Standoff																
Ant on Standoff																
Ant on Tower																
Ant on Tower																

**Observed Safety and Structural Issues During the Mount Mapping**

Issue #	Description of Issue	Photo #
---------	----------------------	---------

1	TOTAL COAX(9):(3)1.5"Ø HYBRID, (6) FH 1 5/8	76
2		
3		
4		
5		
6		
7		
8		

**Mapping Notes**

1. Please report any visible structural or safety issues observed on the antenna mounts (Damaged members, loose connections, tilting mounts, safety climb issues, etc.)
2. If the thickness of the existing pipes or tubing can't be obtained from a general tool (such as Caliper), please use an ultrasonic measurement tool (thickness gauge) to measure the thickness.
3. Please create all required detail sketches of the mounts and insert them into the "Sketches" tab.
4. Please measure and enter the bolt sizes and types under the Members Box in the spreadsheet of the mount type.
5. Take and label the photos of the tower, mounts, connections, antennas and all measurements. Minimum 50 photos are required.
6. Please measure and report the size and length of all existing antenna mounting pipes.
7. Please measure and report the antenna information for all sectors.
8. Don't delete or rearrange any sheet or contents of any sheet from this mapping form.

**Standard Conditions**

1. Obvious safety and structural issues/deficiencies noticed at the time of the mount mapping are to be reported in this mapping. However, this mount mapping is not a condition assessment of the mount.





### Antenna Mount Mapping Form (PATENT PENDING)

FCC #

1203184

Tower Owner:	ATC	Mapping Date:	4/2/2021
Site Name:	ATC: Tartaglia VZW: N Bridgeport CT	Tower Type:	Self Support
Site Number or ID:	ATC:383598, VZW:467325	Tower Height (Ft.):	UNKNOWN
Mapping Contractor:	RKS Design & Engineering LLC.	Mount Elevation (Ft.):	150.9

This antenna mapping form is the property of TES and under **PATENT PENDING**. The formation contained herein is considered confidential in nature and is to be used only for the specific customer it was intended for. Reproduction, transmission, publication, modification or disclosure by any method is prohibited except by express written permission of TES. All means and methods are the responsibility of the contractor and the work shall be compliant with ANSI/ASSE A 10.48, OSHA, FCC, FAA and other safety requirements that may apply. TES is not warranting the usability of the safety climb as it must be assessed prior to each use in compliance with OSHA requirements.

Please Insert Sketches of the Antenna Mount

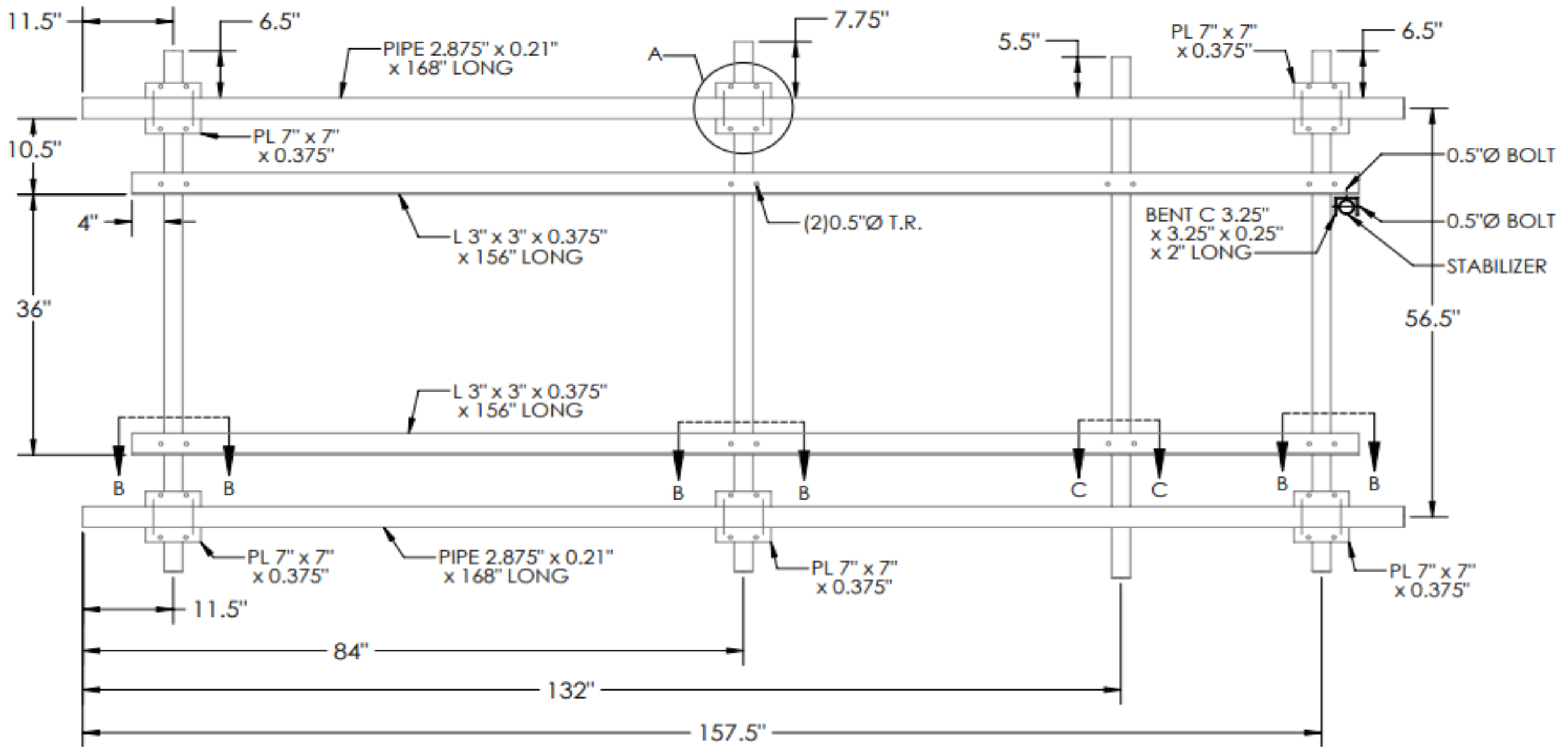

SECTOR A & C

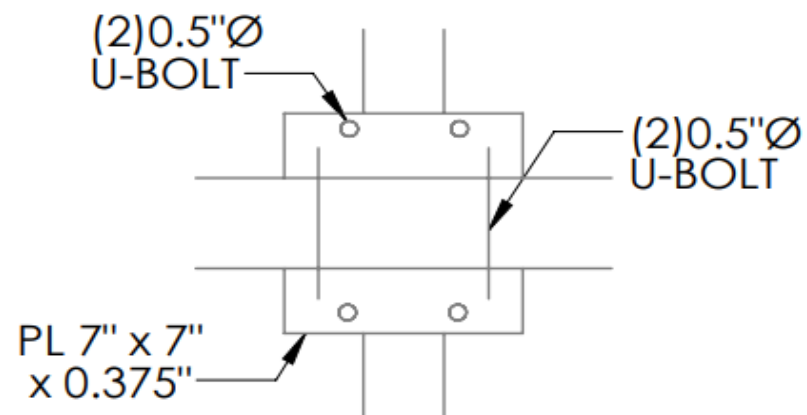

DETAIL A

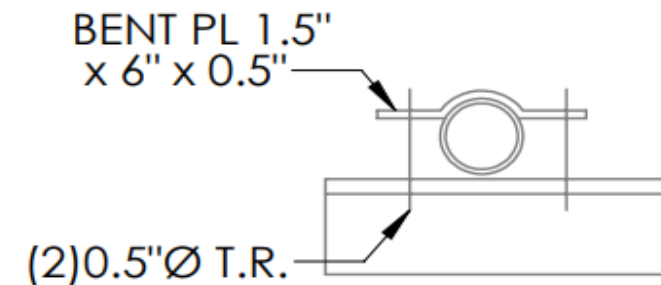

SECTION B-B

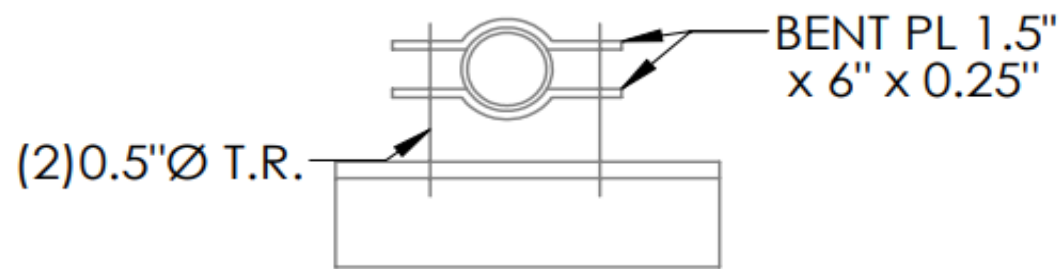

SECTION C-C



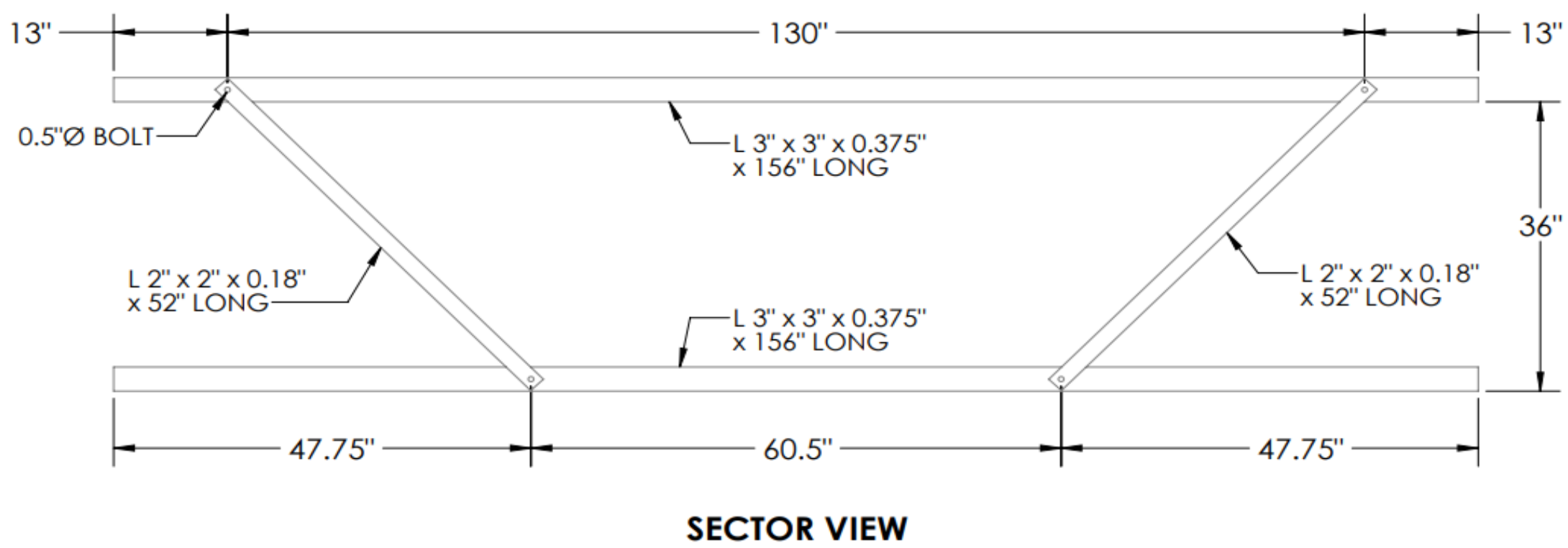
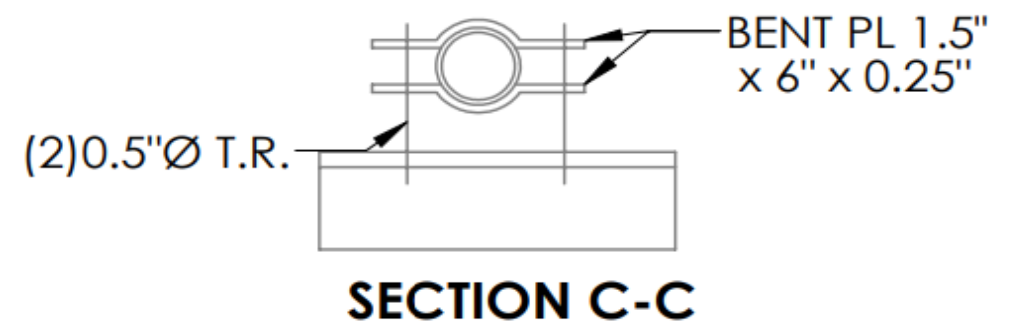
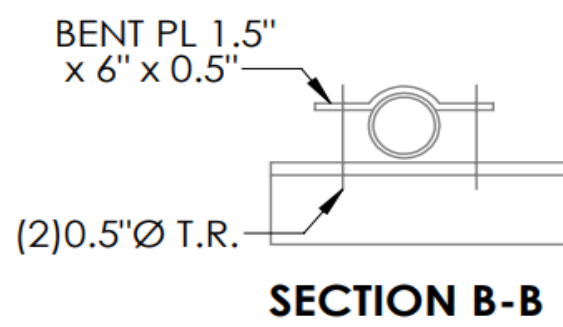
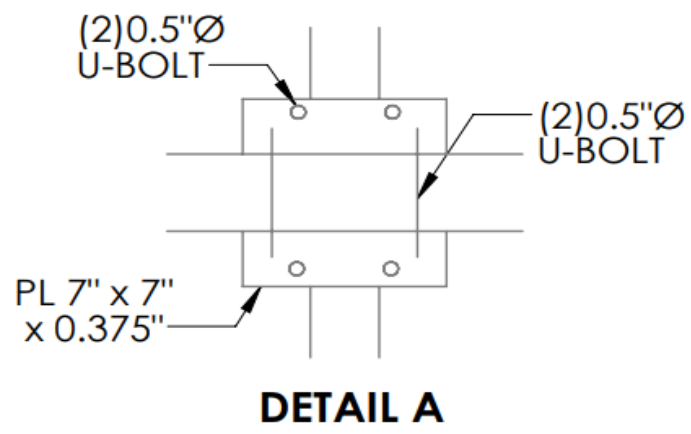
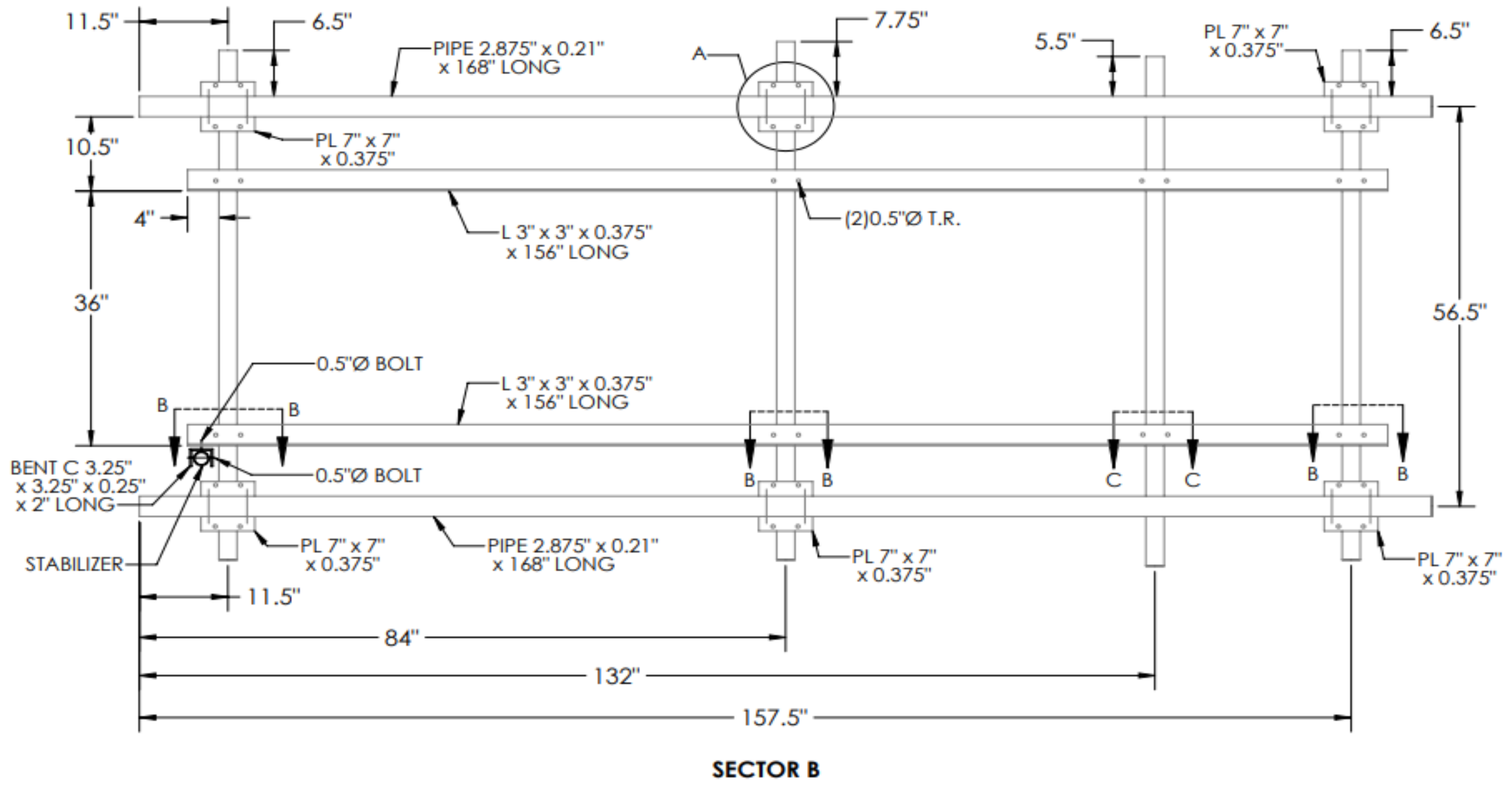



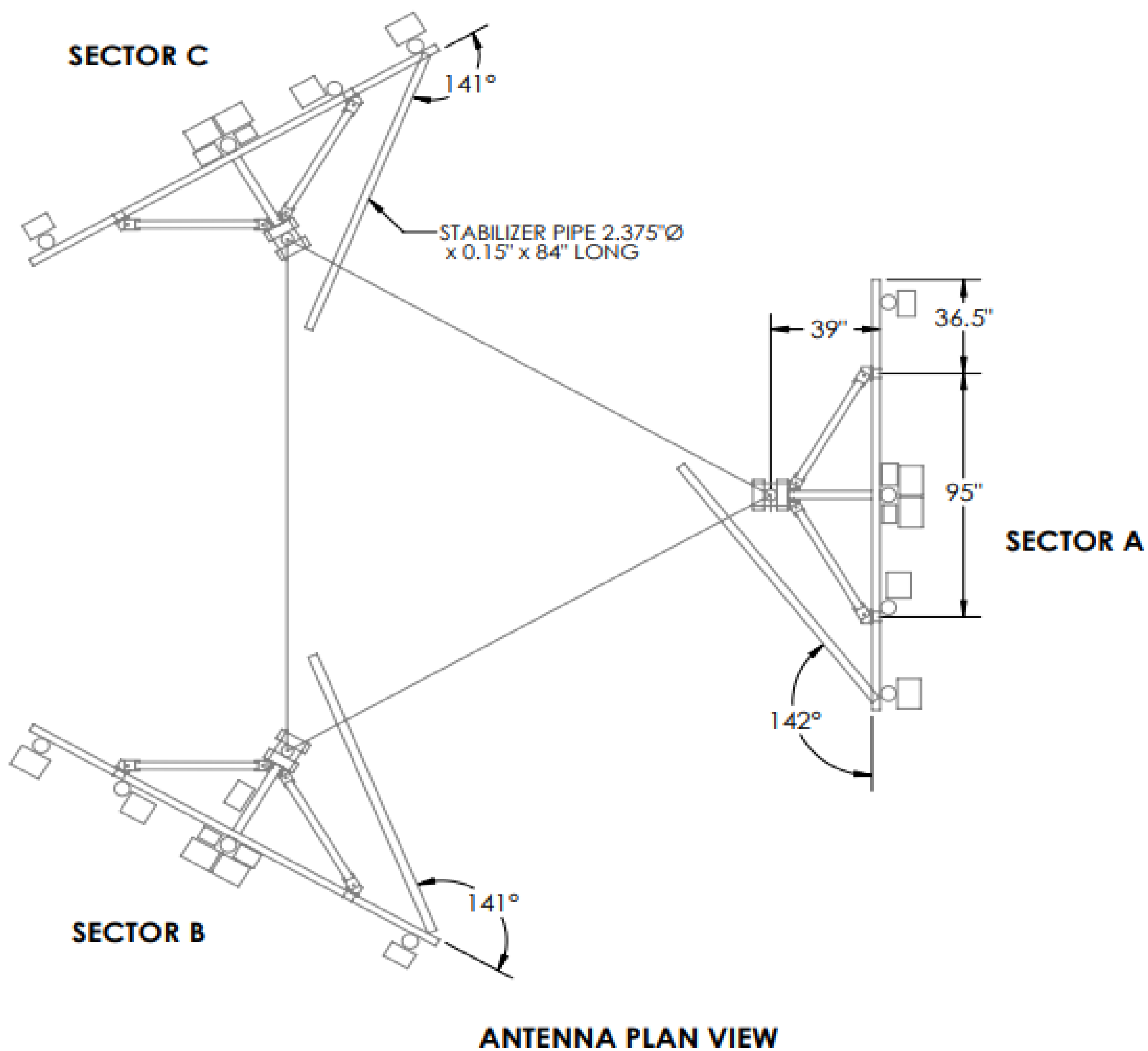

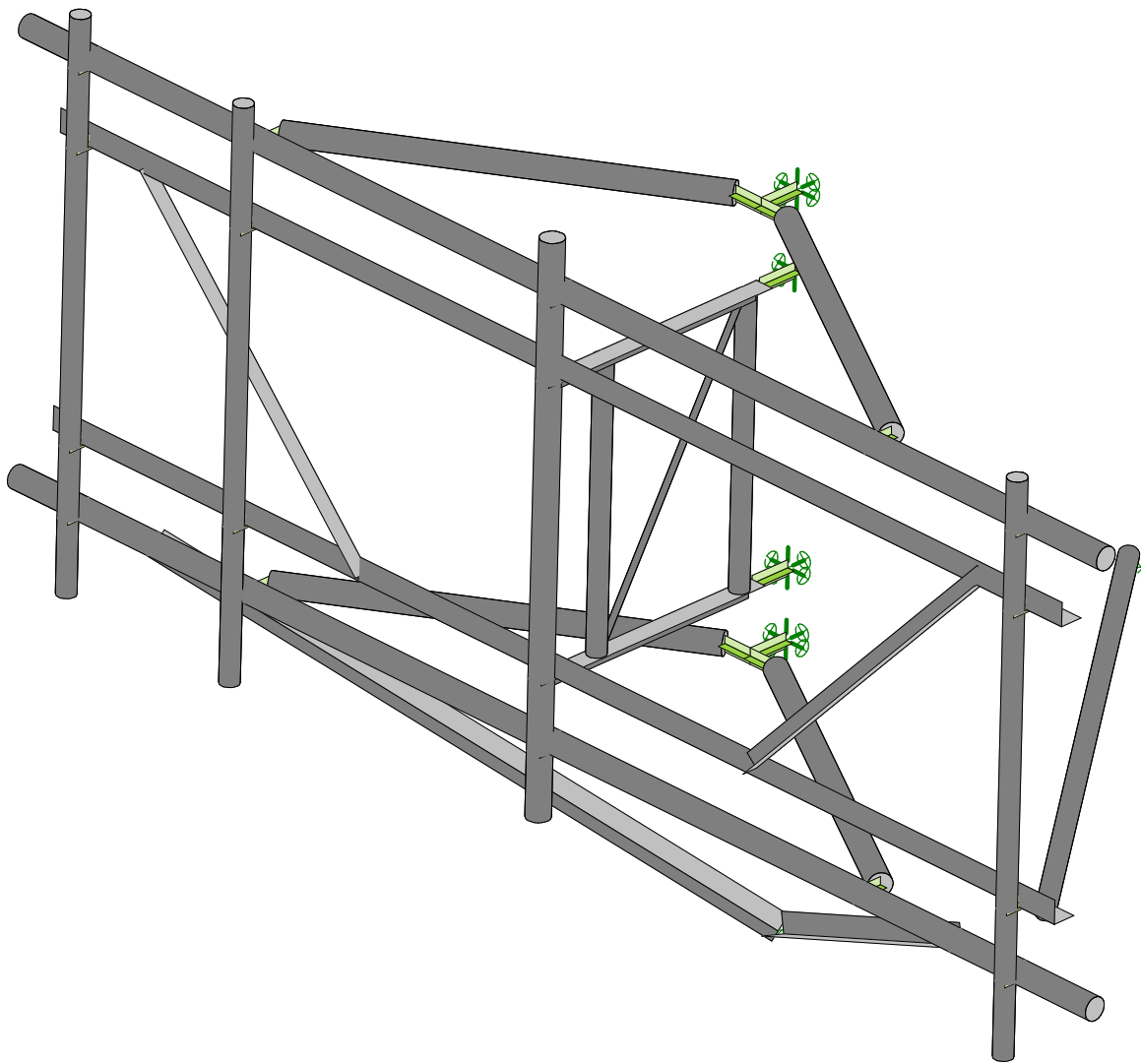
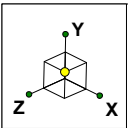

Envelope Only Solution

SK - 4

June 10, 2021 at 8:12 AM

FINAL\_467325-VZW\_MT\_LOT\_B\_...

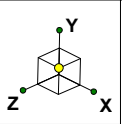

Code Check ( Env )	
Black	No Calc
Red	> 1.0
Pink	.90-1.0
Green	.75-.90
Cyan	.50-.75
Blue	0-.50

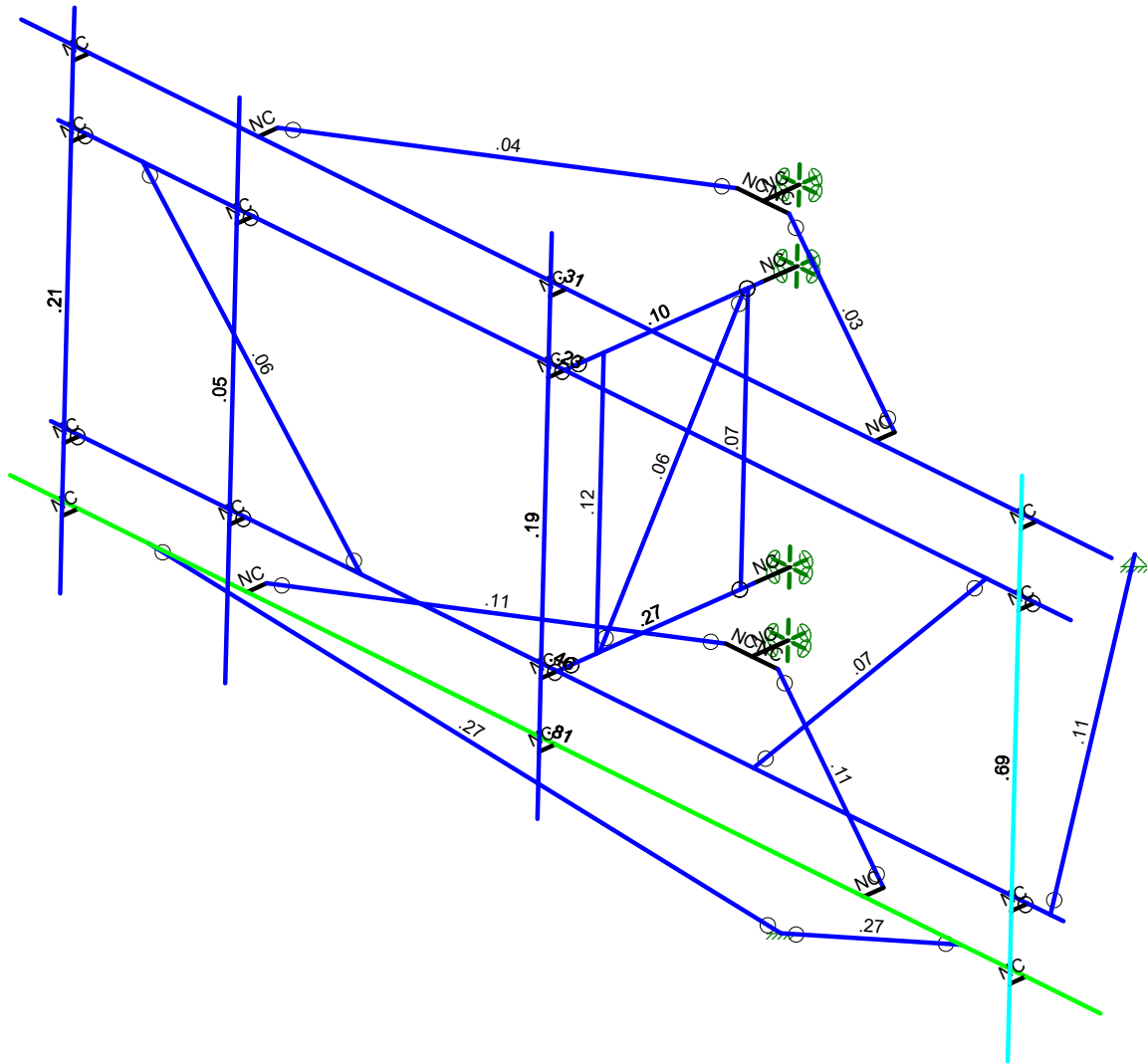

Member Code Checks Displayed (Enveloped)  
Envelope Only Solution

		SK - 5
		June 10, 2021 at 8:12 AM
		FINAL_467325-VZW_MT_LOT_B_...

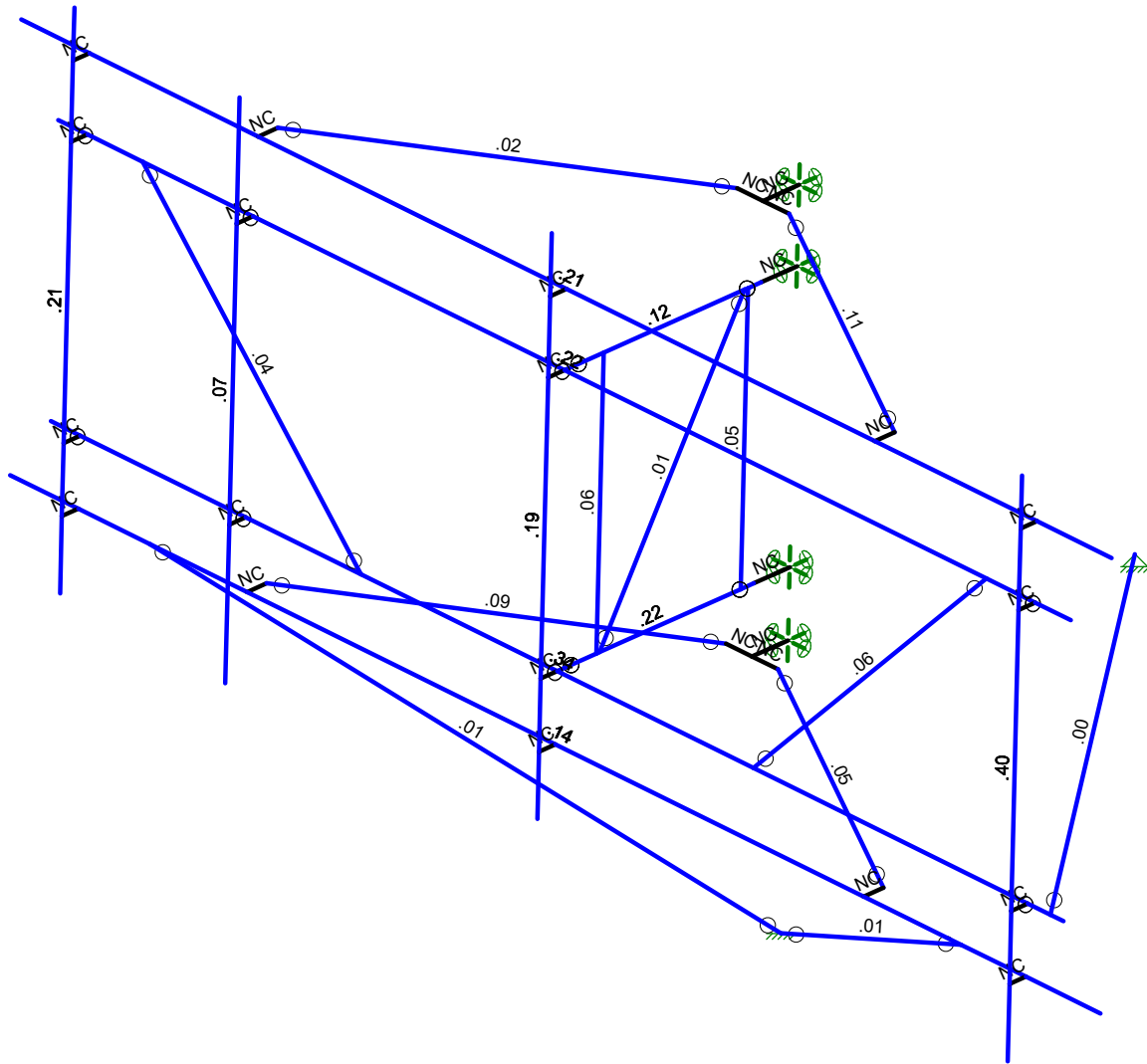
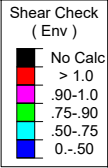
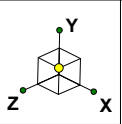

Member Shear Checks Displayed (Enveloped)  
Envelope Only Solution

SK - 6

June 10, 2021 at 8:12 AM

FINAL\_467325-VZW\_MT\_LOT\_B\_...

### Basic Load Cases

	BLC Description	Category	X Gravity	Y Gravity	Z Gravity	Joint	Point	Distributed Area(Me...	Surface(P...
1	Antenna D	None					39		
2	Antenna Di	None					39		
3	Antenna Wo (0 Deg)	None					39		
4	Antenna Wo (30 Deg)	None					39		
5	Antenna Wo (60 Deg)	None					39		
6	Antenna Wo (90 Deg)	None					39		
7	Antenna Wo (120 Deg)	None					39		
8	Antenna Wo (150 Deg)	None					39		
9	Antenna Wo (180 Deg)	None					39		
10	Antenna Wo (210 Deg)	None					39		
11	Antenna Wo (240 Deg)	None					39		
12	Antenna Wo (270 Deg)	None					39		
13	Antenna Wo (300 Deg)	None					39		
14	Antenna Wo (330 Deg)	None					39		
15	Antenna Wi (0 Deg)	None					39		
16	Antenna Wi (30 Deg)	None					39		
17	Antenna Wi (60 Deg)	None					39		
18	Antenna Wi (90 Deg)	None					39		
19	Antenna Wi (120 Deg)	None					39		
20	Antenna Wi (150 Deg)	None					39		
21	Antenna Wi (180 Deg)	None					39		
22	Antenna Wi (210 Deg)	None					39		
23	Antenna Wi (240 Deg)	None					39		
24	Antenna Wi (270 Deg)	None					39		
25	Antenna Wi (300 Deg)	None					39		
26	Antenna Wi (330 Deg)	None					39		
27	Antenna Wm (0 Deg)	None					39		
28	Antenna Wm (30 Deg)	None					39		
29	Antenna Wm (60 Deg)	None					39		
30	Antenna Wm (90 Deg)	None					39		
31	Antenna Wm (120 Deg)	None					39		
32	Antenna Wm (150 Deg)	None					39		
33	Antenna Wm (180 Deg)	None					39		
34	Antenna Wm (210 Deg)	None					39		
35	Antenna Wm (240 Deg)	None					39		
36	Antenna Wm (270 Deg)	None					39		
37	Antenna Wm (300 Deg)	None					39		
38	Antenna Wm (330 Deg)	None					39		
39	Structure D	None		-1					
40	Structure Di	None						22	
41	Structure Wo (0 Deg)	None						44	
42	Structure Wo (30 Deg)	None						44	
43	Structure Wo (60 Deg)	None						44	
44	Structure Wo (90 Deg)	None						44	
45	Structure Wo (120 D...	None						44	
46	Structure Wo (150 D...	None						44	
47	Structure Wo (180 D...	None						44	
48	Structure Wo (210 D...	None						44	
49	Structure Wo (240 D...	None						44	
50	Structure Wo (270 D...	None						44	
51	Structure Wo (300 D...	None						44	
52	Structure Wo (330 D...	None						44	
53	Structure Wi (0 Deg)	None						44	
54	Structure Wi (30 Deg)	None						44	
55	Structure Wi (60 Deg)	None						44	
56	Structure Wi (90 Deg)	None						44	



Company :  
 Designer :  
 Job Number :  
 Model Name :

June 10, 2021  
 8:10 AM  
 Checked By: \_\_\_\_\_

**Basic Load Cases (Continued)**

	BLC Description	Category	X Gravity	Y Gravity	Z Gravity	Joint	Point	Distributed Area(Me...	Surface(P...
57	Structure Wi (120 De..	None						44	
58	Structure Wi (150 De..	None						44	
59	Structure Wi (180 De..	None						44	
60	Structure Wi (210 De..	None						44	
61	Structure Wi (240 De..	None						44	
62	Structure Wi (270 De..	None						44	
63	Structure Wi (300 De..	None						44	
64	Structure Wi (330 De..	None						44	
65	Structure Wm (0 Deg)	None						44	
66	Structure Wm (30 De..	None						44	
67	Structure Wm (60 De..	None						44	
68	Structure Wm (90 De..	None						44	
69	Structure Wm (120 D..	None						44	
70	Structure Wm (150 D..	None						44	
71	Structure Wm (180 D..	None						44	
72	Structure Wm (210 D..	None						44	
73	Structure Wm (240 D..	None						44	
74	Structure Wm (270 D..	None						44	
75	Structure Wm (300 D..	None						44	
76	Structure Wm (330 D..	None						44	
77	Lm1	None					1		
78	Lm2	None					1		
79	Lv1	None					1		
80	Lv2	None					1		

**Load Combinations**

	Description	Solve	P...	S...	B...	Fa...	B...	Fa...	B...	Fa...	B...	Fa...	B...	Fa...	B...	Fa...	B...	Fa...	B...	Fa...	B...	Fa...	
1	1.2D+1.0Wo (0 Deg)	Yes	Y	1	1.2	39	1.2	3	1	41	1												
2	1.2D+1.0Wo (30 Deg)	Yes	Y	1	1.2	39	1.2	4	1	42	1												
3	1.2D+1.0Wo (60 Deg)	Yes	Y	1	1.2	39	1.2	5	1	43	1												
4	1.2D+1.0Wo (90 Deg)	Yes	Y	1	1.2	39	1.2	6	1	44	1												
5	1.2D+1.0Wo (120 Deg)	Yes	Y	1	1.2	39	1.2	7	1	45	1												
6	1.2D+1.0Wo (150 Deg)	Yes	Y	1	1.2	39	1.2	8	1	46	1												
7	1.2D+1.0Wo (180 Deg)	Yes	Y	1	1.2	39	1.2	9	1	47	1												
8	1.2D+1.0Wo (210 Deg)	Yes	Y	1	1.2	39	1.2	10	1	48	1												
9	1.2D+1.0Wo (240 Deg)	Yes	Y	1	1.2	39	1.2	11	1	49	1												
10	1.2D+1.0Wo (270 Deg)	Yes	Y	1	1.2	39	1.2	12	1	50	1												
11	1.2D+1.0Wo (300 Deg)	Yes	Y	1	1.2	39	1.2	13	1	51	1												
12	1.2D+1.0Wo (330 Deg)	Yes	Y	1	1.2	39	1.2	14	1	52	1												
13	1.2D + 1.0Di + 1.0Wi (0 Deg)	Yes	Y	1	1.2	39	1.2	2	1	40	1	15	1	53	1								
14	1.2D + 1.0Di + 1.0Wi (30 De..	Yes	Y	1	1.2	39	1.2	2	1	40	1	16	1	54	1								
15	1.2D + 1.0Di + 1.0Wi (60 De..	Yes	Y	1	1.2	39	1.2	2	1	40	1	17	1	55	1								
16	1.2D + 1.0Di + 1.0Wi (90 De..	Yes	Y	1	1.2	39	1.2	2	1	40	1	18	1	56	1								
17	1.2D + 1.0Di + 1.0Wi (120 D..	Yes	Y	1	1.2	39	1.2	2	1	40	1	19	1	57	1								
18	1.2D + 1.0Di + 1.0Wi (150 D..	Yes	Y	1	1.2	39	1.2	2	1	40	1	20	1	58	1								
19	1.2D + 1.0Di + 1.0Wi (180 D..	Yes	Y	1	1.2	39	1.2	2	1	40	1	21	1	59	1								
20	1.2D + 1.0Di + 1.0Wi (210 D..	Yes	Y	1	1.2	39	1.2	2	1	40	1	22	1	60	1								
21	1.2D + 1.0Di + 1.0Wi (240 D..	Yes	Y	1	1.2	39	1.2	2	1	40	1	23	1	61	1								
22	1.2D + 1.0Di + 1.0Wi (270 D..	Yes	Y	1	1.2	39	1.2	2	1	40	1	24	1	62	1								
23	1.2D + 1.0Di + 1.0Wi (300 D..	Yes	Y	1	1.2	39	1.2	2	1	40	1	25	1	63	1								
24	1.2D + 1.0Di + 1.0Wi (330 D..	Yes	Y	1	1.2	39	1.2	2	1	40	1	26	1	64	1								
25	1.2D + 1.5Lm1 + 1.0Wm (0 ...	Yes	Y	1	1.2	39	1.2	77	1.5	27	1	65	1										
26	1.2D + 1.5Lm1 + 1.0Wm (30...	Yes	Y	1	1.2	39	1.2	77	1.5	28	1	66	1										
27	1.2D + 1.5Lm1 + 1.0Wm (60...	Yes	Y	1	1.2	39	1.2	77	1.5	29	1	67	1										
28	1.2D + 1.5Lm1 + 1.0Wm (90...	Yes	Y	1	1.2	39	1.2	77	1.5	30	1	68	1										







Company :  
 Designer :  
 Job Number :  
 Model Name :

June 10, 2021  
 8:10 AM  
 Checked By: \_\_\_\_\_

**Joint Coordinates and Temperatures (Continued)**

	Label	X [ft]	Y [ft]	Z [ft]	Temp [F]	Detach From Diap...
17	N17	6.125	1.583333	4.996803	0	
18	N18	6.125	1.583333	5.205137	0	
19	N19	6.125	-1.5	4.996803	0	
20	N20	6.125	-1.5	5.205137	0	
21	N21	6.125	2.958333	5.205137	0	
22	N22	6.125	-3.041667	5.205137	0	
23	N23	-5.333333	1.583333	4.996803	0	
24	N24	5.5	1.583333	4.996803	0	
25	N25	-2.4375	-1.5	4.996803	0	
26	N26	2.604166	-1.5	4.996803	0	
27	N27	-6.916666	2.416667	4.996803	0	
28	N28	7.083333	2.416667	4.996803	0	
29	N29	6.125	2.416667	4.996803	0	
30	N30	6.125	2.416667	5.205137	0	
31	N31	-6.916666	-2.25	4.996803	0	
32	N32	7.083333	-2.25	4.996803	0	
33	N33	6.125	-2.25	4.996803	0	
34	N34	6.125	-2.25	5.205137	0	
35	N35	0.083333	1.583333	4.996803	0	
36	N36	0.083333	-1.5	4.996803	0	
37	N37	0.083333	1.583333	2.4968	0	
38	N38	0.083333	-1.5	2.4968	0	
39	N39	0.083333	1.583333	4.496803	0	
40	N40	0.083333	-1.5	4.496803	0	
41	N41	0.083333	1.583333	2.66347	0	
42	N42	0.083333	-1.5	2.66347	0	
43	N43	0.083333	1.583333	2.705137	0	
44	N44	0.083333	-1.5	4.455137	0	
45	N45	0.083333	1.583333	2.038467	0	
46	N46	0.083333	-1.5	2.038467	0	
47	N47	4.041668	2.416667	4.996803	0	
48	N48	-3.875001	2.416667	4.996803	0	
49	N49	4.041668	-2.25	4.996803	0	
50	N50	-3.875001	-2.25	4.996803	0	
51	N51	0.083334	1.583333	5.205137	0	
52	N52	0.083334	-1.5	5.205137	0	
53	N53	0.083334	3.0625	5.205137	0	
54	N54	0.083334	-2.9375	5.205137	0	
55	N59	-3.916666	1.583333	4.996803	0	
56	N60	-3.916666	1.583333	5.205137	0	
57	N61	-3.916666	-1.5	4.996803	0	
58	N62	-3.916666	-1.5	5.205137	0	
59	N63	-3.916666	2.875	5.205137	0	
60	N64	-3.916666	-3.125	5.205137	0	
61	N69	-6.041666	1.583333	4.996803	0	
62	N70	-6.041666	1.583333	5.205137	0	
63	N71	-6.041666	-1.5	4.996803	0	
64	N72	-6.041666	-1.5	5.205137	0	
65	N73	-6.041666	2.958333	5.205137	0	
66	N74	-6.041666	-3.041667	5.205137	0	
67	N75	-6.041666	2.416667	4.996803	0	
68	N76	-6.041666	2.416667	5.205137	0	
69	N77	-6.041666	-2.25	4.996803	0	
70	N78	-6.041666	-2.25	5.205137	0	
71	N79	6.416666	-1.5	4.996803	0	
72	N80	2.011424	-1.5	-0.443218	0	
73	N73A	0.083333	-5.25	2.038467	0	



Company :  
 Designer :  
 Job Number :  
 Model Name :

June 10, 2021  
 8:10 AM  
 Checked By: \_\_\_\_\_

### Joint Coordinates and Temperatures (Continued)

	Label	X [ft]	Y [ft]	Z [ft]	Temp [F]	Detach From Diap...
74	N74A	-5.125001	-2.25	4.996803	0	
75	N75A	5.291668	-2.25	4.996803	0	
76	N80A	0.083334	2.416667	4.996803	0	
77	N81	0.083334	2.416667	5.205137	0	
78	N82	0.083334	-2.25	4.996803	0	
79	N83	0.083334	-2.25	5.205137	0	

### Hot Rolled Steel Section Sets

	Label	Shape	Type	Design List	Material	Design ...	A [in2]	Iyy [in4]	Izz [in4]	J [in4]
1	Dual Mount Pipe	PIPE 2.5	Column	Pipe	A53 Gr. B	Typical	1.61	1.45	1.45	2.89
2	Mount Pipe	PIPE 2.0	Column	Pipe	A53 Gr. B	Typical	1.02	.627	.627	1.25
3	Connection Angle	L2.5x2.5x4	Beam	Single Angle	A36 Gr.36	Typical	1.19	.692	.692	.026
4	Standoff Plate	PL3/8x5	Beam	RECT	A36 Gr.36	Typical	1.875	.022	3.906	.084
5	Pipe Standoff Horiz...	PIPE 2.5	Beam	Pipe	A53 Gr. B	Typical	1.61	1.45	1.45	2.89
6	Standoff Vertical	PIPE 2.0	Column	Pipe	A53 Gr. B	Typical	1.02	.627	.627	1.25
7	Standoff Horizontal	L2.5x2.5x6	Beam	Single Angle	A36 Gr.36	Typical	1.73	.972	.972	.083
8	Standoff Diagonal	SR 0.75	Column	BAR	A36 Gr.36	Typical	.442	.016	.016	.031
9	Face Diagonal	L2x2x3	Column	Single Angle	A36 Gr.36	Typical	.722	.271	.271	.009
10	Face Horizontal	L3X3X4	Beam	Single Angle	A36 Gr.36	Typical	1.44	1.23	1.23	.031
11	Tieback	PIPE 2.0	Beam	Pipe	A53 Gr. B	Typical	1.02	.627	.627	1.25
12	Pipe Face Horizontal	PIPE 2.5	Beam	Pipe	A53 Gr. B	Typical	1.61	1.45	1.45	2.89
13	V-Brace	L2.5x2.5x4	Beam	Single Angle	A36 Gr.36	Typical	1.19	.692	.692	.026

### Hot Rolled Steel Properties

	Label	E [ksi]	G [ksi]	Nu	Therm (/1...Density[k/...	Yield[ksi]	Ry	Fu[ksi]	Rt
1	A36 Gr.36	29000	11154	.3	.65 .49	36	1.5	58	1.2
2	A53 Gr. B	29000	11154	.3	.65 .49	35	1.5	60	1.2
3	A572 Gr.50	29000	11154	.3	.65 .49	50	1.1	65	1.1
4	A992	29000	11154	.3	.65 .49	50	1.1	65	1.1
5	A500 Gr. B 42	29000	11154	.3	.65 .49	42	1.4	58	1.3
6	A500 Gr. B 46	29000	11154	.3	.65 .49	46	1.4	58	1.3

### Member Primary Data

	Label	I Joint	J Joint	K Joint	Rotate(deg)	Section/Shape	Type	Design List	Material	Design Rules
1	M2	N2	N1			RIGID	None	None	RIGID	Typical
2	M4	N6	N5			RIGID	None	None	RIGID	Typical
3	M5	N4	N10		180	Pipe Standoff ...	Beam	Pipe	A53 Gr. B	Typical
4	M6	N3	N9		90	Pipe Standoff ...	Beam	Pipe	A53 Gr. B	Typical
5	M7	N7	N11			Pipe Standoff ...	Beam	Pipe	A53 Gr. B	Typical
6	M8	N13	N15		270	Face Horizontal	Beam	Single Angle	A36 Gr.36	Typical
7	M9	N14	N16		270	Face Horizontal	Beam	Single Angle	A36 Gr.36	Typical
8	M10	N23	N25		90	Face Diagonal	Column	Single Angle	A36 Gr.36	Typical
9	M11	N17	N18			RIGID	None	None	RIGID	Typical
10	M12	N19	N20			RIGID	None	None	RIGID	Typical
11	MP1A	N21	N22			Mount Pipe	Column	Pipe	A53 Gr. B	Typical
12	M14	N8	N12		270	Pipe Standoff ...	Beam	Pipe	A53 Gr. B	Typical
13	M15	N24	N26		270	Face Diagonal	Column	Single Angle	A36 Gr.36	Typical
14	M16	N29	N30			RIGID	None	None	RIGID	Typical
15	M17	N27	N28			Pipe Face Hori...	Beam	Pipe	A53 Gr. B	Typical
16	M18	N33	N34			RIGID	None	None	RIGID	Typical
17	M19	N31	N32			Pipe Face Hori...	Beam	Pipe	A53 Gr. B	Typical
18	M20	N35	N37		90	Standoff Horiz...	Beam	Single Angle	A36 Gr.36	Typical



Company :  
 Designer :  
 Job Number :  
 Model Name :

June 10, 2021  
 8:10 AM  
 Checked By: \_\_\_\_\_

**Member Primary Data (Continued)**

	Label	I Joint	J Joint	K Joint	Rotate(deg)	Section/Shape	Type	Design List	Material	Design Rules
19	M21	N36	N38		90	Standoff Horiz...	Beam	Single Angle	A36 Gr.36	Typical
20	M22	N39	N40			Standoff Vertical	Column	Pipe	A53 Gr. B	Typical
21	M23	N41	N42			Standoff Vertical	Column	Pipe	A53 Gr. B	Typical
22	M24	N44	N43			Standoff Diago...	Column	BAR	A36 Gr.36	Typical
23	M25	N37	N45			RIGID	None	None	RIGID	Typical
24	M26	N38	N46			RIGID	None	None	RIGID	Typical
25	M27	N10	N48			RIGID	None	None	RIGID	Typical
26	M28	N12	N50			RIGID	None	None	RIGID	Typical
27	M29	N9	N47			RIGID	None	None	RIGID	Typical
28	M30	N11	N49			RIGID	None	None	RIGID	Typical
29	M31	N35	N51			RIGID	None	None	RIGID	Typical
30	M32	N36	N52			RIGID	None	None	RIGID	Typical
31	MP2A	N53	N54			Dual Mount Pipe	Column	Pipe	A53 Gr. B	Typical
32	M36	N59	N60			RIGID	None	None	RIGID	Typical
33	M37	N61	N62			RIGID	None	None	RIGID	Typical
34	MP3A	N63	N64			Mount Pipe	Column	Pipe	A53 Gr. B	Typical
35	M41	N69	N70			RIGID	None	None	RIGID	Typical
36	M42	N71	N72			RIGID	None	None	RIGID	Typical
37	MP4A	N73	N74			Mount Pipe	Column	Pipe	A53 Gr. B	Typical
38	M44	N75	N76			RIGID	None	None	RIGID	Typical
39	M45	N77	N78			RIGID	None	None	RIGID	Typical
40	M46	N79	N80			Tieback	Beam	Pipe	A53 Gr. B	Typical
41	M45A	N8	N6			RIGID	None	None	RIGID	Typical
42	M46A	N7	N6			RIGID	None	None	RIGID	Typical
43	M47	N3	N2			RIGID	None	None	RIGID	Typical
44	M48	N4	N2			RIGID	None	None	RIGID	Typical
45	M45B	N74A	N73A			V-Brace	Beam	Single Angle	A36 Gr.36	Typical
46	M46B	N75A	N73A		270	V-Brace	Beam	Single Angle	A36 Gr.36	Typical
47	M49	N80A	N81			RIGID	None	None	RIGID	Typical
48	M50	N82	N83			RIGID	None	None	RIGID	Typical

**Hot Rolled Steel Design Parameters**

	Label	Shape	Length[ft]	Lbyy[ft]	Lbzz[ft]	Lcomp top[ft]	Lcomp bot[ft]	L-torqu...	Kyy	Kzz	Cb	Function
1	M5	Pipe Stando...	4.267			Lbyy						Lateral
2	M6	Pipe Stando...	4.267			Lbyy						Lateral
3	M7	Pipe Stando...	4.267			Lbyy						Lateral
4	M8	Face Horizo...	13	7	2.5	Lbyy						Lateral
5	M9	Face Horizo...	13	2.5	7	Lbyy						Lateral
6	M10	Face Diago...	4.23			Lbyy			.7	.7		Lateral
7	MP1A	Mount Pipe	6			Lbyy						Lateral
8	M14	Pipe Stando...	4.267			Lbyy						Lateral
9	M15	Face Diago...	4.23			Lbyy			.7	.7		Lateral
10	M17	Pipe Face ...	14			Lbyy						Lateral
11	M19	Pipe Face ...	14			Lbyy						Lateral
12	M20	Standoff Ho...	2.5			Lbyy						Lateral
13	M21	Standoff Ho...	2.5			Lbyy						Lateral
14	M22	Standoff Ve...	3.083						.7	.7		Lateral
15	M23	Standoff Ve...	3.083						.7	.7		Lateral
16	M24	Standoff Di...	3.545						.7	.7		Lateral
17	MP2A	Dual Mount ...	6			Lbyy						Lateral
18	MP3A	Mount Pipe	6			Lbyy						Lateral
19	MP4A	Mount Pipe	6			Lbyy						Lateral
20	M46	Tieback	7			Lbyy						Lateral
21	M45B	V-Brace	6.699			Lbyy						Lateral
22	M46B	V-Brace	6.699			Lbyy						Lateral

**Member Point Loads (BLC 1 : Antenna D)**

	Member Label	Direction	Magnitude[lb.k-ft]	Location[ft,%]
1	MP1A	Y	-23.2	1.5
2	MP1A	My	-.015	1.5
3	MP1A	Mz	0	1.5
4	MP3A	Y	-43.55	1
5	MP3A	My	-.029	1
6	MP3A	Mz	0	1
7	MP3A	Y	-43.55	3
8	MP3A	My	-.029	3
9	MP3A	Mz	0	3
10	MP4A	Y	-9.6	.5
11	MP4A	My	-.006	.5
12	MP4A	Mz	0	.5
13	MP4A	Y	-9.6	4.5
14	MP4A	My	-.006	4.5
15	MP4A	Mz	0	4.5
16	MP2A	Y	-31.65	.5
17	MP2A	My	-.021	.5
18	MP2A	Mz	-.018	.5
19	MP2A	Y	-31.65	4.5
20	MP2A	My	-.021	4.5
21	MP2A	Mz	-.018	4.5
22	MP2A	Y	-31.65	.5
23	MP2A	My	-.021	.5
24	MP2A	Mz	.018	.5
25	MP2A	Y	-31.65	4.5
26	MP2A	My	-.021	4.5
27	MP2A	Mz	.018	4.5
28	M22	Y	-10.4	.5
29	M22	My	0	.5
30	M22	Mz	0	.5
31	M22	Y	-84.4	2.5
32	M22	My	0	2.5
33	M22	Mz	0	2.5
34	MP1A	Y	-70.3	3.5
35	MP1A	My	.035	3.5
36	MP1A	Mz	0	3.5
37	M23	Y	-32	1.5
38	M23	My	0	1.5
39	M23	Mz	0	1.5

**Member Point Loads (BLC 2 : Antenna Di)**

	Member Label	Direction	Magnitude[lb.k-ft]	Location[ft,%]
1	MP1A	Y	-30.24	1.5
2	MP1A	My	-.02	1.5
3	MP1A	Mz	0	1.5
4	MP3A	Y	-36.042	1
5	MP3A	My	-.024	1
6	MP3A	Mz	0	1
7	MP3A	Y	-36.042	3
8	MP3A	My	-.024	3
9	MP3A	Mz	0	3
10	MP4A	Y	-51.034	.5
11	MP4A	My	-.034	.5
12	MP4A	Mz	0	.5
13	MP4A	Y	-51.034	4.5







Company :  
 Designer :  
 Job Number :  
 Model Name :

June 10, 2021  
 8:10 AM  
 Checked By: \_\_\_\_\_

**Member Point Loads (BLC 3 : Antenna Wo (0 Deg)) (Continued)**

	Member Label	Direction	Magnitude[lb.k-ft]	Location[ft,%]
28	M22	X	0	.5
29	M22	Z	-14.562	.5
30	M22	Mx	0	.5
31	M22	X	0	2.5
32	M22	Z	-73.132	2.5
33	M22	Mx	0	2.5
34	MP1A	X	0	3.5
35	MP1A	Z	-79.742	3.5
36	MP1A	Mx	0	3.5
37	M23	X	0	1.5
38	M23	Z	-117.312	1.5
39	M23	Mx	0	1.5

**Member Point Loads (BLC 4 : Antenna Wo (30 Deg))**

	Member Label	Direction	Magnitude[lb.k-ft]	Location[ft,%]
1	MP1A	X	28.489	1.5
2	MP1A	Z	-49.345	1.5
3	MP1A	Mx	-.019	1.5
4	MP3A	X	42.483	1
5	MP3A	Z	-73.583	1
6	MP3A	Mx	-.028	1
7	MP3A	X	42.483	3
8	MP3A	Z	-73.583	3
9	MP3A	Mx	-.028	3
10	MP4A	X	68.801	.5
11	MP4A	Z	-119.168	.5
12	MP4A	Mx	-.046	.5
13	MP4A	X	68.801	4.5
14	MP4A	Z	-119.168	4.5
15	MP4A	Mx	-.046	4.5
16	MP2A	X	88.786	.5
17	MP2A	Z	-153.781	.5
18	MP2A	Mx	.031	.5
19	MP2A	X	88.786	4.5
20	MP2A	Z	-153.781	4.5
21	MP2A	Mx	.031	4.5
22	MP2A	X	88.786	.5
23	MP2A	Z	-153.781	.5
24	MP2A	Mx	-.149	.5
25	MP2A	X	88.786	4.5
26	MP2A	Z	-153.781	4.5
27	MP2A	Mx	-.149	4.5
28	M22	X	7.889	.5
29	M22	Z	-13.664	.5
30	M22	Mx	0	.5
31	M22	X	39.871	2.5
32	M22	Z	-69.059	2.5
33	M22	Mx	0	2.5
34	MP1A	X	35.3	3.5
35	MP1A	Z	-61.142	3.5
36	MP1A	Mx	.018	3.5
37	M23	X	64.177	1.5
38	M23	Z	-111.158	1.5
39	M23	Mx	0	1.5

**Member Point Loads (BLC 5 : Antenna Wo (60 Deg))**

	Member Label	Direction	Magnitude[ lb.k-ft ]	Location[ft.-%]
1	MP1A	X	35.03	1.5
2	MP1A	Z	-20.225	1.5
3	MP1A	Mx	-.023	1.5
4	MP3A	X	47.178	1
5	MP3A	Z	-27.238	1
6	MP3A	Mx	-.031	1
7	MP3A	X	47.178	3
8	MP3A	Z	-27.238	3
9	MP3A	Mx	-.031	3
10	MP4A	X	89.393	.5
11	MP4A	Z	-51.611	.5
12	MP4A	Mx	-.06	.5
13	MP4A	X	89.393	4.5
14	MP4A	Z	-51.611	4.5
15	MP4A	Mx	-.06	4.5
16	MP2A	X	124.915	.5
17	MP2A	Z	-72.12	.5
18	MP2A	Mx	-.041	.5
19	MP2A	X	124.915	4.5
20	MP2A	Z	-72.12	4.5
21	MP2A	Mx	-.041	4.5
22	MP2A	X	124.915	.5
23	MP2A	Z	-72.12	.5
24	MP2A	Mx	-.125	.5
25	MP2A	X	124.915	4.5
26	MP2A	Z	-72.12	4.5
27	MP2A	Mx	-.125	4.5
28	M22	X	12.611	.5
29	M22	Z	-7.281	.5
30	M22	Mx	0	.5
31	M22	X	63.334	2.5
32	M22	Z	-36.566	2.5
33	M22	Mx	0	2.5
34	MP1A	X	45.308	3.5
35	MP1A	Z	-26.159	3.5
36	MP1A	Mx	.023	3.5
37	M23	X	101.595	1.5
38	M23	Z	-58.656	1.5
39	M23	Mx	0	1.5

**Member Point Loads (BLC 6 : Antenna Wo (90 Deg))**

	Member Label	Direction	Magnitude[ lb.k-ft ]	Location[ft.-%]
1	MP1A	X	32.185	1.5
2	MP1A	Z	0	1.5
3	MP1A	Mx	-.021	1.5
4	MP3A	X	39.232	1
5	MP3A	Z	0	1
6	MP3A	Mx	-.026	1
7	MP3A	X	39.232	3
8	MP3A	Z	0	3
9	MP3A	Mx	-.026	3
10	MP4A	X	86.032	.5
11	MP4A	Z	0	.5
12	MP4A	Mx	-.057	.5
13	MP4A	X	86.032	4.5
14	MP4A	Z	0	4.5





Company :  
 Designer :  
 Job Number :  
 Model Name :

June 10, 2021  
 8:10 AM  
 Checked By: \_\_\_\_\_

**Member Point Loads (BLC 6 : Antenna Wo (90 Deg)) (Continued)**

	Member Label	Direction	Magnitude[lb.k-ft]	Location[ft. %]
15	MP4A	Mx	-.057	4.5
16	MP2A	X	127.573	.5
17	MP2A	Z	0	.5
18	MP2A	Mx	-.085	.5
19	MP2A	X	127.573	4.5
20	MP2A	Z	0	4.5
21	MP2A	Mx	-.085	4.5
22	MP2A	X	127.573	.5
23	MP2A	Z	0	.5
24	MP2A	Mx	-.085	.5
25	MP2A	X	127.573	4.5
26	MP2A	Z	0	4.5
27	MP2A	Mx	-.085	4.5
28	M22	X	12.132	.5
29	M22	Z	0	.5
30	M22	Mx	0	.5
31	M22	X	59.913	2.5
32	M22	Z	0	2.5
33	M22	Mx	0	2.5
34	MP1A	X	43.176	3.5
35	MP1A	Z	0	3.5
36	MP1A	Mx	.022	3.5
37	M23	X	95.227	1.5
38	M23	Z	0	1.5
39	M23	Mx	0	1.5

**Member Point Loads (BLC 7 : Antenna Wo (120 Deg))**

	Member Label	Direction	Magnitude[lb.k-ft]	Location[ft. %]
1	MP1A	X	35.03	1.5
2	MP1A	Z	20.225	1.5
3	MP1A	Mx	-.023	1.5
4	MP3A	X	47.178	1
5	MP3A	Z	27.238	1
6	MP3A	Mx	-.031	1
7	MP3A	X	47.178	3
8	MP3A	Z	27.238	3
9	MP3A	Mx	-.031	3
10	MP4A	X	89.393	.5
11	MP4A	Z	51.611	.5
12	MP4A	Mx	-.06	.5
13	MP4A	X	89.393	4.5
14	MP4A	Z	51.611	4.5
15	MP4A	Mx	-.06	4.5
16	MP2A	X	124.915	.5
17	MP2A	Z	72.12	.5
18	MP2A	Mx	-.125	.5
19	MP2A	X	124.915	4.5
20	MP2A	Z	72.12	4.5
21	MP2A	Mx	-.125	4.5
22	MP2A	X	124.915	.5
23	MP2A	Z	72.12	.5
24	MP2A	Mx	-.041	.5
25	MP2A	X	124.915	4.5
26	MP2A	Z	72.12	4.5
27	MP2A	Mx	-.041	4.5
28	M22	X	9.454	.5



Company :  
 Designer :  
 Job Number :  
 Model Name :

June 10, 2021  
 8:10 AM  
 Checked By: \_\_\_\_\_

**Member Point Loads (BLC 7 : Antenna Wo (120 Deg)) (Continued)**

	Member Label	Direction	Magnitude[lb.k-ft]	Location[ft,%]
29	M22	Z	5.458	.5
30	M22	Mx	0	.5
31	M22	X	46.162	2.5
32	M22	Z	26.652	2.5
33	M22	Mx	0	2.5
34	MP1A	X	45.308	3.5
35	MP1A	Z	26.159	3.5
36	MP1A	Mx	.023	3.5
37	M23	X	72.905	1.5
38	M23	Z	42.092	1.5
39	M23	Mx	0	1.5

**Member Point Loads (BLC 8 : Antenna Wo (150 Deg))**

	Member Label	Direction	Magnitude[lb.k-ft]	Location[ft,%]
1	MP1A	X	28.489	1.5
2	MP1A	Z	49.345	1.5
3	MP1A	Mx	-.019	1.5
4	MP3A	X	42.483	1
5	MP3A	Z	73.583	1
6	MP3A	Mx	-.028	1
7	MP3A	X	42.483	3
8	MP3A	Z	73.583	3
9	MP3A	Mx	-.028	3
10	MP4A	X	68.801	.5
11	MP4A	Z	119.168	.5
12	MP4A	Mx	-.046	.5
13	MP4A	X	68.801	4.5
14	MP4A	Z	119.168	4.5
15	MP4A	Mx	-.046	4.5
16	MP2A	X	88.786	.5
17	MP2A	Z	153.781	.5
18	MP2A	Mx	-.149	.5
19	MP2A	X	88.786	4.5
20	MP2A	Z	153.781	4.5
21	MP2A	Mx	-.149	4.5
22	MP2A	X	88.786	.5
23	MP2A	Z	153.781	.5
24	MP2A	Mx	.031	.5
25	MP2A	X	88.786	4.5
26	MP2A	Z	153.781	4.5
27	MP2A	Mx	.031	4.5
28	M22	X	6.066	.5
29	M22	Z	10.506	.5
30	M22	Mx	0	.5
31	M22	X	29.957	2.5
32	M22	Z	51.886	2.5
33	M22	Mx	0	2.5
34	MP1A	X	35.3	3.5
35	MP1A	Z	61.142	3.5
36	MP1A	Mx	.018	3.5
37	M23	X	47.613	1.5
38	M23	Z	82.469	1.5
39	M23	Mx	0	1.5

**Member Point Loads (BLC 9 : Antenna Wo (180 Deg))**

	Member Label	Direction	Magnitude[lb.k-ft]	Location[ft,%]
--	--------------	-----------	--------------------	----------------



Company :  
 Designer :  
 Job Number :  
 Model Name :

June 10, 2021  
 8:10 AM  
 Checked By: \_\_\_\_\_

**Member Point Loads (BLC 9 : Antenna Wo (180 Deg)) (Continued)**

	Member Label	Direction	Magnitude[lb.k-ft]	Location[ft.%,]
1	MP1A	X	0	1.5
2	MP1A	Z	65.243	1.5
3	MP1A	Mx	0	1.5
4	MP3A	X	0	1
5	MP3A	Z	100.21	1
6	MP3A	Mx	0	1
7	MP3A	X	0	3
8	MP3A	Z	100.21	3
9	MP3A	Mx	0	3
10	MP4A	X	0	.5
11	MP4A	Z	154.793	.5
12	MP4A	Mx	0	.5
13	MP4A	X	0	4.5
14	MP4A	Z	154.793	4.5
15	MP4A	Mx	0	4.5
16	MP2A	X	0	.5
17	MP2A	Z	194.238	.5
18	MP2A	Mx	-.113	.5
19	MP2A	X	0	4.5
20	MP2A	Z	194.238	4.5
21	MP2A	Mx	-.113	4.5
22	MP2A	X	0	.5
23	MP2A	Z	194.238	.5
24	MP2A	Mx	.113	.5
25	MP2A	X	0	4.5
26	MP2A	Z	194.238	4.5
27	MP2A	Mx	.113	4.5
28	M22	X	0	.5
29	M22	Z	14.562	.5
30	M22	Mx	0	.5
31	M22	X	0	2.5
32	M22	Z	73.132	2.5
33	M22	Mx	0	2.5
34	MP1A	X	0	3.5
35	MP1A	Z	79.742	3.5
36	MP1A	Mx	0	3.5
37	M23	X	0	1.5
38	M23	Z	117.312	1.5
39	M23	Mx	0	1.5

**Member Point Loads (BLC 10 : Antenna Wo (210 Deg))**

	Member Label	Direction	Magnitude[lb.k-ft]	Location[ft.%,]
1	MP1A	X	-28.489	1.5
2	MP1A	Z	49.345	1.5
3	MP1A	Mx	.019	1.5
4	MP3A	X	-42.483	1
5	MP3A	Z	73.583	1
6	MP3A	Mx	.028	1
7	MP3A	X	-42.483	3
8	MP3A	Z	73.583	3
9	MP3A	Mx	.028	3
10	MP4A	X	-68.801	.5
11	MP4A	Z	119.168	.5
12	MP4A	Mx	.046	.5
13	MP4A	X	-68.801	4.5
14	MP4A	Z	119.168	4.5



Company :  
 Designer :  
 Job Number :  
 Model Name :

June 10, 2021  
 8:10 AM  
 Checked By: \_\_\_\_\_

**Member Point Loads (BLC 10 : Antenna Wo (210 Deg)) (Continued)**

	Member Label	Direction	Magnitude[lb.k-ft]	Location[ft,%]
15	MP4A	Mx	.046	4.5
16	MP2A	X	-88.786	.5
17	MP2A	Z	153.781	.5
18	MP2A	Mx	-.031	.5
19	MP2A	X	-88.786	4.5
20	MP2A	Z	153.781	4.5
21	MP2A	Mx	-.031	4.5
22	MP2A	X	-88.786	.5
23	MP2A	Z	153.781	.5
24	MP2A	Mx	.149	.5
25	MP2A	X	-88.786	4.5
26	MP2A	Z	153.781	4.5
27	MP2A	Mx	.149	4.5
28	M22	X	-7.889	.5
29	M22	Z	13.664	.5
30	M22	Mx	0	.5
31	M22	X	-39.871	2.5
32	M22	Z	69.059	2.5
33	M22	Mx	0	2.5
34	MP1A	X	-35.3	3.5
35	MP1A	Z	61.142	3.5
36	MP1A	Mx	-.018	3.5
37	M23	X	-64.177	1.5
38	M23	Z	111.158	1.5
39	M23	Mx	0	1.5

**Member Point Loads (BLC 11 : Antenna Wo (240 Deg))**

	Member Label	Direction	Magnitude[lb.k-ft]	Location[ft,%]
1	MP1A	X	-35.03	1.5
2	MP1A	Z	20.225	1.5
3	MP1A	Mx	.023	1.5
4	MP3A	X	-47.178	1
5	MP3A	Z	27.238	1
6	MP3A	Mx	.031	1
7	MP3A	X	-47.178	3
8	MP3A	Z	27.238	3
9	MP3A	Mx	.031	3
10	MP4A	X	-89.393	.5
11	MP4A	Z	51.611	.5
12	MP4A	Mx	.06	.5
13	MP4A	X	-89.393	4.5
14	MP4A	Z	51.611	4.5
15	MP4A	Mx	.06	4.5
16	MP2A	X	-124.915	.5
17	MP2A	Z	72.12	.5
18	MP2A	Mx	.041	.5
19	MP2A	X	-124.915	4.5
20	MP2A	Z	72.12	4.5
21	MP2A	Mx	.041	4.5
22	MP2A	X	-124.915	.5
23	MP2A	Z	72.12	.5
24	MP2A	Mx	.125	.5
25	MP2A	X	-124.915	4.5
26	MP2A	Z	72.12	4.5
27	MP2A	Mx	.125	4.5
28	M22	X	-12.611	.5



Company :  
 Designer :  
 Job Number :  
 Model Name :

June 10, 2021  
 8:10 AM  
 Checked By: \_\_\_\_\_

**Member Point Loads (BLC 11 : Antenna Wo (240 Deg)) (Continued)**

	Member Label	Direction	Magnitude[lb.k-ft]	Location[ft,%]
29	M22	Z	7.281	.5
30	M22	Mx	0	.5
31	M22	X	-63.334	2.5
32	M22	Z	36.566	2.5
33	M22	Mx	0	2.5
34	MP1A	X	-45.308	3.5
35	MP1A	Z	26.159	3.5
36	MP1A	Mx	-.023	3.5
37	M23	X	-101.595	1.5
38	M23	Z	58.656	1.5
39	M23	Mx	0	1.5

**Member Point Loads (BLC 12 : Antenna Wo (270 Deg))**

	Member Label	Direction	Magnitude[lb.k-ft]	Location[ft,%]
1	MP1A	X	-32.185	1.5
2	MP1A	Z	0	1.5
3	MP1A	Mx	.021	1.5
4	MP3A	X	-39.232	1
5	MP3A	Z	0	1
6	MP3A	Mx	.026	1
7	MP3A	X	-39.232	3
8	MP3A	Z	0	3
9	MP3A	Mx	.026	3
10	MP4A	X	-86.032	.5
11	MP4A	Z	0	.5
12	MP4A	Mx	.057	.5
13	MP4A	X	-86.032	4.5
14	MP4A	Z	0	4.5
15	MP4A	Mx	.057	4.5
16	MP2A	X	-127.573	.5
17	MP2A	Z	0	.5
18	MP2A	Mx	.085	.5
19	MP2A	X	-127.573	4.5
20	MP2A	Z	0	4.5
21	MP2A	Mx	.085	4.5
22	MP2A	X	-127.573	.5
23	MP2A	Z	0	.5
24	MP2A	Mx	.085	.5
25	MP2A	X	-127.573	4.5
26	MP2A	Z	0	4.5
27	MP2A	Mx	.085	4.5
28	M22	X	-12.132	.5
29	M22	Z	0	.5
30	M22	Mx	0	.5
31	M22	X	-59.913	2.5
32	M22	Z	0	2.5
33	M22	Mx	0	2.5
34	MP1A	X	-43.176	3.5
35	MP1A	Z	0	3.5
36	MP1A	Mx	-.022	3.5
37	M23	X	-95.227	1.5
38	M23	Z	0	1.5
39	M23	Mx	0	1.5

**Member Point Loads (BLC 13 : Antenna Wo (300 Deg))**

	Member Label	Direction	Magnitude[lb.k-ft]	Location[ft,%]
--	--------------	-----------	--------------------	----------------



Company :  
 Designer :  
 Job Number :  
 Model Name :

June 10, 2021  
 8:10 AM  
 Checked By: \_\_\_\_\_

**Member Point Loads (BLC 13 : Antenna Wo (300 Deg)) (Continued)**

	Member Label	Direction	Magnitude[lb.k-ft]	Location[ft.%]
1	MP1A	X	-35.03	1.5
2	MP1A	Z	-20.225	1.5
3	MP1A	Mx	.023	1.5
4	MP3A	X	-47.178	1
5	MP3A	Z	-27.238	1
6	MP3A	Mx	.031	1
7	MP3A	X	-47.178	3
8	MP3A	Z	-27.238	3
9	MP3A	Mx	.031	3
10	MP4A	X	-89.393	.5
11	MP4A	Z	-51.611	.5
12	MP4A	Mx	.06	.5
13	MP4A	X	-89.393	4.5
14	MP4A	Z	-51.611	4.5
15	MP4A	Mx	.06	4.5
16	MP2A	X	-124.915	.5
17	MP2A	Z	-72.12	.5
18	MP2A	Mx	.125	.5
19	MP2A	X	-124.915	4.5
20	MP2A	Z	-72.12	4.5
21	MP2A	Mx	.125	4.5
22	MP2A	X	-124.915	.5
23	MP2A	Z	-72.12	.5
24	MP2A	Mx	.041	.5
25	MP2A	X	-124.915	4.5
26	MP2A	Z	-72.12	4.5
27	MP2A	Mx	.041	4.5
28	M22	X	-9.454	.5
29	M22	Z	-5.458	.5
30	M22	Mx	0	.5
31	M22	X	-46.162	2.5
32	M22	Z	-26.652	2.5
33	M22	Mx	0	2.5
34	MP1A	X	-45.308	3.5
35	MP1A	Z	-26.159	3.5
36	MP1A	Mx	-.023	3.5
37	M23	X	-72.905	1.5
38	M23	Z	-42.092	1.5
39	M23	Mx	0	1.5

**Member Point Loads (BLC 14 : Antenna Wo (330 Deg))**

	Member Label	Direction	Magnitude[lb.k-ft]	Location[ft.%]
1	MP1A	X	-28.489	1.5
2	MP1A	Z	-49.345	1.5
3	MP1A	Mx	.019	1.5
4	MP3A	X	-42.483	1
5	MP3A	Z	-73.583	1
6	MP3A	Mx	.028	1
7	MP3A	X	-42.483	3
8	MP3A	Z	-73.583	3
9	MP3A	Mx	.028	3
10	MP4A	X	-68.801	.5
11	MP4A	Z	-119.168	.5
12	MP4A	Mx	.046	.5
13	MP4A	X	-68.801	4.5
14	MP4A	Z	-119.168	4.5

**Member Point Loads (BLC 14 : Antenna Wo (330 Deg)) (Continued)**

	Member Label	Direction	Magnitude[lb.k-ft]	Location[ft, %]
15	MP4A	Mx	.046	4.5
16	MP2A	X	-88.786	.5
17	MP2A	Z	-153.781	.5
18	MP2A	Mx	.149	.5
19	MP2A	X	-88.786	4.5
20	MP2A	Z	-153.781	4.5
21	MP2A	Mx	.149	4.5
22	MP2A	X	-88.786	.5
23	MP2A	Z	-153.781	.5
24	MP2A	Mx	-.031	.5
25	MP2A	X	-88.786	4.5
26	MP2A	Z	-153.781	4.5
27	MP2A	Mx	-.031	4.5
28	M22	X	-6.066	.5
29	M22	Z	-10.506	.5
30	M22	Mx	0	.5
31	M22	X	-29.957	2.5
32	M22	Z	-51.886	2.5
33	M22	Mx	0	2.5
34	MP1A	X	-35.3	3.5
35	MP1A	Z	-61.142	3.5
36	MP1A	Mx	-.018	3.5
37	M23	X	-47.613	1.5
38	M23	Z	-82.469	1.5
39	M23	Mx	0	1.5

**Member Point Loads (BLC 15 : Antenna Wi (0 Deg))**

	Member Label	Direction	Magnitude[lb.k-ft]	Location[ft, %]
1	MP1A	X	0	1.5
2	MP1A	Z	-14.141	1.5
3	MP1A	Mx	0	1.5
4	MP3A	X	0	1
5	MP3A	Z	-20.011	1
6	MP3A	Mx	0	1
7	MP3A	X	0	3
8	MP3A	Z	-20.011	3
9	MP3A	Mx	0	3
10	MP4A	X	0	.5
11	MP4A	Z	-30.359	.5
12	MP4A	Mx	0	.5
13	MP4A	X	0	4.5
14	MP4A	Z	-30.359	4.5
15	MP4A	Mx	0	4.5
16	MP2A	X	0	.5
17	MP2A	Z	-37.613	.5
18	MP2A	Mx	.022	.5
19	MP2A	X	0	4.5
20	MP2A	Z	-37.613	4.5
21	MP2A	Mx	.022	4.5
22	MP2A	X	0	.5
23	MP2A	Z	-37.613	.5
24	MP2A	Mx	-.022	.5
25	MP2A	X	0	4.5
26	MP2A	Z	-37.613	4.5
27	MP2A	Mx	-.022	4.5
28	M22	X	0	.5

**Member Point Loads (BLC 15 : Antenna Wi (0 Deg)) (Continued)**

	Member Label	Direction	Magnitude[lb.k-ft]	Location[ft,%]
29	M22	Z	-3.849	.5
30	M22	Mx	0	.5
31	M22	X	0	2.5
32	M22	Z	-15.593	2.5
33	M22	Mx	0	2.5
34	MP1A	X	0	3.5
35	MP1A	Z	-16.876	3.5
36	MP1A	Mx	0	3.5
37	M23	X	0	1.5
38	M23	Z	-24.094	1.5
39	M23	Mx	0	1.5

**Member Point Loads (BLC 16 : Antenna Wi (30 Deg))**

	Member Label	Direction	Magnitude[lb.k-ft]	Location[ft,%]
1	MP1A	X	6.258	1.5
2	MP1A	Z	-10.84	1.5
3	MP1A	Mx	-.004	1.5
4	MP3A	X	8.571	1
5	MP3A	Z	-14.845	1
6	MP3A	Mx	-.006	1
7	MP3A	X	8.571	3
8	MP3A	Z	-14.845	3
9	MP3A	Mx	-.006	3
10	MP4A	X	13.633	.5
11	MP4A	Z	-23.613	.5
12	MP4A	Mx	-.009	.5
13	MP4A	X	13.633	4.5
14	MP4A	Z	-23.613	4.5
15	MP4A	Mx	-.009	4.5
16	MP2A	X	17.314	.5
17	MP2A	Z	-29.988	.5
18	MP2A	Mx	.006	.5
19	MP2A	X	17.314	4.5
20	MP2A	Z	-29.988	4.5
21	MP2A	Mx	.006	4.5
22	MP2A	X	17.314	.5
23	MP2A	Z	-29.988	.5
24	MP2A	Mx	-.029	.5
25	MP2A	X	17.314	4.5
26	MP2A	Z	-29.988	4.5
27	MP2A	Mx	-.029	4.5
28	M22	X	2.053	.5
29	M22	Z	-3.555	.5
30	M22	Mx	0	.5
31	M22	X	8.438	2.5
32	M22	Z	-14.615	2.5
33	M22	Mx	0	2.5
34	MP1A	X	7.553	3.5
35	MP1A	Z	-13.082	3.5
36	MP1A	Mx	.004	3.5
37	M23	X	13.078	1.5
38	M23	Z	-22.652	1.5
39	M23	Mx	0	1.5

**Member Point Loads (BLC 17 : Antenna Wi (60 Deg))**

	Member Label	Direction	Magnitude[lb.k-ft]	Location[ft,%]
--	--------------	-----------	--------------------	----------------



**Member Point Loads (BLC 17 : Antenna Wi (60 Deg)) (Continued)**

	Member Label	Direction	Magnitude[ <i>lb.k-ft</i> ]	Location[ <i>ft.%</i> ]
1	MP1A	X	8.025	1.5
2	MP1A	Z	-4.633	1.5
3	MP1A	Mx	-.005	1.5
4	MP3A	X	9.874	1
5	MP3A	Z	-5.701	1
6	MP3A	Mx	-.007	1
7	MP3A	X	9.874	3
8	MP3A	Z	-5.701	3
9	MP3A	Mx	-.007	3
10	MP4A	X	18.256	.5
11	MP4A	Z	-10.54	.5
12	MP4A	Mx	-.012	.5
13	MP4A	X	18.256	4.5
14	MP4A	Z	-10.54	4.5
15	MP4A	Mx	-.012	4.5
16	MP2A	X	24.815	.5
17	MP2A	Z	-14.327	.5
18	MP2A	Mx	-.008	.5
19	MP2A	X	24.815	4.5
20	MP2A	Z	-14.327	4.5
21	MP2A	Mx	-.008	4.5
22	MP2A	X	24.815	.5
23	MP2A	Z	-14.327	.5
24	MP2A	Mx	-.025	.5
25	MP2A	X	24.815	4.5
26	MP2A	Z	-14.327	4.5
27	MP2A	Mx	-.025	4.5
28	M22	X	3.334	.5
29	M22	Z	-1.925	.5
30	M22	Mx	0	.5
31	M22	X	13.504	2.5
32	M22	Z	-7.796	2.5
33	M22	Mx	0	2.5
34	MP1A	X	10.015	3.5
35	MP1A	Z	-5.782	3.5
36	MP1A	Mx	.005	3.5
37	M23	X	20.866	1.5
38	M23	Z	-12.047	1.5
39	M23	Mx	0	1.5

**Member Point Loads (BLC 18 : Antenna Wi (90 Deg))**

	Member Label	Direction	Magnitude[ <i>lb.k-ft</i> ]	Location[ <i>ft.%</i> ]
1	MP1A	X	7.641	1.5
2	MP1A	Z	0	1.5
3	MP1A	Mx	-.005	1.5
4	MP3A	X	8.532	1
5	MP3A	Z	0	1
6	MP3A	Mx	-.006	1
7	MP3A	X	8.532	3
8	MP3A	Z	0	3
9	MP3A	Mx	-.006	3
10	MP4A	X	17.988	.5
11	MP4A	Z	0	.5
12	MP4A	Mx	-.012	.5
13	MP4A	X	17.988	4.5
14	MP4A	Z	0	4.5



Company :  
 Designer :  
 Job Number :  
 Model Name :

June 10, 2021  
 8:10 AM  
 Checked By: \_\_\_\_\_

**Member Point Loads (BLC 18 : Antenna Wi (90 Deg)) (Continued)**

	Member Label	Direction	Magnitude[lb.k-ft]	Location[ft,%]
15	MP4A	Mx	-0.12	4.5
16	MP2A	X	25.668	.5
17	MP2A	Z	0	.5
18	MP2A	Mx	-0.17	.5
19	MP2A	X	25.668	4.5
20	MP2A	Z	0	4.5
21	MP2A	Mx	-0.17	4.5
22	MP2A	X	25.668	.5
23	MP2A	Z	0	.5
24	MP2A	Mx	-0.17	.5
25	MP2A	X	25.668	4.5
26	MP2A	Z	0	4.5
27	MP2A	Mx	-0.17	4.5
28	M22	X	3.338	.5
29	M22	Z	0	.5
30	M22	Mx	0	.5
31	M22	X	13.027	2.5
32	M22	Z	0	2.5
33	M22	Mx	0	2.5
34	MP1A	X	9.794	3.5
35	MP1A	Z	0	3.5
36	MP1A	Mx	.005	3.5
37	M23	X	19.967	1.5
38	M23	Z	0	1.5
39	M23	Mx	0	1.5

**Member Point Loads (BLC 19 : Antenna Wi (120 Deg))**

	Member Label	Direction	Magnitude[lb.k-ft]	Location[ft,%]
1	MP1A	X	8.025	1.5
2	MP1A	Z	4.633	1.5
3	MP1A	Mx	-0.005	1.5
4	MP3A	X	9.874	1
5	MP3A	Z	5.701	1
6	MP3A	Mx	-0.007	1
7	MP3A	X	9.874	3
8	MP3A	Z	5.701	3
9	MP3A	Mx	-0.007	3
10	MP4A	X	18.256	.5
11	MP4A	Z	10.54	.5
12	MP4A	Mx	-0.12	.5
13	MP4A	X	18.256	4.5
14	MP4A	Z	10.54	4.5
15	MP4A	Mx	-0.12	4.5
16	MP2A	X	24.815	.5
17	MP2A	Z	14.327	.5
18	MP2A	Mx	-0.25	.5
19	MP2A	X	24.815	4.5
20	MP2A	Z	14.327	4.5
21	MP2A	Mx	-0.25	4.5
22	MP2A	X	24.815	.5
23	MP2A	Z	14.327	.5
24	MP2A	Mx	-0.008	.5
25	MP2A	X	24.815	4.5
26	MP2A	Z	14.327	4.5
27	MP2A	Mx	-0.008	4.5
28	M22	X	2.67	.5

**Member Point Loads (BLC 19 : Antenna Wi (120 Deg)) (Continued)**

	Member Label	Direction	Magnitude[lb.k-ft]	Location[ft,%]
29	M22	Z	1.541	.5
30	M22	Mx	0	.5
31	M22	X	10.17	2.5
32	M22	Z	5.872	2.5
33	M22	Mx	0	2.5
34	MP1A	X	10.015	3.5
35	MP1A	Z	5.782	3.5
36	MP1A	Mx	.005	3.5
37	M23	X	15.505	1.5
38	M23	Z	8.952	1.5
39	M23	Mx	0	1.5

**Member Point Loads (BLC 20 : Antenna Wi (150 Deg))**

	Member Label	Direction	Magnitude[lb.k-ft]	Location[ft,%]
1	MP1A	X	6.258	1.5
2	MP1A	Z	10.84	1.5
3	MP1A	Mx	-.004	1.5
4	MP3A	X	8.571	1
5	MP3A	Z	14.845	1
6	MP3A	Mx	-.006	1
7	MP3A	X	8.571	3
8	MP3A	Z	14.845	3
9	MP3A	Mx	-.006	3
10	MP4A	X	13.633	.5
11	MP4A	Z	23.613	.5
12	MP4A	Mx	-.009	.5
13	MP4A	X	13.633	4.5
14	MP4A	Z	23.613	4.5
15	MP4A	Mx	-.009	4.5
16	MP2A	X	17.314	.5
17	MP2A	Z	29.988	.5
18	MP2A	Mx	-.029	.5
19	MP2A	X	17.314	4.5
20	MP2A	Z	29.988	4.5
21	MP2A	Mx	-.029	4.5
22	MP2A	X	17.314	.5
23	MP2A	Z	29.988	.5
24	MP2A	Mx	.006	.5
25	MP2A	X	17.314	4.5
26	MP2A	Z	29.988	4.5
27	MP2A	Mx	.006	4.5
28	M22	X	1.669	.5
29	M22	Z	2.891	.5
30	M22	Mx	0	.5
31	M22	X	6.513	2.5
32	M22	Z	11.282	2.5
33	M22	Mx	0	2.5
34	MP1A	X	7.553	3.5
35	MP1A	Z	13.082	3.5
36	MP1A	Mx	.004	3.5
37	M23	X	9.984	1.5
38	M23	Z	17.292	1.5
39	M23	Mx	0	1.5

**Member Point Loads (BLC 21 : Antenna Wi (180 Deg))**

	Member Label	Direction	Magnitude[lb.k-ft]	Location[ft,%]
--	--------------	-----------	--------------------	----------------

**Member Point Loads (BLC 21 : Antenna Wi (180 Deg)) (Continued)**

	Member Label	Direction	Magnitude[lb.k-ft]	Location[ft.-%]
1	MP1A	X	0	1.5
2	MP1A	Z	14.141	1.5
3	MP1A	Mx	0	1.5
4	MP3A	X	0	1
5	MP3A	Z	20.011	1
6	MP3A	Mx	0	1
7	MP3A	X	0	3
8	MP3A	Z	20.011	3
9	MP3A	Mx	0	3
10	MP4A	X	0	.5
11	MP4A	Z	30.359	.5
12	MP4A	Mx	0	.5
13	MP4A	X	0	4.5
14	MP4A	Z	30.359	4.5
15	MP4A	Mx	0	4.5
16	MP2A	X	0	.5
17	MP2A	Z	37.613	.5
18	MP2A	Mx	-.022	.5
19	MP2A	X	0	4.5
20	MP2A	Z	37.613	4.5
21	MP2A	Mx	-.022	4.5
22	MP2A	X	0	.5
23	MP2A	Z	37.613	.5
24	MP2A	Mx	.022	.5
25	MP2A	X	0	4.5
26	MP2A	Z	37.613	4.5
27	MP2A	Mx	.022	4.5
28	M22	X	0	.5
29	M22	Z	3.849	.5
30	M22	Mx	0	.5
31	M22	X	0	2.5
32	M22	Z	15.593	2.5
33	M22	Mx	0	2.5
34	MP1A	X	0	3.5
35	MP1A	Z	16.876	3.5
36	MP1A	Mx	0	3.5
37	M23	X	0	1.5
38	M23	Z	24.094	1.5
39	M23	Mx	0	1.5

**Member Point Loads (BLC 22 : Antenna Wi (210 Deg))**

	Member Label	Direction	Magnitude[lb.k-ft]	Location[ft.-%]
1	MP1A	X	-6.258	1.5
2	MP1A	Z	10.84	1.5
3	MP1A	Mx	.004	1.5
4	MP3A	X	-8.571	1
5	MP3A	Z	14.845	1
6	MP3A	Mx	.006	1
7	MP3A	X	-8.571	3
8	MP3A	Z	14.845	3
9	MP3A	Mx	.006	3
10	MP4A	X	-13.633	.5
11	MP4A	Z	23.613	.5
12	MP4A	Mx	.009	.5
13	MP4A	X	-13.633	4.5
14	MP4A	Z	23.613	4.5



Company :  
 Designer :  
 Job Number :  
 Model Name :

June 10, 2021  
 8:10 AM  
 Checked By: \_\_\_\_\_

**Member Point Loads (BLC 22 : Antenna Wi (210 Deg)) (Continued)**

	Member Label	Direction	Magnitude[lb.k-ft]	Location[ft,%]
15	MP4A	Mx	.009	4.5
16	MP2A	X	-17.314	.5
17	MP2A	Z	29.988	.5
18	MP2A	Mx	-.006	.5
19	MP2A	X	-17.314	4.5
20	MP2A	Z	29.988	4.5
21	MP2A	Mx	-.006	4.5
22	MP2A	X	-17.314	.5
23	MP2A	Z	29.988	.5
24	MP2A	Mx	.029	.5
25	MP2A	X	-17.314	4.5
26	MP2A	Z	29.988	4.5
27	MP2A	Mx	.029	4.5
28	M22	X	-2.053	.5
29	M22	Z	3.555	.5
30	M22	Mx	0	.5
31	M22	X	-8.438	2.5
32	M22	Z	14.615	2.5
33	M22	Mx	0	2.5
34	MP1A	X	-7.553	3.5
35	MP1A	Z	13.082	3.5
36	MP1A	Mx	-.004	3.5
37	M23	X	-13.078	1.5
38	M23	Z	22.652	1.5
39	M23	Mx	0	1.5

**Member Point Loads (BLC 23 : Antenna Wi (240 Deg))**

	Member Label	Direction	Magnitude[lb.k-ft]	Location[ft,%]
1	MP1A	X	-8.025	1.5
2	MP1A	Z	4.633	1.5
3	MP1A	Mx	.005	1.5
4	MP3A	X	-9.874	1
5	MP3A	Z	5.701	1
6	MP3A	Mx	.007	1
7	MP3A	X	-9.874	3
8	MP3A	Z	5.701	3
9	MP3A	Mx	.007	3
10	MP4A	X	-18.256	.5
11	MP4A	Z	10.54	.5
12	MP4A	Mx	.012	.5
13	MP4A	X	-18.256	4.5
14	MP4A	Z	10.54	4.5
15	MP4A	Mx	.012	4.5
16	MP2A	X	-24.815	.5
17	MP2A	Z	14.327	.5
18	MP2A	Mx	.008	.5
19	MP2A	X	-24.815	4.5
20	MP2A	Z	14.327	4.5
21	MP2A	Mx	.008	4.5
22	MP2A	X	-24.815	.5
23	MP2A	Z	14.327	.5
24	MP2A	Mx	.025	.5
25	MP2A	X	-24.815	4.5
26	MP2A	Z	14.327	4.5
27	MP2A	Mx	.025	4.5
28	M22	X	-3.334	.5

**Member Point Loads (BLC 23 : Antenna Wi (240 Deg)) (Continued)**

	Member Label	Direction	Magnitude[lb.k-ft]	Location[ft,%]
29	M22	Z	1.925	.5
30	M22	Mx	0	.5
31	M22	X	-13.504	2.5
32	M22	Z	7.796	2.5
33	M22	Mx	0	2.5
34	MP1A	X	-10.015	3.5
35	MP1A	Z	5.782	3.5
36	MP1A	Mx	-.005	3.5
37	M23	X	-20.866	1.5
38	M23	Z	12.047	1.5
39	M23	Mx	0	1.5

**Member Point Loads (BLC 24 : Antenna Wi (270 Deg))**

	Member Label	Direction	Magnitude[lb.k-ft]	Location[ft,%]
1	MP1A	X	-7.641	1.5
2	MP1A	Z	0	1.5
3	MP1A	Mx	.005	1.5
4	MP3A	X	-8.532	1
5	MP3A	Z	0	1
6	MP3A	Mx	.006	1
7	MP3A	X	-8.532	3
8	MP3A	Z	0	3
9	MP3A	Mx	.006	3
10	MP4A	X	-17.988	.5
11	MP4A	Z	0	.5
12	MP4A	Mx	.012	.5
13	MP4A	X	-17.988	4.5
14	MP4A	Z	0	4.5
15	MP4A	Mx	.012	4.5
16	MP2A	X	-25.668	.5
17	MP2A	Z	0	.5
18	MP2A	Mx	.017	.5
19	MP2A	X	-25.668	4.5
20	MP2A	Z	0	4.5
21	MP2A	Mx	.017	4.5
22	MP2A	X	-25.668	.5
23	MP2A	Z	0	.5
24	MP2A	Mx	.017	.5
25	MP2A	X	-25.668	4.5
26	MP2A	Z	0	4.5
27	MP2A	Mx	.017	4.5
28	M22	X	-3.338	.5
29	M22	Z	0	.5
30	M22	Mx	0	.5
31	M22	X	-13.027	2.5
32	M22	Z	0	2.5
33	M22	Mx	0	2.5
34	MP1A	X	-9.794	3.5
35	MP1A	Z	0	3.5
36	MP1A	Mx	-.005	3.5
37	M23	X	-19.967	1.5
38	M23	Z	0	1.5
39	M23	Mx	0	1.5

**Member Point Loads (BLC 25 : Antenna Wi (300 Deg))**

	Member Label	Direction	Magnitude[lb.k-ft]	Location[ft,%]
--	--------------	-----------	--------------------	----------------



Company :  
 Designer :  
 Job Number :  
 Model Name :

June 10, 2021  
 8:10 AM  
 Checked By: \_\_\_\_\_

**Member Point Loads (BLC 25 : Antenna Wi (300 Deg)) (Continued)**

	Member Label	Direction	Magnitude[lb.k-ft]	Location[ft.-%]
1	MP1A	X	-8.025	1.5
2	MP1A	Z	-4.633	1.5
3	MP1A	Mx	.005	1.5
4	MP3A	X	-9.874	1
5	MP3A	Z	-5.701	1
6	MP3A	Mx	.007	1
7	MP3A	X	-9.874	3
8	MP3A	Z	-5.701	3
9	MP3A	Mx	.007	3
10	MP4A	X	-18.256	.5
11	MP4A	Z	-10.54	.5
12	MP4A	Mx	.012	.5
13	MP4A	X	-18.256	4.5
14	MP4A	Z	-10.54	4.5
15	MP4A	Mx	.012	4.5
16	MP2A	X	-24.815	.5
17	MP2A	Z	-14.327	.5
18	MP2A	Mx	.025	.5
19	MP2A	X	-24.815	4.5
20	MP2A	Z	-14.327	4.5
21	MP2A	Mx	.025	4.5
22	MP2A	X	-24.815	.5
23	MP2A	Z	-14.327	.5
24	MP2A	Mx	.008	.5
25	MP2A	X	-24.815	4.5
26	MP2A	Z	-14.327	4.5
27	MP2A	Mx	.008	4.5
28	M22	X	-2.67	.5
29	M22	Z	-1.541	.5
30	M22	Mx	0	.5
31	M22	X	-10.17	2.5
32	M22	Z	-5.872	2.5
33	M22	Mx	0	2.5
34	MP1A	X	-10.015	3.5
35	MP1A	Z	-5.782	3.5
36	MP1A	Mx	-.005	3.5
37	M23	X	-15.505	1.5
38	M23	Z	-8.952	1.5
39	M23	Mx	0	1.5

**Member Point Loads (BLC 26 : Antenna Wi (330 Deg))**

	Member Label	Direction	Magnitude[lb.k-ft]	Location[ft.-%]
1	MP1A	X	-6.258	1.5
2	MP1A	Z	-10.84	1.5
3	MP1A	Mx	.004	1.5
4	MP3A	X	-8.571	1
5	MP3A	Z	-14.845	1
6	MP3A	Mx	.006	1
7	MP3A	X	-8.571	3
8	MP3A	Z	-14.845	3
9	MP3A	Mx	.006	3
10	MP4A	X	-13.633	.5
11	MP4A	Z	-23.613	.5
12	MP4A	Mx	.009	.5
13	MP4A	X	-13.633	4.5
14	MP4A	Z	-23.613	4.5



Company :  
 Designer :  
 Job Number :  
 Model Name :

June 10, 2021  
 8:10 AM  
 Checked By: \_\_\_\_\_

**Member Point Loads (BLC 26 : Antenna Wi (330 Deg)) (Continued)**

	Member Label	Direction	Magnitude[lb.k-ft]	Location[ft,%]
15	MP4A	Mx	.009	4.5
16	MP2A	X	-17.314	.5
17	MP2A	Z	-29.988	.5
18	MP2A	Mx	.029	.5
19	MP2A	X	-17.314	4.5
20	MP2A	Z	-29.988	4.5
21	MP2A	Mx	.029	4.5
22	MP2A	X	-17.314	.5
23	MP2A	Z	-29.988	.5
24	MP2A	Mx	-.006	.5
25	MP2A	X	-17.314	4.5
26	MP2A	Z	-29.988	4.5
27	MP2A	Mx	-.006	4.5
28	M22	X	-1.669	.5
29	M22	Z	-2.891	.5
30	M22	Mx	0	.5
31	M22	X	-6.513	2.5
32	M22	Z	-11.282	2.5
33	M22	Mx	0	2.5
34	MP1A	X	-7.553	3.5
35	MP1A	Z	-13.082	3.5
36	MP1A	Mx	-.004	3.5
37	M23	X	-9.984	1.5
38	M23	Z	-17.292	1.5
39	M23	Mx	0	1.5

**Member Point Loads (BLC 27 : Antenna Wm (0 Deg))**

	Member Label	Direction	Magnitude[lb.k-ft]	Location[ft,%]
1	MP1A	X	0	1.5
2	MP1A	Z	-4.147	1.5
3	MP1A	Mx	0	1.5
4	MP3A	X	0	1
5	MP3A	Z	-6.369	1
6	MP3A	Mx	0	1
7	MP3A	X	0	3
8	MP3A	Z	-6.369	3
9	MP3A	Mx	0	3
10	MP4A	X	0	.5
11	MP4A	Z	-9.838	.5
12	MP4A	Mx	0	.5
13	MP4A	X	0	4.5
14	MP4A	Z	-9.838	4.5
15	MP4A	Mx	0	4.5
16	MP2A	X	0	.5
17	MP2A	Z	-12.345	.5
18	MP2A	Mx	.007	.5
19	MP2A	X	0	4.5
20	MP2A	Z	-12.345	4.5
21	MP2A	Mx	.007	4.5
22	MP2A	X	0	.5
23	MP2A	Z	-12.345	.5
24	MP2A	Mx	-.007	.5
25	MP2A	X	0	4.5
26	MP2A	Z	-12.345	4.5
27	MP2A	Mx	-.007	4.5
28	M22	X	0	.5





**Member Point Loads (BLC 29 : Antenna Wm (60 Deg)) (Continued)**

	Member Label	Direction	Magnitude[lb.k-ft]	Location[ft.-%]
1	MP1A	X	2.226	1.5
2	MP1A	Z	-1.285	1.5
3	MP1A	Mx	-.001	1.5
4	MP3A	X	2.998	1
5	MP3A	Z	-1.731	1
6	MP3A	Mx	-.002	1
7	MP3A	X	2.998	3
8	MP3A	Z	-1.731	3
9	MP3A	Mx	-.002	3
10	MP4A	X	5.681	.5
11	MP4A	Z	-3.28	.5
12	MP4A	Mx	-.004	.5
13	MP4A	X	5.681	4.5
14	MP4A	Z	-3.28	4.5
15	MP4A	Mx	-.004	4.5
16	MP2A	X	7.939	.5
17	MP2A	Z	-4.584	.5
18	MP2A	Mx	-.003	.5
19	MP2A	X	7.939	4.5
20	MP2A	Z	-4.584	4.5
21	MP2A	Mx	-.003	4.5
22	MP2A	X	7.939	.5
23	MP2A	Z	-4.584	.5
24	MP2A	Mx	-.008	.5
25	MP2A	X	7.939	4.5
26	MP2A	Z	-4.584	4.5
27	MP2A	Mx	-.008	4.5
28	M22	X	.802	.5
29	M22	Z	-.463	.5
30	M22	Mx	0	.5
31	M22	X	4.025	2.5
32	M22	Z	-2.324	2.5
33	M22	Mx	0	2.5
34	MP1A	X	2.88	3.5
35	MP1A	Z	-1.663	3.5
36	MP1A	Mx	.001	3.5
37	M23	X	6.457	1.5
38	M23	Z	-3.728	1.5
39	M23	Mx	0	1.5

**Member Point Loads (BLC 30 : Antenna Wm (90 Deg))**

	Member Label	Direction	Magnitude[lb.k-ft]	Location[ft.-%]
1	MP1A	X	2.045	1.5
2	MP1A	Z	0	1.5
3	MP1A	Mx	-.001	1.5
4	MP3A	X	2.493	1
5	MP3A	Z	0	1
6	MP3A	Mx	-.002	1
7	MP3A	X	2.493	3
8	MP3A	Z	0	3
9	MP3A	Mx	-.002	3
10	MP4A	X	5.468	.5
11	MP4A	Z	0	.5
12	MP4A	Mx	-.004	.5
13	MP4A	X	5.468	4.5
14	MP4A	Z	0	4.5



Company :  
 Designer :  
 Job Number :  
 Model Name :

June 10, 2021  
 8:10 AM  
 Checked By: \_\_\_\_\_

**Member Point Loads (BLC 30 : Antenna Wm (90 Deg)) (Continued)**

	Member Label	Direction	Magnitude[lb.k-ft]	Location[ft,%]
15	MP4A	Mx	-.004	4.5
16	MP2A	X	8.108	.5
17	MP2A	Z	0	.5
18	MP2A	Mx	-.005	.5
19	MP2A	X	8.108	4.5
20	MP2A	Z	0	4.5
21	MP2A	Mx	-.005	4.5
22	MP2A	X	8.108	.5
23	MP2A	Z	0	.5
24	MP2A	Mx	-.005	.5
25	MP2A	X	8.108	4.5
26	MP2A	Z	0	4.5
27	MP2A	Mx	-.005	4.5
28	M22	X	.771	.5
29	M22	Z	0	.5
30	M22	Mx	0	.5
31	M22	X	3.808	2.5
32	M22	Z	0	2.5
33	M22	Mx	0	2.5
34	MP1A	X	2.744	3.5
35	MP1A	Z	0	3.5
36	MP1A	Mx	.001	3.5
37	M23	X	6.052	1.5
38	M23	Z	0	1.5
39	M23	Mx	0	1.5

**Member Point Loads (BLC 31 : Antenna Wm (120 Deg))**

	Member Label	Direction	Magnitude[lb.k-ft]	Location[ft,%]
1	MP1A	X	2.226	1.5
2	MP1A	Z	1.285	1.5
3	MP1A	Mx	-.001	1.5
4	MP3A	X	2.998	1
5	MP3A	Z	1.731	1
6	MP3A	Mx	-.002	1
7	MP3A	X	2.998	3
8	MP3A	Z	1.731	3
9	MP3A	Mx	-.002	3
10	MP4A	X	5.681	.5
11	MP4A	Z	3.28	.5
12	MP4A	Mx	-.004	.5
13	MP4A	X	5.681	4.5
14	MP4A	Z	3.28	4.5
15	MP4A	Mx	-.004	4.5
16	MP2A	X	7.939	.5
17	MP2A	Z	4.584	.5
18	MP2A	Mx	-.008	.5
19	MP2A	X	7.939	4.5
20	MP2A	Z	4.584	4.5
21	MP2A	Mx	-.008	4.5
22	MP2A	X	7.939	.5
23	MP2A	Z	4.584	.5
24	MP2A	Mx	-.003	.5
25	MP2A	X	7.939	4.5
26	MP2A	Z	4.584	4.5
27	MP2A	Mx	-.003	4.5
28	M22	X	.601	.5





Company :  
 Designer :  
 Job Number :  
 Model Name :

June 10, 2021  
 8:10 AM  
 Checked By: \_\_\_\_\_

**Member Point Loads (BLC 33 : Antenna Wm (180 Deg)) (Continued)**

	Member Label	Direction	Magnitude[lb.k-ft]	Location[ft.-%]
1	MP1A	X	0	1.5
2	MP1A	Z	4.147	1.5
3	MP1A	Mx	0	1.5
4	MP3A	X	0	1
5	MP3A	Z	6.369	1
6	MP3A	Mx	0	1
7	MP3A	X	0	3
8	MP3A	Z	6.369	3
9	MP3A	Mx	0	3
10	MP4A	X	0	.5
11	MP4A	Z	9.838	.5
12	MP4A	Mx	0	.5
13	MP4A	X	0	4.5
14	MP4A	Z	9.838	4.5
15	MP4A	Mx	0	4.5
16	MP2A	X	0	.5
17	MP2A	Z	12.345	.5
18	MP2A	Mx	-.007	.5
19	MP2A	X	0	4.5
20	MP2A	Z	12.345	4.5
21	MP2A	Mx	-.007	4.5
22	MP2A	X	0	.5
23	MP2A	Z	12.345	.5
24	MP2A	Mx	.007	.5
25	MP2A	X	0	4.5
26	MP2A	Z	12.345	4.5
27	MP2A	Mx	.007	4.5
28	M22	X	0	.5
29	M22	Z	.926	.5
30	M22	Mx	0	.5
31	M22	X	0	2.5
32	M22	Z	4.648	2.5
33	M22	Mx	0	2.5
34	MP1A	X	0	3.5
35	MP1A	Z	5.068	3.5
36	MP1A	Mx	0	3.5
37	M23	X	0	1.5
38	M23	Z	7.456	1.5
39	M23	Mx	0	1.5

**Member Point Loads (BLC 34 : Antenna Wm (210 Deg))**

	Member Label	Direction	Magnitude[lb.k-ft]	Location[ft.-%]
1	MP1A	X	-1.811	1.5
2	MP1A	Z	3.136	1.5
3	MP1A	Mx	.001	1.5
4	MP3A	X	-2.7	1
5	MP3A	Z	4.677	1
6	MP3A	Mx	.002	1
7	MP3A	X	-2.7	3
8	MP3A	Z	4.677	3
9	MP3A	Mx	.002	3
10	MP4A	X	-4.373	.5
11	MP4A	Z	7.574	.5
12	MP4A	Mx	.003	.5
13	MP4A	X	-4.373	4.5
14	MP4A	Z	7.574	4.5

**Member Point Loads (BLC 34 : Antenna Wm (210 Deg)) (Continued)**

	Member Label	Direction	Magnitude[lb.k-ft]	Location[ft,%]
15	MP4A	Mx	.003	4.5
16	MP2A	X	-5.643	.5
17	MP2A	Z	9.774	.5
18	MP2A	Mx	-.002	.5
19	MP2A	X	-5.643	4.5
20	MP2A	Z	9.774	4.5
21	MP2A	Mx	-.002	4.5
22	MP2A	X	-5.643	.5
23	MP2A	Z	9.774	.5
24	MP2A	Mx	.009	.5
25	MP2A	X	-5.643	4.5
26	MP2A	Z	9.774	4.5
27	MP2A	Mx	.009	4.5
28	M22	X	-.501	.5
29	M22	Z	.868	.5
30	M22	Mx	0	.5
31	M22	X	-2.534	2.5
32	M22	Z	4.389	2.5
33	M22	Mx	0	2.5
34	MP1A	X	-2.243	3.5
35	MP1A	Z	3.886	3.5
36	MP1A	Mx	-.001	3.5
37	M23	X	-4.079	1.5
38	M23	Z	7.065	1.5
39	M23	Mx	0	1.5

**Member Point Loads (BLC 35 : Antenna Wm (240 Deg))**

	Member Label	Direction	Magnitude[lb.k-ft]	Location[ft,%]
1	MP1A	X	-2.226	1.5
2	MP1A	Z	1.285	1.5
3	MP1A	Mx	.001	1.5
4	MP3A	X	-2.998	1
5	MP3A	Z	1.731	1
6	MP3A	Mx	.002	1
7	MP3A	X	-2.998	3
8	MP3A	Z	1.731	3
9	MP3A	Mx	.002	3
10	MP4A	X	-5.681	.5
11	MP4A	Z	3.28	.5
12	MP4A	Mx	.004	.5
13	MP4A	X	-5.681	4.5
14	MP4A	Z	3.28	4.5
15	MP4A	Mx	.004	4.5
16	MP2A	X	-7.939	.5
17	MP2A	Z	4.584	.5
18	MP2A	Mx	.003	.5
19	MP2A	X	-7.939	4.5
20	MP2A	Z	4.584	4.5
21	MP2A	Mx	.003	4.5
22	MP2A	X	-7.939	.5
23	MP2A	Z	4.584	.5
24	MP2A	Mx	.008	.5
25	MP2A	X	-7.939	4.5
26	MP2A	Z	4.584	4.5
27	MP2A	Mx	.008	4.5
28	M22	X	-.802	.5

**Member Point Loads (BLC 35 : Antenna Wm (240 Deg)) (Continued)**

	Member Label	Direction	Magnitude[lb.k-ft]	Location[ft,%]
29	M22	Z	.463	.5
30	M22	Mx	0	.5
31	M22	X	-4.025	2.5
32	M22	Z	2.324	2.5
33	M22	Mx	0	2.5
34	MP1A	X	-2.88	3.5
35	MP1A	Z	1.663	3.5
36	MP1A	Mx	-.001	3.5
37	M23	X	-6.457	1.5
38	M23	Z	3.728	1.5
39	M23	Mx	0	1.5

**Member Point Loads (BLC 36 : Antenna Wm (270 Deg))**

	Member Label	Direction	Magnitude[lb.k-ft]	Location[ft,%]
1	MP1A	X	-2.045	1.5
2	MP1A	Z	0	1.5
3	MP1A	Mx	.001	1.5
4	MP3A	X	-2.493	1
5	MP3A	Z	0	1
6	MP3A	Mx	.002	1
7	MP3A	X	-2.493	3
8	MP3A	Z	0	3
9	MP3A	Mx	.002	3
10	MP4A	X	-5.468	.5
11	MP4A	Z	0	.5
12	MP4A	Mx	.004	.5
13	MP4A	X	-5.468	4.5
14	MP4A	Z	0	4.5
15	MP4A	Mx	.004	4.5
16	MP2A	X	-8.108	.5
17	MP2A	Z	0	.5
18	MP2A	Mx	.005	.5
19	MP2A	X	-8.108	4.5
20	MP2A	Z	0	4.5
21	MP2A	Mx	.005	4.5
22	MP2A	X	-8.108	.5
23	MP2A	Z	0	.5
24	MP2A	Mx	.005	.5
25	MP2A	X	-8.108	4.5
26	MP2A	Z	0	4.5
27	MP2A	Mx	.005	4.5
28	M22	X	-.771	.5
29	M22	Z	0	.5
30	M22	Mx	0	.5
31	M22	X	-3.808	2.5
32	M22	Z	0	2.5
33	M22	Mx	0	2.5
34	MP1A	X	-2.744	3.5
35	MP1A	Z	0	3.5
36	MP1A	Mx	-.001	3.5
37	M23	X	-6.052	1.5
38	M23	Z	0	1.5
39	M23	Mx	0	1.5

**Member Point Loads (BLC 37 : Antenna Wm (300 Deg))**

	Member Label	Direction	Magnitude[lb.k-ft]	Location[ft,%]
--	--------------	-----------	--------------------	----------------



Company :  
 Designer :  
 Job Number :  
 Model Name :

June 10, 2021  
 8:10 AM  
 Checked By: \_\_\_\_\_

**Member Point Loads (BLC 37 : Antenna Wm (300 Deg)) (Continued)**

	Member Label	Direction	Magnitude[lb.k-ft]	Location[ft.-%]
1	MP1A	X	-2.226	1.5
2	MP1A	Z	-1.285	1.5
3	MP1A	Mx	.001	1.5
4	MP3A	X	-2.998	1
5	MP3A	Z	-1.731	1
6	MP3A	Mx	.002	1
7	MP3A	X	-2.998	3
8	MP3A	Z	-1.731	3
9	MP3A	Mx	.002	3
10	MP4A	X	-5.681	.5
11	MP4A	Z	-3.28	.5
12	MP4A	Mx	.004	.5
13	MP4A	X	-5.681	4.5
14	MP4A	Z	-3.28	4.5
15	MP4A	Mx	.004	4.5
16	MP2A	X	-7.939	.5
17	MP2A	Z	-4.584	.5
18	MP2A	Mx	.008	.5
19	MP2A	X	-7.939	4.5
20	MP2A	Z	-4.584	4.5
21	MP2A	Mx	.008	4.5
22	MP2A	X	-7.939	.5
23	MP2A	Z	-4.584	.5
24	MP2A	Mx	.003	.5
25	MP2A	X	-7.939	4.5
26	MP2A	Z	-4.584	4.5
27	MP2A	Mx	.003	4.5
28	M22	X	-601	.5
29	M22	Z	-347	.5
30	M22	Mx	0	.5
31	M22	X	-2.934	2.5
32	M22	Z	-1.694	2.5
33	M22	Mx	0	2.5
34	MP1A	X	-2.88	3.5
35	MP1A	Z	-1.663	3.5
36	MP1A	Mx	-.001	3.5
37	M23	X	-4.633	1.5
38	M23	Z	-2.675	1.5
39	M23	Mx	0	1.5

**Member Point Loads (BLC 38 : Antenna Wm (330 Deg))**

	Member Label	Direction	Magnitude[lb.k-ft]	Location[ft.-%]
1	MP1A	X	-1.811	1.5
2	MP1A	Z	-3.136	1.5
3	MP1A	Mx	.001	1.5
4	MP3A	X	-2.7	1
5	MP3A	Z	-4.677	1
6	MP3A	Mx	.002	1
7	MP3A	X	-2.7	3
8	MP3A	Z	-4.677	3
9	MP3A	Mx	.002	3
10	MP4A	X	-4.373	.5
11	MP4A	Z	-7.574	.5
12	MP4A	Mx	.003	.5
13	MP4A	X	-4.373	4.5
14	MP4A	Z	-7.574	4.5



**Member Point Loads (BLC 38 : Antenna Wm (330 Deg)) (Continued)**

	Member Label	Direction	Magnitude[lb.k-ft]	Location[ft,%]
15	MP4A	Mx	.003	4.5
16	MP2A	X	-5.643	.5
17	MP2A	Z	-9.774	.5
18	MP2A	Mx	.009	.5
19	MP2A	X	-5.643	4.5
20	MP2A	Z	-9.774	4.5
21	MP2A	Mx	.009	4.5
22	MP2A	X	-5.643	.5
23	MP2A	Z	-9.774	.5
24	MP2A	Mx	-.002	.5
25	MP2A	X	-5.643	4.5
26	MP2A	Z	-9.774	4.5
27	MP2A	Mx	-.002	4.5
28	M22	X	-.386	.5
29	M22	Z	-.668	.5
30	M22	Mx	0	.5
31	M22	X	-1.904	2.5
32	M22	Z	-3.298	2.5
33	M22	Mx	0	2.5
34	MP1A	X	-2.243	3.5
35	MP1A	Z	-3.886	3.5
36	MP1A	Mx	-.001	3.5
37	M23	X	-3.026	1.5
38	M23	Z	-5.241	1.5
39	M23	Mx	0	1.5

**Member Point Loads (BLC 77 : Lm1)**

	Member Label	Direction	Magnitude[lb.k-ft]	Location[ft,%]
1	M32	Y	-500	0

**Member Point Loads (BLC 78 : Lm2)**

	Member Label	Direction	Magnitude[lb.k-ft]	Location[ft,%]
1	M37	Y	-500	0

**Member Point Loads (BLC 79 : Lv1)**

	Member Label	Direction	Magnitude[lb.k-ft]	Location[ft,%]
1	M9	Y	-250	%100

**Member Point Loads (BLC 80 : Lv2)**

	Member Label	Direction	Magnitude[lb.k-ft]	Location[ft,%]
1	M9	Y	-250	%50

**Member Distributed Loads (BLC 40 : Structure Di)**

	Member Label	Direction	Start Magnitude[lb/ft,...	End Magnitude[lb/ft,F...	Start Location[ft,%]	End Location[ft,%]
1	M5	Y	-5.76	-5.76	0	%100
2	M6	Y	-5.76	-5.76	0	%100
3	M7	Y	-5.76	-5.76	0	%100
4	M8	Y	-7.709	-7.709	0	%100
5	M9	Y	-7.709	-7.709	0	%100
6	M10	Y	-5.693	-5.693	0	%100
7	MP1A	Y	-5.047	-5.047	0	%100
8	M14	Y	-5.76	-5.76	0	%100
9	M15	Y	-5.693	-5.693	0	%100



Company :  
 Designer :  
 Job Number :  
 Model Name :

June 10, 2021  
 8:10 AM  
 Checked By: \_\_\_\_\_

**Member Distributed Loads (BLC 40 : Structure Di) (Continued)**

	Member Label	Direction	Start Magnitude[lb/ft,...	End Magnitude[lb/ft,F...	Start Location[ft, %]	End Location[ft, %]
10	M17	Y	-5.76	-5.76	0	%100
11	M19	Y	-5.76	-5.76	0	%100
12	M20	Y	-6.701	-6.701	0	%100
13	M21	Y	-6.701	-6.701	0	%100
14	M22	Y	-5.047	-5.047	0	%100
15	M23	Y	-5.047	-5.047	0	%100
16	M24	Y	-2.731	-2.731	0	%100
17	MP2A	Y	-5.76	-5.76	0	%100
18	MP3A	Y	-5.047	-5.047	0	%100
19	MP4A	Y	-5.047	-5.047	0	%100
20	M46	Y	-5.047	-5.047	0	%100
21	M45B	Y	-6.701	-6.701	0	%100
22	M46B	Y	-6.701	-6.701	0	%100

**Member Distributed Loads (BLC 41 : Structure Wo (0 Deg))**

	Member Label	Direction	Start Magnitude[lb/ft,...	End Magnitude[lb/ft,F...	Start Location[ft, %]	End Location[ft, %]
1	M5	X	0	0	0	%100
2	M5	Z	-7.671	-7.671	0	%100
3	M6	X	0	0	0	%100
4	M6	Z	-7.671	-7.671	0	%100
5	M7	X	0	0	0	%100
6	M7	Z	-7.671	-7.671	0	%100
7	M8	X	0	0	0	%100
8	M8	Z	-21.321	-21.321	0	%100
9	M9	X	0	0	0	%100
10	M9	Z	-21.321	-21.321	0	%100
11	M10	X	0	0	0	%100
12	M10	Z	-14.214	-14.214	0	%100
13	MP1A	X	0	0	0	%100
14	MP1A	Z	-10.128	-10.128	0	%100
15	M14	X	0	0	0	%100
16	M14	Z	-7.671	-7.671	0	%100
17	M15	X	0	0	0	%100
18	M15	Z	-14.214	-14.214	0	%100
19	M17	X	0	0	0	%100
20	M17	Z	-12.26	-12.26	0	%100
21	M19	X	0	0	0	%100
22	M19	Z	-12.26	-12.26	0	%100
23	M20	X	0	0	0	%100
24	M20	Z	0	0	0	%100
25	M21	X	0	0	0	%100
26	M21	Z	0	0	0	%100
27	M22	X	0	0	0	%100
28	M22	Z	-8.361	-8.361	0	%100
29	M23	X	0	0	0	%100
30	M23	Z	-8.361	-8.361	0	%100
31	M24	X	0	0	0	%100
32	M24	Z	-2.419	-2.419	0	%100
33	MP2A	X	0	0	0	%100
34	MP2A	Z	-12.26	-12.26	0	%100
35	MP3A	X	0	0	0	%100
36	MP3A	Z	-10.128	-10.128	0	%100
37	MP4A	X	0	0	0	%100
38	MP4A	Z	-10.128	-10.128	0	%100
39	M46	X	0	0	0	%100
40	M46	Z	-4.011	-4.011	0	%100



Company :  
 Designer :  
 Job Number :  
 Model Name :

June 10, 2021  
 8:10 AM  
 Checked By: \_\_\_\_\_

**Member Distributed Loads (BLC 41 : Structure Wo (0 Deg)) (Continued)**

	Member Label	Direction	Start Magnitude[lb/ft,...	End Magnitude[lb/ft,F...	Start Location[ft, %]	End Location[ft, %]
41	M45B	X	0	0	0	%100
42	M45B	Z	-14.303	-14.303	0	%100
43	M46B	X	0	0	0	%100
44	M46B	Z	-14.303	-14.303	0	%100

**Member Distributed Loads (BLC 42 : Structure Wo (30 Deg))**

	Member Label	Direction	Start Magnitude[lb/ft,...	End Magnitude[lb/ft,F...	Start Location[ft, %]	End Location[ft, %]
1	M5	X	1.184	1.184	0	%100
2	M5	Z	-2.051	-2.051	0	%100
3	M6	X	5.308	5.308	0	%100
4	M6	Z	-9.194	-9.194	0	%100
5	M7	X	5.308	5.308	0	%100
6	M7	Z	-9.194	-9.194	0	%100
7	M8	X	7.996	7.996	0	%100
8	M8	Z	-13.849	-13.849	0	%100
9	M9	X	7.996	7.996	0	%100
10	M9	Z	-13.849	-13.849	0	%100
11	M10	X	6.274	6.274	0	%100
12	M10	Z	-10.868	-10.868	0	%100
13	MP1A	X	5.064	5.064	0	%100
14	MP1A	Z	-8.771	-8.771	0	%100
15	M14	X	1.184	1.184	0	%100
16	M14	Z	-2.051	-2.051	0	%100
17	M15	X	6.274	6.274	0	%100
18	M15	Z	-10.868	-10.868	0	%100
19	M17	X	4.597	4.597	0	%100
20	M17	Z	-7.963	-7.963	0	%100
21	M19	X	4.597	4.597	0	%100
22	M19	Z	-7.963	-7.963	0	%100
23	M20	X	1.74	1.74	0	%100
24	M20	Z	-3.013	-3.013	0	%100
25	M21	X	1.74	1.74	0	%100
26	M21	Z	-3.013	-3.013	0	%100
27	M22	X	4.18	4.18	0	%100
28	M22	Z	-7.241	-7.241	0	%100
29	M23	X	4.18	4.18	0	%100
30	M23	Z	-7.241	-7.241	0	%100
31	M24	X	1.307	1.307	0	%100
32	M24	Z	-2.264	-2.264	0	%100
33	MP2A	X	6.13	6.13	0	%100
34	MP2A	Z	-10.617	-10.617	0	%100
35	MP3A	X	5.064	5.064	0	%100
36	MP3A	Z	-8.771	-8.771	0	%100
37	MP4A	X	5.064	5.064	0	%100
38	MP4A	Z	-8.771	-8.771	0	%100
39	M46	X	4.413	4.413	0	%100
40	M46	Z	-7.644	-7.644	0	%100
41	M45B	X	3.601	3.601	0	%100
42	M45B	Z	-6.237	-6.237	0	%100
43	M46B	X	8.884	8.884	0	%100
44	M46B	Z	-15.387	-15.387	0	%100

**Member Distributed Loads (BLC 43 : Structure Wo (60 Deg))**

	Member Label	Direction	Start Magnitude[lb/ft,...	End Magnitude[lb/ft,F...	Start Location[ft, %]	End Location[ft, %]
1	M5	X	.009	.009	0	%100
2	M5	Z	-.005	-.005	0	%100

**Member Distributed Loads (BLC 43 : Structure Wo (60 Deg)) (Continued)**

	Member Label	Direction	Start Magnitude[lb/ft,...	End Magnitude[lb/ft,F...	Start Location[ft, %]	End Location[ft, %]
3	M6	X	7.152	7.152	0	%100
4	M6	Z	-4.129	-4.129	0	%100
5	M7	X	7.152	7.152	0	%100
6	M7	Z	-4.129	-4.129	0	%100
7	M8	X	4.616	4.616	0	%100
8	M8	Z	-2.665	-2.665	0	%100
9	M9	X	4.616	4.616	0	%100
10	M9	Z	-2.665	-2.665	0	%100
11	M10	X	7.983	7.983	0	%100
12	M10	Z	-4.609	-4.609	0	%100
13	MP1A	X	8.771	8.771	0	%100
14	MP1A	Z	-5.064	-5.064	0	%100
15	M14	X	.009	.009	0	%100
16	M14	Z	-.005	-.005	0	%100
17	M15	X	7.983	7.983	0	%100
18	M15	Z	-4.609	-4.609	0	%100
19	M17	X	2.654	2.654	0	%100
20	M17	Z	-1.532	-1.532	0	%100
21	M19	X	2.654	2.654	0	%100
22	M19	Z	-1.532	-1.532	0	%100
23	M20	X	9.04	9.04	0	%100
24	M20	Z	-5.219	-5.219	0	%100
25	M21	X	9.04	9.04	0	%100
26	M21	Z	-5.219	-5.219	0	%100
27	M22	X	7.241	7.241	0	%100
28	M22	Z	-4.18	-4.18	0	%100
29	M23	X	7.241	7.241	0	%100
30	M23	Z	-4.18	-4.18	0	%100
31	M24	X	2.601	2.601	0	%100
32	M24	Z	-1.502	-1.502	0	%100
33	MP2A	X	10.617	10.617	0	%100
34	MP2A	Z	-6.13	-6.13	0	%100
35	MP3A	X	8.771	8.771	0	%100
36	MP3A	Z	-5.064	-5.064	0	%100
37	MP4A	X	8.771	8.771	0	%100
38	MP4A	Z	-5.064	-5.064	0	%100
39	M46	X	8.556	8.556	0	%100
40	M46	Z	-4.94	-4.94	0	%100
41	M45B	X	3.086	3.086	0	%100
42	M45B	Z	-1.782	-1.782	0	%100
43	M46B	X	12.237	12.237	0	%100
44	M46B	Z	-7.065	-7.065	0	%100

**Member Distributed Loads (BLC 44 : Structure Wo (90 Deg))**

	Member Label	Direction	Start Magnitude[lb/ft,...	End Magnitude[lb/ft,F...	Start Location[ft, %]	End Location[ft, %]
1	M5	X	2.955	2.955	0	%100
2	M5	Z	0	0	0	%100
3	M6	X	2.955	2.955	0	%100
4	M6	Z	0	0	0	%100
5	M7	X	2.955	2.955	0	%100
6	M7	Z	0	0	0	%100
7	M8	X	0	0	0	%100
8	M8	Z	0	0	0	%100
9	M9	X	0	0	0	%100
10	M9	Z	0	0	0	%100
11	M10	X	7.552	7.552	0	%100

**Member Distributed Loads (BLC 44 : Structure Wo (90 Deg)) (Continued)**

	Member Label	Direction	Start Magnitude[lb/ft,...	End Magnitude[lb/ft,F...	Start Location[ft, %]	End Location[ft, %]
12	M10	Z	0	0	0	%100
13	MP1A	X	10.128	10.128	0	%100
14	MP1A	Z	0	0	0	%100
15	M14	X	2.955	2.955	0	%100
16	M14	Z	0	0	0	%100
17	M15	X	7.552	7.552	0	%100
18	M15	Z	0	0	0	%100
19	M17	X	0	0	0	%100
20	M17	Z	0	0	0	%100
21	M19	X	0	0	0	%100
22	M19	Z	0	0	0	%100
23	M20	X	13.918	13.918	0	%100
24	M20	Z	0	0	0	%100
25	M21	X	13.918	13.918	0	%100
26	M21	Z	0	0	0	%100
27	M22	X	8.361	8.361	0	%100
28	M22	Z	0	0	0	%100
29	M23	X	8.361	8.361	0	%100
30	M23	Z	0	0	0	%100
31	M24	X	3.198	3.198	0	%100
32	M24	Z	0	0	0	%100
33	MP2A	X	12.26	12.26	0	%100
34	MP2A	Z	0	0	0	%100
35	MP3A	X	10.128	10.128	0	%100
36	MP3A	Z	0	0	0	%100
37	MP4A	X	10.128	10.128	0	%100
38	MP4A	Z	0	0	0	%100
39	M46	X	6.117	6.117	0	%100
40	M46	Z	0	0	0	%100
41	M45B	X	7.028	7.028	0	%100
42	M45B	Z	0	0	0	%100
43	M46B	X	7.028	7.028	0	%100
44	M46B	Z	0	0	0	%100

**Member Distributed Loads (BLC 45 : Structure Wo (120 Deg))**

	Member Label	Direction	Start Magnitude[lb/ft,...	End Magnitude[lb/ft,F...	Start Location[ft, %]	End Location[ft, %]
1	M5	X	7.152	7.152	0	%100
2	M5	Z	4.129	4.129	0	%100
3	M6	X	.009	.009	0	%100
4	M6	Z	.005	.005	0	%100
5	M7	X	.009	.009	0	%100
6	M7	Z	.005	.005	0	%100
7	M8	X	4.616	4.616	0	%100
8	M8	Z	2.665	2.665	0	%100
9	M9	X	4.616	4.616	0	%100
10	M9	Z	2.665	2.665	0	%100
11	M10	X	7.983	7.983	0	%100
12	M10	Z	4.609	4.609	0	%100
13	MP1A	X	8.771	8.771	0	%100
14	MP1A	Z	5.064	5.064	0	%100
15	M14	X	7.152	7.152	0	%100
16	M14	Z	4.129	4.129	0	%100
17	M15	X	7.983	7.983	0	%100
18	M15	Z	4.609	4.609	0	%100
19	M17	X	2.654	2.654	0	%100
20	M17	Z	1.532	1.532	0	%100



Company :  
 Designer :  
 Job Number :  
 Model Name :

June 10, 2021  
 8:10 AM  
 Checked By: \_\_\_\_\_

**Member Distributed Loads (BLC 45 : Structure Wo (120 Deg)) (Continued)**

	Member Label	Direction	Start Magnitude[lb/ft,...	End Magnitude[lb/ft,F...	Start Location[ft, %]	End Location[ft, %]
21	M19	X	2.654	2.654	0	%100
22	M19	Z	1.532	1.532	0	%100
23	M20	X	9.04	9.04	0	%100
24	M20	Z	5.219	5.219	0	%100
25	M21	X	9.04	9.04	0	%100
26	M21	Z	5.219	5.219	0	%100
27	M22	X	7.241	7.241	0	%100
28	M22	Z	4.18	4.18	0	%100
29	M23	X	7.241	7.241	0	%100
30	M23	Z	4.18	4.18	0	%100
31	M24	X	2.601	2.601	0	%100
32	M24	Z	1.502	1.502	0	%100
33	MP2A	X	10.617	10.617	0	%100
34	MP2A	Z	6.13	6.13	0	%100
35	MP3A	X	8.771	8.771	0	%100
36	MP3A	Z	5.064	5.064	0	%100
37	MP4A	X	8.771	8.771	0	%100
38	MP4A	Z	5.064	5.064	0	%100
39	M46	X	1.126	1.126	0	%100
40	M46	Z	.65	.65	0	%100
41	M45B	X	12.237	12.237	0	%100
42	M45B	Z	7.065	7.065	0	%100
43	M46B	X	3.086	3.086	0	%100
44	M46B	Z	1.782	1.782	0	%100

**Member Distributed Loads (BLC 46 : Structure Wo (150 Deg))**

	Member Label	Direction	Start Magnitude[lb/ft,...	End Magnitude[lb/ft,F...	Start Location[ft, %]	End Location[ft, %]
1	M5	X	5.308	5.308	0	%100
2	M5	Z	9.194	9.194	0	%100
3	M6	X	1.184	1.184	0	%100
4	M6	Z	2.051	2.051	0	%100
5	M7	X	1.184	1.184	0	%100
6	M7	Z	2.051	2.051	0	%100
7	M8	X	7.996	7.996	0	%100
8	M8	Z	13.849	13.849	0	%100
9	M9	X	7.996	7.996	0	%100
10	M9	Z	13.849	13.849	0	%100
11	M10	X	6.274	6.274	0	%100
12	M10	Z	10.868	10.868	0	%100
13	MP1A	X	5.064	5.064	0	%100
14	MP1A	Z	8.771	8.771	0	%100
15	M14	X	5.308	5.308	0	%100
16	M14	Z	9.194	9.194	0	%100
17	M15	X	6.274	6.274	0	%100
18	M15	Z	10.868	10.868	0	%100
19	M17	X	4.597	4.597	0	%100
20	M17	Z	7.963	7.963	0	%100
21	M19	X	4.597	4.597	0	%100
22	M19	Z	7.963	7.963	0	%100
23	M20	X	1.74	1.74	0	%100
24	M20	Z	3.013	3.013	0	%100
25	M21	X	1.74	1.74	0	%100
26	M21	Z	3.013	3.013	0	%100
27	M22	X	4.18	4.18	0	%100
28	M22	Z	7.241	7.241	0	%100
29	M23	X	4.18	4.18	0	%100



Company :  
 Designer :  
 Job Number :  
 Model Name :

June 10, 2021  
 8:10 AM  
 Checked By: \_\_\_\_\_

**Member Distributed Loads (BLC 46 : Structure Wo (150 Deg)) (Continued)**

	Member Label	Direction	Start Magnitude[lb/ft,...	End Magnitude[lb/ft,F...	Start Location[ft, %]	End Location[ft, %]
30	M23	Z	7.241	7.241	0	%100
31	M24	X	1.307	1.307	0	%100
32	M24	Z	2.264	2.264	0	%100
33	MP2A	X	6.13	6.13	0	%100
34	MP2A	Z	10.617	10.617	0	%100
35	MP3A	X	5.064	5.064	0	%100
36	MP3A	Z	8.771	8.771	0	%100
37	MP4A	X	5.064	5.064	0	%100
38	MP4A	Z	8.771	8.771	0	%100
39	M46	X	.124	.124	0	%100
40	M46	Z	.215	.215	0	%100
41	M45B	X	8.884	8.884	0	%100
42	M45B	Z	15.387	15.387	0	%100
43	M46B	X	3.601	3.601	0	%100
44	M46B	Z	6.237	6.237	0	%100

**Member Distributed Loads (BLC 47 : Structure Wo (180 Deg))**

	Member Label	Direction	Start Magnitude[lb/ft,...	End Magnitude[lb/ft,F...	Start Location[ft, %]	End Location[ft, %]
1	M5	X	0	0	0	%100
2	M5	Z	7.671	7.671	0	%100
3	M6	X	0	0	0	%100
4	M6	Z	7.671	7.671	0	%100
5	M7	X	0	0	0	%100
6	M7	Z	7.671	7.671	0	%100
7	M8	X	0	0	0	%100
8	M8	Z	21.321	21.321	0	%100
9	M9	X	0	0	0	%100
10	M9	Z	21.321	21.321	0	%100
11	M10	X	0	0	0	%100
12	M10	Z	14.214	14.214	0	%100
13	MP1A	X	0	0	0	%100
14	MP1A	Z	10.128	10.128	0	%100
15	M14	X	0	0	0	%100
16	M14	Z	7.671	7.671	0	%100
17	M15	X	0	0	0	%100
18	M15	Z	14.214	14.214	0	%100
19	M17	X	0	0	0	%100
20	M17	Z	12.26	12.26	0	%100
21	M19	X	0	0	0	%100
22	M19	Z	12.26	12.26	0	%100
23	M20	X	0	0	0	%100
24	M20	Z	0	0	0	%100
25	M21	X	0	0	0	%100
26	M21	Z	0	0	0	%100
27	M22	X	0	0	0	%100
28	M22	Z	8.361	8.361	0	%100
29	M23	X	0	0	0	%100
30	M23	Z	8.361	8.361	0	%100
31	M24	X	0	0	0	%100
32	M24	Z	2.419	2.419	0	%100
33	MP2A	X	0	0	0	%100
34	MP2A	Z	12.26	12.26	0	%100
35	MP3A	X	0	0	0	%100
36	MP3A	Z	10.128	10.128	0	%100
37	MP4A	X	0	0	0	%100
38	MP4A	Z	10.128	10.128	0	%100





Company :  
 Designer :  
 Job Number :  
 Model Name :

June 10, 2021  
 8:10 AM  
 Checked By: \_\_\_\_\_

**Member Distributed Loads (BLC 47 : Structure Wo (180 Deg)) (Continued)**

	Member Label	Direction	Start Magnitude[lb/ft,...	End Magnitude[lb/ft,F...	Start Location[ft, %]	End Location[ft, %]
39	M46	X	0	0	0	%100
40	M46	Z	4.011	4.011	0	%100
41	M45B	X	0	0	0	%100
42	M45B	Z	14.303	14.303	0	%100
43	M46B	X	0	0	0	%100
44	M46B	Z	14.303	14.303	0	%100

**Member Distributed Loads (BLC 48 : Structure Wo (210 Deg))**

	Member Label	Direction	Start Magnitude[lb/ft,...	End Magnitude[lb/ft,F...	Start Location[ft, %]	End Location[ft, %]
1	M5	X	-1.184	-1.184	0	%100
2	M5	Z	2.051	2.051	0	%100
3	M6	X	-5.308	-5.308	0	%100
4	M6	Z	9.194	9.194	0	%100
5	M7	X	-5.308	-5.308	0	%100
6	M7	Z	9.194	9.194	0	%100
7	M8	X	-7.996	-7.996	0	%100
8	M8	Z	13.849	13.849	0	%100
9	M9	X	-7.996	-7.996	0	%100
10	M9	Z	13.849	13.849	0	%100
11	M10	X	-6.274	-6.274	0	%100
12	M10	Z	10.868	10.868	0	%100
13	MP1A	X	-5.064	-5.064	0	%100
14	MP1A	Z	8.771	8.771	0	%100
15	M14	X	-1.184	-1.184	0	%100
16	M14	Z	2.051	2.051	0	%100
17	M15	X	-6.274	-6.274	0	%100
18	M15	Z	10.868	10.868	0	%100
19	M17	X	-4.597	-4.597	0	%100
20	M17	Z	7.963	7.963	0	%100
21	M19	X	-4.597	-4.597	0	%100
22	M19	Z	7.963	7.963	0	%100
23	M20	X	-1.74	-1.74	0	%100
24	M20	Z	3.013	3.013	0	%100
25	M21	X	-1.74	-1.74	0	%100
26	M21	Z	3.013	3.013	0	%100
27	M22	X	-4.18	-4.18	0	%100
28	M22	Z	7.241	7.241	0	%100
29	M23	X	-4.18	-4.18	0	%100
30	M23	Z	7.241	7.241	0	%100
31	M24	X	-1.307	-1.307	0	%100
32	M24	Z	2.264	2.264	0	%100
33	MP2A	X	-6.13	-6.13	0	%100
34	MP2A	Z	10.617	10.617	0	%100
35	MP3A	X	-5.064	-5.064	0	%100
36	MP3A	Z	8.771	8.771	0	%100
37	MP4A	X	-5.064	-5.064	0	%100
38	MP4A	Z	8.771	8.771	0	%100
39	M46	X	-4.413	-4.413	0	%100
40	M46	Z	7.644	7.644	0	%100
41	M45B	X	-3.601	-3.601	0	%100
42	M45B	Z	6.237	6.237	0	%100
43	M46B	X	-8.884	-8.884	0	%100
44	M46B	Z	15.387	15.387	0	%100

**Member Distributed Loads (BLC 49 : Structure Wo (240 Deg))**

	Member Label	Direction	Start Magnitude[lb/ft,...	End Magnitude[lb/ft,F...	Start Location[ft, %]	End Location[ft, %]
--	--------------	-----------	---------------------------	--------------------------	-----------------------	---------------------





Company :  
 Designer :  
 Job Number :  
 Model Name :

June 10, 2021  
 8:10 AM  
 Checked By: \_\_\_\_\_

**Member Distributed Loads (BLC 49 : Structure Wo (240 Deg)) (Continued)**

	Member Label	Direction	Start Magnitude[lb/ft,...	End Magnitude[lb/ft,F...	Start Location[ft, %]	End Location[ft, %]
1	M5	X	-0.009	-0.009	0	%100
2	M5	Z	.005	.005	0	%100
3	M6	X	-7.152	-7.152	0	%100
4	M6	Z	4.129	4.129	0	%100
5	M7	X	-7.152	-7.152	0	%100
6	M7	Z	4.129	4.129	0	%100
7	M8	X	-4.616	-4.616	0	%100
8	M8	Z	2.665	2.665	0	%100
9	M9	X	-4.616	-4.616	0	%100
10	M9	Z	2.665	2.665	0	%100
11	M10	X	-7.983	-7.983	0	%100
12	M10	Z	4.609	4.609	0	%100
13	MP1A	X	-8.771	-8.771	0	%100
14	MP1A	Z	5.064	5.064	0	%100
15	M14	X	-0.009	-0.009	0	%100
16	M14	Z	.005	.005	0	%100
17	M15	X	-7.983	-7.983	0	%100
18	M15	Z	4.609	4.609	0	%100
19	M17	X	-2.654	-2.654	0	%100
20	M17	Z	1.532	1.532	0	%100
21	M19	X	-2.654	-2.654	0	%100
22	M19	Z	1.532	1.532	0	%100
23	M20	X	-9.04	-9.04	0	%100
24	M20	Z	5.219	5.219	0	%100
25	M21	X	-9.04	-9.04	0	%100
26	M21	Z	5.219	5.219	0	%100
27	M22	X	-7.241	-7.241	0	%100
28	M22	Z	4.18	4.18	0	%100
29	M23	X	-7.241	-7.241	0	%100
30	M23	Z	4.18	4.18	0	%100
31	M24	X	-2.601	-2.601	0	%100
32	M24	Z	1.502	1.502	0	%100
33	MP2A	X	-10.617	-10.617	0	%100
34	MP2A	Z	6.13	6.13	0	%100
35	MP3A	X	-8.771	-8.771	0	%100
36	MP3A	Z	5.064	5.064	0	%100
37	MP4A	X	-8.771	-8.771	0	%100
38	MP4A	Z	5.064	5.064	0	%100
39	M46	X	-8.556	-8.556	0	%100
40	M46	Z	4.94	4.94	0	%100
41	M45B	X	-3.086	-3.086	0	%100
42	M45B	Z	1.782	1.782	0	%100
43	M46B	X	-12.237	-12.237	0	%100
44	M46B	Z	7.065	7.065	0	%100

**Member Distributed Loads (BLC 50 : Structure Wo (270 Deg))**

	Member Label	Direction	Start Magnitude[lb/ft,...	End Magnitude[lb/ft,F...	Start Location[ft, %]	End Location[ft, %]
1	M5	X	-2.955	-2.955	0	%100
2	M5	Z	0	0	0	%100
3	M6	X	-2.955	-2.955	0	%100
4	M6	Z	0	0	0	%100
5	M7	X	-2.955	-2.955	0	%100
6	M7	Z	0	0	0	%100
7	M8	X	0	0	0	%100
8	M8	Z	0	0	0	%100
9	M9	X	0	0	0	%100



Company :  
 Designer :  
 Job Number :  
 Model Name :

June 10, 2021  
 8:10 AM  
 Checked By: \_\_\_\_\_

**Member Distributed Loads (BLC 50 : Structure Wo (270 Deg)) (Continued)**

	Member Label	Direction	Start Magnitude[lb/ft,...	End Magnitude[lb/ft,F...	Start Location[ft, %]	End Location[ft, %]
10	M9	Z	0	0	0	%100
11	M10	X	-7.552	-7.552	0	%100
12	M10	Z	0	0	0	%100
13	MP1A	X	-10.128	-10.128	0	%100
14	MP1A	Z	0	0	0	%100
15	M14	X	-2.955	-2.955	0	%100
16	M14	Z	0	0	0	%100
17	M15	X	-7.552	-7.552	0	%100
18	M15	Z	0	0	0	%100
19	M17	X	0	0	0	%100
20	M17	Z	0	0	0	%100
21	M19	X	0	0	0	%100
22	M19	Z	0	0	0	%100
23	M20	X	-13.918	-13.918	0	%100
24	M20	Z	0	0	0	%100
25	M21	X	-13.918	-13.918	0	%100
26	M21	Z	0	0	0	%100
27	M22	X	-8.361	-8.361	0	%100
28	M22	Z	0	0	0	%100
29	M23	X	-8.361	-8.361	0	%100
30	M23	Z	0	0	0	%100
31	M24	X	-3.198	-3.198	0	%100
32	M24	Z	0	0	0	%100
33	MP2A	X	-12.26	-12.26	0	%100
34	MP2A	Z	0	0	0	%100
35	MP3A	X	-10.128	-10.128	0	%100
36	MP3A	Z	0	0	0	%100
37	MP4A	X	-10.128	-10.128	0	%100
38	MP4A	Z	0	0	0	%100
39	M46	X	-6.117	-6.117	0	%100
40	M46	Z	0	0	0	%100
41	M45B	X	-7.028	-7.028	0	%100
42	M45B	Z	0	0	0	%100
43	M46B	X	-7.028	-7.028	0	%100
44	M46B	Z	0	0	0	%100

**Member Distributed Loads (BLC 51 : Structure Wo (300 Deg))**

	Member Label	Direction	Start Magnitude[lb/ft,...	End Magnitude[lb/ft,F...	Start Location[ft, %]	End Location[ft, %]
1	M5	X	-7.152	-7.152	0	%100
2	M5	Z	-4.129	-4.129	0	%100
3	M6	X	-.009	-.009	0	%100
4	M6	Z	-.005	-.005	0	%100
5	M7	X	-.009	-.009	0	%100
6	M7	Z	-.005	-.005	0	%100
7	M8	X	-4.616	-4.616	0	%100
8	M8	Z	-2.665	-2.665	0	%100
9	M9	X	-4.616	-4.616	0	%100
10	M9	Z	-2.665	-2.665	0	%100
11	M10	X	-7.983	-7.983	0	%100
12	M10	Z	-4.609	-4.609	0	%100
13	MP1A	X	-8.771	-8.771	0	%100
14	MP1A	Z	-5.064	-5.064	0	%100
15	M14	X	-7.152	-7.152	0	%100
16	M14	Z	-4.129	-4.129	0	%100
17	M15	X	-7.983	-7.983	0	%100
18	M15	Z	-4.609	-4.609	0	%100

**Member Distributed Loads (BLC 51 : Structure Wo (300 Deg)) (Continued)**

	Member Label	Direction	Start Magnitude[lb/ft,...	End Magnitude[lb/ft,F...	Start Location[ft, %]	End Location[ft, %]
19	M17	X	-2.654	-2.654	0	%100
20	M17	Z	-1.532	-1.532	0	%100
21	M19	X	-2.654	-2.654	0	%100
22	M19	Z	-1.532	-1.532	0	%100
23	M20	X	-9.04	-9.04	0	%100
24	M20	Z	-5.219	-5.219	0	%100
25	M21	X	-9.04	-9.04	0	%100
26	M21	Z	-5.219	-5.219	0	%100
27	M22	X	-7.241	-7.241	0	%100
28	M22	Z	-4.18	-4.18	0	%100
29	M23	X	-7.241	-7.241	0	%100
30	M23	Z	-4.18	-4.18	0	%100
31	M24	X	-2.601	-2.601	0	%100
32	M24	Z	-1.502	-1.502	0	%100
33	MP2A	X	-10.617	-10.617	0	%100
34	MP2A	Z	-6.13	-6.13	0	%100
35	MP3A	X	-8.771	-8.771	0	%100
36	MP3A	Z	-5.064	-5.064	0	%100
37	MP4A	X	-8.771	-8.771	0	%100
38	MP4A	Z	-5.064	-5.064	0	%100
39	M46	X	-1.126	-1.126	0	%100
40	M46	Z	-.65	-.65	0	%100
41	M45B	X	-12.237	-12.237	0	%100
42	M45B	Z	-7.065	-7.065	0	%100
43	M46B	X	-3.086	-3.086	0	%100
44	M46B	Z	-1.782	-1.782	0	%100

**Member Distributed Loads (BLC 52 : Structure Wo (330 Deg))**

	Member Label	Direction	Start Magnitude[lb/ft,...	End Magnitude[lb/ft,F...	Start Location[ft, %]	End Location[ft, %]
1	M5	X	-5.308	-5.308	0	%100
2	M5	Z	-9.194	-9.194	0	%100
3	M6	X	-1.184	-1.184	0	%100
4	M6	Z	-2.051	-2.051	0	%100
5	M7	X	-1.184	-1.184	0	%100
6	M7	Z	-2.051	-2.051	0	%100
7	M8	X	-7.996	-7.996	0	%100
8	M8	Z	-13.849	-13.849	0	%100
9	M9	X	-7.996	-7.996	0	%100
10	M9	Z	-13.849	-13.849	0	%100
11	M10	X	-6.274	-6.274	0	%100
12	M10	Z	-10.868	-10.868	0	%100
13	MP1A	X	-5.064	-5.064	0	%100
14	MP1A	Z	-8.771	-8.771	0	%100
15	M14	X	-5.308	-5.308	0	%100
16	M14	Z	-9.194	-9.194	0	%100
17	M15	X	-6.274	-6.274	0	%100
18	M15	Z	-10.868	-10.868	0	%100
19	M17	X	-4.597	-4.597	0	%100
20	M17	Z	-7.963	-7.963	0	%100
21	M19	X	-4.597	-4.597	0	%100
22	M19	Z	-7.963	-7.963	0	%100
23	M20	X	-1.74	-1.74	0	%100
24	M20	Z	-3.013	-3.013	0	%100
25	M21	X	-1.74	-1.74	0	%100
26	M21	Z	-3.013	-3.013	0	%100
27	M22	X	-4.18	-4.18	0	%100

**Member Distributed Loads (BLC 52 : Structure Wo (330 Deg)) (Continued)**

	Member Label	Direction	Start Magnitude[lb/ft,...	End Magnitude[lb/ft,F...	Start Location[ft, %]	End Location[ft, %]
28	M22	Z	-7.241	-7.241	0	%100
29	M23	X	-4.18	-4.18	0	%100
30	M23	Z	-7.241	-7.241	0	%100
31	M24	X	-1.307	-1.307	0	%100
32	M24	Z	-2.264	-2.264	0	%100
33	MP2A	X	-6.13	-6.13	0	%100
34	MP2A	Z	-10.617	-10.617	0	%100
35	MP3A	X	-5.064	-5.064	0	%100
36	MP3A	Z	-8.771	-8.771	0	%100
37	MP4A	X	-5.064	-5.064	0	%100
38	MP4A	Z	-8.771	-8.771	0	%100
39	M46	X	-1.124	-1.124	0	%100
40	M46	Z	-.215	-.215	0	%100
41	M45B	X	-8.884	-8.884	0	%100
42	M45B	Z	-15.387	-15.387	0	%100
43	M46B	X	-3.601	-3.601	0	%100
44	M46B	Z	-6.237	-6.237	0	%100

**Member Distributed Loads (BLC 53 : Structure Wi (0 Deg))**

	Member Label	Direction	Start Magnitude[lb/ft,...	End Magnitude[lb/ft,F...	Start Location[ft, %]	End Location[ft, %]
1	M5	X	0	0	0	%100
2	M5	Z	-2.55	-2.55	0	%100
3	M6	X	0	0	0	%100
4	M6	Z	-2.55	-2.55	0	%100
5	M7	X	0	0	0	%100
6	M7	Z	-2.55	-2.55	0	%100
7	M8	X	0	0	0	%100
8	M8	Z	-5.52	-5.52	0	%100
9	M9	X	0	0	0	%100
10	M9	Z	-5.52	-5.52	0	%100
11	M10	X	0	0	0	%100
12	M10	Z	-4.16	-4.16	0	%100
13	MP1A	X	0	0	0	%100
14	MP1A	Z	-3.544	-3.544	0	%100
15	M14	X	0	0	0	%100
16	M14	Z	-2.55	-2.55	0	%100
17	M15	X	0	0	0	%100
18	M15	Z	-4.16	-4.16	0	%100
19	M17	X	0	0	0	%100
20	M17	Z	-3.921	-3.921	0	%100
21	M19	X	0	0	0	%100
22	M19	Z	-3.921	-3.921	0	%100
23	M20	X	0	0	0	%100
24	M20	Z	0	0	0	%100
25	M21	X	0	0	0	%100
26	M21	Z	0	0	0	%100
27	M22	X	0	0	0	%100
28	M22	Z	-2.935	-2.935	0	%100
29	M23	X	0	0	0	%100
30	M23	Z	-2.935	-2.935	0	%100
31	M24	X	0	0	0	%100
32	M24	Z	-1.589	-1.589	0	%100
33	MP2A	X	0	0	0	%100
34	MP2A	Z	-3.921	-3.921	0	%100
35	MP3A	X	0	0	0	%100
36	MP3A	Z	-3.544	-3.544	0	%100

**Member Distributed Loads (BLC 53 : Structure Wi (0 Deg)) (Continued)**

	Member Label	Direction	Start Magnitude[lb/ft,...	End Magnitude[lb/ft,F...	Start Location[ft, %]	End Location[ft, %]
37	MP4A	X	0	0	0	%100
38	MP4A	Z	-3.544	-3.544	0	%100
39	M46	X	0	0	0	%100
40	M46	Z	-1.404	-1.404	0	%100
41	M45B	X	0	0	0	%100
42	M45B	Z	-3.939	-3.939	0	%100
43	M46B	X	0	0	0	%100
44	M46B	Z	-3.939	-3.939	0	%100

**Member Distributed Loads (BLC 54 : Structure Wi (30 Deg))**

	Member Label	Direction	Start Magnitude[lb/ft,...	End Magnitude[lb/ft,F...	Start Location[ft, %]	End Location[ft, %]
1	M5	X	.394	.394	0	%100
2	M5	Z	-.682	-.682	0	%100
3	M6	X	1.765	1.765	0	%100
4	M6	Z	-3.057	-3.057	0	%100
5	M7	X	1.765	1.765	0	%100
6	M7	Z	-3.057	-3.057	0	%100
7	M8	X	2.07	2.07	0	%100
8	M8	Z	-3.586	-3.586	0	%100
9	M9	X	2.07	2.07	0	%100
10	M9	Z	-3.586	-3.586	0	%100
11	M10	X	1.836	1.836	0	%100
12	M10	Z	-3.181	-3.181	0	%100
13	MP1A	X	1.772	1.772	0	%100
14	MP1A	Z	-3.069	-3.069	0	%100
15	M14	X	.394	.394	0	%100
16	M14	Z	-.682	-.682	0	%100
17	M15	X	1.836	1.836	0	%100
18	M15	Z	-3.181	-3.181	0	%100
19	M17	X	1.47	1.47	0	%100
20	M17	Z	-2.547	-2.547	0	%100
21	M19	X	1.47	1.47	0	%100
22	M19	Z	-2.547	-2.547	0	%100
23	M20	X	.477	.477	0	%100
24	M20	Z	-.827	-.827	0	%100
25	M21	X	.477	.477	0	%100
26	M21	Z	-.827	-.827	0	%100
27	M22	X	1.468	1.468	0	%100
28	M22	Z	-2.542	-2.542	0	%100
29	M23	X	1.468	1.468	0	%100
30	M23	Z	-2.542	-2.542	0	%100
31	M24	X	.859	.859	0	%100
32	M24	Z	-1.487	-1.487	0	%100
33	MP2A	X	1.96	1.96	0	%100
34	MP2A	Z	-3.395	-3.395	0	%100
35	MP3A	X	1.772	1.772	0	%100
36	MP3A	Z	-3.069	-3.069	0	%100
37	MP4A	X	1.772	1.772	0	%100
38	MP4A	Z	-3.069	-3.069	0	%100
39	M46	X	1.545	1.545	0	%100
40	M46	Z	-2.675	-2.675	0	%100
41	M45B	X	.992	.992	0	%100
42	M45B	Z	-1.717	-1.717	0	%100
43	M46B	X	2.446	2.446	0	%100
44	M46B	Z	-4.237	-4.237	0	%100



Company :  
 Designer :  
 Job Number :  
 Model Name :

June 10, 2021  
 8:10 AM  
 Checked By: \_\_\_\_\_

**Member Distributed Loads (BLC 55 : Structure Wi (60 Deg))**

	Member Label	Direction	Start Magnitude[lb/ft,...	End Magnitude[lb/ft,F...	Start Location[ft, %]	End Location[ft, %]
1	M5	X	.003	.003	0	%100
2	M5	Z	-.002	-.002	0	%100
3	M6	X	2.378	2.378	0	%100
4	M6	Z	-1.373	-1.373	0	%100
5	M7	X	2.378	2.378	0	%100
6	M7	Z	-1.373	-1.373	0	%100
7	M8	X	1.195	1.195	0	%100
8	M8	Z	-.69	-.69	0	%100
9	M9	X	1.195	1.195	0	%100
10	M9	Z	-.69	-.69	0	%100
11	M10	X	2.336	2.336	0	%100
12	M10	Z	-1.349	-1.349	0	%100
13	MP1A	X	3.069	3.069	0	%100
14	MP1A	Z	-1.772	-1.772	0	%100
15	M14	X	.003	.003	0	%100
16	M14	Z	-.002	-.002	0	%100
17	M15	X	2.336	2.336	0	%100
18	M15	Z	-1.349	-1.349	0	%100
19	M17	X	.849	.849	0	%100
20	M17	Z	-.49	-.49	0	%100
21	M19	X	.849	.849	0	%100
22	M19	Z	-.49	-.49	0	%100
23	M20	X	2.48	2.48	0	%100
24	M20	Z	-1.432	-1.432	0	%100
25	M21	X	2.48	2.48	0	%100
26	M21	Z	-1.432	-1.432	0	%100
27	M22	X	2.542	2.542	0	%100
28	M22	Z	-1.468	-1.468	0	%100
29	M23	X	2.542	2.542	0	%100
30	M23	Z	-1.468	-1.468	0	%100
31	M24	X	1.709	1.709	0	%100
32	M24	Z	-.986	-.986	0	%100
33	MP2A	X	3.395	3.395	0	%100
34	MP2A	Z	-1.96	-1.96	0	%100
35	MP3A	X	3.069	3.069	0	%100
36	MP3A	Z	-1.772	-1.772	0	%100
37	MP4A	X	3.069	3.069	0	%100
38	MP4A	Z	-1.772	-1.772	0	%100
39	M46	X	2.994	2.994	0	%100
40	M46	Z	-1.729	-1.729	0	%100
41	M45B	X	.85	.85	0	%100
42	M45B	Z	-.491	-.491	0	%100
43	M46B	X	3.37	3.37	0	%100
44	M46B	Z	-1.946	-1.946	0	%100

**Member Distributed Loads (BLC 56 : Structure Wi (90 Deg))**

	Member Label	Direction	Start Magnitude[lb/ft,...	End Magnitude[lb/ft,F...	Start Location[ft, %]	End Location[ft, %]
1	M5	X	.983	.983	0	%100
2	M5	Z	0	0	0	%100
3	M6	X	.983	.983	0	%100
4	M6	Z	0	0	0	%100
5	M7	X	.983	.983	0	%100
6	M7	Z	0	0	0	%100
7	M8	X	0	0	0	%100
8	M8	Z	0	0	0	%100
9	M9	X	0	0	0	%100



Company :  
 Designer :  
 Job Number :  
 Model Name :

June 10, 2021  
 8:10 AM  
 Checked By: \_\_\_\_\_

**Member Distributed Loads (BLC 56 : Structure Wi (90 Deg)) (Continued)**

	Member Label	Direction	Start Magnitude[lb/ft,...	End Magnitude[lb/ft,F...	Start Location[ft, %]	End Location[ft, %]
10	M9	Z	0	0	0	%100
11	M10	X	2.21	2.21	0	%100
12	M10	Z	0	0	0	%100
13	MP1A	X	3.544	3.544	0	%100
14	MP1A	Z	0	0	0	%100
15	M14	X	.983	.983	0	%100
16	M14	Z	0	0	0	%100
17	M15	X	2.21	2.21	0	%100
18	M15	Z	0	0	0	%100
19	M17	X	0	0	0	%100
20	M17	Z	0	0	0	%100
21	M19	X	0	0	0	%100
22	M19	Z	0	0	0	%100
23	M20	X	3.819	3.819	0	%100
24	M20	Z	0	0	0	%100
25	M21	X	3.819	3.819	0	%100
26	M21	Z	0	0	0	%100
27	M22	X	2.935	2.935	0	%100
28	M22	Z	0	0	0	%100
29	M23	X	2.935	2.935	0	%100
30	M23	Z	0	0	0	%100
31	M24	X	2.101	2.101	0	%100
32	M24	Z	0	0	0	%100
33	MP2A	X	3.921	3.921	0	%100
34	MP2A	Z	0	0	0	%100
35	MP3A	X	3.544	3.544	0	%100
36	MP3A	Z	0	0	0	%100
37	MP4A	X	3.544	3.544	0	%100
38	MP4A	Z	0	0	0	%100
39	M46	X	2.141	2.141	0	%100
40	M46	Z	0	0	0	%100
41	M45B	X	1.935	1.935	0	%100
42	M45B	Z	0	0	0	%100
43	M46B	X	1.935	1.935	0	%100
44	M46B	Z	0	0	0	%100

**Member Distributed Loads (BLC 57 : Structure Wi (120 Deg))**

	Member Label	Direction	Start Magnitude[lb/ft,...	End Magnitude[lb/ft,F...	Start Location[ft, %]	End Location[ft, %]
1	M5	X	2.378	2.378	0	%100
2	M5	Z	1.373	1.373	0	%100
3	M6	X	.003	.003	0	%100
4	M6	Z	.002	.002	0	%100
5	M7	X	.003	.003	0	%100
6	M7	Z	.002	.002	0	%100
7	M8	X	1.195	1.195	0	%100
8	M8	Z	.69	.69	0	%100
9	M9	X	1.195	1.195	0	%100
10	M9	Z	.69	.69	0	%100
11	M10	X	2.336	2.336	0	%100
12	M10	Z	1.349	1.349	0	%100
13	MP1A	X	3.069	3.069	0	%100
14	MP1A	Z	1.772	1.772	0	%100
15	M14	X	2.378	2.378	0	%100
16	M14	Z	1.373	1.373	0	%100
17	M15	X	2.336	2.336	0	%100
18	M15	Z	1.349	1.349	0	%100



**Member Distributed Loads (BLC 57 : Structure Wi (120 Deg)) (Continued)**

	Member Label	Direction	Start Magnitude[lb/ft,...	End Magnitude[lb/ft,F...	Start Location[ft, %]	End Location[ft, %]
19	M17	X	.849	.849	0	%100
20	M17	Z	.49	.49	0	%100
21	M19	X	.849	.849	0	%100
22	M19	Z	.49	.49	0	%100
23	M20	X	2.48	2.48	0	%100
24	M20	Z	1.432	1.432	0	%100
25	M21	X	2.48	2.48	0	%100
26	M21	Z	1.432	1.432	0	%100
27	M22	X	2.542	2.542	0	%100
28	M22	Z	1.468	1.468	0	%100
29	M23	X	2.542	2.542	0	%100
30	M23	Z	1.468	1.468	0	%100
31	M24	X	1.709	1.709	0	%100
32	M24	Z	.986	.986	0	%100
33	MP2A	X	3.395	3.395	0	%100
34	MP2A	Z	1.96	1.96	0	%100
35	MP3A	X	3.069	3.069	0	%100
36	MP3A	Z	1.772	1.772	0	%100
37	MP4A	X	3.069	3.069	0	%100
38	MP4A	Z	1.772	1.772	0	%100
39	M46	X	.394	.394	0	%100
40	M46	Z	.228	.228	0	%100
41	M45B	X	3.37	3.37	0	%100
42	M45B	Z	1.946	1.946	0	%100
43	M46B	X	.85	.85	0	%100
44	M46B	Z	.491	.491	0	%100

**Member Distributed Loads (BLC 58 : Structure Wi (150 Deg))**

	Member Label	Direction	Start Magnitude[lb/ft,...	End Magnitude[lb/ft,F...	Start Location[ft, %]	End Location[ft, %]
1	M5	X	1.765	1.765	0	%100
2	M5	Z	3.057	3.057	0	%100
3	M6	X	.394	.394	0	%100
4	M6	Z	.682	.682	0	%100
5	M7	X	.394	.394	0	%100
6	M7	Z	.682	.682	0	%100
7	M8	X	2.07	2.07	0	%100
8	M8	Z	3.586	3.586	0	%100
9	M9	X	2.07	2.07	0	%100
10	M9	Z	3.586	3.586	0	%100
11	M10	X	1.836	1.836	0	%100
12	M10	Z	3.181	3.181	0	%100
13	MP1A	X	1.772	1.772	0	%100
14	MP1A	Z	3.069	3.069	0	%100
15	M14	X	1.765	1.765	0	%100
16	M14	Z	3.057	3.057	0	%100
17	M15	X	1.836	1.836	0	%100
18	M15	Z	3.181	3.181	0	%100
19	M17	X	1.47	1.47	0	%100
20	M17	Z	2.547	2.547	0	%100
21	M19	X	1.47	1.47	0	%100
22	M19	Z	2.547	2.547	0	%100
23	M20	X	.477	.477	0	%100
24	M20	Z	.827	.827	0	%100
25	M21	X	.477	.477	0	%100
26	M21	Z	.827	.827	0	%100
27	M22	X	1.468	1.468	0	%100





Company :  
 Designer :  
 Job Number :  
 Model Name :

June 10, 2021  
 8:10 AM  
 Checked By: \_\_\_\_\_

**Member Distributed Loads (BLC 58 : Structure Wi (150 Deg)) (Continued)**

	Member Label	Direction	Start Magnitude[lb/ft,...	End Magnitude[lb/ft,F...	Start Location[ft, %]	End Location[ft, %]
28	M22	Z	2.542	2.542	0	%100
29	M23	X	1.468	1.468	0	%100
30	M23	Z	2.542	2.542	0	%100
31	M24	X	.859	.859	0	%100
32	M24	Z	1.487	1.487	0	%100
33	MP2A	X	1.96	1.96	0	%100
34	MP2A	Z	3.395	3.395	0	%100
35	MP3A	X	1.772	1.772	0	%100
36	MP3A	Z	3.069	3.069	0	%100
37	MP4A	X	1.772	1.772	0	%100
38	MP4A	Z	3.069	3.069	0	%100
39	M46	X	.043	.043	0	%100
40	M46	Z	.075	.075	0	%100
41	M45B	X	2.446	2.446	0	%100
42	M45B	Z	4.237	4.237	0	%100
43	M46B	X	.992	.992	0	%100
44	M46B	Z	1.717	1.717	0	%100

**Member Distributed Loads (BLC 59 : Structure Wi (180 Deg))**

	Member Label	Direction	Start Magnitude[lb/ft,...	End Magnitude[lb/ft,F...	Start Location[ft, %]	End Location[ft, %]
1	M5	X	0	0	0	%100
2	M5	Z	2.55	2.55	0	%100
3	M6	X	0	0	0	%100
4	M6	Z	2.55	2.55	0	%100
5	M7	X	0	0	0	%100
6	M7	Z	2.55	2.55	0	%100
7	M8	X	0	0	0	%100
8	M8	Z	5.52	5.52	0	%100
9	M9	X	0	0	0	%100
10	M9	Z	5.52	5.52	0	%100
11	M10	X	0	0	0	%100
12	M10	Z	4.16	4.16	0	%100
13	MP1A	X	0	0	0	%100
14	MP1A	Z	3.544	3.544	0	%100
15	M14	X	0	0	0	%100
16	M14	Z	2.55	2.55	0	%100
17	M15	X	0	0	0	%100
18	M15	Z	4.16	4.16	0	%100
19	M17	X	0	0	0	%100
20	M17	Z	3.921	3.921	0	%100
21	M19	X	0	0	0	%100
22	M19	Z	3.921	3.921	0	%100
23	M20	X	0	0	0	%100
24	M20	Z	0	0	0	%100
25	M21	X	0	0	0	%100
26	M21	Z	0	0	0	%100
27	M22	X	0	0	0	%100
28	M22	Z	2.935	2.935	0	%100
29	M23	X	0	0	0	%100
30	M23	Z	2.935	2.935	0	%100
31	M24	X	0	0	0	%100
32	M24	Z	1.589	1.589	0	%100
33	MP2A	X	0	0	0	%100
34	MP2A	Z	3.921	3.921	0	%100
35	MP3A	X	0	0	0	%100
36	MP3A	Z	3.544	3.544	0	%100

**Member Distributed Loads (BLC 59 : Structure Wi (180 Deg)) (Continued)**

	Member Label	Direction	Start Magnitude[lb/ft,...	End Magnitude[lb/ft,F...	Start Location[ft, %]	End Location[ft, %]
37	MP4A	X	0	0	0	%100
38	MP4A	Z	3.544	3.544	0	%100
39	M46	X	0	0	0	%100
40	M46	Z	1.404	1.404	0	%100
41	M45B	X	0	0	0	%100
42	M45B	Z	3.939	3.939	0	%100
43	M46B	X	0	0	0	%100
44	M46B	Z	3.939	3.939	0	%100

**Member Distributed Loads (BLC 60 : Structure Wi (210 Deg))**

	Member Label	Direction	Start Magnitude[lb/ft,...	End Magnitude[lb/ft,F...	Start Location[ft, %]	End Location[ft, %]
1	M5	X	-0.394	-0.394	0	%100
2	M5	Z	0.682	0.682	0	%100
3	M6	X	-1.765	-1.765	0	%100
4	M6	Z	3.057	3.057	0	%100
5	M7	X	-1.765	-1.765	0	%100
6	M7	Z	3.057	3.057	0	%100
7	M8	X	-2.07	-2.07	0	%100
8	M8	Z	3.586	3.586	0	%100
9	M9	X	-2.07	-2.07	0	%100
10	M9	Z	3.586	3.586	0	%100
11	M10	X	-1.836	-1.836	0	%100
12	M10	Z	3.181	3.181	0	%100
13	MP1A	X	-1.772	-1.772	0	%100
14	MP1A	Z	3.069	3.069	0	%100
15	M14	X	-0.394	-0.394	0	%100
16	M14	Z	0.682	0.682	0	%100
17	M15	X	-1.836	-1.836	0	%100
18	M15	Z	3.181	3.181	0	%100
19	M17	X	-1.47	-1.47	0	%100
20	M17	Z	2.547	2.547	0	%100
21	M19	X	-1.47	-1.47	0	%100
22	M19	Z	2.547	2.547	0	%100
23	M20	X	-0.477	-0.477	0	%100
24	M20	Z	0.827	0.827	0	%100
25	M21	X	-0.477	-0.477	0	%100
26	M21	Z	0.827	0.827	0	%100
27	M22	X	-1.468	-1.468	0	%100
28	M22	Z	2.542	2.542	0	%100
29	M23	X	-1.468	-1.468	0	%100
30	M23	Z	2.542	2.542	0	%100
31	M24	X	-0.859	-0.859	0	%100
32	M24	Z	1.487	1.487	0	%100
33	MP2A	X	-1.96	-1.96	0	%100
34	MP2A	Z	3.395	3.395	0	%100
35	MP3A	X	-1.772	-1.772	0	%100
36	MP3A	Z	3.069	3.069	0	%100
37	MP4A	X	-1.772	-1.772	0	%100
38	MP4A	Z	3.069	3.069	0	%100
39	M46	X	-1.545	-1.545	0	%100
40	M46	Z	2.675	2.675	0	%100
41	M45B	X	-0.992	-0.992	0	%100
42	M45B	Z	1.717	1.717	0	%100
43	M46B	X	-2.446	-2.446	0	%100
44	M46B	Z	4.237	4.237	0	%100

**Member Distributed Loads (BLC 61 : Structure Wi (240 Deg))**

	Member Label	Direction	Start Magnitude[lb/ft,...	End Magnitude[lb/ft,F...	Start Location[ft, %]	End Location[ft, %]
1	M5	X	-0.003	-0.003	0	%100
2	M5	Z	.002	.002	0	%100
3	M6	X	-2.378	-2.378	0	%100
4	M6	Z	1.373	1.373	0	%100
5	M7	X	-2.378	-2.378	0	%100
6	M7	Z	1.373	1.373	0	%100
7	M8	X	-1.195	-1.195	0	%100
8	M8	Z	.69	.69	0	%100
9	M9	X	-1.195	-1.195	0	%100
10	M9	Z	.69	.69	0	%100
11	M10	X	-2.336	-2.336	0	%100
12	M10	Z	1.349	1.349	0	%100
13	MP1A	X	-3.069	-3.069	0	%100
14	MP1A	Z	1.772	1.772	0	%100
15	M14	X	-0.003	-0.003	0	%100
16	M14	Z	.002	.002	0	%100
17	M15	X	-2.336	-2.336	0	%100
18	M15	Z	1.349	1.349	0	%100
19	M17	X	-.849	-.849	0	%100
20	M17	Z	.49	.49	0	%100
21	M19	X	-.849	-.849	0	%100
22	M19	Z	.49	.49	0	%100
23	M20	X	-2.48	-2.48	0	%100
24	M20	Z	1.432	1.432	0	%100
25	M21	X	-2.48	-2.48	0	%100
26	M21	Z	1.432	1.432	0	%100
27	M22	X	-2.542	-2.542	0	%100
28	M22	Z	1.468	1.468	0	%100
29	M23	X	-2.542	-2.542	0	%100
30	M23	Z	1.468	1.468	0	%100
31	M24	X	-1.709	-1.709	0	%100
32	M24	Z	.986	.986	0	%100
33	MP2A	X	-3.395	-3.395	0	%100
34	MP2A	Z	1.96	1.96	0	%100
35	MP3A	X	-3.069	-3.069	0	%100
36	MP3A	Z	1.772	1.772	0	%100
37	MP4A	X	-3.069	-3.069	0	%100
38	MP4A	Z	1.772	1.772	0	%100
39	M46	X	-2.994	-2.994	0	%100
40	M46	Z	1.729	1.729	0	%100
41	M45B	X	-.85	-.85	0	%100
42	M45B	Z	.491	.491	0	%100
43	M46B	X	-3.37	-3.37	0	%100
44	M46B	Z	1.946	1.946	0	%100

**Member Distributed Loads (BLC 62 : Structure Wi (270 Deg))**

	Member Label	Direction	Start Magnitude[lb/ft,...	End Magnitude[lb/ft,F...	Start Location[ft, %]	End Location[ft, %]
1	M5	X	-.983	-.983	0	%100
2	M5	Z	0	0	0	%100
3	M6	X	-.983	-.983	0	%100
4	M6	Z	0	0	0	%100
5	M7	X	-.983	-.983	0	%100
6	M7	Z	0	0	0	%100
7	M8	X	0	0	0	%100
8	M8	Z	0	0	0	%100
9	M9	X	0	0	0	%100



Company :  
 Designer :  
 Job Number :  
 Model Name :

June 10, 2021  
 8:10 AM  
 Checked By: \_\_\_\_\_

**Member Distributed Loads (BLC 62 : Structure Wi (270 Deg)) (Continued)**

	Member Label	Direction	Start Magnitude[lb/ft,...	End Magnitude[lb/ft,F...	Start Location[ft, %]	End Location[ft, %]
10	M9	Z	0	0	0	%100
11	M10	X	-2.21	-2.21	0	%100
12	M10	Z	0	0	0	%100
13	MP1A	X	-3.544	-3.544	0	%100
14	MP1A	Z	0	0	0	%100
15	M14	X	-.983	-.983	0	%100
16	M14	Z	0	0	0	%100
17	M15	X	-2.21	-2.21	0	%100
18	M15	Z	0	0	0	%100
19	M17	X	0	0	0	%100
20	M17	Z	0	0	0	%100
21	M19	X	0	0	0	%100
22	M19	Z	0	0	0	%100
23	M20	X	-3.819	-3.819	0	%100
24	M20	Z	0	0	0	%100
25	M21	X	-3.819	-3.819	0	%100
26	M21	Z	0	0	0	%100
27	M22	X	-2.935	-2.935	0	%100
28	M22	Z	0	0	0	%100
29	M23	X	-2.935	-2.935	0	%100
30	M23	Z	0	0	0	%100
31	M24	X	-2.101	-2.101	0	%100
32	M24	Z	0	0	0	%100
33	MP2A	X	-3.921	-3.921	0	%100
34	MP2A	Z	0	0	0	%100
35	MP3A	X	-3.544	-3.544	0	%100
36	MP3A	Z	0	0	0	%100
37	MP4A	X	-3.544	-3.544	0	%100
38	MP4A	Z	0	0	0	%100
39	M46	X	-2.141	-2.141	0	%100
40	M46	Z	0	0	0	%100
41	M45B	X	-1.935	-1.935	0	%100
42	M45B	Z	0	0	0	%100
43	M46B	X	-1.935	-1.935	0	%100
44	M46B	Z	0	0	0	%100

**Member Distributed Loads (BLC 63 : Structure Wi (300 Deg))**

	Member Label	Direction	Start Magnitude[lb/ft,...	End Magnitude[lb/ft,F...	Start Location[ft, %]	End Location[ft, %]
1	M5	X	-2.378	-2.378	0	%100
2	M5	Z	-1.373	-1.373	0	%100
3	M6	X	-.003	-.003	0	%100
4	M6	Z	-.002	-.002	0	%100
5	M7	X	-.003	-.003	0	%100
6	M7	Z	-.002	-.002	0	%100
7	M8	X	-1.195	-1.195	0	%100
8	M8	Z	-.69	-.69	0	%100
9	M9	X	-1.195	-1.195	0	%100
10	M9	Z	-.69	-.69	0	%100
11	M10	X	-2.336	-2.336	0	%100
12	M10	Z	-1.349	-1.349	0	%100
13	MP1A	X	-3.069	-3.069	0	%100
14	MP1A	Z	-1.772	-1.772	0	%100
15	M14	X	-2.378	-2.378	0	%100
16	M14	Z	-1.373	-1.373	0	%100
17	M15	X	-2.336	-2.336	0	%100
18	M15	Z	-1.349	-1.349	0	%100

**Member Distributed Loads (BLC 63 : Structure Wi (300 Deg)) (Continued)**

	Member Label	Direction	Start Magnitude[lb/ft,...	End Magnitude[lb/ft,F...	Start Location[ft, %]	End Location[ft, %]
19	M17	X	-0.849	-0.849	0	%100
20	M17	Z	-0.49	-0.49	0	%100
21	M19	X	-0.849	-0.849	0	%100
22	M19	Z	-0.49	-0.49	0	%100
23	M20	X	-2.48	-2.48	0	%100
24	M20	Z	-1.432	-1.432	0	%100
25	M21	X	-2.48	-2.48	0	%100
26	M21	Z	-1.432	-1.432	0	%100
27	M22	X	-2.542	-2.542	0	%100
28	M22	Z	-1.468	-1.468	0	%100
29	M23	X	-2.542	-2.542	0	%100
30	M23	Z	-1.468	-1.468	0	%100
31	M24	X	-1.709	-1.709	0	%100
32	M24	Z	-0.986	-0.986	0	%100
33	MP2A	X	-3.395	-3.395	0	%100
34	MP2A	Z	-1.96	-1.96	0	%100
35	MP3A	X	-3.069	-3.069	0	%100
36	MP3A	Z	-1.772	-1.772	0	%100
37	MP4A	X	-3.069	-3.069	0	%100
38	MP4A	Z	-1.772	-1.772	0	%100
39	M46	X	-0.394	-0.394	0	%100
40	M46	Z	-0.228	-0.228	0	%100
41	M45B	X	-3.37	-3.37	0	%100
42	M45B	Z	-1.946	-1.946	0	%100
43	M46B	X	-0.85	-0.85	0	%100
44	M46B	Z	-0.491	-0.491	0	%100

**Member Distributed Loads (BLC 64 : Structure Wi (330 Deg))**

	Member Label	Direction	Start Magnitude[lb/ft,...	End Magnitude[lb/ft,F...	Start Location[ft, %]	End Location[ft, %]
1	M5	X	-1.765	-1.765	0	%100
2	M5	Z	-3.057	-3.057	0	%100
3	M6	X	-0.394	-0.394	0	%100
4	M6	Z	-0.682	-0.682	0	%100
5	M7	X	-0.394	-0.394	0	%100
6	M7	Z	-0.682	-0.682	0	%100
7	M8	X	-2.07	-2.07	0	%100
8	M8	Z	-3.586	-3.586	0	%100
9	M9	X	-2.07	-2.07	0	%100
10	M9	Z	-3.586	-3.586	0	%100
11	M10	X	-1.836	-1.836	0	%100
12	M10	Z	-3.181	-3.181	0	%100
13	MP1A	X	-1.772	-1.772	0	%100
14	MP1A	Z	-3.069	-3.069	0	%100
15	M14	X	-1.765	-1.765	0	%100
16	M14	Z	-3.057	-3.057	0	%100
17	M15	X	-1.836	-1.836	0	%100
18	M15	Z	-3.181	-3.181	0	%100
19	M17	X	-1.47	-1.47	0	%100
20	M17	Z	-2.547	-2.547	0	%100
21	M19	X	-1.47	-1.47	0	%100
22	M19	Z	-2.547	-2.547	0	%100
23	M20	X	-0.477	-0.477	0	%100
24	M20	Z	-0.827	-0.827	0	%100
25	M21	X	-0.477	-0.477	0	%100
26	M21	Z	-0.827	-0.827	0	%100
27	M22	X	-1.468	-1.468	0	%100

**Member Distributed Loads (BLC 64 : Structure Wi (330 Deg)) (Continued)**

	Member Label	Direction	Start Magnitude[lb/ft,...	End Magnitude[lb/ft,F...	Start Location[ft, %]	End Location[ft, %]
28	M22	Z	-2.542	-2.542	0	%100
29	M23	X	-1.468	-1.468	0	%100
30	M23	Z	-2.542	-2.542	0	%100
31	M24	X	-.859	-.859	0	%100
32	M24	Z	-1.487	-1.487	0	%100
33	MP2A	X	-1.96	-1.96	0	%100
34	MP2A	Z	-3.395	-3.395	0	%100
35	MP3A	X	-1.772	-1.772	0	%100
36	MP3A	Z	-3.069	-3.069	0	%100
37	MP4A	X	-1.772	-1.772	0	%100
38	MP4A	Z	-3.069	-3.069	0	%100
39	M46	X	-.043	-.043	0	%100
40	M46	Z	-.075	-.075	0	%100
41	M45B	X	-2.446	-2.446	0	%100
42	M45B	Z	-4.237	-4.237	0	%100
43	M46B	X	-.992	-.992	0	%100
44	M46B	Z	-1.717	-1.717	0	%100

**Member Distributed Loads (BLC 65 : Structure Wm (0 Deg))**

	Member Label	Direction	Start Magnitude[lb/ft,...	End Magnitude[lb/ft,F...	Start Location[ft, %]	End Location[ft, %]
1	M5	X	0	0	0	%100
2	M5	Z	-.488	-.488	0	%100
3	M6	X	0	0	0	%100
4	M6	Z	-.488	-.488	0	%100
5	M7	X	0	0	0	%100
6	M7	Z	-.488	-.488	0	%100
7	M8	X	0	0	0	%100
8	M8	Z	-1.355	-1.355	0	%100
9	M9	X	0	0	0	%100
10	M9	Z	-1.355	-1.355	0	%100
11	M10	X	0	0	0	%100
12	M10	Z	-.903	-.903	0	%100
13	MP1A	X	0	0	0	%100
14	MP1A	Z	-.644	-.644	0	%100
15	M14	X	0	0	0	%100
16	M14	Z	-.488	-.488	0	%100
17	M15	X	0	0	0	%100
18	M15	Z	-.903	-.903	0	%100
19	M17	X	0	0	0	%100
20	M17	Z	-.779	-.779	0	%100
21	M19	X	0	0	0	%100
22	M19	Z	-.779	-.779	0	%100
23	M20	X	0	0	0	%100
24	M20	Z	0	0	0	%100
25	M21	X	0	0	0	%100
26	M21	Z	0	0	0	%100
27	M22	X	0	0	0	%100
28	M22	Z	-.531	-.531	0	%100
29	M23	X	0	0	0	%100
30	M23	Z	-.531	-.531	0	%100
31	M24	X	0	0	0	%100
32	M24	Z	-.154	-.154	0	%100
33	MP2A	X	0	0	0	%100
34	MP2A	Z	-.779	-.779	0	%100
35	MP3A	X	0	0	0	%100
36	MP3A	Z	-.644	-.644	0	%100

**Member Distributed Loads (BLC 65 : Structure Wm (0 Deg)) (Continued)**

	Member Label	Direction	Start Magnitude[lb/ft,...	End Magnitude[lb/ft,F...	Start Location[ft, %]	End Location[ft, %]
37	MP4A	X	0	0	0	%100
38	MP4A	Z	-.644	-.644	0	%100
39	M46	X	0	0	0	%100
40	M46	Z	-.255	-.255	0	%100
41	M45B	X	0	0	0	%100
42	M45B	Z	-.909	-.909	0	%100
43	M46B	X	0	0	0	%100
44	M46B	Z	-.909	-.909	0	%100

**Member Distributed Loads (BLC 66 : Structure Wm (30 Deg))**

	Member Label	Direction	Start Magnitude[lb/ft,...	End Magnitude[lb/ft,F...	Start Location[ft, %]	End Location[ft, %]
1	M5	X	.075	.075	0	%100
2	M5	Z	-.13	-.13	0	%100
3	M6	X	.337	.337	0	%100
4	M6	Z	-.584	-.584	0	%100
5	M7	X	.337	.337	0	%100
6	M7	Z	-.584	-.584	0	%100
7	M8	X	.508	.508	0	%100
8	M8	Z	-.88	-.88	0	%100
9	M9	X	.508	.508	0	%100
10	M9	Z	-.88	-.88	0	%100
11	M10	X	.399	.399	0	%100
12	M10	Z	-.691	-.691	0	%100
13	MP1A	X	.322	.322	0	%100
14	MP1A	Z	-.557	-.557	0	%100
15	M14	X	.075	.075	0	%100
16	M14	Z	-.13	-.13	0	%100
17	M15	X	.399	.399	0	%100
18	M15	Z	-.691	-.691	0	%100
19	M17	X	.292	.292	0	%100
20	M17	Z	-.506	-.506	0	%100
21	M19	X	.292	.292	0	%100
22	M19	Z	-.506	-.506	0	%100
23	M20	X	.111	.111	0	%100
24	M20	Z	-.192	-.192	0	%100
25	M21	X	.111	.111	0	%100
26	M21	Z	-.192	-.192	0	%100
27	M22	X	.266	.266	0	%100
28	M22	Z	-.46	-.46	0	%100
29	M23	X	.266	.266	0	%100
30	M23	Z	-.46	-.46	0	%100
31	M24	X	.083	.083	0	%100
32	M24	Z	-.144	-.144	0	%100
33	MP2A	X	.39	.39	0	%100
34	MP2A	Z	-.675	-.675	0	%100
35	MP3A	X	.322	.322	0	%100
36	MP3A	Z	-.557	-.557	0	%100
37	MP4A	X	.322	.322	0	%100
38	MP4A	Z	-.557	-.557	0	%100
39	M46	X	.28	.28	0	%100
40	M46	Z	-.486	-.486	0	%100
41	M45B	X	.229	.229	0	%100
42	M45B	Z	-.396	-.396	0	%100
43	M46B	X	.565	.565	0	%100
44	M46B	Z	-.978	-.978	0	%100





Company :  
 Designer :  
 Job Number :  
 Model Name :

June 10, 2021  
 8:10 AM  
 Checked By: \_\_\_\_\_

**Member Distributed Loads (BLC 67 : Structure Wm (60 Deg))**

	Member Label	Direction	Start Magnitude[lb/ft,...	End Magnitude[lb/ft,F...	Start Location[ft, %]	End Location[ft, %]
1	M5	X	.000595	.000595	0	%100
2	M5	Z	-.000343	-.000343	0	%100
3	M6	X	.455	.455	0	%100
4	M6	Z	-.262	-.262	0	%100
5	M7	X	.455	.455	0	%100
6	M7	Z	-.262	-.262	0	%100
7	M8	X	.293	.293	0	%100
8	M8	Z	-.169	-.169	0	%100
9	M9	X	.293	.293	0	%100
10	M9	Z	-.169	-.169	0	%100
11	M10	X	.507	.507	0	%100
12	M10	Z	-.293	-.293	0	%100
13	MP1A	X	.557	.557	0	%100
14	MP1A	Z	-.322	-.322	0	%100
15	M14	X	.000595	.000595	0	%100
16	M14	Z	-.000343	-.000343	0	%100
17	M15	X	.507	.507	0	%100
18	M15	Z	-.293	-.293	0	%100
19	M17	X	.169	.169	0	%100
20	M17	Z	-.097	-.097	0	%100
21	M19	X	.169	.169	0	%100
22	M19	Z	-.097	-.097	0	%100
23	M20	X	.575	.575	0	%100
24	M20	Z	-.332	-.332	0	%100
25	M21	X	.575	.575	0	%100
26	M21	Z	-.332	-.332	0	%100
27	M22	X	.46	.46	0	%100
28	M22	Z	-.266	-.266	0	%100
29	M23	X	.46	.46	0	%100
30	M23	Z	-.266	-.266	0	%100
31	M24	X	.165	.165	0	%100
32	M24	Z	-.095	-.095	0	%100
33	MP2A	X	.675	.675	0	%100
34	MP2A	Z	-.39	-.39	0	%100
35	MP3A	X	.557	.557	0	%100
36	MP3A	Z	-.322	-.322	0	%100
37	MP4A	X	.557	.557	0	%100
38	MP4A	Z	-.322	-.322	0	%100
39	M46	X	.544	.544	0	%100
40	M46	Z	-.314	-.314	0	%100
41	M45B	X	.196	.196	0	%100
42	M45B	Z	-.113	-.113	0	%100
43	M46B	X	.778	.778	0	%100
44	M46B	Z	-.449	-.449	0	%100

**Member Distributed Loads (BLC 68 : Structure Wm (90 Deg))**

	Member Label	Direction	Start Magnitude[lb/ft,...	End Magnitude[lb/ft,F...	Start Location[ft, %]	End Location[ft, %]
1	M5	X	.188	.188	0	%100
2	M5	Z	0	0	0	%100
3	M6	X	.188	.188	0	%100
4	M6	Z	0	0	0	%100
5	M7	X	.188	.188	0	%100
6	M7	Z	0	0	0	%100
7	M8	X	0	0	0	%100
8	M8	Z	0	0	0	%100
9	M9	X	0	0	0	%100



**Member Distributed Loads (BLC 68 : Structure Wm (90 Deg)) (Continued)**

	Member Label	Direction	Start Magnitude[lb/ft,...	End Magnitude[lb/ft,F...	Start Location[ft, %]	End Location[ft, %]
10	M9	Z	0	0	0	%100
11	M10	X	.48	.48	0	%100
12	M10	Z	0	0	0	%100
13	MP1A	X	.644	.644	0	%100
14	MP1A	Z	0	0	0	%100
15	M14	X	.188	.188	0	%100
16	M14	Z	0	0	0	%100
17	M15	X	.48	.48	0	%100
18	M15	Z	0	0	0	%100
19	M17	X	0	0	0	%100
20	M17	Z	0	0	0	%100
21	M19	X	0	0	0	%100
22	M19	Z	0	0	0	%100
23	M20	X	.885	.885	0	%100
24	M20	Z	0	0	0	%100
25	M21	X	.885	.885	0	%100
26	M21	Z	0	0	0	%100
27	M22	X	.531	.531	0	%100
28	M22	Z	0	0	0	%100
29	M23	X	.531	.531	0	%100
30	M23	Z	0	0	0	%100
31	M24	X	.203	.203	0	%100
32	M24	Z	0	0	0	%100
33	MP2A	X	.779	.779	0	%100
34	MP2A	Z	0	0	0	%100
35	MP3A	X	.644	.644	0	%100
36	MP3A	Z	0	0	0	%100
37	MP4A	X	.644	.644	0	%100
38	MP4A	Z	0	0	0	%100
39	M46	X	.389	.389	0	%100
40	M46	Z	0	0	0	%100
41	M45B	X	.447	.447	0	%100
42	M45B	Z	0	0	0	%100
43	M46B	X	.447	.447	0	%100
44	M46B	Z	0	0	0	%100

**Member Distributed Loads (BLC 69 : Structure Wm (120 Deg))**

	Member Label	Direction	Start Magnitude[lb/ft,...	End Magnitude[lb/ft,F...	Start Location[ft, %]	End Location[ft, %]
1	M5	X	.455	.455	0	%100
2	M5	Z	.262	.262	0	%100
3	M6	X	.000595	.000595	0	%100
4	M6	Z	.000343	.000343	0	%100
5	M7	X	.000595	.000595	0	%100
6	M7	Z	.000343	.000343	0	%100
7	M8	X	.293	.293	0	%100
8	M8	Z	.169	.169	0	%100
9	M9	X	.293	.293	0	%100
10	M9	Z	.169	.169	0	%100
11	M10	X	.507	.507	0	%100
12	M10	Z	.293	.293	0	%100
13	MP1A	X	.557	.557	0	%100
14	MP1A	Z	.322	.322	0	%100
15	M14	X	.455	.455	0	%100
16	M14	Z	.262	.262	0	%100
17	M15	X	.507	.507	0	%100
18	M15	Z	.293	.293	0	%100

**Member Distributed Loads (BLC 69 : Structure Wm (120 Deg)) (Continued)**

	Member Label	Direction	Start Magnitude[lb/ft,...	End Magnitude[lb/ft,F...	Start Location[ft, %]	End Location[ft, %]
19	M17	X	.169	.169	0	%100
20	M17	Z	.097	.097	0	%100
21	M19	X	.169	.169	0	%100
22	M19	Z	.097	.097	0	%100
23	M20	X	.575	.575	0	%100
24	M20	Z	.332	.332	0	%100
25	M21	X	.575	.575	0	%100
26	M21	Z	.332	.332	0	%100
27	M22	X	.46	.46	0	%100
28	M22	Z	.266	.266	0	%100
29	M23	X	.46	.46	0	%100
30	M23	Z	.266	.266	0	%100
31	M24	X	.165	.165	0	%100
32	M24	Z	.095	.095	0	%100
33	MP2A	X	.675	.675	0	%100
34	MP2A	Z	.39	.39	0	%100
35	MP3A	X	.557	.557	0	%100
36	MP3A	Z	.322	.322	0	%100
37	MP4A	X	.557	.557	0	%100
38	MP4A	Z	.322	.322	0	%100
39	M46	X	.072	.072	0	%100
40	M46	Z	.041	.041	0	%100
41	M45B	X	.778	.778	0	%100
42	M45B	Z	.449	.449	0	%100
43	M46B	X	.196	.196	0	%100
44	M46B	Z	.113	.113	0	%100

**Member Distributed Loads (BLC 70 : Structure Wm (150 Deg))**

	Member Label	Direction	Start Magnitude[lb/ft,...	End Magnitude[lb/ft,F...	Start Location[ft, %]	End Location[ft, %]
1	M5	X	.337	.337	0	%100
2	M5	Z	.584	.584	0	%100
3	M6	X	.075	.075	0	%100
4	M6	Z	.13	.13	0	%100
5	M7	X	.075	.075	0	%100
6	M7	Z	.13	.13	0	%100
7	M8	X	.508	.508	0	%100
8	M8	Z	.88	.88	0	%100
9	M9	X	.508	.508	0	%100
10	M9	Z	.88	.88	0	%100
11	M10	X	.399	.399	0	%100
12	M10	Z	.691	.691	0	%100
13	MP1A	X	.322	.322	0	%100
14	MP1A	Z	.557	.557	0	%100
15	M14	X	.337	.337	0	%100
16	M14	Z	.584	.584	0	%100
17	M15	X	.399	.399	0	%100
18	M15	Z	.691	.691	0	%100
19	M17	X	.292	.292	0	%100
20	M17	Z	.506	.506	0	%100
21	M19	X	.292	.292	0	%100
22	M19	Z	.506	.506	0	%100
23	M20	X	.111	.111	0	%100
24	M20	Z	.192	.192	0	%100
25	M21	X	.111	.111	0	%100
26	M21	Z	.192	.192	0	%100
27	M22	X	.266	.266	0	%100



Company :  
 Designer :  
 Job Number :  
 Model Name :

June 10, 2021  
 8:10 AM  
 Checked By: \_\_\_\_\_

**Member Distributed Loads (BLC 70 : Structure Wm (150 Deg)) (Continued)**

	Member Label	Direction	Start Magnitude[lb/ft,...	End Magnitude[lb/ft,F...	Start Location[ft, %]	End Location[ft, %]
28	M22	Z	.46	.46	0	%100
29	M23	X	.266	.266	0	%100
30	M23	Z	.46	.46	0	%100
31	M24	X	.083	.083	0	%100
32	M24	Z	.144	.144	0	%100
33	MP2A	X	.39	.39	0	%100
34	MP2A	Z	.675	.675	0	%100
35	MP3A	X	.322	.322	0	%100
36	MP3A	Z	.557	.557	0	%100
37	MP4A	X	.322	.322	0	%100
38	MP4A	Z	.557	.557	0	%100
39	M46	X	.008	.008	0	%100
40	M46	Z	.014	.014	0	%100
41	M45B	X	.565	.565	0	%100
42	M45B	Z	.978	.978	0	%100
43	M46B	X	.229	.229	0	%100
44	M46B	Z	.396	.396	0	%100

**Member Distributed Loads (BLC 71 : Structure Wm (180 Deg))**

	Member Label	Direction	Start Magnitude[lb/ft,...	End Magnitude[lb/ft,F...	Start Location[ft, %]	End Location[ft, %]
1	M5	X	0	0	0	%100
2	M5	Z	.488	.488	0	%100
3	M6	X	0	0	0	%100
4	M6	Z	.488	.488	0	%100
5	M7	X	0	0	0	%100
6	M7	Z	.488	.488	0	%100
7	M8	X	0	0	0	%100
8	M8	Z	1.355	1.355	0	%100
9	M9	X	0	0	0	%100
10	M9	Z	1.355	1.355	0	%100
11	M10	X	0	0	0	%100
12	M10	Z	.903	.903	0	%100
13	MP1A	X	0	0	0	%100
14	MP1A	Z	.644	.644	0	%100
15	M14	X	0	0	0	%100
16	M14	Z	.488	.488	0	%100
17	M15	X	0	0	0	%100
18	M15	Z	.903	.903	0	%100
19	M17	X	0	0	0	%100
20	M17	Z	.779	.779	0	%100
21	M19	X	0	0	0	%100
22	M19	Z	.779	.779	0	%100
23	M20	X	0	0	0	%100
24	M20	Z	0	0	0	%100
25	M21	X	0	0	0	%100
26	M21	Z	0	0	0	%100
27	M22	X	0	0	0	%100
28	M22	Z	.531	.531	0	%100
29	M23	X	0	0	0	%100
30	M23	Z	.531	.531	0	%100
31	M24	X	0	0	0	%100
32	M24	Z	.154	.154	0	%100
33	MP2A	X	0	0	0	%100
34	MP2A	Z	.779	.779	0	%100
35	MP3A	X	0	0	0	%100
36	MP3A	Z	.644	.644	0	%100



Company :  
 Designer :  
 Job Number :  
 Model Name :

June 10, 2021  
 8:10 AM  
 Checked By: \_\_\_\_\_

**Member Distributed Loads (BLC 71 : Structure Wm (180 Deg)) (Continued)**

	Member Label	Direction	Start Magnitude[lb/ft,...	End Magnitude[lb/ft,F...	Start Location[ft, %]	End Location[ft, %]
37	MP4A	X	0	0	0	%100
38	MP4A	Z	.644	.644	0	%100
39	M46	X	0	0	0	%100
40	M46	Z	.255	.255	0	%100
41	M45B	X	0	0	0	%100
42	M45B	Z	.909	.909	0	%100
43	M46B	X	0	0	0	%100
44	M46B	Z	.909	.909	0	%100

**Member Distributed Loads (BLC 72 : Structure Wm (210 Deg))**

	Member Label	Direction	Start Magnitude[lb/ft,...	End Magnitude[lb/ft,F...	Start Location[ft, %]	End Location[ft, %]
1	M5	X	-.075	-.075	0	%100
2	M5	Z	.13	.13	0	%100
3	M6	X	-.337	-.337	0	%100
4	M6	Z	.584	.584	0	%100
5	M7	X	-.337	-.337	0	%100
6	M7	Z	.584	.584	0	%100
7	M8	X	-.508	-.508	0	%100
8	M8	Z	.88	.88	0	%100
9	M9	X	-.508	-.508	0	%100
10	M9	Z	.88	.88	0	%100
11	M10	X	-.399	-.399	0	%100
12	M10	Z	.691	.691	0	%100
13	MP1A	X	-.322	-.322	0	%100
14	MP1A	Z	.557	.557	0	%100
15	M14	X	-.075	-.075	0	%100
16	M14	Z	.13	.13	0	%100
17	M15	X	-.399	-.399	0	%100
18	M15	Z	.691	.691	0	%100
19	M17	X	-.292	-.292	0	%100
20	M17	Z	.506	.506	0	%100
21	M19	X	-.292	-.292	0	%100
22	M19	Z	.506	.506	0	%100
23	M20	X	-.111	-.111	0	%100
24	M20	Z	.192	.192	0	%100
25	M21	X	-.111	-.111	0	%100
26	M21	Z	.192	.192	0	%100
27	M22	X	-.266	-.266	0	%100
28	M22	Z	.46	.46	0	%100
29	M23	X	-.266	-.266	0	%100
30	M23	Z	.46	.46	0	%100
31	M24	X	-.083	-.083	0	%100
32	M24	Z	.144	.144	0	%100
33	MP2A	X	-.39	-.39	0	%100
34	MP2A	Z	.675	.675	0	%100
35	MP3A	X	-.322	-.322	0	%100
36	MP3A	Z	.557	.557	0	%100
37	MP4A	X	-.322	-.322	0	%100
38	MP4A	Z	.557	.557	0	%100
39	M46	X	-.28	-.28	0	%100
40	M46	Z	.486	.486	0	%100
41	M45B	X	-.229	-.229	0	%100
42	M45B	Z	.396	.396	0	%100
43	M46B	X	-.565	-.565	0	%100
44	M46B	Z	.978	.978	0	%100



Company :  
 Designer :  
 Job Number :  
 Model Name :

June 10, 2021  
 8:10 AM  
 Checked By: \_\_\_\_\_

**Member Distributed Loads (BLC 73 : Structure Wm (240 Deg))**

	Member Label	Direction	Start Magnitude[lb/ft,...	End Magnitude[lb/ft,F...	Start Location[ft, %]	End Location[ft, %]
1	M5	X	-.000595	-.000595	0	%100
2	M5	Z	.000343	.000343	0	%100
3	M6	X	-.455	-.455	0	%100
4	M6	Z	.262	.262	0	%100
5	M7	X	-.455	-.455	0	%100
6	M7	Z	.262	.262	0	%100
7	M8	X	-.293	-.293	0	%100
8	M8	Z	.169	.169	0	%100
9	M9	X	-.293	-.293	0	%100
10	M9	Z	.169	.169	0	%100
11	M10	X	-.507	-.507	0	%100
12	M10	Z	.293	.293	0	%100
13	MP1A	X	-.557	-.557	0	%100
14	MP1A	Z	.322	.322	0	%100
15	M14	X	-.000595	-.000595	0	%100
16	M14	Z	.000343	.000343	0	%100
17	M15	X	-.507	-.507	0	%100
18	M15	Z	.293	.293	0	%100
19	M17	X	-.169	-.169	0	%100
20	M17	Z	.097	.097	0	%100
21	M19	X	-.169	-.169	0	%100
22	M19	Z	.097	.097	0	%100
23	M20	X	-.575	-.575	0	%100
24	M20	Z	.332	.332	0	%100
25	M21	X	-.575	-.575	0	%100
26	M21	Z	.332	.332	0	%100
27	M22	X	-.46	-.46	0	%100
28	M22	Z	.266	.266	0	%100
29	M23	X	-.46	-.46	0	%100
30	M23	Z	.266	.266	0	%100
31	M24	X	-.165	-.165	0	%100
32	M24	Z	.095	.095	0	%100
33	MP2A	X	-.675	-.675	0	%100
34	MP2A	Z	.39	.39	0	%100
35	MP3A	X	-.557	-.557	0	%100
36	MP3A	Z	.322	.322	0	%100
37	MP4A	X	-.557	-.557	0	%100
38	MP4A	Z	.322	.322	0	%100
39	M46	X	-.544	-.544	0	%100
40	M46	Z	.314	.314	0	%100
41	M45B	X	-.196	-.196	0	%100
42	M45B	Z	.113	.113	0	%100
43	M46B	X	-.778	-.778	0	%100
44	M46B	Z	.449	.449	0	%100

**Member Distributed Loads (BLC 74 : Structure Wm (270 Deg))**

	Member Label	Direction	Start Magnitude[lb/ft,...	End Magnitude[lb/ft,F...	Start Location[ft, %]	End Location[ft, %]
1	M5	X	-.188	-.188	0	%100
2	M5	Z	0	0	0	%100
3	M6	X	-.188	-.188	0	%100
4	M6	Z	0	0	0	%100
5	M7	X	-.188	-.188	0	%100
6	M7	Z	0	0	0	%100
7	M8	X	0	0	0	%100
8	M8	Z	0	0	0	%100
9	M9	X	0	0	0	%100

**Member Distributed Loads (BLC 74 : Structure Wm (270 Deg)) (Continued)**

	Member Label	Direction	Start Magnitude[lb/ft,...	End Magnitude[lb/ft,F...	Start Location[ft, %]	End Location[ft, %]
10	M9	Z	0	0	0	%100
11	M10	X	-.48	-.48	0	%100
12	M10	Z	0	0	0	%100
13	MP1A	X	-.644	-.644	0	%100
14	MP1A	Z	0	0	0	%100
15	M14	X	-.188	-.188	0	%100
16	M14	Z	0	0	0	%100
17	M15	X	-.48	-.48	0	%100
18	M15	Z	0	0	0	%100
19	M17	X	0	0	0	%100
20	M17	Z	0	0	0	%100
21	M19	X	0	0	0	%100
22	M19	Z	0	0	0	%100
23	M20	X	-.885	-.885	0	%100
24	M20	Z	0	0	0	%100
25	M21	X	-.885	-.885	0	%100
26	M21	Z	0	0	0	%100
27	M22	X	-.531	-.531	0	%100
28	M22	Z	0	0	0	%100
29	M23	X	-.531	-.531	0	%100
30	M23	Z	0	0	0	%100
31	M24	X	-.203	-.203	0	%100
32	M24	Z	0	0	0	%100
33	MP2A	X	-.779	-.779	0	%100
34	MP2A	Z	0	0	0	%100
35	MP3A	X	-.644	-.644	0	%100
36	MP3A	Z	0	0	0	%100
37	MP4A	X	-.644	-.644	0	%100
38	MP4A	Z	0	0	0	%100
39	M46	X	-.389	-.389	0	%100
40	M46	Z	0	0	0	%100
41	M45B	X	-.447	-.447	0	%100
42	M45B	Z	0	0	0	%100
43	M46B	X	-.447	-.447	0	%100
44	M46B	Z	0	0	0	%100

**Member Distributed Loads (BLC 75 : Structure Wm (300 Deg))**

	Member Label	Direction	Start Magnitude[lb/ft,...	End Magnitude[lb/ft,F...	Start Location[ft, %]	End Location[ft, %]
1	M5	X	-.455	-.455	0	%100
2	M5	Z	-.262	-.262	0	%100
3	M6	X	-.000595	-.000595	0	%100
4	M6	Z	-.000343	-.000343	0	%100
5	M7	X	-.000595	-.000595	0	%100
6	M7	Z	-.000343	-.000343	0	%100
7	M8	X	-.293	-.293	0	%100
8	M8	Z	-.169	-.169	0	%100
9	M9	X	-.293	-.293	0	%100
10	M9	Z	-.169	-.169	0	%100
11	M10	X	-.507	-.507	0	%100
12	M10	Z	-.293	-.293	0	%100
13	MP1A	X	-.557	-.557	0	%100
14	MP1A	Z	-.322	-.322	0	%100
15	M14	X	-.455	-.455	0	%100
16	M14	Z	-.262	-.262	0	%100
17	M15	X	-.507	-.507	0	%100
18	M15	Z	-.293	-.293	0	%100

**Member Distributed Loads (BLC 75 : Structure Wm (300 Deg)) (Continued)**

	Member Label	Direction	Start Magnitude[lb/ft,...	End Magnitude[lb/ft,F...	Start Location[ft, %]	End Location[ft, %]
19	M17	X	- .169	- .169	0	%100
20	M17	Z	- .097	- .097	0	%100
21	M19	X	- .169	- .169	0	%100
22	M19	Z	- .097	- .097	0	%100
23	M20	X	- .575	- .575	0	%100
24	M20	Z	- .332	- .332	0	%100
25	M21	X	- .575	- .575	0	%100
26	M21	Z	- .332	- .332	0	%100
27	M22	X	- .46	- .46	0	%100
28	M22	Z	- .266	- .266	0	%100
29	M23	X	- .46	- .46	0	%100
30	M23	Z	- .266	- .266	0	%100
31	M24	X	- .165	- .165	0	%100
32	M24	Z	- .095	- .095	0	%100
33	MP2A	X	- .675	- .675	0	%100
34	MP2A	Z	- .39	- .39	0	%100
35	MP3A	X	- .557	- .557	0	%100
36	MP3A	Z	- .322	- .322	0	%100
37	MP4A	X	- .557	- .557	0	%100
38	MP4A	Z	- .322	- .322	0	%100
39	M46	X	- .072	- .072	0	%100
40	M46	Z	- .041	- .041	0	%100
41	M45B	X	- .778	- .778	0	%100
42	M45B	Z	- .449	- .449	0	%100
43	M46B	X	- .196	- .196	0	%100
44	M46B	Z	- .113	- .113	0	%100

**Member Distributed Loads (BLC 76 : Structure Wm (330 Deg))**

	Member Label	Direction	Start Magnitude[lb/ft,...	End Magnitude[lb/ft,F...	Start Location[ft, %]	End Location[ft, %]
1	M5	X	- .337	- .337	0	%100
2	M5	Z	- .584	- .584	0	%100
3	M6	X	- .075	- .075	0	%100
4	M6	Z	- .13	- .13	0	%100
5	M7	X	- .075	- .075	0	%100
6	M7	Z	- .13	- .13	0	%100
7	M8	X	- .508	- .508	0	%100
8	M8	Z	- .88	- .88	0	%100
9	M9	X	- .508	- .508	0	%100
10	M9	Z	- .88	- .88	0	%100
11	M10	X	- .399	- .399	0	%100
12	M10	Z	- .691	- .691	0	%100
13	MP1A	X	- .322	- .322	0	%100
14	MP1A	Z	- .557	- .557	0	%100
15	M14	X	- .337	- .337	0	%100
16	M14	Z	- .584	- .584	0	%100
17	M15	X	- .399	- .399	0	%100
18	M15	Z	- .691	- .691	0	%100
19	M17	X	- .292	- .292	0	%100
20	M17	Z	- .506	- .506	0	%100
21	M19	X	- .292	- .292	0	%100
22	M19	Z	- .506	- .506	0	%100
23	M20	X	- .111	- .111	0	%100
24	M20	Z	- .192	- .192	0	%100
25	M21	X	- .111	- .111	0	%100
26	M21	Z	- .192	- .192	0	%100
27	M22	X	- .266	- .266	0	%100



**Member Distributed Loads (BLC 76 : Structure Wm (330 Deg)) (Continued)**

Member Label	Direction	Start Magnitude[lb/ft,...	End Magnitude[lb/ft,F...	Start Location[ft,%]	End Location[ft,%]
28	M22	Z	-.46	-.46	0 %100
29	M23	X	-.266	-.266	0 %100
30	M23	Z	-.46	-.46	0 %100
31	M24	X	-.083	-.083	0 %100
32	M24	Z	-.144	-.144	0 %100
33	MP2A	X	-.39	-.39	0 %100
34	MP2A	Z	-.675	-.675	0 %100
35	MP3A	X	-.322	-.322	0 %100
36	MP3A	Z	-.557	-.557	0 %100
37	MP4A	X	-.322	-.322	0 %100
38	MP4A	Z	-.557	-.557	0 %100
39	M46	X	-.008	-.008	0 %100
40	M46	Z	-.014	-.014	0 %100
41	M45B	X	-.565	-.565	0 %100
42	M45B	Z	-.978	-.978	0 %100
43	M46B	X	-.229	-.229	0 %100
44	M46B	Z	-.396	-.396	0 %100

**Member Area Loads**

Joint A	Joint B	Joint C	Joint D	Direction	Distribution	Magnitude[ksf]
No Data to Print ...						

**Envelope Joint Reactions**

Joint	X [lb]	LC	Y [lb]	LC	Z [lb]	LC	MX [k-ft]	LC	MY [k-ft]	LC	MZ [k-ft]	LC		
1	N1	max	834.545	9	55.129	18	1205.788	12	.216	6	0	51	.195	6
2		min	-812.284	3	27.625	2	-1261.326	6	-.289	12	0	1	-.191	12
3	N5	max	2272.515	11	62.599	18	1865.163	12	.184	12	0	51	.067	6
4		min	-2383.892	5	28.465	48	-3909.751	6	-.363	6	0	1	-.048	12
5	N45	max	104.853	10	628.987	42	355.708	2	.006	12	0	51	.01	6
6		min	-107.702	4	53.464	12	-922.99	31	-.293	42	0	1	-.008	12
7	N46	max	46.278	10	628.911	36	1239.626	2	.141	6	0	51	.03	5
8		min	-31.102	4	-295.609	6	-373.341	8	-.288	36	0	1	-.028	11
9	N80	max	1278.128	6	32.225	19	1556.382	6	0	51	0	51	0	51
10		min	-1291.294	12	9.389	12	-1613.844	12	0	1	0	1	0	1
11	N73A	max	777.911	49	1810.01	15	1728.443	14	.001	6	0	2	0	2
12		min	-929.12	48	790.602	8	675.127	8	0	12	0	8	0	8
13	Totals:	max	1836.834	9	2776.134	18	3321.375	1						
14		min	-1836.827	3	1293.991	12	-3321.34	7						

**Envelope AISC 15th(360-16): LRFD Steel Code Checks**

Member	Shape	Code Check	Loc[ft]	LC	Shear C...	Lo...	Dir	LC	phi*Pn...	phi*...	phi*...	phi*...	Eqn
1	M19	PIPE 2.5	.812	11.083	6	.143	11...	6	11606....	50715	3.596	3.596	...H1-...
2	MP1A	PIPE 2.0	.691	4.5	6	.404	5....	6	20866....	32130	1.872	1.872	...H3-6
3	M9	L3X3X4	.458	6.5	47	.335	3....	42	35548....	46656	1.688	2.257	1 H2-1
4	M17	PIPE 2.5	.308	11.083	6	.211	11...	6	11606....	50715	3.596	3.596	...H1-...
5	M45B	L2.5x2.5x4	.270	3.35	23	.009	6....	6	9664.5...	38556	1.114	2.092	...H2-1
6	M21	L2.5x2.5x6	.268	.495	30	.219	.495	42	45672....	56052	1.512	3.537	...H2-1
7	M46B	L2.5x2.5x4	.266	3.35	15	.008	0	2	9664.5...	38556	1.114	2.092	...H2-1
8	M8	L3X3X4	.227	6.5	45	.225	1....	43	15778....	46656	1.688	2.257	1 H2-1
9	MP4A	PIPE 2.0	.214	5.188	39	.207	4.5	42	20866....	32130	1.872	1.872	...H1-...
10	MP2A	PIPE 2.5	.194	4.5	6	.187	4....	5	37773....	50715	3.596	3.596	...H1-...
11	M22	PIPE 2.0	.124	3.083	38	.065	3....	6	30384....	32130	1.872	1.872	...H1-...





Company :  
 Designer :  
 Job Number :  
 Model Name :

June 10, 2021  
 8:10 AM  
 Checked By: \_\_\_\_\_

**Envelope AISC 15th(360-16): LRFD Steel Code Checks (Continued)**

Member	Shape	Code Check	Loc[ft]	LC	Shear C...	Lo...	Dir	LC	phi*Pn...	phi*...	phi*...	phi*...	Eqn
12	M46	PIPE 2.0	.113	0	6	.004	7	9	17855...	32130	1.872	1.872	...H1-...
13	M14	PIPE 2.5	.112	0	6	.088	4...	6	43695...	50715	3.596	3.596	...H1-...
14	M7	PIPE 2.5	.105	0	6	.048	0	6	43695...	50715	3.596	3.596	...H1-...
15	M20	L2.5x2.5x6	.100	.495	21	.124	.495 z	42	45672...	56052	1.512	3.537	...H2-1
16	M15	L2x2x3	.066	2.115	1	.058	0 z	49	15077...	2339...	.558	1.07	...H2-1
17	M23	PIPE 2.0	.065	0	32	.050	3...	6	30384...	32130	1.872	1.872	...H1-...
18	M10	L2x2x3	.064	2.115	7	.035	0 z	24	15077...	2339...	.558	1.07	...H2-1
19	M24	SR 0.75	.063	1.773	24	.009	0	5	3956.3...	1431...	.179	.179	...H1-...
20	MP3A	PIPE 2.0	.050	3.063	1	.066	4...	12	20866...	32130	1.872	1.872	...H1-...
21	M5	PIPE 2.5	.039	0	2	.022	4...	5	43695...	50715	3.596	3.596	...H1-...
22	M6	PIPE 2.5	.035	0	12	.110	0	12	43695...	50715	3.596	3.596	...H1-...

## I. Mount-to-Tower Connection Check

### RISA Model Data

Nodes (labeled per RISA)	Orientation (per graphic of typical platform)
N46	90
N45	90

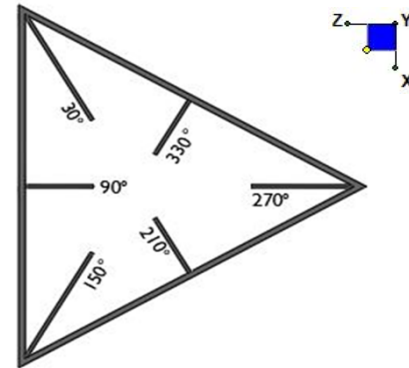

TYPICAL PLATFORM

### Tower Connection Bolt Checks

Any moment resistance?:

Bolt Quantity per Reaction:

$d_x$  (in) (Delta X of typ. bolt config. sketch) :

$d_y$  (in) (Delta Y of typ. bolt config. sketch) :

Bolt Type:

Bolt Diameter (in):

Required Tensile Strength (kips):

Required Shear Strength (kips):

Tensile Strength / bolt (kips):

Shear Strength / bolt (kips):

Tensile Capacity Overall:

Shear Capacity Overall:

yes
4
6
3
A307
0.625
3.4
0.6
10.0
6.0
8.5%*
2.7%

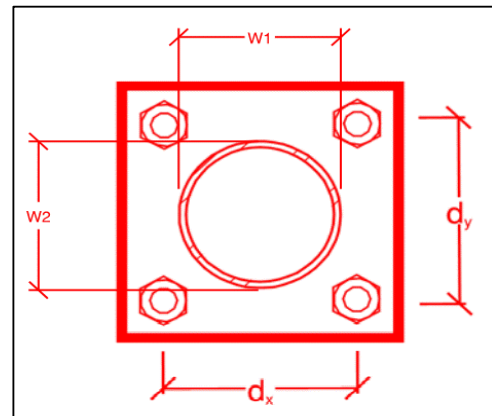

\*Note: Tension reduction not required if tension or shear capacity < 30%

## I. Kickers-Tower Connection Check

### RISA Model Data

Nodes (labeled per RISA)	Orientation (per graphic of typical platform)
N1	90
N5	90

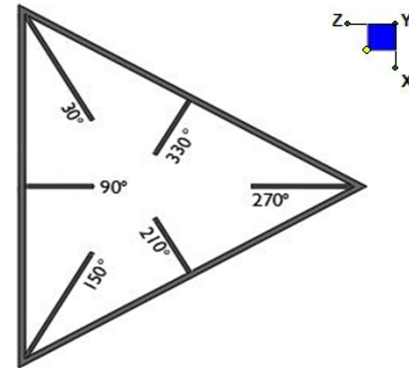

TYPICAL PLATFORM

### Tower Connection Bolt Checks

Any moment resistance?:

Bolt Quantity per Reaction:

$d_x$  (in) (Delta X of typ. bolt config. sketch) :

$d_y$  (in) (Delta Y of typ. bolt config. sketch) :

Bolt Type:

Bolt Diameter (in):

Required Tensile Strength (kips):

Required Shear Strength (kips):

Tensile Strength / bolt (kips):

Shear Strength / bolt (kips):

Tensile Capacity Overall:

Shear Capacity Overall:

yes
4
6
3
A307
0.5
6.8
2.6
6.4
3.8
<b>26.6%*</b>
<b>17.2%</b>

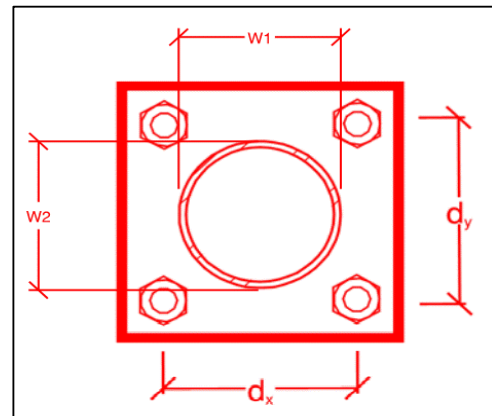

\*Note: Tension reduction not required if tension or shear capacity < 30%

# Mount Desktop – Post Modification Inspection (PMI) Report Requirements

## Documents & Photos Required from Contractor – Mount Modification

---

**Purpose** – to provide MASER CONSULTING CONNECTICUT the proper documentation in order to complete the required Mount Desktop review of the Post Modification Inspection Report.

- Contractor is responsible for making certain the photos provided as noted below provide confirmation that the modification was completed in accordance with the modification drawings.
- Contractor shall relay any data that can impact the performance of the mount or the mount modification, this includes safety issues.

### **Base Requirements:**

- Any special photos outside of the standard requirements will be indicated on the drawings
- Provide “as built drawings” showing contractor’s name, preparer’s signature, and date. Any deviations from the drawings (proposed modification) must be shown.
- Notation that all hardware was properly installed, and the existing hardware was inspected for any issues.
- Verification that loading is as communicated in the modification drawings. NOTE If loading is different than what is conveyed in the modification drawing contact Maser Consulting Connecticut immediately.
- Each photo should be time and date stamped
- Photos should be high resolution and submitted in a Zip File and should be organized in the file structure as depicted in Schedule A attached.
- Contractor shall ensure that the safety climb wire rope is supported and not adversely impacted by the install of the modification components. This may involve the install of wire rope guides, or other items to protect the wire rope.
- The photos in the file structure should be uploaded to <https://pmi.vzwsmart.com> as depicted on the drawings

### **Photo Requirements:**

- Base and “During Installation Photos”
  - Base pictures include
    - Photo of Gate Signs showing the tower owner, site name, and number
    - Photo of carrier shelter showing the carrier site name and number if available
    - Photos of the galvanizing compound and/or paint used (if applicable), clearly showing the label and name
  - “During Installation Photos if provided - must be placed only in this folder
- Photos taken at ground level
  - Overall tower structure before and after installation of the modifications
  - Photos of the appropriate mount before and after installation of the modifications; if the mounts are at different rad elevations, pictures must be provided for all elevations that the modifications were installed

- Photos taken at Mount Elevation
  - Photos showing each individual sector before and also after installation of modifications. Each entire sector must be in one photo to show in the inter-connection of members.
    - These photos should also certify that the placement and geometry of the equipment on the mount is as depicted on the sketch and table in the mount analysis
  - Close-up photos of each installed modification per the modification drawings; pictures should also include connection hardware (U-bolts, bolts, nuts, all-threaded rods, etc.)
  - Photos showing the measurements of the installed modification member sizes (i.e. lengths, widths, depths, diameters, thicknesses)
  - Photos showing the elevation or distances of the installed modifications from the appropriate reference locations shown in the modification drawings
  - Photos showing the installed modifications onto the tower with tape drop measurements (if applicable) (i.e. ring/collar mounts, tie-backs, V-bracing kits, etc.); if the existing mount elevation needs to be changed according to the modification drawings, a tape drop measurement shall be provided before the elevation change
  - Photos showing the safety climb wire rope above and below the mount prior to modification.
  - Photos showing the climbing facility and safety climb if present.

**Material Certification:**

- Materials utilized must be as per specification on the drawings or the equivalent as validated by Maser Consulting Connecticut.
  - If the drawings are as specified on the drawings
    - The contractor should provide the packing list or the materials utilized to perform the mount modification
  - If an equivalent is utilized
    - It is required that the Maser Consulting Connecticut certification of such is included in the contractor submission package. There may be an additional charge for this certification if the equivalent submission doesn't meet specifications as prescribed in the drawings.
- The contractor must certify that the materials meet these specifications by one of these methods.

☐ The Material utilized was as specified on the Maser Consulting Connecticut Mount Modification Drawings and included in the Material certification folder is a packing list or invoice for these materials

☐ The material utilized was an “equivalent” and included as part of the contractor submission is the Maser Consulting Connecticut certification, invoices, or specifications validating accepted status

Certifying Individual: Company \_\_\_\_\_

Name \_\_\_\_\_

Signature \_\_\_\_\_

**Antenna & equipment placement and Geometry Confirmation:**

- The contractor must certify that the antenna & equipment placement and geometry is in accordance with the antenna placement diagrams as included in this mount analysis.
- The contractor certifies that the photos support and the equipment on the mount is as depicted on the antenna placement diagrams as included in this mount analysis.
- The contractor no Maser Consulting Connecticut that the equipment on the mount is not in accordance with the antenna placement diagrams and has accordingly marked up the diagrams or provided a diagram outlining the differences.

Certifying Individual:      Company \_\_\_\_\_

Name \_\_\_\_\_

Signature \_\_\_\_\_

**Special Instructions / Validation as required from the MA or Mod Drawings:**

**Issue:**

Contractor to install safety climb cable guide (Site Pro 1, Part #: 120-203-317 or EOR approved equivalent) in locations where wire rope is rubbing against mount to tower attachments. Contractor to provide photos of safety climb guide installation.

Contractor to relocate existing radio (B5/B13 RRH-BR04C) in position 3 to position 1 mount pipe (position read from in front of mount), see placement diagram for more details.

Contractor to attach existing position 2 mount pipe to round face horizontals with VZWSMART-MSK1 crossover plates, if not currently attached. Positions read from in front of mount.

**Response:**

\_\_\_\_\_

## Schedule A – Photo & Document File Structure

- 📁 VzW Site Number / Name
  - 📁 Base & “During Installation” Photos
  - 📁 Pre-Installation Photos
    - 📁 Alpha
    - 📁 Beta
    - 📁 Gamma
    - 📁 Ground Level
    - 📁 Tape Drop
  - 📁 Post-Installation Photos
    - 📁 Alpha
    - 📁 Beta
    - 📁 Gamma
    - 📁 Ground Level
    - 📁 Tape Drop
    - 📁 Photos of climbing facility and safety climb – If Present
- 📁 Certifications – Submission of this document including certifications
- 📁 Specific Required Additional Photos

Sector: **A**  
 Structure Type: Self Support  
 Mount Elev: 153.90

10069536

6/10/2021

Page: 1



Plan View

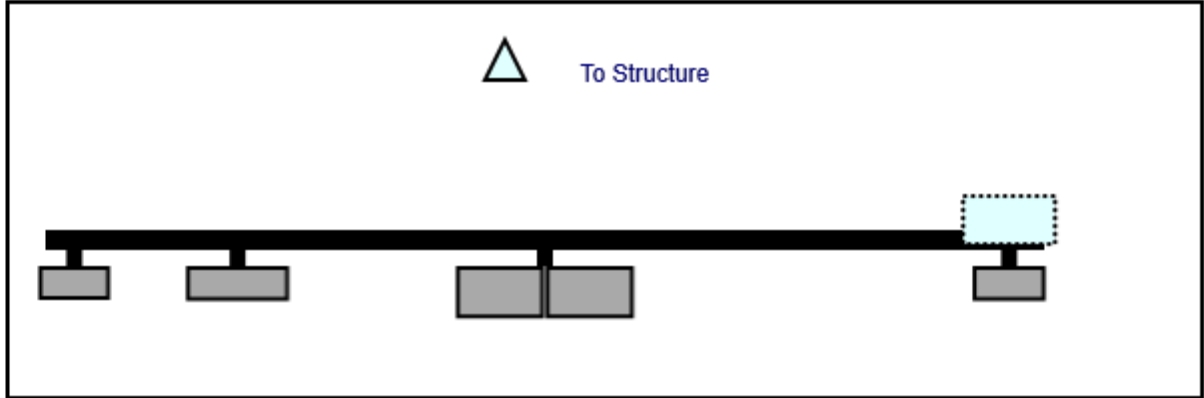

Front View  
Looking at Structure

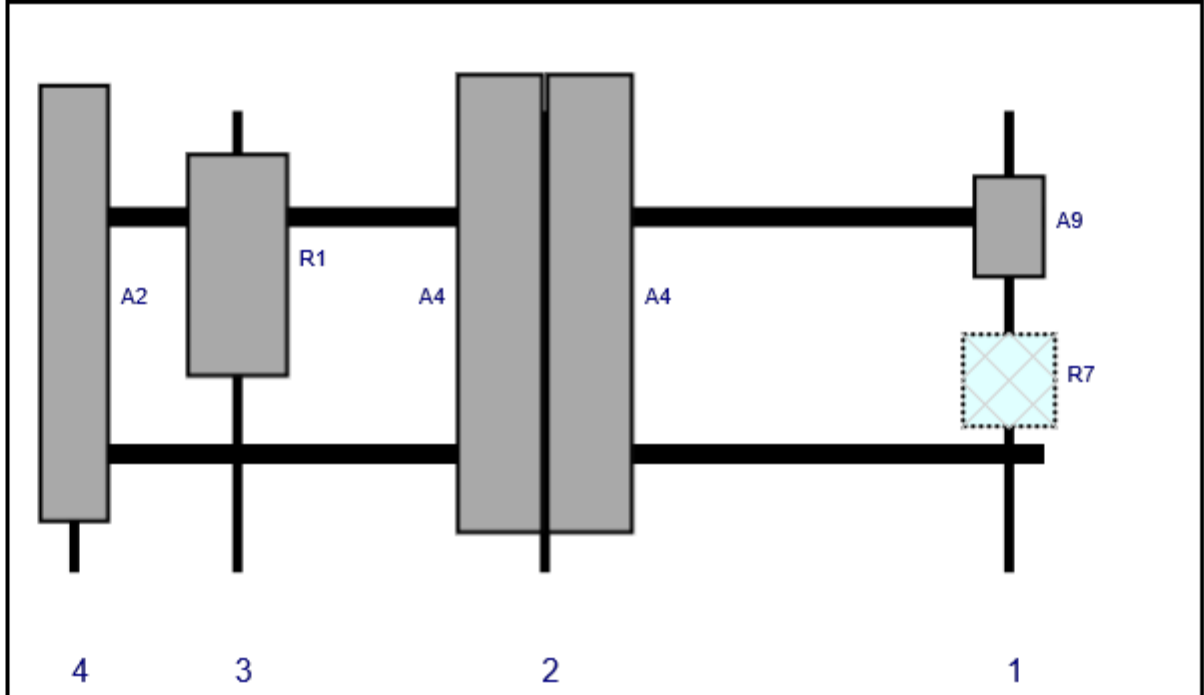

Ref#	Model	Height (in)	Width (in)	H Dist Frm L.	Pipe #	Pipe Pos V	Ant Pos	C. Ant Frm T.	Ant H Off	Status	Validation
A9	XXDWMM-12.5-65-8T-CBRS	16.2	11.4	150.5	1	a	Front	18	0	Retained	04/02/2021
R7	B5/B13 RRR-BR04C	15	15	150.5	1	a	Behind	42	0	Retained	04/02/2021
A4	JAHH-65B-R3B	72	13.8	78	2	a	Front	30	-7	Retained	04/02/2021
A4	JAHH-65B-R3B	72	13.8	78	2	b	Front	30	7	Retained	04/02/2021
R1	MT6407-77A	35.1	16.1	30	3	a	Front	24	0	Added	
A2	BXA-80063-6BF-EDIN-4	68.6	11.2	4.5	4	a	Front	30	0	Retained	04/02/2021



Sector: **B**  
 Structure Type: Self Support  
 Mount Elev: 153.90

10069536

6/10/2021



Page: 2

Plan View

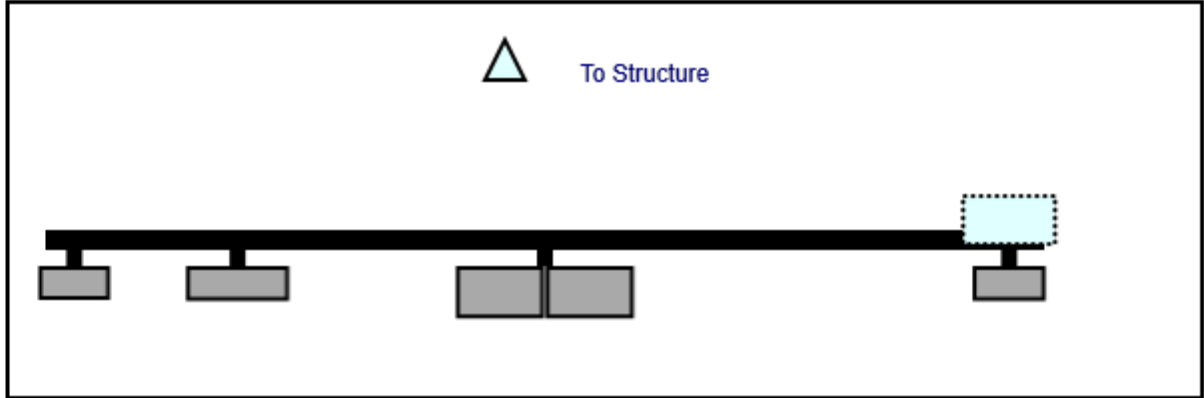

Front View  
Looking at Structure

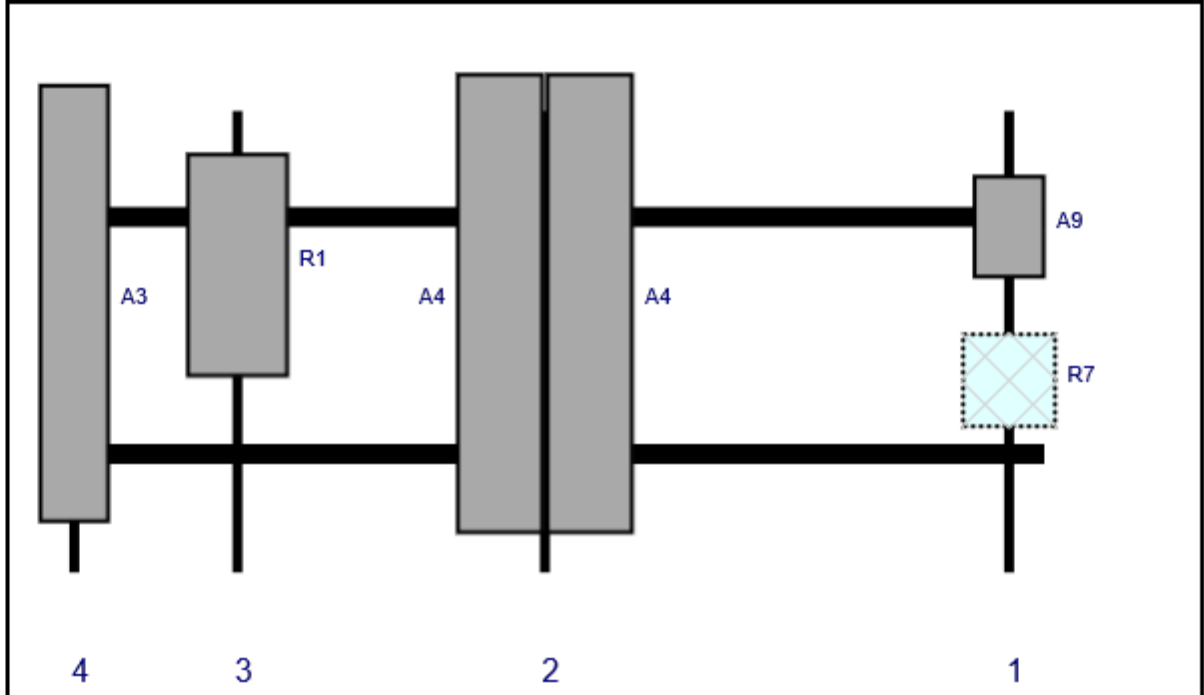

Ref#	Model	Height (in)	Width (in)	H Dist Frm L.	Pipe #	Pipe Pos V	Ant Pos	C. Ant Frm T.	Ant H Off	Status	Validation
A9	XXDWMM-12.5-65-8T-CBRS	16.2	11.4	150.5	1	a	Front	18	0	Retained	04/02/2021
R7	B5/B13 RRH-BR04C	15	15	150.5	1	a	Behind	42	0	Retained	04/02/2021
A4	JAHH-65B-R3B	72	13.8	78	2	a	Front	30	-7	Retained	04/02/2021
A4	JAHH-65B-R3B	72	13.8	78	2	b	Front	30	7	Retained	04/02/2021
R1	MT6407-77A	35.1	16.1	30	3	a	Front	24	0	Added	
A3	BXA-80063-6BF-EDIN-6	68.6	11.2	4.5	4	a	Front	30	0	Retained	04/02/2021

Sector: C  
 Structure Type: Self Support  
 Mount Elev: 153.90

10069536

6/10/2021



Page: 3

Plan View

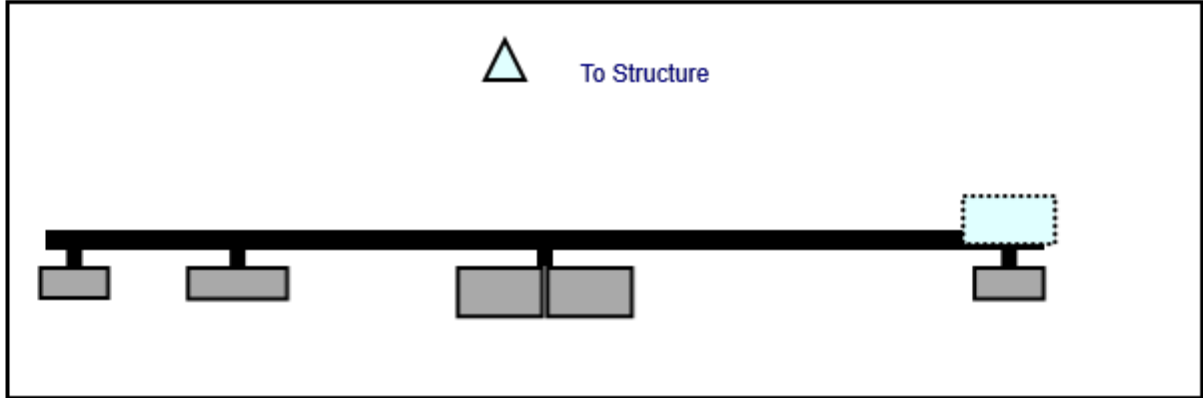

Front View  
 Looking at Structure

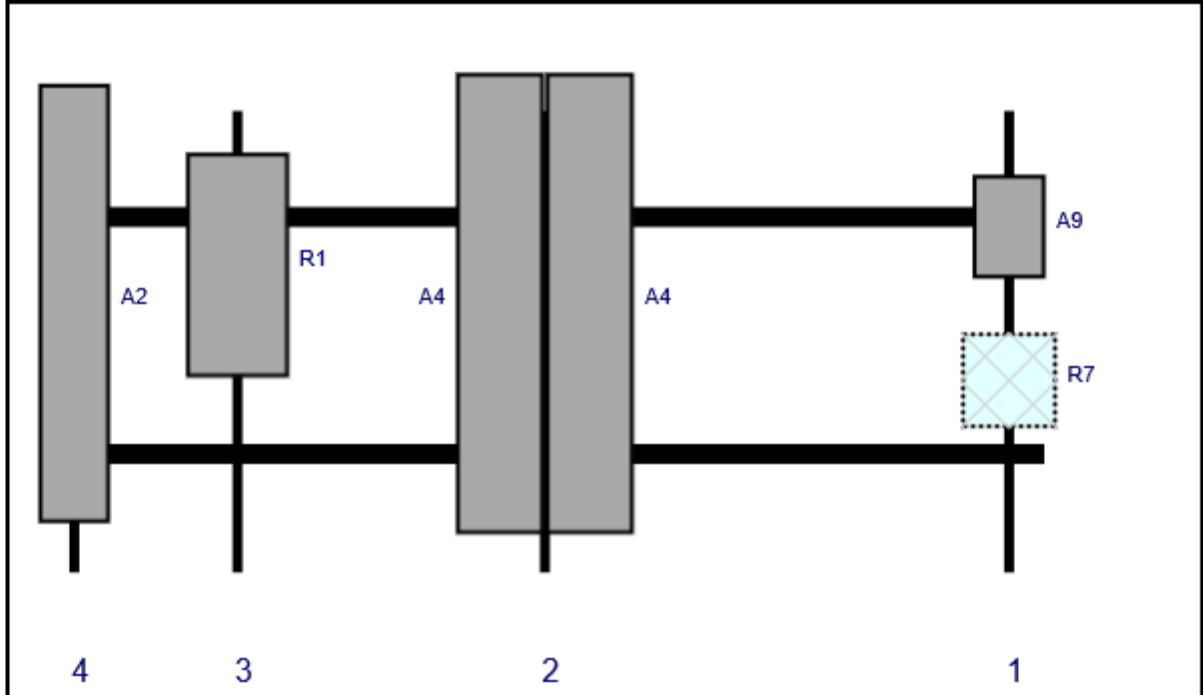

Ref#	Model	Height (in)	Width (in)	H Dist Frm L.	Pipe #	Pipe Pos V	Ant Pos	C. Ant Frm T.	Ant H Off	Status	Validation
A9	XXDWMM-12.5-65-8T-CBRS	16.2	11.4	150.5	1	a	Front	18	0	Retained	04/02/2021
R7	B5/B13 RRH-BR04C	15	15	150.5	1	a	Behind	42	0	Retained	04/02/2021
A4	JAHH-65B-R3B	72	13.8	78	2	a	Front	30	-7	Retained	04/02/2021
A4	JAHH-65B-R3B	72	13.8	78	2	b	Front	30	7	Retained	04/02/2021
R1	MT6407-77A	35.1	16.1	30	3	a	Front	24	0	Added	
A2	BXA-80063-6BF-EDIN-4	68.6	11.2	4.5	4	a	Front	30	0	Retained	04/02/2021

# Maser Consulting Connecticut

<b><u>Subject</u></b>	TIA-222-H Usage	
<b><u>Site Information</u></b>	Site ID:	467325-VZW / N BRIDGEPORT CT
	Site Name:	N BRIDGEPORT CT
	Carrier Name:	Verizon Wireless
	Address:	1330 Chopsey Hill Rd. Bridgeport, Connecticut 06606, Fairfield County
	Latitude:	41.219528°
	Longitude:	-73.201779°
<b><u>Structure Information</u></b>	Tower Type:	Self-Support
	Mount Type:	13.00-Ft Sector Frame

To Whom It May Concern,

We respectfully submit the above referenced Antenna Mount Structural Analysis report in conformance with ANSI/TIA-222-H, Structural Standard for Antenna Supporting Structures and Antennas and Small Wind Turbine Support Structures.

The 2015 International Building Code states that, in Section 3108, telecommunication towers shall be designed and constructed in accordance with the provisions of TIA-222. TIA-222-H is the latest revision of the TIA-222 Standard, effective as of January 01, 2018.

As with all ANSI standards and engineering best practice is to apply the most current revision of the standard. This ensures the engineer is applying all updates. As an example, the TIA-222-H Standard includes updates to bring it in line with the latest AISC and ACI standards and it also incorporates the latest wind speed maps by ASCE 7 based on updated studies of the wind data.

The TIA-222-H standard clarifies these specific requirements for the antenna mount analysis such as modeling methods, seismic analysis, 30-degree increment wind directions and maintenance loading. Therefore, it is our opinion that TIA-222-H is the most appropriate standard for antenna mount structural analysis and is acceptable for use at this site to ensure the engineer is taking into account the most current engineering standard available.

Sincerely,

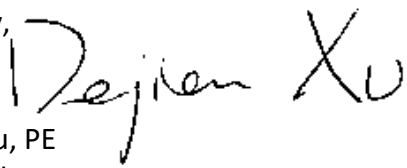

Dejian Xu, PE  
Technical Manager

Site Name: **N BRIDGEPORT CT**

**Cumulative Power Density**

Operator	Operating Frequency	Number of Trans.	ERP Per Trans.	Total ERP	Distance to Target	Calculated Power Density	Maximum Permissible Exposure*	Fraction of MPE
	(MHz)		(watts)	(watts)	(feet)	(mW/cm <sup>2</sup> )	(mW/cm <sup>2</sup> )	(%)
VZW 700	751	4	634	2534	155	0.0038	0.5007	0.76%
VZW CDMA	877.26	2	498	995	155	0.0015	0.5848	0.25%
VZW Cellular	874	4	725	2902	155	0.0043	0.5827	0.75%
VZW PCS	1980	4	1592	6369	155	0.0095	1.0000	0.95%
VZW AWS	2120	4	1633	6534	155	0.0098	1.0000	0.98%
VZW CBRS	3625	4	11	42	155	0.0001	1.0000	0.01%
VZW CBAND	3730.08	4	6531	26125	155	0.0391	1.0000	3.91%

**Total Percentage of Maximum Permissible Exposure**

**7.61%**

\*Guidelines adopted by the FCC on August 1, 1996, 47 CFR Part 1 based on NCRP Report 86, 1986 and generally on ANSI/IEEE C95.1-1992

\*\*Calculation includes a -10 dB Off Beam Antenna Pattern Adjustment pursuant to Attachments B and C of the Siting Council's November 10, 2015 Memorandum for Exempt Modification filings

MHz = Megahertz

mW/cm<sup>2</sup> = milliwatts per square centimeter

ERP = Effective Radiated Power

Absolute worst case maximum values used.



GBRC | City of Bridgeport, GBRC

CURRENT OWNER		TOPO	UTILITIES	STRT / ROAD	LOCATION	CURRENT ASSESSMENT				6015 BRIDGEPORT, CT					
GLOBAL TOWER ASSETS LLC						Description	Code	Appraised	Assessed						
10 PRESIDENTIAL WAY						Com Outbl	2-5	75,820	53,090	<b>VISION</b>					
WOBURN MA 01801						Vac Cm Ld	5-2	367,620	257,330						
<b>SUPPLEMENTAL DATA</b>															
Alt Prcl ID 2778--61B-----		Census Tr CEN728				Special Dis									
Heart Abstract 200:200		Freeze				Assoc Pid#									
GIS ID 2778-61B						Total		443,440	310,420						
RECORD OF OWNERSHIP			BK-VOL/PAGE	SALE DATE	Q/U	V/I	SALE PRICE	VC	PREVIOUS ASSESSMENTS (HISTORY)						
GLOBAL TOWER ASSETS LLC			9695 0074	09-13-2017	U	V	0	04	Year	Code	Assessed	Year	Code	Assessed	
GLOBAL TOWER ASSETS LLC			9500 0294	09-14-2016	U	V	0	03	2018	2-5	53,090	2017	2-5	53,090	
CELL TOWER LEASE ACQUISITION LLC			7342 0302	01-23-2007	U	I	0	03		5-2	257,330	2016	2-5	53,090	
UNISON SITE MANAGEMENT LLC			7342 0299	01-23-2007	U	I	1,925,000	03							
TARTAGLIA REMO			3018 0317	07-06-1992	U	V	700,000								
						Total		310420	Total	310420	Total	310420	Total	310420	
EXEMPTIONS				OTHER ASSESSMENTS				This signature acknowledges a visit by a Data Collector or Assessor							
Year	Code	Description	Amount	Code	Description	Number	Amount	Comm Int							
			Total					0.00							
ASSESSING NEIGHBORHOOD															
Nbhd		Nbhd Name		B		Tracing		Batch							
021															
NOTES															
CELL TOWER ENTRANCE TO LOT OFF OF CHOPSEY AM RD															
BUILDING PERMIT RECORD								VISIT / CHANGE HISTORY							
Permit Id	Issue Date	Type	Description	Amount	Insp Date	% Comp	Date Comp	Comments	Date	Id	Type	Is	Cd	Purpost/Result	
138418	06-12-2018	OT	Telecommunica	20,000	04-13-2018	100	01-10-2018		07-21-2016	RK	02		P	Permit Activity	
117018	03-27-2018		Telecommunica	15,000	04-30-2018	0		Replace Antenna	10-10-2014	RK	02		P	Permit Activity	
6747	06-07-2017		Telecommunica		09-06-2017	100	05-02-2017	C/O 6097	05-12-2014	RK	02		P	Permit Activity	
7023	10-13-2016		Telecommunica	15,000	09-28-2017	100	04-28-2017	C/O #6077	06-28-2013	RK	02		P	Permit Activity	
6731	06-01-2016	OT	Telecommunica	40,000	04-13-2018	100	01-10-2018	COA = Replace Antennas (AT	08-31-2010	RK	02		P	Permit Activity	
6572	04-04-2016		Telecommunica	40,000	10-11-2016	100	10-05-2016	C/O #5896 ANTENNAS REPL	09-03-2009	RK	02		P	Permit Activity	
6482	01-29-2016		Telecommunica	15,000	07-21-2016	100	05-12-2016	C/O #6286 T MOBILE	10-28-2008	AD		91		Com Field Review	
LAND LINE VALUATION SECTION															
B	Use Code	Description	Zone	Land Type	Land Units	Unit Price	Size Adj	Site Index	Cond.	Nbhd.	Nbhd. Adj	Notes	Location Adjustment	Adj Unit P	Land Value
1	200V	Commercial Lnd	RA		3.050 AC	101,500.00	1.00000	0	1.25	2140	0.950	CU		1.0000	120,531.2
Total Card Land Units					3.050 AC	Parcel Total Land Area					3.0500	Total Land Value			367,620



CONSTRUCTION DETAIL			CONSTRUCTION DETAIL (CONTINUED)		
Element	Cd	Description	Element	Cd	Description
Style:	79	Telephone Bldg			
Model	00	Vacant			
Grade:					
Stories:					
Occupancy:					
Exterior Wall 1:					
Exterior Wall 2:					
Roof Structure:					
Roof Cover:					
Interior Wall 1:					
Interior Wall 2:					
Interior Flr 1:					
Interior Flr 2:					
Heat Fuel:					
Heat Type:					
AC Type:					
Total Bedrooms					
Total Full Baths					
Total Half Baths					
Total Xtra Fixtrs					
Total Rooms					
Bath Style:					
Kitchen Style:					
Fireplaces					
Fin Bsmt Area					
Fin Bsmt Qualit					
Bsmt Garages					
.					
<b>CONDO DATA</b>					
Parcel Id		C	Owne		
			B	S	
Adjust Type	Code	Description	Factor%		
Condo Flr					
Condo Unit					
<b>COST / MARKET VALUATION</b>					
Building Value New			0		
Year Built			0		
Effective Year Built					
Depreciation Code					
Remodel Rating					
Year Remodeled					
Depreciation %			0		
Functional Obsol			0		
External Obsolescence			0		
Trend Factor			1.000		
Condition					
Condition %			100		
Percent Good					
RCNLD			0		
Dep % Ovr					
Dep Ovr Comment					
Misc Imp Ovr					
Misc Imp Ovr Comment					
Cost to Cure Ovr					
Cost to Cure Ovr Comment					

No Sketch

OB - OUTBUILDING & YARD ITEMS(L) / XF - BUILDING EXTRA FEATURES(B)										
Code	Description	L/B	Units	Unit Price	Yr Blt	Cond. Cd	% Gd	Grade	Grade Adj.	Appr. Value
FN5	Fence 10'	L	616	20.00	2000		50		0.00	6,160
PAV2	Paving Conc	L	40	4.00	2009		70		0.00	110
TWR	Tower	L	240	200.00	2007		100		0.00	48,000
SHD1	Shed	L	1,200	17.00	1987	A	60	3	1.00	12,240
SHD1	Shed	L	432	17.00	2000	A	60	3	1.00	4,410
SHD1	Shed	L	240	17.00	2000	A	60	3	1.00	2,450
SHD1	Shed	L	240	17.00	2006	A	60	3	1.00	2,450

BUILDING SUB-AREA SUMMARY SECTION							
Code	Description	Living Area	Floor Area	Eff Area	Unit Cost	Undeprec Value	
Ttl Gross Liv / Lease Area		0	0	0			0

