



STATE OF CONNECTICUT  
CONNECTICUT SITING COUNCIL

Ten Franklin Square  
New Britain, Connecticut 06051  
Phone: (860) 827-2935  
Fax: (860) 827-2950

December 19, 2000

Sandy M. Carter  
Verizon Wireless  
20 Alexander Drive  
P.O. Box 5029  
Wallingford, CT 06492

RE: **TS-VER-013-001117** - Cellco Partnership d/b/a Verizon Wireless request for an order to approve tower sharing at an existing telecommunications facility located at 131 Gifford Lane, Bozrah, Connecticut.

Dear Ms. Carter:

At a public meeting held December 14, 2000, the Connecticut Siting Council (Council) ruled that the shared use of this existing tower site is technically, legally, environmentally, and economically feasible and meets public safety concerns, and therefore, in compliance with General Statutes § 16-50aa, the Council has ordered the shared use of this facility to avoid the unnecessary proliferation of tower structures. This facility has also been carefully modeled to ensure that radio frequency emissions are conservatively below State and federal standards applicable to the frequencies now used on this tower.

This decision is under the exclusive jurisdiction of the Council. Any additional change to this facility may require an explicit request to this agency pursuant to General Statutes § 16-50aa or notice pursuant to Regulations of Connecticut State Agencies Section 16-50j-73, as applicable. Such request or notice shall include all relevant information regarding the proposed change with cumulative worst-case modeling of radio frequency exposure at the closest point uncontrolled access to the tower base, consistent with Federal Communications Commission, Office of Engineering and Technology, Bulletin 65. Any deviation from this format may result in the Council implementing enforcement proceedings pursuant to General Statutes § 16-50u including, without limitation, imposition of expenses resulting from such failure and of civil penalties in an amount not less than one thousand dollars per day for each day of construction or operation in material violation.

This decision applies only to this request for tower sharing and is not applicable to any other request or construction.

The proposed shared use is to be implemented as specified in your letter dated November 16, 2000.

Thank you for your attention and cooperation.

Very truly yours,

  
Mortimer A. Gelston  
Chairman

MAG/FOC/laf

c: Honorable Keith J. Robbins, First Selectman, Town of Bozrah  
Ester McNany, SBA, Inc.  
Julie M. Cashin, Esq., Hurwitz & Sagarin, LLC  
J. Brendan Sharkey, VoiceStream Wireless Corporation



STATE OF CONNECTICUT  
CONNECTICUT SITING COUNCIL

Ten Franklin Square  
New Britain, Connecticut 06051  
Phone: (860) 827-2935  
Fax: (860) 827-2950

December 4, 2000

Honorable Keith J. Robbins  
First Selectman  
Town of Bozrah  
Town Hall  
1 River Road  
Bozrah, CT 06334-0158

RE: **TS-VER-013-001117** - Cellco Partnership d/b/a Verizon Wireless request for an order to approve tower sharing at an existing telecommunications facility located at 131 Gifford Lane, Bozrah, Connecticut.

Dear Mr. Robbins:

The Connecticut Siting Council (Council) received this request for tower sharing, pursuant to Connecticut General Statutes § 16-50aa.

The Council will consider this item at the next meeting scheduled for December 14, 2000, at 10:00 a.m. in Hearing Room One, Ten Franklin Square, New Britain, Connecticut.

Please call me or inform the Council if you have any questions or comments regarding this proposal.

Thank you for your cooperation and consideration.

Very truly yours,

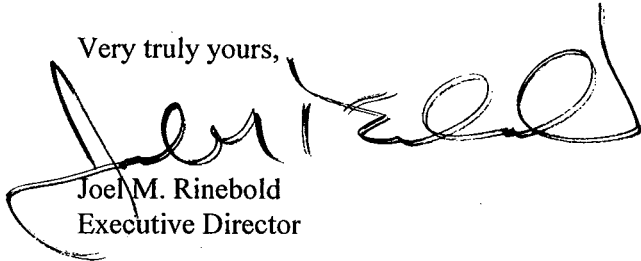

Joel M. Rinebold  
Executive Director

JMR/laf

Enclosure: Notice of Tower Sharing

Network Dept.

The Verizon Wireless logo, featuring a red checkmark above the word "verizon" in a bold, sans-serif font, followed by "wireless" in a smaller, lowercase sans-serif font.

Verizon Wireless  
20 Alexander Drive  
Wallingford, Connecticut 06492

RECEIVED

NOV 17 2000

CONNECTICUT  
SITING COUNCIL

HAND DELIVERED

November 16, 2000

Mr. Mortimer A. Gelston, Chairman  
Connecticut Siting Council  
10 Franklin Square  
New Britain, Connecticut 06051

Re: **Request by Cellco Partnership d/b/a Verizon Wireless for an Order to Approve the Shared Use of a Tower Facility located at 131 Gifford Lane, Bozrah, Connecticut.**

Dear Chairman Gelston:

Pursuant to Connecticut General Statutes (C.G.S.) Sec. 16-50aa, Cellco Partnership d/b/a Verizon Wireless hereby requests an order from the Connecticut Siting Council ("Council") to approve the proposed shared use by Verizon Wireless of an existing tower located at 131 Gifford Lane, Bozrah, Connecticut. The property is owned by John E. and Betty L. Orr and the tower is owned and managed by SBA Towers, Inc. As shown on the attached drawing and as further described below, Verizon Wireless proposes to install antennas on the existing tower and to locate an equipment shelter at the base of the tower. Verizon Wireless requests that the Council finds that the proposed shared use of the tower facility satisfy the criteria stated in C.G.S. Sec. 16-50aa, and to issue an order approving the proposed shared use.

**Background**

Verizon Wireless is licensed by the Federal Communications Commission to provide cellular telephone service in the New London County New England County Metropolitan Area (NECMA), which includes the area to be served by the proposed Bozrah installation.

The facility at 131 Gifford Lane in Bozrah, consists of a an approximately 196 foot AGL lattice tower built by SBA Towers, Inc. and is located on a leased parcel. The lattice tower supports the antennas of Sprint Spectrum PCS and Omnipoint Communications, both wireless carriers which provide mobile communications service to the public pursuant to their FCC license. Verizon Wireless and SBA Towers, Inc. have agreed to the proposed-shared use of this tower pursuant to mutually acceptable terms and conditions. SBA Towers, Inc. has authorized Verizon Wireless to apply for all necessary permits, approvals and authorizations which may be required for the proposed shared use of this facility.

Verizon Wireless proposes to install twelve (12) Decibel Model DB844H90 antennas, approximately 48 inches in height, on a platform with their center of radiation at approximately 165' feet above ground level ("AGL"). Verizon Wireless will also install one (1) GPS antenna on the antenna platform. Equipment associated with these antennas, as well as a 40 KW diesel-fueled emergency stand-by generator, would be located in a new approximately 12-foot x 30-foot equipment building located at the base of the tower.

C.G.S. Sec. 16-50aa provides that, upon written request for approval of a proposed shared use, "if the Council finds that the proposed shared use of the facility is technically, legally, environmentally and economically feasible and meets public safety concerns, the Council shall issue an order approving such shared use" (C.G.S. Sec. 16-50aa©(1).)

### **Discussion**

A. Technical Feasibility. The existing tower is structurally sound and capable of supporting the proposed Verizon Wireless antennas. The tower will not require any structural modification to support the proposed attachments. A copy of the structural design is attached to this application. Verizon Wireless engineers have determined that the proposed antenna installations present minimal potential for interference to or from existing radio transmissions from this location. In addition, the applicant is unaware of any occasion where its operations have caused interference with AM, FM or television reception. The proposed shared use of this tower therefore is technically feasible.

B. Legal Feasibility. Under C.G.S. Sec. 16-50aa, the Council has been authorized to issue an order approving the proposed-shared use of an existing communications tower facility such as the facility at 131 Gifford Lane. (C.G.S. Sec. 16-50aa©(1).) This authority complements the Council's prior existing authority under C.G.S. Sec. 16-50p to issue orders approving the construction of new towers that are subject to the Council's jurisdiction. C.G.S. Sec. 16-50x(a) directs the Council to "give consideration to other state laws and municipal regulations as it shall deem appropriate" in ruling on requests for the shared use of existing tower facilities. Under the authority vested in the Council by C.G.S. Sec. 16-50aa, an order by the Council approving the shared use would permit the applicant to obtain a building permit for the proposed installations.

C. Environmental Feasibility. The proposed shared use would have a minimal environmental effect, for the following reasons:

1. The proposed installations would have an insignificant incremental visual impact, and would not cause any significant change or alteration in the physical or environmental characteristics of the existing site. The addition of the proposed antennas would not increase the height of the tower, and would not extend the boundaries of the tower site, including the placement of the equipment building near the base of the existing tower.
2. The proposed installation would not increase the noise levels at the existing facility by six decibels or more. The only additional noise will occur during emergency use or periodic exercising of the generator.
3. Operation of the additional antennas will not increase the total radio frequency electromagnetic radiation power density, measured at the tower base to a level at or above the applicable standard. "Worst-case" exposure calculations for a point at the base of the tower in relation to operation of Verizon Wireless's and the other carriers' antenna arrays are as follows:

|                  | <u>Applicable<br/>ANSI Stnd</u> | <u>Calculated<br/>"Worst-Case"</u> | <u>Percentage<br/>of Stnd</u> |
|------------------|---------------------------------|------------------------------------|-------------------------------|
| Verizon Wireless | 0.583 mW/cm <sup>2</sup>        | 0.0251 mW/cm <sup>2</sup>          | 4.30%                         |
| Sprint           | 1.000 mW/cm <sup>2</sup>        | 0.0157 mW/cm <sup>2</sup>          | <u>1.57%</u>                  |
| Omnipoint        | 1.000 mW/cm <sup>2</sup>        | 0.0094 mW/cm <sup>2</sup>          | <u>0.94 %</u>                 |
|                  |                                 | Total                              | 6.81%                         |

The collective "worst-case" exposure would be only 6.81% of the ANSI standard, as calculated for mixed frequency sites. Power density levels from shared use of the tower facility would thus be well below applicable ANSI standards.

4. The proposed installations would not require any water or sanitary facilities or generate discharges to water bodies. Operation of the emergency back-up generator will result in limited air emissions, pursuant to R.C.S.A. Section 22a-174-3, the generator will require the issuance of a permit from the Department of Environmental Protection Bureau of Air Management. After construction is complete, the proposed installation would not generate any traffic other than periodic maintenance visits.

The proposed use of this facility would therefore have a minimal environmental effect, and is environmentally feasible.

D. Economic Feasibility. As previously mentioned, the tower owner and the applicant have entered into a mutual agreement to share use of the existing tower on terms agreeable to the parties, and the proposed tower sharing is thus economically feasible.

E. Public Safety Concerns. As stated above, the existing tower is structurally capable of supporting the proposed Verizon Wireless antennas. The Applicant is not aware of any other public safety concerns relative to the proposed tower sharing of the existing tower. In fact, the provision of new or improved cellular phone service in the Bozrah area, especially along the heavily traveled Route 2, and the Town of Bozrah through shared use of the tower is expected to enhance the safety and welfare of area residents and travelers. The public safety benefits of wireless service are further illustrated by the decision of local authorities elsewhere in Connecticut to provide cellular phones to residents to improve local public safety and emergency communications. The proposed shared use of this facility would likewise improve public safety in the Easthampton area.

### Conclusion

For the reasons discussed above, the proposed shared use of the existing telecommunications tower facility at 131 Gifford Lane satisfies the criteria stated in C.G.S. Sec. 16-50aa, and advances the General Assembly's and the Council's goal of preventing the proliferation of towers in Connecticut. The Applicant therefore requests that the Council issue an order approving the proposed shared use.

Mr. Mortimer A. Gelston  
November 16, 2000  
Page 5

Thank you for your consideration of this matter.

Pursuant to Connecticut General Statutes Sec, 16-50v and Section 16-50v-1(a) of the Regulations of Connecticut State Agencies, Verizon Wireless has enclosed a check in the amount of \$500.00 for the required filing fee.

Respectfully yours,

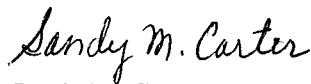

Sandy M. Carter  
Manager – Regulatory  
Verizon Wireless

Attachments

cc: Keith Robbins, First Selectman

Network Dept.



Verizon Wireless  
20 Alexander Drive  
Wallingford, Connecticut 06492

November 16, 2000

Honorable Keith Robbins, First Selectman  
Town Hall  
1 River Road  
Bozrah, Connecticut 06334

Dear Mr. Robbins:

This letter is to inform you that Celco Partnership d/b/a Verizon Wireless plans to install antennas and associated equipment at the existing tower facility located at 131 Gifford Lane, Bozrah, Connecticut. I am enclosing a copy of Verizon Wireless's tower sharing application to the Connecticut Siting Council.

The application fully sets forth the Company's proposal. However, if you have any questions or require further information on our plans or the Siting Council's procedures, please contact me at (203) 294-8519 or Mr. Joel Rinebold, Executive Director of the Connecticut Siting Council at (860) 827-2935.

Sincerely,

A handwritten signature in cursive script that reads "Sandy M. Carter".

Sandy M. Carter  
Manager - Regulatory  
Verizon Wireless

Enclosure





November 13,2000

Sandy Carter  
Regulatory Manager  
Verizon Wireless  
20 Alexander Drive  
Wallingford, CT 06492

RE: SBA Bozrah Facility  
4287 – Gifford Lane

Dear Sandy:

Please consider this as a Letter of Authorization for Verizon to proceed with any and all necessary permits and approvals to collocate on the above referenced facility.

We acknowledge that Verizon has filed a Collocation Application with SBA and that that application has been approved. As always, we look forward to working with you. If I can be of further assistance, please call.

Sincerely,

A handwritten signature in cursive script, appearing to read "Esther K. McNany".

Esther K. McNany  
Territory Manager



**DB842H80N-XY, DB842H90N-XY dB DIRECTOR™ LOG PERIODIC ANTENNAS**  
**DB844H80N-XY, DB844H90N-XY 9-13 dBd GAIN, 40 dB F/B RATIO, 806-960 MHz**



Ideal for cellular and trunking/ESMR applications, these high quality log periodics are now available from Decibel in four new models with 80 or 90 degree horizontal apertures. They're compact, lightweight, and provide an **unmatched front-to-back ratio of 40 dB**.

- **Less Wind Loading** - They measure only 24 or 48 inches (610 or 1219 mm) tall, 8.5 inches deep (216 mm), and 6 inches wide (152 mm). They weigh only 5 or 10 pounds.
- **Downtilt** - Electrical downtilt is available on all 4-foot models, 6°, 8°, 11°, 13°, or for mechanical downtilt, order DB5083 bracket.
- **Null-Fill** - Four-foot models provide null-fill and upper lobe suppression.
- **Most Stringent IM Test** - Each antenna is tested for the absence of IM with 16 carriers at 500 watts of composite power.
- **Sturdy Construction** - Made in the U.S. of high-strength aluminum alloy backs, brass elements and UV resistant ABS plastic radomes. No rivets are used!
- **Lightning Resistant** - All metal parts are grounded.
- **Terminations and Mounts** - All models are available with N-Female or 7/16 DIN connectors. DB380 pipe mount is included.

Ordering information - See table for models to fit your requirements.

**UPS  
Shippable**

**Models Available**

| Model*                      | DB842H80N-XY | DB844H80N-XY | DB842H90N-XY | DB844H90N-XY |
|-----------------------------|--------------|--------------|--------------|--------------|
| Gain - dBd/dBi              | 10/12.1      | 13/15.1      | 9/11.1       | 12/14.1      |
| F/B Ratio - dB              | 40           | 40           | 40           | 40           |
| Horizontal beamwidth**      | 80°          | 80°          | 90°          | 90°          |
| Vertical beamwidth**        | 30°          | 15°          | 30°          | 15°          |
| Height - in. (mm)           | 24 (610)     | 48 (1219)    | 24 (610)     | 48 (1219)    |
| Weight - lbs. (kg)          | 5 (2.3)      | 10 (4.6)     | 5 (2.3)      | 10 (4.6)     |
| Shipping weight - lbs. (kg) | 8 (3.6)      | 15 (6.8)     | 8 (3.6)      | 15 (6.8)     |

\* For 7/16 DIN connectors substitute "E" for "N" in the model numbers. Example: DB842H80E-XY.

\*\* 3 dB from maximum.

Side offset mounting bracket is included. For electrical downtilt of 6°, 8°, 11° or 13° add T6, T8, T11 or T13 before the "N" or "E" in any 4-foot model number. Example: DB844H80T6N-XY. Note: Electrical downtilt causes a gain loss of .05 dB, or, at the horizon, a reduction of 3, 6, 9 or 12 dB on downtilts of 6°, 8°, 11° or 13° respectively. For mechanical downtilt order DB5083 bracket.

**Mechanical Data**

|  |                     |
|--|---------------------|
| Width - in. (mm)                             | 6 (152)             |
| Depth - in. (mm)                             | 8.5 (216)           |
| Height                                       | See table above     |
| Maximum wind speed - mph (km/h)              | 125 (200)           |
| Wind area - ft² (m²)                         |                     |
| 24" (610 mm) antenna                         | 1 (.093)            |
| 48" (1219 mm) antenna                        | 2 (.186)            |
| Wind load (at 100 mph/161 km/h) - lbf (N) kp |                     |
| 24" (610 mm) antenna                         | 40 (178) 18         |
| 48" (1219 mm) antenna                        | 80 (356) 36         |
| Radome                                       | Gray ABS            |
| Backplate                                    | Passivated aluminum |
| Radiators                                    | Brass               |
| Mounting hardware                            | Galvanized steel    |
| Weight                                       | See table above     |

**Electrical Data**

|  |                              |
|--|------------------------------|
| Frequency Range - MHz                    | 806-960                      |
| Gain - dBd                               | See table above              |
| Front-to-back ratio - dB                 | >40                          |
| Beamwidths                               | See table above              |
| VSWR                                     | <1.5:1                       |
| Null-fill and secondary lobe suppression | On 48" (1219 mm) models only |
| Maximum power input - watts              | 500                          |
| Nominal impedance - ohms                 | 50                           |
| Lightning protection                     | All metal parts grounded     |
| Termination                              | N-Female or 7/16 DIN         |

**Typical DB842H80-XY Vertical Pattern**

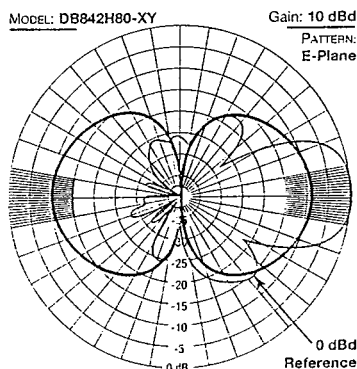

**4-Foot and 2-Foot dB DIRECTORS**

**Typical DB842H90N-XY, DB844H90N-XY Horizontal Pattern**

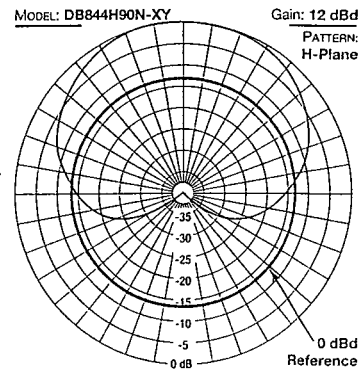

**Typical DB844H90N-XY Vertical Pattern**

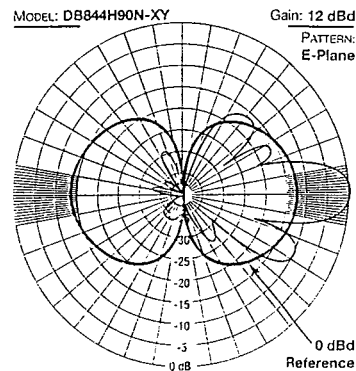

**Base Station Antennas**



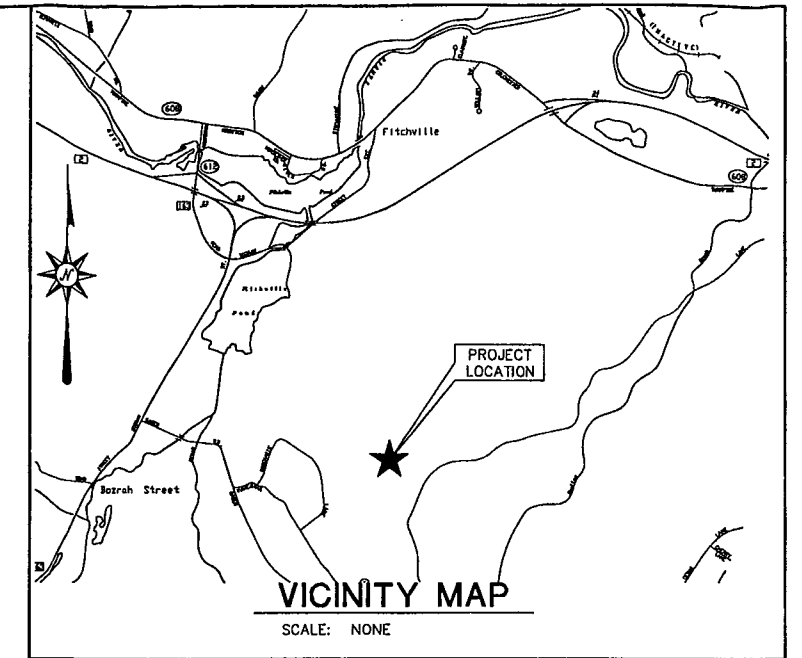
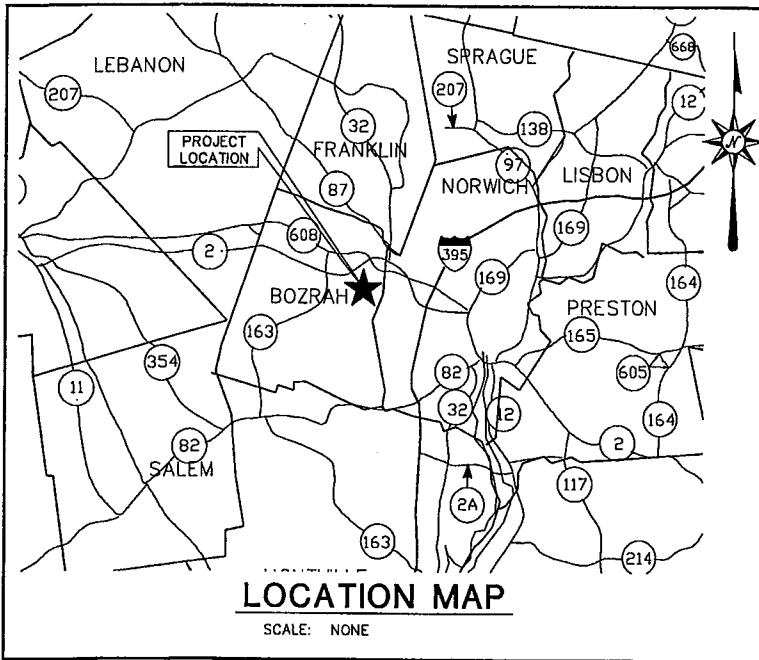

# SITING COUNCIL SUBMISSION

## BOZRAH EAST

# TELECOMMUNICATION FACILITY

131 GIFFORD LANE  
BOZRAH, CONNECTICUT 06334

PREPARED FOR:  
CELLCO PARTNERSHIP DBA  
VERIZON WIRELESS  
20 ALEXANDER DRIVE  
WALLINGFORD, CONNECTICUT 06492

### CONTENTS

SC-1 TITLE SHEET  
SITE PLAN AND ELEVATION

PREPARED BY:



ARCHITECTURE ENGINEERING PLANNING LANDSCAPE ARCHITECTURE  
LAND SURVEYING ENVIRONMENTAL SCIENCES ANALYTICAL SERVICES

355 RESEARCH PARKWAY  
MERIDEN, CONNECTICUT 06450  
(203) 630-1406  
(203) 630-2615 Fax

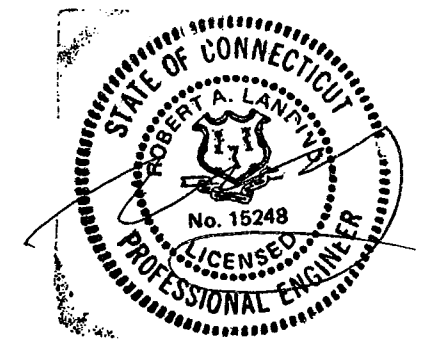

NOT FOR CONSTRUCTION

### DATES

ISSUE DATE: NOVEMBER 1, 2000  
REVISION:

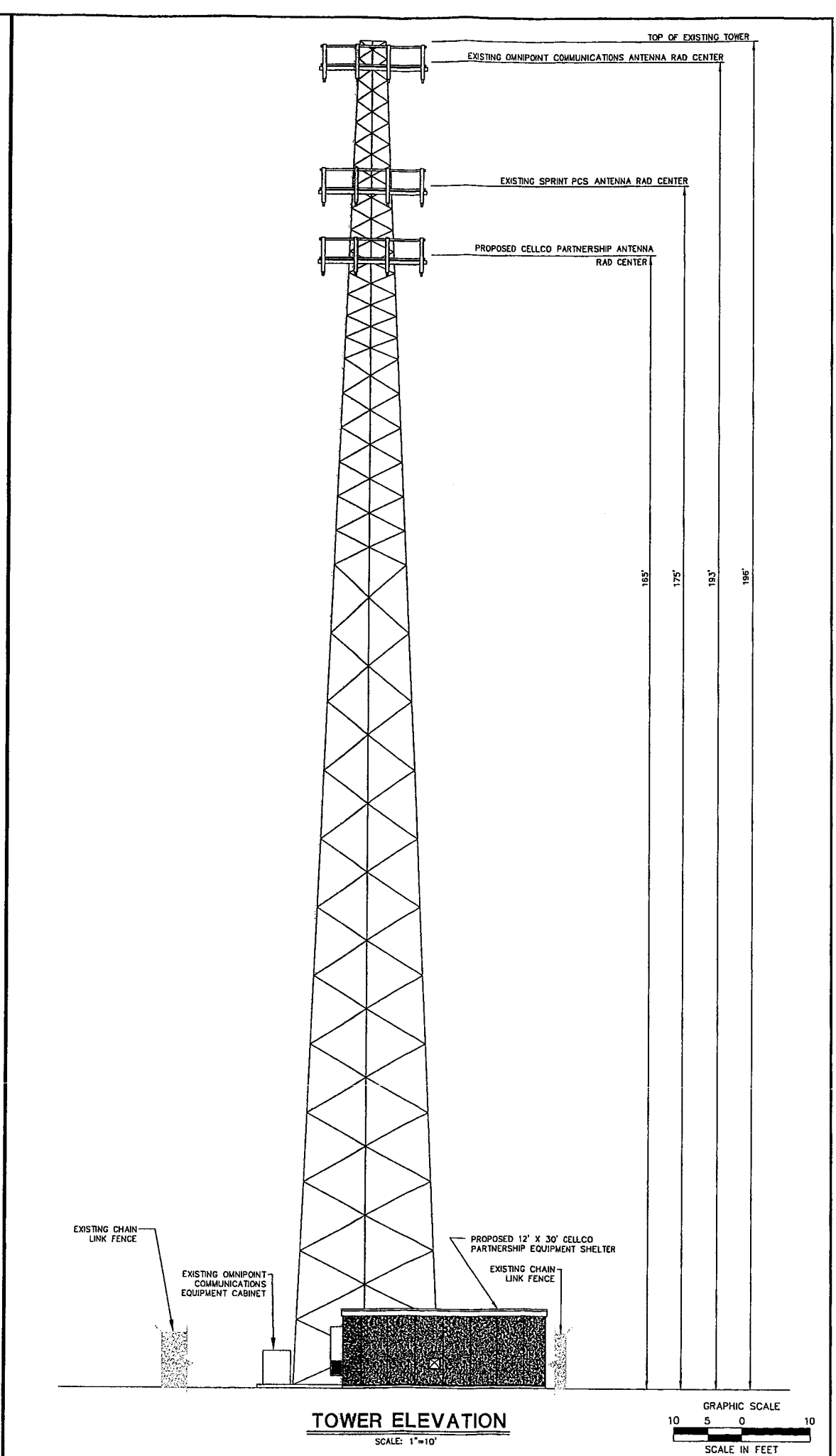
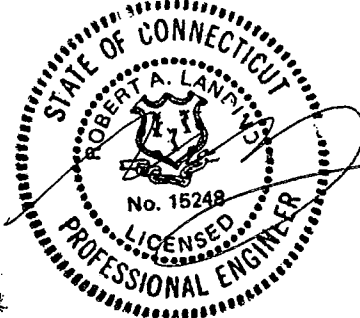
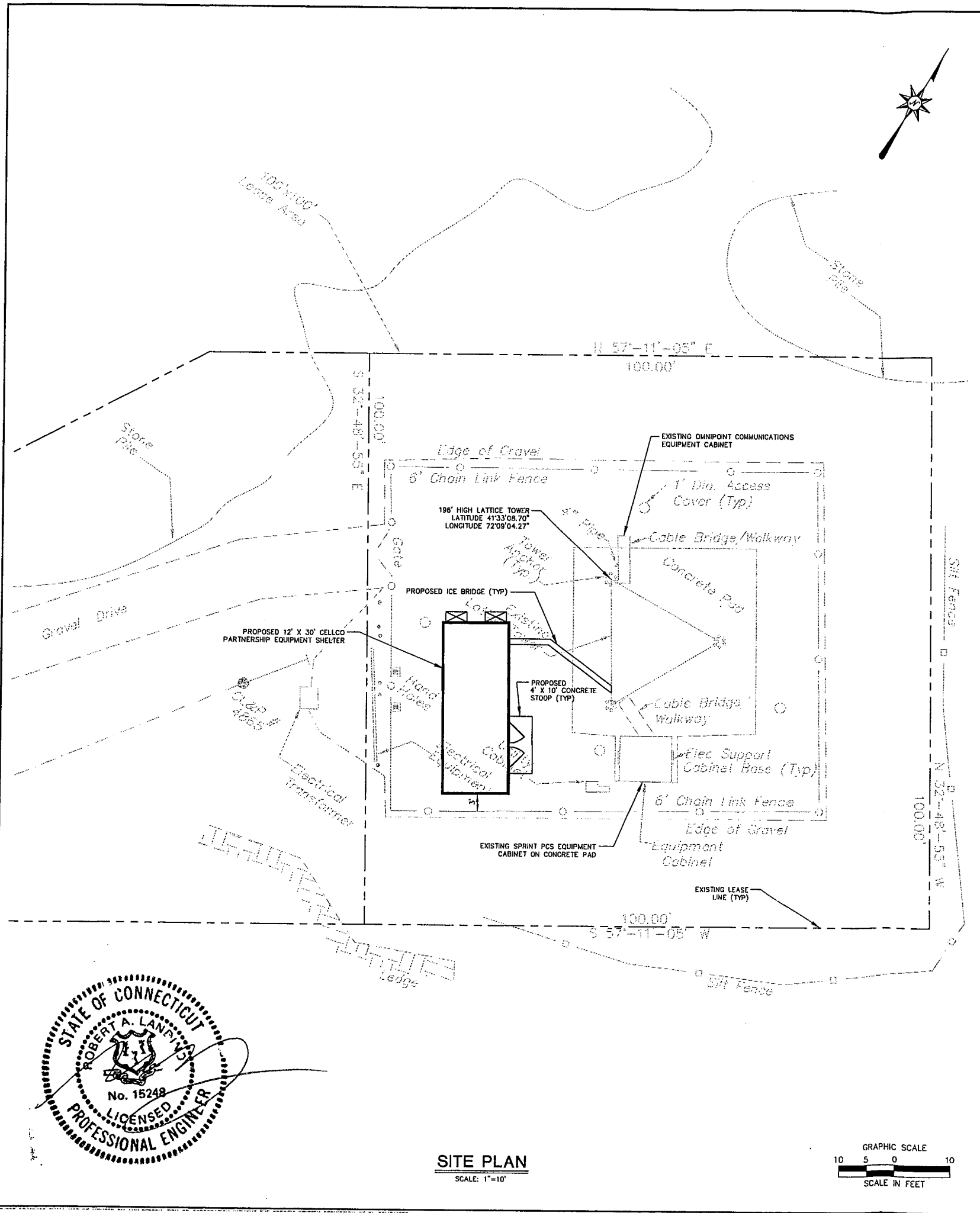

**BL**  
Companies  
ARCHITECTURE  
ENGINEERING  
PLANNING  
LANDSCAPE ARCHITECTURE  
LAND SURVEYING  
ENVIRONMENTAL SCIENCES  
ANALYTICAL SERVICES

355 Research Parkway  
Meriden, CT 06450  
(203) 630-1400  
(203) 630-2615 Fax

**SITE PLAN AND TOWER ELEVATION**  
**BOZRAH EAST TELECOMMUNICATION FACILITY**  
131 GIFFORD LANE  
BOZRAH, CONNECTICUT

| REVISIONS   | No.      | Date | Desc. |
|-------------|----------|------|-------|
| Designed    | R.C.B.   |      |       |
| Drawn       | R.C.B.   |      |       |
| Checked     | R.C.B.   |      |       |
| Approved    | R.A.L.   |      |       |
| Scale       | AS SHOWN |      |       |
| Project No. | 00C787   |      |       |
| Date        | 11/01/00 |      |       |
| CAD File    | SCC78701 |      |       |

Sheet No.  
**SC-1**

SHOP WELD TOP PLATE P/N  
120612 AT TOP OF TOP SECTION.

TOP VIEW  
(ENLARGED)  
ROTATABLE TOP  
(REF ASSEMBLY  
DWG # 130555)

SIDE VIEW  
(ENLARGED)

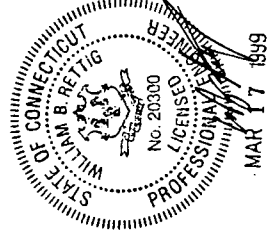
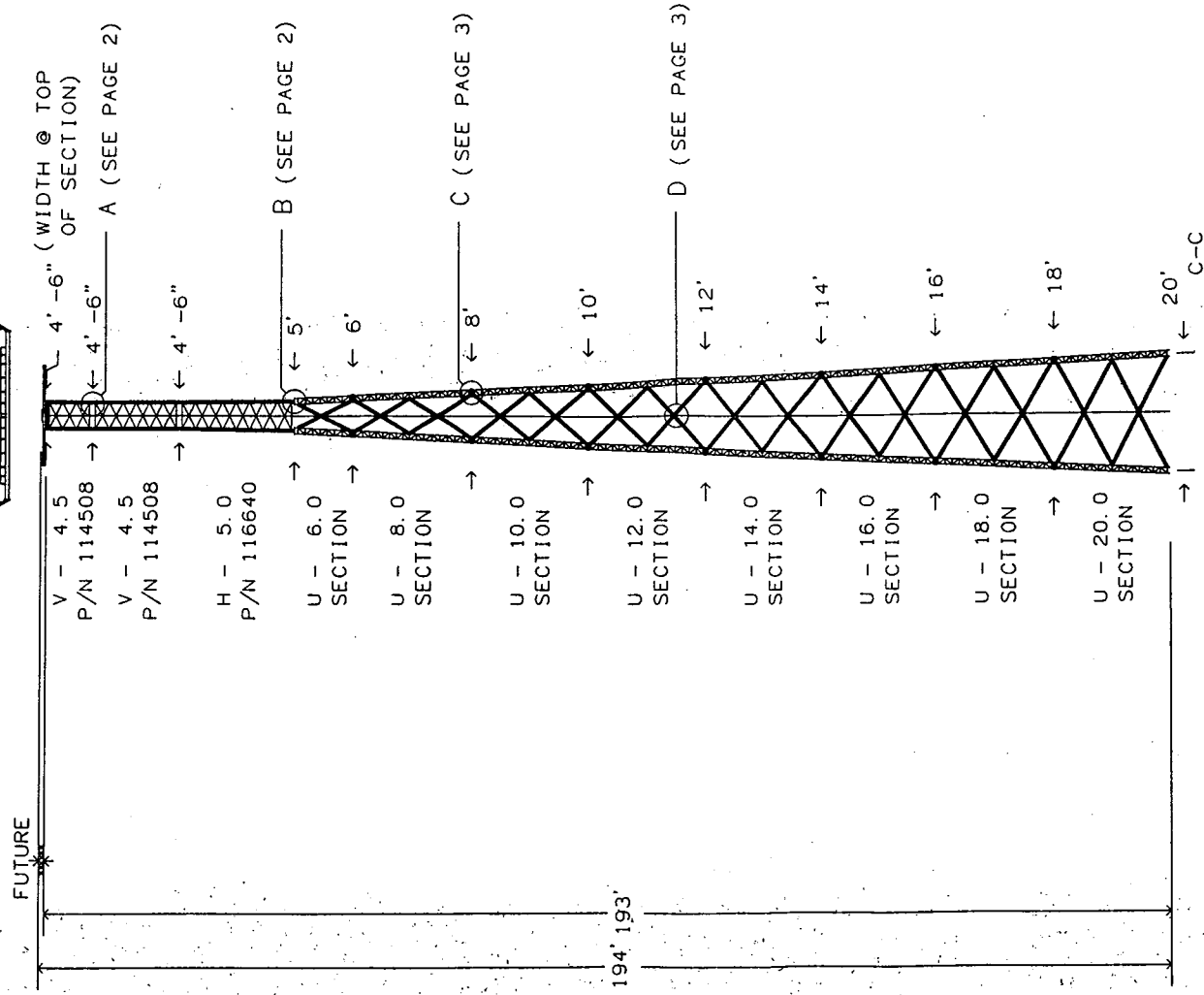
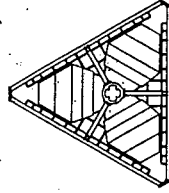

|     |                                   |     |            |
|-----|-----------------------------------|-----|------------|
| E   | REVISED DEPTH BELOW GRADE.        | MBR | 03/16/1999 |
| D   | REVISED FOUNDATION.               | MBR | 03/16/1999 |
| C   | ADDED ROCK ANCHOR DETAILS         | WRH | 02/23/1999 |
| B   | ADDED FOUNDATIONS PER SOIL REPORT | WRH | 02/23/1999 |
| A   | AUTOCAD EDITS                     | MOB | 02/17/1999 |
| REV | DESCRIPTION OF REVISIONS          | INI | DATE       |

From: 81663.DFT - 02/17/99 10:53  
Printed from: 2046691E.DWG \* 03/16/1999 14:58 @ 03/17/1999 13:52

|                                  |                |                                       |                  |
|----------------------------------|----------------|---------------------------------------|------------------|
| SBA, INC.<br>BOZRAH, CONNECTICUT |                | U - 20.0 X 193' SELF-SUPPORTING TOWER |                  |
| APPROVED/ENG.                    | MBR 03/16/1999 | APPROVED/FOUND.                       | N/A              |
| DRAWN BY.                        | MOB            | ENC. FILE NO.                         | A-115466-0-81663 |
| DRAWING NO. 204669-B             |                | PAGE 1 OF 8                           |                  |

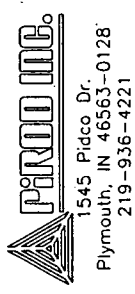

| FABRICATED SECTION DATA 150' - 193' ELEVATION |           |                  |             |               |              |                 |           |
|---|-----------|------------------|-------------|---------------|--------------|-----------------|-----------|
| SECT<br>LEN                                   | SECT<br># | SECTION<br>PART# | LEG<br>SIZE | BRACE<br>SIZE | SECT<br>WT.* | BOLTS AT BOTTOM |           |
|   |           |                  |             |               |              | * DIAM          | LENGTH #  |
| 8'  | V-        | 4-5 114508+      | 1- 3/4 "    | 7/8 "         | 470#         | 5/8 "           | 4" 12     |
| 15'   | V-        | 4-5 114508       | 1- 3/4 "    | 7/8 "         | 884#         | 3/4 "           | 5" 15     |
| 20'   | H-        | 5-0 116640       | 2- 1/4 "    | 1 "           | 1656#        | 1 "             | 3-3/2" 18 |

\*THE WEIGHTS LISTED ARE THEORETICAL. THE ACTUAL WEIGHTS WILL VARY.  
 ALL WEIGHTS SHOULD BE CONFIRMED IN THE FIELD PRIOR TO ERECTION.  
 +WELD TOP PLATE P/N 120612 AT TOP OF TOP SECTION.

A-325 BOLTS  
 SEE TABLE ABOVE

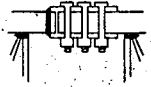

VIEW A  
 TYPICAL LEG CONNECTION  
 FOR FABRICATED SECTIONS

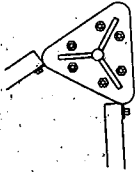

TOP VIEW @ B VIEW B  
 LEG CONNECTION AT 150 FT.  
 USE 1 FLATWASHER UNDER EACH LOCKNUT,  
 FOR LEG CONNECTION ONLY.

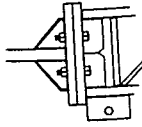

TOP VIEW  
 MARKED LEG

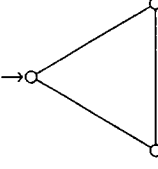

LADDER FACE

THE MARKED LEG OF EACH SECTION IS  
 STAMPED WITH THE 6 DIGITS OF THE  
 TOWER SERIAL #. ASSEMBLE THE TOWER  
 WITH MARKED LEGS TOGETHER. THE  
 MARKED LEG MAY ALSO CONTAIN JOINT  
 NUMBERS STARTING WITH 1 AT THE TOP  
 OF THE BASE SECTION. IF SO, ASSEMBLE  
 WITH JOINTS IN THE PROPER SEQUENCE.

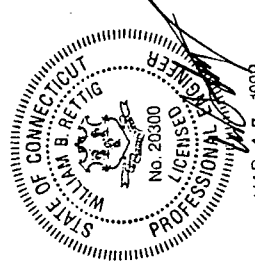

MAR 17 1999

SBA, INC.

BOZRAH, CONNECTICUT  
 U - 20.0 X 193' SELF-SUPPORTING TOWER

|                |     |            |
|----------------|-----|------------|
| APPROVED/ENG.  | WBR | 03/16/1999 |
| APPROVED/FOUND | N/A |            |
| DRAWN BY       | MDB |            |

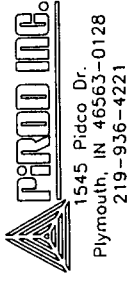

| BREAKDOWN SECTION DATA (12" LEG) 0' - 150' ELEVATION |                |          |           |                   |            |               |                |       |                |                   |                     |                   |                     |
|--|----------------|----------|-----------|-------------------|------------|---------------|----------------|-------|----------------|-------------------|---------------------|-------------------|---------------------|
| SEC #  | SECTION LENGTH | LEG SIZE | LEG PART# | TOP DIAGBOT PART# | DIAG PART# | DIAGONAL FACE | DIAGONAL THICK | ANGLE | SECTION WEIGHT | LEG CONNECT+ DIAM | LEG CONNECT+ LENGTH | DIAG CONNECT DIAM | DIAG CONNECT LENGTH |
| U-6.0  | 10'            | 1- 1/4"  | 105244    |                   | 105556     | 2-1/2"        | 3/16"          | 3/16" | 870#           | 1 "               | 3-1/2"              | 1 "               | 2-1/4"              |
| U-8.0  | 20'            | 1- 1/2"  | 105217    | 105559            | 105562     | 3"            | 3/16"          | 3/16" | 2200#          | 1 "               | 3-1/2"              | 1 "               | 2-1/4"              |
| U-10.0   | 20'            | 1- 3/4"  | 105218    | 105565            | 105568     | 3"            | 3/16"          | 3/16" | 2637#          | 1 "               | 4-1/2"              | 1 "               | 2-1/4"              |
| U-12.0   | 20'            | 2        | 105219    | 116494            | 116495     | 3"            | 5/16"          | 5/16" | 3688#          | 1-1/4"            | 4-1/2"              | 1-1/4"            | 2-3/4"              |
| U-14.0   | 20'            | 2        | 105219    | 113409            | 113410     | 3"            | 5/16"          | 5/16" | 3796#          | 1-1/4"            | 4-1/2"              | 1-1/4"            | 2-3/4"              |
| U-16.0   | 20'            | 2- 1/4"  | 105220    | 113411            | 113412     | 3"            | 5/16"          | 5/16" | 4416#          | 1-1/4"            | 4-1/2"              | 1-1/4"            | 2-3/4"              |
| U-18.0   | 20'            | 2- 1/4"  | 105220    | 127370            | 127371     | 3-1/2"        | 5/16"          | 5/16" | 4770#          | 1-1/4"            | 4-1/2"              | 1-1/4"            | 2-3/4"              |
| U-20.0   | 20'            | 2- 1/4"  | 105220    | 105598            | 105601     | 3-1/2"        | 5/16"          | 5/16" | 4920#          |                   |                     | 1-1/4"            | 2-3/4"              |

\* THE WEIGHTS LISTED ARE THEORETICAL. THE ACTUAL WEIGHTS WILL VARY. ALL WEIGHTS SHOULD BE CONFIRMED IN THE FIELD PRIOR TO ERECTION.

+ USE 1 FLATWASHER UNDER EACH LOCKNUT. FOR LEG CONNECTION ONLY. ALSO USE 1 FLATWASHER UNDER EACH BOLT HEAD WHERE BUSHINGS ARE REQUIRED.

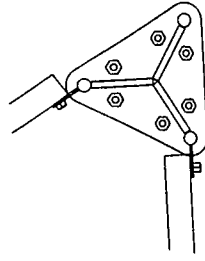

TOP VIEW @ C

USE SPACER #104291 BETWEEN DIAGONALS

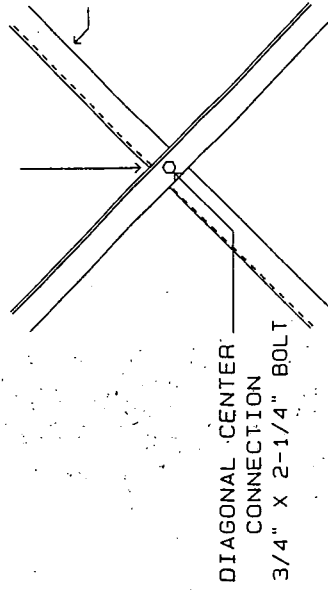

VIEW D (SEE PAGE 1 FOR VIEW DEFINITION)  
TYPICAL BRACE CONNECTION  
#12 SECTIONS

DIAGONAL CONNECTION  
SEE TABLE ABOVE  
FOR BOLT SIZE

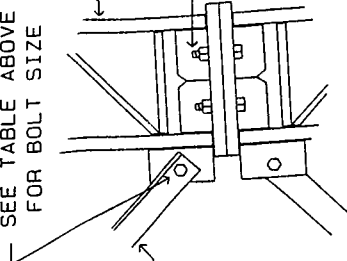

VIEW C  
TYPICAL LEG CONNECTION  
#12 SECTIONS

DIAGONAL BRACE  
SEE TABLE ABOVE  
FOR PART #

LEG CONNECTION  
SEE TABLE ABOVE  
FOR BOLT SIZE  
USE 1 FLATWASHER  
UNDER EACH LOCKNUT.  
ALSO USE 1 FLAT-  
WASHER UNDER EACH  
BOLT WHERE BUSH-  
INGS ARE REQUIRED.

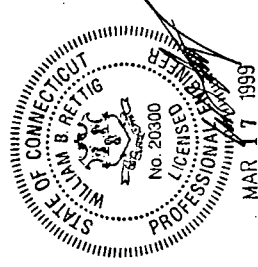

SBA, INC.

BOZRAH, CONNECTICUT

U - 20.0 X 193' SELF-SUPPORTING TOWER

APPROVED/ENG. WBR 03/16/1999

APPROVED/FOUND. N/A

DRAWN BY. MDB

ENG. FILE NO. A-115466-  
ARCHIVE Q-81663

From: 81663.DFT - 02/17/99 10:53

Printed from: 2046693e.DWG - 02/17/1999 10:52 @ 03/17/1999 13:52



1545 Pidco Dr.  
Plymouth, IN 46563-0128  
219-936-4221

DRAWING NO. 204669-B  
PAGE 3 OF 8

GENERAL NOTES

1. TOWER DESIGN CONFORMS TO STANDARD EIA/TIA-222-F FOR 85 MPH BASIC WIND SPEED WITH 0.50" RADIAL ICE WITH LOAD DUE TO WIND REDUCED BY 25% WHEN CONSIDERED SIMULTANEOUSLY WITH ICE.  
TOWER DESIGN CONFORMS TO STANDARD EIA/TIA-222-F FOR 85 MPH BASIC WIND SPEED WITH NO ICE.
2. MATERIAL: (A) SOLID RODS CONFORM TO ASTM A-572 GRADE 50 REQUIREMENTS.  
(B) ANGLES CONFORM TO ASTM A-36 REQUIREMENTS.  
(C) PIPE CONFORMS TO ASTM A-53 TYPE E, GRADE B REQUIREMENTS. (MIN YIELD STRENGTH=42 KSI)  
(D) ALL STEEL PLATES CONFORM TO ASTM A-36 REQUIREMENTS.  
(E) ANCHOR BOLTS CONFORM TO ASTM A-687 REQUIREMENTS.
3. BASE REACTIONS PER EIA/TIA-222-F FOR 85 MPH BASIC WIND SPEED WITH 0.50" RADIAL ICE:  
TOTAL WEIGHT = 65.7 KIPS.                    MAXIMUM COMPRESSION = 448.5 KIPS PER LEG.  
MOMENT = 7388.3 KIP-FT.                    MAXIMUM UPLIFT = 404.7 KIPS PER LEG.  
MAXIMUM SHEAR = 67.0 KIPS TOTAL.
4. BASE REACTIONS PER EIA/TIA-222-F FOR 85 MPH BASIC WIND SPEED WITH NO ICE.  
TOTAL WEIGHT = 41.2 KIPS.                    MAXIMUM COMPRESSION = 401.0 KIPS PER LEG.  
MOMENT = 6708.7 KIP-FT.                    MAXIMUM UPLIFT = 373.6 KIPS PER LEG.  
MAXIMUM SHEAR = 57.0 KIPS TOTAL.
5. FINISH: HOT DIPPED GALVANIZED AFTER FABRICATION.
6. ANTENNAS: 193' - TWELVE DB896 ANTENNAS ON A LOW PROFILE PLATFORM WITH 1-5/8" LINES.  
175' - TWELVE DB896 ANTENNAS ON THREE T-FRAMES WITH 1-5/8" LINES.  
160' - TWELVE DB896 ANTENNAS ON THREE T-FRAMES WITH 1-5/8" LINES.  
145' - TWELVE DB896 ANTENNAS ON THREE T-FRAMES WITH 1-5/8" LINES.  
130' - TWELVE DB896 ANTENNAS ON THREE T-FRAMES WITH 1-5/8" LINES.
7. ALL TRANSMISSION LINES MUST BE PLACED ON PIROD SUPPLIED LINE BRACKETS PART # 127247.
8. REMOVE FOUNDATION TEMPLATE PRIOR TO ERECTING TOWER. INSTALL BASE SECTION WITH MINIMUM OF 2" CLEARANCE ABOVE CONCRETE. GROUT NUTS BELOW BASE SECTION WITH NON-SHRINK GROUT AFTER LEVELING TOWER.
9. MIN. WELDS 5/16" UNLESS OTHERWISE SPECIFIED. ALL WELDING TO CONFORM TO AWS SPECIFICATIONS.
10. ALL BOLTS AND NUTS MUST BE IN PLACE BEFORE THE ADJOINING SECTION(S) ARE INSTALLED.
11. ALL A-325 BOLTS ARE TO BE TIGHTENED TO A SNUG TIGHT CONDITION AS DEFINED BY AISC SPECIFICATION UNLESS OTHERWISE NOTED. A MORE QUANTITATIVE ALTERNATIVE APPROACH TO ACHIEVING A SNUG TIGHT CONDITION IS TO TIGHTEN USING THE TORQUE VALUES FROM DRAWING 123107-A.
12. EIA GROUNDING FOR TOWER.

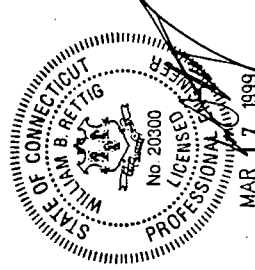

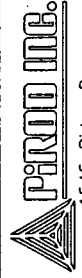
|  |  |   |                                     |
|--|--|---|-------------------------------------|
| SBA, INC.<br>BOZRAH, CONNECTICUT<br>U - 20.0 X 193' SELF-SUPPORTING TOWER                            |  | APPROVED/ENG.    WBR    03/16/1999  |                                     |
|  |  | APPROVED/FOUND    N/A   |                                     |
| DRAWN BY                    JMOB   |  |  1545 Pidco Dr.<br>Plymouth, IN 46363-0128<br>219-936-4221 |                                     |
| From: 81663.DFT - 02/17/99 10:53<br>Printed from: 2046694e.DWG - 02/17/1999 10:52 @ 03/17/1999 13:52 |  | ENG. FILE NO. A-115466-<br>ARCHIVE Q-81663  | DRAWING NO. 204669-B<br>PAGE 4 OF 8 |



FOUNDATION NOTES

1. SOIL AS PER REPORT BY JAWORSKI GEOTECH DATED 12/14/98 (FILE #C98492G).
2. CONCRETE TO BE 4000 PSI @28 DAYS. REINFORCING BAR TO CONFORM TO ASTM A615 GRADE 60 SPECIFICATIONS. CONCRETE INSTALLATION TO CONFORM TO ACT-318 BUILDING REQUIREMENTS FOR REINFORCED CONCRETE. ALL CONCRETE TO BE PLACED AGAINST UNDISTURBED EARTH FREE OF WATER AND ALL FOREIGN OBJECTS AND MATERIALS. A MINIMUM OF THREE INCHES OF CONCRETE SHALL COVER ALL REINFORCEMENT. WELDING OF REBAR NOT PERMITTED.
3. A COLD JOINT IS PERMISSIBLE UPON CONSULTATION WITH PIROD. ALL COLD JOINTS SHALL BE COATED WITH BONDING AGENTS PRIOR TO SECOND POUR.
4. CROWN TOP OF FOUNDATION FOR PROPER DRAINAGE.
5. THE FOUNDATION MUST BEAR ENTIRELY ON CLEAN SOUND BEDROCK. THE ROCK SUBSURFACE MAY BE LEVELED WITH LEAN CONCRETE UPTO 12" MAXIMUM THICKNESS

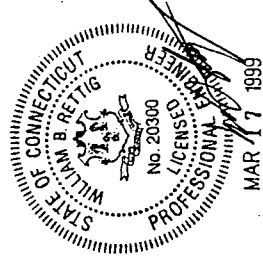

|  |                                   |  |                |
|--|-----------------------------------|--|----------------|
| SBA, INC.<br>BOZRAH, CONNECTICUT                                 |                                   | U - 20.0 X 193' SELF-SUPPORTING TOWER  |                |
| APPROVED/ENG.  | MBR 03/16/1999                    | APPROVED/FOUND                         | MBR 03/16/1999 |
| D  | REVISED FOUNDATION.               | MBR                                    | 03/16/1999     |
| B  | ADDED FOUNDATIONS PER SOIL REPORT | WRH                                    | 02/23/1999     |
| REV  | DESCRIPTION OF REVISIONS          | INI                                    | DATE           |
| From: 81663.DFT - 03/16/1999 15:05                               |                                   | DRAWN BY MDB                           |                |
| Printed from: 20466950.DWG - 03/16/1999 14:58 @ 03/17/1999 13:52 |                                   | ENG. FILE NO. A-115466-0-81663 ARCHIVE |                |
|  |                                   | DRAWING NO. 204669-B                   |                |
|  |                                   | PAGE 5 OF 8                            |                |

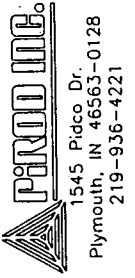

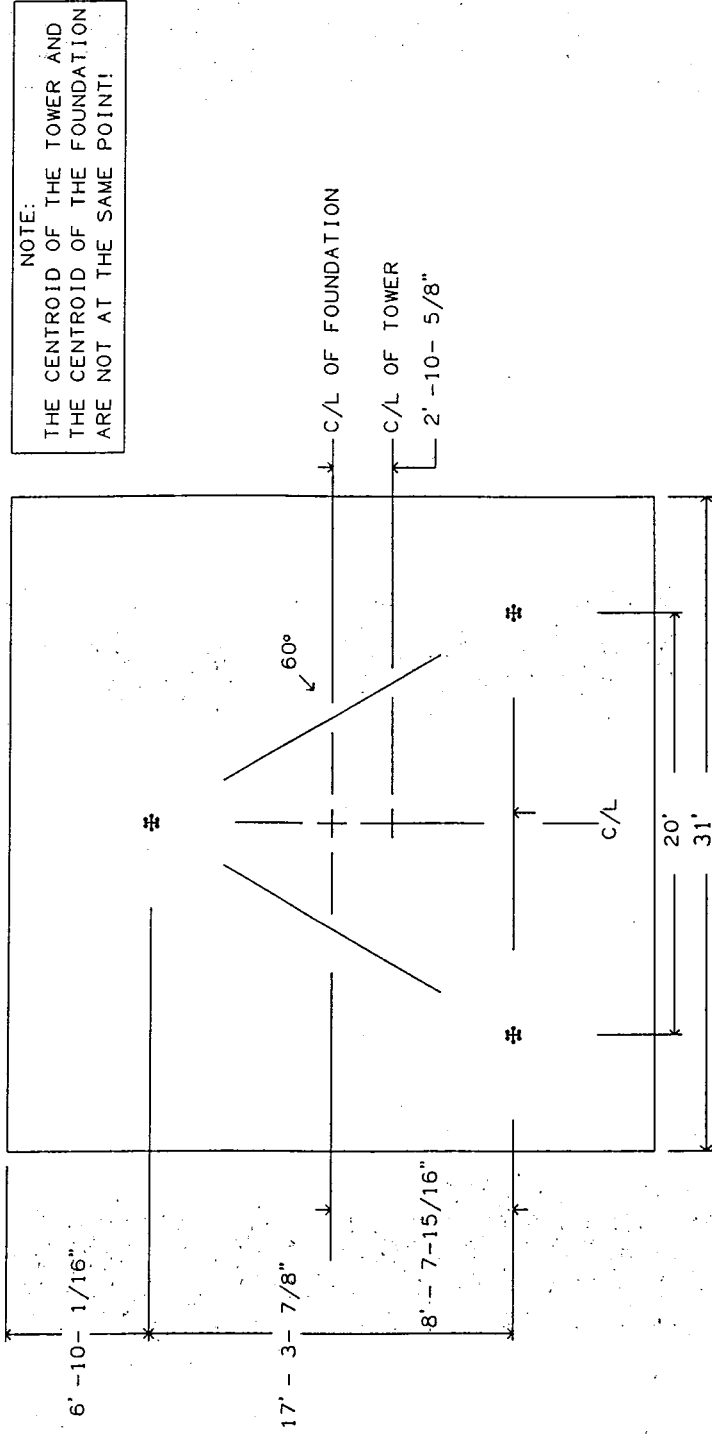

NOTE:  
THE CENTROID OF THE TOWER AND THE CENTROID OF THE FOUNDATION ARE NOT AT THE SAME POINT!

FOR ANCHOR STEEL IDENTIFICATION AND PLACEMENT INFORMATION, SEE PAGE 8 OF THIS DRAWING.

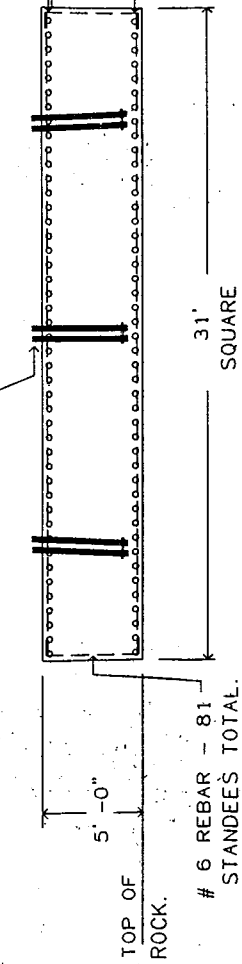

SEE (B) ON PAGE 7.

#11 REBAR - 45 BARS EACH WAY. SEE (A) ON PAGE 7.

#11 REBAR - 45 BARS EACH WAY. SEE (A) ON PAGE 7.

NOTE: ALL REBAR REQUIRES MIN. 3" CONCRETE COVERAGE

TOWER FOUNDATION

89.0 CUBIC YARDS CONCRETE REQUIRED FOR INSTALLATION SPECIFICATIONS AND ADDITIONAL INFORMATION, SEE PAGE 5 OF THIS DRAWING.

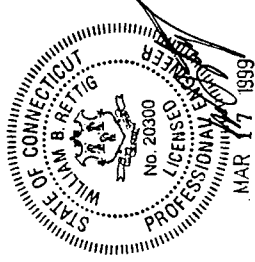

| REV | DESCRIPTION OF REVISIONS          | INI | DATE       |
|-----|-----------------------------------|-----|------------|
| E   | REVISED DEPTH BELOW GRADE.        | MBR | 03/16/1999 |
| D   | REVISED FOUNDATION.               | MBR | 03/16/1999 |
| C   | ADDED ROCK ANCHOR DETAILS         | WRH | 02/23/1999 |
| B   | ADDED FOUNDATIONS PER SOIL REPORT | WRH | 02/23/1999 |

From: 81663.DFT - 03/16/1999 15:33  
Printed from: 2046696E.DWG \* 03/16/1999 16:53 @ 03/17/1999 13:52\$

| APPROVED/ENG.   | MBR       | 03/16/1999 |
|-----------------|-----------|------------|
| APPROVED/FOUND. | MBR       | 03/16/1999 |
| DRAWN BY.       | MDB       |            |
| ENG. FILE NO.   | A-115466- | ARCHIVE    |
| DRAWING NO.     | 204669-B  | PAGE       |
|                 | 6         | OF 8       |

SBA, INC.  
BOZRAH, CONNECTICUT  
U - 20.0 X 193' BASE FOUNDATION

**PIROD MDB**  
1545 Pidco Dr.  
Plymouth, IN 46563-0128  
219-936-4221

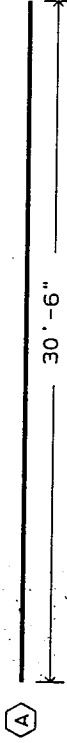

#11 REBAR - 180 PIECES REQ. TOTAL  
APPROX WT = 162.0# EACH, 29160# TOTAL

REBAR SUPPORTS MAY CONSIST OF ANY ACCEPTABLE MEANS OF SECURELY SUPPORTING THE TOP REINFORCEMENT GRID ABOVE THE BOTTOM REINFORCEMENT GRID WHILE MAINTAINING A SEPARATION OF 1'-6" (OUTSIDE REBAR TO OUTSIDE REBAR).

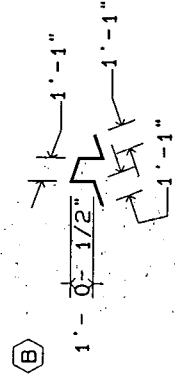

# 6 REBAR - 81 PIECES REQUIRED TOTAL  
TYPE 26 STANDEE PLACED BETWEEN REBAR GRIDS ON NOMINAL 4' SPACING THROUGHOUT  
APPROX UNBENT LENGTH = 5'-5"  
APPROX WT = 8.1# EACH, 656# TOTAL

REBAR DETAIL

TOTAL APPROX REBAR WEIGHT = 29816#  
REINFORCING BAR TO CONFORM TO  
ASTM A615 GRADE 60 SPECIFICATIONS.

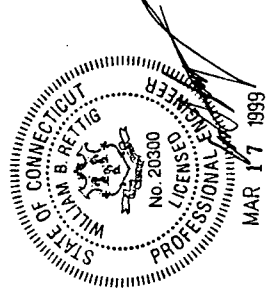

| REV | DESCRIPTION OF REVISIONS          | INI | DATE       |
|-----|-----------------------------------|-----|------------|
| D   | REVISED FOUNDATION.               | WBR | 03/16/1999 |
| C   | ADDED ROCK ANCHOR DETAILS         | WRH | 02/23/1999 |
| B   | ADDED FOUNDATIONS PER SOIL REPORT | WRH | 02/23/1999 |

|                 |     |            |
|-----------------|-----|------------|
| APPROVED/ENG.   | WBR | 03/16/1999 |
| APPROVED/FOUND. | WBR | 03/16/1999 |
| DRAWN BY        | MDB |            |

SBA, INC.  
BOZRAH, CONNECTICUT  
U - 20.0 X 193' REBAR DETAIL

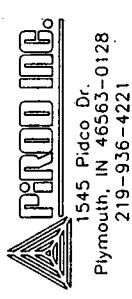

From: 81663.DFT - 03/16/1999 15:05  
Printed from: 20466970.DWG - 03/16/1999 14:59 @ 03/17/1999 13:52

ENG. FILE NO. A-115466-  
ARCHIVE 0-81663

DRAWING NO. 204669-B  
PAGE 7 OF 8

CENTER OF TEMPLATE MUST BE PLACED AS SHOWN.

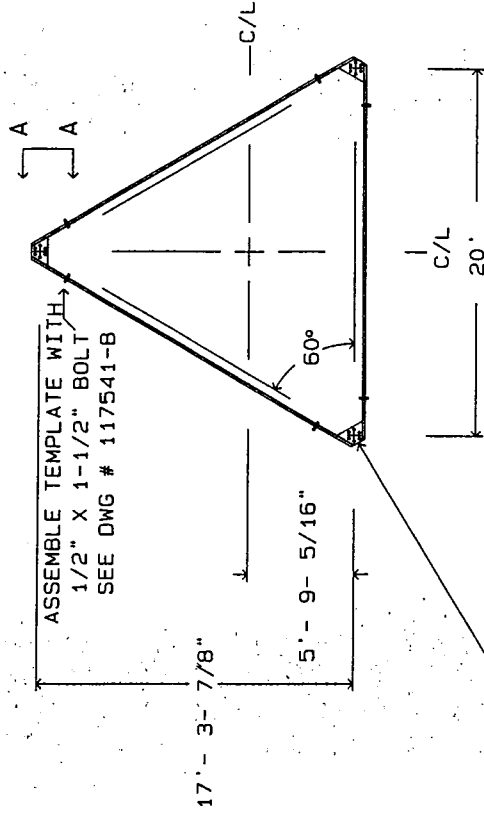

REFERENCE ANGLE = 3.30 DEGREES  
 TEMPLATE MUST BE UTILIZED TO  
 INSURE CORRECT PLACEMENT  
 ← TEMPLATE

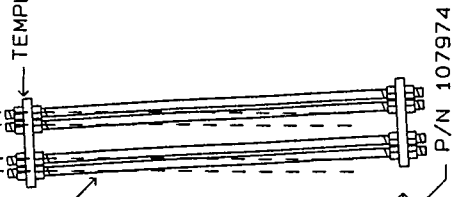

VIEW A - A  
 TEMPLATE P/N 117520 IS REQUIRED FOR INSTALLATION. COLOR CODE OF TEMPLATE MUST MATCH  
 COLOR CODE OF ANCHOR BOLTS. TEMPLATE MUST BE SECURELY DOUBLE-NUTTED TO ANCHOR BOLTS  
 DURING CONCRETE INSTALLATION AND MUST BE LEVEL +/- 1/2".  
 INSTALL TEMPLATE WITH LABEL "UP" FACING UPWARD.  
 INSTALL TEMPLATE WITH SUFFICIENT SPACE BENEATH TO PERMIT FINISHING OF CONCRETE.  
 AND TO FACILITATE TEMPLATE REMOVAL PRIOR TO TOWER ERECTION.

ANCHOR BOLT P/N 103183 - 6 REQUIRED PER LEG  
 DIAMETER = 1- 1/4 " COLOR CODE = PINK/WHITE  
 INSTALL WITH 8.5" OF THREADS EXPOSED  
 GROUT NUTS AFTER LEVELING TOWER

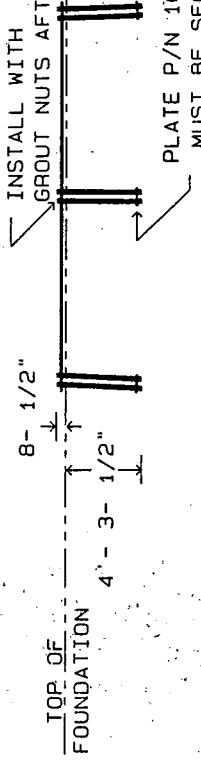

PLATE P/N 107974 (1 REQUIRED PER LEG)  
 MUST BE SECURELY DOUBLE-NUTTED IN PLACE  
 BENDING, STRAIGHTENING OR REALIGNING  
 (HOT OR COLD) OF THE ANCHOR BOLTS BY  
 ANY METHOD IS PROHIBITED.

ATTENTION INSTALLER

1-1/4" DIAMETER ANCHOR STEEL

THE ANCHOR BOLTS PROVIDED FOR THIS PROJECT ARE 1-1/4" DIA. AND COLOR CODED PINK & WHITE.  
 THE CORNER TEMPLATE IS PART NUMBER 117520 FOR A TAPERED TOWER AND SHOULD HAVE SIX 1-9/32"  
 DIA. HOLES ON AN 8" DIA. BOLT CIRCLE. EMBEDMENT PLATES ARE PART NUMBER 107974 WHICH ARE  
 TRIANGULAR AND HAVE SIX 1-5/16" DIA. HOLES ON AN 8" DIA. BOLT CIRCLE.

IF THERE ARE ANY DISCREPANCIES, PLEASE NOTIFY PIROD, INC., PRIOR TO INSTALLATION.

TOWER ANCHOR STEEL PLACEMENT

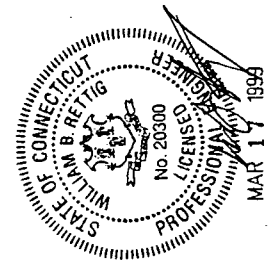

|  |                                   |  |            |
|--|-----------------------------------|--|------------|
| SBA, INC.<br>BOZRAH, CONNECTICUT<br>U - 20.0 X .193' ANCHOR INSTALLATION                                       |                                   | <br>1545 Pirodo Dr.<br>Plymouth, IN 46563-0128<br>219-936-4221 |            |
| APPROVED/ENG.  | MBR                               | 03/16/1999   |            |
| APPROVED/FOUND   | MBR                               | 03/16/1999   |            |
| DRAWN BY   | MOB                               |  |            |
| REV  | DESCRIPTION OF REVISIONS          | INI  | DATE       |
| D  | REVISED FOUNDATION.               | MBR  | 03/16/1999 |
| B  | ADDED FOUNDATIONS PER SOIL REPORT | MRH  | 02/23/1999 |
| From: 81663.DFT - 03/15/1999 15:33<br>Printed from: 2046598D.DWG - 03/16/1999 16:29 @ 03/17/1999 13:52 ARCHIVE |                                   |  |            |
| ENG. FILE NO. A-115466-<br>Q-81663   |                                   | DRAWING NO. 204669-B<br>8 OF 8                                 |            |