



# STATE OF CONNECTICUT

## CONNECTICUT SITING COUNCIL

Ten Franklin Square, New Britain, CT 06051

Phone: (860) 827-2935 Fax: (860) 827-2950

E-Mail: [siting.council@ct.gov](mailto:siting.council@ct.gov)

Web Site: [portal.ct.gov/csc](http://portal.ct.gov/csc)

### VIA ELECTRONIC MAIL

January 12, 2024

Catherine Ware  
SBA Communications Corporation  
134 Flanders Road, Suite 125  
Westborough, MA 01581  
[CWare@sbsite.com](mailto:CWare@sbsite.com)

RE: **TS-DISH-013-231220** - Dish Wireless, LLC request for an order to approve tower sharing at an existing telecommunications facility located at 141 Gifford Lane, Bozrah, Connecticut. **Acknowledgement of Complete Request.**

Dear Catherine Ware:

The Connecticut Siting Council (Council) is in receipt of your correspondence of January 10, 2024 submitted in response to the Council's December 22, 2023 notification of an incomplete request for tower sharing with regard to the above-referenced matter.

The submission renders the request for tower sharing complete and the Council will process the request in accordance with the Federal Communications Commission 60-day timeframe.

Thank you for your attention and cooperation.

Sincerely,

Melanie Bachman  
Executive Director

MAB/ANM/laf



December 13, 2023 - revised 1/02/2024

Melanie Bachman Connecticut Siting Council  
Ten Franklin Square  
New Britain, CT 06051

**RE: Tower Share Application**

**131 Gifford Lane Bozrah, CT 06334**  
**Latitude: Lat.: 41.552517**  
**Longitude: -72.150708**  
**Site#: SBA\_CT01105-S\_BOBOS01169A\_DISH**

Dear Ms. Bachman:

This letter and attachments are submitted on behalf of Dish Wireless LLC. Dish Wireless LLC plans to install antennas and related equipment to the tower site located at 131 Gifford Lane, Bozrah, CT.

Dish Wireless LLC proposes to install three (3) 600/1900/2100 MHz antennas and six (6) RRUs, at the 150-foot level of the existing 196-foot self support tower, one (1) Fiber cables will also be installed. Dish Wireless LLC equipment cabinets will be placed within 7' x 5' lease area. Included are plans by TEP Northeast dated September 25, 2023 Exhibit 10. Also included is a structural analysis prepared by SBA engineering, dated August 31, 2023, confirming that the existing tower is structurally capable of supporting the proposed equipment, attached as Exhibit 8. Also included is a mount analysis prepared by TEP Northeast dated September 15, 2023 confirming that the mount is structurally capable of supporting the proposed equipment, attached as Exhibit 9. This facility was approved by the CT Siting Council on February 11, 1999. Please see attached Exhibit 6.

Please accept this letter as notification pursuant to Regulations of Connecticut State Agencies 16-50aa, of Dish Wireless LLC intent to share a telecommunications facility pursuant to R.C.S.A. 16-50j-88. In accordance with R.C.S.A., a copy of this letter is being sent to Mr. Glenn Pianka - First Selectman and to Mr. Doug Colter Building Official. (Separate notice is not being sent to SBA, as SBA is the tower owner making this submission).

The planned modifications of the facility fall squarely within those activities explicitly provided for in R.C.S.A. 16-50j-89.

1. The proposed modification will not result in an increase in the height of the existing structure. The top of the existing tower is 196-feet and the Dish Wireless LLC antennas will be located at a center line height of 150-feet.
2. The proposed modifications will not result in the increase of the site boundary as depicted on the attached site plan.
3. The proposed modifications will not increase noise levels at the facility by six decibels or more, or to levels



that exceed local and state criteria. The incremental effect of the proposed changes will be negligible.

4. The operation of the proposed antennas will not increase radio frequency emissions at the facility to a level at or above the Federal Communications Commission safety standard. As indicated in the attached power density calculations, the combined site operations will result in a total power density of 9.89% as evidenced by Exhibit 7.

Connecticut General Statutes 16-50aa indicates that the Council must approve the shared use of a telecommunications facility provided it finds the shared use is technically, legally, environmentally, and economically feasible and meets public safety concerns. As demonstrated in this letter, Dish Wireless LLC respectfully indicates that the shared use of this facility satisfies these criteria.

A. Technical Feasibility. The existing self support tower has been deemed structurally capable of supporting Dish Wireless LLC proposed loading. The structural analysis is included as Exhibit 8.

B. Legal Feasibility. As referenced above, C.G.S. 16-50aa has been authorized to issue orders approving the shared use of an existing tower such as this support tower in Bozrah. Under the authority granted to the Council, an order of the Council approving the requested shared use would permit Dish Wireless LLC to obtain a building permit for the proposed installation.

C. Environmental Feasibility. The proposed shared use of this facility would have a minimal environmental impact. The installation of Dish Wireless LLC equipment at the 150-foot level of the existing 196-foot tower would have an insignificant visual impact on the area around the tower. Dish Wireless LLC ground equipment would be installed within the existing facility compound. Dish Wireless LLC shared use would therefore not cause any significant alteration in the physical or environmental characteristics of the existing site. Additionally, as evidenced by Exhibit 7, the proposed antennas would not increase radio frequency emissions to a level at or above the Federal Communications Commission safety standard.

D. Economic Feasibility. Dish Wireless LLC will be entering into an agreement with the owner of this facility to mutually agreeable terms. As previously mentioned, the Letter of Authorization has been provided by the owner to assist Dish Wireless LLC with this tower sharing application.

E. Public Safety Concerns. As discussed above, the tower is structurally capable of supporting Dish Wireless LLC proposed loading.

Dish Wireless LLC is not aware of any public safety concerns relative to the proposed sharing of the existing self support tower. Dish Wireless LLC intentions of providing new and improved wireless service through the shared use of this facility is expected to enhance the safety and welfare of local residents and individuals traveling through Bozrah.

Sincerely,

*Catherine Ware*

**Catherine Ware**

*Site Development Specialist*

**SBA Communications Corporation**

134 Flanders Road, Suite 125

Westborough, MA 01581



917.868.8365 + T  
[CWare@sbsite.com](mailto:CWare@sbsite.com)  
 Attachments:

cc:  
 Mr. Glenn Pianka, First Selectman  
 Bozrah Town Hall 1 River Road Bozrah, CT 06334  
 (860)889-2689

Mr. Doug Colter, Building Official Bozrah  
 Town Hall 1 River Road Bozrah, CT 06334  
 (860)889-2689

**EXHIBIT LIST**

Exhibit 1	Copy of Check	X
Exhibit 2	letter of intent	x
Exhibit 3	FedEx labels recipient notifications	x
Exhibit 4	Property Card	x
Exhibit 5	Property Map	X
Exhibit 6	Zoning Approval	February 11, 1999
Exhibit 7	EME Report	FOX Hill Telecom -12/04/2023
Exhibit 8	Structural Analysis	SBA - 8/31/2023
Exhibit 9	Mount Analysis	TEP Northeast 9/15/2023
Exhibit 10	Construction Drawings	TEP - 9/25/2023

# EXHIBIT 1

Copy of check

**From:**  
**To:**  
**Subject:** [External] CSC zoning filing fee  
**Date:** Thursday, December 7, 2023 2:22:37 PM

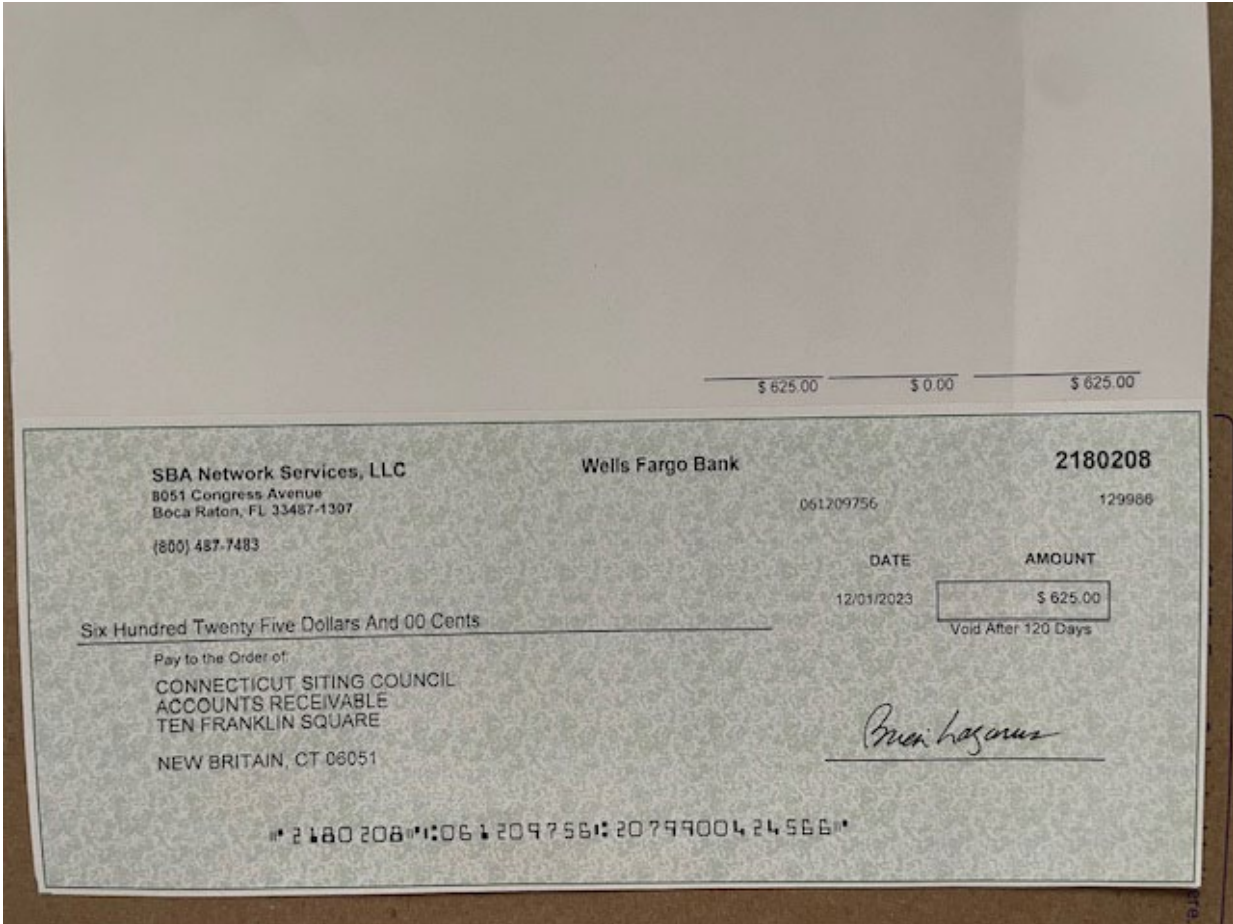

**EXHIBIT 2**

**Letter of Intent**

December 11, 2023

Melanie A. Bachman  
Executive Director  
Connecticut Siting Council  
Ten Franklin Square  
New Britain, CT 06051

RE: **Notice of Intent to Allow Shared Use of the Existing SBA Telecommunications Site**  
**Location: 131 Gifford Lane, Bozrah, CT**  
Dish Wireless Site No: BOBOS01169A  
SBA Site No: CT01105-S

Dear Ms. Bachman:

Please let the following serve as Evidence of Intent to allow Dish's shared use of the existing SBA telecommunications site at **131 Gifford Lane, Bozrah, CT**.

SBA Properties, LLC ("Owner") and Dish Wireless ("Tenant") are entering into a Site Lease Agreement. Tenant will be provided ground space within the existing site compound for its base station equipment and space at the height of 150' for antennas and associated equipment.

Thank you,

*Catherine Ware*

**Catherine Ware**  
*Site Development Specialist*  
SBA COMMUNICATIONS CORPORATION  
134 Flanders Road, Suite 125  
Westboro, MA 01581

(917)868-8365 + C  
[CWare@sbsite.com](mailto:CWare@sbsite.com)



# EXHIBIT 3

## Fedex Labels

ORIGIN ID:BBFA (917) 868-8365  
CATHERINE WARE  
SPA COMMUNICATIONS CORPORATION  
134 FLANDERS ROAD  
WESTBOROUGH, MA 01581  
UNITED STATES US

SHIP DATE: 05JAN24  
ACTWGT: 2.00 LB  
CAD: 255382542/INET4535

BILL SENDER  
TO **ORR RICHARD & DUERRLER PATTI**

**131 GIFFORD LANE**

**BOZRAH CT 06334**

REF: 10-56-92009-6089  
INV: (917) 868-8365  
PO: \_\_\_\_\_ DEPT: \_\_\_\_\_



MON - 08 JAN 12:00P  
PRIORITY OVERNIGHT  
RES  
06334  
CT-US BDL

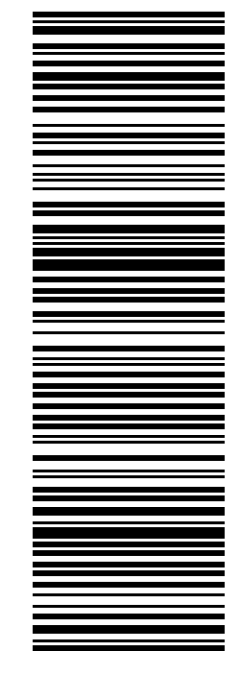

TRK# 7746 7504 6902  
0201  
**K7 SKKA**

After printing this label:  
CONSIGNEE COPY - PLEASE PLACE IN FRONT OF POUCH  
1. Fold the printed page along the horizontal line.  
2. Place label in shipping pouch and affix it to your shipment.

Use of this system constitutes your agreement to the service conditions in the current FedEx Service Guide, available on  
fedex.com. FedEx will not be responsible for any claim in excess of \$100 per package, whether the result of loss, damage,  
delay, non-delivery, misdelivery, or misinformation, unless you declare a higher value, pay an additional charge, document  
your actual loss and file a timely claim. Limitations found in the current FedEx Service Guide apply. Your right to recover from  
FedEx for any loss, including intrinsic value of the package, loss of sales, income interest, profit, attorney's fees, costs, and  
other forms of damage whether direct, incidental, consequential, or special is limited to the greater of \$100 or the authorized  
declared value. Recovery cannot exceed actual documented loss. Maximum for items of extraordinary value is \$1,000, e.g.  
jewelry, precious metals, negotiable instruments and other items listed in our Service Guide. Written claims must be filed  
within strict time limits, see current FedEx Service Guide.

ORIGIN ID: ZRPA (917) 868-8365  
CATHERINE WARE  
SBA COMMUNICATIONS CORPORATION  
101 INTERCHANGE PALZA  
CRANBURY, NJ 08512

SHIP DATE: 18DEC23  
ACTWGT: 2.00 LB  
CAD: 2553825421NET4535

BILL SENDER

UNITED STATES US

TO **MR. DOUG COLTER**  
**TOWN OF BOZRAH BUILDING OFFICIAL**  
**BOZRAH TOWN HALL**  
**1 RIVER ROAD**  
**BOZRAH CT 06334**

REF: 10-56-92009-8089

PO:

DEPT:

INV: (860) 889-2639



J234023101501uv

583J4/2BE4/9AE3

TRK# 0201 7745 0418 7406

TUE - 19 DEC 5:00P  
STANDARD OVERNIGHT

**EB SKKA**

06334

CT-US BDL

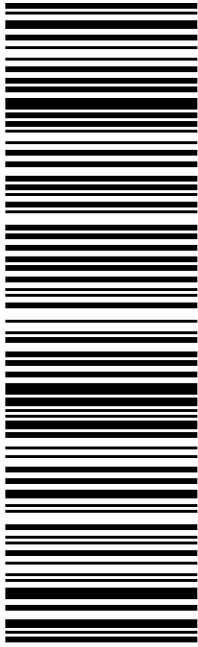

DELIVERY DATE

Tuesday

12/19/23 before 5:00 PM  
Estimated between  
9:30 AM - 1:30 PM

ON TIME

Want updates on this shipment? Enter your email and we will do the rest!

YOUR EMAIL

Jomorrison@sbsite.com

SUBMIT

MORE OPTIONS

Manage Delivery

DELIVERY STATUS

On the way

TRACKING ID

774504187406

FROM  
CRANBURY, NJ US  
*Label Created*  
12/15/23 2:30 PM

WE HAVE YOUR PACKAGE  
FRAMINGHAM, MA  
12/18/23 5:59 PM

ON THE WAY  
At FedEx destination facility  
NORWICH, CT  
12/19/23 8:27 AM

OUT FOR DELIVERY

TO  
BOZRAH, CT US  
*Delivery Date*  
12/19/23 before 5:00 PM  
Estimated between  
9:30 AM - 1:30 PM

ORIGIN ID: ZRPA (917) 868-8365  
CATHERINE WARE  
SBA COMMUNICATIONS CORPORATION  
101 INTERCHANGE PALZA  
CRANBURY, NJ 08512

SHIP DATE: 18DEC23  
ACTWGHT: 2.00 LB  
CAD: 255382542/INET4535

UNITED STATES US

BILL SENDER

TO MR. GLENN PIANKA

TOWN OF BOZRAH - FIRST SELECTMAN  
TOWN HALL - TOWN OF BOZRAH  
1 RIVER ROAD  
BOZRAH CT 06334

REF: 10-56-92009-6089  
INVT: (860) 889-2639

DEPT:

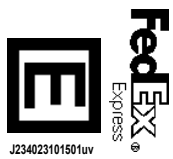
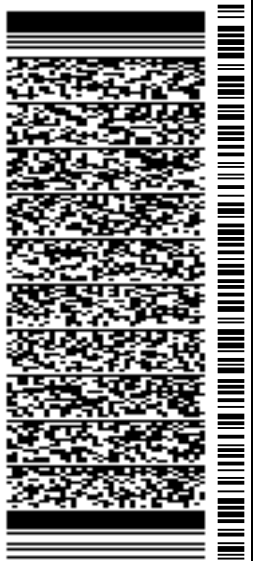

J234023101501uv

TRK# 0201 7745 0398 1285

TUE - 19 DEC 12:00P  
PRIORITY OVERNIGHT

EB SKKA

06334  
CT-US BDL

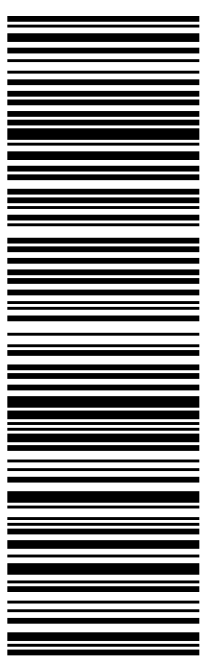

DELIVERY DATE

We're running behind, but your package will still arrive today.

DELIVERY STATUS

Out for delivery

TRACKING ID

774503981285

Today

Estimated between  
9:30 AM - 11:30 AM

Want updates on this shipment? Enter your email and we will do the rest!

YOUR EMAIL Jomorrison@sbsite.com **SUBMIT**

MORE OPTIONS

Manage Delivery

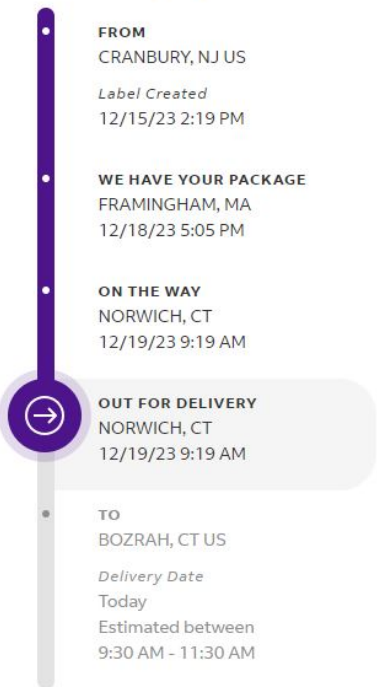

View travel history

ORIGIN ID: ZRPA (917) 868-8365  
CATHERINE WARE  
SBA COMMUNICATIONS CORPORATION  
101 INTERCHANGE PALZA  
CRANBURY, NJ 08512

SHIP DATE: 18DEC23  
ACTWGT: 2.00 LB  
CAD: 2553825421NET4535

UNITED STATES US

BILL SENDER

TO **MS. MELANIE BACHMAN**  
**CONNECTICUT SITING COUNCIL**  
**10 FRANKLIN SQUARE**

583J4/2BE4/9AE3

**NEW BRITAIN CT 06051**

(860) 827-2935

REF: 10-56-92009-8089

PO:

DEPT:



J234023101501uv

TRK# 0201 7745 0387 7809

TUE - 19 DEC 5:00P  
STANDARD OVERNIGHT

**EB BDLA**

06051

CT-US BDL

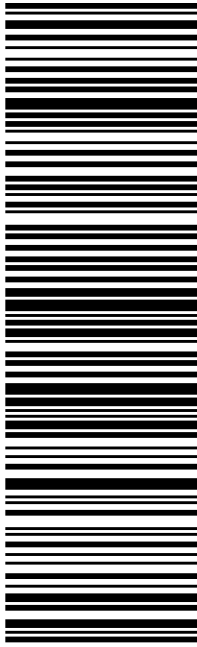

After printing this label:

**CONSIGNEE COPY - PLEASE PLACE IN FRONT OF POUCH**

1. Fold the printed page along the horizontal line.
2. Place label in shipping pouch and affix it to your shipment.

Use of this system constitutes your agreement to the service conditions in the current FedEx Service Guide, available on [fedex.com](http://fedex.com). FedEx will not be responsible for any claim in excess of \$100 per package, whether the result of loss, damage, delay, non-delivery, misdelivery, or misinformation, unless you declare a higher value, pay an additional charge, document your actual loss and file a timely claim. Limitations found in the current FedEx Service Guide apply. Your right to recover from FedEx for any loss, including intrinsic value of the package, loss of sales, income interest, profit, attorney's fees, costs, and other forms of damage whether direct, incidental, consequential, or special is limited to the greater of \$100 or the authorized declared value. Recovery cannot exceed actual documented loss. Maximum for items of extraordinary value is \$1,000, e.g. jewelry, precious metals, negotiable instruments and other items listed in our Service Guide. Written claims must be filed within strict time limits, see current FedEx Service Guide.

# EXHIBIT 4

## Property Card

All information is for assessment purposes only. Assessments are calculated at 70% of the estimated October 1, 2022 market value which was the date of the last revaluation as completed by eQuality Valuation Services, LLC.



Information on the Property Records for the Municipality of Bozrah was last updated on 1/3/2024.



### Parcel Information

Location:	131 GIFFORD LA	Property Use:	Residential	Primary Use:	Residential
Unique ID:	00083400	Map Block Lot:	07/119-B	Acres:	1.9700
490 Acres:	0.00	Zone:	R-1	Volume / Page:	0092/0318
Developers Map / Lot:		Census:	7131		

### Value Information

	Appraised Value	Assessed Value
Land	67,700	47,390
Buildings	265,400	185,780
Detached Outbuildings	29,800	20,860
Total	362,900	254,030

# Owner's Information

## Owner's Data

ORR RICHARD & DUERRLER PATTI  
 131 GIFFORD LANE  
 BOZRAH, CT 06334

## Building 1

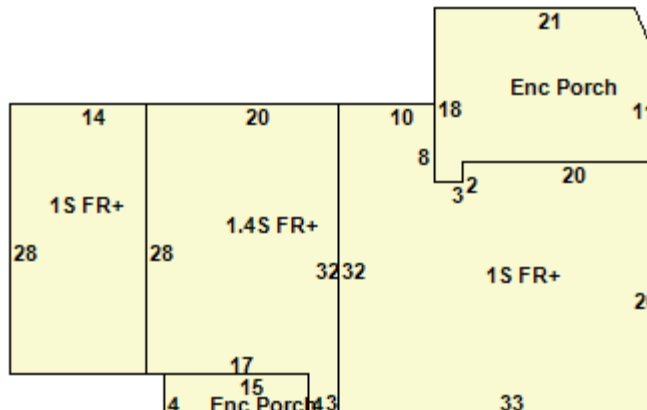

Building Use:	Single Family	Style:	Ranch	Living Area:	2,105
Stories:	1.00	Construction:	Wood Frame	Year Built:	1962
Total Rooms:	9	Bedrooms:	4	Full Baths:	2



Half Baths:	0	Fireplaces:	0	Heating:	Hot Water
Fuel:	Oil	Cooling Percent:	0	Basement Area:	1,876
Basement Finished Area:	0	Basement Garages:	2	Roof Material:	Asphalt
Siding:	Vinyl Siding	Units:	One w/In Law		

### Special Features

Fireplace	1
Hard Wired Generator	1

### Attached Components

Type:	Year Built:	Area:
Enclosed Porch	1962	369
Enclosed Porch	1962	60

### Detached Outbuildings

Type:	Year Built:	Length:	Width:	Area:
Bsmt Foundation	2021	10.00	4.00	40
Patio	2000	10.00	10.00	100

### Owner History - Sales

Owner Name	Volume	Page	Sale Date	Deed Type	Sale Price
ORR RICHARD & DUERRLER PATTI	0092	0318	04/20/2010		\$0
ORR BETTY L	0087	0788	10/24/2007		\$0
ORR JOHN E + BETTY L	0078	0846	11/23/2004		\$0

Owner Name	Volume	Page	Sale Date	Deed Type	Sale Price
ORR JOHN E + BETTY L	0028	0660	10/23/1974		\$0

## Building Permits

Permit Number	Permit Type	Date Opened	Reason
1209-21	Foundation	10/01/2021	EMERGENCY GENERATOR ON 4 X10 CONCRETE PAD- CELL
803-16	Mechanical	08/11/2016	LP GAS TANK WITH PIPING
1206-05		12/08/2005	VINYL SIDING/WINDOWS
303-04		03/06/2004	ANTENNAS/12 X 20 BLDG
902-03		09/04/2003	REPLACE CABINET/4 NEW ANTENNAE
413-02		04/20/2002	CELL TOWER

Information Published With Permission From The Assessor

# EXHIBIT 5

## Property Map

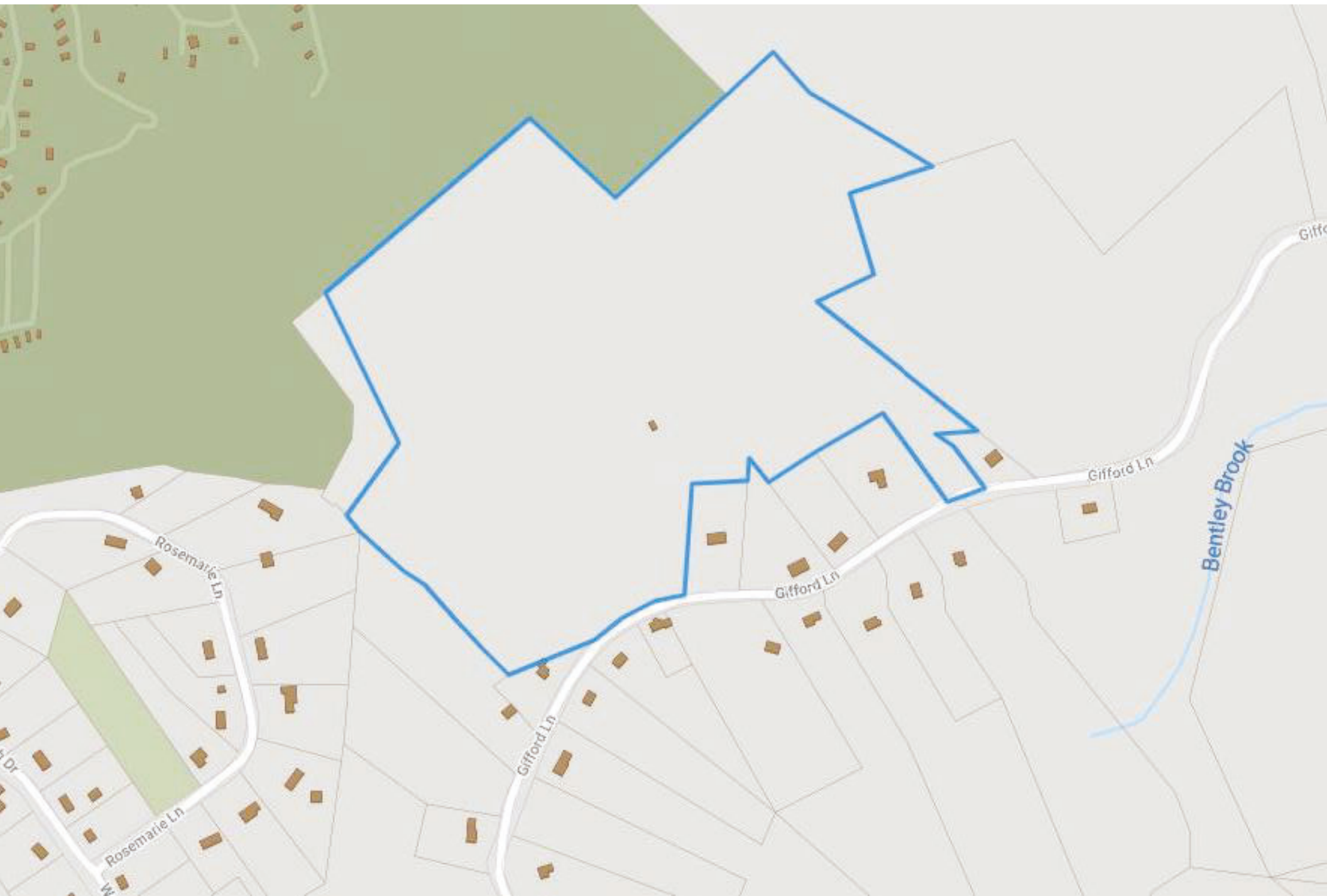

# EXHIBIT 6

## Zoning Approval

**TOWN OF BOZRAH  
PLANNING & ZONING COMMISSION  
TOWN HALL, 1 RIVER ROAD  
BOZRAH, CONNECTICUT 06334**

Notice of Decision

At their regular meeting of February 11, 1999 the Bozrah Planning & Zoning Commission rendered the following decisions:

Fargo Family Partnership, Stockhouse Road. Subdivision creating two building lots on Stockhouse Road which is zoned for Industrial use. **ACTION - Approved.**

SBA Inc., Boca Raton, Florida. Application for a special permit to construct a 196' telecommunications tower at 131 Gifford Lane on property owned by John and Betty Orr. **ACTION - Approved with conditions.**

Town of Bozrah. Proposal to extend a 16" water main northeasterly along Stockhouse Road. This application is submitted in accordance with Section 8-24 of the Connecticut General Statutes as a municipal improvement. **ACTION - The Commission approved the plan and strongly supports the proposal to extend this water main along Stockhouse Road.**

Seymour Adelman, Chairman  
Stephen Seder, Vice-Chairman  
Planning & Zoning Commission

\*\*\*\*\*  
PLEASE PUBLISH THE "BULLETIN" "ONCE AS SOON AS POSSIBLE".

cc:: First Selectman  
Applicant by "Certified Mail"  
Bulletin Board  
Town Clerk  
File

Post-It® Fax Note	7671	Date	2/12/99	# of pages	1
To	R. BARBER, First Selectman	From	R. Seder		
Co.	Town of Bozrah	Co.	SCCOG		
Phone #		Phone #	860-889-2324		
Fax #	887-5449	Fax #	889-1222		

TRANSMISSION VERIFICATION REPORT

TIME : 02/12/1999 10:09  
NAME : SCCOG  
FAX : 860-889-1222  
TEL : 860-889-2324

DATE, TIME	82/12 10:09
FAX NO. /NAME	BULLETIN
DURATION	08:00:37
PAGE(S)	01
RESULT	OK
MODE	STANDARD ECM

TOWN OF BOZRAH  
BOZRAH, CONNECTICUT

DRIVEWAY PERMIT

ISSUED TO SBA, Inc. DATE \_\_\_\_\_

ADDRESS 125 Shaw Street, New London CT 06320

FOR: driveway/access road to telecommunications site at 131 Gifford Lane

YOUR REQUEST TO CONSTRUCT A DRIVEWAY ON LOT NO. 119

MAP NO. 7 TO: Gifford Lane

WHICH IS TOWN PROPERTY, IS GRANTED SUBJECT TO THE FOLLOWING PROVISIONS:  
1. THE DRIVEWAY SHALL BE CONSTRUCTED IN SUCH A MANNER THAT IT DOES NOT INTERFERE WITH THE EXISTING DRAINAGE, THE MOVEMENT OF TRAFFIC, OR THE REMOVAL OF SNOW FROM \_\_\_\_\_

2. THE DRIVEWAY SHALL BE CONSTRUCTED IN SUCH A MANNER THAT IT DOES NOT PERMIT THE RUNOFF OF WATER FROM \_\_\_\_\_ TO ENTER INTO THE PROPERTY OF THE OWNER THEREBY CREATING A NUISANCE TO THE TOWN AND THE OWNER.

3. THE OWNER AND THE CONTRACTOR SHALL BE RESPONSIBLE FOR ALL CLAIMS OF DAMAGE RESULTING FROM THE CONSTRUCTION OF THE DRIVEWAY.

4. THE DRIVEWAY SHALL BE STABILIZED FOR A SUFFICIENT DISTANCE IN FROM TOWN PROPERTY TO PREVENT EROSION ON TO TOWN PROPERTY AND SHALL BE DESIGNED IN A MANNER TO CONFINE THE SURFACE WATER TO THE GUTTER AREAS AND PERMIT FREE FLOWAGE OF THE WATER IN THE WATERWAYS.

5. IF THE DRIVEWAY IS TO BE HARDTOPPED AT A LATER DATE ALLOWANCES MUST BE MADE FOR THE ADDITIONAL CHANGE OF GRADE WHERE THE DRIVEWAY CONNECTS WITH EXISTING WATERWAYS OR TRAVELLED PORTION OF THE TOWN ROAD.

6. THE DISTURBED AREAS WITHIN THE TOWN'S RIGHT-OF-WAY SHALL BE REPAIRED BY THE OWNER OR THE CONTRACTOR

7. WHERE EXISTING EXCAVATIONS OR FILLS WITHIN THE TOWN'S RIGHT-OF-WAY ENDANGER THE LIFE OF EXISTING TREES OR OTHER GROWTHS OR STONES EXIST AS OBSTACLES TO THE ACCESS OR EGRESS TO PROPERTY, SUCH OBSTACLES, TREES, OR GROWTHS, SHALL BE REMOVED AT THE OWNER'S EXPENSE.

  
\_\_\_\_\_  
APPLICANT

\_\_\_\_\_  
FIRST SELECTMAN

# EXHIBIT 7

## EME Report





FOX HILL TELECOM

# Radio Frequency Emissions Analysis Report



**Site ID: BOBOS01169A**

131 Gifford lane  
Bozrah, CT 06334

**December 4, 2023**

**Fox Hill Telecom Project Number: 231063**

<b>Site Compliance Summary</b>	
Compliance Status:	<b>COMPLIANT</b>
Site total MPE% of FCC general population allowable limit:	<b>9.89 %</b>



December 4, 2023

Dish Wireless  
5701 South Santa Fe Drive  
Littleton, CO 80120

## Emissions Analysis for Site: **BOBOS01169A**

Fox Hill Telecom, Inc (“Fox Hill”) was directed to analyze the proposed radio installation for Dish Wireless, LLC (Dish) facility located at **131 Gifford lane, Bozrah, CT**, for the purpose of determining whether the emissions from the Proposed Dish radio and antenna installation located on this property are within specified federal limits.

All information used in this report was analyzed as a percentage of current Maximum Permissible Exposure (% MPE) as listed in the FCC OET Bulletin 65 Edition 97-01 and ANSI/IEEE Std C95.1. The FCC regulates Maximum Permissible Exposure in units of microwatts per square centimeter ( $\mu\text{W}/\text{cm}^2$ ). The number of  $\mu\text{W}/\text{cm}^2$  calculated at each sample point is called the power density. The exposure limit for power density varies depending upon the frequencies being utilized. Wireless Carriers and Paging Services use different frequency bands each with different exposure limits, therefore it is necessary to report results and limits in terms of percent MPE rather than power density.

All results were compared to the FCC (Federal Communications Commission) radio frequency exposure rules, 47 CFR 1.1307(b)(1) – (b)(3), to determine compliance with the Maximum Permissible Exposure (MPE) limits for General Population/Uncontrolled environments as defined below.

General population/uncontrolled exposure limits apply to situations in which the general population may be exposed or in which persons who are exposed as a consequence of their employment may not be made fully aware of the potential for exposure or cannot exercise control over their exposure. Therefore, members of the general population would always be considered under this category when exposure is not employment related, for example, in the case of a telecommunications tower that exposes persons in a nearby residential area.

Population exposure to radio frequencies is regulated and enforced in units of microwatts per square centimeter ( $\mu\text{W}/\text{cm}^2$ ). The general population exposure limit for the 600 MHz band is approximately  $400 \mu\text{W}/\text{cm}^2$ . The general population exposure limit for the 1900 MHz (PCS) and 2100 MHz (AWS / AWS-4) bands is  $1000 \mu\text{W}/\text{cm}^2$ . Because each carrier will be using different frequency bands, and each frequency band has different exposure limits, it is necessary to report the percentage of MPE rather than power density.



FOX HILL TELECOM

Occupational/controlled exposure limits apply to situations in which persons are exposed as a consequence of their employment and in which those persons who are exposed have been made fully aware of the potential for exposure and can exercise control over their exposure. Occupational/controlled exposure limits also apply where exposure is of a transient nature as a result of incidental passage through a location where exposure levels may be above general population/uncontrolled limits (see below), as long as the exposed person has been made fully aware of the potential for exposure and can exercise control over his or her exposure by leaving the area or by some other appropriate means.

Additional details can be found in FCC OET 65.



## CALCULATIONS

Calculations were performed for the proposed upgrades to the Dish Wireless antenna facility located at **131 Gifford lane, Bozrah, CT**, using the equipment information listed below. All calculations were performed per the specifications under FCC OET 65 for far field modeling calculations.

In OET-65, plane wave power densities in the Far Field of an antenna are calculated by considering antenna gain and reflective waves that would contribute to exposure.

Since the radiation pattern of an antenna has developed in the **Far Field** region the power gain in specific directions needs to be considered in exposure predictions to yield an Effective Radiated Power (ERP) in each specific direction from the antenna. Also, since the vertical radiation pattern of the antenna is considered, the exposure calculations would most likely be reduced significantly at ground level, resulting in a more realistic estimate of the actual exposure levels. To determine a worst-case scenario at each point along the calculation radials, each point was calculated using the antenna gain value at each angle of incident and compared against the result using an isotropic radiator at the antenna height with the greater of the two used to yield the more pessimistic far field value for each point along the calculation radial.

Additionally, to model a truly "worst case" prediction of exposure levels at or near a surface, such as at ground-level or on a rooftop, reflection off the surface of antenna radiation power can be assumed, resulting in a potential 1.6 times increase in power density in calculating far field power density values.

With these factors Considered, the worst case **Far Field prediction model** utilized in this analysis is determined by the following equation:

Equation 9 per FCC OET65 for Far Field Modeling

$$S = \frac{33.4 \text{ ERP}}{R^2}$$

S = Power Density (in  $\mu\text{w}/\text{cm}^2$ )

ERP = Effective Radiated Power from antenna (watts)

R = Distance from the antenna (meters)

Predicted far field power density values for all carriers identified in this report were calculated 6 feet above the ground level and are displayed as a percentage of the applicable FCC standards. All emissions values for other carriers were calculated using the same Far Field model outlined above, using industry standard radio configurations and frequency band selection based upon available licenses in this geographic area for emissions contribution estimates.



For each Dish sector the following channel counts, frequency bands and power levels were utilized as shown in *Table 1*:

Technology	Frequency Band	Channel Count	Transmit Power per Channel (W)
5G	n71 (600 MHz)	4	61.5
5G	n70 (AWS-4 / 1995-2020)	4	40
5G	n66 (AWS-4 / 2180-2200)	4	40

*Table 1: Channel Data Table*



The following **Dish** antennas listed in *Table 2* were used in the modeling for transmission in the 600 MHz (n71) frequency band and the 2100 MHz (AWS 4) frequency bands at 1995-2020 MHz (n70) and 2180-2200 MHz (n66). This is based on feedback from Dish regarding anticipated antenna selection. Maximum gain values for all antennas are listed in the Inventory and Power Data table below.

Sector	Antenna Number	Antenna Make / Model	Antenna Centerline (ft)
A	1	Commscope FFVV-65B-R2	150
B	1	Commscope FFVV-65B-R2	150
C	1	Commscope FFVV-65B-R2	150

*Table 2: Antenna Data*

All calculations were done with respect to uncontrolled / general population threshold limits.



## RESULTS

Per the calculations completed for the proposed **Dish** configurations *Table 3* shows resulting emissions power levels and percentages of the FCC’s allowable general population limit.

Antenna ID	Antenna Make / Model	Frequency Bands	Antenna Gain (dBd)	Channel Count	Total TX Power (W)	ERP (W)	MPE %
Antenna A1	Commscope FFVV-65B-R2	n71 (600 MHz) / n70 (AWS-4 / 1995-2020) / n66 (AWS-4 / 2180-2200)	12.15 / 15.95 / 16.25	12	566	17,079.80	1.64
Sector A Composite MPE%							<b>1.64</b>
Antenna B1	Commscope FFVV-65B-R2	n71 (600 MHz) / n70 (AWS-4 / 1995-2020) / n66 (AWS-4 / 2180-2200)	12.15 / 15.95 / 16.25	12	566	17,079.80	1.64
Sector B Composite MPE%							<b>1.64</b>
Antenna C1	Commscope FFVV-65B-R2	n71 (600 MHz) / n70 (AWS-4 / 1995-2020) / n66 (AWS-4 / 2180-2200)	12.15 / 15.95 / 16.25	12	566	17,079.80	1.64
Sector C Composite MPE%							<b>1.64</b>

*Table 3: Dish Emissions Levels*



The Following table (*Table 4*) shows all additional carriers on site and their emissions contribution estimates, along with the newly calculated **Dish** far field emissions contributions per this report. FCC OET 65 specifies that for carriers utilizing directional antennas, the highest recorded sector value be used for composite site emissions values due to their greatly reduced emissions contributions in the directions of the adjacent sectors. For this site, all three sectors have the same configuration yielding the same results for all three sectors. *Table 5* below shows a summary for each **Dish** Sector as well as the composite emissions value for the site.

<b>Site Composite MPE%</b>	
<b>Carrier</b>	<b>MPE%</b>
Dish – Max Per Sector Value	<b>1.64 %</b>
T-Mobile	1.86 %
AT&T	2.92 %
Sprint	0.59 %
Verizon Wireless	2.88 %
<b>Site Total MPE %:</b>	<b>9.89 %</b>

*Table 4: All Carrier MPE Contributions*

Dish Sector A Total:	1.64 %
Dish Sector B Total:	1.64 %
Dish Sector C Total:	1.64 %
Site Total:	9.89 %

*Table 5: Site MPE Summary*





Table 6 below details a breakdown by frequency band and technology for the MPE power values for the maximum calculated **Dish** sector(s). For this site, all three sectors have the same configuration yielding the same results for all three sectors.

Dish _ Frequency Band / Technology Max Power Values (Per Sector)	# Channels	Watts ERP (Per Channel)	Height (feet)	Total Power Density ( $\mu\text{W}/\text{cm}^2$ )	Frequency (MHz)	Allowable MPE ( $\mu\text{W}/\text{cm}^2$ )	Calculated % MPE
Dish n71 (600 MHz) 5G	4	1,008.96	150	4.32	n71 (600 MHz)	400	1.08%
Dish n70 (AWS-4 / 1995-2020) 5G	4	1,574.20	150	2.80	n70 (AWS-4 / 1995-2020)	1000	0.28%
Dish n66 (AWS-4 / 2180-2200) 5G	4	1,686.79	150	2.80	n66 (AWS-4 / 2180-2200)	1000	0.28%
						<b>Total:</b>	<b>1.64 %</b>

Table 6: Dish Maximum Sector MPE Power Values



## Summary

All calculations performed for this analysis yielded results that were **within** the allowable limits for general population exposure to RF Emissions.

The anticipated maximum composite contributions from the Dish facility as well as the site composite emissions value with regards to compliance with FCC's allowable limits for general population exposure to RF Emissions are shown here:

Dish Sector	Power Density Value (%)
Sector A:	1.64 %
Sector B:	1.64 %
Sector C:	1.64 %
Dish Maximum Total (per sector):	1.64 %
Site Total:	9.89 %
Site Compliance Status:	<b>COMPLIANT</b>

The anticipated composite emissions value for this site, assuming all carriers present, is **9.89 %** of the allowable FCC established general population limit sampled at the ground level. This is based upon the far field calculations performed for all carriers identified in this report.

FCC guidelines state that if a site is found to be out of compliance (over allowable thresholds), that carriers over a 5% contribution to the composite value will require measures to bring the site into compliance. For this facility, the composite values calculated were well within the allowable 100% threshold standard per the federal government.

Scott Heffernan  
Principal RF Engineer  
**Fox Hill Telecom, Inc**  
Worcester, MA 01609  
(978)660-3998

# EXHIBIT 8

## Structural Analysis



SBA Communications Corporation  
8051 Congress Avenue  
Boca Raton, FL 33487-1307

T + 561.995.7670  
F + 561.995.7626

sbsite.com

## Structural Analysis Report

### Client: Dish Wireless

Client Site ID / Name: BOBOS01169A / 0  
Application #: 234501, v1

SBA Site ID / Name: CT01105-S / BOZRAH

193' Self Supporting Tower

131 Gifford Lane  
Bozrah, CT 06334-1318  
Lat: 41.552517 Long: -72.150708

Project number: CT01105-DSW-082423

### Analysis Results

Tower	72.5%	Pass
Foundation	58.1%	Pass

Change in tower stress due to mount modification / replacement	N/A
--	-----

Prepared by:

Breann Parreira  
Structural Engineer II  
561-981-7388  
BParreira@sbsite.com

Reviewed by:

Anantha (Shan) Shanubhogue, P.E.  
Senior Manager, Structural Engineering  
561-981-7390  
SShanubhogue@sbsite.com

August 31, 2023

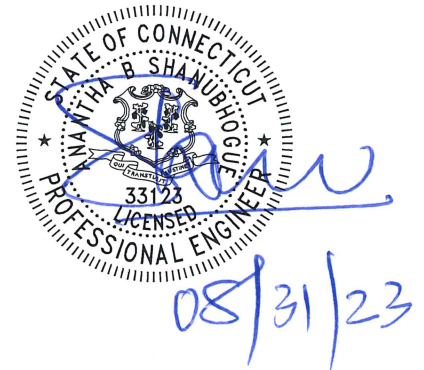

**Table of Contents**

Introduction..... 3

Analysis Criteria ..... 3

Appurtenance Loading ..... 4

    Existing Loading: ..... 4

    Proposed Loading: ..... 5

Analysis Results ..... 6

    Tower ..... 6

    Foundation ..... 6

Conclusions ..... 7

Installation Requirements ..... 7

Assumptions and Limitations ..... 8

    Assumptions ..... 8

    Limitations..... 8

Appendix ..... 9

    Tower Geometry.....

    Coax Layout.....

    tnxTower Report.....

    Foundation Analysis Report.....



## Introduction

The purpose of this report is to summarize the analysis results on the 193' Self Supporting Tower to support the proposed antennas and transmissions lines in addition to those currently installed.

Table 1 List of Documents Used

Item	Document
<b>Tower Design</b>	Pirod, File # A-115466, dated 4/1/1999
<b>Foundation Design</b>	Pirod, File # A-115466, dated 4/1/1999
<b>Geotechnical report</b>	Jaworski Geotech, Inc., Project # C98492G, dated 12/14/1998
<b>Modification drawings</b>	N/A
<b>Mount Analysis</b>	N/A
<b>Latest SA Report</b>	TES, Project # 129196_R2, dated 5/27/2022

## Analysis Criteria

Table 2 Code Related Data

<b>Jurisdiction (State/County/City)</b>	Connecticut / New London / Bozrah
<b>Governing Codes</b>	ANSI/TIA-222-H, 2022 CSBC, 2021 IBC
<b>Ultimate Wind Speed (3-Sec gust)</b>	123 mph
<b>Wind Speed with Ice (3-Sec gust)</b>	50 mph
<b>Service Wind Speed (3-Sec gust)</b>	60 mph
<b>Ice Thickness</b>	1 in
<b>Risk category</b>	II
<b>Exposure Category</b>	B
<b>Topographic Category</b>	1
<b>Crest Height</b>	0 ft.
<b>Ground Elevation</b>	449 ft.
<b>Seismic Parameter <math>S_s</math></b>	0.197
<b>Seismic Parameter <math>S_1</math></b>	0.054

This structural analysis is based upon the tower being classified as a Risk category II; however, if a different classification is required subsequent to the date hereof, the tower classification will be changed to meet such requirement and a new structural analysis will be run.

# Appurtenance Loading

## Existing Loading:

Table 3 Existing Appurtenances

Mount Elev. (ft)	CL Elev. (ft)	Type	Qty	Manufacturer	Model	Feed Line Size	Mount Type Qty.	Carrier
191	191	Panel	3	EMS	RR90-17-02DP	(8) 1-5/8" (3) 1.9" Fiber	Modified Low Profile Platform w/ (1) PRK-1245L, (3) TAP472 and (1) HRK12-U and (3) Sitepro1 SFS-V-L (V-BraceKit)	T-Mobile
		Panel	3	RFS	APXVAALL24_43-U-NA20			
		Panel	3	Ericsson	AIR6419 B41			
		Diplexer	3	Commscope	SDX1926Q-43			
		RRU	3	Ericsson	4449 B71+B85			
		RRU	3	Ericsson	4460 B25 + B66			
182	182	Panel	3	Powerwave	7770	(12) 1-5/8" (4) 3/4" DC (3) 3/8" RET (2) 5/8" Fiber	(3) Sector Frame [Commscope MTC3615]	AT&T
		Panel	3	CCI	HPA-65R-BUU-H8			
		Panel	3	CCI	DMP65R-BU8DA			
		TMA	6	Powerwave	LGP21401			
		Diplexer	6	Powerwave	LGP21902			
		RRU	3	Ericsson	4449 B5/B12			
		RRU	3	Ericsson	RRUS 12			
		RRU	3	Ericsson	RRUS 11			
		RRU	3	Ericsson	RRUS 32			
		RRU	3	Ericsson	RRUS A2			
175	175	OVP	1	Raycap	DC6-48-60-18-8F	(4) 1-1/4" Fiber	(3) Sector Frame w/ Support Rail (3) Sitepro SFSH-L	T-Mobile Sprint
		OVP	1	Raycap	DC6-48-60-0-8C-EV			
		Panel	3	RFS	APXVTM14-C-I20			
		Panel	3	Commscope	NNVV-65B-R4			
		RRU	3	ALU	1900 MHz			
160	160	RRU	6	ALU	800 MHz	(12) 1-5/8" (3) 1-5/8" Hybrid	(3) Modified Sector Frame w/ Support Rail w/ (3) Site Pro 1 SFS-V (V Style Reinforcement Kit), (1) Site Pro 1 Puck (Crossover Plate Assembly), (6) Site Pro 1 SCX7-U (Crossover Plate Assembly), (3) 4" 0" (F.V.) P2 STD Pipe & (3) 8'-0" P2.5 STD Pipe	Verizon
		RRU	3	ALU	TD-RRH 8X20-25			
		Panel	3	Commscope	LNX-6514DS-A1M			
		Panel	6	Andrew	SBNHH-1D65B			
		Panel	3	Samsung	MT6407-77A			
		RRU	3	Samsung	B2/B66A RRH-BR049 (RFV01U-D1A)			
RRU	3	Samsung	B5/B13 RRH-BR04C (RFV01U-D2A)					
100	100	GPS	1	Alcatel Lucent	KS24019-L112A	(1) GPS line	Direct Mount	
30	30	Omni	2	Andrew	PC1N0F-0190B-002M (E-911 Equipment)	(2) 1/2"	Direct Mount	T-Mobile

Note: AT&T loading includes FirstNET equipment



**Proposed Loading:**

Information pertaining to proposed antennas and transmission lines were based upon the Application #: 234501, v1 from Dish Wireless and is listed in Table 4.

*Table 4 Proposed Appurtenances*

Mount Elev. (ft)	CL Elev. (ft)	Type	Qty	Manufacturer	Model	Feed Line Size	Mount Type Qty.	Carrier
150	150	Panel	3	Commscope	FFW-65B-R2	(1) 1.6" Hybrid	(3) Sector Frames [Commscope MTC3975083]	Dish Wireless
		RRU	3	Samsung	RF4450t-71A			
		RRU	3	Samsung	RF4451d-70A			
		OVP	1	Raycap	RDIDC-9181-PF-48			





## Analysis Results

### Tower

The results of the structural analysis are shown below in table 5. Additional information for the tower analysis is provided within the Appendix.

*Table 5 Tower Analysis Summary*

<b>Structural Component</b>	<b>% capacity</b>	<b>Analysis Result</b>
<b>Leg</b>	72.5	Pass
<b>Diagonal</b>	72.2	Pass
<b>Horizontal</b>	19.8	Pass
<b>Top girt</b>	4.8	Pass
<b>Bottom girt</b>	12.3	Pass
<b>Mid Girt</b>	2.5	Pass
<b>Bolt</b>	72.2	Pass
<b>Anchor Bolt</b>	38.2	Pass

### Foundation

The results of the foundation analysis are shown below in table 6. Additional information for the foundation analysis is provided within the Appendix.

*Table 6 Foundation Analysis Summary*

<b>Structural Component</b>	<b>Max Usage (%)</b>	<b>Analysis Result</b>
<b>Foundation</b>	58.1	Pass

## Conclusions

Based on the analysis results, the existing tower and foundation were found to be sufficient to safely support the equipment listed in this analysis. No modification to the tower and foundation is needed at this time.

## Installation Requirements

This analysis was performed under the assumption that the carrier will place the proposed equipment and feed lines at the installation height listed in Table 4 and in accordance with the coax layout shown. TMAs and RRUs are to be installed on existing mounts behind tenant's antennas unless otherwise noted. No equipment is to be installed directly in the climbing path. All equipment is to be installed per mount manufacturer specifications. In case site conditions do not allow for the required installation parameters to be met the carrier must notify SBA Communications Corporation engineers for approval of an alternative placement.

## Assumptions and Limitations

### Assumptions

This analysis was completed based on the following assumptions:

- Tower and foundation were built in accordance to manufacturer specifications.
- Tower and foundation has been properly maintained in accordance with the manufacturer's specifications
- All existing structural members were assumed to be in good condition with no physical damage or deterioration associated with corrosion
- Welds and bolts are assumed able to carry their intended original design loads.
- The configuration of antennas, transmission cables, mounts and other appurtenances are as specified in Table 3 and 4.
- This analysis may be affected if any assumptions are not valid or have been made in error. SBA should be notified to determine the effect on the structural integrity of the tower.

### Limitations

The computer generated analysis performed by the tower software is limited to theoretical capacities of the towers structural members and does not account for any missing or damaged members or connections. The tower and foundation are assumed to have been properly designed, fabricated, installed and maintained, barring any conflicting findings from the most recent inspection.

SBA Communications Corporation has used its due diligence to verify the information provided to perform this analysis. It is unreasonable to perform a more detailed inspection of a tower and its components. This report is not a condition assessment of the tower or foundation.

## Appendix



# COAX LAYOUT

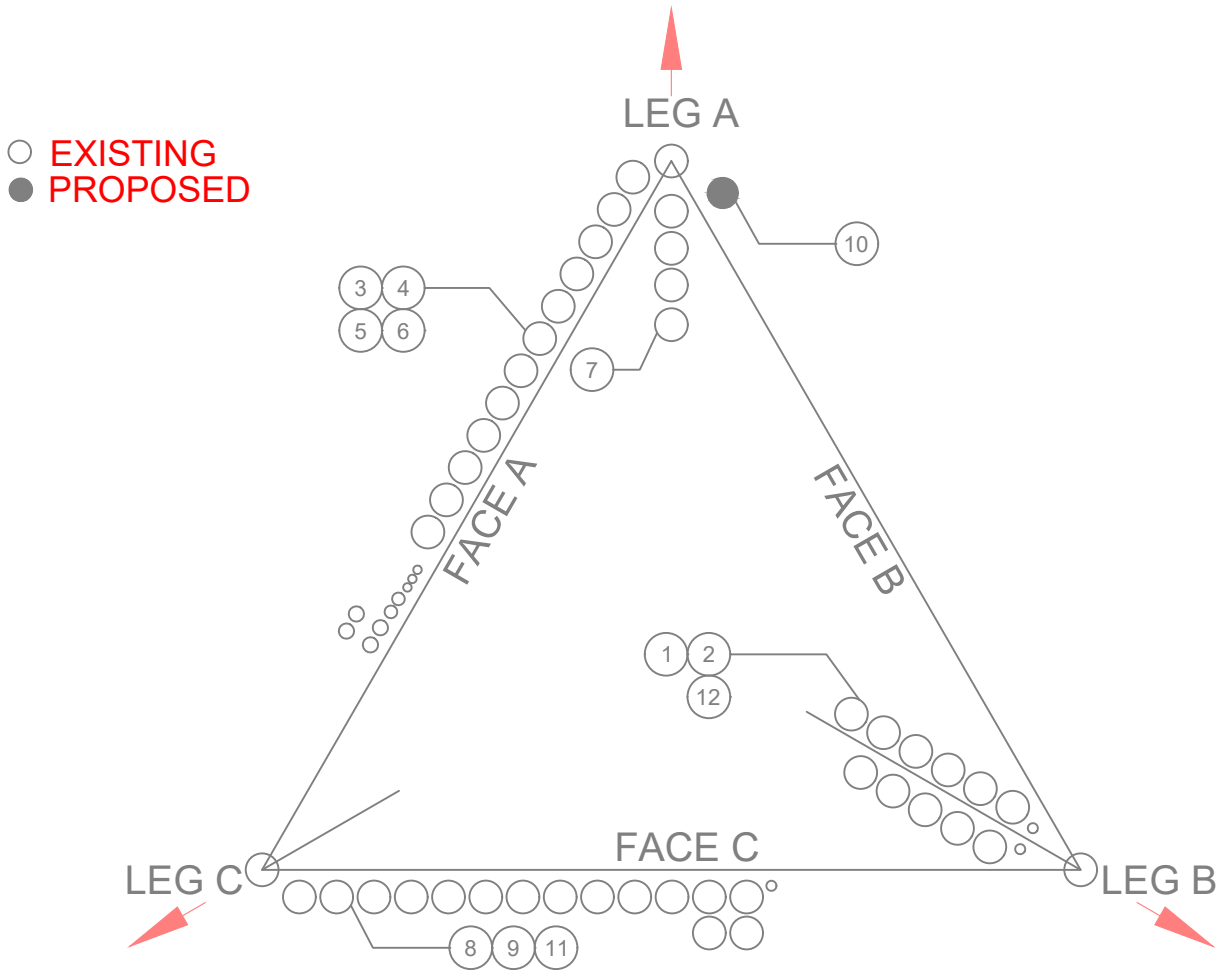

<b>CT01105-S</b>					
#	CARRIER	SIZE	QTY.	ELEVATION	NOTES
1	T-Mobile	1-5/8"	8	191	
2	T-Mobile	1.9"	3	191	Fiber
3	AT&T	1-5/8"	12	182	
4	AT&T	3/4"	4	182	DC Power
5	AT&T	3/8"	3	182	RET
6	AT&T	5/8"	2	182	Fiber
7	TMS	1-1/4"	4	175	Fiber
8	Verizon	1-5/8"	12	160	
9	Verizon	1-5/8"	3	160	Hybrid
10	Dish	1.6"	1	150	Hybrid [Proposed]
11	Verizon	3/8"	1	100	GPS
12	T-Mobile	1/2"	2	30	

<b>tnxTower</b>  <b>SBA Communications</b> 8051 Congress Avenue Boca Raton, Florida Phone: (561) 981-7388 FAX:	<b>Job</b>	<b>Page</b> 1 of 33
	<b>Project</b>	<b>Date</b> 13:53:47 08/31/23
	<b>Client</b>	<b>Designed by</b> Breann Parreira

## Tower Input Data

The main tower is a 3x free standing tower with an overall height of 193.00 ft above the ground line.

The base of the tower is set at an elevation of 0.00 ft above the ground line.

The face width of the tower is 5.00 ft at the top and 22.00 ft at the base.

This tower is designed using the TIA-222-H standard.

The following design criteria apply:

Tower is located in New London County, Connecticut.

Tower base elevation above sea level: 449.80 ft.

Basic wind speed of 123 mph.

Risk Category II.

Exposure Category B.

Simplified Topographic Factor Procedure for wind speed-up calculations is used.

Topographic Category: 1.

Crest Height: 0.00 ft.

Nominal ice thickness of 1.0000 in.

Ice thickness is considered to increase with height.

Ice density of 56 pcf.

A wind speed of 50 mph is used in combination with ice.

Temperature drop of 50 °F.

Deflections calculated using a wind speed of 60 mph.

A non-linear (P-delta) analysis was used.

Pressures are calculated at each section.

Stress ratio used in tower member design is 1.

Local bending stresses due to climbing loads, feed line supports, and appurtenance mounts are not considered.

## Options

<ul style="list-style-type: none"> <li>Consider Moments - Legs</li> <li>Consider Moments - Horizontals</li> <li>Consider Moments - Diagonals</li> <li>Use Moment Magnification</li> <li>√ Use Code Stress Ratios</li> <li>√ Use Code Safety Factors - Guys</li> <li>Escalate Ice</li> <li>Always Use Max Kz</li> <li>Use Special Wind Profile</li> <li>√ Include Bolts In Member Capacity</li> <li>Leg Bolts Are At Top Of Section</li> <li>√ Secondary Horizontal Braces Leg</li> <li>Use Diamond Inner Bracing (4 Sided)</li> <li>SR Members Have Cut Ends</li> <li>SR Members Are Concentric</li> </ul>	<ul style="list-style-type: none"> <li>Distribute Leg Loads As Uniform</li> <li>Assume Legs Pinned</li> <li>√ Assume Rigid Index Plate</li> <li>√ Use Clear Spans For Wind Area</li> <li>√ Use Clear Spans For KL/r</li> <li>Retension Guys To Initial Tension</li> <li>√ Bypass Mast Stability Checks</li> <li>√ Use Azimuth Dish Coefficients</li> <li>√ Project Wind Area of Appurt.</li> <li>Autocalc Torque Arm Areas</li> <li>Add IBC .6D+W Combination</li> <li>√ Sort Capacity Reports By Component</li> <li>Triangulate Diamond Inner Bracing</li> <li>Treat Feed Line Bundles As Cylinder</li> <li>Ignore KL/ry For 60 Deg. Angle Legs</li> </ul>	<ul style="list-style-type: none"> <li>Use ASCE 10 X-Brace Ly Rules</li> <li>√ Calculate Redundant Bracing Forces</li> <li>Ignore Redundant Members in FEA</li> <li>√ SR Leg Bolts Resist Compression</li> <li>All Leg Panels Have Same Allowable</li> <li>Offset Girt At Foundation</li> <li>√ Consider Feed Line Torque</li> <li>√ Include Angle Block Shear Check</li> <li>Use TIA-222-H Bracing Resist. Exemption</li> <li>Use TIA-222-H Tension Splice Exemption</li> <li style="text-align: center;">Poles</li> <li>Include Shear-Torsion Interaction</li> <li>Always Use Sub-Critical Flow</li> <li>Use Top Mounted Sockets</li> <li>Pole Without Linear Attachments</li> <li>Pole With Shroud Or No Appurtenances</li> <li>Outside and Inside Corner Radii Are Known</li> </ul>
--	---	---

<b>tnxTower</b>  <b>SBA Communications</b> 8051 Congress Avenue Boca Raton, Florida Phone: (561) 981-7388 FAX:	<b>Job</b>	<b>Page</b> 2 of 33
	<b>Project</b>	<b>Date</b> 13:53:47 08/31/23
	<b>Client</b>	<b>Designed by</b> Breann Parreira

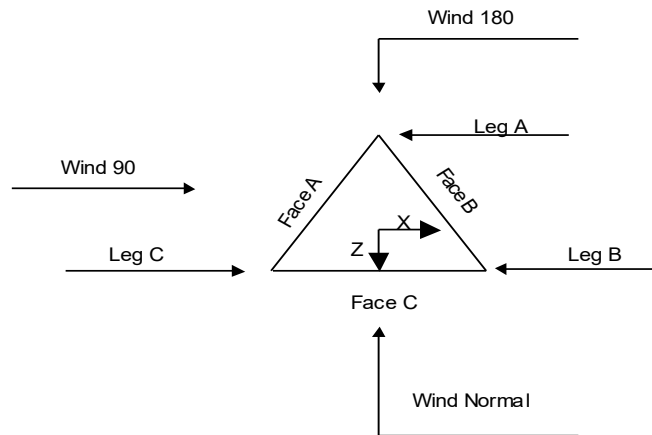

**Triangular Tower**

### Tower Section Geometry

Tower Section	Tower Elevation	Assembly Database	Description	Section Width	Number of Sections	Section Length
	<i>ft</i>			<i>ft</i>		<i>ft</i>
T1	193.00-185.00			5.00	1	8.00
T2	185.00-170.00			5.00	1	15.00
T3	170.00-160.00			5.00	1	10.00
T4	160.00-140.00			6.00	1	20.00
T5	140.00-120.00			8.00	1	20.00
T6	120.00-100.00			10.00	1	20.00
T7	100.00-80.00			12.00	1	20.00
T8	80.00-60.00			14.00	1	20.00
T9	60.00-40.00			16.00	1	20.00
T10	40.00-20.00			18.00	1	20.00
T11	20.00-0.00			20.00	1	20.00

### Tower Section Geometry (cont'd)

Tower Section	Tower Elevation	Diagonal Spacing	Bracing Type	Has K Brace End Panels	Has Horizontals	Top Girt Offset	Bottom Girt Offset
	<i>ft</i>	<i>ft</i>				<i>in</i>	<i>in</i>
T1	193.00-185.00	1.81	X Brace	No	Steps	7.0000	2.0000
T2	185.00-170.00	2.34	X Brace	No	Steps	4.5000	7.0000
T3	170.00-160.00	10.00	X Brace	No	No	0.0000	0.0000
T4	160.00-140.00	10.00	X Brace	No	No	0.0000	0.0000



<b>tnxTower</b>  <b>SBA Communications</b> 8051 Congress Avenue Boca Raton, Florida Phone: (561) 981-7388 FAX:	<b>Job</b>	<b>Page</b> 3 of 33
	<b>Project</b>	<b>Date</b> 13:53:47 08/31/23
	<b>Client</b>	<b>Designed by</b> Breann Parreira

Tower Section	Tower Elevation ft	Diagonal Spacing ft	Bracing Type	Has K Brace End Panels	Has Horizontals	Top Girt Offset in	Bottom Girt Offset in
T5	140.00-120.00	10.00	X Brace	No	No	0.0000	0.0000
T6	120.00-100.00	10.00	X Brace	No	No	0.0000	0.0000
T7	100.00-80.00	10.00	X Brace	No	No	0.0000	0.0000
T8	80.00-60.00	10.00	X Brace	No	No	0.0000	0.0000
T9	60.00-40.00	10.00	X Brace	No	No	0.0000	0.0000
T10	40.00-20.00	10.00	X Brace	No	No	0.0000	0.0000
T11	20.00-0.00	20.00	X Brace	No	No	0.0000	0.0000

### Tower Section Geometry (cont'd)

Tower Elevation ft	Leg Type	Leg Size	Leg Grade	Diagonal Type	Diagonal Size	Diagonal Grade
T1 193.00-185.00	Solid Round	2	A572-50 (50 ksi)	Solid Round	1	A572-50 (50 ksi)
T2 185.00-170.00	Solid Round	2	A572-50 (50 ksi)	Solid Round	1	A572-50 (50 ksi)
T3 170.00-160.00	Truss Leg	#12 - 1.25" - 1.00" conn. (Pirod 105244)	A572-50 (50 ksi)	Equal Angle	L2 1/2x2 1/2x3/16	A36 (36 ksi)
T4 160.00-140.00	Truss Leg	#12 - 1.50" - 1.00" conn. (Pirod 105217)	A572-50 (50 ksi)	Equal Angle	L3x3x3/16	A36 (36 ksi)
T5 140.00-120.00	Truss Leg	#12 - 1.50" - 1.00" conn. (Pirod 105217)	A572-50 (50 ksi)	Equal Angle	L3x3x3/16	A36 (36 ksi)
T6 120.00-100.00	Truss Leg	#12 - 1.75" - 1.25" conn. (Pirod 105218 )	A572-50 (50 ksi)	Equal Angle	L3x3x5/16	A36 (36 ksi)
T7 100.00-80.00	Truss Leg	#12 - 2.00" - 1.25" conn. (Pirod 105219)	A572-50 (50 ksi)	Equal Angle	L3x3x5/16	A36 (36 ksi)
T8 80.00-60.00	Truss Leg	#12 - 2.00" - 1.25" conn. (Pirod 105219)	A572-50 (50 ksi)	Equal Angle	L3 1/2x3 1/2x5/16	A36 (36 ksi)
T9 60.00-40.00	Truss Leg	#12 - 2.25" - 1.25" conn. (Pirod 105220)	A572-50 (50 ksi)	Equal Angle	L3 1/2x3 1/2x5/16	A36 (36 ksi)
T10 40.00-20.00	Truss Leg	#12 - 2.25" - 1.25" conn. (Pirod 105220)	A572-50 (50 ksi)	Equal Angle	L3 1/2x3 1/2x5/16	A36 (36 ksi)
T11 20.00-0.00	Truss Leg	#18 - 2.50" (Pirod 112738-Base Only)	A572-50 (50 ksi)	Double Equal Angle	2L3 1/2x3 1/2x5/16x3/8	A36 (36 ksi)

### Tower Section Geometry (cont'd)

Tower Elevation ft	Top Girt Type	Top Girt Size	Top Girt Grade	Bottom Girt Type	Bottom Girt Size	Bottom Girt Grade
T1 193.00-185.00	Solid Round	1 1/4	A572-50 (50 ksi)	Solid Round	1 1/4	A572-50 (50 ksi)
T2 185.00-170.00	Solid Round	1 1/4	A572-50 (50 ksi)	Solid Round	1 1/4	A572-50 (50 ksi)

### Tower Section Geometry (cont'd)



<b>tnxTower</b>  <b>SBA Communications</b> 8051 Congress Avenue Boca Raton, Florida Phone: (561) 981-7388 FAX:	<b>Job</b>	<b>Page</b> 5 of 33
	<b>Project</b>	<b>Date</b> 13:53:47 08/31/23
	<b>Client</b>	<b>Designed by</b> Breann Parreira

Tower Elevation  ft	Calc K Single Angles	Calc K Solid Rounds	<i>K Factors<sup>1</sup></i>								
			Legs	X Brace Diags	K Brace Diags	Single Diags	Girts	Horiz.	Sec. Horiz.	Inner Brace	
			X Y	X Y	X Y	X Y	X Y	X Y	X Y	X Y	
T5	Yes	Yes	1	1	1	1	1	1	1	1	1
140.00-120.00				1	1	1	1	1	1	1	1
T6	Yes	Yes	1	1	1	1	1	1	1	1	1
120.00-100.00				1	1	1	1	1	1	1	1
T7	Yes	Yes	1	1	1	1	1	1	1	1	1
100.00-80.00				1	1	1	1	1	1	1	1
T8	Yes	Yes	1	1	1	1	1	1	1	1	1
80.00-60.00				1	1	1	1	1	1	1	1
T9	Yes	Yes	1	1	1	1	1	1	1	1	1
60.00-40.00				1	1	1	1	1	1	1	1
T10	Yes	Yes	1	1	1	1	1	1	1	1	1
40.00-20.00				1	1	1	1	1	1	1	1
T11	Yes	Yes	1	1	1	1	1	1	1	1	1
20.00-0.00				1	1	1	1	1	1	1	1

<sup>1</sup>Note: K factors are applied to member segment lengths. K-braces without inner supporting members will have the K factor in the out-of-plane direction applied to the overall length.

### Tower Section Geometry (cont'd)

Tower Elevation  ft	<i>Truss-Leg K Factors</i>					
	<i>Truss-Legs Used As Leg Members</i>			<i>Truss-Legs Used As Inner Members</i>		
	Leg Panels	X Brace Diagonals	Z Brace Diagonals	Leg Panels	X Brace Diagonals	Z Brace Diagonals
T3	1	0.5	0.85	1	0.5	0.7
170.00-160.00						
T4	1	0.5	0.85	1	0.5	0.7
160.00-140.00						
T5	1	0.5	0.85	1	0.5	0.7
140.00-120.00						
T6	1	0.5	0.85	1	0.5	0.7
120.00-100.00						
T7	1	0.5	0.85	1	0.5	0.7
100.00-80.00						
T8	1	0.5	0.85	1	0.5	0.7
80.00-60.00						
T9	1	0.5	0.85	1	0.5	0.7
60.00-40.00						
T10	1	0.5	0.85	1	0.5	0.7
40.00-20.00						
T11	1	0.5	0.85	1	0.5	1
20.00-0.00						

### Tower Section Geometry (cont'd)

<b>tnxTower</b>  <b>SBA Communications</b> 8051 Congress Avenue Boca Raton, Florida Phone: (561) 981-7388 FAX:	<b>Job</b>	<b>Page</b> 6 of 33
	<b>Project</b>	<b>Date</b> 13:53:47 08/31/23
	<b>Client</b>	<b>Designed by</b> Breann Parreira

Tower Elevation ft	Leg		Diagonal		Top Girt		Bottom Girt		Mid Girt		Long Horizontal		Short Horizontal	
	Net Width Deduct in	U	Net Width Deduct in	U	Net Width Deduct in	U	Net Width Deduct in	U	Net Width Deduct in	U	Net Width Deduct in	U	Net Width Deduct in	U
T1 193.00-185.00	0.0000	1	0.0000	1	0.0000	1	0.0000	1	0.0000	1	0.0000	1	0.0000	0.75
T2 185.00-170.00	0.0000	1	0.0000	1	0.0000	1	0.0000	1	0.0000	1	0.0000	1	0.0000	0.75
T3 170.00-160.00	0.0000	1	0.0000	0.75	0.0000	0.75	0.0000	0.75	0.0000	0.75	0.0000	0.75	0.0000	0.75
T4 160.00-140.00	0.0000	1	0.0000	0.75	0.0000	0.75	0.0000	0.75	0.0000	0.75	0.0000	0.75	0.0000	0.75
T5 140.00-120.00	0.0000	1	0.0000	0.75	0.0000	0.75	0.0000	0.75	0.0000	0.75	0.0000	0.75	0.0000	0.75
T6 120.00-100.00	0.0000	1	0.0000	0.75	0.0000	0.75	0.0000	0.75	0.0000	0.75	0.0000	0.75	0.0000	0.75
T7 100.00-80.00	0.0000	1	0.0000	0.75	0.0000	0.75	0.0000	0.75	0.0000	0.75	0.0000	0.75	0.0000	0.75
T8 80.00-60.00	0.0000	1	0.0000	0.75	0.0000	0.75	0.0000	0.75	0.0000	0.75	0.0000	0.75	0.0000	0.75
T9 60.00-40.00	0.0000	1	0.0000	0.75	0.0000	0.75	0.0000	0.75	0.0000	0.75	0.0000	0.75	0.0000	0.75
T10 40.00-20.00	0.0000	1	0.0000	0.75	0.0000	0.75	0.0000	0.75	0.0000	0.75	0.0000	0.75	0.0000	0.75
T11 20.00-0.00	0.0000	1	0.0000	0.75	0.0000	0.75	0.0000	0.75	0.0000	0.75	0.0000	0.75	0.0000	0.75

Tower Elevation ft	Redundant Horizontal		Redundant Diagonal		Redundant Sub-Diagonal		Redundant Sub-Horizontal		Redundant Vertical		Redundant Hip		Redundant Hip Diagonal	
	Net Width Deduct in	U	Net Width Deduct in	U	Net Width Deduct in	U	Net Width Deduct in	U	Net Width Deduct in	U	Net Width Deduct in	U	Net Width Deduct in	U
T1 193.00-185.00	0.0000	0.75	0.0000	0.75	0.0000	0.75	0.0000	0.75	0.0000	0.75	0.0000	0.75	0.0000	0.75
T2 185.00-170.00	0.0000	0.75	0.0000	0.75	0.0000	0.75	0.0000	0.75	0.0000	0.75	0.0000	0.75	0.0000	0.75
T3 170.00-160.00	0.0000	0.75	0.0000	0.75	0.0000	0.75	0.0000	0.75	0.0000	0.75	0.0000	0.75	0.0000	0.75
T4 160.00-140.00	0.0000	0.75	0.0000	0.75	0.0000	0.75	0.0000	0.75	0.0000	0.75	0.0000	0.75	0.0000	0.75
T5 140.00-120.00	0.0000	0.75	0.0000	0.75	0.0000	0.75	0.0000	0.75	0.0000	0.75	0.0000	0.75	0.0000	0.75
T6 120.00-100.00	0.0000	0.75	0.0000	0.75	0.0000	0.75	0.0000	0.75	0.0000	0.75	0.0000	0.75	0.0000	0.75
T7 100.00-80.00	0.0000	0.75	0.0000	0.75	0.0000	0.75	0.0000	0.75	0.0000	0.75	0.0000	0.75	0.0000	0.75
T8 80.00-60.00	0.0000	0.75	0.0000	0.75	0.0000	0.75	0.0000	0.75	0.0000	0.75	0.0000	0.75	0.0000	0.75
T9 60.00-40.00	0.0000	0.75	0.0000	0.75	0.0000	0.75	0.0000	0.75	0.0000	0.75	0.0000	0.75	0.0000	0.75
T10 40.00-20.00	0.0000	0.75	0.0000	0.75	0.0000	0.75	0.0000	0.75	0.0000	0.75	0.0000	0.75	0.0000	0.75
T11 20.00-0.00	0.0000	0.75	0.0000	0.75	0.0000	0.75	0.0000	0.75	0.0000	0.75	0.0000	0.75	0.0000	0.75

**Tower Section Geometry (cont'd)**



<p><b>tnxTower</b></p> <p><b>SBA Communications</b> 8051 Congress Avenue Boca Raton, Florida Phone: (561) 981-7388 FAX:</p>	<b>Job</b>	<b>Page</b> 8 of 33
	<b>Project</b>	<b>Date</b> 13:53:47 08/31/23
	<b>Client</b>	<b>Designed by</b> Breann Parreira

Tower Elevation ft	Leg Connection Type	Leg		Diagonal		Top Girt		Bottom Girt		Mid Girt		Long Horizontal		Short Horizontal	
		Bolt Size in	No.	Bolt Size in	No.	Bolt Size in	No.	Bolt Size in	No.	Bolt Size in	No.	Bolt Size in	No.	Bolt Size in	No.
T11 20.00-0.00	Flange	0.0000 A325N	0	1.0000 A325N	2	1.0000 A325N	0	1.0000 A325N	0	1.0000 A325N	0	1.0000 A325N	0	1.2500 A325N	0

**Feed Line/Linear Appurtenances - Entered As Round Or Flat**

Description	Face or Leg	Allow Shield	Exclude From Torque Calculation	Component Type	Placement ft	Face Offset in	Lateral Offset (Frac FW)	#	# Per Row	Clear Spacing in	Width or Diameter in	Perimeter in	Weight plf
Safety Line (3/8") ***	B	No	No	Ar (CaAa)	193.00 - 8.00	0.0000	0.5	1	1	0.3750	0.3750		0.18
Feedline Ladder (Af) 1 5/8	A	No	No	Af (CaAa)	182.00 - 5.00	0.0000	0.25	1	1	3.0000	1.5000		8.40
3/4" DC Power 3/8" Fiber	A	No	No	Ar (CaAa)	182.00 - 5.00	0.0000	0	12	12	0.5000	1.9800		1.04
5/8"	A	No	No	Ar (CaAa)	182.00 - 5.00	0.0000	0	4	2	0.5000	0.9950		0.47
***	A	No	No	Ar (CaAa)	182.00 - 5.00	0.0000	0	3	3	0.5000	0.4400		0.08
Feedline Ladder (Af) LDF6-50A (1-1/4 FOAM) ***	B	No	No	Af (CaAa)	175.00 - 5.00	-5.0000	0	1	1	3.0000	1.5000		8.40
***	B	No	No	Ar (CaAa)	175.00 - 5.00	-5.0000	0	4	4	0.5000	1.5500		0.66
Feedline Ladder (Af) 1 5/8	C	No	No	Af (CaAa)	162.00 - 5.00	0.0000	0	1	1	3.0000	1.5000		8.40
1 5/8 Hybrid	C	No	No	Ar (CaAa)	162.00 - 5.00	0.0000	0	12	10	0.5000	1.9800		1.04
3/8"	C	No	No	Ar (CaAa)	162.00 - 5.00	0.0000	0	3	3	0.5000	1.9800		1.04
***	C	No	No	Ar (CaAa)	100.00 - 5.00	0.0000	0	1	1	0.3750	0.3750		0.18
1 5/8	C	No	No	Ar (CaAa)	191.00 - 5.00	-5.0000	0	8	4	0.5000	1.9800		1.04
1.9" Fiber	C	No	No	Ar (CaAa)	191.00 - 5.00	-5.0000	0	3	2	0.5000	1.9000		1.04
1/2 ***	C	No	No	Ar (CaAa)	30.00 - 5.00	-5.0000	0	2	1	0.5000	0.5800		0.25
Feedline Ladder (Af) ***	C	No	No	Af (CaAa)	193.00 - 5.00	0.0000	0	1	1	3.0000	1.5000		8.40
Feedline Ladder (Af) 1.6" Hybrid	B	No	No	Af (CaAa)	150.00 - 5.00	0.0000	0	1	1	3.0000	1.5000		8.40
***	B	No	No	Ar (CaAa)	150.00 - 5.00	0.0000	0	1	1	0.5000	1.9800		1.04

<b>tnxTower</b>  <b>SBA Communications</b> 8051 Congress Avenue Boca Raton, Florida Phone: (561) 981-7388 FAX:	<b>Job</b>	<b>Page</b> 9 of 33
	<b>Project</b>	<b>Date</b> 13:53:47 08/31/23
	<b>Client</b>	<b>Designed by</b> Breann Parreira

### Feed Line/Linear Appurtenances Section Areas

Tower Section	Tower Elevation ft	Face	$A_R$	$A_F$	$C_{AA}$ In Face	$C_{AA}$ Out Face	Weight K
			$ft^2$	$ft^2$	$ft^2$	$ft^2$	
T1	193.00-185.00	A	0.000	0.000	0.000	0.000	0.00
		B	0.000	0.000	0.300	0.000	0.00
		C	0.000	0.000	14.924	0.000	0.14
T2	185.00-170.00	A	0.000	0.000	39.984	0.000	0.29
		B	0.000	0.000	4.912	0.000	0.06
		C	0.000	0.000	36.060	0.000	0.30
T3	170.00-160.00	A	0.000	0.000	33.320	0.000	0.24
		B	0.000	0.000	9.075	0.000	0.11
		C	0.000	0.000	30.480	0.000	0.25
T4	160.00-140.00	A	0.000	0.000	66.640	0.000	0.48
		B	0.000	0.000	22.630	0.000	0.32
		C	0.000	0.000	112.480	0.000	0.88
T5	140.00-120.00	A	0.000	0.000	66.640	0.000	0.48
		B	0.000	0.000	27.110	0.000	0.41
		C	0.000	0.000	112.480	0.000	0.88
T6	120.00-100.00	A	0.000	0.000	66.640	0.000	0.48
		B	0.000	0.000	27.110	0.000	0.41
		C	0.000	0.000	112.480	0.000	0.88
T7	100.00-80.00	A	0.000	0.000	66.640	0.000	0.48
		B	0.000	0.000	27.110	0.000	0.41
		C	0.000	0.000	113.230	0.000	0.88
T8	80.00-60.00	A	0.000	0.000	66.640	0.000	0.48
		B	0.000	0.000	27.110	0.000	0.41
		C	0.000	0.000	113.230	0.000	0.88
T9	60.00-40.00	A	0.000	0.000	66.640	0.000	0.48
		B	0.000	0.000	27.110	0.000	0.41
		C	0.000	0.000	113.230	0.000	0.88
T10	40.00-20.00	A	0.000	0.000	66.640	0.000	0.48
		B	0.000	0.000	27.110	0.000	0.41
		C	0.000	0.000	114.390	0.000	0.89
T11	20.00-0.00	A	0.000	0.000	49.980	0.000	0.36
		B	0.000	0.000	20.220	0.000	0.31
		C	0.000	0.000	86.662	0.000	0.67

### Feed Line/Linear Appurtenances Section Areas - With Ice

Tower Section	Tower Elevation ft	Face or Leg	Ice Thickness	$A_R$	$A_F$	$C_{AA}$ In Face	$C_{AA}$ Out Face	Weight K
			in	$ft^2$	$ft^2$	$ft^2$	$ft^2$	
T1	193.00-185.00	A	1.191	0.000	0.000	0.000	0.000	0.00
		B		0.000	0.000	2.205	0.000	0.02
		C		0.000	0.000	21.222	0.000	0.36
T2	185.00-170.00	A	1.183	0.000	0.000	80.699	0.000	1.00
		B		0.000	0.000	13.296	0.000	0.17
		C		0.000	0.000	50.515	0.000	0.82
T3	170.00-160.00	A	1.175	0.000	0.000	67.118	0.000	0.83
		B		0.000	0.000	21.047	0.000	0.29
		C		0.000	0.000	44.008	0.000	0.69
T4	160.00-140.00	A	1.163	0.000	0.000	133.895	0.000	1.65
		B		0.000	0.000	51.068	0.000	0.77
		C		0.000	0.000	170.897	0.000	2.56
T5	140.00-120.00	A	1.147	0.000	0.000	133.391	0.000	1.63
		B		0.000	0.000	59.830	0.000	0.94
		C		0.000	0.000	170.325	0.000	2.54
T6	120.00-100.00	A	1.128	0.000	0.000	132.811	0.000	1.61

<b>tnxTower</b>  <b>SBA Communications</b> 8051 Congress Avenue Boca Raton, Florida Phone: (561) 981-7388 FAX:	<b>Job</b>	<b>Page</b> 10 of 33
	<b>Project</b>	<b>Date</b> 13:53:47 08/31/23
	<b>Client</b>	<b>Designed by</b> Breann Parreira

Tower Section	Tower Elevation ft	Face or Leg	Ice Thickness in	A <sub>R</sub> ft <sup>2</sup>	A <sub>F</sub> ft <sup>2</sup>	C <sub>AA</sub> In Face ft <sup>2</sup>	C <sub>AA</sub> Out Face ft <sup>2</sup>	Weight K
		B		0.000	0.000	59.403	0.000	0.93
		C		0.000	0.000	169.667	0.000	2.51
T7	100.00-80.00	A	1.106	0.000	0.000	132.128	0.000	1.59
		B		0.000	0.000	58.900	0.000	0.92
		C		0.000	0.000	174.064	0.000	2.53
T8	80.00-60.00	A	1.078	0.000	0.000	131.292	0.000	1.56
		B		0.000	0.000	58.285	0.000	0.90
		C		0.000	0.000	173.006	0.000	2.49
T9	60.00-40.00	A	1.042	0.000	0.000	130.206	0.000	1.53
		B		0.000	0.000	57.484	0.000	0.88
		C		0.000	0.000	171.630	0.000	2.44
T10	40.00-20.00	A	0.991	0.000	0.000	128.626	0.000	1.47
		B		0.000	0.000	56.320	0.000	0.85
		C		0.000	0.000	175.193	0.000	2.42
T11	20.00-0.00	A	0.887	0.000	0.000	94.122	0.000	1.03
		B		0.000	0.000	39.865	0.000	0.60
		C		0.000	0.000	132.055	0.000	1.73

### Feed Line Center of Pressure

Section	Elevation ft	CP <sub>x</sub> in	CP <sub>z</sub> in	CP <sub>x</sub> Ice in	CP <sub>z</sub> Ice in
T1	193.00-185.00	0.2765	3.9604	0.7756	2.8722
T2	185.00-170.00	-3.4682	-1.4645	-2.6288	-1.0462
T3	170.00-160.00	-2.5682	-1.6392	-1.9503	-1.2769
T4	160.00-140.00	-1.9954	-0.1555	-1.5063	-0.0385
T5	140.00-120.00	-1.9823	-0.3665	-1.2861	-0.2173
T6	120.00-100.00	-2.2104	-0.3691	-1.4242	-0.2230
T7	100.00-80.00	-2.4777	-0.2534	-1.6050	0.2558
T8	80.00-60.00	-2.6327	-0.2429	-1.7381	0.2744
T9	60.00-40.00	-2.8213	-0.2375	-1.8870	0.2767
T10	40.00-20.00	-3.0131	0.0063	-2.0316	0.8154
T11	20.00-0.00	-2.7583	0.1927	-2.0662	0.9736

### Shielding Factor Ka

Tower Section	Feed Line Record No.	Description	Feed Line Segment Elev.	K <sub>a</sub> No Ice	K <sub>a</sub> Ice
T1	1	Safety Line (3/8")	185.00 - 193.00	0.6000	0.4916
T1	17	1 5/8	185.00 - 191.00	0.6000	0.4916
T1	18	1.9" Fiber	185.00 - 191.00	0.6000	0.4916
T1	21	Feedline Ladder (Af)	185.00 - 193.00	0.6000	0.4916
T2	1	Safety Line (3/8")	170.00 - 185.00	0.6000	0.5867
T2	3	Feedline Ladder (Af)	170.00 - 182.00	0.6000	0.5867



<i>Tower Section</i>	<i>Feed Line Record No.</i>	<i>Description</i>	<i>Feed Line Segment Elev.</i>	<i>K<sub>a</sub> No Ice</i>	<i>K<sub>a</sub> Ice</i>
T2	4	1 5/8	170.00 - 182.00	0.6000	0.5867
T2	5	3/4" DC Power	170.00 - 182.00	0.6000	0.5867
T2	6	3/8" Fiber	170.00 - 182.00	1.0000	1.0000
T2	7	5/8"	170.00 - 182.00	0.6000	0.5867
T2	9	Feedline Ladder (Af)	170.00 - 175.00	0.6000	0.5867
T2	10	LDF6-50A (1-1/4 FOAM)	170.00 - 175.00	0.6000	0.5867
T2	17	1 5/8	170.00 - 185.00	0.6000	0.5867
T2	18	1.9" Fiber	170.00 - 185.00	0.6000	0.5867
T2	21	Feedline Ladder (Af)	170.00 - 185.00	0.6000	0.5867
T3	1	Safety Line (3/8")	160.00 - 170.00	0.6000	0.4337
T3	3	Feedline Ladder (Af)	160.00 - 170.00	0.6000	0.4337
T3	4	1 5/8	160.00 - 170.00	0.6000	0.4337
T3	5	3/4" DC Power	160.00 - 170.00	0.6000	0.4337
T3	6	3/8" Fiber	160.00 - 170.00	1.0000	1.0000
T3	7	5/8"	160.00 - 170.00	0.6000	0.4337
T3	9	Feedline Ladder (Af)	160.00 - 170.00	0.6000	0.4337
T3	10	LDF6-50A (1-1/4 FOAM)	160.00 - 170.00	0.6000	0.4337
T3	12	Feedline Ladder (Af)	160.00 - 162.00	0.6000	0.4337
T3	13	1 5/8	160.00 - 162.00	0.6000	0.4337
T3	14	1 5/8 Hybrid	160.00 - 162.00	0.6000	0.4337
T3	17	1 5/8	160.00 - 170.00	0.6000	0.4337
T3	18	1.9" Fiber	160.00 - 170.00	0.6000	0.4337
T3	21	Feedline Ladder (Af)	160.00 - 170.00	0.6000	0.4337
T4	1	Safety Line (3/8")	140.00 - 160.00	0.6000	0.5033
T4	3	Feedline Ladder (Af)	140.00 - 160.00	0.6000	0.5033
T4	4	1 5/8	140.00 - 160.00	0.6000	0.5033
T4	5	3/4" DC Power	140.00 - 160.00	0.6000	0.5033
T4	6	3/8" Fiber	140.00 - 160.00	1.0000	1.0000
T4	7	5/8"	140.00 - 160.00	0.6000	0.5033
T4	9	Feedline Ladder (Af)	140.00 - 160.00	0.6000	0.5033
T4	10	LDF6-50A (1-1/4 FOAM)	140.00 - 160.00	0.6000	0.5033

<i>Tower Section</i>	<i>Feed Line Record No.</i>	<i>Description</i>	<i>Feed Line Segment Elev.</i>	<i>K<sub>a</sub> No Ice</i>	<i>K<sub>a</sub> Ice</i>
T4	12	Feedline Ladder (Af)	140.00 - 160.00	0.6000	0.5033
T4	13	1 5/8	140.00 - 160.00	0.6000	0.5033
T4	14	1 5/8 Hybrid	140.00 - 160.00	0.6000	0.5033
T4	17	1 5/8	140.00 - 160.00	0.6000	0.5033
T4	18	1.9" Fiber	140.00 - 160.00	0.6000	0.5033
T4	21	Feedline Ladder (Af)	140.00 - 160.00	0.6000	0.5033
T4	23	Feedline Ladder (Af)	140.00 - 150.00	0.6000	0.5033
T4	24	1.6" Hybrid	140.00 - 150.00	0.6000	0.5033
T5	1	Safety Line (3/8")	120.00 - 140.00	0.6000	0.5919
T5	3	Feedline Ladder (Af)	120.00 - 140.00	0.6000	0.5919
T5	4	1 5/8	120.00 - 140.00	0.6000	0.5919
T5	5	3/4" DC Power	120.00 - 140.00	0.6000	0.5919
T5	6	3/8" Fiber	120.00 - 140.00	1.0000	1.0000
T5	7	5/8"	120.00 - 140.00	0.6000	0.5919
T5	9	Feedline Ladder (Af)	120.00 - 140.00	0.6000	0.5919
T5	10	LDF6-50A (1-1/4 FOAM)	120.00 - 140.00	0.6000	0.5919
T5	12	Feedline Ladder (Af)	120.00 - 140.00	0.6000	0.5919
T5	13	1 5/8	120.00 - 140.00	0.6000	0.5919
T5	14	1 5/8 Hybrid	120.00 - 140.00	0.6000	0.5919
T5	17	1 5/8	120.00 - 140.00	0.6000	0.5919
T5	18	1.9" Fiber	120.00 - 140.00	0.6000	0.5919
T5	21	Feedline Ladder (Af)	120.00 - 140.00	0.6000	0.5919
T5	23	Feedline Ladder (Af)	120.00 - 140.00	0.6000	0.5919
T5	24	1.6" Hybrid	120.00 - 140.00	0.6000	0.5919
T6	1	Safety Line (3/8")	100.00 - 120.00	0.6000	0.6000
T6	3	Feedline Ladder (Af)	100.00 - 120.00	0.6000	0.6000
T6	4	1 5/8	100.00 - 120.00	0.6000	0.6000
T6	5	3/4" DC Power	100.00 - 120.00	0.6000	0.6000
T6	6	3/8" Fiber	100.00 - 120.00	1.0000	1.0000
T6	7	5/8"	100.00 - 120.00	0.6000	0.6000
T6	9	Feedline Ladder (Af)	100.00 - 120.00	0.6000	0.6000

<b>Job</b>		<b>Page</b> 13 of 33
<b>Project</b>	CT01105-S Bozrah	<b>Date</b> 13:53:47 08/31/23
<b>Client</b>		<b>Designed by</b> Breann Parreira

Tower Section	Feed Line Record No.	Description	Feed Line Segment Elev.	K <sub>a</sub> No Ice	K <sub>a</sub> Ice
T6	10	LDF6-50A (1-1/4 FOAM)	100.00 - 120.00	0.6000	0.6000
T6	12	Feedline Ladder (Af)	100.00 - 120.00	0.6000	0.6000
T6	13	1 5/8	100.00 - 120.00	0.6000	0.6000
T6	14	1 5/8 Hybrid	100.00 - 120.00	0.6000	0.6000
T6	17	1 5/8	100.00 - 120.00	0.6000	0.6000
T6	18	1.9" Fiber	100.00 - 120.00	0.6000	0.6000
T6	21	Feedline Ladder (Af)	100.00 - 120.00	0.6000	0.6000
T6	23	Feedline Ladder (Af)	100.00 - 120.00	0.6000	0.6000
T6	24	1.6" Hybrid	100.00 - 120.00	0.6000	0.6000
T7	1	Safety Line (3/8")	80.00 - 100.00	0.6000	0.6000
T7	3	Feedline Ladder (Af)	80.00 - 100.00	0.6000	0.6000
T7	4	1 5/8	80.00 - 100.00	0.6000	0.6000
T7	5	3/4" DC Power	80.00 - 100.00	0.6000	0.6000
T7	6	3/8" Fiber	80.00 - 100.00	1.0000	1.0000
T7	7	5/8"	80.00 - 100.00	0.6000	0.6000
T7	9	Feedline Ladder (Af)	80.00 - 100.00	0.6000	0.6000
T7	10	LDF6-50A (1-1/4 FOAM)	80.00 - 100.00	0.6000	0.6000
T7	12	Feedline Ladder (Af)	80.00 - 100.00	0.6000	0.6000
T7	13	1 5/8	80.00 - 100.00	0.6000	0.6000
T7	14	1 5/8 Hybrid	80.00 - 100.00	0.6000	0.6000
T7	15	3/8"	80.00 - 100.00	0.6000	0.6000
T7	17	1 5/8	80.00 - 100.00	0.6000	0.6000
T7	18	1.9" Fiber	80.00 - 100.00	0.6000	0.6000
T7	21	Feedline Ladder (Af)	80.00 - 100.00	0.6000	0.6000
T7	23	Feedline Ladder (Af)	80.00 - 100.00	0.6000	0.6000
T7	24	1.6" Hybrid	80.00 - 100.00	0.6000	0.6000
T8	1	Safety Line (3/8")	60.00 - 80.00	0.6000	0.6000
T8	3	Feedline Ladder (Af)	60.00 - 80.00	0.6000	0.6000
T8	4	1 5/8	60.00 - 80.00	0.6000	0.6000
T8	5	3/4" DC Power	60.00 - 80.00	0.6000	0.6000
T8	6	3/8" Fiber	60.00 - 80.00	1.0000	1.0000
T8	7	5/8"	60.00 - 80.00	0.6000	0.6000
T8	9	Feedline Ladder (Af)	60.00 - 80.00	0.6000	0.6000
T8	10	LDF6-50A (1-1/4 FOAM)	60.00 - 80.00	0.6000	0.6000
T8	12	Feedline Ladder (Af)	60.00 - 80.00	0.6000	0.6000
T8	13	1 5/8	60.00 - 80.00	0.6000	0.6000
T8	14	1 5/8 Hybrid	60.00 - 80.00	0.6000	0.6000
T8	15	3/8"	60.00 - 80.00	0.6000	0.6000
T8	17	1 5/8	60.00 - 80.00	0.6000	0.6000
T8	18	1.9" Fiber	60.00 - 80.00	0.6000	0.6000
T8	21	Feedline Ladder (Af)	60.00 - 80.00	0.6000	0.6000
T8	23	Feedline Ladder (Af)	60.00 - 80.00	0.6000	0.6000
T8	24	1.6" Hybrid	60.00 - 80.00	0.6000	0.6000
T9	1	Safety Line (3/8")	40.00 - 60.00	0.6000	0.6000
T9	3	Feedline Ladder (Af)	40.00 - 60.00	0.6000	0.6000
T9	4	1 5/8	40.00 - 60.00	0.6000	0.6000
T9	5	3/4" DC Power	40.00 - 60.00	0.6000	0.6000
T9	6	3/8" Fiber	40.00 - 60.00	1.0000	1.0000
T9	7	5/8"	40.00 - 60.00	0.6000	0.6000
T9	9	Feedline Ladder (Af)	40.00 - 60.00	0.6000	0.6000
T9	10	LDF6-50A (1-1/4 FOAM)	40.00 - 60.00	0.6000	0.6000
T9	12	Feedline Ladder (Af)	40.00 - 60.00	0.6000	0.6000
T9	13	1 5/8	40.00 - 60.00	0.6000	0.6000

<b>tnxTower</b>  <b>SBA Communications</b> 8051 Congress Avenue Boca Raton, Florida Phone: (561) 981-7388 FAX:	<b>Job</b>	<b>Page</b> 14 of 33
	<b>Project</b>	<b>Date</b> 13:53:47 08/31/23
	<b>Client</b>	<b>Designed by</b> Breann Parreira

Tower Section	Feed Line Record No.	Description	Feed Line Segment Elev.	$K_a$ No Ice	$K_a$ Ice
T9	14	1 5/8 Hybrid	40.00 - 60.00	0.6000	0.6000
T9	15	3/8"	40.00 - 60.00	0.6000	0.6000
T9	17	1 5/8	40.00 - 60.00	0.6000	0.6000
T9	18	1.9" Fiber	40.00 - 60.00	0.6000	0.6000
T9	21	Feedline Ladder (Af)	40.00 - 60.00	0.6000	0.6000
T9	23	Feedline Ladder (Af)	40.00 - 60.00	0.6000	0.6000
T9	24	1.6" Hybrid	40.00 - 60.00	0.6000	0.6000
T10	1	Safety Line (3/8")	20.00 - 40.00	0.6000	0.6000
T10	3	Feedline Ladder (Af)	20.00 - 40.00	0.6000	0.6000
T10	4	1 5/8	20.00 - 40.00	0.6000	0.6000
T10	5	3/4" DC Power	20.00 - 40.00	0.6000	0.6000
T10	6	3/8" Fiber	20.00 - 40.00	1.0000	1.0000
T10	7	5/8"	20.00 - 40.00	0.6000	0.6000
T10	9	Feedline Ladder (Af)	20.00 - 40.00	0.6000	0.6000
T10	10	LDF6-50A (1-1/4 FOAM)	20.00 - 40.00	0.6000	0.6000
T10	12	Feedline Ladder (Af)	20.00 - 40.00	0.6000	0.6000
T10	13	1 5/8	20.00 - 40.00	0.6000	0.6000
T10	14	1 5/8 Hybrid	20.00 - 40.00	0.6000	0.6000
T10	15	3/8"	20.00 - 40.00	0.6000	0.6000
T10	17	1 5/8	20.00 - 40.00	0.6000	0.6000
T10	18	1.9" Fiber	20.00 - 40.00	0.6000	0.6000
T10	19	1/2	20.00 - 30.00	0.6000	0.6000
T10	21	Feedline Ladder (Af)	20.00 - 40.00	0.6000	0.6000
T10	23	Feedline Ladder (Af)	20.00 - 40.00	0.6000	0.6000
T10	24	1.6" Hybrid	20.00 - 40.00	0.6000	0.6000
T11	1	Safety Line (3/8")	8.00 - 20.00	0.6000	0.6000
T11	3	Feedline Ladder (Af)	5.00 - 20.00	0.6000	0.6000
T11	4	1 5/8	5.00 - 20.00	0.6000	0.6000
T11	5	3/4" DC Power	5.00 - 20.00	0.6000	0.6000
T11	6	3/8" Fiber	5.00 - 20.00	1.0000	1.0000
T11	7	5/8"	5.00 - 20.00	0.6000	0.6000
T11	9	Feedline Ladder (Af)	5.00 - 20.00	0.6000	0.6000
T11	10	LDF6-50A (1-1/4 FOAM)	5.00 - 20.00	0.6000	0.6000
T11	12	Feedline Ladder (Af)	5.00 - 20.00	0.6000	0.6000
T11	13	1 5/8	5.00 - 20.00	0.6000	0.6000
T11	14	1 5/8 Hybrid	5.00 - 20.00	0.6000	0.6000
T11	15	3/8"	5.00 - 20.00	0.6000	0.6000
T11	17	1 5/8	5.00 - 20.00	0.6000	0.6000
T11	18	1.9" Fiber	5.00 - 20.00	0.6000	0.6000
T11	19	1/2	5.00 - 20.00	0.6000	0.6000
T11	21	Feedline Ladder (Af)	5.00 - 20.00	0.6000	0.6000
T11	23	Feedline Ladder (Af)	5.00 - 20.00	0.6000	0.6000
T11	24	1.6" Hybrid	5.00 - 20.00	0.6000	0.6000

### User Defined Loads - Seismic

Description	Elevation	Offset From Centroid	Azimuth Angle	$E_v$	$E_{hx}$	$E_{hz}$	$E_h$
	ft	ft	°	K	K	K	K
SL1	193.00	0.00	0.0000	0.28	0.00	0.00	0.64
SL2	185.00	0.00	0.0000	0.48	0.00	0.00	1.12
SL3	170.00	0.00	0.0000	0.27	0.00	0.00	0.52
SL4	160.00	0.00	0.0000	0.45	0.00	0.00	0.87
SL5	140.00	0.00	0.0000	0.36	0.00	0.00	0.59

<b>tnxTower</b>  <b>SBA Communications</b> 8051 Congress Avenue Boca Raton, Florida Phone: (561) 981-7388 FAX:	<b>Job</b>	<b>Page</b> 15 of 33
	<b>Project</b>	<b>Date</b> 13:53:47 08/31/23
	<b>Client</b>	<b>Designed by</b> Breann Parreira

Description	Elevation	Offset From Centroid	Azimuth Angle	$E_v$	$E_{hx}$	$E_{hz}$	$E_h$
	ft	ft	°	K	K	K	K
SL6	120.00	0.00	0.0000	0.40	0.00	0.00	0.55
SL7	100.00	0.00	0.0000	0.43	0.00	0.00	0.48
SL8	80.00	0.00	0.0000	0.45	0.00	0.00	0.39
SL9	60.00	0.00	0.0000	0.49	0.00	0.00	0.31
SL10	40.00	0.00	0.0000	0.48	0.00	0.00	0.19
SL11	20.00	0.00	0.0000	0.50	0.00	0.00	0.09

### Discrete Tower Loads

Description	Face or Leg	Offset Type	Offsets: Horz Lateral Vert	Azimuth Adjustment	Placement	$C_{AA}$ Front	$C_{AA}$ Side	Weight	
			ft ft ft	°	ft	ft <sup>2</sup>	ft <sup>2</sup>	K	
Lightning Rod	C	From Leg	0.00 0.00 0.00	0.0000	193.00	No Ice 1/2" Ice 1" Ice	0.25 0.66 0.97	0.25 0.66 0.97	0.03 0.03 0.04
***									
RR90-17-02DP [56x8x2.75] w/ mount pipe	A	From Leg	3.00 0.00 0.00	0.0000	191.00	No Ice 1/2" Ice 1" Ice	5.31 6.01 6.57	4.27 5.44 6.28	0.06 0.11 0.17
RR90-17-02DP [56x8x2.75] w/ mount pipe	B	From Leg	3.00 0.00 0.00	0.0000	191.00	No Ice 1/2" Ice 1" Ice	5.31 6.01 6.57	4.27 5.44 6.28	0.06 0.11 0.17
RR90-17-02DP [56x8x2.75] w/ mount pipe	C	From Leg	3.00 0.00 0.00	0.0000	191.00	No Ice 1/2" Ice 1" Ice	5.31 6.01 6.57	4.27 5.44 6.28	0.06 0.11 0.17
APXVAALL24-43-U-NA20 [95.9x24x8.5] w/ mount pipe	A	From Leg	3.00 0.00 0.00	0.0000	191.00	No Ice 1/2" Ice 1" Ice	20.24 20.89 21.55	11.03 12.46 13.56	0.17 0.31 0.45
APXVAALL24-43-U-NA20 [95.9x24x8.5] w/ mount pipe	B	From Leg	3.00 0.00 0.00	0.0000	191.00	No Ice 1/2" Ice 1" Ice	20.24 20.89 21.55	11.03 12.46 13.56	0.17 0.31 0.45
APXVAALL24-43-U-NA20 [95.9x24x8.5] w/ mount pipe	C	From Leg	3.00 0.00 0.00	0.0000	191.00	No Ice 1/2" Ice 1" Ice	20.24 20.89 21.55	11.03 12.46 13.56	0.17 0.31 0.45
AIR6419 B41 (36.3x20.9x9) w/ mount pipe	A	From Leg	3.00 0.00 0.00	0.0000	191.00	No Ice 1/2" Ice 1" Ice	7.50 8.34 9.09	4.78 5.85 6.78	0.11 0.18 0.25
AIR6419 B41 (36.3x20.9x9) w/ mount pipe	B	From Leg	3.00 0.00 0.00	0.0000	191.00	No Ice 1/2" Ice 1" Ice	7.50 8.34 9.09	4.78 5.85 6.78	0.11 0.18 0.25
AIR6419 B41 (36.3x20.9x9) w/ mount pipe	C	From Leg	3.00 0.00 0.00	0.0000	191.00	No Ice 1/2" Ice 1" Ice	7.50 8.34 9.09	4.78 5.85 6.78	0.11 0.18 0.25
SDX1926Q-43 [6.9x4.1x2.9]	A	From Leg	3.00 0.00 0.00	0.0000	191.00	No Ice 1/2" Ice 1" Ice	0.24 0.30 0.37	0.17 0.22 0.29	0.06 0.06 0.07
SDX1926Q-43 [6.9x4.1x2.9]	B	From Leg	3.00 0.00 0.00	0.0000	191.00	No Ice 1/2" Ice 1" Ice	0.24 0.30 0.37	0.17 0.22 0.29	0.06 0.06 0.07
SDX1926Q-43 [6.9x4.1x2.9]	C	From Leg	3.00 0.00 0.00	0.0000	191.00	No Ice 1/2" Ice	0.24 0.30	0.17 0.22	0.06 0.06

<b>Job</b>		<b>Page</b> 16 of 33
<b>Project</b>	CT01105-S Bozrah	<b>Date</b> 13:53:47 08/31/23
<b>Client</b>		<b>Designed by</b> Breann Parreira

Description	Face or Leg	Offset Type	Offsets:			Azimuth Adjustment	Placement	C <sub>AA</sub> Front	C <sub>AA</sub> Side	Weight	
			Horz	Lateral	Vert						ft
4449 B71 + B85 (17.9x13.1x10.6)	A	From Leg	0.00			0.0000	191.00	1" Ice	0.37	0.29	0.07
			3.00					No Ice	1.95	1.58	0.08
			0.00					1/2" Ice	2.13	1.74	0.09
			0.00					1" Ice	2.31	1.91	0.12
4449 B71 + B85 (17.9x13.1x10.6)	B	From Leg	3.00			0.0000	191.00	No Ice	1.95	1.58	0.08
			0.00					1/2" Ice	2.13	1.74	0.09
			0.00					1" Ice	2.31	1.91	0.12
			0.00					No Ice	1.95	1.58	0.08
4449 B71 + B85 (17.9x13.1x10.6)	C	From Leg	0.00			0.0000	191.00	1/2" Ice	2.13	1.74	0.09
			3.00					1" Ice	2.31	1.91	0.12
			0.00					No Ice	1.95	1.58	0.08
			0.00					1/2" Ice	2.13	1.74	0.09
4460 B25+B66 (17x15.11x11.85)	A	From Leg	3.00			0.0000	191.00	1" Ice	2.31	1.91	0.12
			0.00					No Ice	2.14	1.68	0.11
			0.00					1/2" Ice	2.32	1.84	0.13
			0.00					1" Ice	2.51	2.01	0.16
4460 B25+B66 (17x15.11x11.85)	B	From Leg	3.00			0.0000	191.00	No Ice	2.14	1.68	0.11
			0.00					1/2" Ice	2.32	1.84	0.13
			0.00					1" Ice	2.51	2.01	0.16
			0.00					No Ice	2.14	1.68	0.11
4460 B25+B66 (17x15.11x11.85)	C	From Leg	0.00			0.0000	191.00	1/2" Ice	2.32	1.84	0.13
			3.00					1" Ice	2.51	2.01	0.16
			0.00					No Ice	2.14	1.68	0.11
			0.00					1/2" Ice	2.32	1.84	0.13
4415 B66A [16.5x13.4x6.2]	A	From Leg	3.00			0.0000	191.00	No Ice	1.84	0.86	0.05
			0.00					1/2" Ice	2.01	0.98	0.06
			0.00					1" Ice	2.19	1.12	0.08
			0.00					No Ice	1.84	0.86	0.05
4415 B66A [16.5x13.4x6.2]	B	From Leg	3.00			0.0000	191.00	1/2" Ice	2.01	0.98	0.06
			0.00					1" Ice	2.19	1.12	0.08
			0.00					No Ice	1.84	0.86	0.05
			0.00					1/2" Ice	2.01	0.98	0.06
4415 B66A [16.5x13.4x6.2]	C	From Leg	0.00			0.0000	191.00	1" Ice	2.19	1.12	0.08
			3.00					No Ice	1.84	0.86	0.05
			0.00					1/2" Ice	2.01	0.98	0.06
			0.00					1" Ice	2.19	1.12	0.08
(1) Low Profile Platform	A	None				0.0000	191.00	No Ice	27.65	27.65	2.17
								1/2" Ice	34.74	34.74	2.83
								1" Ice	41.83	41.83	3.50
***											
7770 [55x11x5] w/ mount pipe	A	From Leg	3.00			0.0000	182.00	No Ice	6.49	5.23	0.08
			0.00					1/2" Ice	7.21	6.41	0.14
			0.00					1" Ice	7.78	7.25	0.20
7770 [55x11x5] w/ mount pipe	B	From Leg	3.00			0.0000	182.00	No Ice	6.49	5.23	0.08
			0.00					1/2" Ice	7.21	6.41	0.14
			0.00					1" Ice	7.78	7.25	0.20
7770 [55x11x5] w/ mount pipe	C	From Leg	3.00			0.0000	182.00	No Ice	6.49	5.23	0.08
			0.00					1/2" Ice	7.21	6.41	0.14
			0.00					1" Ice	7.78	7.25	0.20
HPA-65R-BUU-H8 (92.4"x14.8"x7.4") w/ mount pipe	A	From Leg	3.00			0.0000	182.00	No Ice	13.11	9.46	0.10
			0.00					1/2" Ice	13.72	10.86	0.19
			0.00					1" Ice	14.33	12.11	0.30
HPA-65R-BUU-H8 (92.4"x14.8"x7.4") w/ mount pipe	B	From Leg	3.00			0.0000	182.00	No Ice	13.11	9.46	0.10
			0.00					1/2" Ice	13.72	10.86	0.19
			0.00					1" Ice	14.33	12.11	0.30
HPA-65R-BUU-H8 (92.4"x14.8"x7.4") w/ mount pipe	C	From Leg	3.00			0.0000	182.00	No Ice	13.11	9.46	0.10
			0.00					1/2" Ice	13.72	10.86	0.19
			0.00					1" Ice	14.33	12.11	0.30
DMP65R-BU8DA [96x20.7x7.7] w/ mount pipe	A	From Leg	3.00			0.0000	182.00	No Ice	17.87	10.42	0.14
			0.00					1/2" Ice	18.50	11.85	0.26
			0.00					1" Ice	19.14	12.94	0.40
DMP65R-BU8DA [96x20.7x7.7] w/ mount pipe	B	From Leg	3.00			0.0000	182.00	No Ice	17.87	10.42	0.14
			0.00					1/2" Ice	18.50	11.85	0.26
			0.00					1" Ice	19.14	12.94	0.40
DMP65R-BU8DA	C	From Leg	3.00			0.0000	182.00	No Ice	17.87	10.42	0.14

<p><b>tnxTower</b></p> <p><b>SBA Communications</b> 8051 Congress Avenue Boca Raton, Florida Phone: (561) 981-7388 FAX:</p>	<b>Job</b>		<b>Page</b> 17 of 33	
	<b>Project</b>		<b>Date</b>	
	<b>Client</b>		<b>Designed by</b>	
	CT01105-S Bozrah		13:53:47 08/31/23	
			Breann Parreira	

Description	Face or Leg	Offset Type	Offsets: Horz Lateral Vert ft ft ft	Azimuth Adjustment °	Placement ft	C <sub>AA</sub> Front ft <sup>2</sup>	C <sub>AA</sub> Side ft <sup>2</sup>	Weight K
[96x20.7x7.7] w/ mount pipe			0.00			1/2" Ice 18.50	11.85	0.26
			0.00			1" Ice 19.14	12.94	0.40
(2) LGP21401 (14.4"x9.2"x2.6")	A	From Leg	3.00	0.0000	182.00	No Ice 1.10	0.35	0.01
			0.00			1/2" Ice 1.24	0.44	0.02
			0.00			1" Ice 1.38	0.54	0.03
(2) LGP21401 (14.4"x9.2"x2.6")	B	From Leg	3.00	0.0000	182.00	No Ice 1.10	0.35	0.01
			0.00			1/2" Ice 1.24	0.44	0.02
			0.00			1" Ice 1.38	0.54	0.03
(2) LGP21401 (14.4"x9.2"x2.6")	C	From Leg	3.00	0.0000	182.00	No Ice 1.10	0.35	0.01
			0.00			1/2" Ice 1.24	0.44	0.02
			0.00			1" Ice 1.38	0.54	0.03
(2) LGP21902 [6.3x4.4x3]	A	From Leg	3.00	0.0000	182.00	No Ice 0.23	0.16	0.01
			0.00			1/2" Ice 0.29	0.21	0.01
			0.00			1" Ice 0.36	0.28	0.01
(2) LGP21902 [6.3x4.4x3]	B	From Leg	3.00	0.0000	182.00	No Ice 0.23	0.16	0.01
			0.00			1/2" Ice 0.29	0.21	0.01
			0.00			1" Ice 0.36	0.28	0.01
(2) LGP21902 [6.3x4.4x3]	C	From Leg	3.00	0.0000	182.00	No Ice 0.23	0.16	0.01
			0.00			1/2" Ice 0.29	0.21	0.01
			0.00			1" Ice 0.36	0.28	0.01
4449 B5/B12 (17.9x13.19x9.44)	A	From Leg	3.00	0.0000	182.00	No Ice 0.21	0.15	0.07
			0.00			1/2" Ice 0.30	0.22	0.08
			0.00			1" Ice 0.39	0.29	0.09
4449 B5/B12 (17.9x13.19x9.44)	B	From Leg	3.00	0.0000	182.00	No Ice 0.21	0.15	0.07
			0.00			1/2" Ice 0.30	0.22	0.08
			0.00			1" Ice 0.39	0.29	0.09
4449 B5/B12 (17.9x13.19x9.44)	C	From Leg	3.00	0.0000	182.00	No Ice 0.21	0.15	0.07
			0.00			1/2" Ice 0.30	0.22	0.08
			0.00			1" Ice 0.39	0.29	0.09
RRUS 12 (20.4"x18.5"x7.5")	A	From Leg	3.00	0.0000	182.00	No Ice 3.15	1.29	0.05
			0.00			1/2" Ice 3.36	1.44	0.07
			0.00			1" Ice 3.59	1.60	0.10
RRUS 12 (20.4"x18.5"x7.5")	B	From Leg	3.00	0.0000	182.00	No Ice 3.15	1.29	0.05
			0.00			1/2" Ice 3.36	1.44	0.07
			0.00			1" Ice 3.59	1.60	0.10
RRUS 12 (20.4"x18.5"x7.5")	C	From Leg	3.00	0.0000	182.00	No Ice 3.15	1.29	0.05
			0.00			1/2" Ice 3.36	1.44	0.07
			0.00			1" Ice 3.59	1.60	0.10
RRUS 11 (19.7 x 17" x 7.2")	A	From Leg	3.00	0.0000	182.00	No Ice 2.79	1.19	0.05
			0.00			1/2" Ice 3.00	1.34	0.07
			0.00			1" Ice 3.21	1.50	0.10
RRUS 11 (19.7 x 17" x 7.2")	B	From Leg	3.00	0.0000	182.00	No Ice 2.79	1.19	0.05
			0.00			1/2" Ice 3.00	1.34	0.07
			0.00			1" Ice 3.21	1.50	0.10
RRUS 11 (19.7 x 17" x 7.2")	C	From Leg	3.00	0.0000	182.00	No Ice 2.79	1.19	0.05
			0.00			1/2" Ice 3.00	1.34	0.07
			0.00			1" Ice 3.21	1.50	0.10
RRUS 32 [29.9x13.3x9.5]	A	From Leg	3.00	0.0000	182.00	No Ice 3.31	2.42	0.08
			0.00			1/2" Ice 3.56	2.64	0.10
			0.00			1" Ice 3.81	2.86	0.14
RRUS 32 [29.9x13.3x9.5]	B	From Leg	3.00	0.0000	182.00	No Ice 3.31	2.42	0.08
			0.00			1/2" Ice 3.56	2.64	0.10
			0.00			1" Ice 3.81	2.86	0.14
RRUS 32 [29.9x13.3x9.5]	C	From Leg	3.00	0.0000	182.00	No Ice 3.31	2.42	0.08
			0.00			1/2" Ice 3.56	2.64	0.10
			0.00			1" Ice 3.81	2.86	0.14
RRUS A2 (16.4"x15.1"x3.3")	A	From Leg	3.00	0.0000	182.00	No Ice 2.06	0.49	0.02

<b>tnxTower</b>  <b>SBA Communications</b> 8051 Congress Avenue Boca Raton, Florida Phone: (561) 981-7388 FAX:	<b>Job</b>		<b>Page</b> 18 of 33	
	<b>Project</b>		<b>Date</b>	
	<b>Client</b>		<b>Designed by</b>	
	CT01105-S Bozrah		13:53:47 08/31/23	
			Breann Parreira	

Description	Face or Leg	Offset Type	Offsets: Horz Lateral Vert	Azimuth Adjustment	Placement	C <sub>AA</sub> Front	C <sub>AA</sub> Side	Weight
			ft ft ft	°	ft	ft <sup>2</sup>	ft <sup>2</sup>	K
			0.00			1/2" Ice	2.24	0.03
			0.00			1" Ice	2.43	0.05
RRUS A2 (16.4"x15.1"x3.3")	B	From Leg	3.00	0.0000	182.00	No Ice	2.06	0.02
			0.00			1/2" Ice	2.24	0.03
			0.00			1" Ice	2.43	0.05
RRUS A2 (16.4"x15.1"x3.3")	C	From Leg	3.00	0.0000	182.00	No Ice	2.06	0.02
			0.00			1/2" Ice	2.24	0.03
			0.00			1" Ice	2.43	0.05
DC6-48-60-18-8F (24"x18.5"x11")	A	From Leg	3.00	0.0000	182.00	No Ice	3.70	0.03
			0.00			1/2" Ice	3.94	0.06
			0.00			1" Ice	4.19	0.10
DC6-48-60-0-8C-EV [31.4x10.24x10.24]	B	From Leg	3.00	0.0000	182.00	No Ice	2.74	0.03
			0.00			1/2" Ice	2.96	0.05
			0.00			1" Ice	3.20	0.08
(Commscope P/N: MTC3615)	A	From Leg	3.00	0.0000	182.00	No Ice	27.10	0.52
			0.00			1/2" Ice	34.40	0.80
			0.00			1" Ice	41.70	1.09
(Commscope P/N: MTC3615)	B	From Leg	3.00	0.0000	182.00	No Ice	27.10	0.52
			0.00			1/2" Ice	34.40	0.80
			0.00			1" Ice	41.70	1.09
(Commscope P/N: MTC3615)	C	From Leg	3.00	0.0000	182.00	No Ice	27.10	0.52
			0.00			1/2" Ice	34.40	0.80
			0.00			1" Ice	41.70	1.09
***								
(2) HBXX-6517DS-A2M (74.9x12x6.5) w/ mount pipe	A	From Leg	4.00	0.0000	160.00	No Ice	8.95	0.07
			0.00			1/2" Ice	9.60	0.14
			0.00			1" Ice	10.23	0.22
(2) HBXX-6517DS-A2M (74.9x12x6.5) w/ mount pipe	B	From Leg	4.00	0.0000	160.00	No Ice	8.95	0.07
			0.00			1/2" Ice	9.60	0.14
			0.00			1" Ice	10.23	0.22
(2) HBXX-6517DS-A2M (74.9x12x6.5) w/ mount pipe	C	From Leg	4.00	0.0000	160.00	No Ice	8.95	0.07
			0.00			1/2" Ice	9.60	0.14
			0.00			1" Ice	10.23	0.22
LNX-6514DS-AIM [72.7x11.9x7.1] w/ mount pipe	A	From Leg	4.00	0.0000	160.00	No Ice	8.73	0.09
			0.00			1/2" Ice	9.39	0.16
			0.00			1" Ice	9.98	0.25
LNX-6514DS-AIM [72.7x11.9x7.1] w/ mount pipe	B	From Leg	4.00	0.0000	160.00	No Ice	8.73	0.09
			0.00			1/2" Ice	9.39	0.16
			0.00			1" Ice	9.98	0.25
LNX-6514DS-AIM [72.7x11.9x7.1] w/ mount pipe	C	From Leg	4.00	0.0000	160.00	No Ice	8.73	0.09
			0.00			1/2" Ice	9.39	0.16
			0.00			1" Ice	9.98	0.25
QUAD656C0000x [74.4x20.5x7.2] w/ mount pipe	A	From Leg	4.00	0.0000	160.00	No Ice	13.76	0.10
			0.00			1/2" Ice	14.46	0.20
			0.00			1" Ice	15.09	0.31
QUAD656C0000x [74.4x20.5x7.2] w/ mount pipe	B	From Leg	4.00	0.0000	160.00	No Ice	13.76	0.10
			0.00			1/2" Ice	14.46	0.20
			0.00			1" Ice	15.09	0.31
QUAD656C0000x [74.4x20.5x7.2] w/ mount pipe	C	From Leg	4.00	0.0000	160.00	No Ice	13.76	0.10
			0.00			1/2" Ice	14.46	0.20
			0.00			1" Ice	15.09	0.31
DB-T1-6Z-8AB-0Z [24x24x10]	A	From Leg	4.00	0.0000	160.00	No Ice	4.80	0.04
			0.00			1/2" Ice	5.07	0.08
			0.00			1" Ice	5.35	0.12
DB-T1-6Z-8AB-0Z [24x24x10]	B	From Leg	4.00	0.0000	160.00	No Ice	4.80	0.04
			0.00			1/2" Ice	5.07	0.08
			0.00			1" Ice	5.35	0.12



<b>tnxTower</b>  <b>SBA Communications</b> 8051 Congress Avenue Boca Raton, Florida Phone: (561) 981-7388 FAX:	<b>Job</b>		<b>Page</b> 19 of 33	
	<b>Project</b> CT01105-S Bozrah		<b>Date</b> 13:53:47 08/31/23	
	<b>Client</b>		<b>Designed by</b> Breann Parreira	

Description	Face or Leg	Offset Type	Offsets:		Azimuth Adjustment	Placement	C <sub>AA</sub> Front	C <sub>AA</sub> Side	Weight
			Horz	Vert					
			Lateral		°	ft	ft <sup>2</sup>	ft <sup>2</sup>	K
(2) FD9R6004/2CL-3CL [6.5x5.8x1.5]	A	From Leg	4.00	0.00	0.0000	160.00	No Ice 0.31	0.09	0.00
			0.00	0.00			1/2" Ice 0.39	0.13	0.01
			0.00	0.00			1" Ice 0.47	0.19	0.01
(2) FD9R6004/2CL-3CL [6.5x5.8x1.5]	B	From Leg	4.00	0.00	0.0000	160.00	No Ice 0.31	0.09	0.00
			0.00	0.00			1/2" Ice 0.39	0.13	0.01
			0.00	0.00			1" Ice 0.47	0.19	0.01
(2) FD9R6004/2CL-3CL [6.5x5.8x1.5]	C	From Leg	4.00	0.00	0.0000	160.00	No Ice 0.31	0.09	0.00
			0.00	0.00			1/2" Ice 0.39	0.13	0.01
			0.00	0.00			1" Ice 0.47	0.19	0.01
RRH2x60-AWS [37x11x5]	A	From Leg	4.00	0.00	0.0000	160.00	No Ice 3.50	1.82	0.06
			0.00	0.00			1/2" Ice 3.76	2.05	0.08
			0.00	0.00			1" Ice 4.03	2.29	0.11
RRH2x60-AWS [37x11x5]	B	From Leg	4.00	0.00	0.0000	160.00	No Ice 3.50	1.82	0.06
			0.00	0.00			1/2" Ice 3.76	2.05	0.08
			0.00	0.00			1" Ice 4.03	2.29	0.11
RRH2x60-AWS [37x11x5]	C	From Leg	4.00	0.00	0.0000	160.00	No Ice 3.50	1.82	0.06
			0.00	0.00			1/2" Ice 3.76	2.05	0.08
			0.00	0.00			1" Ice 4.03	2.29	0.11
RRH2X60-1900 [20.08x11.2x7.2]	A	From Leg	4.00	0.00	0.0000	160.00	No Ice 1.87	1.22	0.04
			0.00	0.00			1/2" Ice 2.05	1.37	0.06
			0.00	0.00			1" Ice 2.24	1.52	0.08
RRH2X60-1900 [20.08x11.2x7.2]	B	From Leg	4.00	0.00	0.0000	160.00	No Ice 1.87	1.22	0.04
			0.00	0.00			1/2" Ice 2.05	1.37	0.06
			0.00	0.00			1" Ice 2.24	1.52	0.08
RRH2X60-1900 [20.08x11.2x7.2]	C	From Leg	4.00	0.00	0.0000	160.00	No Ice 1.87	1.22	0.04
			0.00	0.00			1/2" Ice 2.05	1.37	0.06
			0.00	0.00			1" Ice 2.24	1.52	0.08
RRH2x60-700 [37x11x5]	A	From Leg	4.00	0.00	0.0000	160.00	No Ice 3.50	1.82	0.06
			0.00	0.00			1/2" Ice 3.76	2.05	0.08
			0.00	0.00			1" Ice 4.03	2.29	0.11
RRH2x60-700 [37x11x5]	B	From Leg	4.00	0.00	0.0000	160.00	No Ice 3.50	1.82	0.06
			0.00	0.00			1/2" Ice 3.76	2.05	0.08
			0.00	0.00			1" Ice 4.03	2.29	0.11
RRH2x60-700 [37x11x5]	C	From Leg	4.00	0.00	0.0000	160.00	No Ice 3.50	1.82	0.06
			0.00	0.00			1/2" Ice 3.76	2.05	0.08
			0.00	0.00			1" Ice 4.03	2.29	0.11
T-Frame	A	From Leg	4.00	0.00	0.0000	160.00	No Ice 10.25	7.90	0.32
			0.00	0.00			1/2" Ice 15.26	11.61	0.45
			0.00	0.00			1" Ice 20.27	15.32	0.59
T-Frame	B	From Leg	4.00	0.00	0.0000	160.00	No Ice 10.25	7.90	0.32
			0.00	0.00			1/2" Ice 15.26	11.61	0.45
			0.00	0.00			1" Ice 20.27	15.32	0.59
T-Frame	C	From Leg	4.00	0.00	0.0000	160.00	No Ice 10.25	7.90	0.32
			0.00	0.00			1/2" Ice 15.26	11.61	0.45
			0.00	0.00			1" Ice 20.27	15.32	0.59
KS24019-L112A [8x2x2]	A	None			0.0000	100.00	No Ice 0.14	0.14	0.01
							1/2" Ice 0.20	0.20	0.01
							1" Ice 0.26	0.26	0.01
*****									
APXVTM14-C-I20 (56.3"x12.6"x6.3") w/ mount pipe	A	From Leg	3.00	0.00	0.0000	175.00	No Ice 7.13	5.51	0.09
			0.00	0.00			1/2" Ice 7.84	6.69	0.15
			0.00	0.00			1" Ice 8.50	7.73	0.21
APXVTM14-C-I20 (56.3"x12.6"x6.3") w/ mount pipe	B	From Leg	3.00	0.00	0.0000	175.00	No Ice 7.13	5.51	0.09
			0.00	0.00			1/2" Ice 7.84	6.69	0.15
			0.00	0.00			1" Ice 8.50	7.73	0.21
APXVTM14-C-I20 (56.3"x12.6"x6.3") w/ mount	C	From Leg	3.00	0.00	0.0000	175.00	No Ice 7.13	5.51	0.09
			0.00	0.00			1/2" Ice 7.84	6.69	0.15



<b>tnxTower</b>  <b>SBA Communications</b> 8051 Congress Avenue Boca Raton, Florida Phone: (561) 981-7388 FAX:	<b>Job</b>	<b>Page</b> 21 of 33
	<b>Project</b>	<b>Date</b> 13:53:47 08/31/23
	<b>Client</b>	<b>Designed by</b> Breann Parreira

Description	Face or Leg	Offset Type	Offsets:		Azimuth Adjustment	Placement	C <sub>AA</sub> Front	C <sub>AA</sub> Side	Weight
			Horz	Lateral					
			ft	ft	°	ft	ft <sup>2</sup>	ft <sup>2</sup>	K
FVV-65B-R3 (96.5x11.85x7.13) w/ Mount pipe	A	From Leg	3.00	0.0000		150.00	No Ice 11.42	9.63	0.08
			0.00				1/2" Ice 12.04	11.05	0.17
			0.00				1" Ice 12.67	12.32	0.27
FVV-65B-R3 (96.5x11.85x7.13) w/ Mount pipe	B	From Leg	3.00	0.0000		150.00	No Ice 11.42	9.63	0.08
			0.00				1/2" Ice 12.04	11.05	0.17
			0.00				1" Ice 12.67	12.32	0.27
FVV-65B-R3 (96.5x11.85x7.13) w/ Mount pipe	C	From Leg	3.00	0.0000		150.00	No Ice 11.42	9.63	0.08
			0.00				1/2" Ice 12.04	11.05	0.17
			0.00				1" Ice 12.67	12.32	0.27
RF4450t-71A [16.5x15x11]	A	From Leg	3.00	0.0000		150.00	No Ice 2.06	1.51	0.09
			0.00				1/2" Ice 2.24	1.67	0.12
			0.00				1" Ice 2.43	1.83	0.14
RF4450t-71A [16.5x15x11]	B	From Leg	3.00	0.0000		150.00	No Ice 2.06	1.51	0.09
			0.00				1/2" Ice 2.24	1.67	0.12
			0.00				1" Ice 2.43	1.83	0.14
RF4450t-71A [16.5x15x11]	C	From Leg	3.00	0.0000		150.00	No Ice 2.06	1.51	0.09
			0.00				1/2" Ice 2.24	1.67	0.12
			0.00				1" Ice 2.43	1.83	0.14
RF4451d-70A [15x15x8.9]	A	From Leg	3.00	0.0000		150.00	No Ice 1.88	1.11	0.06
			0.00				1/2" Ice 2.05	1.25	0.08
			0.00				1" Ice 2.22	1.39	0.10
RF4451d-70A [15x15x8.9]	B	From Leg	3.00	0.0000		150.00	No Ice 1.88	1.11	0.06
			0.00				1/2" Ice 2.05	1.25	0.08
			0.00				1" Ice 2.22	1.39	0.10
RF4451d-70A [15x15x8.9]	C	From Leg	3.00	0.0000		150.00	No Ice 1.88	1.11	0.06
			0.00				1/2" Ice 2.05	1.25	0.08
			0.00				1" Ice 2.22	1.39	0.10
RDIDC-9181-PF-48 [16.57x14.57x8.15]	A	From Leg	3.00	0.0000		150.00	No Ice 2.01	1.13	0.02
			0.00				1/2" Ice 2.19	1.27	0.04
			0.00				1" Ice 2.37	1.41	0.06
Commscope MTC3975083	A	From Leg	3.00	0.0000		150.00	No Ice 10.60	8.10	0.41
			0.00				1/2" Ice 16.40	12.60	0.54
			0.00				1" Ice 22.20	17.10	0.66
Commscope MTC3975083	B	From Leg	3.00	0.0000		150.00	No Ice 10.60	8.10	0.41
			0.00				1/2" Ice 16.40	12.60	0.54
			0.00				1" Ice 22.20	17.10	0.66
Commscope MTC3975083	C	From Leg	3.00	0.0000		150.00	No Ice 10.60	8.10	0.41
			0.00				1/2" Ice 16.40	12.60	0.54
			0.00				1" Ice 22.20	17.10	0.66
(2) Empty Mount Pipe	A	From Leg	3.00	0.0000		150.00	No Ice 1.43	1.43	0.02
			0.00				1/2" Ice 1.92	1.92	0.03
			0.00				1" Ice 2.29	2.29	0.05
(2) Empty Mount Pipe	B	From Leg	3.00	0.0000		150.00	No Ice 1.43	1.43	0.02
			0.00				1/2" Ice 1.92	1.92	0.03
			0.00				1" Ice 2.29	2.29	0.05
(2) Empty Mount Pipe	C	From Leg	3.00	0.0000		150.00	No Ice 1.43	1.43	0.02
			0.00				1/2" Ice 1.92	1.92	0.03
			0.00				1" Ice 2.29	2.29	0.05

**Truss-Leg Properties**

<p style="text-align: center;"><b>tnxTower</b></p> <p style="text-align: center;"><b>SBA Communications</b> 8051 Congress Avenue Boca Raton, Florida Phone: (561) 981-7388 FAX:</p>	<b>Job</b>	<b>Page</b> 22 of 33
	<b>Project</b>	<b>Date</b> 13:53:47 08/31/23
	<b>Client</b>	<b>Designed by</b> Breann Parreira

Section Designation	Area	Area Ice	Self Weight	Ice Weight	Equiv. Diameter	Equiv. Diameter Ice	Leg Area
	in <sup>2</sup>	in <sup>2</sup>	K	K	in	in	in <sup>2</sup>
#12 - 1.25" - 1.00" conn. (Pirod 105244)	999.6067	2632.6682	0.59	0.36	6.9417	18.2824	3.6816
#12 - 1.50" - 1.00" conn. (Pirod 105217)	1907.4792	5512.2974	0.62	0.67	6.6232	19.1399	5.3014
#12 - 1.50" - 1.00" conn. (Pirod 105217)	1907.4792	5486.8299	0.62	0.66	6.6232	19.0515	5.3014
#12 - 1.75" - 1.25" conn. (Pirod 105218)	2269.1322	6102.1483	0.76	0.63	7.8789	21.1880	7.2158
#12 - 2.00" - 1.25" conn. (Pirod 105219)	2260.7557	5628.3939	1.03	0.64	7.8498	19.5430	9.4248
#12 - 2.00" - 1.25" conn. (Pirod 105219)	2260.7557	5588.0059	1.03	0.62	7.8498	19.4028	9.4248
#12 - 2.25" - 1.25" conn. (Pirod 105220)	2387.7320	5603.4756	1.20	0.61	8.2907	19.4565	11.9282
#12 - 2.25" - 1.25" conn. (Pirod 105220)	2387.7320	5535.5406	1.20	0.57	8.2907	19.2206	11.9282
#18 - 2.50" (Pirod 112738- Base Only)	3724.8211	6903.2459	1.82	0.76	12.9334	23.9696	14.7262

## Load Combinations

Comb. No.	Description
1	Dead Only
2	1.2 Dead+1.0 Wind 0 deg - No Ice
3	0.9 Dead+1.0 Wind 0 deg - No Ice
4	1.2 Dead+1.0 Wind 30 deg - No Ice
5	0.9 Dead+1.0 Wind 30 deg - No Ice
6	1.2 Dead+1.0 Wind 60 deg - No Ice
7	0.9 Dead+1.0 Wind 60 deg - No Ice
8	1.2 Dead+1.0 Wind 90 deg - No Ice
9	0.9 Dead+1.0 Wind 90 deg - No Ice
10	1.2 Dead+1.0 Wind 120 deg - No Ice
11	0.9 Dead+1.0 Wind 120 deg - No Ice
12	1.2 Dead+1.0 Wind 150 deg - No Ice
13	0.9 Dead+1.0 Wind 150 deg - No Ice
14	1.2 Dead+1.0 Wind 180 deg - No Ice
15	0.9 Dead+1.0 Wind 180 deg - No Ice
16	1.2 Dead+1.0 Wind 210 deg - No Ice
17	0.9 Dead+1.0 Wind 210 deg - No Ice
18	1.2 Dead+1.0 Wind 240 deg - No Ice
19	0.9 Dead+1.0 Wind 240 deg - No Ice
20	1.2 Dead+1.0 Wind 270 deg - No Ice
21	0.9 Dead+1.0 Wind 270 deg - No Ice
22	1.2 Dead+1.0 Wind 300 deg - No Ice
23	0.9 Dead+1.0 Wind 300 deg - No Ice
24	1.2 Dead+1.0 Wind 330 deg - No Ice
25	0.9 Dead+1.0 Wind 330 deg - No Ice
26	1.2 Dead+1.0 Ice+1.0 Temp
27	1.2 Dead+1.0 Wind 0 deg+1.0 Ice+1.0 Temp
28	1.2 Dead+1.0 Wind 30 deg+1.0 Ice+1.0 Temp
29	1.2 Dead+1.0 Wind 60 deg+1.0 Ice+1.0 Temp
30	1.2 Dead+1.0 Wind 90 deg+1.0 Ice+1.0 Temp
31	1.2 Dead+1.0 Wind 120 deg+1.0 Ice+1.0 Temp
32	1.2 Dead+1.0 Wind 150 deg+1.0 Ice+1.0 Temp
33	1.2 Dead+1.0 Wind 180 deg+1.0 Ice+1.0 Temp

<p style="text-align: center;"><b>tnxTower</b></p> <p style="text-align: center;"><b>SBA Communications</b> 8051 Congress Avenue Boca Raton, Florida Phone: (561) 981-7388 FAX:</p>	<b>Job</b>	<b>Page</b> 23 of 33
	<b>Project</b>	<b>Date</b> 13:53:47 08/31/23
	<b>Client</b>	<b>Designed by</b> Breann Parreira

<i>Comb. No.</i>	<i>Description</i>
34	1.2 Dead+1.0 Wind 210 deg+1.0 Ice+1.0 Temp
35	1.2 Dead+1.0 Wind 240 deg+1.0 Ice+1.0 Temp
36	1.2 Dead+1.0 Wind 270 deg+1.0 Ice+1.0 Temp
37	1.2 Dead+1.0 Wind 300 deg+1.0 Ice+1.0 Temp
38	1.2 Dead+1.0 Wind 330 deg+1.0 Ice+1.0 Temp
39	Dead+Wind 0 deg - Service
40	Dead+Wind 30 deg - Service
41	Dead+Wind 60 deg - Service
42	Dead+Wind 90 deg - Service
43	Dead+Wind 120 deg - Service
44	Dead+Wind 150 deg - Service
45	Dead+Wind 180 deg - Service
46	Dead+Wind 210 deg - Service
47	Dead+Wind 240 deg - Service
48	Dead+Wind 270 deg - Service
49	Dead+Wind 300 deg - Service
50	Dead+Wind 330 deg - Service
51	1.2 Dead+1.0 Ev+1.0 Eh 0 deg
52	0.9 Dead-1.0 Ev+1.0 Eh 0 deg
53	1.2 Dead+1.0 Ev+1.0 Eh 30 deg
54	0.9 Dead-1.0 Ev+1.0 Eh 30 deg
55	1.2 Dead+1.0 Ev+1.0 Eh 60 deg
56	0.9 Dead-1.0 Ev+1.0 Eh 60 deg
57	1.2 Dead+1.0 Ev+1.0 Eh 90 deg
58	0.9 Dead-1.0 Ev+1.0 Eh 90 deg
59	1.2 Dead+1.0 Ev+1.0 Eh 120 deg
60	0.9 Dead-1.0 Ev+1.0 Eh 120 deg
61	1.2 Dead+1.0 Ev+1.0 Eh 150 deg
62	0.9 Dead-1.0 Ev+1.0 Eh 150 deg
63	1.2 Dead+1.0 Ev+1.0 Eh 180 deg
64	0.9 Dead-1.0 Ev+1.0 Eh 180 deg
65	1.2 Dead+1.0 Ev+1.0 Eh 210 deg
66	0.9 Dead-1.0 Ev+1.0 Eh 210 deg
67	1.2 Dead+1.0 Ev+1.0 Eh 240 deg
68	0.9 Dead-1.0 Ev+1.0 Eh 240 deg
69	1.2 Dead+1.0 Ev+1.0 Eh 270 deg
70	0.9 Dead-1.0 Ev+1.0 Eh 270 deg
71	1.2 Dead+1.0 Ev+1.0 Eh 300 deg
72	0.9 Dead-1.0 Ev+1.0 Eh 300 deg
73	1.2 Dead+1.0 Ev+1.0 Eh 330 deg
74	0.9 Dead-1.0 Ev+1.0 Eh 330 deg

### Maximum Tower Deflections - Service Wind

<i>Section No.</i>	<i>Elevation</i> <i>ft</i>	<i>Horz. Deflection</i> <i>in</i>	<i>Gov. Load</i> <i>Comb.</i>	<i>Tilt</i> <i>°</i>	<i>Twist</i> <i>°</i>
T1	193 - 185	5.630	44	0.2336	0.0131
T2	185 - 170	5.236	44	0.2326	0.0130
T3	170 - 160	4.490	44	0.2167	0.0125
T4	160 - 140	3.857	44	0.2133	0.0119
T5	140 - 120	2.766	44	0.1914	0.0103
T6	120 - 100	1.913	44	0.1518	0.0079
T7	100 - 80	1.278	44	0.1179	0.0064
T8	80 - 60	0.786	44	0.0908	0.0049
T9	60 - 40	0.430	44	0.0626	0.0035
T10	40 - 20	0.190	44	0.0402	0.0021
T11	20 - 0	0.043	44	0.0175	0.0007

<b>tnxTower</b>  <b>SBA Communications</b> 8051 Congress Avenue Boca Raton, Florida Phone: (561) 981-7388 FAX:	<b>Job</b>	<b>Page</b> 24 of 33
	<b>Project</b>	<b>Date</b> 13:53:47 08/31/23
	<b>Client</b>	<b>Designed by</b> Breann Parreira

### Critical Deflections and Radius of Curvature - Service Wind

<i>Elevation</i>	<i>Appurtenance</i>	<i>Gov. Load Comb.</i>	<i>Deflection</i>	<i>Tilt</i>	<i>Twist</i>	<i>Radius of Curvature</i>
<i>ft</i>			<i>in</i>	<i>°</i>	<i>°</i>	<i>ft</i>
193.00	Lightning Rod	44	5.630	0.2336	0.0131	32921
191.00	RR90-17-02DP [56x8x2.75] w/ mount pipe	44	5.530	0.2338	0.0131	32921
185.00	SL2	44	5.236	0.2326	0.0130	30299
182.00	7770 [55x11x5] w/ mount pipe	44	5.095	0.2302	0.0129	178046
175.00	APXVTM14-C-I20 (56.3"x12.6"x6.3") w/ mount pipe	44	4.760	0.2218	0.0127	10508
170.00	SL3	44	4.490	0.2167	0.0125	7433
160.00	(2) HBXX-6517DS-A2M (74.9x12x6.5) w/ mount pipe	44	3.857	0.2133	0.0119	15614
150.00	FVV-65B-R3 (96.5x11.85x7.13) w/ Mount pipe	44	3.274	0.2058	0.0112	15783
140.00	SL5	44	2.766	0.1914	0.0103	23843
120.00	SL6	44	1.913	0.1518	0.0079	19745
100.00	KS24019-L112A [8x2x2]	44	1.278	0.1179	0.0064	39034
80.00	SL8	44	0.786	0.0908	0.0049	33643
60.00	SL9	44	0.430	0.0626	0.0035	41140
40.00	SL10	44	0.190	0.0402	0.0021	58950
30.00	PC1N0F-0190B-002M [3.9x1.6]	44	0.103	0.0286	0.0014	44863
20.00	SL11	44	0.043	0.0175	0.0007	37346

### Maximum Tower Deflections - Design Wind

<i>Section No.</i>	<i>Elevation</i>	<i>Horz. Deflection</i>	<i>Gov. Load Comb.</i>	<i>Tilt</i>	<i>Twist</i>
	<i>ft</i>	<i>in</i>		<i>°</i>	<i>°</i>
T1	193 - 185	23.647	12	0.9815	0.0551
T2	185 - 170	21.989	12	0.9777	0.0545
T3	170 - 160	18.854	12	0.9107	0.0528
T4	160 - 140	16.195	12	0.8961	0.0502
T5	140 - 120	11.611	12	0.8039	0.0433
T6	120 - 100	8.027	12	0.6371	0.0335
T7	100 - 80	5.362	12	0.4946	0.0271
T8	80 - 60	3.299	12	0.3809	0.0206
T9	60 - 40	1.806	12	0.2626	0.0149
T10	40 - 20	0.796	12	0.1685	0.0089
T11	20 - 0	0.180	12	0.0734	0.0031

### Critical Deflections and Radius of Curvature - Design Wind

<i>Elevation</i>	<i>Appurtenance</i>	<i>Gov. Load Comb.</i>	<i>Deflection</i>	<i>Tilt</i>	<i>Twist</i>	<i>Radius of Curvature</i>
<i>ft</i>			<i>in</i>	<i>°</i>	<i>°</i>	<i>ft</i>
193.00	Lightning Rod	12	23.647	0.9815	0.0551	7852
191.00	RR90-17-02DP [56x8x2.75] w/ mount pipe	12	23.226	0.9824	0.0549	7852
185.00	SL2	12	21.989	0.9777	0.0545	7230

<b>tnxTower</b>  <b>SBA Communications</b> 8051 Congress Avenue Boca Raton, Florida Phone: (561) 981-7388 FAX:	<b>Job</b>	<b>Page</b> 25 of 33
	<b>Project</b>	<b>Date</b> 13:53:47 08/31/23
	<b>Client</b>	<b>Designed by</b> Breann Parreira

Elevation	Appurtenance	Gov. Load Comb.	Deflection	Tilt	Twist	Radius of Curvature
ft			in	°	°	ft
182.00	7770 [55x11x5] w/ mount pipe	12	21.395	0.9675	0.0543	42971
175.00	APXVTM14-C-I20 (56.3"x12.6"x6.3") w/ mount pipe	12	19.988	0.9321	0.0537	2502
170.00	SL3	12	18.854	0.9107	0.0528	1770
160.00	(2) HBXX-6517DS-A2M (74.9x12x6.5) w/ mount pipe	12	16.195	0.8961	0.0502	3710
150.00	FVV-65B-R3 (96.5x11.85x7.13) w/ Mount pipe	12	13.743	0.8644	0.0471	3752
140.00	SL5	12	11.611	0.8039	0.0433	5668
120.00	SL6	12	8.027	0.6371	0.0335	4697
100.00	KS24019-L112A [8x2x2]	12	5.362	0.4946	0.0271	9294
80.00	SL8	12	3.299	0.3809	0.0206	8013
60.00	SL9	12	1.806	0.2626	0.0149	9805
40.00	SL10	12	0.796	0.1685	0.0089	14058
30.00	PC1N0F-0190B-002M [3.9x1.6]	12	0.432	0.1201	0.0058	10695
20.00	SL11	12	0.180	0.0734	0.0031	8901

### Bolt Design Data

Section No.	Elevation	Component Type	Bolt Grade	Bolt Size	Number Of Bolts	Maximum Load per Bolt K	Allowable Load per Bolt K	Ratio Load Allowable	Allowable Ratio	Criteria
	ft			in						
T1	193	Leg	A325N	0.6250	5	1.60	27.61	0.058 ✓	1	Bolt DS
T2	185	Leg	A325N	1.0000	6	6.02	54.52	0.110 ✓	1	Bolt Tension
T3	170	Leg	A325N	1.0000	6	7.08	54.52	0.130 ✓	1	Bolt Tension
		Diagonal	A325N	1.0000	1	7.37	10.66	0.691 ✓	1	Member Block Shear
T4	160	Leg	A325N	1.0000	6	15.39	54.52	0.282 ✓	1	Bolt Tension
		Diagonal	A325N	1.0000	1	8.43	11.68	0.722 ✓	1	Member Block Shear
T5	140	Leg	A325N	1.0000	6	22.72	54.52	0.417 ✓	1	Bolt Tension
		Diagonal	A325N	1.0000	1	7.81	11.68	0.669 ✓	1	Member Block Shear
T6	120	Leg	A325N	1.0000	6	29.03	54.52	0.532 ✓	1	Bolt Tension
		Diagonal	A325N	1.0000	1	7.61	19.47	0.391 ✓	1	Member Block Shear
T7	100	Leg	A325N >1"	1.2500	6	34.64	76.32	0.454 ✓	1	Bolt Tension
		Diagonal	A325N	1.2500	1	7.48	20.30	0.369 ✓	1	Member Block Shear
T8	80	Leg	A325N >1"	1.2500	6	39.81	76.32	0.522 ✓	1	Bolt Tension
		Diagonal	A325N	1.2500	1	7.91	23.70	0.334 ✓	1	Member Block Shear
T9	60	Leg	A325N >1"	1.2500	6	44.64	76.32	0.585 ✓	1	Bolt Tension
		Diagonal	A325N	1.2500	1	8.28	23.70	0.349 ✓	1	Member Block Shear
T10	40	Leg	A325N >1"	1.2500	12	24.76	76.32	0.324 ✓	1	Bolt Tension
		Diagonal	A325N	1.2500	1	10.48	23.70	0.442 ✓	1	Member Block Shear

<b>tnxTower</b>  <b>SBA Communications</b> 8051 Congress Avenue Boca Raton, Florida Phone: (561) 981-7388 FAX:	<b>Job</b>	<b>Page</b> 26 of 33
	<b>Project</b>	<b>Date</b> 13:53:47 08/31/23
	<b>Client</b>	<b>Designed by</b> Breann Parreira

Section No.	Elevation ft	Component Type	Bolt Grade	Bolt Size in	Number Of Bolts	Maximum Load per Bolt K	Allowable Load per Bolt K	Ratio Load Allowable	Allowable Ratio	Criteria
T11	20	Diagonal	A325N	1.0000	2	8.89	35.53	0.250 ✓	1	Member Block Shear

### Compression Checks

### Leg Design Data (Compression)

Section No.	Elevation ft	Size	L ft	L <sub>u</sub> ft	Kl/r	A in <sup>2</sup>	P <sub>u</sub> K	φP <sub>n</sub> K	Ratio $\frac{P_u}{\phi P_n}$
T1	193 - 185	2	8.00	0.17	4.0 K=1.00	3.1416	-7.99	141.21	0.057 <sup>1</sup> ✓
T2	185 - 170	2	15.00	2.34	56.2 K=1.00	3.1416	-40.91	112.25	0.364 <sup>1</sup> ✓
T3	170 - 160	#12 - 1.25" - 1.00" conn. (Pirod 105244)	10.02	10.02	45.4 K=1.00	3.6816	-51.40	142.49	0.361 <sup>1</sup> ✓
T4	160 - 140	#12 - 1.50" - 1.00" conn. (Pirod 105217)	20.03	10.02	37.8 K=1.00	5.3014	-107.97	214.86	0.503 <sup>1</sup> ✓
T5	140 - 120	#12 - 1.50" - 1.00" conn. (Pirod 105217)	20.03	10.02	37.8 K=1.00	5.3014	-155.77	214.86	0.725 <sup>1</sup> ✓
T6	120 - 100	#12 - 1.75" - 1.25" conn. (Pirod 105218)	20.03	10.02	32.4 K=1.00	7.2158	-198.05	300.68	0.659 <sup>1</sup> ✓
T7	100 - 80	#12 - 2.00" - 1.25" conn. (Pirod 105219)	20.03	10.02	28.4 K=1.00	9.4248	-236.72	399.87	0.592 <sup>1</sup> ✓
T8	80 - 60	#12 - 2.00" - 1.25" conn. (Pirod 105219)	20.03	10.02	28.4 K=1.00	9.4248	-273.14	399.87	0.683 <sup>1</sup> ✓
T9	60 - 40	#12 - 2.25" - 1.25" conn. (Pirod 105220)	20.03	10.02	25.2 K=1.00	11.9282	-308.24	512.38	0.602 <sup>1</sup> ✓
T10	40 - 20	#12 - 2.25" - 1.25" conn. (Pirod 105220)	20.03	10.02	25.2 K=1.00	11.9282	-344.47	512.38	0.672 <sup>1</sup> ✓
T11	20 - 0	#18 - 2.50" (Pirod 112738- Base Only)	20.03	20.03	32.6 K=1.00	14.7262	-355.05	613.14	0.579 <sup>1</sup> ✓

<sup>1</sup> P<sub>u</sub> / φP<sub>n</sub> controls

### Truss-Leg Diagonal Data

Section No.	Elevation ft	Diagonal Size	L <sub>d</sub> ft	Kl/r	φP <sub>n</sub> K	A in <sup>2</sup>	V <sub>u</sub> K	φV <sub>n</sub> K	Stress Ratio
T3	170 - 160	0.5	1.48	121.0	165.67	0.1963	1.45	3.29	0.442 ✓
T4	160 - 140	0.5	1.47	120.0	238.57	0.1963	1.96	3.34	0.586 ✓



<b>tnxTower</b>  <b>SBA Communications</b> 8051 Congress Avenue Boca Raton, Florida Phone: (561) 981-7388 FAX:	<b>Job</b>	<b>Page</b> 27 of 33
	<b>Project</b>	<b>Date</b> 13:53:47 08/31/23
	<b>Client</b>	<b>Designed by</b> Breann Parreira

Section No.	Elevation ft	Diagonal Size	$L_d$ ft	$Kl/r$	$\phi P_n$ K	$A$ in <sup>2</sup>	$V_u$ K	$\phi V_n$ K	Stress Ratio
T5	140 - 120	0.5	1.47	120.0	238.57	0.1963	1.23	3.34	0.369
T6	120 - 100	0.5	1.46	119.0	324.71	0.1963	0.97	3.38	0.288
T7	100 - 80	0.625	1.45	94.4	424.12	0.3068	1.19	6.96	0.172
T8	80 - 60	0.625	1.45	94.4	424.12	0.3068	0.73	6.96	0.105
T9	60 - 40	0.625	1.43	93.6	536.77	0.3068	0.68	7.01	0.097
T10	40 - 20	0.625	1.43	93.6	536.77	0.3068	3.55	7.01	0.507
T11	20 - 0	0.75	1.73	93.9	662.68	0.4418	1.29	14.36	0.090

### Diagonal Design Data (Compression)

Section No.	Elevation ft	Size	$L$ ft	$L_u$ ft	$Kl/r$	$A$ in <sup>2</sup>	$P_u$ K	$\phi P_n$ K	Ratio $\frac{P_u}{\phi P_n}$
T1	193 - 185	1	5.32	2.57	111.0 K=0.90	0.7854	-1.93	14.35	0.134 <sup>1</sup>
T2	185 - 170	1	5.52	2.67	115.3 K=0.90	0.7854	-5.99	13.35	0.449 <sup>1</sup>
T3	170 - 160	L2 1/2x2 1/2x3/16	9.89	5.19	125.8 K=1.00	0.9020	-8.04	16.32	0.493 <sup>1</sup>
T4	160 - 140	L3x3x3/16	10.80	5.55	113.9 K=1.02	1.0900	-8.97	22.98	0.390 <sup>1</sup>
T5	140 - 120	L3x3x3/16	11.98	6.10	122.8 K=1.00	1.0900	-8.11	20.56	0.395 <sup>1</sup>
T6	120 - 100	L3x3x5/16	13.35	6.76	137.7 K=1.00	1.7800	-8.12	26.86	0.302 <sup>1</sup>
T7	100 - 80	L3x3x5/16	14.68	7.36	149.9 K=1.00	1.7800	-7.96	22.66	0.351 <sup>1</sup>
T8	80 - 60	L3 1/2x3 1/2x5/16	16.29	8.16	141.8 K=1.00	2.0900	-8.36	29.73	0.281 <sup>1</sup>
T9	60 - 40	L3 1/2x3 1/2x5/16	17.97	8.99	156.4 K=1.00	2.0900	-8.45	24.45	0.345 <sup>1</sup>
T10	40 - 20	L3 1/2x3 1/2x5/16	19.72	9.86	171.5 K=1.00	2.0900	-9.26	20.33	0.455 <sup>1</sup>
T11	20 - 0	2L3 1/2x3 1/2x5/16x3/8	26.44	13.56	155.7 K=1.00	4.1800	-20.39	48.15	0.423 <sup>1</sup>

2L 'a' > 74.1952 in - 209

<sup>1</sup>  $P_u / \phi P_n$  controls

### Horizontal Design Data (Compression)

<b>tnxTower</b>  <b>SBA Communications</b> 8051 Congress Avenue Boca Raton, Florida Phone: (561) 981-7388 FAX:	<b>Job</b>	<b>Page</b> 28 of 33
	<b>Project</b>	<b>Date</b> 13:53:47 08/31/23
	<b>Client</b>	<b>Designed by</b> Breann Parreira

Section No.	Elevation ft	Size	L ft	L <sub>u</sub> ft	Kl/r	A in <sup>2</sup>	P <sub>u</sub> K	φP <sub>n</sub> K	Ratio $\frac{P_u}{\phi P_n}$
T1	193 - 185	7/8	5.00	4.83	185.6 K=0.70	0.6013	-0.33	3.94	0.084 <sup>1</sup> ✓
T2	185 - 170	7/8	5.00	4.83	185.6 K=0.70	0.6013	-0.78	3.94	0.198 <sup>1</sup> ✓

<sup>1</sup> P<sub>u</sub> / φP<sub>n</sub> controls

### Top Girt Design Data (Compression)

Section No.	Elevation ft	Size	L ft	L <sub>u</sub> ft	Kl/r	A in <sup>2</sup>	P <sub>u</sub> K	φP <sub>n</sub> K	Ratio $\frac{P_u}{\phi P_n}$
T1	193 - 185	1 1/4	5.00	4.83	129.9 K=0.70	1.2272	-0.22	16.42	0.014 <sup>1</sup> ✓
T2	185 - 170	1 1/4	5.00	4.83	129.9 K=0.70	1.2272	-0.79	16.42	0.048 <sup>1</sup> ✓

<sup>1</sup> P<sub>u</sub> / φP<sub>n</sub> controls

### Bottom Girt Design Data (Compression)

Section No.	Elevation ft	Size	L ft	L <sub>u</sub> ft	Kl/r	A in <sup>2</sup>	P <sub>u</sub> K	φP <sub>n</sub> K	Ratio $\frac{P_u}{\phi P_n}$
T1	193 - 185	1 1/4	5.00	4.83	129.9 K=0.70	1.2272	-0.78	16.42	0.048 <sup>1</sup> ✓
T2	185 - 170	1 1/4	5.00	4.83	129.9 K=0.70	1.2272	-2.02	16.42	0.123 <sup>1</sup> ✓

<sup>1</sup> P<sub>u</sub> / φP<sub>n</sub> controls

### Mid Girt Design Data (Compression)

Section No.	Elevation ft	Size	L ft	L <sub>u</sub> ft	Kl/r	A in <sup>2</sup>	P <sub>u</sub> K	φP <sub>n</sub> K	Ratio $\frac{P_u}{\phi P_n}$
T1	193 - 185	1 1/4	5.00	4.83	129.9 K=0.70	1.2272	-0.40	16.35	0.025 <sup>1</sup> ✓
T2	185 - 170	1 1/4	5.00	4.83	129.9 K=0.70	1.2272	-0.31	16.42	0.019 <sup>1</sup> ✓

<sup>1</sup> P<sub>u</sub> / φP<sub>n</sub> controls

<b>tnxTower</b>  <b>SBA Communications</b> 8051 Congress Avenue Boca Raton, Florida Phone: (561) 981-7388 FAX:	<b>Job</b>	<b>Page</b> 29 of 33
	<b>Project</b>	<b>Date</b> 13:53:47 08/31/23
	<b>Client</b>	<b>Designed by</b> Breann Parreira

## Tension Checks

### Leg Design Data (Tension)

Section No.	Elevation ft	Size	L ft	L <sub>u</sub> ft	Kl/r	A in <sup>2</sup>	P <sub>u</sub> K	φP <sub>n</sub> K	Ratio $\frac{P_u}{\phi P_n}$
T1	193 - 185	2	8.00	0.17	4.0	1.7942	4.50	87.47	0.051 <sup>1 #</sup>
T2	185 - 170	2	15.00	0.58	14.0	3.1416	36.13	141.37	0.256 <sup>1</sup>
T3	170 - 160	#12 - 1.25" - 1.00" conn. (Pirod 105244)	10.02	10.02	45.4	3.6816	42.50	165.67	0.257 <sup>1</sup>
T4	160 - 140	#12 - 1.50" - 1.00" conn. (Pirod 105217)	20.03	10.02	37.8	5.3014	92.34	238.57	0.387 <sup>1</sup>
T5	140 - 120	#12 - 1.50" - 1.00" conn. (Pirod 105217)	20.03	10.02	37.8	5.3014	136.31	238.57	0.571 <sup>1</sup>
T6	120 - 100	#12 - 1.75" - 1.25" conn. (Pirod 105218 )	20.03	10.02	32.4	7.2158	174.15	324.71	0.536 <sup>1</sup>
T7	100 - 80	#12 - 2.00" - 1.25" conn. (Pirod 105219)	20.03	10.02	28.4	9.4248	207.83	424.12	0.490 <sup>1</sup>
T8	80 - 60	#12 - 2.00" - 1.25" conn. (Pirod 105219)	20.03	10.02	28.4	9.4248	238.86	424.12	0.563 <sup>1</sup>
T9	60 - 40	#12 - 2.25" - 1.25" conn. (Pirod 105220)	20.03	10.02	25.2	11.9282	267.85	536.77	0.499 <sup>1</sup>
T10	40 - 20	#12 - 2.25" - 1.25" conn. (Pirod 105220)	20.03	10.02	25.2	11.9282	297.10	536.77	0.553 <sup>1</sup>
T11	20 - 0	#18 - 2.50" (Pirod 112738- Base Only)	20.03	20.03	32.6	14.7262	307.22	662.68	0.464 <sup>1</sup>

<sup>1</sup> P<sub>u</sub> / φP<sub>n</sub> controls

# Based on net area of leg in section below

### Truss-Leg Diagonal Data

Section No.	Elevation ft	Diagonal Size	L <sub>d</sub> ft	Kl/r	φP <sub>n</sub> K	A in <sup>2</sup>	V <sub>u</sub> K	φV <sub>n</sub> K	Stress Ratio
T3	170 - 160	0.5	1.48	121.0	165.67	0.1963	1.45	3.29	0.442
T4	160 - 140	0.5	1.47	120.0	238.57	0.1963	1.96	3.34	0.586
T5	140 - 120	0.5	1.47	120.0	238.57	0.1963	1.23	3.34	0.369
T6	120 - 100	0.5	1.46	119.0	324.71	0.1963	0.97	3.38	0.288
T7	100 - 80	0.625	1.45	94.4	424.12	0.3068	1.19	6.96	0.172
T8	80 - 60	0.625	1.45	94.4	424.12	0.3068	0.73	6.96	0.105

<b>tnxTower</b>  <b>SBA Communications</b> 8051 Congress Avenue Boca Raton, Florida Phone: (561) 981-7388 FAX:	<b>Job</b>	<b>Page</b> 30 of 33
	<b>Project</b>	<b>Date</b> 13:53:47 08/31/23
	<b>Client</b>	<b>Designed by</b> Breann Parreira

Section No.	Elevation ft	Diagonal Size	$L_d$ ft	$Kl/r$	$\phi P_n$ K	$A$ in <sup>2</sup>	$V_u$ K	$\phi V_n$ K	Stress Ratio
T9	60 - 40	0.625	1.43	93.6	536.77	0.3068	0.68	7.01	0.097 ✓
T10	40 - 20	0.625	1.43	93.6	536.77	0.3068	3.55	7.01	0.507 ✓
T11	20 - 0	0.75	1.73	93.9	662.68	0.4418	1.29	14.36	0.090 ✓

### Diagonal Design Data (Tension)

Section No.	Elevation ft	Size	$L$ ft	$L_u$ ft	$Kl/r$	$A$ in <sup>2</sup>	$P_u$ K	$\phi P_n$ K	Ratio $\frac{P_u}{\phi P_n}$
T1	193 - 185	1	5.32	2.57	123.4	0.7854	1.88	35.34	0.053 <sup>1</sup>
T2	185 - 170	1	5.52	2.67	128.1	0.7854	5.91	35.34	0.167 <sup>1</sup> ✓
T3	170 - 160	L2 1/2x2 1/2x3/16	9.89	5.19	83.2	0.5183	7.37	22.55	0.327 <sup>1</sup> ✓
T4	160 - 140	L3x3x3/16	10.80	5.55	73.6	0.6593	8.43	28.68	0.294 <sup>1</sup> ✓
T5	140 - 120	L3x3x3/16	11.36	5.81	76.9	0.6593	7.81	28.68	0.272 <sup>1</sup> ✓
T6	120 - 100	L3x3x5/16	13.35	6.76	90.7	1.0713	7.61	46.60	0.163 <sup>1</sup> ✓
T7	100 - 80	L3x3x5/16	14.68	7.36	99.0	1.0127	7.48	44.05	0.170 <sup>1</sup> ✓
T8	80 - 60	L3 1/2x3 1/2x5/16	16.29	8.16	93.4	1.2452	7.91	54.17	0.146 <sup>1</sup> ✓
T9	60 - 40	L3 1/2x3 1/2x5/16	17.97	8.99	102.7	1.2452	8.28	54.17	0.153 <sup>1</sup> ✓
T10	40 - 20	L3 1/2x3 1/2x5/16	19.72	9.86	112.4	1.2452	10.48	54.17	0.194 <sup>1</sup> ✓
T11	20 - 0	2L3 1/2x3 1/2x5/16x3/8	26.44	13.56	153.9	2.6077	17.78	113.43	0.157 <sup>1</sup> ✓

2L 'a' > 74.1952 in - 212

<sup>1</sup>  $P_u / \phi P_n$  controls

### Horizontal Design Data (Tension)

Section No.	Elevation ft	Size	$L$ ft	$L_u$ ft	$Kl/r$	$A$ in <sup>2</sup>	$P_u$ K	$\phi P_n$ K	Ratio $\frac{P_u}{\phi P_n}$
T1	193 - 185	7/8	5.00	4.83	265.1	0.6013	0.38	19.48	0.019 <sup>1</sup>
T2	185 - 170	7/8	5.00	4.83	265.1	0.6013	0.78	19.48	0.040 <sup>1</sup> ✓

<b>tnxTower</b>  <b>SBA Communications</b> 8051 Congress Avenue Boca Raton, Florida Phone: (561) 981-7388 FAX:	<b>Job</b>	<b>Page</b> 31 of 33
	<b>Project</b>	<b>Date</b> 13:53:47 08/31/23
	<b>Client</b>	<b>Designed by</b> Breann Parreira

Section No.	Elevation ft	Size	L ft	L <sub>u</sub> ft	Kl/r	A in <sup>2</sup>	P <sub>u</sub> K	φP <sub>n</sub> K	Ratio $\frac{P_u}{\phi P_n}$
-------------	-----------------	------	---------	----------------------	------	----------------------	---------------------	----------------------	---------------------------------

<sup>1</sup> P<sub>u</sub> / φP<sub>n</sub> controls

**Top Girt Design Data (Tension)**

Section No.	Elevation ft	Size	L ft	L <sub>u</sub> ft	Kl/r	A in <sup>2</sup>	P <sub>u</sub> K	φP <sub>n</sub> K	Ratio $\frac{P_u}{\phi P_n}$
T1	193 - 185	1 1/4	5.00	4.83	185.6	1.2272	0.18	55.22	0.003 <sup>1</sup> ✓
T2	185 - 170	1 1/4	5.00	4.83	185.6	1.2272	0.79	55.22	0.014 <sup>1</sup> ✓

<sup>1</sup> P<sub>u</sub> / φP<sub>n</sub> controls

**Bottom Girt Design Data (Tension)**

Section No.	Elevation ft	Size	L ft	L <sub>u</sub> ft	Kl/r	A in <sup>2</sup>	P <sub>u</sub> K	φP <sub>n</sub> K	Ratio $\frac{P_u}{\phi P_n}$
T1	193 - 185	1 1/4	5.00	4.83	185.6	1.2272	0.83	55.22	0.015 <sup>1</sup> ✓
T2	185 - 170	1 1/4	5.00	4.83	185.6	1.2272	2.08	55.22	0.038 <sup>1</sup> ✓

<sup>1</sup> P<sub>u</sub> / φP<sub>n</sub> controls

**Mid Girt Design Data (Tension)**

Section No.	Elevation ft	Size	L ft	L <sub>u</sub> ft	Kl/r	A in <sup>2</sup>	P <sub>u</sub> K	φP <sub>n</sub> K	Ratio $\frac{P_u}{\phi P_n}$
T1	193 - 185	1 1/4	5.00	4.83	185.6	1.2272	0.44	39.76	0.011 <sup>1</sup> ✓
T2	185 - 170	1 1/4	5.00	4.83	185.6	1.2272	0.54	55.22	0.010 <sup>1</sup> ✓

<sup>1</sup> P<sub>u</sub> / φP<sub>n</sub> controls

**Section Capacity Table**

<b>Job</b>		<b>Page</b> 32 of 33
<b>Project</b>	CT01105-S Bozrah	<b>Date</b> 13:53:47 08/31/23
<b>Client</b>		<b>Designed by</b> Breann Parreira

Section No.	Elevation ft	Component Type	Size	Critical Element	P K	$\phi P_{allow}$ K	% Capacity	Pass Fail
T1	193 - 185	Leg	2	1	-7.99	141.21	5.7	Pass
T2	185 - 170	Leg	2	41	-40.91	112.25	5.8 (b) 36.4	Pass
T3	170 - 160	Leg	#12 - 1.25" - 1.00" conn. (Pirod 105244)	92	-51.21	142.49	44.2	Pass
T4	160 - 140	Leg	#12 - 1.50" - 1.00" conn. (Pirod 105217)	101	-79.47	214.86	58.6	Pass
T5	140 - 120	Leg	#12 - 1.50" - 1.00" conn. (Pirod 105217)	117	-155.77	214.86	72.5	Pass
T6	120 - 100	Leg	#12 - 1.75" - 1.25" conn. (Pirod 105218 )	132	-198.05	300.68	65.9	Pass
T7	100 - 80	Leg	#12 - 2.00" - 1.25" conn. (Pirod 105219)	147	-236.72	399.87	59.2	Pass
T8	80 - 60	Leg	#12 - 2.00" - 1.25" conn. (Pirod 105219)	162	-273.14	399.87	68.3	Pass
T9	60 - 40	Leg	#12 - 2.25" - 1.25" conn. (Pirod 105220)	177	-308.24	512.38	60.2	Pass
T10	40 - 20	Leg	#12 - 2.25" - 1.25" conn. (Pirod 105220)	192	-344.47	512.38	67.2	Pass
T11	20 - 0	Leg	#18 - 2.50" (Pirod 112738- Base Only)	207	-355.05	613.14	57.9	Pass
T1	193 - 185	Diagonal	1	14	-1.93	14.35	13.4	Pass
T2	185 - 170	Diagonal	1	52	-5.99	13.35	44.9	Pass
T3	170 - 160	Diagonal	L2 1/2x2 1/2x3/16	95	-8.04	16.32	49.3	Pass
T4	160 - 140	Diagonal	L3x3x3/16	106	-8.97	22.98	69.1 (b) 39.0	Pass
T5	140 - 120	Diagonal	L3x3x3/16	121	-8.11	20.56	72.2 (b) 39.5	Pass
T6	120 - 100	Diagonal	L3x3x5/16	136	-8.12	26.86	66.9 (b) 30.2	Pass
T7	100 - 80	Diagonal	L3x3x5/16	151	-7.96	22.66	39.1 (b) 35.1	Pass
T8	80 - 60	Diagonal	L3 1/2x3 1/2x5/16	166	-8.36	29.73	36.9 (b) 28.1	Pass
T9	60 - 40	Diagonal	L3 1/2x3 1/2x5/16	181	-8.45	24.45	33.4 (b) 34.5	Pass
T10	40 - 20	Diagonal	L3 1/2x3 1/2x5/16	193	-9.26	20.33	34.9 (b) 45.5	Pass
T11	20 - 0	Diagonal	2L3 1/2x3 1/2x5/16x3/8	209	-20.39	48.15	42.3	Pass
T1	193 - 185	Horizontal	7/8	32	-0.33	3.94	8.4	Pass
T2	185 - 170	Horizontal	7/8	64	-0.78	3.94	19.8	Pass
T1	193 - 185	Top Girt	1 1/4	5	-0.22	16.42	1.4	Pass
T2	185 - 170	Top Girt	1 1/4	43	-0.79	16.42	4.8	Pass
T1	193 - 185	Bottom Girt	1 1/4	9	-0.78	16.42	4.8	Pass
T2	185 - 170	Bottom Girt	1 1/4	47	-2.02	16.42	12.3	Pass
T1	193 - 185	Mid Girt	1 1/4	11	-0.40	16.35	2.5	Pass
T2	185 - 170	Mid Girt	1 1/4	48	-0.31	16.42	1.9	Pass
						Summary		
						Leg (T5)	72.5	Pass
						Diagonal (T4)	72.2	Pass
						Horizontal (T2)	19.8	Pass
						Top Girt (T2)	4.8	Pass
						Bottom Girt (T2)	12.3	Pass
						Mid Girt (T1)	2.5	Pass
						Bolt Checks	72.2	Pass
						<b>RATING =</b>	<b>72.5</b>	<b>Pass</b>

<p><b><i>tnxTower</i></b></p> <p><b><i>SBA Communications</i></b>  8051 Congress Avenue  Boca Raton, Florida  Phone: (561) 981-7388  FAX:</p>	<b>Job</b>	<b>Page</b> 33 of 33
	<b>Project</b>	<b>Date</b>
	<b>Client</b>	<b>Designed by</b>
	CT01105-S Bozrah	13:53:47 08/31/23
		Breann Parreira

---

Program Version 8.1.1.0 - 6/3/2021 File://f1fs1.sbsite.com/data/Engineering/Structural Analysis/CT/CT01105-S/SADocs/234501, v1/Tower Model/CT01105-S Bozrah.eri





**Self Support Anchor Bolt Check**

**Project Information**

SBA Project # : CT01105-DSW-082423  
 Code : H

**Leg Reaction**

Uplift(kips):	<u>327</u>	Shear (kips) :	<u>38</u>
Comp(kips):	<u>382</u>	Shear (kips) :	<u>45</u>

**Grout**

- 5,000 psi Grout Present
- Use Section 15.7 exemption

**Strength Reduction Factors**

Tension :	<u>0.75</u>
Compression :	<u>0.90</u>
Shear :	<u>0.75</u>
Flexure :	<u>0.9</u>

**Bolt Capacity :** 38.2% *Pass*

**Bolt Information**

Quantity :	<u>6</u>
Diameter (in) :	<u>2</u>
Assumed lar (in) :	<u>3</u>
Bolt Fy (ksi) :	<u>105</u>
Bolt Fu (AISC Table 2-6) (ksi):	<u>125</u>
# of threads (AISC Table 7-17) :	<u>4.5</u>



# Mat Foundation Design for Self Supporting Tower

Date

8/24/2023

<b>Customer Name:</b>	SBA Communications Corp	<b>TIA Standard:</b>	TIA-222-H
<b>Site Name:</b>	Bozrah	<b>Structure Height (Ft.):</b>	193
<b>Site Nmber:</b>	CT01105-S	<b>Engineer Name:</b>	SBA Enginee
<b>Engr. Number:</b>		<b>Engineer Login ID:</b>	

**Foundation Info Obtained from:**

Drawings/Calculations

**Analysis or Design?**

Analysis

**Number of Tower Legs:**

3 Legs

**Base Reactions (Factored):**

(1). Individual Leg:

Axial Load (Kips):	382.0	Uplift Force (Kips):	327.0
Shear Force (Kips):	45.0		

(2). Tower Base:

Total Vertical Load (Kips):	82.0	Total Shear Force (Kips):	58.0
Moment (Kips-ft):	6927.0		

**Foundation Geometries:**

Leg distance (Center-to-Center ft.):	22.0	Mods required -Yes/No ?:	No
Diameter of Pier (ft.):	Round 1.3	Pier Height A. G. (ft.):	0.50
Tower center to mat center (ft):	3.18	Depth of Base BG (ft.):	4.5
Length of Pad (ft.):	32.5	Width of Pad (ft.):	32.5
Thickness of Pad (ft):	5.00		

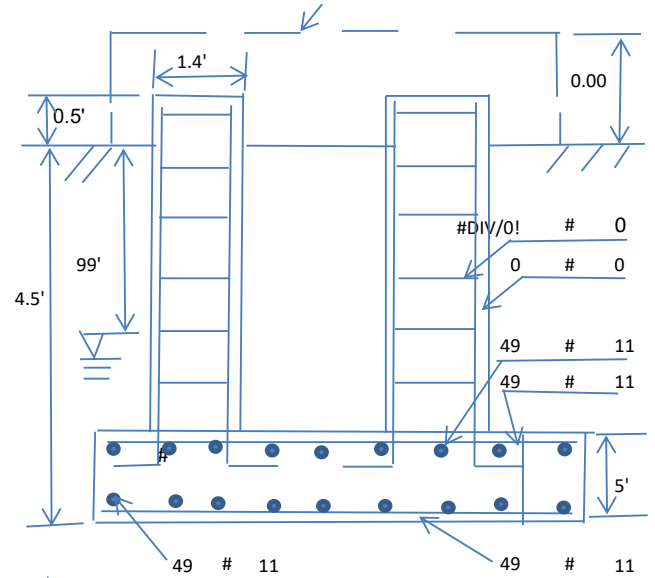

**Material Properties and Rebar Info:**

Concrete Strength (psi):	4000	Steel Elastic Modulus:	29000	ksi
Vertical bar yield (ksi)		Tie steel yield (ksi):		
Vertical Rebar Size #:		Tie / Stirrup Size #:		
Qty. of Vertical Rebars:		Tie Spacing (in):		
Pad Rebar Yield (Ksi):	60	Pad Steel Rebar Size (#):	11	
Concrete Cover (in.):	3	Unit Weight of Concrete:	150.0	pcf

Rebar at the bottom of the concrete pad:

Qty. of Rebar in Pad (L):	49	Qty. of Rebar in Pad (W):	49
---------------------------	----	---------------------------	----

Rebar at the top of the concrete pad:

Qty. of Rebar in Pad (L):	49	Qty. of Rebar in Pad (W):	49
---------------------------	----	---------------------------	----

**Soil Design Parameters:**

Soil Unit Weight (pcf):	120.0	Soil Buoyant Weight:	50.0	Pcf
Water Table B.G.S. (ft):	99.0	Unit Weight of Water:	62.4	pcf
Ultimate Bearing Pressure (psf):	40000	Consider ties in concrete shear strength:		
Consider Soil Lateral Resistance ?	No			

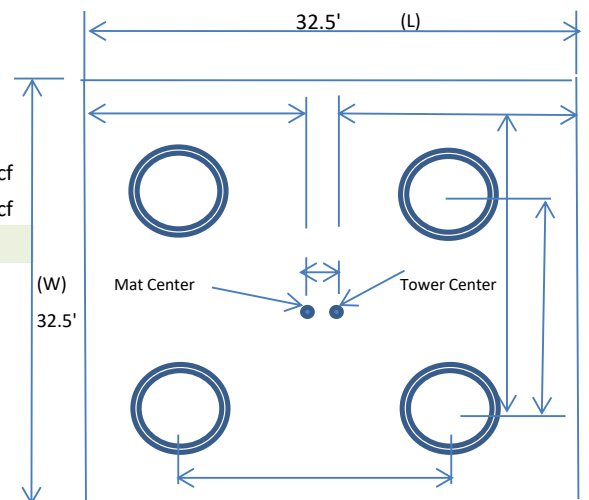
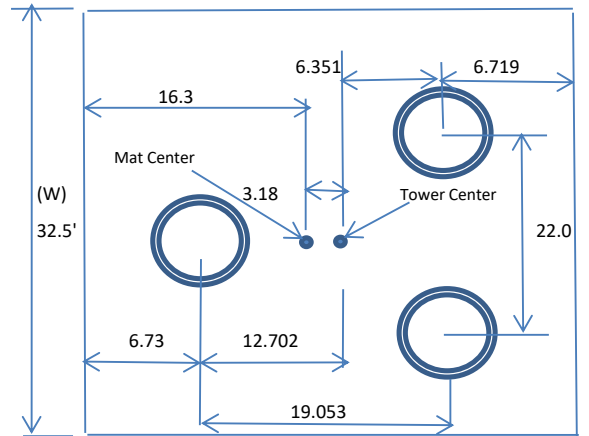

Apply 1.35 for e/w per G/H: 1.35

<b>Foundation Analysis and Design:</b>	Uplift Strength Reduction Factor:	0.75	Compression Strength Reduction Factor:	0.75
Total Dry Soil Volume (cu. Ft.):	2.10	Total Dry Soil Weight (Kips):	0.25	
Total Buoyant Soil Volume (cu. Ft.):	0.00	Total Buoyant Soil Weight (Kips):	0.00	
Total Effective Soil Weight (Kips):	0.25	Weight from the Concrete Block at Top (K):	0.00	
Total Dry Concrete Volume (cu. Ft.):	5283.34	Total Dry Concrete Weight (Kips):	792.50	
Total Buoyant Concrete Volume (cu. Ft.):	0.00	Total Buoyant Concrete Weight (Kips):	0.00	
Total Effective Concrete Weight (Kips):	792.50	Total Vertical Load on Base (Kips):	874.75	

**Check Soil Capacities:**

Calculated Maxium Net Soil Pressure under the base (psf):	2435.21	<	Allowable Factored Soil Bearing (psf):	30000	0.08	OK!
Allowable Foundation Overturning Resistance (kips-ft.):	12926.5	>	Design Factored Momont (kips-ft):	7507	0.58	OK!
Factor of Safety Against Overturning (O. R. Moment/Design Moment):	1.72					OK!

**Check the capacities of Reinforceing Concrete:**

Strength reduction factor (Flexure and axial tension):	0.90	Strength reduction factor (Shear):	0.75
Strength reduction factor (Axial compression):	0.65	Wind Load Factor on Concrete Design:	1.00

**(2).Concrete Pad:**

One-Way Design Shear Capacity (L or W Direction, Kips):	2083.5	>	One-Way Factored Shear (L/W-Dir Kips)	297.3	0.14	OK!
One-Way Design Shear Capacity (Diagonal Dir., Kips):	1788.3	>	One-Way Factored Shear (Dia. Dir, Kips)	430.8	0.24	OK!
Lower Steel Pad Reinforcement Ratio (L or W-Direct. ):	0.0035		Lower Steel Reinf. Ratio (Dia. Dir.):	0.0030		
Lower Steel Pad Moment Capacity (L or W-Dir. Kips-ft):	18775.5	>	Moment at Bottom ( L-Direct. K-Ft):	1769.9	0.09	OK!
Lower Steel Pad Moment Capacity (Dia. Direction,K-ft):	18855.2	>	Moment at Bottom ( Dia. Dir. K-Ft):	3104.2	0.16	OK!
Upper Steel Pad Reinforcement Ratio (L or W -Direction):	0.0035		Upper Steel Reinf. Ratio (Dia. Dir.):	0.0030		
Upper Steel Pad Moment Capacity (L or W-Dir., Kips-ft):	18775.5	>	Moment at the top (L-Dir Kips-Ft):	901.2	0.05	OK!
Upper Steel Pad Moment Capacity (Dia. Direction, K-ft):	18855.2	>	Moment at the top (Dia. Dir., K-Ft):	1228.3	0.07	OK!
Punching Failure Capacity From Down Load (Kips):	2425.9	>	Punch. Failure Factored Shear (K):	382.0	0.16	OK!
Punching Failure Capacity From Uplift (Kips):	2224.5	>	Punch. Failure Factored Shear (K):	327.0	0.15	OK!

**(3). Check Max. eccentricity of Loading:**

The maximum eccentricity of Loading:	8.58	ft.	Allowable eccentricity (0.45 W, ft.):	14.625		OK!
--------------------------------------	------	-----	---------------------------------------	--------	--	-----

# EXHIBIT 9

## Antenna Mount Analysis

September 15, 2023



Dish Wireless  
5701 South Santa Fe Drive  
Littleton, CO 80120

RE:      Dish Site Number:      BOBOS01169A  
            TEP Project Number:     273838.881212  
            Site Address:               131 Gifford Lane  
  Bozrah, CT 06334

To Whom It May Concern:

TEP Northeast (TEP NE) has been authorized by Dish Wireless to perform a mount analysis on the proposed Dish Wireless antenna/RRH mounts to determine their capability of supporting the following loading:

- **(3) FFVV-65B-R2 Antennas (72.0"x19.6"x7.8" – Wt. = 71 lbs. /each)**
- **(3) RF4450t-71A RRH's (16.5"x15.0"x11.0" – Wt. = 95 lbs. /each)**
- **(3) RF4451d-70A RRH's (15.0"x15.0"x8.9" – Wt. = 61 lbs. /each)**
- **(1) RDIDC-9181-PF-48 OVP (16.6"x14.6"x8.2" – Wt. = 22 lbs.)**

*\*Proposed equipment shown in bold*

Mount fabrication drawings prepared by Commscope, P/N MTC3975083, dated November 19, 2014, were used to perform this analysis.

Mount Analysis Methods:

- This analysis was conducted in accordance with EIA/TIA-222-H, Structural Standards for Steel Antenna Towers and Antenna Supporting Structures, the International Building Code 2021 with 2022 Connecticut State Building Code, and AT&T Mount Technical Directive – R22.
- TEP NE considers this mount to be asymmetrical and has applied wind loads in 30 degree increments all around the mount. Per TIA-222-H and Appendix P of the Connecticut State Building Code, the max basic wind speed for this site is equal to 125 mph with a max basic wind speed with ice of 50 mph and a max ice thickness of 1.0 in. An escalated ice thickness of 1.16 in was used for this analysis.
- TEP NE considers this site to be exposure category B; tower is located in an urban/suburban or wooded area with numerous closely spaced obstructions.
- TEP NE considers this site to be topographic category 1; tower is located on flat terrain or the bottom of a hill or ridge.
- TEP NE considers this site to have a spectral response acceleration parameter at short periods,  $S_s$ , of 0.197 and a spectral response acceleration parameter at a period of 1 second,  $S_1$ , of 0.054.
- The mount has been analyzed with load combinations consisting of 500 lbs live load using a service wind speed of 30 mph wind on the worst case antenna. Analysis performed on each antenna pipe to determine worst case location; worst case location was antenna position 2.
- The mount has been analyzed with load combinations consisting of a 250 lbs live load in a worst case location on the mount.
- The proposed mounts will be secured to the existing self supporting tower with threaded rods and steel plates tightened around the tower leg. TEP NE considers the threaded rods as the governing connection members.

Based on our evaluation, we have determined that the Proposed Commscope P/N MTC3975083 mounts **ARE CAPABLE** of supporting the proposed installation.

	Component	Controlling Load Case	Stress Ratio	Pass/Fail
<b>Proposed Mount Rating</b>	14	LC40	36%	<b>PASS</b>

Reference Documents:

- Mount fabrication drawings prepared by Commscope, P/N MTC3975083, dated November 19, 2014.

This determination was based on the following limitations and assumptions:

1. TEP NE is not responsible for any modifications completed prior to and hereafter which TEP NE was not directly involved.
2. All structural members and their connections are assumed to be in good condition and are free from defects with no deterioration to its member capacities.
3. All antennas, coax cables and waveguide cables are assumed to be properly installed and supported as per the manufacturer's requirements.
4. The proposed mounts will be adequately secured to the tower structure per the mount manufacturer's specifications.
5. All components pertaining to Dish Wireless' mounts must be tightened and re-plumbed prior to the installation of new appurtenances.
6. TEP NE performed a localized analysis on the mount itself and not on the supporting tower structure.

Please feel free to contact our office should you have any questions.

Respectfully Submitted,  
TEP Northeast



Michael Cabral  
Director



Daniel P. Hamm, PE  
Vice President

**W**  
**E**



Date: 9/8/2023  
 Project No.: BOBOS01169A  
 Designed By: KM Checked By: MSC



**2.6.5.2 Velocity Pressure Coeff:**

$$K_z = 2.01 (z/z_g)^{2/\alpha}$$

**K<sub>z</sub> = 1.110**

z = 150 (ft)  
 z<sub>g</sub> = 1200 (ft)  
 α = 7.0

$$K_{zmin} \leq K_z \leq 2.01$$

**Table 2-4**

Exposure	Z <sub>g</sub>	α	K <sub>zmin</sub>	K <sub>c</sub>
B	1200 ft	7.0	0.70	0.9
C	900 ft	9.5	0.85	1.0
D	700 ft	11.5	1.03	1.1

**2.6.6.2 Topographic Factor:**

**Table 2-5**

Topo. Category	K <sub>t</sub>	f
2	0.43	1.25
3	0.53	2.0
4	0.72	1.5

$$K_{zt} = [1 + (K_c K_t / K_h)]^2$$

**K<sub>zt</sub> = 1**

*(If Category 1 then K<sub>zt</sub> = 1.0)*

**Category = 1**

$$K_h = e^{(fz/H)}$$

K<sub>h</sub> = 1  
 K<sub>c</sub> = 0.9 (from Table 2-4)  
 K<sub>t</sub> = 0 (from Table 2-5)  
 f = 0 (from Table 2-5)  
 z = 150  
 z<sub>s</sub> = 446 (Mean elevation of base of structure above sea level)  
 H = 0 (Ht. of the crest above surrounding terrain)  
 K<sub>zt</sub> = 1.00 (from 2.6.6.2.1)  
 K<sub>e</sub> = 0.98 (from 2.6.8)

**2.6.10 Design Ice Thickness**

Max Ice Thickness =  
 Importance Factor =

t<sub>i</sub> = 1.00 in  
 I = 1.00 (from Table 2-3)  
 K<sub>iz</sub> = 1.16 (from Sec. 2.6.10)

Date: 9/8/2023  
 Project No.: BOBOS01169A  
 Designed By: KM Checked By: MSC



**2.6.9 Gust Effect Factor**

2.6.9.1 Self Supporting Lattice Structures

$G_h = 1.0$  Latticed Structures > 600 ft

$G_h = 0.85$  Latticed Structures 450 ft or less

$G_h = 0.85 + 0.15 [h/150 - 3.0]$   $h =$  ht. of structure

$h =$  193

$G_h =$  0.85

2.6.9.2 Guyed Masts

$G_h =$  0.85

2.6.9.3 Pole Structures

$G_h =$  1.1

2.6.9 Appurtenances

$G_h =$  1.0

2.6.9.4 Structures Supported on Other Structures

(Cantilevered tubular or latticed spines, pole, structures on buildings (ht. : width ratio > 5))

$G_h =$  1.35

$G_h =$  1.00

**2.6.11.2 Design Wind Force on Appurtenances**

$F = q_z * G_h * (EPA)_A$

$q_z = 0.00256 * K_z * K_{zt} * K_s * K_e * K_d * V_{max}^2$

$q_z =$	<b>41.49</b>
$q_{z(ice)} =$	<b>6.64</b>
$q_{z(30)} =$	<b>2.39</b>

$K_z =$	1.110 (from 2.6.5.2)
$K_{zt} =$	1.0 (from 2.6.6.2.1)
$K_s =$	1.0 (from 2.6.7)
$K_e =$	0.98 (from 2.6.8)
$K_d =$	<b>0.95</b> (from Table 2-2)
$V_{max} =$	125 mph (Ultimate Wind Speed)
$V_{max(ice)} =$	<b>50</b> mph
$V_{30} =$	30 mph

**Table 2-2**

Structure Type	Wind Direction Probability Factor, $K_d$
Latticed structures with triangular, square or rectangular cross sections	0.85
Tubular pole structures, latticed structures with other cross sections, appurtenances	0.95
Tubular pole structures supporting antennas enclosed within a cylindrical shroud	1.00

Date: 9/8/2023  
 Project No.: BOBOS01169A  
 Designed By: KM Checked By: MSC



**Determine Ca:**

**Table 2-9**

Force Coefficients (Ca) for Appurtenances				
Member Type		Aspect Ratio ≤ 2.5	Aspect Ratio = 7	Aspect Ratio ≥ 25
		Ca	Ca	Ca
Flat		1.2	1.4	2.0
Square/Rectangular HSS		$1.2 - 2.8(r_s) \geq 0.85$	$1.4 - 4.0(r_s) \geq 0.90$	$2.0 - 6.0(r_s) \geq 1.25$
Round	C < 39 (Subcritical)	0.7	0.8	1.2
	39 ≤ C ≤ 78 (Transitional)	$4.14/(C^{0.485})$	$3.66/(C^{0.415})$	$46.8/(C^{1.0})$
	C > 78 (Supercritical)	0.5	0.6	0.6

Aspect Ratio is the overall length/width ratio in the plane normal to the wind direction.  
 (Aspect ratio is independent of the spacing between support points of a linear appurtenance.)

Note: Linear interpolation may be used for aspect ratios other than those shown.

Ice Thickness = **1.16 in**      Angle = **0 (deg)**      Equivalent Angle = **180 (deg)**

Appurtenances	Height	Width	Depth	Flat Area	Aspect Ratio	Ca	Force (lbs)	Force (lbs) (w/ Ice)	Force (lbs) (30 mph)
FFVV-65B-R2 Antenna	72.0	19.6	7.8	9.80	3.67	1.25	509	94	29
RF4450t-71A RRH	16.5	15.0	11.0	1.72	1.10	1.20	86	18	5
RF4450t-71A RRH (Side)	16.5	11.0	15.0	1.26	1.50	1.20	63	14	4
RF4450t-71A RRH (Shielded)	16.5	5.5	15.0	0.63	3.00	1.22	32	8	2
RF4451d-70A RRH	15.0	15.0	8.9	1.56	1.00	1.20	78	17	4
RF4451d-70A RRH (Side)	15.0	8.9	15.0	0.93	1.69	1.20	46	11	3
RF4451d-70A RRH (Shielded)	15.0	4.5	15.0	0.46	3.37	1.24	24	7	1
RDIDC-9181-PF-48 OVP	16.6	14.6	8.2	1.68	1.14	1.20	84	18	5
2-1/2" Pipe	2.9	12.0	-	0.24	0.24	1.20	12		
2" Pipe	2.4	12.0	-	0.20	0.20	1.20	10		
1-1/2" Pipe	1.9	12.0	-	0.16	0.16	1.20	8		
5/8" Round Bar	0.6	12.0	-	0.05	0.05	1.20	3		
1/2" Round Bar	0.5	12.0	-	0.04	0.04	1.20	2		

Date: 9/8/2023  
 Project No.: BOBOS01169A  
 Designed By: KM Checked By: MSC



**WIND LOADS**

Angle = 30 (deg)

Ice Thickness = 1.16 in.

Equivalent Angle = 210 (deg)

**WIND LOADS WITH NO ICE:**

Appurtenances	Height	Width	Depth	Flat Area (normal)	Flat Area (side)	Aspect Ratio	Aspect Ratio	Ca (normal)	Ca (side)	Force (lbs) (normal)	Force (lbs) (side)	Force (lbs) (angle)
FFVV-65B-R2 Antenna	72.0	19.6	7.8	9.80	3.90	3.67	9.23	1.25	1.47	509	239	441
RF4450t-71A RRH	16.5	15.0	11.0	1.72	1.26	1.10	1.50	1.20	1.20	86	63	80
RF4450t-71A RRH (Side)	16.5	11.0	15.0	1.26	1.72	1.50	1.10	1.20	1.20	63	86	68
RF4450t-71A RRH (Shielded)	16.5	5.5	15.0	0.63	1.72	3.00	1.10	1.22	1.20	32	86	45
RF4451d-70A RRH	15.0	15.0	8.9	1.56	0.93	1.00	1.69	1.20	1.20	78	46	70
RF4451d-70A RRH (Side)	15.0	8.9	15.0	0.93	1.56	1.69	1.00	1.20	1.20	46	78	54
RF4451d-70A RRH (Shielded)	15.0	4.5	15.0	0.46	1.56	3.37	1.00	1.24	1.20	24	78	37
RDIDC-9181-PF-48 OVP	16.6	14.6	8.2	1.68	0.95	1.14	2.02	1.20	1.20	84	47	75

**WIND LOADS WITH ICE:**

FFVV-65B-R2 Antenna	74.3	21.9	10.1	11.32	5.23	3.39	7.34	1.24	1.41	93	49	82
RF4450t-71A RRH	18.8	17.3	13.3	2.27	1.74	1.09	1.41	1.20	1.20	18	14	17
RF4450t-71A RRH (Side)	18.8	13.3	17.3	1.74	2.27	1.41	1.09	1.20	1.20	14	18	15
RF4450t-71A RRH (Shielded)	18.8	7.8	17.3	1.02	2.27	2.41	1.09	1.20	1.20	8	18	11
RF4451d-70A RRH	17.3	17.3	11.2	2.08	1.35	1.00	1.54	1.20	1.20	17	11	15
RF4451d-70A RRH (Side)	17.3	11.2	17.3	1.35	2.08	1.54	1.00	1.20	1.20	11	17	12
RF4451d-70A RRH (Shielded)	17.3	6.8	17.3	0.82	2.08	2.56	1.00	1.20	1.20	7	17	9
RDIDC-9181-PF-48 OVP	18.9	16.9	10.5	2.22	1.38	1.12	1.80	1.20	1.20	18	11	16

**WIND LOADS AT 30 MPH:**

FFVV-65B-R2 Antenna	72.0	19.6	7.8	9.80	3.90	3.67	9.23	1.25	1.47	29	14	25
RF4450t-71A RRH	16.5	15.0	11.0	1.72	1.26	1.10	1.50	1.20	1.20	5	4	5
RF4450t-71A RRH (Side)	16.5	11.0	15.0	1.26	1.72	1.50	1.10	1.20	1.20	4	5	4
RF4450t-71A RRH (Shielded)	16.5	5.5	15.0	0.63	1.72	3.00	1.10	1.22	1.20	2	5	3
RF4451d-70A RRH	15.0	15.0	8.9	1.56	0.93	1.00	1.69	1.20	1.20	4	3	4
RF4451d-70A RRH (Side)	15.0	8.9	15.0	0.93	1.56	1.69	1.00	1.20	1.20	3	4	3
RF4451d-70A RRH (Shielded)	15.0	4.5	15.0	0.46	1.56	3.37	1.00	1.24	1.20	1	4	2
RDIDC-9181-PF-48 OVP	16.6	14.6	8.2	1.68	0.95	1.14	2.02	1.20	1.20	5	3	4

Date: 9/8/2023  
 Project No.: BOBOS01169A  
 Designed By: KM Checked By: MSC



**WIND LOADS**

Angle = **60** (deg)      Ice Thickness = **1.16** in.      Equivalent Angle = **240** (deg)

**WIND LOADS WITH NO ICE:**

Appurtenances	Height	Width	Depth	Flat Area (normal)	Flat Area (side)	Ratio (normal)	Ratio (side)	Ca (normal)	Ca (side)	Force (lbs) (normal)	Force (lbs) (side)	Force (lbs) (angle)
FFVV-65B-R2 Antenna	72.0	19.6	7.8	9.80	3.90	3.67	9.23	1.25	1.47	509	239	306
RF4450t-71A RRH	16.5	15.0	11.0	1.72	1.26	1.10	1.50	1.20	1.20	86	63	68
RF4450t-71A RRH (Side)	16.5	11.0	15.0	1.26	1.72	1.50	1.10	1.20	1.20	63	86	80
RF4450t-71A RRH (Shielded)	16.5	5.5	15.0	0.63	1.72	3.00	1.10	1.22	1.20	32	86	72
RF4451d-70A RRH	15.0	15.0	8.9	1.56	0.93	1.00	1.69	1.20	1.20	78	46	54
RF4451d-70A RRH (Side)	15.0	8.9	15.0	0.93	1.56	1.69	1.00	1.20	1.20	46	78	70
RF4451d-70A RRH (Shielded)	15.0	4.5	15.0	0.46	1.56	3.37	1.00	1.24	1.20	24	78	64
RDIDC-9181-PF-48 OVP	16.6	14.6	8.2	1.68	0.95	1.14	2.02	1.20	1.20	84	47	56

**WIND LOADS WITH ICE:**

FFVV-65B-R2 Antenna	74.3	21.9	10.1	11.32	5.23	3.39	7.34	1.24	1.41	93	49	60
RF4450t-71A RRH	18.8	17.3	13.3	2.27	1.74	1.09	1.41	1.20	1.20	18	14	15
RF4450t-71A RRH (Side)	18.8	13.3	17.3	1.74	2.27	1.41	1.09	1.20	1.20	14	18	17
RF4450t-71A RRH (Shielded)	18.8	7.8	17.3	1.02	2.27	2.41	1.09	1.20	1.20	8	18	16
RF4451d-70A RRH	17.3	17.3	11.2	2.08	1.35	1.00	1.54	1.20	1.20	17	11	12
RF4451d-70A RRH (Side)	17.3	11.2	17.3	1.35	2.08	1.54	1.00	1.20	1.20	11	17	15
RF4451d-70A RRH (Shielded)	17.3	6.8	17.3	0.82	2.08	2.56	1.00	1.20	1.20	7	17	14
RDIDC-9181-PF-48 OVP	18.9	16.9	10.5	2.22	1.38	1.12	1.80	1.20	1.20	18	11	13

**WIND LOADS AT 30 MPH:**

FFVV-65B-R2 Antenna	72.0	19.6	7.8	9.80	3.90	3.67	9.23	1.25	1.47	29	14	18
RF4450t-71A RRH	16.5	15.0	11.0	1.72	1.26	1.10	1.50	1.20	1.20	5	4	4
RF4450t-71A RRH (Side)	16.5	11.0	15.0	1.26	1.72	1.50	1.10	1.20	1.20	4	5	5
RF4450t-71A RRH (Shielded)	16.5	5.5	15.0	0.63	1.72	3.00	1.10	1.22	1.20	2	5	4
RF4451d-70A RRH	15.0	15.0	8.9	1.56	0.93	1.00	1.69	1.20	1.20	4	3	3
RF4451d-70A RRH (Side)	15.0	8.9	15.0	0.93	1.56	1.69	1.00	1.20	1.20	3	4	4
RF4451d-70A RRH (Shielded)	15.0	4.5	15.0	0.46	1.56	3.37	1.00	1.24	1.20	1	4	4
RDIDC-9181-PF-48 OVP	16.6	14.6	8.2	1.68	0.95	1.14	2.02	1.20	1.20	5	3	3

Date: 9/8/2023  
 Project No.: BOBOS01169A  
 Designed By: KM Checked By: MSC



**WIND LOADS**

Angle = **90** (deg)      Ice Thickness = **1.16** in.      Equivalent Angle = **270** (deg)

**WIND LOADS WITH NO ICE:**

Appurtenances	Height	Width	Depth	Flat Area (normal)	Flat Area (side)	Ratio (normal)	Ratio (side)	Ca (normal)	Ca (side)	Force (lbs) (normal)	Force (lbs) (side)	Force (lbs) (angle)
FFVV-65B-R2 Antenna	72.0	19.6	7.8	9.80	3.90	3.67	9.23	1.25	1.47	509	239	239
RF4450t-71A RRH	16.5	15.0	11.0	1.72	1.26	1.10	1.50	1.20	1.20	86	63	63
RF4450t-71A RRH (Side)	16.5	11.0	15.0	1.26	1.72	1.50	1.10	1.20	1.20	63	86	86
RF4450t-71A RRH (Shielded)	16.5	5.5	15.0	0.63	1.72	3.00	1.10	1.22	1.20	32	86	86
RF4451d-70A RRH	15.0	15.0	8.9	1.56	0.93	1.00	1.69	1.20	1.20	78	46	46
RF4451d-70A RRH (Side)	15.0	8.9	15.0	0.93	1.56	1.69	1.00	1.20	1.20	46	78	78
RF4451d-70A RRH (Shielded)	15.0	4.5	15.0	0.46	1.56	3.37	1.00	1.24	1.20	24	78	78
RDIDC-9181-PF-48 OVP	16.6	14.6	8.2	1.68	0.95	1.14	2.02	1.20	1.20	84	47	47

**WIND LOADS WITH ICE:**

FFVV-65B-R2 Antenna	74.3	21.9	10.1	11.32	5.23	3.39	7.34	1.24	1.41	93	49	49
RF4450t-71A RRH	18.8	17.3	13.3	2.27	1.74	1.09	1.41	1.20	1.20	18	14	14
RF4450t-71A RRH (Side)	18.8	13.3	17.3	1.74	2.27	1.41	1.09	1.20	1.20	14	18	18
RF4450t-71A RRH (Shielded)	18.8	7.8	17.3	1.02	2.27	2.41	1.09	1.20	1.20	8	18	18
RF4451d-70A RRH	17.3	17.3	11.2	2.08	1.35	1.00	1.54	1.20	1.20	17	11	11
RF4451d-70A RRH (Side)	17.3	11.2	17.3	1.35	2.08	1.54	1.00	1.20	1.20	11	17	17
RF4451d-70A RRH (Shielded)	17.3	6.8	17.3	0.82	2.08	2.56	1.00	1.20	1.20	7	17	17
RDIDC-9181-PF-48 OVP	18.9	16.9	10.5	2.22	1.38	1.12	1.80	1.20	1.20	18	11	11

**WIND LOADS AT 30 MPH:**

FFVV-65B-R2 Antenna	72.0	19.6	7.8	9.80	3.90	3.67	9.23	1.25	1.47	29	14	14
RF4450t-71A RRH	16.5	15.0	11.0	1.72	1.26	1.10	1.50	1.20	1.20	5	4	4
RF4450t-71A RRH (Side)	16.5	11.0	15.0	1.26	1.72	1.50	1.10	1.20	1.20	4	5	5
RF4450t-71A RRH (Shielded)	16.5	5.5	15.0	0.63	1.72	3.00	1.10	1.22	1.20	2	5	5
RF4451d-70A RRH	15.0	15.0	8.9	1.56	0.93	1.00	1.69	1.20	1.20	4	3	3
RF4451d-70A RRH (Side)	15.0	8.9	15.0	0.93	1.56	1.69	1.00	1.20	1.20	3	4	4
RF4451d-70A RRH (Shielded)	15.0	4.5	15.0	0.46	1.56	3.37	1.00	1.24	1.20	1	4	4
RDIDC-9181-PF-48 OVP	16.6	14.6	8.2	1.68	0.95	1.14	2.02	1.20	1.20	5	3	3

Date: 9/8/2023  
 Project No.: BOBOS01169A  
 Designed By: KM Checked By: MSC



**WIND LOADS**

Angle = **120** (deg)      Ice Thickness = **1.16** in.      Equivalent Angle = **300** (deg)

**WIND LOADS WITH NO ICE:**

Appurtenances	Height	Width	Depth	Flat Area (normal)	Flat Area (side)	Ratio (normal)	Ratio (side)	Ca (normal)	Ca (side)	Force (lbs) (normal)	Force (lbs) (side)	Force (lbs) (angle)
FFVV-65B-R2 Antenna	72.0	19.6	7.8	9.80	3.90	3.67	9.23	1.25	1.47	509	239	306
RF4450t-71A RRH	16.5	15.0	11.0	1.72	1.26	1.10	1.50	1.20	1.20	86	63	68
RF4450t-71A RRH (Side)	16.5	11.0	15.0	1.26	1.72	1.50	1.10	1.20	1.20	63	86	80
RF4450t-71A RRH (Shielded)	16.5	5.5	15.0	0.63	1.72	3.00	1.10	1.22	1.20	32	86	72
RF4451d-70A RRH	15.0	15.0	8.9	1.56	0.93	1.00	1.69	1.20	1.20	78	46	54
RF4451d-70A RRH (Side)	15.0	8.9	15.0	0.93	1.56	1.69	1.00	1.20	1.20	46	78	70
RF4451d-70A RRH (Shielded)	15.0	4.5	15.0	0.46	1.56	3.37	1.00	1.24	1.20	24	78	64
RDIDC-9181-PF-48 OVP	16.6	14.6	8.2	1.68	0.95	1.14	2.02	1.20	1.20	84	47	56

**WIND LOADS WITH ICE:**

FFVV-65B-R2 Antenna	74.3	21.9	10.1	11.32	5.23	3.39	7.34	1.24	1.41	93	49	60
RF4450t-71A RRH	18.8	17.3	13.3	2.27	1.74	1.09	1.41	1.20	1.20	18	14	15
RF4450t-71A RRH (Side)	18.8	13.3	17.3	1.74	2.27	1.41	1.09	1.20	1.20	14	18	17
RF4450t-71A RRH (Shielded)	18.8	7.8	17.3	1.02	2.27	2.41	1.09	1.20	1.20	8	18	16
RF4451d-70A RRH	17.3	17.3	11.2	2.08	1.35	1.00	1.54	1.20	1.20	17	11	12
RF4451d-70A RRH (Side)	17.3	11.2	17.3	1.35	2.08	1.54	1.00	1.20	1.20	11	17	15
RF4451d-70A RRH (Shielded)	17.3	6.8	17.3	0.82	2.08	2.56	1.00	1.20	1.20	7	17	14
RDIDC-9181-PF-48 OVP	18.9	16.9	10.5	2.22	1.38	1.12	1.80	1.20	1.20	18	11	13

**WIND LOADS AT 30 MPH:**

FFVV-65B-R2 Antenna	72.0	19.6	7.8	9.80	3.90	3.67	9.23	1.25	1.47	29	14	18
RF4450t-71A RRH	16.5	15.0	11.0	1.72	1.26	1.10	1.50	1.20	1.20	5	4	4
RF4450t-71A RRH (Side)	16.5	11.0	15.0	1.26	1.72	1.50	1.10	1.20	1.20	4	5	5
RF4450t-71A RRH (Shielded)	16.5	5.5	15.0	0.63	1.72	3.00	1.10	1.22	1.20	2	5	4
RF4451d-70A RRH	15.0	15.0	8.9	1.56	0.93	1.00	1.69	1.20	1.20	4	3	3
RF4451d-70A RRH (Side)	15.0	8.9	15.0	0.93	1.56	1.69	1.00	1.20	1.20	3	4	4
RF4451d-70A RRH (Shielded)	15.0	4.5	15.0	0.46	1.56	3.37	1.00	1.24	1.20	1	4	4
RDIDC-9181-PF-48 OVP	16.6	14.6	8.2	1.68	0.95	1.14	2.02	1.20	1.20	5	3	3

Date: 9/8/2023  
 Project No.: BOBOS01169A  
 Designed By: KM Checked By: MSC



**WIND LOADS**

Angle = **150** (deg)      Ice Thickness = **1.16** in.      Equivalent Angle = **330** (deg)

**WIND LOADS WITH NO ICE:**

Appurtenances	Height	Width	Depth	Flat Area (normal)	Flat Area (side)	Ratio (normal)	Ratio (side)	Ca (normal)	Ca (side)	Force (lbs) (normal)	Force (lbs) (side)	Force (lbs) (angle)
FFVV-65B-R2 Antenna	72.0	19.6	7.8	9.80	3.90	3.67	9.23	1.25	1.47	509	239	441
RF4450t-71A RRH	16.5	15.0	11.0	1.72	1.26	1.10	1.50	1.20	1.20	86	63	80
RF4450t-71A RRH (Side)	16.5	11.0	15.0	1.26	1.72	1.50	1.10	1.20	1.20	63	86	68
RF4450t-71A RRH (Shielded)	16.5	5.5	15.0	0.63	1.72	3.00	1.10	1.22	1.20	32	86	45
RF4451d-70A RRH	15.0	15.0	8.9	1.56	0.93	1.00	1.69	1.20	1.20	78	46	70
RF4451d-70A RRH (Side)	15.0	8.9	15.0	0.93	1.56	1.69	1.00	1.20	1.20	46	78	54
RF4451d-70A RRH (Shielded)	15.0	4.5	15.0	0.46	1.56	3.37	1.00	1.24	1.20	24	78	37
RDIDC-9181-PF-48 OVP	16.6	14.6	8.2	1.68	0.95	1.14	2.02	1.20	1.20	84	47	75

**WIND LOADS WITH ICE:**

FFVV-65B-R2 Antenna	74.3	21.9	10.1	11.32	5.23	3.39	7.34	1.24	1.41	93	49	82
RF4450t-71A RRH	18.8	17.3	13.3	2.27	1.74	1.09	1.41	1.20	1.20	18	14	17
RF4450t-71A RRH (Side)	18.8	13.3	17.3	1.74	2.27	1.41	1.09	1.20	1.20	14	18	15
RF4450t-71A RRH (Shielded)	18.8	7.8	17.3	1.02	2.27	2.41	1.09	1.20	1.20	8	18	11
RF4451d-70A RRH	17.3	17.3	11.2	2.08	1.35	1.00	1.54	1.20	1.20	17	11	15
RF4451d-70A RRH (Side)	17.3	11.2	17.3	1.35	2.08	1.54	1.00	1.20	1.20	11	17	12
RF4451d-70A RRH (Shielded)	17.3	6.8	17.3	0.82	2.08	2.56	1.00	1.20	1.20	7	17	9
RDIDC-9181-PF-48 OVP	18.9	16.9	10.5	2.22	1.38	1.12	1.80	1.20	1.20	18	11	16

**WIND LOADS AT 30 MPH:**

FFVV-65B-R2 Antenna	72.0	19.6	7.8	9.80	3.90	3.67	9.23	1.25	1.47	29	14	25
RF4450t-71A RRH	16.5	15.0	11.0	1.72	1.26	1.10	1.50	1.20	1.20	5	4	5
RF4450t-71A RRH (Side)	16.5	11.0	15.0	1.26	1.72	1.50	1.10	1.20	1.20	4	5	4
RF4450t-71A RRH (Shielded)	16.5	5.5	15.0	0.63	1.72	3.00	1.10	1.22	1.20	2	5	3
RF4451d-70A RRH	15.0	15.0	8.9	1.56	0.93	1.00	1.69	1.20	1.20	4	3	4
RF4451d-70A RRH (Side)	15.0	8.9	15.0	0.93	1.56	1.69	1.00	1.20	1.20	3	4	3
RF4451d-70A RRH (Shielded)	15.0	4.5	15.0	0.46	1.56	3.37	1.00	1.24	1.20	1	4	2
RDIDC-9181-PF-48 OVP	16.6	14.6	8.2	1.68	0.95	1.14	2.02	1.20	1.20	5	3	4



Date: 9/8/2023

Project No.: BOBOS01169A

Designed By: KM Checked By: MSC



### ICE WEIGHT CALCULATIONS

Thickness of ice: 1.16 in.  
Density of ice: 56 pcf

#### FFVV-65B-R2 Antenna

Weight of ice based on total radial SF area:

Height (in): 72.0  
Width (in): 19.6  
Depth (in): 7.8

Total weight of ice on object: 189 lbs

Weight of object: 71.0 lbs

Combined weight of ice and object: 260 lbs

#### RF4450t-71A RRH

Weight of ice based on total radial SF area:

Height (in): 16.5  
Width (in): 15.0  
Depth (in): 11.0

Total weight of ice on object: 39 lbs

Weight of object: 95.0 lbs

Combined weight of ice and object: 134 lbs

#### RF4451d-70A RRH

Weight of ice based on total radial SF area:

Height (in): 15.0  
Width (in): 15.0  
Depth (in): 8.9

Total weight of ice on object: 33 lbs

Weight of object: 61.0 lbs

Combined weight of ice and object: 94 lbs

#### RDIDC-9181-PF-48 OVP

Weight of ice based on total radial SF area:

Height (in): 16.6  
Width (in): 14.6  
Depth (in): 8.2

Total weight of ice on object: 35 lbs

Weight of object: 22.0 lbs

Combined weight of ice and object: 57 lbs

#### 2-1/2" Pipe

Per foot weight of ice:

diameter (in): 2.88

Per foot weight of ice on object: 6 plf

#### 2" Pipe

Per foot weight of ice:

diameter (in): 2.38

Per foot weight of ice on object: 5 plf

#### 1-1/2" Pipe

Per foot weight of ice:

diameter (in): 1.9

Per foot weight of ice on object: 4 plf

#### 5/8" Round Bar

Per foot weight of ice:

diameter (in): 0.625

Per foot weight of ice on object: 3 plf

#### 1/2" Round Bar

Per foot weight of ice:

diameter (in): 0.5

Per foot weight of ice on object: 2 plf

**Mount Calculations  
(Proposed Conditions)**

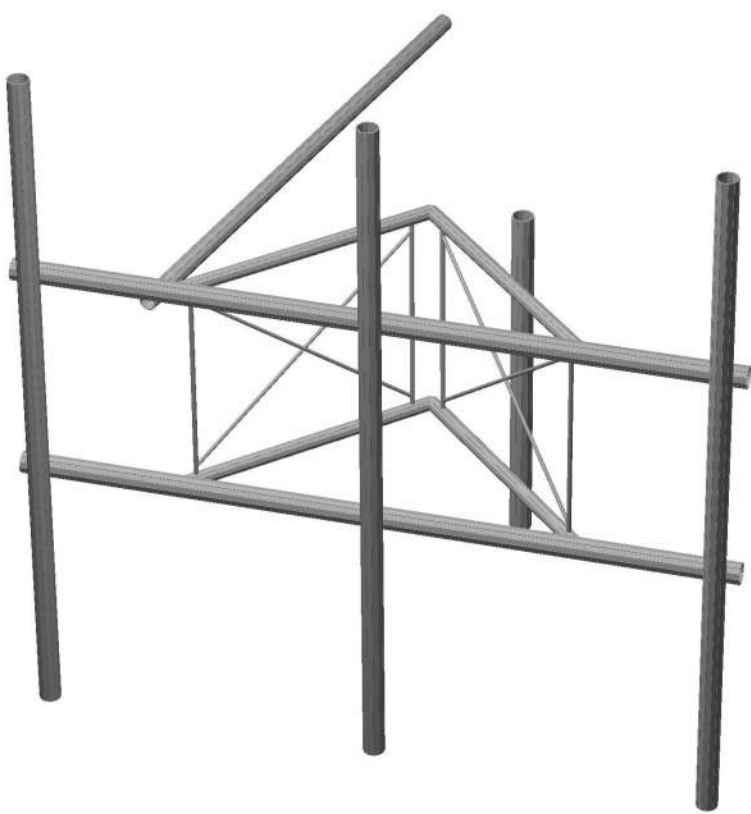

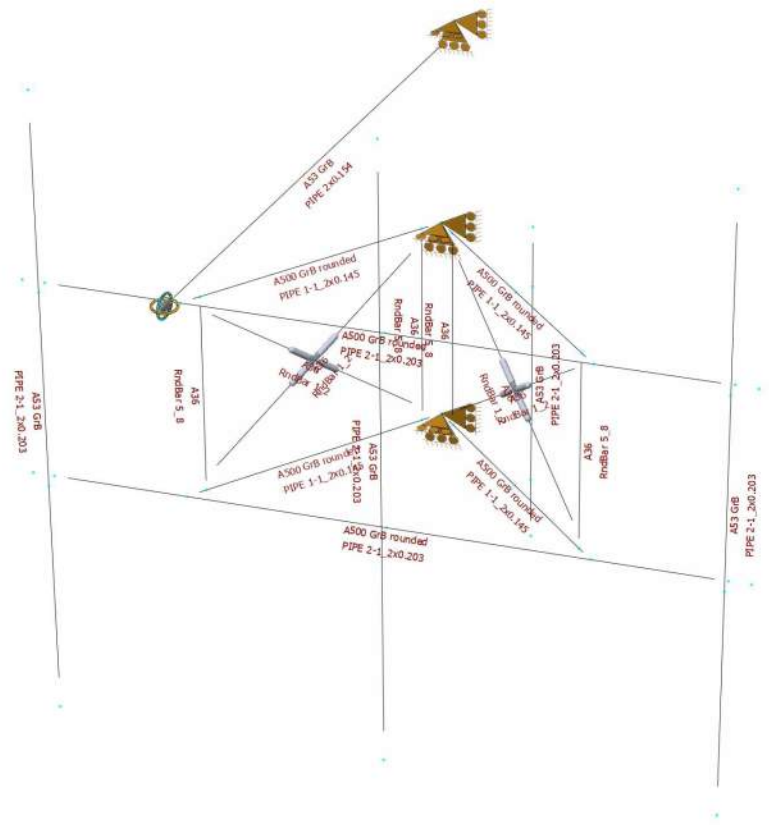



Design status

- Not designed
- Error on design
- Design O.K.
- With warnings

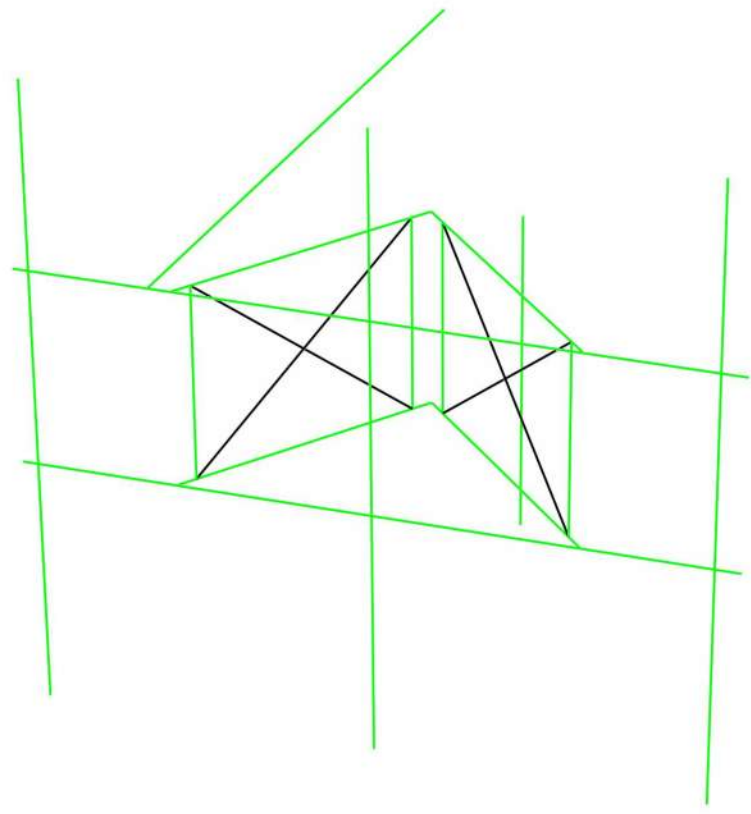

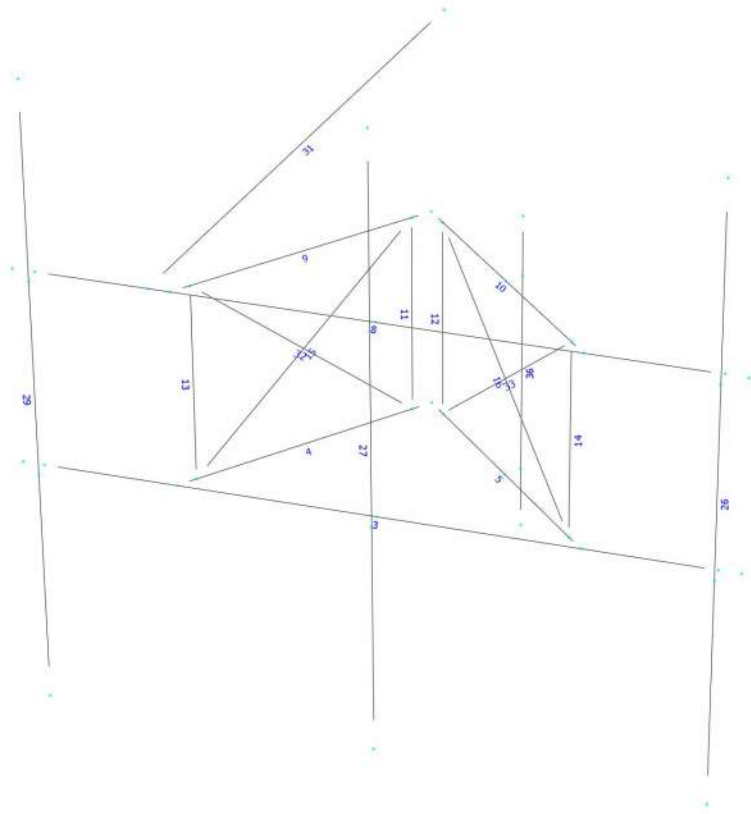

## Load data

### GLOSSARY

Comb : Indicates if load condition is a load combination

### Load Conditions

Condition	Description	Comb.	Category																																																											
D	Dead Load	No	DL																																																											
Wo	Wind Load (NO ICE)	No	WIND																																																											
W30	WL 30deg	No	WIND																																																											
W60	WL 60deg	No	WIND																																																											
W90	WL 90deg	No	WIND																																																											
W120	WL 120deg	No	WIND																																																											
W150	WL 150deg	No	WIND																																																											
Di	Ice Load	No	LL																																																											
WI0	WL ICE 0deg	No	WIND																																																											
WI30	WL ICE 30deg	No	WIND																																																											
WI60	WL ICE 60deg	No </tr <tr> <td>WI90</td> <td>WL ICE 90deg</td> <td>No</td> <td>WIND</td> </tr> <tr> <td>WI120</td> <td>WL ICE 120deg</td> <td>No</td> <td>WIND</td> </tr> <tr> <td>WI150</td> <td>WL ICE 150deg</td> <td>No</td> <td>WIND</td> </tr> <tr> <td>WL0</td> <td>WL 30 mph 0deg</td> <td>No</td> <td>WIND</td> </tr> <tr> <td>WL30</td> <td>WL 30 mph 30deg</td> <td>No</td> <td>WIND</td> </tr> <tr> <td>WL60</td> <td>WL 30 mph 60deg</td> <td>No</td> <td>WIND</td> </tr> <tr> <td>WL90</td> <td>WL 30 mph 90deg</td> <td>No</td> <td>WIND</td> </tr> <tr> <td>WL120</td> <td>WL 30 mph 120deg</td> <td>No</td> <td>WIND</td> </tr> <tr> <td>WL150</td> <td>WL 30 mph 150deg</td> <td>No</td> <td>WIND</td> </tr> <tr> <td>LL1</td> <td>250 lb Live Load Center of Mount</td> <td>No</td> <td>LL</td> </tr> <tr> <td>LL2</td> <td>250 lb Live Load Right End of Mount</td> <td>No</td> <td>LL</td> </tr> <tr> <td>LL3</td> <td>250 lb Live Load Left End of Mount</td> <td>No</td> <td>LL</td> </tr> <tr> <td>LLa1</td> <td>500 lb Live Load Antenna 1</td> <td>No</td> <td>LL</td> </tr> <tr> <td>LLa2</td> <td>500 lb Live Load Antenna 2</td> <td>No</td> <td>LL</td> </tr> <tr> <td>LLa3</td> <td>500 lb Live Load Antenna 3</td> <td>No</td> <td>LL</td> </tr>	WI90	WL ICE 90deg	No	WIND	WI120	WL ICE 120deg	No	WIND	WI150	WL ICE 150deg	No	WIND	WL0	WL 30 mph 0deg	No	WIND	WL30	WL 30 mph 30deg	No	WIND	WL60	WL 30 mph 60deg	No	WIND	WL90	WL 30 mph 90deg	No	WIND	WL120	WL 30 mph 120deg	No	WIND	WL150	WL 30 mph 150deg	No	WIND	LL1	250 lb Live Load Center of Mount	No	LL	LL2	250 lb Live Load Right End of Mount	No	LL	LL3	250 lb Live Load Left End of Mount	No	LL	LLa1	500 lb Live Load Antenna 1	No	LL	LLa2	500 lb Live Load Antenna 2	No	LL	LLa3	500 lb Live Load Antenna 3	No	LL
WI90	WL ICE 90deg	No	WIND																																																											
WI120	WL ICE 120deg	No	WIND																																																											
WI150	WL ICE 150deg	No	WIND																																																											
WL0	WL 30 mph 0deg	No	WIND																																																											
WL30	WL 30 mph 30deg	No	WIND																																																											
WL60	WL 30 mph 60deg	No	WIND																																																											
WL90	WL 30 mph 90deg	No	WIND																																																											
WL120	WL 30 mph 120deg	No	WIND																																																											
WL150	WL 30 mph 150deg	No	WIND																																																											
LL1	250 lb Live Load Center of Mount	No	LL																																																											
LL2	250 lb Live Load Right End of Mount	No	LL																																																											
LL3	250 lb Live Load Left End of Mount	No	LL																																																											
LLa1	500 lb Live Load Antenna 1	No	LL																																																											
LLa2	500 lb Live Load Antenna 2	No	LL																																																											
LLa3	500 lb Live Load Antenna 3	No	LL																																																											

### Distributed force on members

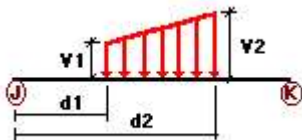

Condition	Member	Dir1	Val1 [Kip/ft]	Val2 [Kip/ft]	Dist1 [ft]	%	Dist2 [ft]	%	
Wo	3	z	-0.012	-0.012	0.00	No	100.00	Yes	
	4	z	-0.008	-0.008	0.00	No	100.00	Yes	
	5	z	-0.008	-0.008	0.00	No	100.00	Yes	
	8	z	-0.012	-0.012	0.00	No	100.00	Yes	
	9	z	-0.008	-0.008	0.00	No	100.00	Yes	
	10	z	-0.008	-0.008	0.00	No	100.00	Yes	
	11	z	-0.003	-0.003	0.00	No	100.00	Yes	
	12	z	-0.003	-0.003	0.00	No	100.00	Yes	
	13	z	-0.003	-0.003	0.00	No	100.00	Yes	
	14	z	-0.003	-0.003	0.00	No	100.00	Yes	
	15	z	-0.002	-0.002	0.00	No	100.00	Yes	
	16	z	-0.002	-0.002	0.00	No	100.00	Yes	
	26	z	-0.012	-0.012	0.00	No	100.00	Yes	
	27	z	-0.012	-0.012	90.00	Yes	100.00	Yes	
			z	-0.012	-0.012	0.00	No	10.00	Yes
	29	z	-0.012	-0.012	0.00	No	100.00	Yes	
	31	z	-0.01	-0.01	0.00	No	100.00	Yes	
	32	z	-0.002	-0.002	0.00	No	100.00	Yes	
	33	z	-0.002	-0.002	0.00	No	100.00	Yes	
	36	z	-0.012	-0.012	0.00	No	100.00	Yes	
	W30	3	z	-0.012	-0.012	0.00	No	100.00	Yes
		4	z	-0.008	-0.008	0.00	No	100.00	Yes
		5	z	-0.008	-0.008	0.00	No	100.00	Yes
		8	z	-0.012	-0.012	0.00	No	100.00	Yes
		9	z	-0.008	-0.008	0.00	No	100.00	Yes
		10	z	-0.008	-0.008	0.00	No	100.00	Yes
		11	z	-0.003	-0.003	0.00	No	100.00	Yes
		12	z	-0.003	-0.003	0.00	No	100.00	Yes
		13	z	-0.003	-0.003	0.00	No	100.00	Yes
		14	z	-0.003	-0.003	0.00	No	100.00	Yes
		15	z	-0.002	-0.002	0.00	No	100.00	Yes
		16	z	-0.002	-0.002	0.00	No	100.00	Yes
		26	z	-0.012	-0.012	0.00	No	100.00	Yes
		27	z	-0.012	-0.012	0.00	No	100.00	Yes
		29	z	-0.012	-0.012	0.00	No	100.00	Yes
		31	z	-0.01	-0.01	0.00	No	100.00	Yes
32		z	-0.002	-0.002	0.00	No	100.00	Yes	
33		z	-0.002	-0.002	0.00	No	100.00	Yes	
36		z	-0.012	-0.012	0.00	No	100.00	Yes	
W60		3	x	-0.012	-0.012	0.00	No	100.00	Yes
		4	x	-0.008	-0.008	0.00	No	100.00	Yes
		5	x	-0.008	-0.008	0.00	No	100.00	Yes
		8	x	-0.012	-0.012	0.00	No	100.00	Yes
		9	x	-0.008	-0.008	0.00	No	100.00	Yes
		10	x	-0.008	-0.008	0.00	No	100.00	Yes
		11	x	-0.003	-0.003	0.00	No	100.00	Yes
		12	x	-0.003	-0.003	0.00	No	100.00	Yes
		13	x	-0.003	-0.003	0.00	No	100.00	Yes
		14	x	-0.003	-0.003	0.00	No	100.00	Yes
		15	x	-0.002	-0.002	0.00	No	100.00	Yes
		16	x	-0.002	-0.002	0.00	No	100.00	Yes
		26	x	-0.012	-0.012	0.00	No	100.00	Yes
		27	x	-0.012	-0.012	0.00	No	100.00	Yes
		29	x	-0.012	-0.012	0.00	No	100.00	Yes
		31	x	-0.01	-0.01	0.00	No	100.00	Yes
		32	x	-0.002	-0.002	0.00	No	100.00	Yes
	33	x	-0.002	-0.002	0.00	No	100.00	Yes	
	36	x	-0.012	-0.012	0.00	No	100.00	Yes	
	W90	3	x	-0.012	-0.012	0.00	No	100.00	Yes
		4	x	-0.008	-0.008	0.00	No	100.00	Yes



	5	x	-0.008	-0.008	0.00	No	100.00	Yes
	8	x	-0.012	-0.012	0.00	No	100.00	Yes
	9	x	-0.008	-0.008	0.00	No	100.00	Yes
	10	x	-0.008	-0.008	0.00	No	100.00	Yes
	11	x	-0.003	-0.003	0.00	No	100.00	Yes
	12	x	-0.003	-0.003	0.00	No	100.00	Yes
	13	x	-0.003	-0.003	0.00	No	100.00	Yes
	14	x	-0.003	-0.003	0.00	No	100.00	Yes
	15	x	-0.002	-0.002	0.00	No	100.00	Yes
	16	x	-0.002	-0.002	0.00	No	100.00	Yes
	26	x	-0.012	-0.012	0.00	No	100.00	Yes
	27	x	-0.012	-0.012	0.00	No	100.00	Yes
	29	x	-0.012	-0.012	0.00	No	100.00	Yes
	31	x	-0.01	-0.01	0.00	No	100.00	Yes
	32	x	-0.002	-0.002	0.00	No	100.00	Yes
	33	x	-0.002	-0.002	0.00	No	100.00	Yes
	36	x	-0.012	-0.012	0.00	No	100.00	Yes
W120	3	x	-0.012	-0.012	0.00	No	100.00	Yes
	4	x	-0.008	-0.008	0.00	No	100.00	Yes
	5	x	-0.008	-0.008	0.00	No	100.00	Yes
	8	x	-0.012	-0.012	0.00	No	100.00	Yes
	9	x	-0.008	-0.008	0.00	No	100.00	Yes
	10	x	-0.008	-0.008	0.00	No	100.00	Yes
	11	x	-0.003	-0.003	0.00	No	100.00	Yes
	12	x	-0.003	-0.003	0.00	No	100.00	Yes
	13	x	-0.003	-0.003	0.00	No	100.00	Yes
	14	x	-0.003	-0.003	0.00	No	100.00	Yes
	15	x	-0.002	-0.002	0.00	No	100.00	Yes
	16	x	-0.002	-0.002	0.00	No	100.00	Yes
	26	x	-0.012	-0.012	0.00	No	100.00	Yes
	27	x	-0.012	-0.012	0.00	No	100.00	Yes
	29	x	-0.012	-0.012	0.00	No	100.00	Yes
	31	x	-0.01	-0.01	0.00	No	100.00	Yes
	32	x	-0.002	-0.002	0.00	No	100.00	Yes
	33	x	-0.002	-0.002	0.00	No	100.00	Yes
	36	x	-0.012	-0.012	0.00	No	100.00	Yes
W150	3	z	0.012	0.012	0.00	No	100.00	Yes
	4	z	0.008	0.008	0.00	No	100.00	Yes
	5	z	0.008	0.008	0.00	No	100.00	Yes
	8	z	0.012	0.012	0.00	No	100.00	Yes
	9	z	0.008	0.008	0.00	No	100.00	Yes
	10	z	0.008	0.008	0.00	No	100.00	Yes
	11	z	0.003	0.003	0.00	No	100.00	Yes
	12	z	0.003	0.003	0.00	No	100.00	Yes
	13	z	0.003	0.003	0.00	No	100.00	Yes
	14	z	0.003	0.003	0.00	No	100.00	Yes
	15	z	0.002	0.002	0.00	No	100.00	Yes
	16	z	0.002	0.002	0.00	No	100.00	Yes
	26	z	0.012	0.012	0.00	No	100.00	Yes
	27	z	0.012	0.012	0.00	No	100.00	Yes
	29	z	0.012	0.012	0.00	No	100.00	Yes
	31	z	0.01	0.01	0.00	No	100.00	Yes
	32	z	0.002	0.002	0.00	No	100.00	Yes
	33	z	0.002	0.002	0.00	No	100.00	Yes
	36	z	0.012	0.012	0.00	No	100.00	Yes
Di	3	y	-0.006	-0.006	0.00	No	100.00	Yes
	4	y	-0.004	-0.004	0.00	No	100.00	Yes
	5	y	-0.004	-0.004	0.00	No	100.00	Yes
	8	y	-0.006	-0.006	0.00	No	100.00	Yes
	9	y	-0.004	-0.004	0.00	No	100.00	Yes

10	y	-0.004	-0.004	0.00	No	100.00	Yes
11	y	-0.003	-0.003	0.00	No	100.00	Yes
12	y	-0.003	-0.003	0.00	No	100.00	Yes
13	y	-0.003	-0.003	0.00	No	100.00	Yes
14	y	-0.003	-0.003	0.00	No	100.00	Yes
15	y	-0.002	-0.002	0.00	No	100.00	Yes
16	y	-0.002	-0.002	0.00	No	100.00	Yes
26	y	-0.006	-0.006	0.00	No	100.00	Yes
27	y	-0.006	-0.006	0.00	No	100.00	Yes
29	y	-0.006	-0.006	0.00	No	100.00	Yes
31	y	-0.005	-0.005	0.00	No	100.00	Yes
32	y	-0.002	-0.002	0.00	No	100.00	Yes
33	y	-0.002	-0.002	0.00	No	100.00	Yes
36	y	-0.006	-0.006	0.00	No	100.00	Yes

### Concentrated forces on members

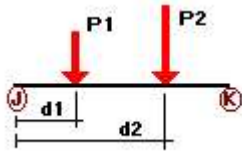

Condition	Member	Dir1	Value1 [Kip]	Dist1 [ft]	%	
D	27	y	-0.036	1.50	No	
		y	-0.036	6.50	No	
		y	-0.095	4.00	No	
		y	-0.061	4.00	No	
Wo	36	y	-0.022	2.00	No	
		27	z	-0.255	1.50	No
			z	-0.255	6.50	No
			z	-0.032	4.00	No
W30	36	z	-0.024	4.00	No	
		27	z	-0.084	2.00	No
			3	-0.221	1.50	No
			3	-0.221	6.50	No
W60	36	3	-0.045	4.00	No	
		27	3	-0.075	2.00	No
			3	-0.153	1.50	No
			3	-0.153	6.50	No
W90	36	3	-0.072	4.00	No	
		27	3	-0.056	2.00	No
			x	-0.12	1.50	No
			x	-0.12	6.50	No
W120	36	x	-0.086	4.00	No	
		27	x	-0.047	2.00	No
			2	-0.153	1.50	No
			2	-0.153	6.50	No
W150	36	2	-0.072	4.00	No	
		27	2	-0.056	2.00	No
			2	-0.221	1.50	No
			2	-0.221	6.50	No
Di	36	2	-0.045	4.00	No	
		27	2	-0.075	2.00	No
			2	-0.153	1.50	No
			y	-0.095	1.50	No

		y	-0.095	6.50	No
		y	-0.039	4.00	No
		y	-0.033	4.00	No
WI0	36	y	-0.035	2.00	No
	27	z	-0.047	1.50	No
		z	-0.047	6.50	No
		z	-0.008	4.00	No
		z	-0.007	4.00	No
WI30	36	z	-0.018	2.00	No
	27	3	-0.041	1.50	No
		3	-0.041	6.50	No
		3	-0.011	4.00	No
WI60	36	3	-0.016	2.00	No
	27	3	-0.03	1.50	No
		3	-0.03	6.50	No
		3	-0.016	4.00	No
WI90	36	3	-0.013	2.00	No
	27	x	-0.025	1.50	No
		x	-0.025	6.50	No
		x	-0.018	4.00	No
WI120	36	x	-0.011	2.00	No
	27	2	-0.03	1.50	No
		2	-0.03	6.50	No
		2	-0.016	4.00	No
WI150	36	2	-0.013	2.00	No
	27	2	-0.041	1.50	No
		2	-0.041	6.50	No
		2	-0.011	4.00	No
WL0	36	2	-0.016	2.00	No
	27	z	-0.015	1.50	No
		z	-0.015	6.50	No
		z	-0.002	4.00	No
		z	-0.001	4.00	No
WL30	36	z	-0.005	2.00	No
	27	3	-0.013	1.50	No
		3	-0.013	6.50	No
		3	-0.003	4.00	No
WL60	36	3	-0.004	2.00	No
	27	3	-0.009	1.50	No
		3	-0.009	6.50	No
		3	-0.004	4.00	No
WL90	36	3	-0.003	2.00	No
	27	x	-0.007	1.50	No
		x	-0.007	6.50	No
		x	-0.005	4.00	No
WL120	36	x	-0.003	2.00	No
	27	2	-0.009	1.50	No
		2	-0.009	6.50	No
		2	-0.004	4.00	No
WL150	36	2	-0.003	2.00	No
	27	2	-0.013	1.50	No
		2	-0.013	6.50	No
		2	-0.003	4.00	No
		2	-0.004	2.00	No
LL1	3	y	-0.25	50.00	Yes
LL2	3	y	-0.25	100.00	Yes
LL3	3	y	-0.25	0.00	Yes
LLa1	26	y	-0.50	50.00	Yes
LLa2	27	y	-0.50	50.00	Yes
LLa3	29	y	-0.50	50.00	Yes

-----

## Self weight multipliers for load conditions

---

Condition	Description	Self weight multiplier			
		Comb.	MultX	MultY	MultZ
D	Dead Load	No	0.00	-1.00	0.00
Wo	Wind Load (NO ICE)	No	0.00	0.00	0.00
W30	WL 30deg	No	0.00	0.00	0.00
W60	WL 60deg	No	0.00	0.00	0.00
W90	WL 90deg	No	0.00	0.00	0.00
W120	WL 120deg	No	0.00	0.00	0.00
W150	WL 150deg	No	0.00	0.00	0.00
Di	Ice Load	No	0.00	0.00	0.00
WI0	WL ICE 0deg	No	0.00	0.00	0.00
WI30	WL ICE 30deg	No	0.00	0.00	0.00
WI60	WL ICE 60deg	No	0.00	0.00	0.00
WI90	WL ICE 90deg	No	0.00	0.00	0.00
WI120	WL ICE 120deg	No	0.00	0.00	0.00
WI150	WL ICE 150deg	No	0.00	0.00	0.00
WL0	WL 30 mph 0deg	No	0.00	0.00	0.00
WL30	WL 30 mph 30deg	No	0.00	0.00	0.00
WL60	WL 30 mph 60deg	No	0.00	0.00	0.00
WL90	WL 30 mph 90deg	No	0.00	0.00	0.00
WL120	WL 30 mph 120deg	No	0.00	0.00	0.00
WL150	WL 30 mph 150deg	No	0.00	0.00	0.00
LL1	250 lb Live Load Center of Mount	No	0.00	0.00	0.00
LL2	250 lb Live Load Right End of Mount	No	0.00	0.00	0.00
LL3	250 lb Live Load Left End of Mount	No	0.00	0.00	0.00
LLa1	500 lb Live Load Antenna 1	No	0.00	0.00	0.00
LLa2	500 lb Live Load Antenna 2	No	0.00	0.00	0.00
LLa3	500 lb Live Load Antenna 3	No	0.00	0.00	0.00

-----

## Steel Code Check

Report: Summary - Group by member

Load conditions to be included in design :

LC1=1.2D+Wo  
LC2=1.2D+W30  
LC3=1.2D+W60  
LC4=1.2D+W90  
LC5=1.2D+W120  
LC6=1.2D+W150  
LC7=1.2D-Wo  
LC8=1.2D-W30  
LC9=1.2D-W60  
LC10=1.2D-W90  
LC11=1.2D-W120  
LC12=1.2D-W150  
LC13=0.9D+Wo  
LC14=0.9D+W30  
LC15=0.9D+W60  
LC16=0.9D+W90  
LC17=0.9D+W120  
LC18=0.9D+W150  
LC19=0.9D-Wo  
LC20=0.9D-W30  
LC21=0.9D-W60  
LC22=0.9D-W90  
LC23=0.9D-W120  
LC24=0.9D-W150  
LC25=1.2D+Di+W10  
LC26=1.2D+Di+W130  
LC27=1.2D+Di+W160  
LC28=1.2D+Di+W190  
LC29=1.2D+Di+W120  
LC30=1.2D+Di+W1150  
LC31=1.2D+Di-W10  
LC32=1.2D+Di-W130  
LC33=1.2D+Di-W160  
LC34=1.2D+Di-W190  
LC35=1.2D+Di-W120  
LC36=1.2D+Di-W1150  
LC37=1.2D+1.6LL1  
LC38=1.2D+1.6LL2  
LC39=1.2D+1.6LL3  
LC40=1.2D+W10+1.6LLa1  
LC41=1.2D+W130+1.6LLa1  
LC42=1.2D+W160+1.6LLa1  
LC43=1.2D+W190+1.6LLa1  
LC44=1.2D+W120+1.6LLa1  
LC45=1.2D+W150+1.6LLa1  
LC46=1.2D-W10+1.6LLa1  
LC47=1.2D-W130+1.6LLa1  
LC48=1.2D-W160+1.6LLa1  
LC49=1.2D-W190+1.6LLa1  
LC50=1.2D-W120+1.6LLa1  
LC51=1.2D-W150+1.6LLa1  
LC52=1.2D+W10+1.6LLa2  
LC53=1.2D+W130+1.6LLa2  
LC54=1.2D+W160+1.6LLa2

LC55=1.2D+WL90+1.6LLa2  
 LC56=1.2D+WL120+1.6LLa2  
 LC57=1.2D+WL150+1.6LLa2  
 LC58=1.2D-WL0+1.6LLa2  
 LC59=1.2D-WL30+1.6LLa2  
 LC60=1.2D-WL60+1.6LLa2  
 LC61=1.2D-WL90+1.6LLa2  
 LC62=1.2D-WL120+1.6LLa2  
 LC63=1.2D-WL150+1.6LLa2  
 LC64=1.2D+WL0+1.6LLa3  
 LC65=1.2D+WL30+1.6LLa3  
 LC66=1.2D+WL60+1.6LLa3  
 LC67=1.2D+WL90+1.6LLa3  
 LC68=1.2D+WL120+1.6LLa3  
 LC69=1.2D+WL150+1.6LLa3  
 LC70=1.2D-WL0+1.6LLa3  
 LC71=1.2D-WL30+1.6LLa3  
 LC72=1.2D-WL60+1.6LLa3  
 LC73=1.2D-WL90+1.6LLa3  
 LC74=1.2D-WL120+1.6LLa3  
 LC75=1.2D-WL150+1.6LLa3

Description	Section	Member	Ctrl Eq.	Ratio	Status	Reference
	<b>PIPE 1-1_2x0.145</b>	<b>4</b>	LC70 at 6.25%	0.18	OK	
		<b>5</b>	LC46 at 6.25%	0.17	OK	
		<b>9</b>	LC70 at 93.75%	<b>0.20</b>	<b>OK</b>	
		<b>10</b>	LC41 at 93.75%	0.19	OK	
	<b>PIPE 2-1_2x0.203</b>	<b>3</b>	LC45 at 78.13%	0.13	OK	
		<b>8</b>	LC58 at 50.00%	0.12	OK	
		<b>26</b>	LC47 at 60.42%	0.10	OK	
		<b>27</b>	LC7 at 62.50%	<b>0.16</b>	<b>OK</b>	
		<b>29</b>	LC69 at 60.42%	0.10	OK	
		<b>36</b>	LC49 at 18.75%	0.02	OK	
	<b>PIPE 2x0.154</b>	<b>31</b>	LC4 at 75.00%	<b>0.12</b>	<b>OK</b>	
	<b>RndBar 1_2</b>	<b>15</b>	LC71 at 0.00%	<b>0.35</b>	<b>With warnings</b>	
		<b>16</b>	LC41 at 100.00%	0.35	With warnings	
		<b>32</b>	LC12 at 100.00%	0.05	With warnings	
		<b>33</b>	LC3 at 0.00%	0.05	With warnings	
	<b>RndBar 5_8</b>	<b>11</b>	LC53 at 0.00%	0.08	OK	
		<b>12</b>	LC46 at 100.00%	0.11	OK	
		<b>13</b>	LC64 at 0.00%	0.35	OK	
		<b>14</b>	LC40 at 0.00%	<b>0.36</b>	<b>OK</b>	

## Geometry data

### GLOSSARY

- Cb22, Cb33 : Moment gradient coefficients
- Cm22, Cm33 : Coefficients applied to bending term in interaction formula
- d0 : Tapered member section depth at J end of member
- DJX : Rigid end offset distance measured from J node in axis X
- DJY : Rigid end offset distance measured from J node in axis Y
- DJZ : Rigid end offset distance measured from J node in axis Z
- DKX : Rigid end offset distance measured from K node in axis X
- DKY : Rigid end offset distance measured from K node in axis Y
- DKZ : Rigid end offset distance measured from K node in axis Z
- dL : Tapered member section depth at K end of member
- Ig factor : Inertia reduction factor (Effective Inertia/Gross Inertia) for reinforced concrete members
- K22 : Effective length factor about axis 2
- K33 : Effective length factor about axis 3
- L22 : Member length for calculation of axial capacity
- L33 : Member length for calculation of axial capacity
- LB pos : Lateral unbraced length of the compression flange in the positive side of local axis 2
- LB neg : Lateral unbraced length of the compression flange in the negative side of local axis 2
- RX : Rotation about X
- RY : Rotation about Y
- RZ : Rotation about Z
- TO : 1 = Tension only member 0 = Normal member
- TX : Translation in X
- TY : Translation in Y
- TZ : Translation in Z

### Nodes

Node	X [ft]	Y [ft]	Z [ft]	Rigid Floor
2	4.00	0.00	0.00	0
3	-4.00	0.00	0.00	0
4	3.75	0.00	0.00	0
5	-3.75	0.00	0.00	0
6	3.75	0.00	0.20	0
7	-3.75	0.00	0.20	0
8	-2.25	0.00	0.00	0
9	2.25	0.00	0.00	0
10	0.00	0.00	-2.25	0
16	4.00	2.50	0.00	0
17	-4.00	2.50	0.00	0
18	3.75	2.50	0.00	0
19	-3.75	2.50	0.00	0
20	3.75	2.50	0.20	0
21	-3.75	2.50	0.20	0
22	-2.25	2.50	0.00	0
23	2.25	2.50	0.00	0
24	0.00	2.50	-2.25	0
33	-3.75	5.00	0.20	0
34	3.75	5.00	0.20	0
35	-3.75	-3.00	0.20	0
36	3.75	-3.00	0.20	0
38	0.00	0.00	0.00	0

39	0.00	0.00	0.20	0
40	0.00	2.50	0.00	0
41	0.00	2.50	0.20	0
42	0.00	5.00	0.20	0
43	0.00	-3.00	0.20	0
52	-2.50	2.50	0.00	0
88	0.1731	2.50	-2.0769	0
120	2.0769	2.50	-0.1731	0
121	-2.0769	0.00	-0.1731	0
122	-0.1731	0.00	-2.0769	0
123	0.1731	0.00	-2.0769	0
124	2.0769	0.00	-0.1731	0
126	-0.1731	2.50	-2.0769	0
156	-2.0769	2.50	-0.1731	0
157	1.125	2.50	-1.125	0
158	1.125	0.00	-1.125	0
159	1.27	2.50	-1.27	0
160	1.27	0.00	-1.27	0
161	1.27	3.25	-1.27	0
162	1.27	-0.75	-1.27	0
51	-1.00	2.50	-6.50	0

## Restraints

Node	TX	TY	TZ	RX	RY	RZ
10	1	1	1	0	0	0
24	1	1	1	0	0	0
51	1	1	1	0	0	0

## Members

Member	NJ	NK	Description	Section	Material	d0 [in]	dL [in]	Ig factor
3	3	2	PIPE 2-1_2x0.203	PIPE 2-1_2x0.203	A500 GrB rounded	0.00	0.00	0.00
4	8	10	PIPE 1-1_2x0.145	PIPE 1-1_2x0.145	A500 GrB rounded	0.00	0.00	0.00
5	9	10	PIPE 1-1_2x0.145	PIPE 1-1_2x0.145	A500 GrB rounded	0.00	0.00	0.00
8	17	16	PIPE 2-1_2x0.203	PIPE 2-1_2x0.203	A500 GrB rounded	0.00	0.00	0.00
9	22	24	PIPE 1-1_2x0.145	PIPE 1-1_2x0.145	A500 GrB rounded	0.00	0.00	0.00
10	23	24	PIPE 1-1_2x0.145	PIPE 1-1_2x0.145	A500 GrB rounded	0.00	0.00	0.00
11	126	122	RndBar 5_8	RndBar 5_8	A36	0.00	0.00	0.00
12	88	123	RndBar 5_8	RndBar 5_8	A36	0.00	0.00	0.00
13	156	121	RndBar 5_8	RndBar 5_8	A36	0.00	0.00	0.00
14	120	124	RndBar 5_8	RndBar 5_8	A36	0.00	0.00	0.00
15	126	121	RndBar 1_2	RndBar 1_2	A36	0.00	0.00	0.00
16	88	124	RndBar 1_2	RndBar 1_2	A36	0.00	0.00	0.00
26	34	36	PIPE 2-1_2x0.203	PIPE 2-1_2x0.203	A53 GrB	0.00	0.00	0.00
27	42	43	PIPE 2-1_2x0.203	PIPE 2-1_2x0.203	A53 GrB	0.00	0.00	0.00
29	33	35	PIPE 2-1_2x0.203	PIPE 2-1_2x0.203	A53 GrB	0.00	0.00	0.00
31	52	51	PIPE 2x0.154	PIPE 2x0.154	A53 GrB	0.00	0.00	0.00
32	156	122	RndBar 1_2	RndBar 1_2	A36	0.00	0.00	0.00
33	120	123	RndBar 1_2	RndBar 1_2	A36	0.00	0.00	0.00



**Orientation of local axes**

---

Member	Rotation [Deg]	Axes23	NX	NY	NZ
12	315.00	0	0.00	0.00	0.00
26	315.00	0	0.00	0.00	0.00
27	315.00	0	0.00	0.00	0.00
29	315.00	0	0.00	0.00	0.00
36	315.00	0	0.00	0.00	0.00

---

**Rigid end offsets**

---

Member	DJX [in]	DJY [in]	DJZ [in]	DKX [in]	DKY [in]	DKZ [in]
15	0.00	-2.00	0.00	0.00	2.00	0.00
16	0.00	-2.00	0.00	0.00	2.00	0.00
31	0.00	-2.00	0.00	0.00	-2.00	0.00
32	0.00	-2.00	0.00	0.00	2.00	0.00
33	0.00	-2.00	0.00	0.00	2.00	0.00

---

**Hinges**

---

Member	Node-J				Node-K				TOR	AXL	Axial rigidity
	M33	M22	V3	V2	M33	M22	V3	V2			
15	0	0	0	0	0	0	0	0	0	0	Tension only
16	0	0	0	0	0	0	0	0	0	0	Tension only
31	1	1	0	0	0	0	0	0	0	0	Full
32	0	0	0	0	0	0	0	0	0	0	Tension only
33	0	0	0	0	0	0	0	0	0	0	Tension only

---

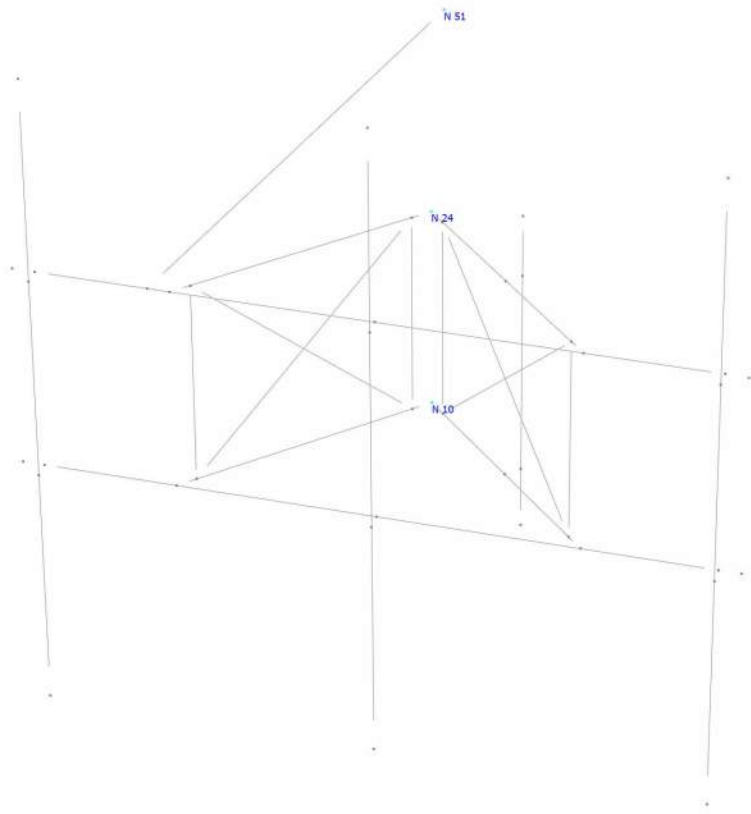

## Analysis result

### Reactions

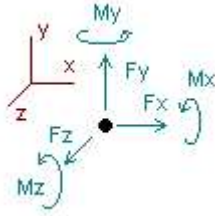

Direction of positive forces and moments

Node	Forces [Kip]			Moments [Kip*ft]		
	FX	FY	FZ	MX	MY	MZ
Condition <b>LC1=1.2D+Wo</b>						
10	0.01513	0.13099	1.27791	0.00000	0.00000	0.00000
24	-0.03248	0.53867	0.03107	0.00000	0.00000	0.00000
51	0.01736	0.01529	-0.06771	0.00000	0.00000	0.00000
SUM	0.00000	0.68494	1.24127	0.00000	0.00000	0.00000
Condition <b>LC2=1.2D+W30</b>						
10	0.24329	0.13231	1.15491	0.00000	0.00000	0.00000
24	0.24582	0.54949	-0.49418	0.00000	0.00000	0.00000
51	-0.09172	0.00314	0.40474	0.00000	0.00000	0.00000
SUM	0.39739	0.68494	1.06547	0.00000	0.00000	0.00000
Condition <b>LC3=1.2D+W60</b>						
10	0.44972	0.12307	0.72806	0.00000	0.00000	0.00000
24	0.53847	0.56903	-1.23388	0.00000	0.00000	0.00000
51	-0.15523	-0.00716	0.81270	0.00000	0.00000	0.00000
SUM	0.83296	0.68494	0.30688	0.00000	0.00000	0.00000
Condition <b>LC4=1.2D+W90</b>						
10	0.48760	0.12065	0.54349	0.00000	0.00000	0.00000
24	0.59012	0.57405	-1.45750	0.00000	0.00000	0.00000
51	-0.17864	-0.00975	0.91401	0.00000	0.00000	0.00000
SUM	0.89907	0.68494	0.00000	0.00000	0.00000	0.00000
Condition <b>LC5=1.2D+W120</b>						
10	0.44920	0.11646	0.36551	0.00000	0.00000	0.00000
24	0.55057	0.57693	-1.53529	0.00000	0.00000	0.00000
51	-0.16681	-0.00844	0.86290	0.00000	0.00000	0.00000
SUM	0.83296	0.68494	-0.30688	0.00000	0.00000	0.00000

Condition **LC6=1.2D+W150**

10	0.24224	0.08543	-0.02845	0.00000	0.00000	0.00000
24	0.27218	0.59882	-1.53631	0.00000	0.00000	0.00000
51	-0.11702	0.00069	0.49929	0.00000	0.00000	0.00000
SUM	0.39739	0.68494	-1.06547	0.00000	0.00000	0.00000

Condition **LC7=1.2D-Wo**

10	0.01367	0.07891	-0.11204	0.00000	0.00000	0.00000
24	0.00365	0.59425	-1.19678	0.00000	0.00000	0.00000
51	-0.01732	0.01179	0.06754	0.00000	0.00000	0.00000
SUM	0.00000	0.68494	-1.24127	0.00000	0.00000	0.00000

Condition **LC8=1.2D-W30**

10	-0.21447	0.07739	0.01103	0.00000	0.00000	0.00000
24	-0.27441	0.58362	-0.67239	0.00000	0.00000	0.00000
51	0.09149	0.02393	-0.40411	0.00000	0.00000	0.00000
SUM	-0.39739	0.68494	-1.06547	0.00000	0.00000	0.00000

Condition **LC9=1.2D-W60**

10	-0.42087	0.08644	0.43817	0.00000	0.00000	0.00000
24	-0.56701	0.56419	0.06781	0.00000	0.00000	0.00000
51	0.15492	0.03431	-0.81287	0.00000	0.00000	0.00000
SUM	-0.83296	0.68494	-0.30688	0.00000	0.00000	0.00000

Condition **LC10=1.2D-W90**

10	-0.45874	0.08877	0.62286	0.00000	0.00000	0.00000
24	-0.61877	0.55923	0.29203	0.00000	0.00000	0.00000
51	0.17844	0.03695	-0.91489	0.00000	0.00000	0.00000
SUM	-0.89907	0.68494	0.00000	0.00000	0.00000	0.00000

Condition **LC11=1.2D-W120**

10	-0.42036	0.09303	0.80080	0.00000	0.00000	0.00000
24	-0.57937	0.55627	0.37027	0.00000	0.00000	0.00000
51	0.16677	0.03564	-0.86418	0.00000	0.00000	0.00000
SUM	-0.83296	0.68494	0.30688	0.00000	0.00000	0.00000

Condition **LC12=1.2D-W150**

10	-0.21342	0.12430	1.19455	0.00000	0.00000	0.00000
24	-0.30118	0.53420	0.37158	0.00000	0.00000	0.00000
51	0.11721	0.02645	-0.50066	0.00000	0.00000	0.00000
SUM	-0.39739	0.68494	1.06547	0.00000	0.00000	0.00000

Condition **LC13=0.9D+Wo**

10	0.01152	0.10499	1.13215	0.00000	0.00000	0.00000
24	-0.02888	0.39682	0.17685	0.00000	0.00000	0.00000
51	0.01736	0.01190	-0.06772	0.00000	0.00000	0.00000
SUM	0.00000	0.51371	1.24127	0.00000	0.00000	0.00000

Condition <b>LC14=0.9D+W30</b>						
10	0.23972	0.10633	1.00916	0.00000	0.00000	0.00000
24	0.24939	0.40761	-0.34841	0.00000	0.00000	0.00000
51	-0.09171	-0.00024	0.40472	0.00000	0.00000	0.00000
SUM	0.39739	0.51371	1.06547	0.00000	0.00000	0.00000
Condition <b>LC15=0.9D+W60</b>						
10	0.44620	0.09672	0.58236	0.00000	0.00000	0.00000
24	0.54199	0.42751	-1.08817	0.00000	0.00000	0.00000
51	-0.15522	-0.01052	0.81269	0.00000	0.00000	0.00000
SUM	0.83296	0.51371	0.30688	0.00000	0.00000	0.00000
Condition <b>LC16=0.9D+W90</b>						
10	0.48408	0.09205	0.39780	0.00000	0.00000	0.00000
24	0.59363	0.43477	-1.31179	0.00000	0.00000	0.00000
51	-0.17864	-0.01311	0.91400	0.00000	0.00000	0.00000
SUM	0.89907	0.51371	0.00000	0.00000	0.00000	0.00000
Condition <b>LC17=0.9D+W120</b>						
10	0.44567	0.09006	0.21982	0.00000	0.00000	0.00000
24	0.55409	0.43545	-1.38959	0.00000	0.00000	0.00000
51	-0.16680	-0.01180	0.86289	0.00000	0.00000	0.00000
SUM	0.83296	0.51371	-0.30688	0.00000	0.00000	0.00000
Condition <b>LC18=0.9D+W150</b>						
10	0.23868	0.05891	-0.17412	0.00000	0.00000	0.00000
24	0.27573	0.45748	-1.39064	0.00000	0.00000	0.00000
51	-0.11702	-0.00268	0.49929	0.00000	0.00000	0.00000
SUM	0.39739	0.51371	-1.06547	0.00000	0.00000	0.00000
Condition <b>LC19=0.9D-W0</b>						
10	0.01008	0.05235	-0.25772	0.00000	0.00000	0.00000
24	0.00724	0.45296	-1.05110	0.00000	0.00000	0.00000
51	-0.01732	0.00840	0.06755	0.00000	0.00000	0.00000
SUM	0.00000	0.51371	-1.24127	0.00000	0.00000	0.00000
Condition <b>LC20=0.9D-W30</b>						
10	-0.21810	0.05065	-0.13468	0.00000	0.00000	0.00000
24	-0.27078	0.44252	-0.52669	0.00000	0.00000	0.00000
51	0.09148	0.02054	-0.40410	0.00000	0.00000	0.00000
SUM	-0.39739	0.51371	-1.06547	0.00000	0.00000	0.00000
Condition <b>LC21=0.9D-W60</b>						
10	-0.42454	0.05990	0.29242	0.00000	0.00000	0.00000
24	-0.56334	0.42289	0.21356	0.00000	0.00000	0.00000
51	0.15492	0.03091	-0.81286	0.00000	0.00000	0.00000
SUM	-0.83296	0.51371	-0.30688	0.00000	0.00000	0.00000

Condition <b>LC22=0.9D-W90</b>						
10	-0.46241	0.06225	0.47710	0.00000	0.00000	0.00000
24	-0.61510	0.41792	0.43779	0.00000	0.00000	0.00000
51	0.17843	0.03355	-0.91489	0.00000	0.00000	0.00000
SUM	-0.89907	0.51371	0.00000	0.00000	0.00000	0.00000
Condition <b>LC23=0.9D-W120</b>						
10	-0.42403	0.06654	0.65503	0.00000	0.00000	0.00000
24	-0.57570	0.41494	0.51603	0.00000	0.00000	0.00000
51	0.16677	0.03224	-0.86418	0.00000	0.00000	0.00000
SUM	-0.83296	0.51371	0.30688	0.00000	0.00000	0.00000
Condition <b>LC24=0.9D-W150</b>						
10	-0.21706	0.09826	1.04877	0.00000	0.00000	0.00000
24	-0.29754	0.39239	0.51737	0.00000	0.00000	0.00000
51	0.11721	0.02305	-0.50067	0.00000	0.00000	0.00000
SUM	-0.39739	0.51371	1.06547	0.00000	0.00000	0.00000
Condition <b>LC25=1.2D+Di+W10</b>						
10	0.01559	0.18527	1.06232	0.00000	0.00000	0.00000
24	-0.01825	0.96797	-0.92382	0.00000	0.00000	0.00000
51	0.00265	0.03051	-0.01150	0.00000	0.00000	0.00000
SUM	0.00000	1.18375	0.12700	0.00000	0.00000	0.00000
Condition <b>LC26=1.2D+Di+W130</b>						
10	0.05973	0.18532	1.02904	0.00000	0.00000	0.00000
24	0.03575	0.97027	-1.03169	0.00000	0.00000	0.00000
51	-0.01840	0.02816	0.07972	0.00000	0.00000	0.00000
SUM	0.07707	1.18375	0.07707	0.00000	0.00000	0.00000
Condition <b>LC27=1.2D+Di+W160</b>						
10	0.05161	0.18501	1.02141	0.00000	0.00000	0.00000
24	0.02636	0.97021	-1.02364	0.00000	0.00000	0.00000
51	-0.01504	0.02853	0.06516	0.00000	0.00000	0.00000
SUM	0.06293	1.18375	0.06293	0.00000	0.00000	0.00000
Condition <b>LC28=1.2D+Di+W190</b>						
10	0.06082	0.18451	0.98350	0.00000	0.00000	0.00000
24	0.03886	0.97134	-1.07308	0.00000	0.00000	0.00000
51	-0.02068	0.02790	0.08958	0.00000	0.00000	0.00000
SUM	0.07900	1.18375	0.00000	0.00000	0.00000	0.00000
Condition <b>LC29=1.2D+Di+W1120</b>						
10	0.05149	0.18358	0.94721	0.00000	0.00000	0.00000
24	0.02920	0.97194	-1.08708	0.00000	0.00000	0.00000
51	-0.01776	0.02823	0.07694	0.00000	0.00000	0.00000
SUM	0.06293	1.18375	-0.06293	0.00000	0.00000	0.00000

Condition **LC30=1.2D+Di+W1150**

10	0.05958	0.18347	0.93819	0.00000	0.00000	0.00000
24	0.03924	0.97250	-1.10947	0.00000	0.00000	0.00000
51	-0.02175	0.02778	0.09421	0.00000	0.00000	0.00000
SUM	0.07707	1.18375	-0.07707	0.00000	0.00000	0.00000

Condition **LC31=1.2D+Di-W10**

10	0.01536	0.18232	0.91252	0.00000	0.00000	0.00000
24	-0.01269	0.97152	-1.05109	0.00000	0.00000	0.00000
51	-0.00267	0.02991	0.01156	0.00000	0.00000	0.00000
SUM	0.00000	1.18375	-0.12700	0.00000	0.00000	0.00000

Condition **LC32=1.2D+Di-W130**

10	-0.02877	0.18226	0.94581	0.00000	0.00000	0.00000
24	-0.06669	0.96922	-0.94323	0.00000	0.00000	0.00000
51	0.01838	0.03227	-0.07966	0.00000	0.00000	0.00000
SUM	-0.07707	1.18375	-0.07707	0.00000	0.00000	0.00000

Condition **LC33=1.2D+Di-W160**

10	-0.02066	0.18257	0.95344	0.00000	0.00000	0.00000
24	-0.05730	0.96929	-0.95127	0.00000	0.00000	0.00000
51	0.01502	0.03189	-0.06510	0.00000	0.00000	0.00000
SUM	-0.06293	1.18375	-0.06293	0.00000	0.00000	0.00000

Condition **LC34=1.2D+Di-W190**

10	-0.02986	0.18307	0.99135	0.00000	0.00000	0.00000
24	-0.06980	0.96816	-0.90183	0.00000	0.00000	0.00000
51	0.02066	0.03252	-0.08953	0.00000	0.00000	0.00000
SUM	-0.07900	1.18375	0.00000	0.00000	0.00000	0.00000

Condition **LC35=1.2D+Di-W1120**

10	-0.02054	0.18400	1.02764	0.00000	0.00000	0.00000
24	-0.06014	0.96755	-0.88782	0.00000	0.00000	0.00000
51	0.01774	0.03220	-0.07688	0.00000	0.00000	0.00000
SUM	-0.06293	1.18375	0.06293	0.00000	0.00000	0.00000

Condition **LC36=1.2D+Di-W1150**

10	-0.02862	0.18411	1.03667	0.00000	0.00000	0.00000
24	-0.07018	0.96700	-0.86543	0.00000	0.00000	0.00000
51	0.02173	0.03264	-0.09416	0.00000	0.00000	0.00000
SUM	-0.07707	1.18375	0.07707	0.00000	0.00000	0.00000

Condition **LC37=1.2D+1.6LL1**

10	0.01441	0.16127	0.94292	0.00000	0.00000	0.00000
24	-0.01440	0.91014	-0.94294	0.00000	0.00000	0.00000
51	-0.00001	0.01353	0.00002	0.00000	0.00000	0.00000
SUM	0.00000	1.08494	0.00000	0.00000	0.00000	0.00000

Condition **LC38=1.2D+1.6LL2**

10	0.65421	0.16637	0.94306	0.00000	0.00000	0.00000
24	-0.65417	0.90505	-0.94326	0.00000	0.00000	0.00000
51	-0.00005	0.01353	0.00020	0.00000	0.00000	0.00000
SUM	0.00000	1.08494	0.00000	0.00000	0.00000	0.00000

Condition **LC39=1.2D+1.6LL3**

10	-0.62541	0.12516	0.94303	0.00000	0.00000	0.00000
24	0.62537	0.94625	-0.94287	0.00000	0.00000	0.00000
51	0.00004	0.01354	-0.00016	0.00000	0.00000	0.00000
SUM	0.00000	1.08494	0.00000	0.00000	0.00000	0.00000

Condition **LC40=1.2D+WL0+1.6LLa1**

10	1.21423	0.21970	1.38955	0.00000	0.00000	0.00000
24	-1.21488	1.25164	-1.34875	0.00000	0.00000	0.00000
51	0.00065	0.01361	-0.00280	0.00000	0.00000	0.00000
SUM	0.00000	1.48494	0.03800	0.00000	0.00000	0.00000

Condition **LC41=1.2D+WL30+1.6LLa1**

10	1.22763	0.21976	1.37976	0.00000	0.00000	0.00000
24	-1.19844	1.25231	-1.38180	0.00000	0.00000	0.00000
51	-0.00585	0.01288	0.02537	0.00000	0.00000	0.00000
SUM	0.02333	1.48494	0.02333	0.00000	0.00000	0.00000

Condition **LC42=1.2D+WL60+1.6LLa1**

10	1.22438	0.21963	1.37669	0.00000	0.00000	0.00000
24	-1.20224	1.25227	-1.37836	0.00000	0.00000	0.00000
51	-0.00446	0.01304	0.01934	0.00000	0.00000	0.00000
SUM	0.01768	1.48494	0.01768	0.00000	0.00000	0.00000

Condition **LC43=1.2D+WL90+1.6LLa1**

10	1.22682	0.21944	1.36604	0.00000	0.00000	0.00000
24	-1.19896	1.25262	-1.39143	0.00000	0.00000	0.00000
51	-0.00586	0.01288	0.02539	0.00000	0.00000	0.00000
SUM	0.02200	1.48494	0.00000	0.00000	0.00000	0.00000

Condition **LC44=1.2D+WL120+1.6LLa1**

10	1.22435	0.21927	1.35578	0.00000	0.00000	0.00000
24	-1.20158	1.25271	-1.39550	0.00000	0.00000	0.00000
51	-0.00509	0.01297	0.02205	0.00000	0.00000	0.00000
SUM	0.01768	1.48494	-0.01768	0.00000	0.00000	0.00000

Condition **LC45=1.2D+WL150+1.6LLa1**

10	1.22759	0.21925	1.35216	0.00000	0.00000	0.00000
24	-1.19757	1.25290	-1.40447	0.00000	0.00000	0.00000
51	-0.00669	0.01279	0.02898	0.00000	0.00000	0.00000
SUM	0.02333	1.48494	-0.02333	0.00000	0.00000	0.00000



Condition **LC46=1.2D-WL0+1.6LLa1**

10	1.21416	0.21884	1.34465	0.00000	0.00000	0.00000
24	-1.21333	1.25267	-1.38623	0.00000	0.00000	0.00000
51	-0.00083	0.01344	0.00359	0.00000	0.00000	0.00000
SUM	0.00000	1.48494	-0.03800	0.00000	0.00000	0.00000

Condition **LC47=1.2D-WL30+1.6LLa1**

10	1.20076	0.21878	1.35443	0.00000	0.00000	0.00000
24	-1.22977	1.25200	-1.35318	0.00000	0.00000	0.00000
51	0.00567	0.01417	-0.02458	0.00000	0.00000	0.00000
SUM	-0.02333	1.48494	-0.02333	0.00000	0.00000	0.00000

Condition **LC48=1.2D-WL60+1.6LLa1**

10	1.20402	0.21890	1.35750	0.00000	0.00000	0.00000
24	-1.22598	1.25203	-1.35662	0.00000	0.00000	0.00000
51	0.00428	0.01401	-0.01856	0.00000	0.00000	0.00000
SUM	-0.01768	1.48494	-0.01768	0.00000	0.00000	0.00000

Condition **LC49=1.2D-WL90+1.6LLa1**

10	1.20158	0.21909	1.36816	0.00000	0.00000	0.00000
24	-1.22926	1.25169	-1.34355	0.00000	0.00000	0.00000
51	0.00568	0.01417	-0.02461	0.00000	0.00000	0.00000
SUM	-0.02200	1.48494	0.00000	0.00000	0.00000	0.00000

Condition **LC50=1.2D-WL120+1.6LLa1**

10	1.20405	0.21926	1.37842	0.00000	0.00000	0.00000
24	-1.22663	1.25160	-1.33948	0.00000	0.00000	0.00000
51	0.00491	0.01408	-0.02127	0.00000	0.00000	0.00000
SUM	-0.01768	1.48494	0.01768	0.00000	0.00000	0.00000

Condition **LC51=1.2D-WL150+1.6LLa1**

10	1.20080	0.21928	1.38204	0.00000	0.00000	0.00000
24	-1.23064	1.25140	-1.33051	0.00000	0.00000	0.00000
51	0.00651	0.01426	-0.02820	0.00000	0.00000	0.00000
SUM	-0.02333	1.48494	0.02333	0.00000	0.00000	0.00000

Condition **LC52=1.2D+WL0+1.6LLa2**

10	0.01446	0.21609	1.38941	0.00000	0.00000	0.00000
24	-0.01519	1.25524	-1.34825	0.00000	0.00000	0.00000
51	0.00073	0.01362	-0.00316	0.00000	0.00000	0.00000
SUM	0.00000	1.48494	0.03800	0.00000	0.00000	0.00000

Condition **LC53=1.2D+WL30+1.6LLa2**

10	0.02788	0.21618	1.37959	0.00000	0.00000	0.00000
24	0.00122	1.25588	-1.38125	0.00000	0.00000	0.00000
51	-0.00577	0.01289	0.02499	0.00000	0.00000	0.00000
SUM	0.02333	1.48494	0.02333	0.00000	0.00000	0.00000

Condition **LC54=1.2D+WL60+1.6LLa2**

10	0.02462	0.21604	1.37653	0.00000	0.00000	0.00000
24	-0.00257	1.25586	-1.37783	0.00000	0.00000	0.00000
51	-0.00438	0.01304	0.01897	0.00000	0.00000	0.00000
SUM	0.01768	1.48494	0.01768	0.00000	0.00000	0.00000

Condition **LC55=1.2D+WL90+1.6LLa2**

10	0.02707	0.21586	1.36586	0.00000	0.00000	0.00000
24	0.00071	1.25619	-1.39089	0.00000	0.00000	0.00000
51	-0.00578	0.01289	0.02503	0.00000	0.00000	0.00000
SUM	0.02200	1.48494	0.00000	0.00000	0.00000	0.00000

Condition **LC56=1.2D+WL120+1.6LLa2**

10	0.02460	0.21568	1.35561	0.00000	0.00000	0.00000
24	-0.00191	1.25629	-1.39498	0.00000	0.00000	0.00000
51	-0.00501	0.01297	0.02169	0.00000	0.00000	0.00000
SUM	0.01768	1.48494	-0.01768	0.00000	0.00000	0.00000

Condition **LC57=1.2D+WL150+1.6LLa2**

10	0.02785	0.21567	1.35198	0.00000	0.00000	0.00000
24	0.00209	1.25647	-1.40394	0.00000	0.00000	0.00000
51	-0.00660	0.01280	0.02862	0.00000	0.00000	0.00000
SUM	0.02333	1.48494	-0.02333	0.00000	0.00000	0.00000

Condition **LC58=1.2D-WL0+1.6LLa2**

10	0.01440	0.21523	1.34451	0.00000	0.00000	0.00000
24	-0.01365	1.25627	-1.38576	0.00000	0.00000	0.00000
51	-0.00075	0.01345	0.00325	0.00000	0.00000	0.00000
SUM	0.00000	1.48494	-0.03800	0.00000	0.00000	0.00000

Condition **LC59=1.2D-WL30+1.6LLa2**

10	0.00098	0.21513	1.35434	0.00000	0.00000	0.00000
24	-0.03006	1.25563	-1.35276	0.00000	0.00000	0.00000
51	0.00575	0.01418	-0.02491	0.00000	0.00000	0.00000
SUM	-0.02333	1.48494	-0.02333	0.00000	0.00000	0.00000

Condition **LC60=1.2D-WL60+1.6LLa2**

10	0.00424	0.21527	1.35740	0.00000	0.00000	0.00000
24	-0.02627	1.25566	-1.35618	0.00000	0.00000	0.00000
51	0.00436	0.01402	-0.01889	0.00000	0.00000	0.00000
SUM	-0.01768	1.48494	-0.01768	0.00000	0.00000	0.00000

Condition **LC61=1.2D-WL90+1.6LLa2**

10	0.00179	0.21545	1.36806	0.00000	0.00000	0.00000
24	-0.02955	1.25532	-1.34312	0.00000	0.00000	0.00000
51	0.00576	0.01418	-0.02494	0.00000	0.00000	0.00000
SUM	-0.02200	1.48494	0.00000	0.00000	0.00000	0.00000

Condition **LC62=1.2D-WL120+1.6LLa2**

10	0.00426	0.21563	1.37831	0.00000	0.00000	0.00000
24	-0.02693	1.25523	-1.33903	0.00000	0.00000	0.00000
51	0.00499	0.01409	-0.02161	0.00000	0.00000	0.00000
SUM	-0.01768	1.48494	0.01768	0.00000	0.00000	0.00000

Condition **LC63=1.2D-WL150+1.6LLa2**

10	0.00101	0.21564	1.38194	0.00000	0.00000	0.00000
24	-0.03093	1.25504	-1.33007	0.00000	0.00000	0.00000
51	0.00659	0.01427	-0.02854	0.00000	0.00000	0.00000
SUM	-0.02333	1.48494	0.02333	0.00000	0.00000	0.00000

Condition **LC64=1.2D+WL0+1.6LLa3**

10	-1.18537	0.15271	1.38950	0.00000	0.00000	0.00000
24	1.18455	1.31861	-1.34794	0.00000	0.00000	0.00000
51	0.00082	0.01363	-0.00356	0.00000	0.00000	0.00000
SUM	0.00000	1.48494	0.03800	0.00000	0.00000	0.00000

Condition **LC65=1.2D+WL30+1.6LLa3**

10	-1.17198	0.15288	1.37964	0.00000	0.00000	0.00000
24	1.20099	1.31917	-1.38092	0.00000	0.00000	0.00000
51	-0.00568	0.01289	0.02462	0.00000	0.00000	0.00000
SUM	0.02333	1.48494	0.02333	0.00000	0.00000	0.00000

Condition **LC66=1.2D+WL60+1.6LLa3**

10	-1.17523	0.15273	1.37659	0.00000	0.00000	0.00000
24	1.19720	1.31916	-1.37751	0.00000	0.00000	0.00000
51	-0.00429	0.01305	0.01860	0.00000	0.00000	0.00000
SUM	0.01768	1.48494	0.01768	0.00000	0.00000	0.00000

Condition **LC67=1.2D+WL90+1.6LLa3**

10	-1.17279	0.15257	1.36591	0.00000	0.00000	0.00000
24	1.20048	1.31949	-1.39058	0.00000	0.00000	0.00000
51	-0.00569	0.01289	0.02466	0.00000	0.00000	0.00000
SUM	0.02200	1.48494	0.00000	0.00000	0.00000	0.00000

Condition **LC68=1.2D+WL120+1.6LLa3**

10	-1.17525	0.15237	1.35567	0.00000	0.00000	0.00000
24	1.19785	1.31959	-1.39468	0.00000	0.00000	0.00000
51	-0.00492	0.01298	0.02133	0.00000	0.00000	0.00000
SUM	0.01768	1.48494	-0.01768	0.00000	0.00000	0.00000

Condition **LC69=1.2D+WL150+1.6LLa3**

10	-1.17201	0.15238	1.35203	0.00000	0.00000	0.00000
24	1.20186	1.31977	-1.40363	0.00000	0.00000	0.00000
51	-0.00652	0.01279	0.02826	0.00000	0.00000	0.00000
SUM	0.02333	1.48494	-0.02333	0.00000	0.00000	0.00000

Condition **LC70=1.2D-WL0+1.6LLa3**

10	-1.18542	0.15186	1.34460	0.00000	0.00000	0.00000
24	1.18609	1.31963	-1.38548	0.00000	0.00000	0.00000
51	-0.00066	0.01346	0.00288	0.00000	0.00000	0.00000
SUM	0.00000	1.48494	-0.03800	0.00000	0.00000	0.00000

Condition **LC71=1.2D-WL30+1.6LLa3**

10	-1.19882	0.15168	1.35446	0.00000	0.00000	0.00000
24	1.16965	1.31906	-1.35250	0.00000	0.00000	0.00000
51	0.00584	0.01420	-0.02530	0.00000	0.00000	0.00000
SUM	-0.02333	1.48494	-0.02333	0.00000	0.00000	0.00000

Condition **LC72=1.2D-WL60+1.6LLa3**

10	-1.19557	0.15183	1.35751	0.00000	0.00000	0.00000
24	1.17344	1.31907	-1.35592	0.00000	0.00000	0.00000
51	0.00445	0.01404	-0.01928	0.00000	0.00000	0.00000
SUM	-0.01768	1.48494	-0.01768	0.00000	0.00000	0.00000

Condition **LC73=1.2D-WL90+1.6LLa3**

10	-1.19801	0.15200	1.36819	0.00000	0.00000	0.00000
24	1.17016	1.31875	-1.34285	0.00000	0.00000	0.00000
51	0.00585	0.01420	-0.02534	0.00000	0.00000	0.00000
SUM	-0.02200	1.48494	0.00000	0.00000	0.00000	0.00000

Condition **LC74=1.2D-WL120+1.6LLa3**

10	-1.19555	0.15219	1.37843	0.00000	0.00000	0.00000
24	1.17279	1.31864	-1.33874	0.00000	0.00000	0.00000
51	0.00508	0.01411	-0.02201	0.00000	0.00000	0.00000
SUM	-0.01768	1.48494	0.01768	0.00000	0.00000	0.00000

Condition **LC75=1.2D-WL150+1.6LLa3**

10	-1.19879	0.15218	1.38207	0.00000	0.00000	0.00000
24	1.16878	1.31847	-1.32979	0.00000	0.00000	0.00000
51	0.00668	0.01429	-0.02894	0.00000	0.00000	0.00000
SUM	-0.02333	1.48494	0.02333	0.00000	0.00000	0.00000

**Envelope for nodal reactions**

Note.- **Ic** is the controlling load condition

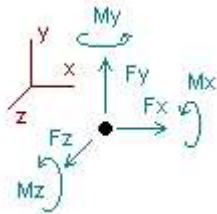

Direction of positive forces and moments

Envelope of nodal reactions for :

LC1=1.2D+W0  
LC2=1.2D+W30  
LC3=1.2D+W60  
LC4=1.2D+W90  
LC5=1.2D+W120  
LC6=1.2D+W150  
LC7=1.2D-W0  
LC8=1.2D-W30  
LC9=1.2D-W60  
LC10=1.2D-W90  
LC11=1.2D-W120  
LC12=1.2D-W150  
LC13=0.9D+W0  
LC14=0.9D+W30  
LC15=0.9D+W60  
LC16=0.9D+W90  
LC17=0.9D+W120  
LC18=0.9D+W150  
LC19=0.9D-W0  
LC20=0.9D-W30  
LC21=0.9D-W60  
LC22=0.9D-W90  
LC23=0.9D-W120  
LC24=0.9D-W150  
LC25=1.2D+Di+W10  
LC26=1.2D+Di+W130  
LC27=1.2D+Di+W160  
LC28=1.2D+Di+W190  
LC29=1.2D+Di+W120  
LC30=1.2D+Di+W150  
LC31=1.2D+Di-W10  
LC32=1.2D+Di-W130  
LC33=1.2D+Di-W160  
LC34=1.2D+Di-W190  
LC35=1.2D+Di-W120  
LC36=1.2D+Di-W150  
LC37=1.2D+1.6LL1  
LC38=1.2D+1.6LL2  
LC39=1.2D+1.6LL3  
LC40=1.2D+W10+1.6LLa1  
LC41=1.2D+W130+1.6LLa1  
LC42=1.2D+W160+1.6LLa1  
LC43=1.2D+W190+1.6LLa1  
LC44=1.2D+W120+1.6LLa1  
LC45=1.2D+W150+1.6LLa1  
LC46=1.2D-W10+1.6LLa1  
LC47=1.2D-W130+1.6LLa1  
LC48=1.2D-W160+1.6LLa1  
LC49=1.2D-W190+1.6LLa1  
LC50=1.2D-W120+1.6LLa1  
LC51=1.2D-W150+1.6LLa1  
LC52=1.2D+W10+1.6LLa2  
LC53=1.2D+W130+1.6LLa2  
LC54=1.2D+W160+1.6LLa2  
LC55=1.2D+W190+1.6LLa2  
LC56=1.2D+W120+1.6LLa2  
LC57=1.2D+W150+1.6LLa2  
LC58=1.2D-W10+1.6LLa2  
LC59=1.2D-W130+1.6LLa2  
LC60=1.2D-W160+1.6LLa2  
LC61=1.2D-W190+1.6LLa2  
LC62=1.2D-W120+1.6LLa2  
LC63=1.2D-W150+1.6LLa2

LC64=1.2D+WL0+1.6LLa3  
 LC65=1.2D+WL30+1.6LLa3  
 LC66=1.2D+WL60+1.6LLa3  
 LC67=1.2D+WL90+1.6LLa3  
 LC68=1.2D+WL120+1.6LLa3  
 LC69=1.2D+WL150+1.6LLa3  
 LC70=1.2D-WL0+1.6LLa3  
 LC71=1.2D-WL30+1.6LLa3  
 LC72=1.2D-WL60+1.6LLa3  
 LC73=1.2D-WL90+1.6LLa3  
 LC74=1.2D-WL120+1.6LLa3  
 LC75=1.2D-WL150+1.6LLa3

Node		Forces						Moments					
		Fx [Kip]	lc	Fy [Kip]	lc	Fz [Kip]	lc	Mx [Kip*ft]	lc	My [Kip*ft]	lc	Mz [Kip*ft]	lc
10	Max	1.228	LC41	0.220	LC41	1.390	LC40	0.00000	LC1	0.00000	LC1	0.00000	LC1
	Min	-1.199	LC71	0.051	LC20	-0.258	LC19	0.00000	LC1	0.00000	LC1	0.00000	LC1
24	Max	1.202	LC69	1.320	LC69	0.517	LC24	0.00000	LC1	0.00000	LC1	0.00000	LC1
	Min	-1.231	LC51	0.392	LC24	-1.536	LC6	0.00000	LC1	0.00000	LC1	0.00000	LC1
51	Max	0.178	LC10	0.037	LC10	0.914	LC4	0.00000	LC1	0.00000	LC1	0.00000	LC1
	Min	-0.179	LC4	-0.013	LC16	-0.915	LC10	0.00000	LC1	0.00000	LC1	0.00000	LC1

**Connection Check**

Date: 9/8/2023  
Project No.: BOBOS01169A  
Designed By: KM Checked By: MSC



### CHECK CONNECTION CAPACITY (Worst Case)

**Reference:** AISC Steel Construction Manual 14th Edition (ASD)

**Bolt Type =** A36 5/8" Threaded Rod

**Allowable Tensile Load =**

$$F_{Tall} = 6673 \text{ lbs.}$$

**Allowable Shear Load =**

$$F_{vall} = 4004 \text{ lbs.}$$

### TENSILE FORCES

**Reaction**  $F = 1536$  lbs. (See Bentley Output)

### SHEAR FORCES

**Reactions in X direction:** 1231 lbs. (See Bentley Output)

**Reactions in Y direction:** 1320 lbs. (See Bentley Output)

**Resultant:** 1805 lbs.

**No. of Supports =** 1

**No. of Rods / Support =** 2

**Tension Design Load / Rods =**

$$f_t = 768.00 \text{ lbs.} < 6673 \text{ lbs.} \text{ Therefore, OK!}$$

**Shear Design Load / Rods =**

$$f_v = 902.46 \text{ lbs.} < 4004 \text{ lbs.} \text{ Therefore, OK!}$$

### CHECK COMBINED TENSION AND SHEAR

$$\begin{array}{rclclcl} f_t / F_T & + & f_v / F_v & \leq & 1.0 & \\ 0.115 & + & 0.225 & = & 0.341 & < 1.0 \text{ Therefore, OK!} \end{array}$$



# EXHIBIT 10

## Construction Drawings



DISH Wireless L.L.C. SITE ID:  
**BOBOS01169A**

DISH Wireless L.L.C. SITE ADDRESS:  
**131 GIFFORD LANE  
BOZRAH, CT 06334**



By Stephen Roth at 3:55:58 PM, 10/4/2023

**SCOPE OF WORK**

THIS IS NOT AN ALL INCLUSIVE LIST. CONTRACTOR SHALL UTILIZE SPECIFIED EQUIPMENT PART OR ENGINEER APPROVED EQUIVALENT. CONTRACTOR SHALL VERIFY ALL NEEDED EQUIPMENT TO PROVIDE A FUNCTIONAL SITE. THE PROJECT GENERALLY CONSISTS OF THE FOLLOWING:

- TOWER SCOPE OF WORK:**
- INSTALL (3) PROPOSED PANEL ANTENNAS (1 PER SECTOR)
  - INSTALL (1) PROPOSED ANTENNA MOUNT
  - INSTALL PROPOSED JUMPERS
  - INSTALL (6) PROPOSED RRUs (2 PER SECTOR)
  - INSTALL (1) PROPOSED OVER VOLTAGE PROTECTION DEVICE (OVP)
  - INSTALL (1) PROPOSED HYBRID CABLE

- GROUND SCOPE OF WORK:**
- INSTALL (1) PROPOSED PPC CABINET
  - INSTALL (1) PROPOSED EQUIPMENT CABINET
  - INSTALL (1) PROPOSED POWER CONDUIT
  - INSTALL (1) PROPOSED TELCO CONDUIT
  - INSTALL (1) PROPOSED TELCO-FIBER BOX
  - INSTALL (1) PROPOSED GPS UNIT
  - INSTALL (1) PROPOSED SAFETY SWITCH (IF REQUIRED)
  - INSTALL (1) PROPOSED FIBER NID (IF REQUIRED)
  - INSTALL (1) PROPOSED METER IN EXISTING SOCKET

SITE INFORMATION	PROJECT DIRECTORY
PROPERTY OWNER: RICHARD ORR AND PATTI DUERRLER ADDRESS: 131 GIFFORD LANE BOZRAH, CT 06334	APPLICANT: DISH Wireless L.L.C. 5701 SOUTH SANTA FE DRIVE LITTLETON, CO 80120
COUNTY: NEW LONDON TOWER TYPE: SELF SUPPORTING TOWER TOWER HEIGHT: 196'-0" AGL HIGHEST APPURTENANCE: 200'-0" AGL GROUND ELEVATION: 451'-0" AMSL TOTAL AMSL: 651'-0" AMSL	TOWER OWNER: SBA TOWERS, LLC 8501 CONGRESS AVE BOCA RATON, FL 33487 PHONE # 561-226-9523
SBA SITE ID: CT01105-S SBA SITE NAME: BOZRAH LATITUDE (NAD 83): 41° 33' 09.06" N 41.552517	SITE DESIGNER: TEP NORTHEAST 45 BEECHWOOD DRIVE NORTH ANDOVER, MA 01845 PHONE # 978-557-5553
LONGITUDE (NAD 83): 72° 09' 02.54" W -72.150708	SITE ACQUISITION: GREGORY COSTELLO GREG.COSTELLO@DISH.COM
ZONING JURISDICTION: TOWN OF BOZRAH, CT	CONSTRUCTION MANAGER: RICHARD BUKER RICHARD.BUKER@DISH.COM
ZONING DISTRICT: RESIDENTIAL	RF ENGINEER: IRMA SEBASTIAN IRMA.SEBASTIAN@DISH.COM
PARCEL NUMBER: 13-07/119-B	
OCCUPANCY GROUP: U	
CONSTRUCTION TYPE: II-B	
POWER COMPANY: BOZRAH LIGHT & POWER	
TELEPHONE COMPANY: TBD	



5701 SOUTH SANTA FE DRIVE LITTLETON, CO 80120



SBA COMMUNICATIONS CORP.  
134 FLANDERS ROAD, SUITE 125 WESTBOROUGH, MA 01581  
TEL: (508) 251-0720  
FAX: (508) 251-1755



45 BEECHWOOD DRIVE, NORTH ANDOVER, MA 01845  
TEL: (978) 557-5553

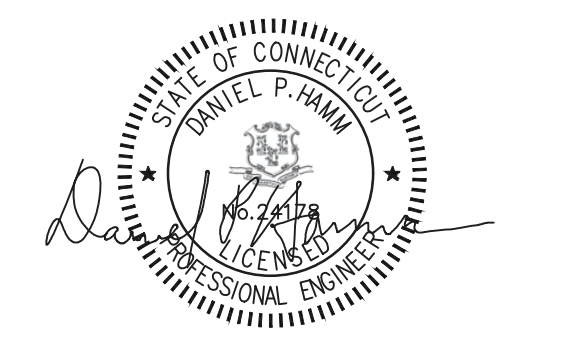

IT IS A VIOLATION OF LAW FOR ANY PERSON, UNLESS THEY ARE ACTING UNDER THE DIRECTION OF A LICENSED PROFESSIONAL ENGINEER, TO ALTER THIS DOCUMENT.

DRAWN BY: TR  
CHECKED BY: VD  
APPROVED BY: DPH

RFDS REV #: 0

**CONSTRUCTION DOCUMENTS**

SUBMITTALS		
REV	DATE	DESCRIPTION
A	09/11/2023	ISSUED FOR REVIEW
B	09/25/2023	ISSUED FOR CONSTRUCTION

A&E PROJECT NUMBER  
**BOBOS01169A**

DISH Wireless L.L.C.  
PROJECT INFORMATION  
**BOBOS01169A  
131 GIFFORD LANE  
BOZRAH, CT 06334**

SHEET TITLE  
**TITLE SHEET**

SHEET NUMBER  
**T-1**

**CONNECTICUT CODE OF COMPLIANCE**

ALL WORK SHALL BE PERFORMED AND MATERIALS INSTALLED IN ACCORDANCE WITH THE CURRENT EDITIONS OF THE FOLLOWING CODES AS ADOPTED BY THE LOCAL GOVERNING AUTHORITIES. NOTHING IN THESE PLANS IS TO BE CONSTRUED TO PERMIT WORK NOT CONFORMING TO THESE CODES

CODE TYPE	CODE
BUILDING	2022 CT STATE BUILDING CODE/2021 IBC W/ CT AMENDMENTS
MECHANICAL	2022 CT STATE BUILDING CODE/2021 IMC W/ CT AMENDMENTS
ELECTRICAL	2022 CT STATE BUILDING CODE/NFPA 70, 2020 NEC

**SHEET INDEX**

SHEET NO.	SHEET TITLE
T-1	TITLE SHEET
A-1	OVERALL AND ENLARGED SITE PLAN
A-2	ELEVATION, ANTENNA LAYOUT AND SCHEDULE
A-3	EQUIPMENT PLATFORM AND H-FRAME DETAILS
A-4	EQUIPMENT DETAILS
A-5	EQUIPMENT DETAILS
A-6	EQUIPMENT DETAILS
E-1	ELECTRICAL/FIBER ROUTE PLAN AND NOTES
E-2	ELECTRICAL DETAILS
E-3	ELECTRICAL ONE-LINE, FAULT CALCS & PANEL SCHEDULE
E-4	PPC NEUTRAL-TO-GROUND SCHEMATIC
G-1	GROUNDING PLANS AND NOTES
G-2	GROUNDING DETAILS
G-3	GROUNDING DETAILS
RF-1	RF CABLE COLOR CODE
GN-1	LEGEND AND ABBREVIATIONS
GN-2	RF SIGNAGE
GN-3	GENERAL NOTES
GN-4	GENERAL NOTES
GN-5	GENERAL NOTES

**SITE PHOTO**



UNDERGROUND SERVICE ALERT CBYD 811  
UTILITY NOTIFICATION CENTER OF CONNECTICUT  
(800) 922-4455  
WWW.CBYD.COM  
CALL 2 WORKING DAYS UTILITY NOTIFICATION PRIOR TO CONSTRUCTION

**GENERAL NOTES**

THE FACILITY IS UNMANNED AND NOT FOR HUMAN HABITATION. A TECHNICIAN WILL VISIT THE SITE AS REQUIRED FOR ROUTINE MAINTENANCE. THE PROJECT WILL NOT RESULT IN ANY SIGNIFICANT DISTURBANCE OR EFFECT ON DRAINAGE, NO SANITARY SEWER SERVICE, POTABLE WATER, OR TRASH DISPOSAL IS REQUIRED AND NO COMMERCIAL SIGNAGE IS PROPOSED.

**11"x17" PLOT WILL BE HALF SCALE UNLESS OTHERWISE NOTED**

CONTRACTOR SHALL VERIFY ALL PLANS, EXISTING DIMENSIONS, AND CONDITIONS ON THE JOB SITE, AND SHALL IMMEDIATELY NOTIFY THE ENGINEER IN WRITING OF ANY DISCREPANCIES BEFORE PROCEEDING WITH THE WORK.

**DIRECTIONS**

**DIRECTIONS FROM BRADLEY INTERNATIONAL AIRPORT:**  
TURN RIGHT ONTO BEACON HILL RD, TURN RIGHT ONTO CT-75/ELLA GRASSO TPKE, TAKE RAMP ON RIGHT FOR I-91/CT-20 E AND HEAD TOWARD HARTFORD/SPRINGFIELD. TAKE RAMP FOR I-91 S AND HEAD FOR HARTFORD. AT EXIT 33 HEAD ON RAMP RIGHT AND FOLLOW SIGNS FOR JENNINGS RD. KEEP STRAIGHT TO GET ONTO I-91 S. TAKE RAMP FOR I-84 E/US-6 E/US-44 E. AT EXIT 55 HEAD RIGHT FOR CT-2 E TOWARD NEW LONDON/NORWICH. AT EXIT 23 HEAD RIGHT FOR RAMP FOR CT-163 TOWARDS BOZRAH/MONTVILLE, KEEP STRAIGHT, HEADING TOWARD BERA HILL WILDLIFE MANAGEMENT AREA/CAMP TADMA SCOUT RESERVATION/MONTVILLE. TURN LEFT ONTO GAGER RD, TURN LEFT ONTO GIFFORD LN.

**VICINITY MAP**

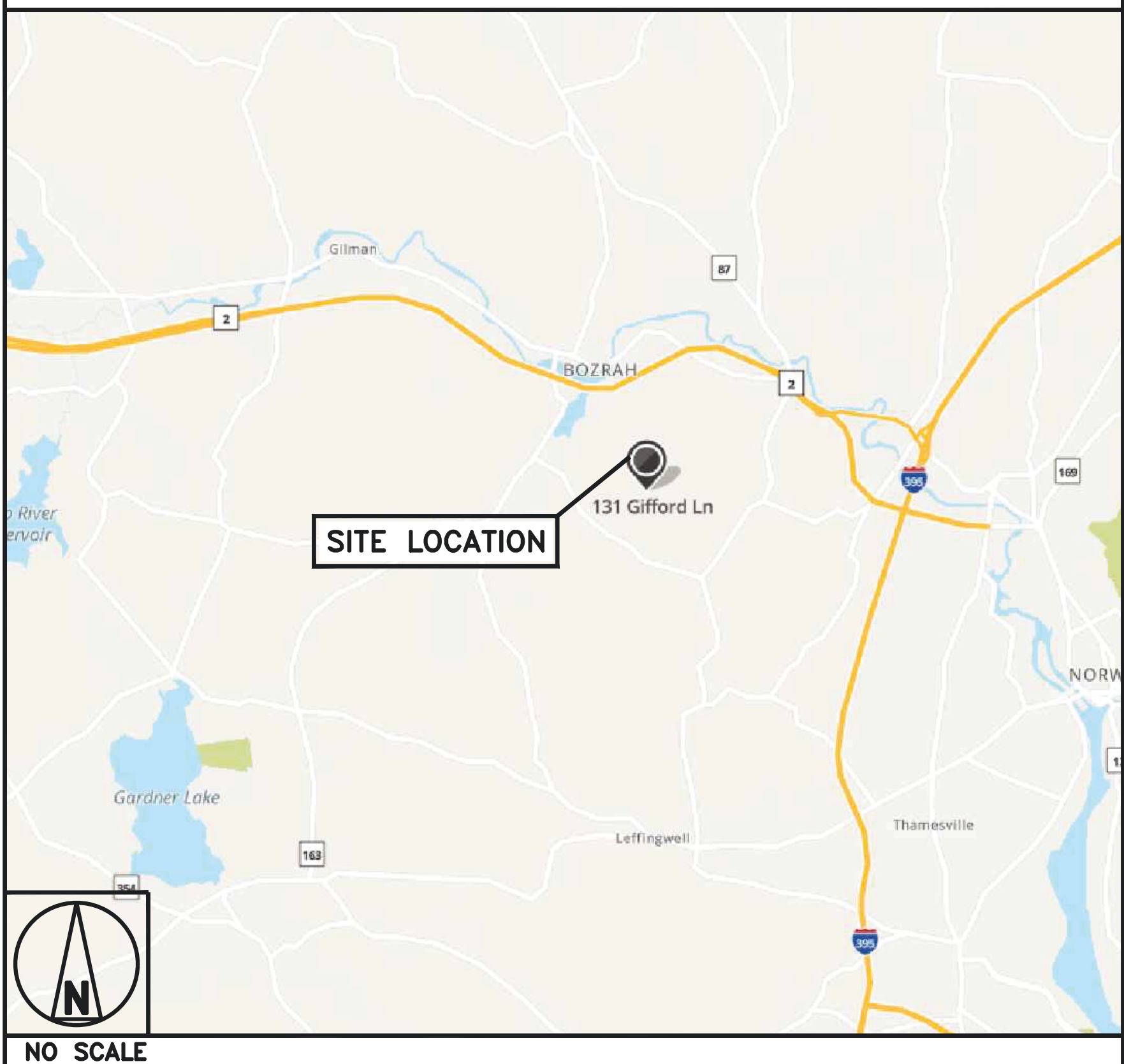

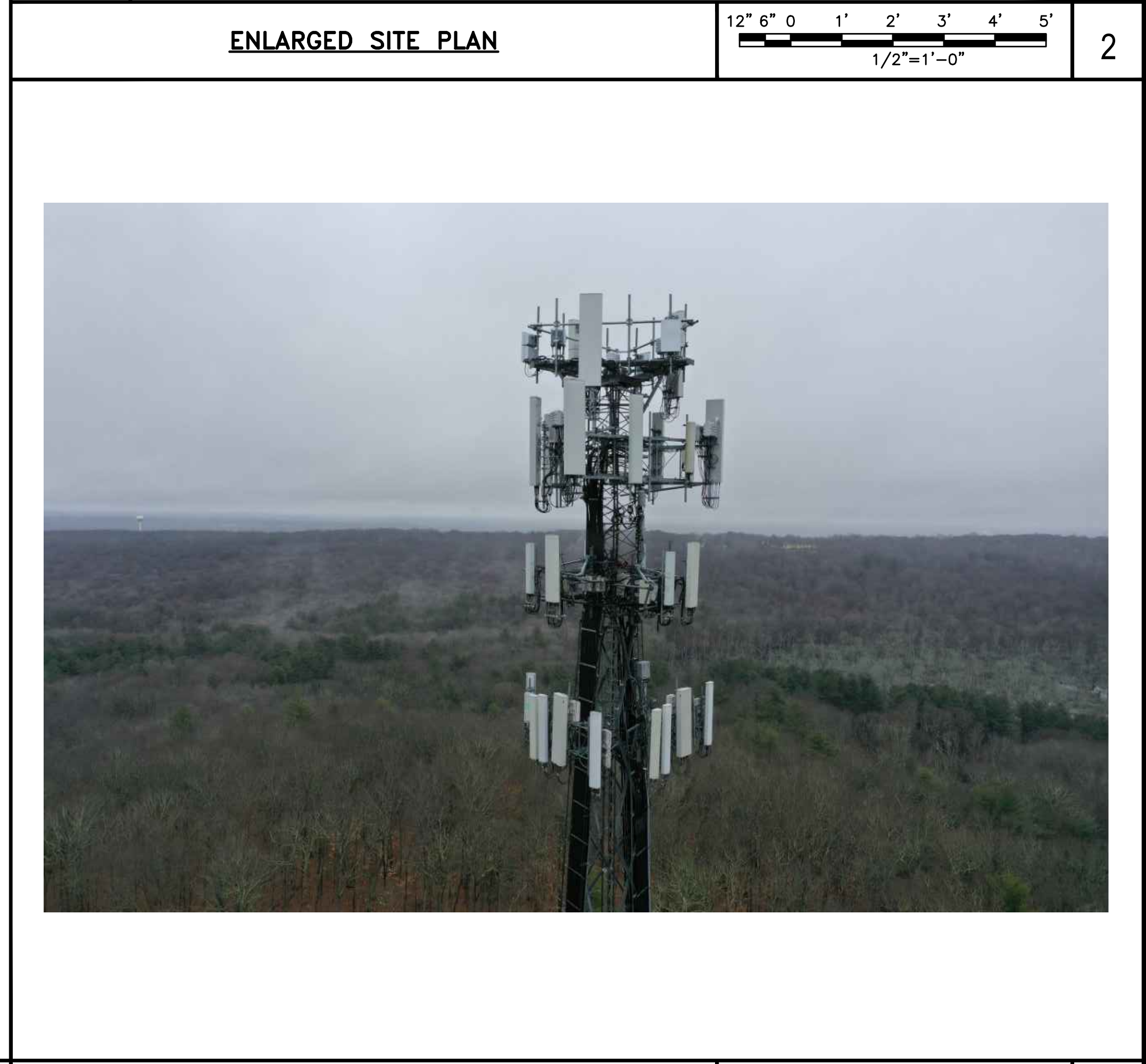
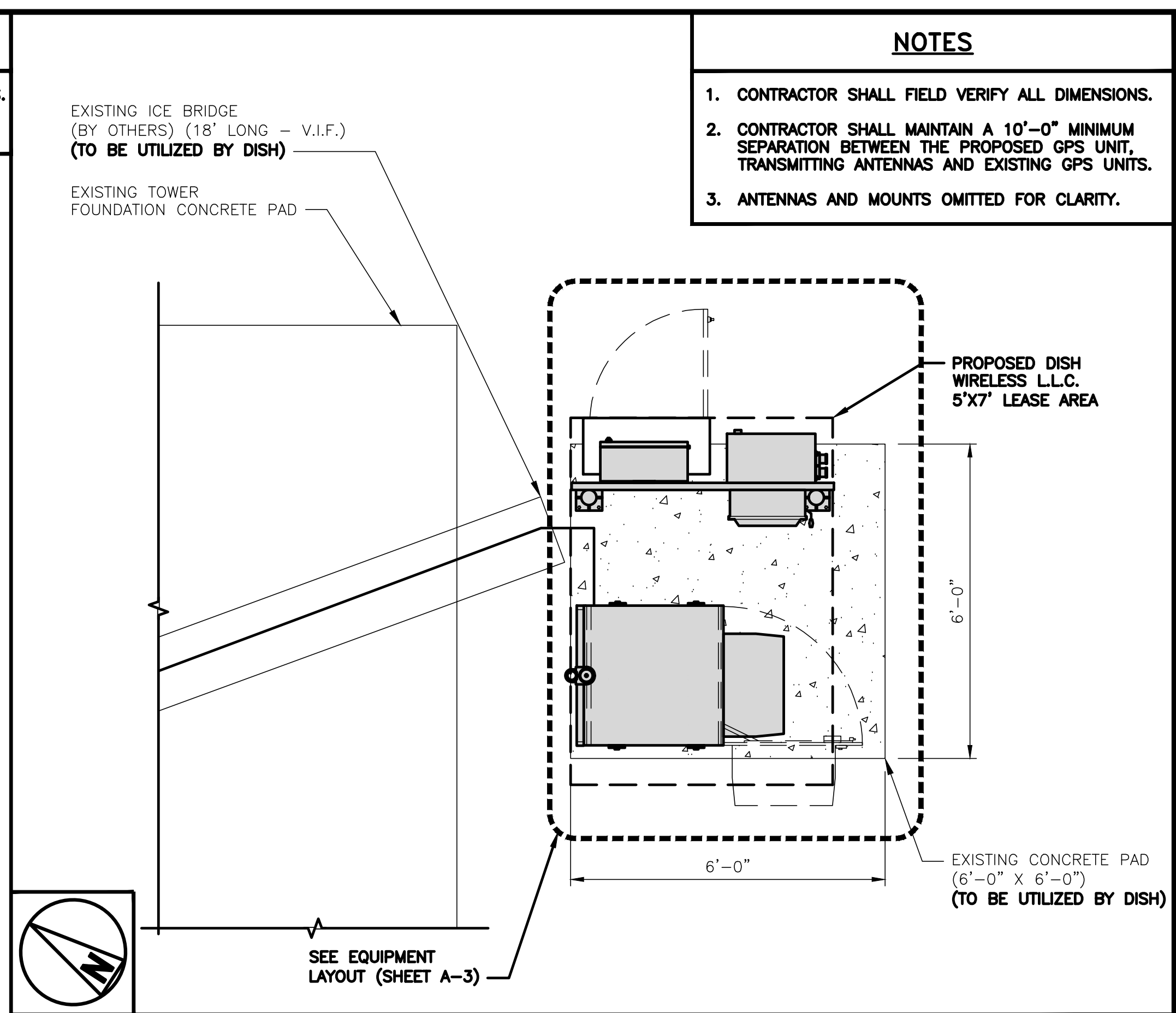
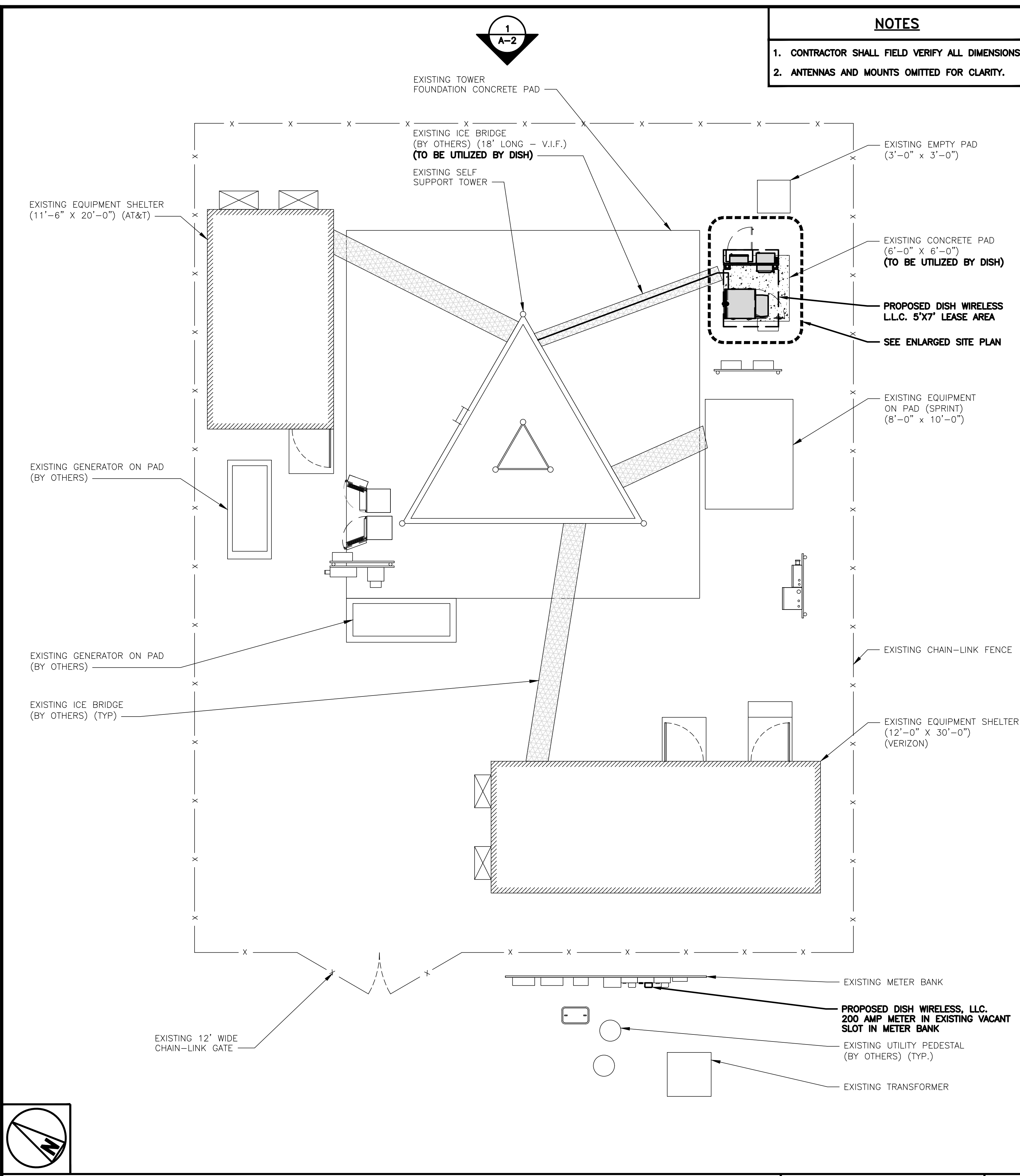

**dish wireless.**

5701 SOUTH SANTA FE DRIVE  
LITTLETON, CO 80120

**SBA**

SBA COMMUNICATIONS CORP.  
134 FLANDERS ROAD, SUITE 125  
WESTBOROUGH, MA 01581  
TEL: (508) 251-0720  
FAX: (508) 251-1755

**TEP NORTHEAST**  
TEP OP CO, LLC.  
45 BEECHWOOD DRIVE, NORTH ANDOVER, MA 01845  
TEL: (978) 557-5553

STATE OF CONNECTICUT  
DANIEL P. HUNN  
REGISTERED PROFESSIONAL ENGINEER

IT IS A VIOLATION OF LAW FOR ANY PERSON, UNLESS THEY ARE ACTING UNDER THE DIRECTION OF A LICENSED PROFESSIONAL ENGINEER, TO ALTER THIS DOCUMENT.

DRAWN BY: TR  
CHECKED BY: VD  
APPROVED BY: DPH

RFDS REV #: 0

**CONSTRUCTION DOCUMENTS**

SUBMITTALS		
REV	DATE	DESCRIPTION
A	09/11/2023	ISSUED FOR REVIEW
B	09/25/2023	ISSUED FOR CONSTRUCTION

A&E PROJECT NUMBER  
BOBOS01169A

DISH Wireless L.L.C.  
PROJECT INFORMATION  
BOBOS01169A  
131 GIFFORD LANE  
BOZRAH, CT 06334

SHEET TITLE  
OVERALL AND ENLARGED  
SITE PLAN

SHEET NUMBER  
**A-1**

- NOTES**
1. CONTRACTOR SHALL FIELD VERIFY ALL DIMENSIONS.
  2. ANTENNA AND MW DISH SPECIFICATIONS REFER TO ANTENNA SCHEDULE AND TO FINAL CONSTRUCTION RFDS FOR ALL RF DETAILS
  3. EXISTING EQUIPMENT AND FENCE OMITTED FOR CLARITY.

- STRUCTURAL NOTES**
- AN ASSESSMENT FOR THE CAPACITY OF THE PROPOSED ANTENNA MOUNT TO SUPPORT THE PROPOSED LOADING HAS BEEN COMPLETED BY: TEP NORTHEAST, DATED: SEPTEMBER 15, 2023
  - PRIOR TO COMMENCING CONSTRUCTION, GC SHALL REFER TO STRUCTURAL ANALYSIS PROVIDED BY SBA, DATED: AUGUST 31, 2023 TO DETERMINE IF THERE ANY SUPPLEMENTAL OR SPECIAL INSTALLATION REQUIREMENTS, OR RELOCATION ARRANGEMENTS.

**SELF SUPPORT TOWER FACE WIDTH AT DISH Wireless L.L.C. RAD CENTER**

**7'-0" AS PER TOWER OWNER SPECIFICATIONS**

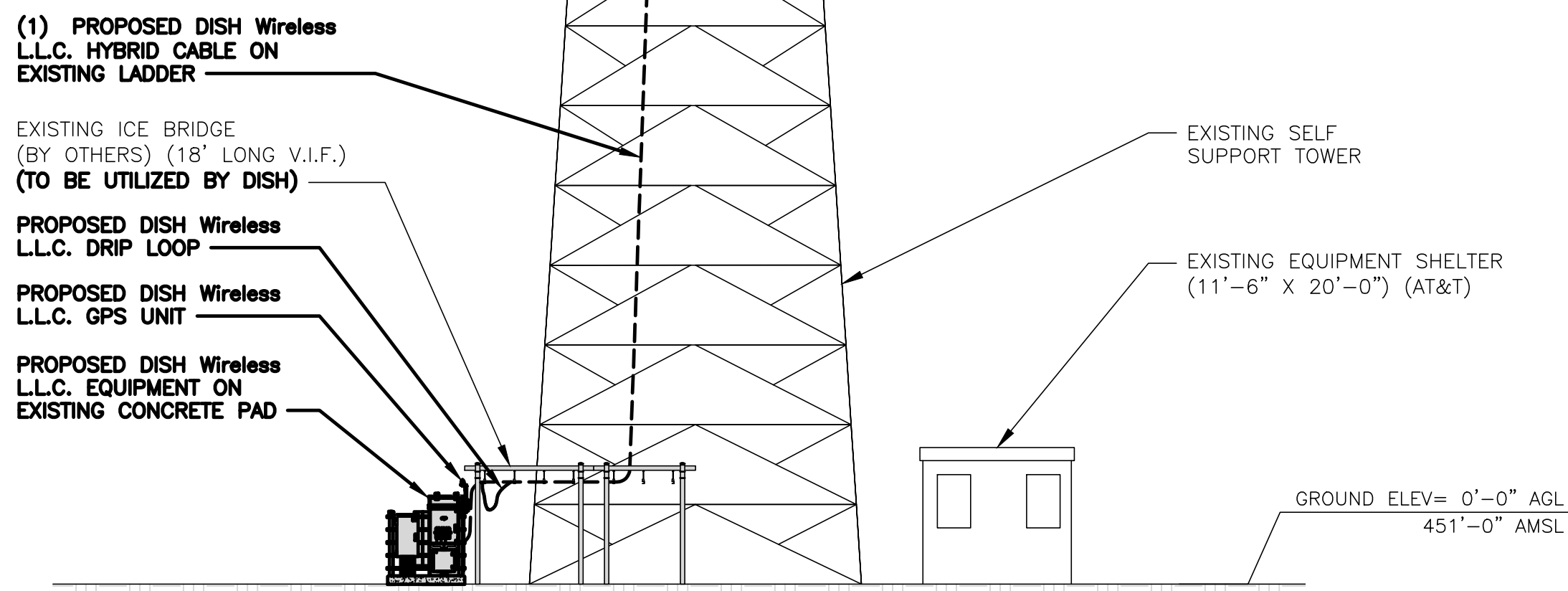
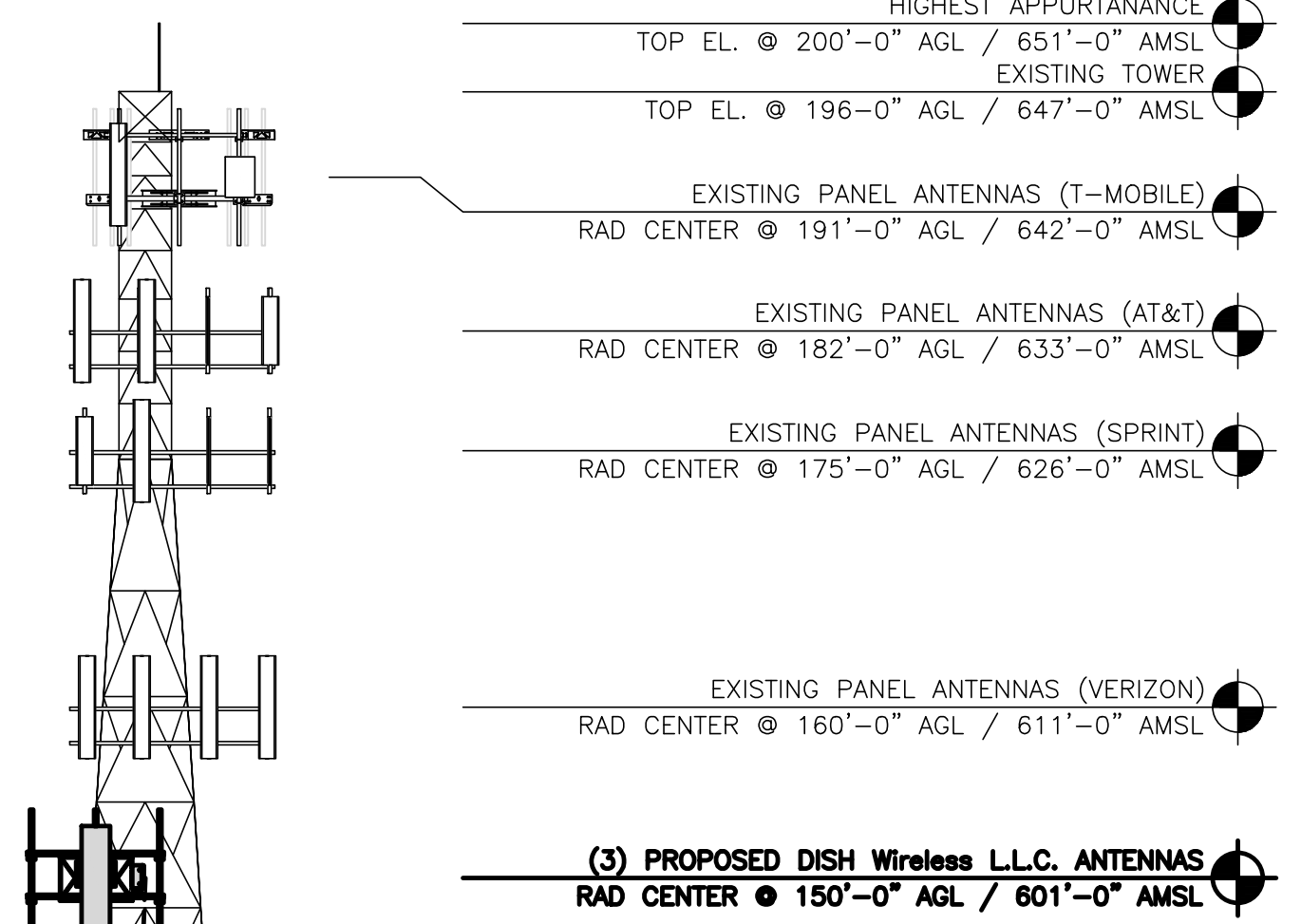

**PROPOSED NORTHEAST ELEVATION**

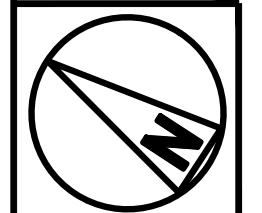
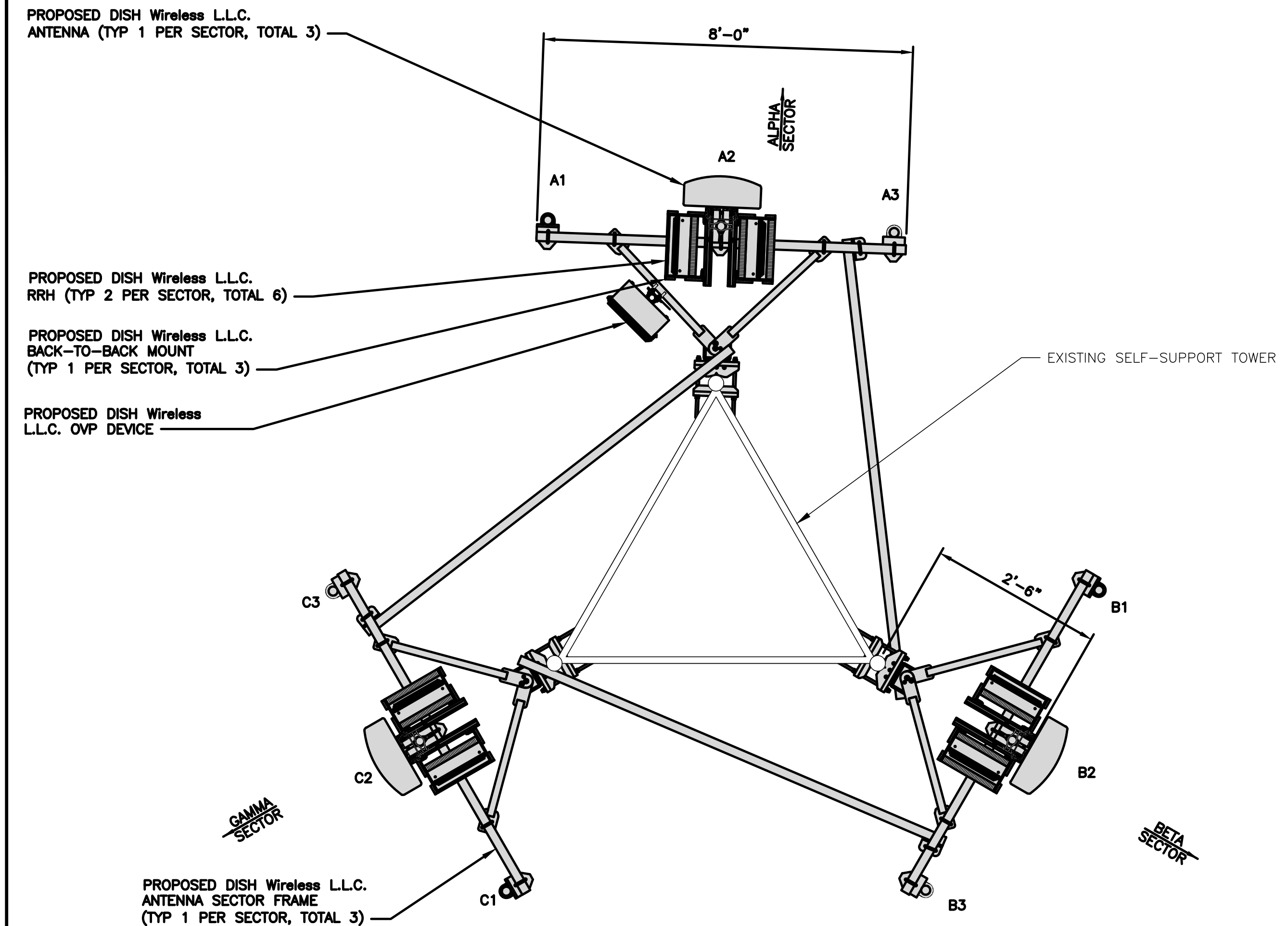
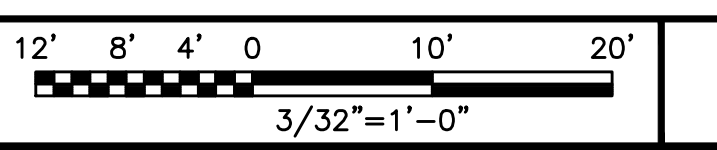

**ANTENNA LAYOUT**

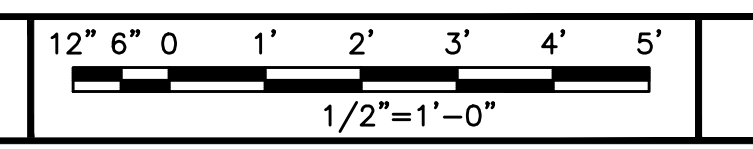

SECTOR POS.	ANTENNA					TRANSMISSION CABLE	RRH			OVP
	EXISTING OR PROPOSED	MANUFACTURER - MODEL NUMBER	TECH	AZIMUTH	RAD CENTER		FEED LINE TYPE AND LENGTH	MANUFACTURER - MODEL NUMBER	TECH	
A1	---	---	---	---	---	(1) HIGH-CAPACITY HYBRID CABLE (180'± LONG)	SAMSUNG - RF4450T-71A SFG-ARR3J601DI	5G	A2	RAYCAP-RDIDC-9181-PF-48
A2	PROPOSED	COMMSCOPE - FFV-65B-R2	5G	60°	150'-0"		SAMSUNG - RF4451D-70A SFG-ARR3KM01DI	5G	A2	
A3	---	---	---	---	---		---	---	---	
B1	---	---	---	---	---	SHARED W/ALPHA	SAMSUNG - RF4450T-71A SFG-ARR3J601DI	5G	B2	SHARED W/ALPHA
B2	PROPOSED	COMMSCOPE - FFV-65B-R2	5G	180°	150'-0"		SAMSUNG - RF4451D-70A SFG-ARR3KM01DI	5G	B2	
B3	---	---	---	---	---		---	---	---	
C1	---	---	---	---	---	SHARED W/ALPHA	SAMSUNG - RF4450T-71A SFG-ARR3J601DI	5G	C2	SHARED W/ALPHA
C2	PROPOSED	COMMSCOPE - FFV-65B-R2	5G	300°	150'-0"		SAMSUNG - RF4451D-70A SFG-ARR3KM01DI	5G	C2	
C3	---	---	---	---	---		---	---	---	

- NOTES**
1. CONTRACTOR TO REFER TO FINAL CONSTRUCTION RFDS FOR ALL RF DETAILS.
  2. ANTENNA AND RRH MODELS MAY CHANGE DUE TO EQUIPMENT AVAILABILITY. ALL EQUIPMENT CHANGES MUST BE APPROVED AND REMAIN IN COMPLIANCE WITH THE PROPOSED DESIGN AND STRUCTURAL ANALYSES.

**ANTENNA SCHEDULE**

NO SCALE 3



5701 SOUTH SANTA FE DRIVE  
LITTLETON, CO 80120



SBA COMMUNICATIONS CORP.  
134 FLANDERS ROAD, SUITE 125  
WESTBOROUGH, MA 01581  
TEL: (508) 251-0720  
FAX: (508) 251-1755



45 BEECHWOOD DRIVE, NORTH ANDOVER, MA 01845  
TEL: (978) 557-5553

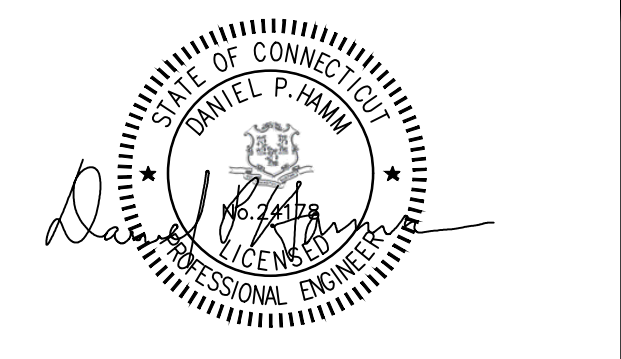

IT IS A VIOLATION OF LAW FOR ANY PERSON, UNLESS THEY ARE ACTING UNDER THE DIRECTION OF A LICENSED PROFESSIONAL ENGINEER, TO ALTER THIS DOCUMENT.

DRAWN BY: TR  
CHECKED BY: VD  
APPROVED BY: DPH

RFDS REV #: 0

**CONSTRUCTION DOCUMENTS**

**SUBMITTALS**

REV	DATE	DESCRIPTION
A	09/11/2023	ISSUED FOR REVIEW
B	09/25/2023	ISSUED FOR CONSTRUCTION

A&E PROJECT NUMBER  
BOBOS01169A

DISH Wireless L.L.C. PROJECT INFORMATION  
BOBOS01169A  
131 GIFFORD LANE  
BOZRAH, CT 06334

SHEET TITLE  
ELEVATION, ANTENNA LAYOUT AND SCHEDULE

SHEET NUMBER  
**A-2**

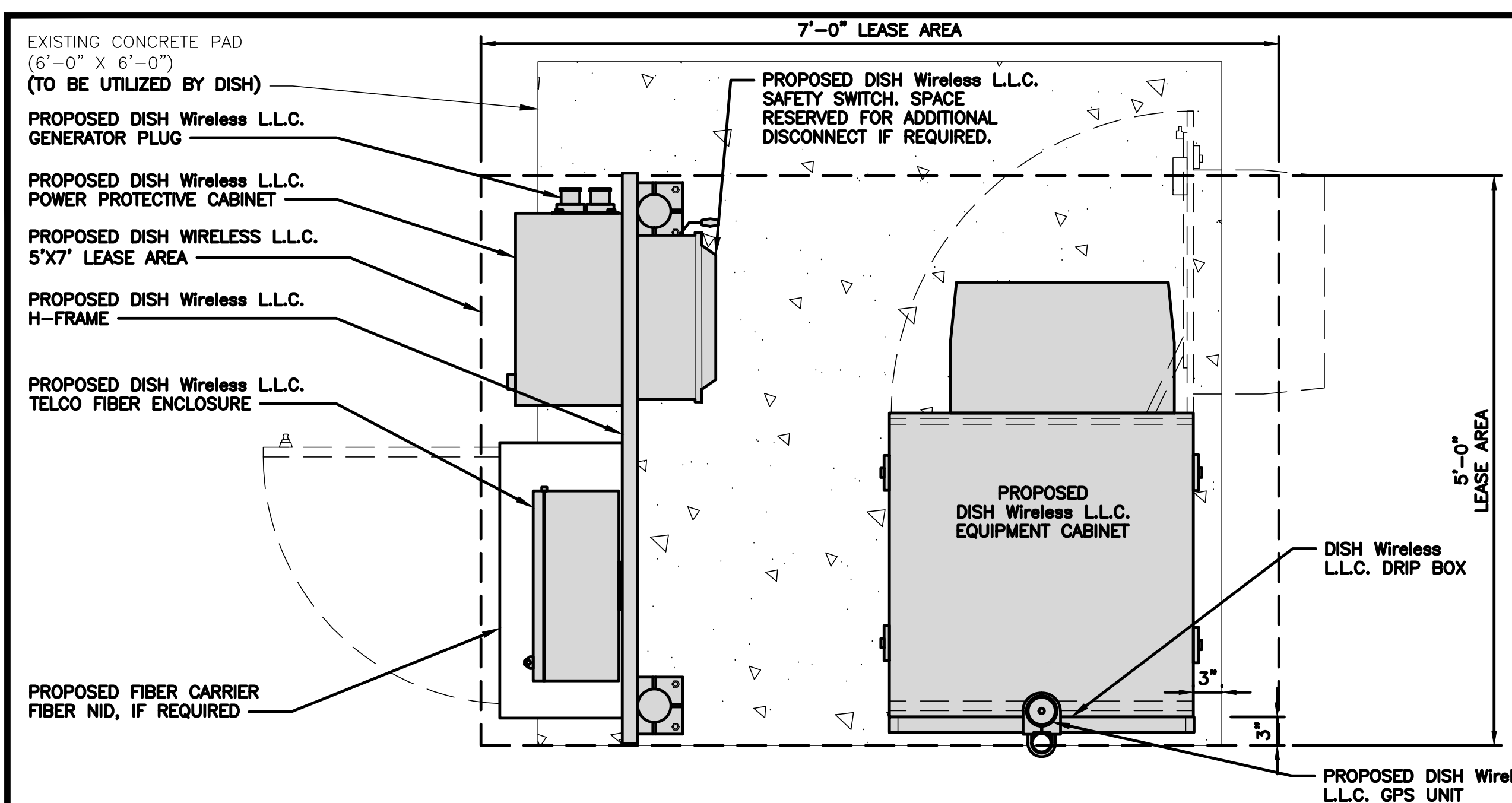

PLATFORM EQUIPMENT PLAN

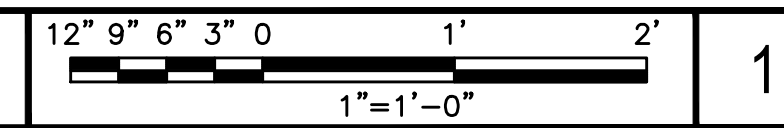

NOTES

- GPS MAY BE MOVED TO ICE BRIDGE OR H-FRAME.
- ALL CONDUIT TO BE ROUTED UNDERGROUND IN PVC COUPLERS. CONDUIT QUANTITY AND SIZES ARE PER ONE-LINE DIAGRAM ON E-3 SHEET OF CDS. (DC PLANT DEPENDENT.)
- CONTRACTOR MAY FIELD INSTALL CONDUIT HOLES IN BOTTOM OF PPC CABINET TO MATCH CONDUIT SIZES. (SEAL TO PPC MANUFACTURER SPECIFICATIONS).
- H-FRAME POSTS ARE STAGGERED TO ALLOW FIBER NID BOXES TO BE INSTALLED CLOSE TO PERIMETER FRAME OF PLATFORM.
- CONDUITS FROM PPC/FIBER DEMARK CABINETS TO EQUIPMENT CABINET (BBU) TO BE ROUTED ON TOP OF EXISTING CONCRETE PAD USING LIQUID TIGHT OR EMT CONDUIT.

NOTES

- CONTRACTOR TO BURY PLATFORM FEET WITH A MINIMUM OF 2" OF FILL PER EXISTING SITE SURFACE
- WEED BARRIER FABRIC TO BE ADDED AT DISCRETION OF DISH Wireless L.L.C. CONSTRUCTION MANAGER AT TIME OF CONSTRUCTION. ONE SHEET 8'x8' INSTALLED UNDER ALL FOUR FEET OF THE PLATFORM (4 MIL BLACK PLASTIC)
- EQUIPMENT CABINET OMITTED FOR CLARITY

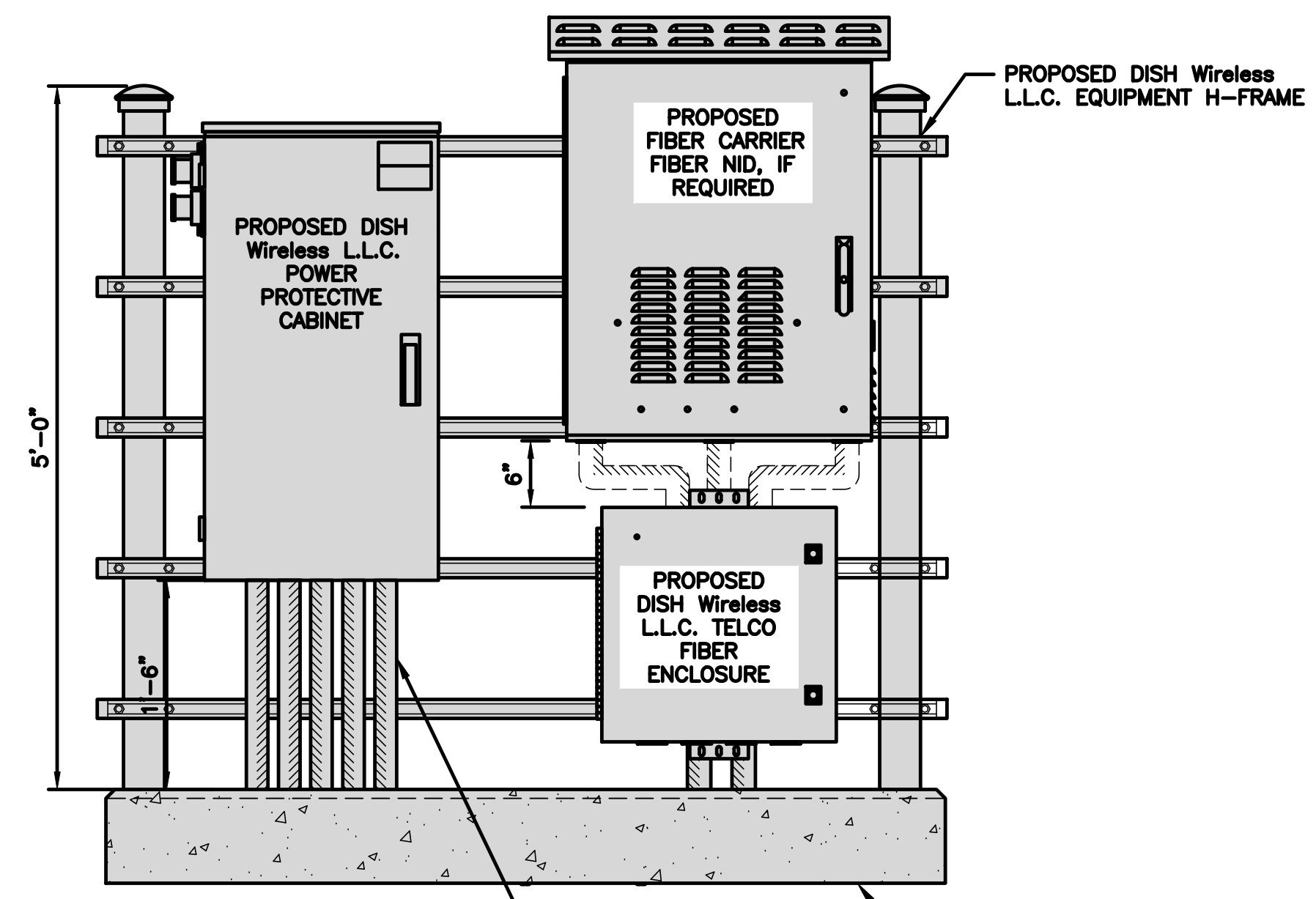

FRONT ELEVATION

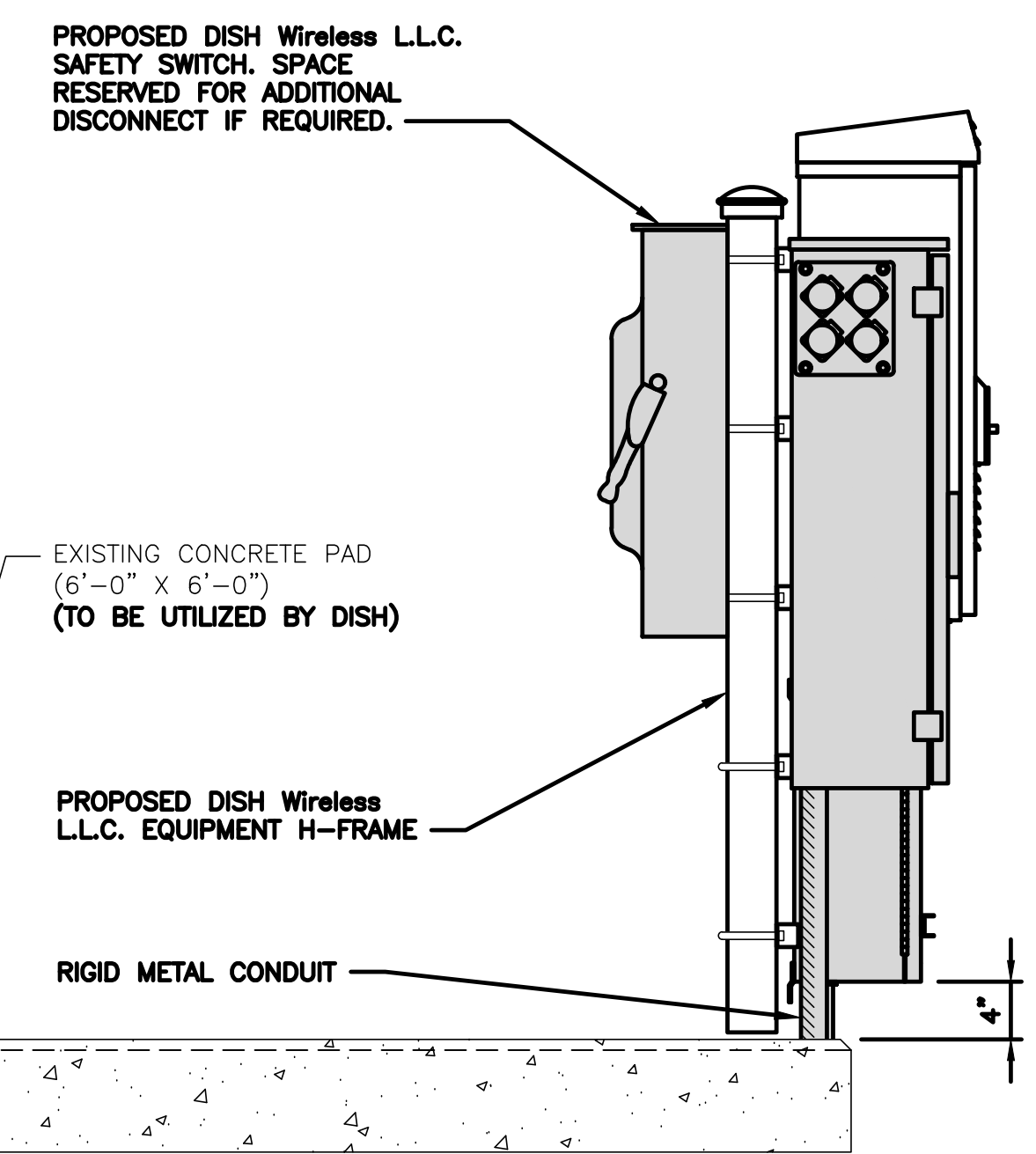

SIDE ELEVATION

NOT USED NO SCALE 2

COMMSCOPE MTC4045HFLD H-FRAME - STAGGERED	
UNISTRUT/SUPPORT RAILS QTY	5
WEIGHT	59.74 lbs

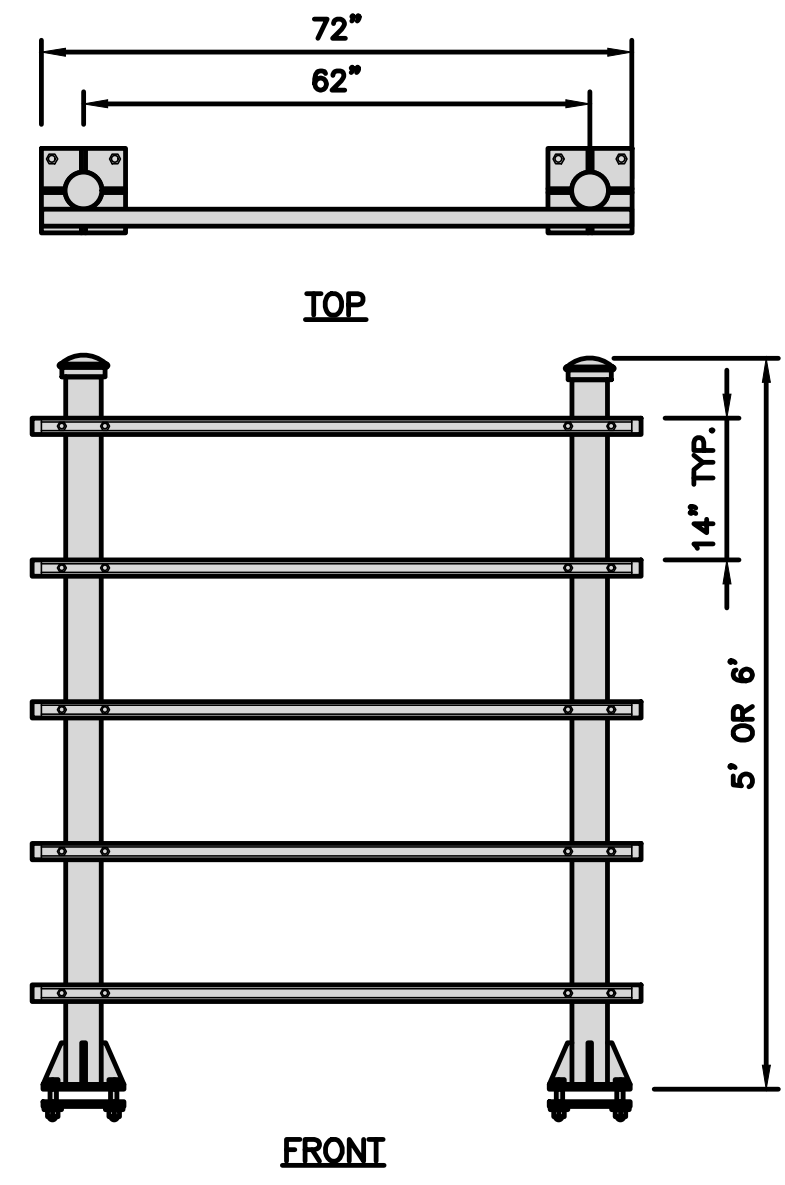

NOTE FOR THE FIELD CREWS:  
CONSULT WITH DISH CM FOR  
H-FRAME POSTS AND  
UNISTRUT PLACEMENTS.

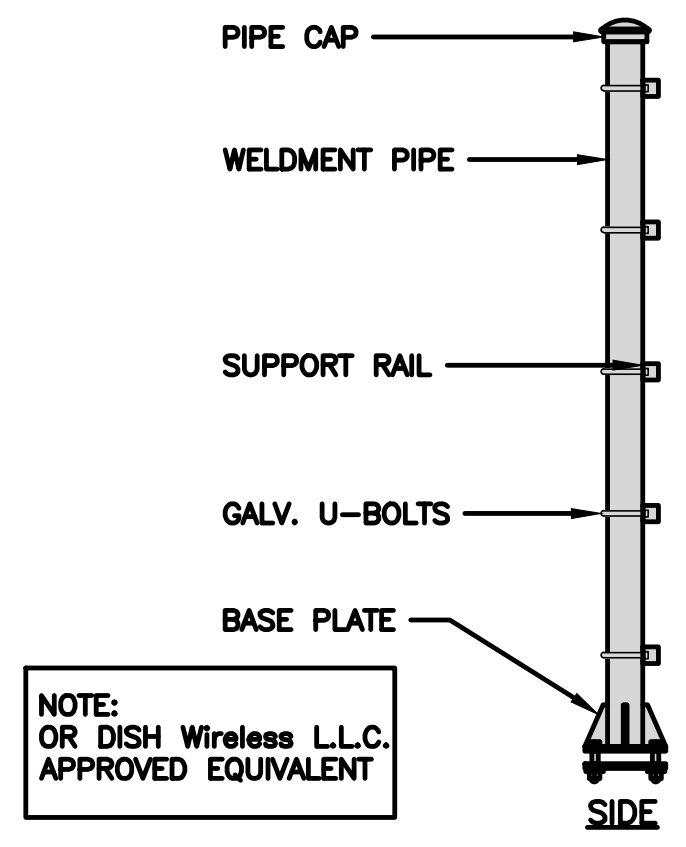

H-FRAME DETAIL

NO SCALE 3

NOT USED

NO SCALE 4

H-FRAME EQUIPMENT ELEVATION

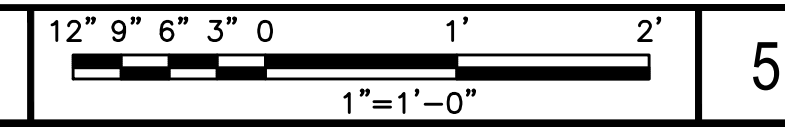

5



5701 SOUTH SANTA FE DRIVE  
LITTLETON, CO 80120



SBA COMMUNICATIONS CORP.  
134 FLANDERS ROAD, SUITE 125  
WESTBOROUGH, MA 01581  
TEL: (508) 251-0720  
FAX: (508) 251-1755



45 BEECHWOOD DRIVE, NORTH ANDOVER, MA 01845  
TEL: (978) 557-5553

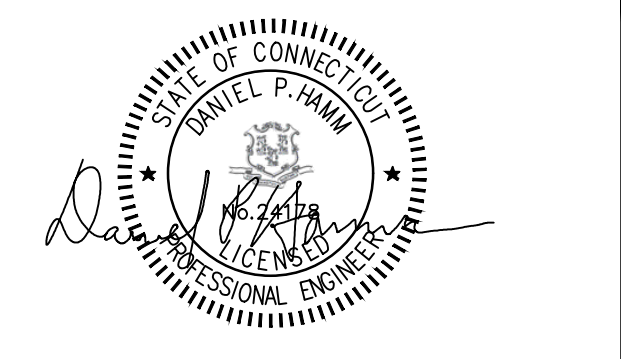

IT IS A VIOLATION OF LAW FOR ANY PERSON,  
UNLESS THEY ARE ACTING UNDER THE DIRECTION  
OF A LICENSED PROFESSIONAL ENGINEER,  
TO ALTER THIS DOCUMENT.

DRAWN BY: TR CHECKED BY: VD APPROVED BY: DPH

RFDS REV #: 0

CONSTRUCTION DOCUMENTS

SUBMITTALS		
REV	DATE	DESCRIPTION
A	09/11/2023	ISSUED FOR REVIEW
B	09/25/2023	ISSUED FOR CONSTRUCTION

A&E PROJECT NUMBER  
BOBOS01169A

DISH Wireless L.L.C.  
PROJECT INFORMATION  
BOBOS01169A  
131 GIFFORD LANE  
BOZRAH, CT 06334

SHEET TITLE  
EQUIPMENT AND  
H-FRAME DETAILS

SHEET NUMBER

A-3

CHARLES INDUSTRY HEX CUBE-PM639155N4	
DIMENSIONS (HxWxD)	74"x32"x32"
POWER PLANT	-48VDC ABB/600W
TOTAL WEIGHT (EMPTY)	408 lbs

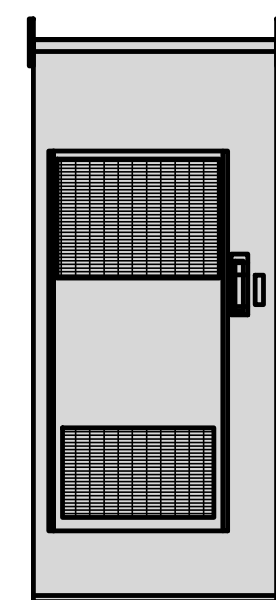
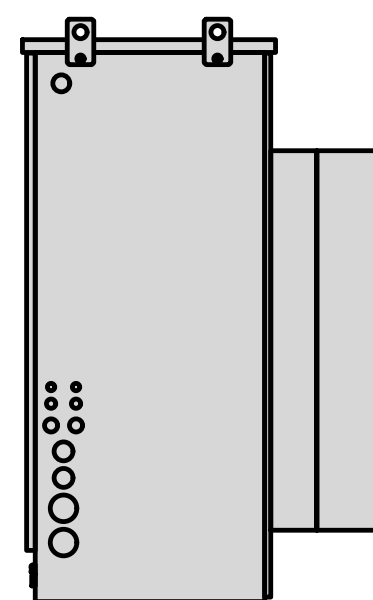
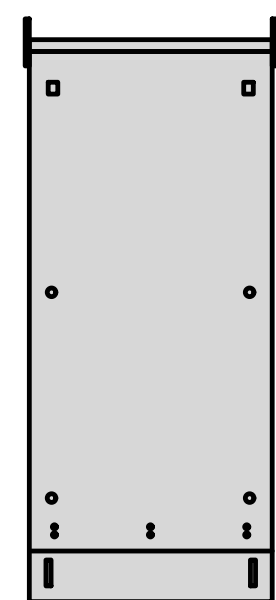
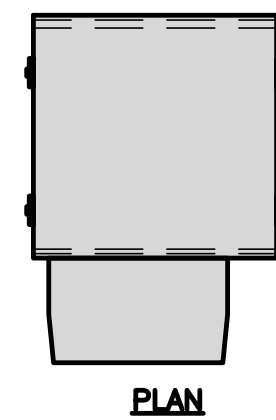

BACK

SIDE

FRONT

CABINET DETAIL

NO SCALE

1

RAYCAP PPC RDIAC-2465-P-240-MTS	
ENCLOSURE DIMENSIONS (HxWxD):	39"x22.855"x12.593
WEIGHT:	80 lbs
OPERATING AC VOLTAGE	240/120 1 PHASE 3W+G

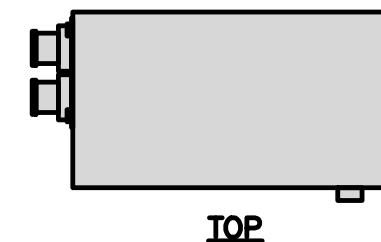

TOP

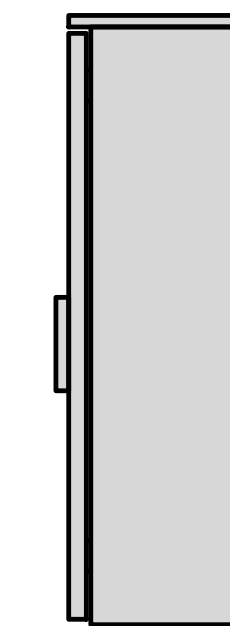
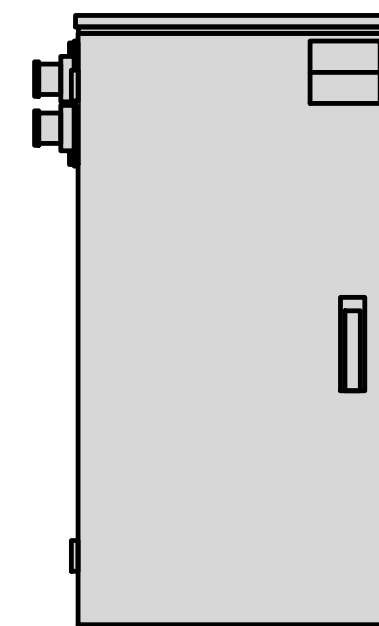
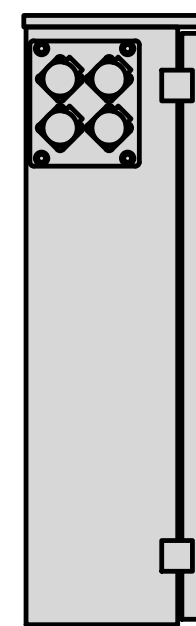
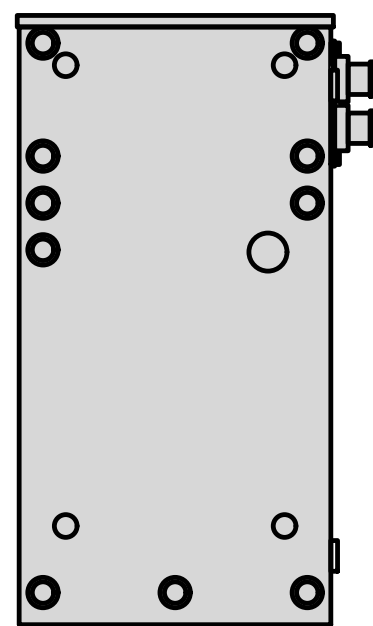

BACK

SIDE

FRONT

SIDE

POWER PROTECTION CABINET (PPC) DETAIL

NO SCALE

2

CHARLES CFIT-PF2020DSH1 FIBER TELCO ENCLOSURE	
ENCLOSURE DIMS (HxWxD)	20"x20"x9"
ENCLOSURE WEIGHT	20 lbs
MOUNTING	WALL
COMPLIANCE	TYPE 4

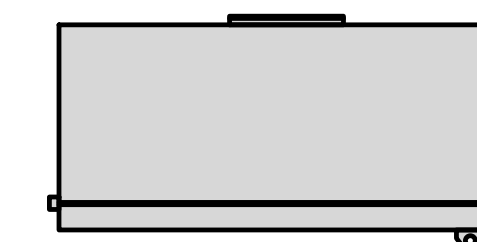

FRONT

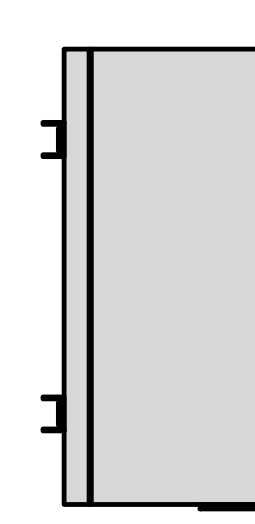

SIDE

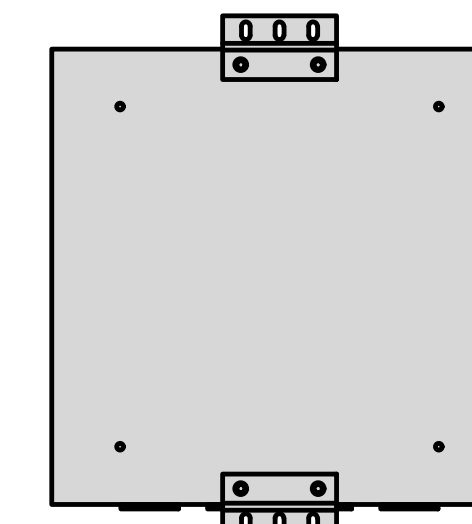

BACK

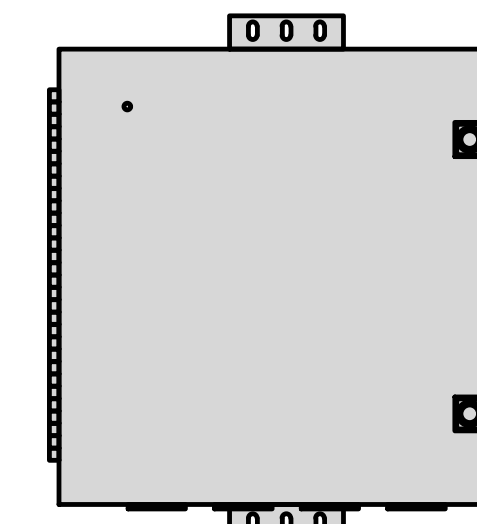

FRONT

FIBER TELCO ENCLOSURE DETAIL

NO SCALE

3

EATON METER SOCKET UNRRS213BEUSE	
METER SOCKET TYPE	RING
ENCLOSURE DIM (HxWxD)	16"x12"x6"
MAIN AMPERE RATING	200A
WEIGHT	18 LBS

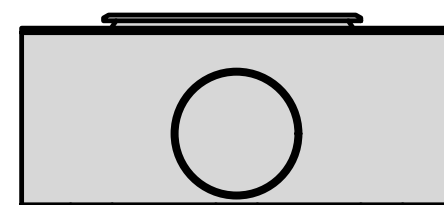

PLAN

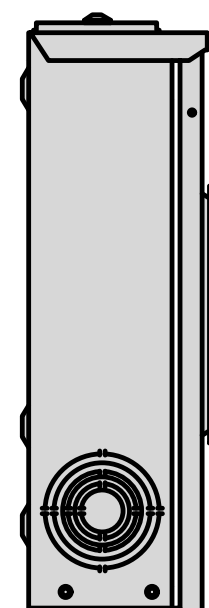

SIDE

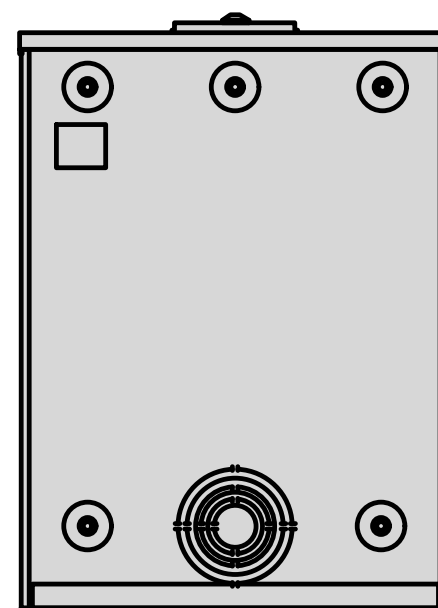

BACK

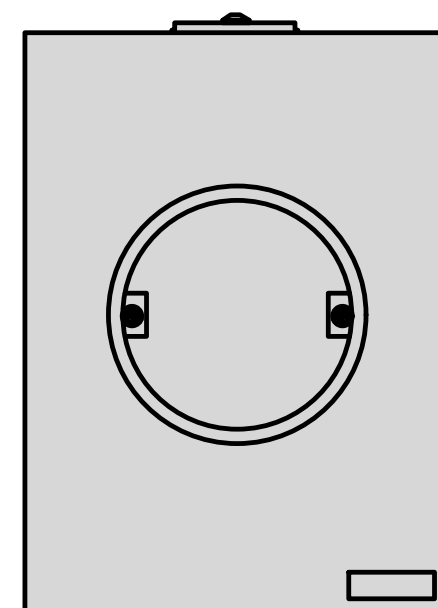

FRONT

METER SOCKET DETAIL

NO SCALE

4

SQUARE D SAFETY SWITCHES D224NRB	
ENCLOSURE DIM (HxWxD)	29.25"x19.00"x8.50"
ENCLOSURE TYPE	NEMA 3R RAINPROOF
UL LISTED	FILE E-2875



TOP

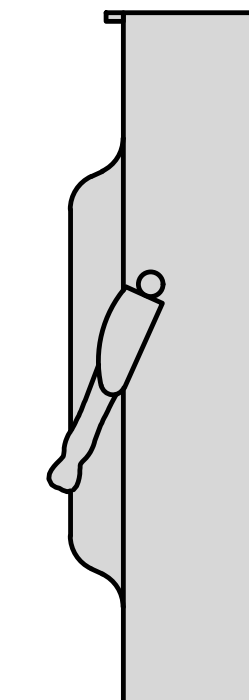

SIDE

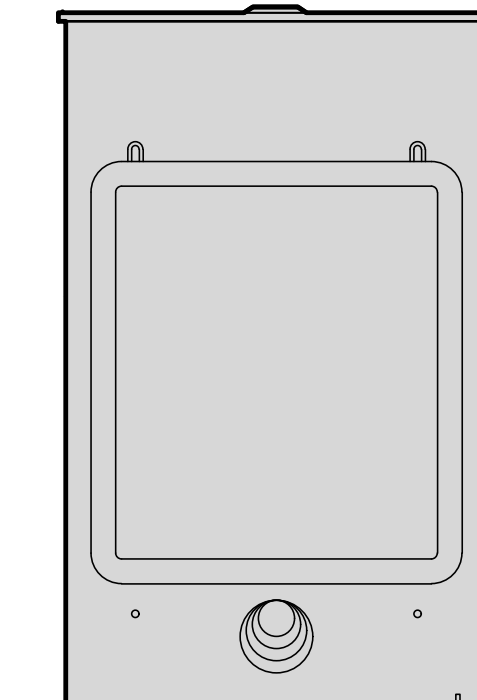

FRONT

SAFETY SWITCH DETAIL

NO SCALE

6

NOT USED

NO SCALE

5

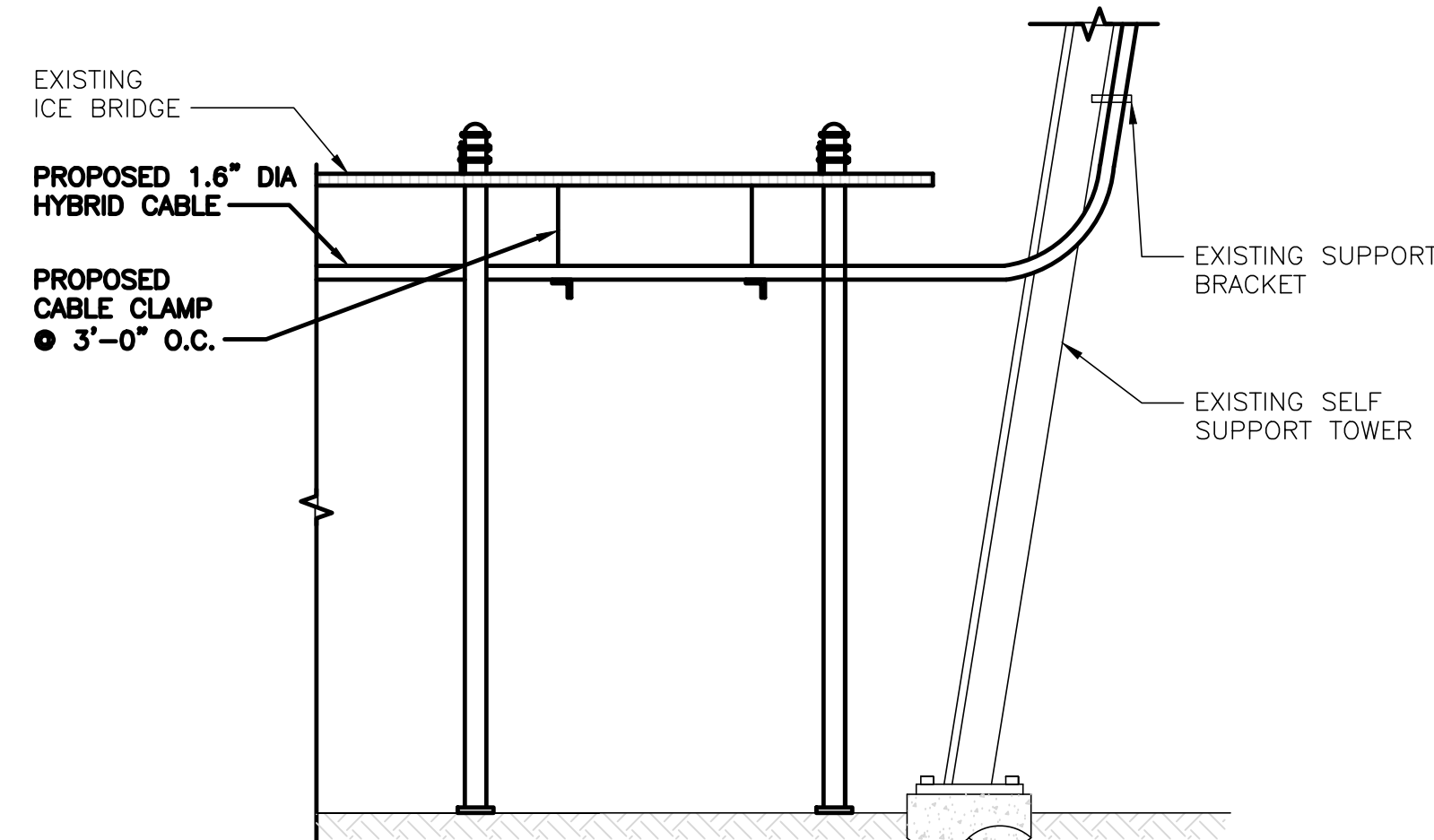

HYBRID CABLE RUN

NO SCALE

7

NO SCALE

8



5701 SOUTH SANTA FE DRIVE  
LITTLETON, CO 80120



SBA COMMUNICATIONS CORP.  
134 FLANDERS ROAD, SUITE 125  
WESTBOROUGH, MA 01581  
TEL: (508) 251-0720  
FAX: (508) 251-1755



45 BEECHWOOD DRIVE, NORTH ANDOVER, MA 01845  
TEL: (978) 557-5553



IT IS A VIOLATION OF LAW FOR ANY PERSON, UNLESS THEY ARE ACTING UNDER THE DIRECTION OF A LICENSED PROFESSIONAL ENGINEER, TO ALTER THIS DOCUMENT.

DRAWN BY: TR  
CHECKED BY: VD  
APPROVED BY: DPH

RFDS REV #: 0

CONSTRUCTION DOCUMENTS

SUBMITTALS		
REV	DATE	DESCRIPTION
A	09/11/2023	ISSUED FOR REVIEW
B	09/25/2023	ISSUED FOR CONSTRUCTION

A&E PROJECT NUMBER  
BOBOS01169A

DISH Wireless L.L.C.  
PROJECT INFORMATION  
BOBOS01169A  
131 GIFFORD LANE  
BOZRAH, CT 06334

SHEET TITLE  
EQUIPMENT DETAILS

SHEET NUMBER  
**A-4**

PCTEL GPSGL-TMG-SPI-40NCB	
DIMENSIONS (DiaxH) MM/INCH	81x184mm 3.2"x7.25"
WEIGHT W/ACCESSORIES	0.75 lbs
CONNECTOR	N-FEMALE
FREQUENCY RANGE	1590 ± 30MHz

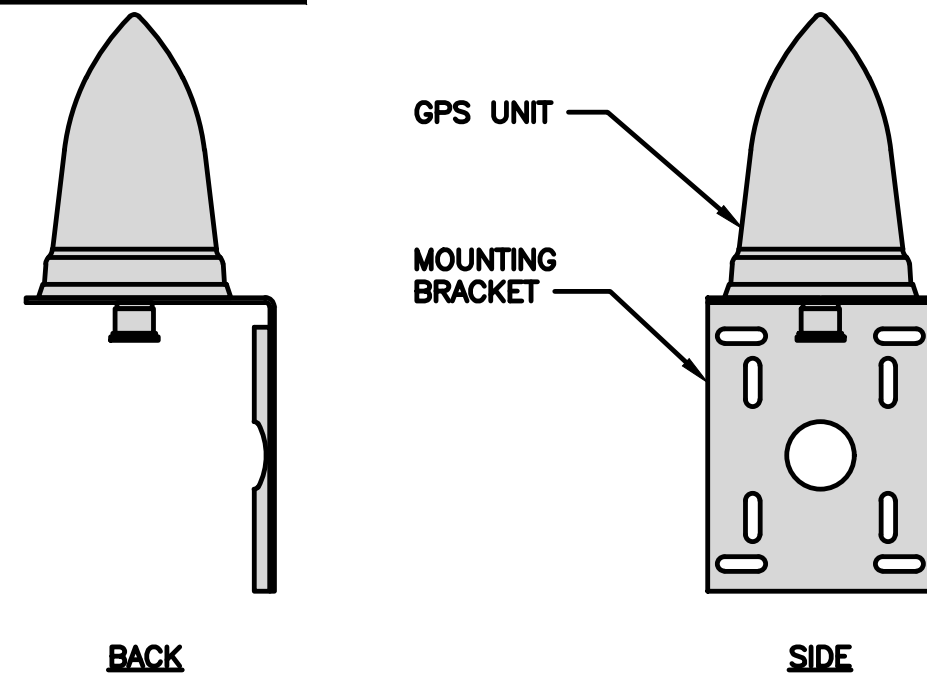

GPS DETAIL

NO SCALE

1

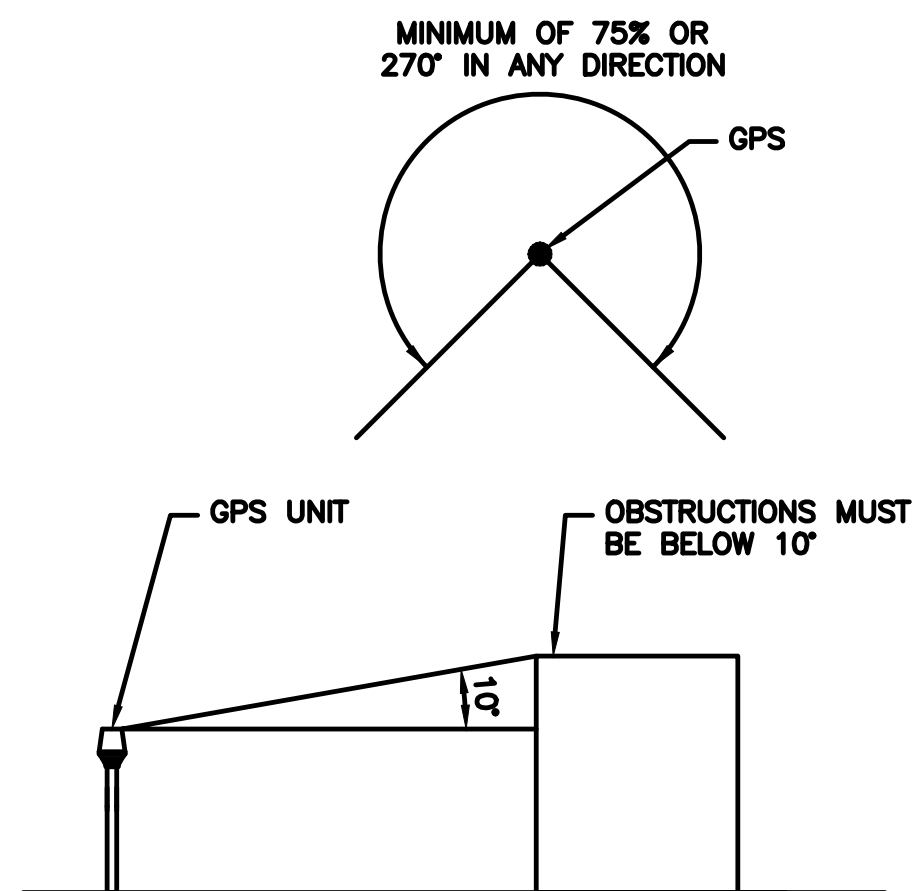

GPS MINIMUM SKY VIEW REQUIREMENTS

NO SCALE

2

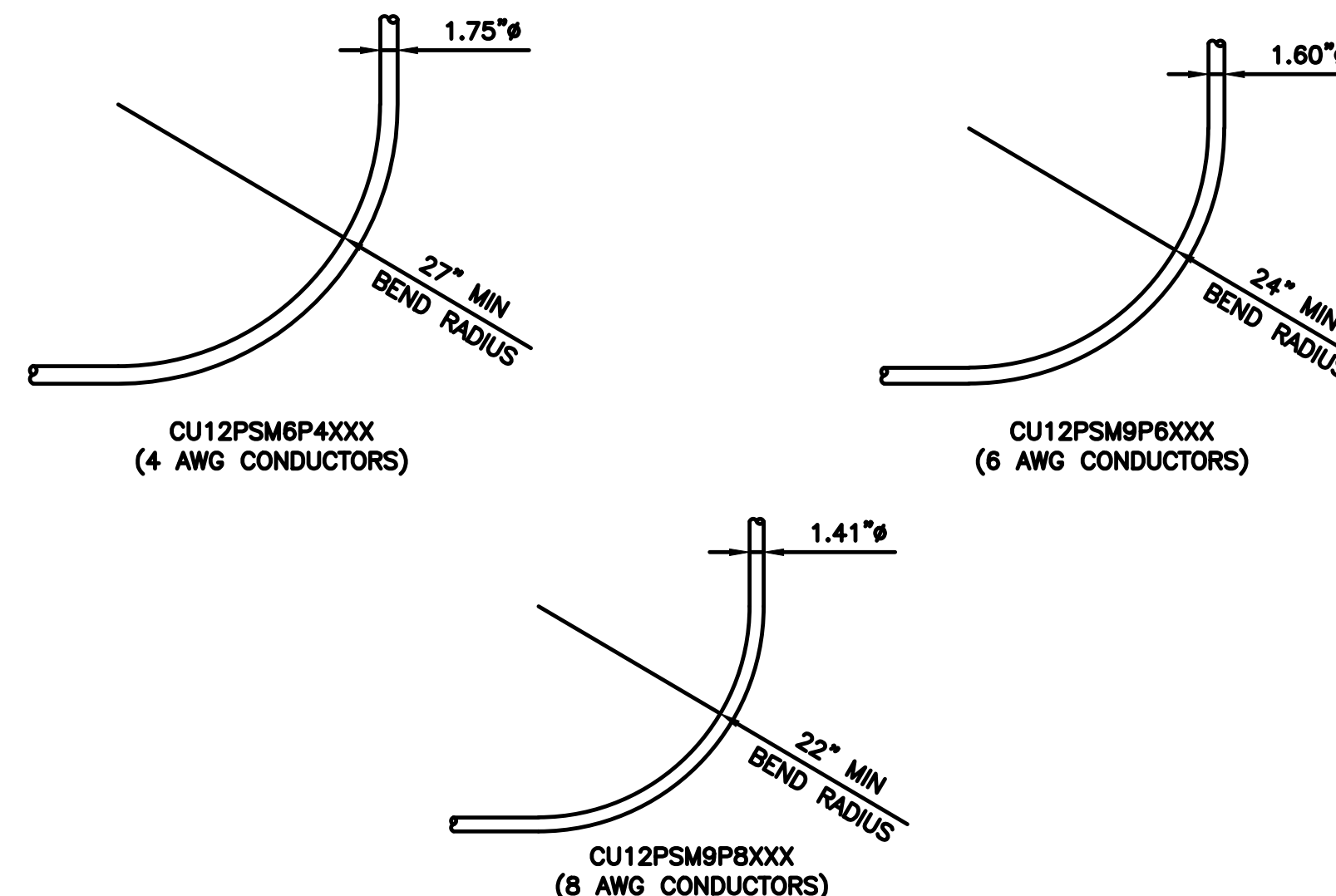
CABLES UNLIMITED HYBRID CABLE  
MINIMUM BEND RADIUSES

NO SCALE

3

## NOTE:

CONTRACTOR SHALL NOT LOOP EXCESS HYBRID OUTSIDE CABINET. EXCESS HYBRID LENGTH IS TO BE ADJUSTED BY STRIPPING JACKET AND SHIELDING AND TERMINATING DC CABLE TO LENGTH. FIBER EXCESS IS TO BE COILED IN FIBER SLACK TRAY INSIDE NETWORK CABINET.

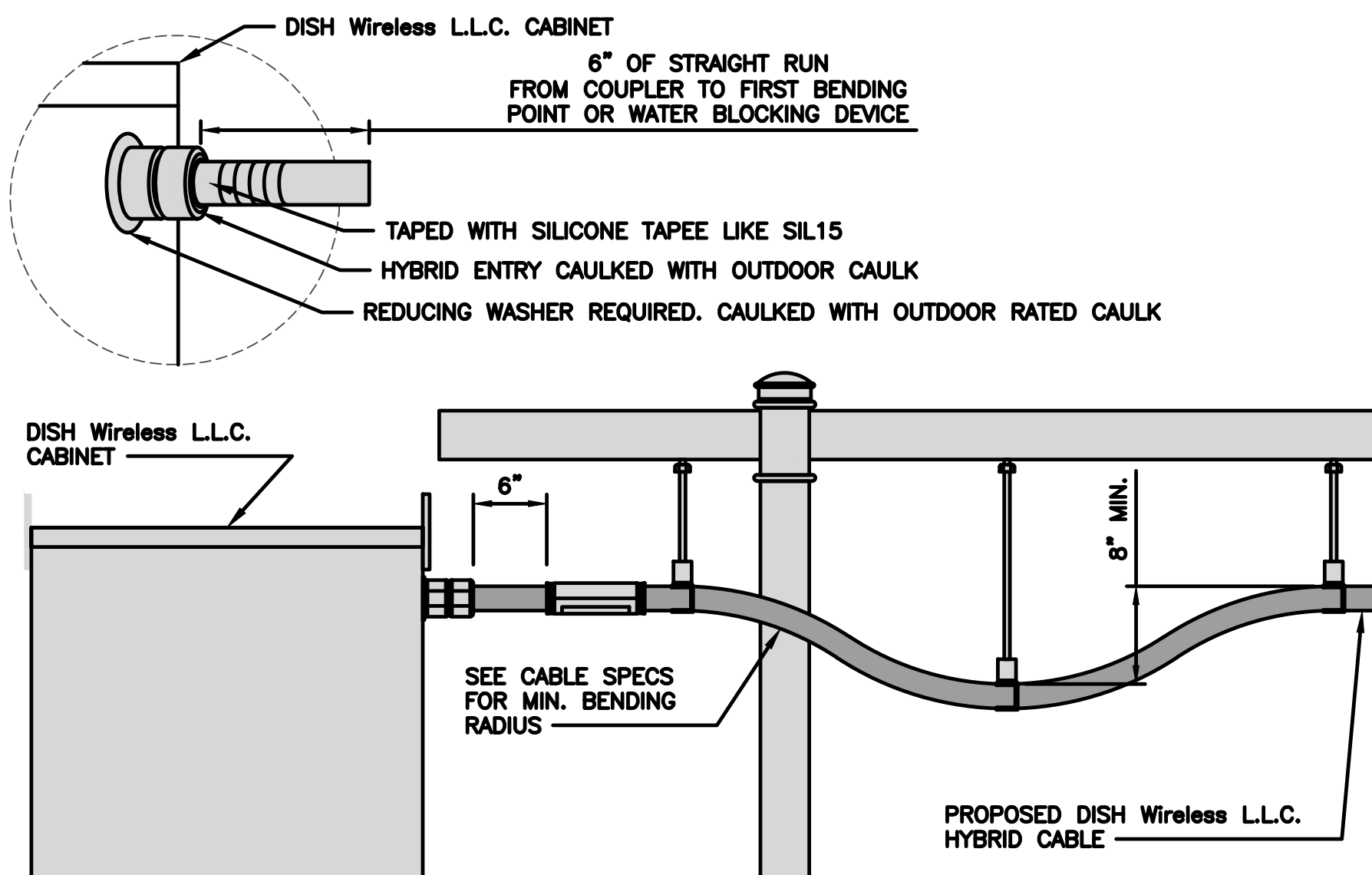

HYBRID CABLE INSTALLATION DETAIL

NO SCALE

5

DISH Wireless L.L.C. DRIP BOX	
DIMENSIONS (HxWxD)	10-1/4" x 5-5/8" x 4-3/8"
ESTIMATED WEIGHT	<5 lbs

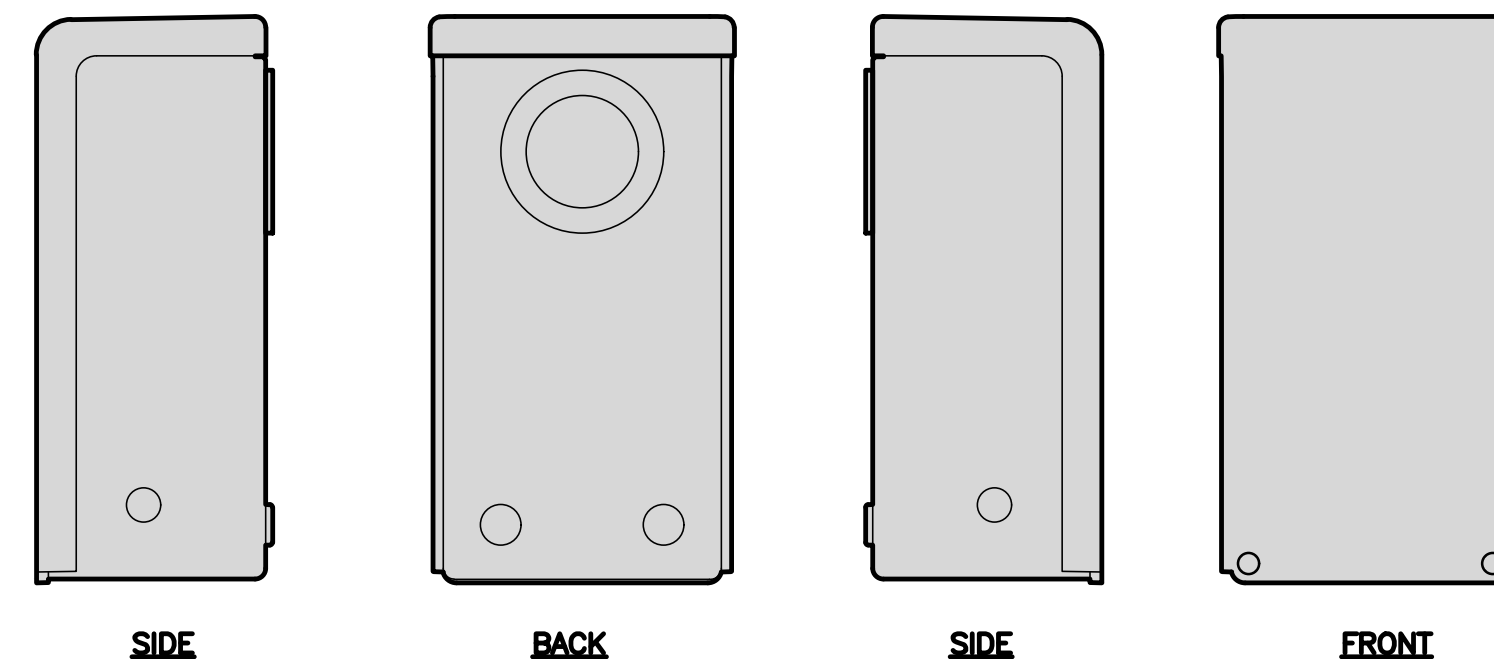

DISH Wireless L.L.C. DRIP BOX DETAIL

NO SCALE

6

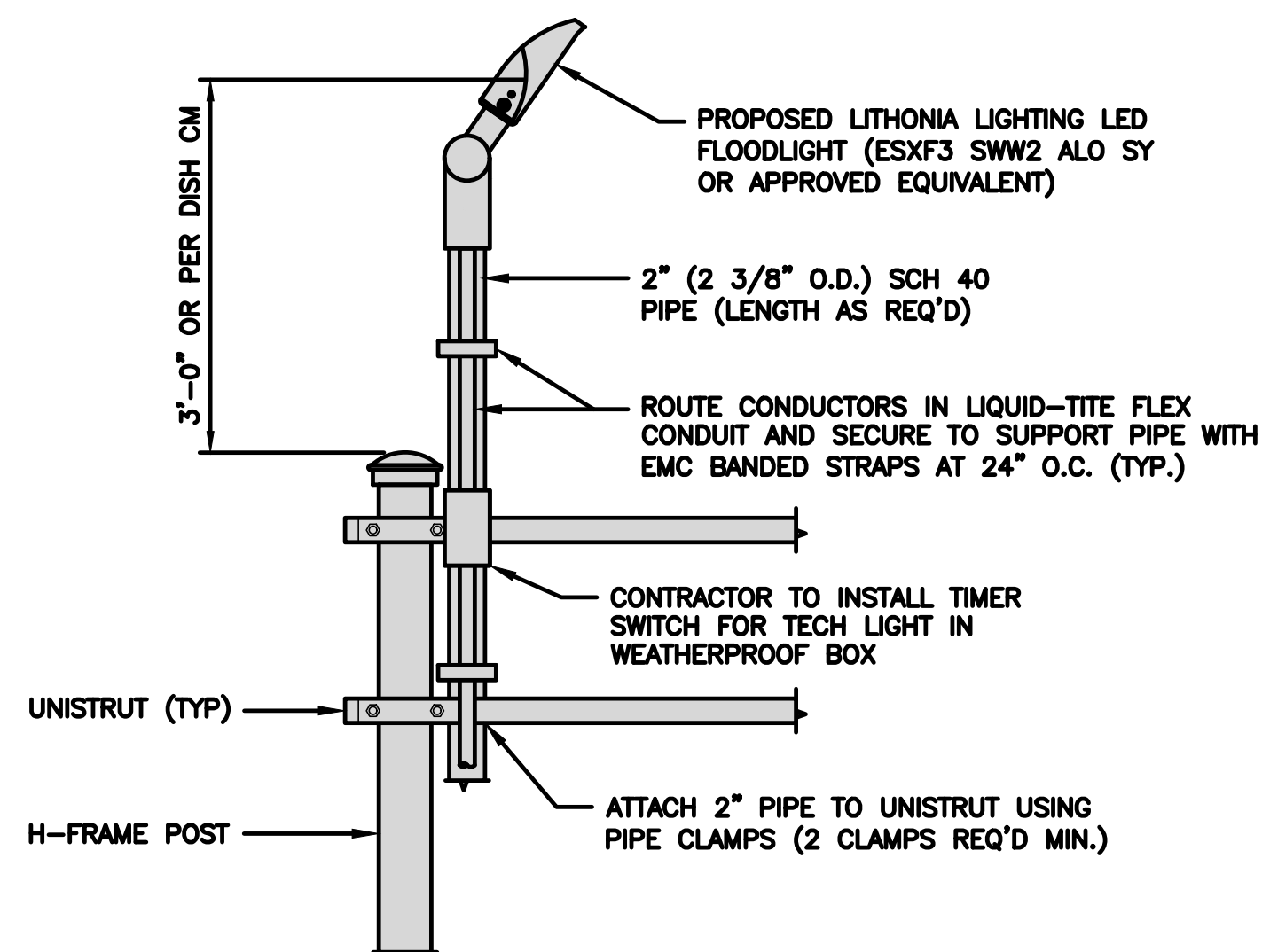

TECH LIGHT DETAIL

NO SCALE

7

NOT USED

NO SCALE

8

NOT USED

NO SCALE

9

**dish**  
wireless.

5701 SOUTH SANTA FE DRIVE  
LITTLETON, CO 80120



SBA COMMUNICATIONS CORP.  
134 FLANDERS ROAD, SUITE 125  
WESTBOROUGH, MA 01581

TEL: (508) 251-0720  
FAX: (508) 251-1755



45 BEECHWOOD DRIVE, NORTH ANDOVER, MA 01845  
TEL: (978) 557-5553

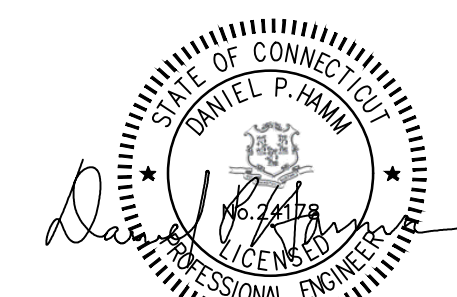

IT IS A VIOLATION OF LAW FOR ANY PERSON,  
UNLESS THEY ARE ACTING UNDER THE DIRECTION  
OF A LICENSED PROFESSIONAL ENGINEER,  
TO ALTER THIS DOCUMENT.

DRAWN BY: CHECKED BY: APPROVED BY:

TR VD DPH

RFDS REV #: 0

CONSTRUCTION  
DOCUMENTS

SUBMITTALS		
REV	DATE	DESCRIPTION
A	09/11/2023	ISSUED FOR REVIEW
B	09/25/2023	ISSUED FOR CONSTRUCTION

A&E PROJECT NUMBER  
BOBOS01169A

DISH Wireless L.L.C.  
PROJECT INFORMATION  
BOBOS01169A  
131 GIFFORD LANE  
BOZRAH, CT 06334

SHEET TITLE  
EQUIPMENT DETAILS

SHEET NUMBER  
**A-5**

<b>SAMSUNG – LOW BAND</b> SFG-ARR3J601DI_RF4450T-71A	
DIMENSIONS (HxWxD)	15"x16.5"x11"
WEIGHT	94.6 lbs
CONNECTOR TYPE	4.3-10 RF CONNECTOR -48VDC
INPUT VOLTAGE	(-36 to 58 VDC)

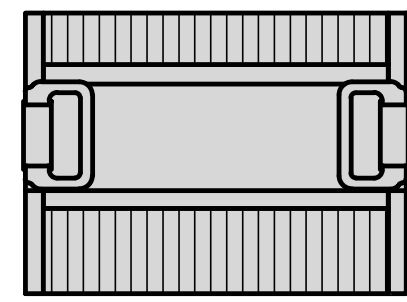

PLAN

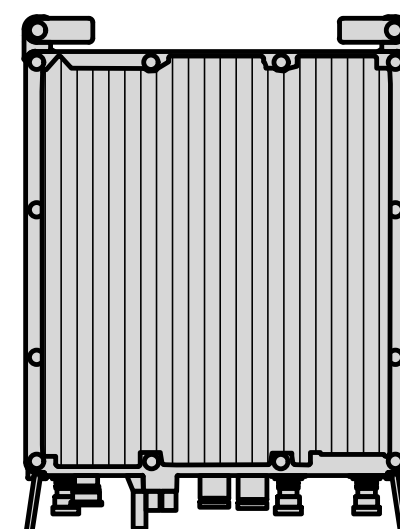

BACK

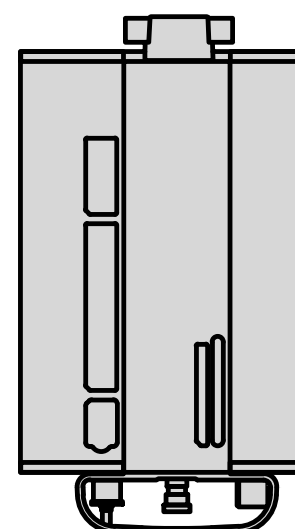

SIDE

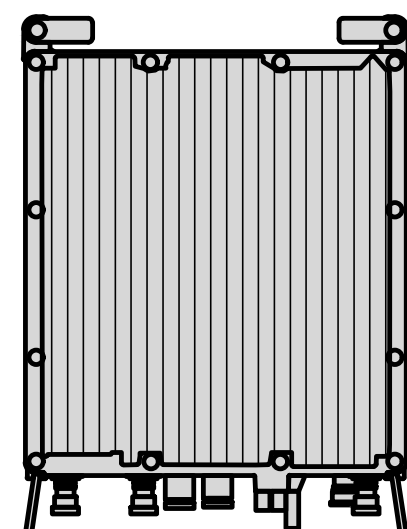

FRONT

RRH DETAIL

NO SCALE

1

<b>SAMSUNG – MID BAND</b> SFG-ARR3KM01DI_RF4451D-70A	
DIMENSIONS (HxWxD)	15"x15"x8.9"
WEIGHT	61.3 lbs
CONNECTOR TYPE	4.3-10 RF CONNECTOR -48VDC
INPUT VOLTAGE	(-36 to 58 VDC)

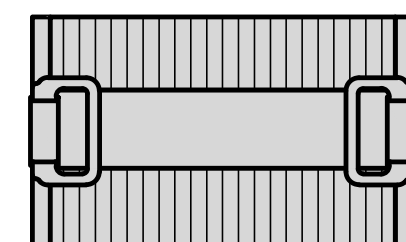

PLAN

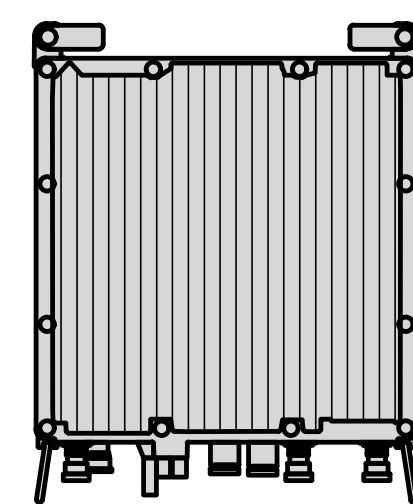

BACK

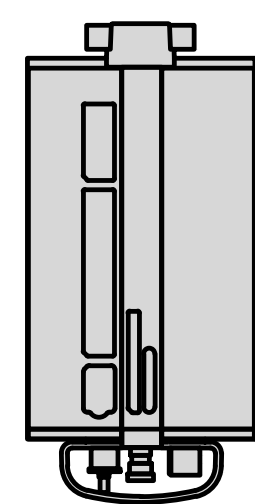

SIDE

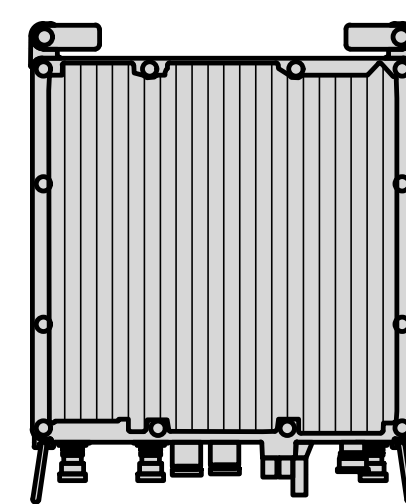

FRONT

RRH DETAIL

NO SCALE

2

<b>SABRE DOUBLE Z-BRACKET</b> C10123155	
DIMENSIONS (HxWxD) (1 BRACKET)	5"x20"x1-13/16"
WEIGHT (FULL ASSEMBLY)	35.79 lbs
PACKAGE QUANTITY	4

#	DESCRIPTION
1	PLATE, CHANNEL BRACKET
2	RRH Z BRACKET, 3/16"
3	THREADED ROD ASSEMBLY 1/2"x12"

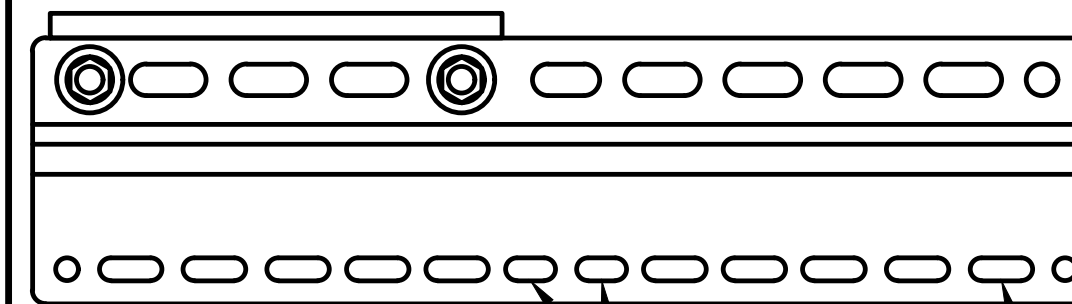

11MM x 24MM SLOTS

11MM x 30MM SLOTS  
40MM ON CENTER

NOTE:  
OR DISH Wireless L.L.C.  
APPROVED EQUIVALENT

RRH MOUNT DETAIL

NO SCALE

3

<b>COMMSCOPE</b> FFV-65B-R2	
DIMENSIONS (HxWxD)	72"x19.6"x7.8"
ANTENNA WEIGHT	70.5 lbs
WEIGHT WITH BRACKETS	84.169 lbs

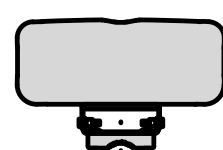

PLAN



BACK

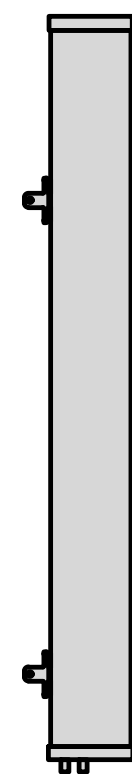

SIDE

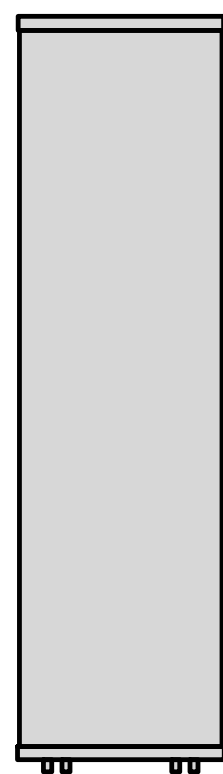

FRONT

ANTENNA DETAIL

NO SCALE

4

<b>RAYCAP RDIC-9181-PF-48</b> DC SURGE PROTECTION (OVP)	
DIMENSIONS (HxWxD)	18.98"x14.39"x8.15"
WEIGHT	21.82 LBS

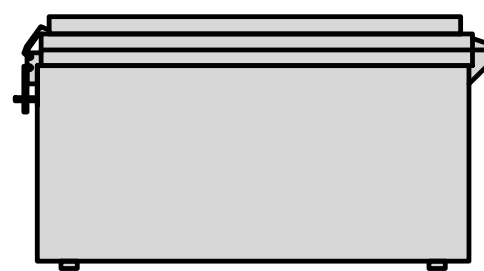

PLAN

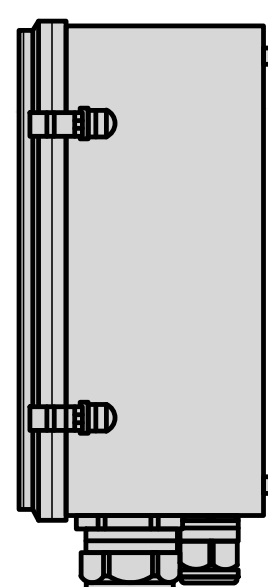

SIDE

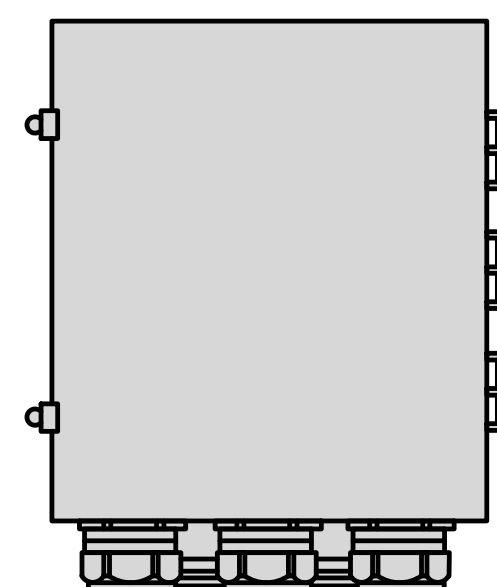

BACK

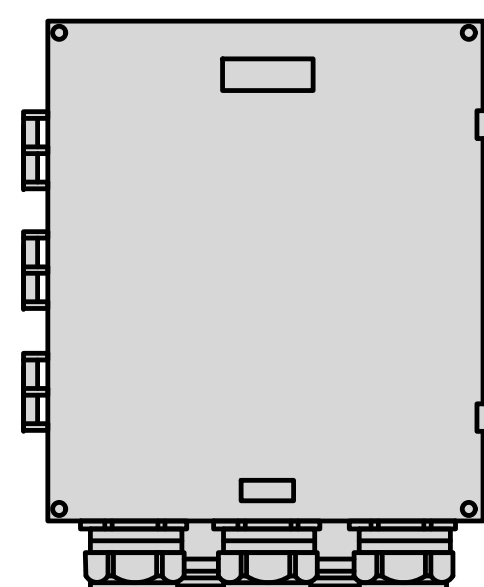

FRONT

SURGE SUPPRESSION DETAIL (OVP)

NO SCALE

7

<b>SITEPRO1 T600</b> UNIVERSAL T-BRACKET	
DIMENSIONS (HxWxL)	2.25"x10.0"x15.25"
WEIGHT/ VOLUME	5.60 LBS

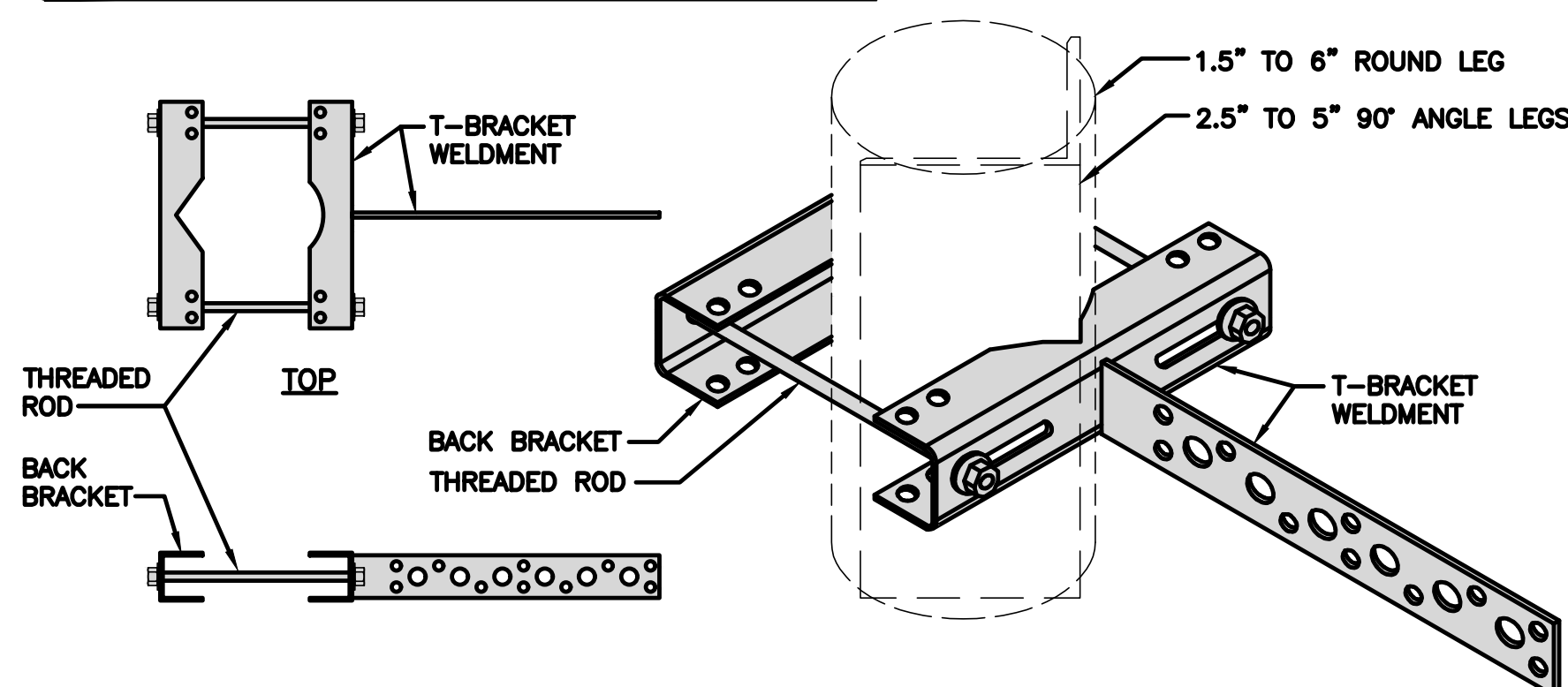

SIDE

ISOMETRIC

NOT USED

NO SCALE

5

<b>COMMSCOPE V-FRAME</b> MTC3975083	
FACE SIZE	8'-0"
WEIGHT	352.136 lbs

NOTE:  
OR DISH Wireless L.L.C.  
APPROVED EQUIVALENT

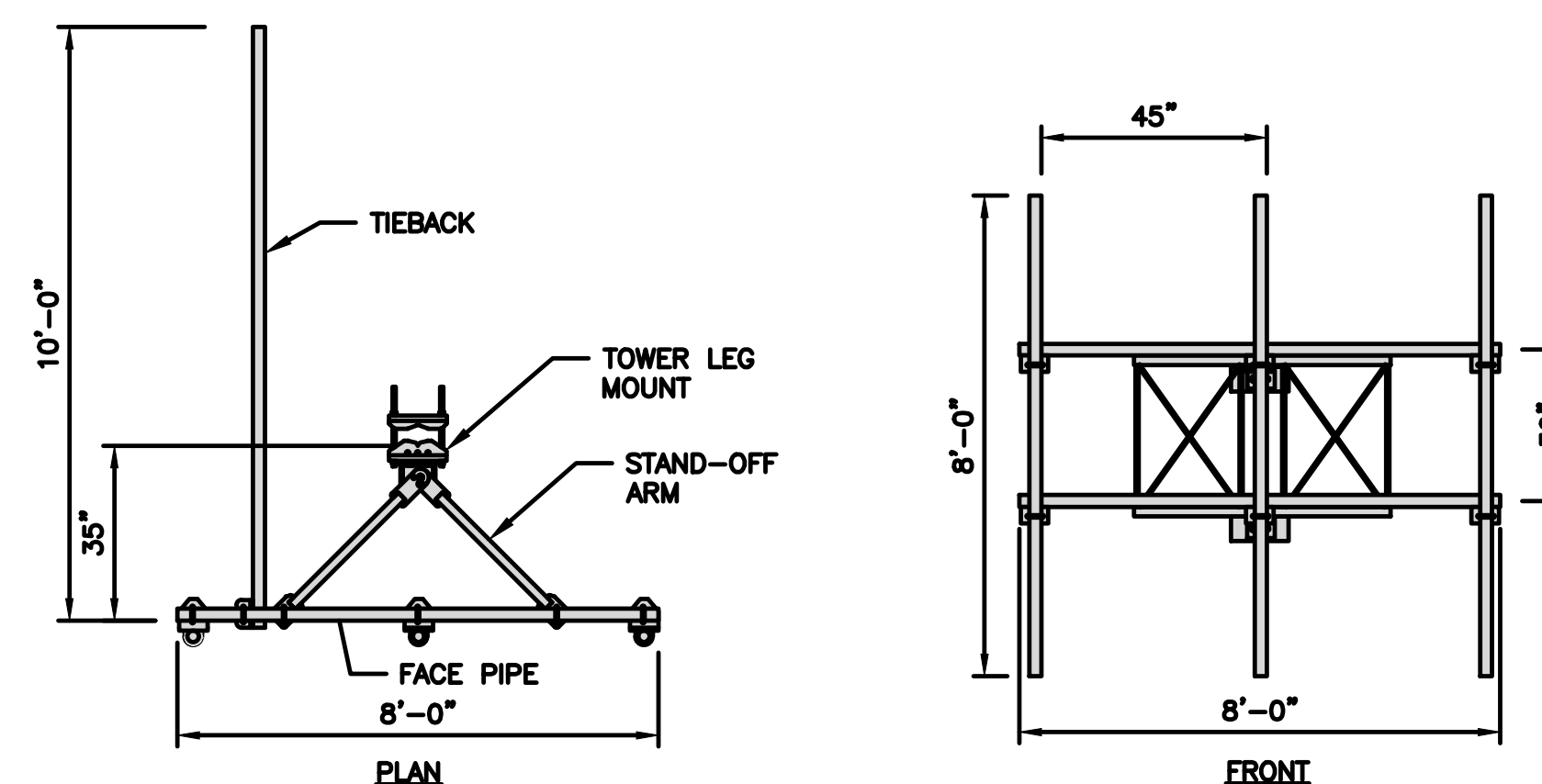

ANTENNA FRAME DETAIL

NO SCALE

9

<b>JMA ANTENNA MOUNT BRACKET</b> #91900318	
TOTAL WEIGHT (WITH BRACKETS)	18 lbs (8.18 Kg)
POLE DIAMETER RANGE	2.5" TO 4.5"

NOTE:  
KIT #91900318: TOP AND BOTTOM BRACKETS  
FOR 4-, 6-, AND 8-FOOT ANTENNAS  
ANTENNA BRACKET NOT PART OF KIT

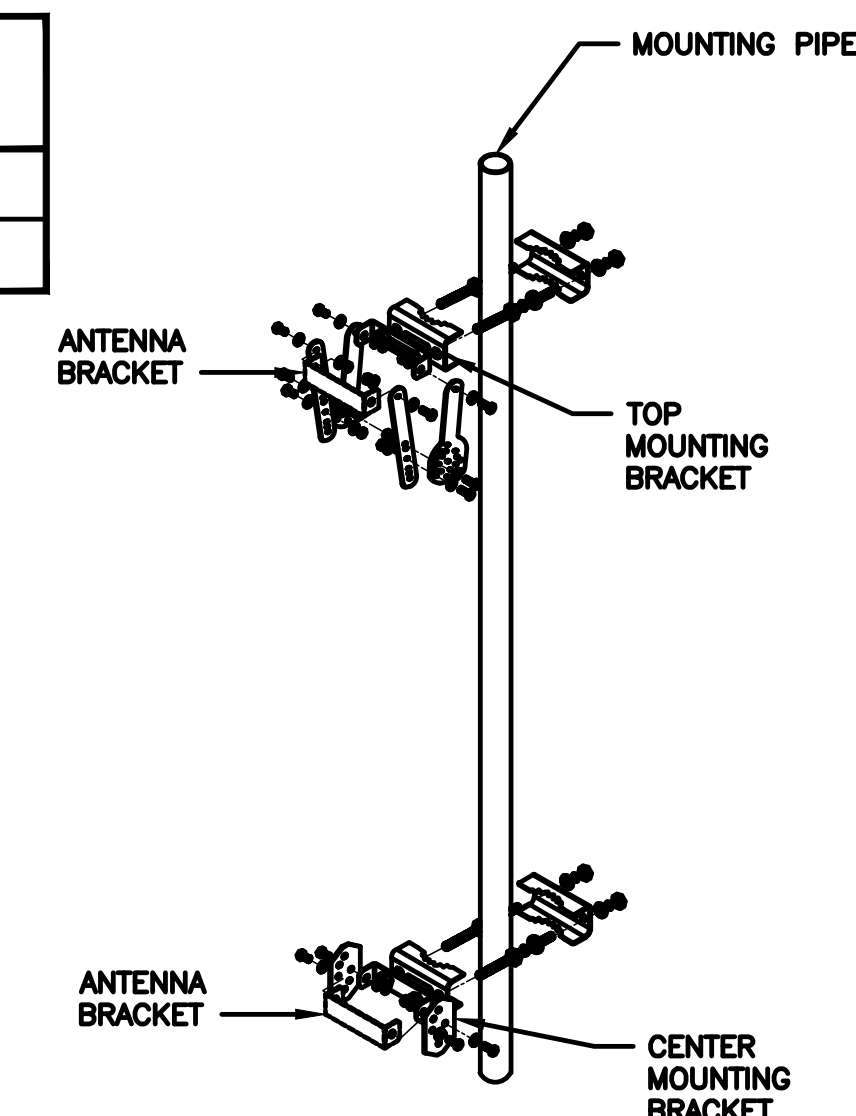

NOTE:  
OR DISH Wireless L.L.C.  
APPROVED EQUIVALENT



5701 SOUTH SANTA FE DRIVE  
LITTLETON, CO 80120



SBA COMMUNICATIONS CORP.  
134 FLANDERS ROAD, SUITE 125  
WESTBOROUGH, MA 01581  
TEL: (508) 251-0720  
FAX: (508) 251-1755



45 BEECHWOOD DRIVE, NORTH ANDOVER, MA 01845  
TEL: (978) 557-5553

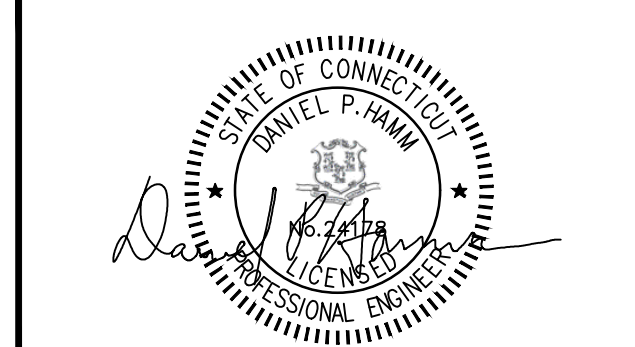

IT IS A VIOLATION OF LAW FOR ANY PERSON,  
UNLESS THEY ARE ACTING UNDER THE DIRECTION  
OF A LICENSED PROFESSIONAL ENGINEER,  
TO ALTER THIS DOCUMENT.

DRAWN BY: CHECKED BY: APPROVED BY:

TR VD DPH

RFDS REV #: 0

CONSTRUCTION DOCUMENTS

SUBMITTALS		
REV	DATE	DESCRIPTION
A	09/11/2023	ISSUED FOR REVIEW
B	09/25/2023	ISSUED FOR CONSTRUCTION

A&E PROJECT NUMBER

BOBOS01169A

DISH Wireless L.L.C.  
PROJECT INFORMATION

BOBOS01169A  
131 GIFFORD LANE  
BOZRAH, CT 06334

SHEET TITLE  
EQUIPMENT DETAILS

SHEET NUMBER

A-6



**NOTES**

1. CONTRACTOR SHALL FIELD VERIFY ALL PROPOSED UNDERGROUND UTILITY CONDUIT ROUTE.
2. ANTENNAS AND MOUNTS OMITTED FOR CLARITY.
3. THE GROUND LEASE PROVIDES BROAD/BLANKET UTILITY RIGHTS. "PWR" AND "FBR" PATH DEPICTED ON A-1 AND E-1 ARE BASED ON BEST AVAILABLE INFORMATION INCLUDING BUT NOT LIMITED TO FIELD VERIFICATION, PRIOR PROJECT DOCUMENTATION AND OTHER REAL PROPERTY RIGHTS DOCUMENTS. WHEN INSTALLING THE UTILITIES PLEASE LOCATE AND FOLLOW EXISTING PATH. IF EXISTING PATH IS NOT AN OPTION, PLEASE NOTIFY TOWER OWNER AS FURTHER COORDINATION MAY BE NEEDED.

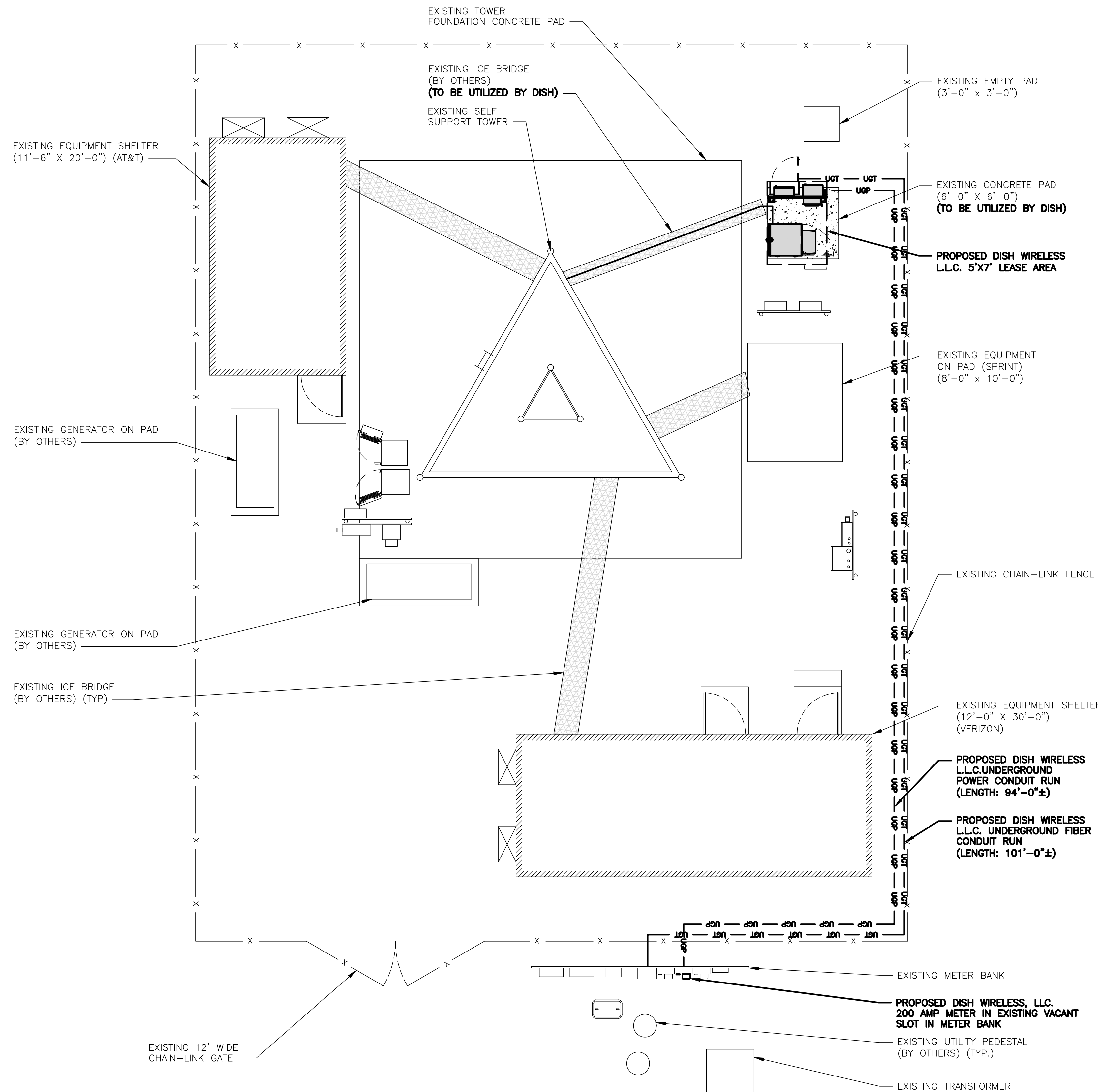

**UTILITY ROUTE PLAN**

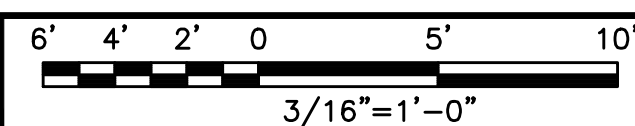

1

DC POWER WIRING SHALL BE COLOR CODED AT EACH END FOR IDENTIFYING +24V AND -48V CONDUCTORS. RED MARKINGS SHALL IDENTIFY +24V AND BLUE MARKINGS SHALL IDENTIFY -48V.

1. CONTRACTOR SHALL INSPECT THE EXISTING CONDITIONS PRIOR TO SUBMITTING A BID. ANY QUESTIONS ARISING DURING THE BID PERIOD IN REGARDS TO THE CONTRACTOR'S FUNCTIONS, THE SCOPE OF WORK, OR ANY OTHER ISSUE RELATED TO THIS PROJECT SHALL BE BROUGHT UP DURING THE BID PERIOD WITH THE PROJECT MANAGER FOR CLARIFICATION, NOT AFTER THE CONTRACT HAS BEEN AWARDED.
2. ALL ELECTRICAL WORK SHALL BE DONE IN ACCORDANCE WITH CURRENT NATIONAL ELECTRICAL CODES AND ALL STATE AND LOCAL CODES, LAWS, AND ORDINANCES. PROVIDE ALL COMPONENTS AND WIRING SIZES AS REQUIRED TO MEET NEC STANDARDS.
3. LOCATION OF EQUIPMENT, CONDUIT AND DEVICES SHOWN ON THE DRAWINGS ARE APPROXIMATE AND SHALL BE COORDINATED WITH FIELD CONDITIONS PRIOR TO CONSTRUCTION.
4. CONDUIT ROUGH-IN SHALL BE COORDINATED WITH THE MECHANICAL EQUIPMENT TO AVOID LOCATION CONFLICTS. VERIFY WITH THE MECHANICAL EQUIPMENT CONTRACTOR AND COMPLY AS REQUIRED.
5. CONTRACTOR SHALL PROVIDE ALL BREAKERS, CONDUITS AND CIRCUITS AS REQUIRED FOR A COMPLETE SYSTEM.
6. CONTRACTOR SHALL PROVIDE PULL BOXES AND JUNCTION BOXES AS REQUIRED BY THE NEC ARTICLE 314.
7. CONTRACTOR SHALL PROVIDE ALL STRAIN RELIEF AND CABLE SUPPORTS FOR ALL CABLE ASSEMBLIES. INSTALLATION SHALL BE IN ACCORDANCE WITH MANUFACTURER'S SPECIFICATIONS AND RECOMMENDATIONS.
8. ALL DISCONNECTS AND CONTROLLING DEVICES SHALL BE PROVIDED WITH ENGRAVED PHENOLIC NAMEPLATES INDICATING EQUIPMENT CONTROLLED, BRANCH CIRCUITS INSTALLED ON, AND PANEL FIELD LOCATIONS FED FROM.
9. INSTALL AN EQUIPMENT GROUNDING CONDUCTOR IN ALL CONDUITS PER THE SPECIFICATIONS AND NEC 250. THE EQUIPMENT GROUNDING CONDUCTORS SHALL BE BONDED AT ALL JUNCTION BOXES, PULL BOXES, AND ALL DISCONNECT SWITCHES, AND EQUIPMENT CABINETS.
10. ALL NEW MATERIAL SHALL HAVE A U.L. LABEL.
11. PANEL SCHEDULE LOADING AND CIRCUIT ARRANGEMENTS REFLECT POST-CONSTRUCTION EQUIPMENT.
12. CONTRACTOR SHALL BE RESPONSIBLE FOR AS-BUILT PANEL SCHEDULE AND SITE DRAWINGS.
13. ALL TRENCHES IN COMPOUND TO BE HAND DUG

**ELECTRICAL NOTES**

NO SCALE

2



5701 SOUTH SANTA FE DRIVE  
LITTLETON, CO 80120



SBA COMMUNICATIONS CORP.  
134 FLANDERS ROAD, SUITE 125  
WESTBOROUGH, MA 01581  
TEL: (508) 251-0720  
FAX: (508) 251-1755



45 BEECHWOOD DRIVE, NORTH ANDOVER, MA 01845  
TEL: (978) 557-5553

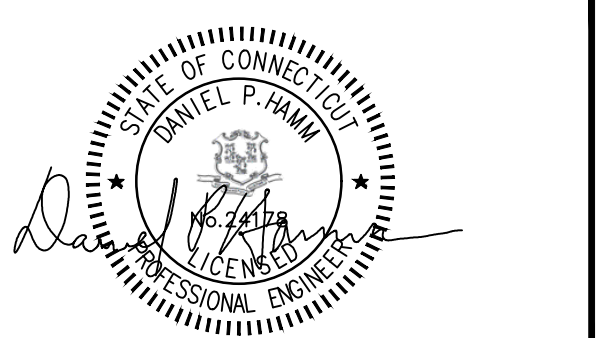

IT IS A VIOLATION OF LAW FOR ANY PERSON, UNLESS THEY ARE ACTING UNDER THE DIRECTION OF A LICENSED PROFESSIONAL ENGINEER, TO ALTER THIS DOCUMENT.

DRAWN BY:	CHECKED BY:	APPROVED BY:
TR	VD	DPH

RFDS REV #: 0

**CONSTRUCTION DOCUMENTS**

SUBMITTALS		
REV	DATE	DESCRIPTION
A	09/11/2023	ISSUED FOR REVIEW
B	09/25/2023	ISSUED FOR CONSTRUCTION

A&E PROJECT NUMBER  
BOBOS01169A

DISH Wireless L.L.C.  
PROJECT INFORMATION  
BOBOS01169A  
131 GIFFORD LANE  
BOZRAH, CT 06334

SHEET TITLE  
ELECTRICAL/FIBER ROUTE  
PLAN AND NOTES

SHEET NUMBER  
**E-1**

**CARLON EXPANSION FITTINGS**

COUPLING END PART#	MALE TERMINAL ADAPTER END PART#	SIZE	STD CTN QTY.	TRAVEL LENGTH
E945D	E945DX	1/2"	20	4"
E945E	E945EX	3/4"	15	4"
E945F	E945FX	1"	10	4"
E945G	E945GX	1 1/4"	5	4"
E945H	E945HX	1 1/2"	5	4"
E945J	E945JX	2"	15	8"
E945K	E945KX	2 1/2"	10	8"
E945L	E945LX	3"	10	8"
E945M	E945MX	3 1/2"	5	8"
E945N	E945NX	4"	5	8"
E945P	E945PX	5"	1	8"
E945R	E945RX	6"	1	8"

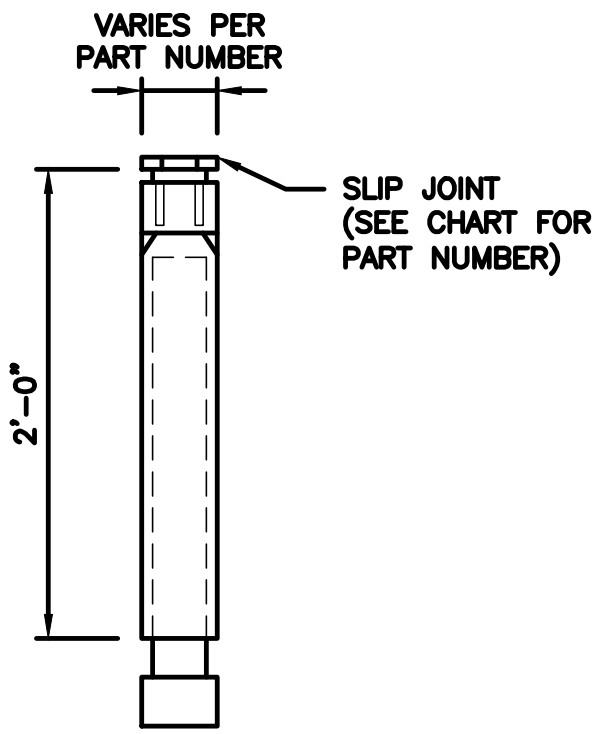

NOTE: CONTRACTOR TO INSTALL EXPANSION FITTING SLIP JOINT AT METER CENTER CONDUIT TERMINATION, AS PER LOCAL UTILITY POLICY, ORDINANCE AND/OR SPECIFIED REQUIREMENT.

**TRENCHING NOTES**

- CONTRACTOR SHALL RESTORE THE TRENCH TO ITS ORIGINAL CONDITIONS BY EITHER SEEDING OR SODDING GRASS AREAS, OR REPLACING ASPHALT OR CONCRETE AREAS TO ITS ORIGINAL CROSS SECTION.
- TRENCHING SAFETY; INCLUDING, BUT NOT LIMITED TO SOIL CLASSIFICATION, SLOPING, AND SHORING, SHALL BE GOVERNED BY THE CURRENT OSHA TRENCHING AND EXCAVATION SAFETY STANDARDS.
- ALL CONDUITS SHALL BE INSTALLED IN COMPLIANCE WITH THE CURRENT NATIONAL ELECTRIC CODE (NEC) OR AS REQUIRED BY THE LOCAL JURISDICTION, WHICHEVER IS THE MOST STRINGENT.

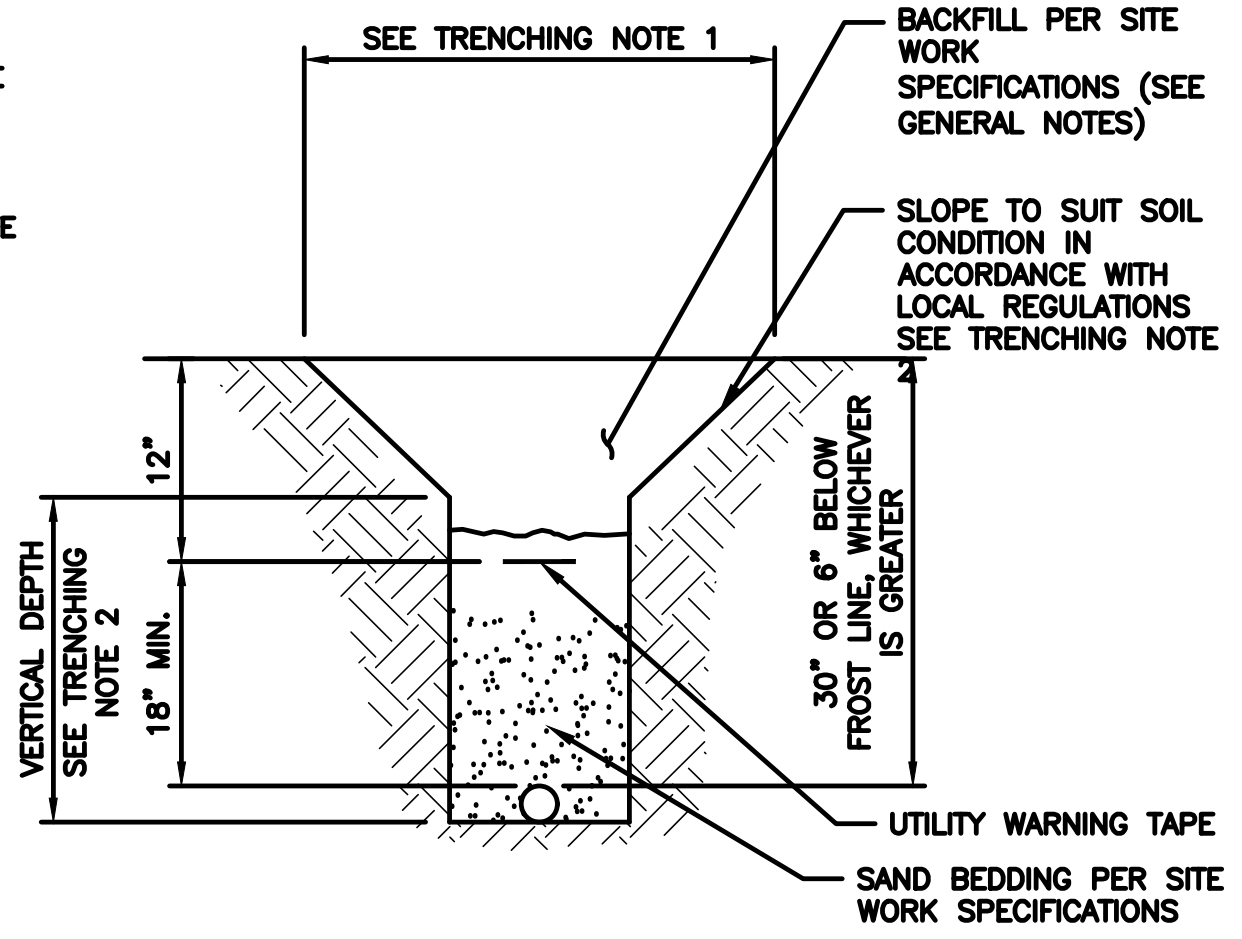

IMPORTANT: UNDERGROUND WARNING/MARKING TAPE SHALL BE BURIED AT A DEPTH OF 12 IN (30 CM) OR LESS BELOW GRADE. THE MINIMUM DISTANCE FROM THE TOP OF THE PIPELINE SHOULD BE 12 IN (30 CM). REQUIRED DEPTH OF PIPELINE SHALL BE 30" BELOW GRADE OR 6" BELOW FROSTLINE, WHICHEVER IS GREATER. EACH RUN OF UNDERGROUND WARNING/MARKING TAPE MUST BE OVERLAPPED BY A MINIMUM OF 20 FT (6 M) OR MUST BE JOINED.

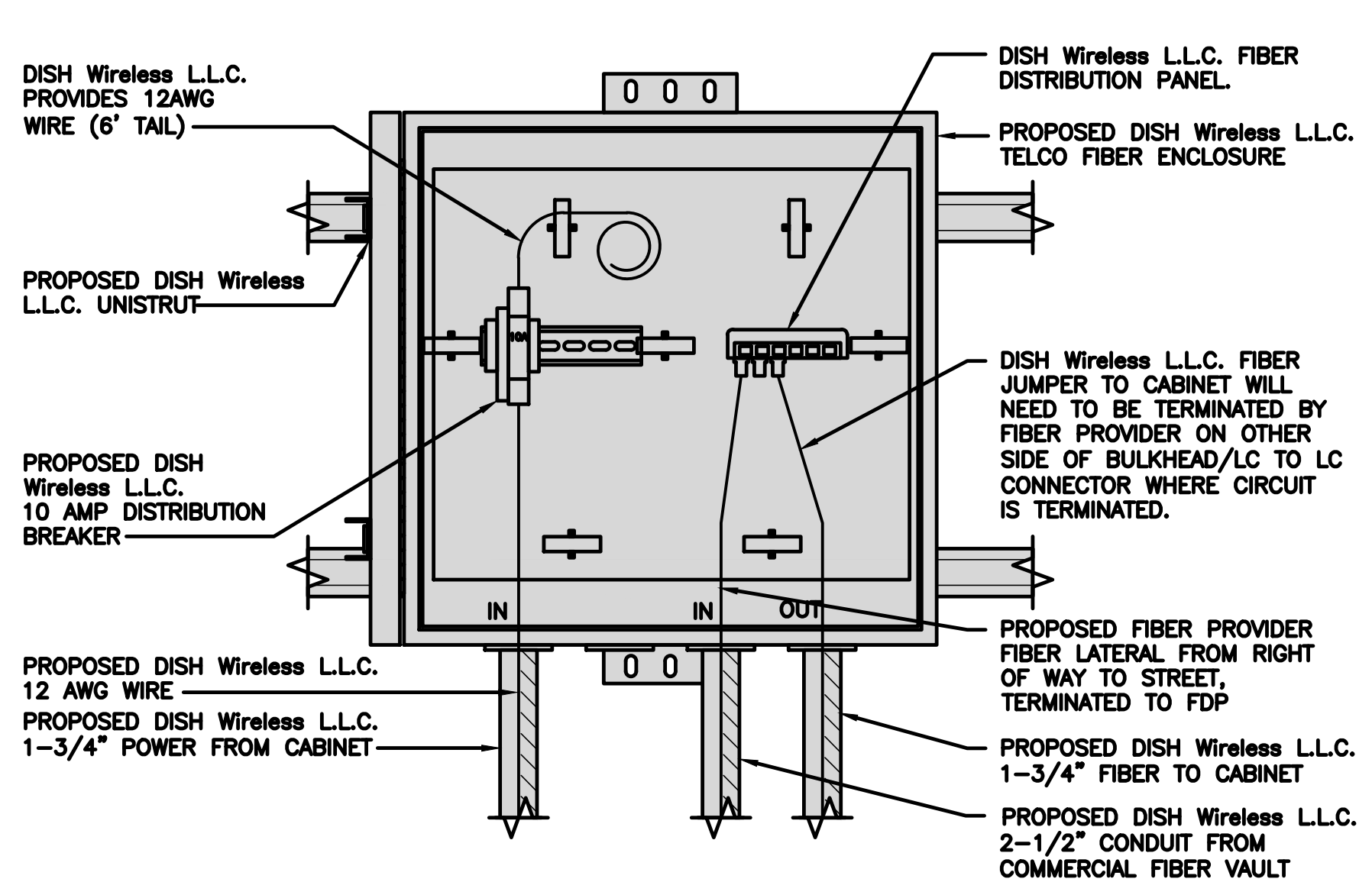

EXPANSION JOINT DETAIL

NO SCALE 1

TYPICAL UNDERGROUND TRENCH DETAIL

NO SCALE 2

DARK TELCO BOX – INTERIOR WIRING LAYOUT

NO SCALE 3

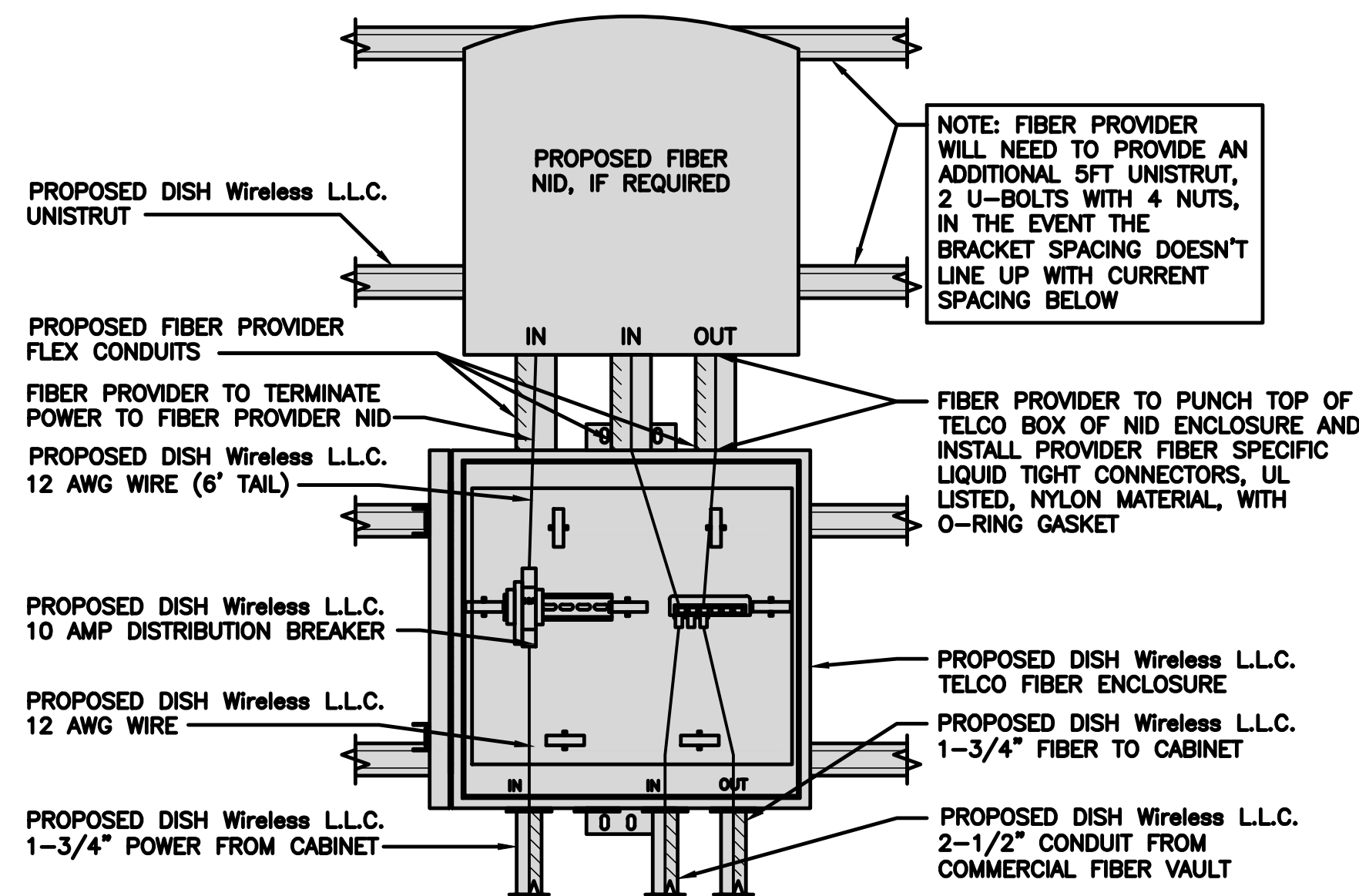

LIT TELCO BOX – INTERIOR WIRING LAYOUT (OPTIONAL)

NO SCALE 4

NOT USED

NO SCALE 5

NOT USED

NO SCALE 6

NOT USED

NO SCALE 8

NOT USED

NO SCALE 9



5701 SOUTH SANTA FE DRIVE  
LITTLETON, CO 80120



SBA COMMUNICATIONS CORP.  
134 FLANDERS ROAD, SUITE 125  
WESTBOROUGH, MA 01581  
TEL: (508) 251-0720  
FAX: (508) 251-1755



45 BEECHWOOD DRIVE, NORTH ANDOVER, MA 01845  
TEL: (978) 557-5553

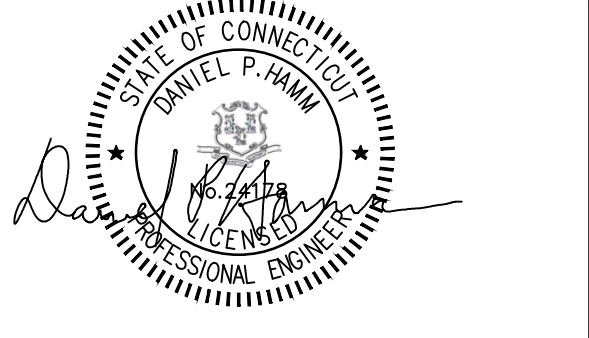

IT IS A VIOLATION OF LAW FOR ANY PERSON, UNLESS THEY ARE ACTING UNDER THE DIRECTION OF A LICENSED PROFESSIONAL ENGINEER, TO ALTER THIS DOCUMENT.

DRAWN BY:	CHECKED BY:	APPROVED BY:
TR	VD	DPH
RFDS REV #:		0

**CONSTRUCTION DOCUMENTS**

SUBMITTALS		
REV	DATE	DESCRIPTION
A	09/11/2023	ISSUED FOR REVIEW
B	09/25/2023	ISSUED FOR CONSTRUCTION

A&E PROJECT NUMBER  
BOBOS01169A

DISH Wireless L.L.C.  
PROJECT INFORMATION  
BOBOS01169A  
131 GIFFORD LANE  
BOZRAH, CT 06334

SHEET TITLE  
ELECTRICAL  
DETAILS

SHEET NUMBER  
**E-2**

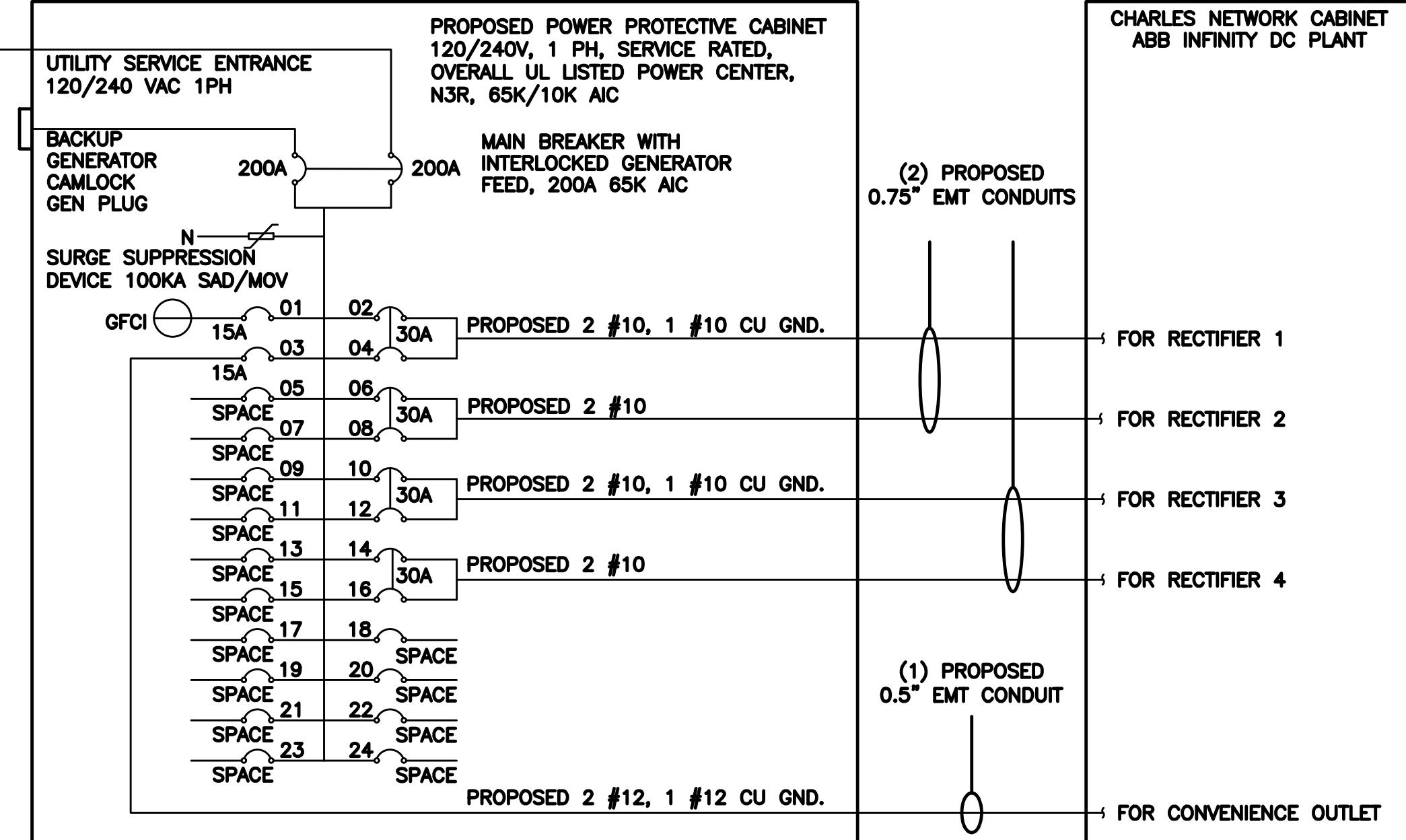
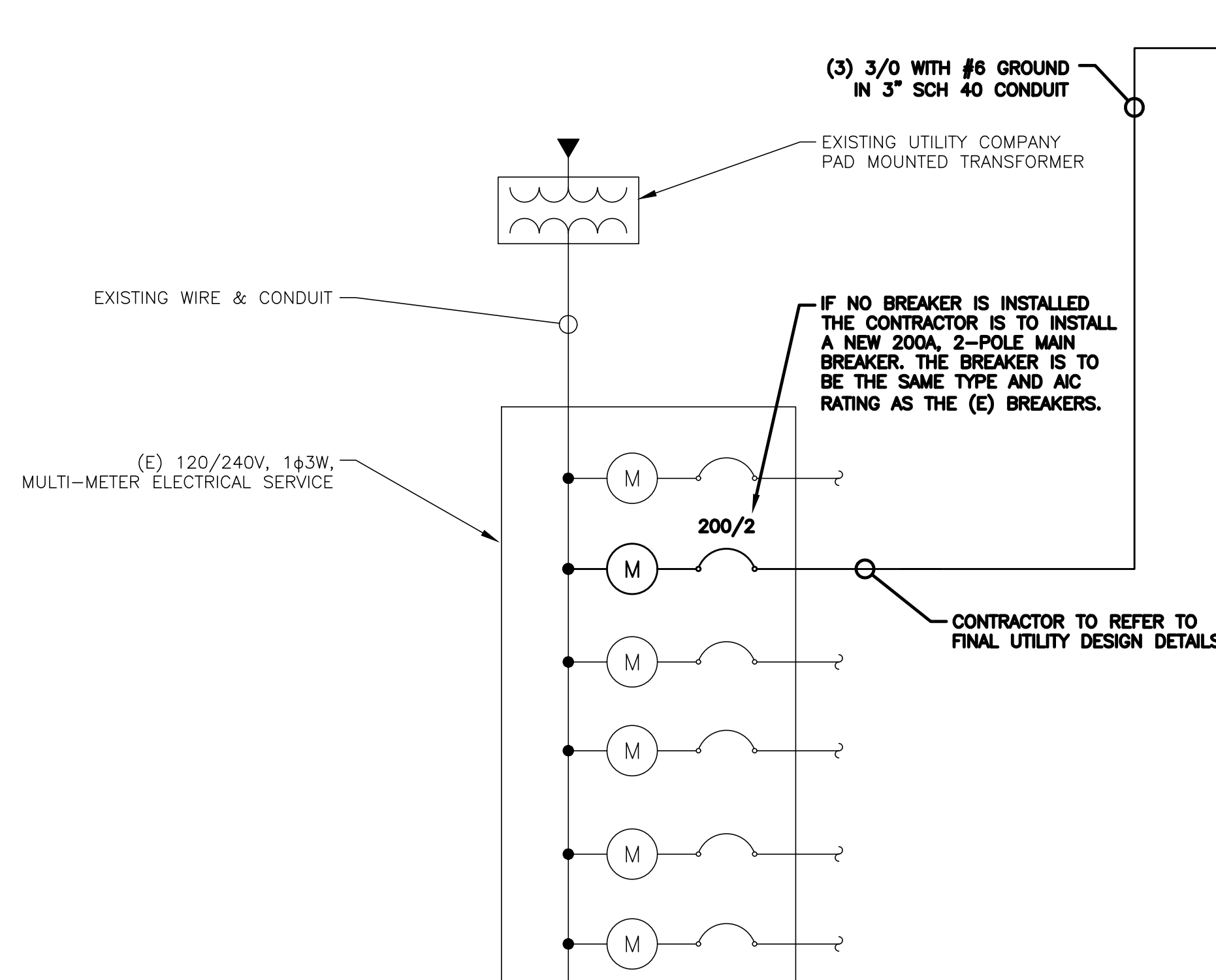

SERVICE/FEEDER CONDUCTOR LENGTH TABLE (BASED ON INDUSTRY STANDARD 3% VOLTAGE DROP AND 5% NEC ALLOWABLE LIMIT)

DESIGN LOADS	CONDUCTOR SIZES					
	250 kcmil AL	300 kcmil AL	3/0 CU	4/0 CU	250 kcmil CU	300 kcmil CU
DISH Wireless L.L.C. MAXIMUM CONTINUOUS LOAD (180A) (NEC ARTICLE 220 & 230 3% VOLTAGE DROP)	130'	155'	145'	180'	215'	255'
DISH Wireless L.L.C. MAXIMUM CONTINUOUS LOAD (180A) (NEC ARTICLE 220 & 230 5% VOLTAGE DROP)	220'	260'	240'	300'	360'	425'

- NOTES:
- 250 MCM/KCMIL AL + #2 AL GRD MAY BE USED AS A REPLACEMENT FOR 3/0 CU + #6 CU GRD SERVICE CONDUCTOR FROM THE DISH Wireless L.L.C. FIRST MEANS OF DISCONNECT/UTILITY COMPANY MEET-ME POINT. REFER TO VALUES ABOVE TO LIMIT VOLTAGE DROP TO 3%.
  - ALUMINUM/COPPER CONDUCTORS MUST BE RATED 75°C.
  - ALUMINUM TO COPPER BUSS CONNECTIONS MUST MEET AND CONFORM TO ANSI AND BE UL LISTED. USE ANTI CORROSION CONDUCTIVE LUBRICANT ON CONNECTIONS.
  - PPC MAIN DISCONNECT CIRCUIT BREAKERS ACCEPT #4 - 300KCMIL AL OR CU CONDUCTORS.
  - VOLTAGE DROP FOR SINGLE METER ENCLOSURE FED FROM TRANSFORMER WITH MULTIPLE CUSTOMERS IS CALCULATED FROM THE TRANSFORMER TO PPC. (SERVICE AND FEEDER CONDUCTOR LENGTH)
  - VOLTAGE DROP FOR MULTI-METER ENCLOSURE IS CALCULATED FROM THE METER TO PPC. (FEEDER CONDUCTOR LENGTH)
  - VOLTAGE DROP CALCULATIONS ARE BASED ON A POWER FACTOR OF 1, A LINE TO GROUND VOLTAGE PER CONDUCTOR OF 120V, NO CORRECTION FACTOR FOR AMBIENT TEMPERATURE OR ADJUSTMENT FACTOR FOR MORE THAN THREE CURRENT-CARRYING CONDUCTORS IN A SINGLE CONDUCT OR RACEWAY. A POWER FACTOR LESS THAN 1 OR VOLTAGE LESS THAN 120 WILL RESULT IN SHORTER DISTANCES THAN SHOWN IN TABLE.

**NOTE:**  
BRANCH CIRCUIT WIRING SUPPLYING RECTIFIERS ARE TO BE RATED UL1015, 105°C, 600V, AND PVC INSULATED, IN THE SIZES SHOWN IN THE ONE-LINE DIAGRAM. CONTRACTOR MAY SUBSTITUTE UL1015 WIRE FOR THWN-2 FOR CONVENIENCE OUTLET BRANCH CIRCUIT.

**BREAKERS REQUIRED:**  
(4) 30A, 2P BREAKER - SQUARE D P/N:Q0230  
(2) 15A, 1P BREAKER - SQUARE D P/N:Q0115

**NOTES**

THE ENGINEER OF RECORD HAS PERFORMED ALL REQUIRED SHORT CIRCUIT CALCULATIONS AND THE AIC RATINGS FOR EACH DEVICE IS ADEQUATE TO PROTECT THE EQUIPMENT AND THE ELECTRICAL SYSTEM.

THE ENGINEER OF RECORD HAS PERFORMED ALL REQUIRED VOLTAGE DROP CALCULATIONS AND ALL BRANCH CIRCUIT AND FEEDERS COMPLY WITH THE NEC (LISTED ON T-1) ARTICLE 210.19(A)(1) FPN NO. 4.

THE (2) CONDUITS WITH (4) CURRENT CARRYING CONDUCTORS EACH, SHALL APPLY THE ADJUSTMENT FACTOR OF 80% PER 2014/17 NEC TABLE 310.15(B)(3)(a) OR 2020 NEC TABLE 310.15(C)(1) FOR UL1015 WIRE.

#12 FOR 15A-20A/1P BREAKER: 0.8 x 30A = 24.0A  
#10 FOR 25A-30A/2P BREAKER: 0.8 x 40A = 32.0A  
#8 FOR 35A-40A/2P BREAKER: 0.8 x 55A = 44.0A  
#6 FOR 45A-60A/2P BREAKER: 0.8 x 75A = 60.0A

CONDUIT SIZING: AT 40% FILL PER NEC CHAPTER 9, TABLE 4, ARTICLE 358.  
0.5" CONDUIT - 0.122 SQ. IN AREA  
0.75" CONDUIT - 0.213 SQ. IN AREA  
2.0" CONDUIT - 1.316 SQ. IN AREA  
3.0" CONDUIT - 2.907 SQ. IN AREA

CABINET CONVENIENCE OUTLET CONDUCTORS (1 CONDUIT): USING THWN-2, CU.

#12 - 0.0050 SQ. IN X 2 = 0.0100 SQ. IN  
#12 - 0.0050 SQ. IN X 1 = 0.0050 SQ. IN <GROUND  
TOTAL = 0.0150 SQ. IN

0.5" EMT CONDUIT IS ADEQUATE TO HANDLE THE TOTAL OF (3) WIRES, INCLUDING GROUND WIRE, AS INDICATED ABOVE.

RECTIFIER CONDUCTORS (2 CONDUITS): USING UL1015, CU.

#10 - 0.0266 SQ. IN X 4 = 0.1064 SQ. IN  
#10 - 0.0082 SQ. IN X 1 = 0.0082 SQ. IN <BARE GROUND  
TOTAL = 0.1146 SQ. IN

0.75" EMT CONDUIT IS ADEQUATE TO HANDLE THE TOTAL OF (5) WIRES, INCLUDING GROUND WIRE, AS INDICATED ABOVE.

PPC FEED CONDUCTORS (1 CONDUIT): USING THWN, CU.

3/0 - 0.2679 SQ. IN X 3 = 0.8037 SQ. IN  
#6 - 0.0507 SQ. IN X 1 = 0.0507 SQ. IN <GROUND  
TOTAL = 0.8544 SQ. IN

3.0" SCH 40 PVC CONDUIT IS ADEQUATE TO HANDLE THE TOTAL OF (4) WIRES, INCLUDING GROUND WIRE, AS INDICATED ABOVE.

PPC FEED CONDUCTORS (1 CONDUIT): USING THWN, AL.

250kcmil AL - 0.3970 SQ. IN X 3 = 1.191 SQ. IN  
#4 AL - 0.0824 SQ. IN X 1 = 0.0824 SQ. IN <GROUND  
TOTAL = 1.2734 SQ. IN

3.0" SCH 40 PVC CONDUIT IS ADEQUATE TO HANDLE THE TOTAL OF (4) WIRES, INCLUDING GROUND WIRE, AS INDICATED ABOVE.

PPC ONE-LINE DIAGRAM

NO SCALE 1

**PROPOSED CHARLES PANEL SCHEDULE**

LOAD SERVED	VOLT AMPS (WATTS)		TRIP	CKT #	PHASE	CKT #	TRIP	VOLT AMPS (WATTS)		LOAD SERVED
	L1	L2						L1	L2	
PPC GFCI OUTLET	180	180	15A	1	A	2	30A	2880	2880	ABB/GE INFINITY RECTIFIER 1
CHARLES GFCI OUTLET			15A	3	B	4	30A	2880	2880	ABB/GE INFINITY RECTIFIER 1
-SPACE-				5	A	6	30A	2880	2880	ABB/GE INFINITY RECTIFIER 2
-SPACE-				7	B	8	30A	2880	2880	ABB/GE INFINITY RECTIFIER 2
-SPACE-				9	A	10	30A	2880	2880	ABB/GE INFINITY RECTIFIER 3
-SPACE-				11	B	12	30A	2880	2880	ABB/GE INFINITY RECTIFIER 3
-SPACE-				13	A	14	30A	2880	2880	ABB/GE INFINITY RECTIFIER 4
-SPACE-				15	B	16	30A	2880	2880	ABB/GE INFINITY RECTIFIER 4
-SPACE-				17	A	18				-SPACE-
-SPACE-				19	B	20				-SPACE-
-SPACE-				21	A	22				-SPACE-
-SPACE-				23	B	24				-SPACE-
VOLTAGE AMPS	180	180						11520	11520	
200A MCB, 1ϕ, 24 SPACE, 120/240V				L1	L2			VOLTAGE AMPS		
MB RATING: 65,000 AIC				11700	11700			AMPS		
				98	98			AMPS		
				98	98			MAX AMPS		
				123	123			MAX 125%		

PANEL SCHEDULE

NO SCALE 2

SHORT CIRCUIT CALCULATIONS

NO SCALE 3

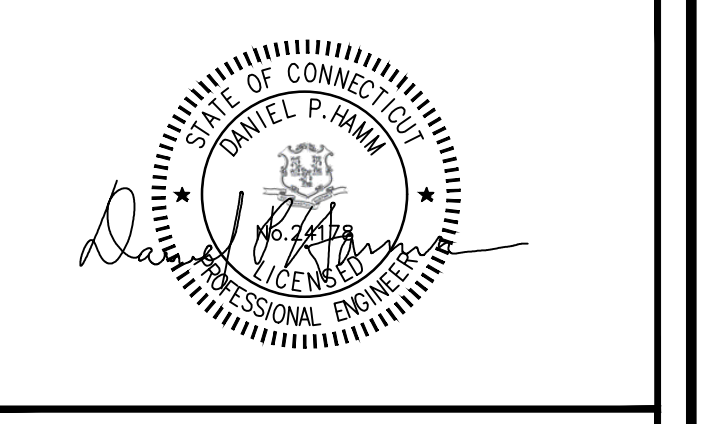

IT IS A VIOLATION OF LAW FOR ANY PERSON, UNLESS THEY ARE ACTING UNDER THE DIRECTION OF A LICENSED PROFESSIONAL ENGINEER, TO ALTER THIS DOCUMENT.

DRAWN BY: TR  
CHECKED BY: VD  
APPROVED BY: DPH

RFDS REV #: 0

CONSTRUCTION DOCUMENTS

SUBMITTALS

REV	DATE	DESCRIPTION
A	09/11/2023	ISSUED FOR REVIEW
B	09/25/2023	ISSUED FOR CONSTRUCTION

A&E PROJECT NUMBER  
BOBOS01169A

DISH Wireless L.L.C.  
PROJECT INFORMATION  
BOBOS01169A  
131 GIFFORD LANE  
BOZRAH, CT 06334

SHEET TITLE  
ELECTRICAL ONE-LINE, FAULT  
CALCS & PANEL SCHEDULE

SHEET NUMBER  
E-3

**NOTES:**

- HAZARD OF ELECTRICAL SHOCK OR BURN. TURN OFF POWER SUPPLYING THIS EQUIPMENT BEFORE WORKING INSIDE.
- 100 OR 200 AMP, 240 VOLTS, SINGLE PHASE ALTERNATING CURRENT CIRCUIT ONLY
- GENERATOR SHORT CIRCUIT RATING: 10,000 / 20,000 AMPS RMS SYMMETRICAL, AMPERES AT 240 VOLTS
- UTILITY SHORT CIRCUIT RATING: 65,000 AMPS RMS SYMMETRICAL, AMPERES AT 240 VOLTS
- SUITABLE FOR USE AS SERVICE EQUIPMENT
- SUITABLE FOR USE IN ACCORDANCE WITH ARTICLE 702 OF THE NATIONAL ELECTRIC CODE ANSI/NFPA 70
- BONDED NEUTRAL WHEN INSTALLED AS SHOWN IN WIRING DIAGRAM
- RAIN PROOF TYPE 3R
- USE CU-AL WIRE 60-75 °C
- EQUIPPED WITH SLIDE BAR MECHANICAL INTERLOCK
- INTERLOCK PROHIBITS BOTH POWER SOURCES FROM BEING IN THE ON POSITION SIMULTANEOUSLY
- EQUIPPED WITH SQUARE D BREAKERS OR ALTERNATIVE MANUFACTURER EQUIVALENT
- WHEN REPLACE LOAD CENTER BREAKERS, USE ONLY SQUARE D (QO TYPE) OF THE SAME RATING OR EQUIVALENT
- WHEN RESETTING BREAKERS TURN TO OFF POSITION, THEN TO ON POSITION
- WARNING: MAKE CONTINUITY CHECK WITH OHM METER TO VERIFY CORRECT PHASING AND GROUNDING CONNECTIONS BEFORE POWER UP
- VERIFY PIN OUT CONFIGURATION OF GENERATOR PRIOR TO USE.
- RISK OF ELECTRIC SHOCK, BOTH ENDS OF DISCONNECTING MEANS MAY BE ENERGIZED. TEST BEFORE SERVICING
- THIS SWITCH BOARD MAY CONTAIN A TAP ON THE SERVICE SIDE OF THE MAIN POWER DISCONNECT FOR REMOTE MONITORING OF UTILITY/STANDBY POWER
- THE NORMAL AC POWER MONITORING CIRCUIT MUST UTILIZE A DISCONNECTING MEANS WITH A SHORT CIRCUIT RATING GREATER THAN THE AVAILABLE INTERRUPTING CURRENT
- A RED PUSH-TO-TRIP BUTTON PROVIDES A MEANS TO MECHANICALLY TRIP THE CIRCUIT BREAKER. THIS ACTION EXERCISES THE TRIPPING PORTION OF THE MECHANISM AND ALLOWS MAINTENANCE CHECK ON THE BREAKER

SUITABLE FOR USE AS SERVICE EQUIPMENT

ELECTRICAL RATING 120/240 VOLTS SINGLE PHASE 60 Hz	
NORMAL AC POWER	GENERATOR POWER
100A	100A
200A	200A

**CAUTION:**

- THE OPERATING HANDLE ASSUMES A CENTER POSITION WHEN THE CIRCUIT BREAKER IS TRIPPED
- THE BREAKER CAN BE RESET BY OPERATING THE HANDLE TO THE EXTREME OFF POSITION AND THEN TO ON
- SLIDE BAR MECHANICAL INTERLOCK TRANSFERS NORMAL AC POWER TO GENERATOR POWER. THE SLIDE BAR MECHANICAL INTERLOCK PROHIBITS BOTH POWER SOURCES FROM BEING IN THE ON POSITION SIMULTANEOUSLY
- TO TRANSFER FROM ON POWER SOURCE TO THE OTHER POWER SOURCE, SWITCH ON BREAKER TO THE OFF POSITION, MOVE THE SLIDE BAR TO THE OTHER SIDE AND THE SWITCH THE OTHER BREAKER TO THE ON POSITION

**200A UTILITY FEED**

LOAD SIZE CIRCUIT BREAKERS				LINE SIDE MAIN CIRCUIT BREAKER					
MFR.	TYPE	POLES	AMP RATING	MFR.	TYPE	AMP RATING	SYMMET. AMP RMS	VOLTS AC	PHASES
SQ-D	QO	1/2	15-100A	SQ-D	QGL	200A	65,000A	240V	2

THIS SWITCHBOARD UTILITY MAIN BREAKER IS SUITABLE FOR USE ON CIRCUIT CAPABLE OF DELIVERING NOT MORE THAN 65,000 RMS SYMMETRICAL AMPS, 240 VOLTS MAXIMUM.

**200A GENERATOR FEED**

LOAD SIZE CIRCUIT BREAKERS				LINE SIDE MAIN CIRCUIT BREAKER					
MFR.	TYPE	POLES	AMP RATING	MFR.	TYPE	AMP RATING	SYMMET. AMP RMS	VOLTS AC	PHASES
SQ-D	QO	1/2	15-100A	SQ-D	QGL	200A	65,000A	240V	2

THIS SWITCHBOARD GENERATOR POWER CIRCUIT IS SUITABLE FOR USE ON A CIRCUIT CAPABLE OF DELIVERING NOT MORE THAN 10,000 RMS SYMMETRICAL AMPS, 240 VOLTS MAXIMUM.

MAXIMUM CONTINUOUS LOADS NOT TO EXCEED 80% OF THE OVER-CURRENT PROTECTIVE DEVICE (CIRCUIT BREAKER AND FUSES) RATINGS EMPLOYED IN OTHER THAN MOTOR CIRCUITS, EXCEPT FOR THOSE CIRCUITS EMPLOYING CIRCUIT BREAKERS MARKED AS SUITABLE FOR CONTINUOUS OPERATION AT 100% OF THEIR RATINGS. CONDUCTORS ARE NOT TO ENTER OR LEAVE THE ENCLOSURE DIRECTLY OPPOSITE THE WIRING TERMINAL

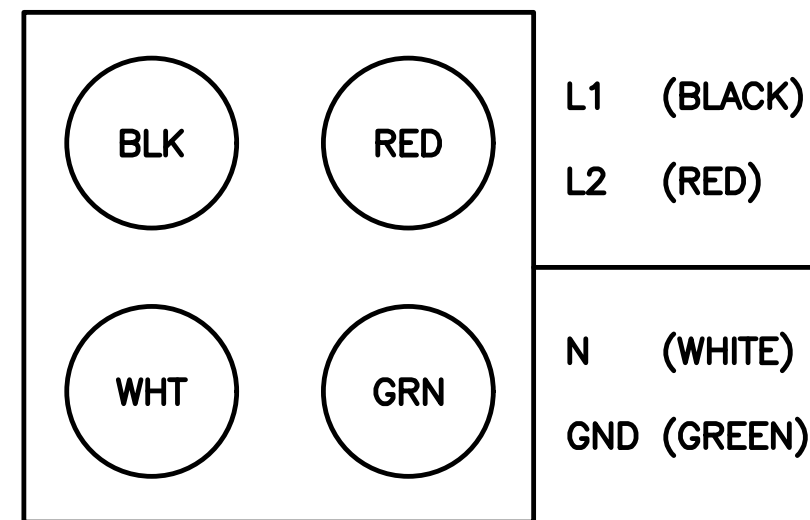

**CAM-LOCK GENERATOR RECEPTACLE**  
(AS VIEWED FROM OUTSIDE OF ENCLOSURE)  
USE LINE UP PIN AS REFERENCE

REFER TO RECEPTACLE FOR MODEL NUMBER

**DANGER:**

HAZARD OF ELECTRICAL SHOCK OR BURN.  
TURN OFF POWER SUPPLYING THIS EQUIPMENT BEFORE WORKING INSIDE.

RAYCAP CUSTOMER SERVICE  
(800) 890-2569

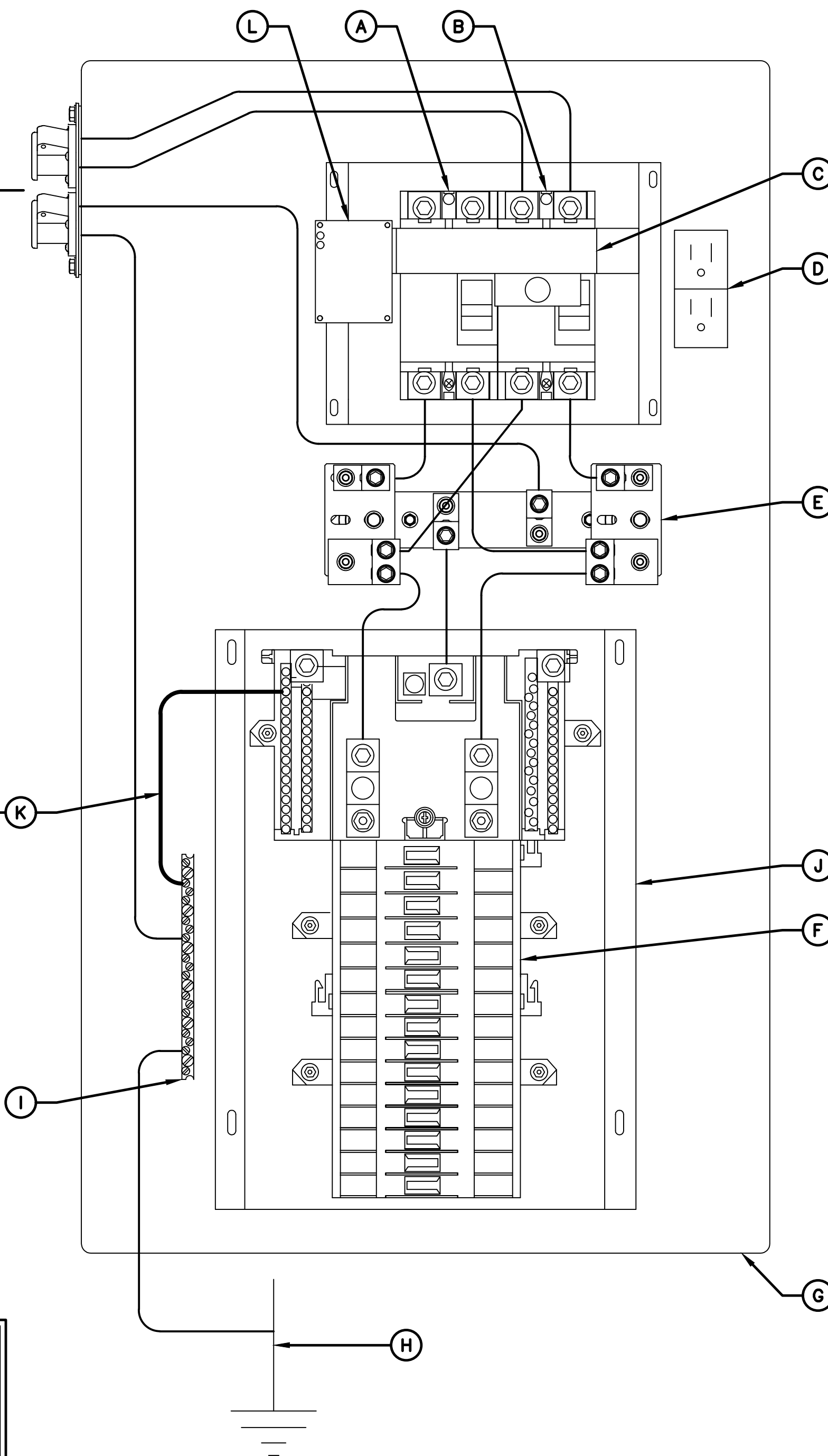

**NEUTRAL-TO-GROUND NOTES:**

- WHEN THE PPC IS USED AS THE SERVICE ENTRANCE DEVICE, THE NEUTRAL TO GROUND BOND NEEDS TO BE ESTABLISHED IN THE PPC.
- WHEN THE SERVICE ENTRY DEVICE IS A MULTI-METER CENTER OR A PRE-PPC DISCONNECT IS USED AND HAS "NEUTRAL TO GROUND" ACCOMMODATIONS, THE NEUTRAL TO GROUND WIRE IN THE PPC IS NOT REQUIRED.
- THE GREEN #6 WIRE IS PROVIDED WITH THE PPC CABINET AS A SEPARATE UNINSTALLED PART TO BE INSTALLED BY CONTRACTOR IF NEEDED.

**NEUTRAL-TO-GROUND BONDING JUMPER**

**INSTALLATION INSTRUCTIONS:**

- IF REQUIRED, THE N-G BONDING KIT SHOULD BE INSTALLED BY QUALIFIED PERSONNEL
- ENSURE THE MAIN BREAKERS ARE OFF
- USE THE GREEN #6 WIRE PROVIDED WITH THE PPC
- INSTALL THE JUMPER AS SHOWN IN THE WIRING DIAGRAM
- TIGHTEN TERMINALS TO TORQUE VALUE SHOWN IN TORQUE TABLE
- PLACE THE PROVIDED "SERVICE" LABEL IN THE SPACE BELOW THE WORDS "AC POWER" LOCATED ABOVE THE MAIN CIRCUIT BREAKER IN THE UPPER PORTION OF THE DEAD FRONT

**LEGEND:**

- A. UTILITY DISCONNECT (SERVICE RATED)
- B. GENERATOR DISCONNECT
- C. MAIN DISCONNECT CIRCUIT BREAKERS W/ MECHANICAL INTERLOCK
- D. GFCI RECEPTACLE 15A
- E. SPD STRIKESORB KELVIN CONNECTION (TYP OF 2)
- F. BREAKER PANEL - 24 POSITION (CONTRACTOR TO ADD APPROPRIATE BREAKER PER ONE-LINE DIAGRAM PANEL SCHEDULE)
- G. POWER PROTECTION CABINET (PPC) (FULLY ASSEMBLED FROM MANUFACTURER)
- H. CONTRACTOR TO ATTACH TO UNDERGROUND GROUNDING HALO OR INSTALL GROUND ROD WHEN REQUIRED BY CODE
- I. GROUND BAR
- J. SQUARE D Q SERIES LOAD CENTER
- K. NEUTRAL-TO-GROUND (N-G) BONDING JUMPER (CONTRACTOR INSTALLED IF REQUIRED)
- L. OPTIONAL SPD STATUS INDICATORS



5701 SOUTH SANTA FE DRIVE  
LITTLETON, CO 80120



SBA COMMUNICATIONS CORP.  
134 FLANDERS ROAD, SUITE 125  
WESTBOROUGH, MA 01581  
TEL: (508) 251-0720  
FAX: (508) 251-1755



45 BEECHWOOD DRIVE, NORTH ANDOVER, MA 01845  
TEL: (978) 557-5553

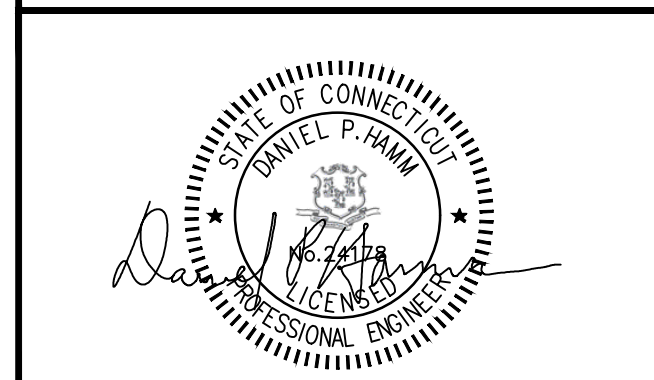

IT IS A VIOLATION OF LAW FOR ANY PERSON, UNLESS THEY ARE ACTING UNDER THE DIRECTION OF A LICENSED PROFESSIONAL ENGINEER, TO ALTER THIS DOCUMENT.

DRAWN BY:	CHECKED BY:	APPROVED BY:
TR	VD	DPH

RFDS REV #: 0

**CONSTRUCTION DOCUMENTS**

SUBMITTALS		
REV	DATE	DESCRIPTION
A	09/11/2023	ISSUED FOR REVIEW
B	09/25/2023	ISSUED FOR CONSTRUCTION

A&E PROJECT NUMBER  
BOBOS01169A

DISH Wireless L.L.C.  
PROJECT INFORMATION  
BOBOS01169A  
131 GIFFORD LANE  
BOZRAH, CT 06334

SHEET TITLE  
PPC NEUTRAL-TO-GROUND SCHEMATIC

SHEET NUMBER

E-4

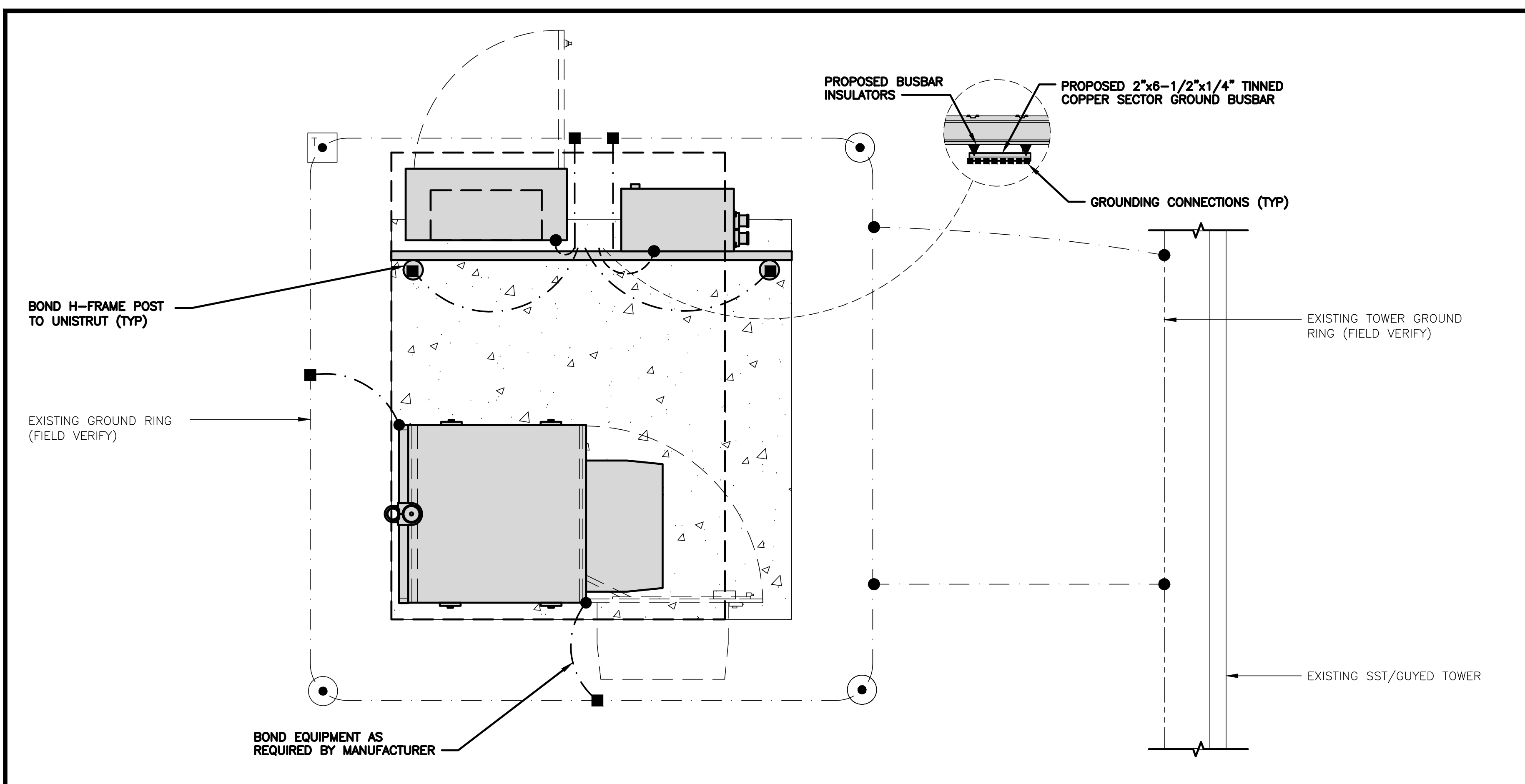

**TYPICAL EQUIPMENT GROUNDING PLAN**

NO SCALE 1

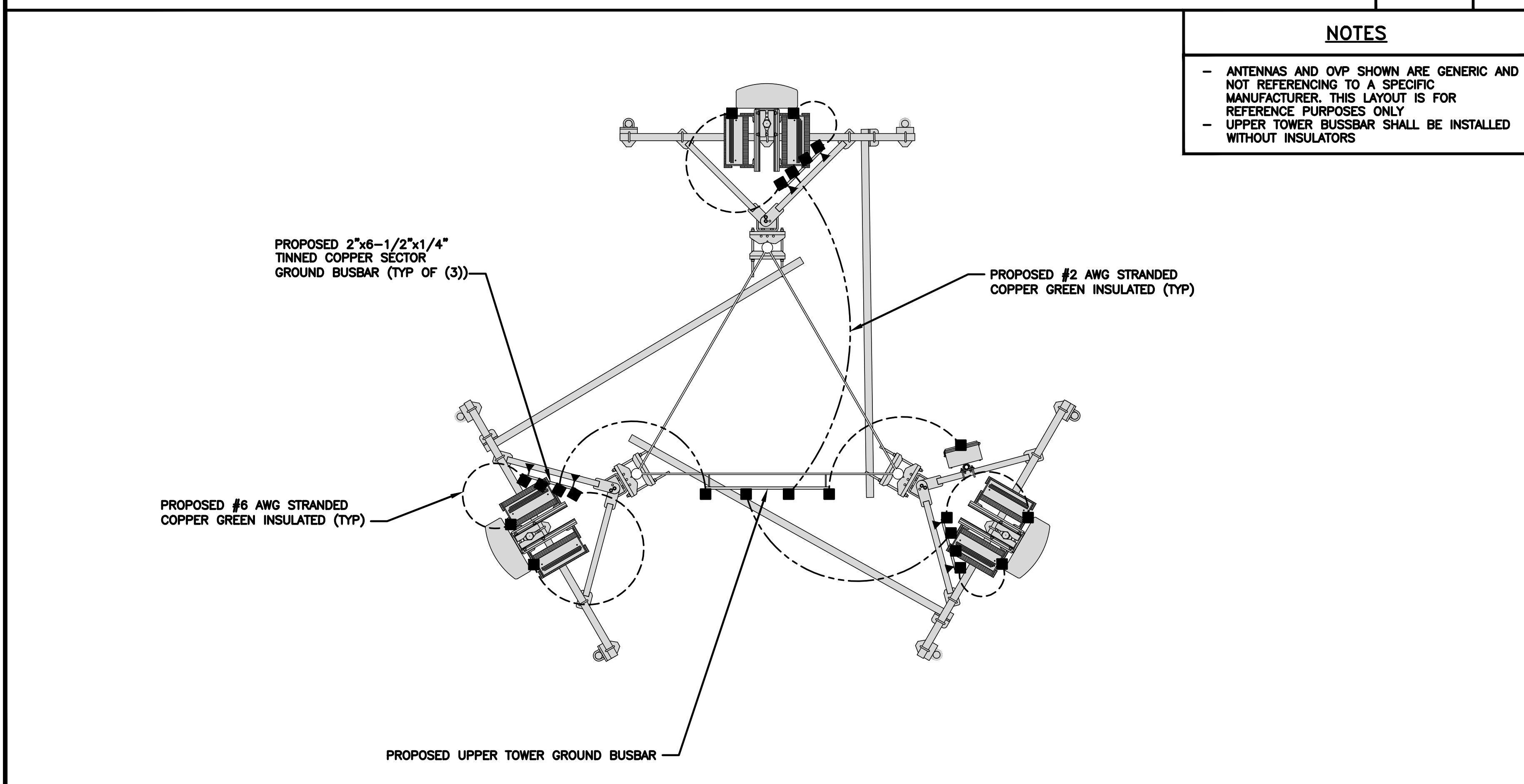

**TYPICAL ANTENNA GROUNDING PLAN**

NO SCALE 2

- EXOTHERMIC CONNECTION
- MECHANICAL CONNECTION
- ▬ GROUND BUS BAR
- GROUND ROD
- TEST GROUND ROD WITH INSPECTION SLEEVE
- #6 AWG STRANDED & INSULATED
- - - - - #2 AWG SOLID COPPER TINNED
- #2 AWG STRANDED & INSULATED
- ▲ BUSS BAR INSULATOR

**GROUNDING LEGEND**

1. GROUNDING IS SHOWN DIAGRAMMATICALLY ONLY.
2. CONTRACTOR SHALL GROUND ALL EQUIPMENT AS A COMPLETE SYSTEM. GROUNDING SHALL BE IN COMPLIANCE WITH NEC SECTION 250 AND DISH Wireless L.L.C. GROUNDING AND BONDING REQUIREMENTS AND MANUFACTURER'S SPECIFICATIONS.
3. ALL GROUND CONDUCTORS SHALL BE COPPER; NO ALUMINUM CONDUCTORS SHALL BE USED.

**GROUNDING KEY NOTES**

- (A) **EXTERIOR GROUND RING:** #2 AWG SOLID COPPER, BURIED AT A DEPTH OF AT LEAST 30 INCHES BELOW GRADE, OR 6 INCHES BELOW THE FROST LINE AND APPROXIMATELY 24 INCHES FROM THE EXTERIOR WALL OR FOOTING.
- (B) **TOWER GROUND RING:** THE GROUND RING SYSTEM SHALL BE INSTALLED AROUND AN ANTENNA TOWER'S LEGS, AND/OR GUY ANCHORS. WHERE SEPARATE SYSTEMS HAVE BEEN PROVIDED FOR THE TOWER AND THE BUILDING, AT LEAST TWO BONDS SHALL BE MADE BETWEEN THE TOWER RING GROUND SYSTEM AND THE BUILDING RING GROUND SYSTEM USING MINIMUM #2 AWG SOLID COPPER CONDUCTORS.
- (C) **INTERIOR GROUND RING:** #2 AWG STRANDED GREEN INSULATED COPPER CONDUCTOR EXTENDED AROUND THE PERIMETER OF THE EQUIPMENT AREA. ALL NON-TELECOMMUNICATIONS RELATED METALLIC OBJECTS FOUND WITHIN A SITE SHALL BE GROUNDED TO THE INTERIOR GROUND RING WITH #6 AWG STRANDED GREEN INSULATED CONDUCTOR.
- (D) **BOND TO INTERIOR GROUND RING:** #2 AWG SOLID TINNED COPPER WIRE PRIMARY BONDS SHALL BE PROVIDED AT LEAST AT FOUR POINTS ON THE INTERIOR GROUND RING, LOCATED AT THE CORNERS OF THE BUILDING.
- (E) **GROUND ROD:** UL LISTED COPPER CLAD STEEL. MINIMUM 1/2" DIAMETER BY EIGHT FEET LONG. GROUND RODS SHALL BE INSTALLED WITH INSPECTION SLEEVES. GROUND RODS SHALL BE DRIVEN TO THE DEPTH OF GROUND RING CONDUCTOR.
- (F) **CELL REFERENCE GROUND BAR:** POINT OF GROUND REFERENCE FOR ALL COMMUNICATIONS EQUIPMENT FRAMES. ALL BONDS ARE MADE WITH #2 AWG UNLESS NOTED OTHERWISE STRANDED GREEN INSULATED COPPER CONDUCTORS. BOND TO GROUND RING WITH (2) #2 SOLID TINNED COPPER CONDUCTORS.
- (G) **HATCH PLATE GROUND BAR:** BOND TO THE INTERIOR GROUND RING WITH TWO #2 AWG STRANDED GREEN INSULATED COPPER CONDUCTORS. WHEN A HATCH-PLATE AND A CELL REFERENCE GROUND BAR ARE BOTH PRESENT, THE CRGB MUST BE CONNECTED TO THE HATCH-PLATE AND TO THE INTERIOR GROUND RING USING (2) TWO #2 AWG STRANDED GREEN INSULATED COPPER CONDUCTORS EACH.
- (H) **EXTERIOR CABLE ENTRY PORT GROUND BARS:** LOCATED AT THE ENTRANCE TO THE CELL SITE BUILDING. BOND TO GROUND RING WITH A #2 AWG SOLID TINNED COPPER CONDUCTORS WITH AN EXOTHERMIC WELD AND INSPECTION SLEEVE.
- (I) **TELCO GROUND BAR:** BOND TO BOTH CELL REFERENCE GROUND BAR OR EXTERIOR GROUND RING.
- (J) **FRAME BONDING:** THE BONDING POINT FOR TELECOM EQUIPMENT FRAMES SHALL BE THE GROUND BUS THAT IS NOT ISOLATED FROM THE EQUIPMENTS METAL FRAMEWORK.
- (K) **INTERIOR UNIT BONDS:** METAL FRAMES, CABINETS AND INDIVIDUAL METALLIC UNITS LOCATED WITH THE AREA OF THE INTERIOR GROUND RING REQUIRE A #6 AWG STRANDED GREEN INSULATED COPPER BOND TO THE INTERIOR GROUND RING.
- (L) **FENCE AND GATE GROUNDING:** METAL FENCES WITHIN 7 FEET OF THE EXTERIOR GROUND RING OR OBJECTS BONDED TO THE EXTERIOR GROUND RING SHALL BE BONDED TO THE GROUND RING WITH A #2 AWG SOLID TINNED COPPER CONDUCTOR AT AN INTERVAL NOT EXCEEDING 25 FEET. BONDS SHALL BE MADE AT EACH GATE POST AND ACROSS GATE OPENINGS.
- (M) **EXTERIOR UNIT BONDS:** METALLIC OBJECTS, EXTERNAL TO OR MOUNTED TO THE BUILDING, SHALL BE BONDED TO THE EXTERIOR GROUND RING. USING #2 TINNED SOLID COPPER WIRE
- (N) **ICE BRIDGE SUPPORTS:** EACH ICE BRIDGE LEG SHALL BE BONDED TO THE GROUND RING WITH #2 AWG BARE TINNED COPPER CONDUCTOR. PROVIDE EXOTHERMIC WELDS AT BOTH THE ICE BRIDGE LEG AND BURIED GROUND RING.
- (O) **DURING ALL DC POWER SYSTEM CHANGES** INCLUDING DC SYSTEM CHANGE OUTS, RECTIFIER REPLACEMENTS OR ADDITIONS, BREAKER DISTRIBUTION CHANGES, BATTERY ADDITIONS, BATTERY REPLACEMENTS AND INSTALLATIONS OR CHANGES TO DC CONVERTER SYSTEMS IT SHALL BE REQUIRED THAT SERVICE CONTRACTORS VERIFY ALL DC POWER SYSTEMS ARE EQUIPPED WITH A MASTER DC SYSTEM RETURN GROUND CONDUCTOR FROM THE DC POWER SYSTEM COMMON RETURN BUS DIRECTLY CONNECTED TO THE CELL SITE REFERENCE GROUND BAR
- (P) **TOWER TOP COLLECTOR BUSS BAR** IS TO BE MECHANICALLY BONDED TO TOWER STEEL.  
  
REFER TO DISH Wireless L.L.C. GROUNDING NOTES.

**GROUNDING KEY NOTES**

NO SCALE 3



5701 SOUTH SANTA FE DRIVE  
LITTLETON, CO 80120



SBA COMMUNICATIONS CORP.  
134 FLANDERS ROAD, SUITE 125  
WESTBOROUGH, MA 01581  
TEL: (508) 251-0720  
FAX: (508) 251-1755



45 BEECHWOOD DRIVE, NORTH ANDOVER, MA 01845  
TEL: (978) 557-5553

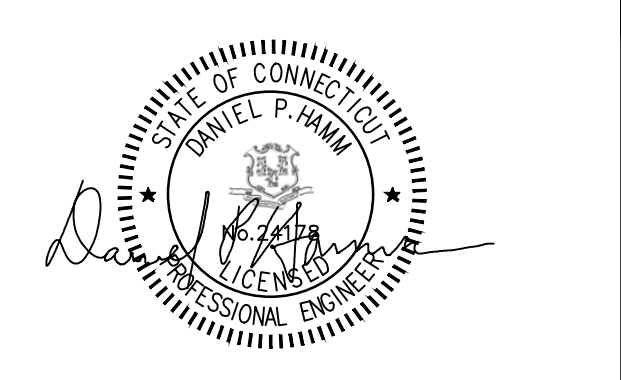

IT IS A VIOLATION OF LAW FOR ANY PERSON, UNLESS THEY ARE ACTING UNDER THE DIRECTION OF A LICENSED PROFESSIONAL ENGINEER, TO ALTER THIS DOCUMENT.

DRAWN BY: TR  
CHECKED BY: VD  
APPROVED BY: DPH

RFDS REV #: 0

**CONSTRUCTION DOCUMENTS**

SUBMITTALS		
REV	DATE	DESCRIPTION
A	09/11/2023	ISSUED FOR REVIEW
B	09/25/2023	ISSUED FOR CONSTRUCTION

A&E PROJECT NUMBER  
BOBOS01169A

DISH Wireless L.L.C.  
PROJECT INFORMATION  
  
BOBOS01169A  
131 GIFFORD LANE  
BOZRAH, CT 06334

SHEET TITLE  
GROUNDING PLANS AND NOTES

SHEET NUMBER  
**G-1**

**NOTES**  
EQUIPMENT CABINET OMITTED FOR CLARITY

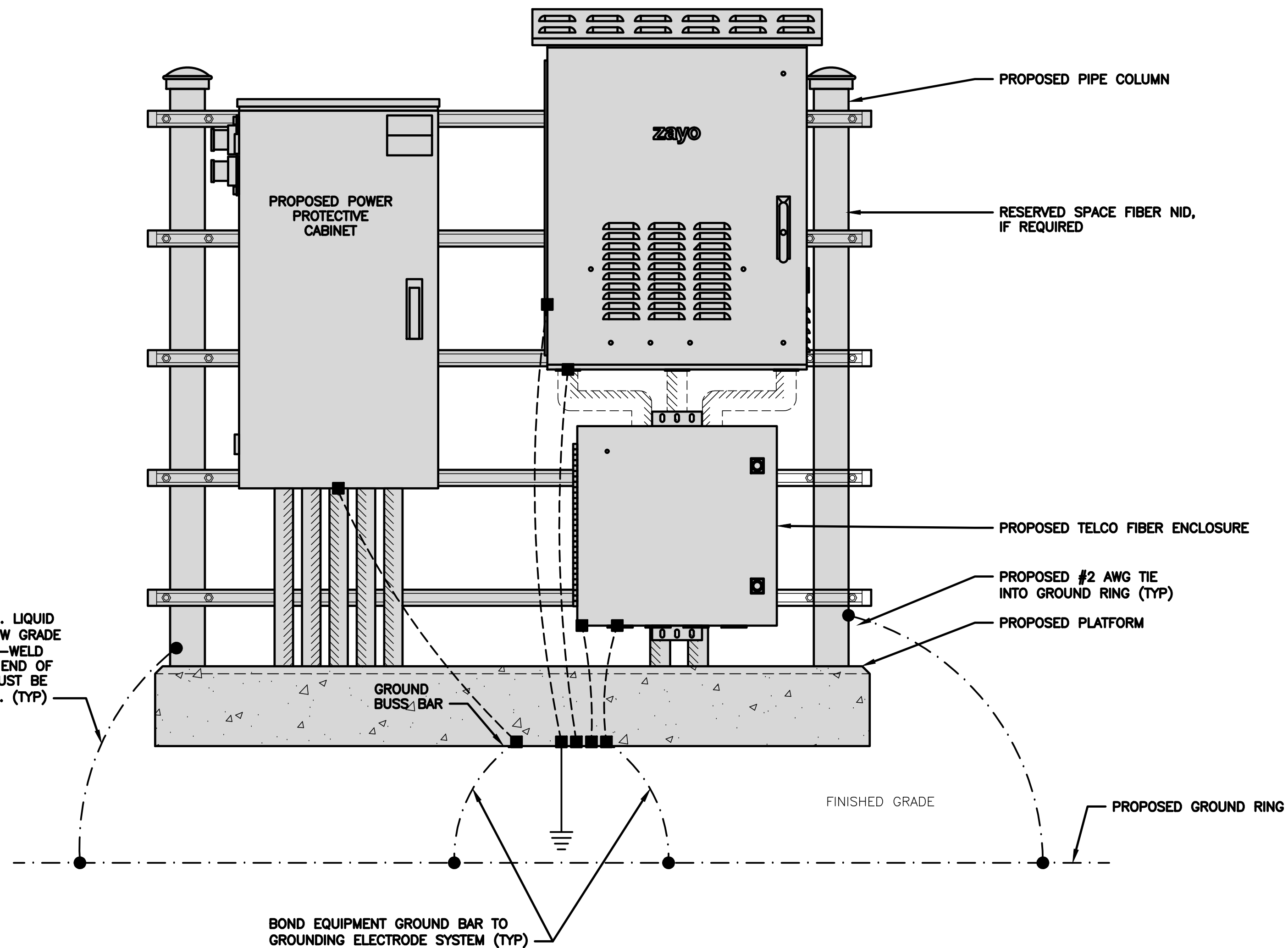

**H-FRAME GROUNDING DETAIL**

NO SCALE 1

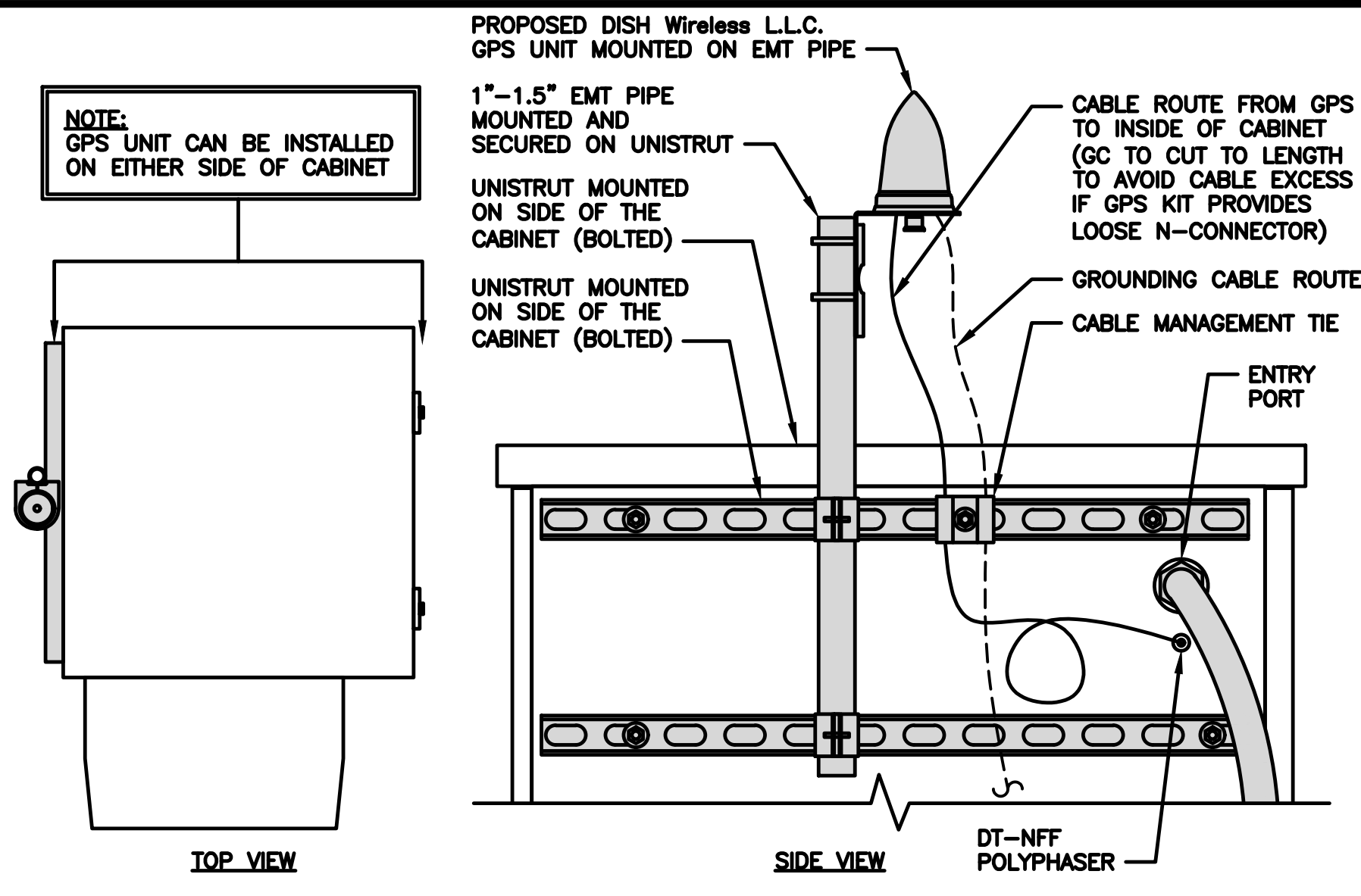

**TYPICAL PCTEL GPS UNIT GROUNDING**

NO SCALE 2

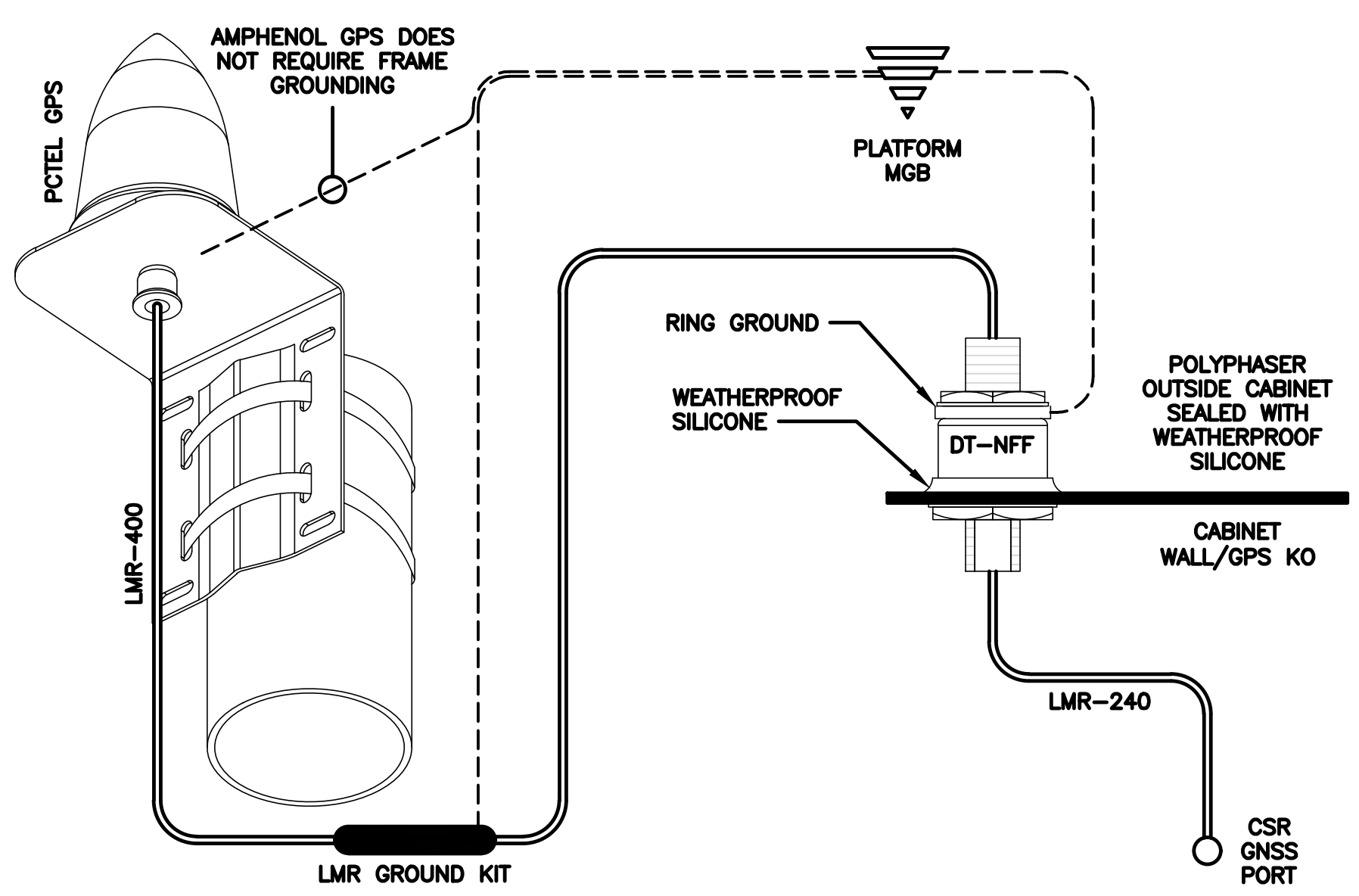

**TYPICAL PCTEL GPS UNIT GROUNDING DIAGRAM**

NO SCALE 3

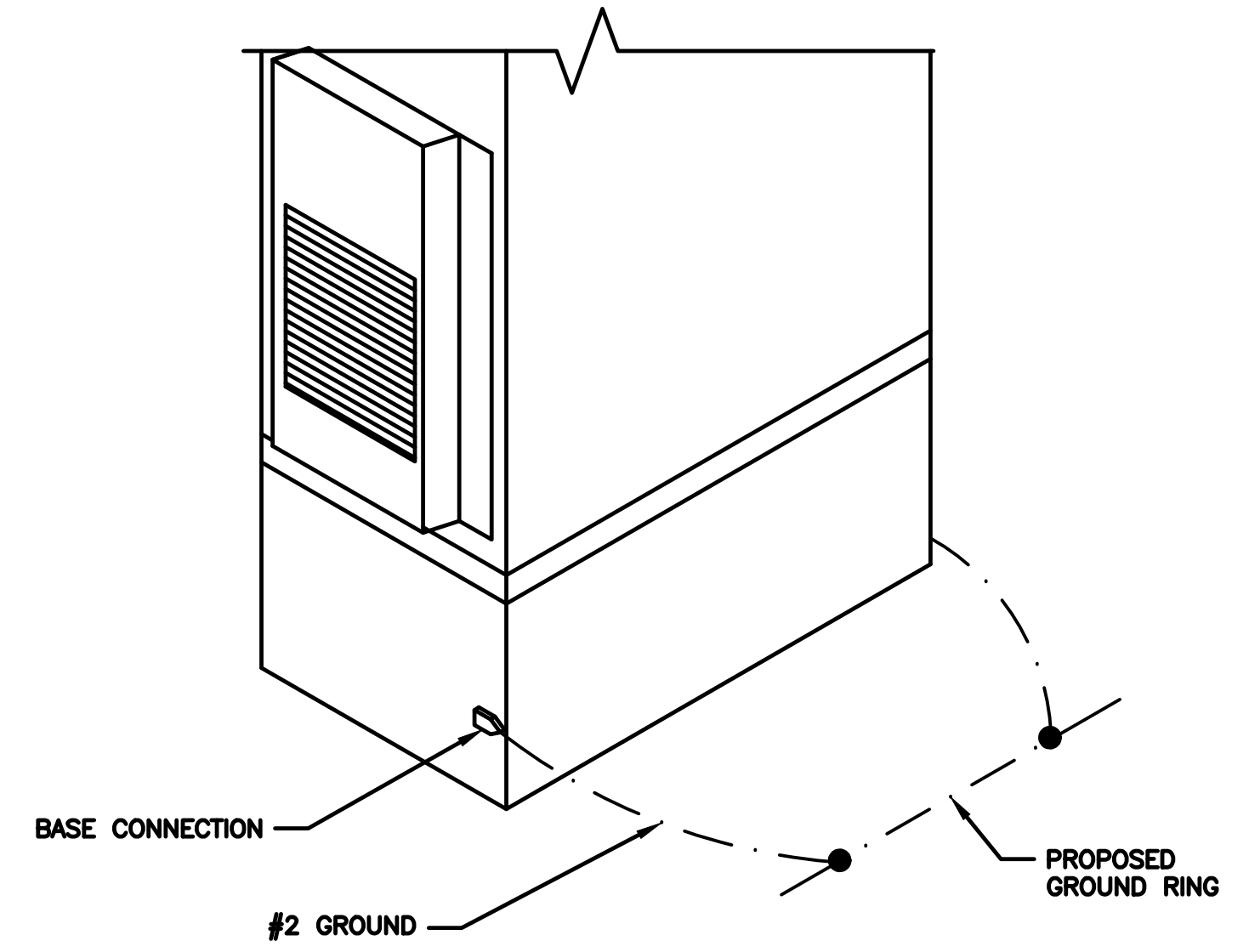

**OUTDOOR CABINET GROUNDING**

NO SCALE 4

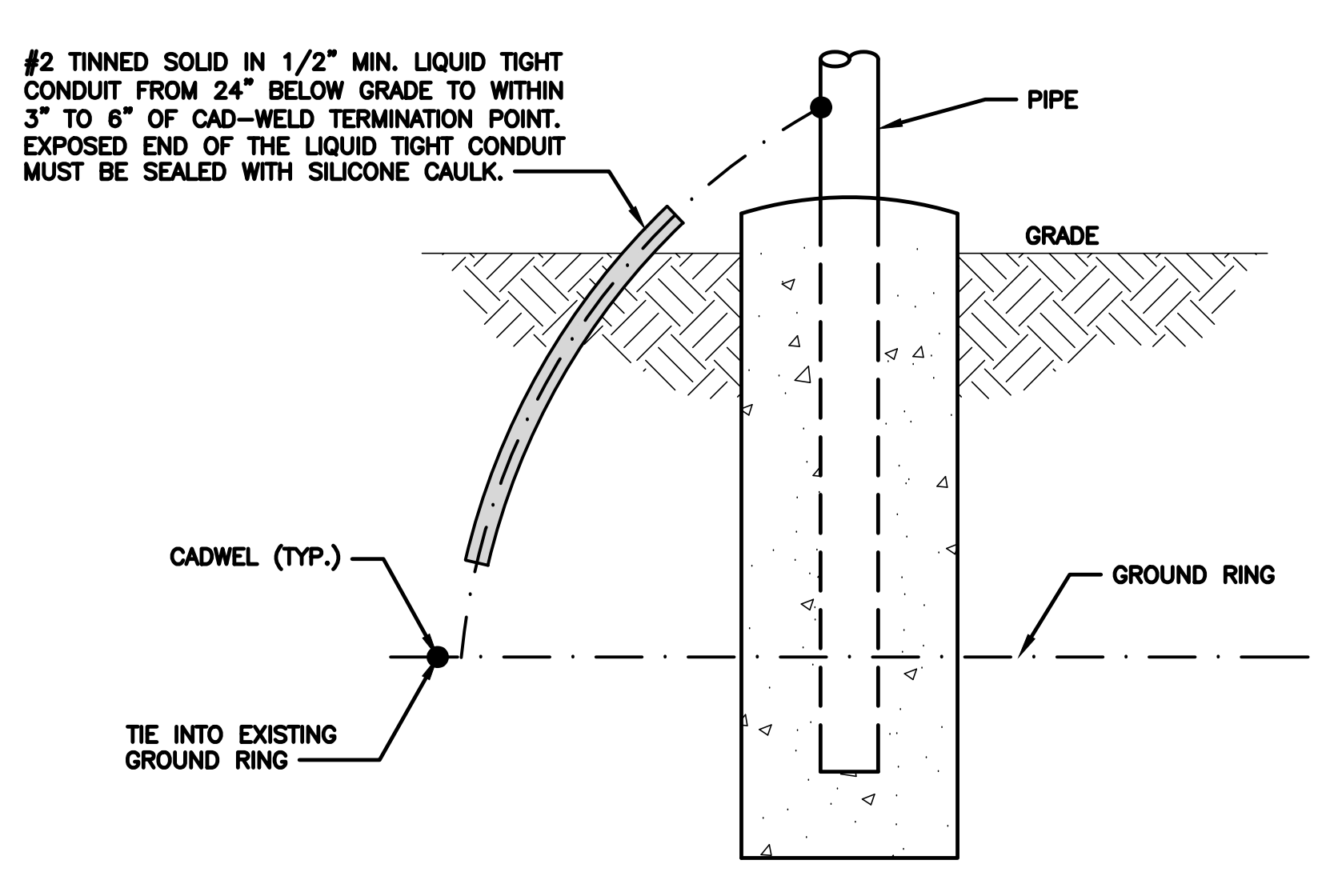

**TRANSITIONING GROUND DETAIL**

NO SCALE 5

NOT USED

NO SCALE 6



5701 SOUTH SANTA FE DRIVE  
LITTLETON, CO 80120



SBA COMMUNICATIONS CORP.  
134 FLANDERS ROAD, SUITE 125  
WESTBOROUGH, MA 01581  
TEL: (508) 251-0720  
FAX: (508) 251-1755



45 BEECHWOOD DRIVE, NORTH ANDOVER, MA 01845  
TEL: (978) 557-5553

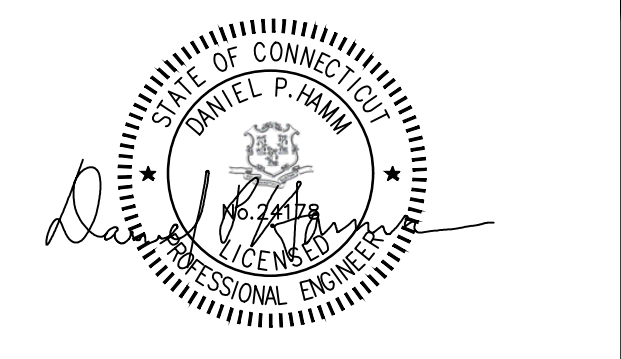

IT IS A VIOLATION OF LAW FOR ANY PERSON, UNLESS THEY ARE ACTING UNDER THE DIRECTION OF A LICENSED PROFESSIONAL ENGINEER, TO ALTER THIS DOCUMENT.

DRAWN BY: TR CHECKED BY: VD APPROVED BY: DPH

RFDS REV #: 0

**CONSTRUCTION DOCUMENTS**

SUBMITTALS		
REV	DATE	DESCRIPTION
A	09/11/2023	ISSUED FOR REVIEW
B	09/25/2023	ISSUED FOR CONSTRUCTION

A&E PROJECT NUMBER  
BOBOS01169A

DISH Wireless L.L.C.  
PROJECT INFORMATION  
BOBOS01169A  
131 GIFFORD LANE  
BOZRAH, CT 06334

SHEET TITLE  
GROUNDING DETAILS

SHEET NUMBER  
**G-2**

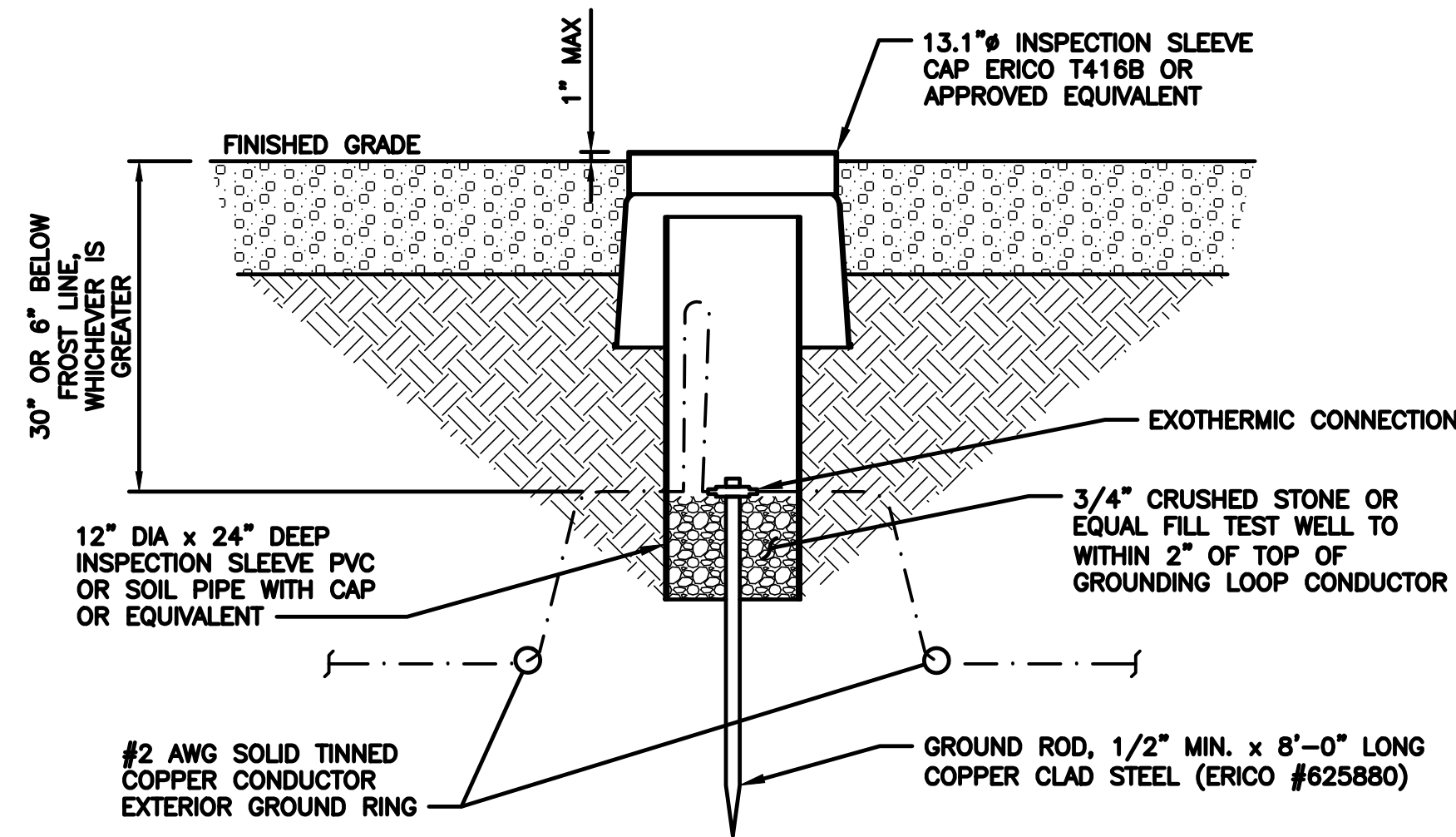

TYPICAL TEST GROUND ROD WITH INSPECTION SLEEVE NO SCALE 1

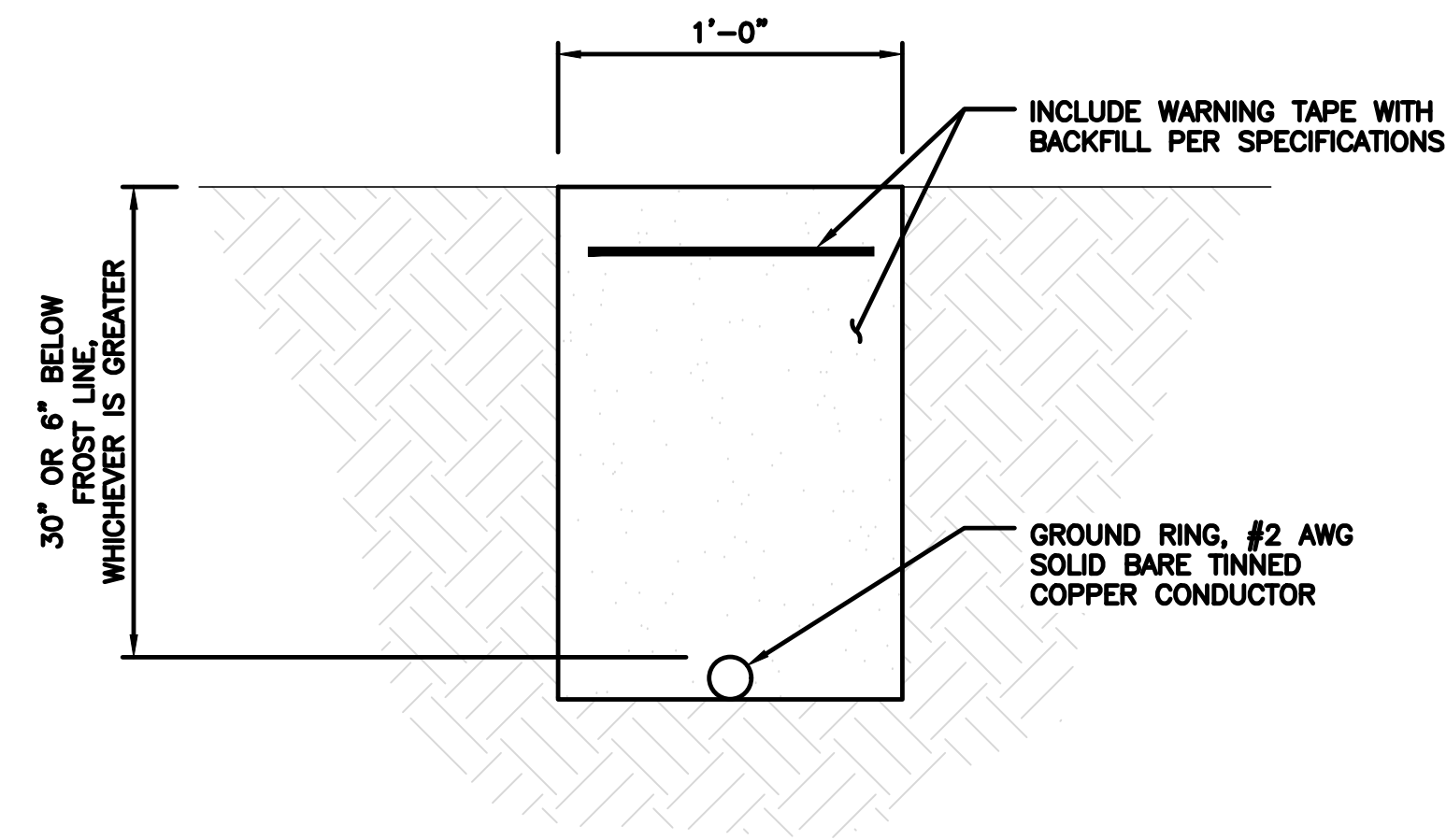

TYPICAL GROUND RING TRENCH NO SCALE 2

1. EXOTHERMIC WELD (2) TWO, #2 AWG BARE TINNED SOLID COPPER CONDUCTORS TO GROUND BAR. ROUTE CONDUCTORS TO BURIED GROUND RING AND PROVIDE PARALLEL EXOTHERMIC WELD.
2. ALL EXTERIOR GROUNDING HARDWARE SHALL BE STAINLESS STEEL 3/8" DIAMETER OR LARGER. ALL HARDWARE 18-8 STAINLESS STEEL INCLUDING LOCK WASHERS, COAT ALL SURFACES WITH AN ANTI-OXIDANT COMPOUND BEFORE MATING.
3. FOR GROUND BOND TO STEEL ONLY: COAT ALL SURFACES WITH AN ANTI-OXIDANT COMPOUND BEFORE MATING.
4. DO NOT INSTALL CABLE GROUNDING KIT AT A BEND AND ALWAYS DIRECT GROUND CONDUCTOR DOWN TO GROUNDING BUS.
5. NUT & WASHER SHALL BE PLACED ON THE FRONT SIDE OF THE GROUND BAR AND BOLTED ON THE BACK SIDE.
6. ALL GROUNDING PARTS AND EQUIPMENT TO BE SUPPLIED AND INSTALLED BY CONTRACTOR.
7. THE CONTRACTOR SHALL BE RESPONSIBLE FOR INSTALLING ADDITIONAL GROUND BAR AS REQUIRED.
8. ENSURE THE WIRE INSULATION TERMINATION IS WITHIN 1/8" OF THE BARREL (NO SHINERS).

TYPICAL GROUNDING NOTES NO SCALE 3

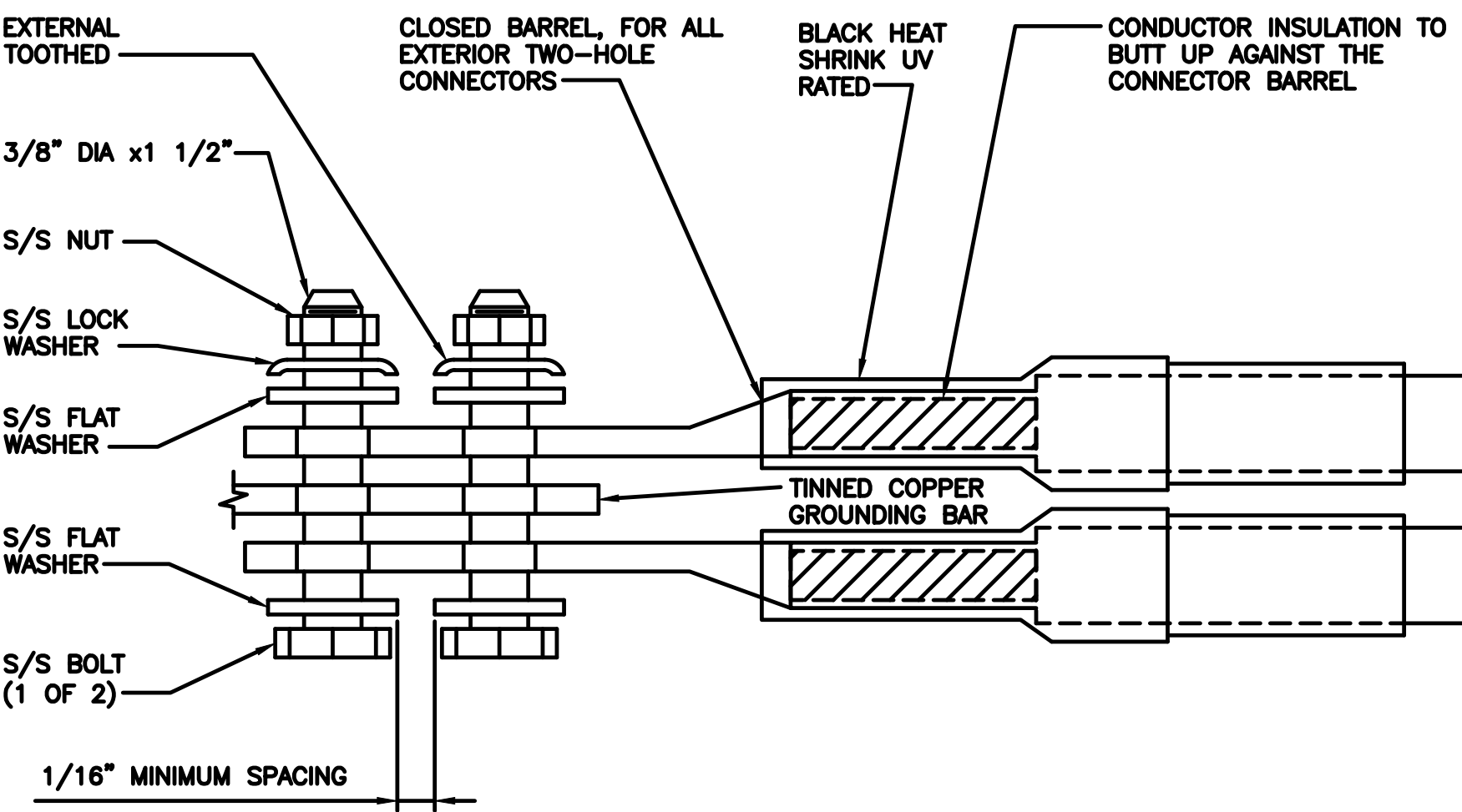

TYPICAL EXTERIOR TWO HOLE LUG NO SCALE 4

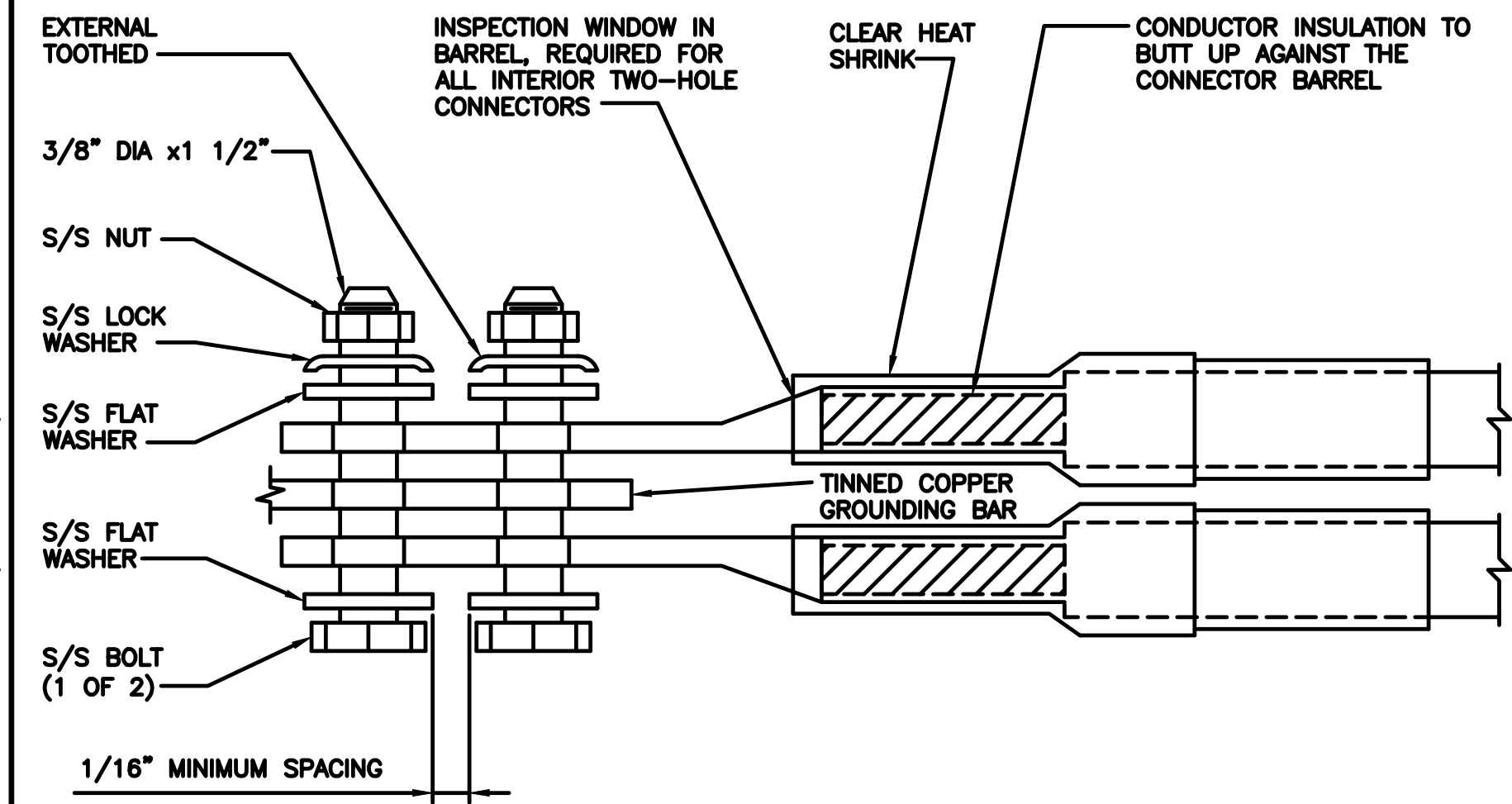

TYPICAL INTERIOR TWO HOLE LUG NO SCALE 5

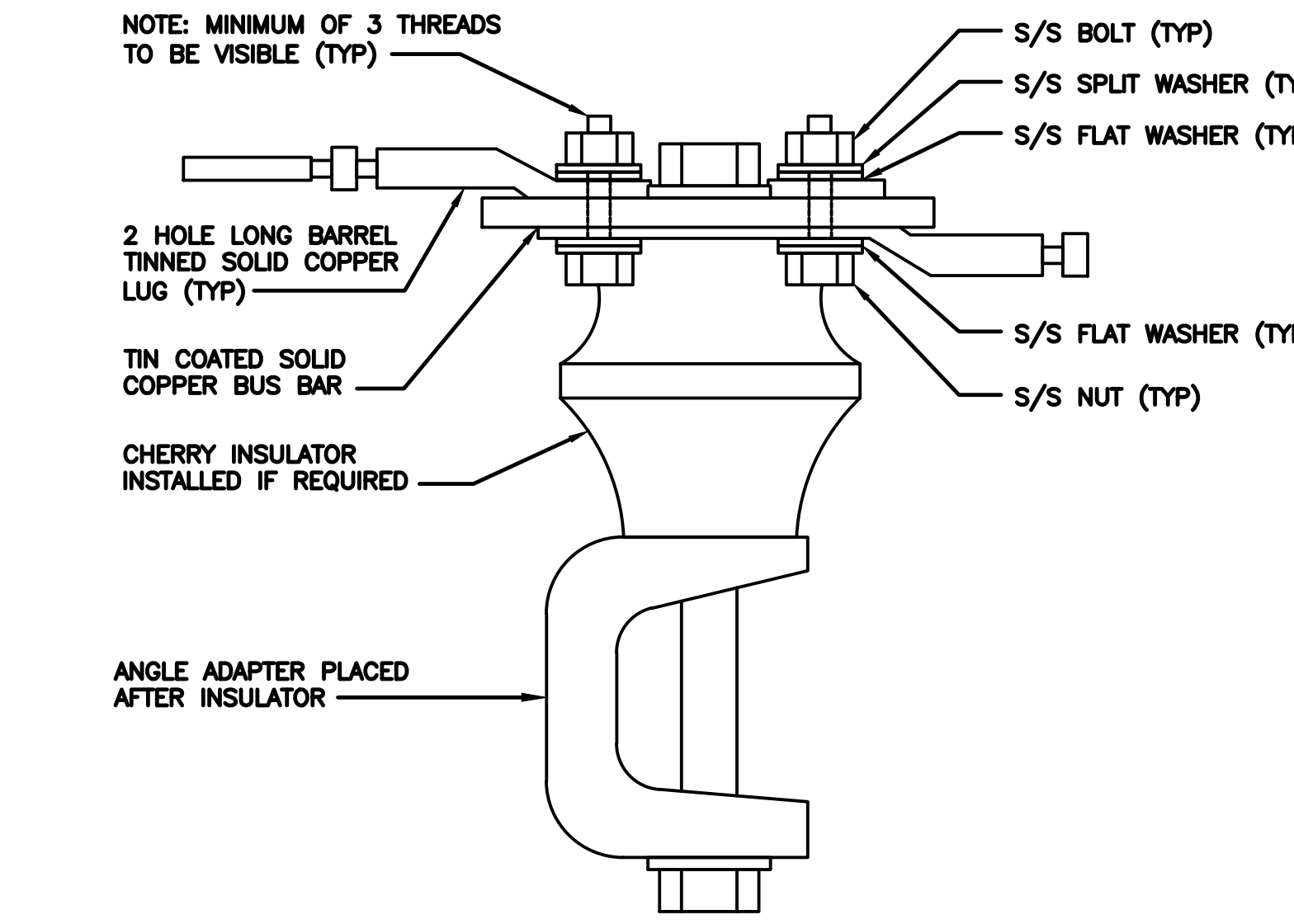

LUG DETAIL NO SCALE 6

NOT USED NO SCALE 7

NOT USED NO SCALE 8

NOT USED NO SCALE 9



5701 SOUTH SANTA FE DRIVE  
LITTLETON, CO 80120



SBA COMMUNICATIONS CORP.  
134 FLANDERS ROAD, SUITE 125  
WESTBOROUGH, MA 01581  
TEL: (508) 251-0720  
FAX: (508) 251-1755



45 BEECHWOOD DRIVE, NORTH ANDOVER, MA 01845  
TEL: (978) 557-5553

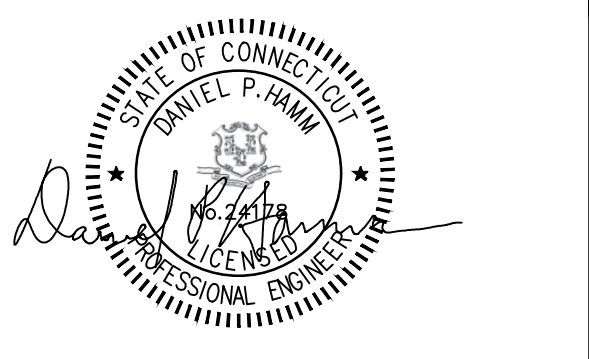

IT IS A VIOLATION OF LAW FOR ANY PERSON, UNLESS THEY ARE ACTING UNDER THE DIRECTION OF A LICENSED PROFESSIONAL ENGINEER, TO ALTER THIS DOCUMENT.

DRAWN BY: TR CHECKED BY: VD APPROVED BY: DPH  
RFDS REV #: 0

CONSTRUCTION DOCUMENTS

SUBMITTALS		
REV	DATE	DESCRIPTION
A	09/11/2023	ISSUED FOR REVIEW
B	09/25/2023	ISSUED FOR CONSTRUCTION

A&E PROJECT NUMBER  
BOBOS01169A

DISH Wireless L.L.C.  
PROJECT INFORMATION  
BOBOS01169A  
131 GIFFORD LANE  
BOZRAH, CT 06334

SHEET TITLE  
GROUNDING DETAILS

SHEET NUMBER  
G-3

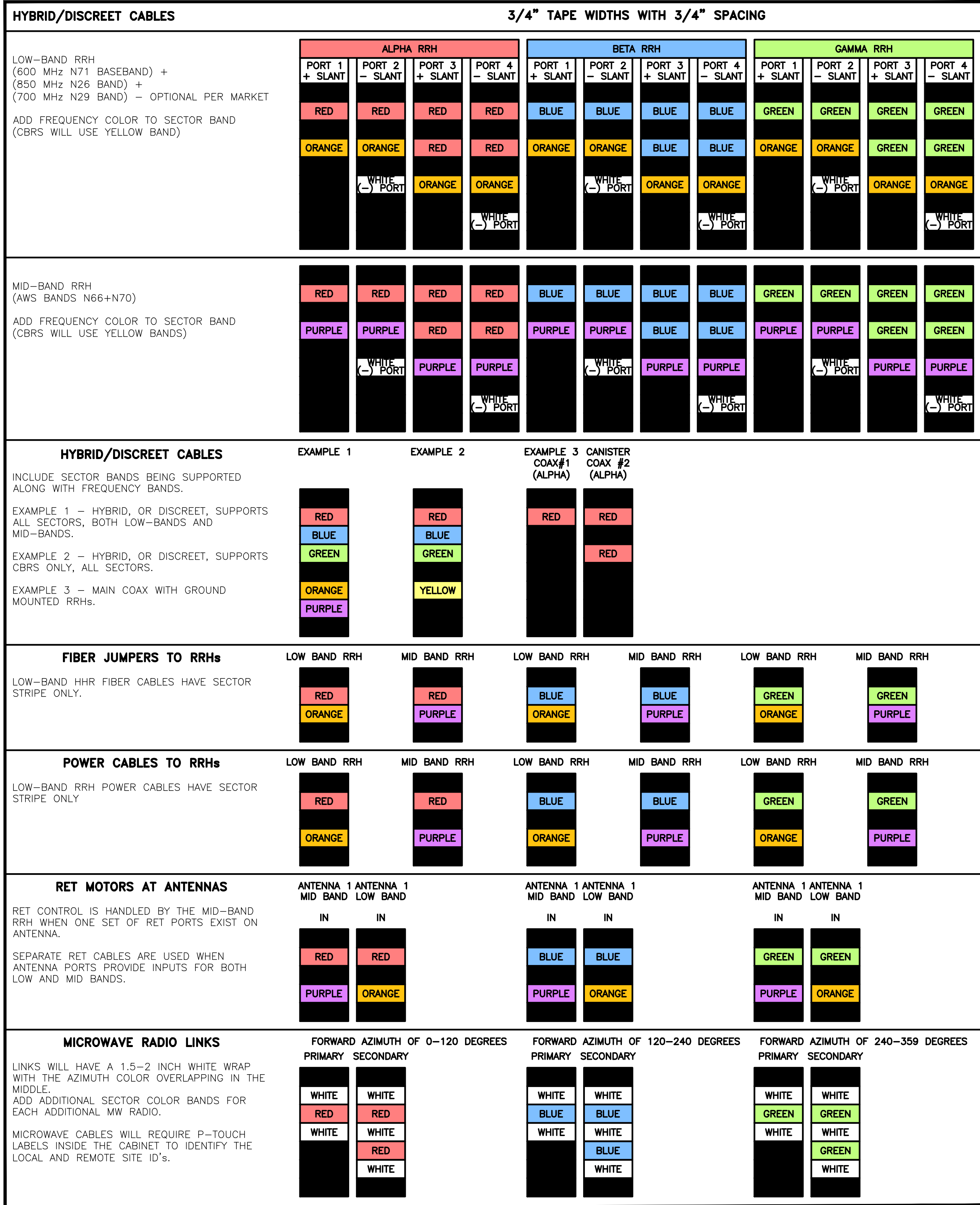

**RF CABLE COLOR CODES**

NO SCALE

1

**NOT USED**

NO SCALE

4

LOW BANDS (N71+N26)  
OPTIONAL - (N29)



AWS  
(N66+N70+H-BLOCK)



CBRS TECH  
(3 GHz)



NEGATIVE SLANT PORT  
ON ANT/RRH



ALPHA SECTOR



BETA SECTOR



GAMMA SECTOR



COLOR IDENTIFIER

NO SCALE

2

**NOT USED**

NO SCALE

3



5701 SOUTH SANTA FE DRIVE  
LITTLETON, CO 80120



SBA COMMUNICATIONS CORP.  
134 FLANDERS ROAD, SUITE 125  
WESTBOROUGH, MA 01581  
TEL: (508) 251-0720  
FAX: (508) 251-1755



45 BEECHWOOD DRIVE, NORTH ANDOVER, MA 01845  
TEL: (978) 557-5553

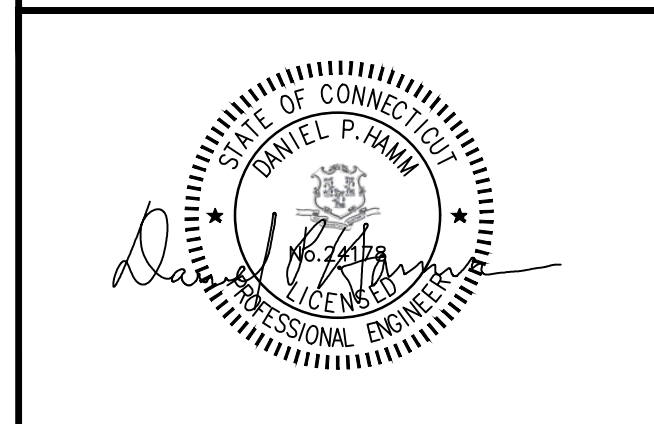

IT IS A VIOLATION OF LAW FOR ANY PERSON, UNLESS THEY ARE ACTING UNDER THE DIRECTION OF A LICENSED PROFESSIONAL ENGINEER, TO ALTER THIS DOCUMENT.

DRAWN BY: CHECKED BY: APPROVED BY:

TR VD DPH

RFDS REV #: 0

**CONSTRUCTION DOCUMENTS**

SUBMITTALS		
REV	DATE	DESCRIPTION
A	09/11/2023	ISSUED FOR REVIEW
B	09/25/2023	ISSUED FOR CONSTRUCTION

A&E PROJECT NUMBER  
BOBOS01169A

DISH Wireless L.L.C.  
PROJECT INFORMATION  
BOBOS01169A  
131 GIFFORD LANE  
BOZRAH, CT 06334

SHEET TITLE  
RF  
CABLE COLOR CODE

SHEET NUMBER  
**RF-1**



EXOTHERMIC CONNECTION  
 MECHANICAL CONNECTION  
 BUSS BAR INSULATOR  
 CHEMICAL ELECTROLYTIC GROUNDING SYSTEM  
 TEST CHEMICAL ELECTROLYTIC GROUNDING SYSTEM  
 EXOTHERMIC WITH INSPECTION SLEEVE  
 GROUNDING BAR  
 GROUND ROD  
 TEST GROUND ROD WITH INSPECTION SLEEVE

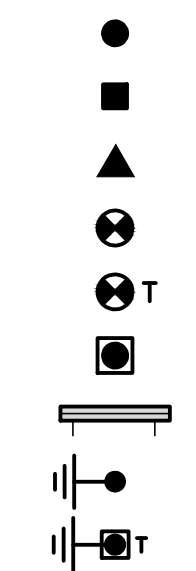

SINGLE POLE SWITCH  
 DUPLEX RECEPTACLE  
 DUPLEX GFCI RECEPTACLE

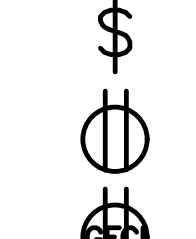

FLUORESCENT LIGHTING FIXTURE (2) TWO LAMPS 48-T8

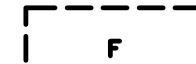

SMOKE DETECTION (DC)  
 EMERGENCY LIGHTING (DC)

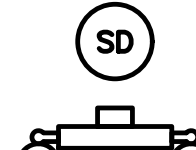

SECURITY LIGHT W/PHOTOCELL LITHONIA ALXW LED-1-25A400/51K-SR4-120-PE-DBBTXD



CHAIN LINK FENCE  
 WOOD/WROUGHT IRON FENCE  
 WALL STRUCTURE  
 LEASE AREA

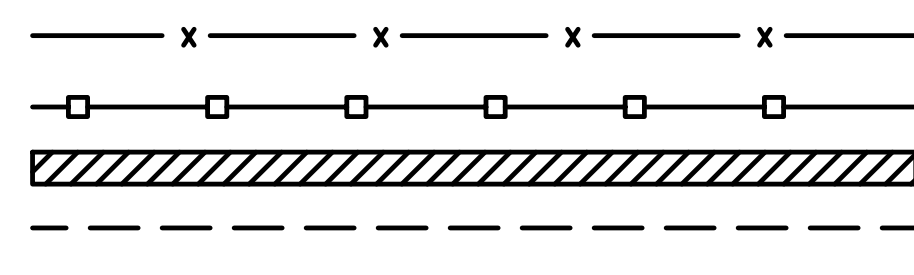

PROPERTY LINE (PL)  
 SETBACKS

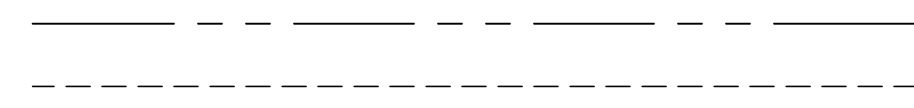

ICE BRIDGE  
 CABLE TRAY

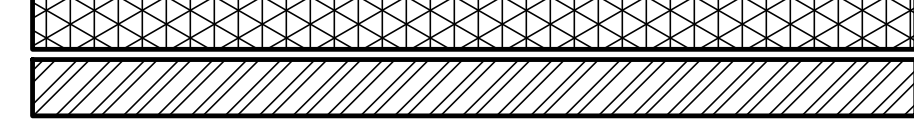

WATER LINE  
 UNDERGROUND POWER  
 UNDERGROUND TELCO

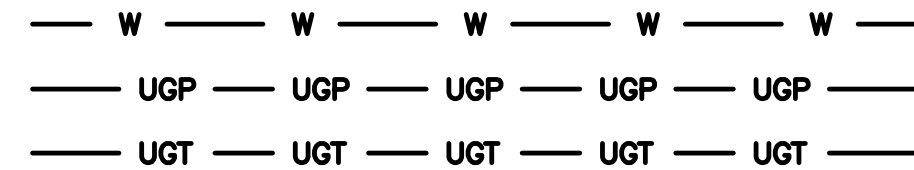

OVERHEAD POWER  
 OVERHEAD TELCO

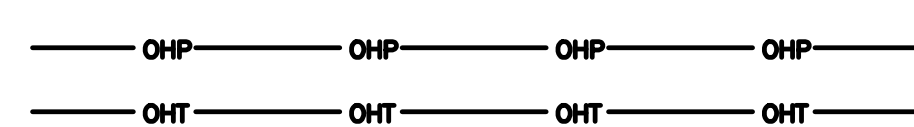

UNDERGROUND TELCO/POWER  
 ABOVE GROUND POWER

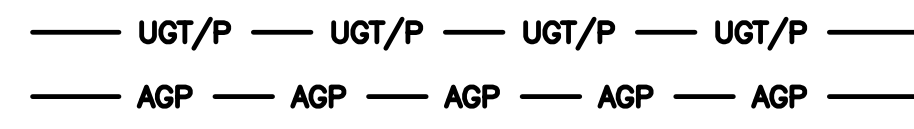

ABOVE GROUND TELCO  
 ABOVE GROUND TELCO/POWER

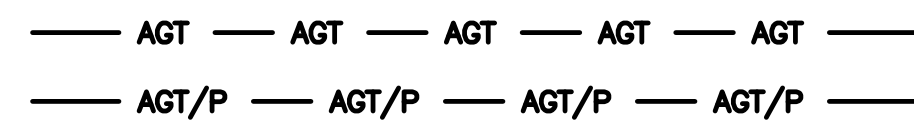

WORKPOINT  
 SECTION REFERENCE

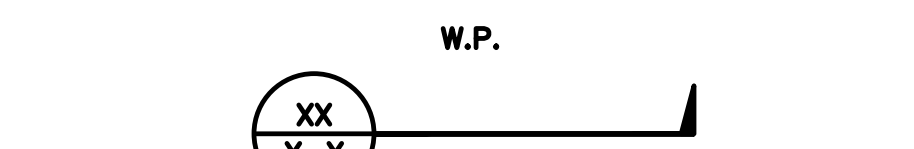

DETAIL REFERENCE

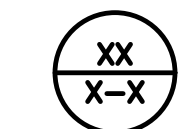

**LEGEND**

AB	ANCHOR BOLT	IN	INCH
ABV	ABOVE	INT	INTERIOR
AC	ALTERNATING CURRENT	LB(S)	POUND(S)
ADDL	ADDITIONAL	LF	LINEAR FEET
AFF	ABOVE FINISHED FLOOR	LTE	LONG TERM EVOLUTION
AFG	ABOVE FINISHED GRADE	MAS	MASONRY
AGL	ABOVE GROUND LEVEL	MAX	MAXIMUM
AIC	AMPERAGE INTERRUPTION CAPACITY	MB	MACHINE BOLT
ALUM	ALUMINUM	MECH	MECHANICAL
ALT	ALTERNATE	MFR	MANUFACTURER
ANT	ANTENNA	MGB	MASTER GROUND BAR
APPROX	APPROXIMATE	MIN	MINIMUM
ARCH	ARCHITECTURAL	MISC	MISCELLANEOUS
ATS	AUTOMATIC TRANSFER SWITCH	MTL	METAL
AWG	AMERICAN WIRE GAUGE	MTS	MANUAL TRANSFER SWITCH
BATT	BATTERY	MW	MICROWAVE
BLDG	BUILDING	NEC	NATIONAL ELECTRIC CODE
BLK	BLOCK	NM	NEWTON METERS
BLKG	BLOCKING	NO.	NUMBER
BM	BEAM	#	NUMBER
BTC	BARE TINNED COPPER CONDUCTOR	NTS	NOT TO SCALE
BOF	BOTTOM OF FOOTING	OC	ON-CENTER
CAB	CABINET	OSHA	OCCUPATIONAL SAFETY AND HEALTH ADMINISTRATION
CANT	CANTILEVERED	OPNG	OPENING
CHG	CHARGING	P/C	PRECAST CONCRETE
CLG	CEILING	PCS	PERSONAL COMMUNICATION SERVICES
CLR	CLEAR	PCU	PRIMARY CONTROL UNIT
COL	COLUMN	PRC	PRIMARY RADIO CABINET
COMM	COMMON	PP	POLARIZING PRESERVING
CONC	CONCRETE	PSF	POUNDS PER SQUARE FOOT
CONSTR	CONSTRUCTION	PSI	POUNDS PER SQUARE INCH
DBL	DOUBLE	PT	PRESSURE TREATED
DC	DIRECT CURRENT	PWR	POWER CABINET
DEPT	DEPARTMENT	QTY	QUANTITY
DF	DOUGLAS FIR	RAD	RADIUS
DIA	DIAMETER	RECT	RECTIFIER
DIAG	DIAGONAL	REF	REFERENCE
DIM	DIMENSION	REINF	REINFORCEMENT
DWG	DRAWING	REQ'D	REQUIRED
DWL	DOWEL	RET	REMOTE ELECTRIC TILT
EA	EACH	RF	RADIO FREQUENCY
EC	ELECTRICAL CONDUCTOR	RMC	RIGID METALLIC CONDUIT
EL	ELEVATION	RRH	REMOTE RADIO HEAD
ELEC	ELECTRICAL	RRU	REMOTE RADIO UNIT
EMT	ELECTRICAL METALLIC TUBING	RWY	RACEWAY
ENG	ENGINEER	SCH	SCHEDULE
EQ	EQUAL	SHT	SHEET
EXP	EXPANSION	SIAD	SMART INTEGRATED ACCESS DEVICE
EXT	EXTERIOR	SIM	SIMILAR
EW	EACH WAY	SPEC	SPECIFICATION
FAB	FABRICATION	SQ	SQUARE
FF	FINISH FLOOR	SS	STAINLESS STEEL
FG	FINISH GRADE	STD	STANDARD
FIF	FACILITY INTERFACE FRAME	STL	STEEL
FIN	FINISH(ED)	TEMP	TEMPORARY
FLR	FLOOR	THK	THICKNESS
FDN	FOUNDATION	TMA	TOWER MOUNTED AMPLIFIER
FOC	FACE OF CONCRETE	TN	TOE NAIL
FOM	FACE OF MASONRY	TOA	TOP OF ANTENNA
FOS	FACE OF STUD	TOC	TOP OF CURB
FOW	FACE OF WALL	TOF	TOP OF FOUNDATION
FS	FINISH SURFACE	TOP	TOP OF PLATE (PARAPET)
FT	FOOT	TOS	TOP OF STEEL
FTG	FOOTING	TOW	TOP OF WALL
GA	GAUGE	TVSS	TRANSIENT VOLTAGE SURGE SUPPRESSION
GEN	GENERATOR	TYP	TYPICAL
GFCI	GROUND FAULT CIRCUIT INTERRUPTER	UG	UNDERGROUND
GLB	GLUE LAMINATED BEAM	UL	UNDERWRITERS LABORATORY
GLV	GALVANIZED	UNO	UNLESS NOTED OTHERWISE
GPS	GLOBAL POSITIONING SYSTEM	UMTS	UNIVERSAL MOBILE TELECOMMUNICATIONS SYSTEM
GND	GROUND	UPS	UNINTERRUPTIBLE POWER SYSTEM (DC POWER PLANT)
GSM	GLOBAL SYSTEM FOR MOBILE	VIF	VERIFIED IN FIELD
HDG	HOT DIPPED GALVANIZED	W	WIDE
HDR	HEADER	W/	WITH
HGR	HANGER	WD	WOOD
HVAC	HEAT/VENTILATION/AIR CONDITIONING	WP	WEATHERPROOF
HT	HEIGHT	WT	WEIGHT
IGR	INTERIOR GROUND RING		

**ABBREVIATIONS**



5701 SOUTH SANTA FE DRIVE  
 LITTLETON, CO 80120



SBA COMMUNICATIONS CORP.  
 134 FLANDERS ROAD, SUITE 125  
 WESTBOROUGH, MA 01581  
 TEL: (508) 251-0720  
 FAX: (508) 251-1755



45 BEECHWOOD DRIVE, NORTH ANDOVER, MA 01845  
 TEL: (978) 557-5553

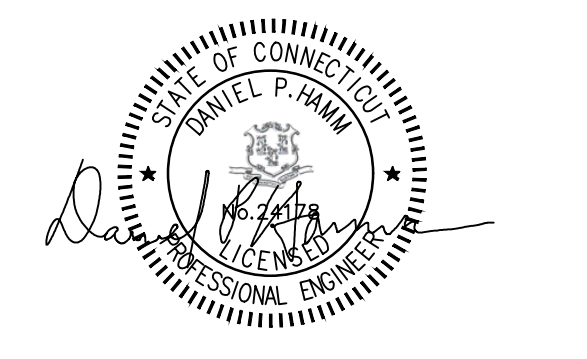

IT IS A VIOLATION OF LAW FOR ANY PERSON,  
 UNLESS THEY ARE ACTING UNDER THE DIRECTION  
 OF A LICENSED PROFESSIONAL ENGINEER,  
 TO ALTER THIS DOCUMENT.

DRAWN BY:	CHECKED BY:	APPROVED BY:
TR	VD	DPH

RFDS REV #: 0

**CONSTRUCTION DOCUMENTS**

SUBMITTALS		
REV	DATE	DESCRIPTION
A	09/11/2023	ISSUED FOR REVIEW
B	09/25/2023	ISSUED FOR CONSTRUCTION

A&E PROJECT NUMBER  
 BOBOS01169A

DISH Wireless L.L.C.  
 PROJECT INFORMATION  
 BOBOS01169A  
 131 GIFFORD LANE  
 BOZRAH, CT 06334

SHEET TITLE  
 LEGEND AND ABBREVIATIONS

SHEET NUMBER  
**GN-1**

SIGN TYPES		
TYPE	COLOR	COLOR CODE PURPOSE
INFORMATION	GREEN	"INFORMATIONAL SIGN" TO NOTIFY OTHERS OF SITE OWNERSHIP & CONTACT NUMBER AND POTENTIAL RF EXPOSURE.
NOTICE	BLUE	"NOTICE BEYOND THIS POINT" RF FIELDS BEYOND THIS POINT MAY EXCEED THE FCC GENERAL PUBLIC EXPOSURE LIMIT. OBEY ALL POSTED SIGNS AND SITE GUIDELINES FOR WORKING IN RF ENVIRONMENTS. IN ACCORDANCE WITH FEDERAL COMMUNICATIONS COMMISSION RULES ON RADIO FREQUENCY EMISSIONS 47 CFR-1.1307(b)
CAUTION	YELLOW	"CAUTION BEYOND THIS POINT" RF FIELDS BEYOND THIS POINT MAY EXCEED THE FCC GENERAL PUBLIC EXPOSURE LIMIT. OBEY ALL POSTED SIGNS AND SITE GUIDELINES FOR WORKING IN RF ENVIRONMENTS. IN ACCORDANCE WITH FEDERAL COMMUNICATIONS COMMISSION RULES ON RADIO FREQUENCY EMISSIONS 47 CFR-1.1307(b)
WARNING	ORANGE/RED	"WARNING BEYOND THIS POINT" RF FIELDS AT THIS SITE EXCEED FCC RULES FOR HUMAN EXPOSURE. FAILURE TO OBEY ALL POSTED SIGNS AND SITE GUIDELINES FOR WORKING IN RF ENVIRONMENTS COULD RESULT IN SERIOUS INJURY. IN ACCORDANCE WITH FEDERAL COMMUNICATIONS COMMISSION RULES ON RADIO FREQUENCY EMISSIONS 47 CFR-1.1307(b)

**SIGN PLACEMENT:**

- RF SIGNAGE PLACEMENT SHALL FOLLOW THE RECOMMENDATIONS OF AN EXISTING EME REPORT, CREATED BY A THIRD PARTY PREVIOUSLY AUTHORIZED BY DISH Wireless L.L.C.
- INFORMATION SIGN (GREEN) SHALL BE LOCATED ON EXISTING DISH Wireless L.L.C. EQUIPMENT.
  - A) IF THE INFORMATION SIGN IS A STICKER, IT SHALL BE PLACED ON EXISTING DISH Wireless L.L.C. EQUIPMENT CABINET.
  - B) IF THE INFORMATION SIGN IS A METAL SIGN IT SHALL BE PLACED ON EXISTING DISH Wireless L.L.C. H-FRAME WITH A SECURE ATTACH METHOD.
- IF EME REPORT IS NOT AVAILABLE AT THE TIME OF CREATION OF CONSTRUCTION DOCUMENTS; PLEASE CONTACT DISH Wireless L.L.C. CONSTRUCTION MANAGER FOR FURTHER INSTRUCTION ON HOW TO PROCEED.

**NOTES:**

1. FOR DISH Wireless L.L.C. LOGO, SEE DISH Wireless L.L.C. DESIGN SPECIFICATIONS (PROVIDED BY DISH Wireless L.L.C.)
2. SITE ID SHALL BE APPLIED TO SIGNS USING "LASER ENGRAVING" OR ANY OTHER WEATHER RESISTANT METHOD (DISH Wireless L.L.C. APPROVAL REQUIRED)
3. TEXT FOR SIGNAGE SHALL INDICATE CORRECT SITE NAME AND NUMBER AS PER DISH Wireless L.L.C. CONSTRUCTION MANAGER RECOMMENDATIONS.
4. CABINET/SHELTER MOUNTING APPLICATION REQUIRES ANOTHER PLATE APPLIED TO THE FACE OF THE CABINET WITH WATER PROOF POLYURETHANE ADHESIVE
5. ALL SIGNS WILL BE SECURED WITH EITHER STAINLESS STEEL ZIP TIES OR STAINLESS STEEL TECH SCREWS
6. ALL SIGNS TO BE 8.5"x11" AND MADE WITH 0.04" OF ALUMINUM MATERIAL

# INFORMATION

This is an access point to an area with transmitting antennas.

Obey all signs and barriers beyond this point.  
Call the DISH Wireless L.L.C. NOC at 1-866-624-6874

Site ID: \_\_\_\_\_

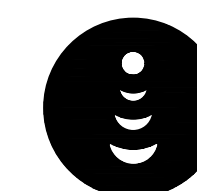

THIS SIGN IS FOR REFERENCE PURPOSES ONLY

NOTICE



Transmitting Antenna(s)

Radio frequency fields beyond this point **MAY EXCEED** the FCC Occupational exposure limit.

Obey all posted signs and site guidelines for working in radio frequency environments.

Call the DISH Wireless L.L.C. NOC at 1-866-624-6874 prior to working beyond this point.

Site ID: \_\_\_\_\_

dish

THIS SIGN IS FOR REFERENCE PURPOSES ONLY

CAUTION



Transmitting Antenna(s)

Radio frequency fields beyond this point **MAY EXCEED** the FCC Occupational exposure limit.

Obey all posted signs and site guidelines for working in radio frequency environments.

Call the DISH Wireless L.L.C. NOC at 1-866-624-6874 prior to working beyond this point.

Site ID: \_\_\_\_\_

dish

THIS SIGN IS FOR REFERENCE PURPOSES ONLY

WARNING



Transmitting Antenna(s)

Radio frequency fields beyond this point **EXCEED** the FCC Occupational exposure limit.

Obey all posted signs and site guidelines for working in radio frequency environments.

Call the DISH Wireless L.L.C. NOC at 1-866-624-6874 prior to working beyond this point.

Site ID: \_\_\_\_\_

dish

THIS SIGN IS FOR REFERENCE PURPOSES ONLY



5701 SOUTH SANTA FE DRIVE  
LITTLETON, CO 80120



SBA COMMUNICATIONS CORP.  
134 FLANDERS ROAD, SUITE 125  
WESTBOROUGH, MA 01581  
TEL: (508) 251-0720  
FAX: (508) 251-1755

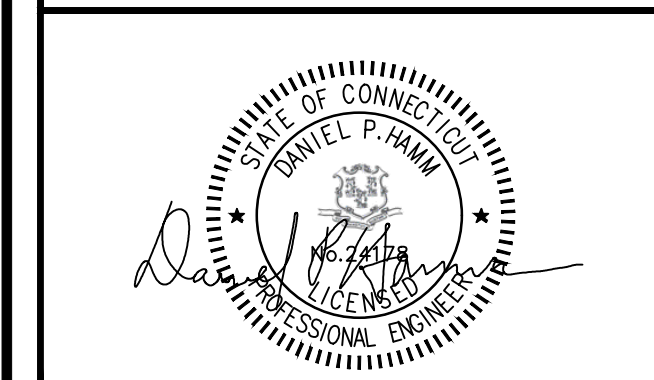

IT IS A VIOLATION OF LAW FOR ANY PERSON, UNLESS THEY ARE ACTING UNDER THE DIRECTION OF A LICENSED PROFESSIONAL ENGINEER, TO ALTER THIS DOCUMENT.

DRAWN BY:	CHECKED BY:	APPROVED BY:
TR	VD	DPH

RFDS REV #: 0

### CONSTRUCTION DOCUMENTS

SUBMITTALS		
REV	DATE	DESCRIPTION
A	09/11/2023	ISSUED FOR REVIEW
B	09/25/2023	ISSUED FOR CONSTRUCTION

A&E PROJECT NUMBER  
BOBOS01169A

DISH Wireless L.L.C.  
PROJECT INFORMATION  
BOBOS01169A  
131 GIFFORD LANE  
BOZRAH, CT 06334

SHEET TITLE  
RF SIGNAGE

SHEET NUMBER  
**GN-2**

**SITE ACTIVITY REQUIREMENTS:**

1. NOTICE TO PROCEED – NO WORK SHALL COMMENCE PRIOR TO CONTRACTOR RECEIVING A WRITTEN NOTICE TO PROCEED (NTP) AND THE ISSUANCE OF A PURCHASE ORDER. PRIOR TO ACCESSING/ENTERING THE SITE YOU MUST CONTACT THE DISH Wireless L.L.C. AND TOWER OWNER NOC & THE DISH Wireless L.L.C. AND TOWER OWNER CONSTRUCTION MANAGER.
2. "LOOK UP" – DISH Wireless L.L.C. AND TOWER OWNER SAFETY CLIMB REQUIREMENT:  
THE INTEGRITY OF THE SAFETY CLIMB AND ALL COMPONENTS OF THE CLIMBING FACILITY SHALL BE CONSIDERED DURING ALL STAGES OF DESIGN, INSTALLATION, AND INSPECTION. TOWER MODIFICATION, MOUNT REINFORCEMENTS, AND/OR EQUIPMENT INSTALLATIONS SHALL NOT COMPROMISE THE INTEGRITY OR FUNCTIONAL USE OF THE SAFETY CLIMB OR ANY COMPONENTS OF THE CLIMBING FACILITY ON THE STRUCTURE. THIS SHALL INCLUDE, BUT NOT BE LIMITED TO: PINCHING OF THE WIRE ROPE, BENDING OF THE WIRE ROPE FROM ITS SUPPORTS, DIRECT CONTACT OR CLOSE PROXIMITY TO THE WIRE ROPE WHICH MAY CAUSE FRICTIONAL WEAR, IMPACT TO THE ANCHORAGE POINTS IN ANY WAY, OR TO IMPEDE/BLOCK ITS INTENDED USE. ANY COMPROMISED SAFETY CLIMB, INCLUDING EXISTING CONDITIONS MUST BE TAGGED OUT AND REPORTED TO YOUR DISH Wireless L.L.C. AND DISH Wireless L.L.C. AND TOWER OWNER POC OR CALL THE NOC TO GENERATE A SAFETY CLIMB MAINTENANCE AND CONTRACTOR NOTICE TICKET.
3. PRIOR TO THE START OF CONSTRUCTION, ALL REQUIRED JURISDICTIONAL PERMITS SHALL BE OBTAINED. THIS INCLUDES, BUT IS NOT LIMITED TO, BUILDING, ELECTRICAL, MECHANICAL, FIRE, FLOOD ZONE, ENVIRONMENTAL, AND ZONING. AFTER ONSITE ACTIVITIES AND CONSTRUCTION ARE COMPLETED, ALL REQUIRED PERMITS SHALL BE SATISFIED AND CLOSED OUT ACCORDING TO LOCAL JURISDICTIONAL REQUIREMENTS.
4. ALL CONSTRUCTION MEANS AND METHODS; INCLUDING BUT NOT LIMITED TO, ERECTION PLANS, RIGGING PLANS, CLIMBING PLANS, AND RESCUE PLANS SHALL BE THE RESPONSIBILITY OF THE GENERAL CONTRACTOR RESPONSIBLE FOR THE EXECUTION OF THE WORK CONTAINED HEREIN, AND SHALL MEET ANSI/ASSE A10.48 (LATEST EDITION); FEDERAL, STATE, AND LOCAL REGULATIONS; AND ANY APPLICABLE INDUSTRY CONSENSUS STANDARDS RELATED TO THE CONSTRUCTION ACTIVITIES BEING PERFORMED. ALL RIGGING PLANS SHALL ADHERE TO ANSI/ASSE A10.48 (LATEST EDITION) AND DISH Wireless L.L.C. AND TOWER OWNER STANDARDS, INCLUDING THE REQUIRED INVOLVEMENT OF A QUALIFIED ENGINEER FOR CLASS IV CONSTRUCTION, TO CERTIFY THE SUPPORTING STRUCTURE(S) IN ACCORDANCE WITH ANSI/TIA-322 (LATEST EDITION).
5. ALL SITE WORK TO COMPLY WITH DISH Wireless L.L.C. AND TOWER OWNER INSTALLATION STANDARDS FOR CONSTRUCTION ACTIVITIES ON DISH Wireless L.L.C. AND TOWER OWNER TOWER SITE AND LATEST VERSION OF ANSI/TIA-1019-A-2012 "STANDARD FOR INSTALLATION, ALTERATION, AND MAINTENANCE OF ANTENNA SUPPORTING STRUCTURES AND ANTENNAS."
6. IF THE SPECIFIED EQUIPMENT CAN NOT BE INSTALLED AS SHOWN ON THESE DRAWINGS, THE CONTRACTOR SHALL PROPOSE AN ALTERNATIVE INSTALLATION FOR APPROVAL BY DISH Wireless L.L.C. AND TOWER OWNER PRIOR TO PROCEEDING WITH ANY SUCH CHANGE OF INSTALLATION.
7. ALL MATERIALS FURNISHED AND INSTALLED SHALL BE IN STRICT ACCORDANCE WITH ALL APPLICABLE CODES, REGULATIONS AND ORDINANCES. CONTRACTOR SHALL ISSUE ALL APPROPRIATE NOTICES AND COMPLY WITH ALL LAWS, ORDINANCES, RULES, REGULATIONS AND LAWFUL ORDERS OF ANY PUBLIC AUTHORITY REGARDING THE PERFORMANCE OF THE WORK. ALL WORK CARRIED OUT SHALL COMPLY WITH ALL APPLICABLE MUNICIPAL AND UTILITY COMPANY SPECIFICATIONS AND LOCAL JURISDICTIONAL CODES, ORDINANCES AND APPLICABLE REGULATIONS.
8. THE CONTRACTOR SHALL INSTALL ALL EQUIPMENT AND MATERIALS IN ACCORDANCE WITH MANUFACTURER'S RECOMMENDATIONS UNLESS SPECIFICALLY STATED OTHERWISE.
9. THE CONTRACTOR SHALL CONTACT UTILITY LOCATING SERVICES INCLUDING PRIVATE LOCATES SERVICES PRIOR TO THE START OF CONSTRUCTION.
10. ALL EXISTING ACTIVE SEWER, WATER, GAS, ELECTRIC AND OTHER UTILITIES WHERE ENCOUNTERED IN THE WORK, SHALL BE PROTECTED AT ALL TIMES AND WHERE REQUIRED FOR THE PROPER EXECUTION OF THE WORK, SHALL BE RELOCATED AS DIRECTED BY CONTRACTOR. EXTREME CAUTION SHOULD BE USED BY THE CONTRACTOR WHEN EXCAVATING OR DRILLING PIERS AROUND OR NEAR UTILITIES. CONTRACTOR SHALL PROVIDE SAFETY TRAINING FOR THE WORKING CREW. THIS WILL INCLUDE BUT NOT BE LIMITED TO A) FALL PROTECTION B) CONFINED SPACE C) ELECTRICAL SAFETY D) TRENCHING AND EXCAVATION E) CONSTRUCTION SAFETY PROCEDURES.
11. ALL SITE WORK SHALL BE AS INDICATED ON THE STAMPED CONSTRUCTION DRAWINGS AND DISH PROJECT SPECIFICATIONS, LATEST APPROVED REVISION.
12. CONTRACTOR SHALL KEEP THE SITE FREE FROM ACCUMULATING WASTE MATERIAL, DEBRIS, AND TRASH AT THE COMPLETION OF THE WORK. IF NECESSARY, RUBBISH, STUMPS, DEBRIS, STICKS, STONES AND OTHER REFUSE SHALL BE REMOVED FROM THE SITE AND DISPOSED OF LEGALLY.
13. ALL EXISTING INACTIVE SEWER, WATER, GAS, ELECTRIC AND OTHER UTILITIES, WHICH INTERFERE WITH THE EXECUTION OF THE WORK, SHALL BE REMOVED AND/OR CAPPED, PLUGGED OR OTHERWISE DISCONTINUED AT POINTS WHICH WILL NOT INTERFERE WITH THE EXECUTION OF THE WORK, SUBJECT TO THE APPROVAL OF DISH Wireless L.L.C. AND TOWER OWNER, AND/OR LOCAL UTILITIES.
14. THE CONTRACTOR SHALL PROVIDE SITE SIGNAGE IN ACCORDANCE WITH THE TECHNICAL SPECIFICATION FOR SITE SIGNAGE REQUIRED BY LOCAL JURISDICTION AND SIGNAGE REQUIRED ON INDIVIDUAL PIECES OF EQUIPMENT, ROOMS, AND SHELTERS.
15. THE SITE SHALL BE GRADED TO CAUSE SURFACE WATER TO FLOW AWAY FROM THE CARRIER'S EQUIPMENT AND TOWER AREAS.
16. THE SUB GRADE SHALL BE COMPACTED AND BROUGHT TO A SMOOTH UNIFORM GRADE PRIOR TO FINISHED SURFACE APPLICATION.
17. THE AREAS OF THE OWNERS PROPERTY DISTURBED BY THE WORK AND NOT COVERED BY THE TOWER, EQUIPMENT OR DRIVEWAY, SHALL BE GRADED TO A UNIFORM SLOPE, AND STABILIZED TO PREVENT EROSION AS SPECIFIED ON THE CONSTRUCTION DRAWINGS AND/OR PROJECT SPECIFICATIONS.
18. CONTRACTOR SHALL MINIMIZE DISTURBANCE TO EXISTING SITE DURING CONSTRUCTION. EROSION CONTROL MEASURES, IF REQUIRED DURING CONSTRUCTION, SHALL BE IN CONFORMANCE WITH THE LOCAL GUIDELINES FOR EROSION AND SEDIMENT CONTROL.
19. THE CONTRACTOR SHALL PROTECT EXISTING IMPROVEMENTS, PAVEMENTS, CURBS, LANDSCAPING AND STRUCTURES. ANY DAMAGED PART SHALL BE REPAIRED AT CONTRACTOR'S EXPENSE TO THE SATISFACTION OF OWNER.
20. CONTRACTOR SHALL LEGALLY AND PROPERLY DISPOSE OF ALL SCRAP MATERIALS SUCH AS COAXIAL CABLES AND OTHER ITEMS REMOVED FROM THE EXISTING FACILITY. ANTENNAS AND RADIOS REMOVED SHALL BE RETURNED TO THE OWNER'S DESIGNATED LOCATION.
21. CONTRACTOR SHALL LEAVE PREMISES IN CLEAN CONDITION. TRASH AND DEBRIS SHOULD BE REMOVED FROM SITE ON A DAILY BASIS.
22. NO FILL OR EMBANKMENT MATERIAL SHALL BE PLACED ON FROZEN GROUND. FROZEN MATERIALS, SNOW OR ICE SHALL NOT BE PLACED IN ANY FILL OR EMBANKMENT.

**GENERAL NOTES:**

1. FOR THE PURPOSE OF CONSTRUCTION DRAWING, THE FOLLOWING DEFINITIONS SHALL APPLY:  
CONTRACTOR: GENERAL CONTRACTOR RESPONSIBLE FOR CONSTRUCTION  
CARRIER: DISH Wireless L.L.C.  
TOWER OWNER: TOWER OWNER
2. THESE DRAWINGS HAVE BEEN PREPARED USING STANDARDS OF PROFESSIONAL CARE AND COMPLETENESS NORMALLY EXERCISED UNDER SIMILAR CIRCUMSTANCES BY REPUTABLE ENGINEERS IN THIS OR SIMILAR LOCALITIES. IT IS ASSUMED THAT THE WORK DEPICTED WILL BE PERFORMED BY AN EXPERIENCED CONTRACTOR AND/OR WORKPEOPLE WHO HAVE A WORKING KNOWLEDGE OF THE APPLICABLE CODE STANDARDS AND REQUIREMENTS AND OF INDUSTRY ACCEPTED STANDARD GOOD PRACTICE. AS NOT EVERY CONDITION OR ELEMENT IS (OR CAN BE) EXPLICITLY SHOWN ON THESE DRAWINGS, THE CONTRACTOR SHALL USE INDUSTRY ACCEPTED STANDARD GOOD PRACTICE FOR MISCELLANEOUS WORK NOT EXPLICITLY SHOWN.
3. THESE DRAWINGS REPRESENT THE FINISHED STRUCTURE. THEY DO NOT INDICATE THE MEANS OR METHODS OF CONSTRUCTION. THE CONTRACTOR SHALL BE SOLELY RESPONSIBLE FOR THE CONSTRUCTION MEANS, METHODS, TECHNIQUES, SEQUENCES, AND PROCEDURES. THE CONTRACTOR SHALL PROVIDE ALL MEASURES NECESSARY FOR PROTECTION OF LIFE AND PROPERTY DURING CONSTRUCTION. SUCH MEASURES SHALL INCLUDE, BUT NOT BE LIMITED TO, BRACING, FORMWORK, SHORING, ETC. SITE VISITS BY THE ENGINEER OR HIS REPRESENTATIVE WILL NOT INCLUDE INSPECTION OF THESE ITEMS AND IS FOR STRUCTURAL OBSERVATION OF THE FINISHED STRUCTURE ONLY.
4. NOTES AND DETAILS IN THE CONSTRUCTION DRAWINGS SHALL TAKE PRECEDENCE OVER GENERAL NOTES AND TYPICAL DETAILS. WHERE NO DETAILS ARE SHOWN, CONSTRUCTION SHALL CONFORM TO SIMILAR WORK ON THE PROJECT, AND/OR AS PROVIDED FOR IN THE CONTRACT DOCUMENTS. WHERE DISCREPANCIES OCCUR BETWEEN PLANS, DETAILS, GENERAL NOTES, AND SPECIFICATIONS, THE GREATER, MORE STRICT REQUIREMENTS, SHALL GOVERN. IF FURTHER CLARIFICATION IS REQUIRED CONTACT THE ENGINEER OF RECORD.
5. SUBSTANTIAL EFFORT HAS BEEN MADE TO PROVIDE ACCURATE DIMENSIONS AND MEASUREMENTS ON THE DRAWINGS TO ASSIST IN THE FABRICATION AND/OR PLACEMENT OF CONSTRUCTION ELEMENTS BUT IT IS THE SOLE RESPONSIBILITY OF THE CONTRACTOR TO FIELD VERIFY THE DIMENSIONS, MEASUREMENTS, AND/OR CLEARANCES SHOWN IN THE CONSTRUCTION DRAWINGS PRIOR TO FABRICATION OR CUTTING OF ANY NEW OR EXISTING CONSTRUCTION ELEMENTS. IF IT IS DETERMINED THAT THERE ARE DISCREPANCIES AND/OR CONFLICTS WITH THE CONSTRUCTION DRAWINGS THE ENGINEER OF RECORD IS TO BE NOTIFIED AS SOON AS POSSIBLE.
6. PRIOR TO THE SUBMISSION OF BIDS, THE BIDDING CONTRACTOR SHALL VISIT THE CELL SITE TO FAMILIARIZE WITH THE EXISTING CONDITIONS AND TO CONFIRM THAT THE WORK CAN BE ACCOMPLISHED AS SHOWN ON THE CONSTRUCTION DRAWINGS. ANY DISCREPANCY FOUND SHALL BE BROUGHT TO THE ATTENTION OF CARRIER POC AND TOWER OWNER.
7. ALL MATERIALS FURNISHED AND INSTALLED SHALL BE IN STRICT ACCORDANCE WITH ALL APPLICABLE CODES, REGULATIONS AND ORDINANCES. CONTRACTOR SHALL ISSUE ALL APPROPRIATE NOTICES AND COMPLY WITH ALL LAWS, ORDINANCES, RULES, REGULATIONS AND LAWFUL ORDERS OF ANY PUBLIC AUTHORITY REGARDING THE PERFORMANCE OF THE WORK. ALL WORK CARRIED OUT SHALL COMPLY WITH ALL APPLICABLE MUNICIPAL AND UTILITY COMPANY SPECIFICATIONS AND LOCAL JURISDICTIONAL CODES, ORDINANCES AND APPLICABLE REGULATIONS.
8. UNLESS NOTED OTHERWISE, THE WORK SHALL INCLUDE FURNISHING MATERIALS, EQUIPMENT, APPURTENANCES AND LABOR NECESSARY TO COMPLETE ALL INSTALLATIONS AS INDICATED ON THE DRAWINGS.
9. THE CONTRACTOR SHALL INSTALL ALL EQUIPMENT AND MATERIALS IN ACCORDANCE WITH MANUFACTURER'S RECOMMENDATIONS UNLESS SPECIFICALLY STATED OTHERWISE.
10. IF THE SPECIFIED EQUIPMENT CAN NOT BE INSTALLED AS SHOWN ON THESE DRAWINGS, THE CONTRACTOR SHALL PROPOSE AN ALTERNATIVE INSTALLATION FOR APPROVAL BY THE CARRIER AND TOWER OWNER PRIOR TO PROCEEDING WITH ANY SUCH CHANGE OF INSTALLATION.
11. CONTRACTOR IS TO PERFORM A SITE INVESTIGATION, BEFORE SUBMITTING BIDS, TO DETERMINE THE BEST ROUTING OF ALL CONDUITS FOR POWER, AND TELCO AND FOR GROUNDING CABLES AS SHOWN IN THE POWER, TELCO, AND GROUNDING PLAN DRAWINGS.
12. THE CONTRACTOR SHALL PROTECT EXISTING IMPROVEMENTS, PAVEMENTS, CURBS, LANDSCAPING AND STRUCTURES. ANY DAMAGED PART SHALL BE REPAIRED AT CONTRACTOR'S EXPENSE TO THE SATISFACTION OF DISH Wireless L.L.C. AND TOWER OWNER
13. CONTRACTOR SHALL LEGALLY AND PROPERLY DISPOSE OF ALL SCRAP MATERIALS SUCH AS COAXIAL CABLES AND OTHER ITEMS REMOVED FROM THE EXISTING FACILITY. ANTENNAS REMOVED SHALL BE RETURNED TO THE OWNER'S DESIGNATED LOCATION.
14. CONTRACTOR SHALL LEAVE PREMISES IN CLEAN CONDITION. TRASH AND DEBRIS SHOULD BE REMOVED FROM SITE ON A DAILY BASIS.



5701 SOUTH SANTA FE DRIVE  
LITTLETON, CO 80120

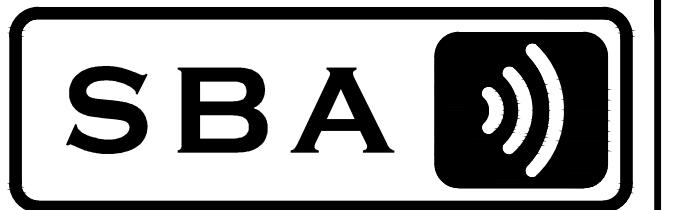

SBA COMMUNICATIONS CORP.  
134 FLANDERS ROAD, SUITE 125  
WESTBOROUGH, MA 01581  
TEL: (508) 251-0720  
FAX: (508) 251-1755



45 BEECHWOOD DRIVE, NORTH ANDOVER, MA 01845  
TEL: (978) 557-5553

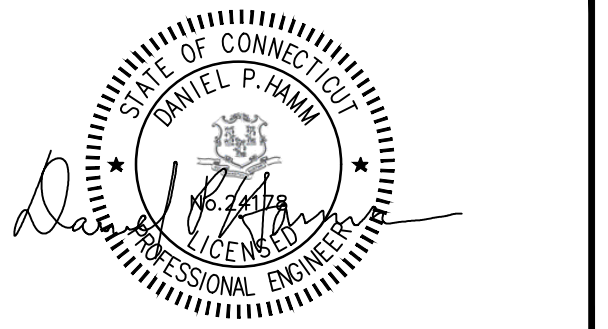

IT IS A VIOLATION OF LAW FOR ANY PERSON, UNLESS THEY ARE ACTING UNDER THE DIRECTION OF A LICENSED PROFESSIONAL ENGINEER, TO ALTER THIS DOCUMENT.

DRAWN BY:	CHECKED BY:	APPROVED BY:
TR	VD	DPH

RFDS REV #: 0

**CONSTRUCTION DOCUMENTS**

SUBMITTALS		
REV	DATE	DESCRIPTION
A	09/11/2023	ISSUED FOR REVIEW
B	09/25/2023	ISSUED FOR CONSTRUCTION

A&E PROJECT NUMBER  
BOBOS01169A

DISH Wireless L.L.C.  
PROJECT INFORMATION  
BOBOS01169A  
131 GIFFORD LANE  
BOZRAH, CT 06334

SHEET TITLE  
GENERAL NOTES

SHEET NUMBER  
**GN-3**

**CONCRETE, FOUNDATIONS, AND REINFORCING STEEL:**

1. ALL CONCRETE WORK SHALL BE IN ACCORDANCE WITH THE ACI 301, ACI 318, ACI 336, ASTM A184, ASTM A185 AND THE DESIGN AND CONSTRUCTION SPECIFICATION FOR CAST-IN-PLACE CONCRETE.
2. UNLESS NOTED OTHERWISE, SOIL BEARING PRESSURE USED FOR DESIGN OF SLABS AND FOUNDATIONS IS ASSUMED TO BE 1000 psf.
3. ALL CONCRETE SHALL HAVE A MINIMUM COMPRESSIVE STRENGTH (f'c) OF 3000 psi AT 28 DAYS, UNLESS NOTED OTHERWISE. NO MORE THAN 90 MINUTES SHALL ELAPSE FROM BATCH TIME TO TIME OF PLACEMENT UNLESS APPROVED BY THE ENGINEER OF RECORD. TEMPERATURE OF CONCRETE SHALL NOT EXCEED 90°f AT TIME OF PLACEMENT.
4. CONCRETE EXPOSED TO FREEZE-THAW CYCLES SHALL CONTAIN AIR ENTRAINING ADMIXTURES. AMOUNT OF AIR ENTRAINMENT TO BE BASED ON SIZE OF AGGREGATE AND F3 CLASS EXPOSURE (VERY SEVERE). CEMENT USED TO BE TYPE II PORTLAND CEMENT WITH A MAXIMUM WATER-TO-CEMENT RATIO (W/C) OF 0.45.
5. ALL STEEL REINFORCING SHALL CONFORM TO ASTM A615. ALL WELDED WIRE FABRIC (WWF) SHALL CONFORM TO ASTM A185. ALL SPLICES SHALL BE CLASS "B" TENSION SPLICES, UNLESS NOTED OTHERWISE. ALL HOOKS SHALL BE STANDARD 90 DEGREE HOOKS, UNLESS NOTED OTHERWISE. YIELD STRENGTH (Fy) OF STANDARD DEFORMED BARS ARE AS FOLLOWS:  
 #4 BARS AND SMALLER 40 ksi  
 #5 BARS AND LARGER 60 ksi
6. THE FOLLOWING MINIMUM CONCRETE COVER SHALL BE PROVIDED FOR REINFORCING STEEL UNLESS SHOWN OTHERWISE ON DRAWINGS:
  - CONCRETE CAST AGAINST AND PERMANENTLY EXPOSED TO EARTH 3"
  - CONCRETE EXPOSED TO EARTH OR WEATHER:
    - #6 BARS AND LARGER 2"
    - #5 BARS AND SMALLER 1-1/2"
  - CONCRETE NOT EXPOSED TO EARTH OR WEATHER:
    - SLAB AND WALLS 3/4"
    - BEAMS AND COLUMNS 1-1/2"
7. A TOOLED EDGE OR A 3/4" CHAMFER SHALL BE PROVIDED AT ALL EXPOSED EDGES OF CONCRETE, UNLESS NOTED OTHERWISE, IN ACCORDANCE WITH ACI 301 SECTION 4.2.4.

**ELECTRICAL INSTALLATION NOTES:**

1. ALL ELECTRICAL WORK SHALL BE PERFORMED IN ACCORDANCE WITH THE PROJECT SPECIFICATIONS, NEC AND ALL APPLICABLE FEDERAL, STATE, AND LOCAL CODES/ORDINANCES.
2. CONDUIT ROUTINGS ARE SCHEMATIC. CONTRACTOR SHALL INSTALL CONDUITS SO THAT ACCESS TO EQUIPMENT IS NOT BLOCKED AND TRIP HAZARDS ARE ELIMINATED.
3. WIRING, RACEWAY AND SUPPORT METHODS AND MATERIALS SHALL COMPLY WITH THE REQUIREMENTS OF THE NEC.
4. ALL CIRCUITS SHALL BE SEGREGATED AND MAINTAIN MINIMUM CABLE SEPARATION AS REQUIRED BY THE NEC.
- 4.1. ALL EQUIPMENT SHALL BEAR THE UNDERWRITERS LABORATORIES LABEL OF APPROVAL, AND SHALL CONFORM TO REQUIREMENT OF THE NATIONAL ELECTRICAL CODE.
- 4.2. ALL OVERCURRENT DEVICES SHALL HAVE AN INTERRUPTING CURRENT RATING THAT SHALL BE GREATER THAN THE SHORT CIRCUIT CURRENT TO WHICH THEY ARE SUBJECTED, 22,000 AIC MINIMUM. VERIFY AVAILABLE SHORT CIRCUIT CURRENT DOES NOT EXCEED THE RATING OF ELECTRICAL EQUIPMENT IN ACCORDANCE WITH ARTICLE 110.24 NEC OR THE MOST CURRENT ADOPTED CODE PRE THE GOVERNING JURISDICTION.
5. EACH END OF EVERY POWER PHASE CONDUCTOR, GROUNDING CONDUCTOR, AND TELCO CONDUCTOR OR CABLE SHALL BE LABELED WITH COLOR-CODED INSULATION OR ELECTRICAL TAPE (3M BRAND, 1/2" PLASTIC ELECTRICAL TAPE WITH UV PROTECTION, OR EQUAL). THE IDENTIFICATION METHOD SHALL CONFORM WITH NEC AND OSHA.
6. ALL ELECTRICAL COMPONENTS SHALL BE CLEARLY LABELED WITH LAMICOID TAGS SHOWING THEIR RATED VOLTAGE, PHASE CONFIGURATION, WIRE CONFIGURATION, POWER OR AMPACITY RATING AND BRANCH CIRCUIT ID NUMBERS (i.e. PANEL BOARD AND CIRCUIT ID'S).
7. PANEL BOARDS (ID NUMBERS) SHALL BE CLEARLY LABELED WITH PLASTIC LABELS.
8. TIE WRAPS ARE NOT ALLOWED.
9. ALL POWER AND EQUIPMENT GROUND WIRING IN TUBING OR CONDUIT SHALL BE SINGLE COPPER CONDUCTOR (#14 OR LARGER) WITH TYPE THHW, THWN, THWN-2, XHHW, XHHW-2, THW, THW-2, RHW, OR RHW-2 INSULATION UNLESS OTHERWISE SPECIFIED.
10. SUPPLEMENTAL EQUIPMENT GROUND WIRING LOCATED INDOORS SHALL BE SINGLE COPPER CONDUCTOR (#6 OR LARGER) WITH TYPE THHW, THWN, THWN-2, XHHW, XHHW-2, THW, THW-2, RHW, OR RHW-2 INSULATION UNLESS OTHERWISE SPECIFIED.
11. POWER AND CONTROL WIRING IN FLEXIBLE CORD SHALL BE MULTI-CONDUCTOR, TYPE SOOW CORD (#14 OR LARGER) UNLESS OTHERWISE SPECIFIED.
12. POWER AND CONTROL WIRING FOR USE IN CABLE TRAY SHALL BE MULTI-CONDUCTOR, TYPE TC CABLE (#14 OR LARGER), WITH TYPE THHW, THWN, THWN-2, XHHW, XHHW-2, THW, THW-2, RHW, OR RHW-2 INSULATION UNLESS OTHERWISE SPECIFIED.
13. ALL POWER AND GROUNDING CONNECTIONS SHALL BE CRIMP-STYLE, COMPRESSION WIRE LUGS AND WIRE NUTS BY THOMAS AND BETTS (OR EQUAL). LUGS AND WIRE NUTS SHALL BE RATED FOR OPERATION NOT LESS THAN 75° C (90° C IF AVAILABLE).
14. RACEWAY AND CABLE TRAY SHALL BE LISTED OR LABELED FOR ELECTRICAL USE IN ACCORDANCE WITH NEMA, UL, ANSI/IEEE AND NEC.
15. ELECTRICAL METALLIC TUBING (EMT), INTERMEDIATE METAL CONDUIT (IMC), OR RIGID METAL CONDUIT (RMC) SHALL BE USED FOR EXPOSED INDOOR LOCATIONS.

16. ELECTRICAL METALLIC TUBING (EMT) OR METAL-CLAD CABLE (MC) SHALL BE USED FOR CONCEALED INDOOR LOCATIONS.
17. SCHEDULE 40 PVC UNDERGROUND ON STRAIGHTS AND SCHEDULE 80 PVC FOR ALL ELBOWS/90s AND ALL APPROVED ABOVE GRADE PVC CONDUIT.
18. LIQUID-TIGHT FLEXIBLE METALLIC CONDUIT (LIQUID-TITE FLEX) SHALL BE USED INDOORS AND OUTDOORS, WHERE VIBRATION OCCURS OR FLEXIBILITY IS NEEDED.
19. CONDUIT AND TUBING FITTINGS SHALL BE THREADED OR COMPRESSION-TYPE AND APPROVED FOR THE LOCATION USED. SET SCREW FITTINGS ARE NOT ACCEPTABLE.
20. CABINETS, BOXES AND WIRE WAYS SHALL BE LABELED FOR ELECTRICAL USE IN ACCORDANCE WITH NEMA, UL, ANSI/IEEE AND THE NEC.
21. WIREWAYS SHALL BE METAL WITH AN ENAMEL FINISH AND INCLUDE A HINGED COVER, DESIGNED TO SWING OPEN DOWNWARDS (WIREMOLD SPECMATE WIREWAY).
22. SLOTTED WIRING DUCT SHALL BE PVC AND INCLUDE COVER (PANDUIT TYPE E OR EQUAL).
23. CONDUITS SHALL BE FASTENED SECURELY IN PLACE WITH APPROVED NON-PERFORATED STRAPS AND HANGERS. EXPLOSIVE DEVICES (i.e. POWDER-ACTUATED) FOR ATTACHING HANGERS TO STRUCTURE WILL NOT BE PERMITTED. CLOSELY FOLLOW THE LINES OF THE STRUCTURE, MAINTAIN CLOSE PROXIMITY TO THE STRUCTURE AND KEEP CONDUITS IN TIGHT ENVELOPES. CHANGES IN DIRECTION TO ROUTE AROUND OBSTACLES SHALL BE MADE WITH CONDUIT OUTLET BODIES. CONDUIT SHALL BE INSTALLED IN A NEAT AND WORKMANLIKE MANNER. PARALLEL AND PERPENDICULAR TO STRUCTURE WALL AND CEILING LINES. ALL CONDUIT SHALL BE FISHED TO CLEAR OBSTRUCTIONS. ENDS OF CONDUITS SHALL BE TEMPORARILY CAPPED FLUSH TO FINISH GRADE TO PREVENT CONCRETE, PLASTER OR DIRT FROM ENTERING. CONDUITS SHALL BE RIGIDLY CLAMPED TO BOXES BY GALVANIZED MALLEABLE IRON BUSHING ON INSIDE AND GALVANIZED MALLEABLE IRON LOCKNUT ON OUTSIDE AND INSIDE.
24. EQUIPMENT CABINETS, TERMINAL BOXES, JUNCTION BOXES AND PULL BOXES SHALL BE GALVANIZED OR EPOXY-COATED SHEET STEEL. SHALL MEET OR EXCEED UL 50 AND BE RATED NEMA 1 (OR BETTER) FOR INTERIOR LOCATIONS AND NEMA 3 (OR BETTER) FOR EXTERIOR LOCATIONS.
25. METAL RECEPTACLE, SWITCH AND DEVICE BOXES SHALL BE GALVANIZED, EPOXY-COATED OR NON-CORRODING; SHALL MEET OR EXCEED UL 514A AND NEMA OS 1 AND BE RATED NEMA 1 (OR BETTER) FOR INTERIOR LOCATIONS AND WEATHER PROTECTED (WP OR BETTER) FOR EXTERIOR LOCATIONS.
26. NONMETALLIC RECEPTACLE, SWITCH AND DEVICE BOXES SHALL MEET OR EXCEED NEMA OS 2 (NEWEST REVISION) AND BE RATED NEMA 1 (OR BETTER) FOR INTERIOR LOCATIONS AND WEATHER PROTECTED (WP OR BETTER) FOR EXTERIOR LOCATIONS.
27. THE CONTRACTOR SHALL NOTIFY AND OBTAIN NECESSARY AUTHORIZATION FROM THE CARRIER AND/OR DISH Wireless L.L.C. AND TOWER OWNER BEFORE COMMENCING WORK ON THE AC POWER DISTRIBUTION PANELS.
28. THE CONTRACTOR SHALL PROVIDE NECESSARY TAGGING ON THE BREAKERS, CABLES AND DISTRIBUTION PANELS IN ACCORDANCE WITH THE APPLICABLE CODES AND STANDARDS TO SAFEGUARD LIFE AND PROPERTY.
29. INSTALL LAMICOID LABEL ON THE METER CENTER TO SHOW "DISH Wireless L.L.C.".
30. ALL EMPTY/SPARE CONDUITS THAT ARE INSTALLED ARE TO HAVE A METERED MULE TAPE PULL CORD INSTALLED.



5701 SOUTH SANTA FE DRIVE  
LITTLETON, CO 80120



SBA COMMUNICATIONS CORP.  
134 FLANDERS ROAD, SUITE 125  
WESTBOROUGH, MA 01581  
TEL: (508) 251-0720  
FAX: (508) 251-1755



45 BEECHWOOD DRIVE, NORTH ANDOVER, MA 01845  
TEL: (978) 557-5553

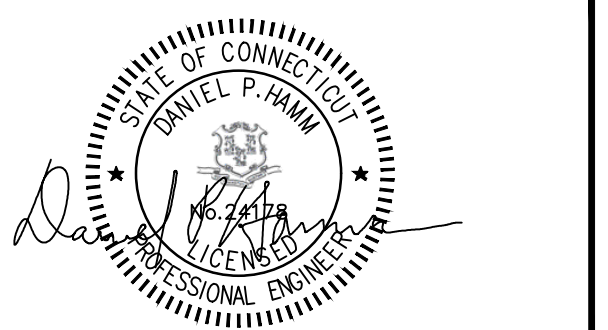

IT IS A VIOLATION OF LAW FOR ANY PERSON, UNLESS THEY ARE ACTING UNDER THE DIRECTION OF A LICENSED PROFESSIONAL ENGINEER, TO ALTER THIS DOCUMENT.

DRAWN BY:	CHECKED BY:	APPROVED BY:
TR	VD	DPH

RFDS REV #: 0

**CONSTRUCTION DOCUMENTS**

SUBMITTALS		
REV	DATE	DESCRIPTION
A	09/11/2023	ISSUED FOR REVIEW
B	09/25/2023	ISSUED FOR CONSTRUCTION

A&E PROJECT NUMBER  
BOBOS01169A

DISH Wireless L.L.C.  
PROJECT INFORMATION  
BOBOS01169A  
131 GIFFORD LANE  
BOZRAH, CT 06334

SHEET TITLE  
GENERAL NOTES

SHEET NUMBER  
**GN-4**

**GROUNDING NOTES:**

1. ALL GROUND ELECTRODE SYSTEMS (INCLUDING TELECOMMUNICATION, RADIO, LIGHTNING PROTECTION AND AC POWER GES'S) SHALL BE BONDED TOGETHER AT OR BELOW GRADE, BY TWO OR MORE COPPER BONDING CONDUCTORS IN ACCORDANCE WITH THE NEC.
2. THE CONTRACTOR SHALL PERFORM IEEE FALL-OF-POTENTIAL RESISTANCE TO EARTH TESTING (PER IEEE 1100 AND 81) FOR GROUND ELECTRODE SYSTEMS, THE CONTRACTOR SHALL FURNISH AND INSTALL SUPPLEMENTAL GROUND ELECTRODES AS NEEDED TO ACHIEVE A TEST RESULT OF 5 OHMS OR LESS.
3. THE CONTRACTOR IS RESPONSIBLE FOR PROPERLY SEQUENCING GROUNDING AND UNDERGROUND CONDUIT INSTALLATION AS TO PREVENT ANY LOSS OF CONTINUITY IN THE GROUNDING SYSTEM OR DAMAGE TO THE CONDUIT AND PROVIDE TESTING RESULTS.
4. METAL CONDUIT AND TRAY SHALL BE GROUNDED AND MADE ELECTRICALLY CONTINUOUS WITH LISTED BONDING FITTINGS OR BY BONDING ACROSS THE DISCONTINUITY WITH #6 COPPER WIRE UL APPROVED GROUNDING TYPE CONDUIT CLAMPS.
5. METAL RACEWAY SHALL NOT BE USED AS THE NEC REQUIRED EQUIPMENT GROUND CONDUCTOR. STRANDED COPPER CONDUCTORS WITH GREEN INSULATION, SIZED IN ACCORDANCE WITH THE NEC, SHALL BE FURNISHED AND INSTALLED WITH THE POWER CIRCUITS TO BTS EQUIPMENT.
6. EACH CABINET FRAME SHALL BE DIRECTLY CONNECTED TO THE MASTER GROUND BAR WITH GREEN INSULATED SUPPLEMENTAL EQUIPMENT GROUND WIRES, #6 STRANDED COPPER OR LARGER FOR INDOOR BTS; #2 BARE SOLID TINNED COPPER FOR OUTDOOR BTS.
7. CONNECTIONS TO THE GROUND BUS SHALL NOT BE DOUBLED UP OR STACKED BACK TO BACK CONNECTIONS ON OPPOSITE SIDE OF THE GROUND BUS ARE PERMITTED.
8. ALL EXTERIOR GROUND CONDUCTORS BETWEEN EQUIPMENT/GROUND BARS AND THE GROUND RING SHALL BE #2 SOLID TINNED COPPER UNLESS OTHERWISE INDICATED.
9. ALUMINUM CONDUCTOR OR COPPER CLAD STEEL CONDUCTOR SHALL NOT BE USED FOR GROUNDING CONNECTIONS.
10. USE OF 90° BENDS IN THE PROTECTION GROUNDING CONDUCTORS SHALL BE AVOIDED WHEN 45° BENDS CAN BE ADEQUATELY SUPPORTED.
11. EXOTHERMIC WELDS SHALL BE USED FOR ALL GROUNDING CONNECTIONS BELOW GRADE.
12. ALL GROUND CONNECTIONS ABOVE GRADE (INTERIOR AND EXTERIOR) SHALL BE FORMED USING HIGH PRESS CRIMPS.
13. COMPRESSION GROUND CONNECTIONS MAY BE REPLACED BY EXOTHERMIC WELD CONNECTIONS.
14. ICE BRIDGE BONDING CONDUCTORS SHALL BE EXOTHERMICALLY BONDED OR BOLTED TO THE BRIDGE AND THE TOWER GROUND BAR.
15. APPROVED ANTIOXIDANT COATINGS (i.e. CONDUCTIVE GEL OR PASTE) SHALL BE USED ON ALL COMPRESSION AND BOLTED GROUND CONNECTIONS.
16. ALL EXTERIOR GROUND CONNECTIONS SHALL BE COATED WITH A CORROSION RESISTANT MATERIAL.
17. MISCELLANEOUS ELECTRICAL AND NON-ELECTRICAL METAL BOXES, FRAMES AND SUPPORTS SHALL BE BONDED TO THE GROUND RING, IN ACCORDANCE WITH THE NEC.
18. BOND ALL METALLIC OBJECTS WITHIN 6 ft OF MAIN GROUND RING WITH (1) #2 BARE SOLID TINNED COPPER GROUND CONDUCTOR.
19. GROUND CONDUCTORS USED FOR THE FACILITY GROUNDING AND LIGHTNING PROTECTION SYSTEMS SHALL NOT BE ROUTED THROUGH METALLIC OBJECTS THAT FORM A RING AROUND THE CONDUCTOR, SUCH AS METALLIC CONDUITS, METAL SUPPORT CLIPS OR SLEEVES THROUGH WALLS OR FLOORS. WHEN IT IS REQUIRED TO BE HOUSED IN CONDUIT TO MEET CODE REQUIREMENTS OR LOCAL CONDITIONS, NON-METALLIC MATERIAL SUCH AS PVC CONDUIT SHALL BE USED. WHERE USE OF METAL CONDUIT IS UNAVOIDABLE (i.e., NONMETALLIC CONDUIT PROHIBITED BY LOCAL CODE) THE GROUND CONDUCTOR SHALL BE BONDED TO EACH END OF THE METAL CONDUIT.
20. ALL GROUNDS THAT TRANSITION FROM BELOW GRADE TO ABOVE GRADE MUST BE #2 BARE SOLID TINNED COPPER IN 3/4" NON-METALLIC, FLEXIBLE CONDUIT FROM 24" BELOW GRADE TO WITHIN 3" TO 6" OF CAD-WELD TERMINATION POINT. THE EXPOSED END OF THE CONDUIT MUST BE SEALED WITH SILICONE CAULK. (ADD TRANSITIONING GROUND STANDARD DETAIL AS WELL).
21. BUILDINGS WHERE THE MAIN GROUNDING CONDUCTORS ARE REQUIRED TO BE ROUTED TO GRADE, THE CONTRACTOR SHALL ROUTE TWO GROUNDING CONDUCTORS FROM THE ROOFTOP, TOWERS, AND WATER TOWERS GROUNDING RING, TO THE EXISTING GROUNDING SYSTEM, THE GROUNDING CONDUCTORS SHALL NOT BE SMALLER THAN 2/0 COPPER. ROOFTOP GROUNDING RING SHALL BE BONDED TO THE EXISTING GROUNDING SYSTEM, THE BUILDING STEEL COLUMNS, LIGHTNING PROTECTION SYSTEM, AND BUILDING MAIN WATER LINE (FERRROUS OR NONFERRROUS METAL PIPING ONLY). DO NOT ATTACH GROUNDING TO FIRE SPRINKLER SYSTEM PIPES.



5701 SOUTH SANTA FE DRIVE  
LITTLETON, CO 80120



SBA COMMUNICATIONS CORP.  
134 FLANDERS ROAD, SUITE 125  
WESTBOROUGH, MA 01581  
TEL: (508) 251-0720  
FAX: (508) 251-1755



45 BEECHWOOD DRIVE, NORTH ANDOVER, MA 01845  
TEL: (978) 557-5553

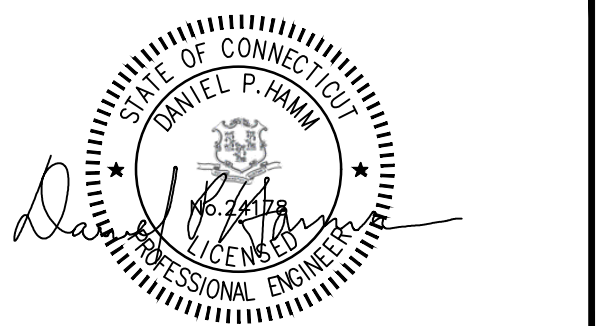

IT IS A VIOLATION OF LAW FOR ANY PERSON, UNLESS THEY ARE ACTING UNDER THE DIRECTION OF A LICENSED PROFESSIONAL ENGINEER, TO ALTER THIS DOCUMENT.

DRAWN BY:	CHECKED BY:	APPROVED BY:
TR	VD	DPH

RFDS REV #: 0

**CONSTRUCTION DOCUMENTS**

SUBMITTALS		
REV	DATE	DESCRIPTION
A	09/11/2023	ISSUED FOR REVIEW
B	09/25/2023	ISSUED FOR CONSTRUCTION

A&E PROJECT NUMBER  
BOBOS01169A

DISH Wireless L.L.C.  
PROJECT INFORMATION  
BOBOS01169A  
131 GIFFORD LANE  
BOZRAH, CT 06334

SHEET TITLE  
GENERAL NOTES

SHEET NUMBER  
**GN-5**