



September 05, 2014

David Martin and
Members of the Siting Council
Connecticut Siting Council
Ten Franklin Square
New Britain, CT 06051

RE: Notice of Exempt Modification
12 Carpenter Road
Bolton CT 06043
T-Mobile #: CTHA076D
N 41° 46' 44.70"
W -72° 27' 55.09"

Dear Mr. Martin and Members of the Siting Council:

On behalf of T-Mobile Northeast LLC, SBA Communications is submitting an exempt modification application to the Connecticut Siting council for modification of existing equipment at a tower facility located at 12 Carpenter Road, Bolton CT.

The 12 Carpenter Road facility consists of a 139' MONOPOLE Tower owned and operated by SBA Infrastructure, LLC. In order to accommodate technological changes and enhance system performance in the State of Connecticut, T-Mobile Northeast LLC plans to modify the equipment configurations at many of its existing cell sites. Please accept this letter and attachments as notification, pursuant to R.C.S.A. Section 16-50j-73, of construction which constitutes an exempt modification pursuant to R.C.S.A. Section 16-50j-72(b)(2). In compliance with R.C.S.A. Section 16-50j-73, a copy of this letter and attachments is being sent to the chief elected official of the municipality in which the affected cell site is located.

T-Mobile Northeast LLC wishes to upgrade their equipment to meet the new standards of 4G technology. The new equipment will allow customers to download files and browse the internet at a high rate of speed while also allowing their phones to be compatible with the latest 4G technology.

Attached is a summary of the planned modifications, including power density calculations reflecting the change in Sprint's operations at the site along with the required fee of \$625.

The changes to the facility do not constitute modifications as defined in Connecticut General Statutes ("C.G.S.") Section 16-50i(d) because the general physical characteristics of the facility will not be



significantly changed or altered. Rather, the planned changes to the facility fall squarely within those activities explicitly provided for in R.C.S.A. Section 16-50j-72(b)(2).

1. The overall height of the structure will be unaffected.
2. The proposed changes will not extend the site boundaries. There will be no effect on the site compound other than the new equipment cabinets.
3. The proposed changes will not increase the noise level at the existing facility by six decibels or more.
4. The changes in radio frequency power density will not increase the calculated "worst case" power density for the combined operations at the site to a level at or above the applicable standard for uncontrolled environments as calculated for a mixed frequency site.

For the foregoing reasons, SBA Communications on behalf of T-Mobile Northeast LLC, respectfully submits that the proposed changes at the referenced site constitute exempt modifications under R.C.S.A. Section 16-50j-72(b)(2).

Please feel free to call me at (508) 251-0720 x 3807 with any questions you may have concerning this matter.

Thank you,

Peter Nute
SBA Communications Corporation
33 Boston Post Road West Suite 320
Marlborough, MA 01752
508-251-0720 x 3807 + T
508-251-1755 + F
Pnute@sbsite.com



**T-Mobile Northeast LLC
Equipment Modification**

12 Carpenter Road, Bolton CT
Site number CTHA076D

Tower Owner: SBA Infrastructure, LLC

Equipment Configuration: MONOPOLE Tower

Current and/or approved:

- (3) RFS APX16PV-16PVL-C
- (3) Comm DTMA1819-00-12
- (6) 1-5/8" Feed Lines
- (1) 1/4" Feed Line

Planned Modifications:

- (3) Ericsson Air B2A/B4P
- (3) Ericsson Air B4A/B2P
- (3) 72"x12" Panels (reserved)
- (3) Ericsson KRY 112 144
- (12) 1-5/8" Feed Lines
- (1) 1-5/8" Fiber Line

Structural Information:

The attached structural analysis demonstrates that the tower and foundation will have adequate structural capacity to accommodate the proposed modifications.

Power Density:

The anticipated Maximum Composite contributions from the T-Mobile facility are 6.47% of the allowable FCC established general public limit. The anticipated composite MPE value for this site assuming all carriers present is 66.57% of the allowable FCC established general public limit sampled at the ground level.

Site Composite MPE%	
Carrier	MPE%
T-Mobile	6.47
Sprint Nextel	5.56 %
Verizon Wireless	27.97 %
AT&T	26.57 %
Site Total MPE %:	66.57 %



September 05, 2014

Robert Morra
First Selectman
Town of Bolton
Town Hall
222 Bolton Center Road
Bolton, CT 06043

RE: Telecommunications Facility @ 12 Carpenter Road, Bolton CT

Dear Mr. Morra,

In order to accommodate technological changes and enhance system performance in the State of Connecticut, T-Mobile Northeast LLC will be changing its equipment configuration at certain cell sites.

As required by Regulations of Connecticut State Agencies (R.C.S.A.) Section 16-50j-73, the Connecticut Siting Council has been notified of the changes and will review T-Mobile's proposal. Please accept this letter as notification under Section 16-50j-73 of construction which constitutes an exempt modification pursuant to R.C.S.A. Section 16-50j-72(b)(2).

The accompanying letter to the Siting Council fully describes Sprint's proposal for the referenced cell site. However, if you have any questions or require any further information on our plans or the Siting Council's procedures, please call me at (508) 251-0720 x 3807.

Thank you,

Peter Nute
SBA Communications Corporation
33 Boston Post Road West Suite 320
Marlborough, MA 01752
508-251-0720 x 3807 + T
508-251-1755 + F
Pnute@sbsite.com



September 05, 2014

Terry L. Veo
23 Bolton Center Road
Bolton CT 06043

RE: Telecommunications Facility @ 12 Carpenter Road, Bolton CT

Dear Terry,

In order to accommodate technological changes and enhance system performance in the State of Connecticut, T-Mobile Northeast LLC will be changing its equipment configuration at certain cell sites.

As required by Regulations of Connecticut State Agencies (R.C.S.A.) Section 16-50j-73, the Connecticut Siting Council has been notified of the changes and will review T-Mobile's proposal. Please accept this letter as notification under Section 16-50j-73 of construction which constitutes an exempt modification pursuant to R.C.S.A. Section 16-50j-72(b)(2).

The accompanying letter to the Siting Council fully describes Sprint's proposal for the referenced cell site. However, if you have any questions or require any further information on our plans or the Siting Council's procedures, please call me at (508) 251-0720 x 3807.

Thank you,

A handwritten signature in blue ink, appearing to read "Peter Nute", is positioned below the "Thank you," text.

Peter Nute
SBA Communications Corporation
33 Boston Post Road West Suite 320
Marlborough, MA 01752
508-251-0720 x 3807 + T
508-251-1755 + F
Pnute@sbsite.com

RADIO FREQUENCY EMISSIONS ANALYSIS REPORT
EVALUATION OF HUMAN EXPOSURE POTENTIAL
TO NON-IONIZING EMISSIONS

T-Mobile Existing Facility

Site ID: CTHA076D

MCF Carpenter Road
14-16 Carpenter Road
Bolton, CT 06043

August 25, 2014

Site Compliance Summary	
Compliance Status:	COMPLIANT
Site total MPE% of FCC general public allowable limit:	66.57 %

August 25, 2014

T-Mobile USA
Attn: Jason Overbey, RF Manager
35 Griffin Road South
Bloomfield, CT 06002

Emissions Analysis for Site: **CTHA076D – MCF Carpenter Road**

EBI Consulting was directed to analyze the proposed T-Mobile facility located at **14-16 Carpenter Road, Bolton, CT**, for the purpose of determining whether the emissions from the Proposed T-Mobile Antenna Installation located on this property are within specified federal limits.

All information used in this report was analyzed as a percentage of current Maximum Permissible Exposure (% MPE) as listed in the FCC OET Bulletin 65 Edition 97-01 and ANSI/IEEE Std C95.1. The FCC regulates Maximum Permissible Exposure in units of microwatts per square centimeter ($\mu\text{W}/\text{cm}^2$). The number of $\mu\text{W}/\text{cm}^2$ calculated at each sample point is called the power density. The exposure limit for power density varies depending upon the frequencies being utilized. Wireless Carriers and Paging Services use different frequency bands each with different exposure limits, therefore it is necessary to report results and limits in terms of percent MPE rather than power density.

All results were compared to the FCC (Federal Communications Commission) radio frequency exposure rules, 47 CFR 1.1307(b)(1) – (b)(3), to determine compliance with the Maximum Permissible Exposure (MPE) limits for General Population/Uncontrolled environments as defined below.

General population/uncontrolled exposure limits apply to situations in which the general public may be exposed or in which persons who are exposed as a consequence of their employment may not be made fully aware of the potential for exposure or cannot exercise control over their exposure. Therefore, members of the general public would always be considered under this category when exposure is not employment related, for example, in the case of a telecommunications tower that exposes persons in a nearby residential area.

Public exposure to radio frequencies is regulated and enforced in units of microwatts per square centimeter ($\mu\text{W}/\text{cm}^2$). The general population exposure limit for the 700 MHz Band is 567 $\mu\text{W}/\text{cm}^2$, and the general population exposure limit for the PCS and AWS bands is 1000 $\mu\text{W}/\text{cm}^2$. Because each carrier will be using different frequency bands, and each frequency band has different exposure limits, it is necessary to report percent of MPE rather than power density.

Occupational/controlled exposure limits apply to situations in which persons are exposed as a consequence of their employment and in which those persons who are exposed have been made fully aware of the potential for exposure and can exercise control over their exposure. Occupational/controlled exposure limits also apply where exposure is of a transient nature as a result of incidental passage through a location where exposure levels may be above general population/uncontrolled limits (see below), as long as the exposed person has been made fully aware of the potential for exposure and can exercise control over his or her exposure by leaving the area or by some other appropriate means.

Additional details can be found in FCC OET 65.

CALCULATIONS

Calculations were done for the proposed T-Mobile Wireless antenna facility located at **14-16 Carpenter Road, Bolton, CT**, using the equipment information listed below. All calculations were performed per the specifications under FCC OET 65. Since T-Mobile is proposing highly focused directional panel antennas, which project most of the emitted energy out toward the horizon, all calculations were performed assuming a lobe representing the maximum gain of the antenna per the antenna manufactures supplied specifications, minus 10 dB, was focused at the base of the tower. For this report the sample point is the top of a 6 foot person standing at the base of the tower.

For all calculations, all equipment was calculated using the following assumptions:

- 1) 2 GSM channels (PCS Band - 1900 MHz) were considered for each sector of the proposed installation. These Channels have a transmit power of 30 Watts per Channel
- 2) 2 UMTS channels (AWS Band – 2100 MHz) were considered for each sector of the proposed installation. These Channels have a transmit power of 30 Watts per Channel.
- 3) 2 LTE channels (AWS Band – 2100 MHz) were considered for each sector of the proposed installation. These Channels have a transmit power of 60 Watts per Channel.
- 4) All radios at the proposed installation were considered to be running at full power and were uncombined in their RF transmissions paths per carrier prescribed configuration. Per FCC OET Bulletin No. 65 - Edition 97-01 recommendations to achieve the maximum anticipated value at each sample point, all power levels emitting from the proposed antenna installation are increased by a factor of 2.56 to account for possible in-phase reflections from the surrounding environment. This is rarely the case, and if so, is never continuous.

- 5) For the following calculations the sample point was the top of a six foot person standing at the base of the tower. The maximum gain of the antenna per the antenna manufactures supplied specifications minus 10 dB was used in this direction. This value is a very conservative estimate as gain reductions for these particular antennas are typically much higher in this direction.
- 6) The antennas used in this modeling are the **Ericsson AIR21 B4A/B2P** for 1900 MHz (PCS) and 2100 MHz (AWS) channels. This is based on feedback from the carrier with regards to anticipated antenna selection. The **Ericsson AIR21 B4A/B2P** has a maximum gain of **15.6 dBd** at its main lobe. The maximum gain of the antenna per the antenna manufactures supplied specifications, minus 10 dB, was used for all calculations. This value is a very conservative estimate as gain reductions for these particular antennas are typically much higher in this direction.
- 7) The antenna mounting height centerline of the proposed antennas is **126.5 feet** above ground level (AGL).
- 8) Emissions values for additional carriers were taken from the Connecticut Siting Council active database. Values in this database are provided by the individual carriers themselves.

All calculations were done with respect to uncontrolled / general public threshold limits.

T-Mobile Site Inventory and Power Data

Sector:	A	Sector:	B	Sector:	C
Antenna #:	1	Antenna #:	1	Antenna #:	1
Make / Model:	Ericsson AIR21 B4A/B2P	Make / Model:	Ericsson AIR21 B4A/B2P	Make / Model:	Ericsson AIR21 B4A/B2P
Gain:	15.6 dBd	Gain:	15.6 dBd	Gain:	15.6 dBd
Height (AGL):	126.5	Height (AGL):	126.5	Height (AGL):	126.5
Frequency Bands	1900 MHz(PCS) / 2100 MHz (AWS)	Frequency Bands	1900 MHz(PCS) / 2100 MHz (AWS)	Frequency Bands	1900 MHz(PCS) / 2100 MHz (AWS)
Channel Count	2	Channel Count	2	# PCS Channels:	2
Total TX Power:	120	Total TX Power:	120	# AWS Channels:	120
ERP (W):	1,888.44	ERP (W):	1,888.44	ERP (W):	1,888.44
Antenna A1 MPE%	1.08	Antenna B1 MPE%	1.08	Antenna C1 MPE%	1.08
Antenna #:	2	Antenna #:	2	Antenna #:	2
Make / Model:	Ericsson AIR21 B4A/B2P	Make / Model:	Ericsson AIR21 B4A/B2P	Make / Model:	Ericsson AIR21 B4A/B2P
Gain:	15.6 dBd	Gain:	15.6 dBd	Gain:	15.6 dBd
Height (AGL):	126.5	Height (AGL):	126.5	Height (AGL):	126.5
Frequency Bands	1900 MHz(PCS) / 2100 MHz (AWS)	Frequency Bands	1900 MHz(PCS) / 2100 MHz (AWS)	Frequency Bands	1900 MHz(PCS) / 2100 MHz (AWS)
Channel Count	4	Channel Count	4	Channel Count	4
Total TX Power:	120	Total TX Power:	120	Total TX Power:	120
ERP (W):	1,888.44	ERP (W):	1,888.44	ERP (W):	1,888.44
Antenna A2 MPE%	1.08	Antenna B2 MPE%	1.08	Antenna C2 MPE%	1.08

Site Composite MPE%	
Carrier	MPE%
T-Mobile	6.47
Sprint Nextel	5.56 %
Verizon Wireless	27.97 %
AT&T	26.57 %
Site Total MPE %:	66.57 %

T-Mobile Sector 1 Total:	2.16 %
T-Mobile Sector 2 Total:	2.16 %
T-Mobile Sector 3 Total:	2.16 %
Site Total:	66.57 %

Summary

All calculations performed for this analysis yielded results that were **within** the allowable limits for general public exposure to RF Emissions.

The anticipated maximum composite contributions from the T-Mobile facility as well as the site composite emissions value with regards to compliance with FCC's allowable limits for general public exposure to RF Emissions are shown here:

T-Mobile Sector	Power Density Value (%)
Sector 1:	2.16 %
Sector 2:	2.16 %
Sector 3 :	2.16 %
T-Mobile Total:	6.47 %
Site Total:	66.57 %
Site Compliance Status:	COMPLIANT

The anticipated composite MPE value for this site assuming all carriers present is **66.57%** of the allowable FCC established general public limit sampled at the ground level. This is based upon values listed in the Connecticut Siting Council database for existing carrier emissions.

FCC guidelines state that if a site is found to be out of compliance (over allowable thresholds), that carriers over a 5% contribution to the composite value will require measures to bring the site into compliance. For this facility, the composite values calculated were well within the allowable 100% threshold standard per the federal government.



Scott Heffernan
RF Engineering Director

EBI Consulting
21 B Street
Burlington, MA 01803`



FDH Engineering, Inc., 6521 Meridien Dr., NC 27616, Ph. 919.755.1012, Fax 919.755.1031

**Structural Analysis for
SBA Network Services, Inc.**

139' Monopole Tower

**SBA Site Name: Bolton 2
SBA Site ID: CT11558-A-02
T-Mobile Site ID: CTHA076D**

FDH Project Number 146AN71400

Analysis Results

Tower Components	65.5%	Sufficient
Foundation	79.1%	Sufficient

Prepared By:

Robert Spivey, EI
Project Engineer

Reviewed By:

Bradley Newman, PE
Senior Project Engineer
CT PE License No. 29630

FDH Engineering, Inc.
6521 Meridien Dr.
Raleigh, NC 27616
(919) 755-1012
info@fdh-inc.com

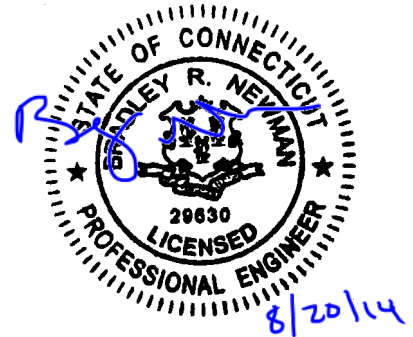

August 20, 2014

Prepared pursuant to TIA/EIA-222-F Structural Standards for Steel Antenna Towers and Antenna Supporting Structures and 2005 Connecticut Building Code

TABLE OF CONTENTS

EXECUTIVE SUMMARY 3

 Conclusions 3

 Recommendations 3

APPURTENANCE LISTING 4

RESULTS 5

GENERAL COMMENTS 6

LIMITATIONS 6

APPENDIX 7

EXECUTIVE SUMMARY

At the request of SBA Network Services, Inc., FDH Engineering, Inc. performed a structural analysis of the monopole located in Bolton, CT to determine whether the tower is structurally adequate to support both the existing and proposed loads pursuant to the *Structural Standards for Steel Antenna Towers and Antenna Supporting Structures, TIA/EIA-222-F* and *2005 Connecticut Building Code (CBC)*. Information pertaining to the existing/proposed antenna loading, current tower geometry, foundation dimensions, and member sizes was obtained from:

- Fred A. Nudd Corporation (Project No. 207-13312) original design drawings dated September 5, 2007
- FDH, Inc. (Job No. 08-08057T) TIA Inspection Report dated September 16, 2008
- SBA Network Services, Inc.

The *basic design wind speed* per the *TIA/EIA-222-F* standards and *2005 CBC* is 85 mph without ice and 38 mph with 1" radial ice. Ice is considered to increase in thickness with height.

Conclusions

With the existing and proposed antennas from T-Mobile in place at 126.5 ft, the tower meets the requirements of the *TIA/EIA-222-F* standards and *2005 CBC* provided the **Recommendations** listed below are satisfied. Furthermore, provided the foundation was designed and constructed to support the original design reactions (see Fred A. Nudd Corporation Project No. 207-13312), the foundation should have the necessary capacity to support the existing and proposed loading. For a more detailed description of the analysis of the tower, see the **Results** section of this report.

Our structural analysis has been performed assuming all information provided to FDH Engineering, Inc. is accurate (i.e., the steel data, tower layout, existing antenna loading, and proposed antenna loading) and that the tower has been properly erected and maintained per the original design drawings.

Recommendations

To ensure the requirements of the *TIA/EIA-222-F* standards and *2005 CBC* are met with the existing and proposed loading in place, we have the following recommendations:

1. The proposed coax must be installed inside the monopole's shaft.
2. RRU/RRH Stipulation: The proposed equipment may be installed in any arrangement determined by the client.

APPURTENANCE LISTING

The proposed and existing antennas with their corresponding cables/coax lines are shown in **Table 1**. *If the actual layout determined in the field deviates from the layout, FDH Engineering, Inc. should be contacted to perform a revised analysis.*

Table 1 - Appurtenance Loading

Existing Loading:

Antenna Elevation (ft)	Description	Coax and Lines ¹	Carrier	Mount Elevation (ft)	Mount Type
137	(3) Antel BXA-70063/6CF (4) Antel BXA-171085/12BF (2) Antel BXA-171063/12BF (2) Antel BXA-70080-6BF (1) Antel BXA-70063-4CF (3) ALU RRH2X40-AWS (1) RFS DB-T1-6Z-8AB-0Z (6) RFS/FD9R6004/2C-31	(12) 1-5/8" (1) 1-5/8" Fiber	Verizon	137	(1) 12.5' Low Profile Platform
126.5	(3) RFS APX16PV-16PVL-C (3) Comm DTMA1819-00-12 (9) Powerwave 7770	(6) 1-5/8" (1) 1/4"	T-Mobile	126.5	(1) 12.5' Low Profile Platform
110	(3) KMW AM-X-CD-16-65-00T (12) Powerwave LGP2140X (6) Ericsson RRUS11 (1) Raycap DC6-48-60-18-8F	(12) 1-5/8" (1) 3/8" RET ² (2) DC ²	AT&T	108.3	(1) 13.4' Low Profile Platform
97 ³	(3) RFS APXV18-206517S-C	(6) 1-5/8"	MetroPCS	97	(3) Pipe Mounts

1. Coax installed inside the pole's shaft unless otherwise noted.

2. AT&T currently has (1) 3/8" RET cable and (2) DC cables installed inside (1) 3" conduit inside the pole shaft.

3. MetroPCS currently has (6) 1-5/8" coax installed outside the pole shaft in a single row.

Proposed Carrier Final Loading:

Antenna Elevation (ft)	Description	Coax and Lines	Carrier	Mount Elevation (ft)	Mount Type
126.5	(3) Ericsson Air B2A/B4P (3) Ericsson Air B4A/B2P (3) 72"x12" Panels (reserved) (3) Ericsson KRY 112 144	(12) 1-5/8" (1) 1-5/8" Fiber	T-Mobile	126.5	(1) 12.5' Low Profile Platform

RESULTS

The following yield strength of steel for individual members was used for analysis:

Table 2 - Material Strength

Member Type	Yield Strength
Tower Shaft Sections	65 ksi
Base Plate	65 ksi
Anchor Bolts	105 ksi

Table 3 displays the summary of the ratio (as a percentage) of force in the member to their capacities. Values greater than 100% indicate locations where the maximum force in the member exceeds its capacity. **Table 4** displays the maximum foundation reactions.

If the assumptions outlined in this report differ from actual field conditions, FDH Engineering, Inc. should be contacted to perform a revised analysis. Furthermore, as no information pertaining to the allowable twist and sway requirements for the existing or proposed appurtenances was provided, deflection and rotation were not taken into consideration when performing this analysis.

See the **Appendix** for detailed modeling information.

Table 3 - Summary of Working Percentage of Structural Components

Section No.	Elevation ft	Component Type	Size	% Capacity*	Pass Fail
L1	139 - 89	Pole	TP34.7x24x0.25	49.4	Pass
L2	114 - 89	Pole	TP44.7x33.13x0.3125	65.5	Pass
L3	89 - 69	Pole	TP55.6x42.6866x0.375	62.4	Pass
	0	Anchor Bolts	(20) 2"Ø on 62" BC	52.5	Pass
	0	Base Plate	PL 68"Ø x 2.5" thk.	42.2	Pass

* Capacities include a 1/3 allowable stress increase for wind.

Table 4 - Maximum Base Reactions

Base Reactions	Current Analysis (TIA/EIA-222-F)	Original Design (ANSI/TIA-222-G)
Axial	33 k	67 k
Shear	24 k	39 k
Moment	2,387 k-ft	4,076 k-ft

* Current analysis reactions are based on allowable stress design which are to be factored by 1.35 per the ANSI/TIA-222-G standard when the original design reactions are based on a load and resistance factor design.

GENERAL COMMENTS

This engineering analysis is based upon the theoretical capacity of the structure. It is not a condition assessment of the tower and its foundation. It is the responsibility of SBA Network Services, Inc. to verify that the tower modeled and analyzed is the correct structure (with accurate antenna loading information) modeled. If there are substantial modifications to be made or the assumptions made in this analysis are not accurate, FDH Engineering, Inc. should be notified immediately to perform a revised analysis.

LIMITATIONS

All opinions and conclusions are considered accurate to a reasonable degree of engineering certainty based upon the evidence available at the time of this report. All opinions and conclusions are subject to revision based upon receipt of new or additional/updated information. All services are provided exercising a level of care and diligence equivalent to the standard and care of our profession. No other warranty or guarantee, expressed or implied, is offered. Our services are confidential in nature and we will not release this report to any other party without the client's consent. The use of this engineering work is limited to the express purpose for which it was commissioned and it may not be reused, copied, or distributed for any other purpose without the written consent of FDH Engineering, Inc.

APPENDIX

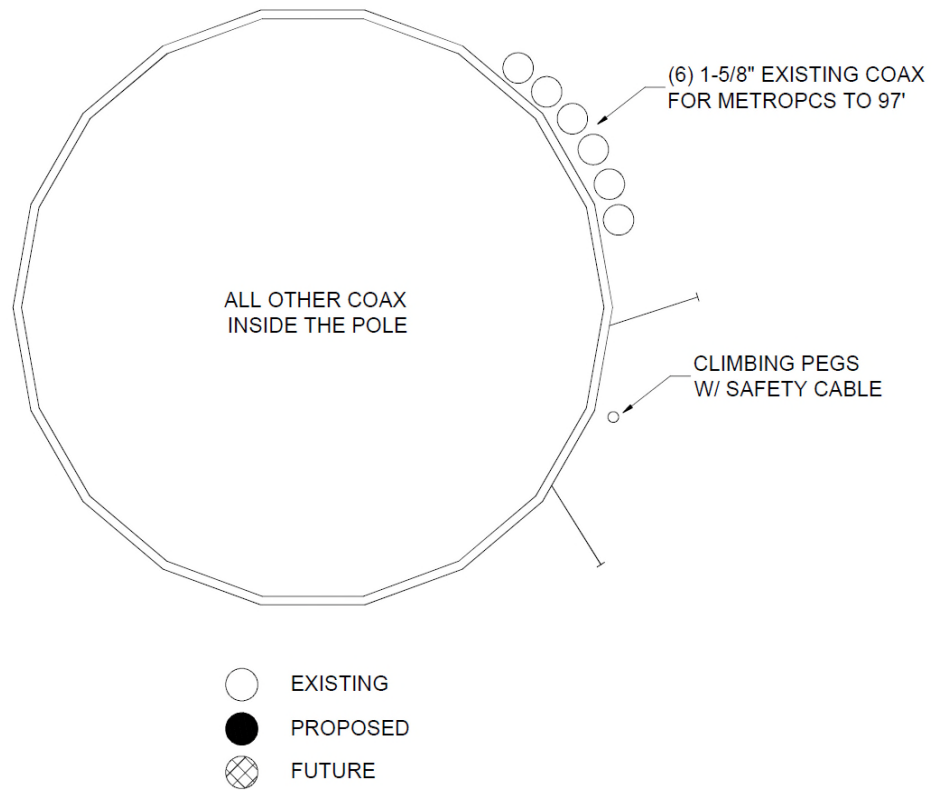
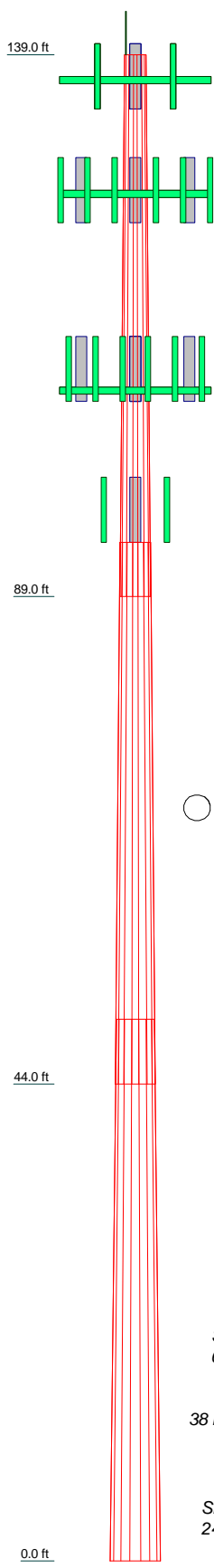

Figure 1—Assumed Coax Layout

Section	1	2	3
Length (ft)	50.00	50.00	50.00
Number of Sides	18	18	18
Thickness (in)	0.2500	0.3125	0.3750
Socket Length (ft)	5.00	6.00	42.6866
Top Dia (in)	24.0000	33.1300	42.6866
Bot Dia (in)	34.7000	44.7000	55.6000
Grade		A572-65	
Weight (K)	3.9	6.5	9.9



DESIGNED APPURTENANCE LOADING

TYPE	ELEVATION	TYPE	ELEVATION
Lightning Rod	139	72" x12" Panel	126.5
12.5' Low Profile Platform	137	72" x12" Panel	126.5
BXA-70063-6CF-2 w/ Mount Pipe	137	72" x12" Panel	126.5
BXA-70063-6CF-2 w/ Mount Pipe	137	KRY 112 144	126.5
BXA-70063-6CF-2 w/ Mount Pipe	137	KRY 112 144	126.5
(2) BXA-171085-12BF w/ Mount Pipe	137	KRY 112 144	126.5
BXA-171085-12BF w/ Mount Pipe	137	13.4' Low Profile Platform	108.3
BXA-171085-12BF w/ Mount Pipe	137	(3) 7700.00 w/Mount Pipe	108.3
BXA-171063/12BF-2 w/ Mount Pipe	137	(3) 7700.00 w/Mount Pipe	108.3
BXA-171063/12BF-2 w/ Mount Pipe	137	(3) 7700.00 w/Mount Pipe	108.3
(2) FD9R6004/2C-3L Diplexer	137	AM-X-CW-16-65-00T-RET w/Mount Pipe	108.3
(2) FD9R6004/2C-3L Diplexer	137	AM-X-CW-16-65-00T-RET w/Mount Pipe	108.3
(2) FD9R6004/2C-3L Diplexer	137	AM-X-CW-16-65-00T-RET w/Mount Pipe	108.3
BXA-70080-6BF w/ Mount Pipe	137	AM-X-CW-16-65-00T-RET w/Mount Pipe	108.3
BXA-70080-6BF w/ Mount Pipe	137	AM-X-CW-16-65-00T-RET w/Mount Pipe	108.3
BXA-70063/4CF w/ Mount Pipe	137	(4) LGP2140X	108.3
RRH2X40-AWS	137	(4) LGP2140X	108.3
RRH2X40-AWS	137	(4) LGP2140X	108.3
RRH2X40-AWS	137	(2) RRUS-11	108.3
DB-T1-6Z-8AB-0Z	137	(2) RRUS-11	108.3
12.5' Low Profile Platform	126.5	(2) RRUS 11	108.3
AIR 21 B2A/B4P w/Mount Pipe	126.5	DC6-48-60-18-8F	108.3
AIR 21 B2A/B4P w/Mount Pipe	126.5	APX18-206517S-C-A20 w/ Mount Pipe	97
AIR 21 B2A/B4P w/Mount Pipe	126.5	APX18-206517S-C-A20 w/ Mount Pipe	97
AIR 21 B4A/B2P w/Mount Pipe	126.5	APX18-206517S-C-A20 w/ Mount Pipe	97
AIR 21 B4A/B2P w/Mount Pipe	126.5		
AIR 21 B4A/B2P w/Mount Pipe	126.5		

MATERIAL STRENGTH

GRADE	Fy	Fu	GRADE	Fy	Fu
A572-65	65 ksi	80 ksi			

TOWER DESIGN NOTES

1. Tower is located in Tolland County, Connecticut.
2. Tower designed for a 85 mph basic wind in accordance with the TIA/EIA-222-F Standard.
3. Tower is also designed for a 38 mph basic wind with 1.00 in ice. Ice is considered to increase in thickness with height.
4. Deflections are based upon a 60 mph wind.
5. TOWER RATING: 65.5%

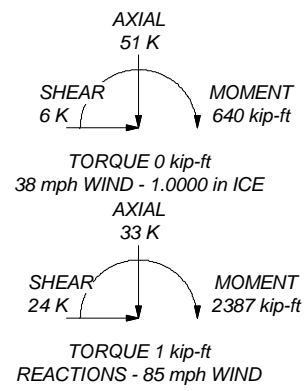

FDH Engineering, Inc.
 6521 Meridian Drive, Suite 107
 Raleigh, North Carolina 27616
 Phone: 9197551012
 FAX: 9197551031

Job: **Bolton 2, CT11558-A-02**
 Project: **146AN71400**
 Client: **SBA Network Services, Inc.** Drawn by: **RSpivey** App'd:
 Code: **TIA/EIA-222-F** Date: **08/20/14** Scale: **NTS**
 Path: Tower Analysis Dwg No. **E-1**

NOTE:
 GENERAL CONTRACTOR TO REFER TO THE STRUCTURAL ANALYSIS BY: FDH ENGINEERING, INC. DATED: AUGUST 20, 2014 AND EQUIPMENT INSTALLATION RECOMMENDATIONS PRIOR TO COMMENCING CONSTRUCTION

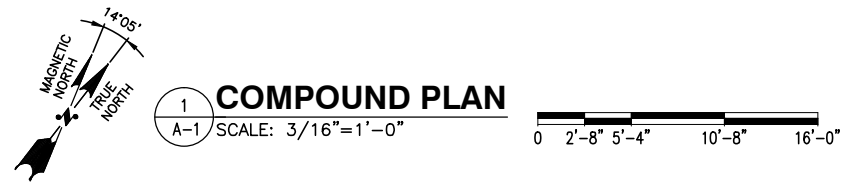
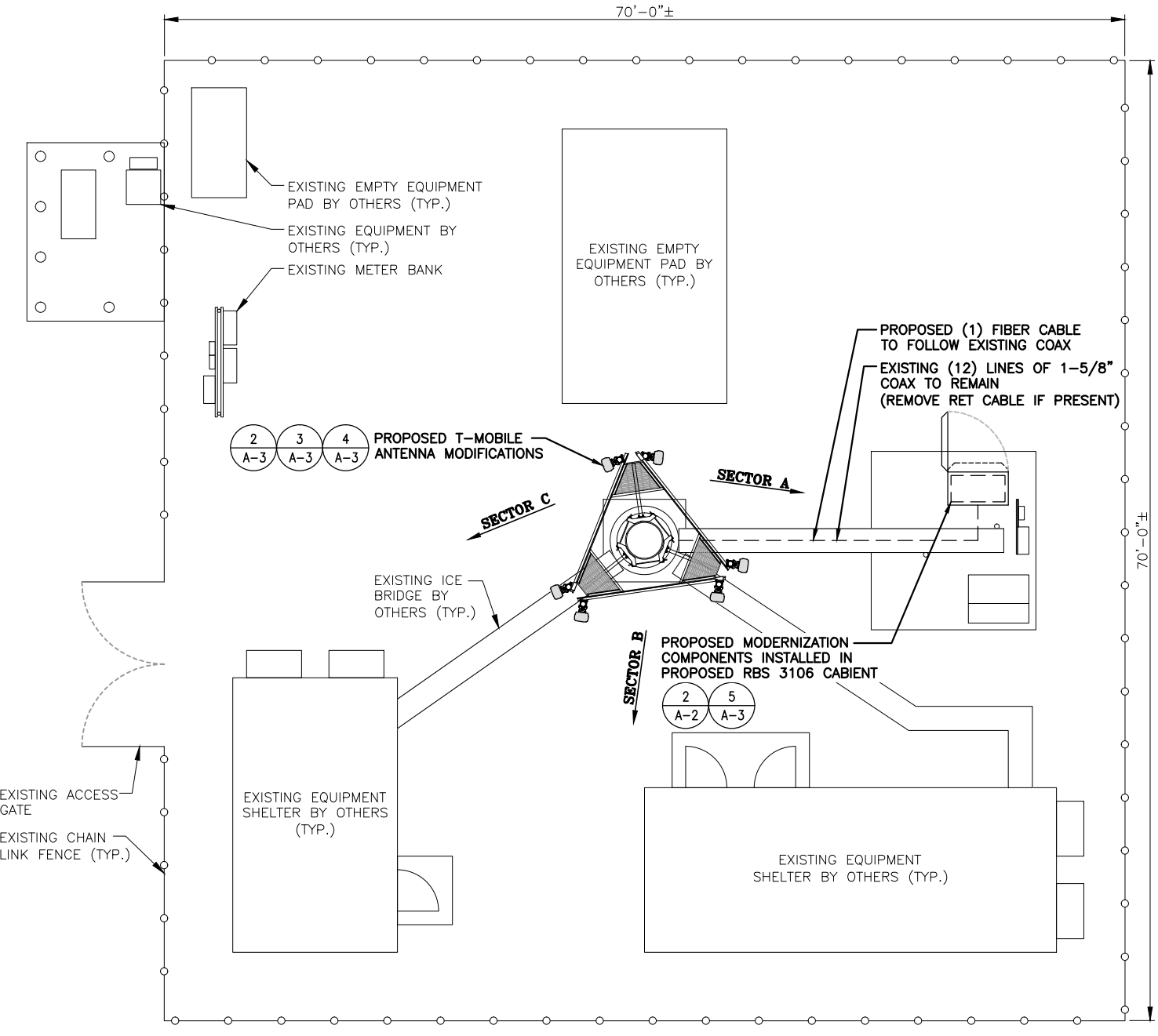

1
 A-1 **COMPOUND PLAN**
 SCALE: 3/16"=1'-0"

1
 A-3 CENTER OF PROPOSED T-MOBILE ANTENNAS
 ELEV. 126.5'± (AGL)

EXISTING GSM/UMTS ANTENNA TO BE REMOVED (TYP. OF 1 PER SECTOR, TOTAL OF 3) AND REPLACED W/ PROPOSED AIR 21 ANTENNAS (TYP. OF 2 PER SECTOR, TOTAL OF 6)

1
 A-3

PROPOSED (1) FIBER CABLE TO FOLLOW EXISTING COAX
 EXISTING (12) LINES OF 1-5/8" COAX TO REMAIN (REMOVE RET CABLE IF PRESENT)

PROPOSED (1) FIBER CABLE TO FOLLOW EXISTING COAX INSIDE MONOPOLE (BUNDLED IN ACCORDANCE WITH SBA PROVIDED STRUCTURAL ANALYSIS)

EXISTING (12) LINES OF 1-5/8" COAX TO REMAIN INSIDE MONOPOLE (REMOVE RET CABLE IF PRESENT)



SOURCE: HDG 08-08-2014

2
 A-1 **PARTIAL ELEVATION PHOTO DETAIL**
 SCALE: N.T.S

T-MOBILE NORTHEAST LLC
 35 GRIFFIN ROAD SOUTH
 BLOOMFIELD, CT 06002
 OFFICE: (860) 648-1116

SBA
 SBA COMMUNICATIONS CORP.
 33 BOSTON POST ROAD W
 MARLBOROUGH, MA 01752
 TEL: (508) 251-1691
 FAX: (508) 251-1755

Hudson Design Group
 1600 OSGOOD STREET
 BUILDING 20 NORTH, SUITE 3090
 N. ANDOVER, MA 01845
 TEL: (978) 557-5553
 FAX: (978) 336-5586

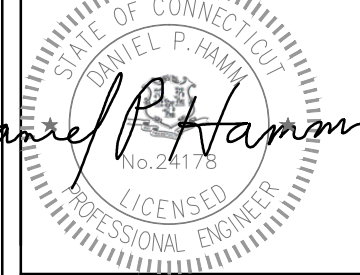

Daniel P. Hamm

APPROVALS

CONSTRUCTION	DATE
RF ENGINEERING	DATE
ZONING/SITE ACQ.	DATE
OPERATIONS	DATE
TOWER OWNER	DATE

PROJECT NO: CTHA076D
 DRAWN BY: MAM
 CHECKED BY: KB

0 08/28/14 ISSUED FOR CONSTRUCTION
SITE NUMBER: CTHA076D
SITE NAME:
BOLTON 2, CT
 12 CARPENTER ROAD
 BOLTON, CT 06043
 TOLLAND COUNTY

SHEET TITLE
 COMPOUND & ELEVATION PLAN

SHEET NUMBER
 A-1

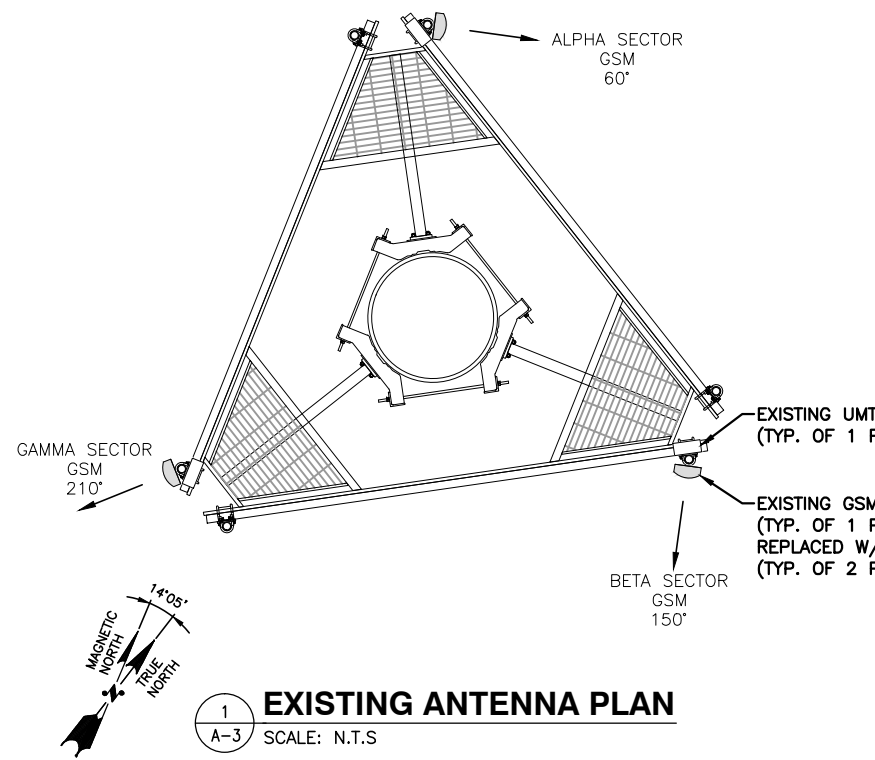

NOTE:
GENERAL CONTRACTOR TO REFER TO THE STRUCTURAL ANALYSIS BY: FDH ENGINEERING, INC. DATED: AUGUST 20, 2014 AND EQUIPMENT INSTALLATION RECOMMENDATIONS PRIOR TO COMMENCING CONSTRUCTION

3
A-3
PROPOSED T-MOBILE AIR 21 ANTENNAS TO REPLACE EXISTING ANTENNAS ON EXISTING MOUNTS (TYP. OF 2 PER SECTOR, TOTAL OF 6) (INSTALL NEW AIR 21 ANTENNAS CENTERED ON THE EXISTING MOUNT)



4
A-3 SCALE: N.T.S.

NOTE:
GENERAL CONTRACTOR TO REFER TO THE STRUCTURAL ANALYSIS BY FDH ENGINEERING, INC. AND EQUIPMENT INSTALLATION RECOMMENDATIONS PRIOR TO COMMENCING CONSTRUCTION

NOTE:
REFER TO THE FINAL RF DATA SHEET FOR FINAL ANTENNA SETTINGS.

EXISTING ANTENNA SCHEDULE

SECTOR	MAKE	MODEL#	SIZE (INCHES)
ALPHA:	RFS	APX16PV_16PVL	55.9x13x3.15
BETA:	RFS	APX16PV_16PVL	55.9x13x3.15
GAMMA:	RFS	APX16PV_16PVL	55.9x13x3.15

PROPOSED ANTENNA SCHEDULE

SECTOR	MAKE	MODEL#	SIZE (INCHES)
ALPHA:	ERICSSON	AIR21 B2A/B4P	56x12x8
	ERICSSON	AIR21 B4A/B2P	56x12x8
BETA:	ERICSSON	AIR21 B2A/B4P	56x12x8
	ERICSSON	AIR21 B4A/B2P	56x12x8
GAMMA:	ERICSSON	AIR21 B2A/B4P	56x12x8
	ERICSSON	AIR21 B4A/B2P	56x12x8

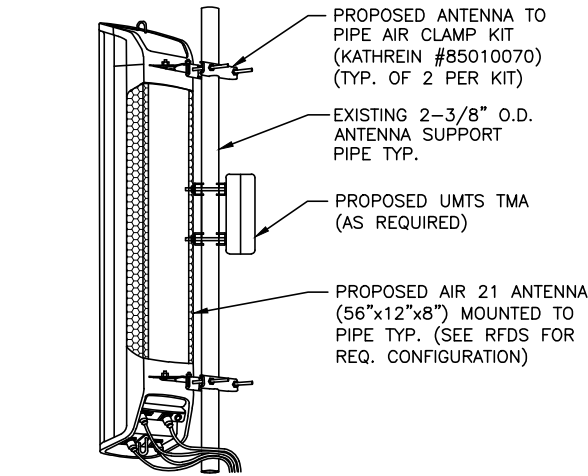
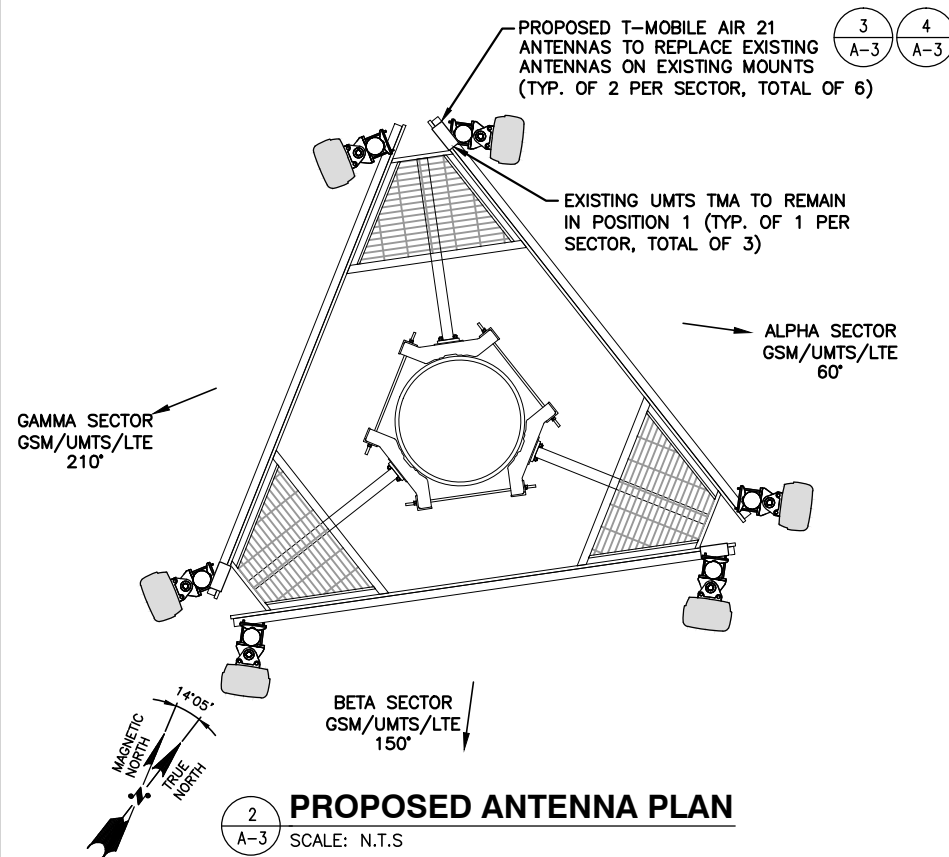

3
A-3 SCALE: N.T.S.

NOTE:
ANCHOR THE BASE PER MANUFACTURERS SPECIFICATIONS & INSTALLATION GUIDELINES

5
A-3 SCALE: N.T.S.

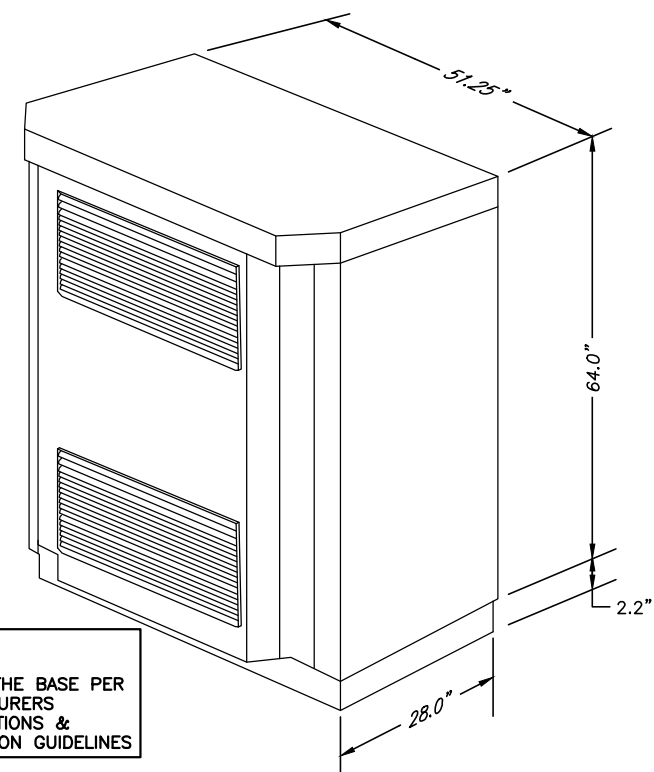

T-MOBILE NORTHEAST LLC
35 GRIFFIN ROAD SOUTH
BLOOMFIELD, CT 06002
OFFICE: (860) 648-1116

SBA
SBA COMMUNICATIONS CORP.
33 BOSTON POST ROAD W
MARLBOROUGH, MA 01752
TEL: (508) 251-1691
FAX: (508) 251-1755

Hudson Design Group
1600 OSGOOD STREET
BUILDING 20 NORTH, SUITE 3090
N. ANDOVER, MA 01854
TEL: (978) 557-5553
FAX: (978) 336-5586

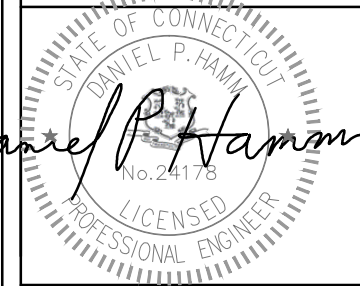

APPROVALS

CONSTRUCTION	DATE
RF ENGINEERING	DATE
ZONING/SITE ACQ.	DATE
OPERATIONS	DATE
TOWER OWNER	DATE
PROJECT NO:	CTHA076D
DRAWN BY:	MAM
CHECKED BY:	KB

0 08/28/14 ISSUED FOR CONSTRUCTION
SITE NUMBER: CTHA076D
SITE NAME: BOLTON 2, CT
12 CARPENTER ROAD
BOLTON, CT 06043
TOLLAND COUNTY

SHEET TITLE
ANTENNA PLAN & DETAILS

SHEET NUMBER
A-3