

280 Trumbull Street
Hartford, CT 06103-3597
Main (860) 275-8200
Fax (860) 275-8299
kbaldwin@rc.com
Direct (860) 275-8345

Also admitted in Massachusetts

January 10, 2014

Melanie A. Bachman
Acting Executive Director
Connecticut Siting Council
10 Franklin Square
New Britain, CT 06051

Re: **Notice of Exempt Modification – Antenna Swap
1021 Blue Hills Avenue, Bloomfield, Connecticut**

Dear Ms. Bachman:

Cellco Partnership d/b/a Verizon Wireless (“Cellco”) currently maintains twelve (12) wireless telecommunications antennas at the 110-foot level on the existing 125-foot tower at the above-referenced address. The tower is owned by SBA. Cellco’s shared use of this tower was approved in 2008. Cellco now intends to replace six (6) of its existing antennas with three (3) model BXA-70063-4CF 850 MHz antennas and three (3) model BXA-171063-12CF 2100 MHz antennas, at the same 110-foot level. Cellco also intends to install three (3) remote radio heads (“RRHs”) behind its 2100 MHz antennas and one (1) HYBRIFLEX™ antenna cable. Included in Attachment 1 are specifications for the replacement antennas, RRHs and HYBRIFLEX™ cable.



Law Offices

BOSTON

PROVIDENCE

HARTFORD

NEW LONDON

STAMFORD

WHITE PLAINS

NEW YORK CITY

ALBANY

SARASOTA

www.rc.com

Please accept this letter as notification pursuant to R.C.S.A. § 16-50j-73, for construction that constitutes an exempt modification pursuant to R.C.S.A. § 16-50j-72(b)(2). In accordance with R.C.S.A. § 16-50j-73, a copy of this letter is being sent to Phillip K. Schenck, Jr., Town Manager for the Town of Bloomfield. A copy of this letter is also being sent to Blue Hills Fire District, the owner of the property at 1021 Blue Hills Avenue.

The planned modifications to the facility fall squarely within those activities explicitly provided for in R.C.S.A. § 16-50j-72(b)(2).

ROBINSON & COLE_{LLP}

Melanie A. Bachman
January 10, 2014
Page 2

1. The proposed modifications will not result in an increase in the height of the existing tower. Cellco's proposed antennas and RRHs will be located at the 110-foot level on the 125-foot tower.
2. The proposed modifications will not involve any change to ground-mounted equipment and, therefore, will not require the extension of the site boundary.
3. The proposed modifications will not increase noise levels at the facility by six decibels or more, or to levels that exceed state and local criteria.
4. The operation of the modified facility will not increase radio frequency (RF) emissions at the facility to a level at or above the Federal Communications Commission (FCC) safety standard. Far Field Approximation tables for each of Cellco's operating frequencies are included behind Attachment 2. The Far Field calculations demonstrate that Cellco's modified facility will operate well within the RF emissions limits established by the FCC.
5. The proposed modifications will not cause a change or alteration in the physical or environmental characteristics of the site.
6. The tower and its foundation can support Cellco's proposed modifications. (*See Structural Analysis included in Attachment 3*).

For the foregoing reasons, Cellco respectfully submits that the proposed modifications to the above-referenced telecommunications facility constitutes an exempt modification under R.C.S.A. § 16-50j-72(b)(2).

Sincerely,



Kenneth C. Baldwin

Enclosures
Copy to:

Phillip K. Schenck, Jr., Bloomfield Town Manager
Blue Hills Fire District
Sandy M. Carter



ATTACHMENT 1

BXA-70063-4CF-EDIN-X

X-Pol | FET Panel | 63° | 13.0 dBd

Replace "X" with desired electrical downtilt.

Antenna is also available with NE connector(s). Replace "EDIN" with "NE" in the model number when ordering.



Electrical Characteristics	696-900 MHz		
Frequency bands	696-806 MHz	806-900 MHz	
Polarization	±45°		
Horizontal beamwidth	65°	63°	
Vertical beamwidth	17°	15°	
Gain	12.5 dBd (14.6 dBi)	13.0 dBd (15.1 dBi)	
Electrical downtilt (X)	0, 2, 3, 4, 5, 6, 8, 9, 10, 12, 14		
Impedance	50Ω		
VSWR	≤1.35:1		
Upper sidelobe suppression (0°)	-16.3 dB	-22.1 dB	
Front-to-back ratio (+/-30°)	-36.1 dB	-34.9 dB	
Null fill	5% (-26.02 dB)		
Isolation between ports	< -30 dB		
Input power with EDIN connectors	500 W		
Input power with NE connectors	300 W		
Lightning protection	Direct Ground		
Connector(s)	2 Ports / EDIN or NE / Female / Center (Back)		
Mechanical Characteristics			
Dimensions Length x Width x Depth	1205 x 285 x 133 mm	47.4 x 11.2 x 5.2 in	
Depth with z-brackets	173 mm	6.8 in	
Weight without mounting brackets	4.5 kg	9.9 lbs	
Survival wind speed	> 201 km/hr	> 125 mph	
Wind area	Front: 0.34 m ² Side: 0.16 m ²	Front: 3.7 ft ² Side: 1.7 ft ²	
Wind load @ 161 km/hr (100 mph)	Front: 498 N Side: 260 N	Front: 111 lbf Side: 55 lbf	
Mounting Options	Part Number	Fits Pipe Diameter	Weight
2-Point Mounting & Downtilt Bracket Kit	36210006	40-115 mm 1.57-4.5 in	4.1 kg 9 lbs
Concealment Configurations	For concealment configurations, order BXA-70063-4CF-EDIN-X-FP		

BXA-70063-4CF-EDIN-X

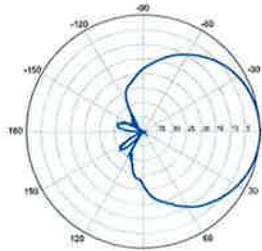

Horizontal | 750 MHz

BXA-70063-4CF-EDIN-0

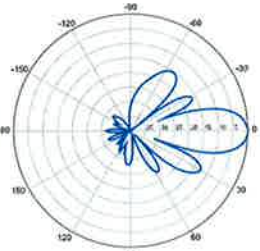

0° | Vertical | 750 MHz

BXA-70063-4CF-EDIN-2

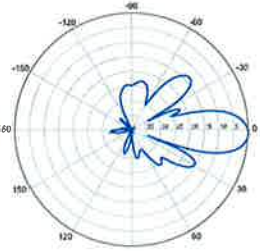

2° | Vertical | 750 MHz

BXA-70063-4CF-EDIN-3



3° | Vertical | 750 MHz

BXA-70063-4CF-EDIN-4

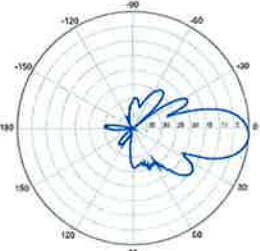

4° | Vertical | 750 MHz

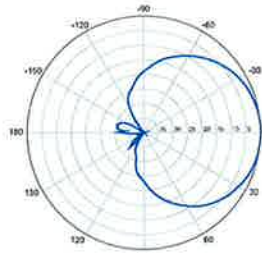

Horizontal | 850 MHz

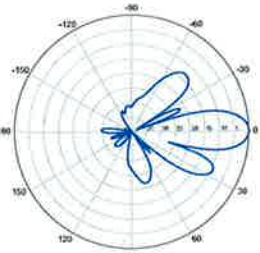

0° | Vertical | 850 MHz

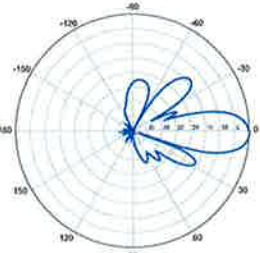

2° | Vertical | 850 MHz



3° | Vertical | 850 MHz

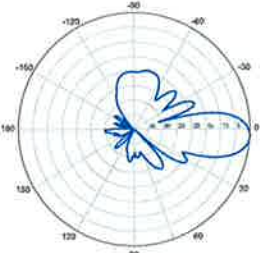

4° | Vertical | 850 MHz

Quoted performance parameters are provided to offer typical or range values only and may vary as a result of normal manufacturing and operational conditions. Extreme operational conditions and/or stress on structural supports is beyond our control. Such conditions may result in damage to this product. Improvements to product may be made without notice.

BXA-70063-4CF-EDIN-X

X-Pol | FET Panel | 63° | 13.0 dBd

BXA-70063-4CF-EDIN-5

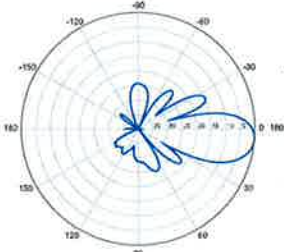

5° | Vertical | 750 MHz

BXA-70063-4CF-EDIN-6

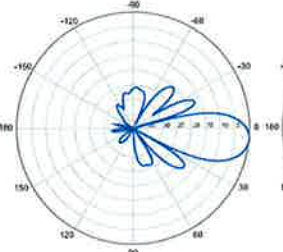

6° | Vertical | 750 MHz

BXA-70063-4CF-EDIN-8

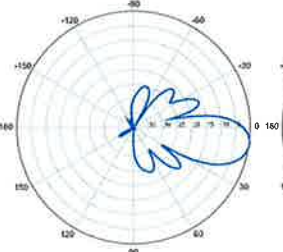

8° | Vertical | 750 MHz

BXA-70063-4CF-EDIN-9

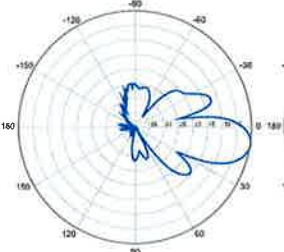

9° | Vertical | 750 MHz

BXA-70063-4CF-EDIN-10

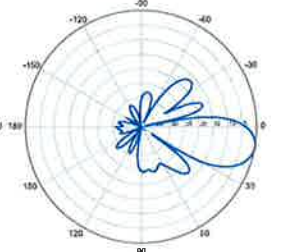

10° | Vertical | 750 MHz

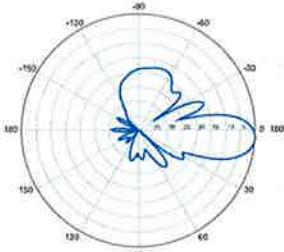

5° | Vertical | 850 MHz

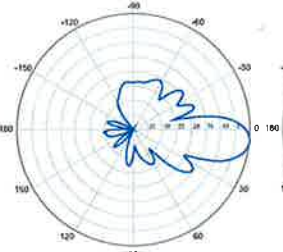

6° | Vertical | 850 MHz

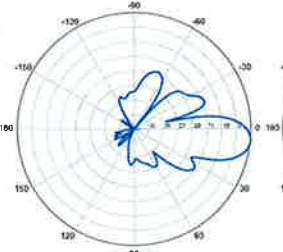

8° | Vertical | 850 MHz

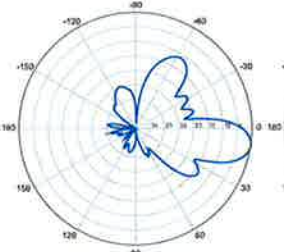

9° | Vertical | 850 MHz

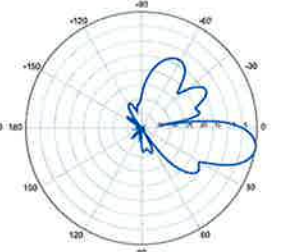

10° | Vertical | 850 MHz

BXA-70063-4CF-EDIN-12

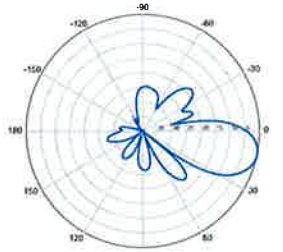

12° | Vertical | 750 MHz

BXA-70063-4CF-EDIN-14

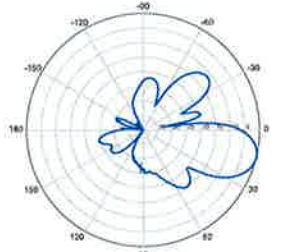

14° | Vertical | 750 MHz

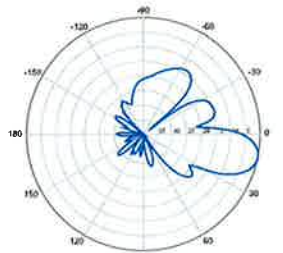

12° | Vertical | 850 MHz

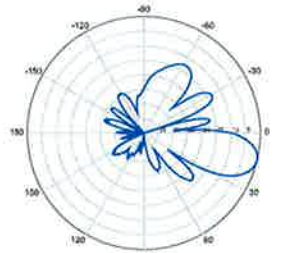

14° | Vertical | 850 MHz

Quoted performance parameters are provided to offer typical or range values only and may vary as a result of normal manufacturing and operational conditions. Extreme operational conditions and/or stress on structural supports is beyond our control. Such conditions may result in damage to this product. Improvements to product may be made without notice.

BXA-171063-12CF-EDIN-X

X-Pol | FET Panel | 63° | 19.0 dBi

Replace 'X' with desired electrical downtilt.

Antenna is also available with NE connector(s). Replace 'EDIN' with 'NE' in the model number when ordering.



Electrical Characteristics	1710-2170 MHz			
Frequency bands	1710-1880 MHz	1850-1990 MHz	1920-2170 MHz	
Polarization	±45°	±45°	±45°	
Horizontal beamwidth	68°	65°	60°	
Vertical beamwidth	4.5°	4.5°	4.5°	
Gain	16.1 dBd / 18.2 dBi	16.5 dBd / 18.6 dBi	16.9 dBd / 19.0 dBi	
Electrical downtilt (X)	0, 2, 5			
Impedance	50Ω			
VSWR	≤1.5:1			
First upper sidelobe	< -17 dB			
Front-to-back ratio	> 30 dB			
In-band isolation	< -25 dB			
IM3 (20W carrier)	< -150 dBc			
Input power	300 W			
Lightning protection	Direct Ground			
Connector(s)	2 Ports / EDIN or NE / Female / Center (Back)			
Operating temperature	-40° to +60° C / -40° to +140° F			
Mechanical Characteristics				
Dimensions Length x Width x Depth	1842 x 154 x 105 mm	72.5 x 6.1 x 4.1 in		
Depth with z-brackets	133 mm	5.2 in		
Weight without mounting brackets	5.8 kg	12.8 lbs		
Survival wind speed	> 201 km/hr		> 125 mph	
Wind area	Front: 0.28 m ² Side: 0.19 m ²	Front: 3.1 ft ² Side: 2.1 ft ²		
Wind load @ 161 km/hr (100 mph)	Front: 460 N Side: 304 N	Front: 103 lbf Side: 68 lbf		
Mounting Options	Part Number	Fits Pipe Diameter		Weight
2-Point Mounting Bracket Kit	26799997	50-102 mm	2.0-4.0 in	2.3 kg 5 lbs
2-Point Mounting & Downtilt Bracket Kit	26799999	50-102 mm	2.0-4.0 in	3.6 kg 8 lbs
Concealment Configurations	For concealment configurations, order BXA-171063-12CF-EDIN-X-FP			

BXA-171063-12CF-EDIN-X

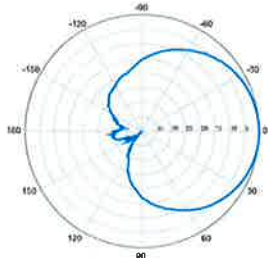

Horizontal | 1710-1880 MHz
BXA-171063-12CF-EDIN-0

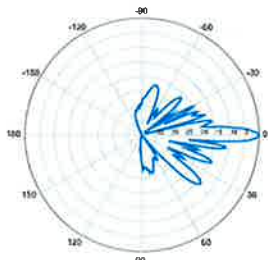

0° | Vertical | 1710-1880 MHz

BXA-171063-12CF-EDIN-X

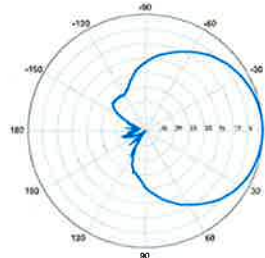

Horizontal | 1850-1990 MHz
BXA-171063-12CF-EDIN-0

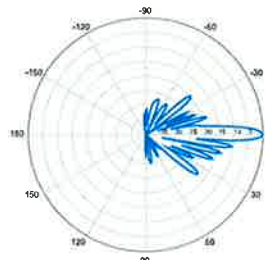

0° | Vertical | 1850-1990 MHz

BXA-171063-12CF-EDIN-X

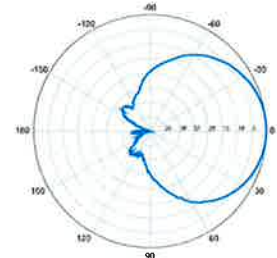

Horizontal | 1920-2170 MHz
BXA-171063-12CF-EDIN-0

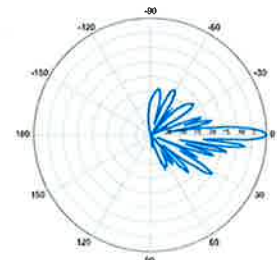

0° | Vertical | 1920-2170 MHz

Quoted performance parameters are provided to offer typical or range values only and may vary as a result of normal manufacturing and operational conditions. Extreme operational conditions and/or stress on structural supports is beyond our control. Such conditions may result in damage to this product. Improvements to product may be made without notice.

BXA-171063-12CF-EDIN-X

X-Pol | FET Panel | 63° | 19.0 dBi

BXA-171063-12CF-EDIN-2

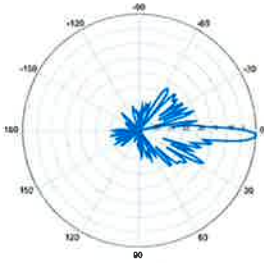

2° | Vertical | 1710-1880 MHz

BXA-171063-12CF-EDIN-5

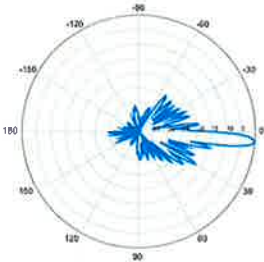

5° | Vertical | 1710-1880 MHz

BXA-171063-12CF-EDIN-2

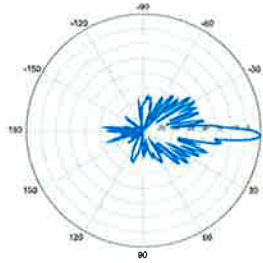

2° | Vertical | 1850-1990 MHz

BXA-171063-12CF-EDIN-5

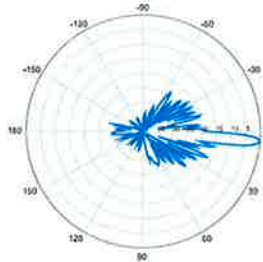

5° | Vertical | 1850-1990 MHz

BXA-171063-12CF-EDIN-2

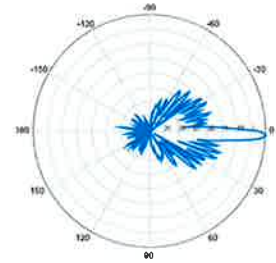

2° | Vertical | 1920-2170 MHz

BXA-171063-12CF-EDIN-5

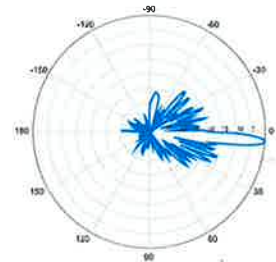

5° | Vertical | 1920-2170 MHz

Quoted performance parameters are provided to offer typical or range values only and may vary as a result of normal manufacturing and operational conditions. Extreme operational conditions and/or stress on structural supports is beyond our control. Such conditions may result in damage to this product. Improvements to product may be made without notice.

Alcatel-Lucent RRH2x40-AWS

REMOTE RADIO HEAD

The Alcatel-Lucent RRH2x40-AWS is a high-power, small form-factor Remote Radio Head (RRH) operating in the AWS frequency band (1700/2100MHz - 3GPP Band 4). The Alcatel-Lucent RRH2x40-AWS is designed with an eco-efficient approach, providing operators with the means to achieve high quality and capacity coverage with minimum site requirements.

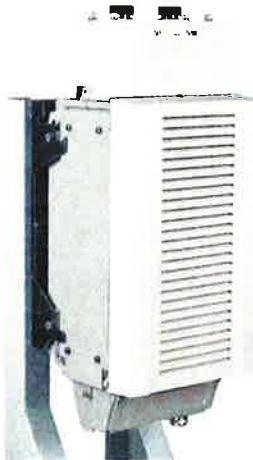

A distributed eNodeB expands deployment options by using two components, a Base Band Unit (BBU) containing the digital assets and a separate RRH containing the radio-frequency (RF) elements. This modular design optimizes available space and allows the main components of an eNodeB to be installed separately, within the same site or several kilometres apart.

The Alcatel-Lucent RRH2x40-AWS is linked to the BBU by an optical-fiber connection carrying downlink and uplink digital radio signals along with operations, administration and maintenance (OA&M) information. The Alcatel-Lucent RRH2x40-AWS has two transmit RF paths, 40 W RF output power per transmit path, and is designed to manage up to four-way receive diversity. The device is ideally suited to support macro coverage, with multiple-input multiple-output (MIMO) 2x2 operation in up to 20 MHz of bandwidth.

The Alcatel-Lucent RRH2x40-AWS is designed to make available all the benefits of a distributed eNodeB, with excellent RF characteristics, with low

capital expenditures (CAPEX) and low operating expenditures (OPEX). The limited space available in some sites may prevent the installation of traditional single-cabinet BTS equipment or require costly cranes to be employed, leaving coverage holes. However, many of these sites can host an Alcatel-Lucent RRH2x40-AWS installation, providing more flexible site selection and improved network quality along with greatly reduced installation time and costs.

Fast, low-cost installation and deployment

The Alcatel-Lucent RRH2x40-AWS is a zero-footprint solution and operates noise-free, simplifying negotiations with site property owners and minimizing environmental impacts. Installation can easily be done by a single person because the Alcatel-Lucent RRH2x40-AWS is compact and weighs less than 20 kg (44 lb), eliminating the need for a crane to hoist the BTS cabinet to the rooftop. A site can be in operation in less than one day — a fraction of the time required for a traditional BTS.

Excellent RF performance

Because of its small size and weight, the Alcatel-Lucent RRH2x40-AWS can be installed close to the antenna. Operators can therefore locate the Alcatel-Lucent RRH2x40-AWS where RF engineering is deemed ideal, minimizing trade-offs between available sites and RF optimum sites. The RF feeder cost and installation costs are reduced or eliminated, and there is no need for a Tower Mounted Amplifier (TMA) because losses introduced by the RF feeder are greatly reduced. The Alcatel-Lucent RRH2x40-AWS provides more RF power while at the same time consuming less electricity.

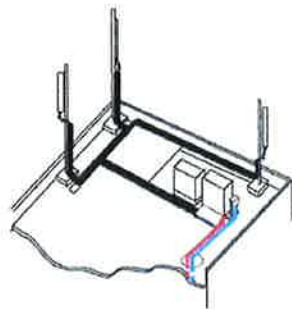

Macro

Features

- Zero-footprint deployment
- Easy installation, with a lightweight unit can be carried and set up by one person
- Optimized RF power, with flexible site selection and elimination of a TMA
- Convection-cooled (fanless)
- Noise-free
- Best-in-class power efficiency, with significantly reduced energy consumption

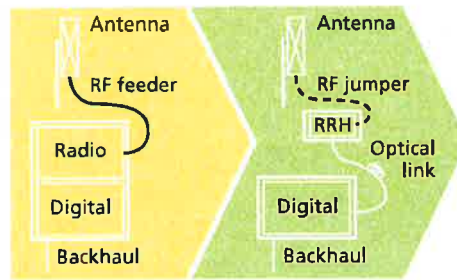

RRH for space-constrained cell sites

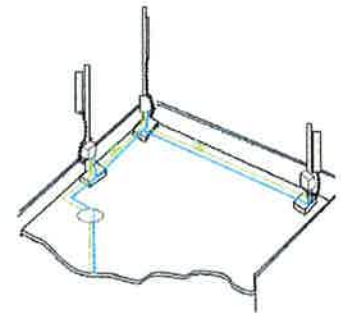

Distributed

Benefits

- Leverages existing real estate with lower site costs
- Reduces installation costs, with fewer installation materials and simplified logistics
- Decreases power costs and minimizes environmental impacts, with the potential for eco-sustainable power options
- Improves RF performance and adds flexibility to network planning

Technical specifications

Physical dimensions

- Height: 620 mm (24.4 in.)
- Width: 270 mm (10.63 in.)
- Depth: 170mm (6.7 in.)
- Weight (without mounting kit): less than 20 kg (44 lb)

Power

- Power supply: -48VDC

Operating environment

- Outdoor temperature range:
 - With solar load: -40°C to +50°C (-40°F to +122°F)
 - Without solar load: -40°C to +55°C (-40°F to +131°F)

- Passive convection cooling (no fans)
- Enclosure protection
 - IP65 (International Protection rating)

RF characteristics

- Frequency band: 1700/2100 MHz (AWS); 3GPP Band 4
- Bandwidth: up to 20 MHz
- RF output power at antenna port: 40 W nominal RF power for each Tx port
- Rx diversity: 2-way or 4-way with optional Rx Diversity module
- Noise figure: below 2.0 dB typical
- Antenna Line Device features
 - TMA and Remote electrical tilt (RET) support via AISG v2.0

Optical characteristics

Type/number of fibers

- Single-mode variant
 - One Single Mode Single Fiber per RRH2x, carrying UL and DL using CWDM
 - Single mode dual fiber (SM/DF)
- Multi-mode variant
 - Two Multi-mode fibers per RRH2x: one carrying UL, the other carrying DL

Optical fiber length

- Up to 500 m (0.31 mi), using MM fiber
- Up to 20 km (12.43 mi), using SM fiber

Digital Ports and Alarms

- Two optical ports to support daisy-chaining
- Six external alarms

www.alcatel-lucent.com Alcatel, Lucent, Alcatel-Lucent and the Alcatel-Lucent logo are trademarks of Alcatel-Lucent. All other trademarks are the property of their respective owners. The information presented is subject to change without notice. Alcatel-Lucent assumes no responsibility for inaccuracies contained herein. Copyright © 2010 Alcatel-Lucent. All rights reserved. CPG2809100912 (09)



HYBRIFLEX™ RRH Hybrid Feeder Cabling Solution, 1-5/8", Single-Mode Fiber

Product Description

RFS' HYBRIFLEX Remote Radio Head (RRH) hybrid feeder cabling solution combines optical fiber and DC power for RRHs in a single lightweight aluminum corrugated cable, making it the world's most innovative solution for RRH deployments.

It was developed to reduce installation complexity and costs at Cellular sites. HYBRIFLEX allows mobile operators deploying an RRH architecture to standardize the RRH installation process and eliminate the need for and cost of cable grounding. HYBRIFLEX combines optical fiber (multi-mode or single-mode) and power in a single corrugated cable. It eliminates the need for junction boxes and can connect multiple RRHs with a single feeder. Standard RFS CELLFLEX® accessories can be used with HYBRIFLEX cable. Both pre-connected and on-site options are available.

Features/Benefits

- Aluminum corrugated armor with outstanding bending characteristics - minimizes installation time and enables mechanical protection and shielding
- Same accessories as 1 5/8" coaxial cable
- Outer conductor grounding - Eliminates typical grounding requirements and saves on installation costs
- Lightweight solution and compact design - Decreases tower loading
- Robust cabling - Eliminates need for expensive cable trays and ducts
- Installation of tight bundled fiber optic cable pairs directly to the RRH - Reduces CAPEX and wind load by eliminating need for interconnection
- Optical fiber and power cables housed in single corrugated cable - Saves CAPEX by standardizing RRH cable installation and reducing installation requirements
- Outdoor polyethylene jacket - Ensures long-lasting cable protection



Figure 1: HYBRIFLEX Series

Technical Specifications

Outer Conductor Armor	Corrugated Aluminum	[mm (in.)]	46.5 (1.83)
Jacket	Polyethylene, PE	[mm (in.)]	50.3 (1.98)
UV-Protection	Individual and External Jacket		Yes
Physical Properties			
Weight, Approximate		[kg/m (lb/ft)]	1.9 (1.30)
Minimum Bending Radius, Single Bending		[mm (in.)]	200 (8)
Minimum Bending Radius, Repeated Bending		[mm (in.)]	500 (20)
Recommended/Maximum Clamp Spacing		[m (ft)]	1.0 / 1.2 (3.25 / 4.0)
Electrical Properties			
DC-Resistance Outer Conductor Armor		[Ω/km (Ω/1000ft)]	0.68 (0.205)
DC-Resistance Power Cable, 8 4mm ² (18AWG)		[Ω/km (Ω/1000ft)]	2.1 (0.307)
Optical Properties			
Version			Single-mode OM3
Quantity, Fiber Count			16 (8 pairs)
Core/Clad		[μm]	50/125
Primary Coating (Acrylate)		[μm]	245
Buffer Diameter, Nominal		[μm]	900
Secondary Protection, Jacket, Nominal		[mm (in.)]	2.0 (0.08)
Minimum Bending Radius		[mm (in.)]	104 (4.1)
Insertion Loss @ wavelength 850nm		dB/km	3.0
Insertion Loss @ wavelength 1310nm		dB/km	1.0
Standards (Meets or exceeds)			UL94-V0, UL1666 RoHS Compliant
Power Properties			
Size (Power)		[mm (AWG)]	8 4 (8)
Quantity, Wire Count (Power)			16 (8 pairs)
Size (Alarm)		[mm (AWG)]	0 8 (18)
Quantity, Wire Count (Alarm)			4 (2 pairs)
Type			UV protected
Strands			19
Primary Jacket Diameter, Nominal		[mm (in.)]	6.8 (0.27)
Standards (Meets or exceeds)			NFPA 130, ICEA S-95-658 UL Type XH-HV-2, UL 44 UL-LS Limited Smoke, UL VW-1 IEEE-383 (1974), IEEE1202/FT4 RoHS Compliant
Environmental Properties			
Installation Temperature		[°C (°F)]	-40 to +65 (-40 to 149)
Operation Temperature		[°C (°F)]	-40 to +65 (-40 to 149)

* This data is provisional and subject to change

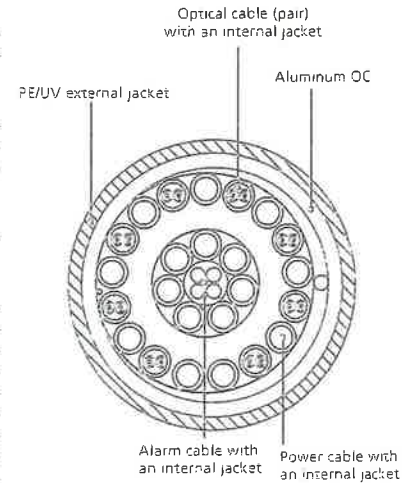

Figure 2: Construction Detail

All information contained in the present datasheet is subject to confirmation at time of ordering

ATTACHMENT 2

Far Field Approximation
with downtilt variation

Estimated Radiated Emission
Single Emitter Far Field Model
Dipole / Wire/ Yagi Antenna Types



Location:	COTTAGE GROVE, CT
Site #:	
Date:	01/09/14
Name:	Mark Brauer
File Name:	Cottage Grove, CT - FF Power
Operating Freq. (MHz)	869.0
Antenna Height (ft):	110.0
Antenna Gain (dBi):	15.2
Antenna Size (in.):	48.0
Downtilt (degrees):	0.0
Feedline Loss (dB):	0.0
Power @ J4 (w):	3685.0

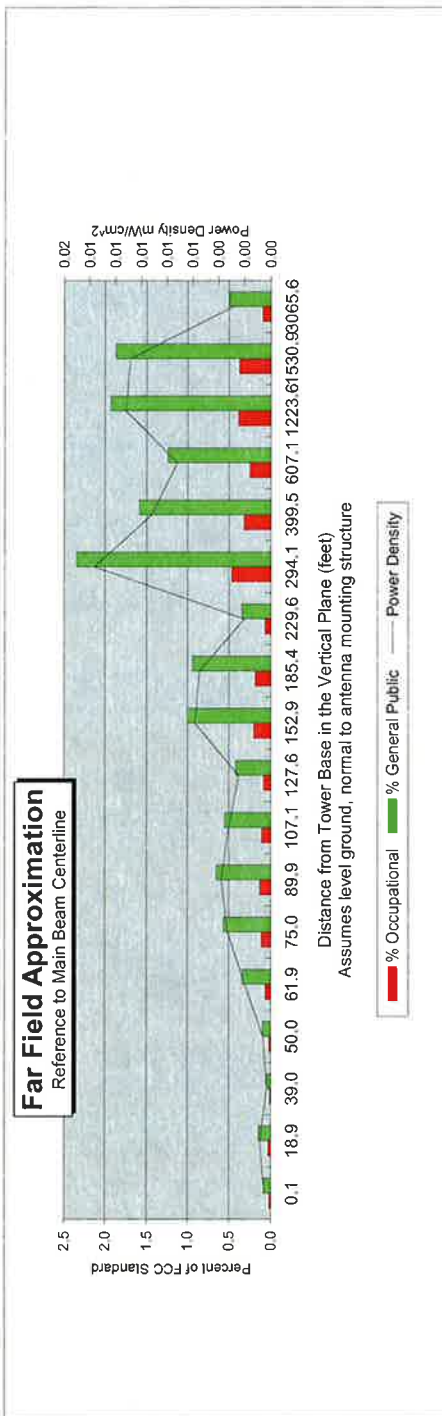

	90.0	80.0	70.0	65.0	60.0	55.0	50.0	45.0	40.0	35.0	30.0	25.0	20.0	15.0	10.0	5.0	4.0	2.0
Calc Angle	107.0	108.7	113.9	118.1	123.6	130.7	139.7	151.4	166.5	186.6	214.1	253.3	313.0	413.6	616.5	1228.3	1534.7	3067.5
Solve for r, dx to antenna	0.1	18.9	39.0	50.0	61.9	75.0	89.9	107.1	127.6	152.9	185.4	229.6	294.1	399.5	607.1	1223.6	1530.9	3065.6
Distance from Antenna Structure Base in Horizontal plane	90	80	70	65	60	55	50	45	40	35	30	25	20	15	10	5	4	2
Angle from Main Beam (reference to horizontal plane)	36.76	34.35	38.52	35.34	29.54	26.8	25.59	25.63	25.99	21.21	20.29	23.24	13.03	12.3	9.92	2	0.2	0
dB down from centerline (referenced to centerline)	2.56	2.56	2.56	2.56	2.56	2.56	2.56	2.56	2.56	2.56	2.56	2.56	2.56	2.56	2.56	2.56	2.56	2.56
Reflection Coefficient (1 to 4, 2.56 typical)	0.00	0.00	0.00	0.00	0.00	0.00	0.00	0.00	0.00	0.01	0.01	0.01	0.01	0.01	0.01	0.01	0.01	0.00
Power Density (mW/cm²)	0.0	0.0	0.0	0.0	0.1	0.1	0.1	0.1	0.1	0.2	0.2	0.1	0.5	0.3	0.2	0.4	0.4	0.1
Percent of Occupational Standard	0.1	0.1	0.1	0.1	0.3	0.6	0.7	0.6	0.4	1.0	0.9	0.3	2.3	1.6	1.2	1.9	1.9	0.5
Percent of General Population Standard																		

Antenna Type BXA-70063-4CF
Max% 2.35%

Instructions:

- 1) Fill in Site Location, Site number, Date, Name of Person Responsible for Date, and enter File Name to be saved as.
- 2) References to J4 refer to a point where the transmission line exits the equipment shelter and proceeds to the antenna(s). There is typically a connector located here where power measurements are made.
- 3) Enter Antenna Height (in feet to bottom of antenna), Antenna Gain (expressed as dBi, add 2.17 to dBd to obtain dBi), Antenna Size (vertical size in inches), Downtilt (in Degrees, enter zero if none), Feedline loss from J4 to Antenna, and J4 Po
- 4) From manufacturer's plots, or data sheet, input Angle from mainbeam and dB below mainbeam centerline.
- 5) Enter Reflection coefficient (2.56 would be typical, 1 for free space)
- 6) Spreadsheet calculates actual power density, then relates as Occupational or General Population percentage of FCC Standard.
- 7) An odd distance may be entered in the rightmost column of the lower table.

Far Field Approximation
with downtilt variation

Estimated Radiated Emission
Single Emitter Far Field Model
Dipole / Wire/ Yagi Antenna Types



Location:	COTTAGE GROVE, CT
Site #:	
Date:	01/09/14
Name:	Mark Brauer
File Name:	Cottage Grove, CT - FF Power

Operating Freq. (MHz)	1945.0
Antenna Height (ft):	110.0
Antenna Gain (dBi):	16.1
Antenna Size (in.):	48.0
Downtilt (degrees):	0.0
Feedline Loss (dB):	0.0
Power @ J4 (w):	4935.0

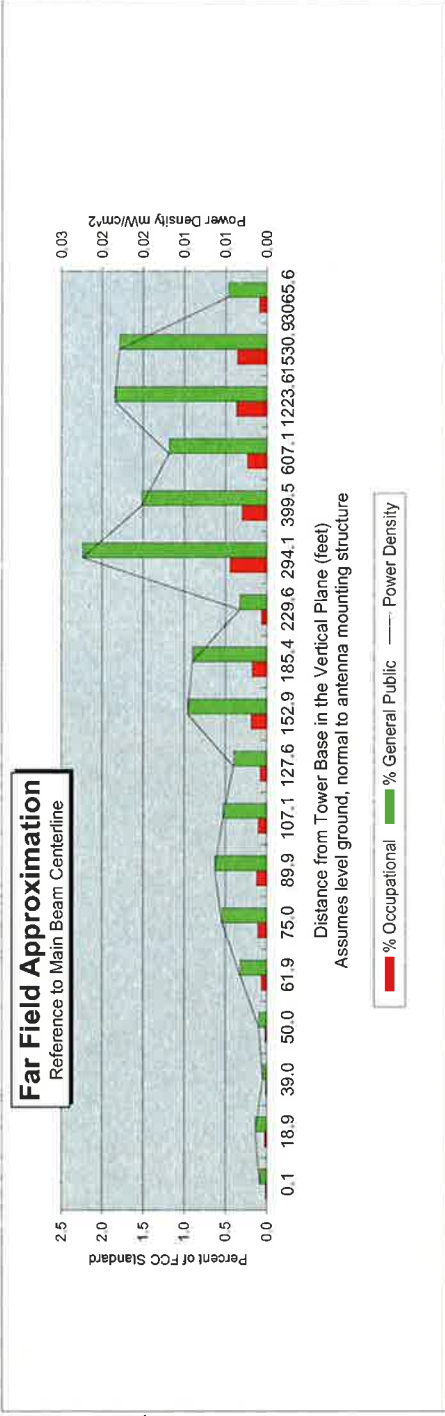

Calc Angle	90.0	80.0	70.0	65.0	60.0	55.0	50.0	45.0	40.0	35.0	30.0	25.0	20.0	15.0	10.0	5.0	4.0	2.0
Solve for r, dx to antenna	107.0	108.7	113.9	118.1	123.6	130.7	139.7	151.4	166.5	186.6	214.1	253.3	313.0	413.6	616.5	1228.3	1534.7	3067.5
Distance from Antenna Structure Base in Horizontal plane	0.1	18.9	39.0	50.0	61.9	75.0	89.9	107.1	127.6	152.9	185.4	229.6	294.1	399.5	607.1	1223.6	1530.9	3065.6
Angle from Main Beam (reference to horizontal plane)	90	80	70	65	60	55	50	45	40	35	30	25	20	15	10	5	4	2
dB down from centerline (referenced to centerline)	36.76	34.35	38.52	35.34	29.54	26.8	25.59	25.63	25.99	21.21	20.29	23.24	13.03	12.3	9.92	2	0.2	0
Reflection Coefficient (1 to 4, 2.56 typical)	2.56	2.56	2.56	2.56	2.56	2.56	2.56	2.56	2.56	2.56	2.56	2.56	2.56	2.56	2.56	2.56	2.56	2.56
Power Density (mW/cm^2)	0.00	0.00	0.00	0.00	0.00	0.01	0.01	0.01	0.00	0.01	0.01	0.00	0.02	0.02	0.01	0.02	0.02	0.00
Percent of Occupational Standard	0.0	0.0	0.0	0.0	0.1	0.1	0.1	0.1	0.1	0.2	0.2	0.1	0.4	0.3	0.2	0.4	0.4	0.1
Percent of General Population Standard	0.1	0.1	0.0	0.1	0.3	0.5	0.6	0.5	0.4	1.0	0.9	0.3	2.2	1.5	1.2	1.8	1.8	0.5

Antenna Type BXA-171063-8BF
Max% 2.24%

Instructions:

- 1) Fill in Site Location, Site number, Date, Name of Person Responsible for Date, and enter File Name to be saved as.
- 2) References to J4 refer to a point where the transmission line exits the equipment shelter and proceeds to the antenna(s). There is typically a connector located here where power measurements are made.
- 3) Enter Antenna Height (in feet to bottom of antenna), Antenna Gain (expressed as dBi, add 2.17 to dBd to obtain dBi), Antenna Size (vertical size in inches), Downtilt (in Degrees, enter zero if none), Feedline loss from J4 to Antenna, and J4 Po
- 4) From manufacturer's plots, or data sheet, input Angle from mainbeam and dB below mainbeam centerline.
- 5) Enter Reflection coefficient (2.56 would be typical, 1 for free space)
- 6) Spreadsheet calculates actual power density, then relates as Occupational or General Population percentage of FCC Standard.
- 7) An odd distance may be entered in the rightmost column of the lower table.

Far Field Approximation
with downtilt variation

Estimated Radiated Emission
Single Emmitter Far Field Model
Dipole / Wire/ Yagi Antenna Types



Location:	COTTAGE GROVE, CT
Site #:	
Date:	01/09/14
Name:	Mark Brauer
File Name:	Cottage Grove, CT - FF Power

Operating Freq. (MHz)	746.0
Antenna Height (ft)	110.0
Antenna Gain (dBi)	16.2
Antenna Size (in.)	52.0
Downtilt (degrees)	0.0
Feedline Loss (dB)	0.0
Power @ J4 (w)	1050.0

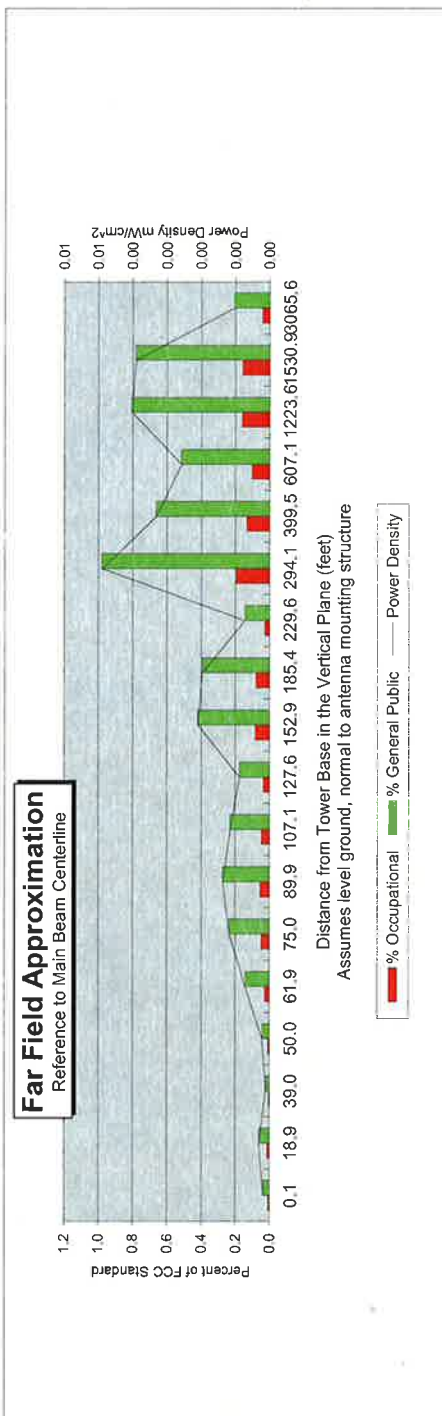

Calc Angle	90.0	80.0	70.0	65.0	60.0	55.0	50.0	45.0	40.0	35.0	30.0	25.0	20.0	15.0	10.0	5.0	4.0	2.0
Solve for r, dx to antenna	107.0	108.7	113.9	118.1	123.6	130.7	139.7	151.4	166.5	186.6	214.1	253.3	313.0	413.6	616.5	1228.3	1534.7	3067.5
Distance from Antenna Structure Base in Horizontal plane	0.1	18.9	39.0	50.0	61.9	75.0	89.9	107.1	127.6	152.9	185.4	229.6	294.1	399.5	607.1	1223.6	1530.9	3065.6
Angle from Main Beam (reference to horizontal plane)	90	80	70	65	60	55	50	45	40	35	30	25	20	15	10	5	4	2
dB down from centerline (referenced to centerline)	36.76	34.35	38.52	35.34	29.54	26.8	25.59	25.63	25.99	21.21	20.29	23.24	13.03	12.3	9.92	2	0.2	0
Reflection Coefficient (1 to 4, 2.56 typical)	2.56	2.56	2.56	2.56	2.56	2.56	2.56	2.56	2.56	2.56	2.56	2.56	2.56	2.56	2.56	2.56	2.56	2.56
Power Density (mW/cm ²)	0.00	0.00	0.00	0.00	0.00	0.00	0.00	0.00	0.00	0.00	0.00	0.00	0.00	0.00	0.00	0.00	0.00	0.00
Percent of Occupational Standard	0.0	0.0	0.0	0.0	0.0	0.0	0.1	0.0	0.0	0.1	0.1	0.0	0.2	0.1	0.1	0.2	0.2	0.0
Percent of General Population Standard	0.0	0.1	0.0	0.0	0.1	0.2	0.3	0.2	0.2	0.4	0.4	0.1	1.0	0.7	0.5	0.8	0.8	0.2

Antenna Type: SLCP 2X6014
Max%: 0.98%

Instructions:

- 1) Fill in Site Location, Site number, Date, Name of Person Responsible for Date, and enter File Name to be saved as.
- 2) References to J4 refer to a point where the transmission line exits the equipment shelter and proceeds to the antenna(s). There is typically a connector located here where power measurements are made.
- 3) Enter Antenna Height (in feet to bottom of antenna), Antenna Gain (expressed as dBi, add 2.17 to dBd to obtain dBi), Antenna Size (vertical size in inches), Downtilt (in Degrees, enter zero if none), Feedline loss from J4 to Antenna, and J4 Po
- 4) From manufacturer's plots, or data sheet, input Angle from mainbeam and dB below mainbeam centerline.
- 5) Enter Reflection coefficient (2.56 would be typical, 1 for free space)
- 6) Spreadsheet calculates actual power density, then relates as Occupational or General Population percentage of FCC Standard.
- 7) An odd distance may be entered in the rightmost column of the lower table.

Far Field Approximation
with downtilt variation

Estimated Radiated Emission

Single Emitter Far Field Model

Dipole / Wire/ Yagi Antenna Types



Location:	COTTAGE GROVE, CT
Site #:	
Date:	01/09/14
Name:	Mark Brauer
File Name:	Cottage Grove, CT - FF Power

Operating Freq. (MHz)	2145.0
Antenna Height (ft)	110.0
Antenna Gain (dBi)	19.1
Antenna Size (in.)	72.0
Downtilt (degrees)	0.0
Feedline Loss (dB)	0.0
Power @ J4 (w)	1750.0

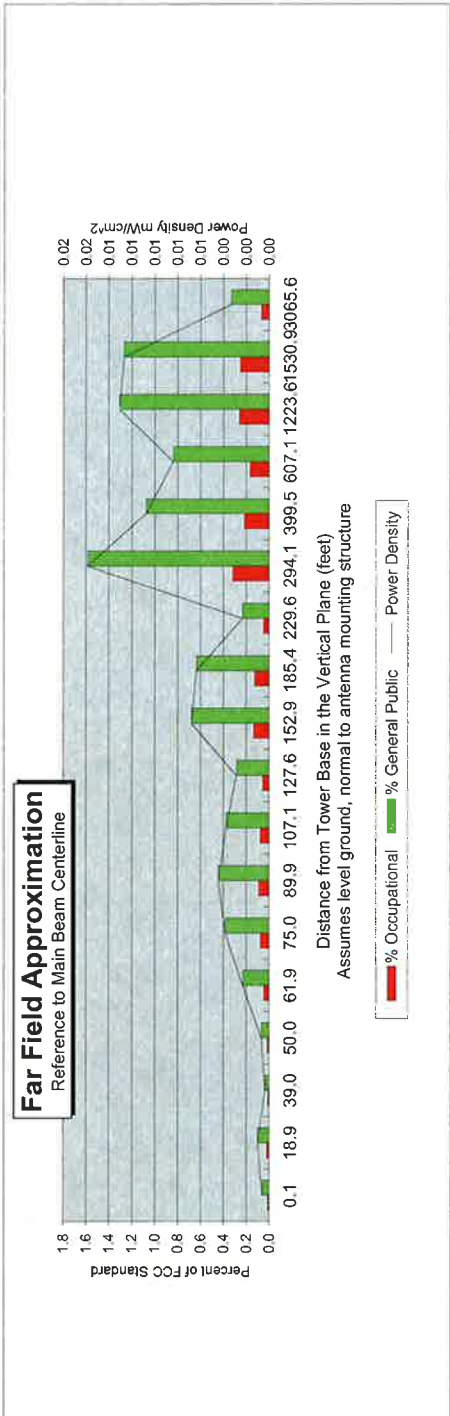

Calc Angle	90.0	80.0	70.0	60.0	55.0	50.0	45.0	40.0	35.0	30.0	25.0	20.0	15.0	10.0	5.0	4.0	2.0	
Solve for r, dx to antenna	107.0	108.7	113.9	118.1	123.6	130.7	139.7	151.4	166.5	186.6	214.1	253.3	313.0	413.6	616.5	1228.3	1534.7	3067.5
Distance from Antenna Structure Base in Horizontal plane	0.1	18.9	39.0	50.0	61.9	75.0	89.9	107.1	127.6	152.9	185.4	229.6	294.1	399.5	607.1	1223.6	1530.9	3065.6
Angle from Main Beam (reference to horizontal plane)	90	80	70	65	60	55	50	45	40	35	30	25	20	15	10	5	4	2
dB down from centerline (referenced to centerline)	36.76	34.35	38.52	35.34	29.54	26.8	25.59	25.63	25.99	21.21	20.29	23.24	13.03	12.3	9.92	2	0.2	0
Reflection Coefficient (1 to 4, 2.56 typical)	2.56	2.56	2.56	2.56	2.56	2.56	2.56	2.56	2.56	2.56	2.56	2.56	2.56	2.56	2.56	2.56	2.56	2.56
Power Density (mW/cm²)	0.00	0.00	0.00	0.00	0.00	0.00	0.00	0.00	0.00	0.01	0.01	0.00	0.02	0.01	0.01	0.01	0.01	0.00
Percent of Occupational Standard	0.0	0.0	0.0	0.0	0.1	0.1	0.1	0.1	0.1	0.1	0.1	0.0	0.3	0.2	0.2	0.3	0.3	0.1
Percent of General Population Standard	0.1	0.1	0.0	0.1	0.2	0.4	0.4	0.4	0.3	0.7	0.6	0.2	1.6	1.1	0.8	1.3	1.3	0.3

Antenna Type BXA-171063-12CF
Max% 1.59%

Instructions:

- 1) Fill in Site Location, Site number, Date, Name of Person Responsible for Date, and enter File Name to be saved as.
- 2) References to J4 refer to a point where the transmission line exits the equipment shelter and proceeds to the antenna(s). There is typically a connector located here where power measurements are made.
- 3) Enter Antenna Height (in feet to bottom of antenna), Antenna Gain (expressed as dBi, add 2.17 to dBd to obtain dBi), Antenna Size (vertical size in inches), Downtilt (in Degrees, enter zero if none), Feedline loss from J4 to Antenna, and J4 Poy
- 4) From manufacturer's plots, or data sheet, input Angle from mainbeam and dB below mainbeam centerline.
- 5) Enter Reflection coefficient (2.56 would be typical, 1 for free space)
- 6) Spreadsheet calculates actual power density, then relates as Occupational or General Population percentage of FCC Standard.
- 7) An odd distance may be entered in the rightmost column of the lower table.

ATTACHMENT 3



FDH Engineering, Inc., 6521 Meridien Drive Raleigh, NC 27616, Ph. 919.755.1012

**Structural Analysis for
SBA Network Services, Inc.**

125' Self-Support Tower

**SBA Site Name: Bloomfield
SBA Site ID: CT01725-A-02
Verizon Site Name: Cottage Grove**

FDH Project Number 13SFTM1400 (R1)

Analysis Results

Tower Components	97.7%	Sufficient
Foundation	86.6%	Sufficient

Prepared By:

Byron K Webb, EI
Project Engineer

Reviewed By:

Christopher M. Murphy, PE
President
CT PE License No. 25842

FDH Engineering, Inc.
6521 Meridien Drive
Raleigh, NC 27616
(919) 755-1012
info@fdh-inc.com



November 15, 2013

Prepared pursuant to TIA/EIA-222-F Structural Standards for Steel Antenna Towers and Antenna Supporting Structures and 2005 Connecticut Building Code

TABLE OF CONTENTS

EXECUTIVE SUMMARY 3

 Conclusions 3

 Recommendations 3

APPURTENANCE LISTING 4

RESULTS 6

GENERAL COMMENTS 8

LIMITATIONS 8

APPENDIX 9

EXECUTIVE SUMMARY

At the request of SBA Network Services, Inc., FDH Engineering, Inc. performed a structural analysis of the existing self-supported tower located in Bloomfield, CT to determine whether the tower is structurally adequate to support both the existing and proposed loads pursuant to the *Structural Standards for Steel Antenna Towers and Antenna Supporting Structures, TIA/EIA-222-F* and *2005 Connecticut Building Code*. Information pertaining to the existing/proposed antenna loading, current tower geometry, the member sizes, soil parameters, and foundation dimensions was obtained from:

- Fred A. Nudd Corporation (Project No. 5566A) original design drawings dated March 11, 1998
- FDH Engineering, Inc. (Project No. 12-06690E G1) Geotechnical Evaluation of Subsurface Conditions dated August 10, 2012
- SBA Network Services, Inc.

The *basic design wind speed* per the *TIA/EIA-222-F* standards and *2005 Connecticut Building Code* is 80 mph without ice and 28 mph with 1" radial ice. Ice is considered to increase in thickness with height.

Conclusions

With the existing and proposed antennas from Verizon in place at 107 ft, the tower meets the requirements of the *TIA/EIA-222-F* standards and *2005 Connecticut Building Code* provided the **Recommendations** listed below are satisfied. Furthermore, provided the foundations were constructed per the original design drawings (see Fred A. Nudd Corp. Project No. 5566A) and utilizing the existing soil parameters (see FDH Engineering, Inc. Project No. 12-06690E G1), the foundations should have the necessary capacity to support the existing and proposed loading. For a more detailed description of the analysis of the tower, see the **Results** section of this report.

Our structural analysis has been performed assuming all information provided to FDH Engineering, Inc. is accurate (i.e., the steel data, tower layout, existing antenna loading, and proposed antenna loading) and that the tower has been properly erected and maintained per the original design drawings.

Recommendations

To ensure the requirements of the *TIA/EIA-222-F* standards and *2005 Connecticut Building Code* are met with the existing and proposed loading in place, we have the following recommendations:

1. The Coax must be installed as shown in **Figure 1**.
2. RRH/RRU stipulation: the proposed equipment may be installed in any arrangement as determined by the client.

APPURTENANCE LISTING

The proposed and existing antennas with their corresponding cables/coax lines are shown in **Table 1**. *If the actual layout determined in the field deviates from the layout, FDH Engineering, Inc. should be contacted to perform a revised analysis.*

Table 1 - Appurtenance Loading

Existing Loading:

Antenna Elevation (ft)	Description	Coax and Lines	Carrier	Mount Elevation (ft)	Mount Type
135	(3) Celwave PD455 Dipoles (2) 20' Omnis	(1) 1-1/4" (2) 1/2" (2) 7/8"	Blue Hills Fire & PD	125	(1) Platform w/ Handrails
125	(3) Ericsson AIR B2A/B4P w/ Mount Pipe (3) Ericsson AIR B4A/B2P w/ Mount Pipe (3) Ericsson KRY 112 144/1 TMDs	(12) 1-5/8" (1) 1-5/8" Fiber Cable	T-Mobile		
120	(9) Decibel DB844H90E-XY w/ Mount Pipe (3) Kathrein 840 10054 w/ Mount Pipe (3) Samsung U-RAS RRUs	(12) 1-1/4" (2) 1/2" (7) 5/16"	Nextel/ Clearwire	120	(3) T-Frames
	(2) Andrew VHL2.5 Dishes (2) Dragonwave Horizon Duo ODUs				
110	(6) Antel LPA-80063/4CF w/ Mount Pipe (3) Antel BXA-171063/8BF w/ Mount Pipe (1) Antel BXA-70080/4CF w/ Mount Pipe (2) Swedcom SLCP 2x6014F w/ Mount Pipe (2) GPS	(18) 1-5/8" (2) 1/2"	Verizon	107	(3) T-Frames
98	(6) Powerwave 7770.00 w/ Mount Pipe (1) KMW AM-X-CD-16-65-00T-RET w/ Mount Pipe	(12) 7/8" (1) 3" Flex Conduit (2) 3/4" DC Power (1) 3/8" Fiber	New Cingular	98	(3) T-Frames
	(2) Andrew SBNH-1D6565C w/ Mount Pipe (6) Powerwave LGP21401 TMAs (6) Ericsson RRUS-11 RRUs (6) Powerwave LGP21903 Diplexers			96	Direct Mount
87	(1) Raycap DC6-48-60-18-8F Surge Arrestor (3) RFS APXVSP18-C-A20 w/ Mount Pipe (3) ALU 1900 MHz RRHs (3) ALU 800 MHz RRHs (3) ALU 800 MHz Filters (4) RFS ACU-A20-N RETs	(3) 1-1/4" Fiber	Sprint	87	(3) T-Frames
75	(3) RFS APXV18-206517S-C w/ Mount Pipe	(6) 1-5/8"	Pocket	75	Direct Mount
51	(1) 2' Omni	---	---	50	(1) Standoff

Proposed Loading:

Antenna Elevation (ft)	Description	Coax and Lines	Carrier	Mount Elevation (ft)	Mount Type
110	(1) Antel BXA-70080/4CF w/ Mount Pipe (2) Swedcom SLCP 2x6014F w/ Mount Pipe (3) Antel BXA-70063/4CF w/ Mount Pipe (3) Antel BXA-171063/8BF w/ Mount Pipe (3) Antel BXA-171063/12CF w/ Mount Pipe (3) Alcatel Lucent RRH2x40WS RRUs (1) RFS/Celwave DB-T1-6Z-8AB-C distribution box (2) GPS	(18) 1-5/8" (2) 1/2" (1) 1-5/8" Hybrid	Verizon	107	(3) T-Frames

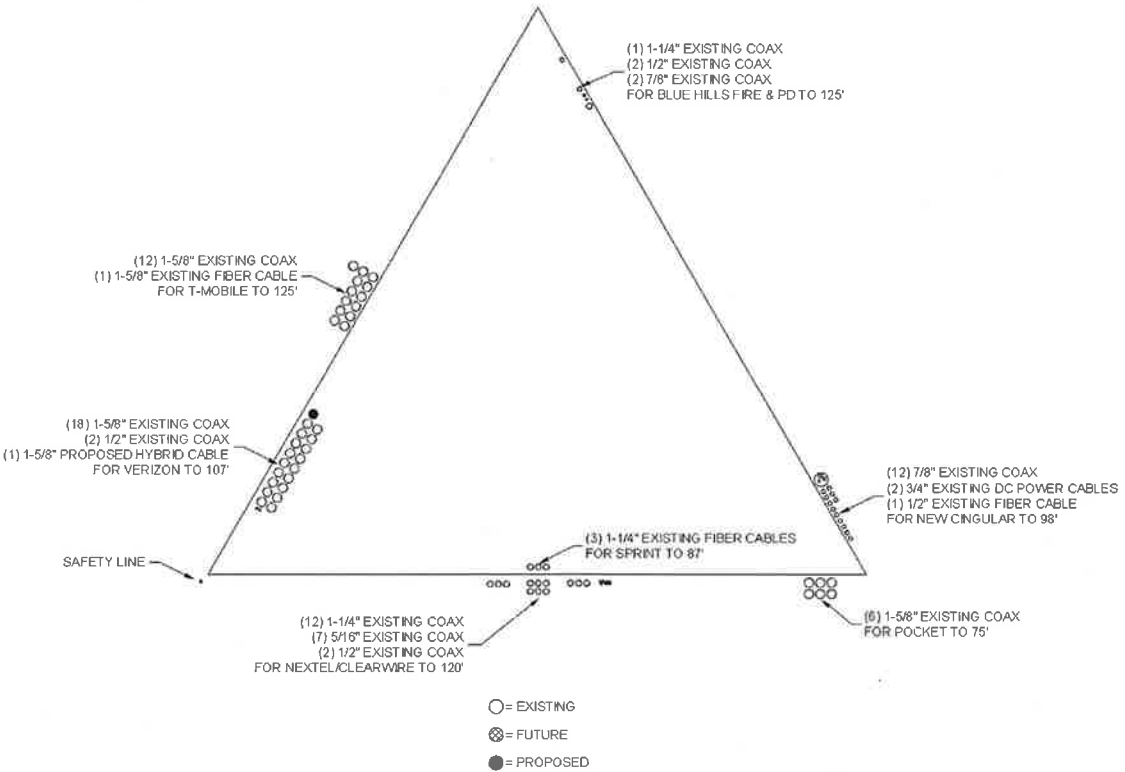

Figure 1 – Coax Layout

RESULTS

The following yield strength of steel for individual members was used for analysis:

Table 2 - Material Strength

Member Type	Yield Strength
Legs	55 ksi
Bracing	36 ksi

Table 3 displays the summary of the ratio (as a percentage) of force in the member to their capacities. Values greater than 100% indicate locations where the maximum force in the member exceeds its capacity. *Note: Capacities up to 100% are considered acceptable.* **Table 4** displays the maximum foundation reactions. **Table 5** displays maximum tilt and twist at service wind speed.

If the assumptions outlined in this report differ from actual field conditions, FDH Engineering, Inc. should be contacted to perform a revised analysis. Furthermore, as no information pertaining to the allowable twist and sway requirements for the existing or proposed appurtenances was provided, deflection and rotation were not taken into consideration when performing this analysis.

See the **Appendix** for detailed modeling information

Table 3 - Summary of Working Percentage of Structural Components

Section No.	Elevation ft	Component Type	Size	% Capacity*	Pass Fail
T1	125 - 120	Leg	P2.5x.203 (2.88 OD)	12.0	Pass
		Diagonal	5/8	40.1	Pass
		Horizontal	L1 1/2x1 1/2x3/16	37.7 46.7 (b)	Pass
		Top Girt	L1 1/2x1 1/2x3/16	17.9	Pass
T2	120 - 100	Bottom Girt	L1 1/2x1 1/2x3/16	22.3	Pass
		Leg	P2.5x.203 (2.88 OD)	72.7	Pass
		Diagonal	L1 1/2x1 1/2x3/16	63.5 85.6 (b)	Pass
T3	100 - 80	Top Girt	L1 1/2x1 1/2x3/16	9.3 15.3 (b)	Pass
		Leg	P3.5x.226 (4.00 OD)	84.1	Pass
		Diagonal	L2x2x3/16	52.6 87.4 (b)	Pass
T4	80 - 60	Leg	P5x.258 (5.563 OD)	76.2	Pass
		Diagonal	L2 1/2x2 1/2x3/16	45.7 97.7 (b)	Pass
T5	60 - 40	Leg	P6x.28 (6.625 OD)	72.4	Pass
		Diagonal	L2 1/2x2 1/2x3/16	53.0 71.0 (b)	Pass
T6	40 - 30	Leg	P6x.28 (6.625 OD)	83.4	Pass
		Diagonal	L3x3x3/16	50.9 72.6 (b)	Pass
T7	30 - 20	Leg	P6x.28 (6.625 OD)	95.0	Pass
		Diagonal	L3x3x3/16	53.4 72.2 (b)	Pass
T8	20 - 0	Leg	P8x.322 (8.625 OD)	67.7	Pass
		Diagonal	L3 1/2x3 1/2x1/4	31.9	Pass

Section No.	Elevation ft	Component Type	Size	% Capacity*	Pass Fail
				59.8 (b)	

Capacities include a 1/3 allowable stress increase for wind.

Table 4 - Maximum Base Reactions

Load Type	Direction	Current Analysis (TIA/EIA-222-F)*	Original Design (EIA/TIA-222-E)
Individual Foundation	Horizontal	17 k	---
	Uplift	192 k	193 k
	Compression	215 k	216 k
Overturning Moment	---	2,222 k-ft	---

*Foundation determined adequate per independent analysis.

Table 5 - Maximum Antenna Rotations at Service Wind Speeds

Centerline Elevation (ft)	Antenna	Tilt (deg)*	Twist (deg)*
120	(2) Andrew VHLP2.5 Dishes	0.4481	0.0296

*Tilt and Twist to be reviewed by the carrier.

GENERAL COMMENTS

This engineering analysis is based upon the theoretical capacity of the structure. It is not a condition assessment of the tower and its foundation. It is the responsibility of SBA Network Services, Inc. to verify that the tower modeled and analyzed is the correct structure (with accurate antenna loading information) modeled. If there are substantial modifications to be made or the assumptions made in this analysis are not accurate, FDH Engineering, Inc. should be notified immediately to perform a revised analysis.

LIMITATIONS

All opinions and conclusions are considered accurate to a reasonable degree of engineering certainty based upon the evidence available at the time of this report. All opinions and conclusions are subject to revision based upon receipt of new or additional/updated information. All services are provided exercising a level of care and diligence equivalent to the standard and care of our profession. No other warranty or guarantee, expressed or implied, is offered. Our services are confidential in nature and we will not release this report to any other party without the client's consent. The use of this engineering work is limited to the express purpose for which it was commissioned and it may not be reused, copied, or distributed for any other purpose without the written consent of FDH Engineering, Inc.

APPENDIX

