

Daniel F. Caruso
Chairman

STATE OF CONNECTICUT

CONNECTICUT SITING COUNCIL

Ten Franklin Square, New Britain, CT 06051

Phone: (860) 827-2935 Fax: (860) 827-2950

E-Mail: siting.council@ct.gov

Internet: ct.gov/csc

August 7, 2007

Steven L. Levine
Real Estate Consultant
New Cingular Wireless PCS, LLC
500 Enterprise Drive
Rocky Hill, CT 06067-3900

RE: **EM-CING-008-014-054-085-110-137-070622** - New Cingular Wireless PCS, LLC
notice of intent to modify existing telecommunications facilities located at 93 Old Amity
Road, Bethany; 405 Brushy Plain Road, Branford; Three Mile Road, Glastonbury; 88
Main Street, Monroe; 10 Sparks Street, Plainville; and 82 Mechanic Street, Stonington,
Connecticut – Bethany Site

Dear Mr. Levine:

At a public meeting held on July 26, 2007, the Connecticut Siting Council (Council) acknowledged your notice to modify the existing telecommunications facility located at 93 Old Amity Road, Bethany, pursuant to Section 16-50j-73 of the Regulations of Connecticut State Agencies. The Branford, Glastonbury, Monroe, Plainville, and Stonington proposals were acknowledged by the Council on July 3, 2007.

The proposed modifications are to be implemented as specified here and in your notice dated June 22, 2007 and additional information received July 5, 2007, including the placement of all necessary equipment and shelters within the tower compound. The modifications are in compliance with the exception criteria in Section 16-50j-72 (b) of the Regulations of Connecticut State Agencies as changes to an existing facility site that would not increase tower height, extend the boundaries of the tower site, increase noise levels at the tower site boundaries by six decibels, and increase the total radio frequencies electromagnetic radiation power densities measured at the tower site boundaries to or above the standard adopted by the State Department of Environmental Protection pursuant to General Statutes § 22a-162. This facility has also been carefully modeled to ensure that radio frequency emissions are conservatively below State and federal standards applicable to the frequencies now used on this tower.

This decision is under the exclusive jurisdiction of the Council. Please be advised that the validity of this action shall expire one year from the date of this letter. Any additional change to this facility will require explicit notice to this agency pursuant to Regulations of Connecticut State Agencies Section 16-50j-73. Such notice shall include all relevant information regarding the proposed change with cumulative worst-case modeling of radio frequency exposure at the closest point of uncontrolled access to the tower base, consistent with Federal Communications Commission, Office of Engineering and Technology, Bulletin 65. Any deviation from this format may result in the Council implementing enforcement proceedings pursuant to General Statutes § 16-50u including, without limitation, imposition of expenses resulting from such failure and of civil penalties in an amount not less than one thousand dollars per day for each day of construction or operation in material violation.

Thank you for your attention and cooperation.

Very truly yours,

Handwritten signature of Daniel F. Caruso in black ink, written in a cursive style.

Daniel F. Caruso
Chairman

DFC/MP/cm

- c: The Honorable Derrylyn Gorski, First Selectman, Town of Bethany
- Robert H. Brinton, Zoning Enforcement Officer, Town of Bethany
- Thomas J. Regan, Esq., Brown Rudnick Berlack Israels LLP
- Christopher B. Fisher, Esq., Cuddy & Feder LLP
- Kenneth Baldwin, Esq., Robinson & Cole LLP
- American Tower Corporation
- Christine Farrell, T-Mobile

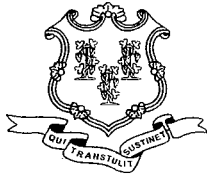

Daniel F. Caruso
Chairman

STATE OF CONNECTICUT

CONNECTICUT SITING COUNCIL

Ten Franklin Square, New Britain, CT 06051

Phone: (860) 827-2935 Fax: (860) 827-2950

E-Mail: siting.council@ct.gov

Internet: ct.gov/csc

July 12, 2007

Steven L. Levine
Real Estate Consultant
New Cingular Wireless PCS, LLC
500 Enterprise Drive
Rocky Hill, CT 06067-3900

RE: **EM-CING-008-014-054-085-110-137-070622** - New Cingular Wireless PCS, LLC notice of intent to modify existing telecommunications facilities located at 93 Old Amity Road, Bethany; 405 Brushy Plain Road, Branford; Three Mile Road, Glastonbury; 88 Main Street, Monroe; 10 Sparks Street, Plainville; and 82 Mechanic Street, Stonington, Connecticut.

Dear Mr. Levine:

At a public meeting held on July 3, 2007, the Connecticut Siting Council (Council) acknowledged your notice to modify these existing telecommunications facilities except for the Bethany facility, pursuant to Section 16-50j-73 of the Regulations of Connecticut State Agencies. The 93 Old Amity Road, Bethany notice was tabled until additional information is received.

The proposed modifications are to be implemented as specified here and in your notice dated June 22, 2007, including the placement of all necessary equipment and shelters within the tower compounds. The modifications are in compliance with the exception criteria in Section 16-50j-72 (b) of the Regulations of Connecticut State Agencies as changes to existing facility sites that would not increase tower heights, extend the boundaries of the tower sites, increase noise levels at the tower site boundaries by six decibels, and increase the total radio frequencies electromagnetic radiation power densities measured at the tower site boundaries to or above the standard adopted by the State Department of Environmental Protection pursuant to General Statutes § 22a-162. These facilities have also been carefully modeled to ensure that radio frequency emissions are conservatively below State and federal standards applicable to the frequencies now used on these towers.

This decision is under the exclusive jurisdiction of the Council. Please be advised that the validity of this action shall expire one year from the date of this letter. Any additional change to any of these facilities will require explicit notice to this agency pursuant to Regulations of Connecticut State Agencies Section 16-50j-73. Such notice shall include all relevant information regarding the proposed change with cumulative worst-case modeling of radio frequency exposure at the closest point of uncontrolled access to the tower base, consistent with Federal Communications Commission, Office of Engineering and Technology, Bulletin 65. Any deviation from this format may result in the Council implementing enforcement proceedings pursuant to General Statutes § 16-50u including, without limitation, imposition of expenses resulting from such failure and of civil penalties in an amount not less than one thousand dollars per day for each day of construction or operation in material violation.

Thank you for your attention and cooperation.

Very truly yours,



Daniel F. Caruso
Chairman

DFC/MP/cm

- c: The Honorable Derrylyn Gorski, First Selectman, Town of Bethany
- Robert H. Brinton, Zoning Enforcement Officer, Town of Bethany
- The Honorable Cheryl P. Morris, First Selectman, Town of Branford
- Justine K. Gillen, Zoning Enforcement Officer, Town of Branford
- Diana Ross, Inland Wetland Enforcement Officer, Town of Branford
- The Honorable Susan Karp, Chairman Town Council, Town of Glastonbury
- Kenith Leslie, Community Development Director, Town of Glastonbury
- Richard J. Johnson, Town Manager, Town of Glastonbury
- The Honorable Andrew J. Nunn, First Selectman, Town of Monroe
- Daniel A. Tuba, Planning Administrator, Town of Monroe
- The Honorable Christopher Wazorko, Town Council Chairman, Town of Plainville
- Shirley Osle, Town Manager, Town of Plainville
- Len Tunderman, Town Planner, Town of Plainville
- The Honorable William S. Brown, First Selectman, Town of Stonington
- Jason Vincent, Town Planner, Town of Stonington
- Thomas J. Regan, Esq., Brown Rudnick Berlack Israels LLP
- Christopher B. Fisher, Esq., Cuddy & Feder LLP
- Kenneth Baldwin, Esq., Robinson & Cole LLP
- American Tower Corporation
- Jeffrey W. Barbadora, Crown Atlantic Company LLC
- Christine Farrell, T-Mobile

Perrone, Michael

From: Levine, Steven [SL3764@att.com]
Sent: Thursday, July 05, 2007 9:10 AM
To: Perrone, Michael
Subject: EM-CING-008-070622 ----- Bethany EM tabled 7/3/07
Attachments: 5632 Structural pdf.pdf

Mike,

Here is the updated structural analysis for the 93 Old Amity Road, Bethany site, as requested by the Council.

As we discussed after the meeting, I inadvertently attached an older analysis to the application instead of the updated report.

Please place this item on the 7/26 agenda for approval.

Thanks.

Please Note my New E-Mail Address: steven.levine@att.com

AT&T Mobility / New Cingular Wireless PCS, LLC

Steve Levine 500 Enterprise Drive, 3rd Fl., Rocky Hill, CT 06067
Real Estate Consultant Office 860-513-7636 Mobile 203-556-1655 Fax 860-513-7190

This e-mail, and any attachments, are intended only for use by the addressee(s) named herein and may contain legally privileged and/or confidential information. It is the property of Cingular Wireless. If you are not the intended recipient of this email, you are hereby notified that any dissemination, distribution or copying of this email, any attachments thereto, and any use of the information contained is strictly prohibited. If you have received this email in error, please notify me at (860-513-7636) and permanently delete the original and any copy thereof.

RECEIVED
JUL 05 2007
CONNECTICUT
SITING COUNCIL

7/5/2007

RECEIVED
JUL 05 2007



88008-PAT
5/21/2007

CONNECTICUT
SITING COUNCIL

AMERICAN TOWER
CORPORATION

Level 1 Structural Evaluation ¹		
ATC Site Number & Name	88008, Bethany CT	Engineering ID: 40480411
Carrier Site Number & Name	5632, Bethany South	
Site Address	93 Old Amity Road Bethany, Connecticut 06524, New Haven County	
Tower Description	337 ft Self Support Tower	
Standards & Codes ²	ANSI/TIA/EIA-222-F (1996) 85 mph w/ 0" radial ice 74 mph w/ 1/2" radial ice	2003 International Building Code 110 mph w/ 0" radial ice

Table 1: Existing and Proposed Antenna Configuration				
HEIGHT (ft)	ANTENNA	CARRIER	COAX	STATUS
338	(1) Rodhe & Schwarz ADD090S on Platform Mount	US Treasury	(2) 7/8"	Existing
310	(1) Sinclair SC281L-D1 (1) Sinclair SC381-L on Side Arm Mounts	US Treasury	(2) 7/8"	Existing
275	(1) Sinclair SC281L-D1 on Side Arm Mount	US Treasury	(1) 7/8"	Existing
250	(12) Decibel DB844H90 on Sector Frame Mounts	Nextel	(12) 1-5/8"	Existing
240	(9) Dapa 58000 on Sector Frame Mounts	Sprint	(9) 1-5/8"	Existing
220	(3) RFS APX16PV-16VLE (6) Remec G20057A1 on Sector Frame Mounts	T-Mobile	(12) 1-5/8"	Existing
183 180 180	(1) Andrew QBW26N (6) Decibel DB844H90 (6) Decibel DB948F85T2E-M on Sector Frame Mounts	Verizon Wireless	(1) 1/2" (6) 1-5/8" (6) 1-5/8"	Existing
165	(6) Powerwave 7770 (6) Powerwave LGP 21401 on Sector Frame Mounts	Cingular	(12) 1-5/8"	Proposed
48	(1) GPS on Side Arm Mount	Sprint	(1) 1/2"	Existing
20	(1) GPS on Side Arm Mount	Nextel	(1) 1/2"	Existing

The subject tower and foundation *are adequate* to support the above stated loads in conformance with specified requirements. ³



5/22/07

I hereby certify that this engineering document was prepared by me or under my direct personal supervision and that I am a duly licensed Professional Engineer under the laws of the State of Connecticut.

¹ The existing and proposed loads of Table 1 are compared to the tower's current design capacity or previous analysis.

² The design wind criteria are compared to the current code requirements.

³ The tower should be re-evaluated as future loads are added or if actual loads are found different from those mentioned in Table 1.

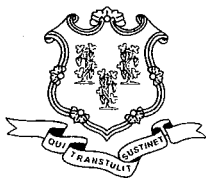

Daniel F. Caruso
Chairman

STATE OF CONNECTICUT
CONNECTICUT SITING COUNCIL

Ten Franklin Square, New Britain, CT 06051
Phone: (860) 827-2935 Fax: (860) 827-2950
E-Mail: siting.council@ct.gov
Internet: ct.gov/csc

June 25, 2007

The Honorable Derrylyn Gorski
First Selectman
Town of Bethany
Town Hall
40 Peck Road
Bethany, CT 06524-3338

RE: **EM-CING-008-014-054-085-110-137-070622** - New Cingular Wireless PCS, LLC notice of intent to modify existing telecommunications facilities located at 93 Old Amity Road, Bethany; 405 Brushy Plain Road, Branford; Three Mile Road, Glastonbury; 88 Main Street, Monroe; 10 Sparks Street, Plainville; and 82 Mechanic Street, Stonington, Connecticut.

Dear Ms. Gorski:

The Connecticut Siting Council (Council) received this request to modify an existing telecommunications facility, pursuant to Regulations of Connecticut State Agencies Section 16-50j-72.

The Council will consider this item at the next meeting scheduled for Tuesday, July 3, 2007 at 1:30 p.m. in Hearing Room One, Ten Franklin Square, New Britain, Connecticut.

If you have any questions or comments regarding this proposal, please call me or inform the Council by July 2, 2007.

Thank you for your cooperation and consideration.

Very truly yours,

S. Derek Phelps
Executive Director

SDP/MP/laf

Enclosure: Notice of Intent

c: Robert H. Brinton, Zoning Enforcement Officer, Town of Bethany

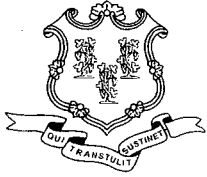

Daniel F. Caruso
Chairman

STATE OF CONNECTICUT
CONNECTICUT SITING COUNCIL

Ten Franklin Square, New Britain, CT 06051
Phone: (860) 827-2935 Fax: (860) 827-2950
E-Mail: siting.council@ct.gov
Internet: ct.gov/csc

June 25, 2007

The Honorable Derrylyn Gorski
First Selectman
Town of Bethany
Town Hall
40 Peck Road
Bethany, CT 06524-3338

RE: **EM-CING-008-014-054-085-110-137-070622** - New Cingular Wireless PCS, LLC notice of intent to modify existing telecommunications facilities located at 93 Old Amity Road, Bethany; 405 Brushy Plain Road, Branford; Three Mile Road, Glastonbury; 88 Main Street, Monroe; 10 Sparks Street, Plainville; and 82 Mechanic Street, Stonington, Connecticut.

Dear Ms. Gorski:

The Connecticut Siting Council (Council) received this request to modify an existing telecommunications facility, pursuant to Regulations of Connecticut State Agencies Section 16-50j-72.

The Council will consider this item at the next meeting scheduled for Tuesday, July 3, 2007 at 1:30 p.m. in Hearing Room One, Ten Franklin Square, New Britain, Connecticut.

If you have any questions or comments regarding this proposal, please call me or inform the Council by July 2, 2007.

Thank you for your cooperation and consideration.

Very truly yours,

S. Derek Phelps
Executive Director

SDP/MP/laf

Enclosure: Notice of Intent

c: Robert H. Brinton, Zoning Enforcement Officer, Town of Bethany

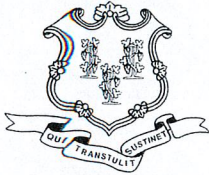

Daniel F. Caruso
Chairman

STATE OF CONNECTICUT

CONNECTICUT SITING COUNCIL

Ten Franklin Square, New Britain, CT 06051

Phone: (860) 827-2935 Fax: (860) 827-2950

E-Mail: siting.council@ct.gov

Internet: ct.gov/csc

June 25, 2007

The Honorable Cheryl P. Morris
First Selectman
Town of Branford
Town Hall
1019 Main Street
P. O. Box 150
Branford, CT 06405-0150

RE: **EM-CING-008-014-054-085-110-137-070622** - New Cingular Wireless PCS, LLC notice of intent to modify existing telecommunications facilities located at 93 Old Amity Road, Bethany; 405 Brushy Plain Road, Branford; Three Mile Road, Glastonbury; 88 Main Street, Monroe; 10 Sparks Street, Plainville; and 82 Mechanic Street, Stonington, Connecticut.

Dear Ms. Morris:

The Connecticut Siting Council (Council) received this request to modify an existing telecommunications facility, pursuant to Regulations of Connecticut State Agencies Section 16-50j-72.

The Council will consider this item at the next meeting scheduled for Tuesday, July 3, 2007 at 1:30 p.m. in Hearing Room One, Ten Franklin Square, New Britain, Connecticut.

If you have any questions or comments regarding this proposal, please call me or inform the Council by July 2, 2007.

Thank you for your cooperation and consideration.

Very truly yours,

S. Derek Phelps
Executive Director

SDP/MP/laf

Enclosure: Notice of Intent

c: Justine K. Gillen, Zoning Enforcement Officer, Town of Branford
Diana Ross, Inland Wetland Enforcement Officer, Town of Branford

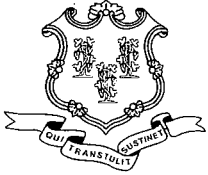

Daniel F. Caruso
Chairman

STATE OF CONNECTICUT
CONNECTICUT SITING COUNCIL

Ten Franklin Square, New Britain, CT 06051
Phone: (860) 827-2935 Fax: (860) 827-2950
E-Mail: siting.council@ct.gov
Internet: ct.gov/csc

June 25, 2007

The Honorable Susan Karp
Chairman Town Council
Town of Glastonbury
2155 Main Street
P. O. Box 6523
Glastonbury, CT 06033

RE: **EM-CING-008-014-054-085-110-137-070622** - New Cingular Wireless PCS, LLC notice of intent to modify existing telecommunications facilities located at 93 Old Amity Road, Bethany; 405 Brushy Plain Road, Branford; Three Mile Road, Glastonbury; 88 Main Street, Monroe; 10 Sparks Street, Plainville; and 82 Mechanic Street, Stonington, Connecticut.

Dear Ms. Karp:

The Connecticut Siting Council (Council) received this request to modify an existing telecommunications facility, pursuant to Regulations of Connecticut State Agencies Section 16-50j-72.

The Council will consider this item at the next meeting scheduled for Tuesday, July 3, 2007 at 1:30 p.m. in Hearing Room One, Ten Franklin Square, New Britain, Connecticut.

If you have any questions or comments regarding this proposal, please call me or inform the Council by July 2, 2007.

Thank you for your cooperation and consideration.

Very truly yours,

S. Derek Phelps
Executive Director

SDP/MP/laf

Enclosure: Notice of Intent

c: Kenith Leslie, Community Development Director, Town of Glastonbury
Richard J. Johnson, Town Manager, Town of Glastonbury

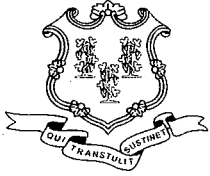

STATE OF CONNECTICUT

CONNECTICUT SITING COUNCIL

Ten Franklin Square, New Britain, CT 06051

Phone: (860) 827-2935 Fax: (860) 827-2950

E-Mail: siting.council@ct.gov

Internet: ct.gov/csc

Daniel F. Caruso
Chairman

June 25, 2007

The Honorable Andrew J. Nunn
First Selectman
Town of Monroe
Town Hall
7 Fan Hill Road
Monroe, CT 06468-1800

RE: **EM-CING-008-014-054-085-110-137-070622** - New Cingular Wireless PCS, LLC notice of intent to modify existing telecommunications facilities located at 93 Old Amity Road, Bethany; 405 Brushy Plain Road, Branford; Three Mile Road, Glastonbury; 88 Main Street, Monroe; 10 Sparks Street, Plainville; and 82 Mechanic Street, Stonington, Connecticut.

Dear Mr. Nunn:

The Connecticut Siting Council (Council) received this request to modify an existing telecommunications facility, pursuant to Regulations of Connecticut State Agencies Section 16-50j-72.

The Council will consider this item at the next meeting scheduled for Tuesday, July 3, 2007 at 1:30 p.m. in Hearing Room One, Ten Franklin Square, New Britain, Connecticut.

If you have any questions or comments regarding this proposal, please call me or inform the Council by July 2, 2007.

Thank you for your cooperation and consideration.

Very truly yours,

S. Derek Phelps
Executive Director

SDP/MP/laf

Enclosure: Notice of Intent

c: Daniel A. Tuba, Planning Administrator, Town of Monroe

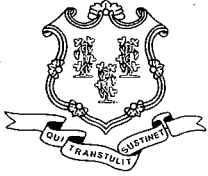

Daniel F. Caruso
Chairman

STATE OF CONNECTICUT

CONNECTICUT SITING COUNCIL

Ten Franklin Square, New Britain, CT 06051

Phone: (860) 827-2935 Fax: (860) 827-2950

E-Mail: siting.council@ct.gov

Internet: ct.gov/esc

June 25, 2007

The Honorable Christopher Wazorko
Town Council Chairman
Town of Plainville
Municipal Center
1 Central Square
Plainville, CT 06062

RE: **EM-CING-008-014-054-085-110-137-070622** - New Cingular Wireless PCS, LLC notice of intent to modify existing telecommunications facilities located at 93 Old Amity Road, Bethany; 405 Brushy Plain Road, Branford; Three Mile Road, Glastonbury; 88 Main Street, Monroe; 10 Sparks Street, Plainville; and 82 Mechanic Street, Stonington, Connecticut.

Dear Mr. Wazorko:

The Connecticut Siting Council (Council) received this request to modify an existing telecommunications facility, pursuant to Regulations of Connecticut State Agencies Section 16-50j-72.

The Council will consider this item at the next meeting scheduled for Tuesday, July 3, 2007 at 1:30 p.m. in Hearing Room One, Ten Franklin Square, New Britain, Connecticut.

If you have any questions or comments regarding this proposal, please call me or inform the Council by July 2, 2007.

Thank you for your cooperation and consideration.

Very truly yours,

S. Derek Phelps
Executive Director

SDP/MP/laf

Enclosure: Notice of Intent

c: Shirley Osle, Town Manager, Town of Plainville
Len Tunderman, Town Planner, Town of Plainville



STATE OF CONNECTICUT

CONNECTICUT SITING COUNCIL

Ten Franklin Square, New Britain, CT 06051

Phone: (860) 827-2935 Fax: (860) 827-2950

E-Mail: siting.council@ct.gov

Internet: ct.gov/csc

Daniel F. Caruso
Chairman

June 25, 2007

The Honorable William S. Brown
First Selectman
Town of Stonington
Town Hall
152 Elm Street
P. O. Box 352
Stonington, CT 06378

RE: **EM-CING-008-014-054-085-110-137-070622** - New Cingular Wireless PCS, LLC notice of intent to modify existing telecommunications facilities located at 93 Old Amity Road, Bethany; 405 Brushy Plain Road, Branford; Three Mile Road, Glastonbury; 88 Main Street, Monroe; 10 Sparks Street, Plainville; and 82 Mechanic Street, Stonington, Connecticut.

Dear Mr. Brown:

The Connecticut Siting Council (Council) received this request to modify an existing telecommunications facility, pursuant to Regulations of Connecticut State Agencies Section 16-50j-72.

The Council will consider this item at the next meeting scheduled for Tuesday, July 3, 2007 at 1:30 p.m. in Hearing Room One, Ten Franklin Square, New Britain, Connecticut.

If you have any questions or comments regarding this proposal, please call me or inform the Council by July 2, 2007.

Thank you for your cooperation and consideration.

Very truly yours,

S. Derek Phelps
Executive Director

SDP/MP/laf

Enclosure: Notice of Intent

c: Jason Vincent, Town Planner, Town of Stonington

ORIGINAL

EM-CING-008-014-054-085-110-137-070622



New Cingular Wireless PCS, LLC
500 Enterprise Drive
Rocky Hill, Connecticut 06067-3900
Phone: (860) 513-7636
Fax: (860) 513-7190

Steven L. Levine
Real Estate Consultant

RECEIVED
JUN 22 2007

CONNECTICUT
SITING COUNCIL

HAND DELIVERED

June 22, 2007

RECEIVED
JUN 22 2007

CONNECTICUT
SITING COUNCIL

Honorable Daniel F. Caruso, Chairman,
and Members of the Connecticut Siting Council
Connecticut Siting Council
10 Franklin Square
New Britain, Connecticut 06051

Re: New Cingular Wireless PCS, LLC notice of intent to modify 6 existing telecommunications facilities located in Bethany, Branford, Glastonbury, Monroe, Plainville, and Stonington

Dear Chairman Caruso and Members of the Council:

In order to accommodate technological changes, implement Uniform Mobile Telecommunications System ("UMTS") capability, and enhance system performance in the State of Connecticut, New Cingular Wireless PCS, LLC ("Cingular") plans to modify the equipment configurations at many of its existing cell sites. Please accept this letter and attachments as notification, pursuant to R.C.S.A. Section 16-50j-73, of construction which constitutes an exempt modification pursuant to R.C.S.A. Section 16-50j-72(b)(2). In compliance with R.C.S.A. Section 16-50j-73, a copy of this letter and attachments is being sent to the chief elected official of each of the municipalities in which an affected cell site is located.

UMTS technology offers services to mobile computer and phone users anywhere in the world. Based on the Global System for Mobile (GSM) communication standard, UMTS is the planned worldwide standard for mobile users. UMTS, fully implemented, gives computer and phone users high-speed access to the Internet as they travel. They have the same capabilities even when they roam, through both terrestrial wireless and satellite transmissions.

Attached are summary sheets detailing the planned changes, including power density calculations reflecting the change in the effect of Cingular's operations at each affected site. Also included is documentation of the structural sufficiency of each tower to accommodate the revised antenna configuration.

The changes to the facilities do not constitute modifications as defined in Connecticut General Statutes ("C.G.S.") Section 16-50i(d) because the general physical characteristics of the facilities will not be significantly changed or altered. Rather, the planned changes to the facilities fall squarely within those activities explicitly provided for in R.C.S.A. Section 16-50j-72(b)(2).

1. In each instance, the height of the overall structure will be unaffected. Modifications to the existing sites include all or some of the following as necessary to bring each site into conformance with the plan:

- Replacement of existing panel antennas with new antennas of similar size, shape, and weight, or, installation of additional antennas of similar size, shape, and weight.
- Installation of small tower mount amplifiers ("TMA's") and/or diplexers to the platform on which the panel antennas are mounted to enhance signal reception.
- Installation of additional or larger coaxial cables as required.
- Installation of an additional equipment cabinet in existing shelters, or on existing or enlarged concrete pads.

None of these modifications will extend the height of the tower.

2. The proposed changes will not extend the site boundaries. There will be no effect on the site compound other than some enlarged equipment pads as noted in the following attachments.

3. The proposed changes will not increase the noise level at the existing facility by six decibels or more.

4. Radio frequency power density may increase due to use of one GSM channel for UMTS transmissions. However, the changes will not increase the calculated "worst case" power density for the combined operations at the site to a level at or above the applicable standard for uncontrolled environments as calculated for a mixed frequency site.

For the foregoing reasons, Cingular Wireless respectfully submits that the proposed changes at the referenced sites constitute exempt modifications under R.C.S.A. Section 16-50j-72(b)(2).

Please feel free to call me at (860) 513-7636 with questions concerning this matter. Thank you for your consideration.

Sincerely,



Steven L. Levine
Real Estate Consultant

Attachments

**CINGULAR WIRELESS
Equipment Modification**

93 Old Amity Road, Bethany, CT
Site Number 5632
Former AT&T cell site
Exempt Modification 9/5/02

Tower Owner/Manager: American Tower

Equipment configuration: Self Supporting Lattice

Current and/or approved: Three Allgon 7250 antennas @ 165 ft c.l.
Six runs 1 5/8 inch coax

Planned Modifications: Remove all three existing antennas
Install three Powerwave 7770 antennas @ 165 ft c.l.
Install six TMA's @ 165 ft
Install two additional outdoor cabinets

Power Density:

Worst-case calculations for existing wireless operations at the site indicate a radio frequency electromagnetic radiation power density, measured at ground level beside the tower, of approximately 12.4 % of the standard adopted by the FCC. As depicted in the second table below, the total radio frequency electromagnetic radiation power density following proposed modifications would be approximately 14 % of the standard.

Existing

Company	Centerline Ht (feet)	Frequency (MHz)	Number of Channels	Power Per Channel (Watts)	Power Density (mW/cm ²)	Standard Limits (mW/cm ²)	Percent of Limit
Other Users *							11.10
Cingular GSM *	165	1900 Band	4	250	0.0132	1.0000	1.32
Total							12.4%

* Per CSC Records

Proposed

Company	Centerline Ht (feet)	Frequency (MHz)	Number of Channels	Power Per Channel (Watts)	Power Density (mW/cm ²)	Standard Limits (mW/cm ²)	Percent of Limit
Other Users *							11.10
Cingular GSM	165	1900 Band	2	654	0.0173	1.0000	1.73
Cingular UMTS	165	880 - 894	1	500	0.0066	0.5867	1.13
Total							14.0%

* Per CSC Records

Structural information:

The attached structural analysis demonstrates that the tower and foundation have sufficient structural capacity to accommodate the proposed modifications. (American Tower, dated 5/21/07)

#5632



AMERICAN TOWER

Structural Analysis Report

Structure : 337 ft Self Supported Tower
ATC Site Name : Bethany, CT
ATC Site Number : 88008
Proposed Carrier : US Coast Guard
Carrier Site Name : RFF Bethany
Carrier Site Number : 1055492
County : New Haven
Eng. Number : 26083121
Date : March 27, 2006
Usage : 100%

Submitted by:
Scott Wirgau, E.I.
Project Engineer

Reviewed by:
Raphael I. Mohamed, P.E.
Engineering Manager

American Tower Engineering Services
400 Regency Forest Drive
Cary, NC 27511
Phone: 919-468-0112

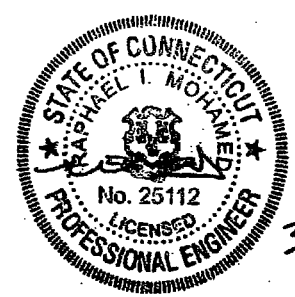

3/27/06

Introduction

The purpose of this report is to summarize results of the structural analysis performed on the 337 ft Self Supported Tower located at 93 Old Amity Road, Bethany, CT 06524, New Haven County (ATC site #88008). The tower information was taken from an analysis by CSEI (Project #02239, dated November 16, 2002).

Analysis

The tower was analyzed using Semaan Engineering Solutions, Inc., Software. The analysis assumes that the tower is in good, undamaged, and non-corroded condition.

Basic Wind Speed: 85 mph (Fastest Mile) / 110 mph (3-Second Gust)
 Radial Ice: 74 mph (Fastest Mile) w/ 1/2" ice
 Code: TIA/EIA-222-F / 2003 International Building Code

Antenna Loads

The following antenna loads were used in the tower analysis.

Existing Antennas

Elev. (ft)	Qty	Antennas	Mount	Coax	Carrier
250	12	Decibel DB844H90E-XY	Sector Frame	(12) 1-5/8"	Nextel
241	9	Dapa 58000	Sector Frame	(9) 1-5/8"	Sprint
220	3	RFS APX16PVL-E	Sector Frame	(12) 1-5/8"	T-Mobile
	6	Remec G20057A1			
180	6	Decibel DB844H90E-XY	Sector Frame	(6) 1-5/8"	Verizon
	6	Decibel 948F85T2E-M		(6) 1-5/8"	
165	6	Allgon 7250.03	Sector Frame	(12) 1-5/8"	AT&T
50	1	GPS QBW-26N	Side Arm	(1) 1/2"	Verizon

Proposed Antennas

Elev. (ft)	Qty	Antennas	Mount	Coax	Carrier
338	1	Antel ADD090S	Side Arm	(2) 7/8"	US Coast Guard
310	1	Sinclair SC281L-DI	Side Arm	(1) 7/8"	
	1	Sinclair SC381-L		(1) 7/8"	
275	1	Sinclair SC281L-DI	Side Arm	(1) 7/8"	

Install proposed coax in same location as existing US Coast Guard coax.

Results

The maximum structure usage is: 100%

Leg Forces	Original Design Reactions	Current Analysis Reactions	% Of Design
Uplift (Kips)	N/A	291.2	N/A
Axial (Kips)	N/A	378.2	N/A
Shear (Kips)	N/A	61.7	N/A

The structure base reactions resulting from this analysis were found to be acceptable through analysis based on geotechnical and foundation information, therefore no modification or reinforcement of the foundation will be required.

Conclusion

Based on the analysis results, the structure meets the requirements per TIA/EIA-222-F and 2003 IBC standards.

The tower and foundation can support the existing and proposed antennas with the TX line distribution as described in this report.

If you have any questions or require additional information, please call 919-466-5086.

Standard Conditions

All engineering services are performed on the basis that the information used is current and correct. This information may consist of, but is not necessary limited, to:

- Information supplied by the client regarding the structure itself, the antenna and feed line loading on the structure and its components, or other relevant information.
- Information from drawings in the possession of American Tower Corporation, or generated by field inspections or measurements of the structure.

It is the responsibility of the client to ensure that the information provided to ATC Engineering Services and used in the performance of our engineering services is correct and complete. In the absence of information to the contrary, we assume that all structures were constructed in accordance with the drawings and specifications and are in an un-corroded condition and have not deteriorated; and we, therefore, assume that their capacity has not significantly changed from the "as new" condition.

All services will be performed to the codes specified by the client, and we do not imply to meet any other codes or requirements unless explicitly agreed in writing. If wind and ice loads or other relevant parameters are to be different from the minimum values recommended by the codes, the client shall specify the exact requirement. In the absence of information to the contrary, all work will be performed in accordance with the latest relevant revision of ANSI/EIA-222.

All services are performed, results obtained, and recommendations made in accordance with generally accepted engineering principles and practices. ATC Engineering Services is not responsible for the conclusions, opinions and recommendations made by others based on the information we supply.



New Cingular Wireless PCS, LLC
500 Enterprise Drive
Rocky Hill, Connecticut 06067-3900
Phone: (860) 513-7636
Fax: (860) 513-7190

Steven L. Levine
Real Estate Consultant

June 21, 2007

Honorable Derrylyn Gorski
1st Selectman
Town Hall, 40 Peck Road
Bethany, CT 06524-3338

Re: Telecommunications Facility – 93 Old Amity Road, Bethany

Dear Ms. Gorski:

In order to accommodate technological changes, implement Uniform Mobile Telecommunications System (“UMTS”) capability, and enhance system performance in the State of Connecticut, New Cingular Wireless PCS, LLC (“Cingular”) will be changing its equipment configuration at certain cell sites.

As required by Regulations of Connecticut State Agencies (“R.C.S.A.”) Section 16-50j-73, the Connecticut Siting Council has been notified of the changes and will review Cingular’s proposal. Please accept this letter as notification under Section 16-50j-73 of construction which constitutes an exempt modification pursuant to R.C.S.A. Section 16-50j-72(b)(2).

The accompanying letter to the Siting Council fully describes Cingular’s proposal for the referenced cell site. However, if you have any questions or require any further information on our plans or the Siting Council’s procedures, please call me at (860) 513-7636 or Mr. Derek Phelps, Executive Director, Connecticut Siting Council at (860) 827-2935.

Sincerely,

Steven L. Levine
Real Estate Consultant

Enclosure

**CINGULAR WIRELESS
Equipment Modification**

405 Brushy Plain Road, Branford, CT
Site Number 2015
Docket 44.1; Exempt Mods 4/89, 9/92, 9/02

Tower Owner/Manager: American Tower

Equipment configuration: Monopole

Current and/or approved: Six CSS DUO1417 antennas @ 153 ft c.l.
Nine runs 7/8 inch coax
Six TMA's @ 153 ft

Planned Modifications: Remove all six existing antennas and coax
Install three Powerwave 7770 antennas @ 153 ft c.l.
Install six new runs 1 5/8 inch coax

Power Density:

Worst-case calculations for existing wireless operations at the site indicate a radio frequency electromagnetic radiation power density, measured at ground level beside the tower, of approximately 31.9 % of the standard adopted by the FCC. As depicted in the second table below, the total radio frequency electromagnetic radiation power density following proposed modifications would be approximately 29.8 % of the standard.

Existing / Approved

Company	Centerline Ht (feet)	Frequency (MHz)	Number of Channels	Power Per Channel (Watts)	Power Density (mW/cm ²)	Standard Limits (mW/cm ²)	Percent of Limit
Other Users *							24.81
Cingular TDMA *	153	880 - 894	16	100	0.0246	0.5867	4.19
Cingular GSM *	153	880 - 894	2	296	0.0091	0.5867	1.55
Cingular GSM *	153	1900 Band	2	427	0.0131	1.0000	1.31
Total							31.9%

* Per CSC records

Proposed

Company	Centerline Ht (feet)	Frequency (MHz)	Number of Channels	Power Per Channel (Watts)	Power Density (mW/cm ²)	Standard Limits (mW/cm ²)	Percent of Limit
Other Users *							24.81
Cingular GSM	153	880 - 894	3	296	0.0136	0.5867	2.32
Cingular GSM	153	1900 Band	2	427	0.0131	1.0000	1.31
Cingular UMTS	153	880 - 894	1	500	0.0077	0.5867	1.31
Total							29.8%

* Per CSC records.

Structural information:

The attached structural analysis demonstrates that the tower and foundation have sufficient structural capacity to accommodate the proposed modifications. (American Tower, dated 6/15/07)

PASSED



AMERICAN TOWER™
CORPORATION

Structural Analysis Report

Structure : 150 ft. ITT Meyer monopole
ATC Site Name : Branford CT 6, CT
ATC Site Number : 302484
Proposed Carrier : Cingular
Carrier Site Name : Branford
Carrier Site Number : 2015
County : New Haven
Eng. Number : 40480521R1
Date : June 15, 2007
Usage : 92.0% (Pole shaft)

Submitted by:
Robert Keith
Project Engineer

American Tower Engineering Services
8505 Freeport Parkway
Suite 135
Irving, TX 75063
Phone: 972-999-8900

Reviewed by:
Jaime Reyes, P.E.
Director of Engineering

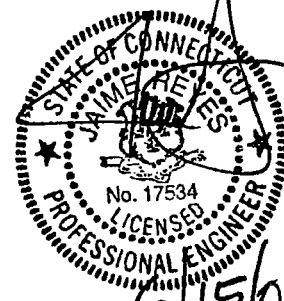

6/15/07

Introduction

The purpose of this report is to summarize results of the structural analysis performed on the 150 ft. ITT Meyer monopole located at Branford CT 6, CT, New Haven County (ATC site# 302484). The tower was originally designed by Paul J. Ford and Company (Job# 29297-629, dated Oct 2, 1997) and manufactured by ITT Meyer (Type "B" per AT&T Spec dated April 13, 1984). The pole base has been modified per SpectraSite Modification Drawing CT-0020 M1. The pole shaft has been structurally modified per ATC Modification Job# 26487334 dated 9/15/06.

Analysis

The tower was analyzed using Semaan Engineering Solutions, Inc., Software. The analysis assumes that the tower is in good, undamaged, and non-corroded condition. A 5% overstress is allowed in the existing structural members to account for program variances.

Basic Wind Speed: 90.0 mph (Fastest Mile) / 110.0 mph (3-Second Gust)
 Radial Ice: 77.9 mph (Fastest Mile) w/ ½" ice
 Code: TIA/EIA-222 Rev F / 2005 Connecticut Supplement to the International Building Code 2003

Antenna Loads

The following antenna loads were used in the tower analysis:

Existing Antennas

Elev. (ft)	Qty	Antennas	Mount	Coax (I/O)	Carrier
156.0	1	4' Omni	Platform w/ Rails	(1) 1 5/8 (I)	USA Mobility
	1	Yagi		(1) ½ (I)	
	2	Decibel DB408		(2) 7/8 (I)	Town of Branford
153.0	6	Cleargain TMD1900		-	Cingular
	3	Diplexer		-	
	1	4' Omni		(1) 1 5/8	USA Mobility
140.0	6	Remec G20057A1 TMA	(3) T-Arm	-	T-Mobile
	6	RFS APX16PV-16PVL-E		(12) 1 5/8 (O)	
113.0	3	Decibel DB932DG90E-M	(3) T-Arm	(3) 1 1/4 (I)	Verizon
	6	Decibel DB844H90E		(6) 1 1/4 (I)	
103.0	2	Decibel DB408	(2) Standoff	(2) 7/8 (I)	Town of Branford
93.0	1	Decibel DB408	(1) Standoff	(1) 7/8 (I)	
16.0	1	Channel Master 1.2 M Dish	Dish Mount	(1) RG6 (O)	USA Mobility

Antenna Loads (continued)**Proposed Antennas**

Elev. (ft)	Qty	Antennas	Mount	Coax (I/O)	Carrier
153.0	6	Powerwave 7770-2	Platform w/ Rails	(6) 1 5/8 (I)	Cingular

Install proposed coax inside monopole.

Results

The existing 150 ft. ITT Meyer monopole with the existing and the proposed antennas is structurally acceptable per TIA/EIA-222 Rev F standards. The maximum structure usage is: 92.0% (Pole shaft).

Additional exit and/or entry ports may be required to accommodate the running of the proposed lines to the proposed antennas. These additional ports **may not** be installed without installation drawings providing the location, size and welding requirements of each port.

To ensure compliance with all conditions of this structural analysis, port installation drawings shall be provided by American Tower's Engineering Department under a subsequent project.

Pole Reactions	Original Design Reactions	Current Analysis Reactions	% Of Design
Moment (ft-kips)	3101.5	2,821.51	91.0
Shear (kips)	33.0	30.93	93.7

The structure base reactions resulting from this analysis are acceptable when compared to the reactions shown on the original structure drawings.

Conclusion

Based on the analysis results, the structure meets the requirements per TIA/EIA-222 Rev F and 2005 Connecticut Supplement to the 2003 IBC standards. The tower and foundation can support the existing and proposed antennas with the TX line distribution as described in this report.

If you have any questions or require additional information, please call 972-999-8900.

Standard Conditions

All engineering services are performed on the basis that the information used is current and correct. This information may consist of, but is not necessary limited, to:

- Information supplied by the client regarding the structure itself, the antenna and feed line loading on the structure and its components, or other relevant information.

- Information from drawings in the possession of American Tower Corporation, or generated by field inspections or measurements of the structure.

It is the responsibility of the client to ensure that the information provided to ATC Engineering Services and used in the performance of our engineering services is correct and complete. In the absence of information to the contrary, we assume that all structures were constructed in accordance with the drawings and specifications and are in an un-corroded condition and have not deteriorated; and we, therefore, assume that their capacity has not significantly changed from the "as new" condition.

All services will be performed to the codes specified by the client, and we do not imply to meet any other codes or requirements unless explicitly agreed in writing. If wind and ice loads or other relevant parameters are to be different from the minimum values recommended by the codes, the client shall specify the exact requirement. In the absence of information to the contrary, all work will be performed in accordance with the latest relevant revision of ANSI/EIA-222.

All services are performed, results obtained, and recommendations made in accordance with generally accepted engineering principles and practices. ATC Engineering Services is not responsible for the conclusions, opinions and recommendations made by others based on the information we supply.

Copyright Semaan Engineering Solutions, Inc

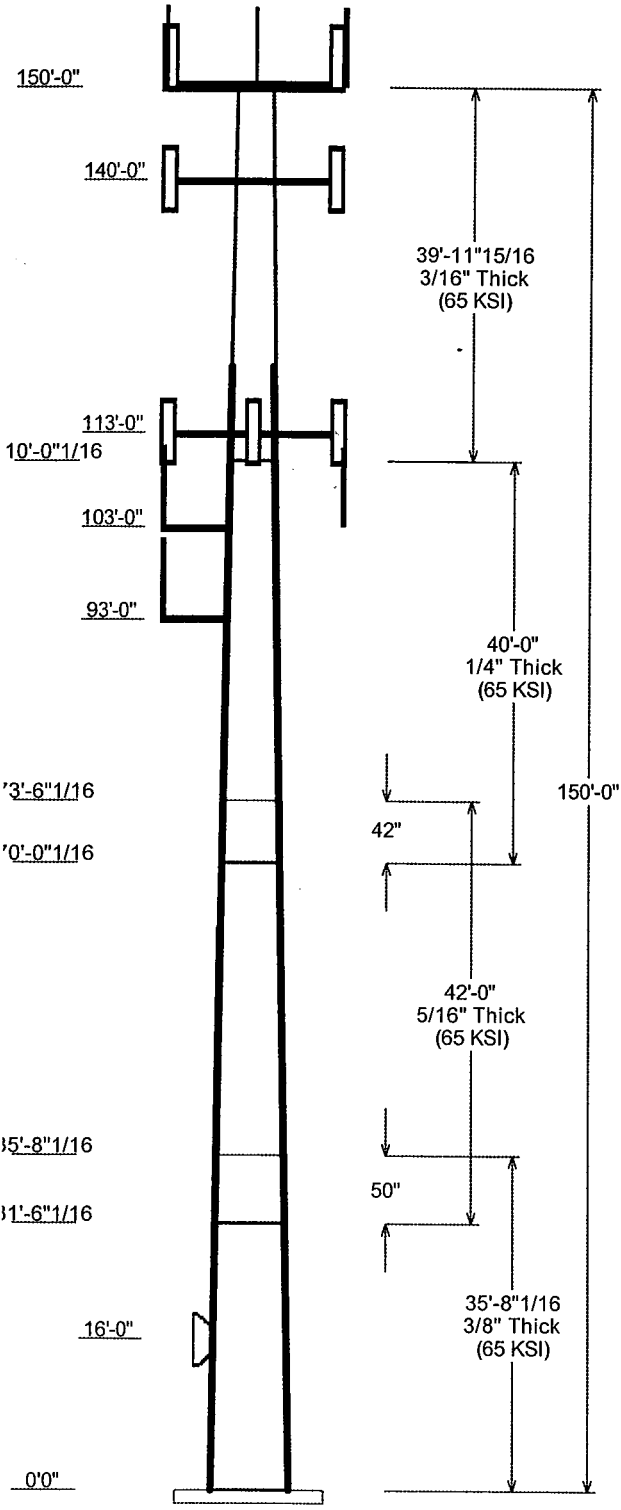

Job Information			
Pole:	302484	Code:	TIA/EIA-222 Rev F
Description:	150 ft. ITT Meyer monopole		
Client:	Cingular		
Location:	Branford CT 6, CT		
Shape:	12 Sides	Base Elev (ft):	0.00
Height:	150.00 (ft)	Taper:	0.156705(in/ft)

Sections Properties							
Shaft Section	Length (ft)	Diameter (in)		Thick Joint (in)	Overlap Length (in)	Steel Taper (in/ft)	Steel Grade (ksi)
		Across Top	Flats Bottom				
1	35.670	31.79	37.38	0.375	0.000	0.156705	65
2	42.000	26.48	33.06	0.313 Slip Joint	50.000	0.156705	65
3	40.000	21.26	27.53	0.250 Slip Joint	42.000	0.156705	65
4	39.997	15.00	21.26	0.188 Butt Joint	0.000	0.156705	65

Discrete Appurtenance			
Attach Elev (ft)	Force Elev (ft)	Qty	Description
150.000	150.000	3	Diplexer
150.000	153.000	6	Powerwave 7770-2
150.000	150.000	1	Yagi
150.000	156.000	2	Decibel DB408
150.000	153.000	6	Cleargain TMD1900
150.000	156.000	1	4' Omni
150.000	150.000	1	Platform w/ Rails
140.000	140.000	3	T-Arm
140.000	140.000	6	Remec G20057A1 TMA
140.000	140.000	6	RFS APX16PV-16PVL-E
113.000	113.000	3	T-Arm
113.000	113.000	3	Decibel DB932DG90E-M
113.000	113.000	6	Decibel DB844H90E
103.000	103.000	1	Standoff
103.000	107.710	2	Decibel DB408
93.000	93.000	1	Standoff
93.000	97.710	1	Decibel DB408
16.000	16.000	1	Channel Master 1.2 M Dish

Linear Appurtenance			
Elev (ft) From	To	Description	Exposed To Wind
0.000	16.000	RG6	No
0.000	66.000	#18 Dywidag bars	No
0.000	93.000	7/8" Coax	No
0.000	103.0	7/8" Coax	No
0.000	113.0	1 1/4" Coax	No
0.000	123.0	#18 Dywidag bars	Yes
0.000	140.0	1 5/8" Coax	Yes
0.000	150.0	1 5/8" Coax	No
0.000	150.0	1 5/8" Coax	No
0.000	150.0	1/2" Coax	No
0.000	150.0	7/8" Coax	No

Load Cases	
No Ice	90.00 mph Wind with No Ice
Ice	77.94 mph Wind with Ice
Twist/Sway	50.00 mph Wind with No Ice

Reactions			
Load Case	Moment (Kip-ft)	Shear (Kips)	Axial (Kips)

No Ice	2821.51	30.93	31.63
Ice	2176.58	21.63	39.48
Twist/Sway	871.83	9.55	31.69

Dish Deflections			
Load Case	Attach Elev (ft)	Deflection (in)	Rotation (deg)
Twist/Sway	16.00	0.388	0.228

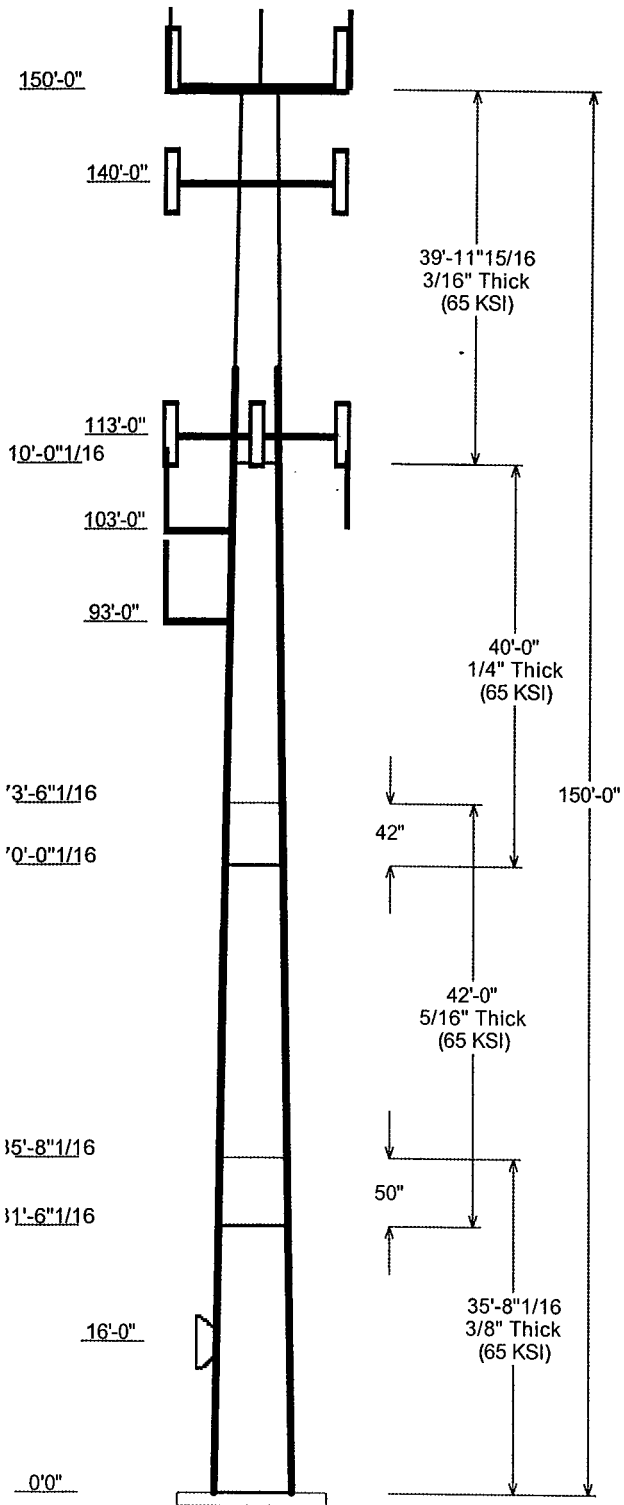



New Cingular Wireless PCS, LLC
500 Enterprise Drive
Rocky Hill, Connecticut 06067-3900
Phone: (860) 513-7636
Fax: (860) 513-7190

Steven L. Levine
Real Estate Consultant

June 21, 2007

Honorable Cheryl P. Morris
1st Selectman, Town of Branford
Town Hall 1019 Main St.
Branford, CT 06405-0150;

Re: Telecommunications Facility – 405 Brushy Plain Road, Branford

Dear Ms. Morris:

In order to accommodate technological changes, implement Uniform Mobile Telecommunications System (“UMTS”) capability, and enhance system performance in the State of Connecticut, New Cingular Wireless PCS, LLC (“Cingular”) will be changing its equipment configuration at certain cell sites.

As required by Regulations of Connecticut State Agencies (“R.C.S.A.”) Section 16-50j-73, the Connecticut Siting Council has been notified of the changes and will review Cingular’s proposal. Please accept this letter as notification under Section 16-50j-73 of construction which constitutes an exempt modification pursuant to R.C.S.A. Section 16-50j-72(b)(2).

The accompanying letter to the Siting Council fully describes Cingular’s proposal for the referenced cell site. However, if you have any questions or require any further information on our plans or the Siting Council’s procedures, please call me at (860) 513-7636 or Mr. Derek Phelps, Executive Director, Connecticut Siting Council at (860) 827-2935.

Sincerely,

Steven L. Levine
Real Estate Consultant

Enclosure

**CINGULAR WIRELESS
Equipment Modification**

Three Mile Road, Glastonbury, CT
Site Number 1100
Docket 174; Exempt Modifications 8/1/02

Tower Owner/Manager: Crown Castle

Equipment configuration: Monopole

Current and/or approved: Nine CSS DUO4-8670 @ 140 ft c.l.
Six TMA's @ 140 ft
Nine runs 1 ¼ inch coax

Planned Modifications: Remove three CSS antennas
Install three Powerwave 7770 antennas @ 140 ft c.l.
Remove three TMA's
Install six diplexers @ 140 ft
Install three additional runs 1 ¼ inch coax (total of 12)

Power Density:

Worst-case calculations for existing wireless operations at the site indicate a radio frequency electromagnetic radiation power density, measured at ground level beside the tower, of approximately 60.5 % of the standard adopted by the FCC. As depicted in the second table below, the total radio frequency electromagnetic radiation power density following proposed modifications would be approximately 56.2 % of the standard.

Existing

Company	Centerline Ht (feet)	Frequency (MHz)	Number of Channels	Power Per Channel (Watts)	Power Density (mW/cm ²)	Standard Limits (mW/cm ²)	Percent of Limit
Other Users *							52.03
Cingular TDMA *	140	880 - 894	16	100	0.0294	0.5867	5.00
Cingular GSM *	140	880 - 894	2	296	0.0109	0.5867	1.85
Cingular GSM *	140	1900 Band	2	427	0.0157	1.0000	1.57
Total							60.5%

* Per CSC Records

Proposed

Company	Centerline Ht (feet)	Frequency (MHz)	Number of Channels	Power Per Channel (Watts)	Power Density (mW/cm ²)	Standard Limits (mW/cm ²)	Percent of Limit
Other Users							52.03
Cingular GSM	140	880 - 894	2	296	0.0109	0.5867	1.85
Cingular GSM	140	1900 Band	1	427	0.0078	1.0000	0.78
Cingular UMTS	140	880 - 894	1	500	0.0092	0.5867	1.56
Total							56.2%

Structural information:

The attached structural analysis demonstrates that the tower and foundation have sufficient structural capacity to accommodate the proposed modifications. (PSG Engineering, Project No. 00701H130-A-160150, dated 5/20/07)



Date: **May 20, 2007**

Veronica Harris
Crown Castle International
1200 McArthur Blvd.
Mahwah, NJ 07430
(201) 236-9094

PSG Engineering, Ltd.
8206 Forest Gate Drive
Sugar Land, TX 77479

Phone: (281) 343-7099
Fax: (281) 343-7127

Subject: Analysis Structural Report

Carrier Designation *Cingular Wireless Co-Locate*
Carrier Site Number: "1100"
Carrier Site Name: "Glastonbury East-Three Mile Rd"

Crown Castle Designation: **Crown Castle BU Number:** 806368
Crown Castle Site Name: HRT 049B 943215
Crown Castle JDE Job Number: 87958

Engineering Firm Designation **PSG Engineering Project Number:** 0701H130-A160150

Site Data **Three Mile Road, Glastonbury, CT, Hartford County**
Latitude 41° 41' 36.3", Longitude -72° 32' 50.4"
145 Foot - Monopole Tower

Dear Ms. Harris,

PSG Engineering, Ltd. is pleased to submit this "Structural Analysis Report" to determine the structural integrity of the aforementioned tower. This analysis has been performed in accordance with the Crown Castle Structural 'Statement of Work' and the terms of Crown Castle Purchase Order Number 239574, in accordance with application 45332, revision 1.

The purpose of the analysis is to determine acceptability of the tower stress level. Based on our analysis we have determined the tower stress level for the structure and foundation, under the following load case, to be:

LC1: Existing + Reserved + Proposed Equipment

Sufficient Capacity

Note: See Table 1 and Table 2 for the proposed and existing/reserved loading.

The analysis has been performed in accordance with the TIA/EIA 222-F standard based upon a wind speed of 80 mph fastest mile (100 mph 3-second gust).

We at *PSG Engineering, Ltd.* appreciate the opportunity of providing our continuing professional services to you and Crown Castle International. If you have any questions or need further assistance on this or any other projects please give us a call.

Respectfully submitted,

Oscar Pedraza, P.E.
President

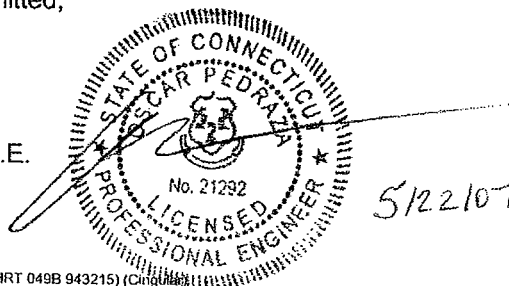

1) INTRODUCTION

The tower superstructure analysis is based on the original tower design by Engineered Endeavors, Inc. dated January 10, 1997 (TIA/EIA-222-E: 90 mph with 1/2" radial ice) and a tower base plate retrofit design by GPD Associates dated March 8, 2005. The tower substructure analysis is based on the original foundation design by Engineered Endeavors, Inc. dated March 25, 1997 and a geotechnical report by Dr. Clarence Welti, P.E., P.C. dated December 16, 1996.

2) ANALYSIS CRITERIA

This tower is designed using the TIA/EIA-222-F standard.
 The following design criteria apply:

- Basic wind speed of 80 mph.
- Nominal ice thickness of 0.5000 in.
- Ice density of 56 pcf.
- A wind speed of 69 mph is used in combination with ice.
- Deflections calculated using a wind speed of 50 mph.
- Feedline torque is considered.
- Pressures are calculated at each section.
- Stress ratio used in tower member design is 1.333

Table Legend
Proposed = (P)
Installed = (I)
Reserved = (R)

Table 1 – Proposed (P) Antenna and Cable Information

Center Line Elevation (feet)	Number Of Antenna	Antenna Manufacturer	Antenna Model	Mount	Number Of Feed Lines	Feed Line Size (Inches)
140	3(P)	Powerwave Technologies	7770.00	-	3(P) (Internal)	1 1/4
	6(P)		LGP13519			

Table 2 – Installed (I) and Reserved (R) Antenna and Cable Information

Center Line Elevation (feet)	Number Of Antenna	Antenna Manufacturer	Antenna Model	Mount	Number Of Feed Lines	Feed Line Size (Inches)
147	6(I)	Decibel	DB844G65ZAXY	Platform w/Handrail (1)	12(I) (Internal)	1 5/8
	6(I)		DB948F85T2E-M		1(I) (Internal)	1/2
	1(I)	Standard	GPS			
*140	*9(I)	*CSS	*DUO1417-8686	Platform w/Handrail (1)	9(I) (Internal)	1 1/4
	*9(I)	*ADC	*Dual Band 800/1900 FullBand Masthead			
128	12(I)	Swedcom	ALP 9212-N	Low Profile Platform (1)	12(I) (Internal)	1 1/4
	2(I)	Standard	GPS		2(I) (Internal)	1/2
117	3(I)+3(R)	Celwave	APN199015	Low Profile Platform (1)	6(I) (Internal)	1 5/8
	6(I)	Standard	TMA			
97	1(I)	EMS Wireless	RR65-18-02DP	Single Standoff (2)	3(I) (External)	1 1/4
96	1(I)	Repeater Technologies	DA1900-39			
87	3(I)+3(R)	Allgon	7250.02	Low Profile Platform (1)	6(I) (External)	1 1/4

*Note: (3) Installed antennas and (3) Installed TMAs will be removed and replaced with proposed loads. (6) Installed antennas, (6) Installed TMAs, mount and all coax lines will remain to support proposed loading.

Table 3 – Original Tower Manufacturer Design Antenna and Cable Information

Center Line Elevation (feet)	Number Of Antenna	Antenna Manufacturer	Antenna Model	Mount	Number Of Feed Lines	Feed Line Size (Inches)
145	15	Swedcom	ALP 9212	Platform w/Handrail (1)	Not Available (Internal)	
140	15	Swedcom	ALP 11011	Platform w/Handrail (1)		
130	15	Swedcom	ALP 9212	Platform w/Handrail (1)		

3) ANALYSIS PROCEDURE

Table 4 – Documents Provided

Document	Remarks	Reference	Source
Original Tower Design	Engineered Endeavors, Inc.	262188	Crown Site Data Manager
Original Foundation Design		974245	
Geotechnical Report	Dr. Clarence Welti, P.E., P.C.	262197	
Tower Retrofit Design	GPD Associates	1037241	
CAD Level Drawing(s)	145',136',126',116',95',87' Level Drawing(s)	-	Crown CAD Dept.

3.1) Analysis Method

RISATower (Version 4.7.2.1), a commercially available software program, was used to create a three-dimensional model of the tower and calculate member stresses for various dead, live, wind, and ice load cases. All loads were computed in accordance with the ANSI/EIA/TIA 222F or the local building code requirements. Selected output from the analysis is included in Appendix A.

3.2) Assumptions

1. Tower and structures were built in accordance with the manufacturer's specifications.
2. The tower and structures have been maintained in accordance with the manufacturer's specifications.
3. The configuration of antennas, transmission cables, mounts, and other appurtenances are as specified in Tables 1 and 2 and the Level drawing(s) listed in Table 4.
4. When applicable, transmission cables are considered to be structural components for calculating wind loads, as allowed by TIA/EIA-222F.

If any of these assumptions are not valid or have been made in error, this analysis may be affected, and PSG Engineering should be allowed to review any new information to determine its effect on the structural integrity of the tower.

4) ANALYSIS RESULTS

Table 5 – Tower Component Stresses vs. Capacity – LC1

Notes	Component	Elevation (ft)	% Capacity	Pass/Fail
RISA Tower Analysis Summary:(Monopole)				
			Summary	
Notes:	Component	Elevation	% Capacity	Pass/Fail
	L1	145 - 92.5	47.4	Pass
	L2	92.5 - 44.7	55.0	Pass
	L3	44.7 - 0	60.0	Pass
Individual Components:				
Notes:	Component	Elevation	% Capacity	Pass/Fail
	Base Plate	-	38.4	Pass
	Anchor Bolts	-	63.0	Pass
	Base Foundation (Soil)	-	24.7	Pass
	Base Foundation (Footing) (Structural)	-	95.7	Pass
	Base Foundation (Pier) (Structural)	-	78.0	Pass
1	Base Foundation (Stability)	-	102.7	Pass
Structure Rating (max from all components) =				102.7%

Note: An overstress of 2.7% is sufficient.

4.1) Recommendations (if applicable)

No modifications are necessary.

Section	1	2	3
Length (ft)	52.50	52.79	51.29
Number of Sides	12	12	12
Thickness (in)	0.3438	0.4375	0.4688
Lap Splice (ft)			6.58
Top Dia (in)	20.5000	33.5105	45.8529
Bot Dia (in)	35.6400	48.6100	60.5000
Grade		A572-65	
Weight (K)	5.5	10.3	13.9

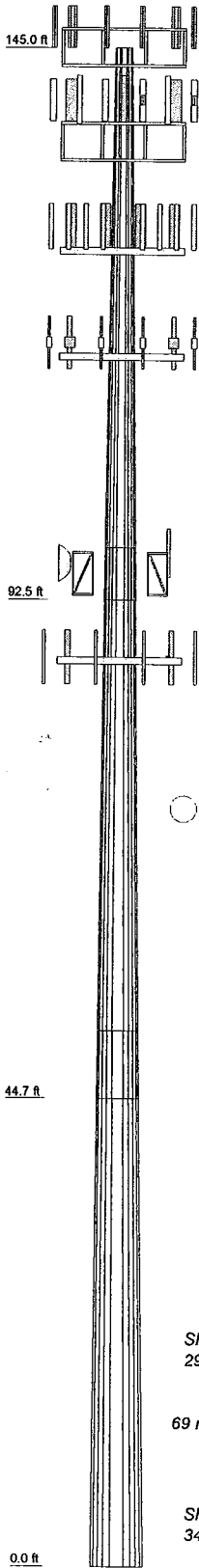

DESIGNED APPURTENANCE LOADING

TYPE	ELEVATION	TYPE	ELEVATION
(2) DB844G65ZAXY w/Mount Pipe	147	(4) ALP 9212-N w/Mount Pipe	128
(2) DB948F85T2E-M w/Mount Pipe	147	(4) ALP 9212-N w/Mount Pipe	128
(2) DB844G65ZAXY w/Mount Pipe	147	GPS	128
(2) DB948F85T2E-M w/Mount Pipe	147	PIROD 13' Low Profile Platform (Monopole)	126
(2) DB844G65ZAXY w/Mount Pipe	147	(2) APN199015 w/Mount Pipe	117
(2) DB948F85T2E-M w/Mount Pipe	147	(2) TMA	117
GPS	147	(2) APN199015 w/Mount Pipe	117
PIROD 13' Platform w/handrail	145	(2) TMA	117
(2) DUO1417-8686 w/Mount Pipe	140	(2) APN199015 w/Mount Pipe	117
7770.00 w/Mount Pipe	140	(2) TMA	117
(2) DD1900 FULL BAND MASTHEAD	140	(2) APN199015 w/Mount Pipe	116
(2) LGP13519	140	PIROD 13' Low Profile Platform (Monopole)	97
(2) DUO1417-8686 w/Mount Pipe	140	RR65-18-02DP w/Mount Pipe	96
7770.00 w/Mount Pipe	140	DA1900-39	95
(2) DD1900 FULL BAND MASTHEAD	140	Pirod 6' Side Mount Standoff (1)	95
(2) LGP13519	140	Pirod 6' Side Mount Standoff (1)	87
(2) DUO1417-8686 w/Mount Pipe	140	(2) 7250.02 w/Mount Pipe	87
7770.00 w/Mount Pipe	140	(2) 7250.02 w/Mount Pipe	87
(2) DD1900 FULL BAND MASTHEAD	140	PIROD 13' Low Profile Platform (Monopole)	87
(2) LGP13519	140	(2) 7250.02 w/Mount Pipe	87
PIROD 13' Platform w/handrail	136		
(4) ALP 9212-N w/Mount Pipe	128		
GPS	128		

MATERIAL STRENGTH

GRADE	Fy	Fu	GRADE	Fy	Fu
A572-65	65 ksi	80 ksi			

TOWER DESIGN NOTES

1. Tower is located in Hartford County, Connecticut.
2. Tower designed for a 80 mph basic wind in accordance with the TIA/EIA-222-F Standard.
3. Tower is also designed for a 69 mph basic wind with 0.50 in ice.
4. Deflections are based upon a 50 mph wind.
5. TOWER RATING: 60%

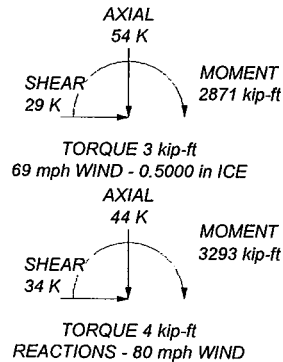

PSG Engineering, Ltd.
 245 Commerce Green Blvd., Suite 240
 Sugar Land, TX 77478
 Phone: 281.265.3444
 FAX: 281.265.3454

Job: PSG Engineering Project Number: 0701H130-A16015			
Project: (806368) (HRT 049B 943215)			
Client: Crown Castle International	Drawn by: PSG	App'd:	
Code: TIA/EIA-222-F	Date: 05/20/07	Scale: NTS	
Path: N:\Production\0701H130\806368.dwg	Dwg No. E-1		



New Cingular Wireless PCS, LLC
500 Enterprise Drive
Rocky Hill, Connecticut 06067-3900
Phone: (860) 513-7636
Fax: (860) 513-7190

Steven L. Levine
Real Estate Consultant

June 21, 2007

Richard J. Johnson, Town Manager
Town of Glastonbury
Town Hall 2155 Main St.
Glastonbury, CT 06033-6523

Re: Telecommunications Facility – Three Mile Road, Glastonbury

Dear Mr. Johnson:

In order to accommodate technological changes, implement Uniform Mobile Telecommunications System (“UMTS”) capability, and enhance system performance in the State of Connecticut, New Cingular Wireless PCS, LLC (“Cingular”) will be changing its equipment configuration at certain cell sites.

As required by Regulations of Connecticut State Agencies (“R.C.S.A.”) Section 16-50j-73, the Connecticut Siting Council has been notified of the changes and will review Cingular’s proposal. Please accept this letter as notification under Section 16-50j-73 of construction which constitutes an exempt modification pursuant to R.C.S.A. Section 16-50j-72(b)(2).

The accompanying letter to the Siting Council fully describes Cingular’s proposal for the referenced cell site. However, if you have any questions or require any further information on our plans or the Siting Council’s procedures, please call me at (860) 513-7636 or Mr. Derek Phelps, Executive Director, Connecticut Siting Council at (860) 827-2935.

Sincerely,

Steven L. Levine
Real Estate Consultant

Enclosure

**CINGULAR WIRELESS
Equipment Modification**

88 Main Street, Monroe
Former AT&T Cell Site
Cell Site number 5189
Exempt Modification approved 5/7/02

Tower Owner/Manager: T-Mobile

Equipment configuration Monopole Tower

Current and/or approved: Three Allgon 7250 panel antennas @ 175 ft c.l. (6 approved)
Six runs 1 5/8 inch coax

Planned Modifications: Remove all three existing antennas
Install three Powerwave 7770 antennas @ 175 ft c.l.
Install 6 TMA's @ 175 ft
Remove one existing outdoor cabinet from existing pad
Install one new outdoor equipment cabinet for UMTS

Power Density:

Worst-case calculations for existing wireless operations at the site indicate a radio frequency electromagnetic radiation power density, measured at ground level beside the tower, of approximately 8.3 % of the standard adopted by the FCC. As depicted in the second table below, the total radio frequency electromagnetic radiation power density following proposed modifications would be approximately 9.1 % of the standard.

Existing

Company	Centerline Ht (feet)	Frequency (MHz)	Number of Channels	Power Per Channel (Watts)	Power Density (mW/cm ²)	Standard Limits (mW/cm ²)	Percent of Limit
Other Users *							7.08
Cingular GSM *	175	1900 Band	4	250	0.0117	1.0000	1.17
Total							8.3%

* Per CSC records.

Proposed

Company	Centerline Ht (feet)	Frequency (MHz)	Number of Channels	Power Per Channel (Watts)	Power Density (mW/cm ²)	Standard Limits (mW/cm ²)	Percent of Limit
Other Users *							7.08
Cingular GSM	175	1900 Band	2	427	0.0100	1.0000	1.00
Cingular UMTS	175	880 - 894	1	500	0.0059	0.5867	1.00
Total							9.1%

* Per CSC records.

Structural information:

The attached structural analysis demonstrates that the tower and foundation have sufficient structural capacity to accommodate the proposed modifications. (Tectonic / Keyes Associates, dated 1/13/2003.)

Cingular is proposing to remove the 3 existing AT&T Allgon antennas and replace them with 3 Powerwave antennas. Additionally, we are proposing to install 6 TMA's. The 2003 structural analysis incorporates 6 Allgon antennas for AT&T and no TMA's. We submit that the 3 antennas not installed and the 6 new TMA's being placed on the tower are essentially equivalent in tower loading.

Moreover, and more importantly, the 2003 structural analysis accounts for 12 Cingular antennas at the 185 ft level of the tower. In fact, there is no loading at 185 ft and never has been. Cingular does not lease this level of the tower, and there is no other indication of a Cingular presence at 185 ft aside from this structural. Council records concur (T-Mobile @ 195 ft; AT&T@ 175 ft; Verizon @ 165 ft).

The attached recent photographs demonstrate a lack of loading at 185 ft.

We respectfully submit that the 12 phantom antennas accounted for in the analysis at 185 ft more than offset the 6 TMA's not accounted.

For reasons stated above, we submit that the 2003 analysis is adequate for present purposes, and that a new structural analysis is not required in support of the proposed modifications.

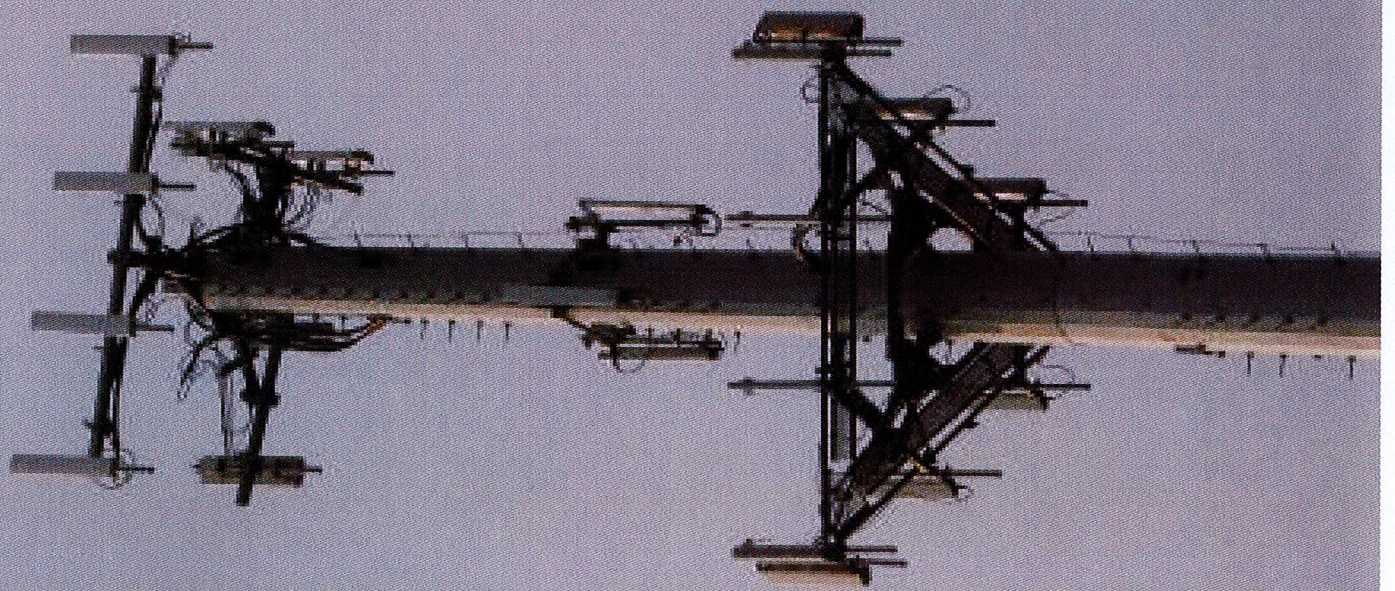



5189

TECTONIC / KEYES ASSOCIATES

Division of TECTONIC Engineering Consultants P.C.

CORPORATE OFFICE:
Mountainville, NY

(800)-829-6531

1344 Silas Deane Highway, Suite 500
Rocky Hill, Connecticut 06067

(860) 563-2341

Fax: (860) 257-4882

www.tectonicengineering.com

Mr. Mark Gauger
Verizon Wireless
99 East River Drive, 9th Floor
East Hartford, CT 06108

January 13, 2003

**RE: W.O. 2994.MONROE
VERIZON WIRELESS SITE MONROE SOUTH
EXISTING 195' MONOPOLE
88 MAIN STREET, MONROE, CT
STRUCTURAL CAPACITY**

Dear Mr. Gauger:

It is our understanding that Verizon is proposing to install antennas on the existing 195' monopole (currently under construction) at the above referenced site. Tectonic/Keyes Associates has performed a limited review of the structure's design for its suitability to support the proposed antennas. This review is based on the following information:

- Design drawings and calculations of 195' Monopole, Voicestream Wireless Site CT-11-215-A, Monroe, CT, by Paul J. Ford and Company on behalf of Summit Manufacturing, LLC, West Hazelton, PA, job no. 29201-0505, Summit Job # 13880, dated 5/4/01, signed and sealed by Kevin P. Bauman, Connecticut PE registration no. 17891.

The existing monopole is 18-sided, with a total height of 195'. It consists of four (4) slip-jointed sections. It has a base width of approximately 5'-2", and tapers to a width of 2'-2" at the top.

The foundation consists of a 8' diameter by 37'-6" deep caisson extending 6" above grade.

The original design was based on ANSI/EIA/TIA-222-F-1996 using a basic wind speed of 85 mph with no ice, and a reduced wind speed of 74 mph in conjunction with 0.5" radial ice. The structure was designed to support the following items:

- 1 – 5/8" Lightning Rod at the top
- 12 EMS RR90-17-00DP panel antennas on 14' T-arm mounts at the top
- 12 EMS RR90-17-00DP panel antennas on a 14' low profile platform at 185'
- 12 EMS RR90-17-00DP panel antennas on a 14' low profile platform at 175'
- 12 EMS RR90-17-00DP panel antennas on a 14' low profile platform at 165'
- 12 EMS RR90-17-00DP panel antennas on a 14' low profile platform at 155'
- 2 – 10' Whip antennas on 6' side arm mounts at 140'

ENGINEERS • SURVEYORS • CONSTRUCTION MANAGERS

An Equal Opportunity Employer

2994.MONROE

2

January 13, 2003

- 2 – 10' Whip antennas on 6' side arm mounts at 120'
- All antenna feed lines were assumed to run inside the pole

The original design criteria also included an Operational (50 mph) wind load case, which limited the sway of the pole. This was not the controlling loading case.

We note that the original design of the pole assumed that the panel antennas at each level would be installed four (4) per sector in a triangular array. This same assumption was used in our structural review.

We understand that the structure is currently supporting or will be supporting the following: nine (9) T-Mobile panel antennas on T-arm mounts at the top; twelve (12) Cingular panel antennas on a low profile platform at 185', and six (6) AT&T panel antennas on a low profile platform at 175'. It is our understanding that these are EMS RR90-17-00DP or similar antennas.

We further understand that Verizon is proposing to install a total of twelve (12) Decibel DB844H90(E)-XY panel antennas on a low profile platform at the 165' level.

In accordance with the provisions of ANSI/TIA/EIA-222-F-1996, "Structural Standards for Steel Antenna Towers and Antenna Supporting Structures", a basic wind speed of 85 mph applies to Fairfield County, CT, where the tower is located.

We have not preformed a detailed structural analysis of the tower, but have compared forces generated from the antennas and mounts of the original design to those generated by the proposed condition. Based on our extensive experience with similar structures and a comparison with the original tower design, it is clear that the tower and its foundation have adequate capacity to support this installation in accordance with current applicable codes.

Please contact this office if you require any further information.

Sincerely,
TECTONIC ENGINEERING & SURVEYING CONSULTANTS, P.C.

John D. Fuller, P.E.
Telecommunications Manager

Cc: File
Rachel Mayo – Robinson & Cole

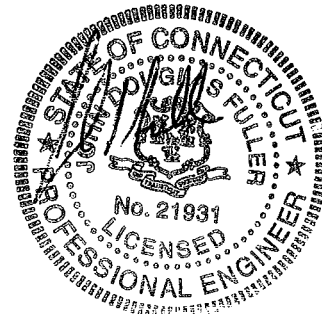

SUMMIT MANUFACTURING, LLC

225 KIWANIS BOULEVARD, WEST HAZLETON, PA 18201
 PHONE: (888) 847-6537 FAX: (888) 460-6885
 VISIT US AT WWW.SUMMITMFG.COM



PAUL J. FORD AND COMPANY
 STRUCTURAL ENGINEERS
 250 East Broad Street, Suite 500, Columbus, Ohio 43215
 (614) 221-6679 Fax: (614) 448-4105 www.PJFweb.com

JOB DATA			
Page 1 of 2	Job No.	29201-0505	
By MFP	Design No.	SUMMIT JOB #13880	
Chk'd By	Date	05-04-2001	
	Rev. No.	Rev. Date	
Pole	195-FT MONOPOLE		
Site	CT-11-215-A, MONROE, CT		
Owner	VOICESTREAM WIRELESS		
Ref. No.			
Design	85 MPH / 74 MPH + 1/2" RADIAL ICE ACCORDING TO TIA/EIA-222-F 1996		

LOAD CASES			
CASE 1	85 MPH WITH NO ICE	DESIGN WIND	
CASE 2	74 MPH WITH 1/2" RADIAL ICE	REDUCED WIND WITH ICE	
CASE 3	50 MPH WITH NO ICE	OPERATIONAL WIND	

POLE SPECIFICATIONS	
Pole Shape Type:	18-SIDED POLYGON
Taper:	0.196026 IN/FT
Shaft Steel:	ASTM A607 GRADE 65
Base PL Steel:	ASTM A572 GRADE 55 (55 KSI)
Anchor Bolts:	2 1/4" Ø x 8'-0" LONG #18J ASTM A615 GRADE 75

ANTENNA LIST		
No.	Elev.	Description
-	TOP	5/8" LIGHTNING ROD
1-12	TOP	(12) EMS RR90-17-00DP PCS PANEL
-	TOP	(3) 14' T-ARM MOUNTS
13-24	185.00	(12) EMS RR90-17-00DP PCS PANEL
-	185.00	14' LOW PROFILE PLATFORM
25-36	175.00	(12) EMS RR90-17-00DP PCS PANEL
-	175.00	14' LOW PROFILE PLATFORM
37-48	165.00	(12) EMS RR90-17-00DP PCS PANEL
-	165.00	14' LOW PROFILE PLATFORM
49-60	155.00	(12) EMS RR90-17-00DP PCS PANEL
-	155.00	14' LOW PROFILE PLATFORM
61-62	140.00	(2) 10' WHIP ANTENNA
-	135.00	6-FT SIDE ARM MOUNT
63-64	120.00	(2) 10' WHIP ANTENNA
-	115.00	6-FT SIDE ARM MOUNT

STEP BOLTS FULL HEIGHT.
 ANTENNA FEED LINES RUN INSIDE OF POLE.

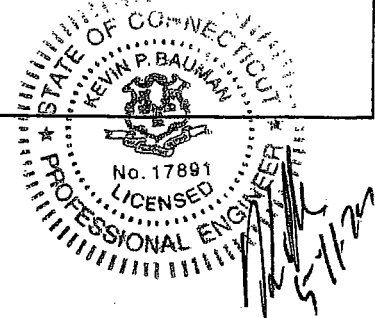

Elevation	85 MPH WIND		50 MPH WIND	
	Lateral Deflection (Inches)	Rotation (sway) (degrees)	Lateral Deflection (Inches)	Rotation (sway) (degrees)
TOP	153.8	6.555	53.1	2.268

SHAFT SECTION DATA					
Shaft Section	Section Length (feet)	Plate Thickness (in.)	Lap Splice (in.)	Diameter Across Flats (inches)	
				@ Top	@ Bottom
1	37.50	0.2500	51.00	26.000	33.351
2	45.00	0.3125	63.00	32.018	40.839
3	45.00	0.3750	72.00	39.185	48.006
4	45.00	0.3750	84.00	46.080	54.901
5	45.00	0.4375		52.779	61.600

NOTE: DIMENSIONS SHOWN DO NOT INCLUDE GALVANIZING TOLERANCES

BASE REACTIONS FOR FOUNDATION DESIGN

MOMENT = 5200 ft-kips
 SHEAR = 38 kips
 AXIAL = 58 kips

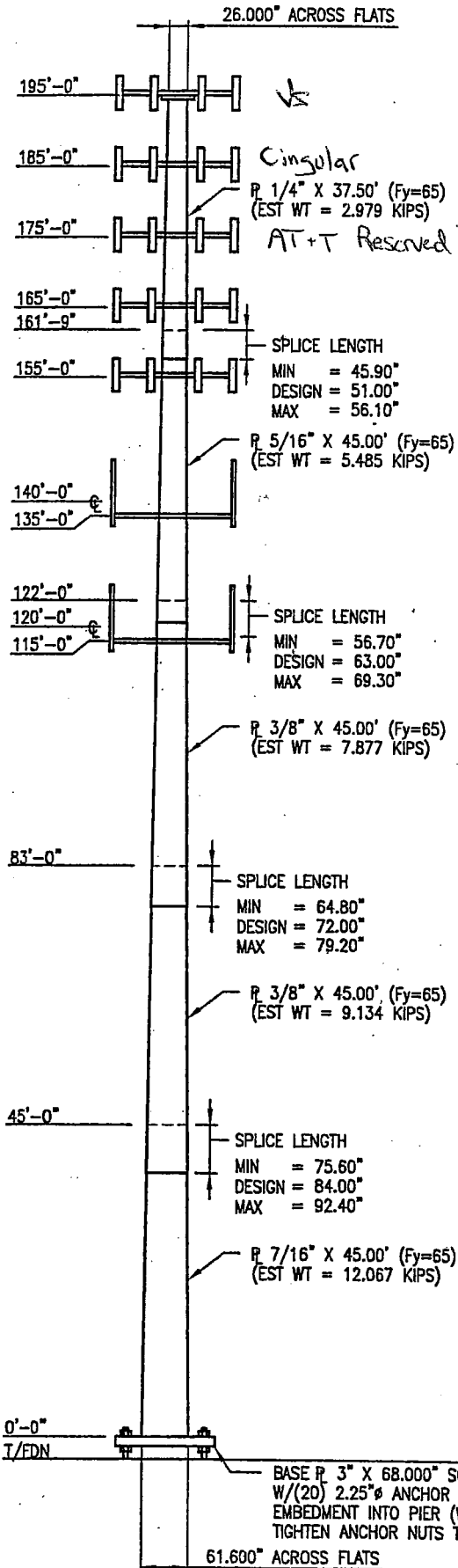

TOWER DRAWINGS \MONOPOLE\292-SUMMIT\292010505MOO1.DWG | 04-MAY-2001 | 10:19



New Cingular Wireless PCS, LLC
500 Enterprise Drive
Rocky Hill, Connecticut 06067-3900
Phone: (860) 513-7636
Fax: (860) 513-7190

Steven L. Levine
Real Estate Consultant

June 22, 2007

Honorable Andrew J. Nunn
Selectman, Town of Monroe
Town Hall, 7 Fan Hill Rd.
Monroe, Connecticut 06468

Re: Telecommunications Facility – 88 Main Street, Monroe

Dear Mr. Nunn:

In order to accommodate technological changes, implement Uniform Mobile Telecommunications System (“UMTS”) capability, and enhance system performance in the State of Connecticut, New Cingular Wireless PCS, LLC (“Cingular”) will be changing its equipment configuration at certain cell sites.

As required by Regulations of Connecticut State Agencies (“R.C.S.A.”) Section 16-50j-73, the Connecticut Siting Council has been notified of the changes and will review Cingular’s proposal. Please accept this letter as notification under Section 16-50j-73 of construction which constitutes an exempt modification pursuant to R.C.S.A. Section 16-50j-72(b)(2).

The accompanying letter to the Siting Council fully describes Cingular’s proposal for the referenced cell site. However, if you have any questions or require any further information on our plans or the Siting Council’s procedures, please call me at (860) 513-7636 or Mr. Derek Phelps, Executive Director, Connecticut Siting Council at (860) 827-2935.

Sincerely,

Steven L. Levine
Real Estate Consultant

Enclosure

**CINGULAR WIRELESS
Equipment Modification**

10 Sparks Street, Plainville, CT
Site Number 1054
Exempt Modifications 11/9/99 and 7/11/02

Tower Owner/Manager: Crown Castle

Equipment configuration: Monopole

Current and/or approved: Six CSS DUO1417 antennas @ 115 ft c.l.
Nine runs 7/8 inch coax
Six TMA's

Planned Modifications: Remove existing antennas
Install six Powerwave 7770 antennas @ 115 ft c.l.
Install six diplexers @ 115 ft
Install 3 additional runs 7/8 inch coax (total of 12)
AT&T installation decommissioned

AT&T Decommissioning:

In addition to modification for UMTS, hereby Cingular gives notice to the Council that the AT&T installation at the site has been decommissioned. AT&T antennas cluster-mounted at the very top of the tower and AT&T coax have been removed, as can be seen in the attached photograph taken shortly before this submission.

Power Density:

Worst-case calculations for existing or prior wireless operations at the site indicate a radio frequency electromagnetic radiation power density, measured at ground level beside the tower, of approximately 31.9 % of the standard adopted by the FCC. As depicted in the second table below, the total radio frequency electromagnetic radiation power density following proposed modifications would be approximately 27.6 % of the standard, including removal of AT&T's contribution.

Existing / Approved

Company	Centerline Ht (feet)	Frequency (MHz)	Number of Channels	Power Per Channel (Watts)	Power Density (mW/cm ²)	Standard Limits (mW/cm ²)	Percent of Limit
Other Users *							19.47
Cingular TDMA *	115	880 - 894	16	100	0.0435	0.5867	7.41
Cingular GSM *	115	880 - 8 94	2	296	0.0161	0.5867	2.74
Cingular GSM *	115	1930 - 1970	2	427	0.0232	1.0000	2.32
Total							31.9%

* Per CSC Records

Proposed

Company	Centerline Ht (feet)	Frequency (MHz)	Number of Channels	Power Per Channel (Watts)	Power Density (mW/cm ²)	Standard Limits (mW/cm ²)	Percent of Limit
Other Users *							17.30
Cingular GSM	115	880 - 894	5	296	0.0402	0.5867	6.86
Cingular GSM	115	1900 Band	1	427	0.0116	1.0000	1.16
Cingular UMTS	115	880 - 894	1	500	0.0136	0.5867	2.32
Total							27.6%

* Per CSC Records. AT&T removed from calculation.

Structural information:

The attached structural analyses demonstrate that the tower and foundation have sufficient structural capacity to accommodate the proposed modifications (URS Corp., dated 6/24/02.) This is corroborated by a more recent, but less detailed analysis by Dewberry-Goodkind dated 9/06. (Attached.) As a result, Cingular submits to the Council that it is not currently necessary to produce a new structural analysis.

Although the attached 2002 structural accounts for 3 fewer 7/8 inch coax than we are proposing to install, the analysis also includes loading for three AT&T antennas cluster-mounted at the top of the tower, as well as associated 1 5/8 inch coax cable. As previously noted, the AT&T equipment has been decommissioned and removed. This more than offsets the three 7/8 inch coax runs that are not included in the proposed Cingular loading.





Dewberry

59 Elm Street
Suite 101
New Haven, Connecticut 06510-2047

203 776 2277
203 776 2288 fax
www.dewberry.com

September 19, 2006

Mr. Jamie Andrews
Nextel Communications, Inc.
9 Crosby Drive
Bedford, MA 01730

**Re: Nextel Communications, Inc.
Plainville CT-1022
10 Sparks Street, Plainville, CT 06477**

Dear Sirs,

In response to your request, the following is our structural assessment of the proposal to remove and replace the 12 panel antennas of the Nextel wireless installation at the above referenced site. The existing antennas, identified as Allgon 7120.16.33.00 will be replaced by Decibel 844G90VTA-SX antennas and will be located at approximately 105 ft above grade level on a 130 ft monopole.

Our assessment is based on an analysis dated July 6, 2001 that was prepared by URS for AT&T Wireless when the tower was extended by 10ft to accommodate the AT&T installation at the top of the pole. According to URS the structural analysis was performed in accordance with the requirements of the ANSI/EIA/TIA-222-F Standard. Section 3108.4 of the 2003 International Building Code (the Connecticut State Building Code) addresses radio and television towers and references EIA/TIA-222-F for the design of antenna supporting structures to resist wind and ice loads.

The analysis by URS was based on an antenna inventory which included panel antennas for AT&T, Sprint, SNET and Nextel located from elevation 105 ft to 135 ft above grade with 10 ft separations. Three load cases were examined using a basic wind speed of 85 mph (fastest mile) for wind load calculations with and without ice and 50 mph for deflection checks. The analysis found that the tower could safely support the loads from the above arrangement of antennas and concluded that the foundations were also adequate since the forces generated at the base of the pole were less than those used for the original design of the 120 -125 ft monopole. The wind area used in the URS analysis for the Nextel antennas is 4.1 ft² per antenna; the replacement antennas will have a wind area of 1.1 ft² each, a 73% reduction. The URS analysis was based on an 85 mph (fastest mile) basic wind speed. The current building code specifies wind speed as a 3-second gust speed and for Plainville the basic speed is 95 mph. Converting the 85 mph fastest mile speed to a 3-second gust speed gives a basic wind speed of approximately 120 mph. Since the wind load is proportional to the square of the wind speed, based on the current code the wind loads could be reduced by 37% and coupled with the 73% reduction in wind area, there is therefore ample capacity in the tower to support the proposed change in configuration of the Nextel antennas.

No information is available on the antenna installations of other carriers on the monopole and this assessment assumes that the wind loading at these locations does not exceed the original design assumptions made by URS, notwithstanding the excess capacity identified above by using the lower basic wind speed permitted by the building code. On the basis of the above it is our opinion that the loads imposed on the tower by the proposed reconfiguration of Nextel antennas can be accommodated without modification to the tower which remains in compliance with the Connecticut State Building Code. Please feel free to contact us if you have any questions.

Very truly yours,

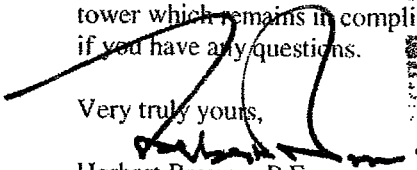
Herbert Browne, P.E.
Director, Building Structures

Dewberry-Goodkind, Inc.

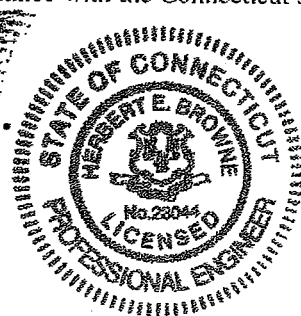

**DETAILED STRUCTURAL ANALYSIS AND
EVALUATION OF 125' EXISTING STEEL POLE
WITH A 10' PIPE EXTENSION FOR NEW
ANTENNA ARRANGEMENT**

**10 Sparks Street
Plainville, Connecticut
Site No.: 1054**

prepared for



Cingular Wireless
500 Enterprise Drive, Suite 3A
Rocky Hill, CT 06067

prepared by

URS

URS CORPORATION
795 BROOK STREET, BUILDING 5
ROCKY HILL, CT 06067
TEL. 860-529-8882

F300002292.02

Revised: June 24, 2002

1. **EXECUTIVE SUMMARY**

This report summarizes the structural analysis of the existing 125' steel pole with a 10' pipe extension located on 10 Sparks Street in Plainville, Connecticut. The analysis was conducted in accordance with the TIA/EIA-222-F standard for wind velocity of 80 mph bare and 70 mph concurrent with 1/2" ice. The antenna loading considered in the analysis consists of all existing and proposed antennas, transmission lines, and ancillary items as outlined on the following page of this report. The proposed Cingular Wireless modification is to replace the existing Cingular Wireless antennas with the antennas listed below:

(6) DUO4-8670 antennas and (6) Cingular @ 115' elevation
amplifiers with low profile platform
and (6) 7/8" coax cable within the
steel pole

(1) GPS antenna with stand-off Cingular @ 60' elevation
and (1) 1/2" coax cable

The results of the analysis indicate the structure to be in compliance with the loading conditions and the material and member sizes for the steel pole and foundation. The steel pole is considered feasible with the TIA/EIA-222-F wind load classification specified above and all the existing and proposed antenna loading.

This analysis is based on:

- 1) Tower and foundation design prepared by Pittsburgh Monopole Division dated January 28, 1997.
- 2) Antenna inventory as specified on the following page of this report.
- 3) TIA/EIA-222-F wind load classification.

This report is only valid as per the assumptions and data utilized in this report for antenna inventory, mounts and associated cables.

If you should have any questions, please call.

Sincerely,
URS Corporation AES

Mohsen Sahirad, P.E.
Senior Structural Engineer

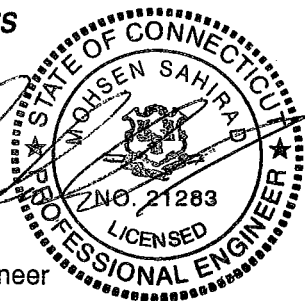

MS/rmn

cc: Mark Burke – Bechtel
Doug Roberts – URS
I.A. – URS
A.A. – URS
CF/Book

Introduction:

A structural analysis of this 125' communications steel pole with a 10' pipe extension was performed by URS Corporation AES (URS) for Cingular Wireless. The steel pole is located on 10 Sparks Street in Plainville, Connecticut.

The structure is self-supporting and was designed by Pittsburgh Monopole Division dated January 28, 1997.

This analysis was conducted to evaluate twist (rotation), sway (deflection), and stress on the steel pole. The analysis was also used to find the effect of the forces to the foundation resulting from the antenna arrangement listed below.

The antenna inventory obtained:

		<u>Antenna Centerline Elevation</u>
(3) DB932DG90E-M antennas flush mounted on the pipe extension and (6) 1 5/8" coax cable within or outside the steel pole	AT&T	@ 135' elevation
(9) DB980H90 antennas with platform w/ handrail and (9) 1-5/8" coax cable within the steel pole	Sprint	@ 125' elevation
(6) DUO4-8670 antennas and (6) amplifiers with low profile platform and (6) 7/8" coax cable within the steel pole	Cingular (proposed)	@ 115' elevation
(12) Allgon 7130.16 antennas with (3) T-Frame mounts and (12) 1-5/8" coax cable within the steel pole	Nextel	@ 105' elevation
(2) GPS antenna with stand-off and (1) 1/2" coax cable	Cingular (proposed)	@ 60' elevation

Note: 1. Porthole may be required. Installation of porthole shall be done per manufacturer suggestion.

2. Cingular Wireless shall conduct verification on the assumption of the antenna and mount configuration and that adequate space is available for routing the coaxial cable inside the steel pole prior to installation. Notify the engineer immediately if any of the assumptions in this report are found to be other than specified.

Structural Analysis:

Methodology:

The structural analysis was done in accordance with TIA/EIA-222-F June 1996, Structural Standard for Steel Antenna Towers and Antenna Supporting Structures, the American Institute of Steel Construction (AISC) and the Manual of Steel Construction; Allowable Stress Design (ASD).

The analysis was conducted using ERI Tower 2.0. Two load conditions were evaluated as shown below which were compared to allowable stresses according to AISC and TIA/EIA. The two load combinations were investigated in ERI Tower 2.0 to determine the stress, sway and rotation.

Load Condition 1 = 80 mph Wind Load (without ice) + Tower Dead Load
Load Condition 2 = 70 mph Wind Load (with ice) + Ice Load + Tower Dead Load

The TIA/EIA standard permits one-third increase in allowable stresses for towers and steel poles less than 700 feet tall. For purposes of this analysis, allowable stresses of the steel pole members were increased by one-third in computing the load capacity.

Evaluation of Steel Pole:

Combined axial and bending stresses on the steel pole structure were evaluated to compare with allowable stresses in accordance with AISC. The calculated stresses under the proposed loading were above the allowable stresses.

Analysis Results:

Our analysis determined that the steel pole and foundation will support the proposed new antenna arrangements under the analysis criteria outlined on the previous page.

Our analysis for the proposed new antenna arrangement and load condition is provided in Appendix A.

Limitations/Assumptions:

This report is based on the following:

1. Tower inventory for antennas and mounts as listed in this report.
2. Tower is properly installed and maintained.
3. All members were as specified in the original design Documents and are in good condition.
4. All required members are in place.
5. All bolts are in place and are properly tightened.
6. Tower is in plumb condition.
7. All members are galvanized.
8. All tower members were properly designed, detailed, fabricated, and installed and have been properly maintained since erection.
9. Foundations were properly constructed to support original design loads as specified in the original design Documents.
10. All co-axial cable is installed within or outside the steel pole, except as noted.

URS is not responsible for any modifications completed prior to or hereafter, which URS is not or was not directly involved. Modifications include but are not limited to:

1. Removing antennas
2. Adding antennas and amplifiers

URS hereby states that this document represents the entire report and that it assumes no liability for any factual changes that may occur after the date of this report. All representations, recommendations, and conclusions are based upon information contained and set forth herein. If you are aware of any information which conflicts with that which is contained herein, or you are aware of any defects arising from original design, material, fabrication, or erection deficiencies, you should disregard this report and immediately contact URS. URS disclaims all liability for any representation, recommendation, or conclusion not expressly stated herein.

Section	1								
Size	P12.75x3/8								
Length (ft)	10.000								
Grade									
Weight (K)	0.5								
Section	2								
Size	P24x3/8								
Length (ft)	45.000								
Grade	A-36M-50								
Weight (K)	4.3								
Section	3								
Size	P36x3/8								
Length (ft)	40.000								
Grade	A-36M-50								
Weight (K)	5.7								
Section	4								
Size	P42x1/2								
Length (ft)	40.000								
Grade	A-36M-50								
Weight (K)	8.9								



DESIGNED APPURTENANCE LOADING

TYPE	ELEVATION	TYPE	ELEVATION
DB932DG90E-M	135	(2) Amp	115
DB932DG90E-M	135	(2) Amp	115
DB932DG90E-M	135	(2) Amp	115
(3) DB980H90	125	(4) Alligon 7130.16	105
(3) DB980H90	125	(4) Alligon 7130.16	105
(3) DB980H90	125	(4) Alligon 7130.16	105
Platform w/handrill	125	T-Frame	105
Low Profile Platform	115	T-Frame	105
(2) DUO4-8670	115	T-Frame	105
(2) DUO4-8670	115	GPS	60
(2) DUO4-8670	115	Stand-off arm	60

MATERIAL STRENGTH

GRADE	YIELD	GRADE	YIELD
A36M-50	50 ksi		

TOWER DESIGN NOTES

1. Tower designed for a 80 mph basic wind in accordance with the TIA/EIA-222-F Standard.
2. Tower is also designed for a 70 mph basic wind with 0.50 in ice.
3. Deflections are based upon a 50 mph wind.
4. Weld together tower sections have flange connections.
5. Connections use galvanized A325 bolts, nuts and locking devices.
6. Installation per TIA/EIA-222-F and AISC Specifications.
7. Tower members are "hot dipped" galvanized in accordance with ASTM A123 and ASTM A153 Standards.
8. TOWER RATING: 86%

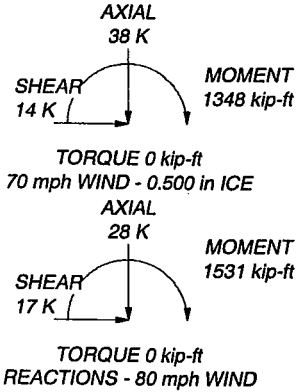

URS CORPORATION		Job: 125' Steel Pole w/ 10' extension	
795 Brook Street, Building 5		Project: Plainville, CT	
Rocky Hill, Connecticut 06067		Cilent: Cingular Wireless	Drawn by: Robert M. Niernied
Phone: (860) 529-8882		Code: TIA/EIA-222-F	Date: 06/24/02
FAX: (860) 529-5566		Path: P:\Telecom\F12\Plainville (Option 1).eri	App'd: _____
			Scale: NT
			Dwg No. E



New Cingular Wireless PCS, LLC
500 Enterprise Drive
Rocky Hill, Connecticut 06067-3900
Phone: (860) 513-7636
Fax: (860) 513-7190

Steven L. Levine
Real Estate Consultant

June 22, 2007

Robert E. Lee, Town Manager
Town of Plainville
Municipal Center, 1 Central Square
Plainville, CT 06062

Re: Telecommunications Facility – 10 Sparks Street, Plainville

Dear Mr. Lee:

In order to accommodate technological changes, implement Uniform Mobile Telecommunications System (“UMTS”) capability, and enhance system performance in the State of Connecticut, New Cingular Wireless PCS, LLC (“Cingular”) will be changing its equipment configuration at certain cell sites.

As required by Regulations of Connecticut State Agencies (“R.C.S.A.”) Section 16-50j-73, the Connecticut Siting Council has been notified of the changes and will review Cingular’s proposal. Please accept this letter as notification under Section 16-50j-73 of construction which constitutes an exempt modification pursuant to R.C.S.A. Section 16-50j-72(b)(2).

The accompanying letter to the Siting Council fully describes Cingular’s proposal for the referenced cell site. However, if you have any questions or require any further information on our plans or the Siting Council’s procedures, please call me at (860) 513-7636 or Mr. Derek Phelps, Executive Director, Connecticut Siting Council at (860) 827-2935.

Sincerely,

Steven L. Levine
Real Estate Consultant

Enclosure

**CINGULAR WIRELESS
Equipment Modification**

82 Mechanic Street, Stonington, CT
Site Number 5748
Former AT&T Wireless Cell Site
Exempt Modifications 11/7/02

Tower Owner/Manager: T-Mobile

Equipment configuration: Stealth Flagpole

CSC Approved: Three Allgon 7250 antennas @ 135 ft c.l.
Three Allgon 7250 antennas @ 129 ft c.l.

Existing: Two Allgon 7250 antennas @ 127 ft c.l.
Four lines 1 ¼ inch coax

Planned Modifications: Remove existing antennas
Install two Powerwave 7770 antennas at 127 ft c.l.
Install four TMA's @ 127 ft

Power Density:

Worst-case calculations for existing wireless operations at the site indicate a radio frequency electromagnetic radiation power density, measured at ground level beside the tower, of approximately 5.7 % of the standard adopted by the FCC. As depicted in the second table below, the total radio frequency electromagnetic radiation power density following proposed modifications would be approximately 7.4 % of the standard.

Existing / Approved

Company	Centerline Ht (feet)	Frequency (MHz)	Number of Channels	Power Per Channel (Watts)	Power Density (mW/cm ²)	Standard Limits (mW/cm ²)	Percent of Limit
Other Users *							3.59
Cingular GSM *	135	1900 Band	2	250	0.0099	1.0000	0.99
Cingular GSM *	129	1900 Band	2	250	0.0108	1.0000	1.08
Total							5.7%

* Per CSC Records

Proposed

Company	Centerline Ht (feet)	Frequency (MHz)	Number of Channels	Power Per Channel (Watts)	Power Density (mW/cm ²)	Standard Limits (mW/cm ²)	Percent of Limit
Other Users *							3.59
Cingular UMTS	127	880 - 894	1	500	0.0111	0.5867	1.90
Cingular GSM	127	1900 Band	2	427	0.0190	1.0000	1.90
Total							7.4%

* Per CSC Records

Structural information:

The attached structural analysis performed for T-Mobile in October 2002 by Semaan Engineering Solutions allots 6 Allgon antennas and 12 lines 1 ¼ inch coax to AT&T (now Cingular) in two of the tower's antenna bays. Cingular's proposal is to place only 2 Powerwave antennas and 4 lines 1 ¼ inch coax in the lower antenna bay and none in the upper bay. The Allgon and Powerwave antennas are roughly equivalent in terms of weight, and antenna wind-loading is not an issue for the stealth flagpole tower. Council records indicate, furthermore, that T-Mobile does not exceed the loading allotted to it by the structural.

Clearly, the 2002 structural analysis, which indicates that the tower and foundation have adequate structural capacity to accommodate earlier Council-approved loading conditions, assigns far more tower loading to Cingular than the current proposal requires. The 2002 structural analysis, therefore, remains valid to sustain the proposed loading conditions.

1047 N. 204th Avenue
Elkhorn, NE 68022
Ph:402-289-1888
Fax:402-289-1861

SEMAAN ENGINEERING SOLUTIONS

150 ft PIROD Flagpole Structural Analysis

Prepared for:
VoiceStream Wireless
12920 SE 38th Street
Bellevue, WA 98006

Site: CT11307C / Stonington / AT&T
Pawcatuck, CT
MECHANIC STREET

October 7, 2002

Mr. Joseph Laurenzano
VoiceStream Wireless
12920 SE 38th Street
Bellevue, WA 98006

Re: Site Number CT11307C – Stonington, Pawcatuck, CT.

Dear Mr. Laurenzano:

We have completed the structural analysis for the existing monopole, located at the above referenced site. The purpose of this analysis is to determine that the existing monopole design is in conformance with the EIA/TIA-222-F standard for the proposed antennae loads installation. Refer to the Review and Recommendations section at the end of this report for the analysis results.

Description of Structure:

The structure is a 150 ft PIROD Flagpole.

Refer to PIROD drawing 151453-B dated October 12, 2000 for a detailed description of the structure.

Method of analysis:

The tower was analyzed using Semaan Engineering Solutions' software suite for communication structures. The structural analysis is performed using the SAPS finite element engine. The method is 3D, non-linear, which accounts for the second order geometric effects due to the displacements. It also treats guys as exact cable elements and therefore is ideal for guyed towers. The analysis was performed in conformance with **EIA/TIA-222-F for 85 mph with 1/2" radial ice.** Wind is applied to the structure, accessories and antennas.

Structure loading:

Per the loading sheet supplied, the analysis was performed using the following loading: (Proposed loading in bold)

Elev. (ft)	Qty.	Antennas and Mounts	Coax	Owner
147.5	3	RR65-19-00DP w/Airtech LNA's Mounted Inside Fiberglass Shroud	(6) 1-5/8	T-Mobile
141.5	3	RR65-19-00DP w/Airtech LNA's Mounted Inside Fiberglass Shroud	(6) 1-5/8	T-Mobile
135.0	3	Allgon 7250 Mounted Inside Fiberglass Shroud	(6) 1-1/4	AT&T
129.0	3	Allgon 7250 Mounted Inside Fiberglass Shroud	(6) 1-1/4	AT&T
150.0	1	12' x 20' Flag		

All new access holes shall be reinforced with welded rims that are compatible with the pole and to be sized and supplied by pole manufacturer.

All transmission lines are assumed running inside of pole shaft. All antennas are assumed to be located completely within the top mounted fiberglass shroud.

Results of Analysis:

Refer to the attached Computer Summary sheets for detailed analysis results.

Structure:

The existing monopole is structurally capable of supporting the existing and proposed antennas. The maximum structure usage is: 96.3%.

Foundation:

Pole Reactions	Original Design Reactions	Current Analysis Reactions	% Of Design
Moment (ft-kips)	660.50	641.80	97.2

The structure base reactions resulting from this analysis do not exceed the ones shown on the original structure drawings.

Review and Recommendations:

Based on the analysis results, the existing structure meets the requirements per the EIA/TIA-222-F standards for a basic wind speed of 85 mph with 1/2" radial ice.

SEMAAN ENGINEERING SOLUTIONS

1047 N.204th Avenue
 Elkhorn, NE 68022
 Phone: 402-289-1888
 Fax: 402-289-1861

Copyright Semaan Engineering Solutions, Inc

Job Information	
Pole :	CT11307C
Description :	
Client :	VoiceStream Wireless-WA
Location :	Stonington, Pawcatuck, CT
Type :	Round Stepped Pole
Height :(ft)	126.000 Taper: 0.0000 (in/ft)

Sections Properties							
Shaft Section	Section Length (ft)	Diameter (in)		Thick (in)	Joint Type	Overlap Length (in)	Steel Grade (ksi)
		Across Flats Top	Across Flats Bottom				
1	30.000	30.00	30.00	0.375		0.000	42
2	30.000	24.00	24.00	0.375	Butt Joint	0.000	42
3	30.000	24.00	24.00	0.375	Butt Joint	0.000	42
4	20.000	24.00	24.00	0.375	Butt Joint	0.000	42
5	16.000	24.00	24.00	0.375	Butt Joint	0.000	42

Discrete Appurtenance					
Attach Elev (ft)	Force Elev (ft)	Type	Qty	Description	
147.500	147.500	Panel	3	RR65-19-00DP w/Airtech LNA's	
141.500	141.500	Panel	3	RR65-19-00DP w/Airtech LNA's	
135.000	135.000	Panel	3	Allgon 7250	
129.000	129.000	Panel	3	Allgon 7250	
126.000	138.000	Other	1	12' x 20' Flag	
126.000	138.000	Other	1	Fiberglass Shroud	

Load Cases / Deflections			
Load Case	Attach Elev (ft)	Translation (in)	Rotation (deg)
<u>No Ice</u>	<u>No Ice Wind Speed = 85.00 mph w/ No Ice</u>		
	126.000	61.31	-3.679
<u>Ice</u>	<u>Ice Wind Speed = 73.61 mph w/ Ice 0.50 in Thick</u>		
	126.000	48.21	-2.891

Reactions			
Load Case	Moment (Kip-ft)	Shear (Kips)	Axial (Kips)
No Ice	641.804	7.485	-13.189
Ice	503.783	5.835	-15.295

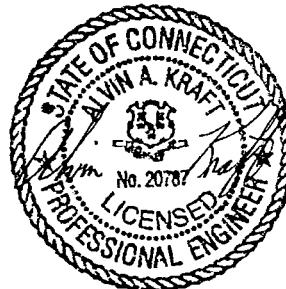
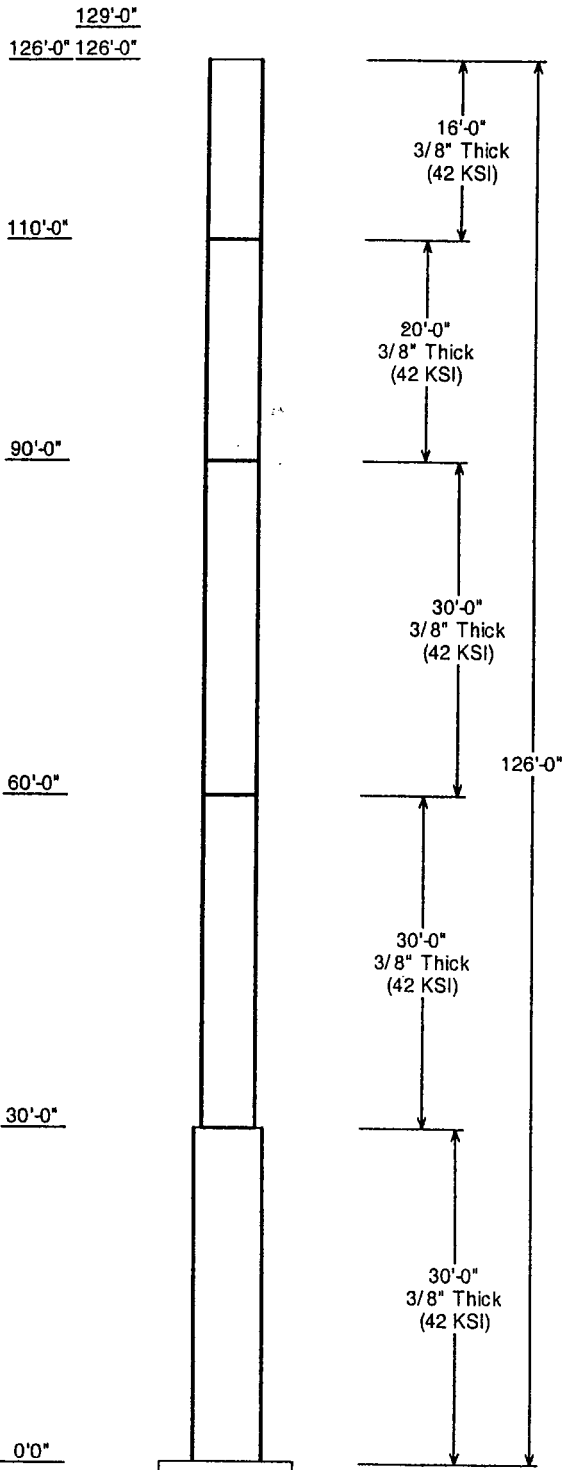

10-08-02



New Cingular Wireless PCS, LLC
500 Enterprise Drive
Rocky Hill, Connecticut 06067-3900
Phone: (860) 513-7636
Fax: (860) 513-7190

Steven L. Levine
Real Estate Consultant

June 21, 2007

Honorable William S. Brown
1st Selectman, Town of Stonington
Town Hall 152 Elm St.
Stonington, CT 06378-0352

Re: Telecommunications Facility – 82 Mechanic Street, Stonington

Dear Mr. Brown:

In order to accommodate technological changes, implement Uniform Mobile Telecommunications System (“UMTS”) capability, and enhance system performance in the State of Connecticut, New Cingular Wireless PCS, LLC (“Cingular”) will be changing its equipment configuration at certain cell sites.

As required by Regulations of Connecticut State Agencies (“R.C.S.A.”) Section 16-50j-73, the Connecticut Siting Council has been notified of the changes and will review Cingular’s proposal. Please accept this letter as notification under Section 16-50j-73 of construction which constitutes an exempt modification pursuant to R.C.S.A. Section 16-50j-72(b)(2).

The accompanying letter to the Siting Council fully describes Cingular’s proposal for the referenced cell site. However, if you have any questions or require any further information on our plans or the Siting Council’s procedures, please call me at (860) 513-7636 or Mr. Derek Phelps, Executive Director, Connecticut Siting Council at (860) 827-2935.

Sincerely,

Steven L. Levine
Real Estate Consultant

Enclosure