



STATE OF CONNECTICUT  
*CONNECTICUT SITING COUNCIL*

Ten Franklin Square, New Britain, CT 06051

Phone: (860) 827-2935 Fax: (860) 827-2950

E-Mail: [siting.council@ct.gov](mailto:siting.council@ct.gov)

Web Site: [portal.ct.gov/csc](http://portal.ct.gov/csc)

**VIA ELECTRONIC MAIL**

October 7, 2020

G. Scott Shepherd  
Site Development Specialist II  
SBA Communications Corporation  
134 Flanders Road, Suite 125  
Westborough, MA 01581

RE: **EM-T-MOBILE-004-200921** – T-Mobile notice of intent to modify an existing telecommunications facility located at 81 Montevideo Road, Avon, Connecticut.

Dear Mr. Shepherd:

The Connecticut Siting Council (Council) is in receipt of your correspondence of October 6, 2020 submitted in response to the Council's October 6, 2020 notification of an incomplete request for exempt modification with regard to the above-referenced matter.

The submission renders the request for exempt modification complete and the Council will process the request in accordance with the Federal Communications Commission 60-day timeframe.

Thank you for your attention and cooperation.

Sincerely,

*s/ Melanie A. Bachman*

Melanie A. Bachman  
Executive Director

MAB/IN/emr

**From:** Glenn Shepherd <GShepherd@sbsite.com>  
**Sent:** Tuesday, October 6, 2020 1:22 PM  
**To:** Fontaine, Lisa <Lisa.Fontaine@ct.gov>  
**Cc:** CSC-DL Siting Council <Siting.Council@ct.gov>  
**Subject:** RE: [External] Council Incomplete Letter for EM-T-MOBILE-004-200921 81 Montevideo Rd., Avon, CT

Lisa, & Siting Council –

Attached please find the corrected filing which includes the signed and stamped Construction Drawings (CDs) prepared by Chappell Engineering 9/4/20 as requested.

Rather than send only the corrected CDs, I thought I would correct the entire filing by removing the incorrect CDs and inserting the corrected CDs, so as to prevent any confusion. You may dispose of the original filing which was sent via email on 9/21/20 and refer to the attached, corrected filing for your review.

My apologies for the error and inconvenience.

Thank You,

**G. Scott Shepherd**

*Site Development Specialist II*

508.251.0720 Ext.3807 + **T**

508.366.2610 + F + **F**

508.868.6000 + C + **C**



Filed by:

G. Scott Shepherd, Site Development Specialist II - SBA Communications  
134 Flanders Rd., Suite 125, Westborough, MA 01581  
508.251.0720 x 3807 - GShepherd@sbsite.com

September 21, 2020

Melanie A. Bachman  
Acting Executive Director  
Connecticut Siting Council  
Ten Franklin Square  
New Britain, CT 06051

**RE: Notice of Exempt Modification**  
**81 Montevideo Rd., Avon, CT**  
**Latitude: 41.803100**  
**Longitude: -72.801300**  
**T-Mobile Site #: CT11284A\_Anchor**

Dear Ms. Bachman:

T-Mobile currently maintains three (3) 600/700/1900/2500 MHz antennas at the 136-foot level of the existing 150-foot Self-Supporting Tower at **81 Montevideo Rd., Avon, CT**. The 150-foot tower is owned by SBA 2012 TC Assets, LLC. The property is owned by Monte LLC. T-Mobile now intends to install one (1) additional 2500 MHz antenna. The new antennas would be installed at the 136-foot level of the tower.

**Please note:** Per the Connecticut Siting Council Website: CSC COVID 19 Guidelines.  
*In order to prevent the spread of Coronavirus and protect the health and safety of our members and staff, as of March 18, 2020, the Connecticut Siting Council shall convert to full remote operations until March 30, 2020. Please be advised that during this time period, all hard copy filing requirements will be waived in lieu of an electronic filing. Please also be advised that the March 26, 2020 regular meeting shall be held via teleconference. The Council's website is not equipped with an on-line filing fee receipt service. Therefore, filing fees and/or direct cost charges associated with matters received electronically during the above-mentioned time period will be directly invoiced at a later date.*

Planned Modifications:

TOWER

Remove:

- N/A

Remove and Replace:

- N/A

Install New:

- (1) Ericsson AIR 6449 B41 - antenna
- (1) Ericsson Radio 4415 B25 – RRU
- (1) 1-5/8" fiber

Existing Equipment to Remain:

- (1) Ericsson AIR32 KRD901146-1\_B66 – antenna
- (1) Ericsson AIR21 KRC118023-1 – antenna
- (1) RFS-APXVAARR24\_43-U-NA20 - antenna
- (1) Ericsson KRY112 144/2 - TMA
- (1) Ericsson 4449 B71+B12 – RRU
- (2) 1-5/8" coax
- (1) ½" coax for GPS (ground)
- (1) 1-5/8" fiber

Entitlements:

- (4) 1-5/8" cable
- (1) 1-1/4" hybrid cable

GROUND

Install New:

- Equipment mounted to proposed 8' x 8' x 6' concrete pad within 8' x 8' lease area in existing compound under proposed 8' x 8' weather canopy.
- Equipment inside existing 6160 equipment cabinet

Original tower was approved by Town of Avon zoning agencies, case# EM-MCM-004-070824 (enclosed), prior to statewide change in law in 2001, which brought it under the CSC's jurisdiction. Approval is for the replacement of a 150' self-support structure. The Tower was later approved by the CSC on Oct. 24, 2007, Docket# EM-MCM-004-070824 (enclosed) There were no further post construction stipulations set. Please see attached.

Please accept this letter as notification pursuant to Regulations of Connecticut State Agencies §16-50j-73, for construction that constitutes an exempt modification pursuant to R.C.S.A. §16.50j-72(b)(2). In accordance with R.C.S.A. § 16.50j-73, a copy of this letter is being sent to the Town of Avon's Director of Planning and Community Development, Hiram Peck III, and Town Manager, Brandon Robertson, as well as to the property owner, Monte LLC. (Separate notice is not being sent to tower owner, as it belongs to SBA.)

The planned modifications to the facility fall squarely within those activities explicitly provided for in R.C.S.A. §16.50j-72(b)(2).



1. The proposed modifications will not result in an increase in the height of the existing structure.
2. The proposed modification will not require the extension of the site boundary.
3. The proposed modifications will not increase noise levels at the facility by six decibels or more, or to levels that exceed state and local criteria.
4. The operation of the replacement antennas will not increase radio frequency emissions at the facility to a level at or above the Federal Communications Commission safety standard.
5. The proposed modification will not cause a change or alteration in the physical or environmental characteristics of the site.
6. The existing structure and its foundation can support the proposed loading.

For the foregoing reasons, T-Mobile respectfully submits that the proposed modifications to the above-referenced telecommunication facility constitute an exempt modifications under R.C.S.A. § 16-50j-72(b)(2).

Sincerely,

G. Scott Shepherd  
Site Development Specialist II  
SBA COMMUNICATIONS CORPORATION  
134 Flanders Rd., Suite 125  
Westborough, MA 01581

508.251.0720 x3804 + T  
508.366.2610 + F  
508.868.6000 + C  
GShepherd@sbsite.com

Attachments

cc: Hiram Peck III, Director of Planning and Community Development/with attachments  
Avon Town Hall, 60 West Main St., Avon, CT 06001  
Brandon Robertson, Town Manager / with attachments  
Avon Town Hall, 60 West Main St., Avon, CT 06001  
Monte LLC / with attachments  
40 Woodland St., Hartford, CT. 06105

Exhibit List

Exhibit 1	Check Copy	X To Be Invoiced by CSC per Covid 19 Guidelines
Exhibit 2	Notification Receipts	x
Exhibit 3	Property Card	x
Exhibit 4	Property Map	x
Exhibit 5	Original Zoning Approval	Town of Holland P&Z Commission 11/10/97
Exhibit 6	Construction Drawings	Chappell Engineering 9/4/20
Exhibit 7	Structural Analysis	TES dated 6/30/20
Exhibit 8	Mount Analysis	TES dated 7/8/20
Exhibit 9	EME Report	EBI Consulting 7/9/20

# EXHIBIT 1

Normally, Exhibit 1 would contain a copy of the check for the filing fee.

# EXHIBIT 2

ORIGIN ID:BFBA (508) 614-0389  
RICK WOODS  
SBA COMMUNICATIONS CORPORATION  
134 FLANDERS RD  
SUITE 125  
WESTBOROUGH, MA 01581  
UNITED STATES US

SHIP DATE: 21/SEP/20  
ACTWGT: 1.00 LB  
CAD: 105843304/NET14280

BILL SENDER

TO **MELANIE A. BACHMAN EXEC. DIR**  
**CONNECTICUT SITING COUNCIL**  
**TEN FRANKLIN SQUARE**

**NEW BRITAIN CT 06051**

(508) 251-0720 X 302 REF: 105692009-6089  
INV.  
PO. DEPT:

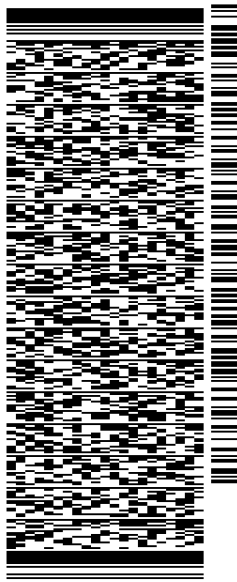

J2020071401uv

56B,J6/1545/B766

TRK# 7715 8106 3611  
0201  
TUE - 22 SEP 10:30A  
PRIORITY OVERNIGHT

**EBBDLA**

06051  
BDL  
CT-US

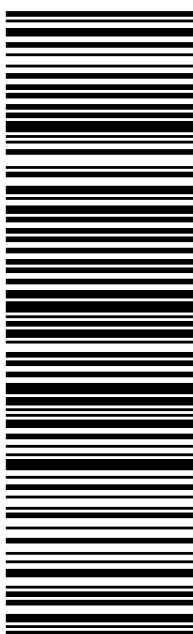

**After printing this label:**

1. Use the 'Print' button on this page to print your label to your laser or inkjet printer.
2. Fold the printed page along the horizontal line.
3. Place label in shipping pouch and affix it to your shipment so that the barcode portion of the label can be read and scanned.

**Warning:** Use only the printed original label for shipping. Using a photocopy of this label for shipping purposes is fraudulent and could result in additional billing charges, along with the cancellation of your FedEx account number.

Use of this system constitutes your agreement to the service conditions in the current FedEx Service Guide, available on fedex.com. FedEx will not be responsible for any claim in excess of \$100 per package, whether the result of loss, damage, delay, non-delivery, misdelivery, or misinformation, unless you declare a higher value, pay an additional charge, document your actual loss and file a timely claim. Limitations found in the current FedEx Service Guide apply. Your right to recover from FedEx for any loss, including intrinsic value of the package, loss of sales, income interest, profit, attorney's fees, costs, and other forms of damage whether direct, incidental, consequential, or special is limited to the greater of \$100 or the authorized declared value. Recovery cannot exceed actual documented loss. Maximum for items of extraordinary value is \$1,000, e.g. jewelry, precious metals, negotiable instruments and other items listed in our ServiceGuide. Written claims must be filed within strict time limits, see current FedEx Service Guide.

ORIGIN ID:BFBA (508) 614-0389  
RICK WOODS  
SBA COMMUNICATIONS CORPORATION  
134 FLANDERS RD  
SUITE 125  
WESTBOROUGH, MA 01581  
UNITED STATES US

SHIP DATE: 21/SEP/20  
ACTWGT: 1.00 LB  
CAD: 105843304/NET4280

BILL SENDER

TO **HIRAM PECK III, DIRECTOR OF PLANNIN**  
**AVON TOWN HALL**  
**60 WEST MAIN ST**

**AVON CT 06001**

(508) 251-0720 X.3807  
INV#  
PO:

REF: 105692009-6089

DEPT:

56B.J6/1545/B766

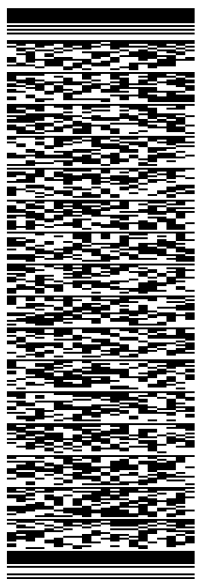

J2020071401uv

TRK# 7715 8111 6652  
0201  
TUE - 22 SEP 10:30A  
PRIORITY OVERNIGHT

**EB EHTA**

06001  
BDL  
CT:US

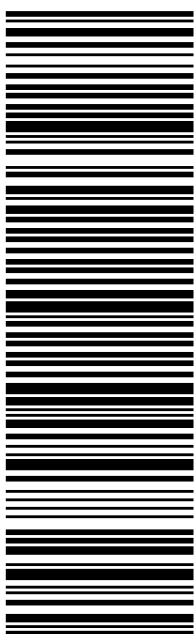

**After printing this label:**

1. Use the 'Print' button on this page to print your label to your laser or inkjet printer.
2. Fold the printed page along the horizontal line.
3. Place label in shipping pouch and affix it to your shipment so that the barcode portion of the label can be read and scanned.

**Warning:** Use only the printed original label for shipping. Using a photocopy of this label for shipping purposes is fraudulent and could result in additional billing charges, along with the cancellation of your FedEx account number.

Use of this system constitutes your agreement to the service conditions in the current FedEx Service Guide, available on fedex.com. FedEx will not be responsible for any claim in excess of \$100 per package, whether the result of loss, damage, delay, non-delivery, misdelivery, or misinformation, unless you declare a higher value, pay an additional charge, document your actual loss and file a timely claim. Limitations found in the current FedEx Service Guide apply. Your right to recover from FedEx for any loss, including intrinsic value of the package, loss of sales, income interest, profit, attorney's fees, costs, and other forms of damage whether direct, incidental, consequential, or special is limited to the greater of \$100 or the authorized declared value. Recovery cannot exceed actual documented loss. Maximum for items of extraordinary value is \$1,000, e.g. jewelry, precious metals, negotiable instruments and other items listed in our ServiceGuide. Written claims must be filed within strict time limits, see current FedEx Service Guide.

ORIGIN ID:BFBA (508) 614-0389  
RICK WOODS  
SBA COMMUNICATIONS CORPORATION  
134 FLANDERS RD  
SUITE 125  
WESTBOROUGH, MA 01581  
UNITED STATES US

SHIP DATE: 21/SEP/20  
ACTWGT: 1.00 LB  
CAD: 105843304/NET4280

BILL SENDER

TO BRANDON ROBERTSON, TOWN MGR.  
AVON TOWN HALL  
60 WEST MAIN ST

AVON CT 06001

(508) 251-0720 X 3807  
INV#  
PO:

REF: 105692009-6089

DEPT:

56B,J6/1545/B766

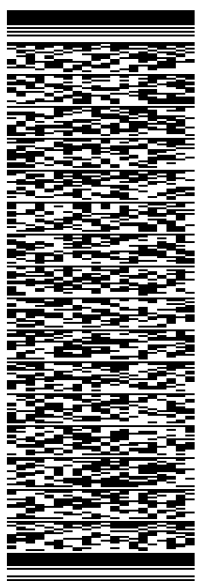

J2020071401uv

TRK# 7715 8113 9127  
0201  
TUE - 22 SEP 10:30A  
PRIORITY OVERNIGHT

EB EHTA

06001  
BDL  
CT:US

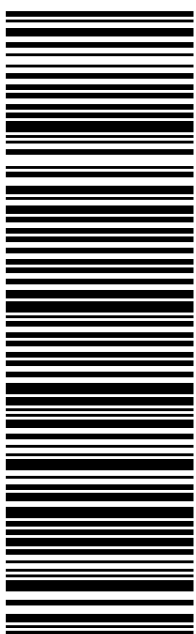

**After printing this label:**

1. Use the 'Print' button on this page to print your label to your laser or inkjet printer.
2. Fold the printed page along the horizontal line.
3. Place label in shipping pouch and affix it to your shipment so that the barcode portion of the label can be read and scanned.

**Warning:** Use only the printed original label for shipping. Using a photocopy of this label for shipping purposes is fraudulent and could result in additional billing charges, along with the cancellation of your FedEx account number.

Use of this system constitutes your agreement to the service conditions in the current FedEx Service Guide, available on fedex.com. FedEx will not be responsible for any claim in excess of \$100 per package, whether the result of loss, damage, delay, non-delivery, misdelivery, or misinformation, unless you declare a higher value, pay an additional charge, document your actual loss and file a timely claim. Limitations found in the current FedEx Service Guide apply. Your right to recover from FedEx for any loss, including intrinsic value of the package, loss of sales, income interest, profit, attorney's fees, costs, and other forms of damage whether direct, incidental, consequential, or special is limited to the greater of \$100 or the authorized declared value. Recovery cannot exceed actual documented loss. Maximum for items of extraordinary value is \$1,000, e.g. jewelry, precious metals, negotiable instruments and other items listed in our ServiceGuide. Written claims must be filed within strict time limits, see current FedEx Service Guide.

ORIGIN ID:BFBA (508) 614-0389  
RICK WOODS  
SBA COMMUNICATIONS CORPORATION  
134 FLANDERS RD  
SUITE 125  
WESTBOROUGH, MA 01581  
UNITED STATES US

SHIP DATE: 21/SEP/20  
ACTWGT: 1.00 LB  
CAD: 105843304/NET4280  
BILL SENDER

TO

MONTE LLC  
40 WOODLAND ST

HARTFORD CT 06105

(508) 251-0720 X 3807 REF: 105692009-6089  
INV# PO: DEPT:

56B,J6/1545/B766

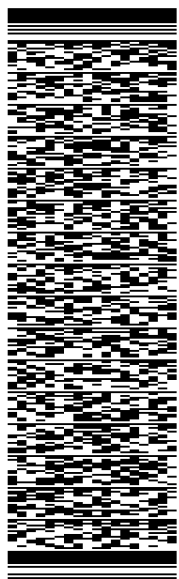

J2020071401uv

TRK# 7715 8116 9873 TUE - 22 SEP 10:30A  
0201 PRIORITY OVERNIGHT

EB KXAA

06105  
CT:US BDL

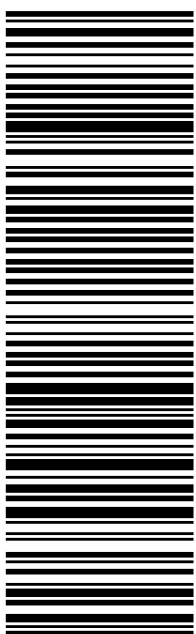

**After printing this label:**

1. Use the 'Print' button on this page to print your label to your laser or inkjet printer.
2. Fold the printed page along the horizontal line.
3. Place label in shipping pouch and affix it to your shipment so that the barcode portion of the label can be read and scanned.

**Warning:** Use only the printed original label for shipping. Using a photocopy of this label for shipping purposes is fraudulent and could result in additional billing charges, along with the cancellation of your FedEx account number.

Use of this system constitutes your agreement to the service conditions in the current FedEx Service Guide, available on fedex.com. FedEx will not be responsible for any claim in excess of \$100 per package, whether the result of loss, damage, delay, non-delivery, misdelivery, or misinformation, unless you declare a higher value, pay an additional charge, document your actual loss and file a timely claim. Limitations found in the current FedEx Service Guide apply. Your right to recover from FedEx for any loss, including intrinsic value of the package, loss of sales, income interest, profit, attorney's fees, costs, and other forms of damage whether direct, incidental, consequential, or special is limited to the greater of \$100 or the authorized declared value. Recovery cannot exceed actual documented loss. Maximum for items of extraordinary value is \$1,000, e.g. jewelry, precious metals, negotiable instruments and other items listed in our ServiceGuide. Written claims must be filed within strict time limits, see current FedEx Service Guide.



# EXHIBIT 3

Property at 00081 MONTEVIDEO ROAD

Prop ID 3180081

Printed 14-Feb-2019 8:15 PM Design and Layout (C) Right/Angles

Administrative Information	
Owner name:	MONTE LLC
Second name:	
Address:	40 WOODLAND STREET
City/state:	HARTFORD CT
Zip:	06105

Building Valuation Summary

		Area	
Dwelling	Frame	1 1/2 story w/bsmt	1,671
Basement	Full		256,410
Heating	Yes	A/C Yes	7,770
Plumbing	3 F/B	1 H/B 3 Add'l fix.	1 Wh/p Saunas
Attic	None	Attic size:	13,600
Additions			186,962
Other Features	WB Stks	RR	29,510
Sub-Total			494,252
Grade	B	Factor 1.2600	622,758
CDU		C&D Factor 1.00	622,758
Depreciation		40 %	373,655
Computed cost value @ 70%			261,559

Location Information						
Map: 015	Clerk map: 04 104					
Lot: 3180081	Neigh.: Zone: RU2A	Vol: 455	Page: 057			
Assessments		Exemptions		Last sale		
Assmt category	Qty	Amount	Exempt Cat	Amount	Sale date: 12-Jan-1987	
Resident Land	2.00	140,000			Sale price: 460,000	
Resident Dwelling	1.00	261,560			Sale valid:	
Resident Outbldg	2.00	1,020			Values	
Resident Excess	.50	2,630			Mkt value :	
Summary		Utilities		Sales ratios		
Total assessments	405,210	Water	Well	Cost/sale :	1.2584	
Total exemptions		Sewer	Septic	Mkt/sale :		
Net assessment	405,210	Gas	None	Assmt/sale:	.8809	

Building additions

Category	Type	Area	Value
G Garages	FRL Attached frame GT 65	704	23,363
L Living Area	FATT Full finished attic	352	9,417
L Living Area	AIR Air conditioning	352	793
P Porches, Patios, Decks	FOFF Frame open first flo	88	3,971
L Living Area	FRFF Frame first floor	148	12,550
L Living Area	AIR Air conditioning	148	333
L Living Area	FRFF Frame first floor	216	18,317
L Living Area	FRUH Frame upper half	216	8,182
L Living Area	BSMT Basement addition	216	2,948
L Living Area	AIR Air conditioning	324	730
L Living Area	FRFF Frame first floor	54	4,579
L Living Area	FRUF Frame upper full	54	3,349
L Living Area	AIR Air conditioning	108	243
L Living Area	FRFF Frame first floor	54	4,579
P Porches, Patios, Decks	FOFF Frame open first flo	54	2,437
L Living Area	FRFF Frame first floor	516	43,757
L Living Area	FRUF Frame upper full	516	32,003
L Living Area	BSMT Basement addition	516	7,043
L Living Area	AIR Air conditioning	1,032	2,324
P Porches, Patios, Decks	DECK Wood deck	308	6,044
Total additions			186,962

Land Information							
Type	Use	Acres/SqFt	Rate	Total	Infl Fact	Value	70% Value
PRIM	11	2,000	400,000	400,000	.50	200,000	140,000
Primary Site		87,120					
RES	12	.500	7,500	3,750		3,750	2,625
Residual		21,780					
		2.500 acres		Total land value		203,750	142,625

Residential Dwelling Information

Subject	Code	Description	Condominium	
Style	02	Cape		
Exterior Walls	01	Clapboards		
Roof Material	01	Asphalt Shingles	Story Height 1.5	
Roof Type	01	Gable		
Foundation	01	Poured Concrete	Total Rooms	8
Interior Walls	02	Drywall	Garage cars	3
Floors	01	Hardwood	Bedrooms	4
Heating System	02	Forced Hot Air	Family Rooms	1
Fuel	01	Oil	Full Baths	3
Attic	99	None	Half Baths	1
Grade	40	B	Addtn'l fixtures	3
Garage	23	Attached 3 car	Whirlpools	1
Area Over Gar.	03	Partial	Saunas	
Basement	01	Full	# Living Units	
Bsmt Fin Qual	02	Rec Room w/o air	M/F stacks	
Air Condition	01	Central Air	W/B stacks	1
Interior Cond	04	Average	W/B openings	2
Exterior Cond	04	Average	Actual Year Built: 1955	

Outbuilding Information

Description	Wid	Len	Area	Rate	Year	Chd	RCN	Depr	Value
RS1 Frame	10	9	90	20.00		C	1,800	50	900
Utility Shed									
RC2 Canopy	8	9	72	15.63		C	1,125	50	560
Value at 70%			1,022	Value at 100%			1,460		

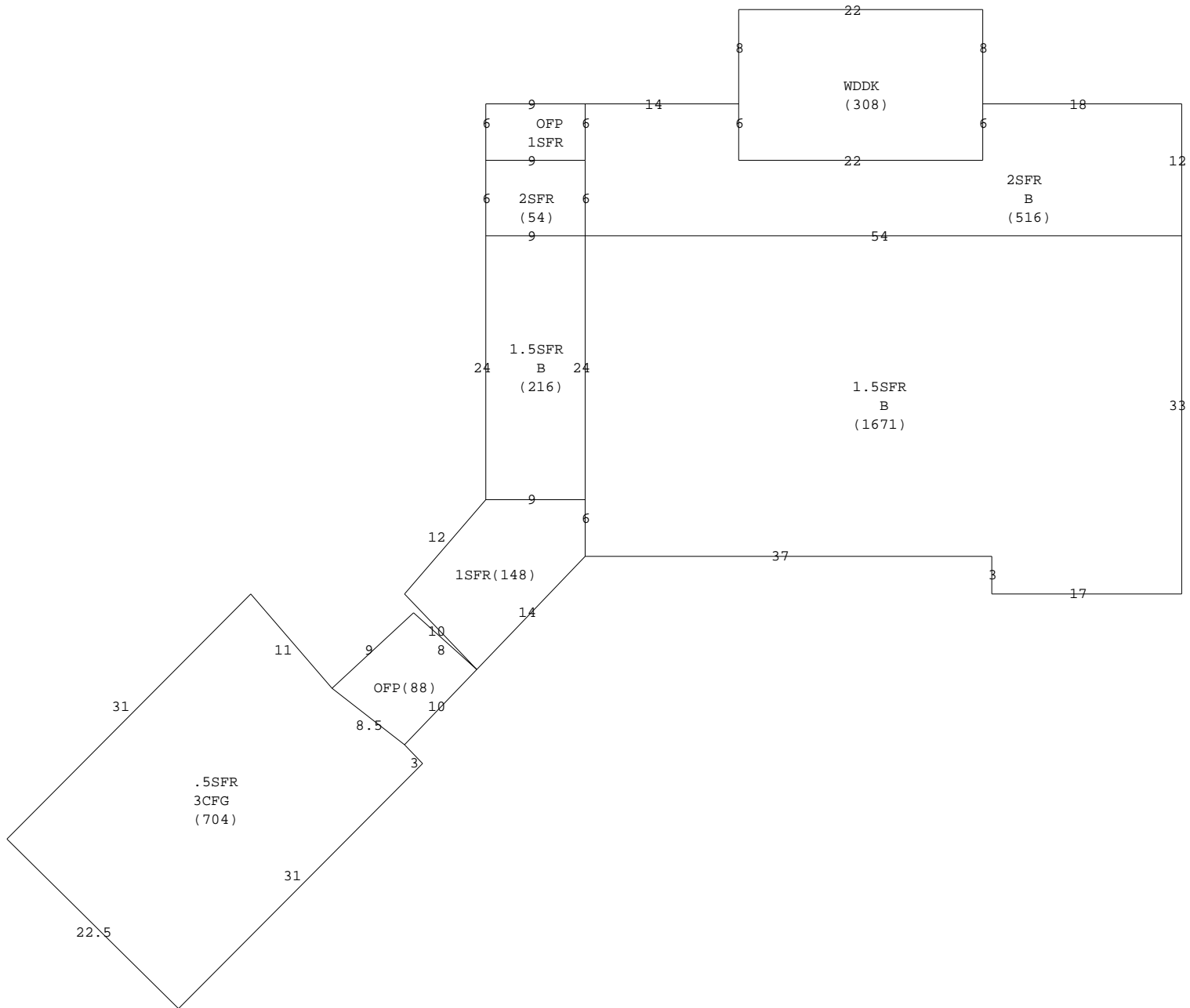

# EXHIBIT 4

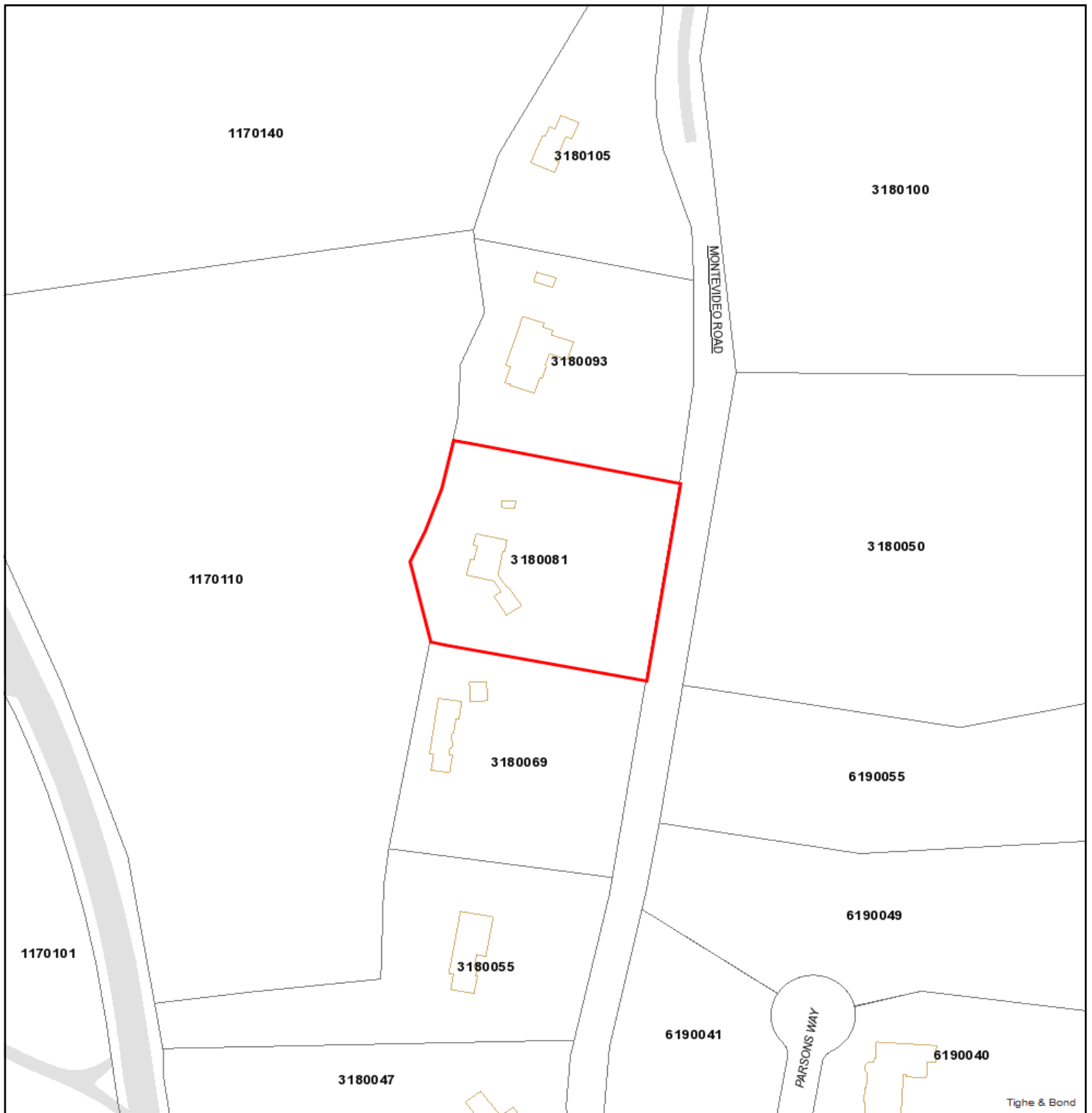

## 81 MONTEVIDEO ROAD

7/30/2020 6:44:12

1"=200'

### Property Information

GISPin	3180081
Location	81 MONTEVIDEO ROAD
Sale Price	460000



The information depicted on this map is for planning purposes only. It is not adequate for legal boundary definition, regulatory interpretation, or parcel-level analyses.

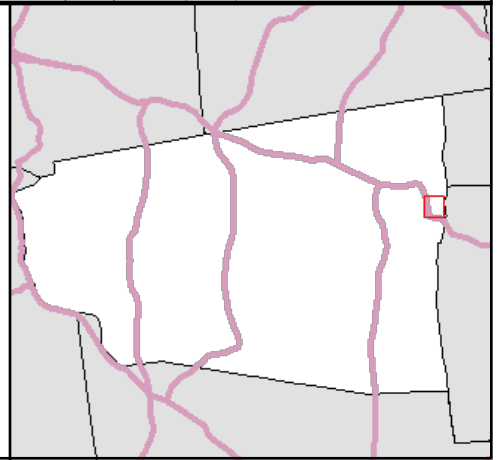

# EXHIBIT 5

SITE NAME: Avon (Montevideo) SITE ID: CT22071-A

Transaction: Message Center Management, Inc. (MCM) Jihan/Sam Toth

**ZONING/PERMITTING COMPLETION FORM**

CT-06

Address: 81 Montevideo Road, Avon, CT 06001

Jurisdiction: Connecticut Siting Council – Zoning (currently) Zoning District: RU2A

Town of Avon - Permitting

Zoning Approval Type: Exempt Modification Case #: EM-MCM-004-070824

Approval Date: 10/16/2007 Approved Height: 150

Conditions of Approval:	Yes
Removal Bond _____	<input type="checkbox"/>
Site Plan Submittal _____	<input type="checkbox"/>
Fall Zone _____	<input type="checkbox"/>
Periodic Inspections _____	<input type="checkbox"/>
Periodic Reporting _____	<input type="checkbox"/>
Approval Renewal _____	<input type="checkbox"/>
Additional Conditions _____	<input type="checkbox"/>

The original tower was approved by Town of Avon zoning agencies prior to a statewide change in the law in 2001 which subsequently brought it under the Connecticut Siting Council's jurisdiction.

Approval is for replacement of a 150 ft. guyed tower with a 150 ft. self-support structure. A routine & periodic inspection of the existing tower in January of 2007 showed the existing tower doesn't meet current structural standards. Therefore, tower needed to be replaced to meet current & future structural safety standards.

Planning/Zoning: \_\_\_\_\_

Phone: \_\_\_\_\_ Email: \_\_\_\_\_

Bldg./Code Enforcement: Susan Gatcomb

Phone: 860-409-4316 Email: sgatcomb@avonct.gov

Submitted by: *Batches Estes* Date: 3/27/2017  
Zoning Compliance

**TO BE COMPLETED BY CORPORATE**

	<u>Yes</u>	<u>No</u>	<u>N/A</u>	
Zoning Approval Attached (required)	<input checked="" type="checkbox"/>	<input type="checkbox"/>	<input type="checkbox"/>	
Building Permit Attached (required)	<input checked="" type="checkbox"/>	<input type="checkbox"/>	<input type="checkbox"/>	<u>Date Recd</u>
<u>08-0916</u>				<u>3/24/2008</u>
Certificate of Occupancy or Compliance (CO) attached (required)	<input checked="" type="checkbox"/>	<input type="checkbox"/>	<input type="checkbox"/>	<u>11/3/2008</u>
Zoning Manager Approval: <u><i>Ashley Masuda</i></u>				Date <u>3/28/2017</u>
<u>Ashley Masuda</u>				



Daniel F. Caruso  
Chairman

# STATE OF CONNECTICUT

## CONNECTICUT SITING COUNCIL

Ten Franklin Square, New Britain, CT 06051

Phone: (860) 827-2935 Fax: (860) 827-2950

E-Mail: [siting.council@ct.gov](mailto:siting.council@ct.gov)

Internet: [ct.gov/csc](http://ct.gov/csc)

October 24, 2007

Christopher B. Fisher, Esq.  
Cuddy & Feder LLP  
445 Hamilton Avenue, 14<sup>th</sup> Floor  
White Plains, NY 10601

RE: **EM-MCM-004-070824** – Message Center Management, Inc. notice of intent to modify an existing telecommunications facility located at 81 Montevideo Road, Avon, Connecticut.

Dear Attorney Fisher:

At a public meeting held on October 16, 2007, the Connecticut Siting Council (Council) acknowledged your notice to modify this existing telecommunications facility, pursuant to Section 16-50j-73 of the Regulations of Connecticut State Agencies with the condition that Message Center Management, Inc. will flag any trees slated for removal in the field and note the same on the construction drawings to be submitted as part of any building permit application.

The proposed modifications are to be implemented as specified here and in your notice dated August 23, 2007 and additional information dated September 28, 2007, including the placement of all necessary equipment and shelters within the tower compound. The modifications are in compliance with the exception criteria in Section 16-50j-72 (b) of the Regulations of Connecticut State Agencies as changes to an existing facility site that would not increase tower height, extend the boundaries of the tower site, increase noise levels at the tower site boundary by six decibels, and increase the total radio frequencies electromagnetic radiation power density measured at the tower site boundary to or above the standard adopted by the State Department of Environmental Protection pursuant to General Statutes § 22a-162. This facility has also been carefully modeled to ensure that radio frequency emissions are conservatively below State and federal standards applicable to the frequencies now used on this tower.

This decision is under the exclusive jurisdiction of the Council. Please be advised that the validity of this action shall expire one year from the date of this letter. Any additional change to this facility will require explicit notice to this agency pursuant to Regulations of Connecticut State Agencies Section 16-50j-73. Such notice shall include all relevant information regarding the proposed change with cumulative worst-case modeling of radio frequency exposure at the closest point of uncontrolled access to the tower base, consistent with Federal Communications Commission, Office of Engineering and Technology, Bulletin 65. Any deviation from this format may result in the Council implementing enforcement proceedings pursuant to General Statutes § 16-50u including, without limitation, imposition of expenses resulting from such failure and of civil penalties in an amount not less than one thousand dollars per day for each day of construction or operation in material violation.

Thank you for your attention and cooperation.

Very truly yours,

Daniel F. Caruso  
Chairman

DFC/MP/cm

c: The Honorable Richard W. Hines, Chairman Town Council, Town of Avon  
Steven V. Kushner, Town Planner, Town of Avon  
Hans Fiedler, Message Center Management, Inc.



August 23, 2007

**BY FEDEX - Priority Overnight**

Hon. Daniel F. Caruso, Chairman  
and Members of the Connecticut Siting Council  
10 Franklin Square  
New Britain, Connecticut 06051

Re: Message Center Management, Inc.  
Notice of Exempt Modification  
Replacement Tower  
81 Montevideo Road, Avon, Connecticut

Dear Chairman and Members of the Council:

On behalf of Message Center Management, Inc. ("MCM"), enclosed please find its notice of exempt modification with respect to the above referenced matter together with a check in the amount of \$500, the filing fee. We respectfully request that this matter be placed on the next Council agenda for acknowledgment. In the interim, should your of the Council's staff have any questions regarding this matter, please do not hesitate to contact us. Thank you.

Very truly yours,

  
Christopher B. Fisher

Enclosures

cc: Phillip K. Schenck, Avon Town Manager  
Steven Kushner, Town Planner  
Maria Scotti, MCM  
Hans Fiedler, MCM

## CONNECTICUT SITING COUNCIL

### **NOTICE OF EXEMPT MODIFICATION BY MESSAGE CENTER MANAGEMENT, INC. ("MCM") REGARDING A REPLACEMENT TOWER AT ITS EXISTING FACILITY IN AVON CONNECTICUT**

Pursuant to Connecticut General Statutes § 16-50g et. seq., and Section 16-50j-72(b)(3) of the Regulations of Connecticut State Agencies adopted pursuant thereto, Message Center Management, Inc. ("MCM") hereby notifies the Connecticut Siting Council of its intent to modify an existing facility located at 81 Montevideo Road, Avon, Connecticut (the "Avon Facility") by replacing the tower to the same height.

#### **The Existing Avon Tower Facility**

The Avon Facility consists of a one hundred fifty (150') foot guyed tower (the "Tower"), building and other improvements located on sizeable parcel of property in the Town of Avon. The Avon Facility is principally used by Omnipoint Communications Inc. ("T-Mobile") and Sprint Spectrum, L.P. ("Sprint") that provide "cellular" services to the public as that term is defined and used in Section 16-50i(a)(6) of the Connecticut General Statutes. The Avon Facility was originally approved by Town of Avon zoning agencies prior to a statewide change in the law in 2001 which subsequently brought it under the Siting Council's jurisdiction.

#### **Reasons for the proposed Tower Replacement**

MCM's consulting engineers completed a routine and periodic inspection of the existing Tower in January of 2007, a copy of which is enclosed. As noted therein, the existing tower does not meet current structural standards. As such a recommendation was made to replace the tower along with other interim measures which MCM has since completed. At this time, MCM is proposing to replace the tower to meet current and future structural safety standards.

#### **Replacement Tower**

As shown on the enclosed plans prepared by URS Corporation, including a survey, site plan, and tower elevation, MCM proposes replacing the existing 150' guyed tower with a self-support lattice tower maintaining the same height and antenna locations (the "Replacement Tower"). The Replacement Tower will be located immediately adjacent to the existing Tower approximately 15' to the east and will be designed to taper to a uniform tower face for a significant portion of its height above grade. No other antenna or equipment modifications are proposed by MCM.

### **MCM's Tower Replacement Constitutes An Exempt Modification**

The proposed replacement of the existing Tower constitutes an exempt modification of an existing facility as defined in Connecticut General Statutes Section 16-50i(d) and Council regulations promulgated pursuant thereto. Specifically 16-50j-72(b)(3) of the Council's regulations provides that, among other exempt modifications, included is a:

Replacement of an existing CATV tower or telecommunications tower and associated equipment with a tower that is no taller than the tower to be replaced....

Here the Replacement Tower is the same height as the existing Tower and as such the modification is exempt from the requirement for any further processing or approvals.

### **MCM's Discussions with Town Planning Officials**

We note that representatives of MCM have discussed this project with Town of Avon Planning Officials regarding the structural issues and different tower replacement options. As part of those discussions MCM noted for the Town that a replacement guyed tower would require substantial tree clearing at the Avon Facility site. In lieu of same, MCM has elected to replace the tower with a self support structure which will continue to accommodate users of the site and have a minimal impact on tree clearing. For reference purposes, we have also included photosimulations of the existing Tower and proposed Replacement Tower.

### **Conclusion**

MCM requests that the Connecticut Siting Council acknowledge that its proposed Replacement Tower at the Avon Facility meets the Council's exemption criteria specified in Section 16-72(b)(3) of its regulations. We note that no other land use or zoning approvals are required for the project pursuant to Section 16-50x of the Connecticut General Statutes. As such, upon receipt of the Council's acknowledgment, MCM intends to procure signed/sealed tower drawings from the manufacturer of the Replacement Tower and file for a building permit from the Town of Avon.

Respectfully Submitted,

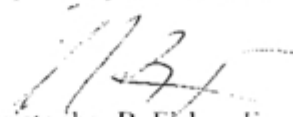

Christopher B. Fisher, Esq.  
On behalf of MCM

cc: Phillip K. Schenck, Avon Town Manager  
Steven Kushner, Town Planner  
Maria Scotti, MCM  
Hans Fiedler, MCM

TECTONIC Engineering & Surveying Consultants P.C.  
955 Little Britain Road  
New Windsor, NY 12553

(845) 567-6656 FAX: (845) 567-8703  
www.lectonicengineering.com

Virginia King  
Message Center Management  
40 Woodland Street  
Hartford, CT 06105

January 30, 2007

**RE: W.O. 3997.07  
AVON TOWER UPGRADE  
81 MONTEVIDEO ROAD  
AVON, CT  
ANALYSIS RESULTS AND RECOMMENDATIONS**

Dear Virginia:

As requested, Tectonic Engineering & Surveying Consultants P.C. has completed an inspection and detailed structural analysis of the existing 150' guyed tower at the above referenced site. The overall configuration of the tower is shown in Figure 1, attached.

The tower was inspected by representatives of Tectonic on 11/28/06. Based on our inspection, there are several items of concern with respect to the physical condition of the tower, as follows:

- Significant external corrosion of the tower mast, especially between the 100' and 130' levels.
- Considering the age of the tower and the use of light gauge steel tubing for the tower legs, we anticipate that internal corrosion may be present. Due to the thin walls of the tubing, even moderate corrosion can significantly reduce the structural capacity of the tower legs.
- The bracing members are very small diameter steel rods. Several are bent, which reduces their effectiveness.
- Some of the leg splice bolts are significantly corroded.
- The guys are small diameter and are generally not sufficiently taut.
- The antenna mounts at the 108' level are heavily corroded.
- Numerous existing cables are inadequately secured, and they are not efficiently bundled to minimize wind loading.

This analysis was performed using Revision G of the TIA-222 standard, as previously discussed. We find that the structure is significantly overloaded in its existing condition, despite the fact that the tower was assumed to be in "like-new" condition for the purpose

of the analysis. In other words, the capacities of the tower members and guys were not adjusted (i.e. reduced) to reflect their actual condition.

As a result of our analysis, we find that:

1. The existing tower is unable to withstand the required wind loading of 95 mph (3-second gust) with no ice accumulation.
2. The maximum wind speed that the tower can safely withstand is less than 60 mph.
3. The existing tower cannot support the required ice loading, even with no wind load acting on it at all.

The primary reasons for the large degree of overstress are:

- a. The small size and limited capacity of the leg and bracing members, as well as the guys.
- b. The inclusion of a topographic factor based on the site location, as required by TIA-222-G.
- c. The larger ice thickness required by TIA-222-G, compared to the previous version of the standard.

We note that previous Structural Analysis reports by Tectonic and at least two (2) other firms show that there were problems related to the capacity of the tower under Revision F of the TIA-222 standard.

Since no information on the existing tower foundation and guy anchors was available, we could not assess their actual capacities. Based on the large overstress in the tower mast and guys, we anticipate that the existing foundations may not have sufficient capacity to resist the required loads.

The tower will need to be upgraded to satisfy the current code requirements, and to provide capacity for modified antenna configurations in the future. Reinforcement is expected to involve the installation of heavy external bracing in approximately the lower half of the tower, and replacing the guys at several levels with larger size guy wires and matching hardware. It will also involve modifications to the tower base foundation and all guy anchors.

Although upgrading the tower to meet these requirements may be technically feasible, it may be as costly and disruptive as the construction of a new replacement tower.

We recommend the installation of a new, sturdier tower on a new foundation, and relocation of all existing antennas thereto, as a better alternative. We understand that

W.O. 3997.07  
Avon Tower Upgrade  
Avon, CT  
Analysis Results and Recommendations

Page 3

January 30, 2007

replacement of the structure does bring up other issues, but it will probably be more economical in the long run.

Anticipating that the processes for approval, procurement, and installation of a replacement tower may take a substantial amount of time, we recommend that the following corrective actions be taken as soon as possible:

1. Retension all of the guys to be between 8% and 10% of their breaking strength.
2. Clean and repaint the deteriorated portions of the tower to minimize further corrosion.
3. Bundle and securely fasten the cables to the tower legs or faces.
4. Perform a simple visual inspection of the structure after any severe wind or ice storm, to verify that no damage has occurred.

In closing, we foresee no problem with removing the two (2) existing T-Mobile panel antennas that are mounted at the 138' level, and reinstalling one (1) panel antenna at a lower elevation, as suggested.

Please contact me if there are any questions on the above.

Sincerely,

**TECTONIC**

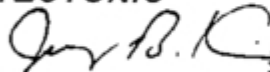

Jeffrey B. Kirby, P.E.  
Chief Structural Engineer



file AvonTowerUpgradeLtr.doc

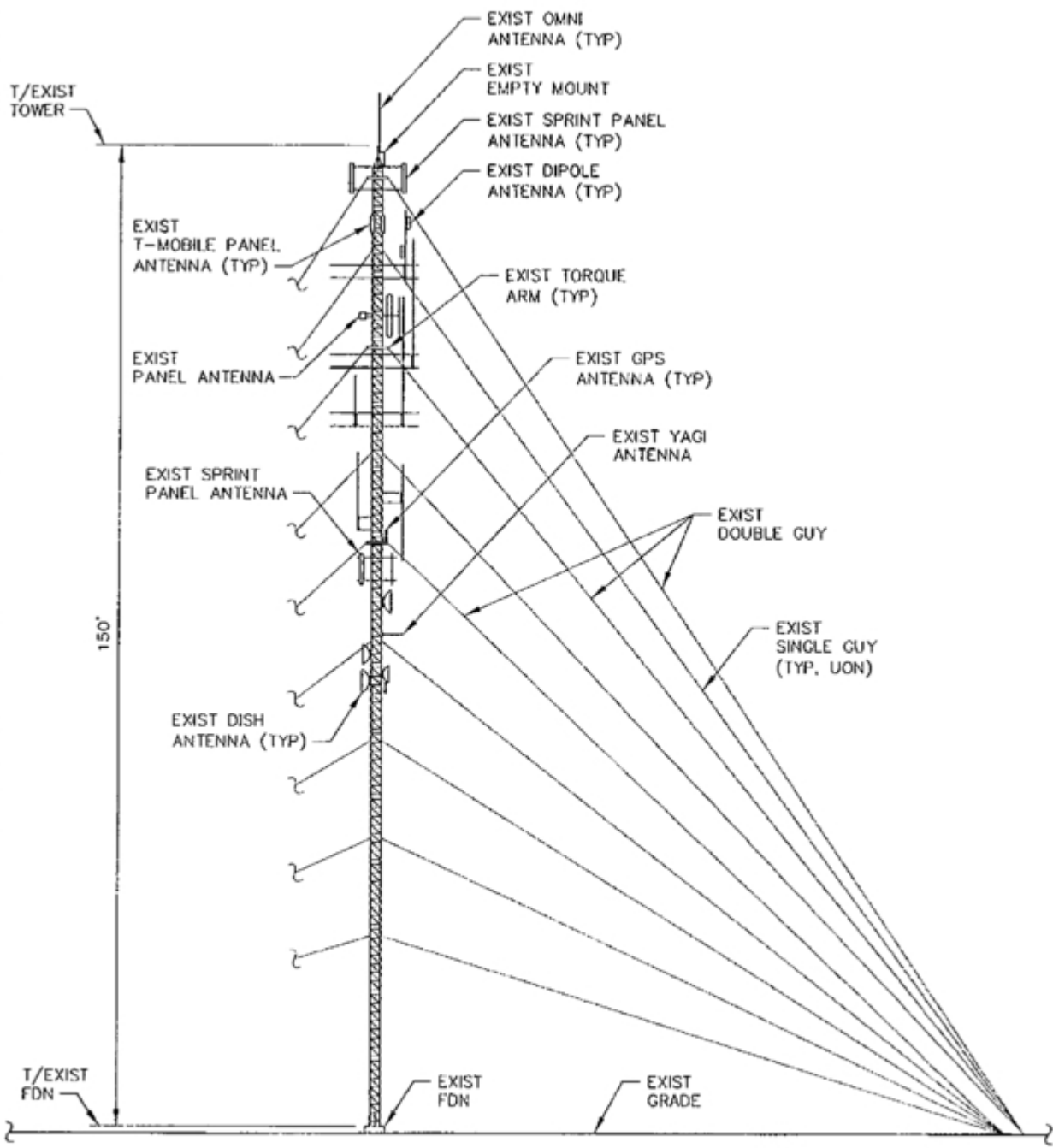
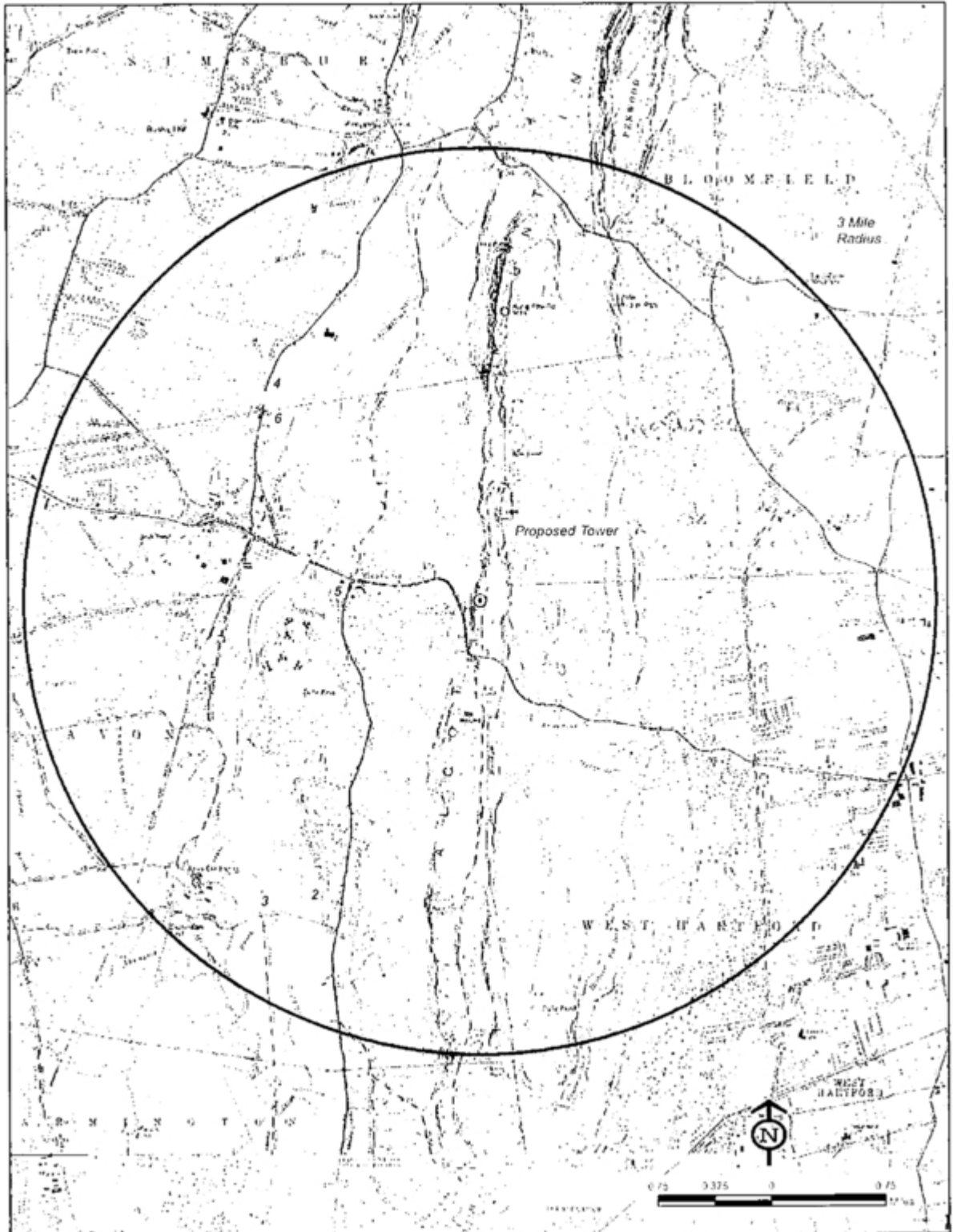

FIGURE 1

# Photolog Documentation

Town of  
**Avon**  
Connecticut







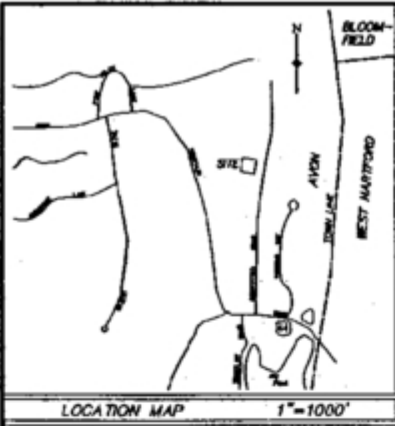

**LEGEND**

**PROPOSED TOWER LOCATION**  
 LATITUDE - 41°-45'-11.00"  
 LONGITUDE - 72°-45'-04.75"  
 NAD 83  
 ELEVATION 746  
 NOV 29

**EXISTING TOWER LOCATION**  
 LATITUDE - 41°-48'-11.00"  
 LONGITUDE - 72°-48'-04.95"  
 NAD 83  
 ELEVATION 747  
 NOV 29

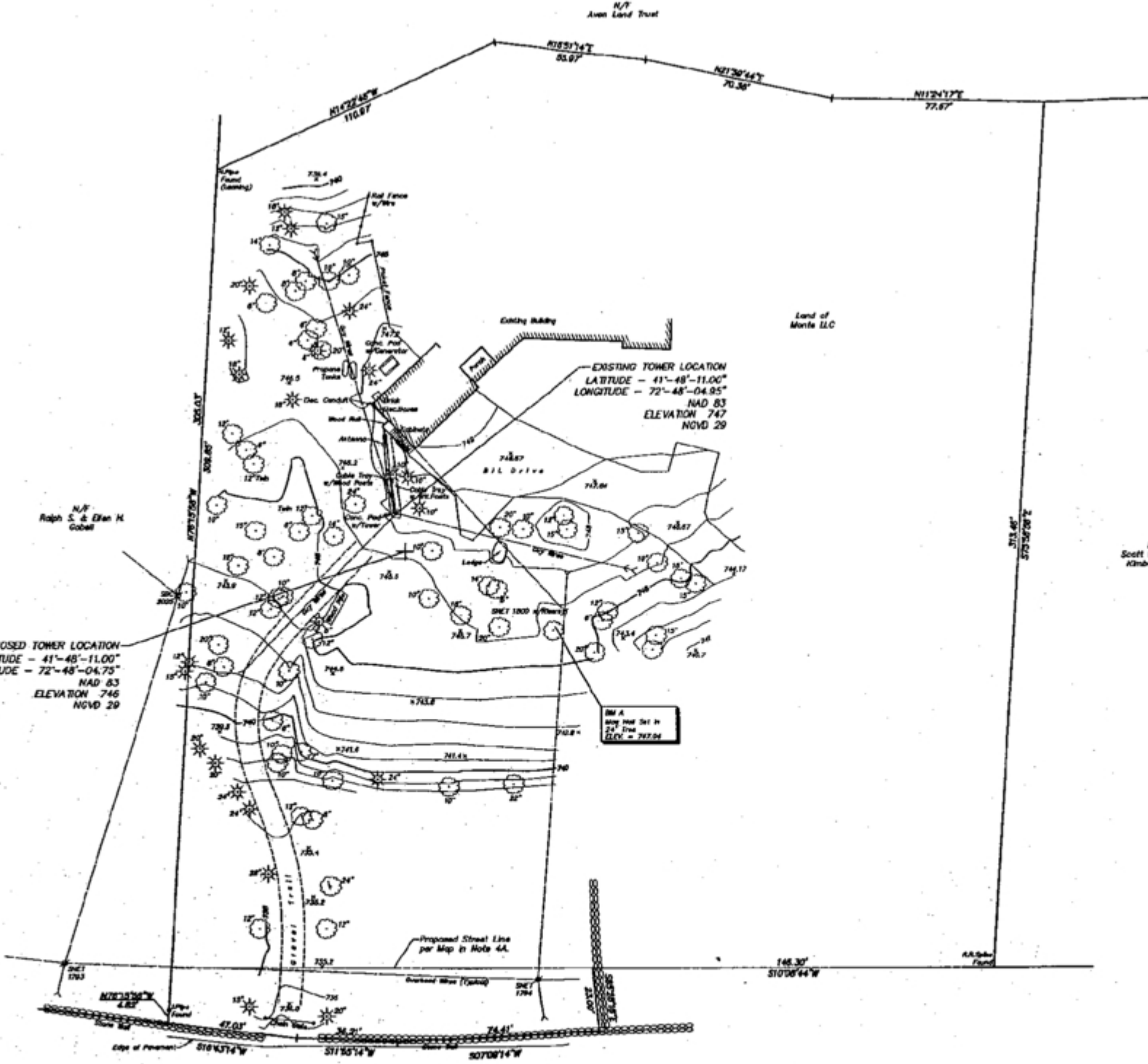

- NOTES**
- THIS SURVEY AND MAP HAVE BEEN PREPARED IN ACCORDANCE WITH THE REGULATIONS OF CONNECTICUT STATE AGENCIES, SECTIONS 20-300-1 THRU 20-300-35 AND THE STANDARDS FOR SURVEYS AND MAPS IN THE STATE OF CONNECTICUT ADOPTED BY THE CONNECTICUT ASSOCIATION OF LAND SURVEYORS, INC. ON SEPTEMBER 26, 1996. THE TYPE OF SURVEY IS A PROPERTY SURVEY AND A T-2 TOPOGRAPHIC SURVEY. THE BOUNDARY DETERMINATION CATEGORY IS A RESURVEY. THE HORIZONTAL AND VERTICAL ACCURACY CONFORMS TO CLASS A-2 & V-2 ACCURACY.
  - MEASUREMENTS REFER TO THE CONNECTICUT COORDINATE SYSTEM (NAD 83) ESTABLISHED WITH GPS.
  - ELEVATIONS REFER TO THE NATIONAL GEODETIC VERTICAL DATUM OF 1988 WHICH IS BASED UPON OUR MEASUREMENT THAT HOLDING THE PARALLELED ELEVATION OF 314.17.
  - REFERENCE IS MADE TO THE FOLLOWING MAPS:
    - PROPERTY OF A. ALBERT LORRY AND BRIGGIDE WELSH, MONTENEVIDE ROAD AVON, CONNECTICUT, BY F. PERRY GLENN, SCALE 1"=100', DATED MAY 1994.
    - MAP SHOWING LAND OWNED BY ROBERT M. & CAROLYN K. HOLDEN, MONTENEVIDE ROAD AVON, CONNECTICUT, BY NEWTON WATKINS, SCALE 1"=30', DATED FEBRUARY 1967.
    - PROPERTY OF HENRY M. ZACHS ET AL. 85 MONTENEVIDE ROAD AVON, CONNECTICUT, BY PETERSEN & HOFFMAN, SCALE 1"=30', DATED AUGUST 1986, REVISED JUNE 1993.
  - THE PROPERTY IS TOGETHER WITH AND SUBJECT TO RIGHTS AND EASEMENTS AS DESCRIBED IN VOLUME 34, PAGE 247 OF THE AVON LAND RECORDS.
  - REFERENCE IS MADE TO A GRANT OF VARIANCE AND SPECIAL EXCEPTION RECORDED IN VOLUME 276, PAGE 163 OF THE AVON LAND RECORDS.
  - REFERENCE IS MADE TO A GRANT OF VARIANCE AND SPECIAL EXCEPTION RECORDED IN VOLUME 323, PAGE 723 OF THE AVON LAND RECORDS.
  - REFERENCE IS MADE TO A GRANT OF VARIANCE AND SPECIAL EXCEPTION RECORDED IN VOLUME 358, PAGE 86 OF THE AVON LAND RECORDS.
  - REFERENCE IS MADE TO A GRANT OF VARIANCE AND SPECIAL EXCEPTION RECORDED IN VOLUME 373, PAGE 301 OF THE AVON LAND RECORDS.
  - REFERENCE IS MADE TO A MEMORANDUM OF LICENSE AGREEMENT RECORDED IN VOLUME 404, PAGE 728 OF THE AVON LAND RECORDS.
  - REFERENCE IS MADE TO A MEMORANDUM OF LICENSE AGREEMENT RECORDED IN VOLUME 458, PAGE 711 OF THE AVON LAND RECORDS.
  - REFERENCE IS MADE TO A MEMORANDUM OF LICENSE AGREEMENT RECORDED IN VOLUME 458, PAGE 714 OF THE AVON LAND RECORDS.
  - UNDERGROUND UTILITY, STRUCTURE AND FACILITY LOCATIONS DEPICTED HEREON HAVE BEEN COMPRISED, IN PART, FROM RECORD MAPPING AND OTHER DATA SUPPLIED BY THE RESPECTIVE UTILITY COMPANIES, GOVERNMENTAL AGENCIES AND/OR OTHER SOURCES. THESE LOCATIONS MUST BE CORROBORATED THROUGHOUT IN ALL CASES. ADDITIONALLY, OTHER BELOW GROUND FEATURES MAY EXIST ON THE SITE, THE EXISTENCE OF WHICH ARE UNKNOWN TO THE CORPORATION AND THE EXISTENCE, SIZE, TYPE AND LOCATION OF ALL SUCH FEATURES MUST BE DETERMINED AND NOTED IN THE FIELD BY THE APPROPRIATE AUTHORITIES PRIOR TO CONSTRUCTION. CALL BEFORE YOU DIG 1-800-822-4435.

PROPERTY & TOPOGRAPHIC SURVEY  
 LAND OF  
**MONTE LLC**  
 81 MONTEVIDEO ROAD  
 AVON, CONNECTICUT  
 PREPARED FOR  
**MESSAGE CENTER MANAGEMENT, INC.**

**MONTEVIDEO ROAD**  
 (PRIVATE ROAD)



TO MY KNOWLEDGE AND BELIEF THIS MAP IS SUBSTANTIALLY CORRECT AS NOTED HEREON

*[Signature]*  
 LAND SURVEYOR, L.S.  
 LICENSE NO. 1400

TRUE AND VALID COPIES OF THIS MAP OR PLAN MUST BEAR THE ORIGINAL SIGNATURE AND EMBOSSED SEAL OF THE ABOVE NAMED LAND SURVEYOR. UNAUTHORIZED REPRODUCTION OR ALTERATION IS PROHIBITED.

No.	Date	Revision description
1	4-20-07	Prepared by: Joseph A. Kelly

Embosmed seal

**URS**  
 Survey and Mapping by  
**URS Corporation AEC**  
 800 Enterprise Drive, Suite 200  
 Bala Cynwyd, Pennsylvania 19004-4000  
 Tel: (610) 835-8882

Scale: 1" = 20'  
 Date: APRIL 2007

Field Book #	Drawn by	Project #
1550-52	M.TORRENT	36024843
Survey #	Drawn by	Checked by
4205	KC	KJA
		Map File #
		T155-3

S:\SURVEY\ACTIVE\34824843\34824843.DWG



LEGEND		
DESCRIPTION	EXISTING	PROPOSED
PROPERTY LINE	---	---
LEASE LINE	---	---
CHAIN LINK FENCE	---	---
CONTOUR LINES	---	---
UNDERGROUND UTILITIES	---	---
UTILITY POLE	---	---
TREE LINE	---	---
SEDIMENTATION FENCE	---	---

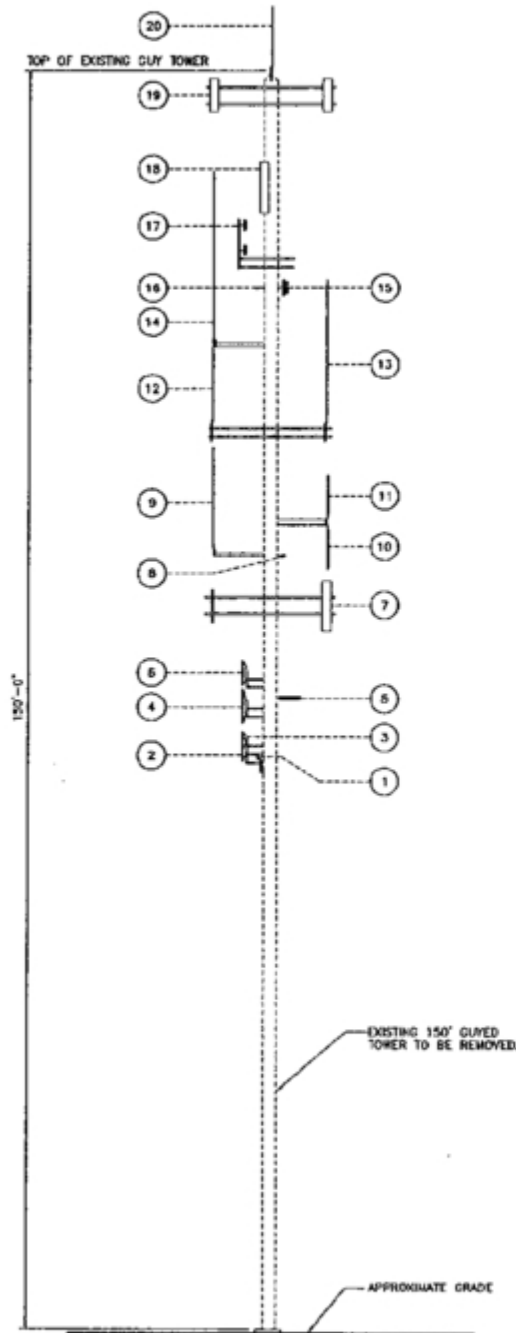

1. GUY WIRES NOT SHOWN FOR CLARITY.

3 EXISTING TOWER ELEVATION  
SC-2 SCALE: 1" = 10'-0"

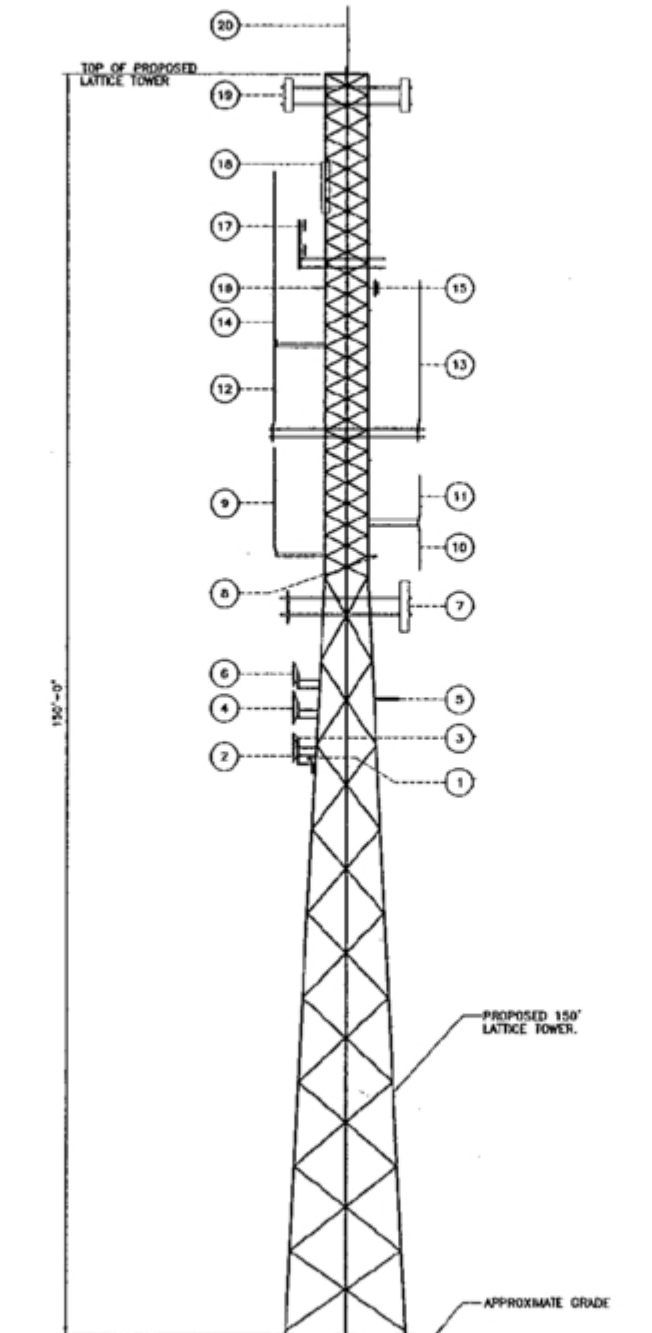

PROPOSED TOWER & FOUNDATION DESIGN BY OTHERS.

2 PROPOSED TOWER ELEVATION  
SC-2 SCALE: 1" = 10'-0"

ANTENNA IDENTIFICATION:		ANTENNA IDENTIFICATION:	
1	ANTENNA: LEG MOUNTED GPS ELEVATION: (AGL) 68'-0"	11	ANTENNA: 5' WHIP ANTENNA ON A 6'-0" SIDE ARM ELEVATION: (AGL) 98'-0"
2	ANTENNA: 3' SOLID DISH ELEVATION: (AGL) 69'-0"	12	ANTENNA: 10' WHIP ANTENNA ON A 6'-0" SIDE ARM ELEVATION: (AGL) 108'-0"
3	ANTENNA: 2' SOLID DISH ELEVATION: (AGL) 70'-0"	13	ANTENNA: 17' WHIP ANTENNA ON A 6'-0" SIDE ARM ELEVATION: (AGL) 108'-0"
4	ANTENNA: 4' SOLID DISH ELEVATION: (AGL) 74'-0"	14	ANTENNA: 20' WHIP ANTENNA ON A 6'-0" SIDE ARM ELEVATION: (AGL) 118'-0"
5	ANTENNA: (1) YAGI ON 3' SIDE ARM ELEVATION: (AGL) 75'-0"	15	ANTENNA: (1) DR225 ON 6' SIDE ARM ELEVATION: (AGL) 124'-0"
6	ANTENNA: 3' SOLID DISH ELEVATION: (AGL) 78'-0"	16	ANTENNA: (1) DB871H105 PANEL ANTENNA ON 3' SIDE ARM ELEVATION: (AGL) 124'-0"
7	ANTENNA: (1x6') PANEL ANTENNA ON 6' SIDE ARM ELEVATION: (AGL) 85'-0"	17	ANTENNA: (1) DR225 ON 3' SIDE ARM ELEVATION: (AGL) 130'-0"
8	ANTENNA: LEG MOUNTED GPS ELEVATION: (AGL) 92'-0"	18	ANTENNA: (2) APXV18-20813-C PANEL ANTENNAS ON (2) 6' SIDE ARM ELEVATION: (AGL) 136'-0"
9	ANTENNA: 12' WHIP ANTENNA ON A 6'-0" SIDE ARM ELEVATION: (AGL) 93'-0"	19	ANTENNA: (3) 7187-05 PANEL ANTENNAS ON (3) 6' SIDE ARM ELEVATION: (AGL) 147'-0"
10	ANTENNA: 8' WHIP ANTENNA INVERTED ON EXISTING SIDE ARM ELEVATION: (AGL) 95'-0"	20	ANTENNA: (1) 8' WHIP ANTENNA (LEG MOUNTED) ELEVATION: (AGL) 150'-0"

NOTE: ALL MEASUREMENTS ARE ABOVE GROUND LEVEL.

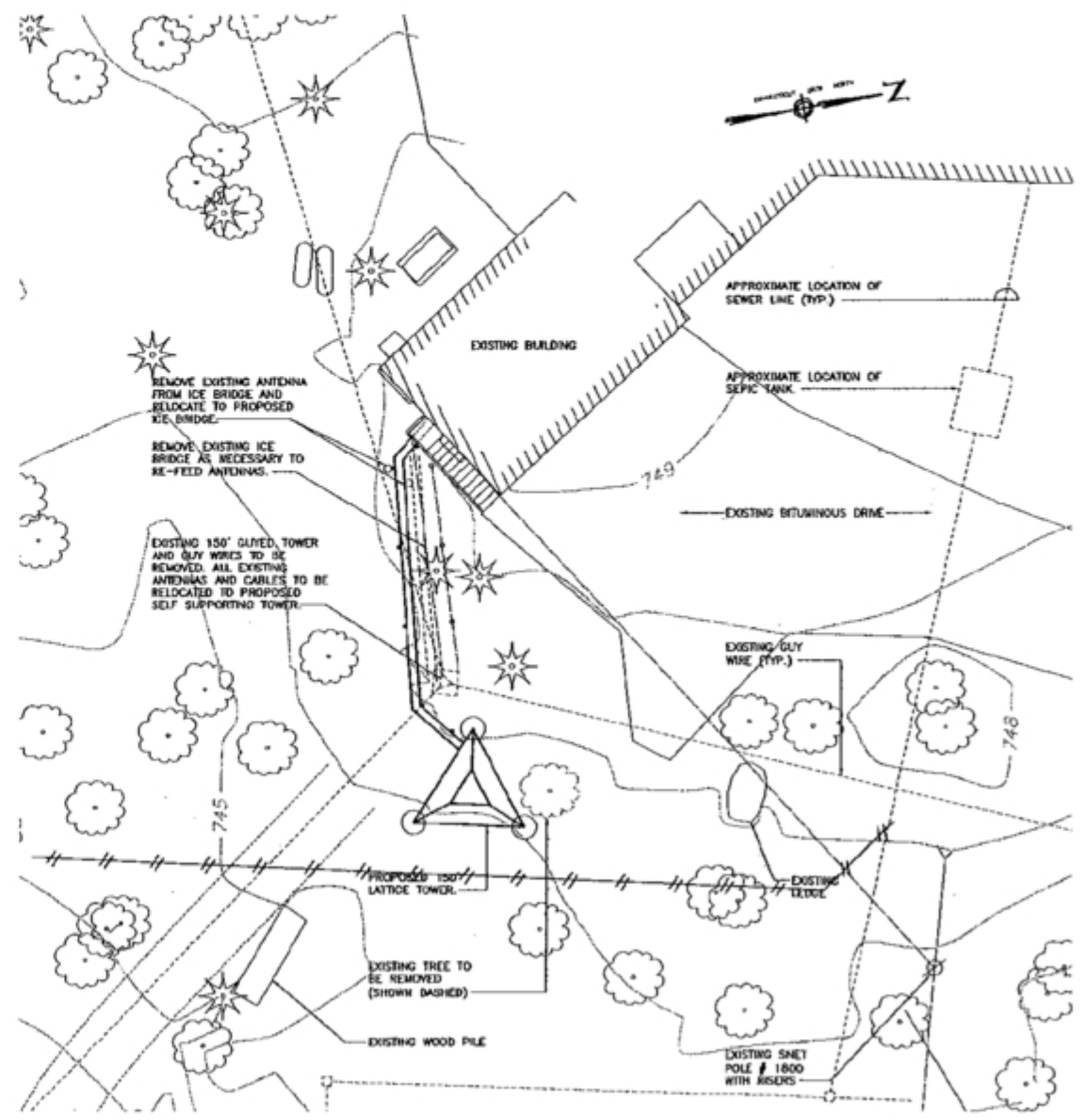

1 PARTIAL SITE PLAN  
SC-2 SCALE: 1" = 10'-0"

MESSAGE CENTER MANAGEMENT  
40 WOODLAND STREET  
HARTFORD, CONNECTICUT 06105

AME FIRM  
**URS CORPORATION AES**  
500 ENTERPRISE DRIVE  
ROCKY HILL, CONNECTICUT  
1-860-520-8882



PROJECT NO: 36924843  
JOB NO: MCM 007  
DRAWN BY: RRH  
CHECKED BY:

ISSUED FOR	
0	08/08/07 REVISION
1	08/10/07 FINAL

AVON  
81 MONTEVIDEO ROAD  
AVON, CONNECTICUT

SCALE: AS NOTED

PARTIAL SITE PLAN AND TOWER ELEVATION

SC-2

**Town of Avon, Conn.**

# **BUILDING PERMIT**

**This card must be posted and visible from the road**

08-0916

3-24-08

D. Williams



# CERTIFICATE OF APPROVAL

## TOWN OF AVON

Tel. 860.409.4316 Fax 860.409.4321  
60 West Main Street Avon Connecticut 06001-3743

LOCATION OF JOB	GIS NO.	ZONE	TYPE OF PERMIT
81 MONTEVIDEO ROAD	3180081	RU2A	BUILDING, ELECTRICAL

OWNER	STREET	CITY	STATE & ZIPCODE
MONTE LLC	40 WOODLAND STREET	HARTFORD	CT 06105

THIS IS TO CERTIFY THAT REPLACEMENT OF EXISTING 150FT. TELECOMMUNICATIONS TOWER AND FENCE

DONE UNDER PERMIT # 08-1405,08-0916,08-0941 ISSUED 7/3/08,3/24/08,3/13/08

SUBSTANTIALLY COMPLIES WITH THE STATE OF CONNECTICUT BUILDING CODE IN EFFECT

DECEMBER 31, 2005, AND IS HEREBY APPROVED.

CONDITIONS OF APPROVAL: NONE

Zoning Approval *[Signature]*  
10-30-08

*[Signature]*  
BUILDING OFFICIAL

FIRE MARSHAL APPROVAL *[Signature]*

11/3/08  
DATE

Engineering Dept. Approval LTP 11/3/08  
Wetlands Approval \_\_\_\_\_

# Final Report of Special Inspections

---

Project: *Message Center Management: MCM-007 / 36924843*

Location: *81 Montevideo Road, Avon, Connecticut 06001*

Owner: *Message Center Management*

Owner's Address: *40 Woodland Street  
Hartford, CT 06105*

Architect of Record: *URS Corporation*

Structural Engineer of Record: *Valmont Structures-Pirot, Inc.  
1545 Pidco Drive, Plymouth, Indiana 46563*

To the best of my information, knowledge and belief, the Special Inspections required for this project, and itemized in the *Statement of Special Inspections* submitted for permit, have been performed and all discovered discrepancies have been reported and resolved other than the following:

Comments:

*(Attach continuation sheets if required to complete the description of corrections.)*

Interim reports submitted prior to this final report form a basis for and are to be considered an integral part of this final report.

Respectfully submitted,

Valmont Structures-Pirot, Inc., 1545 Pidco Drive  
Plymouth, Indiana 46563

William R. Heiden III, P.E.

(Type or print name)

  
Signature

8-13-08

Date



# Final Report of Special Inspections

---

## Agent's Final Report

Project: *Message Center Management: MCM-007 / 36924843*  
*81 Montevideo Road, Avon, Connecticut 06001*

Agent: *URS Corporation A.E.S., 500 Enterprise Drive, Rocky Hill, CT 06067*

Special Inspector: *URS Corporation*

Testing Agency: *JGI Eastern, Inc.*

To the best of my information, knowledge and belief, the Special Inspections or testing required for this project, and designated for this Agent in the *Statement of Special Inspections* submitted for permit, have been performed and all discovered discrepancies have been reported and resolved other than the following:

Comments:

*(Attach continuation sheets if required to complete the description of corrections.)*

Interim reports submitted prior to this final report form a basis for and are to be considered an integral part of this final report.

Respectfully submitted,  
Agent of the Special Inspector  
URS Corporation, 500 Enterprise Drive – Suite 3B  
Rocky Hill, CT 06067

*Richard Sambor, P.E.*

\_\_\_\_\_  
(Type or print name)

*Richard Sambor*  
\_\_\_\_\_  
Signature

\_\_\_\_\_  
Date







**SPECIAL INSPECTION REPORT #1**

Date: 05/29/08

**Client Name:** Message center Management  
**Site Address:** 81 Montevideo Road, Avon, CT  
**Site Type:** Construction of new U14.0x150' Valmont Lattice Tower  
**Site Visit Type:** Special Inspection  
**Project Number:** 36924843.00000 / MCM-007  
**Date of Visit:** May 21, 2008  
**Attendees:** Jason Mead - URS Corporation  
Ray Bayer - Construction Services of Branford, LLC  
Rob Olah, P.E., JGI Eastern, Inc/Terracon (Testing Agency)  
**Weather:** 52<sup>o</sup> Cloudy, 07:30am  
**Prepared by:** Jason Mead  
**Progress / Activities:** Foundation Sub-grade and Material Inspection

The following was noted:

1. Sub-grade: Sub-grade material corresponded with that identified within the geotechnical report prepared by Clarence Welti, P.E., P.C, dated November 6<sup>th</sup>, 2007. Material consisted of moraine soils; fine to medium sand. Base was compacted with a hand-manuevered vibratory compactor. Excavation was dry and free of deleterious materials. Contractor had installed a layer of 3/8" crushed stone at the base of the excavation, per the recommendations of the geotechnical report and was confirmed by JGI. Base of foundation excavation measured 6'-0"+/-. Finished grade shall differentiate by 1 foot vertically from East to West side of the tower base per URS design drawing C-1 and C-2 dated 01/25/08.
2. Rebar/Anchors: Rebar inventory was observed and found to be in conformance with the requirements of the Valmont design documents, i.e., size, quantity and material specification (ASTM A615, Grade 60). Rebar was supplied by Barker Steel Company, Inc. Anchor bolt assembly (x3) provided by the tower manufacturer (Valmont).

cc: Virginia King – Message Center Management  
Jim Maher – Message Center Management  
James Sansone – Building Official Town of Avon  
Ray Bayer/John Centore, Construction Services of Branford, LLC  
William R. Heiden III, P.E Valmont Structures

ICA/AA/CF/Book - URS



**SPECIAL INSPECTION REPORT #2**

Date: 05/29/08

**Client Name:** Message center Management  
**Site Address:** 81 Montevideo Road, Avon, CT  
**Site Type:** Construction of new U14.0x150' Valmont Lattice Tower  
**Site Visit Type:** Special Inspection  
**Project Number:** 36924843.00000 / MCM-007  
**Date of Visit:** May 27, 2008  
**Attendees:** Jason Mead - URS Corporation  
Ray Bayer - Construction Services of Branford, LLC  
Fred Hart - JGI Eastern, Inc/Terracon (Testing Agency)  
Jim Maher - Message Center Management  
James Sansone - Building Official - Town of Avon  
**Weather:** 82<sup>o</sup> Sunny, 12:00noon  
**Prepared by:** Jason Mead  
**Progress / Activities:** Rebar Inspection and Concrete Placement

The following was noted:

- 1. Rebar/Anchors:** Rebar installation was observed and found to be in conformance with the requirements of the Valmont design documents, i.e., size, quantity, spacing and material specification (ASTM A615, Grade 60). Rebar was supplied by Barker Steel. Precast masonry blocks were utilized to attain 3" min bottom cover. Type 26, #5 standees were utilized in accordance with the Valmont design documents to support the top temperature steel from the bottom flexural reinforcement (main bars). Twelve (12) #12 vertical L bars were installed at each pier location and secured at top with one (1) #4 tie. Remaining ties shall be installed once main footing concrete has initially cured. URS noticed that the design documents prepared by Valmont did not include a provision for a minimum of two (2) #4 ties within the top 5in of the pier/column s, per ACI 318 Section 7.10.5.6. URS contacted Valmont to discuss discrepancy. Valmont concurred with URS that an additional tie shall be required. URS notified G.C and building official of this change. Anchor bolt assemblies (x3) were in place and leveled by laser.
- 2. Concrete Placement:** Concrete specification utilized was 4000psi. Min design requirement was 3000psi. URS observed six deliveries out of a total of seven and received batch slips. First concrete delivery arrived at 1:25pm and concrete was placed approximately every 30 minutes thereafter.



**Concrete Placement continued:**

Date: 05/29/08

Concrete was vibrated and evenly distributed. Slump tests and cylinder samples were performed by JGI Eastern, results of which shall be provided under separate cover. A seventh concrete delivery was required to finish the mat pour. Concrete top surface was leveled. Finished concrete was reportedly covered with a tarpaulin to prevent anticipated rain infiltration. URS departed from site at approximately 3:30pm.

cc: Virginia King – Message Center Management  
Jim Maher – Message Center Management  
James Sansone – Building Official Town of Avon  
Ray Bayer/John Centore, Construction Services of Branford, LLC  
William R. Heiden III, P.E Valmont Structures  
ICA/AA/CF/Book - URS

## SPECIAL INSPECTION REPORT #3

Date: 05/29/08

**Client Name:** Message center Management

**Site Address:** 81 Montevideo Road, Avon, CT

**Site Type:** Construction of new U14.0x150' Valmont Lattice Tower

**Site Visit Type:** Special Inspection

**Project Number:** 36924843.00000 / MCM-007

**Date of Visit:** May 28, 2008

**Attendees:** Jason Mead - URS Corporation  
Ray Bayer - Construction Services of Branford, LLC  
Jeff Chapo JGI Eastern, Inc/Terracon (Testing Agency)  
Jim Maher - Message Center Management  
James Sansone - Building Official - Town of Avon

**Weather:** 65<sup>o</sup> Sunny, 11:00am

**Prepared by:** Jason Mead

**Progress / Activities:** Concrete Placement (Three piers)

The following was noted:

**Concrete Placement:** Sonotube forms were installed and adjusted to maintain 3" min side cover from pier vertical rebar. Anchor bolts were checked for alignment and clearance. Two #4 binder ties installed within top 5" per ACI 318 Section 7.10.5.6 and 6" o.c thereafter, for a total of seven (7). Unitex Pro Poxy 204 medium viscosity, multi purpose two component epoxy bonding adhesive was applied to the hardened mat concrete prior to placing of pier concrete. Concrete specification utilized was 4000psi. Min design requirement was 3000psi. Concrete placement consisted of one delivery of approximately 6 cu yds. Batch slip checked for conformance and retained by G.C and JGI Eastern/Terracon. Concrete delivery arrived at 12:10pm. Concrete was placed and evenly distributed. Slump tests, cylinder samples and an air entrainment test were conducted by JGI Eastern, results of which shall be provided under separate cover. Concrete surface was floated and crowned to drain. All three pier concrete placement completed by 1:10pm. URS departed from site at 1:20pm.

cc: Virginia King - Message Center Management  
Jim Maher - Message Center Management  
James Sansone - Building Official Town of Avon  
Ray Bayer/John Centore, Construction Services of Branford, LLC  
William R. Heiden III, P.E Valmont Structures

ICA/AA/CF/Book - URS

# EXHIBIT 6



# AVON\_1

81 MONTEVIDEO ROAD  
AVON, CT 06001  
HARTFORD COUNTY

## SITE NO.: CT11284A

SITE TYPE: 150' SELF-SUPPRT TOWER

RF DESIGN GUIDELINE: 67D5A992DB OUTDOOR

### T-MOBILE NORTHEAST LLC

15 COMMERCE WAY, SUITE B  
NORTON, MA 02766  
(508) 286-2700



SBA COMMUNICATIONS CORP.  
134 FLANDERS ROAD, SUITE 125  
WESTBOROUGH, MA 01581  
(508) 251-0720

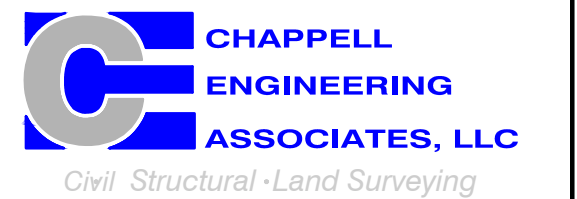

R.K. EXECUTIVE CENTRE  
201 BOSTON POST ROAD WEST, SUITE 101  
MARLBOROUGH, MA 01752  
(508) 481-7400  
www.chappellengineering.com



APPROVALS			
PROJECT MANAGER:	DATE:	ZONING/SITE ACQ.:	DATE:
CONSTRUCTION:	DATE:	OPERATIONS:	DATE:
RF ENGINEERING:	DATE:	TOWER OWNER:	DATE:

T-MOBILE TECHNICIAN SITE SAFETY NOTES	
LOCATION	SPECIAL RESTRICTIONS
SECTOR A:	ACCESS BY CERTIFIED CLIMBER
SECTOR B:	ACCESS BY CERTIFIED CLIMBER
SECTOR C:	ACCESS BY CERTIFIED CLIMBER
SECTOR D:	ACCESS BY CERTIFIED CLIMBER
GPS/LMU:	UNRESTRICTED
RADIO CABINETS:	UNRESTRICTED
PPC DISCONNECT:	UNRESTRICTED
MAIN CIRCUIT D/C:	UNRESTRICTED
NIU/T DEMARC:	UNRESTRICTED
OTHER/SPECIAL:	NONE

SITE NOTES	
1.	THIS IS AN UNMANNED AND RESTRICTED ACCESS TELECOMMUNICATION FACILITY, AND IS NOT FOR HUMAN HABITATION. IT WILL BE USED FOR THE TRANSMISSION OF RADIO SIGNAL FOR THE PURPOSE OF PROVIDING PUBLIC CELLULAR SERVICE. <ul style="list-style-type: none"> <li>• ADA COMPLIANCE NOT REQUIRED.</li> <li>• POTABLE WATER OR SANITARY SERVICE IS NOT REQUIRED.</li> <li>• NO OUTDOOR STORAGE OR ANY SOLID WASTE RECEPTACLES REQUIRED.</li> </ul>
2.	CONTRACTOR SHALL VERIFY ALL PLANS, EXISTING DIMENSIONS, AND CONDITIONS ON JOB SITE. CONTRACTOR SHALL IMMEDIATELY NOTIFY THE ARCHITECT/ENGINEER IN WRITING OF ANY DISCREPANCIES BEFORE PROCEEDING WITH THE WORK. FAILURE TO NOTIFY THE ARCHITECT/ENGINEER PLACE THE RESPONSIBILITY ON THE CONTRACTOR TO CORRECT THE DISCREPANCIES AT THE CONTRACTOR'S EXPENSE.
3.	NEW CONSTRUCTION WILL CONFORM TO ALL APPLICABLE CODES AND ORDINANCES. <ul style="list-style-type: none"> <li>• BUILDING CODE: 2018 CONNECTICUT STATE BUILDING CODE</li> <li>• ELECTRICAL CODE: 2017 NATIONAL ELECTRICAL CODE</li> <li>• STRUCTURAL CODE: TIA/EIA-222-G STRUCTURAL STANDARDS FOR ANTENNA SUPPORTING STRUCTURES AND ANTENNAS.</li> </ul>

GENERAL NOTES	
1. THE CONTRACTOR SHALL GIVE ALL NOTICES AND COMPLY WITH ALL LAWS, ORDINANCES, RULES, REGULATIONS AND LAWFUL ORDERS OF ANY PUBLIC AUTHORITY, MUNICIPAL AND UTILITY COMPANY SPECIFICATIONS, AND LOCAL AND STATE JURISDICTIONAL CODES BEARING ON THE PERFORMANCE OF THE WORK, THE WORK PERFORMED ON THE PROJECT AND THE MATERIALS INSTALLED SHALL BE IN STRICT ACCORDANCE WITH ALL APPLICABLE CODES, REGULATIONS, AND ORDINANCES.	11. THE CONTRACTOR SHALL BE RESPONSIBLE FOR OBTAINING ALL PERMITS AND INSPECTIONS WHICH MAY BE REQUIRED FOR THE WORK BY THE ARCHITECT/ENGINEER, THE STATE, COUNTY OR LOCAL GOVERNMENT AUTHORITY.
2. THE ARCHITECT/ENGINEER HAVE MADE EVERY EFFORT TO SET FORTH IN THE CONSTRUCTION AND CONTRACT DOCUMENTS THE COMPLETE SCOPE OF WORK. THE CONTRACTOR BIDDING THE JOB IS NEVERTHELESS CAUTIONED THAT MINOR OMISSIONS OR ERRORS IN THE DRAWINGS AND OR SPECIFICATIONS SHALL NOT EXCUSE SAID CONTRACTOR FROM COMPLETING THE PROJECT AND IMPROVEMENTS IN ACCORDANCE WITH THE INTENT OF THESE DOCUMENTS.	12. THE CONTRACTOR SHALL MAKE NECESSARY PROVISIONS TO PROTECT EXISTING IMPROVEMENTS, EASEMENTS, PAVING, CURBING, ETC. DURING CONSTRUCTION. UPON COMPLETION OF WORK, THE CONTRACTOR SHALL REPAIR ANY DAMAGE THAT MAY HAVE OCCURRED DUE TO CONSTRUCTION ON OR ABOUT THE PROPERTY.
3. THE CONTRACTOR OR BIDDER SHALL BEAR THE RESPONSIBILITY OF NOTIFYING (IN WRITING) THE OMNIPOT REPRESENTATIVE OF ANY CONFLICTS, ERRORS, OR OMISSIONS PRIOR TO THE SUBMISSION OF CONTRACTOR'S PROPOSAL OR PERFORMANCE OF WORK. IN THE EVENT OF DISCREPANCIES THE CONTRACTOR SHALL PRICE THE MORE COSTLY OR EXTENSIVE WORK, UNLESS DIRECTED IN WRITING OTHERWISE.	13. THE CONTRACTOR SHALL KEEP THE GENERAL WORK AREA CLEAN AND HAZARD FREE DURING CONSTRUCTION AND DISPOSE OF ALL DIRT, DEBRIS, RUBBISH AND REMOVE EQUIPMENT NOT SPECIFIED AS REMAINING ON THE PROPERTY. PREMISES SHALL BE LEFT IN CLEAN CONDITION AND FREE FROM PAINT SPOTS, DUST, OR SMUDGES OF ANY NATURE.
4. THE SCOPE OF WORK SHALL INCLUDE FURNISHING ALL MATERIALS, EQUIPMENT, LABOR AND ALL OTHER MATERIALS AND LABOR DEEMED NECESSARY TO COMPLETE THE WORK/PROJECT AS DESCRIBED HEREIN.	14. THE CONTRACTOR SHALL COMPLY WITH ALL OSHA REQUIREMENTS AS THEY APPLY TO THIS PROJECT.
5. THE CONTRACTOR SHALL VISIT THE JOB SITE PRIOR TO THE SUBMISSION OF BIDS OR PERFORMING WORK TO FAMILIARIZE HIMSELF WITH THE FIELD CONDITIONS AND TO VERIFY THAT THE PROJECT CAN BE CONSTRUCTED IN ACCORDANCE WITH THE CONTRACT DOCUMENTS.	15. THE CONTRACTOR SHALL NOTIFY THE PROJECT OWNER'S REPRESENTATIVE WHERE A CONFLICT OCCURS ON ANY OF THE CONTRACT DOCUMENTS. THE CONTRACTOR IS NOT TO ORDER MATERIAL OR CONSTRUCT ANY PORTION OF THE WORK THAT IS IN CONFLICT UNTIL CONFLICT IS RESOLVED BY THE LESSEE/LICENSEE REPRESENTATIVE.
6. THE CONTRACTOR SHALL OBTAIN AUTHORIZATION TO PROCEED WITH CONSTRUCTION PRIOR TO STARTING WORK ON ANY ITEM NOT CLEARLY DEFINED BY THE CONSTRUCTION DRAWINGS/CONTRACT DOCUMENTS.	16. THE CONTRACTOR SHALL VERIFY ALL DIMENSIONS, ELEVATIONS, PROPERTY LINES, ETC. ON THE JOB.
7. THE CONTRACTOR SHALL INSTALL ALL EQUIPMENT AND MATERIALS ACCORDING TO THE MANUFACTURER'S/VENDOR'S SPECIFICATIONS UNLESS NOTED OTHERWISE OR WHERE LOCAL CODES OR ORDINANCES TAKE PRECEDENCE.	17. ALL UNDERGROUND UTILITY INFORMATION WAS DETERMINED FROM SURFACE INVESTIGATIONS AND EXISTING PLANS OF RECORD. THE CONTRACTOR SHALL LOCATE ALL UNDERGROUND UTILITIES IN THE FIELD PRIOR TO ANY SITE WORK.
8. THE CONTRACTOR SHALL PROVIDE A FULL SET OF CONSTRUCTION DOCUMENTS AT THE SITE UPDATED WITH THE LATEST REVISIONS AND ADDENDUMS OR CLARIFICATIONS AVAILABLE FOR THE USE BY ALL PERSONNEL INVOLVED WITH THE PROJECT.	
9. THE CONTRACTOR SHALL SUPERVISE AND DIRECT THE PROJECT DESCRIBED HEREIN. THE CONTRACTOR SHALL BE SOLELY RESPONSIBLE FOR ALL CONSTRUCTION MEANS, METHODS, TECHNIQUES, SEQUENCES AND PROCEDURES AND FOR COORDINATING ALL PORTIONS OF THE WORK UNDER THE CONTRACT.	
10. THE CONTRACTOR IS RESPONSIBLE FOR PROVIDING ALL NECESSARY CONSTRUCTION CONTROL SURVEYS, ESTABLISHING AND MAINTAINING ALL LINES AND GRADES REQUIRED TO CONSTRUCT ALL IMPROVEMENTS AS SHOWN HEREIN.	

AT LEAST 72 HOURS PRIOR TO DIGGING, THE CONTRACTOR IS REQUIRED TO CALL DIG SAFE AT 811

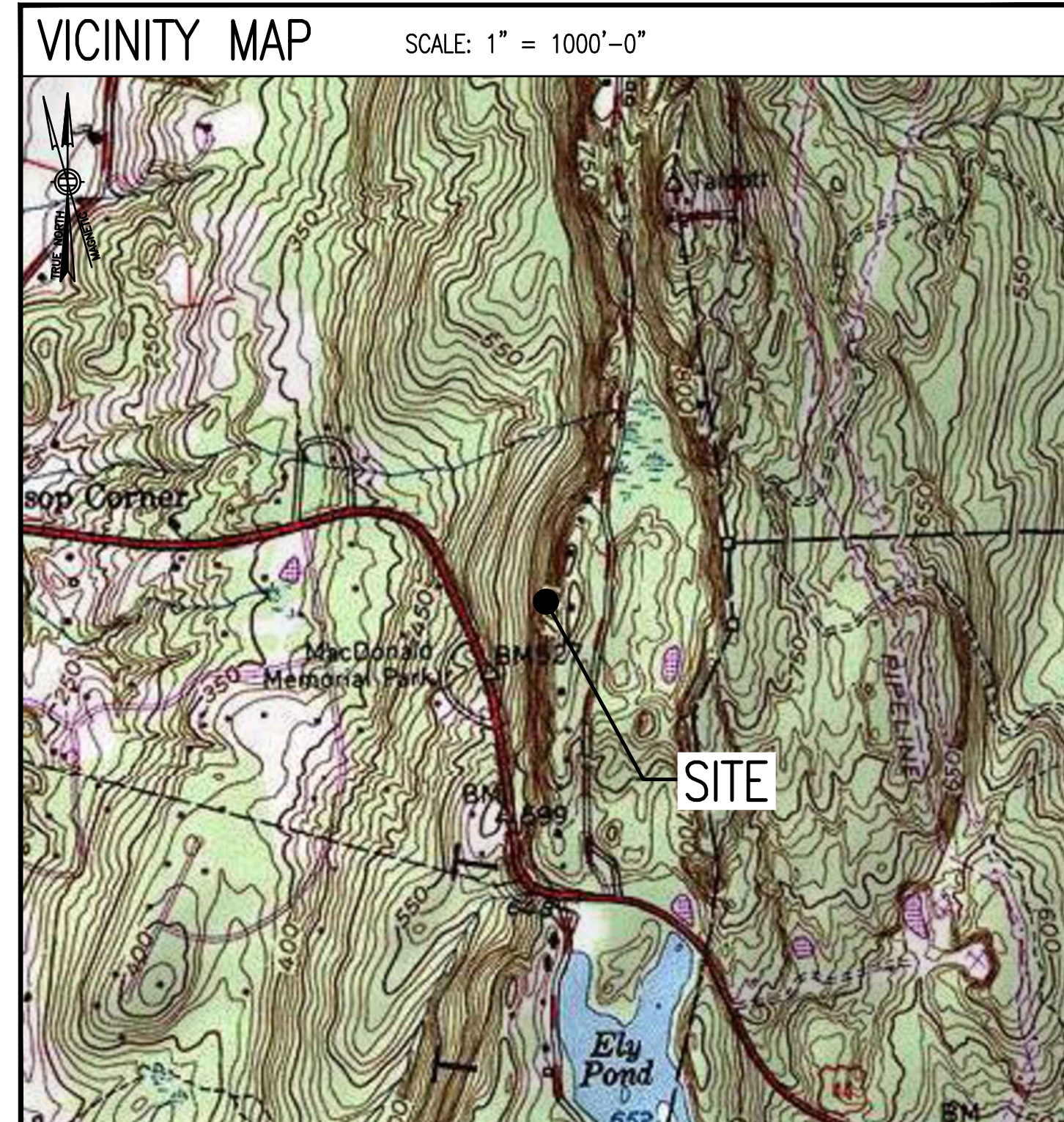

**DO NOT SCALE DRAWINGS**

CONTRACTOR SHALL VERIFY ALL PLANS AND EXISTING DIMENSIONS AND CONDITIONS ON THE JOB SITE AND SHALL IMMEDIATELY NOTIFY THE PROJECT OWNER'S REPRESENTATIVE IN WRITING OF DISCREPANCIES BEFORE PROCEEDING WITH THE WORK OR BE RESPONSIBLE FOR SAME.

SHEET INDEX		
SHEET NO.	DESCRIPTION	REV. NO.
T-1	TITLE SHEET	1
GN-1	GENERAL NOTES	1
A-1	COMPOUND & EQUIPMENT PLANS	1
A-2	TOWER ELEVATION & ANTENNA PLANS	1
A-3	ANTENNA DETAILS	1
A-4	EQUIPMENT DETAILS	1
E-1	ELECTRIC & GROUNDING DETAILS	1

**SPECIAL ZONING NOTE:**  
BASED ON INFORMATION PROVIDED BY T-MOBILE REGULATORY COMPLIANCE PROFESSIONALS AND LEGAL COUNSEL, THIS TELECOMMUNICATIONS EQUIPMENT DEPLOYMENT IS CONSIDERED AN ELIGIBLE FACILITY UNDER THE MIDDLE CLASS TAX RELIEF AND JOB CREATION ACT OF 2012, 47 USC 1455(A), SECTION 6409(A), AND IS SUBJECT TO AN ELIGIBLE FACILITY REQUEST, EXPEDITED REVIEW, AND LIMITED/PARTIAL ZONING PRE-EMPTION FOR LOCAL DISCRETIONARY PERMITS (VARIANCE, SPECIAL PERMIT, SITE PLAN REVIEW, OR ADMINISTRATIVE REVIEW).

PROJECT SUMMARY	
SITE NUMBER:	CT11284A
SBA SITE NUMBER:	CT22071-A
SBA SITE NAME:	AVON (MONTEVIDEO)
SITE ADDRESS:	81 MONTEVIDEO ROAD AVON, CT 06001
PROPERTY OWNER:	MONTE LLC. 40 WOODLAND STREET HARTFORD, CT 06105
TOWER OWNER:	SBA TOWERS, LLC 8501 CONGRESS AVENUE BOCA RATON, FL 33487 PHONE: 561-226-9523
COUNTY:	HARTFORD
ZONING DISTRICT:	RU2A (RURAL RESIDENTIAL)
STRUCTURE TYPE:	SELF-SUPPRT TOWER
STRUCTURE HEIGHT:	150'±
APPLICANT:	T-MOBILE NORTHEAST LLC 15 COMMERCE WAY, SUITE B NORTON, MA 02766
SBA RSM:	STEPHEN ROTH PHONE: 860-539-4920 EMAIL: SRoth@sbase.com
ARCHITECT:	CHAPPELL ENGINEERING ASSOCIATES, LLC. 201 BOSTON POST ROAD WEST, SUITE 101 MARLBOROUGH, MA 01752
STRUCTURAL ENGINEER:	CHAPPELL ENGINEERING ASSOCIATES, LLC. 201 BOSTON POST ROAD WEST, SUITE 101 MARLBOROUGH, MA 01752
SITE CONTROL POINT:	LATITUDE: N.41.8031° (41° 48' 11.00") LONGITUDE W.72.8013° (72° 48' 04.69")

CHECKED BY: JMT

APPROVED BY: JMT

SUBMITTALS			
REV.	DATE	DESCRIPTION	BY
1	08/03/20	ISSUED FOR CONSTRUCTION	CMC
0	07/20/20	ISSUED FOR REVIEW	JRV

SITE NUMBER:  
**CT11284A**

SITE ADDRESS:  
81 MONTEVIDEO ROAD  
AVON, CT 06001

SHEET TITLE  
**TITLE SHEET**

SHEET NUMBER  
**T-1**



**GENERAL NOTES:**

- FOR THE PURPOSE OF CONSTRUCTION DRAWINGS, THE FOLLOWING DEFINITIONS SHALL APPLY:  
CONTRACTOR – T-MOBILE  
SUBCONTRACTOR – GENERAL CONTRACTOR (CONSTRUCTION)  
OWNER – T-MOBILE  
OEM – ORIGINAL EQUIPMENT MANUFACTURER
- PRIOR TO THE SUBMISSION OF BIDS, THE BIDDING SUBCONTRACTOR SHALL VISIT THE CELL SITE TO FAMILIARIZE WITH THE EXISTING CONDITIONS AND TO CONFIRM THAT THE WORK CAN BE ACCOMPLISHED AS SHOWN ON THE CONSTRUCTION DRAWINGS. ANY DISCREPANCY FOUND SHALL BE BROUGHT TO THE ATTENTION OF CONTRACTOR.
- ALL MATERIALS FURNISHED AND INSTALLED SHALL BE IN STRICT ACCORDANCE WITH ALL APPLICABLE CODES, REGULATIONS, AND ORDINANCES. SUBCONTRACTOR SHALL ISSUE ALL APPROPRIATE NOTICES AND COMPLY WITH ALL LAWS, ORDINANCES, RULES, REGULATIONS, AND LAWFUL ORDERS OF ANY PUBLIC AUTHORITY REGARDING THE PERFORMANCE OF THE WORK.
- ALL WORK CARRIED OUT SHALL COMPLY WITH ALL APPLICABLE MUNICIPAL AND UTILITY COMPANY SPECIFICATIONS AND LOCAL, STATE AND FEDERAL JURISDICTIONAL CODES, ORDINANCES AND APPLICABLE REGULATIONS.
- DRAWINGS PROVIDED HERE ARE NOT TO BE SCALED AND ARE INTENDED TO SHOW OUTLINE ONLY.
- UNLESS NOTED OTHERWISE, THE WORK SHALL INCLUDE FURNISHING MATERIALS, EQUIPMENT, APPURTENANCES, AND LABOR NECESSARY TO COMPLETE ALL INSTALLATIONS AS INDICATED ON THE DRAWINGS.
- THE SUBCONTRACTOR SHALL INSTALL ALL EQUIPMENT AND MATERIALS IN ACCORDANCE WITH MANUFACTURER'S RECOMMENDATIONS UNLESS SPECIFICALLY STATED OTHERWISE.
- IF THE SPECIFIED EQUIPMENT CANNOT BE INSTALLED AS SHOWN ON THESE DRAWINGS, THE SUBCONTRACTOR SHALL PROPOSE AN ALTERNATIVE INSTALLATION FOR APPROVAL BY THE CONTRACTOR.
- SUBCONTRACTOR SHALL DETERMINE ACTUAL ROUTING OF CONDUIT, POWER, T1 CABLES AND GROUNDING CABLES AS SHOWN ON THE POWER, GROUNDING AND TELCO PLAN DRAWING. SUBCONTRACTOR SHALL UTILIZE EXISTING TRAYS AND/OR SHALL ADD NEW TRAYS AS NECESSARY. SUBCONTRACTOR SHALL CONFIRM THE ACTUAL ROUTING WITH THE CONTRACTOR AND/OR LANDLORD PRIOR TO CONSTRUCTION.
- THE SUBCONTRACTOR SHALL PROTECT EXISTING IMPROVEMENTS, PAVEMENTS, CURBS, LANDSCAPING AND STRUCTURES. ANY DAMAGED PART SHALL BE REPAIRED AT SUBCONTRACTOR'S EXPENSE TO THE SATISFACTION OF THE OWNER.
- SUBCONTRACTOR SHALL LEGALLY AND PROPERLY DISPOSE OF ALL SCRAP MATERIALS SUCH AS COAXIAL CABLES AND OTHER ITEMS REMOVED FROM THE EXISTING FACILITY.
- SUBCONTRACTOR SHALL LEAVE PREMISES IN CLEAN CONDITION AND RETURN DISTURBED AREAS TO ORIGINAL CONDITIONS.
- THE SUBCONTRACTOR SHALL SUPERVISE AND DIRECT THE PROJECT DESCRIBED HEREIN. THE SUBCONTRACTOR SHALL BE SOLELY RESPONSIBLE FOR ALL CONSTRUCTION MEANS, METHODS, TECHNIQUES, SEQUENCES, AND PROCEDURES FOR COORDINATING ALL PORTIONS OF THE WORK UNDER THE CONTRACT.
- SUBCONTRACTOR SHALL NOTIFY CHAPPELL ENGINEERING ASSOCIATES, LLC 48 HOURS IN ADVANCE OF POURING CONCRETE OR BACKFILLING TRENCHES, SEALING ROOF AND WALL PENETRATIONS AND POST DOWNS, FINISHING NEW WALLS OR FINAL ELECTRICAL CONNECTIONS FOR ENGINEERING REVIEW.
- CONSTRUCTION SHALL COMPLY WITH ALL T-MOBILE STANDARDS AND SPECIFICATIONS.
- SUBCONTRACTOR SHALL VERIFY ALL EXISTING DIMENSIONS AND CONDITIONS PRIOR TO COMMENCING ANY WORK. ALL DIMENSIONS OF EXISTING CONSTRUCTION SHOWN ON THE DRAWINGS MUST BE VERIFIED. SUBCONTRACTOR SHALL NOTIFY THE CONTRACTOR OF ANY DISCREPANCIES PRIOR TO ORDERING MATERIAL OR PROCEEDING WITH CONSTRUCTION.
- THE EXISTING CELL SITES ARE IN FULL COMMERCIAL OPERATION. ANY CONSTRUCTION WORK BY SUBCONTRACTOR SHALL NOT DISRUPT THE EXISTING NORMAL OPERATION. ANY WORK ON EXISTING EQUIPMENT MUST BE COORDINATED WITH CONTRACTOR. ALSO, WORK SHOULD BE SCHEDULED FOR AN APPROPRIATE MAINTENANCE WINDOW USUALLY IN LOW TRAFFIC PERIODS AFTER MIDNIGHT.
- IF THE EXISTING CELL SITE IS ACTIVE, ALL SAFETY PRECAUTIONS MUST BE TAKEN WHEN WORKING AROUND HIGH LEVELS OF ELECTROMAGNETIC RADIATION. EQUIPMENT SHOULD BE SHUTDOWN PRIOR TO PERFORMING ANY WORK THAT COULD EXPOSE THE WORKERS TO DANGER. PERSONAL RF EXPOSURE MONITORS ARE TO BE WORN TO ALERT OF ANY DANGEROUS EXPOSURE LEVELS.

**SITE WORK GENERAL NOTES:**

- THE SUBCONTRACTOR SHALL CONTACT UTILITY LOCATING SERVICES PRIOR TO THE START OF CONSTRUCTION.
- ALL EXISTING ACTIVE SEWER, WATER, GAS, ELECTRIC, AND OTHER UTILITIES WHERE ENCOUNTERED IN THE WORK, SHALL BE PROTECTED AT ALL TIMES, AND WHERE REQUIRED FOR THE PROPER EXECUTION OF THE WORK, SHALL BE RELOCATED AS DIRECTED BY ENGINEERS. EXTREME CAUTION SHOULD BE USED BY THE SUBCONTRACTOR WHEN EXCAVATING OR DRILLING PIERS AROUND OR NEAR UTILITIES. SUBCONTRACTOR SHALL PROVIDE SAFETY TRAINING FOR THE WORKING CREW. THIS WILL INCLUDE BUT NOT BE LIMITED TO A) FALL PROTECTION B) CONFINED SPACE C) ELECTRICAL SAFETY D) TRENCHING AND EXCAVATION.
- ALL SITE WORK SHALL BE AS INDICATED ON THE DRAWINGS AND PROJECT SPECIFICATIONS.
- IF NECESSARY, RUBBISH, STUMPS, DEBRIS, STICKS, STONES AND OTHER REFUSE SHALL BE REMOVED FROM THE SITE AND DISPOSED OF LEGALLY.
- THE SITE SHALL BE GRADED TO CAUSE SURFACE WATER TO FLOW AWAY FROM THE BTS EQUIPMENT AND TOWER AREAS.
- NO FILL OR EMBANKMENT MATERIAL SHALL BE PLACED ON FROZEN GROUND. FROZEN MATERIALS, SNOW OR ICE SHALL NOT BE PLACED IN ANY FILL OR EMBANKMENT.
- THE SUB GRADE SHALL BE COMPACTED AND BROUGHT TO A SMOOTH UNIFORM GRADE PRIOR TO FINISHED SURFACE APPLICATION.
- ALL EXISTING INACTIVE SEWER, WATER, GAS, ELECTRIC AND OTHER UTILITIES, WHICH INTERFERE WITH THE EXECUTION OF THE WORK, SHALL BE REMOVED AND/OR CAPPED, PLUGGED OR OTHERWISE DISCONTINUED AT POINTS WHICH WILL NOT INTERFERE WITH THE EXECUTION OF THE WORK, SUBJECT TO THE APPROVAL OF ENGINEERING, OWNER AND/OR LOCAL UTILITIES.
- THE AREAS OF THE OWNERS PROPERTY DISTURBED BY THE WORK AND NOT COVERED BY THE TOWER, EQUIPMENT OR DRIVEWAY, SHALL BE GRADED TO A UNIFORM SLOPE AND STABILIZED TO PREVENT EROSION AS SPECIFIED IN THE PROJECT SPECIFICATIONS.
- SUBCONTRACTOR SHALL MINIMIZE DISTURBANCE TO EXISTING SITE DURING CONSTRUCTION. EROSION CONTROL MEASURES, IF REQUIRED DURING CONSTRUCTION, SHALL BE IN CONFORMANCE WITH THE LOCAL GUIDELINES FOR EROSION AND SEDIMENT CONTROL.
- THE SUBCONTRACTOR SHALL PROVIDE SITE SIGNAGE IN ACCORDANCE WITH THE T-MOBILE SPECIFICATION FOR SITE SIGNAGE.

**CONCRETE AND REINFORCING STEEL NOTES:**

- ALL CONCRETE WORK SHALL BE IN ACCORDANCE WITH THE ACI 301, ACI 318, ACI 336, ASTM A184, ASTM A185 AND THE DESIGN AND CONSTRUCTION SPECIFICATION FOR CAST-IN-PLACE CONCRETE.
- ALL CONCRETE SHALL HAVE A MINIMUM COMPRESSIVE STRENGTH OF 3000 PSI AT 28 DAYS, UNLESS NOTED OTHERWISE. A HIGHER STRENGTH (400PSI) MAY BE USED. ALL CONCRETE WORK SHALL BE IN ACCORDANCE WITH THE ACI 381 CODE REQUIREMENTS
- REINFORCING STEEL SHALL CONFORM TO ASTM A 615, GRADE 60, DEFORMED UNLESS NOTED OTHERWISE. WELDED WIRE FABRIC SHALL CONFORM TO ASTM A 185 WELDED STEEL WIRE FABRIC UNLESS NOTED OTHERWISE. SPLICES SHALL BE CLASS "B" AND ALL HOOKS SHALL BE STANDARD, UNDO.
- THE FOLLOWING MINIMUM CONCRETE COVER SHALL BE PROVIDED FOR REINFORCING STEEL UNLESS SHOWN OTHERWISE ON DRAWINGS:  
CONCRETE CAST AGAINST EARTH.....3 IN.  
CONCRETE EXPOSED TO EARTH OR WEATHER:  
#6 AND LARGER .....2 IN.  
#5 AND SMALLER & WWF .....1½ IN.  
CONCRETE NOT EXPOSED TO EARTH OR WEATHER OR NOT CAST AGAINST THE GROUND:  
SLAB AND WALL .....¾ IN.  
BEAMS AND COLUMNS .....½ IN.
- A CHAMFER ¾" SHALL BE PROVIDED AT ALL EXPOSED EDGES OF CONCRETE, UNO, IN ACCORDANCE WITH ACI 301 SECTION 4.2.4.
- INSTALLATION OF CONCRETE EXPANSION/WEDGE ANCHORS SHALL BE PER MANUFACTURER'S WRITTEN RECOMMENDED PROCEDURE. THE ANCHOR BOLT, DOWEL OR ROD SHALL CONFORM TO THE MANUFACTURERS RECOMMENDATION FOR EMBEDMENT DEPTH OR AS SHOWN ON THE DRAWINGS. NO REBAR SHALL BE CUT WITHOUT PRIOR CONTRACTOR APPROVAL WHEN DRILLING HOLES IN CONCRETE. SPECIAL INSPECTIONS, REQUIRED BY GOVERNING CODES, SHALL BE PERFORMED IN ORDER TO MAINTAIN MANUFACTURER'S MAXIMUM ALLOWABLE LOADS. ALL EXPANSION/WEDGE ANCHORS SHALL BE STAINLESS STEEL OR HOT DIPPED GALVANIZED. EXPANSION BOLTS SHALL BE PROVIDED BY SIMPSON OR APPROVED EQUAL.
- CONCRETE CYLINDER TIES ARE NOT REQUIRED FOR SLAB ON GRADE WHEN CONCRETE IS LESS THAN 50 CUBIC YARDS (IBC1905.6.2.3) IN THAT EVENT THE FOLLOWING RECORDS SHALL BE PROVIDED BY THE CONCRETE SUPPLIER;  
(A) RESULTS OF CONCRETE CYLINDER TEST PERFORMED AT THE SUPPLIERS PLANT.  
(B) CERTIFICATION OF MINIMUM COMPRESSIVE STRENGTH FOR THE CONCRETE GRADE SUPPLIED.  
FOR GREATER THAN 50 CUBIC YARDS THE GC SHALL PERFORM THE CONCRETE CYLINDER TEST.
- AS AN ALTERNATIVE TO ITEM 7. TEST CYLINDERS SHALL BE TAKEN INITIALLY AND THEREAFTER FOR EVERY 50 YARDS OF CONCRETE FROM EACH DIFFERENT BATCH PLANT.
- EQUIPMENT SHALL NOT BE PLACED ON NEW PADS FOR SEVEN DAYS AFTER PAD IS POURED, UNLESS IT IS VERIFIED BY CYLINDER TESTS THAT COMPRESSIVE STRENGTH HAS BEEN ATTAINED.

**STRUCTURAL STEEL NOTES:**

- ALL STEEL WORK SHALL BE PAINTED OR GALVANIZED IN ACCORDANCE WITH THE DRAWINGS AND T-MOBILE SPECIFICATIONS UNLESS OTHERWISE NOTED. STRUCTURAL STEEL SHALL BE ASTM-A-36 UNLESS OTHERWISE NOTED ON THE SITE SPECIFIC DRAWINGS. STEEL DESIGN, INSTALLATION AND BOLTING SHALL BE IN ACCORDANCE WITH THE AMERICAN INSTITUTE OF STEEL CONSTRUCTION (AISC) "MANUAL OF STEEL CONSTRUCTION".
- ALL WELDING SHALL BE PERFORMED USING E70XX ELECTRODES AND WELDING SHALL CONFORM TO AISC AND AWS D1.1. WHERE FILLET WELD SIZES ARE NOT SHOWN, PROVIDE THE MINIMUM SIZE PER TABLE J2.4 IN THE AISC "MANUAL OF STEEL CONSTRUCTION", 9TH EDITION. PAINTED SURFACES SHALL BE TOUCHED UP.
- BOLTED CONNECTIONS SHALL USE BEARING TYPE ASTM A325 BOLTS (¾") AND SHALL HAVE MINIMUM OF TWO BOLTS UNLESS NOTED OTHERWISE. ALL BOLTS SHALL BE GALVANIZED OR STAINLESS STEEL.
- NON-STRUCTURAL CONNECTIONS FOR STEEL GRATING MAY USE ¾" DIA. ASTM A 307 BOLTS (OTHERWISE)
- CONTRACTOR SHALL SUBMIT SHOP DRAWINGS FOR ENGINEER REVIEW & APPROVAL ON PROJECTS REQUIRING STRUCTURAL STEEL
- ALL STRUCTURAL STEEL WORK SHALL BE DONE IN ACCORDANCE WITH AISC SPECIFICATIONS.

**SOIL COMPACTION NOTES FOR SLAB ON GRADE:**

- EXCAVATE AS REQUIRED TO REMOVE VEGETATION AND TOPSOIL TO EXPOSE NATURAL SUBGRADE AND PLACE CRUSHED STONE AS REQUIRED.
- COMPACTION CERTIFICATION: AN INSPECTION AND WRITTEN CERTIFICATION BY A QUALIFIED GEOTECHNICAL TECHNICIAN OR ENGINEER IS ACCEPTABLE.
- AS AN ALTERNATE TO INSPECTION AND WRITTEN CERTIFICATION, THE "UNDISTURBED SOIL" BASE SHALL BE COMPACTED WITH "COMPACTION EQUIPMENT", LISTED BELOW, TO AT LEAST 90% MODIFIED PROCTOR MAXIMUM DENSITY PER ASTM D 1557 METHOD C.
- COMPACTED SUBBASE SHALL BE UNIFORM AND LEVELED. PROVIDE 6" MINIMUM CRUSHED STONE OR GRAVEL COMPACTED IN 3" LIFTS ABOVE COMPACTED SOIL. GRAVEL SHALL BE NATURAL OR CRUSHED WITH 100% PASSING #1 SIEVE.
- AS AN ALTERNATE TO ITEMS 2 AND 3, THE SUBGRADE SOILS WITH 5 PASSES OR A MEDIUM SIZED VIBRATORY PLATE COMPACTOR (SUCH AS BOMAG BPR 30/38) OR HAND-OPERATED SINGLE DRUM VIBRATORY ROLLER (SUCH AS BOMAG BW 55E). AND SOFT AREAS THAT ARE ENCOUNTERED SHOULD BE REMOVED AND REPLACED WITH A WELL-GRADED GRANULAR FILL AND COMPACTED AS STATED ABOVE.

**COMPACTION EQUIPMENT:**

- HAND OPERATED DOUBLE DRUM, VIBRATORY ROLLER, VIBRATORY PLATE COMPACTOR OR JUMPING JACK COMPACTOR.

**CONSTRUCTION NOTES:**

- FIELD VERIFICATION:  
SUBCONTRACTOR SHALL FIELD VERIFY SCOPE OF WORK, T-MOBILE ANTENNA PLATFORM LOCATION AND UTILITY TRENCHWORK.
- COORDINATION OF WORK:  
SUBCONTRACTOR SHALL COORDINATE RF WORK AND PROCEDURES WITH CONTRACTOR.
- CABLE LADDER RACK:  
SUBCONTRACTOR SHALL FURNISH AND INSTALL CABLE LADDER RACK, CABLE TRAY AND/OR ICE BRIDGE, AND CONDUIT AS REQUIRED TO SUPPORT CABLES TO THE NEW BTS LOCATION.

**ELECTRICAL INSTALLATION NOTES:**

- WIRING, RACEWAY, AND SUPPORT METHODS AND MATERIALS SHALL COMPLY WITH THE REQUIREMENTS OF THE NEC AND TELCORDIA.
- SUBCONTRACTOR SHALL MODIFY OR INSTALL CABLE TRAY SYSTEM AS REQUIRED TO SUPPORT RF AND TRANSPORT CABLE TO THE NEW BTS EQUIPMENT. SUBCONTRACTOR SHALL SUBMIT MODIFICATIONS TO CONTRACTOR FOR APPROVAL.
- ALL CIRCUITS SHALL BE SEGREGATED AND MAINTAIN MINIMUM CABLE SEPARATION AS REQUIRED BY THE NEC AND TELCORDIA.
- CABLES SHALL NOT BE ROUTED THROUGH LADDER-STYLE CABLE TRAY RUNGS.
- EACH END OF EVERY POWER, GROUNDING, AND T1 CONDUCTOR AND CABLE SHALL BE LABELED WITH COLOR-CODED INSULATION OR ELECTRICAL TAPE (3M BRAND, 1/2 INCH PLASTIC ELECTRICAL TAPE WITH UV PROTECTION, OR EQUAL). THE IDENTIFICATION METHOD SHALL CONFORM WITH NEC AND OSHA, AND MATCH INSTALLATION REQUIREMENTS.
- POWER PHASE CONDUCTORS (I.E., HOTS) SHALL BE LABELED WITH COLOR-CODED INSULATION OR ELECTRICAL TAPE (3M BRAND, 1/2 INCH PLASTIC ELECTRICAL TAPE WITH UV PROTECTION, OR EQUAL). PHASE CONDUCTOR COLOR CODES SHALL CONFORM WITH THE NEC AND OSHA.
- ALL ELECTRICAL COMPONENTS SHALL BE CLEARLY LABELED WITH ENGRAVED LAMACOID PLASTIC LABELS. ALL EQUIPMENT SHALL BE LABELED WITH THEIR VOLTAGE RATING, PHASE CONFIGURATION, WIRE CONFIGURATION, POWER OR AMPACITY RATING, AND BRANCH CIRCUIT ID NUMBERS (I.E., PANELBOARD AND CIRCUIT ID'S).
- PANELBOARDS (ID NUMBERS) AND INTERNAL CIRCUIT BREAKERS (CIRCUIT ID NUMBERS) SHALL BE CLEARLY LABELED WITH ENGRAVED LAMACOID PLASTIC LABELS.
- ALL TIE WRAPS SHALL BE CUT FLUSH WITH APPROVED CUTTING TOOL TO REMOVE SHARP EDGES.
- POWER, CONTROL, AND EQUIPMENT GROUND WIRING IN TUBING OR CONDUIT SHALL BE SINGLE CONDUCTOR (#34 AWG OR LARGER), 600 V, OIL RESISTANT THHN OR THWN-2, CLASS B STRANDED COPPER CABLE RATED FOR 90 °C (WET AND DRY) OPERATION; LISTED OR LABELED FOR THE LOCATION AND RACEWAY SYSTEM USED, UNLESS OTHERWISE SPECIFIED.
- SUPPLEMENTAL EQUIPMENT GROUND WIRING LOCATED INDOORS SHALL BE SINGLE CONDUCTOR (#6 AWG OR LARGER), 600 V, OIL RESISTANT THHN OR THWN-2 GREEN INSULATION, CLASS B STRANDED COPPER CABLE RATED FOR 90 °C (WET AND DRY) OPERATION; LISTED OR LABELED FOR THE LOCATION AND RACEWAY SYSTEM USED, UNLESS OTHERWISE SPECIFIED.
- SUPPLEMENTAL EQUIPMENT GROUND WIRING LOCATED OUTDOORS, OR BELOW GRADE, SHALL BE SINGLE CONDUCTOR #2 AWG SOLID TINNED COPPER CABLE, UNLESS OTHERWISE SPECIFIED.
- POWER AND CONTROL WIRING, NOT IN TUBING OR CONDUIT, SHALL BE MULTI-CONDUCTOR, TYPE TC CABLE (#34 AWG OR LARGER), 600 V, OIL RESISTANT THHN OR THWN-2, CLASS B STRANDED COPPER CABLE RATED FOR 90 °C (WET AND DRY) OPERATION; WITH OUTER JACKET; LISTED OR LABELED FOR THE LOCATION USED, UNLESS OTHERWISE SPECIFIED.
- ALL POWER AND GROUNDING CONNECTIONS SHALL BE CRIMP-STYLE, COMPRESSION WIRE LUGS AND WIRENUTS BY HARGER (OR EQUAL). LUGS AND WIRENUTS SHALL BE RATED FOR OPERATION AT NO LESS THAN 75°C (90°C IF AVAILABLE).
- RACEWAY AND CABLE TRAY SHALL BE LISTED OR LABELED FOR ELECTRICAL USE IN ACCORDANCE WITH NEMA, UL, ANS/IEEE AND NEC.
- NEW RACEWAY OR CABLE TRAY WILL MATCH THE EXISTING INSTALLATION WHERE POSSIBLE.
- ELECTRICAL METALLIC TUBING (EMT) OR RIGID NONMETALLIC CONDUIT (I.E., RIGID PVC SCHEDULE 40 OR RIGID PVC SCHEDULE 80 FOR LOCATIONS SUBJECT TO PHYSICAL DAMAGE) SHALL BE USED FOR EXPOSED INDOOR LOCATIONS.
- ELECTRICAL METALLIC TUBING (EMT), ELECTRICAL NONMETALLIC TUBING (ENT), OR RIGID NONMETALLIC CONDUIT (RIGID PVC, SCHEDULE 40) SHALL BE USED FOR CONCEALED INDOOR LOCATIONS.
- GALVANIZED STEEL INTERMEDIATE METALLIC CONDUIT (IMC) SHALL BE USED FOR OUTDOOR LOCATIONS ABOVE GRADE.
- RIGID NONMETALLIC CONDUIT (I.E., RIGID PVC SCHEDULE 40 OR RIGID PVC SCHEDULE 80) SHALL BE USED UNDERGROUND, DIRECT BURIED, IN AREAS OF OCCASIONAL LIGHT VEHICLE TRAFFIC OR ENCASED IN REINFORCED CONCRETE IN AREAS OF HEAVY VEHICLE TRAFFIC.
- LIQUID-TIGHT FLEXIBLE METALLIC CONDUIT (LIQUID-TITE FLEX) SHALL BE USED INDOORS AND OUTDOORS, WHERE VIBRATION OCCURS OR FLEXIBILITY IS NEEDED.
- CONDUIT AND TUBING FITTINGS SHALL BE THREADED OR COMPRESSION-TYPE AND APPROVED FOR THE LOCATION USED. SETSCREW FITTINGS ARE NOT ACCEPTABLE.
- CABINETS, BOXES AND WIREWAYS SHALL BE LISTED OR LABELED FOR ELECTRICAL USE IN ACCORDANCE WITH NEMA, UL, ANS/IEEE AND NEC.
- CABINETS, BOXES AND WIREWAYS TO MATCH THE EXISTING INSTALLATION WHERE POSSIBLE.
- WIREWAYS SHALL BE EPOXY-COATED (GRAY) AND INCLUDE A HINGED COVER, DESIGNED TO SWING OPEN DOWNWARD; SHALL BE PANDUIT TYPE E (OR EQUAL); AND RATED NEMA 1 (OR BETTER) INDOORS, OR NEMA 3R (OR BETTER) OUTDOORS.
- EQUIPMENT CABINETS, TERMINAL BOXES, JUNCTION BOXES, AND PULL BOXES SHALL BE GALVANIZED OR EPOXY-COATED SHEET STEEL, SHALL MEET OR EXCEED UL 50, AND RATED NEMA 1 (OR BETTER) INDOORS, OR NEMA 3R (OR BETTER) OUTDOORS.
- METAL RECEPTACLE, SWITCH, AND DEVICE BOXES SHALL BE GALVANIZED, EPOXY-COATED, OR NON-CORRODING; SHALL MEET OR EXCEED UL 514A AND NEMA OS 1; AND RATED NEMA 1 (OR BETTER) INDOORS, OR WEATHER PROTECTED (WP OR BETTER) OUTDOORS.
- NONMETALLIC RECEPTACLE, SWITCH, AND DEVICE BOXES SHALL MEET OR EXCEED NEMA OS 2; AND RATED NEMA 1 (OR BETTER) INDOORS, OR WEATHER PROTECTED (WP OR BETTER) OUTDOORS.
- THE SUBCONTRACTOR SHALL NOTIFY AND OBTAIN NECESSARY AUTHORIZATION FROM THE CONTRACTOR BEFORE COMMENCING WORK ON THE AC POWER DISTRIBUTION PANELS.
- THE SUBCONTRACTOR SHALL PROVIDE NECESSARY TAGGING ON THE BREAKERS, CABLES AND DISTRIBUTION PANELS IN ACCORDANCE WITH THE APPLICABLE CODES AND STANDARDS TO SAFEGUARD AGAINST LIFE AND PROPERTY.
- ALL ELECTRICAL WORK SHALL BE PERFORMED IN ACCORDANCE WITH THE PROJECT SPECIFICATIONS, NEC AND ALL APPLICABLE LOCAL CODES.
- CONDUIT ROUTINGS ARE SCHEMATIC. SUBCONTRACTOR SHALL INSTALL CONDUITS SO THAT ACCESS TO EQUIPMENT IS NOT BLOCKED.

**T-MOBILE  
NORTHEAST LLC**

15 COMMERCE WAY, SUITE B  
NORTON, MA 02766  
(508) 286-2700



SBA COMMUNICATIONS CORP.  
134 FLANDERS ROAD, SUITE 125  
WESTBOROUGH, MA 01581  
(508) 251-0720

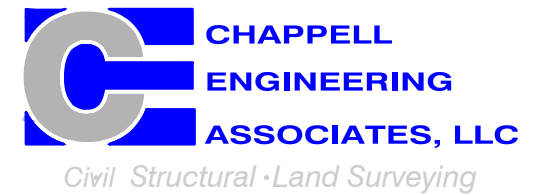

R.K. EXECUTIVE CENTRE  
201 BOSTON POST ROAD WEST, SUITE 101  
MARLBOROUGH, MA 01752  
(508) 481-7400  
www.chappellengineering.com

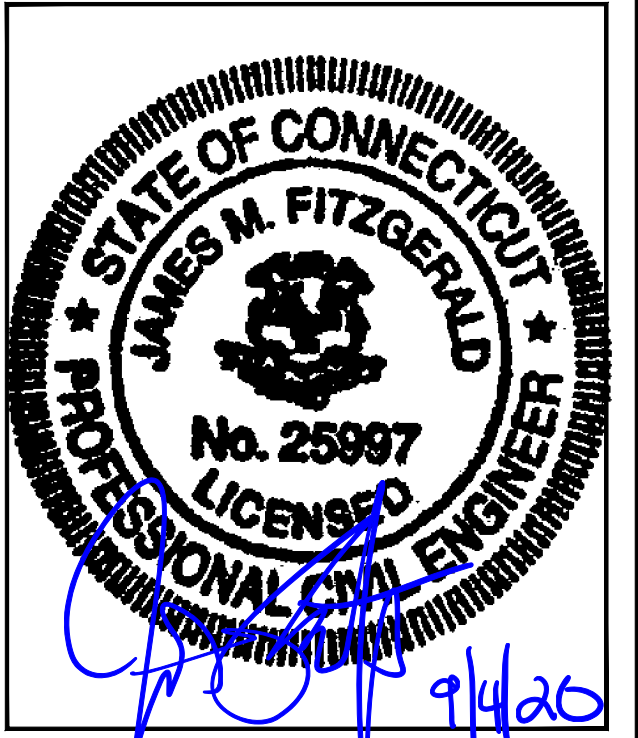

CHECKED BY: JMT

APPROVED BY: JMT

SUBMITTALS			
REV.	DATE	DESCRIPTION	BY
1	08/03/20	ISSUED FOR CONSTRUCTION	CMC
0	07/20/20	ISSUED FOR REVIEW	JRV

SITE NUMBER:  
**CT11284A**

SITE ADDRESS:  
81 MONTEVIDEO ROAD  
AVON, CT 06001

SHEET TITLE  
**GENERAL NOTES**

SHEET NUMBER  
**GN-1**



FEEDLINE SCHEDULE	FEEDLINES	LOCATION
A	EXISTING TO REMAIN: (2) 1-3/8" COAX CABLES (1) 1/2" COAX FOR GPS (1) 6x12 (1-3/8") HCS FIBER CABLE	ROUTED PER TOWER STRUCTURAL ANALYSIS
B	EXISTING TO BE REMOVED: (4) 1-3/8" COAX CABLES	
	PROPOSED: (1) 6x12 (1-3/8") HCS FIBER CABLES	

NOTE:  
EXISTING T-MOBILE EQUIPMENT FEEDLINE INVENTORY BASED ON OBSERVED FIELD CONDITIONS. RFDS AND FEEDLINE LEASING ENTITLEMENTS MAY DIFFER.

**SPECIAL PRE-CONSTRUCTION WORK NOTE (SBA-PROVIDED TOWER STRUCTURAL ANALYSIS SPECIAL EQUIPMENT INSTALLATION REQUIREMENTS):**  
GENERAL CONTRACTOR SHALL FURNISH AND INSTALL ALL SPECIAL OR SUPPLEMENTAL ADDITIONAL TOWER-MOUNTED EQUIPMENT PER RECOMMENDATIONS FROM SBA-PROVIDED TOWER STRUCTURAL ANALYSIS FOR ANY SPECIAL SHIELDING OF TOWER TOP EQUIPMENT AND FOR ANY SPECIAL FEEDLINE BUNDLING OR RELOCATION.

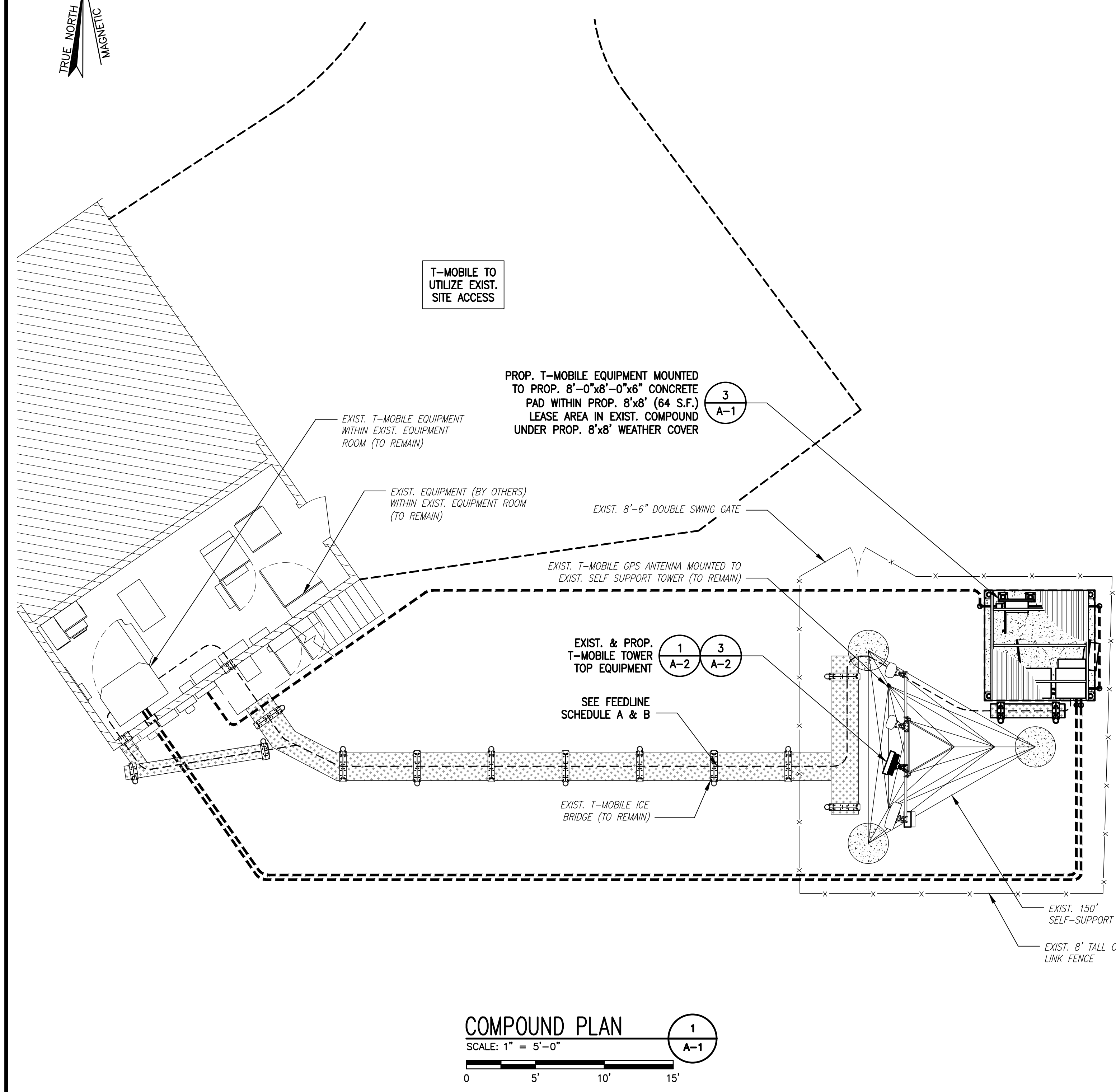
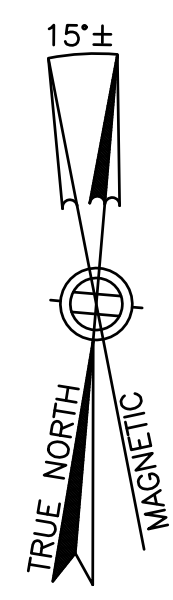

**COMPOUND PLAN**  
SCALE: 1" = 5'-0"  
1 A-1

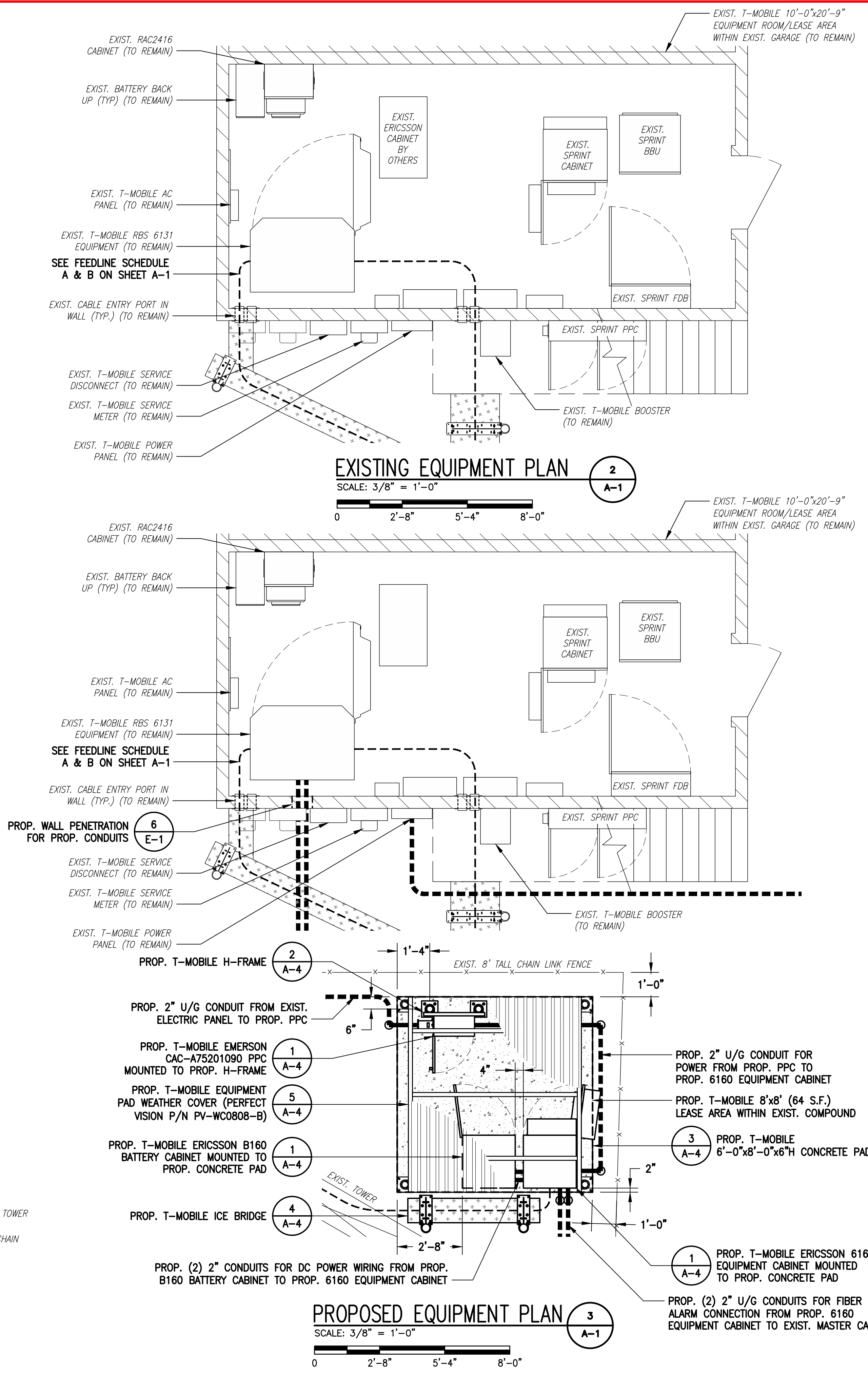

**EXISTING EQUIPMENT PLAN**  
SCALE: 3/8" = 1'-0"  
2 A-1

**PROPOSED EQUIPMENT PLAN**  
SCALE: 3/8" = 1'-0"  
3 A-1

**T-MOBILE  
NORTHEAST LLC**  
15 COMMERCE WAY, SUITE B  
NORTON, MA 02766  
(508) 286-2700



SBA COMMUNICATIONS CORP.  
134 FLANDERS ROAD, SUITE 125  
WESTBOROUGH, MA 01581  
(508) 251-0720

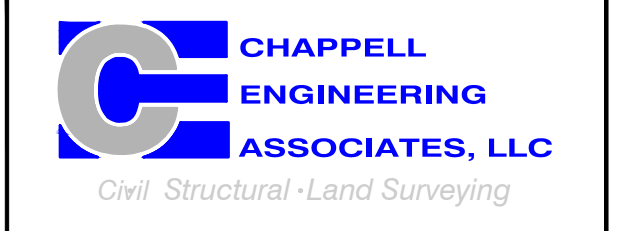

R.K. EXECUTIVE CENTRE  
201 BOSTON POST ROAD WEST, SUITE 101  
MARLBOROUGH, MA 01752  
(508) 481-7400  
www.chappellengineering.com



CHECKED BY: JMT

APPROVED BY: JMT

SUBMITTALS			
REV.	DATE	DESCRIPTION	BY
1	08/03/20	ISSUED FOR CONSTRUCTION	CMC
0	07/20/20	ISSUED FOR REVIEW	JRV

SITE NUMBER:  
**CT11284A**  
SITE ADDRESS:  
81 MONTEVIDEO ROAD  
AVON, CT 06001

SHEET TITLE  
**COMPOUND & EQUIPMENT PLANS**

SHEET NUMBER  
**A-1**







**FINAL ANTENNA CONFIGURATION**

SECTOR	ANTENNA	RAD CENTER	AZIMUTH (TRUE NORTH)	MECHANICAL DOWNTILT	ELECTRICAL DOWNTILT	BAND	TMA/RADIOS	CABLES
GAMMA	RFS APXVAARR24_43-U-NA20	136'-0"± AGL	290°	0°	6°	L600/N600/L700	ERICSSON RADIO 4449 B71+B85	(2) 1-3/8" COAX CABLES (1) 6x12 (1-3/8") HCS FIBER CABLE
	ERICSSON M-MIMO AIR6449 B41	136'-0"± AGL	290°	0°	0°	L2500/N2500	ERICSSON RADIO 4415 B25	
	ERICSSON AIR21 KRC118023-1 B2A/B4P	136'-0"± AGL	290°	0°	4°	G1900/U2100	ERICSSON KRY 112 144/2 TWIN STYLE 1B AWS TMA	
	ERICSSON AIR32 KRD901046-1 B66A/B2A	136'-0"± AGL	290°	0°	6°	L2100/L1900	-	

**CABLE NOTE:** EXISTING (4) 1-3/8" COAX CABLES TO BE REMOVED. SEE FEEDLINE SCHEDULE A & B ON SHEET A-1.

**NOTE:** RFDS REV6 - 05/11/20

**T-MOBILE  
NORTHEAST LLC**

15 COMMERCE WAY, SUITE B  
NORTON, MA 02766  
(508) 286-2700



SBA COMMUNICATIONS CORP.  
134 FLANDERS ROAD, SUITE 125  
WESTBOROUGH, MA 01581  
(508) 251-0720

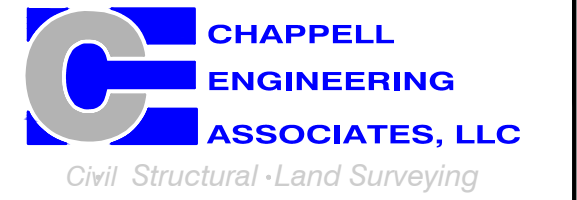

R.K. EXECUTIVE CENTRE  
201 BOSTON POST ROAD WEST, SUITE 101  
MARLBOROUGH, MA 01752  
(508) 481-7400  
www.chappellengineering.com

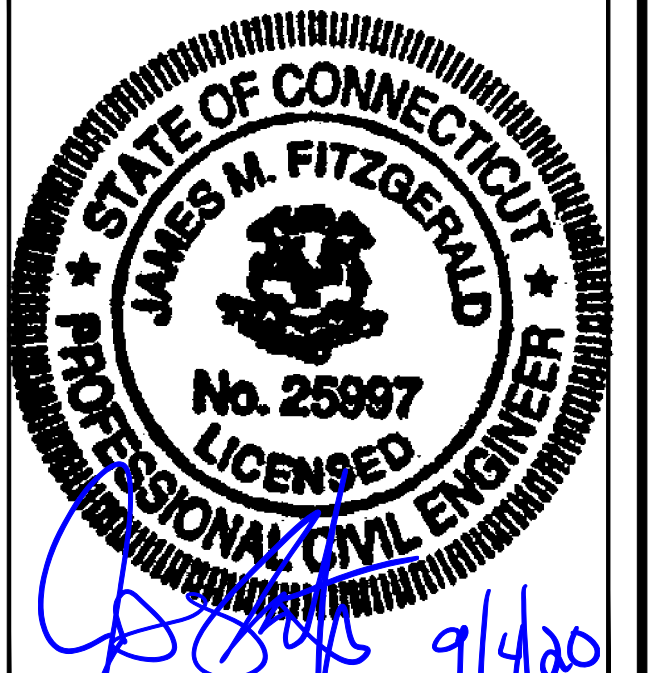

CHECKED BY: JMT

APPROVED BY: JMT

SUBMITTALS			
REV.	DATE	DESCRIPTION	BY
1	08/03/20	ISSUED FOR CONSTRUCTION	CMC
0	07/20/20	ISSUED FOR REVIEW	JRV

SITE NUMBER:  
**CT11284A**

SITE ADDRESS:  
81 MONTEVIDEO ROAD  
AVON, CT 06001

SHEET TITLE  
**ANTENNA DETAILS**

SHEET NUMBER  
**A-3**



**ERICSSON M-MIMO AIR6449 B41 PANEL ANTENNA**  
DIMENSIONS: 33.1"H x 20.5"W x 8.3"D  
WEIGHT: 103.0 lbs  
QUANTITY: TOTAL OF 1

**ANTENNA DETAILS**  
SCALE: N.T.S.

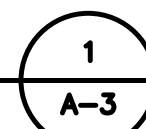

**ERICSSON RADIO 4415 B25**  
DIMENSIONS: 16.5"H x 13.4"W x 5.9"D  
WEIGHT: 46 LBS  
QUANTITY: TOTAL OF 1

**RADIO DETAILS**  
SCALE: N.T.S.

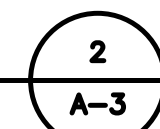

INSTALL PROP. 2-1/2" SCH. 40 PIPE, 72" LONG TO EXIST. SECTOR FRAME WITH PROP. CROSSOVER PLATE KIT (SITE PRO 1 P/N SCX23-K) (TOTAL OF 2)

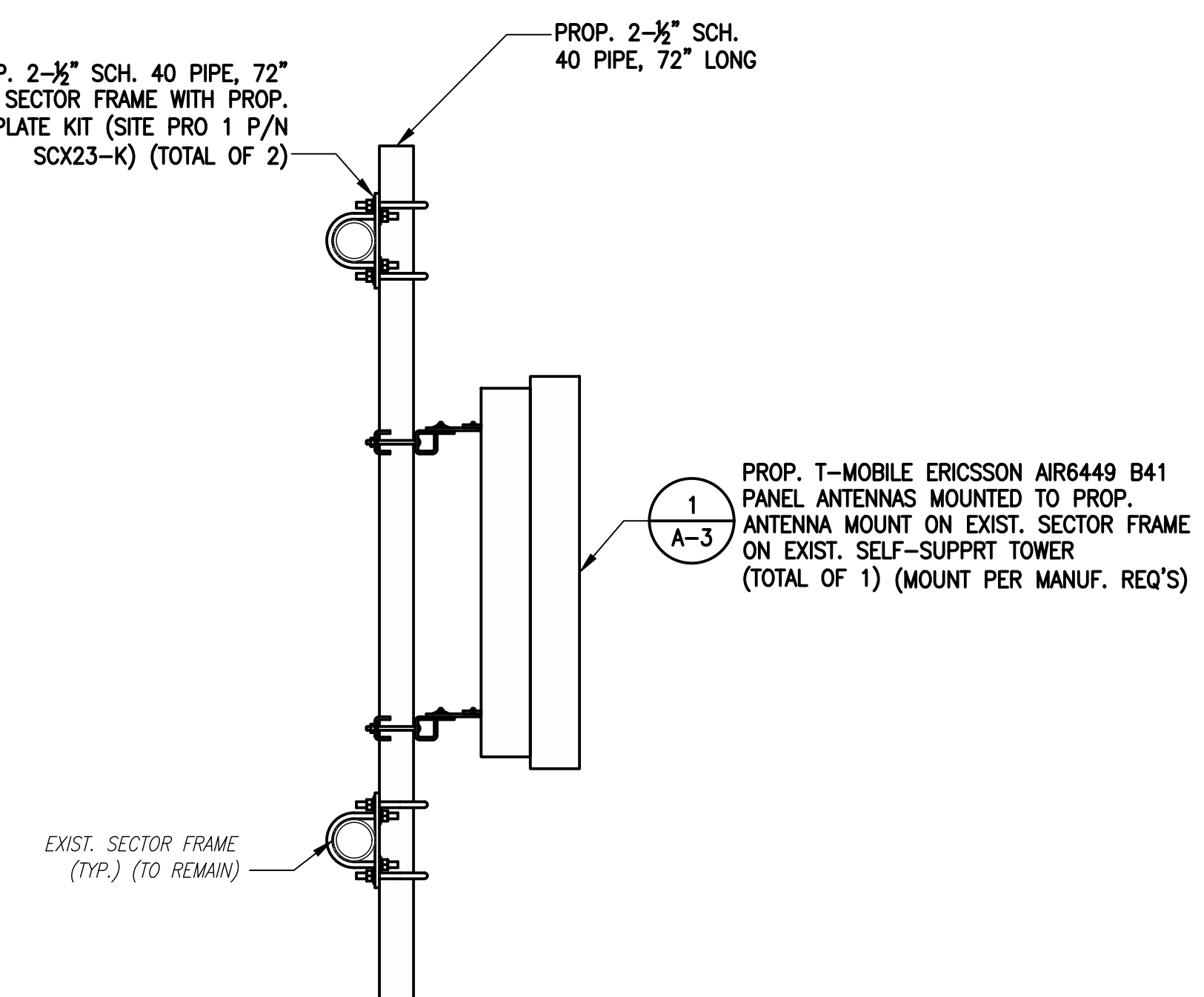

**ANTENNA MOUNTING DETAIL**  
SCALE: N.T.S.

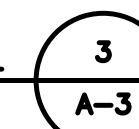





**ERICSSON CAC-A75201090 PPC**  
 DIMENSIONS: 40.0"H x 20.0"W x 10.0"D  
 QUANTITY: TOTAL OF 1

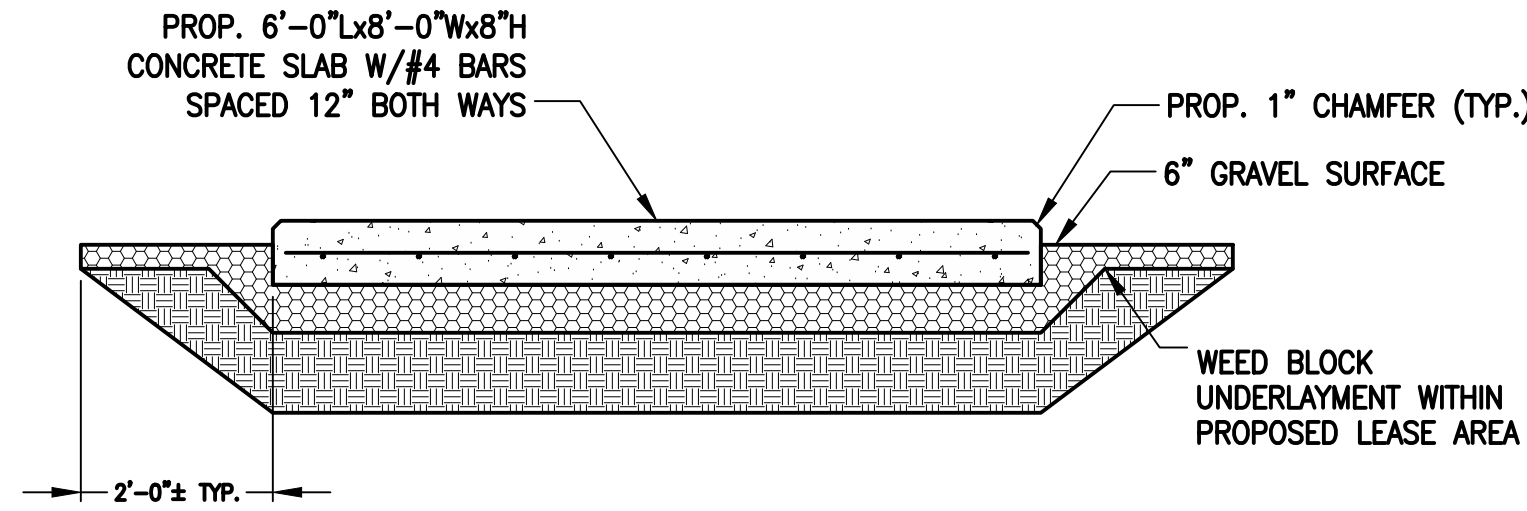

**CONCRETE PAD DETAIL**  
 SCALE: 1/2" = 1'-0" (3/A-4)

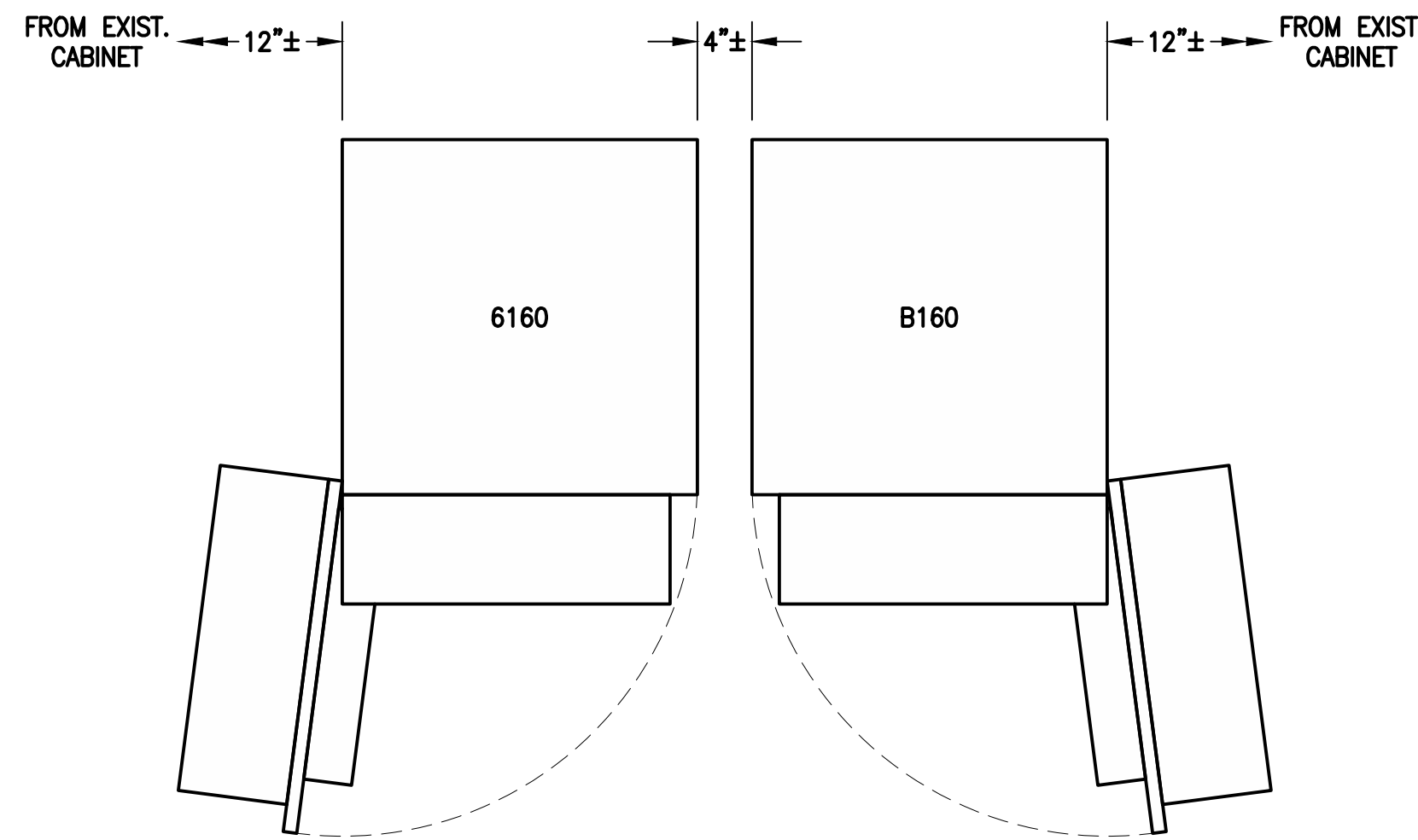

**ERICSSON 6160 SITE SUPPORT CABINET**  
 DIMENSIONS: 63.25"H x 26.0"W x 34.0"D  
 QUANTITY: TOTAL OF 1

**ERICSSON B160 BATTERY CABINET**  
 DIMENSIONS: 63.25"H x 26.0"W x 34.0"D  
 QUANTITY: TOTAL OF 1

**CONCRETE GENERAL NOTES**

- ALL CONCRETE WORK SHALL CONFORM TO ACI 318, "BUILDING CODE REQUIREMENTS FOR REINFORCED CONCRETE" AND TO THE PROJECT SPECIFICATIONS.
- ALL CONCRETE IS TO BE NORMAL DENSITY CONCRETE WITH A MAXIMUM SLUMP OF 4 INCHES. MAXIMUM AGGREGATE SIZE 3/4 INCH. NO ADDITIONAL WATER SHALL BE ADDED TO THE CONCRETE AT THE JOB SITE.
- PROVIDE AIR ENTRAINMENT OF 4 TO 6 PERCENT IN ALL EXPOSED CONCRETE WORK WITH AIR-ENTRAINING ADMIXTURE COMPLYING WITH ASTM C 260. AT TROWEL-FINISHED FLOORS, DO NOT EXCEED AIR-ENTRAINMENT CONTENT OF 3 PERCENT.
- NO HOLES OR SLEEVES SHALL BE MADE THROUGH CONCRETE WORK OTHER THAN THOSE INDICATED ON THE STRUCTURAL DRAWINGS WITHOUT THE APPROVAL OF THE STRUCTURAL ENGINEER.
- ALL FORMWORK OFFSET TOLERANCES (PER ACI 117) TO BE CLASS A.
- FLOOR SLAB TOLERANCES TO ASTM E1155; SPECIFIED OVERALL MINIMUM VALUE OF FLATNESS F F=25 WITH LOCAL MINIMUM F F=17, AND MINIMUM VALUE OF LEVELNESS F F=20 WITH LOCAL MINIMUM F F AND F F WITHIN 72 HOURS OF SLAB CONSTRUCTION.
- CABINETS ON SLAB (IF APPLICABLE), ALLOWABLE CAPACITY OF CONCRETE USED IN DESIGN MIN. 4000 PSI.

**FOUNDATION NOTES:**

- DESIGN INFORMATION AND GENERAL REQUIREMENTS**
  - CODES**
    - DESIGN CONFORMS TO INTERNATIONAL BUILDING CODE 2012.
    - AMERICAN CONCRETE INSTITUTE "BUILDING CODE REQUIREMENTS FOR REINFORCED CONCRETE," ACI 318-08.
  - EARTHWORK**
    - FOUNDATIONS**
      - FOUNDATIONS HAVE BEEN DESIGNED TO BEAR ON (UNDISTURBED RESIDUAL SOILS/COMPACTED STRUCTURAL FILL), CAPABLE OF SAFELY SUPPORTING A NET ALLOWABLE BEARING PRESSURE OF 2000 PSF. IF FOUNDATION CONDITIONS PROVE UNACCEPTABLE AT ELEVATIONS SHOWN, EXCAVATION SHALL BE CARRIED DEEPER AND SHALL BE BACKFILLED WITH LEAN CONCRETE TO PLAN FOOTING BOTTOM, OR REDESIGN OF FOUNDATIONS WILL BE REQUIRED AT THE DIRECTION OF THE ENGINEER.
      - DESIGN, FURNISH AND INSTALL ALL TEMPORARY SHEETING, SHORING AND DRAINAGE NECESSARY TO MAINTAIN THE EXCAVATION AND PROTECT SURROUNDING STRUCTURES AND UTILITIES.
      - THOROUGHLY COMPACT ALL BOTTOM OF FOOTINGS PRIOR TO PLACING ANY CONCRETE.
    - CONCRETE**

**3.1 FORMWORK**

- CONCRETE CONSTRUCTION SHALL CONFORM TO "SPECIFICATIONS FOR STRUCTURAL CONCRETE FOR BUILDINGS," (ACI 301-89).
- FORMWORK SHALL CONFORM TO ACI 301 "SPECIFICATIONS FOR STRUCTURAL CONCRETE FOR BUILDINGS."

**3.2 REINFORCEMENT**

- REINFORCING STEEL ASTM A615, GRADE 60, WELDED WIRE ASTM A185 (FLAT SHEET). LAPS 40 BAR DIAMETERS UNLESS NOTED. BARS SHALL BE SECURELY HELD IN ACCURATE POSITION BY SUITABLE ACCESSORIES, TIE BARS, SUPPORT BARS, ETC. HOOK LENGTHS SHALL BE 12 BAR DIAMETERS.
- CONCRETE COVER FOR REINFORCING BARS SHALL BE AS FOLLOWS, UNLESS OTHERWISE NOTED:
 

FOOTINGS & SLABS CAST AGAINST GROUND	3"
CONCRETE TO BE IN CONTACT WITH GROUND	2"
OR WEATHER AT BARS GREATER THAN #5	1-1/2"
AT BARS #5 OR LESS	4"
CONCRETE NOT TO BE EXPOSED TO GROUND	1-1/2"
OR WEATHER BEAMS, GIRDERS & COLUMNS	3/4"
SLABS & WALLS	3/4"

**3.3 CAST-IN-PLACE CONCRETE**

- MINIMUM 28 DAY CYLINDER STRENGTH AND MAXIMUM SLUMP, PRIOR TO ADDITION OF SUPER PLASTICIZERS, AS FOLLOWS:
 

	F.C. (PSI)	SLUMP
CLASS I FOOTINGS	4000	3"
CLASS II FOOTINGS	4000	3"
CLASS III INTERIOR ELEVATED SLABS & WALLS	4000	4"
CLASS V OTHER WORK	4000	4"
CLASS VI LEAN CONCRETE FOR OVER EXCAVATION OF FOUNDATIONS	2000	N/A
- MIX DESIGN TO BE IN ACCORDANCE WITH ACI 318, CHAPTER 5. NO CALCIUM CHLORIDE OR ADMIXTURE CONTAINING CHLORIDES SHALL BE USED IN ANY CONCRETE.
- COARSE AGGREGATE FOR NORMAL WEIGHT CONCRETE SHALL CONFORM TO ASTM C33 SIZE #57. COARSE AGGREGATE FOR LIGHT WEIGHT CONCRETE SHALL CONFORM TO ASTM C330 GRADED 3/4" TO 1 1/4".
- COLD WEATHER PLACEMENT SHALL COMPLY WITH ACI 306.1.
- HOT WEATHER PLACEMENT SHALL COMPLY WITH ACI 305 R.
- CHAMFER ALL EXPOSED EDGES 3/4".
- THE MAXIMUM TEMPERATURE OF ALL CONCRETE AT DELIVERY TO THE SITE SHALL BE 85F. TOTAL DELIVERY TIME SHALL BE LESS THAN 75 MINUTES.

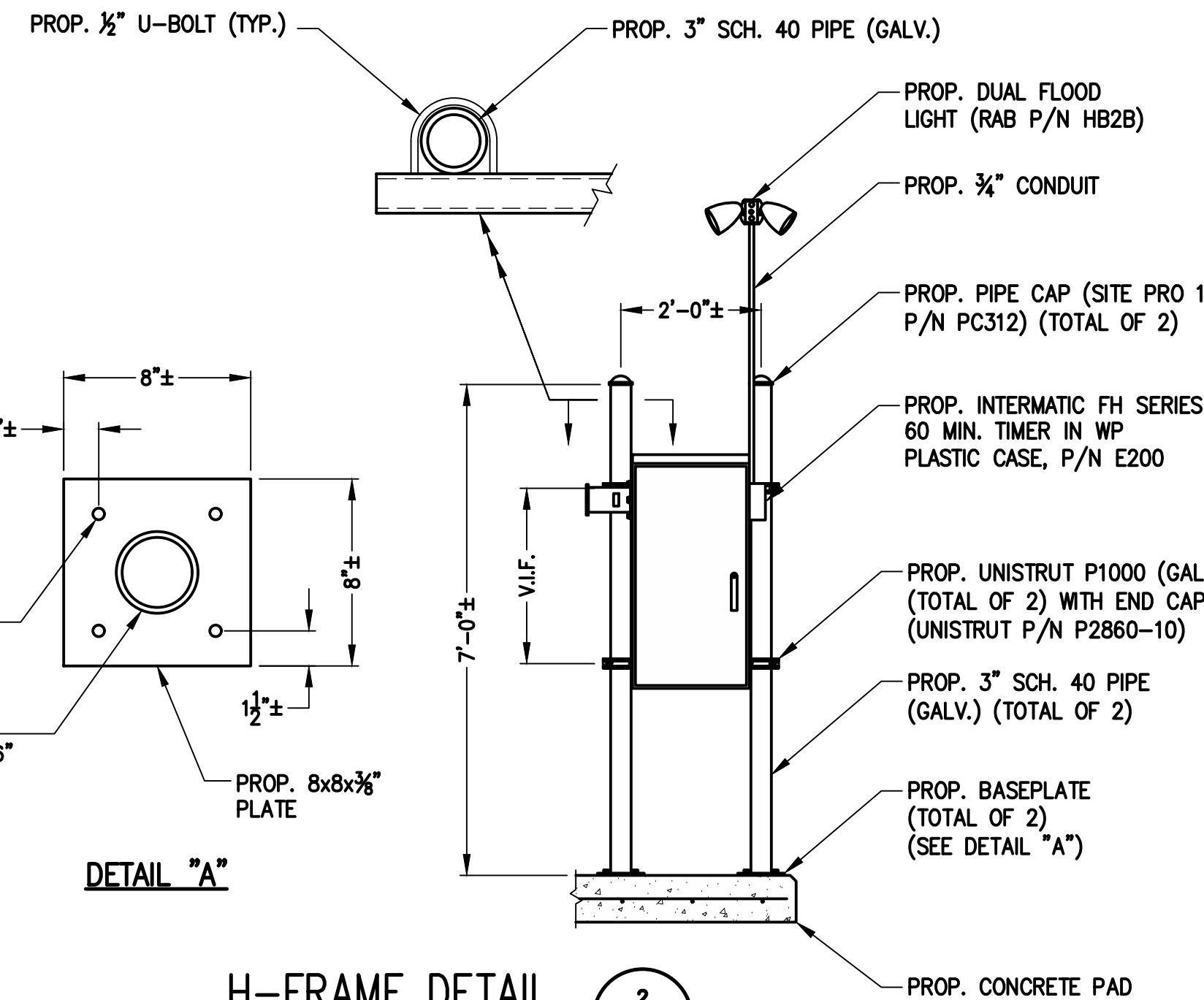

**H-FRAME DETAIL**  
 SCALE: N.T.S. (2/A-4)

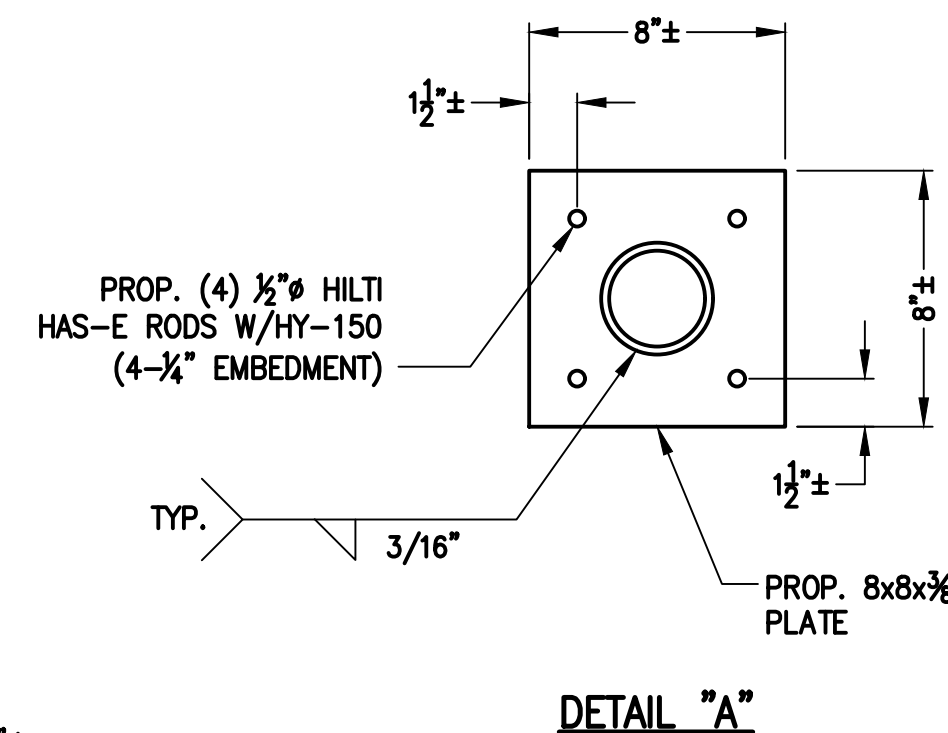

**DETAIL "A"**

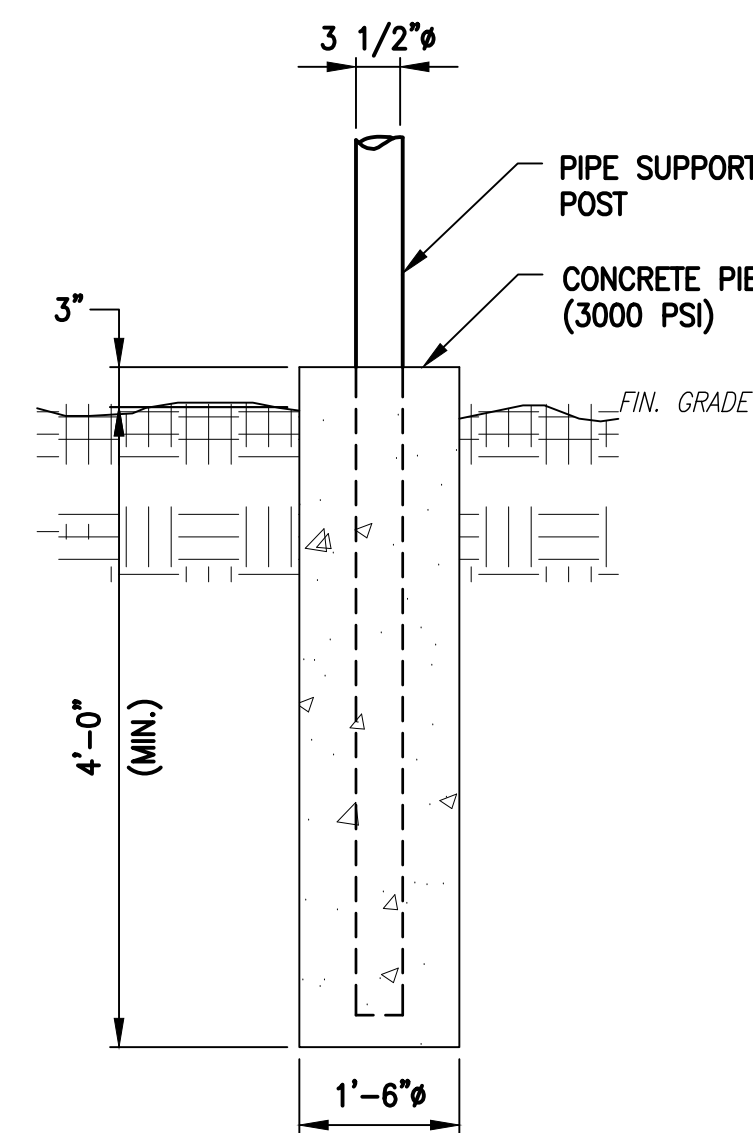

**DETAIL "B"**

- NOTES:**
- FOR EXPOSED LEDGE, PROVIDE GROUT LEVELING PAD. INSTALL (2)-3/8" EXPANSION ANCHORS, (6" LONG).
  - FOR BURIED LEDGE AT LESS THAN 3'-6" BELOW FINISH GRADE, CORE 8" HOLE INTO LEDGE 18" DEEP. FILL AROUND PIPE WITH NON-SHRINK GROUT. USE COAL TAR ON BURIED LENGTH OF PIPE, AND BACKFILL TO FINISH GRADE.
  - FOR CONCRETE, FASTEN BASEPLATE WITH (2)-3/8" EXPANSION ANCHORS, (6" LONG).
  - FOR POSTS ON CONCRETE OR EXPOSED LEDGE, PROVIDE 4"x8"x3/8" BASE PLATE WITH (2)-1/2" HOLES @ 6" O.C.

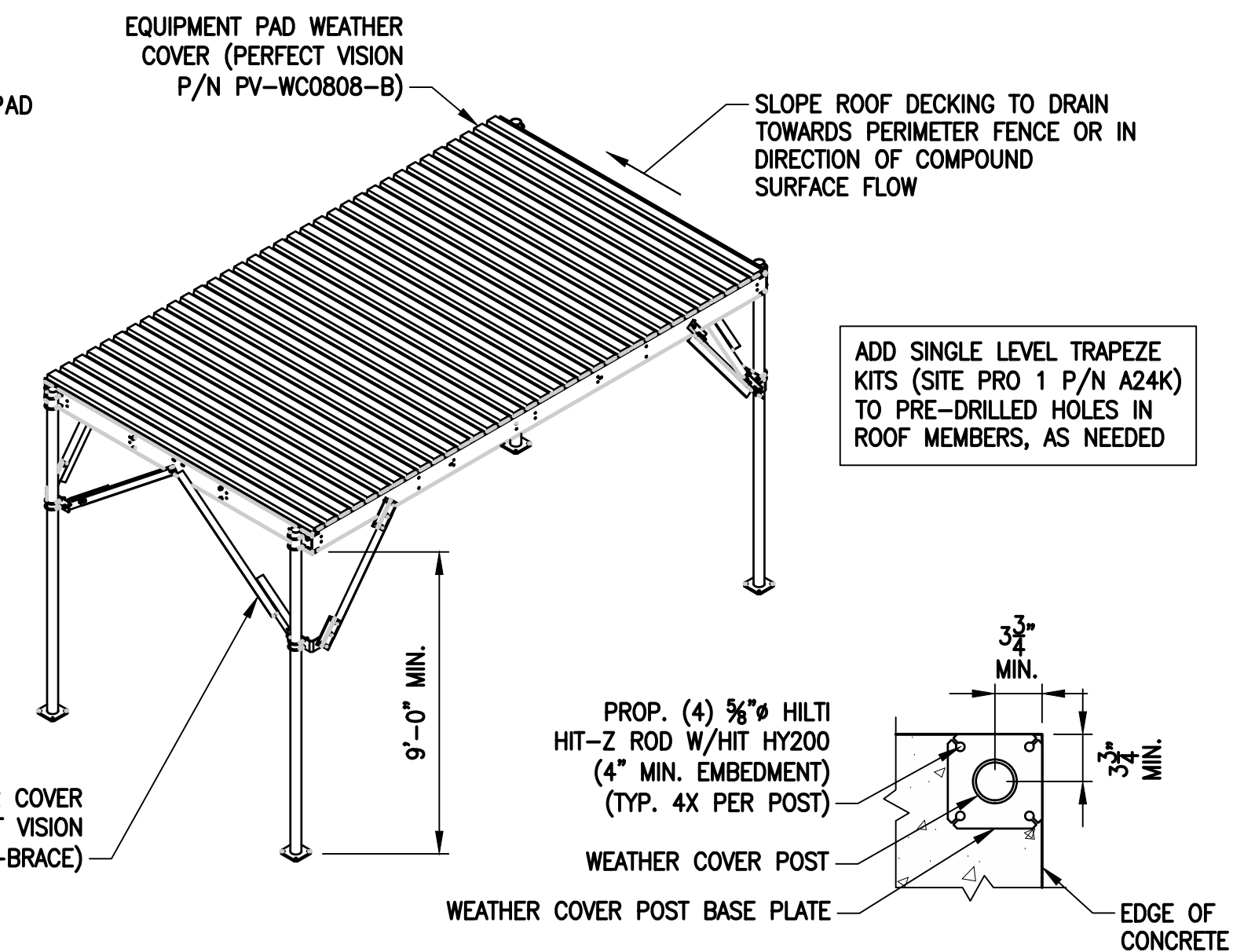

**EQUIPMENT PAD WEATHER COVER DETAIL**  
 SCALE: N.T.S. (5/A-4)

**EQUIPMENT DETAIL**  
 SCALE: N.T.S. (1/A-4)

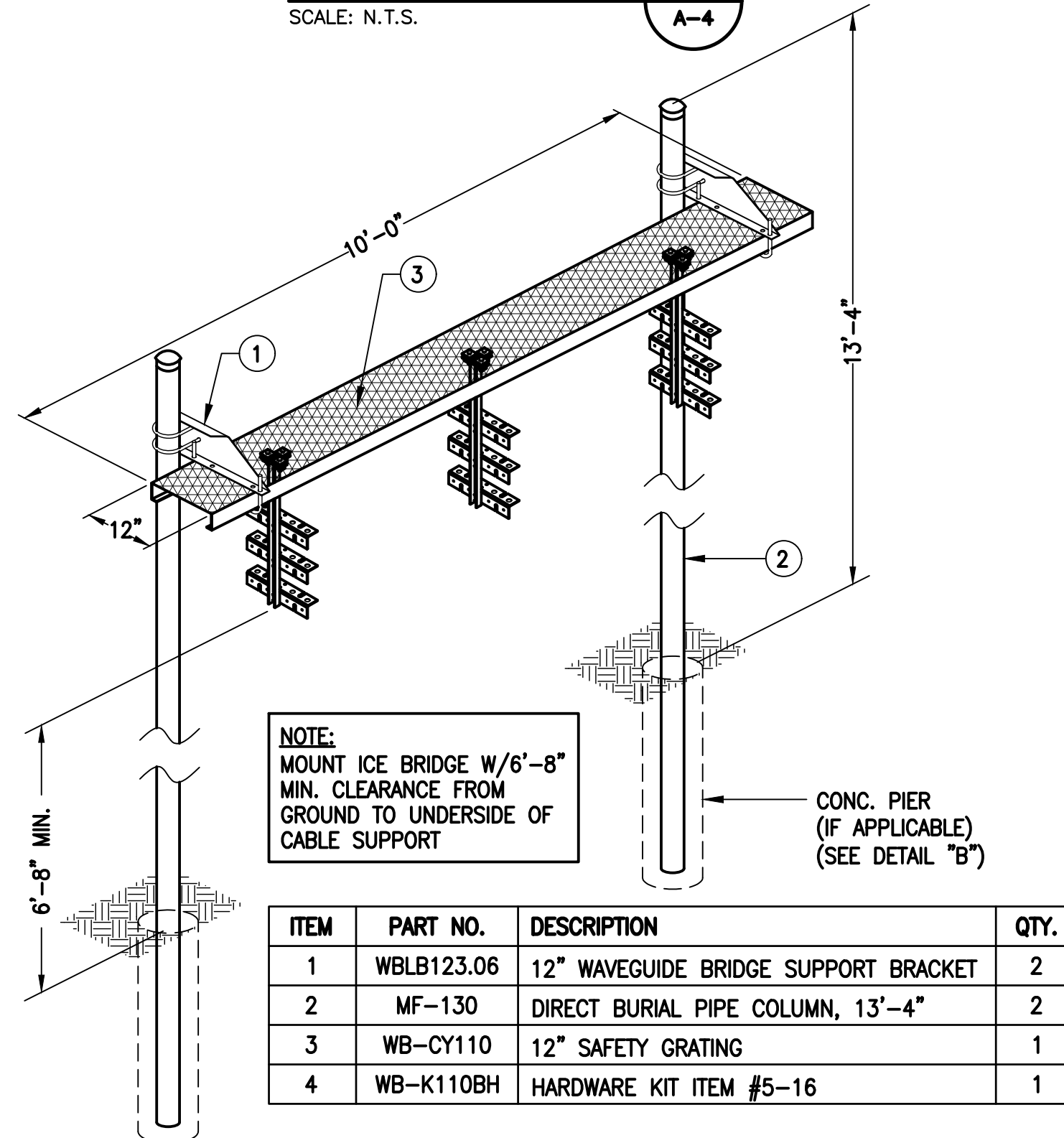

**NOTE:**  
 MOUNT ICE BRIDGE W/6'-8" MIN. CLEARANCE FROM GROUND TO UNDERSIDE OF CABLE SUPPORT

ITEM	PART NO.	DESCRIPTION	QTY.
1	WBLB123.06	12" WAVEGUIDE BRIDGE SUPPORT BRACKET	2
2	MF-130	DIRECT BURIAL PIPE COLUMN, 13'-4"	2
3	WB-CY110	12" SAFETY GRATING	1
4	WB-K110BH	HARDWARE KIT ITEM #5-16	1

**CABLE BRIDGE DETAIL**  
 SCALE: N.T.S. (4/A-4)

**T-MOBILE NORTHEAST LLC**

15 COMMERCE WAY, SUITE B  
 NORTON, MA 02766  
 (508) 286-2700



SBA COMMUNICATIONS CORP.  
 134 FLANDERS ROAD, SUITE 125  
 WESTBOROUGH, MA 01581  
 (508) 251-0720



R.K. EXECUTIVE CENTRE  
 201 BOSTON POST ROAD WEST, SUITE 101  
 MARLBOROUGH, MA 01752  
 (508) 481-7400  
 www.chappellengineering.com



CHECKED BY: JMT

APPROVED BY: JMT

SUBMITTALS			
REV.	DATE	DESCRIPTION	BY
1	08/03/20	ISSUED FOR CONSTRUCTION	CMC
0	07/20/20	ISSUED FOR REVIEW	JRV

SITE NUMBER:  
**CT11284A**

SITE ADDRESS:  
 81 MONTEVIDEO ROAD  
 AVON, CT 06001

SHEET TITLE  
**EQUIPMENT DETAILS**

SHEET NUMBER  
**A-4**



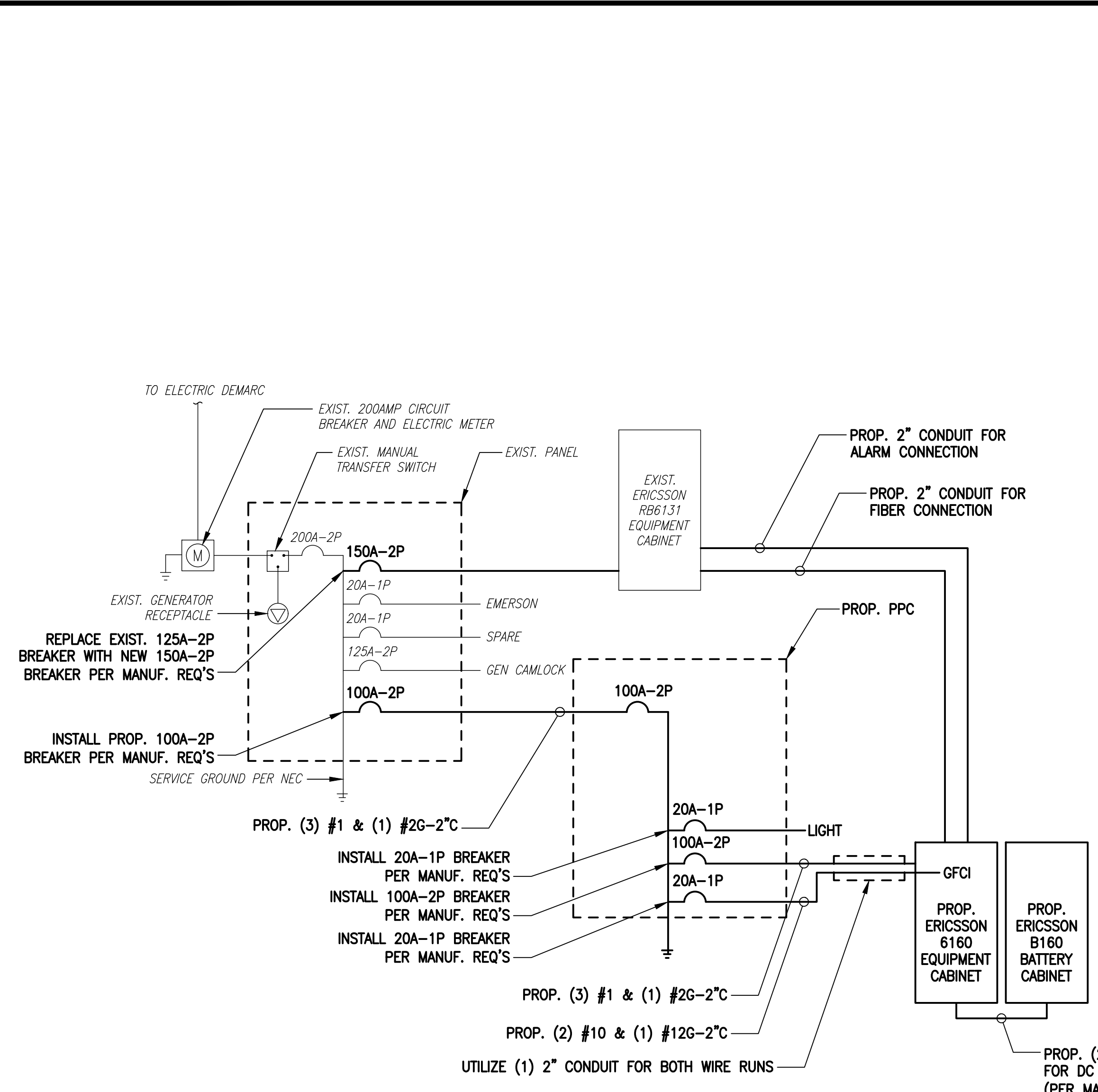

**ONE LINE DIAGRAM**  
SCALE: NOT TO SCALE

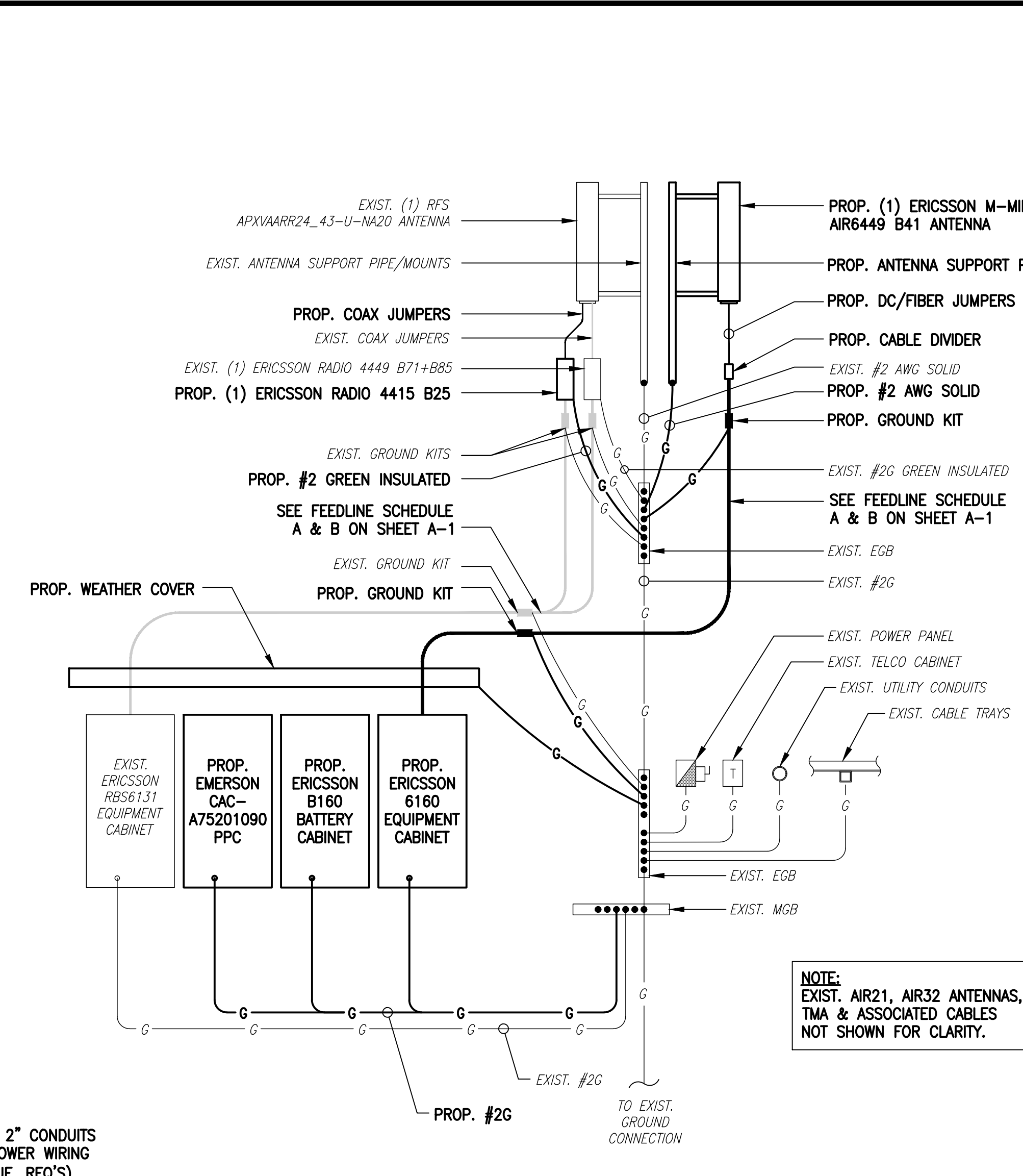

**GROUNDING RISER DIAGRAM**  
SCALE: NOT TO SCALE

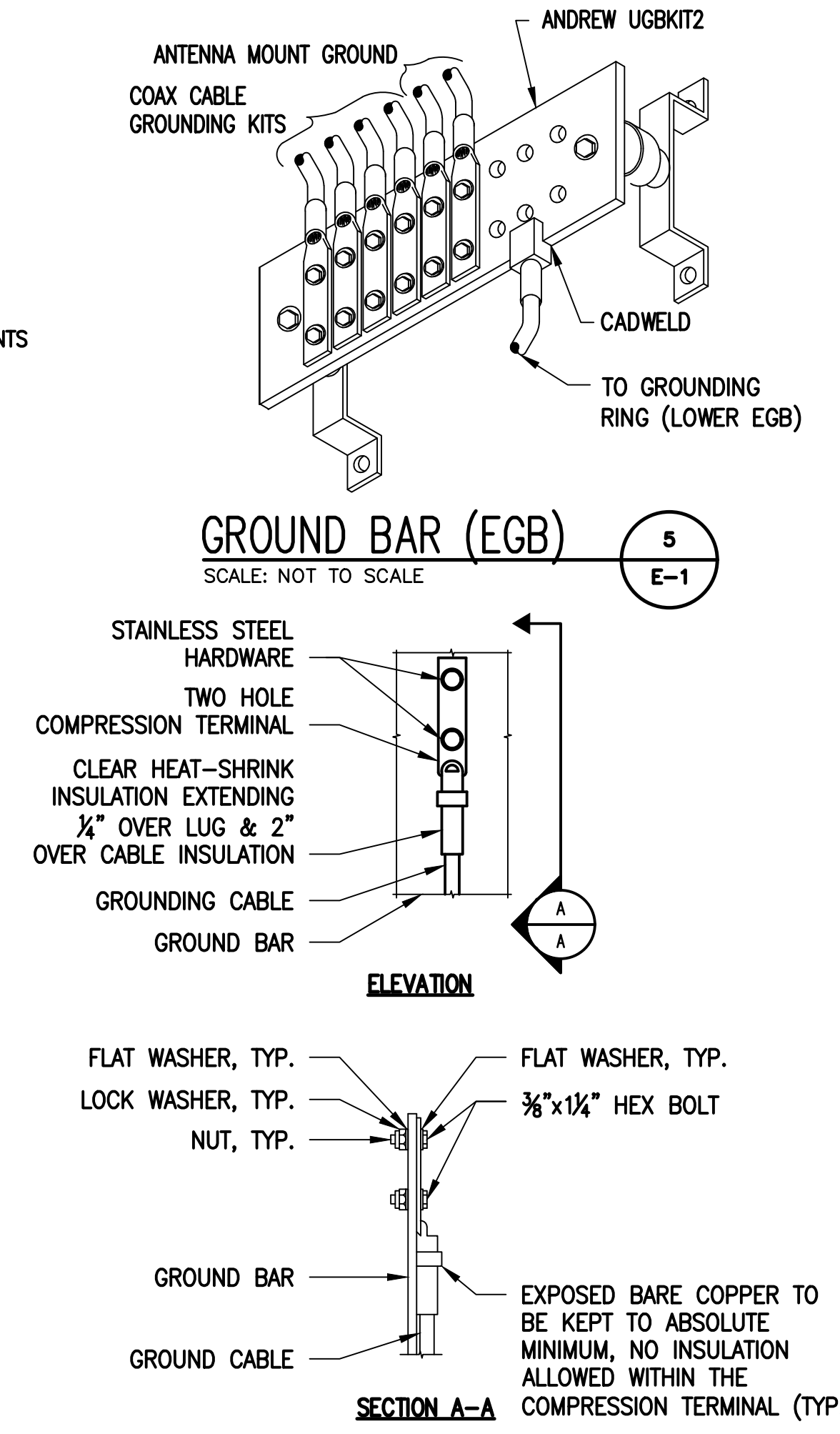

**TYPICAL GROUND BAR CONNECTIONS DETAIL**  
SCALE: NOT TO SCALE

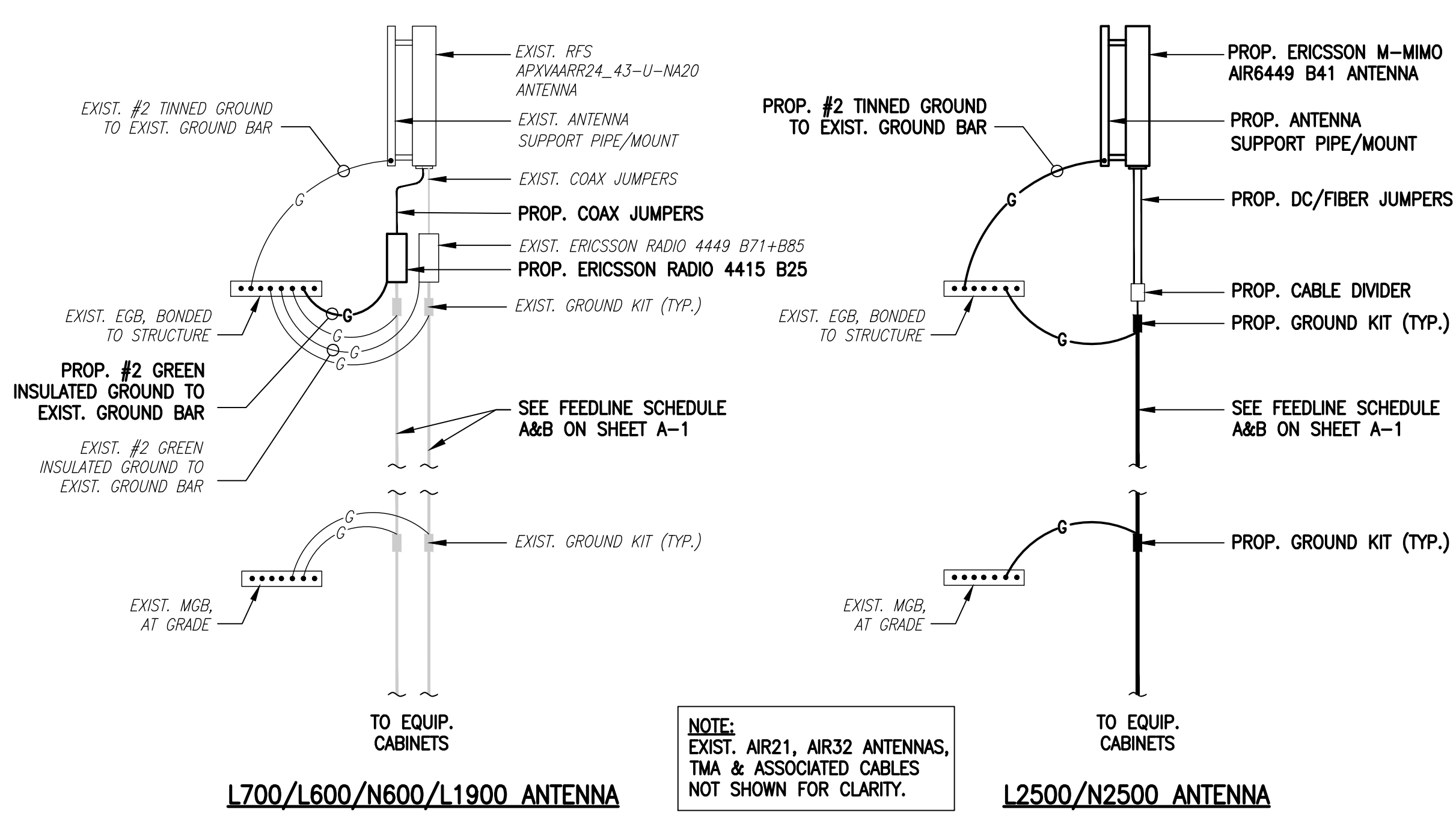

**COAX CABLE CONNECTION AND GROUNDING DETAIL**  
SCALE: NOT TO SCALE

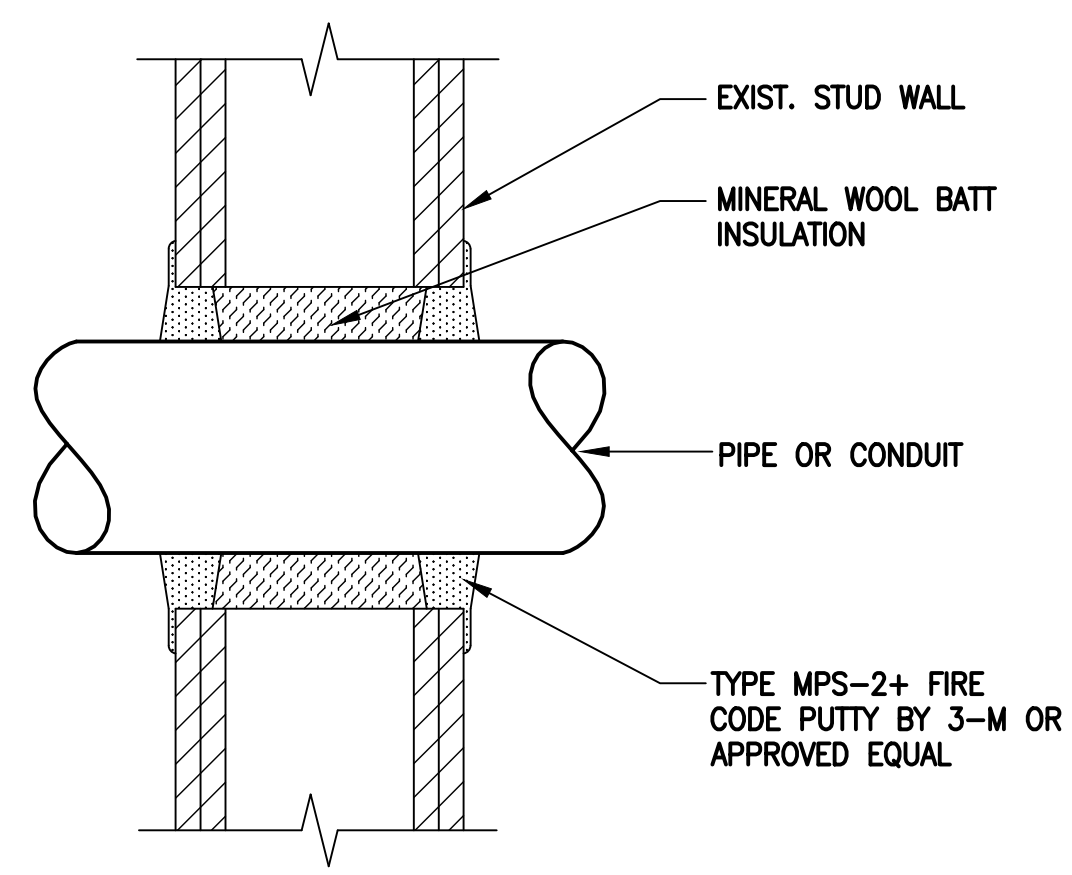

**CONDUIT WALL PENETRATION**  
SCALE: NTS

**ELECTRICAL AND GROUNDING NOTES**

- ALL ELECTRICAL WORK SHALL CONFORM TO THE REQUIREMENTS OF THE NATIONAL ELECTRICAL CODE (NEC) AS WELL AS APPLICABLE STATE AND LOCAL CODES.
- ALL ELECTRICAL ITEMS SHALL BE U.L. APPROVED OR LISTED AND PROCURED PER SPECIFICATION REQUIREMENTS.
- THE ELECTRICAL WORK INCLUDES ALL LABOR AND MATERIAL DESCRIBED BY DRAWINGS AND SPECIFICATION INCLUDING INCIDENTAL WORK TO PROVIDE COMPLETE OPERATING AND APPROVED ELECTRICAL SYSTEM.
- GENERAL CONTRACTOR SHALL PAY FEES FOR PERMITS, AND IS RESPONSIBLE FOR OBTAINING SAID PERMITS AND COORDINATION OF INSPECTIONS.
- ELECTRICAL AND TELCO WIRING OUTSIDE A BUILDING AND EXPOSED TO WEATHER SHALL BE IN WATER TIGHT GALVANIZED RIGID STEEL CONDUITS OR SCHEDULE 80 PVC (AS PERMITTED BY CODE) AND WHERE REQUIRED IN LIQUID TIGHT FLEXIBLE METAL OR NONMETALLIC CONDUITS.
- BURIED CONDUIT SHALL BE SCHEDULE 40 PVC.
- ELECTRICAL WIRING SHALL BE COPPER WITH TYPE XHHW, THWN, OR THININSULATION.
- RUN ELECTRICAL CONDUIT OR CABLE BETWEEN ELECTRICAL UTILITY DEMARCATION POINT AND PROJECT OWNER CELL SITE PPC AS INDICATED ON THIS DRAWING. PROVIDE FULL LENGTH FULL ROPE. COORDINATE INSTALLATION WITH UTILITY COMPANY.
- RUN TELCO CONDUIT OR CABLE BETWEEN TELEPHONE UTILITY DEMARCATION POINT AND PROJECT OWNER CELL SITE TELCO CABINET AND BITS CABINET AS INDICATED ON THIS DRAWING PROVIDE FULL LENGTH FULL ROPE IN INSTALLED TELCO CONDUIT. PROVIDE GREENLEE CONDUIT MEASURING TAPE AT EACH END.
- WHERE CONDUIT BETWEEN BITS AND PROJECT OWNER CELL SITE PPC AND BETWEEN BITS AND PROJECT OWNER CELL SITE TELCO SERVICE CABINET ARE UNDERGROUND USE PVC, SCHEDULE 40 CONDUIT. ABOVE THE GROUND PORTION OF THESE CONDUITS SHALL BE PVC CONDUIT.
- ALL EQUIPMENT LOCATED OUTSIDE SHALL HAVE NEMA 3R ENCLOSURE.
- PPC SUPPLIED BY PROJECT OWNER.
- GROUNDING SHALL COMPLY WITH NEC ART. 250. ADDITIONALLY, GROUNDING, BONDING AND LIGHTNING PROTECTION SHALL BE DONE IN ACCORDANCE WITH "T-MOBILE BITS SITE GROUNDING STANDARDS".
- GROUND COAXIAL CABLE SHIELDS MINIMUM AT BOTH ENDS USING MANUFACTURERS COAX CABLE GROUNDING KITS SUPPLIED BY PROJECT OWNER.
- USE #6 COPPER STRANDED WIRE WITH GREEN COLOR INSULATION FOR ABOVE GRADE GROUNDING (UNLESS OTHERWISE SPECIFIED) AND #2 SOLID TINNED BARE COPPER WIRE FOR BELOW GRADE GROUNDING AS INDICATED ON THE DRAWING.
- ALL GROUND CONNECTIONS TO BE BURNDY HYGROUND COMPRESSION TYPE CONNECTORS OR CADWELD EXOTHERMIC WELD. DO NOT ALLOW BARE COPPER WIRE TO BE IN CONTACT WITH GALVANIZED STEEL.
- ROUTE GROUNDING CONDUCTORS ALONG THE SHORTEST AND STRAIGHTEST PATH POSSIBLE, EXCEPT AS OTHERWISE INDICATED. GROUNDING LEADS SHOULD NEVER BE BENT AT RIGHT ANGLE. ALWAYS MAKE AT LEAST 12" RADIUS BENDS. #6 WIRE CAN BE BENT AT 6" RADIUS WHEN NECESSARY. BOND ANY METAL OBJECTS WITHIN 6 FEET OF PROJECT OWNER EQUIPMENT OR CABINET TO MASTER GROUND BAR OR GROUNDING RING.
- CONNECTIONS TO GROUND BARS SHALL BE MADE WITH TWO HOLE COMPRESSION TYPE COPPER LUGS. APPLY OXIDE INHIBITING COMPOUND TO ALL LOCATIONS.
- APPLY OXIDE INHIBITING COMPOUND TO ALL COMPRESSION TYPE GROUND CONNECTIONS.
- CONTRACTOR SHALL PROVIDE AND INSTALL OMNI DIRECTIONAL ELECTRONIC MARKER SYSTEM (EMS) BALLS OVER EACH GROUND ROD AND BONDING POINT BETWEEN EXIST. TOWER/ MONOPOLE GROUNDING RING AND EQUIPMENT GROUNDING RING.
- CONTRACTOR SHALL TEST COMPLETED GROUND SYSTEM AND RECORD RESULTS FOR PROJECT CLOSE-OUT DOCUMENTATION. 5 OHMS MINIMUM RESISTANCE REQUIRED.
- CONTRACTOR SHALL CONDUCT ANTENNA, COAX, AND LNA RETURN-LOSS AND DISTANCE- TO-FAULT MEASUREMENTS (SWEEP TESTS) AND RECORD RESULTS FOR PROJECT CLOSE-OUT.

**T-MOBILE  
NORTHEAST LLC**

15 COMMERCE WAY, SUITE B  
NORTON, MA 02766  
(508) 286-2700

**SBA**

SBA COMMUNICATIONS CORP.  
134 FLANDERS ROAD, SUITE 125  
WESTBOROUGH, MA 01581  
(508) 251-0720

**CHAPPELL  
ENGINEERING  
ASSOCIATES, LLC**  
Civil Structural-Land Surveying

R.K. EXECUTIVE CENTRE  
201 BOSTON POST ROAD WEST, SUITE 101  
MARLBOROUGH, MA 01752  
(508) 481-7400  
www.chappellengineering.com

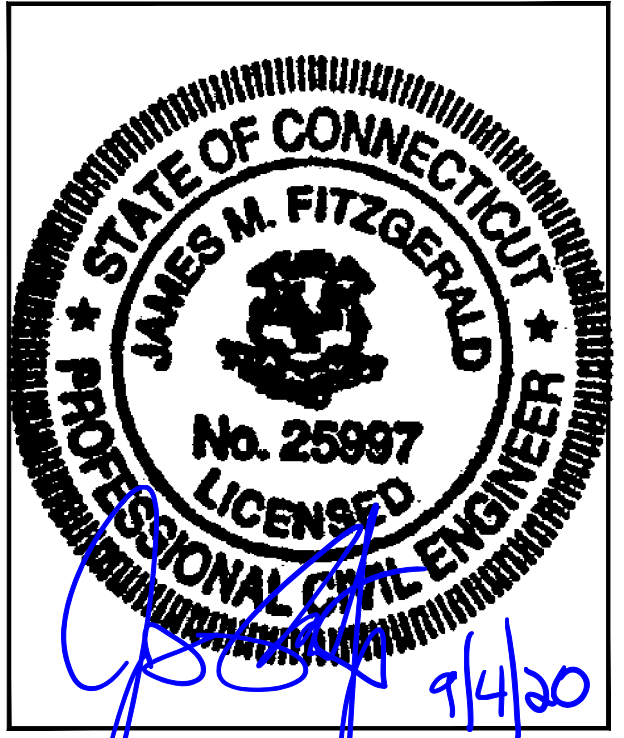

CHECKED BY: JMT  
APPROVED BY: JMT

SUBMITTALS			
REV.	DATE	DESCRIPTION	BY
1	08/03/20	ISSUED FOR CONSTRUCTION	CMC
0	07/20/20	ISSUED FOR REVIEW	JRV

SITE NUMBER:  
**CT11284A**

SITE ADDRESS:  
81 MONTEVIDEO ROAD  
AVON, CT 06001

SHEET TITLE  
**ELECTRIC & GROUNDING  
DETAILS**

SHEET NUMBER  
**E-1**

# EXHIBIT 7





**Tower Engineering Solutions**

Phone (972) 483-0607, Fax (972) 975-9615  
1320 Greenway Drive, Suite 600, Irving, Texas 75038

---

**Structural Analysis Report**

**Existing 150 ft PIROD Self Supporting Tower**

**Customer Name: SBA Communications Corp**

**Customer Site Number: CT22071-A**

**Customer Site Name: Avon (Montevideo)**

**Carrier Name: T-Mobile (App#: 134550, v1)**

**Carrier Site ID / Name: CT11284A / SBA Avon/RT 1777**

**Site Location: 81 Montevideo Road**

**Avon, Connecticut**

**HARTFORD County**

**Latitude: 41.803100**

**Longitude: -72.801300**

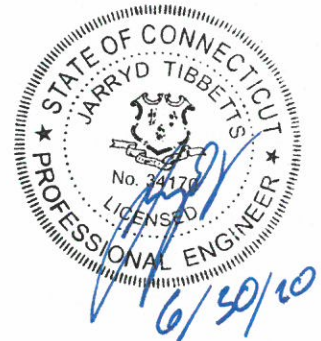

**Analysis Result:**

**Max Structural Usage: 90.0% [Pass]**

**Max Foundation Usage: 75.0% [Pass]**

**Additional Usage Caused by New Mount/Mount Modification: N/A**

**Report Prepared by: Matthew Baker**

## Introduction

The purpose of this report is to summarize the analysis results on the 150 ft PIROD Self Supporting Tower to support the proposed antennas and transmission lines in addition to those currently installed. Any modification listed under Sources of Information was assumed completed and was included in this analysis.

## Sources of Information

<b>Tower Drawings</b>	Valmont Eng. File # A-123251-, Archive # F-1010188, dated 11/29/2007
<b>Foundation Drawing</b>	Valmont Eng. File # A-123251-, Archive # F-1010188, dated 11/29/2007
<b>Geotechnical Report</b>	Dr. Clarence Welti, P.E., P.C Geotechnical Report (for URS Corp. Project # 36924843, Job # MCM 007), dated 11/06/2007
<b>Modification Drawings</b>	N/A

## Analysis Criteria

The rigorous analysis was performed in accordance with the requirements and stipulations of the TIA-222-G-2. In accordance with this standard, the structure was analyzed using **TESTowers**, a proprietary analysis software. The program considers the structure as an elastic 3-D model with second-order effects and temperature effects incorporated in the analysis. The analysis was performed using multiple wind directions.

<b>Wind Speed Used in the Analysis:</b>	Ultimate Design Wind Speed $V_{ult} = 120.0$ mph (3-Sec. Gust)/ Nominal Design Wind Speed $V_{asd} = 93.0$ mph (3-Sec. Gust)
<b>Wind Speed with Ice:</b>	50 mph (3-Sec. Gust) with 1" radial ice concurrent
<b>Operational Wind Speed:</b>	60 mph + 0" Radial ice
<b>Standard/Codes:</b>	TIA-222-G-2 / 2015 IBC / 2018 Connecticut State Building Code
<b>Exposure Category:</b>	B
<b>Structure Class:</b>	II
<b>Topographic Category:</b>	4
<b>Crest Height:</b>	520 ft
<b>Seismic Parameters:</b>	$S_5 = 0.181$ , $S_1 = 0.064$

This structural analysis is based upon the tower being classified as a Structure Class II; however, if a different classification is required subsequent to the date hereof, the tower classification will be changed to meet such requirement and a new structural analysis will be run.

## Existing Antennas, Mounts and Transmission Lines

The table below summarizes the antennas, mounts and transmission lines that were considered in the analysis as existing on the tower.

Items	Elevation (ft)	Qty.	Antenna Descriptions	Mount Type & Qty.	Transmission Lines	Owner
1	159.8	1	10' Omni	Direct	(1) 7/8"	Unknown
2	147.0	2	RFS - APXVSP18-C-A20 - Panel	(3) T-Frames	(4) 1-1/4" Fiber	Sprint Nextel
3		3	RFS - APXVSP18-C-A20 - Panel			
4		3	Alcatel Lucent - RRH2x20-25 - RRH			
5	143.7	3	Alcatel Lucent - 800 MHz RRH	Direct		
6	140.1	3	Alcatel Lucent - 1900 MHz RRH	Direct		
-	136.0	1	Ericsson - AIR 21 - Panel	(1) Sector Frame	(6) 1 5/8" (2) 1 1/4" Hybrid	T-Mobile
-		1	Ericsson - AIR 32 KRD901146-1_B66A - Panel			
-		1	RFS - APXVAARR24_43-U-NA20 - Panel			
-		1	Ericsson - KRY 112 144/2 - TMA			
-		1	Ericsson - 4449 B71 + B12 - RRH			
14	126.8	1	Omni 10'	(1) Standoff	(1) 1 1/4"	Unknown
15		1	Omni 20'	(1) Standoff	(1) 7/8"	
16	113.2	1	Dipole 10'	(1) Standoff	(1) 7/8"	
17	104.5	1	Omni 15'	(1) Standoff	(1) 7/8"	
18	99.8	1	Element 6' - Yagi	Direct	(1) 1/2"	
19	76.8	1	4.5' Parabolic Dish	(1) Standoff	(1) 1/4"	
20	73.0	1	4.5' Parabolic Dish	(1) Standoff	(1) 1/4"	
21	72.4	1	3.0"x2.5' GPS	Direct	(1) 1/2"	
22	67.3	1	3.0"x1.2' GPS	Direct	(1) 1/4"	
23	13.9	1	3.0"x1.5' GPS	(1) Standoff	(2) 1/2"	

## Proposed Carrier's Final Configuration of Antennas, Mounts and Transmission Lines

Information pertaining to the proposed carrier's final configuration of antennas and transmission lines was provided by SBA Communications Corp. The proposed antennas and lines are listed below.

Items	Elevation (ft)	Qty.	Antenna Descriptions	Mount Type & Qty.	Transmission Lines	Owner
7	136.0	1	RFS - APXVAARR24_43-U-NA20 (Octa) - Panel	(1) Sector Frame	(5) 1 5/8" (3) 1 1/4" Hybrid	T-Mobile
8		1	Ericsson - AIR32 KRD901146-1_B66A (Octa) - Panel			
9		1	Ericsson - AIR 21 - Panel			
10		1	Ericsson - AIR6449 B41 - Panel			
11		1	Ericsson - KRY 112 144/2 - TMA			
12		1	Ericsson - Radio 4449 B71 + B12 - RRH			
13		1	Ericsson - Radio 4415 B25 - RRH			

See the attached coax layout for the line placement considered in the analysis.



## **Analysis Results**

The results of the structural analysis, performed for the wind and ice loading and antenna equipment as defined above, are summarized as the following:

Tower Component	Legs	Diagonals	Horizontals
Max. Usage:	<b>90.0%</b>	<b>87.9%</b>	<b>41.8%</b>
Pass/Fail	<b>Pass</b>	<b>Pass</b>	<b>Pass</b>

## **Foundations**

	Compression (Kips)	Uplift (Kips)	Shear (Kips)
Analysis Reactions	278.9	255.2	27.4

The foundation has been investigated using the supplied documents and soils report and was found adequate. Therefore, no modification to the foundation will be required.

## **Operational Condition (Rigidity):**

The maximum twist and sway of the microwave dishes under the operational wind speed as specified in the Analysis Criteria are listed in the table below:

Elevation (ft)	Antenna / Dish	Carrier	Twist (deg)	Sway (deg)
76.8	4.5' Parabolic Dish	Unknown	0.447	0.261
73.0	4.5' Parabolic Dish	Unknown	0.414	0.216

It is recommended that the carriers review the twist and sway values of the microwave dishes.

## **Conclusions**

Based on the analysis results, the existing structure and its foundation were found to be adequate to safely support the existing and proposed equipment and meet the minimum requirements per the ANSI/TIA/EIA 222-G Standard under the design basic wind speed as specified in the Analysis Criteria.

## Standard Conditions

1. This analysis was performed based on the information supplied to **(TES) Tower Engineering Solutions, LLC**. Verification of the information provided was not included in the Scope of Work for **TES**. The accuracy of the analysis is dependent on the accuracy of the information provided.
2. The structural analysis was performance based upon the evidence available at the time of this report. All information provided by the client is considered to be accurate.
3. The analyses will be performed based on the codes as specified by the client or based on the best knowledge of the engineering staff of **TES**. In the absence of information to the contrary, all work will be performed in accordance with the latest relevant revision of ANSI/TIA-222. If wind speed and/or ice loads are different from the minimum values recommended by the EIA/TIA-222 standard or other codes, **TES** should be notified in writing and the applicable minimum values provided by the client.
4. The configuration of the existing mounts, antennas, coax and other appurtenances were supplied by the customer for the current structural analysis. **TES** has not visited the tower site to verify the adequacy of the information provided. If there is any discrepancy found in the report regarding the existing conditions, **TES** should be notified immediately to evaluate the effect of the discrepancy on the analysis results.
5. The client will assume responsibility for rework associated with the differences in initially provided information, including tower and foundation information, existing and/or proposed equipment and transmission lines.
6. If a feasibility analysis was performed, final acceptance of changed conditions shall be based upon a rigorous structural analysis.

## Structure: CT22071-A-SBA

<b>Site Name:</b> Avon (Montevideo)	<b>Code:</b> EIA/TIA-222-G	6/30/2020
<b>Type:</b> Self Support	<b>Base Shape:</b> Triangle	<b>Basic WS:</b> 93.00
<b>Height:</b> 150.00 (ft)	<b>Base Width:</b> 14.00	<b>Basic Ice WS:</b> 50.00
<b>Base Elev:</b> 0.00 (ft)	<b>Top Width:</b> 5.00	<b>Operational WS:</b> 60.00



Page: 1

### Section Properties

Sect	Leg Members	Diagonal Members	Horizontal Members
1	12B 12"BD 1.75"	SAE 3X3X0.3125	
2	12B 12"BD 1.75"	SAE 3X3X0.1875	
3	12B 12"BD 1.75"	SAE 2.5X2.5X0.1875	
4-5	12B 12"BD 1.5"	SAE 2.5X2.5X0.1875	
6	SOL 2 1/4" SOLID	SOL 1" SOLID	SOL 1" SOLID
7	SOL 2" SOLID	SOL 7/8" SOLID	SOL 7/8" SOLID
8	SOL 1 3/4" SOLID	SOL 7/8" SOLID	SOL 7/8" SOLID

### Discrete Appurtenances

Attach Elev (ft)	Force Elev (ft)	Qty	Description
150.00	150.00	1	Lightning Rod
150.00	150.00	1	Beacon
150.00	159.80	1	10' Omni
147.00	147.00	3	T-Frames
147.00	147.00	2	APXVSPP18-C-A20
147.00	147.00	3	APXV9TM14-ALU-I20
147.00	147.00	3	RRH2x20-25
143.70	143.70	3	800 MHz RRH
140.10	140.10	3	1900MHz RRH
136.00	136.00	1	Sector Frame
136.00	136.00	1	APXVAARR24_43-U-NA20
136.00	136.00	1	AIR32
136.00	136.00	1	AIR 21
136.00	136.00	1	AIR6449 B41
136.00	136.00	1	KRY 112 144/2
136.00	136.00	1	4449
136.00	136.00	1	RRUS 4415 B25
119.30	119.30	1	Side Arm (M. Heavy)
119.30	126.80	1	10' Omni
116.30	116.30	1	Side Arm (M. Heavy)
116.30	126.80	1	20' Omni
106.60	106.60	1	Side Arm (M. Heavy)
106.60	113.20	1	10' Dipole
99.80	99.80	1	6' Yagi
96.00	96.00	1	Side Arm (M. Heavy)
96.00	104.50	1	15' Omni
76.80	76.80	1	Side Arm (L. Heavy)
76.80	76.80	1	4.5' Std. Dish
73.00	73.00	1	Side Arm (M. Heavy)
73.00	73.00	1	4' Std. Dish
72.40	72.40	1	3.05 x 2.5 GPS
72.40	72.40	1	3.05 x 1.2 GPS
12.30	13.90	1	Antenna Mount, 24" Short Strai
12.30	12.30	1	3.05 x 1.5 GPS

### Linear Appurtenances

Elev From (ft)	Elev To (ft)	Qty	Description
0.00	150.00	1	7/8" Coax
0.00	147.00	4	1-1/4" Fiber
0.00	147.00	1	W/G Ladder
0.00	136.00	3	1 1/4" Coax
0.00	136.00	5	1 5/8" Coax

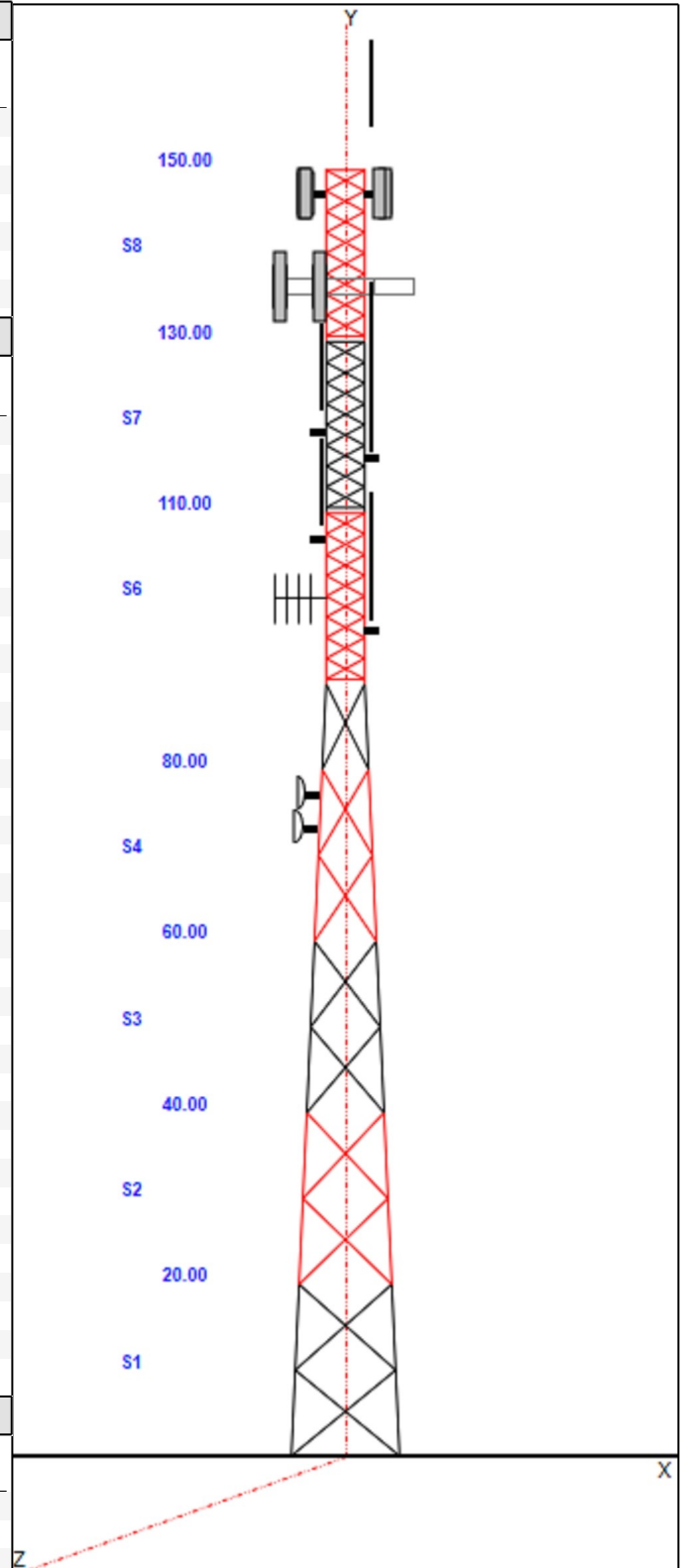

**Structure: CT22071-A-SBA**

<b>Site Name:</b> Avon (Montevideo)	<b>Code:</b> EIA/TIA-222-G	6/30/2020
<b>Type:</b> Self Support	<b>Base Shape:</b> Triangle	<b>Basic WS:</b> 93.00
<b>Height:</b> 150.00 (ft)	<b>Base Width:</b> 14.00	<b>Basic Ice WS:</b> 50.00
<b>Base Elev:</b> 0.00 (ft)	<b>Top Width:</b> 5.00	<b>Operational WS:</b> 60.00



Page: 2

0.00	136.00	1	W/G Ladder
0.00	119.30	1	1 1/4" Coax
0.00	116.30	1	7/8" Coax
0.00	106.60	1	7/8" Coax
0.00	99.80	1	1/2" Coax
0.00	96.00	1	7/8" Coax
0.00	76.80	1	1/4" Coax
0.00	73.00	1	1/4" Coax
0.00	72.40	1	1/2" Coax
0.00	67.30	1	1/4" Coax
0.00	13.90	2	1/2" Coax

**Base Reactions**

Leg	Overturning
Max Uplift: -255.24 (kips)	Moment: 3268.65 (ft-kips)
Max Down: 278.90 (kips)	Total Down: 27.91 (kips)
Max Shear: 27.40 (kips)	Total Shear: 39.75 (kips)

# Structure: CT22071-A-SBA

**Site Name:** Avon (Montevideo)

**Code:** EIA/TIA-222-G

6/30/2020

**Type:** Self Support

**Base Shape:** Triangle

**Basic WS:** 93.00

**Height:** 150.00 (ft)

**Base Width:** 14.00

**Basic Ice WS:** 50.00

**Base Elev:** 0.00 (ft)

**Top Width:** 5.00

**Operational WS:** 60.00

Page: 3

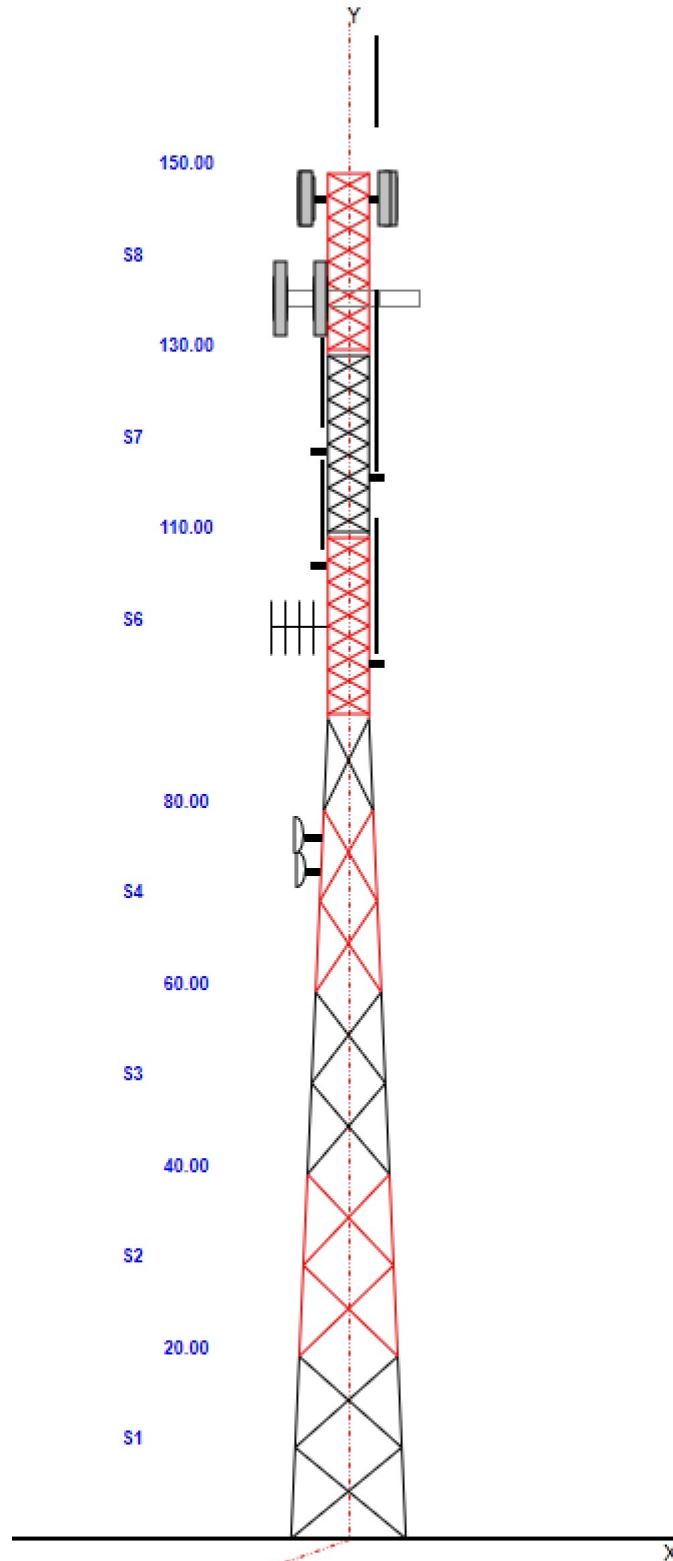

# Structure: CT22071-A-SBA - Coax Line Placement

**Type:** Self Support  
**Site Name:** Avon (Montevideo)  
**Height:** 150.00 (ft)

6/30/2020



Page: 4

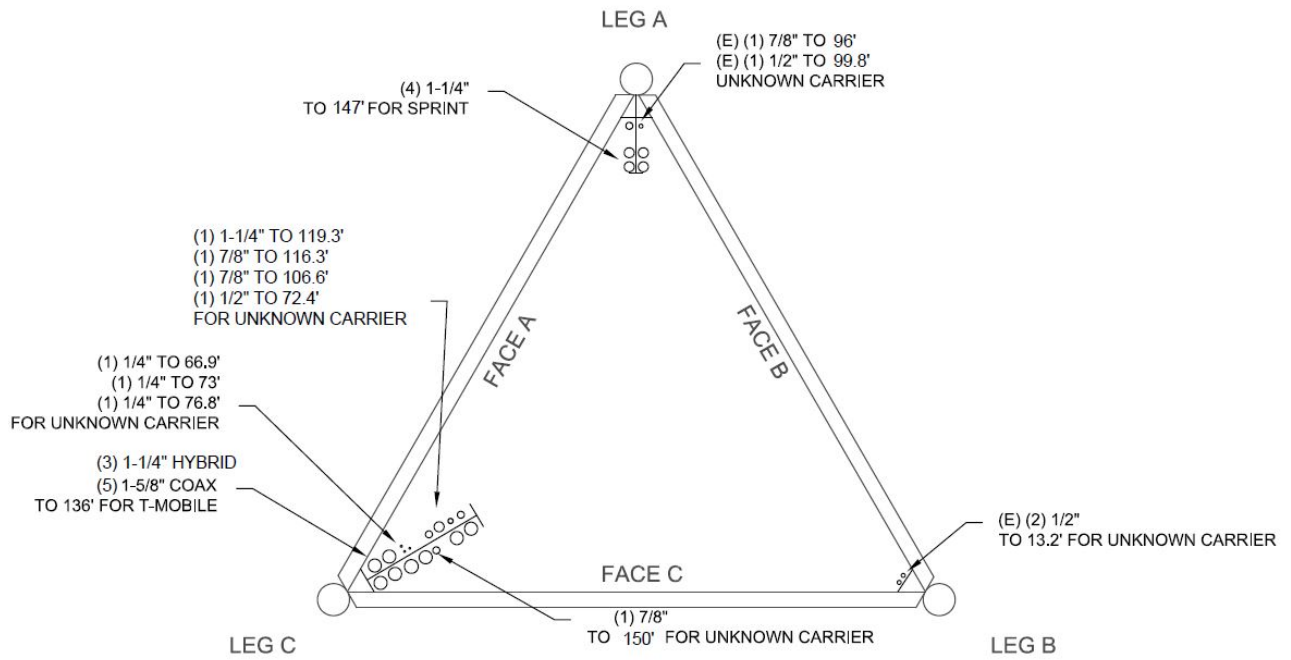

## Loading Summary

<b>Structure:</b> CT22071-A-SBA	<b>Code:</b> EIA/TIA-222-G	6/30/2020
<b>Site Name:</b> Avon (Montevideo)	<b>Exposure:</b> B	
<b>Height:</b> 150.00 (ft)	<b>Crest Height:</b> 520.00	
<b>Base Elev:</b> 0.000 (ft)	<b>Site Class:</b> C - Very Dense Soil	
<b>Gh:</b> 0.85	<b>Topography:</b> 4	<b>Struct Class:</b> II



Page: 5

### Discrete Appurtenances Properties

Attach Elev (ft)	Description	Qty	No Ice		Ice		Len (in)	Width (in)	Depth (in)	Ka	Orientation Factor	Vert Ecc (ft)
			Weight (lb)	CaAa (sf)	Weight (lb)	CaAa (sf)						
150.00	Lightning Rod	1	5.00	0.500	40.77	3.481	72.000	1.000	1.000	1.00	1.00	0.000
150.00	Beacon	1	36.00	2.720	263.52	4.342	28.000	17.500	17.500	1.00	1.00	0.000
150.00	10' Omni	1	25.00	3.000	154.92	9.160	120.000	3.000	3.000	1.00	1.00	9.800
147.00	T-Frames	3	120.00	4.500	298.87	13.461	0.000	0.000	0.000	0.75	0.75	0.000
147.00	APXVSPP18-C-A20	2	57.00	8.020	352.26	12.792	72.000	11.800	7.000	0.80	0.83	0.000
147.00	APXV9TM14-ALU-I20	3	55.10	6.340	335.52	8.275	56.300	12.600	6.300	0.80	0.78	0.000
147.00	RRH2x20-25	3	70.00	4.050	287.75	5.514	26.100	18.600	6.700	0.80	0.67	0.000
143.70	800 MHz RRH	3	53.00	2.490	179.34	4.444	19.700	13.000	10.800	1.00	1.00	0.000
140.10	1900MHz RRH	3	44.00	3.800	230.47	6.174	23.000	13.000	17.000	1.00	1.00	0.000
136.00	Sector Frame	1	400.00	10.000	876.98	24.906	0.000	0.000	0.000	1.00	1.00	0.000
136.00	APXVAARR24_43-U-NA20	1	128.00	20.240	929.62	23.522	95.900	24.000	7.800	0.90	0.70	0.000
136.00	AIR32	1	132.20	6.510	441.18	8.459	57.000	12.900	8.700	0.90	0.86	0.000
136.00	AIR 21	1	91.00	6.090	420.30	8.051	56.000	12.100	7.900	0.90	0.85	0.000
136.00	AIR6449 B41	1	104.00	5.680	351.41	7.367	33.100	20.600	8.600	0.90	0.72	0.000
136.00	KRY 112 144/2	1	11.00	0.410	29.42	1.222	6.900	6.100	2.700	0.90	0.50	0.000
136.00	4449	1	70.00	1.650	209.00	2.640	15.000	13.200	9.300	0.90	0.67	0.000
136.00	RRUS 4415 B25	1	46.00	1.640	116.21	2.520	15.000	13.200	5.400	0.90	0.67	0.000
119.30	Side Arm (M. Heavy)	1	160.00	6.000	397.81	17.914	0.000	0.000	0.000	1.00	1.00	0.000
119.30	10' Omni	1	25.00	3.000	154.55	9.143	120.000	3.000	3.000	1.00	1.00	7.500
116.30	Side Arm (M. Heavy)	1	160.00	6.000	397.81	17.914	0.000	0.000	0.000	1.00	1.00	0.000
116.30	20' Omni	1	55.00	6.000	311.62	18.085	240.000	3.000	3.000	1.00	1.00	10.50
106.60	Side Arm (M. Heavy)	1	160.00	6.000	396.58	17.853	0.000	0.000	0.000	1.00	1.00	0.000
106.60	10' Dipole	1	30.00	3.760	219.08	13.928	120.000	3.000	3.000	1.00	1.00	6.600
99.80	6' Yagi	1	25.00	8.950	457.06	49.456	72.000	60.000	3.000	1.00	1.00	0.000
96.00	Side Arm (M. Heavy)	1	160.00	6.000	396.58	17.853	0.000	0.000	0.000	1.00	1.00	0.000
96.00	15' Omni	1	40.00	4.500	232.11	13.571	180.000	3.000	3.000	1.00	1.00	8.500
76.80	Side Arm (L. Heavy)	1	120.00	4.500	294.78	13.256	0.000	0.000	0.000	1.00	1.00	0.000
76.80	4.5' Std. Dish	1	188.00	26.000	543.97	32.392	48.000	48.000	0.000	1.00	1.00	0.000
73.00	Side Arm (M. Heavy)	1	160.00	6.000	393.04	17.675	0.000	0.000	0.000	1.00	1.00	0.000
73.00	4' Std. Dish	1	188.00	26.000	543.97	32.392	48.000	48.000	0.000	1.00	1.00	0.000
72.40	3.05 x 2.5 GPS	1	0.30	0.380	4.44	2.232	2.600	3.000	0.000	1.00	1.00	0.000
72.40	3.05 x 1.2 GPS	1	0.30	0.240	4.44	1.410	2.600	3.000	0.000	1.00	1.00	0.000
12.30	Antenna Mount, 24" Short Strai	1	50.00	1.500	175.38	4.008	0.000	0.000	0.000	1.00	1.00	1.600
12.30	3.05 x 1.5 GPS	1	0.30	0.260	3.87	1.351	2.600	3.000	0.000	1.00	1.00	0.000
<b>Totals:</b>		<b>45</b>	<b>3,710.40</b>		<b>13,460.73</b>					<b>Number of Appurtenances : 34</b>		

## Loading Summary

<b>Structure:</b> CT22071-A-SBA	<b>Code:</b> EIA/TIA-222-G	6/30/2020
<b>Site Name:</b> Avon (Montevideo)	<b>Exposure:</b> B	
<b>Height:</b> 150.00 (ft)	<b>Crest Height:</b> 520.00	
<b>Base Elev:</b> 0.000 (ft)	<b>Site Class:</b> C - Very Dense Soil	
<b>Gh:</b> 0.85	<b>Topography:</b> 4	<b>Struct Class:</b> II



Page: 6

### Linear Appurtenances Properties

Elev. From (ft)	Elev. To (ft)	Description	Qty	Width (in)	Weight (lb/ft)	Pct In Block	Spread On Faces	Bundling Arrangement	Cluster Dia (in)	Out of Zone	Spacing (in)	Orientation Factor	Ka Override
0.00	150.00	7/8" Coax	1	1.11	0.52	100.00	2	Individual NR		N	0.50	1.00	
0.00	147.00	1-1/4" Fiber	4	1.25	0.95	50.00	3	Block		N	0.50	0.96	
0.00	147.00	W/G Ladder	1	1.00	6.00	100.00	3	Individual NR		N	0.50	1.00	
0.00	136.00	1 1/4" Coax	3	1.55	0.66	50.00	2	Block		N	0.50	1.00	
0.00	136.00	1 5/8" Coax	5	1.98	1.04	50.00	2	Block		N	0.50	1.00	
0.00	136.00	W/G Ladder	1	1.00	6.00	100.00	2	Individual NR		N	0.50	1.00	
0.00	119.30	1 1/4" Coax	1	1.55	0.66	100.00	2	Individual NR		N	0.50	1.00	
0.00	116.30	7/8" Coax	1	1.11	0.52	100.00	2	Individual NR		N	0.50	1.00	
0.00	106.60	7/8" Coax	1	1.11	0.52	100.00	2	Individual NR		N	0.50	1.00	
0.00	99.80	1/2" Coax	1	0.65	0.16	100.00	3	Individual NR		N	0.50	1.00	0
0.00	96.00	7/8" Coax	1	1.11	0.52	100.00	3	Individual NR		N	0.50	1.00	
0.00	76.80	1/4" Coax	1	0.25	0.04	100.00	2	Individual NR		N	0.50	1.00	0
0.00	73.00	1/4" Coax	1	0.25	0.04	100.00	2	Individual NR		N	0.50	1.00	0
0.00	72.40	1/2" Coax	1	0.65	0.16	100.00	2	Individual NR		N	0.50	1.00	0
0.00	67.30	1/4" Coax	1	0.25	0.04	100.00	2	Individual NR		N	0.50	1.00	0
0.00	13.90	1/2" Coax	2	0.65	0.16	100.00	1	Individual IR		N	0.50	1.00	



## Section Forces

<b>Structure:</b> CT22071-A-SBA	<b>Code:</b> EIA/TIA-222-G	6/30/2020
<b>Site Name:</b> Avon (Montevideo)	<b>Exposure:</b> B	
<b>Height:</b> 150.00 (ft)	<b>Crest Height:</b> 520.00	
<b>Base Elev:</b> 0.000 (ft)	<b>Site Class:</b> C - Very Dense Soil	
<b>Gh:</b> 0.85	<b>Topography:</b> 4	<b>Struct Class:</b> II

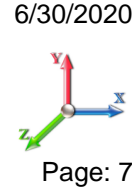

<b>Load Case:</b> 1.2D + 1.6W Normal Wind - P1	1.2D + 1.6W 93 mph Wind at Normal To Face - P1
<b>Wind Load Factor:</b> 1.60	<b>Wind Importance Factor:</b> 1.00
<b>Dead Load Factor:</b> 1.20	
<b>Ice Dead Load Factor:</b> 0.00	<b>Ice Importance Factor:</b> 1.00

Sect Seq	Wind Height (ft)	qz (psf)	Total Area		Ice Round Area (sqft)	Sol Ratio	Cf	Df	Dr	Ice Thick (in)	Eff Area (sqft)	Ice Area		Total Weight (lb)	Weight Ice (lb)	Struct Force (lb)	Linear Force (lb)	Total Force (lb)
			Flat (sqft)	Round (sqft)								Linear (sqft)	Linear (sqft)					
1 1	10.0	35.36	15.937	18.83	0.00	0.13	2.85	1.00	1.00	0.00	24.00	40.81	0.00	4,620.9	0.0	3290.14	1560.21	4,850.35
1 2	30.0	33.86	14.403	18.83	0.00	0.14	2.79	1.00	1.00	0.00	22.72	39.30	0.00	3,969.0	0.0	2919.06	1444.14	4,363.20
1 3	50.0	37.55	10.827	18.83	0.00	0.16	2.75	1.00	1.00	0.00	18.97	39.30	0.00	3,769.5	0.0	2661.35	1601.37	4,262.72
1 4	70.0	39.67	9.814	17.23	0.00	0.18	2.66	1.00	1.00	0.00	17.75	38.41	0.00	3,257.4	0.0	2545.55	1691.46	4,237.01
1 5	85.0	40.71	4.578	8.61	0.00	0.22	2.52	1.00	1.00	0.00	8.70	18.48	0.00	1,608.8	0.0	1214.76	867.24	2,082.00
1 6	100.0	41.42	0.000	15.46	0.00	0.15	2.78	1.00	1.00	0.00	8.93	34.80	0.00	2,534.1	0.0	1396.20	1699.39	3,095.59
1 7	120.0	42.04	0.000	13.66	0.00	0.13	2.84	1.00	1.00	0.00	7.85	29.53	0.00	2,073.5	0.0	1274.26	1529.18	2,803.43
1 8	140.0	42.38	0.000	12.85	0.00	0.12	2.87	1.00	1.00	0.00	7.37	13.29	0.00	1,625.1	0.0	1218.32	694.40	1,912.72
														<b>23,458.4</b>	<b>0.0</b>			<b>27,607.02</b>

<b>Load Case:</b> 1.2D + 1.6W Normal Wind - P2	1.2D + 1.6W 93 mph Wind at Normal To Face - P2
<b>Wind Load Factor:</b> 1.60	<b>Wind Importance Factor:</b> 1.00
<b>Dead Load Factor:</b> 1.20	
<b>Ice Dead Load Factor:</b> 0.00	<b>Ice Importance Factor:</b> 1.00

Sect Seq	Wind Height (ft)	qz (psf)	Total Area		Ice Round Area (sqft)	Sol Ratio	Cf	Df	Dr	Ice Thick (in)	Eff Area (sqft)	Ice Area		Total Weight (lb)	Weight Ice (lb)	Struct Force (lb)	Linear Force (lb)	Total Force (lb)
			Flat (sqft)	Round (sqft)								Linear (sqft)	Linear (sqft)					
1 1	10.0	19.45	15.937	18.83	0.00	0.13	2.85	1.00	1.00	0.00	24.00	40.81	0.00	4,620.9	0.0	1809.58	858.12	2,667.69
1 2	30.0	18.62	14.403	18.83	0.00	0.14	2.79	1.00	1.00	0.00	22.72	39.30	0.00	3,969.0	0.0	1605.49	794.28	2,399.76
1 3	50.0	20.65	10.827	18.83	0.00	0.16	2.75	1.00	1.00	0.00	18.97	39.30	0.00	3,769.5	0.0	1463.74	880.75	2,344.50
1 4	70.0	21.82	9.814	17.23	0.00	0.18	2.66	1.00	1.00	0.00	17.75	38.41	0.00	3,257.4	0.0	1400.05	930.30	2,330.36
1 5	85.0	22.39	4.578	8.61	0.00	0.22	2.52	1.00	1.00	0.00	8.70	18.48	0.00	1,608.8	0.0	668.12	476.98	1,145.10
1 6	100.0	22.78	0.000	15.46	0.00	0.15	2.78	1.00	1.00	0.00	8.93	34.80	0.00	2,534.1	0.0	767.91	934.66	1,702.57
1 7	120.0	23.12	0.000	13.66	0.00	0.13	2.84	1.00	1.00	0.00	7.85	29.53	0.00	2,073.5	0.0	700.84	841.05	1,541.89
1 8	140.0	23.31	0.000	12.85	0.00	0.12	2.87	1.00	1.00	0.00	7.37	13.29	0.00	1,625.1	0.0	670.07	381.92	1,051.99
														<b>23,458.4</b>	<b>0.0</b>			<b>15,183.86</b>

## Section Forces

<b>Structure:</b> CT22071-A-SBA	<b>Code:</b> EIA/TIA-222-G	<b>6/30/2020</b>
<b>Site Name:</b> Avon (Montevideo)	<b>Exposure:</b> B	
<b>Height:</b> 150.00 (ft)	<b>Crest Height:</b> 520.00	
<b>Base Elev:</b> 0.000 (ft)	<b>Site Class:</b> C - Very Dense Soil	
<b>Gh:</b> 0.85	<b>Topography:</b> 4	<b>Struct Class:</b> II

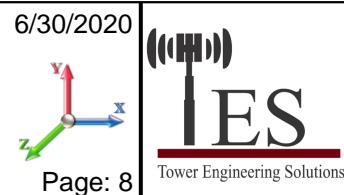

<b>Load Case:</b> 1.2D + 1.6W Normal Wind - P3	1.2D + 1.6W 93 mph Wind at Normal To Face - P3
<b>Wind Load Factor:</b> 1.60	<b>Wind Importance Factor:</b> 1.00
<b>Dead Load Factor:</b> 1.20	
<b>Ice Dead Load Factor:</b> 0.00	<b>Ice Importance Factor:</b> 1.00

Sect Seq	Wind Height (ft)	qz (psf)	Total Area (sqft)		Ice Round Area (sqft)	Sol Ratio	Cf	Df	Dr	Ice Thick (in)	Eff Area (sqft)	Ice Area (sqft)		Total Weight (lb)	Weight Ice (lb)	Struct Force (lb)	Linear Force (lb)	Total Force (lb)
			Flat	Round								Linear	Linear					
1 1	10.0	35.36	15.937	18.83	0.00	0.13	2.85	1.00	1.00	0.00	24.00	40.81	0.00	4,620.9	0.0	3290.14	1560.21	4,850.35
1 2	30.0	33.86	14.403	18.83	0.00	0.14	2.79	1.00	1.00	0.00	22.72	39.30	0.00	3,969.0	0.0	2919.06	1444.14	4,363.20
1 3	50.0	37.55	10.827	18.83	0.00	0.16	2.75	1.00	1.00	0.00	18.97	39.30	0.00	3,769.5	0.0	2661.35	1601.37	4,262.72
1 4	70.0	39.67	9.814	17.23	0.00	0.18	2.66	1.00	1.00	0.00	17.75	38.41	0.00	3,257.4	0.0	2545.55	1691.46	4,237.01
1 5	85.0	40.71	4.578	8.61	0.00	0.22	2.52	1.00	1.00	0.00	8.70	18.48	0.00	1,608.8	0.0	1214.76	867.24	2,082.00
1 6	100.0	41.42	0.000	15.46	0.00	0.15	2.78	1.00	1.00	0.00	8.93	34.80	0.00	2,534.1	0.0	1396.20	1699.39	3,095.59
1 7	120.0	42.04	0.000	13.66	0.00	0.13	2.84	1.00	1.00	0.00	7.85	29.53	0.00	2,073.5	0.0	1274.26	1529.18	2,803.43
1 8	140.0	42.38	0.000	12.85	0.00	0.12	2.87	1.00	1.00	0.00	7.37	13.29	0.00	1,625.1	0.0	1218.32	694.40	1,912.72
														<b>23,458.4</b>	<b>0.0</b>			<b>27,607.02</b>

<b>Load Case:</b> 1.2D + 1.6W 60° Wind - P1	1.2D + 1.6W 93 mph Wind at 60° From Face - P1
<b>Wind Load Factor:</b> 1.60	<b>Wind Importance Factor:</b> 1.00
<b>Dead Load Factor:</b> 1.20	
<b>Ice Dead Load Factor:</b> 0.00	<b>Ice Importance Factor:</b> 1.00

Sect Seq	Wind Height (ft)	qz (psf)	Total Area (sqft)		Ice Round Area (sqft)	Sol Ratio	Cf	Df	Dr	Ice Thick (in)	Eff Area (sqft)	Ice Area (sqft)		Total Weight (lb)	Weight Ice (lb)	Struct Force (lb)	Linear Force (lb)	Total Force (lb)
			Flat	Round								Linear	Linear					
1 1	10.0	35.36	15.937	18.83	0.00	0.13	2.85	0.80	1.00	0.00	20.82	40.81	0.00	4,620.9	0.0	2853.28	1560.21	4,413.49
1 2	30.0	33.86	14.403	18.83	0.00	0.14	2.79	0.80	1.00	0.00	19.83	39.30	0.00	3,969.0	0.0	2548.90	1444.14	3,993.04
1 3	50.0	37.55	10.827	18.83	0.00	0.16	2.75	0.80	1.00	0.00	16.80	39.30	0.00	3,769.5	0.0	2357.56	1601.37	3,958.93
1 4	70.0	39.67	9.814	17.23	0.00	0.18	2.66	0.80	1.00	0.00	15.79	38.41	0.00	3,257.4	0.0	2264.13	1691.46	3,955.59
1 5	85.0	40.71	4.578	8.61	0.00	0.22	2.52	0.80	1.00	0.00	7.78	18.48	0.00	1,608.8	0.0	1086.90	867.24	1,954.14
1 6	100.0	41.42	0.000	15.46	0.00	0.15	2.78	0.80	1.00	0.00	8.93	34.80	0.00	2,534.1	0.0	1396.20	1699.39	3,095.59
1 7	120.0	42.04	0.000	13.66	0.00	0.13	2.84	0.80	1.00	0.00	7.85	29.53	0.00	2,073.5	0.0	1274.26	1529.18	2,803.43
1 8	140.0	42.38	0.000	12.85	0.00	0.12	2.87	0.80	1.00	0.00	7.37	13.29	0.00	1,625.1	0.0	1218.32	694.40	1,912.72
														<b>23,458.4</b>	<b>0.0</b>			<b>26,086.93</b>

## Section Forces

<b>Structure:</b> CT22071-A-SBA	<b>Code:</b> EIA/TIA-222-G	<b>6/30/2020</b>
<b>Site Name:</b> Avon (Montevideo)	<b>Exposure:</b> B	
<b>Height:</b> 150.00 (ft)	<b>Crest Height:</b> 520.00	
<b>Base Elev:</b> 0.000 (ft)	<b>Site Class:</b> C - Very Dense Soil	
<b>Gh:</b> 0.85	<b>Topography:</b> 4	<b>Struct Class:</b> II

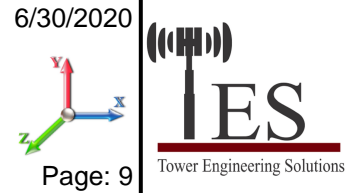

<b>Load Case:</b> 1.2D + 1.6W 60° Wind - P2	1.2D + 1.6W 93 mph Wind at 60° From Face - P2
<b>Wind Load Factor:</b> 1.60	<b>Wind Importance Factor:</b> 1.00
<b>Dead Load Factor:</b> 1.20	
<b>Ice Dead Load Factor:</b> 0.00	<b>Ice Importance Factor:</b> 1.00

Sect Seq	Wind Height (ft)	qz (psf)	Total Area		Ice Round Area (sqft)	Sol Ratio	Cf	Df	Dr	Ice Thick (in)	Eff Area (sqft)	Ice Area		Total Weight (lb)	Weight Ice (lb)	Struct Force (lb)	Linear Force (lb)	Total Force (lb)
			Flat (sqft)	Round (sqft)								Linear (sqft)	Linear (sqft)					
1 1	10.0	19.45	15.937	18.83	0.00	0.13	2.85	0.80	1.00	0.00	20.82	40.81	0.00	4,620.9	0.0	1569.30	858.12	2,427.42
1 2	30.0	18.62	14.403	18.83	0.00	0.14	2.79	0.80	1.00	0.00	19.83	39.30	0.00	3,969.0	0.0	1401.89	794.28	2,196.17
1 3	50.0	20.65	10.827	18.83	0.00	0.16	2.75	0.80	1.00	0.00	16.80	39.30	0.00	3,769.5	0.0	1296.66	880.75	2,177.41
1 4	70.0	21.82	9.814	17.23	0.00	0.18	2.66	0.80	1.00	0.00	15.79	38.41	0.00	3,257.4	0.0	1245.27	930.30	2,175.57
1 5	85.0	22.39	4.578	8.61	0.00	0.22	2.52	0.80	1.00	0.00	7.78	18.48	0.00	1,608.8	0.0	597.80	476.98	1,074.78
1 6	100.0	22.78	0.000	15.46	0.00	0.15	2.78	0.80	1.00	0.00	8.93	34.80	0.00	2,534.1	0.0	767.91	934.66	1,702.57
1 7	120.0	23.12	0.000	13.66	0.00	0.13	2.84	0.80	1.00	0.00	7.85	29.53	0.00	2,073.5	0.0	700.84	841.05	1,541.89
1 8	140.0	23.31	0.000	12.85	0.00	0.12	2.87	0.80	1.00	0.00	7.37	13.29	0.00	1,625.1	0.0	670.07	381.92	1,051.99
														<b>23,458.4</b>	<b>0.0</b>			<b>14,347.81</b>

<b>Load Case:</b> 1.2D + 1.6W 60° Wind - P3	1.2D + 1.6W 93 mph Wind at 60° From Face - P3
<b>Wind Load Factor:</b> 1.60	<b>Wind Importance Factor:</b> 1.00
<b>Dead Load Factor:</b> 1.20	
<b>Ice Dead Load Factor:</b> 0.00	<b>Ice Importance Factor:</b> 1.00

Sect Seq	Wind Height (ft)	qz (psf)	Total Area		Ice Round Area (sqft)	Sol Ratio	Cf	Df	Dr	Ice Thick (in)	Eff Area (sqft)	Ice Area		Total Weight (lb)	Weight Ice (lb)	Struct Force (lb)	Linear Force (lb)	Total Force (lb)
			Flat (sqft)	Round (sqft)								Linear (sqft)	Linear (sqft)					
1 1	10.0	35.36	15.937	18.83	0.00	0.13	2.85	0.80	1.00	0.00	20.82	40.81	0.00	4,620.9	0.0	2853.28	1560.21	4,413.49
1 2	30.0	33.86	14.403	18.83	0.00	0.14	2.79	0.80	1.00	0.00	19.83	39.30	0.00	3,969.0	0.0	2548.90	1444.14	3,993.04
1 3	50.0	37.55	10.827	18.83	0.00	0.16	2.75	0.80	1.00	0.00	16.80	39.30	0.00	3,769.5	0.0	2357.56	1601.37	3,958.93
1 4	70.0	39.67	9.814	17.23	0.00	0.18	2.66	0.80	1.00	0.00	15.79	38.41	0.00	3,257.4	0.0	2264.13	1691.46	3,955.59
1 5	85.0	40.71	4.578	8.61	0.00	0.22	2.52	0.80	1.00	0.00	7.78	18.48	0.00	1,608.8	0.0	1086.90	867.24	1,954.14
1 6	100.0	41.42	0.000	15.46	0.00	0.15	2.78	0.80	1.00	0.00	8.93	34.80	0.00	2,534.1	0.0	1396.20	1699.39	3,095.59
1 7	120.0	42.04	0.000	13.66	0.00	0.13	2.84	0.80	1.00	0.00	7.85	29.53	0.00	2,073.5	0.0	1274.26	1529.18	2,803.43
1 8	140.0	42.38	0.000	12.85	0.00	0.12	2.87	0.80	1.00	0.00	7.37	13.29	0.00	1,625.1	0.0	1218.32	694.40	1,912.72
														<b>23,458.4</b>	<b>0.0</b>			<b>26,086.93</b>

## Section Forces

<b>Structure:</b> CT22071-A-SBA	<b>Code:</b> EIA/TIA-222-G	6/30/2020
<b>Site Name:</b> Avon (Montevideo)	<b>Exposure:</b> B	
<b>Height:</b> 150.00 (ft)	<b>Crest Height:</b> 520.00	
<b>Base Elev:</b> 0.000 (ft)	<b>Site Class:</b> C - Very Dense Soil	
<b>Gh:</b> 0.85	<b>Topography:</b> 4	<b>Struct Class:</b> II
		<b>Page:</b> 10



<b>Load Case:</b> 1.2D + 1.6W 90° Wind - P1	1.2D + 1.6W 93 mph Wind at 90° From Face - P1
<b>Wind Load Factor:</b> 1.60	<b>Wind Importance Factor:</b> 1.00
<b>Dead Load Factor:</b> 1.20	
<b>Ice Dead Load Factor:</b> 0.00	<b>Ice Importance Factor:</b> 1.00

Sect Seq	Wind Height (ft)	Total		Ice Round Area (sqft)	Sol Ratio	Cf	Df	Dr	Ice Thick (in)	Eff Area (sqft)	Ice		Total Weight (lb)	Weight Ice (lb)	Struct Force (lb)	Linear Force (lb)	Total Force (lb)	
		Flat Area (sqft)	Round Area (sqft)								Linear Area (sqft)	Linear Area (sqft)						
1 1	10.0	35.36	15.937	18.83	0.00	0.13	2.85	0.85	1.00	0.00	21.61	40.81	0.00	4,620.9	0.0	2962.49	1560.21	4,522.71
1 2	30.0	33.86	14.403	18.83	0.00	0.14	2.79	0.85	1.00	0.00	20.56	39.30	0.00	3,969.0	0.0	2641.44	1444.14	4,085.58
1 3	50.0	37.55	10.827	18.83	0.00	0.16	2.75	0.85	1.00	0.00	17.35	39.30	0.00	3,769.5	0.0	2433.51	1601.37	4,034.88
1 4	70.0	39.67	9.814	17.23	0.00	0.18	2.66	0.85	1.00	0.00	16.28	38.41	0.00	3,257.4	0.0	2334.49	1691.46	4,025.94
1 5	85.0	40.71	4.578	8.61	0.00	0.22	2.52	0.85	1.00	0.00	8.01	18.48	0.00	1,608.8	0.0	1118.87	867.24	1,986.10
1 6	100.0	41.42	0.000	15.46	0.00	0.15	2.78	0.85	1.00	0.00	8.93	34.80	0.00	2,534.1	0.0	1396.20	1699.39	3,095.59
1 7	120.0	42.04	0.000	13.66	0.00	0.13	2.84	0.85	1.00	0.00	7.85	29.53	0.00	2,073.5	0.0	1274.26	1529.18	2,803.43
1 8	140.0	42.38	0.000	12.85	0.00	0.12	2.87	0.85	1.00	0.00	7.37	13.29	0.00	1,625.1	0.0	1218.32	694.40	1,912.72
<b>23,458.4</b>														<b>0.0</b>	<b>26,466.95</b>			

<b>Load Case:</b> 1.2D + 1.6W 90° Wind - P2	1.2D + 1.6W 93 mph Wind at 90° From Face - P2
<b>Wind Load Factor:</b> 1.60	<b>Wind Importance Factor:</b> 1.00
<b>Dead Load Factor:</b> 1.20	
<b>Ice Dead Load Factor:</b> 0.00	<b>Ice Importance Factor:</b> 1.00

Sect Seq	Wind Height (ft)	Total		Ice Round Area (sqft)	Sol Ratio	Cf	Df	Dr	Ice Thick (in)	Eff Area (sqft)	Ice		Total Weight (lb)	Weight Ice (lb)	Struct Force (lb)	Linear Force (lb)	Total Force (lb)	
		Flat Area (sqft)	Round Area (sqft)								Linear Area (sqft)	Linear Area (sqft)						
1 1	10.0	19.45	15.937	18.83	0.00	0.13	2.85	0.85	1.00	0.00	21.61	40.81	0.00	4,620.9	0.0	1629.37	858.12	2,487.49
1 2	30.0	18.62	14.403	18.83	0.00	0.14	2.79	0.85	1.00	0.00	20.56	39.30	0.00	3,969.0	0.0	1452.79	794.28	2,247.07
1 3	50.0	20.65	10.827	18.83	0.00	0.16	2.75	0.85	1.00	0.00	17.35	39.30	0.00	3,769.5	0.0	1338.43	880.75	2,219.19
1 4	70.0	21.82	9.814	17.23	0.00	0.18	2.66	0.85	1.00	0.00	16.28	38.41	0.00	3,257.4	0.0	1283.97	930.30	2,214.27
1 5	85.0	22.39	4.578	8.61	0.00	0.22	2.52	0.85	1.00	0.00	8.01	18.48	0.00	1,608.8	0.0	615.38	476.98	1,092.36
1 6	100.0	22.78	0.000	15.46	0.00	0.15	2.78	0.85	1.00	0.00	8.93	34.80	0.00	2,534.1	0.0	767.91	934.66	1,702.57
1 7	120.0	23.12	0.000	13.66	0.00	0.13	2.84	0.85	1.00	0.00	7.85	29.53	0.00	2,073.5	0.0	700.84	841.05	1,541.89
1 8	140.0	23.31	0.000	12.85	0.00	0.12	2.87	0.85	1.00	0.00	7.37	13.29	0.00	1,625.1	0.0	670.07	381.92	1,051.99
<b>23,458.4</b>														<b>0.0</b>	<b>14,556.82</b>			

## Section Forces

<b>Structure:</b> CT22071-A-SBA	<b>Code:</b> EIA/TIA-222-G	6/30/2020
<b>Site Name:</b> Avon (Montevideo)	<b>Exposure:</b> B	
<b>Height:</b> 150.00 (ft)	<b>Crest Height:</b> 520.00	
<b>Base Elev:</b> 0.000 (ft)	<b>Site Class:</b> C - Very Dense Soil	
<b>Gh:</b> 0.85	<b>Topography:</b> 4	<b>Struct Class:</b> II

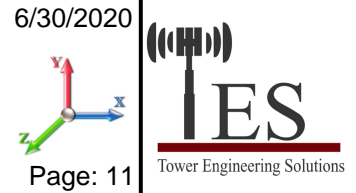

<b>Load Case:</b> 1.2D + 1.6W 90° Wind - P3	1.2D + 1.6W 93 mph Wind at 90° From Face - P3
<b>Wind Load Factor:</b> 1.60	<b>Wind Importance Factor:</b> 1.00
<b>Dead Load Factor:</b> 1.20	
<b>Ice Dead Load Factor:</b> 0.00	<b>Ice Importance Factor:</b> 1.00

Sect Seq	Wind Height (ft)	qz (psf)	Total Area		Ice Round Area (sqft)	Sol Ratio	Cf	Df	Dr	Ice Thick (in)	Eff Area (sqft)	Ice Area		Total Weight (lb)	Weight Ice (lb)	Struct Force (lb)	Linear Force (lb)	Total Force (lb)
			Flat (sqft)	Round (sqft)								Linear (sqft)	Linear (sqft)					
1 1	10.0	35.36	15.937	18.83	0.00	0.13	2.85	0.85	1.00	0.00	21.61	40.81	0.00	4,620.9	0.0	2962.49	1560.21	4,522.71
1 2	30.0	33.86	14.403	18.83	0.00	0.14	2.79	0.85	1.00	0.00	20.56	39.30	0.00	3,969.0	0.0	2641.44	1444.14	4,085.58
1 3	50.0	37.55	10.827	18.83	0.00	0.16	2.75	0.85	1.00	0.00	17.35	39.30	0.00	3,769.5	0.0	2433.51	1601.37	4,034.88
1 4	70.0	39.67	9.814	17.23	0.00	0.18	2.66	0.85	1.00	0.00	16.28	38.41	0.00	3,257.4	0.0	2334.49	1691.46	4,025.94
1 5	85.0	40.71	4.578	8.61	0.00	0.22	2.52	0.85	1.00	0.00	8.01	18.48	0.00	1,608.8	0.0	1118.87	867.24	1,986.10
1 6	100.0	41.42	0.000	15.46	0.00	0.15	2.78	0.85	1.00	0.00	8.93	34.80	0.00	2,534.1	0.0	1396.20	1699.39	3,095.59
1 7	120.0	42.04	0.000	13.66	0.00	0.13	2.84	0.85	1.00	0.00	7.85	29.53	0.00	2,073.5	0.0	1274.26	1529.18	2,803.43
1 8	140.0	42.38	0.000	12.85	0.00	0.12	2.87	0.85	1.00	0.00	7.37	13.29	0.00	1,625.1	0.0	1218.32	694.40	1,912.72
														<b>23,458.4</b>	<b>0.0</b>			<b>26,466.95</b>

<b>Load Case:</b> 0.9D + 1.6W Normal Wind	0.9D + 1.6W 93 mph Wind at Normal To Face
<b>Wind Load Factor:</b> 1.60	<b>Wind Importance Factor:</b> 1.00
<b>Dead Load Factor:</b> 0.90	
<b>Ice Dead Load Factor:</b> 0.00	<b>Ice Importance Factor:</b> 1.00

Sect Seq	Wind Height (ft)	qz (psf)	Total Area		Ice Round Area (sqft)	Sol Ratio	Cf	Df	Dr	Ice Thick (in)	Eff Area (sqft)	Ice Area		Total Weight (lb)	Weight Ice (lb)	Struct Force (lb)	Linear Force (lb)	Total Force (lb)
			Flat (sqft)	Round (sqft)								Linear (sqft)	Linear (sqft)					
1 1	10.0	35.36	15.937	18.83	0.00	0.13	2.85	1.00	1.00	0.00	24.00	40.81	0.00	3,465.7	0.0	3290.14	1560.21	4,850.35
1 2	30.0	33.86	14.403	18.83	0.00	0.14	2.79	1.00	1.00	0.00	22.72	39.30	0.00	2,976.7	0.0	2919.06	1444.14	4,363.20
1 3	50.0	37.55	10.827	18.83	0.00	0.16	2.75	1.00	1.00	0.00	18.97	39.30	0.00	2,827.2	0.0	2661.35	1601.37	4,262.72
1 4	70.0	39.67	9.814	17.23	0.00	0.18	2.66	1.00	1.00	0.00	17.75	38.41	0.00	2,443.1	0.0	2545.55	1691.46	4,237.01
1 5	85.0	40.71	4.578	8.61	0.00	0.22	2.52	1.00	1.00	0.00	8.70	18.48	0.00	1,206.6	0.0	1214.76	867.24	2,082.00
1 6	100.0	41.42	0.000	15.46	0.00	0.15	2.78	1.00	1.00	0.00	8.93	34.80	0.00	1,900.6	0.0	1396.20	1699.39	3,095.59
1 7	120.0	42.04	0.000	13.66	0.00	0.13	2.84	1.00	1.00	0.00	7.85	29.53	0.00	1,555.1	0.0	1274.26	1529.18	2,803.43
1 8	140.0	42.38	0.000	12.85	0.00	0.12	2.87	1.00	1.00	0.00	7.37	13.29	0.00	1,218.8	0.0	1218.32	694.40	1,912.72
														<b>17,593.8</b>	<b>0.0</b>			<b>27,607.02</b>

## Section Forces

<b>Structure:</b> CT22071-A-SBA	<b>Code:</b> EIA/TIA-222-G	6/30/2020
<b>Site Name:</b> Avon (Montevideo)	<b>Exposure:</b> B	
<b>Height:</b> 150.00 (ft)	<b>Crest Height:</b> 520.00	
<b>Base Elev:</b> 0.000 (ft)	<b>Site Class:</b> C - Very Dense Soil	
<b>Gh:</b> 0.85	<b>Topography:</b> 4	<b>Struct Class:</b> II
		Page: 12

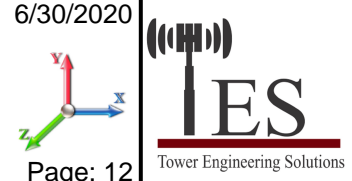

<b>Load Case:</b> 0.9D + 1.6W 60° Wind	0.9D + 1.6W 93 mph Wind at 60° From Face
<b>Wind Load Factor:</b> 1.60	<b>Wind Importance Factor:</b> 1.00
<b>Dead Load Factor:</b> 0.90	
<b>Ice Dead Load Factor:</b> 0.00	<b>Ice Importance Factor:</b> 1.00

Sect Seq	Wind Height (ft)	qz (psf)	Total		Ice Round Area (sqft)	Sol Ratio	Cf	Df	Dr	Ice Thick (in)	Eff Area (sqft)	Ice		Total Weight (lb)	Weight Ice (lb)	Struct Force (lb)	Linear Force (lb)	Total Force (lb)
			Flat Area (sqft)	Round Area (sqft)								Linear Area (sqft)	Linear Area (sqft)					
1 1	10.0	35.36	15.937	18.83	0.00	0.13	2.85	0.80	1.00	0.00	20.82	40.81	0.00	3,465.7	0.0	2853.28	1560.21	4,413.49
1 2	30.0	33.86	14.403	18.83	0.00	0.14	2.79	0.80	1.00	0.00	19.83	39.30	0.00	2,976.7	0.0	2548.90	1444.14	3,993.04
1 3	50.0	37.55	10.827	18.83	0.00	0.16	2.75	0.80	1.00	0.00	16.80	39.30	0.00	2,827.2	0.0	2357.56	1601.37	3,958.93
1 4	70.0	39.67	9.814	17.23	0.00	0.18	2.66	0.80	1.00	0.00	15.79	38.41	0.00	2,443.1	0.0	2264.13	1691.46	3,955.59
1 5	85.0	40.71	4.578	8.61	0.00	0.22	2.52	0.80	1.00	0.00	7.78	18.48	0.00	1,206.6	0.0	1086.90	867.24	1,954.14
1 6	100.0	41.42	0.000	15.46	0.00	0.15	2.78	0.80	1.00	0.00	8.93	34.80	0.00	1,900.6	0.0	1396.20	1699.39	3,095.59
1 7	120.0	42.04	0.000	13.66	0.00	0.13	2.84	0.80	1.00	0.00	7.85	29.53	0.00	1,555.1	0.0	1274.26	1529.18	2,803.43
1 8	140.0	42.38	0.000	12.85	0.00	0.12	2.87	0.80	1.00	0.00	7.37	13.29	0.00	1,218.8	0.0	1218.32	694.40	1,912.72
														<b>17,593.8</b>	<b>0.0</b>			

<b>Load Case:</b> 0.9D + 1.6W 90° Wind	0.9D + 1.6W 93 mph Wind at 90° From Face
<b>Wind Load Factor:</b> 1.60	<b>Wind Importance Factor:</b> 1.00
<b>Dead Load Factor:</b> 0.90	
<b>Ice Dead Load Factor:</b> 0.00	<b>Ice Importance Factor:</b> 1.00

Sect Seq	Wind Height (ft)	qz (psf)	Total		Ice Round Area (sqft)	Sol Ratio	Cf	Df	Dr	Ice Thick (in)	Eff Area (sqft)	Ice		Total Weight (lb)	Weight Ice (lb)	Struct Force (lb)	Linear Force (lb)	Total Force (lb)
			Flat Area (sqft)	Round Area (sqft)								Linear Area (sqft)	Linear Area (sqft)					
1 1	10.0	35.36	15.937	18.83	0.00	0.13	2.85	0.85	1.00	0.00	21.61	40.81	0.00	3,465.7	0.0	2962.49	1560.21	4,522.71
1 2	30.0	33.86	14.403	18.83	0.00	0.14	2.79	0.85	1.00	0.00	20.56	39.30	0.00	2,976.7	0.0	2641.44	1444.14	4,085.58
1 3	50.0	37.55	10.827	18.83	0.00	0.16	2.75	0.85	1.00	0.00	17.35	39.30	0.00	2,827.2	0.0	2433.51	1601.37	4,034.88
1 4	70.0	39.67	9.814	17.23	0.00	0.18	2.66	0.85	1.00	0.00	16.28	38.41	0.00	2,443.1	0.0	2334.49	1691.46	4,025.94
1 5	85.0	40.71	4.578	8.61	0.00	0.22	2.52	0.85	1.00	0.00	8.01	18.48	0.00	1,206.6	0.0	1118.87	867.24	1,986.10
1 6	100.0	41.42	0.000	15.46	0.00	0.15	2.78	0.85	1.00	0.00	8.93	34.80	0.00	1,900.6	0.0	1396.20	1699.39	3,095.59
1 7	120.0	42.04	0.000	13.66	0.00	0.13	2.84	0.85	1.00	0.00	7.85	29.53	0.00	1,555.1	0.0	1274.26	1529.18	2,803.43
1 8	140.0	42.38	0.000	12.85	0.00	0.12	2.87	0.85	1.00	0.00	7.37	13.29	0.00	1,218.8	0.0	1218.32	694.40	1,912.72
														<b>17,593.8</b>	<b>0.0</b>			

## Section Forces

<b>Structure:</b> CT22071-A-SBA	<b>Code:</b> EIA/TIA-222-G	<b>6/30/2020</b>
<b>Site Name:</b> Avon (Montevideo)	<b>Exposure:</b> B	
<b>Height:</b> 150.00 (ft)	<b>Crest Height:</b> 520.00	
<b>Base Elev:</b> 0.000 (ft)	<b>Site Class:</b> C - Very Dense Soil	
<b>Gh:</b> 0.85	<b>Topography:</b> 4	<b>Struct Class:</b> II
		<b>Page:</b> 13



<b>Load Case:</b> 1.2D + 1.0Di + 1.0Wi Normal Wind	1.2D + 1.0Di + 1.0Wi 50 mph Wind at Normal From Face
<b>Wind Load Factor:</b> 1.00	<b>Wind Importance Factor:</b> 1.00
<b>Dead Load Factor:</b> 1.20	
<b>Ice Dead Load Factor:</b> 1.00	<b>Ice Importance Factor:</b> 1.00

Sect Seq	Wind Height (ft)	qz (psf)	Total		Ice Round Area (sqft)	Sol Ratio	Cf	Df	Dr	Ice Thick (in)	Eff Area (sqft)	Ice		Total Weight (lb)	Weight Ice (lb)	Struct Force (lb)	Linear Force (lb)	Total Force (lb)
			Flat Area (sqft)	Round Area (sqft)								Linear Area (sqft)	Linear Area (sqft)					
1 1	10.0	10.22	15.937	63.00	44.17	0.28	2.34	1.00	1.00	2.51	53.37	88.99	83.59	13,408.	8787.9	1084.49	1030.20	2,114.70
1 2	30.0	9.79	14.403	64.56	45.73	0.33	2.22	1.00	1.00	2.76	53.73	85.23	91.86	13,474.	9505.9	990.98	966.17	1,957.14
1 3	50.0	10.85	10.827	63.56	44.72	0.37	2.12	1.00	1.00	2.86	50.57	86.92	95.25	13,106.	9337.2	988.10	1072.49	2,060.58
1 4	70.0	11.47	9.814	60.41	43.18	0.44	1.98	1.00	1.00	2.91	49.45	86.96	82.29	12,146.	8888.9	956.43	1047.86	2,004.29
1 5	85.0	11.77	4.578	29.61	21.00	0.53	1.86	1.00	1.00	2.94	25.40	42.98	29.39	5,734.6	4125.8	472.80	453.34	926.14
1 6	100.0	11.97	0.000	83.90	68.44	0.74	1.78	1.00	1.00	2.96	70.62	84.09	45.54	11,571.	9037.5	1281.73	485.94	1,767.67
1 7	120.0	12.15	0.000	82.45	68.79	0.73	1.78	1.00	1.00	2.97	68.72	79.08	17.64	10,157.	8083.7	1263.75	419.52	1,683.28
1 8	140.0	12.25	0.000	81.84	68.99	0.73	1.78	1.00	1.00	2.98	68.02	39.12	9.94	8,282.0	6656.9	1260.57	217.39	1,477.96
														<b>87,882.0</b>	<b>64423.6</b>			<b>13,991.75</b>

<b>Load Case:</b> 1.2D + 1.0Di + 1.0Wi 60° Wind	1.2D + 1.0Di + 1.0Wi 50 mph Wind at 60° From Face
<b>Wind Load Factor:</b> 1.00	<b>Wind Importance Factor:</b> 1.00
<b>Dead Load Factor:</b> 1.20	
<b>Ice Dead Load Factor:</b> 1.00	<b>Ice Importance Factor:</b> 1.00

Sect Seq	Wind Height (ft)	qz (psf)	Total		Ice Round Area (sqft)	Sol Ratio	Cf	Df	Dr	Ice Thick (in)	Eff Area (sqft)	Ice		Total Weight (lb)	Weight Ice (lb)	Struct Force (lb)	Linear Force (lb)	Total Force (lb)
			Flat Area (sqft)	Round Area (sqft)								Linear Area (sqft)	Linear Area (sqft)					
1 1	10.0	10.22	15.937	63.00	44.17	0.28	2.34	0.80	1.00	2.51	50.18	88.99	83.59	13,408.	8787.9	1019.73	1030.20	2,049.93
1 2	30.0	9.79	14.403	64.56	45.73	0.33	2.22	0.80	1.00	2.76	50.85	85.23	91.86	13,474.	9505.9	937.85	966.17	1,904.02
1 3	50.0	10.85	10.827	63.56	44.72	0.37	2.12	0.80	1.00	2.86	48.41	86.92	95.25	13,106.	9337.2	945.79	1072.49	2,018.28
1 4	70.0	11.47	9.814	60.41	43.18	0.44	1.98	0.80	1.00	2.91	47.49	86.96	82.29	12,146.	8888.9	918.46	1047.86	1,966.33
1 5	85.0	11.77	4.578	29.61	21.00	0.53	1.86	0.80	1.00	2.94	24.48	42.98	29.39	5,734.6	4125.8	455.76	453.34	909.09
1 6	100.0	11.97	0.000	83.90	68.44	0.74	1.78	0.80	1.00	2.96	70.62	84.09	45.54	11,571.	9037.5	1281.73	485.94	1,767.67
1 7	120.0	12.15	0.000	82.45	68.79	0.73	1.78	0.80	1.00	2.97	68.72	79.08	17.64	10,157.	8083.7	1263.75	419.52	1,683.28
1 8	140.0	12.25	0.000	81.84	68.99	0.73	1.78	0.80	1.00	2.98	68.02	39.12	9.94	8,282.0	6656.9	1260.57	217.39	1,477.96
														<b>87,882.0</b>	<b>64423.6</b>			<b>13,776.55</b>

## Section Forces

<b>Structure:</b> CT22071-A-SBA	<b>Code:</b> EIA/TIA-222-G	<b>6/30/2020</b>
<b>Site Name:</b> Avon (Montevideo)	<b>Exposure:</b> B	
<b>Height:</b> 150.00 (ft)	<b>Crest Height:</b> 520.00	
<b>Base Elev:</b> 0.000 (ft)	<b>Site Class:</b> C - Very Dense Soil	
<b>Gh:</b> 0.85	<b>Topography:</b> 4	<b>Struct Class:</b> II
		<b>Page:</b> 14



<b>Load Case:</b> 1.2D + 1.0Di + 1.0Wi 90° Wind	1.2D + 1.0Di + 1.0Wi 50 mph Wind at 90° From Face
<b>Wind Load Factor:</b> 1.00	<b>Wind Importance Factor:</b> 1.00
<b>Dead Load Factor:</b> 1.20	
<b>Ice Dead Load Factor:</b> 1.00	<b>Ice Importance Factor:</b> 1.00

Sect Seq	Wind Height (ft)	qz (psf)	Total Area (sqft)		Ice Round Area (sqft)	Sol Ratio	Cf	Df	Dr	Ice Thick (in)	Eff Area (sqft)	Ice Area (sqft)		Total Weight (lb)	Weight Ice (lb)	Struct Force (lb)	Linear Force (lb)	Total Force (lb)
			Flat	Round								Linear	Linear					
1 1	10.0	10.22	15.937	63.00	44.17	0.28	2.34	0.85	1.00	2.51	50.98	88.99	83.59	13,408.	8787.9	1035.92	1030.20	2,066.12
1 2	30.0	9.79	14.403	64.56	45.73	0.33	2.22	0.85	1.00	2.76	51.57	85.23	91.86	13,474.	9505.9	951.13	966.17	1,917.30
1 3	50.0	10.85	10.827	63.56	44.72	0.37	2.12	0.85	1.00	2.86	48.95	86.92	95.25	13,106.	9337.2	956.37	1072.49	2,028.85
1 4	70.0	11.47	9.814	60.41	43.18	0.44	1.98	0.85	1.00	2.91	47.98	86.96	82.29	12,146.	8888.9	927.95	1047.86	1,975.82
1 5	85.0	11.77	4.578	29.61	21.00	0.53	1.86	0.85	1.00	2.94	24.71	42.98	29.39	5,734.6	4125.8	460.02	453.34	913.35
1 6	100.0	11.97	0.000	83.90	68.44	0.74	1.78	0.85	1.00	2.96	70.62	84.09	45.54	11,571.	9037.5	1281.73	485.94	1,767.67
1 7	120.0	12.15	0.000	82.45	68.79	0.73	1.78	0.85	1.00	2.97	68.72	79.08	17.64	10,157.	8083.7	1263.75	419.52	1,683.28
1 8	140.0	12.25	0.000	81.84	68.99	0.73	1.78	0.85	1.00	2.98	68.02	39.12	9.94	8,282.0	6656.9	1260.57	217.39	1,477.96
														<b>87,882.0</b>	<b>64423.6</b>			<b>13,830.35</b>

<b>Load Case:</b> 1.0D + 1.0W Normal Wind	1.0D + 1.0W 60 mph Wind at Normal To Face
<b>Wind Load Factor:</b> 1.00	<b>Wind Importance Factor:</b> 1.00
<b>Dead Load Factor:</b> 1.00	
<b>Ice Dead Load Factor:</b> 0.00	<b>Ice Importance Factor:</b> 1.00

Sect Seq	Wind Height (ft)	qz (psf)	Total Area (sqft)		Ice Round Area (sqft)	Sol Ratio	Cf	Df	Dr	Ice Thick (in)	Eff Area (sqft)	Ice Area (sqft)		Total Weight (lb)	Weight Ice (lb)	Struct Force (lb)	Linear Force (lb)	Total Force (lb)
			Flat	Round								Linear	Linear					
1 1	10.0	14.72	15.937	18.83	0.00	0.13	2.85	1.00	1.00	0.00	25.97	40.81	0.00	3,850.8	0.0	926.12	405.88	1,332.00
1 2	30.0	14.09	14.403	18.83	0.00	0.14	2.79	1.00	1.00	0.00	24.56	39.30	0.00	3,307.5	0.0	821.15	375.69	1,196.84
1 3	50.0	15.63	10.827	18.83	0.00	0.16	2.75	1.00	1.00	0.00	20.85	39.30	0.00	3,141.3	0.0	761.12	416.59	1,177.71
1 4	70.0	16.51	9.814	17.23	0.00	0.18	2.66	1.00	1.00	0.00	19.26	38.41	0.00	2,714.5	0.0	718.45	440.03	1,158.47
1 5	85.0	16.94	4.578	8.61	0.00	0.22	2.52	1.00	1.00	0.00	9.37	18.48	0.00	1,340.7	0.0	340.48	225.61	566.09
1 6	100.0	17.24	0.000	15.46	0.00	0.15	2.78	1.00	1.00	0.00	8.93	34.80	0.00	2,111.8	0.0	363.22	442.09	805.30
1 7	120.0	17.50	0.000	13.66	0.00	0.13	2.84	1.00	1.00	0.00	7.85	29.53	0.00	1,727.9	0.0	331.49	397.81	729.30
1 8	140.0	17.64	0.000	12.85	0.00	0.12	2.87	1.00	1.00	0.00	7.37	13.29	0.00	1,354.2	0.0	316.94	180.65	497.58
														<b>19,548.6</b>	<b>0.0</b>			<b>7,463.30</b>



## Section Forces

<b>Structure:</b> CT22071-A-SBA	<b>Code:</b> EIA/TIA-222-G	6/30/2020
<b>Site Name:</b> Avon (Montevideo)	<b>Exposure:</b> B	
<b>Height:</b> 150.00 (ft)	<b>Crest Height:</b> 520.00	
<b>Base Elev:</b> 0.000 (ft)	<b>Site Class:</b> C - Very Dense Soil	
<b>Gh:</b> 0.85	<b>Topography:</b> 4	<b>Struct Class:</b> II

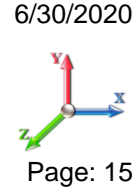

Page: 15

<b>Load Case:</b> 1.0D + 1.0W 60° Wind	1.0D + 1.0W 60 mph Wind at 60° From Face
<b>Wind Load Factor:</b> 1.00	<b>Wind Importance Factor:</b> 1.00
<b>Dead Load Factor:</b> 1.00	
<b>Ice Dead Load Factor:</b> 0.00	<b>Ice Importance Factor:</b> 1.00

Sect Seq	Wind Height (ft)	Total		Ice Round Area (sqft)	Sol Ratio	Cf	Df	Dr	Ice Thick (in)	Eff Area (sqft)	Ice		Total Weight (lb)	Weight Ice (lb)	Struct Force (lb)	Linear Force (lb)	Total Force (lb)	
		Flat Area (sqft)	Round Area (sqft)								Linear Area (sqft)	Linear Area (sqft)						
1 1	10.0	14.72	15.937	18.83	0.00	0.13	2.85	0.80	1.00	0.00	22.79	40.81	0.00	3,850.8	0.0	812.48	405.88	1,218.36
1 2	30.0	14.09	14.403	18.83	0.00	0.14	2.79	0.80	1.00	0.00	21.68	39.30	0.00	3,307.5	0.0	724.86	375.69	1,100.54
1 3	50.0	15.63	10.827	18.83	0.00	0.16	2.75	0.80	1.00	0.00	18.69	39.30	0.00	3,141.3	0.0	682.09	416.59	1,098.68
1 4	70.0	16.51	9.814	17.23	0.00	0.18	2.66	0.80	1.00	0.00	17.30	38.41	0.00	2,714.5	0.0	645.24	440.03	1,085.26
1 5	85.0	16.94	4.578	8.61	0.00	0.22	2.52	0.80	1.00	0.00	8.46	18.48	0.00	1,340.7	0.0	307.22	225.61	532.83
1 6	100.0	17.24	0.000	15.46	0.00	0.15	2.78	0.80	1.00	0.00	8.93	34.80	0.00	2,111.8	0.0	363.22	442.09	805.30
1 7	120.0	17.50	0.000	13.66	0.00	0.13	2.84	0.80	1.00	0.00	7.85	29.53	0.00	1,727.9	0.0	331.49	397.81	729.30
1 8	140.0	17.64	0.000	12.85	0.00	0.12	2.87	0.80	1.00	0.00	7.37	13.29	0.00	1,354.2	0.0	316.94	180.65	497.58
														<b>19,548.6</b>	<b>0.0</b>			<b>7,067.85</b>

<b>Load Case:</b> 1.0D + 1.0W 90° Wind	1.0D + 1.0W 60 mph Wind at 90° From Face
<b>Wind Load Factor:</b> 1.00	<b>Wind Importance Factor:</b> 1.00
<b>Dead Load Factor:</b> 1.00	
<b>Ice Dead Load Factor:</b> 0.00	<b>Ice Importance Factor:</b> 1.00

Sect Seq	Wind Height (ft)	Total		Ice Round Area (sqft)	Sol Ratio	Cf	Df	Dr	Ice Thick (in)	Eff Area (sqft)	Ice		Total Weight (lb)	Weight Ice (lb)	Struct Force (lb)	Linear Force (lb)	Total Force (lb)	
		Flat Area (sqft)	Round Area (sqft)								Linear Area (sqft)	Linear Area (sqft)						
1 1	10.0	14.72	15.937	18.83	0.00	0.13	2.85	0.85	1.00	0.00	23.58	40.81	0.00	3,850.8	0.0	840.89	405.88	1,246.77
1 2	30.0	14.09	14.403	18.83	0.00	0.14	2.79	0.85	1.00	0.00	22.40	39.30	0.00	3,307.5	0.0	748.93	375.69	1,124.62
1 3	50.0	15.63	10.827	18.83	0.00	0.16	2.75	0.85	1.00	0.00	19.23	39.30	0.00	3,141.3	0.0	701.84	416.59	1,118.43
1 4	70.0	16.51	9.814	17.23	0.00	0.18	2.66	0.85	1.00	0.00	17.79	38.41	0.00	2,714.5	0.0	663.54	440.03	1,103.56
1 5	85.0	16.94	4.578	8.61	0.00	0.22	2.52	0.85	1.00	0.00	8.68	18.48	0.00	1,340.7	0.0	315.53	225.61	541.14
1 6	100.0	17.24	0.000	15.46	0.00	0.15	2.78	0.85	1.00	0.00	8.93	34.80	0.00	2,111.8	0.0	363.22	442.09	805.30
1 7	120.0	17.50	0.000	13.66	0.00	0.13	2.84	0.85	1.00	0.00	7.85	29.53	0.00	1,727.9	0.0	331.49	397.81	729.30
1 8	140.0	17.64	0.000	12.85	0.00	0.12	2.87	0.85	1.00	0.00	7.37	13.29	0.00	1,354.2	0.0	316.94	180.65	497.58
														<b>19,548.6</b>	<b>0.0</b>			<b>7,166.71</b>

## Force/Stress Compression Summary

<b>Structure:</b> CT22071-A-SBA	<b>Code:</b> EIA/TIA-222-G	6/30/2020
<b>Site Name:</b> Avon (Montevideo)	<b>Exposure:</b> B	
<b>Height:</b> 150.00 (ft)	<b>Crest Height:</b> 520.00	
<b>Base Elev:</b> 0.000 (ft)	<b>Site Class:</b> C - Very Dense Soil	
<b>Gh:</b> 0.85	<b>Topography:</b> 4	<b>Struct Class:</b> II

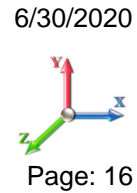

Page: 16

### LEG MEMBERS

Sect	Top Elev	Member	Force		Load Case	Len (ft)	Bracing %			Fy (ksi)	Mem Cap (kips)	Leg Use %	Controls
			(kips)				X	Y	Z				
1	20	12B - 12"BD 1.75"	-269.66	1.2D + 1.6W Normal Wind - P1	10.02	100	100	100	25.99	50.00	308.82	87.3	Member X
2	40	12B - 12"BD 1.75"	-242.62	1.2D + 1.6W Normal Wind - P1	10.02	100	100	100	25.99	50.00	308.82	78.6	Member X
3	60	12B - 12"BD 1.75"	-210.98	1.2D + 1.6W Normal Wind - P1	10.02	100	100	100	25.99	50.00	308.82	68.3	Member X
4	80	12B - 12"BD 1.5"	-176.93	1.2D + 1.6W Normal Wind - P1	10.02	100	100	100	30.32	50.00	222.99	79.3	Member X
5	90	12B - 12"BD 1.5"	-140.13	1.2D + 1.6W Normal Wind - P1	10.02	100	100	100	30.32	50.00	222.99	62.8	Member X
6	110	SOL - 2 1/4" SOLID	-132.52	1.2D + 1.6W Normal Wind - P1	2.42	100	100	100	51.55	50.00	147.32	90.0	Member X
7	130	SOL - 2" SOLID	-65.93	1.2D + 1.6W Normal Wind - P1	2.42	100	100	100	58.00	50.00	110.55	59.6	Member X
8	150	SOL - 1 3/4" SOLID	-19.89	1.2D + 1.6W Normal Wind - P1	2.42	100	100	100	66.28	50.00	78.50	25.3	Member X

### Splices

Sect	Top Elev	Load Case	Top Splice				Load Case	Bottom Splice				Bolt Type	Num Bolts
			Force (kips)	Cap (kips)	Use %			Force (kips)	Cap (kips)	Use %			
1	20	1.2D + 1.6W Normal Wind - P1	250.56	0.00	0.0	1.2D + 1.6W Normal Wind - P1	279.46	0.00					
2	40	1.2D + 1.6W Normal Wind - P1	219.60	0.00	0.0	1.2D + 1.6W Normal Wind - P1	250.56	0.00			1 A325	6	
3	60	1.2D + 1.6W Normal Wind - P1	186.64	0.00	0.0	1.2D + 1.6W Normal Wind - P1	219.60	0.00			1 A325	6	
4	80	1.2D + 1.6W Normal Wind - P1	150.60	0.00	0.0	1.2D + 1.6W Normal Wind - P1	186.64	0.00			1 A325	6	
5	90	1.2D + 1.6W Normal Wind - P1	138.26	0.00	0.0	1.2D + 1.6W Normal Wind - P1	150.60	0.00			1 A325	6	
6	110	1.2D + 1.6W Normal Wind - P1	69.66	0.00	0.0	1.2D + 1.6W Normal Wind - P1	138.26	0.00			1 A325	6	
7	130	1.2D + 1.6W Normal Wind - P1	22.46	0.00	0.0	1.2D + 1.6W Normal Wind - P1	69.66	0.00					
8	150	1.2D + 1.0Di + 1.0Wi 90° Wind	0.51	0.00	0.0	1.2D + 1.6W Normal Wind - P1	22.46	0.00					

### HORIZONTAL MEMBERS

Sect	Top Elev	Member	Force		Len (ft)	Bracing %			Fy (ksi)	Mem Cap (kips)	Num Bolts	Shear Bear		Use %	Controls
			(kips)	Load Case		X	Y	Z				KL/R	Num Holes (kips)		
1	20								0.00	0	0				
2	40								0.00	0	0				
3	60								0.00	0	0				
4	80								0.00	0	0				
5	90								0.00	0	0				
6	110	SOL - 1" SOLID	-1.12	1.2D + 1.6W 60° Wind - P1	5.00	100	100	100	168.00	50.00	6.29	0	0	18	Member X
7	130	SOL - 7/8" SOLID	-1.54	1.2D + 1.6W Normal Wind - P1	5.00	100	100	100	191.96	50.00	3.69	0	0	42	Member X
8	150	SOL - 7/8" SOLID	-1.15	1.2D + 1.6W Normal Wind - P1	5.00	100	100	100	191.96	50.00	3.69	0	0	31	Member X

### DIAGONAL MEMBERS

Sect	Top Elev	Member	Force		Len (ft)	Bracing %			Fy (ksi)	Mem Cap (kips)	Num Bolts	Shear Bear		Use %	Controls		
			(kips)	Load Case		X	Y	Z				KL/R	Num Holes (kips)			Cap (kips)	
1	20	SAE - 3X3X0.3125	-7.74	1.2D + 1.6W Normal Wind - P1	16.80	50	50	50	171.17	36.00	13.73	1	1	31.81	29.9	56	Member Z
2	40	SAE - 3X3X0.1875	-6.15	1.2D + 1.6W 60° Wind - P1	15.24	50	50	50	153.45	36.00	10.46	1	1	31.81	17.9	59	Member Z
3	60	SAE - 2.5X2.5X0.1875	-6.40	1.2D + 1.6W 60° Wind - P1	13.80	50	50	50	167.23	36.00	7.29	1	1	31.81	17.9	88	Member Z
4	80	SAE - 2.5X2.5X0.1875	-6.52	1.2D + 1.6W 60° Wind - P1	12.50	50	50	50	151.56	36.00	8.87	1	1	31.81	17.9	74	Member Z
5	90	SAE - 2.5X2.5X0.1875	-7.11	1.2D + 1.6W 90° Wind - P1	11.42	50	50	50	138.38	36.00	10.64	1	1	31.81	17.9	67	Member Z
6	110	SOL - 1" SOLID	-6.00	1.2D + 1.6W 90° Wind - P1	5.55	50	50	50	119.95	50.00	12.33	0	0			49	Member X
7	130	SOL - 7/8" SOLID	-4.82	1.2D + 1.6W 90° Wind - P1	5.55	50	50	50	137.06	50.00	7.23	0	0			67	Member X
8	150	SOL - 7/8" SOLID	-3.28	1.2D + 1.6W 90° Wind - P1	5.55	50	50	50	137.06	50.00	7.23	0	0			45	Member X

## Force/Stress Tension Summary

<b>Structure:</b> CT22071-A-SBA	<b>Code:</b> EIA/TIA-222-G	<b>6/30/2020</b>
<b>Site Name:</b> Avon (Montevideo)	<b>Exposure:</b> B	
<b>Height:</b> 150.00 (ft)	<b>Crest Height:</b> 520.00	
<b>Base Elev:</b> 0.000 (ft)	<b>Site Class:</b> C - Very Dense Soil	
<b>Gh:</b> 0.85	<b>Topography:</b> 4	<b>Struct Class:</b> II



Page: 17

### LEG MEMBERS

Sect	Top Elev	Member	Force (kips)	Load Case	Fy (ksi)	Mem Cap (kips)	Leg Use %	Controls
1	20	12B - 12"BD 1.75"	247.94	0.9D + 1.6W 60° Wind	50	324.45	76.4	Member
2	40	12B - 12"BD 1.75"	224.00	0.9D + 1.6W 60° Wind	50	324.45	69.0	Member
3	60	12B - 12"BD 1.75"	195.76	0.9D + 1.6W 60° Wind	50	324.45	60.3	Member
4	80	12B - 12"BD 1.5"	164.22	0.9D + 1.6W 60° Wind	50	238.50	68.9	Member
5	90	12B - 12"BD 1.5"	130.38	0.9D + 1.6W 60° Wind	50	238.50	54.7	Member
6	110	SOL - 2 1/4" SOLID	127.92	0.9D + 1.6W 60° Wind	50	178.92	71.5	Member
7	130	SOL - 2" SOLID	63.34	0.9D + 1.6W 60° Wind	50	141.37	44.8	Member
8	150	SOL - 1 3/4" SOLID	19.52	0.9D + 1.6W 60° Wind	50	108.24	18.0	Member

### Splices

Sect	Top Elev	Top Splice					Bottom Splice						
		Load Case	Force (kips)	Cap (kips)	Use %	Bolt Type	Num Bolts	Load Case	Force (kips)	Cap (kips)	Use %	Bolt Type	Num Bolts
1	20	0.9D + 1.6W 60° Wind	230.20	0.00	0.0			0.9D + 1.6W 60° Wind	256.6	0.00			
2	40	0.9D + 1.6W 60° Wind	202.50	0.00	0.0			0.9D + 1.6W 60° Wind	230.2	318.06	72.4	1 A325	6
3	60	0.9D + 1.6W 60° Wind	172.51	0.00	0.0			0.9D + 1.6W 60° Wind	202.5	318.06	63.7	1 A325	6
4	80	0.9D + 1.6W 60° Wind	139.48	0.00	0.0			0.9D + 1.6W 60° Wind	172.5	318.06	54.2	1 A325	6
5	90	0.9D + 1.6W 60° Wind	127.65	0.00	0.0			0.9D + 1.6W 60° Wind	139.4	318.06	43.9	1 A325	6
6	110	0.9D + 1.6W 60° Wind	63.27	0.00	0.0			0.9D + 1.6W 60° Wind	127.6	318.06	40.1	1 A325	6
7	130	0.9D + 1.6W 60° Wind	19.47	0.00	0.0			0.9D + 1.6W 60° Wind	63.27	0.00			
8	150		0.00	0.00	0.0			0.9D + 1.6W 60° Wind	19.47	0.00			

### HORIZONTAL MEMBERS

Sect	Top Elev	Member	Force (kips)	Load Case	Fy (ksi)	Mem Cap (kips)	Num Bolts	Num Holes	Shear Cap (kips)	Bear Cap (kips)	B.S. Cap (kips)	Use %	Controls
1	20	-			36	0.00	0	0					
2	40	-			36	0.00	0	0					
3	60	-			36	0.00	0	0					
4	80	-			36	0.00	0	0					
5	90	-			36	0.00	0	0					
6	110	SOL - 1" SOLID	1.52	1.2D + 1.6W Normal W	50	35.34	0	0				4.3	Member
7	130	SOL - 7/8" SOLID	1.56	1.2D + 1.6W 60° Wind	50	27.06	0	0				5.8	Member
8	150	SOL - 7/8" SOLID	1.04	1.2D + 1.6W 60° Wind	50	27.06	0	0				3.8	Member

### DIAGONAL MEMBERS

Sect	Top Elev	Member	Force (kips)	Load Case	Fy (ksi)	Mem Cap (kips)	Num Bolts	Num Holes	Shear Cap (kips)	Bear Cap (kips)	B.S. Cap (kips)	Use %	Controls
1	20	SAE - 3X3X0.3125	7.52	0.9D + 1.6W 60° Wind	36	46.60	1	1	31.81	29.91	19.47	38.6	Blck Shear
2	40	SAE - 3X3X0.1875	6.45	0.9D + 1.6W 60° Wind	36	28.68	1	1	31.81	17.94	11.68	55.2	Blck Shear
3	60	SAE - 2.5X2.5X0.1875	6.49	0.9D + 1.6W 60° Wind	36	22.55	1	1	31.81	17.94	10.66	60.9	Blck Shear
4	80	SAE - 2.5X2.5X0.1875	7.70	0.9D + 1.6W 60° Wind	36	22.55	1	1	31.81	17.94	10.66	72.2	Blck Shear
5	90	SAE - 2.5X2.5X0.1875	6.88	0.9D + 1.6W 90° Wind	36	22.55	1	1	31.81	17.94	10.66	64.5	Blck Shear
6	110	SOL - 1" SOLID	6.40	1.2D + 1.6W 60° Wind	50	35.34	0	0				18.1	Member
7	130	SOL - 7/8" SOLID	4.74	1.2D + 1.6W 90° Wind	50	27.06	0	0				17.5	Member
8	150	SOL - 7/8" SOLID	3.34	1.2D + 1.6W Normal W	50	27.06	0	0				12.3	Member

## Seismic Section Forces

<b>Structure:</b> CT22071-A-SBA	<b>Code:</b> EIA/TIA-222-G	6/30/2020
<b>Site Name:</b> Avon (Montevideo)	<b>Exposure:</b> B	
<b>Height:</b> 150.00 (ft)	<b>Crest Height:</b> 520.00	
<b>Base Elev:</b> 0.000 (ft)	<b>Site Class:</b> C - Very Dense Soil	
<b>Gh:</b> 0.85	<b>Topography:</b> 4	<b>Struct Class:</b> II

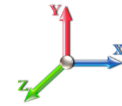

Page: 18

**Load Case: 1.2D + 1.0E**

<b>Dead Load Factor</b>	1.20	<b>Sds</b> 0.144	<b>Ss</b> 0.1810	<b>Fa</b> 1.2000	<b>Ke</b> 0.0000
<b>Seismic Load Factor</b>	1.00	<b>Sd1</b> 0.072	<b>S1</b> 0.0640	<b>Fv</b> 1.7000	<b>Kg</b> 0.0000
<b>Seismic Importance Factor</b>	1.00	<b>SA</b> 0.105	<b>R</b> 3.0000	<b>Vs</b> 0.9799	<b>f1</b> 1.4514

Sect #	Elev (ft)	Wz (lb)	Lateral			Fsz (lb)
			a	b	c	
1	10.00	3901.0	0.01	0.05	0.03	14.30
2	30.00	3307.4	0.08	0.07	0.04	23.64
3	50.00	3141.2	0.21	0.06	0.02	35.27
4	70.00	3371.1	0.41	0.01	0.01	51.64
5	85.00	1340.7	0.61	-0.06	0.02	23.29
6	100.00	2526.7	0.84	-0.12	0.07	51.58
7	120.00	2127.9	1.21	0.01	0.26	75.51
8	140.00	3542.7	1.65	0.93	0.73	273.91

**Load Case: 0.9D + 1.0E**

<b>Dead Load Factor</b>	0.90	<b>Sds</b> 0.144	<b>Ss</b> 0.1810	<b>Fa</b> 1.2000	<b>Ke</b> 0.0000
<b>Seismic Load Factor</b>	1.00	<b>Sd1</b> 0.072	<b>S1</b> 0.0640	<b>Fv</b> 1.7000	<b>Kg</b> 0.0000
<b>Seismic Importance Factor</b>	1.00	<b>SA</b> 0.105	<b>R</b> 3.0000	<b>Vs</b> 0.9799	<b>f1</b> 1.4514

Sect #	Elev (ft)	Wz (lb)	Lateral			Fsz (lb)
			a	b	c	
1	10.00	3901.0	0.01	0.05	0.03	14.30
2	30.00	3307.4	0.08	0.07	0.04	23.64
3	50.00	3141.2	0.21	0.06	0.02	35.27
4	70.00	3371.1	0.41	0.01	0.01	51.64
5	85.00	1340.7	0.61	-0.06	0.02	23.29
6	100.00	2526.7	0.84	-0.12	0.07	51.58
7	120.00	2127.9	1.21	0.01	0.26	75.51
8	140.00	3542.7	1.65	0.93	0.73	273.91

## Support Forces Summary

<b>Structure:</b> CT22071-A-SBA	<b>Code:</b> EIA/TIA-222-G	6/30/2020
<b>Site Name:</b> Avon (Montevideo)	<b>Exposure:</b> B	
<b>Height:</b> 150.00 (ft)	<b>Crest Height:</b> 520.00	
<b>Base Elev:</b> 0.000 (ft)	<b>Site Class:</b> C - Very Dense Soil	
<b>Gh:</b> 0.85	<b>Topography:</b> 4	<b>Struct Class:</b> II
		Page: 19



Load Case	Node	FX (kips)	FY (kips)	FZ (kips)	(-) = Uplift (+) = Down
<hr style="border-top: 1px dashed black;"/>					
1.2D + 1.6W Normal Wind - P1	1	-0.02	278.90	-27.40	
	1a	11.07	-125.51	-6.16	
	1b	-11.05	-125.47	-6.19	
<hr style="border-top: 1px dashed black;"/>					
1.2D + 1.6W Normal Wind - P2	1	-0.02	209.75	-19.57	
	1a	7.78	-90.94	-3.87	
	1b	-7.77	-90.90	-3.89	
<hr style="border-top: 1px dashed black;"/>					
1.2D + 1.6W Normal Wind - P3	1	-0.02	278.90	-27.40	
	1a	11.07	-125.51	-6.16	
	1b	-11.05	-125.47	-6.19	
<hr style="border-top: 1px dashed black;"/>					
1.2D + 1.6W 60° Wind - P1	1	-0.32	141.58	-13.63	
	1a	-11.31	139.71	7.60	
	1b	-21.48	-253.37	-13.08	
<hr style="border-top: 1px dashed black;"/>					
1.2D + 1.6W 60° Wind - P2	1	-0.05	108.22	-9.92	
	1a	-7.96	106.35	5.98	
	1b	-14.93	-186.66	-9.30	
<hr style="border-top: 1px dashed black;"/>					
1.2D + 1.6W 60° Wind - P3	1	-0.32	141.58	-13.63	
	1a	-11.31	139.71	7.60	
	1b	-21.48	-253.37	-13.08	
<hr style="border-top: 1px dashed black;"/>					
1.2D + 1.6W 90° Wind - P1	1	-0.42	9.69	-0.71	
	1a	-19.68	237.23	12.35	
	1b	-18.51	-219.01	-11.64	
<hr style="border-top: 1px dashed black;"/>					
1.2D + 1.6W 90° Wind - P2	1	-0.08	9.68	-0.75	
	1a	-13.95	178.94	9.22	
	1b	-12.68	-160.71	-8.47	
<hr style="border-top: 1px dashed black;"/>					
1.2D + 1.6W 90° Wind - P3	1	-0.42	9.69	-0.71	
	1a	-19.68	237.23	12.35	
	1b	-18.51	-219.01	-11.64	
<hr style="border-top: 1px dashed black;"/>					
0.9D + 1.6W Normal Wind	1	-0.02	276.06	-27.19	
	1a	11.23	-127.59	-6.27	
	1b	-11.21	-127.54	-6.29	
<hr style="border-top: 1px dashed black;"/>					
0.9D + 1.6W 60° Wind	1	-0.33	138.95	-13.42	
	1a	-11.14	137.22	7.49	
	1b	-21.64	-255.24	-13.18	
<hr style="border-top: 1px dashed black;"/>					
0.9D + 1.6W 90° Wind	1	-0.43	7.27	-0.51	
	1a	-19.51	234.60	12.24	
	1b	-18.68	-220.94	-11.73	
<hr style="border-top: 1px dashed black;"/>					
1.2D + 1.0Di + 1.0Wi Normal Wind	1	-0.03	165.66	-13.24	
	1a	5.17	-32.46	-2.67	
	1b	-5.14	-32.55	-2.72	
<hr style="border-top: 1px dashed black;"/>					
1.2D + 1.0Di + 1.0Wi 60° Wind	1	-0.02	99.70	-6.84	
	1a	-5.63	97.57	3.82	
	1b	-10.30	-96.63	-6.18	
<hr style="border-top: 1px dashed black;"/>					

1.2D + 1.0Di + 1.0Wi 90° Wind	1	-0.01	34.50	-0.57
	1a	-9.67	145.35	6.05
	1b	-8.79	-79.20	-5.48
1.2D + 1.0E	1	0.00	14.08	3.84
	1a	3.84	6.92	-2.17
	1b	-3.84	6.92	-2.17
0.9D + 1.0E	1	0.00	11.74	4.04
	1a	4.02	4.59	-2.27
	1b	-4.02	4.59	-2.27
1.0D + 1.0W Normal Wind	1	0.00	79.11	-7.78
	1a	2.53	-27.92	-1.42
	1b	-2.53	-27.93	-1.43
1.0D + 1.0W 60° Wind	1	-0.11	42.87	-4.11
	1a	-3.43	42.08	2.24
	1b	-5.32	-61.70	-3.24
1.0D + 1.0W 90° Wind	1	-0.13	8.06	-0.67
	1a	-5.66	67.82	3.51
	1b	-4.53	-52.63	-2.85

## Max Reactions

Leg		Overturning	
Max Uplift:	-255.24 (kips)	Moment:	3268.65 (ft-kips)
Max Down:	278.90 (kips)	Total Down:	27.91 (kips)
Max Shear:	27.40 (kips)	Total Shear:	39.75 (kips)

## Analysis Summary

<b>Structure:</b> CT22071-A-SBA	<b>Code:</b> EIA/TIA-222-G	6/30/2020
<b>Site Name:</b> Avon (Montevideo)	<b>Exposure:</b> B	
<b>Height:</b> 150.00 (ft)	<b>Crest Height:</b> 520.00	
<b>Base Elev:</b> 0.000 (ft)	<b>Site Class:</b> C - Very Dense Soil	
<b>Gh:</b> 0.85	<b>Topography:</b> 4	<b>Struct Class:</b> II
		<b>Page:</b> 21



### Max Reactions

	Leg	Overturning
Max Uplift:	-255.24 (kips)	Moment: 3268.65 (ft-kips)
Max Down:	278.90 (kips)	Total Down: 27.91 (kips)
Max Shear:	27.40 (kips)	Total Shear: 39.75 (kips)

### Anchor Bolts

Bolt Size (in.): 1.00	Number Bolts: 6
Yield Strength (Ksi): 105.00	Tensile Strength (Ksi): 150.00
Detail Type: C	

**Interaction Ratio: 0.70**

### Max Usages

Max Leg: 90.0% (1.2D + 1.6W Normal Wind - P1 - Sect 6)  
 Max Diag: 87.9% (1.2D + 1.6W 60° Wind - P1 - Sect 3)  
 Max Horiz: 41.8% (1.2D + 1.6W Normal Wind - P1 - Sect 7)

### Max Deflection, Twist and Sway

Load Case	Elevation (ft)	Deflection (ft)	Twist (deg)	Sway (deg)
0.9D + 1.0E - Normal To Face	10.00	0.0044	0.0000	0.0135
	70.00	0.0089	-0.0004	0.0159
	80.00	0.0102	0.0000	0.0183
	95.38	0.0179	-0.0006	0.0274
	100.21	0.0186	0.0000	0.0297
	107.46	0.0225	0.0000	0.0306
	115.38	0.0291	-0.0003	0.0365
	120.21	0.0305	0.0000	0.0377
	135.38	0.0427	0.0001	0.0409
	140.21	0.0461	-0.0001	0.0404
	142.63	0.0478	-0.0001	0.0404
	147.46	0.0512	0.0000	0.0403
	150.00	0.0530	0.0000	0.0409
0.9D + 1.6W 93 mph Wind at 60° From Face	10.00	0.0116	0.2021	0.1047
	70.00	0.4299	1.5820	0.8149
	80.00	0.5710	1.7051	0.9791
	95.38	0.8390	0.2206	1.1005
	100.21	0.9487	1.8686	1.2518
	107.46	1.1130	1.9853	1.2391
	115.38	1.3031	0.7624	1.3282
	120.21	1.4361	2.1420	1.4232
	135.38	1.8485	2.1437	1.5946
	140.21	1.9812	2.1438	1.5917
	142.63	2.0476	2.1437	1.5849
	147.46	2.1811	2.1437	1.6765
	150.00	2.2508	2.1438	1.5939

0.9D + 1.6W 93 mph Wind at 90° From Face	10.00	0.0105	0.2002	0.1019
	70.00	0.4304	1.5669	0.8234
	80.00	0.5710	1.6866	0.9960
	95.38	0.8312	0.0261	0.9808
	100.21	0.9493	1.6808	1.2455
	107.46	1.1126	1.6799	1.1686
	115.38	1.2909	0.0347	0.9833
	120.21	1.4341	1.6788	1.3111
	135.38	1.8446	1.6775	1.5839
	140.21	1.9763	1.6774	1.5759
	142.63	2.0424	1.6775	1.5756
	147.46	2.1748	1.6774	1.7624
	150.00	2.2438	1.6775	1.5845
	-----			
0.9D + 1.6W 93 mph Wind at Normal To Face	10.00	0.0123	0.2033	0.1089
	70.00	0.4377	1.5942	0.7571
	80.00	0.5816	1.7192	0.8870
	95.38	0.8555	-0.0356	1.3748
	100.21	0.9579	1.7123	1.2736
	107.46	1.1259	1.7097	1.4137
	115.38	1.3291	-0.0354	1.9744
	120.21	1.4550	1.7059	1.7004
	135.38	1.8801	1.7033	1.6362
	140.21	2.0162	1.7035	1.6218
	142.63	2.0840	1.7035	1.6181
	147.46	2.2205	1.7032	1.6194
	150.00	2.2946	1.7039	2.5229
	-----			
1.0D + 1.0W 60 mph Wind at 60° From Face	10.00	0.0029	0.0523	0.0278
	70.00	0.1136	0.4094	0.2145
	80.00	0.1508	0.4410	0.2570
	95.38	0.2209	0.0156	0.2884
	100.21	0.2499	0.4515	0.3283
	107.46	0.2930	0.4596	0.3246
	115.38	0.3427	0.0530	0.3466
	120.21	0.3779	0.4703	0.3725
	135.38	0.4864	0.4703	0.4191
	140.21	0.5213	0.4703	0.4181
	142.63	0.5388	0.4703	0.4172
	147.46	0.5740	0.4703	0.4424
	150.00	0.5923	0.4703	0.4196
	-----			
1.0D + 1.0W 60 mph Wind at 90° From Face	10.00	0.0030	0.0521	0.0270
	70.00	0.1135	0.4077	0.2160
	80.00	0.1504	0.4388	0.2611
	95.38	0.2186	0.0063	0.2575
	100.21	0.2496	0.4376	0.3262
	107.46	0.2924	0.4376	0.3063
	115.38	0.3390	0.0071	0.2587
	120.21	0.3766	0.4376	0.3439
	135.38	0.4843	0.4374	0.4156
	140.21	0.5189	0.4374	0.4136
	142.63	0.5362	0.4374	0.4137
	147.46	0.5710	0.4373	0.4622
	150.00	0.5891	0.4373	0.4160
	-----			
1.0D + 1.0W 60 mph Wind at Normal To Face	10.00	0.0034	0.0529	0.0293
	70.00	0.1162	0.4145	0.2011
	80.00	0.1543	0.4471	0.2347
	95.38	0.2263	-0.0094	0.3623
	100.21	0.2536	0.4466	0.3359
	107.46	0.2979	0.4465	0.3730
	115.38	0.3512	-0.0093	0.5192
	120.21	0.3848	0.4463	0.4478
	135.38	0.4966	0.4461	0.4313
	140.21	0.5326	0.4460	0.4277
	142.63	0.5505	0.4460	0.4270
	147.46	0.5865	0.4460	0.4271
	150.00	0.6060	0.4460	0.6624
	-----			



1.2D + 1.0Di + 1.0Wi 50 mph Wind at 60° From Face	10.00	0.0069	0.0455	0.0556	
	70.00	0.2139	0.3522	0.3877	
	80.00	0.2853	0.3787	0.4727	
	95.38	0.4224	0.0623	0.5573	
	100.21	0.4773	0.4294	0.6341	
	107.46	0.5604	0.4657	0.6154	
	115.38	0.6569	0.2130	0.6648	
	120.21	0.7232	0.5100	0.7098	
	135.38	0.9299	0.5108	0.7988	
	140.21	0.9966	0.5108	0.7959	
	142.63	1.0300	0.5107	0.7955	
	147.46	1.0970	0.5107	0.8480	
	150.00	1.1321	0.5108	0.8006	
	-----				
	1.2D + 1.0Di + 1.0Wi 50 mph Wind at 90° From Face	10.00	0.0062	0.0448	0.0523
70.00		0.2120	0.3471	0.3842	
80.00		0.2825	0.3723	0.4760	
95.38		0.4160	0.0133	0.4872	
100.21		0.4740	0.3708	0.6265	
107.46		0.5559	0.3714	0.5641	
115.38		0.6464	0.0180	0.4710	
120.21		0.7165	0.3721	0.6441	
135.38		0.9205	0.3719	0.7876	
140.21		0.9861	0.3719	0.7831	
142.63		1.0191	0.3719	0.7859	
147.46		1.0850	0.3718	0.8883	
150.00		1.1194	0.3719	0.7906	
-----					
1.2D + 1.0Di + 1.0Wi 50 mph Wind at Normal From Face		10.00	0.0047	0.0462	0.0486
	70.00	0.2174	0.3595	0.3817	
	80.00	0.2906	0.3878	0.4465	
	95.38	0.4299	-0.0169	0.7076	
	100.21	0.4810	0.3873	0.6464	
	107.46	0.5663	0.3872	0.7345	
	115.38	0.6704	-0.0164	1.0178	
	120.21	0.7326	0.3870	0.8644	
	135.38	0.9453	0.3868	0.8199	
	140.21	1.0142	0.3868	0.8143	
	142.63	1.0485	0.3868	0.8133	
	147.46	1.1171	0.3867	0.8133	
	150.00	1.1538	0.3869	1.3168	
	-----				
	1.2D + 1.0E - Normal To Face	10.00	0.0043	0.0000	0.0134
70.00		0.0089	-0.0004	0.0160	
80.00		0.0103	0.0000	0.0182	
95.38		0.0179	-0.0006	0.0275	
100.21		0.0186	0.0000	0.0297	
107.46		0.0226	0.0000	0.0307	
115.38		0.0292	-0.0003	0.0366	
120.21		0.0306	0.0000	0.0377	
135.38		0.0428	0.0001	0.0409	
140.21		0.0462	-0.0001	0.0405	
142.63		0.0479	0.0001	0.0405	
147.46		0.0513	0.0000	0.0404	
150.00		0.0531	0.0000	0.0410	
-----					
1.2D + 1.6W 93 mph Wind at 60° From Face - P1		10.00	0.0115	0.2021	0.1047
	70.00	0.4308	1.5820	0.8168	
	80.00	0.5723	1.7051	0.9815	
	95.38	0.8411	0.2213	1.1043	
	100.21	0.9511	1.8692	1.2558	
	107.46	1.1159	1.9863	1.2434	
	115.38	1.3067	0.7652	1.3334	
	120.21	1.4402	2.1436	1.4285	
	135.38	1.8541	2.1453	1.6006	
	140.21	1.9873	2.1454	1.5977	
	142.63	2.0540	2.1453	1.5909	
	147.46	2.1879	2.1452	1.6823	
	150.00	2.2579	2.1454	1.5999	

1.2D + 1.6W 93 mph Wind at 60° From Face - P2	10.00	0.0083	0.2027	0.0794	
	70.00	0.3286	1.5859	0.6513	
	80.00	0.4384	1.7097	0.7823	
	95.38	0.6471	0.1783	0.8617	
	100.21	0.7362	1.8420	0.9973	
	107.46	0.8675	1.9362	0.9815	
	115.38	1.0182	0.6174	1.0604	
	120.21	1.1276	2.0631	1.1371	
	135.38	1.4621	2.0644	1.2964	
	140.21	1.5699	2.0645	1.2945	
	142.63	1.6238	2.0644	1.2890	
	147.46	1.7323	2.0643	1.3828	
	150.00	1.7889	2.0644	1.2965	
	-----				
	1.2D + 1.6W 93 mph Wind at 60° From Face - P3	10.00	0.0115	0.2021	0.1047
70.00		0.4308	1.5820	0.8168	
80.00		0.5723	1.7051	0.9815	
95.38		0.8411	0.2213	1.1043	
100.21		0.9511	1.8692	1.2558	
107.46		1.1159	1.9863	1.2434	
115.38		1.3067	0.7652	1.3334	
120.21		1.4402	2.1436	1.4285	
135.38		1.8541	2.1453	1.6006	
140.21		1.9873	2.1454	1.5977	
142.63		2.0540	2.1453	1.5909	
147.46		2.1879	2.1452	1.6823	
150.00		2.2579	2.1454	1.5999	
-----					
1.2D + 1.6W 93 mph Wind at 90° From Face - P1		10.00	0.0106	0.2002	0.1020
	70.00	0.4312	1.5668	0.8250	
	80.00	0.5721	1.6865	0.9982	
	95.38	0.8330	0.0263	0.9841	
	100.21	0.9514	1.6808	1.2490	
	107.46	1.1152	1.6801	1.1724	
	115.38	1.2941	0.0354	0.9879	
	120.21	1.4378	1.6790	1.3158	
	135.38	1.8496	1.6777	1.5893	
	140.21	1.9818	1.6777	1.5812	
	142.63	2.0480	1.6777	1.5809	
	147.46	2.1809	1.6777	1.7677	
	150.00	2.2501	1.6777	1.5899	
	-----				
	1.2D + 1.6W 93 mph Wind at 90° From Face - P2	10.00	0.0077	0.2013	0.0783
70.00		0.3287	1.5740	0.6595	
80.00		0.4378	1.6952	0.7969	
95.38		0.6383	0.0216	0.7381	
100.21		0.7357	1.6908	0.9908	
107.46		0.8659	1.6903	0.9080	
115.38		1.0048	0.0302	0.6966	
120.21		1.1241	1.6896	1.0226	
135.38		1.4565	1.6885	1.2854	
140.21		1.5632	1.6885	1.2791	
142.63		1.6167	1.6885	1.2788	
147.46		1.7242	1.6885	1.4662	
150.00		1.7800	1.6885	1.2863	
-----					
1.2D + 1.6W 93 mph Wind at 90° From Face - P3		10.00	0.0106	0.2002	0.1020
	70.00	0.4312	1.5668	0.8250	
	80.00	0.5721	1.6865	0.9982	
	95.38	0.8330	0.0263	0.9841	
	100.21	0.9514	1.6808	1.2490	
	107.46	1.1152	1.6801	1.1724	
	115.38	1.2941	0.0354	0.9879	
	120.21	1.4378	1.6790	1.3158	
	135.38	1.8496	1.6777	1.5893	
	140.21	1.9818	1.6777	1.5812	
	142.63	2.0480	1.6777	1.5809	
	147.46	2.1809	1.6777	1.7677	
	150.00	2.2501	1.6777	1.5899	

1.2D + 1.6W 93 mph Wind at Normal To Face - P1	10.00	0.0123	0.2033	0.1092
	70.00	0.4387	1.5942	0.7594
	80.00	0.5831	1.7192	0.8895
	95.38	0.8578	-0.0357	1.3788
	100.21	0.9606	1.7123	1.2780
	107.46	1.1291	1.7097	1.4182
	115.38	1.3331	-0.0354	1.9799
	120.21	1.4594	1.7059	1.7061
	135.38	1.8862	1.7033	1.6423
	140.21	2.0228	1.7035	1.6279
	142.63	2.0909	1.7035	1.6243
	147.46	2.2278	1.7032	1.6255
	150.00	2.3023	1.7039	2.5291
	-----			
1.2D + 1.6W 93 mph Wind at Normal To Face - P2	10.00	0.0090	0.2034	0.0802
	70.00	0.3326	1.5940	0.5898
	80.00	0.4447	1.7191	0.6943
	95.38	0.6601	-0.0276	1.1308
	100.21	0.7418	1.7137	1.0173
	107.46	0.8764	1.7118	1.1569
	115.38	1.0401	-0.0277	1.6875
	120.21	1.1422	1.7087	1.4097
	135.38	1.4885	1.7066	1.3361
	140.21	1.5995	1.7067	1.3235
	142.63	1.6547	1.7067	1.3200
	147.46	1.7660	1.7065	1.3218
	150.00	1.8270	1.7070	2.2234
	-----			
1.2D + 1.6W 93 mph Wind at Normal To Face - P3	10.00	0.0123	0.2033	0.1092
	70.00	0.4387	1.5942	0.7594
	80.00	0.5831	1.7192	0.8895
	95.38	0.8578	-0.0357	1.3788
	100.21	0.9606	1.7123	1.2780
	107.46	1.1291	1.7097	1.4182
	115.38	1.3331	-0.0354	1.9799
	120.21	1.4594	1.7059	1.7061
	135.38	1.8862	1.7033	1.6423
	140.21	2.0228	1.7035	1.6279
	142.63	2.0909	1.7035	1.6243
	147.46	2.2278	1.7032	1.6255
	150.00	2.3023	1.7039	2.5291
	-----			

	<b>Mat Foundation Design for Self Supporting Tower</b>			Date 6/30/2020
	Customer Name:	SBA Communications Corp	EIA/TIA Standard:	EIA-222-G
	Site Name:		Structure Height (Ft.):	150
	Site Number:	CT22071-A-SBA	Engineer Name:	M. Baker
	Engr. Number:	94598	Engineer Login ID:	

**Foundation Info Obtained from:**

**Analysis or Design?**

**Number of Tower Legs:**

**Base Reactions (Factored):**

(1). Individual Leg:

Axial Load (Kips):	278.9	Uplift Force (Kips):	255.2
Shear Force (Kips):	27.4		

(2). Tower Base:

Total Vertical Load (Kips):	27.9	Total Shear Force (Kips):	39.8
Moment (Kips-ft):	3268.7		

**Foundation Geometries:**

Leg distance (Center-to-Center ft.):	14.0	Mods required -Yes/No ?:	No
Diameter of Pier (ft.):	Round 4.0	Pier Height A. G. (ft.):	0.50
Tower center to mat center (ft):	2.02083	Depth of Base BG (ft.):	6.0
Length of Pad (ft.):	23	Width of Pad (ft.):	23
Thickness of Pad (ft):	2.50		

**Material Properties and Rebar Info:**

Concrete Strength (psi):	3000	Steel Elastic Modulus:	29000	ksi
Vertical bar yield (ksi):	60	Tie steel yield (ksi):	60	
Vertical Rebar Size #:	8	Tie / Stirrup Size #:	4	
Qty. of Vertical Rebars:	12	Tie Spacing (in):	6.0	
Pad Rebar Yield (Ksi):	60	Pad Steel Rebar Size (#):	8	
Concrete Cover (in.):	3	Unit Weight of Concrete:	150.0	pcf

Rebar at the bottom of the concrete pad:

Qty. of Rebar in Pad (L):	26	Qty. of Rebar in Pad (W):	26
---------------------------	----	---------------------------	----

Rebar at the top of the concrete pad:

Qty. of Rebar in Pad (L):	26	Qty. of Rebar in Pad (W):	26
---------------------------	----	---------------------------	----

**Soil Design Parameters:**

Soil Unit Weight (pcf):	120.0	Soil Buoyant Weight:	50.0	Pcf
Water Table B.G.S. (ft):	99.0	Unit Weight of Water:	62.4	pcf
Ultimate Bearing Pressure (psf):	12000	Consider ties in concrete shear strength:	Yes	
Consider Soil Lateral Resistance ?	Yes	Enter soil C (psf) or Phi (deg.):	30.0	Deg. (W)
		Depth to ignor lateral resistance	1.0	Ft. 23'

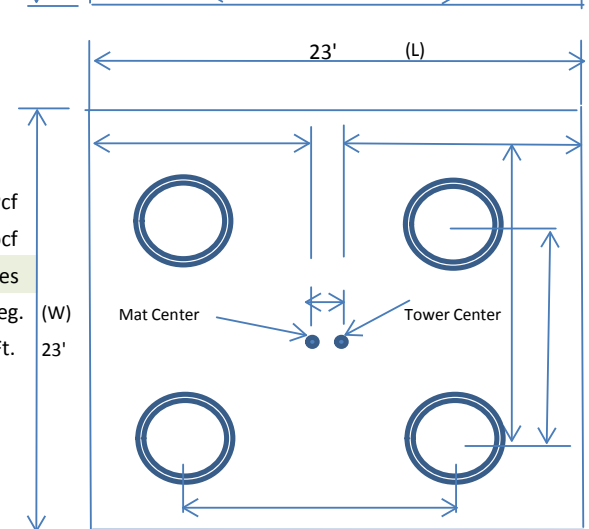
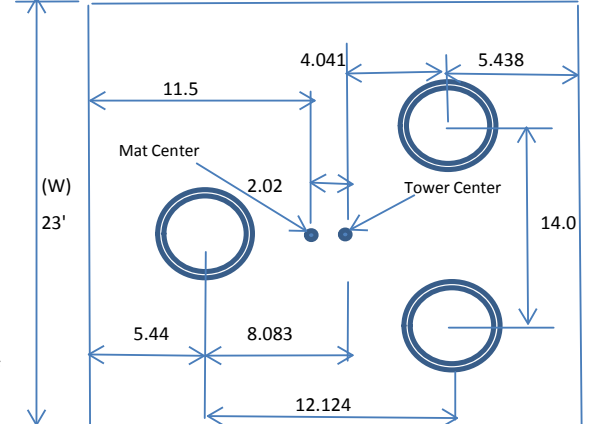
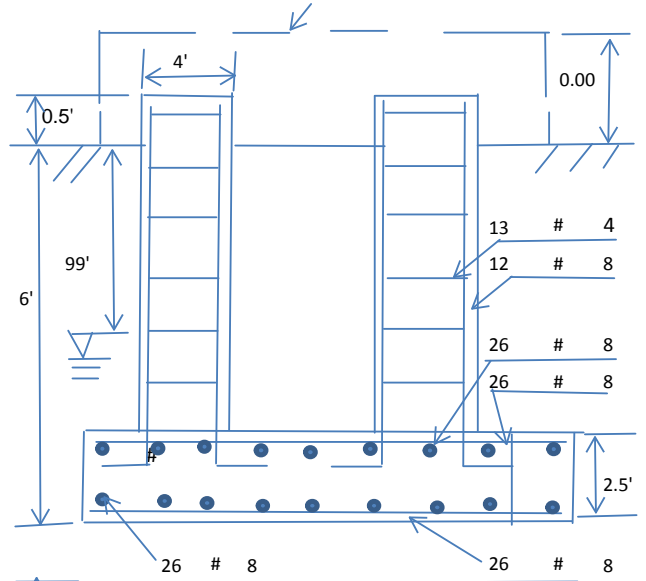

<b>Foundation Analysis and Design:</b>	Uplift Strength Reduction Factor:	0.75	Compression Strength Reduction Factor:	0.75
Total Dry Soil Volume (cu. Ft.):	1719.55	Total Dry Soil Weight (Kips):	206.35	
Total Buoyant Soil Volume (cu. Ft.):	0.00	Total Buoyant Soil Weight (Kips):	0.00	
Total Effective Soil Weight (Kips):	206.35	Weight from the Concrete Block at Top (K):	0.00	
Total Dry Concrete Volume (cu. Ft.):	1473.30	Total Dry Concrete Weight (Kips):	220.99	
Total Buoyant Concrete Volume (cu. Ft.):	0.00	Total Buoyant Concrete Weight (Kips):	0.00	
Total Effective Concrete Weight (Kips):	220.99	Total Vertical Load on Base (Kips):	455.25	

**Check Soil Capacities:**

Calculated Maxium Net Soil Pressure under the base (psf):	3334.67	<	Allowable Factored Soil Bearing (psf):	9000	0.37	OK!
Allowable Foundation Overturning Resistance (kips-ft.):	4744.0	>	Design Factored Momont (kips-ft):	3550	0.75	OK!
Factor of Safety Against Overturning (O. R. Moment/Design Moment):	1.34					OK!

**Check the capacities of Reinforceing Concrete:**

Strength reduction factor (Flexure and axial tension):	0.90	Strength reduction factor (Shear):	0.75			
Strength reduction factor (Axial compression):	0.65	Wind Load Factor on Concrete Design:	1.00			
<b>(1) Concrete Pier:</b>						
Vertical Steel Rebar Area (sq. in./each):	0.79	Tie / Stirrup Area (sq. in./each):	0.20			
Calculated Moment Capacity (Mn,Kips-Ft):	459.6	>	Design Factored Moment (Mu, Kips-Ft)	106.8	0.23	OK!
Calculated Shear Capacity (Kips):	215.1	>	Design Factored Shear (Kips):	27.4	0.13	OK!
Calculated Tension Capacity (Tn, Kips):	511.9	>	Design Factored Tension (Tu Kips):	255.2	0.50	OK!
Calculated Compression Capacity (Pn, Kips):	2386.9	>	Design Factored Axial Load (Pu Kips):	278.9	0.12	OK!
Moment & Tension Strength Combination:	0.23	OK!	Check Tie Spacing (Design/Req'd):	0.50		
Pier Reinforcement Ratio:	0.005		Reinforcement Ratio is too small			

**(2).Concrete Pad:**

One-Way Design Shear Capacity (L or W Direction, Kips):	600.9	>	One-Way Factored Shear (L/W-Dir Kips)	155.1	0.26	OK!
One-Way Design Shear Capacity (Diagonal Dir., Kips):	511.0	>	One-Way Factored Shear (Dia. Dir, Kips)	189.7	0.37	OK!
Lower Steel Pad Reinforcement Ratio (L or W-Direct. ):	0.0028		Lower Steel Reinf. Ratio (Dia. Dir.):	0.0025		
Lower Steel Pad Moment Capacity (L or W-Dir. Kips-ft):	2368.5	>	Moment at Bottom ( L-Direct. K-Ft):	498.4	0.21	OK!
Lower Steel Pad Moment Capacity (Dia. Direction,K-ft):	2291.7	>	Moment at Bottom ( Dia. Dir. K-Ft):	1147.3	0.50	OK!
Upper Steel Pad Reinforcement Ratio (L or W -Direction):	0.0028		Upper Steel Reinf. Ratio (Dia. Dir.):	0.0025		
Upper Steel Pad Moment Capacity (L or W-Dir., Kips-ft):	2368.5	>	Moment at the top (L-Dir Kips-Ft):	194.4	0.08	OK!
Upper Steel Pad Moment Capacity (Dia. Direction, K-ft):	2291.7	>	Moment at the top (Dia. Dir., K-Ft):	352.9	0.15	OK!
Punching Failure Capacity (Kips):	1019.1	>	Punch. Failure Factored Shear (K):	278.9	0.27	OK!

# EXHIBIT 8



**Tower Engineering Solutions**

Phone (972) 483-0607, Fax (972) 975-9615  
1320 Greenway Drive, Suite 600, Irving, Texas 75038

---

## **Antenna Mount Analysis Report**

**Existing 150-Ft Self Support Tower**

**Customer Name: SBA Communications Corp**

**Customer Site Number: CT22071-A-SBA / Avon (Montevideo)**

**Customer Site Name: Avon (Montevideo)**

**Carrier Name: T-Mobile (App#: 134550, V1)**

**Carrier Site ID / Name: CT11284A / SBA Avon/RT 1777**

**Site Location: 81 Montevideo Road**

**Avon, Connecticut**

**HARTFORD County**

**Latitude: 41.803100**

**Longitude: -72.801300**

Exp.01/31/2021



**Analysis Result:**

**Max Structural Usage: 61.5%[Pass]**

07/08/2020

**Report Prepared By: Neena Thapa**

## **Introduction**

The purpose of this report is to summarize the analysis results on the (1) Sector Frame at 136.00' elevation to support the proposed antenna configuration. Any modification listed under Sources of Information was assumed completed and was included in this analysis.

## **Sources of Information**

Mount Drawings	Mount Mapping by SGS, dated 6/24/2020
Antenna Loading	Provided by SBA Application #: 134550, v1, dated 6/17/2020
Modification Drawings	N/A

## **Analysis Criteria**

Basic Wind Speed Used in the Analysis:  $V_{ULT} = 120$  mph (3-Sec. Gust) / Equivalent to  
 $V_{ASD} = 93$  mph (3-Sec. Gust)

Basic Wind Speed with Ice: 50 mph (3-Sec. Gust) with 1" radial ice concurrent

Operational Wind Speed: 60 mph +0" Radial ice

Standard/Codes: ANSI/TIA/EIA 222-G/2015 IBC/2018 CSBC

Exposure Category: B

Structure Class: II

Topographic Category: 4

Crest Height (Ft): 135

The site is a Risk Category II structure per IBC Table 1604.5. This site does not support emergency communication equipment for first responders such as fire departments, police, hospitals, ambulance services or any of the facilities listed for Risk Categories III and IV. The scope of work detailed in this structural analysis does not include items that are a part of emergency service as the 911 or essential facility service of an emergency response system.

## **Mount Information**

(1) Sector Frame at 136.00'

## **Final Antenna Configuration**

- 1 RFS APXVAARR24\_43-U-NA20 (Octa)
- 1 Ericsson AIR32 KRD901146-1\_B66A (Octa)
- 1 Ericsson AIR 21
- 1 Ericsson AIR6449 B41
- 1 Ericsson KRY 112 144/2
- 1 Ericsson Radio 4449 B71 + B12
- 1 Ericsson Radio 4415 B25



In addition to the proposed equipment loading, a 500 lb serviceability load was also considered in this analysis in accordance with TIA requirements.

### **Analysis Results**

Our calculations have determined that under design wind load the existing mounts will be structurally adequate to support the proposed antenna configuration. The maximum structural usage is 61.5%, which occurs in the face horizontal. The proposed equipment must be installed as stipulated in the Final Antenna Configuration section of this report. The analysis results are void if the proposed equipment is not installed in accordance with this report.

### **Attachments**

1. Mount Photos
2. Antenna Placement Diagram
3. Mount Mapping Information
4. Analysis Calculations

## Standard Conditions

1. The loading configuration as analyzed in this report is as provided from the customer. Any deviation from this design shall be communicated to TES to verify deviation will not adversely impact the analysis.
2. The analysis is based on the presumption that the antenna mount members and components along with any existing reinforcement items have been correctly and properly designed, manufactured, installed and maintained.
3. All the existing structural members were assumed to be in good condition with no physical damage or deterioration associated with corrosion. The mount analysis is not a condition assessment of the mount.
4. The mount analysis was performed in accordance with the loading provided, and if applicable the modification required to support the additional loading.
5. If the mount is modified, installation must adhere to the configuration communicated in the modification drawings.
6. The modification drawings are not intended to convey means or methods. These are the responsibility of the installing contractor.
7. Rigging plan review is available if the contractor requires for a construction class IV or other if required. Review fee would apply.
8. The mount modification package was created based upon information provided for the mount loading. The underlying tower is assumed to provide support and sufficient rigidity to support the mount loads as a tower analysis was not part of the mount analysis.
9. TES is not responsible for modifications to climbing facilities unless communicated to TES in writing.



**Structure: CT22071-A-SBA - Avon (Montevideo)**

Sector: **A**

7/8/2020

Structure Type: Self Support

Mount Elev: 136.00

Page: 1



**Plan View**

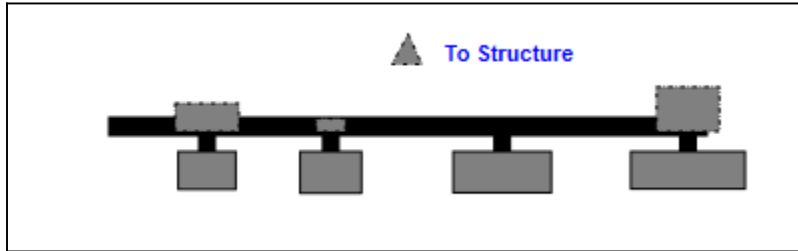

**Front View**

Looking Toward Structure

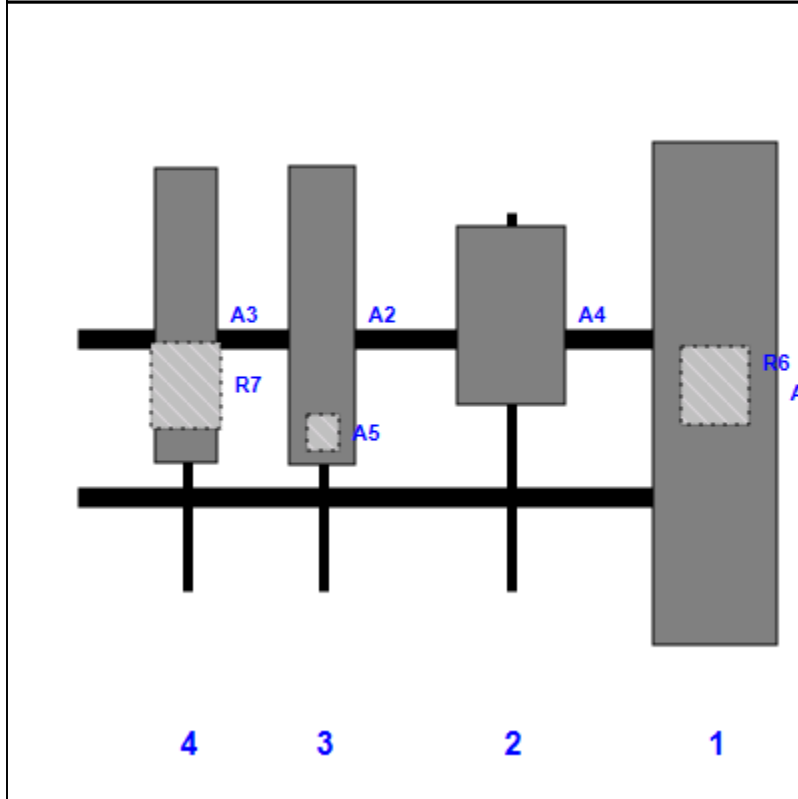

Ref #	Model	Height (in)	Width (in)	H Dist Left	Pipe #	Pipe Pos V	Pos	From Top	H Offset	Status	Validation
A1	RFS	95.90	24.00	122.0	1	a	Front	34.50			
R6	Ericsson Radio 4449 B71 +	15.00	13.20	122.0	1	a	Behind	33.00			
A4	Ericsson AIR6449 B41	33.90	20.60	83.00	2	a	Front	19.50			
A2	Ericsson AIR32	57.00	12.90	47.00	3	a	Front	19.50			
A5	Ericsson KRY 112 144/2	6.90	6.10	47.00	3	a	Behind	42.00			
A3	Ericsson AIR 21	56.00	12.10	21.00	4	a	Front	19.50			
R7	Ericsson Radio 4415 B25	16.50	13.40	21.00	4	a	Behind	33.00			



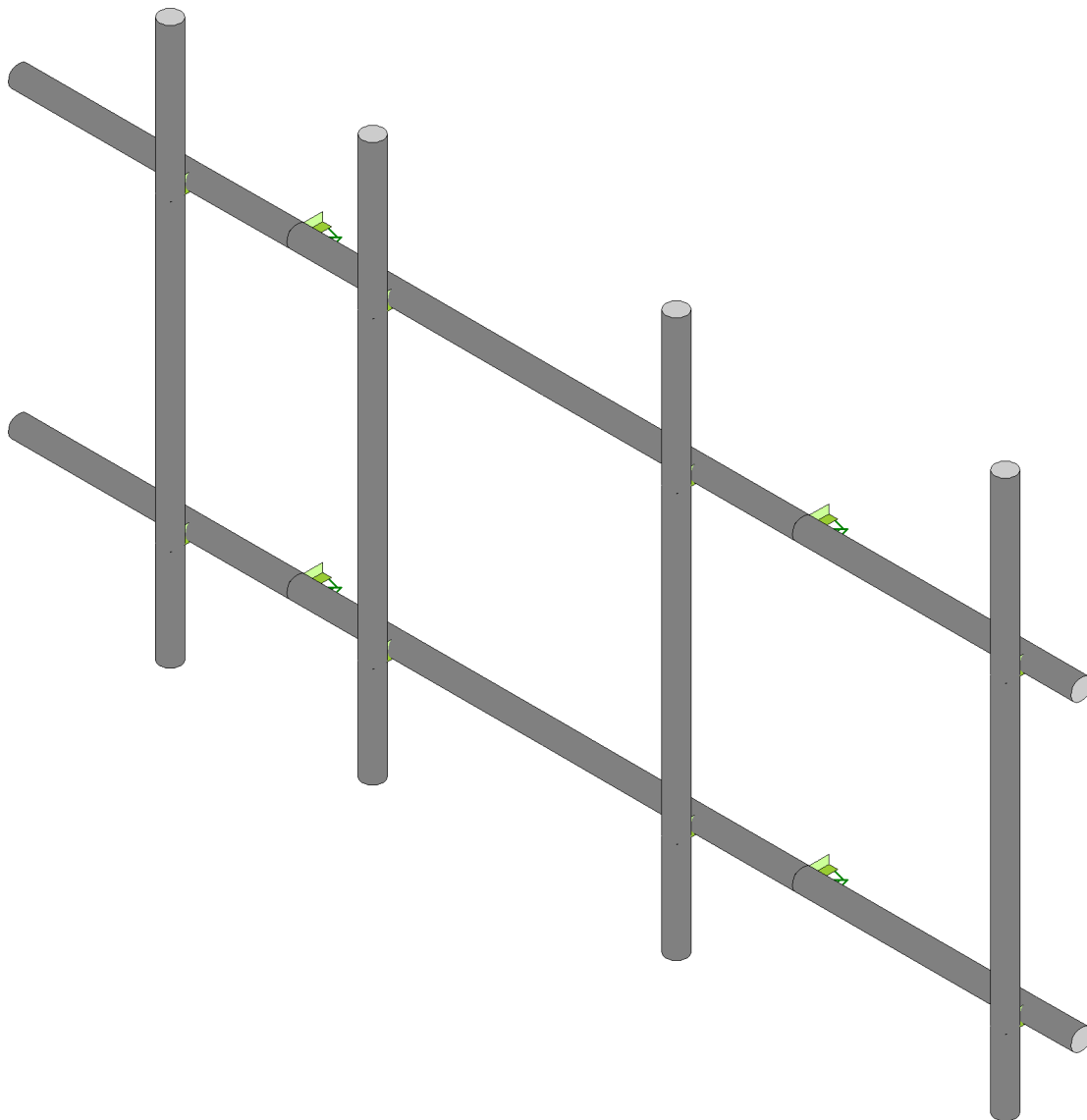
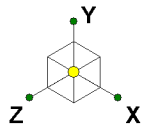

Loads: BLC 24,

Tower Engineering Solutio...

CT22071-A-SBA\_Mt\_LOT\_Loads Only\_Sector A\_G

SK - 1

July 8, 2020 at 2:40 PM

TES Project No. 94597

CT22071-A-SBA\_94597\_G\_RISA\_L...

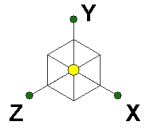

Code Check (Env)	
Black	No Calc
Red	> 1.0
Magenta	.90-1.0
Green	.75-.90
Cyan	.50-.75
Blue	0-.50

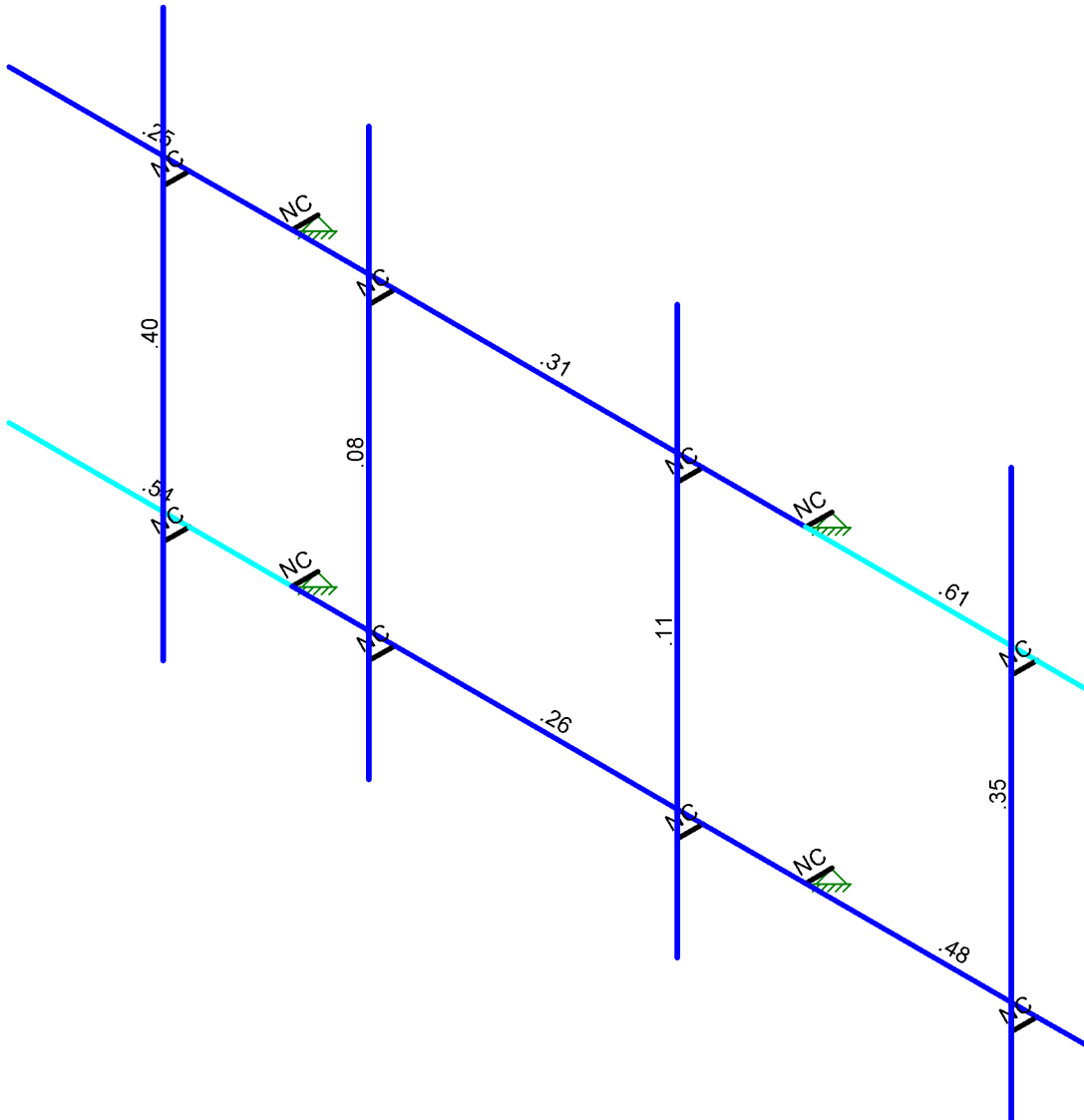

Member Code Checks Displayed (Enveloped)  
 Loads: BLC 24,  
 Results for LC 1, 1.2D+1.6W (Front)

Tower Engineering Solutio...

CT22071-A-SBA\_MT\_LOT\_Loads Only\_Sector A\_G

SK - 2

July 8, 2020 at 2:41 PM

TES Project No. 94597

CT22071-A-SBA\_94597\_G\_RISA\_L...

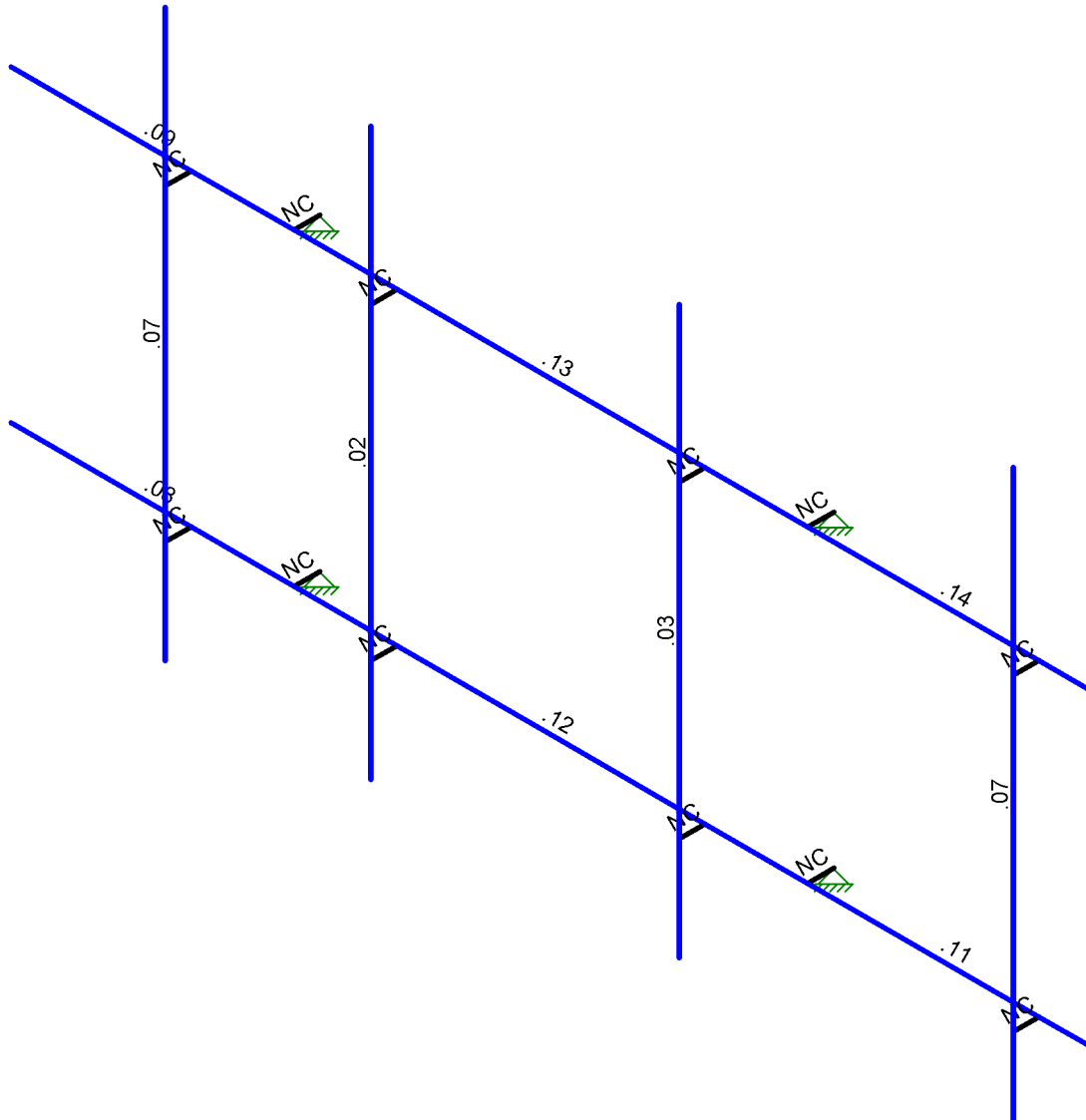
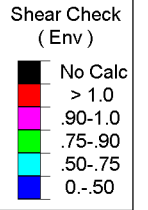
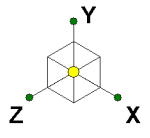

Member Shear Checks Displayed (Enveloped)  
 Loads: BLC 24,  
 Results for LC 1, 1.2D+1.6W (Front)

Tower Engineering Solutio...	CT22071-A-SBA_Mt_LOT_Loads Only_Sector A_G	SK - 3
		July 8, 2020 at 2:41 PM
TES Project No. 94597		CT22071-A-SBA_94597_G_RISA_L...

































# EXHIBIT 9

RADIO FREQUENCY EMISSIONS ANALYSIS REPORT  
EVALUATION OF HUMAN EXPOSURE POTENTIAL  
TO NON-IONIZING EMISSIONS

T-Mobile Existing Facility

Site ID: CT11284A

Avon\_I  
81 Montevideo Road  
Avon, Connecticut 06001

**July 9, 2020**

**EBI Project Number: 6220002987**

Site Compliance Summary	
Compliance Status:	<b>COMPLIANT</b>
Site total MPE% of FCC general population allowable limit:	<b>13.69%</b>



July 9, 2020

T-Mobile

Attn: Jason Overbey, RF Manager  
35 Griffin Road South  
Bloomfield, Connecticut 06002

Emissions Analysis for Site: CT11284A - Avon\_1

EBI Consulting was directed to analyze the proposed T-Mobile facility located at **81 Montevideo Road** in **Avon, Connecticut** for the purpose of determining whether the emissions from the Proposed T-Mobile Antenna Installation located on this property are within specified federal limits.

All information used in this report was analyzed as a percentage of current Maximum Permissible Exposure (% MPE) as listed in the FCC OET Bulletin 65 Edition 97-01 and ANSI/IEEE Std C95.1. The FCC regulates Maximum Permissible Exposure in units of microwatts per square centimeter ( $\mu\text{W}/\text{cm}^2$ ). The number of  $\mu\text{W}/\text{cm}^2$  calculated at each sample point is called the power density. The exposure limit for power density varies depending upon the frequencies being utilized. Wireless Carriers and Paging Services use different frequency bands each with different exposure limits; therefore, it is necessary to report results and limits in terms of percent MPE rather than power density.

All results were compared to the FCC (Federal Communications Commission) radio frequency exposure rules, 47 CFR 1.1307(b)(1) – (b)(3), to determine compliance with the Maximum Permissible Exposure (MPE) limits for General Population/Uncontrolled environments as defined below.

General population/uncontrolled exposure limits apply to situations in which the general population may be exposed or in which persons who are exposed as a consequence of their employment may not be made fully aware of the potential for exposure or cannot exercise control over their exposure. Therefore, members of the general population would always be considered under this category when exposure is not employment related, for example, in the case of a telecommunications tower that exposes persons in a nearby residential area.

Public exposure to radio frequencies is regulated and enforced in units of microwatts per square centimeter ( $\mu\text{W}/\text{cm}^2$ ). The general population exposure limits for the 600 MHz and 700 MHz frequency bands are approximately  $400 \mu\text{W}/\text{cm}^2$  and  $467 \mu\text{W}/\text{cm}^2$ , respectively. The general population exposure limit for the 1900 MHz (PCS), 2100 MHz (AWS) and 11 GHz frequency bands is  $1000 \mu\text{W}/\text{cm}^2$ . Because each carrier will be using different frequency bands, and each frequency band has different exposure limits, it is necessary to report percent of MPE rather than power density.

Occupational/controlled exposure limits apply to situations in which persons are exposed as a consequence of their employment and in which those persons who are exposed have been made fully aware of the potential for exposure and can exercise control over their exposure. Occupational/controlled exposure limits also apply where exposure is of a transient nature as a result of incidental passage through a location where exposure levels may be above general population/uncontrolled limits (see below), as long as the exposed person has been made fully aware of the potential for exposure and can exercise control over his or her exposure by leaving the area or by some other appropriate means.

Additional details can be found in FCC OET 65.

## **CALCULATIONS**

Calculations were done for the proposed T-Mobile Wireless antenna facility located at 81 Montevideo Road in Avon, Connecticut using the equipment information listed below. All calculations were performed per the specifications under FCC OET 65. Since T-Mobile is proposing highly focused directional panel antennas, which project most of the emitted energy out toward the horizon, all calculations were performed assuming a lobe representing the maximum gain of the antenna per the antenna manufacturer's supplied specifications, minus 10 dB for directional panel antennas and 20 dB for highly focused parabolic microwave dishes, was focused at the base of the tower. For this report, the sample point is the top of a 6-foot person standing at the base of the tower.

For all calculations, all equipment was calculated using the following assumptions:

- 1) 2 LTE channels (600 MHz Band) were considered for each sector of the proposed installation. These Channels have a transmit power of 30 Watts per Channel.
- 2) 1 NR channel (600 MHz Band) was considered for each sector of the proposed installation. This Channel has a transmit power of 80 Watts.
- 3) 2 LTE channels (700 MHz Band) were considered for each sector of the proposed installation. These Channels have a transmit power of 30 Watts per Channel.
- 4) 4 GSM channels (PCS Band - 1900 MHz) were considered for each sector of the proposed installation. These Channels have a transmit power of 30 Watts per Channel.
- 5) 4 LTE channels (PCS Band - 1900 MHz) were considered for each sector of the proposed installation. These Channels have a transmit power of 60 Watts per Channel.

- 6) 2 UMTS channels (AWS Band - 2100 MHz) were considered for each sector of the proposed installation. These Channels have a transmit power of 30 Watts per Channel.
- 7) 2 LTE channels (AWS Band – 2100 MHz) were considered for each sector of the proposed installation. These Channels have a transmit power of 60 Watts per Channel.
- 8) 2 LTE channels (BRS Band - 2500 MHz) were considered for each sector of the proposed installation. These Channels have a transmit power of 40 Watts per Channel.
- 9) 2 NR channels (BRS Band - 2500 MHz) were considered for each sector of the proposed installation. These Channels have a transmit power of 40 Watts per Channel.
- 10) All radios at the proposed installation were considered to be running at full power and were uncombined in their RF transmissions paths per carrier prescribed configuration. Per FCC OET Bulletin No. 65 - Edition 97-01 recommendations to achieve the maximum anticipated value at each sample point, all power levels emitting from the proposed antenna installation are increased by a factor of 2.56 to account for possible in-phase reflections from the surrounding environment. This is rarely the case, and if so, is never continuous.
- 11) For the following calculations, the sample point was the top of a 6-foot person standing at the base of the tower. The maximum gain of the antenna per the antenna manufacturer's supplied specifications, minus 10 dB for directional panel antennas and 20 dB for highly focused parabolic microwave dishes, was used in this direction. This value is a very conservative estimate as gain reductions for these particular antennas are typically much higher in this direction.
- 12) The antennas used in this modeling are the for the RFS APXVAARR24\_43-U-NA20 for the 600 MHz / 600 MHz / 700 MHz / 1900 MHz channel(s), the Ericsson AIR 6449 for the 2500 MHz / 2500 MHz channel(s), the Ericsson AIR 32 for the 1900 MHz / 2100 MHz channel(s), the Ericsson AIR 21 for the 1900 MHz / 2100 MHz channel(s) in Sector C. This is based on feedback from the carrier with regard to anticipated antenna selection. All Antenna gain values and associated transmit power levels are shown in the Site Inventory and Power Data table below. The maximum gain of the antenna per the antenna manufacturer's supplied specifications, minus 10 dB for directional panel antennas and 20 dB for highly focused parabolic microwave dishes, was used for all calculations. This value is a very conservative estimate as gain reductions for these particular antennas are typically much higher in this direction.
- 13) The antenna mounting height centerline of the proposed antennas is feet above ground level (AGL).

- 14) Emissions values for additional carriers were taken from the Connecticut Siting Council active database. Values in this database are provided by the individual carriers themselves.
- 15) All calculations were done with respect to uncontrolled / general population threshold limits.



## T-Mobile Site Inventory and Power Data

Sector:	C
Antenna #:	1
Make / Model:	RFS APXVAARR24_43-U-NA20
Frequency Bands:	600 MHz / 600 MHz / 700 MHz / 1900 MHz
Gain:	12.95 dBd / 12.95 dBd / 13.35 dBd / 15.65 dBd
Height (AGL):	feet
Channel Count:	7
Total TX Power (W):	320 Watts
ERP (W):	8,466.41
Antenna C1 MPE %:	2.74%
Antenna #:	2
Make / Model:	Ericsson AIR 6449
Frequency Bands:	2500 MHz / 2500 MHz
Gain:	22.05 dBd / 22.05 dBd
Height (AGL):	136 feet
Channel Count:	4
Total TX Power (W):	160 Watts
ERP (W):	25,651.93
Antenna C2 MPE %:	4.99%
Antenna #:	3
Make / Model:	Ericsson AIR 32
Frequency Bands:	1900 MHz / 2100 MHz
Gain:	15.35 dBd / 15.85 dBd
Height (AGL):	136 feet
Channel Count:	4
Total TX Power (W):	240 Watts
ERP (W):	8,728.31
Antenna C3 MPE %:	1.70%
Antenna #:	4
Make / Model:	Ericsson AIR 21
Frequency Bands:	1900 MHz / 2100 MHz
Gain:	15.35 dBd / 15.35 dBd
Height (AGL):	136 feet
Channel Count:	8
Total TX Power (W):	240 Watts
ERP (W):	8,226.43
Antenna C4 MPE %:	1.60%

Site Composite MPE %	
Carrier	MPE %
T-Mobile (Max at Sector C):	11.02%
Sprint	2.67%
<b>Site Total MPE % :</b>	<b>13.69%</b>

T-Mobile MPE % Per Sector	
T-Mobile Sector C Total:	11.02%
Site Total MPE % :	13.69%

### T-Mobile Maximum MPE Power Values (Sector C)

T-Mobile Frequency Band / Technology (Sector C)	# Channels	Watts ERP (Per Channel)	Height (feet)	Total Power Density ( $\mu\text{W}/\text{cm}^2$ )	Frequency (MHz)	Allowable MPE ( $\mu\text{W}/\text{cm}^2$ )	Calculated % MPE
T-Mobile 600 MHz LTE	2	591.73	136.0	2.30	600 MHz LTE	400	0.58%
T-Mobile 600 MHz NR	1	1577.94	136.0	3.07	600 MHz NR	400	0.77%
T-Mobile 700 MHz LTE	2	648.82	136.0	2.52	700 MHz LTE	467	0.54%
T-Mobile 1900 MHz LTE	2	2203.69	136.0	8.57	1900 MHz LTE	1000	0.86%
T-Mobile 2500 MHz LTE	2	6412.98	136.0	24.93	2500 MHz LTE	1000	2.49%
T-Mobile 2500 MHz NR	2	6412.98	136.0	24.93	2500 MHz NR	1000	2.49%
T-Mobile 1900 MHz LTE	2	2056.61	136.0	8.00	1900 MHz LTE	1000	0.80%
T-Mobile 2100 MHz LTE	2	2307.55	136.0	8.97	2100 MHz LTE	1000	0.90%
T-Mobile 1900 MHz GSM	4	1028.30	136.0	8.00	1900 MHz GSM	1000	0.80%
T-Mobile 2100 MHz UMTS	4	1028.30	136.0	8.00	2100 MHz UMTS	1000	0.80%
						<b>Total:</b>	<b>11.02%</b>

• NOTE: Totals may vary by approximately 0.01% due to summation of remainders in calculations.

## Summary

All calculations performed for this analysis yielded results that were **within** the allowable limits for general population exposure to RF Emissions.

The anticipated maximum composite contributions from the T-Mobile facility as well as the site composite emissions value with regards to compliance with FCC's allowable limits for general population exposure to RF Emissions are shown here:

T-Mobile Sector	Power Density Value (%)
Sector C:	11.02%
T-Mobile Maximum MPE % (Sector C):	11.02%
Site Total:	13.69%
Site Compliance Status:	<b>COMPLIANT</b>

The anticipated composite MPE value for this site assuming all carriers present is **13.69%** of the allowable FCC established general population limit sampled at the ground level. This is based upon values listed in the Connecticut Siting Council database for existing carrier emissions.

FCC guidelines state that if a site is found to be out of compliance (over allowable thresholds), that carriers over a 5% contribution to the composite value will require measures to bring the site into compliance. For this facility, the composite values calculated were well within the allowable 100% threshold standard per the federal government.