

STATE OF CONNECTICUT
CONNECTICUT SITING COUNCIL

IN RE:

APPLICATION OF NORTH ATLANTIC TOWERS, LLC
and NEW CINGULAR WIRELESS PCS, LLC (AT&T)
FOR A CERTIFICATE OF ENVIRONMENTAL
COMPATIBILITY AND PUBLIC NEED FOR THE
CONSTRUCTION, MAINTENANCE AND OPERATION
OF A TELECOMMUNICATIONS TOWER FACILITY
AT ONE OF TWO SITES: 171 SHORT BEACH ROAD,
BRANFORD, OR 82 SHORT BEACH ROAD,
EAST HAVEN, CONNECTICUT

DOCKET NO. 427

September 24, 2012

APPLICANTS

NORTH ATLANTIC TOWERS, LLC and NEW CINGULAR WIRELESS PCS, LLC (AT&T)
RESPONSE TO SITING COUNCIL INTERROGATORIES SET III

- Q1. Determination of the diameter of a tower with three interior flush-mounted antennas that could be constructed at either proposed site given that a recent AT&T installation of the same type was 36" in diameter.
- A1. As shown in the conceptual drawing included in Attachment 1, the diameter of a monopole with internally flush mounted antennas and related equipment is approximately four (4) feet. The enclosed drawing depicts the configuration of three (3) internally flush-mounted antennas, required cables and equipment (remote radio head units (RRH) and tower mounted amplifiers (TMA)) at one mounting level. As shown in the attached drawing, at one level, there are three (3) antennas, or one (1) antenna per sector with one (1) RRH unit and two (2) TMAs installed directly below the antennas. As set forth in the record in this proceeding and shown in the attached drawing, AT&T requires three (3) levels of antennas for a tower design with internally flush-mounted antennas.

The configuration shown in the attached conceptual drawing represents AT&T's current design requirements including LTE. Prior towers in the 36" diameter range did not account for LTE designs. In fact, the AT&T facility approved in Docket No. 404 (Redding) in January of 2011, which included internally flush-mounted antennas, was not based on AT&T's current design requirements for LTE, and it was noted in that Docket on the record that the diameter could be in excess of 40" for co-location and future equipment needs. An approximately (4) four-foot diameter and three (3) levels of antennas are now required for a tower design with internally flush-mounted antennas to accommodate AT&T's current design requirements.

Given these requirements and the minimum height for both AT&T and Verizon for coverage, a tower design with internally flush-mounted antennas is not feasible for the proposed East Haven Site (Site B). As demonstrated in the record in this proceeding, the height of the proposed East Haven facility is limited to 103' AGL in compliance with

both an FAA determination and a SHPO determination. Multiple levels of antennas required or both AT&T and Verizon would exceed 103' AGL and therefore cannot be accommodated at the proposed East Haven Site with a tower with interior mounted antennas. This type of design could be facilitated at the Branford Site which does not have the same regulatory constraints, though it is not preferred or recommended by the carriers as a technical/operational matter due to the impacts such a configuration has on network. In addition, the multiple levels of antennas required for both AT&T and Verizon for this type of design would necessitate a height increase at the proposed Branford Site.

- Q2. More information regarding the differing tree heights selected for the visibility analysis at both sites. Submit a revised visibility map if necessary.
- A2. The visibility analyses for both proposed Sites included a tree canopy height of 50 feet. The reference to a 65-foot tree canopy height on page 3 of the Visual Resource Evaluation Report for the proposed East Haven Site should be 50 feet. Thus, no revisions to the visibility maps are required. While the height of several trees in the vicinity of the proposed East Haven Site are in the 65-70-foot range, an average tree canopy height of 50 feet was used in the visibility analysis for the proposed East Haven Site for consistency in the visual analysis between the two proposed sites.

SUPPLEMENTAL INFORMATION

Parcels on Briarwood Lane in Branford

As set forth in the record in this proceeding, the parcels on Briarwood Lane in the Town of Branford are improved with two to three story multi-family structures. At the September 11, 2012 continued hearing, there was some discussion among the parties and intervenors regarding the possibility of a rooftop wireless facility on either of these multi-family buildings. The height of the existing multi-family buildings at three stories and a rooftop wireless facility at either location on Briarwood Lane would not provide adequate reliable service to the area where service is needed. Thus, a rooftop wireless facility at either location on Briarwood Lane is not a viable alternative.

Tower Configuration with Interior Flush Mounted Antennas and Exterior Mounted Cables

At the September 11, 2012 hearing, a tower configuration that included internally mounted antennas with externally mounted cables was discussed. While structurally possible, this configuration is not feasible from a radio frequency perspective for a multi-carrier installation. In this configuration, the exterior cables for the interior antennas near the top of the tower/pole will be mounted over the interior antennas at lower levels, thus obstructing the antennas at the lower levels. Therefore, this configuration – interior mounted antennas with exterior mounted cables – is not a viable design alternative.

CERTIFICATE OF SERVICE

I hereby certify that on this day, a copy of the foregoing was sent electronically and by overnight mail to the Connecticut Siting Council and:

Kenneth C. Baldwin, Esq.
Robinson & Cole LLP
280 Trumbull Street
Hartford, CT 06103-3597
(860) 275 8345
KBALDWIN@RC.com

Sarah Pierson
63 Hilton Avenue
East Haven, CT 06512
(203) 215 6635
Sarahpierson@att.net

Keith Ainsworth, Esq.
Evans, Feldman & Ainsworth, L.L.C.
261 Bradley Street, P.O. Box 1694
New Haven, Connecticut 06507-1694
(203) 772-4900
krainsworth@snet.net

Niki Whitehead
9 Hilton Avenue
East Haven, CT 06512
(203) 467-9705

Richard Moreland
8 Hilton Avenue
East Haven, CT 06512
(203) 467 1779
Richard.Moreland@live.com

Bruce H. Williams, Jr.
54 Hilton Avenue
East Haven, CT 06512
Bhw2@att.net

James Edward Berardi
90 Short Beach Road
East Haven, CT 06512
Jim.berardi@att.net

Daniel Criscuolo, Sr.
Pamela Maki
100 Short Beach Road
East Haven, CT 06512
pamelamaki@gmail.com

Dated: September 24, 2012

Lucia Chiochio
Lucia Chiochio

cc: Dan Shriver, NAT, LLC; Michele Briggs, AT&T; John Stevens, Infinigy Engineering PLLC; Tony Wells, C-Squared Systems, Inc.; Martin Lavin, C-Squared Systems, Inc.; David Vivian, SAI; Michael Libertine, All-Points Technology Corporation, P.C.; Randy Howse; Christopher Fisher, Esq.

ATTACHMENT 1

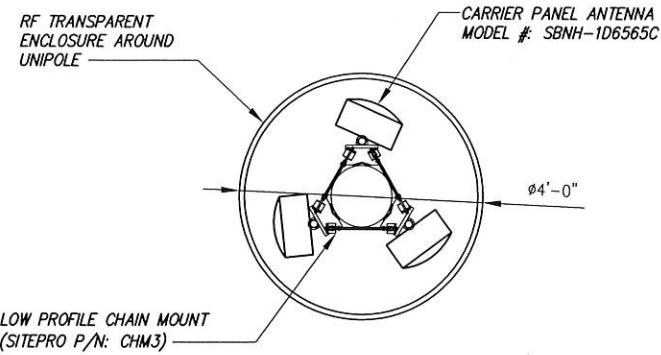

NOTE:
AT&T TMA'S AND RRH'S ARE TO BE INSTALLED BELOW
AT&T PANEL ANTENNAS WITHIN 10' SECTION

1 SECTION AT AT&T ANTENNA ARRAY (120'-110' AGL)
SCALE: 1"=3'

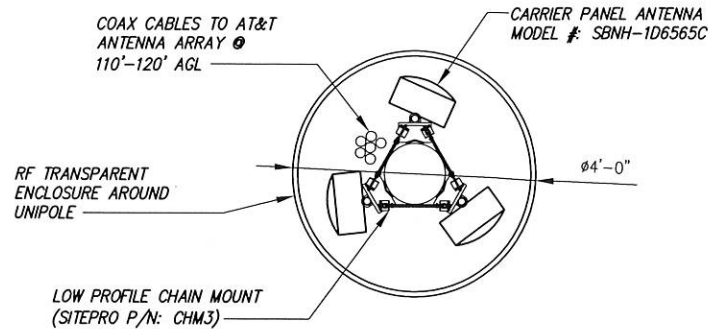

NOTE:
AT&T TMA'S AND RRH'S ARE TO BE INSTALLED BELOW
AT&T PANEL ANTENNAS WITHIN 10' SECTION

2 SECTION AT AT&T ANTENNA ARRAY (110'-100' AGL)
SCALE: 1"=3'

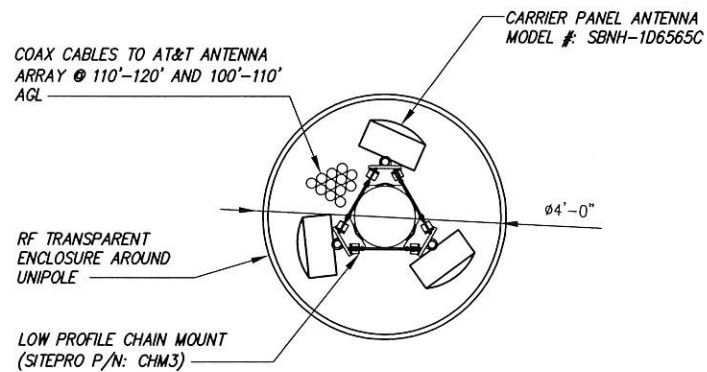

NOTE:
AT&T TMA'S AND RRH'S ARE TO BE INSTALLED BELOW
AT&T PANEL ANTENNAS WITHIN 10' SECTION

3 SECTION AT AT&T ANTENNA ARRAY (100'-90' AGL)
SCALE: 1"=3'

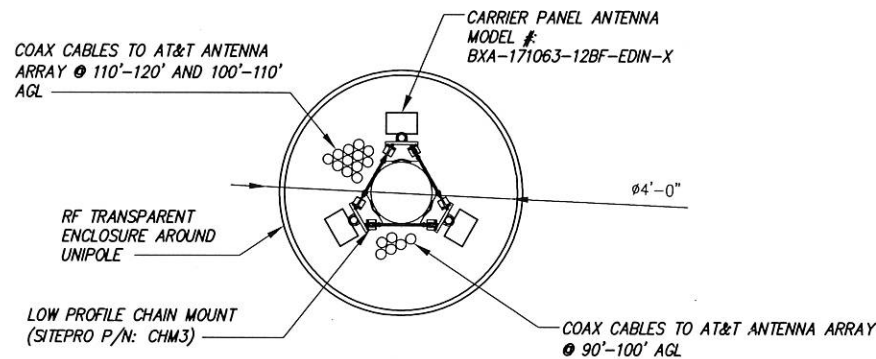

NOTE:
AT&T WIRELESS TO INSTALL (1) TMA OR (1) RRU DIRECTLY
BELOW EACH ANTENNA AT EACH ANTENNA LOCATION:
TMA DIMENSIONS = 14.25" (H) x 11.46" (W) x 4.17" (D)
RRU DIMENSIONS = 25" (H) x 15" (W) x 6.7" (D)

4 SECTION AT VERIZON WIRELESS ANTENNA ARRAY (90'-80' AGL)
SCALE: 1"=3'

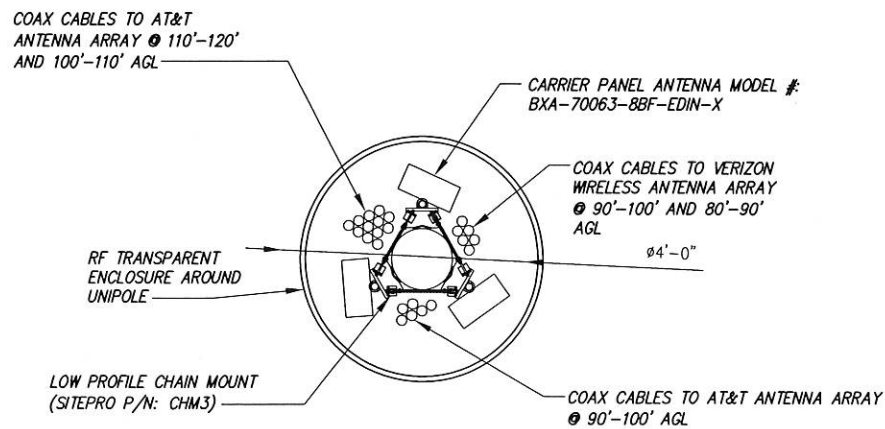

5 SECTION AT VERIZON WIRELESS ANTENNA ARRAY (80'-70' AGL)
SCALE: 1"=3'

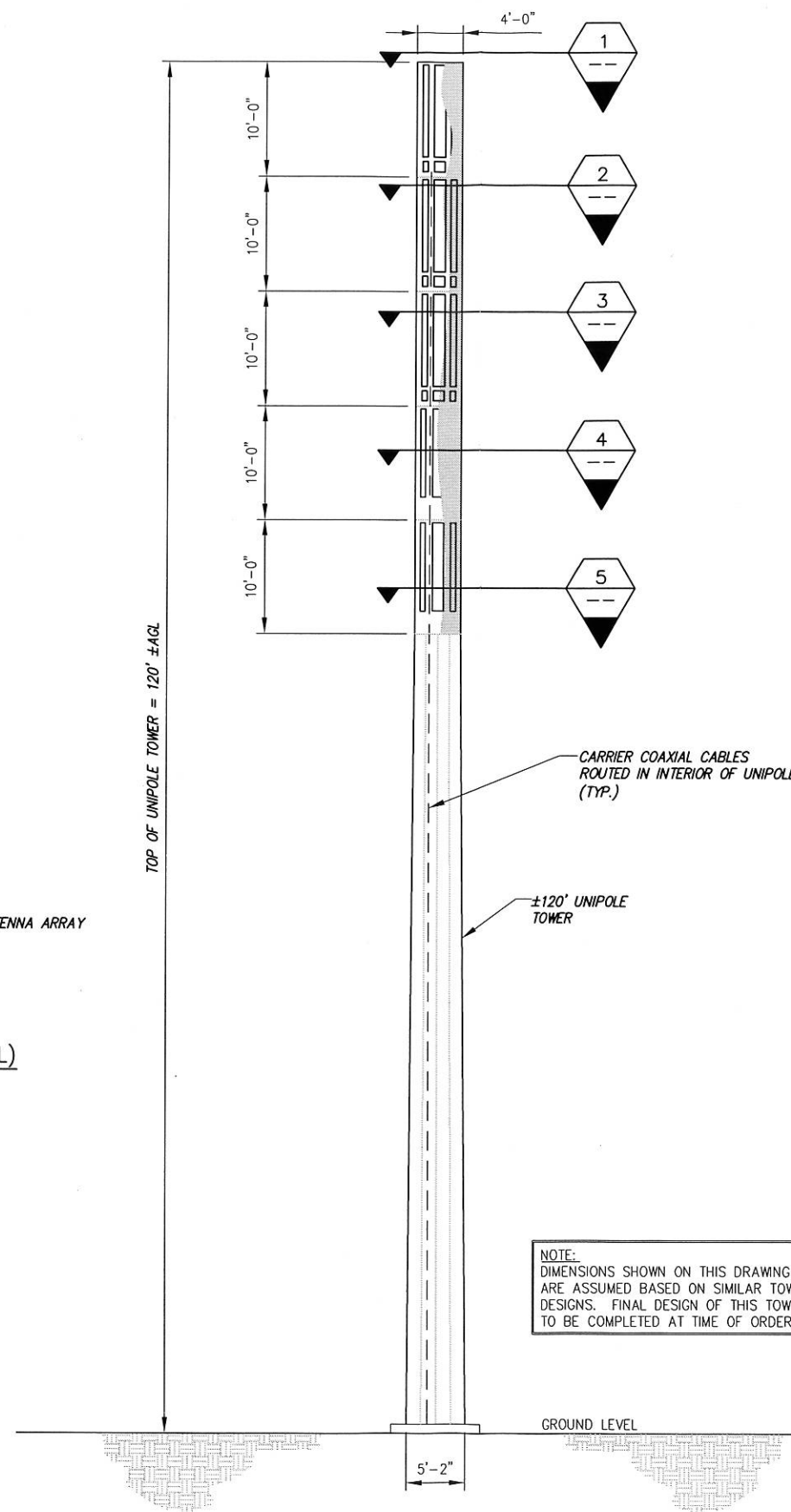

TOP OF UNIPOLE TOWER = 120' ± AGL

NOTE:
DIMENSIONS SHOWN ON THIS DRAWING
ARE ASSUMED BASED ON SIMILAR TOWER
DESIGNS. FINAL DESIGN OF THIS TOWER
TO BE COMPLETED AT TIME OF ORDER

6 ELEVATION VIEW
NOT TO SCALE

Design. Build. Deliver.
INFINIGY

11 Herbert Drive
Latham, NY 12110
Office # (518) 690-0790
Fax # (518) 690-0793

UNAUTHORIZED ALTERATION OR ADDITION
TO THIS DOCUMENT IS A VIOLATION OF
APPLICABLE STATE AND/OR LOCAL LAWS

1	PER RF ENGINEER	AJD	9/24/12
0	ISSUED FOR REVIEW	SKB	9/17/12
No.	Submital / Revision	App'd	Date
Drawn:	SKB	Date:	9/17/12
Designed:	AGF	Date:	9/17/12
Checked:	AJD	Date:	9/17/12

Project Number
226-000

Project Title
UNIPOLE SCHEMATIC LAYOUT

Prepared For



THIS DOCUMENT IS THE DESIGN PROPERTY AND
COPYRIGHT OF INFINIGY ENGINEERING, PLLC.
NO PART OF THIS DOCUMENT IS TO BE
REPRODUCED, COPIED, OR TRANSMITTED IN
ANY FORM OR BY ANY MEANS, WITHOUT THE
EXPRESS WRITTEN CONSENT OF THE CREATOR
IS STRICTLY PROHIBITED.

Drawing Scale:
AS NOTED

Date:
9/24/12

Drawing Title

CONCEPTUAL UNIPOLE PLAN

Drawing Number

EX1