

EXHIBIT G

PROJECT SUMMARY

SCOPE OF WORK: ARX WIRELESS IS PROPOSING TO INSTALL THE FOLLOWING IMPROVEMENTS:
 104 FOOT TOWER AND FOUNDATION
 50'x50' FENCED COMPOUND
 POWER AND TELCO UTILITIES
 AT&T EQUIPMENT CABINETS WITH GENERATOR ON 13'x8' CONCRETE PAD, SIX (6) AT&T ANTENNAS, AND TWELVE (12) RRHs WITH ASSOCIATED CABLING AND APPURTENANCES.

SITE ADDRESS: 43 OSGOOD AVENUE
 NEW BRITAIN, CT 06053

LATITUDE: N41° 41' 07.87"
 LONGITUDE: W72° 47' 25.06"

PROPERTY OWNER: OSGOOD AVENUE PROPERTY LLC
 119 LIBERTY STREET
 NEWINGTON, CT 06111

MAP/LOT/BLOCK: C5B 115

POWER COMPANY: EVERSOURCE
 TELEPHONE COMPANY: FRONTIER COMMUNICATIONS

TOWER OWNER/APPLICANT: ARX WIRELESS INFRASTRUCTURE, LLC.
 KEITH COPPINS
 (203) 623-3287
 110 WASHINGTON AVENUE
 NORTH HAVEN, CT 06473



TECHNICAL REPORT
SITE NUMBER: CT0090
SITE NAME: NEW BRITAIN

TECH REPORT

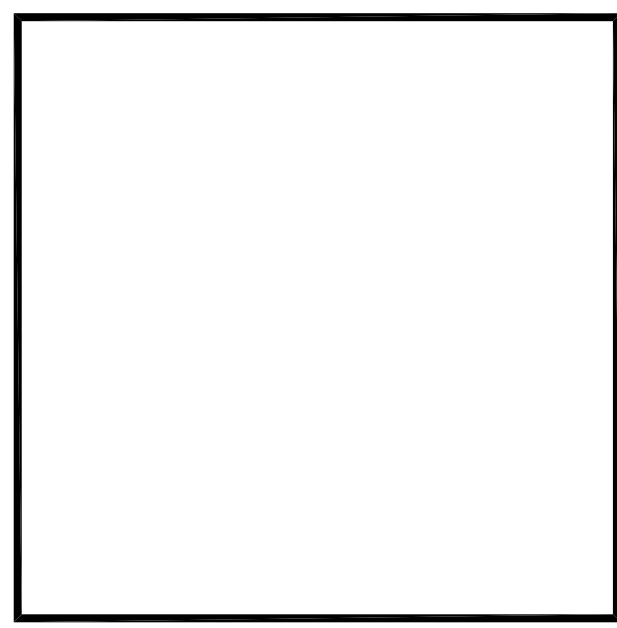
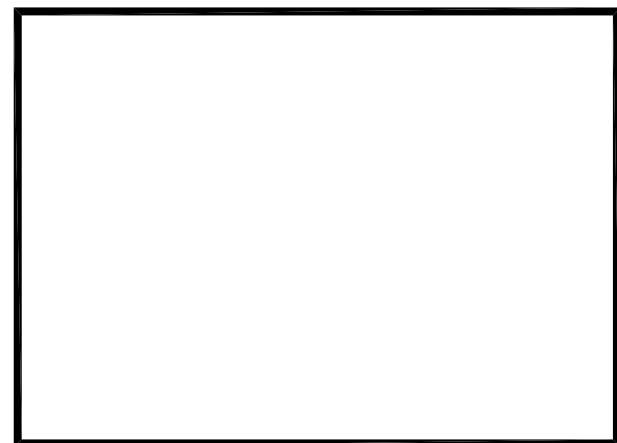

CHECKED BY: DJR

APPROVED BY: DJR

DRAWING INDEX

REV

VICINITY MAP

GENERAL NOTES

- T-1 TITLE SHEET
- SURVEY
- TR-1 SITE PLAN
- TR-2 COMPOUND PLAN AND ELEVATION

- 1
- 1
- 1

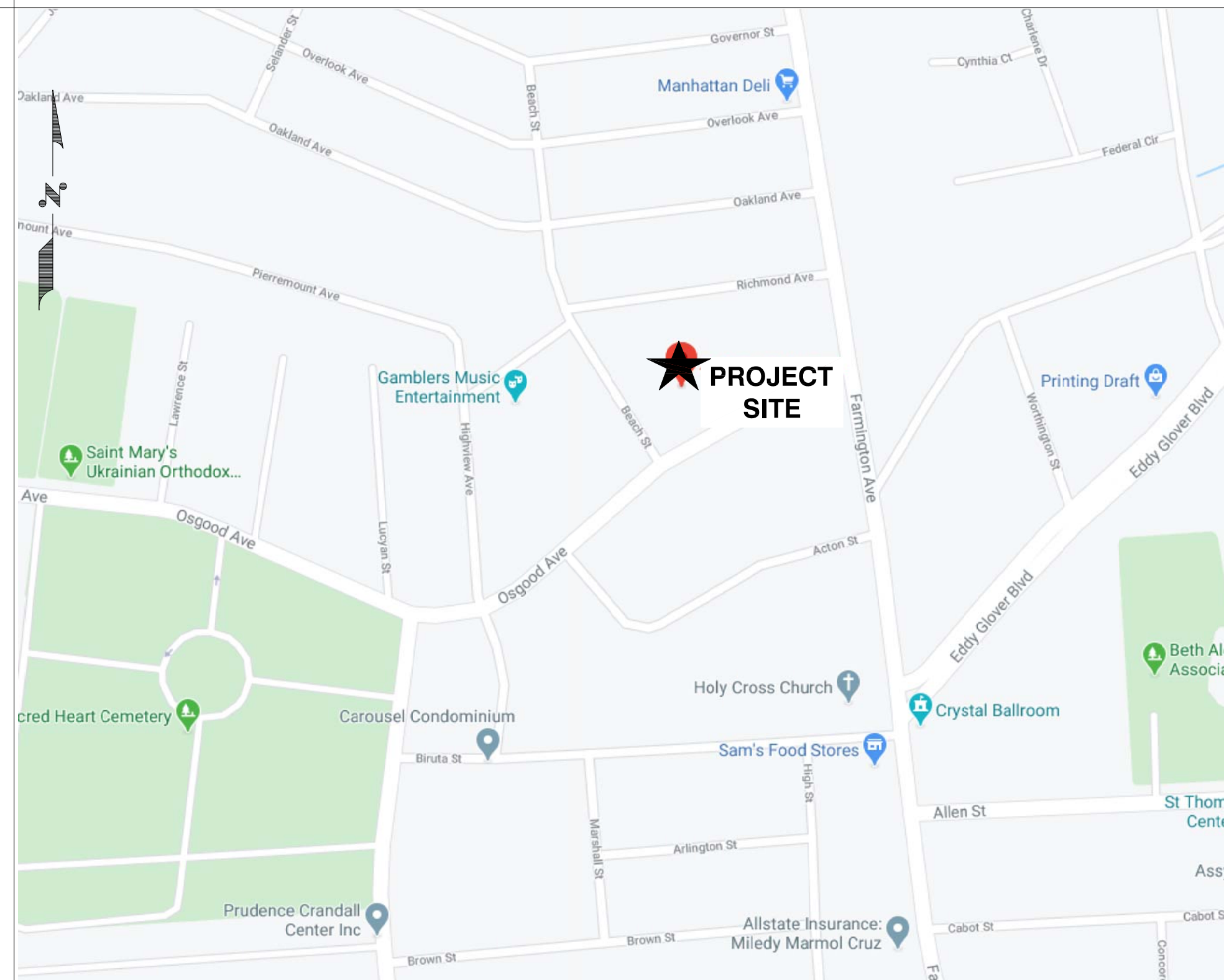

1. THIS DOCUMENT IS THE CREATION, DESIGN, PROPERTY AND COPYRIGHTED WORK OF ARX WIRELESS. ANY DUPLICATION OR USE WITHOUT EXPRESS WRITTEN CONSENT IS STRICTLY PROHIBITED. DUPLICATION AND USE BY GOVERNMENT AGENCIES FOR THE PURPOSES OF CONDUCTING THEIR LAWFULLY AUTHORIZED REGULATORY AND ADMINISTRATIVE FUNCTIONS IS SPECIFICALLY ALLOWED.
2. THE FACILITY IS AN UNMANNED PRIVATE AND SECURED EQUIPMENT INSTALLATION. IT IS ONLY ACCESSED BY TRAINED TECHNICIANS FOR PERIODIC ROUTINE MAINTENANCE AND THEREFORE DOES NOT REQUIRE ANY WATER OR SANITARY SEWER SERVICE. THE FACILITY IS NOT GOVERNED BY REGULATIONS REQUIRING PUBLIC ACCESS PER ADA REQUIREMENTS.

SUBMITTALS

REV.	DATE	DESCRIPTION	BY
2	11/12/2020	ISSUED FINAL	
1	09/02/2020	ISSUED FOR REVIEW	KAM
0	08/18/2020	ISSUED FOR REVIEW	KAM

SITE NAME:

CT0090
 NEW BRITAIN

SITE ADDRESS:

43 OSGOOD AVENUE
 NEW BRITAIN, CT 06053

SHEET TITLE

SITE PLAN

SHEET NUMBER

T-1

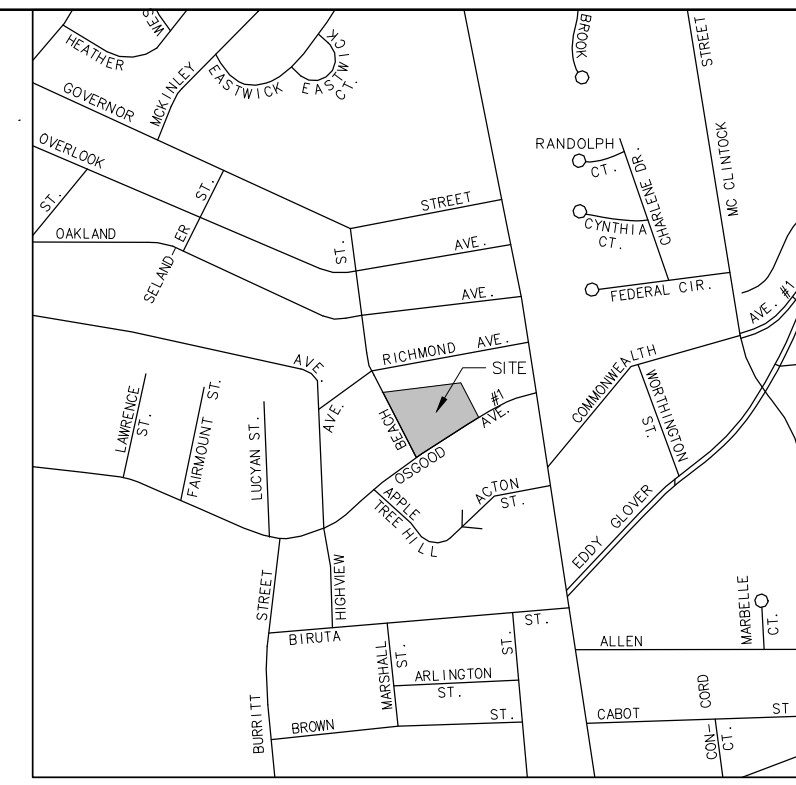

LOCATION MAP
NOT TO SCALE

**BENCHMARK "A"
MAG NAIL
IN UTILITY POLE
ELEV.=338.45'**

**BENCHMARK "C"
NE STEP CORNER
ELEV.= 343.53'**

**BENCHMARK "B"
MAG NAIL IN
UTILITY POLE
ELEV.=340.26'**

Beach Street

Osgood Avenue

EXISTING CONDITIONS LEGEND

- | | | | |
|--|------------------------|--|--|
| | EDGE OF WOODS | | ST - STORM SEWER LINE |
| | DECIDUOUS TREE | | S - SANITARY SEWER LINE |
| | CONIFEROUS TREE | | W - WATER LINE |
| | SHRUB/BUSH | | G - GAS LINE |
| | SIGN | | SIG - SIGNAL WIRE LINE |
| | UTILITY POLE | | C - CABLE LINE |
| | LIGHT POLE | | FO - FIBER OPTIC LINE |
| | HYDRANT | | LPS - LOW PRESSURE SEWER LINE |
| | WATER SHUTOFF | | E - ELECTRIC LINE |
| | GAS VALVE | | OHU - OVERHEAD UTILITIES |
| | WATER VALVE | | T - TELEPHONE LINE |
| | MONUMENT | | (S) SANITARY MANHOLE (SMH) |
| | IRON PIN / IRON ROD | | (D) DRAINAGE MANHOLE (DMH) |
| | HANDICAP SPACE | | (C) CATCHBASIN (CB) |
| | HAND HOLE | | (B) METAL POST/BOLLARD (BOL) |
| | ELEC. METER | | (E) ELECTRIC MANHOLE (MHE) |
| | GAS METER | | (U) UNKNOWN MANHOLE |
| | PROPERTY LINE | | (T) TELEPHONE MANHOLE (MHT) |
| | EASEMENT | | (V) VENT PIPE |
| | 10' MAJOR CONTOUR LINE | | (CNO) COULD NOT OPEN |
| | 5' MINOR CONTOUR LINE | | (F) FLOW DIRECTION |
| | WOOD FRAMED | | (M) MAG NAIL |
| | CHAIN LINK FENCE | | (WLF #1081) WETLAND FLAG (DELIMITED BY OTHERS) |
| | WIRE FENCE | | (WET) WETLAND LINE (DELIMITED BY OTHERS) |
| | CLEANOUT | | (E) EDGE OF WATER (BY AERIAL IMAGE) |
| | MONITORING WELL | | (EP) ELECTRIC PEDESTAL |
| | STONEWALL | | (G) GUY WIRE |
| | | | (F.F.) FINISHED FLOOR ELEVATION |
| | | | (S) SPOT ELEVATION |
| | | | (M) MAILBOX |

- NOTES:**
- THIS SURVEY AND MAP HAS BEEN PREPARED IN ACCORDANCE WITH THE REGULATIONS OF CONNECTICUT STATE AGENCIES, SECTIONS 20-300b-1 THRU 20-300b-20 AS AMENDED, AND THE "STANDARDS FOR SURVEYS AND MAPS IN THE STATE OF CONNECTICUT" ADOPTED BY THE CONNECTICUT ASSOCIATION OF LAND SURVEYORS, INC. THE TYPE OF SURVEY IS A PROPERTY SURVEY, THE BOUNDARY DETERMINATION CATEGORY IS A RESURVEY. THIS SURVEY CONFORMS TO A HORIZONTAL ACCURACY CLASS A-2, VERTICAL ACCURACY CLASS V-3 AND TOPOGRAPHIC ACCURACY CLASS T-2.
 - BEARINGS REFER TO THE CONNECTICUT COORDINATE SYSTEM (NAD 83) AS DERIVED USING GLOBAL NAVIGATION SATELLITE SYSTEM (GNSS) SURVEY METHODS IN APRIL, 2020.
 - ELEVATION AS DEPICTED HEREON ARE REFERENCED TO THE NORTH AMERICAN VERTICAL DATUM (NAVD) OF 1988 AS DERIVED USING GLOBAL NAVIGATION SATELLITE SYSTEM (GNSS) SURVEY METHODS.
 - REFERENCE IS MADE TO THE FOLLOWING MAP:
 - "MAP SHOWING PROPERTY OF GAME-A-TRON CORPORATION 45 OSGOOD AVE. NEW BRITAIN, CONN." SCALE: 1"=20'; DATED: JULY 20, 1983; PREPARED BY: G.S. JARMOLINSKI ASSOCIATES.
 - "MAP OF PROPERTY PREPARED FOR THE JUSTUS S. BEACH TRUST AGREEMENT, 5 OSGOOD AVENUE, NEW BRITAIN, CONNECTICUT." SCALE: 1"=20'; DATED: FEBRUARY 9, 2008; PREPARED BY: DAVID G. HINTZ LAND SURVEYING, L.L.C.
 - "PROPERTY / BOUNDARY SURVEY FINAL SUBDIVISION PLAT, PROPOSED RESIDENTIAL SUBDIVISION, DAMIANS CONSTRUCTION SUBDIVISION, PROPERTY LOCATED AT RICHMOND AVENUE, NEW BRITAIN CONNECTICUT." SCALE: 1"=20'; DATED: AUGUST 5, 2011; PREPARED BY: MBA ENGINEERING, INC.
 - "PROPERTY / BOUNDARY SURVEY MAP SHOWING PROPOSED CONVEYANCE OF PARCEL FROM PROPERTY KNOWN AS #52 RICHMOND AVENUE TO PROPERTY KNOWN AS #46 RICHMOND AVENUE, LOCATED AT RICHMOND AVENUE, NEW BRITAIN CONNECTICUT." SCALE: 1"=20'; DATED: OCTOBER 30, 2012; PREPARED BY: MBA ENGINEERING, INC.
 - UNDERGROUND UTILITY, STRUCTURE AND FACILITY LOCATIONS DEPICTED HEREON HAVE BEEN COMPILED, IN PART, FROM RECORD MAPPING AND OTHER DATA SUPPLIED BY THE RESPECTIVE UTILITY COMPANIES. GOVERNMENTAL AGENCIES AND/OR OTHER SOURCES. THESE LOCATIONS MUST BE CONSIDERED APPROXIMATE IN NATURE. ADDITIONALLY, OTHER SUCH FEATURES MAY EXIST ON THE SITE, THE EXISTENCE OF WHICH ARE UNKNOWN TO WESTON & SAMPSON. THE EXISTENCE, SIZE AND LOCATION OF ALL SUCH FEATURES MUST BE DETERMINED AND VERIFIED IN THE FIELD BY THE APPROPRIATE AUTHORITIES PRIOR TO CONSTRUCTION. CALL BEFORE YOU DIG 1-800-922-4455.

N/F
5 Osgood Ave.
Justine C. Beach
Edward F. Beach
Co-Trustees
Vol. 1759 PG. 1205

REVISIONS	
DATE	DESCRIPTION

TO MY KNOWLEDGE AND BELIEF THIS MAP IS SUBSTANTIALLY CORRECT AS NOTED HEREON

Gordon R. Matson 7/17/20
GORDON R. MATSON, PLS LICENSE NO. 70445

TRUE AND VALID COPIES OF THIS MAP OR PLAN MUST BEAR THE ORIGINAL SIGNATURE AND EMBOSSED SEAL OF THE ABOVE NAMED LAND SURVEYOR. UNAUTHORIZED REPRODUCTION OR ALTERATION IS FORBIDDEN.

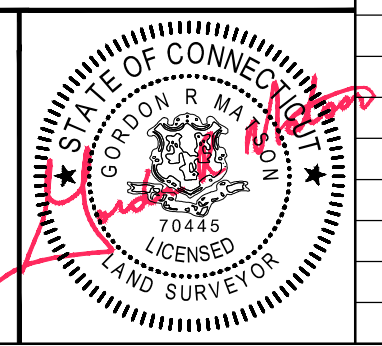

PROPERTY & TOPOGRAPHIC SURVEY
PREPARED FOR
ABCOM
#43 OSGOOD AVENUE
TOWN OF NEW BRITAIN
COUNTY OF HARTFORD STATE OF CONNECTICUT

Weston & Sampson
Weston & Sampson Land Surveyors Inc.
273 Dividend Road Rocky Hill, CT 06067 (860) 513-1473

CAD FILE:
DATE: JULY 16, 2020 SHEET 1 OF 1
SCALE: 1"=20' DRAWING NO.: ENG20-0605



AECOM
 500 ENTERPRISE DRIVE
 ROCKY HILL, CONNECTICUT
 (860)-529-8882



CHECKED BY: DJR

APPROVED BY: DJR

SUBMITTALS			
REV.	DATE	DESCRIPTION	BY
2	11/12/2020	ISSUED FINAL	
1	09/02/2020	ISSUED FOR REVIEW	KAM
0	08/18/2020	ISSUED FOR REVIEW	KAM

SITE NAME:
 CT0090
 NEW BRITAIN
 SITE ADDRESS:
 43 OSGOOD AVENUE
 NEW BRITAIN, CT 06053

SHEET TITLE
 SITE PLAN

SHEET NUMBER
TR-1

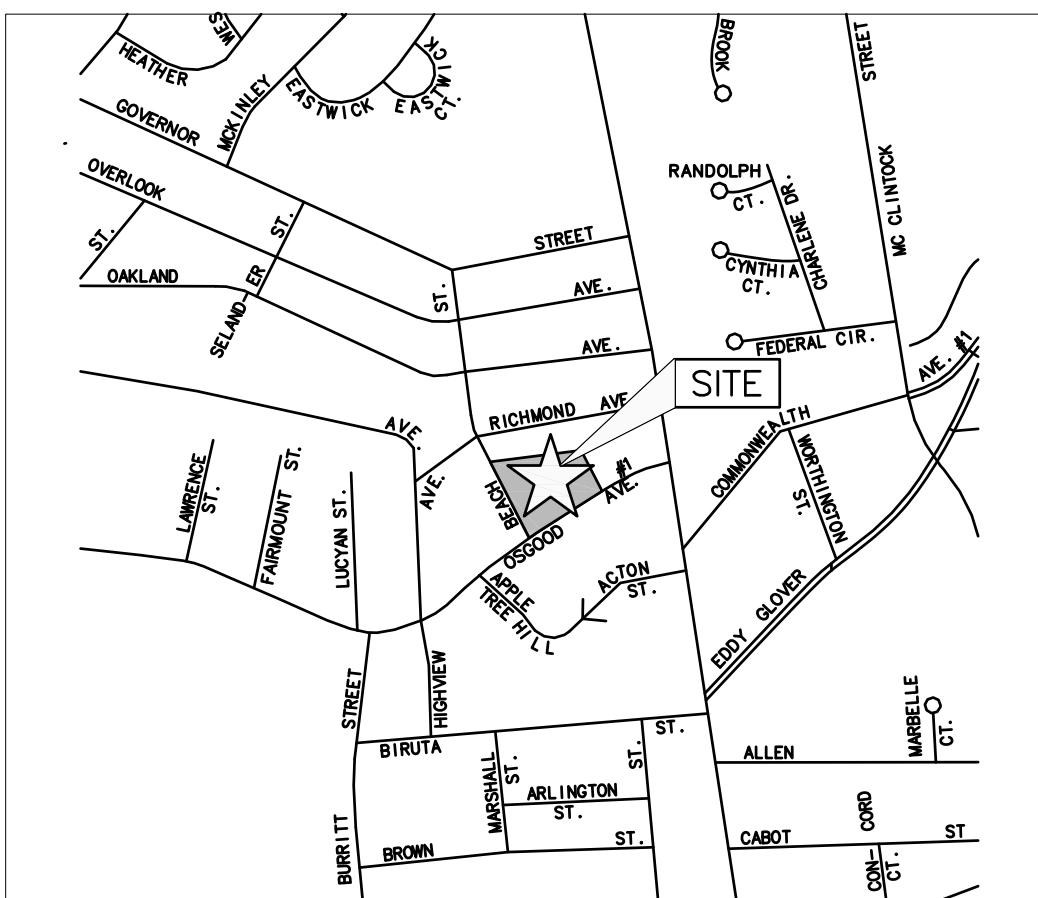

VICINITY MAP
 SCALE: N.T.S.

CENTER OF STRUCTURE LAT: N41° 41' 07.87"
 COORDINATES: LONG: W72° 47' 25.06"

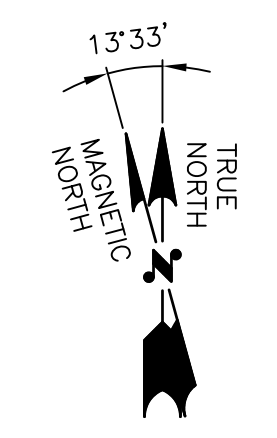
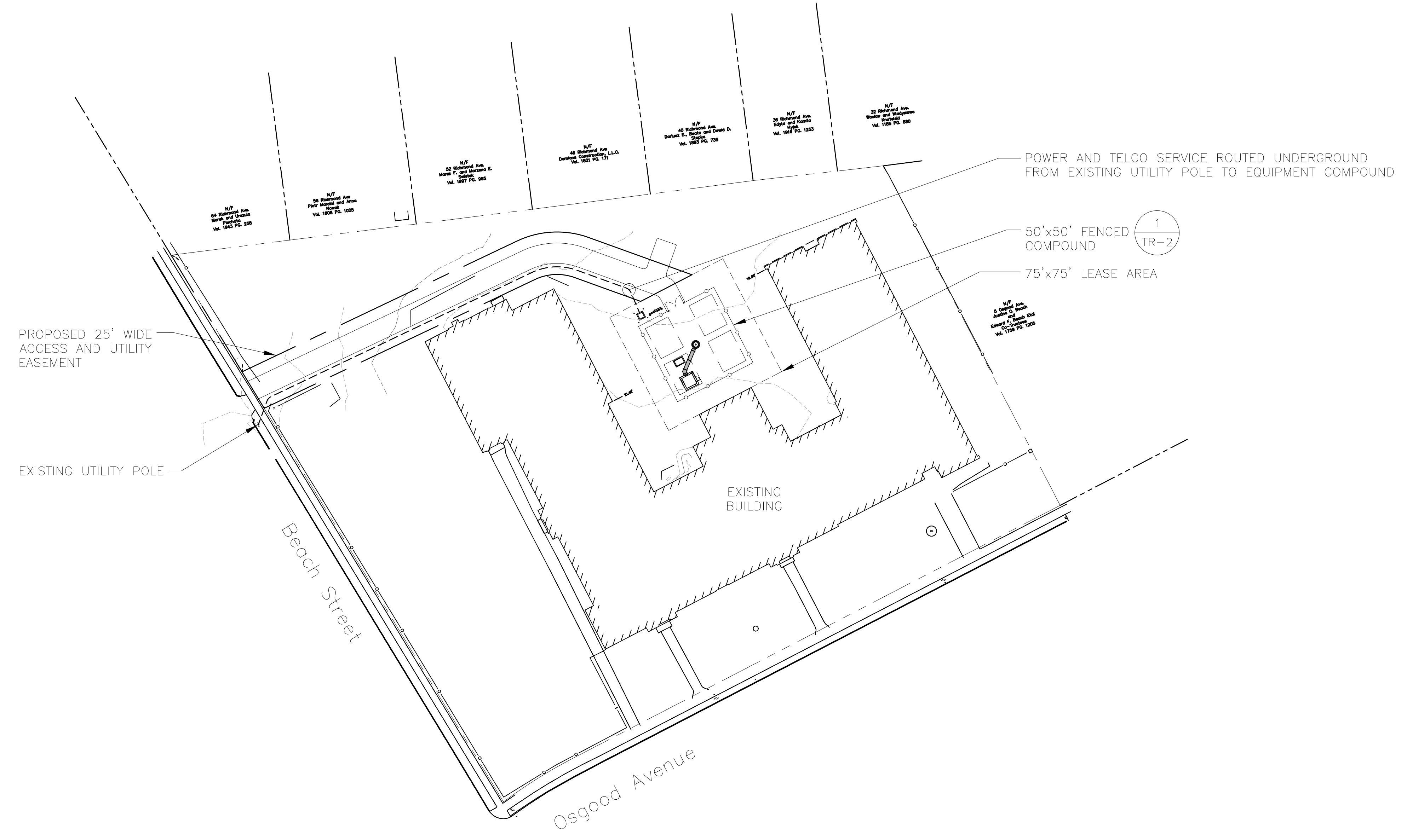

SITE PLAN
 22x34 SCALE: 1"=40'-0"
 11x17 SCALE: 1"=80'-0"

1
 TR-1

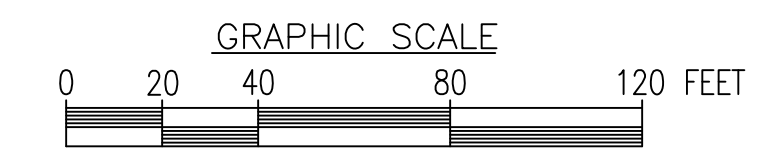



AECOM
 500 ENTERPRISE DRIVE
 ROCKY HILL, CONNECTICUT
 (860)-529-8882



CHECKED BY: DJR

APPROVED BY: DJR

SUBMITTALS			
REV.	DATE	DESCRIPTION	BY
2	11/12/2020	ISSUED FINAL	
1	09/02/2020	ISSUED FOR REVIEW	KAM
0	08/18/2020	ISSUED FOR REVIEW	KAM

SITE NAME:
 CT0090
 NEW BRITAIN
 SITE ADDRESS:
 43 OSGOOD AVENUE
 NEW BRITAIN, CT 06053

SHEET TITLE
 COMPOUND PLAN
 AND ELEVATION

SHEET NUMBER
TR-2

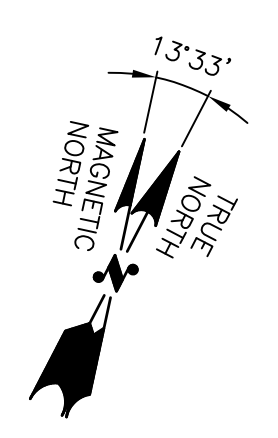
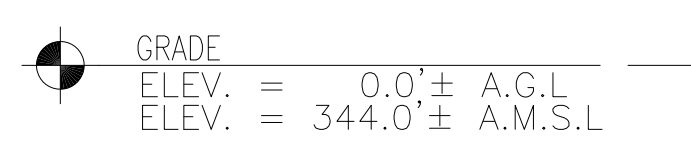
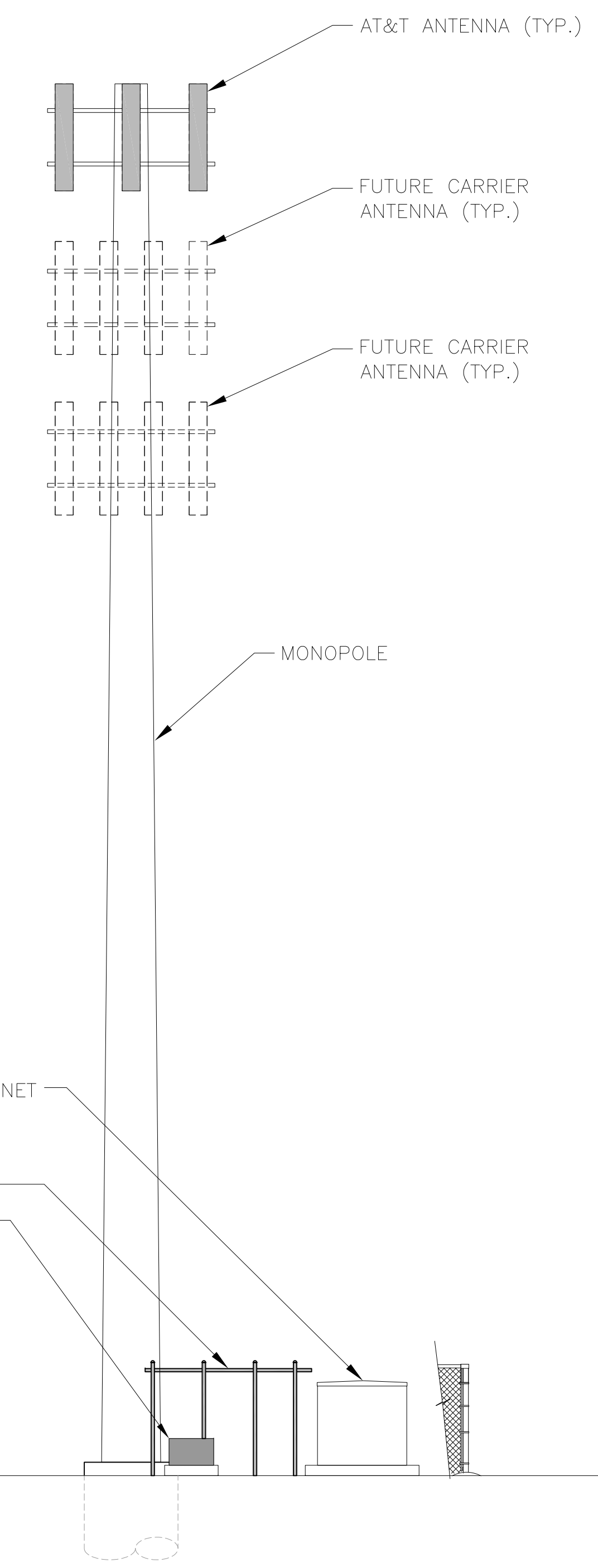
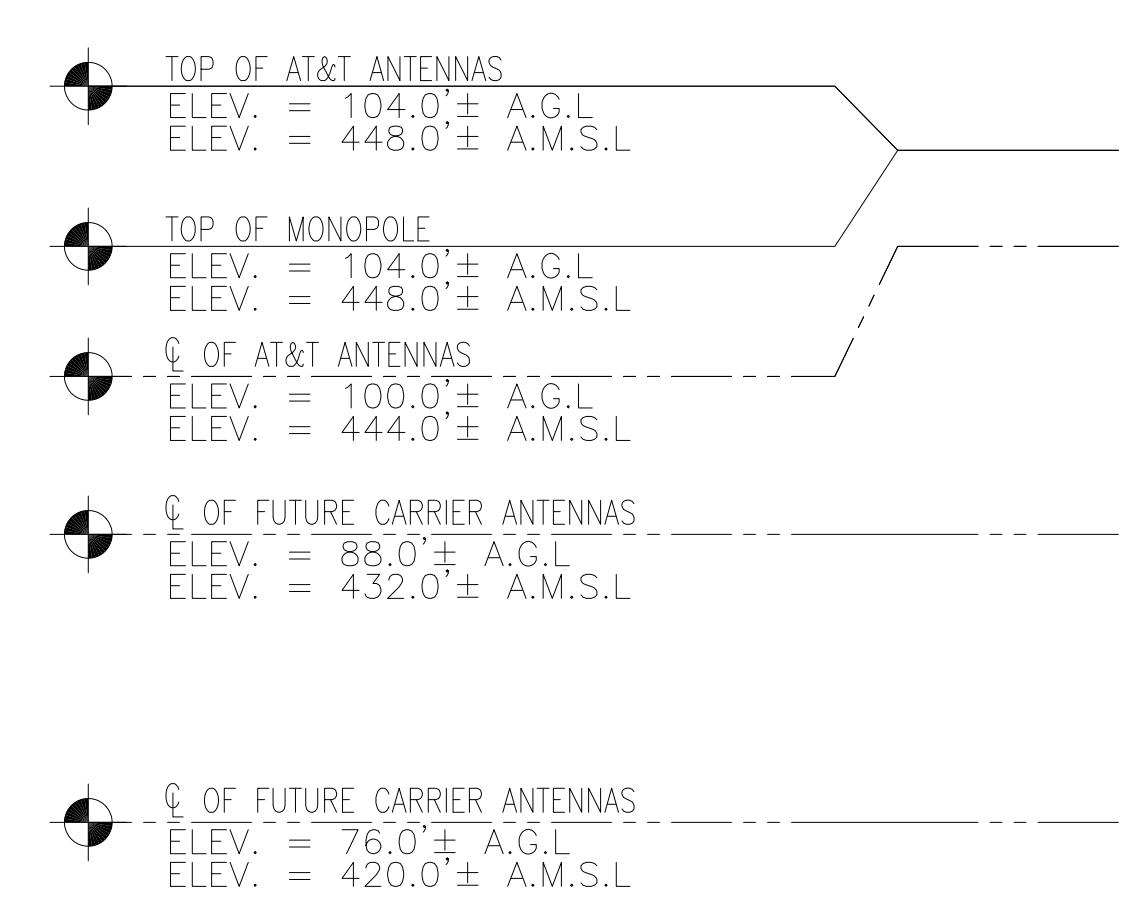
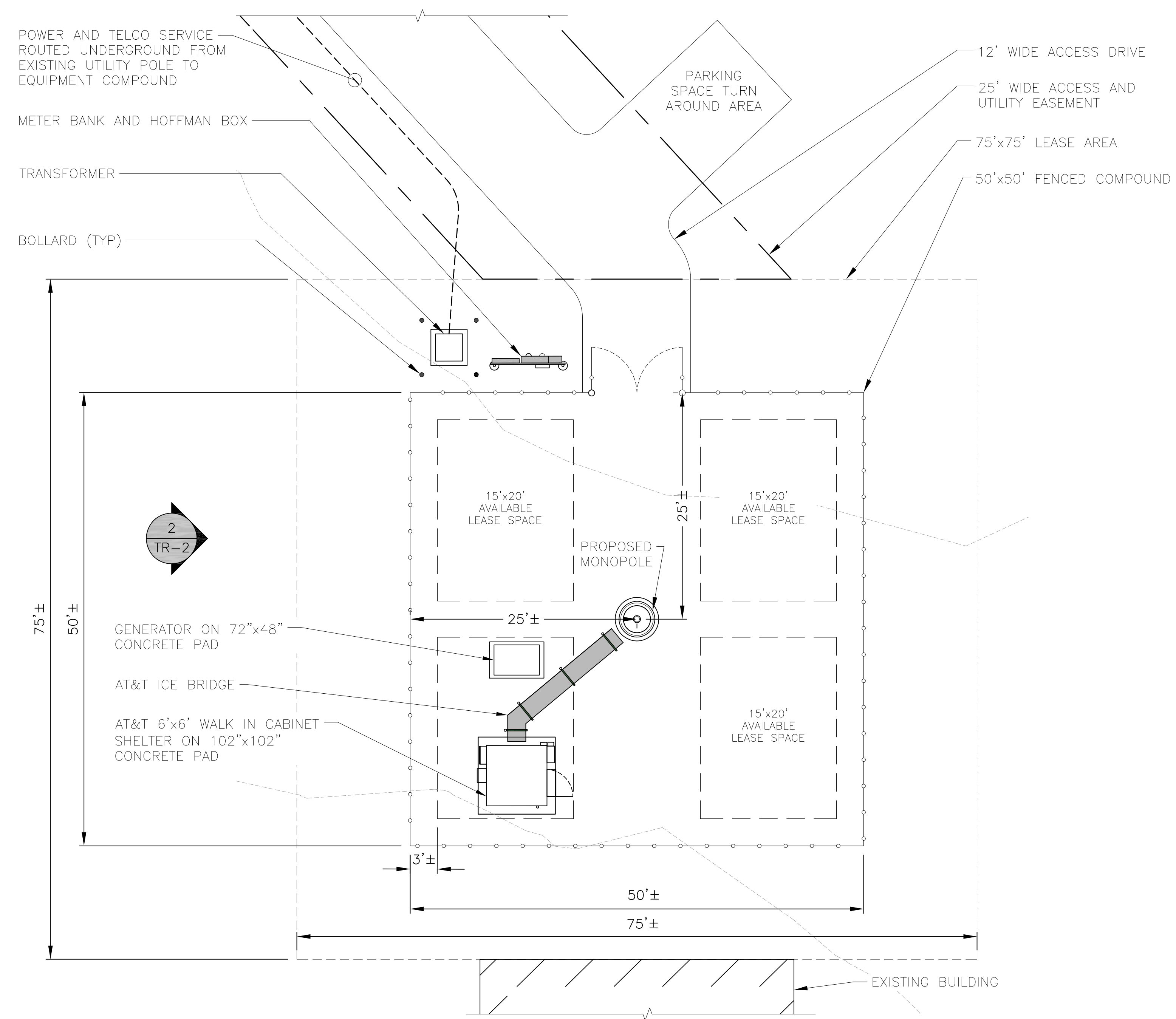

COMPOUND PLAN
 22x34 SCALE: 1/8"=1'-0"
 11x17 SCALE: 1/16"=1'-0"

1
 TR-2

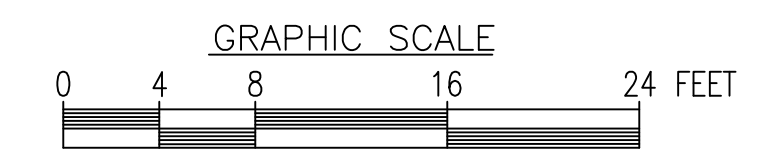

NORTH ELEVATION
 22x34 SCALE: 1"=10'-0"
 11x17 SCALE: 1"=20'-0"

2
 TR-2

