



Criminal Justice Information System Governing Board Meeting

January 27, 2022



Agenda

PROJECT UPDATE AND STRATEGY

- Continued Success – GA9 Full Arrest/Misdemeanor Summons Pilot Status
- Workflow Deployment Strategy and Integration Update
- CJIS-CT Collaboration with Stakeholders
- Integration with RMS Vendor System Update
- Search Deployment and Training Update
- Clean Slate Legislative Initiative
- Additional CJIS-CT Projects and Analytics

CJIS OPERATIONAL SUPPORT & FINANCIALS

- Integration, Deployment, and Enterprise Architecture
- Integrated Project Plan Gantt Chart
- Overview of Financials
- Key Success Factors for CISS Deployment
- Program Risks & Mitigations



CJIS Information Sharing System

Workflows

- **Goals for CJIS state-wide criminal justice information sharing system**
 - Facilitate immediate, seamless information sharing between Connecticut Criminal Justice Agencies
 - Improve the efficiency of Criminal Justice Agencies as they carry out their daily data sharing processes

Latest Accomplishments

- Search Deployment and Training Update
 - Router connectivity and deployment efforts continuing
 - Synergizing Workflow and Search
- CISS Search Internet Access POC
 - DPDS in Pilot Mode
- RMS Vendor Integration Progress
- Clean Slate Legislation
- Continued successful full End to End Arrest processing with all Stakeholder agencies (Judicial/DCJ/CJIS/DESPP/NexGen) full integration Pilot testing in the UAT environment
 - Workflow enhancement package v11.3 package deployed to production on 1/14/22
 - WebMethods (CISS) v10.5 deployed to production on 1/2/22
 - Development for workflow functionality enhancement v11.4 kicked off on 1/18/22.



CISS Interoperability Workflow Status

- GA9 Pilot with Clinton PD successfully kicked off on August 27 with the following observations noted
 - Arrest and Summons Activity generated by Clinton PD continues to be lower than anticipated
 - Clinton PD turnaround time for arrest/misdemeanor package development is improving to less than 24 hours
 - Additional workflow process improvements continue to be identified by all agencies and are being implemented as part of the pilot process
 - Additional RMS requirements were identified, developed, fully tested and pushed into pilot on 12/15 with improved arrest package data quality noted
 - Workflow enhancement v11.3 was developed, tested, and moved to production on 1/14/22
- Middletown PD and Troop F added to GA9 Pilot to increase Arrest Volume to Pilot
 - Middletown PD fully integrated and sending arrest/misdemeanor packages since 11/1/21
 - Court Liaison officer training completed on 11/7. Officer and command staff PD training negatively impacted due to covid-19 constraints.
 - CT State Police working on Policy and Procedures and will utilize the Pseudo Production Server in the near future.



Statewide JD Workflow Deployment

Seq #	JD	CJIS Team	GA	Projected Completion Date
1	Middlesex	Team A	GA 9 - Middletown	2/18/2022
2	Tolland	Team A	GA-19 Tolland	4/1/2022
3	Windham	Team A	GA-11 Windham	4/29/2022
4	Waterbury	Team A	GA-4 Waterbury	6/10/2022
5	Ansonia/Milford	Team A	GA-5 Derby	7/8/2022
5	Ansonia/Milford	Team B	GA-22 Milford	7/8/2022
6	New London	Team A	GA-10 New London	8/26/2022
6	New London	Team B	GA-21 Norwich	8/26/2022
7	Stamford	Team A	GA-1 Stamford	10/14/2022
7	Stamford	Team B	GA-20 Norwalk	10/14/2022
8	Litchfield	Team A	GA-18 Torrington	12/30/2022
9	New Britain	Team A	GA-15 New Britain	12/30/2022
10	New Haven	Team A	GA-23 New Haven	4/28/2023
10	New Haven	Team B	GA-7 Meriden	4/28/2023
11	Fairfield	Team A	GA-2 Bridgeport	6/23/2023
12	Hartford	Team A	GA-12 - Manchester	6/30/2023
12	Hartford	Team B	GA-13 Enfield	6/30/2023
12	Hartford	Team A	GA-14 Hartford	6/30/2023
13	Danbury	Team A	GA-3 Danbury	9/22/2023

Table represents Police Departments using NexGen RMS software. Accucom and IMC police departments will be provided as the RMS systems are integrated with CISS.



Partner Agency Updates

Tech Team Status

Accomplishments

- Bond Processing; FTA/VOP processing; Document Handling on the Clerk's Queue, and DESPP requests have been completed through User Acceptance Testing and were released with CISS 11.3. The Arrest Deletion Process is currently in UAT for final approval.
- Continued identification and development of improved RMS document handling functionality geared towards improving quality and efficiency for all stakeholder agencies.

In Development

- The Combo CR/MV Clerk Queue Notifications are required prior to Go Live.
- Continue RMS development of enhancements to drive quality and efficiency.
- CISS Replacement of the CRMVS Friday File processing including CIB Dispositions
- CISS Replacement of the DMV Extracts
- CISS/DCJ Release v11.4 (DCJ Downstream Messaging) in final development phase
- Final test case preparation has begun to support new workflow functionality to support DCJ Review/Release/Hold/Redaction of critical arrest documentation to downstream agencies.

Post-Production Work

- Reconciliation Automation for the daily data transfer process



Partner Agency Updates

Business Team Status

- Business pilot process has been implemented at G.A. 9 with evaluation of new process ongoing.
- G.A. 9 began accepting electronic Arrest Packets on August 30, 2021, from Clinton PD in the UAT Pilot testing environment.
- G.A. 9 began accepting electronic Misdemeanor Summons Packets on October 28, 2021, from Middletown PD in the UAT Pilot testing environment
- There continues to be positive feedback from all end users. All changes/enhancements to the electronic process will continue to be evaluated and prioritized through the change management process accepted by all participating agencies.



Partner Agency Updates

OTHER AGENCY UPDATES

- DESPP – Reverse communication from LiveScan to the RMS is in progress
- DPDS – CISS Search Internet Access Pilot Initiative is active
- DOC – CISS Delivery of Dispositions using the MVP Portal
- DMV – CISS Delivery of Early Arrest Notifications and Dispositions using the MVP Portal
- DMV - Integration - CISS Search for Driver Services



CISS Workflow Deployment – Update

EARLY ARREST NOTIFICATION (EAN) – RMS (Level 1)

- Deployment has restarted, +1 up to 17 PDs currently sending
- NexGen has tied EAN with LiveScan Interface (about 50 PDs)

ELECTRONIC ARREST PACKAGE – RMS (Level 2)

- UAT Pilot - Multi-Agency Testing Program with Production Data is currently running
 - Clinton & Middletown & CT State Police Pseudo-Prod Servers are online
 - CT State Police participation in Pilot, HQ Policy and Procedure Group and Troop F
 - Court Clerks, Judicial, DCJ are evaluating electronic versions of arrests vs. the official paper copy

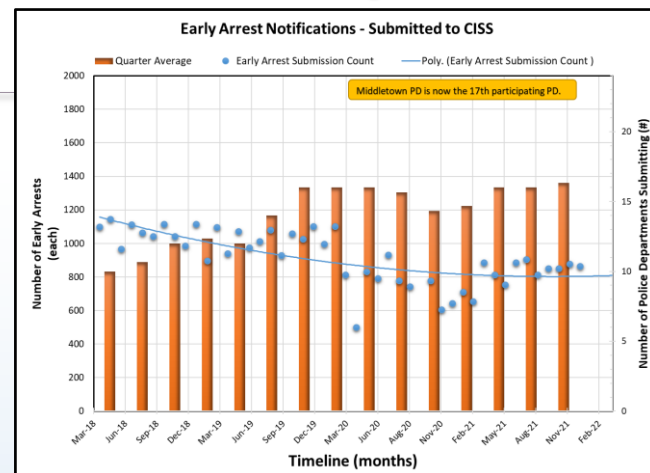

RMS VENDORS – Development and Programing Activities

- NexGen
 - Workflow Pilot Integration testing with full arrest packages in UAT (Level 2 - Certification)
- Accucom
 - Programming Level 2 arrest package generation in RMS (SYSTEST) – Target UAT Pilot 3/1/22
- Central Square
 - IMC RMS integration with CISS with Level 1 programming is progressing to target, completing final testing. Level 2 Kickoff was in November, developers are very active with a winter push.
 - Negotiating Contracts with Central Square’s 2 other main RMS systems in CT



CISS Quarters' Update FY 2022 Q3 Progress

*Group C is on hold and contingent upon Workflow Deployment. East Hampton PD and Portland PD were fully connected to CISS Search via the new Combined Collect | CJIS router.

GROUP A*: CURRENT UPDATES

11 PDs + DMV Avon Branford Bristol State Capitol Police New Haven East Lyme Southington W. Hartford Westport Windsor Wolcott Bristol		
	FY 2022 Q2 Progress	FY 2022 Q3 Progress
New Collect CJIS Router PDs Connected	6	9
Older Standalone Router PDs Connected	2	2
Total PDs Connected	73%	100%
Total PDs Full Onboarding Completed (Connectivity + Training)	4	5
Total PDs Reported	8	11

GROUP B*: CURRENT UPDATES

7 PDs Cheshire Coventry Groton Town Naugatuck South Windsor Suffield Bridgeport		
	FY 2022 Q2 Progress	FY 2022 Q3 Progress
New Collect CJIS Router PDs Connected	6	9
Older Standalone Router PDs Connected	2	1
Total PDs Connected	100%	100%
Total PDs Full Onboarding Completed (Connectivity + Training)	3	4
Total PDs Reported	9 (8 Lcl* + 1 CSP)	7** (Lcl)

* Lcl = Municipal (Local) | CSP = State Police PD **CSP + 1 Lcl Moved to GA-9 Deployment

GROUP D* (FY 2022 Q3): CURRENT STATUS

10 PDs Watertown Danbury East Hartford East Windsor Enfield Waterbury Wilton Woodbridge Middletown ECC Simsbury	
	FY 2022 Q3 Progress
New Collect CJIS Router PDs Connected	6
Older Standalone Router PDs Connected	4
Total PDs Connected	100%
Total PDs Full Onboarding Completed (Connectivity + Training)	2
Total PDs Reported	10



CISS Connectivity and Training Tentative Schedule

“Service Excellence” Initiative Tentative Schedule:

Group A: Jan-Mar 2021-5

1. Avon PD-[COM-CNNX]
2. Branford- [COM-CNNX] [T-10%]
3. Capitol Police [COM-CNNX] [T-10%]
4. New Haven PD [COM-CNNX]
5. East Lyme [COM-CNNX]
6. Southington PD- [COM-CNNX] [T-67%]
7. West Hartford PD [COM-CNNX]
8. Westport PD [LEG-CNNX]
9. Windsor PD [COM-CNNX] [T-59%]
10. Wolcott PD [COM-CNNX] [T-9%]
11. Bristol PD [LEG-CNNX] [T-31%]
12. DMV [T-Ongoing for more groups]

Group B: Apr-June 2021

1. Cheshire PD [COM-CNNX] [T-9%]
2. Coventry PD [COM-CNNX]
3. Groton Town [COM-CNNX] [T-81%]
4. Naugatuck PD [COM-CNNX]
5. South Windsor PD [COM-CNNX]
6. Suffield PD [COM-CNNX] [T-TBD]
7. Bridgeport PD [LEG-CNNX]
8. North Branford

Group C: July-Sep 2021

(Focus: Team Assisted with Workflow Deployment instead: Early Arrest Notifications.

CISS Onboarding dependent upon Workflow project.)

GA 9 (14 PDs)

Group D: Oct-Dec 2021

1. Watertown PD [COM-CNNX] [T-2%]
2. Danbury [LEG-CNNX] [T-TBD]
3. East Hartford [COM-CNNX] [T-24%]
4. East Windsor [COM-CNNX*] [T-88%]
5. Enfield PD [LEG-CNNX]
6. Waterbury [LEG-CNNX] [T-TBD]
7. Wilton PD [LEG-CNNX] [T-TBD]
8. Woodbridge PD [COM-CNNX]
9. Middletown ECC [COM-CNNX] [T-TBD]
10. Simsbury [COM-CNNX][AW-Val] [T-TBD]
11. Darien
12. Hamden

Group E: Jan-Mar 2022*

1. Stonington PD [COM-CNNX]
2. Greenwich PD [T-4%]
3. CCSU
4. Vernon GA 19
5. Norwich PD [T-50%]
6. UCONN Univ.-Storrs
7. UCONN Health Center (Farmington)
8. UCONN Avery Point Campus Police
9. UCONN Hartford Campus Police
10. UCONN Stamford
11. UCONN Waterbury Campus Police

Team A

Group F: Apr-June 2022*

1. Union (Troop C) GA 19
2. Somers (Troop C) GA 19
3. Tolland (Troop C) GA 19
4. Mansfield (Troop C) GA 19
5. Ellington (Troop C) GA 19
6. Andover (RST) GA 19
7. Bolton (RST) GA 19
8. Columbia (RST Troop K) GA 19
9. Hebron (RST) GA 19
10. Stafford (RST Troop C) GA 19
11. Willington (RST Troop C)GA 19

* Tentative Schedule subject to change. Additional arresting agency deployments to be scheduled beyond June 2022.

Green: Training, Connectivity to CISS Search [COM-CNNX=New COMBINED Router or LEG-CNNX=Legacy Router], & Customer Service Complete

Brown: [C]Pending Connectivity to New COMBINED (COLLECT/CJIS) , [AW] Awaiting Response from PD, [T] Training, or [M]May Be Moved to an Earlier Group

Black= 2022 Season for Service Excellence Initiative has not begun or has not finished.



Historical Trend: Bi-Monthly Statistics

FY 2022 Q1: Goal 13,000 Trained

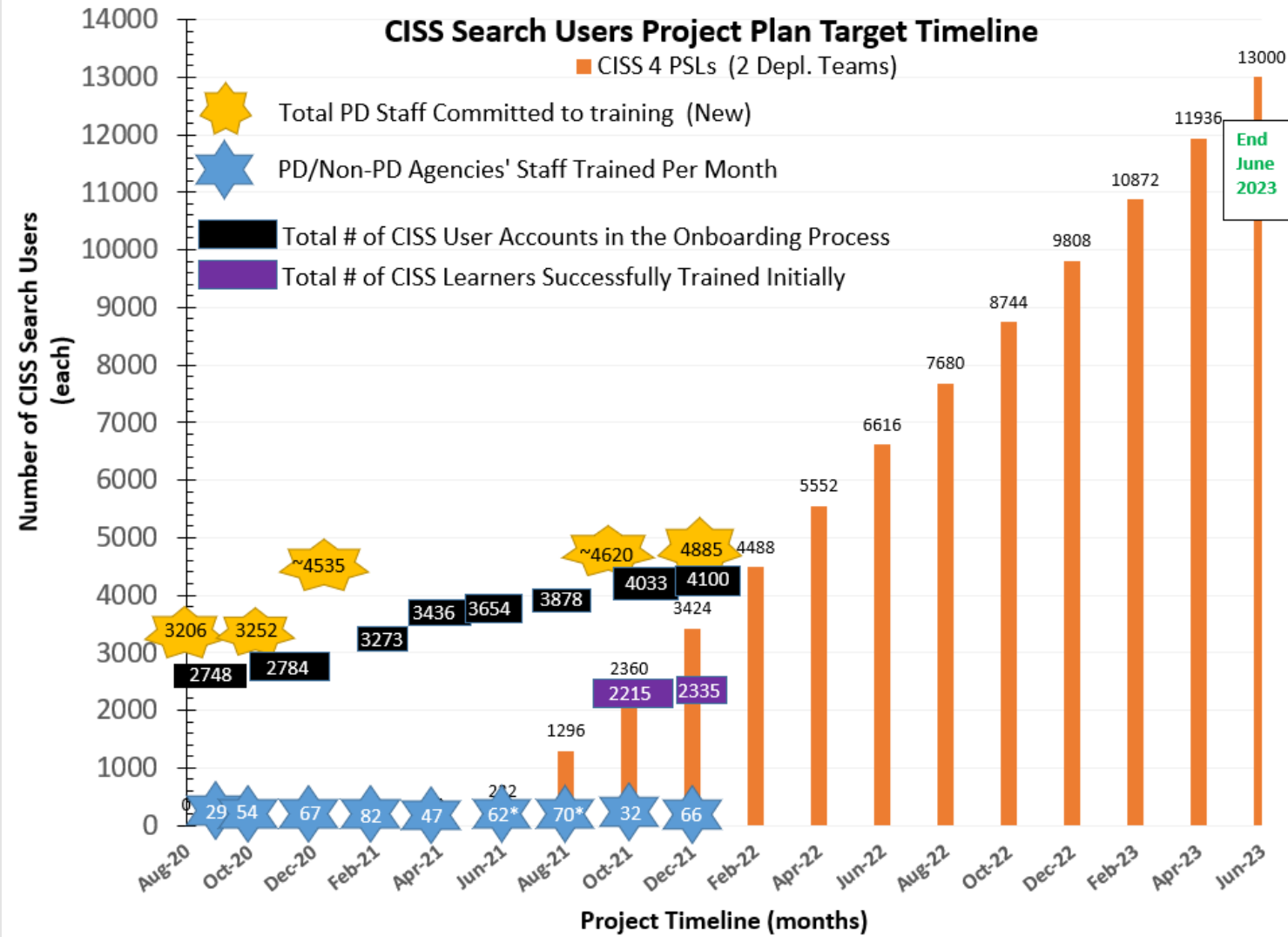

Risks:

1. Onboarding Project Members are currently shared with the Workflow Deployment Project.
2. Starting Oct 2021 "All Time Trained" numbers out of 13,000 goal reported. CJIS is working to refine the report for accurate reporting.

Mitigations:

- a) CJIS has hired a new retired police officer as a customer service liaison and is in the process of hiring additional staff.
- b) Live CISS Search Internet access is expected to assist with increasing training numbers for PDs concerned about having access immediately after training.



CISS Service Excellence Onboarding Improvement Model (In Progress...)

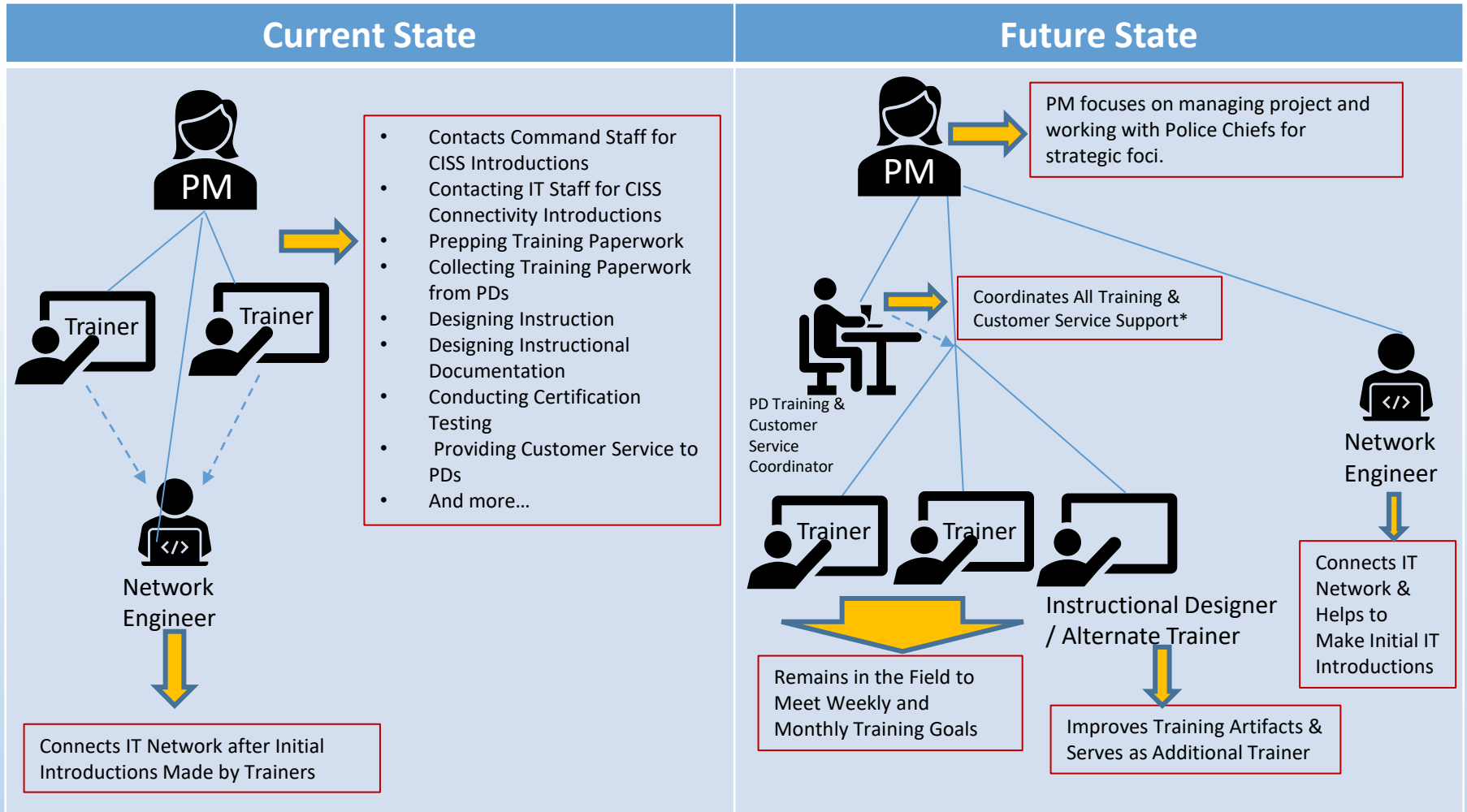

* Training Coordinator may make initial IT Introductions.



Router Connectivity & Upgrades

Calendar Year 2021 Service Excellence Initiative: (Connectivity Only)

PD Sites:

Validating 2021
Current Connectivity
Status of

71 of 97*

Connected to CISS Search via:

- CJIS Standalone Router,
- new CJIS/COLLECT Deployed Router,
- or PD Router

Stats Reported Oct 2021

64 of 95 Connected

Stats Reported Jan 2022

*71 of 97 Connected

*This number may change if CJIS is scoped to connect more arresting agencies.

Some agencies not yet in scope are represented in red.

** Some areas in yellow have a % of PDs connected in a multi-PD area.

***CJIS walked PDs through validations. We are awaiting PD sign off now that connectivity is complete.

~DEC 2020

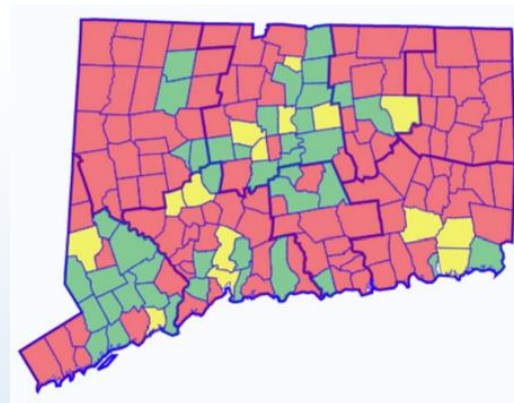

DEC 2021**

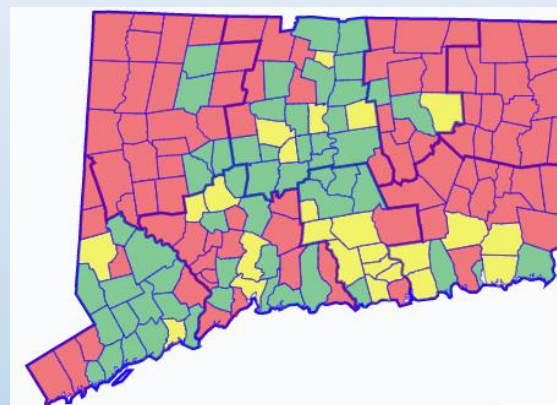

- Access to CISS Search
- Connectivity to CISS in progress
- No access to CISS Search



Clean Slate – System Development



General Assembly

January Session, 2021

Raised Bill No. 1019

LCO No. 4387

- Clean Slate (P.A. 21-32/33) - Erasure of criminal justice records, initiated by operation of law or by individual petition – based on statutory criteria.
- Clean Slate IT Initiative: Automated Erasure based on statute criteria is the focus of the Clean Slate Information Technology Initiative.
- DESPP/CCH – Collaborative processing via CISS Workflow and agency integration to distribute Clean Slate Notification Messages to support Automatic Record Updates.
- Multi-Agency Collaboration: Judicial Branch, DOC, CISS: Coordinating Sentence Completion Aggregation - Probation, Fines, Incarceration Discharge Notices.
- CJIS/CISS Workflow proven technology for messaging software and network endpoint connectivity – Component reuse and Extension.



Clean Slate – System Process Flow

Clean Slate Processing and Agency Information Exchange

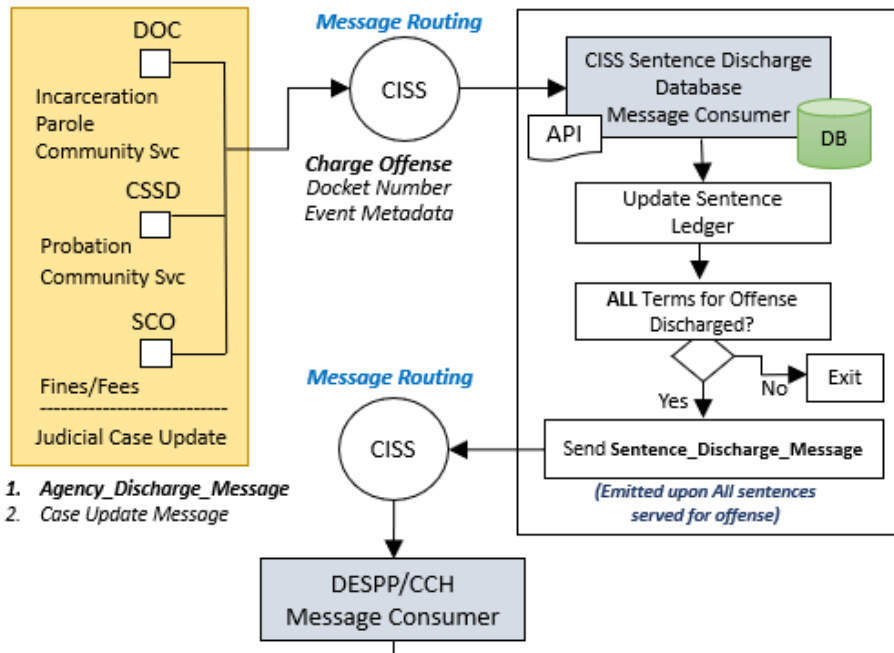

1. Agency_Discharge_Message
2. Case Update Message

- To meet Clean Slate Criteria for Offense Sentence Completion, CISS will Develop and Host a Sentence Discharge Database.
- Includes Sentence Aggregation from multiple Agencies and related Message Exchange.

- Clean Slate – DESPP/CCH Automated Erasure Processing.
- DESPP/CISS Clean Slate Notification Messaging.

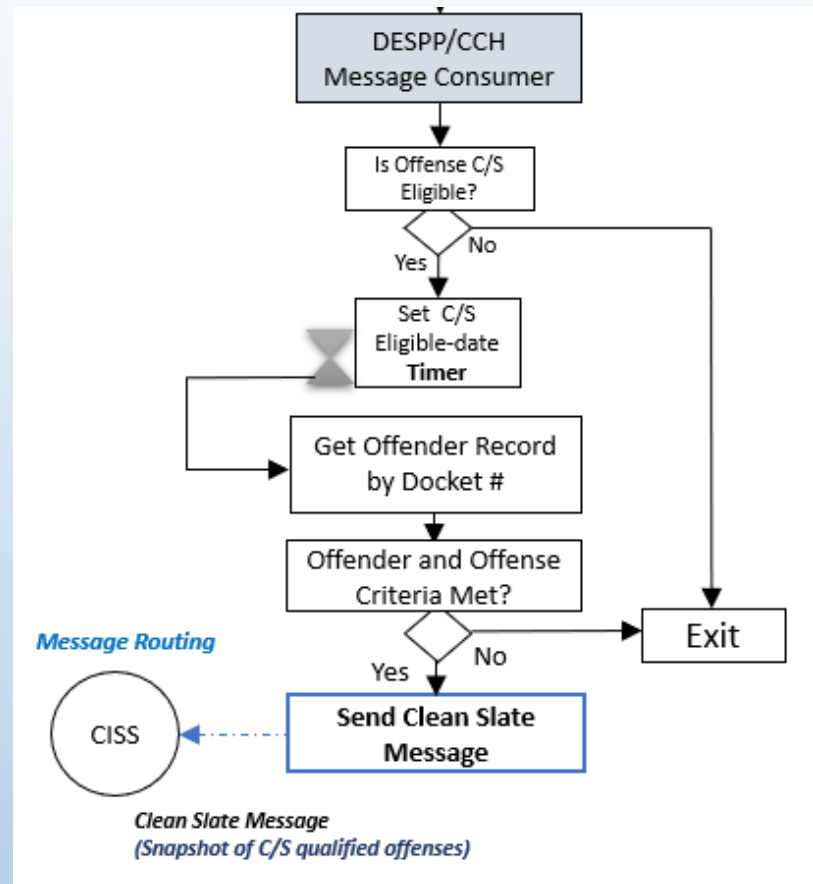



CISS Project Portfolio Gantt Chart

CISS Projects	2021				2022				2023				2024			
	Q1	Q2	Q3	Q4	Q1	Q2	Q3	Q4	Q1	Q2	Q3	Q4	Q1	Q2	Q3	Q4
CISS Workflow Deployment			GA-9	GA 19	GA-11	GA-4	GA-5/22	GA10/21	GA 1/20	GA 15/18	GA 7/23	GA 2/12	GA 13/14	GA-11	GA 3 Q1 2024	GA-4
1-RMS Vendor Integration for CISS Workflow (NexGen, Accucom, IMC)			Level 1 and 2 Deployment													
2-Additional RMS Vendors To Be Negotiated (Inform, ProSuite, etc.)					Level 1 and 2 Deployment											
CISS Search User Training and Access	Train and Provide Access for Approx.. 13,000 Users															
1-Internet Access to CISS Search			Build, Test, Deploy													
CISS Infrastructure & Application Upgrades/Changes	Development, Test, Deploy to Production															
1-Jazz Upgrade to 7.0.2			Development, Test, Deploy to Production													
2-CISS SharePoint 2019 Migration			Development, Test, Deploy to Production													
3-WebMethods Upgrade to 10.5			Development, Test, Deploy to Production													
4-MultiVue Upgrade and Optimization			Development, Test, Deploy to Production													
5-AutoCUAR Application and CISS/ISIM Integration			Development, Test, Deploy to Production													
Other Projects Requested by Stakeholders																
1-State Marshal Portal Upgrades versions 1.5 and 2.0					Version 1.		Version 2.0									
2-CCSU Police Use of Force System			Phase 2		Phase 3											
3-GFIPM Revision, New Agency Onboarding, Training, Legal Evals, Security, Federation			Development, Test, Deploy to Production													
4-Clean Slate (Criminal Record Erasure Reporting)					Development, Test, Deploy to Production											

Key Points:

- CISS Workflows with ALL RMS Vendors – Start September 2021 and Target end date by Q4 2024
- NexGen, Accucom, IMC, RMS Vendors - Target end date for full arrest package is March 2024
- Inform, ProSuite RMS Vendors – Target start date is Q1 2022 to negotiate and execute agreement contract to build and deploy CISS API for workflows is Q4 2024
- CISS Search – 2,335 users currently trained, expect to train remaining 10+K users by Q4 2023



CJIS Capital Budget

CISS FY22 CAPITAL BUDGET SUMMARY

<u>CAPITAL INVESTMENT</u>	Amounts
Bond Funds Provided from June 2011 to June 2020 Inclusive for Phase 1*	\$ 60,920,000
CJIS Appropriated Bond Funds for CISS Phase-2 Out of the \$8.9M*	\$ 4,998,000
Total Bond Funds Received for Phase 1 and Appropriations for Phase 2	\$ 65,918,000
<u>CAPITAL EXPENSES</u>	
CISS Phase 1 Expenses	\$ 57,762,963
Bond Funds Expended from July 2020 - December 2021 Inclusive for Phase 2	\$ 6,309,572
Total Costs for CISS Phase 1 and Phase 2	\$ 64,072,535
Remaining Bond Funds for Phase 2 Deployment*	\$ 1,845,464.57

Note: *Total Bond Funds Received for Phase 1 are 60,920,000. Approved Bond Funds for Phase-2 are \$8,924,328.



CJIS Operational Budget for FY22-23

CISS GENERAL FUND OPERATIONAL BUDGET SUMMARY

<u>FISCAL YEAR</u>	<u>FY22</u>	<u>FY23</u>
General Fund Budget	\$ 3,196,772	\$ 3,212,881
General Fund FY19 Rollover Funds for FY 22 Requested	\$ 434,020	\$ 353,276
¹ Aproximate Adjustment by OPM to Replace Inmate Phone Revenue		\$ 2,200,000
Total Funding for General Funds²	\$3,630,792	\$5,766,157
Inmate Phone Revenue Budget for State Positions and Maint. & Support	\$ 5,097,152	\$ -
Total Expected Annual Operational Budget	\$8,727,943	\$5,766,157
Notes:		
1 - Includes state positions and maintenance vendor costs. Adjustment does not include fringe benefits. OPM to cover fringe benefits. Approved vacant positions are not included.		
2 -CJIS is working to reduce annual costs. Software AG Costs Reduced from \$520K to \$180K Annually for FY22 and FY23		



CISS Scope Completion & Deployment Phase

Key Success Factors

Secure CJIS Funding

Funding for Operational Support and Implementation of Phase 2

Status



Notes

FY22 and FY23 budgets are in place. General Fund with FY19 Rollover to cover FY22 and FY23 gaps if needed. Bond funds of \$8.9M received and being used for deployment of CISS.

CISS Operational Support

State Employee Hiring



State employee hiring on hold. Consultants used to supplement operational support needs. Also working with DAS-BITS for future plan for support.

Maintenance and Support Vendor



AIC contract for support funded from Inmate Phone Revenue which end 6/30/21. General funds will be used instead.

CJIS Consultants



Bond Funding in place. Plan being executed to complete CISS state-wide deployment.

Cost Reduction and Right Sizing



CISS is negotiating with vendors to reduce costs significantly. We are also updating our “end state” organizational needs for more efficiency, effectiveness and stakeholder satisfaction.

Other Factors

- Federal Grant Opportunities for CJIS Projects



CISS Key Project Risks & Mitigation

#1 RMS Vendor Participation Does Not Provide 90% + of All Arrests to CISS

Mitigation:

- Contract largest RMS vendors with CISS to get 90%+ arrest information in the state. NexGen, Accucom and now IMC started connectivity work as well. CJIS is negotiating with Central Square to connect two more RMS vendors Systems to CISS.
- Support Law Enforcement Agencies (LEAs) to migrate to RMS vendors connected to CISS.
- CISS Connectivity required to be Standard in CT Contracts and add in new legislation.
- Provide solution(s) for LEAs with non-CISS connected RMS.

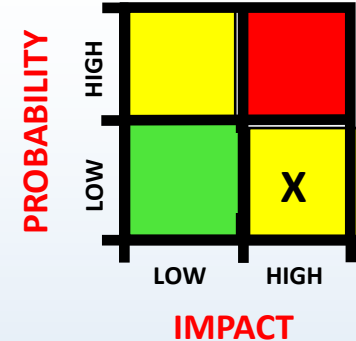

#2 Stakeholder Support. Current CJIS Agency state budgets do not include funding for resources to implement the CISS.

Mitigation:

- Tiger Teams - CJIS will continue to provide technical and logistical resources support to Agencies for CISS integration with their systems and implementation state-wide.

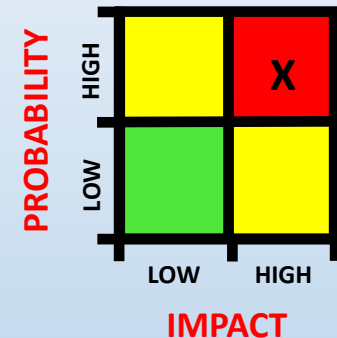



CISS Key Project Risks & Mitigation

#3 COVID-19 pandemic will cause delays and increase costs in the deployment of CISS Workflows and Search.

Mitigation:

- CJIS is working with each Stakeholder impacted by the COVID-19 and new variants to help with any CISS deployment work by offering resources that may be needed.
- We are also moving CISS scope from the future to the present that must be completed in order to successfully deploy CISS with the funding and schedule planned.

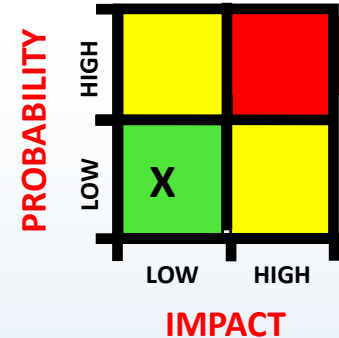

#4 SharePoint, Software AG, MultiVue and Other Key Applications in CISS need to be upgraded over the next 24 months or significant issues will occur.

Mitigation:

- CJIS is in the process of upgrading key applications while deploying CISS Workflows and Search.

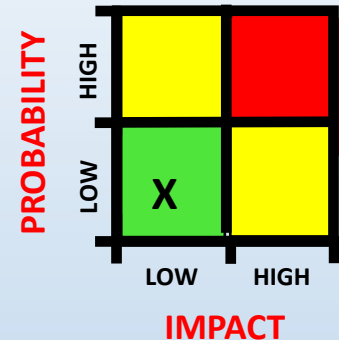

#5 Criminal Justice Agency Partner personnel retirements expected to be significant over the next two years and will cause delays to schedule and increase costs.

Mitigation:

- CJIS is working with our Agency Partners to identify retirements that can impact CISS deployment early and will work with Agencies to have a backup person in place.

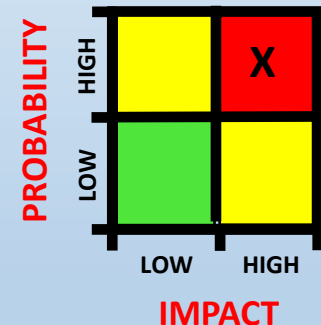



CJIS Governing Board 2022 Meeting Schedule

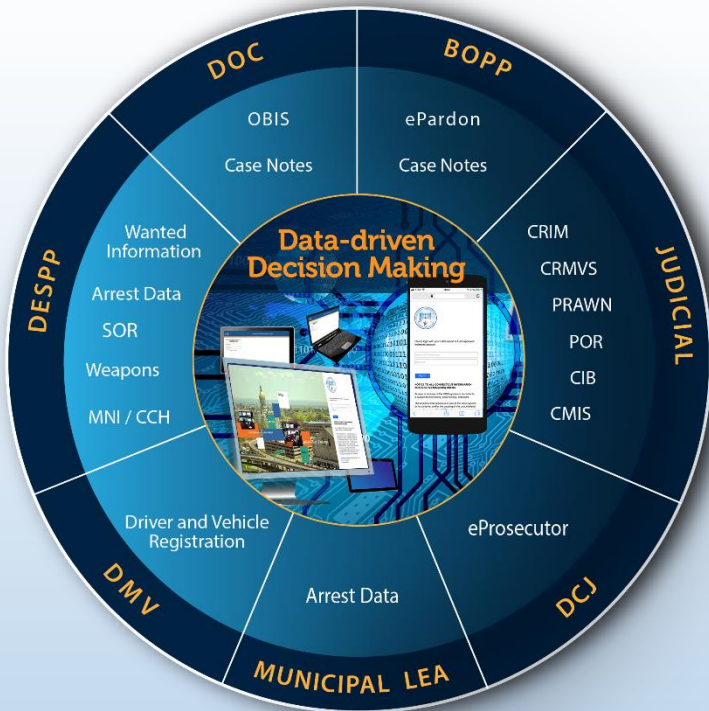

Next Meeting

April 28, 2022

Location To be determined

For questions and comments email

CJIS.HelpDesk@ct.gov

CISS Dashboard

<https://dashboard.cjis-ciss.ct.gov>



CJIS Governing Board Appendix



CJIS Special Projects & Analytics



Agency Name	CISS Search	CISS Workflow	CJIS Analytics	Current Status
New Agency Onboarding - Departments of DCP, DSS, DRS	✓			Active
DMV - Driver Services IB-53/Judicial CR-39	✓		✓	Complete - Ended
DMV - Monitoring Driver Instructors	✓		✓	Complete - Ended
Combined CJIS/COLLECT Routers	✓	✓		Deployment (98% +) PD LANs - Active
DOC & DMV MVP Dispositions		✓	✓	Complete - Ended
OPM – New Arrests Report & DCJ - Docket Reports			✓	Complete - Ended
CT Sentencing Commission (SA 19-17) – Study Disparities in Pretrial & Sentencing Outcomes			✓	Part 1 Complete Part 2 - Active
State Marshals Self Service Portal (C.G.S §14-10 & C.G.S §6-38a)			✓	Ver. 1 LIVE - Complete Ver. 1.5 - Active
Criminal Record Erasure Reporting (HB 5019 & SB 403)			✓	Active
Police Use of Force Transparency (PA 19-90)		✓	✓	Phase 1 Complete Phase 2 - Pilot
CISS Search Available via Internet	✓			Pilot
DOL – Incarceration Validation Portal (DOC)	✓		✓	Re-Evaluation with DOC
CISS Workflow Tracking, Delivery & Recovery Dashboard		✓	✓	Active

* Other Notables: Racial Profiling Upgrade, BOPP & DESPP Data Exchanges , DMHAS – Misdemeanor Competency Evaluations