

**Guidebook for Fieldtrips in Connecticut
and South Central Massachusetts
New England Intercollegiate Geological Conference**

74th ANNUAL MEETING

THE UNIVERSITY OF CONNECTICUT
STORRS, CONNECTICUT

OCTOBER 2-3, 1982

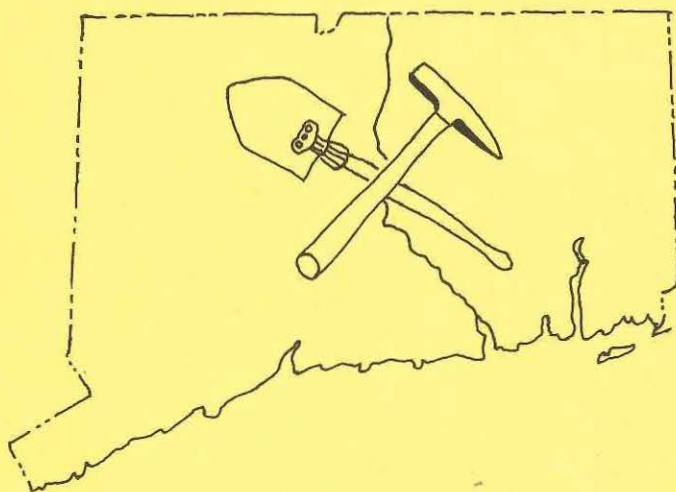

STATE GEOLOGICAL AND NATURAL HISTORY SURVEY
OF CONNECTICUT

THE NATURAL RESOURCES CENTER

DEPARTMENT OF ENVIRONMENTAL PROTECTION

1982

GUIDEBOOK NO. 5

NEW ENGLAND INTERCOLLEGIATE GEOLOGICAL CONFERENCE

74TH ANNUAL MEETING

THE UNIVERSITY OF CONNECTICUT
STORRS, CONNECTICUT

October 2, and 3, 1982

GUIDEBOOK FOR FIELDTRIPS IN CONNECTICUT AND SOUTH CENTRAL MASSACHUSETTS

Editors

Raymond Joesten
Department of Geology and Geophysics
The University of Connecticut
Storrs, CT

Sidney S. Quarrier
State Geological and Natural History
Survey of Connecticut
Department of Environmental Protection
Hartford, CT

STATE GEOLOGICAL AND NATURAL HISTORY SURVEY
OF CONNECTICUT
THE NATURAL RESOURCES CENTER
DEPARTMENT OF ENVIRONMENTAL PROTECTION
1982
GUIDEBOOK NO. 5

STATE GEOLOGICAL AND NATURAL HISTORY SURVEY
OF CONNECTICUT

THE NATURAL RESOURCES CENTER
DEPARTMENT OF ENVIRONMENTAL PROTECTION

Honorable William A. O'Neill, Governor of Connecticut
Stanley J. Pac, Commissioner of the Department
of Environmental Protection

STATE GEOLOGIST
DIRECTOR, NATURAL RESOURCES CENTER
Hugo F. Thomas, Ph.D.

For information on ordering this guidebook and other publications of the Connecticut Geological and Natural History Survey, consult the List of Publications available from the Survey, Department of Environmental Protection, State Office Building, Hartford, CT 06115. Telephone: (203) 566-3540.

NEW ENGLAND INTERCOLLEGIATE GEOLOGICAL CONFERENCE
74TH ANNUAL MEETING

honoring

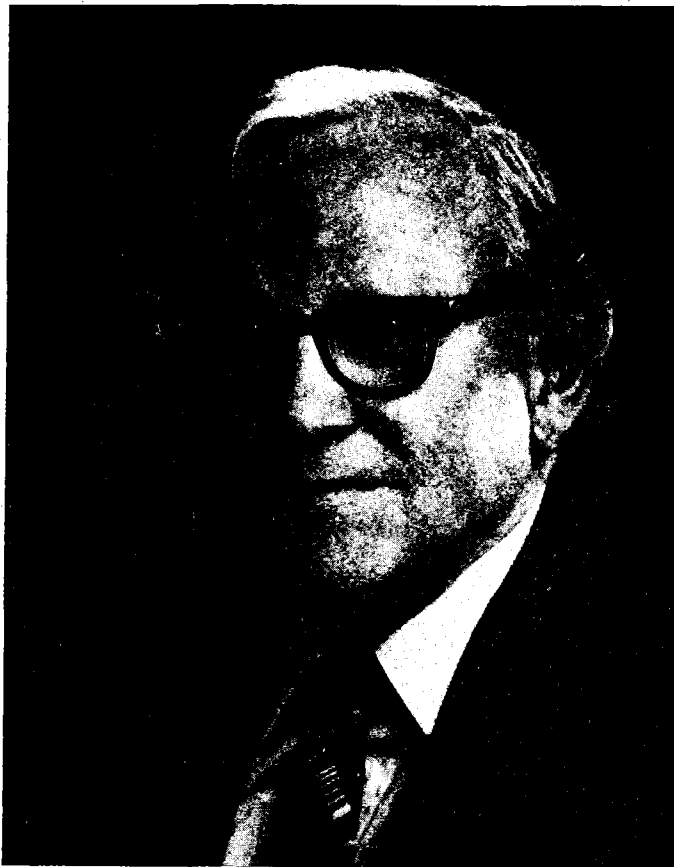

JOE WEBB PEOPLES

The state surficial and bedrock maps included in this Guidebook are the result of several decades of directed geologic investigations. In addition to the efforts of the many geologists who mapped one or more quadrangles and those of the compilers who tackled the sometimes difficult task of reconciling differing geologic interpretations to arrive at a consistent map, the contribution of Joe Webb Peoples stands out. As a Commissioner of the State Geological and Natural History Survey for more than two decades and as Director and State Geologist for twelve years, he played a key role in the many events that moved this work forward. In particular, Joe provided direction, encouragement, and support for the individual mapping projects and fostered productive cooperation between the State Survey, the U.S.G.S., and individual university geologists. With foresight he led the Legislature to support preparation of a new state base map that is to be used in printing the geologic maps. A hallmark of Joe's contribution was the vitality and fellowship that characterized the annual summer conference, each followed by an evening at "Peoples Choice", Joe and Ruth Peoples' residence, overlooking the river in Middle Haddam, Connecticut.

(Photo by Burian-Moss)

NEW ENGLAND INTERCOLLEGIATE GEOLOGICAL CONFERENCE

Dabney Caldwell, Secretary
Department of Geology
Boston University
Boston, MA 02215

Conference Organization:

Raymond Joesten and Lawrence Chestnut
Department of Geology and Geophysics
The University of Connecticut
Storrs, CT 06268

Sidney S. Quarrier
State Geological and Natural History
Survey of Connecticut
Department of Environmental Protection
Hartford, CT 06115

A special word of thanks is in order for all of the secretaries and illustrators whose extra effort at producing crisp, camera-ready copy on a tight deadline has made this Guidebook the attractive piece of work that it is.

The fact that a locality is described in this guidebook does not imply that the public has access to the locality. Stopping on a limited access highway is forbidden by a regulation of the State Traffic Commission, which prohibits all vehicles from stopping or parking on any part of the highway. These regulations also prohibit pedestrians on any limited access highway. Field trip features on these highways can be viewed from other ground. In other instances, stops on private property require permission of the owner. Anyone planning to go on this field trip should check carefully the suggested stops, and do nothing to jeopardize their use by geologists in the years ahead.

EDITOR'S PREFACE

The NEIGC comes to Connecticut at an opportune time, as state-wide syntheses of both Quaternary Geology and Bedrock Geology have recently been completed, thus providing a framework tying together the 17 field trips presented in this Guidebook. As several trip leaders are quick to point out, however, the geologic record is not everywhere susceptible to unique interpretation. Not surprisingly, consensus has yet to be reached on some aspects of Connecticut geology. Several localities described herein promise to be the site of lively discussion on the first weekend in October, 1982, and for some time thereafter.

It is a privilege to be able to include with this Guidebook, the 1982 Preliminary Bedrock Geological Map of Connecticut, compiled by John Rogers. The map has evolved over a period of 34 years, during which time much of the state was mapped at 7 1/2 minute quadrangle scale, while structural and stratigraphic interpretations more or less continuously changed. It is a tribute to John's geologic insight as well as his perseverance, that he has been able to trace defensible geologic contacts across quadrangle boundaries in a state known more for its extensive glacial deposits than for continuity of bedrock exposure. John emphasizes that alternate structural interpretations are possible, and these are provided by the authors of trips P2, P4, P6, P7, and P9.

We are also fortunate to be able to include, in advance of publication, a portion of the Quaternary Geologic Map of Connecticut, compiled by Janet Stone, Phil Schafer, and Betty London of the U.S.G.S. and Woodrow Thompson of the Maine Geological Survey. Trip Q1, which accompanies the map, illustrates the concepts of stagnation zone retreat and morphosequence deposition which provide the guiding paradigm for compilation of the map.

A rival hypothesis for the deglaciation of Southern New England, which necessarily leads to a different set of map units on a Quaternary geologic map, is that of basin-wide ice stagnation. The leaders of trip Q3 each offer alternative interpretation of the mode of deglaciation of the Shetucket River Basin.

The continued success of the NEIGC is due entirely to the trip leaders, who share freely of their intimate knowledge of the rocks or glacial deposits as they actually occur in the field, patiently endure merciless criticism of their favorite exposures, and, above all, take time which might be more profitably spent in the field or lab to provide a written record of the field facts on which the maps and interpretations ultimately are based. We thank them all.

THE EDITORS

TABLE OF CONTENTS

HONORING JOE WEBB PEOPLES iii

EDITOR'S PREFACE v

INDEX OF PUBLISHED GEOLOGIC QUADRANGLE MAPS OF CONNECTICUT vi

YET ANOTHER PRELIMINARY GEOLOGICAL MAP OF CONNECTICUT
 John Rogers, Compiler 1

QUATERNARY GEOLOGY

Q1 THE SURFICIAL GEOLOGIC MAPS OF CONNECTICUT ILLUSTRATED BY A FIELD TRIP
 IN CENTRAL CONNECTICUT
 Janet R. Stone, J.P. Schafer, and Elizabeth H. London 5

Q2 ANATOMY OF THE CHICOPEE READVANCE, MASSACHUSETTS
 Fredrick D. Larsen 31

Q3 MODE OF DEGLACIATION OF SHETUCKET RIVER BASIN
 Robert F. Black and Sherman M. Clebnik 49

Q4 SEDIMENTATION IN A PROGLACIAL LAKE: GLACIAL LAKE HITCHCOCK
 Gail Ashley, George Thomas, Michael Retelle, and
 Joseph Hartshorn 89

MESOZOIC GEOLOGY

M1 JURASSIC REDBEDS OF THE CONNECTICUT VALLEY: (1) BROWNSTONES OF THE
 PORTLAND FORMATION; (2) PLAYA-PLAYA LAKE-OLIGOMICTIC LAKE MODEL FOR
 PARTS OF THE EAST BERLIN, SHUTTLE MEADOW AND PORTLAND FORMATIONS
 John F. Hubert, James Michael Gilchrist, and Alan A. Reed 103

M2 PALEONTOLOGY OF THE MESOZOIC ROCKS OF THE CONNECTICUT VALLEY
 Nicholas G. McDonald 143

M3 MESOZOIC VOLCANISM IN NORTH CENTRAL CONNECTICUT
 Norman H. Gray 173

M4 COPPER OCCURRENCES IN THE HARTFORD BASIN OF NORTHERN CONNECTICUT
 Norman H. Gray 195

PALEOZOIC AND PRECAMBRIAN GEOLOGY

P1 AN INVESTIGATION OF THE STRATIGRAPHY AND TECTONICS OF THE KENT AREA,
 WESTERN CONNECTICUT
 Richard A. Jackson and Leo M. Hall 213

P1A	CHRONOLOGY OF METAMORPHISM IN WESTERN CONNECTICUT: Rb-Sr AGES Douglas G. Mose and Susan Nagel	247
P2	THE BONEMILL BROOK FAULT ZONE, EASTERN CONNECTICUT Maurice H. Pease	263
P3	HIGH GRADE ACADIAN REGIONAL METAMORPHISM IN SOUTH-CENTRAL MASSACHUSETTS Peter Robinson, Kurt T. Hollocher, Robert J. Tracy, and Craig W. Dietsch	289
P4	STRATIGRAPHY AND STRUCTURE OF THE WARE-BARRE AREA, CENTRAL MASSACHUSETTS Peter Robinson, Michael T. Field, and Robert D. Tucker	341
P5	LAKE CHAR FAULT IN THE WEBSTER, MASSACHUSETTS AREA: EVIDENCE FOR WEST-DOWN MOTION Arthur G. Goldstein	375
P6	STRUCTURAL RELATIONS AT THE JUNCTION OF THE MERRIMACK PROVINCE, NASHOBA THRUST BELT AND THE SOUTHEAST NEW ENGLAND PLATFORM IN THE WEBSTER-OXFORD AREA, MASSACHUSETTS, CONNECTICUT, AND RHODE ISLAND Patrick J. Barosh	395
P7	THE STRUCTURAL GEOLOGY OF THE MOODUS SEISMIC AREA, SOUTH-CENTRAL CONNECTICUT Patrick J. Barosh, David London, and Jelle de Boer	419
P8	MULTI-STAGE DEFORMATION OF THE PRESTON GABBRO, EASTERN CONNECTICUT H. Roberta Dixon	453
P9	STRUCTURE AND PETROLOGY OF THE WILLIMANTIC DOME AND THE WILLIMANTIC FAULT, EASTERN CONNECTICUT Robert P. Wintsch and James S. Fout	465

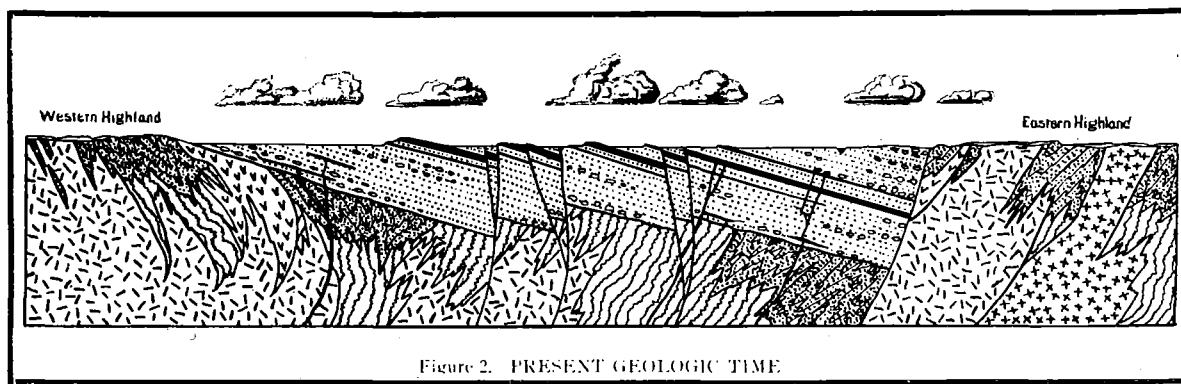

Cross Section of Central Connecticut From Joseph Barrell, 1915, Central Connecticut in the Geologic Past, State Geological and Natural History Survey of Connecticut, Bulletin No. 23.

It seems fitting to introduce these field trips with a caveat from the Introduction to an earlier synthesis of Connecticut geology, which with appropriate modification, is equally applicable to the glacial and bedrock trips that follow.

"At that time I knew the length of the bibliography of New England glaciology better than I knew its content, and I not unnaturally thought that the chief facts and relationships were established, and that areal details and refinements might be all I could hope to add to our knowledge of glaciation of Southern New England. Once in the field, however, I realized that the state of affairs was altogether different from what my reading had lead me to expect.

Richard Foster Flint
The Glacial Geology of Connecticut
1930

Yet another Preliminary Geological Map of Connecticut
John Rodgers, compiler

The 1982 Preliminary Bedrock Geological Map of Connecticut, presented with this guidebook, follows in the wake of similarly named maps dated 1956 and 1906 and of Percival's superb pioneer map of 1842. The present 2-color map is preliminary to a full-color map scheduled to be published in the next two years by the Connecticut Geological and Natural History Survey, in cooperation with the United States Geological Survey.

Any compiled map is fundamentally dependent on detailed mapping done by many individuals over a considerable period of time, and the present map is very much so. In 1948, the Commissioners of the Connecticut Geological and Natural History Survey called a meeting to discuss what work the Survey should be supporting to justify its existence to the State. As regards geology, that meeting called for systematic quadrangle mapping of the State, both bedrock and surficial, on the then new 7½' topographic base maps. Work began at once and is still continuing; the State Survey has now published 39 Quadrangle Reports in its own series, and its cooperative project with the U.S. Geological Survey has produced 85 maps in the latter Survey's Geologic Quadrangle Map series. These Maps and Reports are nearly evenly divided between surficial and bedrock geology. The bedrock maps alone are the work of nearly 40 different geologists over a period of 30 years. Moreover, many unpublished maps by these and nearly as many others were available for the compilation.

Because so many different people have been involved, ideas on the bedrock geology have been and still are very diverse, yet compilation demanded taking a stand on many unsettled questions. As a result the map is probably entirely satisfactory to hardly anyone and is definitely unsatisfactory to some of those whose basic information was used and who must not be blamed for its imperfections as they are uncovered over the years. No map (or geologic article), whether labelled Preliminary or not, can be anything more than a progress report on how the geology looks now to certain individuals; other individuals will see it differently, and only time and further work will tell how much of each point of view is correct. All users of the map must therefore keep firmly in mind that the map expresses only one of the possible interpretations, the one that seemed to the compiler most consistent with other parts of the map and with the facts as he then knew them.

Let us pass in review some of the more significant current controversies about the geology of Connecticut. As shown by the small tectonic map accompanying these remarks, Connecticut divides naturally into three regions - the Eastern and Western Highlands separated by the Central Lowlands. The Lowlands are underlain by lower Mesozoic sedimentary and volcanic rocks that rest on and conceal rocks of the Western Highlands; both are separated from the rocks of the Eastern Highlands by the Eastern Border Fault. Even the geology of the Central Lowlands has disputed points, notably the nature, number and placement of the faults, which may extend well beyond where they cut the three basalt lava-flow units and are readily recognized and mapped.

The Western Highlands is further divided in two by "Cameron's Line", apparently an old thrust fault that was later severely folded and perhaps in part reactivated. The rocks to the west of this line include three major groups of rock units: Massifs of Proterozoic gneissic basement, an early Paleozoic shelf ("miogeosynclinal") sedimentary sequence (now metamorphosed); and an upper unit mostly of schist that for some geologists is simply the normal upper part of the cover, but for others (including the compiler) is part of the great Taconic allochthons, thrust sheets extending from west-central Vermont to southeastern New York. The rocks to the east of "Cameron's Line" in the Connecticut Valley Synclinorium, are even more controversial. Clearly they were originally a sequence or several sequences of sedimentary and volcanic ("eugeosynclinal") rocks, but they have been intensely deformed, metamorphosed, and cut by intrusive rocks, probably several times. The original stratigraphic sequence and correlation of these rocks is currently in vigorous debate; what is shown on the map and its explanation may well require modification or in the end may prove to be totally wrong. The relation of the rocks in the southeastern part of this region (beyond the East Derby fault) is especially uncertain. This area has been distinguished on the tectonic map and the explanation of the main map as the Orange-Milford terrane.

The rocks of the Eastern Highlands fall into three major groups: those along the western side, in the Bronson Hill Anticlinorium, are dominated by metaigneous rocks, both metavolcanic and metaintrusive; those in its central part, the Merrimack Synclinorium, by metasedimentary rocks (but the stratigraphic sequence and age of those rocks is particularly controversial); those along its eastern and southern sides, the Avalonian terrain, belong to all three kinds but appear to be some what older than the others. This third group is separated from the rest by a prominent line of faulting and mylonitization along the Honey Hill and Lake Char faults (for the full name of the latter, see the explanation of the main map), but the nature of these faults is in dispute. Recent paleomagnetic investigations suggest indeed that the rocks of the third group are "exotic", not formed directly to the southeast of those of the other two groups but far away, perhaps in the other hemisphere, and brought to their present position quite late in the Paleozoic, in which case the Honey Hill and Lake Char faults would represent (or conceal) a major strike-slip fault of San Andreas type.

Another major question concerning the Eastern Highlands (indeed to a considerable extent the Western Highlands as well) is whether the present-day distribution of the rocks is principally the result of repeated, extreme (recumbent) folding and large-scale horizontal movement or of repeated fracturing and nearly vertical faulting. The compiler, as the map shows, accepts the first view, and sees the map pattern as more like "spaghetti" than like "broken glass" (though admitting that in several areas the spaghetti was later cut up by a meat cleaver). A proponent of the second view would produce a very different map.

In concluding, the compiler wishes to express his very great debt to all those who have encouraged and enabled him to finish the job. All the geologists who have worked in the systematic bedrock-mapping project for Connecticut have made their results available to him, much of it before

publication; furthermore the many discussions and field trips with them over the years have been very rewarding. A series of helpful draftsmen have drawn successive versions of the map, notably Nathaniel Gibbons, Craig Dietsch, and Jessie Arnold. Supervisors on the U.S. Geological Survey - Lincoln R. Page, Norman Hatch, Douglas W. Rankin - have provided all kinds of material and other support. John B. Lucke, Joe Webb Peoples, Hugo Thomas, and Sidney Quarrier, successive Directors and Assistant Directors of the Connecticut Geological and Natural History Survey during the 30 years of the project, have not only kept it going but repeatedly urged the compiler to put together and distribute for criticism "preliminary, preliminary" compilations as the data came in. Finally, all the others to whom I am indebted, named or not named, will I hope permit me to dedicate this map to Joe Peoples, for his long and valuable service to the State, for his never-failing interest in the compilation and its progress (when there was any), and for his continuing friendship.

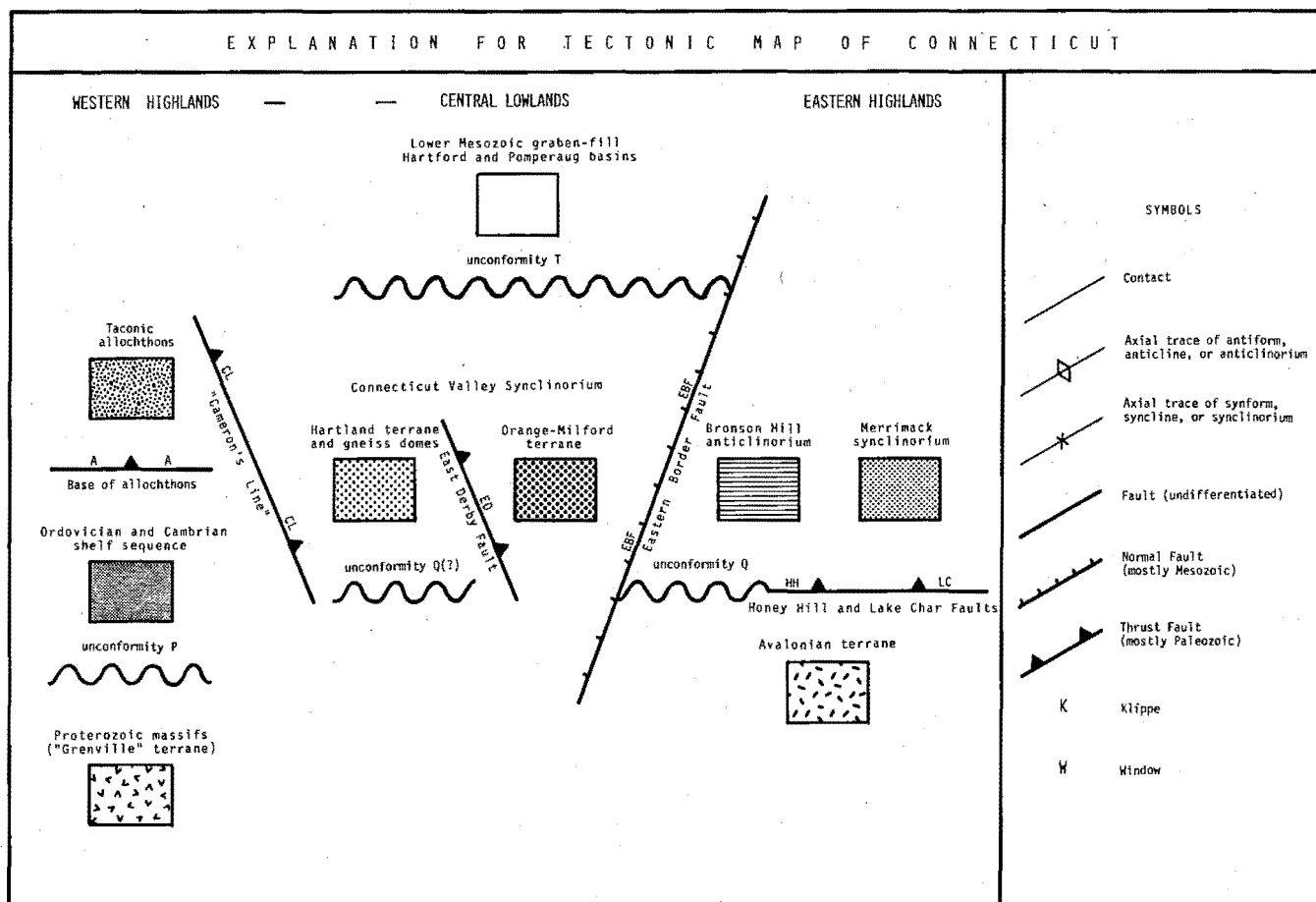

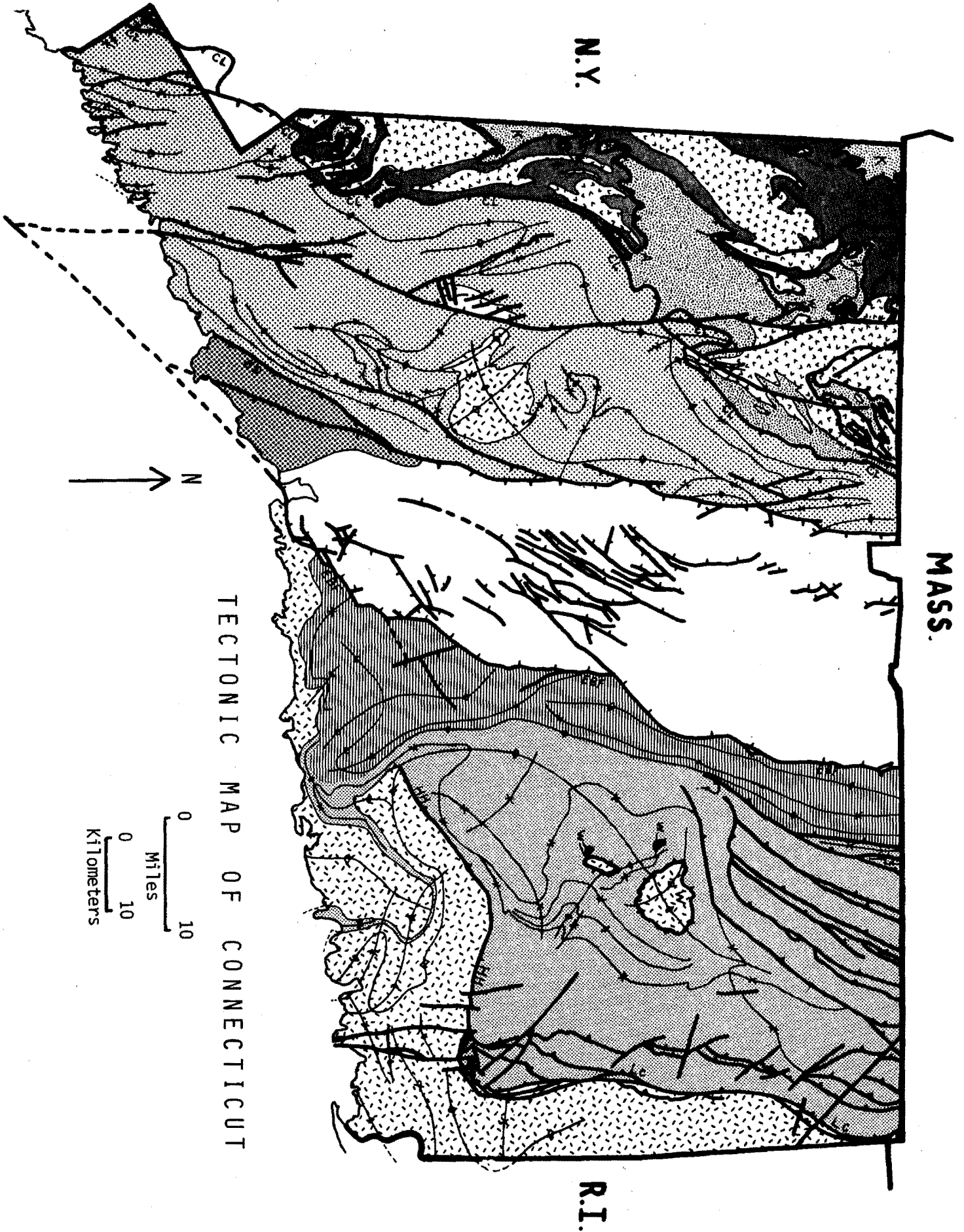

TECTONIC MAP OF CONNECTICUT

Quaternary Geology

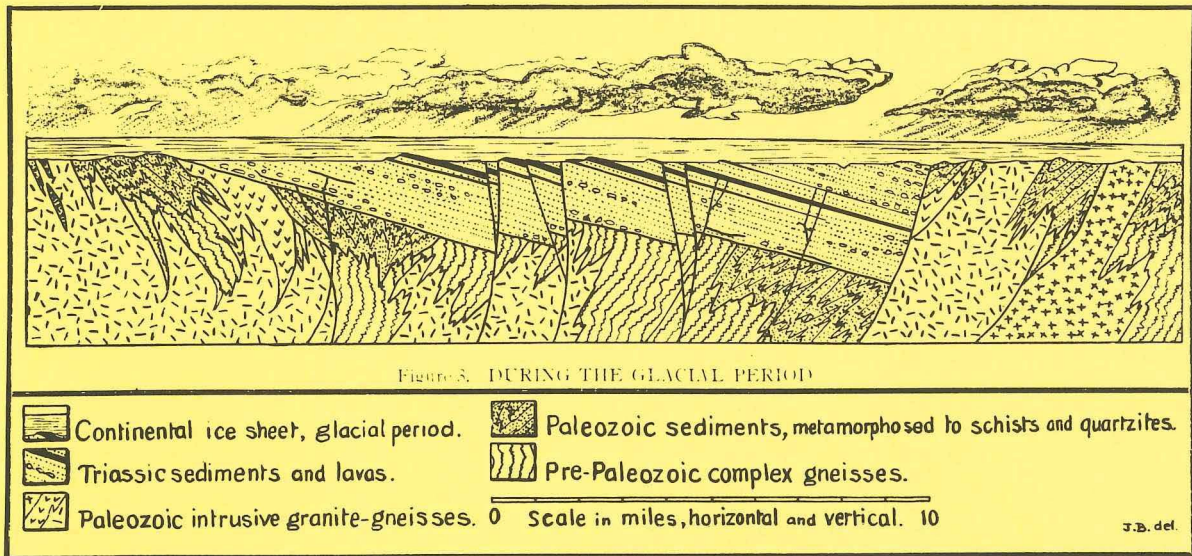

Q1	THE SURFICIAL GEOLOGIC MAPS OF CONNECTICUT ILLUSTRATED BY A FIELD TRIP IN CENTRAL CONNECTICUT	5
Q2	ANATOMY OF THE CHICOPEE READVANCE, MASSACHUSETTS	31
Q3	MODE OF DEGLACIATION OF SHETUCKET RIVER BASIN	49
Q4	SEDIMENTATION IN A PROGLACIAL LAKE, GLACIAL LAKE HITCHCOCK	89

Q1-1

THE SURFICIAL GEOLOGIC MAPS OF CONNECTICUT
ILLUSTRATED BY A FIELD TRIP IN CENTRAL CONNECTICUT

by

Janet R. Stone, J. P. Schafer, and Elizabeth H. London
U. S. Geological Survey, Reston, VA 22092

INTRODUCTION

Two maps of the surficial deposits of Connecticut have been compiled by the authors and Woodrow B. Thompson (Maine Geological Survey). Both maps show glacial till, stratified glacial deposits, and postglacial deposits, but the main difference between the maps is in the ways that the stratified glacial deposits (glaciolacustrine and glaciofluvial) are shown. The surficial materials map emphasizes the areal and vertical distribution of different textures relative to depositional environment. The Quaternary geologic map emphasizes the history of those deposits and the information they provide about the retreat of the last ice sheet. Figure 1 shows a preliminary version of this map for part of central Connecticut.

Connecticut is covered by 75 full or nearly full U.S. Geological Survey topographic quadrangle maps (7 1/2', 1:24,000), and 42 partial ones. Of these, 68 were covered by U.S. Geological Survey published or open-filed maps of surficial geology, 16 by Connecticut Geological and Natural History Survey maps, and 14 by unpublished data from various authors. All the quadrangle maps were reviewed by us, and a few quadrangles were extensively remapped; reconnaissance mapping was performed in the remaining quadrangles. In the course of compiling this large body of data into two coherent State maps, based on a consistent interpretive rationale, we have taken greater or lesser liberties with the original studies.

Measurements are given either in metric or in both metric and U.S. customary units, except that altitudes taken from topographic maps are given only in feet.

GLACIAL TILL

On both maps, areas of "thick till" (more than about 5 m thick) are distinguished from the areas of thin, discontinuous till in which bedrock crops out extensively. The surface relief of thin till is controlled mostly by the irregularities of the bedrock surface. Thick till is much smoother; it commonly forms drumlins, and also drumlin heads and tails banked against bedrock hills. Till is commonly 30 m thick or more in drumlins, and reaches a maximum thickness of about 60 m.

Drumlins and glacial grooves trend south-southeast in most of Connecticut. They generally trend southwest to west-southwest on the west side of the Connecticut Valley, and southeast on the east side of the valley; these diverging trends reflect the major lobation of the relatively thick ice in the valley during retreat. In a few places on the west side of the valley, grooves trending west of south cross older grooves trending east of south, or reddish-brown till derived from the Mesozoic sedimentary rocks of the valley overlies gray till derived from the crystalline rocks of the western uplands. These relationships result from changing directions of ice movement caused by lobation during retreat of the last ice sheet.

The two-till stratigraphy previously described for Connecticut (Pessl and Schafer, 1968; Pessl, 1971) has been strengthened by identification of the lower, older till beneath the upper till in almost all parts of the State. The till in most drumlins and other thick-till areas is believed to be mostly lower till, mantled by thin and discontinuous upper till. Not only the materials but also the general orientations of drumlins appear to have survived from the earlier glaciation. We still lack adequate evidence to decide whether the earlier glaciation in which the lower till was deposited was of early Wisconsinan or Illinoian age.

STRATIFIED GLACIAL DEPOSITS AS SHOWN ON THE SURFICIAL MATERIALS MAP

The surficial materials map portrays the texture of surface and subsurface stratified deposits, based on surface observations and subsurface data, and extended by inference from depositional models. Thicknesses of textural units are shown by selected point data from wells and test holes. Map units in which coarse-grained material overlies fine-grained material, shown as stack units such as sg/s and sg/s/f (fig. 2), indicate the pervasive deltaic bodies of sediment. Map units in which finer grained materials overlie coarser grained sediments are shown as stack units such as f/sg, s/sg, and s/f/sg; the general interpretation of these is that slightly older, coarser grained sediments deposited near an ice margin are overlain by younger distal sediments laid down when the ice margin had retreated farther away. Thus, the surficial materials map not only provides textural information useful to planners and engineers interested in the development of unconsolidated materials and ground-water aquifers, but also is a companion to and enhances the Quaternary geologic map by supporting such inferences about depositional environment.

STRATIFIED GLACIAL DEPOSITS AS SHOWN ON THE QUATERNARY GEOLOGIC MAP

The stratified glacial deposits of Connecticut result mainly from the interaction of three factors: 1) the form of the landscape across which the ice was retreating; 2) the form of the margin of the retreating ice; and 3) the locations of the principal meltwater streams emerging from the ice. These factors are not independent of one another; the form of the landscape influences the other two to a considerable extent.

We believe that the character of these deposits in all parts of Connecticut fully supports their interpretation through two closely related concepts: stagnation-zone retreat and morphosequence deposition (Currier, 1941; Jahns, 1941; Koteff, 1974; Koteff and Pessl, 1981). These concepts have roots more than a century old, were articulated in present form four decades ago, and have since been exemplified in many quadrangle studies.

Stagnation-zone retreat means that the retreating margin of active ice is fringed by a continuous zone of dead ice, too thin to transmit forward motion. The dead ice encroaches on the active ice by retreat of the shear zone that separates them. The dead ice disappears very irregularly because of differences in such factors as ice thickness, topographic position, thickness of mantling debris, and flow of meltwater through the ice. Therefore, detached ice masses of various sizes and shapes persist well beyond the fringe of continuous dead ice.

The systematic and predictable ponding of large and small glacial lakes in north-draining valleys at high and low altitudes is clear evidence of generally northward retreat of the ice. The available evidence indicates that the direction of retreat in most places was approximately opposite to the direction of ice advance as shown by drumlins and glacial grooves. Retreat was to the north-northwest in most of the eastern and western parts of the State, but was in other directions, such as northeast or northwest, where controlled by lobation.

Morphosequence deposition occurs in contact with or in front of dead ice. A morphosequence is the basic mappable chronologic unit of stratified glacial deposits. It is the body of sediment formed in a particular valley during a particular time (perhaps in the range of 10 to 150 years), as meltwater streams aggraded their beds, filled proglacial ponds and lakes, and built up to a maximum level, commonly controlled by a spillway or by other deposits or remnant ice downstream. The heads of many morphosequences probably extended well up into the dead-ice zone and perhaps as far as the active ice, but melting of adjacent and subjacent ice generally destroyed such headward parts, or caused

them to be collapsed downward and later buried; the part of a deposit containing evidence of presence of active ice is not likely to have been preserved. The ice-marginal or ice-contact position at the head of an ideal morphosequence is taken as the scarp between the severely collapsed headmost part of the deposit and the part that retains some of the flattish top at or close to the original level of deposition. That scarp defines the outer margin of the fringe of continuous dead ice. A minimum measure of the width of the fringe is given by the extent of the collapsed deposits headward of the ice contact, especially by the length of esker segments. Such data, together with inferences made from the topographic setting and texture of deposits about the proximity of continuous high-standing ice, indicate likely widths of 0.5 to 2 km in most places for the fringe of continuous dead ice. Few morphosequences extend downstream more than 10 to 15 km, and most are shorter; evidently the regime of meltwater streams changed downstream from aggradational to balanced or degradational. The ending of deposition of one morphosequence and beginning of another occurred because of such events as opening of a new and lower spillway, retreat of the margin of the source ice, or shifting of position of meltwater flow within the ice.

Most units for the Quaternary geologic map are groups of 2 to 12 or more morphosequences of common depositional setting, formed along the same or related paths of flow of meltwater. These units are inherently chronologic, because retreat of the ice generally resulted in changes from one path of flow to another, and thus from one group of deposits to another. Where drainage divides are transverse or oblique to the direction of ice retreat, paths of escape of meltwater were first held to higher positions against or through uplands, and then gradually lowered as lower paths were uncovered in valleys. Of the very large number of morphosequences (several to 25 per 7 1/2' quadrangle, probably close to 1000 total in Connecticut), only a small number of particularly large or significant ones are shown individually on the State map. The composite units, of course, represent longer time intervals than do single morphosequences.

Four main depositional settings have emerged from the process of compilation, and are used for broader categories of the map units. These four settings embrace almost all the meltwater deposits, regardless of the great variety of local detail. The distinctions depend on glaciolacustrine versus glaciofluvial deposition, occurrence in south-draining versus north-draining valley, and upland versus lowland position. The four depositional categories are: 1) major glacial lakes in lowlands; 2) ice-marginal ponding in north-draining valleys in uplands; 3) glaciolacustrine-glaciofluvial systems in south-draining valleys; and 4) glaciofluvial systems. Of course these categories grade into one another, and placement of some map units in one of the categories can be somewhat arbitrary. The four categories, each of which is described below, are distinguished on the State map by contrasting groups of colors.

Major glacial lakes in lowlands occupied areas shown in greens and blues on the State map. The map units include not only deltas and lake-bottom deposits, but also glaciofluvial feeder deposits graded to deltas. Formal glacial-lake names have been given only to those lakes in which sizable bodies of open water existed. Estimates of postdepositional crustal tilting can be obtained from the deposits only of lakes that had long-lasting stable levels that were controlled by spillways over glacial till or bedrock.

Some of the major lakes were impounded in north-draining valleys by the retreating ice; such lakes commonly show successively lower stages related to the exposure of successively lower spillways. (North-draining streams are tributary to the main streams of Connecticut, which all drain south to Long Island Sound.) Examples include Lake Danbury in the Still River valley of west-central Connecticut, and Lakes Winsted and Norfolk in the Still River and Blackberry River valleys of northwestern Connecticut.

Lakes of this type grade by decrease in size into those of the second category, ice-marginal ponding in north-draining valleys in uplands.

Some glacial lakes came into existence in south-draining valleys as a result of temporary blocking by bulky bodies of stratified drift. The longest lived of such lakes were those whose outlets were established over spillways floored by glacial till or bedrock rather than over easily eroded drift dams. Examples are Lake Hitchcock in the Connecticut Valley, and Lakes Southington (Stops 8 and 9) and Farmington (Stop 13) in the narrow valley on the west side of Talcott Mountain. Even though Lake Middletown (Stops 4, 5, and 6) did overflow over its drift dam in the valley of the lower Connecticut River, this lake survived for a considerable time, perhaps because the dam extended far downstream.

Other drift-dammed lakes in south-draining valleys persisted not as large water bodies that lengthened as the ice retreated, but as successive small, somewhat overlapping lakes. The dams of such lakes may be renewed by deposition of additional morphosequences or "shingles" at successive retreatal positions of the ice margin; each such deposit is a delta built behind the previous one, and may fill the space forward to the ice-contact scarp of the preceding delta. Lacustrine deposits of this kind occur in the Shetucket River valley in the Willimantic quadrangle, and along the Quinebaug River valley. Such deposits grade by decrease in size and continuity into deposits of the third category, glaciolacustrine-glaciofluvial systems in south-draining valleys.

Ice-marginal ponding in north-draining valleys in uplands occurred where the ice was retreating from drainage divides that were transverse or oblique to the direction of ice retreat. The deposits of the ponds and small lakes are shown on the State map in shades of purple. All these deposits are deltaic, and many of the deltas filled the small basins in which they were built. These lake deposits include isolated single deltaic morphosequences that are perched against sags in east-west divides, groups of nearby but separated deposits related to spillways at different altitudes, and series of contiguous deltas in single valleys. Deposits of the last type may approach those of some major lakes in size and character. Map units in this category occur throughout the State. Good examples occur on the north slope of the Hanging Hills, Meriden quadrangle (unit hh, fig. 1; Stop 10); in the central and north-central part of the Mount Carmel quadrangle; and in the northeast part of the Haddam quadrangle.

Glaciolacustrine-glaciofluvial systems in south-draining valleys are the results of temporary blocking of valleys by combinations of stratified drift and masses of dead ice. Their deposits are shown on the State map in shades of brown. Glaciofluvial gravel and sand, including topset beds, are at the surface in almost all places, and many of these deposits look like glaciofluvial terraces at first glance. However, deeper exposures generally reach lacustrine foreset or bottomset beds, and logs of wells and test holes very commonly record thick subsurface bodies of fine-grained sediments.

Some of these deposits consist of series of deltaic "shingles" like those of the last-described type of major glacial lakes. Commonly, however, the shingled character is not obvious, because of lack of topographic differentiation between successive deltas, perhaps because the upper glaciofluvial beds overlap from one segment to another. Glaciofluvial beds lie directly on bottomset beds at some places where shallow lakes drained or filled up completely before deltas built forward. Coarse glaciofluvial materials extend to the till/bedrock floors of these valleys in other places, particularly where the floors are shallow.

The deposits of this category are abundant in south-draining valleys of all parts of the State except those occupied by major glacial lakes. A good example is map unit lc (fig. 1; Stop 1) along the lower Connecticut River below Middletown. The conclusion is clear that, even in valleys nominally open for free southward drainage, the incidents of deposition around the disappearing ice generally resulted in at least local ponding.

Glaciofluvial systems, unaccompanied by ponding, occurred in remarkably few places in Connecticut. Their deposits are shown on the State map in orange. Most of them produced sand and gravel terrace deposits that erosionally overlie other valley deposits (commonly glaciolacustrine), and that we call meltwater terrace deposits. The largest and best known is the Quinnipiac valley terrace (unit qt, fig. 1; Stop 7). Glaciofluvial deposits also occur in south-draining valleys that were too open and steep for ponding to take place; however, many such deposits are too small and isolated to be shown as separate map units, and have been included in an undifferentiated category. The glaciofluvial category, as we have used it, does not include the glaciofluvial components of other categories: delta topset beds, glaciofluvial feeders graded to deltas, and the various glaciofluvial components of the glaciolacustrine-glaciofluvial systems category.

SPECIAL TOPICS

Dominance of glaciolacustrine deposition. A major conclusion we have drawn from our compilation of the glacial geology of Connecticut is that most of the meltwater sediments were deposited in or graded to glacial lakes, both large and small. On R. F. Flint's 1930 "Map showing the glacial geology of Connecticut", most of the stratified drift is mapped as "sand and gravel deposits in local temporary lakes (dammed by ice and controlled by spillways)" (Flint, 1930). The new Quaternary geologic map of Connecticut reflects our concurrence with Flint's early observation of pervasive deltaic bedding in these deposits as well as our strong disagreement with his regional-stagnation model, which he later retracted (Flint, 1932). The "ubiquitous gravel cap", the recurrence of sg/s textural stacking in many well and test-hole logs, and the multitude of pits exposing flat-lying gravelly beds overlying dipping sand beds all demonstrate the deltaic nature of most meltwater deposits.

The glacial lake in Long Island Sound. Regional compilation supports the existence of a major glacial lake in Long Island Sound at about present sea level, as has long been suggested. Because of the interaction between postglacial tilt of the water plane of the former lake and the northward convexity of the present shoreline, deltas built into this lake are exposed above present sea level only between Westport and Clinton. Topset/foreset contacts in the New Haven delta plain, illustrated by Lougee (1938, pl. IIA), occur at about 22 ft in altitude. At Fairfield, in the Mill River delta, the topset/foreset contact is estimated from well logs to occur at present sea level. If lake level was stable, these deltas have been tilted upward to the north-northwest at about 3 ft/mi (0.6 m/km) by postglacial rebound. Deltas south of the zero isobase of the inferred water plane (i.e., east of Clinton and west of Westport) probably exist below present sea level. Recent work by Williams (1981) shows foreset stratification in bodies of sand offshore from Norwalk and from Saybrook at the mouth of the Connecticut River.

Glacial Lake Middletown is the name we propose for a lake that first developed along the Connecticut River and in the Mattabesset River basin. It was impounded by a long mass of slightly earlier deposits (unit lc, fig. 1) in the lower Connecticut River valley at and south of The Straits, and the spillway of the lake was over these deposits. Accordant delta levels, basin geometry resulting in ice-margin positions trending northwest-southeast, and the extent of the Berlin clays all indicate that Lake Middletown occupied both the Middletown and the Berlin-New Britain basins. Delta surfaces in Cromwell (lmr) and in the Newington (lmn) and New Britain (lmw) areas all stand at altitudes of about 150 ft, and topset/foreset contacts are at approximately 135 ft. Deltas in Rocky Hill (lmd) that were graded to the Dividend Brook spillway were temporarily ponded to a higher level than Lake Middletown; this spillway over delta sand and gravel (lmr) was not eroded lower than its level of 129 ft because of the presence of

the water of Lake Middletown at its mouth. Erosional lowering of the dam of Lake Middletown evidently was very slow. When the ice uncovered the low part of the Mattabeset-Connecticut divide where the New Britain spillway of Lake Hitchcock would later exist Lake Middletown persisted at a level high enough to spread across the divide into the upper Connecticut River basin; when the ice retreated from the north end of Cedar Mountain, this water body spread east into the south end of the basin later occupied by Lake Hitchcock. Deltaic deposits in Glastonbury and Manchester, lake-bottom deposits in Glastonbury and East Hartford, and deltaic and lake-bottom deposits in West Hartford all occur at altitudes accordant with Lake Middletown but too high to have been controlled by any possible early level of the New Britain spillway. Not until Lake Middletown had dropped to below 110 ft could the New Britain spillway come into use as the control for Lake Hitchcock. This drop did not happen until the ice had retreated north of West Hartford and Manchester, and quite possibly not until it had retreated to Windsor and Windsorville.

The Cromwell-Rocky Hill delta complex (controlled by Lake Middletown), which became the dam for Lake Hitchcock, was built higher than the place on the Mattabeset-Connecticut divide at which the New Britain spillway later was established. Had Lake Hitchcock overflowed across the deltaic dam, erosion would have been rapid. Instead, the dam failed probably by ground-water sapping, powered by the head of water in the lake, at a time when Lake Middletown already had drained.

Glacial Lake Hitchcock, the large and long-lived lake in the Connecticut Valley, has been extensively described by previous workers (Hartshorn and Colton, 1967; Hartshorn and Koteff, 1968; and many earlier references). Highlights emphasized by regional compilation are: 1) The New Britain spillway started out at about 110 ft in altitude and was not eroded down to its present altitude of about 70 ft until sometime after the ice margin had retreated into Massachusetts. 2) When the gap through Talcott Mountain at Tariffville was uncovered, the water level in the Farmington River-Salmon Brook valley west of the gap dropped, probably to the level of Lake Hitchcock; large bodies of deltaic sediment were deposited in this glacial Lake Tariffville. 3) The extensive Farmington delta is actually three deltaic deposits built into Lake Hitchcock at three different levels. The southern part has an ice-contact head and was built into the highest level of Lake Hitchcock (Hartshorn and Colton, 1967). Plane-table leveling of a topset/foreset contact in the Bloomfield town landfill gave an altitude of 178.6 ft; adjusted for postglacial tilt, the altitude indicates an early level for the New Britain spillway of about 110 ft. When the lake level had dropped somewhat, the Farmington River, flowing through the Tariffville gap, entrenched the ice-contact delta and built another delta northeastward into the lake in the Bradley Field area. As the lowest levels of the lake were reached, the Farmington River again entrenched, and deposited deltaic material southeastward into the lake. 4) On the east side of the Hitchcock basin, a complex series of deposits occurs in which high-level ice-contact and non-ice-contact deltas were entrenched by slightly later meltwater and meteoric water flowing down tributary valleys such as the Hockanum and Scantic. Low-level deltas occur at the mouths of these valleys. 5) Postglacial tilt of about 4.2 ft/mi (0.8 m/km) upward to the north in the Lake Hitchcock basin, established in Massachusetts by Jahns and Willard (1942) and extended to Connecticut by Koteff (1967), has been corroborated by the present study. Extrapolation of this amount of tilt across the State has aided in reasonable interpretation of many deposits.

The Middletown readvance? Till or ice-contact stratified deposits overlying glaciolacustrine clay in the Middletown-Berlin-New Britain area were described by Flint in 1933 (p. 969), and were suggested to be evidence that the clays predated the last ice advance in the area. Flint in 1953 (p. 899) attributed this overriding of the clays to a late-glacial readvance of more than 16 mi from north to south. Other occurrences of

stratified deposits under till were described by Simpson (1959) and Deane (1967). The term "Middletown readvance", which had come into informal use, was first used in print by Schafer and Hartshorn (1965, p. 121).

Descriptions of other localities of readvance in the Connecticut Valley (for instance, Larsen and Hartshorn, 1982) indicate that minor fluctuations of the ice margin occurred several times, and that no basis exists for correlation of such fluctuations with events near Boston, not to mention with glacial substages in New York and the Midwest (Flint, 1953). Furthermore, we are now uncertain that any late-glacial readvance took place in the Middletown area. Probably many of the occurrences of till over stratified deposits represent the main advance of late-Wisconsinan ice, or even the activity of the earlier ice sheet believed to have deposited much of the thick till (*cf.* Stop 3). The exposures of a disturbed zone ("till equivalent") on top of clay in Berlin and Middletown listed by Flint and Cushman (1953) have long since vanished; however, similar features in the present Kane pit (Stop 5) may be explained as load and ice-rafting structures. We believe that the Middletown-Berlin clays, across which the ice allegedly readvanced, and the Cromwell deltas, which show no sign of having been overridden, all were deposited in glacial Lake Middletown within the same general period of time. Postulating a readvance event between them would require the existence of two glacial lakes, an earlier one having bottom deposits but no deltas, and a later one having deltas but no bottom deposits. Finally, we wish to mention that there is no feature that could be referred to as a Middletown moraine (Sirkin, 1967), and that the pollen-diagram features once thought to record cooling at the time of a Middletown readvance (Leopold, 1956) are now believed to be artifacts of relative pollen statistics (Davis, 1965).

Minor end moraines. We have shown the small moraines of southeastern Connecticut (Goldsmith, 1982) on our maps. We have shown those of south-central Connecticut (Flint and Gebert, 1976) with considerable modification, as they were seriously overmapped. We agree in general with the extension of the moraines west-southwestward into Long Island Sound (Flint and Gebert, 1976; Williams, 1981). Black (1982) rejected the interpretation of the mapped moraines as features formed at an active ice margin. Much of Black's criticism was anticipated by Goldsmith (1982), and much was based on setting up too narrow a definition of a moraine.

We have identified a few moraines north of the coastal moraine belt; they are in the central part of the Colchester quadrangle, in Meshomasic State Forest in the Middle Haddam quadrangle, and in the northwest part of the South Coventry quadrangle. These moraines reflect a more irregular ice margin than do the ones in southeastern Connecticut.

Regional stagnation? Dissent from State-wide use of the twin concepts of stagnation-zone retreat and morphosequence deposition has recently been expressed by Black (1977, 1979, 1982). Using as his main example the Shetucket-Willimantic basin, he has urged the alternative of basin-wide regional stagnation. Space does not permit a detailed rebuttal of his arguments here. We commonly disagree with both his descriptions and his interpretations of field situations (as he presumably would with ours). We believe that many of his conclusions either are incorrect or do not indicate what is claimed. The net result is our conviction that the hypothesis of basin-wide stagnation is in contradiction to the great bulk of the evidence. In fact, the Shetucket-Willimantic basin seems to us to contain one of the best portrayals of stagnation-zone retreat and morphosequence deposition in eastern Connecticut, and our depiction of the area on the State maps reflects our belief.

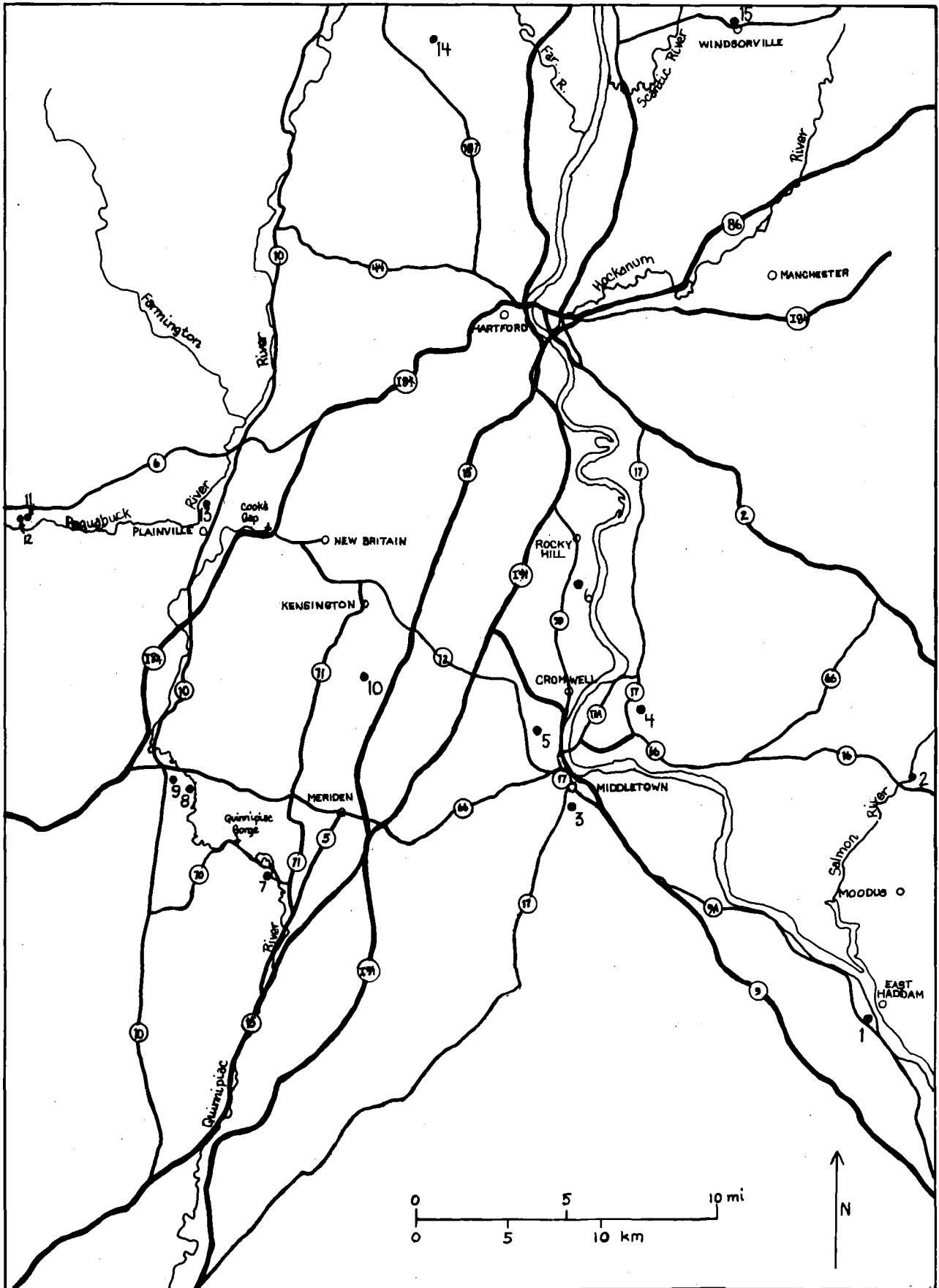

Figure 3. Map showing locations of field trip stops.

FIELD TRIP STOPS

The stops on this trip (fig. 3) have been chosen both to demonstrate the units shown on the Quaternary geologic and surficial materials maps of Connecticut and to illustrate some of the particular glacial geologic features of central Connecticut. Almost all the stops are on private property, and permission should be obtained before visiting them. Stops occur in the following quadrangles, which all are covered by U.S. Geological Survey topographic maps (scale 1:24,000, contour interval 10 ft): Bristol, Broad Brook, Deep River, Hartford South, Meriden, Middle Haddam, Middletown, Moodus, New Britain, Southington, and Windsor Locks. Other quadrangles useful for travel between stops are Haddam, Hartford North, and Manchester.

STOP 1. State Highway Dept. pit at Tylerville, town of Haddam, Deep River quadrangle. Entrance is east off Connecticut Route 9A, 0.15 mi (0.25 km) south of junction with Route 82.

The delta topset and foreset bedding exposed in this pit is an example of that seen in deposits along the lower Connecticut River valley. These deposits have previously been described as "outwash valley train" (Flint, 1953, 1975, 1978). O'Leary (1977) recognized that these deposits were not one outwash body but a series of ice-contact morphosequences built as the ice retreated northward up the valley. Our work indicates that the lower Connecticut River deposits (unit Ic, fig. 1) are a succession of ice-contact deltaic sequences, each one ponded behind the last (see discussion above under heading "Glaciolacustrine-glaciofluvial systems in south-draining valleys"). Subsurface data from logs of wells and test holes as well as deep pit exposures indicate that deltaic deposition was extensive. Surface textures in these sediments grade from coarser to finer within individual sequences. The profile of deposits along the Connecticut River in the Deep River quadrangle (O'Leary, 1977, C-C') shows the "shingled" surface gradients of four morphosequences.

STOP 2. Salmon River till cut, town of Colchester, Moodus quadrangle. Cut on east side of Salmon River, about 750 m east of Connecticut Route 16 bridge.

The base of this natural exposure of many years standing was cleaned off by the June 1982 flood, which exposed about 1 m of dirty gravel beneath the lower till. When visited in July 1982, the cut was being "stabilized" under direction of the U.S. Army Corps of Engineers. The July exposure:

- 5-7 m upper till, sandy, light yellowish gray; no inclusions of lower till except a few "schlieren".
- 4-6 m upper till containing numerous inclusions of lower till. Inclusions mostly subhorizontal slabs, 0.3-1.5 m long; some having obscure borders; some having sharp borders and having stained joints inside.
- 6 m lower till, sandy, yellowish brown to brown. Considerable groundwater flow at contact; till only moderately compact where wet. Jointed zone removed by erosion?

STOP 3. Marino Crane Service cut, in Middletown, Middletown quadrangle. Cut is adjacent to Marino building, on south side of Mill Street, which runs between South Main Street (Connecticut Route 17) and Ridge Road.

The locality is a long, discontinuously exposed cut in the thick till unit (fig. 1). The cut exposes till and laminated fine-grained sediments (laminites) in the north and east sides of a drumlin. Laminites are fairly common in drumlins in central Connecticut. In these drumlins, laminites occur as cores, as ice-thrust wedges, and as interbeds with till; some of them evidently predate the last glaciation because they are associated with the older till.

The major units exposed at Marino are a body of laminites and two tills (fig. 4). The laminites are between the tills; the lower contact is a surface of unconformity, and the upper contact, as exposed in the north cut, is a shear zone. Other units, less well exposed, are a small lens of sand at the top of the southeast end of the cut and a body of sand and pebble gravel beneath the till near the base of the cut. The lower, compact, fine-grained till contains sandy lenses and a relatively small percentage of clasts, chiefly subangular pebbles, cobbles, and small boulders. The matrix of the till contains streaks of silt and clay that may be deformed laminae.

The laminites include two facies that grade vertically into one another. One facies is pebbly and contains diamicton lenses; the other is relatively free of diamicton and stones, but contains concentrations of granules along bedding planes. Laminae in the pebbly facies are generally thicker and coarser grained than their less stony counterparts, which are composed chiefly of silt and clay. The laminites are broadly warped, dip south-southeast, and are deformed around stones and diamicton lenses; convolute structures, probably formed by loading, are common.

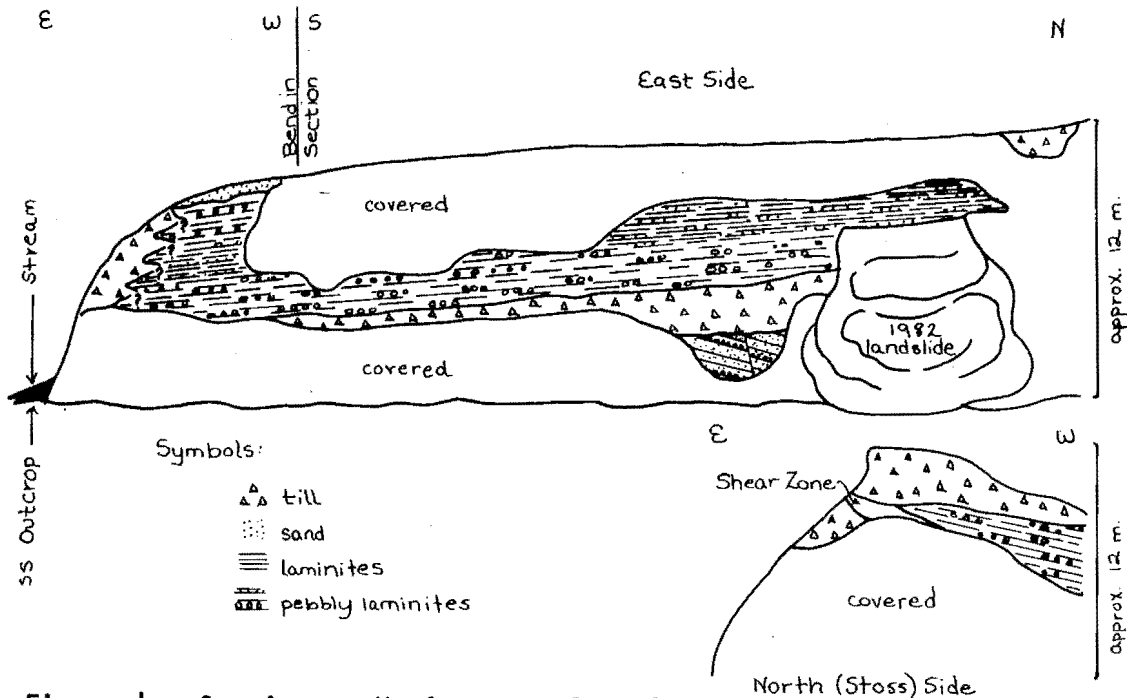

Figure 4. Section at Marino cut, Stop 3.

The overlying till is exposed at the north and southeast ends of the locality. In the north cut, till and laminites interpenetrate along folds and faults. Detached slabs of laminated fine-grained sediments appear to have been interthrust from the northwest with till. The till in this cut is compact, sandy, and stony. The clasts include many well-rounded pebbles and cobbles. At the southeast end, the upper till either is draped over the laminites or grades into them; this contact has not been well exposed.

An ice sheet apparently overrode the deposits of a proglacial lake at this locality. The lake may have been impounded in Sumner Brook valley when an advancing ice sheet encroached upon the north-sloping terrain. Lacustrine sedimentation took place close to the ice margin; this proximity is indicated by the abundance of small stones and diamicton in the laminated fine-grained sediments. The diamicton may have been shed from an ice shelf or from icebergs, or it may have been injected into the lake at the base of the glacier by subaqueous mass flows.

Q1-11

STOP 4. Pit behind Portland Burying Ground, town of Portland, Middle Haddam quadrangle. Pit is on south side of cemetery on Bartlett Street, which turns east off Connecticut Route 17, about 1.2 mi (2 km) north of junction of Connecticut Routes 17 and 66.

The main cut in this pit exposes 7.5 m of west- to northwest-dipping foreset beds composed of plane-bedded and ripple-bedded medium to fine sand. The top of the main face is at about 140 ft in altitude. Small cuts above it show 2 m of topset beds composed of pebble gravel and sand; thus a topset/foreset contact altitude of approximately 140 ft is inferred. Bottomset beds of very fine sand are exposed in the lower south slope of the delta. The form of the delta and its westerly foreset dip directions indicate that it was built by meltwater from the east, between the stagnant ice margin to the north and a probable detached ice block to the south.

The Portland Burying Ground delta is part of a stratified drift complex that fills a buried channel of the Connecticut River. The bottom of the channel is from 100 to more than 200 ft below sea level; the deposits in this channel contain a chain of deep kettles including Jobs Pond. The Jobs Pond deposits, which have been treated as one entity by previous investigators, were considered by Flint (1953) to be part of one glaciofluvial outwash body that filled the Connecticut River channel from Rocky Hill to Long Island Sound. More recently, Hartshorn and Colton (1967) differentiated them from the deposits at Rocky Hill. We have divided the Jobs Pond deposits into two units; one is continuous with deposits in the Connecticut River channel to the south (unit 1c, fig. 1), which now are thought to be largely deltaic; the other is graded to glacial Lake Middletown (1mj) and is also deltaic. Unit 1c deposits were laid down before the ice margin retreated from Straits Hill; glacial Lake Middletown opened after the ice margin retreated from Straits Hill. The Portland Burying Ground delta was one of the first deposits that was graded to glacial Lake Middletown.

STOP 5. Michael Kane Brick Co. pit, Middletown, Middletown quadrangle. Entrance is on east side of Connecticut Route 72, 0.8 mi (1.3 km) north of the intersection of Route 72 and Westfield Street.

The pit exposes lake-bottom deposits of glacial Lake Middletown (unit 1, fig. 1). These deposits, called the Berlin clay by Deane (1967), consist of reddish-brown silt and clay in couplets that are commonly 5 cm thick. The Berlin clay supposedly was overridden by the so-called Middletown readvance (see discussion above). Part of the evidence for this event was what Flint called "till equivalent" (Flint and Cushman, 1953; Simpson, 1959). Although that term was not formally defined, it evidently refers to features observed on the Berlin clay in some exposures: a zone of contorted varves, or a layer of homogeneous silt and clay that includes remnants of deformed varves and/or pebbles and cobbles. The Kane pit (actually a pit 0.3 km south of the present active pit) was included in the itinerary for a 1953 field trip (Flint and Cushman, 1953) and listed as "till equivalent on varved clay"; the stop was omitted on the actual trip, but J. P. Schafer noted that Flint described the locality as showing "upper 18 inches of clay contorted, with scattered stones." That is the only cited evidence in Middletown itself for what has come to be called the Middletown readvance. The following section is exposed in the southeast corner of the active pit:

Q1-12

- 0.8 m spoil
- 1.4 m thinly to very thinly bedded, fine to very fine sand in which bedding is contorted.
- 0.15 m stratified medium to very coarse sand, containing some small pebble gravel.
- 0.3 m massive very fine sand and silt; bed contains a detached block of the same sediments. Embedded stones have been seen in this stratum in exposures nearby.
- 0.15 m stratified medium to very coarse sand, granule gravel, and small pebble gravel, containing a trace of silt; poorly sorted.
- erosional contact ————
- 0.45 m rhythmically bedded, very fine sand, silt, and clay; total of three couplets with weak convolutions. Uppermost bed is greasy clay, which is thickened and thinned where penetrated by overlying sand and gravel bed. Each lamina consists of many microlaminations; contacts are gradational within and between couplets.
- 9.0 m varved silt and clay. The varves are thinner and slightly finer grained than the rhythmites above them, and are undisturbed except for broad warping. An additional 3 m of clay is reported from test holes in this pit that do not reach bedrock.

The deposits above the rhythmites are shown as a stream terrace unit (st) on the map in figure 1, and appear to be continuous with 3 m of sand and pebble gravel that is exposed in excavations about 200 m east-southeast of this section. We believe that these sediments were deposited soon after the lake was drained, when Lake Hitchcock overflow water was still coming down the Matabesset drainage.

The deformed structures shown by some beds in this section are interpreted by us as syndepositional load structures. The occurrence of stones scattered through a silt and sand stratum, not shown in the measured section but seen in several nearby sections, is attributed by us to such processes as foundering of thin gravel layers or rafting by river or lake ice. These two types of features possibly were interpreted by Flint as "till equivalent", especially if they occurred at a place where the postlake alluvial sediments were thinner and their character less obvious than at the present pit. Of course, what Flint saw more than three decades ago may have been something quite different from what we see here now.

We question the occurrence of a readvance at Middletown because of stratigraphic relationships in the basin. The massive Cromwell delta complex 3 km north (Stop 6) was deposited in glacial Lake Middletown occupying this basin. Because these deltas were not overridden by ice, any readvance must have preceded their deposition, and the lake-bottom facies associated with the deltas would of necessity overlie the readvance stratum. No lake-bottom sediments overlie the "till equivalent" zones as described by Flint and others. We suggest, therefore, that the lake-bottom facies of the Cromwell deltas is the varved sequence exposed here at Kane pit, and that any "glacially contorted material" may have resulted from such processes as load deformation, ice rafting of stones into shallow lake-bottom sediments, or thrust or drag caused by grounded icebergs.

Q1-13

STOP 6. Pit northeast of Mustard Bowl, town of Rocky Hill, Hartford South quadrangle. Turn east from Main Street (Connecticut Route 99), 0.1 mi (0.15 km) north of Brook Street, onto new street, and travel 0.75 mi (1.2 km); pit entrance on right at intersection with Dividend Road.

The Cromwell-Rocky Hill delta complex consists of a southern part in Cromwell that was built into open waters of glacial Lake Middletown, and a northern part in Rocky Hill that was controlled in altitude by the Dividend Brook spillway (fig. 5). The pit is in the first delta to be controlled by that spillway, which started out at about 150 ft; the altitude of the topset/foreset contact in the pit is estimated to be at 149 ft. The spillway was fairly rapidly cut down to its present 129-ft level; no further deepening took place because glacial Lake Middletown stood near this level at the spillway mouth. On the map (fig. 1), all these deltas are part of the glacial Lake Middletown map unit, but the more southerly ones controlled by the open lake are subunit lmr and the more northerly ones controlled by the Dividend Brook spillway are subunit lmd. Previous workers (Hartshorn and Koteff, 1968; Hartshorn and Colton, 1967; Langer, 1977) considered the Dividend Brook spillway to be an early high-level control for glacial Lake Hitchcock (see above discussion of the lake).

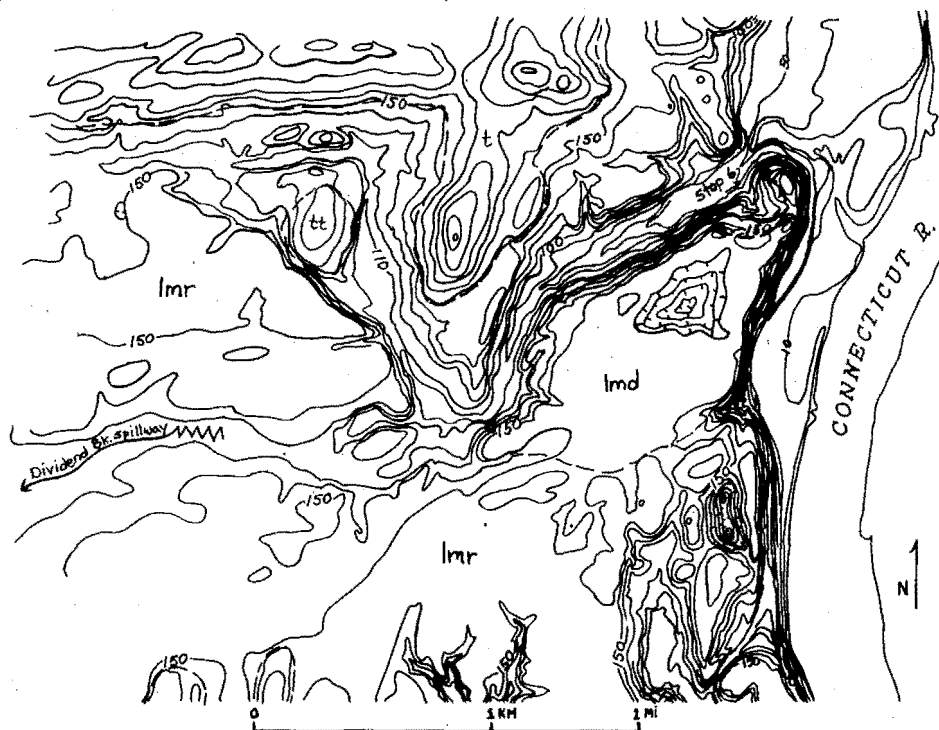

Figure 5. Topography of the Dividend Brook spillway and adjacent deposits from the U.S. Geological Survey topographic map of the Hartford South 7 1/2' quadrangle, 1952 edition. See Stop 6 for description.

The pit exposes about 30 m of ice-contact and deltaic sediments. The northeastern part shows highly collapsed fluvial topset beds composed of coarse gravel. Toward the distal end of the collapsed zone, these beds are collapsed 4-5 m (measured from the uncollapsed topset level), yet show little evidence for intrastratal deformation. The southwestern part of the pit exposes noncollapsed deltaic topset and foreset beds. In the lower foresets, fine to medium sand occurs in ripple-drift cross-laminated units, interbedded with planar beds and festoon crossbeds. In the middle to upper foreset beds, pebbly sand, pebble gravel, medium to coarse sand and silty sand beds dipping 10 to 15° toward the southwest show planar beds and tangential crossbeds. Topset beds are composed of approximately 3 m of pebble-cobble gravel and sand in fluvial planar beds.

Just southwest of this pit, collapse of topset and foreset beds toward the Mustard Bowl kettle was shown in a former pit centered on the kettle. The surface of the isolated ice block that produced the kettle was at least partly below lake level, perhaps weighed down by deposits. At the end of deposition, the ice block was mostly or completely buried by delta sediments derived from meltwater streams issuing from the main ice mass to the northeast.

STOP 7. Pit on west side of Meriden-Markham Municipal Airport, town of Wallingford, Meriden quadrangle. Access is by dirt road that turns west off Hanover Street near power line, 1.3 mi (2 km) south of junction (as Evansville Avenue) with Main Street (Connecticut Route 70) in South Meriden. Pit is just west of the landing strip and north of a small stream.

The pit exposes two glaciofluvial units. The lower unit is reddish-brown pebble-cobble gravel, mostly in horizontal planar beds 10-20 cm thick. Stones are imbricated; crossbeds occur in 30 cm sets. The upper unit consists of 1.5 m of yellowish-gray pebbly coarse sand containing tangential crossbeds in 10-20-cm sets. Stone counts in these units showed:

yellow sand	-	64 percent crystalline clasts
		34 percent Triassic-Jurassic sedimentary clasts
		2 percent Triassic-Jurassic basalt clasts
red-brown gravel	-	14 percent crystalline clasts
		48 percent Triassic-Jurassic sedimentary clasts
		38 percent Triassic-Jurassic basalt clasts

The ice margin probably stood in the vicinity of the Hanging Hills in Meriden when the lower gravel was deposited. Gravel deposits in Sodom Brook valley coarsen northward and are cobble and boulder gravel near Beaver Pond. Base level for this unit was probably glacial Lake Quinnipiac to the south. Lake Quinnipiac varved silt and clay underlie these fluvial units from here southward.

The yellow pebbly sand here is part of the well-known Quinnipiac valley train (Flint, 1934; Lougee, 1938; Porter, 1960; La Sala, 1961; Hanshaw, 1962) deposited predominantly by meltwater coming out of the western highlands down the Pequabuck and Farmington River drainages (Krynine, 1937), which are underlain by crystalline rocks. This deposit is about 47 km long; it heads at Farmington where its surface is at 210 ft in altitude, and extends to North Haven where its surface is at 35 ft. It slopes southward with a gradient of about 6 ft/mi (1.1 m/km), of which about 4 ft/mi (0.75 m/km) is postglacial tilt. We call this deposit the Quinnipiac Valley terrace, glaciofluvial unit qt (fig. 1). Like other meltwater terraces in the State, these terrace deposits were laid down by meltwater that terraced and eroded slightly older deposits. The meltwater that deposited the Quinnipiac terrace sediments first eroded into deltaic and lacustrine deposits of glacial Lake Southington, the water level of glacial Lake Southington having slowly dropped as the barrier at the Quinnipiac Gorge was eroded. The meltwater, which came mostly from the spillway of glacial Lake Farmington to the north, must have carried the material eroded from the Southington deposits through the gorge and out onto the surface of the glacial Lake Quinnipiac sediments in the lower Quinnipiac River valley. No crystalline-derived material could be carried southward, however, until the waters of glacial Lake Farmington (unit lf, fig. 1) had also dropped. Ice-contact deltas graded to this lake occur as far north as Avon. Therefore, the crystalline-derived yellow sand and fine gravel of the Quinnipiac terrace must have been laid down during the time of ice retreat from Avon to Tariffville. When the Tariffville gap was opened, water levels in the valley dropped from approximately 300 ft down to about 200 ft in altitude, causing the Farmington River joined by the Pequabuck River to turn northward, thereby ending the supply of meltwater and sediment to the Quinnipiac valley.

Q1-15

STOP 8. County Wide Construction Co. pit, town of Cheshire, Southington and Meriden quadrangles. Entrance is north from East Johnson Avenue 0.3 mi (0.5 km) west of junction with Cheshire Street.

This pit and that at Stop 9 expose the internal structure of ice-contact deltaic morphosequence 2 (fig. 2), which is an esker-fed delta (fig. 6) built into glacial Lake Southington (unit ls, fig. 1). When the ice margin retreated north of the Mill River-Quinnipiac River drainage divide, ponded deposits (unit md), graded to local spillways over that divide, were laid down in four north-draining valleys. The easternmost of these deposits in the Broad Brook valley appears to have blocked the Quinnipiac Gorge and impounded the waters of glacial Lake Southington, which expanded to the north as retreat of the ice margin continued.

The exposure shows an excellent oblique view of foreset beds dipping southwesterly. The northeast end of the pit shows foresets of pebble-cobble gravel and sand in crosscutting planar beds that dip 25-30°. In the middle face, a 1.5-m-thick bed of fining-upward boulder-cobble gravel occurs; this gravel may be the result of a subaqueous gravity flow down the foreset slope. The southwest end of the face shows finer grained foresets dipping 10-20°; the fine to medium sand and silty sand beds consist of characteristic ripple-drift and drape laminations in cosets 0.3 m thick; coarse sand to granule gravel layers consist of planar beds filling troughs 10-20 m wide and 2-5 m thick. The southwest slope of the delta was probably a free-front foreset slope.

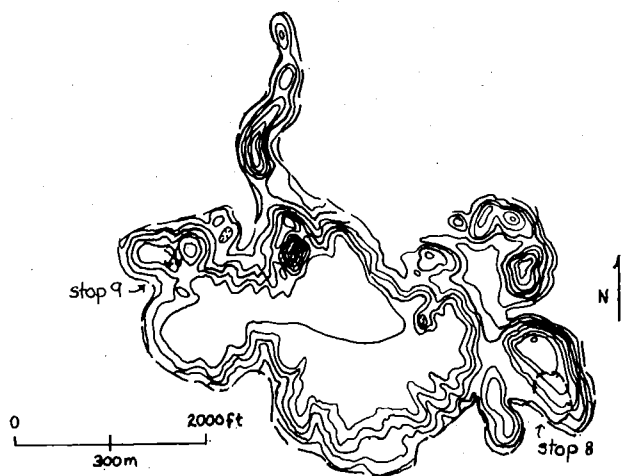

Figure 6. Topography of the "Lougee delta" from the U.S. Geological Survey topographic map of the Southington 7 1/2' quadrangle. See Stops 8 and 9 for description.

STOP 9. Pipeline pit, town of Cheshire, Southington quadrangle. Entrance is east off Connecticut Route 10, 0.2 mi (0.3 km) north of junction with East Johnson Avenue.

The stop is at the "Lougee delta" (fig. 6). R. J. Lougee made a plane-table map of this delta, using a 5-ft contour interval, and published it in his 1938 monograph "Physiography of the Quinnipiac-Farmington Lowland in Connecticut". Most of his observations and interpretations in this early work are supported by our current compilation.

From the corner of the field immediately south of the pit area, the flat surface of the delta can be viewed; looking northeast from this point, a section of the esker that fed the delta can be seen. This landform is an excellent example of an ice-contact delta fed by an ice-channel stream. The esker, which may or may not have been built in a tunnel, extends from the proximal edge of the delta where its altitude is 200 ft, northward for approximately 1 km; at its northern tip, it is at 150 ft. An excavation in the esker several years ago revealed reddish-brown cobble-pebble gravel.

The pit, which is on the west edge of the delta, shows minor collapse. The fluvial topset beds exposed in the westernmost part of the pit are pebble-cobble gravel and sand in slightly collapsed horizontal beds. The eastern part of the pit shows foreset beds cut by high-angle faults.

STOP 10. Swede Pond pit, town of Berlin, Meriden quadrangle. Entrance is at the end of a new development road which runs east off Elton Road, 0.25 mi (0.4 km) south of the junction with Kensington Road.

On the way to Stop 10, climb from Meriden on Route 71 (Capitol Avenue) toward the scarp of the Hanging Hills, and into a fault-controlled notch where steep active basalt talus slopes are present below the cliffs. Cross the divide, emerge into Hatchery Brook valley, and descend over successively lower delta surfaces. This valley and Belcher Brook valley to the east, where the stop is located, are two of several valleys that drain the north slope of the Hanging Hills. In each of these valleys, meltwater was ponded between the retreating ice margin and local cols, and deltas were deposited at successively lower altitudes as progressively lower outlets from the valleys were uncovered. The result was the deposition of a large deltaic complex on the north slope of the Hanging Hills; these deltas are mapped collectively as one unit (hh, fig. 1). At least 12 ice-contact deltaic morphosequences can be differentiated within these deposits.

At the Swede Pond pit, the typical deltaic nature of such deposits can be seen. The pit is cut into the 195-ft surface of the lowest (youngest) sequence graded to a 165-ft spillway across the divide, 4.5 km to the south. Topset beds are not now visible in the pit; a good exposure of foreset bedding shows pebble-gravel and sand beds dipping steeply toward the southwest in the upper level of the pit; and finer grained, more gently dipping topset beds are exposed in the lower level.

STOP 11. Barnum Road pit, town of Bristol, Bristol quadrangle. Entrance to pit is at the end of Barnum Road. This road is not identified on the topographic map; it turns south off Terryville Avenue (U.S. Route 6), 0.1 mi (0.15 km) west of the junction with Hill Street.

The main attraction at this pit is the crosscutting relationship of striations and grooves seen on a recently uncovered whaleback outcrop of gneiss of the Collinsville Formation. Large, straight, long grooves trending south-southeast ($160-164^{\circ}$) are crossed by short and less regular striae trending south-southwest to southwest ($195-229^{\circ}$). The striations are an excellent demonstration of the change in direction of ice movement on the west side of the Connecticut Valley lowland as a result of lobation of the ice margin during retreat. During the maximum of glaciation, when ice movement was generally south-southeast, the large grooves were produced. During retreat, when ice of the Connecticut Valley lobe impinged on the edge of the western highlands, direction of ice movement was southwest; hence, the smaller southwest-trending striae cross the slightly older south-southeast-trending grooves.

In the pit to the east of this outcrop, most of the faces are slumped, but topset and foreset bedding can be seen. This deposit is part of the same delta exposed at the next stop. Unusually abundant and large flakes of muscovite, derived from The Straits Schist which crops out nearby, occur in the foreset beds in this pit.

STOP 12. Scalia Brothers pit, town of Bristol, Bristol quadrangle. Entrance to pit is east off Barlow Street which turns south off Terryville Avenue (U.S. Route 6), 0.3 mi (0.5 km) west of junction with Hill Street.

This pit and the one at Stop 11 are in a flat-topped delta at an altitude of 640-650 ft. The delta is part of an extensive complex of primarily deltaic sediments (unit br, fig. 1) deposited in high-level lakes impounded against the upland in the Pequabuck River valley by the Connecticut Valley ice lobe. Deposits in the southern part of this complex

Q1-17

were graded to a spillway at 625 ft across the Pequabuck-Naugatuck divide. In this pit 3 m of topset beds composed of cobble-pebble gravel and sand disconformably overlies 8 m of coarse sand, pebbly sand, and silty sand beds. The sand beds consist of 20-50-cm sets of tangential crossbeds alternating with subhorizontal planar beds; current directions are westerly. Little readily apparent dip of these beds can be seen, but the morphology and structure of the surrounding deposit and the basin geometry indicate that the sand must have been deposited below a water plane. These lacustrine beds in which current structures predominate may have been deposited subaqueously under constricted flow conditions, or they may actually be proximal bottomset beds. Pebbly sand foreset beds dipping gently to the southwest that are about 4 m thick are exposed at the north end of the main face, stratigraphically below the other sand. Collapse structures are visible in the north part of the pit. Our interpretation at this pit is an example of the way in which regional relationships of ice-margin and basin geometry impose constraints on the interpretation of sedimentary structures.

STOP 13. Russack Brothers sand and gravel pit, town of Plainville, New Britain quadrangle. The pit is bounded by the Farmington-Plainville town line, the railroad, and the Pequabuck River. The entrance is off Hyde Road, which is now the main artery of an industrial park. The new road layout is different from that shown on the topographic map. We will visit the southern section of the pit.

The pit shows lacustrine sediments of glacial Lake Farmington (unit lf, fig. 1) overlain by glaciofluvial deposits of the Quinnipiac valley terrace (unit qt). Terrace sand and gravel 3-4 m thick have been removed from most of the area, but a few patches remain. The Quinnipiac terrace is at 205 ft in altitude here, 4 km south of its head at Farmington.

In the south part of the pit, two facies of Lake Farmington sediments are exposed. In the upper facies, 1-2 m of moderate-brown, massive very fine sand and silt grade downward into laminated very fine sand, silt and clay. The lower facies consists of 1-2 m of light-gray fine to medium sand in distal bottomset beds dipping gently to the north; planar beds alternate with 0.3-0.5-m climbing-ripple sets. The climbing ripples show northerly paleocurrent directions indicating that the source of these sands was the Pequabuck drainage to the south. The overlying fine-grained sediments were most likely laid down as slightly later lake-bottom sediments during deposition of ice-contact deltas to the north; those lake-bottom sediments pinch out southward and are absent at the south end of the pit.

During the time of ice retreat through Plainville and Farmington and northward to Avon, glacial Lake Farmington occupied the Farmington-Quinnipiac valley. The valley was blocked to the south by deposits of glacial Lake Southington; the spillway for the lake was over till and bedrock at about 190 ft in altitude, 2.4 km northwest of Southington center. Interstate Route 84 now goes through this spillway. Deltaic sediments graded to this lake occur as far north as Avon; as much as 80 m of lake-bottom silt and clay underlies the deltaic and terrace sediments.

STOP 14. The "red and white" pit, town of Windsor, Windsor Locks quadrangle. Turn north off Prospect Hill Road, 0.15 mi (0.2 km) east of junction with Blue Hills Avenue (Connecticut Route 187). Travel 0.5 mi (0.8 km) to tobacco barns; continue on dirt road past barns to pit.

The red and white pit is so named for the contrasting colors of the gravel and sand beds. The contrast seems to be texturally controlled and has been observed in other exposures of sediments presumably derived from Triassic-Jurassic rocks. Gravel beds and fine-grained layers are red-brown; medium to fine sand layers are light gray to almost white. Establishing the provenance of the "white" sand would make a good thesis topic for someone.

The deposits here also are deltaic; the channeled surface cut into the foreset sands by the streams depositing the topset gravels displays as much as a meter of relief. The

surface here stands at 205 ft in altitude; the deposit extends southward for approximately 2 km and stands 10-20 ft higher than the high-level Lake Hitchcock deltaic sediments that surround it. The 190-195-ft water level indicated by the topset/foreset contact here, adjusted for postglacial tilt, projects to the New Britain spillway at 135-140 ft in altitude, too high for Lake Hitchcock. This delta possibly was deposited in an exceptionally large hole in stagnant ice; however, we suggest that it may have been controlled instead by the glacial Lake Middletown water plane still persisting in the Hitchcock basin. Deposits at about the same altitude, which are probably deltaic (no cuts seen), occur on the east side of the basin, near the moraine of Stop 15.

STOP 15. Windsorville moraine(?) pit, town of East Windsor, Broad Brook quadrangle. From Windsorville intersection (Thrall Road, by Ketch Brook), go northwest 0.45 mi (0.75 km) to V intersection, at which bear right; Boutin pit is on right in 0.2 mi (0.3 km).

The narrow ridge (fig. 7) just north of Windsorville is about 1.2 km long, trends north-northeast, and has a sharp ice-contact slope on its north side. The front slope of the ridge overlooks a sand plain having a conspicuous southeast slope of about 6.5 m/km (35 ft/mi), which may be seen along Thrall Road. The ridge lacks exposures; whatever its composition, it stands 3-15 m above surrounding deposits, and presumably marks an ice-contact position on the east side of the Connecticut Valley lobe. The position may be correlative with that represented by the ice-contact delta at Stop 14.

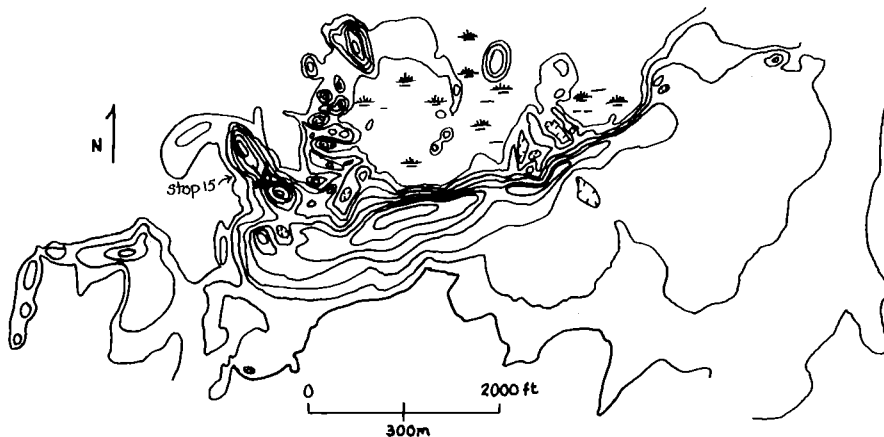

Figure 7. Topography of the Windsorville "moraine" from U.S. Geological Survey topographic map of the Broad Brook 7 1/2' quadrangle. See Stop 15 for description.

The pit is in collapsed deposits just north of the west end of the ridge. A slumped cut at the north side is at least partly in till. A slumped cut at the south side is in collapsed sand and gravel. The main active face, in the bottom of the south part of the pit, exposes sand deposited in a small lake and an interbedded layer of reddish-brown till. The till is at least 1 m thick to the east, and thins to the west in a way that is suggestive of a flowtill. However, the sand is deformed beneath the till, in one place by a 1-m-thick zone of recumbent folds and flat faults, and the deformation is more indicative of overriding than of flowtill deposition.

References Cited

- Black, R. F., 1977, Regional stagnation of ice in northeastern Connecticut; An alternative model of deglaciation for part of New England: *Geological Society of America Bulletin*, v. 88, p. 1331-1336.

- ___ 1979, Regional stagnation of ice in northeastern Connecticut; An alternative model of deglaciation for part of New England—Reply: Geological Society of America Bulletin, v. 90, p. 118-120.
- ___ 1982, Modes of deglaciation of Connecticut; A review, in Larson, G. J., and Stone, B. D., eds., Late Wisconsinan glaciation of New England: Dubuque, Iowa, Kendall/Hunt Publishing Company, p. 77-100.
- Currier, L. W., 1941, Disappearance of the last ice sheet in Massachusetts by stagnation zone retreat abs. : Geological Society of America Bulletin, v. 52, p. 1895.
- Davis, M. B., 1965, Phytogeography and palynology of northeastern United States, in Wright, H. E., Jr., and Frey, D. G., eds., The Quaternary of the United States: Princeton, N.J., Princeton University Press, p. 377-401.
- Deane, R. E., 1967, The surficial geology of the Hartford South quadrangle, with map: Connecticut Geological and Natural History Survey Quadrangle Report 20, 43 p.
- Flint, R. F., 1930, The glacial geology of Connecticut: Connecticut Geological and Natural History Survey Bulletin 47, 294 p.
- ___ 1932, Deglaciation of the Connecticut Valley: American Journal of Science, 5th series, v. 24, p. 152-156.
- ___ 1933, Late-Pleistocene sequence in the Connecticut Valley: Geological Society of America Bulletin, v. 44, p. 965-988.
- ___ 1934, Late-glacial features of the Quinnipiac-Farmington lowland in Connecticut: American Journal of Science, 5th series, v. 27, p. 81-91.
- ___ 1953, Probable Wisconsin substages and late-Wisconsin events in northeastern United States and southeastern Canada: Geological Society of America Bulletin, v. 64, p. 897-919.
- ___ 1975, The surficial geology of the Essex and Old Lyme quadrangles, with maps: Connecticut Geological and Natural History Survey Quadrangle Report 31, 41 p.
- ___ 1978, The surficial geology of the Haddam quadrangle, with map: Connecticut Geological and Natural History Survey Quadrangle Report 36, 27 p.
- Flint, R. F., and Cushman, R. V., 1953, Surficial geology of the Hartford-Middletown area, Conn., Itinerary for Trip C, in New England Intercollegiate Geological Conference, 45th Annual Meeting, Hartford, Conn., Oct. 10-11, 1953, Guidebook for field trips in Connecticut : 2 p.
- Flint, R. F., and Gebert, J. A., 1976, Latest Laurentide ice sheet; New evidence from southern New England: Geological Society of America Bulletin, v. 87, p. 182-188.
- Goldsmith, Richard, 1982, Recessional moraines and ice retreat in southeastern Connecticut, in Larson, G. J., and Stone, B. D., eds., Late Wisconsinan glaciation of New England: Dubuque, Iowa, Kendall/Hunt Publishing Company, p. 61-76.
- Haeni, F. P., and Anderson, H. R., 1980, Hydrogeologic data for south-central Connecticut: Connecticut Water Resources Bulletin 32, 43 p.

- Hanshaw, P. M., 1962, Surficial geology of the Meriden quadrangle, Connecticut: U.S. Geological Survey Geologic Quadrangle Map GQ-150.
- Hartshorn, J. H., and Colton, R. B., 1967, Geology of the southern part of glacial Lake Hitchcock and associated deposits, Trip E, in New England Intercollegiate Geological Conference, 59th Annual Meeting, Amherst, Mass., Oct. 13, 14, 15, 1967, Guidebook for field trips in the Connecticut Valley of Massachusetts: p. 73-88.
- Hartshorn, J. H., and Koteff, Carl, 1968, Lake-level changes in southern glacial Lake Hitchcock, Connecticut-Massachusetts abs., in Abstracts for 1967: Geological Society of America Special Paper 115, p. 268-269.
- Jahns, R. H., 1941, Outwash chronology in northeastern Massachusetts abs.: Geological Society of America Bulletin, v. 52, p. 1910.
- Jahns, R. H., and Willard, M. E., 1942, Late Pleistocene and Recent deposits in the Connecticut Valley, Massachusetts: American Journal of Science, v. 240, p. 161-191, 265-287.
- Koteff, Carl, 1967, Postglacial tilt in southern New England abs., in Abstracts for 1966: Geological Society of America Special Paper 101, p. 113-114.
- _____, 1974, The morphologic sequence concept and deglaciation of southern New England, in Coates, D. R., ed., Glacial geomorphology: Binghamton, N.Y., State University of New York, Publications in Geomorphology, p. 121-144.
- Koteff, Carl, and Pessl, Fred, Jr., 1981, Systematic ice retreat in New England: U.S. Geological Survey Professional Paper 1179, 20 p.
- Krynine, P. D., 1937, Glacial sedimentology of the Quinnipiac-Pequabuck lowland in southern Connecticut: American Journal of Science, 5th series, v. 33, p. 111-139.
- Langer, W. H., 1977, Surficial geologic map of the Glastonbury quadrangle, Hartford and Middlesex Counties, Connecticut: U.S. Geological Survey Geologic Quadrangle Map GQ-1354.
- Larsen, F. D., and Hartshorn, J. H., 1982, Deglaciation of the southern portion of the Connecticut Valley of Massachusetts, in Larson, G. J., and Stone, B. D., eds., Late Wisconsinan glaciation of New England: Dubuque, Iowa, Kendall/Hunt Publishing Company, p. 115-128.
- La Sala, A. M., Jr., 1961, Surficial geology of the Southington quadrangle, Connecticut: U.S. Geological Survey Geologic Quadrangle Map GQ-146.
- Leopold, E. B., 1956, Two late-glacial deposits in southern Connecticut: National Academy of Sciences Proceedings, v. 42, p. 863-867.
- Lougee, R. J., 1938, Physiography of the Quinnipiac-Farmington lowland in Connecticut: Colby College Monograph 7, 64 p.
- Mazzaferro, D. L., 1973, Hydrogeologic data for the Quinnipiac River basin, Connecticut: Connecticut Water Resources Bulletin 26, 54 p.

Q1-21

- O'Leary, D. W., 1977, Surficial geologic map of the Deep River quadrangle, Connecticut: U.S. Geological Survey Geologic Quadrangle Map GQ-1370.
- Pessl, Fred, Jr., 1971, Till fabrics and till stratigraphy in western Connecticut, in Goldthwait, R. P., ed., Till; A symposium: Columbus, Ohio, Ohio State University Press, p. 92-105.
- Pessl, Fred, Jr., and Schafer, J. P., 1968, Two-till problem in Naugatuck-Torrington area, western Connecticut, in New England Intercollegiate Geological Conference, 60th Annual Meeting, New Haven, Conn., Oct. 25-27, 1968, Guidebook for fieldtrips in Connecticut: Connecticut Geological and Natural History Survey Guidebook 2, Trip B-1, 25 p.
- Porter, S. C., 1960, The surficial geology of the Wallingford quadrangle, with map: Connecticut Geological and Natural History Survey Quadrangle Report 10, 42 p.
- Schafer, J. P., and Hartshorn, J. H., 1965, The Quaternary of New England, in Wright, H. E., Jr., and Frey, D. G., eds., The Quaternary of the United States: Princeton, N.J., Princeton University Press, p. 113-128.
- Simpson, H. E., 1959, Surficial geology of the New Britain quadrangle, Connecticut: U.S. Geological Survey Geologic Quadrangle Map GQ-119.
- Sirkin, L. A., 1967, Correlation of late glacial pollen stratigraphy and environments in the northeastern U.S.A.: Review of Palaeobotany and Palynology, v. 2, p. 205-218.
- Williams, S. J., 1981, Sand resources and geological character of Long Island Sound: U.S. Army Corps of Engineers, Coastal Engineering Research Center Technical Paper 81-3, 65 p.

ROAD LOG FOR TRIP Q1

Distances were measured from topographic maps, and will be slightly different from (generally less than) distances recorded on the road.

MILES

- 0.0 Meeting place: Tylerville (town of Haddam, Deep River quadrangle), intersection of Conn. 9A and 82; parking area for stores at SE angle of intersection. Go SE on Conn. 9A.
- 0.15 Turn left (NE) at entrance to pit.
- 0.35 STOP 1. Return to pit entrance.
- 0.6 Turn right (NW) on Conn. 9A.
- 0.75 Turn right (NE) on Conn. 82. Cross Connecticut River.
- 1.7 East Haddam village; turn left (N) on Conn. 149. Enter Moodus quadrangle at 5.4 mi.
- 7.2 Turn left (N) on Trowbridge Road, which becomes Water Hole Road.
- 9.7 Turn left (NW) on Conn. 16. Cross Salmon River.
- 10.2 Turn right (NE) on River Road.
- 10.7 Park and wade river to STOP 2. (Alternatively, park at covered bridge near Conn. 16 bridge, and walk up E bank.) Return SW on River Road.
- 11.2 Turn right (NW) on Conn. 16. Pit in complexly collapsed gravel and sand on right at 11.3 mi. Enter Middle Haddam quadrangle at 14.1 mi.
- 16.3 Turn left (W) on Conn. 66; old pit in delta on left. Another old pit in delta (unit 1c, fig. 1) on left at Axelrod Tire at 18.4 mi.
- 20.1 Turn right (N) on Conn. 17. Cross from crystalline rocks of eastern highlands onto Jurassic redbeds.
- 21.2 Turn right (E) on Bartlett Street. Turn right at pit entrance road by house at 21.3 mi. or walk in from back of Portland Burying Ground just to E.
- 21.55 STOP 4. Return on Bartlett Street and Conn. 17 to Conn. 66.
- 23.0 Turn right (W) on Conn. 66. Enter Middletown quadrangle at 24.1 mi. Go through Portland and cross Connecticut River to Middletown.
- 26.2 Continue straight ahead (S) on Main Street (where Conn. 66 turns right on Washington Street).
- 27.15 Bear right (S) on Ridge Road.
- 27.2 Turn right (W) on Mill Street.
- 27.35 STOP 3. Marino Crane Service site on left; park near street. Return to Conn. 66.
- 28.5 Turn left (W) on Conn. 66 (Washington Street).
- 28.9 Turn right (NW) on Conn. 72.
- 30.4 Turn right (E) at Michael Kane Brick Co. entrance. Cross railroad on dirt track, then turn left (N) to clay pit.
- 30.9 STOP 5.

Alternative route from Stop 1 if Stop 2 is omitted:

- (0.6 Turn left (SE) on Conn. 9A.
- (0.8 Turn right (SW) on Conn. 82.
- (3.0 Turn right (NW) on entrance ramp for northbound Conn. 9. Enter Haddam quadrangle at 3.5 mi, Middle Haddam quadrangle at 10.3 mi, and Middletown quadrangle at 14.1 mi.
- (14.6 Exit from Conn. 9 at Interchange 12.
- (14.7 Turn left (W) on Bow Lane.
- (14.9 Bear right (NW) on Saybrook Road.
- (15.2 Turn left (W) on Mill Street.

- (15.55) STOP 3. Marino Crane Service site on left; park near street. From here to STOP 4 (21.4 mi), reverse the route described above. Then return to Middletown and continue on Conn. 66 to Conn. 72 (26.5 mi), and turn rt to STOP 5 (28.5 mi) as described above.

-
- From STOP 5 (30.9 mi), return to entrance.
- 31.4 Turn right (N) on Conn. 72.
- 32.9 Bear right (N) on Conn. 3.
- 33.8 Turn right (E) on Evergreen Road.
- 35.1 Turn left (N) on Conn. 99 (Main Street). Enter Hartford South quadrangle at 36.0 mi.
- 37.5 Turn right (E) on new divided street.
- 38.3 At intersection with Dividend Road, turn right into pit entrance.
- 38.6 STOP 6. Return to Conn. 99.
- 39.7 Turn right (N) on Conn. 99.
- 40.3 Turn left (W) on West Street. Dinosaur State Park on left at 41.1 mi.
- 42.0 Turn left (S) on entrance ramp for southbound Interstate 91. Enter Middletown quadrangle at 44.0 mi and Meriden quadrangle at 50.3 mi.
- 51.6 Bear right (SW) on exit ramp from Interstate 91 to Conn. 15 (Wilbur Cross Parkway). Enter Wallingford quadrangle at 54.5 mi.
- 55.2 Exit from Connecticut 15 at Interchange 66.
- 55.3 Turn left on U.S. 5.
- 55.6 Turn right (W).
- 55.7 Turn right (NW) on Church Street.
- 56.4 Yalesville; turn right on Hanover Street. Enter Meriden quadrangle at 57.0 mi.
- 57.1 Turn left (W) on dirt track that bends N, goes under power lines, past a small pit, across a little stream, and turns E to pit on W side of airstrip.
- 58.0 STOP 7. Return to Hanover Street.
- 58.9 Turn left (N) on Hanover Street, which becomes Evansville Avenue.
- 60.2 South Meriden; turn left (W) on Conn. 70 (Main Street). This highway enters Quinnipiac Gorge at 60.6 mi; weathered New Haven Arkose (Triassic) at left.
- 62.2 Bear right (NW) from Conn. 70.
- 62.4 Turn right (N) on Cheshire St.
- 64.0 Turn left (W) on East Johnson Avenue.
- 64.3 Turn right (N) at pit entrance (2nd track).
- 64.4 STOP 8. Return to East Johnson Avenue.
- 64.5 Turn right (W) on East Johnson Avenue. Enter Southington quadrangle at 64.55 mi. Road climbs over front of delta; old pit in foreset slope on left at 64.8 mi.
- 65.4 Turn right (N) on Conn. 10.
- 65.6 Turn right at pit entrance, along pipeline.
- 65.75 STOP 9. Return to Conn. 10.
- 65.9 Turn right (N) on Conn. 10.
- 66.6 Turn right (E) on Conn. 66. Enter Meriden quadrangle at 67.4 mi. Dinosaurs in back yard on left at 68.7 mi. Turn right on ramp to new part of Conn. 66 at 68.95 mi.
- 71.0 Exit from Conn. 66.
- 71.1 Turn left (N) on Conn. 71 (Capitol Avenue). Active talus slopes on right below Holyoke Basalt cliffs, at 71.6-72.1 mi. Beginning at 72.5 mi, road is on ponded meltwater deposits that are discussed under Stop 10.
- 74.1 Turn right (E) on Orchard Road.

Q1-24

- 75.1 Turn left (N) on Kensington Road.
- 76.4 Turn right (S) on Elton Road.
- 76.65 Turn left (E) on new street to pit.
- 76.8 STOP 10. Return to Kensington Road.
- 77.2 Turn right (E) on Kensington Road, then N. Enter New Britain quadrangle at 78.7 mi.
- 79.5 Kensington; turn left (NW); becomes Corbin Avenue.
- 82.4 Turn left (W) on ramp to westbound expressway.
- 83.6 Expressway joins westbound Interstate 84 and passes through the Cooks Gap wind gap (a segment of a Tertiary stream course?); quarries in Holyoke Basalt on both sides.
- 83.9 Exit from Interstate 84 at Interchange 34.
- 84.1 Turn right (NE).
- 84.3 Turn left (NW) on Conn. 72. Enter Bristol quadrangle at 86.4 mi.
- 90.4 Turn right (N) on Conn. 69. Cross onto crystalline rocks of western highlands at 88.5 mi.
- 91.1 Turn left (W) on U.S. 6.
- 92.4 Turn left (S) on Barnum Road; enter pit across small stream.
- 92.6 STOP 11. Return to U.S. 6.
- 92.8 Turn left (W) on U.S. 6.
- 93.0 Turn left (S) on Barlow Street.
- 93.35 Turn left (E) into pit.
- 93.45 STOP 12. Two more pits 0.25 and 0.5 mi. SE of this one. Return to U.S. 6.
- 93.9 Turn right (E) on U.S. 6.
- 100.6 Turn right (S) on New Britain Avenue.
- 100.9 Turn right on Hyde Road.
- 101.2 Turn left (SE) into large pit area. (Road location uncertain because Hyde Road has been relocated.) Go S to S part of pit area.
- 101.9 STOP 13. Return to U.S. 6.
- 103.2 Turn right (E) on U.S. 6. Cross basalt ridge.
- 107.3 Turn left (NE) on ramp to eastbound Interstate 84. Enter Hartford South quadrangle at 109.8 and Hartford North quadrangle at 112.6 mi.
- 115.1 Exit from Interstate 84 to northbound Interstate 91. Enter Windsor Locks quadrangle at 122.8 mi.
- 122.8 Exit from Interstate 91 at Interchange 38.
- 123.0 Turn right (NW) on Conn. 75.
- 123.2 Turn left (SW) on Day Hill Road.
- 125.8 Turn left (SW) on Prospect Hill Road.
- 126.8 Turn right (N) on paved road.
- 127.3 Continue to N on dirt track beside row of tobacco barns, to pit.
- 127.6 STOP 14. Return to Interstate 91.
- 132.2 Turn left (N) from Conn. 75 onto ramp to northbound Interstate 91. Cross Connecticut River and enter Broad Brook quadrangle at 135.9 mi.
- 136.5 Exit from Interstate 91 at Interchange 44 to southbound U.S. 5.
- 137.8 Turn left (E) on Tromley Road. Road bends left and crosses Scantic River at 140.0 mi, bends right and crosses Broad Brook Road at 140.7 mi. Moraine of Stop 15 behind St. Catherines Cemetery on left at 141.9 mi.
- 142.2 Windsorville; turn left (NE) on Thrall Road. Moraine ridge just to left, exceptionally steep sand plain on right (fig. 7). Bear left on Thrall Road, turn right on Chamberlain Road, East Road, and Clark Rd.
- 144.3 Windsorville; turn right (W). Bear right (N) at 144.8 mi.

Q1-25

- 144.55 Turn right (E) into pit.
144.65 STOP 15. Return to Windsorville.
145.0 Windsorville; turn right (SW) on Wapping Road.
145.1 To reach Storrs, turn left (SE) on Rockville Road, which becomes Windsorville Road; then by Conn. 74 and 195.
To reach southbound Interstate 84, continue SW on Wapping Road, bear left on Miller Road and right on Graham Road, and join Conn. 194. At Wapping (South Windsor), go S on Buckland Road, then right (W) on Burnham Street and left (SE) on Windsor Street to Interstate 84 at Interchange 93.

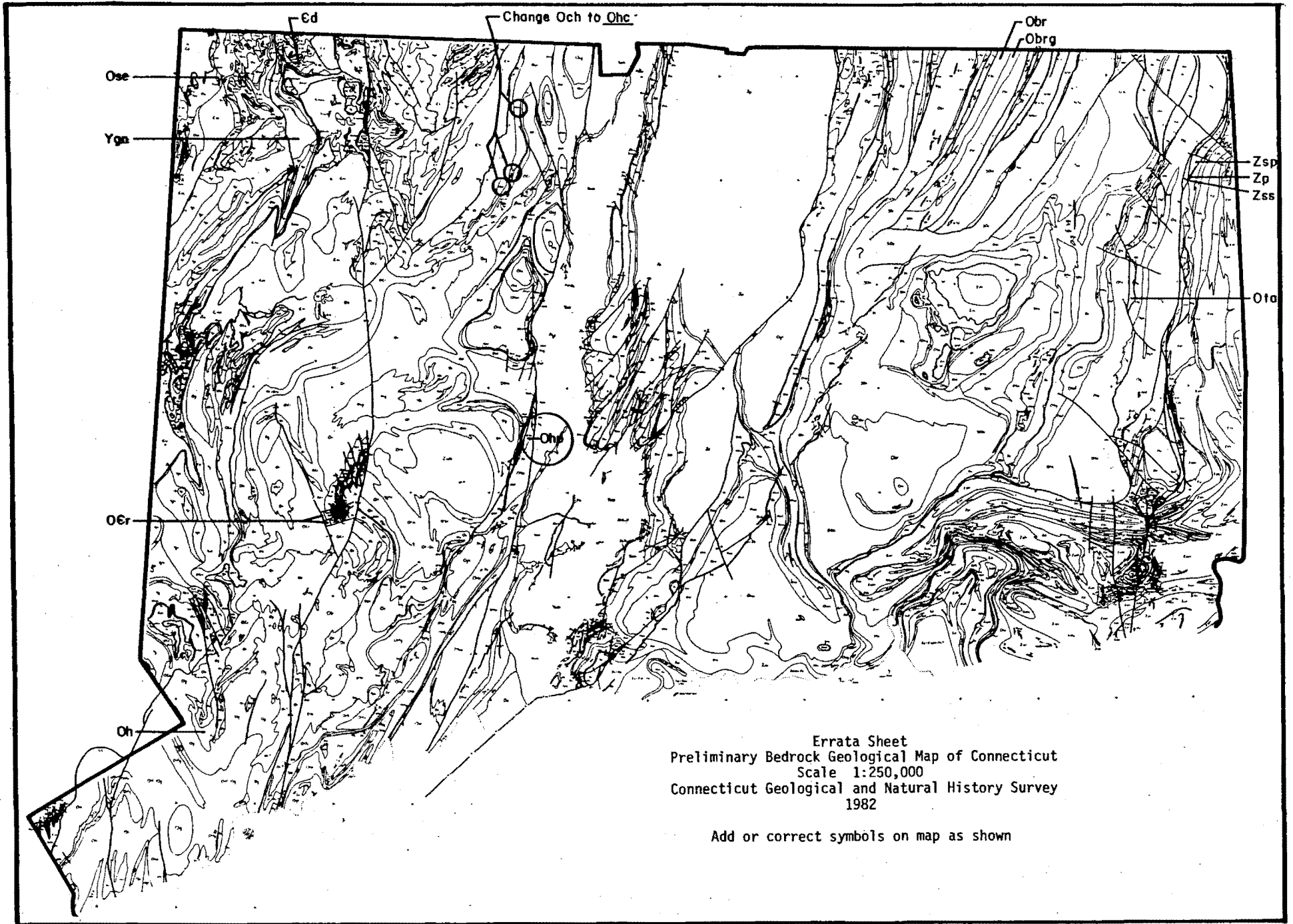

"ANATOMY OF THE CHICOPEE READVANCE,
MASSACHUSETTS"

by

Frederick D. Larsen
Department of Earth Science
Norwich University
Northfield, Vermont 05663

The area traversed on this field trip lies in the Easthampton, Mt. Tom, and Springfield North 7.5-minute U.S. Geological Survey topographic quadrangles in the Connecticut Valley Lowland of Western Massachusetts. The terrain is underlain by terrestrial arkosic sedimentary rocks and tholeiitic basalts of Late Triassic and Early Jurassic age (Cornet and others, 1973). The rocks were deposited in a down-faulted half graben produced by the rifting of eastern North America from Africa (Van Houten, 1977). The arkosic sedimentary rocks form two lowlands separated by a hogback held up by the resistant Holyoke Basalt. The Connecticut Valley Lowland is bordered on both the east and west by Paleozoic high-grade metamorphic and igneous rocks of the New England Uplands.

During retreat of the last ice sheet the Connecticut Valley Lowland of Massachusetts was occupied by active ice consisting of two sublobes separated by the Holyoke Basalt ridge (Fig. 1). That the Connecticut Valley was filled with ice while the tributary valleys were free of ice is shown by sets of ice-contact deposits, mainly kame terraces, that step down toward the axis of the main valley. In the Belchertown, Ludlow, Mount Tom, and Easthampton quadrangles, ice-contact slopes associated with these kame terraces trend north-south and are collapsed toward the center of the Connecticut Valley (Fig. 2). That the ice was an active lobe as opposed to a stagnant tongue is shown by radial patterns of striations for both sublobes (Fig. 3). In addition, erratics of Jura-Triassic rocks have been pushed onto crystalline rocks to the southeast and southwest of their source area in late-glacial time (Fig. 4).

When the margin of the eastern sublobe was in the southern part of the Springfield North quadrangle, the ice margin readvanced southward 3 to 4km, or underwent a period of oscillatory retreat for several years over the same north-south distance. The main evidence for readvance consists of reddish-brown, compact, lodgement till overlying deformed stratified drift, which in turn overlies till of the main ice advance. Other evidence consists of glaciotectonic features such as thrust faults, shear zones, overturned folds of lacustrine sediment and exotic blocks of deformed sediment.

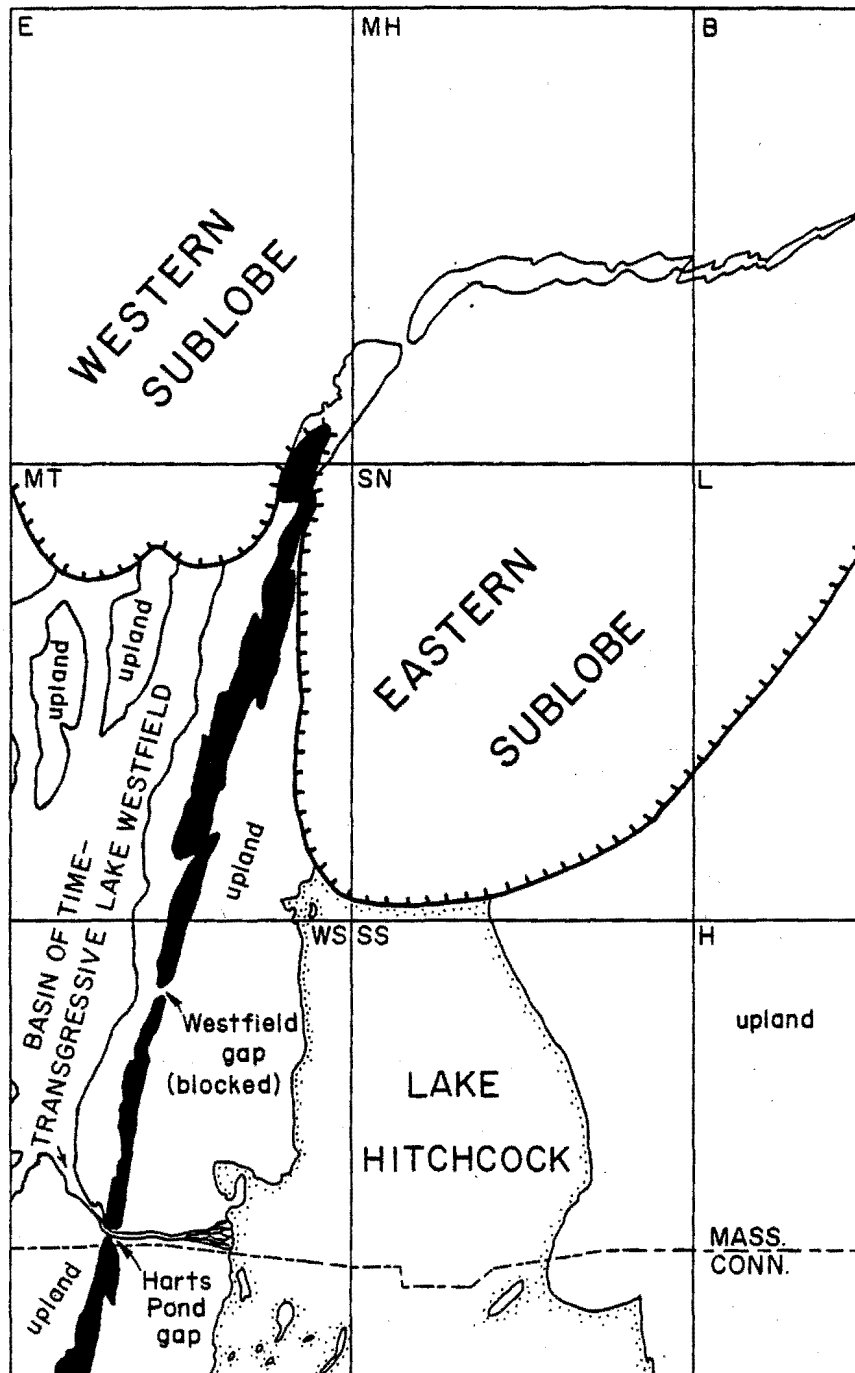

Figure 1. The Connecticut Valley sublobes in late-glacial time. Glacier is outlined by hachured line. Rectangles are U.S.G.S. 7.5-minute quadrangles: E, Easthampton; MH, Mt. Holyoke; B, Belchertown; MT, Mt. Tom; SN, Springfield North; L, Ludlow; WS, West Springfield; SS, Springfield South; H, Hampden. Solid black area is Holyoke Basalt ridge.

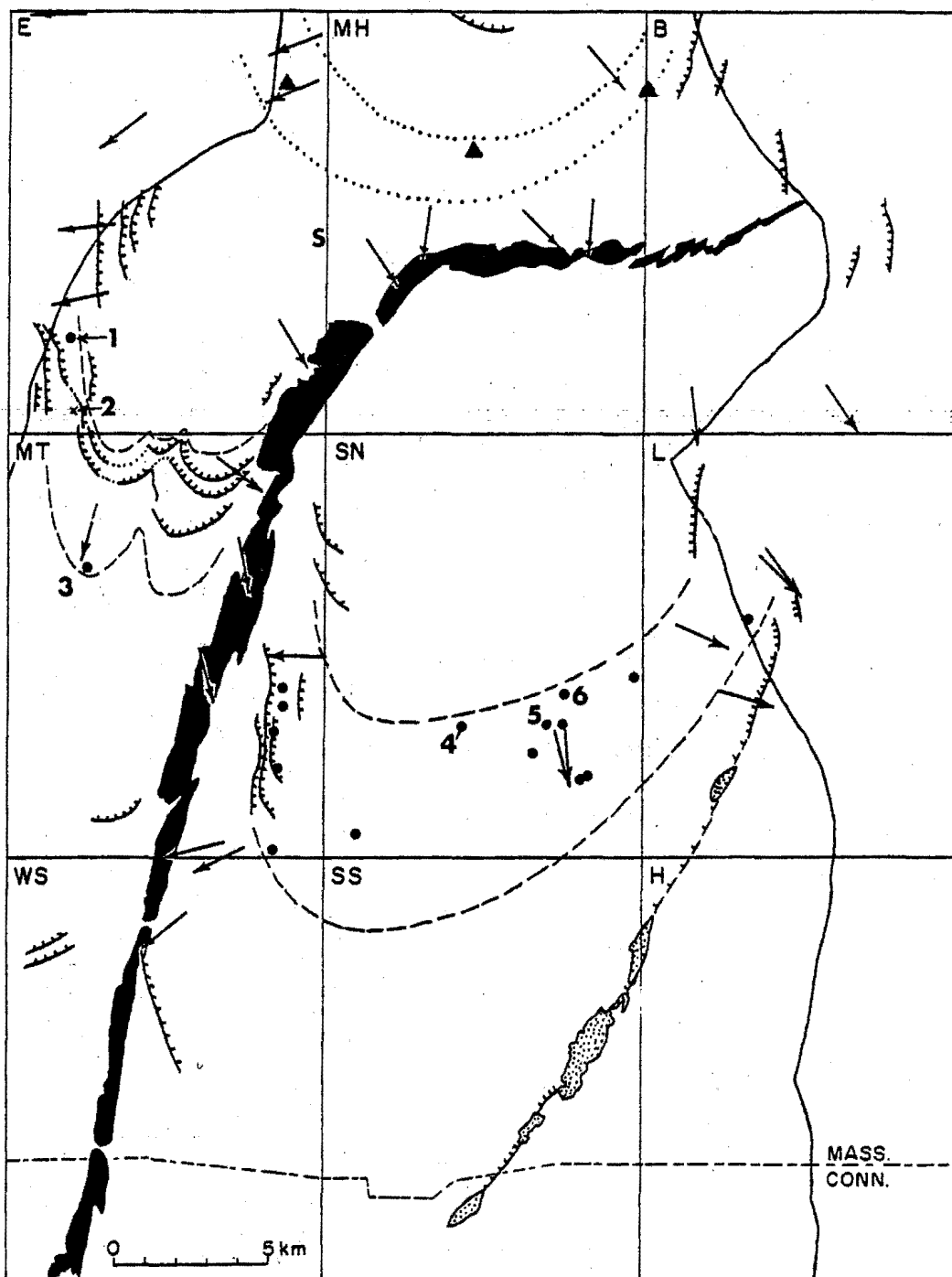

Figure 2. Map of selected striations (arrows), ice-contact slopes (hachured lines; hachures on side of ice), and readvance localities (solid circles, Chicopee readvance; solid triangles, Camp Meeting readvance). Dashed lines enclose area of Chicopee readvance; dotted lines enclose area of Camp Meeting readvance. Ice-contact deposits shown in stippled pattern. Numbers are field trip stops; S, start of trip; see Fig. 1 for quadrangle names.

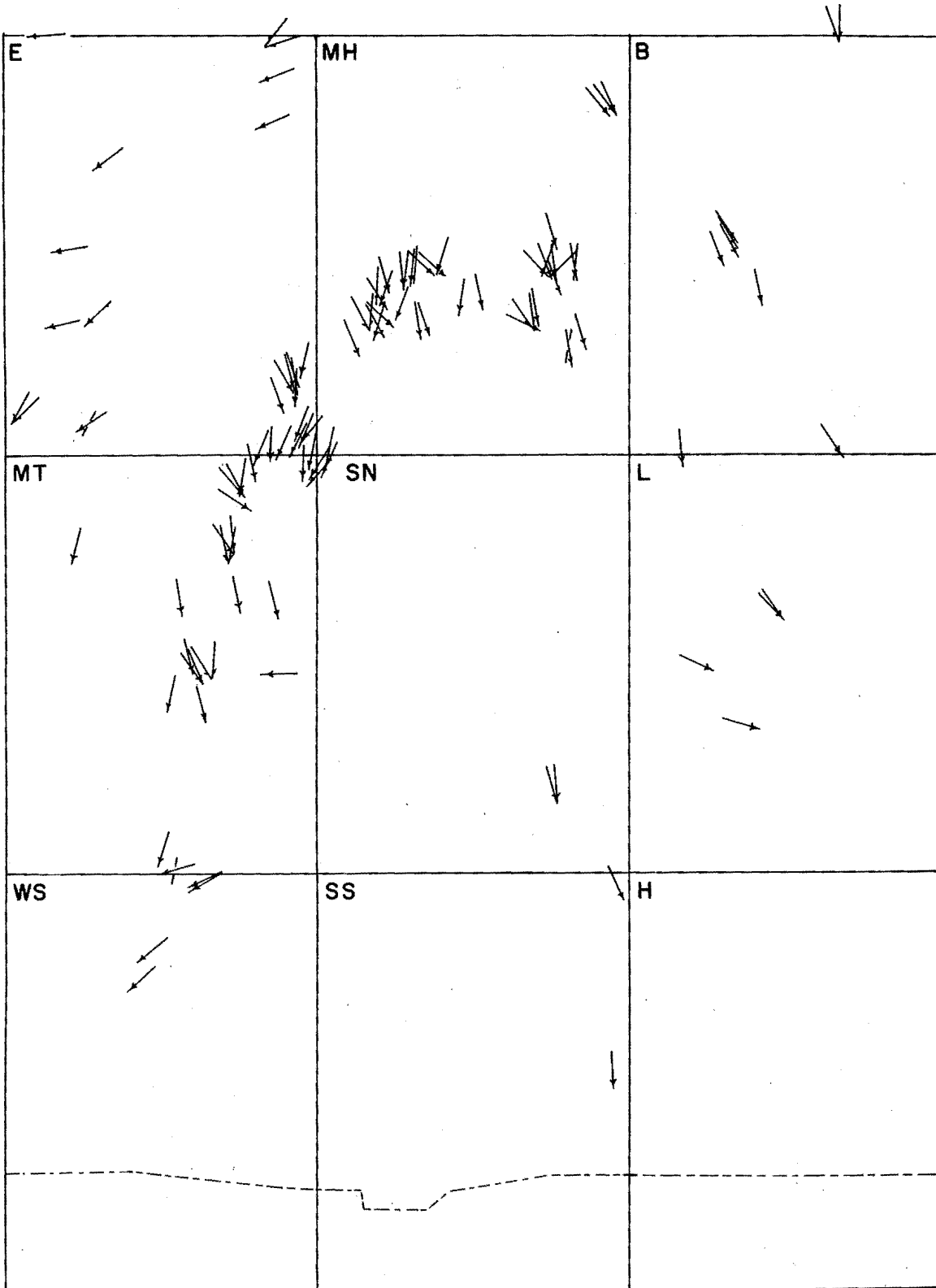

Figure 3. Map of striations in the southern part of the Connecticut Valley of Massachusetts. High concentrations of striations occur on the Holyoke Basalt ridge and on crystalline rocks in the northwest and the east. Location of striations at point of arrow. See Fig. 1 for quadrangle names.

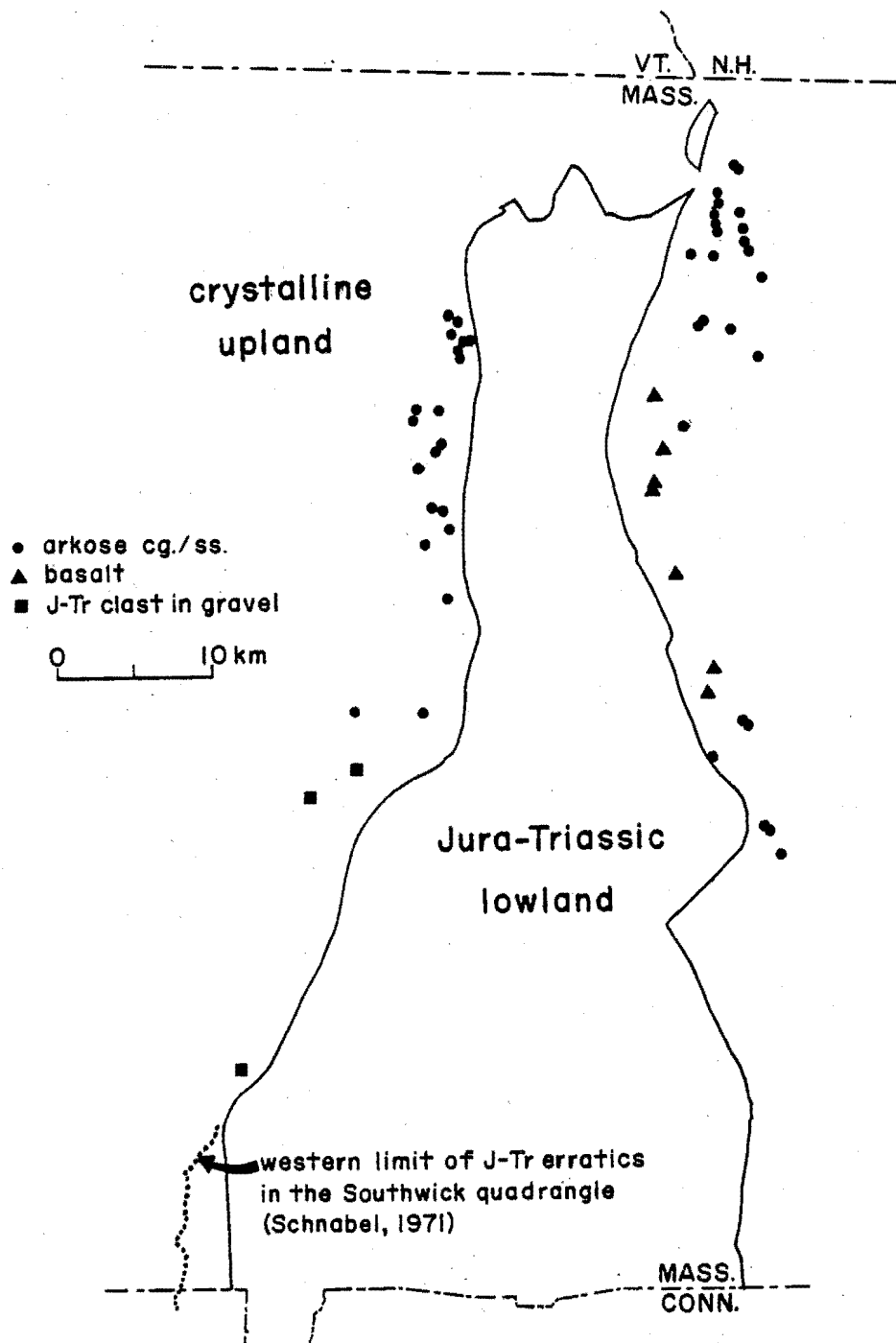

Figure 4. Distribution of erratics of Jura-Triassic rocks overlying crystallines. Erratics were transported east and west from their source area in the Connecticut Valley in late-glacial time.

Evidence for the Chicopee readvance is found at 15 localities east of the Holyoke Basalt ridge and in a 3- to 4.5-km wide zone that loops across the Connecticut Valley from the Ludlow quadrangle on the east to the Mt. Tom quadrangle on the west (Fig. 2). Two readvance localities west of the basalt ridge are correlated with those east of the ridge.

I first discovered evidence for the Chicopee readvance in November, 1968, just north of the border between the Mt. Tom and Easthampton quadrangles. During 1969, other readvance localities were identified in the southeast portion of the Mt. Tom quadrangle. No formal name for the readvance was suggested or used at that time (Larsen, 1972). The readvance locality in the southwest part of the Easthampton quadrangle (Stop 1) was discovered in 1974. Readvance localities in the Springfield North quadrangle (Stops 4,5,6) were mapped in 1977 and one was located in the Ludlow quadrangle in 1978.

J. P. Schafer used the term "Mt. Tom readvance" on drawings used for a paper presented in 1979 at the Northeast Section of the Geological Society of America. That designation by Schafer was for the readvance in the Mt. Tom quadrangle and has nothing to do with Mt. Tom, elevation 1,205 ft. highest peak on the Holyoke Basalt ridge. The term "Mt. Tom readvance" was used by Koteff and Pessl (1981) and it also appeared in an end paper in the symposium volume (Larson and Stone, 1982) in which Larsen and Hartshorn (1982) first used the term "Chicopee readvance". I urge use of the term "Chicopee readvance" as defined in this paper in place of "Mt. Tom readvance".

Further, I recommend use of the term "Camp Meeting readvance" for the readvance of the Connecticut Valley lobe in the north half of the Mt. Holyoke quadrangle, northwest corner of the Belchertown quadrangle, and northeast corner of the Easthampton quadrangle as shown in Figure 2. The latter site is the location of the Camp Meeting cutting (railroad cut) where B. K. Emerson (1898) described three readvances of glacial ice.

Because exposures of surficial deposits are so ephemeral it is probably useless to designate a type locality for the Chicopee readvance. However, if a type locality were to be designated it should be the Chicopee River section (Stop 4). Many readvance localities are in active pits that change from month to month and several of the best readvance localities have already been destroyed. The Chicopee River section is located at the base of a steep bank adjacent to the Chicopee River. Although badly overgrown by vegetation and suffering from mass movements, the site is off the beaten path but is accessible. Chances are good that readvance tills and overlying varved sediments can be excavated at this site for the next decade or two.

The main purpose of this field trip is to observe the various types of evidence for the Chicopee readvance. Those readvance localities that will not be visited or have already been destroyed will be

briefly described here so the reader will have a broader understanding of the nature of the evidence. Figure 5 is the southeast corner of the Mt. Tom quadrangle showing readvance localities as dark symbols. Cross-cutting striations in the southwest corner of Figure 5 are located at the tip of the S 70°W arrow. Here, striations of the main ice advance trend S 10°W parallel to stream-lined topography and whalebacks cut in fault blocks of Holyoke Basalt. Striations trending S 70°W are found only on the crests of whalebacks and must represent lobate spreading of the eastern sublobe or possible readvance as the last glacial event at this site.

Striations trending due west were found in the northeast corner of Figure 5. They are at right angles to the due-south trend of drumlins east of the Holyoke Basalt ridge and represent, again, active spreading of the eastern sublobe. Lodgement till over gravel was found at two localities southwest of Ingleside. The more northerly site was a small exposure in a pit just north of the present Holiday Inn and was not studied in detail although similar small exposures occurred just to the northwest. The more southerly symbol represents a compact brown till, 1.2 to 1.8m thick, exposed in a 50-m trench along Westfield Road. In the middle 15m of the trench the till was observed to rest on clean hard-packed gravel of probable outwash origin.

Three meters of lodgement till overlying 3.3 m. of thrust-faulted sand were observed in a temporary borrow pit 0.3 of a mile west of Mont Marie (Figs. 5 and 6). The thrust-faulted sand was overlain by a zone 0.15 to 0.9m thick of slices and lenses of material intermediate in composition between the underlying sand and the reddish-brown till above. This zone is interpreted to be a shear zone produced by glacial ice overriding fluvial sand. Mapping to the southeast indicated that the fluvial sand rested on lacustrine deposits that in turn overlie reddish-brown till in Tannery Brook (Fig. 6). The till in Tannery Brook is believed to be the result of the main ice advance (Late Wisconsinan) and the upper till the result of the Chicopee readvance. The upper portion of section X-Y (Fig. 6) now lies under the parking lot of the Ingleside shopping center.

The southwest-trending arrow on the flank of Bradley Mountain (Fig. 5) represents a till fabric measured about 1.5m below the ground surface. Measurement was difficult and time consuming because of lack of elongated clasts. The predominant lithology was arkosic siltstone and shale, the pebbles of which were usually platy or blocky in shape. The modal direction of the fabric is S 38°W. The possibility of southwest movement of late-glacial ice is reinforced by the obvious east-west asymmetry of Bradley Mountain, Prospect Hill, and several drumlins north of Ingleside.

The boring record for the site 0.4 of a mile east of Bradley Mountain, as based on the number of blows to advance a split spoon a given distance, has at the surface 2.4m of sand (21 and 39 blows), followed by 3.0m of till (89 and 123 blows), 2.4m of sand (39 and

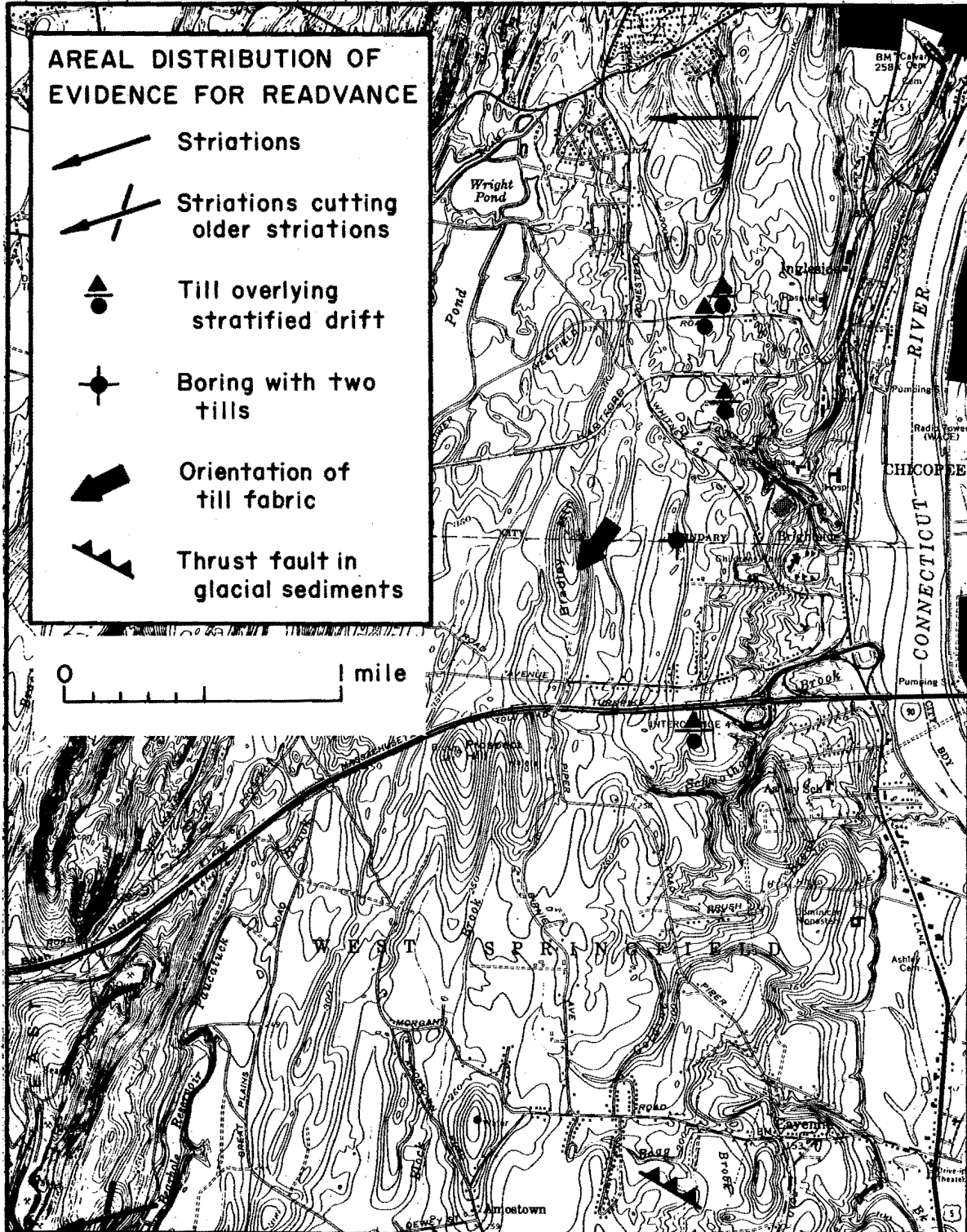

Figure 5. Southeast portion of Mt. Tom 7.5-minute quadrangle showing the areal distribution of evidence for readvance.

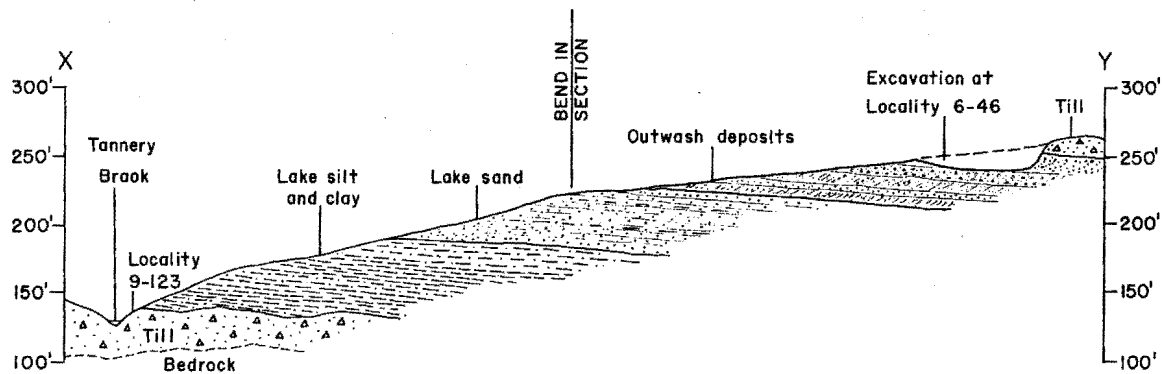
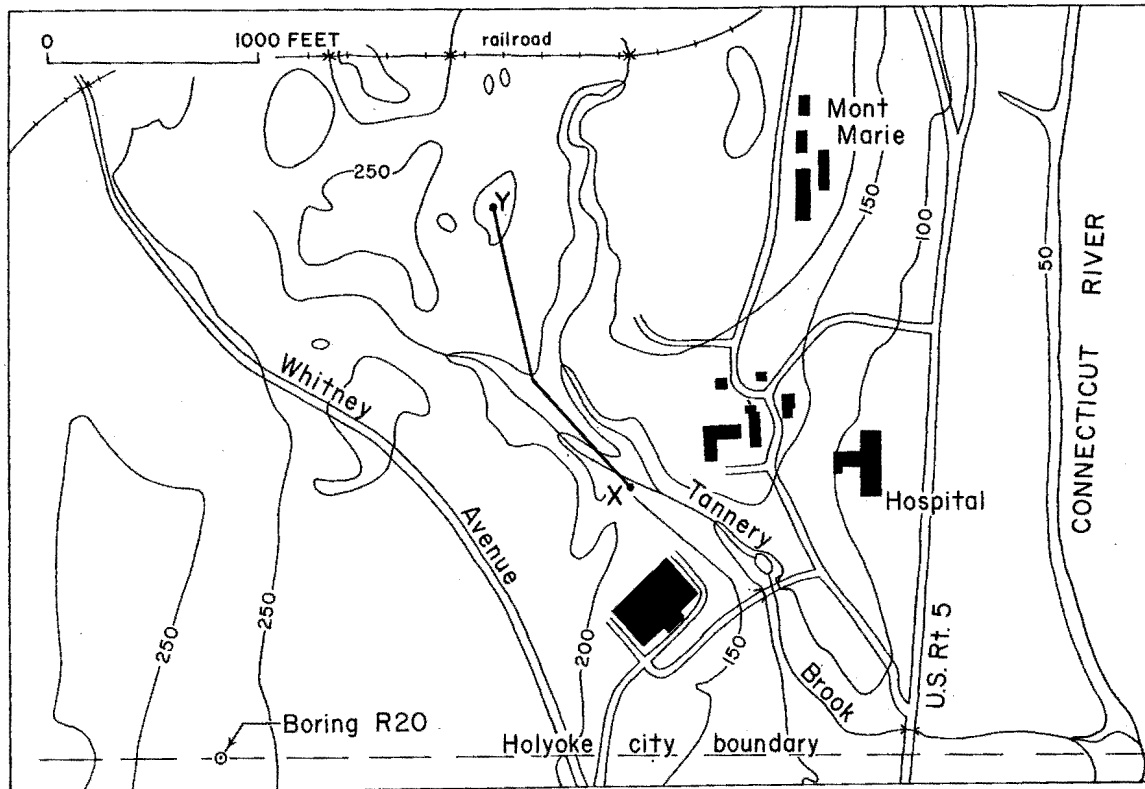

Figure 6. Map and cross section of readvance locality west of Mont Marie.

blows), and at the bottom 2.7m of till (139 and 174 blows). The upper till is believed to be the readvance till of the site west of Mont Marie.

In 1969, two readvance tills were exposed on the west side of a pit just south of the Massachusetts Turnpike at Interchange 4 (Fig. 5). The sequence sand-till-sand-till-sand occurred in a curving exposure 105m long and 2.4 to 3.6m high. Both tills displayed irregular layers of varying composition, which formed by mixing two end members. One end member consists of a brown till, the other of olive-gray clay and dark brownish-red silt of lacus-

trine origin. Such irregular layering would be expected if an ice margin readvanced or oscillated in a water body such as glacial Lake Hitchcock. It is my opinion that the lower till, which is 3m thick, represents a longer period of readvance than does the upper till, and that there is a third till at depth that represents the main, Late Wisconsinan advance of ice in this area.

The first evidence for the Chicopee readvance that was found consists of glaciotectionic structures southwest of Cayenne in the southeast corner of the Mt. Tom quadrangle (Fig. 5). In an exposure 12m long and 3.6m high, lacustrine sediments have been overturned and thrust-faulted to the southwest in the form of a nappe (Fig. 7). An envelope of gray varves and olive lacustrine sands surrounds a core of brown till, all of which are truncated at the base and thrust over brown lacustrine sands. An auger hole 1.5m away from the face under the crest of the fold in varved clay penetrated 0.9m of brown sand, 0.3m of gray varves, and 0.1m of olive sand. The thrust fault at the base of the nappe structure strikes N 70°W and dips 50° to the northeast. The crest of the fold in varved clay plunges 15° toward S 60°E. The structures described here may not signify a major readvance but merely a slight readvance by an active ice lobe.

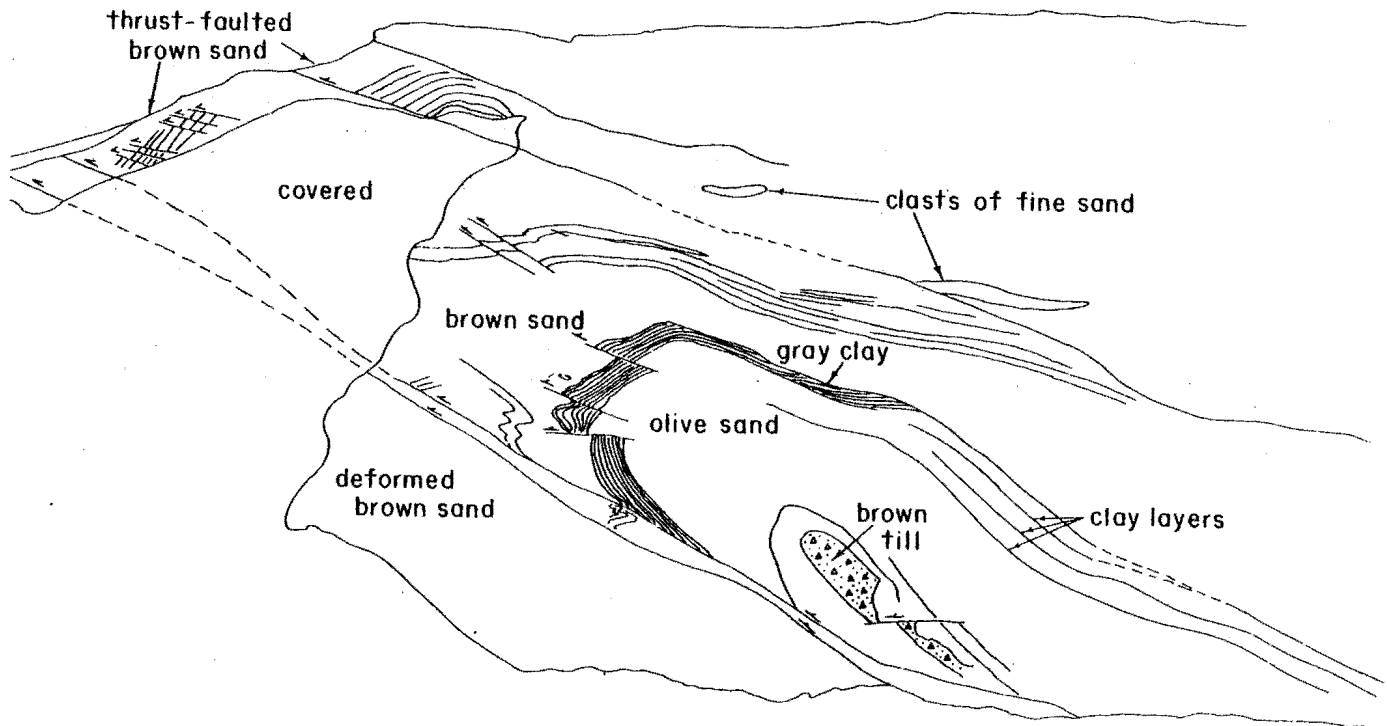

Figure 7. View west-northwest of nappe and associated thrust faults. Exposure slopes toward observer and is 3.6m high at brown till. Traced from a photograph.

East of the Connecticut River the first readvance locality encountered is that at Center Auto Parts, Center Street, Chicopee. The locality is in the southwest corner of the Springfield North quadrangle (Fig. 2). From the top down were: (1) 1.8m undisturbed clay-silt varves, (2) 0.06m brown till, (3) 1.0m deformed and thrust-faulted clay silt varves, (4) 1.5m grayish-brown till, (5) 0.4m brown fine sand, brown silt, gray silty clay, (6) 0.2 (plus) m brown till. Thickness of individual units changed abruptly along the east-west trend of the face. I believe the two upper tills represent two readvances, however minor, and that they may be correlative with two readvance tills at the locality already described 3.4km to the northwest and at Stop 6.

In the southeast portion of the Springfield North quadrangle are two readvance localities adjacent to each other (Fig. 2). The more westerly of the two consists of lacustrine fine sand with ripple-drift cross-lamination. The exposure displayed numerous anastomosing thrust faults and a pervasive fracture cleavage that dipped steeply to the southeast. There was no evidence on the surface of till or erratics, however the sediment had been highly tectonized probably by overriding ice of the Chicopee readvance. The more easterly of the two readvance localities consisted of a large block of lacustrine sediment that had been rotated 90° and was in direct contact with topset and foreset beds of a delta. The minimum dimensions of the block, which had been partially removed by excavating equipment, were 3.6m by 7.2m in a vertical exposure facing west. The block was rounded and extended at least 2.4m to the east under the deltaic beds. Bedding in the block was vertical and had been offset apparently to the south or southeast along two subhorizontal thrust faults. It could be argued that this exotic block resulted from collapse of ice-contact deposits, however, because there are so many readvance features nearby, I favor an ice-shove origin.

The remaining undescribed readvance localities consist of readvance till overlying deposits of stratified drift, the deformation of which ranges from none to moderate. These undescribed localities are significant but are not as spectacular as the planned field trip stops.

ACKNOWLEDGEMENTS

The opportunity to study the surficial geology in the four quadrangles in which evidence for the Chicopee readvance could be found was presented by the U.S. Geological Survey. Much of the above text was taken from Larsen (1972) and Larsen and Hartshorn (1982). Joseph H. Hartshorn suggested the original study on the Mt. Tom quadrangle and many of his ideas are incorporated in this paper. (Figures 1-4 from Larsen and Hartshorn, 1982; figures 5-7 from Larsen, 1972).

Starting point for field trip Q5 is on Conz St. in Northampton, Mass., 0.25 mi. north of Exit 18, Interstate I-91. From Storrs, Route 32 north, 29 mi. to Palmer, Mass., Interchange 8 on Massachusetts Turnpike; west via Mass Pike, 17 mi. to West Springfield, Interchange 4; north via Interstate I-91, 13 mi. to Exit 18, Northampton.

Road Log

Mileage

- START: EASTHAMPTON QUADRANGE
- 0.0 Begin mileage count on Conz St. in front of Towne House Motor Lodge. Proceed NW on Conz St. on former flood plain of Mill River.
 - 0.4 Turn left (SW) at sign with arrow to routes 9 and 10.
 - 0.5 Stop sign, turn left (S) on Route 10, flat for next 0.9 of a mile is underlain by bottom sediments of glacial Lake Hitchcock
 - 1.4 Cross Mill River Diversion
 - 2.3 Hill to right is a drumlin, route follows contact between till (R) and lake-bottom sediments (L)
 - 2.9 Route rises up on till ridge, note boulders.
 - 3.4 Back on lake-bottom sediments
 - 4.1 Turn right (SW) on West St.
 - 4.2 Caution, sharp turn in road, climb back up to lake-bottom sediments
 - 5.2 View left to Mt. Tom Range underlain by Holyoke Basalt
 - 5.3 Stop sign. Turn right (NW) on Loudville Road
 - 6.7 Cross Torrey St. at Lake Hitchcock shoreline. Gravel flat just to W is interpreted to be the top of a small delta built into Lake Hitchcock.
 - 6.9 Top of ice-contact delta built into Lake Manhan.
 - 7.3 Park in field on left side of road. Walk S on W side of field. Turn E at corner, proceed about 50m, follow red-flagged trail southward

STOP 1. North Branch of the Manhan River Section (Fig. 2 and Fig. 8). From the base up, the section consists of: (1) gray till, (2) deformed gray lacustrine sediment and "till equivalent", 2m, (3) reddish-brown compact till, 1.3m, (4) angular clasts blanketed by lake-bottom sands, 0.5m, (5) fine to medium sand with ripple-drift cross-lamination, indicating transport direction to the east, 3m, (6) pebbly coarse sand in delta forests, 2-3m, (7) pebble gravel and coarse sand in delta topsets with some dune bedding, 2-2.5m, (8) eolian fine sand with pebbles. The older gray till was formed by ice moving south-southeast off the crystalline upland just 0.7km northwest of Stop 1. The reddish-brown till and "till equivalent" were formed when the margin of the western sublobe readvanced southwest across lacustrine sediments.

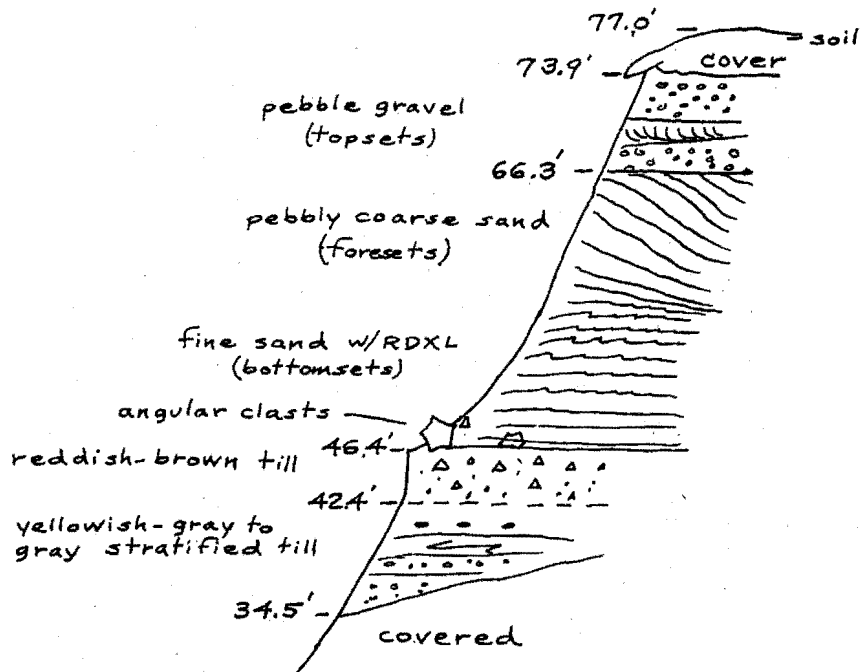

Figure 8. Stratigraphic section of North Branch of the Manhan River measured by hand-leveling, Oct. 28, 1977.

- Proceed W on Loudville Road
- 7.7 Gray gneisses and schists of Paleozoic age exposed on right.
- 7.9 Turn sharp left (S) on Mineral St just beyond bridge over North Branch
- 8.4 Mine Road enters from right at town line
- 8.5 Lead Mine Lodge on left is located 100m north of old south shaft of Loudville lead mine. Lead deposits are believed to be associated with Jura-Triassic mineralization. Most of the lead was mined during the Civil War for Union troops. Route traveled is underlain by till.
- 9.3 Cross brook, road rises onto gravel flat
- 9.5 Cold Spring Road enters from right
- 10.2 Park on right, walk SE on road to pit entrance on L

STOP 2. Striations cut in Triassic arkosic pebbly sandstone. An obscure early set of striations trends S 32°W and is cut by a younger set trending S 52°W. Even if the observer is unwilling to accept the S 32°W - set there is no doubt that the S 52°W - set, taken with other nearby striations, represents active lobation in late-glacial time. The gravel at this site is on a fluvial grade that is slightly lower than that of the Southampton delta, 1.2 mi to the south. This indicates that the gravels at Stop 2 formed slightly after the ice margin melted back from its position on the north side of the Southampton delta.

Proceed SE on Cold Spring Road.

- 10.4 Turn right (SSW) on Glendale Road.
- 10.5 Stop sign, turn right (SW) on Pomeroy Meadow Road.
- 10.7 Road rises up onto proximal, ice-contact end of Southampton delta. The delta was formed between the till ridge on the W and the lobe of ice on the NE. Melt-water streams building the delta flowed southerly into glacial Lake Manhan.
- 10.0 Enter Mount Tom Quadrangle
- 12.0 Stop sign, turn right (SSW) on Route 10.
- 12.2 Leave topset portion of delta
- 12.4 Terrace on left underlain by varved silt and clay
- 12.6 Center of Southampton village
- 13.4 Cross Manhan River
- 13.5 Turn left (W) on Moose Brook Road
- 14.2 Turn right (SW) into Southampton town dump.

STOP 3. Southampton Town Dump. When first studied in September, 1968, the active face was 400 ft southeast of its present position. In 1968, a layer of compact reddish-brown diamicton 0.3m thick and 3.3m below the surface, was interpreted as flowtill. No deformational structures resulting from ice shove were noted in the 0.6 to 0.9m of fine sand underlying the till. In 1977 thrust-faulted and overturned beds of fine sand were noted about 200 ft southeast of the present active face. In addition, a discontinuous layer of compact lodgement till was observed near the top of the section. The base of the till truncated beds of light brown medium to coarse sand and dark brown very fine sand that had been sheared and overturned. In July, 1982, the section on the southwest face consisted from the base up of: (1) a covered section, 6.6m, (2) fine to very fine sand, silt and clay in proximal varves, 3.3m, (3) pebbly coarse sand, 0.7m, (4) fine sand with ripples, 0.3m, (5) reddish-brown, hard, compact till with pebbles, 1.3m, (6) pebbly coarse sand, 1m, (7) eolian fine sand with pebbles, 0.6m. The till is believed to represent a minor readvance.

- Proceed NW on Moose Brook Rd.
- 15.0 Turn left (SSE) on Route 10. Route is on till-covered Triassic bedrock for 2.5 mi with views to the E of the Holyoke Basalt ridge.
- 18.0 Red light, continue due S on Routes 10 and 202.
- 18.3 Route drops from bedrock ridge onto surface of Barnes outwash delta, a feature formed in time-transgressive glacial Lake Westfield with outlet at Harts Pond gap. (Fig. 1).
- 20.4 Road drops from surface of Barnes outwash delta to surface of terrace cut by the outlet stream from glacial Lake Manhan which drained through Westfield gap.
- 20.9 Turn right (W) at entrance to Mass Pike, Interchange 3. Proceed E on Mass Pike through sections cut in Barnes delta and onto till-covered bedrock.
- 24.0 Turnpike passes through Bush Notch formed where faults offset the Holyoke Basalt ridge. Holyoke Basalt outcrops on both sides of Turnpike. (Fig. 5).
- 25.0 Outcrops of Hampden Basalt.
- 25.2 Cut in drumlin
- 25.8 Outcrop of Portland Arkose under I-91 bridge.
- 26.8 Cross the Connecticut River

Q2-15

- 27.0 ENTER SPRINGFIELD NORTH QUADRANGLE
Turnpike crosses flood plain of Connecticut River and then climbs up on lake-bottom sediments of Lake Hitchcock with small dunes oriented WNW.
- 29.4 Turn right and leave Mass. Pike at Interchange 5 which is on the shoreline of Lake Hitchcock.
- 29.9 Turn right (E) after leaving toll booth.
- 30.1 Turn right (S) on Route 33.
- 30.4 Turn right (SW) in order to turn E on Fuller Road
- 30.7 Red light. Proceed straight ahead (E) on Fuller Road
- 30.9 Turn right (SSW) into St. Patrick's Cemetery located on a high terrace (about 185 ft. elev) of the Chicopee River. Proceed to SE corner of cemetery. Walk about 345 ft. WSW to top of recent landslide scar. Descend with caution, watch for broken glass.

STOP 4. Chicopee River Section. Prior to 1977, a large sewer line was emplaced along the north bank of the Chicopee River. This activity resulted in the undercutting and subsequent slumping of steep banks of lacustrine sediment south of St. Patrick's Cemetery. In the exposures thus formed a compact, reddish-brown to brown, readvance till was observed to overlie various types of stratified sediment (Fig. 9). As already mentioned (p. Q5-6), readvance till may be available for study at this site for some time in the future.

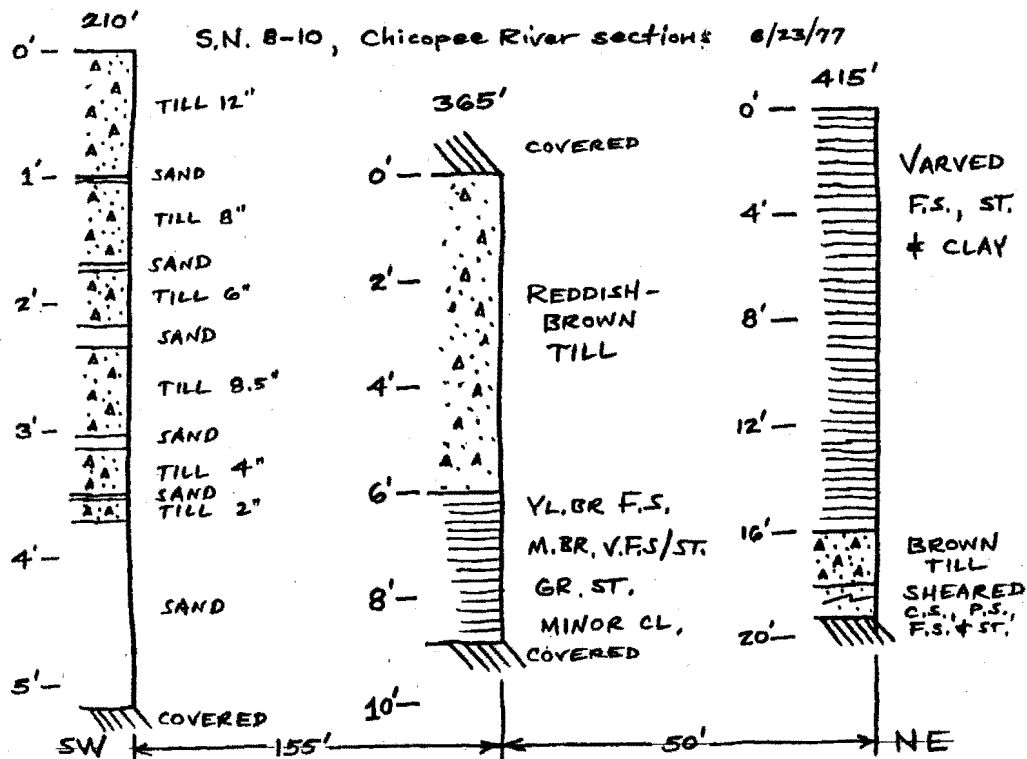

Figure 9. Field sketches of stratigraphic sections south of St. Patrick's Cemetery, Fuller Road, Chicopee. Numbers at top of columns are distances northeast of small brook where it enters Chicopee River south of cemetery.

- 31.3 Proceed E on Fuller Road. Road descends to lower terrace (elev. 175 ft) on right and eventually to the flood plain of the Chicopee River.
- 32.7 Turn left (N) on access to I-291 northbound
- 33.0 Red light. Proceed straight ahead (N), I-291 becomes Burnett Road.
- 33.3 Turn right (E) on New Lombard Road
- 33.7 Turn sharp right (WSW) on side road adjacent to pit, make U-turn and park

STOP 5 Baskin sand pit. When first observed in 1977 this pit was less than one-half the size of the present pit. Reddish-brown lodgement till was exposed on the southeast side of the pit. A curved exposure with deltaic beds 9m high extended southwest, west, and then northwest from the till. Dune bedding in deltaic topsets indicated transport directions between due west and southwest. No evidence of readvance was noted at that time. By July, 1982, the pit had been expanded nearly to its present size, its growth being limited by powerlines. At the western end of the pit were exposed a series of imbricate thrust faults striking N 70°E and dipping 38°NW. Within the sediments above the thrust faults was a sloping surface marked by pebbles and small lenses of reddish-brown till. I interpret the sloping surface as a gliding plane upon which the margin of the eastern sublobe readvanced a short distance. The readvancing ice was relatively clean as it left little debris on the gliding plane when it melted.

Proceed E on side road.

- 34.1 Turn left (NW) on New Lombard Road
- 34.4 Turn right (NE) on Burnett Road
- 35.2 Turn right (S) into Ahearn pit

STOP 6. Ahearn pit. Figure 10 is a pace-and-compass map of the south and west portions of the Ahearn pit as it existed in June, 1977. A broad roadway formed by excavating equipment descended from the west end of the pit on a smooth gradient to the deepest part of the pit at distance 575 ft. At distance 197 ft., a 0.3m-layer of reddish-brown till crossed the roadway and climbed southeastward on the south face of the pit. Below the till, beds of lacustrine sediment were sheared and folded (bottom of column A, Fig. 10). Below the shear zone were beds of yellowish-brown to light brown fine sand with ripple-drift cross-lamination indicating transport directions in the southwest quadrant. Above the till and shear zone were undeformed beds of medium to coarse sand grading up into pebble gravel in dune crossbeds dipping west and southwest. North of the roadway only small clasts of till and a few pebbles were found associated with the deformed zone which rose to the northeast. The deformed zone was overlain by undeformed deltaic sediments and marked by highly sheared lacustrine sediments. In some places along the trace of the deformed zone, no deformational structures were observed. The zone, a glaciotectionic gliding plane at the base of the ice, was traced around a spur ridge to a small pit at B (Fig. 10). Here, lenses of till and small pebbles separate 2.2m of fine-grained lacustrine from 3.3 of coarser-grained lacustrine from 3.3 of coarser-grained fluvial beds. The

whole aspect is one of a readvance of glacial ice over the front of a delta that is building westward into Lake Hitchcock. By July, 1982, the pit has been extended to the west revealing a second readvance till. The south face has been altered but the first readvance till can be observed to climb over deltaic beds.

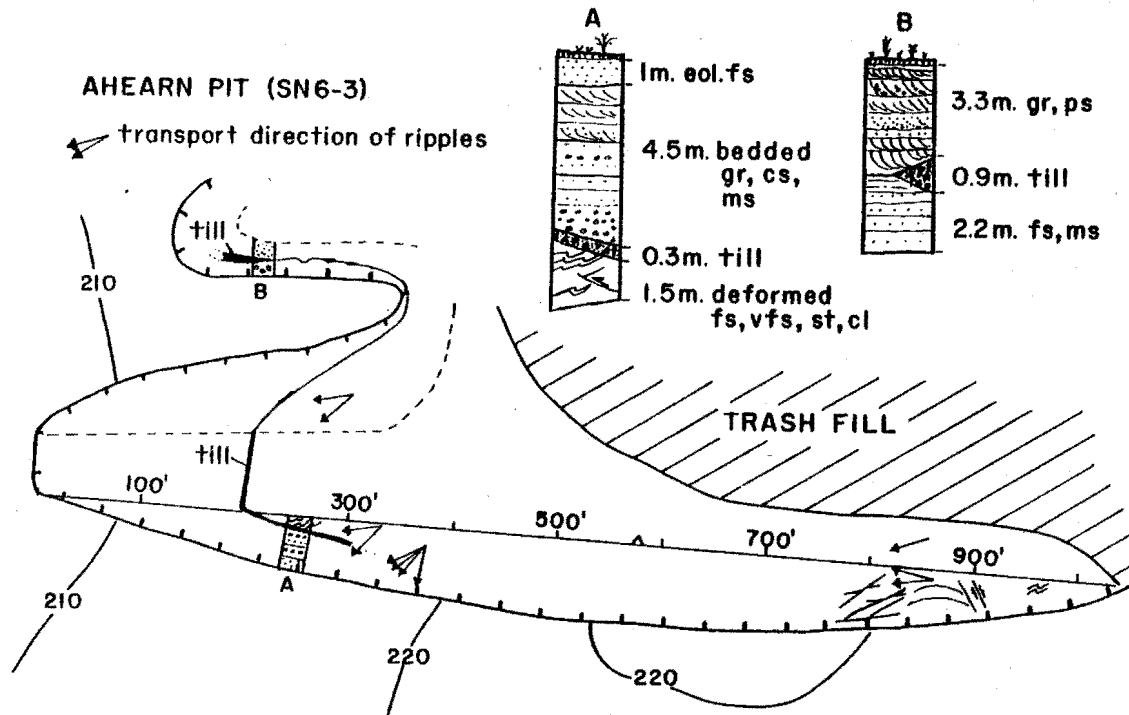

Figure 10. Pace-and-compass map and measured sections of the Ahearn pit, Chicopee. North is at top of map. Dashed line and bar scale represent base of steep slope. Solid line connecting two till bodies is the glaciotectionic gliding surface upon which the readvancing glacier moved. (June 15, 1977)

End of trip. Turn left (W) on Burnett Road to Mass. Pike Interchange 6. To reach Storrs take Mass. Pike east to Palmer, Exit 8, then Route 32 south 2.5 mi. to Rt. 195, turn left (E) to U. Conn. 4 miles.

REFERENCES

- Cornet, Bruce, Traverse, Alfred, and McDonald, N.G., 1973, Fossil spores, pollen, and fishes from Connecticut indicate Early Jurassic age for part of the Newark Group: *Sci.*, v. 182, p. 1243-1247.
- Emerson, B.K., 1891, *Geology of Old Hampshire County, Massachusetts, comprising Franklin, Hampshire, and Hampden counties*: U. S. Geol. Survey Monograph 29, 790 p.

Koteff, C. and Pessl, F., Jr., 1981. Systematic ice retreat in New England: U.S. Geol. Survey Prof. Paper 1179, p.20.

Larsen, F. D., 1972. Surficial geology of the Mt. Tom quadrangle, Massachusetts: U.S. Geol. Survey open file series, no. 1794, 273p.

Larsen, F. D., and Hartshorn, J. H., 1982, Deglaciation of the southern portion of the Connecticut Valley of Massachusetts, in Larson, G. J., and Stone, B. D., 1982, eds., Late Wisconsinan Glaciation of New England: Kendall/Hunt Pub. Co., Dubuque, Iowa, p. 115-128.

Larson, G. J., and Stone, B. D., 1982, eds., Late Wisconsinan Glaciation of New England: Kendall/Hunt Pub. Co., Dubuque, Iowa, 242p.

Van Houten, F. B., 1977, Triassic-Liassic deposits of Morocco and eastern North America: comparison: Am. Assoc. Petrol. Geol. Bull., v. 61, p. 79-99.

MODE OF DEGLACIATION OF SHETUCKET RIVER BASIN

Robert F. Black, Department of Geology & Geophysics, University of Connecticut, Storrs, CT 06268

Sherman M. Clebnik, Earth and Physical Sciences Department, Eastern Connecticut State College, Willimantic, CT 06226

INTRODUCTION

For several decades the concept of stagnation-zone retreat has dominated the thinking of many geologists mapping the glacial deposits of New England. In this concept the margin of the last continental ice sheet covering New England is considered to have retreated northward in small steps wherein the outer zone, generally 1 to 3 km wide, stagnated along the boundary of actively flowing ice. In contrast, basin-by-basin stagnation was proposed recently as a mode of deglaciation in the highlands of Connecticut. In this concept ice in entire drainage basins up to tens of kilometers across stagnated simultaneously when the continental ice thinned sufficiently to cut off resupply of ice to the heads of basins. The Shetucket River basin of northeastern Connecticut was used as the initial model.

This field guide is an attempt to present both sides of the debate. The field trip leaders, listed above alphabetically for convenience, have split their responsibility for the Road Log. Black is primary leader for the first four stops and Clebnik the last four. Opposing concepts and evidence with interpretations will be presented at each stop. It will be apparent to participants that only a fraction of the evidence can be presented. Hence, individual papers, following the Road Log, provide additional background for participants on the trip. These papers also permit opportunity for rebuttal of the newer literature. The Road Log and individual papers are designed to stand alone.

ROAD LOG

General Instructions

Lunch is not included in the trip even though we have a lunch stop with rest facilities. Please plan ahead for your own amenities.

Assemble at STOP 1 at 8:00 a.m. From the west on I-86 exit 100 on Route 44 east; from the northeast on I-86 exit 102 on Route 320 south. We will go in caravan slowly between stops in order for you to see a variety of morphologic features en route. The more important features will be cited in the road log. If you leave the caravan en route, please pull over and wave on the rest of the caravan to avoid having it follow you.

0.0 STOP 1

mile

Becker Construction Corp. sand and gravel pit, north side of Route 44 and 0.5 mile (0.8 km) west of Route 320, about 5 miles (8 km) north of the University of Connecticut, Storrs. This pit provides the best exposures of high-level morphologic sequences, as mapped, in the upper part of the Shetucket River basin (Pease, 1975) (see Figure 1).

The map legend (Pease, 1975) states: "Conat Brook area -- Three thick sequences mapped in the southeast corner of the quadrangle along the east side of Conat Brook valley. The two highest sequences Qgc1 and Qgc2, consist of coarse boulder and cobble gravel near the ice-contact head of outwash and grade southward through intermixed sand and gravel to well-stratified kame terraces of sand and minor pebble gravel near quadrangle border. Deposits are well exposed in large active gravel pits north and south of State Highway 44. The lower sequence Qgc3 is of intermixed sand and gravel." These deposits are considered the oldest in the quadrangle (Pease, 1975).

Excerpts from the narrative of Pease (1975) follow with annotations. "Deglaciation began with gradual thinning of the ice sheet and northward migration of the marginal zone of stagnant ice. During this ice wastage, glaciofluvial deposits were laid down by melt-water streams flowing from the receding ice sheet. As the ice retreated, the head of each younger sequence of stratified drift generally was laid down successively farther north, and, concurrently as the ice downwasted in each major valley, successively younger deposits were graded to successively lower outlets."

"The distribution of glaciofluvial deposits on the map is in general agreement with the distribution shown by White [1947] in the areas where he mapped, but his concept of terrace levels is not used in this report. Instead, the stratified drift is divided into units of contemporaneously formed deposits graded to a common base level within a single drainage area. Such a unit was first described by Jahns (1941, 1953) as a morphologic sequence forming a chronologic unit ranging from coarse strongly collapsed ice-contact deposits at the upper end of deposition to finer less collapsed outwash deposits downstream from a marginal zone of stagnant ice. None of the sequences in this quadrangle represents an ideally complete morphologic sequence; most are only fragmentary remnants of the upper parts of an ideal sequence." Black does not agree that "only fragmentary remnants" remain. During operations in the pit these past years, continuous sheets of flood gravel and sand were revealed whose age relations I interpret are reversed from those of Pease (Black, 1977, p. 1333; Black, 1979, p. 120). "The sequences are composed of sand and gravel dumped by melt-water streams, mostly in contact with

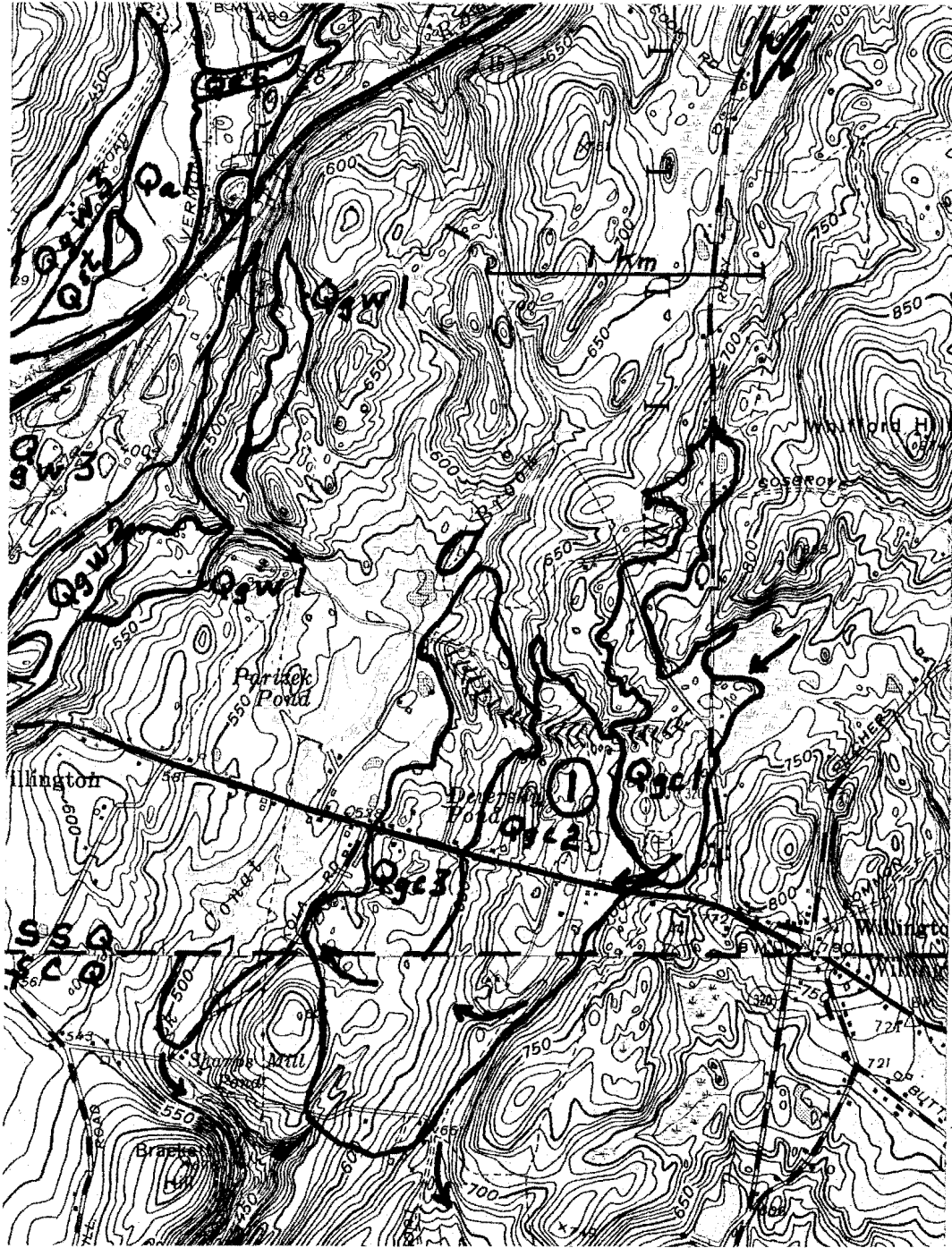

Figure 1.-Stop 1. Southeast corner of Stafford Springs Quadrangle (SSQ) and northeast corner of South Coventry Quadrangle (SCQ), showing the distribution of the Conat Brook sequences (Qgc1-3) (Pease, 1975) and extension southward into ice-contact deposits (Frankel, ms.). Part of the Willimantic River sequences (Qgw1-3) are also shown. Barbs are esker or crevasse fill. Arrows show former water flow.

stagnant ice; they generally are successively younger to the north. Most of these deposits are well stratified but show a wide range of textures and degree of sorting. The topography commonly is hummocky with closed depressions and irregular ridges caused by melting of buried or supporting ice. Collapse structures, such as tilted, contorted, and faulted beds are common."

Whifford Hill, 974 ft (297 m) elevation, and 1.2 miles (1.9 km) northeast of the pit, is the highest part of the landscape in the vicinity, and the Willimantic River to the west, at about 355 ft (108 m), is the lowest (Fig. 1). "The highest and oldest sequence, Qgc1 was deposited marginal to the stagnant ice when the head of outwash was just south of where Ruby Road [Route 320] crosses Conat Brook and when ice filled the valley of Conat Brook to an altitude of about 750 ft (229 m). Map units Qgc2 and Qgc3 are kame-terrace deposits formed at successively lower altitudes and graded to successively lower base levels downstream." Black raises the question: How far did stagnant ice extend to the south on the upland as well as in the valleys while these deposits were laid down? It is his contention that ice extended to the south end of the Shetucket River basin. The only control of base level was ice and drift down valley tens of kilometres (Black, 1977 and 1979).

"An arcuate ridge of coarse gravel and sand that stands 10 to 20 ft (3 to 7 m) high heads in sequence Qgc1 at an altitude of 720 ft [219 m] and descends in a westerly direction, convex to the south, across all three Conat Brook sequences to terminate at an altitude of about 580 ft [177 m]. Evidently, a crevasse in the stagnant ice of Conat Brook was present throughout deposition of all three sequences. Breaks in the continuity of this ridge at contacts between sequences suggest partial erosion of the crevasse filling as each successively lower terrace was formed." Black postulates that this ridge may be in part an esker derived from water that came from the southwest side of Whifford Hill.

"After deposition of unit Qgc1, melt water evidently carved a channel in the southern end of this sequence just west of the junction of State Highway 44 and Ruby Road [Route 320] and fed sand and gravel to sequence Qgc2. Similar melt-water channels mark the southern ends of sequences Qgc2 and Qgc3 just to the south in the South Coventry quadrangle." Where was the ice margin during each of these episodes? Note that the south end of Qgc2, south of Route 44, must have had an ice wall to support the lacustrine deposits.

"Ice must have filled the valley of Conat Brook and covered most of the remainder of the quadrangle during the deposition of the Conat Brook sequences, but continuing

retreat of the stagnant ice front then opened up outlets that controlled deposition of the high-level ice-contact deposits in the valleys of the Willimantic River and Roaring Brook." Black asserts that a "stagnant ice front" need not retreat in order to open lower outlets. Water merely flowed around and under the disintegrating ice more freely so "water tables" dropped. "The altitude of the east-draining melt-water spillway north of Parizek Pond for sequence Qgw1 is 530 ft [162 m] and that at the divide between Conat and Frink Brooks 650 ft [198 m], suggesting that Qgr1 is slightly older than Qgw1." However, Black (1979, p. 120) has water flow northward into Frink Brook and, thence, to Roaring Brook as well as southward. "Stagnant ice blocks filled most of the Roaring Brook and Willimantic River valleys at this time, and sequences Qgr2 and Qgw2 represent brief recessional positions of the ice as melt water first started to flow down the two valleys. Ice still blocked Roaring Brook gorge at the time of deposition of sequence Qgr3, but thereafter, melt water from Roaring Brook must have supplied sediments to the kame terraces of sequence Qgw3 in the Willimantic River valley. The youngest glaciofluvial deposits in Roaring Brook, sequence Qgr4, were not deposited until ice had receded from Roaring Brook to expose the bedrock threshold at about 700 ft [213 m] altitude south of the bend in Stoughton Brook near the east border of the quadrangle."

As shown by orientation of drumlins and of striae (the closest about 2 miles, 3.2 km, north of Becker pit) and by the distribution of Triassic-Jurassic erratics, the regional movement of ice was south-southeast. This is across the general grain of the topography, particularly the axes of the major valleys. General relief is about 200 m (656 ft). However, the divide at the head of Middle River, headwater of the Willimantic River and the Shetucket River, is only about 612 ft (187 m). In that divide many collapsed features of stratified drift attest to outwash on ice through the gap from the lake in the south Monson area at that elevation. Lakes to the north in the Palmer area were about 670 ft (204 m). They also drained south to the Shetucket River basin. Black believes that stagnation was widespread in the uplands from the Palmer-Monson area of Massachusetts southward through the Shetucket River basin simultaneously. Deglaciation of the highlands preceded the lowlands in most areas. Much of the sand and gravel in the lower part of the basin is believed to have been transported southward on ice from the head of the basin. Openings in the ice increased with time, allowing ice-walled lakes to be established at all levels.

En route to Stop 2. Turn right, west, from Becker Construction Corp.

0.3 Turn left, south, on Kollar Road (Kola Road on Figure 1).

- 0.5 Pit in sand and gravel on left is part of sequence Qgc3 (Pease, 1975). Water flowed southward in Conat Brook.
- 0.6 Enter South Coventry Quadrangle. Surficial geology by Larry Frankel (unpublished) follows concept of regional stagnation.
- 1.0 T-intersection with Luchon Road. Turn left, eastward. Conat Brook on right bends south and southwest in a deep rock gorge.
- 1.6 At sharp bend in Luchon Road, to the right, south, sand and gravel equivalent to Qgc2, crops out in the road bank and near house on right. On left, east, at about 665 ft (203 m) is head of drainage channel with ice wall on west which Black believes carried some water southward toward ice-walled lakes on upland.
- 2.2 Upland lake area, north-central part of Figure 2. Sediments deposited around and over ice blocks up to about 600 ft (183 m) elevation. Drainage in part went southwestward toward South Willington.
- 3.1 Junction Pinney Hill Road (Daleville Road on Figure 2). Cisar Road continues ahead. Turn right, west.
- 3.3 Junction Cedar Swamp Road (Latham Road on Figure 2) and Ridge Road to north. Turn left, south on Cedar Swamp Road.
- 3.9 STOP 2

Walk 0.1 mile (0.2 km) east on lane to pit, property of Michael Nogas. See Figure 2. Delta sands in pitted plain up to about 600 ft (183 m) elevation, surrounding Cedar Swamp. Locally water came from north and northwest. South end of swamp is at 560 ft (171 m), but stratified deposits extend down Cedar Swamp Brook valley to about 430 ft (131 m). Drainage went to the Willimantic River. Ice must have been present in the center and southern parts of the swamp when the delta was deposited. Some water and sediment in the northern part were contributed, Black believes, from Qgc2 sequence at the Becker pit. Extensive stratified sand and gravel deposits also cover the surface westward to the Willimantic River (Black, 1977, Fig. 4; Black, 1979, p. 118-119).

Continue southward on Cedar Swamp Road (Topich Road on Figure 2).

- 4.8 Junction Route 195. Turn left, east.
- 5.2 STOP 3



Figure 2.—Stops 2 and 3. Northeast part of South Coventry Quadrangle, showing distribution of stratified drift inside barbed line and till outside (Frankel, ms.).

Crevasse fill (or esker) crosses road. Property of Bob Gardiner Co., Inc. and occupied by Xenogen. Typical dead-ice feature on upland, associated with ice mass in Cedar Swamp. See Figure 2. Outlet to south down Cedar Swamp Brook to the Willimantic River. The crevasse fill is separated from a kame complex to the northwest by a short gap now occupied by swamp (Frankel, unpublished ms.). Much of the feature was excavated in 1967 and studied by Frankel. In its southern part coarse sand, pebbly sand, and fine gravel were capped by coarse bouldery gravel. That capping was absent in the northern part, and sediment was finer-grained generally than in the southern part. More fragments of Triassic-Jurassic clastics were seen in it than other deposits in the area. Limited exposures seen by Black suggested feeding from the sides in the lower part, making that part a crevasse fill and not an esker.

Continue eastward.

- 5.7 Junction Route 195 and Route 44A. Turn right, southwest.
- 6.4 Cedar Swamp Brook, outlet for Cedar Swamp.
- 6.5 Junction Birch Road. Turn left, south.
- 6.9 Junction Hunting Lodge Road. Continue ahead, southwest.
- 7.0 Hunting Lodge Road goes southeast. Continue ahead, southwest on Birch Road (Weaver Road on topographic map).
- 7.6 Junction Bone Mill Road (Pumping Station Road on topographic map). Turn left, southeast.
- 8.2 Junction Ravine Road (Hopkins Road on topographic map). Turn right, west. Cedar Swamp Brook on left.
- 9.0 Junction Route 32. Turn left, southeast.
- 9.3 Cross Cedar Swamp Brook. Note extensive kettled terrace deposits, continuing southward. Many knobs of sand and gravel in Eagleville Lake were derived from drainage down Cedar Swamp Brook under ice in the Willimantic River valley (Black, 1977, p. 1333).
- 9.7 De Siato Sand and Gravel Corp. on right, west.
- 10.1 Cross Eagleville Brook, former outlet for ice-walled lakes on the uplands at the University of Connecticut. See Black (1977, Fig. 4).
- 10.2 Junction Route 275 in Eagleville. Continue southward on Route 32.
- 10.7 Cross Dunham Brook, a former outlet for an upland lake. See

Black (1977, Fig. 4).

- 10.9 Junction Mansfield City Road (Dunhamtown Road on topographic map). Turn left, east. Till on bedrock upland.
- 12.2 Enter Spring Hill Quadrangle. Surficial geology (Rahn, 1971) follows concept of regional stagnation. See also Pease (1970).
- 13.3 Crossroads in Mansfield City. Turn left, east, on Browns Road.
- 14.4 Junction with Crane Hill Road. Continue ahead, east, on Browns Road.
- 15.2 Junction Route 195. Turn right, south, and immediately turn left, east, at stop light, on Route 89. Extensive kame terrace (Rahn, 1971).
- 16.4 Entrance to Mansfield Landfill on left, immediately east of Fenton River.

STOP 4

Drive to northwest end of landfill. See Figure 3. Rahn (1971) has mapped kame terraces, kames, and ice-channel fillings in this part of the Fenton River valley. The upper level of sedimentary fill is about 300 ft (91 m). Typically, fluvial sandy gravel overlies well-stratified lacustrine sands that are common to all major tributaries of the Shetucket River (Black, 1977). They are graded to a presumed ice-drift dam southeast of Willimantic. Most land forms in the Fenton River valley are believed to be primary. The Fenton River has done little excavating of the deposits since glacial times. Excavations, bore holes, and seismic and resistivity studies by members of the Environmental Geology class under Black's direction have revealed a complex assemblage of stratified drift and local till in the area to bedrock that is 13 to 72 ft (4 to 22 m) below the surface. The bedrock slopes southwestward toward the Fenton River.

- 17.3 Return to Route 89. Turn right, south.
- 18.5 Junction Route 195. Turn left, south.
- 19.0 Junction Bassettes Bridge Road at traffic light (Bassett Bridge Road on Figure 3). Turn left, east, onto kettled kame terrace.
- 19.8 Dike for flood control.
- 19.9 Entrance to Mansfield Hollow Park on left, north. Turn in and drive to end of road.

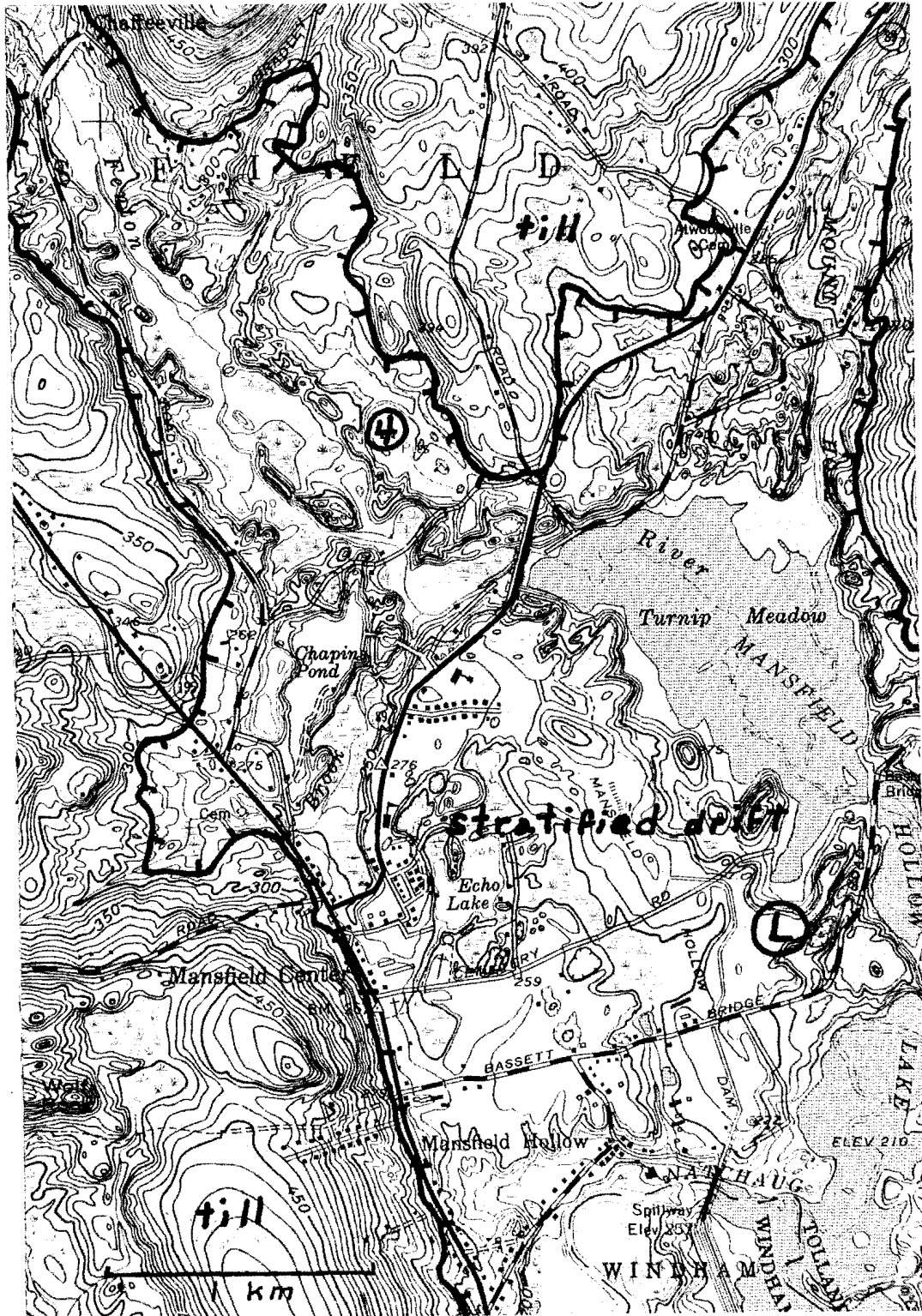

Figure 3.—Stop 4 and Lunch Stop, south-central part of Spring Hill Quadrangle. Stratified drift inside barbed line and till outside (after Rahn, 1971).

20.2 LUNCH STOP AND REST ROOMS

20.5 Exit park at Bassettes Bridge Road. Turn left, east, on kettled kame terrace (Rahn, 1971).

21.1 Cross Bassettes Bridge. To the left, north, a kame forms an island in Mansfield Hollow Lake.

22.1 Junction Hall Road. Continue straight.

For Optional Stop A:

Turn left, north, onto Hall Road.

1.2 Crossroads at Bedlam Corner. Continue straight.

1.3 Turn right, east, onto Palmer Road.

1.8 Optional Stop A

At left, west, is the entrance to excavation along the east side of a kame plain (Rahn, 1971). This landform and associated ice-contact deposits occur in Stonehouse Brook Valley, a tributary to the Natchaug River, about 0.6 mi (1 km) to the south. The kame plain is about 2000 ft (600 m) long, 900 ft (270 m) wide, and 300 ft (91 m) in elevation (the same as the kame at Stop 4). The excavation exposes cobble gravel over sand. Tension faults are common at the north end. Features resembling ice-wedge casts (Black, 1976 and ms.), also evidently related to tension features, are exposed in the west face.

Reverse route and return to Bassettes Bridge Road. Turn left, southeast, from Hall Road onto Bassettes Bridge Road.

22.9 Junction North Windham Road. Bend left, southeast.

For Optional Stop B:

Turn right, west, onto North Windham Road. See Figure 4. This road parallels the Natchaug River, about 600 ft (180 m) to the south.

0.3 Optional Stop B

Parking area adjacent to barricade across road reveals sand and gravel of a kame terrace (Rahn, 1971). Walk past the barricade and along the continuation of North Windham



Figure 4.- Part of Spring Hill (SH) and Willimantic (WI) Quadrangles, showing Stops 5 and 6 and Optional Stop B. Glacial deposits generalized after Rahn (1971) and Clebrik (1980) respectively. Qsh2-4 are morphosequences, ic is ice contact, kt is kame terrace, k is kame, al is alluvium, and af is artificial fill.

Q3-13

Road, which sharply bends right, northwest. The bend of the road is at the south end of a group of ice-channel fillings (Rahn, 1971), trending northwesterly. The longest is about 3000 ft (900 m). The road follows the south half and exposes bouldery gravel. About 1300 ft (390 m) northwest of the bend in the road, a trail diverges northerly, following the main filling. Kettles are prominent. This group of ice-channel fillings is aligned with others to the south in the Willimantic quadrangle, which are northwest of the gorge at the head of Ballymahack Brook. See Stop 6.

Walk back to the parking area. Return to Bassettes Bridge Road and turn right, southeast.

-
- 23.0 Junction of five roads just southeast of the Natchaug River. Counting clockwise, take the third road angling to the right, south. A church and cemetery will be on the left side in 0.1 mile.
- 23.3 Junction Route 6 and Route 203 at North Windham. Turn right, west, onto Route 6. This intersection is just south of the north margin of the Willimantic quadrangle. The remainder of the field trip is in this quadrangle. Clebnik (1980) followed the concept of stagnation-zone retreat in mapping the glacial deposits.
- 23.6 South end of gravel dike of Mansfield Hollow Dam on right, north.
- 24.5 STOP 5

Turn right, north, into parking lot of East Star Lodge, 44 A.F. & A.M. At northwest corner of building, follow trail trending northerly for about 550 ft (165 m); then turn left, west, and walk another 250 ft (75 m). See Figure 4. As described in the accompanying article by Clebnik, this topographic bench is at the north end of the third morphosequence identified along the Natchaug-Shetucket River Valley. Just north, about 15 ft (4.5 m) lower in elevation, are the runways of Windham Airport on the surface of the fourth (younger) morphosequence. At this location, outcrops of Willimantic Gneiss, conspicuously weathered in places, occur along the edge of the bench. Bouldery stratified drift also is revealed on the bench.

East-northeast of the above location abandoned excavations in stratified drift exist along the bench, and, at about 2000 ft (600 m) an abandoned quarry exposes hornblende gneiss, the Willimantic Gneiss, and some pegmatite veins.

Return to parking lot. Exit left, northeast, onto Route 6.

- 25.7 Junction Route 6 and Route 203 at North Windham. Turn right, south, onto Route 203.
- 26.2 Junction Jordan Lane, adjacent to East Connecticut Regional Educational Service Center. Turn left, south, onto Jordan Lane.
- 26.6 STOP 6

Park near the dirt road opposite La Barre Drive. See Figure 4. Walk up the hill to the east of Jordan Lane into a complex of ice-contact features of dirty cobble-boulder gravel and sand. The dirt road parallels the south flank of one ice-contact ridge about 0.5 mi (0.8 km) long, which trends northwesterly. The southeast end terminates at a divide. On the opposite side, a bedrock gorge with large pot holes heads in Ballymahack Brook Valley. Black (1977, Fig. 5, p. 1333, and 1979, p. 119) concluded that meltwater flowed both to the northwest and southeast from the divide, with the latter carrying a heavier load of debris. Clebnik (1980, p. 36) envisaged that meltwater discharged from the northwest unidirectionally through the gorge to the southeast. An esker system represented by the ice-channel fillings north to and including those at Optional Stop B in the Spring Hill Quadrangle provided the water and debris. These viewpoints are elaborated in the accompanying article by Clebnik and in Clebnik and Mulholland (1979).

Continue southwest on Jordan Lane.

- 26.8 Junction Route 203. Turn left, south, onto Route 203, on a conspicuous kame terrace (Clebnik's third morphosequence).
- 28.6 Junction Route 203 and Route 14. Continue left, south, on combined Routes 203/14. On the southwest side of the intersection, cobbly gravel is exposed south of the garage. This deposit is part of Clebnik's (1980) third morphosequence (see accompanying article), the head of which was viewed at Stop 5. Black submits that the texture, sorting, and other characteristics of the gravel are incompatible with a source at Stop 5, at least 2.5 miles (3.7 km) north, considering the characteristics of the material there.
- 29.0 At the right, west, a topographic break separates Clebnik's third (at red barn) and fourth morphosequences.
- 29.4 Crossroads at Windham Center (Windham on topographic quadrangle). Angle right, south, on Route 203.
- 30.1 Junction Route 203 and Jerusalem Road. Turn left, south, onto Jerusalem Road. Ice-contact topography to right, west, of road, but road rises onto till.

- 31.5 After major bend in Jerusalem Road, ice-contact topography is conspicuous to right, south.
- 31.9 Junction Insalaco Drive. Turn left, north.
- 32.2 STOP 7

Park at barricade near end of pavement. See Figure 5. Walk northeast along dirt road (private property), which at first approximates the till-stratified drift contact (see surficial geologic map, Clebrik, 1980). To the left, north, of the road, several feet of till (grayish upper till) covers the Scotland Schist. Insalaco Drive and the northeast segment of the dirt road are on high-level, ice-contact stratified drift, included by Clebrik (see accompanying article) in the first morphosequence along the Shetucket River Valley. The continuation of the dirt road northeastward, about 800 ft (240 m) from the end of the pavement, descends to a lower level of stratified drift near Frog Brook. Clebrik (see accompanying article) regards this lower level as part of the second morphosequence. Black regards both sequences as overlapping temporally. The second is thought to have been deposited on thick ice in Frog Brook Valley, subsequently collapsed and kettled as seen today. These materials came through the Ballymahack-Frog Brook drainageway. They are considered instrumental in building the ice-drift barrier in the Shetucket River from Frog Brook downstream to the narrows (Black, 1977).

The road crosses a kame terrace and associated ice-channel fillings. About 800 ft (240 m) southeast of the bend in the dirt road, a pit in the kame terrace reveals bouldery gravel. (The pit is incorrectly located in the higher level stratified drift on Clebrik's (1980) surficial geological map.) Return on Insalaco Drive to Jerusalem Road. Turn right and return to Route 203.

- 34.3 Turn left, southwest, onto Route 203.
- 34.7 At left, southeast side of road, excavation into an ice-contact deposit, morphosequence 3. At right, west, entrance to Hain Bros., Inc., sand-and-gravel operation.

For Optional Stop C:

Turn right, west, into Hain Bros., Inc. See Figure 5. Follow dirt road to office building and seek permission for access.

This operation is at the south end of a flat-topped deposit of stratified drift on the east side of the Shetucket River. Several pits have been opened at different levels. These

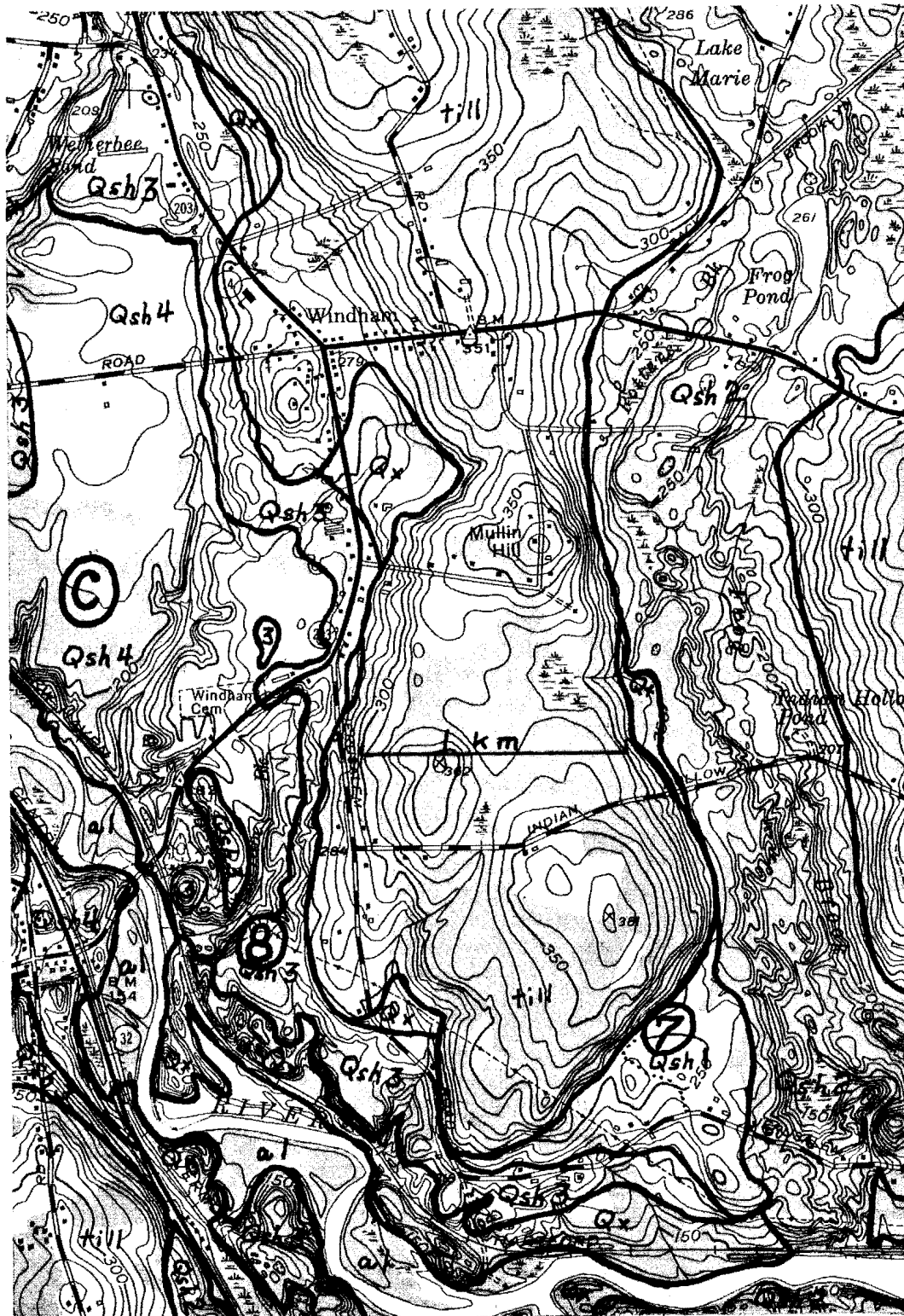

Figure 5.- Part of Willimantic Quadrangle, showing Steps 7 and 8 and Optional Stop C. Qsh1-4 and Qx are morphosequences (Clebnik, 1980).

excavations plus bore-hole data indicate that interbedded, sandy, pebble- to cobble-gravel and sand overlie a thick sequence of sand, silt, and minor clay (Clebnik, 1980, p. 26-28). The fine sediment commonly exhibits ripple-drift cross lamination. The gravelly sediment on top displays cross-bedding and cut-and-fill structures. Evidently, this sequence formed as a delta or as lacustrine deposits with fluvial gravel on top. Downward-tapering structures resembling ice-wedge casts have been exposed in the gravelly zone, and may have been caused by creep of the deposits toward the Shetucket River (Clebnik, 1980, p. 28-31; Black, 1976, p. 17-18; and Black, ms.). Clebnik (see accompanying article) includes this body of stratified drift in the fourth morphosequence along the Shetucket-Natchaug River valleys.

Return to Route 203.

34.9 STOP 8

Turn left, east, onto a gravel road (property of the J.S. Nasin Co.). See Figure 5. Follow road for about 0.3 mi (0.5 km) and park near top of pits. This kame complex is part of the ice-contact stratified drift flanking the Shetucket River. Excavations expose bouldery gravel overlying sand. This deposit and an elongate one just to the east have been included by Clebnik in the third morphosequence (see accompanying article). Adjacent lower level stratified drift has been assigned to the fourth morphosequence or to the uncorrelated deposits. Black would lump many of them together. The top of the kame affords a broad view of landforms in the surrounding region. Black submits that the characteristics of the material and the topography belie a source at Stop 5, the head of morphosequence 3.

Return to Route 203.

35.5 Turn left, southwest.

35.7 Shetucket River.

36.0 Junction of Route 203 and Route 32 at South Windham. END OF CONVOYED FIELD TRIP. For optional stops see below.

To head north to Willimantic and U.S. Route 6, turn right onto Route 32. To reach the University of Connecticut at Storrs, follow Route 195 from Willimantic.

To head south to Norwich and the Connecticut Turnpike,

Route 52, turn left onto Route 32.

For north-bound travelers Optional Stop D:

At Route 32, South Windham, mile 36.0, continue straight across intersection from Route 203 onto Main Street.

- 0.1 Crossroads. Turn right, north, onto South Windham Road. A white church with steeple should be on the left, west, after turning.
- 0.3 To the right, north, excavations into an ice-contact deposit are visible. The excavations are on the Miller Bros., Inc., property on the west side of Route 32, approx. 0.3 mi (0.5 km) north of the South Windham junction.
- 1.3 Junction Richmond Lane on right, east, followed immediately by junction Bush Hill Road on left, west (Rush Hill Road on topographic quadrangle). Continue north.
- 1.4 STOP D:

Excavation on left, west. This ice-contact deposit is flat-topped and lobate. The excavation exposes bouldery gravel overlying predominantly sand. The bedding dips generally southward. This deposit evidently is a delta. Clebnik (see accompanying article) includes it in the third morphosequence which here heads up the Willimantic River, southwest of the city.

For south-bound travelers Optional Stop E:

At South Windham, mile 36.0, turn left, south, from Route 203 onto Route 32.

- 1.4 Ice-contact topography is conspicuous to the left, east.
- 1.7 Bridge over railroad tracks at Williams Crossing. To the left, east-northeast, note the broad tract of ice-contact stratified drift adjacent to the Shetucket River, which flows easterly. Clebnik (1980) has divided the deposits in this area into those of the first and second morphosequences. Just east of this tract, the Shetucket River enters a gorge that both Clebnik (1980) and Black (1977 and 1979) identified as a base-level control for meltwater draining southward from the Shetucket River basin. (The large building located on the tract is the Ralston-Purina mushroom-growing and -processing plant.)
- 2.4 Turn left, east, onto Pleasure Hill Road.

- 2.7 Road descends into the head of southward flowing Beaver Brook valley (not the same Beaver Brook that is north of Stop 7). (On the topographic quadrangle Pleasure Hill School is shown at the west side of the valley.) Clebnik (1980, p. 35-36) suggested that this valley may have served as a meltwater outlet when deposits of the first morphosequence were accumulating in the Shetucket River Valley to the north. However, Black (1979, p. 119-120) disagreed with that inference.
- 3.3 Turn right, south, onto Robinson Road (Robinson Hill Road on the topographic quadrangle).
- 4.1 Junction Route 207. Turn left, east. After the turn, outcrops of Scotland Schist flank Route 207.
- 4.4 Turn right, south, onto Under the Mountain Road. Just after the turn, to the left, east, is an embankment trending southeasterly. It is part of an abandoned trolley line that once extended between Willimantic and Baltic.
- 4.8 OPTIONAL STOP E

At right, west, entrance to dirt road. Park here. Walk the dirt road to the west about 200 ft (61 m) to a trail on the right, north. That trail ascends the hill westward toward a saddle on the south side of Ayers Mountain.

The saddle ranges from about 350 to 380 ft (105 to 114 m) in elevation and is lined with bedrock, the Scotland Schist. The bedrock walls on both east and west sides of the divide contain numerous incipient to well-developed water-worked surfaces and potholes. Black (1977, p. 1336; 1979, p. 120) has proposed that meltwater possibly flowed both to the east and west from a moulin situated over the mountain.

Return to Under the Mountain Road. Drive north toward Route 207.

- 5.2 Junction Route 207. Turn left, west.
- 5.8 Gagers Pond at the right, north. The pond is located in a pocket of stratified drift along Beaver Brook Valley. The Pleasure Hill School area, viewed previously, is to the north.
- 6.6 Junction of Route 207 and Route 32 at N. Franklin Center. To travel south, toward Norwich and the Connecticut Turnpike, Route 52, turn left onto Route 32.

REFERENCES

- Black, Robert F., 1976, Periglacial features indicative of permafrost: Ice and soil wedges. *Quaternary Research*, v. 6, p. 3-26.
- Black, Robert F., 1977, Regional stagnation of ice in northeastern Connecticut: An alternative model of deglaciation for part of New England. *Geol. Soc. of Amer. Bull.*, v. 88, p. 1331-1336.
- Black, Robert F., 1979, Regional stagnation of ice in northeastern Connecticut: An alternative model of deglaciation for part of New England: Reply. *Geol. Soc. of Amer. Bull.*, Part 1, v. 90, p. 118-120.
- Black, Robert F., manuscript, Pseudo-ice-wedge casts of Connecticut. Submitted for publication.
- Clebnik, Sherman M., 1980, The surficial geology of the Willimantic Quadrangle. *Connecticut Geol. and Nat. History Survey, Quadrangle Report No. 39*, 45 p.
- Clebnik, Sherman M., and Mulholland, J. W., 1979, Regional stagnation of ice in northeastern Connecticut: An alternative model of deglaciation for part of New England: Discussion. *Geol. Soc. of Amer. Bull.*, Part 1, v. 90, p. 117-118.
- Frankel, Larry, manuscript, The surficial geology of the South Coventry Quadrangle. Submitted for publication.
- Jahns, R. H., 1941, Outwash chronology in northeastern Massachusetts (abs.). *Geol. Soc. of Amer. Bull.*, v. 52, n. 12, pt. 2, p. 1910.
- Jahns, R. H., 1953, Surficial geology of the Ayer Quadrangle, Massachusetts. *U.S. Geol. Survey Geologic Quadrangle Map GQ-21*.
- Pease, Maurice H., Jr., 1970, Pleistocene stratigraphy observed in a pipeline trench in east-central Connecticut and its bearing on the two-till problem. *U.S. Geol. Survey Prof. Paper 700-D*, p. 36-48.
- Pease, Maurice H., Jr., 1975, Surficial geologic map of the Stafford Springs Quadrangle, Connecticut. *U.S. Geol. Survey Geologic Quadrangle Map CQ-1216*.
- Rahn, Perry H., 1971, The surficial geology of the Spring Hill Quadrangle. *Connecticut Geol. and Nat. History Survey Quadrangle Report No. 26*, 31 p.
- White, S. E., 1947, Two tills and the development of glacial drainage in the vicinity of Stafford Springs, Connecticut.

MODE OF DEGLACIATION OF THE SHETUCKET RIVER BASIN

Robert F. Black
Department of Geology & Geophysics
University of Connecticut
Storrs, CT 06268

INTRODUCTION

The Shetucket River basin encompasses an area of about 1,300 km² (400 miles²) in northeastern Connecticut (about 10% of the state) and a negligible amount in Massachusetts. The irregular basin is roughly 40 km (25 miles) east to west and 60 km (37 miles) north to south. The basin has local relief of 50 to 100 m (164 to 328 ft) and maximum relief of 394 m (1293 ft). It lies between the lowland of the Connecticut River on the west and the Quinebaug River on the east. To the north, irregular highlands extend tens of kilometres, but, significantly, they are cut by deep valleys draining west or east. The stream valleys in the basin are controlled by bedrock structure, although the streams flow mostly on a thick veneer of glacial deposits.

The concept of regional stagnation of ice in Connecticut reached its zenith decades ago (Flint, 1930), albeit not a universally accepted concept (Koteff and Pessl, 1981). In the last four decades the concept of stagnation-zone retreat has dominated the thinking of most mappers (Schafer and Hartshorn, 1965; Koteff, 1974; Koteff and Pessl, 1981), including those in the Shetucket River basin (Black, 1977). "Opposing views regarding the configuration of the waning ice sheet; the condition of the ice, whether active or stagnant; and the rhythm of deglaciation, whether systematic and orderly or random and chaotic, have repeatedly been argued in the literature" (Koteff and Pessl, 1981, p. 1).

Black (1977) attempted to show that the Shetucket River basin during wastage of the ice sheet was controlled topographically by the sill depth at the head separating it from the Connecticut River valley. In that valley an actively moving ice lobe extended well out from the main continental ice sheet. "As the continental ice thinned, a threshold was reached wherein ice flow to the Shetucket River basin was cut off. This initiated widespread stagnation in the basin and downwasting in situ, in contrast with frontal retreat" (Black, 1982, p. 77). Clebnik and Mulholland (1979) took issue with portions of the brief scenario envisioned for the Shetucket River basin, and Black (1979) amplified some of his original contentions. "In essence I propose that the eastern and western highlands of Connecticut were deglaciated by

intermittent overall northward retreat of ice involving widespread stagnation within individual drainage basins. This is in contrast to the stagnation-zone retreat of a correlatable margin across Connecticut. However, frontal retreat seems applicable to ice in the major north-south valleys, especially the Connecticut River Valley." (Black, 1982, p. 78).

This brief summary focuses on Black's interpretation of the mode of deglaciation of the Shetucket River basin. Only part of the argument and information are summarized here. Some specific unpublished information is presented to rebut comments in the literature. Clearly, as all favor some stagnation of the ice, the questions are how large an area stagnated at one time and what was its relation to active ice.

OUTLINE OF ARGUMENT

Positive and negative lines of evidence were used to support the concept of massive stagnation in the Shetucket River basin (Black, 1977, 1979, and 1982). "Positive evidence includes especially (1) deposits and landforms that indicate ice barriers stood to the south, on highlands, while ice-walled lakes extended many kilometres to the north...; (2) flow of water both north and south from ice at bedrock divides, leaving ice-contact stratified drift deposits from those divides to valley bottoms, over distances of many kilometres...; and (3) a water-table effect in and around wasting ice tens of kilometres up all major valleys from an ice and drift dam in the lower part of the basin... Negative evidence includes (1) lack of unequivocal evidence for an ice margin across the basin, (2) inability to relate one local morphologic sequence (as mapped) to another, and (3) recent excavations that reveal that age relations in some critical sequences in the Stafford Springs quadrangle are reversed from those required by the morphologic-sequence concept" (Black, 1977, p. 1331).

Further, Black (1979, p. 120) stated: "I have not been able to find any deposits or features that unequivocally demonstrate the existence of an active ice margin during the wastage of ice in the Shetucket River basin. Dead-ice features are common. All things considered, I find it difficult to force the stratified drift deposits of the Shetucket River basin into the concept of stagnation-zone retreat, whereas they fall easily into a model of regional stagnation." "The reconstructed ice surface over a distance of more than 30 km [19 miles] had a gradient averaging only about 3.3 m/km [17 ft/mile], and the ice was distinctly less than 100 m [328 ft] thick. This was not actively flowing ice. The stagnation zone was at least 10 to 30 times the width of the normal dead-ice margin as described in the sequence concept in New England (Koteff, 1974)" (Black, 1982, p. 83).

DISCUSSION

Since 1977, several publications allude to specifics on the glacial history of the Shetucket River basin. Some are at variance with my thesis. The opportunity to rebut some of them is utilized here. No effort is made to comment on surrounding areas to avoid undue length.

Zizka (1978) completed the surficial geologic map of the Columbia Quadrangle of which part is in the southwestern portion of the Shetucket River basin. He concluded that the distribution of glacial materials within the quadrangle did not provide unequivocal support for either regional stagnation nor stagnation-zone retreat. However, he favored the concept of regional stagnation as being more in line with the local evidence and outlined several supporting reasons.

Clebnik (1980) described the glacial geology of the Willimantic Quadrangle in terms of morphologic sequences. His report was written prior to Black (1977) and, hence, does not incorporate or rebut my thesis. However, Clebnik and Mulholland (1979) have discussed it, and Black (1979) replied. As several stops will be made in the Willimantic Quadrangle, specific comments will be made in the Road Log.

Goldsmith and Schafer (1980) stated "Ice-marginal positions in the Shetucket-Willimantic basin record systematic northward and northwestward retreat, and the ice margin gradually evolved into the east margin of the great Connecticut Valley lobe." This concept was expanded by Goldsmith (1982) for all of southeastern Connecticut, but no additional evidence was given for the Shetucket River basin. "Only a very few possible morainal segments have been noted north of the coastal morainal belt in eastern Connecticut. Lack of development was probably most likely due to an accelerating rate of ice retreat which did not allow minor fluctuations of ice regimen to produce stillstands" (Goldsmith, 1982, p. 74).

Koteff and Pessl (1981, p. 10 and 11) refer to a "very short, segment of a probable end moraine near South Coventry." The linear ridge along Anderson Road (Figure 1) is in the Skungamaug River valley, south of Tolland. That feature was examined by them on a "Little Friends of the Pleistocene" trip that I led. Time and inclement weather did not permit a thorough examination of my evidence, and now the locality has no exposures. Many new homes and landscaping do not make a stop there worthwhile. The "end moraine" is comprised of lenses and irregular bodies of stratified sand and gravel complexly intermixed with sandy till or colluvium and with a surface cover locally of till. No imbrication up valley was seen as in an end moraine. The topography is irregular (Figure 1). The western part is lower than the eastern, which rises up onto a bedrock supported upland.

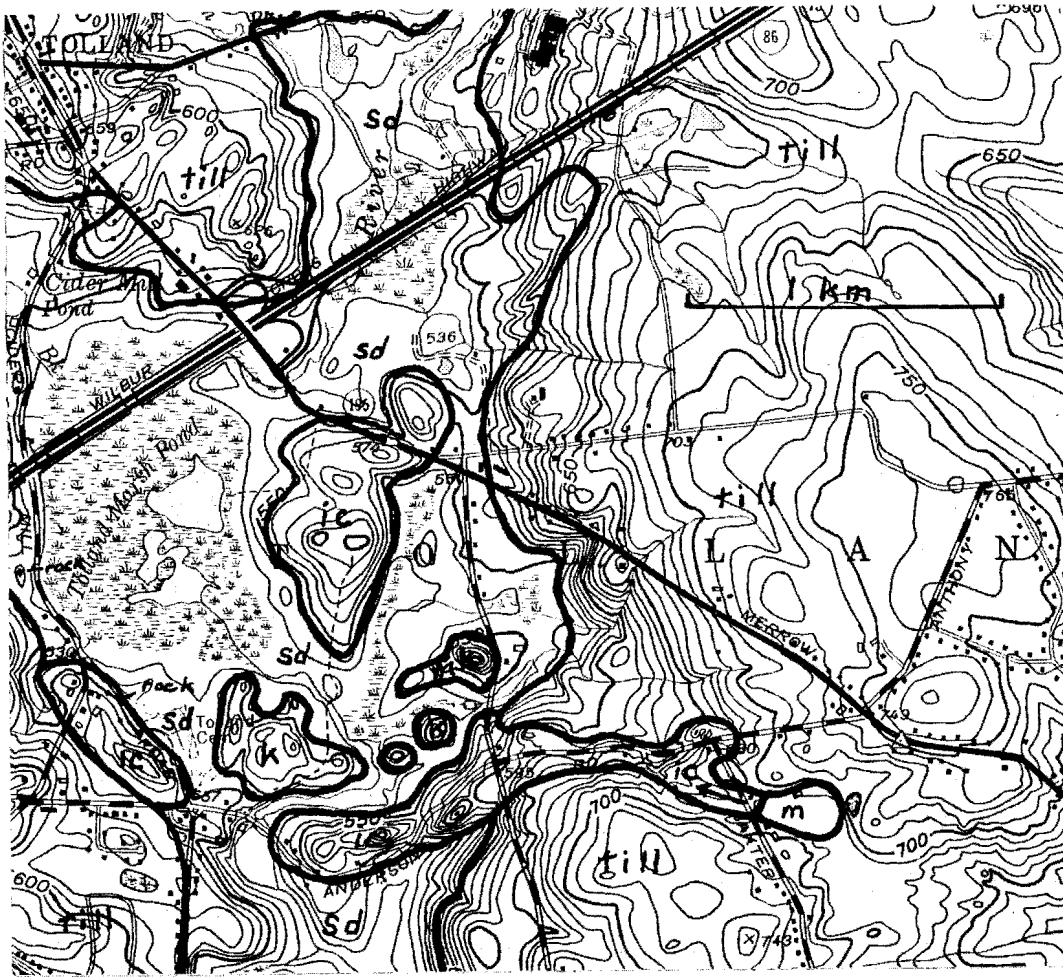

Figure 1.- Part of South Coventry Quadrangle, showing glacial deposits generalized in part from Frankel (ms.). Sd is stratified drift, ic is ice contact, k is kame, m is moulin, and mk is moulin kame.

My interpretation is that water from a moulin to the east flowed uphill across the upland and deposited sand and gravel in, on, and adjacent to the ridge. Water apparently did not flow south and east into the Willimantic River valley until later, possibly because the thicker ice there than in the Skungamaug was tight to its bed. The association

immediately north of a moulin kame of sand and gravel covered with till and of other dead ice features surrounding the kettle, called Tolland Marsh Pond, led me to call the ridge a dead-ice feature. Rock crops out and apparently controlled the localization of some features, but was not seen in the linear ridge in the valley. No evidence of a front of active ice was seen. The irregular topography both north and south of the marsh narrows the valley of the Skungamaug River, making conditions favorable for stagnation, not for an active ice front.

Black (1977, p. 1336) estimated that stratified drift covers about 18% of the Shetucket River basin and that its volume, based on isopach maps of Thomas et al. (1967), is equivalent to a layer perhaps 1 m (3.3 ft) thick over the entire basin. Pessl and Frederick (1981) subdivided the basin into 73 sub-basins and calculated the sediment volume by summation of a series of truncated cones, each defined by isopach contours from Thomas et al. (1967). Their result was 1.3 km^3 (0.3 miles^3) (precisely the same thickness as mine as the basin encompasses $1,300 \text{ km}^2$). However, to this value they added an additional 0.7 km^3 (0.2 miles^3) "to account for the volume of stratified drift that occurs above the water table."

Pessl and Frederick (1981, Tables 1 and 2) compiled sediment volumes in selected glaciers and ice-marginal zones of selected glaciers and related these to the amount of stratified drift that should be present in the Shetucket River basin. On the basis of these examples, only a very small percentage of the stratified drift in the Shetucket River basin can be accounted for. However, most examples cited are cold-based glaciers or are valley glaciers with rock beds. Hence, I do not consider them to be representative examples. Using typical values for the amount of basal debris in temperate ice, they (p. 95) calculate that the amount of sediment available from a wasting ice mass occupying the Shetucket River basin would be only about 0.13 km^3 (0.03 miles^3), or only about 6% of the total volume estimated in the basin. In none of their calculations do they consider the fact that the main portion of the landscape, as today, was covered with till and stratified drift when the last ice came in under complex flow regimes. Pease (1970) documents vividly the resulting deposits as seen in a 17-mile-long (27 km) trench that extended from Spring Hill on Route 195 in southwest Spring Hill Quadrangle northeast through Hampton and Danielson Quadrangles, to the southwest corner of the Putnam Quadrangle. Bedrock formed only a small percentage of the land surface then as now. The last ice advanced over highly irregular topography with relief of hundreds of metres. It generated a mixed zone between

the existing till and the subsequent till, which is several metres thick in many places. In large areas the last ice entirely removed the deeply weathered profile on the older till, incorporating and reworking that material under conditions that were clearly wet based (Black, 1980).

During deglaciation earth flows and flowtill mixed with glaciofluvial deposits at most till-terrace breaks in slope. Runoff from high-level deposits of coarse sand and gravel and slope wash brought huge quantities of material to lower levels. Thus, 2 m (6.6 ft) or so of stratified material reworked from the landscape is not unreasonable, but expected. I find no correlation in the amount of debris in existing glaciers flowing over rock under conditions that have existed for thousands of years, so that everything loose has long since been moved, to the situation that must have obtained in the Shetucket River basin during the last ice advance and its decay. I see no need for the "dirt machine" to operate within the Shetucket River basin during a step by step retreat. I suspect it operated at different times at the very head of the basin, along the divide with the Connecticut River lowland, as the ice front vacillated there (Larsen and Hartshorn, 1982). Debris may well have been carried on ice from the head to the lower reaches of the basin (Black, 1979, p. 119). The abundance of Triassic-Jurassic erratics from the Connecticut River lowland attest to the basal flow of ice in the lowland as it struggled to cross the divide under compressing flow regime. Once over the divide the ice was under alternately compressing and extending flow as it went across the grain of the Shetucket River basin, distributing those erratics in all parts of the basin, except possibly the extreme northeast corner.

I conclude that the case for marginal retreat of an active ice front with intermittent still stands in the Shetucket River basin has not been substantiated.

REFERENCES

- Black, Robert F., 1977, Regional stagnation of ice in northeastern Connecticut: An alternative model of deglaciation for part of New England. *Geol. Soc. America Bull.*, v. 88, p. 1331-1336.
- Black, Robert F., 1979, Regional stagnation of ice in northeastern Connecticut: An alternative model of deglaciation for part of New England: Reply. *Geol. Soc. America Bull.*, Part 1, v. 90, p. 118-120.
- Black, Robert F., 1980, Evidence of permafrost during the latest Wisconsinan ice advance and retreat in Connecticut. (abs.) *American Quat. Assoc. Abstracts and Program*, p. 25.
- Black, Robert F., 1982, Modes of deglaciation of Connecticut: A review. In "Late Wisconsinan Glaciation of New England", G. J. Larson and B. D. Stone, eds., p. 77-100, Kendall/Hunt Pub. Co.
- Clebnik, Sherman M., 1980, The surficial geology of the Willimantic Quadrangle. *Connecticut Geol. and Nat. Hist. Survey Quad. Report No. 39*, 45 p.
- Clebnik, Sherman M., and Mulholland, J. W., 1979, Regional stagnation of ice in northeastern Connecticut: An alternative model of deglaciation for part of New England: Discussion. *Geol. Soc. America Bull.*, Part 1, v. 90, p. 117-118.
- Flint, Richard Foster, 1930, The glacial geology of Connecticut. *Connecticut Geol. and Nat. Hist. Survey Bull. No. 47*, 294 p.
- Goldsmith, Richard, 1982, Recessional moraines and ice retreat in southeastern Connecticut. In "Late Wisconsinan Glaciation of New England", G. J. Larson and B. D. Stone, eds., p. 61-76, Kendall/Hunt Pub. Co.
- Goldsmith, Richard, and Schafer, J. P., 1980, Deglaciation of eastern Connecticut. (abs.) *Geol. Soc. America Abstracts with Programs*, v. 12, n. 2, p. 38-39.
- Koteff, Carl, 1974, The morphologic sequence concept and deglaciation of southern New England. In "Glacial Geomorphology", D. R. Coates, ed., State University of New York, Binghamton, N.Y., p. 121-144.

- Koteff, Carl, and Pessl, Fred, 1981, Systematic ice retreat in New England. U. S. Geol. Survey Prof. Paper 1179, 20 p.
- Larsen, Frederick D., and Hartshorn, Joseph H., 1982, Deglaciation of the southern portion of the Connecticut valley of Massachusetts. In "Late Wisconsinan Glaciation of New England", G. J. Larson and B. D. Stone, eds., p. 115-128, Kendall/Hunt Pub. Co.
- Pease, Maurice H., 1970, Pleistocene stratigraphy observed in a pipeline trench in east-central Connecticut and its bearing on the two-till problem. U. S. Geol. Survey Prof. Paper 700-D, p. 36-48.
- Pessl, Fred, and Frederick, Jan E., 1981, Sediment source for melt-water deposits. Annals of Glaciology, v. 2, p. 92-96.
- Schafer, J. P., and Hartshorn, J. H., 1965, The Quaternary of New England. In "The Quaternary of the United States", H. E. Wright and D. G. Frey, eds., p. 113-128, Princeton University Press.
- Thomas, Mendall P., Bednar, Gene A., Thomas, Chester E., and Wilson, William E., 1967, Water resources inventory of Connecticut, Part 2, Shetucket River basin. Connecticut Water Resources Bull. No. 11, 96 p.
- Zizka, Michael A., 1978, The surficial geology of the Columbia Quadrangle. M. S. thesis, University of Connecticut, 81 p.

MODE OF DEGLACIATION IN THE
WILLIMANTIC AREA, CONNECTICUT

Sherman Clebnik
Eastern Connecticut State College
Earth & Physical Sciences Department
Willimantic, CT 06226

Introduction

The way in which deglaciation took place in New England is a topic that has received much attention in the past (Koteff and Pessl, 1981, p. 205). Two different modes of deglaciation were proposed: (1) the predominantly downward wasting of inactive ice mantling a broad area, or (2) the lateral retreat, generally from south toward the north in New England, of an active ice front, perhaps fringed by stagnant ice.

Using the second model, some geologists in recent decades have mapped sequences, or "morphosequences," of stratified drift. As described by Koteff (1974) and Koteff and Pessl (1981), a morphosequence includes one to many discrete stratified-drift deposits laid down peripheral to the ice sheet within one brief episode during deglaciation. At a shear zone occurring at the boundary of the live and marginal, stagnant ice, debris is transported to the surface of the ice, and subsequently is re-distributed by meltwater flowing away from the glacier.

In recent years articles once again have considered the style of deglaciation in New England, and some of these have focused on eastern Connecticut. Black (1977), elaborating on ideas first briefly presented by Black and Frankel (1976), has questioned if stagnation-zone retreat is an appropriate model of deglaciation for the Shetucket River drainage basin of eastern Connecticut. He has accepted the identification of morphosequences and the inference of lateral retreat of the ice of other areas, but believes that in the Shetucket River basin the evidence is better explained by regional downwasting of the ice. According to Black, ice that spread southeasterly from the nearby Connecticut Valley became stranded over the Eastern Highland as the ice sheet waned. Thus, a broad mass of inactive ice wasted mainly downward in the Shetucket River basin. Black (1977, p. 1331) refers to two sets of evidence in support of that conclusion:

"...Positive evidence includes especially (1) deposits and landforms that indicate ice barriers stood to the south, on highlands, while ice-walled lakes extended many kilometres to the north...; (2) flow of water both north and south from ice at bedrock divides,

leaving ice-contact stratified drift deposits from those divides to valley bottoms, over distances of many kilometres...; (3) a water-table effect in and around wasting ice tens of kilometres up all major valleys from an ice drift dam in the lower part of the basin... Negative evidence includes (1) lack of unequivocal evidence for an ice margin across the basin, (2) inability to relate one local morphologic sequence (as mapped) to another, and (3) recent excavations that reveal that age relations in some critical sequences in the Stafford Springs quadrangle are reversed from those required by the morphologic-sequence concept."

Clebnik and Mulholland (1979) queried some of the points made by Black (1977). In response, Black (1979) amplified some of his previous ideas.

Pessl and Frederick (1981) approached the controversy over the style of deglaciation, specifically in the Shetucket River basin, by examining the amount of sediment released by regional downwasting and by lateral retreat. In regional downwasting, stratified drift is derived from debris in the melting stagnant ice. In lateral retreat, the shear zone in the active ice bordering the peripheral stagnant ice would be the source of debris redistributed by meltwater--an operation coined the "dirt machine" by Koteff (1974, p. 136 and 141) and Koteff and Pessl (1982, p. 12-15). Pessl and Frederick (1981) reviewed literature concerning the amount of debris present in the basal parts of existing glaciers in order to assess the volume of sediment that reasonably could be released from melting stagnant ice. They also calculated from subsurface data the volume of stratified drift in the Shetucket River basin. The information led them to conclude that stagnant ice would not have been an adequate source for the volume of sediment in the study area and, therefore, that active ice presumably was present during deglaciation. This reasoning supports stagnation-zone retreat.

Goldsmith and Schafer (1980) and Goldsmith (1982) described the characteristics of small recessional moraines in the coastal region of eastern Connecticut. The moraines are thought to have been constructed adjacent to active ice during retreat from the terminal position at Long Island. Inland from the coastal region, moraines are scarce or lacking, perhaps due to an increased rate of ice retreat (Goldsmith, 1982, p. 74), but an orderly northward recession of the ice margin is revealed by morphosequences. In particular, Goldsmith and Schafer (1980, p. 39) stated that for the Shetucket-Willimantic basin, the ice-marginal positions indicate a northward and northwestward retreat.

Black (1982) reinforced and expanded the viewpoint earlier introduced (Black, 1977) for regional downwasting in certain basins. He examined reported end moraines in southeastern

Connecticut, and concluded that the features classified as end moraines have been misinterpreted. Thus, they should not be used to define former halts in the retreat of active ice. That conclusion obviously contrasts with the thinking of Goldsmith and Schafer (1980) and Goldsmith (1982).

Deglaciation in the Willimantic Quadrangle

The Willimantic 7½-minute quadrangle encompasses the south-central portion of the Shetucket River basin. The Willimantic River and Natchaug River, both flowing generally from the north, join near the City of Willimantic in the north-central part of the quadrangle. The drainage then continues southeastward as the Shetucket River, except in the east-central part of the quadrangle where the river abruptly turns eastward.

Clebnik (1980) mapped the surficial geology of the Willimantic quadrangle. He divided the stratified-drift deposits into morphosequences, presumably generated during stagnation-zone retreat. The characteristics of these morphosequences, the rationale for delineating them, and some limitations and criticisms of the model will be covered below.

Geologists who mapped the surficial geology of quadrangles adjoining the Willimantic quadrangle have interpreted contrary modes of deglaciation. These quadrangles range from encompassing just a small part of the Shetucket River basin (e.g., Fitchville quadrangle) to being entirely within the basin (e.g., Spring Hill and South Coventry quadrangles). A model for stagnation-zone retreat was adopted for the stratified drift in the Fitchville and Norwich quadrangles, respectively south and southeast of the Willimantic quadrangle (Pessl, 1966; Hanshaw and Snyder, 1962). No explicit statement about the style of deglaciation appears on the surficial geological map of the Scotland or Hampton quadrangle (Dixon and Shaw, 1962; Dixon and Pessl, 1966), respectively east and northeast of the Willimantic quadrangle. However, the younger deposits occur lower in a valley or toward the north, a situation compatible with stagnation-zone retreat.

Zizka (1978) studied the surficial geology in the Columbia quadrangle, west of the Willimantic quadrangle. With reference to the concepts of downwasting vs. lateral retreat, he noted (p. 57) that the deposits do not "...provide unequivocal support for either approach. However, the writer favors the concept of regional stagnation as being more in line with local evidence."

For the Spring Hill and South Coventry quadrangles, respectively north and northwest of the Willimantic quadrangle, Rahn (1971) and Frankel (1968) favored the concept of downwasting.

With reference to morphosequences in the Willimantic quadrangle or any other area, the suitability of this approach can be appraised in the following way. One should be able to demonstrate

certain characteristics within the stratified-drift deposits in order to delineate morphosequences and associated former positions of the retreating ice front (Koteff, 1974, and Koteff and Pessl, 1981). Of course, as more of these aspects are shown, the more convincing the reconstruction becomes.

(A) The head of the morphosequence ought to be identified. If the morphosequence originated directly against stagnant ice, then the upper end in a valley would be an ice-contact head of outwash.

(B) The top surface of a morphosequence represents the gradient at which meltwater was flowing downvalley away from the ice front. The upper surface presently is apt to be irregular due to collapse or erosion following accumulation of the sediment. In profile a long morphosequence displays a ramp-like form (e.g., Koteff and Pessl, 1981, fig. 2). That form is most likely to be prominent where the upper end of the morphosequence is an ice-contact head of outwash.

(C) At the downvalley end of a morphosequence there may be less collapse and fewer kettleholes due to the decreased influence of the stagnant-ice zone. A long morphosequence is more apt to reveal that than a short one.

(D) Due to the nature of meltwater transport away from the ice margin, an overall textural gradation from coarser to finer material may be recognizable downvalley. For example, while bouldery sediment may have been deposited near the ice front, it may be absent further downvalley. This gradation is most likely to be seen in a long morphosequence. Given the variability of sedimentary characteristics in ice-contact stratified drift, a consistent textural change may not always be recognized.

(E) The meltwater that built up the deposits of the morphosequence was flowing to some base-level control. Determination of that control would be helpful; however, some were ephemeral or would not be visible under present conditions (Koteff, 1974, p. 123-124; Koteff and Pessl, 1981, p. 6).

(F) In some situations, characteristics of the deposits may allow decisive identification of the direction in which the meltwater flowed. One could then ascertain that the deposits of the morphosequence were being built in a particular direction away from the inferred ice margin. For example, if the morphosequence included glaciofluvial sediments grading downvalley into glaciolacustrine sediments, excavations in the latter might reveal delta foreset beds dipping downvalley. Another possibility would involve the discharge of meltwater from an ice channel into an ice-marginal lake. Today that situation would be represented by an esker leading into a kame delta-- landforms that probably would be readily interpreted.

(G) At a particular cross-section of a valley, multiple

morphosequences ideally would appear as a series of steps, with the younger morphosequence occurring lower in the valley than the older one. Distinct topographic breaks would separate the surfaces of contiguous morphosequences. Because the ice front was retreating further upvalley as each new morphosequence was being built, the characteristics of each morphosequence from the top to the bottom of the valley side ought to vary for reasons given above. For example, while the upper morphosequence might be rather coarse and have many kettleholes, the lower one might be finer and have fewer kettleholes.

Clebnik (1980) identified several morphosequences, usually at least several miles in length, along the Shetucket River valley and its tributaries in the Willimantic quadrangle.

The first morphosequence (Clebnik, 1980: Qsh₁): The earliest morphosequence is situated along the east-west trending part of the Shetucket River near the Windham-Franklin border. The deposits included in this morphosequence are close to one another but not contiguous, are irregular in outline, and rise several tens of feet higher than adjacent deposits assigned to a different morphosequence. The tops of these deposits are above 250 feet in elevation and locally are over 270 feet. At some places a steep slope separates the first morphosequence from the adjacent one; elsewhere the slope is gradual and the boundary is less distinct.

These deposits are thought to have built up directly next to stagnant ice that occurred in the east-west segment of the Shetucket River valley. Based on the distribution of the deposits, the boundary between the active ice and the zone of stagnant ice presumably extended roughly east-west just north of the deposits (for example, near South Windham center). The lateral extension of that ice front can be tentatively associated with stratified drift in neighboring areas. To the west, in the southwestern part of the Willimantic quadrangle, stratified drift occurs along Susquetonscut Brook valley as far north as the vicinity of Owunnegunsett Hill (Clebnik, 1980: Qsq₂). In the next valley to the west, that of Pease Brook, stratified drift also extends northward to a similar latitude (Clebnik, 1980: Qp₂). In the Scotland quadrangle to the east, high-level deposits along Merrick Brook and Waldo Brook valleys (Dixon and Shaw, 1965: Qgs₁) might have headed at this ice position.

A prime candidate for a base-level control for morphosequences situated in the Shetucket River and tributary valleys is the gorge along the Shetucket River just east of the eastern margin of the Willimantic quadrangle (that is, in the western side of the Scotland quadrangle). Ice and drift could have plugged the gorge above the level, approximately 110 feet in elevation, at which the Shetucket River now flows.

Although the Shetucket River gorge was not rejected as a possible outlet for meltwater for the first morphosequence,

Clebnik (1980, p. 35) suggested another route as well. He mapped stratified drift at an elevation of about 250 feet at the northern end of Beaver Brook valley in North Franklin (the Pleasure Hill School location). Thus, it seemed that meltwater could have escaped southward along the valley of Beaver Brook. However, Black (1970, p. 119) reported that the proposed outlet is till-lined and felt that the evidence favors drainage through the Shetucket River gorge.

The second morphosequence (Clebnik, 1980: Qsh₂): This morphosequence is much longer than the first. It starts along the upland in the northeastern quarter of the Willimantic quadrangle, extends southward along the valleys of Beaver Brook*, Ballymahack Brook, and Frog Brook in the eastern side of the quadrangle, continues to and beyond the Shetucket River gorge, and includes stratified drift in the valley at the very southeastern corner of the quadrangle. The continuous ice front is thought to have extended in a southwest-northeast direction across the upland noted above.

Meltwater building up the deposits of the second morphosequence presumably was derived from three sites. The first is located in the southeastern corner of the Spring Hill quadrangle, just north of the northeastern corner in the Willimantic quadrangle. There, the surface of the stratified drift (Rahn, 1971) near the Natchaug River is at approximately 300 feet in elevation, but to the east (close to the eastern edge of the Spring Hill quadrangle) it abruptly rises to over 400 feet. This break in topography is interpreted to mark a former ice margin from which meltwater would have travelled eastward and then southward.

The direction of meltwater flow for those high-level deposits has been depicted on surficial geologic maps, and interestingly, there is a discrepancy in the data. At the southwestern corner of the Hampton quadrangle (which is east of the Spring Hill quadrangle), Dixon and Pessl (1966) depicted in three places a southward flow for stratified-drift unit Qqb₃. The meltwater would have progressed into the northern end of Beaver Brook valley. The surface of the stratified drift in that valley does decrease in elevation toward the south, thus supporting the concept of southward flow. On the other hand, at the southeastern corner of Spring Hill quadrangle, Rahn (1971) had one arrow, symbolizing "average flow direction in a delta or channel," pointing westward. It is not clear if that arrow represents all of the stratified drift throughout that area or if it is limited

*This Beaver Brook in Windham is not the same stream as Beaver Brook in North Franklin, cited above in the description of the first morphosequence.

to features seen in a pit next to the arrow. If the latter, the possibility exists that a local deviation from an overall flow direction was observed. Nevertheless, the existence of that westward direction is troublesome to the interpretation being made here, especially because the basis and strength of information about flow direction on either surficial geologic map is not exactly known.

The second source of meltwater discharge is at the northern end of Ballymahack Brook valley. A bedrock gorge at an elevation of approximately 400 feet exhibits evidence of fluvial erosion. Current drainage through the gorge is slight. Coarse stratified drift included in the second morphosequence rapidly descends to the south from the gorge. At the northwestern edge of the gorge is an esker. Clebnik (1980, p. 36) has interpreted that meltwater flowed from an ice channel at the northwestern side of the gorge and transported sediment to the south along Ballymahack Brook valley.

The esker adjacent to the gorge is about a half-mile long and trends northwest-southeast. From the gorge, it descends about 120 feet in elevation to the northwest. This esker appears to be linked with another segment, trending north-south, near North Windham center at the northern edge of the Willimantic quadrangle. In turn, there is another aligned segment in the southern part of the Spring Hill quadrangle (Rahn, 1971). These segments altogether extend about two miles from the gorge to a broad area of ice-contact stratified drift around Mansfield Hollow Lake.

In the south-central portion of the Spring Hill quadrangle, stratified drift in the valleys of the Fenton River and Mount Hope River merge with that around Mansfield Hollow Lake. Eskers and kames are common in those valleys. Although separated, the eskers in those two valleys and that near North Windham form a Y-pattern and suggest a tributary system. Furthermore, Rahn (1971, p. 20-21), in discussing ice-contact deposits of the Fenton River and Mount Hope River valleys and in the Mansfield Hollow Lake area, pointed out that the meltwater-flow direction was similar to that of modern streams, in other words, generally southward. Eskers were not excluded from that conclusion. Thus, Clebnik (1980, p. 36) inferred that these eskers represent former meltwater drainage flowing southward into the northern part of the Willimantic quadrangle.

A third possible source of meltwater would be the ice front in the Shetucket River valley. Deposits included in the second morphosequence occur just southeast of South Windham center, and, presumably, the ice margin continued westerly from the upland in the northeastern part of the Willimantic quadrangle. The exact location of the former ice margin in the Shetucket River valley or in the upland west of the valley is not clear. Some stratified-drift deposits mapped in the upland south of Willimantic might be related to that ice position.

Black, (1977, p. 1333 and fig. 5; 1979, p. 119) has interpreted some of the features noted above differently. First, he felt that meltwater drained from the gorge at the head of Ballymahack Brook valley both to the northwest (where the esker is located) and to the south. He explained why discharge only toward the southeast from an ice channel seemed unreasonable. Indeed, there is a nearby precedent for Black's conception that drainage proceeded in two directions from a central site. Dixon and Pessl (1966) portrayed a stratified-drift deposit (Qgb₁) in the southwestern corner of the Hampton quadrangle with flow headed from a saddle between till-covered hills both toward the south along Merrick Brook valley and to the northwest toward South Chaplin center. This latter direction is now manifested by an esker, about 1½ miles long, which extends into the Spring Hill quadrangle.

Secondly, Black believed that ice formerly occupied the swampy area east of Lake Marie (at the southern end of Ballymahack Brook valley) and prevented drainage to the east while meltwater flowed southward along Frog Brook valley. On his surficial geologic map, Clebник (1980) included all of the stratified drift in the vicinity of Lake Marie in the second morphosequence, part of which continued east along Beaver Brook valley toward a saddle in the Scotland quadrangle.

The third morphosequence (Clebник, 1980; Qsh₃) This morphosequence included deposits of stratified drift at the southern side of the Willimantic River in Willimantic; at the north-central part of the Willimantic quadrangle between the Natchaug River and the upland east of the river; and along the Shetucket River valley as far south as the area southeast of South Windham center. The continuous ice front presumably extended from the Willimantic River valley northeasterly toward North Windham center, the latter stretch generally following the trend of U.S. Route 6.

A significant topographic break between the surface levels of the stratified drift in the vicinity of Route 6 is interpreted to mark the position of the former ice margin. This break is readily seen in the area between Route 6 and the Windham Airport at the northern edge of the Willimantic quadrangle. One can stand on a topographic bench along which bouldery stratified drift is revealed, and look northward and down upon the smooth surface identified as the fourth morphosequence where the runways occur. The bench is evidently bedrock-supported in places for outcrops do exist, but elsewhere outcrops are absent. The runways are at an elevation of approximately 235-245 feet, whereas the surface of the stratified drift on the bench locally reaches over 280 feet. About a mile south of the western end of the airport, the topographic break is also prominent at the Willimantic Country Club and Catholic Cemetery Road. No bedrock outcrops are known there.

With the ice front near Route 6, meltwater flowed southward along Potash Brook valley (which is east of and parallel to the Natchaug River valley). Blocks of stagnant ice apparently occupied the now swampy depressions common to Potash Brook valley.

In the Willimantic River valley stratified drift on the southern side stands higher than that on the northern side of the valley. Southeast of Willimantic, the ice front may have protruded along the Shetucket River valley to the area where Potash Brook enters the Shetucket River. Just southeast of that confluence, a deposit sloping to the south and having a conspicuous kettlehole at its northwestern side is included in the third morphosequence. Stagnant ice is thought to have occurred to the east and southeast of that deposit, and explains the steep, presumably ice-contact slopes bordering deposits of the third morphosequence near Windham Center.

The fourth morphosequence (Clebnik, 1980; Qsh₄): The final morphosequence identified along the continuous, north-to-southeast trending valley of the Natchaug and Shetucket Rivers encompasses stratified drift at the lowest level above stream terraces or the modern floodplain. Within the Willimantic quadrangle, most of this morphosequence is represented by two large tracts of stratified drift.

The southernmost of these two tracts is located just east of the Shetucket River and west to southwest of Windham center. The surface is generally at an elevation of 200 to 225 feet. This stratified drift presumably filled in an area vacated by stagnant ice. As was noted above, the surface is generally separated along the eastern side by an abrupt slope from the higher-level deposits of the third morphosequence. Excavations at the western side of this tract, north of Connecticut Route 203, have revealed gravelly sediment overlying a thick sequence of finer sediments, mostly sand and silt. The stratigraphy and characteristics of these sediments suggest deposition in a deltaic environment.

The second major tract occurs along the eastern side of the Natchaug River. Although some knolls near the northern edge of the Willimantic quadrangle rise above 250 or 260 feet in elevation, most of the surface at or near the Windham Airport is about 235 to 245 feet. To the south, near Connecticut Route 14, the surface is approximately 225 feet in elevation. The prominent topographic break dividing these deposits from those of the third morphosequence was previously mentioned.

Because this morphosequence extends to the northern border of the Willimantic quadrangle, the ice margin apparently was north of the quadrangle when the stratified drift in this morphosequence was accumulating. However, the position of the ice margin has not been ascertained.

Conclusions

The position of the ice margin has been inferred for three of the four morphosequences identified in the Shetucket-Natchaug valley and its tributaries within the Willimantic quadrangle. Those positions are based on the geographical distribution of the morphosequences and, in some cases, on the presence of a topographic break at the northern end of the morphosequence. The lengthy morphosequences display a surface declining toward the base-level control. A southward fining of the overall texture in the long morphosequences is not as clear as has been demonstrated in other localities. However, the opposite, a southward coarsening, is not known to occur. The surfaces of neighboring morphosequences are at different elevations and in places are distinctly separated by abrupt slopes.

Thus, this description of morphosequences associated with the Shetucket-Natchaug valley is not without inadequacies. However, it seems to satisfy enough of the criteria cited previously to serve as a workable scheme of deglaciation in the Willimantic area. Certainly, it may be weakened or strengthened by further investigation. For example, with reference to the esker at the northwestern side of the gorge in Ballymahack Brook valley, would stone counts indicate a source to the north or south of the gorge?

Acknowledgement

A preliminary copy of this report benefited from a review by Henry I. Snider, Eastern Connecticut State College.

References Cited

- Black, R. F., 1977, Regional stagnation of ice in northeastern Connecticut--an alternative model of deglaciation for part of New England: *Geol. Soc. America Bull.*, v. 88, p. 1331-1336.
- _____, 1979, Regional stagnation of ice in northeastern Connecticut--an alternative model of deglaciation for part of New England: Reply: *Geol. Soc. America Bull.*, v. 90, part 1, p. 118-120.
- _____, 1982, Modes of deglaciation of Connecticut--a review, in Larson, G. J. and Stone, B. D., eds., Late Wisconsinan glaciation of New England: Dubuque, Iowa, Kendall-Hunt, p. 77-100.
- _____, and Frankel, Larry, 1976, Deglaciation of the Shetucket River basin, northeastern Connecticut (abs.): *Geol. Soc. America Abstracts with Programs*, v. 8, no. 2, p. 135-136.
- Clebrik, S. M., 1980, The surficial geology of the Willimantic quadrangle: *Conn. Geol. Nat. History Survey Quad. Report* 39, 45 p.
- _____, and Mulholland, J. W., 1979, Regional stagnation of ice in northeastern Connecticut--an alternative model of deglaciation for part of New England: Discussion: *Geol. Soc. America Bull.*, v. 90, part 1, p. 117-118.
- Dixon, H. R. and Pessl, Fred, Jr., 1966, Geologic map of the Hampton quadrangle, Windham County, Conn.: U.S. Geol. Survey Geol. Quad. Map GQ-468.
- _____, and Shaw, C. E., Jr., 1965, Geologic map of the Scotland quadrangle, Conn.: U.S. Geol. Survey Geol. Quad. Map GQ-392.
- Frankel, Larry, 1968, The surficial geology of the South Coventry quadrangle: unpublished manuscript, 63 p.
- Goldsmith, Richard, 1982, Recessional moraines and ice retreat in southeastern Connecticut, in Larson, G. J. and Stone, B. D., eds., Late Wisconsinan glaciation of New England: Dubuque, Iowa, Kendall-Hunt, p. 61-76.

- _____, and Schafer, J.P., 1980. Deglaciation in eastern Connecticut (abs.): Geol. Soc. America Abstracts with Programs, v. 12, p. 38-39.
- Hanshaw, P.M. and Snyder, G.L., 1962, Surficial geology of the Norwich quadrangle, Conn.: U.S. Geol. Survey Geol. Quad. Map GQ-165.
- Koteff, Carl, 1974, The morphologic sequence concept and deglaciation of southern New England, in Coates, D.R., ed., Glacial geomorphology: State Univ. of N.Y. at Binghamton, Pub. in Geomorphology, pl 121-144.
- _____, and Pessl, Fred, Jr. 1981, Systematic ice retreat in New England: U.S. Geol. Survey Prof. Paper 1179, 20 p.
- Pessl, Fred, Jr., 1966, Surficial geologic map of the Fitchville quadrangle, New London County, Conn.: U.S. Geol. Survey Geol. Quad. Map GQ-485.
- _____, and Frederick, J.E., 1981, Sediment source for melt-water deposits: Annals of Glaciology, v. 2, p. 92-96.
- Rahn, P.H., 1971, The surficial geology of the Spring Hill quadrangle: Conn. Geol. Nat. History Survey Quad. Report 26, 31 p.
- Zizka, M.A. 1978, The surficial geology of the Columbia quadrangle; M.S. Thesis, Univ. of Conn., Storrs, 81 p.

Trip Q4

SEDIMENTATION IN A PROGLACIAL LAKE:
GLACIAL LAKE HITCHCOCK

BY

Gail M. Ashley^{*}, George M. Thomas^{**}, Michael J. Retelle^{**},
and Joseph H. Hartshorn

INTRODUCTION

The retreat of continental ice sheets in temperate latitudes produces water in such volumes that a significant proportion of glacial sedimentation is dominated by meltwater related processes. With a shift toward warmer climates during the Late Wisconsinan, huge subcontinent-sized ice sheets began to melt producing sediment charged streams on, within, and under the ice. Meltwater was commonly confined in tunnels whose walls might be ice, drift, and/or rock. Ice contact stratified drift formed as these heavily laden streams drained from the glacier depositing material onto or around stagnating ice. In areas of unobstructed drainage proglacial outwash streams carried sediment away from the ice margin forming valley trains and outwash plains.

Drainage was commonly impeded by topographic barriers composed of ice and/or glacial drift. This resulted in the creation of ponds and lakes in front of the retreating glaciers. Prominent and insignificant glacial lakes were commonplace features of late-glacial time and remnants are still seen in the landscape today as deltas, beaches, spillways and varved clay or other lake-bottom sediments. Lake Agassiz of the western mid-continent and the glacial Great Lakes are known to all geologists, whatever their discipline. Southern New England had many glacial lakes, including those in Cape Cod Bay, the Taunton-Plympton area, the Sudbury-Concord area, the Merrimac Valley, the Nashua Valley, the Quinebaug Valley, the Hoosic-Housatonic drainage, and the largest and longest lived of all, the Connecticut Valley glacial lake: glacial Lake Hitchcock. Figure 1 shows the location of glacial Lake Hitchcock in southern New England.

As melting on the surface of the continental glacier and at its outer margin exceeded the supply of ice moving south, the ice front retreated northward from its outer limits on Long Island to a position north of Middletown. The Middletown readvance took place between about 14,000 and 13,500 years ago, and the ice then melted back to the vicinity of Rocky Hill. There a mile-wide dam of stratified drift was deposited across the valley. Excavations in the dam show that it was deposited as a series of coalescent deltas in a glacial lake (Glacial Lake Rocky Hill, Langer, 1977) at about 135 ft. altitude. This mass of debris acted as a dam for glacial meltwater during the

* Department of Geological Sciences, Rutgers State University

** Department of Geology and Geography, University of Massachusetts

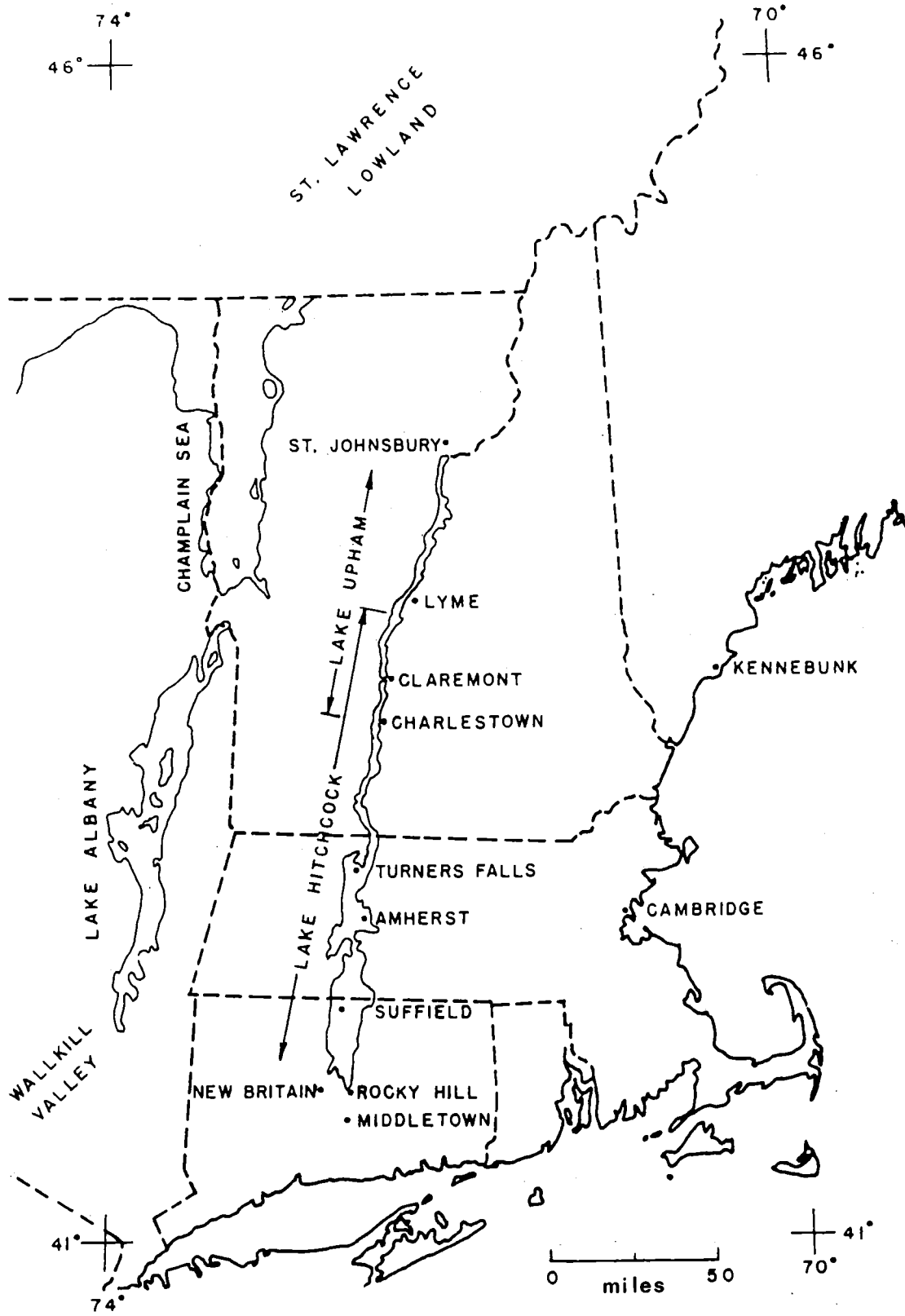

Figure 1 Map of New England showing extent of glacial Lake Hitchcock.

continued ice-front retreat in the Connecticut Valley. The beginning of the lake has been arbitrarily given the date of 13,700 B.P. because it was in the approximate time period of 14-13,500 B.P. that the glacier stood in central Connecticut (Flint, 1956).

Elevations taken from beaches and from topset/foreset contacts in deltas show that Lake Hitchcock had at least three stable lake levels south of the Mt. Holyoke Range (Hartshorn and Colton, 1967). The earliest, and highest, level was a short-lived stage at about 150 ft. This stage drained southwestward across the dam, eventually downcutting into the delta to a temporary base level at about 130 ft. This stage is called the Dividend Brook stage (figure 2). To the west of the Hartford-Rocky Hill divide, a separate lower lake developed. This lake represented the early New Britain stage. As the ice retreated north of the divide that separated the two lakes, the eastern lake drained into the early New Britain stage lake. Thus the lower New Britain spillway (originally at approximately 110 ft.) controlled the water level of the expanding glacial Lake Hitchcock. By the time the ice retreated north of the Mt. Holyoke Range, the outlet at New Britain had apparently stabilized and only one stable water plane is observed for the remaining lake to the north.

The weight of the Laurentide Ice Sheet created a crustal downwarping which increased in magnitude to the north. Due to this isostatic depression, the waters of Lake Hitchcock were always in direct contact with the glacier front. The lake was able to grow northward and still have its level controlled at the southern end by the New Britain spillway. Rapid drainage, and thus the end of the lake, occurred when the dam was breached at Rocky Hill (Schafer and Hartshorn, 1965).

Flint (1956) placed the lake drainage at 10,700 B.P., based on two radiocarbon dates. One date is thought to be pre-lake drainage ($10,710 \pm 330$ B.P.) and the other post-lake ($10,650 \pm 320$ B.P.). The only estimate of lake duration using radiocarbon dating is based on this one date of $10,710 \pm 330$ B.P. Thus, according to Flint, Lake Hitchcock lasted 3,000 years at most. This is in disagreement with varve counts by Antevs (1922), which suggested a duration of 4,100 years.

GLACIAL LAKE SEDIMENTATION

As the glacier retreated up the Connecticut Valley, the large ice mass became a decreasing influence on the southern portions of the elongate lake. Lake Hitchcock probably was not homogeneous in physical characteristics because of seasonal variations in lake water temperature. Most lacustrine circulation is directly related to thermal conditions within a lake. A well-developed thermocline enhances surface circulation. Fall and spring overturns are dependent upon significant annual fluctuations in lake temperature. Overturns and the thermocline are important factors in temperate lakes but are of less importance in subpolar and polar lakes. Although some lake currents probably existed in all parts of Lake Hitchcock, the best circulation occurred in areas farthest from the glacial front.

Concentration of suspended sediment is the most important factor affecting water density, differences in temperature being negligible by comparison. In glacial lake sedimentation, the absolute density of the lake water is not as important as the density contrast between the lake and the inflowing streams. By analogy with modern glacial streams, streams coming directly from the glacier would have a much higher sediment concentration (i.e., were

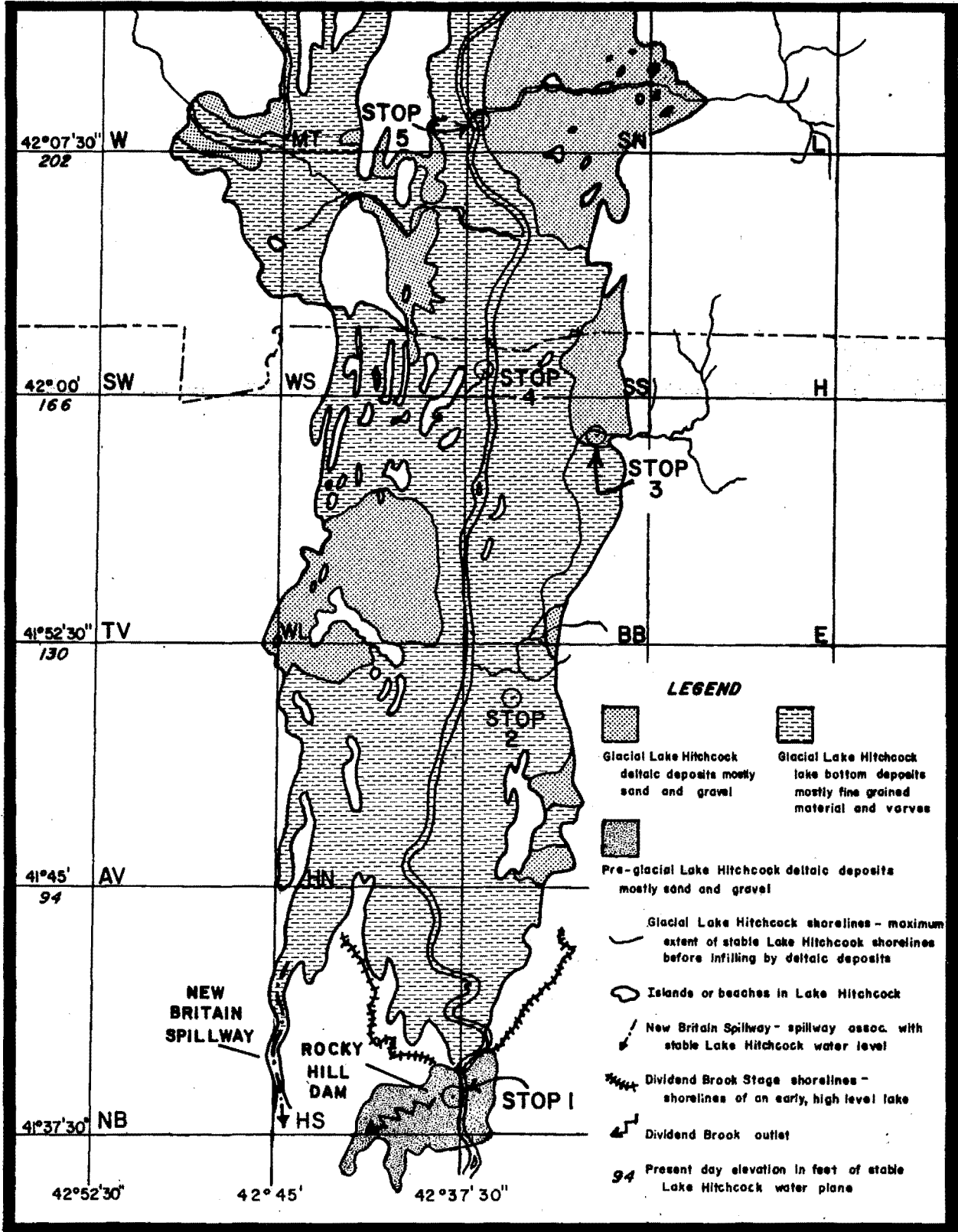

Figure 2 Generalized geologic map of the southern portion of glacial Lake Hitchcock and associated features.

Q4-5

more dense) than streams draining ice-free valleys around the southern end of the lake. Depending upon their relative densities, the major means of sediment distribution would be grouped into underflow, interflow, and overflow.

Using the above suggested limnological conditions as a framework the following mode of deposition is proposed. Sediment was carried to the lake from the glacier or from stagnant ice masses, first directly from the glacier and later by overland streams. Sand and gravel was deposited on the deltas while the finer fraction continued into the lake and flowed at a level determined by its density and that of the lake.

Sediment entered Lake Hitchcock at a number of discrete points. This incoming sediment contained clay that eventually was distributed throughout the lake by currents. The clay settled continuously, unless interrupted by currents, but accumulated in significant amounts only during the winter when coarser material was made less available. The extremely fine-grained winter layer permits the inference that the lake, which was over 60 m deep in some places, was not cleared of suspended sediment during the winter. Thus the clay composing a winter layer does not necessarily represent the same volume of clay brought in during the previous summer. Thickness of the clay layer would be more likely related to concentration of suspended sediment near the lake bottom and length of settling time. Because clay layers tend to be relatively constant in thickness, both of the above factors must have been fairly consistent from year to year.

Most of the sedimentary structures found in the silt layer, such as erosional contacts, crossbedding, and multiple graded beds, are best explained by a bottom current (density underflow). As a stream heavily laden with suspended sediment entered the lake, it flowed down the prodelta slope and out onto the lake floor, depositing sediment as it went. Since streamflow is usually continuous, one can expect that underflow would also be continuous and not like a single-pulse marine turbidity flow. Although flow is continuous, sediment content would certainly vary; multiple graded beds might be explained best by fluctuations in sediment content of the entering stream. Two reasons for these fluctuations could be the diurnal melt cycle or varying runoff due to storms.

During the summer and in succeeding years density flows overlapped and interfingered as deposition occurred on different areas of the deltas, causing bottom currents to flow in a new direction. A flow pattern such as this would tend to fill in low areas and perhaps flow around highs. The summer layer varies greatly in physical characteristics between localities. The clay layer deposited each winter blanketed this complex silt deposit and imprinted a rhythmic nature on the otherwise very diverse sediments.

ROAD LOG for Trip Q4

Assembly Point: Rocky Hill Howard Johnson's Parking lot, southeast of I-91 at exit 24, Rt. 9.

Refer to figure 2, geologic map of southern Lake Hitchcock and figure 3, stop location map with cultural features to locate stops with reference to U.S.G.S. 7½ minute quadrangles. Quadrangles denoted by letter code on figures as follows: AV, Avon; BB, Broad Brook; E, Ellington; G, Glastonbury; H, Hampton; HN, Hartford North; HS, Hartford South; L, Ludlow; M, Manchester; MA, Marlborough; MT, Mount Tom; NB, New Britain; R, Rockville; SN, Springfield

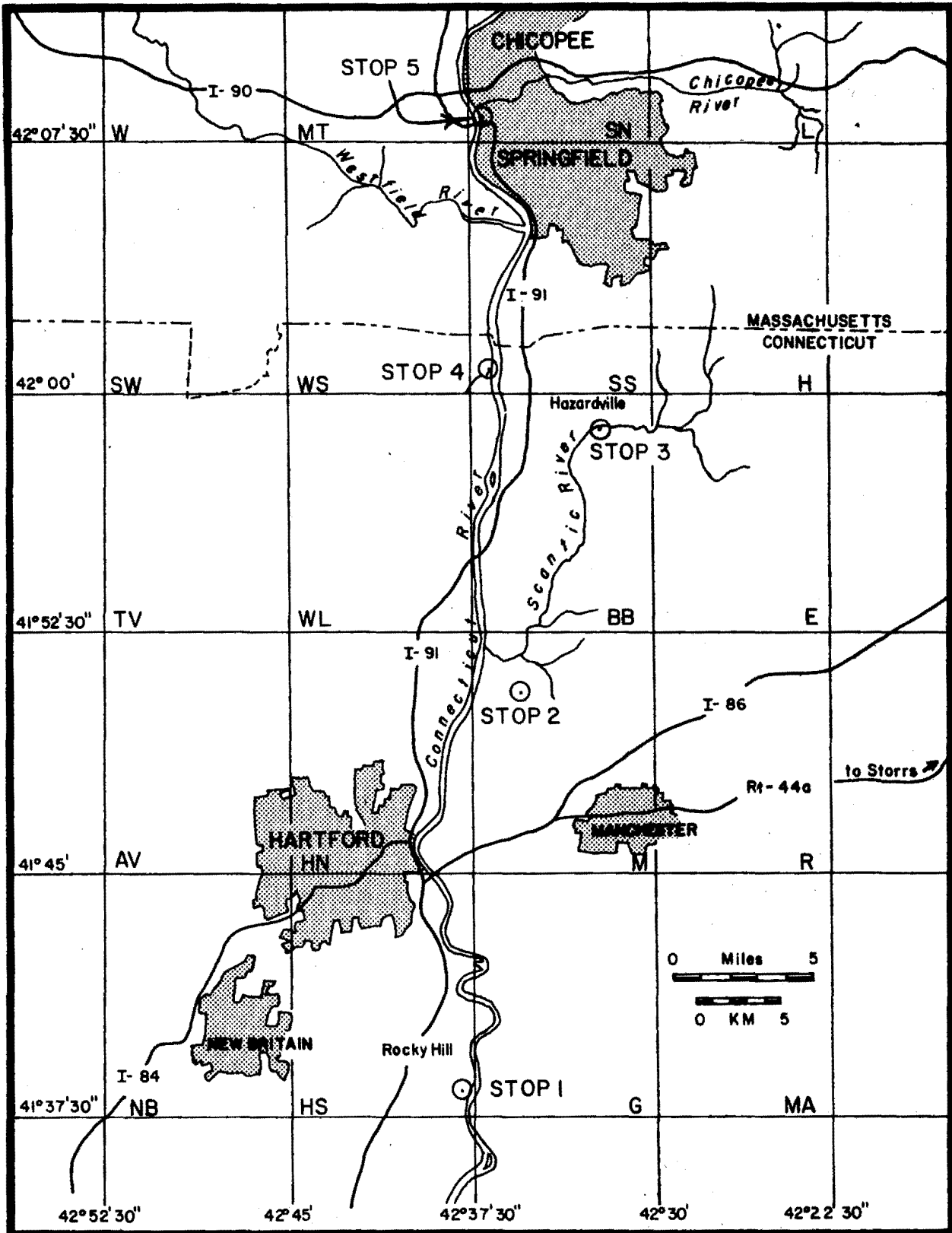

Figure 3 Area of this field trip with stop locations, cultural features and 7½ minute quadrangle locations.

Q4-7

North; SS, Springfield South; SW, Southwick; TV, Tariffville; W, Woronoco; WL, Windsor Locks; WS, West Springfield.

Cumulative mileage

START: HARTFORD SOUTH QUADRANGLE

- 0.0 Turn right (southeast) on Route 9 from Howard Johnson's parking lot.
- 0.9 Rocky Hill, is visible on the left as a ridge. It is an outcrop of basalt, with glacial polish, grooves and striations trending about S20°W. Continue past the junction of Route 160 and get in left lane.
- 1.5 Turn left down Dividend Brook Road. This is a heavily populated area, please go slow.
- 2.2 Stop sign (Forest St.). There are several abandoned and active gravel pits on the right side. Proceed straight on Dividend Road.
- 2.4 Second stop sign. We are now on a flat river terrace at around 40 ft.
- 2.7 Third stop sign at Old Forge St. Proceed straight across onto old gravel road, crossing Dividend Brook. The Dividend Brook valley was utilized as the outlet for an early higher stage of Lake Hitchcock, the Dividend Brook stage.

STOP 1. Enter gravel pit. This pit is located in a large complex kame delta. The delta was deposited into glacial Lake Rocky Hill (Langer, 1977) filling the narrow Connecticut Valley. Once the ice retreated the delta acted as a dam, preventing southward drainage of melt water. Glacial Lake Hitchcock formed between the retreating ice front and the Rocky Hill dam.

Cobble gravel topset beds, gravel foreset beds and sandy foresets have been exposed at various times. The detritus is dominantly reddish-brown indicating the Jurassic-Triassic provenance of the sand and gravel, with the balance comprised of crystalline material from the eastern and western bordering highlands. Variable dip direction of the foreset beds indicates that the dam actually is a complex of coalescing deltaic lobes.

Exit from pit and return to Dividend Road. Watch the three STOP signs.

- 4.2 Approach Y- intersection of Route 9. Travel north on Route 9, crossing the intersection of Route 160. Continue to Route I-91.
- 5.5 Get on Route I-91 northbound (right turn). At Putnam exit there is a good view of the present day floodplain of the Connecticut River. The city of Hartford is seen on the left. Stay on I-91.

HARTFORD NORTH QUADRANGLE

- 11.6 Go through underpass. As you ascend slope on the highway, beware of merging traffic on the right. As you pass exit 34, Route 157, (15.0 miles) get ready for exit in 3/4 mile, to Bissell Bridge (toll). Follow the sign for Route 291, Wilson, South Windsor, Bissell Bridge (16.0 miles) to Exit 35. Turn right at end of ramp on "to Route 159". Cross junction with Route 159. Continue straight ahead. Follow Route 291 to South Windsor and East Hartford.
- 17.2 Cross Connecticut River, stop and pay toll (35 cents). Sand dunes, some as high as 40 feet (12 m), are visible on the stream terrace deposits in this area. The stream terrace deposits, some of which may be glaciofluvial in origin are up to 20 feet (6 m) thick, overlying as much as 150 feet (45 m) of fine grained glacio-lacustrine sediments. This overlies the Jurassic Portland formation.
- 19.0 Get in left lane for left turn. Proceed north on Route 5 along post-glacial stream terraces.

21.7 Take a right turn at light onto Strong Road, then an immediate left onto Brickwood Lane. Turn right into Kelsey Ferguson Brick Co.

STOP 2. This exposure is in the only active clay pit in glacial Lake Hitchcock and provides a rare glimpse into the bottom sediments. Located 2.6 km from the lake shore and deposited in 14 - 20 m of water, the couplets are composed of a thin silt layer and thicker clay layer. Total varve thickness averages about 100 varves per meter.

Grain-size analyses show that the couplets, on the whole, are extremely fine. The "silt layer" is more than half clay, with a mean grain size between 8.4ϕ and 9ϕ . Clay layers have a mean grain size of 11ϕ . The upper surface of the clay layer is usually uneven, due to burrowing organisms and subsequent filling of the cavities with the overlying silt.

Each couplet shows a color change from bottom to top and thus appears to be a graded bed. However, microscopic examination of impregnated thin sections reveals two distinctive sedimentary units: a thin "silt layer" and a thicker clay layer. The silt was probably carried to the site by density underflows during periods of high runoff. Except for these periodic influxes of silt, sedimentation at this locality was restricted to a slow raining out of clay from suspension. The extremely fine grain size of the clay particles, combined with the platy habit of the clay minerals maintained the particles in suspension for long periods of time. Slow moving lake currents were sufficient to transport the clays far from the original source area. Thus the clays settled from suspension year round.

Return to Route 5 and turn right (north). Again you are travelling over post-glacial Connecticut River terraces.

BROAD BROOK QUADRANGLE

- 23.6 Junction of Route 191 at Phelps Road.
- 25.9 Till hill pokes through terrace on right.
- 26.7 Large till hill, Prospect Hill, cored by Jurassic Portland Formation, is flanked by stream terrace, lacustrine and beach sediments.
- 27.2 Diagonal right turn following large I-91 signs.
- 27.5 Swing left to Springfield/Hartford.
- 27.7 Swing right to Springfield, continue on I-91 north.
- 32.7 Exit 47E, Route 190 east. At the end of the off ramp take a right (east). Colton (1965) mapped great expanses of this area as sand dune deposits, mantling much of the post-glacial stream terraces. Individual, discrete linear dune ridges up to 6 m high may project above the terrace level
- 35.1 Take right lane as you approach Enfield Pharmacy for gentle curve to the right. Enter town of Hazardville.
- 35.4 Right turn on South Maple Street, 100 feet short of Gulf station, proceeding downhill to bridge over Scantic River. Cross bridge.
- 35.8 Pull off road on left side, below the outcrop

STOP 3. There are two sections to observe at this stop. Figure 4 illustrates a composite measured section for the road side exposure (section A). Section B is exposed on an east-facing cut bank slope to the east of section A. Near the base of section A, a till unit of variable thickness overlies deformed lacustrine silt and sand (varves?). The till is dark reddish brown "valley facies" till of Juro-Triassic provenance which in this section consists of several subunits. Two cobbly till units 10-30 cm thick are each capped by sand and silt graded beds. The till may have originated as: 1) a

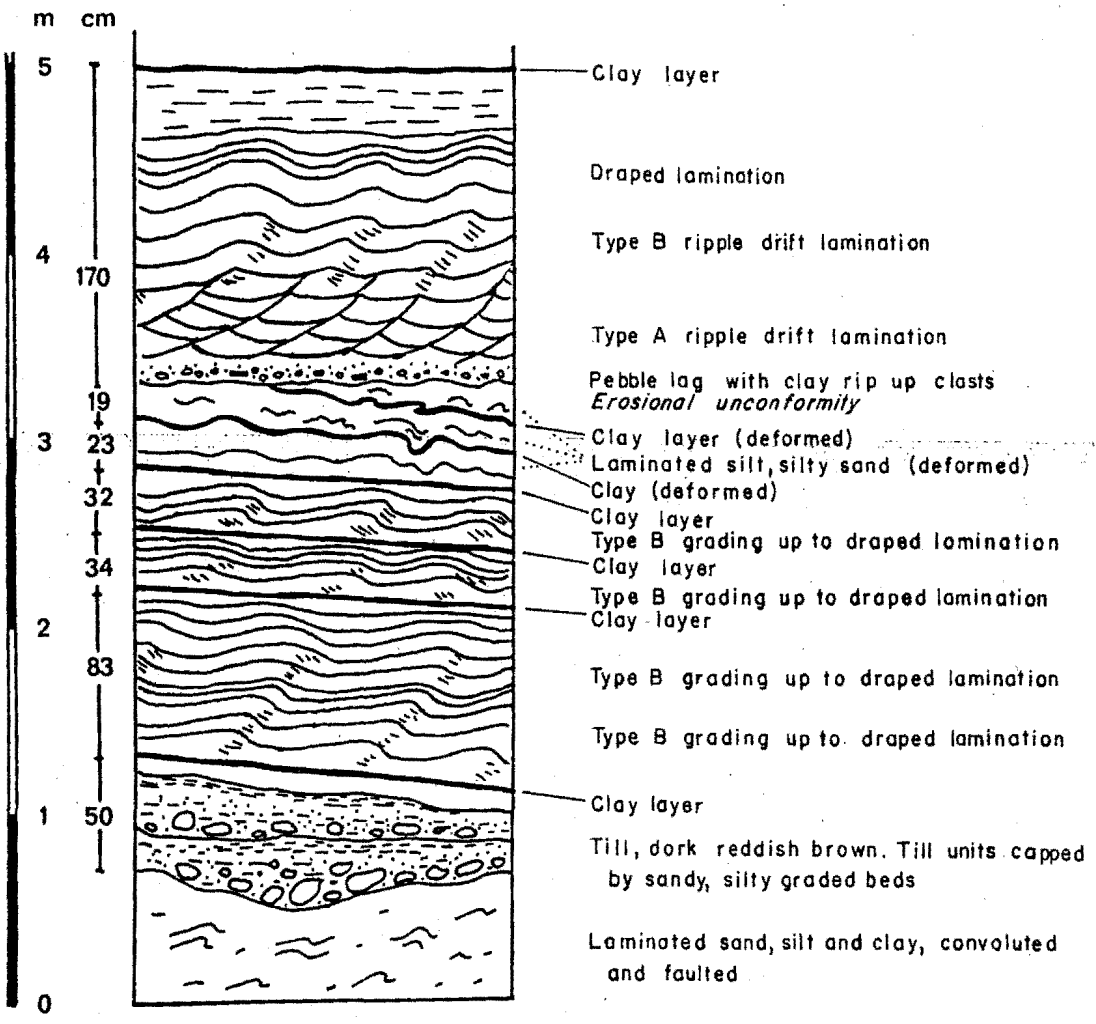

Figure 4 Composite measured section, Scantic River delta Hazardville, Connecticut.

flowtill deposited from local ice or icebergs adjacent to the delta. The graded bedding overlying the till would indicate fines settling from suspension following the main debris flow into the lake down the delta foreslope, 2) till deposited by a readvance pulse of local valley ice. The deformation of the underlying lacustrine silt and sand appears to be greater than that accomplished by instability, loading and dewatering of the fine sediment in the delta foreslope. Moreover, the till unit may possibly be correlated laterally with the dark reddish brown till in section B.

Overlying the till is a section of glaciolacustrine laminated silts and silty sands separated by winter clay layers 0.7 to 2.0 cm thick. This glaciolacustrine section can be divided into two facies, a lower, more distal facies and an upper, more proximal facies.

The lower section consists of silty fine sand with type B ripple drift lamination grading upwards into silty draped lamination (Jopling and Walker, 1968 and Gustavson et al., 1975). At least 5 sequences each overlain by clay layer are represented in the lower glaciolacustrine facies. These ripple drift sequences, indicative of turbid prodelta gravity current deposition, decrease in thickness upsection. This may indicate that the source of these sediments is becoming more distal as the ice front at the apex of the delta is retreating, or that the locus of sedimentation is slowly shifting to another area of the delta foreset.

The lower glaciolacustrine section, which dips approximately 5° to the west is separated from the upper section by a horizontal to sub-horizontal erosional unconformity. A pebbly lag gravel which also contains tabular rip up clasts of clay layers, can be seen along the truncation. The upper glaciolacustrine section consists of medium to coarse sand at the base grading upwards to medium to fine sand and silts. The section is dominated by type A ripple drift lamination grading upward to type B and draped lamination before being capped by a clay layer. The coarser grain size, thicker summer accumulation and appearance of type A ripple drift indicates a higher, energy more proximal sedimentation regime in contrast to that in the lower sequence.

Section B is a thicker section which is stratigraphically comparable to Section A. Section B is found by following the dirt road east along the river from the bridge. At this section, the basal lacustrine unit, approximately 1.7 meters thick, is overlain by 2.6 meters of red till. Above the till, three meters of glaciolacustrine fine sands and silts include undisturbed layers and broken pieces of clay laminae. The section is topped by post-glacial fluvial sands and cobbly gravels under almost one meter of eolian mantle. This is a steep dangerous outcrop. Please be careful and considerate of those people below you.

LUNCH STOP

- Turn around. Go back over the bridge and up the hill to the light. Turn left at the light on Hazard Ave. (36.1 miles) and head west. Pass the Texaco station. Stoplight (36.4 miles). Curve to the left as we go past Enfield Pharmacy again. Proceed west on Route 190.
- 38.6 Junction with I-91. Pass over the highway, continuing west on Route 190. Pass roadcut of Mesozoic redbeds in Enfield.
- 39.3 Suffield town line, east bank of Connecticut River. Head of canal on left.
- Junction 190 and 159. Turn right (north). Pass over top of drumlin and over Rawlins Brook, which exposes lake clays. After crossing Brook, take first right. Stay on River Blvd. Do not cross bridge over Connecticut River.
- SPRINGFIELD SOUTH QUADRANGLE
- 41.7 Park on right side of road, just past small culvert over Deep Brook.

Q4-11

STOP 4. This outcrop is located approximately 125 meters east of River Blyd. and is exposed in a cutbank on the north side of Deep Brook. The stream has cut through the overlying alluvial deposits exposing varved clay and till in the stream bank. The red color of the till (5YR 3/3) reflects its Mesozoic provenance. Note the predominance of striated, red clasts in the stream bed that have eroded from the till.

The outcrop (Figure 5) is capped by approximately 3 meters of fine alluvial sand. The sand appears stratified, however, the stratification is a

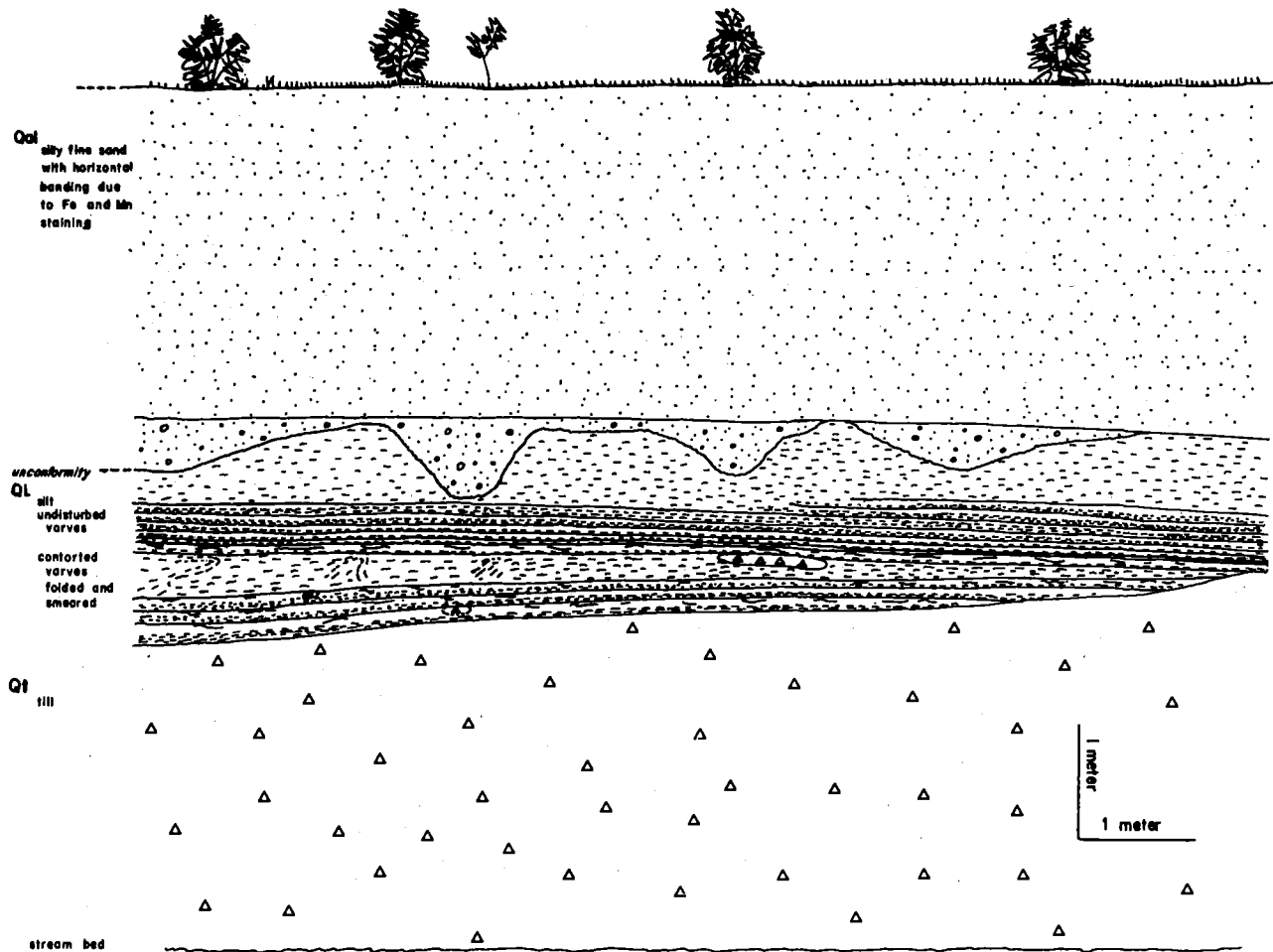

Figure 5 Sketch of outcrop along Deep Brook - stop 4.

result of post-depositional Fe and Mn staining, and not of depositional processes. Conformably below the sand is a highly permeable, heavily stained, coarse sand pebble gravel varying in thickness from 0 to 1 meter. The gravel is an alluvial lag deposited on the former lake bottom by the postglacial Connecticut River. Unconformably below the gravel is a silt layer varying in thickness from 0 to 1 meter. Below the silt there are at least six undeformed varve couplets best exposed at the eastern end of the outcrop. The varves at this locality are relatively thick with the clay layer ranging from 1.8 cm to

about 4.5 cm and the silt layer varying in thickness from 2 cm to 15 cm. Each clay layer consists of two parts. The lower part is a dark brown (10YR 3/3) greasy clay with a sharp upper boundary that is sometimes relatively coarse grained (very fine sand to silt). The upper part is a dark reddish brown (5YR 3/3) clay or silty clay that in several varves coarsens upward into the overlying silt. At other varve localities where this bi-colored clay layer is seen it always follows this pattern of red over brown. Size analysis has shown that the dark brown clay is actually 20% silt and 80% clay. The reddish brown clay is slightly coarser: 30% silt and 70% clay, with the clay being consistently coarser than the clay in the brownish layer. The "silt" layer is 85% silt, approximately 15% clay and < 1% sand.

The undeformed varves conformably overlie a minimum of 4 varve couplets that have been severely deformed. The deformation in these varves is indicated by 1) folding of the varves, 2) stringers of reddish clay in the brown clay and visa versa, 3) inconsistent lateral varve thickness, and 4) pods and lenses of till included within the varves. The deformation is thought to have resulted from a minor oscillation of the ice front with a minimum of 4 years between the initial retreat and subsequent overriding by ice. The deformed varves conformably overlie a massive dark reddish brown (5YR 3/3) till. This till contains 57% sand and gravel, 29% silt and 14% clay.

- Continue on River Blvd. swinging west to intersection with Route 159.
- 42.1 Turn right (north) onto Route 159. The highway passes to the west of an elongate till ridge and drumlin. At 42.9 miles, pass Saint Alphonsus College, situated on the drumlin crest.
- 43.3 Massachusetts-Connecticut state line. Pass Riverside Park on right.
- 44.3 Stoplight. Proceed straight ahead on Route 159, swinging to the west. Pass over rise to terrace level left and ahead of you. Lower terraces to the right (east) of you are floodplain deposits of the Connecticut River. You are riding over terraces formed by the establishment of post-lake drainage, redepositing sand and gravel of higher delta and outwash terraces over glaciolacustrine silts and clays.
- 45.5 Pass through the town of Agawam, noting nice old New England houses in the center of town. Cemetery on left. Note the contrast of marble headstones and those made of Portland Formation brownstone. Junction Route 57. Turn right toward Route 5 (Springfield) to Routes 5-91. Follow signs to I-91. Cross Connecticut River to I-91 North (Springfield/Chicopee signs). Curve left. Pass through Springfield on I-91. A large area below the highway about 25 feet above the river level was flooded during the 1936 and 1938 floods. Floodplain scarp is visible rising to the east (right).
- SPRINGFIELD NORTH QUADRANGLE
- Note signs for I-391, North--Chicopee.
- 53.3 Exit to I-391 Chicopee. Road ends 500 feet. At exit 2, turn sharp left (53.9).
Cross to right side under bridge and head south. Outcrop is on the left (east side of road) before bridge over Connecticut River.

STOP 5. The Chicopee Delta, the largest of the Gilbertian deltas fringing Lake Hitchcock, shows varved clay grading into varved deltaic deposits by a gradual thickening of individual layers. At any one site, a prograding delta

is shown mainly in the thickening of the coarse layer from 1.5 to 75 cm (occasionally as thick as 1 m). Dimensions of the clay layers remain relatively constant, from 0.75 cm to 1.25 cm.

The basal sediments (not presently exposed) were derived mainly from the glacial lobe within the valley. As the ice receded northward, however, glacial ice on the uplands became the dominant sediment source supplying debris to the major east or west flowing rivers draining into the lake.

Delta growth is reflected in the sedimentary structures occurring in the coarse summer layer. Multiple graded beds are common at the distal portion of the prodelta slope, whereas ripple-drift and draped lamination dominate the proximal portion. These sedimentary structures indicate that during most of delta construction there was abundant sediment and rapid deposition. This, in turn, implies that the bulk of delta building occurred when glacial ice occupied the drainage basin of a particular delta. The nearby ice may have limited the vegetation and thus allowed more sediment to be transported to the lake.

This sequence of varves was deposited as delta foresets in 26-30 m of water. The summer layers are medium to fine silt (7.5ϕ mean grain size) coarsening to 5.6ϕ at the top. The winter layers are dominantly clay with a mean grain size of 10.7ϕ at the base of the section grading to 9.1ϕ at the top of the section.

A section exposed during construction of an exit ramp to I-95, 400 m directly to the east, revealed 13.7 m of varved deltaic sediments. Figure 6

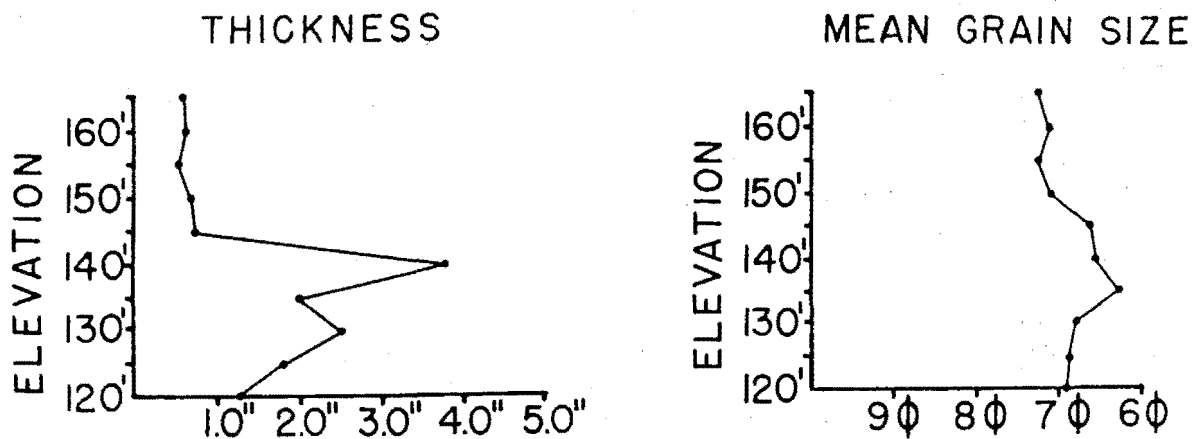

Figure 6 Plot of elevation vs. thickness and elevation vs grain size, for a section just east of stop 5.

illustrates an upsection coarsening of the silt layer and an accompanying increase in thickness, followed by a sharp decrease in thickness and a slight fining of grain size. Although these changes could represent a shift in the

delta distributary supplying sediment to the site, it is more likely the result of major diversion of meltwater as deglaciation proceeded northward out of the Chicopee River drainage basin.

To return to I-91, turn around (head north) and follow signs for I-91.

REFERENCES CITED

- Antevs, E., 1922, The recession of the last ice sheet in New England. *Am. Geog. Soc. Research Ser.*, no. 11, 120 p.
- Ashley, G.M., 1972, Rhythmic sedimentation in glacial Lake Hitchcock, Massachusetts-Connecticut: Univ. of Massachusetts, Amherst. *Geology Dept. Contribution No. 10*, 148 p.
- Colton, R.B., 1965, Geologic map of the Broad Brook quadrangle, Hartford and Tolland counties, Connecticut: U.S. Geol. Survey Geol. Quad. Map GQ434.
- Flint, R.F., 1956, New radiocarbon dates and late Pleistocene stratigraphy: *Am. Journ. Sci.*, v. 254, p. 265-287.
- Gustavson, T.C., Ashley, G.M., and Boothroyd, J.C., 1975, Depositional sequences in glaciolacustrine deltas, *in* Jopling, A.V., and McDonald, B.C., eds., *Glaciofluvial and glaciolacustrine sedimentation: Soc. Econ. Paleontologists and Mineralogists Spec. Pub. No. 23*, p. 264-280.
- Hartshorn, J.H., and Colton, R.B., 1967, Geology of the southern part of glacial Lake Hitchcock and associated deposits: *in* Guidebook to field trips, New England Intercollegiate Geol. Conf., Amherst, Massachusetts, p. 73-88.
- Jopling, A.V., and Walker, R.G., 1968, Morphology and origin of ripple-drift cross-lamination with examples from the Pleistocene of Massachusetts: *Jour. Sed. Petrology*, s.38, p. 971-984.
- Langer, W.H., 1977, Surficial geologic map of the Glastonbury quadrangle, Hartford and Middlesex Counties, Connecticut: U.S. Geological Survey Geol. Quad. Map 1354.
- Schafer, J.P., and Hartshorn, J.H., 1965, The Quaternary of New England, *in* Wright, H.E., Jr., and Frey, D.G., eds., *The Quaternary of the United States: Princeton, N.J., Princeton Univ. Press*, p. 113-128.

Mesozoic Geology

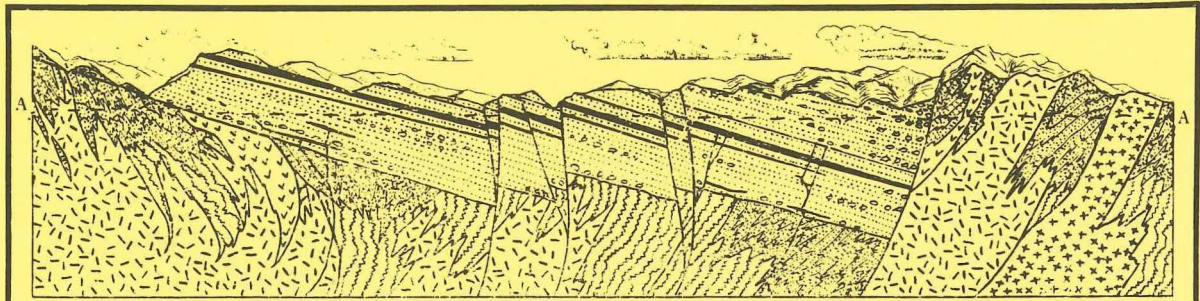

Figure 6. BLOCK MOUNTAINS OF THE EARLY JURASSIC

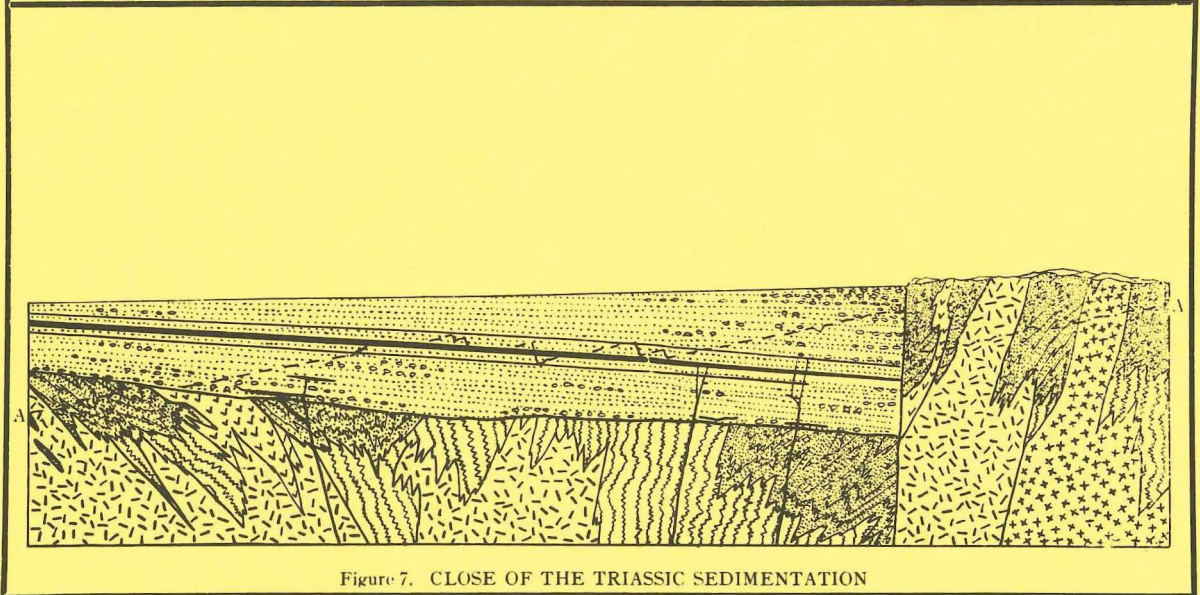

Figure 7. CLOSE OF THE TRIASSIC SEDIMENTATION

M1	JURASSIC REDBEDS OF THE CONNECTICUT VALLEY: (1) BROWNSTONES OF THE PORTLAND FORMATION; AND (2) PLAYA-PLAYA LAKE-OLIGOMICTIC LAKE MODEL FOR PARTS OF THE EAST BERLIN, SHUTTLE MEADOW AND PORTLAND FORMATIONS	103
M2	PALEONTOLOGY OF THE MESOZOIC ROCKS OF THE CONNECTICUT VALLEY	143
M3	MESOZOIC VOLCANISM IN NORTH-CENTRAL CONNECTICUT	173
M4	COPPER OCCURRENCES IN THE HARTFORD BASIN OF NORTHERN CONNECTICUT . .	195

JURASSIC REDBEDS OF THE CONNECTICUT VALLEY: (1) BROWNSTONES OF THE
PORTLAND FORMATION; AND (2) PLAYA-PLAYA LAKE-OLIGOMICTIC LAKE MODEL
FOR PARTS OF THE EAST BERLIN, SHUTTLE MEADOW, AND PORTLAND FORMATIONS

By

John F. Hubert
Department of Geology and Geography
University of Massachusetts
Amherst, Massachusetts 01003

James Michael Gilchrist
Independent Petroleum Geologist
530 Crossgates Boulevard
Slidell, Louisiana 70458

Alan A. Reed
Chevron Oil Company
P. O. Box 446
La Habra, California 90631

INTRODUCTION

The following description of the Buckland Brownstone Quarry in Manchester (stop 8) extends the earlier Guide to the Mesozoic Redbeds of Central Connecticut (Hubert *et al.*, 1978). After the description of the Buckland brownstone quarry, we discuss the model for the playa-playa lake-oligomictic lake system, including an interpretation of the playa redbeds in the East Berlin Formation at stop 6. An expanded version of the objectives of our trip, the regional setting, and an abstract of the paleographic history are given in pages 1-8 of the 1978 guidebook.

This publication is Guidebook No. 4 of the Connecticut Geological and Natural History Survey. For information on ordering the guidebook and other publications of the Survey, consult the List of Publications available from the Department of Environmental Protection, State Office Building, Hartford, Connecticut 06115.

During our NEIGC trip, we present an overview of the history of the sedimentary and volcanic fill of the rift valley in Late Triassic and Early Jurassic time. We shall focus on interpretation of depositional environments, using primary sedimentary structures and stratigraphic sequences. The paleoenvironments emphasized are: alluvial-fan conglomerate (stop 1); paleosol caliche profiles (stop 2); braided-river sandstone and floodplain mudstone (stops 2, 5, 8), symmetrical cycles of gray mudstone-black shale-gray mudstone that accumulated in carbonate-producing alkaline lakes (stop 7); redbeds of playa-lake origin (stop 6); and playa red mudstones (stops 6, 7).

STOP 8. BUCKLAND BROWNSTONE QUARRY IN THE PORTLAND FORMATION, MANCHESTER

Little I ask; my wants are few;

I only wish a hut of stone

(A very plain brown stone will do),

That I may call my own;

And close at hand is such an one,

In yonder street that fronts the sun.

Contentment

Oliver Wendell Holmes

Location

The brownstone quarry is in the small community of Buckland in the northwest corner of Manchester, Connecticut (Figs. 1, 2). Including small exposures, the quarry encompasses 45 m of section, approximately 1620 to 1665 m up in the 2,000 or so meters of the Portland Formation (Fig. 3; Sidney Quarrier, personal communication).

To reach the quarry, leave I-94 at Exit 93 and proceed northwest on Windsor Street. Turn right (east) on Burnham Street and then left (north) on Buckland Road. The quarry is hidden by trees and brush on the east side of Buckland Road, opposite the Hartman Tobacco Farm. These roads are shown on the Manchester 7.5 minute topographic quadrangle, which, however, does not show the site by a quarry symbol. Coltin (1965) shows the quarry on his bedrock geologic map of the Manchester quadrangle.

The Buckland quarry is privately owned and information about access should be obtained by contacting the State Geological and Natural History Survey of Connecticut, Department of Environmental Protection, State Office Building, Hartford, Connecticut 06115. Do not climb the rock faces.

Objective of Stop 8

At this stop we see a quarry where brownstones was mined for many years with peak activity in the late 19th century. The quarry yielded a stone of high quality with thick beds of plane-bedded sandstone made hard by albite cement and of a lovely shade of red produced by hematite pigment. In the building trade it was called "redstone".

In its early days, Buckland was known as Jambstone Plain because of the numerous slabs of brownstone taken from the Buckland quarry for use as

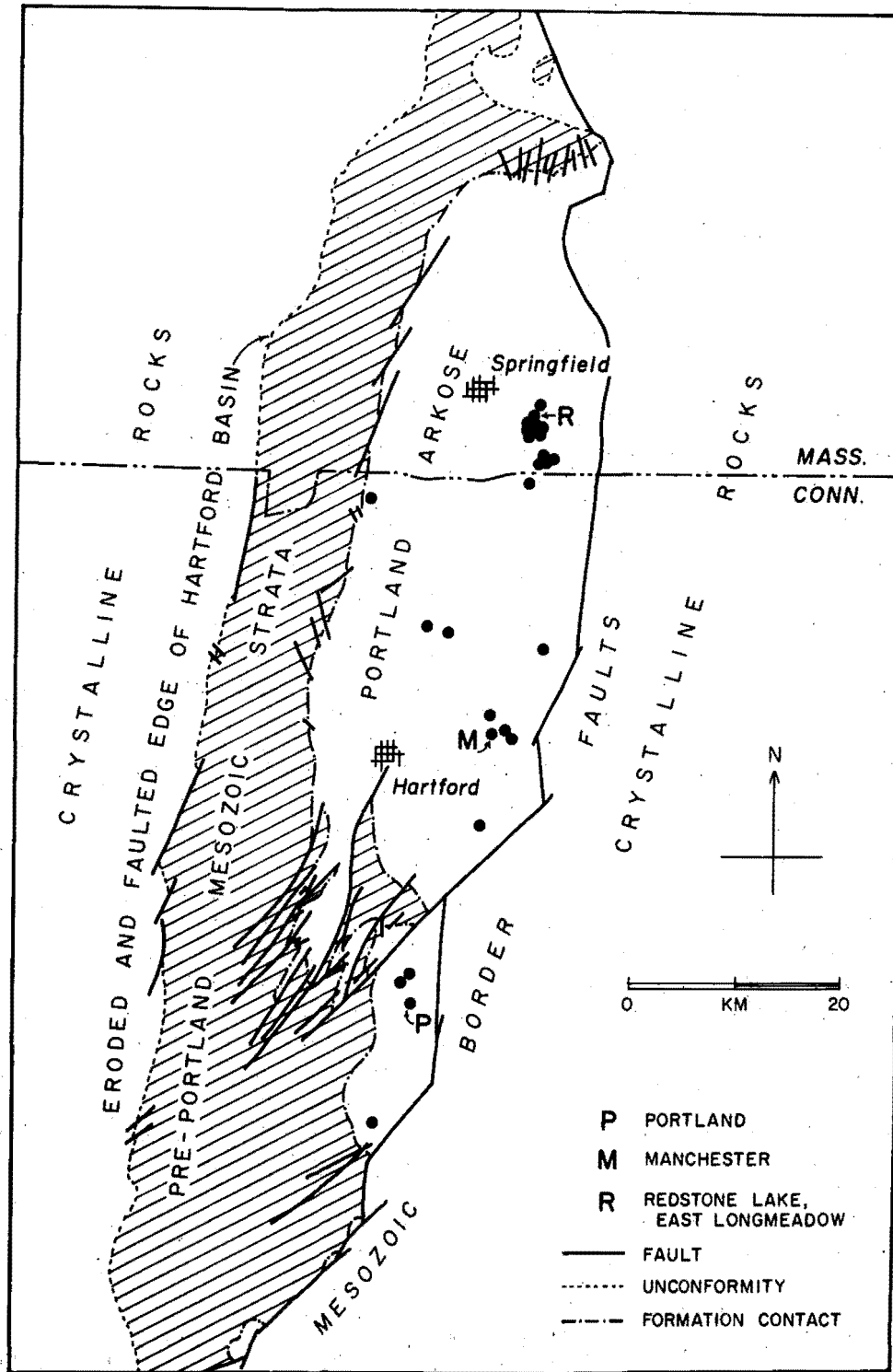

Fig. 1. Location of brownstone quarries in the Portland Formation in the Connecticut Valley, compiled largely from Smith (1982). The Buckland quarry (stop 8) is labelled M at Manchester.

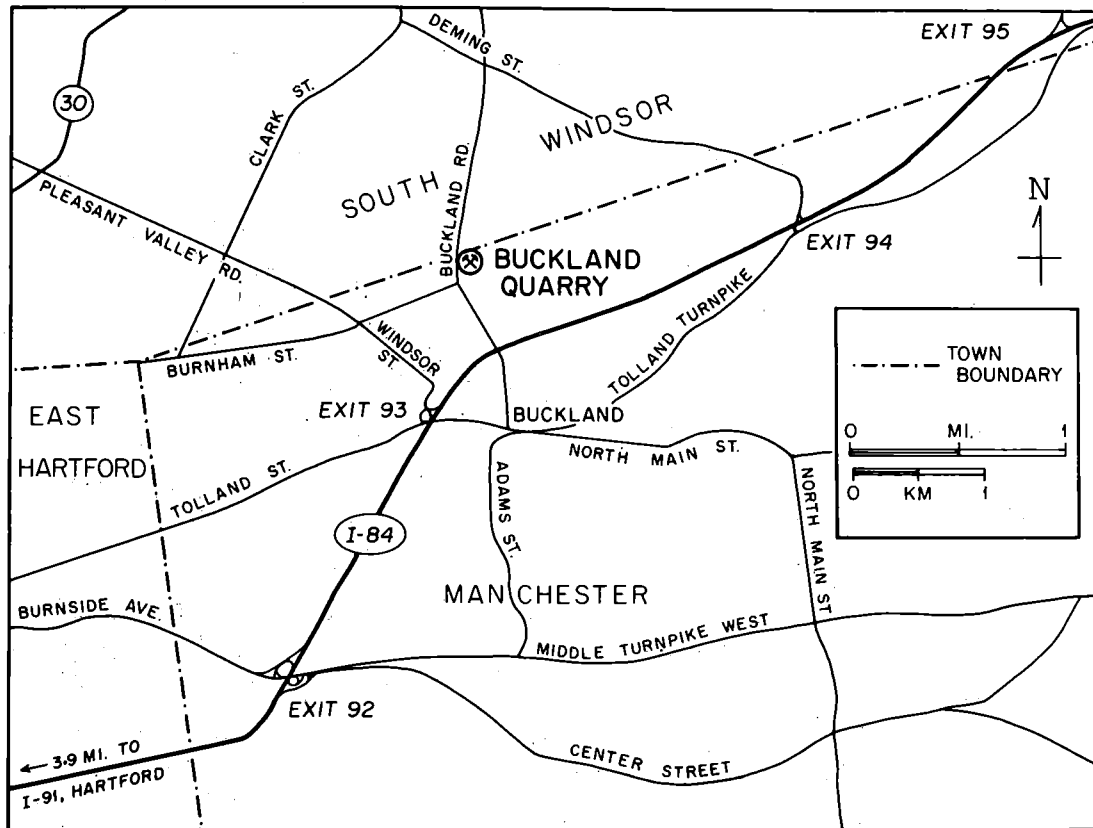

Fig. 2. Location of the Buckland brownstone quarry, Manchester.

doorstones (jambstones; Buckley, 1973, p. 11). Many of the older houses in the Manchester area have the upper section of their foundations, the part seen by visitors, made of large slabs of Buckland stone (Buckley, 1973, p. 11). This brownstone was also widely used in bridges and the older gravestones.

The primary sedimentary structures in the sequence show that the Early Jurassic river was braided and subject to high energy, shallow floods. As the flows waned, plane beds of sand accumulated under upper flow regime conditions. The brownstones at the Buckland quarry are only 7 km from the eastern border fault and are inferred to have accumulated just down slope from an alluvial fan (Fig. 4).

REGIONAL SETTING AND PALEOCLIMATE

In Early Jurassic time, the fluvial redbeds and lacustrine gray mudstones of the Portland Formation accumulated in a subtropical rift valley at about 15°N paleolatitude (Van Houten, 1977, p. 93). Rivers flowed from highlands east of a fault-bounded escarpment, across alluvial fans and onto the valley floor, which at times was the site of perennial lakes (Fig. 4).

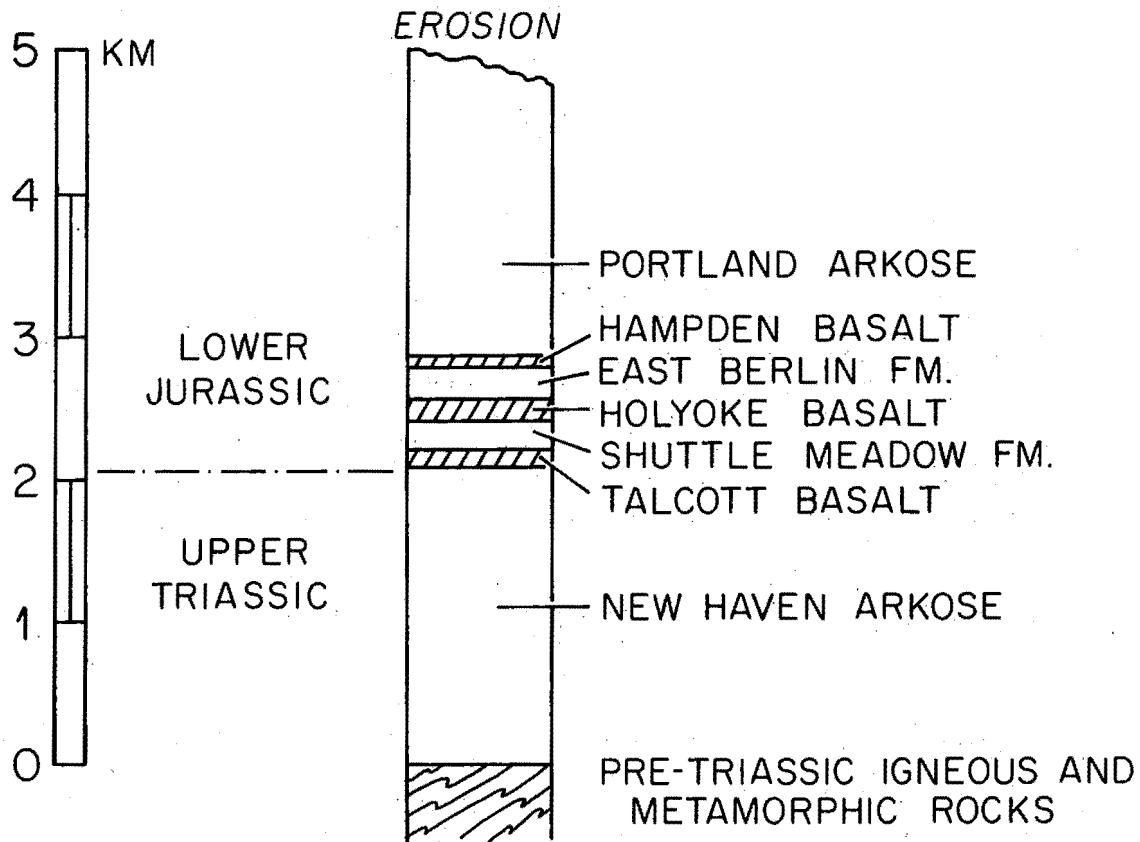

Fig. 3. Stratigraphic column for the Mesozoic rocks of central Connecticut with generalized thickness of the units.

Numerous horizons of caliche paleosols in the New Haven Arkose testify to Late Triassic semiaridity with perhaps 100 to 500 mm of seasonally distributed precipitation (Hubert, 1978, p. 164). With the onset of the Early Jurassic, the climate became wetter, as evidenced by multiple horizons of lacustrine gray mudstone and black shale in each of the Shuttle Meadow, East Berlin, and Portland Formations. The gray muds in some of these perennial, alkaline lakes mantled the valley floor from New Haven northward to the structural divide at Amherst between the Hartford and Deerfield basins and westward to the Pomperaug outlier (Hubert *et al.*, 1978, p. 96). These lakes exceeded 5,000 km², a size comparable to Great Salt Lake. Spores, pollen, leaves, and stems are common in the lacustrine gray mudstone, defining three Jurassic palyno-floral zones (Cornet, 1977, p. 265). The flora shows that, in comparison with the Late Triassic, the climate in the Early Jurassic became progressively slightly cooler and wetter, perhaps due to northwest drifting of the American continental plate (Cornet, 1977, p. 269).

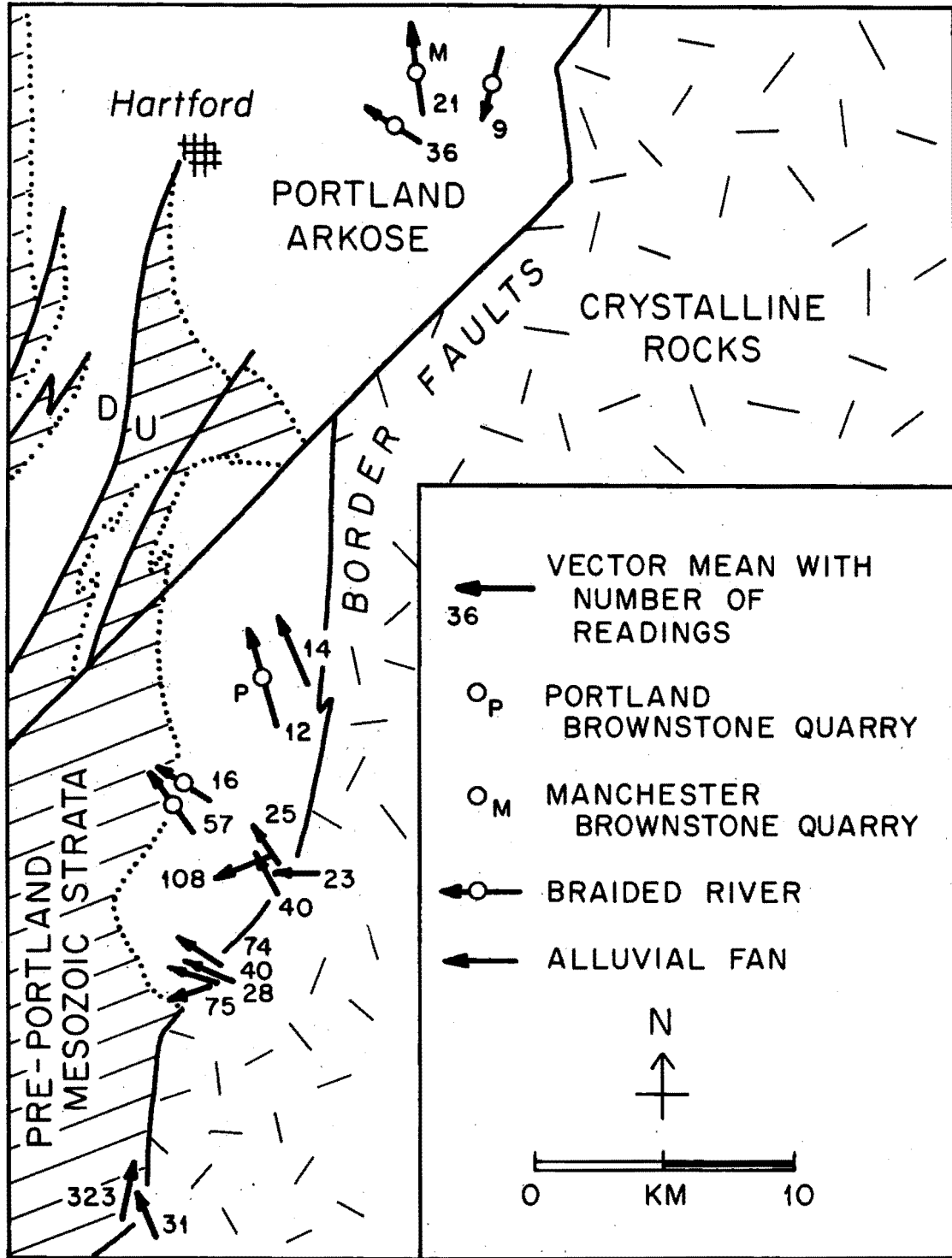

Fig. 4. Location of the brownstone quarries at Buckland in Manchester and at Portland. Each paleocurrent arrow is the vector mean for an outcrop of either alluvial-fan or braided-river facies. Each vector mean is significant at the 0.95 percent level when tested by the Rayleigh statistic L.

Increased precipitation in the Early Jurassic is further supported by the stratigraphic distribution of pebbly-sandy mudstones of debris-flow origin, such as occur today preferentially on arid to semiarid alluvial fans. Debris-flow mudstones are interbedded with alluvial-fan conglomerates of the New Haven Arkose along I-91 opposite the electric power plant at Holyoke, Massachusetts, but are absent in the section of alluvial-fan conglomerates of the Portland Formation along the border fault south of Durham, Connecticut (Hubert *et al.*, 1978, p. 11; Gilchrist, 1979, p. 65-80.

Prolonged episodes of semiaridity did occur within the overall somewhat wetter climate of the Early Jurassic as shown by caliche paleosols in fluvial sandstone and mudstone of the Portland Formation at exit 92 of I-86 in Manchester, Connecticut (Gilchrist, 1979, p. 151). As discussed below, the sedimentary structures in the brownstones imply flash floods and/or sharp peaks in river discharge, an interpretation compatible with seasonal precipitation under semiarid conditions.

DESCRIPTION OF THE BROWNSTONE

Geometry of the Brownstone Bodies

A picture of the three-dimensional geometry of the brownstones is provided by the vertical exposures above the water in the quarries at Portland and in photographs and sketches of quarry operations at Portland and East Longmeadow (Fig. 5; Asher and Adams, 1876, p. 185; Allbee, 1894, p. 21; Champlin, 1944, p. 91). The brownstones are laterally continuous, sheet-like bodies that vary from about 1 to 6 m in thickness, averaging about 2 m. Viewed in the paleo-upriver direction, the thicker sandstone bodies show about 2 m of lateral thinning across the quarry walls. The base of each sheet sandstone is fairly level with only shallow scours cut into the underlying strata. The ratio of sheet sandstone to overbank mudstone is about 20 to 1 with the thickest bed of mudstone less than a meter.

Lithological Facies

The brownstone sequences at the Manchester and Portland quarries are made of eight lithological facies defined by sedimentary structures and grain size (Figs. 6, 7). A vertical succession made of a single facies is termed a unit. The colors cited are from the Munsell Color Chart. After the facies are introduced, we describe the individual flood sequences which are made of one or more of the facies.

Plane-bedded sandstone (facies Sh) is the characteristic and dominant facies in the brownstones, comprising 79 percent of the cumulative thickness of the sections (Figs. 8, 9, 10). They range from very fine to very coarse sandstone, sometimes pebbly, with medium and coarse sandstone most common. Parting lineation is present on some of the infrequent horizontal exposures. The units vary from 1 to 172 cm in thickness, averaging 30. They tend to be laterally continuous, commonly extending across the quarry walls for some tens of meters.

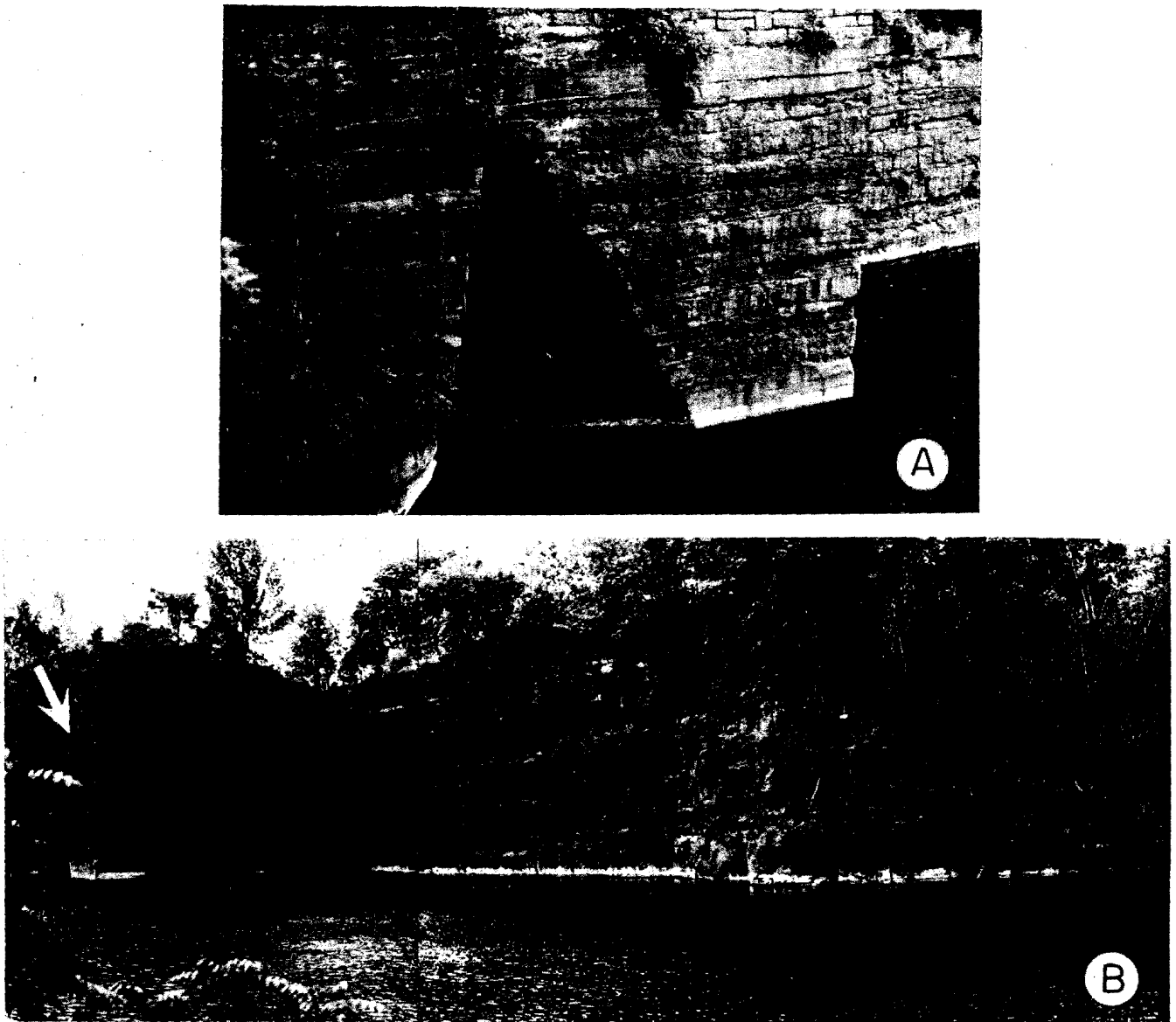

Fig. 5. Two views of a quarry in Portland, illustrating the lateral persistence of the brownstone layers. (A). View towards S66W almost perpendicular to the paleoflow direction, which is towards N18W (Fig. 7). The vertical rock wall is about 20 m high. (B). View towards S15E almost directly up the paleo-river system. The arrow points to the rock wall shown in (A).

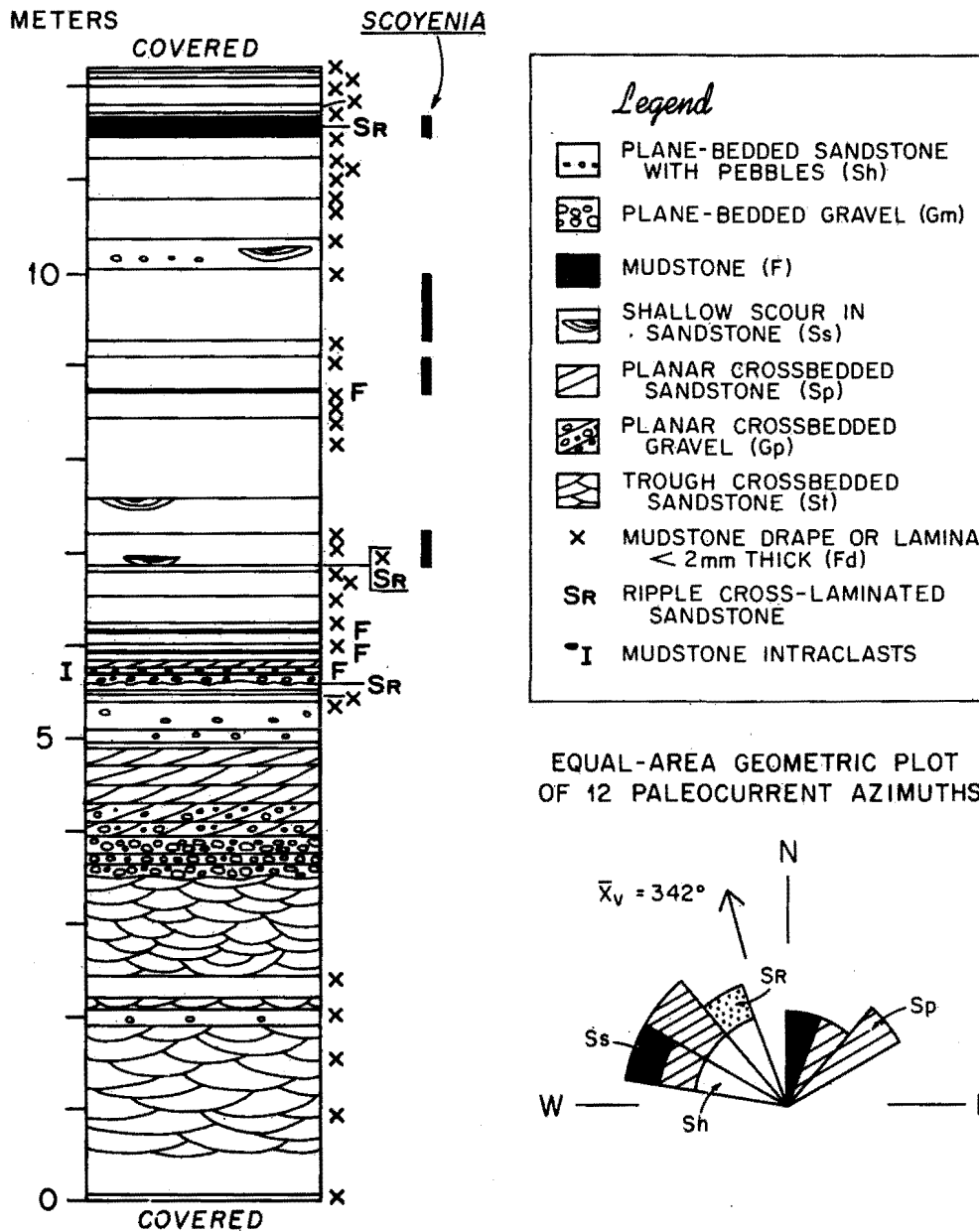

Fig. 7. Measured section and paleocurrents for a 12.2-m interval near the top of the main brownstone quarry at Portland.

That plane-bedded sandstone is the dominant facies in the brownstones is also shown by the blocks used in building construction. For example, the lovely Trinity Church of 1874 in Portland was built with stone from the Portland quarries using blocks that average about 30 by 50 cm in size. A sampling of 100 blocks shows that the facies in them are 57 percent plane-bedded sandstone, 32 percent plane-bedded sandstone and crossbedded sandstone, 6 percent crossbedded sandstone, 2 percent plane-bedded sandstone and ripple cross-laminated sandstone, 1 percent plane-bedded sandstone and sandstone-filled scour, 1 percent plane-bedded sandstone and horizontally laminated mudstone, and 1 percent horizontally laminated mudstone. The choicest stone was used in doorframes and engraved blocks in the church and as gravestones and obelisks (Figs. 8, 9). These are nearly always plane-bedded sandstone of fine and medium grain size in blocks up to 2 to 3 m in length.

Crossbedded sandstone (facies Sx) averages 13 percent of the sections in units that consist either of a single crossbed set or superimposed sets. The units vary from 10 to 111 cm, averaging 49. Trough sets are slightly more abundant than planar sets. The sets range in thickness from 6 to 28 cm averaging 16, except for one set of 111 cm.

Plane-bedded gravel (facies Gm) forms 3 percent of the sections. By definition a Gm unit must be at least 2 clasts thick. The units vary from 3 to 21 cm in thickness, averaging 11. The gravel is clast-supported, imbricated, and has a sand matrix.

Horizontally laminated mudstone (facies F). These thinly laminated sandy mudstones comprise 2 percent of the sections in layers from 0.1 to 17 cm, averaging 2.9. Where the mudstone is a thin (less than 2 mm) lamina that covers or drapes the underlying bedform, then it is designated facies Fd (Figs. 6, 7).

A sandstone-filled scour (facies Ss) is a broad shallow scour about 10 cm in depth that was filled by crudely cross-laminated sand. The inclined laminae are parallel to the underlying scour surface and dip at only a few degrees, showing that they are not bedform crossbeds. These sand-filled scours form 2 percent of the sections, always as solitary features within the Sh facies.

There is one 33-cm set of planar crossbedded gravel (facies Gp) in the Portland sequence (Fig. 7).

Ripple cross-laminated sandstone (facies Sr) averages less than 1 percent of the thickness of the sections in units of 0.5 to 2 cm thickness.

Densely packed burrows of the arthropod Scoyenia penetrate the sand and mud facies at numerous levels in both sections (Figs. 6, 7).



Fig. 8. Plane-bedded sandstone used as gravestone. Trinity Church, Portland.



Fig. 9. Plane-bedded brownstone in graveyard at Trinity Church, Portland.

Markov Chain Analysis of Facies Transitions

In order to determine preferred facies transitions in the fluvial sequences of the brownstone quarries at Manchester and Portland, the combined 26.8 m of the two sections were analyzed for the presence of the Markov property. When it is present, the probability of occurrence of any particular facies is not random, but is in part predictable from and thus "dependent on", the adjacent underlying facies. An embedded Markov chain was used, where each facies transition is tabulated, yielding a transition count matrix (Miall, 1973, p. 349).

The resulting Markov chain for the brownstone quarries is based on the positive probability values of the difference matrix (Fig. 11). These values are obtained by subtracting the independent trial probabilities (that is, the transition probabilities for a random sequence of these six facies when the Markov property is not present) from the transition probability matrix. The positive difference values cited in Figure 11 are the transitions that occurred more commonly than expected under a random selection process. A chi-square test shows that there is a greater than 99.9 percent probability that the Markov property is present in the brownstone sequences.

Redstone Lake Quarry, East Longmeadow, Massachusetts

The brownstones in the Redstone Lake quarry, formerly known as the Maynard quarry (Fig. 12), are similar to the brownstones at Buckland and Portland, but are not included in the statistical calculations because only 3 m are exposed above the lake. From 1965-1972, the Redstone Lake quarry was reopened to provide 20-ton blocks of brownstone for the library at New York University at Washington Square in New York City.

DEPOSITION OF THE BROWNSTONES

Although separated in time and place, the rivers that deposited the brownstones at Buckland and Portland were sand-bed rivers subject to repeated floods. The measured sections average 95 percent sandstone, 3 percent conglomerate, and 2 percent mudstone (Fig. 10). The distinctive plane-bedded sandstones comprise 94 percent of the section at Buckland and 60 percent at Portland. As discussed next, the plane beds of sand accumulated from shallow, rapidly moving flows during the waning stages of floods.

Flood Deposits

Here and there in the brownstones one can see distinctive sequences of sedimentary structures produced by the rapid waning of flood waters followed by fallout of mud from suspension. The sequences appear as preferred facies transitions in the Markov chain (Fig. 10). The most common sequences at the Buckland and Portland quarries, in order of decreasing abundance, are as follows.

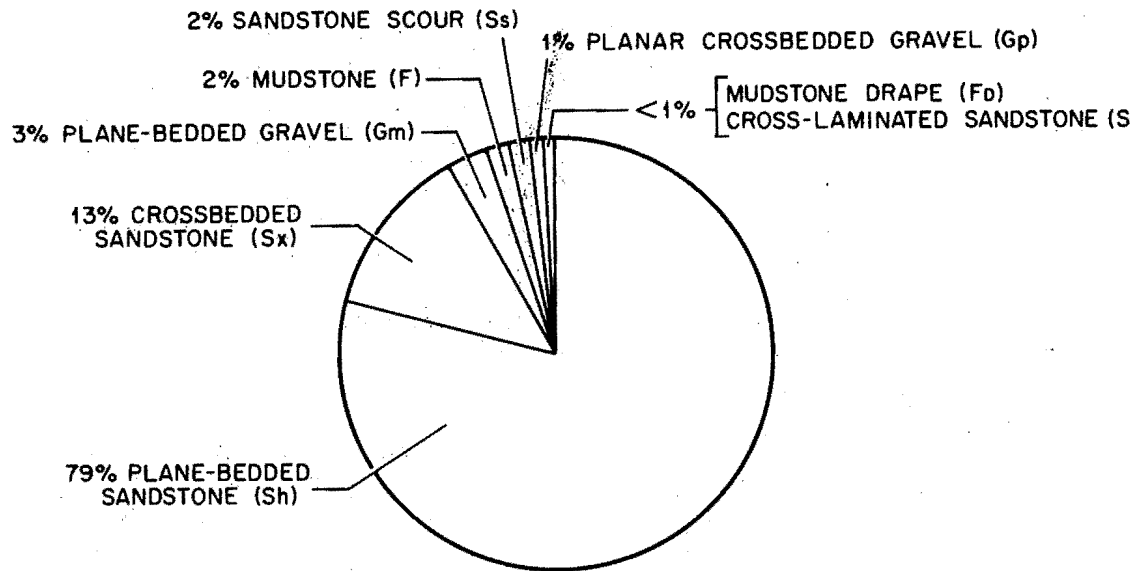

Fig. 10. Average proportions of the sedimentary structures in the combined brownstone sequences at Buckland and Portland (Figs. 6 and 7). The percentages are based on the cumulative thicknesses of the structures and not on the number frequency of occurrence.

1. The majority of the sequences are either plane-bedded sandstone (Sh), sometimes pebbly, + mudstone drape (Fd) or plane-bedded sandstone with thin lenses of mudstone + mudstone drape (Fd). Similar waning-flood sequences of 0.5 to 2 m thickness occur in the Trentishoe Formation of Middle Devonian age in Devon, England (Tunbridge, 1981, p. 84) and in the Lower Carboniferous of northwestern Ireland (Graham, 1981, p. 200). In both formations, a scour surface is overlain by plane-bedded sandstone and then a mudstone drape. Plane-bedded sandstone also dominates the distal alluvial-plain facies of the Lower Paleozoic Piekenier Formation in South Africa (Vos and Tankard, 1981, p. 190). In these three formations, the plane-bedded sandstone and mudstone drapes are attributed to channel floods with rapidly waning flow followed by fallout of mud from suspension.

2. Much less common are plane-bedded sandstone (Sh) + cross-laminated sandstone (Sr).

3. There are a few sequences of plane-bedded gravel (Gm) + plane-bedded sandstone (Sh) + mudstone drape (Fd). The mudstone drape is commonly partly removed by erosion before deposition of the succeeding sand layer.

4. Less common still are crossbedded sandstone (Sx) + plane-bedded sandstone (Sh). A mud lamina that settles from suspension has a low

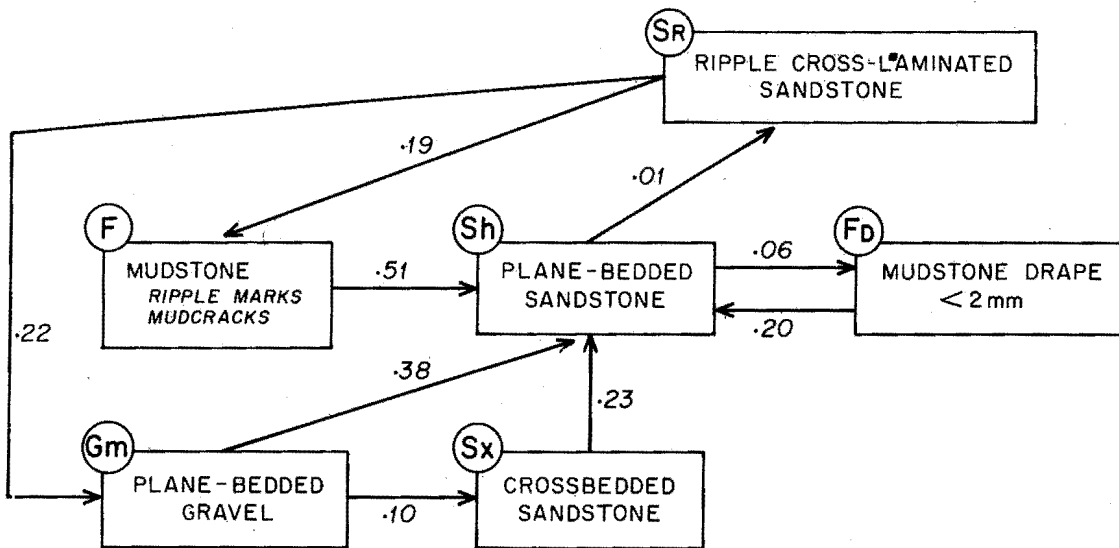

Fig. 11. Markov-chain analysis for the combined brownstone sequences in the Buckland and Portland quarries (Figs. 6 and 7). The probability values are the positive values from the difference matrix constructed by 197 facies transitions.

preservation potential. Although mud drapes do occur on some plane-bedded sandstones, many must be assumed to have been removed by the swirling rush of the succeeding flood.

Many units of plane-bedded sandstone are of nearly uniform color and grain size, suggesting that each accumulated in a single flood. Succeeding units differ slightly in color and grain size.

Some mud laminae within or between units of plane-bedded sandstone may be due to mud settling from suspension during one flood event, which then continued to deposit plane beds of sand (Fig. 13). The cause of these alternations may have been a pulsating supply of sediment due to large-scale eddies in the current. Another possibility is that local areas within a flow experienced temporary lower flow velocities.

One of the floods scoured a sequence of plane-bedded sandstone to produce a scarp 1.3 m high, as seen at the Buckland quarry (Figs. 6, 14). The scarp evidently reflects a shift in the location of the margin of a main channel. The base of the erosion surface is veneered by pebbles, which in turn are overlain by planar crossbed sets and then plane-bedded sandstone. The rarity of mudstone clasts in the brownstones is evidence of non-channelized sheet flow without undercutting and collapse of mud banks along the river.

Much of the time the river beds were dry. Floods of brief duration followed by desiccation are indicated by the waning flood sequences and the presence of mudcracks in some of the mudstone drapes.

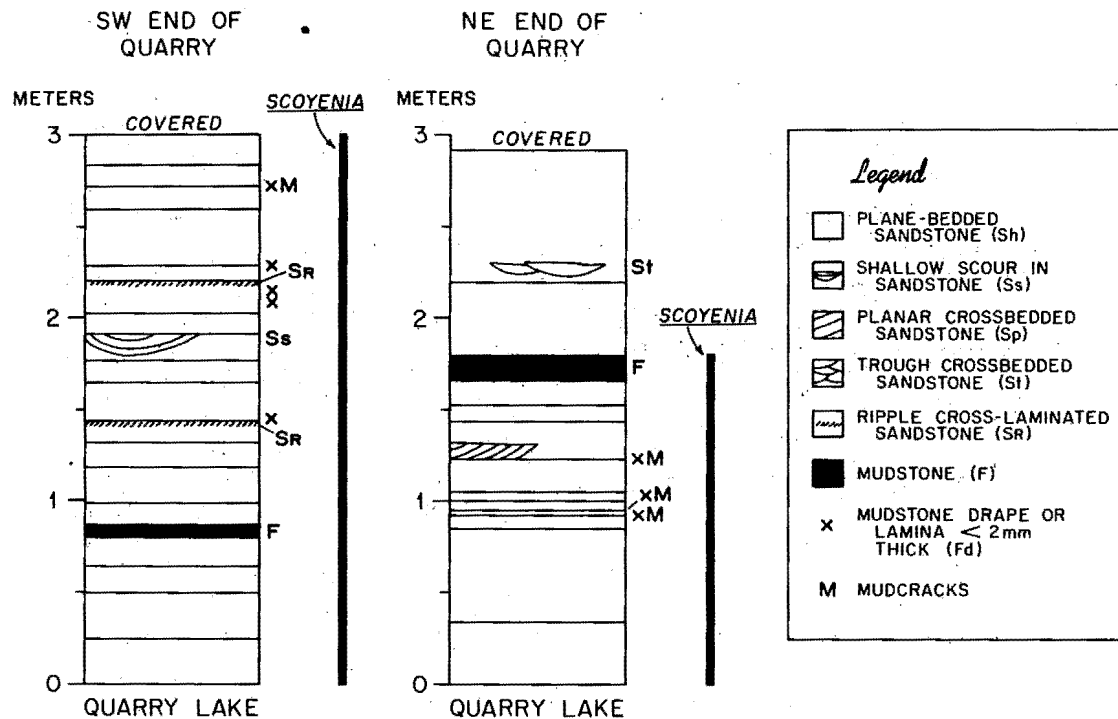

Fig. 12. Measured sections in the brownstone quarry at Redstone Lake in East Longmeadow, Massachusetts.

Bijou Creek in semiarid northeastern Colorado may provide an analog for the depositional processes that produced the brownstones. There, a flood in June, 1965, deposited a layer of sand mostly 60 to 90 cm in thickness with 90 percent plane beds (McKee *et al.*, 1967). This sand layer not only mantled the 2 to 3-m deep channel of Bijou Creek, but extended for about a kilometer out onto the floodplain. Lenses of mud and ripple cross-laminated sand occur in the plane-bedded sand (McKee *et al.*, 1967, p. 839). Superimposed 5 to 10-cm sets of trough crossbedded sand are confined to areas scoured by the flood in the channel. In general, recognition is growing of the importance of high energy, rare floods in depositing thick sedimentation layers of high preservation potential.

That the plane beds of sand in the brownstones formed in shallow, vigorous flows is reflected by several observations. (1) An erosive scour occurs at the base of many units of plane-bedded sandstone. (2) The sand is of relatively coarse grade, mostly medium to very coarse. (3) There is primary current lamination in the plane-bedded sandstone. (4) Pebbles and cobbles of igneous and metamorphic rocks lie as isolated clasts in the laminae of many of the plane-bedded sandstones. Pebbles were not abundantly supplied to the rivers, but the strength of most of the flows was great enough to have swept along and deposited layers of gravel clasts if they had been available.

Most of the nearly horizontal laminae were evidently produced by repetition of a cycle of "burst" and "sweep" within the turbulent boundary layer that separates the fully turbulent main body of the flow from the thin viscous sublayer adjacent to the sand bed (Bridge, 1978, p. 7). Each burst-sweep cycle takes a few seconds and the major bursting events can spread a lamina of sand over a meter or so.

Parallel, nearly horizontal laminae of sand can form by down-river migration of repetitive bed forms of (1) "flat dunes", also known as "low amplitude sand waves", which are a few cm high (Smith, 1971, p. 69), (2) low relief ripples 2 to 8 mm high, and (3) low amplitude waves also 2 to 8 mm high (McBride et al., 1975, p. 136). These mechanisms appear to have been less important in generating the plane beds of the brownstones because (1) pebbles and cobbles are present in some laminae, (2) cross-laminae are rare in the thicker laminae, and (3) ripples and crossbed sets occur only occasionally within the units of plane-bedded sandstone.

LIFE ALONG THE EARLY JURASSIC RIVERS

The Buckland quarry has been the most productive locality for dinosaur bones in the Connecticut Valley (Buckley, 1973, p. 7; Galton, 1976, p. 3). From 1884 to 1890, three well preserved skeletons of prosauropod dinosaurs were found here in the sandstones, namely two of Ammosaurus major and one of Anchisaurus polyzelus. Two fragmentary specimens also have been collected in the quarry. Prosauropod dinosaurs are widely known from several formations of Late Triassic age and Lower Jurassic age.

The first skeleton, Ammosaurus major Marsh, was discovered during quarrying operations in October 1884. Mr. Wolcott, owner of the quarry, set the fossil aside and sent word to Professor Othniel Charles Marsh of Yale University, who arranged for its purchase. Unfortunately, he found that the skull and fore quarters had been shipped from the quarry in a sandstone ("redstone") block destined for use in bridge construction. In 1967, John Ostrom of Yale University learned that a new highway, including bridges, was to be built through Manchester and he renewed the search for the missing bones. For years, some residents of Manchester had thought that possibly the bridge was the 12-m span of redstone over Hop Brook at Bridge Street in south Manchester (Spiess and Bidwell, 1924, p. 2). Ostrom surveyed more than 60 redstone bridges and was able to confirm that this was the bridge. In the summer of 1969, 85 years after its construction, the bridge was demolished. Ostrom's team hosed and cleaned more than 300 likely blocks and were rewarded with the missing half of the right femur in an abutment block of redstone weighing some 250 kg. The other bones remain unlocated, waiting for a future treasure hunt. A second abutment block contained several dinosaur bones not assignable to a specific genus (Time magazine, November 7, 1969, p. 53; Buckley, 1973, p. 7-8; Galton, 1976, p. 5).

Ammosaurus and Anchisaurus were herbivorous dinosaurs. Both were small, some 1.3 to 2 m in length, and lightly built, as illustrated in reconstructions (Lull, 1953, p. 119; Galton, 1976, p. 9). In his summary of their

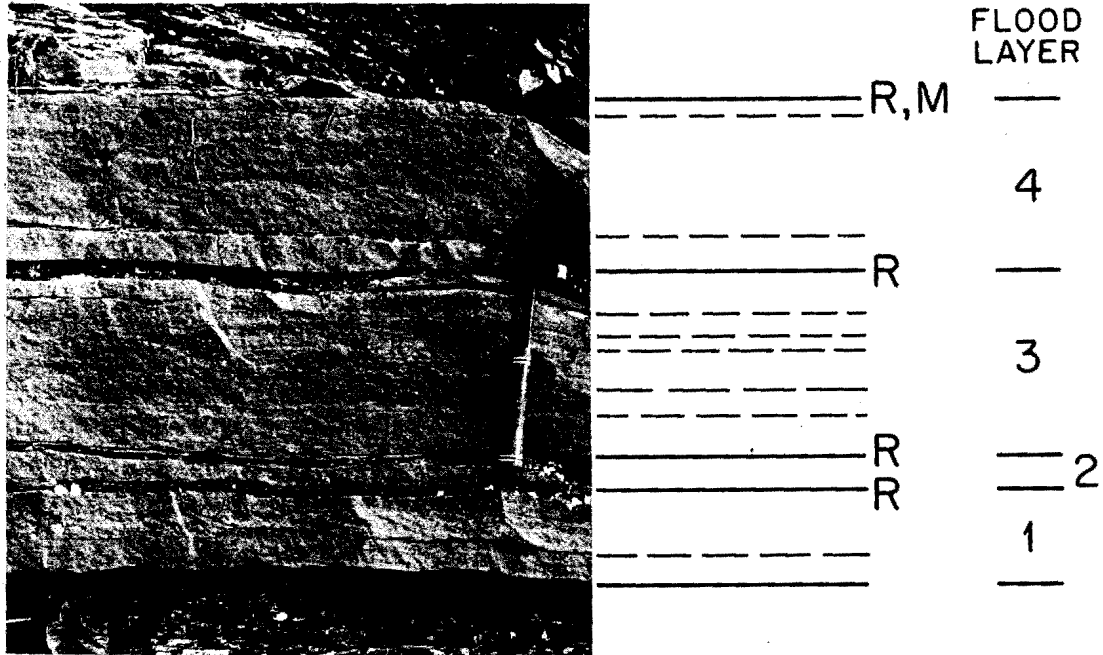

Fig. 13. Four sequences of sandstone and mudstone interpreted as four flood events (numbers 1 to 4) in a brownstone quarry at Portland. Sequence three has 5 laminae of mudstone (dashed lines) that were deposited during the flood. Each of the four flood events is mainly recorded by plane-bedded sandstone units and each flood event ends with ripple cross-laminated mudstone (letter R). The desiccation mudcracks (letter M) at the top of the fourth flood sequence show that the surface dried out after the flood. The thicker mudstones below the first and above the fourth sequence reflect overbank sedimentation, presumably during a number of floods.

biology, Galton (1976, p. 89-91) noted that Ammosaurus and Anchisaurus mostly travelled by quadrupedal locomotion, but could easily assume a bipedal stance, for example when necessary for defense. These dinosaurs lacked cheeks and self-sharpening teeth (tooth-to tooth occlusion) so that they chewed plant material inefficiently, especially coarse, tough fibers. Perhaps this is why they and the other prosauropods became extinct in the Jurassic and were replaced by the diverse and more efficient other kinds of dinosaurs (Galton, 1976, p. 90).

In 1897, Hine's quarry at East Longmeadow yielded a calcite-filled cast in brownstone of most of the skeleton of the crocodile Stegomosuchus longipes, reconstructed by Olsen (1980, p. 46, 49) to have been about 28 cm long.

Several taxa of reptile footprints, including dinosaurs, were encountered during quarrying of brownstones at Portland, Buckland, and East Longmeadow. Paul Olsen (personal communication) notes that the following forms were found

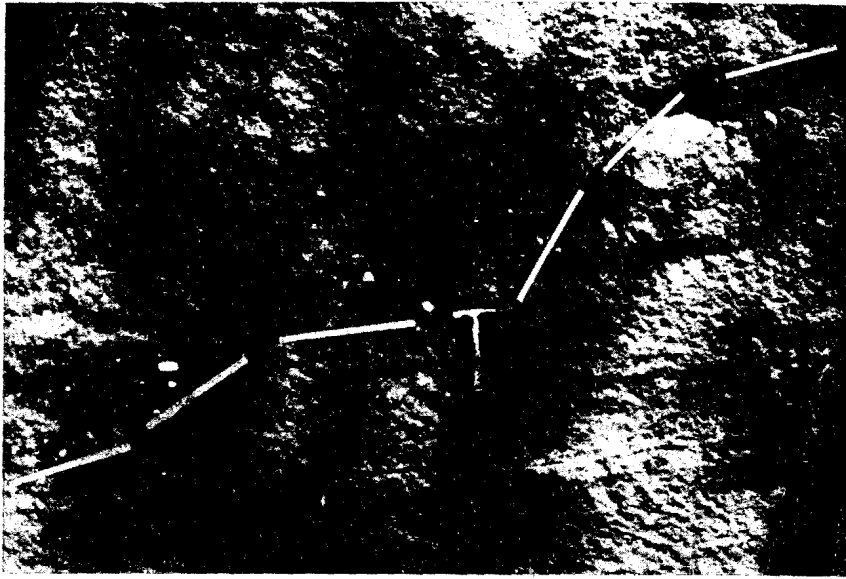

Fig. 14. Channel-margin scarp cut into plane-bedded sandstone between 3.2 and 4.5 m in the measured section at the Buckland quarry (Fig. 6).

at the Portland quarries; (1) small to large Grallator-type footprints (equals Grallator, Anchisauripus, and Eubrontes) made by carnivorous therotod dinosuars; (2) small tracks of the crocodiliomorph Batrachopus, of which one of the makers might be Stegomosuchus; (3) Anomoepus-type footprints made by herbivorous ornithischian dinosaurs, and (4) the large prints of the crocodiliomorph Otozoum.

Plants grew along the banks of the sand rivers and on the islands in the braided channels. Numerous casts of tree logs up to 30 cm in diameter and more than a meter long were found at the Portland quarries (Ward, 1900, p. 226; Rice and Foye, 1927, p. 61-62). There are fragments up to 45 cm in length of the tall horsetail Equisetites at Redstone Lake quarry in East Longmeadow.

Much of the time the water table was just below the sandy bed of the rivers, as evidenced by Scoyenia burrows that penetrate through the sand and mud (Figs. 6, 7, 12). These tubes are about 1 cm in diameter and comprise tunnel networks. In the Upper Triassic red mudstones of the Durham Basin of North Carolina, Scoyenia burrows are associated with the freshwater crayfish Clytiopsis sp., implying that these crayfish constructed the burrows (Olsen, 1977, p. 60). Scoyenia was evidently adapted to live in sand and mud flats saturated with water most of the time (William Baird, personal communication). The life cycle of crayfish requires that eggs be laid in water, but the burrows could have been filled with air during a prolonged drought or seasonally in a semiarid climate.

VOLUME PERCENT COMPOSITION OF 23 SANDSTONES

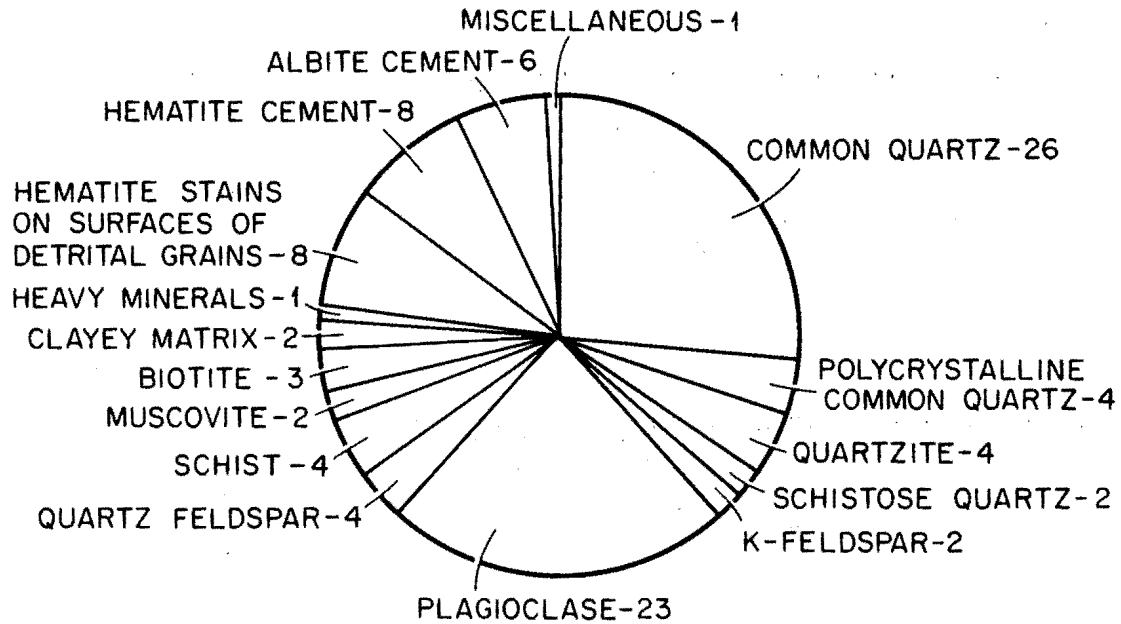

Fig. 15. Average composition of 23 brownstone samples.

PETROLOGY OF THE BROWNSTONES

Composition of the Sandstones

The petrographic composition of 23 sandstones was measured by point-count modal analysis. Each thin section was stained with sodium cobaltinitrite to differentiate K-feldspar from plagioclase and Alizarin red-S and potassium ferricyanide to distinguish carbonate minerals. Two hundred points were counted per thin section to determine the volumetric proportions of the petrographic components (Fig. 15). The detrital framework grains were then recalculated to 100 percent, omitting authigenic cements and clayey matrix less than 30 μm (Fig. 16).

When plotted on a classification triangle (Folk, 1968, p. 124), the brownstones are arkoses and lithic arkoses (Fig. 17). The sands were transported by rivers that flowed westward from the fault-bounded highlands on the east side of the valley (Fig. 4). The rocks exposed in the highlands were high-grade schists and feldspathic gneisses of Precambrian to Middle Paleozoic age with some granitic intrusives. The importance of metamorphic rocks is shown by the combined 20 percent of quartzite, schist, mica, and schistose quartz in the framework grains (Fig. 16). Feldspar comprises 34 percent of the framework grains, of which 92 percent is plagioclase, entirely albite to calcic oligoclase.

M1-21

VOLUME PERCENT COMPOSITION OF 23 SANDSTONES FRAMEWORK GRAINS

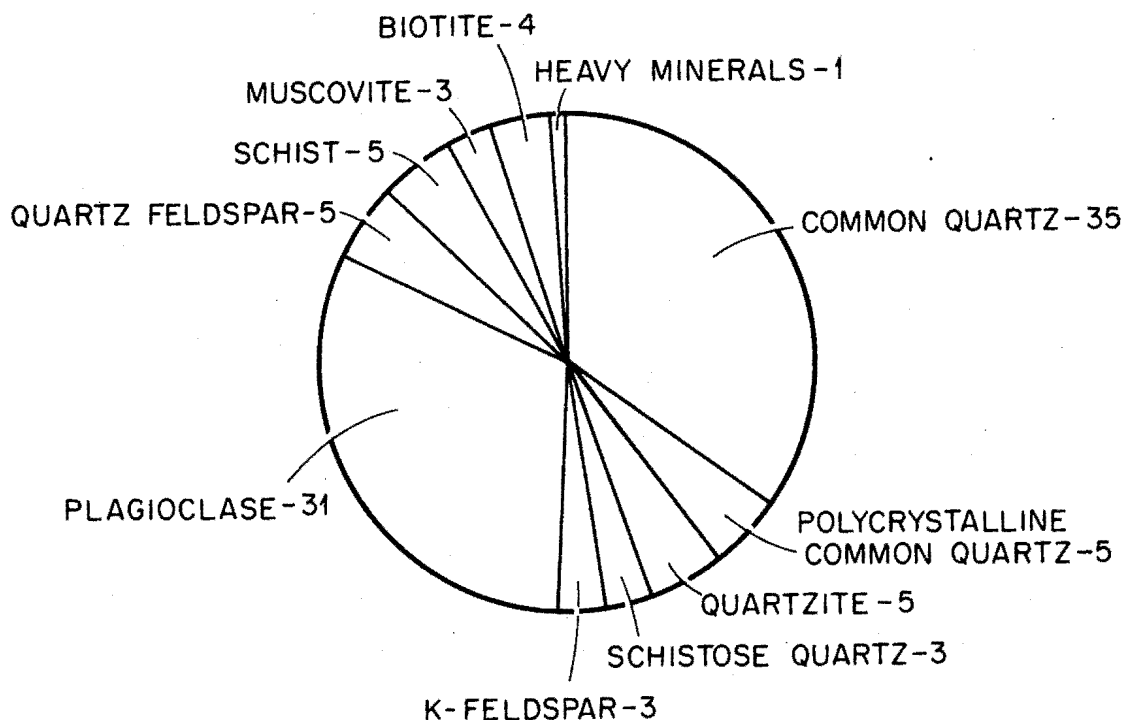

Fig. 16. Average composition of the framework grains of 23 brownstone samples.

The toughness and durability of the brownstones so useful in a building stone are provided by albite cement, which is abundant in every sample and averages 6 percent by volume (Fig. 15). The albite occurs as overgrowths on detrital plagioclase grains and as intergranular mosaics of crystals, some of which are idiomorphic (Figs. 18, 19; Heald, 1956, p. 1156). A few sandstones also contain from a trace to 3 percent of quartz overgrowths.

Albite was precipitated from groundwater enriched in sodium due to slow intrastratal solution of the detrital albite-oligoclase grains, which comprise 31 percent of the framework grains. The evidence consists of the pitting of the surfaces of many plagioclase grains. Furthermore, the interiors of almost all of the plagioclase grains are altered to clay, vacuoles, and minute bubbles, especially along the cleavages. The albite overgrowths and cement are not altered. Fresh plagioclase grains are rare, which is the opposite of what one expects in sand transported a few kilometers from rugged highlands east of the border fault. Albite cement is rare in terrestrial sandstones of all geologic ages because of the absence of marine pore water to provide sodium.

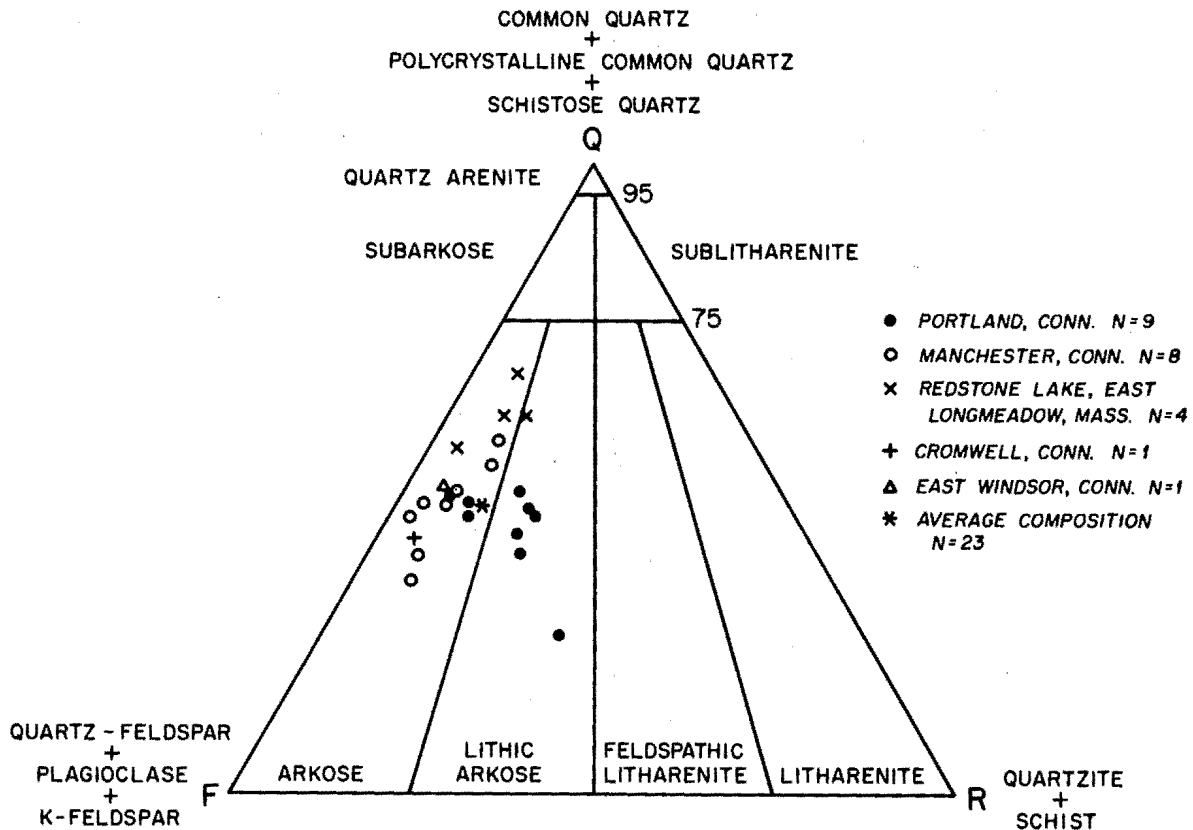

Fig. 17. Petrographic classification (Folk, 1968) of 23 brownstone samples.

Color of the Building Stone

Brownstone has always been the popular name of the sandstone form the Mesozoic quarries of the Connecticut Valley (Fig. 1). In the quarrying and architectural trades, however, a distinction is made between brownstone and redstone. The Portland quarry produced typical brownstone, whereas the Buckland quarry in Manchester and Redstone Lake quarry in East Longmeadow yielded redstone.

The color of the dry, rough-cut surface of the brownstones averages pale red (10R 6/2) on the Munsell Color Chart. The Buckland redstone is also pale red (5R 6/2) with some laminae of grayish pink (5R 8/2). At East Longmeadow, the redstones are pale reddish brown (10R 5/4) with some beds grayish red (10R 4/2).

The letter R indicates that the sandstone is of red hue; 5R is the middle of the red hue and as the numbers increase to 10R there is more yellow and less red. The redstones have more red and less yellow than the brownstones. The value ("lightness") is shown by the number above the

M1-23



Fig. 18. Buckland brownstone with albite (A) cement that fills former interstitial pore. Mechanically trapped silt and clay float in the albite cement. Hematite (H) rims the detrital grains, including altered detrital plagioclase (P). The biotite flake (B) is almost completely altered to hematite.

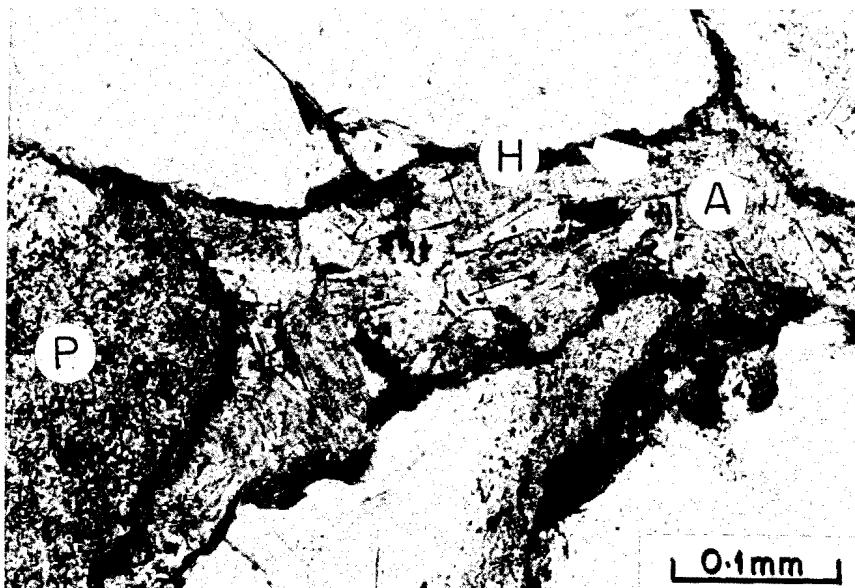

Fig. 19. Cement of albite (A), in part as crystals, fills former pore space in Buckland brownstone. The albite contains abundant dust inclusions. Hematite (H) stains occur on the detrital grains, including an altered plagioclase (P). "Late" authigenic hematite (arrow) stains some of the albite crystals.

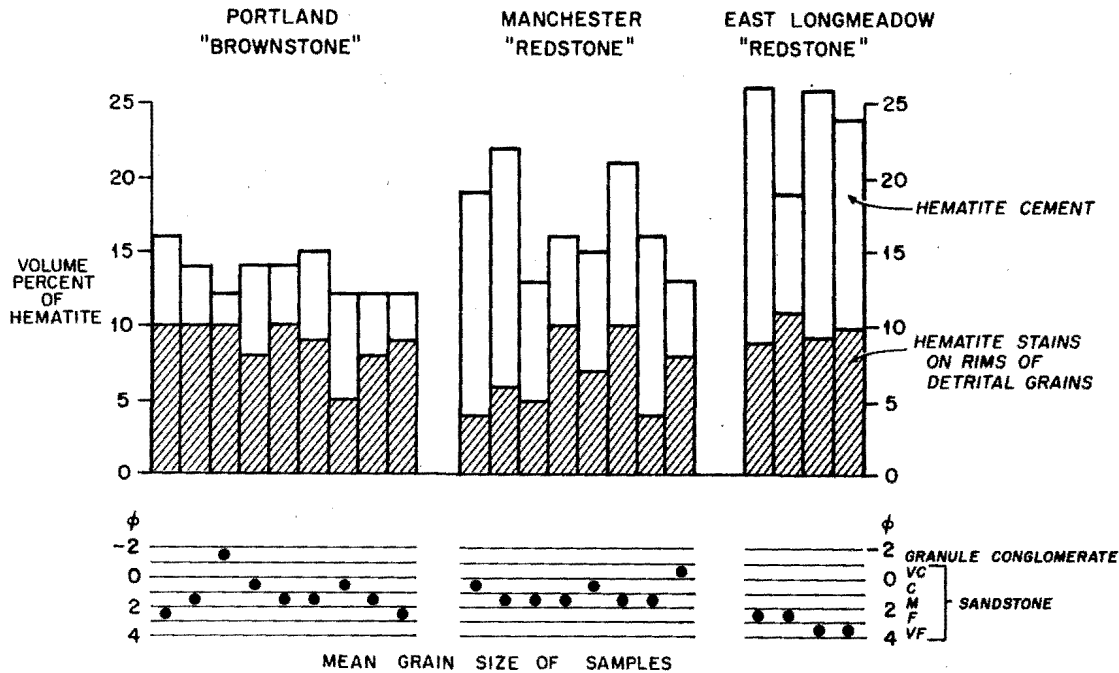

Fig. 20. Proportions of "late" authigenic hematite and hematite stains on rims of grains in modal analyses of 23 brownstone samples. The mean grain size of each brownstone is shown along the bottom of the diagram.

" / ", with 5 the middle of the 0 to 10 scale from black to white. The sandstones are of about average value. The chroma is shown by the number below the " / ", which increases from 0 to 20 as the "strength" intensifies. The building stones are consistently of low chroma.

Origin of the Hematite Pigment

The hematite pigment that colors the redbeds of the Portland Formation was generated after deposition in two ways. The first depends on the fact that the surfaces of detrital grains in almost every climate are stained brown or yellow brown by hydrated iron oxides, collectively called limonite. These soil-generated limonite stains convert to hematite by aging and dehydration over some tens of thousands of years in oxidizing, alkaline pore waters. This process is universal in redbeds (Van Houten, 1961, p. 112). In the 23 sandstones from quarries in the Portland Formation, hematite surface stains on detrital grains average 8 percent by volume (Fig. 15).

The second process is that sandstones can become progressively reddened with hematite pigment over tens of millions of years by post-depositional dissolution of Fe-silicate grains, notably biotite, amphibole, pyroxene, and epidote (Walker, 1967). This mechanism generated about 3 volume-percent

hematite cement in the red sandstones of the East Berlin Formation of central Connecticut (Hubert and Reed, 1978, p. 182). Hematite cement comprises 8 percent in the 23 sandstones of the Portland Formation and commonly coats the earlier albite cement (Fig. 19). An important source of the iron in the hematite cement was detrital biotite, which averages 4 percent of the framework grains; many biotite flakes are heavily altered to hematite. Quartzose biotite schists are also abundant.

The reason for the contrast between the redstones of the Buckland and East Longmeadow quarries and the brownstones of the Portland quarry is the greater amount of "late" hematite cement in the redstones, specifically 10 percent at Buckland and 14 percent at East Longmeadow, contrasted with 4 percent at Portland (Fig. 20). The average proportions of hematite surface stains dehydrated from limonite is about the same in redstones and brownstones, namely 7 percent at Buckland, 10 percent at East Longmeadow, and 9 percent at Portland. The redstones thus have more total hematite pigment, namely 17 percent at Buckland and 24 percent at East Longmeadow compared to 13 percent for the brownstones at Portland.

The greater amount of "late" hematite cement in the redstones compared to brownstones is not due to a finer grain size of the redstones with increased surface area for hematite stains. The 23 samples of redstone and brownstone are similar in average grain size, varying from very fine sandstone to granule conglomerate (Fig. 20). Seventeen of the samples are of fine, medium, or coarse sandstones, a group which includes both redstones and brownstones.

ACKNOWLEDGMENTS

Stimulating discussions with Bruce Cornet, Paul Olsen, Sidney Quarrier, Peter Robinson, and Donald Wise helped clarify our concepts of the sedimentology of the brownstones and the stratigraphy and tectonic history of the Hartford Basin. John Bridge, Joseph Hartshorn, Paul Olsen, and Sidney Quarrier critically read the manuscript and made helpful suggestions for its improvement. Sidney Quarrier of the Department of Environmental Protection of the State of Connecticut generously shared his unpublished results on the stratigraphy of the Portland Formation. The line drawings were drafted by Marie Litterer, Scientific Illustrator of the Department of Geology/Geography, University of Massachusetts. The research was supported in part by the Division of Earth Science, U.S. National Science Foundation, NSF Grant EAR 76-02741.

REFERENCES CITED

- Allbee, B. H., 1894, The famous Connecticut brownstone: Stone, v. 9. p. 1-31.
- Asher, J.R. and Adams, G.H., 1896, New Columbian railroad atlas and pictorial album of American industry: Asher and Adams, New York, N.Y.

- Bridge, J. S., 1978, Origin of horizontal lamination under turbulent boundary layers: *Sedimentary Geol.*, v. 20, p. 1-16.
- Buckley, W. E., 1973, *A New England Pattern: The History of Manchester, Connecticut*: Pequot Press, Chester, Conn. 348 p.
- Champlin, W. S., 1944, The history of the town of East Longmeadow written to commemorate the town's fiftieth anniversary 1894-1944: *Town of East Longmeadow, Massachusetts*, 126 p.
- Colton, R. B., 1965, Geologic map of the Manchester quadrangle, Connecticut; U. S. Geol. Surv. Geol. Quad. Map GQ-433.
- Cornet, Bruce, 1977, Palynostratigraphy and age of the Newark Supergroup: Ph.D. Diss., Dept. Geosci., Penn. State Univ., University Park, Penn., 505 p.
- Folk, R. L., 1968, *Petrology of Sedimentary Rocks*: Austin, Texas, Hemphill Pub. Co., 182 p.
- Galton, P. M., 1976, Prosauropod dinosaurs (reptilia: saurischia) of North America: Postilla, Peabody Museum of Yale Univ. number 169, 98 p.
- Gilchrist, J. M., 1979, Sedimentology of the Lower to Middle Jurassic Portland Arkose of Central Connecticut: M. S. thesis, Dept. Geol/Geog., Univ. of Mass., Amherst, Mass., 166 p.
- Graham, J. R., 1981, Fluvial sedimentation in the Lower Carboniferous of Clew Bay, County Mayo, Ireland: *Sedimentary Geol.*, v. 30 p. 195-230.
- Heald, M. T., 1956, Cementation of Triassic arkoses in Connecticut and Massachusetts: *Bull. Geol. Soc. Amer.*, v. 67, p. 1133-1154.
- Hubert, J. F., 1978, Paleosol caliche in the New Haven Arkose, Newark Group, Connecticut Valley: *Palaeogeography, Palaeoclimatology, Palaeoecology*, v. 23, p. 151-168.
- Hubert, J. F. and Reed, A. A., 1978, Red-bed diagenesis in the East Berlin Formation, Newark Group, Connecticut Valley: *Jour. Sedimentary Petrol.*, v. 48, p. 175-184.
- Hubert, J. F., Reed, A. A., Dowdall, W. L., and Gilchrist, J. M., 1978, *Guide to the Mesozoic Redbeds of Central Connecticut*: State Geol. and Natural History Survey of Conn., Guidebook No. 4, 129 p.
- Lull, R. S., 1953, Triassic life of the Connecticut Valley: *State Geol. and Natural History Survey of Conn.*, Bull. 81, 336 p.
- McBride, E. F., Shepherd, R. G., and Crawley, R. A., 1975, Origin of

- parallel, near-horizontal laminae by migration of bed forms in a small flume: *Jour. Sedimentary Petrol.*, v. 45, p. 132-139.
- McKee, E. D., Crosby, E. J., and Berryhill, H. L., 1967, Flood deposits, Bijou Creek, Colorado, June, 1965: *Jour. Sedimentary Petrol.*, v. 37, p. 839-851.
- Miall, A. D., 1973, Markov chain applied to an ancient alluvial plain succession: *Sedimentology*, v. 20, p. 347-364.
- Olsen, P. E., 1980, A comparison of the vertebrate assemblages from the Newark and Hartford basins (early Mesozoic, Newark Supergroup) of eastern North America: in *Aspects of Vertebrate History: Essays in Honor of Edwin Harris Colbert* (Ed. by L. L. Jacobs): Museum of Northern Arizona Press, Flagstaff, p. 35-53.
- Olsen, P. E., 1977, Stop 11, The Triangle Brick Quarry: in *Field Guide to the Geology of the Durham Triassic Basin* (Ed. by G. L. Bain and B. W. Harvey): North Carolina Dept. Natural and Economic Resources, Raleigh, p. 59-60.
- Rice, W. N. and Foye, W. G., 1927, Guide to the Geology of Middletown, Connecticut, and vicinity: State Geological and Natural History Survey of Conn., Bull. 41, 137 p.
- Smith, Charles, 1982, Bibliography of mines and quarries of Connecticut: open-file report to the State Geological and Natural History Survey of Conn., Hartford, 26 p.
- Smith, N. D., 1971, Pseudo-planar stratification produced by very low amplitude sand waves: *Jour. Sedimentary Petrol.*, v. 41, p. 69-73.
- Spiess, Mathias and Bidwell, P. W., 1924, History of Manchester, Connecticut: Centennial Committee of the Town of Manchester, Conn.: 306 p.
- Tunbridge, I. P., 1981, Sandy high-energy flood sedimentation--some criteria for recognition, with an example from the Devonian of S. W. England: *Sedimentary Geol.*, v. 28, p. 79-96.
- Van Houten, F. B., 1977, Triassic-Liassic deposits of Morocco and eastern North America: comparison: *Am. Assoc. Petrol. Geol. Bull.*, v. 61, p. 79-99.
- Van Houten, F. B., 1961, Climatic significance of red beds: in Nairn, A. E. M., ed., *Descriptive Palaeoclimatology*: Interscience, N. Y., p. 89-139.
- Vos R. G., and Tankard, A. J., 1981, Braided fluvial sedimentation in the lower Paleozoic Cape Basin, South Africa: *Sedimentary Geol.* v. 29, p. 171-194.

Walker, T. R., 1967, Formation of red beds in modern and ancient deserts: Geol. Soc. Am. Bull., v. 78, p. 352-368.

Ward, L. F., 1900, Status of the Mesozoic floras of the United States: first paper: the older Mesozoic: U. S. Geol. Surv. 20th Annual Report, Pt. II, p. 211-430.

ROAD LOG

The road log starts at stop 1, continues through to the last stop (stop 8), and then returns to stop 1, forming a complete cycle. The user may start a trip at any stop and return to it using the log.

MILES

0.0	0.0	<u>STOP 1.</u> PORTLAND FORMATION, DURHAM.
		Park at two-story yellow house inside the Y-junction of routes 17 and 77 in Durham, Connecticut. At the Y-junction, walk east across the road and plunge into the woods. The 13-m rock ledge is about 30 m east of the road.
		Leave the parking area on the west side and turn left (south) on route 17.
4.1	4.1	The ridge on the right is the Holyoke Basalt.
7.8	3.7	Turn right on route 22.
8.1	0.3	Junction with route 150. Take left fork, following route 22.
11.5	3.4	Turn right on route 5.
12.3	0.8	Proceed through underpass; turn left onto I-91 and go south.
14.2	1.9	Leave I-91 at Exit 10 (route 40; Mt. Carmel, Hamden).
16.3	2.1	<u>STOP 2.</u> NEW HAVEN ARKOSE, NORTH HAVEN.
		Stop in breakdown lane of route 40. The illustrations for stop 2 refer to the north side of the roadcut. Proceed west on route 40.
17.1	0.8	Turn left (south) on route 10.

- 17.3 0.2 Turn around in parking lot of Our Lady of Mt. Carmel Church on left side of street and proceed north on route 10.
- 17.5 0.2 Turn right on route 40.
- 19.9 2.4 Take I-91 toward Hartford. As you enter I-91, the intrusive basalt of Sleeping Giant is ahead on the left. His head is on the west and feet on the east.
- 23.1 3.2 The roadcut on the right is New Haven Arkose with caliche horizons.
- 25.1 2.0 The roadcuts on both sides of I-91 are New Haven Arkose with caliche horizons.
- 27.1 2.0 New Haven Arkose on both sides of I-91.
- 30.2 3.1 New Haven Arkose along the center strip of I-91.
- 30.5 0.3 On the left are the Hanging Hills of Meriden (Holyoke Basalt). The TV installations are on West Peak.
- 31.4 0.9 The cliffs on the right are Holyoke Basalt.
- 32.4 1.0 Take exit 17 to the right following the sign to "route 66 west."
- 33.1 0.7 Take left fork toward route 66 west.
- 34.4 1.3 Go right toward route 66 west.
- 34.7 0.3 Junction with route 66 west.
- 35.2 0.5 New Haven Arkose on right in roadcut.
- 35.6 0.4 Leave route 66 at exit 6. Stop 3 is behind the G. Fox store seen on the north side of route 66.
- 35.9 0.3 Turn left into Meriden Square.
- 36.0 0.1 Turn left and drive around the perimeter of the parking lot to behind the G. Fox store, which is at the left end of the shopping center.
- 36.4 0.4 STOP 3. TALCOTT BASALT, MERIDEN.
- The outcrop is directly behind the G. Fox store. Proceed to northwest corner of parking lot.
- Turn left at stop sign and go up the hill. Holyoke Basalt is on the skyline.

- 36.9 0.5 Turn right at traffic lights on route 71 (Capitol Avenue).
- 37.3 0.4 Holyoke Basalt is on the right and also ahead on left at bend in road.
- 39.9 2.6 Go left on Butler Street (note that there is no street sign at this end of Butler Street).
- 40.1 0.2 Turn left on Park Drive.
- 41.0 0.9 Cross first bridge; turn right and proceed over second bridge onto Percival Park Road. Drive carefully because this road is very narrow. You are passing the north end of Merimere Reservoir.
- 41.6 0.6 You are driving up the dip slope of the Holyoke Basalt.
- 42.4 0.8 Turn left on road to East Peak. The right fork leads to West Peak.
- 42.8 0.4 STOP 4. EAST PEAK OF THE HANGING HILLS OF MERIDEN.
Park in parking lot and ascend to top of stone tower. Leave parking lot by exit adjacent to stone tower in order to follow one-way loop. Return down Percival Park Road.
- 43.3 0.5 Drive past road on left that goes to West Peak.
- 44.5 1.2 Go past end of Merimere Reservoir.
- 44.7 0.2 Cross bridge and turn right on Reservoir Avenue.
- 45.1 0.4 Holyoke Basalt forms cliffs across lake on right.
- 45.5 0.4 View of stone tower on right.
- 46.0 0.5 Go through underpass below route 66. Turn right at second road into parking lot of Hubbard Park, Meriden.
- LUNCH STOP
Leave parking lot by turning left on unnamed park road. Drive past Mirror Lake on the right.
- 46.8 0.8 Turn right at traffic lights on west Main Street.
- 47.5 0.7 Sign for junction with route 66.
- 47.7 0.2 Cross bridge and immediately past traffic lights turn left and park on unfinished access road.

STOP 5. NEW HAVEN ARKOSE ALONG ROUTE 66, MERIDEN.

Proceed west on route 66, following sign to I-84.

- 50.1 2.4 Turn right at traffic lights on road leading to route 10.
- 50.2 0.1 Turn right on route 10.
- 50.8 0.6 Turn left on access road to I-84 and go east on I-84.
- 52.6 1.8 Hills on left are Lower Paleozoic crystalline rocks west of the Mesozoic redbeds.
- 54.1 1.5 New Haven Arkose with caliche horizons adjacent to and under bridge.
- 55.8 1.7 New Haven Arkose on both sides of I-84.
- 57.1 1.3 TV towers on Holyoke Basalt seen to the north.
- 57.4 0.3 Leave I-84 at Exit 34 leading to route 66 west.
- 57.6 0.2 Turn left at stop sign. Holyoke Basalt to right on skyline.
- 58.1 0.5 Turn right on route 72. Go past Getty Gas station and park on south side of road in pull-off just before entrance sign to Holiday Inn.

STOP 6. SHUTTLE MEADOW FORMATION, PLAINVILLE.

The quarry is on the north side of the road. Please do not climb the rock faces. This is a working quarry and the blocks are loose. Do not examine rock face behind the Getty Gas station because the owner does not allow visitors and has two guard dogs. The Tomasso trap rock quarry in the Holyoke Basalt is on the south side of I-84. Proceed east on route 72.

- 59.7 1.6 Turn right to follow route 72 at the Texaco station. Go over the bridge and continue on route 72 east.
- 64.8 5.1 Bridge over routes 5/15.
- 64.9 0.1 Roadcuts with the type section of the East Berlin Formation (Lehmann, 1959, p. 16-21). The measured section (section 1 on Fig. 35) shows symmetrical lake cycles and river-channel sandstone and red mudstone. The contact with the overlying Hampden Basalt is especially well exposed. The measured section of the 33 m of exposed basalt details 8 lava flows (Chapman, 1965, Fig. 12). Watch out for high-speed cars - this is a major east-west road.

- 68.2 3.3 Underpass beneath I-91 with Hampden Basalt on left.
- 68.8 0.6 Turn left at traffic lights on Coles Road (route 217).
- 69:5 0.7 Turn left on North Road. Just ahead is underpass beneath I-91.
- 70.3 0.8 Junction with Pasco Hill Road. Drive straight ahead on road marked "dead end".
- 70.9 0.6 Turn around at dead end of road.
- 71.2 0.3 Park on right just before bridge over brook. Trail to stop 7 begins on left (east) side of road about 10 m beyond (south) of bridge. Follow trail to large roadcuts in unfinished access lanes to I-91.

STOP 7. EAST BERLIN FORMATION, CROMWELL.

Proceed south again on "dead end" road.

- 71.3 0.1 Red sandstone and mudstone in the East Berlin Formation on left.
- 71.6 0.3 Junction with Pasco Hill Road. Proceed directly ahead on North Road.
- 72.4 0.8 Turn right on Coles Road.
- 73.0 0.6 Turn right at traffic lights onto route 72 west.
- 73.4 0.4 Turn right onto entrance ramp to I-91 north. On the right is the Hampton Basalt.
- 76.5 3.1 On the right you are passing Exit 23, which leads to West Street (go east) and the Dinosaur State Park.
- 77.0 0.5 Outcrop of Hampton Basalt on right.
- 77.2 0.2 Redbeds of the Portland Formation on right.
- 77.6 0.4 Fluvial channel sandstone and red mudstone of the East Berlin Formation.
- 84.7 7.1 Move over to right hand lane and turn right onto I-84.
- 85.4 0.7 Stay in right hand lane.
- 85.7 0.3 Take Exit 30 for I-84 east.

- 88.9 3.2 I-84 ends and I-86 continues.
- 90.5 1.6 Straight ahead are hills of Paleozoic metamorphic rocks east of the border fault of the Connecticut Valley.
- 91.4 0.9 On left are pebbly sandstone and sandstone of the Portland Formation.
- 92.4 1.0 Leave I-86 by Exit 93.
- 92.5 0.1 Turn left at stop light across the street from McDonalds.
- 92.6 0.1 At traffic light turn sharp right onto Windsor Street. You are passing the J. C. Penney Catalog Distribution Center on the left. Note the entrance ramp to I-86 west on the right.
- 93.2 0.6 At the red tobacco barn turn right onto Pleasant Valley Road.
- 94.0 0.8 STOP 8. BUCKLAND BROWNSTONE QUARRY IN THE PORTLAND FORMATION, MANCHESTER.
- Park at intersection of Buckland Street and Pleasant Valley Road. The quarry is hidden in the woods east of Buckland Street. An historical marker for the quarry is located on Buckland Street about opposite to the south end of the quarry. To reach the quarry walk into the woods east of Buckland Street about 15 m northeast of the intersection of Buckland Street and Pleasant Valley Road.
- Be careful crossing Buckland Street. It is a high speed road.
- Do not climb the quarry walls.
- Note the lush growth of poison ivy!
- To leave stop 8, drive west on Pleasant Valley Road.
- 94.2 0.2 Turn left (south) onto Windsor Street. The sign for Windsor Street is hidden behind red tobacco barn number 25. You will pass the J. C. Penney Catalog Distribution Center on the right.
- 94.8 0.6 Turn left into the entrance to Exit 93 and proceed west on I-86.
- 95.9 1.1 Fluvial red sandstone and pebbly sandstone of the Portland Formation on the right.

- 96.2 0.3 On the right you are passing red sandstones of the Portland Formation along the ramp for Exit 92. Incipient caliche paleosols can be examined along the north side of the exit ramp (Gilchrist, 1979, p. 151).
- 98.5 2.3 I-86 ends and I-84 begins.
- 99.7 1.2 Continue straight ahead on I-84.
- 100.1 0.4 Move to left lane to be ready to go south on I-91.
- 100.8 0.7 Take Exit 54 towards I-91 south.
- 101.4 0.6 Move to right lane to be ready to take Exit 1 leading to I-91.
- 101.6 0.2 Take Exit 1 and proceed south on I-91.
- 103.3 1.7 On the right is the Hampton Basalt.
- 104.0 0.7 On the right are fluvial channel sandstone and mudstone of the East Berlin Formation.
- 104.2 0.2 On the left is the Hampton Basalt.
- 104.5 0.3 Move to the left lane in preparation for left turn onto route 9 at Exit 22-S.
- 105.6 1.1 At Exit 22-S turn left onto divided route 9.
- 107.2 1.6 The hills on the horizon directly ahead are Paleozoic metamorphic rocks east of the border fault of the Connecticut Valley.
- 111.9 4.7 Turn right onto route 17.
- 112.4 0.5 Proceed around the traffic circle and continue south on route 17.
- 113.2 0.8 Sandstone of the Portland Formation on the right.
- 114.6 1.4 Durham Historical District with lovely old homes.
- 115.8 1.2 Take the right fork and continue on route 17. Escarpment on left follows the Mesozoic border fault that separates Paleozoic metamorphic rocks on the east from the Portland Formation on the west.
- 116.0 0.2 Turn left onto route 77.

116. 1 0.1 STOP 1. PORTLAND FORMATION, DURHAM.

End of field trip.

DISCUSSION OF PLAYA-PLAYA LAKE-OLIGOMICTIC LAKE SYSTEM

Introduction

Since publication of our guidebook in 1978, great progress has been made in a process-products model for the stratigraphic sequences and primary sedimentary structures formed on playas in semiarid to arid rift valleys (Hardie *et al.*, 1978). Also now well understood is the evolution of playa brines from dilute inflow waters during subsurface flow of groundwater from alluvial fans to the playa (Eugster and Hardie, 1978; Eugster, 1980). A further advance is the playa-playa lake-oligomictic lake system (Boyer, 1982).

In this model, a closed-basin playa can cover most of the floor of a rift valley when precipitation is consistently less than evaporation over many years. Storms in the fault-bounded highlands generate mud-laden flood waters that pass down alluvial fans, move over the adjoining sandflats, and pond on the playa where mud settles from suspension. With runoff amounts somewhat greater than evaporation, playa-lakes become established. These lakes are relatively short lived and shallow with oxidizing bottom water. Over time, dissolved ions become increasingly concentrated in the alkaline water. The preservation of limonite stains on the mud and sand leads to rebeds as the limonite slowly dehydrates to authigenic hematite. When precipitation consistently exceeds evaporation, an oligomictic lake will occupy the basin of the former playa. Over thousands of years, this relatively deep, nearly continuously stratified lake produces the characteristic record of gray and black mudstone, commonly with calcite or dolomite laminae.

East Berlin Formation

In the East Berlin Formation at stop 6, we now recognize that the redbeds formerly interpreted by us as a fluvial system are playa and playa-lake mudstones and sandstones. The gray and black mudstones and sandstones remain interpreted as the deposits of oligomictic lakes. The evidence for a playa and playa-lake origin of the redbeds is as follows.

Stratigraphic Framework. These redbeds occur in a terrestrial sequence in a rift valley. Semiaridity dominated Late Triassic time as evidenced by numerous caliche paleosols in the New Haven Arkose.

Bedding Features. The beds of red mudstone extend completely across the outcrops for more than tens of meters with uniform thickness and only a few cm of relief along the bedding planes. Most of the beds are 1 to

3 m in thickness. They comprise about half of the total sequence.

Mudcracks and Raindrop Impressions. Many of the bedding planes have mudcracks, which attest to repeated wetting and drying. The deeper mudcracks exceed 50 cm. Raindrop impressions occur on a few bedding planes.

Sorting. The mudstones are poorly sorted mixtures of silt and clay with some sand.

Fossils. The insect burrows and other trace fossils are now being studied by Elisabeth Gierlowski Kordesch in her Ph.D. dissertation at Case Western Reserve University. Shelly fossils are absent.

Evaporite Minerals. Multiple horizons of dolomite and ferroan dolomite nodules and septarian nodules occur in the mudstones. Some nodules are deformed in syndimentary slumps and others show compaction of mud laminae over them. The carbonate in the nodules commonly grew as acicular to stubby crystals oriented perpendicular to the surfaces of detrital grains, especially mica. This is a displacive fabric that reflects pushing aside of the unlithified mud. The original carbonate was presumably Mg-*Calcite*, later converted during burial diagenesis to dolomite and ferroan dolomite.

The carbonate in these nodules was evidently precipitated within the mud beneath former shallow, alkaline and somewhat saline lakes that had contracted and dried up due to inadequate annual runoff. This interpretation is favored by the restriction of the dolomite nodules to specific mudstone beds and the presence of dolomite that outlines mudcracks at the top of some of the nodule-bearing beds. Also, similar dolomite nodules occur in mudcracked gray mudstone that accumulated during wide lateral fluctuations of the shorelines of some of the oligomictic lakes during their initial and final stages.

Small amounts of gypsum occur in some beds of red mudstone as thin layers and dispersed in the mud, especially in beds with dolomite concretions. Some of the crystals are in a more or less vertical orientation. Others have been dissolved to molds or are now dolomite pseudomorphs.

Absent are both bedded gypsum and pervasively disrupted fabrics in sandstone or mudstone that would be expected with extensive displacive precipitation of evaporite minerals within the vadose zone of a playa. Possibly much of the time the water table was too far beneath the playa surface to provide a steady flow of groundwater in nearsurface aquifers.

Analcime has not been found in the playa red mudstones, but small amounts do occur in some of the lacustrine gray mudstones (April, 1978, p. 100).

Graded Beds. The graded beds are a few to about 30 cm in thickness and have smooth lower surfaces, except rarely when there is 10 to 30 cm of basal scour. The graded beds are of various types, including climbing ripples with erosion of the stoss sides of the ripples. Others show planed-bedded sandstone followed by ripples. A few show planar or trough crossbed sets with mud drapes over and between dune crests. In some of these beds, the crossbeds are made of alternating laminae of sand and mud. The graded beds record the rapid deceleration of floodwaters on encountering the low gradient of the playa, with initial deposition of sand, followed by fallout of mud from suspension. Similar graded beds are an important component of the playa sequence of redbeds in the Upper Triassic Blomidon Formation, Nova Scotia (Hubert et al., 1981; Hubert and Hyde, 1982).

Figure 35 on page 78 of the guidebook (Hubert et al., 1978), shows these playa and playa-lake mudstones (labelled flood plain mudstone) with the graded beds and other flood units (labelled stream channel and shallow oxidized lake on flood plain). The paleocurrent data for these redbeds show that the low gradient surfaces of the playas sloped towards all four quadrants at various times during accumulation of the sequence. On the average, the playa surfaces sloped towards the northeast.

Summary

The playa-playa lake-oligomictic lake continuum is a unifying concept for the cycles of lacustrine gray and black mudstone interbedded with red mudstone and sandstone in parts of the East Berlin, Shuttle Meadow, and Portland Formations in the Hartford Basin and the Turners Falls Sandstone in the Deerfield Basin. The playas with their internal drainage were situated in the subtropical rift valley at about 20°N paleolatitude. Given this setting, the control for the repeated cycles of playas and oligomictic lakes was long-term fluctuation in precipitation.

The laminite rock made of alternating laminae of kerogen-bearing gray to black mud and light-colored dolomite is a distinctive signature of these oligomictic lakes (Hubert et al., 1976; Olsen et al., 1982). Multiple horizons of these lacustrine laminites interbedded with playa red mudstones occur in the East Berlin Formation (Carey, 1974; Hubert et al., 1978; Reed, 1976), Shuttle Meadow Formation, Portland Formation (Irwin, 1982), and the Turners Falls Sandstone (Handy, 1976; Hubert work in progress).

References

- April, R. H., 1978, Clay mineralogy and geochemistry of the Triassic-Jurassic sedimentary rocks of the Connecticut Valley: Ph.D diss., Dept. Geology/Geography, Univ. Mass., Amherst, Mass. 206 p.

- Boyer, B. W., 1982, Green River laminites: does the playa-lake model really invalidate the stratified-lake model?: *Geology*, v. 10, p. 321-324.
- Carey, P. J., 1974, Sedimentology of inferred mud flat and lake deposits, East Berlin Formation, Holyoke, Massachusetts: M. S. report, Dept. Geology/Geography, Univ. Mass., 95 p.
- Eugster, H. P., 1980, Geochemistry of evaporitic lacustrine deposits: *Ann. Rev. Earth and Planetary Sci.*, v. 8, p. 35-63.
- Eugster, H. P. and Hardie, L. A., 1978, Saline lakes: *in* A. Lerman, ed., *Chemistry, Geology, and Physics of Lakes*: Springer-Verlag, N. Y., p. 237-293.
- Handy, Walter A., 1976, Depositional history and diagenesis of lacustrine and fluvial rocks of the Turners Falls and Mount Toby transition, North-Central Massachusetts: M. S. thesis, Dept. Geology/Geography, Univ. Mass., 115 p.
- Hardie, L. A., Smoot, J. P., and Eugster, H. P., 1978, Saline Lakes and their deposits: *in* A. Matter and Tucker, M. E., ed., *Modern and Ancient Lake Sediments*: International Assoc. Sedimentologists, Spec. Pub. No. 2, p. 7-41.
- Hubert, J. F. and Hyde, M. G., 1982, Sheet flow deposits of graded beds and mudstones on an alluvial sandflat-playa system: Upper Triassic Blomidon redbeds, St. Mary's Bay, Nova Scotia: *Sedimentology*, v. 29, in press.
- Hubert, J. F., Hyde, M. G., and Mertz, K. A., 1981, Sandflat-playa model: the Upper Triassic Blomidon redbeds of Nova Scotia: abs. vol. *Geol. Soc. Amer. meeting, Cincinnati*, p. 477.
- Hubert, J. F., Reed, A. A., and Carey, P. J., 1976, Paleogeography of the East Berlin Formation, Newark Group, Connecticut Valley: *Amer. Jour. Sci.*, v. 276, p. 1183-1207.
- Hubert, J. F., Reed, A. A., Dowdall, W. L., and Gilchrist, J. M., 1978, Guide to the Mesozoic Redbeds of Central Connecticut: *State Geol. and Natural History Survey of Conn.*, Guidebook No. 4, 129 p.
- Irwin, D. J., 1982, Sedimentology and petrology of the Jurassic Portland Formation, Hartford Basin: M. S. thesis in progress, Dept. Geology/Geography, Univ. Mass., Amherst, Mass.
- Olsen, P. E., McClune, A. R., and Thomson, K. S., 1982, Correlation of the early Mesozoic Newark Supergroup by vertebrates, principally fishes: *Amer. Jour. Sci.*, v. 282, p. 1-44.

Reed, A. A., 1976, Stratigraphy, depositional environments and sedimentary petrology of the Lower Jurassic East Berlin Formation, central Connecticut: M. S. thesis, Dept. Geology/Geography, Univ. Mass., Amherst, Mass., 175 p.

M2-1

Trip M2

PALEONTOLOGY OF THE MESOZOIC ROCKS OF THE
CONNECTICUT VALLEY

by

Nicholas G. McDonald
Westminster School
Simsbury, Conn.

Geologic Setting

The Mesozoic rocks of the Connecticut Valley (Hartford and Deerfield basins) occupy an elongated, partially fault-bounded trough extending over 160 km from near the northern border of Massachusetts to Long Island Sound. This trough, along with a number of similar half grabens along the eastern coast and continental margin of North America, formed as a result of tensional stresses during the early stages of rifting of North America and Africa (Van Houten, 1977; Manspeizer, *et al.*, 1978). More than 4000 meters of predominantly red, gray and black clastic sediments and tholeiitic basalt were deposited in the basin during its roughly 35 million year existence in the late Triassic and early Jurassic (Cornet, 1977). The stratigraphic sequence in the Connecticut Valley is summarized below in figure 1.

The paleogeography and paleoclimate of the Connecticut Valley have been outlined by Krynine (1950) and Hubert, *et al.* (1978). The basal strata, the New Haven and Sugarloaf Arkoses, are dominantly alluvial fan and braided stream redbeds laid down by rivers which flowed from the crystalline highlands to the east. Abundant caliche paleosols suggest that the paleoclimate was tropical and semi-arid, with perhaps 100-500 mm of seasonal rain and a long dry season (Hubert, 1978). Only scant reptile remains have been recovered from these basal formations. Volcanic activity in the basin began almost concurrently with the arrival of the Jurassic, and basaltic lava and agglomerate (the Talcott Formation) disrupted drainage patterns and lowered the gradient of the basin floor. The dislocation of streams, coupled with periods of increased rainfall (Hubert, *et al.*, 1976; 1978), resulted in the floodplain mudstones and ephemeral and perennial lake facies which characterize the Shuttle Meadow Formation. The Shuttle Meadow is highly fossiliferous; reptile footprints are common in the fine-grained redbeds, well-preserved, articulated fossil fishes and plants are present in the microlaminated black shales, and plant fragments are locally found in the gray mudstones.

Similar alluvial fan, floodplain and lacustrine paleoenvironments are reflected by the strata of the East Berlin Formation, deposited after the extrusion of the Holyoke Basalt. The East Berlin is also rich in fossils. The climate was tropical and varied from humid to semi-arid (Hubert, *et al.*, 1976). A third major interruption of drainage, created by the flows of the Hampden Basalt, probably aided the development of extensive lacustrine conditions during the deposition of the lower portion of the Portland Formation. Some of the most productive fossil fish localities occur in perennial lake-bed strata of the basal Portland. The upper Portland rocks are largely an alluvial fan-alluvial plain facies consisting of red sandstones and mudstones (Gilchrist, 1979). Locally, the upper Portland Formation has produced numerous fossil footprints.

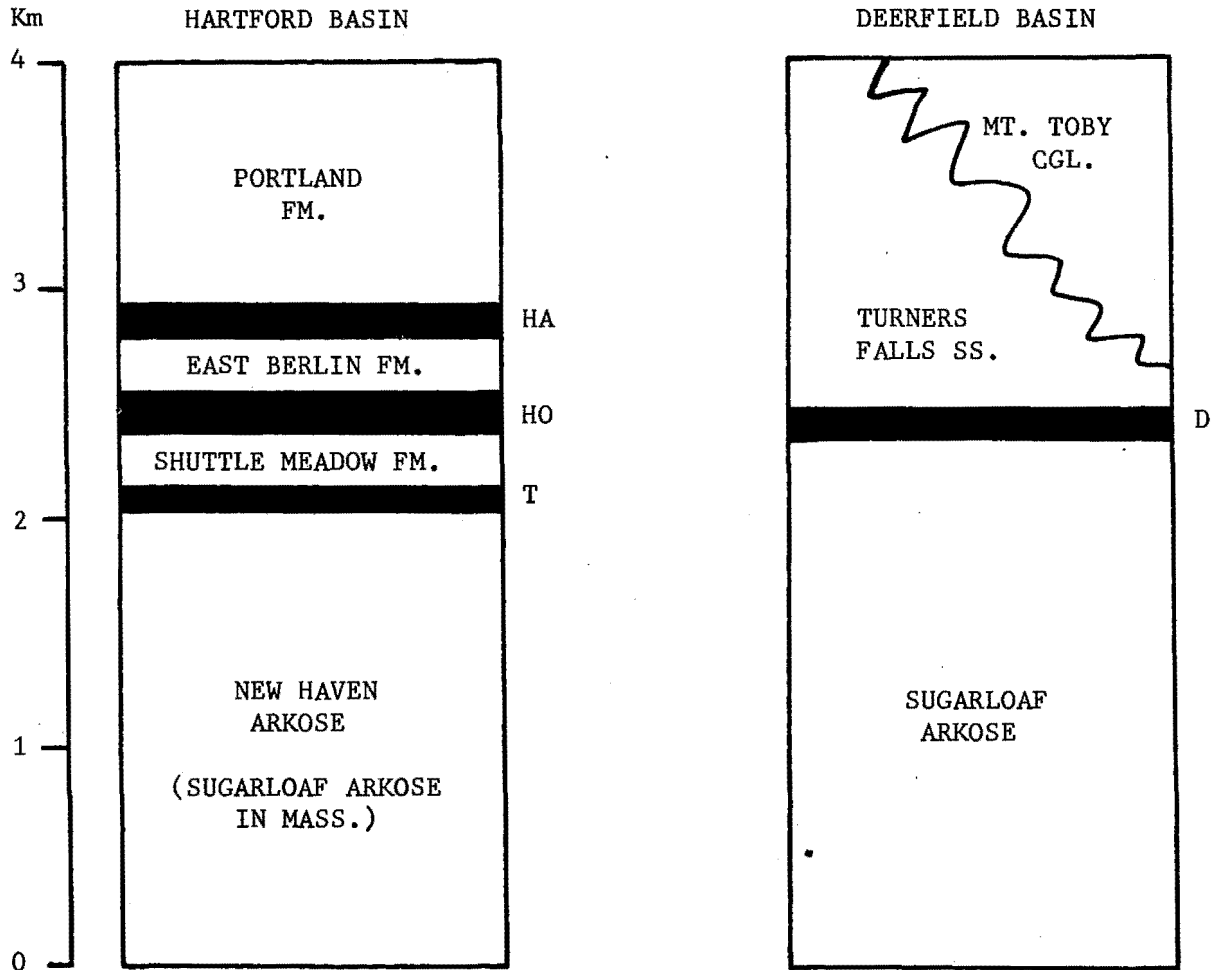

Figure 1. Stratigraphic nomenclature in the Connecticut Valley (after Hubert, et al., 1976). Solid black color represents the basaltic formations: HA = Hampden Basalt; HO = Holyoke Basalt; T = Talcott Basalt; D = Deerfield Basalt.

The Mount Toby Conglomerate and Turners Falls Sandstone of northern Massachusetts overlie the Sugarloaf Arkose and Deerfield Basalt; they largely reflect alluvial fan, alluvial plain, floodplain and local lacustrine depositional environments (Wessel, 1969). de Boer (1968) has equated the Talcott and Deerfield Basalts of the Hartford and Deerfield basins, but the Mount Toby Conglomerate and Turners Falls Sandstone cannot at present be directly correlated with the sedimentary formations of southern Massachusetts and Connecticut (Hubert, et al., 1976). Fossil fishes are abundant in the lacustrine dark shales of the Deerfield basin, reptile tracks and invertebrate trails are common in the fluvial units of that region.

Historical Review

History does not record when fossils were first discovered in the Mesozoic strata of the Connecticut Valley, but they first began to attract

scientific attention at the beginning of the nineteenth century. Colbert (1970) reports that reptile tracks were observed in South Hadley, Massachusetts in 1800; however, they were not described in the literature until Edward Hitchcock's classic report of 1836. Fossil fishes and plants from Westfield, Connecticut were noted by Benjamin Silliman, Sr. as early as 1816, in the first edition of Cleaveland's Mineralogy. This may be the earliest mention of fossil fish from the United States. Smith (1820) documents the discovery, in 1818, of reptile skeletal remains in East Windsor, Connecticut, and soon after, the important fossil fish and plant localities at Middlefield, Connecticut and Sunderland, Massachusetts were described (see Silliman, 1818; Hitchcock, 1818). By the mid-1820's, nearly a dozen productive fossil localities had been discovered and recorded in scientific journals; by 1840, with the inclusion of the myriad of fossil footprint sites up and down the Valley, the number of known fossil localities was above forty and was rapidly increasing. By the middle of the nineteenth century, the Connecticut Valley had achieved world-wide acclaim for its paleontology, particularly its reptile footprints and fishes. Paleontological research in the Valley was initially led by Edward Hitchcock, Sr., J. H. and W. C. Redfield and James Deane; Benjamin Silliman, Sr. provided valuable contributions and encouragement for this research through the American Journal of Science. Noteworthy European geologists including Agassiz, Brongniart, Egerton and Lyell collected in the Valley or conducted research on local fossils. In the last century, more reports on paleontological topics were published than articles in any other subject area of Connecticut Valley geology.

The latter half of the nineteenth and the early years of this century saw the continuation of active paleontological investigations in the Connecticut Valley. The distribution, structure and systematics of the fossil fishes were detailed in the publications of Newberry (1879, 1888), Loper (1891, 1899) and Eastman (1911). The paleobotany of the region was briefly summarized by Newberry (1888). Marsh (1885, 1893) and others produced skeletal descriptions and reconstructions of the ancient reptiles of the Valley, and Lull (1904, 1915) provided the only detailed re-assessment of the fossil footprints since Hitchcock's Ichnology of 1858.

The middle decades of this century saw an apparent decline in interest in the Mesozoic paleontology of the Valley. Only a handful of reports were published, none of which treated the fauna or flora in any detail. The exact locations of many fossil sites became obscure, and several valuable localities were destroyed or covered by dam or construction projects. Paleontological research in the Valley essentially stagnated for fifty years.

With the recent publications of Cornet and Traverse in palynology and paleobotany, Schaeffer, McDonald, Olsen and others in paleoichthyology, and Baird, Colbert, Coombs, Galton and Ostrom on the reptiles and their tracks, paleontological research is once again flourishing in the Valley. Most of the classic fossil fish and plant localities have been rediscovered; these and new locations have been excavated. Revised systematic descriptions of most of the fishes have been published. Similar studies on the prosauropod dinosaurs of the Valley have been completed. Interest in the fossil footprints has been greatly stimulated by the discovery, in 1966, of

the extensive trackways in the East Berlin Formation at Rocky Hill, Connecticut. The next section of this report will outline some of the new data on fossils and paleoecology revealed by these recent studies.

Resumé of the Fauna and Flora

Reptiles

The skeletal remains of reptiles are exceptionally rare in the Mesozoic rocks of the Connecticut Valley. Only a few specimens exist, and many of these are fragmentary. Most of the reptile remains are preserved in coarse redbed lithologies of the New Haven and Portland Formations; these rocks represent alluvial fan-floodplain paleoenvironments in which abrasion and oxidizing conditions quickly led to the destruction of organic remains. The best-known species are the prosauropod dinosaurs Anchisaurus polyzelus and Ammosaurus major (Galton, 1971, 1976; Galton and Cluver, 1976). Anchisaurus was a slender-footed, bipedal dinosaur, 2 - 2½ meters in length; Ammosaurus was a broad-footed, 1 - 3 meter bipedal prosauropod. Both forms were presumably herbivores (Galton, 1976), though Lull (1953) suggested a partly carnivorous diet for Anchisaurus.

The coelurosaur Coelophysis, originally described under the name of Podokesaurus (Talbot, 1911), is represented in the Valley by at least two fragmentary skeletons from the Portland Formation (Colbert and Baird, 1958; Colbert, 1964) and by a tooth (Galton, 1976) from the Shuttle Meadow Formation. Coelophysis is well known from the Triassic of New Mexico; it was an active, lightly-built, bipedal dinosaur, a meter or two in length, and probably fed on insects, smaller reptiles and perhaps fishes (Colbert, 1970). Other forms include the small, heavily-armored, quadrupedal Stegomus (Marsh, 1896) and Stegomosuchus (Emerson and Loomis, 1904; Huene, 1922), which may be aetosaurs or primitive crocodiles (Walker, 1968; Galton, 1971). The crocodile-like phytosaurs, commonly found in many other Triassic regions, are represented only by a single skeletal fragment from the New Haven Arkose. The specimen was named Belodon validus by Marsh (1893), but is probably too fragmentary for generic assignment (Lull, 1953; Olsen, 1980a). Ostrom (1967, 1969) has documented the discovery of a procolophonid reptile referable to Hypsognathus from the presumed New Haven Arkose in Meriden, Connecticut. The procolophonids were small, quadrupedal herbivores, similar to some modern lizards. The most recent reptilian find is that of a nearly complete skull of a small, undescribed sphenodontid rhynchocephalian from the New Haven Arkose of Meriden (Olsen, 1980a).

Reptile Tracks

In contrast to the scarcity of reptile skeletal parts, the footprints and trackways of reptiles are in great abundance in the Valley. They have been found in all the sedimentary formations, though they are conspicuously rare in the New Haven Arkose and equivalents. Lull (1953) has listed close to fifty established localities of fossil footprints, but that number is certainly very conservative.

M2-5

Unfortunately, rarely has it been possible to equate the footprint types with the observed skeletal remains from the Valley. Many of the existing track genera represent presently unknown reptile types; Galton (1976) has noted that prosauropod tracks (such as might be made by Anchisaurus or Ammosaurus) are almost completely lacking in the Jura-Triassic rocks of North America.

The majority of the reptile tracks in the Valley seem to be those of small dinosaurs or crocodile-like reptiles (Olsen, 1980a). Colbert (1970) has suggested that the taxa Grallator and Anchisauripus represent small coelurosaurian (theropod) dinosaurs; Eubrontes and Gigandipus may be the tracks of large carnivorous theropod dinosaurs; Anomoepus and Sauropus perhaps were made by ornithischian dinosaurs. Lull (1953) has suggested that Batrachopus tracks were made by a reptile allied to Stegomosuchus; Colbert and Baird (1958) refer Otozoum to a descendant of the cheirotheriid thecodont stock. Many of the other footprint types may be from small thecodonts (such as Stegomus) or perhaps even amphibians. In his most recent classification, Lull (1953) has recognized over forty-five different footprint genera; the reader is referred to his report and that of Baird (1957) for specific descriptions and systematics. It should be noted that the last comprehensive study of Connecticut Valley footprint faunules is now nearly thirty years old, and certainly the subject is in need of a major reexamination.

Fishes

After reptile tracks, fossil fishes are the next most abundant type of fossil found in the Connecticut Valley. Not less than twenty productive sites are presently known (McDonald, 1975). The fishes are largely restricted to the microlaminated, perennial-lake black shales and limestones of the Shuttle Meadow, East Berlin and Portland Formations in the Hartford basin and the Mount Toby Conglomerate and Turners Falls Sandstone of the Deerfield basin. The absence of fishes in the Triassic formations of the Valley (the New Haven and Sugarloaf Arkoses) reflects the paucity of lacustrine facies in those beds. Unlike the reptile skeletons, which usually were quickly decomposed, the stagnant, euxinic, lake-bottom environments where the fish skeletons accumulated limited bacteria and scavenger action, and retarded decomposition. The fossil fishes from the Connecticut Valley are usually whole and articulated, though quality of preservation varies greatly from locality to locality.

Four genera of fishes are presently recognized in the Valley (see figure 2). The most common genus is the holostean Semionotus; it has been recovered from all the known fossil fish sites in the Valley. Semionotus was a medium to large-sized (up to 40 cm long), heavily-built, usually fusiform fish with a short mouth armed with peg-like or conical teeth. The small mouth and mobile maxillae of Semionotus indicates that it could engulf prey by suction; the jaw structure also suggests browsing and nibbling; its diet may have included sessile organisms and a wide variety of plankton (Schaeffer, 1967).

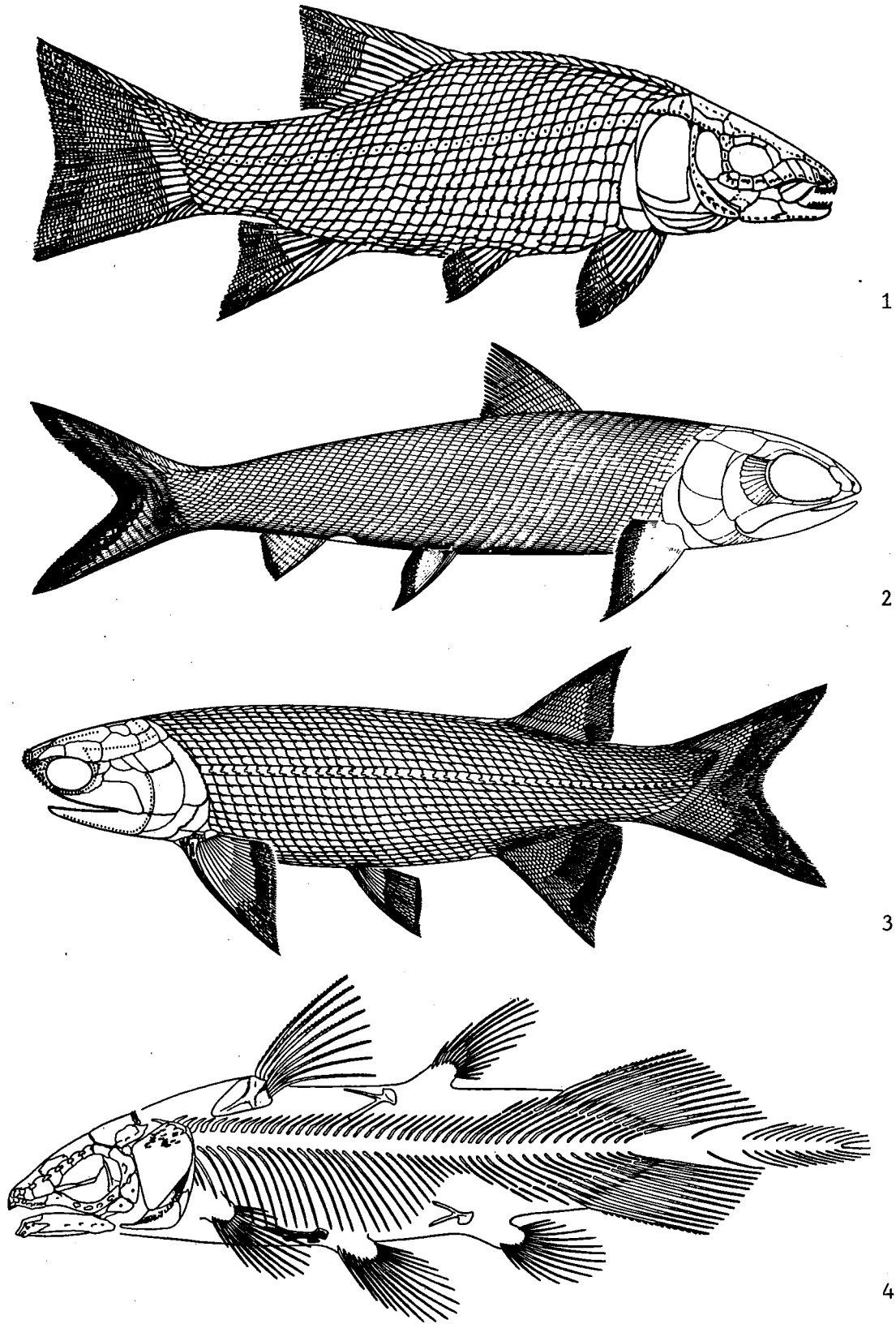

Figure 2. Restorations of Mesozoic fishes. (1) a generalized semionotid, after Olsen (pers. comm., 1975); (2) *Ptycholepis marshi*, after Schaeffer, *et al.* (1975); (3) *Redfieldius gracilis*, after Schaeffer and McDonald (1978); (4) *Diplurus newarki*, a close relative of *D. longicaudatus*, after Schaeffer (1952). See text for sizes and descriptions.

Taxonomic distinction of Semionotus species has been attempted by many past authors (notably Redfield, 1841; Newberry, 1888; and Eastman, 1911), but most of these descriptions are vague and overlapping. Because of the present confusion regarding Semionotus systematics, many modern authors have avoided recognizing any species of Connecticut Valley semionotids. Olsen, et al. (1982), however, have pointed out that certain "groups" of semionotid species are readily separable from one another when dorsal-ridge-scale morphology, shape and size of frontal bones and other characteristics are compared. These authors have recognized four distinct "species groups" of semionotids in the Connecticut Valley: (1) the "Semionotus micropterus group," dominated by fishes with banjo-shaped dorsal ridge scales, occurring in the Shuttle Meadow and East Berlin Formations; (2) the "Semionotus elegans group," characterized by semionotids with a strongly-abbreviated heterocercal tail, distinctive frontals, and oval, concave-spined anterior dorsal ridge scales; these fishes are found in the lower Portland Formation; (3) the "Semionotus tenuiceps group," including fishes with large, elaborate dorsal ridge scales which sometimes create a hunchbacked appearance, found in the formations of the Deerfield basin; and (4) the "small scale group," consisting of semionotids with small and simple dorsal ridge scales, also occurring in the Deerfield basin. The semionotid form called Acentrophorus chicopensis (Newberry, 1888) from the middle-upper Portland Formation is always very poorly preserved and should be considered as indeterminate (Olsen, 1980a).

The advanced chondrosteian fish Redfieldius occurs in considerable numbers in the Shuttle Meadow, East Berlin and Portland Formations of the Hartford basin; its presence in the Deerfield basin, though noted by a few authors, is regarded as highly doubtful (Schaeffer and McDonald, 1978). Redfieldius was a medium-sized, fusiform fish, averaging 20 cm in length from the snout to the tip of the caudal fin. It is readily distinguished from Semionotus by its characteristic skull-bone ornamentation, by the extreme posterior position of the dorsal fin and by the relatively small, delicate fulcra on all the fins. The snout of Redfieldius is covered by tiny conical tubercles, and resembles a pincushion. Schaeffer (1967) has suggested that these tubercles supported a large, fleshy upper lip, and that Redfieldius was a bottom feeder, scooping up detritus with its upper lip and subterminal mouth. A single species of Redfieldius, R. gracilis, is presently recognized from the rocks of the Connecticut Valley (Schaeffer and McDonald, 1978). The redfieldiid Dictyopyge (see Lull, 1953), has not been found in the Connecticut Valley.

The chondrosteian Ptycholepis is a relatively rare form; it has been found only at three localities in the Shuttle Meadow Formation (Schaeffer, et al., 1975). Ptycholepis was a fish of slender proportions, with delicate fins; its length from the snout to the tip of the caudal fin averages 15-17 cm. It is easily recognized by its narrow, ridged and grooved body scales and its distinctive skull-bone ornamentation. The large mouth was armed with numerous small teeth and could be opened widely; presumably Ptycholepis was an active predator. One species, P. marshi, is known from the local rocks (Schaeffer, et al., 1975). Because other species of this fish are found only in marine deposits in Europe, Schaeffer (1967) intimated that Ptycholepis marshi may have been euryhaline, and entered the Connecticut Valley lowland from the sea. This might explain its rarity.

The coelacanth Diplurus longicaudatus (Schaeffer, 1948, 1952) is the least common of the Connecticut Valley fossil fishes. Fewer than ten, mainly fragmentary specimens have been recovered from the Shuttle Meadow and East Berlin Formations. Diplurus was the largest of the known fishes in the Valley, with a maximum length of nearly 80 cm. It is easily recognized by its thin, elliptical, ridged scales, its two fan-shaped dorsal fins, its supplementary caudal fin, a well-ossified postcranial skeleton and many other characteristics. Available evidence suggests that D. longicaudatus was one of the apex predators of the Connecticut Valley lakes, with a diet consisting largely of other fishes.

Coprolites

Fecal remains are common in most of the perennial lacustrine deposits of the Valley. They have been observed at nearly all of the localities which produce articulated fish. They vary in shape from round or ovoid to cigar-shaped, and range in length from a few millimeters to greater than 15 cm. Most are structureless masses of black, carbonaceous material, but several, particularly from the East Berlin Formation, contain dissociated fish scales and bones. Chemical analyses of some of the larger coprolites (Dana and Hitchcock, 1845; Cornet, pers. comm., 1972) reveal a high phosphatic content; probably this indicates derivation from a vertebrate-eating predator. Diplurus longicaudatus and some of the robust semionotids quickly come to mind as the possible sources of these large coprolites; it is intriguing to note that a 60+ cm specimen of Diplurus recently obtained from the Shuttle Meadow Formation (Bluff Head locality, North Guilford, Connecticut) seems to contain one of these phosphatic coprolites. A number of Semionotus and Redfieldius specimens from the same locality also contain small, round, knobby or grainy coprolites markedly dissimilar to the larger "diplurid" type. Other fecal-pellet-sized coprolites presumably have an invertebrate source. A study of Connecticut Valley coprolites by the author is in progress.

Invertebrates

The fossil record of invertebrates in the Connecticut Valley is disappointingly sparse. The abundant burrows, tracks and trails at several localities and the great numbers of higher-order consumers (fishes and reptiles) in the Valley testify that a large and diverse invertebrate population must have existed. Clearly, adverse preservational conditions account for the absence of fossil remains. The oxidizing alluvial fan and floodplain environments in which most of the Connecticut Valley redbeds formed were not conducive to the preservation of organic matter; likewise, invertebrates were scarce and rarely preserved in the stagnant, toxic lake waters which deposited the microlaminated black shale strata.

In 1900, a sandstone slab containing the impressions of unionid bivalves was discovered in a glacial boulder near Wilbraham, Massachusetts (Emerson, 1900). These pelecypod casts were later examined by Schuchert and Troxell and designated Unio wilbrahamensis and Unio emersoni. The largest specimen has an internal length of 47 mm, is 22 mm high and 10 mm

wide (Troxell, 1914). Modern unios occupy stream and shallow-water lake habitats. The "fossil shell" from Easthampton, Massachusetts, described by E. Hitchcock, Jr. (1856), is regarded as a weathered concretion by Lull (1953). No other credible molluscan remains from the Valley have been reported in the literature.

The existence of fossil insect larvae in the rocks of the Connecticut Valley has been well documented (Hitchcock, 1858; Scudder, 1886; Lull, 1953). Over one hundred specimens of the insect, called Mormolucoides articulatus, are known from localities in the Turners Falls, Massachusetts area and from Cromwell, Connecticut. The specimens are usually preserved in gray-black shale. The larvae are typically composed of thirteen segments, appendages are generally not preserved; most specimens average 1 - 2 cm in length and 2 - 3 mm in width. The form is regarded as the larva of a sialidan neuropteran (Lull, 1953).

The discovery of the fossil remains of bivalved crustaceans of the order Conchostraca (clam shrimp) near Holyoke, Massachusetts was briefly noted by Lull (1912). Other specimens have been recently obtained from Durham, Connecticut, Agawam, Massachusetts (Olsen, pers. comm., 1977) and from Chicopee, Massachusetts (Cornet, 1977). In the summer of 1980, a richly fossiliferous horizon of these arthropods was discovered by the author at the Westfield, Connecticut fossil fish locality (see p. M2-21) in the East Berlin Formation. The conchostracans are contained in beds of platy, dark gray, silty shale 11 cm above the microlaminated, calcareous black shale fishbeds at the site. The original chitinous exoskeletons of the animals have been replaced by calcite; most specimens are poorly preserved, but the concentric growth lines of the carapace are clearly visible in a number of individuals. These fossils are broadly ovate in outline and most average 2 mm in length. They differ in size and shape from most of the other described conchostracans from the eastern American Mesozoic, and may constitute an as yet undescribed species of the genus Cyzicus. An examination of other East Berlin lacustrine exposures has resulted in the identification of these fossils at two additional sites, in Durham and Cromwell, Connecticut. Rare ostracod shells have been reported from the East Berlin Formation near Holyoke, Massachusetts (Carey, 1974) and from the Shuttle Meadow Formation, Plainville, Connecticut (Hubert, et al., 1978). A morphologic and systematic examination of Connecticut Valley fossil crustaceans by the author is in progress.

The tracks and trails of invertebrates have been observed at many localities throughout the Valley, but they are particularly common in the gray-red, ephemeral lacustrine-floodplain shales and mudstones in the Turners Falls, Massachusetts region. As many as twenty-seven separate track genera have been recognized, including the supposed trackways of larval and adult insects, crustaceans, myriapods, annelids, mollusks and other forms (Hitchcock, 1858; Lull, 1953). The reader is referred to Lull's report for specific taxonomic and descriptive details.

There is much evidence of burrowing and bioturbation in certain lithologies in the Valley, but little is known of the organisms involved in the process. Carey (1974) has noted horizontal and vertical burrows

(similar to those made by annelid worms) in the East Berlin Formation near Holyoke, Massachusetts; several authors, including Wessel (1969), have described the abundant burrows in the Turners Falls Sandstone in the Turners Falls area. Olsen (1980b) has described Scoyenia, the possible burrows of crayfish, from the Triassic Lockatong Formation of New Jersey; Stevens and Hubert (1980) have recognized similar burrows in alluvial plain mudstones of the Sugarloaf Arkose in the Deerfield basin.

Paleobotany/Palynology

Fossil plants in the Valley strata have been known at least since 1816, when they were found at the Westfield fossil fish locality (Stop 5) in Connecticut (Cleaveland, 1816). Carbonized leaves and stems are moderately abundant in most of the Jurassic gray-black lithologies in the region; coarser rocks, particularly white-brown sandstones, frequently preserve bits of carbonized wood and stem fragments. Plant root casts, pedotubules and rhizoconcretions are extremely common in some red floodplain mudstone and channel sandstone facies of the New Haven and Sugarloaf Arkoses (Hubert, 1978; Stevens and Hubert, 1980). Casts of tree trunks have been seen in the Portland Arkose, at the Portland, Connecticut brownstone quarries (Newberry, 1888), in the New Haven Arkose near Bristol, Connecticut (Silliman, Jr., 1847), and at other locations. Krynine (1950) and Hubert, et al. (1978) have observed probable algal structures in the thin limestones at the base of the Shuttle Meadow Formation; algal kerogens from the Portland Formation were noted by Robbins, et al. (1979). In spite of the widespread occurrence of plant remains in the Valley, however, most of the specimens are poorly preserved and fragmentary. Compared to the Triassic basins in Virginia and North Carolina, the Connecticut Valley has yielded a sparse flora. The extensive coal swamp and paludal lithologies found in the southern basins have few counterparts in the Valley; thus, most of the abundant plant life that existed was not fossilized.

The flora of the local rocks consists largely of cycadeoids, conifers, horsetails and ferns, and has been described in some detail by Newberry (1888) and Cornet (1977). Cornet has recognized several types of conifers, including the leaf genera Brachyphyllum and Pagiophyllum and the cone genera Cheirolepidium and Hirmerella. He also has found the cycadeoid Otozamites, the horsetail Equisitites and the ferns Dictyophyllum and Clathropteris meniscoides (see Hitchcock, Jr., 1855; Hitchcock, 1861). Other researchers have described Baiera, Palissya, Taeniopteris and Loperia from the Connecticut Valley, but the recognition of most of these genera is based on incomplete material, and is subject to question (Cornet, pers. comm., 1982).

The most significant recent paleobotanical revelations have come from the studies of Cornet on the pollen and spores of the Valley (Cornet, et al., 1973; Cornet and Traverse, 1975; Cornet, 1977). More than thirty-six palynologically productive localities have been identified in the Valley; all the local sedimentary formations have produced pollen and spore samples, but most of the sites are in the green, gray or black shales and siltstones of the Jurassic formations (those above the Talcott and Deerfield Basalts). The palynofloras are typically dominated by pollen

of the Corollina (Hirmerella) type, indicating that conifers were the major constituent of the flora. Twenty-seven genera and forty-two species of pollen were described by Cornet and Traverse (1975). They suggest that local palynofloras reflect a warm, seasonally wet and dry climate. Identification of these microfossils has facilitated the correlation of the Connecticut Valley strata with the European Triassic-Jurassic type sections. The dramatic result of this correlation (along with other evidence) has been the recognition that much of the Connecticut Valley section is Jurassic in age, the Triassic-Jurassic boundary presumably occurring just below the oldest extrusive basalts in both the Hartford and Deerfield basins. The upper part of the Portland Formation may be as young as Middle Jurassic (Cornet, 1977).

Road Log and Stop Descriptions

Mileage

0.0 Trip will assemble at the scenic overlook above the Connecticut River on Mass. Rt. 2, north of the town of Turners Falls. The assembly point is west of the bridge connecting Turners Falls and Riverside (Gill), Massachusetts. From Interstate 91, take exit 27 and proceed east on Rt. 2 for approximately 2.3 miles. The scenic overlook will be on your right. Allow two hours travel time from UCONN (Storrs) to the assembly point.

Stop 1. Turners Falls Locality.

Extensive exposures of the Turners Falls Sandstone and Deerfield Basalt are found along the north bank of the Connecticut River in Gill, Massachusetts (Greenfield 7.5 min. quadrangle). Note: These exposures lie downstream of the Turners Falls dam and are inaccessible when the dam gates are open.

The exposures at this locality are among the thickest and most continuous in the Deerfield basin, and consist of red, gray and whitish alluvial fan sandstones and minor conglomerate; red-brown, distal fan-floodplain sandstone and siltstone; brick-red to maroon mudflat siltstone and mudstone; and two or perhaps three cycles of gray-black lacustrine siltstone and shale. The rocks at this locality have previously been described by Wessel, et al. (1967), Soloyanis (1972), Handy (1976) and Kuniholm (1980). Fossils (particularly fishes) are concentrated primarily in the uppermost lacustrine unit exposed at the base of the dam, a columnar section and description of which is given below in figure 3.

The fossiliferous lacustrine unit at Turners Falls is approximately 7.5 meters thick and is composed of interbeds of the following lithologies: (1) soft, fissile, light gray shale which readily decomposes into centimeter-sized chips; (2) brittle, platy, microlaminated, dark gray, calcareous, silty shale; and (3) hard, platy to flaggy, partly microlaminated, dark gray siltstone. The microlaminated shales are common in the lower half of the unit but become increasingly scarce near the top. The siltstones are thin, often lenticular and concretionary at the base of the unit, but

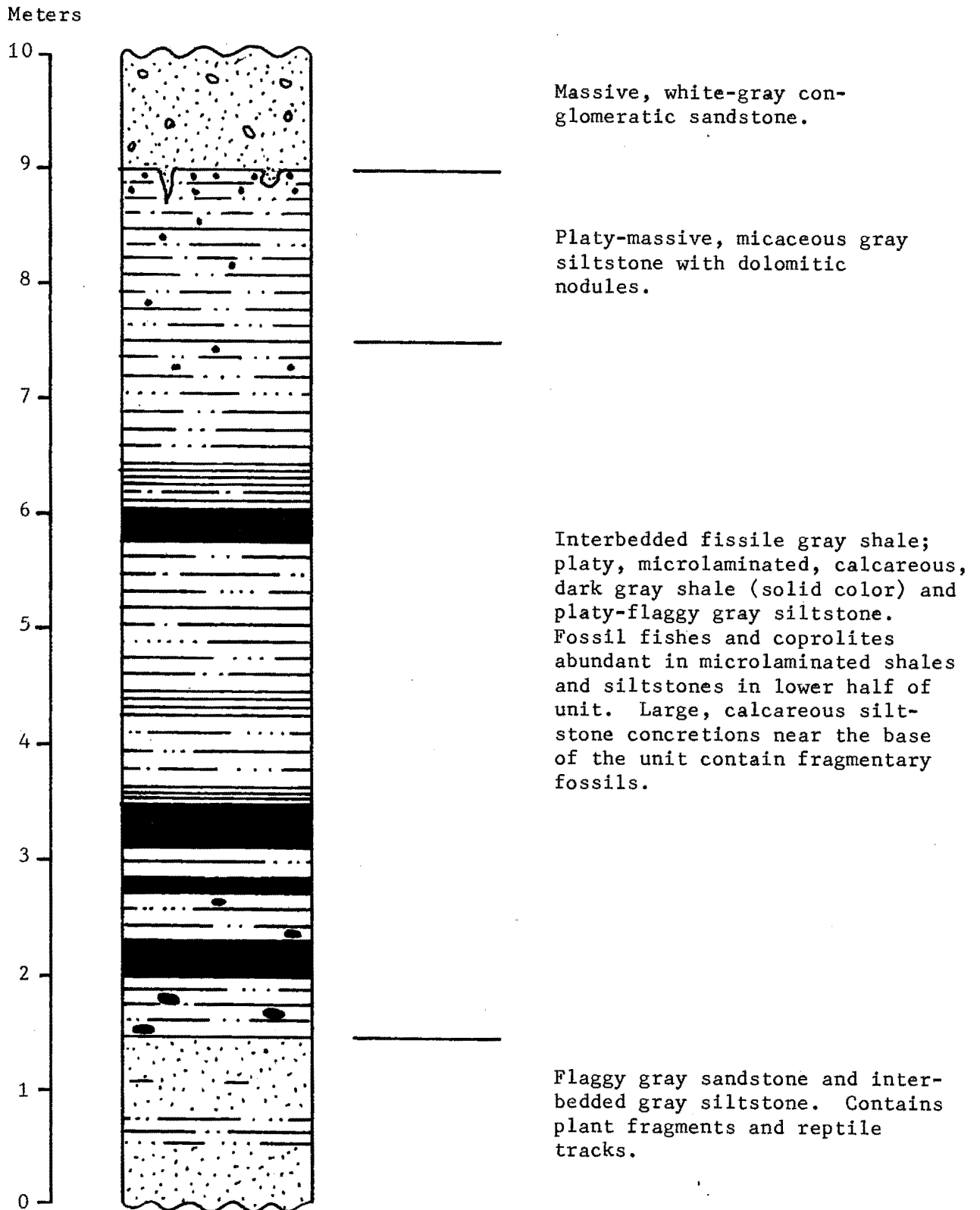

Figure 3. Generalized stratigraphic column of the uppermost lacustrine sequence in the Turners Falls Sandstone at Stop 1, Turners Falls, Massachusetts.

become thicker (up to 10 cm) and are the dominant lithology in the upper half of the sequence. The siltstone concretions are frequently calcareous and are broadly ovoid in shape; they can be as much as 20 cm long and 10 cm in diameter. Typically, the large concretions have a core of organic material, usually a fossil fish or coprolite. Smaller dolomitic or septarian nodules are common in the siltstones toward the top of the unit; these do not usually contain fossils. Scattered pyrite cubes and sparry calcite veins are found in some of the finer-grained beds. The lacustrine unit has been subject to a significant amount of deformation. Slickensides and small fault traces are abundant on many bedding surfaces; the lower half of the unit displays several large, tight, symmetric folds. The repetition of beds by folding has substantially increased the thickness of the unit.

The fossiliferous unit is underlain by flaggy, medium gray, fine to medium-grained sandstone with interbeds of platy, micaceous, medium gray siltstone. The fossil beds grade upward into platy-flaggy, dark gray, nodular siltstone, which in turn is overlain by hard, flaggy to massive, micaceous, medium gray siltstone with abundant dolomitic nodules. The top of the nodular beds exhibits large cracks which are filled with white-gray conglomeratic sandstone from the unit above.

The lacustrine sequences at Turners Falls are in many ways similar to the lacustrine cycles described by Thomson (1979) and Olsen (1980b). For example, detrital cycles in the Triassic lakes of the Lockatong Formation in New Jersey and Pennsylvania consist of three distinct lithologic divisions: (1) a basal transgressive facies, consisting of platy to massive gray siltstones (sometimes containing plant fossils and reptile footprints) which accumulated in shallow water as the lake was forming and expanding; (2) a microlaminated to coarsely laminated, black, gray or green, often calcareous siltstone or shale, containing fossil fishes, developed when the lake was at maximum depth; and (3) a regressive facies, composed of thickly-bedded to massive, gray or gray-red siltstone or sandstone, sometimes bearing reptile footprints and root horizons, formed as the lake filled in or dried up. In the measured section at Turners Falls, the transgressive facies is at least two meters thick, and its lithology and fossils are reflective of shallow water deposition. The deep water facies is well represented by about six meters of microlaminated shale and more massive siltstone, both of which contain fossil fish. The regressive facies is nearly 1.5 meters thick, and its lithology mirrors the gradual return to shallow water deposition. The uppermost part of the lake cycle at Turners Falls has been interpreted as a paleosol by Soloyanis (1972). The lacustrine cycles at Turners Falls thus record the expansion and eventual filling-in of large lakes.

Fossil fishes from this site were first mentioned in the literature by Emmons in 1857, but presumably the site was known much earlier by Hitchcock and others (McDonald, 1975). The fishes are most abundant in the microlaminated shale beds; frequently it is impossible to split the rock without hitting a fish. Fishes are less common in the siltstone beds, but often are found at the center of calcareous siltstone concretions in the lower two meters of the unit. The fishes in the microlaminated shales are preserved whole, are very compressed and are usually covered by a thin layer of rock. Those in the siltstones are less crushed and better preserved; fishes in the concretions tend to be fragmentary or dissociated.

The fishes from the Turners Falls locality are all semionotids of the "Semionotus tenuiceps" and "small scale" groups of Olsen, et al. (1982). They average 7 - 15 cm in length, but a few robust forms reach lengths of up to 40 cm.

Coprolites are also common in the microlaminated beds and rarely in the siltstone concretions. Two distinct types are present: ovoid, black masses up to 5 cm long, and smaller, grainy, irregular pellets averaging less than 1 cm in length. Identifiable plant remains are conspicuously rare, though charcoal-like bits of wood are sometimes encountered. In the sandstone strata directly beneath the fish beds, carbonized plant stem fragments and indistinct reptile footprints were seen. Well preserved reptile tracks, burrows and plant debris are abundant in certain of the fluvial and mudflat facies at this locality. Over the years, more reptile tracks have come from the Turners Falls area than from any other region in the Valley. The noteworthy variety, abundance and accessibility of the Turners Falls fossils make the site the most promising of all the Mesozoic fossil localities in Massachusetts.

From Stop 1, proceed west on Mass. Rt. 2 toward Interstate 91.

- 0.1 Exposures of Deerfield Basalt and underlying Sugarloaf Arkose on south side of road.
- 2.3 Entrance ramp for Interstate 91 South; bear left.
- 2.7 Intersection with Interstate 91 South. Exposures of Sugarloaf Arkose along east side of road. Roadcuts through the Sugarloaf continue for the next few miles.
- 3.9 Bridge over the Green River.
- 6.3 View of the Pocumtuck Range to the east; underlain by the Sugarloaf Arkose and Deerfield Basalt.
- 9.4 Bridge over the Deerfield River.
- 10.7 View of North and South Sugarloaf Mountains; underlain by Sugarloaf Arkose and type sections of the Formation.
- 14.8 Whately plain; exposures of Mesozoic bedrock are rare in this region. The junction of the Deerfield and Hartford basins occurs a short distance to the south, but is poorly exposed.
- 22.1 Panoramic view of the Holyoke-Mount Tom Range. The spectacular ridges are capped by the Holyoke Basalt.
- 26.8 Exposures of uppermost Sugarloaf Arkose occur along both sides of the highway and continue for 0.2 miles.
- 27.0 A thin, lacustrine black shale unit in the Sugarloaf is exposed on the west side of the highway. Coprolites, plant fossils and Semionotus have been collected here; it also is the only Massachusetts locality to have produced Redfieldius and

Ptycholepis. The beds are considered equivalents of the Shuttle Meadow Formation.

- 27.3 Outcrops of the Holyoke Basalt on the west side of the highway.
- 29.4 Exposures of the Granby Tuff; presumed equivalent to the Hampden Basalt.
- 30.2 Mountain Park road overpass; a thick section of the East Berlin Formation is seen in the northbound lane. A well-developed perennial lake cycle is exposed (see Carey, 1974; Hubert, et al., 1976); fossils include plant fragments, burrows and trails, dinosaur tracks and rare ostracods.
- 31.3 Exposures of East Berlin redbeds on the west side of the highway.
- 31.9 Exit 17. Leave the Interstate at this point; bear right.
- 32.1 Intersection with Mass. Rt. 141 (Easthampton Road); turn right (north).
- 32.9 Intersection with Southampton Road; turn left (south).
- 33.7 Intersection with Mountain Road; continue south on Southampton Road.
- 34.0 Exposures of massive conglomeratic arkose of the Sugarloaf, with thin, plant-rich shaly unit. Turn into the small dirt road just past the exposures (on the left) and park.

Stop 2. Clathropteris Locality, Holyoke.

A limited section of the upper Sugarloaf Arkose is exposed in a roadcut along Southampton Road, 2.5 km west of Holyoke, Massachusetts (Mount Tom 7.5 min. quadrangle). The rocks at the site consist largely of massive, buff-white conglomeratic arkose, but included in these coarse alluvial-fluvial units is a thin lens of fine-grained strata rich in fossil plant remains. The fossiliferous unit is 35 cm thick at its maximum, but the beds quickly thin out laterally. The unit is easily weathered and has been actively quarried in recent years; a short, narrow cave presently reveals its position. The fossiliferous beds are soft, platy to fissile, light gray to buff siltstone and shale, grading into coarse, flaggy, gray-buff sandstone at the base and top.

This locality is noteworthy because of its unusual density of well-preserved megafossil plants. The plants are found as carbon residues and as detailed impressions. Of particular mention are the abundant fronds of the fern Clathropteris meniscoides; specimens exceeding 20 cm in length have been obtained. This is one of the few places in the Valley where the fossils of this plant can be collected. Stems of the horsetail Equisitites are also common; it is not unusual to find these over 10 cm in length. The lower beds in the unit display evidence of root and rhizome penetration (Cornet, pers. comm., 1973). Certain horizons in the rock are filled with plant debris; it is very possible that other plant types will

be identified. The locality has produced pollen and spores (mainly fern spores) and is one of the palynologically important sites listed by Cornet and Traverse (1975). This fossiliferous unit appears to represent a local, short-lived fluvial swamp or near-channel floodplain pond environment. The well-preserved condition of the floral remains testifies that they were not transported a great distance before burial.

From Stop 2, proceed north on Southampton Road, retracing the route back to Interstate 91.

- 35.1 Intersection with Mass. Rt. 141; turn right (south).
- 35.9 Intersection with Interstate 91 entrance ramp; turn left. Continue south on the Interstate.
- 42.9 Bridge over the Connecticut River, connects West Springfield and Chicopee.
- 45.7 Springfield, Massachusetts.
- 51.3 Massachusetts-Connecticut State line.
- 59.2 Bridge over the Connecticut River, connects East Windsor and Windsor Locks.
- 70.4 Hartford, Connecticut.
- 73.7 Wethersfield Cove. Along the southeast side of the cove, exposures of the Portland Formation have yielded many species of reptile tracks.
- 77.9 Exposures of the Hampden Basalt on both sides of the road.
- 78.5 Exposures of East Berlin Formation redbeds on the east side of the road. Reptile tracks were found here during the building of the highway.
- 79.0 Exit 23. Leave the Interstate at this point; bear right.
- 79.2 Intersection with West Street; turn left (east).
- 80.2 Dinosaur State Park on the right; turn into the lot and park.

Stop 3. Dinosaur State Park, Rocky Hill.

No paleontological tour of the Valley could be complete without a visit to the spectacular reptile trackways of the East Berlin Formation at Dinosaur State Park, Rocky Hill, Connecticut (Hartford South 7.5 min. quadrangle). The site was discovered in 1966, during foundation excavations for a new State building. Exposures at the site have revealed nearly 2,000 reptile tracks, most of which have been reburied for preservation.

The present geodesic building at the Park houses some 500 tracks. The geology and paleontology of the locality have been discussed by Byrnes (1972) and Ostrom (1968). The track-bearing units at Rocky Hill are the gray arkoses, siltstones and mudstones in the upper portion of an East Berlin lacustrine cycle (see figure 5). The rocks display abundant ripple marks, raindrop impressions and mud cracks, indicative of shallow water deposition. The strata at the Park are located approximately 20 meters below the Hampden Basalt; they have been correlated with the stratigraphically highest lacustrine cycle at Stop 4 (Byrnes, 1972).

To date, three or four genera of reptile tracks have been identified at Dinosaur Park, namely Eubrontes, Anchisauripus, Batrachopus and possibly Grallator (Ostrom, 1968). However, the Eubrontes impressions far outnumber the other types, and presently are the only tracks visible in situ at the Park. The tracks of Eubrontes are broad, three-toed impressions ranging in length from 25 to 40 cm.

The size of the tracks and the distance between successive Eubrontes impressions suggests that the adult trackmakers were over two meters tall and some six meters long. Unfortunately, none of the known reptile skeletons from the Valley compare favorably with the Eubrontes footprints, and the specific type of reptile that made the tracks is not yet known. Ostrom (1968) has suggested that the footprints are those of a medium-sized carnivorous dinosaur, possibly a carnosaur. The skeletal remains which are the best match for the Eubrontes tracks are those of Dilophosaurus, a bipedal, carnivorous dinosaur from the early Mesozoic strata in Arizona (Richard Krueger, pers. comm., 1982). A life-size model of Dilophosaurus can be seen at the Park.

More than 40 separate Eubrontes trackways are exposed on the main footprint layer; most trackways are randomly oriented. This is in direct contrast to the situation at the Mount Tom site, north of Holyoke, Massachusetts, where Ostrom (1972) has described nineteen parallel Eubrontes trackways. He suggests that the makers of Eubrontes prints may have been gregarious. Coombs (1980) has further postulated that some of the Rocky Hill trackmakers had the ability to swim, based on his recognition of several rows of claw scratches on the surface of the main track horizon at Rocky Hill. He proposes that the claw marks were made by a half-submerged reptile pushing itself along the bottom with the tips of its toes.

From Stop 3, proceed west on West Street, toward Interstate 91.

81.2 Intersection with entrance ramp for Interstate 91; turn left (south). Continue south on the Interstate.

83.1 -

83.4 Extensive exposures of the East Berlin Formation and Hampden Basalt in four roadcuts to the west. These roadcuts were intended to be part of another exit from the Interstate, but the exit was never completed. These cuts are our next stop, but as access from the Interstate is unlawful, they will be reached via a secondary road.

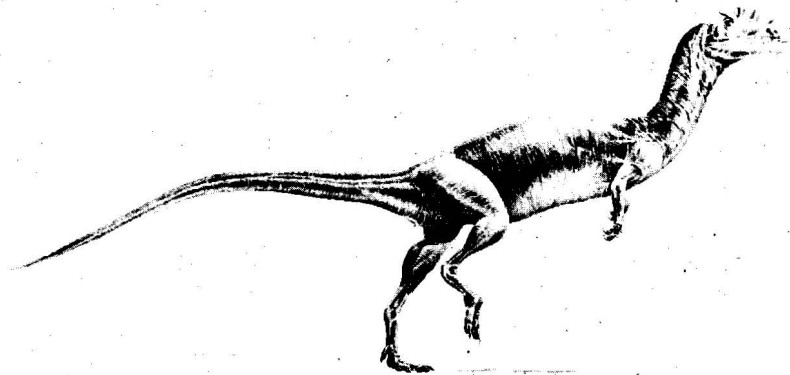

Figure 4. Top: Exposures of the main footprint horizon at Dinosaur Park, Rocky Hill, Connecticut, at an early stage of excavation. Note the abundant Eubrontes trackways. Photo by John Howard.

Bottom: Restoration of Dilophosaurus, suggested Eubrontes trackmaker at Rocky Hill. Sketch by Robert Bakker.

- 84.3 Exit 21. Leave the Interstate at this point; bear right.
- 84.7 Intersection with Conn. Rt. 72; turn left (east).
- 84.9 Underpass beneath Interstate 91; Hampden Basalt on left (north) side of road.
- 85.4 Intersection with Conn. Rt. 217 (Coles Road); turn left (north).
- 86.3 Intersection with North Road; turn left (west). Immediately ahead is Interstate 91 underpass.
- 86.8 Junction with Pasco Hill Road; continue straight ahead on road marked "dead end."
- 87.5 Turn around at the end of the road.
- 87.8 Park on right, just before bridge over brook. Trail to Stop 4 begins on left (east) side of road about 10 meters beyond (south of) bridge. Follow trail to large roadcuts.

Stop 4. Route 9 and Interstate 91 Interchange, Cromwell.

Sixty-two meters of the uppermost East Berlin Formation plus the lower portion of the Hampden Basalt are exposed in a series of four unpaved roadcuts at the intersection of Conn. Rt. 9 and Interstate 91 in Cromwell, Connecticut (Middletown and Hartford South 7.5 min. quadrangles).

This locality is of particular importance because it offers one of the largest exposures of the fossiliferous East Berlin Formation and because it displays most of the typical lithologies of the Formation. The exposures at this site have been described in detail by Klein (1968) and by Hubert, et al. (1976; 1978). They consist of 24% gray-black mudstone, shale and sandstone (perennial lakes), 61% red mudstone (floodplains), 8% thin, evenly-bedded red sandstone and siltstone (shallow, oxidized lakes) and 7% pale-red channel sandstone (river channels). There are three symmetrical perennial lake cycles exposed at this locality (see figure 5); these are of special interest because of their potential for fossils. The reader is referred to the reports of Hubert, et al. for further lithologic and paleoecologic data on this site.

Most of the fossils from this locality have come from the gray mudstone and gray-black shale beds of the lacustrine facies. A large portion of each lacustrine cycle is palynologically productive; some laminae in the gray mudstones have produced carbonized leaf and twig fragments of the conifers Brachyphyllum and Pagiophyllum (Cornet, 1977). Leafy shoots up to 20 cm in length are occasionally found, particularly in the highest lacustrine cycle where the mudstone is most weathered and accessible. Charcoal-like bits of wood are frequently found in the black shale beds. A recent excavation in the fissile-platy, microlaminated black shales of the middle cycle has resulted in the discovery of conchostracans (Cyzicus sp.), small, grainy coprolites and rare isolated fish scales. Dinosaur tracks have been recovered from the gray mudstone and siltstone units and also from some of the redbeds at the site; at least one red siltstone/mudstone bed contains a horizon with the numerous dissociated scales and

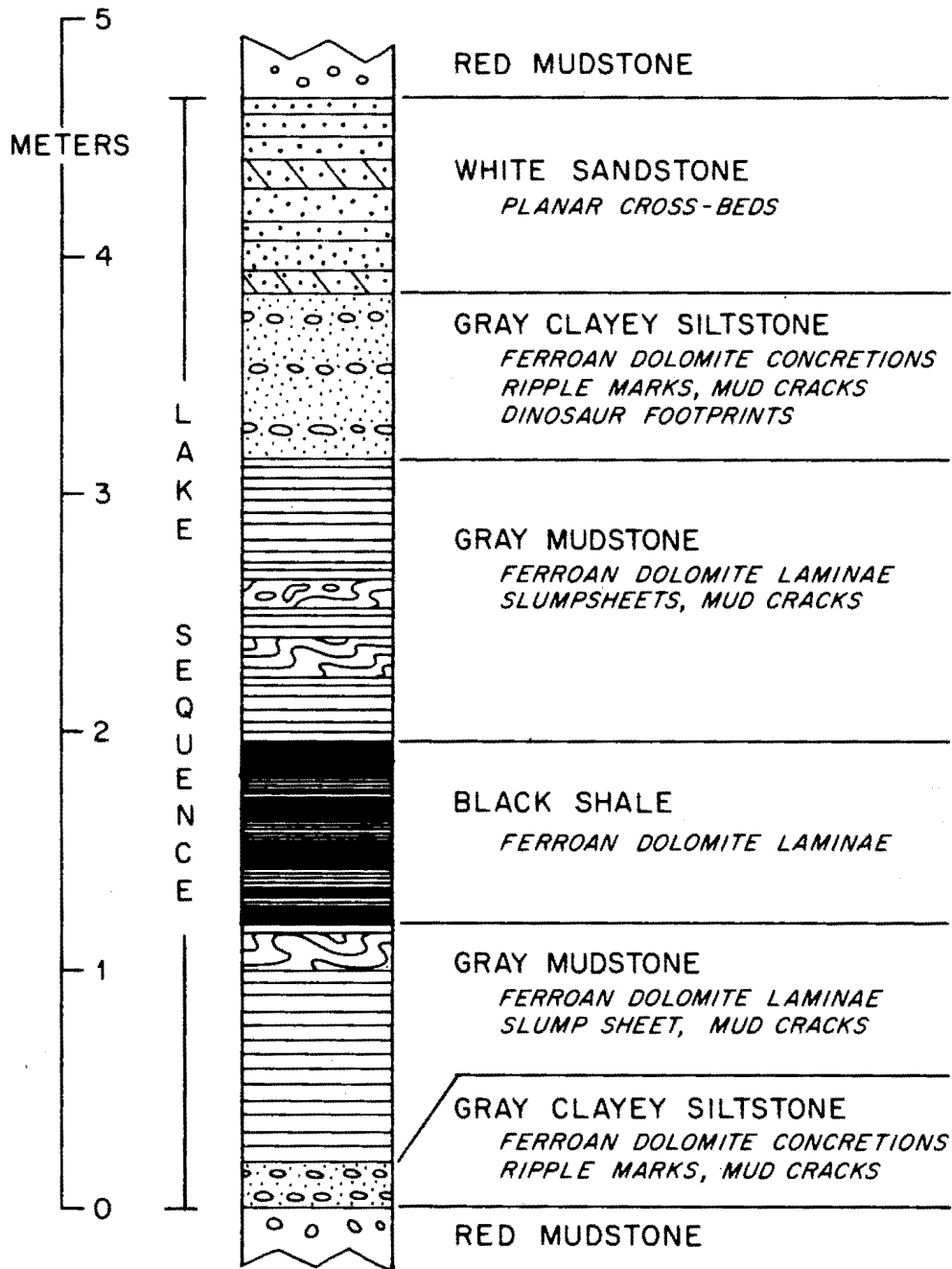

Figure 5. Symmetrical perennial lake cycle in the East Berlin Formation, Stop 4, Cromwell, Connecticut (after Hubert, *et al.*, 1978). Fish scales, conchostracans and coprolites occur in the fissile, microlaminated black shales; pollen, spores and megafossil plant fragments are found in the shales and mudstones. Reptile tracks, invertebrate trails and burrows are locally abundant in the siltstones, sandstones and red mudstones.

bones of Semionotus. Burrows and trails of invertebrates are contained in the various gray and red lithologies. Even though this locality has not produced the noteworthy fossil fishes and reptile tracks found at other East Berlin sites, it is significant because of its diversity of fossils (tracks, fish, conchostracans, plants, burrows, trails) and because of the potential that such a large section of exposed strata holds.

From Stop 4, proceed south on North Road, retracing the route to Conn. Rt. 217.

- 88.9 Intersection with Rt. 217 (Coles Road); turn right (south).
- 89.5 Intersection with Conn. Rt. 72; continue straight ahead at lights.
- 89.8 West Lake Condominiums on right (west).
- 90.4 Orchard Hill Lane on left; turn in and park in front of "dead end" sign. On both sides of the entrance to this lane are exposed East Berlin redbeds. These have produced reptile tracks and also contain a horizon of Semionotus scales and bones. To reach Stop 5, walk about 50 meters north along Rt. 217, then proceed west across a field to reach Miner Brook.

Stop 5. Westfield Locality.

The fossiliferous lacustrine strata of the East Berlin Formation are exposed in the bed of Miner Brook, approximately 1 km north of the village of Westfield, Connecticut (Middletown 7.5 min. quadrangle). More than three meters of gray-black shale and mudstone outcrop along strike in the stream channel for a distance of at least 50 meters.

As the columnar section below reveals, the perennial lake sequence at Westfield bears a close resemblance to the symmetrical lacustrine cycles seen at Stop 4. The center of the Westfield cycle consists of richly fossiliferous (fish, plants, conchostracans, coprolites), hard, platy to flaggy, calcareous, distinctly microlaminated dark gray shale. This shale is overlain and underlain by sparsely fossiliferous, platy to fissile, pyritic, micaceous, medium gray silty shale with no distinct light and dark microlaminae. These shale beds accumulated in the deep, stagnant central portions of a large lake (Hubert, et al., 1978). Fissile to hackly, medium gray mudstones are found above and below the shale beds; these contain fragmentary plant fossils and accumulated at shallower depths where scavengers and bioturbators were active. The massive gray sandstones at the top and bottom of the lacustrine cycle are shoreline deposits, as the abundant reptile footprints and ripple marks in the lower sandstone imply.

The Westfield site is the oldest recorded fossil fish and plant locality in the Connecticut Valley. Fossils were discovered in Westfield prior to 1816, during unsuccessful excavations for coal. Fossil fishes and coprolites are most abundant and best preserved near the center of the 30+ cm thick microlaminated shale beds; fishes from the upper and lower parts of the unit are rare and are little more than faint organic smears. Nearly all the fishes from Westfield are whole. No fishes have

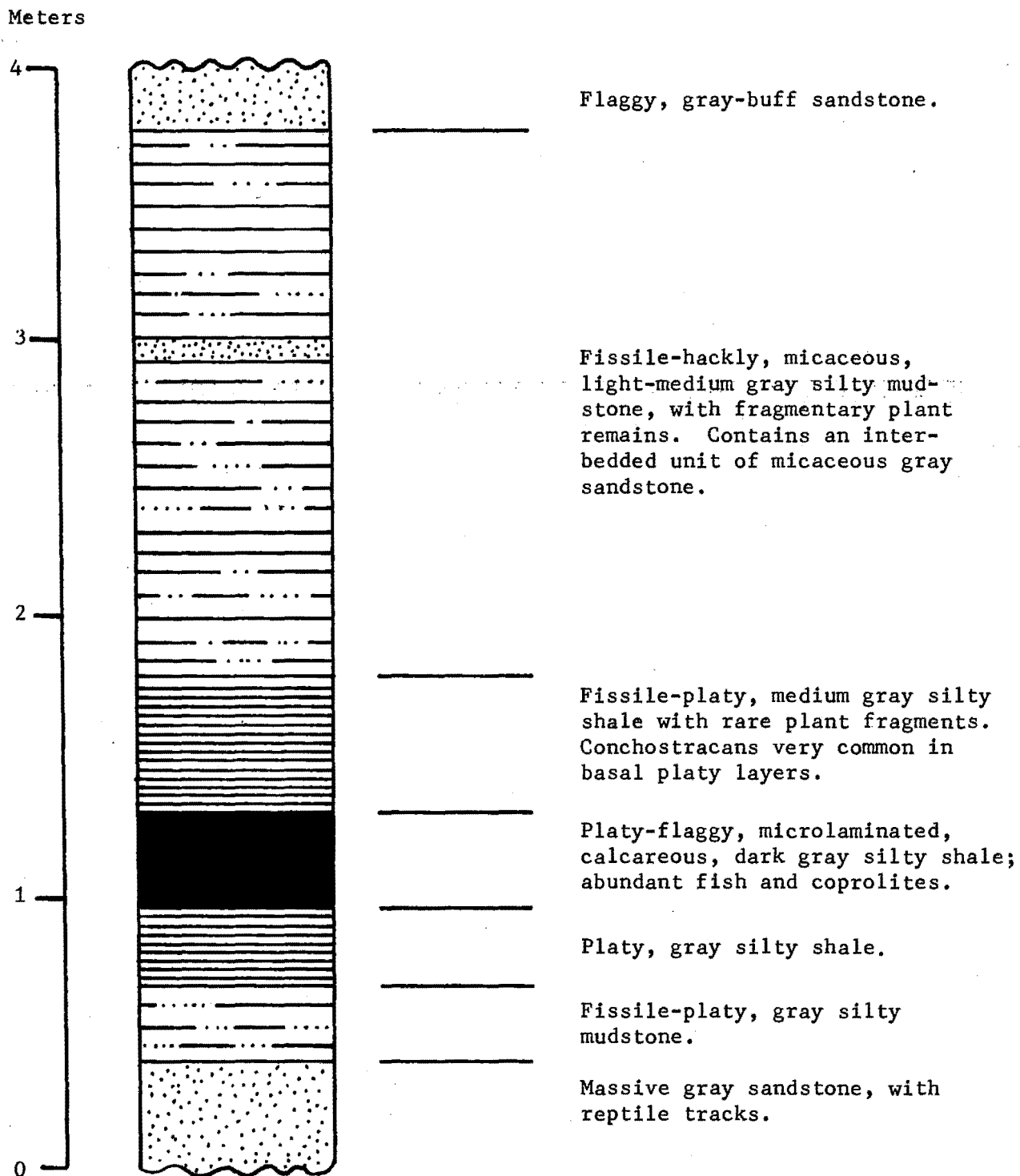

Figure 6. Generalized stratigraphic column of the lacustrine sequence in the East Berlin Formation at Stop 5, Westfield, Connecticut.

been found above or below the microlaminated unit. Fishes collected from this site include about equal numbers of Redfieldius gracilis and semi-onotids of the "S. micropterus group" of Olsen, et al. (1982). Diplurus longicaudatus has also been found, though only a handful of specimens exist. Both the "diplurid" and small, irregular, grainy varieties of coprolites (see p. M2-8) are common at Westfield. Above the distinctly microlaminated shales occurs a 10+ cm thick unit of platy, dark gray shale containing conchostracans (see p. M2-9). Strap-like plant fragments and coalified bits of wood occur throughout the section, but few plant remains are identifiable. A ledge of gray sandstone below the fish bed contains numerous, small, Anchisauripus-like reptile tracks.

From Stop 5, proceed north on Conn. Rt. 217.

- 91.3 Intersection of Rt. 217 with Rt. 72; turn right (east) at lights.
- 92.3 Intersection with Conn. Rt. 9; turn right (south) on entrance ramp. Proceed south on Rt. 9.
- 93.0 Exposures of the Portland Arkose in the stream gully to the east have produced abundant dinosaur tracks.
- 95.5 Bridge over the Connecticut River, connecting Middletown and Portland. Just north of the bridge in Portland are the famous brownstone quarries which have produced dinosaur tracks and impressions of fossil trees.
- 96.3 Junction with Conn. Rt. 17; turn right.
- 96.8 Rotary; bear left and continue south on Rt. 17.
- 99.0 Monte Green Inne; exposures of coarse redbeds of the Portland Formation in parking lot.
- 100.6 Weigh station on right (west); pull in to parking lot and stop. To reach Stop 6, walk directly west across the fields and through the woods for approximately .7 km. When you intersect a small brook, follow it downstream (north) to the gorge where the rocks are best exposed.

Stop 6. Middlefield Locality.

A picturesque exposure of the dark shales of the lower Portland Formation is revealed in the narrow gorge of a small, north-flowing stream which drains into the Laurel Brook Reservoir near the Durham town line, some 3 km southeast of the village of Middlefield, Connecticut (Middletown 7.5 min. quadrangle). Nearly 20 meters of section are exposed in the bed and along the banks of the stream. Note: This is not the famous "Durham" fossil fish locality, which is located south of the town of Durham.

The rocks at the Middlefield site have been described recently by Gilchrist (1979). As his columnar section (figure 7) shows, the exposures reflect alternating fluvial and lacustrine paleoenvironments. One large

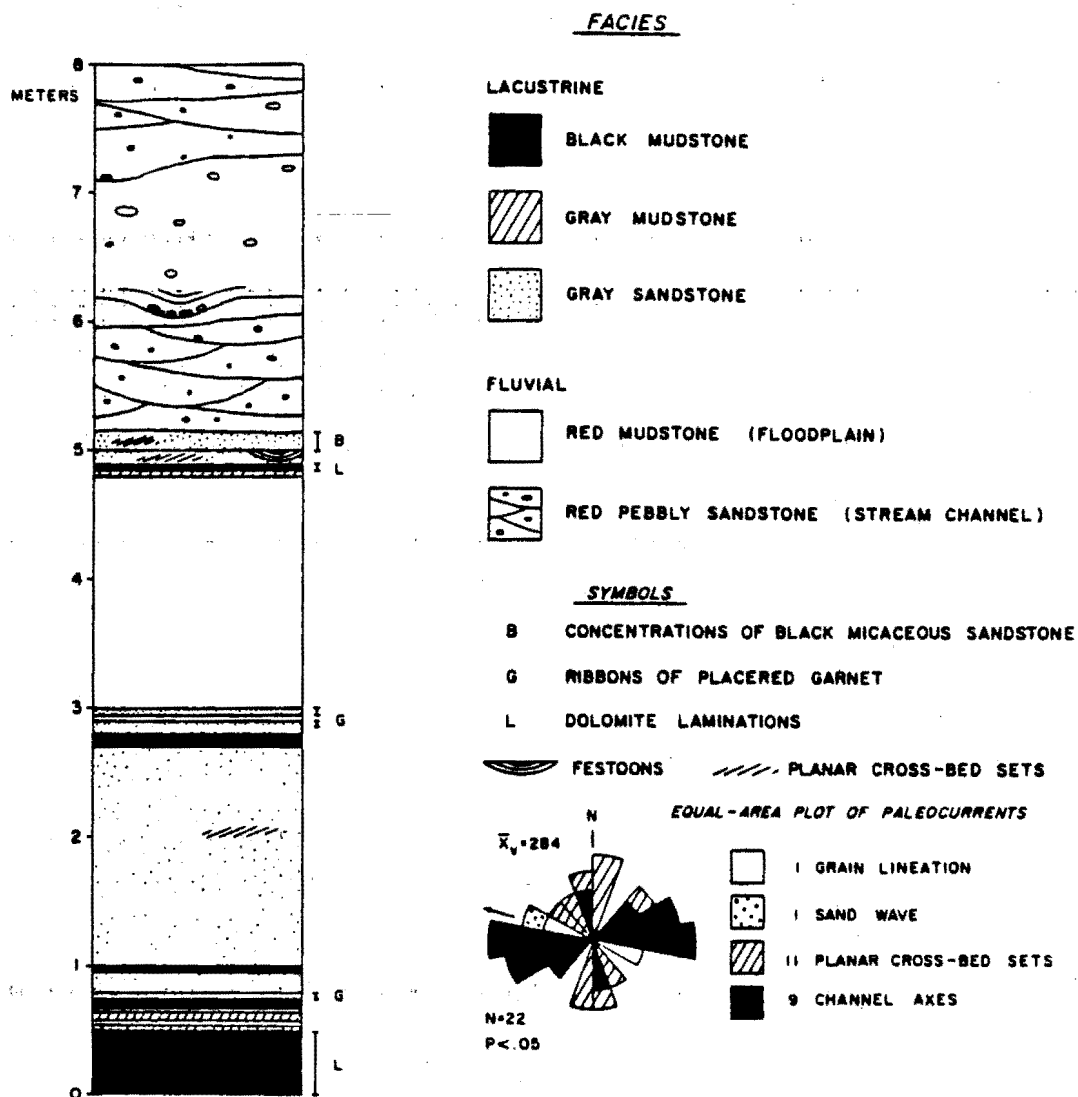

Figure 7. Columnar section of the non-symmetrical lacustrine strata of the lower Portland Formation at Stop 6, Middlefield, Connecticut (after Gilchrist, 1979). Paleocurrents are exclusively for the lacustrine facies. The basal lacustrine unit has produced large numbers of semionotid and redfieldiid fishes. Reptile tracks and fragmentary plant remains are occasionally found in the fluvial facies.

and four small perennial lake sequences are present in the section; however, there are no symmetrical cycles of gray mudstone-black shale-gray mudstone, as in the East Berlin Formation. The basal lacustrine facies is the thickest (.5 m), and from it have come nearly all the fossils (mainly fishes) found at the locality. The fossiliferous beds at Middlefield are platy to flaggy, calcareous, microlaminated, dark gray silty shales with interbeds of massive, light gray micaceous siltstone.

The Middlefield locality ranks second only to the Durham site (in the Shuttle Meadow Formation) in its historical and paleontological significance. It has been known to geologists since at least 1818, when Benjamin Silliman, Sr. made a reference to the fossil fishes there. The Redfields, Newberry and Loper are among the notable geologists who collected and described the fossils at Middlefield. Thousands of fishes have been obtained from the site over the years, and the locality is still very popular with modern collectors. Semionotids of the "S. elegans group" (Olsen, et al., 1982) are the most abundant fishes at Middlefield; specimens of Redfieldius are also frequently encountered. The only existing co-type of Redfieldius gracilis was collected at this site in 1836 by J. H. Redfield. Diplurus and Ptycholepis have not been found at Middlefield. The overall preservation of the fishes varies markedly; some examples are no more than vague organic smears, other specimens are well preserved and finely detailed. Nearly all the fishes are whole. Coprolites and plant fossils are present in the Middlefield beds, but they are not common. Reptile tracks have been observed in some of the fluvial lithologies.

End of trip. To reach Interstate 91 northbound, proceed north on Rt. 17 to Middletown, then north on Rt. 9 to Cromwell and the intersection with I-91. To reach New Haven and the shoreline, continue south on Rt. 17.

References

- Baird, Donald, 1957, Triassic reptile footprint faunules from Milford, New Jersey: Mus. Comp. Zool. Bull., v. 117, p. 447-520.
- Byrnes, J. B., 1972, The bedrock geology of Dinosaur State Park, Rocky Hill, Connecticut: M.S. Thesis, Univ. of Conn., Storrs, Conn., 244 p.
- Carey, P. J., 1974, Sedimentology of inferred mud flat and lake deposits, East Berlin Formation, Holyoke, Massachusetts: M.S. Report, Univ. of Mass., Amherst, Mass., 95 p.
- Cleaveland, Parker, 1816, An elementary treatise on mineralogy and geology, etc.: Boston, Cummings and Hilliard, 668 p.
- Colbert, E. H., 1964, The Triassic dinosaur genera Podokesaurus and Coelophysus: Am. Mus. Novit., no. 2168, p. 1-12.
- Colbert, E. H., 1970, Fossils of the Connecticut Valley: The age of dinosaurs begins (revised edition): Conn. Geol. Nat. Hist. Surv. Bull., no. 96, 32 p.

- Colbert, E. H. and Baird, Donald, 1958, Coelurosaur bone casts from the Connecticut Valley Triassic: *Am. Mus. Novit.*, no. 1901, p. 1-11.
- Coombs, W. P., Jr., 1980, Swimming ability of carnivorous dinosaurs: *Science*, v. 207, p. 1198-1200.
- Cornet, Bruce, 1977, The palynostratigraphy and age of the Newark Super-group: Ph.D. Diss., Penn. State Univ., University Park, Penn., 505 p.
- Cornet, Bruce and Traverse, Alfred, 1975, Palynological contributions to the chronology and stratigraphy of the Hartford basin in Connecticut and Massachusetts: *Geosci. Man*, v. 11, p. 1-33.
- Cornet, Bruce, Traverse, Alfred and McDonald, N.G., 1973, Fossil spores, pollen and fishes from Connecticut indicate early Jurassic age for part of the Newark Group: *Science*, v. 182, p. 1243-1247.
- Dana, S.L. and Hitchcock, Edward, 1845, Analysis of coprolites from the New Red Sandstone formation of New England: *Am. Jour. Sci.*, 1st Ser., v. 48, p. 46-60.
- deBoer, Jelle, 1968, Paleomagnetic differentiation and correlation of the late Triassic volcanic rocks in the central Appalachians (with special reference to the Connecticut Valley): *Geol. Soc. Am. Bull.*, v. 79, p. 609-626.
- Eastman, C. R., 1911, Triassic fishes of Connecticut: *Conn. Geol. Nat. Hist. Surv. Bull.*, no. 18, 77 p.
- Emerson, B. K., 1900, A new bivalve from the Connecticut River Trias: *Am. Jour. Sci.*, 4th Ser., v. 10, p. 58.
- Emerson, B. K. and Loomis, F. B., 1904, On Stegomus longipes, a new reptile from the Triassic sandstones of the Connecticut Valley: *Am. Jour. Sci.*, 4th Ser., v. 17, p. 377-380.
- Emmons, Ebenezer, 1857, American geology, etc., part 6: Albany, N.Y., Sprague and Co., 152 p.
- Galton, P.M., 1971, The prosauropod dinosaur Ammosaurus, the crocodile Protosuchus, and their bearing on the age of the Navajo Sandstone of northeastern Arizona: *Jour. Paleontol.*, v. 45, p. 781-795.
- Galton, P.M., 1976, Prosauropod dinosaurs (Reptilia: Saurischia) of North America: *Postilla*, no. 169, 98 p.
- Galton, P.M. and Cluver, M.A., 1976, Anchisaurus capensis (Broom) and a revision of the Anchisauridae (Reptilia, Saurischia): *South Afr. Mus. Ann.*, v. 69, p. 121-159.
- Gilchrist, J. M., 1979, Sedimentology of the Lower to Middle Jurassic Portland Arkose of central Connecticut: M.S. Thesis, Univ. of Mass., Amherst, Mass., 166 p.

- Handy, W. A., 1976, Depositional history and diagenesis of lacustrine and fluvial sedimentary rocks of the Turners Falls and Mount Toby transition, north-central Massachusetts: M.S. Thesis, Univ. of Mass., Amherst, Mass., 115 p.
- Hitchcock, Edward, 1818, Remarks on the geology and mineralogy of a section of Massachusetts on Connecticut River, etc.: Am. Jour. Sci., 1st Ser., v. 1, p. 105-116.
- Hitchcock, Edward, 1836, Ornithichnology - description of the foot-marks of birds (Ornithichnites) on New Red Sandstone in Massachusetts: Am. Jour. Sci., 1st Ser., v. 29, p. 307-340.
- Hitchcock, Edward, 1858, Ichnology of New England: Boston, Commonwealth of Massachusetts, 220 p.
- Hitchcock, Edward, 1861, Additional facts respecting the Clathropteris of Easthampton, Massachusetts: Am. Assoc. Adv. Sci. Proc., v. 14, p. 158-159.
- Hitchcock, Edward, Jr., 1855, Description of a new species of Clathropteris, discovered in the Connecticut Valley sandstone: Am. Jour. Sci., 2nd Ser., v. 20, p. 22-25.
- Hitchcock, Edward, Jr., 1856, A new fossil shell in the Connecticut River sandstone: Am. Jour. Sci., 2nd Ser., v. 22, p. 239-240.
- Hubert, J. F., 1978, Paleosol caliche in the New Haven Arkose, Newark Group, Connecticut: Palaeogeog. Palaeoclim. Palaeoecol., v. 24, p. 151-168.
- Hubert, J. F., Reed, A. A. and Carey, P. J., 1976, Paleogeography of the East Berlin Formation, Newark Group, Connecticut Valley: Am. Jour. Sci., v. 276, p. 1183-1207.
- Hubert, J.F., Reed, A. A., Dowdall, W. L. and Gilchrist, J. M., 1978, Guide to the redbeds of central Connecticut: Conn. Geol. Nat. Hist. Surv. Guidebook, no. 4, 129 p.
- Huene, F. R. von, 1922, The Triassic reptilian order Thecodontia: Am. Jour. Sci., 5th Ser., v. 4, p. 22-26.
- Klein, G. deV., 1968, Sedimentology of Triassic rocks in the lower Connecticut Valley; In: Orville, P.M., (ed.), Guidebook for fieldtrips in Connecticut: New England Intercoll. Geol. Conf., 60th Annu. Mtg., New Haven: Conn. Geol. Nat. Hist. Surv. Guidebook, no. 2, trip C-1, p. 1-19.
- Krynine, P.D., 1950, Petrology, stratigraphy and origin of the Triassic sedimentary rocks of Connecticut: Conn. Geol. Nat. Hist. Surv. Bull., no. 73, 247 p.

- Kuniholm, J. G., 1980, Depositional interpretation of the late Triassic and early Jurassic sedimentary strata exposed at Turners Falls, Massachusetts: B.A. Honors Thesis, Amherst College, Amherst, Mass., 66 p.
- Lehmann, E. P., 1959, The bedrock geology of the Middletown quadrangle, with map: Conn. Geol. Nat. Hist. Surv. Quad. Rept., no. 8, 40 p.
- Loper, S. W., 1891, Fossils of the Anterior and Posterior Shales; In: Davis, W. M. and Loper, S. W., Two belts of fossiliferous black shale in the Triassic formation of Connecticut: Geol. Soc. Am. Bull., v. 2, p. 425-430.
- Loper, S. W., 1899, Fossiliferous black shales: Pop. Sci. News, v. 33, p. 97-98.
- Lull, R. S., 1904, Fossil footprints of the Jura-Trias of North America: Boston Soc. Nat. Hist. Mem., v. 5, p. 461-557.
- Lull, R. S., 1912, The life of the Connecticut Trias: Am. Jour. Sci., 4th Ser., v. 33, p. 397-422.
- Lull, R. S., 1915, Triassic life of the Connecticut Valley: Conn. Geol. Nat. Hist. Surv. Bull., no. 24, 285 p.
- Lull, R. S., 1953, Triassic life of the Connecticut Valley (Revised): Conn. Geol. Nat. Hist. Surv. Bull., no. 81, 336 p.
- Manspeizer, Warren, Puffer, J. H. and Cousminer, H. L., 1978, Separation of Morocco and eastern North America: A Triassic-Liassic stratigraphic record: Geol. Soc. Am. Bull., v. 89, p. 901-920.
- Marsh, O. C., 1885, Names of extinct reptiles: Am. Jour. Sci., 3rd Ser., v. 29, p. 169.
- Marsh, O. C., 1893, Restoration of Anchisaurus: Am. Jour. Sci., 3rd Ser., v. 45, p. 169-170.
- Marsh, O. C., 1896, A new belodont reptile (Stegomus) from the Connecticut River sandstone: Am. Jour. Sci., 4th Ser., v. 2, p. 59-62.
- McDonald, N.G., 1975, Fossil fishes from the Newark Group of the Connecticut Valley: M.A. Thesis, Wesleyan Univ., Middletown, Conn., 230 p.
- Newberry, J. S., 1879, Descriptions of new fossil fishes from the Trias: N.Y. Acad. Sci. Ann., v. 1, p. 127-128.
- Newberry, J. S., 1888, Fossil fishes and fossil plants of the Triassic rocks of New Jersey and the Connecticut Valley: U.S. Geol. Surv. Monogr., v. 14, 152 p.

- Olsen, P. E., 1980a, A comparison of the vertebrate assemblages from the Newark and Hartford basins (early Mesozoic, Newark Supergroup) of eastern North America; In: Jacobs, L. L., (ed.), Aspects of vertebrate history: essays in honor of Edwin Harris Colbert: Flagstaff, Ariz., Northern Ariz. Press, p. 35-53.
- Olsen, P. E., 1980b, Fossil great lakes of the Newark Supergroup in New Jersey; In: Manspeizer, Warren, (ed.), Field studies of New Jersey geology and guide to field trips: N.Y. State Geol. Assoc., 52nd Annu. Mtg., Rutgers Univ., Newark, N.J., p. 352-398.
- Olsen, P. E., McCune, A. R. and Thomson, K. S., 1982, Correlation of the early Mesozoic Newark Supergroup by vertebrates, principally fishes: Am. Jour. Sci., v. 282, p. 1-44.
- Ostrom, J. H., 1967, (On the discovery of Hypsognathus in Connecticut): Discovery, v. 3, p. 59.
- Ostrom, J. H., 1968, The Rocky Hill dinosaurs; In: Orville, P.M., (ed.), Guidebook for fieldtrips in Connecticut: New England Intercol. Geol. Conf., 60th Annu. Mtg., New Haven: Conn. Geol. Nat. Hist. Surv. Guidebook, no. 2, trip C-3, p. 1-12.
- Ostrom, J. H., 1969, (On the preparation of Hypsognathus from the New Haven Arkose of Connecticut): Discovery, v. 4, p. 127.
- Ostrom, J. H., 1972, Were some dinosaurs gregarious?: Palaeogeog. Palaeoclim. Palaeoecol., v. 11, p. 287-301.
- Redfield, J. H., 1837, Fossil fishes of Connecticut and Massachusetts, with a notice of an undescribed genus: N.Y. Lyceum Nat. Hist. Ann., v. 4, p. 35-40.
- Redfield, W. C., 1841, Short notices of American fossil fishes: Am. Jour. Sci., 1st Ser., v. 41, p. 24-28.
- Robbins, E. I., Niklas, K. J. and Sanders, J. E., 1979, Algal kerogens in the Newark Group lakebeds - their bearing on the early Mesozoic history of the Atlantic continental margin: Palynology, v. 3, p. 291.
- Schaeffer, Bobb, 1948, A study of Diplurus longicaudatus, with notes on the body form and locomotion of the Coelacanthini: Am. Mus. Novit., no. 1378, p. 1-32.
- Schaeffer, Bobb, 1952, The Triassic coelacanth fish Diplurus, with observations on the evolution of the Coelacanthini: Am. Mus. Nat. Hist. Bull., v. 99, p. 25-78.
- Schaeffer, Bobb, 1967, Late Triassic fishes from the western United States: Am. Mus. Nat. Hist. Bull., v. 135, p. 285-342.
- Schaeffer, Bobb, Dunkle, D. H. and McDonald, N. G., 1975, Ptycholepis marshi Newberry, a chondrosteian fish from the Newark Group of eastern North America: Fieldiana: Geol., v. 33, p. 205-233.

- Schaeffer, Bobb and McDonald, N. G., 1978, Redfieldiid fishes from the Triassic-Liassic Newark Supergroup of eastern North America: *Am. Mus. Nat. Hist. Bull.*, v. 159, p. 129-174.
- Scudder, S. H., 1886, The oldest known insect larva, Mormolucoides articulatus, from the Connecticut River rocks: *Boston Soc. Nat. Hist. Mem.*, v. 3, p. 431-438.
- Silliman, Benjamin, 1818, Notice of Eaton's Index to the Geology of the Northern States, etc.: *Am. Jour. Sci.*, 1st Ser., v. 1, p. 69-70.
- Silliman, Benjamin, Jr., 1847, On fossil trees found at Bristol, Connecticut, in the New Red Sandstone: *Am. Jour. Sci.*, 2nd Ser., v. 4, p. 116-118.
- Smith, Nathan, 1820, Fossil bones found in red sandstone: *Am. Jour. Sci.*, 1st Ser., v. 2, p. 146-147.
- Soloyanis, S. C., 1972, Upper Triassic fluviatile and lacustrine sediments, Turners Falls, Massachusetts: B.A. Honors Thesis, Smith College, Northampton, Mass., 86 p.
- Stevens, R. L. and Hubert, J.F., 1980, Alluvial fans, braided rivers, and lakes in a fault-bounded semiarid valley: Sugarloaf Arkose (late Triassic-early Jurassic), Newark Supergroup, Deerfield basin, Massachusetts: *Northeastern Geol.*, v. 2, p. 100-117.
- Talbot, Mignon, 1911, Podokesaurus holyokensis, a new dinosaur from the Triassic of the Connecticut Valley: *Am. Jour. Sci.*, 4th Ser., v. 31, p. 469-479.
- Thomson, K. S., 1979, Old lakes and new fossils: some important discoveries found in eastern seaboard excavations: *Yale Alumni Mag. Jour.*, v. 42, p. 25-27.
- Troxell, E. L., 1914, Unios in the Triassic of Massachusetts: *Am. Jour. Sci.*, 4th Ser., v. 38, p. 460-462.
- Van Houten, F. B., 1977, Triassic-Liassic deposits of Morocco and eastern North America: comparison: *Am. Assoc. Pet. Geol. Bull.*, v. 61, p. 79-99.
- Walker, A.D., 1968, Protosuchus, Proterochampsa and the origin of phytosaurs and crocodiles: *Geol. Mag.*, v. 105, p. 1-14.
- Wessel, J. M., 1969, Sedimentary history of Upper Triassic alluvial fan complexes in north-central Massachusetts: *Univ. Mass. Dept. Geol. Contrib.*, no. 2, 157 p.
- Wessel, J. M., Hand, B. M. and Hayes, M.O., 1967, Sedimentary features of the Triassic rocks in northern Massachusetts; In: Robinson, Peter, (ed.), *Guidebook for field trips in the Connecticut Valley of Massachusetts*: New England Intercolli. Geol. Conf., 59th Annu. Mtg., Amherst, Mass., trip L, p. 154-165.

Mesozoic Volcanism in North-Central Connecticut

Norman H. Gray
Department of Geology and Geophysics
University of Connecticut, Storrs, CT

Introduction

Silliman at Yale and Hitchcock at Amherst College began the study of the volcanic rocks of the Connecticut River Valley over 150 years ago. Since their day field excursions have often been organized to view various features shown by these rocks. In recent times the NEIGC has visited a number of important exposures in central Massachusetts (Brophy 1959, Brophy et al 1967) and southern Connecticut (deBoer 1968a, Sanders 1970). Today's excursion concentrates on the volcanics in an area of the Hartford basin not covered on these previous trips.

Three principal basalt flows occur in northern Connecticut. From oldest to youngest these are referred to today as the Talcott, Holyoke and Hampden (Lehmann, 1959). Although all are basalts, they are individually distinct and differ from one another chemically, mineralogically and structurally.

Talcott

The Talcott is a complex multiple sheet composed of many small flows which were piled on top of one another over a period of several years. Its total thickness ranges from 50m at Meriden to 20m north of Farmington. An erosional unconformity thins and truncates the flow near Newgate Prison in East Granby.

The lower half of the Talcott is generally massive but the presence locally of chilled flow surfaces and imbricated pillowed sheets attests to its true composite nature. The rest of the flow is typically a complex pile of apparently randomly interbedded massive, pillowed and/or vesicular sheets of variable extent and thickness.

Minor pillow-like features are associated with interflow boundaries and are widely distributed through the flow. Thick sequences of pillows however are found only in restricted zones, none of which extend more than a kilometer along strike (Fig. 1). The pillows in these zones are elongated lobate tubular tongue shaped bodies, 1/2 to 2m in diameter which are interconnected in overlapping distributary-like networks. Separate totally detached pillows are not common. The smallest pillows typically occur at the base of pillowed sheets. Size increases upwards and in many minor flows the upper portions are massive.

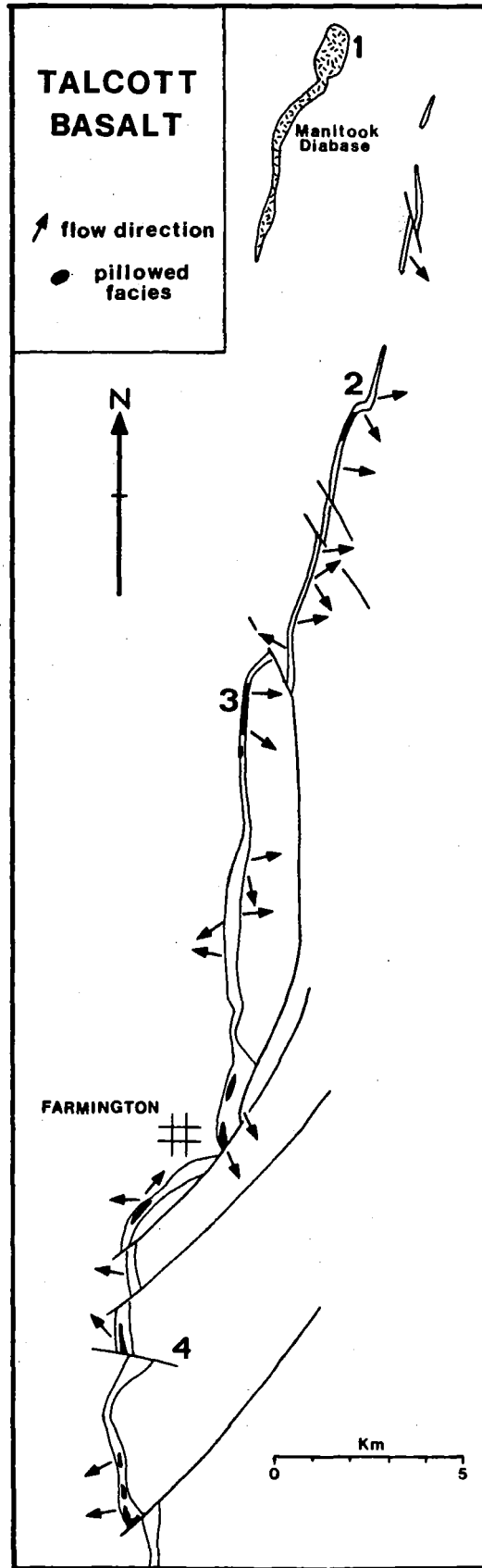

Figure 1. Mean flow directions in the Talcott basalt. Field trip localities indicated by stop number.

The evidence suggests pillows were formed when small flows entered shallow lakes. As major flows advanced to a lake, the displaced waters flooded embayments between massive flow lobes where the localized thick pillowed sequences developed.

Regional mapping of flow indicators in the Talcott suggests a western source north of Farmington and a separate eastern source for the flow further south. (Figure 1).

Although the interpretation of the chemical data available (see Schnabel, 1969) is complicated by the secondary alteration of most samples, the Talcott basalt seems to be characteristically olivine normative. Indeed, every chilled sample from the flow contains recognizable pseudomorphs of olivine phenocrysts. The original olivine is variously replaced by serpentine, quartz, calcite or chalcedony but the crystal form and outline is unmistakable.

Holyoke

The Holyoke sheet is relatively simple stratigraphically. South of Farmington, it consists of two massive 50m thick flows. Only the top few meters of each are vesicular. The lower flow thins just north of Farmington and only the upper flow is present in northern Connecticut. Although the chemical data available is limited, both flows seem to be quartz normative.

Although rare, tilted vesicles at the lower contacts suggest a south or southwestern source for both the upper and lower Holyoke flows in Connecticut (see Manspiezer 1969).

Hampden

The Hampden basalt is typically massive and ranges in thickness from about 20 to 30m. Its base is much more vesicular than either the Holyoke or Talcott. Tilted pipestem vesicles are present at almost every exposure of its lower contact and generally indicate a southwesterly source (Figure 2). Large fragments and meter thick layers of vesicular basalt are found near the base of the Hampden at some localities. Whether this indicates two separate major flows as found in southern Massachusetts (Colton and Hartshorn 1966) is not yet established.

Although most of the available analyses are of altered samples the Hampden consistently seems to contain larger percentage total iron than either of the other flows. The Holyoke averages about 12 %, the Talcott 9.0 %, whereas the Hampden typically contains around 14 % (Schnabel, 1969).

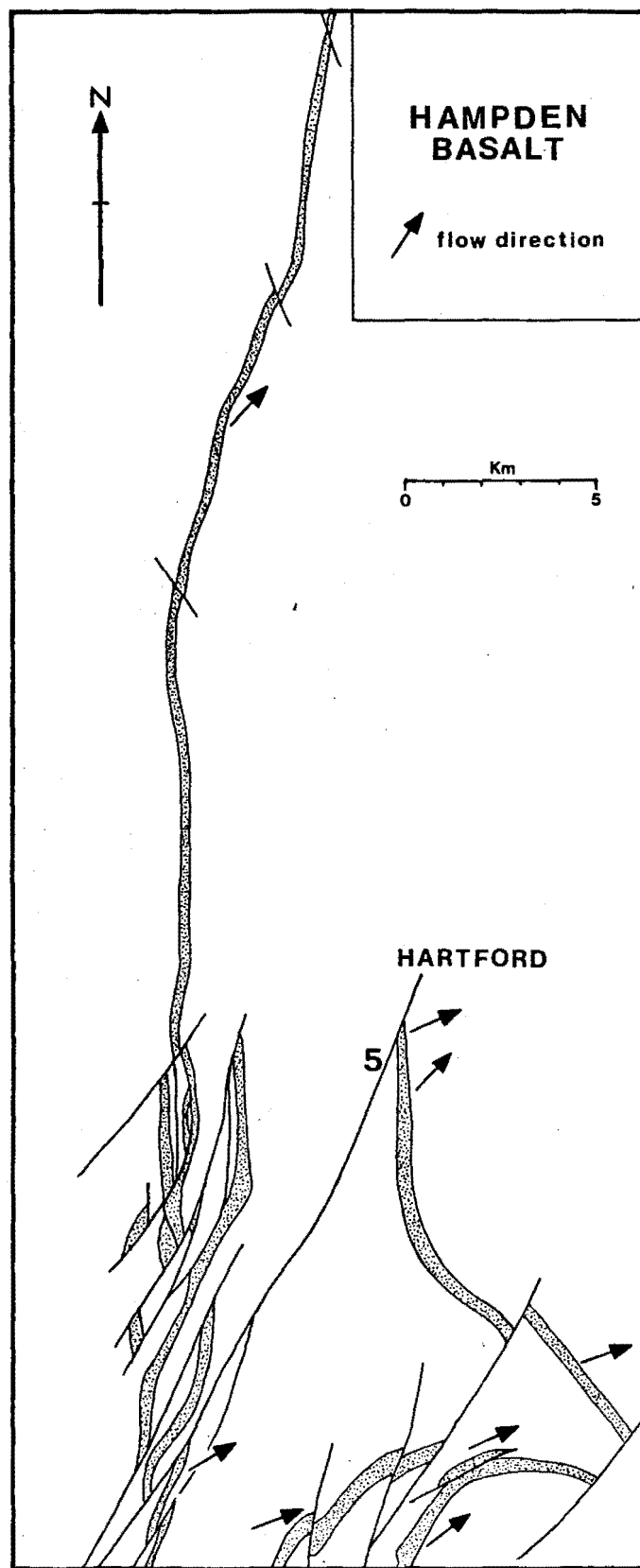

Figure 2. Mean flow directions in the Hampden basalt. Field trip localities indicated by stop number.

Stop 1 Quarry on Manitook Mountain, Suffield, (Tariffville quadrangle GQ-370).

Park cars at the intersection of Quarry and Phelps roads. Follow the access road to the bench at base of the quarry face. Just before the road reaches bench level, outcrops on right (west side) expose a conformable chilled lower contact of Manitook diabase against bleached coarse grained New Haven arkose. At south end of the quarry the diabase is clearly transgressive and discordantly cuts down through 20m of section in a horizontal distance of less than 300m. Partial melting at quartz-feldspar grain boundaries is evident in thin sections of the bleached arkose from the contact.

On the cliff face south of the quarry, meter wide apophyses of chilled diabase extend several meters below the main contact. One fragment of arkose, several meters across, can be seen completely surrounded by diabase.

In the quarry itself early cooling related joints are prominent. These form large nearly vertical columns averaging a meter or more in diameter. Many of the joint surfaces are marked by small horizontal steps at half meter intervals. This feature is typical of true columnar jointing and represents slight changes in the direction of joint propagation as the mode of advance cyclically alternates between brittle and plastic fracturing. An interesting group of curved columns at the southern end of the quarry apparently marks a sharp inflection in the contact. Columns initially propagate perpendicular to the contact but since they continually compete with each other for the strain energy developed ahead of them as cooling progresses, the survivors eventually end up parallel to one another. It is interesting and perhaps significant to note that the type of columnar jointing developed here is found only in surface flows and relatively shallow intrusives.

Throughout most of the quarry the diabase is extremely homogeneous and relatively featureless. However, high on the quarry face irregular lenses of coarse grained pegmatitic diabase segregations containing large centimeter sized curved pyroxenes and patches of granophyric intergrowths are conspicuous. Mineralogically similar pegmatitic diabase occurs in 10 to 60 cm thick sheets in the center of the Holyoke flow at Tariffville (Stop 2). Large blocks of the pegmatitic material lie at the base of the quarry eliminating the necessity of climbing the rather steep face.

Discussion

Manitook Mountain is the most northern of the Barndoor Intrusions, a series of roughly concordant 60 to 180 meter thick, sheet-like diabase bodies intruded into the New Haven

arkose along the western margin of the Hartford basin. The intrusives outcrop as small knobs and hills from the Avon-Farmington town line to Manitoak Mountain on the Connecticut-Massachusetts border, a distance of 30 km. Published aeromagnetism suggests the intrusives may extend at depth to the south-east. Scattered diabase outcrops and a detailed gravity tranverse by Banks (1982) along Phelps Road indicates another large concealed intrusive body just east of Manitoak.

The petrographic features of the Barndoor intrusions are described by Kroll (1976). The textural features of the diabase are quite variable and to a degree unique. Kroll (1976) ascribes the textural complexity to repeated injections of partially crystalline material during the solidification of previously emplaced melts. This interpretation suggests the Barndoor intrusives acted as conduits for either higher level intrusives or surface flows. The extensive partial melting of the arkose adjacent to the Manitoak body also points to the feeder role of the intrusives. The identity of the flow fed by the intrusives is a subject of some controversy. DeBoer (1968b) on the basis of paleomagnetism correlated the Barndoors with the Holyoke flow. Indeed, the major chemistry of the two are not dissimilar, both being slightly quartz normative although the Holyoke typically is richer in iron. Kroll (1976) on the other hand matches the intrusives with the olivine normative Talcott on the basis of their Cr and Ni contents.

Stop 2 The Talcott Basalt in the Farmington River Gorge,
Tariffville (Tariffville quadrangle GQ-370).

Park 100 meters north of the Rt. 189 roadcut in Tariffville in the large parking lot behind the old factory building on Tunxis Street. Walk south along Rt. 189. The lower contact of the Talcott and several meters of the underlying New Haven arkoses and siltstones are exposed at the north end of the roadcut. Continue on the east side of 189 to the south end of the roadcut. The vesicular upper surface of the lower Talcott flow is exposed here. Its contact with the overlying upper flow complex is marked by a flow breccia of volcanic fragments and pillow lobes set in a red siltstone matrix. The upper flow complex is partially exposed along the west side of the Rt. 189. Its apparent thickness is probably magnified here by small faults striking 015° . Just before the first outcrop of the Holyoke basalt on the east side of the road descend directly to the rapids at a bend in the Farmington River. The uppermost contact of the Talcott flow, the lower contact of the Holyoke and the entire Shuttle Meadow formation are exposed here. The upper flow complex outcrops along the river north from this point to the washed out bridge at the end of Tunxis Street. If the river is not too high we will return to the cars by this route otherwise we will have to retrace our previous steps.

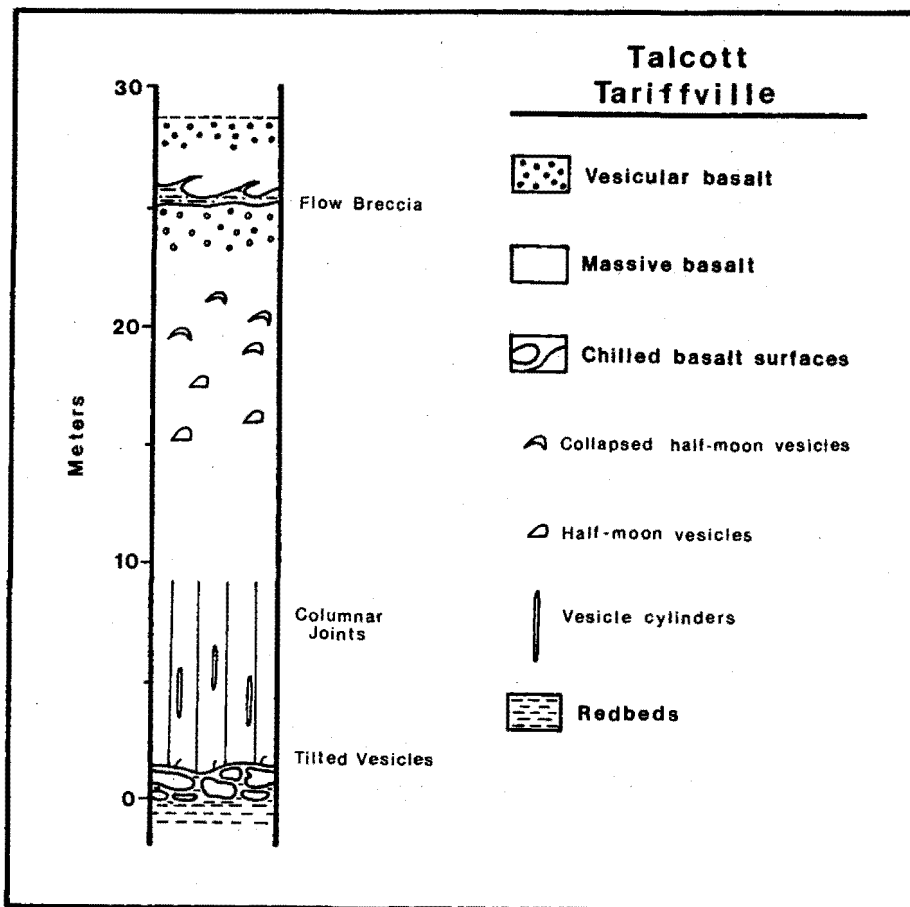

Figure 3. Measured section of the Talcott basalt at Tariffville, Stop 2.

Discussion

Outcrops in the Farmington River Gorge at Tariffville provide an almost complete section from the base of the Talcott to the top of the Hampden. Exposures of the upper contacts of the Talcott and Holyoke first described by Rice (1886) were one of the key localities cited by Davis (1898) to prove the extrusive nature of the main trap sheets of the Connecticut River valley.

Talcott basalt

The Talcott here consists of two main flow units. The lower flow is about 30 meters thick and is generally massive except for its pillowed base and vesicular upper surface. The upper flow complex consists of several thin, interfingering flow lobes, many of which are pillowed. An agglomerate of variable thickness containing a wide size range of basaltic fragments mixed with red sediments marks the upper boundary of the lower flow.

The pillows at the base of the lower flow are intimately intermixed with the underlying sediment. Spaces between, and fractures within the pillows are filled with a mixture of the red sediment and palagonitized fragments of pillow rinds. In outcrops on the north side of the Farmington River, pillows can be seen a meter below the main contact buried in red sediment. Evidently the underlying sediment was water saturated when the Talcott flow first arrived.

As is typical of the Talcott contact metamorphic effects here are negligible. The sediments are unbleached and fissile right up to the lower contact of the flow.

Cooling related joints outlining columns 0.5 meters in diameter originate in the massive basalt just above the pillows and extend upwards 6 meters. The set of columns which normally emanate from the top of a flow are here either poorly developed or have been obliterated by later tectonic jointing.

The upper half of the lower flow is characterized by the presence of flat bottomed "half-moon" vesicles 5-20 cm in diameter. These cavities probably originated at the base of the flow as pockets of air trapped between advancing tongues of lava. If quickly covered by additional hot lava these pockets rise slowly through the flow until trapped by the cooling melt near the top. A variety of minerals, principally calcite, quartz and prehnite now fill the half-moon vesicles. Abundant centimeter sized rectangular gash-like crystal cavities in these fillings indicate the former presence of anhydrite.

Half way along the exposure on the north side of the road a peculiar half meter wide breccia dike cuts the flow. Fragments of basalt are set in a datolite cemented arkosic matrix. Both Davis (1898) and Rice (1886) suggested this breccia filled a open fissure in the flow. On the south side of the road the same breccia contains fewer basalt fragments and dips at a much lower angle.

Shuttle Meadow Sediments

A complete 17 meter section of the Shuttle Meadow formation is exposed along the banks of the Farmington River below the Rt. 189 roadcut. The lower half of the section consists of clastic red sandstones and shales. Rounded pebbles and cobble sized fragments of basalt are found in the sediments immediately above the Talcott. Calcite filled evaporite crystal casts up to 5 cm in size occur in abundance in some layers. The crystal outline of the larger casts suggests the original mineral was glauberite. The smaller casts which become more abundant higher in the section are either collapsed or so poorly developed that their original identity cannot be established with certainty.

Finely laminated gray soda-rich mudstones form most of the upper half of the section. Microcrystalline albite and chlorite are the principal constituents. The origin of the rock is somewhat obscure but it seems likely that the present mineralogy is the result of reactions between an original clay-rich sediment and hot soda-rich pore waters during the cooling of the overlying Holyoke flow. Increase in the grain size and a decrease in the fissility of mudstone are also noticeable near the Holyoke contact.

Holyoke basalt

Except for its vesicular upper surface the 120m thick Holyoke flow is essentially massive. In contrast to the Talcott its lower contact is sharp and relatively featureless. A few rare tilted vesicles at its base indicate the flow from the south. Half meter thick sills and dikes of pegmatitic diabase are common in the middle of the flow and are exposed further down the river.

Stop 3 Talcott flow at King Philip's Cave, Talcott Mountain State Park. Lunch at Heublein Tower.
(Avon quadrangle, GQ-134)

The yellow trail to the Heublein Tower starts on the park road and winds up the vesicular upper surface of the Talcott flow. Park cars along this road and follow the trail for 0.5 km to the first viewpoint overlooking the Farmington River Valley. Manitoak Mountain and the Barndoor Hills are clearly visible from here. King Philip's Cave lies directly below us at this point, but our descent will be by a much easier route one

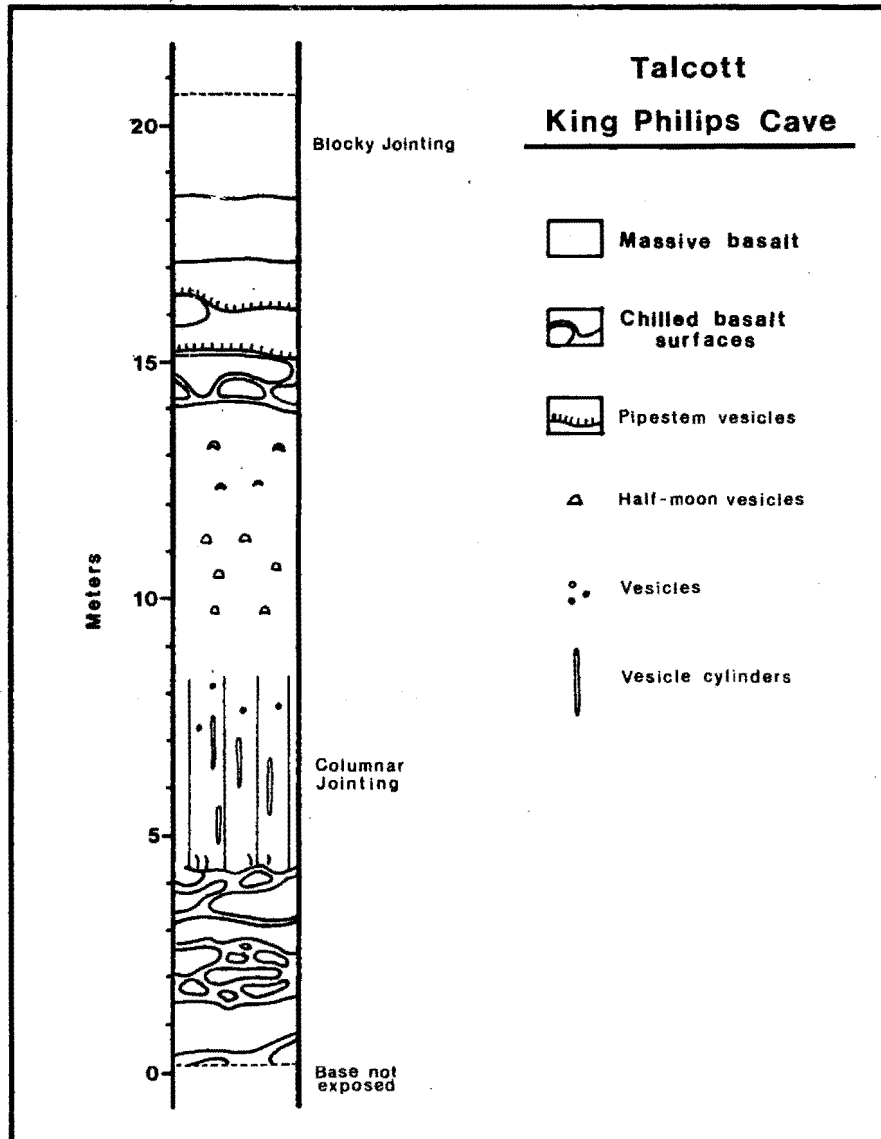

Figure 4. Measured section of the Talcott basalt 30 meters south of King Philip's Cave. Stop 3.

hundred meters to the north. The path should be marked by red flagging tape for our trip. Once at the base of the cliff, work south along the Talcott flow. A thick (7-10 m) pillowed sequence lies at the base of the flow here and is overlain by columnarly jointed massive basalt. King Philip's Cave is a collapsed lava tunnel high on the cliff in this massive unit.

A smaller cave occurs in a thick minor flow within the pillowed sequence a short distance north of King Philip's Cave.

Retrace the path to the top of the cliff and continue along the park trail an additional 1.2 km to the Heublein Tower. For most of the route, the trail follows a terrace on the side of Talcott Mountain formed by the easily eroded Shuttle Meadow formation. The formation does not outcrop here but numerous loose blocks of red and grey sediments attest to its presence. Just before reaching the Tower, the trail climbs onto the splinter jointed Holyoke flow.

The view from the top of the tower is instructive as well as spectacular. Basalt ridges can be traced from the Holyoke range south to Long Island Sound. On a clear day the observation platform is an ideal spot to view the structure of the entire Connecticut River Valley.

Discussion

Tubular pillow-like features ranging in diameter from 0.5 to 3 meters are developed in the lower third of the Talcott flow over a distance of several hundred meters north and south of King Philip's Cave. A change in the sense of imbrication of small flows in the vicinity of the cave suggests the pillowed sequence formed in a shallow lake separating two major eastwardly advancing lobes of the Talcott. The massive columnarly jointed basalt which overlies the pillows records the time when the lake receded from this site. The base of the massive unit is pillowed in places and the chilled margins of pillows can be seen in all stages of being remelted and reincorporated into the massive basalt.

King Philip's Cave is in the massive portion of the flow. Several lines of evidence suggest the cave was originally a major lava tunnel. From below, the coarse calcite cemented breccia produced by the collapse of the tunnel roof is visible and columnar joints which prove the cave existed before cooling can be seen radiating from the cave walls into the surrounding massive basalt. The climb to the cave is tricky and not recommended but once inside a series of originally horizontal closely spaced ridges on the cave walls are the most conspicuous feature visible. These may represent a succession of different lava levels or the buckling of the cave walls during cooling. The blocky basalt which overlies the roof breccia and forms the overhang is a separate later flow.

The small cave is associated with a 3 meter thick massive sheet within the lower pillowed sequence. Although the evidence is not as convincing, it may also be a collapsed lava tube. This cave is presently filled, not with a coarse breccia but rather by pillowed material which dribbled down from the overlying minor flow.

Stop 4 Contact of the Upper and Lower Holyoke flows at
Cooks Gap, Plainville (New Britain quadrangle,
GQ-494)

Park on the road directly opposite the main entrance to the little used quarry on the north side of Cooks Gap. A complete section of Lower Holyoke flow is exposed in this and adjacent quarries. The contact with underlying Shuttle Meadow sediments outcrops in the small quarry 600 meters to the west. Contact metamorphic effects there include the bleaching of the normally red sediments and the development of steam vesicles in the shales as much as 2 meters below the flow. The purpose of this stop, however, is to examine the contact relations of the upper and lower flows. To that end, follow the access road to the main bench level. The quarry here has been excavated in the uppermost 20 meters of the 50 meter thick lower flow. A near horizontal discontinuity in the jointing pattern is visible midway up the western face and can be traced through the entire quarry. Continue up the road onto the vesicular upper surface of the lower flow. The partially quarried knob off the east is a small remnant of the splinter jointed upper flow. To view a reasonable exposure of the contact between the two flows, it is necessary to walk around to the eastern face of this knob. Return to cars by the same route.

Discussion

The presence of two flows in the Holyoke was first recognized in the vicinity of Meriden by Davis (1898). Although both flows can be traced to Farmington, only the upper flow is present further north. In the area of Cooks Gap both flows are about 50 meters thick, have a zone of half-moon vesicles near their tops, and have a vesicular upper surface.

The nature and intensity of jointing in the two flows is one of the few ways of distinguishing them in the field. The younger flow characteristically breaks along slightly curved near vertical joints into decimeter-sized splinter-like columns. The lower flow is much less intensely fractured and generally splits into meter thick slabs parallel to its base. The character of the jointing is not completely uniform through either flow. The horizontal discontinuity in the fracture pattern 10 meters below the top of the lower flow at Cooks Gap is particularly noteworthy as it may record the thickness of the upper crust when the second flow erupted.

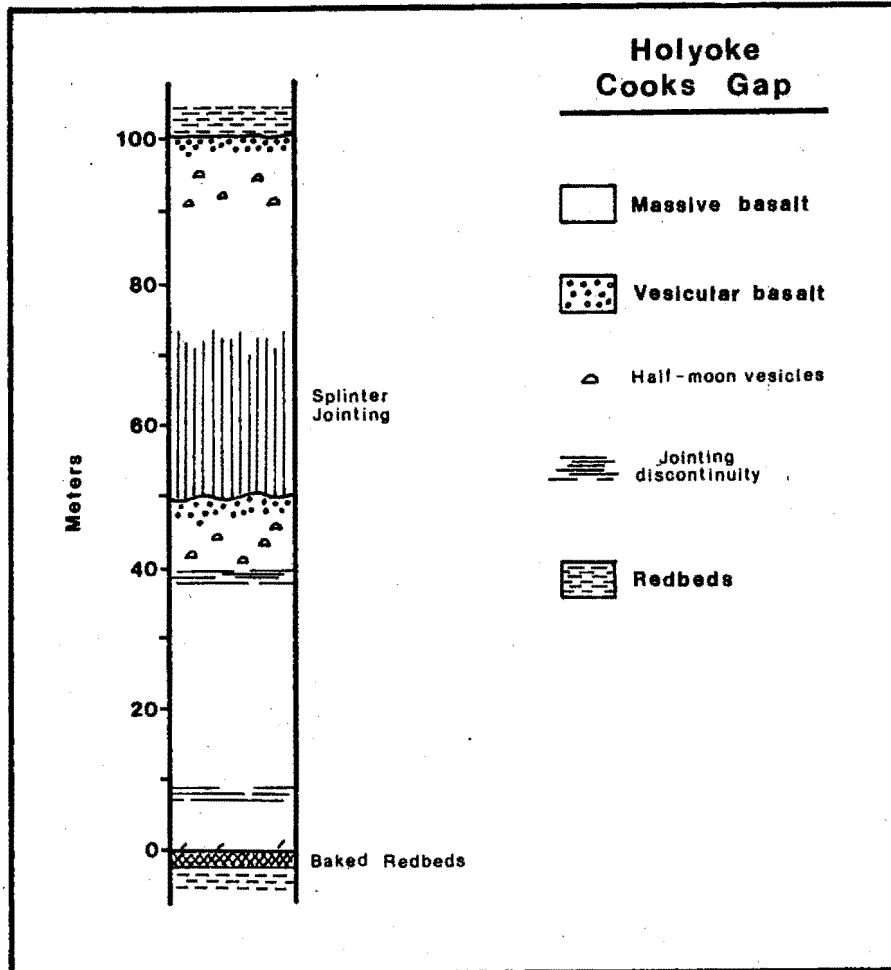

Figure 5. Measured section of the Holyoke basalt at Cooks Gap, Stop 4.

The vesicular upper surface of the first flow is irregular with local relief on the order of a meter or more. Although reddened the surface suffered little erosion before the eruption of the second flow. Depressions and fissures where one might have expected weathered detritus to accumulate are filled entirely by younger basalt. The base of the upper flow is extremely fine grained and massive. Vesicles are rare but xenoliths of the vesicular crust of the underlying flow are not uncommon.

Stop 5 Hampden Basalt, Rock Ridge Park, Hartford. (Hartford North, GQ-223, and Hartford South quadrangles)

Park near the corner of Summit and Vernon streets. The view from the vantage point here is quite instructive. A major fault zone runs along the base of the cliff truncating the Hampden in the cemetery just north of us and cutting off the Holyoke along the edge of Cedar Mountain 2 km to the southwest. The cumulative effect of this and other faults in the poorly exposed area to the west is to downdrop the basalts approximately 1500 meters. The displaced flows outcrop on the Talcott and Farmington Mountain ridges 5 km west of us.

Descend the stairs to the base of the cliff. Red shales and sandstones outcrop beneath the flow here. Within a meter of the contact the sediments have lost both their fissility and their red color. Calcite filled steam vesicles are locally abundant in the baked sediments. The chilled base of Hampden is marked by a thin scoriaceous layer and large numbers of elongated and tilted pipestem vesicles. Near vertical vesicle cylinders, 3-4 cm in diameter and 1-2 meters in length are common 2 meters above the base.

An irregular half meter-wide barite-quartz vein fills and cements a fault breccia along the base of the cliff. The lower contact of the basalt is downdropped a meter to the east along this small fault. The same sense of displacement is also shown by the drag of the sediments. The major fault lying just west of us here has a different orientation and the opposite sense of displacement.

Return to the top of the cliff to a set of glacially polished knobs just south of the stairs. Massive basalt is here cut by several en echelon near horizontal sills of vesicular basalt 1-5 cm thick.

A 2 meter thick sequence of 10-30 cm thick sheets of both vesicular and massive basalt interbedded with a breccia containing angular basalt fragments set in a fine grained basalt matrix overlies the vesicular top of the main flow. An outcrop of this peculiar breccia is located on the east side of Summit Street just north of Vernon Street. The origin of this unit is something of a problem. Is it a local feature produced by lava squeezed out of the underlying sheet when parts of it collapsed or is it a separate younger flow?

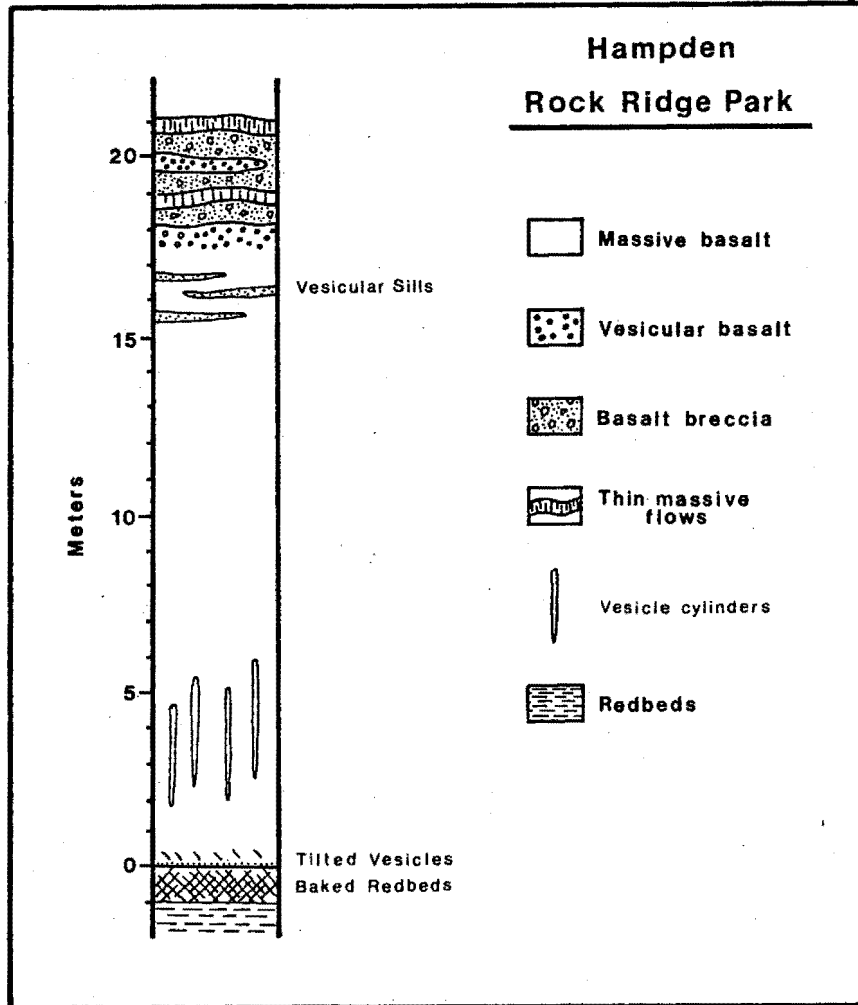

Figure 6. Measured section of the Hampden basalt at Rock Ridge Park. Stop 5.

If both time and enthusiasm permit, we will visit the nearby Hyland Park where the lower contact of the Hampden is better exposed. Proceed south on Summit past Trinity College and turn onto Zion Street. Park in the lot at the intersection of New Britain and Zion Streets and walk south along the contact exposed at the base of the cliff. The calcite filled steam vesicles in the baked mudstones below the flow here are about the same size and are tilted and elongated in the same direction as the pipestem vesicles in the overlying basalt. Some of the best developed vesicle cylinders in the Connecticut basalts can also be found along the cliff face here.

Discussion

Rock Ridge Park occupies the former site of a large trap and sandstone quarry which supplied the city of Hartford with building and paving stone from the mid 1700's to the end of the nineteenth century. Although landscaping has concealed the contact in places, the base of the Hampden basalt was originally exposed for the entire 1.5 km length of the quarry. Generations of Connecticut geologists were familiar with this site. Silliman described the quarry in 1830 and Davis included Monograph. Chapman (1965) published a section of the Hampden basalt measured in the park.

The main Hampden flow is about 20m thick. Chapman (1965) interpreted the 1 to 5 cm layers of vesicular basalt in the upper third of the flow to be flow boundaries. However, the facts that these sheets have sharp well-defined upper and lower contacts, are everywhere parallel to the main sheeting joints, and are stacked on top of one another in an en echelon fashion suggest they are simply late sills injected into the upper crust of the flow as parts of it foundered during cooling.

References

- Banks, W., 1982, Detailed Gravity Profile And Structural Interpretation Of The Triassic Basin Of Northern Connecticut, M.Sc. Thesis University of Connecticut, Storrs.
- Brophy, G.P., 1959, Volcanics in the Holyoke Range: in NEIGC Guidebook 49th Ann. Mtg. p.39-43.
- Brophy, G.P., Foose, R.M., Shaw, F.C., Szelsely, T.S., 1967, Triassic geologic features in the Connecticut Valley near Amherst Mass: in NEIGC Guidebook 59th Ann. Mtg.
- Chapman, R.W., 1965, Stratigraphy and petrology of the Hampden basalt in Central Connecticut: Geological and Natural History Survey of Connecticut, Report Investigations No. 3. 38p.
- Colton, R.B., and Hartshorn, J.H., 1966, Bedrock geologic map of the West Springfield quadrangle, Massachusetts and Connecticut: U.S. Geol. Survey Quad. Map GQ-537.
- Davis, W.M., 1898, The Triassic formation of Connecticut: U.S. Geol. Survey, 18th Ann. Rept., Pt. 2, p. 1-192.
- de Boer, J., 1968a, Late Triassic volcanism in the Connecticut Valley and related structure: in NEIGC Guidebook 60th Ann. Mtg.
- _____ 1968b, Paleomagnetic differentiation and correlation of the late Triassic volcanic rocks in the central Appalachians: Geol. Soc. America Bull. v. 79, p. 609-626.
- Kroll, R. L., 1976, Barndoor diabase intrusions, north-central Connecticut: Bull. Geol. Soc. America, v. 87, p. 1449-1454.
- Lehmann, Elroy, 1959, The bedrock geology of the Middletown quadrangle: Geological and Natural History Survey of Connecticut, Quad. Rept. 8, 40p.
- Manspeizer, Warren, 1969, Paleoflow directions in Late Triassic basaltic lava of the Newark Basin and their regional implication: Geol. Soc. America, Atlantic City, N.J., Mtg., abs. vol., p. 142.
- Rice, W.N., 1886, On the trap and sandstone in the gorge of the Farmington River at Tariffville, Connecticut: Am. Jour. Sci., v. 132.

Sanders, J.E., 1970, Stratigraphy and structure of the Triassic strata of the Gaillard Graben, south-central Connecticut: Geological and Natural History Survey of Connecticut, Guidebook No. 3, 15p.

Schnabel, R.W., 1969, Chemical analysis of selected samples of diabase and basalt from Connecticut: U.S. Geol. Survey Open-File Rept., 4p.

Silliman, B., 1830, Igneous origin of some trap rocks: Am. Jour. Sci., v. 17, p. 119-132.

Road Log for trip M-3

7 1/2 minute topographic quadrangles traversed:

Windsor Locks, Tariffville, Avon, New Britain, Hartford South and Hartford North.

Assemble at Old Newgate Prison in the public parking lot. The prison may be reached from I-91 by taking the Bradley International Airport exit. Be alert to follow signs for Old Newgate Prison and Rt. 20. Do not follow the highway all the way to the airport. Rt. 20 runs through the center of East Granby. On Rt. 20, 0.8 miles west of the traffic lights in East Granby turn right (north) onto Newgate Road. The parking lot is just past the ruins of Newgate Prison.

Newgate Prison is on the site of one of the first copper mines in colonial North America. See trip M-4.

Miles

- | | |
|------|--|
| 0.0 | Start mileage count. On leaving parking lot turn left (north) onto Newgate Road. |
| 0.6 | Y junction. Take right fork and continue on Newgate Road. |
| 2.5 | T junction. Turn left (west) onto Phelps St. |
| 2.6 | Entering Tariffville quadrangle. |
| 4.1 | <u>STOP 1</u> - Quarry on Manitook Mountain, Suffield. |
| 4.1 | South on Quarry Road along the eastern edge of the Manitook intrusive. |
| 5.7 | Hungary, Continue straight. Quarry Road becomes Hungary Road. |
| 7.5 | Granby center. At first stop sign jog right (west) then left at traffic lights onto Rt. 189 south. |
| 7.6 | Left again at next traffic light to continue on Rt. 189 south. |
| 11.1 | Tariffville. Turn left (east) onto Tunxis Street. Immediately turn left again into parking area behind the old factory building. |
| | <u>STOP 2</u> - Talcott basalt in the Farmington River Gorge, Tariffville. |
| 11.1 | Turn left (south) back onto Rt. 189 south but before reaching roadcut take a sharp right (west) onto Rt. 315 (Elm St.) |

- 11.5 At stop sign turn left onto Winthrop Street to continue on Rt. 315.
- 12.2 Turn left onto Quarry Road. The quarry referred to here exploited the red sandstone which outcrops on the steep slope along the edge of the road.
- 13.2 Turn left onto Terrys Plain Road.
- 14.1 Entering Avon quadrangle.
- 14.5 Y-junction, bear left and continue south on Terrys Plain Road.
- 15.3 Stop sign. Continue south on E. Wheatogue Road.
- 16.1 Turn left (east) onto Rt. 185.
- 17.2 Entrance to Talcott Mountain State Park. Turn right (south) onto park road.
- 17.5 STOP 3 - Talcott flow at King Philip's Cave, Talcott Mountain State Park.
- 17.5 Return to park entrance.
- 17.8 Turn left (west) onto Rt. 185.
- 18.8 Keep to your left and remain on Rt. 185.
- 19.0 Turn left (south) immediately before bridge onto Nod Road. King Philip's Cave is visible on the Talcott Cliff east of us here.
- 22.2 Traffic lights at Rt. 44 intersection. Continue straight across and follow Rt. 10 south (Waterville Road).
- 26.1 Entering New Britain quadrangle.
- 27.8 Traffic lights at Rt. 4 intersection. Cross Rt. 4 and stay on Rt. 10 south.
- 30.1 Bear left at Y-junction to leave Rt. 10 and follow Cooke Street.
- 31.5 T-junction. Turn left (east) onto Rt. 372.
- 32.1 Traffic lights. Continue straight on Rt. 372.
- 32.6 STOP 4 - Contact of the upper and lower Holyoke flows at Cooks Gap, Plainville. Park on south side of road in front of the D.O.T. white trailer.
- 32.6 Return west on Rt. 372.
- 33.1 Continue west through traffic lights and follow signs for Rt. 84 east. Do not turn onto Rt. 84 west.
- 34.2 Follow signs onto Rt. 84 east.

- 36.2 Contact of upper and lower Holyoke flows.
- 41.3 Roadcut through a faulted sliver of the Hampden basalt.
- 42.4 Entering Hartford South quadrangle.
- 45.2 Entering Hartford North quadrangle.
- 46.9 Leave highway at the Capitol Ave. exit and follow signs for Trinity College.
- 47.3 Turn right at sign for Trinity College and then right again onto Capitol Ave.
- 47.8 Left onto Park Terrace and follow signs for Trinity College.
- 48.4 Turn left onto Summit Street.
- 48.5 Cross Zion St. and continue up the hill to the gates of Trinity College at Vernon Street.
- 48.7 STOP 5a - Hampden basalt, Rock Ridge Park, Hartford. Park along Summit Street.
- 48.7 Continue south on Summit.
- 48.9 Y-junction, bear right onto College Terrace.
- 49.0 Turn left onto Zion Street.
- 49.4 Stop sign at New Britain Ave. Cross into parking area in front of Hyland Park Center.
- STOP 5b - Hampden basalt, Hyland Park, Hartford.
- End of trip.

To return to I-84 retrace route along Zion, Summit and Park Terrace. Turn left onto the Sigourney Street on-ramp at 50.9 and then sharp right onto I-84 East at 51.0.

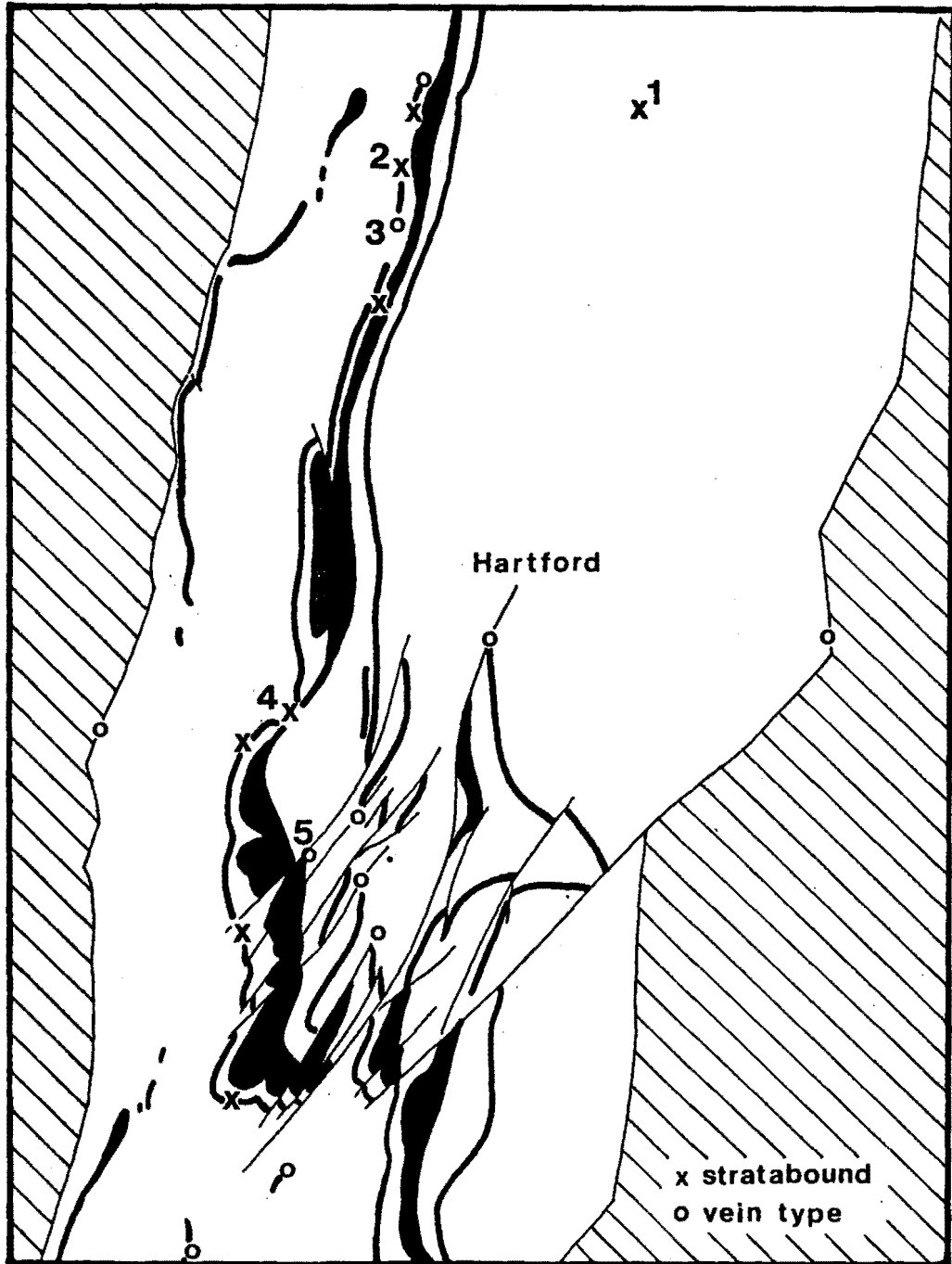

Figure 1. Regional distribution of copper occurrences in the Connecticut Valley. Numbers refer to stops on trip M-4. Black areas - basalt.

The original cellular structure of the wood is well preserved only where replaced by sulfides. This suggests that the copper mineralization here is very early and probably predates significant compaction.

The presence of copper in this general area is mentioned in land transactions in 1737 and 1758. In the early 1800's the locality was widely known for its "coal", the carbonized wood fragments. Today gray sandstones containing the "copper" and "coal" are carefully avoided in quarrying in favor of the monotonous red shales, which apparently make a much better brick.

Stop 2 Newgate Prison and Mine (Windsor Locks Quadrangle, GQ-388)

History

Copper was first discovered in the Newgate Prison area in 1705. Two years later the first mining company in America was organized to work the deposits. Although numerous pits, adits, and various underground workings testify to the scale of the operations, the venture never proved especially profitable. The mines absorbed much more capital than their output ever provided in return. By 1741, when all operations ceased, more than \$200,000 had been spent to recover little more than 100 tons of ore which averaged 12% Cu (Richardson, 1928).

Water was one of the most difficult problems faced by the early miners. Between 1721 and 1730 a 100 meter tunnel was driven to drain one of the principal deposits. These workings were subsequently used as the State Prison from 1773 to 1827.

In 1831 the mines were reopened by the Phoenix Mining Company. Forty-two experienced miners were induced to emigrate from Europe to work the deposits. The old workings were pumped out and some ore extracted. A major tunnel designed to provide drainage for the mines at North Hill, one kilometer north of Newgate, was started but never completed. In total about \$50,000 was invested in the enterprise before it was finally abandoned in 1836 (Anonymous, 1956).

Two other attempts in 1855 and 1901 to reopen the mines also ended in failure. The interest and energies of the principles in these ventures were directed to selling stock rather than mining and little work seems to have been actually accomplished.

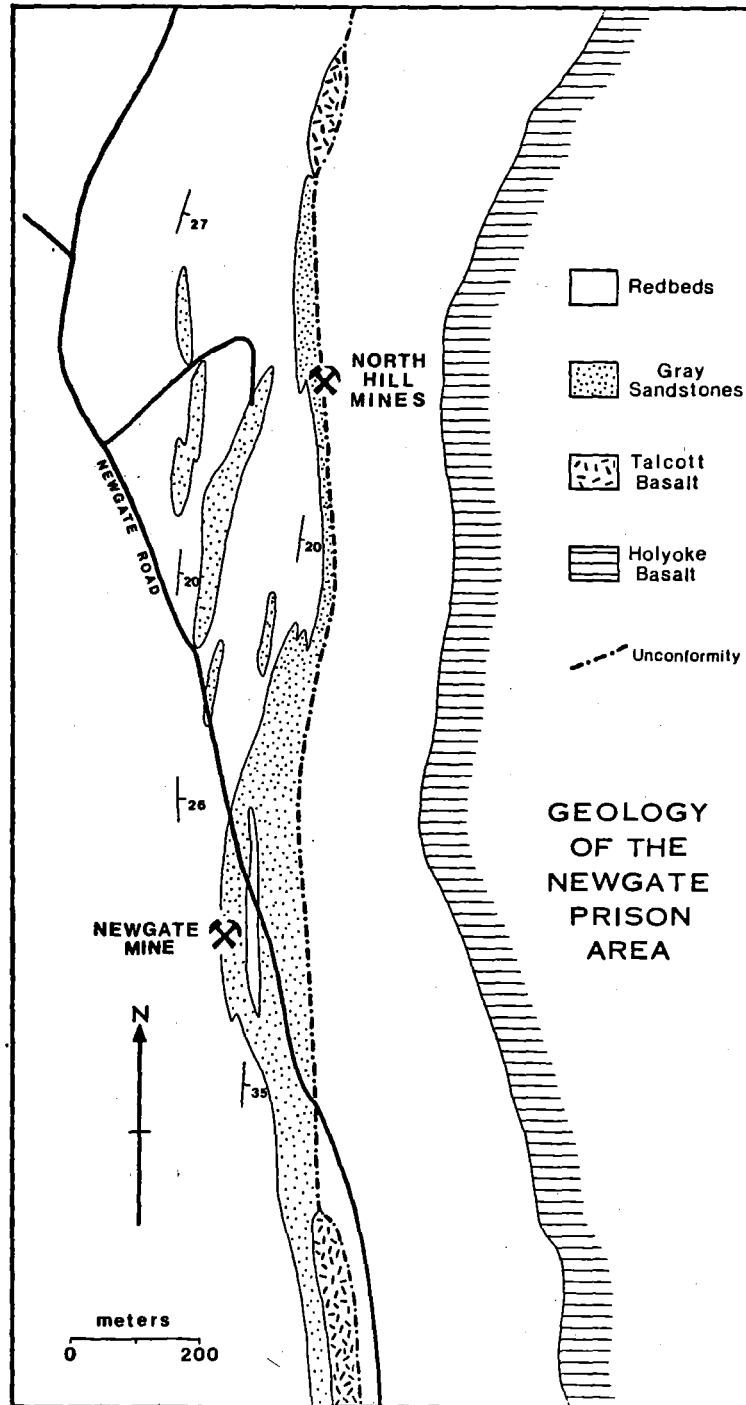

Figure 2. Generalized geology of the Newgate Prison area. Adapted from Perrin (1976).

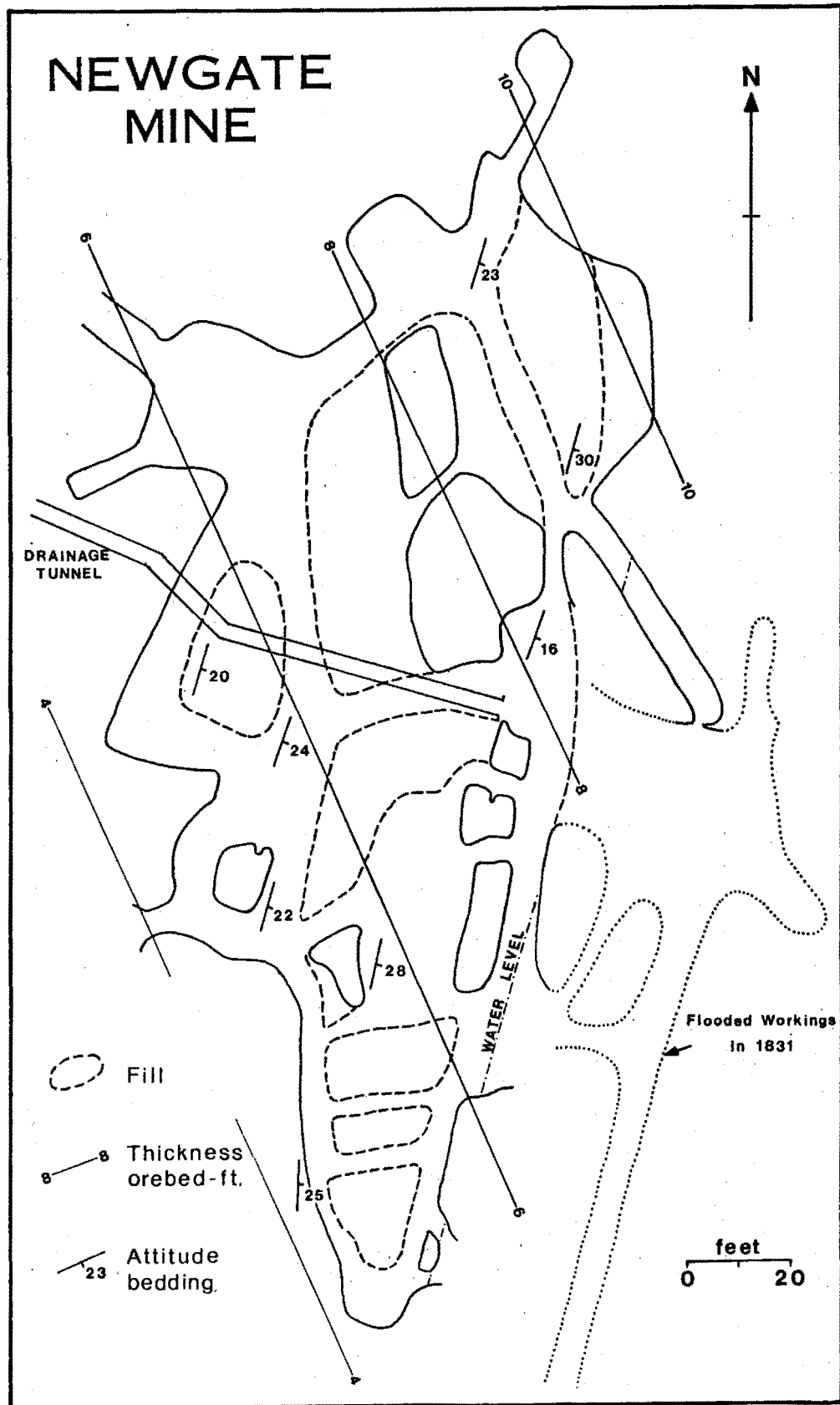

Figure 3. Underground workings at the Newgate mine. The flooded section of the mine was probably enlarged between 1831 and 1836 but no survey of the post 1831 workings exists.

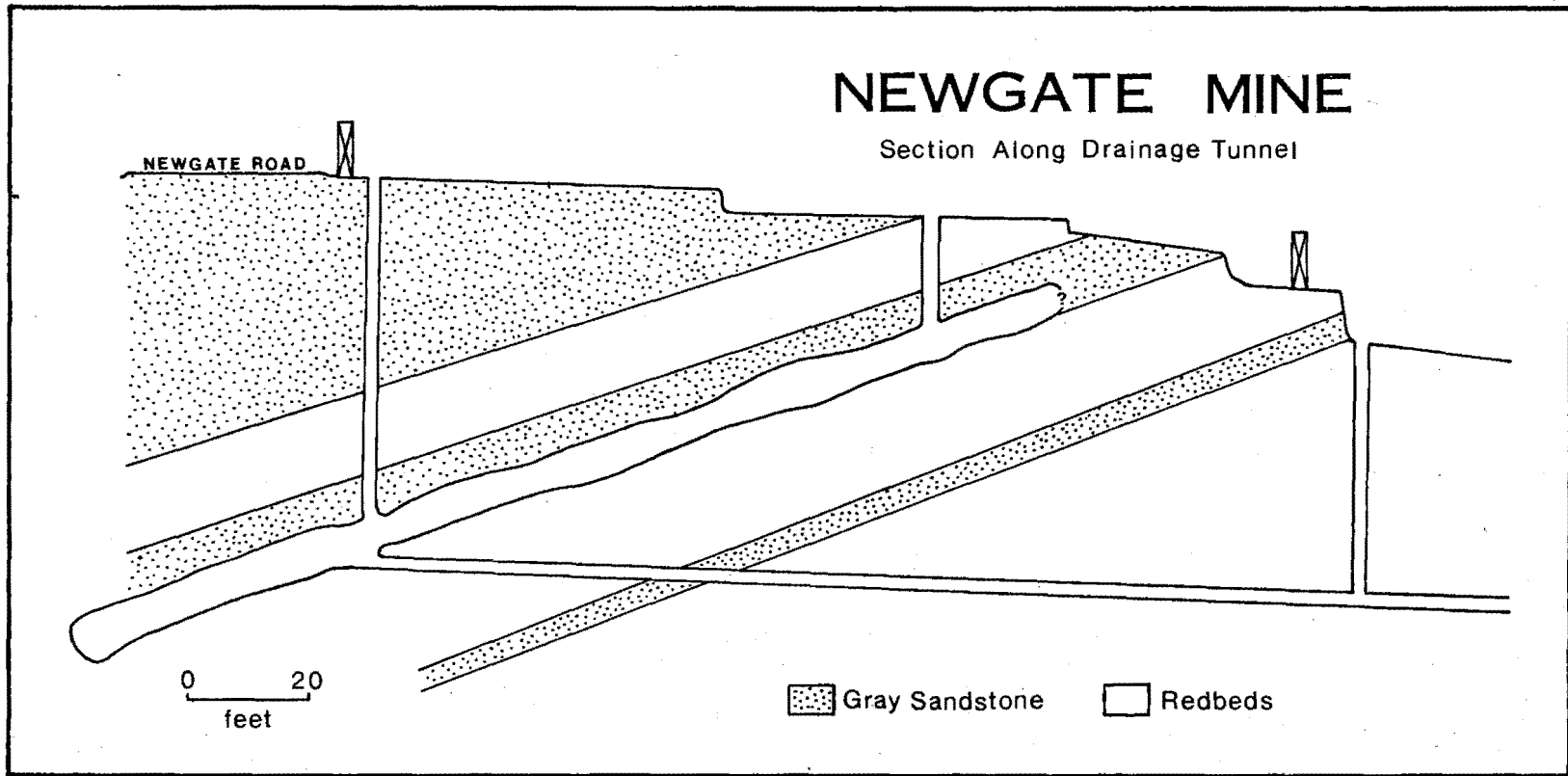

Figure 4. Vertical section through the Newgate mine.

Mineralization

The early miners traced the mineralization several kilometers north and south of Newgate, leaving a trail of pits and trenches. The mineralized zone closely follows an unconformity which lies just above the stratigraphic level of the Talcott flow. The Talcott itself is truncated by the unconformity and is absent over much of the mineralized area.

The mineralization occurs only in gray to black sediments. Interbedded red colored sandstones and shales are barren. Finely disseminated pore filling early diagenetic bornite and chalcopyrite, locally partially replaced by chalcocite, are the principle ore minerals. Malachite and cuprite are much more conspicuous but are secondary after the sulfides. Gray sandstones lying less than 20 meters below the unconformity are the most heavily mineralized. Copper averages less than 1% in most of the Cu bearing gray beds, but in the vicinity of the North Hill mines, the average is somewhat higher (2-5%).

The main deposit at Newgate Prison is stratigraphically lower and texturally distinct from the widespread disseminated mineralization. It also is higher grade. Copper averages between 2.5 to 10%, and silver up to 10 oz/ton. The ore occurs in a peculiar 2 meter thick arkosic sandstone which except for a few thin interbeds of black mudstone is essentially structureless. Large sections of the bed were cemented by ferroan dolomite prior to significant compaction and mineralization. Copper sulfides were first precipitated in the uncemented portions of this sandstone early in its diagenesis as millimeter sized nodular concretions. Later, the initial texture was modified when post-compaction less reduced solutions replaced the sulfides and precipitated chalcocite. The ore occurs in curious mottled patches surrounding centimeter sized porous areas within which the calcite and ferroan dolomite cements of the host sandstone have been dissolved.

The activities of the early miners clearly show that they recognized the connection between high grade ore and the rusty weathering ferroan dolomite cemented sandstones. Wherever such sandstones occurred, both in the mine and outside, they have been thoroughly investigated even if barren.

The mottled ore bearing sandstone at Newgate is slightly discordant and lenses out to the southwest. In the western half of the mine it is separated from the footwall redbeds by a thin (0-10 cm) intraformational breccia containing pebble sized clasts of iron-rich dolostone. The ore bed is overlain by finely laminated gray channel sandstones. Further information on the geology of the mine can be found in Perrin (1976).

Figure 5
Schematic Cross Section Newgate Mine

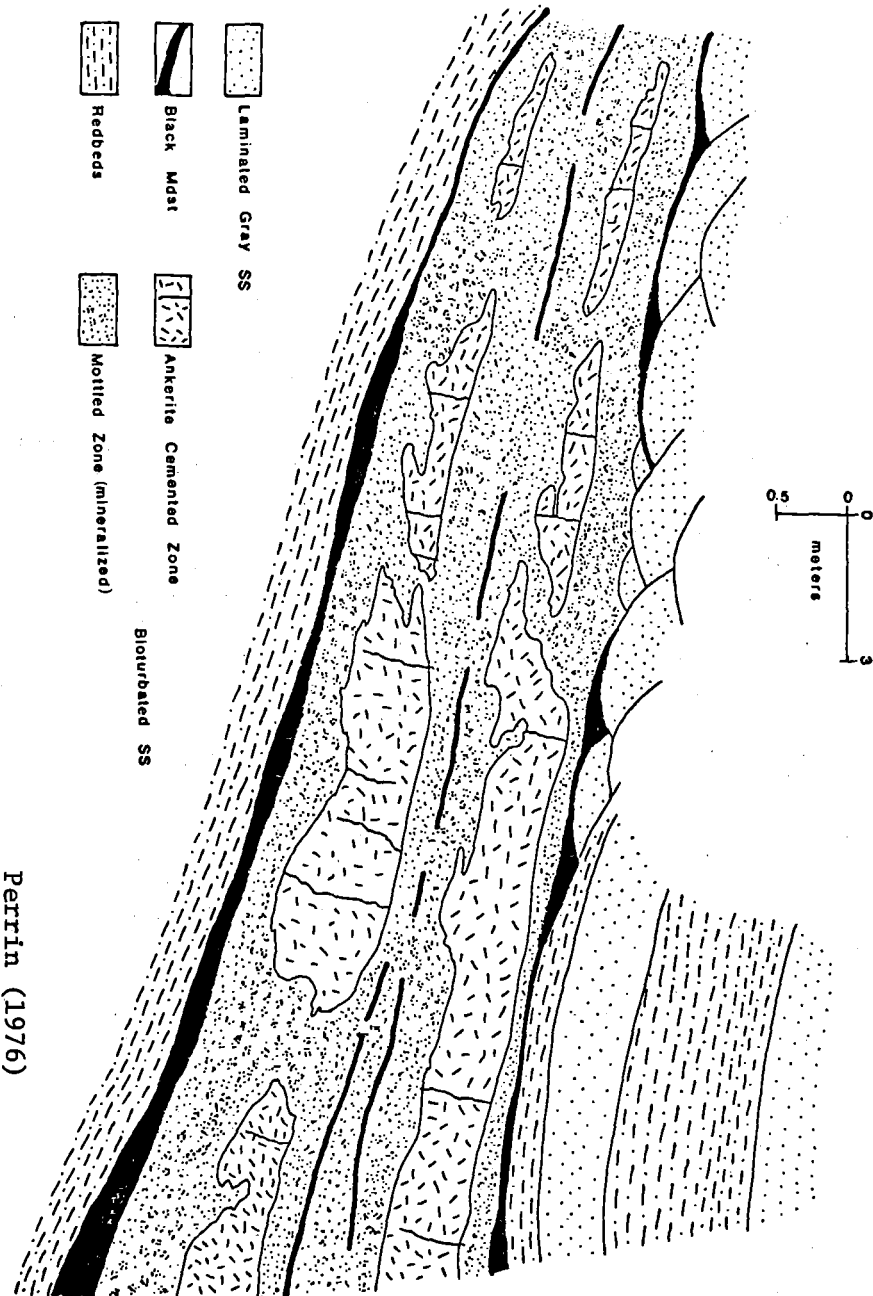

Perrin (1976)

Small amounts of uranium are associated with the disseminated copper mineralization especially at the North Hill Mines. (Schabel and Eric, 1964, Truesdell and Zollinger, 1977). The mottled chalcocite ore at Newgate is distinctly less radioactive.

Origin

The disseminated copper sulfides precipitated in the pore spaces between detrital grains early in the diagenetic history of the gray sandstones. The relationship of this mineralization to the Talcott unconformity suggest saline copper bearing solutions percolated down into the sediments from the surface during that erosional interval. Considering the extent of the mineralized zone, the total amount of copper introduced into the sediments is substantial. The ultimate source of the metal is something of a mystery, but the presence of altered and mineralized angular trachyte fragments in sedimentary breccias along the unconformity north of Newgate Prison suggests that hydrothermal activity may have been associated with post-Talcott acid vulcanism. The Higley Copper deposit to be seen at the next stop might represent the subsurface plumbing for one of the hydrothermal hotsprings which brought copper rich waters to the surface.

The mottled high-grade chalcocite ore was the result of a major change in the chemistry of groundwaters late in the diagenetic history of the sediments. Partial dissolution of the well cemented ferroan dolomite sandstones produced a favorable local environment for the precipitation of the copper leached from the overlying disseminated ore. The cause of the change in water chemistry is not obvious. Perhaps the cooling of the Holyoke sheet generated groundwater circulation which flushed new waters through the mineralized zone.

Stop 3 Higley Copper Mine, East Granby (Windsor Locks Quadrangle, GQ-388)

Mineralization

The Higley Mine is quite unlike Newgate even though they are only 2.5 km apart and lie at the same stratigraphic level. Bornite, chalcopyrite, and carbonates fill hematite stained fractures and vesicles in basalt near the amygdaloidal upper surface of the lower Talcott flow. The amygdaloid, especially where mineralized, is altered to ferroan dolomite.

The amygdaloid is overlain by unmineralized greenish-black altered basalt. A coarse breccia consisting of large angular fragments of basalt, and a white altered trachyte set in a medium grained red sedimentary matrix lies on the apparently eroded upper surface of the basalt. The breccia itself is overlain by finely laminated red siltstones. Small fractures in some of the white trachyte blocks are mineralized.

The source of the trachyte is a mystery. The large angular fragments could not have been transported far but the trachyte does not outcrop locally. The breccia is probably either a mudflow or a talus deposit along an active fault. Whatever the origin, the mineralized trachyte blocks, both here and north of Newgate, certainly point to a post-Talcott volcanic event closely associated with the copper mineralization.

History

The Higley Mine was operated on a small scale in the 1700's and for a brief period from 1831 to 1836. The first coins minted in America were struck from Higley copper between 1729 and 1739. The metal was purportedly of great purity and the coins were sought after by eighteenth century jewelers as an alloy for their gold (Johnson, 1896). Not surprisingly, very few examples of the Higley Coppers survived.

Origin

With such meager information visible at the surface, it is difficult to speculate on the origin of the Higley deposit. The disposition of the adit and shaft suggest the eastward dipping amygdaloidal flow surface was the main object of mining activities. However, the local farmers insist that the workings extended underneath the barn to the west away from the amygdaloid. If true, the mineralization would probably have followed a vein system parallel to the prominent NW faults in the area.

These two possibilities have different implications regarding the relationship between the Higley and Newgate deposits. An extensive vein system at Higley could be the hydrothermal source for the early diagenetic disseminated mineralization in the sediments at Newgate. On the other hand if the ore is confined to the permeable amygdaloidal basalt, then Higley like Newgate may have been formed from waters originating at the Talcott unconformity.

Stop 4 Talcott basalt; roadcut on Rt. 4, Farmington
(New Britain Quadrangle, GQ-494)

The mineralization at this stop is typical of small strata-bound copper occurrences in the Connecticut Valley redbeds. Malachite, chrysocolla, and azurite stain fractures and bedding planes in the vicinity of thin, gray channel filling sediments within a dominantly red shale and siltstone sequence. The source of the secondary copper minerals is chalcocite nodules up to 1 cm in diameter which are widely scattered through the gray sandstones. Limonite pseudomorphs after early diagenetic pyrite demonstrate that sulfate

M4-11

reducing conditions were present in the fine grained gray sediments soon after deposition. The permeable channel sandstones were thus the ideal location for migrating groundwaters to precipitate copper.

The mineralized sandstones lie only a half meter below the base of the Talcott basalt. Although the Talcott here shows no obvious contact metamorphic effects, the host of secondary minerals in the basalt (anhydrite, chalcedony, datolite, prehnite, analcite, apophyllite, chabazite, scolecite, heulandite, and calcite) points to interaction of the cooling flow with the local groundwater. The conspicuous absence of copper bearing minerals in the basalt and the simple nodular texture of the primary chalcocite, suggests that the copper mineralization postdates the cooling of the Talcott.

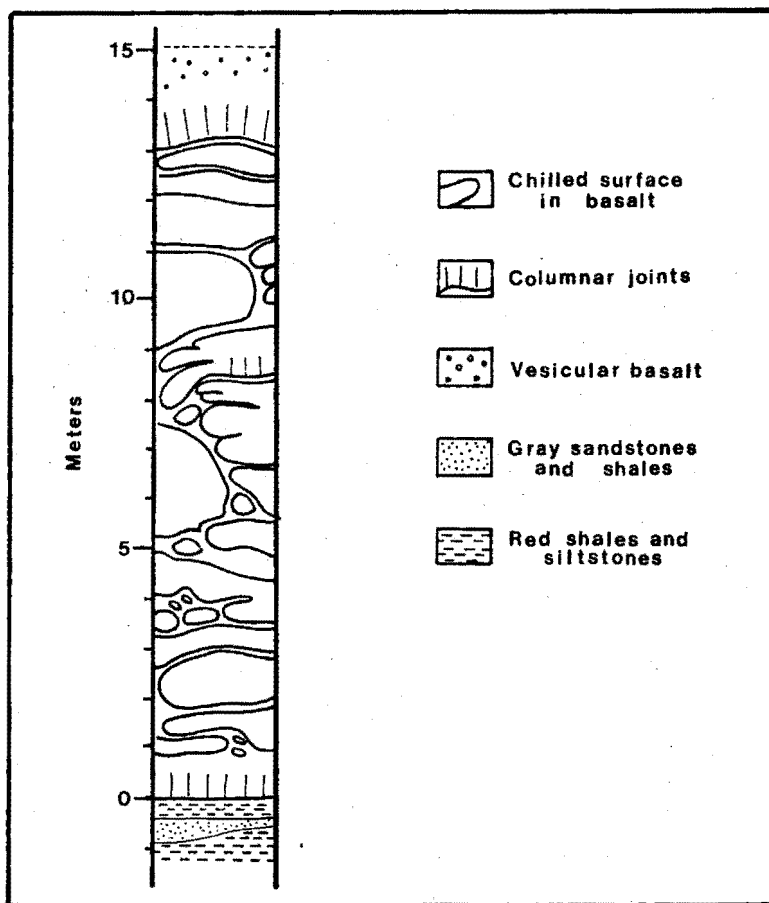

Figure 6. Measured section of the Talcott flow on Rt. 4, Farmington (Stop 4).

The Talcott at this outcrop is a pile of pillowed minor flows (Figure 6). Although not the object of this trip, the pillows are nicely exposed here and are well worth examining.

At the east end of the roadcut the Talcott abuts against red sediments along a vertical fault. Another smaller fault is marked by an intensely fractured zone in the basalt half way along the roadcut.

The contact between the lower and upper Holyoke flows, outcrops on the SE side of the road interchange. Since the lower flow is 30 to 50 meters thick a major fault of at least that displacement must run under the traffic lights at the interchange.

Stop 5 Carbonate-Quartz-Barite Veins at Columbus Blvd. exit, Rt. 72, New Britain (New Britain Quadrangle, GQ-494)

Introduction

Carbonate-quartz-barite veins are developed along many of the post-Hampden faults in the structurally complex area between Cheshire and Hartford. Sulfides, especially chalcopryrite and bornite, occur in some veins, but the mineralization is typically spotty and rarely amounts to much. A number of exploratory pits and shafts were sunk in the New Britain area during the 1700's, but there is no record of serious mining activity. However, the barite in similar veins at Cheshire was profitably exploited between 1838 and 1877 (Fritts, 1962).

Description

The Columbus Boulevard vein is one of the best examples of the carbonate-quartz-barite veins exposed in the Connecticut Valley. The vein here follows a small fault which cuts the chloritized upper part of the Holyoke basalt. A few centimeters of sediments containing pebble and sand-sized basalt fragments cap the top of the outcrop on the north side of the exit ramp. The same sediments also filled open fractures which extended down into the flow.

Basalt bordering the vein is silicified and bleached to a light gray color. This type of alteration is typical of the N45°W faults in the New Britain area irrespective of the presence of the carbonate-quartz-barite veins.

M4-13

Vein filling was accomplished initially by the deposition of quartz, calcite, and ferroan dolomite in open spaces along the active fault zone. Movement continued throughout this phase frequently brecciating previously deposited vein material. After faulting ceased barite which occurs in plumose crystal groups up to 20 cm long, filled the open space in the center of the vein and cemented the carbonate-quartz breccias. The ferroan dolomite of the carbonate zone is oxidized to a dark red-brown color at the boundary of the barite zone. Cavities between barite crystals are filled by small amounts of drusy quartz, ferroan dolomite, and aragonite.

Sphalerite, chalcopyrite, galena, and minor amounts of barite, chalcocite, covellite, and tennantite fill open spaces and replace carbonates within the quartz-carbonate zones. Sphalerite was the first sulfide deposited. Galena and chalcopyrite followed later.

Vitreous black carbonaceous spheres, 1 to 5 mm in diameter, occur throughout the vein but are most abundant along the boundary of the quartz-carbonate and barite zones. Presumably these spheres were droplets of oil suspended in the hydrothermal fluids which became accidentally trapped during the deposition of the vein minerals.

The quartz in the vein contains both liquid and gas filled fluid inclusions. The homogenization temperatures of both types of inclusions fall between 123°C and 198°C (Ryan, pers. comm. 1982). Apparently boiling occurred occasionally during deposition.

Origin

Each of the minerals deposited in the carbonate-quartz-barite veins can also be found as a diagenetic phase in the sediments. This fact strongly suggests that the normal faulting which is clearly closely associated with the veins, opened up fractures which allowed deep diagenetic waters access to the surface. The regionally spotty distribution of the sulfide mineralization indicates the local nature of the sources. The metals in the Columbus Boulevard vein were probably derived from a black shale in the Shuttle Meadow formation. In Cooks gap, 1.7 km to the west, Shuttle Meadow shales contain pyrite, chalcopyrite, and sphalerite.

References

- Anonymous, 1956, The Phoenix Mining Company 1830-1836, Connecticut Historical Society Bull. 21, No. 3, p. 88-93.
- Fritts, C.E., 1962, The Barite Mines of Cheshire, The Cheshire Historical Society, Cheshire Connecticut.
- Johnson, Mrs. Mary (Coffin), 1896, The Higleys and their Ancestry, An old colonial family. D. Appleton and Company, New York, 738p.
- Perrin, J., 1976, Geology of the Newgate Prison Mine, East Granby, Connecticut [M.S. thesis] University of Connecticut, Storrs, CT.
- Richardson, Creel, 1928, A History of the Simsbury Copper Mines. [M.A. thesis] Trinity College, Hartford, CT.
- Schnabel, R.W., and Eric, J.H., 1964, Bedrock geologic map of the Windsor Locks quadrangle, Hartford County, Connecticut: U.S.G.S. Geol. Quad. Map GQ-388.
- Truesdell, D.B. and Zollinger, R.C., 1977, Preliminary study of the Uranium potential of the Triassic-Jurassic basin in Connecticut and Massachusetts. U.S. Dept. of Energy, Grand Junction Office, GJBX-68(77).

M4-15

Road Log for Trip M-4

7 1/2 minute Topographic Quadrangles traversed:

Broad Brook, Windsor Locks, Tariffville, Avon, New Britain. Assemble at S.W. corner of the Enfield Mall parking lot (do not confuse with the neighboring Enfield Square). Enfield Mall is on the North side of Rt. 190 (Hazard Ave.) just east of I-91. If using I-91 be sure to take Rt. 190 East exit.

Miles

- 0.0 Start mileage count, leave parking lot, turn right (west) onto Rt. 190 (Hazard Ave.)
- 0.6 Roadcuts in red shales of the Portland formation
- 1.0 Bridge over the Connecticut River
- 1.6 Traffic lights, turn left onto Rt. 159
- 2.1 Pass Thrall Ave. on right
- 2.2 Turn left onto unmarked side road leading to K and F quarry. If gates are open we may drive into the quarry otherwise it may be necessary to park along Rt. 159.
- STOP 1 - K and F Suffield Brick Quarry.
- 2.2 Resume road log at entrance on Rt. 159. Continue south on Rt. 159.
- 2.5 Turn right (west) onto Bridge St.
- 3.1 Entering Windsor Locks quadrangle
- 4.4 Traffic lights. Turn right (north) onto Rt. 75 (N. Main St.)
- 4.5 Traffic lights. Turn left (west) onto Rt. 168. Holyoke ridge clearly visible to the west.
- 6.0 Turn left (south) onto Sheldon St.
- 8.1 Follow sharp curve to the left (south) and proceed south along N. Main St. - S. Stone St. Road follows ridge formed by the Hampden basalt.
- 10.4 East Granby. Turn right (west) at traffic lights onto Rt. 20.
- 10.8 Road climbs onto Holyoke ridge.
- 11.2 Turn right (north) onto Newgate Road, following signs for Old Newgate Prison.
- 12.4 Turn left into Public Parking lot at Newgate Prison.

STOP 2 - Newgate Prison and Mine.

- 12.4 Turn right (south) out of parking lot onto Newgate Road.
- 13.4 Intersection with Rt. 20. Continue straight (south) onto Holcomb St.
- 14.4 Turn left (east) into gravel driveway leading to a white farmhouse. Park along edge of the cultivated field on the righthand side of the driveway.

STOP 3 - Higley Copper Mine.

- 14.4 Turn left (south) onto Holcomb St.
- 14.4 Entering Tariffville quadrangle.
- 15.5 At stop sign turn left (south) onto Rt. 189 (Hartford Ave.).
- 16.8 Sharp right onto Rt. 315 South (Elm St.).
- 17.2 Stop sign. Turn left (south) to continue on Rt. 315 (Winthrop St.).
- 17.9 Turn left onto Quarry Road.
- 18.1 Red sandstone quarries along left (east) side of road.
- 18.9 Turn left onto Terrys Plain Road.
- 19.8 Entering Avon quadrangle.
- 20.2 Y-junction bear left (east) to continue south on Terrys Plain Road.
- 21.0 Stop sign. Continue straight (south) onto what now becomes E. Wheatogue Road.
- 21.8 Turn left (east) onto Rt. 185.
- 23.0 Turn left (north) into Penwood State Park and follow park road to Picnic Area. The Talcott basalt outcrops at the entrance but the road climbs out and follows the Holyoke for most of its length.
- 24.5 Lunch stop.
- 24.5 Retrace route back along park road to Rt. 185.
- 25.9 Turn right (west) onto Rt. 185.
- 27.0 Keep to your left to remain on Rt. 185.
- 27.2 Just before bridge over the Farmington River turn left (south) onto Nod Road. King Philips cave is visible high on the Talcott basalt cliff to the east.

- 30.4 Traffic light at intersection with Rt. 44. Continue straight across and follow Rt. 10 south (Waterville Road).
- 34.3 Entering New Britain quadrangle.
- 36.0 Traffic lights. Turn left (east) onto Rt. 4 (Farmington Ave.).
- 36.2 Bear left on Rt. 4.
- 36.8 Roadcut in the Talcott basalt and underlying sediments.
- 36.8 Follow signs for 4 East (Farmington Ave.) around interchange.
- 37.0 Just past traffic lights pull off into the parking area on the right next to outcrops of the splinter jointed Upper Holyoke basalt flow. Walk back along road to the outcrop of the Talcott Basalt.
- STOP 4 - Talcott Basalt.
- 37.0 Leaving parking area turn left (west) onto Rt. 4. At traffic lights turn left onto I-84 access road.
- 37.1 Keep to the right and follow signs for I-84 west (Waterbury).
- 37.6 Bear right onto I-84W.
- 41.2 Follow signs for Rt. 72 East at exit 35.
- 41.2 Roadcuts here expose the contact between the splinter jointed upper Holyoke flow and the vesicular upper surface of the lower Holyoke flow.
- 43.5 Exit Rt. 72E at Columbus Blvd.
- 43.6 Turn right at traffic lights onto Cedar and Lake Streets. Park on Lake Street. Walk back to exit ramp.
- 43.7 STOP 5 - Carbonate-Quartz-Barite Veins at the Columbus Blvd. exit of Rt. 72.
- 43.7 Continue on Lake Street to its T-junction with W. Main St.
- 43.8 Turn right (west) at traffic lights onto W. Main St.
- 44.3 Underpass under Rt. 72.
- 44.8 Traffic lights. Turn left onto Corbin Ave.
- 49.0 Rt. 72 Field Trip ends here. Rt. 72W leads onto I-84. Rt. 72E leads to Rt. 15. Roadcuts of the Hampden basalt along Rt. 72E are cut by several conspicuous carbonate-quartz + barite veins. At the Ellis St. exit these veins contain chalcopyrite and bornite but no galena or sphalerite.

Paleozoic and Precambrian Geology

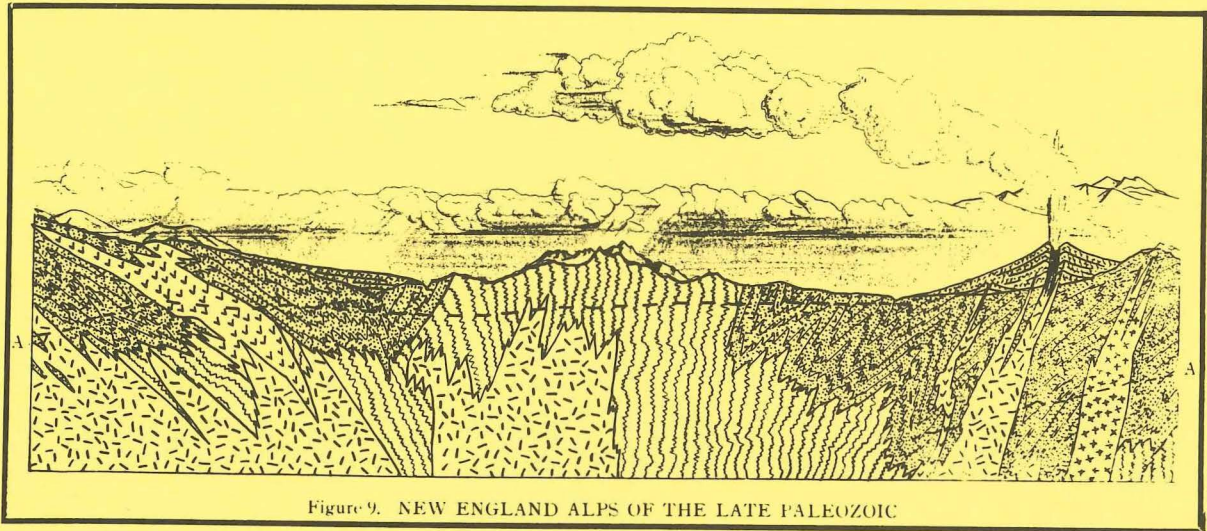

Figure 9. NEW ENGLAND ALPS OF THE LATE PALEOZOIC

P1	AN INVESTIGATION OF THE STRATIGRAPHY AND TECTONICS OF THE KENT AREA, WESTERN CONNECTICUT	213
P1A	CHRONOLOGY OF METAMORPHISM IN WESTERN CONNECTICUT: Rb-Sr AGES	247
P2	THE BONEMILL BROOK FAULT ZONE, EASTERN CONNECTICUT	263
P3	HIGH GRADE ACADIAN REGIONAL METAMORPHISM IN SOUTH-CENTRAL MASSACHUSETTS	289
P4	STRATIGRAPHY AND STRUCTURE OF THE WARE-BARRE AREA, CENTRAL MASSACHUSETTS	341
P5	LAKE CHAR FAULT IN WEBSTER, MASSACHUSETTS AREA: EVIDENCE FOR WEST-DOWN MOTION	375
P6	STRUCTURAL RELATIONS AT THE JUNCTION OF THE MERRIMACK PROVINCE, NASHOBA THRUST BELT AND THE SOUTHEAST NEW ENGLAND PLATFORM IN THE WEBSTER-OXFORD AREA, MASSACHUSETTS, CONNECTICUT, AND RHODE ISLAND	395
P7	THE STRUCTURAL GEOLOGY OF THE MOODUS SEISMIC AREA, SOUTH-CENTRAL CONNECTICUT	419
P8	MULTI-STAGE DEFORMATION OF THE PRESTON GABBRO, EASTERN CONNECTICUT	453
P9	STRUCTURE AND PETROLOGY OF THE WILLIMANTIC DOME AND THE WILLIMANTIC FAULT, EASTERN CONNECTICUT	465

AN INVESTIGATION OF THE STRATIGRAPHY AND TECTONICS
OF THE KENT AREA, WESTERN CONNECTICUT

Richard A. Jackson
Exxon, Exploration Dept., Denver, Co. 80201

Leo M. Hall
Dept. Geol. and Geog., University of Massachusetts,
Amherst, Mass. 01002

INTRODUCTION

The detailed stratigraphy and tectonics of the complexly deformed autochthon and allochthon of the Manhattan Prong is correlated with a similar stratigraphy and structural framework of the Taconic area of western Connecticut. This correlation (Robinson and Hall, 1980; Hall, 1980) is based on detailed mapping in both the Manhattan Prong (Hall, 1968, 1976, and 1980) and the southern Taconics (Ratcliffe, 1969, 1975; Zen, 1969, 1972). Since the Kent area (Fig. 1) lies between these two regions, correlative stratigraphy (Fig. 2) and tectonic history can be demonstrated. This trip will examine the detailed stratigraphy of the autochthon and allochthon of the Kent area, and the geometry and relative timing of deformation.

REGIONAL SETTING

Precambrian rocks are exposed in the Housatonic Highlands (Stop 1), the Hudson Highlands, and in several locations within the Kent area (Stop 6). Except for the occurrence of Triassic/Jurassic rocks in the Pomperaug Basin, the rocks in western Connecticut and adjacent parts of New York State are metamorphosed Lower Paleozoic miogeoclinal and eugeoclinal rocks (Fig. 1). Paleozoic plutons, such as the Ordovician Candlewood Lake Pluton (Mose and Nagel, appended to this report; Stop 4) in the Kent area (Fig. 1), are also present in the region.

Rocks in the western and northern portions of the Kent area are in the sillimanite-K-feldspar zone. The grade of Paleozoic regional metamorphism decreases both eastward and westward from this high grade zone (Balk, 1936; Barth, 1936; Vidale, 1974; Jackson, 1980) (Fig. 1). The metamorphic history of the rocks is complex, as Acadian metamorphic effects overlap Taconian metamorphic effects in the region. With the high metamorphic grade there is an intimate structural involvement of the Precambrian basement with the Paleozoic cover rocks (Hall, *et al.*, 1975; Hall, 1980).

STRATIGRAPHY

Precambrian rocks of igneous and sedimentary origin are unconformably overlain by Cambrian quartzites and schists of the Lowerre Quartzite (Stops 1, 5 and 6) and the Cambrian/Ordovician carbonate bank Inwood Marble sequence (Figs. 2 and 4). The eastern exposures of the Lowerre

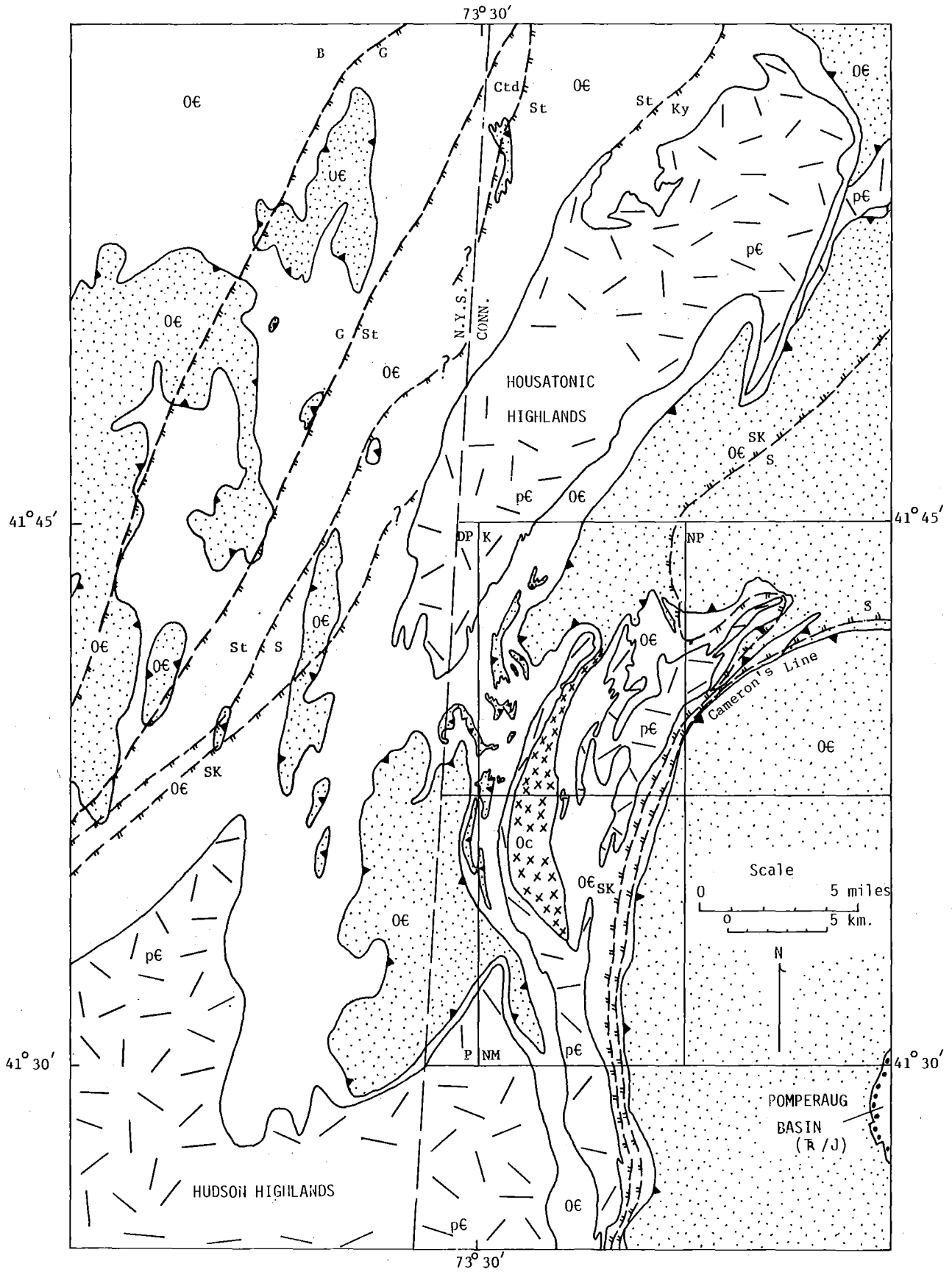

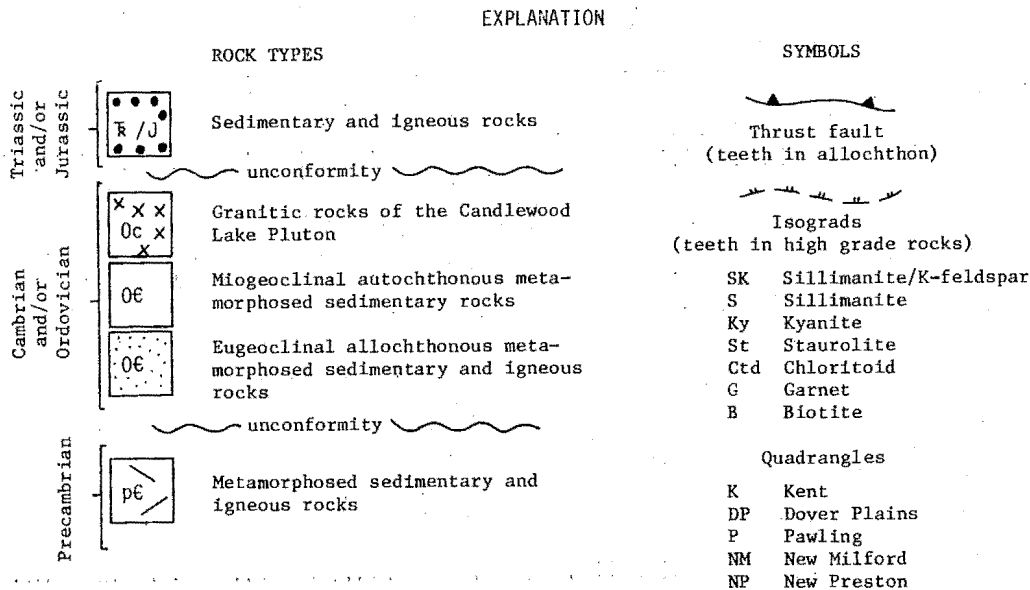

Figure 1. Generalized geologic map of western Connecticut and adjacent eastern New York State (compiled from Balk, 1936; Barth, 1936; Fisher, et.al., 1972; Vidale, 1974; Robinson and Hall, 1980; Zen, 1981). The Kent area includes the Kent (Jackson, 1980), New Preston (Gates, 1952; Dana, 1977), New Milford (Caldwell, personal communication, 1975), and the Connecticut portions of the Dover Plains and Pawling (Jackson, reconnaissance mapping) quadrangles.

LOCATION AGE	KENT QUADRANGLE THIS REPORT		MANHATTAN PRONG AREA, NEW YORK	DUTCHESS COUNTY NEW YORK	WESTERN MASSACHUSETTS AND CONNECTICUT	WESTERN VERMONT	
MIDDLE ORDOVICIAN	MANHATTAN A	GRANULITE MEMBER CALCITE MARBLE MEMBER	MANHATTAN SCHIST	A-MEMBER INTERBEDDED MARBLE AND SCHIST	WALLOOMSAC FORMATION BALMVILLE LIMESTONE	WALLOOMSAC FORMATION INTERBEDDED LIMESTONE AND SCHIST	IRA FORMATION WIPPLE MARBLE MEMBER
EARLY ORDOVICIAN	ERODED		ERODED		STOCKBRIDGE-WAPPINGER GROUP	STOCKBRIDGE FORMATION	CHIPMAN FORMATION BASCOM FORMATION CUTTING DOLOMITE SHELBURNE FORMATION
CAMBRIAN	INWOOD MARBLE	B-MEMBER A-MEMBER	INWOOD MARBLE	C-MEMBER B-MEMBER A-MEMBER	BRIARCLIFF DOLOMITE PINE PLAINS FM. STISSING DOLOMITE	UNIT-G UNIT-F UNIT-E UNIT-D UNIT-C UNIT-B UNIT-A	DANBY FORMATION WINOOSKI DOLOMITE MONKTON QUARTZITE DUNHAM DOLOMITE
	LOWERRE QUARTZITE		LOWERRE QUARTZITE		POUGHQUAG QUARTZITE	CHESHIRE QUARTZITE DALTON FORMATION	CHESHIRE QUARTZITE DALTON FORMATION
PRECAMBRIAN	GNEISSES		FORDHAM GNEISS		GNEISSES	BERKSHIRE MASSIF GNEISSES	MOUNT HOLLEY COMPLEX

Figure 2. Proposed regional correlation of the miogeosynclinal stratigraphic subdivisions in the Kent quadrangle, based on a similar diagram of Hall (1968a, 1968b, 1976).

Quartzite consist of schistose granulite and schist (Stops 5 and 6), whereas quartzite and conglomeratic quartzite are common in the west (Stop 1). This may represent a time-transgressive sequence with the rocks in the east deposited in deeper water and prior to those in the west. The base of the Inwood Marble consists of a thick-bedded dolomite marble with thin interbedded quartz granulite, calc-silicate, calcite marble, and dolomite marble higher in the section (Stop 2 and Optional Stop A). These rocks in turn are unconformably overlain by Middle Ordovician calcite marble and schistose granulite of Manhattan A (Stops 2 and 4). Locally, Manhattan A rocks are in direct contact with Inwood Marble (Stop 2) or locally, with Lowerre Quartzite (Fig. 3).

The autochthonous stratigraphy is physically overlain by an allochthonous sequence of Cambrian and/or Ordovician eugeoclinal schists, granulites, gneisses and amphibolites of Manhattan C and the Moretown Formation (Fig. 3). The detailed stratigraphy within Manhattan C is seen at Optional Stop B. The correlation between the autochthonous and allochthonous rocks of the Kent area is shown in Figure 4. A major tectonic and stratigraphic boundary, Cameron's Line (Rodgers, *et al.*, 1956; Merguerian, in press), occurs east and southeast of the rocks of the Kent area (Fig. 1). Mafic and ultramafic igneous bodies occur locally along its trend. A sequence of schist, quartzite, amphibolite, and gneiss of the eugeoclinal Moretown Formation is east of Cameron's Line (Fig. 3).

STRUCTURAL GEOLOGY

Basement in the Housatonic Highlands and elsewhere within the Kent area underwent a Precambrian, presumably Grenvillian, deformation with the development of folds and associated axial plane foliation. Previously these folded rocks were in turn intruded by Late Precambrian granite that presumably became gneissic during Paleozoic deformation (Stops 1 and 6). Precambrian structural elements are truncated by the unconformity beneath the overlying Cambrian Lowerre Quartzite (Stops 1 and 6).

The geologic map pattern (Fig. 3) is the result of a sequence of thrust faults and several major stages of folding during the Paleozoic (Jackson, 1980). Taconic orogenic activity produced thrust faults and major isoclinal folds (Figs. 5 and 6) with a well developed axial plane schistosity which is the dominant schistosity of the Paleozoic rocks in the area. The thrust sheets formed prior to or contemporaneous with this folding. Separate thrust sheets transported Cambrian Manhattan C rocks westward over the autochthonous stratigraphy (Stops 3 and 4 and Optional Stop B). It is proposed that Manhattan C was deposited at nearly the same time as, or somewhat earlier than, the Lowerre Quartzite, but further offshore to the east. The rocks reached the sillimanite-K-feldspar grade of metamorphism during Taconian deformation and the Candlewood Lake Pluton (Stop 4) and related pegmatites invaded the autochthonous and allochthonous rocks while these rocks were still hot (Jackson, 1980). The radiometric dating of this pluton (Mose and Nagel,

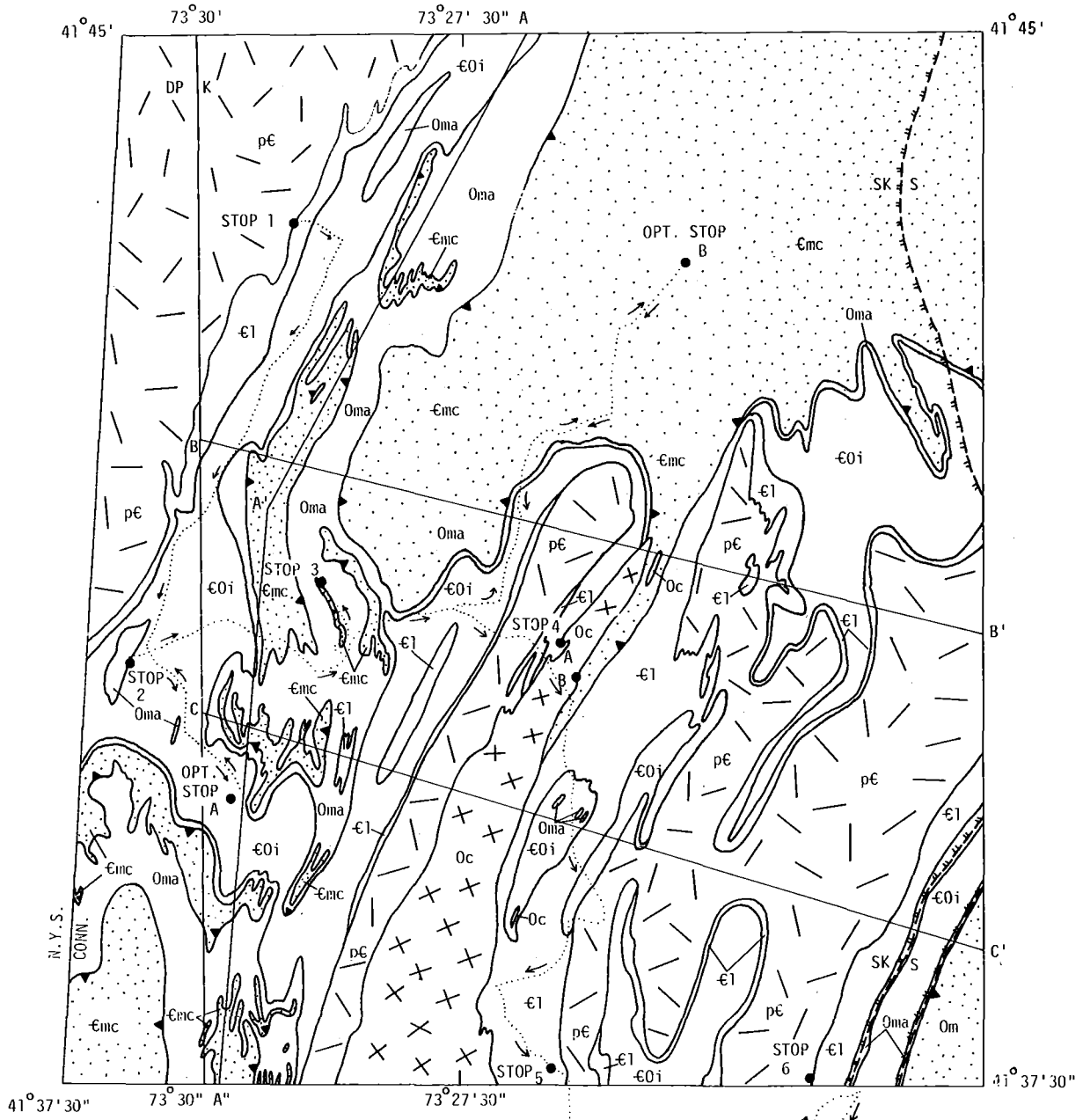

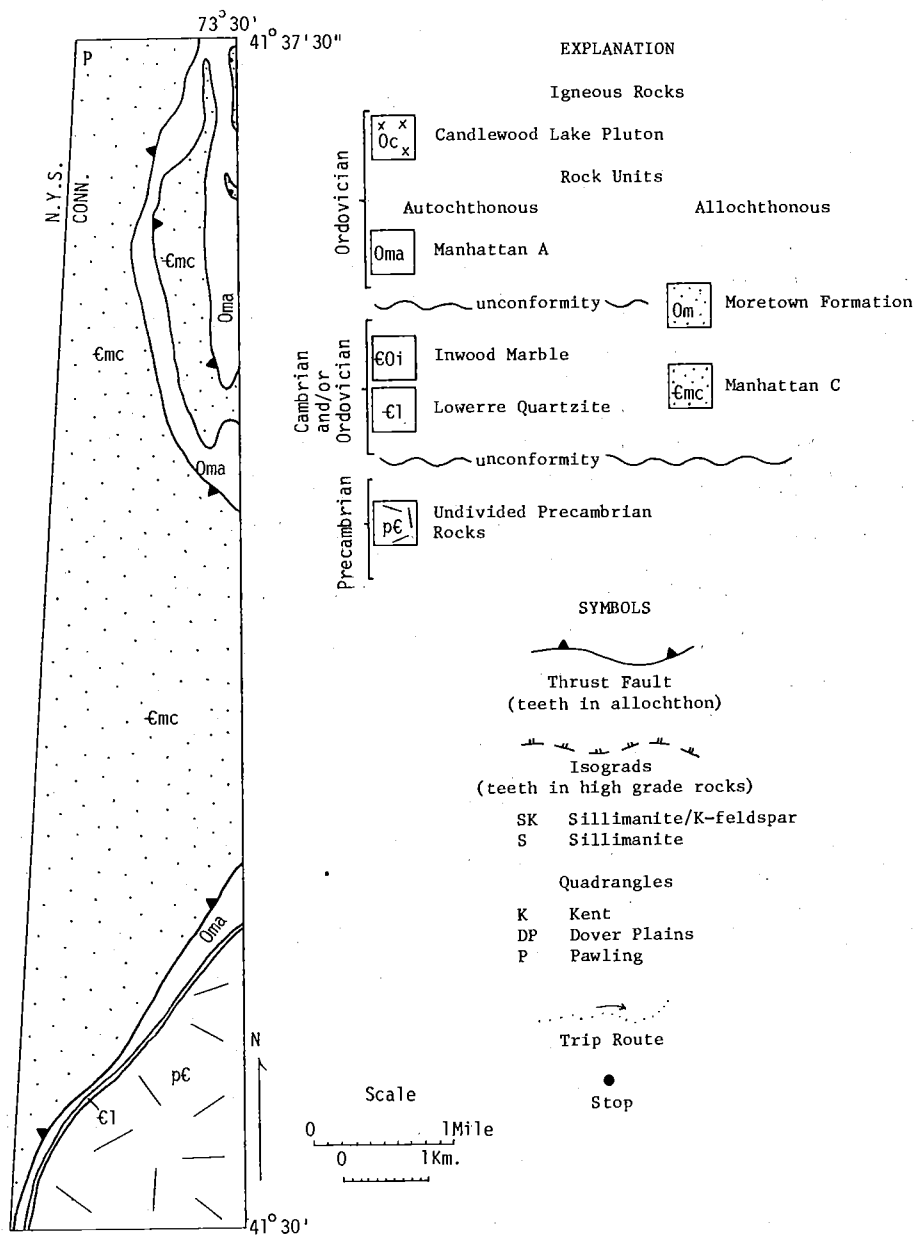

Figure 3. Generalized geologic maps of the Kent (Jackson, 1980), Dover Plains and Pawling (Jackson, unpublished reconnaissance mapping) quadrangles, indicating trip route, stops, and structural sections AA'A", BB', and CC'.

AGE	AUTOCHTHONOUS SEQUENCE	ALLOCHTHONOUS SEQUENCE
ORDOVICIAN	MANHATTAN A GRANULITE MEMBER CALCITE MARBLE ERODED	? — ? — ? — ? — MORETOWN FORMATION ? — ? — ? — ? —
	CAMBRIAN	INWOOD MARBLE B-MEMBER A-MEMBER
LOWERRE QUARTZITE		MANHATTAN C SILICEOUS GRANULITE AMPHIBOLITE SCHISTOSE GRANULITE SCHISTOSE GNEISS ? — ? — ? —
PRECAMBRIAN GNEISSES		

Figure 4. Proposed correlation of allochthonous rocks and autochthonous rocks in the Kent quadrangle.

appended to this report) provides a control on the timing of the various phases of deformation, so that Acadian deformation is interpreted to have followed the thrusting, early folding, and intrusion of the Candlewood Lake Pluton (Stop 4). Acadian deformation produced large-scale, nearly vertical, isoclinal to open folds, trending north or northeast. These folds dominate the map pattern (Fig. 3) and their geometry is illustrated in structure sections BB' and CC' (Fig. 6). Finally, a late stage of deformation occurred with two associated, or conjugate, sets of folds developing with respective northeast and northwest axial planar slip cleavages. A summary of the deformational history of the Kent area is provided in Figure 7.

ACKNOWLEDGEMENTS

We wish to thank the Connecticut State Geological and Natural History Survey for providing generous financial support. The cooperation extended to us by the personnel of the Kent School (Stop 1), South Kent School (Stop 3), and the Eliot D. Pratt Education Center (Stop 6) is greatly appreciated.

TRIP PURPOSE

Located between the southeastern Taconics and the Manhattan Prong, the stratigraphy and structural geology of the Kent area is critical to any regional synthesis. The purpose of this trip is to illustrate the important stratigraphic relationships and to define the deformational episodes that have effected the rocks of the area. Although they are disrupted by thrust faulting and several major episodes of folding, a clear time/stratigraphic equivalence between the autochthonous Lowerre Quartzite and the allochthonous Manhattan C is recognized. Two unconformities, one that is basal Paleozoic and another that is Middle Ordovician have been traced through the area. Radiometric dating of the Candlewood Lake Pluton, a granitic intrusive body, and the structural relationships of this pluton to the surrounding rocks indicates that major thrusting and an early, recumbent phase of folding with its associated sillimanite/K-feldspar metamorphism occurred during the Taconian orogeny. Deformation subsequent to the emplacement of the granite is inferred to be Acadian.

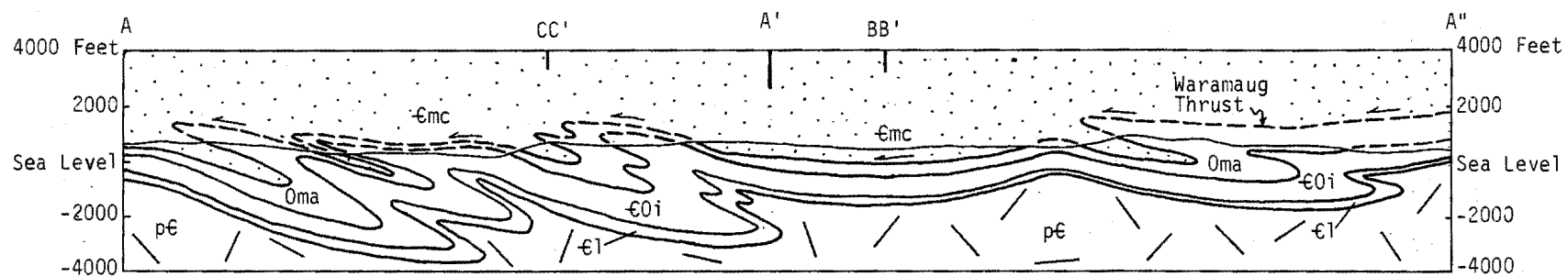

Figure 5. Generalized structure section AA'A'' indicating the Waramaug Thrust and the intimate relationship between the Precambrian basement and Paleozoic cover rocks during Taconian folding, D₂. Section is drawn facing west.

P1-11

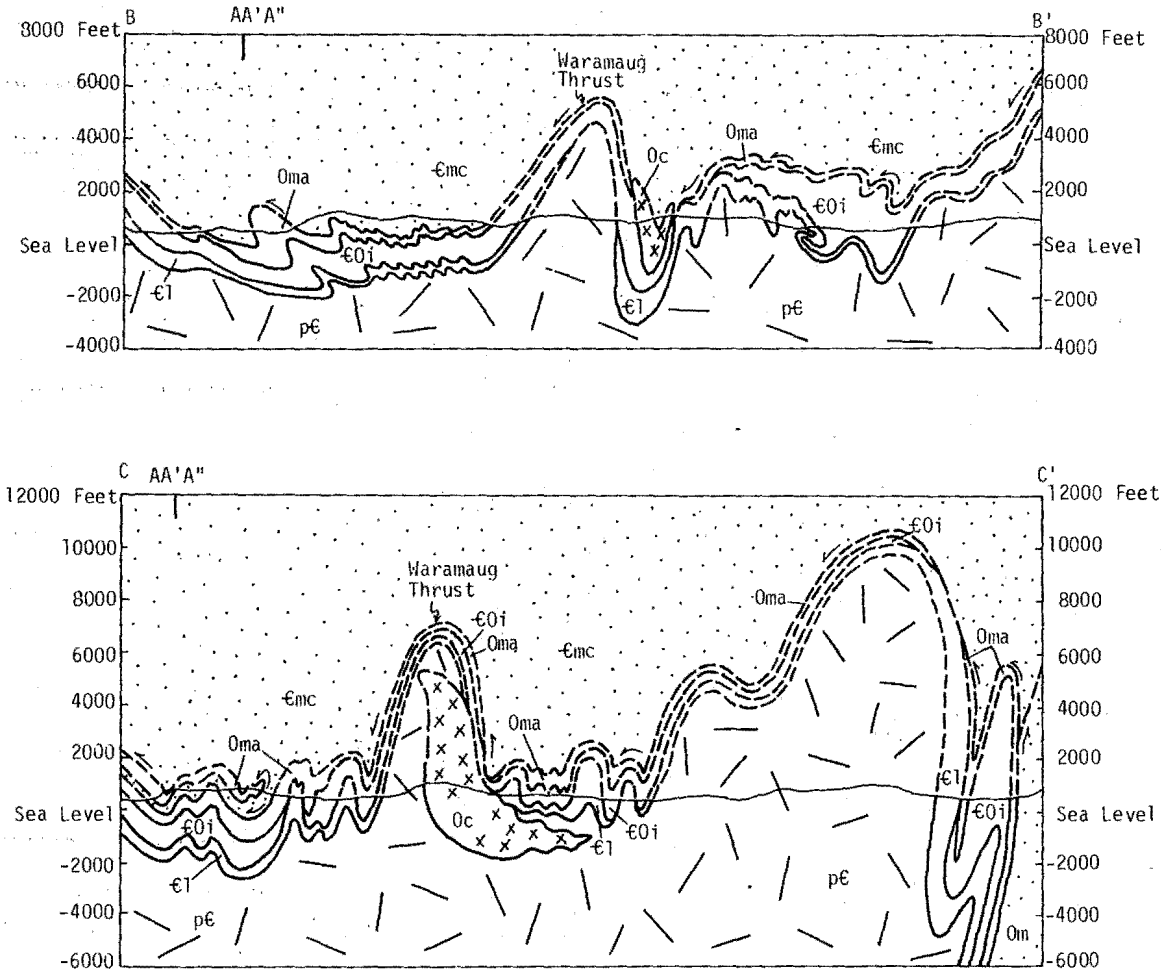

Figure 6. Generalized structural sections BB' and CC' indicating the dominance of the Acadian deformation, D₃.

DEFORMATIONAL EVENT	DESCRIPTION	IGNEOUS INTRUSION	OROGENY
D ₄	Major open conjugate folds, contemporaneous northeast and northwest axial plane cleavage. Interference with D ₃ folds locally producing dome and basin features.		Acadian(?)
D ₃	Major isoclinal to open folds; vertical axial plane cleavage. North to northeast trending. Possible metamorphism to kyanite/staurolite grade.		Acadian
D ₂	Major isoclinal folds; overturned to west; deform thrust slices; strong axial plane schistosity; peak metamorphism to sillimanite/K-feldspar grade. Thrust sheets emplaced westward, bring eugeoclinal rocks over miogeoclinal rocks. Locally, isoclinal folds developed within the sheets prior to or during sheet emplacement.	Candlewood Lake Pluton (Ordovician; Mose and Nagel, this report)	Taconian
	<p>~~~~~ Middle Ordovician Unconformity ~~~~~</p> <p>Erosion associated with block faulting (?) has Manhattan A resting on Inwood Marble or locally, Lowerre Quartzite.</p> <p>~~~~~ Basal Paleozoic Unconformity ~~~~~</p>		
D ₁	Foliation subparallel to gneissic layering; no minor folds noted. Grade of metamorphism unknown.	Pink Granitic Gneiss truncates early foliation and gneissosity	Late Precambrian (?) Grenville

Figure 7. Chronology of tectonic events in the Kent area, Western Connecticut.

Pl-13

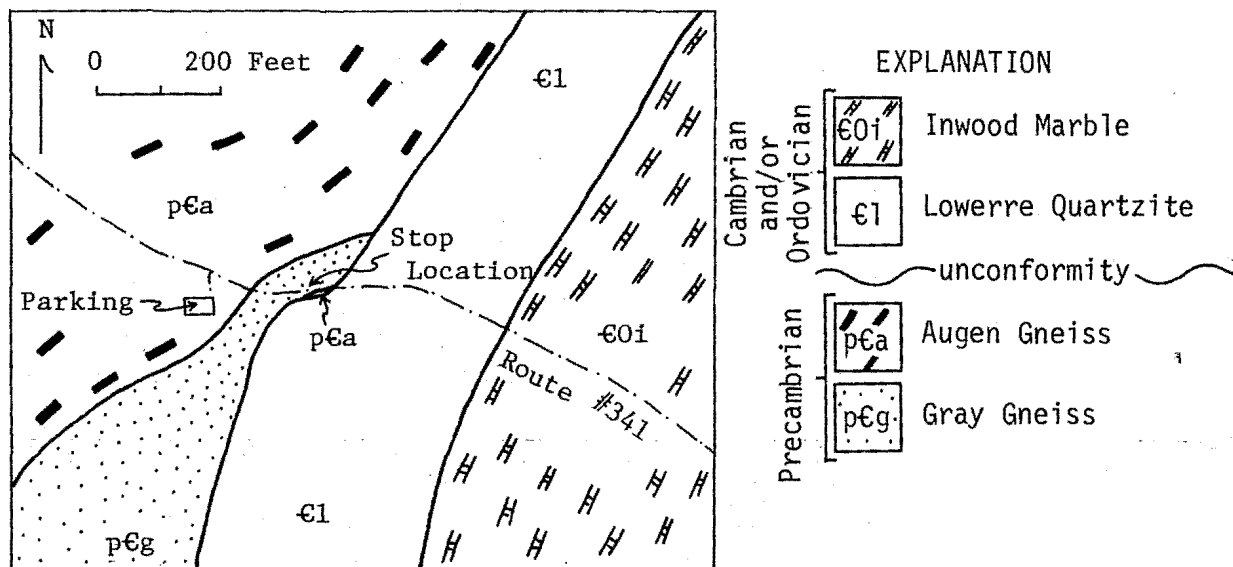

Figure 8. Geologic map of the region in the vicinity of Stop 1.

ROAD LOG

From the Hartford, Connecticut area follow Route #84 west to Route #7 in Danbury. Drive north along Route #7 to Route #341 in Kent Village.

The assembly point is the Kent School Ice Arena parking lot (Fig. 8), located on Route #341 approximately 0.6 miles west of the Route #7/#341 intersection in Kent Village.

Stop 1. Kent School Road Cut. The road cut, located along the east edge of the Housatonic Highlands (Fig. 8) is in Precambrian gneisses that are overlain unconformably by the Cambrian Lowerre Quartzite. Two Precambrian rock units, Pinkish Granitic Augen Gneiss and the Gray Gneiss, are exposed in the cut (Fig. 8). The latter consists of interlayered gray, biotite gneisses, hornblende gneisses, and amphibolite. The Augen Gneiss is also present near Stop 6 (Fig. 18A, p€a) in the core of the Bear Hill Anticline.

The Augen Gneiss is a well foliated pink and pale-pinkish gray, biotite-quartz-plagioclase-microcline augen gneiss with widely scattered concentrations of garnet. The pale-pinkish gray augen gneiss contains more plagioclase. Minor thin, dark-gray biotite gneisses with hornblende and epidote are locally interlayered with the augen gneiss.

The Gray Gneiss unit includes five main rock types, all of which are penetrated by granitic layers: well foliated, gray hornblende-biotite-quartz-plagioclase gneiss, fine-grained, siliceous, gray, biotite-plagioclase-quartz gneiss, dark-gray, garnet-hornblende-quartz-biotite-plag-

isoclase gneiss, dark-gray biotite amphibolite, and light-gray calc-silicate rock.

The Lowerre Quartzite consists of interbedded light-brown or buff-weathering quartzite and coarse-grained conglomeratic quartzite. This is the western facies of the Lowerre Quartzite. Locally, along strike, there are interbeds of schistose quartzite and feldspathic quartzite with quartz/feldspar nodules, similar to the rocks of the eastern facies noted at Stop 6. Deeply weathered micaceous conglomeratic quartzite 3-5 feet thick is present at the base of the Lowerre and appears to be sheared. The Precambrian Augen Gneiss underlies this conglomerate.

All of the rocks have been deformed by folding and faulting. Minor folds in the Precambrian rocks represent at least two phases of deformation and at least one phase of folding is represented in the Lowerre Quartzite. Faults are prominent particularly in the gneisses and shearing is evident at the Precambrian-Lowerre contact.

Minor structural features measured at this road cut are shown on the three equal area plots in Figure 9. Structural data recorded from the Precambrian rocks on the north side of the road (Fig. 9-B) show numerous fold axes clustered about the pole to the great circle defined by poles to foliation. These are the axes of the earlier of two sets of folds present in the Precambrian here and they plunge S22E at 42° (Fig. 9-B). Trends of these fold axes are scattered from S07E to S40E, and the associated axial plane foliation strikes from N20W to N20E and dips 70°-80° easterly. The age of this folding is possibly Acadian, D₃ (Fig. 7). Foliation that is parallel or subparallel to the compositional layering, also folded by this deformation, formed during an even earlier deformation, probably Grenvillian, D₁ (Fig. 7). Poles to this foliation constitute a well defined great circle and beta maximum. Crinkles, D₄ (Fig. 7), deform both the compositional layering foliation and the axial plane foliation of the southeast plunging folds. These crinkle axes trend from S26W to S58W and plunge gently to moderately southwest (Fig. 9-B). Biotite lineation trends from S35E to N85E and plunges moderately eastward. The biotite lineation appears to be deformed by the southeast plunging folds and therefore to have formed prior to the southeast plunging folds. Several fairly good candidates for early isoclinal folds associated with the lineation and foliation are on the south side of the road. Several faults strike northeasterly and dip moderately southeast.

D₃ (Fig. 7) phase folds, which deform the compositional layering foliation and mineral lineation, have a somewhat different orientation on the south side of the road (Fig. 9-C). With the exception of one fold axis trending east-southeast, these fold axes on the south side of the road trend from S02E to S08E and plunge moderately south. Poles to the layering foliation lie on a well defined great circle, the pole to which is parallel to the axes of earlier phase minor folds (Fig. 9-C). Many faults and shear zones with associated granitic rocks are present on the south side of the road and most trend northeast to east-northeast and dip moderately to steeply southeast (Fig. 9-C).

P1-15

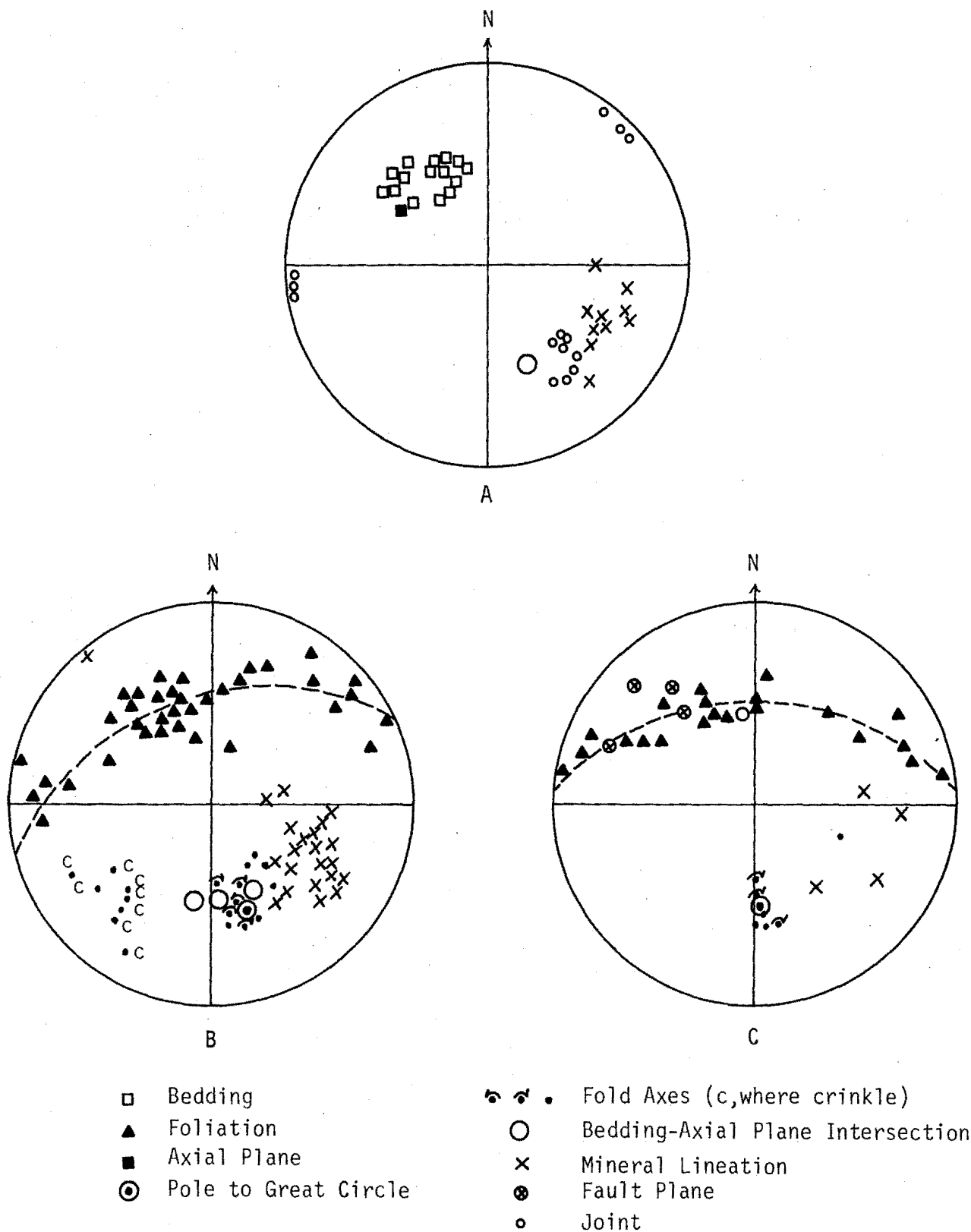

Figure 9. Equal-area diagrams summarizing structural data from the Lowerre Quartzite (A) and from the Precambrian basement north of the road (B) and south of the road (C) at Stop 1.

Bedding in the Lowerre Quartzite south of the road dips moderately southeast and strikes from N30E to N80E (Fig. 9-A). A poorly defined cleavage is locally present and is subparallel to bedding and one poorly defined minor fold has been found in the Lowerre at this locality. It was not possible to accurately measure the fold axis directly but it clearly plunges moderately southeastward. The axial plane of this fold strikes approximately N37E and dips 39SE and the intersection of the axial plane with bedding is S30E, 37SE (Fig. 9-A). Quartz and tourmaline lineations near this fold plunge S57E at 31° and S47E at 20°. Considering the orientation of features related to the deformation, it is proposed that the minor fold, cleavage and mineral lineations formed during the Taconic Orogeny, D₂ (Fig. 7).

Three prominent joint sets are present in the quartzite (Fig. 9-A). The most prominent set trends northeast and dips moderately northwest, another set trends N10W and is nearly vertical, while the third set trends approximately N45W and is nearly vertical.

A three to five foot thick zone of shearing is evident near the Precambrian-Lowerre contact. Both the Augen Gneiss and micaceous quartz conglomerate were involved in this shearing as indicated by the cataclastic texture and deep weathering of both rocks in this zone. The shearing is believed to represent minor, local shearing along the contact between rocks of contrasting ductility during folding.

Mileage		
<u>Total</u>	<u>Interval</u>	
0.0	-	Leave the parking lot and turn right (east) on Route #341, crossing the Housatonic River in a short distance.
0.4	0.4	Route #341/#7 intersection in Kent Village. Turn right (south) on Route #7. The Housatonic Highlands are on the west and the hills to the east are held up by allochthonous Manhattan C schists. The Housatonic River Valley is underlain by members of the Inwood Marble.
3.2	2.8	Cliffs of Precambrian gneisses are seen adjacent to the Housatonic River on the west.
4.0	0.8	Turn right (west) on Bulls Bridge Road and drive through the covered bridge.
4.2	0.2	<u>Stop 2. Bulls Bridge</u> (Fig. 10). Park in the dirt parking facility on the left side of the road, adjacent to the Housatonic River, past a small bridge.

Cambrian and/or Early Ordovician Inwood Marble Member B is unconformably overlain by Middle Ordovician Manhattan A in the Bulls Bridge area. Descend to the rock exposures in the Housatonic River on the downstream side of the open bridge, adjacent to the parking lot (Fig. 10). Station A (Fig. 10) - Inwood Marble Member B here consists of massive, light-gray dolomite marble; tan-weathering siliceous dolomite marble; tan-weathering quartz granulite; and minor tan/orange-weathering calcite

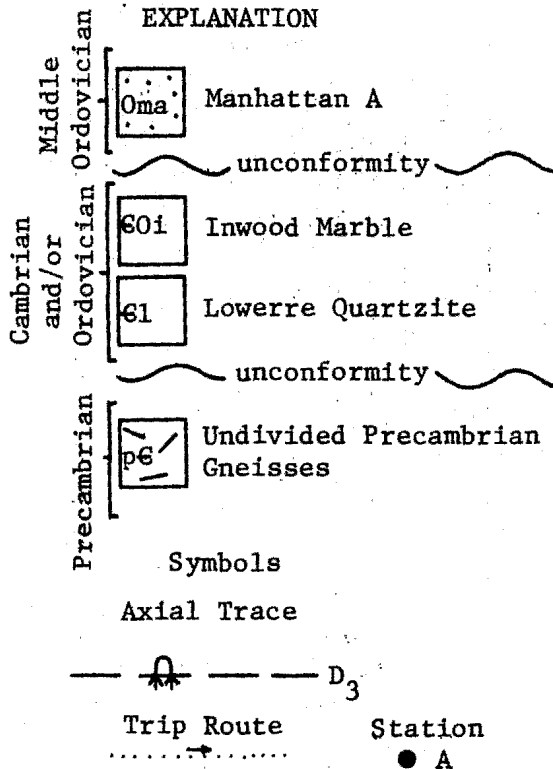
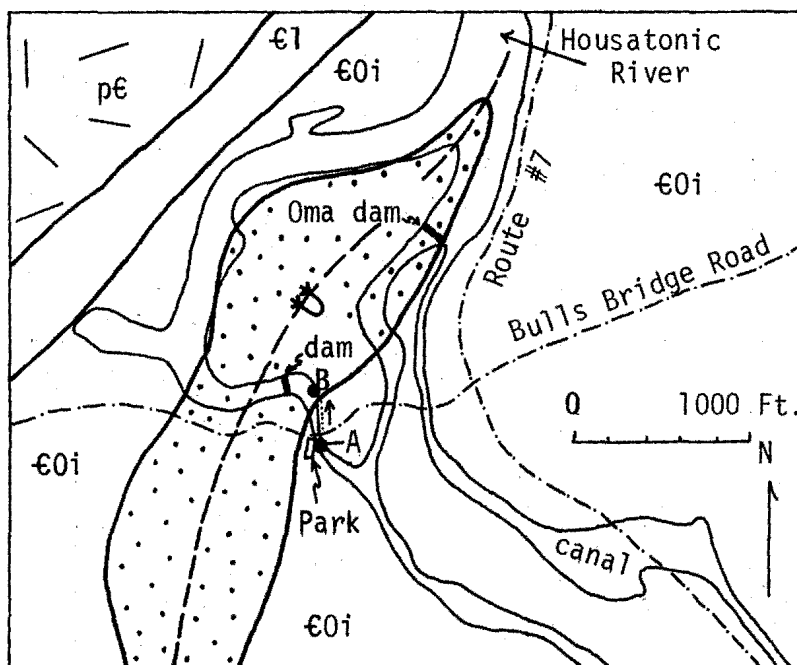

Figure 10. Generalized geologic map in the vicinity of Stop 2.

marble. Tremolite knots up to $\frac{1}{2}$ inch across are locally abundant. Station B (Fig. 10) - Walk several hundred feet upstream from the bridge, across exposures of thin, interbedded Inwood Marble. These beds contrast sharply with well foliated, rusty/sulfidic- or tan-weathering, gray to dark-gray, (muscovite)-biotite-quartz-plagioclase schist, schistose granulite, and calcareous granulite of the Granulite Member of Manhattan A. Interlayered orange/tan-weathering, well foliated, phlogopitic calcite marble is locally present. The Middle Ordovician unconformity separates Manhattan A from Inwood Marble.

The structural geology in the Bulls Bridge area is dramatically displayed by the abundant minor folds in the river exposures. Manhattan A (Station B) is in the trough of a map-scale, D_3 (Fig. 7) syncline, overturned to the west (Fig. 10). The Middle Ordovician unconformity, exposed north of the bridge at Station B, is on the eastern, overturned limb of this fold so that Middle Ordovician Manhattan A is physically beneath Cambrian and/or Early Ordovician Inwood Marble. Numerous minor D_3 folds are isoclinal to open, plunge gently south-southwest, and have axial surfaces that trend from N10E to N30E, and dip steeply northwest or southeast. Locally, these folds deform an earlier foliation, D_2 (Fig. 7), parallel or subparallel to layering.

The gentle warping of the axial trace of the large syncline (Fig. 10) is caused by D_4 (Fig. 7) folding. Minor southward plunging open folds of this stage are present at Station A with axial surfaces that trend N40W to N70W and dip moderately to steeply southwest.

- 4.2 - Leave the parking facility and turn right (east) across the bridges, retracing the route on Bulls Bridge Road to Route #7.
- 4.4 0.2 Intersection of Route #7 and Bulls Bridge Road.
If not going to Optional Stop A proceed across Route #7, continuing on Bulls Bridge Road.

Road Log For Optional Stop A

- 0.0 - Turn right (south) on Route #7.
- 1.1 1.1 Optional Stop A. Housatonic River. Park on the right side of the road and walk down the stream that crosses Route #7 at the sharp corner to the rock exposure in the Housatonic River.

The rocks at this stop display multiple deformation in the Inwood Marble, Member B. These rocks consists of thin interbedded dolomite marbles, quartz granulites, and minor calcite marble. These rock types are discussed more fully at Bulls Bridge (Stop 2).

Three phases of folding deform the rocks; D_2 , D_3 , and D_4 (Fig. 7). D_2 minor isoclinal folds have locally well defined axial plane foliation that trends west-northwest and dips moderately southwest or northeast. Minor fold axes plunge moderately southeast or north (Fig. 11-A).

D_2 axial plane foliation and bedding are deformed into abundant cren-

Pl-19

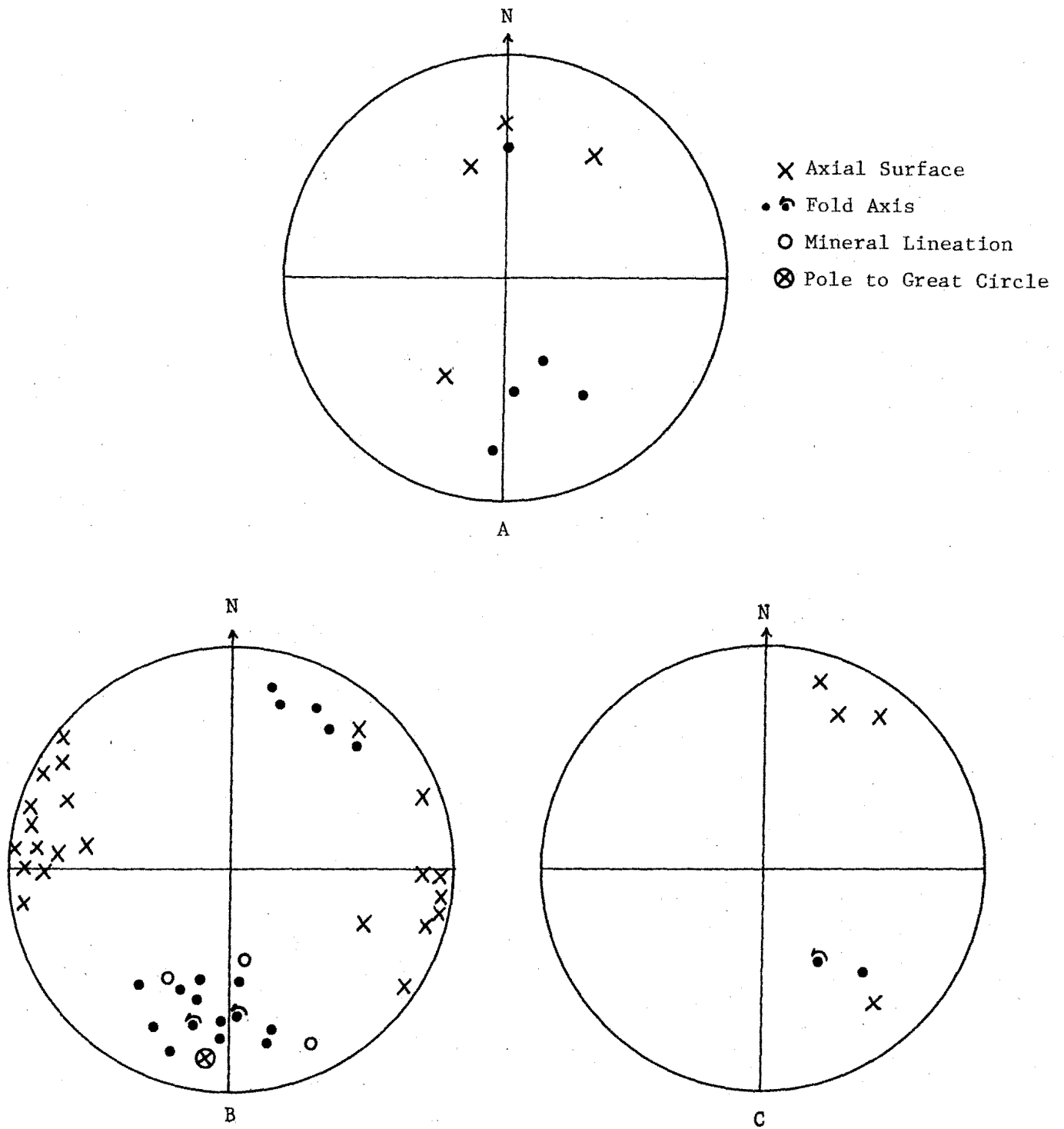

Figure 11. Equal-area diagrams summarizing structural data from the Inwood Marble at Optional Stop A, including D₂ (A), D₃ (B), and D₄ (C) events.

ulations and minor open to isoclinal folds of D_3 age. Axial surfaces trend from N24W through north to N36E and dip steeply northeast or northwest. Associated minor fold axes plunge gently to moderately north or south. The pole to the great circle defined by poles to bedding and D_2 foliation is parallel to the south plunging minor D_3 fold axes (Fig. 11-B).

D_4 axial surfaces trend northwest or northeast and dip steeply southwest or northwest, respectively (Fig. 11-C). Minor crenulation axes plunge moderately southeast. Age relations between the northwest and the northeast cleavages can not be determined and they are thought to be contemporaneous.

- 1.1 - Return back to the vehicles, carefully turn around and retrace Route #7 to Bulls Bridge Road.
 - 2.2 1.1 Turn right (east) on Bulls Bridge Road.
-
- 4.4 - Intersection of Route #7 and Bulls Bridge Road. Proceed across Route #7, continuing on Bulls Bridge Road.
 - 5.4 1.0 Low lying exposures of Manhattan C schist on either side of the road.
 - 6.2 0.8 Entrance of South Kent School. Proceed along Bulls Bridge Road.
 - 6.7 0.5 Turn left (north) into the school grounds near a small pond.
 - 6.8 0.1 Turn right (east) at the sign indicating the direction to the boat house.
 - 7.0 0.2 Bear left on the dirt road.
 - 7.3 0.3 Stop 3. Hatch Pond (Fig. 12). Park in the lot adjacent to the boat house.

At this stop rocks of Manhattan C are in thrust contact with autochthonous Middle Ordovician Manhattan A. Walk on the path that starts behind the boat house, trailing the shoreline of Hatch Pond. The rock exposures on the left (west) are schists of the allochthonous Manhattan C which occur in the trough of a map-scale D_3 (Fig. 7) syncline (Fig. 12). Ascending a hill the path divides into an upper and lower trail. Walk on the lower path near the water. At this location partially buried outcrops of massive, white to gray, calcite marble and dark-gray schistose granulite of Manhattan A are exposed.

Continue along the path close to the shoreline where there are several large exposures of the Granulite Member of Manhattan A. These rocks are interlayered, well foliated to weakly foliated, tan to rusty/sulfidic-weathering, gray or dark-gray, (muscovite)-biotite-quartz-plagioclase micaceous to schistose granulites, with locally abundant thin, discontinuous quartz stringers parallel to foliation; light-gray, well foliated calcareous schist or granulite; and thin-bedded, light-gray, calcite marble.

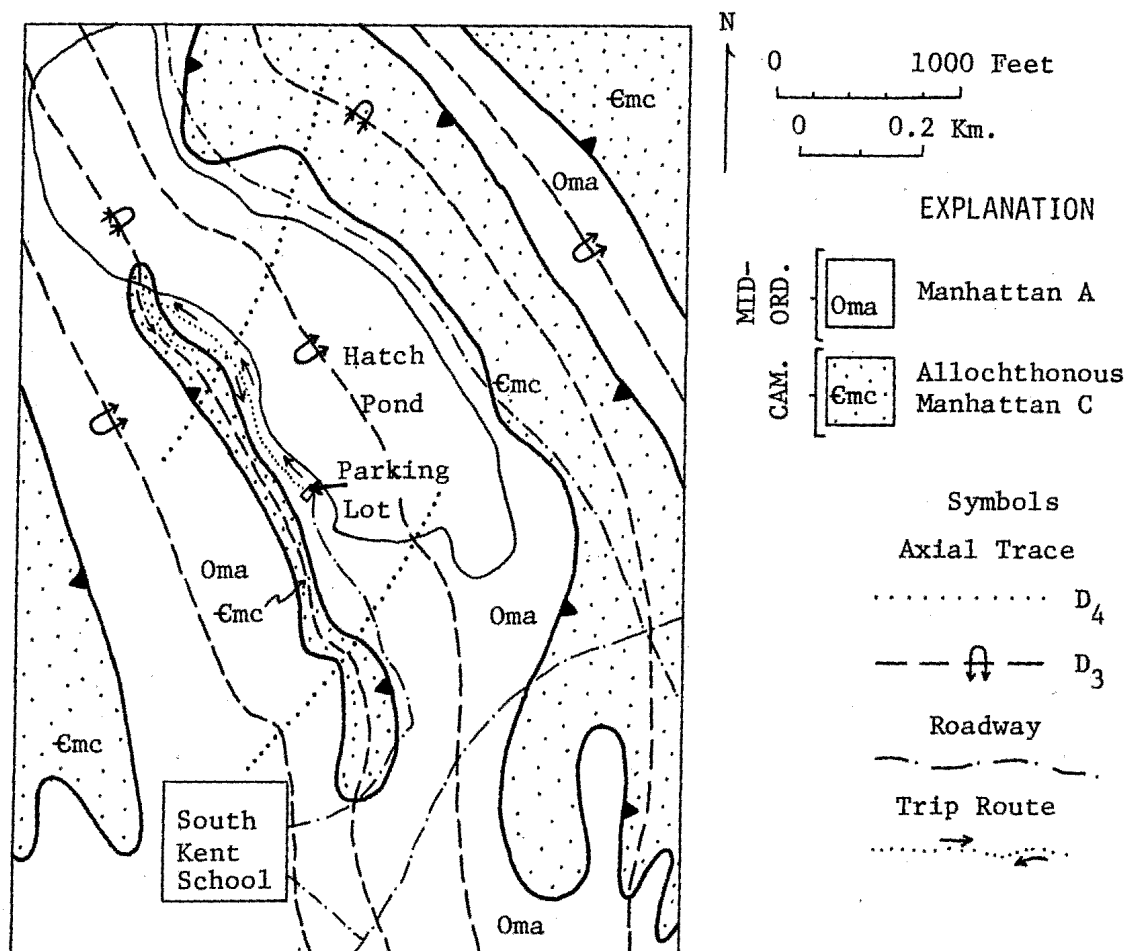

Figure 12. Generalized geologic map in the vicinity of Stop 3.

Rocks of Manhattan C occupy the the upper parts of this hill. Although not actually exposed here, the thrust separating allochthonous Manhattan C from autochthonous Manhattan A is crossed a short distance further along the path. The remaining rock exposures along the northern section of the path are in Manhattan C and are interlayered, tan or reddish tan to light-gray, garnet-sillimanite-quartz-biotite-muscovite schist and granulitic schist. The schistose layers, especially noted on higher parts of the hill, have abundant sillimanite knots, 1/8 inch across, that give the weathered outcrop surface a "warty" appearance. Thin quartz lenses parallel to foliation may be stretched pebbles. One inch thick, discontinuous glassy gray quartzite layers are locally noted. These layers are lithically reminiscent of glassy quartzite beds in the autochthonous Lowerre Quartzite (Stops 1 and 6). This supports the proposal that Manhattan C is an eastern facies equivalent of the Lowerre Quartzite that has been transported westward across the autochthon.

At this stop there is evidence for three separate phases of folding; D₂, D₃, and D₄ (Fig. 7). A structural analysis of the area was made and the data are displayed on the equal area diagram in Figure 13.

Following the emplacement of Manhattan C the rocks were deformed into isoclinal, possibly recumbent, folds, D₂, with axial planar schistosity,

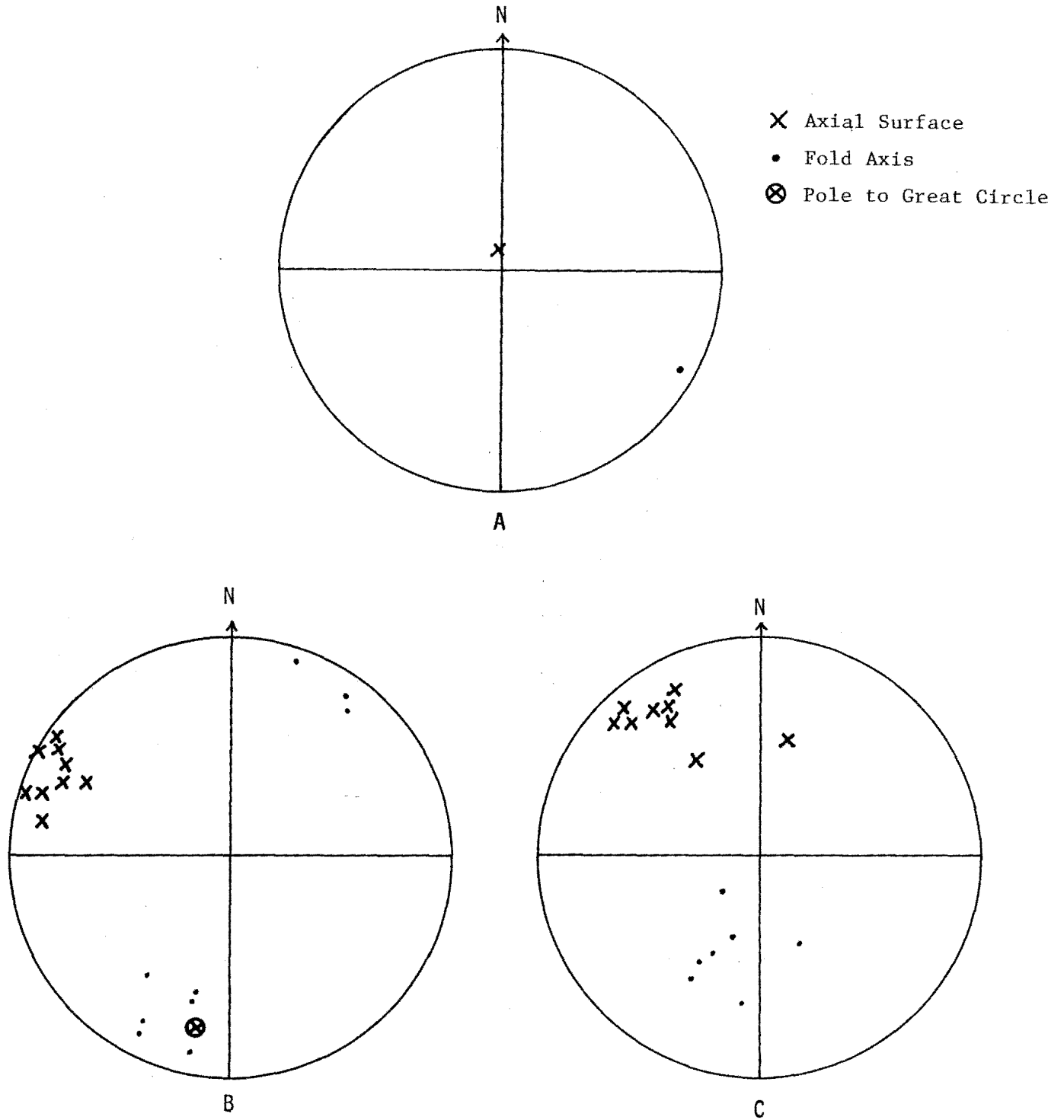

Figure 13. Equal-area diagrams summarizing structural data for Stop 3, including D_2 (A), D_3 (B), and D_4 (C) events.

the dominant planar feature in the rocks at this stop. One early minor fold is noted (Fig. 13-A) and its axial plane schistosity trends east-west, dips gently south, and has an axis plunging gently southeast. This corresponds well with the regional trend of D_2 fold axes, plunging either northwest or southeast.

Abundant D_3 minor folds and crenulations, are present and are related to the dominant D_3 map-scale folding in the Hatch Pond area (Fig. 12). These large folds, open to isoclinal and overturned to the west, have Manhattan C in the troughs of the synclines and Manhattan A in the cores of the anticlines. This stop is in the axial region of a D_3 syncline (Fig. 12). Evidence for D_3 folding consists of minor folds and crenulations that deform bedding and D_2 schistosity. These minor folds have axial surfaces that trend from N10E to N34E and dip steeply southeast and axes that plunge gently northeast or southwest (Fig. 13-B). A pole to the great circle that contains the poles of the D_2 schistosity plots in the southwest, nearly coincident with D_3 minor fold axes, indicating the effect of this later deformation on earlier axial surfaces.

Map-scale folds, D_4 , having northeast axial trends deform earlier, D_3 , folds in the Hatch Pond area (Fig. 12). In the rocks at this stop these D_4 folds are crenulations in the earlier schistosity having axial planes trending from N43E to N63E, dipping moderately or steeply southeast (Fig. 13-C). Crenulation axes plunge moderately southwest or southeast. One late minor fold has an axial plane that trends N78W and dips 53SW. Within the Kent area two distinct axial plane trends for the D_4 phase, northeast and northwest, are noted. Both appear to be contemporaneous, and the D_4 event is described as having a conjugate set of cleavages.

- 7.3 - Walk back to the parking lot along the trail. Leave the parking lot and retrace the route back to Bulls Bridge Road.
- 7.9 0.6 Turn left (east) on Bulls Bridge Road.
- 8.2 0.3 Intersection of South Kent Road. Proceed across the intersection onto Camps Flat Road.
- 8.8 0.6 Geer Mountain Road on the left (north).
If not going to Optional Stop B, continue along Camps Flat Road.

Road Log For Optional Stop B

- 0.0 - Turn left (north) on Geer Mountain Road.
Highlands on the east are Precambrian gneisses.
- 1.7 1.7 Bear right (east) on Flat Rock Road.
- 1.8 0.1 Majestic southward view for the next $\frac{1}{4}$ mile along Flat Rock Road.
- 2.4 0.6 Turn left (north) on South Road.
- 3.1 0.7 Turn right (east) on Route #341.
- 3.9 0.8 Optional Stop B. Bald Hill Road Cut (Fig. 14). Park along the right hand side of the road.

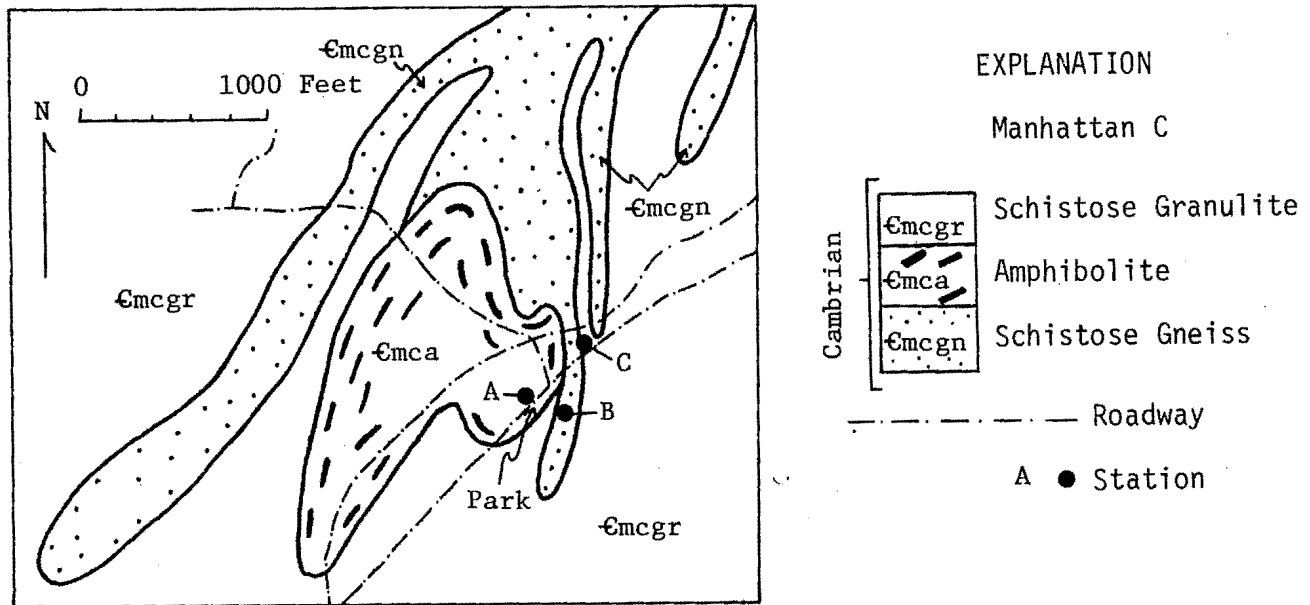

Figure 14. Generalized geologic map in the vicinity of Optional Stop B.

This long road cut exposes three mapped units of allochthonous Cambrian Manhattan C, including the Schistose Gneiss, Amphibolite, and Schistose Granulite Members (Fig. 14).

Station A (Fig. 14) - The Amphibolite Member is at the southwestern tip of the road cut. It is a dark-gray or black, well foliated to slabby amphibolite and hornblende gneiss, locally with abundant thin quartz-feldspar layers. Since this part of the road cut is in the hinge area of a map-scale, open, D_3 (Fig. 7) fold, the foliation is nearly horizontal. The amphibole lineation on foliation surfaces may be related to an earlier, D_2 event (Fig. 7).

Station B (Fig. 14) - Walk across the road to a small knob. This is the Schistose Gneiss Member and consists of well foliated, tan- to tan/gray-weathering, garnet-sillimanite-quartz-feldspar-biotite-muscovite schist and schistose granulite with abundant sillimanite knots, $\frac{1}{4}$ inch across. These knots give the weathered surface a "wart-like" appearance. Numerous thin ($\frac{1}{8}$ to $\frac{1}{4}$ inch) quartz stringers are parallel to foliation.

Station C (Fig. 14) - Walk back across the road to examine the remaining up hill parts of the west road cut. The Amphibolite Member is in contact with schists of the Schistose Gneiss Member. Here the schists do not contain the sillimanite knots, so distinctive at Station B. Within approximately 20 feet the schists are interlayered and gradational with more massive rocks of the Schistose Granulite Member in the remaining parts of the road cut. The Schistose Granulite Member consists of the following rocks, all mutually gradational: massive, light-gray to gray, micaceous granulite; well foliated, gray, schistose granulite; tan/gray, coarse, sillimanite-mica schist with abundant $\frac{1}{4}$ to $\frac{1}{2}$ inch quartz/feldspar stringers or lenses parallel to foliation; and light-gray and dark-gray schistose gneiss.

P1-25

The schists at the north end of the cut display abundant D_3 (Fig. 7) crenulations, plunging gently north or south, in earlier D_2 axial plane foliation. Steep slickensided fault surfaces trending nearly parallel to the roadway give evidence for late shearing.

3.9 - Turn around and retrace the same route to Camps Flat Road.

7.8 3.9 Turn left (east) on Camps Flat Road.

8.8 - Geer Mountain Road on the left (north). Proceed along Camps Flat Road.

9.6 0.8 Cross a small stream and the road becomes Meetinghouse Hill Road.

9.7 0.1 Stop 4. The Candlewood Lake Pluton at Peet Hill (Fig. 15). Pull over to the right side of the road. Do not block private driveways.

This stop demonstrates the intrusive relationship of the Ordovician Candlewood Lake Pluton to allochthonous Manhattan C, and subsequent phases of deformation affecting the rocks. Samples were collected at Station A for radiometric dating (Mose and Nagel, appended to this report). Exposures of the pluton extend from a short distance north of Stop 4 southward for several miles into the New Milford quadrangle (Fig. 1). There, it is named for Candlewood Lake. Towering rock cliffs of the granite can be seen south-southwest of Station B, on Rock Cobble Hill. Much of the area underlain by the Candlewood Lake Pluton has previously been referred to as the New Milford Massif (Rodgers, *et al.*, 1956), considered Precambrian. Mapping has shown that the pluton intrudes autochthonous rocks ranging in age from Precambrian to Middle Ordovician and the allochthonous Cambrian Manhattan C (Fig. 3).

Station A (Fig. 15) - Follow a well defined trail, near where the small stream crosses the road, to Peet Cemetery past several large granite boulders. Since the trail ends at the cemetery, proceed north adjacent to the stream. Several outcrops of massive, tan-weathering, white dolomite marble of Cambrian Inwood Marble Member A lie along the west bank of the stream. Pass a small knob of granite adjacent to the stream, proceeding in an upstream direction toward a large hill.

The large, obvious rock exposure on this hill is of the granite of the Ordovician Candlewood Lake Pluton. The valley to the right (east) is underlain by calcite marble of Manhattan A. The stream valley on the left (west) has Inwood Marble Member A. It is known (Stop 2) that Manhattan A rests unconformably on older rocks and this unconformity is in the area between these two valleys (Fig. 15).

Ascend the right (east) side of the hill to several low lying, moss-covered outcrops. These exposures are locally of well bedded, orange/tan-weathering phlogopite-calcite marble and massive, light-gray dolomite marble of the Calcite Marble Member of Manhattan A. In the lowest outcrop on the east side of the hill bedding trends approximately east-west and dips north into the hill. Within two feet of this marble exposure is the massive to weakly foliated, light-gray or tan, (muscovite)-biotite

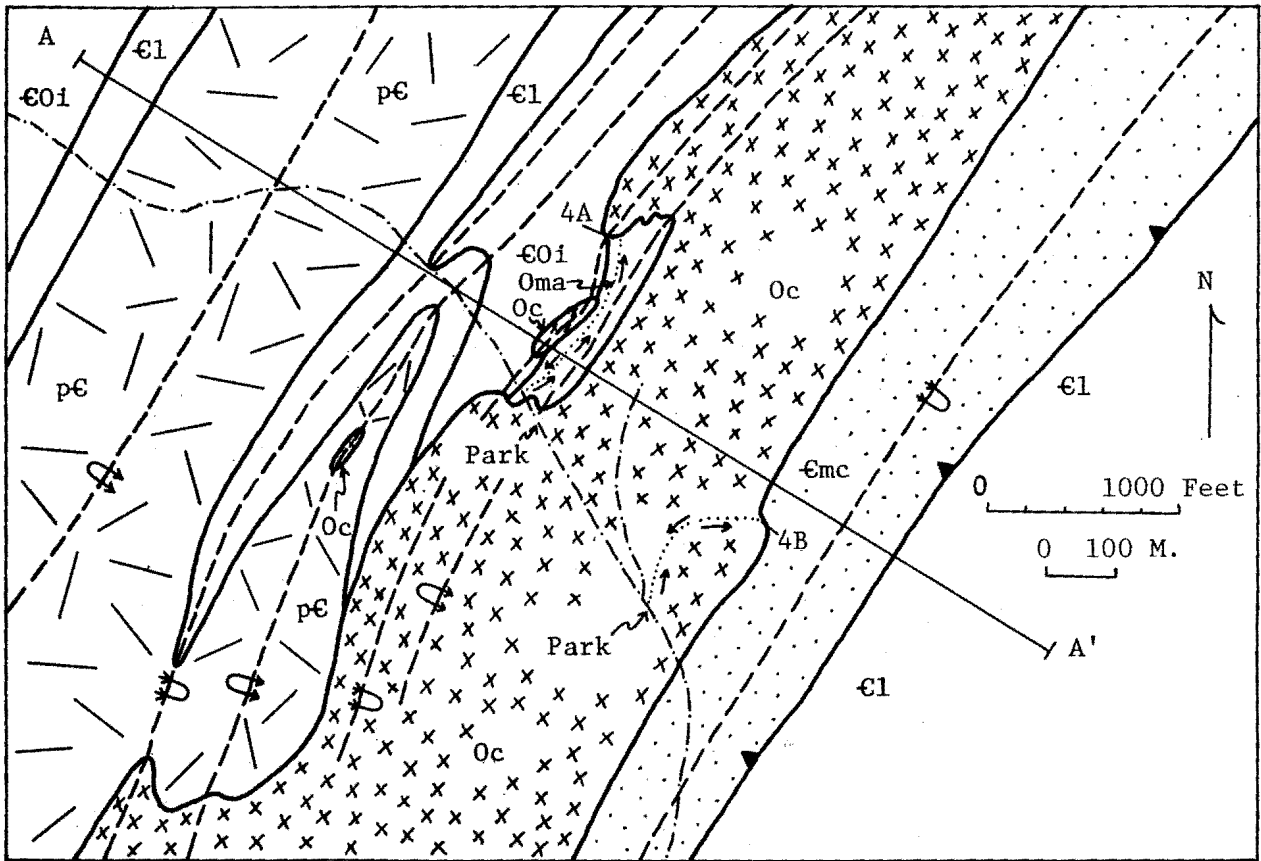

EXPLANATION

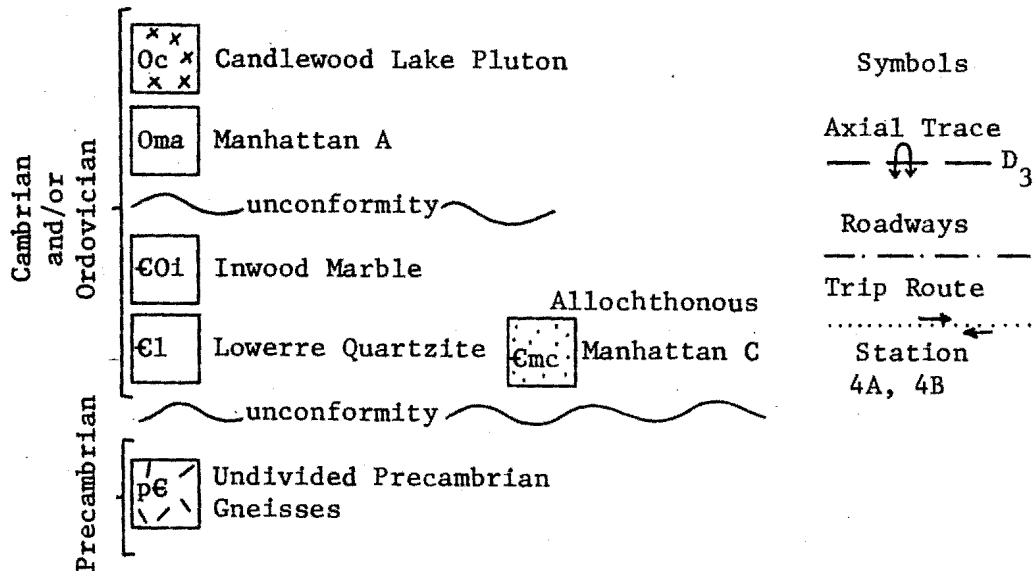

Figure 15. Generalized geologic map of the vicinity of Stop 4, indicating stations A and B at separate localities.

granite. Locally, pegatite and quartz dikes cut through the granite. The proximity of the marble to the massive granite exposure clearly demonstrates the intrusive nature of the Candlewood Lake Pluton.

Minor open folds, D_3 (Fig. 7), in the well bedded phlogopite-calcite marble have axial plane foliation trending approximately N55E, dipping steeply northwest and axes gently to moderately plunging northeast. Foliation in the granite trends N60E and dips moderately northwest, indicating that the dominant foliation in the granite at Station A is related to D_3 folding. Better evidence for the structural interpretation of the Candlewood Lake Pluton is demonstrated at Station B.

9.7 - Return to the vehicles and proceed south along Meetinghouse Hill Road.

9.9 0.2 Station B (Fig. 15) - Drive beyond the intersection with Peet Hill Road, and pull over to the side of the road. Walk up a small, bushy valley adjacent to Peet Hill Road, ascending to a large outcrop at the top of the steep slope. Manhattan C is exposed in numerous outcrops southward along this slope. An excellent exposure is located approximately 1500 feet south in a cliff adjacent to the road, and is mentioned in passing in this trip travel log.

Manhattan C at the Station B exposure is interlayered, schistose granulite and well foliated, coarse-grained, reddish tan- or gray-weathering, garnet-sillimanite-quartz-feldspar schist with locally abundant sillimanite nodules up to 1/2 centimeter across. Locally, thin quartz/feldspar stringers, up to 1/2 centimeter thick, are elongate parallel to foliation. Weakly foliated to well foliated light-gray or tanish gray, (muscovite)-biotite granite, the Candlewood Lake Pluton truncates this layering. This is the eastern contact of the granite (Fig. 15).

On close examination of this outcrop the foliation, that is the dominant planar feature in the metasedimentary rocks, penetrates the Candlewood Lake Pluton. Since the granite has been dated (Mose and Nagel, appended to this report) as Ordovician, it intruded the rocks prior to the development of the foliation during the Taconic Orogeny. This foliation is axial planar to isoclinal folds, D_2 (Fig. 7), illustrated in structure section AA' (Fig. 5) for the Kent quadrangle. There is no evidence for a contact aureole, suggesting that the granitic material injected into the schists while they were still quite hot. Sillimanite/K-feldspar grade of metamorphism was reached during the Taconic Orogeny. Thus, the pluton intruded the rocks during the Taconian deformation and at the time of its peak metamorphism.

Abundant folds and crenulations deform the granite/schist intrusive contact and the earlier foliation. The minor folds have axial surfaces trending N40E to N50E, dipping steeply northwest or southeast, and axes that plunge gently north. Figure 15 indicates several map-scale axial traces, correlated in age with these minor folds for the Stop 4 area. The geometry of the folding is displayed in structure section AA' (Fig. 16). This section shows these folds to be overturned to the west clearly de-

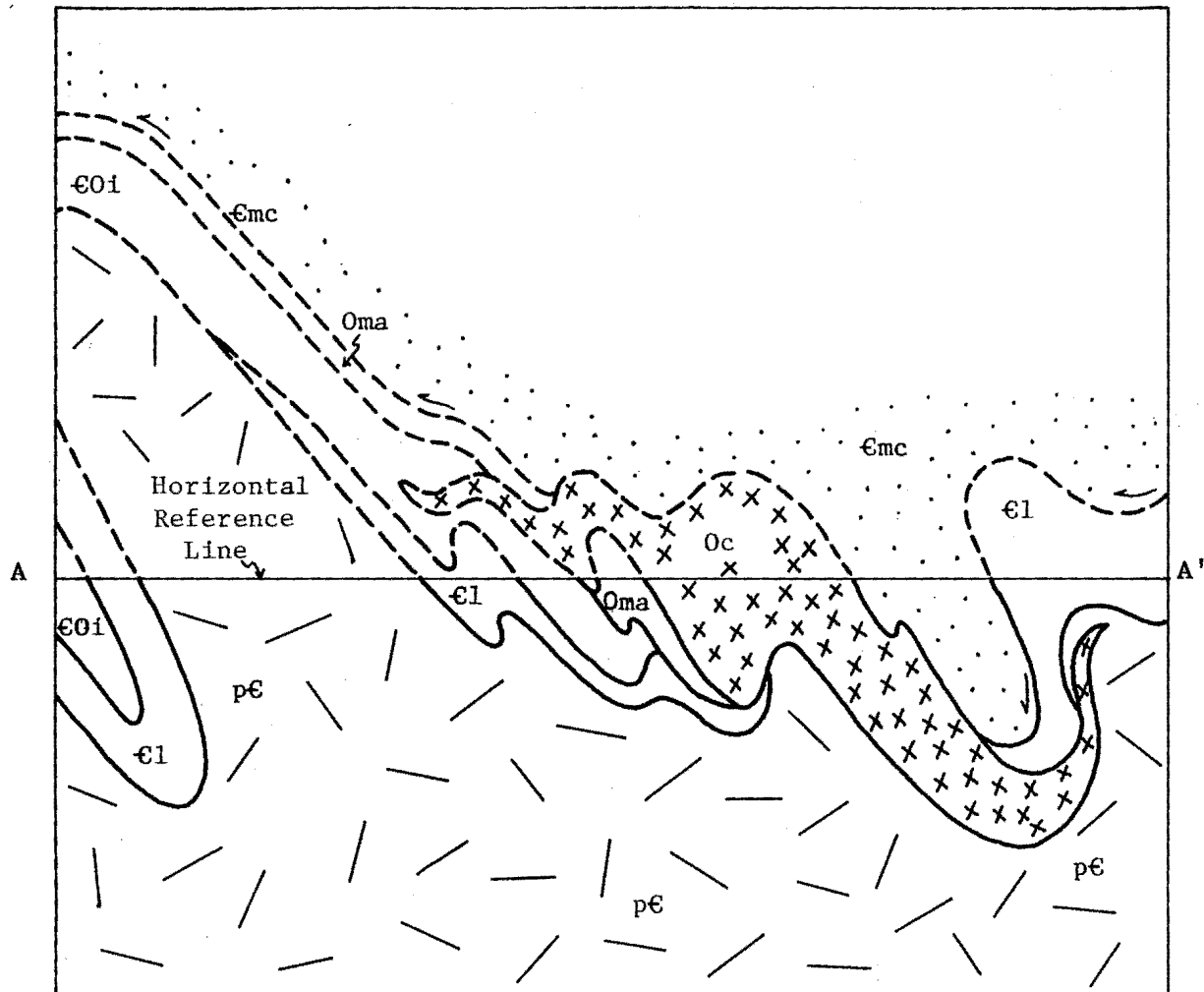

Figure 16. Structure section AA' from the geologic map for Stop 4 (Figure 15). The Ordovician Candlewood Lake Pluton (Oc) intrudes autochthonous and allochthonous rocks and is deformed by Acadian, D₃ (Figure 7), folds.

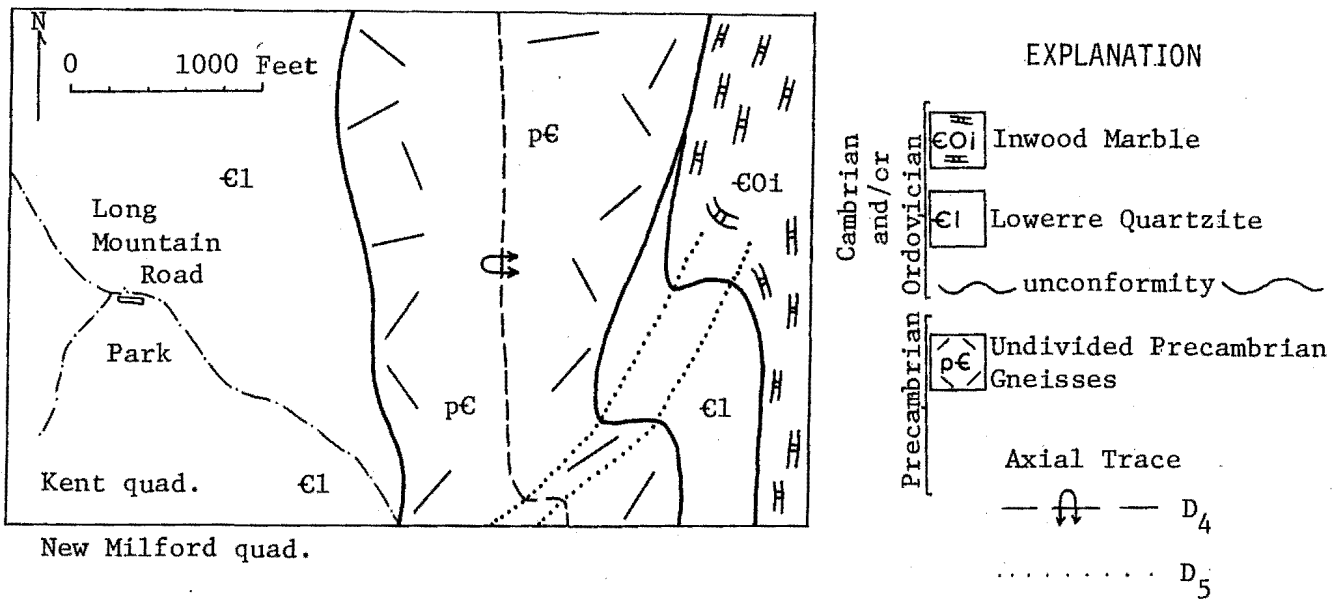

Figure 17. Generalized geologic map of the vicinity of Stop 5.

forming the Candlewood Lake Pluton, an elongate slab of varied thickness. This later folding, D₃ (Fig. 7) is interpreted to have developed during the Acadian, since it involves the deformation of the Taconian Candlewood Lake Pluton.

- 9.9 - Return to the vehicles and proceed south along Meetinghouse Hill Road.
- 10.0 0.1 Large exposure of Manhattan C schists on the left (east). Highland to the west is the Candlewood Lake Pluton.
- 10.6 0.6 Stop and bear right (south) onto West Meetinghouse Hill Road.
- 11.8 1.2 Turn right (west) on Hine Road.
- 13.0 1.2 Turn left (south) on Long Mountain Road.
- 13.6 0.6 Stop 5. Long Mountain Road (Fig. 17). Park along the right side of the road. This short stop is to examine schists of the Lowerre Quartzite. Walking southeast along Long Mountain Road numerous exposures on the adjacent hillside can be examined. The Lowerre Quartzite here consists of interlayered, coarse-grained, reddish tan-weathering, sillimanite-garnet-quartz feldspar schist with sillimanite nodules locally up to 1 centimeter across, and quartzose feldspathic schist. The schists are lithically similar to those in allochthonous Manhattan C seen at Stops 3 and 4, and at Optional Stop B. Lithic correlation supports the proposal that Lowerre Quartzite is a sedimentary facies equivalent of Manhattan C.

The dominant schistosity, axial planar to early, D₂ (Fig. 7), regional isoclinal folds, has the sillimanite nodules lying within it. The schistosity and sillimanite nodules are in turn deformed by noticeably abundant crenulations with axial surfaces trending N30E to N60E and dipping steeply northwest. These minor crinkle folds display a counter-clockwise movement

sense and axes that plunge gently to moderately northeast. At the map-scale these late folds, D₄ (Fig. 7), clearly deform the Acadian, D₃, Long Mountain Anticline (Fig. 17) that is cored by Precambrian Gray Biotite Gneiss.

- 13.6 - Return to the vehicles and proceed south along Long Mountain Road.
- 15.1 1.5 Turn right (south) on Aspetuck Road.
- 15.6 0.1 Turn left (east) back onto Long Mountain Road.
- 16.1 0.5 Turn right (south) on Merryall Road.
- 16.8 0.7 Turn left (north) on Paper Mill Road.
- 18.6 1.8 Stop 6. East Limb of the Bear Hill Anticline (Fig. 18A). Drive into the Pratt Education Center parking lot. Walk west along the road to the pasture entrance on the right.

This ridge, the west slope of the East Aspetuck River valley, is underlain by Precambrian rocks exposed in the core of the Bear Hill Anticline, with Cambrian Lowerre Quartzite on the lower parts of the slope (Fig. 18A). Four mappable Precambrian rock units have been defined here (Fig. 18A) and Cambrian to Middle Ordovician carbonate rocks are exposed further east in the East Aspetuck River valley. Middle Ordovician Manhattan A calcite marble occurs in the trough of the Aspetuck Syncline and rests unconformably on Lowerre Quartzite on the west and Inwood Marble on the east (Fig. 18A). A short traverse will be made here to study the Precambrian rocks and the Lowerre Quartzite.

Ascend the east slope of the ridge past low outcrops of Lowerre Quartzite to a terrace.

Station A (Fig. 18A) - The rock exposure on the east side of the terrace is the lower portion of the Lowerre Quartzite which lies unconformably on Precambrian gneisses. It consists of well foliated, reddish weathering, feldspar-mica-quartz granulite that has thin laminae (1/8 to 1/2 inch thick) of quartzite and quartzose schist interbedded with well foliated, gray- to tan-weathering, quartz-feldspar schistose granulite with nodules of quartz and feldspar (1/4 to 1/2 inch across) and minor beds of gray-weathering, massive micaceous and feldspathic quartzite.

Station B (Fig. 18A) - Walk west across the terrace to several outcrops of foliated light-pink to pink, biotite-quartz-feldspar gneiss with local pink microcline augen. The abundance of biotite and degree of development of foliation are directly related and the foliated appearance is varied because of the abundance of biotite differing from place to place.

Station C (Fig. 18A) - Walk northeast, parallel to the unconformity approximately 800 feet, past several rock exposures in the gray, biotite-hornblende gneiss and dark-gray, well foliated, amphibolite (p6ha). Both contacts of this unit (p6ha) are truncated along the unconformity at the base of the Lowerre (Fig. 18A).

Structural data were collected at this station, approximately 75 feet west of the unconformity (Fig. 18B). Two phases of minor folds are present and the earlier of these deforms a foliation parallel to compositional

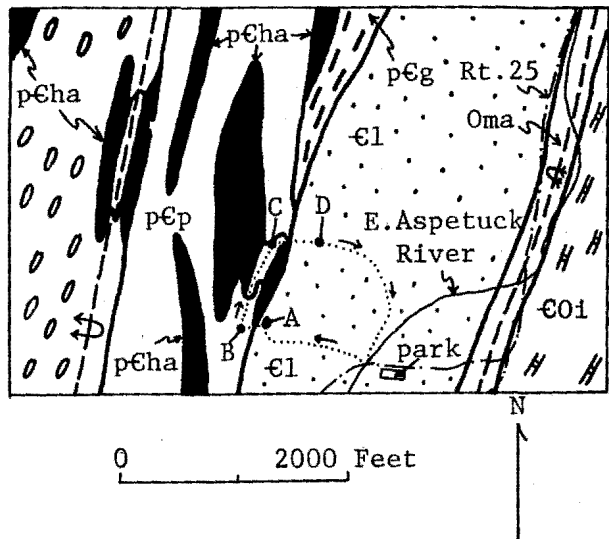
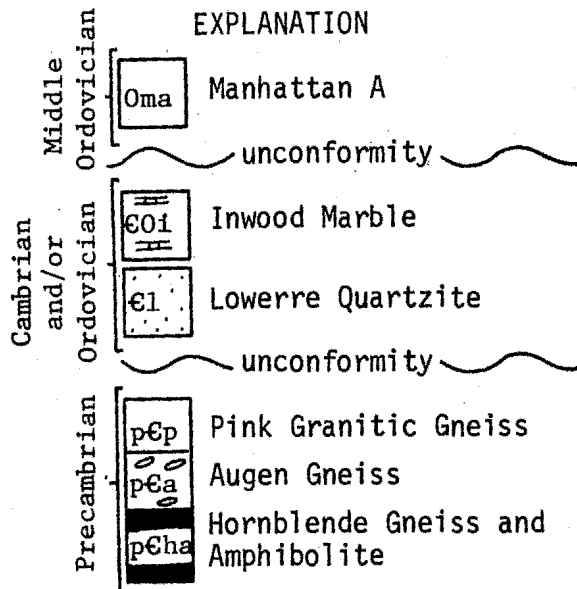
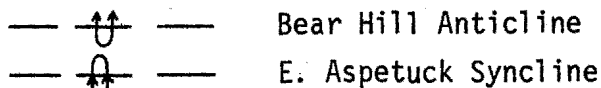

Figure 18A. Geologic map of the region in the vicinity of Stop 6.



Symbols

Axial Trace



Trip Route

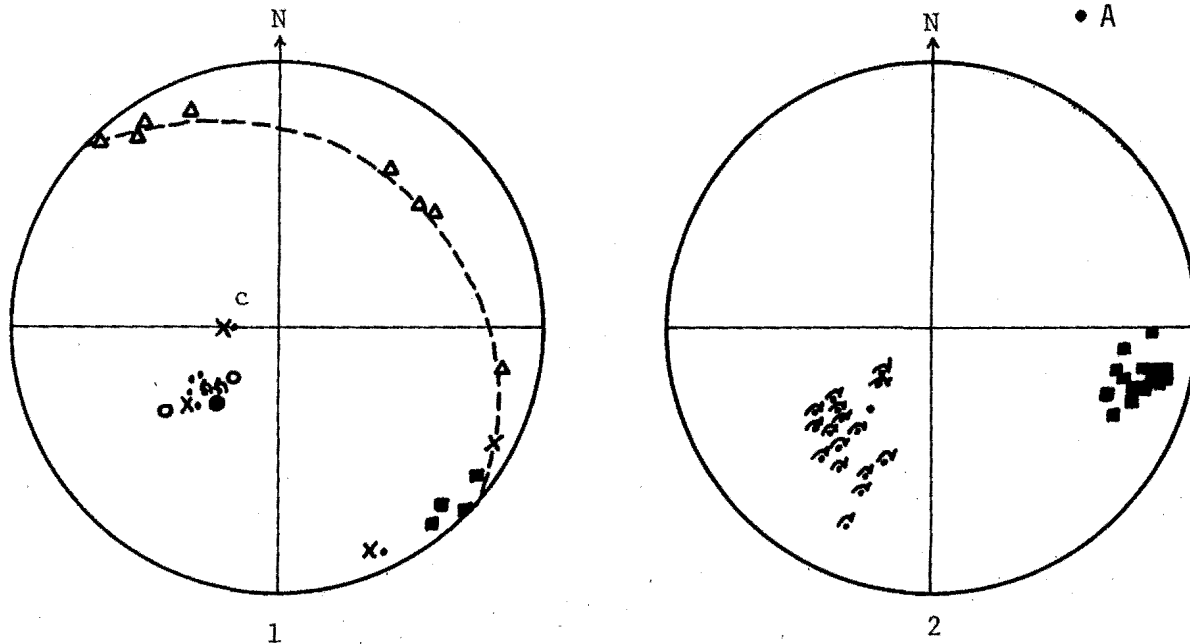
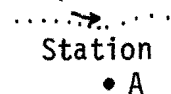

- Fold Axes (c, where crinkle)
- Axial Surface
- Mineral Lineation

- Layering-Axial Surface Intersection
- Foliation
- Pole to Great Circle

Figure 18B: Equal-area diagrams that summarize structural data from the Precambrian basement (1) and from the Lowerre Quartzite (2) at Stop 6.

layering very likely formed in the Grenville Orogeny during a phase of folding, D₁ (Fig. 7), that preceded the early folds that are so obvious here. The axes of the minor folds have an average plunge of 50 southwesterly and some of the folds have a counterclockwise rotation sense, but the shear sense of most is indeterminate (Fig. 18B-1). The axial planes trend northeast and dip steeply northwest (Fig. 18B-1). These earlier folds, D₂ (Fig. 7) are thought to be Taconic in age and related to a large, map-scale fold, in the Precambrian units (Fig. 18A). Crinkle folds that deform earlier features at this exposure and other nearby points represent a later phase of deformation, D₃ or D₄, possibly Acadian (Fig. 7). The wide variation in the plunge of the crinkles is probably due to the varied attitude of previously folded foliation upon which the crinkles were formed.

Station D (Fig. 18A) - Proceed east crossing a small stream and ascend the small ridge where pink quartz-feldspar gneiss (p6p) is present a few feet west of the unconformity and a deeply weathered zone is in the gneiss adjacent to the unconformity. Well bedded Lowerre Quartzite, similar to that at Station A, is further east of the unconformity here. Continuing up the ridge, the exposures of quartzite in the first 50-75 stratigraphic feet are predominantly thinly laminated granulite and quartzose schist with quartz-feldspar nodules. The stratigraphic section continues upward in the Lowerre to the east, over the ridge crest, and down the hillside. The thinly laminated beds and quartzose schists are less abundant with the dominant rock type being the massive gray- to tannish gray-weathering, mica-feldspar quartzite, with local thin quartzite laminae, and feldspathic quartzite. This entire rock exposure represents the eastern, deeper water facies of Lowerre Quartzite. While feldspathic and schistose in the lower parts, cleaner interbedded quartzites are abundant higher up in the section. The massive gray or tannish quartzites are similar to those found near Stop 1 adjacent to the Housatonic Highlands.

One phase of minor folds is present in both foliation and bedding in the Lowerre (Fig. 18B-2). These folds have a clockwise rotation sense and an average plunge of 45 southwesterly. An earlier foliation, D₂ (Fig. 7) is deformed by these folds. The axial planes trend north-northeast and dip steeply northwest (Fig. 18B-2). Locally a well developed axial plane cleavage can be noted in the hinge area of these minor folds. The minor folds of this phase of deformation, which are located on the east limb of the Bear Hill Anticline (Fig. 18A), have the proper rotation sense for an anticline to the west and thus are assumed to be genetically related to the large anticline. The Bear Hill Anticline and Aspetuck Syncline (Fig. 18A) were produced during the Acadian Orogeny, D₃ (Fig. 7).

Walk down the hill to a path adjacent to the East Aspetuck River, and follow it back to Paper Mill Road.

To return to the University of Connecticut Campus continue along Paper Mill Road for 0.2 miles, turn right (south) on Routes #202/25 toward New Milford. In New Milford follow Route #7 south to Route #84 in Danbury. Travel Route #84 to Hartford, Connecticut.

REFERENCES CITED

- Balk, R., 1936, Structural and petrologic studies in Dutchess County, New York. Part I, Geologic structure of sedimentary rocks: Geol. Soc. America Bull., V. 46, p. 685-774.
- Barth, T.F.W., 1936, Structural and petrologic studies in Dutchess County, New York. Part II, Petrology of Paleozoic rocks: Geol. Soc. America Bull., V. 46, p. 775-846.
- Dana, R.H., Jr., 1977, Stratigraphy and structural geology of the Lake Warmaug area, western Connecticut: M.S. thesis, University of Massachusetts, 108p.
- Gates, R.M., 1952, The geology of the New Preston quadrangle: Conn. Geol. and Nat. Hist. Survey Quad. Report No. 2 (Misc. Ser. 5), 46p.
- Hall, L.M., 1968, Times of origin and deformation of bedrock in the Manhattan Prong, *in* Zen, E-an, White, W.S., Hadley, J.B., and Thompson, J.B., eds., Studies of Appalachian geology: northern and maritime: New York, Interscience Publishers, p. 117-127.
- _____, 1976, Preliminary correlation of rocks in southwestern Connecticut: Geol. Soc. America Memoir 148, p. 337-349.
- _____, 1980, Basement-cover relations in western Connecticut and southeastern New York, *in* Wones, D.R., ed., The Caledonides in the USA: I.G.C.P. Project 27: Caledonide Orogen, 1979 Meeting, Blacksburg, Virginia: Virginia Polytechnic Institute and State University, Memoir No. 2, p. 299-306.
- Hall, L.M., Heleneck, H.L., Jackson, R.A., Caldwell, K.G., Mose, D., and Murray, D.P., 1975, Some basement rocks from Bear Mountain to the Housatonic Highlands, *in* N.M. Ratcliffe, ed., New England Intercollegiate Geol. Conf., 67th Ann. Mtg. Guidebook: City College of C.U.N.Y., p. 1-29.
- Hall, L.M. and Robinson, P., Stratigraphic and tectonic subdivisions of southern New England, Geol. Assoc. Canada (in press).
- Jackson, R.A., 1980, Autochthon and allochthon of the Kent quadrangle, western Connecticut: Ph.D. thesis, University of Massachusetts, 147 p.
- Merguerian, C., Tectonic significance of Cameron's Line in the vicinity of the Hodges Complex - an imbricate thrust model for western Connecticut: Amer. Jour Science (in press).
- Ratcliffe, N.M., 1969, Structural and stratigraphic relations along the Precambrian front in southwestern Massachusetts, *in* Bird, J.M. ed., Guidebook for field trips in New York, Massachusetts, and Vermont: New England Intercollegiate Geol. Conf., 61st Ann. Mtg., Albany, N.Y., 1969, p. 1-1 to 1-21.

- Ratcliffe, N.M., Bird, J.M., and Bahrami, B., 1975, Structural and stratigraphic chronology of the Taconide and Acadian polydeformational belt of the central Taconics of New York State and Massachusetts, in N.M. Ratcliffe, ed., New England Intercollegiate Geol. Conf., 67th Ann. Mtg. Guidebook: City College of C.U.N.Y., p. 55-86.
- Robinson, P., and Hall, L.M., 1980, Tectonic synthesis of southern New England, in Wones, D.R., ed., The Caledonides in the USA: I.G.C.P. Project 27: Caledonide Orogen, 1979 Meeting, Blacksburg, Virginia: Virginia Polytechnic Institute and State University Memoir, No. 2, p. 73-82.
- Rodgers, J., Gates, R.M., Cameron, E.M., Ross, R.J., Jr., 1956, Preliminary geologic map of Connecticut: Conn. Geol. and Nat. Hist. Survey, scale 1:253,440.
- Vidale, R.J., 1974, Vein assemblages and metamorphism in Dutchess County, New York: Geol. Soc. America Bull., V. 85, p. 303-306.
- Zen, E-an, 1969, Stratigraphy, structure, and metamorphism of the Taconic allochthon and surrounding autochthon in Bashbish Falls and Egremont quadrangles and adjacent areas, in Bird, J.M., ed., Guidebook for field trips in New York, Massachusetts, and Vermont: New England Intercollegiate Geol. Conf., 61st Ann. Mtg., Albany, N.Y., 1969, p. 3-1 to 3-41.
- _____, 1972, The Taconide Zone and Taconic orogeny in the western part of the northern Appalachian orogen: Geol. Soc. America Special Paper 135, 72p.
- _____, 1981, Metamorphic mineral assemblages of slightly calcic pelitic rocks in and around the Taconic allochthon, southwestern Massachusetts and adjacent Connecticut and New York: U.S. Geol. Survey Prof. Paper 1113, 128p.

PIA-1

CHRONOLOGY OF METAMORPHISM IN WESTERN CONNECTICUT: Rb-Sr AGES

Douglas G. Mose and M. Susan Nagel, Department of Geology,
George Mason University, Fairfax, VA 22030

INTRODUCTION

The Paleozoic granitic rocks of western Connecticut (Fig. 1) are muscovite plus biotite granitic rocks that are massive to foliated. They were first grouped under the name "Thomaston Granite" (Rice and Gregory, 1906; Gregory and Robinson, 1907; Agar, 1934). The type Thomaston occurs in an abandoned quarry at Reynold's Bridge south of the city of Thomaston as a small dike-like body. The Thomaston group is now known to include many granites, pegmatites and granitic gneisses and so the name "Thomaston Granite" is now considered to be a name for all the Paleozoic granitic rocks in western Connecticut.

In the past 25 years, the Thomaston has been subdivided into three granite types based on rock composition and texture. The name Nonewaug-type was introduced in the Woodbury quadrangle by Gates (1954), replacing the name Woodbury granite for this variety of the Thomaston. The name Mine Hill-type was introduced in the Roxbury quadrangle (Gates, 1959), and the name Tyler Lake-type was introduced in the Cornwall quadrangle (Gates, 1961).

The relative ages of these three types of granite is poorly known except to say that the Nonewaug-type appears post-tectonic and the Mine Hill-type and Tyler Lake-type appear to be syn- or pre-tectonic, Gates and Bradley (1952, p. 13) report that the Nonewaug-type granite in sills and dikes cut the Town Hill granite gneiss which is similar to the Mine Hill-type (see below). In the Woodbury quadrangle, Gates (1954, p. 14) reports that granite and pegmatite dikes which probably come from the Nonewaug pluton cut granitic gneiss similar to the Mine Hill-type. In the following section, it will be shown that a simple separation of pre- or syn-tectonic granite from late syn- or post-tectonic granite is useful for this area, and that while the Nonewaug-type is a good representative of the late syn- or post-tectonic granite, the Mine Hill-type is a good representative for the pre- or syn-tectonic granite. The Tyler Hill-type appears to be an example of Mine Hill-type granite that has been deformed by cataclasis. It will also be shown that the Rb-Sr ages of the granites support their relative ages as determined by field relationships.

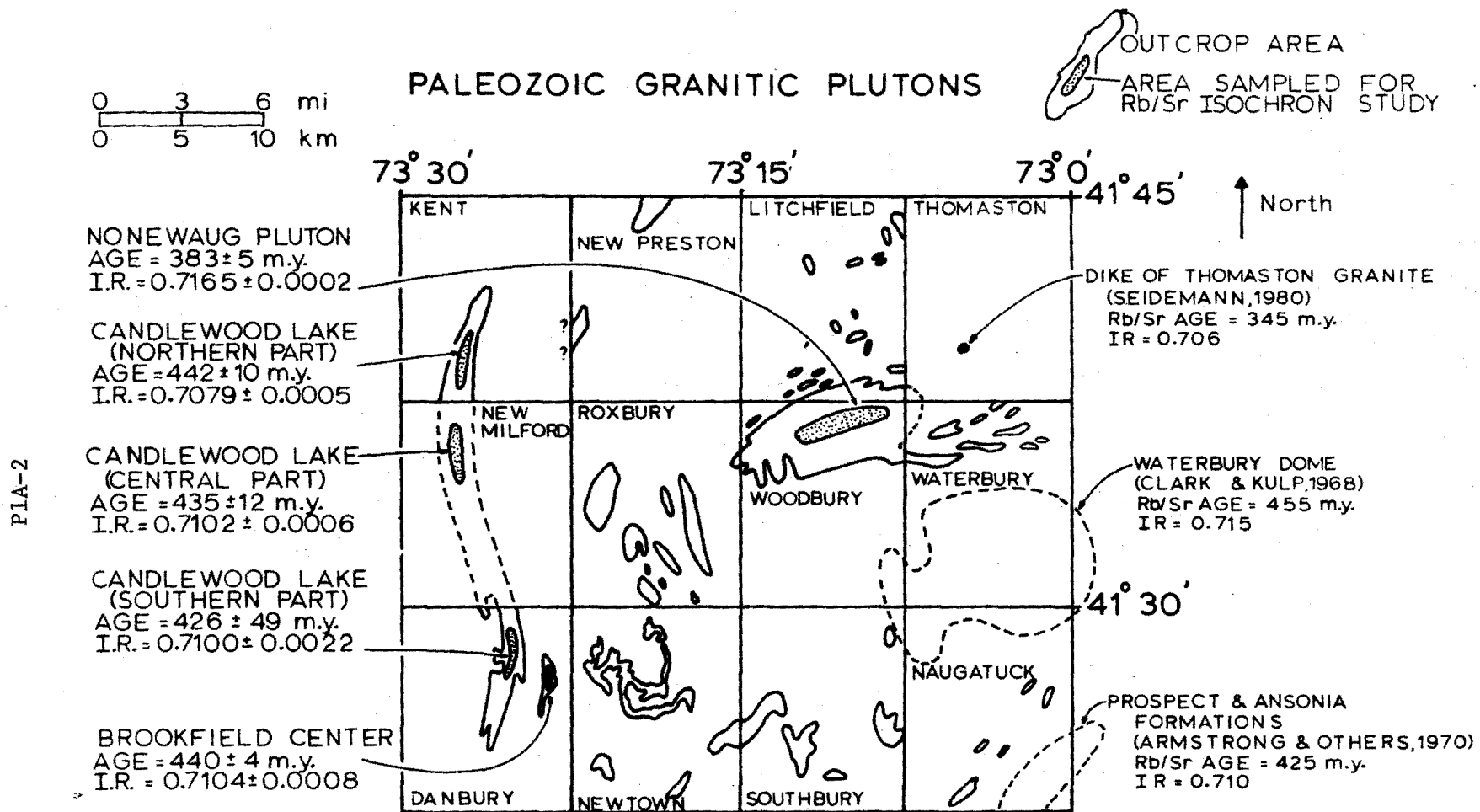

Figure 1. Quadrangle maps in western Connecticut showing the outcrop areas of granitic rocks of Paleozoic age (Kent from Jackson, 1980; New Preston from Gates and Bradley, 1952; Litchfield from Gates, 1951; Roxbury from Gates, 1959; Waterbury from Gates and Martin, 1967; Danbury from Clarke, 1958; Newtown from Stanley and Caldwell, 1976; Southbury from Scott, 1974; Naugatuck from Carr, 1960).

PLA-3

TYPES OF THOMASTON GRANITE

The Nonewaug-type granite is found mostly in the Woodbury quadrangle (Gates, 1954) but parts of the main body extend into the Litchfield (Gates, 1951, p. 11-12), Roxbury (Gates, 1959) and Waterbury (Gates and Martin, 1967, p. 26) quadrangles. Similar rock has been identified in the Torrington (Martin, 1970, p. 41-44), Newtown (Stanley and Caldwell, 1976, p. 38) and New Preston (Gates and Bradley, 1952, p. 12-14) quadrangles.

The characteristics of the granite are as follows:

1. It is an unfoliated granite which shows no cataclasis and which shows textural layering. The layers are from about 1 cm to 1 m thick and are composed of fine-grained to pegmatitic material. Sometimes the granite shows a "patchy texture" in which finer-grained material is surrounded by pegmatitic material.
2. It contains graphic granite crystals which are about 1 to 150 cm in diameter (most are 4 - 10 cm) and which commonly occur as layers or isolated crystals (plum pudding texture) in a fine-grained matrix. The graphic granite is mostly intergrowths of microcline and quartz, but sometimes of plagioclase and quartz, especially near plumose muscovite. The outer parts of the graphic granite crystals usually contain poikilitically included patches of fine-grained granite.
3. It contains plumose muscovite, an intergrowth of muscovite and quartz, which occurs in a matrix of fine-grained granite, and only in areas where graphic granite is present. The muscovite plumes are megascopic and up to 40 cm long (Gates, 1954, p. 15) or they are microscopic (Martin, 1970, p. 41).
4. It is composed of sodic plagioclase and microcline (plagioclase/microcline ratio is greater than 1), quartz, muscovite and biotite (muscovite/biotite ratio is greater than 1).
5. Xenoliths of country rock in the granite and roof pendants appear to not have been rotated (Martin, 1970, p. 41; Gates, 1951, p. 12).

The Nonewaug-type granite is generally thought to be a post-tectonic intrusion which is generally concordant with its host rock but shows local discordance and crosscutting dikes. It will be proposed, based on isotopic evidence, that the pegmatitic material, graphic granite and plumose muscovite result from late-stage infusions of alkali-rich

fluids. This would agree with Gates (1954, p. 18) who suggested that the "patchy texture", porphyroblastic graphic granite and plumose muscovite are related to the activity of interstitial liquid in zones of relatively low pressure caused by structural activity during emplacement of the pluton.

The Mine Hill-type granite is found mostly in the Roxbury quadrangle (Gates, 1959), but granite gneiss of the Mine Hill-type has also been found in the Kent (Jackson, 1980, p. 42-44), New Preston (Gates and Bradley, 1952, p. 12-14), Litchfield (Gates, 1951, p. 12), Woodbury (Gates, 1954, p. 13-15), Waterbury (Gates and Martin, 1967, p. 26-28), Danbury (Stanley and Caldwell, 1976, p. 16-17; Clarke, 1958, p. 38-41), Newtown (Stanley and Caldwell, 1976, p. 16), Southbury (Scott, 1974, p. 26-27) and Naugatuck (Carr, 1960, p. 18-19) quadrangles.

The characteristics of the granite are as follows:

1. It is a foliated fine-medium grained granite gneiss with mineral segregation in the form of coarse muscovite on the foliation planes. Some layers are coarser than others, but none are pegmatitic.
2. It locally shows a small amount of cataclasis, and replacement of microcline by plagioclase is common.
3. It contains no graphic granite or plumose muscovite.
4. It is composed of sodic plagioclase and microcline (plagioclase/microcline ratio is greater than 1), quartz, muscovite and biotite (muscovite/biotite ratio is greater than 1).

The Mine Hill-type granite is thought to be a pre- or syn-metamorphic granite gneiss which had little metamorphic effect on its host rocks. It is generally concordant with the host rock, but produced cross-cutting dikes.

The Tyler Lake-type granite is found mostly in the West Torrington (Gates and Christensen, 1965, p. 30-31) and Cornwall (Gates, 1961, p. 26-27) quadrangles, though a small part of this pluton extends into the Torrington quadrangle (Martin, 1970, p. 29-41). Similar rock has been found in the New Preston quadrangle (Gates and Bradley, 1952, p. 12-13).

The characteristics of this granite are as follows:

1. Its texture ranges from massive to gneissic. It is a fine to medium-grained granite that is locally pegmatitic. The pegmatite occurs in parallel layers a few cm thick or as irregularly shaped patches.

P1A-5

2. It shows extensive cataclasis in which the felsic minerals are bent, curved, broken and granulated, and large megacrysts of quartz, microcline and plagioclase are set in a fine-grained matrix.
3. It contains no graphic granite, plumose muscovite, or muscovite-rich foliation planes.
4. In areas where strong cataclasis is exhibited (Tyler Lake area: Gates, 1961, p. 26; Gates and Christensen, 1965, p. 30), it is composed of sodic plagioclase and microcline (plagioclase/microcline ratio is less than 1), quartz, muscovite and biotite (muscovite/biotite ratio is about 1). However, in other areas of weaker cataclasis (Torrington area: Gates and Christensen, 1965, p. 30; Martin, 1970, p. 40), the rock composition is similar to that of the Mine Hill-type granite.

The Tyler Lake-type granite is generally thought to be a syn-tectonic intrusion which had little metamorphic effect on its host rocks. It shows discordant relationships along its border. In areas of relatively little cataclasis, it is similar to the Mine Hill-type granite gneiss.

Rb-Sr STUDY: TECHNIQUE

Samples were collected from granite gneiss, locally known as the Candlewood Lake granite gneiss and the Brookfield Center granite gneiss in the Kent, New Milford and Danbury quadrangles (Fig. 1). Samples were also collected from the Nonewaug-type granite in the Woodbury and Waterbury quadrangles (Fig. 1). Sample locations are given in Appendix 1.

The Rb-Sr isotopic analyses were conducted using the process described in Ellwood and others (1980). The half-life for the radiometric decay of ^{87}Rb is 4.89×10^{10} years (decay constant is $1.42 \times 10^{-11} \text{ yr}^{-1}$). The isotopic data are given in Appendix 2.

The Rb-Sr ages and initial $^{87}\text{Sr}/^{86}\text{Sr}$ ratios on the isochron diagrams were calculated using the regression treatment of York (1966). The one-standard-deviation experimental error in $^{87}\text{Rb}/^{86}\text{Sr}$ was calculated to be 2 percent; the one-standard-deviation experimental error in $^{87}\text{Sr}/^{86}\text{Sr}$ was calculated to be 0.05 percent. These error estimates were derived from an examination of duplicate analyses done over the past seven years. The errors assigned to the reported isochron ages and initial $^{87}\text{Sr}/^{86}\text{Sr}$ ratios are given at the 68 percent confidence level (1 sigma). Visual examinations of the fit of the Rb-Sr data to isochron lines are given in Figures 2-6. The data on the isochron

PLA-6

diagrams are presented as 2 sigma error boxes (center of box $\pm 4\%$ for $^{87}\text{Rb}/^{86}\text{Sr}$ and 0.10% for $^{87}\text{Sr}/^{86}\text{Sr}$).

Rb-Sr STUDY: RESULTS

The granitic gneiss that is locally known as the Candlewood Lake pluton in the Kent, New Milford and Danbury quadrangles was studied in three areas (Fig. 1; App. 1).

	AGE	INITIAL $^{87}\text{Sr}/^{86}\text{Sr}$
Northern Part of the Pluton (Fig. 2)	442 ± 10 m.y.	0.7079 ± 0.0005
Central Part of the Pluton (Fig. 3)	435 ± 12 m.y.	0.7102 ± 0.0006
Southern Part of the Pluton (Fig. 4)	426 ± 49 m.y.	0.7100 ± 0.0002

The granite gneiss that is locally known as the Brookfield Center pluton yielded an age of 440 ± 4 m.y. and an initial $^{87}\text{Sr}/^{86}\text{Sr}$ ratio of 0.7104 ± 0.008 (Fig. 5). It seems reasonable to conclude that the Candlewood Lake and the Brookfield Center plutons were both emplaced at some time between 435 and 445 m.y. ago with an initial $^{87}\text{Sr}/^{86}\text{Sr}$ ratio of about 0.710.

The granite that is locally known as the Nonewaug pluton in the Woodbury and Waterbury quadrangles was studied with care to note the petrography of the collected samples. As mentioned earlier, several texturally unusual varieties occur in the pluton. These include pegmatitic material, graphic granite and plumose muscovite. Samples which exhibited these properties as well as samples which did not were collected for the Rb-Sr study and the sample properties were noted (App. 3) when the data were plotted on an isochron diagram. It became clear that the texturally unusual samples did not yield a linear array on an isochron diagram, and that the samples which were composed of fine to medium-grained granite did yield a linear array. It was concluded that the texturally unusual samples probably owe their textures to the activity of interstitial liquids existed at a time when the pluton was mostly crystallized so the liquids could not chemically (and isotopically) mix with most of the pluton. The samples of Nonewaug-type granite which do not show pegmatites, graphic granite or plumose muscovite in the immediate vicinity of the sample site yield an isochron age (Fig. 6) of 383 ± 5 m.y. and an initial $^{87}\text{Sr}/^{86}\text{Sr}$ ratio of 0.7165 ± 0.0002 (an isochron generated by all the samples yields an age of 350 ± 31 m.y. and an initial $^{87}\text{Sr}/^{86}\text{Sr}$ ratio of 0.7189 ± 0.0016).

P1A-7

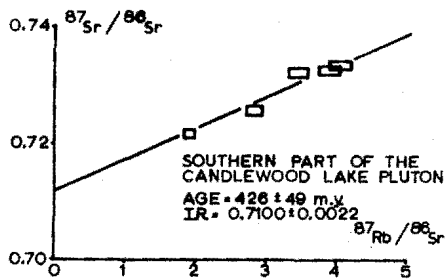
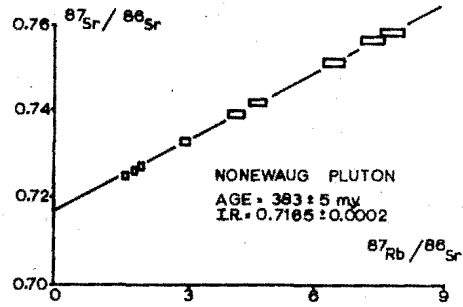
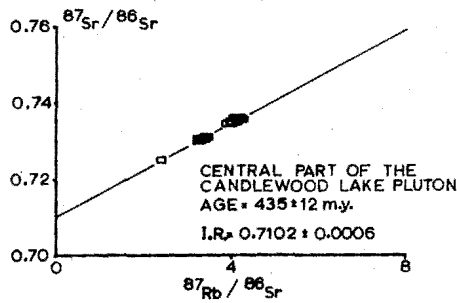
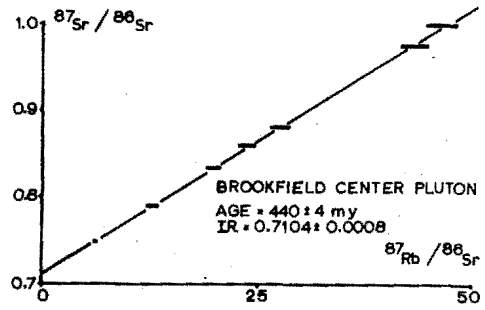
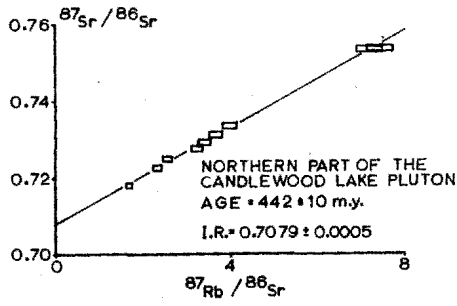

Figures 2-6. Rb-Sr isochron diagrams.

CONCLUSIONS

The granites and granite gneisses of western Connecticut have been grouped under the name Thomaston granite. This group has been subdivided into the Mine Hill-type which is a granite gneiss that is probably a pre- or syntectonic granite, the Tyler Lake-type which is probably the Mine Hill-type that is cataclastically deformed, and the Nonewaug-type that is probably a syn- or post-tectonic granite.

The granite gneiss in the Kent, New Milford and Danbury quadrangles is the Mine Hill-type and yields an age of about 445 to 435 m.y. and an initial $^{87}\text{Sr}/^{86}\text{Sr}$ ratio of about 0.710. The Nonewaug-type granite yields an age of about 390 to 380 m.y. and an initial $^{87}\text{Sr}/^{86}\text{Sr}$ ratio of about 0.716.

The other available age determinations from this area yield similar ages. Rb-Sr data from the foliated Prospect and Ansonia formations by Armstrong and others (1970) yield an age of about 425 m.y. (age recalculated using the new ^{87}Rb half-life estimate of 48.9 b.y.). Although the origin of the Prospect and Ansonia are in doubt, Carr (1960, p. 17-19) favors a pre- or syn-metamorphic igneous origin for both units. The possibility that the Prospect and Ansonia are in some way related to the pre- or syn-metamorphic Candlewood Lake pluton is suggested by the identical age and initial $^{87}\text{Sr}/^{86}\text{Sr}$ ratio for these rocks.

The only other Rb-Sr age determination on whole-rock samples comes from the Waterbury Formation, where Clark and Kulp (1968) determined an age of about 455 m.y. and a high initial $^{87}\text{Sr}/^{86}\text{Sr}$ ratio. As pointed out by Scott (1974, p. 14), the interpretation of this age is unclear, and is presently thought to be either the time of Waterbury Formation deposition or metamorphism.

There is one age determination from this area which was obtained using the Rb-Sr whole-rock plus muscovite (two-point isochron) technique. Seidemann (1980) determined the age using a sample from a "Thomaston Granite" unfoliated dike. The age, at about 345 m.y., is similar to the age obtained from the post-tectonic Nonewaug pluton reported in this study.

It is interesting to note that all the plutonic rocks in this area have relatively high initial $^{87}\text{Sr}/^{86}\text{Sr}$ ratios. High initial ratios such as these have long been known to be characteristic of plutons derived from the melting of ^{87}Rb enriched rock such as the continental crust. Figure 7, a plot of initial $^{87}\text{Sr}/^{86}\text{Sr}$ ratios vs the time of crystallization, shows that there appears to be a linear relationship between the initial ratios and the

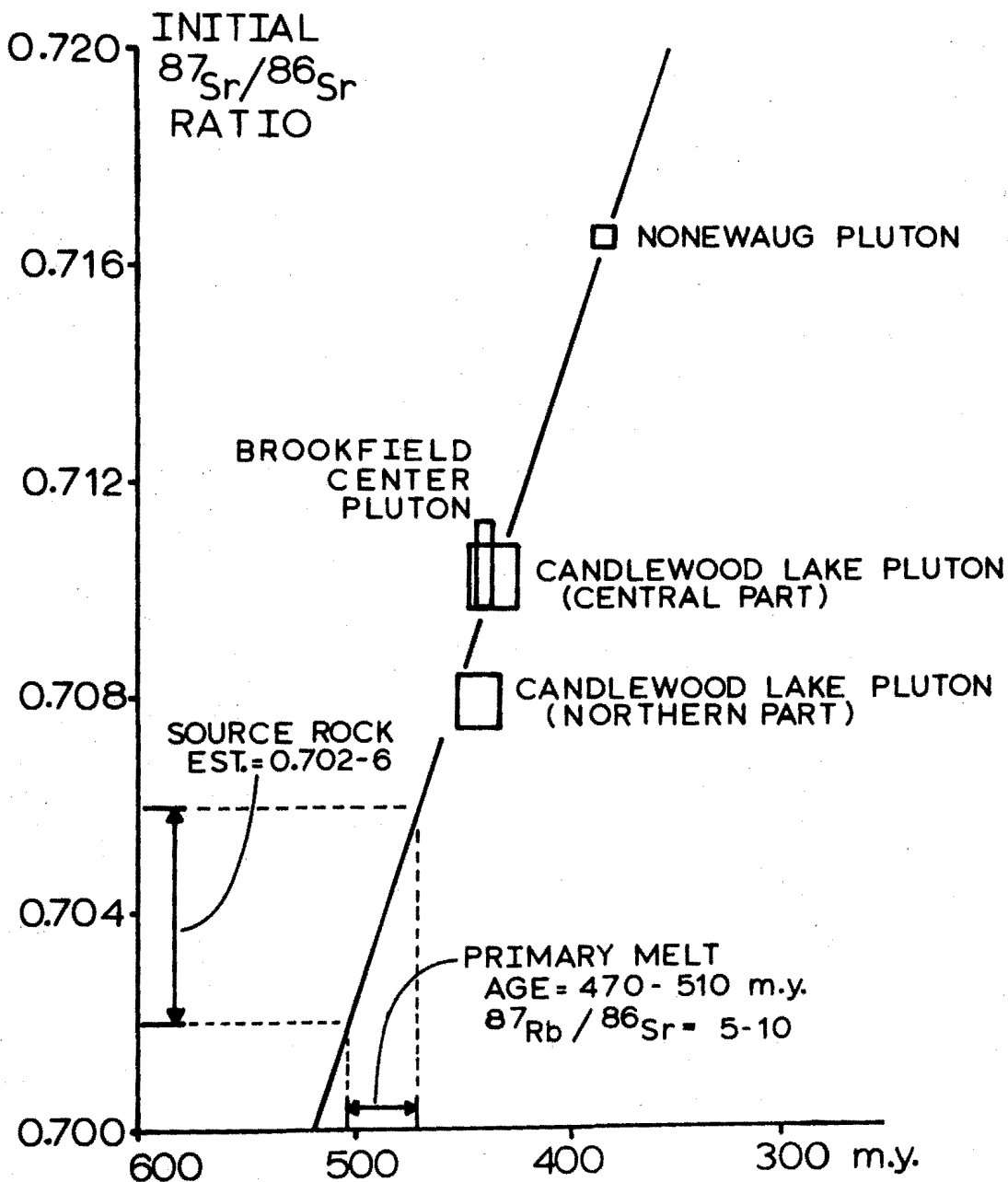

Figure 7. Initial $^{87}\text{Sr}/^{86}\text{Sr}$ ratio vs age of crystallization for plutons in western Connecticut that have been precisely dated by the Rb-Sr whole-rock technique. The slope of the best-fit line corresponds to the increase in $^{87}\text{Sr}/^{86}\text{Sr}$ that could be produced in a "primary melt" with a $^{87}\text{Rb}/^{86}\text{Sr}$ ratio of about 5 to 10.

crystallization times. Such a relationship could be explained in two ways. In the first model, these granites in western Connecticut were initially formed by partial melting at about 490 (\pm 20) m.y. ago at some depth greater than their present crustal level. Fractions of this "parent magma" are thought to have moved upward prior to, during, and after the recrystallization which produced the metamorphic rocks now exposed at the surface. The viability of this model, which calls for a long interval (from about 490 m.y. to about 380 m.y.) during which the granite remained liquid at a depth greater than the present erosional level, is presently unclear. The alternative model is one in which granitic melts are repeatedly generated by pre-, syn- and post-metamorphic melting events. The viability of this model seems equally unclear. Perhaps future studies will reveal the real process which formed these Paleozoic granitic rocks of western Connecticut.

The major metamorphic event which recrystallized this area is probably bracketed in time by the crystallization ages of the granite gneiss and the massive granite. If this is true, the Rb-Sr ages reported in this study indicate that the metamorphic event occurred between about 440 and 380 m.y. ago, an interval which corresponds to the time between the end of the Ordovician and the beginning of the Devonian. Additional studies on other examples of the Mine Hill-type, Tyler Lake-type, and Nonewaug-type may eventually better define the event which recrystallized the sedimentary and volcanic rocks of western Connecticut.

PLA-11

References Cited

- Armstrong, R.L., Barton, J.M., Carmalt, S.W., and Crowley, W.P., 1970, Geochronologic studies of the Prospect, Ansonia and Milford Formations, southern Connecticut: Contributions to Geochronology in Connecticut, State Geological and Natural History Survey of Connecticut, Rept. of Inv. no. 5, p. 19-27.
- Agar, W.M., 1934, The granites and related intrusives of western Connecticut: Am. Jour. Sci., v. 27, p. 354-373.
- Carr, M.H., 1960, The bedrock geology of the Naugatuck quadrangle: State Geological and Natural History Survey of Connecticut, Quad. Rept. no. 9, 25 p.
- Clarke, J.W., 1958, The bedrock geology of the Danbury quadrangle: State Geological and Natural History Survey of Connecticut, Quad. Rept. no. 7, 47 p.
- Clark, G.S., and Kulp, J.L., 1968, Isotopic age study of metamorphism and intrusion in western Connecticut and southeastern New York: Am. Jour. Sci., v. 266, p. 865-894.
- Ellwood, B.B., Whitney, J.A., Wenner, D.B., Mose, D.G., and Amerigian, G., 1980, Age, paleomagnetism, and tectonic setting of the Elberton granite, northeast Georgia Piedmont: Jour. Geophys. Res., v. 85, p. 6521-6533.
- Gates, R.M., 1951, The bedrock geology of the Litchfield quadrangle: State Geological and Natural History Survey of Connecticut, Misc. Ser. 3, 13 p.
- Gates, R.M., 1954, The bedrock geology of the Woodbury quadrangle: State Geological and Natural History Survey of Connecticut, Quad. Rept. no. 3, 23 p.
- Gates, R.M., 1959, Bedrock geology of the Roxbury quadrangle, Connecticut: Geologic Quadrangle Maps of the United States, U.S. Geol. Survey Map GO-121.
- Gates, R.M., 1961, The Bedrock geology of the Cornwall quadrangle: State Geological and Natural History Survey of Connecticut, Quad. Rept. no. 11, 35 p.
- Gates, R.M., and Bradley, W.C., 1952, The geology of the New Preston quadrangle: State Geological and natural History Survey of Connecticut, Misc. Ser. no. 5, 46 p.
- Gates, R.M., and Christensen, N.I., 1965, The bedrock geology of the West Torrington quadrangle: State Geological and Natural History Survey of Connecticut, Quad. Rept. no. 17, 38 p.
- Gates, R.M., and Martin, C.W., 1967, The bedrock geology of the Waterbury quadrangle: State Geological and natural History Survey of Connecticut, Quad. Rept. no. 22, 36 p.
- Gregory, H.E., and Robinson, H.H., 1907, Preliminary geological map of Connecticut: Connecticut Geol. Nat. History Survey Bull., v. 7, 39 p.
- Jackson, R.A., 1980, Autochthon and allochthon of the Kent quadrangle, western Connecticut: University of Massachusetts, unpub. Ph.D. thesis, 147 p.

PIA-12

- Martin, C.W., 1970, The bedrock geology of the Torrington quadrangle: State Geological and Natural History Survey of Connecticut, Quad. Rept. no. 25, 53 p.
- Rice, W.N., and Gregory, H.E., 1906, Manual of the geology of Connecticut: Connecticut Geol. Nat. History Survey Bull., v. 6, 273 p.
- Scott, R.B., 1974, The bedrock geology of the Southbury quadrangle: State Geological and natural History Survey of Connecticut, Quad. Rept. no. 30, 63 p.
- Seidemann, D.E., 1980, K-Ar and Rb-Sr dates for the Reynolds Bridge gneiss and a post-metamorphic Thomaston granite dike at Reynolds Bridge, Connecticut: Contributions to Geochronology in Connecticut II: State Geological and Natural History Survey of Connecticut, Rept. of Inv. no. 10, p. 13-19.
- Stanley, R.S., and Caldwell, K.G., 1976, The bedrock geology of the Newtown quadrangle: State Geological and Natural History Survey of Connecticut, Quad. Rept. no. 33, 43 p.
- York, D., 1966, Least-squares fitting of a straight line: Can. Jour. Physics, v. 44, p. 1079-1086.

PIA-13

Appendix 1. Sample locations in western Connecticut.

	Quadrangle	Latitude	Longitude
Candlewood Lake- northern part			
NM 11	Kent	41° 37' 52"	73° 27' 21"
NM 12	Kent	41 37 53	73 27 22
NM 13	Kent	41 37 54	73 27 23
NM 14	Kent	41 37 55	73 27 23
NM 15	Kent	41 37 55	73 27 24
NM 16	Kent	41 37 52	73 27 24
NM 17	Kent	41 37 52	73 27 24
NM 18	Kent	41 40 40	73 26 33
NM 19	Kent	41 40 40	73 26 33
NM 20	Kent	41 40 34	73 26 37
Candlewood Lake- central part			
NM 1	New Milford	41° 37' 00"	73° 28' 00"
NM 2	New Milford	41 37 00	73 28 00
NM 3-10	New Milford	41 35 11	73 27 42
Candlewood Lake- southern part			
RA 4	Danbury	41° 27' 35"	73° 25' 17"
RA 5	Danbury	41 29 8	73 25 45
RA 6	Danbury	41 29 7	73 25 43
RA 7	Danbury	41 29 12	73 25 44
RA 8	Danbury	41 28 52	73 25 23
Brookfield Center			
RA 1	Danbury	41° 27' 35"	73° 23' 12"
RA 3	Danbury	41 28 2	73 23 33
RA 12	Danbury	41 28 6	73 23 25
RA 13	Danbury	41 28 10	73 23 26
RA 14	Danbury	41 27 35	73 23 25
RA 15	Danbury	41 27 55	73 23 23
RA 16	Danbury	41 28 3	73 23 10
Nonewaug Pluton (* = used in isochron)			
NON 11	Woodbury	41° 36' 35"	73° 10' 58"
NON 12*	Woodbury	41 36 33	73 10 55
NON 13*	Woodbury	41 36 35	73 10 48
NON 14*	Woodbury	41 36 36	73 10 46
NON 15*	Woodbury	41 36 38	73 10 47
NON 16*	Woodbury	41 36 39	73 10 49
NON 17*	Woodbury	41 36 37	73 10 40
NON 18*	Woodbury	41 36 59	73 10 41
NON 19	Woodbury	41 36 59	73 10 35

Appendix 1. continued.

	Quadrangle	Latitude	Longitude
Nanewaug Pluton (* = used in isochron)			
NON 21	Woodbury	41° 36' 57"	73° 08' 20"
NON 22*	Woodbury	41 36 30	73 11 11
NON 23	Woodbury	41 36 24	73 11 46
NON 24*	Woodbury	41 36 14	73 12 43
NON 25	Woodbury	41 36 47	73 12 27
NON 26*	Waterbury	41 36 47	73 06 46

Appendix 2. Rb-Sr isotopic data. Isotopic ratio are given as atomic ratios and isotope concentrations are given as parts per million.

SAMPLE	$^{87}\text{Sr}/^{86}\text{Sr}$	^{86}Sr	^{87}Rb	$^{87}\text{Rb}/^{86}\text{Sr}$
Candlewood Lake- Northern Part				
NM 11	0.7248	18.35	47.39	2.55
NM 12	0.7292	16.13	55.34	3.39
NM 13	0.7275	16.85	54.76	3.21
NM 14	0.7334	15.09	60.75	3.98
NM 15	0.7224	20.18	47.46	2.33
NM 16	0.7312	15.91	58.74	3.65
NM 17	0.7225	21.84	51.20	2.32
NM 18	0.7533	9.90	74.31	7.42
NM 19	0.7533	8.86	64.24	7.17
NM 20	0.7179	26.18	44.32	1.67
Candlewood Lake- Central Part				
NM 1	0.7252	5.94	14.38	2.40
NM 2	0.7308	7.05	23.25	3.26
NM 3	0.7349	13.89	55.60	3.96
NM 4	0.7310	16.12	55.60	3.41
NM 5	0.7360	13.36	56.83	4.21
NM 6	0.7353	13.53	55.58	4.06
NM 7	0.7363	13.61	56.90	4.13
NM 8	0.7307	15.60	54.10	3.43
NM 9	0.7302	16.53	54.56	3.26
NM 10	0.7313	16.56	57.50	3.43

Appendix 2. continued

Candlewood Lake- Southern Part

RA 4	0.7218	18.43	35.40	1.90
RA 5	0.7328	13.54	52.88	3.86
RA 6	0.7338	13.03	52.93	4.02
RA 7	0.7259	14.04	40.00	2.82
RA 8	0.7325	12.44	43.12	3.43

Brookfield Center

RA 1	0.7488	11.02	68.51	6.15
RA 3	0.8802	2.44	67.61	27.37
RA 12	0.7886	3.91	48.96	12.37
RA 13	1.0047	1.41	65.91	46.25
RA 14	0.8336	2.50	49.93	19.71
RA 15	0.8589	2.21	52.54	23.50
RA 16	0.9748	1.79	77.71	82.94

Nonewaug Pluton (* indicates samples used for isochron age;
see App. 3)

NON 11	0.7295	14.81	30.87	2.06
NON 12*	0.7324	13.77	42.12	3.02
NON 13*	0.7514	7.90	51.27	6.41
NON 14*	0.7264	19.03	35.87	1.86
NON 15*	0.7271	18.68	36.70	1.94
NON 16*	0.7420	8.33	39.01	4.63
NON 17*	0.7395	13.02	54.47	4.14
NON 18*	0.7256	17.75	29.21	1.63
NON 19	0.7329	14.41	52.75	3.62
NON 21	0.7336	19.50	35.14	1.78
NON 22*	0.7563	7.10	52.47	7.31
NON 23	0.7518	7.20	50.46	6.93
NON 24*	0.7582	6.78	53.06	7.73
NON 25	0.7372	16.63	47.48	2.82
NON 26*	0.7341	15.00	51.93	3.42

Appendix 3. Textural comments on the Nonewaug-type granite. Samples identified with a (*) were used to calculate the isochron age of the pluton.

SAMPLE	COMMENT
NON 11	Plumose muscovite in area
NON 12*	Medium-grained granite
NON 13*	Medium-grained granite
NON 14*	Medium-grained granite
NON 15*	Medium grained granite
NON 16*	Medium-grained granite
NON 17*	Medium-grained granite
NON 18*	Medium-grained granite
NON 19	Plumose muscovite in area
NON 21	Metasedimentary selvages of biotite in sample
NON 22*	Medium-grained granite
NON 23	Pegmatitic sample
NON 24*	Fine to medium-grained granite
NON 25	Pegmatitic sample
NON 26*	Medium to coarse-grained granite

P2-1

The Bonemill Brook Fault
Eastern Connecticut

by

M. H. Pease, Jr.
Waterville Valley, N.H.

INTRODUCTION

The crystalline rocks of eastern Connecticut (fig. 1) include parts of four regional geologic terranes. These are: 1) The Glastonbury-Killingworth domes, 2) the Merrimack eugeosyncline, 3) the Putnam-Nashoba thrust belt and 4) the Southeast New England platform. Each terrane occurs in a separate structural block, and no stratigraphic correlation has yet been possible between them.

The boundaries are major fault zones along which regional tectonic transport has occurred. The Glastonbury-Killingworth domes structural region is separated on the east from the Merrimack eugeosyncline region along the steeply dipping northerly-striking Bonemill Brook fault zone. The eugeosynclinal rocks have overridden on the east rocks of the Putnam-Nashoba thrust belt at the structural position of the Clinton-Newbury fault zone of Massachusetts, this position being occupied in Connecticut almost entirely by the Canterbury Gneiss (see fig. 1 of field trip P-6 for the location of the Clinton-Newbury fault zone in Massachusetts). The western boundary of the Southeast New England platform is overlain by the Putnam-Nashoba thrust belt along the Lake Char fault, and the platform rocks south of the Honey Hill fault zone are overridden by eugeosynclinal rocks as well as thrust belt rocks.

The Willimantic dome (fig. 1) is a structural window in the core of which are exposed rocks correlated with those of the Southeast New England platform separated by the Willimantic fault from rocks correlated with the Putnam-Nashoba thrust belt. The Willimantic fault therefore lies in the structural position of both the Honey Hill and Lake Char faults warped across the dome. The Canterbury Gneiss again occupies the structural position of the Clinton-Newbury fault zone separating thrust belt rocks from structurally higher eugeosynclinal rocks.

It is becoming recognized that movement along these major breaks must have originally occurred at high metamorphic grade under extreme conditions of differential stress that produced ductile movement rather than brittle fracture. Features characteristic of brittle faults such as fault breccia, gouge, and closely spaced fractures are not present except where there has been reactivation under conditions of much lower pressure and temperature. Instead one finds conditions approaching melting that result in ductile attenuation and alignment of stratigraphic elements in the plane of transport. This commonly is accompanied by the development of migmatite and even gneissoid pegmatite and under slightly lower conditions of temperature and

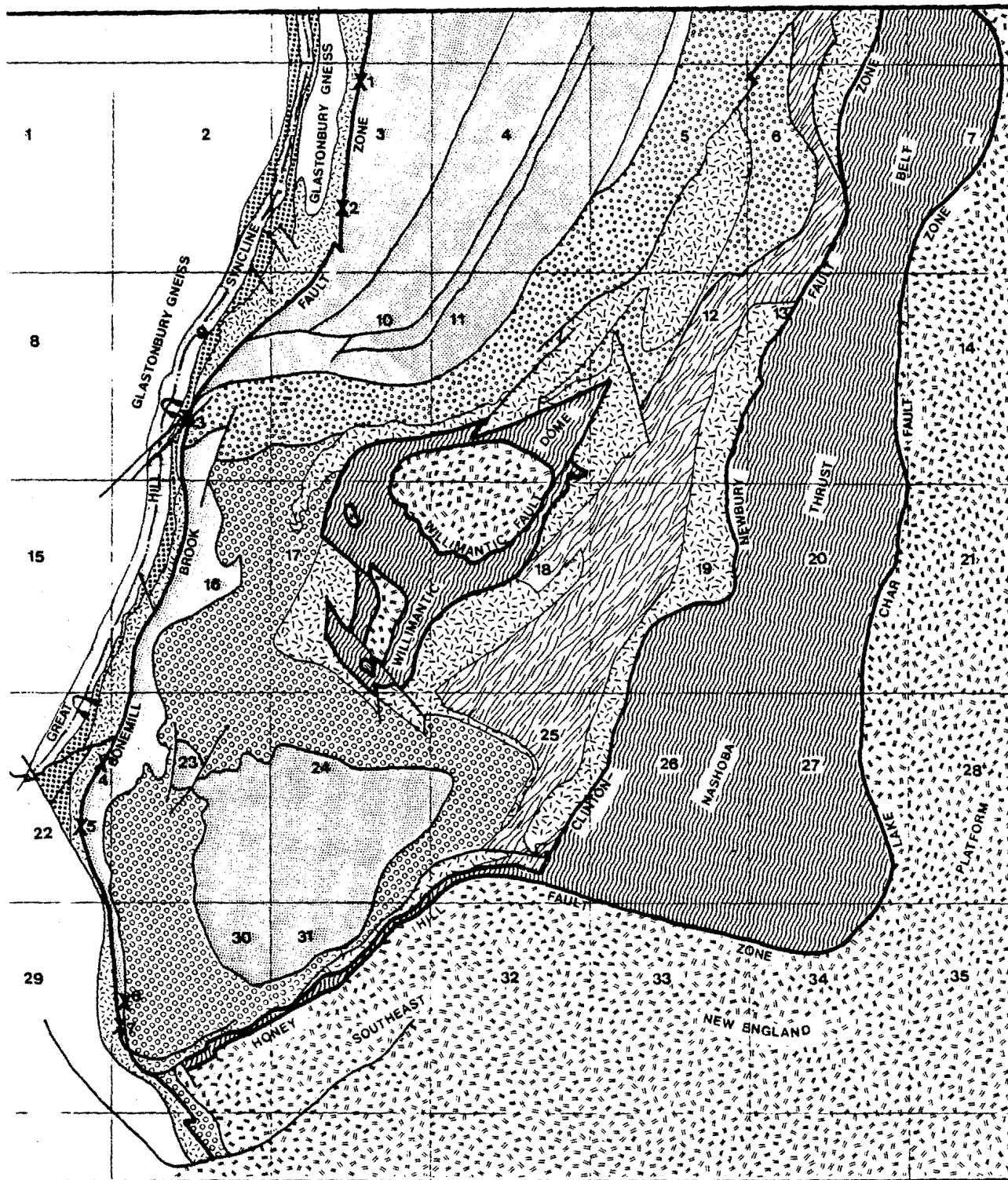

Fig. 1. Geologic sketch map of eastern Connecticut showing the distribution of the four major structural regions and the tectonic boundaries between them. X-3: Field trip stop locations; heaviest lines separate the major structural regions; medium lines represent faults; thin lines are intrusive contacts. The 7½-minute quadrangles are numbered and listed in Table 2.

KILLINGWORTH-GLASTONBURY
DOMES

GREAT HILL SYNCLINE SEQUENCE



Monson Gneiss

epiclastic
Littleton Fm.,
Clough Fm.

volcaniclastic
Partridge Fm.,
Ammonoosuc Fm.

BONEMILL BROOK FAULT ZONE

EXPLANATION

MERRIMACK
EUGEOSYNCLINE

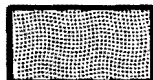

Brimfield Group:
Mt. Pisgah Fm.
Hamilton Reservoir Fm.
Bigelow Brook Fm.

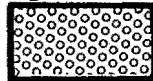

Hebron Fm.
(undivided equivalent
in Connecticut to
Paxton Group)

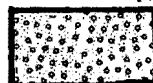

Paxton Group
Southbridge Fm.
lower Paxton



Oakdale Fm.



Intrusives,
including Canterbury
Gneiss and Lebanon
Gabbro

PUTNAM-NASHOBA
THRUST BELT



CLINTON-NEWBURY TECTONIC BOUNDARY

HONEY HILL, LAKE CHAR AND WILLIMANTIC FAULT ZONE



SOUTHEAST NEW
ENGLAND PLATFORM

pressure, the formation of mylonite, mylonite schist and blastomylonite. Deformation appears to have continued over a significant period of geologic time along a pressure/temperature gradient of decreasing metamorphic grade. One finds such retrograde features as quartz-feldspar rodding and chlorite slickensides in fault zones where the major tectonic transport has apparently taken place under strain of sufficient intensity to develop high grade metamorphic minerals such as sillimanite, orthoamphibole or even potassium feldspar (Wintsch, 1979).

Table 1 Quadrangle list to accompany tectonic map of eastern Connecticut (fig. 1)

1	Broad Brook	18	Willimantic
2	Ellington	19	Scotland
3	Stafford Springs	20	Plainfield
4	Westford	21	Oneco
5	Eastford	22	Middle Haddam
6	Putnam	23	Moodus
7	Thompson	24	Colchester
8	Manchester	25	Fitchville
9	Rockville	26	Norwich
10	South Coventry	27	Jewett City
11	Spring Hill	28	Voluntown
12	Hampton	29	Haddam
13	Danielson	32	Montville
14	East Killingly	33	Uncasville
15	Glastonbury	34	Old Mystic
16	Marlborough	35	Ashaway
17	Columbia		

Recognition of the major structural breaks at the boundaries of structural regions has greatly changed the interpretation of the structural geology of eastern Connecticut. The interpretation of previous workers has been that the axis of a major regional recumbent syncline, the Hunts Brook-Chester syncline, traces a sinuous path from south of the Honey Hill fault to the northeast corner of the state (fig. 2) and that all of the strata west of this axis and east of the Monson Gneiss are overturned. The continuity of this structure is dependent upon correlation of all of the metamorphosed stratified rock of eastern Connecticut with a simple stratigraphic sequence established along the Bronson Hill anticlinorium in New Hampshire (Billings, 1956). This sequence can be traced from New Hampshire across Massachusetts into Connecticut along the Great Hill syncline on the east flank of the Glastonbury dome but recent mapping in eastern Connecticut and adjacent Massachusetts indicates that it cannot be traced farther with any confidence even along strike into the Killingworth dome and that it does not exist in other structural regions of eastern Connecticut.

BONEMILL BROOK FAULT ZONE

The purpose of this field trip is to examine one of these major tectonic boundaries, the Bonemill Brook fault zone (fig. 1). The fault

will be seen at several locations along its trace. The evidence for its existence will be reviewed and the difficulty in recognizing it in outcrop will be shown. The fault zone, trending in a generally northerly direction, separates the Glastonbury-Killingworth dome structural region from the Merrimack eugeosynclinal structural region. Rocks in the domal region were deposited as an island arc sequence of relatively thin volcanoclastic sediments deposited on a volcanic basement. On the east flank of the Glastonbury dome, a basal quartzite marks an unconformity between the volcanoclastic terrane and the base of a younger epiclastic sequence (fig. 1). Rock types on the east flank of the Killingworth dome, on the other hand, are complexly layered and lack a coherent stratigraphy. In contrast, the Merrimack eugeosynclinal basin consists of an extremely thick sequence of epiclastic strata with only minor volcanoclastic material.

The Bonemill Brook fault zone is a conspicuous boundary on a regional scale. A variety of stratigraphic units and structures are cut out against it along its east side. The upper part of the Brimfield Group is gradually cut out southward in the Stafford Springs area where these strata strike at a low angle into the fault. In the Rockville quadrangle, lower parts of the Brimfield Group and strata of the Southbridge Formation swing abruptly westward between several thrust sheets that are cut off by the Bonemill Brook fault. Brimfield Group rocks again are juxtaposed against the fault in the Marlborough, Middle Haddam and Moodus quadrangles. Here gently dipping strata of the Brimfield Group steepen into sub-parallel alignment with the fault zone. In the Deep River area, strata of the Hebron Formation are crumpled up against the Monson along the fault.

On the west side, units tend to parallel the fault more closely, but in detail the fault can be seen to cross-cut stratigraphy. The Monson Gneiss is present on the west side of the fault along its entire length, but the lower part of the Monson is progressively cut out along the flank of the Glastonbury dome and in the Rockville area all but the upper few tens of meters appear to have been cut out by the fault. Along the flank of the Killingworth dome, the Monson appears to be represented by a narrow belt of cataclastically deformed plagioclase gneiss caught up entirely within the fault zone.

The striking change in the grain of the bedrock geology across the Bonemill Brook fault zone permits easy recognition of the zone on most regional maps derived by remote sensing methods. The location of this tectonic boundary shows up well on the small scale aeromagnetic and gravity maps that include eastern Connecticut and the fault trace can be delineated along much of its trace on small scale air-photos and LANDSAT imagery.

Despite the fact that the Bonemill Brook fault is well defined on a regional scale, the zone itself may be difficult to identify as a major tectonic boundary when mapped in the field. Foliation and compositional layering on both sides of the fault commonly are warped into subparallel alignment with the fault. The contact itself is rarely exposed and where it can be located to within a narrow zone of cover, the outcrops on either side may not be conspicuously deformed (STOP 3). Cataclastic deformation, whether ductile or brittle, is not everywhere apparent and is not necessarily strongest right at the tectonic boundary (STOP 6).

P2-7

Various features within the Bonemill Brook fault zone do show, however, that this is a fault boundary. The near parallel alignment of units on opposite sides of the fault may at first suggest a conformable stratigraphic contact, but the stratigraphic units do impinge at a low angle against the fault. Lithologies change as the fault is followed along strike, and attitudes across the boundary locally show an angular relation to the fault (STOP 3). Deformational features also appear to be sporadically exposed. When the contact is between relatively rigid plagioclase gneiss and plastic mica schist the strain of tectonic transport may be taken up entirely by ductile deformation in the schist (STOP 1), leaving the plagioclase gneiss showing almost no effect except perhaps for a subtle accentuation of fine scale layering and fluxion streaking as a result of bedding plane slip parallel to the direction of movement.

DUCTILE DEFORMATIONAL FEATURES

Various small scale structures are indicative of ductile deformation along the Bonemill Brook fault. 1) Mylonite, mylonitic schist and blastomylonite all characterized by streaked out fluxion structures are commonly present. 2) Tightly appressed intrafolial folds with axial planes oriented subparallel to the fault surface increase in abundance toward the fault contact; where these show a sense of asymmetry, it is indicative of the direction of tectonic transport. 3) The amount of pegmatitic material in these rocks increases toward the fault, whether in the form of stringers and augen in blastomylonite or as discrete gneissoid pegmatites and pegmatitic gneiss bodies; these lie generally subparallel to and are folded and sheared with foliation and layering, but in detail most contacts are discordant. 4) Migmatite, in which stringers and augen of gneissoid pegmatitic material predominate.

The large rotated tectonic blocks common on the Willamantic fault (Wintsch, 1979) are not conspicuous along the Bonemill Brook fault. This may be partly a function of the dip of the fault surface. Tectonic blocks might be more likely to tear loose and rotate along a near horizontal thrust surface whereas shearing will be more likely along high-angle faults.

CONCLUSIONS

A thick sequence of eugeosynclinal strata that covers a large part of northeastern and east-central New England has been jammed into eastern Connecticut. This sequence of the Merrimack eugeosynclinal structural region has been progressively cut out southward along the Bonemill Brook fault zone, against the volcanic rock of the Glastonbury and Killingworth domes. This large scale tectonic transport evidently occurred at high metamorphic grade. The strain at these high temperature and pressure conditions approached plastic flow. Stratigraphic units are warped into subparallel alignment along the fault zone, and lithologic contacts at many places along the fault zone are tightly bonded, showing little evidence of major tectonic transport.

The sense of regional transport appears to be right-lateral with the east side (eugeosynclinal rocks) moved south. The east side also appears to have moved up relative to the west side, considering that

rocks of the highest metamorphic grade are restricted to the east side of the fault.

The orientation of asymmetric folds and mineral lineation can be interpreted to support this regional sense of transport, but the amount of dip-slip relative to strike-slip movement is not known and appears to vary along the fault. The total amount of transport also is not known, but, considering the juxtaposition of rock formed in such contrasting environmental conditions, the order of magnitude may be 10s to 100s of kilometers.

The principal deformation along the Bonemill Brook fault zone probably occurred during the Acadian orogeny because rocks above the Silurian unconformity in the Great Hill syncline have been squeezed into a narrow belt subparallel to the fault.

ROAD LOG

MAPS- 7.5-minute quadrangle maps covered in this road log are the Stafford Springs (STOPS 1 and 2), Rockville (STOP 3), Middle Haddam (STOPS 4 and 5) and Deep River (STOPS 6 and 7).

Road log begins in the parking lot at the McDonald's Restaurant in the Stafford Shoppers Plaza on Rt. 190 between Stafford Springs and West Stafford. To get to Stafford Springs from Storrs take Rt. 195 northwest to Rt. 32. Follow Rt. 32 north to Stafford Springs.

- 0.0 Start road log facing west on Rt 190 at shopping plaza.
- 0.2 0.2 Turn right on road to Orcutts.
- 1.0 0.8 Turn left just past railroad crossing.
- 1.5 0.5 Turn left (north) on Rt. 32.
- 2.4 0.9 Turn right (east) on Sunset Road.
- 3.1 0.7 Culvert under road at Steep Gutter Brook. Turn cars around facing west.

STOP 1 - Steep Gutter Brook.

The trace of the Bonemill Brook fault in this area follows a prominent topographic trough trending about N 10° E, crossing the road at the culvert. Pelitic schist and gneiss of the Hamilton Reservoir Formation of the Brimfield Group lies east of the trough, felsic gneiss and amphibolite of the Monson Gneiss lies west of it. The trace of the fault in these exposures is pinned down to within 20 m by outcrops on opposite sides of the trough.

Features to note in these exposures are:

1. Subparallel alignment with the fault of foliation and layering in both formations (a common feature

along many ductile fault zones).

2. Conspicuous cataclastic textures in the pelitic schists of the Hamilton Reservoir Formation and lack of conclusive evidence for cataclastic deformation of the Monson. Is deformation entirely absorbed by the more pelitic rocks, or is the thinly parted felsic gneiss of the Monson near the contact wholly or in part the result of ductile attenuation?
3. Down dip lineation of sillimanite and quartz feldspar rodding in the Hamilton Reservoir Formation and similar down dip mineral lineation of amphiboles and biotite in the Monson. What does this say about the direction of movement on the fault?

Examine the outcrops of Hamilton Reservoir Formation on the north side of the road east of the fault. Note the mylonitic fluxion structure in these rocks - best observed on joints normal to foliation. Note the down-dip quartz-feldspar rodding and similar aligned orientation of sillimanite needles. Many sillimanite needles are kinked with apparent crinkle axes approximately parallel to lineation.

Walk west and then south along the west side of the trough to outcrops of Monson Gneiss, mostly layered felsic gneiss with amphibolite. The amphibolite outcrop in the stone wall appears to be a steeply plunging fold nose but a unique orientation of axis or axial plane could not be determined. Walk to the southeast corner of the field behind the house. Note that the attitude of foliation and layering along the ridge is about N 10° E parallel to the trough. In an outcrop just below the break in slope, the distribution and alignment of brown amphibole on a north-facing joint surface faintly outlines asymmetric folds with an east-side-moving-up sense of movement. Is ductile deformation responsible for the formation of the brown amphibole? Is the sense of the folds indicative of sense of movement on the fault?

Walk upstream for about 50 m to a low outcrop of thinly layered plagioclase gneiss exposed beneath a maple tree almost at stream level. This appears to be the nearest outcrop of Monson Gneiss to the Hamilton Reservoir schist exposed on the ridge to the east. The N 30° E strike of foliation and layering suggests that the exposure might have been detached and rotated slightly, but it appears to be essentially in place. The gneiss is fine-grained with closely spaced planar partings. Down-dip

quartz-feldspar streaking is evident and brown amphibole needles are aligned with a persistent down-dip lineation except for fan-shaped aggregates on some foliation surfaces. How much of the fabric in this rock is the result of ductile deformation? Why is the brown amphibole present instead of black hornblende that is characteristic of the Monson?

Return to cars along the ridge of pelite schist east of the trough. Note the same fabrics and orientation of structures along this ridge as is exposed in the road cuts.

Return to Rt. 32.

- 3.8 0.7 Turn left (south) at Rt. 32.
- 6.1 2.3 Pass intersection with Rt. 190. Continue on 32 to Stafford Springs.
- 7.1 2.0 Center of Stafford Springs. Turn right (south) on Rt. 32.
- 8.9 1.8 Bridge over Willimantic River. Turn right immediately beyond bridge.
- 9.2 0.3 Entrance to Girl Scout Camp - Turn right and drive along north side of Sweetheart Lake to parking lot just beyond west end of lake.

STOP 2 Bonemill Brook (fig. 3)

In this area for which the Bonemill Brook fault was named the fault again separates the Hamilton Reservoir Formation on the east from the Monson Gneiss. Rocks of the Hamilton Reservoir Formation are overturned on the west flank of the Mt. Pisgah syncline. The Mt. Pisgah Formation, the youngest formation of the Brimfield Group, lies along the axis of the syncline. The Furnace Brook fault follows the syncline and cuts out the trace of the axis here (fig. 3). The entire syncline itself is cut out to the south against the Bonemill Brook fault and the Hollow Brook fault, a splay from the Bonemill Brook.

Exposures are sparse close to the fault boundary in Bonemill Brook valley. We will look at four localities. Walk along the woods road to an area with picnic tables. Climb the hill on the north to a hiking trail blazed and marked by the symbol for Sweet Heart Camp. A very small low outcrop on the way to this trail shows the best cataclastic textures, but it is difficult to find. Follow the trail north to about the 500 ft. contour. The

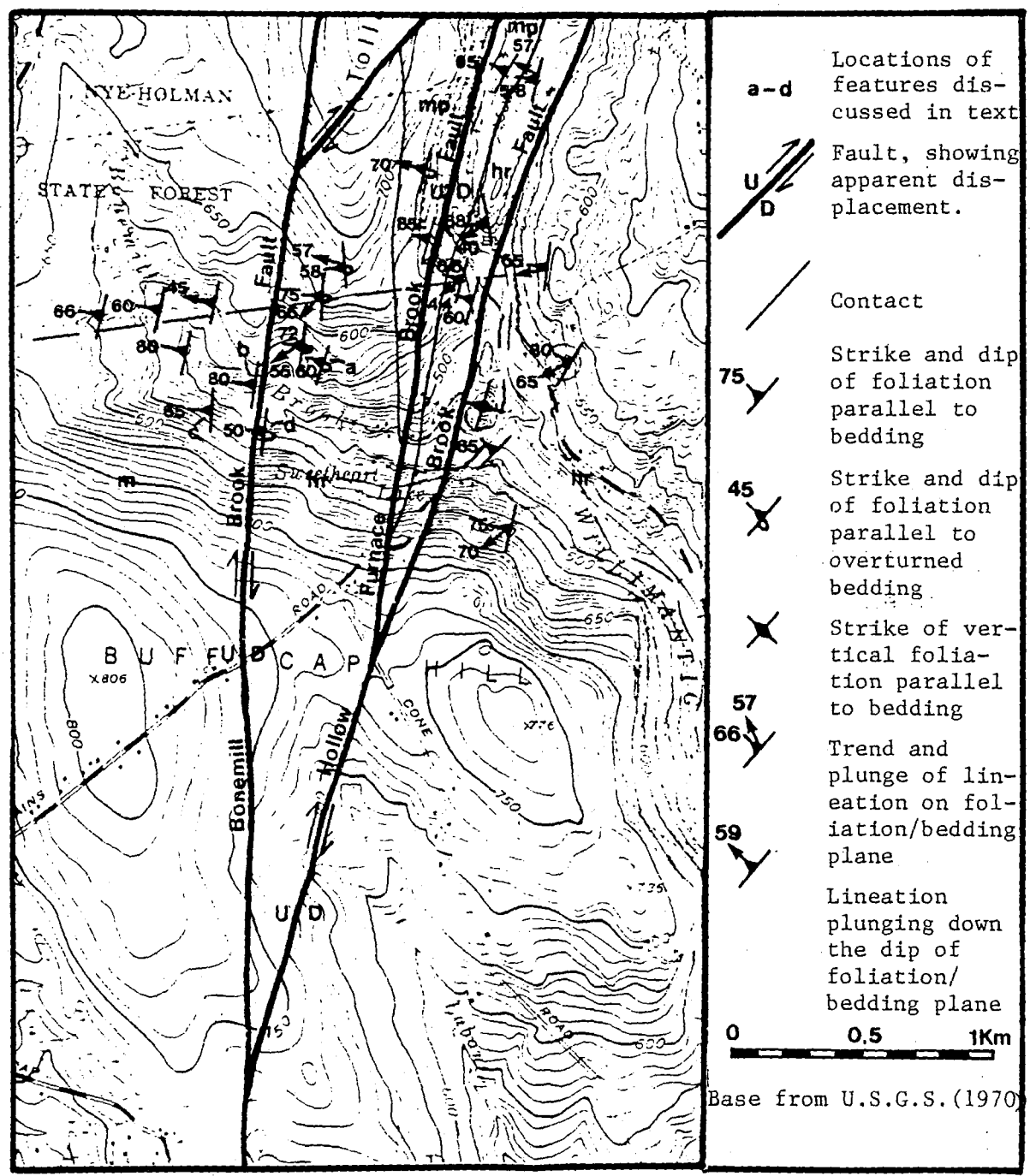

Figure 3 - Stop 2. Geology of the Bonemill Brook fault zone in the Bonemill Brook area, Stafford Springs quadrangle, Connecticut.

outcrop (loc. a) is above the trail to the east and about 150 m from the picnic area.

The rock is rusty-weathering sillimanite-graphite-bearing quartz-feldspar-biotite-garnet-gneiss typical of the Hamilton Reservoir Formation. Textures are no more noticeably cataclastic than in most of the Hamilton Reservoir Formation. Foliation and layering appear to strike slightly more easterly than the trace of the fault as mapped, but this does not appear to be structurally significant (fig. 3).

Continue along hiking trail across a Bonemill Brook tributary. Leave trail and follow tributary down to brook. Walk up stream to outcrop (loc. b) in the stream. This outcrop is of thinly interlayered light-and dark-gray fine-grained plagioclase gneiss with varied amounts of biotite and hornblende. The composition is typical for the Monson, but the rock is finer-grained, more evenly layered and more closely parted than most of the Monson in this area. Note the elongation of the feldspar porphyroblasts, note the weathered layers of almost pure biotite and the concordant quartzite veins, as much as 25 cm thick and pegmatite lenses.

How much of the structure and texture in these rocks can be attributed to cataclasis? Is the fine grain size and thin layering simply a relic clastic feature, or can at least part of it be attributed to milling and flattening along a tectonic boundary? Primary stratification appears to have been warped into subparallel alignment along much of the Bonemill Brook zone. Perhaps bedding plane surfaces acted as planes of least resistance to take up the strain along this boundary resulting in granulation and thin layering parallel to bedding. Are the biotite-rich layers the result of primary compositional difference or are they the result of a mineral reconstitution in response to stress? The occurrence of quartz veins parallel to layers indicates that they were planes of weakness well after the peak of tectonic deformation.

Climb the stream bank immediately above the outcrop and walk southwest along a log-skid trail to an area of abundant blocks of Monson Gneiss (loc. c). The largest block here appears to be attached or nearly attached bedrock sticking up above the float. Its attitude of N 5° E 65° W would indicate this. This rock, about 150 m west of the fault trace, is more typical of the Monson Gneiss, coarser grained and less thinly parted than that exposed in the

stream.

Walk eastward, maintaining approximately the same contour, for about 200 m, to the first ravine. Follow this down to an exposure of rusty weathering schist (loc. d). The exposure is mostly sandy pelitic schist with several resistant calc-silicate-bearing layers in the upper part. It has an apparent blastomylonitic texture, but then much of the schist in the Hamilton Reservoir Formation has a mylonitic texture.

The trace of the Bonemill Brook fault appears to be pinned down to less than 50 m across strike in this area although the distance between control outcrops is perhaps 200 m.

Return to cars by continuing down this ravine and across a swampy area. Pick up the woods road north of the brook and walk east to cars.

- | | | |
|------|-----|---|
| 9.2 | 0.3 | Starting from entrance to camp, return to Rt. 32. |
| 0.5 | 0.3 | Turn right (south) on Rt. 32. |
| 11.7 | 2.2 | Pass under Rt. I-86. Continue south on Rt. 32. |
| 13.2 | 1.5 | Veer to left at fork in road and cross Rt. 44.
Continue south on Rt. 32. |
| 16.6 | 3.4 | Pass intersection of Rt. 195. Continue south on Rt. 32. |
| 18.9 | 2.3 | Turn right (west) on Rt. 44A at stop light. |
| 22.7 | 3.8 | Intersection Rt. 31. Continue west on Rt. 32. |
| 26.1 | 3.4 | Turn right at Vernon Rd. Turn around and park along side. |

STOP 3 - Bolton Notch (fig. 4).

Structural and stratigraphic discontinuity across the Bonemill Brook fault is quite apparent in the Bolton Notch area. The Monson Gneiss again lies on the west side of the fault, but here less than 10 m of the felsic plagioclase gneiss is exposed beneath layered amphibolite of the Ammonoosuc volcanics. A complete section of the Great Hill syncline sequence striking generally parallel to the strike of the fault is well exposed in roadcuts and along the railroad grades in this area. The sequence

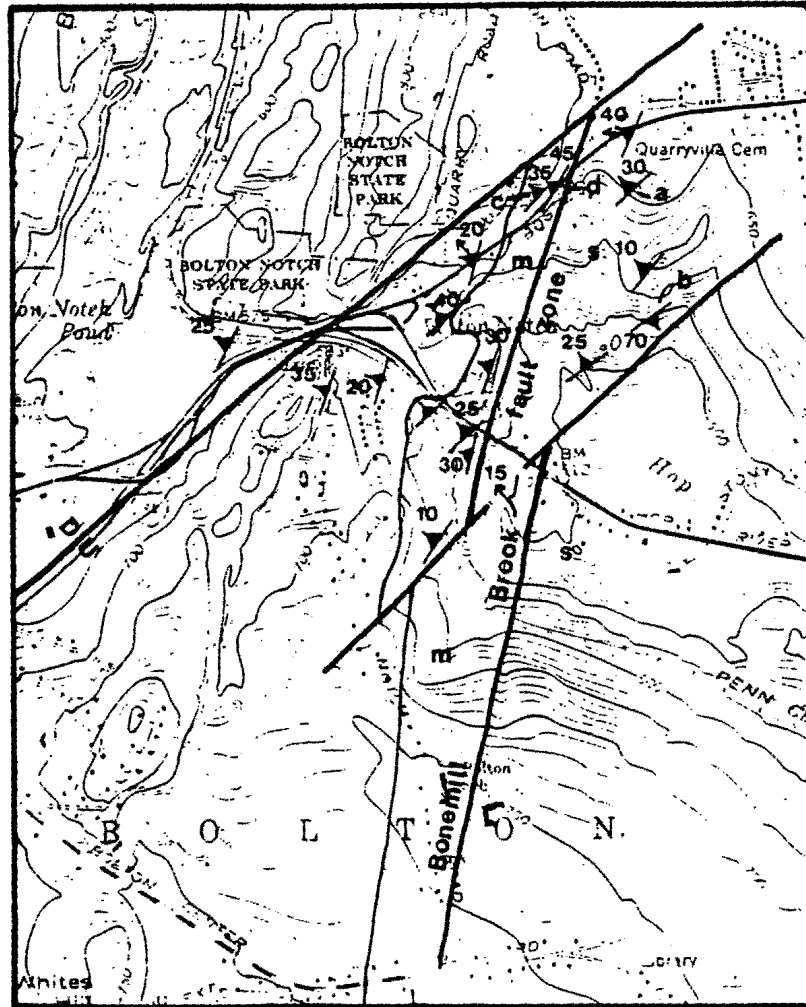

Figure 4 - Stop 3. The trace of the Bonemill Brook fault zone in the vicinity of Bolton Notch, Rockville quadrangle, Connecticut.

(See explanation, figure 3.)

above the Monson, including the Ammonoosuc, Partridge, Clough and Littleton Formations is less than 250 m thick. The Southbridge Formation lies east of the fault. The Southbridge is poorly exposed but the strike of slabby layering in a few low outcrops shows a distinct angular relation to the trace of the fault (fig. 4). The Bonemill Brook fault appears to be offset in the Bolton Notch area by at least one northeast-trending high-angle fault (fig. 4). The geologic mapping is incomplete here and additional work is needed along the ridge to the north and south of the notch to determine the presence or absence of similar offset of the Great Hill syncline sequence.

Walk south into the woods across highway Rt. 44A from the junction of Vernon Road. Find low exposures of slabby, friable, somewhat rusty-weathering, calc-silicate-bearing, granular biotite schist. This is the Southbridge Formation, quite unlike the pelitic rocks of the Hamilton Reservoir Formation exposed against the fault at the previous 2 stops. Note the gentle northwest-dipping rock striking toward the trace of the fault (loc. a). Continue walking due south for about 300 m across a swampy area to the next knobs. A heterogeneous assortment of slabby rock typical of the Southbridge is found mostly as float but with some in place; the strike here is also toward the trace of the Bonemill Brook fault. In an outcrop (loc. b) at the break in slope on the south side of this series of knobs, layering dips steeply to the southeast and the strike is turned more easterly. This abrupt steepening of attitude appears to be the result of drag along the northeast-trending fault that is believed to offset the trace of the Bonemill Brook fault farther southwest.

Return to Rt. 44A and walk west to the large outcrop of Monson Gneiss exposed north of the road (loc. c). This thickly-layered felsic gneiss is typical of much of the Monson Gneiss exposed to the north. The layering in this outcrop does not look far removed from normal sedimentary stratification. One might expect to see relict sedimentary structures, but no cross bedding or graded bedding has been identified.

Cross the road to the easternmost exposure of felsic gneiss (loc. d). This is a relatively massive, weakly foliated gneiss with little compositional banding or parting parallel to the foliation. It is a quartz-plagioclase gneiss;

the mafic has gone to chlorite and much of the feldspar is pink. Examination of the naturally weathered surface on the back side of this outcrop shows a fairly prominent fluxion streaking of the quartz and feldspar. This outcrop is the closest exposure to the fault and the retrograde mineralization suggests that late movement in this area may have occurred at lower temperatures and pressures than were in effect during the principal movement on the fault.

Return west along Rt. 44A to the rusty schist exposures of the Partridge Formation exposed on the north side of the road. The covered area between the Monson and Partridge presumably is underlain by layered amphibolite of the Ammonoosuc Volcanics that is well exposed around the corner on Rt. 6.

Additional points of interest in the Bolton Notch area are in the canyon behind the shopping center across the highway and on the back side of the 100 ft high northeast-trending knob to the south of the canyon. Among the features to see are a large rotated block of Monson Gneiss, the significance of which has not been determined, a 2 m thick quartzite vein that traverses a southeast-facing exposure at the north end of the knob and lies at the approximate contact between Ammonoosuc amphibolite and overlying rusty Partridge schist, and evenly thinly layered felsic Monson Gneiss less than 10 m thick with some suggestion of cataclastic texture lined up parallel to the trace of the fault.

Drive west on Rt. 44A through Bolton Notch.

- | | | |
|------|-----|---|
| 27.2 | 1.0 | Bear right off 4-lane highway onto Rt. 6. |
| 28.9 | 0.8 | Turn left at light and drive south on Rt. 85. |
| 30.4 | 1.6 | Turn right where Rt. 85 turns right. |
| 31.2 | 0.8 | Pass road intersection. Continue south on Rt. 85. |
| 35.9 | 4.1 | Turn right (west) onto Rt. 94 where Rt. 85 ends. |
| 36.0 | 0.1 | Turn immediately left (south) on West Street. |
| 37.5 | 1.5 | Turn right (west) onto Martin Road (West Road). |
| 38.6 | 1.1 | Turn left (south) onto Jones Hollow Road. |
| 40.8 | 2.2 | Cross under Rt. 2 overpass. |

- 41.1 0.3 Turn left (southwest).
- 41.4 0.3 Turn right (south) onto Rt. 66 at stop light.
- 42.9 1.5 Pass Intersection Saner Road. Continue west on Rt. 66.
- 45.1 2.2 Enter East Hampton. The next stop is the lunch stop. If you have not brought a lunch you can probably get lunch fixings in town.
- 45.8 0.7 Turn left (south) on Rt. 196 at light in East Hampton.
- 46.3 0.5 Stop sign in East Hampton Center.
- 46.4 0.1 Bear right with Rt. 196.
- 47.2 0.8 Turn right (west) onto Rt. 16 at stop light.
- 47.7 0.5 Park cars in side road subparallel to Rt. 16 south, On the left side. This is the lunch stop. We can eat somewhere along the abandoned railroad grade that we will be following.

Walk west to outcrops on either side of Rt. 16.

STOP 4 - East Hampton.

At this locality we shall again cross the Bonemill Brook fault zone. The boundary again is between thinly-layered felsic gneiss and amphibolite of the Monson on the west and rusty-weathering schist and gneiss of the Brimfield Group on the east. The Monson in this area is thinly-layered; it strikes consistently about N 10° W and dips very steeply to the west. Primary layering in the Brimfield Group is difficult to find and appears to be highly contorted by an abundance of gneissoid pegmatite, but the general strike appears to be more easterly and the dip less steep to the west than is true of the Monson. A large block several meters across of banded gneiss in the Brimfield rocks appears to be rotated into the plane of the fault zone in a manner similar to the tectonic blocks along the Willimantic fault described by Wintsch (1979).

Examine the outcrops of Monson Gneiss on both sides of the highway. These outcrops are just west of the trace of the Bonemill Brook fault which trends about S 10° W down the valley on the east. Thinly interlayered felsic plagioclase gneiss and amphibolite with smooth planar parting surfaces again are

exposed west of the fault. The layering appears to represent relict stratification in meta-volcaniclastic rocks. No relict primary sedimentary features appear to be present within the layers nor is there any evidence of the cataclastic deformation that might be expected so close to a major fault zone. Is it possible that the strain has been taken up along relict stratification planes, these planes having been accentuated by movement and alignment of mineral grains parallel to them?

Note the isoclinal fold axes plunging steeply to the southwest and the similarly plunging mineral lineation that may be related to movement on the Bonemill Brook fault. These axial planes are believed to be aligned in the plane of the fault surface and movement on the fault to be normal to the plunge. The steep plunge of fold axes and mineral lineation then would indicate that the principal movement is strike-slip with a minor dip-slip component. If the strike slip was right-lateral, the dip-slip would be down on the west side.

Walk north to the railroad grade and turn east. A small low outcrop on the north side of the grade consists of biotite muscovite schist and amphibolite. It belongs to the metavolcaniclastic rocks of the Glastonbury dome, not to the Brimfield Group rocks exposed east of the fault. There is evidence of moderate cataclastic deformation in this outcrop.

Continue along the railroad grade, east along the valley and across the fault to extensive exposures of rusty-weathering, sulfidic, graphitic schist and gneiss of the Brimfield Group. Bedding features are not evident except for a few resistant calc-silicate bearing lenses. Quartz and feldspar in the form of stringers and augen of gneissoid pegmatite several meters thick make up the bulk of the rock in these exposures. Schistosity anastomoses around large bodies of pegmatite and layering is comparably warped. The variable attitudes of foliation, N 45° to 75° E, dipping 25° to 75° W, strike generally more easterly than the regional trend of the fault.

Near the east end of this railroad cut at the north side nearly vertical compositional layering trends about N 15° E through a width of about one meter. This attitude is sharply discordant with adjacent compositional layering and the structure is not apparent in exposures on the south side. This may represent a tectonic block aligned subparallel to

the trace of the Bonemill Brook fault.
Retrace steps along the railroad grade back to cars.

Continue west on this side road.

- 48.3 0.5 Turn left (south) onto Chestnut Hill Road.
49.3 1.0 Pass old Chestnut Hill Road intersection.
50.2 0.9 Turn around at top of steep hill and park.

STOP 5, Pine Brook.

At this locality outcrops within 75m of each other on opposite sides of the Bonemill Brook fault can be seen. Walk due west. Almost continuous exposures extend from just over the lip of the hill to the base of the steep slope. Gneissoid pegmatite predominates near the top and sills of pegmatitic material are abundant throughout these outcrops. They invade brownish-gray weathering, weakly layered, irregularly foliated sillimanite schist. Fresh exposures of the schist are seen in the excavation for a new house about 200 m to the south off the right side of the road. It is a biotite-muscovite-sillimanite schist with stringers and augen of feldspar and quartz. Foliation is conspicuous, but quite irregular. The dip is essentially vertical and the strike appears to vary from N 40° W to north. A vein quartz layer lies in the plane of foliation. It thins from about a meter at the base to less than 20 cm at the top of the outcrop. No striking evidence of cataclastic deformation can be seen.

The schist at the base of the hill appears to be finer-grained, with thinly-parted intervals as much as 20 cm wide. It is the nearest outcrop to the contact and the attitude is N 20° W near vertical, parallel to the trace of the contact, but no more evidence of cataclastic deformation occurs here than to the east.

Walk due west for about 75 m to a small knob with outcrops of layered light- and medium-gray plagioclase gneiss with amphibolite layers. This is the thinly evenly layered gneiss typical of Monson in most places adjacent to the fault. Again it looks like relict sedimentary bedding.

Surprisingly little obvious deformation is noticeable in rocks so close to a major fault zone. Could a zone of more intense deformation be confined to the narrow covered area between outcrops, or is

the abundant pegmatitic material the result of deformation and feldspathization in the fault zone with shearing taking place along folia in the schist?

Climb back up the hill and return to the cars.

Return north on Chestnut Hill Road.

- 51.1 0.9 Turn right (east) onto Old Chestnut Hill Road.
- 51.8 0.7 Turn right on Young Street - Rt. 196.
- 54.7 2.9 Pass intersection Rt. 151 - Continue south on Rt. 196 & 151.
- 55.1 0.4 Cross Salmon River bridge.
- 56.4 1.3 Turn right onto Jonesville Road.
- 57.1 0.7 Turn right onto Rt. 149.
- 58.3 1.2 Outcrops of relatively undisturbed Hebron Formation on left.
- 60.9 1.6 Join with Rt. 82 in East Haddam.
- 61.1 0.2 Cross bridge over Connecticut River.
- 62.0 0.9 Turn left at stop light onto Rt. 9A at Tylerville.
- 62.4 0.4 Turn right onto Rt. 82, which connects to Rt. 9.
- 63.3 0.9 Park cars along right, north, side of road west of large road cuts.

STOP 6, Rt. 82 connector - eastern exposures.

A ductile fault zone, the Cremation Hill fault zone of David London (see Barosh and others - Trip P-7, this guidebook) is well exposed. It lies east of the Bonemill Brook fault zone entirely within the Merrimack eugeosyncline structural region, separating rocks of the Hebron Formation from rocks of the Brimfield Group on the west. These western strata correlate best with the upper part of the Brimfield Group. There may thus be several kilometers of apparent stratigraphic separation across this fault zone. The tectonic boundary that separates the eugeosynclinal rocks from the domal rocks, the Bonemill Brook fault zone, is exposed at STOP 7 about one kilometer to the southwest along this road.

The Cremation Hill fault zone appears to

coalesce with the Bonemill Brook fault zone to the south in the Deep River area where the Hebron lies in direct contact with the Monson Gneiss. Both the Hebron and Monson in this area exhibit a cataclastic fabric.

Rock types on either side of and within the Cremation Hill fault zone are well exposed in these roadcuts along the Rt. 82 connector. Minor structures are well displayed. Strata of the Hebron Formation exposed east of the Connecticut River dip gently to moderately westward and are essentially undeformed. On the west side of the river, however, the Hebron has been crumpled by east-over-west compression in a broad zone against the east side of the fault zone. Foliated gneiss and gneissoid pegmatite occurs in this crumpled zone and increases in abundance as the Cremation Hill fault zone is approached.

The fault contact is marked by exposures of migmatitic gneiss with numerous stringers and porphyroblasts of pegmatitic material. The pegmatitic stringers and augen decrease in abundance to the west away from the boundary and the rock becomes more schistose, but most of the schist exposed in road cuts from here to STOP 7 exhibit a distinct blastomylonitic fabric. The migmatization is believed to have been developed as a result of ductile strain along the Cremation Hill fault zone (see Barosh and others, this guide book). This entire belt of blastomylonitic rusty schist and gneiss might be considered a fault slice of Brimfield Group rock caught between the Cremation Hill fault zone and the Bonemill Brook fault zone.

Sillimanite lineations are relatively consistent in the schist between the Cremation Hill and Bonemill Brook fault zones. They plunge 20° - 25° , S 5° - 30° E. The direction of movement appears to be normal to this lineation. Such a direction of movement would produce a right-lateral component on a near vertical northerly-trending fault. A few isoclinal folds on both sides of the fault observed in plan view also indicate a right-lateral sense of movement. The subhorizontal crinkle fold axes and mineral lineation trend in a N 10° W direction in the Hebron Formation. The sense of asymmetry of these crinkle folds and of large scale folds suggests an east-over-west sense of transport normal to the trace of the fault and to mineral lineation. This is compatible with sillimanite lineation that plunges gently north or south within the migmatite where foliation is near

vertical. All of these small scale structures indicate a general movement of east over west with a right-lateral component, with only a minor difference in trend indicated on either side of the fault.

The sense of movement on outcrop scale folds with sheared limbs, that are exposed in the outcrops of Hebron nearest the fault, however, suggest that upper rocks have slid down to the east or possibly have been underthrust to the west. This may represent later movement or the result of adjustments when the asymmetric folds were jammed against the fault.

In order to get a better view of the deformation in the Hebron as the fault zone is approached, it is best to climb to the top of the large road cut on the northwest side. From the top we can see a vertical section in the northwest-facing roadcut exposures (light permitting) and underfoot is exposed the plan view. The Hebron consists of medium-gray, granular biotite schist with 1 to 5 cm thick interlayers that are lighter brownish-gray calc-silicate bearing. Light gray stringers and pods of feldspar and quartz pegmatitic material are conspicuous in the outcrop and bring out the configuration of the layering with which they are folded. The felsic stringers conform in general to the calc-silicate layering, but boundaries do vary and offshoots that cut across the foliation are common.

The dominant structural pattern in the vertical face is of asymmetric folds with amplitudes larger than the height of the outcrop showing east-over-west transport and near vertical western limbs. A prominent crinkle fold pattern is superposed on the large amplitude folds but a consistent sense of asymmetry is not readily apparent. Small scale, near vertical, tight isoclinal folds are commonly shown by calc-silicate layering, but these too show no sense of asymmetry in the vertical face.

In the plan view exposed here on top of the roadcut, the crinkle fold axis has a much more consistent trend than is apparent in the vertical exposure. It is the most persistent structure on the outcrop surface, trending N 5° E to N 20° W and nearly horizontal. Where compositional layering is steeply dipping, the strike is persistently N 10° W indicating that the axes of the crinkle folds are oriented the same as large scale folds. Axes of small scale isoclinal folds in the calc-silicate layers also trend about N 10° W and a few show a distinct

asymmetry in plan view that indicates the east side has moved south.

Walk back to road level and examine exposures of Hebron in lower outcrops to the west on both sides of the road. Note the large scale asymmetric folds with sheared-off limbs. The apparent sense of asymmetry seems to indicate that the rocks on the west have slid down over rocks to the east.

Note the thick pegmatitic bodies folded with the folds and the increasing amount of syntectonic pegmatitic material incorporated in the rock as the fault contact is approached.

Walk southwest around the corner from the large exposures of pegmatitic gneiss. A knob exposed in the woods here is the nearest outcrop to the Hebron of the Cremation Hill migmatite. It is micaceous migmatite unlike the pegmatitic gneiss of the Hebron. Pavement exposures in the cleared area west of the knob are less quartzo-feldspathic, but are still migmatitic with a strong blastomylonitic fabric. A small asymmetric fold shows a right-lateral east-moving-south sense of transport. The steep dip of the migmatite is exposed in a small trench just south of the pavement outcrop.

Walk across to the northwest side of the road to exposures below the culvert. Layering in the schist here appears to be severely stretched out. Fluxion structure is apparent, but the schist contains few pegmatitic layers. Continue northwest to exposures of blastomylonitic rock just beyond an abandoned paved road. Layers of pegmatitic material make up a large part of this outcrop. The pegmatitic layers are aligned with the foliation in a general sense but cross-cut the foliation in detail.

Return to cars.

Drive southwest along the connector road. Observe outcrops of blastomylonitic schist of the Brimfield Group on either side of the highway.

64.4 1.1

Park cars on the northwest side of highway before the large outcrop.

STOP 7 - Rt 82 Connector at north ramp Rt. 9.

The Bonemill Brook fault zone, forming the tectonic boundary between the Monson plagioclase gneiss and amphibolite of the Killingworth dome structural region and the Brimfield rusty-weathering

biotite-sillimanite schist of the Merrimack eugeosynclinal structural region, is exposed in this outcrop. The contact appears to be a simple welded metamorphic contact, but cataclastic deformation does exist along it and it is quite possible that the strain of tectonic dislocation is spread out across the entire width of the blastomylonitic schist that lies between this contact and the Cremation Hill fault zone. The narrow belt of Monson on the east flank of the Killingworth dome also shows the effects of compression and stretching parallel to the Bonemill Brook fault. Plagioclase gneiss with thinly-laminated and attenuated layering and curvilinear foliation surfaces can be seen in all the exposures of Monson along Rt. 9 south of this exit.

The contact is exposed for several meters along the face of this outcrop. The surface is broadly warped in a near vertical plane. Tightly appressed isoclinal folds with axial planes subparallel to the contact are present on both sides of the contact. The schist on the east is exceedingly contorted over the width of the outcrop. Contorted stringers of pegmatitic material are abundant. The felsic Monson Gneiss is tightly folded for about 25 cm on the west side of the contact. Tongues of schist appear to be folded into the gneiss at the contact. The orientation of the axes and sense of asymmetry of the folds is not at all consistent along the fault boundary, but there is some indication of right-lateral, east-side-moving-south movement as on the Cremation Hill fault.

Climb to the top of the roadcut from the northeast end. Use extreme caution in walking on this exposure. A non-layered, dark gray biotite granulite is exposed in the first low outcrops. This lithology commonly is interlayered with rusty weathering biotite-sillimanite schist in the upper part of the Hamilton Reservoir Formation of the Brimfield Group in the Stafford Springs area.

At the top of the outcrop, highly contorted schist with pegmatite stringers is exposed. Walk southwest along the outcrop to where the contact forms the cliff face. Tightly appressed, exceedingly irregular folds have disrupted the compositional layering in felsic Monson Gneiss right along the edge of the cliff face. Rusty schist of the Brimfield is plastered along the cliff face. An isoclinal fold with a subhorizontal axis is exposed in the schist half way down the face. The contact is quite sharp, but tongues of schist appear to be squeezed into the

gneiss along sheared folds.

The felsic gneiss grades into a migmatitic schist west of the contact. This in turn grades into an interval of rusty granular mica schist. This is not the Brimfield lithology. It appears to be a cataclastically deformed migmatitic rock. The schist grades westward into more felsic gneiss which is in sharp contact with banded amphibolite.

Walk southwest down the outcrop across felsic gneiss, amphibolite, pegmatite and granite gneiss. Return to car along the base of the outcrop. Look for the fault surface. It begins about the end of the bushes. END OF FIELD TRIP. The best way to return to Storrs, CT, is north on Routes 9, I-84, I-86 and 195. Rt. 9 east on I-84 and I-86 to Rt. 195 and thence north to Storrs.

REFERENCES

- Barosh, P.J., London, David, and deBoer, Jelle, 1982, Structural geology of the Moodus seismic area, south-central Connecticut: in New England Intercol. Geol. Conf., 74th Ann. Mtg., Univ. of Connecticut; Connecticut Geol. and Nat. History Survey Field Trip P-7.
- Billings, M.P., 1956, Bedrock geology: part 2 of The geology of New Hampshire, State Plan. Devel. Comm., 203 p.
- Dixon, H.R., and Lundgren, L.W., Jr., 1968, Structure of eastern Connecticut: in Zen, E-an, White, W.S., Hadley, J.B., and Thompson, J.B., Jr., Studies of Appalachian geology-northern and maritime: New York, Interscience Publishers, p. 219-229.
- Wintsch, R.P., 1979, The Willimantic fault; a ductile fault in eastern Connecticut: American Jour. Sci., v. 279., p. 367-393.

P3-1

Trip P-3

HIGH GRADE ACADIAN REGIONAL METAMORPHISM

IN SOUTH-CENTRAL MASSACHUSETTS

by

Peter Robinson
 Kurt T. Hollocher
 Department of Geology and Geography
 University of Massachusetts
 Amherst, Massachusetts 01003

Robert J. Tracy
 Craig W. Dietsch
 Department of Geology and Geophysics
 Yale University
 New Haven, Connecticut 06520

INTRODUCTION

The purpose of this field trip is to examine and discuss some of the highest grade rocks in the central Massachusetts-northern Connecticut Acadian metamorphic high, which includes some of the highest grade Paleozoic metamorphic rocks in the entire Appalachians. The trip begins in rocks that crystallized above the breakdown of muscovite and proceeds upgrade from there. The region in question lies east of the gneiss domes of the Bronson Hill anticlinorium (Figure 1) in the heart of the Merrimack synclinorium. Naturally there will be some discussion of the stratigraphy and structure of the region, which is controversial, but emphasis will be placed on metamorphism and how it relates to tectonic history. Those interested in more details on stratigraphy and structure should refer to Trip P-4 (this volume).

Early petrologic work in central Massachusetts was done by B.K. Emerson (1898, 1917) who gave some remarkably accurate descriptions of mineral assemblages in a variety of rocks. Heald (1950) first brought out the significance of the sillimanite-orthoclase zone in New England based on his work in southwestern New Hampshire. The first modern study in Massachusetts was by Barker (1962) on rocks near Sturbridge and nearby Union, Connecticut. This was followed by Hess (1969, 1971) who did electron probe studies of zoned garnet and coexisting biotite and cordierite near Sturbridge.

Our own work in the very high grade rocks was begun by Robinson (1967) in the Quabbin Reservoir area and was followed up by a detailed study of the sillimanite-orthoclase isograd by Tracy (1975, 1978). Meanwhile detailed geologic mapping and petrographic description were extended southward from Quabbin by Peper (1966, 1967, 1976, 1977a, 1977b), eastward and northeastward from Quabbin by Field (1975) and Tucker (1977), and northward from the Connecticut State Line by Seiders (1976), Moore (1978), and Pomeroy (1974, 1975, 1977). As part of the compilation work for the Massachusetts bedrock map in the late 70's Robinson had the task of examining all of these areas,

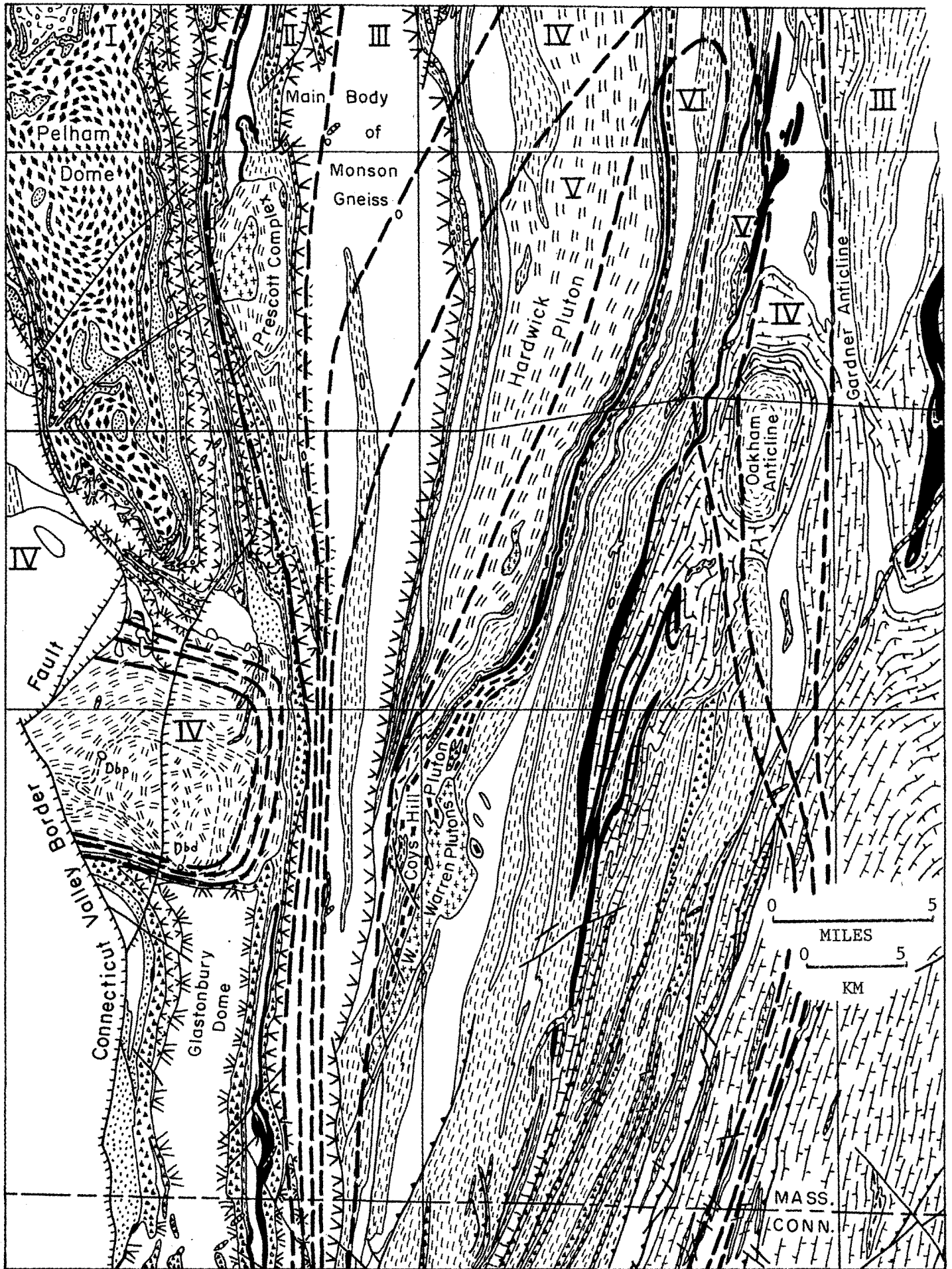
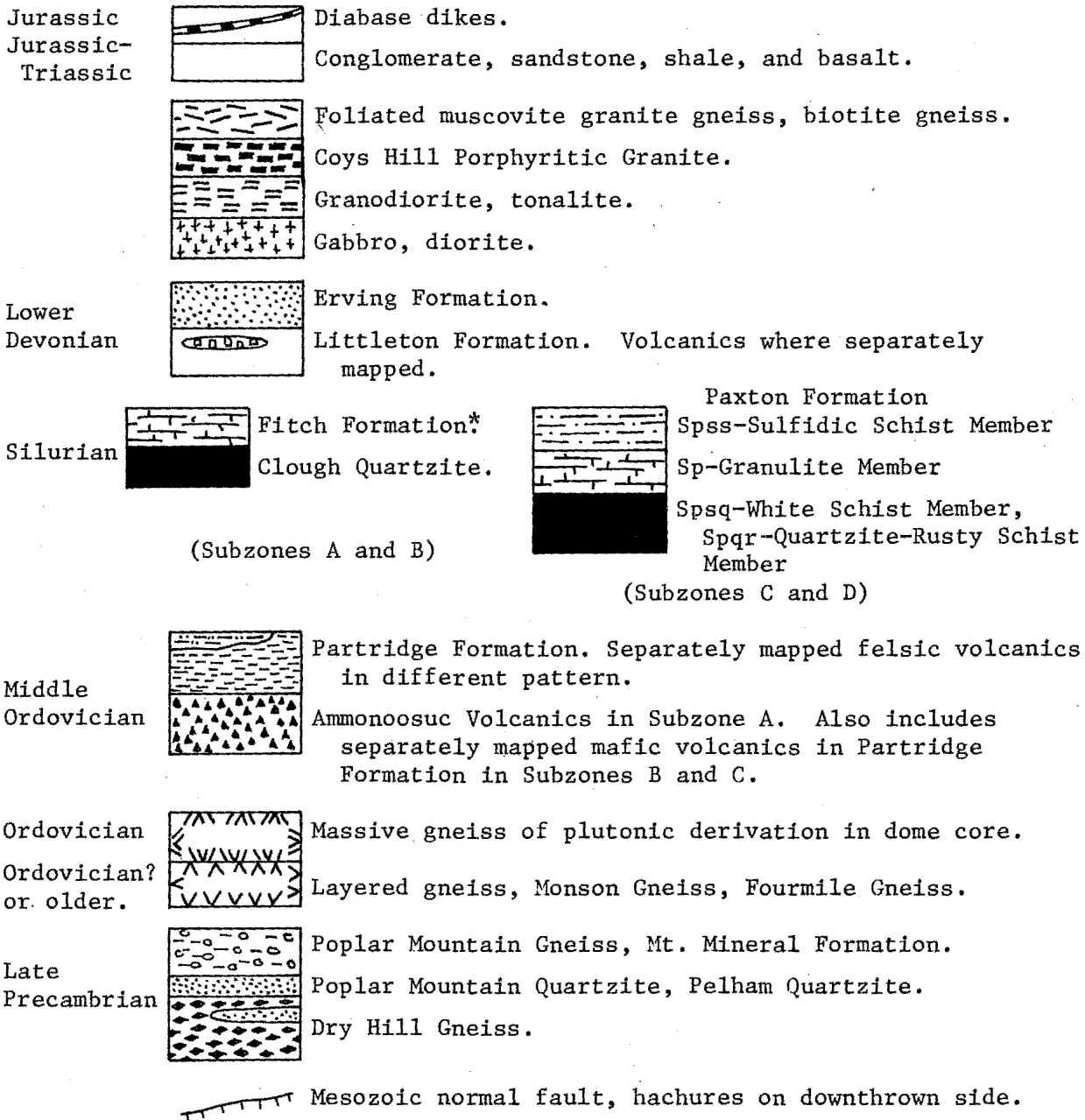

Figure 1. Generalized bedrock geologic map of south-central Massachusetts, showing metamorphic zones and location of cross section, Trip P-4, Figure 2. No attempt is made to pattern all very small areas. Metamorphic zones are described in the text.

EXPLANATION
(Use also for Figure 30)



* Fitch Formation shown solid black in Subzone B.

in part with the guidance of the various authors, and several papers and abstracts based on collected material were published (Robinson et al., 1975; Tracy et al., 1975; Robinson, 1976; Tracy, Robinson, and Field, 1976; Tracy, Robinson, and Thompson, 1976; Robinson and Tracy, 1976; Robinson and Tracy, 1977; Robinson, Tracy and Pomeroy, 1977; Tracy and Robinson, 1978a; Tracy and Robinson, 1978b; Robinson, Tracy and Tucker, 1978; Robinson, 1979; Robinson and Tracy, 1979; Tracy and Robinson, 1980; Shearer and Robinson, 1980).

ACKNOWLEDGEMENTS

Our petrologic work in central Massachusetts has been supported over the years by grants from the National Science Foundation Geochemistry and Geology Programs as well as grants from the U.S. Geological Survey. During compilation work Robinson had access to unpublished maps and had the benefit of personal guidance in the field by J. D. Peper, M. T. Field, R. D. Tucker, J. S. Pomeroy, and M. H. Pease. Further important samples were discovered by Charles Shearer, Heather Stoddart, David Klepacki, Peter D'Onfro, Lewis D. Ashwal, and Erland P. Kennan. During this work we had helpful discussions with and encouragement from Alan B. Thompson, J. B. Thompson, J. L. Rosenfeld, R. D. Tucker, S. A. Morse, H. W. Jaffe, J. T. Cheney, John Brady, Charles Shearer, J. C. Schumacher, D. R. Wones, D. M. Rye, R. A. Berner, C. V. Guidotti, Peter Blüel, M. J. Holdaway, and Werner Schreyer. Many of the figures were expertly lettered by Marie Litterer. The text was typed in all versions by Gerda Kunkel. To each of these persons and institutions we express our grateful acknowledgement.

REGIONAL METAMORPHIC ZONES IN PELITIC SCHISTS

The central Massachusetts metamorphic high east of the Connecticut Valley border fault has been divided into six zones (Figure 1 and Figure 2A) based on mineral assemblages in pelitic schists (Tracy, Robinson and Thompson, 1976; Robinson, Tracy and Tucker, 1978). In Zone I, the Kyanite-Staurolite Zone, the typical assemblage in pelitic schists is quartz-muscovite-biotite-garnet-staurolite-graphite-ilmenite \pm pyrrhotite \pm plagioclase. Less abundant schists, generally with more magnesian bulk compositions, contain kyanite in addition, or kyanite without staurolite (Robinson, 1963). In Zone II, the Sillimanite-Staurolite-Muscovite Zone, the typical assemblage in pelitic schists is quartz-muscovite-biotite-garnet-staurolite-sillimanite-graphite-ilmenite \pm pyrrhotite \pm plagioclase. In the lower grade part of Zone II similar schists lacking sillimanite are also abundant, whereas in the higher grade part similar sillimanite schists without staurolite are very abundant. In Zone III, the Sillimanite-Muscovite Zone, the typical assemblage in pelitic schists is quartz-muscovite-biotite-garnet-sillimanite-graphite-ilmenite \pm pyrrhotite \pm plagioclase, similar to staurolite-free rocks in the upper part of Zone II. In Zone IV, the Sillimanite-Muscovite-K feldspar Zone, the typical assemblage is quartz-muscovite-orthoclase-plagioclase (An₂₀₋₃₅)-biotite-garnet-sillimanite-graphite-ilmenite \pm pyrrhotite. At any one locality rocks with more sodic plagioclase than in the typical assemblage have sillimanite-orthoclase without muscovite, whereas rocks with more calcic plagioclase have sillimanite-muscovite without orthoclase (Tracy 1975, 1978). In Zone V, the Sillimanite-K Feldspar Zone, the typical assemblage in pelitic schists is quartz-orthoclase-plagioclase-biotite-garnet-silliman-

ite-graphite-ilmenite \pm pyrrhotite and no muscovite is found in prograde rocks of any available composition. This is the lowest grade zone to be visited on the field trip. In Zone VI, the Sillimanite-K Feldspar-Garnet-Cordierite Zone, the typical assemblage in pelitic schists (and gneisses) is quartz-orthoclase-plagioclase-biotite-garnet-cordierite-sillimanite-graphite-ilmenite \pm pyrrhotite. At certain stratigraphic levels in Zone VI as well as locally in Zones IV and V there are extremely sulfide-rich rocks lacking garnet, commonly with rutile in place of ilmenite, and in rare instances pyrite in place of most of the pyrrhotite. The genesis of these rocks is discussed below.

GENERAL SEQUENCE OF PROGRADE REACTIONS

The possible reactions by which the typical garnet-biotite-staurolite schists of Zone I are converted to sillimanite-bearing schists in Zone II have been considered at length by Robinson (1963) and Hall (1970). Several problems are still unresolved, but it appears that the appearance of aluminum silicate is controlled by one or more continuous reactions:

- 1) Staurolite + Muscovite + Mg-richer Biotite + Quartz
= Sillimanite + Fe-richer Biotite + H₂O
- 2) Na-richer Muscovite + Quartz
= Sillimanite + Albite + K-richer Muscovite + H₂O

and possibly by effects of zoning in garnets.

The general reaction by which staurolite-bearing schists of Zone II are converted to staurolite-free schists of Zone III is probably

- 3) Staurolite + Muscovite + Quartz = Sillimanite + Biotite + Garnet + H₂O.

Because of variable Mn/Fe in garnet and possibly Zn/Fe in staurolite, this reaction should be considered also as continuous over a very limited temperature range. The significance of Zn in the staurolite-out reaction is equivocal. Of analyzed staurolites from 16 rocks, 13 have less than 5% Zn staurolite component, two have between 5 and 10% and one has about 17%. That reaction 3) is a staurolite-out reaction for pelitic compositions only is dramatically demonstrated by the occurrence of staurolite in Zone IV in a quartz-sillimanite-staurolite-cordierite-plagioclase assemblage.

The change from sillimanite-muscovite assemblages in Zone II through sillimanite-muscovite-orthoclase assemblages in Zone IV to sillimanite-orthoclase assemblages in Zone V has been studied extensively by Tracy (1975,1978). The controlling reaction is a continuous one essentially involving continuous increase in muscovite and K feldspar K/Na ratios and plagioclase Ca/Na ratios:

- 4) Na-richer Muscovite + Na-richer Plagioclase + Quartz
= K-richer Muscovite + K-feldspar + Sillimanite+Ca-richer Plagioclase
+ H₂O

The Na lost from muscovite and from plagioclase in this reaction goes to make a larger amount of K feldspar, which is more sodic than muscovite. The Zone III-Zone IV boundary is defined by the first appearance of sillimanite-K feldspar in schists with the most sodic plagioclase composition, in practice about An₂₀. The Zone IV-Zone V boundary is defined by the last appearance of muscovite in schists with the most calcic plagioclase, in practice about

FIGURE 2. METAMORPHIC MAPS OF CENTRAL MASSACHUSETTS.

Metamorphic Zones	
VI	Garnet-cordierite-sillimanite-K-feldspar
V	Sillimanite-K-feldspar
IV	Sillimanite-muscovite-K-feldspar
III	Sillimanite-muscovite
II	Sillimanite-staurolite
I _k	Kyanite-staurolite
I _A	Andalusite-staurolite
G	Garnet
B	Biotite
C	Chlorite
R-J	Mesozoic sedimentary and volcanic rocks

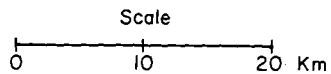

FIGURE 2A. LOCALITIES WITH SPECIAL METAMORPHIC FEATURES.

- Rocks showing evidence for pre-Acadian high pressure sillimanite-orthoclase grade metamorphism with Acadian kyanite zone overprint.
- Kyanite with fibrolitic sillimanite overgrowths.
- ◆ Sillimanite pseudomorphs after andalusite (many more localities not shown).
- ▼ Local occurrences of coexisting sillimanite-microcline in Zones II and III.
- Muscovite in pegmatite, Zone VI.
- ▽ Staurolite in non-pelitic rock in Zone IV
- Cordierite in gedrite gneisses, Zones I and II. In both locations examples can be found of retrograde replacement of cordierite by kyanite + chlorite + quartz.
- ⌘ Finely recrystallized mylonites, Zones IV and V. Many localities not shown.
- || Very finely recrystallized mylonites, Zone VI.
- ◇ Retrograde sillimanite + green biotite after cordierite in Zone VI.
- ▨ Zones of thorough retrograde metamorphism at New Salem (Hollocher, 1981) and Quabbin Hill.

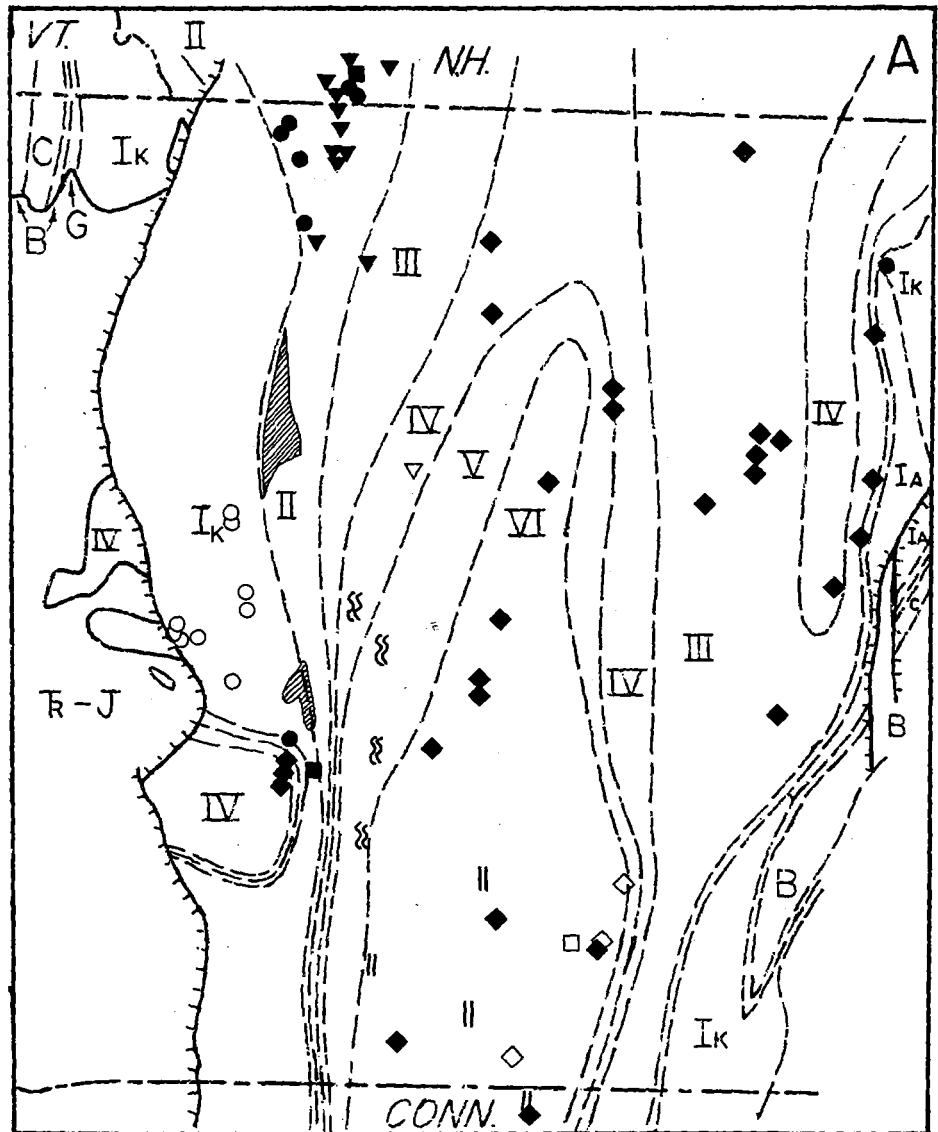
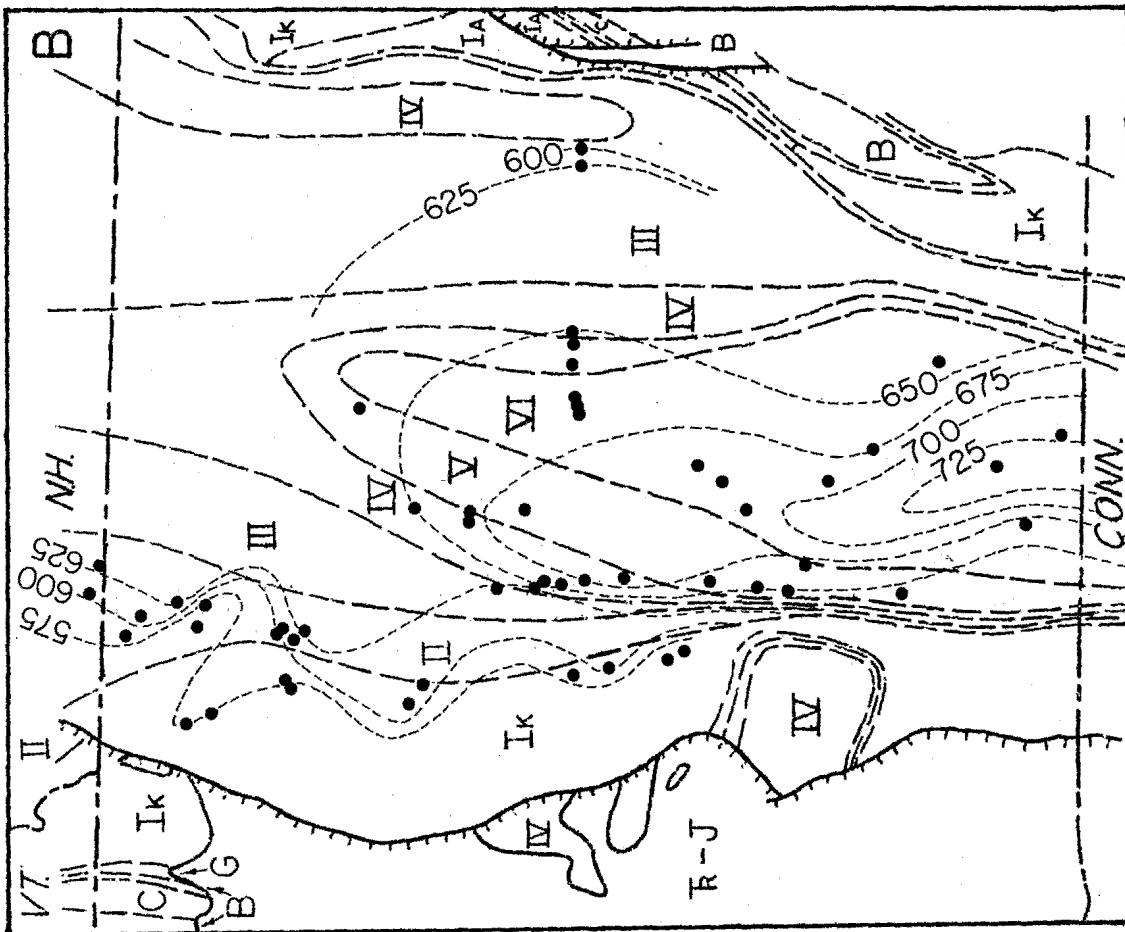
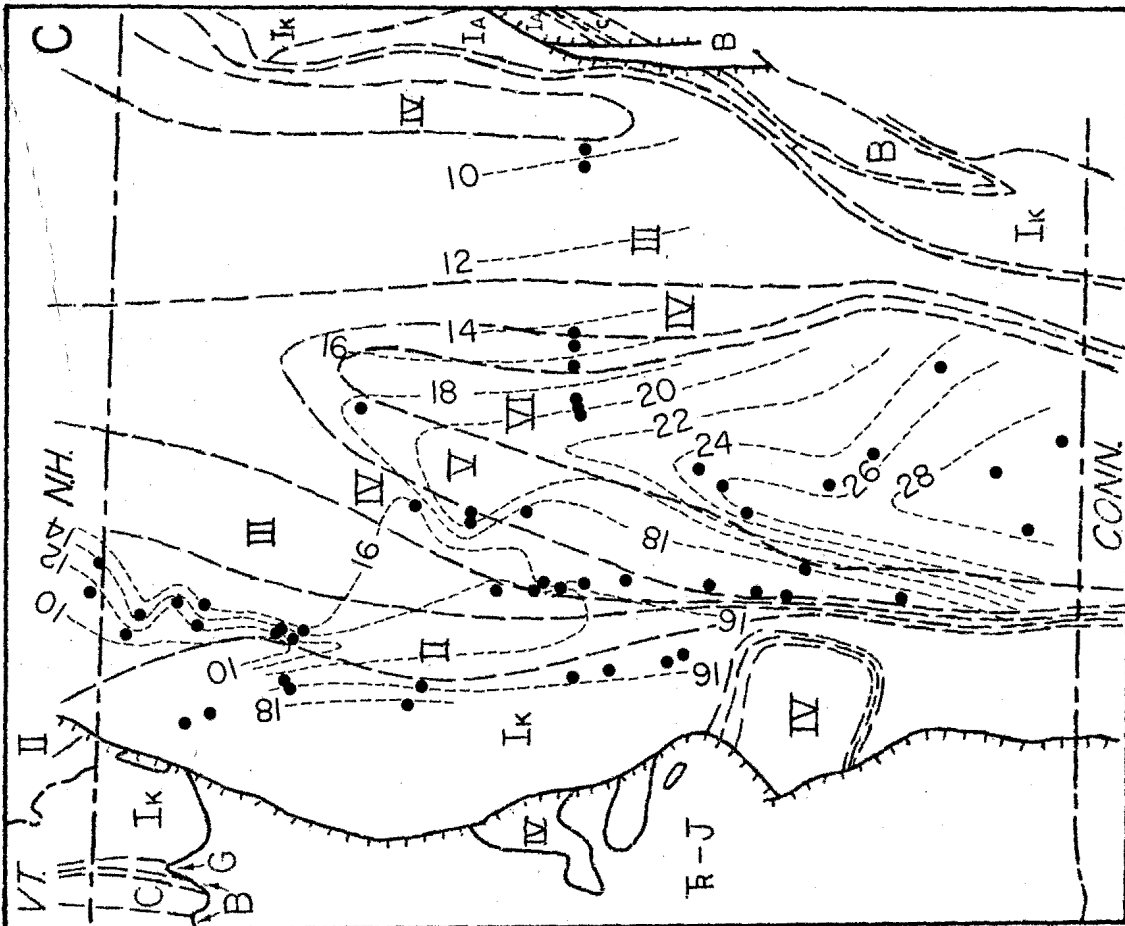

FIGURE 2B. CONTOUR MAP SHOWING POSITION OF ESTIMATED ISOTHERMS AND LOCALITIES STUDIED.

FIGURE 2C. CONTOUR MAP SHOWING MAXIMUM PYROPE CONTENT OF GARNET IN PELITIC SCHISTS AND LOCALITIES STUDIED.

P3-7



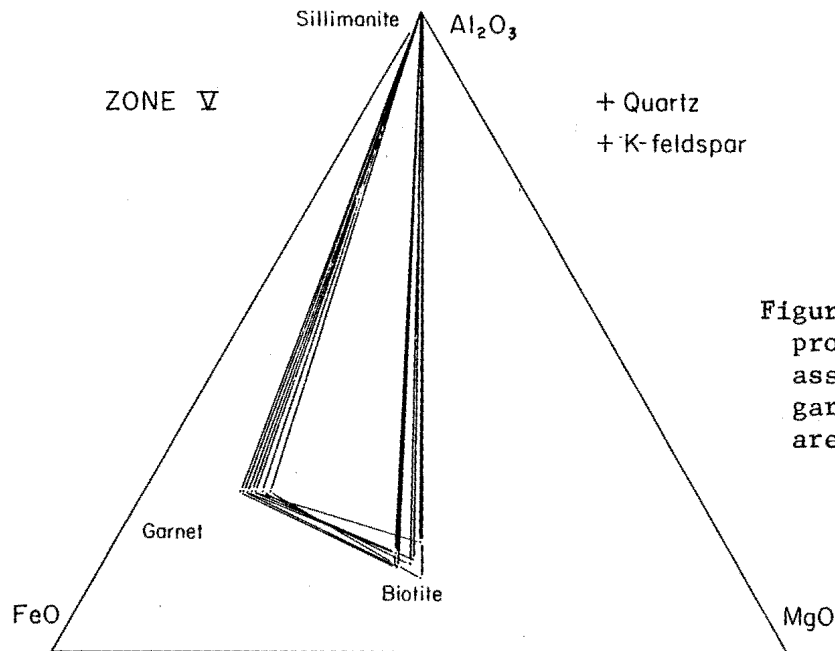
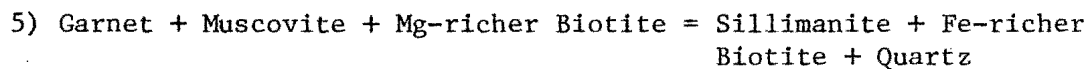

Figure 3A. Quartz + K-Feldspar projection of pelitic schist assemblages in Zone V. Only garnet core compositions are shown.

An₃₃. Within Zone IV muscovite compositions range from 7% down to about 2% paragonite component in the highest grade rocks. The highest grade muscovites contain 10-20% of a celadonite component and .04 to .08 Ti ions per 11 oxygens as compared to .01 to .05 in lower grade muscovites.

So long as muscovite is stable in Zones III and IV there is little pro-grade change in the Fe/(Fe+Mg) ratios of garnets and biotites in sillimanite-garnet-biotite assemblages. A fairly obvious reason is to be found in the controlling reaction:



First inspection suggests that since the K + Na of muscovite must be exactly balanced by the K+Na of biotite, the H₂O must balance and the reaction is fluid conservative and hence is likely to have a very small ΔS . However, C. V. Guidotti (pers. comm. 1982) has called attention to the well known fact that muscovites have higher Na than coexisting biotites and hence that albite component of plagioclase should be added to the right-hand side of the equation. This would increase the ΔS of the reaction and would slightly favor the sillimanite + biotite side of the reaction with increasing grade.

Once muscovite has been entirely replaced by K-feldspar in Zone V the situation is entirely reversed. K-feldspar takes the place of muscovite in reaction 5), the amount of H₂O produced on the left hand side is large and so is the ΔS . This is rewritten as

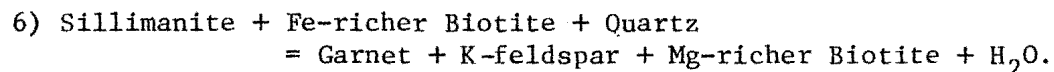

This powerful dehydration reaction is responsible for major changes in mineral compositions. The Mg contents of garnets and biotites in the sillimanite-biotite-garnet-K feldspar assemblage increase progressively from values typical of Zone V (Figure 3A) to the higher values characteristic of Zone VI

P3-9

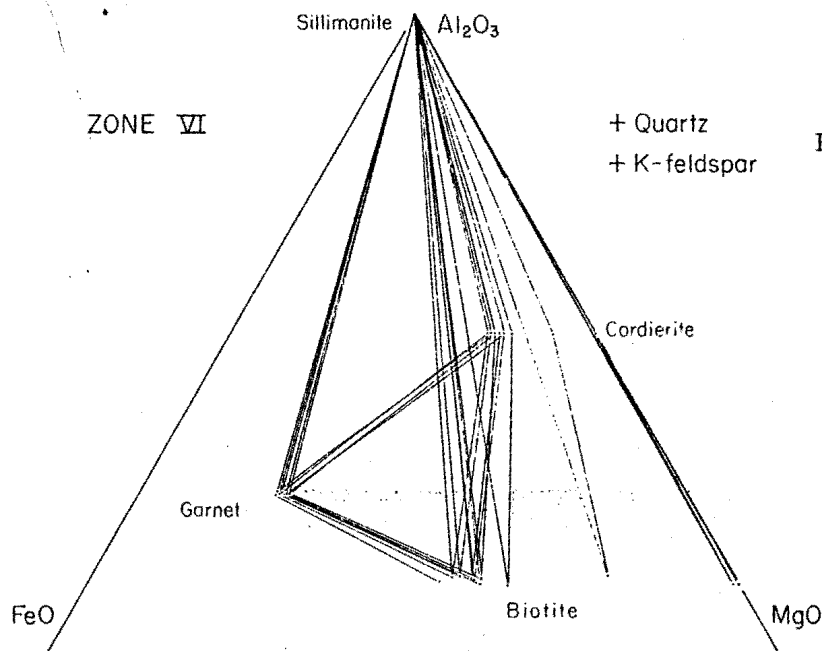
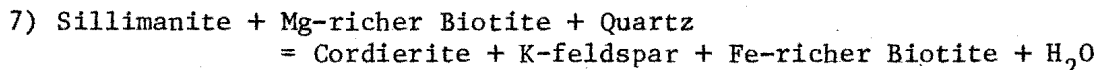

Figure 3B. Quartz + K-Feldspar projection of some pelitic schist assemblages in Zone VI. Only garnet core compositions are shown and some more recent garnet assemblage data is not included. The extremely magnesian assemblages are all indeed three-phase assemblages!

(Figure 3B). In Zone VI this garnet reaction "collides" with a similar powerful dehydration reaction involving cordierite and moving in the reverse direction:



This "collision" produces the Sillimanite-Orthoclase-Garnet-Cordierite-Biotite assemblages typical of Zone VI. These two continuous Fe-Mg reactions are illustrated qualitatively in T-X projection in Figure 20. The shift in garnet compositions in pelitic schists caused by reaction 6) is also illustrated in a map of maximum pyrope content (Figure 2C). From a maximum of pyrope 16-18 in Zones I-IV the content increases to pyrope 25 or more in parts of Zone VI. This is accompanied by a change of X_{Mg} biotite in the same assemblage from near .50 to near .60.

Aside from the changes in major assemblages the distribution of Al-silicate polymorphs is instructive. The only Al-silicate in Zone I is kyanite. In Zone II the bulk of the Al-silicate is fibrolitic sillimanite growing mainly from the breakdown of micas, but there are a few occurrences of kyanite overgrown by fibrolitic sillimanite (Figure 2A). Straight prismatic sillimanite is scarce until Zone IV where it replaces fibrolite while orthoclase replaces muscovite. All sillimanite in Zones V and VI is in well crystallized acicular prisms. A characteristic of many rocks in Zone VI as well as the northern and eastern portions of Zones V, IV, and III are 3 cm to 10 cm long, 1 cm thick sillimanite prisms that have an internal structure of disoriented rhomb shaped prismatic segments and inclusion patterns indicative of sillimanite pseudomorphs after andalusite (Rosenfeld, 1969). The distribution of these pseudomorphs is shown in Figure 2A. In Zones III and IV the pseudomorphs are commonly accompanied by fibrolite growing from micas in the matrix. Another common feature of Zone VI are retrograde replacements of cordierite or less commonly garnet (+K feldspar) by biotite and well formed prismatic sillimanite (see Tracy and Dietsch, 1982). In these

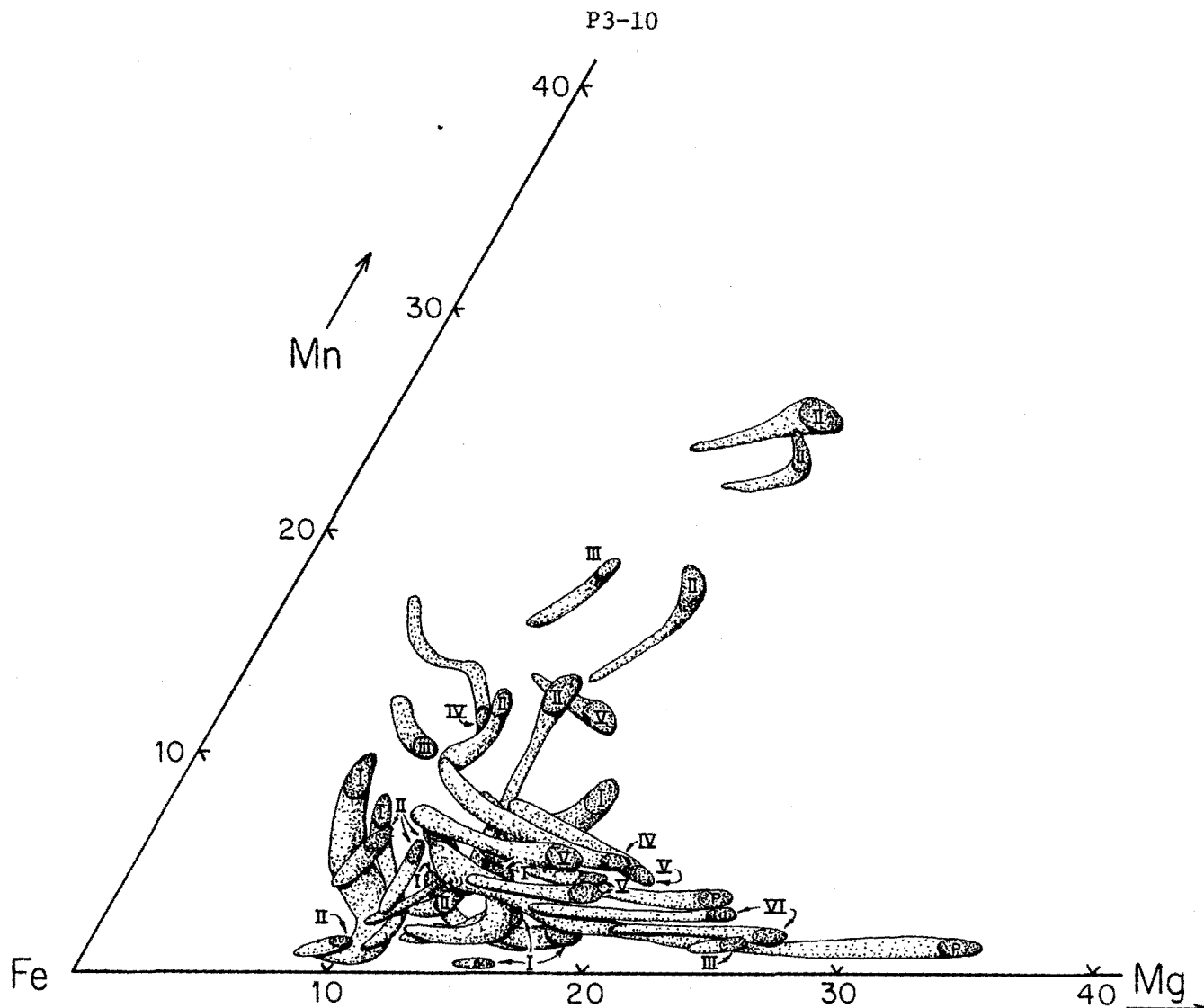

Figure 4. Mn-Fe-Mg composition trends of zoned garnets from various metamorphic zones (I-VI) in central Massachusetts. Dark "heads" represent garnet cores, lighter "tails" represent rims. "P" designates polymetamorphic garnets from the Pelham dome.

retrograde intergrowths the biotite is usually a light green very-low-Ti variety quite different from the usual deep red biotite, and is easily mistaken for chlorite in hand specimen. The overall impression is that fibrolite forms where Al-silicate is forming in prograde reactions involving the breakdown of micas. In Zones V and VI where sillimanite is reacting out in favor of garnet or cordierite, the remaining sillimanite recrystallizes in the prismatic form, as it does when sillimanite is forming from retrograde replacement of cordierite or garnet.

CHARACTER AND SIGNIFICANCE OF ZONED GARNETS

Compositional zoning in garnets and some other metamorphic minerals was known long before the days of the electron probe, and such knowledge has been greatly expanded by probe studies. The fact that garnets are more commonly

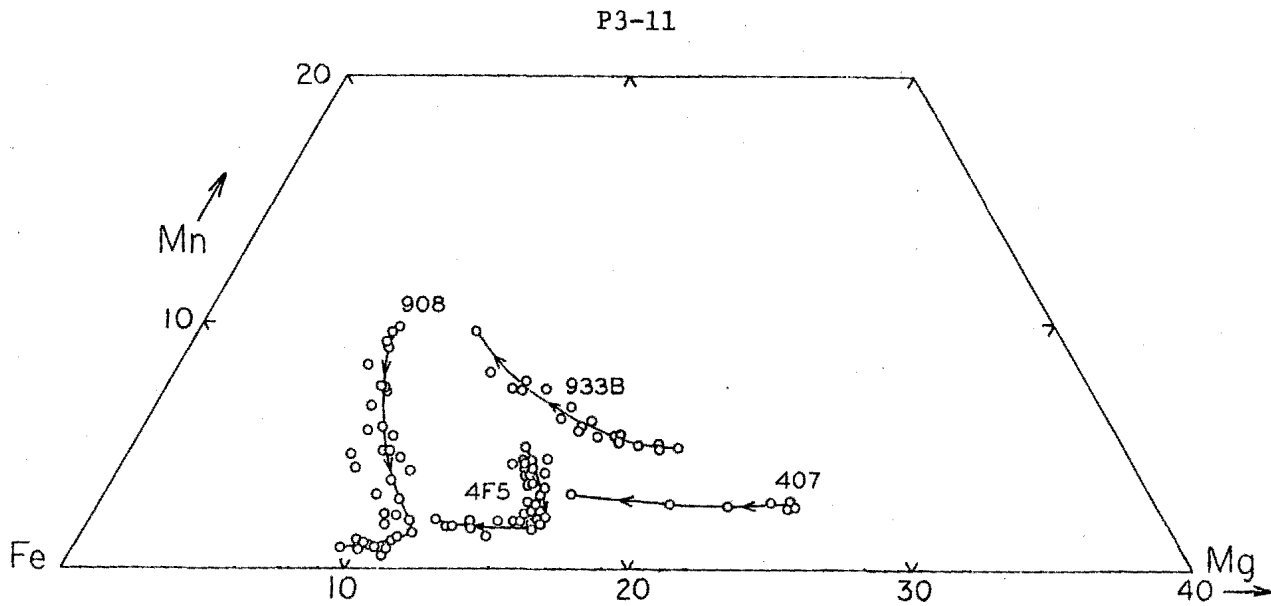

Figure 5. Mn-Fe-Mg composition trends of zoned garnets representative of the three types prevalent in central Massachusetts. 908 and 4F5 are type A. 933B is type B. 407 is type C.

zoned than most other metamorphic minerals must be due to the slow rates of diffusion of chemical components through the dense garnet structure as compared to most other minerals at the same temperature. Rather than a detriment, this slow diffusion is a benefit because it permits garnets to preserve in their interiors the evidence for metamorphic events earlier than the events recorded by the exterior of the garnet and the surrounding matrix of the rock (Hollister, 1966; Tracy, Robinson, and Thompson, 1976; Thompson, Tracy, Lyttle, and Thompson, 1977).

The chemical patterns of zoning in garnets from pelitic schists in various metamorphic zones in central Massachusetts are illustrated in Figure 4. This image was once described as "a can of worms" but the patterns can essentially be sorted out into three main types for which examples are given in a chemical plot in Figure 5 and in spatial maps in Figure 6.

Type A garnets are illustrated by 908 and 4F5 in Figure 5 and by Figure 6A. These garnets occur mainly in Zones I and II. They characteristically have spessartine-enriched cores and rims which are enriched in almandine-pyrope components. They appear to have grown under prograde metamorphic conditions in which new material was added to garnet rims by reactions involving surrounding minerals, but in which the diffusion rate within garnet was too slow to permit the interior to equilibrate with the exterior during the metamorphism. In some examples (Thompson, Tracy, Lyttle and Thompson, 1977) such garnets contain inclusions giving a record of lower grade metamorphic assemblages quite different from the assemblages in the rock surrounding the garnet. The almandine-enriched outer rims in garnets 908 and 4F5 are at present controversial because it is not certain whether they represent a change in the ruling prograde reaction affecting garnet or whether they represent a retrograde equilibrium such as has affected type B garnets.

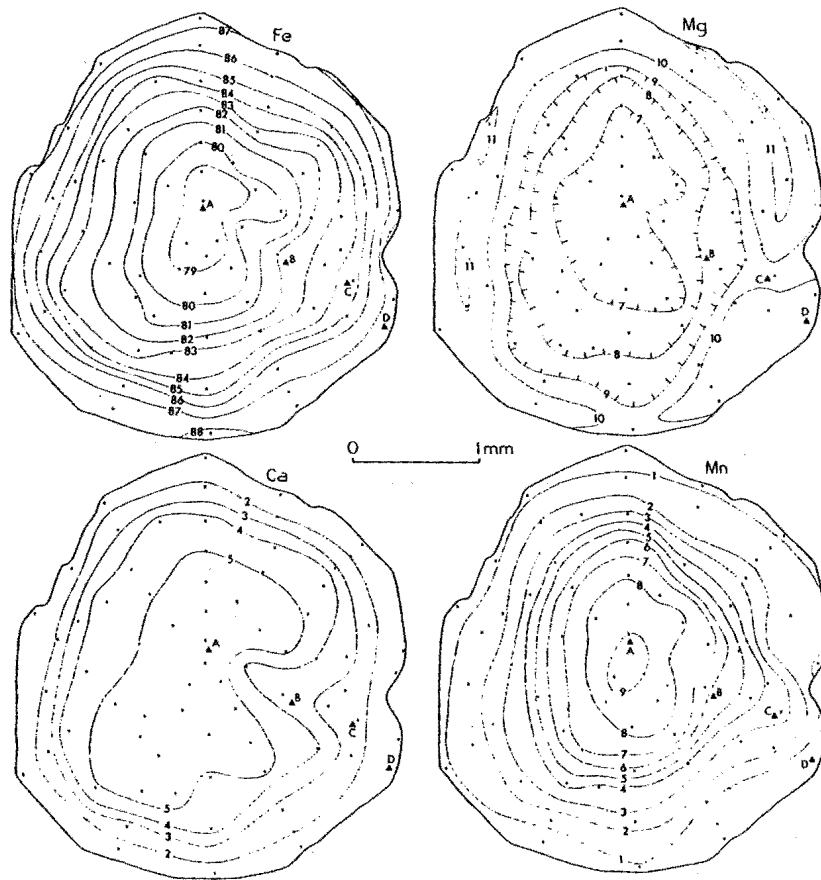

Figure 6A. Contour maps of mole % Fe, Mg, Ca, and Mn in garnet 908, Zone I, a typical type A zoned garnet. The assemblage is quartz-muscovite-biotite-garnet-staurolite. Dots are analysis points.

Type B garnets, which are most important in Zones IV and V, and are illustrated by 933B in Figures 5 and 6B, tend to have relatively homogeneous almandine- and pyrope-rich cores with continuous rims of pyrope-depleted spessartine-enriched composition. If these garnets, once at lower grade, had zoning patterns similar to Type A garnets, then such zoning has been removed by active diffusion at higher grade. However, these garnets may have grown originally under different conditions so that they did not inherit interiors with Type A zoning. The sense of composition change in Type B garnets is almost exactly the reverse of the prograde change implied by reaction 6) that best explains major changes in mineralogy between Zones V and VI. This strongly suggests that the exteriors of the garnets were affected by a retrograde continuous hydration reaction, essentially the reverse of the prograde dehydration. The fact that the outer rims of the garnets are continuous even when the grains have awkward anhedral shapes, and that the rims are continuous regardless of what the garnet is touching, are strongly suggestive that retrograde re-equilibration with the surrounding rock took place through the medium of a pervasive intergranular fluid. This is also suggested by the homogeneous compositions of matrix minerals such as biotite. The suggestion of the presence of a slight amount of fluid during early stages of metamorphic cooling may be important in understanding the degree of late stage recrystallization of mylonites and the development of other late stage tectonic fabrics.

P3-13

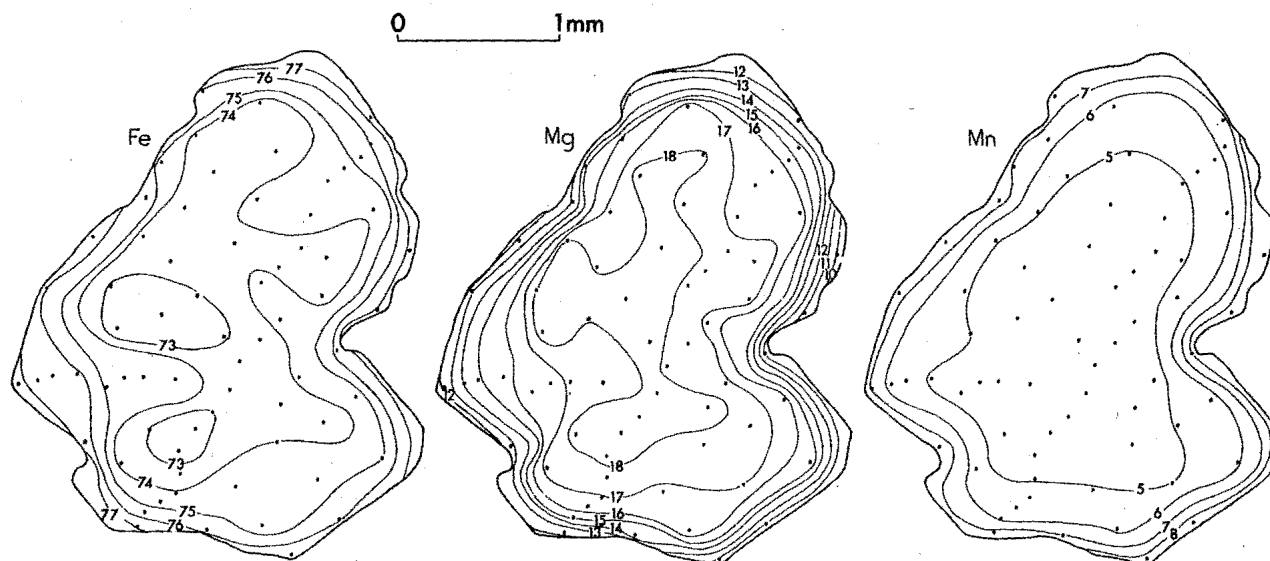

Figure 6B. Contour maps of mole % Fe, Mg, and Mn in garnet 933B, Zone IV, a typical type B zoned garnet. Ca content varies little. The assemblage is quartz-orthoclase-biotite-garnet-sillimanite. Dots are analysis points.

The most spectacular examples of Type B garnets are to be found in the Late Precambrian Mount Mineral Formation in the core of the Pelham gneiss dome in Zone I. These rocks appear to have enjoyed a Late Precambrian or Early Paleozoic metamorphism at least as intense as Acadian Zone VI and then underwent partial re-equilibration under much more hydrous Acadian conditions of Zone I. Garnets from two such rocks are illustrated in Figure 4 and indicated with a "P". In the most extreme sample the relict cores are pyrope 35 whereas the continuous rims and edges of biotite-filled cracks are retrograded to about pyrope 12!

Type C garnets, which predominate in Zone VI and are illustrated by 407 in Figures 5 and 6C, tend to have homogeneous interiors like Type B, but this homogeneous character also extends to the edge of the garnet, except where the garnet is in direct contact with another ferromagnesian mineral such as biotite or cordierite. Where such a contact does occur the garnet-rim is enriched greatly in almandine and slightly in spessartine component. In most cases the contacting biotite or cordierite shows a corresponding local depletion in Fe and enrichment in Mg relative to the matrix biotite, strongly indicating that a localized retrograde ion exchange reaction has taken place near the mutual contact. Type C garnets were first described in central Massachusetts and interpreted in this way by Hess (1971). The absence of retrograde rims away from biotite and cordierite contacts suggests there was no significant amount of fluid present during retrograde conditions to bring about equilibration between garnet exteriors and the matrix minerals. This suggested shortage of fluid may explain why mylonites in Zone VI tend to show a much weaker degree of metamorphic recrystallization than do mylonites in lower grade rocks.

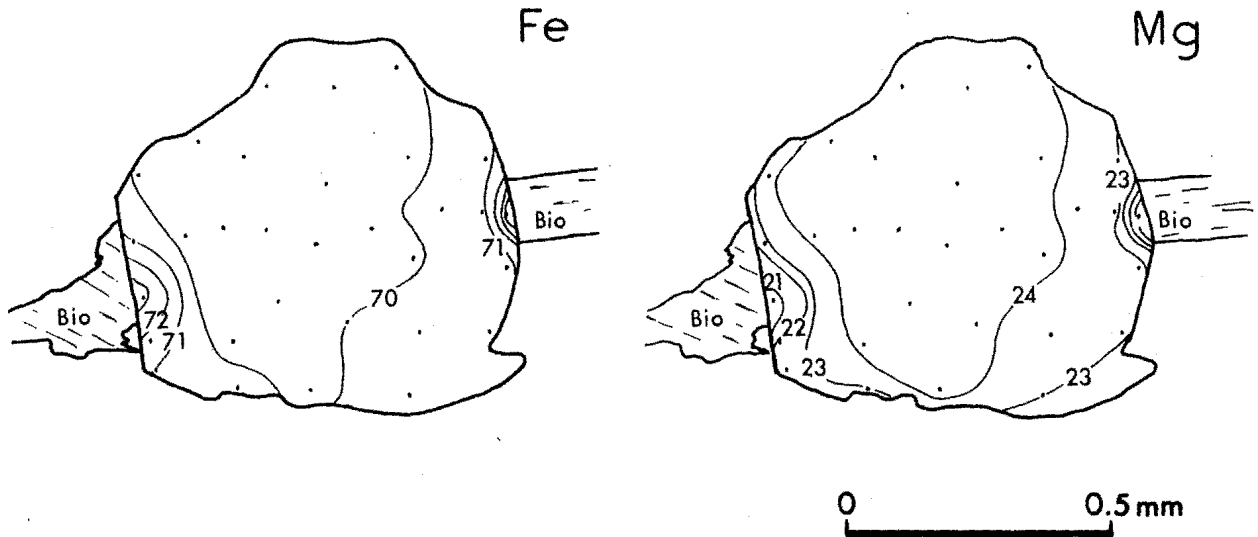

Figure 6C. Contour maps of mole % Fe and Mg in garnet FW 407, Zone VI, a typical type C zoned garnet. Ca and Mn content varies little. The assemblage is quartz-orthoclase-biotite-garnet-cordierite-sillimanite. Dots are analysis points.

ZONED GARNETS IN THE INTERPRETATION OF TEMPERATURE AND PRESSURE OF METAMORPHISM

Estimates of temperature and pressure of metamorphism can be made by comparing compositions of existing minerals in rocks with theoretical or experimental estimates of what those compositions should be under different conditions. Whatever calibration is chosen, a chief problem is to know which minerals were in equilibrium under the metamorphic condition being studied, and whether the apparent equilibrium does in fact represent the peak metamorphic condition of interest. The fictional ideal of two homogeneous minerals quenched direct from peak metamorphic conditions is rarely to be realized and any rock with two homogeneous minerals is always under suspicion of having equilibrated under retrograde conditions. With this in mind, a rock containing a zoned mineral such as garnet coexisting with biotite is somewhat comforting for the simple reason that some of the problems and pitfalls cannot be overlooked.

Under ideal circumstances with Type A garnets perfectly equilibrated between their edges and the surrounding matrix, one could obtain the peak conditions represented by the edge, and would have to forego other estimates unless there were an appropriate suite of included minerals. If some Type A garnets have retrograded rims, then they have some of the problems of Type B garnets to be discussed below and geothermometry is that much more difficult.

The problems of interpreting Type B garnets, with their retrograde rims formed by a retrograde continuous hydration reaction, are illustrated in a simple K-feldspar projection in Figure 7. The initial peak metamorphic assemblage consists of sillimanite, garnet G1 and biotite B1. In the continuous retrograde reaction the outer part of the garnet reacts with matrix biotite to produce a new more-hydrated low temperature assemblage of silliman-

P3-15

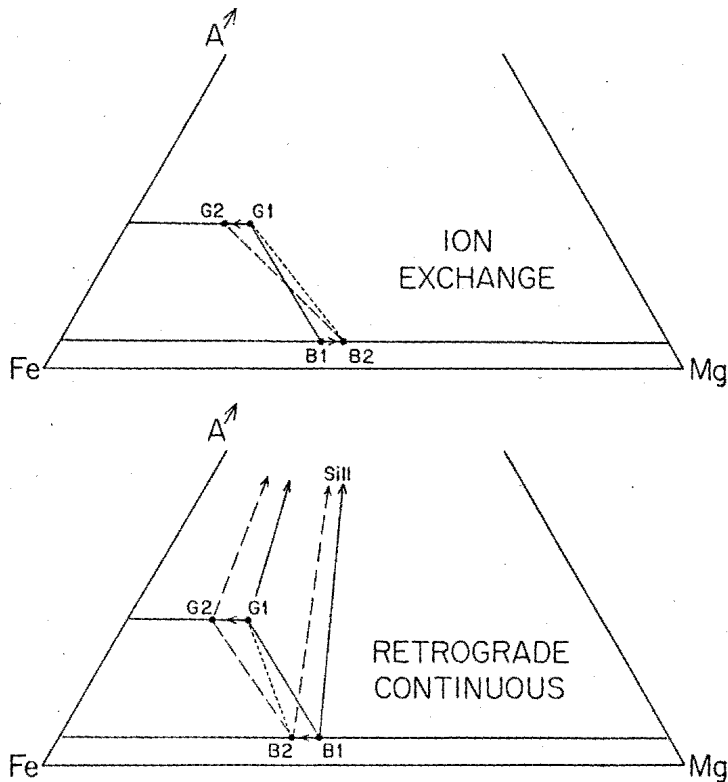

Figure 7. Quartz + K-Feldspar projections of garnet and biotite compositions involved in retrograde reactions. Retrograde ion exchange is typical of Type C garnets of Zone VI. Retrograde continuous reaction, a net hydration reaction is typical of Type B garnets in Zones IV and V.

ite, garnet rim G2 and biotite B2. In estimating temperature using $K_{D}^{GAR-BIO}$ we can estimate the retrograde temperature using G2 and B2, but we cannot estimate the prograde temperature because we do not have any biotite B1 left to compare with the garnet core G1. If we compare garnet core G1 with matrix biotite B2 we get a synthetic temperature which is necessarily much higher than the prograde temperature. The silliness of this is illustrated for one of the two Pelham dome samples where pairing of the relict core of the retrograded garnet with the matrix biotite gives a temperature estimate of 910°C! However, there are other aspects of retrograde continuous garnet zoning that make the outlook somewhat less depressing than implied in Figure 7.

The interpretation of Type C garnets in their purest form is the most straightforward of all. This is because both garnet and biotite are zoned away from their mutual contacts. Comparison of G2 and B2 at mutual contacts permits estimation of the retrograde equilibration, whereas comparison of G1 and B1 away from contacts permits estimation of peak metamorphic conditions. Several samples we have studied in Zone V seem to have some of the features of both Type B and Type C garnets.

Details of garnet zoning paths in terms of Mn, Fe and Mg are shown in Figure 8 for one Type C and two Type B examples. In FW407 (Type C) the interpretation is simple. Fe-rich biotite in the matrix is paired with Mg-rich garnet in the cores to give a peak temperature, whereas Mg-rich biotite and Fe-rich garnet at the mutual contact give a retrograde re-equilibration temperature. In 933B (Type B) there is only one biotite composition, now in equilibrium with the garnet rim. The dashed line indicates a possible peak metamorphic tie line to a fictive prograde biotite that is more

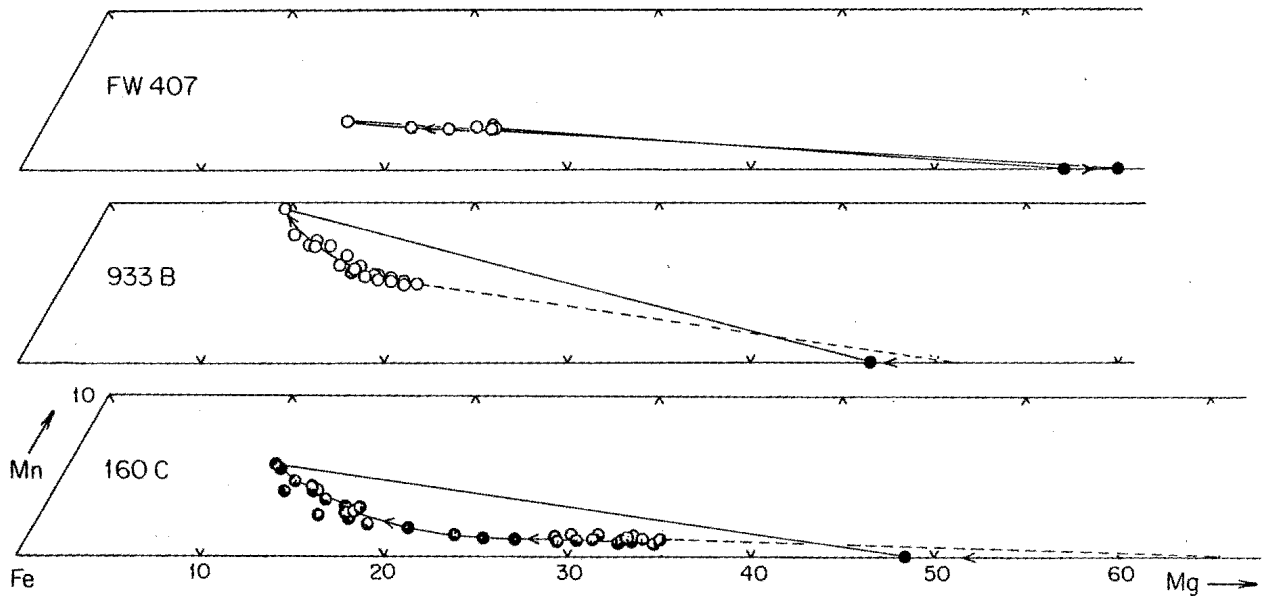

Figure 8. Compositions of zoned garnets and coexisting biotites in three rocks in central Massachusetts. 160 C is from polymetamorphic schist of the Pelham Gneiss dome. Compositions are projected on an MnO, MgO, FeO base from quartz, orthoclase, and sillimanite.

magnesian than the retrograde biotite. In 160C (Type B from the Pelham dome) the one biotite composition (Mg48) coexists with the garnet rim and a fictive tie line extends from the garnet core to a fictive prograde biotite near Mg₆₅ for a reasonable temperature. In the following section a qualitative attempt is made, to model these garnet composition trajectories using a theory of equilibrium and fractional metamorphic recrystallization and to see what effect this modelling has on temperature estimates.

The Fe-Mg-Mn compositions of coexisting garnets and biotites in Zone IV and V rocks can be qualitatively modelled in the system $\text{SiO}_2\text{-Al}_2\text{O}_3\text{-K}_2\text{O-MgO-FeO-MnO-H}_2\text{O}$ by considering SiO_2 , KAlSi_3O_8 and Al_2SiO_5 to be in excess. The garnet and biotite then plot on the FeO-MgO-MnO plane, for which the FeO corner is shown in Figure 8 and Figure 9. Compositions of the coexisting minerals at constant pressure are controlled by temperature and hence essentially by $K_{\text{D,Fe-Mg}}^{\text{GAR-BIO}}$ and by $a_{\text{H}_2\text{O}}$ which influences the progress of the continuous dehydration (or hydration) reaction (6). There are many different equilibrium projections for this plane dependent on temperature and $a_{\text{H}_2\text{O}}$. A set of diagrams representing a particular retrograde hydration sequence from 700°C down to 600°C is given in Figure 9. It should be emphasized that this is but one of a multitude of equilibrium sequences dependent on the rate of temperature decline versus the rate of hydration. Another limiting example (not shown in the format of Figure 9) would be where retrograde hydration takes place at constant temperature.

The sequence of equilibrium diagrams in Figure 9 is used to model garnet compositions in Figure 10. In the upper part of Figure 10 the initial state consists of one garnet composition, the most magnesian shown, and also one biotite composition, also the most magnesian shown. These are assumed to be in equilibrium at 700°C under the conditions shown in the top section of

P3-17

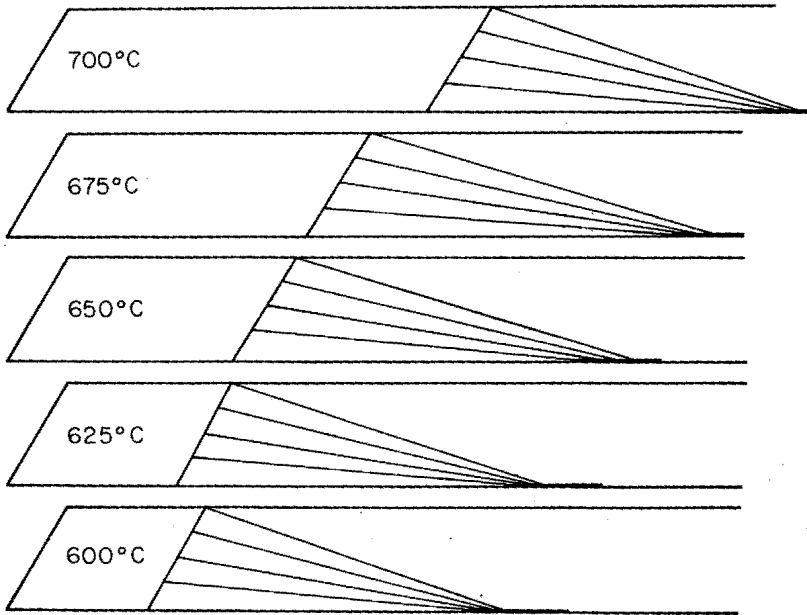

Figure 9. MnO, MgO, FeO projections (see above) showing a sequence of equilibrium relations for a single cooling sequence involving decline of T and increasing activity of H₂O.

Figure 9. Two rock bulk compositions, both with the same minerals and on the same tie line are evaluated, one rich in garnet and poor in biotite, the other with about 60% garnet and 30% biotite. We now move to a new equilibrium at 675°C and more hydrated. Note that the two bulk compositions are no longer on the same tie line. The rock with the higher biotite content has a more magnesian biotite and a slightly more manganesean garnet (open symbols) than in the more garnet-rich assemblage. Note also that during the equilibrium hydration reaction the amount of biotite increases and the amount of garnet decreases in both samples. With further equilibrium hydration the two paths representing two bulk compositions originally on the same tie line diverge even more. Furthermore there is a greater change in garnet composition in the garnet-poor assemblage and a greater change in biotite composition in the biotite-poor assemblage. The lower half of Figure 10

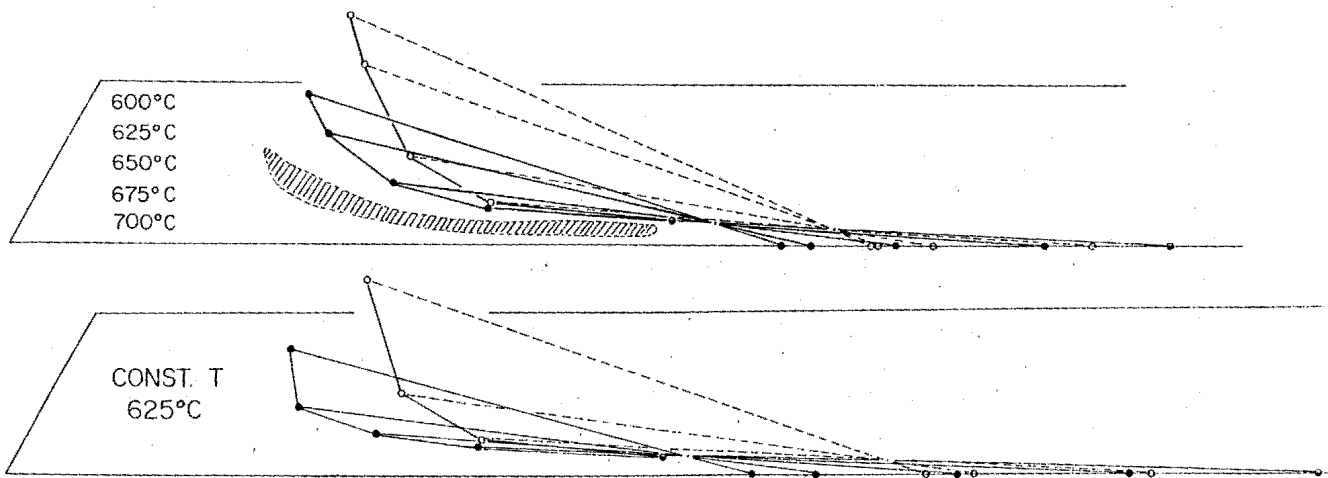

Figure 10. MnO, MgO, FeO projections (see above) showing sequences of equilibrium garnet and biotite compositions for two different cooling-hydration sequences and for two different bulk compositions each. Shaded region is zoning path of polymetamorphic garnet from the Pelham Gneiss dome.

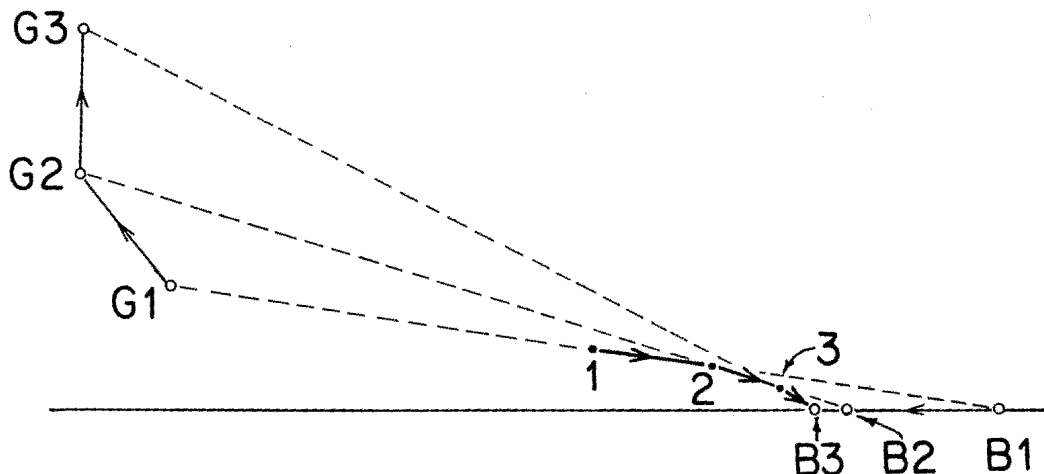

Figure 11. Illustration (in increments) of the theory of retrograde metamorphic fractional recrystallization.

shows similar effects but using a retrograde hydration path at a constant temperature of 625°C. From these diagrams we note that the shape of the equilibrium path is dependent on both the bulk composition and the range of temperature change during hydration. Paths are more curved when garnet is less abundant or temperature falls less.

The real production of retrograde-zoned garnet is not an equilibrium process but a disequilibrium process. As temperature declines diffusion rates decline and this gives less and less of the total volume of garnet a chance to equilibrate with the surrounding matrix. In much the same way that igneous minerals grow coatings which prevent them from equilibrating with the surrounding magma and thus causing fractional igneous crystallization, the exterior of the garnet acts as a coating to prevent equilibration and thus causing fractional metamorphic recrystallization. Fractional metamorphic recrystallization of garnet removes some garnet from the effective bulk composition at each stage, thus moving the composition away from garnet and toward biotite along the tie lines.

Although true fractional metamorphic recrystallization is a continuous process, its nature can be understood in terms of a series of increments as illustrated in Figure 11. Consider a peak metamorphic assemblage consisting of garnet G1 and biotite B1 (plus quartz, K feldspar, and sillimanite) in rock of bulk composition 1. Move then to a retrograde condition where part of the interior of the garnet is incapable of equilibrating with the matrix, thus moving the effective bulk composition to 2. Then reequilibrate composition 2 to give garnet G2 on the outsides of the garnets and homogeneous biotite B2 in the matrix. In the next increment even less of the garnet is capable of reacting, thus moving the effective bulk composition to 3. Effective bulk composition 3 then reequilibrates to give garnet G3 and biotite B3 and so on until the effective bulk composition includes no garnet and reequilibration ceases. In the natural continuous process the effective volume of reequilibration in garnet decreases continuously, the effective bulk composition moves away from garnet continuously, and edge garnet and matrix biotite reequilibrate continuously.

P3-19

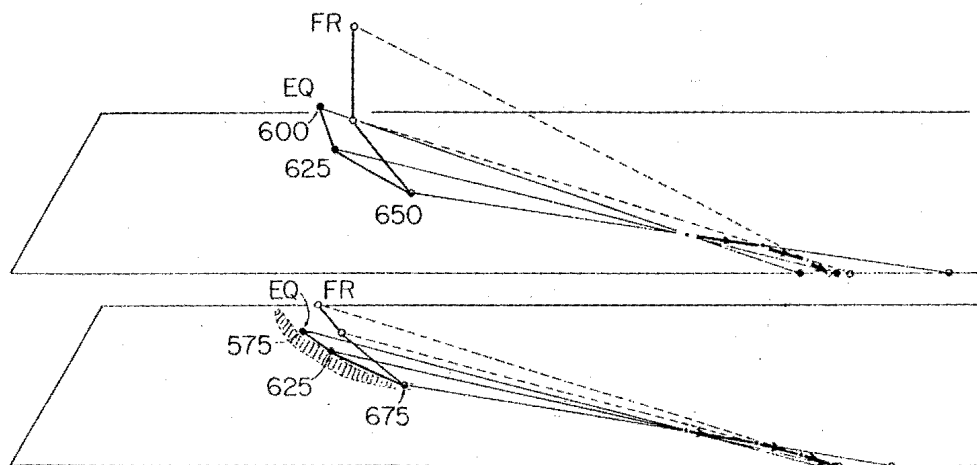

Figure 12. Application of retrograde metamorphic fractional recrystallization theory to two cooling-hydration sequences. In each example fractional recrystallization causes a more curved composition path than equilibrium recrystallization. Shaded region is zoning bath of garnet 933B.

Figure 11 has some important lessons for garnet-biotite geothermometry in rocks that have undergone continuous retrograde hydration reactions. In rocks with a garnet-rich effective bulk composition continuous retrograde hydration will bring about large changes in matrix biotite composition, while garnet rims change relatively less, thus opening the door to false high temperature estimates based on garnet core and matrix biotite. In rocks with a biotite-rich effective bulk composition continuous retrograde hydration will bring about small or even negligible changes in matrix biotite composition, while garnet rims change greatly, thus making possible quite reasonable estimates of peak metamorphic temperatures, provided some of the original garnet core is preserved. Ferry and Spear (1978) seem to have understood this principle well in designing their garnet-biotite equilibrium experiments. To get a minimum of disequilibrium garnet zoning and a maximum equilibration of matrix biotite they chose garnet-rich bulk compositions, just the opposite of the situation most favorable for geothermometry.

Fractional and equilibrium garnet compositional paths are compared in two examples in Figure 12, together with the natural fractional path in sample 933B. In each example the fractional path is more curved than the equilibrium path for the same starting bulk composition, but the change of biotite composition is less. The fact that the natural fractional path is less curved than the model fractional paths seems to reflect the garnet-rich bulk composition in this rock, as does the false peak metamorphic temperature of 740° that was obtained, as compared to $650-675^{\circ}\text{C}$ for more biotite-rich rocks in this zone. The model paths can also be a result of incorrect details in the equilibrium sections of Figure 9. In summary, it appears that more quantitative modelling of retrograde garnet zoning paths using diffusion data may ultimately yield some information on rates of retrograde cooling and hydration.

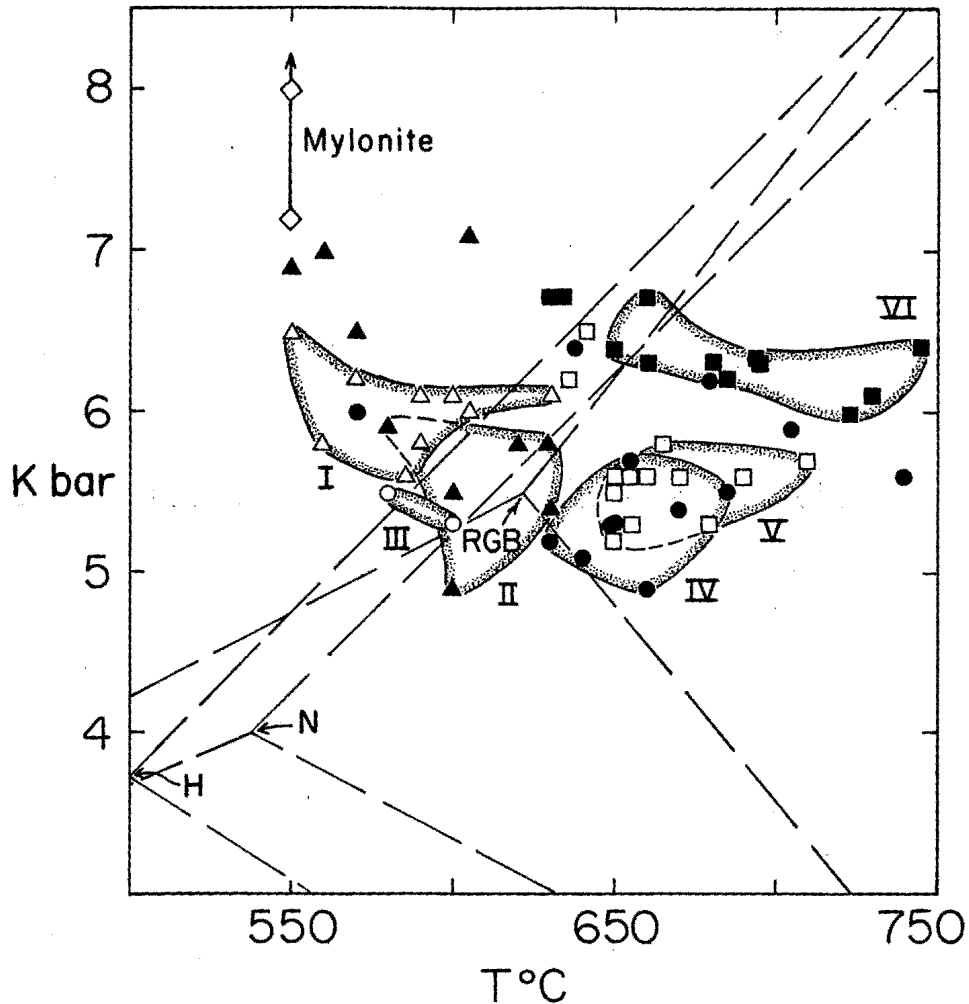

Figure 13. P-T diagram showing some estimated temperatures and pressures for metamorphism based on individual specimens in central Massachusetts. Typical pressure estimates for Zones I-V are minimum pressures only, because assemblages have quartz-sillimanite-garnet only and do not have cordierite. The same is true of the mylonite. Pressure estimates for Zone VI and for one non-pelitic rock in Zone II are based on quartz-sillimanite-garnet-cordierite. Zone I, open triangles; Zone II, closed triangles; Zone III, open circles; Zone IV, closed circles; Zone V, open squares; Zone VI, closed squares. Aluminum silicate triple points are from Richardson, Bell, and Gilbert (1969, RGB), Newton (1966-N) and Holdaway (1971-H)

With the preceding problems in mind we have prepared estimates of peak metamorphic temperatures using the calibration of Thompson (1976) for a number of garnet-biotite and garnet-cordierite rocks in each metamorphic zone. These values have been plotted and crudely contoured in Figure 2B. For those containing the assemblage quartz-sillimanite-garnet-cordierite, an estimate of pressure was also obtained based on the theoretical calibration of Tracy et al. (1976) and for those containing quartz-sillimanite-garnet without cordierite an estimate of minimum pressure. These results are plotted on a P-T diagram in Figure 13 together with several versions of the Al-silicate triple point.

P3-21

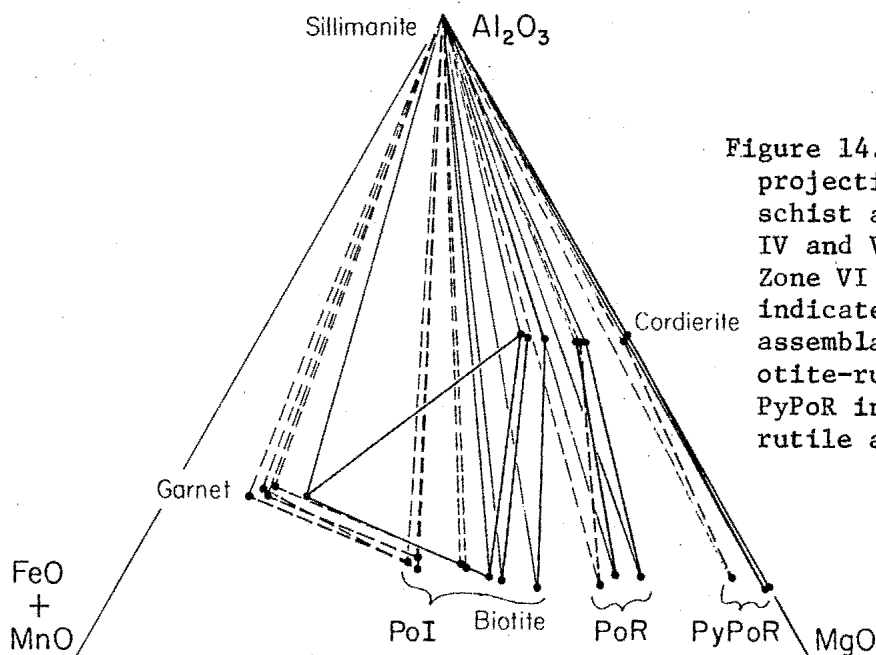

Figure 14. Quartz + K-feldspar projection of sulfidic pelitic schist assemblages from Zones IV and V (dashed tie lines) and Zone VI (solid tie lines). PoI indicates pyrrhotite-ilmenite assemblages, PoR indicates pyrrhotite-rutile assemblages, and PyPoR indicates pyrite-pyrrhotite-rutile assemblages.

EFFECT OF SULFIDES ON THE ASSEMBLAGES OF SILICATES AND OXIDES IN PELITIC SCHISTS

Sulfidic-graphite schists abound in central Massachusetts. These include the well known pyrrhotite schists characteristic of the Middle Ordovician Partridge Formation and also the still more sulfidic White Schist Member of the Paxton Formation. The latter was first defined by Field (1975) and is now known to extend along strike more than half way across the state. Regional studies now suggest it is certainly correlative with the Silurian Smalls Falls Formation of northwestern Maine (see Trip P-4) where Guidotti et al. (1975, 1977, pers. comm. 1982) have done detailed petrologic studies. The first quantitative reports of these rocks in Massachusetts were given by Tracy, Robinson and Field, 1976; Robinson and Tracy, 1977; and Tracy and Rye, 1981, and the following discussion is based mainly on those reports plus other data in a detailed paper in preparation by Tracy and Robinson.

The silicate assemblages in some sulfide-graphite-bearing pelitic schists from Zones IV and V (dashed tie lines) and Zone VI (solid tie lines) are shown in quartz + K feldspar projection in Figure 14. Zone V assemblages include sillimanite-garnet-biotite-orthoclase in the Partridge Formation and one sillimanite-cordierite-biotite-orthoclase assemblage from the White Schist Member. The figure shows only one Zone IV assemblage of sillimanite-cordierite-biotite-orthoclase-muscovite from the White Schist Member. Zone VI assemblages include sillimanite-garnet-cordierite-biotite-orthoclase assemblages from the Partridge Formation, and a variety of sillimanite-cordierite-biotite-orthoclase assemblages with different Fe/Mg ratios from the White Schist Member. It is important to note that in this projection under one condition of pressure, temperature and activity of H_2O or fluid composition there should only be one equilibrium triangle for the sillimanite-cordierite-biotite assemblage, not the whole array shown. The variation

P3-22

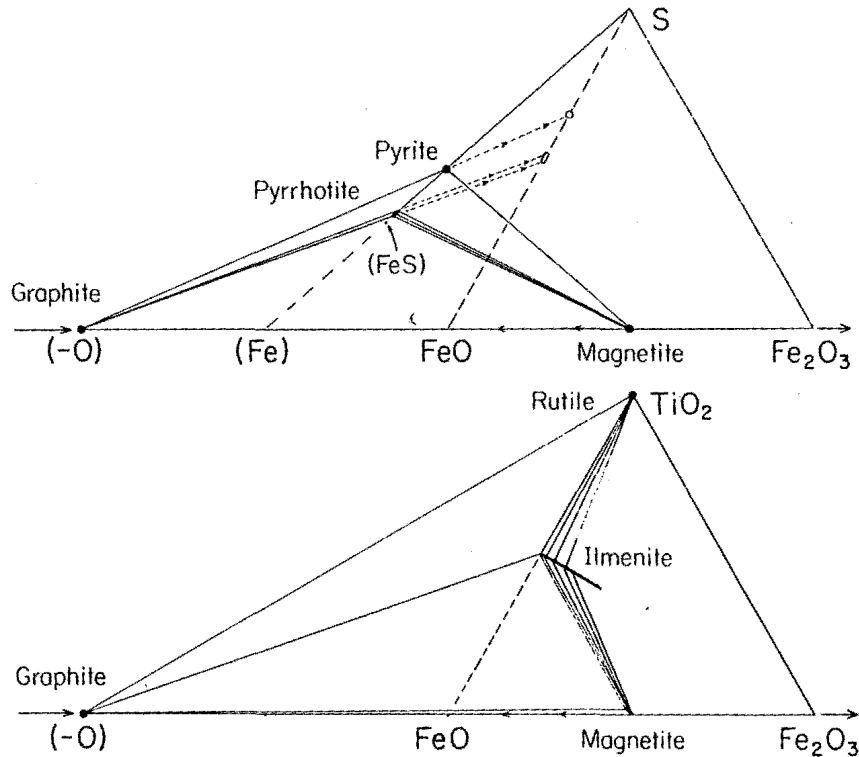

Figure 15. Projections of mineral compositions from C-O-H fluid in the systems FeO-Fe₂O₃-S and FeO-Fe₂O₃-TiO₂ using the method of Thompson (1972).

shown, hence, must be due either to different P-T conditions or different activity of H₂O conditions at different outcrops. A model based on variable aH₂O is considered below.

Letter symbols in Figure 14 indicate the characteristic sulfide and Ti-oxide assemblage to be found in each group of silicate assemblages. The more Fe-rich silicate assemblages contain pyrrhotite and ilmenite. Modestly Mg-rich assemblages contain pyrrhotite and rutile, and the most magnesian assemblages contain pyrite, pyrrhotite, and rutile. It is our purpose to explore this systematic relationship below.

Thompson (1970) has shown how assemblages in the system Fe-O-C-H can be conveniently projected from H₂O and CO₂ onto the line FeO-Fe₂O₃. In this scheme of things, represented by the bases of both triangles in Figure 15, graphite projects at -1 Fe₂O₃ and native Fe at -½Fe₂O₃. To this base has been added S so that we can see the relations between graphite, magnetite, pyrrhotite and pyrite, and TiO₂ so that we can see the relations between graphite, magnetite, ilmenite, and rutile in equilibrium with C-O-H fluid. In the upper part of Figure 16 the two parts of Figure 15 are combined in a tetrahedron showing all significant graphite assemblages. These graphite assemblages may also be shown more easily using a graphite projection onto the triangular plane TiO₂-S-FeO as in the lower part of Figure 16. To this convenient graphite projection we may now add MgO and form a tetrahedron TiO₂-S-FeO-MgO in which we may treat ferromagnesian minerals. The universal ferromagnesian silicate in these assemblages is biotite which would appear on or close to the FeO-MgO line by projection from quartz and K-feldspar. Aluminum saturation of biotite in such assemblages is provided by garnet, sillimanite, cordierite or any combination of the three.

P3-23

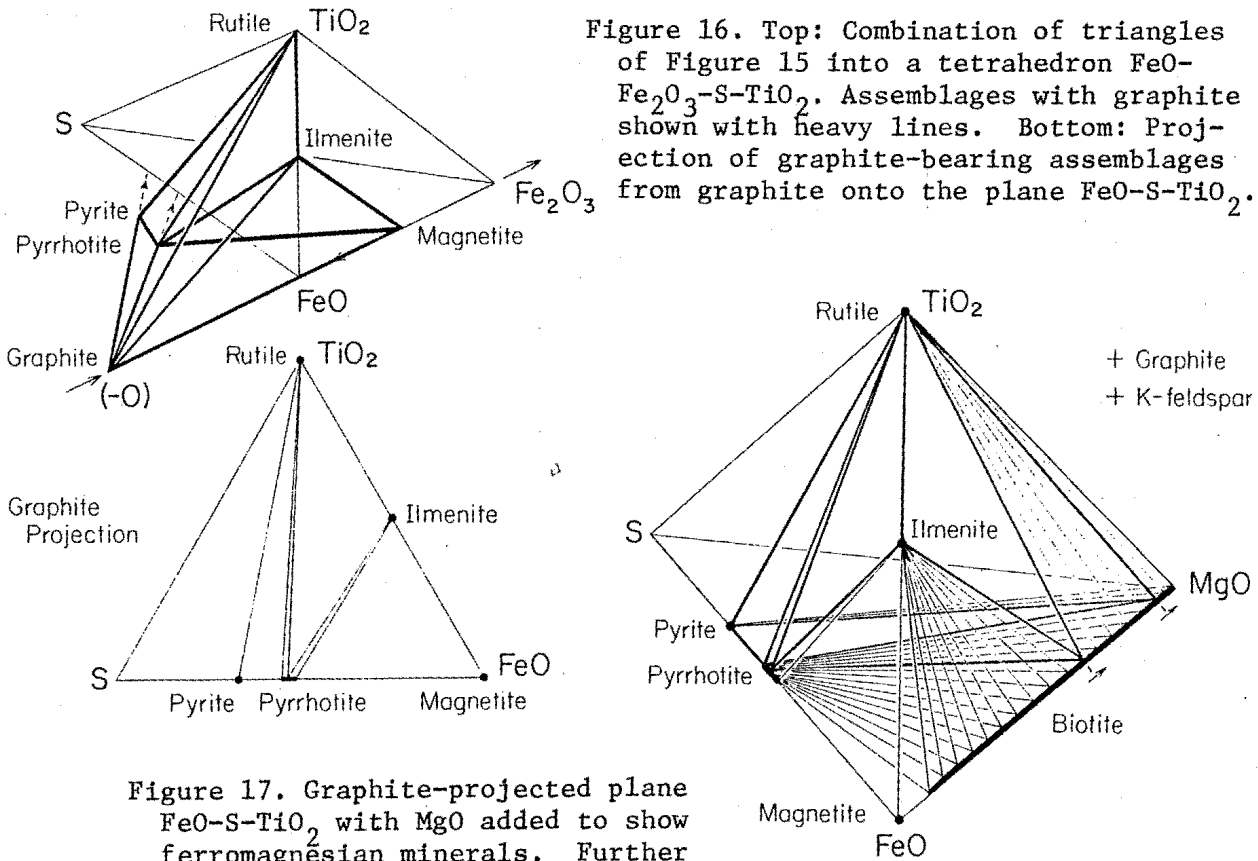

Figure 16. Top: Combination of triangles of Figure 15 into a tetrahedron $FeO-Fe_2O_3-S-TiO_2$. Assemblages with graphite shown with heavy lines. Bottom: Projection of graphite-bearing assemblages from graphite onto the plane $FeO-S-TiO_2$.

Figure 17. Graphite-projected plane $FeO-S-TiO_2$ with MgO added to show ferromagnesian minerals. Further projection from quartz and K-feldspar permits portrayal of biotite.

The volume of Figure 17 is filled by four phase assemblages and three-phase tie planes as follows, beginning in the Fe-rich corner. The most Fe-rich rocks would have (graphite)-magnetite-pyrrhotite-ilmenite-biotite. We have not definitely observed this assemblage in central Massachusetts, but a comparable assemblage (graphite)-magnetite-pyrrhotite-ilmenite-grunerite-olivine (no quartz) has been described in the Littleton Formation in Zone II by Huntington (1975). Next comes a large array of three phase tie planes (graphite)-pyrrhotite-ilmenite-biotite corresponding to the middle region of Figure 14. This is followed by the four-phase volume (graphite)-pyrrhotite-ilmenite-rutile-biotite and then the array of tie planes (graphite)-pyrrhotite-rutile-biotite. For still more magnesian compositions there is the four phase volume (graphite)-pyrrhotite-pyrite-rutile-biotite and finally the array of tie planes (graphite)-pyrite-rutile-biotite. As will be discussed below, the composition of biotite in equilibrium with ilmenite and rutile (front face of tetrahedron) is a function of a dehydration reaction in which the biotite becomes more Mg-rich with increasing grade. Similarly the composition of biotite in equilibrium with pyrrhotite and pyrite (base of tetrahedron) is also a function of a prograde reaction, in this case a mixed volatile reaction.

In order to understand more about the origin of these sulfide-rich rocks we will now take a brief excursion into sedimentary geochemistry using the bottom of Figure 17 as a chemographic work space. Consider an environment slightly below the ocean sediment interface in which organic matter, sulfur-

reducing bacteria, and detrital ferromagnesian minerals are interacting. For simplicity's sake, detrital grains can be considered as two extreme kinds, fine-grained highly reactive grains and coarser detrital grains that resist equilibration with interstitial fluid until low grade metamorphic conditions are reached. To further simplify, assume that all detrital grains have the same $Mg/(Mg + Fe)$ ratio of .50 as illustrated in Fig. 18A. In the early diagenetic stages reactive detrital grains are attacked by fluids or sulfur-reducing bacteria to produce an assemblage of pyrite plus iron-depleted Mg-rich silicate grains having a bulk composition on the line between the detrital composition and S. Between diagenesis and low grade metamorphic re-equilibration the pelite would contain three significant components, pyrite, reacted Mg-rich silicate, and non-reacted Fe-Mg silicate. During low grade metamorphism the reacted and non-reacted silicate components would equilibrate to produce a mean ferromagnesian silicate composition coexisting with pyrite.

Sulfur isotope data (Tracy and Rye, 1981) is consistent with a model in which a diagenetic reaction occurs between sedimentary sulfur, reactive detrital ferromagnesian grains and organic carbon. All of the analyzed sulfides from White Schist Member samples have $\delta^{34}S$ ranging from -25‰ to -29‰. These very light sulfur values could only have originated through bacterial reduction of porewater sulfate in an open-system sedimentary environment. Sedimentary sulfides form from reaction of bacterially-produced H_2S and reactive detrital iron-bearing minerals (Berner, 1971). A modern analogue of this process can be found in the highly reducing deep zones of the Black Sea, where sedimentary sulfides have virtually identical values to those in the White Schist Member.

Figure 18B illustrates the possible variability of low grade pyrite plus ferromagnesian silicate rocks produced by the processes described above. Double-dashed lines illustrate the variable bulk compositions attainable from fixed detrital compositions of Mg25 Mg50 and Mg75 and proportions of reactive grains ranging from 0 to 100%. The heavy-dashed lines illustrate variable bulk compositions attainable with constant proportions of reactive grains of 50% and 10%, but with variable detrital compositions. The combination of variable detrital compositions and variable proportions of reactive grains can produce a very wide range of low-grade bulk compositions in the FeO-MgO-S triangle available for higher-grade reactions.

The continuous Fe-Mg reaction controlling the composition of biotite in equilibrium with ilmenite and rutile in Figure 17 is illustrated, in terms of X_{Mg} versus temperature, and fluid composition versus temperature, in Figure 19 (left). Although ilmenite can have some Mg it is probably greatly exaggerated in this figure and the end member reaction involving geikielite is probably never realized under geologic conditions. The graphite-saturated fluid composition is expressed in terms of the ratio $CO_2/(CO_2 + H_2O)$. It is possible for this to go to negative ratios (not shown), indicating a methane component. Individual isopleths are shown for biotites of different X_{Mg} . Since the reaction is a dehydration the isopleths have maxima at $CO_2/(CO_2 + H_2O) = 0$.

The continuous Fe-Mg reaction controlling the composition of biotite in equilibrium with pyrite and pyrrhotite is illustrated, in terms of X_{Mg} versus temperature, and fluid composition versus temperature, in Figure 19 (right). Although pyrrhotite might have a tiny amount of Mg, the idea of an Mg "pyrrho-

P3-25

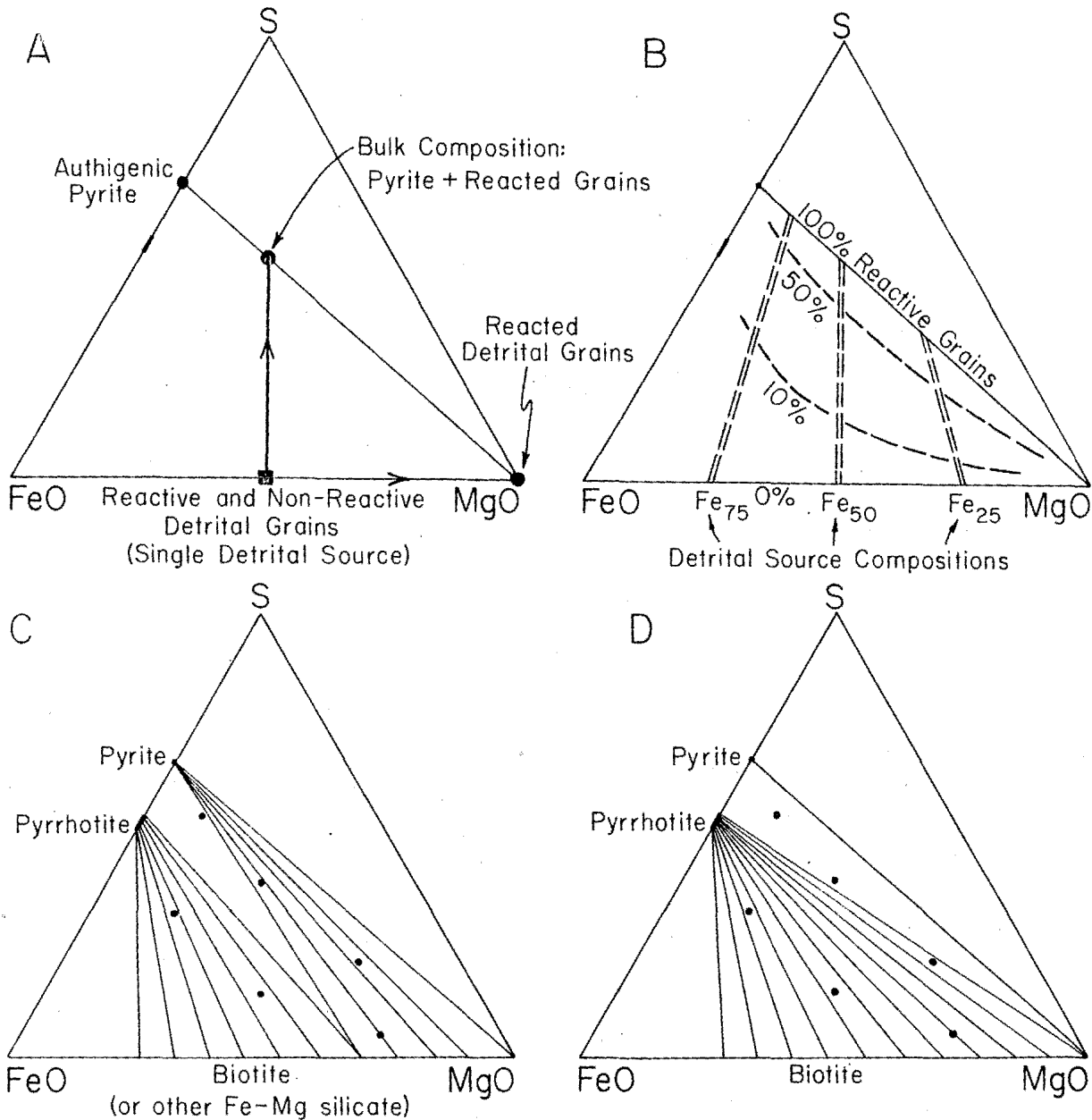

Figure 18. Diagenetic and metamorphic evolution of sulfidic shale portrayed in graphite projection on the plane FeO-S-MgO.

A) Reaction of detrital grains with sulfur (H_2S , etc.) to produce sediment with three components; pyrite, reacted detrital grains, and non-reacted detrital grains.

B) Range of low grade schist bulk compositions dependent on detrital source composition and percent of reactive grains.

C) Progress of continuous devolatilization reaction
 $Fe\text{-richer biotite} + \text{pyrite} + \text{graphite} =$
 $\text{pyrrhotite} + K\text{-feldspar} + Mg\text{-richer biotite} + 2H_2O + 3CO_2$
 across various bulk compositions.

D) Termination of the continuous reaction when all Fe is removed from biotite. Note that pyrite is still retained in some bulk compositions and is even more abundant than pyrrhotite in some.

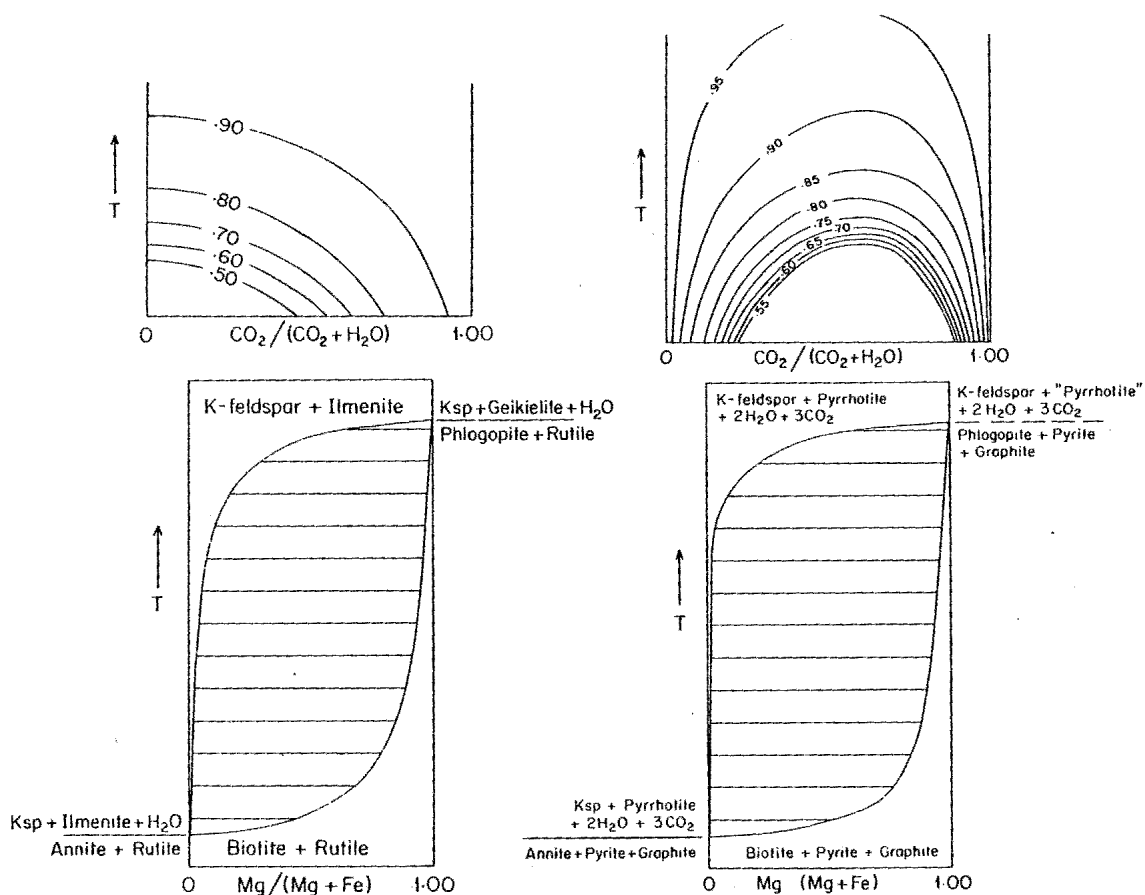

Figure 19. Temperature-composition diagrams and temperature-fluid composition diagrams for biotite in equilibrium with rutile-ilmenite (left) and pyrite-pyrrhotite (right). The fluid is C-O-H fluid in equilibrium with graphite and the ratio $CO_2 / (CO_2 + H_2O)$ can range from -1 to +1, but only the positive region is shown.

tite" end member is ludicrous for metamorphic conditions, but the biotite limb of this "fat man" (A.B. Thompson, pers. comm. 1977) is illustrative of what goes on. This reaction is a mixed volatile reaction consuming both H_2O -bearing biotite and graphite to produce H_2O and CO_2 in a ratio of 2 to 3. On the fluid composition diagram isopleths of constant Mg content of biotite go through maxima at 60% CO_2 . Since primary fluids were probably H_2O -rich, this reaction can enrich the fluid in CO_2 , thus reducing a_{H_2O} and providing for variability in the silicate assemblages.

The progress of the biotite-pyrite-pyrrhotite equilibrium through a range of bulk compositions is illustrated in Figure 18 C and D. This permits one to observe directly the effect of bulk composition and particularly proportion of primary reactive grains on the sulfide-silicate assemblages produced in later metamorphism. In Figure 18C the pyrite-pyrrhotite equilibrium has progressed part way across the diagram, and there are three assemblages: pyrrhotite-biotite, pyrrhotite-pyrite-biotite, and pyrite-biotite. Note in particular that in the pyrrhotite-biotite assemblage in rocks of the same bulk Fe/Mg ratio, those with a large amount of pyrrhotite will have more magnesian silicates. This effect has been well noted in modes by

P3-27

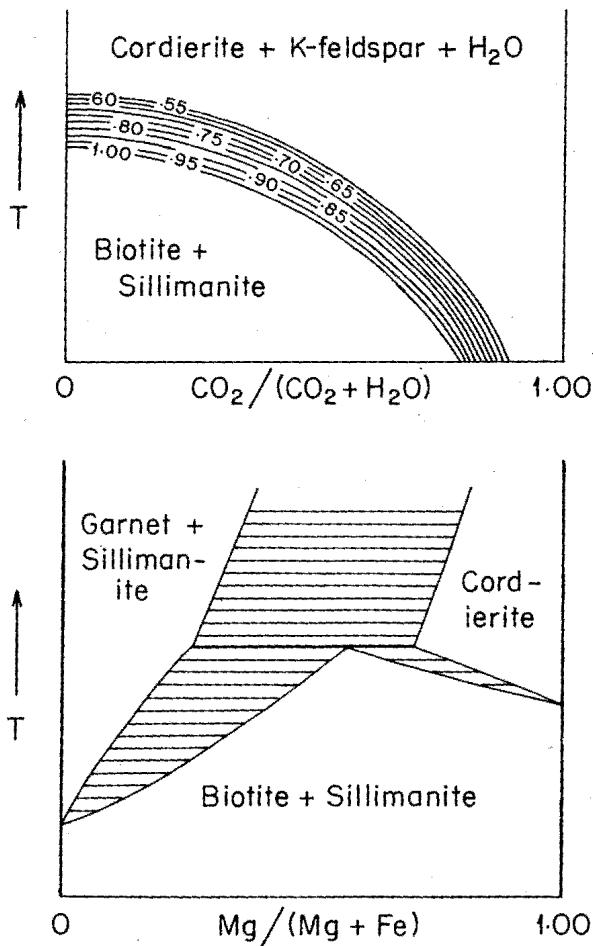

Figure 20. Temperature-composition diagram (bottom) for the cordierite line in the quartz and K-feldspar projected system $\text{SiO}_2\text{-FeO-MgO-Al}_2\text{O}_3\text{-K}_2\text{O}$, showing three T-X loops. On left: biotite + sillimanite = garnet + K-feldspar + H₂O (reaction 6). On right: biotite + sillimanite = cordierite + K-feldspar + H₂O (reaction 7). In middle: cordierite = quartz + garnet + sillimanite + H₂O. At top is temperature-fluid composition diagram for reaction 7 with isopleths for X_{Mg} biotite.

Henry and Guidotti (1981), and Mohr and Newton (1981). In Figure 18D the pyrite-pyrrhotite reaction has gone virtually to completion so that pyrrhotite and pyrite coexist with essentially end member silicates. It will be noted that for some bulk compositions originally very rich in reactive silicate grains there is not enough Fe in the bulk silicate composition to make more than a token amount of pyrrhotite even at very high grade. This appears to have been the case at the outcrop we will visit at Stop 4, where we originally reported that there was no pyrrhotite at all (Tracy et al., 1976).

We now think that the variable compositions in sillimanite-cordierite-biotite-orthoclase assemblages may be a direct consequence of their variable sulfide content and variable progress of the mixed volatile pyrrhotite-producing reaction which dilutes H₂O with CO₂ in the fluid phase. The controlling silicate reaction [see reaction 7) above] is shown in terms of X_{Mg} and temperature and in terms of fluid composition in Figure 20. This is a continuous dehydration reaction and hence attains a maximum temperature in the presence of H₂O-rich fluid. Because of the Fe/Mg distribution between biotite and cordierite this reaction begins at lowest temperature in pure Mg compositions and proceeds thence to more Fe-rich compositions. This is reflected in biotite composition isopleths on the fluid composition diagram.

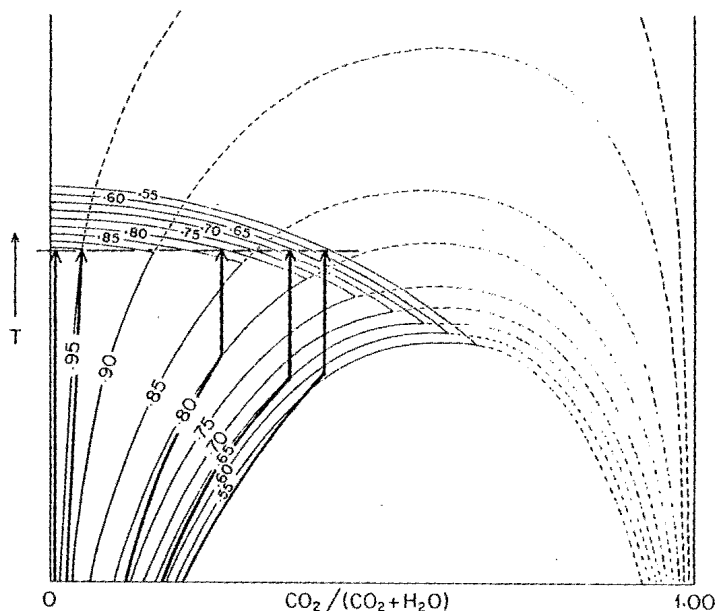

Figure 21. Temperature-fluid composition diagram for silicate reaction 7 and the pyrite-pyrrhotite-biotite reaction. Isopleths show X_{Mg} of biotite in equilibrium with various fluids and either sillimanite-cordierite-K-feldspar-biotite or biotite-pyrite-pyrrhotite. Dark lines show equilibrium fluid paths for five different compositions of sulfidic schists.

Figure 21 is a fluid composition diagram combining the biotite composition isopleths of the pyrrhotite-producing reaction in Figure 17 (right) with the biotite isopleths of the biotite + sillimanite = cordierite + K feldspar reaction of Figure 20. The evolution of five different sulfide-bearing rocks is illustrated, each with a different amount of sulfide and hence a different composition of low grade metamorphic silicate. The rock with the least magnesian metamorphic silicate encounters the pyrrhotite-producing reaction first, causing the fluid to become enriched in CO_2 and for the biotite composition to become more Mg-rich until all pyrite is used up with biotite $X_{Mg}.56$. Two more-magnesian bulk compositions produce pyrrhotite until all pyrite is used up with biotites at $X_{Mg}.65$ and $.80$. Two still more magnesian silicate bulk compositions only begin to produce pyrrhotite at very high metamorphic grade and still have plenty of pyrite left with biotites of $X_{Mg}.95$ and $.99$. It is now easy to see that the total history of sulfide-silicate interactions has produced an array of biotite X_{Mg} ratios and also an array of CO_2 contents in the metamorphic fluids with less magnesian biotites corresponding to more CO_2 -rich fluids. This array then encounters the fluid dependent silicate reaction at a temperature close to the beginning of reaction for pure Mg silicate and H_2O -rich fluid. This is also the temperature for the beginning of reactions for more Fe-rich compositions where the reaction temperature is lowered by CO_2 in the fluid. The end result of this speculation is that it appears possible for every bulk composition to lie within the pseudo-binary silicate loop provided the fluid composition is right.

Although we have previously described the metamorphic fluid as a C-O-H fluid, it actually contains hydrogen sulfide. Fluid composition in FW-882, an assemblage containing pyrite + pyrrhotite + graphite, was calculated by Tracy and Rye (1981); at $650^\circ C$ and 6 kilobars, the $\log f_{O_2}$ was -18.9 and the mole fractions of species in the fluid were: H_2O 0.68, CO_2 0.18, H_2S 0.12, CH_4 0.02, H_2 0.003. The calculation of fluid composition for the assemblage pyrrhotite + graphite under the same conditions shows that the ratio of H_2O and CO_2 is approximately the same, but X_{H_2S} drops to about 0.02. High H_2S in the first fluid is a direct result of the high f_{S_2} which is buffered by pyrite + pyrrhotite.

P3-29

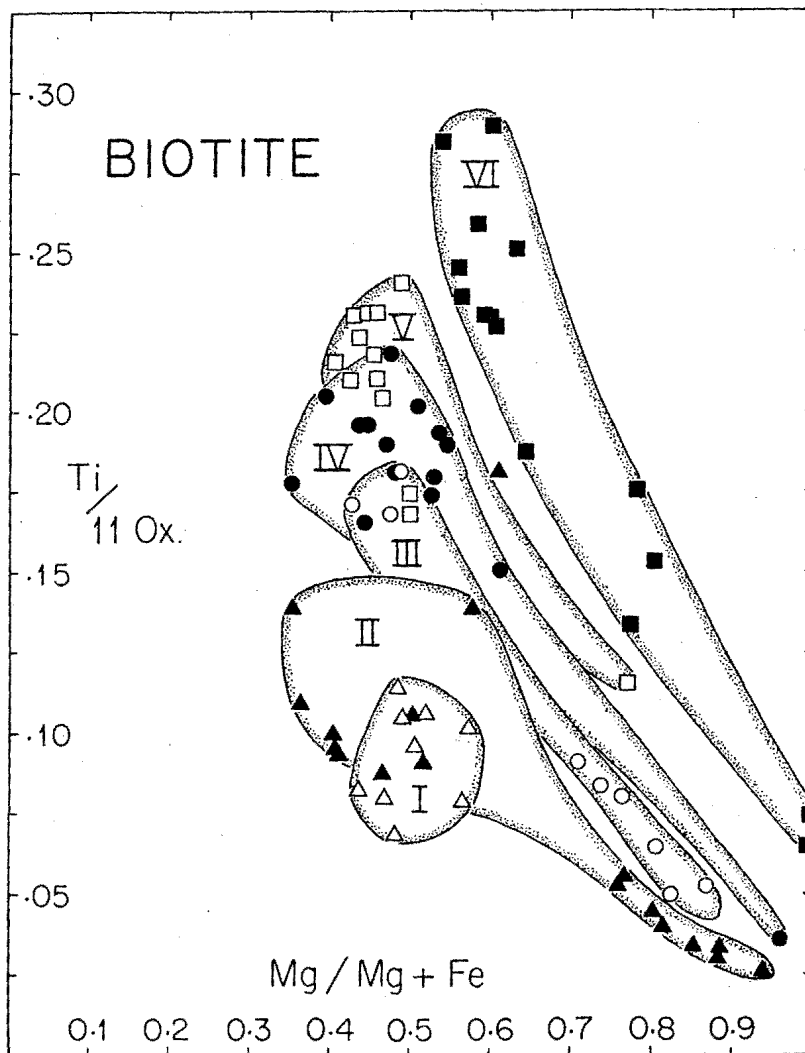

Figure 22. $Mg/(Mg+Fe)$ and $Ti/11 \text{ Ox.}$ for biotites in alumina-saturated and titania-saturated schists in central Massachusetts as shown by presence of Al-silicate, garnet, or staurolite and ilmenite or rutile respectively. Zone I, open triangles; Zone II, closed triangles; Zone III, open circles; Zone IV, closed circles; Zone V, open squares; Zone VI, closed squares. Magnesian compositions from Zones II and III are from the Smalls Falls Formation in Maine (Guidotti et al., 1977).

An indication of much higher X_{H_2S} in the rocks containing pyrrhotite + pyrite occurs in the form of sulfur-bearing cordierite. Probe analyses of cordierites in all the pyrite + pyrrhotite assemblages yield H_2S of about 2 weight %. On the other hand, sulfur has not been found in cordierite from any rock in which only pyrrhotite occurs no matter how much modal pyrrhotite there is. Apparently the cordierite is able to accommodate H_2S in its structural channels, but only when the X_{H_2S} of the fluid is exceptionally high, as in pyrite + pyrrhotite-bearing rocks.

RELATION BETWEEN Ti CONTENT AND Fe-Mg RATIO IN BIOTITES

The sulfide-silicate relations and rocks described above provide biotites of a wide range of Fe-Mg ratios all in equilibrium with quartz, muscovite or K feldspar or both, Al silicate, and a Ti mineral, either ilmenite or rutile. Guidotti et al. (1977) recognized the potential for studying the effect of Fe-Mg ratio on Ti content of Ti-saturated biotites in the Smalls Falls Formation in Maine and showed that biotites of the same metamorphic grade show a dramatic decrease in Ti content with increasing Mg ratio. They reasonably ascribed this to size limitations in the biotite structure. Equivalent biotites in central Massachusetts show an even wider range of compositions and metamorphic grades, as illustrated in Figure 22 [we have added Mg-rich samples from Maine in Zones II and III to fill out the picture]. Although there are local irregularities, the overall trend of increasing Ti content with metamorphic grade and decreasing Ti with Mg content are dramatically borne out. Intermediate biotites from Zone VI contain 2-3 times as much Ti as Zone II biotites from both Massachusetts and Maine, and the same is true of Mg end members from Zone VI as compared with a projected Mg-end member composition from Maine.

RELATIONS BETWEEN METAMORPHISM AND TECTONIC DEVELOPMENT

The central Massachusetts-northern Connecticut Acadian metamorphic high occurred in a region dominated by three major episodes of Acadian deformation: 1) regional nappes with east to west overfolding of tens of kilometers, 2) west to east backfolding of previous axial surfaces on a scale of tens of kilometers, with development of a powerful east-west trending linear fabric and synchronous ductile mylonite zones, and 3) a pattern of tight folds and linear fabrics associated with gravitationally induced rise of gneiss domes in the Bronson Hill anticlinorium. On the west side, the metamorphic high has an overhang of hotter rocks overfolded onto cooler rocks as a result of the early nappes. On the east side the high also overhangs, probably as a result of backfolding.

Before and during the early nappe stage the region was intruded by a variety of sheet-like calc-alkaline plutons ranging in composition from gabbros through voluminous biotite tonalites to granites, generally yielding intrusion ages around 400 m.y. Evidence for early low pressure metamorphism is preserved in the widespread occurrence of sillimanite pseudomorphs after andalusite (Figure 2A) and at least one relict contact metamorphic aureole adjacent to augite-hornblende diorite (Shearer and Robinson, 1980). Peak metamorphic conditions were attained early in the backfold stage over a broad region east of the gneiss domes, resulting in widespread sillimanite-orthoclase-garnet-cordierite assemblages in pelitic schists and rare orthopyroxene-augite-orthoclase-garnet assemblages in felsic volcanics. Detailed geothermometry and geobarometry suggests peak metamorphic temperatures up to 740°C and pressures of about 6.4 kbar, with abundant evidence for local fluid-absent melting. At many locations the peak metamorphic fabric is cut by ductile mylonites containing the east-west linear fabric of the late backfold stage. The planar and linear fabric of the mylonites is deformed by north- and northeast-trending minor folds and axial plane foliation associated with the dome stage of deformation.

P3-31

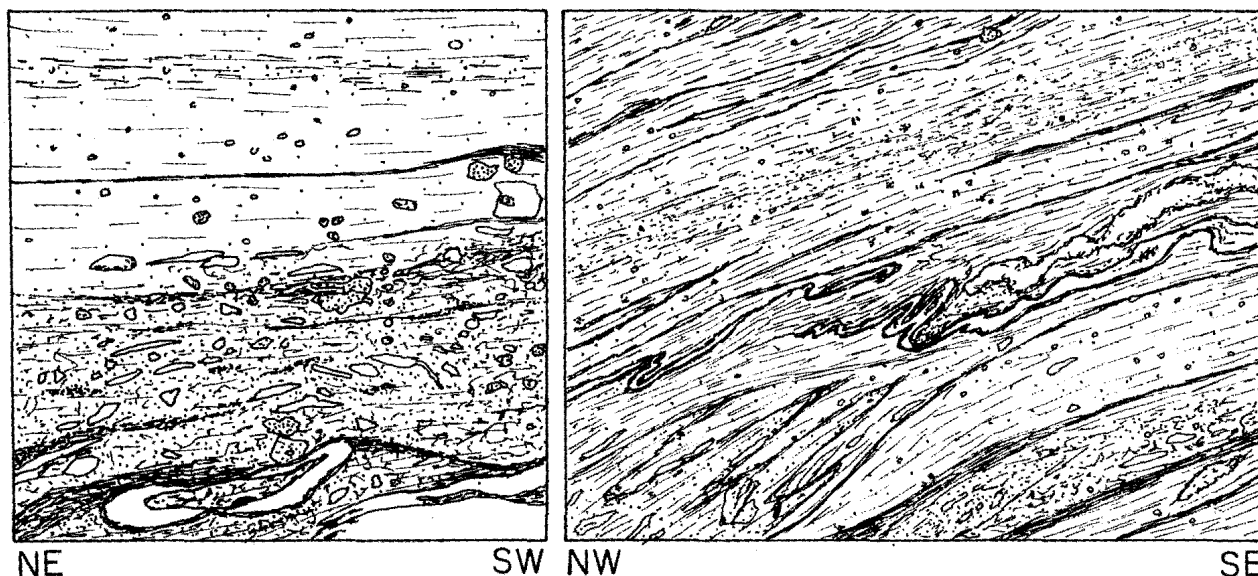

Figure 23. Sketches from two oriented thin sections of a single chip of mylonite from Stop 6. Left-hand section (about 9 mm wide) shows lower contact of mylonite and is perpendicular to quartz rodding in the mylonite. Schist below the mylonite is strongly sheared and contains the doubly-plunging nose of a northeast-trending fold in ribbon quartz. The schist also contains garnet, not present in the host of the analyzed sample. Right-hand section (about 12 mm wide, same scale) is entirely within mylonite and is perpendicular to axes of northeast-trending folds in mylonitic foliation.

The mineral assemblages produced by recrystallization of fine-grained material in mylonites represents an unusual opportunity to study a metamorphic facies produced in a similar bulk composition under different metamorphic conditions. The mylonites recognized in Zones IV and V look fine-grained in outcrop but appear recrystallized to reasonable grain size in thin section. The mineral assemblages in these mylonites have garnet compositions similar to retrograde garnets in the same region. One Zone V mylonite has secondary muscovite of two kinds, a low Ti muscovite replacing K feldspar and a high Ti muscovite associated with matrix biotite that is very like the highest grade prograde muscovites from Zone IV.

The mylonites recognized in Zone VI tend to be much finer-grained and recrystallization is recognized only under high power. It seems probable that this lesser degree of recrystallization is related to less or no interstitial fluid, as suggested by the features of Type C garnets. A continuous 1.5 cm thick mylonite at Stop 6 has been investigated in detail. The mylonite lies within a layer of sillimanite-cordierite-biotite-orthoclase schist in an outcrop with abundant coarse-grained sillimanite-garnet-cordierite-biotite schist and cordierite-bearing pegmatite. The mylonite contains porphyroclasts of feldspar and cordierite set in a very fine but strongly oriented pleochroic matrix dominated by biotite with extremely fine-grained feldspar, quartz, and an Al-silicate that is probably sillimanite. Locally within the matrix are tiny anhedral garnets, some with oriented inclusions suggesting the garnets grew at the same time the mylonitic foliation was being deformed in a series of tight northeast-trending folds. Typical mineral assemblages

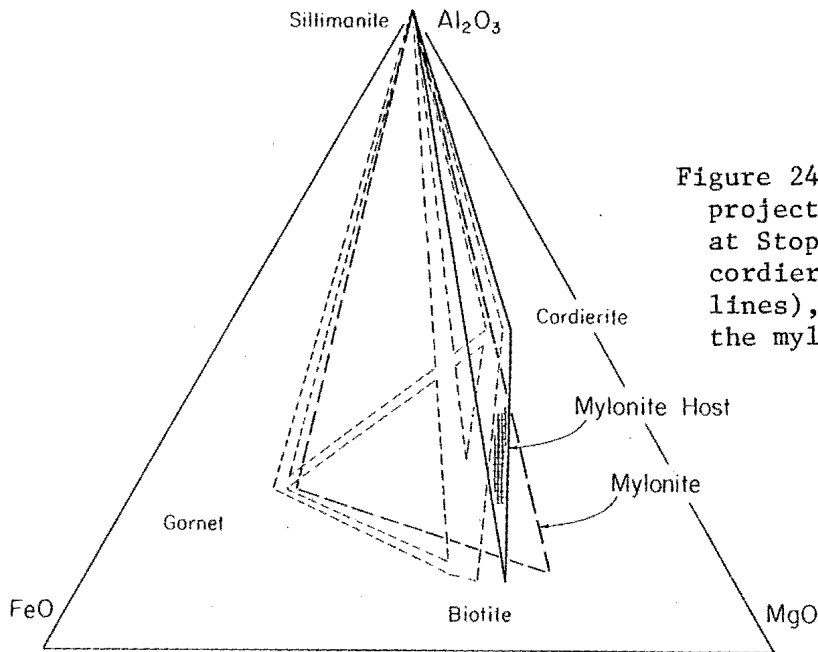

Figure 24. Quartz + K-feldspar projection of mineral compositions at Stop 6., including garnet-cordierite gneisses (light dashed lines), the mylonite host, and the mylonite.

in Zone VI as well as the assemblage of the mylonite host rock are shown in Figure 24, together with the mineral assemblages of the mylonite which seems to have the same bulk composition as its host. The garnet is slightly more pyrope-rich than garnets elsewhere in the outcrop, the biotite is dramatically more Mg-rich (and Ti-poorer) than the biotite of the host rock. The garnet-biotite K_D suggests recrystallization at about 550°C and if interpreted in the usual way, would suggest a recrystallization pressure as high as 7-8 kbar (Figure 25). This is in a region where a number of rocks contain

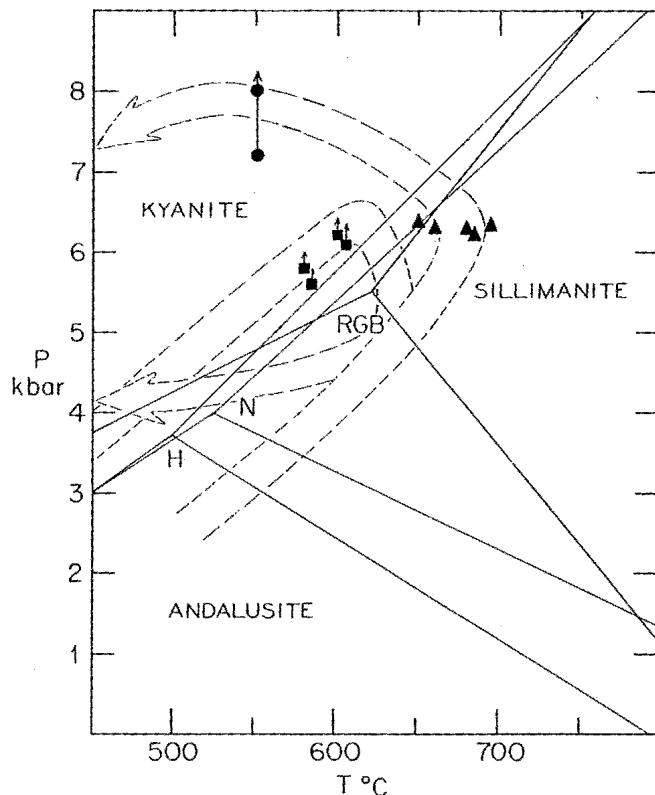

Figure 25. Contrasting P-T trajectories for rocks in the Bronson Hill anticlinorium and Merrimack synclinorium. Synclinorium rocks passed through the andalusite zone en route to peak conditions at 675°C and 6.3 kbar. Assemblage in mylonite suggests it recrystallized at 550°C and 7-8 kbar. Anticlinorium rocks reached about 6 kbar through the kyanite zone, then moved barely into the sillimanite zone where some formed cordierite by unloading. In cooling the kyanite zone was again entered as shown by kyanite-chlorite-quartz replacement of cordierite.

P3-33

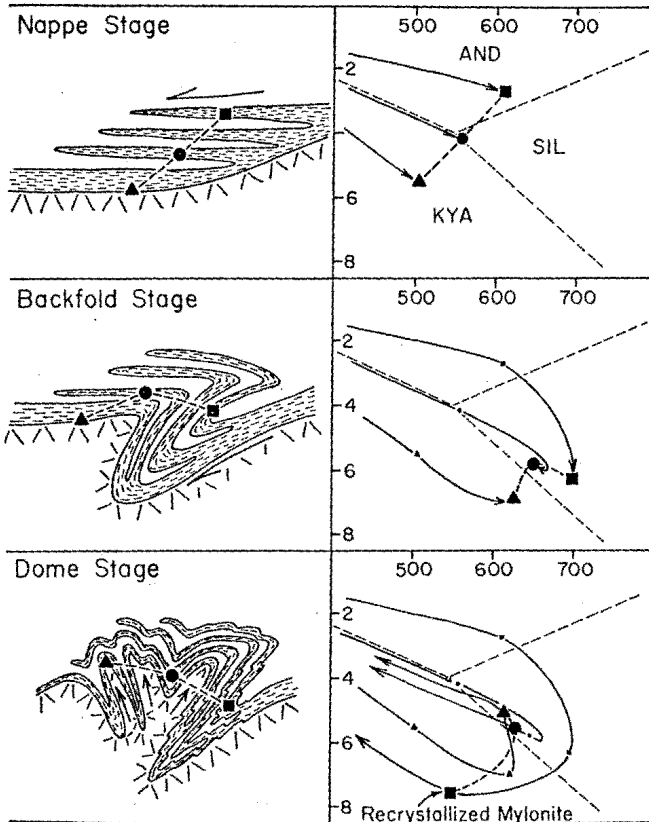

Figure 26. Tectonic cartoons and P-T diagrams to show the relations between regional tectonics and metamorphism. P-T trajectories are shown for three locations in the structure that currently lie on the earth's surface. A metamorphic field gradient connecting points on the present surface is shown in its various prior spatial and P-T orientations.

sillimanite pseudomorphs after andalusite suggesting earlier low pressure crystallization.

Complimentary to this evidence of increasing pressure of metamorphism east of the gneiss domes, development of late cordierite and cordierite + corundum reaction rims on sillimanite in gedrite gneisses in the domes is evidence of tectonic unloading related to doming (Robinson and Jaffe, 1969a; Schumacher, 1980). This "dome path", as illustrated also in Figure 25, is further constrained by the occurrence of retrograde inergrowths of kyanite-chlorite-quartz as an alteration of large cordierites in the same outcrops.

An attempt is made in Figure 26 to relate metamorphism as reflected in metamorphic trajectories of rocks from three different metamorphic zones to tectonic development. In the nappe stage we see rocks to the east and high in the nappe pile undergoing metamorphism in the andalusite zone while rocks close to dome basement at the bottom of the pile form kyanite. In the backfold stage the previous high level rocks are pushed down rather dramatically to much deeper levels as they reach the peak of metamorphism, whereas those close to dome basement move only slightly. In the dome stage, mylonites in the eastern zone seem to have been pushed to even higher pressures, while the rocks near the domes went through release accompanying the rise of the domes. Meanwhile rocks situated in an intermediate position may have followed a path more or less down and then up the same geothermal gradient.

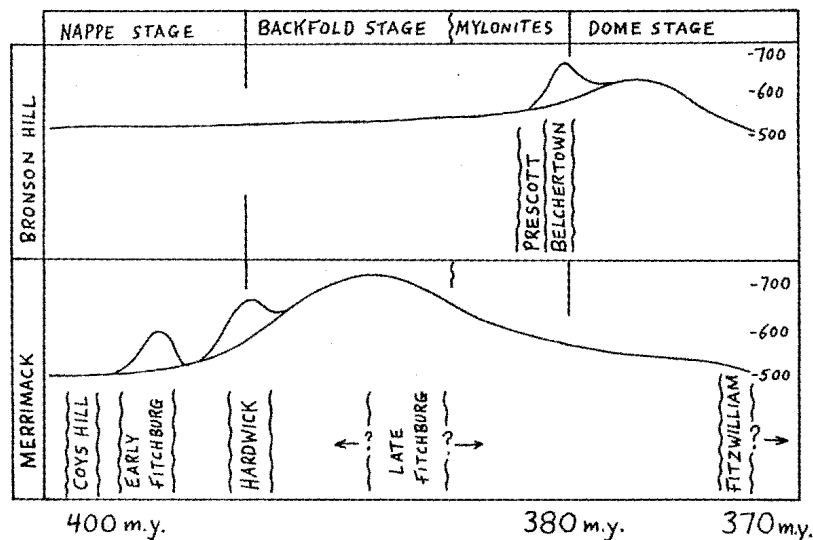

Figure 27. Contrasting relationships of metamorphism and plutonic activity with respect to tectonic stages in the Bronson Hill anticlinorium and Merrimack synclinorium, central Massachusetts.

We have speculated as to how the central Massachusetts rocks got to granulite facies conditions in the first place. One possibility is that the rocks suffered rather massive dehydration and melting at the time they were at relatively high level in the nappe stage. Once large amounts of H_2O -rich fluid had been driven or melted out at high level, the rocks would have been pre-treated for the high pressure dry conditions needed to obtain assemblages characteristic of the granulite facies.

The late Acadian Belchertown pluton truncates isoclinal folds of early stages within the regional kyanite zone. A linear septum of mica schist in the pluton records a progressive inward increase in metamorphic grade from kyanite to sillimanite-staurolite to sillimanite-muscovite zones. The inner end is a schist free of muscovite and of K feldspar (which may have been melted away) with very abundant sillimanite pseudomorphs after andalusite. A primary core of orthopyroxene-augite quartz monzodiorite yields a zircon age of 380 m.y. (Ashwal et al. 1979). The outer part of the pluton has been metamorphically hydrated to hornblende gneiss with development of planar and linear fabric identical to the dome stage fabric of the country rocks. A K-Ar age of 361 m.y. on metamorphic hornblende from this gneiss suggests the end of dome-stage recrystallization. Thus, the Acadian deformation and metamorphism was complex and protracted over a period of at least 40 million years.

Figure 27 shows some of these temporal relations and also contrasts the metamorphism in the eastern part of the area in the Merrimack synclinorium with that in the Bronson Hill anticlinorium. In the east contact metamorphism associated with plutons seems to have been heavily overprinted by the regional peak which was overprinted by mylonites. In the west the Belchertown intrusion seems to have caused a local peak stronger than the slightly later regional recrystallization associated with the dome stage.

P3-35

Figure 28. Quartz and plagioclase projection showing assemblages in metamorphosed mafic and felsic igneous rocks in Zones IV and V.

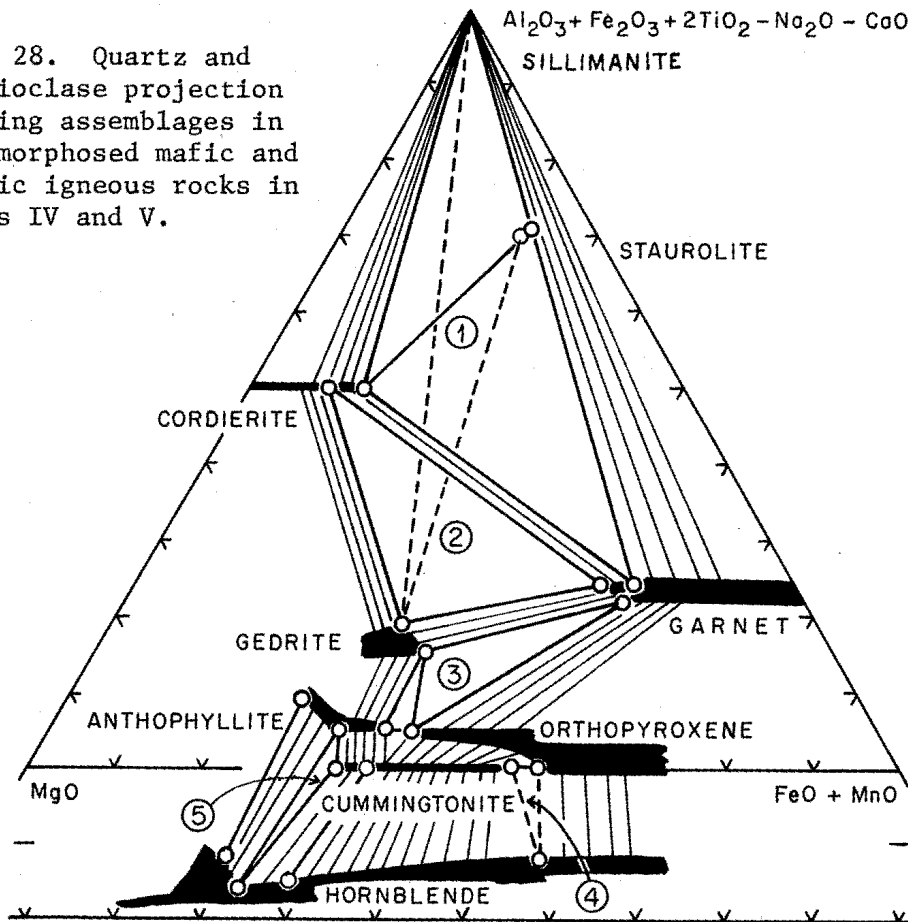

PROGRESSIVE METAMORPHISM OF MAFIC AND FELSIC IGNEOUS ROCKS

Fairly extensive studies of metamorphosed mafic rocks, particularly Ca-poor amphibolites, have been done or are being done in Zones I and II (Robinson and Jaffe 1969a, 1969b; Robinson et al., 1971; Schumacher, 1980a, 1980b, 1981a, 1981b, 1981c) and will not be touched on here. Data from preliminary work on assemblages in Zones IV and V are plotted in a modified plagioclase projection in Figure 28. Analytical data have been published by Robinson, et al. (1969), mineral data have been given by Robinson and Tracy (1979), a more detailed exposition is given by Robinson et al. (1981), and new data have been added by Hollocher. The diagram shows five key assemblages, most of which coexist with quartz and plagioclase.

- 1) Sillimanite-staurolite-cordierite-garnet in non-pelitic aluminous gneiss. (12 miles north northeast of Stop 1).
- 2) Cordierite-garnet-gedrite with retrograde staurolite and kyanite (?) (dashed tie lines) (two miles north of Stop 1).
- 3) Gedrite-garnet-orthopyroxene with minor anthophyllite enclosed in gedrite (0.2 mile north of Stop 2).
- 4) Orthopyroxene-cummingtonite-hornblende (two miles north Stop 1)
- 5) Anthophyllite-primitive cummingtonite-hornblende (Robinson et al., 1969, 6 miles north of Stop 1).

P3-36

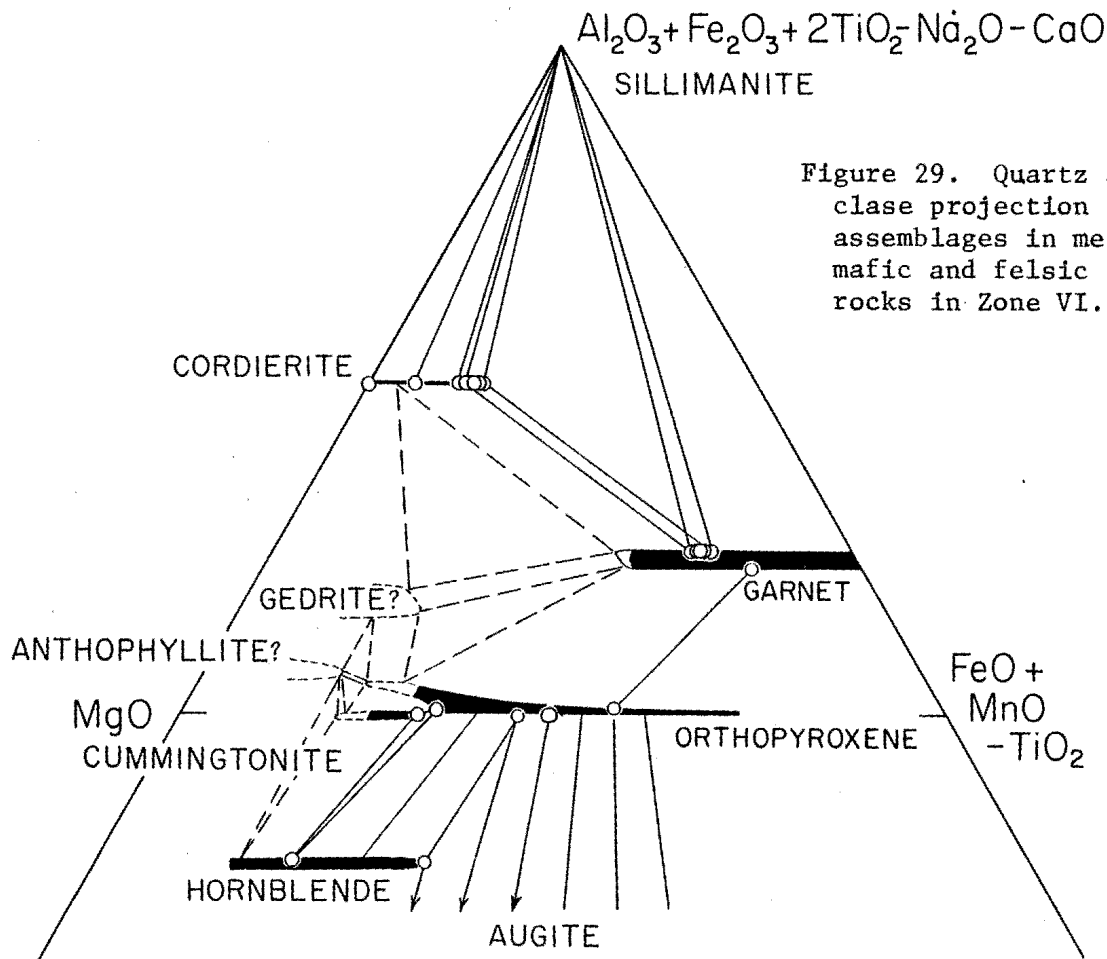

Figure 29. Quartz and plagioclase projection showing assemblages in metamorphosed mafic and felsic igneous rocks in Zone VI.

There are three changes in these rocks as compared to comparable rocks at lower grade: A) garnet-cordierite tie lines prevent gedrite from occurring with sillimanite or staurolite, B) Orthopyroxene replaces cummingtonite by a continuous Fe-Mg reaction and has related the iron-rich end of the field, and C) Cummingtonite in equilibrium with anthophyllite and hornblende has moved to more Mg-rich compositions.

Data from assemblages in Zone VI are plotted in Figure 29. These include pelitic garnet-cordierite assemblages permitted by the sillimanite + biotite = garnet + cordierite + K feldspar reaction. Orthopyroxene has moved to much more magnesian compositions, but cummingtonite still persists (see description of Trip P-4, Stop 7). One garnet-orthopyroxene assemblage found by Hollocher not only has quartz and plagioclase but orthoclase and biotite, indicating reaction toward the most characteristic granulite facies assemblage. In lower alumina compositions hornblende breaks down by a continuous Fe-Mg reaction to orthopyroxene-augite-plagioclase. In the outcrop at Stop 9, the hornblende breakdown reaction has already passed the bulk composition, leaving orthopyroxene (En 52) -augite-plagioclase plus secondary cummingtonite and hornblende.

Experimental data at 4900 bars on the breakdown of Fe-Mg cummingtonite in the presence of H₂O-rich fluid (Fonarev and Korolkov, 1980) suggest cummingtonite with X_{Mg} of .425 would break down to orthopyroxene + quartz at 780°C. Both the more magnesian composition of cummingtonite and the suggested lower temperature of around 700°C in Zone VI point up the fact that the fluid, if any, would have had a greatly reduced H₂O content.

ROAD LOG FOR TRIP P-3

The entire route and part of the approach for trip P-3 is shown in Figure 30. Roughly one hour should be allowed for the drive north from Storrs, Connecticut to the rendezvous at Stop 1 at 9:00 A.M. The approach is northwest from Storrs on Route 195 to Route 32 and then north via Route 32 through Stafford Springs Connecticut and Monson, Massachusetts. When Route 32 merges at a sharp left (west) turn with U.S. Route 20 West take the next sharp right turn onto Breckenridge Road. This shortcut (dash-dot line) takes one directly north over an overpass of the Mass. Turnpike and directly back to Route 32 in Palmer Center, thus avoiding downtown Palmer and traffic lights entirely. Continue north on Route 32 to Ware Town Line and 0.4 mi. beyond to railroad underpass.

- 0.0 Begin road log at railroad underpass, Route 32 (see B on Fig. 30).
- 0.1 Bridge over Ware River.
- 1.2 Crossroads, turn sharp left (north) on Anderson Road
- 1.5 Road cut in Monson Gneiss on right.
- 2.2 Stop sign at T junction with Route 9. Turn left (west) on Route 9.
- 2.8 Large Road cut on right (north) side. This is Stop 1. However continue west to safe place for turnaround.
- 3.1 Small tarred driveway entrance to garage permits easy turnaround on straight stretch. Return west on Route 9.
- 3.4 Road cut on left (north) side of highway. Pull off as far to right as possible and cross highway with care.

Stop 1 (30 minutes approximately) (Winsor Dam Quadrangle) Middle Ordovician Partridge Formation exposed in the center of the Greenwich syncline on the crest of Brimstone Hill. This exposure shows a selection of lithic types typical of the Partridge Formation in the Quabbin Reservoir area, particularly in the lower part of the section close to contacts with Ammonoosuc Volcanics or Monson Gneiss. The exposure (Figure 31) consists of about 50% sulfidic schist and 50% metamorphosed volcanics including both felsic gneisses and amphibolites. These are strongly folded about north-south trending subhorizontal fold axes of the dome stage. Most of the rocks, including a variety of recrystallized mylonites, contain a strong subhorizontal mineral lination parallel to folds of the dome stage.

Proceed to east end of cut (beyond edge of drawing) where best mica schist is exposed. The assemblage here, typical of Zone V, is quartz-orthoclase-garnet-biotite-sillimanite-graphite-ilmenite-pyrrhotite (sample 507B of Tracy, 1978). The rock has a mylonitic aspect and most of the orthoclase is concentrated in watery clear megacrysts with crushed borders set in a

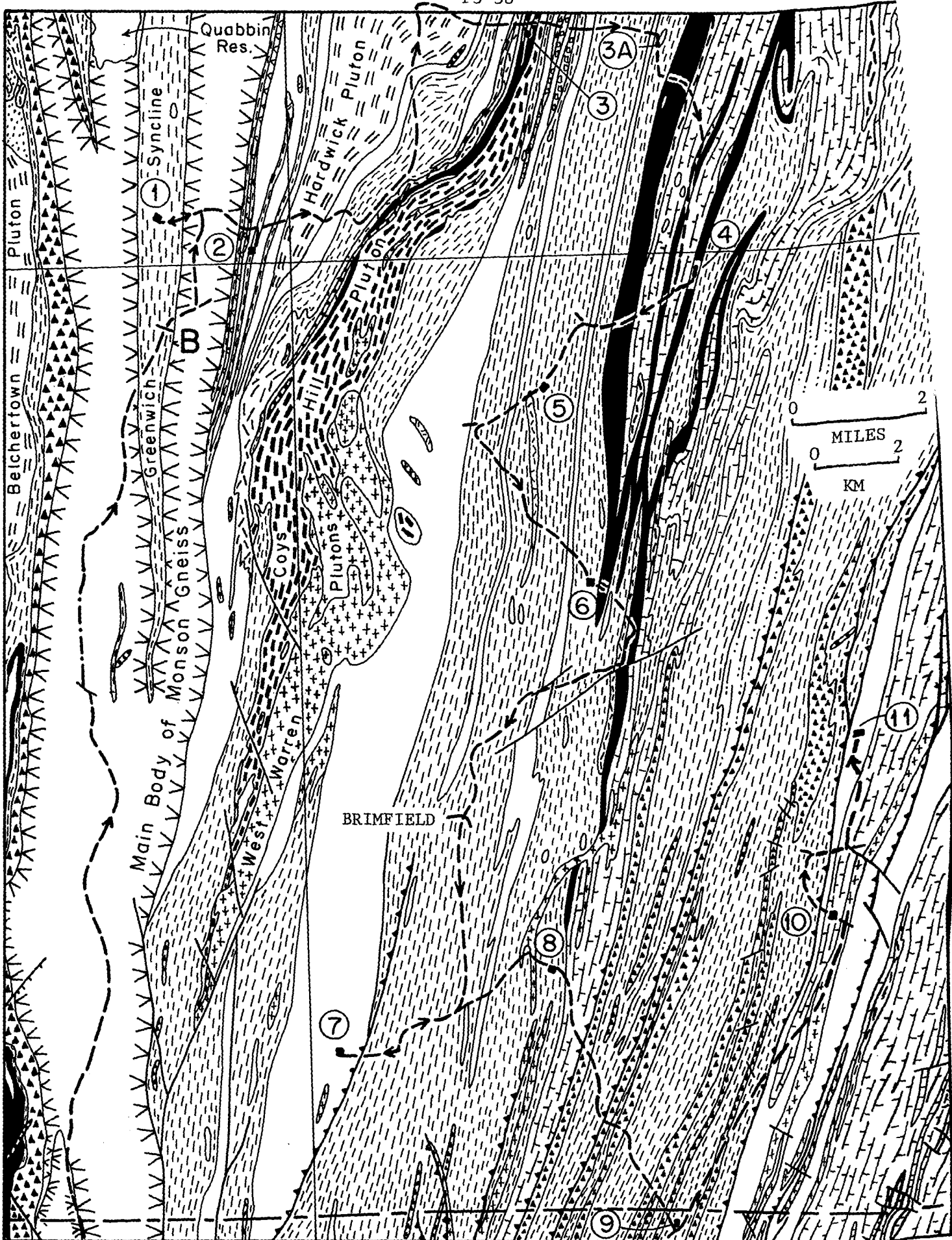

Figure 30. (opposite) Bedrock geologic map of south-central Massachusetts showing route of Trip P-3 and location of stops. For explanation see Figure 1.

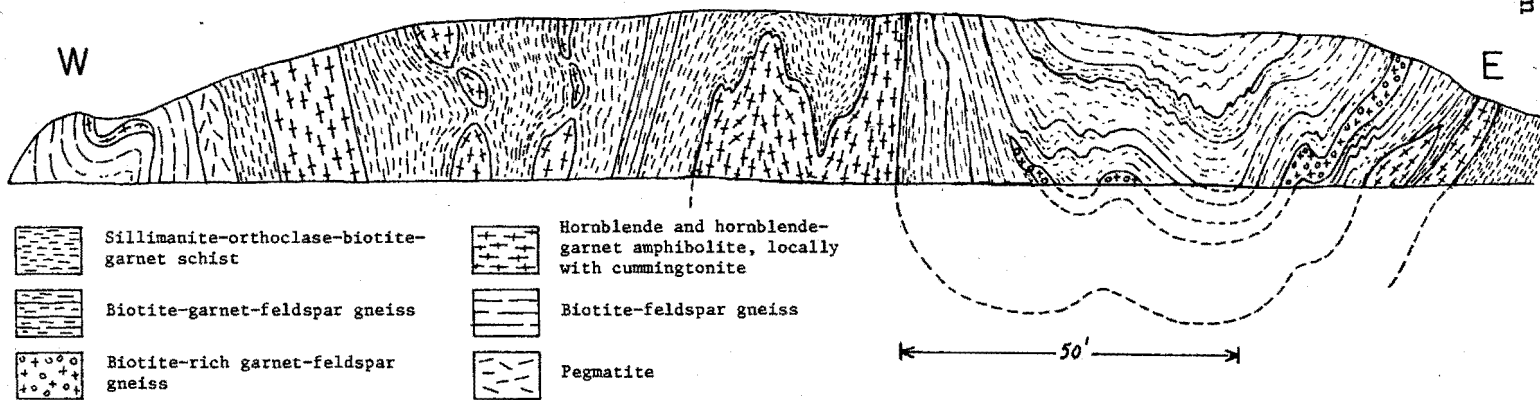
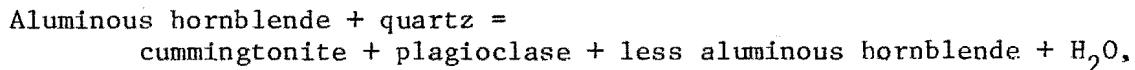

Figure 31. Free-hand sketch of road cut in Partridge Formation at Stop 1. Low outcrops of sillimanite schist extend about 50 feet farther east. Prominent fold axes are subhorizontal, trend north-south, and are of the dome stage.

finer lineated matrix crammed with fine prismatic sillimanites. The garnet shows only a modest amount of retrograde zoning with compositions of core and rim() as follows: Almandine 76.5 (78.1), Pyrope 16.2 (14.5), Spessartine 3.7 (3.8) Grossular 3.6 (3.7) Biotite has X_{Mg} of .460 and Ti/11 Oxygens of .211. The orthoclase has a composition Or^{85.7}, Ab 13.5, An 0, Cn 0.8 and the plagioclase is An 27.9 Ab 70.5, Or 1.6. The orthoclase lattice parameters indicate an intermediate orthoclase structural state. The ilmenite is about 96% FeTiO₃, 3% Fe₂O₃ and 1% MnTiO₃. The rock is extremely rich in biotite and poor in garnet and yields an estimated prograde Gar-Bio temperature of 660°C and a retrograde temperature of 620°C.

The biotite-garnet-feldspar gneiss in the eastern half of the drawing is interpreted as a metamorphosed peraluminous volcanic rock. The potassic feldspar in this rock has the composition Or 91.9, Ab 6.7, An 0, Cn 1.4 and has the structural state of microcline as compared to orthoclase in the adjacent schist. In the outcrops studied in the region it is usual for the K-feldspars in felsic gneisses to have a lower structural state than those produced in pelitic schists at the peak of metamorphism.

The amphibolite in the central part of the outcrop is dominated by brownish-green hornblende but contains modest amounts of brown cummingtonite which are particularly abundant and coarse in cross-cutting felsic patches interpreted as incipient melt segregations. The Mg-rich cummingtonite can be considered as a product of the following prograde dehydration reaction:



or as a product of a similar reaction producing plagioclase-rich melt. At this grade orthopyroxene + quartz is already stable in more Fe-rich bulk compositions (see Figure 28) and at higher grade would proxy for cummingtonite in the above equations, making them into more significant dehydrations.

The amphibolite near the eastern end of the outcrop contains patches with the assemblage hornblende-garnet-cummingtonite but these are collected with difficulty. The felsic gneiss at the east end of the cut appears to be a metamorphosed rhyolite.

Proceed east on Route 9.

4.3 Ware Center

4.6 Small road cut on left in hornblende amphibolite of Monson Gneiss. Contains coarse segregation pegmatites of quartz, blue gray plagioclase and cummingtonite.

4.8 Outcrops at and beyond crest of hill. This is Stop 1 of Trip P-4 at the east contact of Monson Gneiss.

5.1 Turn right (south) in sharp turn onto Gould Road (not Gould Street).

5.6 Turn right (west) through gate into parking lot of Ware High School.

P3-41

Stop 2. (40 minutes approximately including time for maps, discussion, etc.) (Winsor Dam Quadrangle) Middle Ordovician Partridge Formation exposed in man-made exposures in the "Ware High School Belt." This schist, somewhat higher grade than at Stop 1, is interesting in that it contains two different sillimanite lineations, an earlier E-W trending lineation of the back-fold stage, and a later, more prominent, southwest-plunging lineation of the dome stage.

The assemblage here is quartz-orthoclase-garnet-biotite-sillimanite-graphite-ilmenite-pyrrhotite (sample D23, unpublished data). Here the orthoclase is finer-grained and in the matrix along with beautifully formed small sillimanite prisms and rare garnets. The garnet is zoned with three significant different compositions at the core, at the rim adjacent to quartz and feldspar [] and at the rim adjacent to biotite () as follows: Almandine 74.7 [75.2](78.2), Pyrope 18.6[16.8](13.1), Spessartine 4.0[4.3](5.3) and Grossular 3.3 [3.7](3.5). The matrix biotite has X_{Mg} of .489 and Ti/11 Oxygens of .240, but close to garnet contacts X_{Mg} goes up to .536 with Ti down to .197. Thus the garnet at this locality seems to have some of the aspects of both Type B and Type C garnets with slight zoning around all edges, but with much stronger zoning adjacent to biotite. The temperature estimate based on garnet core and matrix biotite is 665° C, while garnet rim vs biotite rim yield 520°C. The ilmenite in this rock is about 96% FeTiO₃, 2% Fe₂O₃, 1% MgTiO₃ and 1%MnTiO₃. The orthoclase is Or 87.6 Ab 11.6 An0 Cn 1.1 and the plagioclase is An 29.7, Ab 71.6, Or 0.6.

- 5.7 Leave parking lot. Turn left(north) on Gould Road.
- 6.3 Return to stop sign at Route 9. Turn right (east) on Route 9.
- 7.1 Junction with Route 32 in Ware. Continue straight (east) on Routes 9 and 32.
- 8.7 Turn left off of Route 9 and proceed north on Route 32. West Brookfield Town Line.
- 10.5 New Braintree Town Line. High hills to left are held up by tonalites of the Hardwick pluton, the largest pluton in central Massachusetts.
- 11.7 Turn right (east) onto New Braintree Road just before Route 32 crosses Ware River.
- 13.7 Park right on New Braintree Road at junction where Tucker Road comes in from south. Note large rounded outcrop in pasture to southwest. Walk south on Tucker Road to opening in fence thence southeast and west to top of knob, thence north to best part of outcrop.

Stop 3 (30 minutes approximately) (Ware Quadrangle) Littleton Formation in the Big Garnet syncline. This rock unit has been traced more or less continuously from the Ware Quadrangle at least as far north as Route 2. Its structural setting is discussed under Stop 5 of Trip P-4 and illustrated in Figure 10 of trip P-4. The rock type has been dubbed "pastureite" by Alan Thompson in honor of this beautiful glacially-smoothed outcrop. No hammers please!

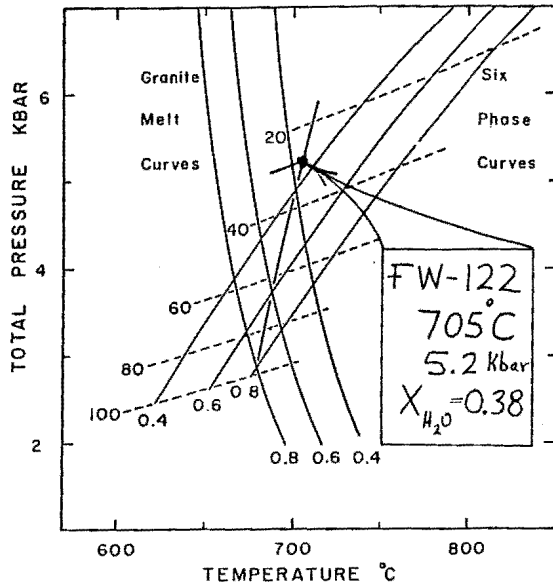

Figure 32. P-T diagram from Holdaway and Lee (1977) showing intersections of six phase curves (quartz-orthoclase-sillimanite-garnet-biotite-cordierite) and granite melt curves to produce a fluid-absent melt curve. Dashed lines are X_{Fe} of cordierite. Suggested conditions of fluid-absent melting at Stop 3 are indicated. X_{H_2O} in the fluid phase would be 0.38 only in the special case at the intersection of the three sets of curves.

Aside from a few layers of calc-silicate granulite, the rock in this outcrop can be described in two parts— a medium-grained schist (or gneiss) consisting of quartz, orthoclase, plagioclase, garnet, cordierite, biotite and ilmenite and a network of slightly deformed cross-cutting felsic veins consisting of quartz, orthoclase, plagioclase, and cordierite with striking 2 to 4 cm euhedral to subhedral garnets. All the garnet is remarkably uniform in composition except where in direct contact with biotite or cordierite, and has the following compositions for core and rim (): Almandine 69.6 (70.9), Pyrope 24.2 (22.8), Spessartine 2.8 (7.9), Grossular 3.4 (3.4). The biotite has X_{Mg} of .566 (compare with Stops 1 and 2) and Ti/11 oxygens of .236. The cordierite has X_{Mg} of .710. Using the calibrations of Thompson (1976) GAR-BIO and GAR-CRD both yield estimated temperatures of 685°C. Using the pressure calibration for coexisting quartz-sillimanite-garnet-cordierite of Tracy et al., 1976, this assemblage yields an estimated pressure of 6.2 kbar. In addition, a sample from this outcrop contains coarse sillimanite that appears to be pseudomorphous after andalusite.

An obvious explanation suggested by several visitors for the cross-cutting feldspathic rims as well as for the two sizes of garnets is that the veins were formed by segregation of melt and that the large garnets grew in contact with melt. M. J. Holdaway has suggested that aqueous fluid may have been largely carried away during earlier stages of melting, perhaps at the breakdown of muscovite, and that the present texture is due to fluid absent melting permitted by breakdown of biotite in the six phase assemblage quartz-sillimanite-K feldspar-garnet-cordierite-biotite. Figure 32 shows Holdaway's calculated model where "six phase curves" for different fictive X_{H_2O} values in fluid intersect granite melt curves for different X_{H_2O} to produce a fluid-absent melt curve. Dashed lines are isopleths of X_{Fe} of cordierite in the six phase assemblage. Taking the cordierite at X_{Fe} of .29 from this outcrop and assuming the outcrop lay on the fluid-absent melt curve, the rock yields an estimated temperature of 705°C and a pressure of 5.2 kbar. The diagram also shows that if the rock were exactly at an intersection of all three curves so that fluid could be present, it could have an X_{H_2O} no greater than 0.38.

Continue east on New Braintree Road.

- 15.7 T junction. Turn right(south). Note rounded masses of ultramafic rock in pasture.
- 15.8 Small road cut in bushes at left

Stop 3A. (Optional, 10 minutes) (Ware Quadrangle) The New Braintree biotite-olivine hornblendite in contact with sulfidic schist of the Partridge Formation in the Wickaboag Pond anticline. This body, some 60 m (200 ft) thick and 400 m (1300 ft) long is the only ultramafic body known in this part of Massachusetts. It bears some resemblance to the series of olivine-hornblendites described by Wolff (1978) from the Partridge Formation near the Bronson Hill anticlinorium but lacks the green spinel and chlorite characteristic of those rocks. The thin section described by Field contains 78% hornblende, 12% biotite, 7% olivine (Fo 70 approx.), 1% orthopyroxene (En 75 approx.) and 2% pyrite. Contact relations and mode of emplacement of this body are poorly understood, partly because most of the other outcrops in the vicinity are pegmatite.

A so-called "Wehrlite" supposedly from this locality is described by Emerson (1917) and is listed in Washington's (1917) Professional Paper 99. However, Field (1975) has shown that the analysis, the norm, and Emerson's detailed outcrop description all fit a large outcrop of orthopyroxene gneiss in the Littleton Formation to be visited on Trip P-4, Stop 7.

Continue south,

- 16.3 Bear left at junction.
- 16.6 North Brookfield Town Line on sharp right bend.
- 16.9 Bear right at intersection.
- 17.1 Bear right at intersection.
- 17.4 West Brookfield Town Line, Barrett Road.
- 18.2 Low outcrops on left, high outcrops on right. This is Stop 11A of Trip P-4.
- 19.2 Junction just beyond transformer, Wigwam Road with North Brookfield Road, Route 67. Make acute left turn and proceed northeast on Route 67.
- 19.6 Hereford Cow sign on left. Park on highway or in barnyard depending on number of vehicles. Proceed north on foot through gate and along long northeast-trending outcrop.

Stop 4. (40 minutes approximately) (Warren Quadrangle) White Schist Member of the Paxton Formation. For discussion of stratigraphy see trip P-4 Stop 11. The outcrop has an irregular smoothed surface covered by a thick crust of iron oxides and sulfates. The outcrop surface is covered by 3-5 cm pits inside of which fresh pyrite is usually visible. In spite of extensive search

we have found only traces of pyrrhotite in this outcrop, but are still inclined to believe much of its character is due to weathering of pyrrhotite. Partly weathered rock just beneath this crust looks white because of the abundance of colorless silicates. Much fresher rock has a bluish look.

The outcrop consists of two main rock types, sillimanite- and biotite-bearing quartzites, and aluminous schists with variable proportions of sillimanite, biotite, and cordierite. The biotites vary from very pale reddish brown iron-bearing ones to colorless Mg-end members. Our first impression was that these were muscovites in a very retrograded fault zone, but their nearly uniaxial interference figures showed they are biotites. The assemblage in two analyzed samples is quartz-orthoclase-plagioclase-biotite-cordierite-sillimanite-graphite-rutile-pyrite-(pyrrhotite?). The X_{Mg} of biotite in the samples is .995 and .999 (0.04 weight % FeO) and they contain .065 and .074 Ti/11 oxygens (see Figure 22). The cordierites which are charged with graphite appear as black to bluish lumps. They are essentially pure Mg end members with 0.00 weight % FeO and only a trace (.08%) of MnO. Even where charged with detrital zircons these cordierites lack pleochroic haloes, presumably because of lack of iron to be oxidized by alpha bombardment. This cordierite also contains approximately 2 weight % H₂S, due to unusually high sulfur fugacity in the pyrite + pyrrhotite assemblage. The K-feldspar has a composition Or 91.5 Ab 8.4 An 0.1 and plagioclase is An 32.7 Ab 57.6 Or 0.8. The rutile is closer to pure TiO₂ than from most localities because there is no FeO. Because of the extreme narrowness (to put it mildly) of the sillimanite-biotite-cordierite "field" this rock essentially lies on the univariant reaction MgBiotite + Sillimanite = Mg cordierite + K feldspar, and can only be considered divariant because of the Na content of the K feldspar. The name White Schist came partly from the appearance of the broken outcrop and partly by analogy with the Mg-rich kyanite-talc rocks studied by Schreyer (1974) in Tanzania and Afghanistan.

Leave farm and return southwest on Route 67.

20.5 Center of West Brookfield (lunch supplies). Merge with Route 9 and continue west on Route 9 and 67.

21.5 Turn left (southwest) on Route 67 and off of Route 9.

22.8 Large rotten roadcut on left. Park as far to right as possible and cross highway carefully.

Stop 5. (15 minutes approximately) (Warren Quadrangle) Partridge Formation in the Pleasant Brook anticline. A typical fine- to medium-grained Zone VI schist with the assemblage quartz-orthoclase-plagioclase-biotite-garnet-cordierite-sillimanite-graphite-ilmenite-pyrrhotite (sample FW-407). Although coated with a thin oxide crust, excellent fresh material can be collected here. The zoned Type C garnet in Figure 6C was collected at this locality. The most magnesian garnet cores and most retrograded rims adjacent to biotite () have the following compositions: Almandine 69.7 (77.7), Pyrope 24.7 (16.0), Spessartine 2.2 (3.0), and Grossular 3.4 (3.3). Note the delicate purplish tint of these pyrope-rich garnets. Matrix biotite has X_{Mg} of .572 and Ti/11 oxygens of .245 and biotite at garnet contacts goes to X_{Mg} .600. The cordierite has X_{Mg} of .714. Compositions of garnet core

and matrix biotite, and of garnet core and cordierite both yield temperature estimates of 680°C and the assemblage quartz-sillimanite-garnet-cordierite gives an estimated pressure of 6.3 kbar. Retrograde garnet and biotite rims indicate a retrograde temperature of 530°C.

Proceed southwest on Route 67 into Warren.

23.7 Sharp left (south) next to Warren Retirement Manor and before railroad overpass.

23.8 T junction. Turn left (east) onto Southridge Street and proceed southeast.

26.3 Sign to "Breezlands." Follow it on Southbridge Road.

26.8 Road cut begins on right near crest of hill.

26.9 Stop right on down-grade where rotten outcrops appear on both sides of road.

Stop 6. (30 minutes approximately plus 20 minutes for lunch) (Warren Quadrangle) Partridge Formation in the Wickaboag Pond anticline. This is locality WN-1 where J.S. Pomeroy discovered the mylonite that we have studied in detail and which is extensively discussed in the text. This is also the northernmost garnet-cordierite locality studied by Paul Hess (1971). The mylonite is less than 1 cm thick and is exposed on a very rotten part of the outcrop that could be damaged by hammering. In that vicinity it is possible to see the internal E-W lineation in the mylonite caused by elongate quartz rods and to see a parallel sillimanite lineation in the country rocks. The later NE-trending sillimanite lineation may also be seen. The folding of the mylonite foliation cannot be seen in the outcrop, but appears in thin section as a west-over-east overfold (Figure 23).

Several samples of coarse-grained gneiss from this outcrop with garnet-biotite, sillimanite-garnet-biotite-cordierite and sillimanite-biotite-cordierite assemblages have been partially analyzed. Garnets range up to 25.7% pyrope content. Biotite coexisting with sillimanite, garnet and cordierite has X_{Mg} of .604 and Ti/11 oxygens of .290. A nearby sample of the same assemblage without garnet contains biotite with X_{Mg} of .591 and Ti/11 oxygens of .230. This evidence of slightly crossing tie lines suggests some slight retrograde re-equilibration.

It is the dream of all petrologists to obtain numbers from outcrops. This outcrop yielded an instantaneous and direct determination on a field trip in spring 1981, thanks to the sharp eyes of graduate student Chris Fulton. The number is 8 and is formed by two coalescing hollow globular clusters of graphite plates inside an orthoclase crystal in a cordierite pegmatite. This sample will be shown and advice and assistance sought.

Continue south (downhill) on Southbridge Road.

27.0 Small outcrop of White Schist Member of Paxton Formation on left.

27.9 Large outcrop of White Schist Member in bushy bank on right.

- 28.0 Triangle junction. Bear right onto Brookfield Road.
- 28.1 Second triangle junction at Cheney Orchards sign. Bear right again.
- 28.3 Brimfield Town Line.
- 29.1 Underpass beneath Mass. Turnpike.
- 31.5 Sherman Pond on left (east) of Brookfield Road.
- 32.5 Center of Brimfield (Wales Quadrangle) Bear right for 100 yards then cross Route 20 at traffic light and proceed south on Route 19 toward Wales.
- 34.6. Wales Town Line.
- 36.6 Wales Elementary School on right.
- 36.8 Wales Country Store on left. Turn right (west) off Route 19 on to Monson Road.
- 37.6 Monson Road bears left(south). Continue straight on McBride Road.
- 37.8 Outcrop on right, huge boulder on left. This is Stop 7, however, proceed up road to next intersection for turnaround.
- 38.1 Pull over as far to right as possible just west of outcrop.

Stop 7, (20 minutes approximately) (Wales quadrangle) Well bedded coarse gray schist of the Littleton Formation near Mt. Pisgah. This is an opportunity to collect very fresh material fairly similar to the rock in the pasture at Stop 3 though probably richer in sillimanite and cordierite. Figure 33 is a map showing a small but very homogeneous garnet from this locality. A typical composition is Almandine 67.2 Pyrope 29.0, Spessartine 1.1, and Grossular 2.7. The biotite has X_{Mg} of .629 and Ti/11 oxygens of .252. We have not yet analyzed the cordierite. The garnet and biotite yield an estimated temperature of 665°C and the garnet composition in the quartz sillimanite-garnet-cordierite assemblage gives an estimated pressure of 6.7 kbar.

Proceed east on McBride road.

- 38.3 Return to Monson Road and proceed east.
- 39.1 Turn left(north) on Route 19 at Wales Country store.
- 40.3 Bear right (little warning) onto Holland Road.
- 40.9 Holland Town Line. Road deteriorates and is called North Wales Road.
- 41.8 Stop sign. Turn right (southeast) on Brimfield-Holland Road.
- 42.3 Road cut in bushy slope on right. Pull well to right before the outcrop.

P3-47

MT. PISGAH

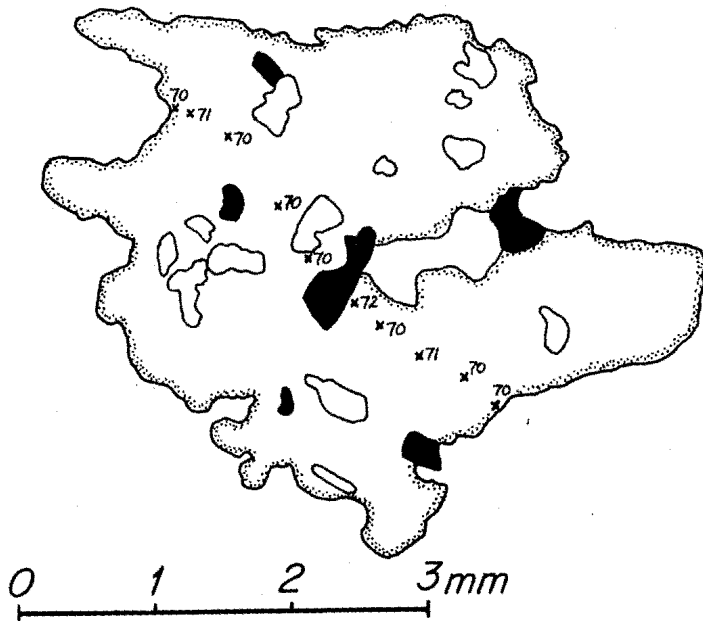

Figure 33. Map showing 100 Fe/(Mg+Fe) for a garnet in sillimanite-orthoclase-garnet-cordierite schist of Littleton Formation at Stop 7.

Stop 8. (15 minutes approximately) (Wales Quadrangle) Sulfidic schist of the Partridge Formation in the Wickaboag Pond anticline. The outcrop is predominantly coarse-grained gneiss with the assemblage quartz-orthoclase-plagioclase-biotite-garnet-cordierite-sillimanite-graphite-ilmenite-pyrrhotite with variable amounts of sillimanite. There are several interesting mylonites in the outcrop, but they are not so fine-grained as the one at Stop 6 and are full of porphyroclasts rather than porphyroblasts of new minerals.

Probe analyses of garnet yielded compositions of core and of rim adjacent to biotite () as follows: Almandine 65.2 (73.7), Pyrope 29.5 (21.2), Spessartine 1.4 (1.6), Grossular 3.9 (3.4). Matrix biotite has X_{Mg} of .584 and Ti/Il oxygens of .275, whereas biotite against garnet has X_{Mg} as high as .604. Garnet core and matrix biotite yield a temperature estimate of 745°C, the highest reliable estimate we have obtained in the region, whereas garnet rim and biotite rim yield 580°C. Composition of core garnet in the quartz-sillimanite-garnet-cordierite assemblage suggests a pressure of 6.4 kbar.

Proceed southeast on Holland-Brimfield Road,

44.5 Junction with Stafford Road in Holland. Continue straight.

45.8 Causeway across Hamilton Reservoir.

In 1979 Robinson and Klepacki collected samples from the rubble of schist and pegmatite on the south side of the causeway that is presumably derived from nearby excavations. These have yielded primary assemblages as well as two retrograde features that have been studied in detail by Tracy and Dietsch (1982). The primary garnet core and retrograded rims adjacent to biotite and cordierite have yielded the following compositions:

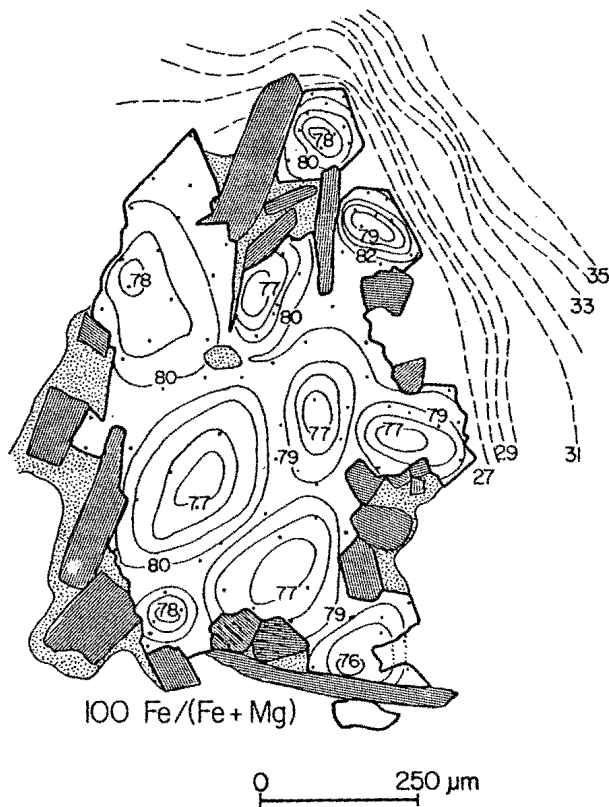

Figure 34. Garnet-sillimanite-quartz aggregate growing inside cordierite in sample WL-6A from Hamilton Reservoir. Sillimanite is lined; quartz is stippled. Contours in garnet and cordierite are 100 Fe/(Fe+Mg). Dots are individual probe analysis points.

Almandine 73.4 (76.4); Pyrope 21.6 (18.9); Spessartine 2.0 (1.8); Grossular 3.0 (3.0). The primary cordierite has X_{Mg} of .652. Together these yield an estimated temperature of 720°C. However, the garnet and cordierite are considerably more Fe-rich than in other outcrops in this region and their compositions in the quartz-sillimanite-garnet-cordierite assemblage give a pressure estimate of only 5.9 kbar, hinting that the coarse crystals in this rock may have formed at an earlier stage in the metamorphism than those in some other rocks in the region.

Along cordierite-K feldspar contacts and locally along garnet-K feldspar contacts there are coarse intergrowths of prismatic sillimanite, pale green low-Ti biotite, and quartz produced by continuous retrograde hydration reactions involving local transport of K_2O but apparently not TiO_2 . That the retrograde reactions are continuous hydrations is shown by the fact that the green biotite adjacent to garnet has X_{Mg} of .555, the green biotite adjacent to cordierite has X_{Mg} of .606, while the primary biotite has X_{Mg} of .598.

The more remarkable retrograde feature, illustrated in Figure 34, are clusters of intergrown garnet, sillimanite, and quartz inside large cordierite crystals, that appear to have formed by direct breakdown of cordierite during cooling and increasing pressure. The garnets appear to have nucleated as several grains in a cluster which then coalesced to form larger continuously zoned patches. As the garnet grew, it became more Fe-rich, whereas the shrinking cordierite in contact with the growing garnet became more Mg-rich. The compositions of the most Mg-rich garnet and most

P3-49

Fe-rich garnet () in the intergrowth are: Almandine 76.5(80.1); Pyrope 23.5 (16.2), Spessartine 2.0 (2.7), Grossular 1.9 (1.0). The host cordierite (see above) has X_{Mg} of .650 whereas the most Mg-rich cordierite adjacent to growing garnet has X_{Mg} of .751. Using the calibration of A. B. Thompson (1976) the most magnesian garnet paired with the host cordierite gives a temperature estimate of about 740°C. This temperature must be a false one, because none of the new garnet could have grown from cordierite without changing its composition some. However, using any reasonable temperature estimate, down to 650°C, the initial garnet composition in this sillimanite-garnet-quartz-cordierite intergrowth gives pressures of 6.0 to 6.3 kbar. The most Fe-rich garnet is paired with the most Mg-rich cordierite giving a retrograde temperature below 500°C. If these were still in equilibrium with quartz and sillimanite it would have been at pressures of 6.5-8 kbar.

47.4 Connecticut State Line marked by obscure stone post in bushes to left.

47.6 Large roadcut on left at T intersection. Interstate 86 visible ahead. Park in grassy area on right.

Stop 9. (20 minutes approximately) (Wales Quadrangle) Hypersthene-augite plagioclase gneiss and diopside calc-silicate and marble in Partridge Formation. The principal outcrop is a dark gneiss consisting of quartz, andesine (with coarse orthoclase exsolution lamellae), orthopyroxene, augite, biotite, ilmenite, and minor to major amounts of secondary cummingtonite and hornblende after pyroxenes. The host plagioclase has a composition of An43.1 Ab55.9 Or1.0 Cn0, with orthoclase exsolution lamellae having a composition of An0.3 Ab9.4 Or86.5 Cn3.8. The celsian component is unusually high and may have promoted exsolution. Orthopyroxene and clinopyroxene have the following compositions:

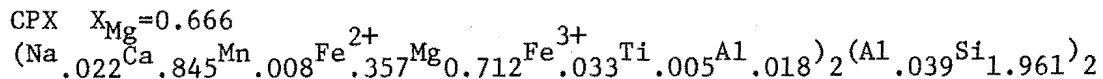
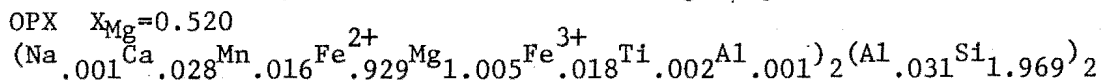

Biotite is red-brown with X_{Mg} of 0.536 and 0.273 Ti/11 Oxygens, typical for Ti-saturated rocks of this grade. Ilmenite has a typically pedestrian composition of 93% FeTiO₃, 4% Fe₂O₃, 2% MgTiO₃, and 1% MnTiO₃. This rock has the right bulk composition to have once been an amphibolite in which all amphibole has now broken down, probably by a continuous Fe-Mg and Ca-Na reaction hornblende + quartz = orthopyroxene + augite + plagioclase. A similar but somewhat more magnesian assemblage from some miles to the north (see Figure 29) still contains hornblende together with its breakdown products. Note that the biotite here coexists with hypersthene but not with K-feldspar. However, a more iron-rich assemblage from some miles to the north does contain hypersthene, K-feldspar, and garnet (see Figure 29). The coarsest pyroxene crystals (best seen by light brown color on weathered surfaces at top of outcrop) occur in felsic patches that appear to have been melt segregations; however, the pyroxenes are as or more abundant in the fine-grained matrix. It is possible that melt segregations formed and solidified before the main pyroxene-forming reaction. Note darker brown secondary cummingtonite rims and local larger crystals.

For several years the white fibrous crystals in the calc-silicate outcrop were alleged by some to be wollastonite. This was checked out exhaustively by Alan Thompson (pers. comm. 1978) and the crystals are scapolite. Note diopside, abundant quartz-calcite contacts and fine euhedral sphene.

Proceed right at T intersection, then turn left (east) on bridge across Interstate 86, then enter entrance ramp for I86 NORTH.

- 49.0 Long cuts in rusty schists of Partridge Formation on right.
- 51.0 Long cuts of purple biotite granulites of the Paxton Formation and pegmatite on right.
- 53.1 Take exit for Old Sturbridge Village.
- 53.2 Turn left (west) at end of exit ramp and take bridge across I86. At T junction at west end of bridge turn right (north)
- 53.4 Entrance gate to Old Sturbridge Village with roadcut on right. Pull to right of pavement at wide spot.

Stop 10 (10 minutes approximately) (Southbridge Quadrangle) Gray biotite-garnet granulites, and calc-silicate granulites of the Paxton Formation with abundant pegmatite and tight isoclinal folds.

Continue northwest on Old Sturbridge Village Road.

- 54.2 Stop sign. Continue straight.
- 54.6 Junction with Route 20. Turn right (east).
- 54.9 Ramp to I86 South bears right. Stay straight on Route 20.
- 55.1 Get into left turn lane and turn left (north) onto New Boston Road (small sign). Proceed north.
- 56.7 Bridge over Mass. Turnpike. Cross and park at wide spot on right. Step over fence on right and climb down under bridge on north side of Turnpike to large road cut behind protective railings.

Stop 11. (30 minutes approximately) (East Brookfield Quadrangle). This lies in a very narrow belt of gray-weathering aluminous schist with subordinate calc-silicate that has been assigned to the Littleton Formation. After descending to road level walk quickly west to far end of outcrop and then work your way slowly back to bridge. The dominant rock type here is beautifully coarse quartz-orthoclase-plagioclase-biotite-garnet-cordierite-sillimanite-graphite gneiss in which cordierite, garnet, and sillimanite can be exceedingly coarse.

Within the gneiss are two sills of garnet and garnet-sillimanite pegmatite usually showing a very strong deformational fabric. A composition map of a garnet from the pegmatite is shown in Figure 35. This portion of the pegmatite apparently contains no sillimanite and no primary biotite, but does contain retrograde low Ti biotite at contacts between garnet and K

P3-51

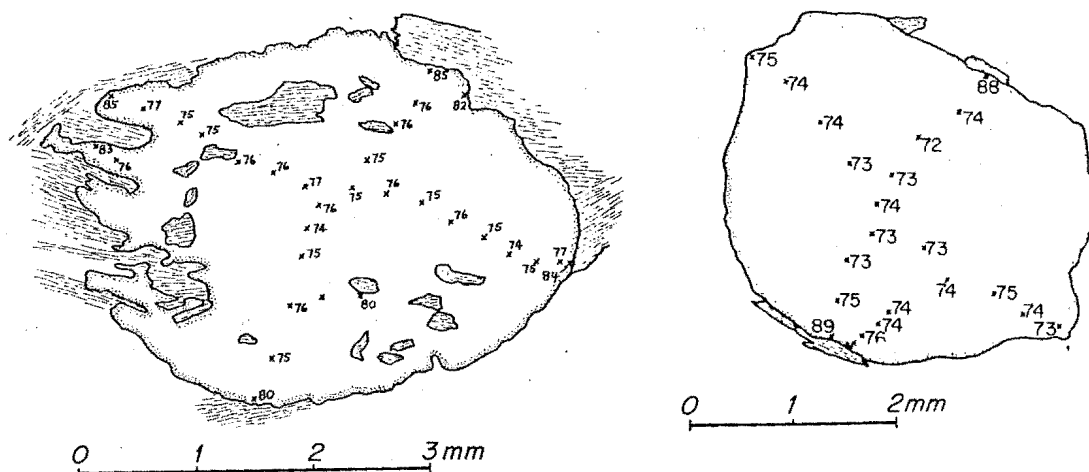

Figure 35. Maps showing 100 Fe/(Fe+Mg) for garnets from Stop 11. Left: Garnet from mafic selvage on pegmatite consisting of biotite-garnet-sillimanite-cordierite. Surrounding biotite is red-brown Ti-rich variety. Right: Garnet from sillimanite-free portion of pegmatite. All biotite is secondary low-Ti green variety formed by retrograde reaction between garnet and K-feldspar.

feldspar. Next to the retrograde green biotite, the garnet shows extremely abrupt zoning. Compositions of garnet core and of garnet rim next to green biotite () are as follows: Almandine 70.7 (82.5), Pyrope 26.0 (11.8), Spessartine 2.4 (3.9), Grossular 0.9 (1.8). The retrograde green biotite has X_{Mg} of .464 and .013 Ti/11 oxygens. When paired with the garnet rim this green biotite gives a temperature estimate of 545°C. In the pegmatite at the far end there are local patches of graphite and of fairly coarse white mica that appears to be muscovite (! ?). Elsewhere the sillimanite-rich portions of the pegmatite may be metamorphosed equivalents of muscovite pegmatite.

Along the contacts of the pegmatites are dark layers up to 0.3 meters thick consisting almost exclusively of biotite, garnet, sillimanite, and cordierite. These appear to be either restite layers left behind during melting of the pegmatite or metamorphosed reaction rims between pegmatite and country rock (Note high specific gravity of specimens). In a few places there are layers of pure cordierite up to 4 cm thick at the contact between these layers and the pegmatite. A composition map of a small garnet in one of these layers is shown in Figure 35. The garnet is fairly homogeneous except where in contact with surrounding biotite () yielding the following compositions: Almandine 72.0 (82.1), Pyrope 24.9 (14.6), Spessartine 1.2 (2.0); Grossular 1.9 (1.4). Typical biotite has X_{Mg} of .597 and .230 Ti/11 oxygens. Garnet core and matrix biotite yield an estimated temperature of 635°C. In the absence of quartz the sillimanite-garnet-cordierite assemblage can be used to estimate a maximum pressure of 6.7 kbar.

This is end of trip. Return south down New Boston Road to Route 20. Turn right (west) on 20 and then get on ramp for Route 86 South. Retrace route back past Stop 9 and on into Connecticut, ultimately to Route 32, then 195 to Storrs.

REFERENCES See consolidated list after Trip P-4.

P4-1

Trip P-4

STRATIGRAPHY AND STRUCTURE OF THE WARE-BARRE AREA,
CENTRAL MASSACHUSETTS

by

Peter Robinson
Department of Geology and Geography
University of Massachusetts
Amherst, Massachusetts 01003

Michael T. Field
230 Halligan Ave.
Worthington, Ohio 43085

Robert D. Tucker
Department of Geology and Geophysics
Yale University
New Haven, Connecticut 06520

INTRODUCTION

The purpose of this trip is to consider a sequence of lithic units in a traverse eastward from the well known belt of the Bronson Hill anticlinorium into the heart of the Merrimack synclinorium. The mapping covered was part of a larger project to carry stratigraphic and structural correlation across central Massachusetts from the Connecticut Valley to the Worcester area, which became incorporated in the U.S.G.S. project to compile a Bedrock Geologic Map of Massachusetts. The initial steps were taken by Field (1975) in the Ware area, one of the few places where correlation efforts are not entirely blocked by large plutons (Figure 1). Tucker (1977) carried the correlations of Field northeastward to the crest of the Oakham anticline and eventually to the Mt. Wachusett area, though that is not to be covered here.

Three stratigraphic-structural interpretations have been applied in recent years to this large region, in which, for the most part, the bedding and foliation dip west toward the Bronson Hill anticlinorium (Figure 2).

The interpretation proposed by Peper et al. (1975) and more recently supported by Pease and Barosh (1981) is that the west-dipping sequence is essentially homoclinal with tops west and is tens of kilometers thick even though broken by a number of thrust faults. This thick section is then in fault contact with the very thin, better known, stratigraphic sequence of the Bronson Hill anticlinorium along the Bone Mill Brook fault at the east edge of the Monson Gneiss.

2) The interpretation proposed by Field (1975), Tucker (1977) and Robinson (1979), is that the sequence of the Merrimack Synclinorium, like that of the Bronson Hill anticlinorium, is involved in three very complex

phases of folding: A) early nappes with east-over-west overfolding that caused many repetitions of units, followed by B) backfolding of early axial surfaces toward the east, to create the dominant west-dipping attitudes, followed by C) tight folding associated with the rise of the gneiss domes. Within this interpretation it is also recognized that there are important facies and thickness changes, particularly within the Silurian, between the thinner western sequence and the thicker eastern sequence of the Merrimack trough.

3) The interpretation proposed by Rodgers (1981) is that the stratigraphic repetitions recognized in 2) above are the result of fault imbrication by the thrust faults in 1) above, and that the whole complex should be viewed as an accretionary prism in which underthrusting and sedimentation were in part contemporaneous through Ordovician, Silurian and Devonian time on the east side of an island arc in the position of the Bronson Hill anticlinorium. Robinson and Tucker (in press) have prepared a detailed reply to this proposal.

An additional question for detailed attention has to do with correlations to western Maine and whether certain rocks assigned to the Littleton and Partridge Formations might suitably be assigned to the Perry Mountain Formation and C Member of the Rangeley Formation.











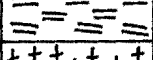
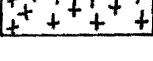
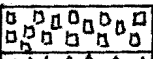
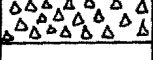

ACKNOWLEDGEMENTS

The research of Robinson, Field, and Tucker was supported by Grants from the National Science Foundation Geology Program and the U.S. Geological Survey Branch of Eastern Environmental Geology. Robinson was also supported by Grants from the National Science Foundation Geochemistry Program. During the course of work valuable and even heated discussion was provided by J. D. Peper, M. H. Pease, J. S. Pomeroy, P. H. Osberg, N. L. Hatch, R. H. Moench, J. B. Lyons, John Rodgers, and E-an Zen. Valuable field assistance and observations were provided by David Klepacki, Heather Stoddart, Frank Smith, and Eileen Belvin. Peter J. Thompson, Virginia L. Peterson, and Kurt T. Hollocher helped prepare the road log and/or assisted on the field trip. Several of the figures were lettered by Marie Litterer. The text was typed by Gerda Kunkel. To each of these persons and institutions we express our grateful acknowledgement.

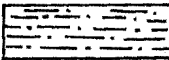
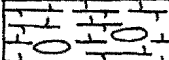
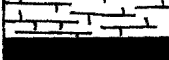
P4-3

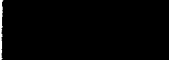
Figure 1. (turn next page) Generalized bedrock geologic map of part of central Massachusetts, showing route of field trip and location of cross section of Figure 2. Same symbols are used in Figures 7, 9, 11, and 12 together with letter symbols in parentheses.

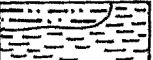
EXPLANATION

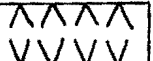
Jurassic		Diabase dikes (Jd).
		Foliated granite gneiss, biotite gneiss (gg).
		Gneiss of Ragged Hill (Drh).
Devonian		Coys Hill Porphyritic Granite (Dchg). Separate pattern for lenses of mafic gneiss (Dchm).
		Granodiorite, tonalite (Dht).
		Hornblende gabbro, diorite (Dgdi).
	Littleton Formation	
Lower Devonian		Feldspar Gneiss Member (Dlf).
		Orthopyroxene Gneiss Member (Dlo).
		Pelitic Schist Member (Dl).
	Paxton Formation	
		Sulfidic Schist Member (Spss)
		Granulite Member (Sp).
		Amphibolite where separately mapped (Spa).
Silurian		Fitch Formation (Sf).
	(Subzone B)	
		White Schist Member (Spw).
		Quartzite-Rusty Schist Member (Spqr).
	(Subzones C and D)	
Middle Ordovician		Partridge Formation (Ops, Opa, Opl). Separately mapped felsic gneiss in different pattern.
		Ammonoosuc Volcanics in Subzone A. Also includes separately mapped mafic volcanics in Partridge Formation in Subzones B and C (Opa).
Ordovician? or older.		Monson Gneiss (OZmo).

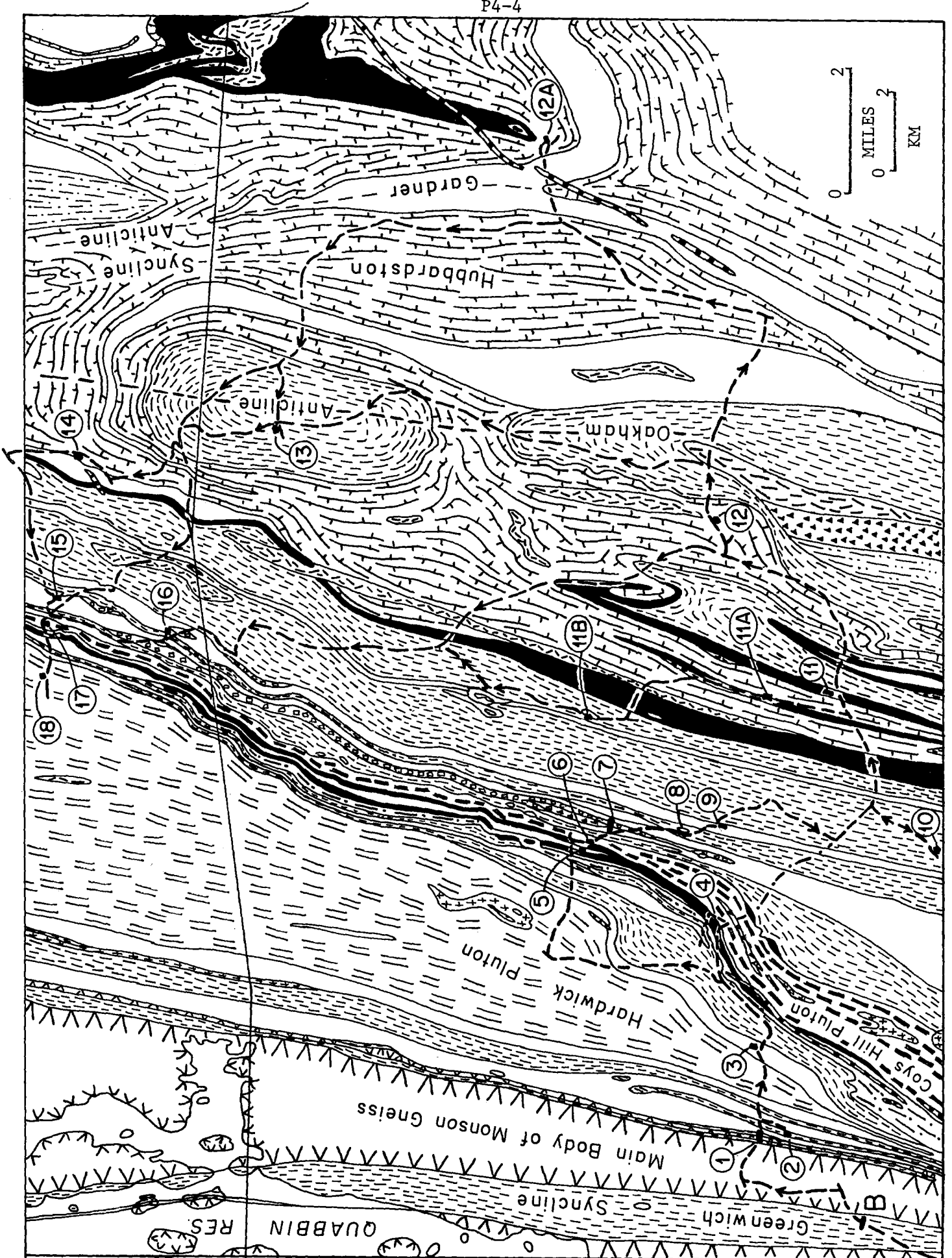

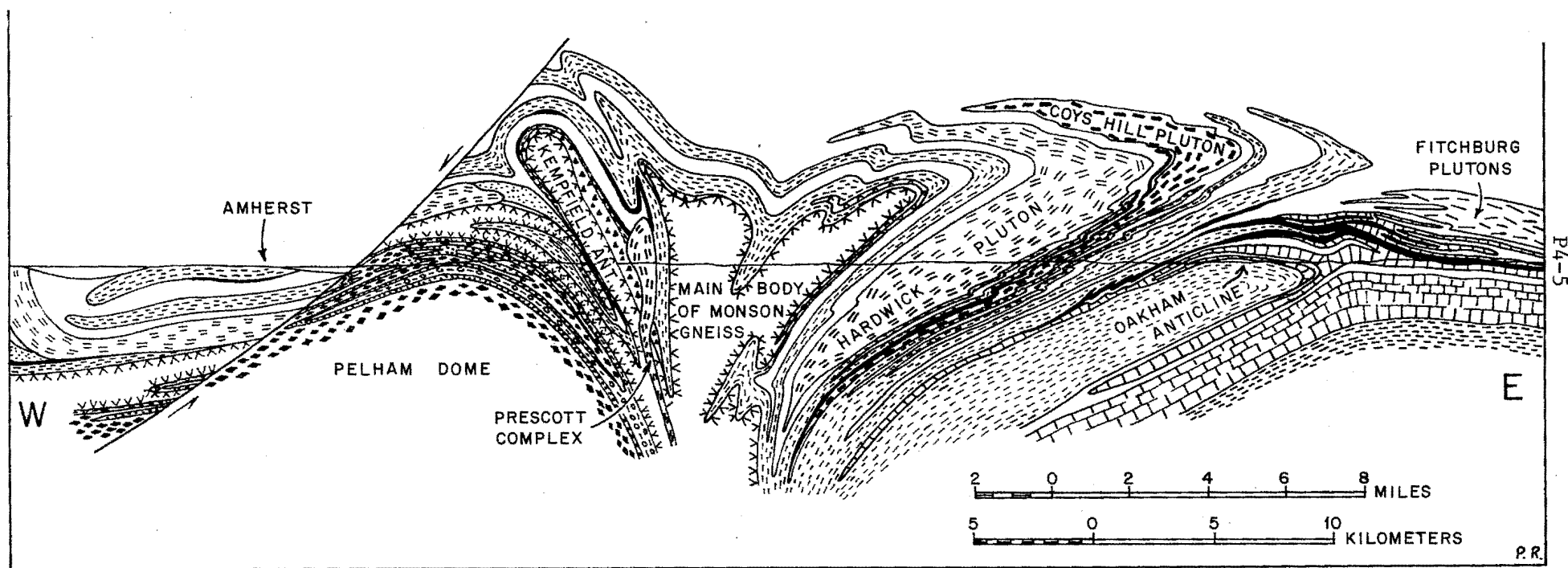

Figure 2. Bedrock geologic cross section across central Massachusetts. Line of section (although not full length of it) is shown in Figure 1, and also in Trip P-3, Figure 1. In the two eastern straight segments the section follows the line of Quabbin Aqueduct Tunnel described in detail and sampled by Fahlquist (1935). Detailed sections on parts of this line are given by Field (1975) and Tucker (1977).

BRIEF SUMMARY OF STRATIGRAPHY AND STRUCTURAL DEVELOPMENT

Details of pre-Silurian stratigraphy and correlation problems have been covered extensively elsewhere (Field, 1975; Tucker, 1977, Robinson 1979 Robinson, 1981) and will not be discussed here. A major portion of recent research has gone into correlation of Siluro-Devonian rocks and particularly the transition from the sequence involving very thin Silurian strata (Clough Quartzite and Fitch Formation) on the Bronson Hill anticlinorium to the much thicker Silurian sequence (Paxton Formation, etc.) of the Merrimack synclinorium. Particularly fruitful have been comparisons with the similar but more fossiliferous sequences in western and central Maine (Moench and Boudette, 1970; Ludman, 1976; Osberg, 1980; Robinson, 1981) and more recently attempts to link Maine and central New Hampshire (Hatch, Moench, and Lyons, 1981, and in preparation). Some of these ideas are tentatively summarized in Figures 3 and 4.

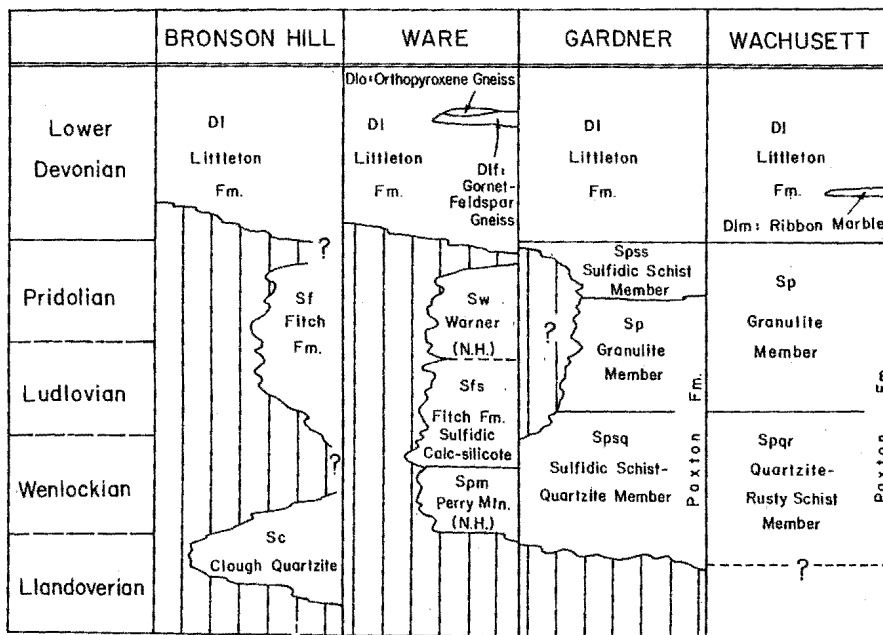

Figure 3. Preliminary Silurian-Lower Devonian correlation chart for central Massachusetts and southernmost New Hampshire. Each column represents the typical sequence to be found in one of four stratigraphic-tectonic subzones as defined by Robinson (1979). In the Ware Zone, Warner and Perry Mountain are only known with certainty in New Hampshire, and Peter Thompson (personal communication 1982) has tentatively identified Rangely C below Perry Mountain. Sulfidic Fitch (Sfs) is identical to Francestown of New Hampshire. In the Gardner Zone the unit Spsq used here and on the State Map is identical to Spw, White Schist Member of Field, used in this guidebook. Very recent correlation adjustments near bottom of the section suggested by Hatch, Moench, and Lyons, in press, and by P. H. Osberg, personal communication, April, 1982, are not incorporated.

P4-7

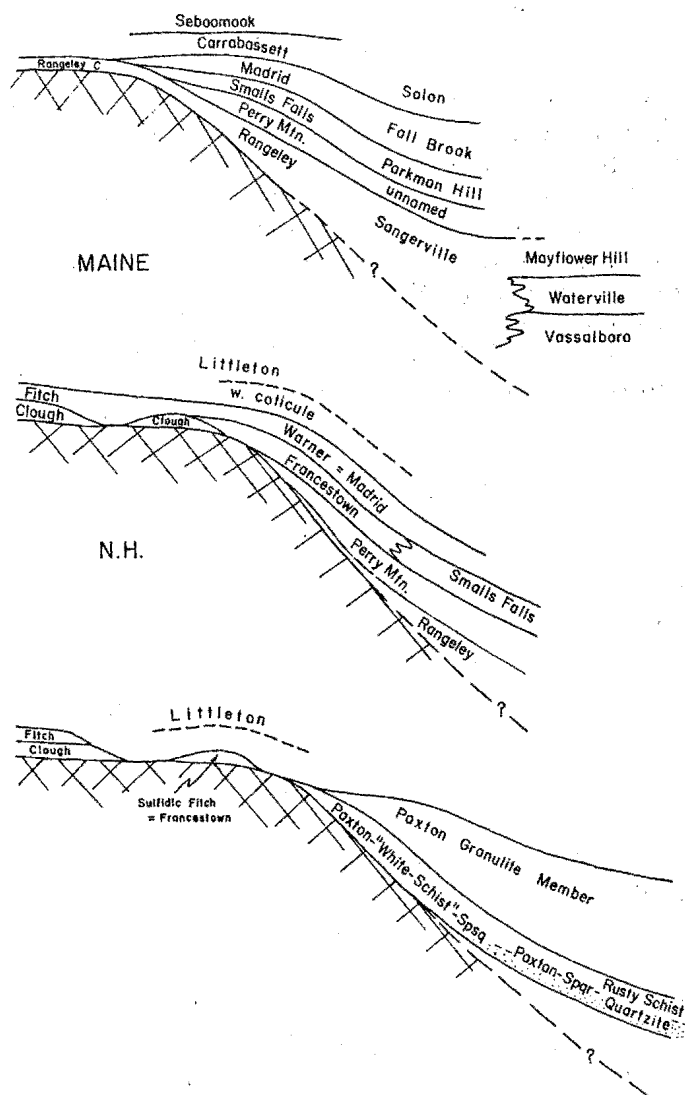

Figure 4. Restored schematic E-W stratigraphic profiles on the western margin of the Merrimack synclinorium showing comparative facies relations and unit names of Silurian-Lower Devonian rocks in western Maine, central New Hampshire, and central Massachusetts. Recent (1982) ideas on strata beneath the Rangely in Maine and New Hampshire are not included.

Some current ideas about the structural development of the region during the Devonian Acadian orogeny are summarized in cartoon form in Figure 5. The earliest stage of deformation was that of nappes with major east-west overfolding. This nappe formation seems to have been roughly contemporaneous with early stages of regional metamorphism and the intrusion of a series of quasi-concordant plutonic sheets. In the eastern part of the region, probably high in the pile of nappes, this seems to have been accompanied by rather low pressure facies series metamorphism with widespread production of andalusite. In the western part of the region it appears that hot, relatively dry, rocks were being folded westward over cool wet rocks to produce a major "metamorphic overhang" that persisted through later stages.

In the second major stage of deformation the axial surfaces of the earlier nappes were back-folded on a major scale into recumbent folds or nappes directed from west toward east. Peak metamorphic conditions seem to have been reached during this stage with extensive development of sillimanite-orthoclase-garnet-cordierite assemblages indicative of temperatures up to 700°C and pressures to 6 kbar from pelitic schists previously containing andalusite. In the middle and late parts of this stage a powerful E-W

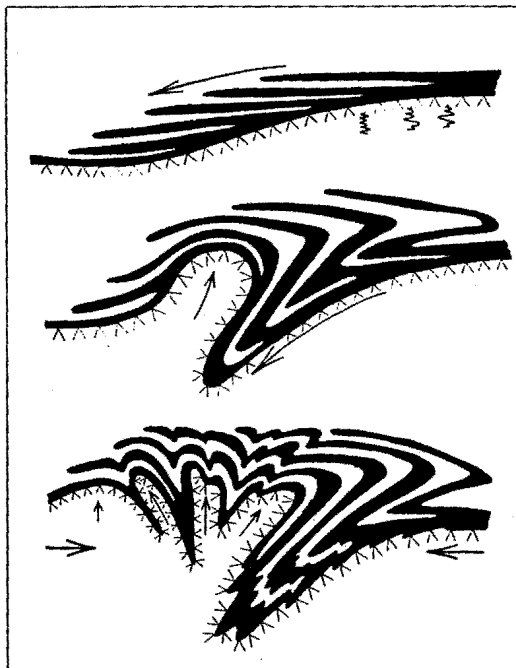

Figure 5. Cartoon of the sequence of major deformations in the Bronson Hill anticlinorium and Merrimack synclinorium, central Massachusetts and adjacent New Hampshire (from Hall and Robinson, 1982).

Top: Early Acadian nappes overfolded from east to west with heated rocks in the east overfolded onto cooler rocks in the west.

Middle: Backfolding of early nappe axial surfaces with overfolding from west to east. Late in this stage there was extensive mylonitization due to high strain rates on a series of west-dipping surfaces.

Bottom: Gneiss dome stage involving tight to isoclinal folding of earlier axial surfaces and the gravitational upward movement of low density gneisses into heavier mantling strata.

trending tectonic fabric of mineral lineations and minor fold axes seems to have been formed in metamorphosed sedimentary and plutonic rocks alike. This E-W fabric is also contained in some ductile mylonites that clearly truncate minerals formed during peak metamorphism (Figure 6).

Both the E-W trending linear fabric and the foliation in mylonites are deformed by a series of northeast-trending folds with associated mineral lineations. This northeast-trending system increases in intensity westward, obliterating the earlier E-W fabric (Figure 6), and can definitely be traced into the pattern of folds and lineations associated with the formation of gneiss domes and anticlines of the Bronson Hill anticlinorium in the third or dome stage of major regional deformation.

Involvement of Lower Devonian strata and the radiometric dates on early Acadian plutons (Lyons and Livingston, 1977; Daniel Lux, pers. comm. 1982) suggest the early stages of the Acadian orogeny took place 410-400 million years ago, synchronous with intense phases of the Caledonian Orogeny of Scandinavia. The Belchertown pluton, which truncates folds of the earlier stages of deformation, has an unmetamorphosed pyroxene-rich core that yields a zircon age of 380 million years (Ashwal et al., 1979). However, the outer part of the pluton was converted into a hornblende-biotite gneiss during the dome stage of deformation, and metamorphic hornblende thus produced yields a hornblende K-Ar cooling age of 361 million years. Thus, it appears that the Acadian Orogeny was not a brief, abrupt event (Naylor, 1971), but was prolonged over 40 to 50 million years, and roughly comparable in time of development to the European Alps.

P4-9

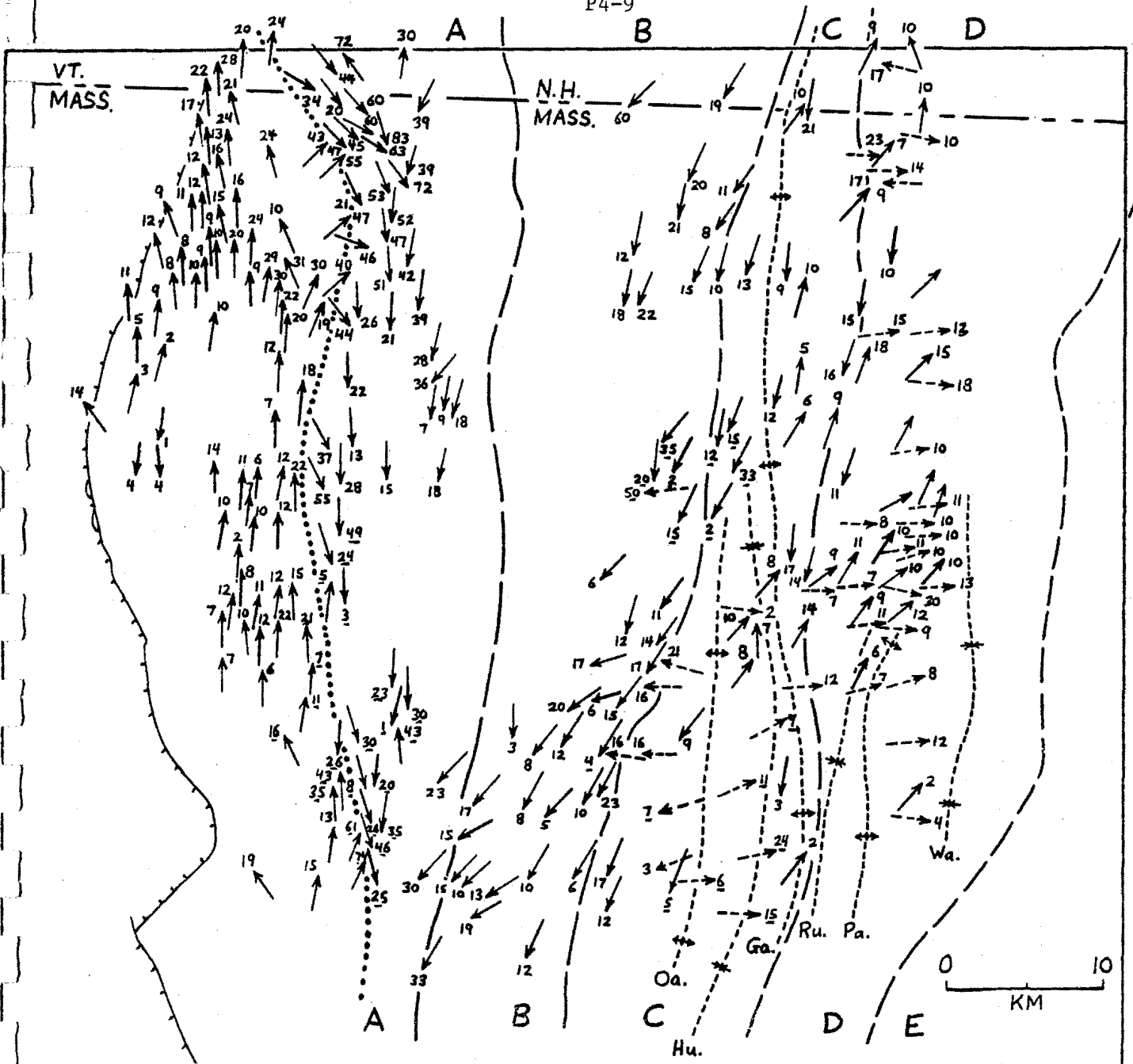

Figure 6. Linear structure summary map for central Massachusetts compiled from available data by Robert D. Tucker, 1978. Some available data in central, south-eastern and southern portions has not yet been added. Dashed arrows - trend and plunge of stage II lineations and minor fold axes. Solid arrows - trend and plunge of stage III lineations and minor fold axes. Each arrow represents mean trend and plunge determined from equal area plot of linear features measured in a single sub-area. Underlined number indicates selected individual measurement in area of sparse coverage or incomplete plotting. Long-dashed lines are boundaries between stratigraphic-tectonic subzones. Short-dashed lines are traces of axial surfaces of late anticlines and synclines: Oa. - Oakham anticline; Hu. - Hubbardston syncline; Ga. - Gardner anticline; Ru. - Rutland syncline; Pa. - Paxton anticline; Wa. - Wachusett syncline. Dotted line is trace of the "swirl" of stage III lineation in the Bronson Hill zone. The trace is defined as the approximate line where stage III lineation and minor fold axes plunge due east.

STRATIGRAPHIC-TECTONIC SUBZONES

As a convenience for description Robinson (1979) divided the bedrock geology of central Massachusetts into five stratigraphic-tectonic subzones (see Figure 6), based on Siluro-Devonian stratigraphy and tectonic style, four of which extend into the area of trip P-4 (Figure 1).

Subzone A is characterized by thin near-shore Silurian strata (Clough Quartzite and Fitch Formation) unconformably overlain by Lower Devonian quartzose sandstone and shale (Littleton Formation). In Subzone A, the Bronson Hill Zone, in the Ware area the dominant rock is Ordovician or older Monson Gneiss, but east of the main body there is a highly attenuated nappe with a core of Monson Gneiss (visited at Stop 1) and two additional nappes with cores of Partridge Formation (one to be visited at Stop 2).

In Subzone B, the Ware Zone, the Silurian is extremely thin (Fitch Formation, pyrrhotite calc-silicate) or absent, and the zone is characterized by widespread Lower Devonian quartzose sandstone and shale (Littleton) interleaved with some volcanics and with plutonic sheets. The Coys Hill pluton shows amazing coherence with the stratigraphy and seems to lie within or in place of the Littleton Formation. The Hardwick pluton seems concordant in the Ware area, but is locally cross-cutting to the north. When last seen to the south the pluton is a zone of mylonite about 100 feet across. The Gneiss of Ragged Hill is locally cross-cutting but the main body seems to stay within the confines of a single anticline. Structurally the zone is characterized by tight repetitions of Devonian and Ordovician strata believed to be the backfolded roots of Penninic nappes structurally higher than those of Subzone A. Other deformational episodes of Subzone A can be traced across Subzone B. It is remarkable that the rock units that make up the western 70% of the Ware Zone at the top of Figure 1 are mashed into the western 20% of it at the south edge. Thus although there is considerable shearing and development of ductile mylonite along the east margin of the Monson Gneiss it is no more important there than elsewhere in the area, and should not be taken to indicate a single major fault.

Subzone C, the Gardner Zone, is marked by an apparently abrupt eastward thickening of Silurian strata (Paxton Formation) including basal shales and quartzites of Small Falls (Maine) type (White Schist Member) and a thick section of calcareous feldspathic strata (Granulite Member) possibly derived in part from an eastern volcanic source. Devonian (Littleton) strata contain more feldspathic shale, and less aluminous shale and quartzose sandstone than further west. Stratigraphic repetitions again appear to be mainly due to early-stage nappes, but apparently with a major contribution from second-stage backfolding, particularly in the poorly understood area in Figure 1 southwest of the Oakham anticline. Subzone C marks the abundant appearance of intermediate age E-W lineation of cataclastic aspect that becomes dominant in subzone D. This lineation appears to relate to the backfolding and/or the cataclasis that immediately followed it, and is clearly older than the NE-SW trending lineation related to dome stage folds that dominate further west. In Subzone C, northeast-southwest trending folds equated with the dome stage further west are warped over gently north-south trending foliation arches to form a broad, complex anticlinorium including the Oakham anticline, Hubbardston syncline, and Gardner anticline.

P4-11

Stratigraphically Subzone D, the Wachusett Mountain Zone, is characterized by the same Silurian calcareous feldspathic (Paxton) strata as Subzone C, plus a thin continuous sulfidic quartzite (Paxton quartzite-rusty schist member). Silurian strata are overlain by metamorphosed black shale of probable Devonian age, in which are interleaved extensive sheet-like intrusives of biotite tonalite and biotite-muscovite granite that constitute the Fitchburg plutons. Structurally Subzone D is characterized by very tight early isoclinal folds with nearly flat axial surfaces and by a late synclinal axis at the location of the Fitchburg plutons. Dominant mineral lineations and minor folds trend E-W, but locally N to NNE trending eastward overturned to recumbent folds, probably of the dome stage, are superimposed on this.

ROAD LOG FOR TRIP P-4

The entire route for trip P-4 is shown in Figure 1. To get details on how to reach the beginning point (B in Figure 1) read instructions in the road log of Trip P-3 and Figure 30 of Trip P-3.

- 0.0 Begin road log at railroad underpass, on Route 32 (B on Figure 1).
- 0.1 Bridge over Ware River.
- 1.2 Crossroads, turn sharp left (north) on Anderson Road.
- 1.5 Road cut in Monson Gneiss on right.
- 2.2 Stop sign at T junction with Route 9. Turn right (east) on Route 9.
- 2.3 Ware Center.
- 2.6 Small road cut on left in hornblende amphibolite of Monson Gneiss.
- 2.8 Outcrops at and beyond crest of hill.
- 2.9 Park as far off on right side of Route 9 as possible. Walk back (west) to small road cuts in Monson Gneiss at crest of hill.

Stop 1. (45 minutes approximately) (Winsor Dam Quadrangle.) The purpose of this stop is to observe the sequence of rock units that occurs along the east margin of the main body of Monson Gneiss and has been traced continuously from the Mt. Grace quadrangle to here.

The Monson Gneiss at the crest of the ridge dips about 40° west and consists of plagioclase gneiss with magnetite and homogeneous hornblende amphibolite layers up to 30 cm thick that may be deformed dikes. A pervasive down-dip linear fabric especially notable in amphibolites is assigned to the backfold stage, but is locally confused by later slickensides. The sub-horizontal coarse linear fabric including quartz rods in gneiss is related to the dome stage. At the east end of the outcrop are post-metamorphic (Mesozoic?) fractures with secondary epidote.

Walk 350 feet east along road to modest outcrop of rusty Partridge Formation sulfidic schist and amphibolite. This belt of Partridge Formation, interpreted as a nappe stage isoclinal syncline, characteristically contains about 50% of amphibolite and other metamorphosed volcanics. To the north it also contains many of the bodies of olivine-spinel hornblendite described in detail by Wolff (1978). A few hundred yards north of here we have found the assemblage gedrite-orthopyroxene-garnet-plagioclase. Both down dip (backfold stage) and horizontal (dome stage) linear fabrics are present, and the west edge of the outcrop is a mylonitic schist with a strong down-dip fabric.

Walk 175 feet east and turn left (north) on obscure trail just east of bullrush swamp to large outcrop 50 feet north of road. This is the thinly laminated gneiss and amphibolite of the North Orange band of Monson Gneiss. Locally amphibolites are up to 20 cm thick. Contact relations in the Orange area (Robinson, 1963) demonstrated that this narrow band of gneiss is the core of an early nappe. This is exactly the same layer exposed near Route 2 and visited on NEIGC 1967 Trip B, Stop 8 and also the Caledonides in the U.S.A., Caledonide Orogen 1979, stop 6A. Note obscure isoclinal folds in foliation.

Return to highway and walk 150 feet east to driveway on left (north). In bushes northwest of driveway are small outcrops of rusty Partridge schist east of the gneiss band. On the side of the driveway is a small outcrop of pegmatite and mylonitized gray schist of the Littleton Formation with biotite, coarse sillimanite, garnet and K feldspar.

Cross highway (south) and enter Potter driveway. Behind house is an extensive outcrop of gray garnet-biotite-sillimanite schist of the Littleton Formation with abundant watery orthoclase megacrysts and some pegmatite. Subhorizontal (dome stage) lineation is evident.

Proceed east on Route 9.

3.1 Turn sharp right (south) on Gould Road (not Gould Street).

3.6 Turn right through gateway to Ware High School and park by outcrop.

Stop 2. (15 minutes approximately) (Winsor Dam Quadrangle). Rusty weathering sillimanite-pyrrhotite schist of the Partridge Formation in a narrow isoclinal anticline. For petrographic details see Trip P-3, Stop 2. The rock contains two different sillimanite lineations, an earlier E-W trending lineation of the backfold stage, and a later, more prominent southwest-plunging lineation of the dome stage.

Leave parking lot and turn left (north) on Gould Road.

4.2 Stop Sign. Turn right (east) onto Route 9.

5.1 Junction with Route 32 in center of Ware. Stay on Route 9 east.

5.5 Bridge over Ware River.

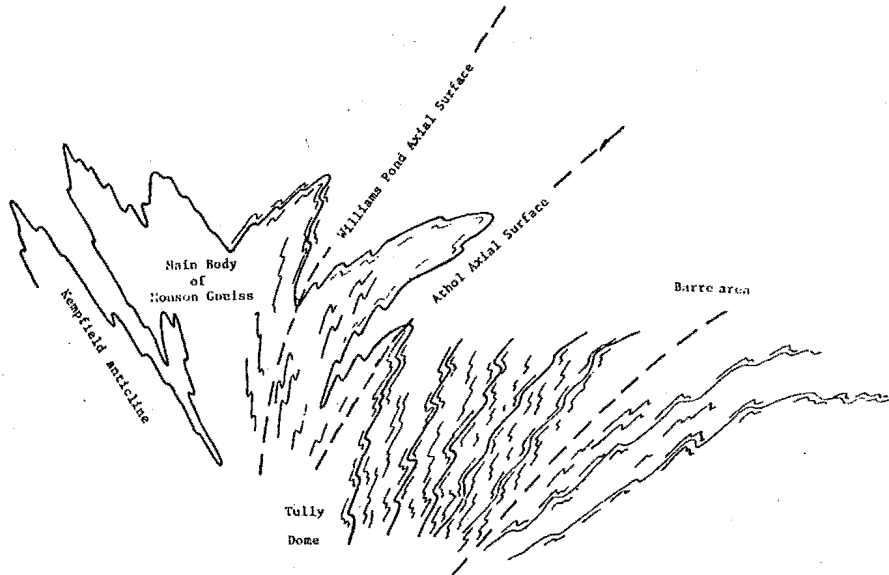

Figure 8. Diagrammatic section of relationships of dome stage fold asymmetry across part of west-central Massachusetts (from Tucker, 1977). East from the Athol axial surface to the central part of the Barre area, dome stage minor folds have east-side-up asymmetry. East of the Kruse Road syncline approximately, such minor folds reverse their asymmetry.

- 5.7 Turn right (south) into factory parking lot and park. Walk to north side of Route 9 and along sidewalk (west) to side street on north side which is on east side of Ware River. Walk up side street to rock garden and outcrop on left.

Stop 3. (15 minutes approximately) (Ware Quadrangle) The rock here is gray weathering sillimanite-garnet-biotite schist assigned to the Littleton Formation. Beautifully developed southwest plunging asymmetric folds in foliation of the dome stage have west dipping axial surfaces and show east-side-up movement sense. This fold asymmetry is characteristic of a huge region in central Massachusetts between the Athol and Barre axial surfaces as shown in Figure 8. In spite of the consistent pattern of asymmetries we do not understand their full significance and we have not located many major fold hinges related to them.

Leave parking lot. Turn right (east) onto Route 9.

- 6.7 Junction. Route 32 turns left. Stay on 9.
- 7.4 Low outcrops on left. Sulfidic Fitch Formation.
- 7.6 Left turn across traffic to dirt road which is old Route 9.
- 7.7 Stop just before crest of hill where outcrop appears on both sides of road. Pull well over as normal automobiles will be left here for several hours.

Stop 4. (1 hour 15 minutes approximately) (Ware Quadrangle) The purpose of this stop is to examine the sequence of lithic units westward from the Coys Hill Granite. In the western part of this traverse there will be a chance to examine rocks which we feel have the best chance to be re-interpreted as Perry Mountain or Rangeley equivalents, both because of their lithology and because a much more certain correlation with Perry Mountain-Rangeley has been made by Peter Thompson (pers. comm. 1981) along strike in the Monadnock area.

Walk north on wood road that is closest to rock exposures on Old Route 9 and bear left into picnic site under huge overhangs of Coys Hill Granite. At this locality and most in Massachusetts the Coys Hill is a coarse gneiss in which most of the K-feldspar megacrysts have tectonically rounded ends. The abundant garnet grains are probably metamorphic porphyroblasts rather than igneous phenocrysts to be seen in the center of the Cardigan pluton in New Hampshire.

Squeeze north between fallen rocks along east side of Coys Hill outcrop to trail that leads west. Turn north (right) on wood road at T intersection. Wood road runs directly along the contact between Coys Hill Granite and sulfidic Fitch Formation (=Francestown), and larger outcrops of Fitch may be seen in slope due west of pond. Follow wood road north to powerline and turn left (west and uphill) on powerline to small outcrop of Fitch Formation. Like the Francestown Formation, this rock is a graphite-rich feldspathic calc-silicate rock dominated by quartz and calcic plagioclase (usually An₆₀₋₈₀) with diopside, sphene, and pyrrhotite. Biotite, microcline, scapolite, actinolite, and calcite occur in a few samples but are much less important. Continue west and downhill along powerline over broken outcrops of Fitch Formation to third bump west of crest where there are large outcrops of the Gneiss of Ragged Hill. In the Ware area the main body of this gneiss occurs only in a narrow belt interpreted by Field as a nappe stage anticline, but within the anticline the gneiss locally cuts across the stratigraphy. The rock is a quartz-plagioclase (An₂₀₋₃₀)-K feldspar gneiss with the composition of granite, granodiorite, or tonalite. Both biotite and garnet are characteristic, ilmenite is common, and several samples also contain sillimanite. The unit is interpreted as an Acadian intrusion that came in before or during the nappe stage and was present in all subsequent deformations.

Cross small stream and boggy ground to more outcrops of Gneiss of Ragged Hill but just beyond this cross into rusty feldspathic sillimanite-garnet schist mapped as Partridge Formation, Lyon Road type. In bed of stream just beyond is contact with gray weathering garnet-rich schist mapped as Littleton Formation. Travel off powerline around north side of next depression viewing large outcrops of quartzose gray garnet-sillimanite-orthoclase schist (+ cordierite) with calc-silicate footballs. Could this be equivalent to the Perry Mountain Formation? Move southwestward back to powerline and across contact of overlying unit which is well exposed in powerline for several hundred yards and consists of brown to red-rusty weathering feldspathic schist with calc-silicate footballs mapped as Partridge Formation, Lyon Road type. Could this be equivalent to the Rangeley C of central New Hampshire? Southward this area appears to connect with the previous area of rusty schist in what was interpreted as a recumbent fold in which the gray schist hinges out.

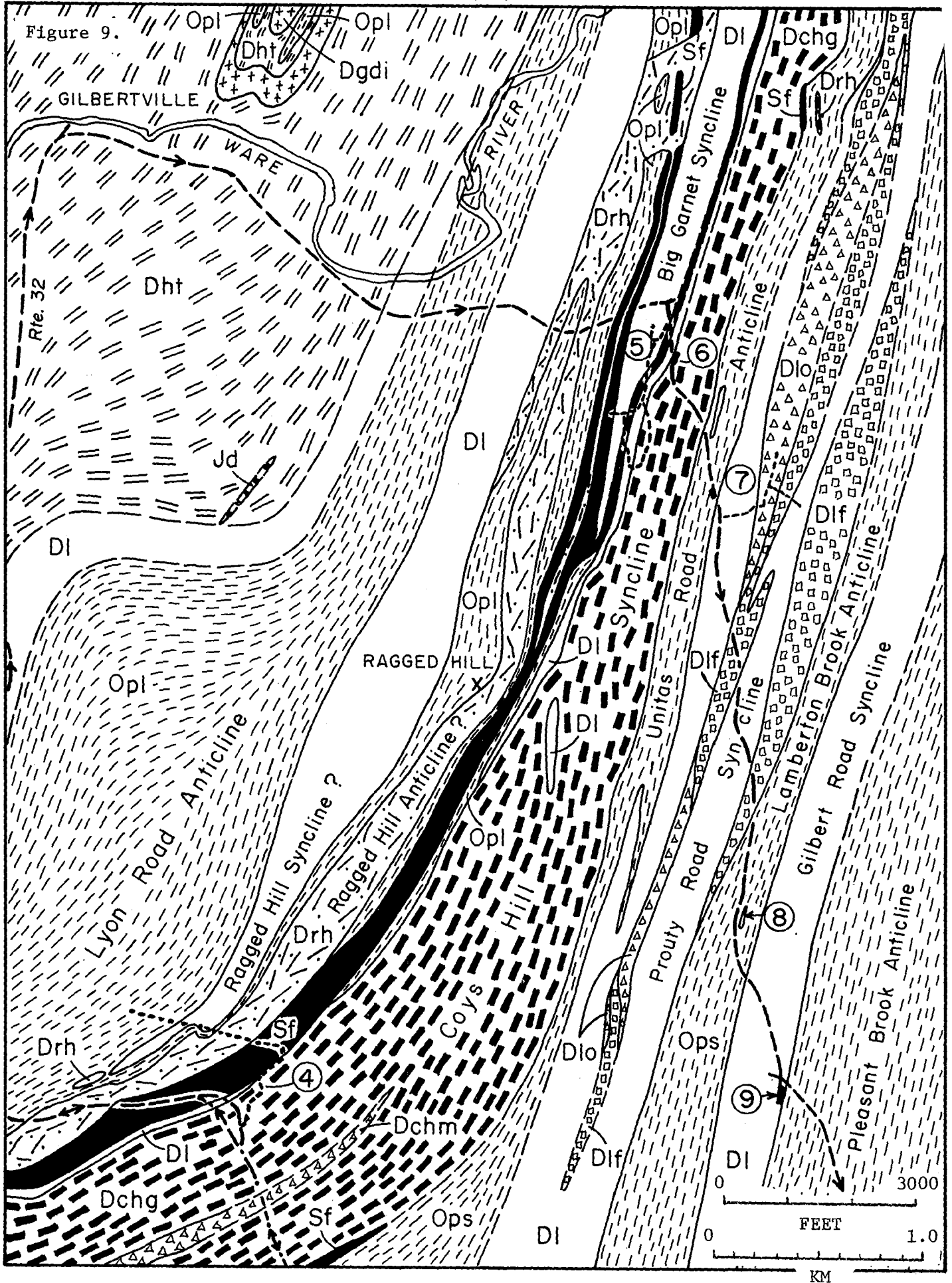

Return east along the powerline, avoiding highest point of ridge by trail on south side and continuing directly south to vehicles on wood road.

Only high clearance vans, trucks, and jeeps should go beyond here. After the traverse along Tucker Road (Stops 5-9) vans will return you here. Consolidate and bring lunch. Vans, etc. proceed east through pass.

- 7.8 Turn right (west) onto new Route 9 and retrace route.
- 8.9 Turn right (north) on Route 32. West Brookfield Town Line.
- 9.8 Hill to west (left) held up by tonalites of the Hardwick Pluton.
- 10.7 New Braintree Town Line.
- 11.9 Turn right (east) on New Braintree Road just before Route 32 crosses railroad and Ware River.
- 13.9 Turn right (south) onto Tucker Road. (Far end of pasture with large outcrop.)
- 14.0 Park at entrance to field on right or if there is no room drive up short steep section of road to good parking and walk back.

Stop 5. (1 hour approximately) (Ware Quadrangle) Lunch will probably be held here before the walk. Walk west and northwest through pasture to large knob outcrop of Big Garnet Member of Littleton Formation. For detailed discussion of petrology see Trip P-3, Stop 3. Walk south off outcrop and on crude road through pasture several hundred yards to flagged route that cuts westward across brook to east-facing cliff of Big Garnet Member. Easy ascent and descent of cliff to see Fitch Formation above the Big Garnet Member. Near contact the Big Garnet Member has less garnet and is more quartzose, with possible but improbable graded bedding. From base of cliff follow flagged route along slope to small excavation showing Fitch Formation below the Big Garnet Member. South of here 0.3 mile the two belts of Fitch merge around the end of the Big Garnet Member, forming one of the few recognizable hinges of a nappe stage fold in the Ware area. This map pattern and structural interpretation of this part of the Ware area are illustrated in exaggerated fashion in Figure 10.

From excavation follow flagging southeast to outcrop where coarse garnet rock just above Coys Hill pluton can be seen, then east to large outcrop of Coys Hill granite. Follow flagging across brook to east and then follow rough woodroad north and back to vehicles. Note loose blocks in pasture of white sulfidic sillimanite-rich schist which come from dip slope of the Fitch Formation. These pelitic interbeds are not common but they do suggest a transition to the correlative White Schist Member of the Paxton Formation (Smalls Falls equivalent) to be seen at Stop 11.

From pasture entrance drive up steep rise noting small outcrop and dip slope surface of sulfidic Fitch on right.

- 14.1 Outcrop of Big Garnet Member of Littleton Formation in bed of road.

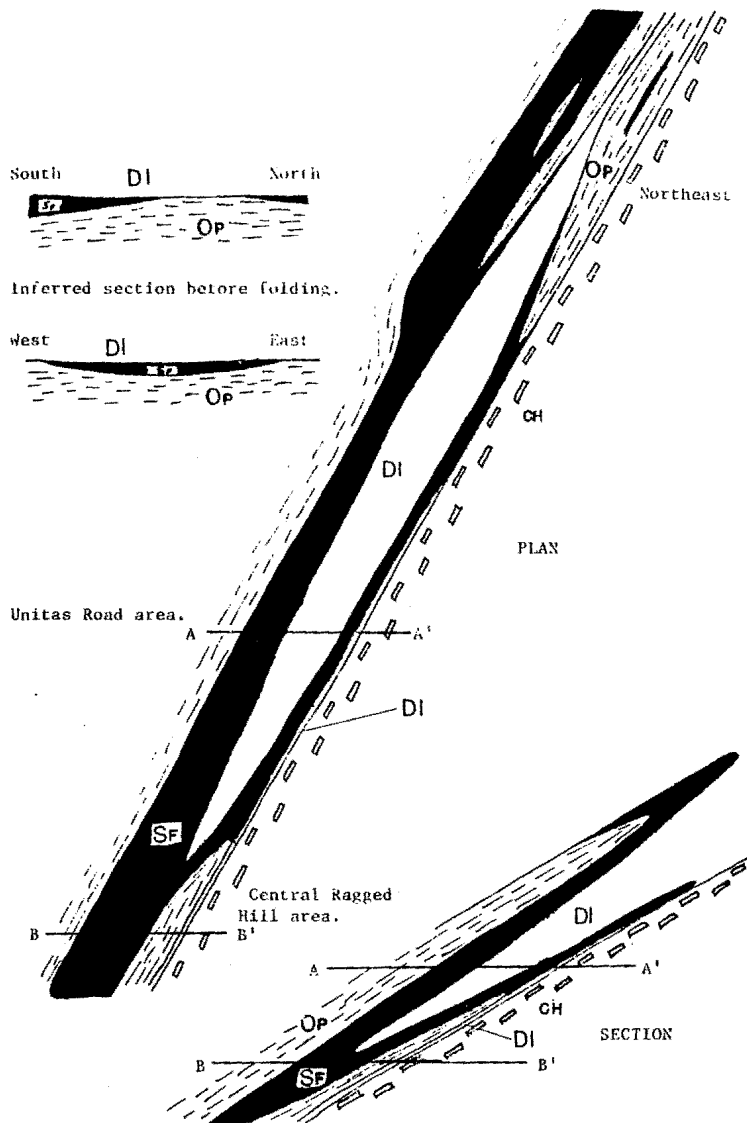

Figure 10. Exaggerated diagrammatic map and section of the Big Garnet syncline and the Fitch Formation with the Gneiss of Ragged Hill not shown. The thinning of the Fitch Formation to the east and west, and next to the Littleton Formation in the northeast, is shown as it is and as it is inferred to have been before nappe stage folding. Coys Hill Granite (CH) is believed to occupy the stratigraphic position of the Littleton Formation.

Stop 6. (15 minutes approximately) (Ware Quadrangle) This is the upper contact zone of the Coys Hill pluton. The contact lies about 20 feet east of the road. Walk back (north) 100 feet and take small trail 100 feet east to small clean exposure of highly foliated Coys Hill Granite. Outcrops in front of vehicles (south) and below the road on the west side are Littleton Formation with garnets up to 5 cm diameter.

Continue up Tucker Road past several outcrops of Coys Hill Granite and over several dips and rises.

14.5 Stop by north end of 10-20' rib of rusty schist on right. Park on right.

Stop 7. (1 hour approximately) (Ware Quadrangle) Examine rib of rusty weathering feldspathic schist of the Partridge Formation. This lies directly east of the Coys Hill Pluton and forms the core of the Unitas Road anticline. Typical schists contain sillimanite, orthoclase, plagioclase, biotite, garnet, graphite, and pyrrhotite.

Walk southeast on Tucker Road. At 200 feet note roadbed outcrop of gray-weathering Littleton schist. At 275 feet-roadbed outcrop of granitic gneiss. At 475 feet note roadbed outcrop of coarse gray garnet-sillimanite schist of Littleton Formation on west limb of Prouty Road syncline. Excellent loosepieces and small outcrops on northeast side of road (also poison ivy). Typical assemblage is quartz-sillimanite-garnet-biotite \pm plagioclase \pm orthoclase \pm cordierite.

Cross over crest of rise and at 500 feet turn left (east) on flagged route through woods. Traverse 400 feet east then northeast along west-facing ledge to excellent exposure of coarse well layered garnet-sillimanite schist of Littleton Formation. Note well developed southwest plunging minor fold in foliation of the dome stage.

Cross east over crest of knob then about N70E to low broken outcrop of Littleton Formation Orthopyroxene Gneiss Member. Turn north-northeast on west side of knob 940' and traverse parallel to strike to twin blazed trees near second broken outcrop of hypersthene gneiss. Turn east-southeast and walk 100 feet to large low east-facing outcrop of Littleton Formation Feldspar Gneiss Member. This rock unit, which is widespread in the Prouty Road syncline as well as the Gilbert Road syncline is difficult to distinguish from foliated pegmatite. Here it consists mainly of quartz, orthoclase, plagioclase, and garnet, but elsewhere biotite is also present. The rock is interpreted as a metamorphosed rhyolite, and may indeed have been melted during metamorphism.

Continue at S70E about 200 feet across small valley and low ridge to small east-facing outcrops of sillimanite-garnet schist of Littleton Formation on east limb of Prouty Road syncline.

Return by same route to twin blazed trees. Turn N20E and proceed down ridge 300 feet to very large knob outcrop of Orthopyroxene Gneiss. According to Emerson (1917) (see Field, 1975, p. 61) this is the outcrop from which he collected a sample that was analyzed and appeared in Washington (1917) Professional Paper 99. The rock generally consists of andesine or labradorite, orthopyroxene, cummingtonite, and biotite with or without hornblende, quartz, or magnetite. The results of electron probe analyses of a sample from this outcrop are plotted in Trip 3, Figure 29, as a three-phase field cummingtonite-orthopyroxene-hornblende. An important aspect of this is the small difference in Mg/(Mg+Fe) ratio between cummingtonite ($X_{Mg}=.69$) and orthopyroxene ($X_{Mg}=.66$). The hornblende has $X_{Mg}=.79$ and tetrahedral Al of 1.33, and the plagioclase is An52. The two coexisting amphiboles have spectacular exsolution lamellae. The rock from Washington's (1917) analysis shows 50% SiO₂ and a norm of 1.11, ab 6.81, an 15.01, hy 69.66, ol 1.31, mt 2.09, il 1.52, ap 0.67. Since the analyzed rock contains no normative diopside, the original description of the rock as wehrlite seems hardly appropriate. In outcrop the rock shows a very weak foliation formed by elongate plagioclase patches. There are also numerous thin veins normal to foliation which seem to be filled with secondary cummingtonite. The Hypersthene Gneiss Member because of its stratigraphic limitations is considered most probably to have been a flow or flows of andesite of unusual composition, although an intrusive origin certainly cannot be ruled out.

Return to vehicles by same route past twin blazed trees.

Continue south on Tucker Road.

14.7 Town corner post on left side of road.

15.6 Obvious outcrop knob on left side of road.

Stop 8. (10 minutes approximately) (Ware Quadrangle) Exposure of Partridge Formation in center of Lambertton Brook anticline. Dominant rock type is quartz-plagioclase-biotite-garnet-pyrrhotite schist with or without sillimanite and graphite. A thin layer presumably derived from mafic volcanic rock consists of orthopyroxene (poikilitic crystals up to 6 cm long), cumingtonite, plagioclase, and biotite, and is exposed at the top of the knob.

Proceed south on Tucker Road.

16.1 Junction with Ragged Hill Road. Cross intersection onto Gilbert Road and park on right. Outcrop is in the southeast sector of the intersection. Watch out for poison ivy!

Stop 9. (10 minutes approximate) (Ware Quadrangle). Outcrop is beautiful gray coarse-grained sillimanite-garnet schist with well developed quartzose beds that is typical of the Littleton Formation in the Gilbert Road syncline. Further north in the Barre area this syncline contains the best example of graded bedding at Stop 16.

Turn around and head east on Ragged Hill Road (downhill)

16.7 Turn right (south) onto Wickaboag Road.

17.1 Sharp right turn (southwest) onto Snow Road (no sign, Stanwood King mailbox)

18.0 T junction with Route 9. To retrieve vehicles turn right (west) and drive 2.1 miles to crest of Coys Hill. To continue trip turn left (east).

18.6 Turn right (southwest) off Route 9 onto Route 67.

19.9 Large road cut of rusty schist on left. Park on right and cross road. WATCH FOR TRAFFIC.

Stop 10. (10 minutes approximately) (Warren Quadrangle) Extremely rusty-weathering sillimanite schist of the Partridge Formation in the Pleasant Brook anticline. For detailed description of petrology see Trip P-3, Stop 5. This extremely friable rock type forms few natural exposures, which are dominated by more resistant granular schists and granulites. This belt of rock is the same one that passes through the village of Brimfield and was assigned to the Upper Schist Member of the Hamilton Reservoir Formation by Pomeroy (1977). The assignment of these rocks to the Ordovician has been strengthened by an Ordovician zircon age of 440 m.y. on a diorite sill, the Hedgehog Hill Gneiss, intruding these rocks in northernmost Connecticut (Pease and Barosh, 1981, p. 23).

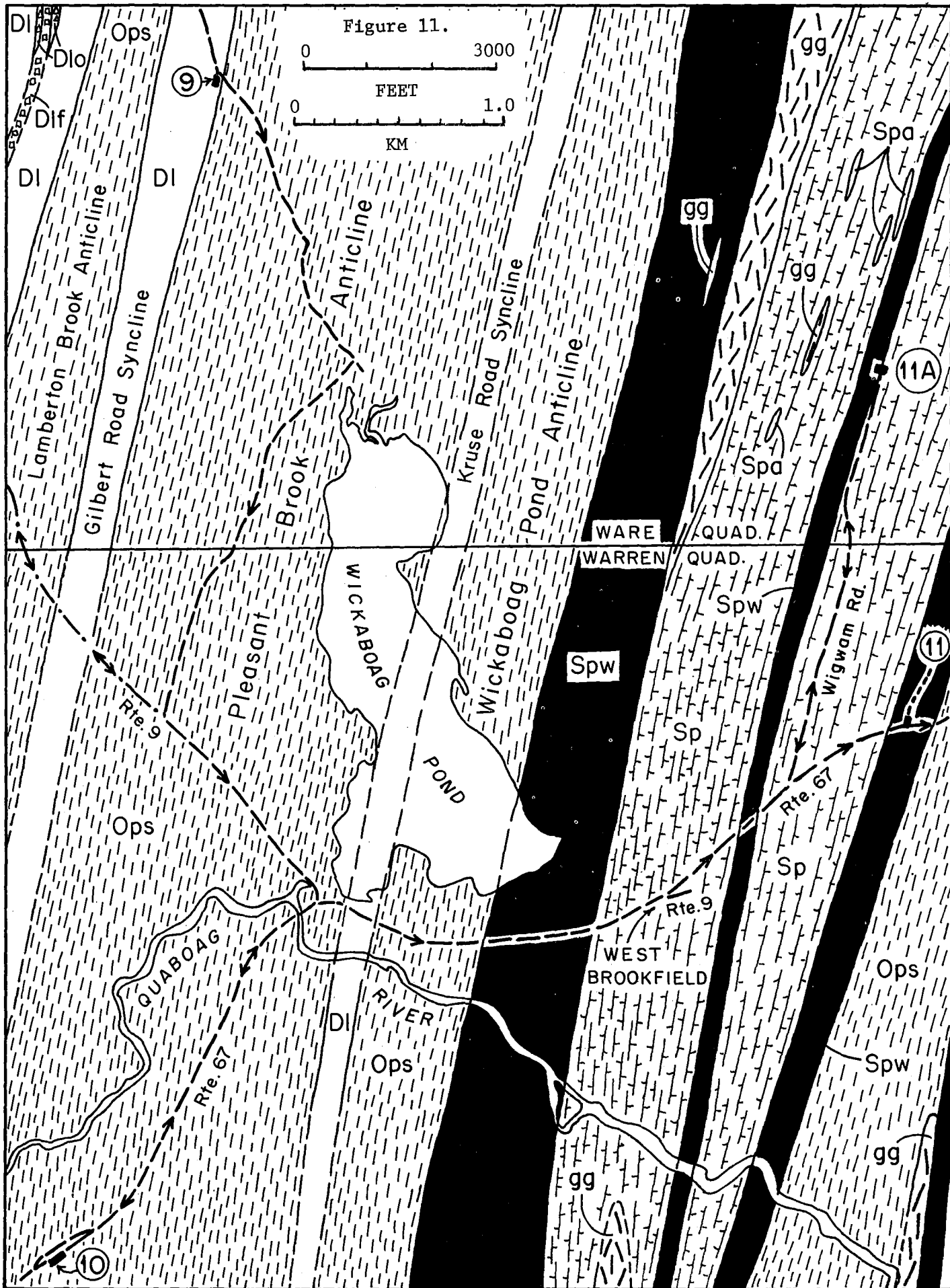

Proceed short distance on Route 67.

- 20.1 Turn right at Mark's Auto Sales onto old Route 67 northeast-bound.
- 20.2 Re-enter new Route 67. Turn left (northeast)
- 21.4 Junction with Route 9. Take ramp to right (east).
- 21.5 Enter Route 9.
- 22.5 Center of West Brookfield. Bear left on Route 67.
- 23.3 Hereford Cow sign on left. Park on highway or in barnyard depending on number of vehicles. Proceed north on foot through, and along long northeast-trending outcrop.

Stop 11. (20 minutes approximately) (Warren Quadrangle). This is one of the largest and best exposures of the White Schist Member of the Paxton Formation, which all are agreed is correlative with the Middle Silurian Smalls Falls Formation in western Maine. This is based not only on its unusual mineralogical characteristics (see detailed discussion in Trip 4 text and Stop 4) but on its position in the sequence in contact with the Granulite Member of the Paxton Formation which is extremely similar to the Madrid Formation. This rock type was included in the Upper Schist Member of the Hamilton Reservoir Formation by Pomeroy (1977), although he did show it as a separate rock type locally. In the field it is distinguished from pyrochite schists of the Partridge Formation by the extremely pale Mg-rich biotites, by the abundance of rutile and total absence of ilmenite and garnet, and locally by the presence of pyrite.

The formal road log ends at Stop 11. Beyond this there are several options depending on remaining time, if any. The remaining stops are linked together in a series of options with general descriptions of routes. Topographic maps are recommended. All stops are described individually at the end.

Full Option. This can include Stops 12, 12A, 13, 14, 15, 16, 17, and 18 but omits 11A and 11B.

East on Route 67 to center of North Brookfield, then east and northeast on School Street to southeast side of Tarbell Hill. Stop near Pecks Farm and descend slope a few feet below road to outcrops of Stop 12. (North Brookfield Quadrangle).

Continue on School Street to Hillsville Road. Follow Hillsville, Spencer and North Brookfield Roads east to Route 31 at Hillsville. Turn left (north) on Route 31 and follow through North Spencer to stream draining Eames Pond. Park near bridge on Nanigian Road which is parallel to Route 31 and descend into stream which is Stop 12A (Paxton Quadrangle).

Return west on Route 31 to North Spencer. Travel north on Rockland Road-Pleasant Dale Road to Route 122 and turn northwest. Follow Route 122 to Old Turnpike Road. To skip Stop 13 stay on Route 122. Follow Old Turnpike Road west to junction with Coldbrook Road. Stop 13 lies on Old Turnpike Road just west of junction (North Brookfield Quadrangle).

P4-23

Drive north on Coldbrook Road to Route 122 and turn left (west). Turn right on old railroad grade, just beyond Ware River Bridge, then around to left onto Old Worcester Road. To skip Stop 14, stay on Route 122 into Barre. Turn north (right) on Granger Road at junction 822, then right again at junction 861. About 0.1 mile beyond bottom of long downgrade look for steep driveway angling in from left and cliff in trees to left (west). Park on right about 0.2 mi south of road junction for Riverside Cemetery and walk to cliff which is Stop 14 (Barre Quadrangle). Drive north along river road to pavement at Route 62. Turn left (west) toward Barre. Eventually Route 62 passes deep valley of Prince River and begins ascent toward Barre. Take first left off Route 62 and park at south end of switchback to examine outcrop in trees to south which is Stop 15 (Barre Quadrangle).

Continue on same road which leads directly back into Route 62 and center of Barre. Take South Street 1.8 miles south past Quabbin Regional High School to powerline just beyond junction 873. Park and walk southeast 0.1 mile along powerline to large knob outcrop which is Stop 16 (Barre Quadrangle).

Return to center of Barre on South Street and follow Route 122 northwest 0.1 mile to sharp southwest (left) turn. 0.1 mile beyond is clean outcrop in lawn on left. This is Stop 17 (Barre Quadrangle). Continue west on Route 122 to waist-high outcrop on right which is Stop 18 (Petersham Quadrangle).

Oakham Option. Similar to Full Option but omits Stop 12A. From Stop 12 on School Street turn east on Hillsville Road to Mad Brook Road and thence to Oakham Road which becomes North Brookfield Road in Oakham. Turn left toward Oakham Village on Corner Road and north from Oakham on Cold Brook Road to Stop 13 to rejoin Full Option.

Barre Option. Direct route north from Stop 11 to Barre and graded bedding at Stop 16. Follows Route 67 through North Brookfield to Barre Plains and junction with Route 32. Take Route 32 west 0.5 mile to junction with South Street near Adams Cemetery. Turn right (northeast) on South Street and stay left (uphill) at next fork leading to powerline and Stop 16.

New Braintree-Barre Option. Includes stops 11A, 11B, then direct to Barre. From Stop 11 return southwest 0.4 miles on Route 67 to Wigwam Road. Sharp turn north onto Wigwam Road and travel north 1.0 mile to point where there is low outcrop on right and high outcrop on left. Powerline is 0.1 mile too far. This is Stop 11A (Ware Quadrangle).

Proceed north on Wigwam Rd. Stay straight at next junction, bear left at next two junctions and bear right onto West Brookfield Road at junction beyond New Braintree Town Line. Stop at small outcrop in bushes to right about 0.1 mile south of junction with Gilbertville Road. This is Stop 11B.

North on West Brookfield Road through center of New Braintree to right turn onto Barre Cut-off Road that leads direct to Route 67 and Barre Option.

Individual Stops

Stop 11A. (15 minutes approximately) (Ware quadrangle) This stop is along a contact between the Granulite Member of the Paxton Formation to the east, and the White Schist Member to the west which appears in a narrow belt interpreted as an isoclinal anticline. The best granulite is to be seen on the east sides of outcrops east of the road. The rocks are slabby and well layered on a scale of 2-3 cm. Although diopside-calc-silicate layers are subordinate, the purple biotite granulite usually has either labradorite or bytownite. The White Schist on the other side of the road is excessively rusty and abundant white mica looks like secondary muscovite, but it is in fact nearly pure Mg biotite.

Stop 11B. This stop is to examine the New Braintree olivine-hornblendite in the Wickaboag Pond anticline of Partridge Formation. The rock is described under Trip P-3, Stop 3A. In this region in Massachusetts ultramafic rocks seem to be confined to rocks of pre-Silurian age except for ultramafic bodies in the Belchertown pluton. However, the contact relations and origin of this body are very poorly known.

Stop 12. (15 minutes approximately) (North Brookfield Quadrangle). Gently west-dipping purple biotite granulite of the Paxton Formation on west limb of the Oakham anticline. Although calc-silicate rock is not abundant, the plagioclase in these granulites is usually labradorite or bytownite. Note pervasive but obscure E-W trending mineral lineation formed by elongate quartz and plagioclase grains. This is assigned to the backfold stage.

Stop 12A. (15-30 minutes) (Paxton Quadrangle) This locality was accidentally rediscovered by Tucker and Robinson on a late autumn evening in 1976. We think it is likely to be the type locality of the Paxton Schist of Emerson, because it is by far the largest natural exposure of the unit anywhere near Paxton. The rock consists of the same typical purple granulites with minor pegmatite and thin lenses of diopside calc-silicate. The section dips very gently and uniformly east on the east limb of the Gardner anticline. Foliation surfaces show both east-west (backfold stage) and northeast-trending (dome stage) linear fabrics. By climbing out of the gorge by the mill and walking north several hundred feet on a wood road it is possible to climb up through the Paxton Granulite Member and into the Paxton Quartzite and Rusty Schist Member capping a hill. This rock bears some similarity to an unnamed Silurian quartzite (Perry Mountain equivalent) described by Osberg (1980) on the Kennebec River, Maine which lies stratigraphically below the Fall Brook Formation that correlates with the Paxton Granulite Member. Our present interpretation is then that all or most of the "type section" is upside down! Return to cars by road beside gorge.

Stop 13. (10 minutes approximately) (North Brookfield Quadrangle) Low outcrop on north side of Old Turnpike Road is one of the few easily accessible outcrops of the pyrrhotite-sillimanite schists of the Partridge Formation in the core of the Oakham anticline. Specimens from Quabbin Tunnel (Tucker, 1977) show quartz-plagioclase-orthoclase-biotite-garnet-sillimanite± muscovite-graphite-pyrrhotite assemblages indicative of metamorphic Zone IV. One tunnel specimen from close to the Paxton contact on the west limb has all the characteristics of the White Schist Member, but could not be located

at the contact with certainty. Note foliation dipping 7° west-southwest, and mineral lineation, presumably of the dome stage, plunging 6° southwest.

Stop 14. (30 minutes approximately) (Barre Quadrangle) Ascend face of cliff by easy ramp to cabin at top, examining superb exposures of typical Granulite Member of the Paxton Formation. In the Barre area the typical granulite member consists of quartz, labradorite, orthoclase and biotite usually with thin green calc-silicate beds dominated by diopside and plagioclase with or without actinolite, clinozoisite and sphene. Beds of sulfidic schist range from scarce to abundant.

Walk west and southwest from cabin through zone in which granulite, rusty schist, and gray schist seem to be interlayered, until all outcrops are gray schist. The gray schist typically consists of quartz, plagioclase, orthoclase, biotite, garnet, muscovite, and graphite, with or without sillimanite. This unit was originally mapped by Tucker (1977) as a Gray Graphite Schist Member of the Paxton Formation stratigraphically below the Granulite Member, but Tucker and Robinson have since reinterpreted it as Littleton Formation stratigraphically above. In either case the contact appears to be gradational.

To reach road follow woodroad that loops around south end of cliff.

Stop 15. (15 minutes approximately) (Barre Quadrangle) Exposure is 100 feet from bend of switch-back road and consists of Littleton Formation in the Prouty Road syncline close to the contact with the Partridge Formation to the east. Bedding is involved in dome stage folds with typical east-side-up movement sense. The long limbs dip about 12° NW. When this is deciphered it is clear that graded beds show tops west.

Stop 16. (25 minutes approximately) (Barre Quadrangle) Upper surface of knob under powerline shows superb outcrop of well bedded coarse garnet-sillimanite schist of the Littleton Formation in the Gilbert Road syncline, close to the contact of the Partridge Formation to the west. Except where complicated by dome stage folds excellent graded bedding dips 33° west and is overturned. Tucker (1977) has published a list of ten graded bedding localities in the Prouty Road and Gilbert Road synclines near Barre. Of these 4 are right-side up and 6 are upside down.

Stop 17. (20 minutes approximately) (Barre Quadrangle) This clean outcrop of Coys Hill Granite serves as something of a local Rosetta Stone for structural and metamorphic history. It appears to show evidence of the following events:

- 1) Crystallization of microcline megacrysts, probably as igneous phenocrysts.
- 2) Formation of pervasive tectonic foliation including rounding of megacrysts, probably during the regional nappe stage.
- 3) Intrusion of fine-grained granitic dikes, cross-cutting the tectonic feldspar foliation.

P4-27

- 4) Deformation of foliation and of dikes by conspicuous west-plunging folds, with south over north movement sense, probably from early in the back-fold stage.
- 5) Development of ductile mylonite zones that cross-cut the west-plunging folds. Locally these seem to have a north over south movement sense, and a strong down-dip linear fabric.
- 6) Development of weak southwest-plunging linear fabric assigned to the dome stage.

At back of lawn there are small outcrops of big garnet Littleton Formation overlying the Coys Hill Granite.

Stop 18. (10 minutes approximately) (Barre Quadrangle) Excellent waist-high exposure shows typical biotite tonalite of the Hardwick pluton. Foliation dips very gently west and there is also a well developed dome stage lineation.

REFERENCES CITED

- Ashwal, L. D., Leo, G. W., Robinson, Peter, Zartman, R. E., and Hall, D. J., 1979, The Belchertown quartz monzodiorite pluton, west-central Massachusetts, a syntectonic Acadian intrusion. *American Journal of Science* v. 279, p. 936-969.
- Barker, Fred, 1962, Cordierite-garnet gneiss and associated microcline-rich pegmatite at Sturbridge, Massachusetts and Union, Connecticut. *American Mineralogist*, v. 47, p. 907-918.
- Berner, R. A., 1971, Principles of chemical sedimentology. McGraw Hill, New York, 240 p.
- Emerson, B. K., 1898, Geology of old Hampshire County, Massachusetts. U.S. Geological Survey Monograph 29, 790 p.
- Emerson, B. K., 1917, Geology of Massachusetts and Rhode Island. U.S. Geological Survey Bulletin 597, 289 p.
- Fahlquist, F. E., 1935, Geology of region in which Quabbin Aqueduct and Quabbin Reservoir are located; Appendix to report of Chief Engineer. Annual Report of the Metropolitan District Water Supply Commission, Commonwealth of Massachusetts, Public Document No. 147, 47 p.
- Ferry, J. M. and Spear, F. S., 1978, Experimental calibration of the partitioning of Fe and Mg between biotite and garnet. *Contributions to Mineralogy and Petrology* 66, 113-117.
- Field, M. T., 1975, Bedrock Geology of the Ware Area, Central Massachusetts. Contribution No. 22, (Ph.D. thesis), Department of Geology and Geography, University of Massachusetts, Amherst, 186 p.

- Fonarev, V. I. and Korolkov, G. Ja., 1980, The assemblage orthopyroxene + cummingtonite + quartz. The low-temperature stability limit. Contributions to Mineralogy and Petrology v. 73, p. 413-420.
- Guidotti, C. V., Cheney, J. T., and Guggenheim, Stephen, 1977, Distribution of titanium between coexisting muscovite and biotite in pelitic schists from northwestern Maine. American Mineralogist, v. 62, p. 438-448.
- Guidotti, C. V., Cheney, J. T., and Conatore, P. D., 1975, Coexisting cordierite + biotite + chlorite from the Rumford quadrangle, Maine. Geology, v. 3, p. 147-148.
- Hall, D. J., 1970, Composition variations in biotites and garnets from kyanite and sillimanite zone mica schists, Orange area, Massachusetts and New Hampshire. Contribution No. 4 (M.S. thesis), Geology Department, University of Massachusetts, Amherst, 110 p.
- Hall, L. M. and Robinson, Peter, 1982, Stratigraphic-tectonic subdivisions of southern New England, p. 15-41, in P. St. Julien and J. Beland, eds., Major structural zones and faults of the Northern Appalachians. Geological Association of Canada Special Paper 24.
- Hatch, N. L., Jr., Moench, R. H. and Lyons, J. B., 1981, Silurian-Devonian section and correlations across northeastern New Hampshire. Geological Society of America Abstracts with Programs, v. 13, p. 137.
- Heald, M. T., 1950, Structure and petrology of the Lovewell Mountain quadrangle, New Hampshire. Bulletin Geological Society of America, v. 61, p. 43-89.
- Henry, D. J. and Guidotti, C. V., 1981, Implications of the sulfide-silicate interactions in staurolite grade metapelites in NW Maine (abstract). EOS, v. 62, p. 435-436.
- Hess, P. C., 1969, The metamorphic paragenesis of cordierite in pelitic rocks. Contributions to Mineralogy and Petrology, v. 24, p. 191-207.
- Hess, P. C., 1971, Prograde and retrograde equilibria in garnet-cordierite gneisses in south-central Massachusetts. Contributions to Mineralogy and Petrology, v. 30, p. 177-195.
- Holdaway, M. J., 1971, Stability of andalusite and the aluminum-silicate phase diagram. American Journal of Science v. 271, p. 97-131.
- Holdaway, M. J. and Lee, S. M., 1977, Fe-Mg cordierite stability in high-grade pelitic rocks based on experimental, theoretical, and natural observations. Contributions to Mineralogy and Petrology, v. 63, p. 175-198.
- Hollister, L. S., 1966, Garnet zoning: An interpretation based on the Rayleigh fractionation model. Science, v. 154, p. 1647-1651.

- Hollocher, Kurt, 1981, Retrograde metamorphism of the Lower Devonian Littleton Formation in the New Salem area, west-central Massachusetts. Contribution No. 37 (M.S. thesis), Department of Geology and Geography, University of Massachusetts, Amherst, 268 p.
- Huntington, J. C., M.S., 1975, Mineralogy and Petrology of Metamorphosed Iron-rich Beds in the Lower Devonian Littleton Formation, Orange Area, Massachusetts. Contribution No. 19 (M.S. thesis), Department of Geology and Geography, University of Massachusetts, Amherst, 106 p.
- Ludman, Allan, 1976, Fossil-based stratigraphy in the Merrimack synclinorium, central Maine, in Page, L. R., ed., Contributions to the stratigraphy of New England. Geological Society of America Memoir 148. p. 65-78.
- Lyons, J. B., and Livingston, D. E., 1977, Rb-Sr age of the New Hampshire Plutonic Series. Bulletin Geological Society of America v. 88, p. 1808-1812.
- Moench, R. H. and Boudette, E. L., 1970, Stratigraphy of the northwest limb of the Merrimack synclinorium in the Kennebago Lake, Rangeley, and Phillips quadrangles, western Maine. New England Intercollegiate Geologic Conference, 62nd Annual Meeting, Guidebook, p. 1-25.
- Mohr, D. W. and Newton, R. C., 1981, Role of sulfur fugacity in metamorphism of mica schists (abstract). EOS, v. 62, p. 436.
- Moore, G. E., Jr., 1978, Preliminary geologic map of the Southbridge quadrangle, Massachusetts and Connecticut. U.S. Geological Survey open file map 78-220.
- Naylor, R. S., 1971, Acadian orogeny: An abrupt and brief event. Science v. 172, p. 558-560.
- Newton, R. C., 1966, Kyanite-andalusite equilibrium from 700° to 800°C. Science v. 153, p. 170-172.
- Osberg, P. H., 1980, Stratigraphic and structural relations in the turbidite sequence of south-central Maine. New England Intercollegiate Geologic Conference, 72nd Annual Meeting, Guidebook, p. 278-296.
- Pease, M. H., Jr. and Barosh, P. J., 1981, Distribution and structural significance of the Oakdale Formation in northeastern Connecticut: New England Intercollegiate Geologic Conference, 73rd Annual Meeting, Guidebook, p. 17-34.
- Peper, J. D., 1966, Stratigraphy and structure of the Monson area, Massachusetts and Connecticut. Ph.D. thesis, University of Rochester, 126 p.
- Peper, J. D., 1967, Stratigraphy and structure of the Monson area, Massachusetts and Connecticut. New England Intercollegiate Geological Conference, 59th Annual Meeting, Guidebook, 105-113.
- Peper, J. D., 1976a, Preliminary Bedrock Geologic Map of the Palmer quadrangle, Mass. U.S. Geological Survey open file report 76-489, 21 p.

- Peper, J. D., 1977a, Bedrock geologic map of the Hampden quadrangle, Massachusetts and Connecticut: U.S. Geological Survey Geol. Quad. Map GQ-1368.
- Peper, J. D., 1977b, Bedrock geologic map of the Monson quadrangle, Massachusetts and Connecticut: U.S. Geological Survey Geol. Quad. Map GQ-1374.
- Peper, J. D., Pease, M. G., Jr., and Seiders, V. M., 1975, Stratigraphic and structural relationships of the Brimfield Group in northeast-central Connecticut and adjacent Massachusetts. U. S. Geological Survey Bulletin 1389, 31 p.
- Pomeroy, J. S., 1974, The diorite at West Warren, south-central Massachusetts. U. S. Geological Survey Open-File Report 74-138, 44 p.
- Pomeroy, J. S., 1975, Preliminary bedrock geologic map of the East Brookfield quadrangle, Worcester County, Massachusetts. U.S. Geological Survey Open-File map 75-530.
- Pomeroy, J. S., 1977, Bedrock geologic map of the Warren quadrangle, Massachusetts. U.S. Geological Survey Geol. quad. Map GQ-1538.
- Richardson, S. W. , Gilbert, M. C., and Bell, P. M., 1969, Experimental determination of kyanite-andalusite and andalusite-sillimanite equilibria: the aluminosilicate triple point. American Journal of Science, v. 267, p. 259-272.
- Robinson, Peter, 1963, Gneiss domes of the Orange area, Massachusetts and New Hampshire. Ph.D. Thesis, Harvard University, 253 p.
- Robinson, Peter, 1967, Geology of the Quabbin Reservoir area, central Massachusetts. New England Intercollegiate Geologic Conference, 59th Annual Meeting, Guidebook, p. 114-127.
- Robinson, Peter, Tracy, J., and Ashwal, L. D., 1975, Relict sillimanite-orthoclase assemblage in kyanite-muscovite schist, Pelham dome, west-central Massachusetts (abstract). Transactions of the American Geophysical Union v. 56, p. 466.
- Robinson, Peter, 1976, Correlation, tectonics, and metamorphism, south-central New England. Geological Society of America, Abstracts with Programs, v. 8, p. 257.
- Robinson, Peter, 1979, Bronson Hill anticlinorium and Merrimack synclinorium in central Massachusetts, in Skehan, J. W., S. J. and P. H. in the northeast Appalachian, Project 27, Caledonide Orogen 1979, Weston, Massachusetts, p. 126-150.
- Robinson, Peter, 1981, The basement-cover enigma in the gneiss domes of central New England, U.S.A. (Abstract, Uppsala Caledonide Symposium) Terra Cognita, v. 1, p. 70.

P4-31

- Robinson, Peter and Jaffe, H. W., 1969a, Aluminous enclaves in gedrite-cordierite gneiss from southwestern New Hampshire. *American Journal of Science*, v. 267, p. 389-421.
- Robinson, Peter and Jaffe, H. W., 1969b, Chemographic exploration of amphibole assemblages from central Massachusetts and Southwestern New Hampshire. *Mineralogical Society of America, Special Paper No. 2*, p. 251-274.
- Robinson, Peter, Jaffe, H. W., Klein, Cornelis Jr. and Ross, Malcolm Ross, 1969, Equilibrium coexistence of three amphiboles. *Contributions to Mineralogy and Petrology*, v. 22, p. 248-258.
- Robinson, Peter, Ross, Malcolm, and Jaffe, H. W., 1971, Composition of the anthophyllite-gedrite series, comparisons of gedrite and hornblende, and the anthophyllite-gedrite solvus. *American Mineralogist* v. 56, p. 1005-1041.
- Robinson, Peter, Spear, F. S., Schumacher, J. C., Laird, Jo, Klein, Cornelis, Evans, B. W., and Doolan, B. L., 1981, Amphiboles in metamorphic rocks: natural occurrence and theory, in Veblen, D. R. and P. H. Ribbe, Editors. *Reviews in Mineralogy, Volume 9B, Amphiboles: Petrology and Experimental Phase Relations*, Mineralogical Society of America, Washington, D.C., p. 1-227.
- Robinson, Peter and Tracy, R. J., 1976, Retrograde garnet zoning paths produced in continuous hydration reactions in high grade pelitic schists, central Massachusetts. *Geological Society of America, Abstracts with Programs* v. 8, p. 1072-1073.
- Robinson, Peter and Tracy, R. J., 1977, Sulfide-silicate-oxide equilibria in sillimanite-K-feldspar grade pelitic schists, central Massachusetts. *EOS*, v. 58, p. 524.
- Robinson, Peter, and Tracy, R. J., 1979, Gedrite-cordierite, gedrite-orthopyroxene, and cummingtonite-orthopyroxene assemblages from ferromagnesian gneisses, sillimanite-K-feldspar zone, central Massachusetts. *Geological Society of America, Abstracts with Programs* v. 11, p. 504.
- Robinson, Peter, Tracy, J., and Pomeroy, J. S., 1977, High pressure sillimanite-garnet-biotite assemblage formed by recrystallization of mylonite in sillimanite-cordierite-biotite-orthoclase schist, central Massachusetts. *Geological Society of America, Abstracts with Programs*, v. 9, p. 1144-1145.
- Robinson, Peter, Tracy, R. J., and Tucker, R. D., 1978, The Acadian (Devonian) metamorphic high of central Massachusetts. *Geological Society of America, Abstracts with Programs* v. 10, p. 479-480.
- Rodgers, John, 1981, The Merrimack Synclinorium in northeastern Connecticut. *American Journal of Science* v. 281, p. 176-186.

- Rosenfeld, J. L., 1969, Stress effects around quartz inclusions in almandine and the piezothermometry of coexisting aluminum silicates. *American Journal of Science* v. 267, p. 317-351.
- Schreyer, W., 1974, Whiteschist, a new type of metamorphic rock formed at high pressures. *Geologische Rundschau* v. 63, p. 597-609.
- Schumacher, J. C., 1980a, Detailed stratigraphy of the metamorphosed Middle Ordovician Ammonoosuc Volcanics, Warwick gneiss dome, north-central Massachusetts. *Geological Society of America, Abstracts with Programs* v. 12, 81.
- Schumacher, J. C., 1980b, Gedrite of extreme Al and Na content in the metamorphosed Ammonoosuc Volcanics, sillimanite-staurolite zone, central Massachusetts. *Geological Society of America, Abstracts with Programs* v. 12, 518.
- Schumacher, J. C., 1981a, Preliminary geochemistry of the metamorphosed Ammonoosuc Volcanics, north-central Massachusetts. *Geological Society of America, Abstracts with Programs* v. 13, p. 175.
- Schumacher, J. C., 1981b, Coexisting hornblende-cordierite-gedrite in gedrite-cordierite gneiss, southwestern New Hampshire (abstract). *EOS* v. 62, p. 422.
- Schumacher, J. C., 1981c, Compositions of sapphirine, staurolite, zincian spinel, and calcic plagioclase from aluminous enclaves in gedrite-cordierite gneiss, southwestern New Hampshire. *Geological Society of America, Abstracts with Programs* v. 13, p. 549.
- Seiders, V. M., 1976, Bedrock geologic map of the Wales quadrangle, Massachusetts and Connecticut. U.S. Geologic Survey Geologic Quadrangle Map GQ-1320.
- Shearer, C. K. and Robinson, Peter, 1980, Constant temperature metamorphism of an H₂O activity gradient in a pre-existing contact aureole, Peterham, Massachusetts (abstract). *EOS*, v. 61, p. 389.
- Thompson, A. B., 1976, Mineral reactions in pelitic rocks: I. Prediction of P-T-X (Fe-Mg) phase relations. *American Journal of Science* v. 276, p. 401-424.
- Thompson, A. B., Tracy, R. J., Lyttle, P. T. and Thompson, J. B., Jr., 1977, Mineral reactions and A-Na-K and A-F-M facies types in the Gassetts schist, Vermont. *American Journal of Science*, v. 277, p. 1124-1151.
- Thompson, J. B., Jr. 1972, Oxides and sulphides in regional metamorphism of pelitic schists. 24th International Geologic Conference, section 10. p. 27-35.
- Tracy, R. J., 1975, High grade metamorphic reactions and partial melting in pelitic schist, Quabbin Reservoir area, Massachusetts. Contribution No. 20 (Ph.D. thesis), Department of Geology and Geography, University of Massachusetts, Amherst, 127 p.

- Tracy, R. J., 1978, High grade metamorphic reactions and partial melting in pelitic schist, west-central Massachusetts. *American Journal of Science* v. 278, p. 150-178.
- Tracy, R. J. and Dietsch, C. W., 1982, High temperature retrograde reactions in pelitic gneiss, central Massachusetts. *Canadian Mineralogist*, in press.
- Tracy, R. J., and Robinson, Peter, 1978, Metamorphic isograd mapping in central Massachusetts and the study of changing mineral compositions in metamorphism. *Geological Society of America, Abstracts with Programs* v. 10, p. 89.
- Tracy, R. J. and Robinson, Peter, 1978, Determination of metamorphic P-T trajectories and their relation to Acadian deformation patterns in central New England, U.S.A. *Symposium on Metamorphism in the Caledonides, Dublin, Ireland - Aug. 1978*.
- Tracy, R. J. and Robinson, Peter, 1980, Evolution of metamorphic belts: Information from detailed petrologic studies, *in The Caledonides in the U.S.A.*, D. R. Wones, ed., V.P.I. and S.U. *Memoir* 2, p. 189-195.
- Tracy, R. J., Robinson, Peter, and Field, M. T., 1976, Phase relations of natural pure magnesian cordierite and biotite from pyrite sillimanite-orthoclase schist, central Massachusetts (abstract). *Transactions of the American Geophysical Union*, v. 57, p. 338-339.
- Tracy, R. J., Robinson, Peter, and Thompson, A. B., 1975, Garnet composition and zoning in the determination of temperature and pressure of metamorphism, central Massachusetts. *International Conference on Geothermometry and Geobarometry. Extended Abstracts*, 4 p.
- Tracy, R. J., Robinson, Peter and Thompson, A. B., 1976, Garnet composition and zoning in the determination of temperature and pressure of metamorphism, central Massachusetts. *American Mineralogist* v. 61, p. 762-775.
- Tracy, R. J. and Rye, D. M., 1981, Origin and mobility of sulfur in graphitic schists, central New England. *Geological Society of America, Abstracts with Programs for 1981*, v. 13, p. 569.
- Tucker, R. D., M.S., 1977, Bedrock geology of the Barre area, central Massachusetts. *Contribution No. 30 (M.S. thesis)*, Dept. of Geology and Geography, University of Massachusetts Amherst, 132 p.
- Washington, H. S., 1917, Chemical analyses of igneous rocks. *U.S. Geological Survey Professional Paper* 99, 1201 p.
- Wolff, R. A., M.S., 1978, Ultramafic lenses in the Middle Ordovician Partridge Formation, Bronson Hill anticlinorium, Central Massachusetts. *Contribution No. 34 (M.S. thesis)*, Department of Geology and Geography, University of Massachusetts, Amherst, 162 p.

LAKE CHAR FAULT IN THE WEBSTER, MASSACHUSETTS AREA:
EVIDENCE FOR WEST-DOWN MOTION

Arthur G. Goldstein
Dept. of Geology
Colgate University
Hamilton, N.Y. 13346

ABSTRACT

The Lake Char fault is mapped as the contact between basement and cover and has been proposed as a thrust (west-up) fault. In the Webster, Massachusetts area, the fault forms a wide zone of mylonite. Based on mesoscopic structural analysis, the fault had a west-down component of motion and is not a thrust fault. Also, mylonitization, the major evidence for faulting, was a discreet structural event in a long sequence of ductile and brittle deformations. Therefore, the fault is interpreted as having a geologically brief life span.

INTRODUCTION

The southeastern New England fault system (Fig. 1) is composed of a number of mylonite zones which occur at the contact between Avalonian (~ 600 my) acidic metaigneous rocks and overlying metapelites and metabasites. The faults are commonly low-angle, are marked by wide zones of mylonites and have previously been described as having a thrust (west-over-east) component (Dixon and Lundgren, 1968). Despite suggestions that this fault system may mark a collisional suture, detailed structural analyses have not been common. This trip visits localities with key structural relationships within the Lake Char fault zone (for obvious reasons, this is usually called the Lake Char fault zone). The conclusions which arise from examination of these exposures are:

(1) Based on rotation senses of intrafolial folds in mylonite and the sense of shear at the margins of small mylonite zones, the Lake Char fault in this area is not a thrust fault. Rather, the upper plate moved down with prominent northwest-trending mineral lineations marking the motion direction.

(2) Movement on the Lake Char fault occurred as a single discreet structural event during a long history of folding and faulting. The fault does not represent a profound crustal weakness which was reactivated over a long time interval.

Figure 1. Tectonic map of southeastern New England showing the names and locations of the southeastern New England fault system and some other major faults (after Dixon, 1976, Dixon and Lundgren, 1968, Castle et al., 1976; and Wintsch, 1979). The shaded square represents the area covered in greater detail in Figure 2.

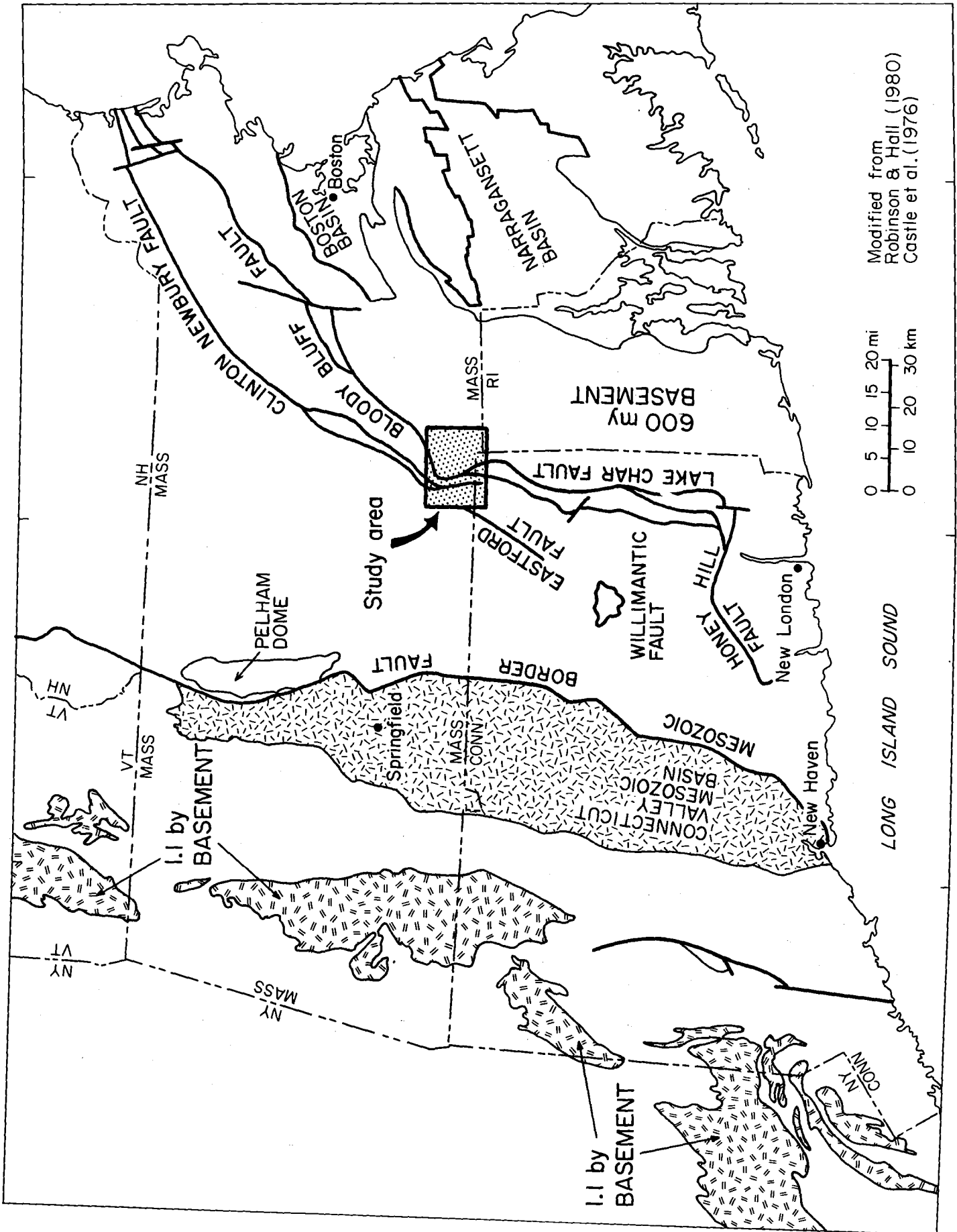

FIGURE 1

STRATIGRAPHY

The stratigraphic names used in this guide are those defined by Dixon (1964). The basement complex comprises the Hope Valley Alaskite, a well foliated microcline, plagioclase, quartz, muscovite, \pm biotite, \pm garnet gneiss and the Plainfield quartzite. Overlying these, on the upper plate of the Lake Char fault, the lowest portion of the cover sequence is the Quinebaug Fm., a unit poorly exposed in the Webster area, but composed of hornblende schists and gneisses and nonresistant calcareous metasediments.

The Tatnic Hill Fm. overlies the Quinebaug Fm. with the contact marked as the first appearance of rusty-weathering gneiss. The contact is commonly sharp without any apparent gradation between the two units. The internal stratigraphy of the Tatnic Hill Fm. is well known and well displayed in the Webster area. The lower member is composed of, in ascending order, a rusty-weathering gneiss which commonly contains large amphibolite bodies with altered ultramafic blocks, a biotite gneiss and a sillimanite-garnet-plagioclase-quartz gneiss. Overlying the lower member are the Fly Pond member, a non-resistant calcareous gneiss and the Yantic Member, a quartz-oligoclase-biotite-muscovite schist.

The Tatnic Hill Fm. is overlain by Siluro-Ordovician metasediments, which are intruded by a granitic sill, the Ayer granite. Localities for this field guide will be predominantly in the lower member of the Tatnic Hill Fm., although some stops will highlight other lithologies.

STRUCTURAL GEOLOGY

With the exception of the Lake Char fault zone, of course, the most prominent structure in the Webster area is the Douglas Woods anticline (Fig. 2). This broad, northwest plunging fold affects basement and cover in which it folds both layering and foliation. The fold itself has no associated axial plane foliation and does not have mesoscopic parasitic folds associated with it. Dixon (personal comm., 1976) has mapped isoclinal folds by Plainfield Fm. in the Hope Valley Alaskite (Fig. 2) which also appear to be folded by the Douglas Woods Anticline.

Figure 2. Geologic map of portions of Oxford, Webster, Leicester, and Worcester South, Massachusetts 7 $\frac{1}{2}$ ' U.S.G.S. quadrangles covered by this study (modified after Barosh, 1976, and H.R. Dixon, personal communication, 1976). The extent of the mylonite zone as mapped by criteria described in the text is shown in the shaded pattern. Numbers are localities referred to in the text. The rectangle at the southern margin of the map is an area of detailed study referred to in the text. No distinction has been made between the Lake Char and Bloody Bluff faults since they are a continuous surface, although, technically, the fault on the north limb, labeled Lake Char fault, would be the southernmost extent of the Bloody Bluff fault.

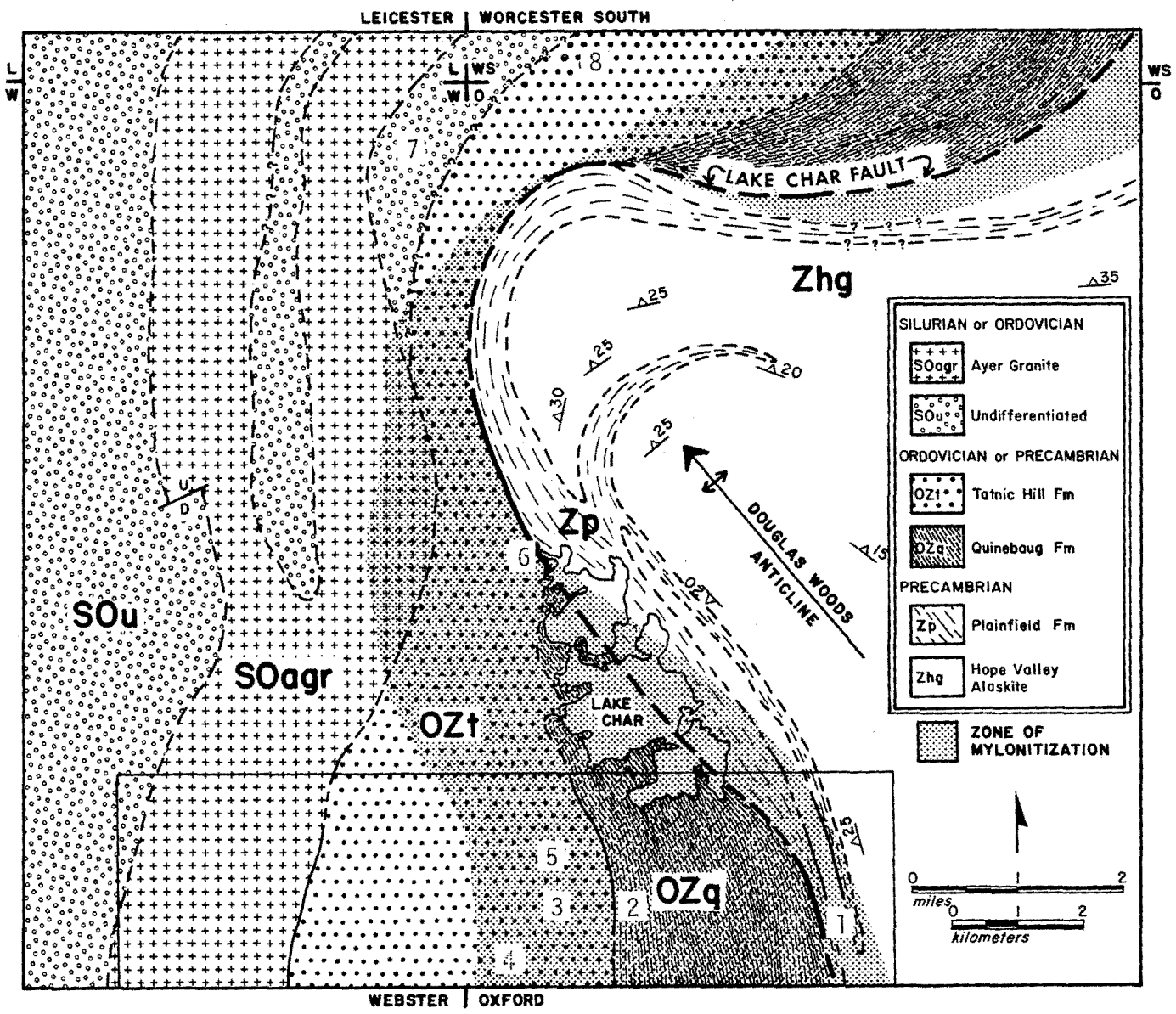

Figure 2

Mesoscopic structural analysis. As noted by Dixon (1964) and many others, the internal stratigraphy of the Quinebaug and Tatnic Hill Fms. is suggestive of a homocline; that is, repetitions of this stratigraphy are almost non-existent. This is quite surprising because the deformational history deduced from mesoscopic structural analysis is quite complex. The structural diagrams in figure 3 and the following discussion are derived largely from the detailed analysis of exposures in the southern portions of the Oxford and Webster 7½' quadrangles (rectangular area at the bottom of Fig. 2). The relationships developed in that region have been accurate when applied as a model for reconnaissance in other portions of the fault system and are similar in some respects to the structural history proposed by Nelson (1976) for a portion of the Bloody Bluff fault.

D1 - First isoclinal folding. At several localities (Stops #4 and #8, this trip) are isoclinal folds which do not fold a foliation, but have a strong axial plane foliation which is folded by later folds. At Stop #4, it is clear that the layering being folded is original sedimentary bedding. These rare occurrences of D1 fold hinges do not allow their orientations to be described in any consistent manner.

D2 - Second isoclinal folding. These folds are the most common in this area. They fold an earlier foliation (D1) and have an axial plane foliation of their own. Their axes plunge shallowly to the south-southwest and their axial planes strike essentially north-south and dip moderately to the west (Fig. 3). Sillimanite, hornblende and biotite lineations are parallel to their axes. These folds are well illustrated at Stops #5 and #8 and the optional Stop #7. They clearly predate the Douglas Woods Anticline since their orientations vary around the hinge of the Douglas Woods Anticline (compare Stops #5 and #8).

D3 - Mylonitization. It is proposed that mylonitization and thus Lake Char faulting occurred after D2. This is based on their relative orientations around the Douglas Woods Anticline and the relationships at Stop #8. Mylonitic foliation (fluxion structure) generally parallels a pre-existing foliation and probably resulted from slip initiated on that older foliation. Prominent mineral lineations, quartz, feldspar, biotite and others, on mylonitic foliation plunge shallowly to the northwest or southeast (Fig. 3) and mark the motion direction for Lake Char faulting (Stops #1 and #6). At Stops #1, #4, #6, and #8 the polarity of slip can be determined and at all four the upper plate moved down in a northwest direction. Thus, the Lake Char fault in this area could be termed a low-angle normal fault, although that phrase connotes crustal extension which may not have been the driving force for the Lake Char fault. The fault is perhaps better thought of as a tectonic slide. Temperatures during Lake Char faulting were between 525°C and 600°C (Goldstein, 1982) and the deformation mechanisms for both quartz and feldspar were translation glide and climb.

D4 - Late folding. D3 mylonitic foliation is folded by late folds whose axes parallel D2 folds (Fig. 3). These folds lack an axial plane foliation and thus are easily distinguished from D2 folds.

D5 - Ductile normal faulting. These high-angle faults commonly are not discreet fractures but have zones of shear up to 10 cm. wide. They cut D3 mylonitic foliation (Stop #4) and break some areas into horsts and grabens (Stop #5). Their orientations (Fig. 4) bear no relationship to fabric elements of D3 mylonitic fabrics and thus are not believed to be related in any way to movement on the Lake Char fault.

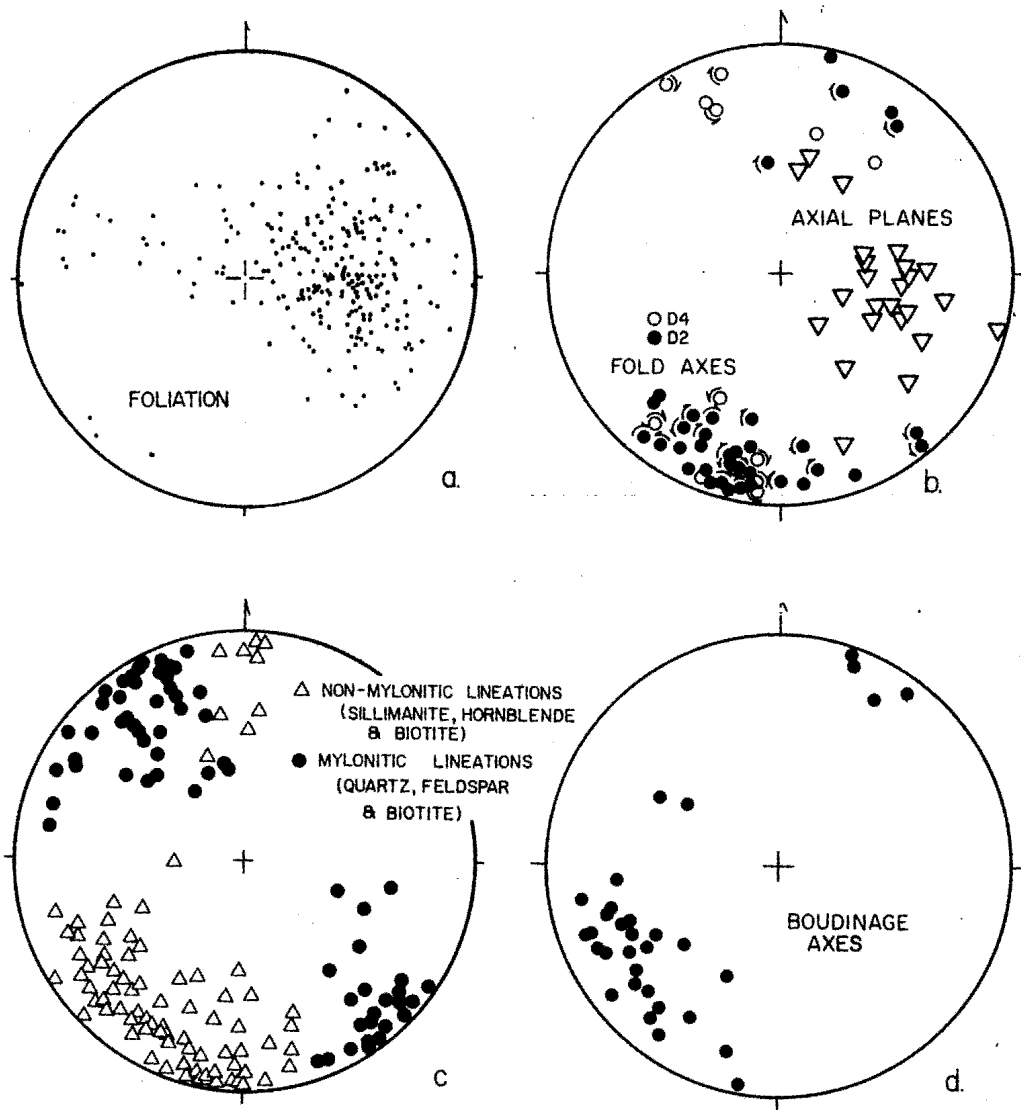

Figure 3. Orientations of mesoscopic structural elements within the area of detailed study shown in Figure 2, plotted on the lower hemispheres of equal-area nets. (a) Orientations of poles to 236 foliation (D1, D2 and D3) planes, (b) Orientations of 36 D2 fold axes, 13 D4 fold axes and 24 poles to D2 axial planes, (c) Orientations of 65 mylonitic (D3) mineral lineations and 83 pre-mylonitic (D1 and D2) mineral lineations, (d) Orientations of 32 boudin neck lines.

P5-7

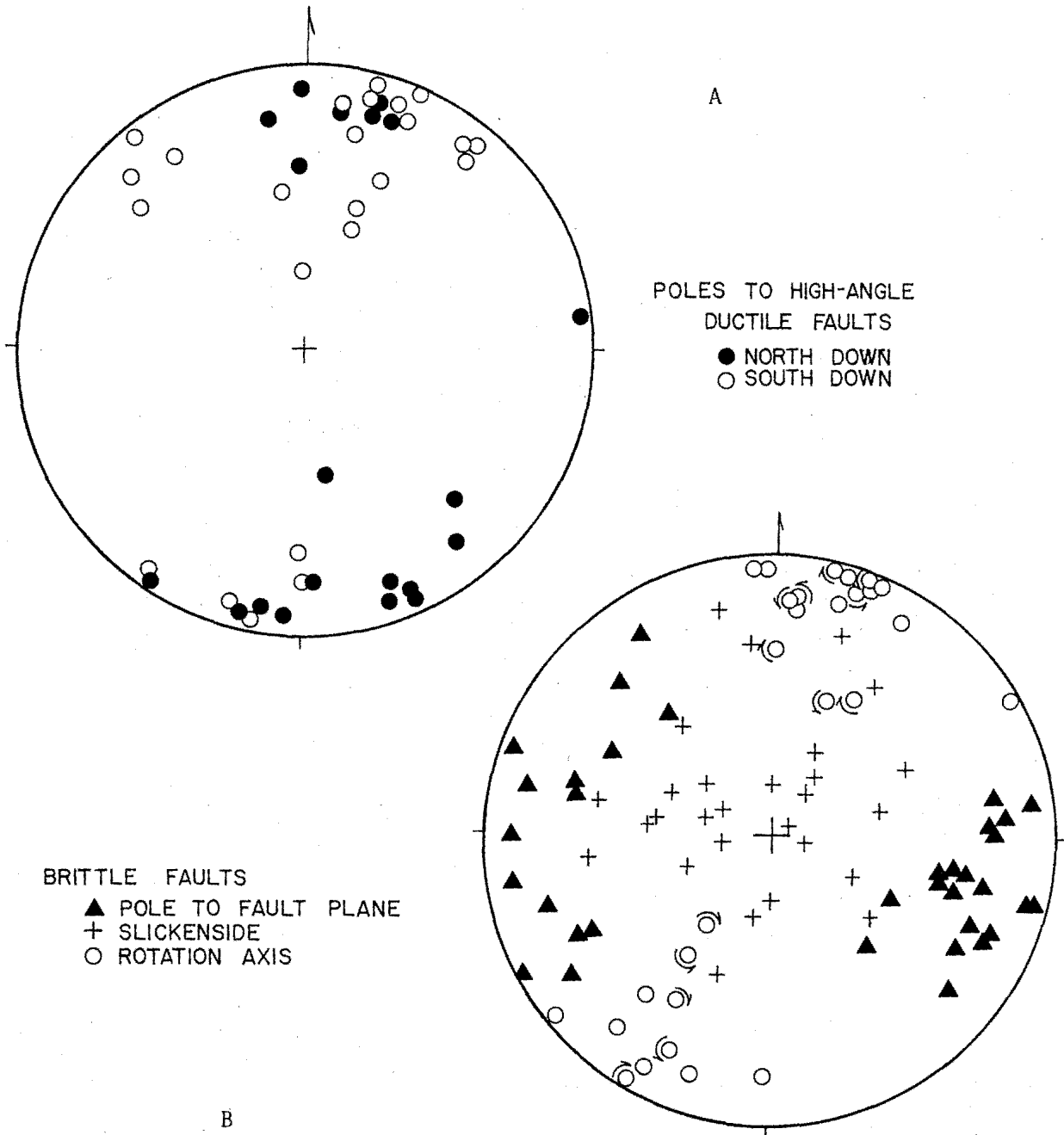

Figure 4. Lower hemisphere, equal-area plots of fabric elements for late faults. (a) Poles to high-angle ductile faults (D5). (b) Fabric elements for brittle faults (D6).

D6 - Brittle normal faulting. Also present at many exposures are brittle faults which appear as slickensided fractures. Although no direct evidence gives their timing with respect to D5, the lower temperatures suggested by true brittle behavior are consistent with the age relationships proposed here. The orientations of those faults and of their kinematic elements (Fig. 4) suggest an origin associated with Triassic rifting.

Although these conclusions have been based on an area only a little larger than a 7½' quadrangle, they represent the first detailed structural analysis carried out along the southeastern New England fault system. The results disagree strongly with previous statements that the fault system is composed of thrust faults with long movement histories. For the Webster area, there is an apparent relationship in timing and orientation between mylonization and the Douglas Woods Anticline. For that reason, I propose an origin of the Lake Char fault which involves basement-cover decollément during basement diapirism (Fig. 5). Strain localization would have resulted from the differing mechanical-chemical behavior of basement versus cover. Quartzofeldspathic basement rocks accommodated strain in a purely mechanical fashion whereas the metapelites and metabasites of the cover sequence underwent mineral reactions usually resulting in the production of phyllosilicates, thereby weakening the rock further. It remains to be seen if this model will be applicable to the remaining portions of the fault system.

REFERENCES CITED

- Barosh, P.J., 1974, Preliminary bedrock geologic map of the Webster quadrangle, Mass.-Conn.: U.S. Geol. Survey Open File Map 74-192.
- Dixon, H.R., 1964, The Putnam Group of eastern Connecticut: U.S. Geol. Survey Bull. 1194-C, p. C1-C12.
- Dixon, H.R. and Lundgren, L.W., 1968, The structure of eastern Connecticut, in Zen, E-An, and others, eds., Studies in Appalachian geology, northern and maritime: New York, Wiley Interscience, p. 219-229.
- Goldstein, A.G., 1982, Progressive microstructural development of high-temperature mylonite from the Lake Char fault, northeastern Connecticut (abs.): Abstracts with Programs, v. 14, no. 1 and 2, p. 21.
- Nelson, A.E., 1976, Structural elements and deformational history of rocks in eastern Massachusetts: Geol. Soc. America Bull., v. 87, p. 1377-1383.

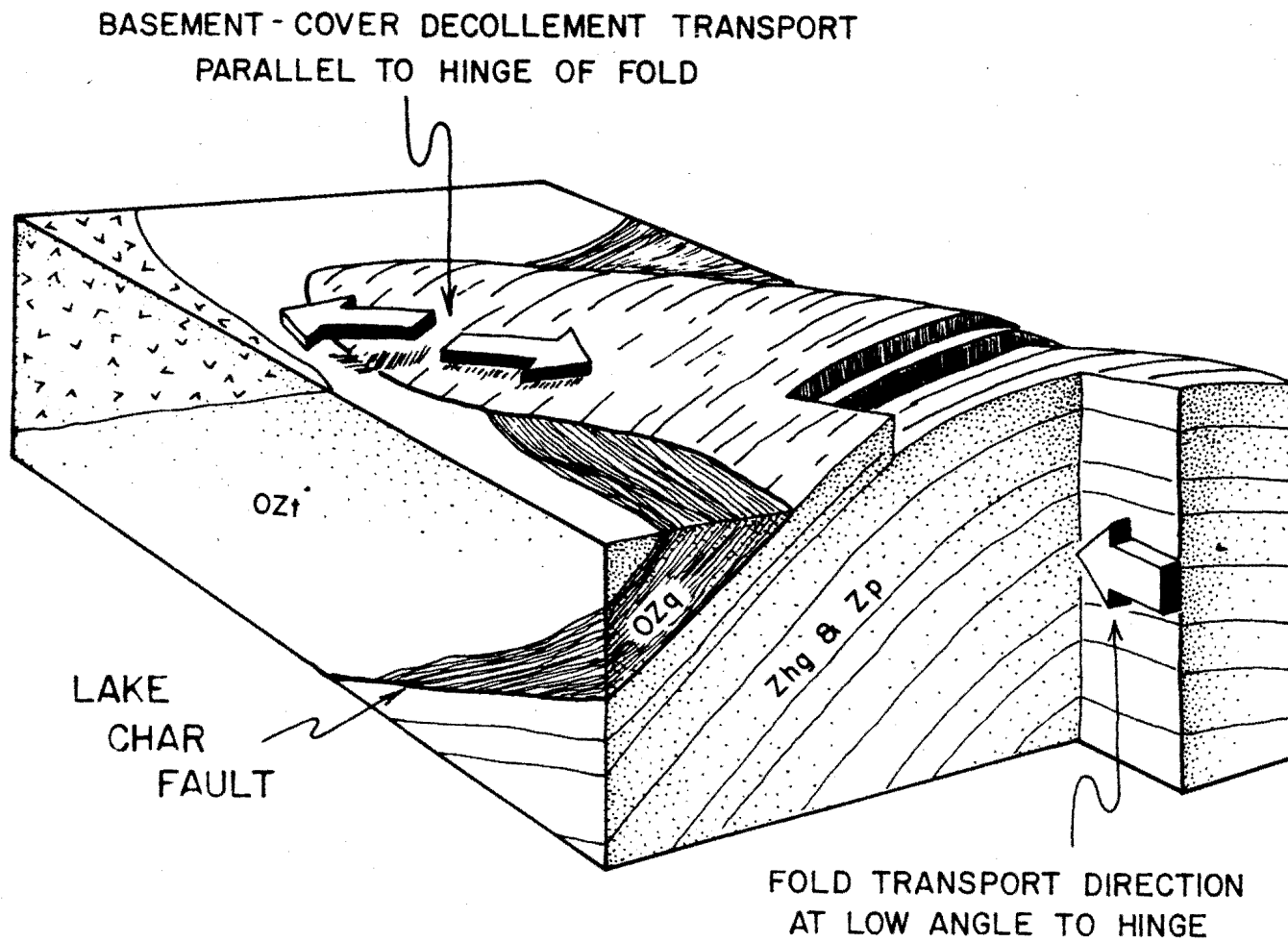

Figure 5. Block diagram of the Webster, Mass. area showing structural elements. The geometry of tectonic transport for folding and mylonitization suggests a model of basement-cover decollement during basement diapirism.

ROAD LOG

Assembly Point: Thompson Spirit Shoppe, East Thompson, Conn., immediately east of exit 100 off Rt. 52.

Directions: From Storrs, take Rt. 44A east to Rt. 44 east. Follow this approximately 20 miles, through Putnam, Conn. to Rt. 52. Enter Rt. 52 north and leave approximately 8 miles later at exit 100, E. Thompson-Wilsonville. Travel east on Wilsonville Road for approximately .5 mi. to the first stop sign. Turn left (north) and travel approximately .1 mi. on Webster Road to the Thompson Spirit Shoppe on the left.

Mileage:

<u>Cumulative</u>	<u>Interval</u>	
		<u>Travel south</u> on Webster Road.
.1	.1	Quinebaug Fm. in small roadcut on your right.
.6	.5	<u>Turn left</u> (east) onto Porter Plain Rd. This traverses a rather wide area in which the Quinebaug Fm. is overlain by glacial outwash materials.
1.8	1.2	<u>Turn right</u> (south) onto Sand Dam Road.
2.0	.2	<u>Turn left</u> (east) at triangle onto E. Thompson Road.
2.1	.1	<u>Firehouse</u> on left.
2.7	.6	<u>Cross</u> abandoned railroad grade.
2.9	.2	<u>Stop #1.</u> Park across from small bungalo and driveway.

NOTE: This stop traverses privately-owned property. The owners have been very cooperative. Please guarantee that future field trips will be possible by being courteous and non-destructive.

STOP #1.

This traverse takes us from partially mylonitized Hope Valley Alaskite stratigraphically up-section toward the Lake Char fault. You will be able to observe the progressive decrease in grain size and a thin, quartzitic interlayer which displays intrafolial folds having a rotation sense consistent with west-down motion on the Lake Char fault. You may wish to visit a nearby locality where the Hope Valley Alaskite is unmylonitized. The closest is approximately .5 miles east on E. Thompson Road on the left (north) side of the road. The grain sizes of the major mineralogical components of the Alaskite at that locality are shown on Figure 6 as point #8 on the right of the diagram. This traverse start at Point #5 and progresses to Point #1.

To begin the traverse, walk up the driveway across from the parking area and enter the woods to the right (east). On the east side of this ridge there are a number of large natural exposures which contain the contact between the Alaskite and an infold of Plainfield quartzite. Immediately above the contact, the Alaskite has large, ellipsoidal feldspars in a fine-grain quartz, feldspar and mica matrix. This matrix is mylonitic in origin and the bimodal grain size derives from the relative resistance to intracrystalline deformation between quartz and feldspar. Toward the west, as you approach the Lake Char fault, the grain sizes diminish rapidly and on the west side of the ridge are

P5-11

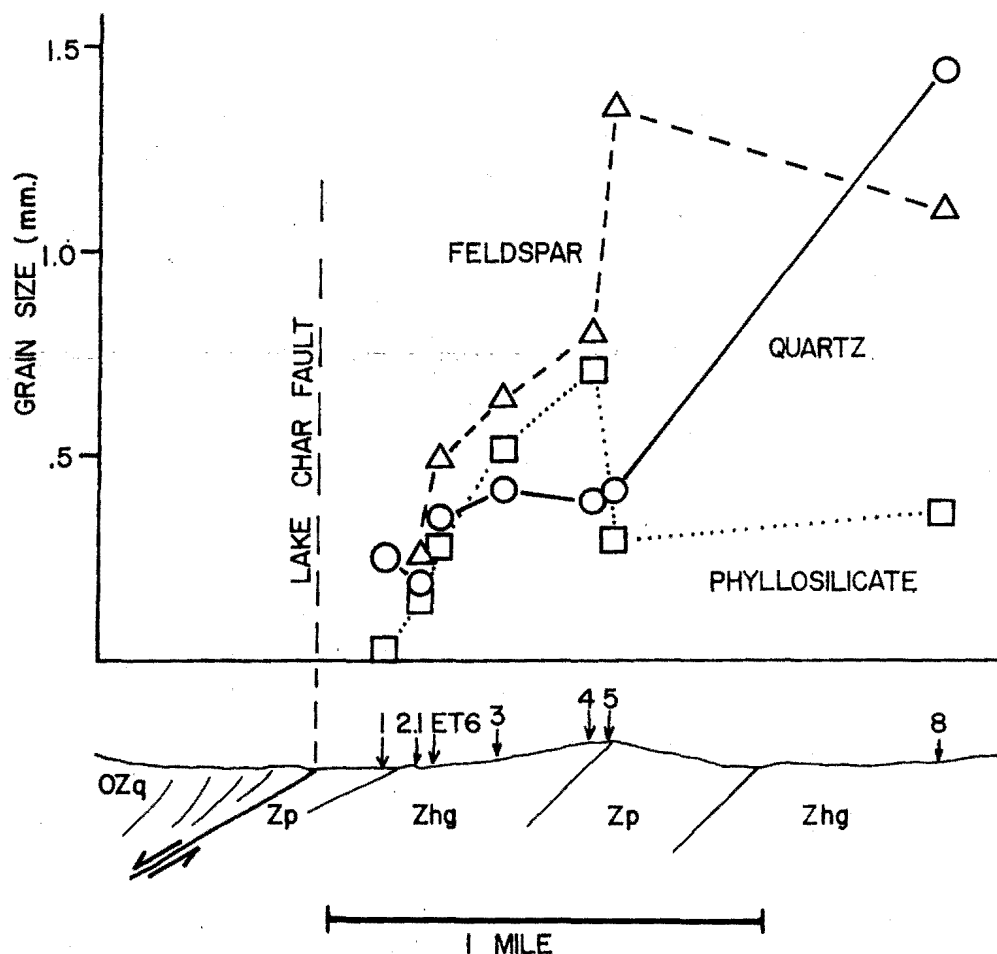

Figure 6. Grain sizes of major minerals in the Hope Valley Alaskite along a traverse toward the Lake Char fault, Stop #1.

exposures of the same Alaskite but with a highly reduced grain size. Proceed down the west side of the ridge to a small valley, on the west side of that valley is a small ridge composed of micaceous quartzites. These quartzites are mylonitized, have a prominent mineral lineation and display small, overturned, intrafolial folds. The folds have rotation senses which require west-down motion (Fig. 7).

NOTE: These folds are rare... do not remove them! There are many loose blocks of mylonitic quartzite which can be collected without hammering. CAUTION! Trained Attack Dogs have been kept at a shack not more than a hundred meters away, to the west and have attacked and bitten the author. Should you meet a German Shepard in these woods, remain immobile until he loses interest or his keeper arrives.

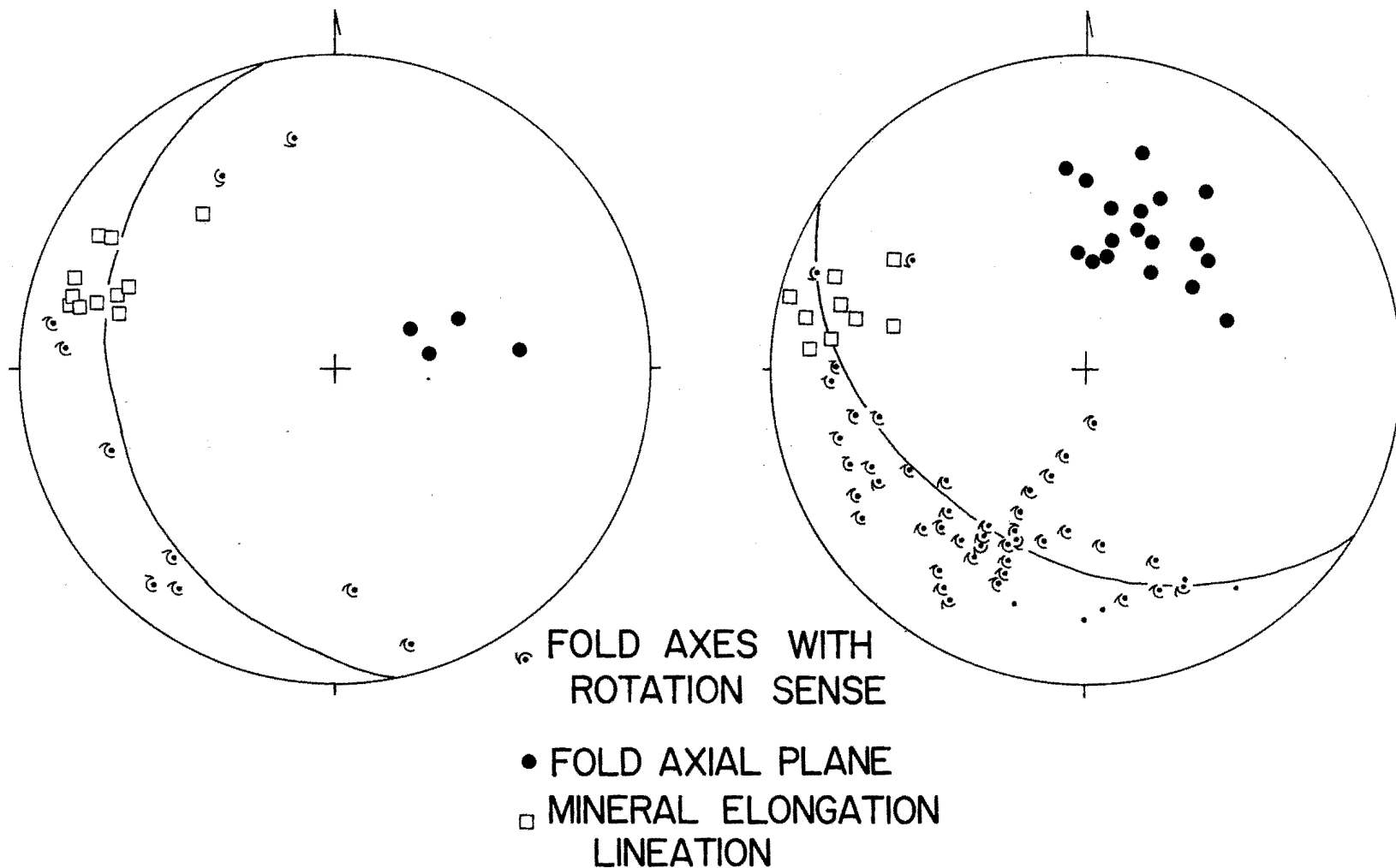

Figure 7. Orientation of fault-related folds at two locations along the Lake Char fault, plotted on the lower hemispheres of equal area nets. (a) Orientations and rotation sense of 10 intrafolial fold axes, poles to 4 of their axial planes and 11 mineral elongation lineations from Locality 3 (Fig. 2). (b) Orientations and rotation senses of 48 axes of folds in D1 foliation, poles to 18 of their axial planes and 9 mineral elongation lineations from Locality 4 (Fig. 2).

P5-13

Further to west are exposures of mylonitized alaskite, quartzite, an area of no exposure which marks the Lake Char fault and metabasites of the Quinebaug Fm. Those metabasites contain very infrequent mesoscopic structural features.

Mileage:

Return to vehicles and turn around and proceed west on E. Thompson Road.

<u>Cumulative</u>	<u>Interval</u>	
-------------------	-----------------	--

3.8	.9	<u>Turn right</u> (north) onto Sand Dam Road.
4.0	.2	<u>Turn left</u> (west) onto Porter Plain Rd.
5.2	1.2	<u>Turn right</u> (north) onto Webster Road.
5.7	.5	Stop #2 (optional).

STOP #2.

Turn right across from Wilsonville Road on dirt road into abandoned sand and gravel quarry. Exposures of mylonitized upper Quinebaug Fm. are on the left. These exposures contain good examples of D5 ductile faults with associated epidote mineralization.

Return to Webster Road and cross to Wilsonville Road.

Mileage:

<u>Cumulative</u>	<u>Interval</u>	
-------------------	-----------------	--

6.0	.3	Stop #3.
-----	----	----------

Stop #3.

Park before reaching roadcuts at entrance to Rt. 52. You have crossed the contact between the Quinebaug Fm. and the Tatnic Hill Fm. and the roadcuts are in the rusty-weathering gneiss of the lower member of the Tatnic Hill Fm. You have also crossed a gradational contact between mylonitized rocks and unmylonitized rocks and are in a thin, unmylonitized zone which can be traced both northward and southward along Rt. 52. At this locality (Fig. 8) you can see the rusty-weathering gneiss with sillimanite lineations plunging shallowly to the south-southwest and with textbook boudinage. A fault (of unknown age or structural affinity) marks the lower contact between rusty-weathering gneiss and an amphibolite body which can also be traced northward and southward along Rt. 52. The upper contact between mylonitized and unmylonitized is covered between the northbound and southbound lanes of Rt. 52. On the southbound entrance ramp are good examples of D4 folds deforming mylonitized rusty-weathering gneiss.

Mileage:

<u>Cumulative</u>	<u>Interval</u>	
-------------------	-----------------	--

7.1	1.1	<u>Proceed west</u> on Wilsonville Rd.
7.3	.2	<u>Turn left</u> (south) onto Stawicki Rd.
		<u>Park on right</u> across from house with spectacular outcrop in backyard.

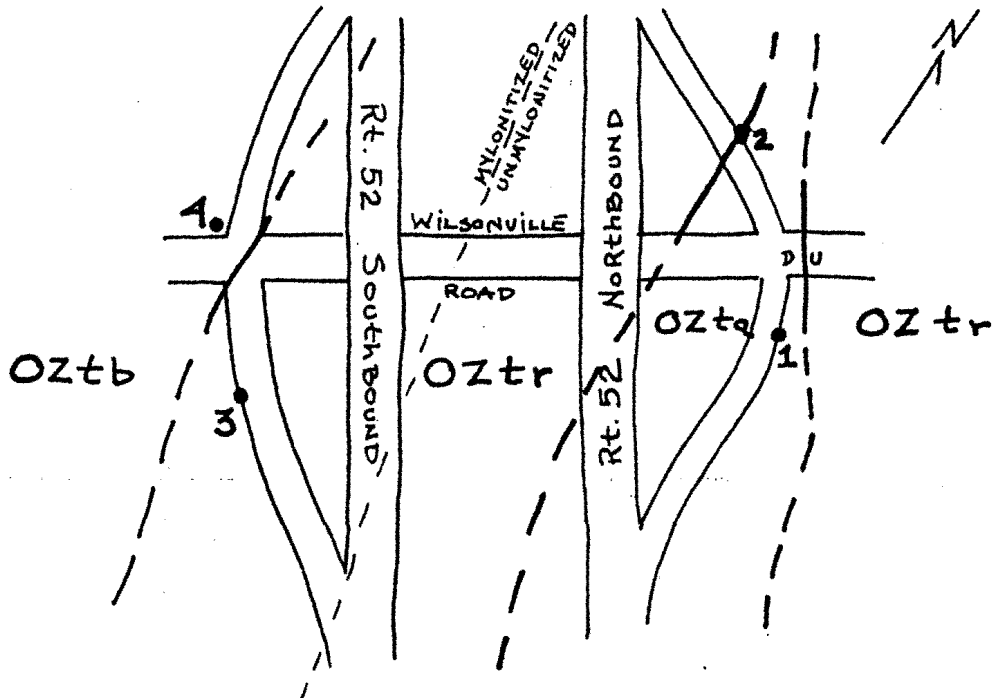

Figure 8. Geologic sketch map of Stop #3. Numbers refer to points of interest: 1 - Amphibolite within rusty-weathering gneiss; 2 - Nature of contact between amphibolite and overlying rusty-weathering gneiss; 3 - D4 folds in mylonitized rusty-weathering gneiss; 4 - Lithology of mylonitized biotite gneiss.

STOP #4.

This is perhaps one of the finest exposures in the Webster area. However, it is the backyard of a private residence. ABSOLUTELY NO HAMMERS! As before, please be nondestructive and courteous to insure that others will be allowed to visit this locality. If you are following this guide without the author, please knock on the door and ask permission to look at the outcrop. The owners have been patient and tolerant and, I am sure, cannot understand why anyone would be so interested in their "rock garden".

A map of this exposure is shown in Figure 9a and the orientations of structural elements in Figure 9b. The exposure is of sillimanite gneiss of the lower member of the Tatnic Hill Fm. A small shear zone traverses the western side of the exposure. This outcrop is located toward the upper limit of the Lake Char mylonite zone and the shear zone crosscuts the foliation in the sillimanite gneiss. This allows us to see the sense of rotation at the bottom and top of the shear zone (labeled as B and C respectively on Figure 9a). Considering the prominent mineral lineation as the direction of movement on the shear zone together with the sense of rotation at the margins requires that movement on the shear zone was west-down.

This locality also has an excellent example of a D1 fold hinge (labeled as A on Figure 9a). If more exposures were devoid of lichen and glacial cover, such as this one is, we would have a much easier time deciphering the evolution of the area.

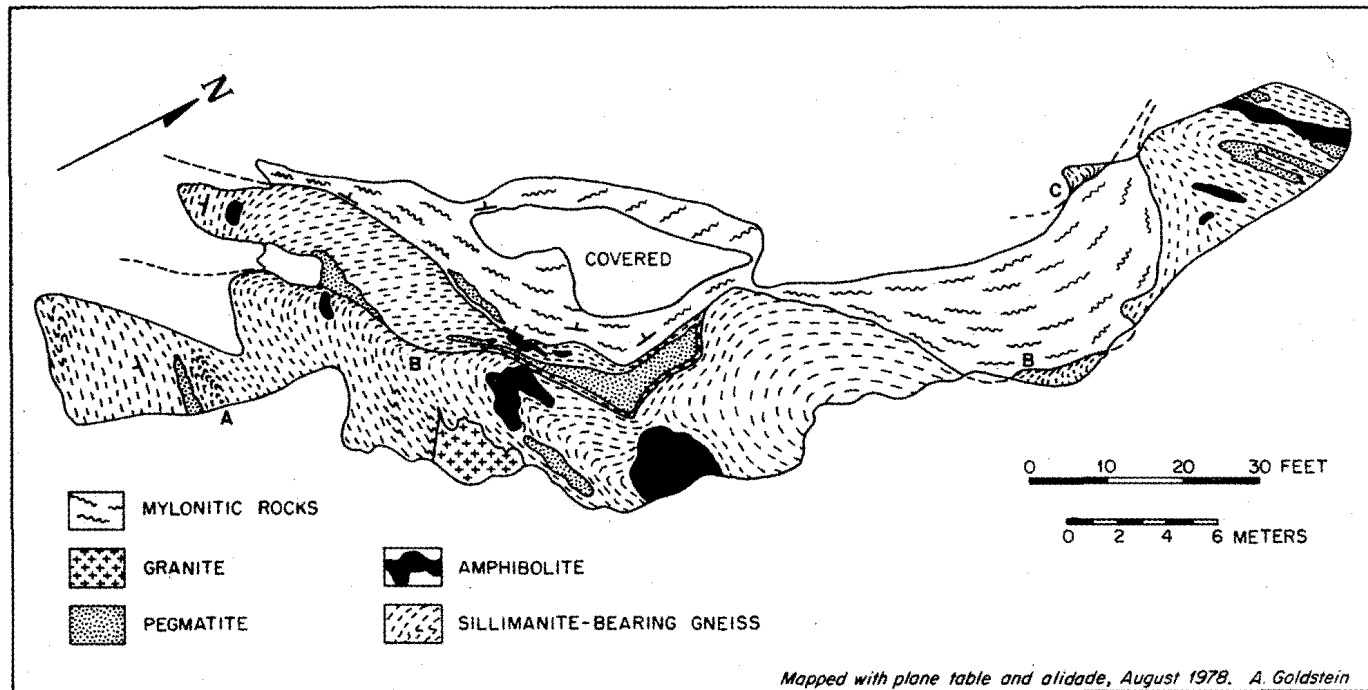

Figure 9. Geologic map of Stop #4 and orientations of structural fabric elements at Stop #4. A - Geologic map of Stop #4. Letters indicate points of interest: A. D1 fold hinge; B. Base of shear zone with rotation sense; C. Top of shear zone with rotation sense. B - Lower hemisphere, equal-area plot of structural data from Stop #4. Orientations of late (D5?) faults are shown as strike vectors with length proportional to the number of faults.

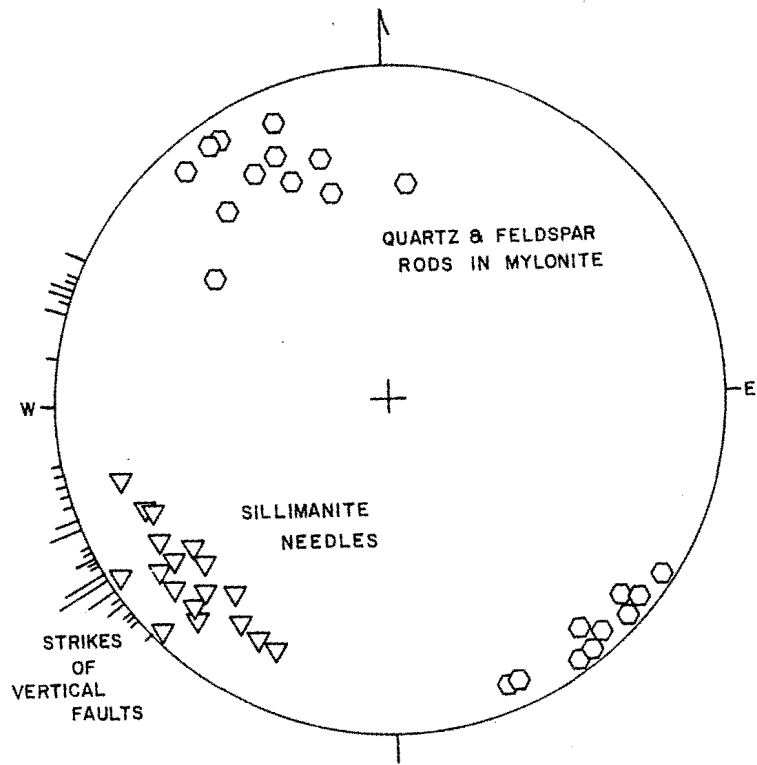

Figure 9b

Mileage:

<u>Cumulative</u>	<u>Interval</u>	
7.5	.2	<u>Turn around</u> and proceed north on Stawicki Rd.
8.6	1.1	<u>Turn right</u> (east) onto Wilsonville Road.
9.2	.6	<u>Turn left</u> onto Rt. 52 Northbound.
		Stop #5.

STOP #5.

Park on right side of highway before roadcuts. These roadcuts are in the lower member of the Tatnic Hill Fm. and are unmylonitized as were the cuts at Stop #3. Features to be examined at this locality are D2 isoclinal folds and D5 ductile faults. The cuts are at a small angle to the foliation, making viewing of the folds difficult at first. A map and cross sections of the roadcuts appear in Figure 10. A number of high-angle faults cut the exposures into a series of small fault blocks. The northwest-striking faults are D5 whereas the northeast-striking faults, particularly the fault at about the middle of the west side, are D6. The D5 ductile faults form horsts and grabens (section A-A'). Within one "ductile graben" is a good example of a D2 fold hinge, which can be seen two-thirds of the way southward on the west side of the median. Across the southbound lane is a minor D2 fold. These folds are deforming a pre-existing foliation (D1) and have an axial plane foliation of their own creating hinge-parallel intersection lineations. Note also, at this locality, ultramafic blocks in the rusty-weathering gneiss and amphibolite. These have been altered to talc with an actinolite rim.

Mileage:

<u>Cumulative</u>	<u>Interval</u>	
12.0	2.8	<u>Proceed north</u> on Rt. 52.
12.2	.2	<u>Take Exit #2</u> , Rt. 16, Webster-Douglas.
12.5	.3	<u>Turn left</u> (west), out of exit, onto Gore Road.
		<u>Park</u> in lot on left across from Cranston Print Works Co.

STOP #6.

Walk east, back toward road cuts at Rt. 52. Small quasi-exposures in the small park immediately east of the parking lot are of the rusty-weathering gneiss. Although many of these blocks are not in place, this is believed to be natural and not a dump of quarried material. The roadcuts at Rt. 52 are in the Plainfield Fm. Thus, the Lake Char fault lies between the park and the roadcuts. The park exposures are mylonitic whereas the roadcuts are not. The rather thin zone of mylonitization in the basement complex observed at Stop #1 has narrowed to the point of being imperceptible (Fig. 2). The exposures of Plainfield Fm. have a foliation parallel to the layering (either a D1 or D2 foliation) and both layering and foliation are pervasively folded on a small scale. The folds have a rigidly consistent rotation sense and are believed to be a result of slip on the Lake Char fault. As at Stop #1, the orientations and rotation senses of these folds define west-down movement on the Lake Char fault (Fig. 7b).

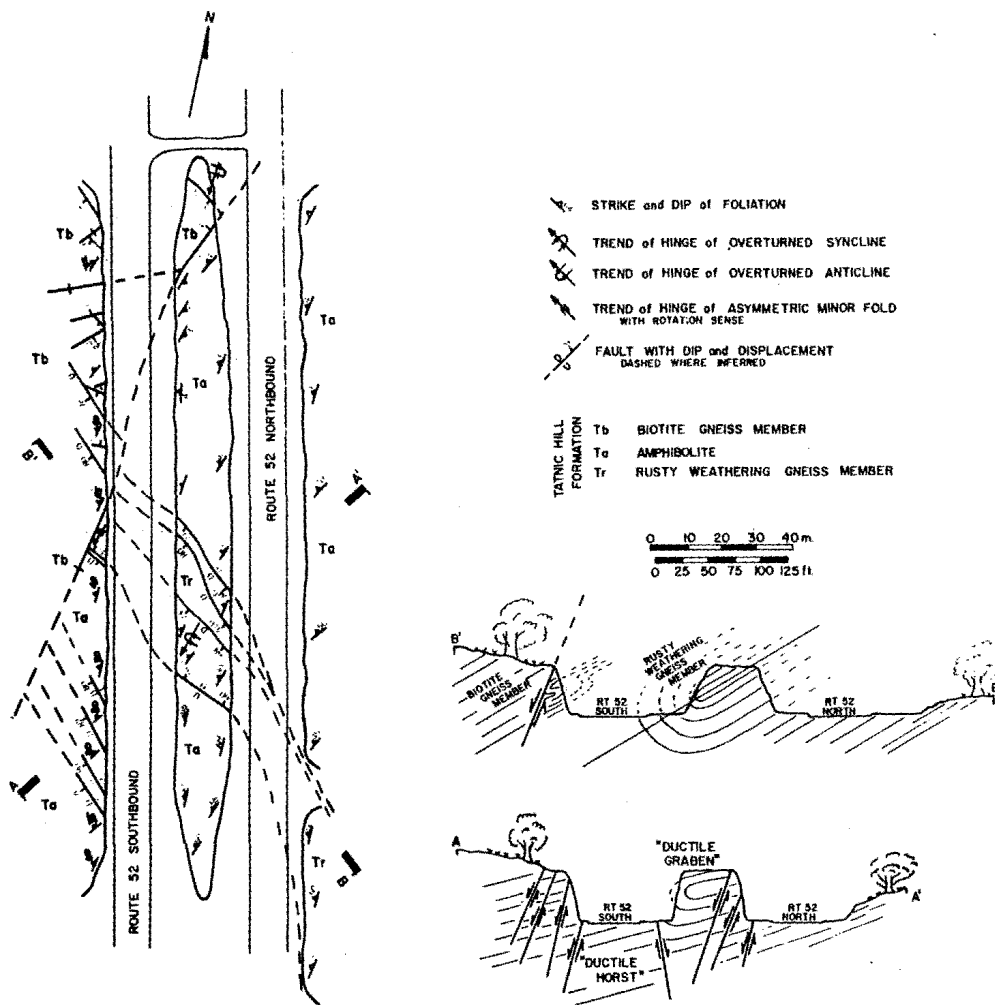

Figure 10. Geologic map and cross sections of Stop #5.

Mileage:

<u>Cumulative</u>	<u>Interval</u>
12.8	.3
13.7	.9
16.0	2.3
17.2	1.2

Proceed east on Gore Rd.

Turn right (south) onto Rt. 52 north.

Road cuts in Plainfield Fm.

Road cuts in biotitic facies of basement complex

Exit 4W, Sutton Road, Oxford. Road cuts on right are rusty-weathering and biotite gneiss of the Tatnic Hill Fm. North end of cut displays excellent example of D1 fold hinge; note steepening of layering and foliation toward Lake Char fault immediately to the south.

Mileage:

<u>Cumulative</u>	<u>Interval</u>	
18.1	.9	<u>Cross Rt. 12.</u>
19.2	1.1	<u>Turn right onto unnamed road.</u>
19.5	.3	<u>Stop #7 (optional)</u>

STOP #7.

Park on left at crest of hill. The spillway cuts for the Hodges Village dam expose a facies of Silurian metasediments referred to as Hodges Village Fm. by Barosh (1974). These rocks contain graded beds which allow determination of facing direction. They are overturned. In addition, there is an intersection between bedding and a cleavage which is axial-planar to minor folds. The geometry of the bedding-cleavage intersection defines the exposures as being on the lower limb of an isoclinal anticline overturned to the west. In these Silurian rocks, only two foldings have been recognized (D2 and D4). It follows that D1 was a pre-Silurian event.

Mileage:

<u>Cumulative</u>	<u>Interval</u>	
19.8	.3	<u>Turn around and travel south on unnamed road.</u>
20.9	1.1	<u>Turn left (east) onto Sutton Road.</u>
21.5	.6	<u>Cross Rt. 12.</u>
22.7	1.2	<u>Enter Rt. 52 north.</u>
		<u>Stop #8.</u>

Stop #8.

Stop at large road cut on right. This locality is on the northern limb of the Douglas Woods Anticline where layering and foliation strike east-west. Because of this, the road cut give a clearer picture of the structure. The road cut exposes unmylonitized biotite gneiss of the Tatnic Hill Fm. A sketch of the major features of the road cut and the orientations of structural elements are shown in Figure 11. Evidence for the first three deformations is present. A felsic layer at about the center of the road cut marks a D1 axial plane is folded by large D2 isoclinal folds. Two small shear zones cut the D2 folds and contain intrafolial folds which define the movement as north-down. Mineral lineations in the shear zones probably record the motion direction and are parallel to mineral lineations in mylonite at other localities within the Lake Char fault zone. For this reason the small shear zones at Stop #8 are believed to be related to movement on the Lake Char fault.

End of trip.

To return to Storrs, turn around at the next exit to the north and take Rt. 52 south to Rt. 44 in Putnam. To get to other areas, Rt. 20 intersects Rt. 52 approximately 10 miles to the north.

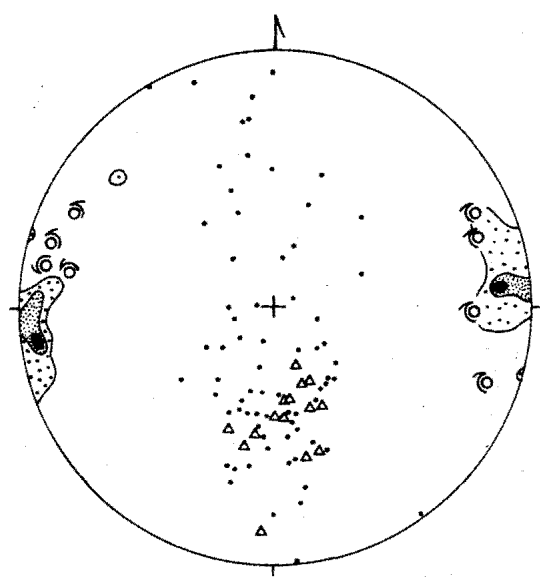
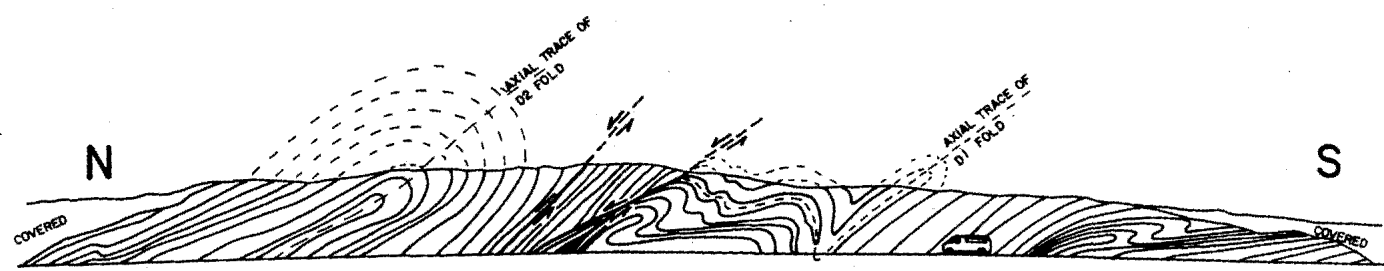

• POLE TO D1 FOLIATION
 ▲ POLE TO D3 MYLONITIC FOLIATION
 ⊙ FOLD AXIS (D2) WITH ROTATION SENSE
 CONTOURS ARE D1 FOLIATION INTERSECTIONS
 4%, 8% and 10% per 1% area

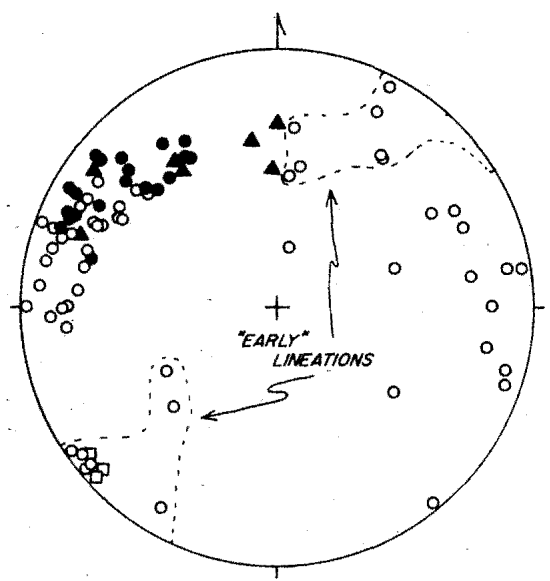

IN COUNTRY ROCK IN MYLONITE

○ BIOTITE LINEATION ●
 □ QUARTZ-FELDSPAR LINEATION ▲
 □ SILLIMANITE LINEATION

Figure 11. Sketch of Stop #8 and lower hemisphere, equal-area diagrams of structural data from that locality. The sense of slip on shear zones is determined from the sense of rotation at intrafolial folds.

Structural Relations at the Junction of the Merrimack Province, Nashoba Thrust Belt and Southeast New England Platform in the Webster-Oxford area, Massachusetts, Connecticut and Rhode Island

by

Patrick J. Barosh
Department of Geology and Geophysics,
Weston Observatory, Boston College

INTRODUCTION

The Nashoba thrust belt forms the largest structural discontinuity known in the northeastern United States (fig. 1) apparently separating blocks belonging to Paleo-African and North American plates that collided here. The Webster-Oxford area lies astride the narrowest and most complex part of this belt where it bends from a north trend in Connecticut to a northeast trend in Massachusetts.

An extensive mapping project was conducted in this area from 1971 to 1976 by the U.S. Geological Survey to work out the stratigraphy and connect the structure in a broad region around Worcester from northeastern Connecticut to northeastern Massachusetts. Detailed and reconnaissance mapping was completed on seven 7.5-minute quadrangles and joins were made with previously mapped geology in the surrounding quadrangles. This resulted in an integrated geologic map of the region (Barosh, 1976c; Barosh and others, 1977). Since then additional stratigraphic studies with the assistance of new age determinations have led to a better understanding of the structure and tectonic history. Many age assignments have changed since a preliminary discussion of this area was presented in 1976 (Barosh, 1976b and 1976c).

The purpose of the field trip is to see examples of the major structures that converge in the Webster-Oxford area and of the stratigraphic units that characterize the structural provinces that meet here. The trip will emphasize deformational features along the Clinton-Newbury and Bloody Bluff-Lake Char fault zones that bound the Nashoba thrust belt. The juxtaposition of the number of major structures and provinces here offers an unusual opportunity to see a wide variety of features in a relatively small area.

The area records many complex events so that a full tectonic history is too long to be included here. Presented below is a very brief outline of the major structural and stratigraphic features and a discussion of the timing of the principal periods of deformation.

REGIONAL GEOLOGIC SETTING

The Webster-Oxford area encompasses the junction of the Nashoba thrust belt, Southeast New England platform and Merrimack province. It also contains slivers from the Nashua trough caught up in the Clinton-Newbury fault zone (fig. 2).

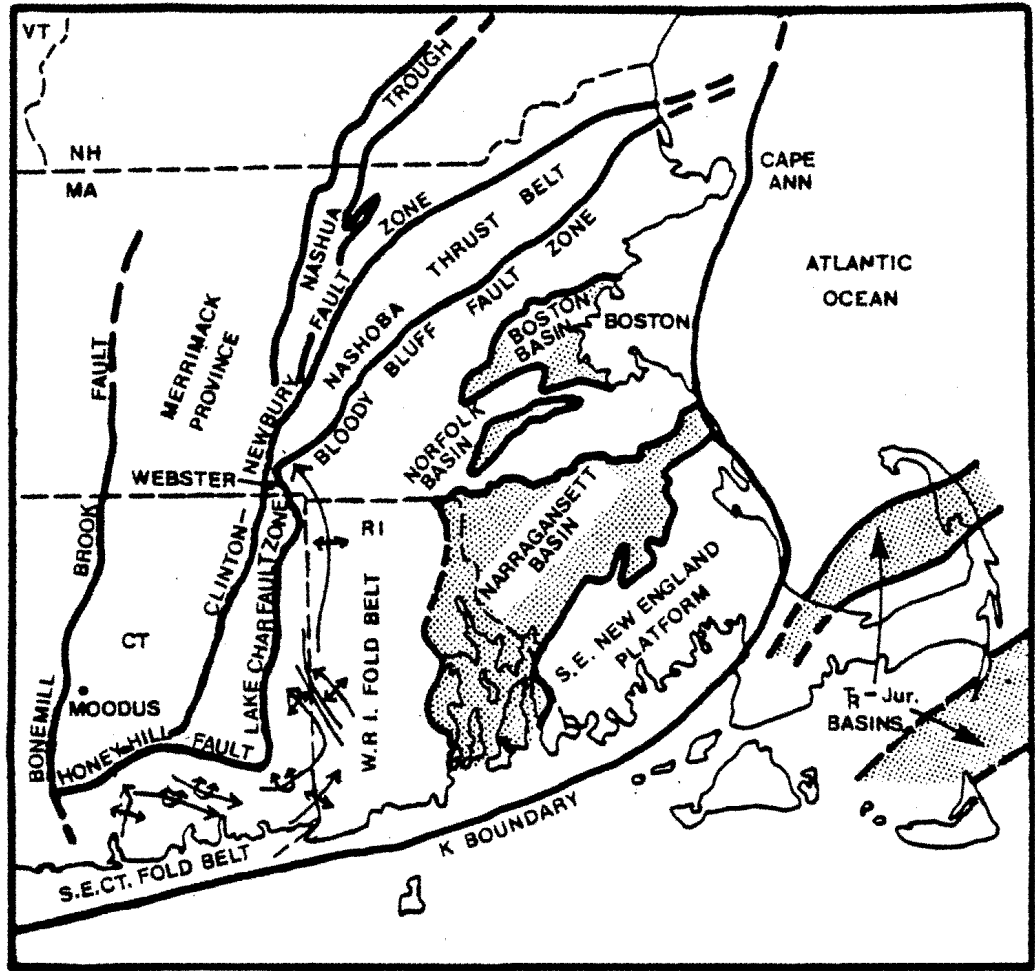

Fig. 1 Sketch map of Southeastern New England showing the three major tectonic provinces, basins and fold belts.

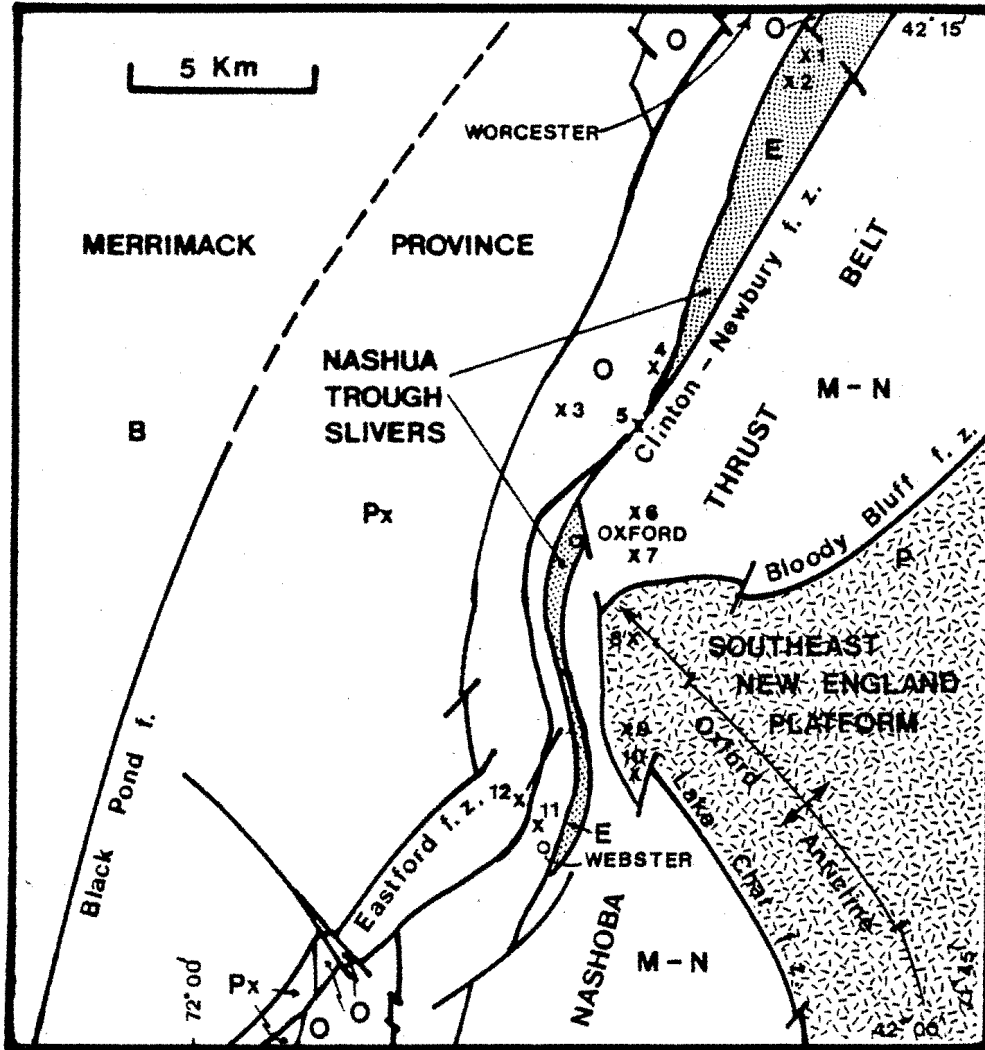

Fig 2 Sketch map of the Webster-Oxford area showing structural provinces, major fault zones, folds and general distribution of stratigraphic units; intrusive rocks are not shown separately. Explanation: P, Plainfield Fm.; M-N, Marlboro and Nashoba Fms.; E, Eliot Fm.; O, Oakdale Fm.; Px, Paxton Gp.; B, Brimfield Gp.

No stratigraphic correlation has been possible between the pre-Ordovician rocks of these fault-bounded provinces and the rocks in them probably formed at considerable distances from one another. Fault slivers of younger rock also occur along the borders of the Nashoba thrust belt in northeastern Massachusetts: Late Silurian-Early Devonian distal turbidites and Middle-Pennsylvanian argillites in the Clinton-Newbury zone on its west side and Late Silurian-Early Devonian volcanic and sedimentary rock and Late Triassic sedimentary rock in the Bloody Bluff fault zone on its east side. These attest to repeated movements along the thrust belt.

The Nashoba thrust belt is very wide in northeastern Massachusetts, narrows drastically in the Webster-Oxford area and widens again in eastern Connecticut (fig. 1). The nearly 18 kilometers of high-grade volcanoclastic rock measured northwest of Boston (Bell and Alvord, 1976) thins to a few hundred meters at Oxford due to omission by thrust faults. Many of the thrust zones in the belt are invaded by Early to Middle Paleozoic granitic rock, largely anatectic in origin. The units present in this area consist of the Marlboro Formation (Quinebaug in CT), Nashoba Formation of Hanson (Tatnic Hill in CT) and the Tadmuck Brook Schist (not known in CT). These form a volcanoclastic sequence that consists mainly of thin, well-bedded amphibolite, a mixture of light-gray gneiss, schist, amphibolite and marble and sillimanite-muscovite schist. The belt is characterized by steeply west-dipping thrust faults with west over east and right-lateral components of movement.

The Southeast New England platform consists largely of plutonic rocks of Late Precambrian age with pendants and borders of older volcanogenic rock and quartzite and some basins and intrusives of younger rock. This older rock nearby is referred to as the Westboro Formation, Plainfield Formation or Blackstone Series in Massachusetts, Connecticut or Rhode Island respectively. The Late Precambrian intrusions were syntectonically deformed into a series of broad northerly-trending folds along the Connecticut-Rhode Island border, the Western Rhode Island fold belt (Barosh and Hermes, 1981) (fig. 1). The northernmost fold of this belt extends into the Webster-Oxford area. These Precambrian folds bend to the west into southeastern Connecticut, where they become more deformed and are generally overturned to the south (fig. 1). Faults related to the Boston basin, that is filled by rocks of Eocambrian, Cambrian and Ordovician (?) age, (Kaye and Zartman, 1980), extend westward and impinge upon the Bloody Bluff fault zone to the northwest of Oxford.

The Merrimack province to the west forms a thick, moderately to shallowly west-dipping wedge of high metamorphic grade pre-Ordovician meta-graywacke, schist and gneiss, composing the Oakdale Formation, Paxton Group and Brimfield Group in ascending order. Moderately northwest-dipping thrust faults deform the province. These thrust faults have large displacements in Connecticut (Peper, Pease and Seiders, 1975), but decrease in displacement to the north in east-central Massachusetts where the rock is relatively little deformed. The linear intrusive granitic rock bodies near and along the Clinton-Newbury zone appear to be of anatectic origin and controlled by these thrust faults. The structures along these thrust in the Webster-Oxford area indicate west over east movement with a right-lateral component. A high-angle fault, the Eastford fault, extends northeastward into the Clinton-Newbury zone in the Webster-Oxford area (fig. 2). Displacement of the

Canterbury (Eastford) Gneiss across the Eastford thrust fault near the Connecticut-Massachusetts border indicates an apparent right-lateral displacement of 4 km. This fault is younger than the thrust faults which it parallels and it cuts out the trace of the Wangumbang Lake thrust fault in Connecticut (M.H. Pease, Jr., written commun.). The Eastford fault may also cut a thrust that appears to lie just southeast of it in this area.

The tectonic development of the region is believed to have taken place along the colliding border of two continental plates. The Nashoba thrust belt apparently represents the west-dipping subduction zone between the Southeast New England platform, a fragment of a former plate on the east, and the Merrimack province, apparently represents a foreland basin of the North American plate (Barosh, 1979). The rocks of the Merrimack province appear to be derived from the west, perhaps from a volcanic arc along the Glastonbury dome. Fault patterns and Paleozoic dike studies suggest that overall movement took place when the maximum compressive stress was oriented east-northeast -- west-southwest. The greatest amount of deformation appears to have been pre-Late Silurian, because rock of this age is much less metamorphosed and intruded than older rock.

The greatest deformation on the Southeast New England platform is in the Late Precambrian rocks along its western edge where Late Precambrian (600-620 m.y.) folds are present. Late Precambrian intrusive rocks along the Lake Char and Bloody Bluff faults are intensely sheared whereas the Ordovician Cape Ann granite and Salem gabbro-diorite along the Bloody Bluff fault are faulted, but not intensely sheared. The Nashoba thrust belt parallels the general configuration of these folds suggesting that thrusting was contemporaneous with or post-dates the folding and was a late syntectonic Precambrian event. It is also possible that the configuration of the Late Precambrian folds somehow acted as a surface upon which later thrusting occurred.

The Nashoba thrust belt experienced a number of later pulses of movement in the Paleozoic and suffered at least mild metamorphism in the Webster-Oxford area during the Devonian and Permian. During Mesozoic time faults within the belt may have been locally reactivated as normal faults. The Webster-Oxford area is seismically quiet today, demonstrating that complex Paleozoic structure need not be an indication of present day tectonic activity.

WEBSTER-OXFORD AREA

The diverse array of structures and stratigraphic units that characterize the regional structural provinces and their boundary faults are well displayed in the Webster-Oxford area.

STRATIGRAPHY

An understanding of the stratigraphy in the region has evolved slowly. A generally good reconnaissance stratigraphy was developed by Perry and Emerson (1903) and Emerson (1917) in the region and much of their stratigraphic nomenclature is still in use. The stratigraphy in several nearby areas studied by the U.S. Geological Survey has been traced into this area (Peck, 1976; Moore, written commun. Pease, 1972; Bell and Alvord; 1976; and Dixon, 1964). Special studies of the

Oakdale Formation and Paxton Group were made during the mapping of this region (Barosh and Pease, 1981; Barosh, in prep.).

An attempt was originally made (Barosh, 1976c) to correlate between major structural provinces. However, as the data on radiometric ages, metamorphic grade, internal stratigraphy, correlation and structure accumulated it became apparent that no stratigraphic correlation be made between the major structural blocks. The faults appear to have had major movement and the rocks may have been deposited at great distance from one another (fig. 3).

Merrimack Province	Nashua Trough	Nashoba Thrust Belt	SE New England Platform
Brimfield Gp.	Late Slurian - Early Devonian	Tadmuck Brook Schist	Precambrian
Paxton Gp.		Nashoba Fm.	
Oakdale Fm.		Marlboro Fm.	
Fault	Eliot Fm.	Fault	Intrusion
Pre-Ordovician		Pre-Ordovician	

Fig. 3 Stratigraphic columns for structural provinces in the Webster-Oxford area. Correlation cannot be made between columns.

A very brief description and latest age assignments of the units present for each structural province are given below.

Southeast New England Platform

Plainfield Formation (Precambrian)

The Plainfield Formation was first named by Rice and Gregory (1906) as the Plainfield Quartz Schist from exposures along the eastern border of Connecticut. The formation consists of medium-grained quartzite interbedded with fine-to medium-grained biotite-muscovite schist and

chlorite schist. The quartzite is light gray to buff in medium to thick beds where it forms almost all the section, and medium gray with greenish and purplish casts in thin beds where it is interbedded with pelitic schists. The Westboro Formation, in Massachusetts, which is correlative with part of the Plainfield Formation, is intruded by rocks dated as Late Precambrian (Nelson, 1975). The base of the Plainfield is everywhere cut out by intrusive rock; the upper contact is faulted.

Nashoba Thrust Belt

Marlboro Formation (Pre-Ordovician)

Bedded to massive amphibolite forms the Marlboro Formation (Emerson, 1917; Bell and Alvord, 1976). This amphibolite is generally medium-to coarse-grained and dark gray to nearly black; it weathers slightly lighter gray and contains a few beds of quartzo-feldspathic gneiss. The basal contact is faulted, and the upper contact with the Nashoba Formation is gradational, although it may be locally faulted. The correlative of the Marlboro Formation in Connecticut is the Quinebaug Formation. The Marlboro and the overlying Nashoba Formation and Tadmuck Brook Schist are considered pre-Middle Ordovician in age by Alvord (1975) on the basis of radioactive-age dating.

Nashoba Formation (Pre-Ordovician)

The Nashoba Formation of Hanson (1956) was redescribed by Bell and Alvord (1976), whose work is summarized by Alvord (1976). The Nashoba is used here in its original broader sense, which includes the Shawsheen and Fish Brook Gneisses at the base. Briefly, this very thick unit is characterized by light- to medium-gray, medium-to coarse-grained, medium-bedded quartzo-feldspathic gneiss; beds of amphibolite and various types of schist and marble occur at various horizons. The Nashoba is overlain by the Tadmuck Brook Schist at a slight angular discordance which probably represents an unconformity but could be due to faulting. The Nashoba correlates with the Tatnic Hill Formation of Connecticut.

Tadmuck Brook Schist (Pre-Ordovician)

The Tadmuck Brook Schist of Bell and Alvord (1976) is known in this area only as thin lenses within the Clinton-Newbury fault zone. It is composed of rusty weathering, silvery, medium- to dark-gray sillimanite-biotite-quartz-muscovite schist interlayered with quartz-chlorite-biotite-sericite phyllite. It is generally sheared and its upper contact is faulted.

Merrimack Province

Oakdale Formation (Pre-Ordovician?)

The Oakdale Formation, originally the Oakdale Quartzite of Emerson (1917), consists of medium- to dark-gray or greenish-gray thin-bedded metasilstone to phyllite which weathers light- to medium-gray or greenish- or brownish-gray. It is very silicic and well-laminated locally. Several intervals within the formation contain partings and thin beds of muscovite schist (Barosh and Pease, 1981). The contact

with the overlying basal beds of the Paxton Group appears faulted in the Webster area, but in an adjacent part of the Worcester South quadrangle it appears conformable. The Oakdale Formation is the oldest known stratigraphic unit in the Merrimack province and is considered pre-Ordovician in age as the stratigraphically higher Brimfield Group is cut by an Ordovician intrusion. The formation can be traced from southern Connecticut into Southern Maine, where it correlates with the lower part of the Berwick Formation (Pease and Barosh, 1981).

Paxton Group (Pre-Ordovician)

The Paxton Quartz Schist of Emerson (1917) consist of medium-gray, thin- to medium-bedded, fine- to coarse-grained metagraywacke which weathers the same color or slightly darker with a brownish cast. The beds have a schistose to granulose structure and are composed mainly of quartz, biotite, and feldspar, which gives them a salt and pepper appearance. Calc-silicate-bearing beds occur at many intervals throughout the section. The upper part of the Paxton has been informally designated the Southbridge Formation by Pease (1972). The lower part is being redescribed as a new formation (Barosh, in prep.) distinguished from the Southbridge Formation by its fine grain size and thinner, more laminae bedding. The contact between the two is gradational. The top of the Southbridge is bounded by the Black Pond fault (fig. 2).

Bigelow Brook Formation (Pre-Ordovician)

The Bigelow Brook Formation is the basal formation of the Brimfield Group (Peper, Pease and Seiders, 1975). Its lower gneiss member forms the top of the stratigraphic sequence discussed here. The lower gneiss member consists of light- to medium-gray, lighter gray to rusty weathering, medium- to coarse-grained quartz-biotite-feldspar gneiss interbedded with schist. Some gneiss is calc-silicate-bearing, and sillimanite is common. The Bigelow Brook Formation is considered to stratigraphically overlie the Southbridge Formation (Peper, Pease and Seiders, 1975).

The age of the Brimfield group must be Ordovician or older because rock near the top of the sequence is cut by an intrusive rock that has yielded an Ordovician date (Zartman and Naylor, in press). Rock of the Brimfield Group is known to extend from south-central Connecticut to at least central New Hampshire (M.H. Pease, Jr., oral commun.).

Nashua Trough

Eliot Formation (Late Silurian-Early Devonian)

The Eliot Formation consists of a relatively uniform sequence of light greenish-gray weathering sericite or muscovite phyllite and schist. The formation is generally well bedded, thin bedded and contains graded beds. It is commonly folded and shows a secondary foliation not parallel to bedding at several localities. This feature has not been recognized in other formations of the area. A thin unit of greenish to purplish medium-gray thin-bedded metasiltstone interbedded with phyllite forms a lower unit in the Eliot. These strata, which are present only in fault slivers in the Webster-Oxford area, have been

traced in a belt of discontinuous exposures within the Nashua trough (Smith and Barosh, 1981)(fig. 1) from here to southern Maine, the type area. They are stratigraphically equivalent to units 2, 3 and probably unit 4 as mapped by Peck (1975, 1976) in the Clinton quadrangle. The Eliot Formation in southern Maine has been assigned a Silurian age by Hussey (1962) by correlation with fossiliferous rock in central Maine. Peck (1975, 1976) considers the sequence in the Clinton quadrangle, units 1-4, to range from Silurian to Devonian in age.

STRUCTURE

The broad, open, north-plunging Oxford anticline is the most conspicuous structure of the Southeast New England Platform in the Webster-Oxford area (STOP 8). It is cored by granitic rock of the Sterling Plutonic group with quartzite and schist of the Plainfield Formation occurring as pendants around the outer rim and as xenoliths. Flow foliation, well developed in the granitic rock, and bedding in the Plainfield are closely parallel.

The anticline is bordered on the north by the Bloody Bluff fault zone (STOP 7) and on the west by the Lake Char fault zone (STOP 10) (figs. 2 and 4). Both faults occupy the same structural position and bring amphibolite of the Nashoba thrust belt, the Marlboro (Quinebaug) Formation, against the platform (STOP 7). The Nashoba belt contains within it several thrust faults that converge from the north and south toward the area, cutting one another out and causing a confusing array of overlapping mylonite zones and thrust slices of sheared, rotated blocks (STOP 6). These moderately to steeply northwest-dipping thrust faults are roughly parallel to the bedding and steepen to the east. The faults have confused the stratigraphy within the Nashoba Formation and the light gray gneiss present here cannot be readily correlated with the members subdivided to the north by Bell and Alvord (1976) or to the south by Dixon (1964). The Clinton-Newbury fault zone, forming the west side of the belt, is well exposed northeast of Oxford where shearing and mylonitization can be seen to increase progressively toward the zone. A fault sliver of probable Tadmuck Brook Schist is preserved in the zone here (STOP 5). A small fault slice of Late Silurian-Early Devonian thin-bedded phyllite of the Eliot Formation lies between Oxford and Webster. A much larger sliver of the same formation (STOPS 1 and 2) occurs to the north in Worcester where it forms the ridge upon which Holy Cross University is situated. These slivers are displaced fragments of the Nashua trough that have been caught up in the Clinton-Newbury fault zone (figs. 1 and 2). The trough is an elongate block, between northern Worcester, Massachusetts and Nashua, New Hampshire, of younger, less deformed rock, preserved between two high-angle thrust faults within the Merrimack province (Smith and Barosh, 1981). The position of these slivers to the southwest of the end of the trough strongly suggests right-lateral movement along the fault zone. These rocks are not exposed south of Webster.

A series of quartz monzonite intrusions, the Ayer intrusive complex, has invaded the position of the Clinton-Newbury fault zone in Webster (STOPS 11 and 12). Xenoliths of mylonite are found in places. Renewed fault movement may have occurred at the border of this intrusive. Similar elongate granitic bodies of probable anatexic origin occur west of this zone in the Merrimack province and also appear to be controlled by earlier thrust faults. Farther south in Connecticut the position of

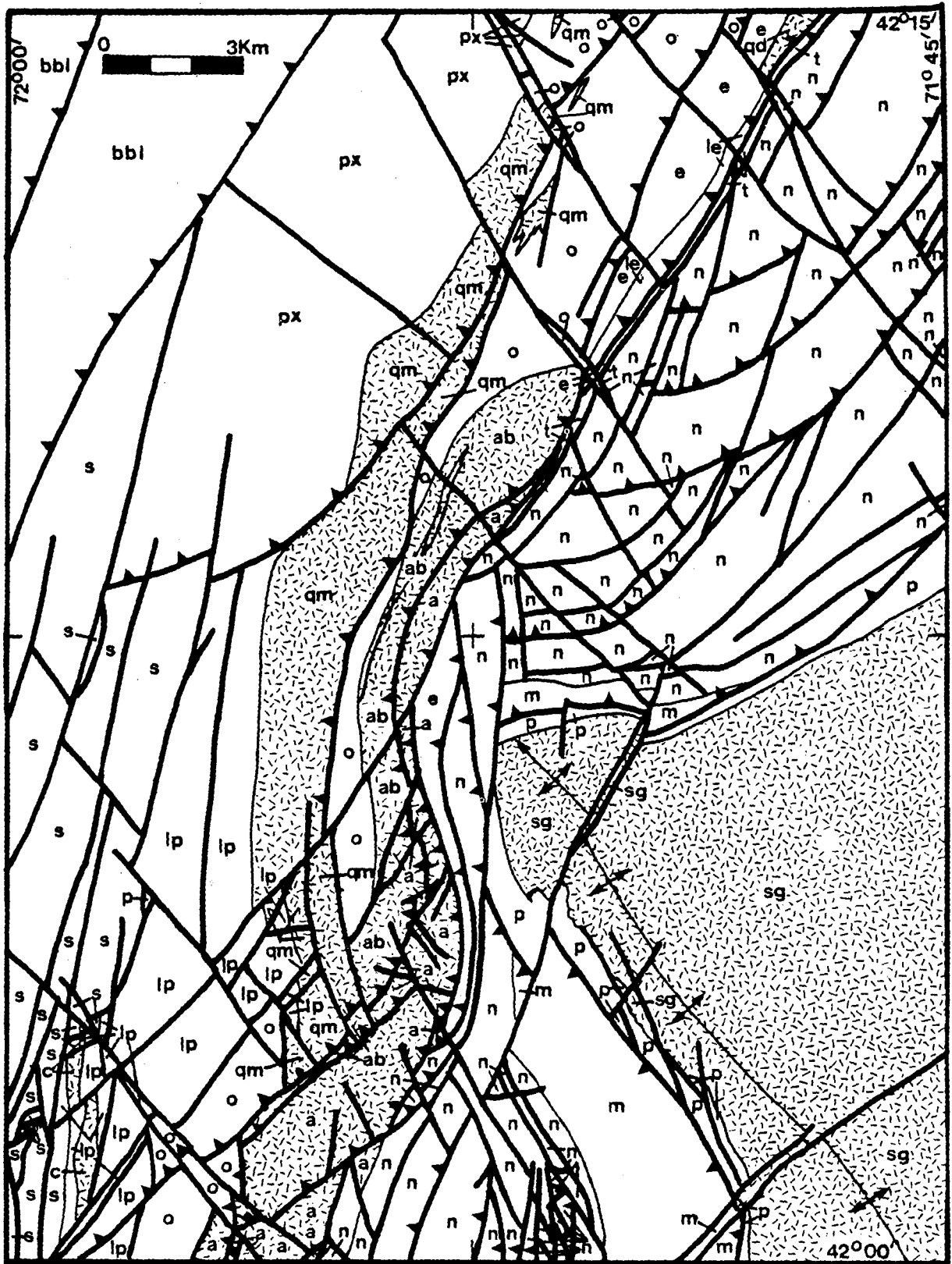
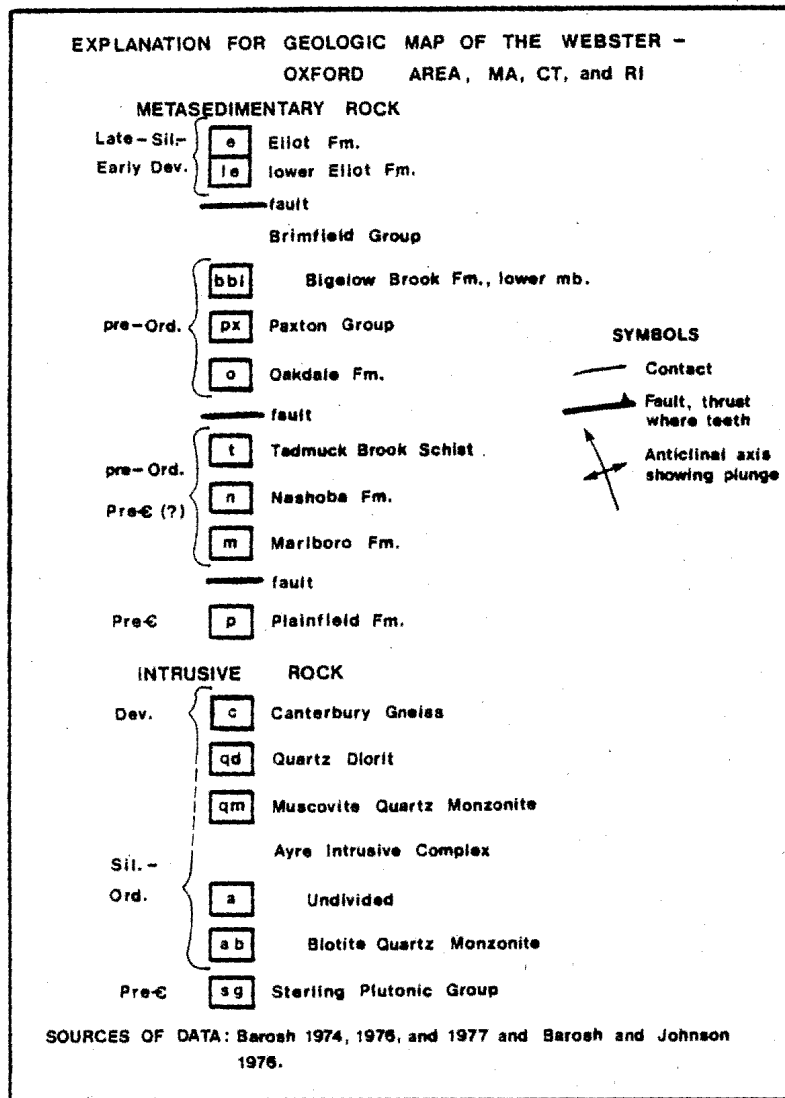

Fig. 4 Geologic map of the Webster-Oxford area, MA, CT, and RI.



the Clinton-Newbury is invaded by the Canterbury Gneiss, a muscovite quartz monzonite.

The Oakdale Formation (STOPS 3, 4 and 11) lies against the Clinton-Newbury fault zone on the west and is the lowest stratigraphic unit of the Merrimack province. This formation is composed of thin-bedded meta-siltstone and forms the lowland upon which most of Worcester is situated. It is highly deformed locally against the fault zone (STOP 4) and is locally cut out entirely by faults and intrusive rock near Oxford. The Oakdale is overlain a short distance to the west by meta-graywacke of the Paxton Group, which occurs as fine-to-coarse-grained schistose granulite.

Many late, small, northwest-trending and some north-trending faults cut the earlier thrust faults (fig. 4). These appear to be brittle structures with wide fracture zones and thus, despite their relatively small displacements, are etched out by erosion.

AGE OF PRINCIPAL DEFORMATION

The three major structural provinces in the Webster-Oxford area appear to represent separate pre-Ordovician areas of deposition, although all appear to have received an important contribution from volcanic sources. The main period of deformation recorded in the Southeast New England platform was in the Late Precambrian, whereas the principal metamorphism and intrusive activity to the west in Massachusetts can only be dated as pre-Late Silurian, the assumed age of the phyllite on the basis of correlation with fossiliferous rock in Maine and New Hampshire. These metasedimentary rocks in the Nashua trough are less metamorphosed than the adjacent older rock and are not intruded whereas abundant foliated intrusive rock has invaded the juxtaposed rock. Many of the intrusive bodies that cut the Nashoba and Merrimack provinces have yielded Ordovician or Silurian radiometric dates. These rocks appear to be anatexic in origin and follow earlier fault zones which possibly could have originated during a Late Precambrian deformation. Several elongate foliated intrusive bodies that cut the Merrimack province have been dated as Devonian. The Ayer complex that invades the Clinton-Newbury fault zone in the Webster-Oxford area is dated as Ordovician to Silurian, whereas the Canterbury Gneiss that intrudes it across much of Connecticut is dated as Devonian (Zartman and Naylor, in press). The Ordovician to Silurian deformational effects appear more important in this area whereas the Devonian effects may have been stronger farther south. Deformation accompanied by intrusion does appear to have continued much later along the west side of the Nashoba thrust belt than along the east. Clearly, the area along the Nashoba belt records a great number of movements and intrusive events in the Early Paleozoic with subsequent movements during the rest of the Paleozoic and some apparent reactivation during the Mesozoic. It probably represents the most active zone of deformation during the development of the Appalachians in New England.

ACKNOWLEDGEMENTS

I wish to thank the dozen field assistants that helped map the area, and the geologists of the surrounding areas, and especially M.H. Pease, Jr., and L.R. Page for their help and discussions over the years. I thank both the U.S. Geological Survey and the U.S. Nuclear Regulatory

Commission for their support. I also thank M.H. Pease, Jr. and P.V. Smith for their assistance in editing, P.R. Lagace and P.V. Smith for drafting the illustrations and Dorothy M. Sheehan, Patricia Tassia and Ralph Aoki for typing and retyping the manuscript.

REFERENCES

- Alvord, D.C., 1975, Preliminary bedrock geologic maps of the Westford and Billerica quadrangles, Middlesex County, Massachusetts: U.S. Geol. Survey open-file report 75-387.
- , 1976, Field guide to the Pre-Silurian eugeosynclinal metamorphic rock sequence occurring between the Bloody Bluff and Clinton-Newbury faults, Concord, Billerica, Westford quadrangles, Massachusetts: in Barry Cameron, ed., Geology of southeastern New England, New England Intercoll. Geol. Conf., 68th Ann. Meeting, Science Press, Princeton, N.J., p. 315-333.
- Barosh, Patrick J., 1974, Preliminary bedrock geological map of the Webster Quadrangle, Massachusetts-Connecticut: U.S. Geol. Survey open-file Rept. 74-192, 2 p., map scale 1:24,000.
- , 1976a, The western Rhode Island fold belt (abs.): Geol. Soc. America, Abs. with Programs, v. 8, no. 2, p. 127-128.
- , 1976b, Faults and related deformation in the Clinton-Newbury--Bloody Bluff fault complex of eastern Massachusetts: in Barry Cameron, ed., Geology of southeastern New England: New England Intercoll. Geol. Conf., 68th Ann. Meeting, Science Press, Princeton, N.J., p. 301-314.
- , 1976c, Stratigraphy of the Webster-Worcester region, Massachusetts: in Barry Cameron, ed., Geology of southeastern New England: New England Intercoll. Geol. Conf., 68th Ann. Meeting, Science Press, Princeton, N.J., p. 352-365.
- , 1976d, Preliminary bedrock geologic map of the Oxford quadrangle, Massachusetts, Connecticut and Rhode Island: U.S. Survey open-file rept., 76-622, 5 p., scale 1:24,000.
- , 1977, Preliminary map showing bedrock geology superposed on an aeromagnetic base map of the Worcester region, Massachusetts, Connecticut, and Rhode Island, U.S. Geol. Survey open-file rept. 77-131, 38 p., 2 pl., scale 1:125,000.
- , 1979, Paleozoic plate boundary conditions in southeastern New England: Geol. Soc. America Abs. with Programs, v. 11, no. 1, p. 2-3.
- , in prep, The Paxton Group.
- Barosh, P.J. and Hermes, O.D., 1981, General structural setting of Rhode Island and tectonic history of southeastern New England, in Boothroyd, J.C. and Hermes, O.D., eds., Guidebook to geologic field studies in Rhode Island and adjacent areas: New England Intercoll. Geol. Conf., 73rd Ann. meeting, Univ. of R.I., Kingston, R.I., p. 1-15.
- Barosh, P.J., and Johnson, C.K., 1976, Reconnaissance bedrock geologic map of Leicester quadrangle, Massachusetts, U.S. Geol. Survey open-file rept. 76-814, 9 p., scale 1:24,000.
- Barosh, P.J., and Pease, M.H., Jr., 1981, Correlation of the Oakdale and Paxton Formations with their equivalents from eastern Connecticut to southern Maine (abs): Geol. Soc America, Abs. with Programs, v. 13, no. 3, p. 122.

- Barosh P.J., Fahey, R.J., and Pease, M.H., Jr., 1977, Preliminary compilation of the bedrock geology of the land area of the Boston 2-degree sheet, Massachusetts, Connecticut, Rhode Island, Maine and New Hampshire: U.S. Geol. Survey Open-File Rept. 77-285, 91 p., map scale 1:250,000.
- Bell, K.G., and Alvord, D.C., 1976, Pre-Silurian stratigraphy of northeastern Massachusetts: in Page, L.R., ed., Contributions to the stratigraphy of New England: Geol. Soc. America Mem. 148, p. 179-216.
- Dixon, H.R., 1964, The Putnam Group of eastern Connecticut: U.S. Geol. Survey Bull. 1194-C, 12 p.
- Emerson, B.K., 1917, Geology of Massachusetts and Rhode Island: U.S. Geol. Survey Bull. 704, 132 p.
- Gore, R.Z., 1976, Ayer crystalline complex of Ayer, Harvard and Clinton, Massachusetts: in Lyons, P.C., and Brownlow, A.H., eds., Studies in New England Geology: Geol. Soc. America Mem. 146, p. 103-125.
- Hanson, W.R., 1956, Geology and mineral resources of the Hudson and Maynard quadrangles, Massachusetts: U.S. Geol. Survey Bull. 1038, 104 p.
- Hussey, A.M., II, 1962, The geology of southern York County, Maine: Maine Geol. Survey Spec. Studies Ser. no. 4, 67 p.
- Kaye, C.A., and Zartman, R.E., 1980, A late Proterozoic Z to Cambrian age for the stratified rocks of the Boston Basin, Massachusetts, USA, in Wones, D.R., ed., The Caledonides in the USA: Virginia Polytech. Inst. and State Univ., Dept. Geol. Sci. Mem. 2, p. 257-264.
- Nelson, A.E., 1975, Bedrock geologic map of the Natick quadrangle, Middlesex and Norfolk counties, Massachusetts: U.S. Geol. Survey Geol. Quad. Map GQ-1028.
- Pease, M.H., Jr., 1972, Geologic map of the Eastford quadrangle, Windham and Tolland Counties, Connecticut: U.S. Geol. Survey Geol. Quad. Map GQ-1023, scale 1:24,000.
- Pease, M.H., Jr., and Barosh, P.J., 1981, Distribution and structural significance of the Oakdale formation in northeastern Connecticut: in Boothroyd, J.C., and Hermes, O. D., eds., Guidebook to Geologic Field Studies in Rhode Island and adjacent areas: New England Intercoll. Geol. Conf. 73rd Ann. Mtng., Univ. of R. I., Kingston, R.I. p. 17-34.
- Peck, J.H., 1975, Preliminary bedrock geologic map of the Clinton quadrangle, Worcester county, Massachusetts: U.S. Geol. Survey open-file Report 75-658, scale 1:24,000.
- , 1976, Silurian and Devonian stratigraphy in the Clinton quadrangle, central Massachusetts: in Page, L.R., ed., Contributions to the Stratigraphy of New England: Geol. Soc. America Mem. 148, p. 241-252.
- Peper, J.D., Pease, M.H., Jr., and Seiders, V.M., 1975, Stratigraphic and structural relationships of the Brimfield Group in northeast-central Connecticut and adjacent Massachusetts: U.S. Geol. Survey Bull. 1389, 31 p.
- Perry, J.H., and Emerson, B.K., 1903, Geology of Worcester, Massachusetts: Worcester Nat. Hist. Soc., 166 p.
- Rice, W.N., and Gregory, H.E., 1906, Manual of the geology of Connecticut: Connecticut Geol. and Nat. History Survey Bull. 6, 132 p.

- Smith, P.V., and Barosh, P.J., 1981, Structural geology of the Nashua trough, southern New Hampshire (abs.): Geol. Soc. America Abs. with Programs, v. 13, no. 3, p. 178.
- Wintsch, R.P., 1975, Feldspathization as a result of deformation: Geol. Soc. America Bull., v. 86, p. 35-38.
- Zartman, R.E., and Naylor, R.S., in press, Structural implications of some radiometric ages of igneous rocks in southeastern New England: Geol. Soc. America Bull.

ROAD LOG

MAPS - 7.5-minute quadrangle maps covered on this road log are the Worcester South (STOPS 1, 2, 4, 5 and 6), Leicester (STOP 3), Oxford (STOPS 7, 8, 9 and 10), and Webster (STOPS 11 and 12). Field Stop locations are shown on figure 2.

MILEAGE

- 0 Start at Howard Johnson's Hotel, College Square, Worcester, MA, on east side of Rt. 290 at exit 11, just south of Holy Cross's stadium. (To reach the start from the University of Connecticut at Storrs, travel north on Rt. 320 to Rt. 86, northeast to Rt. 90-the Mass Pike- and north on Rt. 290. Allow 1.3 hours). Drive southeast uphill on College St. (becomes Pakachoag St. to south). Holy Cross College on left.
- 0.3 Turn left into college at gate 7, at east side of field house opposite Boyden St. Keep to right and drive to top of hill.
- 0.5 Park near entrance to Hart Recreational Center, modern brick building.

STOP 1 - Overview of area and contorted Eliot Formation.

This high point affords a good general view of the region from which the general geologic setting can be seen. Holy Cross is situated on a ridge formed by a northeast-trending fault sliver of Eliot Formation, of Late Silurian or Early Devonian age, along the Clinton-Newbury fault zone. Two very small fault slivers of phyllite of Pennsylvanian age lie along the north end of this Eliot sliver, east of Worcester center. The ridge is interrupted by the Blackstone River valley, northeast of Holy Cross, that follows a younger northwest-trending transverse fault. The position of the main break of the Clinton-Newbury fault zone can be seen to the east in the valley (seen from the east side of the Hart Center) where it passes just this side of the large long building and freight yards. The rolling hills farther east are composed of the Nashoba Formation. A very thin band of Tadmuck Brook Schist, which overlies the Nashoba, lies against the east side of the fault zone. Downtown Worcester, seen to the north, lies in a broad valley, northwest of the ridge of Eliot, underlain by the Oakdale Formation. The type area of Oakdale lies to the north-northwest beyond Worcester. The hills forming the northwest side of the valley are the type area of the more resistant rock of the Paxton Group, that overlies the Oakdale.

Highly contorted Eliot Formation forms small scattered outcrops in the lawn in front of the Hart Center. The new swimming pool behind the center is built into the Eliot. The

folding appears to be very irregular. General structural details can best be seen in the loose blocks lying near the entrance to the Center, which exhibit crinkled folds with strong axial plane cleavage that is about perpendicular to the poorly preserved general bedding. The folding appears to be the result of compression of the sliver during faulting and not directly related to any regional fold episode.

Return to College St.

0.7 Turn left up College St.

1.0 Park at entrance to Dutton St., sign on left. Walk to end of the short dirt road on the right and into woods about 50 m to top of ridge.

STOP 2, Eliot Formation.

Examine extensive scattered outcrops of medium-to dark-gray, thin-bedded, metamudstone-phyllite. The 0.5 to 2 cm-beds have well-developed graded bedding and appear to have formed as a distal turbidite sequence (Peck, 1976). The sedimentary features are much better displayed here as rocks are less deformed than STOP 1. Overturned beds are present. Return to car and continue south on College St. Scattered outcrops of Eliot formation occur along the sides of the road.

2.9 Turn right on Burnap St.

3.1 Turn left at bottom of hill onto Southbridge St. and cross iron bridge.

3.7 Pass Sears on left, Toys-R-Us on right. Rocks bordering parking lot in Toys-R-Us came from outcrop blasted for building. Boulders consist of metasiltstone and phyllite with many sedimentary features well displayed, including some graded bedding. This was previously considered unusual Oakdale Formation (Barosh, 1976c), but is now thought to be a fault sliver of the basal Eliot Formation.

4.2 Pass under Massachusetts Turnpike, Rt. 90.

4.6 Pass under expressway Rt. 290.

6.0 Veer right at signals at junction Rts. 12 and 20. Driving over Oakdale Formation.

6.6 Turn left onto Rt. 12 south. Biotite quartz monzonite forms the hill to the left. The ridge to the right is composed of muscovite quartz monzonite, "Fitchburg granite".

7.1 Park on right near outcrop opposite Dry Vin Cleaners.

STOP 3, Oakdale Formation.

Typical greenish medium-gray silicic laminated metasiltstone of the Oakdale Formation well bedded in thin beds that are folded and cut in places by small low-angle faults. This kind of silicic rock is probably why the unit was first called the Oakdale Quartzite. A short distance to the south the intrusive rocks on either side of the Oakdale merge, pinching it out. The Oakdale reappears in the same position about a mile farther southwest.

Turn around and proceed north on Rt. 12.

- 7.6 Turn right onto Rt. 20.
- 8.2 Stay to right on Rt. 20.
- 9.1 Pass entrance to Rt. 52 south.
- 9.4 Turn right onto entrance to Rt. 52 north.
- 9.6 Turn right again onto exit to Rt. 20 south.
- 9.8 Park off side of roadway on cloverleaf.

STOP 4, Deformed Oakdale Formation.

The Oakdale Formation exposed in the road cuts is strongly deformed into complex folds cut by a few irregular small thrust faults. The western branch of the Clinton-Newbury fault zone lies just east of these exposures in the valley flooded by the northern end of Eddy Pond and the Oakdale is deformed against it. Similar strongly deformed metasedimentary rock occurs elsewhere against the fault zone. Proceed to end of exit lane and right onto Rt. 20 west.

- 10.1 Turn right into entrance Rt. 52 south, towards Webster.
- 10.7 You should now be on Rt. 52 heading south, passing Eddy Pond, which lies along the Clinton-Newbury fault zone. Exposure of highly sheared rock forming part of the fault zone can be seen near the road on the opposite side of the pond.
- 12.0 Park on far right edge of road at Oxford town line, just beyond power lines. Use extreme caution walking near roadway.

STOP 5. Clinton-Newbury fault zone.

Outcrop to right, west of road, composed of moderately foliated, sheared, biotite quartz monzonite, one of the younger intrusive rocks in the area. Cross southbound lane carefully to median strip and continue eastward across it. The shearing of the quartz monzonite increases eastward to

produce a mylonite along the east side of the median; small xenoliths in the quartz monzonite are sheared out into very thin, dark gray lenses. Medium gray, rusty weathering schist is exposed in the low roadcut along the east edge of the median. This appears to be a thin fault sliver of the Tadmuck Brook Schist, the highest unit in the Nashoba thrust belt. The west edge of this unit marks the main break in the fault zone. The roadcuts to the east of the northbound lane expose highly sheared to mylonitized medium gray gneiss of the Nashoba Formation. During construction of Rt. 52 the entire roadway was cleaned off, exposing a north-trending cross fault just southwest of here that offset the Clinton-Newbury zone about 50 m right-laterally.

Return to car.

- 12.2 Pass roadcuts to left that expose many steeply west-dipping slickensided surfaces on the mylonitized Nashoba. These represent later more brittle movement than the mylonite. They are perhaps the results of Mesozoic movement that reactivated portions of the thrust fault as a normal fault apparently with the west side down.

- 14.4 Park off road at right opposite high roadcut on left.

STOP 6, Thrust-fault complex cutting the Nashoba Formation.

Complex of moderately north-dipping shears, thrust faults, and overturned folds with north-dipping axial planes. Consistently north over south transport, which is a local deviation from the regional northwest over southeast transport. The foliation and mylonitization parallels relict bedding. The observed layering is thus a result of a combination of causes. Many of the thrust faults have pegmatite, both foliated and nonfoliated, along them. Field evidence suggests that many of these developed during thrusting; porphyroblasts of feldspar and quartz form in blastomylonites, increase in amount and coalesce, forming pegmatites. The geochemistry of this type of mineral growth was studied by Wintsch (1975). In this area, the Marlboro-Nashoba sequence has undergone radical tectonic thinning by omission along both the Bloody Bluff and Clinton-Newbury fault zones and a series of internal faults. The exposed thickness decreases from about 18,000 m northwest of Boston (Bell and Alvord, 1976) to less than 1,000 m south of Oxford center.

- 15.3 Turn right beyond bridge on exit 4E, Sutton Ave.
- 15.6 Turn right, east on Sutton Ave.
- 15.7 Turn right again onto entrance to Rt. 52 north.

- 16.2 Turn right once more on exit just beyond bridge.
- 16.4 Park on shoulder to right at upper end of roadcuts. Cross carefully to roadcut on left, east side.

STOP 7. Contact of Marlboro Formation (Quinebaug Formation) with Nashoba Formation of Hanson (1956) (Tatnic Hill Formation).

These metasedimentary rocks are well-bedded, with foliation parallel to bedding. However, the shearing and mylonitization are also parallel to bedding at this location, which makes it difficult to see primary bedding features.

Amphibolite at the south end of the cut, and also underlying the valley to the south, is correlated with the Sandy Pond Member of the Marlboro Formation of Bell and Alvord (1976); it is correlated in Connecticut with the Quinebaug Formation of Dixon (1964). The Marlboro is composed of dark-gray layered amphibolite containing a few beds of quartzo-feldspathic gneiss. In much of the upper part of the formation, beds are 0.5- to 10-cm thick, but beds 1 m or so thick are not uncommon. In the northern part of the roadcut is light- to medium-gray, medium-bedded micaceous quartzo-feldspathic gneiss which forms the most common lithology in the Nashoba Formation correlated with the Tatnic Hill Formation in Connecticut (Dixon, 1964). Sillimanite occurs in this gneiss, but is difficult to identify in outcrop. The few large garnets found in the gneiss here are unusual. A bed of amphibolite is present within the lower part of the Nashoba. This may be a fault sliver of Marlboro or it may be a stratigraphic unit within the Nashoba. Thin amphibolite intervals are common in the Nashoba.

The rocks here are highly sheared and faulted. They are just above a major regional thrust, the Bloody Bluff fault zone, that underlies the valley to the south. Light-gray pegmatite, both foliated and nonfoliated, is present along many of the shears and thrust faults. The highly sheared bedding steepens southward across this exposure, towards the Bloody Bluff fault zone. At two places nearby, a few miles to the east and less than a mile to the west, the entire Marlboro Formation is cut out against this fault (fig. 4).

Walk to south side of Sutton Ave. and look south. The valley on this side of the hill is underlain by amphibolite of the Marlboro Formation against the Bloody Bluff fault zone. The hill on the other side forms the nose of the large north-west-plunging Oxford anticline, that is part of the South-east New England platform. It is cored by light pinkish-gray foliated quartz monzonite of Late Precambrian age that intrudes quartzite of the Plainfield Formation, which forms a rim around the nose.

- 16.5 Turn right on Sutton Ave.
- 16.6 Turn right again onto Rt. 52 south. You should now be heading south on Rt. 52.
- 17.4 Cross Bloody Bluff fault zone. Drill core taken along Rt. 52 in preparation for the highway construction has provided geologic control over covered areas such as this along the highway to locate any projected structures much more accurately.
- 18.0 Cross anticlinal axis.
- 18.1 Park on shoulder on right within roadcut just before bridge and sign for Webster. Use caution near roadway.

STOP 8, Precambrian granitic rock and xenoliths of Plainfield Formation.

Gneissic quartz monzonite, that is part of the Sterling plutonic group, crops out on both sides of the roadway. This location is near the contact with the Plainfield and xenoliths of quartzite and chlorite schist of this formation are present. Many xenoliths are partially digested by the intrusive rock and contacts are gradational. The intrusive rock is moderately to strongly foliated. The feldspars are generally rounded rather than sheared and fractured and the foliation appears to have developed more by flowage than by shearing, in contrast to the previous two stops. The rock has generally undergone alteration, which has produced pink feldspar and has chloritized the mafic minerals. The foliation in the intrusive and the foliation and bedding in the Plainfield are parallel. Many small faults cut the rock here; several are nearly parallel to the road, dipping steeply to the west, and a few are approximately perpendicular to the road. An east-dipping thrust fault is present on the left and on the right a steeply dipping, slickensided fault plane is exposed. A number of late faults and fracture zones, with alteration along them, cross at about N 80° W with dips 70°-90° N.

Continue southward.

- 20.2 Park on shoulder on right near light gray outcrop. Again use caution near roadway.

STOP 9, Plainfield Formation.

Good examples of relatively undeformed Plainfield Formation can be seen here. Light gray, thin-to medium - bedded quartzite crops out on the right. To the left in the median strip is an exposure of thin-bedded quartzite with interbedded thin beds and partings of greenish medium-gray

chloritic schist. Larger exposures occur to the east along the northbound roadway. A few meters to the right of the road, beyond the fence, and closer to the Lake Char fault, the Plainfield is sheared and bedding is difficult to see.

Continue southward.

- 20.8 Turn right onto exit 2, Webster, and drive through a roadcut in Plainfield Formation.
- 21.0 Turn right onto Rt. 16 west.
- 21.1 Turn left into parking lot opposite Cranston Print Works Company and park near east end. Walk back 0.3 miles to top of exit 2 ramp just driven through and then turn around and walk back towards Rt. 16 examining the roadcuts along the way. STOP 10 - Lake Char fault zone and sheared Plainfield Formation. Highly sheared greenish to purplish medium-gray, thin-bedded, interbedded dirty quartzite and schistose pelitic beds. Shearing and foliation parallel bedding. At the top of the cut some bedding can be seen in the thicker layers of light gray to buff quartzite. Southward down the cut the bedding is lost as the shearing increases towards the Lake Char fault, which passes just southwest of the cut. The layers at the west edge of the outcrop, next to the fire plug, are broken up. Many layers are crinkled and contorted, probably due to the difference in competence between alternating layers of quartzite and schist. The Lake Char fault zone occupies the same structural position as the Bloody Bluff fault zone.

Return to car.

- 21.2 Turn left from parking lot onto highway, cross through signals and continue down Main St., Rt. 12.
- 22.0 Veer left at fork.
- 22.4 Pass Webster Town Hall on left.
- 22.7 Pass Dudley townline.
- 22.9 Turn right at signal and continue straight across next road and under pedestrian bridge of old factory.
- 23.2 Turn left onto Faxfield St.
- 23.3 Park just beyond power line. Examine outcrops on right side of road and beneath powerline.

STOP 11, Intrusive complex along the Clinton-Newbury fault zone.

The Clinton-Newbury fault zone here and to the south in Connecticut has been invaded by intrusive rock. It can be shown in the Webster quadrangle that the zone between the Nashoba and Oakdale Formations has been repeatedly intruded, demonstrating a long period of crustal weakness and deformation along this boundary. Intrusive bodies in this area tend to be long and narrow. Some intruded fault zones are shown by discordance between rocks on either side of the intrusive body and by xenoliths of mylonite and rock from both the Nashoba and Oakdale Formations. Some also have later fault movement along contacts. This may show up as stronger foliation and the alteration of biotite to sericite and muscovite near the contact. This is the case along the thrust fault that separates the undivided Ayer from the biotite quartz monzonite phase of the Ayer (fig. 4). The intrusive rocks appear to represent anatectic melts. The Ayer Intrusive Complex is composed of several intermixed, closely related, fine-grained to porphyritic intrusions approximately of quartz monzonite composition. The complex is formed of a coarse-grained porphyry cut by fine- to medium-grained muscovite-bearing quartz monzonite with a coarse porphyritic phase. Commonly, the latter has invaded the former as a series of closely spaced tongues. Much of this complex is part of the Ayer Granite of Emerson (1917) and similar to that described north of Worcester by Gore (1976). Here both the light gray, coarse-grained porphyritic and medium-grained, muscovite-bearing varieties can be seen in outcrops and float.

Return to car.

Turn around and proceed back towards intersection.

23.5 Turn left.

23.6 Veer left onto Carlton St.

24.1 Park on right just beyond roadcut

STOP 12, Pendant of Oakdale Formation.

The western edge of the intruded Clinton-Newbury fault zone was crossed a short distance to the east. Here a pendant of Oakdale Formation lies in muscovite quartz monzonite just west of the fault zone. The Oakdale is thin-bedded, greenish-gray metasiltstone that is slightly to moderately folded. In this general area the Clinton-Newbury fault zone swings and cuts southwestward across the north-striking units to the west; this makes the structure very complex in detail. The position of the Clinton-Newbury fault zone continues southward through eastern Connecticut to just north of the

Honey Hill fault zone, but is invaded by the Canterbury granite gneiss and the trace of the fault is not readily seen.
END OF FIELD TRIP. (To return to Storrs, CT. take Rt. 52 south to Putnam, CT., and then Rts. 44 and 44A west).

P7-1

Structural Geology of the Moodus Seismic area, south-central Connecticut

by

P.J. Barosh, Weston Observatory, Boston College,
 David London, University of Oklahoma,
 and Jelle de Boer, Wesleyan University

INTRODUCTION

The area around Moodus, Connecticut (fig. 1) is one of the most continuously seismically active places in the northeastern United States. Indian legends from pre-colonial times noted the area for its earthquakes. The name Moodus is derived from the Indian name Morehemoodus meaning "place of noises" (Chapman, 1840).

The earthquakes are very shallow, and are accompanied by "noises": rumbling and booming sounds (Ebel and others, 1982) created when the high frequency vibrations of the ground couple with the atmosphere. Earthquakes of less than magnitude 1 have been felt and ones as small as magnitude 0 have been heard (Ebel and others, 1982). The area, thus, has a class of earthquakes that are heard but not felt! The Indian medicine men attributed these noises to the voice of mother earth.

The largest known earthquake in the Moodus area occurred on May 16, 1791, and was felt across all of southern New England. This earthquake had an intensity of about VII, causing slight damage in the Moodus area (Boston Edison Company, 1976). Activity had been low in recent times, up to about 3 years ago. Since then earthquake swarms, numbering a few hundred events each, have occurred in September, 1980, September-October, 1981 and June, 1982 (fig. 2).

An analysis of the earthquake activity at Moodus is of interest as a source of information concerning the cause of seismicity in the region and for evaluation of the seismic hazard at the nearby Connecticut Yankee nuclear power plant. Several investigations in and around the Moodus area have been conducted in the past six years under the auspices of the New England Seismotectonic Study, funded by the U.S. Nuclear Regulatory Commission and in cooperation with the Connecticut Geological and Natural History Survey. These studies include compilation of all available geologic data, five seasons of detailed geologic mapping in and around the Moodus area, a detailed gravity survey of south-central Connecticut, mapping and fracture analysis of the Higganum dike, analysis of Landsat, topographic and aeromagnetic lineaments in the region, mapping of the Pleistocene terraces along the Connecticut River, investigations of recent rock movements, a near-shore magnetic survey in Long Island Sound and the installation of a five station seismic array in the Moodus area. These studies have added greatly to our knowledge of the geology and seismicity of the area. The general distribution of lithologies had been delineated by Lundgren (1963, 1979) Lundgren and Ashmead (1971) and Eaton and Rosenfold (1972), but the structural geology of the Moodus area as it is presently known bears little resemblance to what it was thought to have been six years ago. The bedrock geology of the region is very complex, and much more needs to be done to fully understand it, but detailed studies of *

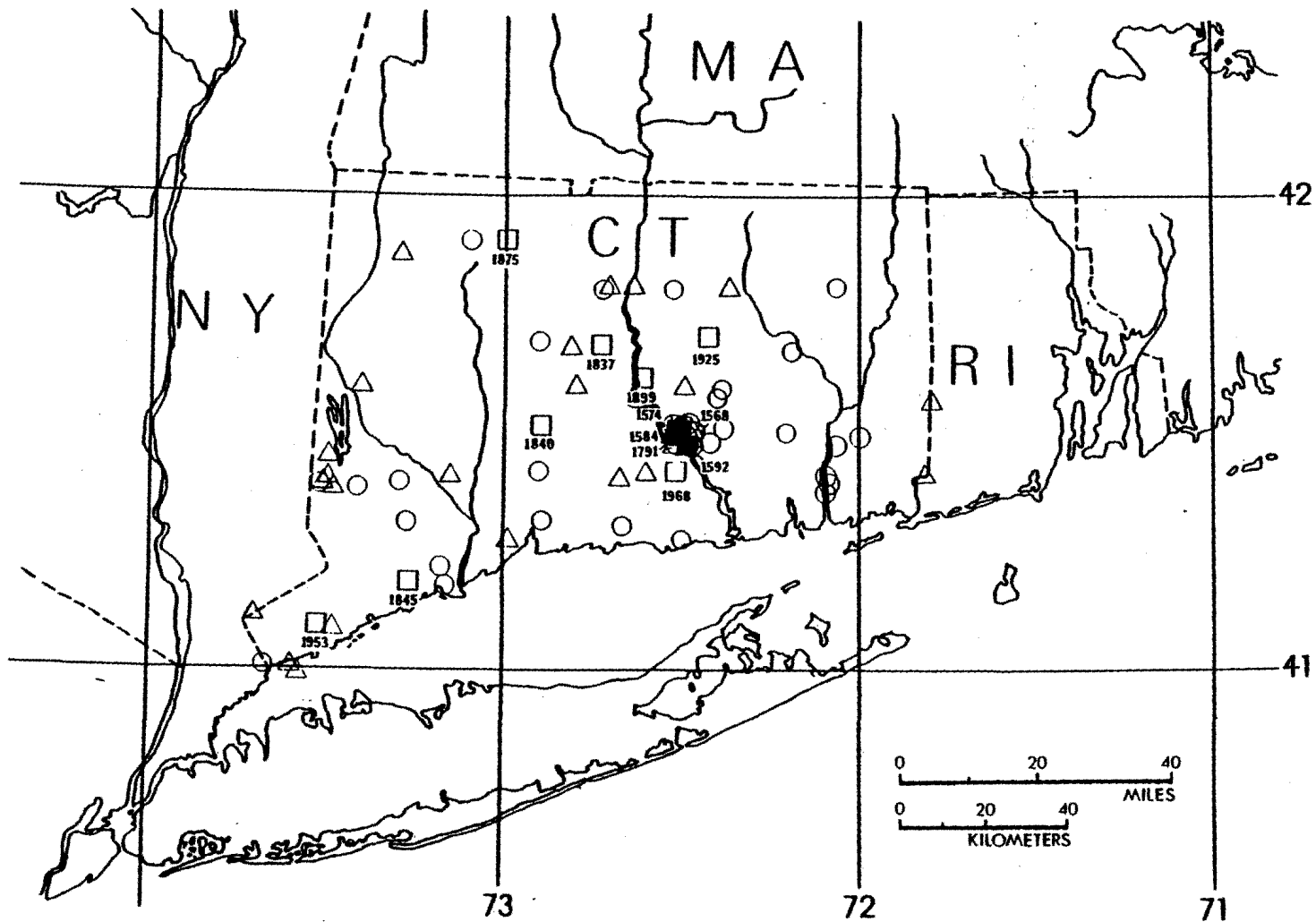

Fig. 1. Historical seismicity of Connecticut. The symbols show the maximum modified Mercalli intensity for the events: ○ = III, △ = IV, □ = V, ● = VI, and ■ = VII. Moodus is located in the area of the concentration of seismicity on the map. The figure is from Chiburis (1981).

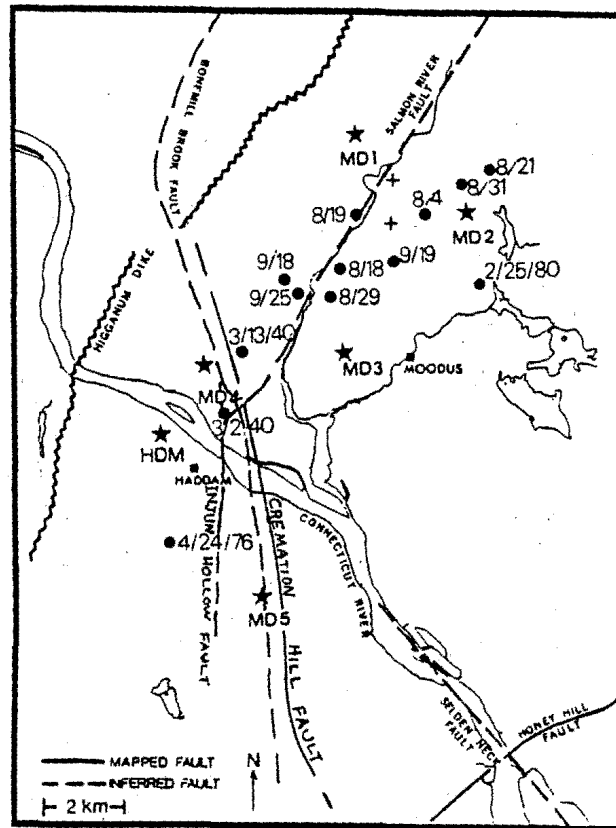

Fig. 2. Map of recent seismicity and tectonics of the Moodus area. The dates of the locations of events from the 1981 swarm are shown, as well as dates and locations from previously located events. Locations of the Moodus network stations are shown as stars, and sites of the two temporary stations which were installed after the August 4 event are shown as crosses. Modified from Ebel and others, 1982.

of the Moodus area (fig. 3) and to the south provide a start in revealing the structure (London, in prep. and Wintsch, in prep. and this volume).

The purpose of this guide is to describe what is presently known about the structural setting of the area of the Moodus earthquakes and to show examples of the variety of deformational structures found there. These structures present a wide range of age of formation and deformational features from very ductile to very brittle. This report borrows heavily from many others involved in these investigations: M.H. Pease, Jr., Brian Koch, J.F. Kick, R.P. Wintsch, J.S. Sawyer, S.E. Carroll, S.S. Quarrier, E.F. Chiburis, J.E. Ebel, Vladimir Vudler, Michael Celata, and Ralph Aoki. It is also indebted heavily to M. H. Pease, Jr., P.V. Smith and P. Lagace for their editing and drafting expertise and to Ralph Aoki, Dorothy M. Sheehan, Joy O'Malley, and Patricia Tassia for manuscript preparation.

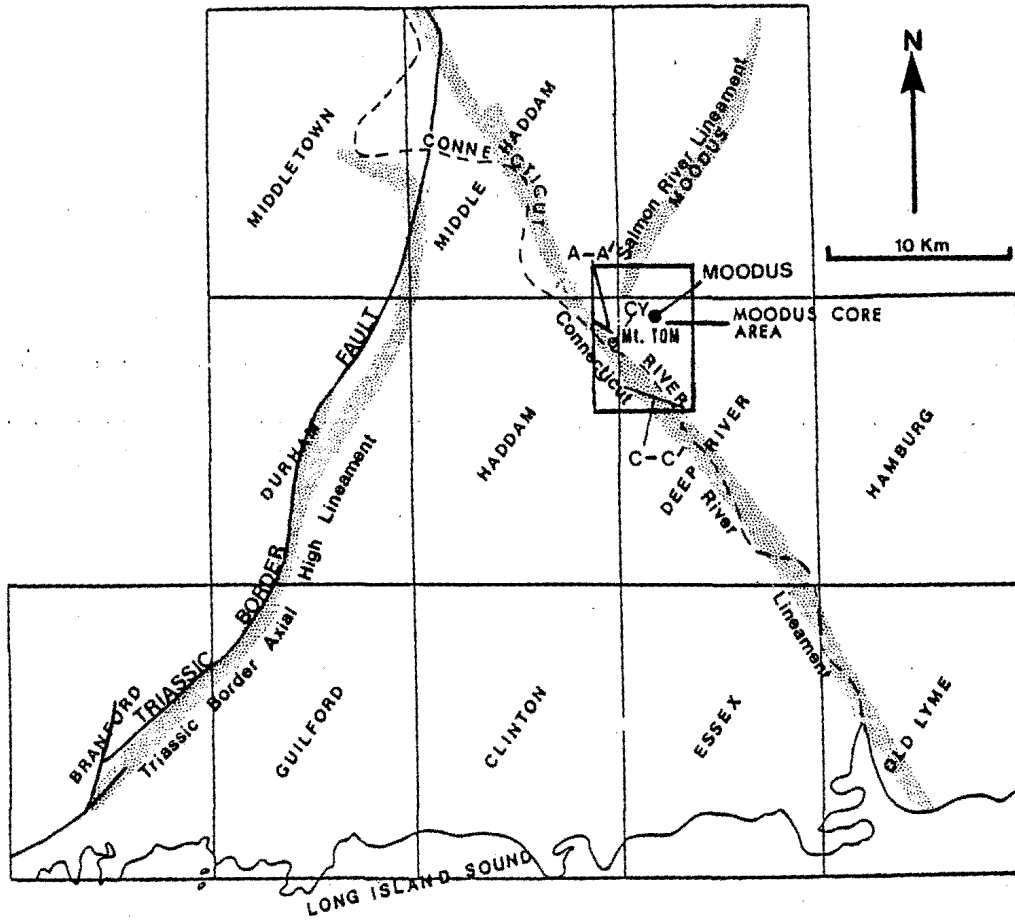

Figure 3. Index map of the Moodus area, south-central Connecticut, showing 7.5-minute quadrangles, selected gravity lineaments, and position of cross sections. Explanation: CY, Connecticut Yankee Nuclear Power Plant; stippling gravity lineament; A-A' and C-C', cross sections.

REGIONAL STRUCTURAL SETTING

The Moodus area lies in a complex region composed of six distinct structural provinces: the Hartford graben, Killingworth dome, Glastonbury dome, Merrimack province, Southeast Connecticut fold belt portion of the Southeast New England platform and a thin remnant of the Nashoba thrust belt (fig. 4). Major fault zones separate these provinces (fig. 4). The Honey Hill fault zone is a north-dipping thrust fault that, along with a sliver of the Nashoba thrust belt, separates the Merrimack province from the Southeast Connecticut fold belt and has local relative north over south movement. It is part of the largest fault system known in New England and probably represents an Early Paleozoic plate boundary that may have begun movement as early as Late Precambrian (Barosh, this volume, Trip P6, fig. 1). Most of the length of the fault bounding the north side of the Nashoba thrust sliver along the Honey Hill fault has been intruded by the Devonian Canterbury Gneiss. The Nashoba thrust belt is much wider along the eastern boundary of Connecticut (see Barosh, this volume, Trip P6, fig. 1 and M.H. Pease, Jr., this volume, Trip P2, fig. 1).

The Bonemill Brook fault zone (see M.H. Pease, Jr., this volume, Trip P2) is a northerly-trending, steeply dipping zone dividing the Merrimack province from the provinces to the west. The Honey Hill fault zone is cut off on the west by a northerly-trending fault sliver of steeply dipping deformed rock about 800 m wide that lies on the east side of the Bonemill Brook Fault. The Bonemill Brook fault zone has not been mapped south of the Falls River fault zone (fig. 4); it may continue southwards, but the structure is extremely complex and is as yet unresolved. What happens west of this zone to the Honey Hill and the underlying rocks of the southeast Connecticut fold belt is as yet unknown. However, the kinds of structures at the southern end of the Killingworth dome area are very similar to the kinds of structures south of the Honey Hill and a continuation of the fault may lie in this area.

A broad northwest-trending zone of structural dislocation divides the Glastonbury and Killingworth domes. This zone extends northwestward from the Moodus area mainly along the northeast side of the Connecticut river. Major structural features on either side of this zone terminate against it. This zone is herein named the Middle Haddam fault zone and is described in greater detail in the section on pre-Mesozoic structures.

A normal, extensional, border fault along the east side of the Hartford graben separates the graben from the domes to the east. This fault appears to be a composite fault zone; northeast-trending segments of the fault appear to extend into the Killingworth dome. A strong linear gravity high follows the border fault (Kick, 1982) (fig. 3). It is highest where the thick lava flows in the graben abut the border and may represent a basaltic intrusion that came up the fault and fed the flows.

The provinces exhibit different structural styles and contain separate stratigraphic sequences and, except for continuation of the Monson Gneiss across the boundary between the Killingworth and Glastonbury domes, correlation between provinces must be mainly conjectural.

The structure of the area has previously been considered to consist of long, narrow, sinuous folds with negligible faulting other than along the Honey Hill fault zone (Lundgren, 1963) (fig. 5). The immediate area of Moodus is shown to be formed of two regional folds: the Chester syncline and the Monson

Figure 5. Generalized geologic map of south-central Connecticut showing the regional geology interpreted as a series of folds (Lundgren, 1963).

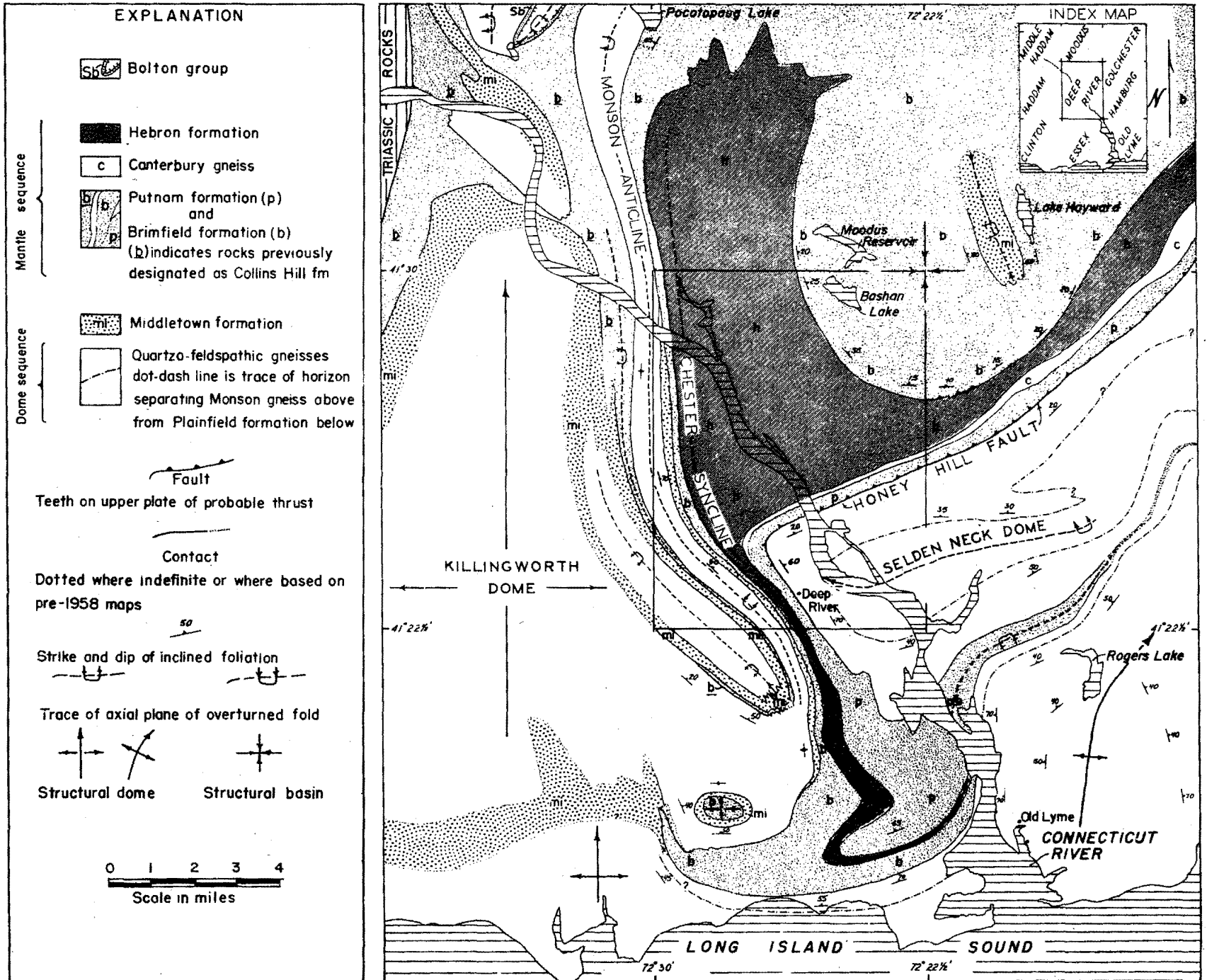

Explanation for figure 6.

SYMBOLS

X 2

FAULTSDashed when inferred,
teeth where thrust fault

Intruded

FOLDS

Anticlinal axis, arrow showing plunge

Synclinal axis, arrow showing
plunge

Synclinal axis, overturned

DIKES

Diabasic (Early Jurassic)

Ultramafic (Paleozoic)

FIELD STOPS

Stops in road log

INITIALS**FAULTS**

B.F. Border fault
M.H. Middle Haddam
B.B. Bonemill Brook
I.H. Injun Hollow
C.H. Cremation Hill
F.R. Falls River
S.N. Seldon Neck
H.H. Honey Hill

FOLDS

G H Great Hill syncline
K D Killingworth dome
M Moodus anticline
V P Vincent Pond basin
L Lyme anticline

DIKE SYSTEM

H.D. Higganum dike

P7-9

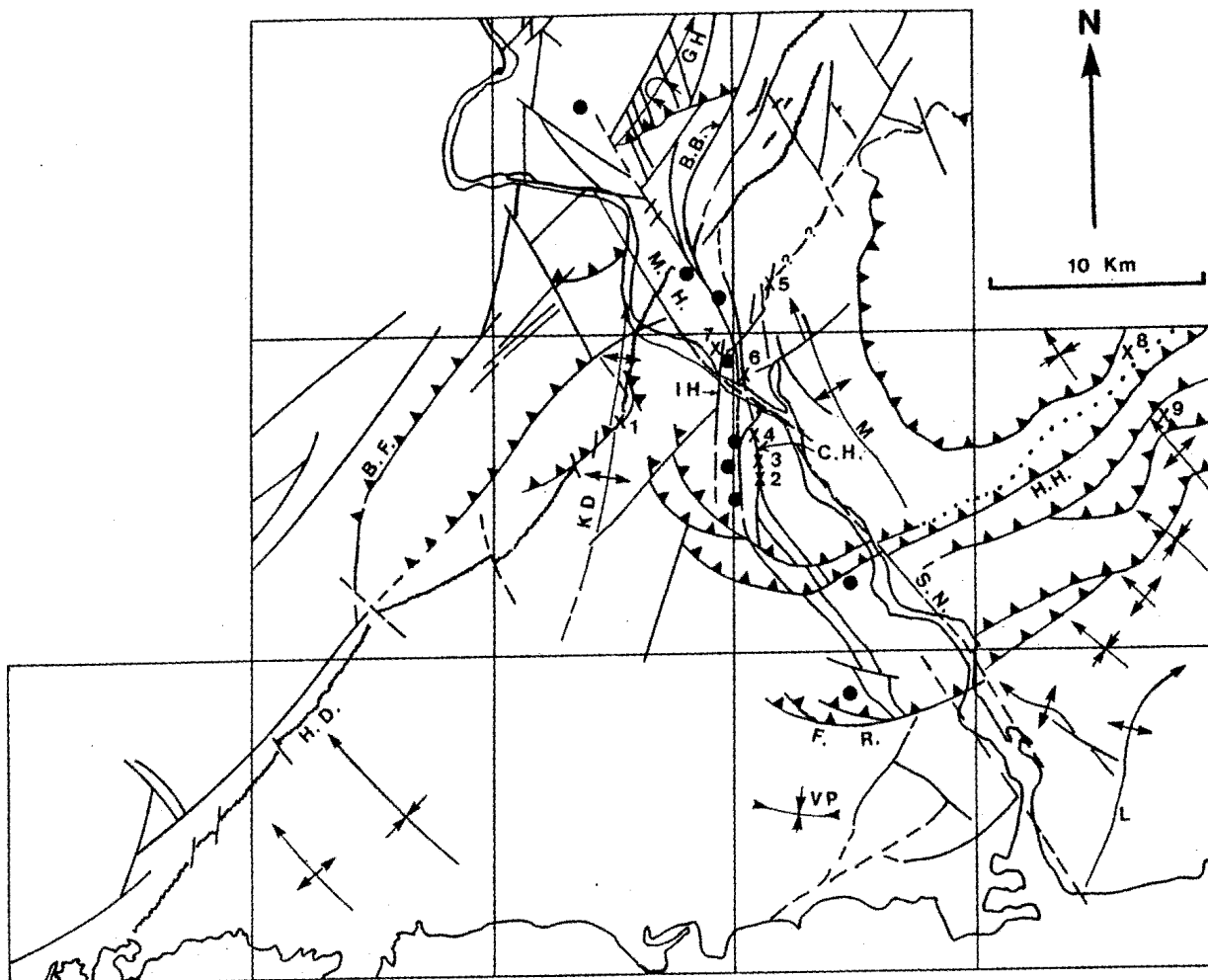

Fig. 6 Generalized geologic structure map of south-central Connecticut (after unpublished data from M.H. Pease, Jr., P.J. Barosh, Jelle de Boer, David London, R.P. Wintsch, Brian Koch, R.J. Fahey and others, and Sawyer and Carroll, 1982).

STRUCTURE OF THE MOODUS AREA

The earthquakes near Moodus occur mainly near the western border of the Merrimack province, where a number of diverse structural features of different ages and deformational styles converge (Barosh, 1981a). The deformational styles vary with both age and structural province. The ductile and mixed ductile and brittle features appear to be all pre-Mesozoic, and the brittle features Mesozoic or younger; this appears to reflect a greater depth of formation for the former. These characteristics are of great help in separating structures by probable age. Considerable information is available on the relative ages of pre-Mesozoic structures but little is definitely known about their absolute ages.

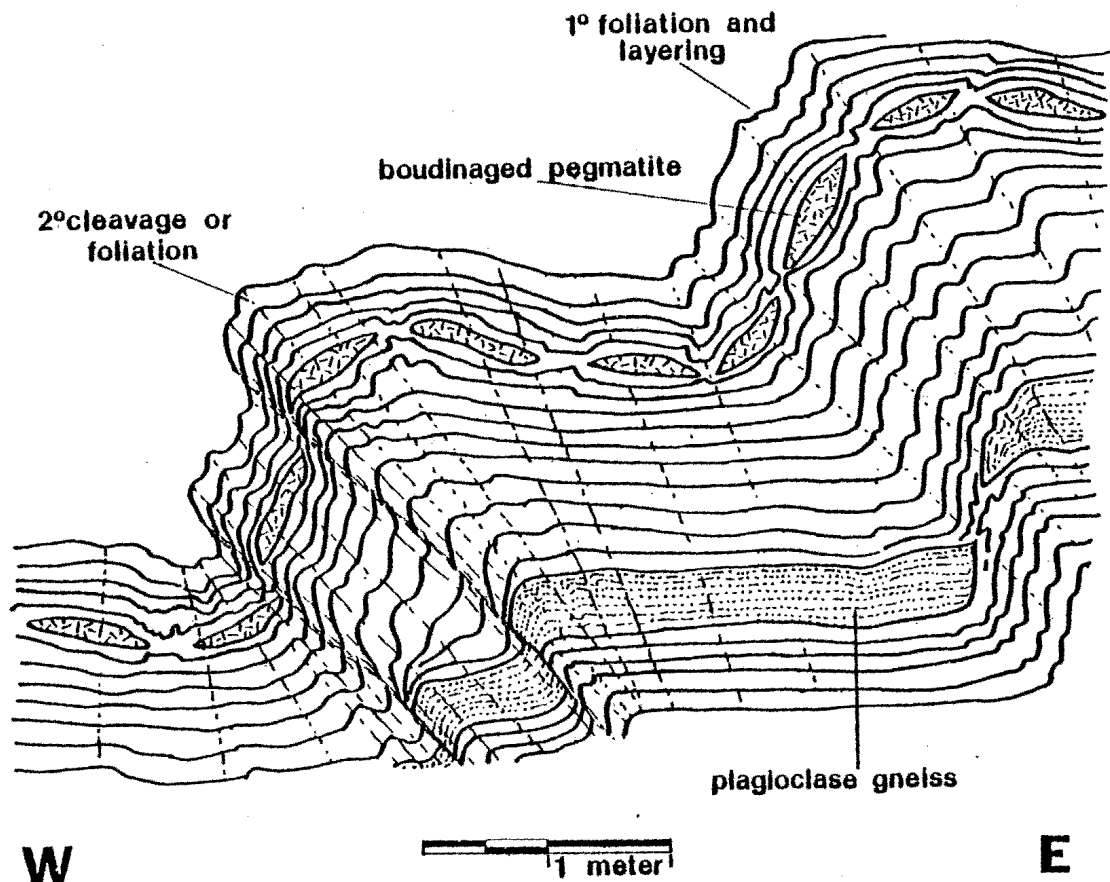

Figure 7. Schematic cross section of typical small-scale structure in the Hebron formation, north-looking view. Bedding and foliation are folded by north-trending folds with asymmetric near horizontal axes showing east over west transport. Boudinaged pegmatite bodies commonly show both dextral and sinistral rotations, and many pegmatites are doubly boudinaged, forming quilted or pancake patterns. (London, in prep.).

PRE-MESOZOIC STRUCTURES

The broad northwest-trending and gently plunging axis of the Moodus anticline deforms rock of the Hebron Formation and passes east of the town center (fig. 6). Much of its northeastern limb is covered by very gently dipping rock of the Erimfield Group that apparently has been thrust slightly over it. Its southwest limb gradually steepens to moderate to vertical dips to the west where it meets and is cut off by the Cremation Hill fault zone (STOPS 2, 3, 4 and 6) (fig. 8). The Hebron Formation is highly deformed adjacent to the fault and is intruded by many irregular pegmatite bodies (fig. 7) (STOP 2). The pegmatites formed during deformation, probably not as an anatexic melt, but under near melt conditions (London, 1982). Elsewhere, the

bedding within the Hebron Formation is generally undeformed, except for local zones that are contorted and cut by small reverse faults (fig. 8). The faults are mostly axial planar shears that strike north and display east over west transport. These small zones of deformation lie in and appear to control the location of many of the small valleys and gullies in the area.

The Cremation Hill fault zone has been feldspathized under conditions approaching a melt and is expressed at the surface as a zone of migmatites. Sheared and rotated blocks occur within this foliated migmatitic zone. Structures along and within the fault zone indicate right-lateral movement with the east side up. However, a few local exceptions are present (figs. 6 and 8). The Cremation Hill fault zone may be part of the same general zone of movement as the Bonemill Brook fault zone.

The Bonemill Brook fault zone lies to the west of the Cremation Hill fault zone and is separated from it by slivers of gneiss and schist that appear to belong to the Brimfield Group (M.H. Pease, Jr., this volume, Trip P2). The Bonemill Brook fault zone forms the eastern boundary of the Monson Gneiss that occurs in both the Glastonbury and Killingworth domes.

The north-striking Injun Hollow fault zone lies west of the Bonemill Brook fault zone in the Moodus area (figs. 6, 8 and 9) (STOP 7). It is a steeply dipping reverse fault with indications of left-lateral movement. Movement along it has continued over a long period and both early ductile and late brittle features are found. The movement along it and some of the other faults has sheared the rock into interleaved fault-bounded lenses with little coherent order (fig. 9).

The style and orientation of folds and foliation are different within the Cremation Hill fault zone from those to the east and west (fig. 10). The foliation trends across the Injun Hollow fault zone are also different (fig. 10).

South of Moodus the Bonemill Brook fault zone is cut by several small thrust faults that dip about 45° north and have north over south relative movement (fig. 6). They commonly curve from a westerly to a northwest trend as they are followed westward. The larger ones make curving valleys crossing the northerly-trending ridges and valleys that reflect differential erosion of the northerly striking lithologic units. These thrust faults and fractures related to them are commonly invaded by post-tectonic Permian pegmatite. Roadcuts along Route 9 expose great numbers of these north-dipping pegmatites. The largest of these faults is the Falls River fault that passes through the towns of Centerbrook and Ivoryton and terminates several units on the north-side (fig. 6) (Wintsch, in prep.); this termination was previously considered the nose of the Ivoryton synform (Lundgren, 1964) (fig. 5).

The north end of the Killingworth dome to the west is a fairly well defined, large, north-plunging anticline (Eaton and Rosenfeld, 1972, Lundgren, 1979); in contrast, its southern end is very poorly defined and it may not be a dome. A very gently north-dipping thrust fault trends northeastward across the anticline towards the Moodus area (STOP 1), but appears to end against or merge with a northwest-trending thrust fault just east of Route 9. The very low angle of this fault, 10° - 25° N, and associated syntectonic pegmatite suggest it is older than the westerly-trending thrust faults mentioned above. The amount and sense of movement on this thrust are not known as its observed trace is entirely within one stratigraphic unit.

A parallel and probably similar northwest-dipping fault lies to the northwest in the Haddam quadrangle and yet another farther northwest in the Durham quadrangle. The trace of the later one is closely followed locally by

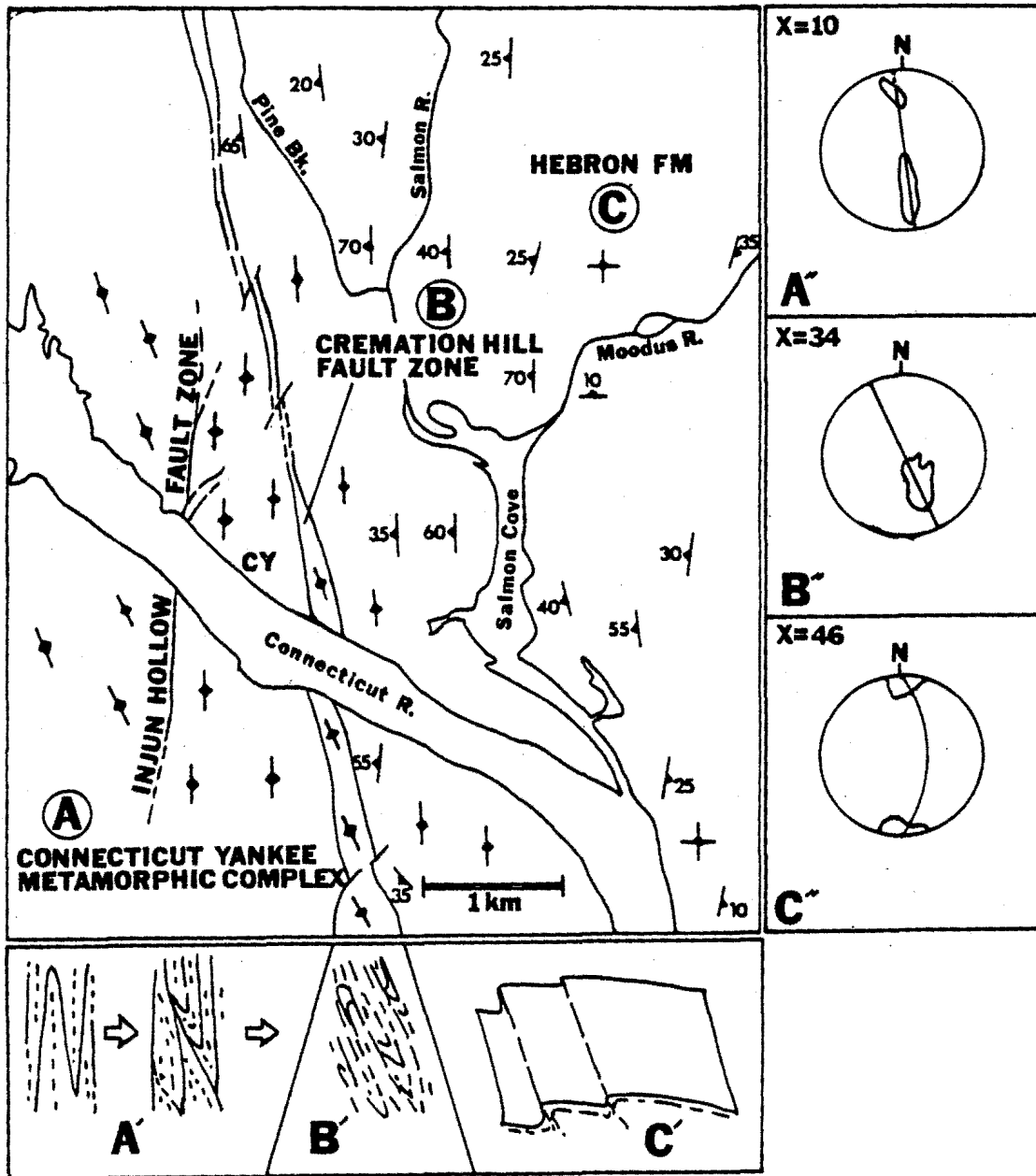

Figure 10. Foliation and small-scale folds in the Moodus area.

Figure 10. Foliation and small-scale folds in the Moodus area. This figure illustrates the style and orientation of folds and foliation in three distinct provinces in the Moodus area: the Connecticut Yankee (CY) Metamorphic Complex (A), the Cremation Hill fault zone (B), and the Hebron Formation (C). The CY complex (London, ms., 1982) includes pegmatites and a wide variety of metamorphic rocks that were given formational assignments of Monson, Middletown, and Collins Hill (and its equivalents) by previous workers. Folds within the CY complex are isoclinal passive-shear folds with sub-vertical axial planes that strike N 5° W (A''). Most axes are subhorizontal, although a few appear to have been rotated slightly about broad subhorizontal folds with axes trending east-northeast. Foliation is everywhere axial planar to the isoclinal folds. From west to east across the CY complex, primary layering and foliation are cut by a secondary schistosity that strikes N 20°-30° W. The secondary foliation develops progressively into well-defined shear surfaces with right-lateral and largely strike-slip offset. (A'). The continuity of layering becomes increasingly disrupted toward the east, as thin, smooth rock slivers have been transported over one another. The secondary northwest-trending schistosity becomes increasingly pervasive into the zone mapped as the Cremation Hill fault zone (B). Within the Cremation Hill zone, the N 20°-30° W schistosity is the only foliation (B'), and original (?) layering is almost completely destroyed. These migmatitic rocks apparently have been feldspathized as a result of deformation. Small asymmetric flexure folds and "xenoliths" generally show dextral rotation along axes that plunge steeply to the south-southeast (B''). This style and orientation of folding ends abruptly against the Hebron Formation. The Hebron is a flat-lying, to steeply-dipping formation with prominent zones of asymmetric, subhorizontal, N-S-trending flexure folds with east-over-west transport (C', C''; figures 7 and 9, and STOP 2). A secondary axial planar foliation is very weakly developed; reverse faults along axial planar shears are common and usually are accompanied by (b) rodded quartz and (a) slickensides in retrograde chlorite.

P7-15

the Mesozoic border fault of the Hartford graben (fig. 6).

A steep 3-milligal gravity gradient forms a prominent northwest-trending linear feature along the northeast side of the Connecticut River between the Glastonbury and Killingworth domes (Kick, 1982) (fig. 3). This appears to represent a fault. Most of the geologic contacts within this lineament also trend northwestward (Eaton and Rosenfeld, 1972) and structures on either side end against it; these include the anticlinal nose of the Killingworth dome and the Great Hill syncline and adjacent west flank of the Glastonbury dome. The Maromas Gneiss, a granitic intrusion, lies largely within this zone of discordance and has strong northwest striking foliation. The Maromas is identical in appearance to the Middle Ordovician Glastonbury Gneiss to the north and is apparently part of the same intrusion (M.H. Pease, Jr., oral commun.). Strong northwest-trending joint sets are present where the lineament was examined (J.S. Sawyer, written commun.) and prominent northwest-trending topographic and LANDSAT lineaments lie in the zone. The Great Hill syncline ends at a lake that lies on a prominent northwest lineament. The combination of all these features requires some kind of fault zone, herein named the Middle Haddam fault zone. It is a broad complex zone that will require detailed mapping to unravel. The north boundary of the zone is shown on figure 4. The actual faults depicted on figure 6 along this boundary and within the zone to the south are largely interpreted on the basis of topography and local attitude discordance. They may be relatively late and minor features in this major zone of discordance. The zone may be quite old and may have controlled the intrusion of the Maromas.

The Middle Haddam fault zone does not appear to offset the Bonemill Brook fault at the surface. The northern boundary appears to merge with the Bonemill Brook fault where it makes a bend to the southeast. This area of "merging" is in the seismically active area. The gravity and topographic features apparently associated with the Middle Haddam fault zone continue southeastward down the Connecticut River and may represent faulting not exposed at the surface. Both gravity and aeromagnetic features are offset left-laterally across this zone down the Connecticut River. The gravity anomalies appear to be offset 5 to 6 km left-laterally across this zone (Kick, 1982). The topographic features could have resulted from reactivation of a basement structure in the Mesozoic. The Selden Neck fault appears to be a small, late, left-lateral feature down the lower Connecticut River and a small fault may lie in the river in the Haddam quadrangle (fig. 6). These, however, appear to be much too small to explain the geophysical features.

Another feature suggesting a deep structure is a northwest-trending belt of small ultramafic bodies that lies near the Connecticut River (Sawyer, 1979) (STOP 7) (fig. 6). This belt follows approximately the Middle Haddam and the southern part of the Bonemill Brook fault zones. These bodies may indicate the former presence of deep fractures along these zones. An understanding of the Middle Haddam fault zone must wait on additional field work.

MESOZOIC AND YOUNGER STRUCTURES

The northeast-trending, west-dipping to vertical Early Jurassic Higganum diabase dike zone (STOP 1) is the most prominent known Mesozoic feature passing through the Moodus area. This zone of dikes extends from Long Island Sound to near Portland, Maine and apparently represents a deep fracture zone in the crust, although it does not necessarily follow a fault zone at the surface. The dike locally follows the surface trace of an early thrust fault

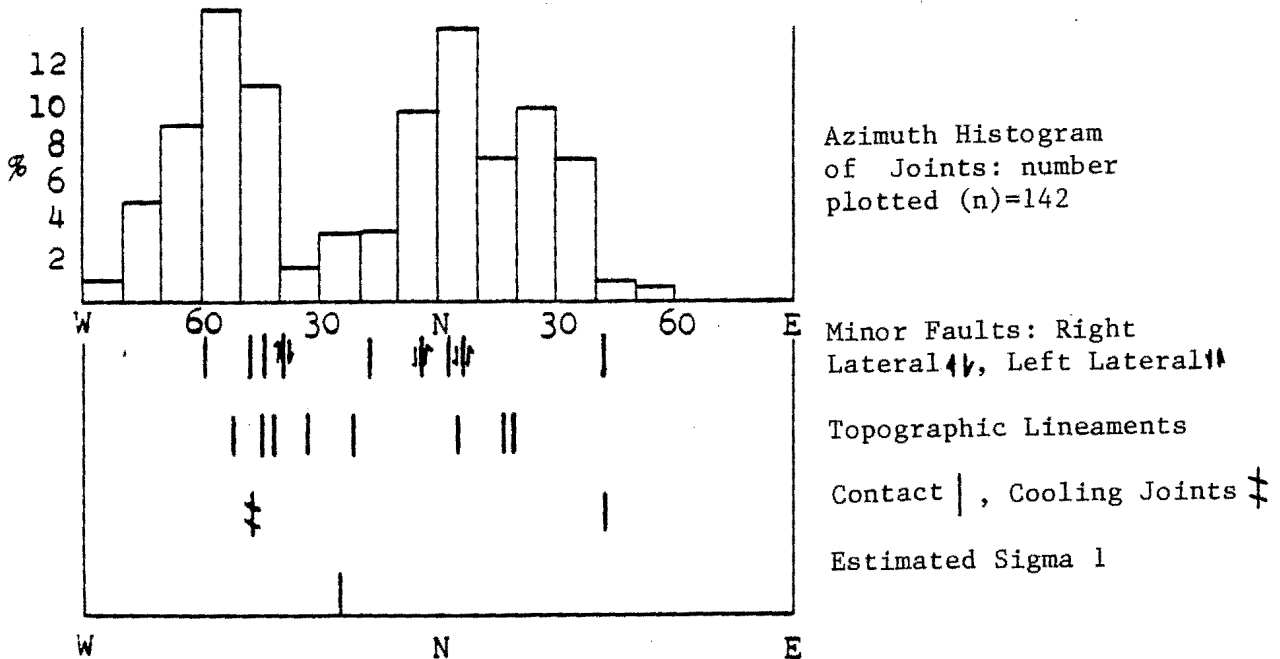

Figure 11. Typical azimuth histogram of joints for a segment of the Higganum dike near the village of Higganum, CT. (Sawyer and Carroll, 1982)

west of Moodus (STOP 1) (fig. 6). The local northwest dip of the normally vertical dike may be due to some deflection of the dike by the thrust zone. The dike is cut by small faults that have northerly and northwesterly trends. Fractures in the dike near Higganum, Connecticut may have been produced by a subhorizontal axis of compression oriented approximately north-northwest--south-southeast (Sawyer and Carroll, 1982) (fig. 11).

Abundant small northeast-, northwest-, and north-trending faults, that may be Mesozoic in age, cut rocks of the Moodus area (fig. 6). The northwest-trending faults appear to be the youngest. These faults are exposed at places in roadcuts and other fresh excavations in bedrock and have steeply dipping fractures and shear zones with slickensides, breccia and gouge (STOPS 1 and 9); these zones are easily eroded and are rarely exposed in natural outcrop. Many of the topographic and LANDSAT lineaments in the region have the same trends as these small faults and may be controlled by them.

The northwest-trending Connecticut River forms the most prominent lineament in the area. The Selden Neck fault, which has an apparent 0.7 km left-lateral offset and is well expressed topographically, may extend northwest up the river to near the mouth of the Salmon River (fig. 6). Projection of mapped contacts from opposite sides of the Connecticut River where it flows east in the Middle Haddam quadrangle indicates that a fault with right-lateral offset of about 200 m lies beneath the river.

The northeast-trending Salmon River forms another very prominent lineament that may be fault controlled. It crosses the nose of the Moodus anticline and appears to be controlled by small faults in the northeast (R. J. Fahey, written commun.) and southeast corners of the

Moodus quadrangle, but its center has yet to be mapped in detail (STOP 5). A gravity low forms a lineament along the river (Kick, 1982) that is not explained by lithologic differences at the surface (fig. 3). The river also has several north- and northwest-trending jogs along its course that follow topographic lineaments extending across it.

No recent offsets have been identified in the Moodus area, but mapping is still incomplete. Recent displacement of bedrock, however, is known to have taken place along Route 11, east of Moodus, where drill hole scars are offset across small thrust faults in roadcuts (Block and others, 1979) (STOP 8). The movement is up, north side over the south. The greatest offset occurs in the exposures that are cut on both sides between the roadways; little is seen in the outer cuts. This movement is similar to that reported from quarries and other highway construction in the region and is apparently from a release of residual strain due to changes in pressure caused by removal of the rock. It is not possible to determine when this strain was imposed on these rocks because the direction of recent movement in the road cuts is approximately the same as the apparent direction of earlier movements dating possibly as far back as the Precambrian.

MOODUS EARTHQUAKES

The Moodus noises have been ascribed to the anger of Indian gods due to the arrival of English ones, subterranean explosions, a mysterious substance in the neighborhood and glacial rebound (Chapman, 1840). None of these explanations appears adequate. Studies in New England indicate that earthquakes are almost certainly caused by movement on faults generated by tectonic strain (Barosh, 1981b). The number of structures converging at Moodus does make it an unusual area and show it has a long history of tectonic events. Recent movement probably has occurred on structures along the Salmon River because earthquake activity has taken place mainly along the south side of the river (fig. 2), near topographic lineaments extending from jogs in the channel (Barosh and Pease, 1981). The earlier earthquakes are too poorly located to permit associating them with any specific structure. The larger of the many small seismic events presently occurring along the Salmon river might well be generated by some combination of movements on brittle faults along and transverse to the river. Such movements might change the local stress conditions, resulting in movement on old structures due to residual strain release, such as happened along Route 11 (STOP 8), and initiation of a swarm of tiny earthquakes.

FAULT CHARACTERISTICS

The structure of the region developed in several episodes over a long period of time, from Late Precambrian to post-Jurassic. The earthquakes at Moodus apparently indicate continued deformation to the present. The relative timing of deformation is inferred from features indicative of the relative depth (deep, intermediate or shallow) at the time of deformation, with the shallow (brittle) deformation presumed the youngest. The older structures are believed to have developed under much greater pressures and temperatures than the younger ones. Consequently, the structures, especially the faults, vary widely in their characteristics, from deep ductile to shallow brittle features. This variation in fault characteristics and the presence of both compressional and extensional features provide a wide, albeit sometimes confusing, variety of structures to be seen in the region, but is useful in sorting out relative ages.

The deepest deformation is characterized by the development of a strongly mylonitic texture in gneiss, by the growth of feldspar porphyroblasts and quartz-feldspar rods, by migmatization, and by folding to which the alignment of primary minerals is axial planar. Somewhat shallower deformation is characterized by folding of foliation and layering, accompanied by the development of a mineral lineation normal to the direction of movement.

Deformation at intermediate depth is characterized by retrograde metamorphism along structures that appear to have been produced under conditions of low metamorphic grade (zeolite to greenschist facies). The various types of retrograde deformation structures including quartz rods and veins, K-feldspar plus chlorite alteration zones, massive mylonite recrystallized to chlorite and chloritized slickensides are most abundant near shear or fault zones. In the Moodus area, these deformation features are concentrated in broad fault bands, some of which, such as the Injun Hollow fault zone (STOP 7), are up to 200 meters wide. Slickensides in chlorite are by far the most common of these features; such slickensides can be found in most rock types, and they occur in most excavations into bedrock.

Deformation at shallow depths is manifested as tectonic jointing and slickensiding without accompanying retrograde metamorphism, the development of sheared zones of crushed or granulated rock and, with more intense shearing, the production of silty or clayey gouge. Joints are by far the most common of these features in the Moodus area, although not all of them have been produced by tectonic deformation. Slickensides without attendant retrograde alteration are present, but rare. Zones of crushed or finely milled rocks are seldom exposed in natural outcrop, as these zones are very easily eroded and become stream drainages or topographic troughs.

REFERENCES

- Barosh, P.J., 1981a, Structural setting of the Moodus earthquakes, south-central Connecticut: in Barosh, P.J., ed., New England Seismotectonic Study activities during fiscal year 1979: U.S. Nuc. Reg. Comm. Rept. NUREG/CR-2131, p. 93-97.
- , 1981b, Causes of seismicity in the eastern United States: a preliminary appraisal: in Beavers, J.E., ed., 1981, Earthquakes and earthquake engineering: the eastern United States, v. 1, p. 397-417, Ann Arbor Science.
- Barosh, P.J., and Pease, M.H., Jr., 1981, Geologic structure in the area of the 1981 Moodus earthquakes, south-central Connecticut: Earthquake Notes, v. 52, no. 3, p. 8-9.
- Block, J.W., Clement, R.C., Lew, L.R., and de Boer, Jelle, 1979, Recent thrust faulting in southeastern Connecticut: Geology, v. 7, p. 79-82.
- Boston Edison Company, 1976, Historical seismicity of New England: Boston Edison Co., Pilgram Unit 2., Docket No. 50-471, 641 p.
- Brookins, D.G., 1970, A summary of geochronological data for pegmatites of the Middletown, Connecticut area accumulated mainly since 1952: in Armstrong, R.L., Barton, J.M., Besancon, J.R., Brookins, D.G., Carmalt, S.W., and Crowley, W.P., Contributions to geochronology in Connecticut: Connecticut Geol. Nat. History Rept. Invest. 5, p. 10-18.
- Chapman, Henry, 1840, Notes on the Moodus earthquakes: Silliman's Jour., v. 39, p. 338-339.

P7-19

- Chiburis, E.F., 1981, Seismicity, recurrence rates and regionalization of the northeastern United States and adjacent southeastern Canada: U.S. Nuc. Reg. Comm. Rept. NUREG/CR 2309, 76 p.
- Dixon, H.R., and Lundgren, L.W., Jr., 1968, Structure of eastern Connecticut: in Zen, E-an, White, W.S., Hadley, J.B., and Thompson, J.B., Jr., Studies of Appalachian geology-northern and maritime: New York, Interscience Publishers, p. 219-229.
- Eaton, G.P., and Rosenfeld, J.L., 1972, Preliminary bedrock geologic map of the Middle Haddam quadrangle, Connecticut: U.S. Geol. Survey open-file rept., scale 1:24,000.
- Ebel, J.E., Vudler, Vladimir, and Celata, Michael, 1982, The 1981 microearthquake swarm near Moodus, Connecticut: Geophysical Research Letters, v. 9, no. 4, p. 397-400.
- Kick, J.F., 1982, A gravity investigation of south-central Connecticut: New England Seismotectonic Study report for U.S. Nuc. Reg. Comm., Weston Observatory, Boston College, 16 p., scale 1:62,500.
- London, David, 1982, Non-anatectic migmatite and feldspathic blastomylonite associated with ductile faulting in the Moodus seismic area, Connecticut: Carnegie Inst. Wash., Geophys. Lab., open-file rept.
- , in prep., Bedrock geology of the Moodus area, south-central Connecticut: New England Seismotectonic Study Rept. for U.S. Nuc. Reg. Comm., Weston Observatory, Boston College, 50 p., scale 1:12,000.
- Lundgren, L.W., Jr., 1963, The bedrock geology of the Deep River quadrangle: Connecticut Geol. Nat. History Survey Quad. Rept. 13, 40 p., scale 1:24,000.
- , 1964, The bedrock geology of the Essex quadrangle: Connecticut Geol. Nat. History Survey Quad. Rept. 15, 36 p., scale 1:24,000.
- , 1979, The bedrock geology of the Haddam quadrangle: Connecticut Geol. Nat. History Survey Quad. Rept. 37, 44 p., scale 1:24,000.
- Lundgren, L.W., Jr., and Ashmead, Lawrence, 1966, Bedrock Geology of the Hamburg quadrangle: Connecticut Geol. Nat. History Survey Quad. Rept. 19, scale 1:24,000.
- Lundgren, L.W., Jr., Ashmead, Lawrence, and Snyder, G.L., 1971, The bedrock geology of the Moodus and Colchester quadrangles: Connecticut Geol. Nat. History Survey Quad. Rept. 27, 24 p., scale 1:24,000.
- Pease, M.H., Jr., 1982, The Bonemill Brook fault, eastern Connecticut: in New England Intercoll. Geol. Conf., 74th Ann. Mtng., Univ. of CT.: Connecticut Geol. and Nat. History Survey.
- Sawyer, J.S., 1979, The Collins Hill metagabbro and other Alpine type² rocks of the Bronson Hill anticlinorium: Unpub. honors thesis, Wesleyan University, Middletown, Connecticut.
- Sawyer, J.S., and Carroll, S.E., 1982, Fracture deformation of the Higganum dike, south-central Connecticut: U.S. Nuclear Regulatory Comm. Rept. NUREG/CR-2479, 52 p.
- Wintsch, R.P., in prep., Bedrock geology of the Centerbrook-Chester area, south-central Connecticut: New England Seismotectonic Study Rept. for U.S. Nuc. Reg. Comm., Weston Observatory, Boston College.

ROAD LOG

MAPS. 7.5-minute quadrangle maps covered in this road log are the Middle Haddam (STOP 1), Deep River (STOPS 2, 3, 4, 5 and 7), Moodus (STOP 6), Haddam (STOP 8) and Hamburg (STOPS 8 and 9). The STOPS are shown on figure 6.

MILEAGE

0 Start at interchange Rts. 9 and 81; exit 9, Higganum, on Rt. 9 (marked as exit 8 on topo. map).

Park at southwest side of interchange on Rt. 81 at bottom of entrance ramp to Rt. 9 south (To reach the start from the University of Connecticut at Storrs, travel west on Rt. 44A and Rt. 84 to Hartford and thence south on Rt. 91 to Rt. 9. Allow nearly an hour).

STOP 1, Paleozoic thrust fault cutting the Killingworth dome, Mesozoic (?) high-angle reverse fault and Early Jurassic Higganum diabase dike.

This complex of outcrops was chosen primarily for its array of tectonic features which originated under varied conditions of rock strength. The metamorphic rocks provide excellent examples of ductile flow folding and thrust faulting, whereas the diabase dike is laced with cooling joints and fractures resulting from brittle deformation. Three areas of outcrop in this interchange provide details of these different deformation styles.

Area 1 - Outcrops along the southeast side of Rt. 81 northeast of Rt. 9.

The metamorphic units belong to the relatively broad contact zone between the Haddam Gneiss and Middletown Formation. They consist predominantly of felsic gneiss and amphibolite of volcanic origin. Sillimanite occurs as the highest metamorphic index mineral. The meta-volcanics contain northeast-trending flow folds with subhorizontal axes. The axes of the folds show a large variation in trend, as much as 45°, and suggest either decollement movement, or the effects of subsequent shearing along thrust faults. The direction of tectonic transport appears to be predominantly to the southeast, but evidence for the opposite sense of tectonic transport can be found as well. Axial plane cleavage which has developed locally suggests transport to the northwest.

Amphibolitic units clearly outline many of the folds. The folds are intersected and offset along low angle thrust planes, which contain pegmatites which are deformed by boudinage or shearing or both. These pegmatites occur throughout the Killingworth dome along north-dipping low-angle thrust faults and high-angle reverse faults. They appear to have been injected during deformation and are therefore considered syntectonic. The "concordant" syntectonic pegmatites are cut and intersected by younger "discordant"

post-tectonic pegmatites determined to be Permian in age by radiometric and paleomagnetic studies. A detailed study of cross-cutting relations and petrology of the pegmatites in this region shows a continuum, suggesting a common age. However, the earlier pegmatites are known to be pre-Permian elsewhere in eastern Connecticut. The earliest syntectonic "pegmatites" are sodic and composed of oligoclase, quartz, and mica. Their emplacement was followed by foliated adamellites, white adamellites and pink trondhjemites, respectively. The post-tectonic sequence starts with pink adamellites, followed by red granites, and "exotic" trondhjemites. The syntectonic pegmatites are generally more sodic, and more radioactive; the post-tectonic pegmatites are more potassic and may contain minerals with relatively volatile elements, such as beryl, tourmaline, apatite and fluorite.

Area 2 - Roadcuts along entrance ramp to Rt. 9 south.

Facing northeast, the outcrop can be seen to contain a series of small nappes, thrust sheets. Northeast-trending flow folds are intersected and offset along a low-angle thrust fault, separating different blocks. In this specific outcrop the direction of thrust motion is difficult to determine. Thrusting could be interpreted to have been either northward or southward. Elsewhere in the dome, however, it is clearly southward. Boudins of sheared pegmatite occur locally along the thrust planes. At both ends of the outcrop the thrust zone is cut by steeply-dipping north- and east-northeast-striking faults. Motion along the north-striking faults appears to have been primarily strike-slip with a slight reverse, up-dip component. The well exposed fracture on the southeast end is a reverse fault with an offset of about 3 m. It is characterized by a wide zone of brecciation, containing narrow, mylonitic slivers. The fault was intruded by a basalt dike. The latter is weathered and no paleomagnetic age determination could be made. However, emplacement of this dikelet is undoubtedly related to that of the nearby Early Jurassic Higganum dike. The fault, which existed in the Jurassic, but is younger than the Permian or older thrust faults which it intersects, is most probably of Early Triassic age. The degree of brecciation suggests a relatively shallow depth of deformation.

Area 3 - Roadcuts along the exit ramp from Rt. 9 south.

Exposed here is part of the Higganum dike, a major tectonic feature which extends northeastward from Long Island Sound to southern Maine. At this locality the dike dips approximately 45° NW, and probably intruded a thrust zone. Magnetic profiles show, however, that it becomes subvertical with depth. Its width varies from 50 to 165m. The quartz tholeiitic dike was emplaced during the Early Jurassic, about 175 m.y. ago. Its emplacement postdates vulcanism in the Connecticut valley. The dike forms part of a regional dike system

which extends throughout the Appalachians and is believed to have been emplaced along older faults during shearing with predominant left-lateral rotation.

The dike is characterized by large cooling joints, with excellent plumose patterns, which outline the massive columns; it is intersected by tectonic joints and faults with slickensided surfaces. The dominant fault set here is subvertical and trends northwest. Conjugate sets occur elsewhere. A detailed study of several hundred faults in the dike at 32 locations indicates that the "young" faults developed in response to subhorizontal compressive stress aligned north-northwest--south-southeast (Sawyer and Carroll, 1982). In summary, the following tectonic features can be observed at this interchange.

1. Northeast-trending flow folds, possibly of Acadian age, with subhorizontal axes. The direction of tectonic transport of these folds is predominantly to the southeast in the Killingworth dome, but local evidence has been found for reverse tectonic transport.

2. East-trending, north-dipping, low-angle thrust faults and reverse faults. Pegmatites were intruded and deformed during shearing along these fractures. The youngest (post-tectonic) pegmatites are Permian.

3. A northeast-trending diabase dike which was emplaced along a subvertical zone of shearing and extension during the Early Jurassic. A small dikelet, probably of similar age, that intruded an east-northeast-trending reverse fault. This fault may be of Early Triassic age and perhaps indicates that some compressional movement continued into the Mesozoic. By this time, however, rock units were significantly more brittle.

4. Northwest-trending, high-angle shear faults, with significant strike-slip components, intersect the Jurassic diabase. The principal compressive stress was oriented north-northwest--south-southeast.

Return to car, enter entrance to Rt. 9 south.

- 5.0 Turn right off Rt. 9 onto exit 7, East-Haddam--Moodus, and cross over Rt. 9 on Rt. 82.
- 5.8 Pass roadcut on left, that exposes the Bonemill Brook fault zone. Monson Gneiss to west separated from rusty schist of the Brimfield Group on east (see M. H. Pease, Jr., this volume, STOP 7).
- 6.8 Pass Cremation Hill fault at culvert.
- 7.1 Stop on shoulder on right next to large roadcut.

STOP 2, Cremation Hill fault zone and deformed Hebron Formation.

This exposure of the fault zone shows well the deformation of the Hebron and the concentration of pegmatite along the fault (fig. 7). The contorted rocks of the Hebron in the roadcut are part of the western flank of the large Moodus anticline (fig. 9). The Hebron Formation consists of thin-to medium-bedded medium-gray fine- to coarse-grained schistose granulite with thin light greenish-gray bands and lenses containing calc-silicate minerals. The foliation is parallel to the bedding. Note the large and small scale asymmetric folds with nearly horizontal north-trending axes (fig. 7). These and other small scale structures within the fault zone suggest that the vertical component of movement along the fault is east side up. The well-bedded schistose granulite rock of the Hebron is generally much less disturbed than is seen here. Abundant pegmatite occurs as wispy lenses to large bodies. Some is boudined and foliated and appears to be syntectonic. Pegmatite commonly forms in the Hebron along shears, small thrust faults and as lenses in folds where it is deformed. These commonly form in irregular shapes that are not necessarily due to later folding. The contorted bedding and pegmatite here is the result of deformation along the Cremation Hill fault.

Walk back, southwest, towards road sign Rt. 9 north and south, to culvert. Notice the increasing amount of deformation and of pegmatite. Some slickensided late fault surfaces can be seen cutting the massive pegmatite; mostly near vertical and trending N 20°-30° E. Strongly foliated migmatite with schist folia at culvert represents Cremation Hill fault. The steeply plunging fold axes of xenoliths in the pegmatite in the fault zone contrast with the near horizontal axes in the Hebron to the east (fig. 10) and indicate lateral movement along the fault. Other good exposures lie on the other side of the highway, just west of a circular asphalted area a short distance off the road. Low exposures of schist are present along the side of the highway slightly farther west of these. This rusty sillimanite schist probably belongs to the upper part of the Brimfield Group (M. H. Pease, Jr. this volume) indicating that the lower part is missing along the fault.

Return to car and proceed east.

- 7.9 Turn right, south, onto Rt. 9A, Middlesex Turnpike.
- 8.3 Turn right onto New Old Chester road.
- 8.35 Turn right again onto Old Old Chester road.
under Rt. 82.

- 9.2 Park beyond low overpass, Rt. 82. Walk along previous continuation of road for about 200 m to Roaring Brook.

STOP 3 - Cremation Hill fault zone.

This stop will also examine the nature of the contact between rock of the Hebron formation and that to the west. Along Roaring Brook, the Hebron again consists of layered schistose granulite composed of quartz, diopside, phlogopite and plagioclase and also in places carbonate and scapolite. The beds strike north-northwest and dip 20° - 30° WSW. As at the previous stop, the Hebron here is folded about sub-horizontal, north-trending axes with asymmetric east-over-west transport. Broad low-amplitude, symmetrical folds that plunge shallowly to the west-southwest also occur. At the small exposure in Roaring Brook, the Hebron ends abruptly against a migmatitic gneiss that strikes N 20° W and dips vertically. The migmatite contains sheared slivers of Hebron that are deformed plastically, a ductile deformation quite unlike that seen elsewhere in the Hebron section. Just to the west are migmatitic muscovite- and K-feldspar-rich gneisses and schists that do not appear to be part of the Hebron section. This contact at Roaring Brook is the eastern exposure of a broad zone of ductile faulting termed the Cremation Hill fault zone (London, in prep.).

Return to car and retrace route to Rt. 9A.

- 10.5 Turn left onto Rt. 9A.
- 11.2 Pass Tylerville and junction Rt. 82 east to Moodus.
- 13.1 Turn left onto Old Turnpike road off Rt. 9A at fork in road.
- 13.13 Turn left, south, onto Old Ely road.
- 13.7 Park at powerline crossing. Walk to trail beneath powerline on west side of road.

STOP 4, Cremation Hill fault zone.

The trail uphill exposes the bedded diopside-phlogopite-bearing schistose granulite of the Hebron Formation in which scapolite is abundant. The beds dip about 30° to the west-southwest. The fault contact between the Hebron and rocks to the west is not exposed here, but outcrops in the woods to the north consist of unzoned, quartz-poor pegmatite that contains xenoliths of the Hebron and migmatitic stringers that may be assimilated Hebron granulite. At the crest of the hill, the power line cut exposes a thin band of migmatite and feldspathic blastomylonite that strikes approximately N 10° W through the Moodus area. This zone of migmatite is interpreted as the broad Cremation Hill ductile fault zone on the

basis of (1) discordance to regional strike of the other rock types, (2) small-scale folds and mineral lineations in rocks within and surrounding the zone, and (3) the occurrence of deformed xenoliths of rocks that are present on both sides of the zone (London, 1982). The progressive feldspathization of aluminous schist exposed here suggests that the feldspathization of this rock is not the direct result of an anatectic melt. The schist west of the migmatitic zone consists of an apparent prograde assemblage of quartz, muscovite, sillimanite, albite, biotite, garnet, graphite, tourmaline, and some iron sulfide. With increasing migmatization, the graphite disappears, iron sulfides are oxidized to a pervasive hematite stain, and sillimanite is replaced by coarse, pseudomorphic patches of muscovite as the migmatitic zone is approached from the west. The disappearance of sillimanite does not appear to be the result of cordierite-producing reaction between sillimanite and garnet or biotite. Progressive development of K-feldspar porphyroblasts consumes muscovite and quartz. The resultant rock near the fault contact with the Hebron consists of 65-85% coarse-grained K-feldspar, 5-25% plagioclase, 5% fine-grained, 1-3 mm, shreds of relict biotite and garnet, and 5% coarse-grained euhedral muscovite that cuts the foliation. This late-stage muscovite may have been produced as the feldspathized rock attempted to maintain equilibrium with increasingly acidic fluids. Quartz is rare or absent in many of these feldspathized "pegmatitic" samples. This thin band of migmatite was mapped as Brimfield Schist in the Deep River area (Lundgren, 1963). A suggested stratigraphic correlation of this band of rocks with the Tatnic Hill Formation in the southeast Connecticut fold belt constituted much of the argument for a major recumbent synform, the Chester syncline of Dixon and Lundgren (1968). The mineralogy and fabric of the feldspathized rock and feldspathic migmatite, however, appear to be primarily the result of deformation and metamorphism, perhaps metasomatism, and are not directly related to any primary depositional characteristics of the rock. Several different rock types are involved in the feldspathization, and each original rock type produces a distinctive feldspathic rock.

The Cremation Hill fault zone may form an eastern branch of the Bonemill Brook fault zone that has been extended southward through this area (see M.H. Pease, Jr., this volume). The Cremation Hill fault zone itself has been followed north approximately 3 km into the Middle Haddam quadrangle, where the migmatitic gneiss and schist were included within the Schist of East Hampton by Eaton and Rosenfeld (1972). Delineation of the Cremation Hill zone beyond the southern half of the Middle Haddam quadrangle will require detailed field studies.

Two consequences of this recent study, therefore, are (1) that the thin band of migmatite and feldspathic rock is not

necessarily correlative with schist of the Brimfield Group or any other time-stratigraphic unit, and (2) that the migmatite delineates the trace of a ductile fault zone that separates rocks of the Hebron Formation from those to the west. Both of these interpretations contradict the supporting evidence for the Chester syncline in this area.

Return to car and go back to Rt. 9A.

- 14.3 Turn right onto Rt. 9A.
- 16.2 Turn left at Tylerville onto Rt. 82 east, to Moodus.
- 16.8 Bridge over Connecticut River, Hebron exposed on left, north side of east end of bridge.
- 17.1 Turn left onto Rt. 149, to Moodus.
- 18.0 Hebron Formation exposed on right for the next mile. Note the nearly undeformed bedding.
- 19.8 Turn left onto Johnsonville Road.
- 20.1 Pass Mt. Tom 0.5 mi. to left, west, one of the traditional locations for the Moodus noises. Cave Hill, 1.2 mi. ahead is the other.
- 20.4 Turn left onto Rt. 151, Moodus road, at stop sign.
- 21.3 Pass Cave Hill on right.
- 21.7 Turn right before bridge.
- 21.9 Turn left onto dirt road, proceed 0.1 mile and park above Salmon River.

STOP 5, Structural control of the Salmon River.

The Salmon River forms one of the most pronounced topographic lineaments in the area and the earthquakes of 1980, 81 and 82 occurred in a zone that extended from near here northeastward mainly along the southern side of the river. The area is not mapped in detail. No large fault has yet been found along the river, but at least small ones follow it southwest of here. The bedding of the Hebron Formation and small faults parallel the sides of the river in the bluff below the parking area and on the west side of the dam to the north. Exposures of Hebron in the river bed show some deformation. A brief reconnaissance to the northeast found a joint set parallel to the local trend of the river at each exposure seen along the river. These observations indicate that the river is structurally controlled whether or not recent faults are found. Examine the rocks in the area and

note the pegmatite in the bank on the northwest side of the dam. This coarse non-foliated pegmatite belongs to the set of Permian pegmatites that cut the region. The pegmatite cutting the Hebron at STOP 2 appears much older.
Return to highway.

- 22.3 Turn right, north, on Rt. 151 and cross over the Salmon River.
- 22.7 Veer left on Rt. 151.
- 24.9 Turn left at sign - "Connecticut Valley Energy".
- 25.9 Turn left at fork, just beyond fire station on left onto Upper road.
- 26.8 Pass School House Hill Road on right.
- 27.2 Turn left at fork.
- 28.1 Pass electrical substation building on left and pass through gate. Hebron Formation on right.
- 28.5 Park at left at top of decline after passing under power lines.

Walk down hill along road about 100m to first old stone wall on left. Turn right, west-northwest, and go into the brush towards Connecticut Yankee nuclear power plant. Cross over slight knob of Hebron Formation adjacent to road. Walk down slope to concrete box under powerline and up rocky spur just beyond.

STOP 6, Cremation Hill fault zone.

The spur is composed of migmatite along the fault zone; a mixture of schist and some blocks of Hebron in pegmatitic material. Note the discontinuities in flow fabric and rotated folded blocks along this fault zone filled by feldspathized material. This, together with the previous STOPS 2, 3 and 4 helps to demonstrate that the Cremation Hill fault zone is a continuous mappable structure exhibiting deep-seated ductile deformation along its length.

Return to car, turn around and drive back towards fork near fire station.

- 31.1 Veer left at fork in road onto Middle Haddam Road.
- 32.5 Veer left at fork onto Injun Hollow Road.
- 34.0 Park at right on wide shoulder used for turning around; The Connecticut Yankee power plant is just out of sight down the road. Walk back 50 m to beyond small culvert under road and

enter woods to east, uphill side. Proceed north angling uphill into Injun Hollow. Please use caution when climbing around the old quarries and steep slopes.

STOP 7, Injun Hollow fault zone, brittle faults and ultramafic intrusion.

This stop offers examples of most of the rock types exposed in the Moodus area and exposes the Injun Hollow fault zone that displays both Paleozoic ductile features and Mesozoic (?) brittle ones and other relatively young brittle faults. The trip begins in typical exposures of the Monson Gneiss. Proceeding northeastward and uphill into the hollow, the Monson Gneiss ends abruptly against pegmatite, followed by a 50-meter-wide interval of schist, gneiss, and amphibolite. At the crest of the hollow, and mainly within the schist, is a small near vertical lens of ultramafic rock, striking N 10° W, that appears to originally have been pyroxenite (the lens is just north of the upper end of the steep stream gully that leads to the road culvert). The pyroxenite is now partially replaced by relatively fine-grained, acicular hornblende that cuts across grain boundaries and is lineated and foliated parallel to the regional trend in this area. The only exposed contact of the ultramafic body is with K-feldspar-rich pegmatite; apparent reaction between these two rocks has produced coarse-grained biotite at their contact. To the south in the Deep River area, all similar ultramafics occur in amphibolite and gneiss on the east flank of the Monson Gneiss; the ultramafic at Injun Hollow is the first such body to appear on the west side of the Monson (Sawyer, 1979).

The interval of schist, gneiss and amphibolite is bordered to the west, in the quarries, by a prominently lineated and foliated gneiss that may be a recrystallized phase of the Monson. This appears to be part of the west flank of the near vertical Injun Hollow fault zone, that strikes about N 10° E along the east side of the hollow. Quartz and plagioclase are conspicuously lineated; biotite and hornblende are segregated into thin (1-2 mm) folia that are continuous over several square meters of quarried outcrop surface. It is the presence of these folia that facilitated the quarrying of this rock into rectangular slabs. Continuing to the northeast, the Monson is succeeded again by ortho-amphibole-bearing gneiss and schist and by aluminous schist, although the sequence of layering is different from that seen below.

Pegmatite and quartz veins are abundant in these exposures. The pegmatite is muscovite- and tourmaline-rich, displays sharp contacts with the host rock, has relatively thin border zones, and consists principally of quartz-K-feldspar block pegmatite with centrally located quartz cores. It is distinctly different from

pegmatitic rock in the Cremation Hill fault zone (STOPS 2,3,4 and 6) and in the Hebron Formation (STOP 2).

Rock in the Injun Hollow area appears to have suffered shearing deformation over a long period. This is shown by a continuum of subparallel mineral lineations produced from conditions of high metamorphic grade (upper amphibolite facies, presumably deep-seated and "old") to low metamorphic grade (lower greenschist facies, and relatively shallow and "young"). In the border phase of the Monson Gneiss the segregation of biotite and hornblende into thin but continuous folia also indicates relatively high pressure and temperature that did not produce a cataclastic texture. At some intermediate pressure and temperature, shearing deformation produced planes of rodded quartz with cataclastic feldspar in the mylonitic gneiss. All of this deformation predates the intrusion of the pegmatites and thus is older than 261 ± 4 m. y. before the present (Brookins, 1970). Younger, Mesozoic (?) and shallower shearing deformation produced slickensides in fine-grained chlorite, and chlorite and K-feldspar bleached, oxidized (?) zones adjacent to shears. In the quarries, these shear surfaces can be seen to follow pre-existing planar structures. In one quarry exposure, a slickensided surface covers about 20 square meters of outcrop surface along foliation trending N 20° W before the shear surface veers off abruptly N 30° E along a pegmatite contact. Closely spaced fractures also are localized in planar swarms, but their relation to the "chlorite grade" deformation is not clear.

Throughout the entire episode of faulting, the sense of offset appears to have been left-lateral with west-side-up and largely strike-slip. The amount of offset is difficult to estimate, because most of the deformation is subparallel to layering and foliation; however, the strike of layering and foliation is north in rocks east of the fault zone, but N 20° W in rocks west of the fault. Angular discordance in the fault zone can be seen along the east side of Injun Hollow. The fault zone continues south of the Connecticut River, where it occurs mostly in aluminous schists and is not well exposed; however, the same angular discordance of strike, north versus N 20° W, exists in rocks flanking the fault zone. The Injun Hollow fault zone disappears under glacial drift just north of the stop area, and it has not been recognized in the Middle Haddam and Moodus quadrangles. It appears to cut north-northeastward across the Monson Gneiss and may reappear in rock east of the Monson.

The exposures at Injun Hollow reflect the complex interleaving and the discontinuity of rock units that is characteristic of the Bronson Hill sequence in this region. In this immediate area, there is no consistent lithologic variation across strike that would indicate a repetition of lithologic units by folding as has been suggested by Dixon and Lundgren (1968) and others. Individual rock units in the

interval mapped as Middletown Formation and Collins Hill Formation (Eaton and Rosenfeld, 1972, Lundgren, 1979) rarely extend for more than a few tens of meters along strike. The chaotic variation of rock types seen here may be due in part to primary deposition in an unstable tectonic environment; however, it appears to result largely from the subsequent deep-seated ductile deformation that has transported thin, smooth, fault-bounded slivers of rock over one another.

Three subvertical brittle fracture zones trending N 30° E, north, and N 20° W intersect in the area of Injun Hollow, one of the few places in the Moodus area where such a fracture intersection occurs. The relative timing of fractures is not clear here, although the northwest-trending fractures cut all others elsewhere to the east and southeast.

Return to car and turn around.

Return to Rt. 151, Moodus Road.

- 36.7 Turn right onto Rt 151 and follow it south through Moodus.
- 44.2 Turn left, east, onto Mount Parnassus Road, 50 m south of intersection of Rt. 151 with Rt. 82.
- 52.0 Veer right onto Salem Road.
- 53.0 Turn right onto Mill Lane Road.
- 54.0 Turn left onto Witch Meadow Road.
- 54.5 Turn right onto Rt. 11 south.
- 55.8 Park at large roadcut in southbound lane. Use caution when walking along roadway.

STOP 8- Fault reactivation due to highway construction.

The Hebron Formation, which consists predominantly of calc-silicate-bearing schistose granulite, is tilted slightly north, and contains flow folds with approximately horizontal axes and northward tectonic transport and many boudinaged sodic "pegmatites". The outcrop is intersected by a series of north-northwest-dipping shear planes which mainly follow bedding contacts. The best exposed thrust zone occurs on the south end of the outcrop in the divider strip. It is characterized by a 30 cm shear zone, which is leached. In a zone about 4m above and below this shear zone occur slickensided mylonitic thrust planes along which the vertical drill hole scars from highway construction have been offset updip (Block and others, 1979). Thrust planes generally trend N 55°±20° E and dip 15° ± 10° NNW: a conjugate set of antithetic shears occurs with a trend of N 45°-55° E.

P7-31

Construction of this segment of Route 11, from Colchester to Route 82, Salem, began in 1970. Shortly after construction, it was noticed that a number of drill hole scars in the freshly exposed outcrop were offset. Displacement was southward up shallow north-dipping foliation and thrust planes and generally amounted to a few cm. It initially appeared to be a blasting phenomena, but this possibility was discounted for most offsets when blast patterns and volume of displaced rock were analyzed. In addition it was found that the direction and amount of slip did not vary significantly over a distance of almost 10 miles, whereas the road bends from north to northwest. The following data characterized the drill hole scar offsets:

- a. Displacements are invariably updip on planes inclined from 5° to 30° .
- b. Displacement occurs either parallel or at slight angles to the road bed. The mean direction is $S 32^{\circ} \pm 5^{\circ} E$.
- c. Displacement varies between 0.5 and 6.0 cm with a mean value of 2.6 cm.

Shortly after blasting it was decided to monitor 5 sets of drill holes for possible future motion. Measurements were made every 6 months over a period of 10 years. Of these five holes, three showed significant creep in subsequent years, one had little motion, and one none.

Most interesting is the behaviour of one of the sets of drill holes in the Brimfield Schist further north. Initial offset of the drill holes amounted to 19.2 cm. Over a period of 9 years this offset increased to 43.6 cm. No discernible motion has occurred along the slip plane in the last few years, 1980 to 82. Thus, offset caused by creep amounted to more than 50% of the total. Creep rate averaged about 27 mm/yr. The movement shows a direct relation to roadcut excavation. More offset occurs on outcrops in the divider strip, that have been cut on both sides and thus are freer to move than on the outer exposures. A survey did not find any offset of water wells in the area subsequent to the highway construction, as would be expected if the creep rate operated away from the road (J.S. Sawyer, written commun.).

The shear planes along which the motion occurred are characterized by well developed slickensides which provide evidence for an earlier phase of deformation. Earlier thrusting was directed $S 54^{\circ} E$. The recent motion is $S 32^{\circ} E$, suggesting that the direction of strain release may have rotated some 20° in clockwise fashion. The Early Jurassic Higganum dike has been deformed by stress that appears to have been oriented $S 27^{\circ} E - N 27^{\circ} W$. This coincidence

in the direction and types of strain release suggests that the strain may have been imposed as early as the Early Jurassic. It is possible, however, that these stresses already existed at the time of emplacement of the dike and are of Permian origin or older. The direction of movement on the nearby Honey Hill fault zone, that originated at least in the early Paleozoic, is to the south-southeast and the principal direction of transport in the syntectonically deformed Late Precambrian granites, south of the Honey Hill fault, is also to the south-southeast. The movement appears to represent strain released due to the rock adjusting to new conditions of confining pressure caused by highway construction and is not due to recent stress. Whether or not the strain was imposed recently or during the Mesozoic, Paleozoic or even Precambrian cannot be determined. Many similar rock movements have been noticed earlier in quarries and more recently in other highway cuts.

The importance of these movements to the seismicity at Moodus is that the larger amount of offset that occurred during construction probably produced a few small low magnitude earthquakes. "Noises" were heard during times when no blasting occurred and one or two water wells within about 50 m of the road were effected. No instrumentally recorded seismicity is known to be associated with these, but the seismograph network at that time would have been too sparse to record it. Movements of this amplitude along old structures might well be producing the swarms of small shallow aftershock earthquakes occurring along the Salmon River.

Continue south on Rt. 11.

- 56.4 Pass over Honey Hill fault zone.
- 57.2 Park to left on divider strip beyond barrier at the end of the highway.

STOP 9, Thrust and normal faults.

The gneiss here consists of a sequence of light-gray biotite-poor and dark-gray biotite-rich varieties that is near the boundary of the Monson and Mamacoke Formations (Lundgren and Ashmead, 1966) of Precambrian age. The roadcuts are intersected by a series of low-angle thrust faults and some small folds. Thrust planes move upward in the section to the south, suggesting southeast motion. In several places one can see northeast-trending, north dipping normal faults which connect thrusts at different levels and contain quartz-albite veins. Significant drag along these faults indicates a degree of ductility in the rock which cannot be seen along younger fractures. These faults may be caused by backward sliding of the rockmass in the late stages of thrusting.

Thrust and associated normal faults are intersected by dense sets of conjugate joints and normal faults. The majority trend northeast and dip $55^\circ \pm 10^\circ$ SE. The antithetic normal faults have similar trends but dip more steeply northward indicating monoclinic symmetry. The best conjugate set can be seen in the outcrop of the divider strip. Here a normal fault shows 1.7m of offset of a mafic gneiss and a conjugate normal fault south of it offsets the same unit in opposite sense about 1m. These faults and associated joints formed pathways for hydrothermal solutions, which left epidote, chlorite, quartz and hematite. Paleomagnetic analysis of the red stained feldspar in 2.5 cm wide zones on either side of the joints, provided Early Triassic paleopoles.

The following tectonic events can be recognized in STOPS 8 and 9.

1. Development of northeast-trending flow folds of Acadian(?) age with subhorizontal axes indicating northward transport.
2. Emplacement of sodic "pegmatite" parallel to the bedding and along low-angle, north-dipping thrust planes. The pegmatite was subsequently sheared and boudinaged. North-dipping normal faults connect the thrust faults. They contain quartz-albite veins and may have formed in the late stages of pegmatite formation. Significant drag in both the hanging and foot blocks indicates a certain degree of ductility of the rock.
3. Reactivation of north-dipping low-angle faults by southeast thrusting; a motion perhaps opposite to that in the earlier deformation stage. Movement resulted in the development of mylonitic (slickensided) and sheared-brecciated zones. At the time of southeast thrusting the rocks appear to have been mostly brittle.
4. Development of a conjugate set of northeast-trending normal faults and joints. Southeast-dipping faults and joints predominate. Hydrothermal solutions followed these fractures and left a chemical remanent magnetization of Early Triassic age.
5. Continued release of strain and continued motion along the thrusts, whether abruptly (possibly causing very low magnitude earthquakes) or by creep.

END OF FIELD TRIP.

(To return to Storrs, CT, follow Rt. 11 north to Colchester, Rt. 85 north to Hebron, Rts. 66 and 84 northeast to Rt. 195 and thence north to Storrs.)

MULTISTAGE DEFORMATION OF THE PRESTON GABBRO, EASTERN CONNECTICUT

H. Roberta Dixon
U. S. Geological Survey
Denver Federal Center
Denver, Colorado, 80225

INTRODUCTION

The Preston Gabbro is an irregular, but generally oval shaped body which underlies approximately 45 sq. km. in southeastern Connecticut. It is exposed in two areas; a larger northern one in the Jewett City quadrangle, and a smaller one to the south, mostly in the Old Mystic quadrangle, but with a small part along the southern border of the Jewett City quadrangle. The Preston Gabbro has been studied previously by Loughlin (1912) and Sclar (1958). From both field and geophysical studies, the Preston has been interpreted to be a west-dipping laccolithic pluton, 1200 to 1800 m. thick (Griscom and Bromery, 1968, p.426). This interpretation applies to the larger northern part of the pluton, as gabbro in the smaller southern part occurs in irregular fault blocks (Richard Goldsmith, written commun., 1980). The pluton consists largely of gabbro, much of which is hydrothermally altered, but a zone of diorite to quartz diorite about 300 m. thick occurs along the outer margins, in what is interpreted to be an upper shell over the gabbro. The pluton intruded the Quinebaug Formation on the north and west sides and is separated from the Plainfield Formation and Sterling Plutonic Group on the east by the Lake Char fault and on the south by its extension, the Honey Hill fault (Dixon and Lundgren, 1968). The pluton has been complexly faulted by both high-angle and thrust faults, especially in the southern part. In the northern part, numerous small faults and shear zones occur in gabbro exposures, but these could not be traced beyond a given outcrop, and only a few through going faults were recognized.

DESCRIPTION OF THE PRESTON GABBRO

The Preston Gabbro as now exposed apparently represents the upper part of a larger, differentiated pluton that has been cut off at the base by the Lake Char fault. Because of the extensive hydrothermal alteration, different compositions could be mapped in only a general way. Fresh gabbro is most common in the central core of the pluton. The gabbro is for the most part quite felsic, containing 50 percent or more labradorite. Clinopyroxene is the most abundant mafic mineral, and in many of the samples examined is the only mafic other than magnetite-ilmenite. Olivine or hypersthene may be present in small amounts, and locally either one may be the predominant mafic mineral. Gabbro containing less than 50 percent labradorite is present locally; Loughlin (1912) reported a sample containing 15 percent plagioclase and the remainder clinopyroxene and ilmenite. Gabbro as mafic as this is rare, however, and no true ultramafic rocks have been identified. If ultramafics formed they are not now exposed at the surface, and either they are buried at deeper levels within the pluton or they are beneath the Lake Char fault.

On the north, west, and less continuously the south, sides of the pluton, gabbro grades into an upper shell of diorite to quartz diorite. The diorite also may occur along the east side, and it is exposed along the southeast side, but much of the rock along the east side is so thoroughly mylonitized that its original composition cannot now be determined other than that it was mafic. The diorite consists of green hornblende, calcic andesine, and minor quartz and biotite. Much of the diorite is hydrothermally altered also, although fresh diorite is present locally, and in many areas alteration was not strong enough to destroy the original subophitic texture of the rocks. At least some of the hornblende apparently is pseudomorphic after clinopyroxene, as a few samples have a core of pyroxene preserved in the hornblende. More commonly, however, the hornblende replacing pyroxene is crowded with very fine grained opaque minerals, and is associated with small rounded blebs of quartz. Other hornblende is clear and without the small quartz blebs, and is probably an original magmatic mineral. Aside from the small quartz blebs, some diorite samples contain as much as 5 percent interstitial quartz, which also is considered to be a magmatic mineral.

Small trondhjemite dikes, rarely more than a meter thick, cut the diorite and the adjacent Quinebaug Formation and form a late felsic differentiate in the upper part of the pluton. The trondhjemite contains oligoclase, quartz, minor biotite and microcline, and as much as 1 percent zircon. Most trondhjemite is moderately to strongly cataclastic. One dike which is slightly altered, but which is not cataclastic, cuts the diorite-Quinebaug contact near the northeast corner of the pluton; the Quinebaug of this area is strongly cataclastic. A U-Th-Pb zircon age of 424 ± 5 m.y. (R. Zartman, written commun., 1980) was determined from a sample of this dike and indicates a Silurian age for intrusion of the gabbro.

The time of intrusion of the gabbro relative to the metamorphism and deformation of the adjacent rocks has been the subject of some discussion. Loughlin (1912, p. 38-40) interpreted the inclusions in the diorite to be hornfels, and on this basis, as well as the presence of foliated rocks near the edges of the pluton, concluded that the gabbro was intruded prior to regional metamorphism. Sclar (1958), on the other hand, concluded that the gabbro was emplaced after regional metamorphism but prior to cataclastic deformation. My work on the Preston Gabbro confirms Sclar's interpretation with the exception that cataclasis preceded as well as succeeded gabbro intrusion. Loughlin's hornfels inclusions are, for the most part, inclusions of cataclastic Quinebaug, many of which are present in undeformed diorite. The intensity of cataclasis of the inclusions is variable, and in some the original metamorphic gneissosity is still apparent. Foliated gabbro and diorite are as common within the pluton as they are near the edges, and this foliation is the result of cataclasis rather than of regional metamorphism. In places, especially along the Lake Char fault on the eastern margin of the pluton, and locally elsewhere, cataclasis is intense and the gabbro has been converted to mylonite. Thus, the sequence of deformation and intrusion is: (1) regional metamorphism of the area, including the Tatnic Hill and Quinebaug Formations and probably the rocks of the lower plate of the Lake Char-Honey Hill fault; (2) cataclastic deformation of at least the Tatnic Hill and Quinebaug Formations; (3) gabbro intrusion; (4) continued cataclastic deformation and mylonitization of gabbro and adjacent rocks along the Lake Char-Honey Hill fault; (5) late faulting, at least in part high angle, offsetting the mylonites.

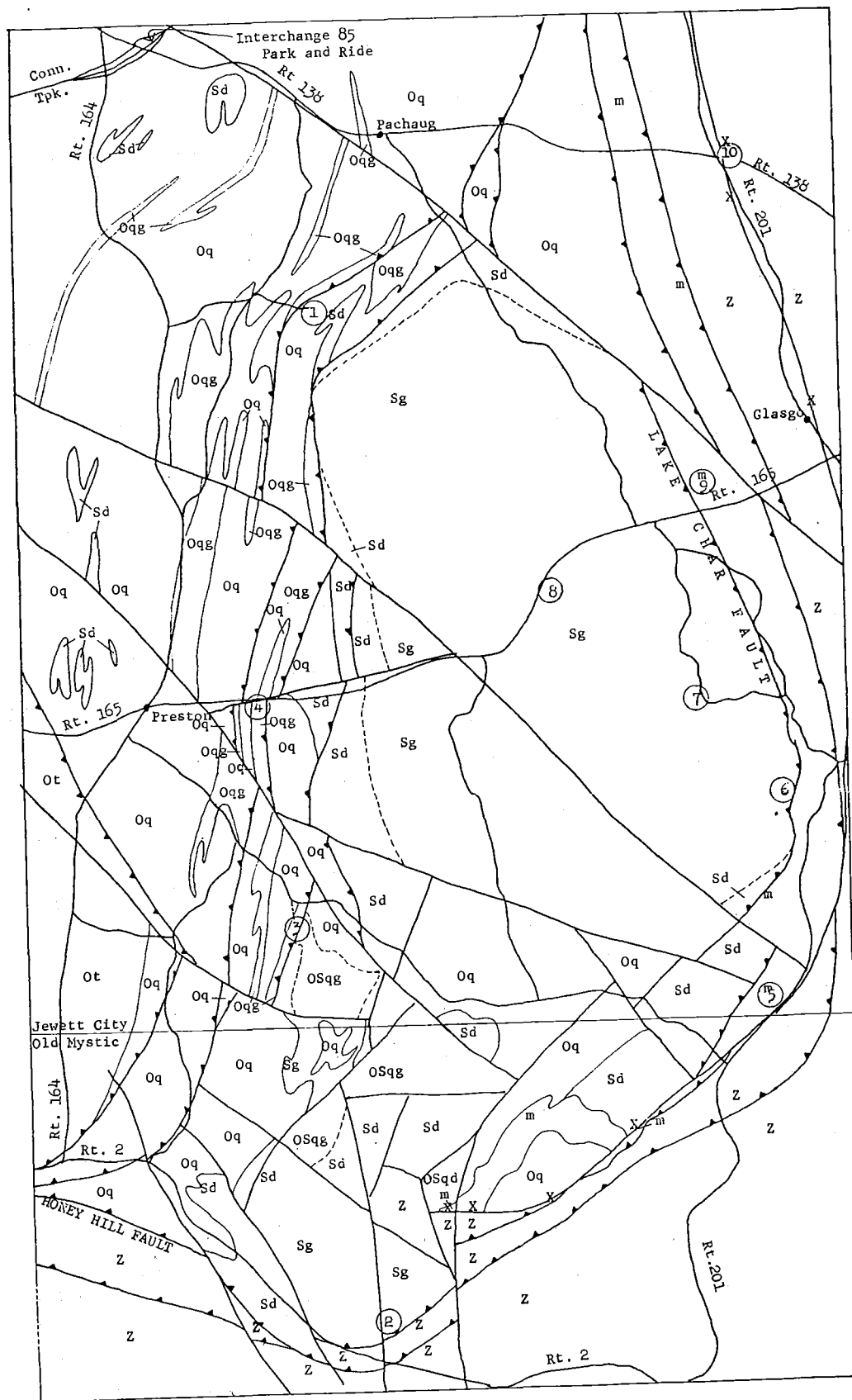

EXPLANATION

m Mylonite (in the Jewett City quad. symbols are located approximately over available outcrops)

SILURIAN

Sd Preston diorite
Sg Preston gabbro

ORDOVICIAN TO PRECAMBRIAN Z

Ot Tatnic Hill Formation
Oq Quinebaug Formation
Oqg Granite gneiss of the Quinebaug Formation
OSqg Quinebaug Formation and Preston gabbro intimately intermixed

PRECAMBRIAN Z

Z Gneisses of the lower plate undivided; includes Sterling Plutonic Group, metavolcanic gneiss, and Plainfield Formation

X Exposures of vein quartz along a Triassic fault

--- Contact, dashed where gradational

--- High angle fault

--- Thrust fault

③ Field trip stop

0 0.5 1 Mile

Generalized geologic map of the Preston Gabbro, Connecticut (Old Mystic quadrangle from R. Goldsmith, written comm., 1980)

If the gabbro was intruded during the Silurian, regional metamorphism and the first stage of cataclasis of at least the Tatnic Hill and Quinebaug Formations are Early Silurian or older, and the second stage of cataclasis, involving the gabbro, is Late Silurian or younger. The first stage of cataclasis may be related to early movement on the Lake Char-Honey Hill fault, or may be related to other faults; cataclasis and faulting along the contact between Quinebaug Formation and the overlying Tatnic Hill Formation is probably older than at least the final stages of cataclasis along the Lake Char-Honey Hill fault. The second stage of cataclasis definitely is related to movement on the Lake Char-Honey Hill fault, and affected rocks of both the upper and lower plate. Multistage cataclasis of the lower plate rocks has not been demonstrated, although it was suggested by Lundgren and Ebblin (1972). If there has been significant movement along the Lake Char-Honey Hill fault, which has also not been demonstrated, the Quinebaug, the Tatnic Hill and the Preston gabbro of the upper plate, may have been separated from the gneisses of the Plainfield Formation and the Sterling Plutonic Group of the lower plate by a considerable distance, and the two groups of rocks may have had different deformational histories until they were brought together along the fault.

Hydrothermal alteration of the gabbro may have accompanied either the cataclastic deformation of step 4 in the sequence or the late faulting (Step 5), or both. Many of the hydrothermally altered rocks are not cataclastic, although in the most strongly altered rocks determining whether they were also cataclastically deformed is difficult. The presence of quartz-chlorite veins along small faults in some areas of intense hydrothermal alteration suggests that at least some the alteration accompanied late faulting. The youngest faults are marked by intermittent exposures of vein quartz and breccia, the largest of which is the Lantern Hill quartz vein in the Old Mystic quadrangle, south of the map area. These faults are probably Triassic in age (Rogers, 1970, p. 111).

P8-5

Road Log

The meeting place for the Preston Gabbro trip will be Interchange 85 of the Connecticut Turnpike, which includes Rt. 164 and Rt. 138, at the Park and Ride parking lot. Those driving from the west will exit the turnpike at Rt. 164, continue straight, across 164 to Rt. 138; turn left onto 138, cross the overpass over the turnpike and turn right to the Park and Ride area. Those driving from the east will exit the turnpike on Rt. 138, continue straight across 138 and turn right into the parking lot. We will be returning to Interchange 85 at the end of the trip, so consolidate cars as much as possible. Meeting time will be 8:30 a.m.

To get to the meeting place from Storrs, the shortest route is to take Rt. 195 south from Storrs to Willimantic (about 8 mi.); Rt. 32 south from Willimantic to Rt. 2 (about 12 mi.); Rt 2 east to the Connecticut Turnpike (about 1 mi.); and the turnpike east to Interchange 85 (about 8 mi.). The total distance is about 30 miles. An alternative route is longer, but the driving time would be about the same as it avoids Willimantic, and the roads are faster. Take Rt. 195 north from Storrs to Rt. 44A (about 1 mi.); Rt. 44A and 44 east to Rt. 101 at Pomfret (17 mi.); Rt. 101 east to the Connecticut Turnpike (5 mi.); and the turnpike south and east to Interchange 85 (about 18 mi.). The total distance is about 40 miles.

The trip will be primarily in the Jewett City quadrangle, but Stop 2 will be in the Old Mystic quadrangle.

Mileage

- 0.0 Turn left out of parking lot and go west to Rt. 164.
- 0.2 Turn left onto Rt. 164.
- 1.3 Fork in road; keep left
- 2.1 Turn left.
- 2.7 Turn left onto Browning Rd, and in about 200 feet make a right turn onto Crary Rd.
- 3.1 STOP 1. Park in front of farm buildings at the end of the paved road. Walk south about 800 feet to a small knoll; it is best to keep to the east side of the stone wall east of the farm to avoid the swamp. CAUTION--poison ivy is abundant.
On the north side of the knoll, dark-gray, medium-grained diorite cuts cataclastic Quinebaug Formation. The Quinebaug in this area includes both felsic granite gneiss and mafic varieties, mainly garnet-biotite-hornblende-quartz-plagioclase gneiss. Samples of the Quinebaug from this general area show 50-100 percent granulation of the constituent minerals. The less strongly granulated rocks contain plagioclase clasts as long as 1 mm length in a very fine grained matrix. The diorite is subophitic, and contains green hornblende, andesine, and minor biotite and quartz. Quartz occurs both as rounded blebs

associated with the green hornblende and as irregular interstitial, grains. The rounded blebs of quartz are residual silica from the hornblendization of pyroxene. The diorite here is not cataclastically deformed. On the south side of the knoll is a trondhjemite dike, apparently cutting the Quinebaug-diorite contact. The rock is light gray, medium grained, and contains 75 percent oligoclase, 11 percent quartz, 7 percent biotite (partly chloritized), 4 percent hematite, and about 1 percent zircon. The thin section of the trondhjemite shows minor granulation along grain boundaries, and minor alteration, but the rock is not cataclastic. Zircons from this rock gave a 424 ± 5 m.y. age. Deposition, metamorphism and cataclastic deformation of the Quinebaug Formation must be older than 424 m.y.

Turn the cars around and return to Browning Rd.

- 3.5 Turn left onto Browning Rd.
- 5.1 Intersection with Rt. 164; take left fork onto Rt. 164.
- 6.3 Town of Preston; continue south on Rt. 164.
- 8.6 Enter Old Mystic quadrangle.
- 9.3 Intersection with Rt. 2; turn left onto Rt. 2.
- 10.3 Outcrops of Quinebaug Formation on the left.
- 11.3 Outcrops of Preston Gabbro on the left.
- 11.8 Turn left onto Old Rt. 2.
- 12.1 STOP 2. Pull cars off on the right side of the road. A road cut on the north side of the road exposes mylonitized gabbro. Sclar (1958, p. 70-74) gives a detailed petrographic description of the rocks in this exposure. The intensity of cataclasis increases from west to east in this exposure, and the mylonite on the southeast side is ultrafine grained and well layered, whereas that on the northwest side is not quite so strongly cataclastic, and is massive. The layered mylonites are so thoroughly granulated that identification of the constituent minerals is difficult, except for a few fine clasts of hornblende and plagioclase. The light-colored laminae may be thoroughly granulated and attenuated grains of plagioclase, or they may have been small felsic dikes that are completely granulated. Sclar (1958) interpreted some of the mylonite in this exposure to have been originally an amphibole gneiss associated with the metamorphic complex, and the rest to have been gabbro. The rocks are so thoroughly granulated it is impossible to be sure what the original rock was, but more likely all of the mylonite in this exposure was originally gabbro. Deformation of the gabbro must have been younger than 424 m.y.

Proceed east on Old Rt. 2.

- 12.3 Turn right onto Rt. 2.

- 13.5 Turn right onto Wattson Rd.
- 14.5 Enter the Jewett City quadrangle.
- 15.1 Intersection with Hollowell Rd.; keep to the right.
- 15.9 Turn right onto Preston-N. Stonington Rd. (Road names in local usage do not agree with those on the topographic map. The map usage is followed here.)
- 16.4 STOP 3. Take a right fork onto a dirt trail and park the cars near the small house left of the trail. Walk south along the trail about 800 feet. Exposures along the trail are of cataclastic Quinebaug Formation, mostly the felsic granite gneiss, though with some interlayered mafic gneiss. The felsic gneiss is light colored, and very fine grained, and is composed mainly of oligoclase and quartz with lesser amounts of biotite-chlorite and epidote. The mafic rocks are composed of varying proportions of plagioclase, hornblende, quartz, chlorite and epidote. About 60-100 percent of the constituent minerals are granulated. East of the trail are numerous exposures of cataclastic Quinebaug and of massive, coarse- to medium-grained diorite which is altered but not cataclastic. The less strongly altered diorite is composed primarily of green hornblende, and andesine, minor opaque minerals, biotite, and quartz and varying amounts of chlorite and epidote. A subophitic texture is apparent in diorite which is not thoroughly altered. The diorite contains inclusions of strongly cataclastic Quinebaug, both the felsic and mafic varieties. Where locally sheared in this area, the diorite is difficult to distinguish from the Quinebaug. The cataclasis of the Quinebaug was older than intrusion of the gabbro-diorite, and thus was older than 424 m.y.; shearing of the diorite is younger than 424 m.y.
- Return to the cars, turn left on North Stonington Rd.
- 18.0 Turn right onto 164.
- 18.2 Stop light at Preston City, turn right onto Rt. 165.
- 18.8 STOP 4; LUNCH. Turn right into Folly Worke Brook roadside park. Intermittent exposures for about 1600 ft. (500 m) along Rt. 165, from the roadside park east, cross the Quinebaug-Preston contact. Road cuts at the park are moderately cataclastic granite gneiss of the Quinebaug Formation. The foliation is defined by a biotite streaking, which forms a faint lamination. Several small faults are recognized by slicked surfaces, which are diverse in attitude, and the plunge of the slickensides ranges from horizontal to vertical. To the east along the road are low-lying exposures of amphibolite, hornblende gneiss, and granite gneiss. A high-angle fault, approximately paralleling the road, cuts the exposures on the south side of the road. East of the farm road (Strawberry Camp Grounds) are exposures of mylonitic Quinebaug. The rocks are of various phases of the

Quinebaug; all are about 100 percent granulated, and locally there is healed breccia. Small dikelets of ultramylonite are present. East of the mylonite is about 600 feet of no exposure, and then low lying exposures of Preston diorite on the north side of the road. The diorite is medium grained and is composed of green hornblende, andesine, and about 5 percent quartz, both as rounded blebs associated with hornblende, and as irregular interstitial grains. The diorite is not cataclastic; thus cataclasis of the Quinebaug Formation in these exposures must be older than 424 m.y.

Return to the cars and turn right onto Rt. 165.

- 20.4 Turn right onto Northwest Corner Rd.
- 22.9 Turn left onto N. Stonington Rd.
- 23.6 Fork in road; keep right
- 23.7 Enter Old Mystic quadrangle
- 24.3 Intersection with Rt. 201; turn left onto Rt. 201.
- 24.7 Enter Jewett City Quadrangle.
- 25.0 STOP 5. Pull onto the wide grassy area on the left (west) side of the road. Walk into the woods on the west side of the road. Several low cliffs are of mylonite, and were described and illustrated by Lundgren and Ebblin (1972). The rocks here are so thoroughly granulated that identification of the original rock is not possible, although it probably is from the lower plate of the Lake Char fault. Both felsic and mafic mylonite are exposed, and the felsic mylonite is probably Hope Valley Alaskite Gneiss, and the mafic mylonite is probably metavolcanic rock, which is exposed east of the Rt. 201 where it is not so strongly cataclastic. For the most part, the mylonites here are too fine grained to identify the constituent minerals with the microscope. Various stages of folding are seen from irregular open folds, to tight isoclinal folds of layers about 5 mm thick. A general N30°W cataclastic lineation is axial to the tight isoclinal folds. Cataclasis here is associated with the Lake Char fault and is younger than 424 m.y.

Turn back onto Rt. 201 and continue north.

- 26.2 STOP 6. Turn left onto a farm road, and drive up to the house. Park the cars by the house, and walk through the animal pens to the cliff exposures behind the pens. Be sure to KEEP THE GATE CLOSED, so the geese will not get out. The rock in the cliffs is mylonitic gabbro on the extreme east side of the Preston pluton. Mylonite here is massive and unlayered, although along the hill slope both north and south local areas of layered mylonite are exposed. Probably the layering occurs in areas containing felsic dikes, which are more readily granulated and attenuated than is the gabbro. Strong cataclasis of the gabbro is apparent in only a narrow zone immediately adjacent to the fault; in the upper part of the cliff, the intensity of cataclasis

has decreased to the point where some constituent minerals of the gabbro are recognizable in the hand sample. Proximity to the Lake Char fault is indicated by felsic mylonite from the lower plate on the sides of the small gulley just east of the cliff; the felsic mylonite may be boulders rather than outcrop, but, if so, the boulders cannot have moved far. Cataclasis here is associated with the Lake Char fault and is younger than 424 m.y.

Return to Rt. 201.

26.5 Turn left onto Rt. 201.

26.7 Turn left onto unnamed road.

27.3 Turn left onto Youngs Rd.

27.9 STOP 7. Go straight onto the dead end road, and park cars by the side of the road just west of the bend in Youngs Road. Numerous low-lying exposures of gabbro occur on both sides of the road. Much of the gabbro is hydrothermally altered, but fresh gabbro is exposed in a small area on the south side of the road. No thin section is available from the gabbro right here, but thin sections from nearby exposures indicate that the rock of the general area is a clinopyroxene-olivine gabbro. The gabbro here is not cataclastic, although there are small local zones of foliated gabbro.

Turn around and continue north on Youngs Road.

29.0 Turn left onto Rt. 165.

29.8 STOP 8. Pull off the road onto the wide shoulder on the right. On the east side of the road are exposures of porphyritic gabbro. The gabbro is hydrothermally altered so that none of the original mafic minerals are still present in the rock, but labradorite is still fairly fresh. Hornblendized pyroxene, as much as 10 cm in diameter, is unusually large in this exposure. Porphyritic gabbro is common in the central part of the pluton, but the pyroxene, or hornblendized pyroxene grains, are commonly 0.5-1.5 cm in diameter. Symplectite coronas of actinolite, opaque minerals and chlorite surround alteration masses of amphibole and suggest that originally the rock contained olivine. At the east end of the exposures the gabbro is thoroughly altered so that only minor plagioclase is left, and the rock consists mainly of epidote, chlorite and pale green amphibole.

Turn cars around and return east on Rt. 165

30.8 Turn left onto a dirt road called Burdic Lane

31.2 STOP 9. Pull cars off the road on the left. Exposures of mylonite on the top and east side of the knoll (note that the topographic map locates the top of the knoll about 200 ft. west of the road, whereas it is actually just uphill from the road). Again, the rock is so thoroughly granulated that the original rock cannot be identified with any certainty. Just above the road is a rusty weathering mafic

mylonite that was probably mafic metavolcanic rocks of the lower plate. The mafic mylonite has a slatey cleavage and a crinkle lineation on the cleavage surfaces, but folding has not been observed. The mylonite on the top of the knoll is granitic in composition, and much is strongly epidotized; it probably is Hope Valley Alaskite Gneiss. Mylonite here is lineated and folded, but the prominent cataclastic lineation is folded around the axis of the main visible folds and thus is not axial to them. The tight isoclinal folding observed at Stop 5 has not been seen here. Cataclasis is associated with the Lake Char fault and is younger than 424 m.y.

Turn cars around and return to Rt. 165

- 31.6 Turn left onto Rt. 165
- 32.7 Turn left onto Rt. 201
- 34.9 Turn right onto Rt. 138, and in less than 0.1 mile turn left into the old road alignment of Rt. 138.

STOP 10 Vein quartz, somewhat brecciated, along a north-trending fault. This is one of a series of intermittent exposures of vein quartz that occur along a line from the town of Glasco north into the Plainfield quadrangle to the north, and mark the trace of a late, high-angle fault. At stop, 10 nothing much is visible but the quartz, but in some exposures the vein quartz is associated with silicified, but recognizable Hope Valley Alaskite Gneiss. This fault is interpreted to be related to the faulting that resulted in the large vein quartz at Lantern Hill in the Old Mystic quadrangle to the south, although they are not on line, and is thought to be Triassic in age.

Turn the cars around and turn right onto Rt. 138 and return to the Connecticut Turnpike. Interchange 85 is about 4 miles west.

REFERENCES CITED

- Dixon, H. R., and Lundgren, L. W., Jr., 1968, Structure of eastern Connecticut, in Zen, E-an and others, eds., Studies of Appalachian geology--Northern and maritime: New York, Interscience Publishers, p. 219-229.
- Griscom, Andrew, and Bromery, R. W., 1968, Geologic interpretation of aeromagnetic data for New England, In Zen, E-an and others, eds., Studies of Appalachian geology--Northern and maritime: New York, Interscience Publishers, p. 425-436.
- Loughlin, G. F., 1912, The gabbros and associated rocks at Preston, Connecticut: U. S. Geological Survey Bulletin 492, 158 p.
- Lundgren, Lawrence, and Ebblin, Claude, 1972, Honey Hill fault in eastern Connecticut; regional relations: Geological Society of America Bulletin, v. 83, p. 2773-2794.
- Rodgers, John, 1970, The tectonics of the Appalachians: New York, Wiley-Interscience, 271 p.
- Sclar, C. B., 1958, The Preston gabbro and the associated metamorphic gneisses, New London County, Connecticut: State of Connecticut Geological and Natural History Survey Bulletin 88, 131 p.

Structure and Petrology of the Willimantic Dome
and the Willimantic Fault, Eastern Connecticut.

Robert P. Wintsch,
James S. Fout¹
Department of Geology
Indiana University
Bloomington
Indiana

INTRODUCTION

The Willimantic dome is centered between the north trending Bronson Hill anticlinorium to the west and the domes of the Avalonian terrane south and east of the Honey Hill-Lake Char faults. (Fig. 1). The rocks of the Willimantic dome are divided into three units: a quartz-plagioclase-microcline gneiss or granofels (Willimantic gneiss), a plagioclase-quartz-amphibole-biotite gneiss, and the largely pelitic schists and gneisses of the Tatnic Hill formation (Fig. 2). This trip of five stops is designed as an introduction to these three rock types and to the major structural and petrologic features of the ductile Willimantic fault zone. The larger scale structure and stratigraphy are of regional interest, but are difficult to evaluate in the context of this trip. The first two stops are to gneissic units in the core of the Willimantic dome, where regional relationships can be discussed, but not tested. The latter three stops show different parts of the Willimantic fault zone on three sides of the Willimantic dome (Fig. 2).

GEOLOGIC SETTING

The circular outcrop pattern defined by the two gneissic units at Willimantic outlines the Willimantic dome. However, the smaller exposures of plagioclase gneiss SW of the dome, and outlined by the oval shaped outcrop patterns of the Willimantic fault on Fig. 1, suggest a structure more closely resembling a doubly plunging anticline. Whatever the overall geometry, the shallow dips of foliation and of lithologic boundaries suggest that it is a very low amplitude structure.

Regional correlation of the three units in the Willimantic dome suggests that they belong to the Avalonian terrane to the east rather than to the Bronson Hill sequence to the west. The composition of the metarhyolitic Willimantic gneiss (Stop 2) is very similar to the Hope Valley alaskite of Day et al (1980) and may be equivalent to it.

1. Present address: Exxon Co., USA, 2000 Classen Center, Oklahoma City, OK 73106

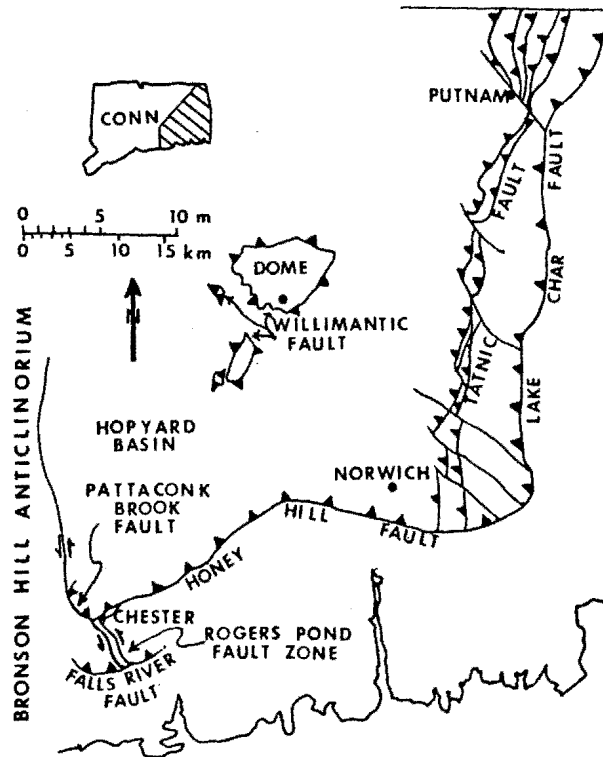

Fig. 1. Map showing the distribution of selected features around the Willimantic dome, eastern Connecticut. The Willimantic, Tatnic and Honey Hill faults probably define a single thrust fault the movement of which was to the southeast. The four areas of exposure of the Willimantic fault constitute windows through the fault and outline the areas extent of the Willimantic dome.

The mineralogy and composition of the plagioclase gneiss unit is indistinguishable from the gneiss at Hadlyme, immediately south of the Honey Hill fault near Chester (Fig. 1) but does not coincide with the Monson gneiss of the Bronson Hill anticlinorium (Wintsch and Grant, 1980; Wintsch and Pease, this volume). The Tatnic Hill formation, with its distinctive internal stratigraphy is well represented around the Willimantic dome, which is 15 km west of the type area in Danielson (Dixon, 1964). However, the Tatnic Hill formation has not been identified west of Chester in the Bronson Hill anticlinorium. We thus believe that the Willimantic dome is part of the Avalonian terrane to the east, and should not be related to the Bronson Hill anticlinorium.

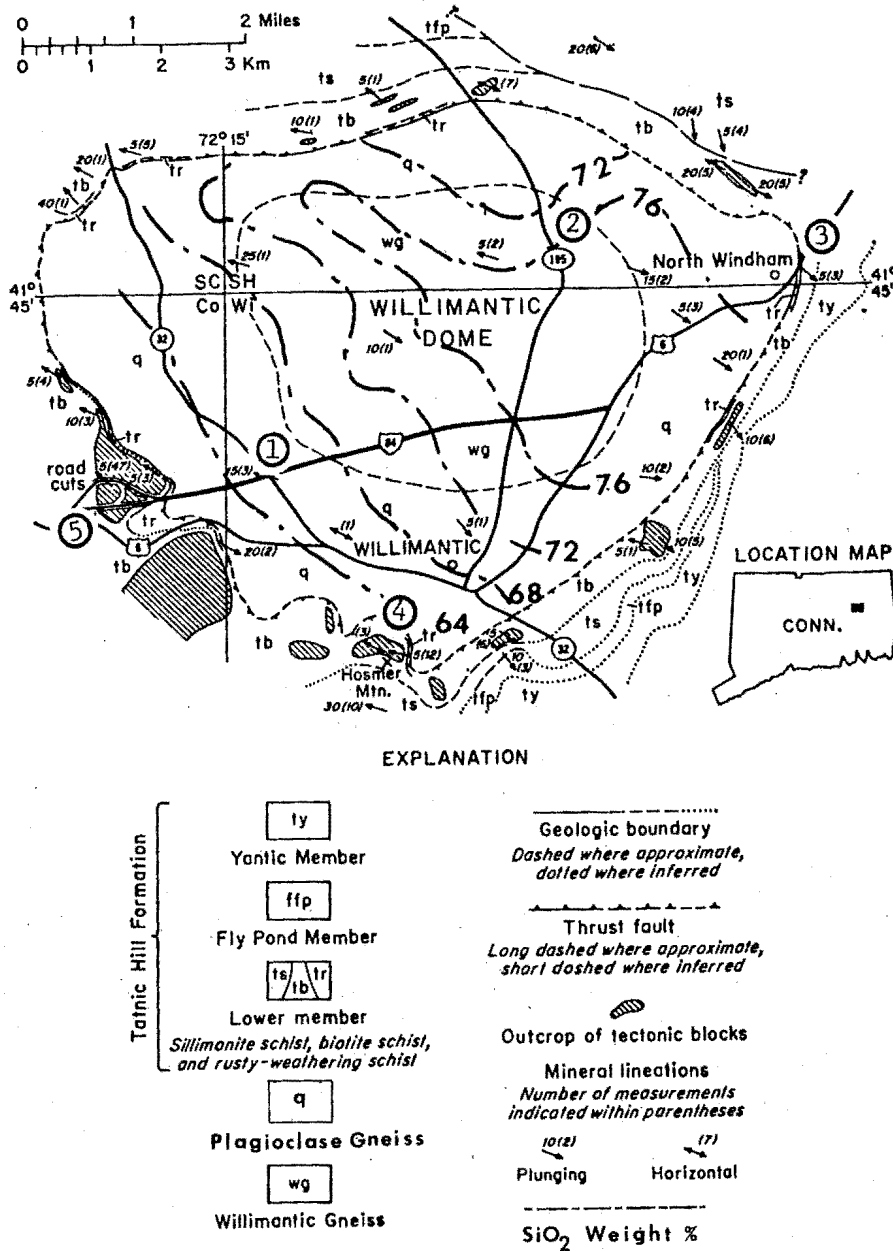

Fig. 2. Geologic map of the Willimantic dome, after Wintsch (1979). The dashed line separates rocks of the Brimfield Group structural trend (to the northeast) from rocks containing fabrics of the Willimantic fault. The concentration of SiO₂ (in wt %) in these rocks is given by the dot-dashed contours. A similar NW bearing trend is established by most major and trace elements, and the termination of these contours by the Willimantic fault suggests that the fault has cut out some of the plagioclase gneiss especially in the NW and SE. [Field trip stops are given by the circled numbers, and the University of Connecticut campus is 1 mile north of the map on State Route 195.]

WILLIMANTIC FAULT

An understanding of the Willimantic fault is best obtained when it is placed in a regional context. The reoccurrence of the Tatnic Hill formation, accompanied by intense ductile deformation at its base, along the Tatnic, Willimantic and Honey Hill faults (Fig. 1) suggests that these faults represent a single ductile fault zone (Wintsch, 1979). The Willimantic dome would then be a window through this fault surface, and the fault zone would underlie much of northeastern Connecticut. Most movement on this fault system was to the SE, as indicated by imbrication, NW trending tear faults, and the thrusting of high grade rocks over lower grade rocks along the Tatnic fault, by the southwest vergence of small scale open folds, and by the clockwise rotation (facing north) of boudins and porphyroblasts. In the Willimantic area ductile deformation is most intense near the base of the Tatnic Hill formation (Stops 3, 4, 5), but it is also present in the underlying gneissic rocks (Stops 1, 2). Some rupture is also suggested on the small scale by intensely deformed mylonitic schists (Stops 4, 5) and on the large scale by the truncation of compositional contours of the plagioclase gneiss (Stop 1). Total displacement is not easily determined, but must be of the order of kilometers (Wintsch, 1979). These relationships further suggest that at least some of the deformation on the Willimantic fault postdates the development of the Willimantic dome.

The maximum grade of metamorphism recorded in these rocks is upper amphibolite facies (Stop 5). However, mineral assemblages within discrete shear zones locally record lower or much lower grade conditions than this. That these lower grade assemblages developed during deformation and not after it is indicated by the strong foliation and lineation defined by the constituent minerals and by rotated feldspar porphyroblasts. The amphibolite facies conditions recorded by the mineral assemblages in these rocks suggests that most deformation on the Willimantic and Tatnic faults occurred at these high grades, although syntectonic greenschist facies assemblages in some shear zones at stop 5 do indicate minor deformation at these lower grade conditions. This is in contrast to the Honey Hill fault, which was more thoroughly reactivated under greenschist facies conditions, especially along the Pattaconk Brook fault in the east, and south of Norwich to the west (Fig. 1).

One particularly useful way of deciphering the deformation history along the Willimantic fault is through mineral lineations. These lineations share a strong northwest bearing, and may be defined by hornblende as sillimanite needles, biotite streaks, kyanite blades (rare) feldspar (+ quartz) rods, muscovite-chlorite streaks, quartz rods and slickensides. Together these lineations define a retrograde metamorphic path, along which sequential deformation events caused progressively lower grade assemblages to develop in different shear zones. The occurrence of andalusite at stop 4 establishes a very important upper pressure limit to this path, and allows semi-quantitative construction of this path as shown in Fig. 3.

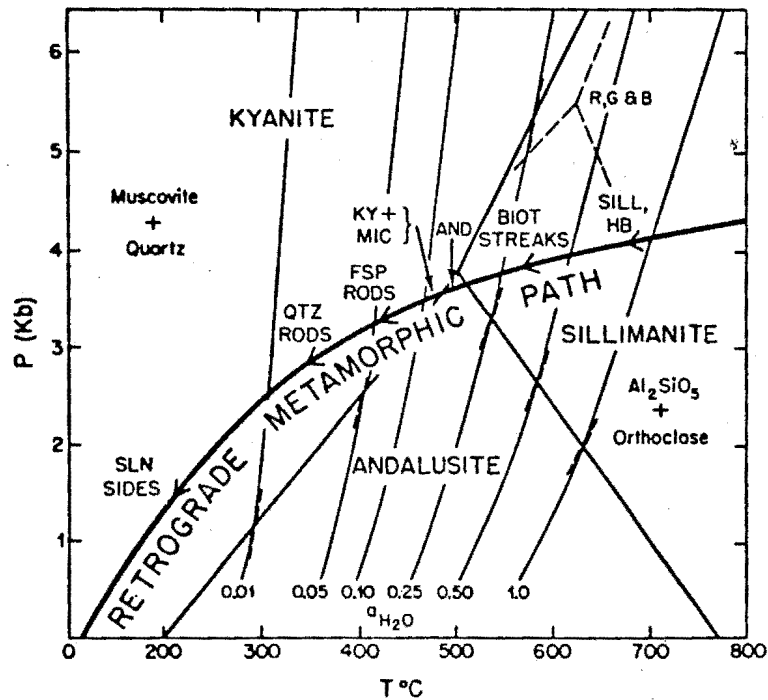

Fig. 3. The retrograde metamorphic path defined by mineral assemblages in ductile shear zones in the Willimantic fault. Many assemblages contain mineral lineations which developed at the various conditions equal to or greater than those indicated on the curve. The occurrence of andalusite (AND) at Stop 4 establishes an upper temperature limit to the curve. The 400°C temperature estimate for feldspar rods is taken from Fig. 5. Contour lines show the position of the equilibrium: muscovite + quartz = microcline + Al_2SiO_5 + H_2O for various activities of H_2O (standard state = real gas at P, T). The occurrence kyanite + microcline (KY + MIC) in ductile shear zones at Stop 5 establishes the maximum activity of H_2O ($a_{\text{H}_2\text{O}}$) of 0.10 (near-vertical contours) in these shear zones. The curve would be displaced to higher pressure conditions if the triple point of Richardson, Gilbert and Bell (R, G & B) (1969) were used instead of the Holdaway (1971) point.

The average bearing of these lineations in the Willimantic area is strongly NW-SE, but in the Putnam area (Hudson, 1982) and along the Honey Hill fault (Wintsch, unpub. data) bearing changes from NW to NS with decreasing metamorphic grade. The small (10°) counter clockwise rotation of transport direction suggested by Wintsch (1979) for the Willimantic area is probably not significant, and in view of the clockwise rotation of lineation bearing in the other areas, is probably not real (see also Stop 5). All the data taken together now suggest a clockwise rotation of lineation bearing at least 60° during the retrograde interval 700° - 300°C (Fig. 3). In view of the recent radiometric uplift curves of Dallmeyer (written comm.) and Sutter and Wintsch (in prep) this deformation was active by 290 my and ceased by 230 my, making it Hercynian in age.

A major question we would like to raise throughout this trip is what strain induced reactions could occur, or have occurred in these rocks. From a theoretical point of view, the work done on a rock by deforming it may take the form of heat, elastic strain energy, plastic strain energy and surface energy. The amount of energy expended on the Willimantic fault is not known, but the retrogradation of mineral compositions and assemblages in high strain zones here suggests that this energy is sufficient to provide the activation energy for retrogradation of the shear zones to the P-T conditions prevailing during their deformation. This appears to account for the highly variable metamorphic grade recorded in these deformed rocks. Some of the energy expended by deforming a rock is stored as lattice energy (dislocations, deformation twinning, subgrain walls) and some is stored as surface energy (through grain size reduction). The former will increase the solubility of the deformed crystal, and could lead to the supersaturation of that mineral in the grain boundary fluid. The latter will allow spontaneous surface exchange reactions to take place, which will increase the pH of the grain boundary fluid thus destroying solid-fluid equilibrium. Through these mechanisms the mechanical energy added to the rock is transformed to chemical energy in the fluid, which causes overstepping of high variance mineral reactions. These processes should lead to the development of syntectonic porphyroblasts of hornblende (Stop 1) and feldspar (Stop 1, 3, 4, 5) and to the oxidation of iron (Wintsch, 1975; 1981). The progress of such reactions should correlate positively with strain, and this relationship may be assessed at most stops on this trip.

ROAD LOG

Assemble at the west end of the Willimantic Plaza parking lot at the west edge of Willimantic on Rt. 32, 0.5 mi east of the Rt. 32 exit off I-84 at 8:30 AM. From the University of Connecticut in Storrs, take Rt. 195 south 7 mi to I-84 at the Willimantic town line, proceed west on Frontage road following I-84 west signs. Exit at Rt. 32 and proceed left, 0.5 mi on Rt. 32 to assembly point. Breakfast is available from 7 AM at fast food drive-in, 0.4 mi east on Rt. 32.

This trip follows narrow roads and parking space is in short supply at some stops. Please help reduce the number of cars on the trip to the absolute minimum by sharing rides and filling each car to capacity. The last stop is just 2 mi from the assembly point so that drivers need not go far out of their way to return riders.

Proceed on foot, 0.4 mi west on Rt. 32 to roadcuts on the westbound (Hartford) on ramp to I-84.

Stop 1, road cuts along the entrance ramp to I-84 from Rt. 32, is some of the best exposures of the plagioclase gneiss in the Willimantic area. The rock is a medium gray gneiss consisting of mm grains of plagioclase, quartz, hornblende, biotite and magnetite. Foliation is defined by a parallel alignment of disseminated biotite flakes and by a composition banding of quartz-, plagioclase- and hornblende-rich layers. The foliation is parallel to lithologic boundaries between amphibolite and plagioclase gneiss in these rocks, and to pelitic schist-plagioclase-gneiss contacts in other outcrops.

The bulk composition of this plagioclase gneiss is similar to a silica-poor dacite (Fig. 4), with SiO_2 varying from 62-72 wt %. Judging from the parallel contacts with the included amphibolites and rare metasediments, it was probably deposited as a volcanoclastic rock. Its composition is indistinguishable from the plagioclase gneiss at Hadlyme (Wintsch and Grant, 1980), which with its similar lithologic setting is evidence that the two units are equivalent. Snyder (1964; 1967) equated the plagioclase gneiss here with the Quinebaug formation 15 km to the east. However, the Quinebaug formation has a much more varied composition, and if these two units are time correlative, a sedimentary facies change must be involved.

Several amphibolite boudins are exposed in this outcrop. In one case the same boudin is exposed twice along the southern semi-circular cut: once at waist level at the west end once 6m above the road at the east end. Coarse grained quartz, plagioclase and K-feldspar occur at boudin necks. The margin of one boudin (southern exposure, 2m elevation) have been deformed into a fold like structure, and now envelope this felsic mineral. The boudins do not form a radial pattern around the Willimantic dome, as would be expected if their development were related to extension during the emplacement of the dome. On the contrary, their general NW-SE bearing in both the plagioclase gneiss and the Tatnic Hill formation is more easily explained by a boudin axis rotation during thrusting (Wintsch, 1979). Several undeformed pegmatites cut the gneiss. They tend to be mineralogically and texturally zoned, with very coarse grained quartz cores, K-feldspar-rich intermediate zones, and plagioclase-rich rims: a classic zoning pattern. They are clearly younger than the plagioclase gneiss, and thus do not offer a source for the deformed concordant, feldspar-rich veins which are common on both sides of the road.

The metamorphic petrology of these rocks reflects more its uplift history than the maximum P-T conditions of the metamorphism. This gneiss must have been metamorphosed to the upper amphibolite facies conditions of the overlying Tatnic Hill formation. The 650-700°C temperatures calculated from the compositions of coexisting biotite and (rare, unzoned) garnet probably represent minimum estimates of these conditions. The growth of rotated porphyroblasts of hornblende, plagioclase and K-feldspar probably occurred at these conditions. However, the equigranular mosaic of crystals with large interfacial angles typical of these conditions is not found. Quartz

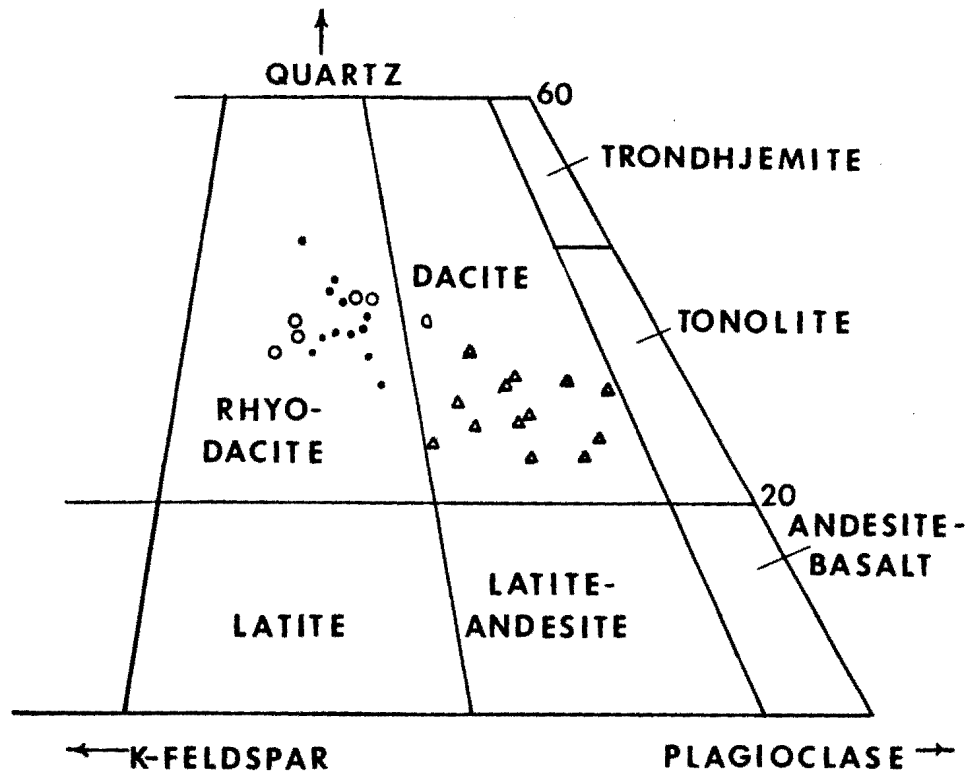

Fig. 4. The normative classification of gneisses from the Willimantic dome. Triangles represent plagioclase gneiss, closed circles represent Willimantic gneiss. The composition of the Hope Valley alaskite (open circles) from Day et al (1980) is included for comparison.

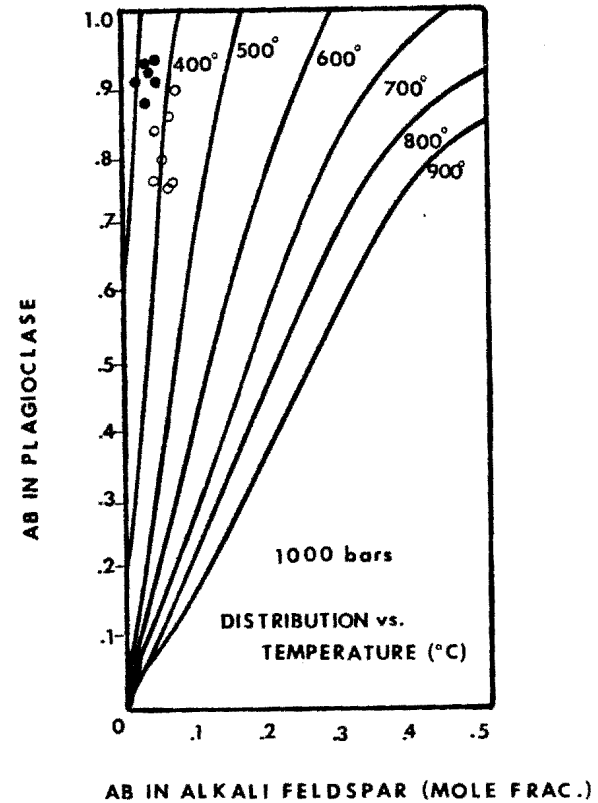
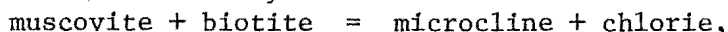

Fig. 5. The compositions of coexisting plagioclase and microcline from the Willimantic gneiss (filled circles) and the plagioclase gneiss (open circles). The calculated isotherms are from Whitney and Stormer (1977). The data suggest that the feldspars from the plagioclase gneiss equilibrated between 390-430°C, and that those in the Willimantic gneiss equilibrated between 310-360°C. The feldspars and quartz in the plagioclase gneiss form rod-shaped grains, whereas in the Willimantic gneiss only the quartz is rod-shaped. The temperature at which rod-shaped feldspars disappear in these rocks is about 375°C, a temperature used to help in the construction of Fig. 3.

and feldspar crystals up to 3mm long are set in a matrix of crystals 1/10th this size. Lower amphibolite to upper greenschist facies conditions are reflected in the low structural state of the K-feldspar in the matrix, and in the alterations of amphibole to biotite and or epidote, of biotite to chlorite, and of plagioclase and microcline to white mica. These highly metasomatic replacement reactions indicate at least a local redistribution of K, Na, and Ca (among others), which could lead to the resetting of alkali exchange equilibria to the temperatures of this alteration. The 390-430°C temperatures calculated from the compositions of coexisting microcline and plagioclase (Fig. 5) are compatible with the above alteration reactions, and suggest that this exchange equilibrium could be part of this lower grade reequilibration. The pervasive occurrence of chlorite with microcline in the plagioclase gneiss establishes lower greenschist facies conditions by the reaction:



and confirms the implication above that some of this alteration occurred at relatively low grade metamorphic conditions.

It is possible that deformation contributed to the partial readjustment of this assemblage to these lower grade conditions. The lineations defined by rod-shaped crystals of quartz and feldspar, by biotite streaks, and by hornblende needles indicate a penetrative tectonic influence on this assemblage. This strain apparently caused undulose extinction in the larger crystals, and reduced the grain size of others to produce the present bimodal distribution of grain size. This increased lattice and surface energy may have provided the activation energy for some of these retrograde modifications. The strong preferred orientation of the above linear structures at N 55° W is identical to the orientation of lineations in the Willimantic fault zone. This suggests that this ductile deformation occurred during deformation in the Willimantic fault. Return to cars at assembly point.

- 00.0 Begin road log at main entrance to parking lot of Willimantic Plaza. Cumulative distance is in miles. Turn right onto Rt. 32 at signal.
- 00.2 Turn right at signal onto eastbound (Providence) ramp for I-84.
- 01.4 Leave I-84 at exit marked University of Connecticut, Rt. 195.
- 01.6 Left turn at signal at bottom of ramp, through underpass.
- 01.8 Right turn onto frontage road.
- 02.6 Left turn onto Rt. 195 at signal. Proceed north on 195. Hills to west of road underlain by Willimantic Gneiss. Road runs on kame terrace.
- 04.0 Right turn onto Mansfield Hollow Road. Easy to miss this turn, just past a curve to left. (You get a second chance at Bassetts Bridge Road about 1 mile ahead where you turn right at signal and follow signs to Mansfield Hollow Dam.)

- 04.5 Turn right at stop sign on Mansfield Hollow Extension.
- 04.6 Park in Mansfield Hollow Dam parking area. The falls on the Natchaug River have powered mills in the Hollow since c1730. The Kirby Mill, just west of the falls, was built in 1882 of Willimantic Gneiss quarried nearby. Mansfield Hollow Dam, completed by the Corps of Engineers in 1952, was built to prevent recurrence of flooding in Willimantic, which was devastated in the hurricane of 1938. The dam is built at the confluence of the Fenton, Mount Hope and Natchaug Rivers, about 3 miles upstream of the point where the Natchaug joins the Willimantic. The dam proved its worth in August 1955 when heavy rains associated with Hurricane Diane produced a peak discharge in the Willimantic river upstream of the city that was 1.6 times that recorded in the '38 hurricane. Release of water stored in the reservoir after passage of the flood crest held maximum water-levels in the city to just below that of the mean annual flood. It was estimated that losses of \$3,200,000 were prevented, equal in amount to one half the cost of the dam.

Walk down grassy slope to outcrops at base of dam to stop 2.

Stop 2, at the spillway of Mansfield Hollow Dam is to one of the freshest exposures of the Willimantic gneiss. It is a massive, gray to buff weathering, quartz, microcline, oligoclase granofels, with an average grain size of 1/2 - 2mm. Biotite, magnetite and retrograde muscovite, chlorite and sphene are accessory minerals. Foliation in this rock is defined by the parallel alignment of the minor phyllosilicates, and includes a lineation defined primarily by quartz-rods with aspect ratios up to 1:5. These lineations are difficult to recognize in the field, and can only be seen on surfaces parallel to the plane which contains them.

The composition of this gneiss is rhyodacitic (Fig. 4) and is rather uniform throughout its exposure. The upper contact of this gneiss appears to be sharp, although the small lenses of this gneiss present within the plagioclase gneiss suggest that the contact is inerlayered. The composition of the Hope Valley alaksite is very similar to the Willimantic gneiss (Fig. 4), and also underlies a plagioclase gneiss and the Tatnic Hill formation in extreme eastern Connecticut. These features are compatible with the suggestion of Day et al (1980) that this gneiss was deposited as a volcanic rock, and if true, it would suggest a very wide area of deposition of the rhyodacitic protolith.

The metamorphism of this granofels, like the plagioclase gneiss at stop 1 must have reached upper amphibolite facies conditions, but K_D 's between coexisting oligoclase and K-feldspar (maximum microcline, according to unit cell refinements) suggests equilibration to temperatures as low as 350°C (Fig. 5). Some of these feldspars are rod-shaped, but aspect ratios rarely exceed 1:3. The orientation of the quartz and feldspar rods is strongly N 55°W, again compatible with

strain associated with the Willimantic fault. The distribution of feldspar compositions shows a surprising decrease in apparent equilibration temperature with decreasing depth in the structure. This drop in apparent temperature is accompanied by an increase in the proportion of quartz rods to feldspar rods. Our working hypothesis is that plastic strain (dislocation creep) was responsible for the rod shaped crystals as well as for inducing the exchange equilibrium between the feldspars. If this is correct, then the temperatures recorded would reflect the temperature at which plastic deformation in the feldspars ceased. The data would also suggest that feldspars become significantly stronger than quartz below 350°C, in agreement with the experiments of Tullis and Yund (1980). Assessment of this hypothesis requires TEM and microfabric work, not yet undertaken. One conclusion which we can make with confidence, however, is that neither the exchange equilibria nor the mineralogy of the Willimantic gneiss reflect in any way the upper amphibolite facies metamorphic conditions which it must have experienced. Return to cars.

- 04.6 Leave parking lot by Mansfield Hollow Ext.
- 04.8 Continue straight past stop sign onto Mansfield Hollow Road, climbing out of the Hollow onto kame terrace.
- 05.0 Turn right at stop sign onto Bassetts Bridge Road. Kettles on both sides of road.
- 05.4 Crossing dike for Mansfield Hollow Dam.
- 07.0 Road curves to right at "Y" intersection with Bedlam Road. Outcrops of plagioclase gneiss in woods to east of road.
- 07.8 Turn left across bridge over Natchaug River.
- 07.9 Turn left at stop sign onto Old Rt. 6.
- 08.2 Pull off and park at side of road just before intersection of Old Rt. 6 with Rt. 6. Cross Rt. 6 to roadcuts of stop 3.

Stop 3, at road cuts on Rt. 6 near North Windham is included to illustrate some of the ductile deformation in the Tatnic Hill formation on the east side of the Willimantic dome. A sub-pelitic biotite-quartz-plagioclase schist with amphibolite layers (now boudinaged) representing the lower part of the biotite schist unit of the lower member of the Tatnic Hill formation is exposed here. The rock contains less garnet and sillimanite and is finer grained than most of this unit (compare with Stop 4, 5). It nevertheless contains isoclinal folds, amphibolite boudins and small scale tectonic blocks which are part of the evidence for high strain in the Willimantic fault zone. Return to cars.

- 08.2 Turn right on Rt. 6 and proceed south.
- 08.8 Signal at junction with Rt. 203.

- 09.1 Crossing E- end of Mansfield Hollow Dam.
- 10.6 Crossing I-84.
- 11.8 Crossing Natchaug River, entering Willimantic. Continue on Rt. 6.
- 12.7 Left on Rt. 32 at traffic circle. Pass through mill building and cross Willimantic River.
- 12.8 Hard right beneath railroad bridge and up steep ramp onto Pleasant Street. If you get to the signal, you went too far. The mill complex of the American Thread Company is built largely of plagioclase gneiss quarried in the hill section of the city. Willimantic, the "Thread City", grew up around mills built to take advantage of "The Seven Falls of the Willimantic River", cut into plagioclase gneiss.
- 13.5 Turn left onto Rt. 289, Mountain Street, driving along the east flank of Hosmer Mountain.
- 14.1 Park off pavement just before reaching intersection with South-ridge Road.

Stop 4, at several road cuts on the east side of Hosmer Mountain shows the best profile across the contact between the plagioclase gneiss and the Tatnic Hill Formation. The plagioclase gneiss is similar to that at Stop 1. The rusty weathering base of the Tatnic Hill Formation is well exposed along the road section, and the overlying biotite schist unit crops out in natural exposures SW of Hosmer Mt.

Of particular interest in this outcrop is the apparent strain gradient across the contact. Strain is difficult to quantify in these rocks, because of the lack of strain indicators, but an increase in the development of boudinage (of the plagioclase gneiss and included amphibolites), of small scale folding, and of plagioclase and hornblende porphyroblasts can be seen as the contact is approached. Across the contact into the Tatnic Hill Formation evidence of strain continues to be abundant until the zone of tectonic blocks is reached, where strain becomes very heterogenous.

The contact itself is exposed some 20m above the road surface near the southern end of the outcrop. Please do not sample the outcrop! Textures present on weathered surfaces should be left of all to see! The Tatnic Hill Formation here is a mylonitic schist, and relative to the precursor rock has undergone a 10-50 X grain size reduction. This schist contains a lower grade assemblage, and probably has experienced a higher strain than any of the surrounding rocks. The apparent discordance of this schist with the rocks both above and below suggests that some of the later strain in these rocks cut across both units. Farther south along the road upper amphibolite facies assemblages and structures dominate. These include intra-folial folds, boudinage, tectonic blocks, and feldspathization - evidence of the earlier, completely ductile deformation.

1
2
3
4
5
6
7
8
9
10
11
12
13
14
15
16
17
18
19
20
21
22
23
24
25

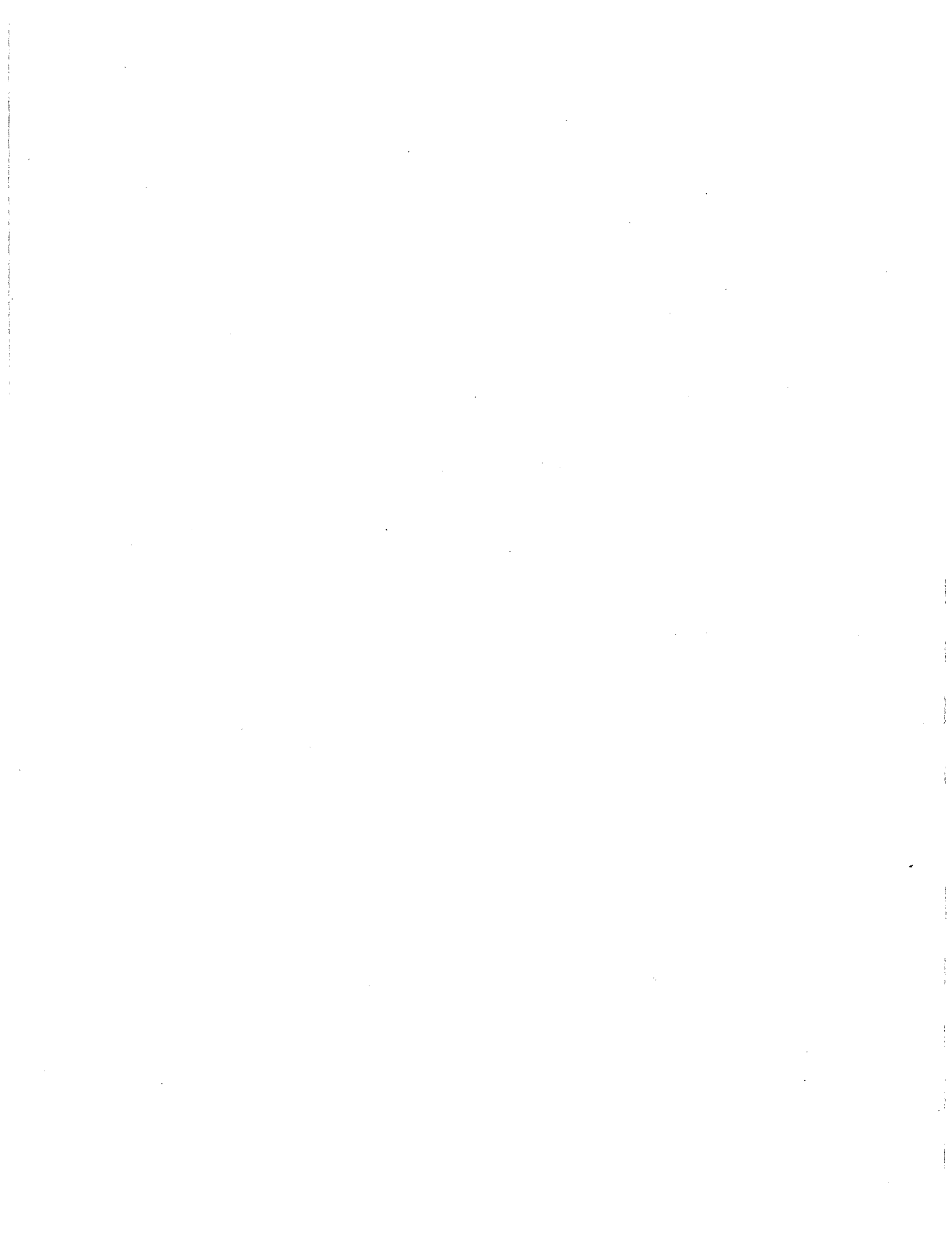

The first several meters of the Tatnic Hill Formation provide outstanding examples of strain induced reactions. These rocks contain both kyanite and andalusite rather than the expected sillimanite. Both aluminosilicates embay, and andalusite also includes biotite, and both are associated with magnetite, suggesting the oxidation reaction (Wintsch, 1981):

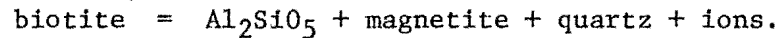

Hematite is also present in these rocks as thin blades intergrown with biotite. As grain size is reduced in these rocks, there is a decrease in SiO_2 , Na_2O and CaO relative to Al_2SiO_5 , and an increase in the $\text{Fe}_2\text{O}_3/\text{FeO}$ ratio. This correlation of oxidized assemblage with small grain size supports the proposal of Wintsch (1981) that a pH increase caused by surface exchange could have been responsible for this oxidation. Thus the mineralogy and even the composition of these rocks do not reflect the upper amphibolite facies conditions which the rocks once experienced. Rather, they reflect a complex set of metasomatic reactions which by some path were probably strain induced at conditions near the Al_2SiO_5 triple point. Return to cars.

- 14.1 Turn left onto Southridge Road.
- 14.6 Left at stop onto South Street.
- 15.0 Left at stop onto Pleasant Street.
- 15.5 Right at stop, follow signs for Rt. 32 down hill and across Willimantic River.
- 15.8 Turn left onto Rt. 6, Rt. 32 west at signal.
- 16.5 Veer right at signal at "Y" intersection onto Rt. 32.
- 17.5 Turn right onto I-84 west (Hartford) ramp, passing Stop 1.
- 18.8 Enter road cuts in lower member of Tatnic Hill Formation. The spectacular tectonic blocks, obvious in the road cuts, are not readily apparent in surface exposures. Cost of these roadcuts was greatly in excess of the annual budget for the NSF Earth Science Section.
- 19.8 Cross Rt. 6 at signal and turn right into Commuter Parking Lot. Get out and walk.

As a compact group, cross Rt. 6 and Rt. 66 at the signal and proceed up the median of I-84 staying well away from traffic. These road cuts are among the most important exposures in Eastern Connecticut. Please do nothing to jeopardize their use by future geologists.

Stop 5, is to the road cuts along the unfinished interchange between I-84 and State Rt. 6. These truly spectacular exposures are made even more enjoyable by the fact that I-84 has not been completed, and we will not be distracted by menacing traffic. A sketchmap (Fig. 6) of these cuts is provided for reference to specific locations.

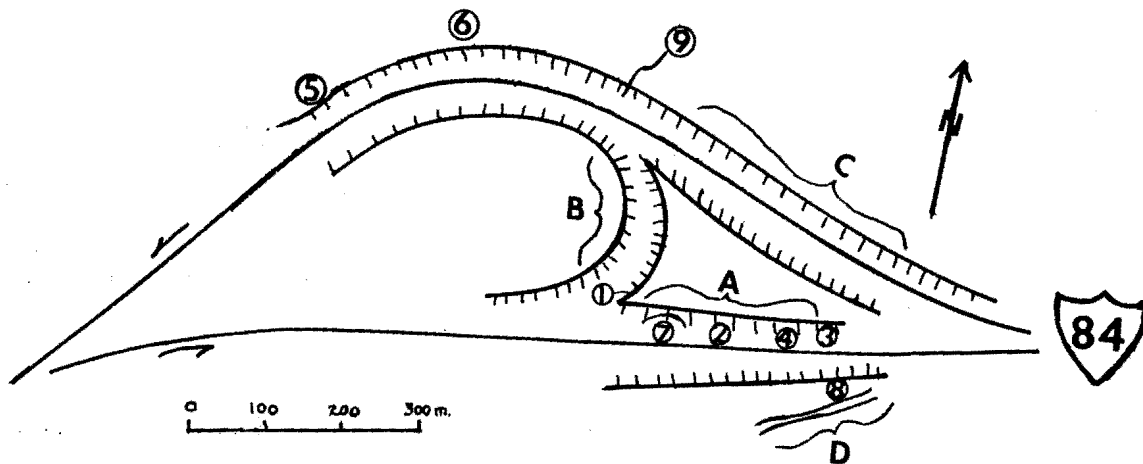

Fig. 6. A sketch map of the road cuts along the interchange of I-84 and U.S. Rt. 6 5km east of Willimantic showing the approximate locations of features described in the text of Stop 5.

The most stunning feature exposed in these outcrops are the large and very large tectonic blocks. They are best viewed from a distance of 30m or more, particularly on face A (Fig. 6). For those especially interested in these structures, a walk through all the cuts is imperative. Note particularly the lack of correlation of structures on either side of the road at C (Fig. 6). These blocks may have developed first as large drag folds, eventually evolving into these discrete blocks as strain is concentrated on the long limbs (Fig. 7). However, many blocks do not show these rotation features, and some degree of mega-boudinage caused by extension during thrusting was probably also involved.

Augen gneiss, blastomylonitic gneiss, mylonitic schist and mylonite are present in order of decreasing abundance in these rocks. The highest grade assemblages are best preserved in the augen gneisses inside the tectonic blocks (e.g. eastend, face A, Fig. 6). In the shear zones surrounding and cutting these blocks kyanite-bearing lower grade assemblages occur as blastomylonitic schist and gneiss (face B and locality 1, if not collected out) Still lower grade slabby mylonitic schists are well exposed on the natural cliff face at D, south of the road. True mylonites are rare, but late, fine grained, middle to lower greenschist facies mylonite 2 cm thick is present in the steeply west dipping shear zone which cuts the entire exposure at 2. This shear zone demonstrates that macroscopically ductile deformation persisted to these low grade conditions. A brittle fracture zone occurs at 3, where the K-feldspar-chlorite-epidote bearing assemblage reflects very shallow, alteration of this zone. Finally chlorite-rich slickensided joint surfaces dipping steeply N-NW commonly cut all these rocks.

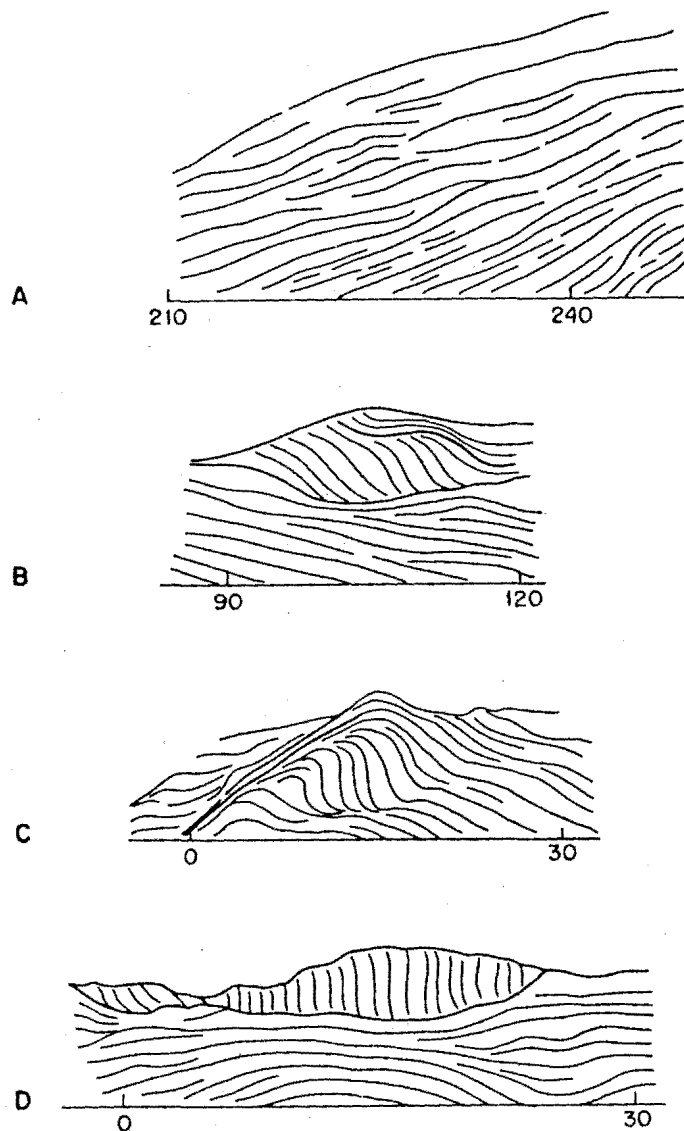

Fig. 7. Possible stages of evolution of a tectonic block from Wintsch (1979): a structure characteristic of the Willimantic fault. Figs. A through D were traced from north facing photographs and can be seen at localities 4, 2, 9 and 6 respectively of Fig. 6. The sequence suggests that these blocks develop as drag folds during thrusting from west to east. Other structures (face a, Fig. 6) suggest that boudinage may also be important.

Several other rock types are present in these cuts. Interlayered in the blastomylonite are at least 28 distinct amphibolite layers, all boudinaged (east end, face A). Successive boudinage of a large amphibolite boudin at its tapering neck can be seen at 4 (Fig. 6). Several 30-50cm thick layers of marble are present at 5. Diopside

is present in some of this marble, and we have collected hornblende porphyroblasts up to 10cm in diameter from the margins of one of these. A 2m diameter pod of ultramafic rock, now chlorite-talc schist is present at 6.

Mineral lineations are common in these rocks, and are usually defined by sillimanite needles and biotite streaks which plunge gently N50°W. Wintsch (1979) proposed that a 10° counterclockwise rotation of mineral lineation orientations existed in these rocks. Since then, clockwise rotations have been identified in the Putnam area (Hudson, 1982), along the Honey Hill fault and in the Deep River area (Wintsch, unpub. data). North bearing lineations are very well developed in the relatively rare greenschist facies mylonitic schists in the natural exposures at D (Fig. 4). This shows that thrusting to the SE under amphibolite facies conditions was followed by thrusting to the S under greenschist facies conditions. Thus the same clockwise rotation of compression direction identified in other areas is also present here.

Strain induced metamorphic reactions are common in these rocks. As at stop 4, the reequilibration of high grade assemblages to lower grades in discrete shear zones is wide spread. Most conspicuous in these rocks is the development of orthoclase and plagioclase porphyroblasts in blastomylonites and augen gneiss. These fit all the criteria outlined by Wintsch (1975) for syntectonic, strain induced growth.

The occasional inclusion of kyanite blades in microcline is significant. Reference to the retrograde metamorphic path of Fig. 2 shows that these porphyroblasts must have developed at conditions less than the Al_2SiO_5 triple point: conditions much too low for melting to have been involved. Moreover, the equilibrium:

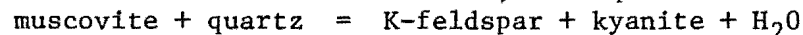

provides an upper limit to the a_{H_2O} which was present at the time of porphyroblast development. The stability of muscovite + quartz (calculated from the data in Helgeson et al 1978) is contoured for a_{H_2O} (standard state = P, T of the real gas). If the triple point of Holdaway (1971) is adopted, the maximum a_{H_2O} in these shear zones is seen to be 0.10, reflecting a fugacity of 80 b out of the possible 800 b of pure H_2O at these P-T conditions. It is not likely that an aqueous fluid was diluted by CO_2 because carbonates are rare in these shear zones, and fluids of a low oxygen fugacity may be ruled out by the presence of hematite in some of these shear zones. We cannot conceive of any other gases which could have been present in the necessary amounts and leave no trace on the assemblage. We are thus forced to the conclusion that a fluid 'phase' as such was not present during the retrogression of these shear zones - only an aqueous intergranular film. Because of this significance of the occurrence of kyanite + K-feldspar, we would be grateful if all discoveries of this assemblage on this trip would be brought to our attention.

Many other topics can be discussed at this stop. Is there evidence for boudins or fold axis rotation in these rocks? Is the rock forming the antiformal structure at 7 a candidate for the steady state foliation of Means (1981)? What is the relationship between the kyanite in the schists and the kyanite in the veins at 1 and 8 (Fig. 6)? What are the implications of the low activity of H_2O on the generation of the pegmatite veins? Return to cars.

- 19.8 Proceed east on I-84 for a last look at the tectonic blocks.
- 21.7 Exit at Rt. 32 to return to pick up cars at Willimantic Plaza. Take Rt. 32 to I-86 for points east and west. Continue on I-84 to Rt. 195 exit to reach University of Connecticut.

Acknowledgements. We are grateful to many friends for help and encouragement in this project, especially H.R. Dixon and M.H. Pease, Jr. Some of this work was supported by the Department of Geology, Indiana University. The Department of Geology, University of Connecticut kindly provided access to core samples from the Willimantic dome. We are grateful to Ray Joesten for preparing the road log in our absence, and to L. Enoch, Department of Earth Sciences, University of Leeds, and to K. Wolfe and L. Musiker of the University of Connecticut for help in manuscript preparation.

REFERENCES

- Day, H.W., Brown, V.Max., Abraham, Kurt., 1980. Precambrian (?) crystallization and Permian (?) metamorphism of hypersolvus granite in the Avalonian terrane of Rhode Island. *Geol. Soc. America Bull.* 91, p. 389-391; p. 1669-1741.
- Dixon, H.R., 1964. The Putnam Group of eastern Connecticut. *U.S. Geol. Survey Bull.* 1194-C, p. C1-C12.
- Helgeson, H.C., Delaney, J.M., Nesbitt, H.W., Bird, D.K. 1978. Summary and critique of the thermodynamic properties of rock-forming minerals. *Am. Jour. Sci.*, 278A, 229p.
- Holdaway, M.J., 1971. Stability of andalusite and sillimanite and the aluminium silicate phase diagram. *Am. Jour. Sci.* 271, 97-131.
- Hudson, M.R. Ms., 1982. Mineralogy, petrology and structure of the Tatnic Hill Formation, Putnam, Connecticut. M.A. Thesis, Indiana Univ. 30lp.
- Means, W.D. 1981. The concept of steady state foliation. *Tectonophysics*, 78, p. 179-200.
- Richardson, S.W., Gilbert, M.C., and Bell, P.M., 1969. Experimental determination of kyanite-andalusite and andalusite-sillimanite equilibria; the aluminium silicate triple point. *Am. Jour. Sci.* 267, p. 259-272.

- Snyder, G.L., 1964. Bedrock Geology of the Willimantic Quadrangle, Connecticut. U.S. Geol. Survey, Geol. Quad. Map G Q 335, Scale 1:24,000.
- Snyder, G.L., 1967. Bedrock Geologic map of the Columbia Quadrangle, east-central Connecticut. U.S. Geol. Survey, Geol. Quad. Map G Q 592, Scale 1:24,000.
- Tullis, J.A., and Yund, R.A., 1980. Hydrolytic weakening of experimentally deformed Westerly granite and Hale albite rock. *J. Structural Geol.* 2, 439-451.
- Whitney, J.A., Stormer, J.C. Jr., 1977. The distribution of $\text{NaAlSi}_3\text{O}_8$ between coexisting microcline and plagioclase and its effect on geothermometric calculations. *Am. Min.* 62, 687-691.
- Wintsch, R.P. 1975. Feldspathization as a result of deformation. *Geol. Soc. America Bull.* 85, p. 35-38.
- Wintsch, R.P. 1979. The Willimantic fault: a ductile fault in eastern Connecticut. *Am. Jour. Sci.*, v. 279, p. 367-393.
- Wintsch, R.P. 1981. Syntectonic Oxidation. *Am. Jour. Sci.* 281, p. 1223-1239.
- Wintsch, R.P., and Grant, N.K., 1980. Major element, rare earth element and Sr isotope geochemistry of "Monson gneisses", eastern Connecticut (abstr.). *Geol. Soc. Am. Abstr. Programs.* v. 12, p. 89.

1
2
3
4
5
6
7
8
9
10
11
12
13
14
15
16
17
18
19
20
21
22
23
24
25

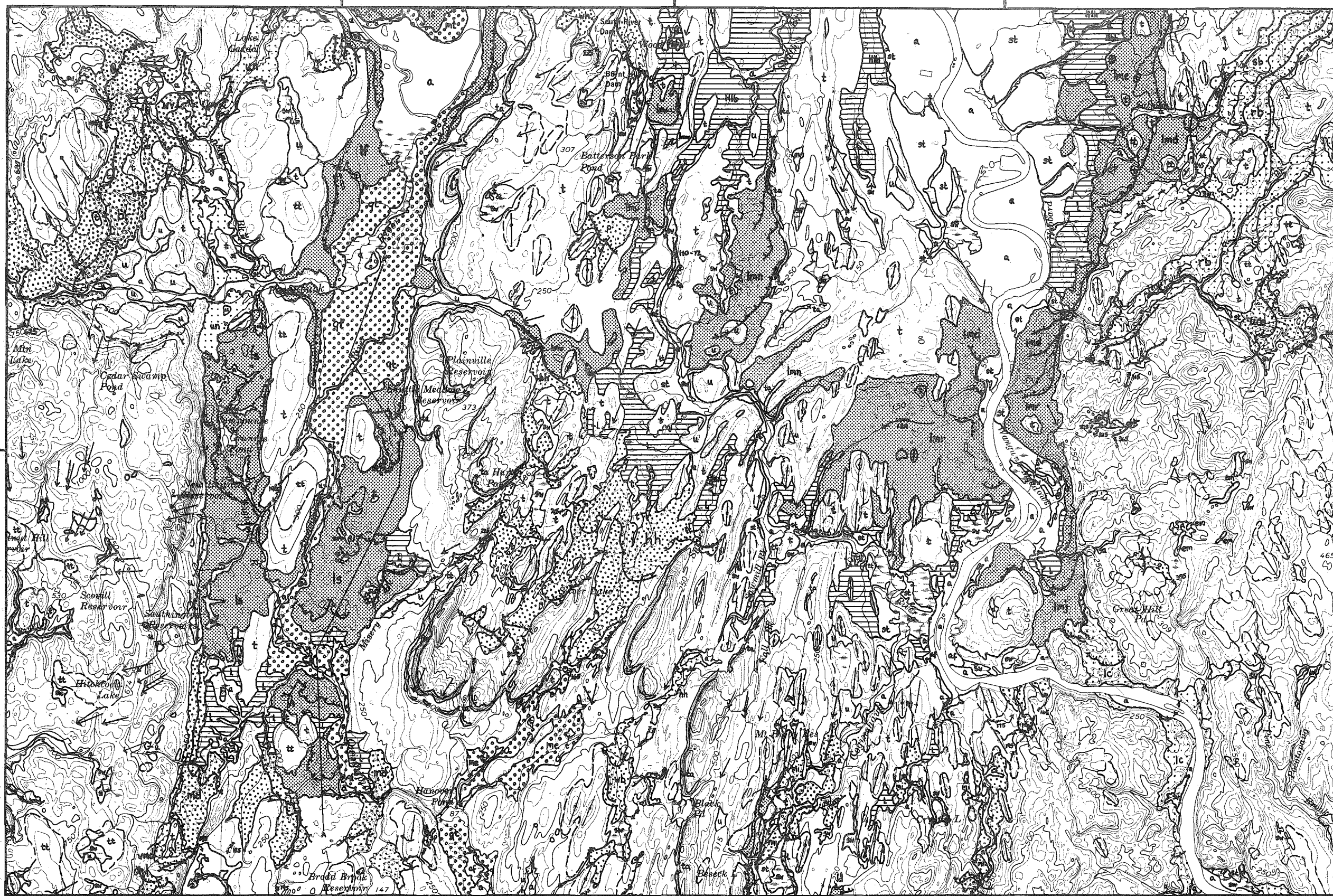

Correlation chart

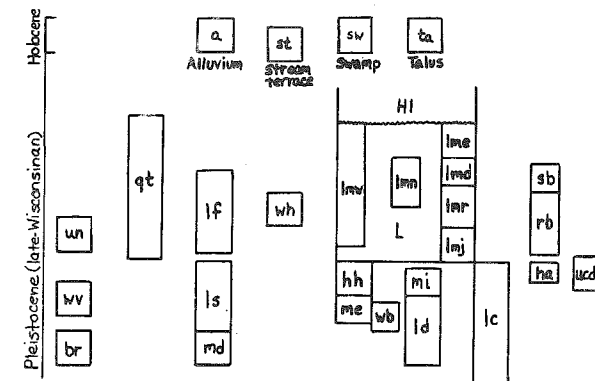

DEPOSITS OF MAJOR GLACIAL LAKES IN LOWLANDS

- ls glacial Lake Southington
- lf glacial Lake Farmington
- ld glacial Lake Durham
- lm glacial Lake Middletown
- lmj Jobs Pond deltas
- lmr Cromwell deltas
- lmd Dividend Bk stage deltas
- lme eastern margin deltas
- lmn Newington deltas
- lmw western margin deltas
- Hl glacial Lake Hitchcock
- Hhh high-level Hockanum delta
- Hlh low-level Hockanum delta

DEPOSITS OF ICE-MARGINAL PONDS IN NORTH-DRAINING VALLEYS IN UPLANDS

- br Bristol delta complex
- wv Whigville deposits
- md Mill R. Divide delta deposits
- wh West Hartford deltas
- hh Hanging Hills deltaic complex
- wb Willow Bk. deposits
- ucd upper Conn. R. Divide deposits
- mi south Middletown deposits
- ha Hales Bk. deposits
- p uncorrelated

DEPOSITS OF GLACIOLACUSTRINE-GLACIOFLUVIAL SYSTEMS IN SOUTH-DRAINING VALLEYS

- lc lower Conn. R. deposits
- un Unionville deposits
- rb Roaring Bk. deposits
- sb Salmon Bk. deposits

DEPOSITS OF GLACIOFLUVIAL SYSTEMS

- qt Quinnipiac valley terrace
- me Meriden deposits

LAKE-BOTTOM DEPOSITS

- Hlb Lake Hitchcock clays
- l lake-bottom deposits of Lakes Southington, Farmington, Durham and Middletown

Figure 1. Preliminary Quaternary geologic map of the Bristol, New Britain, Hartford South, Glastonbury, Southington, Meriden, Middletown, and Middle Haddam quadrangles, central Connecticut; scale 1:125,000.

(from Trip Q1, The surficial geologic maps of Connecticut illustrated by a field trip in central Connecticut by J.R. Stone, J.P. Schafer, and E.H. London; Connecticut Geological and Natural History Survey Guidebook 5.)

- Map Symbols
- direction of striae
 - drumlin axis
 - meltwater channel
 - ice-margin position, ticks point up ice
 - glacial lake spillway, altitude in feet

OTHER MAP UNITS

- t till and bedrock
- tt thick till (>5m)
- u undifferentiated stratified deposits
- em Meshomasic end moraine
- af artificial fill

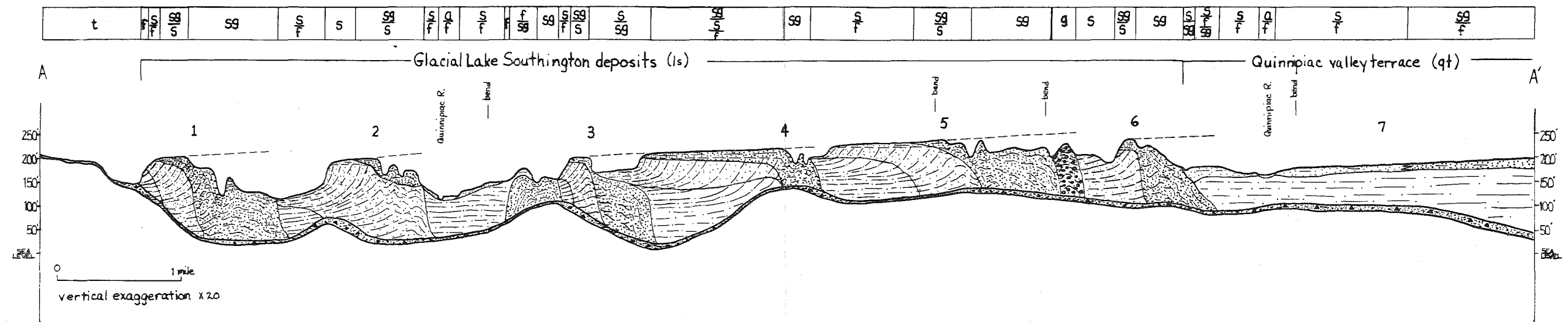
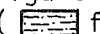



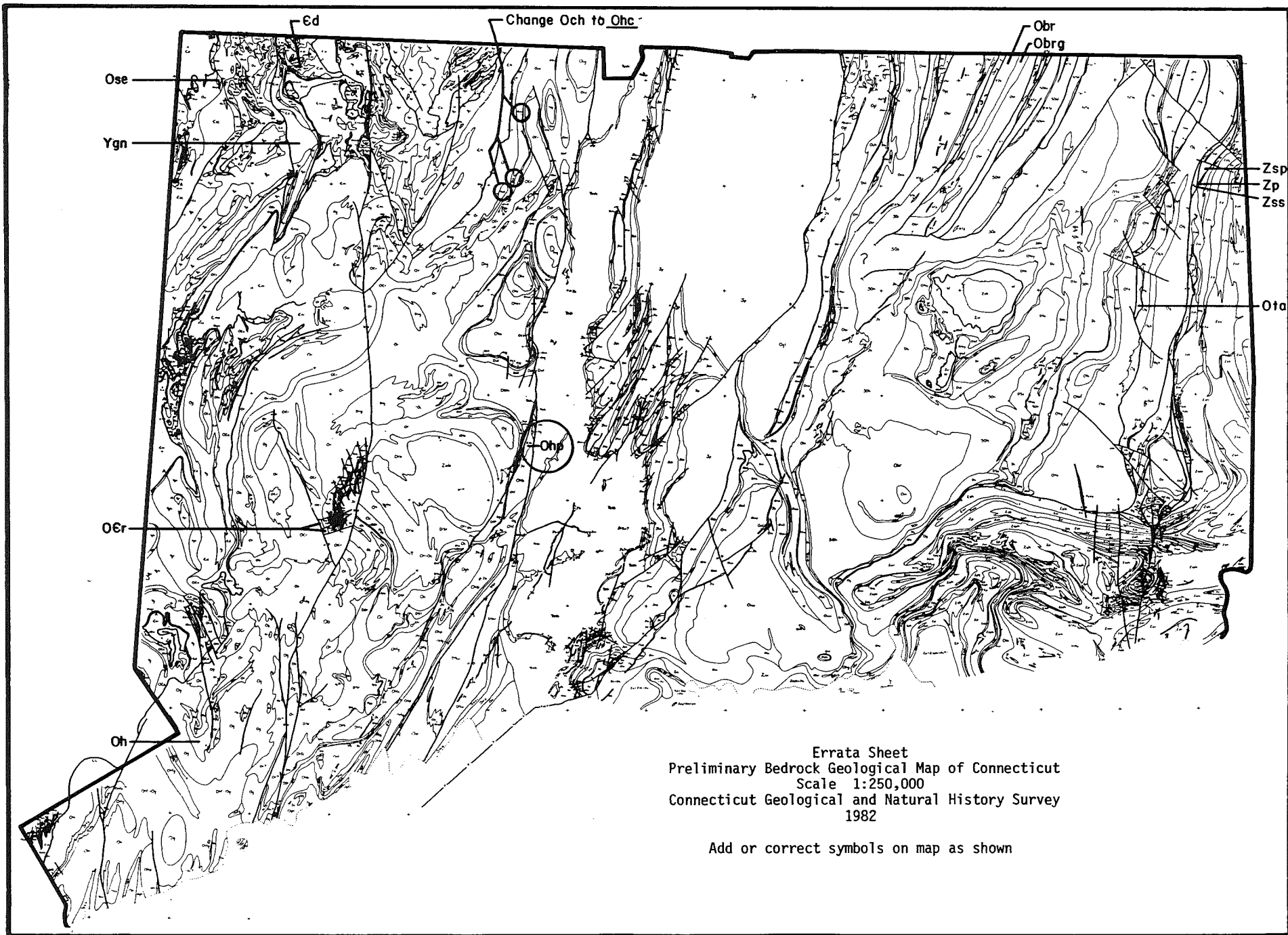

Figure 2. Longitudinal section in the upper Quinnipiac River valley. See section line A-A' in figure 1. Section shows texture ( fines,  sand,  sand and gravel,  gravel) and bedding (schematically by dashed lines) in seven morphosequences. The distribution of subsurface textures is based on close point data control from more than 150 test hole and well logs (Haeni and Anderson, 1980; Mazzaferro, 1973). This section crosses six ice-contact deltaic sequences (numbered in chronologic order of deposition from south to north) deposited in glacial Lake Southington. Dashed tangential lines reconstruct probable gradients of fluvial topset surfaces prior to collapse. The ice-contact forms at north ends and free-front delta slopes at south ends, and the textural gradation from coarse at the ice-contact head to fine at the distal end of each morphosequence, indicate separate depositional events during which sediment came from the stagnant zone of the ice margin, which systematically retreated northward. Bar across top of section indicates surficial materials map units along the line of this section: g = gravel, sg = sand and gravel, s = sand, f = fines, a = alluvium, t = till and bedrock. Read stack units such as $\frac{sg}{s}$ as sand and gravel overlying sand.



EXPLANATION

<p>WESTERN HIGHLANDS</p> <p>CONNECTICUT VALLEY SYNCLINORIUM</p> <p>INDIGENOUS AND CAROLINIAN SHELF SEQUENCE</p> <p>STRATIFIED ROCKS</p> <p>PROTEROZOIC BASIS (CHUREVILLE TERRANE)</p>	<p>CENTRAL LOWLANDS</p> <p>HARTFORD AND POMPERAUG MESOZOIC BASINS</p> <p>BRONSON HILL ANTECLINORIUM</p> <p>MERRIMACK SYNCLINORIUM</p> <p>INTRUSIVE ROCKS</p> <p>AVALLONIAN TERRANE</p>	<p>EASTERN HIGHLANDS</p> <p>AVALLONIAN TERRANE</p>
--	--	--

SYMBOLS

<p>Intensive rocks</p> <p>Stratified rocks</p> <p>Basement rocks</p> <p>Basement rocks with mafic dykes</p> <p>Basement rocks with mafic dykes and granitic intrusions</p> <p>Basement rocks with mafic dykes and granitic intrusions and mafic sills</p> <p>Basement rocks with mafic dykes and granitic intrusions and mafic sills and mafic sills</p> <p>Basement rocks with mafic dykes and granitic intrusions and mafic sills and mafic sills and mafic sills</p> <p>Basement rocks with mafic dykes and granitic intrusions and mafic sills and mafic sills and mafic sills and mafic sills</p>	<p>Basement rocks with mafic dykes and granitic intrusions and mafic sills and mafic sills and mafic sills and mafic sills</p> <p>Basement rocks with mafic dykes and granitic intrusions and mafic sills and mafic sills and mafic sills and mafic sills</p> <p>Basement rocks with mafic dykes and granitic intrusions and mafic sills and mafic sills and mafic sills and mafic sills</p> <p>Basement rocks with mafic dykes and granitic intrusions and mafic sills and mafic sills and mafic sills and mafic sills</p> <p>Basement rocks with mafic dykes and granitic intrusions and mafic sills and mafic sills and mafic sills and mafic sills</p> <p>Basement rocks with mafic dykes and granitic intrusions and mafic sills and mafic sills and mafic sills and mafic sills</p>	<p>Basement rocks with mafic dykes and granitic intrusions and mafic sills and mafic sills and mafic sills and mafic sills</p> <p>Basement rocks with mafic dykes and granitic intrusions and mafic sills and mafic sills and mafic sills and mafic sills</p> <p>Basement rocks with mafic dykes and granitic intrusions and mafic sills and mafic sills and mafic sills and mafic sills</p> <p>Basement rocks with mafic dykes and granitic intrusions and mafic sills and mafic sills and mafic sills and mafic sills</p> <p>Basement rocks with mafic dykes and granitic intrusions and mafic sills and mafic sills and mafic sills and mafic sills</p> <p>Basement rocks with mafic dykes and granitic intrusions and mafic sills and mafic sills and mafic sills and mafic sills</p>
--	---	---

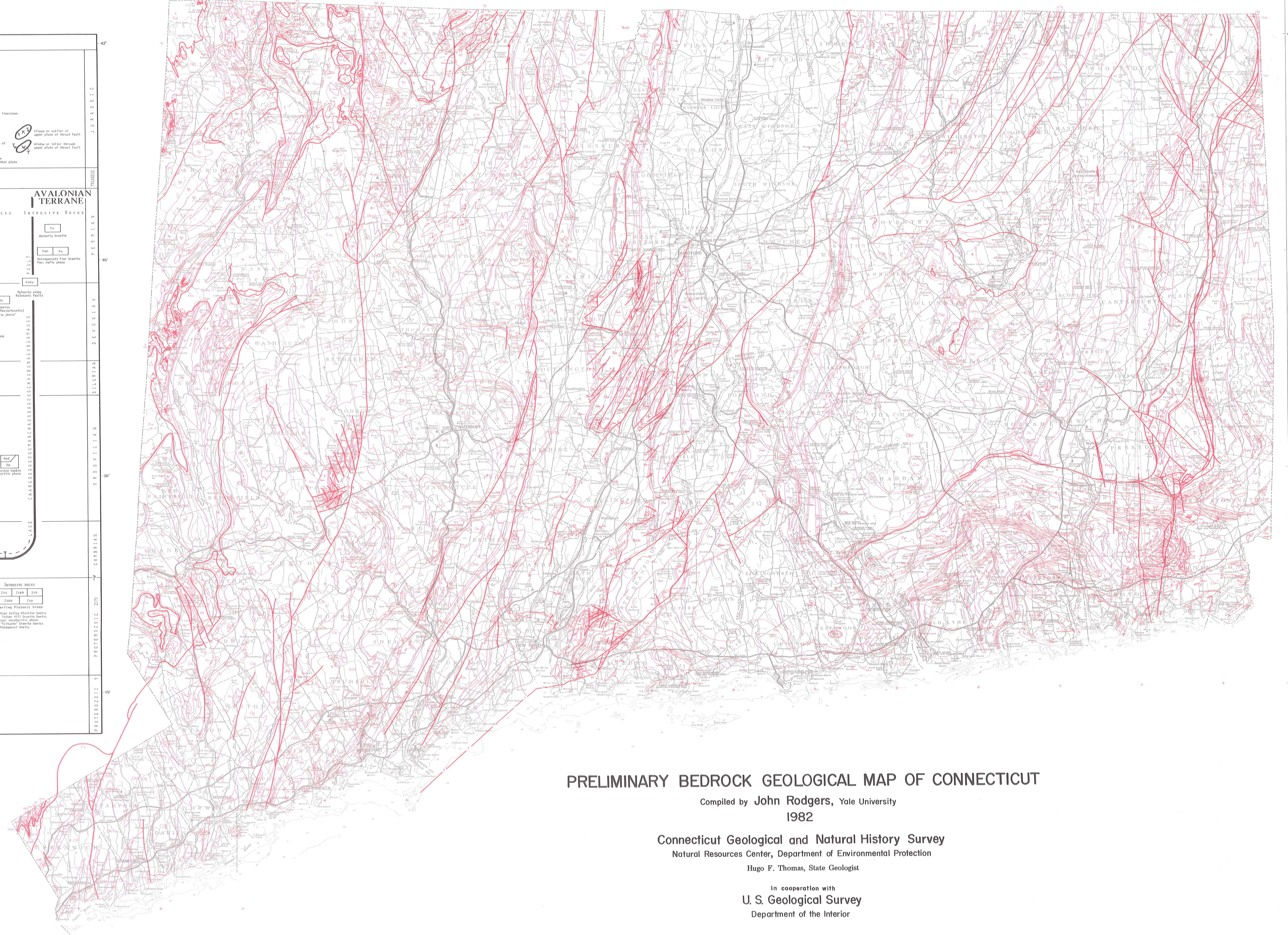

PRELIMINARY BEDROCK GEOLOGICAL MAP OF CONNECTICUT
 Compiled by John Rodgers, Yale University
 1982
 Connecticut Geological and Natural History Survey
 Natural Resources Center, Department of Environmental Protection
 Hugo F. Thomas, State Geologist
 In cooperation with
 U. S. Geological Survey
 Department of the Interior

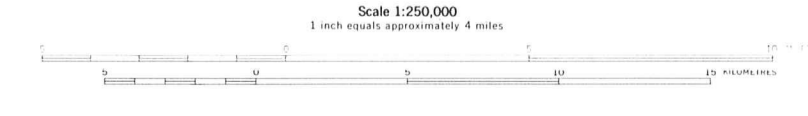

NOTE

This preliminary map is the final draft of the state bedrock geological map that is being prepared as a full color publication. The colored map will include supporting information such as: description of map units, cross sections, and references. This information is on file and may be inspected at the State Survey office. Most of the map compilation is based on published quadrangle geological maps and reports that are listed in the *List of Publications* which is available from Connecticut Geological and Natural History Survey, Department of Environmental Protection, State Office Building, Hartford, Connecticut 06106.