

2020 Connecticut State Building and Fire Codes

Find the most current schedule at <https://portal.ct.gov/DASCodeChange>

Completed: 2020 Amendments Drafted and Code Change Proposals Received

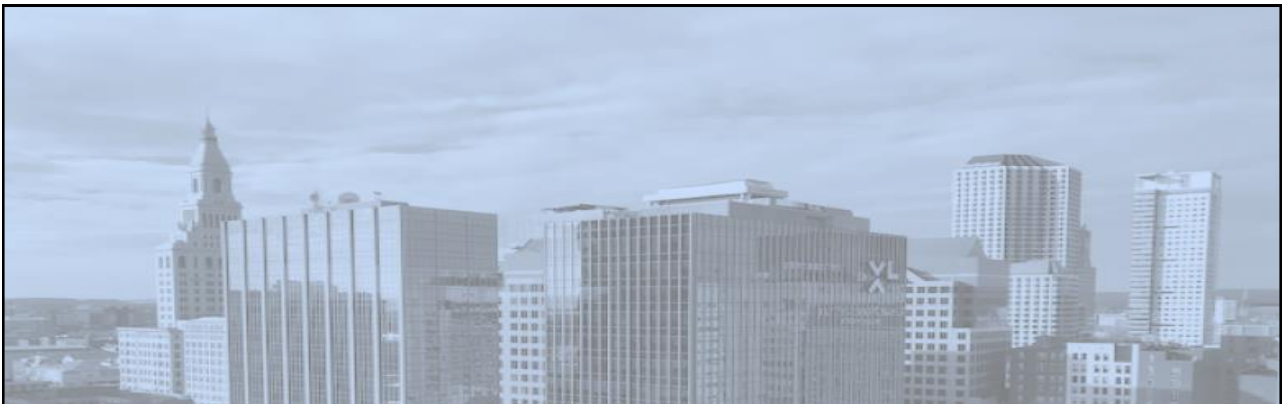
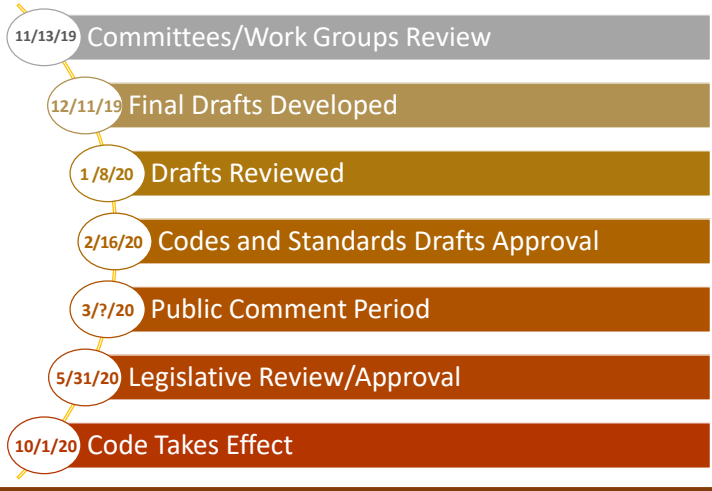

From Soup to Nuts: 2020 State Building Code Updates

Spring 2020 Career Development Series

Darren Hobbs, Manager of Technical Services
Office of the State Building Inspector

DAS Office of Education and Data Management



Introduction

- About the Office of the State Building Inspector
- Why building inspectors are needed
- Why we change the code so often
- Proposed 2020 SBC
 - IBC, IRC, IPC, IMC, NEC portions

About OSBI



What We Do

- **State Construction** – Plan Review & Inspections
- **State Building Code** Adoption
- **Modifications**, accessibility exemptions etc.
- **Town Assists, Daily telephone & e-mail** support
- **Educational events**
- **Elevator**, escalator etc. inspections
 - 29-191 – 29-215 of the CTGS
- **Boiler**, hot water heater etc. inspections
 - 29-232 – 29-244 of the CTGS

The OSBI Team

- Joe Cassidy
- Darren Hobbs



- Paul Bette
- William Hannon
- Michael Fuschi
- Colin Jefferies
- Vishnu Khade
- David Kopjanski
- Mark Leone
- Scott Phelps
- John Tye

- **Plus:**
 - Elevator team (8)
 - Boiler team (3)



Doing Business With Us

- **Joe Cassidy's e-mail on 2/26/20 – did you all receive it?**
- **OSBI Modifications, interpretations etc:**
 - E-Mail to: DAS.OSBI@ct.gov (preferred method)
 - Fax: 860-713-7410 (poor quality)
 - Mail: No need to mail if you have e-mailed / faxed it
- **Calls: 860-713-5900**
- Joseph.Cassidy@ct.gov / Darren.Hobbs@ct.gov

OSBI Web Page

- State Building Code
 - Past & Present
- Mod forms etc.
- Enforcement letters
- State Building Inspector Advisories
- Code Changes / Adoption
- Links to OEDM content

<https://portal.ct.gov/DAS/Office-of-State-Building-Inspector/Office-of-State-Building-Inspector>

OSBI Quick Links

| | |
|---|---|
| State Building Inspector <ul style="list-style-type: none"> • State Building Code • Safety Code for Elevators and Escalators • Safety Code for Boilers and Hot Water Heaters • State Building Inspector Advisories / Memos • Contact Us | Connecticut State Building Code <ul style="list-style-type: none"> • 2018 State Building Code • 2016 State Building Code • Prior State Building Codes • Model Codes • Draft Abatement Letters |
| Modifications and Interpretations <ul style="list-style-type: none"> • Building Code Modifications • Building Code Interpretations • Accessibility Exemptions (Waivers) • Lift / LULA approvals • State Building Inspector Advisories / Memos | Codes and Standards Committee <ul style="list-style-type: none"> • Codes and Standards Committee • Codes Amendment Subcommittee • Appeals |
| State Construction Oversight <ul style="list-style-type: none"> • Plan Review and Inspection by OSBI | Related Agencies <ul style="list-style-type: none"> • Office of the State Fire Marshal • Office of Education and Data Management • Department of Consumer Protection |
| Building Officials <ul style="list-style-type: none"> • List of Building Officials By Town • Licensing of Building Officials • Continuing Education of Building Officials • Check Your CE Credits (for Building Officials & Fire Marshals) | Related Resources <ul style="list-style-type: none"> • Connecticut Fire Safety and Fire Prevention Codes • Contractor licensing • eLicense Lookup • CONCORD Business Lookup |



Why Building Inspectors Are Needed

When you need a permit
to build a deck, but
not to store a boat.



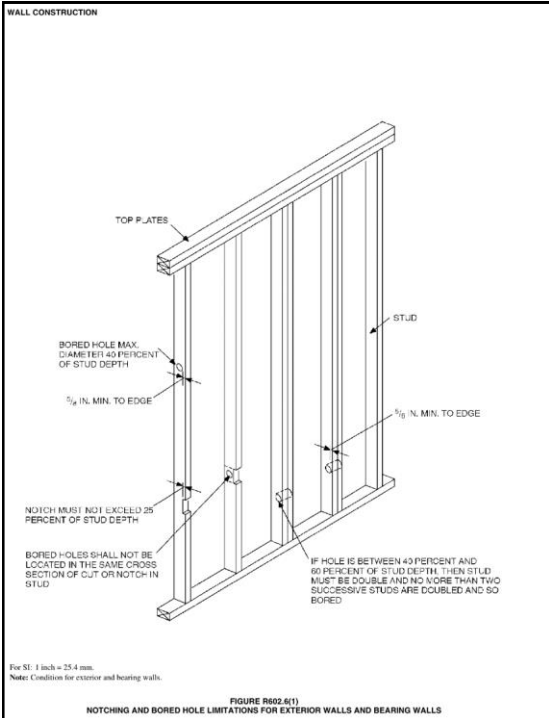

P2603.2.1 Protection against physical damage.

...less than **1 1/4 inches (31.8 mm)** from the nearest edge of the member...

Such plates shall cover the area of the pipe where the member is notched or bored, and shall extend not less than 2 inches (51 mm) above sole plates and below top plates.

Note:
Mechanical section of residential code says: "...less than 1 1/2 inches..."

TOP PLATE

2" Below Top Plate



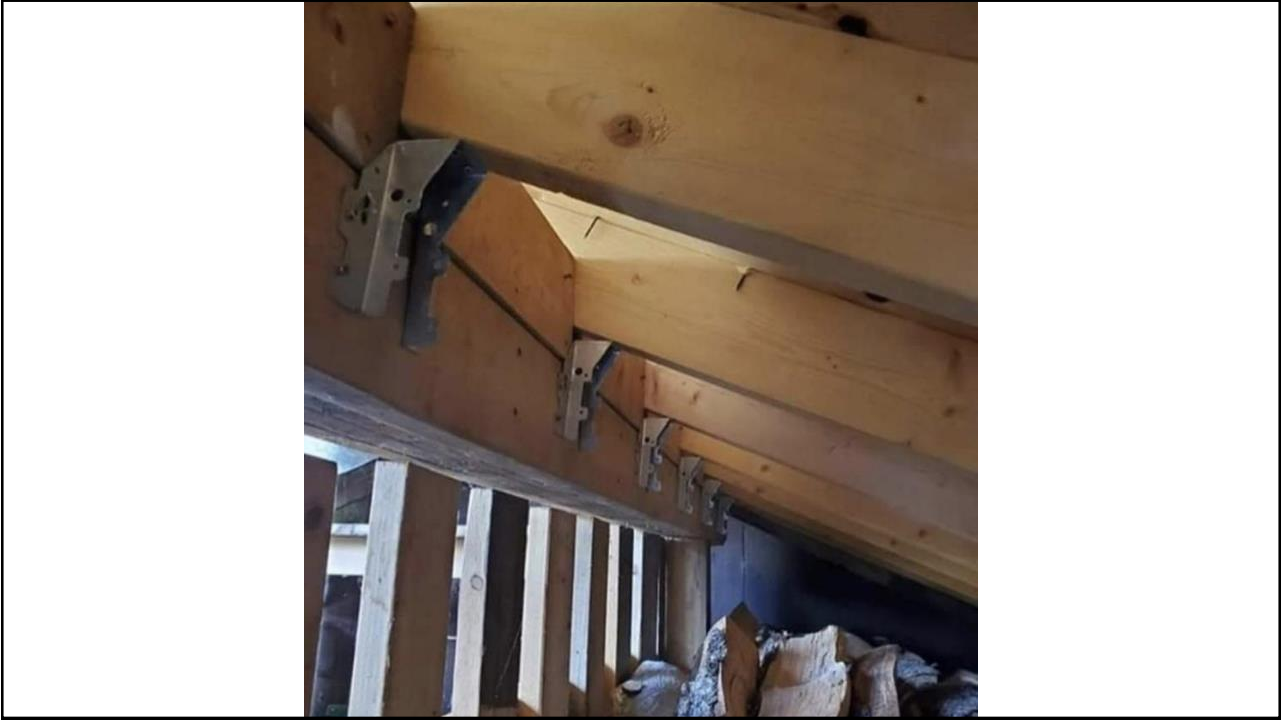





Building Ready for TCO?

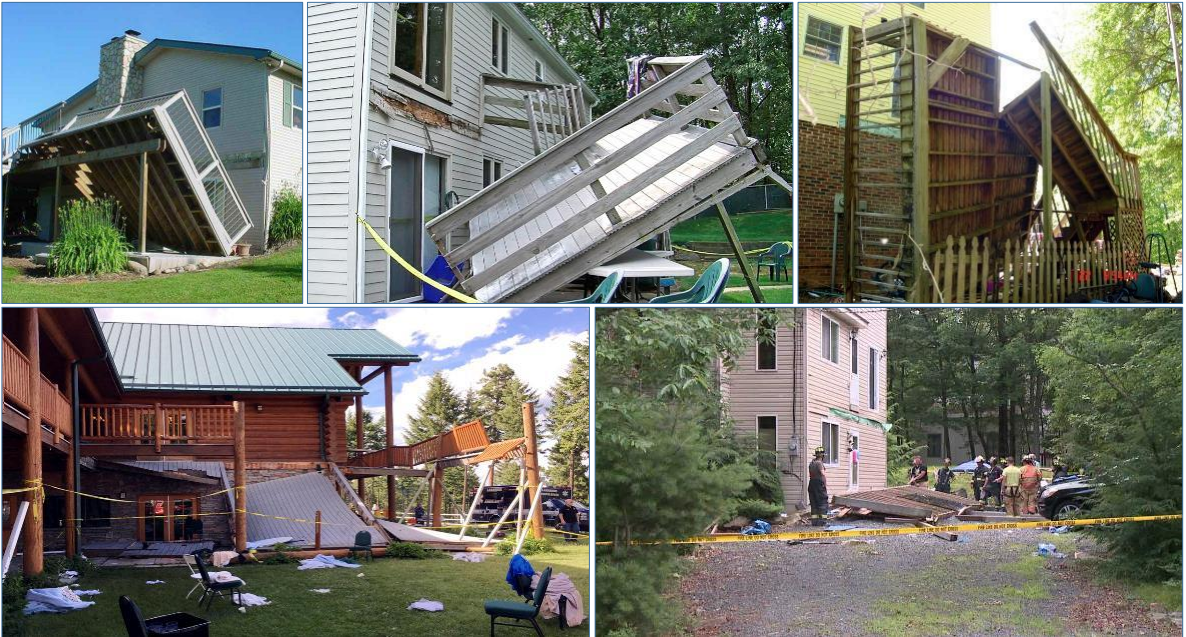



5.8 quake hits Va.; Felt along U.S. East Coast

AUGUST 23, 2011 / 9:48 PM / CBS/AP



MINERAL, Va. - The most powerful earthquake to strike the East Coast in 67 years shook buildings and rattled nerves from South Carolina to Maine on Tuesday. Frightened office workers spilled into the streets in New York, and parts of the White House, Capitol and Pentagon were evacuated.

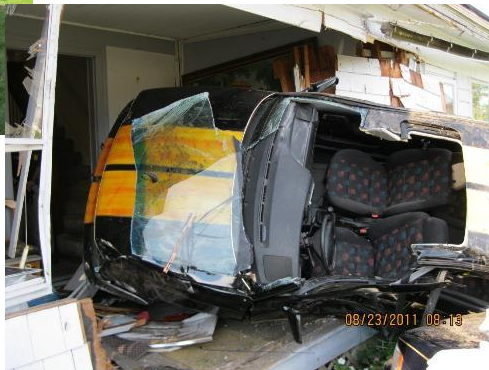

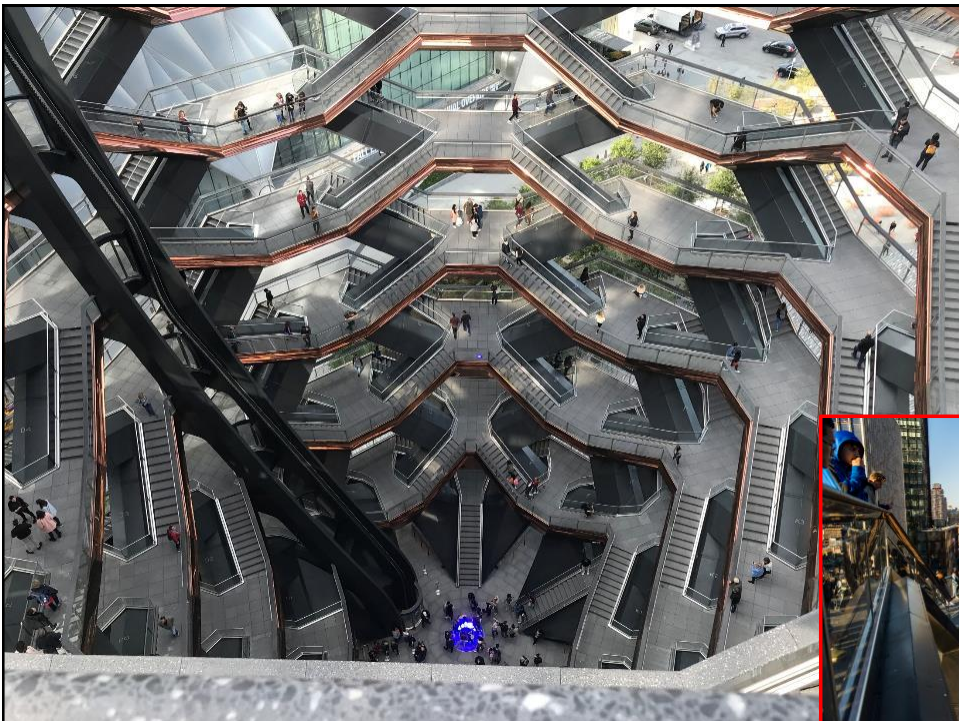

“Vessel”, NYC

- 16 stories
- 150-foot high
- 154 flights
- 1-mile of stairs
- 2,500 steps
- 80 landings



NYC Lawmakers Pushing To Overturn 1948 Law, Allow Drones To Do Building Inspections

December 22, 2019 at 7:56 pm

Filed Under: [Dave Carlin](#), [Drones](#), [Eric Adams](#), [Erica Tishman](#), [Justin Brannan](#), [Local TV](#), [New York City Council](#), [NYC Department of Buildings](#)



Refreshers

Exempt Work

- Exempt Work – 105.2
- Exempt from permit requirements
 - “Permits shall not be required...”
- No building permit required, no building permit fee payable.
- Must still meet code though.



Who Can Pull Permits?

- Owner in fee or their authorized agent.
 - 29-263, 105.3.3
- Does not need to be licensed contractor.
- If it is a licensed contractor...
 - CGS sec. 20-338b Contractor Permit Application
 - Licensed contractor may sign application as authorized agent.
 - May further delegate application signature.
 - Proper documentation.
- Home improvement contractor
 - CGS Ch.400

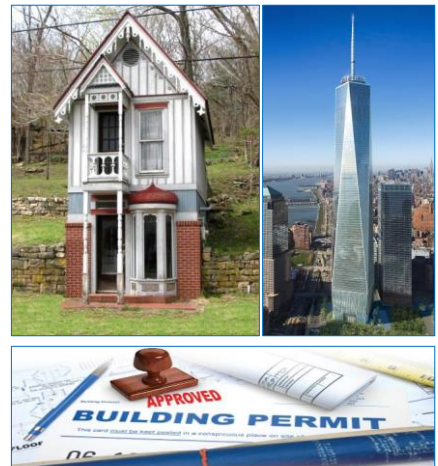

Who Can Do The Work?

- Single family, owner occupied (or intended to be)
 - Owner, all trades
 - House flippers?
 - If contractor hired for trades, must be licensed.
 - CGS 20-340
- All other situations
 - Trades work requires licensed contractor
- Department of Consumer Protection matter.
 - Building Officials are eyes and ears on ground.

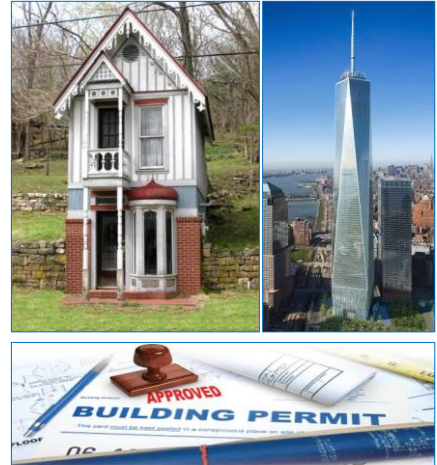

Violations & Penalties

- Procedural or technical
- Connecticut General Statutes
 - 29-254(a) Fine for violation of SBC
 - \$200-\$1000, and/or
 - 6 months of license plate fabrication duties
- Work without permit is a violation of SBC
 - “Double Fee” penalty not permissible
- Written notice ----> Prosecution
 - Form letters provided on DAS web site



Why We Change The Code So Often

Statutory Basis

- Statewide CT building code since September 1st, 1971
 - 1971, 1978, 1987, 1989, 1994, 1999, 2005, 2016, **2018**... 2020
- CT General Statute 29-252 / 29-252 (a) requires that:
 - Shall be “recognized model code”
 - The code shall be revised as deemed necessary to incorporate any subsequent revisions to the code **not later than eighteen months** following the date of first publication of such subsequent revisions to the code.
 - Authorization to make amendments
 - Administrative; Geotechnical; Weather related; As prompted by legislative actions; Other matters as required



Benefits of New Model Codes

- Meeting energy conservation targets
- Improvements and clarifications in code language
- Emerging technologies, products and concepts
- 2018 ICC Codes
 - Tiny Homes
- 2021 ICC Codes
 - Shipping containers
 - 3D-printed tiny homes
 - Mass Timber



Code Evolution



3D-Printed Homes



Mass Timber



AMERICAN WOOD COUNCIL

<https://awc.org/tallmasstimmer>



The Current Code Change Cycle

What We Are Adopting

- **2016 State Building Code (SBC) - Previous**
 - 2012 ICC model codes: IRC, IRC, IPC, IMC, IEBC, IECC
 - 2014 National Electrical Code (NEC)
 - 2009 Accessibility Standard
- **2018 State Building Code (SBC) - Current**
 - 2015 ICC model codes: IRC, IRC, IPC, IMC, IEBC, IECC
 - 2017 National Electrical Code
 - 2009 Accessibility Standard
- **2020 State Building Code (SBC) - Proposed**
 - 2018 ICC model codes: IRC, IRC, IPC, IMC, IEBC, IECC
 - 2020 National Electrical Code (NEC)
 - 2009 Accessibility Standard



What We Are Adopting

- **2022 State Building Code (SBC) - Projected**
 - 2021 ICC model codes: IRC, IRC, IPC, IMC, IEBC, IECC
 - 2020 National Electrical Code (NEC)
 - 2009 Accessibility Standard
- **2025 State Building Code (SBC) - Projected**
 - 2024 ICC model codes: IRC, IRC, IPC, IMC, IEBC, IECC
 - 2023 National Electrical Code
 - 2009 Accessibility Standard
- **2028 State Building Code (SBC) - Projected**
 - 2027 ICC model codes: IRC, IRC, IPC, IMC, IEBC, IECC
 - 2026 National Electrical Code (NEC)
 - 2009 Accessibility Standard



When We Are Adopting It

- | | |
|-----------------------------------|------------------------|
| • Effective Date (Target): | October 1, 2020 |
| <hr/> | |
| • Draft to Codes & Standards: | November 30, 2019 |
| • Public Comment & hearing: | Winter / Spring 2020 |
| • Final draft: | Spring 2020 |
| • Legislative approval: | Spring 2020 |
| • CT Versions of IRC/IBC: | Summer 2020 |



Hot Topics in Current Connecticut Cycle

76 formal code change proposals, inc:

- Structural requirements
- Tent ballasting
- Energy code – ratings / testing / standards
- Blue wavelength light – 3,000K limit
- Electric vehicle charging for new homes
- Swing up grab bar for accessible restrooms
- NFPA 96 vs IMC

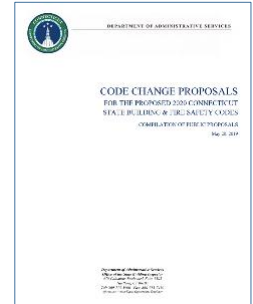

<https://portal.ct.gov/DAS/Office-of-State-Building-Inspector/Building-and-Fire-Code-Adoption-Process>

DISCLAIMER

What follows are proposed adoptions and code changes and are all subject to:

final Codes & Standards Committee approval,
a public comment review and hearing,
and legislative approval.



Code Changes

2018 International Residential Code (IRC)

Code Changes

2018 International Residential Code (IRC)

- Chapter 1 – Scope & Administration
 - **R101.2 Scope**
 - Now lists instances where IBC allows users to use IRC.
 - Not a change in scope
 - Will be amended by CT to reflect CT specifics

■ **R101.2 Scope.** The provisions of this code shall apply to the construction, *alteration*, movement, enlargement, replacement, repair, *equipment*, use and occupancy, location, removal and demolition of detached one- and two-family dwellings and *townhouses* not more than three stories above *grade plane* in height with a separate means of egress and their *accessory structures* not more than three stories above *grade plane* in height.

■ **Exception:** The following shall be permitted to be constructed in accordance with this code where provided with a residential fire sprinkler system complying with Section P2904:

1. Live/work units located in *townhouses* and complying with the requirements of Section 419 of the *International Building Code*.
2. Owner-occupied lodging houses with five or fewer guestrooms.
3. A care facility with five or fewer persons receiving custodial care within a dwelling unit.
4. A care facility with five or fewer persons receiving medical care within a dwelling unit.
5. A care facility for five or fewer persons receiving care that are within a single-family dwelling.



Code Changes

2018 International Residential Code (IRC)

- Chapter 1 – Scope & Administration
 - **R110.1 Use & Occupancy**
 - Change of occupancy definition added to Chapter 2
 - Consider the five sub-categories under the 101.2 scope

[RB] CHANGE OF OCCUPANCY. A change in the use of a building or portion of a building that involves a change in the application of the requirements of this code.

Code Changes

2018 International Residential Code (IRC)

- Chapter 2 – Definitions
 - **Access (to)**
 - That which enables a device, an appliance or equipment to be reached by ready access or by a means that first requires the removal or movement of a panel, door or similar obstruction.
 - **Ready Access (to)**
 - That which enables a device, appliance or equipment to be directly reached, without requiring the removal or movement of any panel, door or similar obstruction.

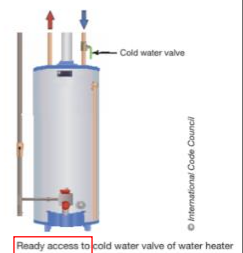
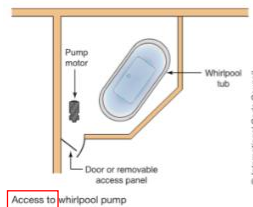

Code Changes

2018 International Residential Code (IRC)

- Chapter 2 – Definitions

- **Crawl Space (new)**

- An underfloor space that is not a basement.

- **Basement (existing)**

- A story that is not a story above grade plane. (see “Story above grade plane”)

- **Story above grade plane (existing)**

- Any story having its finished floor surface entirely above grade plane, or in which the finished surface of the floor next above is either of the following:
 1. More than 6 feet (1829 mm) above grade plane.
 2. More than 12 feet (3658 mm) above the finished ground level at any point.



Code Changes

2018 International Residential Code (IRC)

- Windborne Debris Region

- Changes in national wind speed data
 - ASCE 7-2016
 - Connecticut wind speeds lowered
 - No more wind born debris regions in Connecticut for IRC one- and two-family dwellings & townhouses (Note: IBC different)



Code Changes

2018 International Residential Code (IRC)

• Chapter 3 – Building Planning

• **R302.4.2 Membrane penetrations**

- New exception #4:
- Ceiling membrane penetrations by listed luminaires or by luminaires protected with listed materials that have been tested for use in fire-resistance-rated assemblies and are installed in accordance with the instructions included in the listing.



Code Changes

2018 International Residential Code (IRC)

• Chapter 3 – Building Planning

• **R302.5.1 Opening protection**

- Dwelling-garage opening
- Now allows use of an “automatic closing device”
- Electro-magnet hold open
- Electro-mechanical closer
- Integral or separate smoke or heat detectors

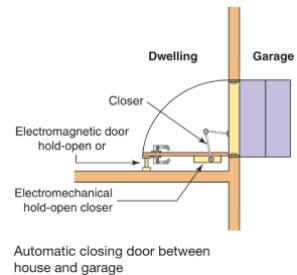

Code Changes

2018 International Residential Code (IRC)

• Chapter 3 – Building Planning

• **R302.13 Fire protection of floors**

- Exception #2 amended
- Now electric heat is a trigger for protection of floor
- *Floor assemblies located directly over a crawl space not intended for storage or for the installation of fuel-fired or electric-powered heating appliances.*

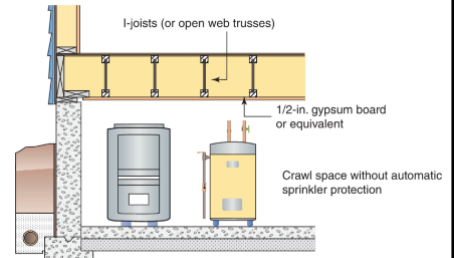

Protection required on underside of floor assembly over a crawl space with fuel-fired or electric-powered heating equipment

Code Changes

2018 International Residential Code (IRC)

• Chapter 3 – Building Planning

• **R308.4.2 Glazing adjacent to doors**

- Where the glazing is on a wall perpendicular to less than 180 degrees (3.14 rad) from the plane of the door in a closed position and within 24 inches (610 mm) of the hinge side of an in-swinging door.
- Addresses people being pushed into the adjacent glazing by the swinging doors – hence hinge side.

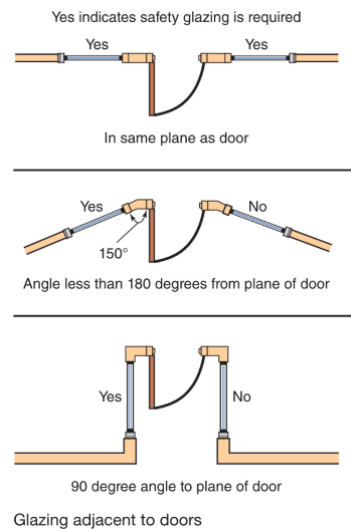

Code Changes

2018 International Residential Code (IRC)

Chapter 3 – Building Planning

- **R311.7.8.2 Handrail projection.** Handrails shall not project more than 4 ½ inches (114 mm) on either side of the stairway.
 - **Exception:** Where nosings of landings, floors, or passing flights project into the stairway reducing the clearance at passing handrails, handrails shall project **not more than 6 ½ inches** (165 mm) into the stairway, provided that the stair width and handrail clearance are not reduced to less than that required.

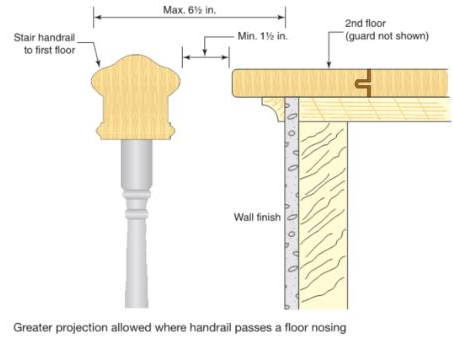

Code Changes

2018 International Residential Code (IRC)

Chapter 3 – Building Planning

- **R311.7.3 Vertical rise.** A flight of stairs shall not have a vertical rise larger than **~~147~~ 151 inches** (~~3734~~ 3835 mm) between floor levels or landings.
 - 10' ceilings
 - Open plan layouts
 - Longer spans
 - Deeper joists

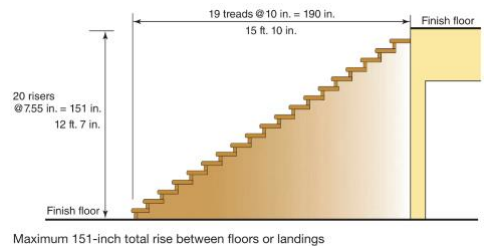

Code Changes

2018 International Residential Code (IRC)

- Chapter 3 – Building Planning
 - **R311.7.11 Alternating tread devices.**
 - Not normally permitted to be used as part of the means of egress
 - New exception allows their use as follows:
 - *Alternating tread devices are allowed to be used as an element of a means of egress for lofts, mezzanines, and similar areas of 200 gross square feet (18.6 m²) or less where such devices do not provide exclusive access to a kitchen or bathroom.*

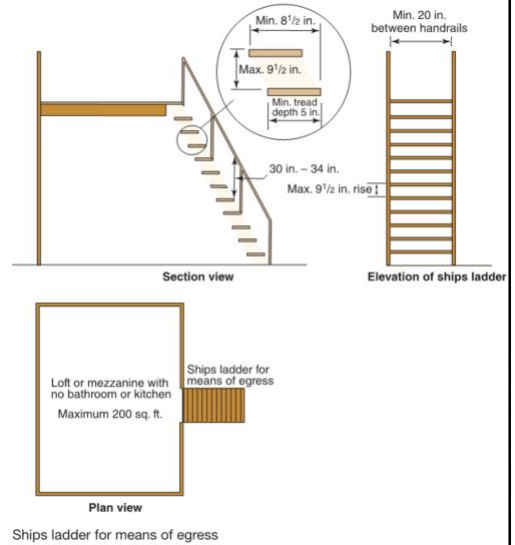

Code Changes

2018 International Residential Code (IRC)

- Chapter 3 – Building Planning
 - **R311.7.12 Ships ladders.**
 - Not normally permitted to be used as part of the means of egress
 - New exception allows their use as follows:
 - *Ships ladders are allowed to be used as an element of a means of egress for lofts, mezzanines, and similar areas of 200 gross square feet (18.6 m²) or less where such devices do not provide exclusive access to a kitchen or bathroom.*

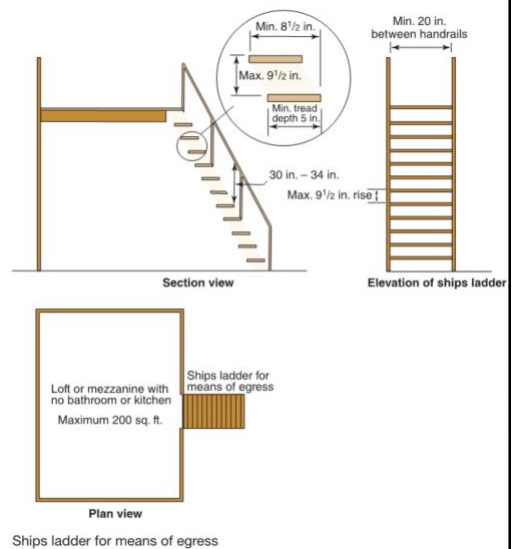

Code Changes

2018 International Residential Code (IRC)

- Chapter 3 – Building Planning
 - **R312.1 Guards**

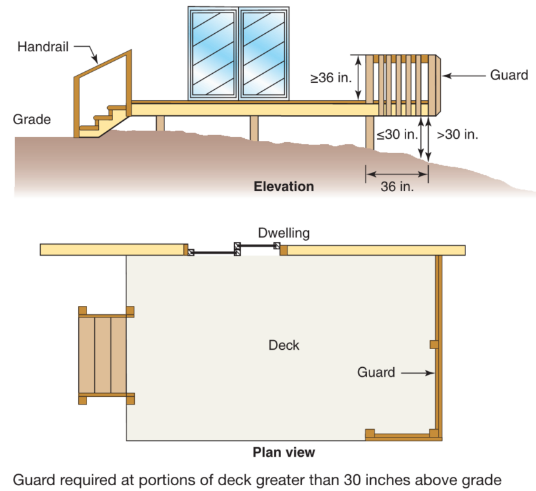

Code Changes



2018 International Residential Code (IRC)

- Chapter 3 – Building Planning
 - **R325.6.1 Habitable attic dormers**
 - **Current (2018) SBC code** reads if you add a dormer of any size to an attic, it makes it a story.
 - **Model code** would allow any size dormer without making attic a story.
 - **Draft 2020 SBC** proposes allowing 50% dormers before considering attic a story.

Proposed 2020 SBC, 2018 IRC Amd:

*(Add) **R325.6.1 Habitable attic dormers.** A habitable attic with dormers shall be considered to be a story where the aggregate width of all dormers in the roof exceeds 50 percent of the aggregate width of the sloped roofs of the attic. The width of the roof shall be measured at a horizontal plane halfway between the eave and the ridge of the roof and the width of dormers shall be measured from exterior face to exterior face of the dormer walls.*



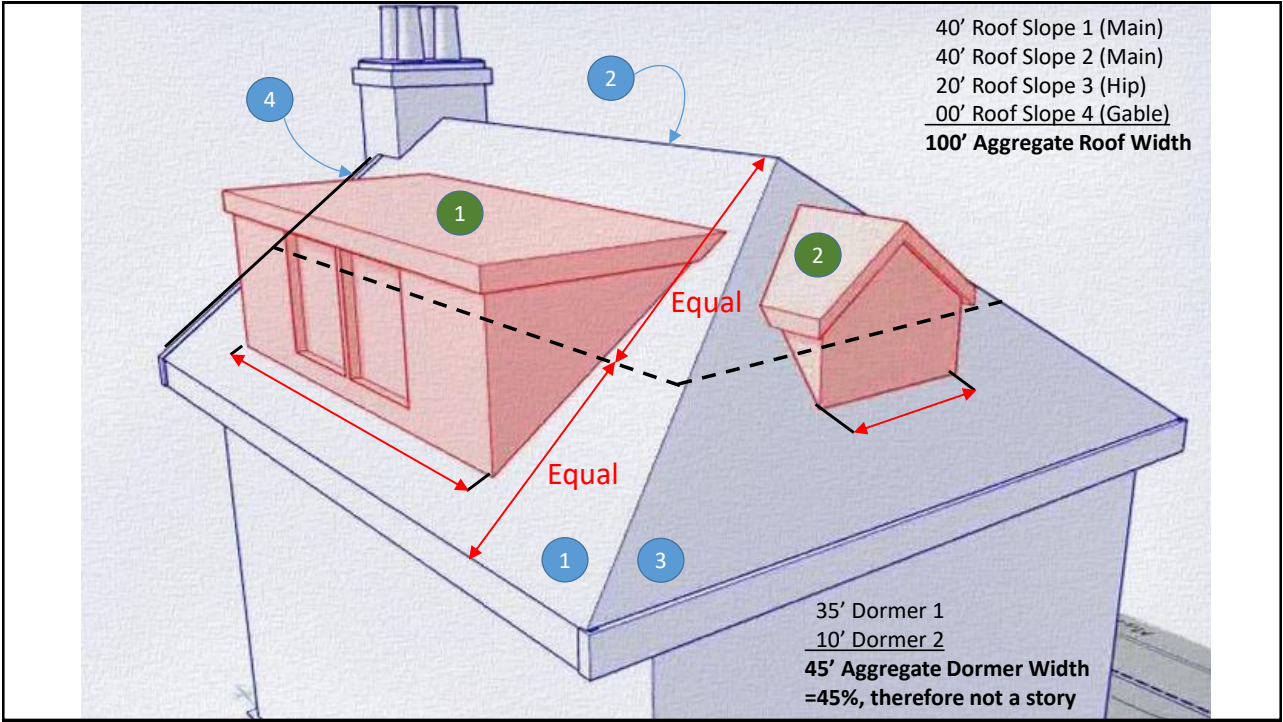

Code Changes



2018 International Residential Code (IRC)

- Chapter 3 – Building Planning
 - **R326.6.4 Barrier exceptions**
 - Swimming pool barriers – power cover exception
 - Defaulting to model code
 - ASTM F1346
 - Up to 8’ wide: 275 lb (1 Ch. 1 Ad.)
 - Greater than 8’ wide: 485 lb (1 Ch. 2 Ad.)
 - Surface drainage after rainfall
 - Deflection openings
 - Perimeter openings

Proposed 2020 SBC, 2018 IRC Amd:

(Add) **R326.6.4 Barrier exceptions** . Where spas or hot tubs are equipped with a lockable safety cover complying with ASTM F1346 and **swimming pools are equipped with a powered safety cover complying with ASTM F1346**, the areas where those spas, hot tubs or pools are located shall not be required to comply with R326.6.1 through R326.6.3.



Code Changes

2018 International Residential Code (IRC)

• Chapter 4 – Foundations

• **R507 Exterior decks**

- Major rework of section
- 507.2 Materials
- 507.3 Footings
- 507.4 Deck posts
- 507.5 Deck beams
- 507.6 Deck joists
- 507.7 Decking
- 507.8 Vertical & lateral supports
- 507.9 Vertical & lateral supports at band joist

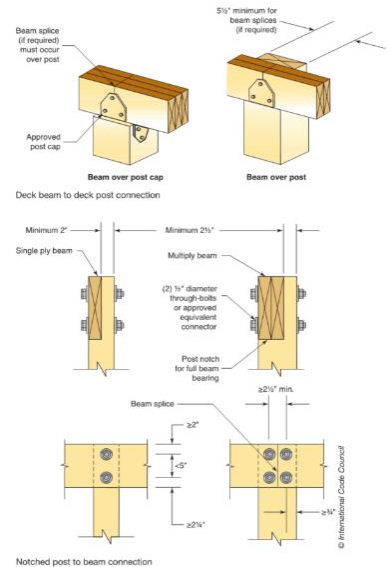

Code Changes

2018 International Residential Code (IRC)

• Chapter 9 – Roof Assemblies

• **R905.17 Building integrated PV roof panels...**

- ...directly applied to the roof deck
- New section
- Deck requirements, deck slope
- Underlayment, ice barrier
- Material standards
- Attachment
- Wind resistance



Code Changes

2018 International Residential Code (IRC)

• Chapter 10 – Chimneys & Fireplaces

• **R1005.8 Insulation shield**

- New requirement
- Where factory-built chimney passes through insulated assembly
- Shield required, min. No. 26 gage
- Provide clearance required by chimney manufacturer
- Terminate min. 2" above insulation
- Secured in place



Code Changes

2018 International Residential Code (IRC)

• Chapter 11 – Energy Conservation

• **N1103.3.6 Ducts buried within ceiling insulation**

- New section
- Ducts shall be insulated
- Duct buried in ceiling insulation
 - Exception if less than 3 feet from supply outlet
- Deeply buried, effective R-25
- Ducts located in conditioned space

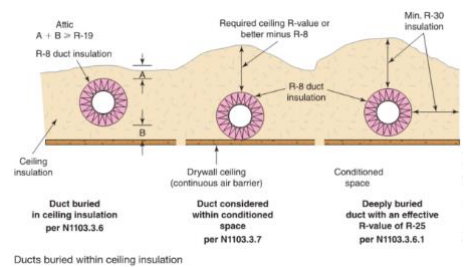

Code Changes

2018 International Residential Code (IRC)

- Chapter 11 – Energy Conservation
 - **N1104.1 Lighting equipment (mandatory)**
 - Amended
 - Now not less than 90% of the permanently installed lighting fixtures are required to contain only high-efficiency lamps.



High-efficacy lamps, such as LED lamps, are required in 90 percent of permanent lighting fixtures

Code Changes

2018 International Residential Code (IRC)

- Chapter 13 – General Mechanical System Requirements
 - **M1305.1.1 Access to furnaces within compartments**
 - Minimum working space clearances deleted
 - Now defers to manufacturer's instructions
 - Still requires min. 24" door opening, large enough to allow removal of largest appliance
 - Still requires min. 30" deep level service space.

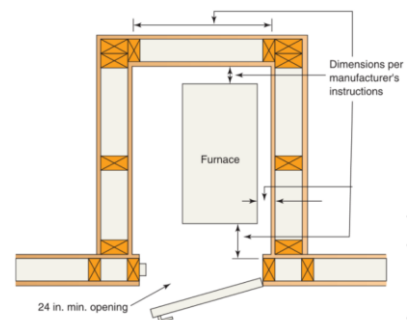

The access and clearance requirements for furnaces in compartments have been removed in favor of the manufacturer's instructions.

Code Changes

2018 International Residential Code (IRC)

- Chapter 15 – Exhaust Systems
 - **M1502.3.1 Exhaust termination outlet...**
 - Dryer exhaust ducts
 - Undiminished in size
 - The passageway of dryer exhaust duct terminals shall be undiminished in size and shall provide an **open area of not less than 12.5 square inches (8065 mm²)**

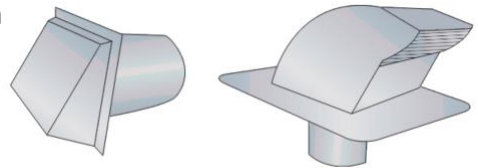

Wall and roof terminations for dryer exhaust must be undiminished in size and provide 12.5 square inches of area.

Code Changes

2018 International Residential Code (IRC)

- Chapter 15 – Exhaust Systems
 - **M1503.6 Makeup air required**
 - Previously amended by CT
 - Now defaulting to model code
 - 2009 & 2012 IRC required a motorized damper
 - 2015 IRC added option for gravity damper
 - 2018 IRC limits to fuel-fired appliances with gravity (passive) venting system
 - Aligns with ASHRAE 62.2

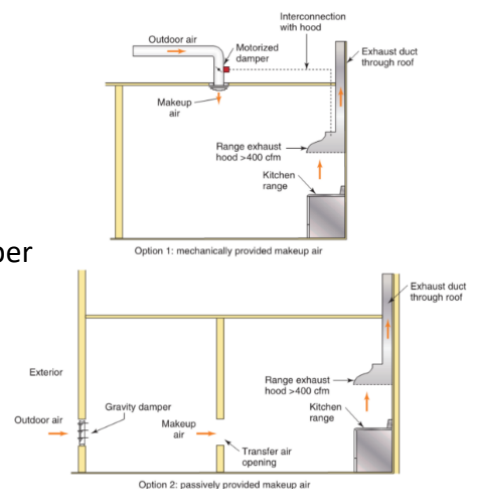

Makeup air is required for exhaust rates greater than 400 cfm unless all fuel-fired appliances are direct vent or mechanical draft.



Code Changes

2018 International Residential Code (IRC)

Chapter 15 – Exhaust Systems

M1503.6 Makeup air required

- Applies where building has one or more gas, liquid or solid fuel-burning appliance
- Exhaust systems capable of > 400 cfm
- Make up air approx. equal required
- Make up air from same room or other room via ducts or openings
- Damper gravity or electrically operated
- Does not apply to direct-vent or mechanical draft venting system

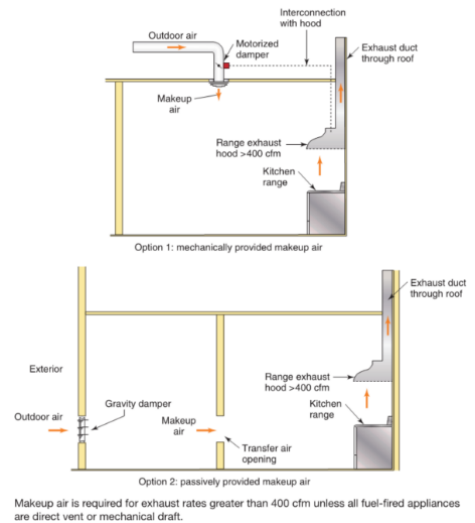

Code Changes

2018 International Mechanical Code (IMC)

Chapter 15 – Exhaust Systems

M1504.4.2 Duct installation

- *Where dryer exhaust ducts are enclosed in wall or ceiling cavities, such cavities shall allow the installation of the duct without deformation.*
- Proposed Connecticut amendment for one- and two-family dwellings:
 - *M1502.4.2 Exception: Manufactured oval duct with an equivalent diameter of 4" shall be allowed.*

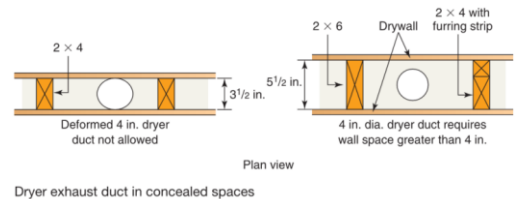

Code Changes

2018 International Residential Code (IRC)

• Chapter 15 – Exhaust Systems

• Definitions

- **DIRECT-VENT APPLIANCE.** A fuel-burning appliance with a sealed combustion system that draws all air for combustion from the outside atmosphere and discharges all flue gases to the outside atmosphere.
- **MECHANICAL DRAFT SYSTEM.** A venting system designed to remove flue or vent gases by mechanical means, that consists of an induced draft portion under non-positive static pressure or a forced draft portion under positive static pressure.
 - **Forced draft venting system...**
 - **Induced draft venting system...**
 - **Power venting system...**

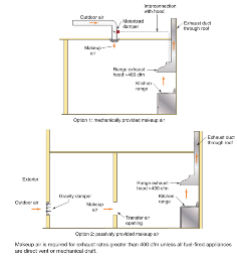

Code Changes

2018 International Residential Code (IRC)

• Chapter 21 – Hydronic Piping

• Chapter 25 – Plumbing Systems

- **M2101.10 Tests (hydronic piping)**
- **P2503.7 Tests (water distribution piping)**
 - PEX piping now allowed to be tested with air or gas if manufacturer permits
 - Plastic Pipe and Fittings Association
 - Still 15 minute minimum. Now no maximum.

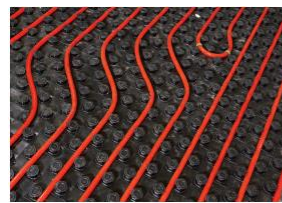

PEX radiant floor heat piping



Air testing of PEX piping must follow the manufacturer's instructions.

Code Changes

2018 International Residential Code (IRC)

• Chapter 24 – Fuel gas

• **M2420.5.1 Located within same room**

- Access to gas shut off valve
- *Such shutoff valves shall be provided with access.*
- **NEW:** *Shutoff valves serving movable appliances, such as cooking appliances and clothes dryers, shall be considered to be provided with access where installed behind such appliances.*

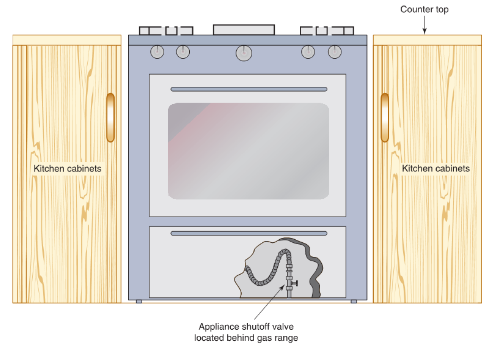

Shutoff valve behind gas range meets the requirement for access

Code Changes

2018 International Residential Code (IRC)

• Chapter 24 – Fuel gas

• **M2447.2 Prohibited location**

- Commercial cooking appliances are now permitted in dwelling units:

Where the installation is designed by a licensed professional engineer in compliance with the manufacturer's installation instructions.



Commercial cooking appliances are permitted with an engineered design

Code Changes

2018 International Residential Code (IRC)

- Chapter 27 – Plumbing systems
 - **P2713.1 Bathtub waste outlets & overflows**
 - Bathtub overflow not required



An overflow is not required for a bathtub

Code Changes

2018 International Residential Code (IRC)

- Chapter 27 – Plumbing systems
 - **P2903.5 Water hammer**
 - *A water hammer arrestor shall be installed where quick-closing valves are utilized.*
 - **QUICK-CLOSING VALVE.** A valve or faucet that closes automatically where released manually or controlled by mechanical means for fast-action closing.
 - Washing machines, dishwashers etc.
 - Was required prior to 2009 IRC
 - Now reintroduced & aligns with IPC

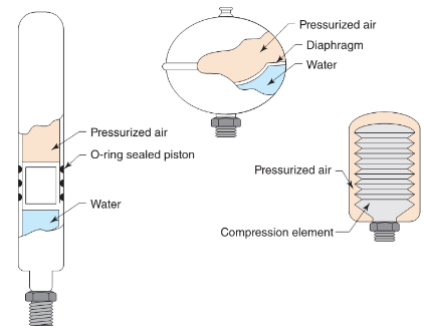

Examples of mechanical water hammer arrestors

Code Changes

2018 International Residential Code (IRC)

- Chapter 29 – Water Supply & Distribution

- P2906.6.1 Saddle tap fittings**

- The use of saddle tap fittings and combination saddle tap and valve fittings shall be prohibited.*
 - Subject to bumping & twisting
 - When valve combo, increase leakage potential
 - Impacts refrigerator water dispensers, ice makers etc.
 - Aligns with IPC

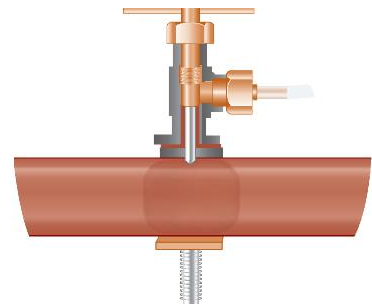

Saddle tap fitting

Code Changes

2018 International Residential Code (IRC)

- Chapters 34-43 – Electrical

- Electrical chapters of IRC**

- Deleted
 - Users directed to 2020 NEC
 - Issuing with syncing of 2018 IRC with 2020 NEC & number of amendments

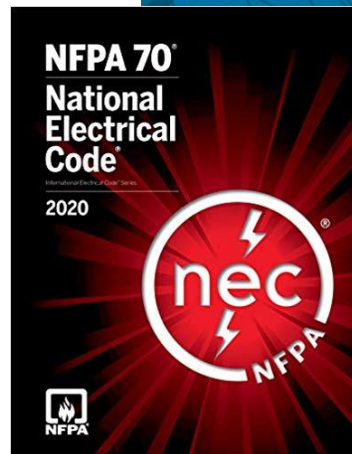
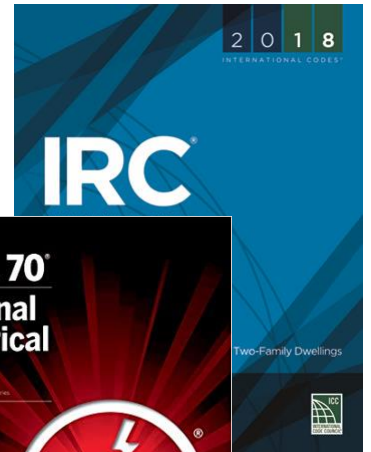

Code Changes

2018 International Residential Code (IRC)

Chapter 37 — Branch Circuit & Feeder Reqs.

~~E3703.5~~ **E3703.5 Garage branch circuits**

- Not less than one separate 20A circuit
- Can also serve readily accessible outdoor receptacles

~~E3901.9~~ **E3901.9 Basements, garages...**

- Receptacle in each parking bay

Code Changes

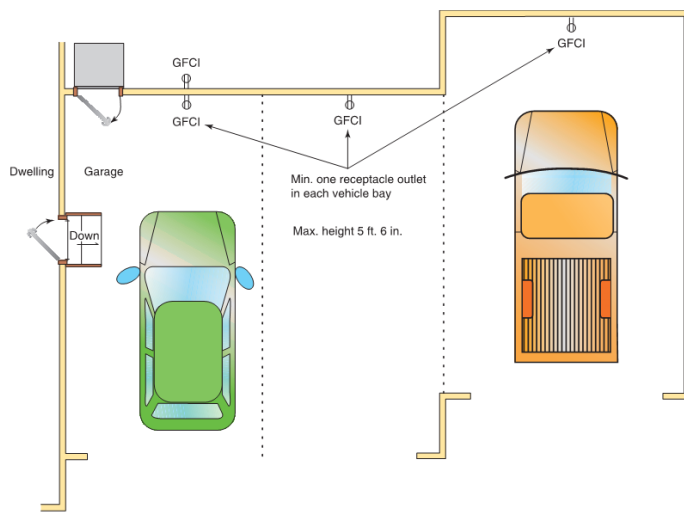

Receptacle outlet required in each vehicle space in garage

© International Code Council

Code Changes

2018 International Residential Code (IRC)

• Appendix Q – Tiny Houses

- **TINY HOUSE.** A dwelling that is 400 square feet (37 m²) or less in floor area excluding lofts.
- **LOFT.** A floor level located more than 30 inches (762 mm) above the main floor, open to the main floor on one or more sides with a ceiling height of less than 6 feet 8 inches (2032 mm) and used as a living or sleeping space.



Code Changes

2018 International Residential Code (IRC)

• Appendix Q – Tiny Houses

- GoFundMe initiative
- Code consultant hired to draft new Appendix
- Went through ICC process
- Became Appendix Q in 2018 IRC



Proposed Tiny House Code 2018 IRC

\$10,605 of \$10k goal

Raised by 253 people in 5 months



Code Changes

2018 International Residential Code (IRC)

- Appendix Q – Tiny Houses
 - Appendix allows limited reductions:
 - Minimum ceiling height 6'8" (6'4" in bathrooms, toilet rooms, kitchens)
 - Lofts minimum area 35sf.
 - Allows stairs, ladders, alternating tread devices, ships ladders for loft access
 - Loft stairs & ladders reduced criteria



Code Changes

2018 International Building Code (IBC)



Code Changes

2018 International Building Code (IBC)

• Chapter 2 - Definitions:

- **Greenhouse:** A structure or thermally isolated area of a building that maintains a specialized sunlit environment used for and essential to the cultivation, protection or maintenance of plants. [New]
 - 303.4 (Group A-3) if public access for viewing
 - 309.1 (Group M) if public access for mercantile
 - 312.1.1 (Group U) if not classified as other use
 - Table 506.2, footnote (i) – allowable area



Code Changes

2018 International Building Code (IBC)

• Chapter 2 - Definitions:

- **Repair garage:** A building, structure or portion thereof used for servicing or repairing motor vehicles. [New]



Code Changes

2018 International Building Code (IBC)

- Chapter 3 - Use and Occupancy
 - **Self-service storage facility (mini-storage)**
 - **Classify as S-1** due to reasonable expectation that they will contain a considerable amount of combustible materials.



Code Changes

2018 International Building Code (IBC)

- Chapter 4 - Special Requirements
 - **Enclosure of atriums**
 - **New exception #4:** A fire barrier is not required between the atrium and the adjoining spaces where the atrium is not required to be provided with a smoke control system.



Code Changes

2018 International Building Code (IBC)

- Chapter 4 - Special Requirements
 - **Maximum smoke compartment size (I-2, Cond. 2)**
 - Max compartment size of 40,000 sf now only for compartments with single occupant rooms or no patient rooms.

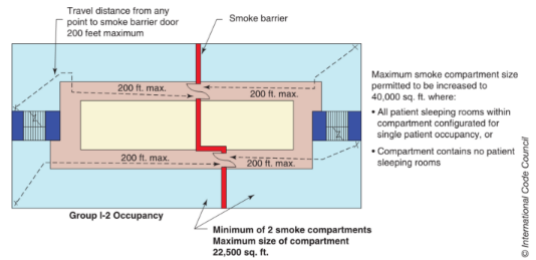

Code Changes

2018 International Building Code (IBC)

- Chapter 4 - Special Requirements
 - **Independent egress (smoke compartments)**
 - 407.5.4 independent egress. A means of egress shall be provided from each smoke compartment created by smoke barriers without having to return through the smoke compartment from which means of egress originated. **Smoke compartments that do not contain an exit shall be provided with direct access to not less than two adjacent smoke compartments.**

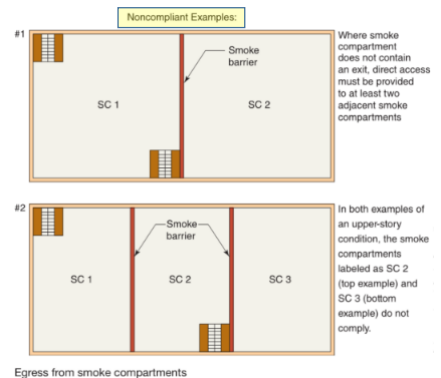

Code Changes

2018 International Building Code (IBC)

- Chapter 4 - Special Requirements
 - **Corridor protection in assisted living**
 - **420.7 Group I-1 assisted living housing units...** shared living spaces, group meeting or multipurpose therapeutic spaces...
 - Six (6) criteria to be met if they are open to the corridor.
 - Walls, no sleeping or treatment, fire detection or quick response sprinklers, no obstruction of egress

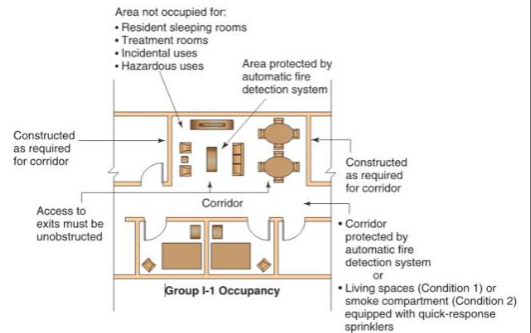

Code Changes

2018 International Building Code (IBC)

- Chapter 4 - Special Requirements
 - **Cooking facilities in assisted living**
 - **420.8 Group I-1 cooking facilities...** with domestic cooking appliances...
 - Nine (9) criteria to be met if they are open to the corridor.
 - Max 30 occupants served, type of appliance, no obstruction of egress, domestic cooking hoods to IMC, ignition prevention, fuel / power shut off, 120 min shut off timer, portable fire extinguisher

- Appliances limited to ovens, cooktops, ranges, warmers and microwaves
- Fuel and electrical supply to cooking equipment be provided with shut-off accessible only to staff
- Timer to deactivate cooking appliances within 2 hours

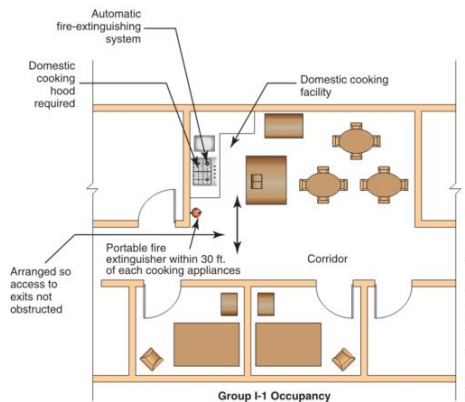

Group I-1 kitchen/dining spaces

Code Changes

2018 International Building Code (IBC)

- Chapter 4 - Special Requirements
 - **Children’s play structures**
 - 424.1 Children’s play structures **General**. Children’s play structures installed inside all occupancies covered by this code that exceed 10 feet (3048 mm) in height ~~and~~ **or** 150 square feet (14m²) in area shall comply with Sections 424.2 through 424.5.
 - Added “or” instead of “and”, meaning more play structures will now be regulated.



Code Changes

2018 International Building Code (IBC)

- Chapter 4 - Special Requirements
 - **Medical Gas Systems**
 - New section 427
 - Brings over construction requirements from IFC
 - Room construction
 - Gas cabinet exhaust, ducts, shafts & sprinklers

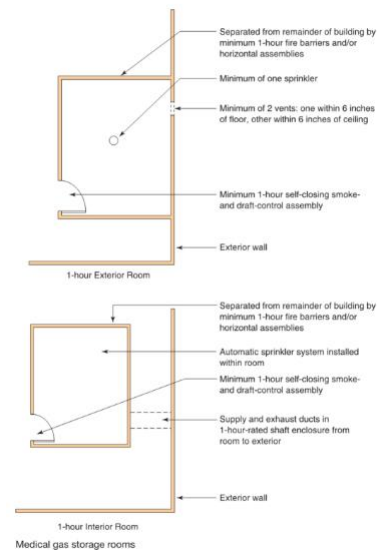

Code Changes

2018 International Building Code (IBC)

- Chapter 4 - Special Requirements
 - **Higher Education Laboratories**
 - New section 428
 - New definition in chapter 2
 - Allowable quantities in control areas can be exceeded if lab meets 428
 - Separation, fire resistance, construction, ventilation, standby / emergency power, liquid tight floor, fire extinguishing



Code Changes

2018 International Building Code (IBC)

- Chapter 5 - Building Heights & Areas
 - **503.1.4 Occupied Roofs**
 - Limits use of occupied roof to an occupancy that is permitted by Table 504.4 for the story immediately below the roof
 - Exception: if building sprinklered throughout and occupant notification provided on roof

Example:
 If building of Type VA construction,
 Group B: 4 stories max. (S)
 Group A-3: 3 stories max. (S)

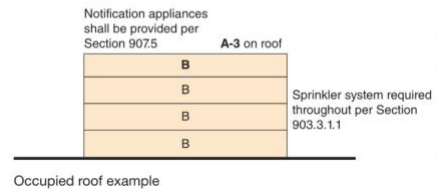

Code Changes

2018 International Building Code (IBC)

- Chapter 5 - Building Heights & Areas
 - **510.2 Horizontal building separation allowance**
 - Where **vertical offsets** are provided as part of a horizontal assembly, the vertical offset and the structure supporting the vertical offset shall have a fire-resistance rating of not less than 3 hours.

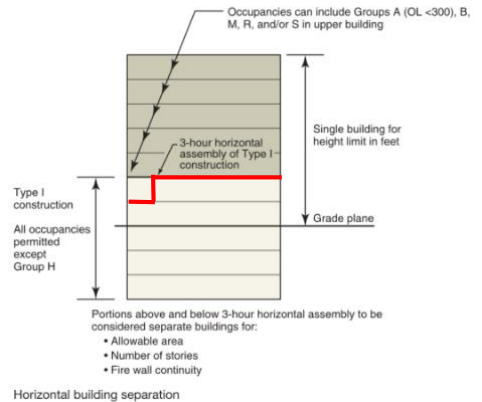

Code Changes

2018 International Building Code (IBC)

- Chapter 7 – Fire & Smoke Protection Features
 - **705.2.3 Combustible projections**
 - No significant technical change
 - Section relocated from 1406 to 705.2.3



Code Changes

2018 International Building Code (IBC)

- Chapter 7 – Fire & Smoke Protection Features
 - **712.1.3 Escalator and stairway openings**
 - Includes openings for stairways which are not a portion of the means of egress.
 - Option 1: Limit opening size, include draft curtain and closely space sprinklers; or
 - Option 2: Use automatic shutters

(Amd) 712.1.3 Escalator and stairway openings.

Where a building is equipped throughout with an *automatic sprinkler system* in accordance with Section 903.3.1.1, vertical openings for escalators or stairways which are not a portion of the means of egress shall be permitted where protected in accordance with Section 712.1.3.1 or 712.1.3.2.

(Amd) **712.1.3.1 Opening Size.** Protection by a draft curtain and closely spaced sprinklers in accordance with NFPA 13 shall be permitted where the area of the vertical opening between stories does not exceed twice the horizontal projected area of the escalator or stairway. In other than Groups B and M, this application is limited to openings that do not connect more than four stories.

Code Changes

2018 International Building Code (IBC)

- Chapter 7 – Fire & Smoke Protection Features
 - **712.1.3 Escalator and stairway openings**
 - Includes openings for stairways which are not a portion of the means of egress.
 - Option 1: Limit opening size, include draft curtain and closely space sprinklers; or
 - Option 2: Use automatic shutters



712.1.3.2 Automatic shutters. Protection of the vertical opening by approved shutters at every penetrated floor shall be permitted in accordance with this section. The shutters shall be of noncombustible construction and have a fire-resistance rating of not less than 1.5 hours. The shutter shall be so constructed as to close immediately upon the actuation of a smoke detector installed in accordance with Section 907.3.1 and shall completely shut off the well opening. Escalators shall cease operation when the shutter begins to close. The shutter shall operate at a speed of not more than 30 feet per minute (152.4 mm/s) and shall be equipped with a sensitive leading edge to arrest its progress where in contact with any obstacle, and to continue its progress on release therefrom.

Code Changes

2018 International Building Code (IBC)

- Chapter 7 – Fire & Smoke Protection Features
 - **713.8.1 Prohibited penetrations**
 - 2012 IBC added allowance for penetrations of outer membrane of exit enclosure (but not other shafts)
 - 2018 IBC adds same allowance for shafts

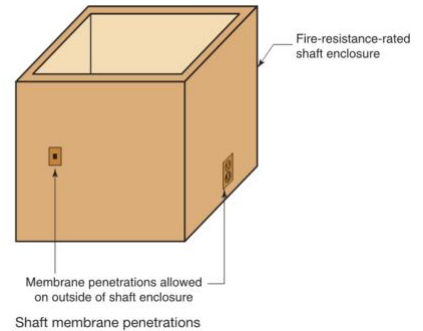

Code Changes

2018 International Building Code (IBC)

- Chapter 9 – Fire Protection & Life Safety Features
 - **907.2.1 Group A**
 - Occupant load >100 above or below level of exit discharge
 - Manual fire alarm system required

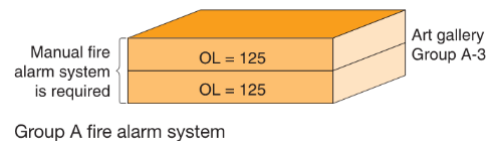

Code Changes

2018 International Building Code (IBC)

- Chapter 9 – Fire Protection & Life Safety Features
 - **907.2.10 Group R-4**
 - Manual fire alarm system and automatic smoke detection no longer required
 - Under review by CT

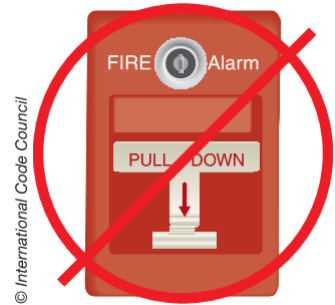

Fire alarm system not required in Group R-4

Code Changes

2018 International Building Code (IBC)

- Chapter 10 – Means of Egress
 - **Table 1004.5 Occupant Load**
 - Business areas now 150 gross (was 100)
 - New *concentrated business use areas*
 - Call centers, trading floors, data processing centers
 - 50 gross

TABLE 1004.1-2 1004.5 Maximum Floor Area Allowances Per Occupant

| Function of Space | Occupant Load Factor ^a |
|---------------------------------|-----------------------------------|
| Business areas | 100/150 gross |
| Concentrated business use areas | See Section 1004.8 |



Code Changes

2018 International Building Code (IBC)

- Chapter 10 – Means of Egress
 - **1010.1.4.4 Locking... educational**
 - New requirements
 - Unlockable from outside room by key or other approved means
 - Openable from within room per 1010.1.9, inc. single operation
 - Prohibits modifications of listed panic hardware, fire door hardware or closers



Code Changes

2018 International Building Code (IBC)

- Chapter 10 – Means of Egress
 - **1010.1.4.4.1 Remote operation of locks**
 - Remote operation of locks complying with Section 1010.1.4.4 shall be permitted.
 - **1010.1.9.8 Delayed egress (Group E)**
 - Classrooms with occupant load <50



Code Changes

2018 International Building Code (IBC)

• Chapter 10 – Means of Egress

• **1010.1.9.12 Stairway doors (locking)**

- Previously limited to:
 - (i) four or fewer stories with simultaneous; unlocking; and
 - (ii) high rise with simultaneous unlocking and communication system
- **Now includes >4 stories, but lower than high rise, with simultaneous unlocking**

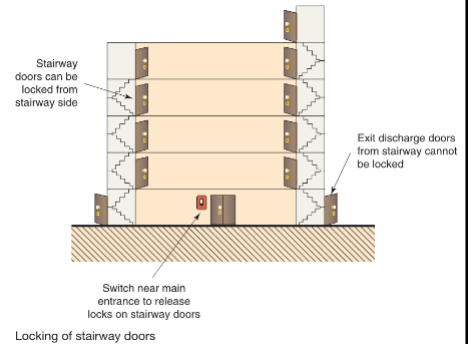

Code Changes

2018 International Building Code (IBC)

• Chapter 10 – Means of Egress

• **1025.1 General (luminous markings)**

- No longer required in I-2, I-3 or I-4
- Trained staff
- Defend in place
- Generators monitored & maintained

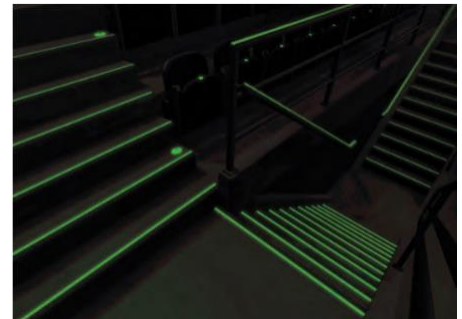

Code Changes

2018 International Building Code (IBC)

- Chapter 11 – Accessibility

- **Gaming areas**

- New definitions: *gaming, gaming area, gaming machine type, gaming table type*
 - Amended requirement:



1109.15 Gaming machines and gaming tables. At least two percent of the total, but not fewer than one, of each gaming machine type and gaming table type shall be *accessible*. Where multiple gaming areas occur, accessible gaming machines and gaming tables shall be distributed throughout.

Code Changes



2018 International Building Code (IBC)

- Chapter 11 - Accessibility

- **Chapter 2 – Definition**

- **1109.2.1.2 – Family or assisted-use toilet rooms**

- **2902.1.2.1 – Single-user toilet / bathing rooms**

- New CT requirement



Code Changes



2018 International Building Code (IBC)

- Chapter 11 - Accessibility
 - **1109.2.5 Additional grab bar**
 - Swing grab bar reintroduced in draft



Code Changes

2018 International Building Code (IBC)

- Chapter 15 – Roof Assemblies...
 - **1507.18 Building-Integrated PV Panels**
 - New section & definition
 - Deck requirements
 - Deck slope
 - Underlayment
 - High wind attachment
 - Ice Barrier
 - Attachment



Code Changes



2018 International Building Code (IBC)

- Chapter 16 – Structural Design

1608.4 Snow loads on adjacent buildings. A new structure or addition that exceeds the height of an adjacent existing building shall not be constructed within 20 feet (6.1 m) of that existing building.

Exceptions:

1. No additional snow drift loads are induced on the roof of the existing lower building.
2. Any additional snow drift loads induced on the roof of the existing lower building are less than the magnitude of the snow drift loads that would have already existed on the lower roof in the same location.
3. The load-carrying capacity of the roof of the existing lower building is capable of supporting the additional snow drift loads.

Snow drift loads shall be derived in accordance with Section 7.7 of ASCE 7. A statement from a professional engineer shall be provided as confirmation of the applicability of any of the exceptions.

Code Changes **DELETE?**

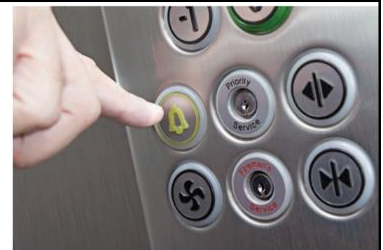

2018 International Building Code (IBC)

- Chapter 30 – Elevators & Conveying Systems

- **3001.2 Emergency elevator communication systems for the deaf, hard of hearing and speech impaired.**

An emergency two-way communication system shall be provided that:

1. Is a visual and text-based and a video-based 24/7 live interactive system.
2. Is fully accessible by the deaf, hard of hearing and speech impaired, and shall include voice-only options for hearing individuals.
3. Has the ability to communicate with emergency personnel utilizing existing video conferencing technology, chat/text software or other approved technology.

Code Changes

2018 International Building Code (IBC)

• Chapter 30 – Elevators & Conveying Systems

• 3006.2.1 Rated corridors

- Where corridors are required to be fire-resistance rated in accordance with Section 1020.1, elevator hoistway openings shall be protected in accordance with Section 3006.3.

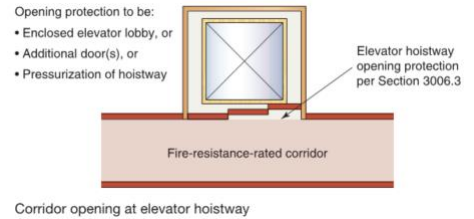

Code Changes

2018 International Building Code (IBC)

• Chapter 30 – Elevators & Conveying Systems

• 3008.1.1 Number of occupant evacuation elevators

- Still elective
- Previously, if choice made to utilize then all elevators had to comply
- Now, able to nominate which elevators will be for evacuation - min one per bank
- Egress analysis criteria given

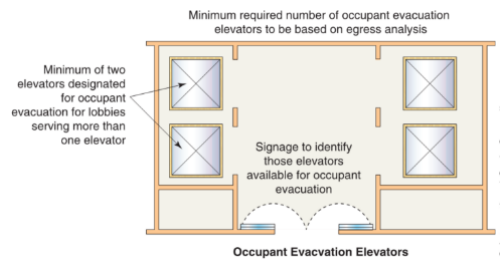

Code Changes

2018 International Building Code (IBC)

- Chapter 31 – Special Construction
 - **3113 Relocatable buildings**
 - Manufactured after effective date of code
 - Not those used as dwellings
 - New – IBC 3113
 - Existing – IEBC Chapter 14
 - Supplemental information
 - Manufacturer’s data plate
 - BO authorized to accept approved inspection agency report(s)



Code Changes

2018 International Building Code (IBC)

- Appendix N
 - **Replicable Buildings (New)**
 - Consistent application
 - Faster disaster recovery
 - Quicker turnaround in plan review
 - Prototypical construction documents
 - Detailed submittal requirements
 - Site specific matters
 - Under review by CT



Code Changes

2018 International Plumbing Code (IPC)

Code Changes

2018 International Plumbing Code (IPC)

- Chapter 2 – Definitions

- **Full-Open Valve**

- *A water control or shutoff component in the water supply system piping that, where adjusted for maximum flow, the flow path through the component's closure member is not a restriction in the component's through-flow area.*

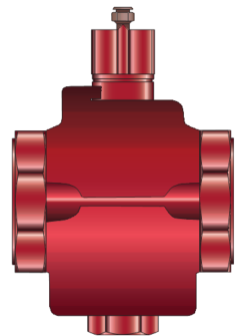

Code Changes

2018 International Plumbing Code (IPC)

- Chapter 3 – General Regulations
 - **305.6 Protection against physical damage**
 - ...less than ~~1 1/2~~ 1 1/4 inches from the nearest edge...

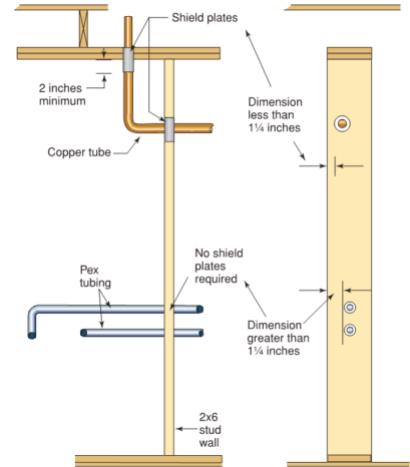

Code Changes

2018 International Plumbing Code (IPC)

- Chapter 3 – General Regulations
 - **308.10 Thermal expansion tanks**
 - *A thermal expansion tank shall be supported in accordance with the manufacturer's instructions. Thermal expansion tanks shall not be supported by the piping that connects to such tanks.*

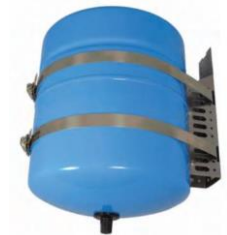

Code Changes

2018 International Plumbing Code (IPC)

- Chapter 4 – Fixtures, Faucets & Fixture Fittings
 - **Table 403.1 ...Required Plumbing Fixtures**
 - “Occupancy” column has been removed
 - “For greater flexibility and accuracy.”
 - “For plumbing fixture requirements, Description of Use is far more accurate and allows the code official to better assess the plumbing fixture requirements for buildings and spaces.”

TABLE 403.1 Minimum Number of Required Plumbing Fixtures^a
(See Sections 403.1.1 and 403.2)

| Classification | Description | Water Closets | | Lavatories | | Bathubs/ Showers | Drinking Foundation | Other |
|----------------|-------------|---------------|--------|------------|--------|---------------------|------------------------|-------|
| | | Male | Female | Male | Female | | | |

Code Changes

2018 International Plumbing Code (IPC)

- Chapter 4 – Fixtures, Faucets & Fixture Fittings
 - **Table 403.1 Gaming Area Plumbing Fixtures**
 - *A thermal expansion tank shall be supported in accordance with the manufacturer’s instructions. Thermal expansion tanks shall not be supported by the piping that connects to such tanks.*



| Classification | Description | Water Closets (Urinals: See Section 419.2) | | Lavatories | | Bathubs/ Showers | Drinking Foundation | Other |
|----------------|--------------|---|--|---|--------|---------------------|------------------------|----------------|
| | | Male | Female | Male | Female | | | |
| Assembly | Gaming areas | 1 per 100 for the first 400 and 1 per 250 for the remainder exceeding 400 | 1 per 50 for the first 400 and 1 per 150 for the remainder exceeding 400 | 1 per 250 for the first 750 and 1 per 500 for the remainder exceeding 750 | — | — | 1 per 1,000 | 1 service sink |



Code Changes



2018 International Plumbing Code (IPC)

- Chapter 4 – Fixtures, Faucets & Fixture Fittings
 - **Table 403.1 ...Required Plumbing Fixtures**
 - **Public swimming pools**
 - New model code footnote deleted by CT:
 - *“f. The required number and type of plumbing fixtures for outdoor public swimming pools shall be in accordance with Section 609 of the International Swimming Pool and Spa Code.”*
 - Reason: model code points to ISPSC, which Connecticut does not adopt or reference.



Code Changes

2018 International Plumbing Code (IPC)

- Chapter 4 – Fixtures, Faucets & Fixture Fittings
 - **403.1.3 Lavatory distribution**
 - Lavatories shall be distributed proportionately

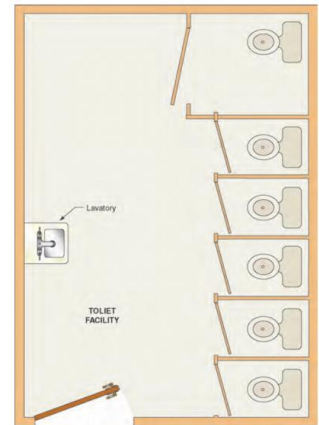

Code Changes

2018 International Plumbing Code (IPC)

- Chapter 4 – Fixtures, Faucets & Fixture Fittings
 - **405.3.5 Urinal partitions**
 - The horizontal dimension between walls or partitions at each urinal shall be not less than 30 inches (762 mm).

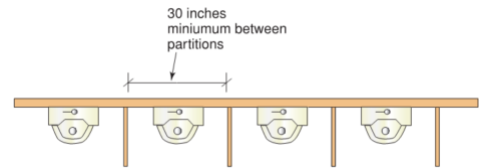

Code Changes

2018 International Plumbing Code (IPC)

- Chapter 4 – Fixtures, Faucets & Fixture Fittings
 - **409.4 Residential dishwasher waste connection**
 - Moved & clarified
 - *The waste connection of a residential dishwasher shall connect directly to a wye branch fitting on the tailpiece of the kitchen sink, directly to the dishwasher connection of a food waste disposer, or through an air break to a standpipe. The waste line of a residential dishwasher shall rise and be securely fastened to the underside of the sink rim or counter top.*

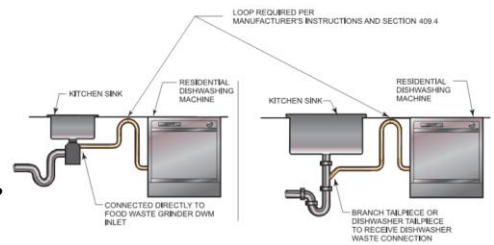

Code Changes

2018 International Plumbing Code (IPC)

- Chapter 4 – Fixtures, Faucets & Fixture Fittings
 - **411.3 Water supply**
 - Emergency shower or eyewash station
 - *Where hot and cold water is supplied... the temperature... shall only be controlled by a temperature actuated mixing valve complying with ASSE 1071.*



Code Changes

2018 International Plumbing Code (IPC)

- Chapter 4 – Fixtures, Faucets & Fixture Fittings
 - **Section 422 – Health Care Fixtures...**
 - **DELETED**
 - To avoid conflict with federal and state regulations
 - *Long ago, when many of the requirements for health care fixtures and equipment were put into code, the health care industry did not have as robust of internal standards systems*
 - **Section 713 – Health Care Plumbing**
 - **DELETED**



Code Changes

2018 International Plumbing Code (IPC)

- Chapter 6 – Water Supply and Distribution
 - **608.17.1.1 Carbonated beverage**
 - **608.17.1.2 Coffee and noncarbonated**
 - Backflow protection for drink dispensers
 - Different standards for:
 - Carbonated
 - Coffee & noncarbonated

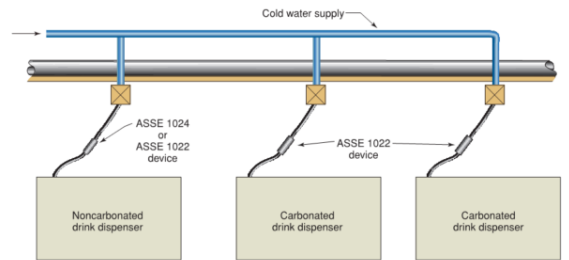

Code Changes

2018 International Plumbing Code (IPC)

- Chapter 7 – Sanitary Drainage
 - **701.8 Drainage piping in food service areas**
 - **DELETED**
 - Exposed soil or waste piping shall not be installed above any working, storage or eating surfaces in food service establishments.

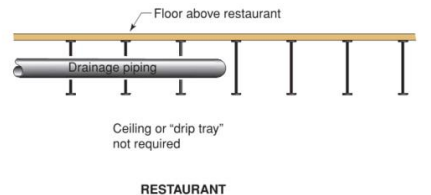

Ceiling or "drip trays" under piping above food areas not required

Code Changes

2018 International Mechanical Code (IMC)

Code Changes

2018 International Mechanical Code (IMC)

- Chapter 4 – Ventilation
 - **403.3.2.5 Ventilating equipment**
 - *Exhaust equipment serving single dwelling units shall be listed and labeled to provide the minimum required air flow in accordance with ANSI/AMCA 210-ANSI/ASHRAE 51.*
 - Exhaust fans don't necessarily have the advertised flow rate.
 - Additional listing / labeling requirement.
 - Does not require field testing.



Code Changes

2018 International Mechanical Code (IMC)

- Chapter 5 – Exhaust Systems
 - **504.4 Exhaust installation**
 - *Clothes dryer exhausts shall be sealed in accordance with Section 603.9.*
 - Section 603.9 says: *Joints, longitudinal and transverse seams and connections in ductwork shall be securely fastened and sealed with welds, gaskets, mastics (adhesives), mastic-plus-embedded-fabric systems, liquid sealants or tapes.*
 - Check listing and labeling of sealant.



Code Changes

2018 International Mechanical Code (IMC)

- Chapter 5 – Exhaust Systems
 - **504.4.1 Clothes dryer exhaust termination**
 - *504.4.1 Exhaust termination outlet and passageway size. The passageway of dryer exhaust duct terminals shall be undiminished in size and shall provide an **open area of not less than 12.5 square inches** (8065 mm²).*
 - Equivalent to 4 inch round duct.
 - To limit flow resistance, which is implicit in allowable length.



Dryer duct terminals must provide a minimum opening of 12.5 square inches.

Code Changes

2018 International Mechanical Code (IMC)

- Chapter 5 – Exhaust Systems
 - **506.5.2 Pollution-control units**
 - New section / new requirements
 - 15 different criteria must be met, inc.:
 - Listing & labeling
 - Mounting & securing
 - Access for servicing and cleaning
 - Mounting height, exhaust location
 - Fire suppression
 - Wash-down drains
 - Protection from freezing



Pollution control unit

Code Changes

2018 International Mechanical Code (IMC)

- Chapter 6 – Duct Systems
 - **602.2.1.8 Pipe and duct insulation within plenums.**
 - Shall have a flame spread index of not more than 25 and a smoke developed index of not more than 50.
 - ASTM E84 or UL 723, using the specimen preparation and mounting procedures of ASTM E2231.
 - Pipe and duct insulation shall not flame, glow, smolder or smoke when tested in accordance with ASTM C411 at the temperature to which they are exposed in service

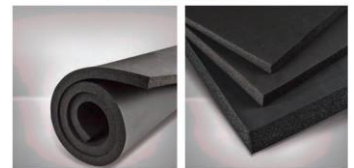
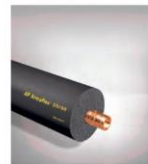

Pipe and duct insulation for use in plenums must meet the limitations and conditions specified in Section 602.2.1.8.



Code Changes

2018 International Mechanical Code (IMC)

- Chapter 6 – Duct Systems
 - **606.2.1 Supply air systems.**
 - Smoke detectors in **supply air** systems.
 - Delete CT amendment.
 - Revert to model code: **return air**



Code Changes

2018 International Mechanical Code (IMC)

- Chapter 14 – Solar Thermal Systems
 - **Sections 1401-1404**
 - Substantial rewrite for consistency with current technology

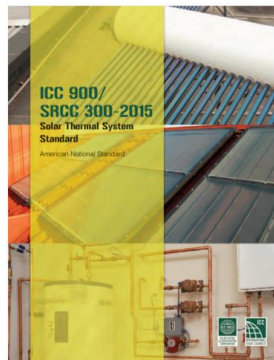

Solar thermal systems shall be listed and labeled in accordance with ICC 900/SRCC 300.

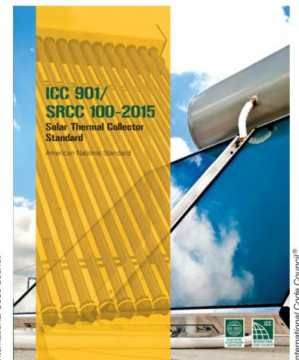

Solar thermal collectors and panels shall be listed and labeled in accordance with ICC 901/SRCC 100.

Code Changes

2020 National Electrical Code (NEC)

Code Changes

2020 National Electrical Code (NEC)

- Highlights:
- **110.22 Identification of disconnecting means** – circuit source (other than 1 & 2 family)
- **210.8 GFCI protection** – expanded requirements
- **220.12 Lighting load for non-dwelling occupancies** – now limited to non-dwellings
- **230.67 Surge protection** – new requirements for dwellings

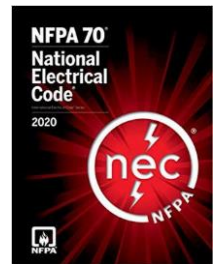

Code Changes

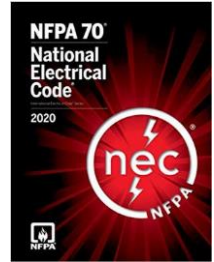

2020 National Electrical Code (NEC)

- Highlights:
- **230.71 Number of service disconnects** – tightens rules around max. six disconnects
- **230.85 Emergency disconnects** – one & two family; readily accessible exterior location
 - **CT Amendment:** For new one- and two- family dwelling units...
- **242 Overvoltage protection** – reorganized and expanded
- **625 Electric vehicle power transfer systems** – includes bidirectional current flow

Wrap Up



Wrap Up

- Codes always changing
 - Energy conservation
 - Advances in technology
 - Specific issues
- Track the new code adoption
- Projects with **permits applied for** after the adoption date will be under the 2018 ICC codes
 - Current proposed adoption date October 1, 2020.
- Stay engaged and have your say.



Use of OEDM Training Materials

Use of Office of Education and Data Management (OEDM) training materials must be approved in writing by the State of Connecticut, Department of Administrative Services' Office of Communications. In approving of such use, the State of Connecticut assumes no liability associated with such use, including, but not limited to, the user's dissemination of any inaccurate information or interpretation in connection with its use of these training materials. Use of the training materials is at the sole risk of the user, and the State's approval of the use does not constitute an endorsement of the user or its intended use.

146



2020 State Building Code

Spring 2020 Update

QUESTIONS?

