

## 2020 Connecticut State Building & Fire Codes : Projected Development Timetable

Most current schedule will be posted at <https://portal.ct.gov/DASCodeChange>

- Drafting of 2020 SBC amendments 1/1/19 – 2/28/19
- **Code Change Proposals Received** 2/1/19 – 4/30/19  
*Code Change Proposal Form on Web*
- Committees/Work groups Review 3/1/19 – 6/30/19
  - Codes Amendment Subcommittee
  - Work groups
- Final drafts development 7/1/19 – 8/31/19
- Review drafts 9/1/19 – 10/31/19
- Codes & Standards Drafts Approval 11/13/19
- **Public comment period** 12/1/19 – 2/29/20
- Legislative review/approval 3/1/20 – 5/31/20
- Effective 10/1/20

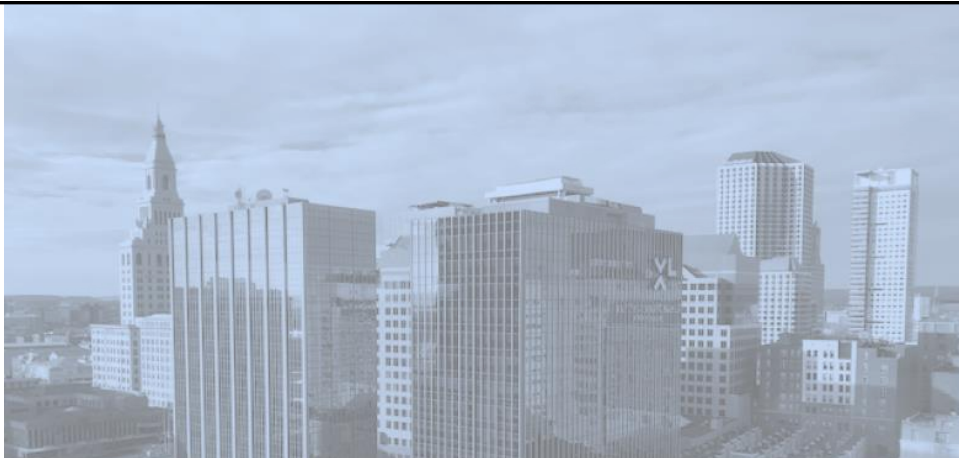

### Motor Fuel-Dispensing Facilities 2015 IFC Chapter 23

Spring 2019 Career Development Series

John Doucette, Fire And Life Safety Specialist  
Chuck Kiessler, Fire And Life Safety Specialist

DAS Office of Education and Data Management



# Motor Fuel Dispensing Facilities



## Class objective

- Identify the Statutes and Codes that cover construction and operational requirements for new and existing Motor fuel dispensing and refueling facilities.
- Understand installation of tanks, piping, and dispensing equipment.
- Removal of Underground storage tanks, gasoline and diesel fuel.
- Testing of newly installed tanks, piping and associated equipment prior to operation.
- Using this presentation the AHJ should feel comfortable inspecting a new and existing motor fueling facility from permit to completion.



# Components of a motor fueling system

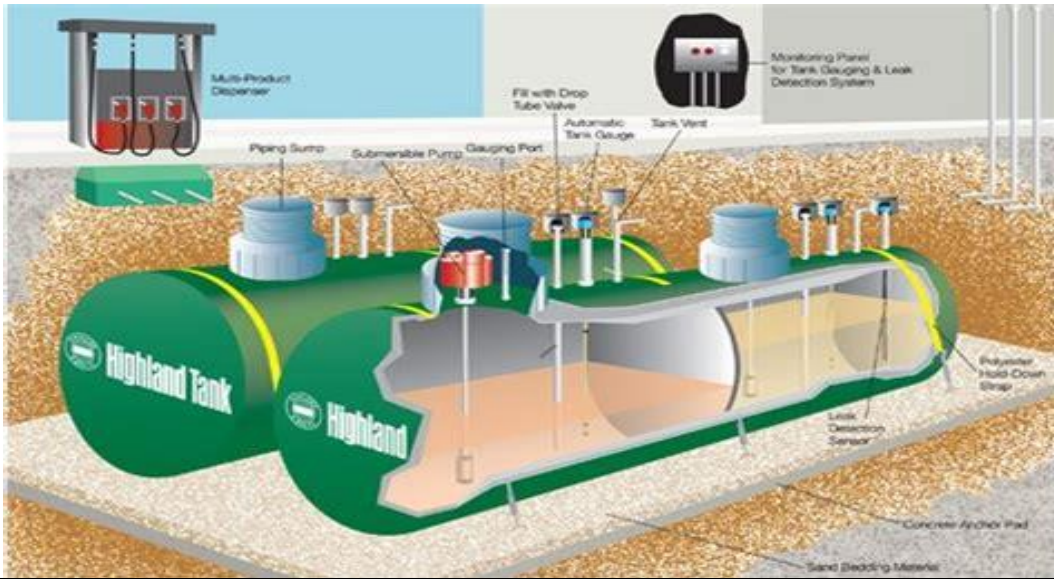

## WARNING!!!

### This is not a Plan Review Template

- Please be advised there are other Code Sections in IFC Chapters 23 and 57, NFPA 30 Chapters 21 and 23, NFPA 30A, NFPA 1 Chapters 42 and 66 that need to be included in YOUR Plan Review.
- This presentation **does not** cover the brick and mortar parts of building a new motor fueling station. This presentation refers to the Sections of IFC that pertain to motor fueling.

## Permits and Plan Submittal

- Plan submittal and review found in Sec. 104 of Part I of Administrative portion of CSFSC 2018 Edition.
- Permit Requirement found in Sec. 105 of Part I of Administrative portion of CSFSC 2018 Edition.

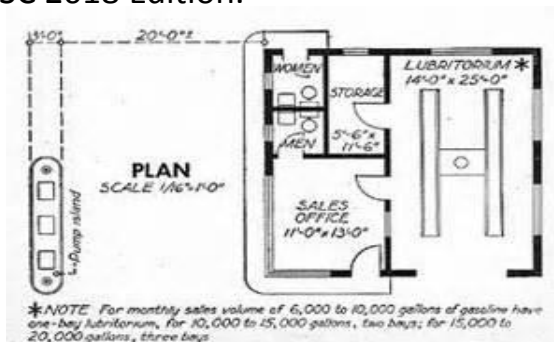

# Location of UST's and Dispensing Devices

## IFC 2015 Edition

- 5704.2.11 UST Location
- 2303.1 Dispenser Location

## Site Plan

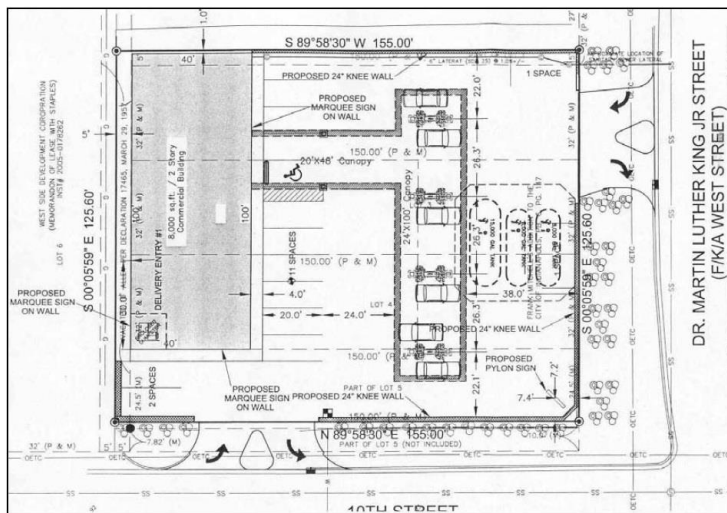

## Removal of Existing UST

- IFC 5704.2.14.1 has been deleted from Part III of the CFSC
- NFPA 1 2015 Edition Chapter 42.3.3.1 (Underground Tanks) sends us to NFPA 30 (**2018 Edition**) Chapters 21 and 23

## UST Removal

- (1) The steps described in 21.7.4.3.3(1) through 21.7.4.3.3(5) shall be followed.
- (2) All exposed piping, gauging and tank fixtures, and other appurtenances, including the vent, shall be disconnected and removed.
- (3) All openings shall be plugged, leaving a 1/4 in. (6 mm) opening to avoid buildup of pressure in the tank.
- (4) The tank shall be removed from the excavated site and shall be secured against movement.



## UST Removal

- (5) Any corrosion holes shall be plugged.
- (6) The tank shall be labeled with its former contents, present vapor state, vapor-freeing method, and a warning against reuse.
- (7) The tank shall be removed from the site as authorized by the authority having jurisdiction, preferably the same day

## UST Removal

- **21.7.4.3.3**
- (1) All applicable authorities having jurisdiction shall be notified.
- (2)\*A safe workplace shall be maintained throughout the pre-scribed activities.
- (3) All flammable and combustible liquids and residues shall be removed from the tank, appurtenances, and piping and shall be disposed of in accordance with regulatory requirements and industry practices, using a written procedure.



## UST Removal

- (4) The tank, appurtenances, and piping shall be made safe by either purging them of flammable vapors or inerting the potential explosive atmosphere. Confirmation that the atmosphere in the tank is safe shall be by testing of the atmosphere in the tank is safe shall be by testing of the atmosphere using a combustible gas indicator if purging, or an oxygen meter if inerting, at intervals in accordance with written procedures.
- (5) Access to the tank shall be made by careful excavation to the top of the tank.

## UST Removal





## Installation of UST



## Part III CFSC

- Part IV of IFC is Special Occupancies and Operation.  
**NOTE: This is not to be confused with Part IV of CFSC!!!!**
- Part IV of IFC Chapter 23. MOTOR FUEL-DISPENSING FACILITIES AND REPAIR GARAGES



## Underground Tanks



## UST Installation





## Underground tank installation Code Section(s)

- **5704.2.11**
- **Underground tanks.** Underground storage of flammable and *combustible liquids in tanks shall comply with Section 5704.2 and Sections 5704.2.11.1 through 5704.2.11.4.2.*
  - Location
  - Depth and cover
  - Overfill protection
  - Leak prevention
  - Inventory control
  - Leak detection



## Depth of Cover



## UST (cont)



## Tank testing prior to cover

- Section 5704.2.12.1 Acceptance Testing
  - Testing to be done prior to placing it in service (NFPA 30 Sec 21.5)
- Section 5704.2.12.2 Testing of underground tanks
  - Tightness test witnessed by AHJ
  - Approval of tank and piping testing by AHJ prior to covering

## Remote tank sumps and pumps

- IFC 2015 2306.6.3 sends us to NFPA 30A 2018 Edition.  
Section 6.4 (NFPA 30A)
  - Listed
  - Leak Detection Device



## UST (cont)



## Remote tank sumps and pumps



## UST (cont)



Spill  
Bucket

## Spill Bucket



## UST Fill Spill buckets



## Spill Bucket

Drain that if opened will introduce rain water etc back into the UST. This liquid is Haz waste and should be pumped out and disposed of properly





## Fill Spill buckets



## Tank Venting

- IFC 2015 Edition Chapter 57
- Tank Venting Shall be in Accordance with 5704.2.7.3.1 through 5704.2.7.3.5.3
  - Vent Lines
  - Vent Line Flame arrestors and Pressure-vacuum vents
  - Vent Pipe Outlets



## Tank Venting (cont)

### IFC language continued

- Installation of Vent piping
- Manifolding
- Underground Tanks
- Tanks storing Class I liquids

## UST Tank Vent Piping



## Flame Arrestor



## Piping to Dispensers



## Piping (Cont)

- 2306.6.3 Piping, valves, fittings and ancillary equipment for underground tanks.
  - IFC Chapters 57 and NFPA 30A
    - Galvanic and corrosion protection
    - Leak detection
    - Special materials
    - Piping supports
    - Backflow protection
    - Flexible connections
    - Testing

## PIPING SYSTEMS



**5703.6.3 Testing....** piping, before being covered, enclosed or placed in use, **shall**

- be hydrostatically tested to 150 percent of the maximum anticipated pressure
- or pneumatically tested to 110 percent of the maximum anticipated pressure
- but not less than 5 (psig).
- This test shall be maintained for a sufficient time period to complete visual inspection of joints and connections.
- For not less than 10 minutes, there shall be no leakage or permanent distortion.
- Care shall be exercised to ensure that these pressures are not applied to vented storage tanks.
- Such storage tanks shall be tested independently from the piping.

## Manufacturer's Instructions recommended Testing of piping and devices

- Air testing of primary product lines
  - Manufacturer installation instructions recommend test pressure (50 psi)
- Air testing of secondary containment lines
  - Manufacturer installation instructions recommends test pressure (5psi)



## Nupi Smart flex piping



## Double wall product piping

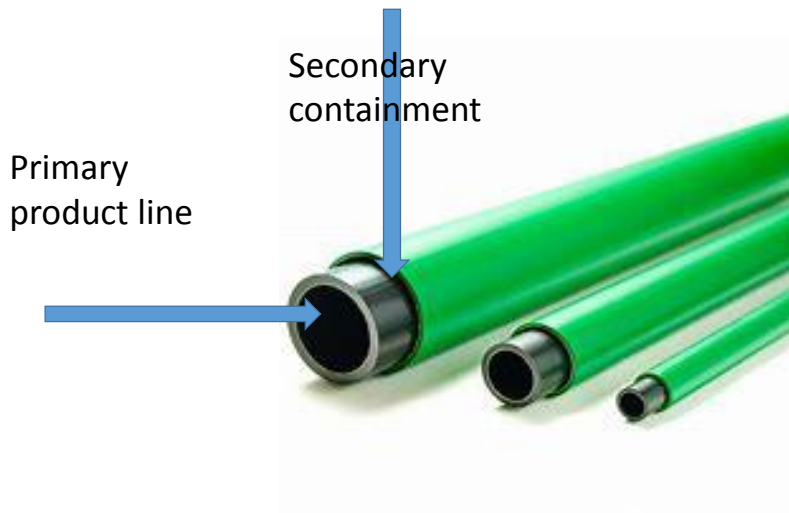

## Primary Product line



## Product Line Testing



2306.6.3 Piping, valves, fittings and ancillary equipment for underground tanks.

IFC Chapters 57 and NFPA 30A

- **5.4.1 General. All piping and secondary containment piping** Shall be tested before being covered, enclosed, or placed in service in accordance with the requirements of Section 27.7 of NFPA 30, *Flammable and Combustible Liquids Code*.

## Secondary containment piping testing NFPA 30A

- **5.4.2\* Secondary Containment Piping.**
- In addition to the test required in 5.4.1, secondary containment-type piping shall have the interstitial space (annulus) tested hydrostatically or with air pressure at minimum gauge pressure of 34.5 kPa (5 psi) or shall be tested in accordance with the listing or the manufacturer's instructions. The pressure source shall be closed from the system being tested to ensure that the test is being conducted on a closed system.







**DISPENSER ISLAND**



## 2306.6.3 Piping, valves, fittings and ancillary Testing of the dispenser sump for liquid tight



TIME OUT



## Crash Valve Installation

- IFC 2306.7.4
- This Code Section is for new installation.
- Specific installation regarding location, orientation and connection
- In accordance with MFG installation instructions
- Tested at time of installation.
- Maintained in accordance with NFPA 1



After Crash Valve



After Crash Valve



## Bottom of Crash Valve after crash



## Electrical Requirements IFC 2301.5 Electrical

### **IFC 2301.5 Sends us to NFPA 30A and NFPA 70**

- **8.3 Installation in Classified Locations.**

**8.3.1 Where Class I liquids are stored, handled, or dispensed,** electrical wiring and electrical utilization equipment shall be designed and installed in accordance with the requirements for Class I, Division 1 or Division 2 classified locations, as set forth in 8.3.2 and in *NFPA 70, National Electrical Code*.

- *Exception: The storage, handling, and dispensing of methyl alcohol-based windshield washer fluids shall not cause an area to be designated as a hazardous (classified) location.*



## Electrical Requirements (cont)

- **8.3.2\*** Table 8.3.2 shall be used to delineate and classify areas for the purposes of installing electrical wiring and electrical utilization equipment where Class I liquids are stored, handled, or dispensed. [See also Figure 8.3.2(a) and Figure 8.3.2(b).]
- *Exception: The extent of the classified area around a vacuum-assist blower shall be permitted to be reduced if the blower is specifically listed for such reduced distances.*

## Classified areas adjacent to dispensers

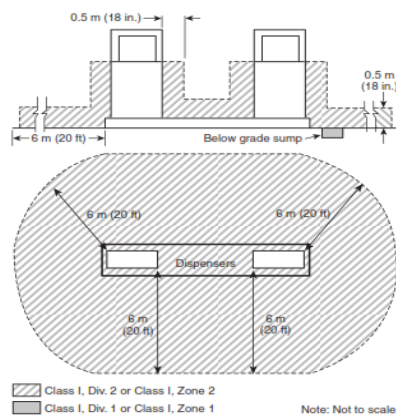

FIGURE 8.3.2(a) Classified Areas Adjacent to Dispensers.



## Electrical Power

- **(1) Fittings.**
  - Enclosures that contain connections or equipment shall be provided with an integral sealing means, or sealing fittings listed for the location shall be used. Sealing fittings shall be listed for use with one or more specific compounds and shall be accessible.
- **(2) Compound.**
  - The compound shall provide a seal to minimize the passage of gas and/or vapors through the sealing fitting and shall not be affected by the surrounding atmosphere or liquids. The melting point of the compound shall not be less than 93°C (200°F).

## Electrical (cont)

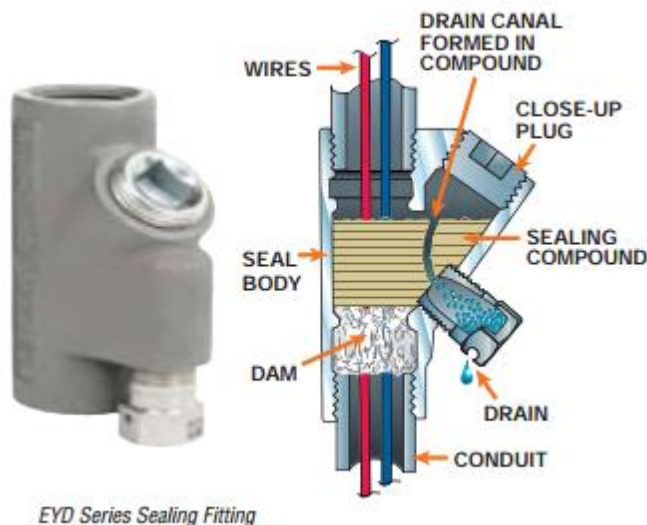

## 1<sup>st</sup> step for sealing electrical fittings (EY's)



## Sealing compound





## Dispenser Installation



## Listed Equipment

IFC 2015 Edition

- **2306.7.1 Listed equipment. Electrical equipment, dispensers, hose, nozzles and submersible or subsurface pumps used in fuel-dispensing systems shall be *listed*.**



## Dispenser Installation

- 2015 Edition IFC Chapter 23
  - 2306.7.3 Mounting of Dispensers
- IFC Section 312 has been deleted, therefore we use CSFPC for vehicle protection**
- Sec. 100.10 Where an area addressed in this code pertains to a construction feature, the Connecticut State Fire Safety Code shall prevail. Where the CSFSC or SBC are silent on an issue, the provisions of this code shall apply

## Vehicle Protection at dispensers

- NFPA 1 2015 Edition
- 42.5.3.4 Dispensing devices shall be mounted on a concrete island or shall be otherwise protected against collision damage by means acceptable to the AHJ..... They have to be installed according to the manufacturers installation instructions.



## Flexible piping inside the sump



## Dispenser Installation

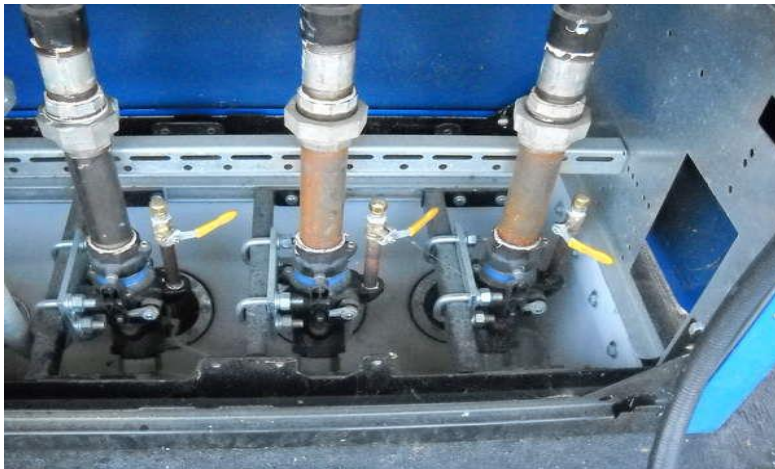

## Emergency Disconnect Switches

- **2303.2 Emergency disconnect switches.**
- **Approved**, clearly identified and readily accessible
- At an *approved location*
- The emergency disconnect switch for exterior fuel dispensers shall be located within 100 feet (30 480 mm) of, but not less than 20 feet (6096 mm) from, the fuel dispensers.

## Emergency Stop (cont)

- If the fuel dispenser is powered by stand-by or emergency power in addition to normal street power test function under both power sources.
- Testing of the device is done with product flowing.



## EMERGENCY Disconnect Switch



## Dispenser Hose

- **2306.7.5 Dispenser hoses** shall be not more than 18 feet (5486 mm) in length unless otherwise *approved*.  
*Dispenser hoses shall be listed and approved. When not in use, hoses shall be reeled, racked or otherwise protected from damage.*
- **2306.7.5.1 Emergency breakaway devices.** Dispenser hoses for Class I and II liquids shall be equipped with a *listed emergency breakaway device designed to retain liquid on both sides of a breakaway point.*



## Dispenser Hose



## Breakaway Device

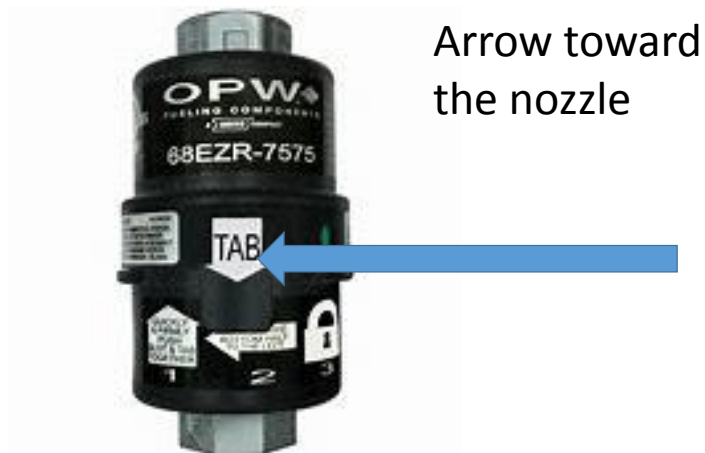

## Fuel Delivery Nozzle

- **2306.7.6 Fuel delivery nozzles.**

A listed automatic-closing-type hose nozzle valve with or without a latch-open device shall be provided on island-type dispensers used for dispensing Class I, II or III liquids.

Nozzle



## Final grading and tank pad installation



## NFPA 1 Operations and Maintenance Chapter 42 Refueling 2015 Edition





## Refueling

### 2018 CSFPC

(Amd) **42.2.1.1** Fuel processes at automotive service stations, service stations located inside buildings, and fleet vehicle service stations, shall comply with CSFSC, SBC, NFPA 30A, *Code for Motor Fuel Dispensing Facilities and Repair Garages*, and Sections 42.2 through 42.8.

## Chapter 42

### 42.3.2 General Requirements.

**42.3.2.1** Liquids shall be stored in the following:

- (1) Approved closed containers that do not exceed 60 gal capacity and are located outside buildings
- (2) Tanks or approved closed containers located inside motor fuel dispensing facilities or repair garages
- (3) Aboveground tanks, underground tanks, and containers in accordance with the requirements of 42.3.3
- (4) Tanks supplying marine service stations in accordance with 42.9.2.



**42.4.2.5** Each fill pipe shall be identified by color code or other marking to identify the product for which it is used.

#### Fills

- Fills are **color coded**
- Yellow = **diesel**
- Brown = **kerosene**
- Red = **Perm. Unl.**
- White = **Reg. Unl.**
- Blue = **Mid grade Unl.**



## Chapter 42

**42.5.3.3** A control shall be provided that will permit the pump to operate only when a dispensing nozzle is removed from its bracket or normal position with respect to the dispensing device and the switch on this dispensing device is manually actuated. This control shall also stop the pump when all nozzles have been returned to their bracket normal non-dispensing position.



## Chapter 42

**42.5.3.4** Dispensing devices shall be mounted on a concrete island or shall otherwise be protected against collision damage by means acceptable to the AHJ. Dispensing devices shall be securely bolted in place.

**42.5.3.5** Dispensing devices used to fill portable containers with home heating fuels shall be located at least 20 ft (6 m) from any dispensing devices for motor fuels.



## Chapter 42 Fuel Dispensing Systems

- **42.5.3.6 Inspections**
  - Periodically Inspected by a knowledgeable person to verify properly working and not leaking.
- **42.5.3.6.1 Exterior Inspections**
  - Visual inspection weekly documented. (Hose, hose nozzle valve, breakaway valve, hose swivel).
- **42.5.3.6.2 Internal Dispenser Cabinet Inspections**
  - Inspected for leaks, damage, corrosion, weathering, at least monthly and documented



## BREAKAWAY DEVICE



## DISPENSERS



# DISPENSERS



## DISPENSERS



## Fuel Dispensing Devices

### **42.5.5 Requirements for Dispensing Hose.**

- All hose shall be listed.
- Hose length shall not exceed 18' at automotive stations.



## Fuel Dispensing Devices

### 42.5.5.2

On Class I & II liquids dispensing hose, a listed emergency breakaway device designed to retain liquid on both sides of the breakaway point.



## Fuel Dispensing Devices

### 42.5.3.6.3 Maintenance

Only person knowledgeable in performing the require maintenance shall perform the work.

All electrical power to the dispensing devices, and associated equipment control circuits shall be shut off at the main electrical disconnect panel.

The emergency shutoff valve at the dispenser, if installed, shall be closed.

All traffic and unauthorized persons shall be prevented from coming within 20' of the dispensing device.



## Chapter 42

### **42.5.4 Requirements for Remote/Submersible Pumps.**

Each pump shall have a listed leak detection device for the piping and dispensing system and tested at least annually.

## Chapter 42

### **42.7 Operational Requirements.**

**42.7.1 Scope.** Section 42.7 shall apply to those requirements that relate to the operation of motor fuel dispensing facilities and fuel dispensing systems.

#### **42.7.2 Basic Requirements.**

**42.7.2.1\* Inventory Control.** Accurate daily inventory records shall be maintained and reconciled for all liquid fuel storage tanks for indication of possible leakage from tanks or piping. The records shall be kept on the premises or shall be made available to the AHJ for inspection within 24 hours of a written or verbal request.





## Chapter 42



## Chapter 42

### **42.7.2.5 Basic Fire Control.**

- Sources of Ignition (20')
- Fire Extinguishers (80 B:C 100') ( Maximum TD to an extinguisher)
- Fire Suppression Systems (where required)
- Signs (Warning signs)



## Chapter 42

**42.7.4.2** There shall be at least one attendant on duty while the self-service facility is open for business. The attendant's primary function shall be to supervise, observe, and control the dispensing of Class I liquids while said liquids are being dispensed.



### Responsibility of the Attendant NFPA 1 Section 42.7.4.3

- (1) Prevent the dispensing of Class I liquids into portable containers not in compliance with 9.2.3.1
- (2) Prevent the use of hose nozzle valve latch-open devices that do not comply with 6.6.1
- (3) Control sources of ignition
- (4) Immediately activate emergency controls and notify the fire department of any fire or other emergency
- (5) Handle accidental spills and fire extinguishers if needed



## Responsibility of Attendant (cont)

**42.7.4.3.1** The attendant or supervisor on duty shall be mentally and physically capable of performing the functions and assuming the responsibility prescribed in 42.7.4. [30A:9.4.3.1]

**42.7.4.4** Operating instructions shall be conspicuously posted in the dispensing area. [30A:9.4.4]

## NFPA 1 Annual Crash Valve Testing

### **For operational requirements NFPA 1 references 30A**

**6.3.9.1** The automatic-closing feature of this valve shall be tested at the time of installation and at least once a year thereafter by manually tripping the hold-open linkage. Records of such tests shall be kept at the premises or shall be made available for inspection by the authority having jurisdiction within 24 hours of a verbal or written request.



## On Demand Fueling

- (Add) **42.12 On Demand Fueling.**
- (Add) **42.12.1** On demand fueling shall be in accordance with the requirements of NFPA 30A.
- (Add) **42.12.1.1** The 2018 edition of NFPA 30A as adopted by this code are amended for use in the State of Connecticut as follows:  
NFPA 30A Section 14.2.3.1 The vehicle operator training shall be approved by the State Fire Marshal.



### Use of OEDM Training Materials

Use of Office of Education and Data Management (OEDM) training materials must be approved in writing by the State of Connecticut, Department of Administrative Services' Office of Communications. In approving of such use, the State of Connecticut assumes no liability associated with such use, including, but not limited to, the user's dissemination of any inaccurate information or interpretation in connection with its use of these training materials. Use of the training materials is at the sole risk of the user, and the State's approval of the use does not constitute an endorsement of the user or its intended use.

104



# Motor Fuel Dispensing Facilities



Office of the State Fire Marshal

450 Columbus Blvd

Hartford , Ct, 06103

John Doucette, Fire And Life Safety Specialist

[John.Doucette@Ct.gov](mailto:John.Doucette@Ct.gov)

Chuck Kiessling, Fire And Life Safety Specialist

[Chuck.Kiessling@Ct.gov](mailto:Chuck.Kiessling@Ct.gov)

**THE  
END**

