



State of Connecticut
Department of Administrative Services
Division of Construction Services
Office of Education and Data Management

*Office of Education and Data Management
Fall 2016 Career Development Series*

Significant Changes to the IPC

Presented by
Carlo Sarmiento, B.O., City of Derby

This presentation will review the significant changes to the 2012 International Plumbing Code portion of the new 2016 Connecticut State Building Code effective October 1, 2016. Changes to definitions and general requirements will be presented, including water heaters, water supply and distribution, and storm drainage.

International Plumbing Code

- Chapter 1 Scope and Administration
- Chapter 2 Definitions
- Chapter 3 General Regulations
- Chapter 4 Fixture, Faucets and Fixtures Fittings
- Chapter 5 Water Heaters
- Chapter 6 Water Supply and Distribution
- Chapter 7 Sanitary Drainage
- Chapter 8 Indirect/Special Waste
- Chapter 9 Vents
- Chapter 10 Traps, Interceptors, and Separators
- Chapter 11 Storm Drainage
- Chapter 12 Special Piping and Storage Systems
- Chapter 13 Gray Water Recycling Systems
- Chapter 14 Referenced Standards

Presentation Notes:

- Slides throughout this presentation will:
- a. Identify the significant changes in the IPC,
 - b. Provide ICC's basic grouping of the change as modification, clarification, addition or deletion,
 - c. Provide a Short Summary of Change,
 - d. Identify the Code Section(s) effected by the change(s).
 - e. Connecticut Amendments will be typed in red.
 - f. Slides will provide 2012 code information followed by explanatory materials, diagrams and tables along with general comparisons when needed to the 2003 IPC.
- This Presentation is for training proposes only, refer directly to the 2016 State Building Code for actual code language.

Chapter 1
Scope and Administration

CHAPTER 1 – SCOPE AND ADMINISTRATION

- The following slides highlight the code sections within the IPC Chapter 1 with Connecticut Amendments.
- (Amd) **101.1 Title.** The 2012 International Plumbing Code and this Section shall be known as the 2012 International Plumbing Code portion of the 2016 State Building Code, hereinafter referred to as "the code" or "this code".

Chapter 1

(Amd) 101.2 Scope.

Noted Exceptions to the scope of this code:

1. Detached one- and two-family dwellings and multiple single-family dwellings (townhouses) not more than three stories high with separate means of egress and their accessory structures shall comply with the 2012 International Residential Code portion of the State Building Code.
2. Plumbing systems in existing buildings undergoing repair, alteration, addition or change of occupancy may comply with the 2012 International Existing Building Code portion of the State Building Code.

Chapter 1

(Add) 101.2.1 Gas.

(Add) 101.2.2 Electrical.

Section 102 - Applicability

(Amd) 102.6 Historic buildings.

Chapter 1

(Del) **SECTION 103 – DEPARTMENT OF PLUMBING INSPECTION.**

(Add) **SECTION 103 – ENFORCEMENT AGENCY**

(Add) **103.2 Appointment.**

(Add) **103.3 Employees.**

(Add) **103.4 Restriction of employees.**

Chapter 1

(Del) **SECTION 104 – DUTIES AND POWERS OF CODE OFFICIAL**

(Add) **SECTION 104 – DUTIES AND POWERS OF BUILDING OFFICIAL**

(Add) **104.1 General.**

Chapter 1

Section 105 - Approval

(Amd) **105.1 Modifications.**

(Add) **105.1.1 Action on application.**

(Add) **105.1.2 Records.**

(Add) **105.1.3 Accessibility exemption.**

Chapter 1

Section 106 - Permits

(Amd) 106.1 When Required.

(Add) 106.2.1 State agency exemptions.

(Amd) 106.4 By whom application is made.

Chapter 1

(Amd) 106.5 Permit issuance.

(Amd) 106.5.6 Retention of construction documents.

Exception: In accordance with the provisions of subsection (e) of section 29-261 of the Connecticut General Statutes, upon receipt of a written request signed by the owner of plans and specifications on file for a single-family dwelling or out-building, the building official shall immediately return the original plans and specifications to the owner after a certificate of occupancy is issued with respect to the plans and specifications.

(Del) 106.6.1 Work commencing before permit issuance.

(Amd) 106.6.2 Fee schedule.

(Amd) 106.6.3 Fee refunds.

Chapter 1

Section 107 – Inspections and Testing

(Add) 107.2.6 Posting of required inspections.

(Add) 107.8 Notification of inspection and testing results.

Chapter 1

(Amd) **108.4 Violation penalties.**

(Amd) **108.5 Stop work orders.**

(Del) **SECTION 109 – MEANS OF APPEAL**

(Add) **SECTION 109 – MEANS OF APPEAL.**

(Add) **109.1 Means of appeal.**

Chapter 2

Definitions

Chapter 2

CHAPTER 2 – DEFINITIONS

(Amd) **201.3 Terms defined in other codes.**

(Add) **202.1 Definitions. Add or amend the following definitions:**

(Add) **BUILDING OFFICIAL.**

(Amd) **REGISTERED DESIGN PROFESSIONAL.**

Chapter 2

Plumbing Fixture Definition

CHANGE TYPE: Modification

CHANGE SUMMARY: The definition of "plumbing fixture" has been modified to include fixtures such as waterless urinals.

2012 CODE: Section 202

Plumbing Fixture.

Chapter 2

Plumbing Appliance Definition

CHANGE TYPE: Clarification

CHANGE SUMMARY: The definition of "plumbing appliance" has been changed to clarify the difference between appliances and fixtures.

2012 CODE: Section 202

Plumbing Appliance

Chapter 2

Grease Interceptor Definition

CHANGE TYPE: Modification

CHANGE SUMMARY: The definition of "grease interceptor" has been modified for consistency with current industry terms for the two general types of grease interceptors being used in plumbing installations.

2012 CODE: Section 202

Grease Interceptor.

Hydromechanical.

Gravity.

Chapter 3 General Regulations

Chapter 3

Material identification and third-party certification

CHANGE TYPE: Clarification

CHANGE SUMMARY: The identification requirements for plumbing products and materials have been clarified.

2012 CODE: 303.1 Identification.

303.4 Third-Party Certification.

Chapter 3

CHAPTER 3 - GENERAL REGULATIONS

(Amd) **305.4 Freezing.** A water, soil or waste pipe shall not be installed outside of a building, or concealed in outside walls or in any place subjected to freezing temperature, unless adequate provision is made to protect such pipe from freezing by insulation or heat or both. Water service pipe shall be installed not less than 48 inches deep.

(Del) **305.4.1 Sewer depth.** Delete without substitution.

(Del) **312.10.1 Inspections.** Delete without substitution.

(Amd) **312.10.2 Testing.** Required reduced pressure principle, double check, pressure vacuum breaker, reduced pressure detector fire protection, double check detector fire protection, and spill-proof vacuum breaker backflow preventer assemblies and hose connection backflow preventers shall be tested at the time of installation by individuals or agencies qualified to perform such inspections. It shall be the responsibility of the owner to have such tests performed and copies of test reports shall be given to the local building official. The testing procedure shall be performed in accordance with one of the following standards:

- ASSE 5013, ASSE 5015, ASSE 5020, ASSE 5047, ASSE 5048,
- ASSE 5052, ASSE 5056, CSA B64.10 or CSA B64.10.1.

Chapter 3

Parallel Water Distribution Systems

CHANGE TYPE: Modification

CHANGE SUMMARY: In parallel water distribution systems, the hot and cold water piping may now be grouped in the same pipe bundle.

2012 CODE: 308.9 Parallel Water Distribution Systems.

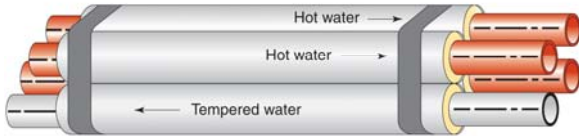

Example of insulated bundle piping

Chapter 3

Chapter 3

Sealing of Annular Spaces at Penetrations

CHANGE TYPE: Modification

CHANGE SUMMARY: The provisions for sealing any annular spaces created at piping penetrations have been revised to be consistent with the building envelope sealing requirements of the *International Energy Conservation Code*.

2012 CODE: 305.3 Pipes through foundation walls and 315.1 Sleeves Sealing of Annular Spaces.

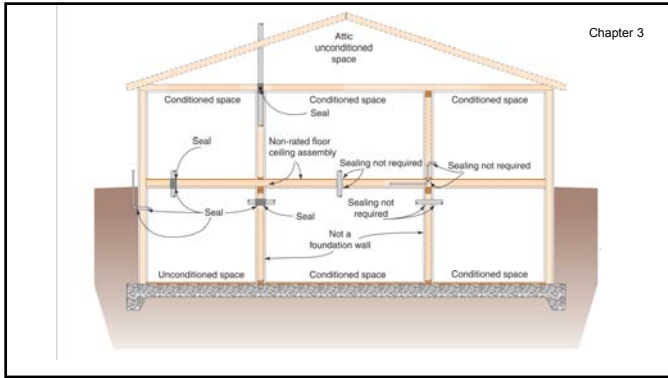

Chapter 4

Fixtures, Faucets and Fixture Fittings

Chapter 4

Table 403.1 Minimum Number of Required Plumbing Fixtures

CHANGE TYPE: Modification

CHANGE SUMMARY: Service sinks are no longer required in Group B and M occupancies where the occupant load does not exceed 15.

Chapter 4

TABLE 403.1 (IBC TABLE 2902.1) Minimum Number of Required Plumbing Fixtures* (See Sections 403.2 and 403.3)

No.	Classification	Occupancy	Description	Other
2	Business	B	Buildings for the transaction of business, professional services, other services involving merchandise, office buildings, banks, light industrial and similar uses	1 service sink ⁴
6	Mercantile	M	Retail stores, service stations, shops, salesrooms, markets and shopping centers	1 service sink ⁴

g. For business and mercantile occupancies with an occupant load of 15 or fewer, service sinks shall not be required.

***Reader's Note:** Other changes may occur in Table 403.1 that will be addressed in different areas of this presentation portions of the table not addressed remain unchanged.

Chapter 4

CHAPTER 4 – FIXTURES, FAUCETS AND FIXTURE FITTINGS

(Amd) **403.1 Minimum number of fixtures.** Plumbing fixtures shall be provided for the type of occupancy and in the minimum number shown in Table 403.1. Types of occupancies not shown in Table 403.1 shall be considered individually by the building official. The number of occupants shall be determined in accordance with the International Building Code. Occupancy classification shall be determined in accordance with the International Building Code.

Exceptions:

- The following minimum fixtures shall be provided in Group R-1 bed and breakfast establishments: Water closets – one per two guest rooms; lavatories – one per two guest rooms; bathtubs/showers – one per two guest rooms. Plumbing fixtures in Group R-1 bed and breakfast establishments shall be permitted to be accessed from hallways and corridors and to be shared by guests.
- Child washing and diaper changing facilities shall be permitted in lieu of bathtubs or showers in Group I-4 child care occupancies.

Chapter 4

Separate Toilet Facilities in Group M Occupancies

CHANGE TYPE: Modification

CHANGE SUMMARY: The exemption from separate plumbing facilities for each sex in Group M mercantile occupancies now applies where the occupant load of the occupancy does not exceed 100.

2012 CODE: 403.2 Separate Facilities

Chapter 4

(Amd) **403.2 Separate facilities.** Where plumbing fixtures are required, separate facilities shall be provided for each sex.

Exceptions:

1. Separate facilities shall not be required for dwelling units and sleeping units.
2. Separate facilities shall not be required in structures or tenant spaces with a total occupant load, including both employee and customers, of 15 or fewer.
3. Separate facilities shall not be required in mercantile occupancies in which the maximum occupant load is 100 or fewer.
4. Toilet rooms in Educational Group E Kindergarten and day care occupancies, and in Institutional Group I-4 child day care may be designated as unisex which are primarily for children's use.

(Del) **403.2.1 Family or assisted-use toilet facilities serving as separate facilities.** Delete without substitution.

Chapter 4

Relationship of Toilet Rooms and Food Preparation Areas

CHANGE TYPE: Addition

CHANGE SUMMARY: The IBC requirement prohibiting the opening of toilet rooms directly into food preparation areas is now also established in the IPC.

2012 CODE: 403.3.2 Toilet Room Location.

Chapter 4

(Del) **403.2.1 Family or assisted-use toilet facilities serving as separate facilities.** Delete without substitution.

(Amd) **405.3.4 Water closet compartment.** Each water closet utilized by the public or employee shall occupy a separate compartment with walls or partitions and a door enclosing the fixture to ensure privacy.

Exceptions:

1. Water closet compartments shall not be required in a single-occupant toilet room with a lockable door.
2. Toilet rooms located in Educational Group E Kindergarten and day care occupancies, and in Institutional Group I-4 child day care and containing two or more water closets shall be permitted to have one water closet without an enclosing compartment provided the toilet room is accessed through a door or other configuration to provide privacy.
3. This provision is not applicable to toilet areas located within Group I-3 housing areas.



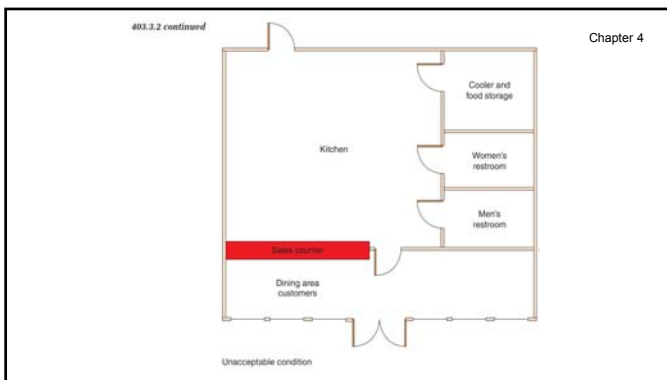

Chapter 4

Locking of Toilet Room Doors

CHANGE TYPE: Addition

CHANGE SUMMARY: Locking devices are now specifically prohibited on the egress door of toilet rooms designed for multiple occupants.

2012 CODE: 403.3.6 Door Locking.

Drinking Fountain Locations

CHANGE TYPE: Addition

CHANGE SUMMARY: Where drinking fountains are required, the permitted locations of the fountains have been specified regarding their placement in multi-tenant facilities, similar to the permitted locations for required public toilet facilities.

2012 CODE: 403.5 Required Drinking Fountains

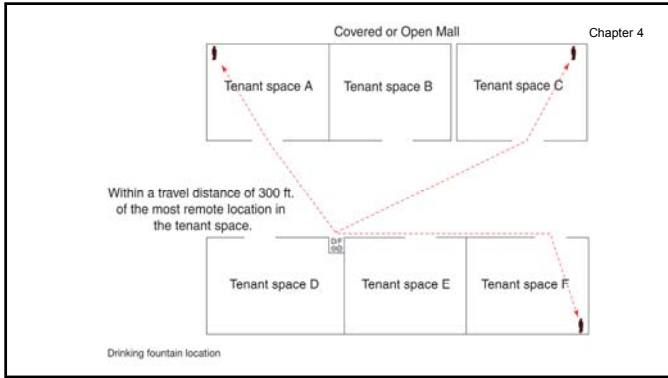

Chapter 4

Minimum Water Closet Compartment Size

CHANGE TYPE: Modification

CHANGE SUMMARY: The minimum depth of a water closet compartment containing a wall-hung water closet has been reduced from 60 inches to 56 inches.

2012 CODE: 405.3.1 Water Closets, Urinals, Lavatories, and Bidets.

Chapter 4

Amd) 405.3.5 Urinal partitions. Each urinal utilized by the public or employees shall occupy a separate area with walls or partitions to provide privacy. The walls shall begin at a height not greater than 12 inches (305 mm) from and extend not less than 60 inches (1524 mm) above the finished floor surface. The walls or partitions shall extend from the wall surface at each side of the urinal not less than 18 inches (457 mm) or to a point not less than 6 inches (152 mm) beyond the outermost front lip of the urinal measured from the finished backwall surface, whichever is greater.

Exceptions:

1. Urinal partitions shall not be required in a single occupant or family/assisted-use toilet room with a lockable door.
2. Toilet rooms located in Educational Group E Kindergarten and day care occupancies, and in Institutional Group I-4 child day care and containing two or more urinals shall be permitted to have one urinal without partitions provided the toilet room is accessed through a door or other configuration to provide privacy.

Chapter 4

Floor and Wall Drainage Connections

CHANGE TYPE: Modification

CHANGE SUMMARY: The use of a waste connector and sealing gasket is now permitted as an acceptable means to connect floor outlet plumbing fixtures, allowing for water closet installations that are provided with a gasketed waste tube outlet connection.

2012 CODE: 405.4 Floor and Wall Drainage Connections.

Chapter 4

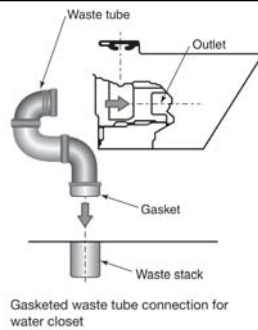

Chapter 4

Bathtub Waste Outlets and Overflows

CHANGE TYPE: Modification

CHANGE SUMMARY: Bathtubs are now required to be equipped with an overflow, and the required stopper must be watertight.

2012 CODE: 407.2 Bathtub Waste Outlets and Overflows.

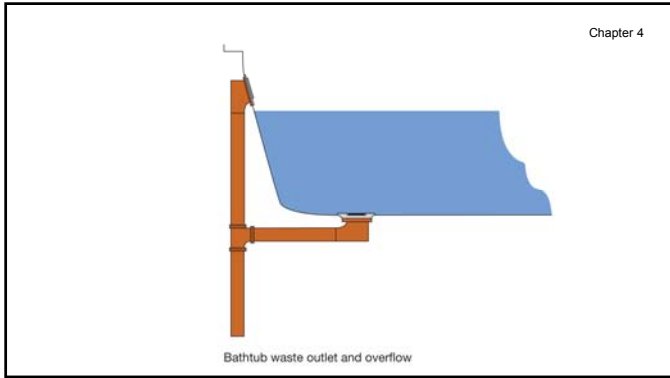

Chapter 4

Minimum Required Number of Drinking Fountains

CHANGE TYPE: Modification

CHANGE SUMMARY: The IBC provisions addressing the minimum required number of drinking fountains have been replicated in the IPC to provide clarity and consistency of application.

2012 CODE: 410.1 Approval.

410.2 Minimum Number.

Exception

410.3 Substitution.

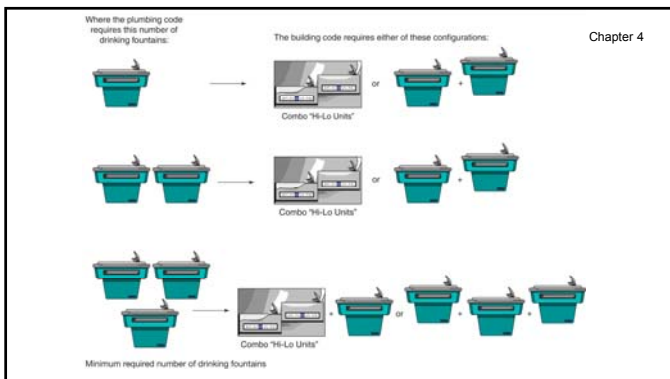

(Add) **412.5 Connection required.** Floor drains shall connect to the sanitary sewer system or to an on-site holding tank(s) when the discharge contains petroleum-based oil, grease, sand or other harmful or hazardous substances. Interceptors and separators shall be provided in accordance with Section 1003 when floor drains connect to the sanitary sewer system, and shall be installed in accordance with the Public Health Code of the State of Connecticut adopted pursuant to section 19a-36 of the Connecticut General Statutes. Floor drains shall not be connected to a storm sewer, a storm drainage system or a storm building drain. Floor drains shall have trap seals in accordance with Section 1002.4.

Shower Pan Liner Materials

Chapter 4

CHANGE TYPE: Addition

CHANGE SUMMARY: Recognition of an acceptable shower pan liner system using liquid-type, trowel-applied, load-bearing, bonded waterproof materials has been added to the current listing of acceptable shower floor liner methods.

2012 CODE: 417.5.2.6 Liquid Type, Trowel Applied, Load Bearing, Bonded Waterproof Materials.

Water Closet Personal Hygiene Devices

CHANGE TYPE: Addition

CHANGE SUMMARY: The recognition of performance standard ASME A112.4.2 now ensures the protection of the public by setting temperature limits and minimum acceptable backflow protection requirements for water closet personal hygiene devices.

2012 CODE: 424.9 Water Closet Personal Hygiene Devices.

Chapter 14:
ASME
A112.4.2-2003 (R2008) Water Closet Personal Hygiene Devices

Chapter 5
Water Heaters

Chapter 5

Water Heater Storage Tank Relief Valves

CHANGE TYPE: Clarification

CHANGE SUMMARY: It has been clarified that water heaters with separate storage tanks shall be provided with complying temperature and pressure protection.

2012 CODE: 504.4.1 Installation.

Chapter 5

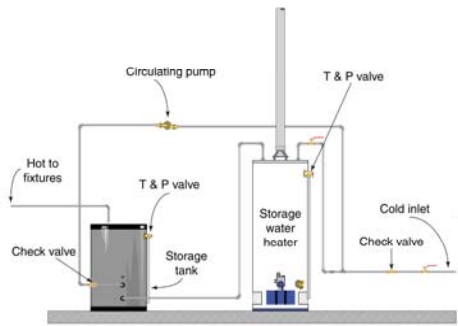

Chapter 5

Water Heater Pans

CHANGE TYPE: Modification

CHANGE SUMMARY: It has been clarified that drain pans are only required for storage-tank-type water heaters or hot water storage tanks.

2012 CODE: 504.7 Required Pan.

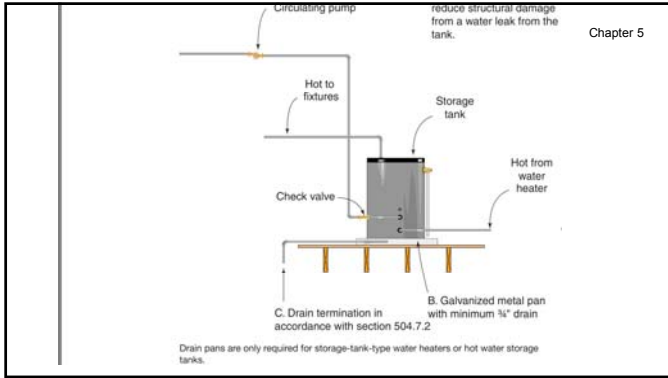

Chapter 6 Water Supply and Distribution

Chapter 6

Polyethylene of Raised-Temperature (PE-RT) Plastic Tubing

CHANGE TYPE: Addition

CHANGE SUMMARY: Polyethylene of raised-temperature (PE-RT) plastic hot and cold water tubing and distribution systems are now recognized by the IPC.

CHAPTER 6 - WATER SUPPLY AND DISTRIBUTION

(Add) **605.2.1 Lead content of drinking water pipe and fittings.** Pipe, pipe fittings, joints, valves, faucets and fixture fittings utilized to supply water for drinking or cooking purposes shall comply with NSF 372 and shall have a weighted average lead content of 0.25 percent or less.

(Amd) **608.17 Protection of individual water supplies.** An individual water supply shall be located and constructed so as to be safeguarded against contamination in accordance with the Public Health Code of the State of Connecticut adopted pursuant to section 19a-36 of the Connecticut General Statutes.

(Del) **608.17.1 through 608.17.8.** Delete subsections and referenced table without substitution.

TABLE 308.5 Hanger Spacing

Piping Material	Maximum Horizontal Spacing (Feet)	Maximum Vertical Spacing (Feet)
Polyethylene of Raised Temperature (PE-RT) pipe	2.67 (32 inches)	10 ⁰

**Reader's Note: Other changes may occur in Table 308.5 that will be addressed in different areas of this presentation portions of the table not addressed remain unchanged.*

TABLE 605.3 Water Service Pipe

Material	Standard
Polyethylene of raised temperature (PE-RT) plastic tubing	ASTM F 2769

**Reader's Note: Other changes may occur in Table 605.3 that will be addressed in different areas of this presentation portions of the table not addressed remain unchanged.*

TABLE 605.4 Water Distribution Pipe

Material	Standard
Polyethylene of raised temperature (PE-RT) plastic tubing	ASTM F 2769

**Reader's Note: Other changes may occur in Table 605.4 that will be addressed in different areas of this presentation portions of the table not addressed remain unchanged.*

TABLE 605.5 Pipe Fittings

Material	Standard
Fittings for polyethylene of raised temperature (PE-RT) plastic tubing	ASSE 1061; ASTM F 877; ASTM F 1807; ASTM F 2080; ASTM F 2098; ASTM F 2159; ASTM F 2434; ASTM F 2735; CSA B137.5
Fittings for cross-linked polyethylene (PEX) plastic tubing	ASSE 1061; ASTM F 877; ASTM F 1807; ASTM F 1960; ASTM F 2080; ASTM F 2093; ASTM F 2159; ASTM F 2434; ASTM F 2735; CSA B137.5

605 Continued

Chapter 6

***Reader's Note:** Other changes may occur in Table 605.5 that will be addressed in different areas of this presentation; those portions of the table not addressed remain unchanged.

605.25 Polyethylene of Raised Temperature Plastic. Joints between polyethylene of raised temperature plastic tubing and fittings shall be in accordance with Section 605.25.1 and Section 605.25.2.

605.25.1 Flared Joints. Flared pipe ends shall be made by a tool designed for that operation.

605.25.2 Mechanical Joints. Mechanical joints shall be installed in accordance with the manufacturer's instructions. Fittings for polyethylene of raised temperature plastic tubing shall comply with the applicable standards listed in Table 605.5 and shall be installed in accordance with the manufacturer's installation instructions. Polyethylene of raised temperature plastic tubing shall be factory marked with the applicable standards for the fittings that the manufacturer of the tubing specifies for use with the tubing.

Chapter 14:

ASTM

F 2735-09 Standard Specification for SDR9 Cross-linked Polyethylene (PEX) and Raised Temperature (PE-RT) Tubing

F 2769-09 Polyethylene of Raised Temperature (PE-RT) Plastic Hot and Cold-Water Tubing and Distribution Systems

***Reader's Note:** Other changes may occur in the standards in Chapter 14 that will be identified in different areas of this presentation.

Chapter 6

Table 605.3 Polyethylene (PE) Water Service Pipe

CHANGE TYPE: Addition

CHANGE SUMMARY: Reference standard AWWA C901, "Polyethylene (PE) Pressure Pipe and Tubing, ½ in. (13 mm) Through 3 in. (76 mm), for Water Service," has been added to the list of standards in Table 605.3 regulating PE plastic water service pipe and tubing.

Chapter 6

TABLE 605.3 Water Service Pipe

Material	Standard
Polyethylene (PE) plastic pipe	ASTM D 2239; ASTM D 3035; AWWA C901; CSA-B137.1
Polyethylene (PE) plastic tubing	ASTM D 2737; AWWA C901; CSA B137.1

***Reader's Note:** Other changes may occur in Table 605.3 that will be addressed in different areas of this presentation portions of the table not addressed remain unchanged.

Chapter 14:

AWWA

C901-08 Polyethylene (PE) Pressure Pipe and Tubing, ½ in. (13 mm) Through 3 in. (76 mm), for Water Service

***Reader's Note:** Other changes may occur in the standards in Chapter 14 that will be identified in different areas of this presentation

Chapter 6

Table 605.3 PEX Water Service Pipe

CHANGE TYPE: Addition

CHANGE SUMMARY: Reference standard AWWA C904, "Cross-Linked Polyethylene (PEX) Pressure Pipe, ½ in. (12 mm) Through 3 in. (76mm) for Water Service," has been added to the list of standards in Table 605.3 regulating PEX water service piping.

Chapter 6

CHANGE TYPE: Addition

CHANGE SUMMARY: Reference standard AWWA C904, "Cross-Linked Polyethylene (PEX) Pressure Pipe, ½ in. (12 mm) Through 3 in. (76 mm) for Water Service," has been added to the list of standards in Table 605.3 regulating PEX water service piping.

2012 CODE:

TABLE 605.3 Water Service Pipe

Material	Standard
Cross-linked polyethylene (PEX) plastic pipe and tubing	ASTM F 876; ASTM F 877; AWWA C904; CSA B137.5

**Reader's Note: Other changes may occur in Table 605.3 that will be addressed in different areas of this presentation portions of the table not addressed remain unchanged.*

Chapter 6

Labeling of Water Distribution Pipes in Bundles

CHANGE TYPE: Addition

CHANGE SUMMARY: Water distribution piping that is installed in bundles must now be labeled for content and direction of flow.

2012 CODE: 606.7 Labeling of Water Distribution Pipes in Bundles.

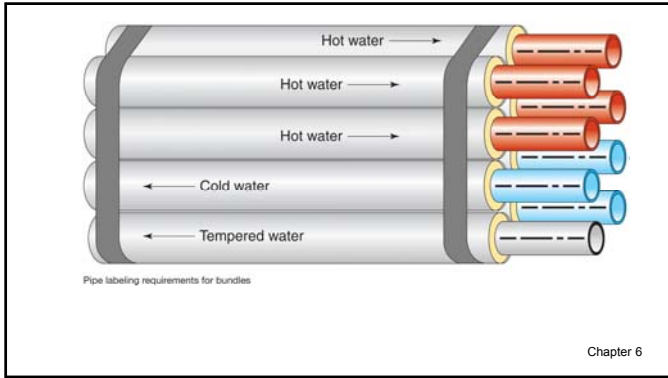

Water-Temperature-Limiting Means Chapter 6

CHANGE TYPE: Modification

CHANGE SUMMARY: A water heater thermostat is now prohibited from being used as the temperature-limiting device where the code requires a limit for hot or tempered water.

2012 CODE: 607.1.1 Temperature Limiting Means.

Hot or Tempered Water Supply to Fixtures

CHANGE TYPE: Modification

CHANGE SUMMARY: The maximum distance between a hot water supply source and all fixtures served by the supply source has been reduced from 100 feet to 50 feet.

2012 CODE: 607.2 Hot or Tempered Water Supply to Fixtures

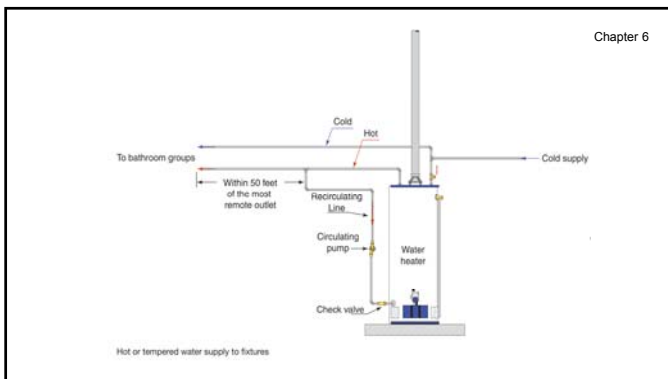

Chapter 6

Hot Water Piping Insulation

CHANGE TYPE: Addition

CHANGE SUMMARY: The *International Energy Conservation Code (IECC)* requirement for insulating hot water piping in automatic temperature maintenance systems is now also a provision in the IPC.

2012 CODE: 607.5 Pipe Insulation.

Chapter 6

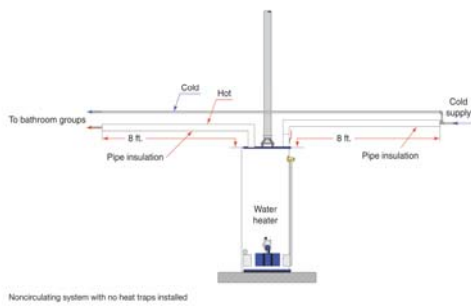

Noncirculating system with no heat traps installed

Chapter 6

Identification of Nonpotable Water

CHANGE TYPE: Modification

CHANGE SUMMARY: Wherever nonpotable water systems are installed, including outside of the building, the piping must be identified.

2012 CODE: 608.8 Identification of Nonpotable Water.



Identification of nonpotable water

Chapter 7 Sanitary Drainage

Chapter 7

CHAPTER 7 – SANITARY DRAINAGE

(Amd) **701.2 Sewer required.** Buildings in which plumbing fixtures are installed and premises having drainage piping shall be connected to a public sewer, where required, or an approved private sewage disposal system in accordance with the Public Health Code adopted under authority of section 19a-36 of the Connecticut General Statutes.

Chapter 7

**Connections to offsets and bases of stacks,
Horizontal Branch Connections**

CHANGE TYPE: Modification

CHANGE SUMMARY: Horizontal branches are now permitted to connect at any point in a stack above or below a horizontal offset. In addition, horizontal branches are now allowed to connect to the base of stacks at a point located not less than 10 times the diameter of the drainage stack downstream from the stack.

2012 CODE: 704.3 Connections to Offsets and Bases of Stacks.

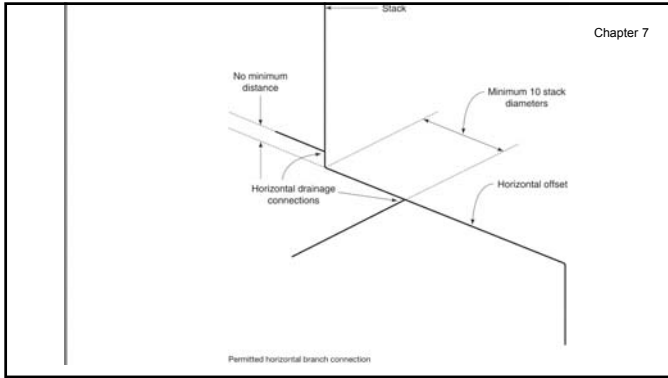

Chapter 7

Chapter 7

Omission of Vents for Horizontal Stack Offsets. Horizontal Branch Connections

Omission of Vents for Horizontal Stack Offsets

Table 709.1 Drainage Fixture Units for Bathroom Groups

CHANGE TYPE: Modification

CHANGE SUMMARY: Where fixtures are provided in addition to those in a bathroom group, the footnote addressing additional drainage fixture unit values is now also applicable to those bathroom groups not located within dwelling units.

Chapter 7

2012 CODE:

TABLE 709.1 Drainage Fixture Units for Fixtures and Groups

Fixture Type	Drainage Fixture Unit Value as Load Factors	Minimum Size of Trap (inches)
Bathroom group as defined in Section 202 (1.6 gpf water closet) ^f	5	—
Bathroom group as defined in Section 202 (water closet flushing greater than 1.6 gpf) ^f	6	—

^f For fixtures added to a dwelling unit-bathroom group, add the dfu value of those additional fixtures to the bathroom group fixture count.

***Reader's Note:** Other changes may occur in Table 709.1 that will be addressed in different areas of this presentation portions of the table and its footnotes not addressed remain unchanged.

Sump Pump and Ejector Discharge Pipe and Fittings

Chapter 7

CHANGE TYPE: Addition

CHANGE SUMMARY: Materials acceptable for use in sump pump and ejector pipe and fittings materials are now specifically listed.

2012 CODE: 712.3.3 Discharge Fittings.

712.3.3.1 Materials.

712.3.3.2 Ratings.

Sump Pump Connection to the Drainage System

CHANGE TYPE: Modification

CHANGE SUMMARY: Where sump pumps connect to the drainage system, they are now permitted to connect to a building sewer, building drain, soil stack, waste stack, or horizontal branch drain.

2012 CODE:

712.3.5 Pump Connection to the Drainage System.

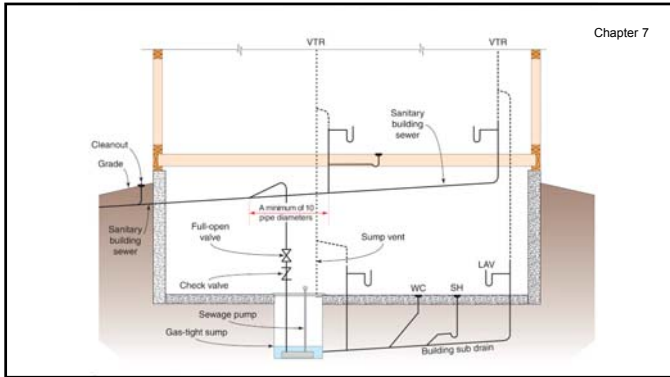

Chapter 7

Fixture Protection from Sewage Backflow

Chapter 7

CHANGE TYPE: Modification

CHANGE SUMMARY: In the determination of backwater valve protection from sewage backflow, the use of the finished floor elevation where the fixtures are installed rather than the flood level rim of the fixtures provides a new point of reference.

2012 CODE: 715.1 Sewage Backflow.

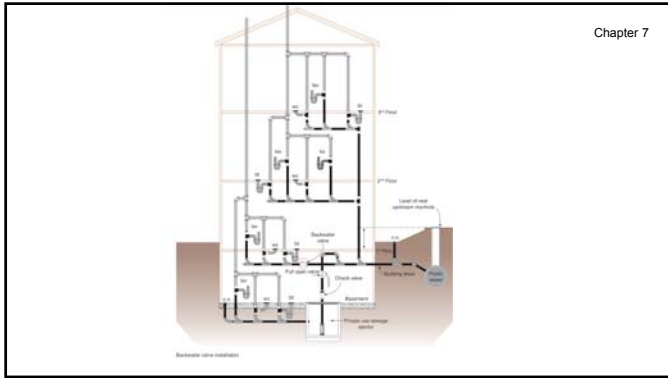

Chapter 8

Prep Sinks, Waste Piping and Receptors

Chapter 8

Indirect Discharge of Food Preparation Sinks

CHANGE TYPE: Modification

CHANGE SUMMARY: Sinks used for food preparation and consumption purposes are no longer permitted to connect directly to the drainage system.

2012 CODE: 802.1.8 Food Utensils, Dishes, Pots and Pans Sinks. Sinks

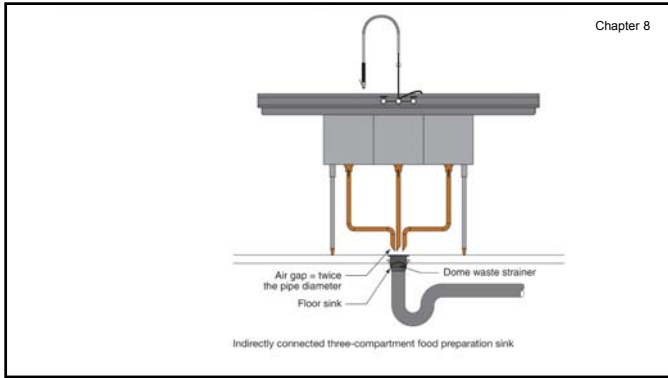

Chapter 8

Installation of Waste Piping

CHANGE TYPE: Modification

CHANGE SUMMARY: The thresholds at which indirect waste piping is required to be trapped have been increased and an exception has been added to address clear waste water.

2012 CODE: 802.2 Installation.

Exception:

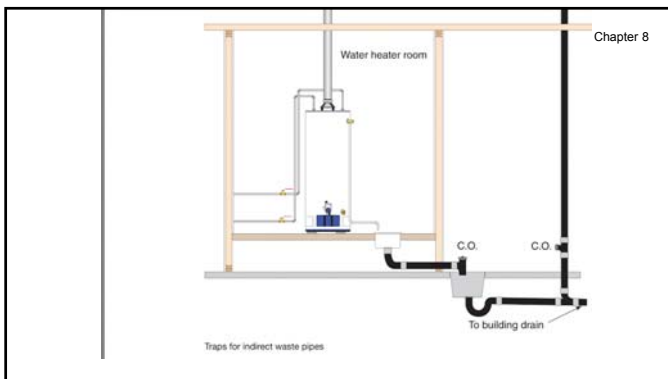

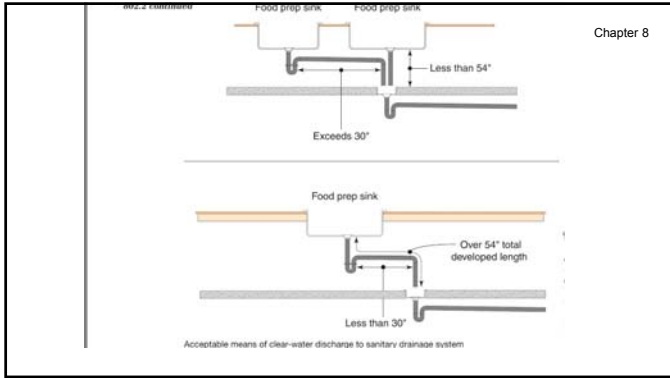

Chapter 8

Prohibited Locations for Waste Receptors

CHANGE TYPE: Modification

CHANGE SUMMARY: The list of locations where waste receptors cannot be located has been expanded to specifically include plenums, crawlspaces, attics, and interstitial spaces above ceilings and below floors.

2012 CODE: 802.3 Waste Receptors.

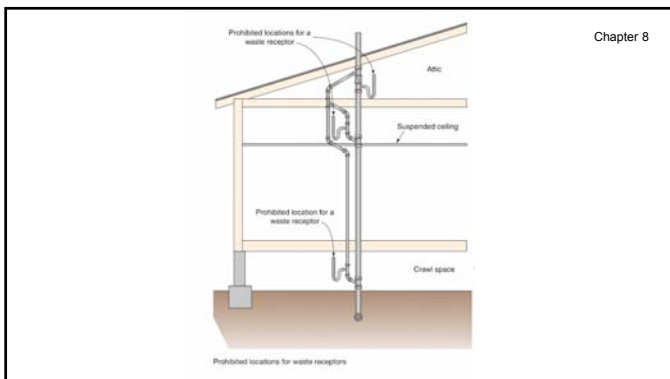

Chapter 9 Vents

Chapter 9

Air Admittance Valves for Chemical Waste Vent Systems

CHANGE TYPE: Modification

CHANGE SUMMARY: Air admittance valves complying with reference standard ASSE 1049, "Performance Requirements for Individual and Branch-Type Air Admittance Valves for Chemical Waste Systems," are now permitted to be used for venting chemical waste systems.

2012 CODE: 901.3 Chemical Waste Vent Systems.

918.8 Prohibited Installations.

Chapter 14:
ASSE
ASTM

Chapter 9

CHAPTER 9 – VENTS

(Amd) **903.1 Roof extension.** Open vent pipes that extend through a roof shall be terminated not less than 12 inches above the roof, except that where a roof is to be used for any purpose other than weather protection, the vent extensions shall terminate not less than 7 feet above the roof.

(Del) **903.2 Frost closure.** Delete without substitution.

Chapter 9

Location of Vent Terminals

CHANGE TYPE: Modification

CHANGE SUMMARY: The prohibited locations for vent terminals have been revised to provide consistency with the IMC.

2012 CODE: 903.5 Location of Vent Terminal

Chapter 9

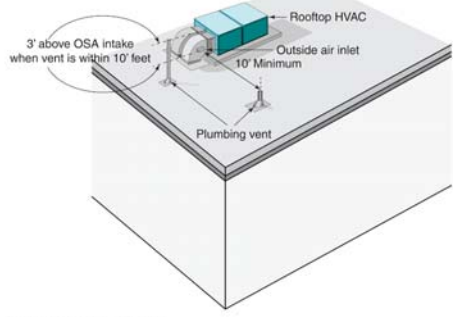

Chapter 9

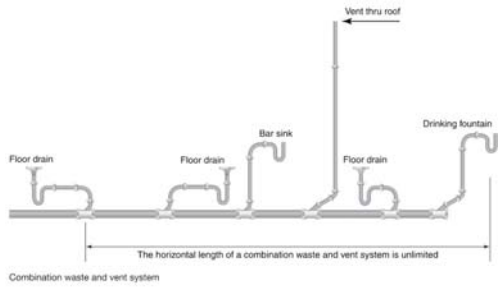

Chapter 9

Combination Waste and Vent System Sizing

CHANGE TYPE: Clarification

CHANGE SUMMARY: The length of a combination waste and vent system is unlimited.

2012 CODE: 915.2 Connection.

Chapter 9

Single-Stack Vent Systems

CHANGE TYPE: Addition

CHANGE SUMMARY: The single-stack vent system method, similar to the Philadelphia stack drainage system, has been added as an acceptable venting system.

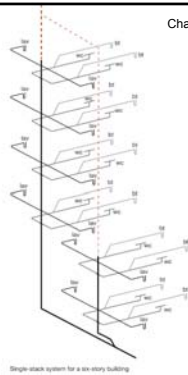

Chapter 9

SECTION 917 SINGLE STACK VENT SYSTEM

917.1 Where Permitted.

917.2 Stack Size.

917.3 Branch Size.

917.4.1 Water Closet Connection.

Chapter 9

TABLE 917.2 Single Stack Size

MAXIMUM CONNECTED DRAINAGE FIXTURE UNITS			
Stack Size (inches)	Stacks less than 75 feet in height	Stacks 75 feet to less than 160 feet in height	Stacks 160 feet and greater in height
3	24	NP	NP
4	225	24	NP
5	480	225	24
6	1,015	480	225
8	2,320	1,015	480
10	4,500	2,320	1,015
12	8,100	4,500	2,320
15	13,600	8,100	4,500

For SI: 1 inch = 25.4 mm, 1 foot = 304.8 mm.

Single-Stack Vent Systems

Chapter 9

Exception

917.4.2 Fixture Connections.

917.4.3 Vertical Piping in Branch.

917.5 Minimum Vertical Piping Size from Fixture.

917.6 Additional Venting Required.

917.7 Stack Offsets.

917.8 Prohibited Lower Connections.

917.9 Sizing Building Drains and Sewers.

Chapter 10

Traps, Interceptors and Separators

Chapter 10

Floor Drains in Multi-Level Parking Structures

CHANGE TYPE: Modification

CHANGE SUMMARY: Floor drains in multi-level parking garages are no longer required to have individual traps, provided the drains are connected to a main trap before discharge to a combined sewer.

2012 CODE: 1002.1 Fixture Traps.

Exceptions

Chapter 10

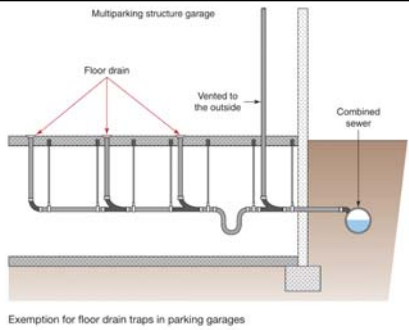

Chapter 10

CHAPTER 10 - TRAPS, INTERCEPTORS AND SEPARATORS

(Amd) **1003.3 Grease interceptors.** Grease interceptors that serve plumbing systems connected to private, on-site septic systems shall comply with the requirements of Sections 1003.3.1 to 1003.3.5, inclusive and in accordance with the Public Health Code. Grease interceptors that serve plumbing systems connected via a sanitary sewer to a publicly owned treatment works shall comply with the Department of Energy and Environmental Protection's General Permit for the Discharge of Wastewater Associated with Food Preparation Establishments.

Interceptors and Separators

Chapter 10

CHANGE TYPE: Clarification

CHANGE SUMMARY: It has been clarified that required interceptors and separators are permitted to be located downstream of the building drain.

2012 CODE: 1003.1 Where Required

Alternate Grease Interceptor Locations

CHANGE TYPE: Modification

CHANGE SUMMARY: Grease interceptors are now permitted to be installed in series instead of requiring replacement of an existing grease interceptor that is too small.

2012 CODE: 1003.3.1 Grease Interceptors and Automatic Grease Removal Devices Required

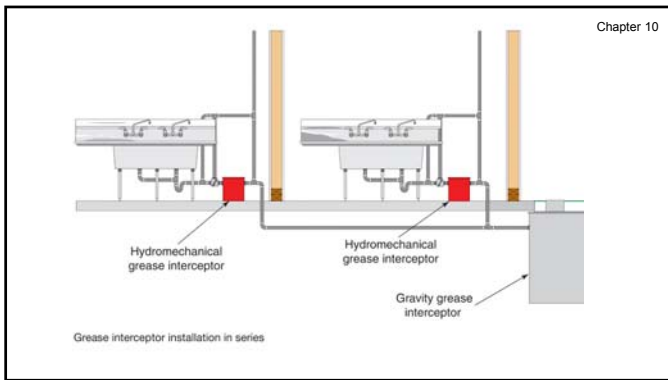

Hydromechanical Grease Interceptors

Chapter 10

CHANGE TYPE: Clarification

CHANGE SUMMARY: In regard to grease interceptors, the new term "hydromechanical" provides a clear distinction from gravity interceptors in order to provide clarity regarding the applicable requirements for each type of interceptor.

2012 CODE: 1003.3.4 Hydromechanical Grease Interceptors and Automatic Grease Removal Devices.

Exception

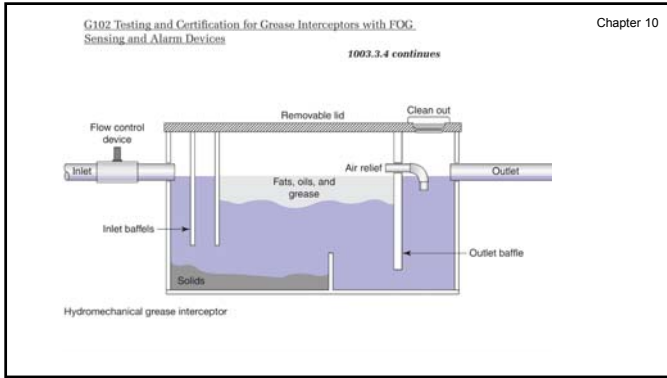

Chapter 11 Roof Drainage

Chapter 11

Roof Drain Strainers

CHANGE TYPE: Modification

CHANGE SUMMARY: Outdated code requirements have been replaced with new provisions that properly address the installation and sizing of roof drains.

2012 CODE:

1105.1 General.

1105 continues

Chapter 11

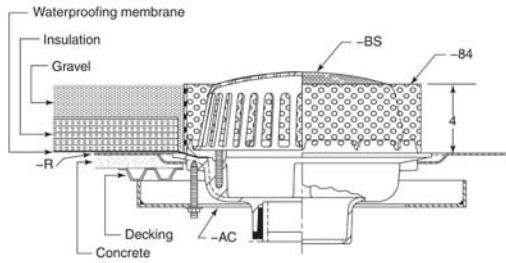

Specification cutaway view of a roof drain installation (Courtesy of Zum Industries, LLC)

Chapter 11

Siphonic Roof Drainage Systems

CHANGE TYPE: Addition

CHANGE SUMMARY: New requirements have been added to address the design of siphonic roof drainage systems by referencing the standard ASPE 45 for design of the system and ASME A112.6.9 for use of the roof drain.

2012 CODE: SECTION 1107 SIPHONIC ROOF DRAINAGE SYSTEMS

1107.1 General.

Chapter 12

Special Piping and Storage Systems

Chapter 12

CHAPTER 12 – SPECIAL PIPING AND STORAGE SYSTEMS

(Amd) 1201.1 Scope. The provisions of this chapter shall govern the design and installation of piping and storage systems for non-flammable medical gas systems and non-medical oxygen systems. All maintenance and operation of such systems shall be in accordance with the Connecticut State Fire Prevention Code.

Chapter 13

Gray Water Recycling Systems

Chapter 13 Gray-Water Recycling Systems

Chapter 13

CHANGE TYPE: Addition

CHANGE SUMMARY: Provisions addressing gray-water recycling systems have been relocated from Appendix C to a new Chapter 13 in the body of the code.

2012 CODE:

Chapter 13 (Gray-Water Recycling System)

***Reader's Note:** Gray water has been added to Chapter 2 (Definitions) Gray Water, Waste discharged from lavatories, bathtubs, showers, clothes washers, and laundry trays.

***Reader's Note:** An exception has been added to Section 301.3 to allow gray-water-producing fixtures to be connected to a gray-water collection system where a gray-water recycling system is to be installed.

301.3 Connections to Drainage System.

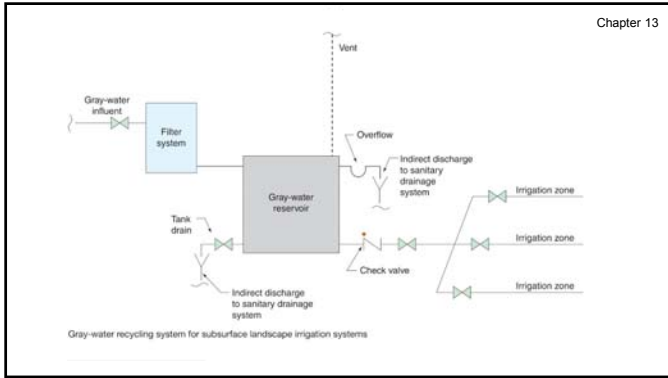

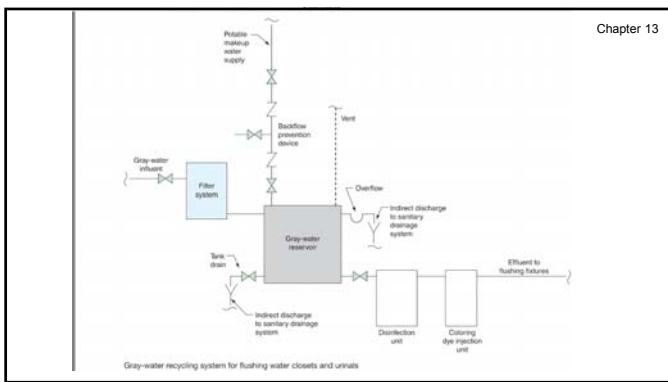

Chapter 13

Gray-Water Recycling Systems Continued

Exceptions: Bathtubs, showers, lavatories, clothes washers, and laundry trays shall not be required to discharge to the sanitary drainage system where such fixtures discharge to an approved gray water system for flushing of water closets and urinals or for subsurface landscape irrigation.

CHAPTER 13
GRAY-WATER RECYCLING SYSTEMS
SECTION C101 1301 GENERAL

1301.1 Scope.

**Reader's Note: All of the remaining sections of Appendix C have been relocated with their complete text and renumbered accordingly in the new Chapter 13.*

Chapter 13

CHAPTER 13 – GRAY WATER RECYCLING SYSTEMS

(Del) 1303.1 through 1303.11. Delete subsections and referenced tables and replace with the following:

(Add) 1303.1 **Subsurface landscape irrigation systems.** Subsurface landscape irrigation systems shall comply with the Public Health Code of the State of Connecticut.

Chapter 14
Referenced Standards

CHAPTER 14 – REFERENCED STANDARDS

(Amd)

NFPA

National Fire Protection Association
1 Batterymarch Park
Quincy, MA 02269-9101

Standard
reference
number—year
of publication
Title

Referenced in code
section number

- (Add) 02-11 Hydrogen Technologies Code 101.2.1
- (Add) 54-12 National Fuel Gas Code 101.2.1
- (Amd) 70—14 National Electrical Code 502.1, 504.3, 1114.1.3

(Del) **APPENDIX A – PLUMBING PERMIT FEE SCHEDULE.** Delete Appendix A without substitution.

Chapter 14

The End
