

Emergency Power Systems for Life Safety

IBC 2702 Emergency and Standby Power Systems (CT Supplement and Amendments)

Installation
Emergency and Standby power systems shall be installed in accordance with the IBC, NFPA 110, NFPA 111 and listed per UL 2200

Maintenance
Emergency and standby power systems shall be maintained and tested in accordance with the CT Fire Safety Code

IBC Requires for:	Emergency Power	Standby Power
Group A Occupancy: Voice/Alarm Communication Systems	907.5.2.2.4	
Smoke Control Systems		909.11
Exit signs	011.6.3	
MOE Illuminator	006.3	
Accessible MOE elevators		007.4
Accessible MOE platform lifts		007.5
Horizontal sliding doors		008.14.3
Semiconductor fabrication facilities	45.0.0	
Membrane structures in facilities		02.a.2
Membrane structures Exit signs	Fire Safety Code	
Hazardous materials	04.5.3	41.5.3
Highly toxic and toxic materials	Fire Safety Code	
Organic peroxides: Silane gas		Fire Safety Code
Pyrophoric materials	Fire Safety Code	
Covered and open market buildings		402.7.3
High-rise buildings	403.4.8	403.5.g
Underground buildings	405.8	405.9
Group 1-occupancies: doors	408.4.2	
Airport traffic control towers		412.3
Elevators		3003.1.3007.9 and 3008.9
Smokeproof enclosures		909.20.6.2

CT Fire Safety Code

NFPA 101

- 3. Emergency generators, where required for compliance with this code, shall be tested and maintained in accordance with NFPA 110, Standard for Emergency and Standby Power Systems.
- 4. Stored electrical energy systems shall be maintained in accordance with NFPA 111, Standard on Stored Electrical Energy Emergency and Standby Power Systems.

NFPA 1 Uniform Fire Code

- 2. Stationary generators required by this code, the building code, or other NFPA codes and standards shall be maintained in accordance with NFPA 110, Standard for Emergency and Standby Power Systems.
- 3. Stored electrical energy systems required by this code, the building code, or other NFPA codes and standards shall be maintained in accordance with NFPA 111, Standard on Stored Electrical Energy Emergency and Standby Power Systems

To be adopted in 2015 ? Maybe 2016?

CSFPC and CSFC

Will adopt 2010 versions of NFPA 110 and NFPA 111

Will also adopt 2014 version of NFPA 70, the NEC

NFPA 110

**Standard for
Emergency and
Standby Power
Systems**

Scope of NFPA 110

NFPA 110 covers construction, installation, maintenance and operational testing requirements for Emergency Power Supply Systems (EPSS) (1.1.2)

Terms

EPS---Emergency Power Supply
EPSS---Emergency Power Supply Systems
AHJ---Authority Having Jurisdiction
Shall---Mandatory Requirement
Should---Advised, but not required

Class

This defines the minimum amount of hours that the EPSS can operate at its rated load without being refueled or recharged

Type

This defines the maximum amount of seconds that the load terminals of the EPSS transfer switch can be without acceptable electrical power

Level

Level 1 - System shall be installed when failure of the equipment to perform could result in loss of human life or serious injuries. (4.4.1)

Level 2 - Systems shall be installed when failure of the EPSS to perform is less critical to human life and safety and where the AHJ shall permit a higher degree of flexibility that provided by a Level I system. (4.4.2)

Example

Class 72 (Minimum Hours of Run Time)

Type 10 (Transfer Time in seconds)

Level 1 (Life Safety)

Control Function

A control panel shall be provided and shall contain the following. (5.6.5.1)

- ❖ 1) Automatic remote start capability.
- ❖ 2) Run-off-automatic switch.
- ❖ 3) Shutdowns.
- ❖ 4) Alarms.
- ❖ 5) Controls.

Safety Indications – Control Panel
Visual Requirements T-5.6.5.2

Over Crank	Low cranking voltage
Low water temp	Low battery voltage
High engine temp per-alarm	Battery charger AC failure
Low lube oil pressure pre-alarm	Lamp test
Low coolant level	Contacts for local & remote common alarm
EPS supplying load	Low starting air pressure
Control switch not in auto	Low starting hydraulic pressure
High battery voltage	Air shutdown damper when used

**Safety Indications – Control Panel
Shutdown of EPS Indications**
5.6.5.2(3) T-5.6.5.2

- Overcrank
- Overspeed
- Low lube oil pressure
- High engine temperature
- Remote emergency stop
- Air shutdown damper when used

**Safety Indications – Control Panel
Remote Audible Requirements**
T-5.6.5.2

- Level – 1**
- ❖ Overcrank
 - ❖ Low coolant temp
 - ❖ High engine temp pre- alarm
 - ❖ Low lube oil pressure pre-alarm
 - ❖ Overspeed
 - ❖ Low coolant level

Safety Indications

- Level – 2**
- ❖ Control switch not in automatic position
 - ❖ Low cranking voltage
 - ❖ Contact for local & remote common alarm
 - ❖ Audible alarm silencing switch
 - ❖ Air shutdown damper when in used

Remote Stop

All installations shall have a remote manual stop station of a type to prevent inadvertent or unintentional operation located outside the room housing the prime mover, when installed inside, or elsewhere on the premises where the prime mover is located outside the building (5.6.5.6)

- ❖ A.5.6.5.6 – For systems located outdoors, the manual shutdown should be located external to the weatherproof enclosure and should be appropriately identified.

Control Panel - Location

A remote, common audible alarm shall be provided as specified in 5.6.5.2(4) that is powered by storage battery & located outside of the EPS service room at a work site observable by personnel (5.6.6)
In Hi-Rise buildings this must be in the Fire Control Room or Command Center.

Remote Start

In high-rise buildings, section 911.1.5 of the 2012 International Building Code and section 508.1.5 of the 2012 International Fire Code require for both emergency and standby generators:

- ❖ Power status indicators, system supervision with manual start and a transfer feature to be provided at the fire command center.

Location

The EPS shall be located in a separate room for Level I installation (7.2.1).

- ❖ The room shall have a minimum 2-hour rating. Outside enclosures (should) must protect from snow, rain, and wind (7.2.1.1).

The EPS shall have a minimum clearance of 3 feet on all sides for inspection, maintenance, repairs, etc. (7.2.5)

Battery Lighting

The Level 1 & Level 2 EPS equipment location(s) shall be provided with battery-powered emergency lighting.

- ❖ Does not apply units outdoors. (7.3.1)
- ❖ Lighting (both normal and unit equipment) shall be fed from the load side of the transfer switch (7.3.2).

Fuel Supply

Diesel Fuel Class II Fuel

- ❖ Most generators use diesel as a fuel supply.
- ❖ Fuel tanks must be sized according to the specific EPS class (7.9.1).
- ❖ Limited to 660 gallons if inside a building (7.9.1.1)
 - The tank must meet requirements of NFPA-30, 2012 and NFPA-37, 2010
 - NFPA 30, 22.4.2.6 limits to 660 gallons

Fuel Supply

Natural Gas

- ❖ Some generators use natural gas.
- ❖ Supply for the generator must be on the supply side of the main gas shut-off for the building (7.9.7) –This may require a separate meter.
- ❖ The shut off for the generator gas supply shall be marked as such and the building main gas shut off needs to indicate the existence of the separate shutoff for the EPSS (7.9.8).

Acceptance Test

An on-site acceptance test shall be conducted as a final approval test for all EPSS.

- ❖ The AHJ shall be given advance notice of the acceptance test in order to witness the test (7.13.3).

Maintenance Requirements & Operational Testing

Maintenance Requirements come from Chapter 8



Routine Maintenance

Reliability and facility infrastructure health are not guaranteed simply by investing in and installing new equipment. Unexpected failures can compromise even the most robust facility infrastructure if appropriate testing, maintenance and due diligence techniques are not employed

Criteria

- 1.* The routine maintenance and operational testing program shall be based on all of the following:
- 1) Manufacturer's recommendations
 - 2) Instruction manuals
 - 3) Minimum requirements of this chapter
 - 4) The authority having jurisdiction

Maintenance Requirements Documentation



8.2.1* At least two sets of instruction manuals for all major components of the EPSS shall be supplied

8.2.4

Replacement for parts identified by experience as high mortality items shall be maintained in a secure location(s) on the premises.



8.2.4.1

Consideration shall be given to stocking spare parts as recommended by the manufacturer.



Maintain Records

- ❑ Keep it simple
- ❑ Section A provides suggested maintenance logs and schedules.



Maintenance Requirements ATS

Transfer switches shall be subjected to a maintenance and testing program that includes the following:

- ❖ Monthly testing and operation
- ❖ Annually
- ❖ Checking of connections
- ❖ Inspection or testing for evidence of overheating and excessive contact erosion
- ❖ Removal of dust and dirt.
- ❖ Replacement of contacts when required (8.3.5)

a. 8.3.8 A fuel quality test shall be performed at least annually.....



8.4.2 Diesel generator sets ... Shall be exercised at least once monthly.....



- ❑ 8.4.7 Circuit breakers shall be exercised annually.
- ❑ Systems in excess of 600 volts shall be exercised every 6 months and tested under overload conditions every 2 years.





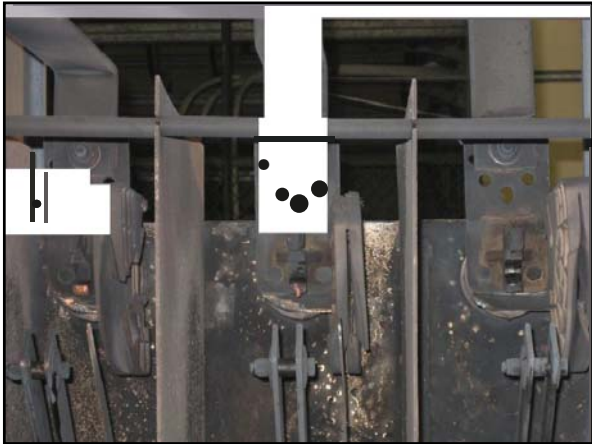

8.4.9 – 8.4.9.7

- Once every 3 years, the system is required to run with connected load for four hours. The load shall be at least 30% of the name plate rating. "Pull the Plug" testing is not required.

Maintenance Requirements Testing

EPSS, Including all appurtenant components, shall be inspected WEEKLY and exercised under load MONTHLY (8.4.1).
A log should be kept of the weekly and monthly checks / exercises.
Sample maintenance logs are available in Annex A of the NFPA-110 documents.
Routine Maintenance program shall be over-seen by a properly instructed individual (8.4.5).

Typical Log Sheet items

- Check Oil Level
- Check Coolant Level
- Walk-Around for obvious damage
- Inspect Fuel System
- Check Belts
- Inspect Batteries
- Check Block Heater Operation
- Check Oil Pressure
- Check Frequency and Voltage





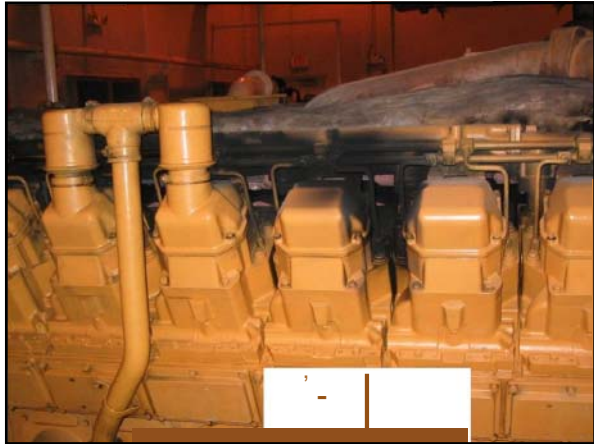



Jumped Belt

Maintenance Requirements Monthly Testing

Section 8.4.2 - Diesel generator sets in service shall be exercised at least once monthly, for a minimum of 30 minutes, using one of the following methods:

- ❖ 1) Loading that maintains the minimum exhaust gas temperatures as recommended by the manufacturer.
- ❖ 2) Under operating temperature conditions and at not less than 30 percent of the EPS nameplate kW rating.

Maintenance Requirements Annual Load Bank Testing

Section 8.4.2.3 Diesel-powered EPS installation that do not meet the requirements of 8.4.2 shall be exercised monthly with the available EPSS load and exercised annually with supplemental loads at:

25% of nameplate rating for 30 minutes, followed by 50% of nameplate for 30 minutes followed by;

75% of nameplate for 60 minutes; for a total of 2 continuous hours.

Maintenance Requirement 36 Month Load Bank Testing

Section 8.4.9 Level 1 EPSS shall be tested for the duration of its as-assigned class (see Section 4.2)

- ❖ for at least 4 hours, at least once within every 36 months.

Section 8.4.9.1 The load shall be the EPSS system load running at the of the test.

- ❖ The test shall be initiated by opening all switches or breakers supplying normal power to the EPSS.

Maintenance Requirements Time Delays

Load tests of generator shall include complete cold start (8.4.4).

Time Delays should be set as follows:

- ❖ On start: 1 second minimum
- ❖ Transfer to emergency: no minimum
- ❖ Return to normal: 5 minutes minimum
- ❖ Shutdown: 5 minutes minimum

Transfer switches shall be operated monthly (8.4.6).

Maintenance Requirements

Section A-5.6.4.5.1 recommends that lead-acid starting batteries be replaced every 24 to 30 months.





Transfer Time

For any generator serving emergency lighting, the load must be picked up by the generator within 10 seconds.

- ❖ See section 7.9.1.2 of the Life Safety Code
- ❖ See article 700.12 of the 2011 NEC

Fire Extinguisher

A fire Extinguisher should be kept in close proximity to the generator and should be a type for the hazard. Typically a minimum 3A, 40B, C extinguisher within 30 feet of the generator and in the path of egress.

NFPA-111

**Standard on
Stored Electrical Energy
Emergency and
Standby Systems**

Scope NFPA 111

- 2. Installation, maintenance, operation, and testing requirements as they pertain to the performance of the emergency power supply system (EPSS)
- 3. Does not pertain to lighting unit equipment or UPSs

Terms

SEPSS – Stored Emergency Power Supply System

- ❖ UPS or a motor generator, powered by a stored electrical energy source, together with a transfer switch and all necessary control equipment to make the system functional

Types of SEPSS Table 4.2.2

Type	Interruption Time
Type O	No interruptions – UPS carrying load, 0 sec
Type U	UPS system with utility as preferred source
Type A	0.25 cycle: 0.0042 sec
Type B	1.0 cycle: 0.0167 sec
Type 10	10 sec
Type M	Manual stationary or non-automatic

Installation Acceptance

7.6.1

Upon completion of the installation of the SEPSS, the system shall be tested to ensure conformity with the requirements of this standard with respect to both power output and function

7.6.2

On site acceptance test

- ❖ Batteries fully charged

Battery Based Acceptance Test

- 1) Open normal power supply switch or CB
- 2) All emergency loads shall be included
- 3) Time delay until loads assumed shall be observed and recorded
- 4) Voltage, current supplied by the battery bank shall be recorded
- 5) After 15 minute duration, record the voltage and current of the battery bank
- 6) Restore normal power supply
- 7) Transfer time shall be observed

Full Load Test

Load test to be immediately after 24 hour recharge following acceptance test (7.6.2.3)

- ❖ Performed on site connected load
 - Load bank permitted to augment site load
- ❖ Duration of load test to be 60% of class for which SEPSS is rated
- ❖ Voltage and current to be recorded each minute
- ❖ After test all bus bar bolts shall be inspected and repaired as necessary and retorqued to specifications
- ❖ Any batteries and bus bars that have failed shall be replaced and so noted on test reports

Routine Maintenance and Operational Testing

The SEPSS shall have routine maintenance and operational testing based on the manufacturer's recommendations, instruction manuals, and the minimum requirements of this chapter and subject to the approval of the AHJ (8.1)

Manuals and Tools

1. At least 2 sets of instructional manuals for the SEPSS shall be supplied by the manufacturer
2. For level 1, one set of the instructions shall be kept with the equipment, the other in a secure location
3. Special tools and testing devices shall be available for use when needed

Maintenance and Operational Testing

1. The SEPSS shall be maintained so that the system can supply the service quality within the time specified by the type and for the time specified by the class
2. A routine maintenance and operational testing program shall be initiated immediately following the acceptance test or any repairs or component replacement

Records

1. Records shall be reproducible
 - ❖ Log
 - ❖ Notice of failures and replacements
 - ❖ Identification of personnel
 - ❖ Documentation of tests

Level 1 Equipment

8.4.1 Inspected monthly and tested per manufacturer's recommendations

Inspection of Equipment

2. Shall include:
- 1) Visual check
 - 2) Electrolyte level
 - 3) Terminals cleaned
 - 4) Cell voltages recorded
 - 5) Specific gravities recorded
 - 6) Plate condition and sediments
 - 7) Lamps, meters and controls checked for operation
 - 8) Load values

Load Testing

- 8.4.3.1 Output voltage, battery voltage and duration of test recorded at beginning and end of test for each battery set
4. SEPSS shall be checked annually at full load for 60% of class
5. Written record of all checks to be maintained and shall be accessible to the AHJ
6. Tests to be performed by qualified persons

NFPA 70

**National
Electrical
Code**

Article 250 Grounding and Bonding

**(Add) 250.104 (B) Corrugated
Stainless Steel Tubing (CSST).**
CSST gas piping shall be bonded in
accordance with manufacturer's
installation instructions.

Article 445 Generators
445.1 Scope

Article 445 covers the installation of generators.
Generators, associated wiring, and equipment
must be installed in accordance with the
additional requirements:

- Article 695. Fire Pumps
- Article 700. Emergency Systems
- Article 701. Legally Required Standby Systems
- Article 702. Optional Standby Systems

www.NECode.com Mike Holt Enterprises,
Inc. © 72

445.11 Marking

Each generator must be provided with a nameplate indicating the number of phases, rating in kilowatts, volts and amperes corresponding to the rating.

www.NECcode.com

Mike Holt Enterprises, Inc. ©

73

445.13 Ampacity of Conductors

The ampacity of the conductors from the generator to distribution devices containing overcurrent protection must not be less than 115 percent of the nameplate current rating of the generator. Fig 445-1

www.NECcode.com

Mike Holt Enterprises, Inc. ©

74

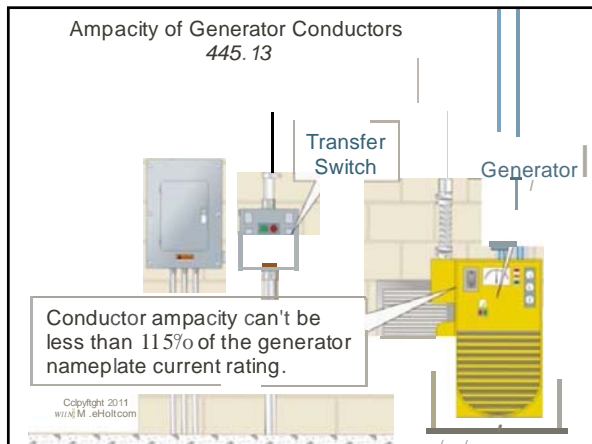

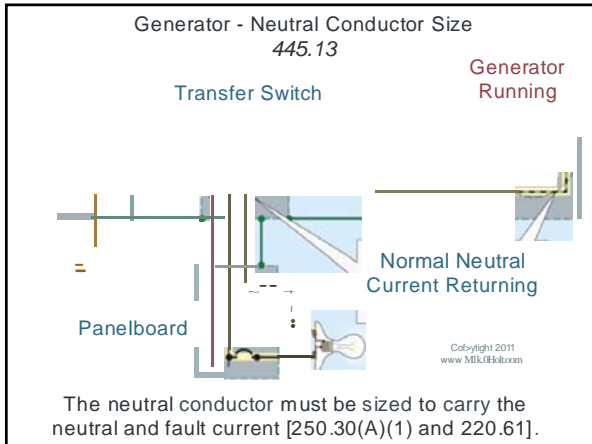

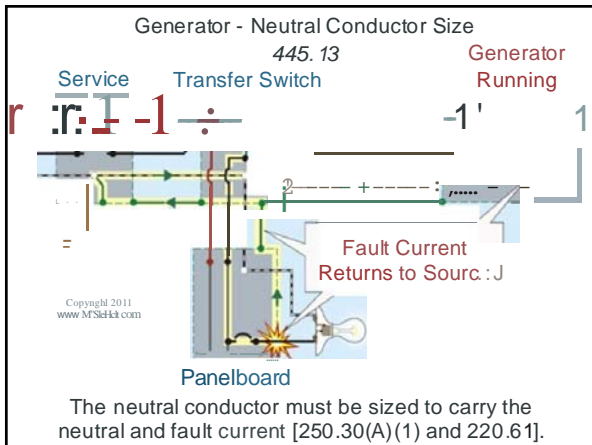

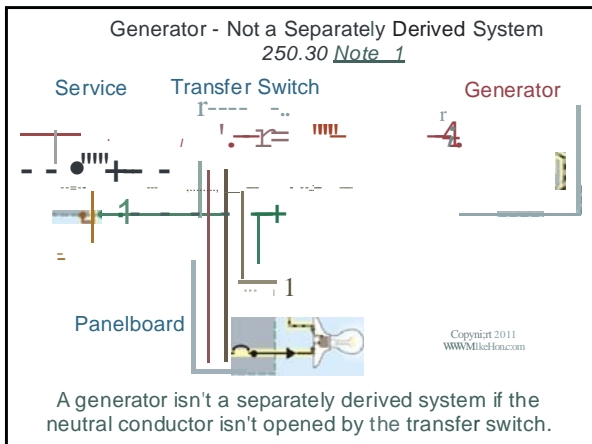

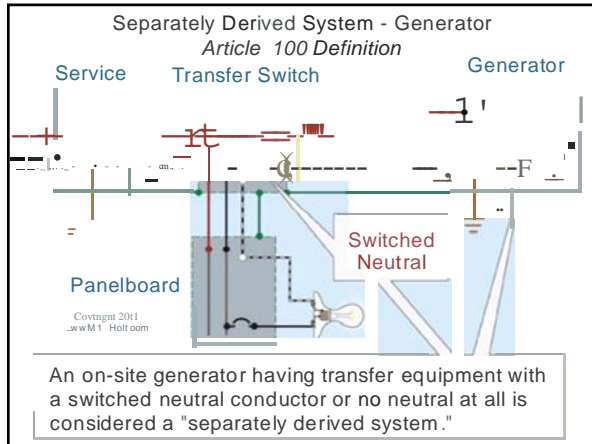

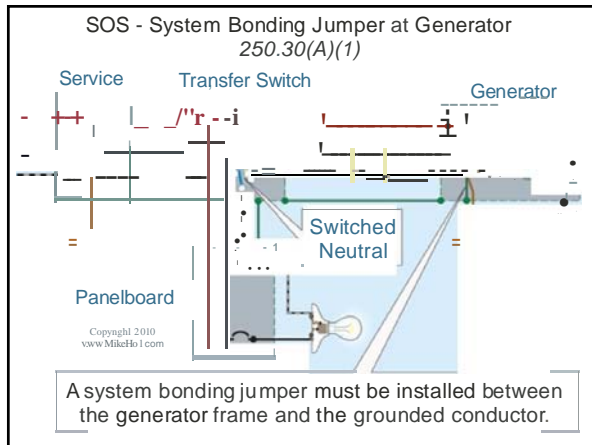

445.18 Disconnecting Means

Generators must have one or more disconnecting means that disconnects all protective devices and control apparatus. Fig 445-5

www.NECCode.com Mike Holt Enterprises, Inc. © 81

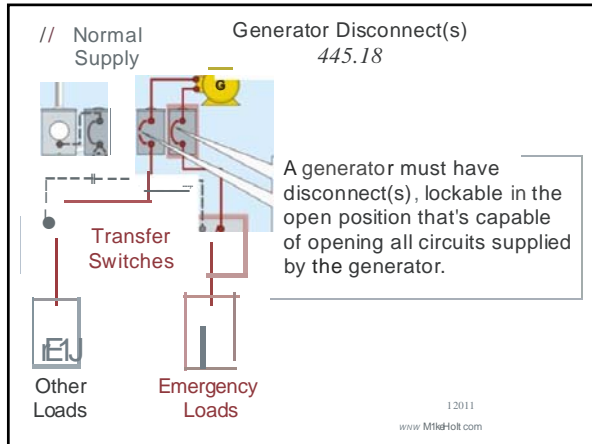

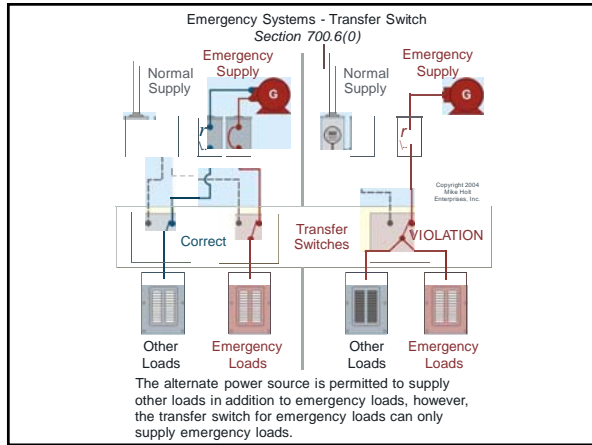

Article 700 Emergency Systems
700.1 Scope

Article 700 is intended to apply to the installation, operation, and maintenance of emergency systems.

84

700.1 Scope

Emergency power systems are those systems legally required and classed as emergency by a governmental agency having jurisdiction.

These systems are intended to automatically supply illumination and/or power essential for safety to human life.

85

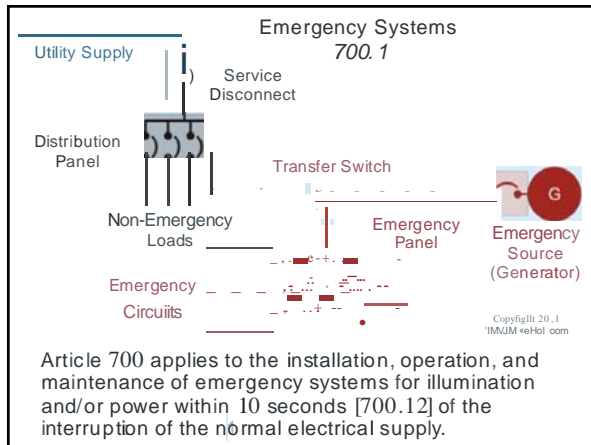

Article 700 applies to the installation, operation, and maintenance of emergency systems for illumination and/or power within 10 seconds [700.12] of the interruption of the normal electrical supply.

700.1 Scope

FPN No. 3: Emergency power systems are generally installed where artificial illumination is required for safe exiting and for panic control in buildings...

Emergency power systems may also provide power to maintain life, fire detection and alarm systems, elevators, fire pumps, public safety communications systems, industrial processes where interruption would produce serious life safety or health hazards.

87



90.3 Application of Other Articles

Except as modified by this article, all other requirements contained in Chapters 1 through 4 of the NEC apply.

89

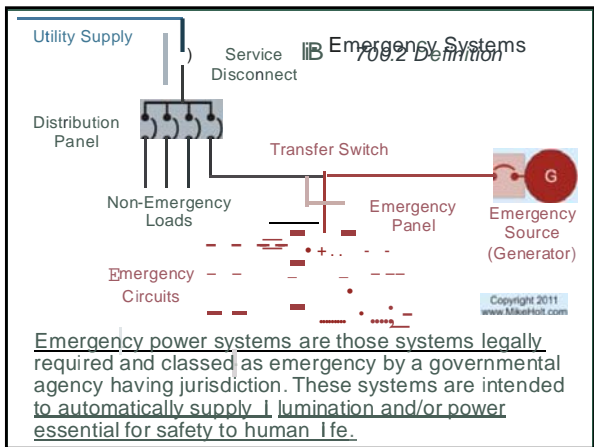

700.2 and 700.24 Automatic Load Control Relay

- **Relay, Automatic Load Control.** A device used to energize switched or normally-off lighting equipment from an emergency supply in the event of loss of the normal supply, and to de-energize or return the equipment to normal status when the normal supply is restored.
- **Informational Note:** For requirements covering automatic load control relays, see ANSI/UL 924, Emergency Lighting and Power Equipment.
- **700.24 Automatic Load Control Relay.** If an emergency lighting load is automatically energized upon loss of the normal supply, a listed automatic load control relay shall be permitted to energize the load. The load control relay shall not be used as transfer equipment.

700.2 and 700.24 Automatic Load Control Relay (Emergency Systems)

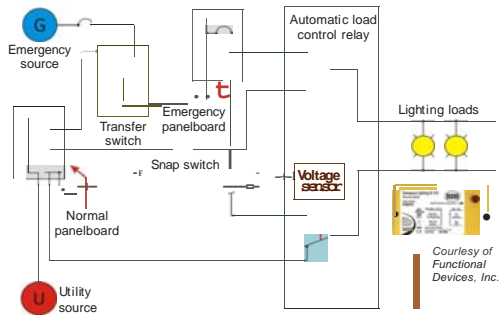

700.3 Tests and Maintenance

Emergency power testing consists of acceptance testing and operational testing.

700.4 Tests and Maintenance

(A) Conduct or Witness Test. To ensure that the emergency power system meets or exceeds the original installation specification, the AHJ must conduct or witness an acceptance test of the emergency system upon completion and periodically afterward.

94

700.4 Tests and Maintenance

(B) Tested Periodically. Emergency power systems must be periodically tested to ensure that adequate maintenance has been performed and that the systems are in proper operating condition.

Running the emergency power system under load is often considered an acceptable method of operational testing.

95

700.4 Tests and Maintenance

(C) Battery Systems Maintenance. Where batteries are used, the AHJ shall require periodic maintenance.

96

700.4 Tests and Maintenance

(D) Written Record. A written record shall be kept of all required tests and maintenance.

97

700.4 Tests and Maintenance

(E) Testing Under Load. Means for testing all emergency lighting and power systems during maximum load conditions shall be provided.

98

700.4 Capacity

(A) Capacity and Rating. An emergency system power source must have adequate capacity to carry safely all emergency loads that are expected to operate simultaneously.

99

700.4 Capacity

(B) Selective Load Pickup, Load Shedding, and Peak Load Shaving. If an alternate power source has adequate capacity, it can supply emergency loads, legally required standby loads, and optional standby system loads.

100

700.4 Capacity

(B) Selective Load Pickup, Load Shedding, and Peak Load Shaving. If the alternate power source does not have adequate capacity to carry the entire load, it must have automatic selective load pickup and load shedding to ensure adequate power in the following order of priority:

- (1) The emergency circuits,
- (2) The legally required standby circuits, and
- (3) The optional standby circuits.

101

700.5 Transfer Equipment

(A) General. Transfer equipment must be automatic, identified for emergency use, and approved by the AHJ.

102

700.5 Transfer Equipment

(D) Use. Transfer equipment must supply only emergency loads.

103

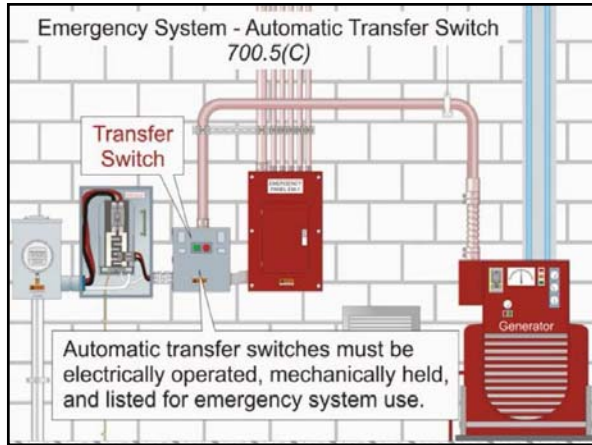

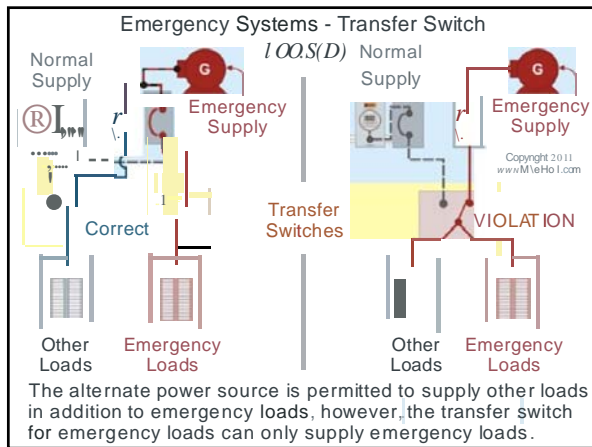

Signs for Emergency Sources
700.7(A)

CAUTION
TWO SOURCES OF SUPPLY
Emergency Power Source
Located in Electric Room
Room 100 Located on
NW corner of building

A sign must be placed at the service entrance equipment indicating the type and location of on-site emergency power sources.

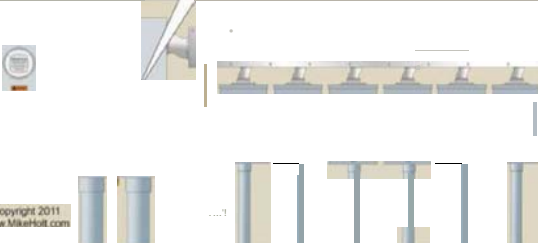

Copyright 2011
www.MikeHolt.com

700.8 Surge Protection (Emergency Systems) W

A listed surge protective device (SPD) shall be installed in or on all emergency systems switchboards and panelboards

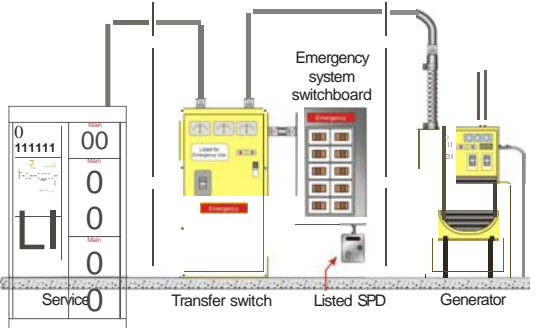

Service, Transfer switch, Listed SPD, Emergency system switchboard, Generator



700.7 Signs.

(Amd) (A) **Emergency Sources.** A sign shall be placed at the service-entrance equipment, at the meter location, and on any equipment up to the service-entrance equipment indicating type and location of on-site emergency power sources.

Exception: A sign shall not be required for individual unit equipment as specified in 700.12(F).

700.9 Wiring

(A) Identification. All boxes and enclosures, transfer switches, generators, and power panels for emergency circuits must be permanently marked as a component of an emergency system. Fig 700-4

www.NECcode.com

Mike Holt Enterprises, Inc. ©

110

Emergency System - Circuit Identification
700.10(A)



Identification may be by color code, sign, or other permanent form of identification.

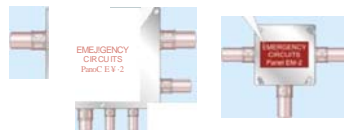

Colored raceways and fittings are permitted (not required).

Copyright © 2011, www.MikeHolt.com

All boxes and enclosures containing emergency circuits must be permanently marked so they'll be readily identifiable as a part of the emergency circuit or system.

700.9 Wiring

(B) Wiring. All emergency wiring must be kept independent of all other wiring, except:

- (1) Transfer equipment enclosures. Fig 700-5
- (2) Luminaires supplied from two sources of power.
- (3) A luminaire junction box supplied from two sources.

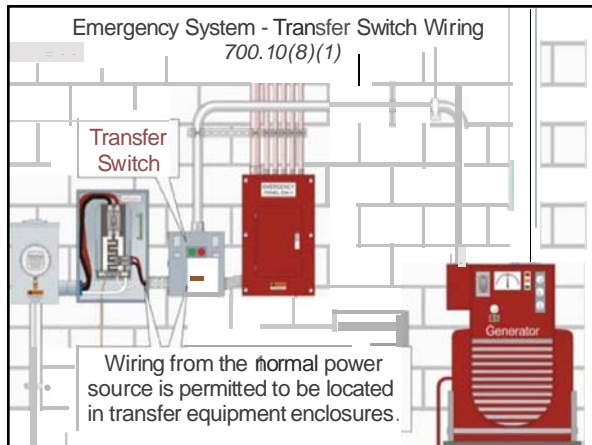

700.9 Wiring

(C) Wiring Design and Location.
Emergency wiring circuits must be located to minimize the hazards that might cause failure due to flooding, fire, icing, vandalism, or other adverse conditions.

700.9 Wiring

New subsection clarifies that emergency, legally required, and optional standby circuits may be supplied from a single generator or distribution switchboard that separates emergency circuits in different vertical sections from other loads.

©MikeHolt.com

Slide 115

700.10(D)(1) Feeder-Circuit Wiring (Emergency System)

Safe and systematic operation of emergency electrical systems is critical for heavily populated buildings and for high-rise occupancies

Fire protection requirements for emergency system feeder circuits help maintain the reliability as well as the performance of the emergency electrical system

Revision increases reliability and performance by providing more time to safely evacuate the building in an emergency

700.10(0)(1) Feeder-Circuit Wiring

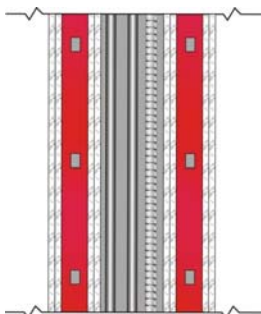

Feeder circuit wiring requiring fire protection
Note: Wiring supports are not shown

- Feeder-circuit wiring shall meet one of the following conditions:
- (1) Be installed in spaces fully protected by an approved automatic fire suppression system
 - (2) Be a listed electrical circuit protective system with a min. 2-hour fire rating
 - (3) Be protected by a listed (electrical system) thermal barrier system with a min. 2-hour fire rating
 - (4) Be protected by a listed fire-rated assembly (min. fire rating of 2 hours) containing only emergency wiring circuits
 - (5) Be encased in a min. of 50 mm (2 in.) of concrete
 - (6) Be a cable listed to maintain circuit integrity for not less than 1 hour

Copyright © 2011 IMAEI 2011

700.12 General Requirements

In the event of failure of the normal supply, emergency power must be available within 10 seconds.

Emergency equipment must be located so as to minimize the hazards that might cause complete failure due to flooding, fires, icing, or vandalism.

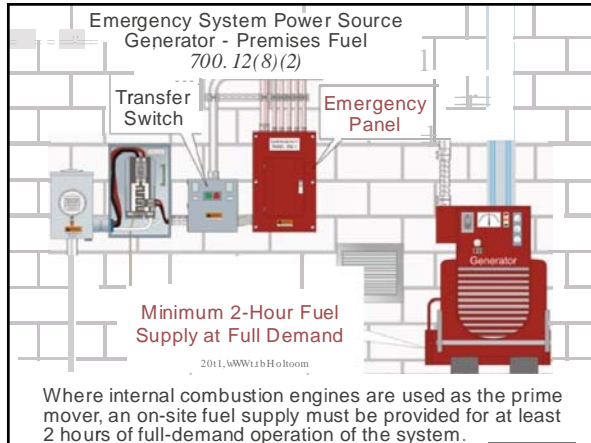

700.12 General Requirements

(B) Generator Set.

(6) Outdoor Generator Sets. Where an outdoor-housed generator is equipped with a readily accessible disconnecting means located within sight of the building or structure, an additional disconnecting means isn't required on or at the building or structure for the generator feeder conductors that serve or pass through the building or structure. Fig 700-7

Emergency System - Generator Disconnect
700.12(8)(6)

Generator Disconnect
of Required on Building

Generator Disconnect

Maximum
50 ft

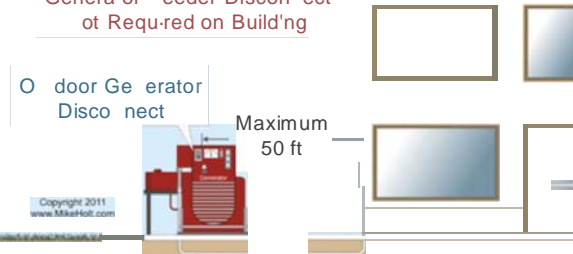

Copyright 2011
www.MikeHolt.com

A disconnect isn't required on or at the building or structure if the generator disconnect is readily accessible and within sight of the building.

700.12 General Requirements

(D) Separate Service. An additional service can be used as a source of power, where acceptable to the AHJ. Fig 700-8

Tapping ahead of the normal service equipment isn't permitted to serve as the required emergency source of power. Fig 700-9

www.NECCode.com Mike Holt Enterprises, Inc. 122

Emergency System - Equipment
Taps Ahead of Service
Section 700.12(0)

VIOLATION
Connections for emergency systems cannot be within or before the service disconnect enclosure.

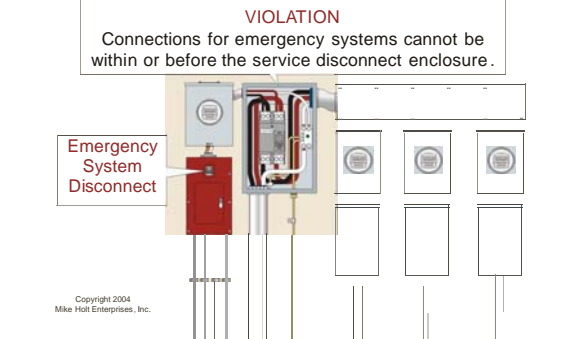

Emergency System Disconnect

Copyright 2004
Mike Holt Enterprises, Inc.

700.12 General Requirements

(F) Unit Equipment. Individual unit equipment must consist of the following: Figure 700-10

- (1) A rechargeable battery,
- (2) A battery charging means,
- (3) Provisions for one or more lamps, and
- (4) A relaying device to energize the lamps automatically upon failure of the supply to the unit equipment.

www.NECode.com

Mike Holt Enterprises, Inc. ©

124

Emergency System Power - Unit Equipment
700.12(F)

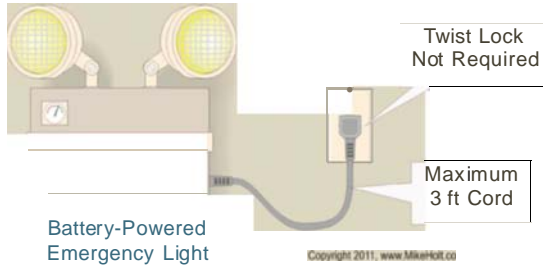

The branch circuit that supplies unit equipment (battery pack) must be the same branch circuit that supplies the normal lighting in the area, but the unit equipment must be connected ahead of any local switches.

Emergency System Power - Unit Equipment
700.12(F)

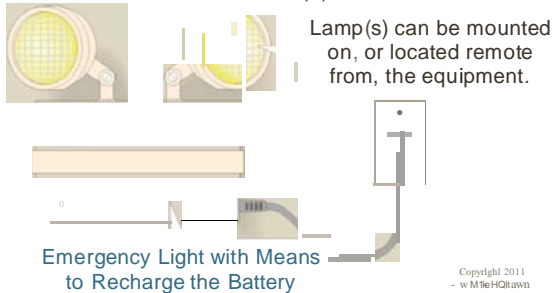

The battery-powered emergency light must contain a relay device to automatically energize the lamp when there's a power failure to the unit.

700.12 General Requirements

(F) Unit Equipment. Emergency battery pack equipment must be connected on the same branch-circuit that supplies the normal lighting in the area, but ahead of any local switches. Fig 700-11

The branch circuit that feeds the emergency lighting battery pack equipment must be clearly identified at the distribution panel.

www.NECode.com

Mike Holt Enterprises, Inc. ©

127

700.12(F) Ex. No. 2 Unit Equipment

The unit equipment is required to be connected to the branch circuit serving the normal lighting in the area and connected ahead of any local switches

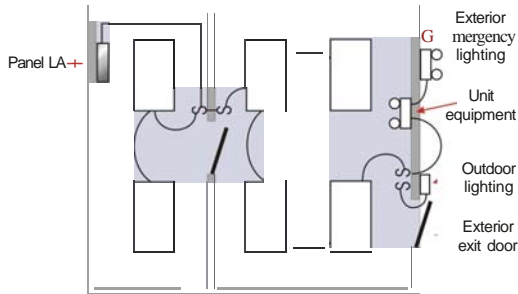

A new exception permits exterior emergency lighting to be supplied by the unit equipment serving the area immediately inside the exit door

Copyright © JAEI 2011



**700.12(F)(2)(3) Exception
Installation of Unit Equipment**

700.12(F) reformatted into a list format.
Main rule at 700.12(F)(2)(3) requires the branch circuit feeding unit equipment to be the same branch circuit as that serving the normal lighting in the area and connected ahead of any local switches.
Exception allows a separate branch circuit for unit equipment if it originates from the same panelboard as that of the normal lighting circuits and is provided with a lock-on feature.
Exception only applies in a separate and uninterrupted area supplied by a minimum of three normal lighting circuits that are not part of a multiwire branch circuit.

**700.12(F)(2)(3) Exception
Installation of Unit Equipment (cont.)**

210.4(B) requires each multiwire branch circuit be provided with a means to "simultaneously disconnect" all ungrounded conductors at the point where the branch circuit originates.
If a multiwire branch circuit were allowed to be used to comply with this exception, there would be an increased possibility of leaving the area in total darkness.
If one circuit of a multiwire branch circuit were to trip, both circuits will trip due to the "simultaneous" disconnecting means requirement.

**700.12(F)(2)(3) Exception
Installation of Unit Equipment**

The branch circuit feeding emergency lighting unit equipment shall be the same branch circuit as that serving the normal lighting in the area and connected ahead of any local switches

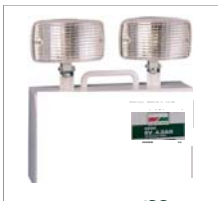

Exception: In a separate and uninterrupted area supplied by a minimum of three normal lighting circuits that are not part of a multiwire branch circuit, a separate branch circuit for unit equipment is permitted if it originates from the same panelboard as that of the normal lighting circuits and is provided with a lock-on feature

Copyright © 2014

Emergency System Power - Unit Equipment
Section 700.12(F)(4)

Battery-Powered
Emergency Light

Maximum
3 ft Cord

Twist Lock
Not Required

Copyright 2004
Mike Holt Enterprises, Inc.

The branch circuit that supplies unit equipment (battery pack) must be the same branch circuit that supplies the normal lighting in the area, but the unit equipment must be connected ahead of any local switches.

700.15
Loads on Emergency Branch Circuits

Emergency circuits must supply no loads, other than those required for emergency use.

www.NECCode.com Mike Holt Enterprises, Inc. 134

700.19 Multiwire Branch Circuits

Branch circuits for emergency power or lighting prohibited from being part of a multiwire branch circuit.

Emergency systems, circuits, and equipment are intended to supply, distribute, and control electricity for illumination, power, or both, when the normal electrical supply or system is interrupted.

It's critical that these emergency circuits are built and maintained to supply continual and reliable power.

210.4(B) requires each multiwire branch circuit be provided with a means to "simultaneously disconnect" all ungrounded conductors at the point where the branch circuit originates.

This new requirement will prevent the unnecessary opening of all poles of a multiwire branch circuit when an overload, ground-fault, or short-circuit occurs on one pole of the multiwire branch circuit.

700.19 Multiwire Branch Circuits

The branch circuit serving emergency lighting and power circuits shall not be part of a multiwire branch circuit

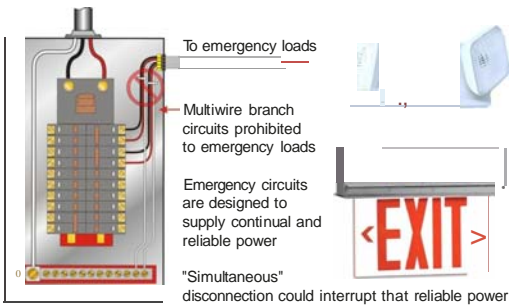

To emergency loads

Multewire branch circuits prohibited to emergency loads

Emergency circuits are designed to supply continual and reliable power

"Simultaneous" disconnection could interrupt that reliable power



700.24 Directly Controlled Luminaires

Emergency system luminaire and all external bypass controls are required to be individually listed for use in emergency systems.

These directly controlled luminaires respond to an external control input to bypass normal control upon loss of normal power.

Emergency lighting systems are required to be designed and installed so that the failure of any individual lighting element, such as the burning out of a lamp, cannot leave in total darkness any space that requires emergency illumination.

A new class of light-emitting diode (LED) luminaire has emerged and is being used in emergency lighting systems.

Some of these LED luminaires are currently not listed for this emergency application and may or may not have sufficient reliability or predictable performance for use in emergency systems.

700.24 Directly Controlled Luminaires

Emergency system luminaire and all external bypass controls are required to be individually listed for use in emergency systems



Where emergency illumination is provided by one or more directly controlled luminaires that respond to an external control input to bypass normal control upon loss of normal power, such luminaires and external bypass controls shall be individually listed for use in emergency systems

700.25 Accessibility

The branch-circuit overcurrent protection devices for emergency circuits must be accessible to authorized persons only.

www.NECode.com

Mike Holt Enterprises, Inc. ©

139

700.27 Coordination

Overcurrent protection devices for emergency power systems must be selectively coordinated with all supply-side overcurrent protective devices.

www.NECode.com

Mike Holt Enterprises, Inc. ©

140

700.27 Ex. Coordination (*Emergency Systems*)

An exception omits selective coordination of emergency systems when no additional loads are affected by the opening of the second upstream device

700.27 generally requires all emergency systems to be selectively coordinated with the overcurrent devices installed on their supply side

A properly functional selectively coordinated system localizes an overcurrent condition to the circuit conductors or equipment in which an overload or ground fault has occurred

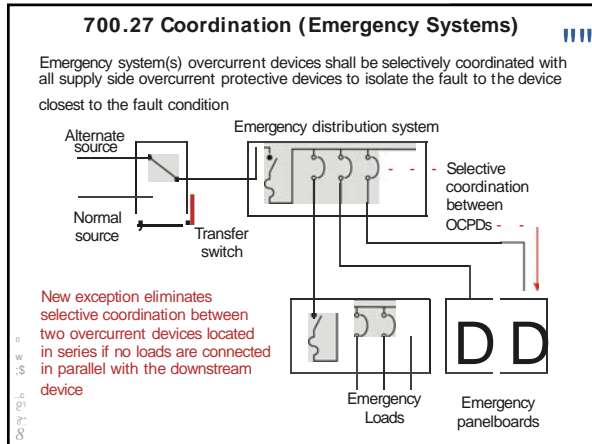



700.28 Selective Coordination (Emergency Systems)

A licensed professional engineer or other qualified persons must design and select the selective coordination of the overcurrent protective devices for emergency systems.

In an effort to aid in the enforcement of this essential issue with emergency systems, this new language seeks to identify who is responsible for the design and selection of the OCPD for selective coordinated for emergency systems.

New requirement also provides verified selective coordination documentation as part of the construction documents available to the AHJ.

Emergency systems are an important enough aspect of the overall electrical system that justification is warranted to selective coordination being performed by a licensed professional engineer or a "qualified person."

700.28 Selective Coordination (Emergency Systems) (cont.)

A licensed professional engineer or other qualified persons must design and select the selective coordination of the overcurrent protective devices for emergency systems.

This same new "licensed professional engineer or other qualified persons" selective coordination provision was implemented at the following locations during the 2014 *NEC* development process:

- 620.62 Elevators, Escalators, (Etc.)
- 701.27 Optional Standby Systems
- 708.54 Critical Operations Power Systems (COPS)

700.28 Selective Coordination (Emergency Systems) C1)

A licensed professional engineer or other qualified persons must now design and select the selective coordination of the overcurrent protective devices for emergency systems

Documentation is required to be made available to those authorized to design, install, inspect, maintain, and operate the system

This same new "licensed professional engineer or other qualified persons" selective coordination provision was implemented at the following locations:

- 620.62 Elevators, Escalators, (Etc.)
- 701.27 Legally Required Standby Systems
- 708.54 Critical Operations Power Systems (COPS)



© Mike Holt, Inc.

Article 701—Legally Required Standby Systems

Legally required standby systems provide electric power to aid in firefighting, rescue operations, control of health hazards, and similar operations, and are required by federal, state, municipal, or other regulatory codes.

701.1 Scope

The provisions of Article 701 apply to the installation, operation, and maintenance of legally required standby systems.

701.2 Definitions

Legally Required Standby System. Those systems classed as legally required by any governmental agency having jurisdiction.

These systems are intended to automatically supply power to selected loads (other than emergency circuits) in the event of failure of the normal power source.

701.2 Definitions

FPN: Legally required standby systems typically supply loads that, when stopped, could create hazards, or hamper rescue or firefighting operations.

701.5 Tests and Maintenance

Legally required standby system testing consists of acceptance testing and operational testing.

701.5 Tests and Maintenance

(A) Conduct or Witness Test. To ensure that the legally required standby system meets or exceeds the original installation specification, the AHJ must conduct or witness an acceptance test of the emergency system upon completion of the installation, and periodically afterward.

701.5 Tests and Maintenance

(B) Tested Periodically. Legally required standby systems must be periodically tested to ensure that adequate maintenance has been performed and that the systems are in proper operating condition.

Running the legally required standby system to power the loads of the facility is often considered an acceptable method of operational testing.

701.5 Tests and Maintenance

(C) Battery Systems Maintenance. Where batteries are used, the AHJ is to require periodic maintenance.

701.5 Tests and Maintenance

(D) Written Record. A written record must be kept of all required tests and maintenance.

701.5 Tests and Maintenance

(E) Testing Under Load. Means for testing all legally required standby systems, with the maximum anticipated load condition, must be provided.

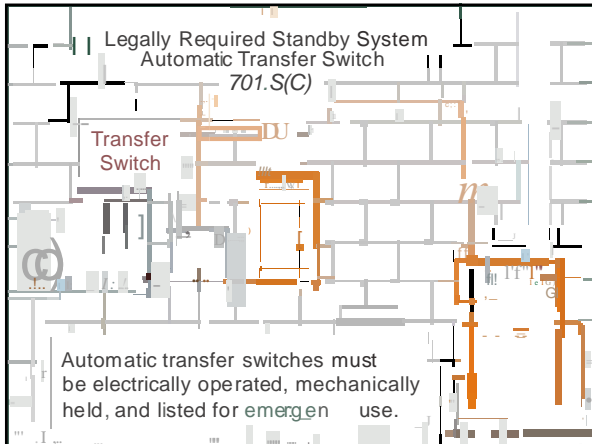

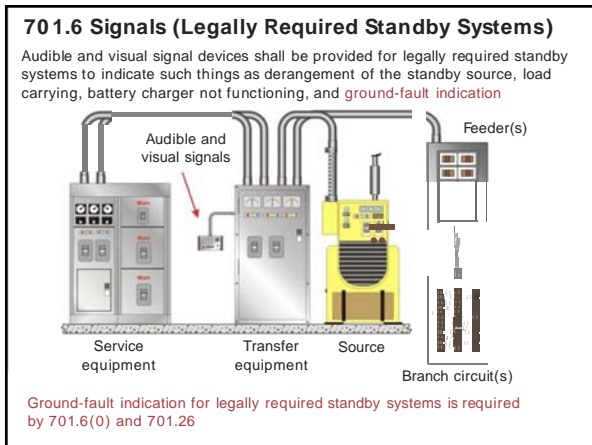





701.6 Capacity and Rating

A legally required standby system must have adequate capacity to carry safely all loads that are expected to operate simultaneously.

www.NECcode.com

Mike Holt Enterprises, Inc. ©

161

701.6 Capacity and Rating

The legally required standby alternate power source can supply legally required standby and optional standby system loads where:

- (1) The alternate power source has adequate capacity.
- (2) Where automatic selective load pickup and load shedding ensures adequate power to the legally required standby circuits.

www.NECcode.com

Mike Holt Enterprises, Inc. ©

162

701.7 Signs.

(Amd) **(A) Mandated Standby.** A sign shall be placed at the service entrance, at the meter location, and on any equipment up to the service-entrance equipment indicating type and location of on-site legally required standby power sources.

Exception: A sign shall not be required for individual unit equipment as specified in 701.12(G).

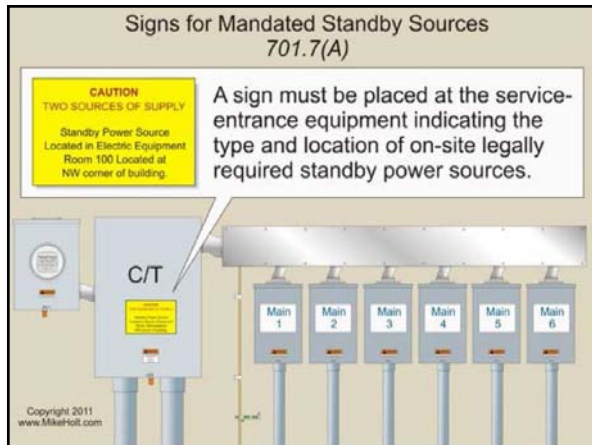

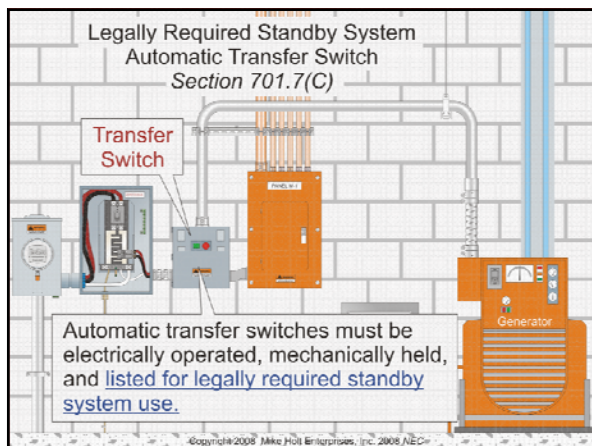

701.10 Wiring

Legally required standby system wiring can occupy the same raceways, cables, boxes, and cabinets with other general wiring.

701.11 Legally Required Standby Systems

If the normal supply fails, legally required power must be available within 60 seconds.

701.11 Legally Required Standby Systems

- (B) Generator Set.
- (5) Outdoor Generator Sets. Where an outdoor-housed generator is equipped with a readily accessible disconnecting means located within sight (within 50 ft) of the building or structure, an additional disconnecting means isn't required on or at the building or structure for the generator feeder conductors that serve or pass through the building or structure. Fig 701-3

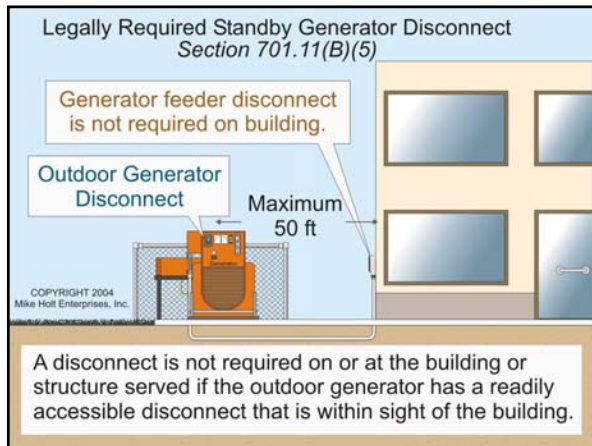

701.11
Legally Required Standby Systems

(D) Separate Service. An additional service can be used as a source of power, where acceptable to the AHJ. Fig 700-4

www.NECCode.com Mike Holt Enterprises, Inc. 170

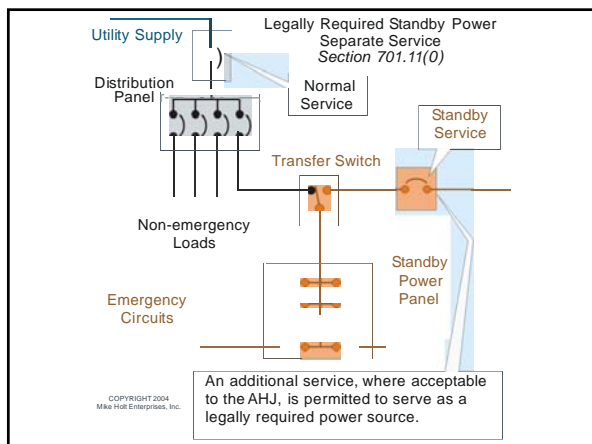

701.11
Legally Required Standby Systems

(E) Connection Ahead of Service Disconnecting Means. Where acceptable to the AHJ, connection located ahead of, but not within, the same cabinet, enclosure, or vertical switchboard section as the service disconnecting means is permitted.
Fig 701-5

www.NECode.com Mike Holt Enterprises, Inc. 172

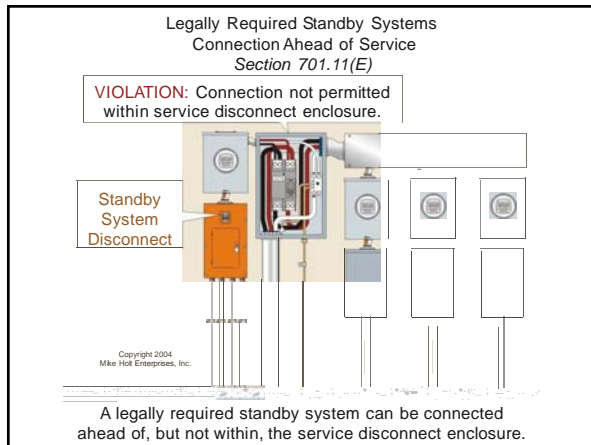

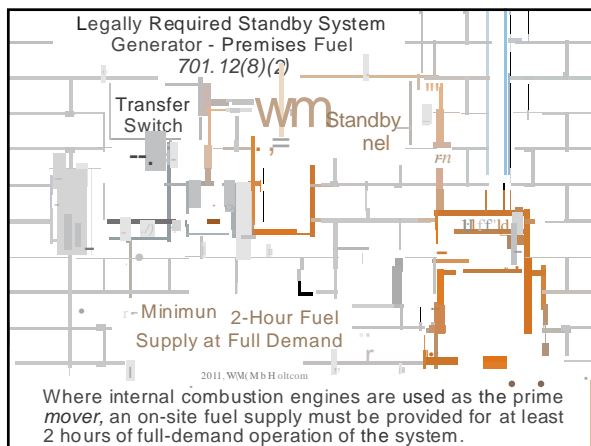

Legally Required Standby Generator Disconnect
701.12(8)(5)

Generator Feeder Disconnect
isn't Required on Building

Outdoor Generator
Disconnect

Maximum
50 ft

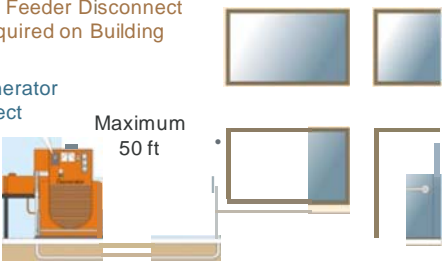

Copyright 2011
www.tuhott.com

A disconnect isn't required on or at the building or structure served if the outdoor generator has a readily accessible disconnect that's within sight of the building.

Legally Required Standby Power Separate Service
701.12(0)

Utility Supply

Distribution Panel

Normal Service

Transfer Switch

Standby Service

Utility Supply

Standby Power Panel

Non-Emergency Loads

Legally Required Circuits

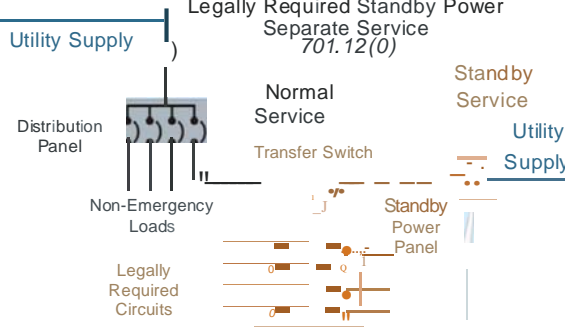

An additional service, where approved by the AHJ, is permitted to serve as an emergency power source.

Legally Required Standby Systems Connection Ahead of Service
701.12(E)

VIOLATION: Connection isn't permitted within the service disconnect enclosure.

Standby System Disconnect

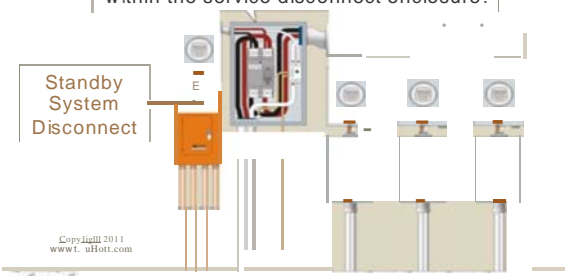

Copyright 2011
www.tuhott.com

A legally required standby system can be connected ahead of, but not within, the service disconnect enclosure.

701.15 Accessibility

The branch-circuit overcurrent protection devices for legally required standby circuits must be accessible to authorized persons only.

www.NECcode.com

Mike Holt Enterprises, Inc. ©

178

701.18 Coordination

Overcurrent protection devices for legally required power systems must be selectively coordinated with all supply-side overcurrent protective devices.

www.NECcode.com

Mike Holt Enterprises, Inc. ©

179

Article 702—Optional Standby Power Systems

Optional standby systems are intended to protect public or private facilities; or property where life safety doesn't depend on the performance of the system.

©MikeHolt.com

Slide 180

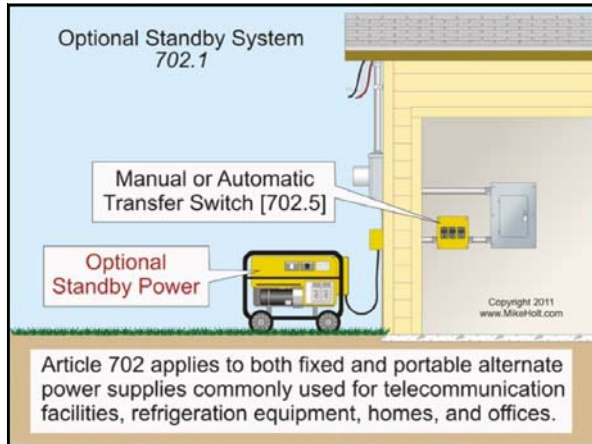

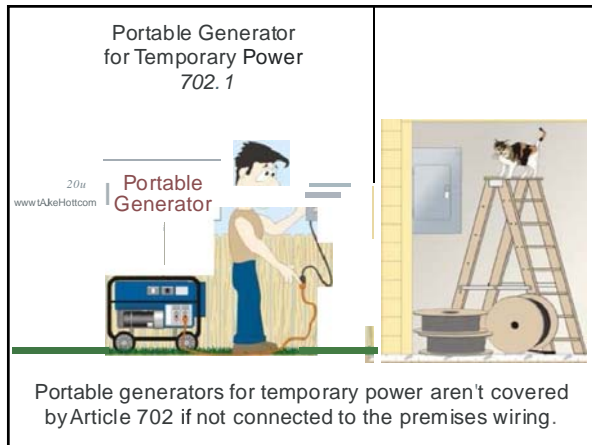

702.1 Scope

The systems covered by Article 702 consist of those that are permanently installed, including prime movers, and those that are arranged for a connection to a premises wiring system from a portable alternate power supply. Fig 702-1

www.NECode.com Mike Holt Enterprises, Inc. 183



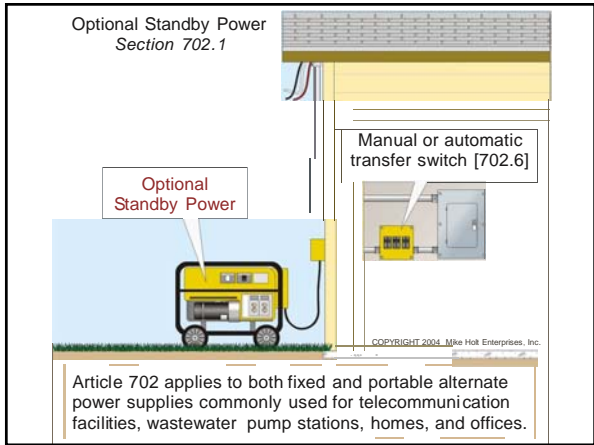

702.1 Scope

A portable generator used for temporary power, like those used on construction sites, doesn't fall within the scope of Article 702 unless the generator is connected to the premises wiring. Fig 702-2

www.NECcode.com Mike Holt Enterprises, Inc. © 186

702.2 Definition

Optional Standby Systems. Optional standby systems are intended to supply power to public or private facilities or property where life safety doesn't depend on the performance of the system.

702.2 Definition

FPN: Optional standby systems typically provide electric power for processes that, when stopped could cause discomfort, economic loss, serious interruption of the process, or damage to the product or process.

702.5 Capacity and Rating

An optional standby system must have adequate capacity to carry safely all loads that are expected to operate simultaneously.

The user of the optional standby system can select the loads connected to the system.

702.5 Capacity and Rating

Manual Transfer Switch - When a manual transfer switch is used, the user of the optional standby system selects the loads to be connected to the system, which determines the system size.

©MikeHolt.com

Slide 190

702.5 Capacity and Rating

The sizing for optional standby power systems is now based on the type of transfer switch used; manual versus automatic.

©MikeHolt.com

Slide 191

ASSEMBLY 0C3751 81AM		GENERATOR SET DATA		MADE IN USA
MODEL	0047460	SERIAL	4010206	
TYPE CODE	SG025-A161.5N36PDSYC	ENGINE NO.	0A4531A	
RATED KW	25	RATED KVA	25	UPSIZING ALT.KW [N/A]
VOLTS	120/240	AMPS	208.4/104	
PHASE	1	POWER FACTOR	1.0	HERTZ 60
ALT. R.P.M.	3600	ENG. R.P.M.	3600	PROD. DATE 10/26/04
GENERAC POWER ELECTRIC, INC. WAUKESHA, WI				
CLASS <input type="checkbox"/> ROTOR <input type="checkbox"/> STATOR WINDING INSULATION AT 40°C AMBIENT				
UNIT CONFIGURED FOR: VOLTAGE HERTZ PHASE				

Standby System Capacity - Automatic Transfer Equipment
702.4(B)(2)(a)



The optional standby power source must have adequate capacity to supply the full load transferred.

Copyright 2011, www.MikeHolt.com

Standby System Capacity
702.4(B)



Optional Standby Power

For existing facilities, the optional standby source can be sized to the maximum demand data available for 1 year, or the average power demand of a 15-minute period over a minimum of 30 days [220.87].

Copyright 2011 www.MikeHolt.com

702.6 Transfer Equipment

A transfer switch is required for all fixed or portable optional standby power systems.

www.NECode.com Mike Holt Enterprises, Inc. © 195

702.6 Transfer Equipment

Ex: Transfer switch not required for temporary connection, where written safety procedures and conditions of maintenance and supervision ensure that only qualified persons will service the installation if:

- The normal supply is physically isolated by a lockable disconnecting means or
- The normal supply conductors are disconnected.

www.NECode.com

Mike Holt Enterprises, Inc. ©

196

702.7 Signs.

(Amd) (A) **Standby.** A sign shall be placed at the service-entrance equipment, at the meter location, and on any equipment up to the service-entrance equipment that indicates the type and location of on-site optional standby power sources. A sign shall not be required for individual unit equipment for standby illumination.

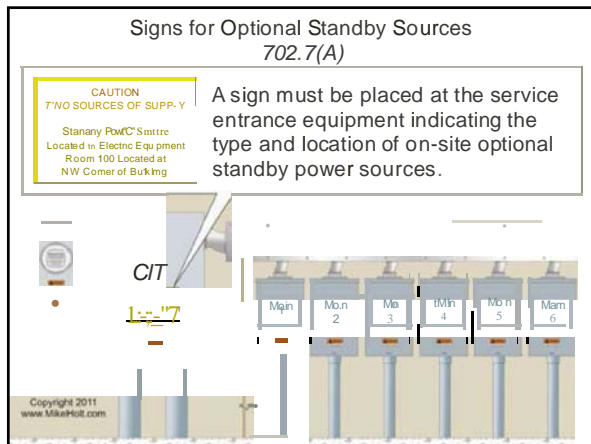

702.7(C) Signs for Power Outlet (Optional Standby Systems)

Optional standby system power inlets used for a temporary connection to a portable generator require a warning sign to be placed near the inlet to indicate the type of derived system involved (*bonded or floating neutral*).

The warning sign would indicate a separately derived (bonded neutral) system or a non-separately derived (floating neutral) system.

What determines if a generator is not a separately derived system is if the grounded (neutral) conductor is solidly interconnected to a service-supplied system grounded conductor.

New manufacturer's marking provision has been added at 445.11 requiring indication whether or not the generator neutral is bonded to the generator frame.

702.7(C) Signs for Power Outlet (Optional Standby Systems) (cont.)

Optional standby system power inlets used for a temporary connection to a portable generator require a warning sign to be placed near the inlet to indicate the type of derived system involved (*bonded or floating neutral*).

**WARNING:
FOR CONNECTION OF A SEPARATELY DERIVED
(BONDED NEUTRAL) SYSTEM ONLY**

OR

**WARNING:
FOR CONNECTION OF A SEPARATELY DERIVED
(FLOATING NEUTRAL) SYSTEM ONLY**

702.7(C) Signs for Power Outlets



Optional standby system power inlets used for temporary connection to a portable generator require a warning sign to be placed near the inlet to indicate the type of derived system involved (*bonded or floating neutral*)

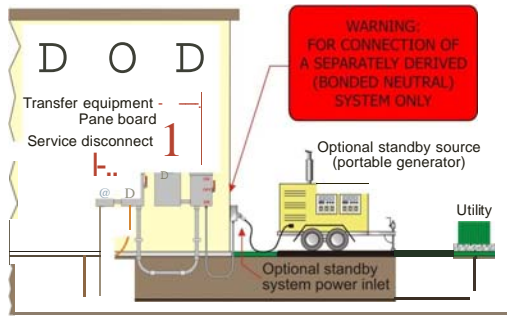

702.9 Wiring

The optional standby system wiring can occupy the same raceways, cables, boxes, and cabinets with other general wiring.

**702.10
Portable Generators**

Generators must be grounded and bonded in accordance with 250.30 or 250.34. Fig 702-4

Optional Standby Power
Portable Generator Grounding
Section 702.10

Portable generators must be grounded in accordance with the requirements of Article 250, specifically 250.30 and 250.34.

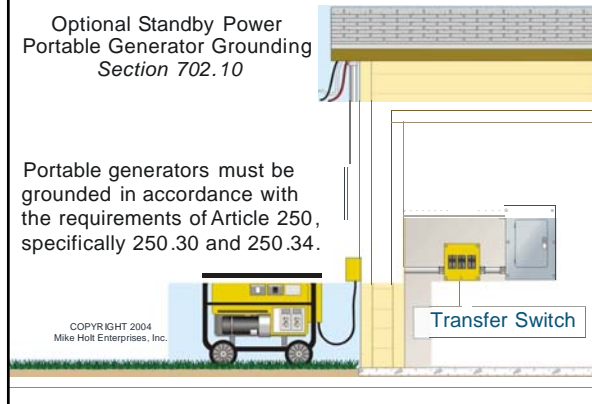

702.11 Outdoor Generator Sets

Where an outdoor-housed generator is equipped with a readily accessible disconnecting means that is located within sight of the building or structure, an additional disconnecting means isn't required for the generator feeder conductors that serve or pass through the building or structure.

www.NECode.com Mike Holt Enterprises, Inc. © 205

702.12 Outdoor Generator Sets

Outdoor generator sets has been divided into two subsections:

- ❖ 702.12(A) Permanently Installed Generators and Portable Generators Greater Than 15 kW.
- ❖ 702.12(B) Portable Generators 15 kW or Less.

Portable generators (*rated 15 kW or less*) using a flanged inlet or other cord- and plug-type connection, permitted to omit a disconnecting means where ungrounded conductors serve or pass through a building or structure.

702.12(A) incorporated a new reference to 445.18 for an outdoor housed generator set equipped with a readily accessible disconnecting means located within sight of the building or structure supplied.

Outdoor Generator Sets - Generator Disconnect 702.12

Generator Feeder Disconnect
Not Required on Building

Outdoor Generator
Disconnect

Maximum
50 ft

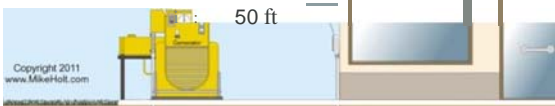

A disconnect isn't required on or at the building or structure if the generator disconnect is readily accessible and within sight of the building. _____

702.12 Outdoor Generator Sets (cont.)

Small portable generators connected by means of a flanged inlet and a flexible cord- and plug-type connection were not considered with regard to the disconnecting means at the building or other structure supplied required by 225.31 in previous text.

These small portable generators (*found mostly in residential applications*) are often installed without a disconnecting means other than the above-mentioned flanged inlet and flexible cord.

